

San Francisco

October, 1923

RADIO



UNIVERSITY OF CALIFORNIA
 AT LOS ANGELES
 AUG 20 1936
 LIBRARY

John
 MARICOVA
 Kelly

25 Cents

*Worthwhile
Articles by:*

Dr. F. A. Kolster
 S. G. McMeen
 D. B. McGown

Lloyd Jacquet
 Jesse Marsten
 Paul Oard

R. F. Yates
 Edward T. Jones
 L. H. Montagne



It Bridges the Vastness of Space

SINCE Marconi first successfully spanned the Atlantic Ocean, with the wireless telegraph, radio has ever been outstanding as an invention of unlimited importance to humanity.

In 1909 the broadcasting of that now famous distress call, CQD, from the sinking passenger liner, S. S. Republic, established in the eyes of the entire world the tremendous importance of radio on the high seas.

In 1912, when that gigantic liner, the S. S. Titanic, struck an iceberg far from shore, in the north Atlantic, with thousands of passengers aboard, it was the SOS call of her wireless that brought rescue ships from all parts of the ocean. Here again radio demonstrated to the world its great service in the saving of human life.

During the war communication controlled the destinies of armies. Here radio played an exclusive part in the establishing of communication between ships at sea, from ship to shore, and from aeroplane to ground, where the use of wires was impossible.

In recent years the development of the vacuum tube has not only improved radio for the purpose of marine, commercial and military communications, but through radio telephony and public broadcasting, has established a new and even greater service to humanity.

Cunningham Vacuum Tubes are the product of years of research and experimental work by the Engineers of that great scientific organization, the Research Laboratory of the General Electric Company.

Cunningham Tubes are standard for all makes of receiving sets. Each of the numerous types have been designed to operate with maximum efficiency in one or more of the various applications of vacuum tubes to the radio art.

*A Specially
Designed Tube
For Every
Radio Use*

Patent Notice: *Cunningham tubes are covered by patents dated 11-7-05, 1-15-07, 2-18-08, and others issued and pending. Licensed for amateur, experimental and entertainment use in radio communication. Any other use will be an infringement.*

Cunningham Radio Tubes	
C-301A—6 Volts ¼ amp. Amplifier	\$6.50
C-299—3 Volts .06 amp. Dry Battery Det. & Amp.	6.50
C-300—6 Volts Gas Content Detector	5.00
C-11—1.1 Volts .25 amp. Dry Battery Det. and Amp. Special Base.	6.50
C-12—Similar to C-11 with standard base.	6.50

E. J. Cunningham Inc.



Home Office:
248 First Street
San Francisco, Calif.

154 West Lake Street
Chicago, Illinois

30 Church Street
New York City, N. Y.

No wireless receiving set complete without

Magnavox Radio

The Reproducer Supreme

IT has been the dream of every Radio user to own in one unit a Power Amplifier and electro-dynamic Reproducer, thus insuring perfect Radio reproduction.

After exhaustive study and tests by our engineers, this has been successfully accomplished, and the new instruments of the unit type here illustrated in one and two stages of amplification may now be had through Magnavox dealers everywhere.

There is now a Magnavox for every receiving set. The full line embraces:

Magnavox Reproducers

- R2 with 18-inch curvex horn . \$60.00
- R3 with 14-inch curvex horn . 35.00
- M1 with 14-inch curvex horn.
Equipped with binding posts
and a five foot flexible cord;
requires no battery for the field. 35.00

Magnavox Combination Sets

- A1-R consisting of electro-dynamic Reproducer with 14-inch curvex horn and 1-stage of amplification 59.00
- A2-R consisting of electro-dynamic Reproducer with 18-inch curvex horn and 2 stages of amplification 95.00
- Special: with 14-inch curvex horn as illustrated . . . 85.00

Magnavox Power Amplifiers

- A1—new 1-stage Power Amplifier 27.50
- AC-2-C—2-stage Power Amplifier 55.00
- AC-3-C—3-stage Power Amplifier 75.00

Magnavox Products can be had of good dealers everywhere. Ask for a demonstration.

THE MAGNAVOX CO.

OAKLAND, CALIFORNIA

370 Seventh Ave., New York

World pioneers in the development and manufacture of sound amplifying apparatus



UNIVERSITY OF CALIFORNIA
AT LOS ANGELES
AUG 20 1936
LIBRARY

**New Magnavox
Combination Set**

A2-R insures convenient and perfect Radio reproduction. Designed especially to meet the requirements of receiving sets used in the home.

Magnavox Reproducers and Amplifiers

Tell them that you saw it in RADIO

RADIO

Established 1917 as Pacific Radio News

Volume V

for OCTOBER, 1923

Number 10

CONTENTS for OCTOBER, 1923

Radiatorial Comment	9
Resonance Wave Coil for Reducing Static, By S. R. WINTERS.....	10
A Simple Talk on Radio, By DR. F. A. KOLSTER.....	11
The Four-Circuit Tuner, By LLOYD JACQUET.....	13
Wanted—More Standardization, By RAYMOND FRANCIS YATES.....	16
Improving Amplification, By SAMUEL G. MCMEEN.....	17
The Universal Receiving Set, By EDWARD T. JONES.....	19
On Being A Radio Operator, By COLIN KELLEY.....	20
A Power Box Drama, By PAUL OARD.....	21
Design of Transmitter Equipment, By D. B. MCGOWN.....	22
How to Prolong Tube Life, By JESSE MARSTEN.....	22
Design and Computation of Aerials, By L. M. MONTAGNE.....	23
Improving the Single-Circuit Receiver, By PAUL OARD.....	25
Home Radio Shop Practice, By D. B. MCGOWN.....	26
Rigging Up The Radio Shop, By RAYMOND FRANCIS YATES.....	27
How a Vacuum Tube Works, By H. M. FREEMAN.....	28
The Design and Function of Inductance Coils, By JESSE MARSTEN..	29
How to Measure Transformer Losses, By L. R. FELDER.....	32
Wired Radio For Broadcasting Purposes, By BERT T. BONAVENTURE	33
Queries and Replies on C. W. Practice, By GERALD M. BEST.....	35
Puncture-Proof C. W. Power Condensers of High Capacity.....	36
By DR. A. E. BANKS	
X-L Filament Tubes	37
Digest of Recent Radio Patents.....	38
With The Amateur Operators.....	39
Calls Heard	40
Letters To The Editor.....	41
New Apparatus and Supplies from the Radio Manufacturers.....	42

RADIO is Published Monthly by the Pacific Radio Publishing Co., Inc.,
Pacific Building, San Francisco, Calif.

ARTHUR H. HALLORAN	Editor
LAWRENCE MOTT	Associate Editor
LOUIS TREVISIO	Art Editor
GERALD M. BEST	Technical Adviser
G. E. BURKS	Engineering Draughtsman
H. W. DICKOW	Advertising Manager

Branch Offices: 17 West 42nd St., New York City, Telephone Longacre 8248; 157E. Ontario St., Chicago; 761 Spitzer Bldg., Toledo, Ohio; 52 Irving Street, Boston, Telephone Copley 5107-R; 1102 Republic Bldg., Kansas City, Mo.; Suite 511, 456 So. Spring St., Los Angeles, Cal., Telephone 12050; 2218 Third W., Seattle, Wash., Telephone Elliot 1903.

European Representatives: Compagnie Universelle De Representation wt de Commerce. Rue des Fortifications, 69, Anvers, Belgium.

Advertising Forms Close on the First of the Month Preceding Date of Issue.

Issued Monthly, 25c a copy. Subscription price \$2.50 per year in the U. S., \$3.00 per year elsewhere. Instructions for change of address should be sent to the publisher two weeks before the date they are to go into effect. Both old and new addresses must always be given.

Entered as second-class matter at the Post Office at San Francisco, Calif., under the Act of March 3, 1879.

Copyright 1923, by the Pacific Radio Publishing Co., Inc.

\$500.00 Prize Cover Contest

To call forth readers' ideas as to what they would like to see as front cover illustrations during 1924 the publishers offer \$500.00 in prizes for the best suggestions submitted. These are divided into twelve capital prizes for ideas actually adopted and eighty-eight other prizes to reward those who send in suggestions.

The contest is open to every reader. Ideas are wanted, not finished drawings. These ideas will be submitted to the artists who are designing the covers and they will make the paintings in color. Consequently, a word picture or rough sketch is all that is needed.

The requisites for a front cover illustration are that it should attract favorable attention, embody some application of radio, and, if possible, contain an element of humor. It should be dignified and yet human. Each suggestion should be made with a particular month in mind so as to be seasonable. For instance, the summer months' covers might show the use of radio out-of-doors. The capital prizes will be awarded on the basis first of merit and second of appropriateness for a given month.

The prizes are as follows:

- 1st prize—\$125.00 Cardwell R. F. Receiver.
- 2nd prize—\$25.00 Atlas Amplitone.
- 3rd prize—\$25.00 Atlas Amplitone.
- 4th prize—\$13.50 Atlas Amplitone Unit.
- 5th prize—\$13.50 Atlas Amplitone Unit.
- 6th prize—\$8.00 Atlas Adjustable Diaphragm Phones.
- 7th prize—\$8.00 Atlas Adjustable Diaphragm Phones.
- 8th prize—\$8.00 Atlas Adjustable Diaphragm Phones.
- 9th prize—\$8.00 Atlas Adjustable Diaphragm Phones.
- 10th prize—\$8.00 Atlas Adjustable Diaphragm Phones.
- 11th prize—Gottschalk Loud Speaker.
- 12th prize—Gottschalk Loud Speaker.
- 13th-22nd prizes—Chelton Midget Vernier Variable Condenser.
- 23rd-32nd prizes—Standard Radio Record Book.
- 33rd-42nd prizes—A. C. Variable Condenser.
- 43rd-62nd prizes—Citizen Radio Call Book.
- 63rd-72nd prizes—A. C. Variometer.
- 73rd-82nd prizes—Work-Rite Variocoupler.
- 83rd-100th prizes—C. W. Manual.

With such a large list of prizes every worthwhile idea is assured a reward, even if it does not win a capital prize.

The judges of the contest are Col. J. F. Dillon, Inspector Sixth Radio District; Louis Treviso, Art Editor of RADIO; Arthur Halloran, Editor of RADIO.

The contest opens October 1, 1923, and closes October 31st, 1923. Announcement of winners will be made in the December issue and the January cover will be one of the prize winners. Prizes will be sent as soon as the judges announce their decisions.



“Music and Beauty make life pleasant”
Yang Chu.

The New GREBE Broadcast Receiver
delights both ear and eye—

Doctor My.

REGENERATION and Tuned Radio Frequency Amplification find their first successful combination in this Receiver. The 20-foot silk-covered wire, readily concealed behind the picture moulding, is the only antenna required. The attractively finished walnut cabinet has compartments for all necessary batteries. Write for “GREBE Radio in the Well-Appointed Home”



GREBE RADIO

Licensed under
Armstrong U. S.
Pat. No. 1113149

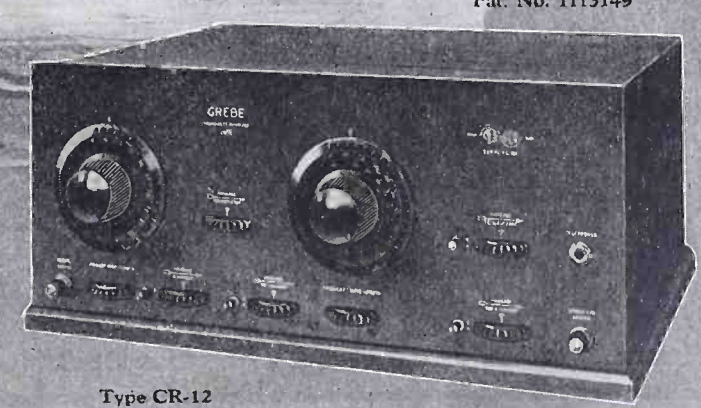

Type CR-12

A. H. GREBE & COMPANY, Inc.
Richmond Hill, N.Y.
Western Branch, 451 East 3rd St., Los Angeles, Cal.

Tell them that you saw it in RADIO



“What panel shall I use?”

ONE of the first questions you probably will ask yourself when you get ready to build your radio set will be about the choice of a good panel. Your answer will determine, to a large extent, the efficiency of your set.

Of course you want a panel that has superior insulating properties. Celoron Radio Panels are used by fans who appreciate the value of a good radio panel. They have high dielectric strength and great volume and surface resistivity. Celoron panels are uniform in quality, and do not warp or crack.

You will find Celoron panels easy to saw, drill, and tap. They engrave evenly without feathering, and enable you to build a set that is neat and attractive as well as efficient.

Approved by Uncle Sam

Celoron Radio Panels are approved by the U. S. Navy Department Bureau of Engineering and the U. S. Signal Corps. Many of the leading manufacturers of

radio equipment use Celoron in their standard parts.

Each panel is wrapped separately in glassine paper and carries complete instructions for working and finishing. Ask your dealer for one of the following sizes:

1—6 x 7 x $\frac{1}{8}$	5—7 x 18 x $\frac{3}{8}$
2—7 x 9 x $\frac{1}{8}$	6—9 x 14 x $\frac{3}{8}$
3—7 x 12 x $\frac{1}{8}$	7—7 x 21 x $\frac{3}{8}$
4—7 x 14 x $\frac{3}{8}$	8—7 x 24 x $\frac{3}{8}$
9—12 x 14 x $\frac{3}{8}$	

We also furnish Celoron in full-sized sheets and can cut special sizes if desired. If your dealer has not yet stocked Celoron panels, ask him to order for you, or write direct to us. Indicate by number the size you want.

Send for free booklet

Our booklet, “Tuning in on a New World,” contains a list of the leading broadcasting stations in the United States and Canada, several efficient radio hook-ups, and an explanation of the symbols used in radio diagrams. Write at once and be sure of getting yours before the supply is exhausted.

To radio dealers: Send for special dealer price list showing standard assortments

Diamond State Fibre Company

BRIDGEPORT (near Philadelphia) PENNSYLVANIA

BRANCH FACTORIES AND WAREHOUSES

BOSTON CHICAGO SAN FRANCISCO

Offices in Principal Cities

In Canada: Diamond State Fibre Company of Canada, Limited, 245 Carlaw Ave., Toronto

CONDENSITE
CELORON
 STANDARD RADIO PANEL

Tell them that you saw it in RADIO

A New Thrill

Should be a part of your radio equipment

Clear reception with plenty of volume is necessary to satisfactorily listen to distant stations:

Kellogg head sets should not be classed as ordinary radio receivers. Today Kellogg stands foremost in the manufacture of a high-grade head set that actually surprises listeners in comparative tests.

Maximum volume, unusual clearness, extreme lightness in weight, are a few of the many outstanding advantages. The head band is unusually light, though durably built. The receivers are easily adjusted to fit the head, and can be detached from the holders when desired.

The magnets are of special tested steel and hardened by our own special method which controls the heat and time electrically and mechanically, eliminating any possible variation as when manually controlled.

The magnet windings are of great accuracy, the mountings, end plates, wire, insulation, etc. are of the highest grade and of the best material suited for the purpose.

Our twenty-five years experience in building receivers for telephone work has proven invaluable in turning out a real radio receiver of merit.

Hundreds of voluntary testimonial letters tell us of the superiority of Kellogg head sets in actual comparative tests, barring none.

Listen-in tonight with a pair of Kellogg receivers and get a new thrill from your radio set. Kellogg radio products are all in a class by themselves from a quality, service and appearance standpoint. With Kellogg radio equipment, USE IS THE TEST.

KELLOGG SWITCHBOARD & SUPPLY COMPANY
CHICAGO

COLUMBUS

KANSAS CITY

SAN FRANCISCO

PORTLAND

Kellogg apparatus exclusively is used in building The Symphony Receiver

Tell them that you saw it in RADIO

The Royalty



of Radio

New Additions to

Beautiful New Furniture Models— Simplified Tuning—Self-contained

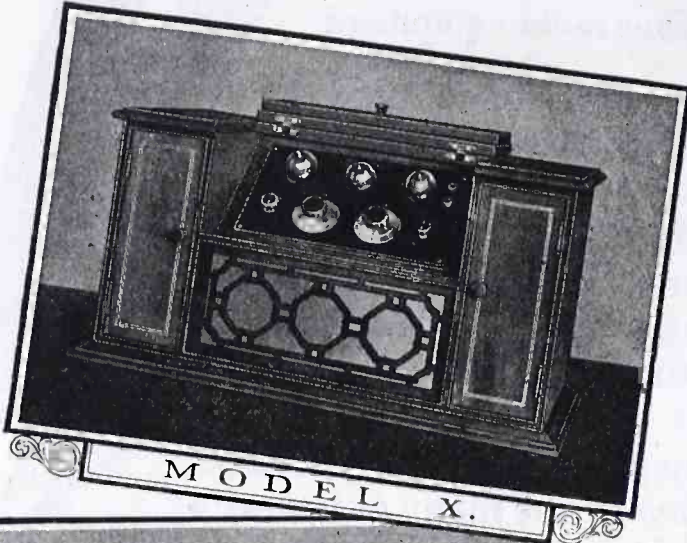

MODEL X.

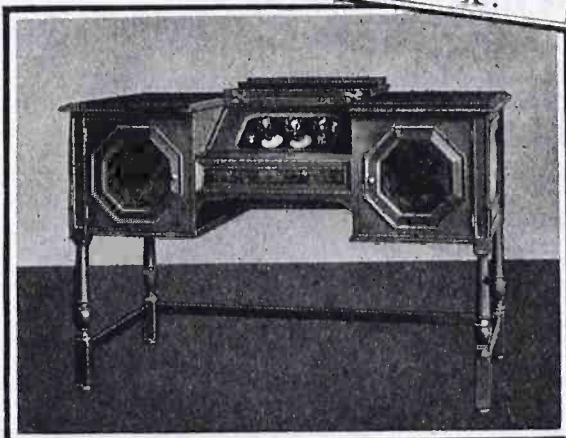

JACOBEAN CONSOLE MODEL



SPANISH DESK MODEL

The three new Kennedy Furniture Models illustrated on this page are the very last word in radio receiving sets. Even if attention were drawn no further than their exterior beauty, their purity and harmony of design alone would be instantly appreciated.

The receiver in each is a new achievement of the Kennedy Engineering Staff. Extreme simplicity of tuning is attained with the same selectivity and long-distance reception that have made Kennedy sets so well and favorably known. Only two dials are used—one for "tuning in" or selecting the desired station, the other to control sound volume. Adjustment is provided for very fine tuning.

These models are complete and self-contained. They operate on dry battery tubes for which internal space is provided, although any standard tubes—including storage battery type—may be used. Two stages of audio amplification—built-in loud speaker with unusually clear and distortionless qualities of reproduction. Highly polished Formica control panels. Gold-plated metal trimmings on front—including dials. Respond to all broadcasting wave-lengths. Each complete with three dry-battery tubes, all dry batteries and Kennedy 3000-ohm phones with plug, for individual reception.

Kennedy Model X. Beautiful hand rubbed Mahogany cabinet with inlay of Satin Wood and Ebony. The tracery, in delicate contrast with background, is suggestive of the marquetry workers of King William's time. Price, complete.....\$285.00

Kennedy Jacobean Console Model. Exemplifies the late Jacobean design. Built of American Walnut with artistically matched paneling, which contributes the rich subdued effect almost always associated with true elegance. Price, complete.....\$775.00

Kennedy Spanish Desk Model. An adaptation of the Spanish with a free intermingling of the effects of the Moorish influence. This is particularly in evidence in the panel. Cabinet finished either in Mahogany or American Walnut. Interior lined completely with Golden Bird's-eye Maple. Price, complete....\$825.00

KENNEDY

The Royalty  of Radio

the Kennedy Line

A New Popular-Priced Model, Head Phones and Loud Speaker

The apparatus shown on this page is of the same high character as the more elaborate Furniture Models. The sets were designed to fill the demand for high quality at a popular price, and, with the wonderfully improved head phones and separate loud speaker unit, they provide Kennedy apparatus for every home.

Kennedy Model V. Incorporates the new Kennedy receiver and two-stage amplifier at moderate cost. Same type of radio unit as higher priced Furniture Models, but without loud speaker. Highly polished Formica control panel. German silver dials. Space for batteries. All dry batteries, three dry-battery tubes and Kennedy phones with plug, complete..\$125.00
Receiver only, without phones, tubes or batteries....\$ 86.50

Kennedy Type-281. One of the sets that has won recognition for the Kennedy line. An extremely selective three-circuit receiver. Solid Mahogany cabinet. Brilliantly polished Formica control panel, black etched dials, heavily nickel-plated metal parts. Wave-length range 175 to 900 meters. Designed for 6-volt tubes but can be used with dry-battery tubes as well.
Receiver only.....\$ 90.00
Receiver and two-stage audio amplifier.....\$145.00

Kennedy Type-311, 522 Portable. Neat, compact, portable. Easily tuned—highly selective and efficient. Designed for all standard tubes, including dry-battery type. Detector and two stages of audio amplification. Wave-length range 150 to 600 meters. Complete with three dry-battery tubes, all dry batteries and Kennedy phones, with plug.....\$137.50

Kennedy Loud Speaker. The same as used in the new Kennedy Furniture Models. Remarkable fidelity of reproduction with total absence of unpleasant distortion. No separate batteries required. Price, complete with 6 ft. cord..\$30.00

Kennedy Head Phones. Perfection in mechanical and electrical design results in unusual volume with rich tonal purity. No rattle or blare. Extremely sensitive on weak and distant signals. Light and snug fitting. Resistance 3000 ohms. Price per set, with 6 ft. cord.....\$9.00

See the new sets and parts at the nearest Kennedy dealer or write us direct for literature. State type of set in which you are interested.

DEALERS Write or wire for exclusive Kennedy proposition.

THE COLIN B. KENNEDY COMPANY
SAINT LOUIS

SAN FRANCISCO

All Kennedy receiving sets are regenerative—Licensed under Armstrong U. S. Patent No. 1,113,149.

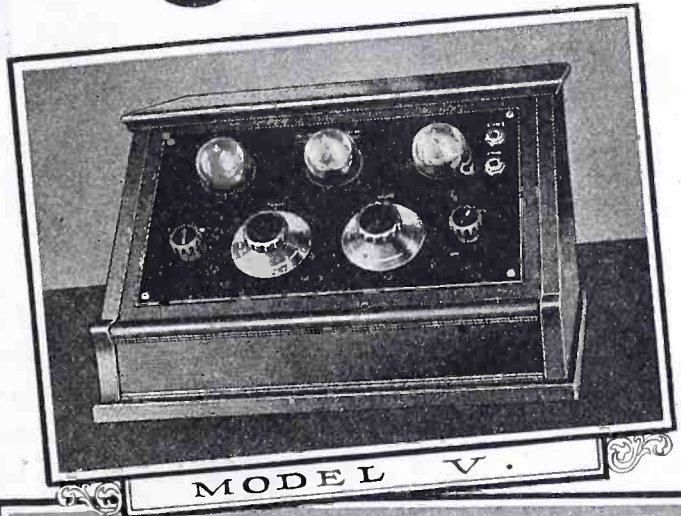

MODEL V.

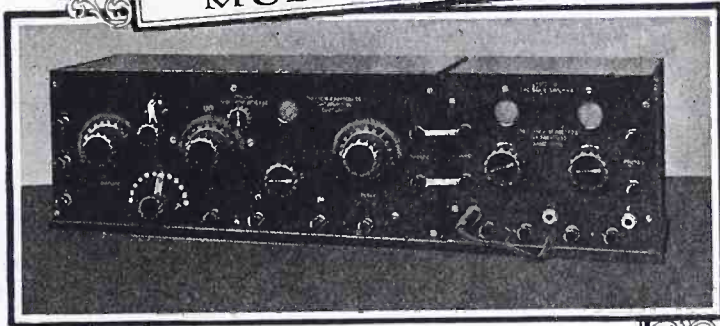

TYPE ~ 281.



PORTABLE COMBINATION SET

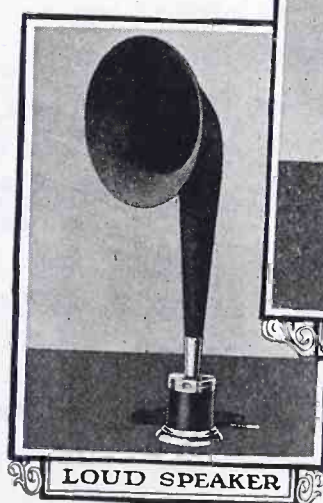

LOUD SPEAKER



PHONES

7

KENNEDY

Tell them that you saw it in RADIO

For Accuracy

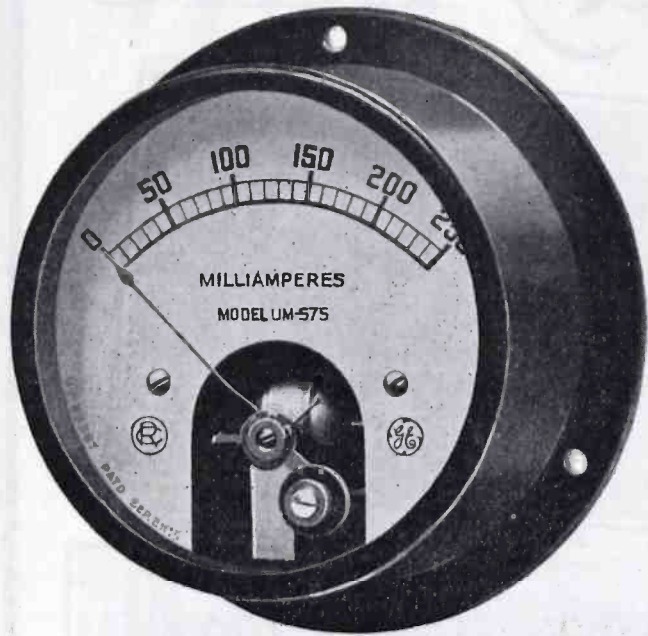

The D. C. Instruments have a high-grade improved D'Arsonval movement; models UM-580 and UM-581 use a thermocouple unit that will stand 30% overload for two minutes.

RCA METERS Type DO

For use with the five watters, there is UM-575 to tell you how many milliamperes the tubes are drawing in the plate circuit—UM-578 to tell you the plate circuit volts—and either UM-530 or UM-580 to register the amperes you are putting into the antenna circuit. These meters will handle four UV-202's used as oscillators.

For use with the "big bottles," the UV-203's, there is UM-576 to show the plate milliamperes—UM-579 to keep track of the high voltage—and either UM-533 or UM-581 to show the antenna circuit amperes. Two UV-203's may be used with this quartet of meters.

UM-575	D. C., 0-250 milli-ammeter	\$15.50
UM-576	D. C., 0-500 milli-ammeter	15.50
UM-578	D. C., 0-500 voltmeter	22.00
UM-579	D. C., 0-1500 voltmeter	40.00
UM-530	Hot Wire Ammeter, 0-2.5	6.00
UM-533	Hot Wire Ammeter, 0-5.0	6.25
UM-580	Thermoammeter, 0-2.5	20.00
UM-581	Thermoammeter, 0-5.0	20.00

Type DO Instruments are of the miniature class, $3\frac{1}{2}$ inches in diameter, full glass front and are of the surface mounting type. They project $1\frac{1}{2}$ -inch from the panel, except models UM-530 and UM-533, which project but $\frac{3}{4}$ -inch. The scale is a silvered background with engraved black markings. The scale does not touch the case which reduces to a minimum danger of shock through contact with the case.

Radio Corporation of America

Sales Dept. Suite 2069
233 Broadway
New York

District Sales Offices
10 So. LaSalle Street
Chicago, Illinois

433 California Street
San Francisco, California

Tell them that you saw it in RADIO

Radiotorial Comment

THE abuse of a privilege generally means its withdrawal. This is what happened when the Department of Commerce prohibited amateur transmission during the evening broadcast hours. But unfortunately the innocent are made to suffer with the guilty. And now comes the question as to how the innocent may regain this privilege.

For it is a mere privilege and not a right, as some amateurs fondly imagined. Repeatedly has this point been emphasized in these columns. But as such warnings were not effective, it became necessary for the Department to issue its drastic restrictions.

There is yet hope that the bars may be let down for the C. W. transmitter which does not interfere with broadcast reception. How this hope may be realized is told by A. H. Babcock elsewhere in these columns. Briefly, the answer is good behavior—the elimination of key thumps, the development of good filters, strict observance of wavelength restrictions, and a due regard for the rights of others. Whenever an amateur or a group of amateurs can prove that these things have been accomplished and will be maintained—when they can come forward with clean hands—then their plea will be likely to be given favorable consideration.

This likelihood is based upon the statement of D. B. Carson, Commissioner of the Bureau of Navigation, to the editor of RADIO that “it is the belief of this office that experience will show that no harm will be done if the amateurs having C. W. transmitters are not required to observe a silent period, and if this proves true the Secretary will no doubt be willing to remove the restrictions from stations of this class.” This is certainly sufficient assurance to warrant an effort to justify and secure the needed changes next year.

BEFORE the wonders of radio become commonplace in the daily performance of the world’s work it is timely to point out that radio today surpasses in romance the wildest dreams of the ancients. The Greek myths or the “Arabian Nights” tell of nothing more marvelous or mysterious. Strange, also, is the fact that radio is actually doing the most picturesquely unusual things of which our forebears could conceive in their fondest imaginings of the conquest of time and space.

Here is a great and powerful genie, bottled up since the dawn of creation, liberated by the genius of Science, and now harnessed to the will of man. Mercury, as the bearer of the messages of the gods, was as slow as a snail when compared with radio as the bearer of the messages of men. In less than a twinkling of an eye, words of hope, warnings of danger, messages of love, the news of the day or the prosaic details of business may be flashed to the uttermost parts of the earth with the speed of light. Nevermore need man be cut off from his fellows. Radio communication has dwarfed the earth.

The adventures of Sinbad the Sailor pale into insignificance in comparison with the life of the modern ship operator who is in touch with all parts of the world in his wanderings over the boundless main, who can summon help with his S. O. S., and even be guided in his course by the radio compass.

Aladdin’s lamp was most insignificant as compared to the vacuum tube, by whose tiny glow the faintest signals may be detected and amplified into stentorian tones, and whose versatility is so great that it is the most powerful transmitter as well as the most sensitive receiver of electromagnetic impulses. And parenthetically it may be added that all the riches of Aladdin, Croesus, and

Midas, rolled together, were as nothing compared with the money that is made through the aid of this wonder talking bottle.

Many years ago Edward Bellamy wrote a book called “Looking Backward.” As the acme of human accomplishments through the centuries it told of being able to hear the most entrancing music out of the air by merely pushing a button, a feat which even a child today can do at will. Radio is taking music, entertainment, and instruction to the masses, and as a result will come a greater development of the aesthetic side of man.

Than radio there is nothing more wondrous in the tales of King Arthur or the sagas of the Norse gods. The modern scientist is already able to transmute matter and thus virtually end the search for the philosopher’s stone. The modern radio-equipped airplane does more than the magic carpet of Bagdad, the radio-equipped submarine fulfills the promises of Jules Verne. Verily the wisdom of Solomon was that of a child in comparison with the knowledge possessed by the modern man of science.

INSTEAD of the usual—or may we not say the unusual—forecast of what you will read in November RADIO, and it certainly will be up to the editorial standard that we are trying to maintain, the Contents page of this issue gives the details of an interesting contest in which every reader can take part. We want some new ideas for appropriate subjects for the front covers during 1924 and offer \$500.00 in prizes to encourage suggestions. You can be a prize winner, if you will.

Resonance Wave Coil for Reducing Static

By S. R. Winters

This account of successful experiment in static elimination by the Signal Corps is suggestive of similar work that may be done by amateurs. Recommended dimensions and procedure are given for amateur work.

THE resonance wave coil, a hollow cardboard tube around which insulated wire is wound, has been recently adapted to reduce static in connection with a special receiver, which is being used in the accompanying picture by Dr. Louis Cohen, consulting engineer; Major-General George O. Squier, Chief Signal Officer, and Lieutenant-Colonel J. O. Mauborgne, all of the Signal Corps, War Department. The first type of resonance wave coil, which was developed by the Signal Corps several years ago, consisted of a hollow cardboard tube, 38 in. long and $2\frac{3}{4}$ in. in diameter, around which was wound a single layer of No. 32 insulated wire, 100 turns to the inch. Terminal binding posts were placed at each end and a brass collector ring slid along the tube so as to collect the wireless signals of varying wavelengths and deliver them to the tube grid.

The radio research laboratories of the Signal Corps have improved the design by using double-banked winding and two metal bands, thus enabling two operators to receive wireless signals of different wavelengths simultaneously from the same coil.

A grounded "guard tube" from one-third to one-half the length of the resonance wave coil is placed at one end of the coil and the metal "collector ring" at the other. The purpose of the "guard tube" is to drain off the static and undesired signals through a rejector circuit. For instance, if the latter is in resonance with a wavelength of 400 meters, all other frequencies are drained off to the ground. The 400-

meter signals are admitted through the resonance wave coil to the collector ring.

In devising a "rejector circuit," the amateur or novice should use heavy wire for the windings on the cardboard tube and also employ a variable condenser with low losses. The Signal Corps suggests the use of a .001 mfd. variable condenser shunted across a resonance wave coil comprised of 55 turns No. 14 D. C. C. wire, threaded around a cardboard tube $3\frac{3}{4}$ in. in diameter. The condenser, preferably, should be insulated with hard rubber.

The collector ring and guard tube may be made of brass. They should fit snugly on the wire-wound cardboard tube. A convenient arrangement is to cover the winding with a layer of thin paper and then employ brass tubing that will barely slide smoothly over this paper. The guard tube is not necessarily split but the metal band for collecting the waves must be.

Dr. Louis Cohen indicates that regeneration may be employed in the "resonance wave coil receiver" by the use of a tickler in the conventional manner or by employing a plate-circuit variometer. In either instance a tuned secondary circuit is necessary. Regeneration may be accomplished in the absence of additional windings of wire on the cardboard tube.

The resonance wave coil receiving set may be used as a common single-circuit or as an inductively-coupled tuner. The latter unit, however, is likely to result in excessive sharpness of tuning. Likewise, the "resonance wave coil

receiver" may be used with a tuned antenna system, which because of its extreme selectivity will require additional adjustments. In this instance a switch is provided so that the resonance wave coil may be connected above the tuned primary circuit when receiving weak signals or below (at the ground connection) when receiving strong signals through interference.



Large Resonance Wave Coil Mounted on Motor Truck

The experiments have included the splitting of the "guard tube" into two parts and the adding of a second resonance wave coil on which the metal ring functions in assembling the wireless waves. The two cardboard tubes used in this way are wound in the same manner. Such an electric circuit permits of the use of receiving instruments of practically any design.

As indicated in a preceding paragraph, the resonance wave coils may differ widely in the size of wire and the manner of winding. However, the Signal Corps ventures certain suggestions in this particular that may prove of value in charting the course of experiments in making these coils as "static eliminators." For the purpose of receiving music and speech, on wavelengths ranging from 200 to 600 meters, a single layer of wire of No. 30. B. & S. gauge, 18 inches long on a cardboard tube 3 or 4 inches in diameter, is suggested.

The Signal Corps has thus far obtained gratifying results by use of the resonance wave coil in suppressing atmospheric disturbances. When "static" was prevalent, it has been possible to receive clearly wireless signals from NPL, the high-power radio-telegraph station of the United States Navy Department at San Diego.

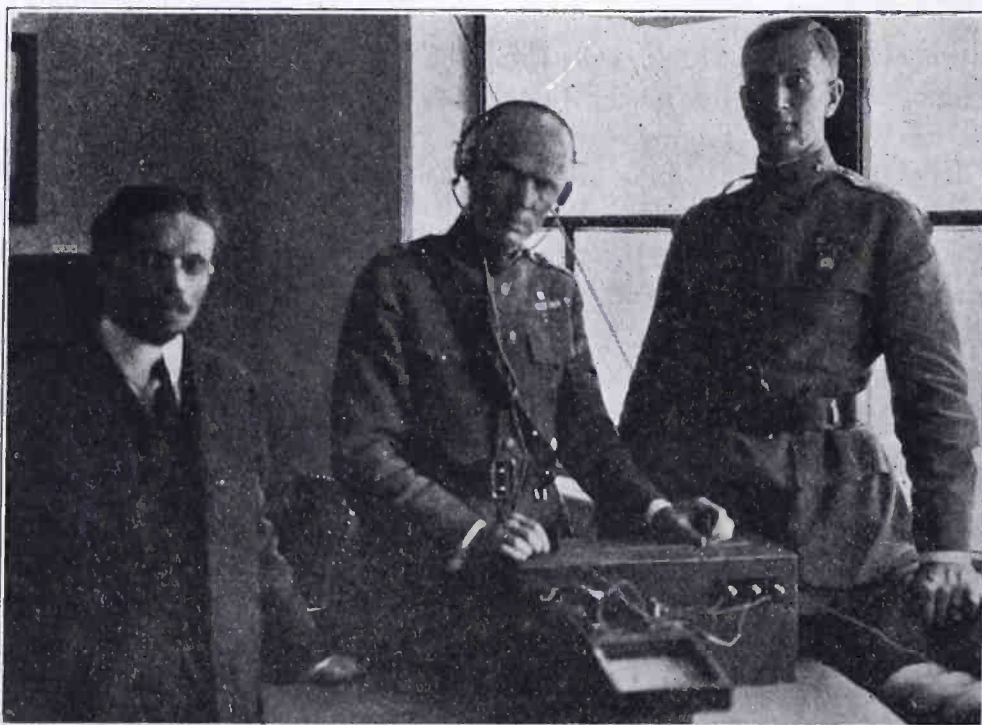

Dr. Louis Cohen, Major-General George O. Squier and Lieutenant-Colonel J. O. Mauborgne with Resonance Coil Wave Receiver

A Simple Talk on Radio

By Dr. F. A. Kolster

The man with the deepest knowledge of a subject can generally explain it in the most understandable terms, as he does not have to hide his ignorance with technicalities. Dr. Kolster, through his years of experience with the U. S. Bureau of Standards and more recently with the Federal Telegraph Co., really knows radio. Consequently what he has to say about selectivity, loop aeri-als and the radio compass is at once authoritative and understandable.

THE development and perfection of the radio telephone has resulted in popularizing radio to such an extent that, from a comparatively obscure and mysterious science, it has, at once, become one of the most popular and fascinating innovations the world has ever known.

Thousands of homes are equipped with radio receiving instruments and radio is destined to play as important a part in our every-day life as does music, art, literature and other entertaining and educational things.

It is, therefore, desirable that everyone should have an elementary knowledge of the fundamental principles of radio in order that good judgment may be exercised in the choice of receiving equipment, and further, that best results may be obtained through the proper manipulation and adjustment of the instruments. A radio receiving set is not a music box, nor is it an automatic musical instrument or talking machine. It is strictly a piece of electrical machinery which operates in accordance with well-defined electrical laws.

As many of you know, radio communication is carried through space by means of electromagnetic waves, traveling at a speed of approximately 186,000 miles, or 300,000,000 meters, per second. The length of these waves ranges in present practice, from 150 meters or less to 20,000 meters or more, depending upon the nature of the transmission. While it has been the custom in radio practice to speak of the length of the wave, it has been recently recommended, for engineering reasons, that the frequency of the wave be used rather than the wavelength. The wave frequency is merely the number of waves which pass a given point in one second, and therefore is a function of their speed and length. The frequency of a wave is expressed in cycles or kilocycles. A wavelength of 300 meters, for example, means a wave frequency of 1,000,000 cycles, or 1,000 kilocycles, per second, and is obtained merely by dividing the speed by the length of the wave.

For broadcasting stations, waves up to nearly 600 meters in length have been allocated by the government, depending upon the class and location of the station. The wave at KPO, for example, is 420 meters in length, it has a frequency of about 714,000 cycles per second, that is to say, 714,000 radio

waves each 420 meters long passing your receiving antenna every second.

Good broadcast reception and immunity from interference depend upon utilizing selective receiving means. By selectivity, we mean that property of a receiving device which, by virtue of electrical tuning, permits the reception of a given wave to the exclusion of others differing but slightly in length.

One of the primary laws of electricity is that an electric current will seek the path of least resistance. Now, the radio wave is very conscientious in obeying this law, and as it travels over the earth's surface it is continually seeking paths of least resistance. Every receiving antenna offers such a path if it has been tuned to receive this wave. When you adjust the variable condenser or the tuning inductance of your receiving set, what you are really doing is making a path of least resistance for some particular wave; in other words, you are offering an inducement to this wave to come into your home to entertain you.

Now, unfortunately some other passing wave whose length or frequency is but slightly longer or shorter than that which you have coaxed in may find easy entrance into your receiving set because of its non-discriminating or, to be more technical, because of its non-selective character. This, of course, results in interference of a most annoying kind and I think you will agree with me that it does not pay to be too hospitable with these radio waves. Your receiving station should be a path of least resistance for one and only one wave at a time, even at the expense of having to make more than a single adjustment. When receiving over moderate distances, the use of the rotatable coil or loop in place of the ordinary antenna will materially help in reducing interference by virtue of its selective and directive properties. It is through the combination of selectivity and directivity accomplished by simple adjustments that broadcast reception will eventually be materially improved.

In the development and design of broadcast receiving equipment, the radio engineer is confronted with very severe requirements, somewhat as follows:

- 1st. Maximum sensitivity for long-distance reception.
- 2nd. Maximum Selectivity and immunity from interference.

3rd. Extreme simplicity of adjustment.

4th. Reasonable cost.

It is a comparatively simple matter to meet any one of these requirements by itself, but to successfully accomplish all of them in a single device is a task which presents some difficulty.

World-wide public interest has had a great stimulating effect in the development of radio, and I predict that many new methods and devices will be introduced from time to time which will bring radio to a still higher state of perfection to the end that it may be of greater usefulness and of greater enjoyment to all.

Loop Reception

EVERY radio circuit is made up of inductance, capacitance and resistance. Inductance may be obtained by winding several turns of wire on a cylindrical form or on a spool, the value of this inductance depending upon the size of the wire, the number of turns and the size and shape of the form upon which the wire is wound. Capacitance is obtained by alternately opposing metallic surfaces, one set of these surfaces being insulated from the opposing set. Such a device is called a condenser and the value of its capacitance is determined by the area of the opposing surfaces, the number of such surfaces and the distance by which they are separated.

Inductance and capacitance are the important and necessary elements of all radio circuits. Resistance, however, is inherent and should in general be reduced to a minimum.

An electrical circuit containing inductance, capacity and resistance is analogous to the mechanical system which has inertia, elasticity and friction, and we may say that an inductance coil has electrical inertia, a condenser has electrical elasticity and resistance corresponds to friction. Both are vibratory systems which may be attuned to any given period of vibration; in the one case we have vibrations or oscillations of electrical current and in the other mechanical vibrations or periodic motion.

In the ordinary antenna circuit, as used in present-day radio communication, we find, in general, that the inductance of the circuit is concentrated in the form of coil, to be found inside of the receiving cabinet, and that the capa-

city of the circuit is formed by a wire or group of wires elevated above ground, these wires forming one surface of a condenser, and the earth forming the opposing surface.

It may be said, therefore, that energy is received in the radio antenna circuit by virtue of the fact that its condenser is exposed to the incoming radio wave, or in other words, that the wave enters the system by way of its condenser, thereafter to be transferred to its inductance coil.

In the receiving loop we have what may be considered as the reverse of the antenna system. In loop reception, energy is received by virtue of the fact that the inductance of the circuit is exposed to the incoming radio wave, or, in other words, the radio wave enters the receiving system by way of its inductance coil, thereafter to be transferred to its condenser.

The use of the rotatable receiving loop or inductance coil is recommended because of its directional properties. It gives greater freedom from interference and is not affected by static or atmospheric disturbances to as great an extent as is the antenna.

Fundamentally the receiving efficiency of a loop depends upon the area enclosed by the windings, the number of turns of wire with which it is wound and the resistance of the circuit to which it is connected.

To obtain full advantage of the very desirable features of the receiving loop, it is important that all of the laws which govern the efficiency of the receiving loop system throughout be faithfully obeyed.

The Radio Compass

WHILE public interest in radio lies chiefly and most naturally in broadcast reception, radio finds its most important and its most essential application as a means of communication with ships at sea. Here, it serves to safeguard life and property. More recently, radio, through the development of the radio compass, has become of still greater importance in navigation, and particularly in promoting the safety of life and property at sea.

The Government Lighthouse Service operates and maintains an extensive system of navigational aids, including lighthouses and lightvessels, which are equipped with powerful lights and sound signaling devices, and everyone who has sailed upon the seas is familiar with the welcome sight of the flashing light or with the assuring sound of the fog horn.

Unfortunately, however, during fog or thick weather, these navigational aids do not serve their purpose adequately because light does not penetrate fog and sound signals are extremely unreliable and cannot be depended upon to indicate direction or distance. Even under favorable weather conditions, the most

modern devices for visual or sound signaling are limited to comparatively short distances.

Radio waves are unaffected by fog or thick weather and they can be transmitted over much greater distances than either light or sound waves. Any lighthouse or lightvessel equipped with a radio transmitter, therefore, becomes an effective radio fog signaling station whose characteristic signal may be readily received by all ships within range, irrespective of weather conditions.

The radio compass is a nautical instrument which not only receives the radio fog signaling wave sent out by the lighthouse or lightship, but enables the navigator to determine immediately the direction or bearing of this signaling station. In other words, the radio compass is a device which is used to take the bearing of invisible radio beacons whose locations are shown on navigational charts. From such bearings the navigator is immediately informed as to his position.

One cannot fully appreciate this new and simple aid to navigation unless he is somewhat familiar with the science of navigation. Since the days of the earliest mariners, navigation has depended upon astronomical observations, that is to say, upon observations of the sun and stars. When it is most important for the navigator to know his bearings, such as in foggy and stormy weather, the sun and stars are obscured and invisible so that he is temporarily lost and must resort to dead reckoning and await clear weather before his position can be checked. The science of navigation has depended, since its earliest days, upon visibility, but now for the first time, through the aid of radio and the radio compass, it is possible for the navigator to know his position at all times regardless of weather conditions.

The radio fog signaling station is sometimes referred to as a radio beacon. There are already a number of these beacons on the Atlantic Coast and within a short time several lighthouses and lightvessels on the Pacific will become radio signaling stations in addition to the San Francisco and Blunts Reef lightships, which are now in commission.

The equipment used for fog signaling consists of a simple radio transmitter automatically operated. The wavelength used for this purpose is 1000 meters and each lightvessel or lighthouse has its own characteristic signal by which it is identified.

The radio compass is generally installed over the chart room or pilot house of the ship, where it is convenient for use by the navigator. The device consists of a rotatable coil directly exposed to the radio wave and acted upon by the wave with varying degrees of intensity as the coil is rotated about its vertical axis. When the plane of the coil is at right angles to the direction in

which the transmitting source lies, the signal intensity becomes zero. This position of silence is critical or sharply defined, and therefore indicates with great accuracy the direction or bearing of the signaling station. The bearing is read directly from the ship's magnetic or gyro compass to which the radio compass is attached, and therefore immediately gives the bearing with respect to magnetic north, or true north, depending upon whether a magnetic or gyro compass is used.

Personal experience in the development and practical application of the radio compass enables me to predict, with assurance, that radio will have a revolutionary effect upon navigation. Every important lighthouse and every lightvessel will, in the near future, become a radio beacon and radio will thus play an important part as a navigational aid. The radio compass will become as much a part of every ship's equipment as the magnetic compass, sextant and pelorus now are, and finally, through this new application of radio, life and property at sea will become more effectively protected than ever before in the history of navigation.

TEACHING RADIO TO SLEEPING STUDENTS PROVES A SUCCESS

Further reports from the Naval Air Station at Pensacola, Fla., on the success that has been attained in teaching radio code to student aviators in their sleep give interesting information on the progress of this novel and useful experiment. In fact it may be said that the experimental stage in the trials has been passed and the method has become standard, as a means of saving students from failure in the course.

When the test was started twelve students were unsatisfactory in their progress in radio code. After two nights during which radio code was sent to the students in their sleep only two of the students were unsatisfactory, and these two men had left before the experiment was finished, professing disbelief in it.

The procedure has been to have the students sleep on the tables in the radio room where the code is taught in the regular school periods. Operators send messages at varying speeds all night. The students concentrate on the messages that are sent through until they drop off to sleep. To quote a report on the subject:

"It is very interesting to watch the students during one of these night periods. If the operator intentionally and continuously makes errors in sending the students will toss around most unusually in their sleep. If the sending stops or the rate of sending changes appreciably, it is sure to disturb them, and in most cases will arouse them. Even in the midst of their deepest slumbers, the call 'S.O.S.' at a different rate of speed will awaken them instantly."

The Four-Circuit Tuner

By Lloyd Jacquet, A. M. I. R. E.

This is an authorized account of the Cockaday circuit which has been successfully tried out by many builders. It is unusually lucid in the explanation of the theory and operation of the fourth circuit. The construction of this set is recommended where selectivity is wanted.

THERE are fundamentally two types of regenerative circuits: the capacitive and the inductive feedback. In the first, the feed-back of the plate circuit energy into the grid circuit is accomplished by means of the internal capacity of the vacuum tube connected in the circuit. In the second, a plate winding is coupled inductively to the grid winding, the regeneration being controlled by varying the amount of coupling between the two coils.

When a wave train is intercepted by the antenna system, and the energy is transferred by electromagnetic induction from the antenna or primary tuning circuit into the secondary or grid circuit, there is a certain amount of the original energy lost. This loss causes a decrease in signal strength, and is due largely to the absorption of part of this energy in overcoming the electrical inertia of the circuits. In other words, this energy encounters resistance in its flow. This resistance we will call positive resistance, and it is present in all radio circuits. If, therefore, it were possible to overcome this positive resistance in radio circuits, or in the grid circuit, for example, we would be enabled to obtain a much stronger response in the headphones because of the increased plate current.

This is the function which the regenerative circuit performs. When an impulse is induced in the grid circuit of such a receiver it produces a rush of current through the plate circuit, which conforms in amplitude to the grid voltage, and if a certain amount of this energy is fed back again, the resistance losses of the grid circuit can be compensated for. That is to say, the signal strength obtainable in the grid circuit will be brought to the original strength, or to that which it would have if there were no positive resistance in the circuit. In other words, the grid positive resistance can be neutralized by a cer-

tain amount of what we shall term "negative resistance" to an amount sufficient to overcome it entirely.

But we find that, practically, this point cannot be reached, for just before it is attained, the tube "spills over," and the circuit begins to oscillate, and the signals will assume a "mushy" tone, or otherwise suffer from distortion.

The control of the regeneration in the circuits mentioned above is effected

stop it unless the filament current is adjusted, or the capacity of the grid condenser is decreased. These two methods prove to be difficult and inefficient in practice.

With this arrangement, however, it was found that all of the energy fed into the grid circuit was re-fed, regardless of the wavelength, back into the grid circuit from the plate circuit. The stronger the incoming signal, the greater

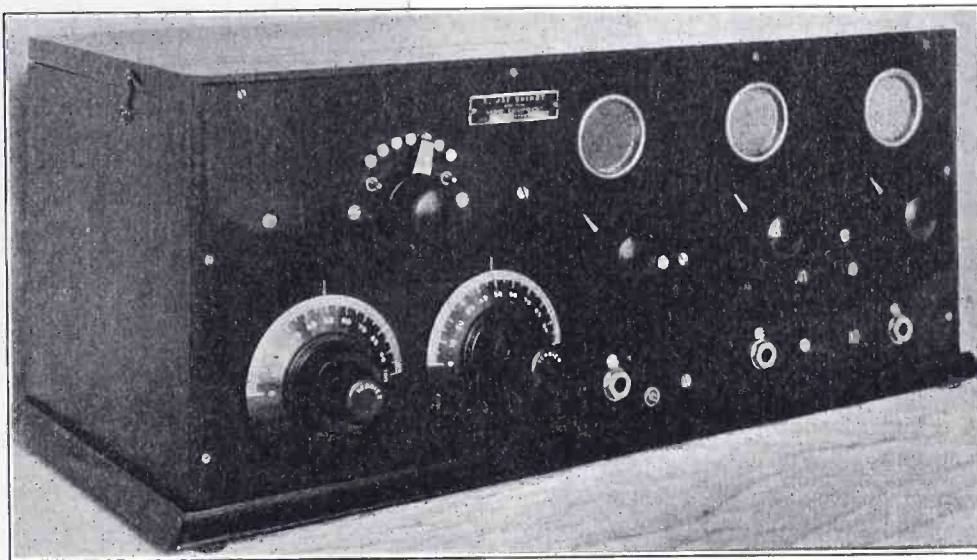

Fig. 2. Completed Set in Cabinet

by various methods of adjusting the feed-back, that is, by strengthening the signals received by neutralizing the positive resistance of the circuit with a theoretical negative resistance.

One of the simplest oscillating circuits available to the experimenter today is the familiar "ultra-audion" circuit. It is a steady oscillator, though critical for receiving purposes, and its main drawback is a feature which really should be an advantage: the plate circuit is untuned. When an impulse is transferred to the grid circuit, it is re-fed through the tube capacity, thus making up for the grid losses, and the circuit will begin to oscillate. Once this circuit is set to oscillating, it is difficult to

the feed-back action, and in cases of exceptionally strong signals, such as those from a nearby station or from a burst of static, the circuit oscillates violently. The trouble was evident: there was too much energy present in the grid circuit; the negative resistance reached a value which was proportionately too high for an increase of the initial signal strength.

After considering the difficulties inherent in such a circuit, but appreciating the extreme simplicity of control, a method for absorbing enough energy from the grid circuit so that the circuit would almost oscillate and thus remain in its most stable and sensitive condition was devised by Lawrence M. Cockaday,

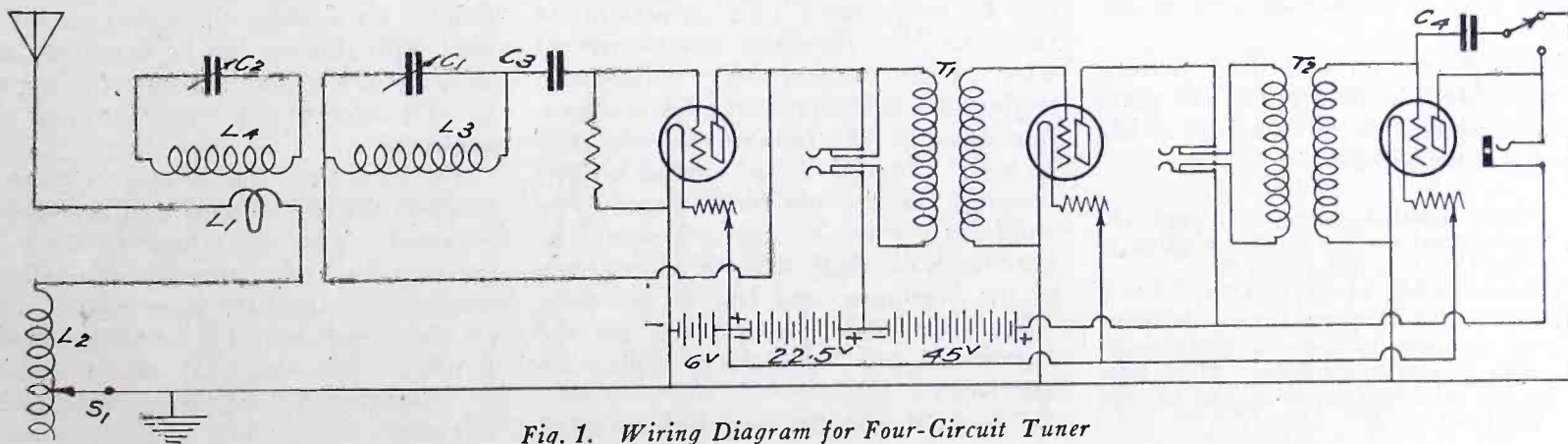

Fig. 1. Wiring Diagram for Four-Circuit Tuner

an amateur experimenter better known as 2XK.

This was finally accomplished by a method which increased the positive resistance of the input circuit until it would just cease to oscillate. An "absorption" circuit was coupled directly to the grid circuit of the tube, as shown in Fig. 1.

By means of this "stabilizer circuit" as Cockaday termed it, if a weak signal is received, only a small amount of energy is taken from the grid circuit. If, on the contrary, a very strong signal is received with the same adjustment of the apparatus, a larger absorption of energy will take place from the grid circuit, and the adjustment will remain at the critical regenerative point; it will be practically self-stabilizing.

In the familiar regenerative receiver, when the wavelength of the tuning circuit is altered, the feed-back must be re-adjusted, and this adjustment must be made for every change in the wavelength. With the stabilizer circuit in operation, this is not the case, as the regeneration remains constant throughout the wavelength tuning range.

In this new method of regenerative control, the stabilizer circuit L_4 is placed in close proximity to the secondary or grid circuit coil. It consists of a fixed inductance, of comparatively low resistance, across which is shunted a variable condenser C_2 with a low minimum capacity.

This is the "fourth circuit," and the amount of energy extracted from the grid circuit by it is sufficient to provide an extremely accurate means of controlling regeneration.

The four-circuit tuner, as may be gathered from a study of Fig. 1, is extremely simple of construction. No variometers, vario-couplers, tickler or feed-back coils are necessary. The elimination of complicated apparatus in the construction makes for simplicity of operation.

The list of materials which will be needed for the construction is given below. Every piece of apparatus purchased should be selected with the utmost care and should be of the best. Poor results will follow the use of inferior or defective apparatus. This is particularly true of the variable condensers and of the tube socket, as both of these play an important part in the circuit.

This is what you will need to construct the four-circuit tuner. The parts purchased should be of the best grade and of standard make.

1. Tubing, about 8 inches long and $3\frac{3}{4}$ inches in diameter, for the winding of coils L_1 , L_2 , L_3 and L_4 .
2. 1 pound of No. 18 S.C.C. wire.
3. Knobs and dials, about 3 inches in diam.
4. Two variable condensers, .0005 mfd., with vernier attachments. Must have a low minimum capacity, and be well insulated.

5. Fixed condenser, mica, .0025 mfd.
6. Mica fixed condenser .002 mfd.
7. Grid leak, between 1 and 2 megohms.
8. Three sockets, bakelite bases.
9. Three rheostats, one of which should have a vernier control.
10. One single-circuit jack.
11. One double-circuit jack.
12. Jefferson amplifying transformers, small type.
13. Binding posts.
14. Switch points.
15. Bus wire, spaghetti tubing and screws, nuts and bolts.
16. Detector bulb, UV-201, C-301, or other hard tube.
17. Amplifier tubes, 2 UV-201 or C-301.
18. Cabinet and panel, about 7 by 15 inches.

After all of the material has been purchased, the work of laying out the panel may begin. It is not necessary to follow the writer's design, although it

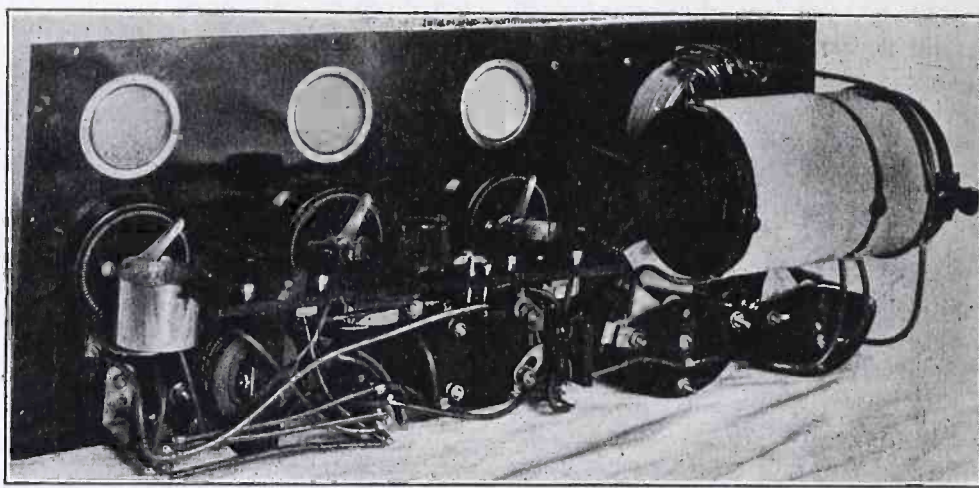

Fig. 3. Rear View of Panel Mounting

will be found that the results will vary widely if at least the important details are not adhered to. Holes are marked for two variable condensers, and the location of the switch blade and contact points is also determined. Ventilating holes are provided for the vacuum tube, and another one for the rheostat shaft.

It is now easy to mount all of the apparatus in their respective places. Before this is done, however, the panel may be given a dull finish by means of a fine grade of sand paper and linseed oil, rubbed with pumice stone. This is entirely up to the taste of the builder.

Next, the coils for tuning and controlling the circuit are made. It is important in this stage of the work, that instructions be followed exactly, otherwise the results will be very uncertain and unsatisfactory. The length of the tubing is measured to $5\frac{5}{8}$ in. First, coil L_4 is wound. This consists of 34 turns of No. 18 single cotton-covered wire. Right next to this winding, and in the same direction, *but with a separation equal to the thickness of one turn of wire*, the coil L_3 is wound on the remainder of the tube for 65 turns. The windings are completed, and should be fastened with small dabs of sealing wax at the beginning and end of the coils. These two coils, L_4 and L_3 , are the stabilizer and secondary coils respectively.

To wind the primary coil, a small

length of the tubing about $1\frac{3}{8}$ in. in length is secured. This should be of the same diameter as that of the tube upon which L_3 and L_4 were wound. This coil, L_2 , is a bank winding consisting of 43 turns, tapped at the beginning, the 3rd, 7th, 13th, 21st, 31st, and last turns. This bank winding process may prove too difficult for some constructors, so it is advisable to wind this coil in a single layer and tapped as indicated, if trouble is experienced with it. A larger tube, about 3 in. in length, will be necessary in that case.

Upon the coil winding, L_4 , the small loop of wire, L_1 , which makes up the primary winding, is placed. Bus wire, $1/16$ in. square will be suitable. It should be located about $1/4$ in. from the

beginning of the coil. All circuits are wired with busbar. Not only does this look neater, but it will be easier to trace out the circuits, and the set will work better. The diagram should be followed carefully for the wiring. Particular attention should be given to the wiring of the filament, plate and grid circuits of the first tube. These are important points to watch. As there are no body capacity effects, there is no need to shield any part of this set.

A good idea of the finished product can be had from Fig. 4. As can be seen, most of the apparatus and instruments are mounted directly on the panel, and the unit is self-supporting. It can now be placed within the cabinet.

Either a soft or a hard tube may be used as the detector. Consequently, any of the tubes available on the market today, including any of the dry cell family, are usable. The antenna to be used with this set can be of almost any size, within reason of course. A good ground connection should not be neglected.

Be sure that the receiver circuit is properly wired by checking it against the diagram. The first thing to do is to determine whether the circuit oscillates freely when the tube is in place. This can be ascertained by listening for the familiar low-pitched sound which is characteristic of any regenerative receiver.

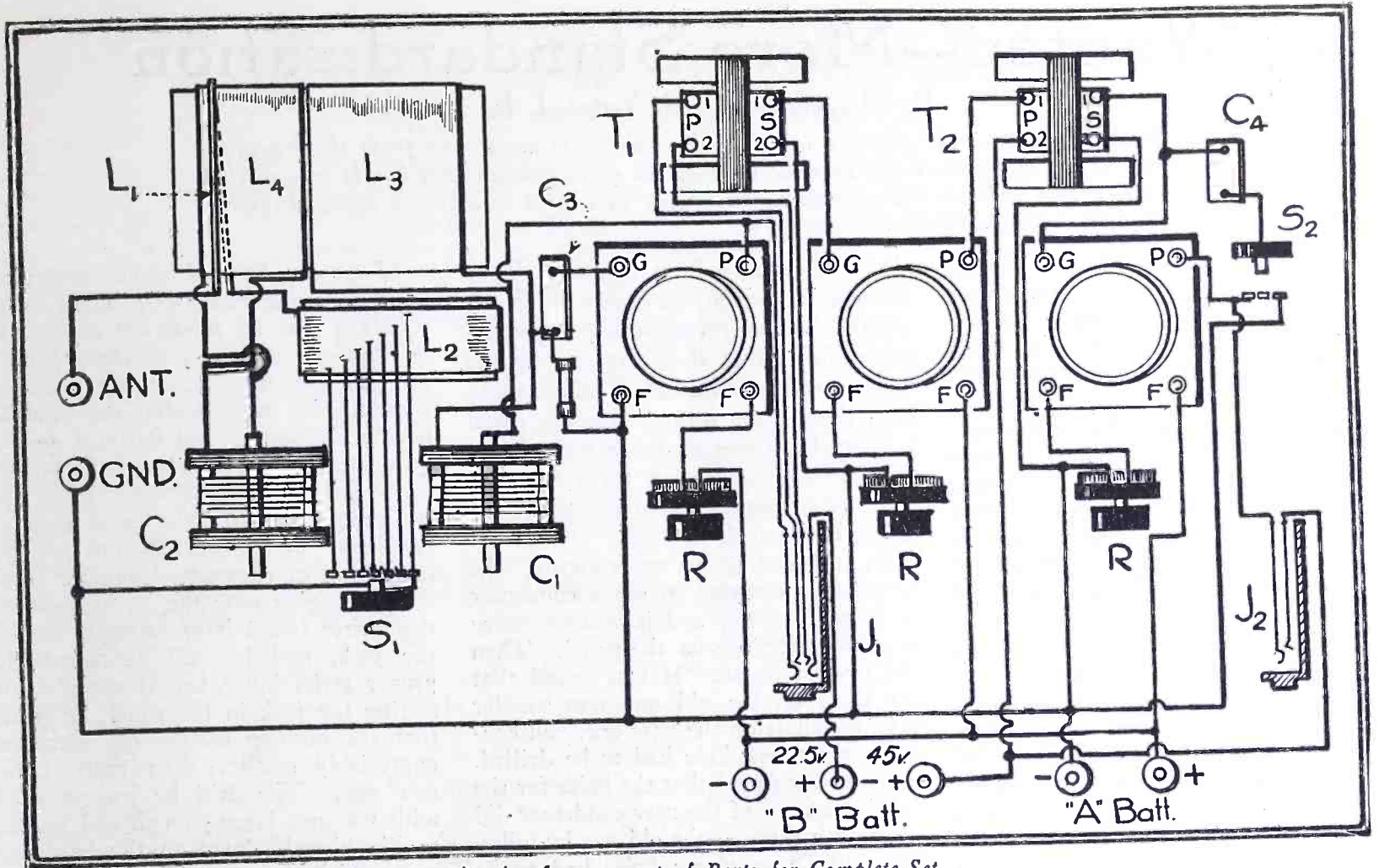

Fig. 4. Arrangement of Parts for Complete Set

Now everything is ready for a trial. A little study of the various controls will help understand their purpose. In the first place, it must be remembered that the antenna tuning is accomplished by means of the aerial switch. To tune the secondary circuits, variable condenser C_1 is used. The control of regeneration is accomplished by means of the variable condenser C_2 located in the stabilizer circuit so that the dial reading will be approximately 90 degrees. The filament control is then increased to a point just below that which would set the circuit into oscillation. With the antenna tuning switch, the secondary condenser, a signal is tuned in. Now it will be necessary to use *only* C_1 and C_2 to tune the signals in so as to secure the loudest response. To increase the strength of the signal, it is necessary to increase the feed-back with more current from the plate circuit. This is done by revolving the control C_2 to a lower value, which will adjust the stabilizer circuit accurately. If necessary, a readjustment of the control C_1 may be made, with a further adjustment of C_2 to increase or decrease regeneration. In this way a louder signal will be obtained, and tuning will be extremely sharp.

Thus it will be noticed that the lower the value at which C_2 is placed the more freely the circuit will oscillate. Then it is only a matter of finding the correct setting for C_2 and adjusting C_1 for the correct wavelength. A high value for condenser C_2 will be used for tuning in voice or spark signals on the

higher waves, while a comparatively smaller value is necessary for amateur C. W. signals.

A few of the interesting facts and peculiarities of this circuit can be reviewed as follows: Regeneration is not affected by re-tuning or altering the adjustment of the antenna circuits; the constants of the antenna circuit make little or no difference on the other circuits; there is no body-capacity effect, and, even when receiving C. W. signals, the operator's hands may be placed on any part of the receiver, even on the bare antenna connection, without disturbing the stability of the circuit; the antenna may be directly grounded, and yet the signals will be received, though a trifle weaker.

The tuning with this fourth circuit makes for high selectivity, and for the elimination of all local interference. This is a highly desirable feature when it is desired to differentiate between two stations on almost the same wavelength transmitting simultaneously.

With the new Federal regulations as to wavelength allotments to broadcasting stations the range of this set (150-550 meters) will be thoroughly appreciated. And the fact that in future broadcasting, stations will operate with but a difference of but 2 to 3 meters in wavelengths, this type of tuner will be all the more valuable because of its unusual selective features.

It is found that it is easy to tune out interference even of a local source once the operator familiarizes himself with the circuit, and provided also that the

stations are not transmitting simultaneously on the same wavelength.

In actual tests, it was possible to tune out WJZ, Newark, N. J., a local station, and to tune in KDKA, Pittsburgh, Pa., several hundred miles away, so that the latter station came in almost as loud, although these two stations are but two meters apart. This was true also of WFAF and WOC and other stations.

Station KFI, in California, can be picked up in New York at will, and the English broadcasting station, 2LO, in London, has been heard several times during the past winter, in New York.

To protect dry cell tubes from accidental burn-out connect a 10-watt, 110-volt Mazda lamp in one of the leads from the B battery. This will limit the current to less than 100 milliamperes as the lamp filament resistance is 10 or 12 times as high when hot as when cold. Its resistance when cold is so low that it will have little effect. This practice will also show up a B battery short or leakage if the lamp filament becomes incandescent.

If the Baldwin 'phone you are using for the loud-speaker rattles badly on everything you put into it, the trouble is probably in the phone itself, and not in your set. Take some collodion, or metal lacquer, or even "New Skin," and put a good-sized drop on the little disc in the center of the diaphragm. Make this drop big enough to cement the little washer fast, and let it dry completely before you use it. This usually clears the trouble very well.

Wanted--More Standardization

By Raymond Francis Yates, I. R. E.

Standardization is the greatest need in radio today. It must come from the manufacturers, and will come when they realize that the radio public wants it. It is suggested that readers write to the manufacturers urging that steps be taken to bring about the changes suggested by Mr. Yates.

TRUE to the spirit of Aesop's Fables, one never gives much thought to standardization in radio until one attempts to fabricate a receiving set with so-called standard parts. In constructing the more elaborate type of receiver it is indeed easy to see that our manufacturers have made little effort to meet on common ground for common good. In neglecting to do this they have been responsible for countless and needless beads of perspiration, and not a few cuss words. In following such a stupid course the radio manufacturers have by no means assisted the art. Quite the contrary, they have held it back.

It would take very little co-operation to bring our radio parts to a more interchangeable basis. Many of the needed changes are small, yet they are important. The automobile manufacturers eventually got together on standardization and they were faced with problems that would pale those of radio into insignificance. The electrical industry, too, has succeeded in bringing about tranquility where chaos once reigned and in every field of human endeavor we find this effort toward simplification through systematic standardization.

Complete universality and interchangeability is the most desirable change that could come in the radio industry at this time. Some manufacturers argue that progress in this direction interferes with originality of design and ease of manufacture. But does it? If carried to the extreme it may. All of our lamp sockets take ordinary lamps, but the manufacturer is free to construct his socket any way he wishes as long as it conforms to this one necessity of standard practice. He can ornament the thing if he likes or he can make it large or small, but he must have the standard screw thread. The manufacturer of the flashlight must standardize to a certain extent, but he is given plenty of latitude and license to add those things to his product that will give it the mark of distinction.

Even if standardization did thwart originality a trifle it would do no harm, for originality has been done to death in radio, and the unbridled imagination of many so-called radio designers have given birth to innumerable freaks. To be original is fine; to combine originality with practicability is great; but to be nothing but original is foolishness.

In radio there is need for both mechanical and electrical standardization. Numerous simple little mechanical features that would add to usefulness and

convenience have been ignored. Take the simple variable condenser as an example. We can forgive our manufacturers for rating their capacity by the number of plates instead of microfarads, even though the former does not mean a thing, but there are other little things that we cannot forgive them for, and these relate especially to mounting the device on a panel.

In remodeling a set recently, the writer had occasion to use a condenser of larger capacity and it was necessary to remove the one on the panel. Then the trouble began. It was found that the shaft on the old one was smaller than the shaft on the new one, and consequently a new hole had to be drilled. Then it was found that the holes for the holding screws of the new condenser did not match those of the old one by miles. Of course, more new holes had to be drilled. Now here is a simple little thing that causes a great deal of annoyance and trouble and that could be rectified so easily that it seems almost a shame that it is not done. In the writer's case he had three ugly holes left on the panel and he either had to tolerate this or go ahead and drill up a whole new panel. Would a standard equilateral triangle with the holding screws at each point interfere with the design of the condenser? Would standard threads and screw lengths arranged for standard panels and standard counter-sinks interfere with originality that might be spent upon a device of this nature? How nice it would be to have a standard template so that when we wanted to mark up our panel for a condenser we could go ahead and do it regardless of the type of condenser.

After the said condenser was mounted in place the writer attempted to adjust to its shaft the dial of a well-known manufacturer—(he had to buy a new dial because the hole in the old one was too small) and found, much to his disgust, that the shaft of the condenser did not protrude enough to catch the set screw on the dial, yet a standard panel was used. In such a case one does not know whether to blame the manufacturer of the condenser or the manufacturer of the dial, but it is evident that the sensible thing would be for these manufacturers to get together and standardize on their shafts and standardize on their dials. The changes needed would be so simple and the result so profoundly beneficial that the whole thing appears silly.

What can be said about condensers holds true for rheostats. There is no standard way of mounting a rheostat, no standard shaft, no standard knob—nothing is standard. Every manufacturer has his own peculiar notion about how a rheostat should be built and he goes ahead and builds it. The answer to the problem being, it would seem, that we should all buy the same kind of rheostats. But we all do not like the same kind of rheostats, hence the mess.

In changing over the set in question, the writer found it necessary to change the jack, and he had purchased the proper style, but when it came to inserting the jack in the panel, he found that the bushing on the old jack was appreciably smaller than that of the new one. The drill he had to work with was not large enough and he had to hie himself down to the hardware store and buy a new one.

While speaking on the subject of jacks it is lamentable that more care has not been taken in giving plugs a standard dimension and holding to it more strictly. The writer has plugs that would not fit some jacks and that fitted others so loosely that they were almost useless. On some plugs there are ball tips, others pointed tips, and it makes all the difference in the world as far as contact is concerned.

Take the simple matter of phone cords. They usually wear out before the phones and that means buying a new set. Some phones are arranged to take the cord with the terminals on the outside and some on the inside. In the former case the phone tip is useless and in the case of the punched terminal it is usually necessary to do a lot of shopping before a cord provided with them can be found.

The writer is not presenting this article as a serious study of the standardization. Rather he has just turned crank and is voicing his disapproval of the most annoying little things.

From the electrical standpoint there are many improvements in standardization that could be made with little or no trouble. Let us take the impedance of tubes, transformers and phones for example. For greatest efficiency the impedance of all of these devices should match each other. But do they? Some phones have a d.c. resistance of 4000, some 2000 and some 3000 ohms. Few transformer manufacturers have made an effort to build transformers for tubes even though this action is desirable.

Continued on page 91

Improving Amplification

By Samuel G. McMeen

Directions are here given for using the "push-pull" circuit to increase volume and decrease distortion in both audio and radio-frequency amplification. Suggestions are also made regarding biasing batteries and the reduction of distortion by excluding the "B" battery current from the telephone receiver.

ONE of the happy ways in which the difficulties due to distortion from the second stage of audio-frequency amplification may be side-stepped can be found by using the "push-pull" circuit. This method associates two tubes in such a way that when one is causing an increase of current in its plate circuit, the other is causing a decrease. When, therefore, the proper transformer connections exist, the output is an alternating current exactly adapted to the work it has to do.

The simplest form of this "push-pull" hook-up is shown in Fig. 1, asso-

advisable. As to the A battery, the same 6-volt storage battery is used on all tubes, though two such units are shown in the drawing for the sake of simplicity.

The action of the two amplifying tubes is a little different from that of a single tube. The connections of the first secondary winding causes one grid to become more negative at the time the other grid is becoming more positive, with relation to the filament in both cases. Thus when the current in one plate circuit is increasing that in the other is decreasing. An increase in

houses, the alternative is to use a pair of ordinary transformers. The connections then take the form shown in Fig. 2, being merely to put two trans-

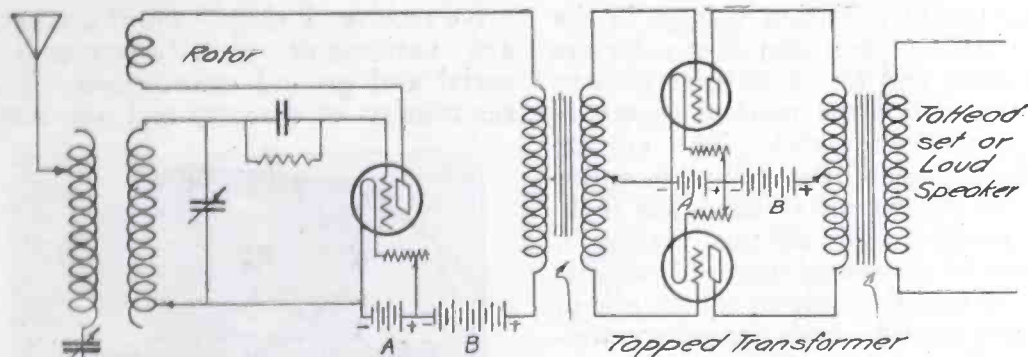

Fig. 1. "Push-pull" Arrangement of Amplifying Tubes Using Special Tapped Transformer

ciated with a popular type of regenerative circuit with three windings. We do this because this type of tuner and detector gives excellent results with one stage of amplification, and as a good many readers have such a circuit in use they may like to add this further improvement. Any good circuit will do, however, and will be improved by the addition of the two-tube amplifying unit.

An amplifying transformer precedes and another follows the pair of amplifier tubes, these transformers differing from the ordinary type in that the first has a tap in the middle of the primary winding, and the second a tap in the middle of the secondary. The arrangement of the terminals of these tapped windings will be noticed to be wholly symmetrical; that is, the grids of the amplifying tubes receive the outer windings of the first secondary, and the plates of those tubes receive the outer windings of the secondary primary, while the middle taps go respectively to the negative A and positive B battery terminals.

Two B batteries are shown in the sketch, because the detector tube requires less voltage in the plate circuit than do the amplifier tubes. The detector B battery shall be what the maker recommends; the amplifier tubes will take what you have, up to 100 volts, not less than 45 volts being

a transformer winding produces a current in the other winding of that transformer in an opposite direction, while a decrease produces a current in the same direction. Look at Fig. 1 again with this last statement in mind, and you will see that there will result a succession of alternating impulses in the secondary whenever there is a succession of polarities in the grids of the amplifying tubes. This is an action much to be desired, and one that is exactly suited to the best response of the final telephone device, whether a headset or a loud speaker.

As the transformers with mid-winding taps are not obtainable at all supply

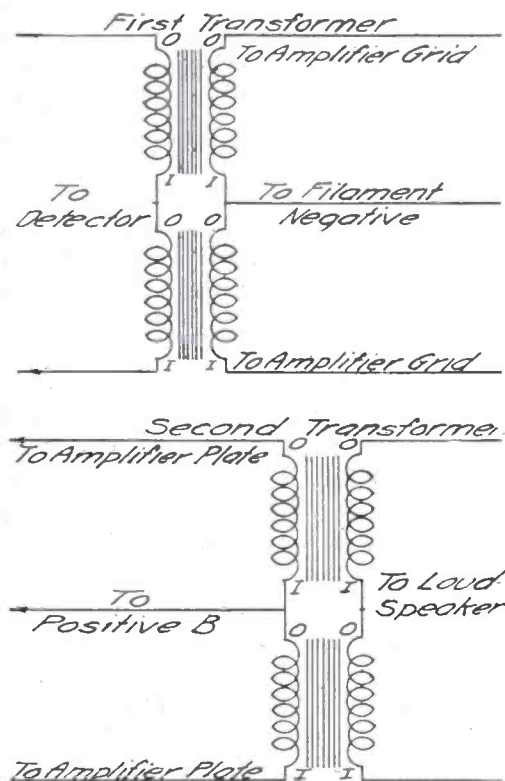

Fig. 2. "Push-pull" Arrangement with Two Transformers instead of Special Tapped Transformer

formers in series as to both their primary and secondary windings respectively. Trial may be necessary to be sure that the poling is such that the action is that wanted. If the transformers are all of the same make, with the inner and outer terminals of the windings marked, the matter will be simple if the figure be followed, the lettering I and O meaning inner and outer. If the terminals on the transformers are marked 1 and 2 instead of inner and outer, it is safe to assume

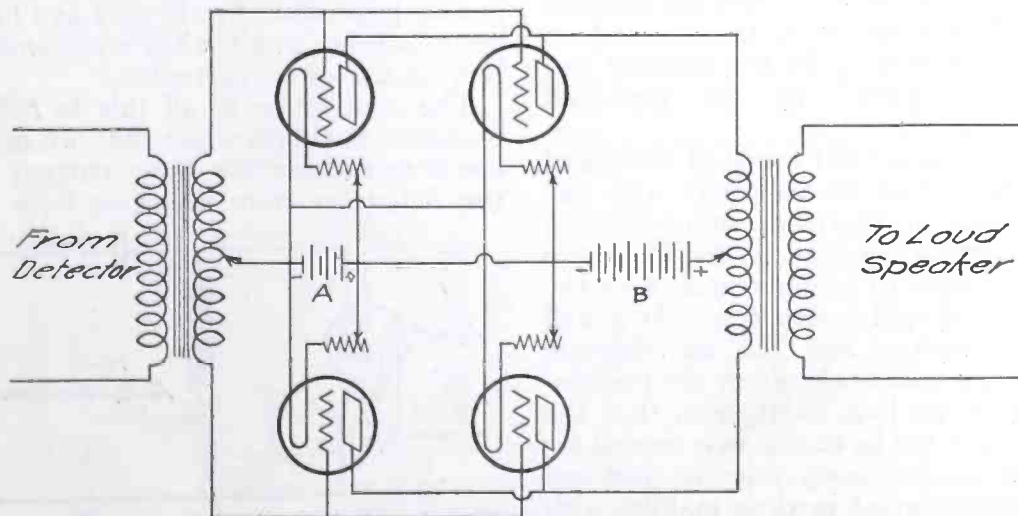

Fig. 3. "Push-pull" Arrangement with Four Amplifying Tubes Co-operating in One Stage

that 1 and 2 may be read to mean *I* and *O*, and the results will be pretty sure to come out right.

Assuming that tapped transformers are to be had or have been made, we recommend to the ambitious and critical amateur a trial of the circuit shown in Fig. 3. It is a further carrying-out of the original principle, but has two tubes in parallel on each side of the backbone of the amplifying portion of the hookup. This arrangement was originally designed for use in commercial wire service as a substitute for the use of larger tubes, in the desire to keep as nearly to a tube standard as possible for the sake of simplicity and uniformity. But the good results that are to be had from it remind us that the Marconi Company has at Carnarvon, and perhaps elsewhere, great banks of small receiving tubes on racks as a preferable alternative to one or a few large tubes. Their report is that the use of the small tubes gives better results. In the several arrangements here described, the tubes except the detector may be either amplifiers or power tubes. The same order of excellent results as come from the use of the single power tube as the amplifying unit in a receiving set will be found to follow in these cases.

Let us add the reminder that both of the arrangements here treated amount to but a single stage of amplification, with the advantage of limited distortion, but with larger volume than the usual type of amplification with a single-tube single-stage arrangement.

This type of equipment is well adapted for use together with radio-frequency amplification, and in such use the high-frequency amplifiers shall be placed in the series before the detector. That is, cut the wire that leads from the secondary condenser just between that condenser and the grid leak, and cut also the wire that leads from the secondary condenser to the *A* battery. Into this cut of four ends insert whatever number of stages of radio-frequency amplification meets your fancy. In this way the distant signals are amplified before detection by the radio-frequency tubes, and signals not otherwise audible are brought in. These are then transformed to audible frequency by the detector and finally amplified by the push-pull combination.

We have not yet heard of the use of middle-tapped transformers and the push-pull arrangement in connection with radio-frequency stages, but there would seem to be no reason why the method should not succeed. It is well worth trying, and the transformers have the advantage, from the point of view of the handcraftsman, that the wire need not be so fine as is needed for the audio-frequency side; so that one may experiment in their making with less loss of patience and time and less moral danger generally.

As was pointed out in the description of the single-tube, one-stage set shown with the amplifiers in Fig. 1, the use of power tubes of higher rated voltage than six volts permits the omission of the filament rheostat, in which case the hook-up takes, as far as the amplifiers are concerned, the form shown in Fig. 4, in which is also shown the use of a

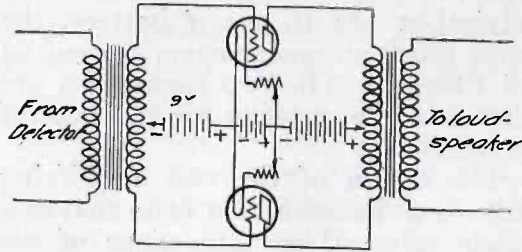

Fig. 4. "Push-Pull" Amplification without Rheostat and with Biasing C Battery

biasing *C* battery treated in the next paragraph. Any tube that gives good results with all the resistance cut out of the rheostat may be used without the rheostat at all.

The use of a biasing voltage in the grid circuit of any amplifier tube has its merits, and for those that wish to add this detail the method shown in Fig. 4 will be useful. The voltage required is 9, and may be had from dry cells, as the circuit resistance is high. The positive side of this biasing *C* battery is connected to the filaments and the negative side to the middle of the first transformer's secondary winding. It is easy to remember the polarities after once noting that they are all in a series relation from left to right in the picture, each positive joining the next negative.

In many forms of telephone systems there is a useful arrangement of inductances and capacitances whereby direct current is excluded from and alternating current is admitted to the telephone receiver. This is readily and happily done by taking advantage of the facts that an inductance tends to be "opaque" to alternating currents of even the average voice-frequency, while a condenser of say two microfarads is practically "transparent" to those currents. Conversely, and equally fortunately for us, the inductance passes direct current as readily as if it were merely possessed of resistance and had no inductance at all, while a condenser is opaque to direct currents.

The application of all this to radio problems is simply this: that we may use it to exclude the direct current of the *B* battery from whatever form of

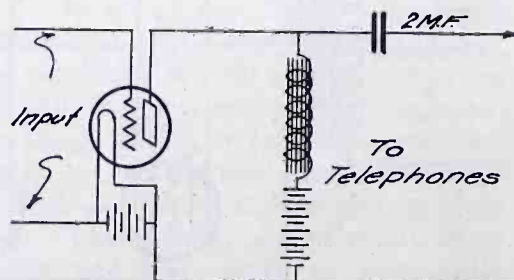

Fig. 5. Method of Delivering Output to Telephones without Polarizing Effect of Direct Current

telephone receiver we may be using, while letting every essential function remain. One of the ways of applying the principle is shown in Fig. 5. The condenser is of 2 mfd. of the telephone type, and the inductance may be any high-resistance, iron-cored, many-turn coil that is handy. One of the units of a Ford coil will do, though so high a resistance is not essential. The action is perhaps wholly obvious, but we will hazard the explanation that the condenser screens the telephone from the influence of direct current with the advantage of lessening distortion, and the required alternating current is passed to the condenser and receiver by the action of the iron-cored inductance.

MORE VOLUME FROM THE SINGLE CIRCUIT

By VICTOR A. ULRICH

To get greater volume and purity of tone from my single-circuit regenerative receiver I simply shunt a standard variometer directly across the aerial and ground connections. The set consists of detector and one stage

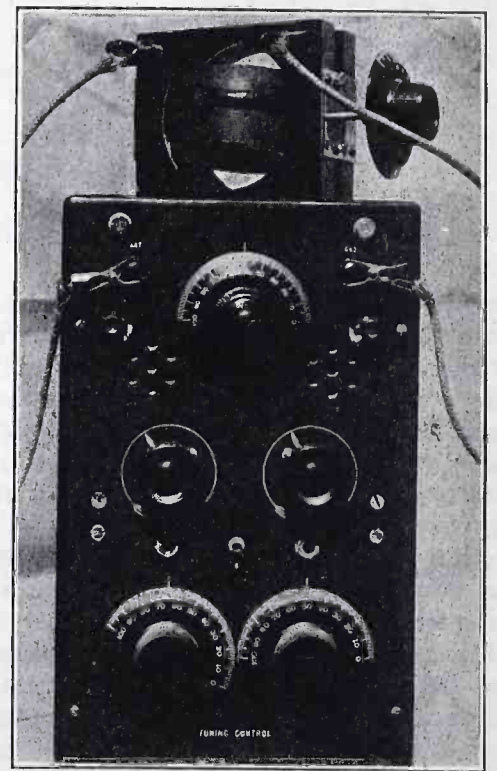

Increasing Volume with a Variometer

of audio-frequency amplification and with this arrangement gives greater selectivity, a better tone and only slightly less volume than with an added stage of amplification. The Los Angeles stations are satisfactorily heard on a loud speaker at San Francisco.

As may be noted from the picture, the Workrite variometer may be conveniently placed on top of the cabinet. The upper dial controls an 11-plate variable condenser with vernier. The center knobs control the detector and amplifier rheostats. The two lower dials operate the rotors of a Lemco No. 100 broadcast coupler. The jack switches on either side of the upper dial cut in or out the condenser when tuning for short or long waves.

The Universal Receiving Set

By Edward T. Jones, I. R. E.

To be able to combine the advantages of either a single or triple circuit receiver in one instrument at will is an accomplishment that will be welcomed by many. Of value also is the author's account of the how and why of getting the best results from either combination.

SO much has been written lately, both pro and con, about the single- and triple-circuit receivers that there has been formed two groups of radio constructors, the one building the single-circuit tuner and the other the triple-circuit tuner. Printed descriptions describe one or the other type, and if it happens to be a description of a single-circuit tuner, those interested in the

at the lower right hand corner provide the input of the secondary and variometer to the detector amplifier unit. The two posts on the upper right hand provide an outlet for the plate variometer and is connected in the plate circuit of the detector tube by connecting these two posts to the two provided on the upper left hand corner of the detector-amplifier unit—box No. 3.

Box No. 3 is the detector two-stage amplifier unit. No potentiometer is shown, although it is recommended that one be used.

The boxes are shown completed and hooked up as a three-circuit receiver in Fig. 1a. For a complete diagram of connections see Fig. 2.

The two boxes, No. 1 and No. 3 can next be connected as shown in Fig. 3. This provides a single-circuit receiver with detector and two stages of audio-frequency amplification. Diagram of connections is given in Fig. 4.

Sizes of boxes and other constructional data will be omitted because there has been a considerable number of articles treating on that phase of this subject. Besides, it is preferable to leave this to the builder, who will no doubt make use of material he already has or will purchase to his own liking.

Insofar as the separation of two waves originating at two broadcasting stations operating on the same wavelength is concerned, it would be criminal ignorance to dispute the fundamentals of radio. There has not been developed as yet a device for which the above claims have been made. It is not possible to do so.

Continued on page 59

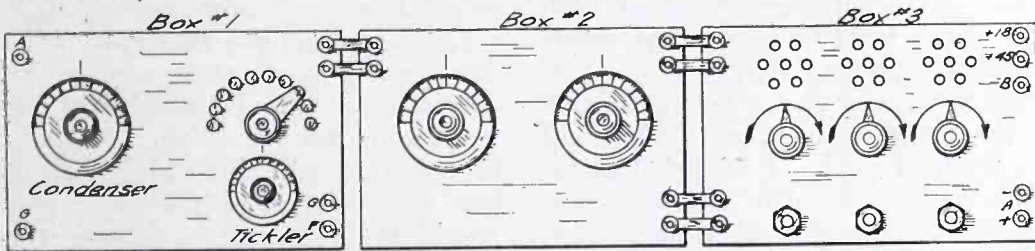

Fig 1a. The Complete Assembly

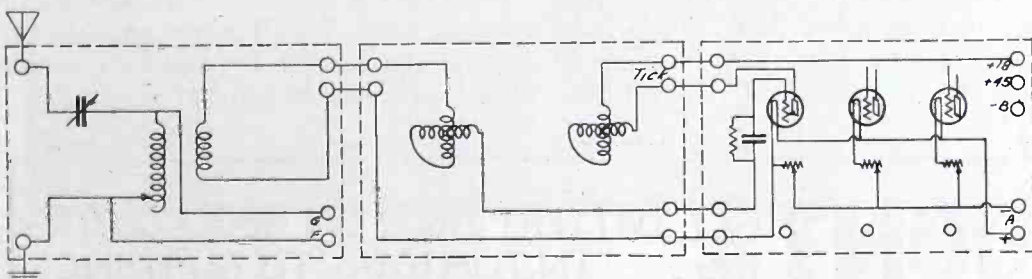

Fig. 1b. Hook-up of the Three Units as a Three-Circuit Receiver

construction of the three-circuit tuner can not make use of the design and constructional data, and vice-versa. It is the object of this article to show how a universal receiving set can be constructed and with it either of the types can be used, at the will of the operator.

A glance at Fig. 1b will suffice to furnish a general idea of the receiving set as a whole. This set consists of three individual units. Box No. 1 is the tuner, which contains a 23-plate vernier variable condenser, a vario-coupler and its attendant switch points, switch arm and secondary dial. Two binding posts are furnished for the aerial and ground connections on the left hand. Two binding posts at the upper right hand corner of the box provide an output for the secondary or tickler coil of the vario-coupler; while two binding posts at the lower right hand corner are provided to connect the condenser and vario-coupler to the input of box No. 3 (detector amplifier) when box No. 2 is omitted, thus changing the receiver to the single-circuit type.

Box No. 2 contains two variometers, one for the grid circuit and one for regeneration, which is connected in the plate circuit. The two posts in the upper left hand corner permit connecting the grid variometer in series with the vario-coupler secondary, while the two posts

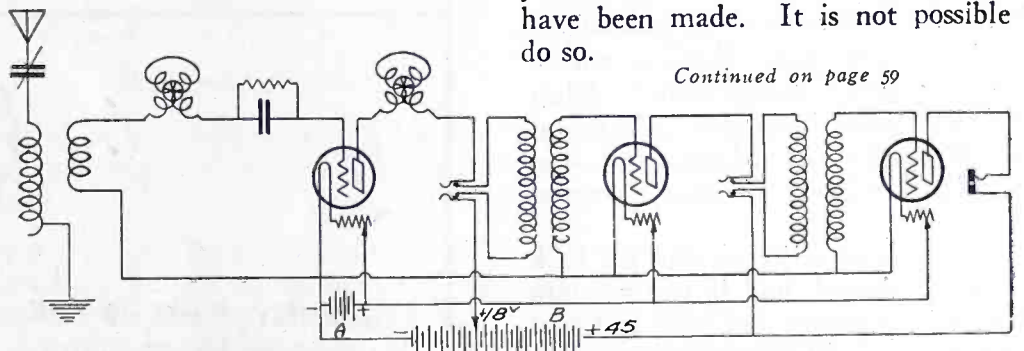

Fig. 2. Diagram of Connections as a Three-Circuit Receiver

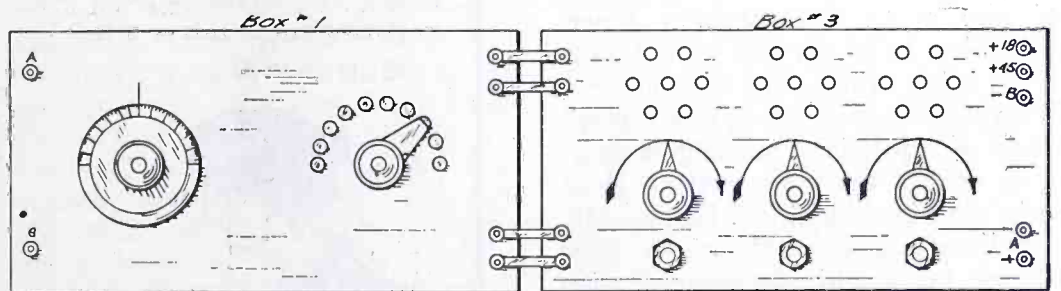

Fig. 3. Hook-up as a Single-Circuit Receiver

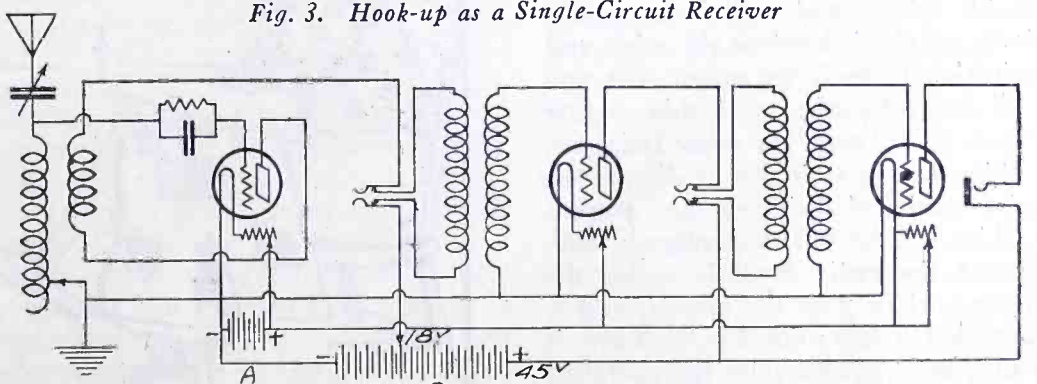

Fig. 4. Diagram of Connections as Single-Circuit Receiver

ON BEING A RADIO OPERATOR

By COLIN KELLEY

I HAVE been a radio operator for fifteen years. This seems a terrible thing to admit, but it is true except for the time I fell out with radio and became a salesman for six weeks. These six weeks convinced me that radio was better than selling, especially for me.

Radio has a very peculiar fascination, and the added faculty of making anyone associated with it a "nut." I get as much kick out of listening to a concert as the fellow who just broke into the listening game, and when it comes to pushing stuff through static, that little "R" from the other end of the line gives me as much joy as the first time I called "AX" and got an answer over a carborundum detector. I can't think of anything I would rather do than be around radio apparatus, and can't understand anyone wanting to be around anything else. Therefore I must be one of the aforesaid "nuts."

It used to be that you went up and told a hard-boiled district superintendent what a fine operator you were, and you went out on a ship, or maybe you went to a shore job, or possibly you didn't. Then something new opened up, and of course, an application was filed with the newest outfit. The theory was (and is) "take your spoon where the soup is."

Then someone came along and started all this business about licenses, which, while very good statesmanship, didn't cause an increase in salaries. It meant farewell to the old Morse code, but personally I believe this was a step in advance.

Now you have a license, and the back of it gets indorsed, and if you get into a broil with someone you have to spend several hours to get someone else to sign it for you.

In starting out as an operator, a person does best to go out as a second operator for a few trips. The first operator will usually see that you do not commit a breach of regulations, misconduct yourself, or neglect the brass. About three months' training along these lines usually accomplishes one of two things—it either sends you home with the determination to finish school and enter the family business, or else it hardens the mind and constitution to such an extent that you are all ready to take out a ship as first operator, or as "only" on some freighter.

While we are at it, let us discuss the relative merits of freighters and passenger ships. The maroon-colored book says that the radio et al is under the supreme authority of the master, and it means what it says; but I never knew it to worry anyone, especially the operator. Anyhow, on a passenger ship, the oper-

ators eat in the passenger saloon (O, that word saloon, how it recalls the good old days), and get plenty of good food, if enough portions are ordered. But they also enjoy all the privileges of a monkey in the zoo—they can look on, but not take part. Incidentally, uniforms are usually necessary. On a freighter, the operator has a good deal of time to himself, and can dress as carelessly as he pleases. But O, the grub! I repeat, O, the grub! I once got so that I couldn't eat beef unless it had little white things on it, and couldn't bear the taste of coffee that hadn't been re-boiled about four times. But either way, it's great stuff, because you can go to your receiver for solitude, and comfort yourself and stomach by listening to someone trying to get a message over about 1200 miles at the same time seventeen others are doing the same thing.

And what can any other occupation for the "workingman" offer that will compensate for the rare privilege of sitting up half the night amusing yourself and then sleeping till noon the next day?

A friend, who happened to be a physician, once remarked that being a radio operator was the best thing he knew of outside of a profession. I told him that

one might call radio operating a profession. His reply was "Yes, you might." He expressed it all in a few words.

It is noticeable what a difference broadcasting has made in radio. It seems as though the interest and application of radio that should long ago have been recognized have just been actively utilized. The many police and fire departments all over the country, the power companies and isolated mines and construction camps have within the last two years developed an enormous network of stations throughout the land; and last, but not least what a multitude of Radio Experts have blossomed to the fore. Especially the type that make definite statements about the inefficiency of radio-frequency and vibrating crystals.

One has about ten chances in radio today where formerly there was but one in operative radio, and a number of opportunities in merchandising, but the idea of trying to sell fibre-ended condensers for an ex-drygoods merchant doesn't appeal to the writer, although it may have its advantages. So, taking everything into consideration, if I live another thirty years, I will write another little article on how it feels to be the oldest radio operator in point of service.

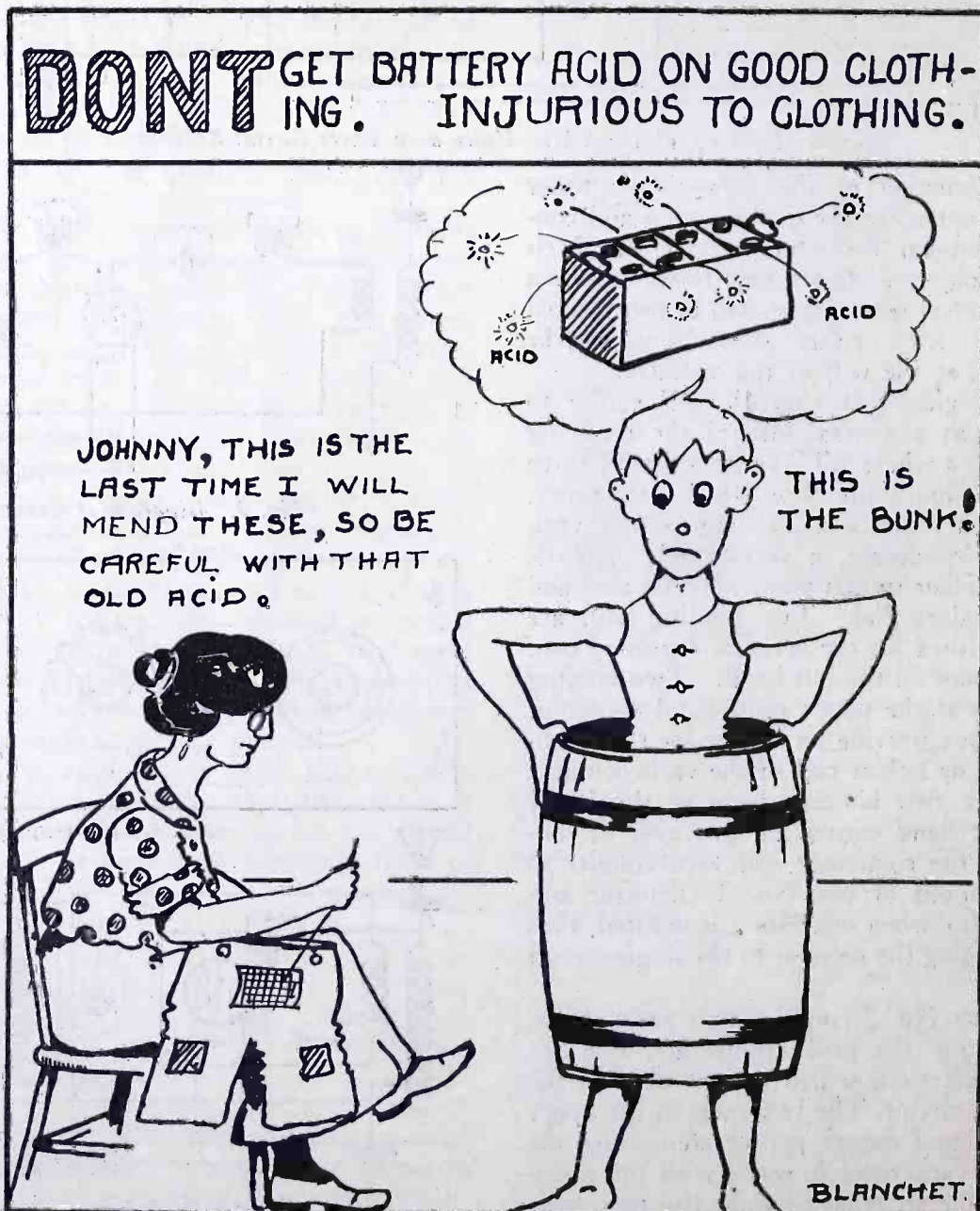

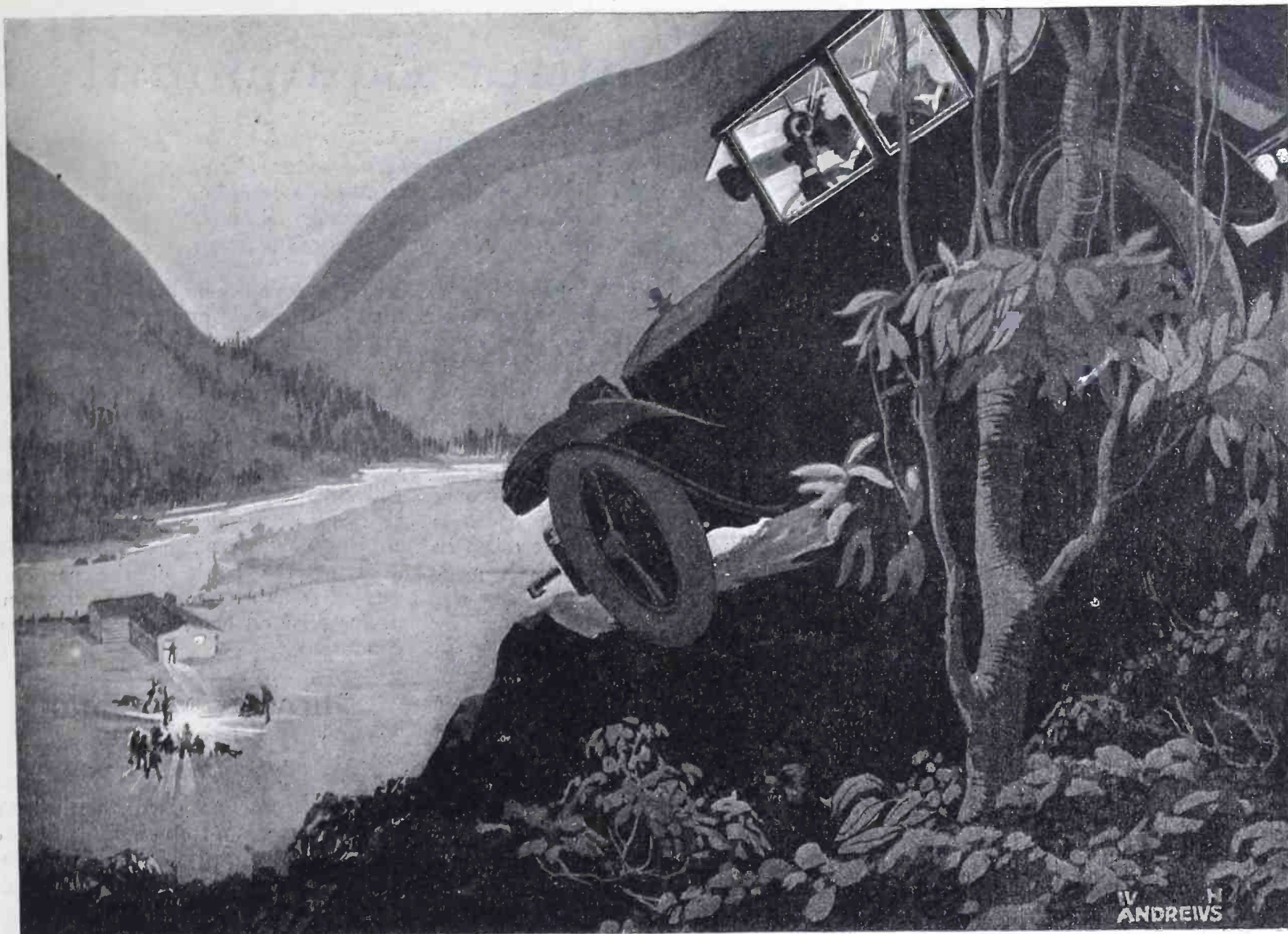

To the canyon's bottom from the car's loud speaker reverberated the Parson's voice, "Thou Shalt Not Kill."

A Power Box Drama

By Paul Oard

Aside from the development of an interesting plot, with a goodly seasoning of humor, this story gives a suggestion that many an amateur is likely to adopt. It is essentially a radio tale by a radio engineer.

THE long, low hung car that slipped along the highway was in itself enough to attract attention. Its rakish lines combined with a color scheme that shouted out loud, bespoke class and speed in no mistakable tones. But it wasn't the car itself that served so much to make observers look twice—it was its method of asking for the road when desiring to pass another machine, or in signaling a pedestrian to watch his step. Warning signals on automobiles are of either the horn or whistle type, with tones that either politely request the right of way, or more stridently demand it, but this particular machine carried a signal that was as different from other signals as are the latest tube transmitters different from the smoke telegraph of the Indians. Gently it warned you to one side of the road, or stridently "cussed you out" in beautifully modulated English if a tendency was shown to take more than your just share of the road.

When young Bruce Barklay turned his thoughts toward a rest after a hard

year's grind in the radio game, during which time he had accumulated a fair share of profits, it was but natural that he should incorporate radio into his plans. There was nothing particularly new in his outfitting his car with radio equipment, but Bruce did such a thoroughly good job of it as to win commendation from even hard boiled juice jerkers who had cut their eye teeth on old United straight gaps and carborundum detectors. Then one night, while idly listening to a world-famous orator addressing a crowd of thousands through the medium of the loud speaking equipment now so familiar in public rostrums, dawned the great idea, and forthwith there was added to his already elaborate outfit a three stage power box amplifying unit, a sensitive bowl transmitting microphone, and a generator driven off the engine of the car.

Barklay substituted a fifty watt tube in the last stage of the amplifier in place of the usual five watt, and built under the chassis of the car a spruce horn, placed well toward the front of

the machine. The bowl transmitter he so placed that it could be swung upward and secured to the ceiling (his car was an enclosed one) when not in use.

Cars moving along the highway would show a tendency to jump into the ditch under a startled operator's driving, when in thundering accents a voice would politely request the right of way. And when the driver would pull over to one side and look back in utter amazement, the orange colored car that Barklay drove would still be a half mile down the road. Or again the car would burst into song, Barklay possessing a fine baritone voice that he was not ashamed of. Under full power his voice could be heard for well over a mile on quiet atmosphere, and the effect of some old popular song rolling forth from the swiftly moving, and otherwise silent vehicle, was uncanny in the extreme, particularly to the hundreds who had never heard such a device.

Barklay derived considerable publicity from his efforts. Some of it

Continued on page 48

Design of Transmitter Equipment

By D. B. McGown

Some general suggestions are here given for the benefit of the amateur contemplating the construction of a C. W. set. Taken in conjunction with the author's preceding article on the design of a receiving set and his following one in November RADIO on the design of amplifiers, this series makes rather a complete treatise on radio design.

THE first factors to be considered in the design of a transmitter are the wavelength ranges desired, the type to be used, and the power output wanted. Especial care must be taken in its construction so that it may withstand the high voltages customarily used to excite the antenna circuit and that it may have a good over-all efficiency.

In the design of a vacuum tube transmitter for pure C. W. on amateur wavelengths we may assume that the set is to operate with a certain type of tube on a wavelength of 200 meters. We may assume the use of 50-watt tubes for example. These tubes require a source of high potential for their plate voltage, and a source of low potential for their filament current. We will not have any great changes to make in the emitted wave, so we will not need all the variable factors that are needed for a receiving set. The set, once adjusted and barring accidents, will not be changed materially, unless something breaks down, or is changed deliberately.

The circuit to be used is also a more important consideration than in the case of an inductively coupled receiving set. We generally find that each person prefers some specific circuit, due either to his personal equation or to his familiarity with the circuit. If any of the common types of radiating tube circuits are carefully adjusted to their optimum values, there should be little difference in their operation. If we get six amperes from a Hartley circuit and the same from a Meissner, using the *same* tubes on the *same* antenna, with all other conditions similar, there should be no difference in the effective range, provided some of the energy is not radiated in the form of a harmonic, which increases the ammeter reading.

That is, six amperes on a given wavelength in a given station has theoretically the same range, no matter what the circuit. Actually this is not the case, as, in addition to the radiation of harmonics, the wave form of the antenna current changes conditions, even if the ammeter reads the same. Each circuit also possesses certain advantages in tuning. The Colpitts has only two particular adjustments. The Hartley has three. The Meissner has three circuits to adjust, but, nevertheless, it is not hard to tune. The Colpitts is easy to tune, but the series antenna condenser is usually a source of loss, unless it is well designed. The actual circuit to be used should be determined by the designer.

Besides the circuit and panel layout, the correct design of the inductance coils, the control circuits, the d.c. supply, including the filter, etc., should all be given careful attention. The inductance coils can be calculated as described by the author in September RADIO.

The "keying" circuit should be studied carefully, in order to obtain proper and rapid action, and if large power is to be handled, care should be taken to eliminate the arcing that will take place if the high voltage d.c. is broken directly. This can be accomplished either by proper arrangement of the circuits, so that the key opens and closes the grid, or other control circuit, in which case only a small current is broken, or by a relay key, with a large shunt condenser to cut down the arc.

The plate supply circuit is one that needs very careful attention in the design. If the d.c. supply is to be pure and unvarying, a very carefully built filter is essential. The design of a filter system is rather a problem, not because the basic frequency is hard to eliminate, as in the case with 60-cycle rectifier a.c., but because audio-frequency harmonics are often present and pass through the filter, if the latter is not designed to cut them off. The insulation of the various condensers and coils is a matter that also requires very serious attention. Many articles on filters have appeared in various publications, and it is not our place here to discuss this matter in further detail.

The use of a radio telephone transmitter presupposes that the builder is not particularly interested in the use of telegraph, and, as a matter of fact, there are few cases where stations are used for both purposes. The transmission of speech, in a clear and undistorted manner is such a tremendous problem that no one should undertake to build such a station, unless he is familiar with the requirements of land-line telephony, and even then he should avoid it, unless he is thoroughly familiar with the design of vacuum tube amplifiers and their component parts. This refers likewise to the construction of an amplifier for operation on the output of a receiving set. It is easy to get an amplifier that will "talk," but it is hard to build one that will not distort the speech.

If the designer knows exactly what he wants a particular set to do he first considers ALL the problems connected with its service, and then the possibility of obtaining standard parts which will

ease the problem of building to a point that will not interfere with the efficiency of the set. After a gradual balancing of the entire proposition, the actual construction is started, and the set built and completed. Often all these proposed steps are carried out mentally, by the builder, or may not even be considered in detail, as there seem so many that are self-evident, but generally, a project of design consists of carefully studying the needs of the particular service, and then adapting the apparatus, or material on hand to carry out these conditions.

HOW TO PROLONG TUBE LIFE

By JESSE MARSTEN

A brief consideration of the theory of electron emission from the filament of the vacuum tube will show the best method of operation so as to prolong the tube life. The life of a tube depends upon the temperature at which its filament is worked. A filament operated at 2490 degrees evaporates twice as fast as one operated at 2542 degrees and hence will last only half as long.

The life of a tube is arbitrarily defined as the number of hours it takes the diameter of the tube to decrease by 10 per cent of its initial value. This decrease may be secured in a short time by operating at high temperature, or in long time at low temperature. But as a certain electron emission must be obtained to produce the results required of the tube, 2000 hours has been chosen as a reasonable life. Consequently that constant filament temperature which will reduce the filament diameter by 10 per cent in 2000 hours is called the safe temperature. It is the temperature at which the tube filament should be operated to secure maximum life and maximum operating efficiency.

As there is no direct measure of filament temperature in the tube, reliance must be placed upon the indirect indication of an ammeter, volt meter or watt meter. Since the filament is evaporating continuously the temperature conditions are variable. There are three methods of controlling these conditions so as to keep the filament nearly constant in temperature—by operating it either with constant current, constant voltage or constant power.

With constant current the power consumption and consequently the tem-

Continued on page 58

Design and Computation of Aerials

By L. H. La Montagne

The importance of good aerial construction becomes manifest when it is understood that an aerial is the cheapest kind of amplifier. While the facts given in this article are intended primarily for the guidance of the transmitting amateur, they should not be amiss when it comes to putting up a receiving aerial.

THE first problem of the radio enthusiast is to decide what kind of aerial he needs, and what size it shall be. There are also numerous structural details which arise, but as no two installations are exactly the same, these questions must be solved by the individual on the ground. The various dimensions are generally chosen from those of a neighbor which have given satisfactory results. But as no two locations have exactly the same dimensions, etc., it would be better if the dimensions could be approximated before erection, especially if we desire to operate on a certain wavelength as under the new amateur regulations. In the following, an attempt will be made to give the various factors that enter into the determination of the dimensions of an aerial, and their values as far as possible, so as to allow an aerial to be chosen to fit any local conditions. Of course, no one but the builder can decide whether to put one pole of the aerial system on the hen house or a handy tree, but that is what makes radio work interesting.

The various types to choose from are limited to the following: T, L, umbrella, cage and loop aerials, with the L and cage aerials being in most favor at the present. Each type has its advantages and disadvantages and these should be fully considered before erecting any particular one. In general, the advantages desired are that the aerial be not too directional, easy to erect; and that the transmitting and reception efficiencies be as high as possible, where one aerial is used for both purposes.

The inverted L aerial shares honors with the cage type as being used the most. Nearly all receiving aerials are of the L type with one wire. For transmitting, four to eight wires are used in the flat-top of the L aerial, the exact number being determined by how much money the individual wants hanging in the air. The T aerial consists of a flat-top with the lead taken from the center instead of end as is the case with the L aerial. The T type is less directional than the L, and, for a given size, has less inductance, and hence a lower fundamental, which permits an increase in its size as compared to the L aerial. The lead-in of the T is also well away from all guy wires which are liable to absorb energy, which should be kept in mind.

The umbrella type consists of four wires or more sloping downward from a central mast like the ribs of an umbrella. A vertical wire leads to the top

of the mast, and all wires are connected to this conductor. This type of aerial is practically non-directional. The capacity of an umbrella aerial is very large, since a large amount of ground is covered by the sloping wires. The inductance is only slightly larger than that of the vertical wire leading to the top of the mast. The main objection to the use of this type is that a large amount of ground space is required, since each wire or system of wires must be fastened to an individual dead-man. Four wires set on the points of the compass, each wire being about 80 ft. long, sloping from 50 ft. at the top to 10 ft. at the ground, will make a good experimental aerial, but otherwise its use is confined chiefly to large stations on account of the structural details which are beyond the average radio worker.

The cage aerial, as its name implies, consists of a number of wires equally spaced on hoops. Except for size, its theoretical and actual advantages over the L aerial are not very obvious, and it is a question as to which is the most efficient type to use, though excellent results are to be had with the cage. Some are using an L aerial with the two outer wires in the form of a cage, with a single intervening strand, either present or omitted entirely. The advantage claimed is that since the outer wires are supposed to carry the most current, the resistance should be as low as possible. The size of cage aerials is difficult to compute even approximately, and the dimensions are taken from some aerial that has been tried and gives the wavelength desired.

The loop aerial, consisting of a flat spiral or coil, needs little description. It is used for a substitute for the outdoor aerial, cutting down interference. The loop is limited in use due to the fact that several steps of radio-frequency amplification must be added to compensate for the lack of energy picked up. If the loop approaches the size of the outdoor aerial, the energy picked up is nearly as great. All leads from the loop should be as short as possible, and, in direction finding, all capacity to other wires, houses, etc., should be avoided.

In general, no matter what type is chosen, the wires must be clear of all trees, buildings, etc., and must not be strung so that the wires could fall on any power line, telephone or telegraph wires. The power lines should be most carefully avoided, as disastrous results are sure to follow to all concerned if the aerial falls upon the high voltage power

wires. This point cannot be overemphasized. Care should be taken that the aerial is clear, and as high as possible, of any wires, trees, buildings, etc., which would act as a shield. The wires should all be carefully soldered with a non-corrosive flux, and enough lap allowed so that there is no danger of pulling the wires apart when strained. The proper way to make the lap is to have the center twists far apart to allow for soldering, and the final turns close and as tight as possible.

In choosing the number of wires, it should be kept in mind that for receiving one wire will be sufficient, but that in sending four or more should be used, so as to have as much capacity in the flat-top as possible. The spacing between centers of wires in multi-wire aerials is taken at from 1/40 to 1/30 of the length. The spacing of cage aerials is haphazard at present, and depends upon what size of hoops are available.

The question of insulation has been discussed in RADIO before, so nothing much needs to be added. With the advent of high power C. W. transmitters, the question of insulation has become a serious problem, and the only solution at the present seems to be to employ plate glass insulators with holes drilled in each end for the wires. The longer these insulators are the better, but 18 in. long by 1/4 in. thick by 2 in. wide will answer for most purposes. The glass should be wiped off every few months to remove the dirt that collects. For receiving sets and low power transmitters, the various composition and porcelain insulators may be used. The prime requisite of any aerial is insulation, and no harm is done if the aerial is over-insulated, but poor results will be had if the insulation is defective in any way. Insulators should not be placed so that they are in parallel, as the efficiency of the individual insulator is lowered and no good is gained.

The position and type of lead-in has a very important part in the results obtained in any radio work, whether receiving or transmitting, but the latter will show up any defects more quickly, due to the larger amount of power used. For transmitting work, a cage lead-in should be used, not only because the resistance is reduced in this part of the circuit, but a lower wavelength may be obtained, in many cases amounting to a considerable proportion of the total. The cage lead-in may consist of the same number and size of wire as used in the main aerial, and arranged on small

hoops which need not be over 6 in. in diameter, made of heavy copper wire. The lead-in should have a sufficient number of hoops, and stretched tight enough to prevent the wires from twisting together, as this would partially destroy the purpose of the cage lead-in. In all cases, the lead-in should never come near any metal object or building, as far as practicable. The actual entrance into the building is a cause of a large loss, as the insulation used is generally not sufficient. To make a good entrance insulator, a piece of plate glass about a foot square and a quarter of an inch thick, should be drilled with a hole for a threaded rod to which the wires may be rigidly fastened and soldered. To prevent the nuts on the threaded rod from cracking the glass, rubber washers may be placed under them, which will also make a water-tight joint.

The next item is the size of wire to be used. While the actual size would depend upon the span, No. 14 B&S hard-drawn copper wire will answer for any spans up to 125 ft. Above this, it would be safer to use No. 12 wire. Phosphor bronze wire is used for long spans but the cost is considerably higher. The solid wire, despite theory, will not give an appreciably higher resistance than stranded wire. From tests on loop aerials, it has been found that the heavier the wire the better the results obtained. Care should be taken that all the wires should be as well insulated as possible, both from the frame and other objects.

The accompanying graphs and tables will enable anyone to obtain the more important constants of aerials, with the inverted L type most particularly in mind. These data will allow the selection of the aerial which is most desirable for any particular installation. It must be borne in mind, however, that anything but actual measurements will not be absolutely accurate, as the position of buildings, trees, other wires, etc., have a decided effect on the various constants. For all ordinary work, though,

the results will be accurate enough for preliminary design work.

In the design of the primary of a tuning transformer (loose-coupler, etc.), the most important factor to be considered is the capacity of the aerial, as this, together with the series condenser, determines the wavelength range with a given inductance. In all but extremely accurate work, the inductance of the aerial is not considered, as it is only a small per cent of the total inductance used in the tuning elements. Table I gives the capacity of the inverted L four-

TABLE I.
Capacity of Inverted L-aerials, in Mfds.

Height (feet)	Length of Flat-Top (feet)			
	40	60	80	100
30	.000209	.000287	.000370	.000454
40	.000199	.000281	.000359	.000441
60	.000194	.000273	.000343	.000432
80	.000193	.000269	.000338	.000427
100	.000192	.000266	.000336	.000424

wire aerial, spaced 2 ft., and of No. 14 B&S wire. The capacity of the lead-in has been added to calculated capacity of the flat-top portion of the aerial. However, due to difficulty in the exact calculation of the capacity of the aerial lead-in, this value must be approximated, and, as used in this table, represents about twenty per cent of the flat-top calculated capacity. While the figures are given for four-wire aerials, other types and sizes may have their capacity approximated by selecting the size of L aerial that comes closest to the one under consideration. The capacity of a single-wire receiving aerial may be taken at half of the values shown for the four-wire aerial. For other size aerials not given in the table, the capacity may be obtained by interpolating between the values given, or the actual calculations carried out as explained later.

The use of this table is as follows: Suppose we wish to obtain the capacity of a four-wire aerial, 40 ft. long, 40 ft. high, spacing 2 ft., with No. 14 wire. From the table, we find that the capacity, including the lead-in, is .000199 mfd. Then again suppose our aerial is 45 ft. instead of 40 ft. in height.

From the table we observe that for an increase of 20 ft. in height the capacity is decreased .000005 mfd. Since the height under consideration is quarter-way between these values, we must subtract .000001 mfd. from the value for 40 ft., thus giving the capacity as .000198 mfd. If a single wire had been used, the capacity would be half (using 40 ft. as the height) of .000199 mfd. or .0000995 mfd. From these figures, it will be realized that the usual small aerial has a very small capacity as compared with the condensers used in a transmitting or receiving set. However, this aerial capacity has a very important bearing on the wavelength range of the receiving tuning inductance and has to be carefully considered in all design work.

The next important item in the selection of an aerial is the natural or fundamental wavelength. This wavelength is determined by the capacity and the small amount of inductance present. The fundamental wavelength of an aerial for receiving sets may vary within wide ranges, due to the fact that a series condenser is used to change the fundamental wavelength, but, in transmitting sets, this condenser is not always desirable. For this reason, the fundamental wavelength of the transmitting set must be below the transmitting wave, just how much depending upon the design of the transmitting set. But for 200 meters, the fundamental wavelength should not be over 170 meters to allow for proper transfer of energy in the tuning inductances. Almost everyone is familiar with the rule to allow about 110 ft. for the total length of lead-in and flat-top if the transmitting wave is to be 200 meters. With the contemplated laws, this rule will no longer be effective, and some such graph as shown in Fig. 1 will be necessary to determine the size of aerial required for a given transmitting wavelength. The fundamental should be about 30 meters below the actual desired transmitting wave, although no hard or fast rule should be made. This graph does not taken into consideration the effect of trees, buildings, etc., and if there is more than the usual amount in the vicinity of the aerial, a slightly lower fundamental wavelength should be used to compensate for their effect. The radio constructor should use his best judgment in any work like this. The fundamental wavelength of a T-aerial will be half of that given for an L-aerial of the same flat-top length. If we have an L-aerial 60 ft. high and 120 ft. long, the fundamental wavelength will be 340 meters. If this aerial is changed to a T, the wavelength will then be 170 meters.

Table II allows us to select a size of loop that will fit in with the construction materials available more nearly than

Continued on page 62

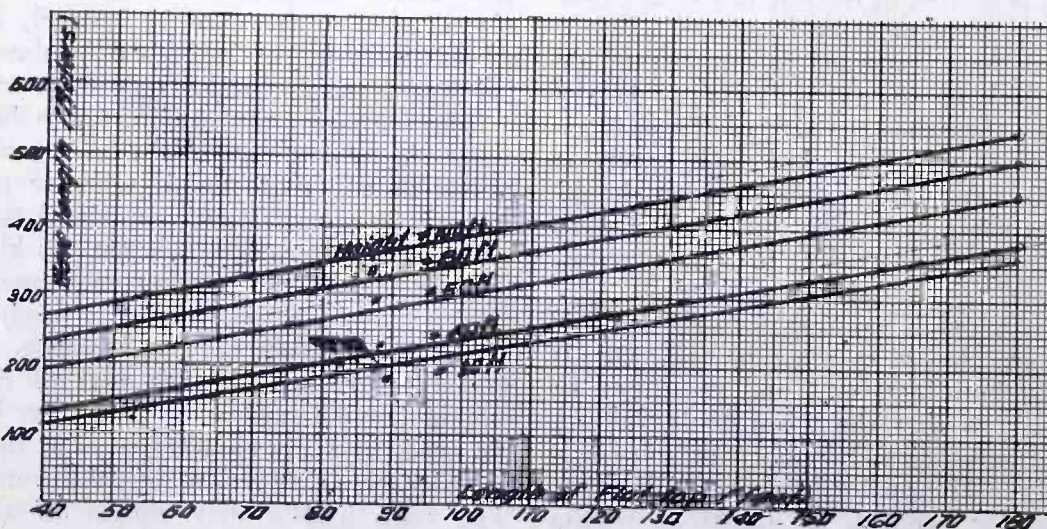

Fig. 1. Natural Wavelengths of 4-Wire Inverted L Aerials With 2-Ft. Spacing and 4 No. 14 Wire Bunched Lead-in

Improving the Single-Circuit Receiver

By Paul Oard

Notwithstanding the criticism directed against the single-circuit receiver, its simplicity of control is likely to keep it as the novice's favorite. With the author's suggestions it may be made to eliminate much of the interference of which the B.C.L. complains.

IT is a generally accepted belief that a ground connection is essential to reception of signals and music, and, furthermore, that the ground should be a thorough one. While this holds true for the crystal detector types and for the so-called three-circuit receivers, it does not apply so particularly to the regenerative single-circuit receiver. At times a decided improvement under certain operating conditions will be noted in the manipulation of this last type if the ground connection is done away with entirely.

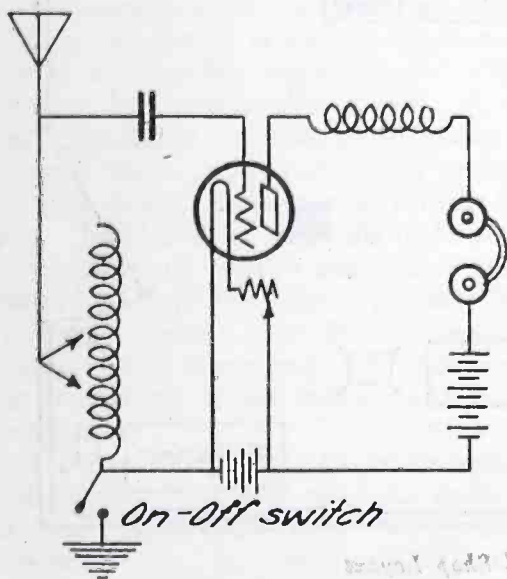

Fig. 1. "On and Off" Switch in Single Circuit

The placing of a small on-and-off snap switch in the ground lead, enabling the operator to connect and disconnect at will, is advantageous. The elimination of the ground connection permits of sharper tuning, therefore less interference, and an actual decrease of static, with no noticeable loss in receiving efficiency.

With the ground lead removed, it will be necessary to advance the wavelength dial a few graduations higher on the scale. If the instrument is one which is not thoroughly shielded from capacity effects, the removing of the ground lead may make it necessary to allow for an increased capacity effect in setting the wavelength dial. The tuning will be sharper, however, and particularly noticeable in the case of a long antenna.

The statement that static is oftentimes decreased without loss in strength of signals may seem a trifle far-fetched. However, in this case, the proof of the pudding is decidedly in the eating. The writer has found in radio demonstrations that the removal of the ground lead so cleared up music as to call forth exclamations of approval from a critical audi-

ence, who, while not understanding the reason, sensed the change for the better instantly.

Interference from spark stations, which on high antennas often ranges over several taps of the tuning inductance, is likewise noticeably decreased, and in many cases done away with entirely.

Summing up the last two paragraphs indicates that while continuous wave stations suffer but little loss in signal strength, that damped wave signals, and static, likewise of highly damped characteristic, are noticeably affected by elimination of the ground, and therefore this characteristic of the standard regenerative single-circuit receivers may be taken advantage of by the operator readily.

The simpler type of tube sets oftentimes afford the operator some trouble in the securing of a satisfactory adjustment on the detector tube, particularly where the tube is somewhat critical in adjustment. Practically all operators know what it is to be able to tune in the "whistle" of a broadcasting station, yet be unable to clear up the voice or music. This is oftentimes noticeable in receivers not provided with grid bias, and using B batteries not connected to allow of variation in voltage.

The necessity of using grid leaks, adjustable B batteries and a potentiometer may be done away with by means of the "circuit control." This is nothing but a 400-ohm rheostat connected directly be-

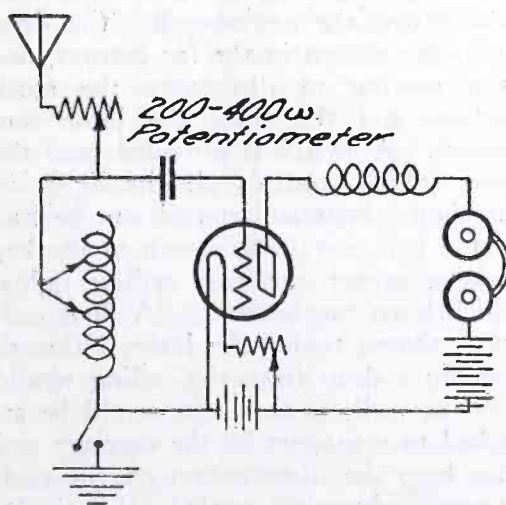

Fig. 2. "Circuit Control" With Potentiometer

tween the antenna and the instrument. Stations that are otherwise impossible to clear up, may be tuned in perfectly with such a device. An ordinary potentiometer is used, but is connected as a rheostat would be—in series. A 200-ohm potentiometer will give good results. The device acts as a damper on

continuous waves, and affords a control that is of considerable value. A potentiometer with vernier control is preferable. This device may be used with any regenerative type, single, two or three circuit, to advantage. It may also be connected directly in the plate lead with good results, although in the reception of some signals it will be found that there will be a detuning effect that must be compensated for in the wavelength controls. This is not apparent where the device is inserted in the antenna circuit.

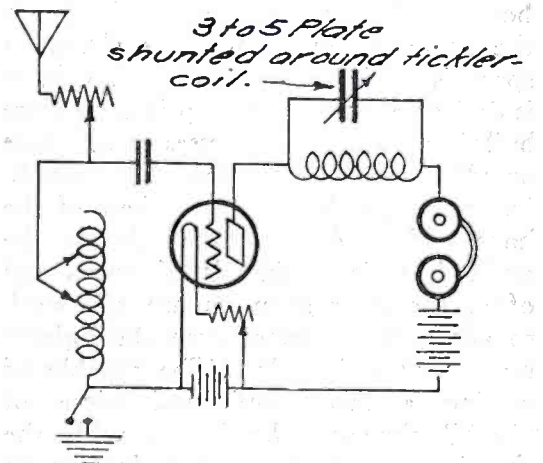

Fig. 3. Variable Condenser to Secure Broader Regeneration

As far as known, the use of this device is original with the author, who has yet to note its use in broadcast reception. Its utter simplicity, and the ease with which a station may be cleared up make it of extreme value.

Many single-circuit receivers go into regeneration with a suddenness that is annoying to the operator. This is more noticeable when a critical detector tube is used, or the antenna is of short length. The "circuit control" takes care of this trouble to a large extent. Another method, not generally known to the average broadcast listener, although, I believe, familiar enough to the experimenter and amateur, is the shunting of a small variable condenser across the plate coil. The regenerative dial may be then adjusted close to the regenerating point, and then brought up gradually into proper regeneration by the variable condenser. A three or five-plate condenser is best for the purpose. The novice should use a little care in connecting the condenser into the circuit, as it is generally necessary to remove the panel of the receiver to make connections, it is advisable that tubes be removed from their sockets, and caution used in not allowing connecting wires to come in contact with any but the leads for which they are intended.

Home Radio Shop Practice

By D. B. McGown

Detailed directions are here given for the layout and equipment of a model radio shop. Of especial value are the suggestions to be followed in the selection of the lathe, drill-press and grinder.

THE layout of a shop for making radio sets at home depends largely upon the amount and kind of work the builder intends doing, as well as upon his skill as a machinist. As the operations usually performed in the home shop are turning, drilling, grinding, sawing, winding, assembling and finishing, this account will be confined to a description of the tools and methods used in these operations without reference to more difficult processes such as punching, forging, milling and engraving.

The most convenient location for the home radio shop will generally be in the basement, or garage. If plenty of space is available outside the house, it is desirable to put the shop in a separate building, as many processes cause noise or odors which bring forth strenuous objections from the other members of the household. Attic space should be avoided, as it is difficult of access and often the floor supports are too weak to adequately support even the lightest machinery and tools. The trouble of carting a large unfinished piece of "junk" through the house, with the chances of causing serious damage to the furnishings thereof, often will be enough cause to force the shop-owner to seek other quarters.

After suitable quarters have been located, decision should be made as to classes of work to be done. Shop work comes under "hand" and "machine" work classifications. For example, the manufacture of banked-wound coils is strictly a "hand" operation, as the operator must, through his own skill, form the shapes of the various turns so that they will conform to the peculiar twists and evolutions that they encounter in the formation of such a coil. The turning out of a bakelite ring, for a wave-meter coil, is, on the other hand, a "machine" operation, as the lathe, on which the work is accomplished, is the primary means of accomplishing the desired result, the skill of the operator in the working of the lathe being of secondary importance.

The layout of the shop is largely a matter of personal preference. One layout that is believed to be satisfactory is shown in Fig. 1. Here is a 12x14 ft. room located in a detached one-story building. A shop should be well lighted and ventilated, both for day and night work. A large number of windows are desirable. In daylight working, all points where much work is to be carried on should have separate windows. In the suggested layout one window is

provided beside each of the machines and another over the work bench, where most of the work will center. Almost all operations require exactness, and if there is not sufficient light to properly illuminate the work there are bound to be serious errors.

If work is to be performed at night, artificial lighting is just as important. Fig. 1 also shows the layout for the lighting system. General illumination is provided by two 250-watt lamps in

should be placed in such positions and at such heights as will be most convenient for the particular operation in hand.

The outlets for motors and other power sources are not shown, as their location depends on the types of tools used, and the power required by each. A gas outlet is provided back of the vise, on the work-bench, as such a source is needed for the operation of a torch, or gas burner.

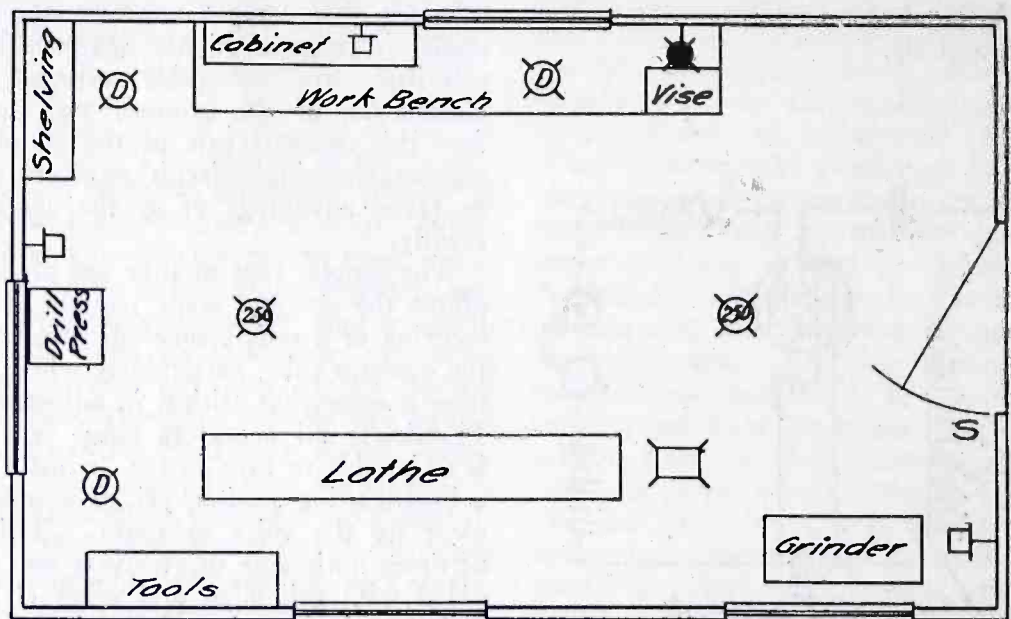

Fig. 1. Suggested Shop Layout

the ceiling, the indirect system being preferable if the interior is finished. Separate lights are shown over the work-bench, lathe and other tools. A light should be installed inside of the tool cabinet over the work-bench. The drop lights are shown in the far corners, one each serving to illuminate the stock shelves, and the other the lathe tool cabinet. A switch is provided near the door, which controls all the lights in the shop. Separate control can be had by the keys installed in each of the key sockets, except the two ceiling lights, which burn continuously. A floor outlet is shown under the lathe, although possibly a drop from the ceiling would serve as well, as the latter could be attached to a support on the carriage and thus keep the illumination on the tool, or work, where it is needed. Tin shades should be provided and all portable lamps should be provided with guards, to protect the bulbs from injury. Carbon filament lamps are, incidentally, the best for portable service, as they are much less liable to damage from shock. No particular attention is given in the diagram to the heights of the various outlets. These should not be located at the so-called "standard" heights, but

The power-operated tools to be installed will be determined entirely by the user and also state of his pocket-book. The shop shown has a lathe, drill-press and grinder, with which most of the common operations can be performed. The addition of a small circular saw is probably the next most desirable tool, or a small band-hacksaw would also be very useful. Either of these could be mounted on a wooden frame, provided with casters, and when not in use could be rolled back out of the way; current being supplied from a long portable cord, or a concealed outlet could be mounted in the floor.

The actual selection of a lathe should be the subject of considerable thought. Lathes are either "screw-cutting" or "speed" lathes. The former term is applied to the type of machine lathe, or "engine lathe," which is used for the turning of metal, and more particularly for the turning of heavy pieces of work, where a tool is held firmly attached to, or in, a tool holder, and either automatic or hand-feed used to move the tool in a definite pre-determined position, in relation to the motion of the work. Screw-cutting lathes are used for count-

Continued on page 78

Rigging Up the Radio Shop

By Raymond Francis Yates

This article describes the necessary tools and their set-up. It will be followed by another one on the manipulation of hand-operated lathe-tools and some shop kinks and short-cuts.

The Necessary Tools

THERE is a great deal of difference between *making* a radio set and assembling one. Not a small number of serious experimenters would like to make more of the parts that they use in their work, but a common belief that the equipment necessary to do this would entail the expenditure of a large sum of money prevents them from doing so. This is not necessarily true. The financial outlay necessary for an outfit sufficient to do everything that the home experimenter would wish to have done is surprisingly small, totaling less than \$50. Then too, it is well to remember that such an outfit, once purchased, will account for considerable saving, since less dependence is placed on outside sources, which means not only a saving in money, but sometimes a saving in time. For instance, with this little outfit we can wind coils in almost less time than it takes to tell. We can turn up variometer forms, cut switch points, make binding posts, and even polish up the surface of a new cabinet and buff metal parts.

The first thing on the list is the lathe, and for the purpose of the radio experimenter the writer has chosen the Goodell-Pratt No. 29½. This little tool is entirely practical and comes fitted with a screw tail-stock, a taper hole in both ends of the live spindle, and a special spindle for carrying buffing and grinding wheels. It is also provided with a small drill chuck and a "T" rest. It will serve admirably, not only for turning wood or metal, by hand, but for grinding as well; consequently we can leave the power grinder out of the list. The lathe retails for \$11.00.

The next thing on the list is a small power drill. Although the lathe can be used as a drilling tool, it is not nearly as convenient as a little sensitive drill with a ¼-in. round sewing-machine belt. These little machines can be purchased on the open market for from \$8 to \$10 and oftentimes a trip to a second-hand machine exchange will be profitable to the searcher. While this search is being made it will be well to dig up a small length of 1-in. shafting, (about 5 ft. long), together with three 10-in. pulleys made to accommodate 1-in. belting. A little rust won't hurt, especially in view of the fact that kerosene, a little emery cloth and a trifle of elbow grease will remove it. Some second-hand 1-in. belting can also be used, and this can be picked up for a few cents a foot. The exact footage will depend upon the type

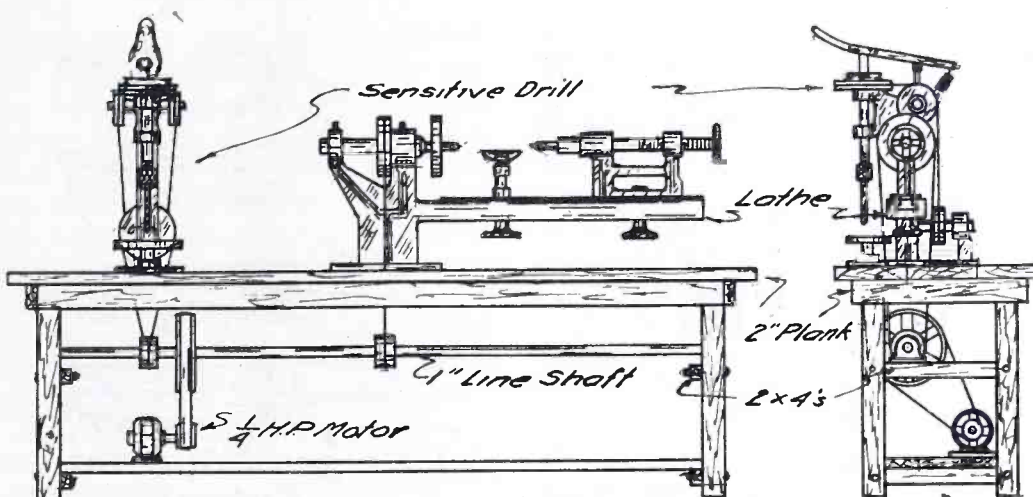

Bench Details

of machinery used, and the writer is going to leave this to the experimenter.

It will be necessary to build a substantial bench, and we will note from the drawing that the line shaft is carried below with the belts running through the top of the bench to the lathe and the drill. This is a very practical, space-conserving arrangement. The legs of the bench are cut from 4x4's, and these are not a bit too heavy. Two-in. planking is used for the top. This may sound a little heavy, but when we remember that we do not want the bench to vibrate and hop all over the floor this measurement will appear more consistent with our object. Stove bolts should be used where possible and especially for the cross pieces that hold the bearings of the line shaft. As few nails as possible should be used in holding together the bench. Screws and bolts are preferable. It is well to remember also that the constant racking of a ¼-h.p. motor, together with the machinery, is a force that will eventually tell on a sloppy job, and to do fairly decent lathe work it is necessary that our lathe revolve with as little vibration as possible.

It will be necessary to make up a couple of brass bearings for the line shaft. It is not wise to use steel, since steel revolving within steel is not a healthy mechanical condition. It may be advisable to enlist the services of the lathe mechanic at the local garage to get these bearings drilled and reamed out exactly one inch. In fact, while we are rummaging around in the machinery exchange, it might be well to keep our eyes peeled for a couple of 1-inch bab-bitted bearings. Their size or shape does not make a great deal of difference, since we can strap them down if necessary.

The lathe and the drill press should be bolted down and we must make sure

that the belt is lined up perfectly, as if it is not it will slip off or run on the edge of the pulley with a consequent increase in slippage. The motor used should be about a ¼ h.p., with a speed of from 1200 to 1500 r.p.m. The lathe we are using is a speed type and all sensitive drills should be run at high speed. Consequently we do not want to reduce

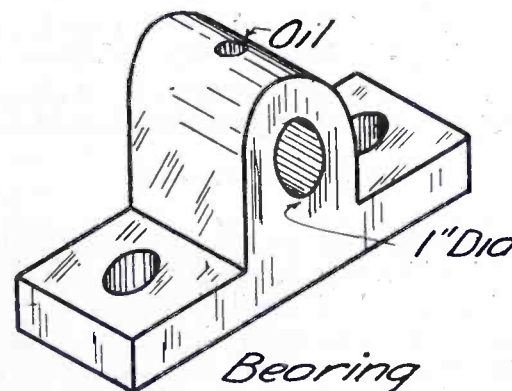

the speed of the motor a great deal, and the driving pulley on the line shaft need not be over twice as large in diameter as the pulley of the motor shaft. This will give us a speed somewhere in the neighborhood of 700 r.p.m., which is just about right for a lathe of this type. Motors of this nature are costly when purchased new, but in larger cities we have too many second-hand motor and electrical shops to make it necessary to purchase a new one.

After the machinery is all set up ready to run it may be advisable to put a little beeswax on the belts because there is a tendency toward slipping at this high speed. The proper way to lace a belt is illustrated.

The outlay for small tools need not amount to much, but what is purchased should be good. A cheap tool is a very costly investment, and it takes four cheap tools to give the service of one good one. The following list is necessary:

- 1 set of screw drivers
- 1 machinist's square
- 1 4-in. x 1/2-in. No. 60. grit Carborundum wheel
- 1 8-in. hacksaw
- 1 machinist's small ball pein hammer
- 1 each 6-32, 8-32 and 10-32 taps and dies
- 1 die holder
- 1 tap holder
- 1 scribe
- 1 scale
- 1 small vise
- 1 pair spring dividers
- 1 set small number drills
- 1 pair of calipers
- 2 pairs of pliers
- 1 set of files
- 1 small wrench

No use will be found for micrometers or other sensitive measuring tools, since there is no occasion to employ them in most radio work.

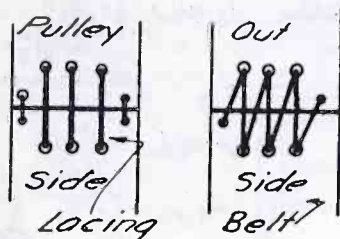

Before being able to use the lathe, it will be necessary to grind up some wood and metal-turning hand tools from old files. The shape of these tools is illustrated. In grinding the ends on these

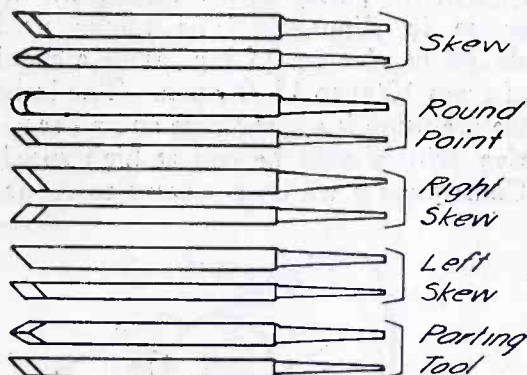

Metal Turning Tools

let us take care not to burn the metal. It should not be left in contact with the grinding wheel until it becomes red hot. This will temper it in such a way that the nose will be soft and entirely lacking in cutting power. While grinding it is necessary to have a receptacle of cold water nearby in which the tools should be dipped repeatedly. After the rough grinding is done it will be well to trim up the edges with a little hand carborundum stone of very fine grit.

The wood-turning tools are turned up in the same way. All of the tools should be provided with good fitting file handles.

The equipment just described is sufficient for a good start, and as time goes on we can conveniently add little things that will help out a great deal. Increasing our supply of taps and dies and drills never does any harm, but even with the devices described it is possible to do a wide range of work providing we use our ingenuity. A good mechanic is a good inventor, especially a mechanic with a limited tool equipment. He must constantly call upon his creative faculties to help him out of little difficulties that he naturally meets with small equipment.

Before ending this installment, the

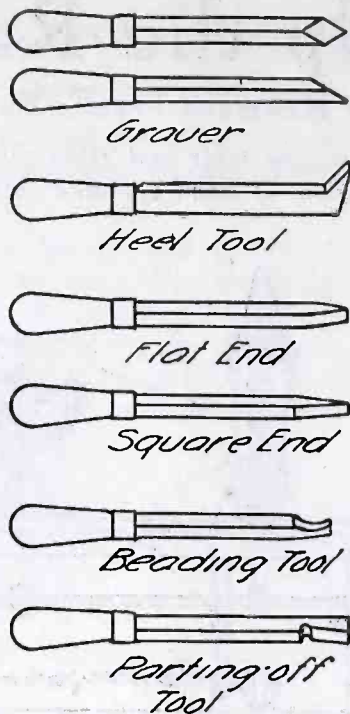

Wood Tools

writer wishes to point out that it is not altogether necessary that a power drive should be used. It is most convenient to be sure, but if it is necessary to keep expenses down to the bone, a foot drive can be employed.

(To be concluded)

HOW A VACUUM TUBE WORKS

By H. M. FREEMAN
Research Engineer Westinghouse
Electric & Mfg. Co.

Much has been written about the mechanism by which the sound at the broadcasting station is converted into electrical energy and is sent out from the transmitting antenna in all directions in the form of electro-magnetic waves. A receiving antenna lies in the path of these waves and therefore picks up a very minute fraction of the electrical energy sent out from the transmitting station. This energy exists in the form of an extremely small electric current in the receiving antenna and must be converted back into a form suitable for making the audible signal which is heard in the telephone receivers. It is the function of the receiving tube to perform this conversion process which is necessary before the energy collected from the transmitting station can be heard by the ear.

There are three elements in the vacuum tube, filament, grid and plate, which are the vital parts of the receiving tube and, when connected into the receiving circuit in the proper way, act together to produce from the incoming electrical disturbance a form of energy which can be converted into a reproduction of the original sound initiated at the broadcasting station.

In order to receive with a tube, the filament must be heated by passing an electrical current through it. When a

metallic substance is heated in a vacuum it shoots out from its surface millions of extremely minute particles called electrons. These electrons are small negative charges of electricity, the smallest known subdivisions of matter, and upon them the whole action of the tube is dependent. The filament is there for the sole purpose of shooting these electrons out into the space in the bulb where they can be made use of.

Having heated the filament of the tube to a very dull red, we have a condition where electrons are being evaporated out of the filament at a rate determined by the temperature of the metal, and if the electrons have no place in particular to go, an equilibrium condition is reached where the filament is surrounded by a cloud of electrons which are in a state of constant agitation and change, a number coming out of the filament and an equal number returning to it each second.

Now let the plate be connected through the telephone receivers to the positive pole of a 22 1/2-volt battery called the B battery. The negative pole of this battery is connected to one end of the filament. The plate is therefore "positive" in potential and the negative particles of electricity coming out of the filament are attracted towards the plate just as unlike poles of a magnet are attracted to each other. A stream of negative particles of electricity is pulled from the filament into the plate, and an electrical circuit is thereby completed, so that the B battery is forcing a current through a circuit containing the telephones and the space between plate and filament.

But in the space between plate and filament is the grid which normally allows the stream of electrons to flow freely through its mesh to the plate. If a voltage is applied to the grid, however, the stream of electrons will be deflected so that some of them go to the grid or are driven back to the filament, and the amount of current flowing between filament and plate is thus varied. Any variation in this current means a variation in the current through the telephone receivers and this of course means a sound. Therefore an electrical impulse impressed on the grid of the tube appears as sound in the telephone receivers.

It is this property of the structure of the tube which makes it possible to hear the results of the electrical impulses intercepted by your antenna. The antenna with its tuning system is connected in such a way that the variations of electrical energy which form the incoming signal are impressed on the grid of your tube. Because of the way in which the electron stream is controlled, a very small amount of energy impressed on the grid will make a relatively large varia-

Continued on page 86

The Design and Function of Inductance Coils

By Jesse Marsten

This constitutes a complete treatise on the subject, and is written in the simplest terms. After discussing general principles it takes up the several types of fixed and variable inductances for receiving sets with brief comment on choke coils and transmitting inductances.

THE inductance coil is one of the two main parts of every radio-frequency circuit, the other being the condenser. As the efficiency of such a circuit depends upon the efficiency of its individual parts, inductance design is therefore a question of considerable importance. Radio inductance coils are made in a variety of forms, depending upon the uses to which they are put. The design is therefore limited by the function and the conditions to be met. Thus a coil whose principal function is to transfer energy by induction to another circuit, as a coupler, must be designed differently from one which is not permitted to act inductively on other circuits. However, there are certain definite requirements which every radio inductance must meet if it is to be efficient.

L/R Ratio

If an actual figure of merit were assigned to an inductance coil it would probably be the ratio of the inductance to the effective high-frequency resistance of the coil, namely L/R . The greater this ratio, the more efficient is the inductance coil. Resistance, no less in an inductance coil than in any other electrical circuit, is wasteful of energy, and thus decreases the efficiency of the circuit. In a pure inductance, one without resistance or capacity, the current lags 90 degrees behind the applied voltage. All of the energy is stored in the magnetic field. If there is any resistance in the coil the magnetic energy is less by the amount lost in the resistance. Furthermore resistance in a radio-frequency circuit broadens the tuning and decreases selectivity in a receiver.

The effective high-frequency resistance of a coil is essentially due to the ohmic high-frequency resistance of the wire and to effective resistance interposed by the distributed capacity of the coil. This latter will be discussed below. The minimum resistance of any given length of wire is its direct current resistance. At high frequencies this is increased, due to skin effect, the current traveling only through a thin outside layer of the wire. The distance the current penetrates into the wire is directly proportional to the wavelength. Thus the resistance at high wavelengths is less than for low wavelengths. In order to reduce this effect, which is most prominent in solid wire, it is necessary to use specially braided or stranded wire, called "litzendraht," or flat copper strip, or copper tubing. The latter two

are principally used for transmission coils, while litzendraht may be used either for receiving or transmitting coils. The skin effect decreases with the diameter of the solid wire. For very thin wires the skin effect is very small and there is no advantage in using litz wire. Furthermore experiment shows that a frequency is reached where the effective resistance of litz wire becomes greater than that of solid. This occurs at the very high frequencies around 300 meters. At these low wavelengths, therefore, no advantage is gained in using litzendraht instead of solid wire.

Any given length of wire, say one ft., will have a definite ohmic high-frequency resistance at a given wavelength (variations in resistance due to redistribution of current when coil is wound in different shapes are here neglected as small compared to the total resistance). But its inductance will depend upon the shape in which it is wound. It may have as many different values of inductance as there are shapes in which it may be wound. But there is one particular shape of coil for which the inductance will be a maximum for this length of wire. This particular shape will therefore be the most efficient design, since L is a maximum, R is constant, and the L/R ratio is a maximum. Thus the efficient design of inductance coils may be regarded from this point of view. The choice of the best shape i.e. the shape which will yield the maximum inductance for a minimum length of wire.

It is found that the shape of the coil which gives the maximum inductance for a given length of wire is a compact bundle with turns close together, something like the shape in which wire factories wind a bundle of lamp cord. The nearest approach to this shape in commercial practice is the compact multi-layer coil. However, it is not always possible in practical work to use such a shape, nor, in fact, is it always desirable. Unless proper precautions are observed such a winding may yield undesirable capacity effects as discussed below.

All other factors being equal, then, for a given inductance that coil is the most efficient whose L/R ratio is a maximum. This is the first essential of efficient inductance design.

Coil Capacity

The function of an inductance coil is to produce a certain electro-magnetic effect. This can be fully achieved only when the entire current flows through

the coil conductively, that is, when the current flows from point to point *through the wire*, thus traversing every point of the coil. Current should not flow through the coil in any other way. This condition is generally not obtained in most practical inductance coils on account of the presence of *distributed capacity*.

Any two conducting bodies with an insulating medium between them constitute a condenser, and if there is a difference of potential between them a capacity current will flow. Every turn in an inductance coil is a conductor. Thus any two turns of a coil constitute a miniature condenser whose dielectric is the insulation on the wire, the insulating material of the winding form, shellac, etc. Since there is always a difference of potential between any two turns in an inductance coil, a capacity current leaks from turn to turn through the dielectric of the coil capacity. These leakage currents are therefore not effective in producing electro-magnetic effects, but are, in fact, a great detriment to the efficient performance of the coil.

The harmful effects of coil capacity come first from the poor dielectric of the coil. Dielectric losses due to capacity currents through it are therefore very high, and the coil resistance is consequently increased. In the second place, apart from dielectric absorption, the mere presence of distributed capacity increases the apparent resistance of the coil. This is due to the fact that the distributed capacity behaves like a shunt capacity across the coil, thus producing an oscillatory circuit of frequency corresponding to the inductance and capacity of the coil. This circuit will therefore absorb considerable energy at its frequency, thus producing an increase in the effective coil resistance. This effect is most marked at the natural period of the coil. The well known harmful effects of hanging-on ends are directly attributable to this phenomenon. In the third place distributed capacity has a short-circuiting influence on the coil, since it behaves like a condenser across the coil terminals. The terminal voltage is therefore reduced.

There are three ways in which capacity effects may be reduced:

1. The capacity of two conductors is inversely proportional to the distance between them. Thus by spacing the turns of a coil far apart the distributed capacity may be reduced. From a practical point of view too large spacing can-

not be employed. However, certain methods of winding give this effect without sacrificing too much space.

2. Reduction of voltage between adjacent turns reduces the leakage currents. By properly winding the coil it can be arranged that adjacent turns will have small potential differences between them.

3. The use of much solid insulating material in the coil will result in high dielectric losses. Air is practically a perfect dielectric, the losses in it being a minimum. Wherever possible, use should be made of this natural medium as the coil dielectric.

Receiving Coils With Fixed Inductances

The single layer solenoid is the simplest and possibly oldest type of coil, as shown in Fig. 1, which illustrates a

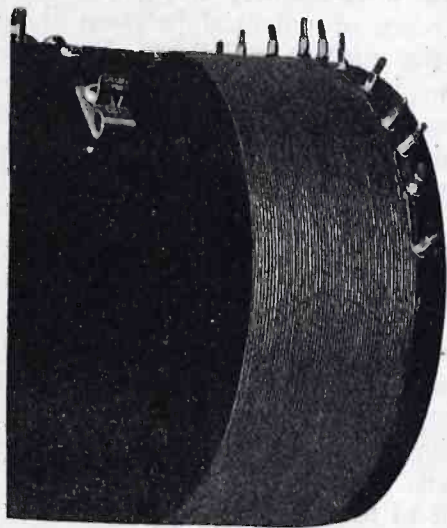

Fig. 1. Single Layer Solenoid

variable inductance, variation being secured by bringing out taps at different points of the winding. This type of coil is best used for short wave work where low values of inductance are required. Thus relatively few turns are used. Such coils are closely wound, that is, the turns are close together.

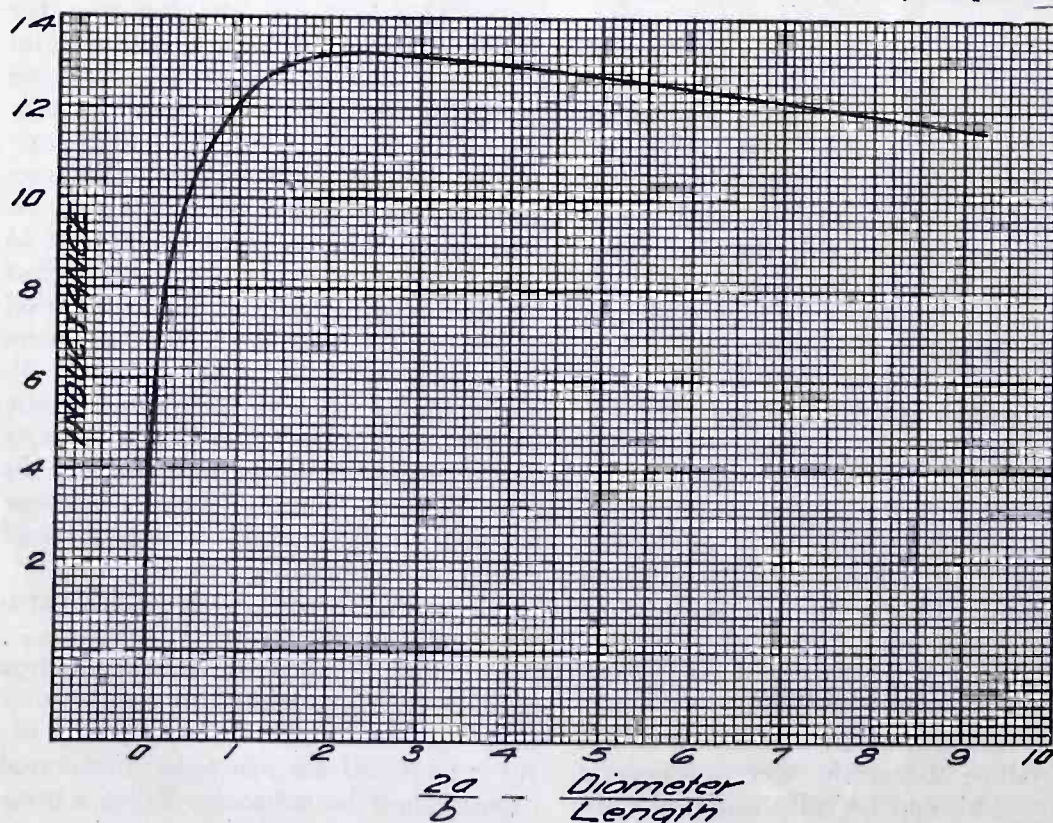

Fig. 2. Variation of Inductance With Size of Single Layer Solenoid

Hence the distributed capacity between successive turns is high. However, since few turns are used, the total distributed capacity of the single layer coil is relatively small. The distributed capacity becomes prominent when large inductances are used requiring a large number of turns. They are inefficient due to large distributed capacity and bad hanging-on end effects, and are awkward and inefficient from a space-economy standpoint. Furthermore, they require more wire for a given inductance than other types of windings. Long single layer solenoids are therefore not used.

In the design of single layer solenoids it is evident that a given inductance may be secured with a form of small diameter and long length or large diameter and small length. Between these two extremes there is a certain definite relationship between coil diameter and length which will yield the most efficient coil, that is, the coil for which the ratio L/R is a maximum. Fig. 2 shows how the inductance of a coil with a given diameter and length of wire varies with the shape of the coil. It is seen that the maximum inductance is obtained when the ratio of diameter to length of coil is 2.46. However, from the shape of the curve, it is seen that there is not a very marked variation of inductance for coils whose diameter to length ratio varies between 1 and 5. Thus there is a fairly wide latitude in the choice of shape for single layer coils. Hence the particular choice of shape is often determined by other engineering and economic considerations, such as availability of any particular size of winding forms, relative costs of different sizes of forms, mounting space limitations, etc.

Single-layer coils are generally wound on cylindrical forms. From their construction they naturally require solid

supporting forms. To reduce losses in the dielectric of these forms low loss material should be used. Glass was formerly used, but on account of its fragility is not now used, though its dielectric qualities are good. Hard rubber is a very high grade dielectric, bakelite and similar compositions coming next.

Multi-Layer Solenoids

Where high inductances are required the single-layer solenoid is inefficient for reasons given above. By winding a

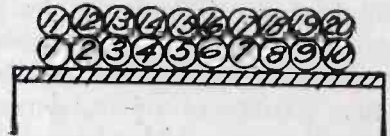

Fig. 3. Multi-Layer Winding Giving High Distributed Capacity and High Voltages Between Turns of Different Layers

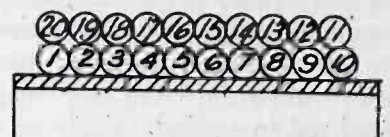

Fig. 4. Multi-Layer Winding Giving High Distributed Capacity and Increasing Potentials Between Turns of Different Layers

number of layers of wire over the first, higher inductances may be secured in smaller space than if single-layer coils were used. However, ordinary winding methods applied to multi-layer solenoids produce very inefficient coils. Fig. 3 and 4 illustrate the two ordinary methods of winding a two-layer solenoid. More layers may be wound in the same way. In both types of windings the turns are very close together, thus making the distributed capacity between turns high. Furthermore, the difference of potential between contiguous turns in both layers is very great. In Fig. 3 the difference between any turn in the top layer and that underneath it, as between turns 2 and 12, is the voltage of 10 turns of

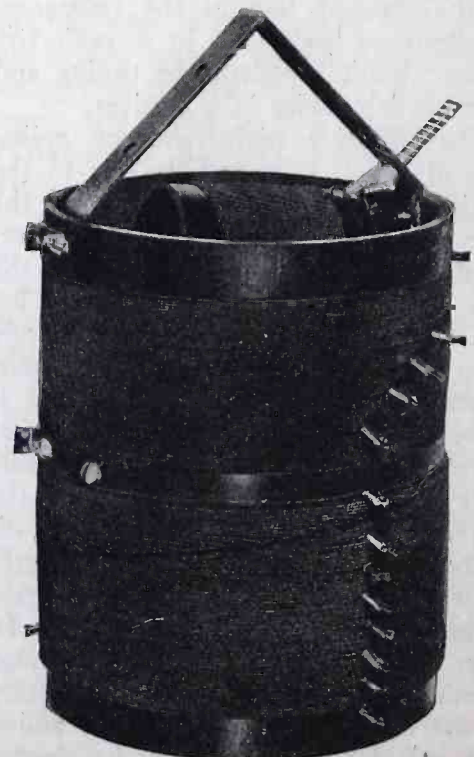

Fig. 5. Bank-Wound Coil (at bottom)

the coil, namely the voltage across the entire first layer. In the winding scheme of Fig. 4 this difference of potential increases from that between two adjacent turns to that between 20 turns. Thus the difference of potential between turns 10 and 11 is the minimum possible, namely that between two successive turns. But the difference of potential between turns 1 and 20 is that of the entire coil. Due to these high voltages between contiguous turns in both layers the capacity currents are high and losses great. Such coils are extremely inefficient and should not be used.

Bank Winding

To reduce these high capacity losses due to the large voltages between contiguous turns of multi-layer coils, a

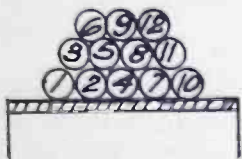

Fig. 6. Bank Winding to Reduce Potential Between Contiguous Turns

method of winding called "bank winding" is used. Such a coil is well illustrated in Fig. 5, the coil on the bottom being bank wound. The principle underlying this winding method is shown in Fig. 6, which shows a three-layer bank-wound coil. The same system may be applied to any number of layers. In Fig. 6 the maximum difference of potential between contiguous turns of different layers, as between turns 15 and 11, is seen to be that of four turns. The losses in such windings are therefore considerably reduced.

This type of coil is most frequently used as a loading coil for increasing the wavelength of a circuit. To cover a wide range of wavelengths the coil is tapped at different points, thus permitting the use of only that portion of the coil required to reach the desired wavelength. The method of tapping is well illustrated in Fig. 5.

This method of tapping a bank-wound coil is quite general. It has, however, one marked disadvantage. Due to its distributed capacity, the entire coil and portions of the coil have natural periods of vibration. Should any of these periods resonate with any of the wavelengths being received there would be considerable absorption of the received energy by that part of the coil which had this period, irrespective of how much of the coil was actually in circuit. Thus suppose the first tap of the banked loading coil in Fig. 5 is in use, and that this inductance tunes the circuit to 800 meters. Although the rest of the coil is not in circuit, it is both conductively and inductively coupled to the portion of the coil which is in circuit. The entire coil thus acts as the secondary of an auto-transformer and if its inductance and distributed capacity give it a natural wavelength of 800

meters or near it, much of the received energy will be lost by absorption in the coil. Or even if any part of the coil has this wavelength the same effect will take place. This absorption of energy is equivalent to increasing the resistance of the coil, thus decreasing its efficiency. This frequently is the cause for non-regeneration at certain wavelengths in poorly designed tuners. At these wavelengths there is often present a coil or part of a coil which tunes to the received waves and absorbs much energy. As stated, this is equivalent to the introduction of resistance which prevents regeneration at those waves.

The remedy for this is that no part of the loading coil should have a natural wave-length within the range of wave-lengths received. The most practical way in which this feature may be

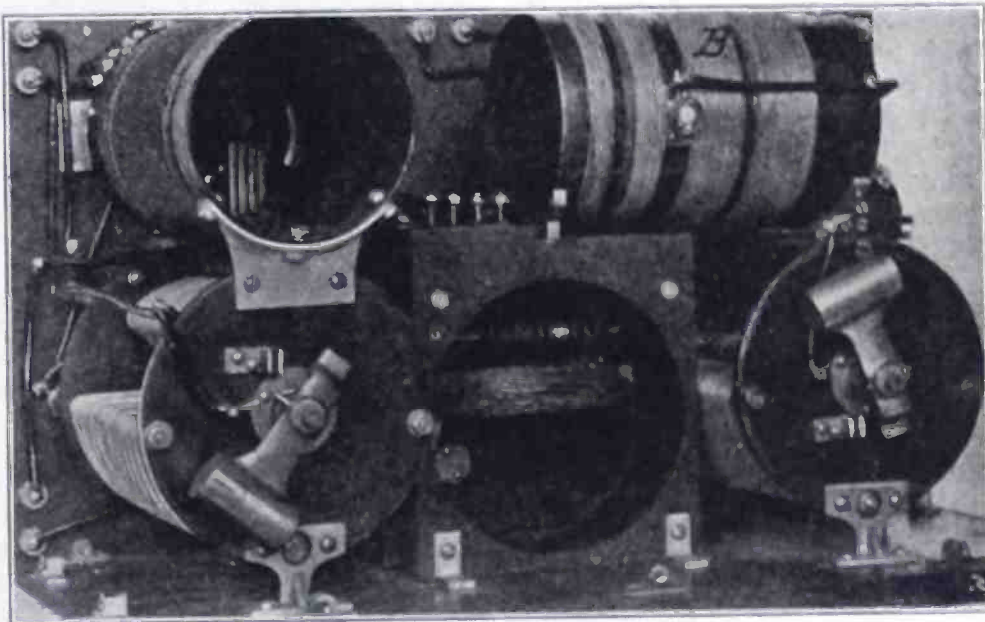

Fig. 7. 300 to 3000 Meter Receiver

secured in the above type of coil is to wind the coil in sections, as in the loading coil in the upper right-hand corner of Fig. 7. This picture represents a receiver designed for wavelengths between 300 and 3000 meters. The three-layer bank-wound coil is used to load the circuit up to 3000 meters. It is wound in four sections, these sections being so designed that the natural wavelength of each section is below 300 meters. An inductance switch is employed to connect the sections together when required. There is, therefore, no possibility of any of the sections of the coil absorbing any energy due to their own resonant periods. Such a method of winding is preferable to one solid winding where the dead-end effect is considerable. The same considerations apply to the tapping of single-layer coils of high inductance. Prof. Morecroft states, as a result of certain measurements, that no coil should be tapped at less than half the winding. This means only one tap per coil. For high inductance multi-layer coils, which must have their inductance varied, the sectional winding here suggested, as in Fig. 7, is the only suitable winding.

Compact Multi-Layer Coils
With the object of reducing the space occupied by multi-layer cylindrical coils

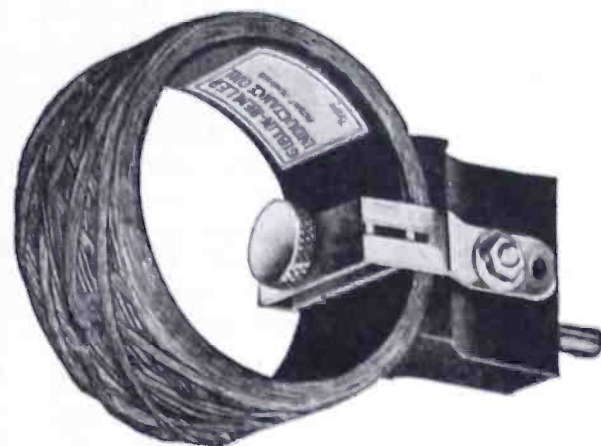

Fig. 8. Honey-Comb Coil

and the distributed capacity, there have been developed within the past few years

a number of different types of compact multi-layer coils having rectangular sections. Figs. 8 and 10 illustrate these types of coil. The construction of these coils aims to increase the distance between layers and to have turns touching at as few points as possible. Fig. 8 represents the "honeycomb" coil, so called because of its similarity to honey-

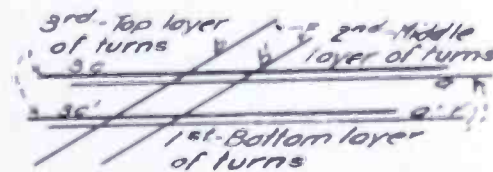

Fig. 9. Principle of Honey-Comb Coil Winding

comb cellular structure. Fig. 9 illustrates the principle on which this is wound. In the first place the turns in each layer are spaced, as turns a and a' , thereby resulting in a decrease of the distributed capacity between turns. Secondly, the successive layers cross each other at angles, as aa' and bb' . Thus the wires in each layer touch those in succeeding layers in points only, and not along their entire length as coils in Figs.

Continued on page 84

HOW TO MEASURE TRANSFORMER LOSSES

By L. R. FELDER

MANY amateurs and electrical experimenters have often wanted to measure the losses in electrical apparatus such as transformers. They have not been able to do this primarily for lack of measuring instruments, such as the necessary wattmeters. This difficulty may be overcome by the use of the following method which has been found to give quite accurate results with practically no measuring instruments.

The only instruments needed are a timepiece and a thermometer. The two losses of importance in transformers are the iron or core loss, and the copper loss. The first is measured with the secondary on open circuit, and the second is measured with full load current flowing through transformer. This may be secured either by short circuiting the secondary of the transformer if it has an inherent high reactance or by loading the secondary until full load current flows. Each of these losses is dissipated in heat which results in raising the temperature of the iron core or copper winding or both. The method of measurement is then based on the following physical principles. The dissipation of a certain amount of energy in iron or copper, as the case may be, will raise the temperature of the iron or copper a certain definite amount per second. If we can then determine the rate at which the transformer losses raise the temperature of the transformer, by dividing this rate by the former we will have the total energy lost in the transformer. This will be more apparent as we proceed.

The transformer whose losses are to be measured is connected in the usual fashion. Since we will confine our attention to the iron or core loss for the moment, to illustrate this method, the secondary is left open. The iron loss varies with the exciting voltage. The most important loss occurs at the working voltage, hence the generator field rheostat should be set at the position to give this working voltage, or if the exciting voltage is obtained from a 110 volt power line simply connect the primary of transformer to line.

The thermometer should have a maximum reading of about 212 degrees Fahrenheit, since any well designed piece of electrical equipment will never reach this value of temperature. The thermometer should be placed in close and direct contact with the iron core of the transformer, since the core is heated by the iron loss, and should be thoroughly packed in cotton waste. Note the reading of the thermometer when it is in contact with the cold core and record it in your data book. The switch should now be closed. The transformer draws a very small current

which magnetizes the core. Due to eddy currents and hysteresis the iron heats up, and these losses are supplied by the small power consumed by the transformer on no load. The temperature of the core will therefore begin to rise, and temperature readings should be taken of the core every few minutes. The rise in temperature at the start is the greatest, hence a reading should be taken, say every three minutes. After a while the rate at which the temperature begins to rise decreases. At this stage of the measurement temperature readings of the core may be taken every 5 or 7 minutes.

A point is reached where the rate at which the core heats up is equal to the rate at which it radiates heat. In other words the core cannot continually rise in temperature since an unlimited amount of energy is not being wasted in it. It will be observed then that the temperature rise begins to fall more and more until it has practically a constant value. There is no need to run the transformer any more since the conditions are now constant and stable. If the transformer is poorly designed it is possible that the temperature will continue to rise to very high values since the losses are great. In such case the temperature should not be run over 100 degrees, since the insulation may be injured. When the temperature reaches the above constant value, or about 100 degrees in the case of the poorly designed transformer, the switch should be opened and the transformer allowed to cool. Readings of the core temperature should again be taken every 5 minutes until it reaches its initial value. In running this test care should be taken in the case of high-frequency generators, such as 500 cycle alternators, that the frequency is constant for variations in frequency result

in variations of core loss. With the data obtained by the above run two curves should be drawn: one showing the temperature rise against time, the other showing the cooling curve, namely temperature fall against time. Such actual curves are shown in the accompanying graphs. This concludes the experimental work. The determination of the core loss is now a matter of calculation.

The following preliminary calculation gives us our starting point. The method is to determine first the rate at which the temperature of one pound of water will rise when power at the rate of 1 watt is lost in it.

$$\begin{aligned} 1 \text{ Horse Power} &= 33,000 \text{ ft.-lbs. per minute} \\ 1 \text{ Horse Power} &= 746 \text{ Watts} \\ 746 \text{ Watts} &= 33,000 \text{ ft.-lbs. per minute} \\ &33,000 \\ 1 \text{ Watt} &= \frac{33,000}{746} = 44.2 \text{ ft.-lbs. per minute} \end{aligned}$$

The above calculation simply gives us the equivalent of 1 watt of power in terms of foot-pounds of work per minute, which is required to simplify our calculation. It is found by experiment that when we dissipate 778 foot-pounds of work in a pound of water the heat generated will raise the temperature of the pound of water by one degree Fahrenheit. That is the mechanical equivalent of heat is

$$1 \text{ pound-degree Fahrenheit} = 778 \text{ ft.-lbs. for water}$$

If 778 foot-pounds of work are expended on one pound of water each minute then the pound of water will rise in temperature at the rate of 1 degree Fahrenheit per minute. If 778 foot-pounds per minute will raise the temperature of one pound of water at the rate of 1 degree Fahrenheit per minute, then 44.2 foot-pounds per minute will only raise the temperature of one pound of water at the rate of $44.2/778$ times 1 degree Fahrenheit per minute.

Continued on page 92

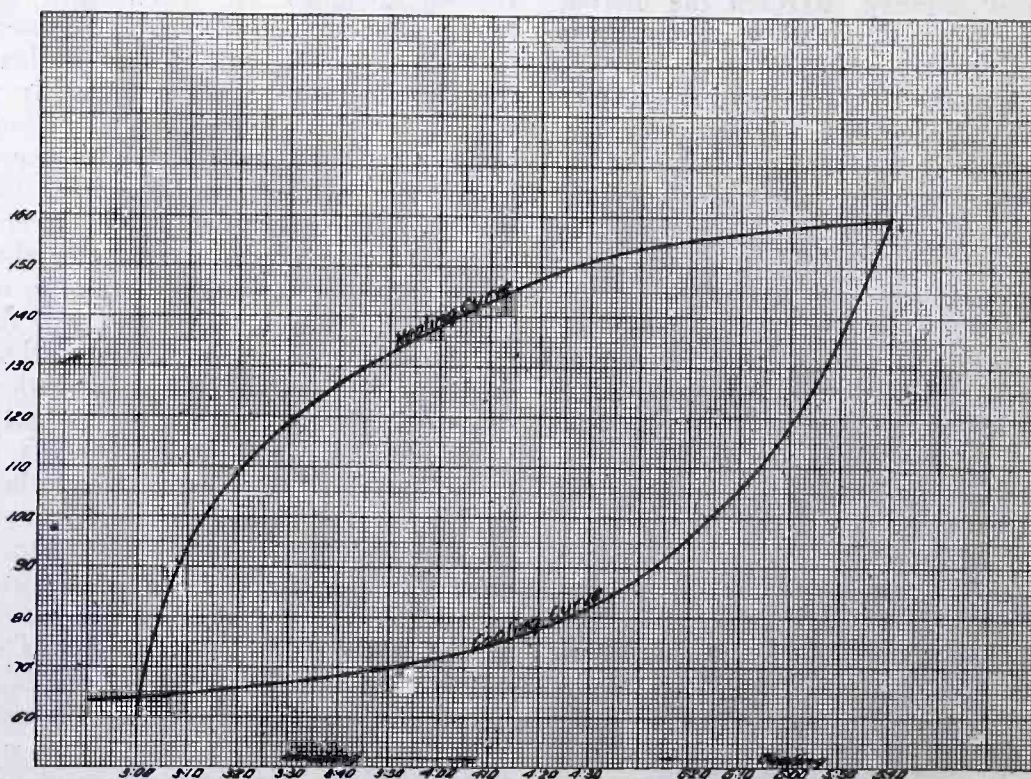

Heating and Cooling Curves

Wired Radio for Broadcasting Purposes

By Bert T. Bonaventure

Besides telling of the use of line radio for broadcasting by power companies, considerable additional information is here given on communication between power houses and substations. Much of the latter is taken from a recent report of the Pacific Coast Electrical Association. This article constitutes the most complete report on what has been accomplished so far by others than the American Tel. & Tel. Co.

ALTHOUGH the idea of utilizing the transmission lines of a central power station for radio communication purposes had been advanced as early as 1911, it has remained for the present chaotic condition in the broadcasting situation to bring into due prominence some of the actual work being done along these lines. Wired wireless is a method for transmitting currents of radio frequency along a wire or system of wires which serves as the transmission medium between the sending station and the receiver. In space radio, the medium which serves the above purpose is the hypothetical ether.

Wired radio is the invention of Major-General George O. Squier, who has been actively interested in the present and past experiments and installations of wired radio. The advantages of this system, as compared with space radio, are manifold and are even so desirable that the idea is now being put to commercial use. Due to the fact that the radio wave is directed to its destination and that a condition can be obtained where practically no energy is radiated from the system, wired radio reduces interference to a negligible quantity and makes possible the use of only small powers to cover relatively large areas.

Before wired radio could be put into commercial use exhaustive tests had to be carried out in order to determine the peculiarities in the characteristics of its transmission. An extensive series of experiments were conducted in various parts of the country, such as Cleveland, New York and Washington, D. C. In the last mentioned city, the cooperation of the Radio Section of the Bureau of Standards was obtained. The results of these experiments gave interesting data which later proved of considerable value.

In order that the broadcast service be supplied to a maximum number of customers with the minimum possible losses in the intermediate power apparatus connected to the line, the transmitter should operate into the 2,000 to 3,000-volt feeders. It had been relatively easy to transmit by wired radio over a long transmission line where the line provided a direct connection for an unobstructed flow of high-frequency energy from the transmitter to receiver. But when transmitting into the 3,000-volt feeders, it is necessary for the radio-frequency currents to pass over a vast wire network, spreading out in all directions,

interconnecting at numerous points and containing hundreds of distribution transformers. Whether the high-frequency currents could traverse the transformers unaided, or whether by-pass circuits had to be placed around such reactances, was a question that only experiment could settle. It proved possible with no changes to the distribution system and with only a slight amount of assistance to the radio frequency currents, to obtain sufficient energy for the satisfactory operation of a crystal receiver plugged into a light socket, using remarkably small transmitting powers.

It was found further, that with the proper choice of wavelength for any given installation, practically all of the energy transferred to the line by the transmitter was propagated along the wire. It was expected, from a study of the theory of wired radio energy propagation that the attenuation of the

radio-frequency energy would increase with decreasing wavelengths and that large powers would have to be used to cover a given distance. Actual tests showed, however, that there is an optimum wavelength at which no appreciable radiation into space occurs. On one line, short wavelengths up to 710 meters gave considerable radiation in the form of true electromagnetic waves, while at 13,000 meters poor reception was obtainable both on an antenna and by wired radio. On an intermediate wave of 3,800 meters, excellent wired radio reception was possible with almost no observable reception on an antenna. The existence of "blind spots" when using short wavelengths was relatively frequent in occurrence. No reception could be obtained at these spots, due apparently to the fact that the high-frequency current was reflected by power apparatus on the line and stationary

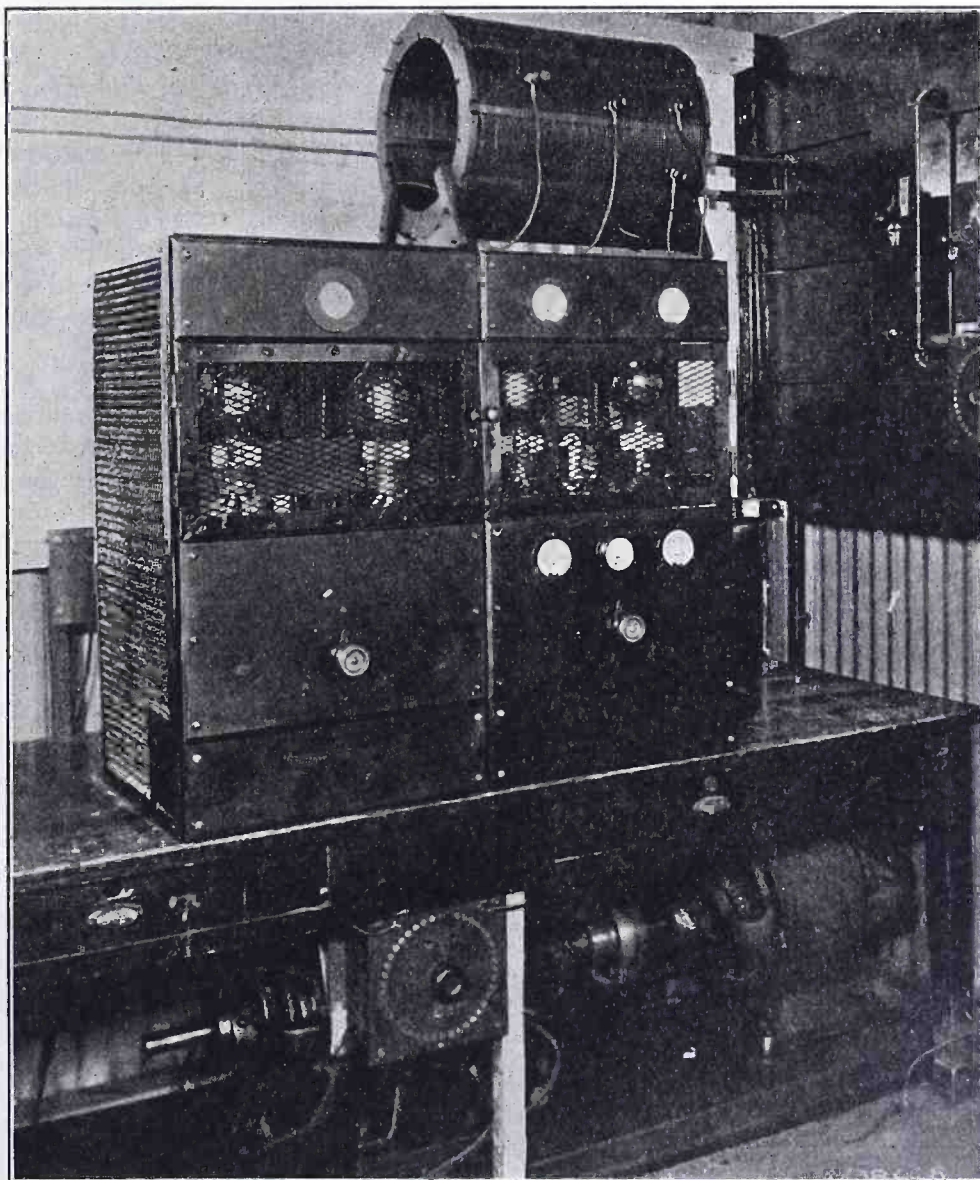

Westinghouse Carrier Wave Broadcasting Outfit

waves with nodes of minimum reception and loops of maximum reception thus created. Small changes in the transmitted wavelengths seemingly had no effect in moving the nodes along the wire. On short wavelengths the transmitted energy is subject to a very rapid attenuation and the desired working distances cannot be consistently covered. With longer wavelengths, both these objectionable restrictions were removed.

Wired radio is free from interference by the 60-cycle power, due to the high reactance offered to this frequency by the wired radio circuits. With a line voltage of 110 volts, the current flow through the tuned circuits is very small, since the reactance measures around 1,000,000 ohms. To the high frequencies of the transmitter, however, these circuits have a zero reactance due to the series tuning.

Several circuits for the transmitter were tried as well as different methods of connecting the receiver to the line. Experiment shows that it does not materially matter which two of the three high voltage wires the transmitter works into. Only one of the three phases is used in receiving and that the ground connection, which is made in the normal manner, is also used. Other methods, both of transmitting and receiving, were tried with favorable results.

A number of transmitting and receiving sets may be operated simultaneously without causing interference as a result of the different frequencies to which the apparatus may be tuned. The effect of the operation of high power, high frequency energy into the distribution system in no way interferes with the system, nor does it subject the attached apparatus to any damaging influences.

At the present time, the Richmond Light and Railroad Company of Staten Island, N. Y., is maintaining a wired radio broadcasting station in the Livingston powerhouse. Special receivers, both crystal and vacuum tube, have been developed for use on the company's lighting lines. The attached wire is plugged directly into a lamp socket. Essentially designed for uni-wave operation, the receiver has but one control, a variable condenser, that takes care of slight variations in the transmitted frequency. The current for the tube sets can be drawn from the lighting circuit, or storage batteries may be used. Both of these receivers have been provided with special insulation so that the Underwriter's requirements are met. There is no danger of receiving a shock from the head receivers.

At the Staten Island installation, provision is made to re-broadcast entertainment and news sent out by space radio broadcasting stations. A loop receiver, with enough stages of radio frequency amplification to insure reliable reception at all times is used in conjunction with

enough audio-frequency amplification to feed directly into the modulating circuit of the transmitter. By a system of jacks and plugs this receiver may be disconnected and announcements, local lectures and entertainment may be sent out from the studio installed in the powerhouse for that purpose.

For a small monthly payment, the company rents out the desired type of receiver to its consumers, or the sets may be purchased outright if desired. The operation of wired radio is dependable at all times and the trouble and cost of maintaining an out-door antenna is dispensed with. In addition, all the necessary current for the operation of a receiver may be drawn from the lighting line itself.

Broadcasting over the power distribution systems has been successfully accomplished in several other instances, particularly by the Wired Radio Co., Inc., over the electric distribution system of the Potomac Electric Power Company in Washington, D. C., and vicinity. In one of its recent demonstrations a 500-watt radiophone transmitter of somewhat special design was installed in the Georgetown substation of the Potomac company, and its output transmitted to the 2,300-volt distribution lines through high voltage condensers. A number of receiving sets were plugged into lamp sockets, connected to the 115-volt lines in widely separated districts of Maryland and the District of Columbia, and good reception was obtained with simple crystal receiving sets. The transmitting capacity required was very much less than anticipated, tests indicating that from .5 to 2 watts per square mile of electric lighting network would probably be sufficient to satisfy the requirements.

This system of broadcasting to the public, in the opinion of a committee of the Pacific Coast Electrical Association, may be applied to advantage in some localities, but it is very doubtful if it will ever be generally used by power companies, since the many "space" broadcasting stations offer such a variety of program that the average "radio fan" will not be content to confine his listening to the program of a single "carrier current" broadcasting station. Yet as a means for earning and maintaining the good will of customers, wired radio can be turned into a very useful tool in the hands of public utility companies.

Substation Communication

IN addition to its use for broadcasting, line radio is also being successfully applied to point-to-point communication by a number of power companies. One of the most recent of these is that installed by the Westinghouse Elec. & Mfg. Co. on the lines of the Consumers Power Co. of Michigan. Eventually this company will have 600 miles of

transmission line utilized for telephone service.

Two sets are already in use between Battle Creek and Jackson, one transmitting at 60,000 cycles and the other at 50,000 cycles. There are two transmitting sets and two receiving sets in service working through single telephone instruments, with the result that the service is duplex and both parties may talk and listen simultaneously.

To communicate with Battle Creek, the load dispatcher at Jackson has only to lift his telephone receiver from the hook. This automatically lights the tubes and starts up the radio transmitting apparatus about half a mile away in the Jackson steam plant of the company. The dispatcher then turns the dial on his instrument to the number assigned to the Elm Street steam plant in Battle Creek. The operation of this dial sends out modulated high frequency impulses over the high tension transmission line through a sending antenna strung parallel to the power line for about 1,000 feet. These impulses are picked up on the receiving antenna at the Elm Street plant and cause a selector there to step around and stop at the proper point and, through the operation of a system of relays, rings a bell or sounds a horn in the booth of the Battle Creek station.

The Battle Creek operator unhooks his telephone receiver. This automatically starts up the transmitting radio set at Battle Creek. He then hears the Jackson voice sent out by the Jackson transmitter, and Jackson hears his voice which goes out through the Battle Creek transmitter. The two voices pass each other, carried on different wavelengths, going through different transmitting radio units, but all is tied into the two ordinary telephone instruments and controlled through them.

One of the principal difficulties which had to be surmounted in the full development of this system of communication was to neutralize the currents induced in the receiving antenna by the powerful currents in the transmitting antenna. Every radio fan knows how difficult this would be from his experience with the squeals and howls from even the small receivers in his immediate vicinity. This end is accomplished by apparatus in the balancer box at the left of the radio receiver. When properly adjusted, this balancing apparatus serves to neutralize the currents induced by the transmitting antenna in the adjacent radio receiving circuits and thus permit simultaneously the two-way communication which is an essential factor to the commercial development of high-frequency telephony.

While the radio impulses which transmit the voice are carried upon the high voltage power lines, tests have shown that in event of line failure the radio

Continued on page 87

QUERIES & REPLIES

ON C.W. PRACTICE

BY
Gerald M. Best
TECHNICAL ADVISOR



Questions submitted for answer in this department should be typewritten or in ink, written on one side of the paper. All answers of general interest will be published. Readers are invited to use this service without charge, except that 25c per question should be forwarded when personal answer by mail is wanted.

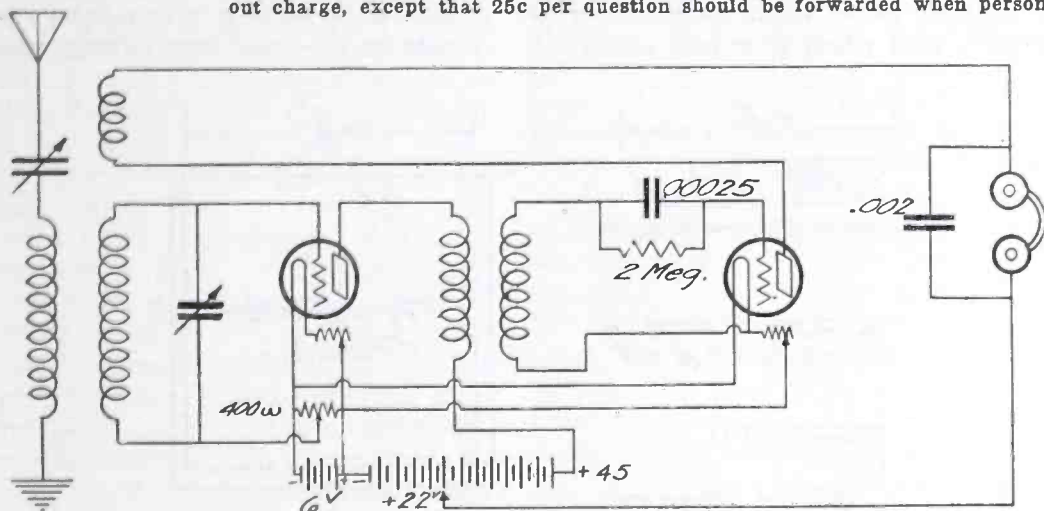

Fig. 1

Please add a one-stage radio-frequency amplifier to the detector unit which I now have.—G. K., Berkeley, Calif.

The addition of a radio-frequency amplifier is shown in Fig. 1.

Please publish an exact diagram of the Kennedy Short Wave Receiver.—L. L., Rialto, Calif.

This circuit is shown in Fig. 2.

Can you tell me why my UV-199 tubes give me so much trouble from spilling? Reception is excellent with this

receiver, will cause a beat note, and the resulting howls that you are experiencing. Try using less inductance in the tickler coil, and I am sure you can cure the trouble.

Please publish the diagram of a good filter to be used in filtering the output of a 20-jar chemical rectifier operating from 550 v.a.c. Which of the standard circuits is the best for transmitting, with regard to distance, simplicity and ease of tuning? In a chemical rectifier, must the materials be chemically pure? If so,

where can they be procured?—A. E. W., Watsonville, Calif.

A diagram of a good filter is shown in Fig. 3. This filter will have a fairly low cut-off point, and should deliver practically pure d.c. to your transmitter. The Hartley

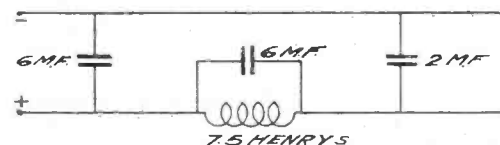

Fig. 3

circuit has the least number of adjustments, but many prefer the British aircraft, or reversed feed-back circuit, on account of the sharp decrement, and unusual efficiency. The reversed feed-back circuit is also easy to tune and while it requires more apparatus than the Hartley circuit, the additional expense is worth while. The lead and aluminum plates in a chemical rectifier should be absolutely pure, although it is not as important with the lead as with the aluminum plates. The solution should be made by dissolving a good grade of borax in distilled water, until the water has taken up as much of the chemical as is possible. If tap water is used, the chemicals present will unite with the borax to form compounds which will soon prevent the proper operation of the rectifier. Firms which supply chemists usually carry pure aluminum and lead. You might try Justinian Caire, 573 Market St., San Francisco, Calif.

Please publish a reflex circuit using a WD-11 tube, with Erla reflex transformer. How much plate voltage can a WD-11 tube stand, and how much should I have for this circuit?

—A. W., Victoria, B. C.

The circuit you wish is shown in Fig. 4. A WD-11 tube should not be subjected to plate potentials exceeding 60 volts. In this case 45 volts is specified, as that amount should be ample to take care of the reflex circuit.

Is there any advantage in the circuit shown in Fig. 3, page 32, of March RADIO? How will this work with WD-11 tubes?—E. J. C., Chico, Calif.

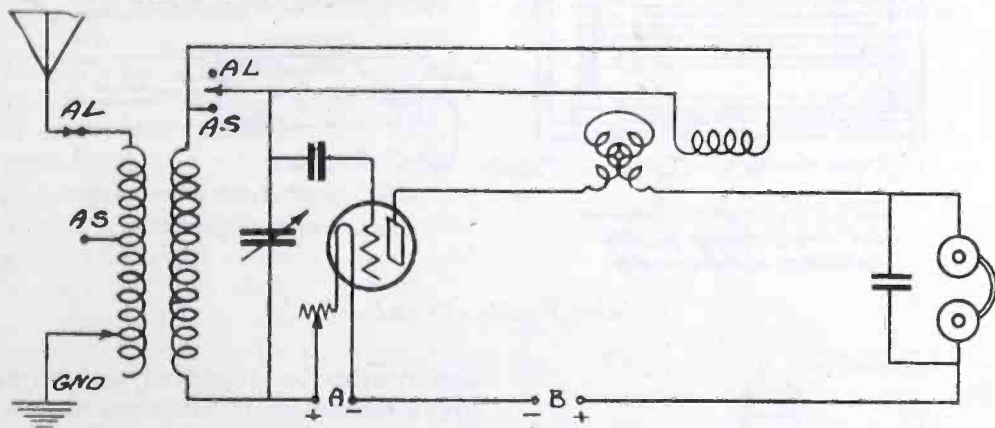

Fig. 2

exception. Am using a single-circuit tuner with "C" battery arrangement for the amplifiers. After adjusting my rheostat to the critical point, it starts to howl, and cannot be cured.—D. B. S., Chesterfield, Ind.

The principal trouble is probably too large a tickler coil for that type of tube. Some tubes are better oscillators than others, and I would change tubes around in the set to determine if one will have less tendency to oscillate than the others. The UV-199 tube is not rated as having a critical filament current, like the UV-200, and hence should not normally be adjusted by means of the filament voltage or current, being set at .06 amperes. Perhaps you use your tickler coil too much, and cause your set to oscillate at the same frequency as the incoming wave, so that for a few seconds you may hear the station very well, and then a slight change in either the transmitting station, or your

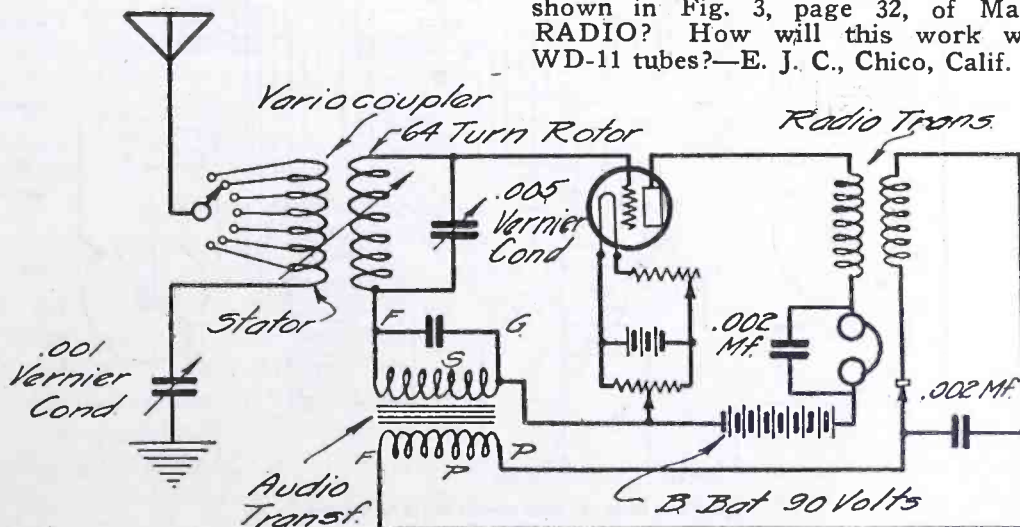

Fig. 4

The circuit you mention should work very well if properly adjusted. The tubes you now have may not be good ones, and I would try another set if possible. If it works satisfactorily with UV-200 and 201 tubes, indications would be that your WD-11 tubes are in trouble.

Please publish a one-tube super-regenerative circuit, using honeycomb coils.—G. D., Toppenish, Wash.

Such a circuit is described in detail in August RADIO, Page 17, under the title "A Wonder One-Tube Portable 'Super'."

Please give me the construction data for the choke coil in the Reinartz circuit. Would a 1/2 mfd. condenser be too large for use in the grid circuit of a C. W. transmitter? Why?—L. F., Los Gatos, Calif.

By choke coil I assume you mean the main tuning unit of a Reinartz tuner. This coil is usually constructed as shown in Fig. 5, the points where the antenna and ground connections are placed being indicated in the diagram. If you were supplying your C. W.

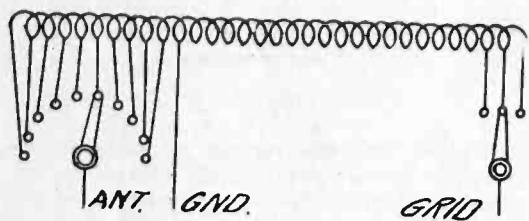

Fig. 5

transmitter with a.c. for plate voltage, a 1/2 mfd. condenser would be of fairly low resistance to 60 cycle a.c., and would draw a considerable amount of current from the transformer. The grid condenser is usually selected so that its reactance to high frequencies will be low, but with high reactance to low frequencies. Hence, a condenser of .0005 is the custom. In the case of a pure d.c. supply, the 1/2 mfd. condenser might do all right, but one of much smaller capacity is preferable at any rate.

Kindly publish the circuit diagram of the Colin B. Kennedy Universal Receiver.—E. H. A., Wausau, Nebr.

This circuit is shown in detail in Fig. 6.

ERRATA NOTICE—Several subscribers have called attention to a draftsman's error in Fig. 1, p. 35, September RADIO. The wire from the .001 secondary condenser to the negative of the filament battery should be omitted.

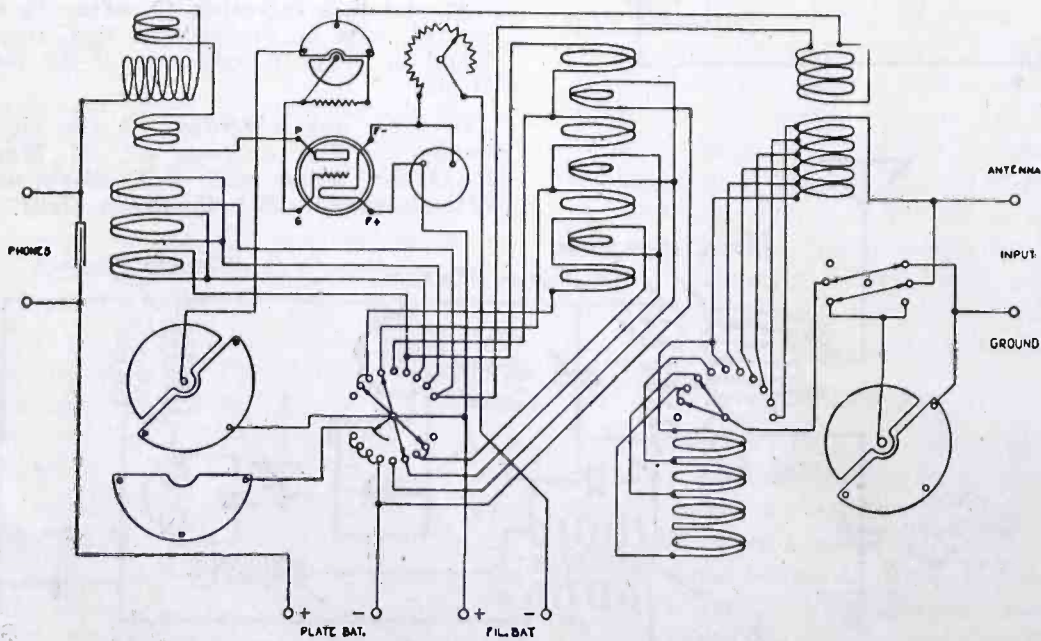

WHERE WIRES CROSS THEY DO NOT CONNECT UNLESS THE CROSSING IS DOTTED, THIS →

Fig. 6

PUNCTURE PROOF C. W. POWER CONDENSER OF HIGH CAPACITY

By DR. A. E. BANKS, 6XN

It is almost a daily experience among amateurs using C. W. to hear the plaintive wail of despair due to the demise of the regulation condensers in use across the high potential lines. The necessity for a higher capacity than is ordinarily available in the commercial units on sale, compels the use of multiple paper condensers, in series parallel, and when puncture occurs it

may involve several units, making the accident quite expensive. Were puncture an annual event only, there might be little cause for complaint, but it is a thing which usually happens right in the middle of successful transmission, and often the transmitter is kept intermittently out of commission for a period of weeks or until the amateur decides to reduce his potential to where the transmission is not performing as he knows it can.

There is little use in arguing that less potential is what a given tube rates. Amateurs do their own rating, basing

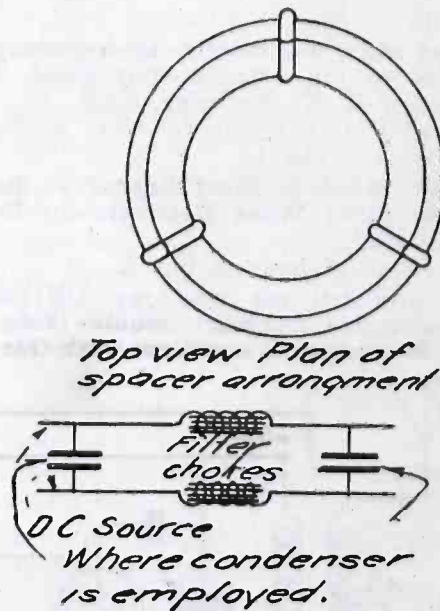
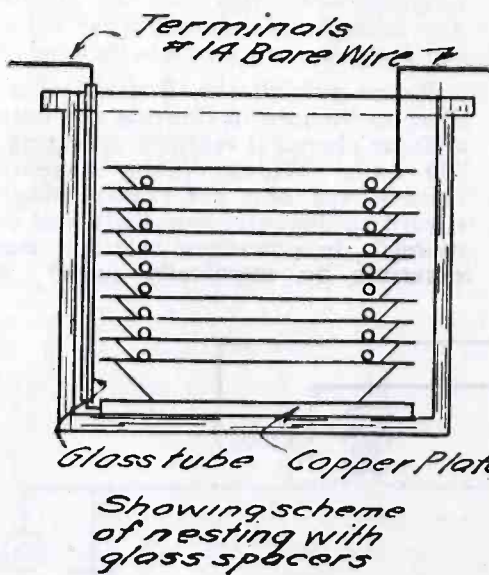
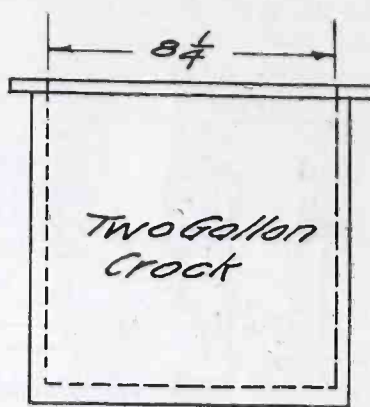
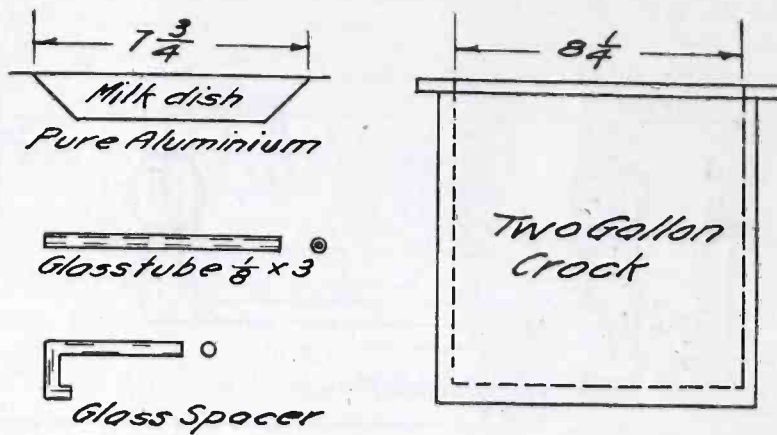

Assembly Details of Condenser

the results on reported audibility at given distances, in addition to antenna ammeter readings with different constants in use.

We have successfully defeated the high cost of condensers by resorting to the "5, 10 and 15 cent stores" in the following described manner, and the resulting condensers are above reproach, performing in a manner equal to any, having very high capacity, and being absolutely puncture proof, but best of all having an unlimited life, and requiring no attention. It is hoped that the description may bring joy to some of the brethren of the key.

The materials required are one 2-gallon crock, 10 aluminum milk dishes measuring 7 3/4 in. across the tops (the crock measures 8 1/4 in. inside dimension), 27 glass spacers (made up of 1/8 in. glass tubing in 3 in. lengths

and bent appropriately in bunsen burner), 1 lb. sodium phosphate, 2 gals. transil oil, and distilled water sufficient to dissolve the phosphate.

First cut the 3 in. pieces of tubing, using 3-cornered file. Then holding in wooden clothes pin, or regulation test tube holder, heat in flame till tubing bends at an acute angle producing a miniature walking cane in effect. Get all spacers as nearly alike as possible.

Solder a piece of No. 14 bare copper wire to a plate of copper, passing the wire through a length of glass tubing long enough to reach from the bottom to top of crock. Place copper plate in bottom of crock with glass insulated wire well over to the wall of same. Next place one of the aluminum dishes on the copper plate. Place about 1/2 in. of a saturated solution of sodium phosphate in dish. Next place three of the glass spacer tubes in position allowing the short arm to overhang the rim of dish, and equally spacing tubes to give firm support and prevent accidental shorting of units after assembly. Now nest another dish inside the first, placing solution in it and spacers, and proceeding thus, till all dishes, spacers etc. are in place. The top dish is supplied with a plate of copper and wire and the condenser is complete. Next gently pour transil oil down the side of crock till it is full and thus seal the various units, thereby preventing evaporation.

When assembly is complete, the condenser should be placed on the line to "form." It is best to partially "form" it on 110 volts, using lamps to control current if necessary. Later place on the lines and finish "forming."

Since this apparatus is acting solely as a condenser and not passing current when in use, there is no heating and in our case after using for three months no evaporation. The actual capacity of a given condenser cannot be stated but using materials as above described it will probably run about 30 mfd.

Pure aluminum is of course of the utmost importance for proper function, and fortunately it has been found that utensils made of spun aluminum are practically always of high grade stuff.

The only warnings thought necessary are that the glass spacers are made to actually *space* the nested dishes—that the solution be enough to cause contact between units but not enough to overflow, that the oil seal all air gaps in the jar and that the "forming" be patiently and properly done.

The accompanying sketch will possibly assist in visualizing the "how" of it.

As to whether the apparatus is worth while after completion, this point is left to the reader's discretion bearing in mind that paper condensers at \$1 and \$2 per, run into money and later into junk—both at high rates of speed. Again there are electrolytic condensers on the market but at four times the

price of one of these home made type, and they only stand about 300 volts. The condenser described will handle a couple of thousand volts very nicely. If a million volts should be foolishly applied the resulting puncture immediately heals and VOILA! She still condenses!

X-L FILAMENT TUBES

The new X-L tungsten filament employed in the tubes manufactured by the General Electric Co. for the Radio Corporation of America as UV-199 and UV-201A and for E. T. Cunningham, Inc., as C-299 and C-301A, is the nearest approach to the ideal yet reached in filament manufacture. This filament consists of tungsten and a small per cent of thorium, the latter giving it its greater electron activity for lower energy consumption. Thus, for the same life the UV-201A or C-301A, with X-L filament, has an electron emission of 45 milliamperes from 1.25 watts as compared to an emission of 7.5 milliamperes from 5 watts consumption of the UV-201 or C-301 with the old tungsten filament. Furthermore, the emission from the new filament is just as uniform and the tube noises are practically eliminated by the lower operating temperature.

The new filament also has lower electron emission per unit of length, thus making possible the use of a longer filament and correspondingly larger plate area so as to increase the mutual conductance. With the same life, voltage and amperage, the X-L filament may be twice as long and has an electron emission 24 times as great as the pure tungsten filament. The UV-201A and C-301A have a filament length of 48 mm., an approximate mutual conductance of 475 and delivers twice as much energy as a UV-201 or C-301 with a filament length of 38 mm. and a conductance of 300. Thus there is over 50 per cent increase in mutual conductance and double the energy output as an amplifier. These figures are based on an approximate life of 1000 hours, at their rated filament voltages of 4 1/2 and 6 respectively with 40 volts on the plate and zero voltage on the grid.

If the new filament is operated at abnormally high temperature the electron emission at first will be great but will soon fall off to even less than normal value. This is due to the fact that the rate of evaporation of thorium from the surface is more rapid than the diffusion of thorium from the filament interior to the surface and the surface is no longer covered with thorium but with tungsten. This may be corrected by operation at normal temperature for the same length of time that it was operated at abnormal temperatures. In extreme cases operation at three times normal voltage for a fraction of a minute followed by a period of operation

at normal temperature will bring sufficient thorium to the surface for good results.

As the UV-199 and C-299 tubes operate at 3 volts and require only 60 milliamperes they are admirably suited to operation from dry cells. From 3 No. 6 cells connected in series, 1 tube may be operated 387 hours, 2 tubes 200 hours, 3 tubes 126 and 4 tubes 92 hours if used two hours daily. Three flashlight cells will have a life of 30, 14 or 7 hours respectively for 1, 2 or 3 tubes. The characteristic is similar to the UV-201. They are especially suitable for radio-frequency amplification, as their small size gives a corresponding low capacity between electrodes. They should be used with their special base instead of an adapter to the standard receptacle because of its lower capacity effect. A 30-ohm rheostat is recommended for 1 tube, 15 ohms for two and 10 ohms for three tubes connected in parallel from three dry cells in order that the grid potential does not exceed 3 volts. Cushion-mounting is necessary to eliminate microphonic sounds. With 80 volts on the plate there should be a negative bias of from 3 to 4.5 volts on the grid.

NEW YORK NATIONAL GUARD RADIO PLANES

By DONALD H. SHORT

Two air planes at the Miller Field, Staten Island headquarters of the 102nd Observation Squadron of the

Radio-Equipped Plane of 102nd Observation Squadron
Short-Commercial Photo.



27th Division Air York National equipped with receiving sets. a ground station room equip kw. rotary of the plane transmitter storage bat a phone tubes furn

copper wire which is released from reel and drawn down by an 8-lb. sinker. By means of the equipment the aviator is in constant communication with the ground and can direct artillery fire and assist in maintaining battle formations of the planes.

Service New Guard are radio and receiving sets. There is also and instruction room equipped with a 1 spark set. One sets is a spark operated by a tery and the other set with two VT-2 operated from power ished from a generator operated by an air-driven propeller beneath the fuselage. The plane aerial is a single 300-ft.

DIGEST OF RECENT RADIO PATENTS

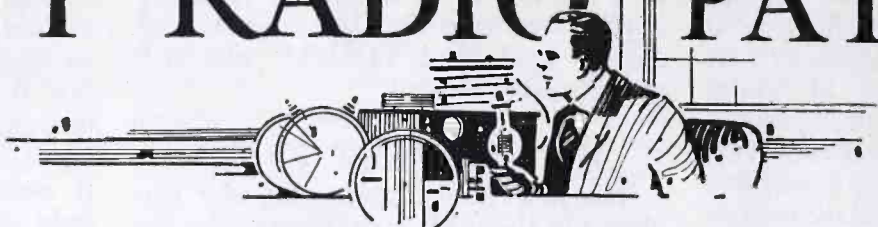

Prepared by White, Prost & Evans, Patent Attorneys, San Francisco, who have been particularly active in the radio field for many years, and from whom may be obtained further information regarding any of the patents listed below.

D. G. McCaa, Pat. No. 1,459,308; June 19, 1923. Signaling apparatus.

A static elimination scheme for receiving systems is described, in which the signaling energy as well as the static disturbances cause beats to be produced, but only the signaling beats affect the phones materially. To effect this result, a local source of oscillations V_2 is provided for combining its output with the incoming energy. The result, due to the nature of static, is to produce very large amplitude, comparatively low frequency beats with the static energy, and the usual form of beat effect with the signal energy. By the aid of coils S_1, S_2 , a double detector V is connected in such a way that normally no energy is transmitted thereby, due to the differential arrangement of coils P_1, P_2 in the output circuit. However, another local source V_1 is adjustably coupled as by coil P_3 to produce beats and to affect coils S_1, S_2 differently, so that secondary beat effects are produced. For the static energy, these secondary beat effects are stated to be inaudible. A feature of the invention resides in the use of a rotatable coil for primary P_3 and its exact adjustability to secure best results.

R. H. Marriott, Pat. No. 1,460,801; July 3, 1923. Directional Radio Receiving System.

A unidirectional receiving system is described, in which a loop I is used as the raised conductor for an antenna circuit 1-4-5-22-23-8. The unidirectional effect is obtained by transferring to the inductance 2 in the loop circuit some of the energy received in the antenna, by aid of the thermionic device 6-7-9, and the receiver or amplifier 16

is coupled to the coil 2 so as to be sensitive to the resultant energy.

G. W. Pickard, Pat. No. 1,460,439; July 3, 1923. Interference Preventer.

A device for segregating the desired signaling wave from interfering waves is described, in which the important step is the conversion of the radio-frequency waves into sound waves of the same frequency by aid of telephone T_1 and causing the resultant sound waves (of the same frequency but much shorter wavelength) to be reflected from the grating RG . This grating is arranged to operate analogously to an optical grating, whereby only waves of a definite length are reflected. The reflected waves affect a receiver T_2 , whence they may be amplified and transformed into intelligible signals.

P. J. Armagnat, Pat. No. 1,460,636; July 3, 1923. Wavemeter.

It may be mathematically proven that in a circuit as shown, where the wavelength of the current in coil 1 is desired, and where the circuit including coil 4 is a calibrated oscillating circuit variably coupled as by coil 2 to the circuit of coil 2, that by proper adjustment of this coupling, as well as of the detector circuit coupling 5 and resistor 3, the telephone 7 will give zero response when the circuit of coil 4 is in sharp resonance. This gives a null method of determining resonance which permits more accurate adjustment of the oscillating calibrated circuit.

G. H. Clark, Pat. No. 1,461,754; July 17, 1923. Transmitting and receiving apparatus for wireless telegraphy.

In telegraphing by the usual dot and dash methods, the dots and dashes have a tendency to tail off; i.e. they are not clearly defined, due to the persistence of the transmitting current after the source is disconnected from the antenna, and also to the persistence of the received current in the receiving apparatus. To correct this effect, a very large damping resistance 32 is inserted in the transmitting antenna after each signaling impulse; this reduces tailing off at the transmitter end. Simultaneously, at the end of each signaling impulse, impulses of opposite phase are transmitted for a short time, as by the aid of a generator 15 having an e.m.f. opposed to that of the signaling generator 14. This has the effect of nullifying the tailing off at the receiving station.

R. V. L. Hartley, Pat. No. 1,462,038; July 17, 1923. Modulating system.

A scheme for modulating carrier waves is described, in which only the side bands are transmitted. For this purpose transformers 4 and 7 are provided, the secondaries 11-12, and 17-18 of which are arranged to neutralize each other when no signals are sent. Modulation is secured by oppositely varying, by the aid of microphone 29 and coils 26 and 27, the permeability of the bars 8 and 14 of the transformer cores. These bars are brought up to the proper point of saturation by direct current excitation. Furthermore, the circuit through the primary coils 9, 10, 15 and 16, and the condenser 20 is tuned to the carrier frequency, so that the carrier frequency source 5 need supply only an excitation current to the transformers.

Continued on page 76

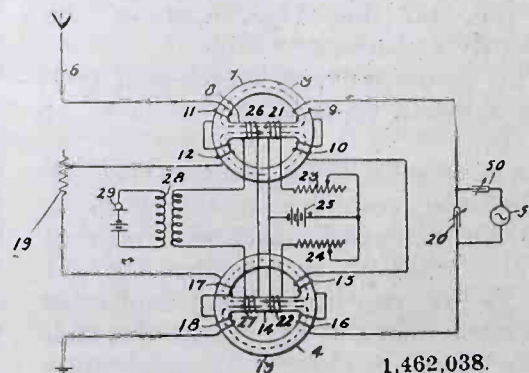
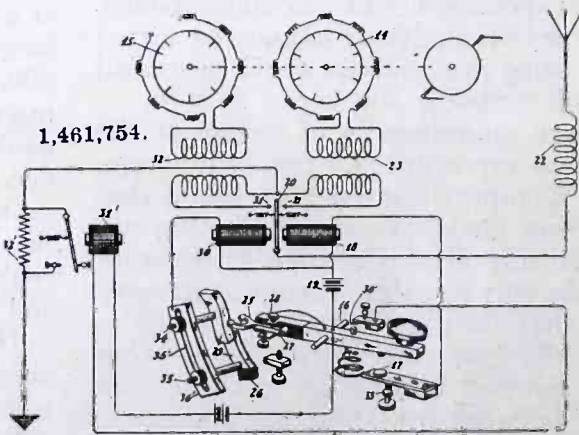
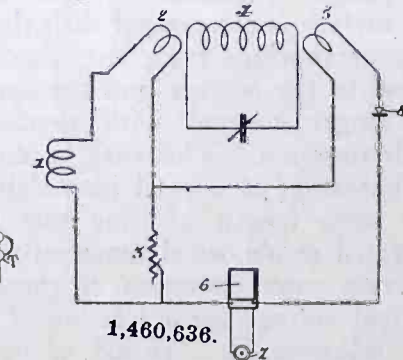
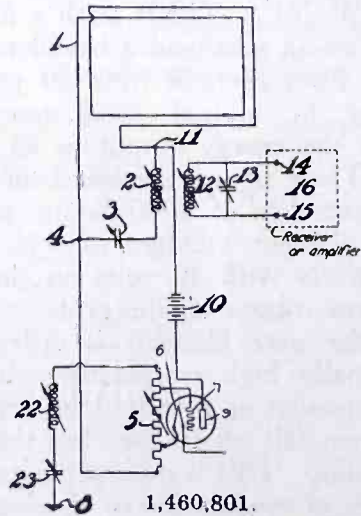
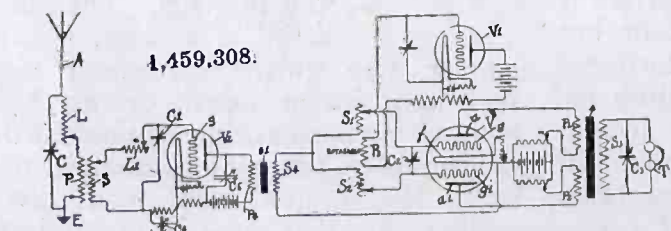
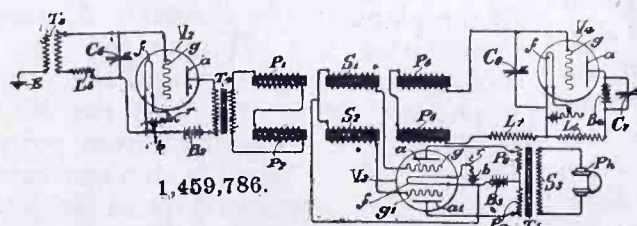
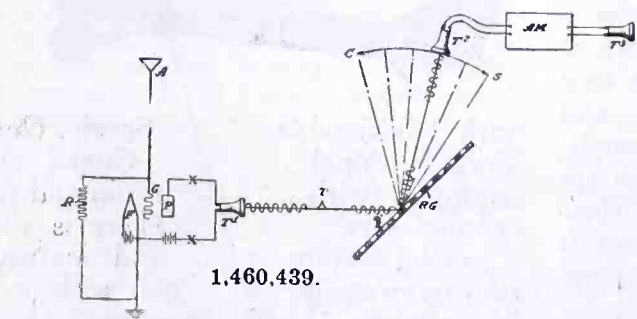

WITH THE AMATEUR OPERATORS

OBERLIN COLLEGE RADIO 8YAE

Radio Station 8YAE in the physics laboratory at Oberlin College, Oberlin, Ohio, has been very active in relay work, and has often been reported on the Pacific coast. The best DX worked is with 7SC and 6XAD. Reliable communication has been established with all districts in the United States and Canada with the 10-watt transmitter shown in the picture. The transmitter is familiar to a large number of the west coast gang, as it was in operation at 6AWP in Santa Ana, Calif., last year.

The 5-watt tubes are employed in a Colpitts circuit. The plate potential is supplied by an Acme 200 and "wrecked" by a twelve-jar rectifier with lead and aluminum plates in a saturated solution of borax. The filter system consists of two 2-mfd. condensers and a 1.5 henry choke. Although the set has been made to operate very well as a radio-telephone, straight C. W. has been employed at this station. An antenna current of 1.8 to 2.0 is obtained on a wave of 220 meters; 500 volts at 100 mils on the plates and filaments constant at 7.8 volts.

Two complete receivers are shown in the picture. The one on the left, used for 200 meter work exclusively, is a single-circuit affair with one stage of audio-frequency amplification. Either through the design of the receiver (modeled after one described in the March, 1922, RADIO) or for some other reason, this set does not seem to possess the fault common to most single-circuits—non-selectivity. A Wireless Shop condenser with vernier is used in the antenna lead.

The other receiver shown on the right is used for broadcast reception only. A regenerative or a non-regenerative may be employed with this apparatus. There are two steps of r. f., detector, and a W. E. power amplifier and loud speaker. At the extreme left is a General Radio wavemeter.

The antenna at 8YAE is 6 wires, 55 ft. high, swung between two of the college buildings. An 8-wire counterpoise directly beneath it at a height of 15 ft. is used entirely in transmission. A small indoor antenna is sometimes used for reception to work through QRN.

This last winter a staff of four operators kept the traffic moving at a lively rate, and the little old bottles could always be depended upon to get through. A 100-watt set is being installed for relay work this winter.

REGAINING LOST PRIVILEGES

By A. H. BABCOCK
Director Sixth District A.R.R.L.

The new regulations have been disappointing to many because they prohibit all transmission during certain hours. Many of us who have been using well-filtered a.c. in our plate circuits feel that we have done all that is reasonable in guarding against interfering with the BCL. But have we? How many of us have thought about "key thumps"? Not many, if one may judge by what is heard any evening. Again; some have thought that a filter is made by combining any old choke coil with any kind of condenser that would stand up under the strain; and if it broke down perhaps the choke was left alone on the job. Yet again, how many of us know of our own knowledge that our wave is within the new legal limits?

Failure to observe just these things during the past year has forced the Department of Commerce to cut us off entirely during certain hours; and the recovery of the privilege of transmitting at all hours will depend on our conduct during the coming winter.

When the officials of the American Radio Relay League endeavored to secure this concession, we were informed that just as soon as the amateurs developed transmitting circuits free from key thumps, showed a real appreciation of what a well-filtered circuit means, and stopped crowding above 200 meters by any amount they thought would get by, due consideration would be given to our requests.

It becomes important, therefore, to determine who is to blame for this condition of affairs, and to direct him along the way toward better compliance with the law, and a decent regard for the rights of others. It is more often the newcomer who is not well informed and who rushes in with a poorly-designed set. Sometimes it is the carelessly indifferent fellow who doesn't care.

Very seldom is it the smart Aleck who thinks because dad beats the prohibition enforcement, and brags about it; because brother and sister, "step on it," and defy all motoring rules, he must be as "big" as they, and in his small way beat our traffic laws. This sort of cub must be sought out and dealt with ruthlessly; for, in contrast with those other violators of the law who drink or drive themselves into trouble, unless he

is run down and curbed, he hurts, not himself but us, who are obeying the law and are helping to build up the art.

The others, the careless and the ignorant, are easily helped. A friendly tip telephoned; as for example, some of you have heard, "Say OM, aren't you a little above 200?" "Why, is that so?" "Yes, you're crowding 250 awful close; better get down." "Gee, how come, Billy Keyponder told me I was O.K.," etc. What Billy said cuts no figure when the R.I. sends out a warning. It is your business to know where you are; and a wavemeter can be built by anyone who has a spare 0.0005 variable condenser and a piece of tubing and a little fine wire. The R.I. will check it for you free; and will be glad to help you.

As to the key thumps and filters: Read July and August Q.S.T. and learn how to prevent the one and to make the other.

Now fellows, here is a fine chance to pull off something worth while, particularly on the Pacific Coast. You know it was the success of our Pacific Plan that won concessions for the 6th District and those of the 7th District who followed it. Just think what it would mean if we could, by our scrupulous observance of the law and of the rights of others, secure a modification of the Regulations to permit operation of the proper kind during the quiet hours; what a help it would be for all of us who can't spend the night at our favorite sport, and what a gloat we would have on the other parts of the country where no such co-operation exists as we know it on the West Coast.

Every time you hear the cluck-cluck of the key thumper, or the grumble of a poorly-filtered circuit, or a wave that is over the limit, call him on the telephone, and ask his help, ask him to play the game with us, offer to help him get right; but, whatever you do, don't make him sore, don't pitch into him unless he is a chronic offender. When he becomes that, why just take it up with your Club and get the gang after him.

NEWS OF AMATEUR OPERATORS

Call 6ZP has been assigned to Lloyd E. West, ex-6IV, 342 Main St., Riverside, Calif.

The Q RA of 6AFT, ex 5AIF, is 7526½ Figueroa St., Los Angeles, Calif.

Call 7IO, formerly assigned to H. E. Welch, Route 8, Salem, Oregon, now is held



Radio 8YAE

by Mr. E. M. Wright, 14 North Ninth Street, at Nampa, Idaho.

7VF is now located at 419 N. 12th St., Corvallis, Oregon, and is operated by B. W. Powell. 7VF is now on the job with a 50-watt and a 10-watt set. All reports from stations logging 7VF greatly appreciated.

6BML has been reissued to Joseph St. Pierre of 1100 W. 3rd St., Pomona, Calif.

Call 6ZJ has been assigned to Carlos S. Mundt, 1501 Palm Ave., Fresno, Calif. His old call of 6AJ will be retained for portable experimentation.

8RY, A. C. Bates, formerly at Burton, Ohio, is now at Sullivan, Ohio, where he will soon be QRO with a W. E. 50-watter.

The QRA of 6AGN, ex 1ARP, is C. J. Paddon, Bisbee, Ariz.

Call 9LM has been reissued to Burton E. Bodine, 7000 Virginia Ave., St. Louis, Mo., who has a 10-watt C. W. phone set.

RADIO STATION 6JD

Radio Station 6JD, operated by V. M. Bitz, 1429 West 53rd St., Los Angeles, Calif., sent several complete messages which were heard in Australia and New Zealand during the recent Australian tests. That 7000 miles are covered with a radiation of 11 amperes bespeaks efficient operation.

The antenna consists of two wooden masts, 80 ft. high, 50 ft. apart, supporting a 9-wire cage, 48 ft. long. The hoop at free end is 7 ft. in diameter, made of 3/4 in., copper

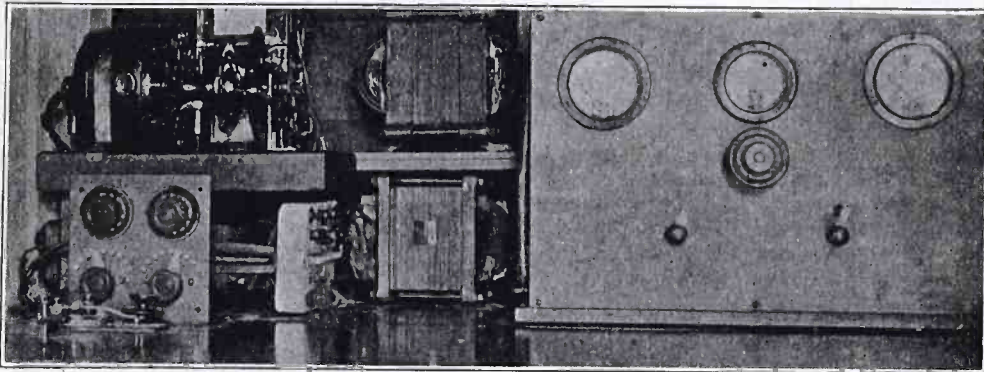

Rectifiers, Transformers, Filter and Sending Panel at 6JD

tubing. The hoop at the lead-in end is 1 ft. in diameter, the lead-in being an 80-ft., four-wire cage, 6 in. in diameter. The counterpoise is ten strips of 3/8-in. copper ribbon 50 ft. long, radial under antenna.

The transmitter consists of three pancake coils, 16 turns each, with variable sliding contacts, each controlled by knobs from front of panel. From front the coils are, first, antenna; second, grid; third, plate. The outside turn of the antenna coil goes to antenna outside of second coil to grid, sliding contact of second coil to filament, inside of second coil to outside of third coil. Sliding contact of third coil to by-pass condenser, by-

pass condenser to plate. There are three sockets, mounted on rear panel, two 50-watters in parallel, and one 5 watt. When the five-watt tube is used, the 50-watt tubes are raised up, so the pin in the tube rests on top of the socket, thereby cutting them out of the circuit, the same method is used with the five-watter, when the fifties are used. The radiation with the five-watter is 2 1/2 TCA, with 140 mills on plate, at 900 volts. Best work with it was with 6ZAC and 9DKY, approximately two thousand miles each. Considerable traffic was handled with both of these stations using the five-watter.

With the two 50-watters the radiation is 7 TCA, 410 mills, at 1750 volts. The best work was with 2ACB, during May, 1923, through heavy QRM. Signals have been reported from all parts of North America, Hawaii, New Zealand and Australia. During the test with Australia one 250-watt tube was used, mounted temporarily over the 5-watt socket. With this tube the radiation was 11 TCA, with 500 mills at 2000 volts, on plate. The plate supply for this equipment was supplied by synchronous rectifier, the motor being of special design, built by the owner. This motor runs 3600 r.p.m. on 60 cycles, and giving a very quick break, with a 4 1/2-in. disc.

Practically all reports from distant stations state that the signals from this equipment as pure DC. During the test with Australia, arrangements were made for the stations to send their code letters and calls. After about

a week of that kind of signals the operator at 6JD asked for a message from the Radio Journal, and without pre-arrangement proceeded to send messages to the listeners in Australia. The first one started on Saturday morning, May 16th, as follows: "Send calls of first ten stations heard; will pay half tolls. SIC., Radio Journal." On Tuesday, May 19th, the Cablegram arrived with calls of first ten stations, thereby letting us know our signals were being heard and copied. Two more messages were sent and copied by listeners during the tests. These messages were also copied by two listeners in New Zealand, one station reporting the signals from 6JD readable 50 ft. from the loud speaker, using two steps of radio, detector and two of audio amplification. Also many reports from all parts of the United States and Canada, who copied these messages complete.

NEW RADIO CATALOGS

Eisemann Magneto Corporation of Brooklyn, N. Y., have issued a handsome catalog of Eisemann products, including head phones, variometers, variocouplers, condensers, transformers, units and panels.

The H. H. Eby Manufacturing Company, 40 S. 7th St., Philadelphia, have ready for distribution their latest catalog, No. 15. This catalog illustrates their complete line of metal and insulated binding posts as well as other electrical specialties they manufacture. Catalog will be sent free upon request.

CALLS HEARD

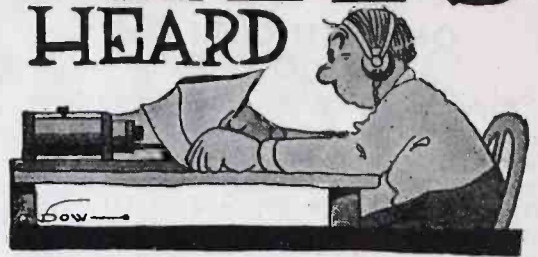

Readers are invited to send in lists of calls heard from stations distant 250 miles or more from their own station

By 6BGC, 415 W. Lexington Dr., Glendale, Cal. 5vo, 5ahl, 5aky, (6fy), 6oh, 6ov, 6lv, 6tu, 6tv, (6hp), (6aa), (6acz), 6agv, (6anb), 6alx, (6aoc), (6aol), (6aos), 6aly, 6akh, 6adp, 6adh, (6arb), 6atc, (6atv), 6aoh, 6auu, 6avv, 6bak, 6bcj, (6bcl), (6bez), 6bff, 6bfl, 6bfy, 6bgy, 6biq, 6big, (6bka), 6bly, 6bll, 6bjy, 6btt, 6bpv, 6bsj, 6bsd, 6buy, 6cac, (6cbl), 6cbw, (6cbd), 6cel, 6cej, 6cet, 6ckl, (6ckr), (6ckf), 6ccu, 6cjb, (6cjj), (6cjk), 6cjl, 6zam, (6chl), 7ak, 7br, 7bj, 7by, 7ln, 7age, 7agv, 7tq, 7zu, 9ape, 9bxq, 9avz, 9avc, 9caa, 9ccy, 9zt. Anyone hearing my C. W. will pse qsl.

By 2WR, 1075 Chancellor Ave., Hilton, N. J., with Reinartz with one step A. F. amplification.

C. W.: 1dl, 1ee, 1ez, (1ll), (1sk), 1uj, 1ze, 1aco, (1acu), 1al, (1at), (1avk), (1bes), (1brq), (1bvr), 1edo, (1cmp), (1cpi), 1cpn, (1cpo), 3em, (3fa), (3gc), 3he, (3km), 3lk, 3me, (3sg), (3tf), 3uu, (3vh), (3vo), 3wf, 3abj, (3aef), 3agn, (3ahp), 3apr, (3arp), (3auv), (3bbv), (3bcj), 3bdo, (3bfu), 3bhl, 3bhv, 3bnu, (3bsb), (3buy), 3bva, (3cdk), 3cdn, (3cel), 3cfv, 3chf, 3chg, 4bq, 4dx, (4fg), (4ft), (4gl), 4hr, (4jk), (5hl), 5ns, 5nz, (8bf), (8ef), 8gz, 8hj, 8hv, 8ij, 8kg, 8lt, (8tc), (8up), 8vy, 8wa, 8wv, (8zf), 8zz, 8adk, 8ago, 8ahq, 8aio, (8amp), (8avd), (8bei), (8bda), (8bdv), (8bfh), 8bgl, 8bkt, (8bnh), (8bno), (8boa), 8boy, 8bqs, 8bre, (8bvr), (8bwz), 8bzy, (8cdc), (8edi), 8cjd, 8cmt, (8cp), (8csj), (8cur), 8cuv, (8dgc), 8dkm, 8xae, (8zae), 9mm, 9vz, (9aaw), (9bhd), (9brk), 9bro, 9byt, 9cgt. Canadians: 2bn, (2cg), (2ic), (3ds), (3gk), (3kg), 3ta, 3tr, 3xn, 9bc, Arctic expedition wnp. Will gladly qsl to any of the above by card. Would appreciate any reports of my 100 watt C. W.

By 6UA, Thos. R. Rannels, 202 E. 53 St., Los Angeles, Calif., Maywood Station.

C. W.: 5adb, 5arb, 5lg, 5za, 5zak, 6ape, 6arb, 6atq, 6aty, (6biq), 6buy, 6gr, 6rm, 6tv, 6uo, 6uw, 7gw, 7ln, 7ot, 7tq, 7zn, 7zu, 7zv, 7zw, 7zy, 9aim, 9amb, 9ban, 9bxm, 9caa, 9eea. Anyone hearing my 5-watt C. W. pse qsl, all cards answered.

By 9BFI, 4511 Colfax Ave. So., Minneapolis, Minn.

1aeg, 1ajx, 1bac, 1bbo, 1bcg, 1ccg, 1cmp, 1pj, 2ani, 2awl?, 2crj, 2cxl, 2bn, 2cg, 2gd, 2ig, 2rp, 3abw, 3bvy, 3cok, 3csj, 3bp, 3co, 3ck, 3gd, 3oh, 3xn, 3zs?, 4cn, 4cs, 4fg, 4ft, 4gx, 4ku, 4mi, 4mk, 4us, 5ag, 5ahp, 5aiu, 5aiv, 5be, 5ca, 5cc, 5fv, (5gj), 5gm, 5hm, 5ku, 5kw, 5ll, 5mo, 5mn, 5ma, 5nh, (5ns), 5ps, (5rl), 5sn, 5xw, 5zav, 6cgd, 6ka, 7zv, (8aa), 8aap, 8aag, (8ada), 8aeb, 8aio, 8aju, (8aoq), 8aot, 8ape, 8apx, (8apt), 8awp, 8aws, 8axn, 8axo, 8azo, 8bbg, 8bci, 8bda, 8bdu, 8bei, (8bfh), (8bgl), 8bhe, 8bhv, 8bjv, 8bjw, 8bjo, 8blc, 8bno, 8btt, 8bur, 8buv, (8buz), (8buz), (8bxh), 8bxx, 8bzc, 8bzy, 8ced, 8cej, 8ccr, 8cie, (8cnr), 8cnw, 8cqh?, 8crw, 8csj, 8cu, 8cur, 8cuv, 8cve, 8cxm, 8da, 8dfa, 8dgl, 8dkm, 8dzy, 8zal?, 8ab, 8cp, 8es, 8fm, 8gz, 8hv, 8hw, 8ij, 8iw, 8jj, 8kg, 8nv, 8oe, 8pd, 8rj, 8ss, 8ux, 8vy, 8vt, 8tx, 8wl, 8zw, 8zz. Canadian: 2rg, 3adn, 3bp, 3gk, 3ko, 4gx, (3xn). W1 qsl to any of above if they request.

U. S. 2CSA at St. Andrews, New Brunswick, Canada, July 15—August 10.

U. S.: 1aa, 1bq, 1de, 1dl, 1ee, 1kx, 1il, 1sk, 1vk, 1vv, 1xp, 9ze, 1aco, 1acu, 1adj, 1aez, 1aig, 1akb, 1akl, 1apt, 1aqi, 1aqm, 1arf, 1auc, 1avp, 1bri, 1btf, 1bsb, 1bvr, 1ccz, 1cdm, 1cfi, 1cib, 1emp, 1cpd, 1cpi, 1cpn, 1cql, 1cur, 1cxd, 2ad, 2be, 2cf, 2di, 2el, 2fp, 2fs, 2gk, 2hw, 2im, 2kk, 2om, 2ta, 2wi, 2abm, 2afp, 2aie, 2ais, 2bir, 2bqb, 2buy, 2bx, 2bv, 2cbg, 2cei, 2cgt, 2chm, 2cjr, 2cjp, 2clu, 2cow, 2cnz, 2epa, 2eph, 2crq, 2cva, 2cve, 2cx, 2cxl, 3cn, 3fr, 3fs, 3ge, 3gk, 3he, 3jg, 3lk, 3me, 3qv, 3ta, 3tc, 3tr, 3aee, 3abw, 3aga, 3ahp, 3ahr, 3akr, 3aky, 3ats, 3auo, 3avm, 3bcj, 3bfe, 3bgt, 3bpl, 3bob, 3bqj, 3bqo, 3bta, 3buc, 3bur, 3bva, 3cdn, 3cel, 3cfv, 3chf, 3cho, 4fs, 4gx, 4lj, 5mo, 5xw, 5adg, 8al, 8bf, 8kh, 8lt, 8nb, 8ok, 8qm, 8tc, 8th, 8tx, 8qv, 8vy, 8zd, 8zr, 8zw, 8zz, 8adg, 8amm, 8amw, 8aju, 8ari, 8atp, 8avd, 8awp, 8axx, 8ayb, 8bci, 8bcp, 8bda, 8bgl, 8bjj, 8blv, 8bno, 8bog, 8brm, 8buv, 8buz, 8ccx, 8cdc, 8cdd, 8cgj, 8ckn, 8cmt, 8cmu, 8cpd, 8cp, 8cx, 8cse, 8csi, 8cty, 8cur, 8cuu, 8cuv, 8ddc, 8dgl, 8dgv, 8dl, 8do, 8zae, 9ep, 9uc, 9aou, 9bak, 9blo, 9bnb, 9byt, 9cuv, 9dek, 9dgo, 9dro.

Canadian: 2am, 2cg, 2cn, 2ic, 2on, 3bf, 3bp, 3ds, 3ge, 3he, 3in, 3zs, 3adn, 9bc. wnp, nss Fone—8awp. Above heard on 2 stages R. F. on homemade regen. neutrodyne. Anyone wishing qsl drop ord to 2csa in N. J.

Continued on page 44

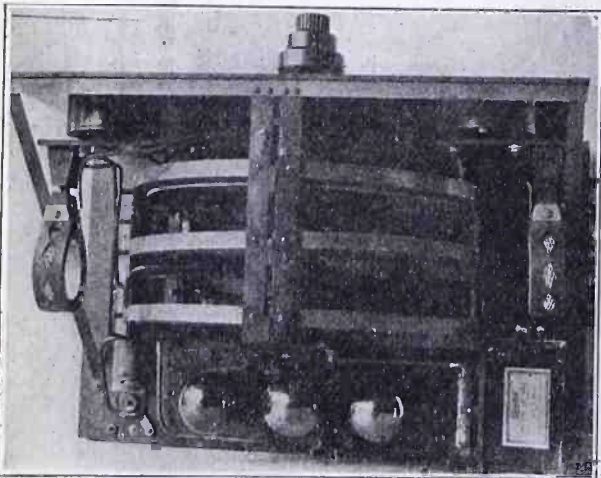

Top View of Set at 6JD Showing Coils of Meisner Circuit

LETTERS TO THE EDITOR

A Master Control Switch

Sir: Having been annoyed by the awkwardness of the plug and jack system and wishing to have automatic filament control, I constructed this switch at a small cost and have been pleased with its performance ever since, so I thought I would pass it on to some one else so that they, too, would be able to do away with their jacks.

The materials necessary are: a piece of bakelite, a small piece of phosphor bronze or spring brass, a 2-in. piece of 1/4-in. brass rod threaded 8/32, a small brass bushing, eight taps, a spring, a few 8/32 screws and nuts.

The piece of bakelite is cut and squared 2 1/2 in. x 2 3/4 in. and then drilled according to the diagram, taking care to drill the holes for the combined stops and mounting posts a little large so that they may be adjusted to stop the switch at the right place.

The smaller piece of bakelite, 1 3/8 in. by 3/4 in. is squared and drilled and then the phosphor bronze is cut to shape and fastened to the bakelite with small screws or rivets. After it has been securely fastened one segment is cut from the rest with a hacksaw. Care must be taken to see that the cut segment is on the left side when the switch blade is up and to the top as shown in the diagram or the switch will not work.

After the 1/4-in. rod is cut in the lengths shown, the 1-in. piece is mounted on the small piece of bakelite so that it is on the opposite side from the blades. If you plan to use a dial or pointer with a hole smaller

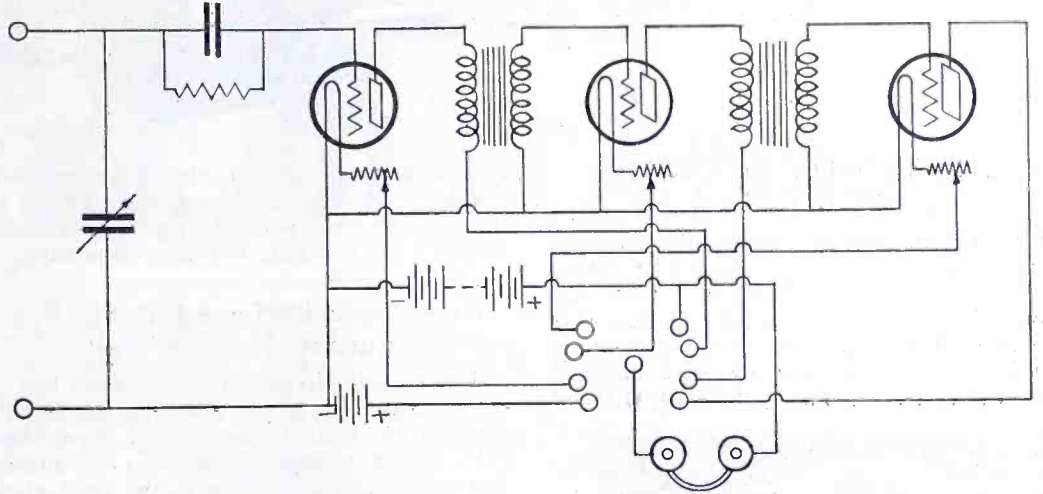

Wiring Diagram for Master Control Switch

than 1/4 in. this shaft will have to be changed accordingly.

The next thing to do is to mount the taps, bushing and stops on the base. The initial tap in both sets will have to be filed so that the top is slightly round or the switch blade will not move easily. The blades are then bent slightly so that they will have sufficient tension and the separate one is connected to the shaft with a piece of the bronze.

After the pressure of the spring is adjusted the lock nuts are tightened and the stops fixed so that the switch stops in the right place and then it is ready for mounting on the panel. It is wired according to the accompanying diagram, care being taken to see that the right taps are used.

CARL PENTHER.

Real C. W. Supply

Sir: I have been having such wonderful success with a high-voltage storage battery which I constructed, that I thought some brother hams might like to make one also. The cost is nothing compared to either an m.g. or rectified a.c. As no filtering system is required and the wave produced is the purest d.c. possible, great DX can be secured with very little ant. current. During July, with heavy QRM and an ant. current of only 1 amp., the extreme east coast was worked. This with one 5-watt tube. Neighboring stations with 3 and 4 amperes in the ant. using rect. a.c. have not been able to work eastern stations.

Continued on page 61

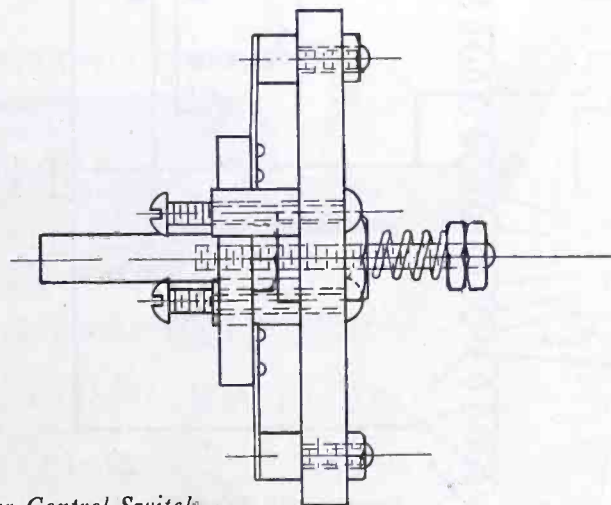
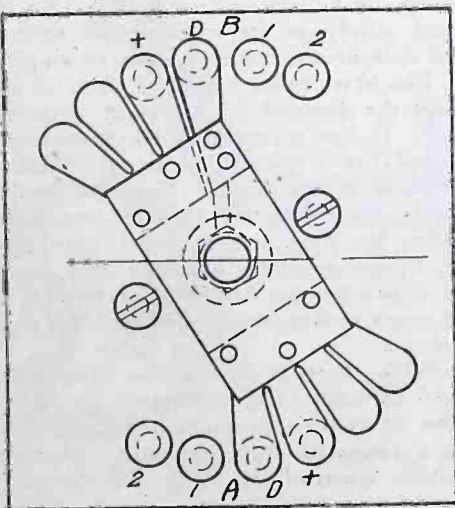
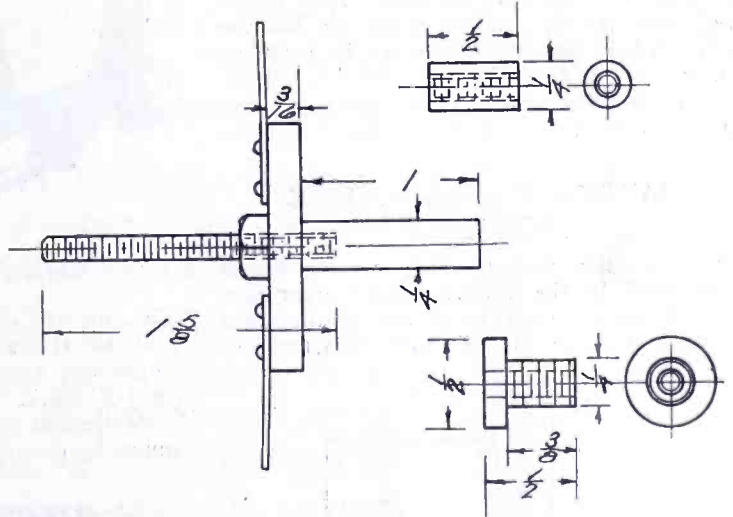
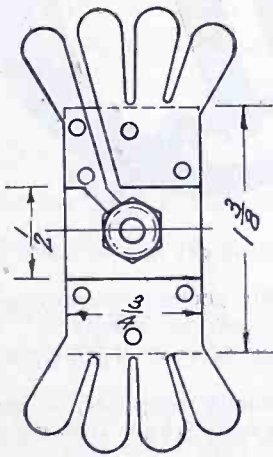
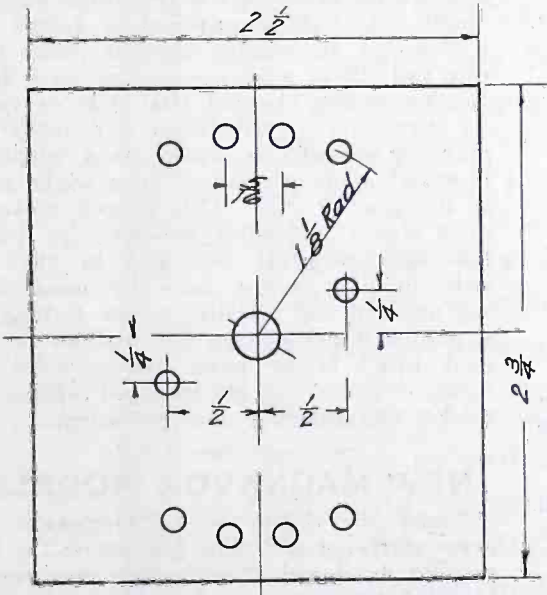

Details of Master Control Switch

FROM THE RADIO MANUFACTURERS

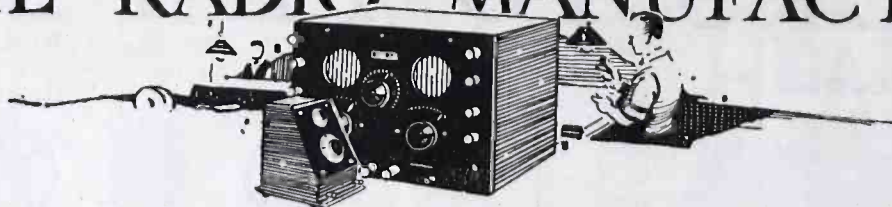

SICKLES WOVEN INDUC-TANCE COILS

A novel and effective means for winding inductance coils is utilized by The Radio Mfg. Co. of Springfield, Mass. Each coil is wound from a single length of insulated wire in such a form as to be self-supporting after impregnation in moisture-proof material and so as to have a minimum of distributed

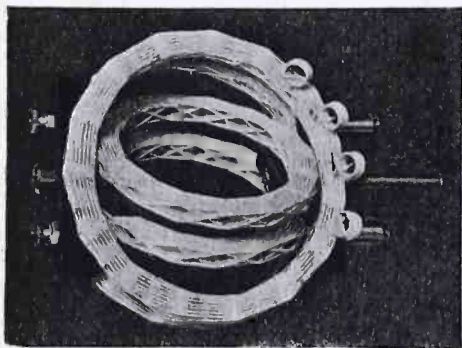

Variocoupler Made With Sickles Woven Inductance Coils

capacity. The coils are made up in various sizes and tappings to meet any intended wavelength requirements. This form of winding is known as the Sickles Diamond Weave and may be seen in the accompanying picture of two such coils mounted in a variocoupler.

Standard coils of various styles are made for use in building receivers employing the Reinartz or Green circuits, for radio-frequency circuits, wave traps or loading coils. They are also made up in complete variometer and variocoupler units. Each coil is carefully packed in an attractive box and accompanied by full directions for use.

IMPROVED REINARTZ HOOK-UP

In connection with the Reinartz coil which is marketed by the Tristan Sales Corporation of New York City through an arrangement between Eugene T. Turney Laboratories,

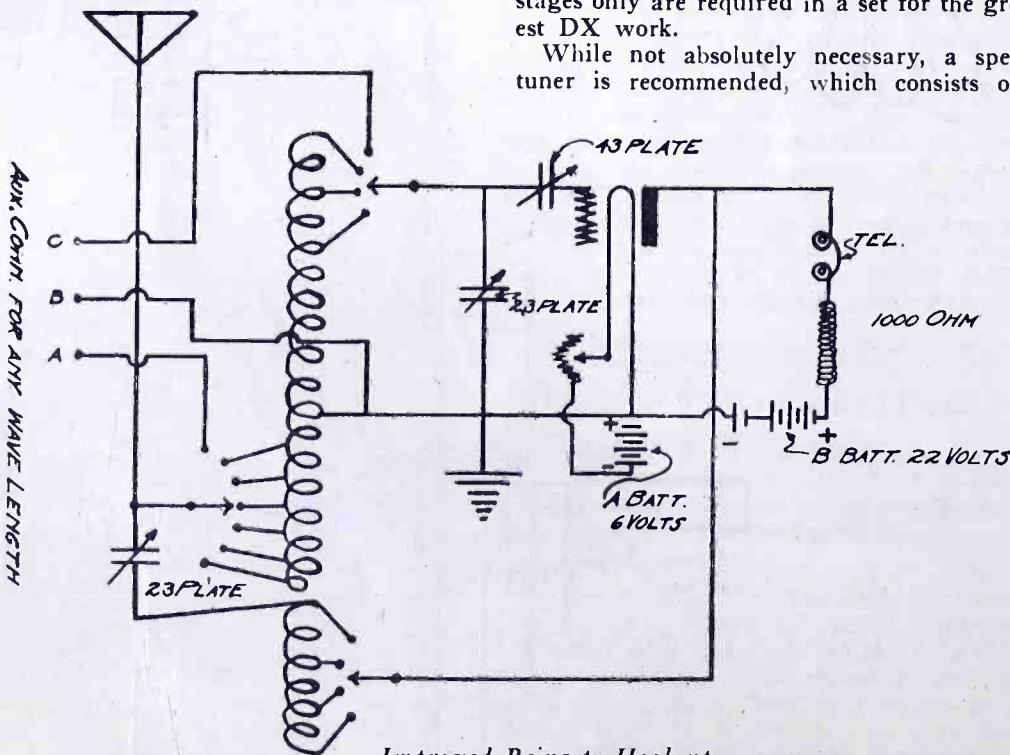

Improved Reinartz Hook-up

Inc., and John L. Reinartz, there has been devised an improved hook-up adjusted to take in the new wave bands as established May 15, 1923. This is shown herewith.

New York Perfected Radio-Fre-quency Transformer

A new radio-frequency transformer has recently been placed on the market by the New York Coil Company, of New York City, which possesses a number of unusual features. First of which is the total elimination of tubes of any description to support the two windings. A patented construction is employed which consists of a framework composed of bakelite which touches the two coils at the four points. Windings of the two coils employ a special radio cement which gives a skeleton construction, so that there is practically no dielectric material within the magnetic field of the two coils which is claimed to eliminate radio-frequency losses to a marked degree.

These transformers are of the tuned type, requiring an 11-plate condenser placed across the secondary winding. The ratio is 4 to 1.

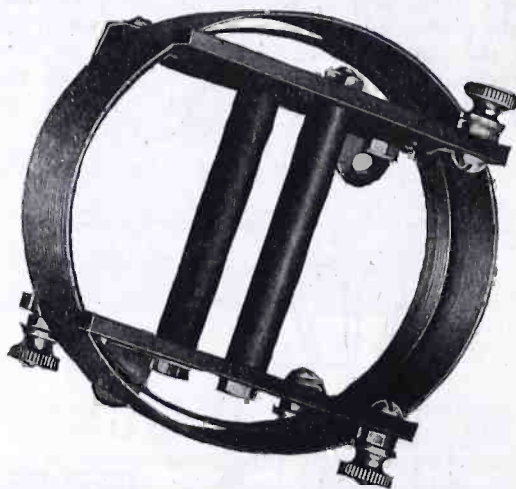

Radio-Frequency Transformer

The novelty of this skeleton construction is said to result in marked efficiency. Two stages only are required in a set for the greatest DX work.

While not absolutely necessary, a special tuner is recommended, which consists of a

secondary of 60 turns in the middle of which is arranged a primary of but five turns with a tap brought out at each turn. Remarkable selectivity is claimed. Reception on a loop or a very small indoor aerial is extremely satisfactory, and it is claimed the difficulties heretofore experienced with radio-frequency are eliminated. Range is from 250 to 550 meters.

GLOBE COMBINATION JACK BINDING POST

The Globe combination jack binding post manufactured by the Globe Phone Mfg. Co. of Reading, Mass., is designed to overcome some of the objectional features of the ordinary binding post. In appearance it is like

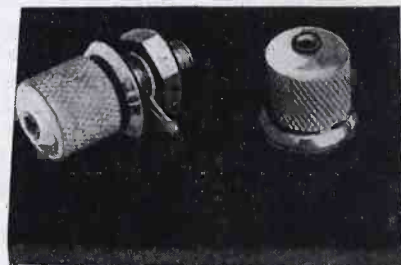

Globe Combination Jack Binding Post

a miniature drill-chuck with a high polished nickel finish. It is universal in design and will accept all regular sizes of phone cord tips and direct wire connections sizes from No. 10 to No. 14, also fork style or spade tip terminals. Connections are made by plugging straight in, similar to a telephone jack and made permanent by a slight twist of the knurled cap. This method makes a short circuit impossible between tips which has been a great objection in the old style binding post. Also all connections are uniform and parallel as the turning of a post will not change the position of the cord tips. Globe posts are mounted by means of a nut and are equipped with a lug washer for soldering wire connections.

NEW MAGNAVOX MODELS

Under the slogan of "a Magnavox for every receiving set," The Magnavox Co. has recently developed a number of new models to supplement their standard electro-dynamic reproducers and power amplifiers. Of especial interest to the owners of dry battery receiving sets is the new type M-1 which requires no battery for the field. This may be used singly or in combination with either the new or old models of power amplifiers.

The new model amplifier, A-1, is made to meet the demand for a 1-stage power amplifier. It has a special finish metal case with a bakelite terminal board for efficient connections at the back. The new models are made up either for separate attachment to either the new or old model reproducers or as a complete unit with the M-1 reproducer in either one or two-stage styles. A unique Magnavox feature is the modulator to control volume.

With these additions the Magnavox line now includes ideal apparatus for every purpose of radio reproduction and amplification in a range of sizes and prices placing them within reach of all.

Continued on page 66

FIL-KO-STAT CONQUERS DISTANCE



SHUTS OUT NOISE

**Full Resistance
30 Ohms**
Takes the place of other rheostat or filament control without re-drilling holes in panel.

PUT A FIL-KO-STAT ON YOUR SET TODAY. You will hear stations you believed to be far beyond its range. You will get greater distance! Louder signals! Finer adjustment! NOISELESS OPERATION! A. S. Allsup, of Kansas City, writes, "Since using my Fil-Ko-Stat I have picked up 5 stations I never heard before."

The FIL-KO-STAT is the filament control of INFINITE adjustment, with a fine adjustment area 18 times greater than a wire rheostat, and several times greater than the next best filament control.

There are no screws to tamper with on the FIL-KO-STAT. No wires! No discs to chip or break! No adjustments to puzzle! Triple tested and adjusted at the factory to the ideal "off" for UV200, 201, 201A, WD11, WD12, UV199, DV6A, W. E. Peanut and all other tubes including 5 watt transmitting tubes. Hailed by amateur and professional radio men as the greatest step forward in the development of the tuning possibilities of the vacuum tube.

FIL-KO-STAT supremacy is proven by every test!!

Price

\$2

Recommended and sold by dealers in high quality radio supplies.



MADE AND GUARANTEED BY **IX INSTRUMENT CO.**

RADIO STORES CORPORATION

SOLE INTERNATIONAL DISTRIBUTORS

Dept. R. 10 218-222 West 34th Street New York

In Canada \$2.75

Tell them that you saw it in RADIO

You Will Want This Book

Send 10c for "Radio Pocket Reference" by W. G. Merritt Garvey (of New York World Radio Staff), tables, 17 hook-ups, diagrams, etc. Reading this interesting book, we discovered that Mr. Garvey recommended the FIL-KO-STAT for fine filament control. We bought an edition of these books, and will send a copy anywhere at handling cost of 10c.



Crewol
THE PERMANENT DETECTOR

The only crystal detector that has won such universal approval. Eliminates usual crystal detector difficulties. Adjusted to maximum efficiency and held there by vibration-proof base. Crystal protected from dust and moisture by glass enclosure. No complicated adjustments to get out of order. Needs no attention. Simplifies and improves the operation of your set. Fully patented. Unconditionally guaranteed **\$2**

Write for Booklet

RANDEL WIRELESS COMPANY
2 Central Ave. Newark, N. J.

Approved!



The Champ—VARIOMETER No. 53
Approved as a Record Breaker

Approved because it makes 600 meters.
Approved because perfectly constructed.
Approved because it has a genuine mahogany stator and a kiln dried rotor.
Approved because of Fahnestock spring clip connections and non-conductive adhesive.
Approved because—you'll know why when you

GET ONE FOR \$3.50
20 Diagrams FREE With Each

For sale at your dealer's—otherwise send the \$3.50 directly to the manufacturer and you will be supplied postpaid.

G. H. FISCHER & CO.
123 Liberty St. New York City

IF YOU HAD A FRIEND in New York who would buy whatever radio equipment you needed from the smallest part to the complete set either assembled or un-assembled—who would personally test each article you desired—who would gladly and freely advise you when you needed help—who was not interested in any radio manufacturer—who carried out your instructions to the letter and did it promptly, prepaying all shipping charges—and at prices less than if you did your own buying—he would be a real friend indeed! Well, here he is—write at once and get acquainted with the friendly service and money-saving story of the Personal Service Purchasing Bureau, Dept. 14, 505 Fifth Ave., New York City.

CALLS HEARD
Continued from page 40

By 9DQH, 523 3rd Ave., Southeast Minneapolis, Minn.
All C. W.: 9aa, 9fg, 9mf, 9pg, 9dc, 9yu, 9abc, 9abu, 9adf, 9adz, 9aec, 9agx, 9aib, 9ape, 9aqd, 9ate, 9avz, 9axa, 9ate, 9baf, 9bgc, 9bgh, 9bgw, 9bkj, 9bke, 9bre, 9buo, 9bwn, 9bxc, 9bxj, 9cdu, 9ofz, 9cin, 9ckm, 9eki, 9etv, 9cuo, 9cxc, 9cxh, 9cxp, 9cxv, 9dex, 9djo, 9dkx, 9dli, 9dpw, 9dtu, 9dz, 9eak, 9ebt, 9eea, 9egy, 9ehj, 9ehy, 9ekf, 9eky, 9ep, 9er, 9on, 9rr, 9sck, 9sly, 9sahr, 9aik, 9amp, 9atx, 9bdr, 9bkz, 9bfq, 9bhf, 9bjs, 9bom, 9cei, 9cnl, 9cpe, 9erc, 9exu, 9exw, 9dke, 9ef, 9qh, 9zu, 9ah, 9ai, 9afs, 9ajr, 9afs, 9aoc, 9arb, 9bje, 9ek, 9ol, 9ga, 9g, 9js, 9ol, 9uk, 9zp, 9aib, 9zav, 9zaba, 9hh, 9xm, 9zo, 9adp, 9ccu, 9aql, 9vh, 9cxl, 9il, 9boq, Canadian 9si, 9an, 9ni, 9co, 9bp.

Any one hearing my 5 watts sigs. pse. qsl by card. Any of the above may have cds. by request.

By Canadian 41C, W. G. Stunden, 615 9 Ave. N. W., Calgary, Can.
3bvp, 6bh, 6chl, 6ti, 6arb, 6awt, 6acm, 6clv?, 6ov, 6pl, 7hm, 7zn, 7zv, 7auu, 9dv, 9duq, 9daw. Can. 5go, 4er, 4cl, 5ac, 5ah, 4ao, 9bx.

Any one hearing my C. W. sigs. pls. qsl 5 watts here.

By 6BLV-6XAS, Brooke Sawyer, 1209 Crenshaw Blvd., Los Angeles, Calif.
5cn (Can.), 5lg, 5zak, 6acm, (6acz), (6alx), 6aol, (6aou), 6atv, (6aty), 6avf, 6aws, 6awt, 6bai, 6bez, (6bfl), 6big, (6bip), (6bnt), (6bop), (6bql), (6bsj), (6bcd), 6cbu, 6ccu, 6cfi, 6hp, 6km, 6ly, 6no, 6rm, 6tv, (6uw), 6ze, 7age, (7br), 7ef, 7io, 7iy, 7ln, 7mc, (7to), 7zu, (9amb), 9bun, 9bxz, 9caa, 9evc.

Reports on 6blv will be greatly appreciated.

By 7VN, D. E. Huntington, Kalama, Wash.
(Spark #): 6abx, 6ac#, 6aca, 6acz, 6ahu, 6alv, 6alx, 6aol, 6aos#, 6ape, 6atc, 6atv, 6aty, 6aup, 6auu, 6auy, 6avf, 6avr, 6avv, 6awx, 6bah, 6bel, 6bcm, 6bcn, 6ber, 6blz, 6bfl, 6bge, 6bic, 6bip, 6bjq, 6blv, 6bmd, 6bos#, 6brf, 6btt, 6bte#, 6bul, 6bun, 6buo, 6buy, 6bvg, 6bvs, 6cbd, 6cbu, 6ccu, 6cet, 6cej, 6cfz, 6cgw, 6chl, 6chv, 6cje, 6ckf, 6cmr, 6dd, 6eb, 6fy, 6gt#, 6gr, 6gx, 6hc#, 6hp, 6jx, 6ka, 6no, 6od#, 6pl, 6rk, 6rm, 6tv, 7add, 7af, 7af, 7iw, 7je, 7ln, 7ne#, 7nz, 7sz, 7tq, 7we, 7ws, 9amb, Canadian, 4cl, 5ct, 5en.

By J. H. Eckardt, 3402 Illinois Ave., Fresno, Calif.
3ajg, 5lg, 5kw, 5ado, 5sk, 6rm, 6cbu, 6apw, other sixes too numerous, 7na, 7zu, 7tq, 7abs, 7afw, 7wm, 7wx, 7oh, 7ks, 7adp, 7adm, 7aby, 7zv, 7dh, 7afn, 7hm, 7wp, 7iy, 7br, 7agi, 7ln, 7zn, 9cfy, 9bxq, 9bxa, 9czg, 9ql, 9cvc, 9cta, 9bjk, 9zt, 9caa, 9cpu, 9bun, 9ecu, 9eae, 9dli.

By 6BPZ, 2114 Crenshaw Blvd., Los Angeles, Calif.
(5lc), (5adb), 5ado, (6hp), (6tv), (6ams), (6alv), (6ani), (6aty), (6bel), 6ber, (6big), (6bql), (6zh), (7br), (7bj), (7cf), (7eb), 7go, 7gp, 7ln, 7ln, 7lr, (7ly), (7pf), (7qi), 7wm, (7ws), 7lu, 7zd, (7zf), (7abs), (7aby), 7abp, 7adp, 7af, (7akc), 7agv, 9bci, 8bf, 9dr, 9zt, 9alb, (9amb), (9bjk), 9bun, (9caa), 9cvc, 9czg, (9dli), Can. 5cn, 5go.

5-watts used—qsls appreciated and answered.

By 6BVG, August, S. F. Wainwright, 1926 Delta Street, Los Angeles, Calif.
4eb, (5ado), 5aky, (5ahd), (5lg), 5kw, 7abs, sixes too numerous, 7af, 7age, 7ags, 7akt, 7br, (7bj), (7gp), 7go, 7iy, 7ly, 7ln, 7nn, (7qo), (7zf), 7zd ex 7zu, 7zn, 7zv, 7wm, 8zz, 9aav, 9awg, 9apw, (9amb), 9bjk, 9bch, 9bxq, (9caa), 9cci, 9cvc, 9dli, 9dte, 9dtt, 9eky, 9eae, (9zt), (Can. 5go).

At 6BUH, 337 Westminster Ave., Salt Lake City, Utah
4cl Can?, 4hy, 5atc, 5ahd, 5ay, 5aky, 5ado, 5hl, 5lg, 5lr, 5za, 5zo, 5zav, 5zat, 6ao, 6auu, 6aol, 6awt, 6abu-sp, 6ar-sp, 6arb, 6alu, 6ajd, 6alk, 6apw, 6auz, 6avd, 6aih-sp, 6aqu, 6aqt, 6afq, 6auq, 6aoc, 6aos, 6auw, 6bkn, 6bih, 6bji, 6bbc, 6bip, 6bun, 6bqc, 6bqd, 6bsg, 6bnu, 6blv, 6bur, 6bka, 6bah, 6buq, 6bez, 6bwp, 6bua, 6bjq, 6bic, 6brf, 6bql, 6bkh, 6bvs, 6bug, 6bbh, 6bod, 6bip, 6bpz, 6boq, 6ekt, 6ebi, 6cih, 6can, 6cgw, 6chl, 6ech, 6edf, 6ekf, 6cjb, 6cax, 6cmr-like local, 6cnr, 6dd, 6km, 6fh, 6hc-sp, 6jd, 6ux, 6ea, 6eo, 6nx, 6hv, 6pl, 6tc, 6fc, 6id, 6ik, 6et, 6ka, 6tv, 6fy, 6zi, 7afw, 7aiy, 7ahw, 7abs, 7abb, 7adh, 7bj, 7cd-sp, 7ei, 7hc, 7it, 7iy, 7iw, 7ln, 7nt, 7pj, 7sf, 7tq, 7pw, 7zd, 7zu, 7zf, 7zv, 7zn, 8ake de 8a?, 9apw, 9amb, 9aul, 9aim, 9avc, 9auu, 9btt, 9bri, 9bjc, 9bun, 9bvo, 9bjk, 9bjh, 9buq, 9bxm, 9bxq, 9cga, 9cgy, 9cmk, 9cfy, 9cfj, 9caa, 9cgl, 9cjs, 9cvc, 9cip, 9cd, 9czg, 9dli, 9dez, 9ddj, 9dte, 9dwn, 9eae, 9eea, 9ha, 9uh, 9ve, 9fow wrkng 5tp-how cum?, QRK 6buh?

By 6BUH, 337 Westminster Ave., Salt Lake City, Utah
1ara, 1bho, 4hh-Can., 5aq, 5bb, 5go, 5kw, 5vh, 5zava, 6afv, 6amx, 6aol, 6atc, 6aqp, 6acm, 6anb, 6ahu, 6ape, 6avv, 6awx, 6atj, 6ahj, 6ahf, 6avp, 6aic-sp, 6aag, 6abd, 6bgy, 6bkd, 6bin, 6bve, 6bld, 6bfl, 6bic, 6bu, 6bqr, 6bvg, 6buo, 6bqa, 6bgd, 6bvs, 6bbr, 6brs, 6bes, 6bhk, 6cgd, 6cdr, 6cge, 6cgf, 6cje, 6cbd, 6chv, 6cue?, 6chi, 6cay, 6cec, 6cjl, 6cgg, 6ckr, 6edd, 6ec, 6ff, 6gr, 6hc-sp, 6jx, 6lu, 6mh, 6od, 6iv, 6ur, 6vc-sp, 6xad, 6xbc, 6zam, 6zr, 7afn, 7amv, 7age, 7fd, 7cq, 7go, 7gp, 7hj, 7hs, 7lp, 7nn, 7we, 7zg, 7zp, 7zz, 9avz, 9alk, 9auw, 9arz, 9ayu, 9bx, 9bak, 9bxa, 9bkf, 9ccz, 9dfh, 9zt. All heard on detector only.

Continued on page 46
Tell them that you saw it in RADIO



WALNART
Trouble Proof
RADIO
Apparatus.

Walnut Friction Vernier Adjuster enables you to tune in the elusive station that you always pass by. Fits any panel—only one hole to drill. Price 25c

“Walnat”
10 point
Inductance
Switch

Only one hole to drill in panel. Make all connections before inserting in panel. Contacts are smooth and positive. Base and knob genuine Bakelite, all metal parts nickel plated. A time and money saver—and improves your set. Price complete \$1.00.

“Walnat”
Trouble Proof
Variable Condensers

Insure quick, accurate tuning. Plates are pressed and locked into supporting posts. Positive spring contact.

Plates	Plain	Vernier
3	\$1.50
5	1.65
13	2.25	\$4.25
23	3.00	5.00
43	3.50	6.00

All above will be sent postpaid on receipt of price; but ask your dealer first.

WALNART ELECTRIC MFG. CO.
Dept. 201—1249 W. Van Buren Street
Chicago, Illinois

BARGAINS

Read the **RADIOADS** on page 94. Many good radio bargains are listed. What have you for sale or exchange?

Use the Radioads!
THEY PAY!



"I traveled 20,000 miles in one evening!"

Mr. M. J. Doherty, of Oak Park, Ill., writes: "Many nights I hear Station KHJ (Los Angeles), CFCN (Calgary, Canada), WEAJ (New York) and others as far away. In one evening of four hours and twenty minutes I heard 30 stations, scattered all over the continent. These stations were a total distance of 20,575 miles from my home."

Many wonderful and unsurpassed distance records have been made during 12 years' wide use of Tuska-made radio instruments.

Tuska Popular No. 225

3-bulb Regenerative Receiving Set. Piano finish mahogany cabinet. Amplifier switch. Concealed binding posts. Armstrong circuit, licensed under Patent No. 1,113,149. Price \$75, without bulbs, batteries or loud speaker. Ask for special circular No. 12-D, describing this set.

*Let the
day's troubles
sink with the sun*

THEN turn to your Tuska Radio, and be whisked around the world as if by magic. A touch of the dials, and you are in Davenport, listening to a singer with a voice like a nightingale. A slight movement brings you to Philadelphia to hear the rolling, majestic music of the greatest organ. Regretfully you turn away, to pick up the latest flashes of news from New York. In those few precious hours between work and sleep, you live in Radio Fairyland, where you are master of distance and ruler of a host of entertainers.

Will you give your family or yourself the pleasures of Tuska Radio, which educates, soothes, amuses, and takes all of you traveling inexpensively? Here is the

receiver that always works; that annihilates miles; that brings in music and voices sweetly, clearly and undistorted. It is the ideal set for busy people who want the thrills of radio without the tinkering.

For a dozen years, Tuska-built radio receivers have been famous for advanced design and painstaking New England workmanship. The Tuska receiving set of to-day is not only up to date; it will still be good for service in five years or more. Tuska Radio will give you hundreds of dollars of value in joy for every dollar it costs you. It will never disappoint you or your company.

Address of nearest dealer sent on request.

THE C. D. TUSKA CO.
Hartford, Conn.

TUSKA RADIO

Tell them that you saw it in RADIO

New York Coil Company's Radio Products

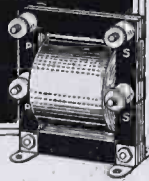

Are leaders everywhere in quality, ease of installing and utmost efficiency

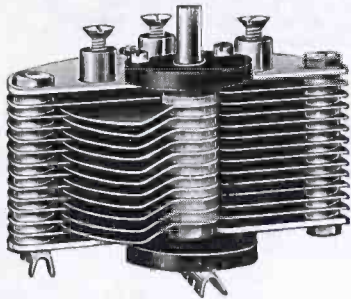

11 Plate... **\$1.50**
23 Plate... **2.00**
43 Plate... **3.00**
3 Plate... **1.25**



Supplementary Vernier
Condenser—**\$1.00**

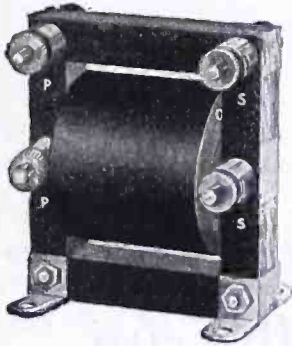

Amplifying
distortionless
Transformers,
correct for any
tubes.
Price **\$4.00**

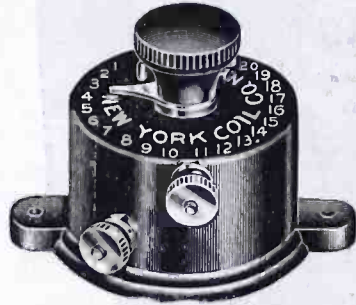

Variable Grid Leak.
Price **\$1.50**

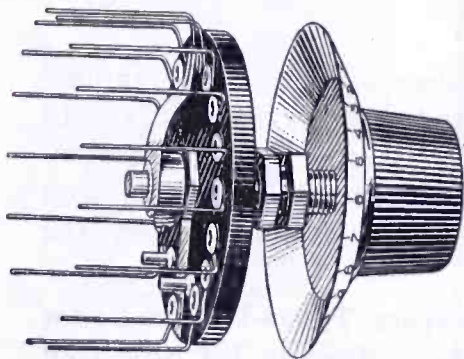

Inductance Tap Switch, but one hole to drill, furnished with 15 wire connections. No soldering. Price **\$1.50**

All described in new literature

New York Coil Company

338 Pearl Street

New York City, N. Y.

LAST CHANCE

The price of LEFAX RADIO HANDBOOK increased to **\$5.00**

We have less than 100 copies on hand and we will dispose of them at the old price of \$3.50. This includes greatly enlarged free monthly service fillers.

ORDER NOW AND SAVE \$1.50!

No orders accepted after October 30th

"RADIO"—Pacific Building—San Francisco

CALLS HEARD

Continued from page 44

By Jack Stevenson, 5108 Wadsworth St., Los Angeles, Calif.

5ado, 5ags, 5aky gra?, 5jf, 5kw, 5lg, 5ns, 5za, 6afg, 6afh, 6afq, 6ahf, 6ajs, 6aka, 6alq, 6alv, 6any, 6aoi, 6apg, 6apu, 6arb, 6arf, 6aru, 6auq, 6auu, 6aux, 6avb, 6awt, 6awx, 6aza, 6bg, 6bas, 6bbh, 6bcd, 6bck, 6bez, 6bgs, 6big, 6biq, 6bne, 6bos, 6bru, 6bud, 6buy, 6bva, 6bwx, 6cbq, 6cbu, 6ccu, 6cfd, 6cfl, 6cfo, 6cgo, 6cjb, 6ckr, 6et, 6fz, 6jq, 6lr, 6nj, 6nv, 6qw, 6to, 6tv, 6vo, 6uq, 7ax, 7hr, 7io, 7je, 7ln, 7lu, 7ot, 7sg, 7to, 7zf, 7zn, 9apd, 9br, 9bun, 9bxq, 9caa, 9cvc, 9dos, 9ds, 9zt, Mex. j. h.

By 6BLV-6XAS, Brooke Sawyer, 1209 Crenshaw Blvd., Los Angeles, Calif.

5tm, 5lg, 5zh, 5ns, 5aky, 5mn (Can.), 5go (Can.), (6abk), 6km, 6aoi, (6bip), 6acz, 6hp, 6uo, 6biq, 6arb, 6ams, 6vd, (6cfl), 6bos, 6ckp, 6fy, 6anb, 6cja, 6cbu, 6avv, 6cmi, 6cej, 6tu, 6tv, 6bcu, 6aou, 6bcl, 6ao, 6afq, 7bj, 7ln, 7mc, 7zf, 7br, 7je, 7ih, 7fd, 7ly, 7nn, 7wm, 7to, 7abs, 7nk, 7agv, 7so, 7we, 7adp, 8bci, (9cvc), 9dli, 9bq, 9aim, (9amb), 9bxz, (9caa), 9bjk, 9zt, 9eae, (9bun), 9zg.

By 6CLW, 1645 Cedar St., Berkeley, Calif.

C. W.: Can.—5go, 9bx, 9bp, 9bw.
U. S.—1adj, 1ado, 3ar, 3bv, 3xm, 4eb, 4nt, 5ado, 5ae, 5ct, 5fh, 5go, 5hl, 5la, 5lg, 5mb, 5mi, 5ra, 5sf, 5su, 5zak, 5zav, 6aak, 6aat, 6adr, 6ags, 6ahv, 6ajj, 6aip, 6akr, 6akk, 6amd, 6amr, 6aol, 6aqa, 6app, 6arx, 6asc, 6asr, 6asy, 6atg, 6ato, 6auj, 6avl, 6avs, 6auy, 6awl, 6awu, 6bae, 6bah, 6bal, 6bar, 6baw, 6bbe, 6bbe, 6bbu, 6bef, 6beg, 6beo, 6bet, 6bge, 6bhb, 6bj, 6bjg, 6bjl, 6bjk, 6bjq, 6bju, 6bjw, 6bjy, 6bka, 6bks, 6bll, 6blv, 6bob, 6bqa, 6bqv, 6brb, 6brk, 6bry, 6bsi, 6bst, 6bsu, 6bt, 6bue, 6bul, 6bun, 6bvd, 6bvq, 6bvl, 6buq, 6but, 6bwe, 6bwl, 6caa, 6car, 6car, 6cbf, 6cbi, 6cbl, 6cbu, 6cer, 6ced, 6cek, 6cfu, 6cfy, 6cfz, 6cgd, 6cgo, 6chj, 6cu 6dk, 6ec, 6eg, 6ej, 6ek, 6en, 6eo, 6es, 6av, 6ir, 6ka, 6kg, 6ko, 6ku, 6ld, 6lh, 6mh, 6mr, 6mt, 6ns, 6od, 6oi, 6pl, 6pp, 6ql, 6qq, 6qr, 6rm, 6sh, 6th, 6tn, 6tw, 6uk, 6uw, 6uy, 6ul, 6ut, 6uy, 6xk, 6xw, 6xx, 6yc, 6zc, 6zh, 6zn, 6zo, 6zr, 6zu, 6zz, 7abb, 7abs, 7adc, 7adg, 7adu, 7adv, 7aea, 7aej, 7afe, 7af, 7af, 7af, 7ag, 7aif, 7ak, 7ar, 7be, 7bj, 7cl, 7cu, 7dh, 7du, 7gf, 7ha, 7hm, 7hs, 7im, 7io, 7ix, 7iy, 7js, 7kf, 7ln, 7lr, 7mb, 7mc, 7mk, 7my, 7na, 7ng, 7nn, 7nu, 7ny, 7nz, 7oa, 7oh, 7om, 7ro, 7sm, 7sn, 7ta, 7to, 7tt, 7tx, 7ui, 7ua, 7wm, 7wx, 7xi, 7xq, 7ya, 7zc, 7ze, 7zj, 7zu, 7zr, 7zn, 8atn, 8bso, 8is, 8sb, 8xae, 9abu, 9asi, 9auw, 9aum, 9bie, 9bjj, 9bjk, 9bkj, 9bxn, 9ccy, 9ceh, 9cfy, 9cjk, 9cuj, 9cuj, 9cvc, 9cwj, 9dfh, 9eea, 9ees, 9egg, 9sr, 9ts, 9uu, 9zt, 9zn.
Phone 7xi, 9zn. Any stn wishing further chk, pse qsl crd to 6CLW, abv. address.

By 7VF, 419 N. 12th St., Corvallis, Ore.

C. W.: 4dn, Can. 4hf, 5ga, 5mn, 5zas, 5zav, 8hv, 9aic, 9amb, 9axx, 9bjk, 9bq, 9bun, 9cvs, 9ei, 9ekf, 9zt. Pse notice new QRA of 7VF.

By 6BUF, 4257 23rd St., San Francisco (One tube.)

C. W.: 6aiv, 6ajd, 6anb, 6aoi, 6apl, 6apw, 6aru, 6awx, 6bic, (6biq), 6bpz, 6brf, 6buo, 6bun, 6cah, 6cbu, 6cfl, 6cfz, 6cgf, (6che), 6ckl, 6cmx, 6eb, 6fy, 6km, 6od, 7aby, 7adp, 7ak, 7bj, 7by, 7it, 7ln, 7ly, 7mc, 7nn, 7to, 7wm, 7zf, 7zn, 7zv, 9amb, 9bjk, 9bun, 9cfy, 9cvc, 5ado.
Fone: 6brf (vy. qsa.). Anyone hearing my 5 watts, rectified a.c.-C. W., please qsl card and qrk. All cards answered. (Note new qra of 6BUF.)

By 3BHV, Washington, D. C.

All C. W.: 5ac, 5da, 5mo, 5vy, 5acm, 5aec, 5zas, 9ig, 9mc, 9uc, 9zy, 9aau, 9aav, 9ahj, 9aoy, 9aps, 9arc, 9arz, 9awg, 9awk, 9axx, 9bmu, 9bpv, 9bq, 9bq, 9brk, 9bzi, 9cfk, 9cpt, 9cyq, 9dek, 9dhg, 9dhp, 9dis, 9dli, 9drr, 9edo. Crds to any of the above on request.

By 9ZT, D. C. Wallace, 54 Penn Ave. N., Minneapolis, Minn.

C. W.: 1er, 1bo, (1beg), 1bes, 1bsj, (1bwj), (1crw), 2bnz, 2brc, 3ab, 3bv, 3iw, 3sg, 3brf, (3bva), (3chg), 4eb, 4gl, 5gi, 5gn, (5gp), 5nj, (5ns), (5sk), 5uc, 5uo, (5aba), (5acq), 5ajj, (5akn), 5amh?, 5xab, (6hp), (6km), 6tv, 6arb, (6aru), (6awt), (6bjq), (6bvg), (6cbu), 7zn, (7agv); Can. 2bn; Mex. jh.

The H. H. Eby Manufacturing Company, manufacturers of binding posts and electrical specialties, have moved their business establishment to 40 S. 7th St., Philadelphia. In their new quarters they will have better facilities for serving the growing needs of their trade.

The Universal Bradleystat subdues static in Cuba!

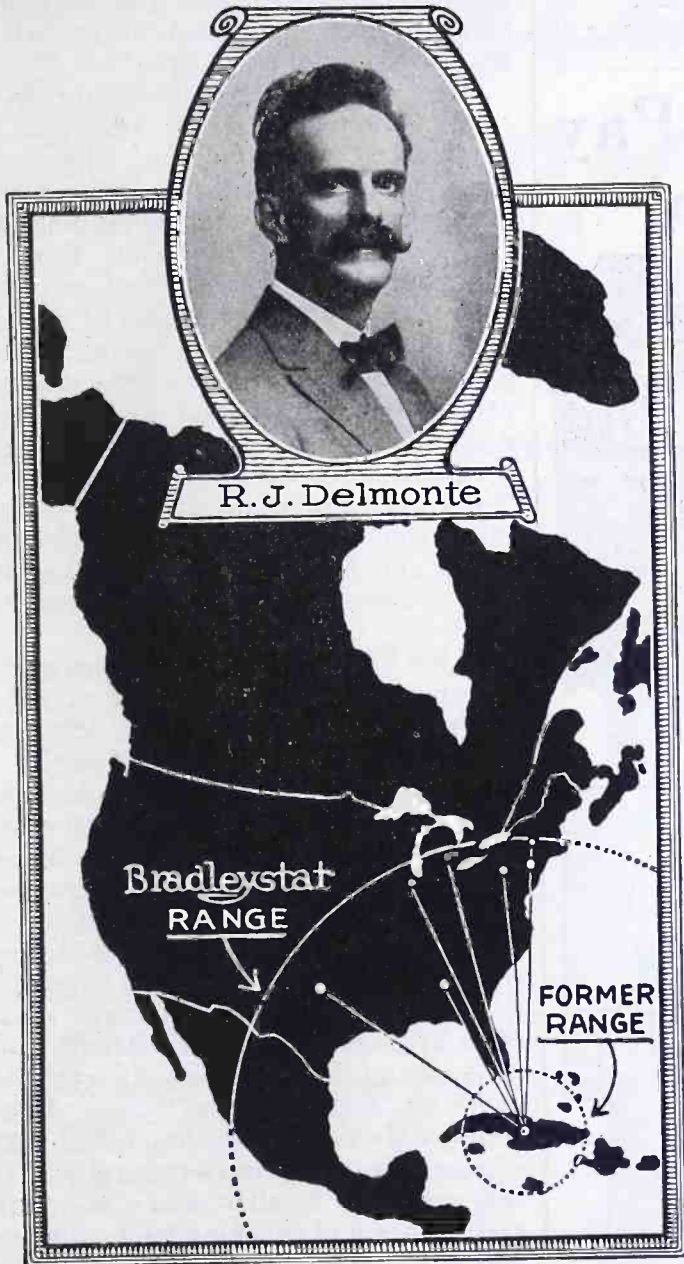

Remarkable improvement in radio reception follows installation of Bradleystats and amazes experimenter in Tropics. Read his letter!

Camaguey, Cuba, July 17th, 1923

"My experimental room is located in the center of Cuba, amidst the Gulf, which is reputed to be the general headquarters of static and all atmospheric disturbances of the whole universe.

I had my sets equipped with wire rheostats having vernier adjustments and my radius of reception was 350 miles from Havana with imperfect reception from Atlanta, Georgia.

After installing Bradleystats, I increased the radius 1000 miles without distortion and picked up Detroit, Schenectady, Pittsburgh, Fort Worth and other stations. When static is performing one of its infernal displays, I lower the filament heat with the Bradleystat to reduce noises. There is only one point of filament heat where this condition is fulfilled and the wire rheostat cannot furnish this with critical detector tubes.

For this reason, I claim the Bradleystat is the only apparatus for controlling filament heat, and if proper adjustment is made, static noises are practically eliminated.

Yours very truly,

The Universal Bradleystat

provides perfect, stepless, noiseless filament control for every tube on the radio market. Try any tube with the Universal Bradleystat.

Retail Price

\$1.85

P. P. 10c extra

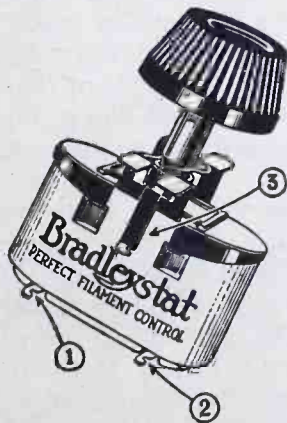

Guaranteed for one year

Beware of Imitations—Avoid Substitutes

Numerous attempts have been made, without success, to duplicate Bradleystat performance by using carbon powder in tubes and other containers instead of the scientifically-prepared graphite discs found only in the genuine Bradleystat. For perfect filament control and uninterrupted performance, be sure to ask for the Bradleystat. The name Bradleystat is embossed on the porcelain container for your protection.

Allen-Bradley Co.

Electric Controlling Apparatus

288 Greenfield Ave.

Milwaukee, Wis.

THE ALLEN-BRADLEY CO. HAS BUILT GRAPHITE DISC RHEOSTATS FOR OVER TWENTY YEARS

Tell them that you saw it in RADIO

We Repair

RADIO TUBES

WD-11 \$3.50	UV-199 \$3.50
WD-12 3.50	C-299 3.50
UV-200 2.50	UV-201A 3.75
UV-201 3.00	C-301A 3.75
C-300 2.50	UV-202 4.00
C-301 3.00	C-302 4.00
DV-6 3.00	DV-6A 3.75

Mail orders solicited and promptly attended to.

H. & H. RADIO CO.

P. O. Box 22-M Clinton Hill Sta., Newark, N. J.

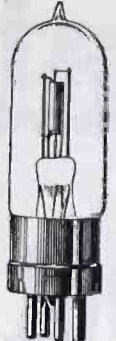

Dealer's
Special
Discount

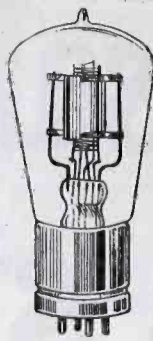

Agent's
Special
Discount

You Can Fill One of These Big-Pay Positions Waiting in Radio!

\$2500 to \$10,000 a Year

NO other training offers such opportunity for success as a Certified Radio-trician. Honor, power, position, wealth—all are easily possible for those who enter this great new profession NOW, while it is growing.

Now the Easiest Growing Business

Radio has jumped into the front rank of the world's great industries, yet it is only in its infancy. Its vast, amazing possibilities are as yet undiscovered in a large measure. And great as it is today, it will be a thousand times greater tomorrow! The man who gets into Radio today—who prepares NOW to grow up with this wonderful new science—will have a great share in its glorious future.

Master Radio at Home

To the ambitious man, Radio offers greater opportunities for success than any other profession or trade. It offers you a wonderful position, interesting work, and a fine salary. Radio spells SUCCESS.

The National Radio Institute, known the world over as the largest Radio Training Organization, will prepare you quickly in your spare time at home to qualify for the position you want. Hundreds of our graduates are today reaping big returns from their instructions. Some of them are radio inspectors and engineers. Others are in charge of land and sea stations. Still others are in charge of radio departments in stores or are in business for themselves.

Pick Out the Job You Want We Will Help You Get it

Brief list of the positions in the radio field today and the salaries paid.

- Radio Mechanic, \$1,500 to \$4,000 a year.
- Radio Inspector, \$1,800 to \$4,500 a year.
- Radio Salesman, \$2,000 to \$10,000 a year.
- Radio Engineer, \$3,500 a year and up.
- Radio Executives, up to \$15,000 a year.
- Radio Instructor, \$200 to \$500 a month.
- Radio Draftsman, \$7 to \$15 a day.
- First-Grade Ship Operator, \$105 a month, all expenses paid.
- Second-Grade Ship Operator, \$95 a month, all expenses paid.
- Third-Grade Ship Operator, \$85 a month, all expenses paid.
- Commercial Land Station Operator, \$150 a month and up.
- Broadcasting Station Operator, \$125 to \$250 a month.

Big Money—Easy Work

Most of our graduates when they started our course, knew little or nothing about Radio. Yet, in a few short months, our instruction qualified them to earn big money as Certified Radio-tricians. The same instruction, the same help that brought quick success to these men, is now offered to you. You have the same opportunities, you have the same prospect they had. Take advantage of them. Get into Radio NOW. Grow up with it. Advance with it.

Send for FREE Book

We have just prepared a wonderful book which is filled with the latest information about the wonderful opportunities in this newest and fastest growing profession. It will be sent to you absolutely FREE. Send for this book. It will tell you all about how we prepare



you for, and help you to get or secure the wonderful positions open in this fascinating field. Mail coupon for this book NOW! National Radio Institute Dept. 10-J, Washington, D. C.

National Radio Institute, Dept. 10-J.
Washington, D. C.

Send me your wonderful book, "Your Opportunity in Radio" with full particulars about the opportunities in Radio, and how you will quickly train me in my spare time at home to become a Certified Radio-trician. Also tell me how your free Employment Service will help me to a position and particulars of your special short-time offer.

Name..... Age.....
Street.....
City..... State.....

Tell them that you saw it in RADIO

A POWER BOX DRAMA

Continued from page 21

threatened to prove embarrassing. An irate traffic officer hailed him into court for imitating a fire siren in the midst of noon day traffic, thereby effectually clearing the streets so that the right of way was left undisputed to him. A foxy lawyer friend laughed the case out of court, for there was nothing in the statutes that forbade the use of an imitation fire siren, and column writers of the local newspapers derived much material from such questions as "when is a fire siren not a fire siren?"

After his exploit of breaking up a colored revival meeting when, at a particularly tense moment, the audience was well under the spell of the evangelist, Barklay started reading the Ghost Scene from Hamlet, from a clump of trees where he had secreted his car, and thereby produced a near riot. Only his faithful promises to "be good" in the future caused the district attorney to release him with nothing more than a severe lecture. Privately, the district attorney indulged in a good laugh over the affair, although it had taken the combined efforts of both the police and fire departments to handle the situation that Barklay had created.

BARKLAY, at peace with the world and himself, was speeding over the highway that stretches back into the Mother Lode section of California—that part of the country where in days of 49 the red shirted prospector toiled for the yellow metal. With him was his good friend and radio co-worker, James Brendt. The objective of their trip was one of the little mining towns that dot Calaveras county, where Barklay intended to make radio tests at a spot noted for "dead" conditions in radio reception. In a former camping trip to the Silver Lake country above, Barklay had noted with interest the peculiar characteristics in this particular locality, and it was with the intention of checking back on these conditions that he was making the trip.

For awhile, Barklay amused Brendt and himself by utilizing the power box to its fullest volume. They had left the thin black ribbon of pavement, and were now in the rolling foothill region. About a hundred yards ahead, and a little to one side of them, an inquisitive coyote loped along, one eye cocked on the orange colored car, now slowed down to an easy pace, while the two observed him with interest. Barklay snapped on the three stage switch.

"Yee-owp" he said, in what he conceived to be best coyote style.

As the blood curdling volume of sound rolled forth from the spruce horn, the coyote shifted from his easy lope into high gear in one startled move, and disappeared over the hill

Continued on page 50

Radio Catalogue Free—

**Write us
a post card—**

Address Dept. 39-R

and we will send you free this 52 page catalogue of radio sets and parts. It also contains explanation of radio terms, map and list of broadcasting stations and much radio information, including an explanation of successful hook-ups and circuits.

You will be amazed at the low prices Ward's quote. A complete tube set having a range of 500 miles and more, including tubes, head set, batteries, and antenna equipment, as low as \$23.50.

This catalogue contains everything for the expert and amateur. Complete sets and every improved part for building sets, all the most up-to-date devices—at the lowest possible prices.

Headquarters for Radio

Montgomery Ward & Co. is headquarters for Radio, selling everything direct by mail without the usual "Radio-profits." Why pay higher prices? Ward quality is the best and the prices will often save you one-third. Everything sold under our Fifty Year Old Guarantee,—Your Money Back if You Are Not Satisfied. Write today for your copy of this complete 52-page Radio Book.

Write to our house nearest you. Address Dept. 39-R

Chicago Kansas City St. Paul Portland, Ore. Ft. Worth

Montgomery Ward & Co.

The Oldest Mail Order House is Today the Most Progressive





The World's Most Popular Battery Charger

Nothing speaks so eloquently of HOMCHARGER satisfaction as the fact that thru sheer merit alone it has become the *standard* by which all other battery chargers are judged. Over 125,000 HOMCHARGERS already in use offer the most convincing proof that it is the most efficient, economical and fool-proof battery charger at any price.

A NEW TRADE-MARK FOR A TRIED AND PROVEN PRODUCT

Its phenomenal success has led to the introduction of many inferior and make-shift imitations. To insure our reputation and protect the buying public against substitution, the Radio De Luxe HOMCHARGER henceforth will be sold under a new Trade-Mark, viz.:

**GOLD SEAL
HOMCHARGER**

Retaining the same fundamentally correct operating principle and beautiful appearance of our Radio De Luxe model, it is a step nearer ultimate perfection through adoption of several construction refinements dictated by the policy of Progress.

HOMCHARGER'S 10 POINTS OF SUPERIORITY

1. **Simple**—Only one moving and wearing part, replaceable after thousands of hours use for \$1.00. Will last a lifetime.
2. **Efficient**—Uses less than one-half the current of any bulb or liquid type rectifier. Will charge any radio or automobile battery for a nickel.

3. **Quick**—Its high charging rate of 7 amperes eliminates long waiting for battery to become charged. Will charge any "A" or "B" battery over night, or three times as fast as a 2-ampere machine.
4. **Clean**—No expensive bulbs to break or acids to spill or replace. No acid fumes. Charges without muss, fuss or bother.
5. **Dependable**—Tungsten contacts insure continuous operation—prevent sticking and stopping.
6. **Fool-Proof**—Can be operated by anyone. Attach to lamp socket and connect battery either way, it will always charge. High-grade ammeter eliminates guess work.
7. **Safe**—No danger of shock or fire. Tested and approved by Fire Insurance Underwriters everywhere. Gives tapering charge—will not overheat or injure battery.
8. **Beautiful**—Mahogany and Gold Finish.
9. **Unqualifiedly Guaranteed.**
10. **Popularly Priced**—Retail at \$18.50 complete (\$22.00 Canada). No extras to buy. Sold by all dealers.

FREE BROADCASTING LIST. Send today for Free List of Broadcasting Stations, and Circular Describing the Gold Seal Homcharger.

DEALERS! JOBBERS!

GOLD SEAL HOMCHARGERS will outsell any other radio device this season. "GOLD SEAL Business Builders" illustrates many attractive sales helps and explains how we are prepared to cooperate with the Trade in making this a "HOMCHARGER Year." Send for your copy and Trade Discounts, TODAY.

**Insist
on the GOLD SEAL**

It is your protection against substitution. When buying order by name and verify by the GOLD SEAL, which appears on the carton as well as the nameplate.

WESTERN DISTRIBUTOR:

BERTRAM SMITH

516 San Fernando Bldg., Los Angeles, Cal.

Shipments to all points west of Rockies from Los Angeles stock.

The Automatic Electrical Devices Co., 117 West Third St., Cincinnati, O.

~ Largest Manufacturers of Vibrating Rectifiers in the World ~



CITIZENS RADIO CALL BOOKS

ALMOST SOLD OUT—
ORDER YOUR COPY TODAY!

50c—Postpaid anywhere

"RADIO", Pacific Building, San Francisco

Continued from page 48

in a cloud of dust. A quarter of a mile ahead an irate teamster, cussing out a hard boiled team of mules, was paralyzed to hear his team addressed in a rolling voice of thunder. Barklay, with memories of boyhood days on the farm, had opened up on the mules with enthusiasm, to their utter humility, for what mule can stand up against three stages of power amplification, especially when handled by one who knew them as did Barklay. Then tiring of his sport, Barklay stepped on the throttle and the car passed with a rush.

Ahead the road grew dim as dusk began to fall, and Barklay switched on his lights. They shot through a small town with Barklay rendering "Hail, hail the gang's all here," and out onto the open highway again. Sweeping around a curve, Barklay threw on his brakes as looming ahead of them he saw an upturned car, a figure signaling them to stop. Reaching for the automatic pistol that was stowed under the dash ready for a possible holdup, Barklay withdrew his hand as he saw the glitter of an officer's star on the coat of the man. Behind him several men struggled with the overturned car. Barklay saw that both front wheels were smashed.

"I'm the sheriff" announced the man with the star. "There's a lynching bee in progress up the road, and I and my deputies were on the way there when our car overturned. I'll have to commandeer your car, I'm afraid. It's a matter of life and death—we may be too late now."

"I'm at your service," responded Barklay promptly.

"Thanks. Pile in fellows" called out the sheriff to those struggling with the car. They had finally pulled it to one side out of the way of possible traffic.

Barklay's staunch car groaned with the weight of the six heavy men who clambered aboard. The sheriff slipped into the front seat between Brendt and Barklay. As the car again slid forward, he explained rapidly.

"There's been a bootleg joint running full blast up the road for some time, and I have had one of my deputies, Jackson, working on the case gathering evidence. He raided the place alone this afternoon, just after a big gang went up there from the Cassidy mine—they laid off today. Most of them are foreigners, and one of them hit Jackson over the head with a billet of wood and felled him. The whole gang were pretty well lit up and they tied him and threw him into a back room. Then they got thoroughly stewed and proposed to lynch him. Jackson came to while they were discussing the matter. He was thrown into the room in which the country line telephone is installed, and he managed to get the receiver down and reach me

Continued on page 52

The Masterbuilders of History

IN EGYPT

great obelisks stand as monuments of achievement to the masterbuilders of the ancient world. Symbolizing accuracy, durability and beauty each obelisk stands firmly on its foundation despite the passage of centuries.

Wars have surged within their shadows. Dynasties have come and gone. New peoples, new races, new civilizations have flourished and fallen, yet the obelisks of Egypt remain as marvels of engineering skill and artistic achievement.

The same ideals of efficiency, ruggedness and craftsmanship are expressed in the Cardwell rotor-grounded condenser. Their correctness is acknowledged by many authorities of engineering distinction:

DOW COCKADAY REINARTZ
WARNER LYNCH HAMMOND

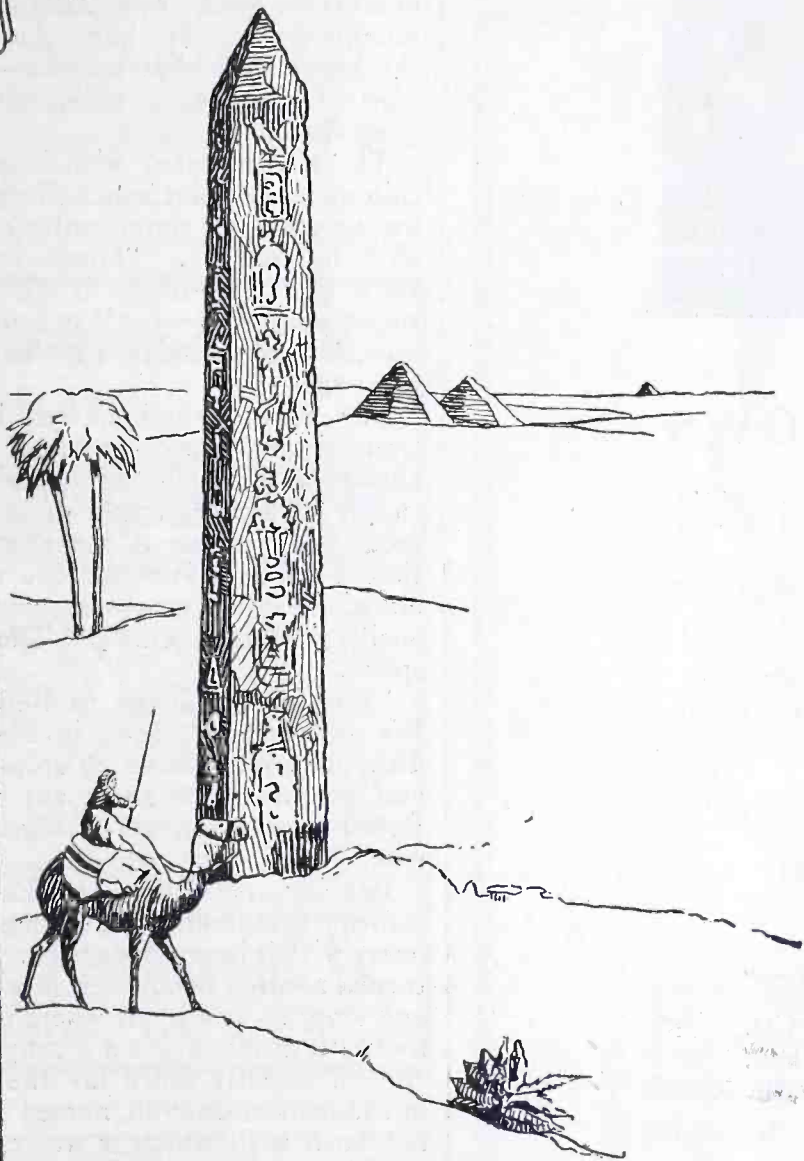

Using Cardwell rotor-grounded condensers will often add a thousand miles to your receiving range. They have such infinitesimal losses at the highest radio frequencies that no one has been able to determine their effective resistance. It is doubtful if engineers can design condensers of greater efficiency. Interference and "body capacity" are unknown with Cardwells.

A Post Card Brings You an Education on Condensers
Ask for Booklet T

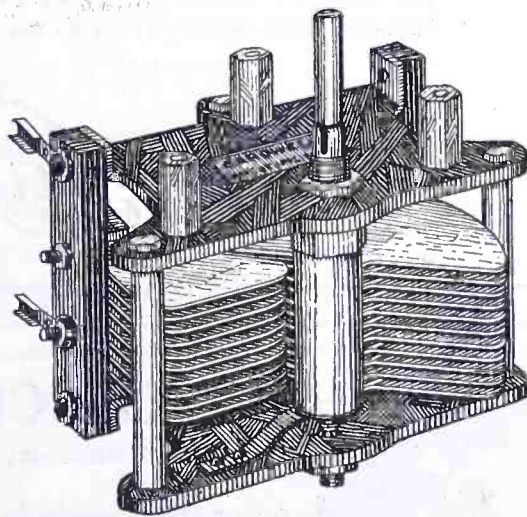

PRICES VARY FROM THREE TO THREE HUNDRED DOLLARS.

SOLD ONLY THROUGH RESPONSIBLE DEALERS.

Tell them that you saw it in RADIO

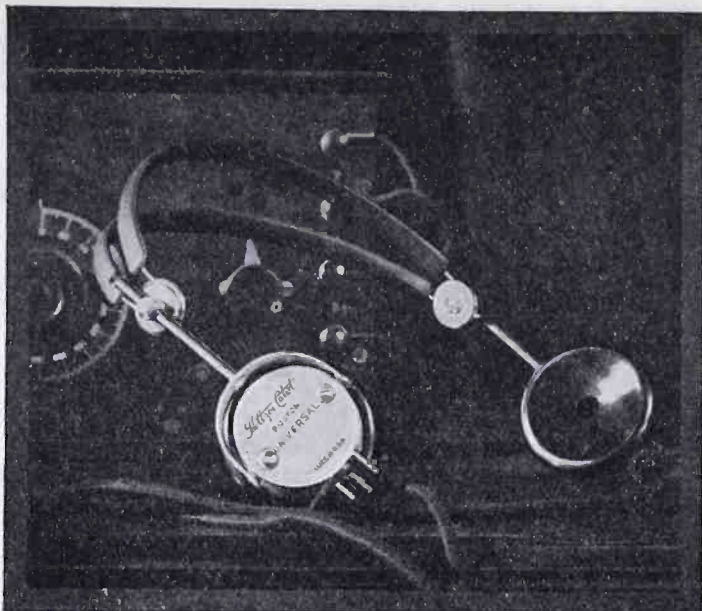

THE RADIO EXPERT KNOWS

That the varied and harmonious strains of music coming through his set—are nothing but electric current till they reach his headphones.

That the highest priced outfit is mediocre without the best headphones obtainable.

That perfect headphones preclude scientific knowledge, superior skill, and long experience in their manufacture.

That the Holtzer-Cabot Electric Company has devoted 25 years of constant research and painstaking manufacture to sensitive telephone instruments.

That the perfected Holtzer-Cabot Universal No. 2 is the ideal Headset for any radio outfit.

Holtzer-Cabot Universal No. 2, \$8.50

Holtzer-Cabot National No. 4, \$5.50

Be Sure to send for a copy of our booklet

"What You Should Know About Radio Reception."

THE HOLTZER-CABOT ELECTRIC CO.

125 AMORY STREET, BOSTON, MASS.

6161-65 South State Street - - Chicago, Ill.

Dept. C

Holtzer-Cabot
BUSINESS ESTABLISHED 1875

HEAD-SETS

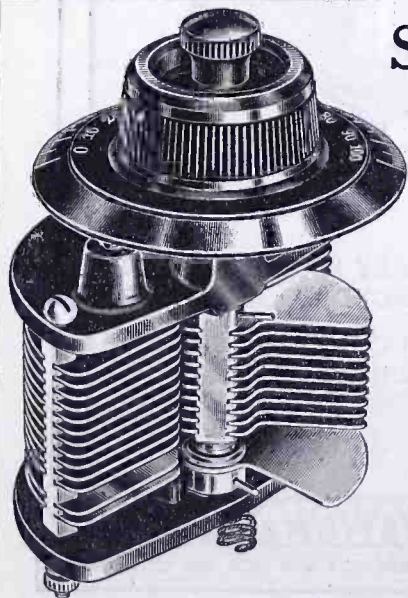

SEXTON CONDENSERS

16 Different Types and Sizes

An additional model in standard and balanced sizes

Most compact vernier condenser built.
Furnished with 3 inch black bakelite dial.
Separate button for vernier control.
Ball thrust bearing insures perfect action.

For name of Distributor write our Western Representative, F. L. Tomlinson, P. O. Box No. 2308, San Francisco, or

THE HARTFORD INSTRUMENT CO., Inc.

308 Pearl Street

Hartford, Conn.

Continued from page 50

through the central office. They must have caught him at the telephone, because everything was cut off while he was still talking—I heard him cry out, and then I couldn't get anything more."

Barklay, listening as his car shot around curve after curve of the narrow mountain road, was driving as he seldom drove. He knew Jackson for the brave man that he was—just the kind of a fellow to tackle the whole gang alone.

The sheriff noted with interest the shining dash upon which Barklay had incorporated his radio controls. "Radio eh," he queried. "Great stuff—my kid's got one—made it all himself, smart youngster—can't get much just now, says the sciatica is too bad. Well what the—?"

For Barklay had spoken into the transmitter, clearing the road of a car ahead as though by magic. The sheriff caught a glimpse of astonished faces peering out of the car as they shot by. The faces of the deputies blanched as the machine swung perilously around a curve. The sheriff spoke.

"The joint belongs to Red Blake. It's off the road, down in Manzanita Canyon. We'll have to stop the car and go down the short cut on foot. Better slow down, we are almost there now."

Barklay nodded. He knew the country hereabouts well through familiarity with it in previous trips. The car turned another bend, then slowed down and stopped at a point where a narrow footpath dropped down a canyon wall. Almost directly down lay the bottom of Manzanita Canyon, named after the red bush with which it was carpeted.

"Oh my God," groaned the sheriff.

A red glare illumined the canyon. At the bottom, clearly visible in the light of a huge fire capered a drunken crowd. Standing out against the glare was outlined the figure of one clearly not of the crowd. He was bound.

"Too late, I'm afraid," said the sheriff in a heavy voice. They mean to burn him at the stake. Our only hope is that we can get within shooting distance with our pistols. None of us have our rifles."

Already the deputies were out of the car and sliding down the steep path. Barklay had turned the lights out. The glare of the fire was sufficient to show the men the path without revealing them from below. The sheriff made ready to follow his men. He spoke to the one remaining of the force, whom Barklay now noticed walked with a decided limp.

"Parson, you had better stay here. I'm afraid that you can never make it in time down there. Our guns are the only argument left." Then hurriedly

Continued on page 54

Tell them that you saw it in RADIO

"A-B-C of Radio"

An illustrated
non-technical
radio book

25c Per Copy

"RADIO"
Pacific Building
San Francisco

Troublesome Static Overcome

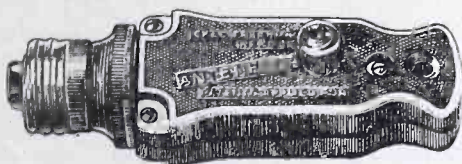

ANTENELLA

No aerial or antenna needed.

Eliminates aerial, outside wiring, lightning arresters and other inconveniences inductive to poor reception. Plug Antenella in any lighting socket and you can enjoy Radio in any room in your house. No current consumed.

New Improved Antenella
Now Only **\$1.25**

At your dealer's—otherwise send purchase price and you will be supplied postpaid.

Chas. Freshman Co. Inc.
Radio Condenser Products
106 SEVENTH AVE., NEW YORK

H & H Radio Material

Nutmeg Brand

Based on 30 Years' Manufacturing
and Electrical Development-Work

We carefully fill orders direct where the goods are not sold locally, if sent along with the name and address of your dealer.

Features of H. & H. Variable Air Condensers: Double-cone bearings with adjustment screw; smoothest possible action. Blades assembled with absolute precision; anchored solidly in large supporting posts—proper spacing is permanent.

Aluminum alloy blades; extra large brass center post; bakelite ends. The utmost in engineering skill, at prices you may well take advantage of:

W 605 5-Plates, .000125 mfd.	\$2.50
W 611 11-Plates, .00025 mfd.	3.00
W 623 23-Plates, .0005 mfd.	3.50
W 643 43-Plates, .001 mfd.	4.00
W 621 11-Plates with Vernier Dial Control	4.25
W 633 23-Plates with Vernier Dial Control	5.00
W 643 43-Plates with Vernier Dial Control	6.00

Ask for interesting circulars.

THE HART & HEGEMAN MFG. CO.
HARTFORD, CONN.



EEISEMANN Head Phones represent unexcelled value. Comparative tests prove their excellence and superior qualities. Complete satisfaction is assured.

The design is simple, practical and correct.

These phones are comfortable when worn for long periods, are extraordinarily sensitive and reproduce sound with unusual clarity.

Other Radio Products:

Variometers	Detector units
Variocouplers	A. F. Amplifier units
Variable Condensers	Metal Panels

Complete catalogue on request

EISEMANN MAGNETO CORPORATION

William N. Shaw, President
BROOKLYN, N. Y.

DETROIT

CHICAGO

SAN FRANCISCO

Tell them that you saw it in RADIO

A NEW FROST-FONE

*with bakelite
shells and caps*



No. 172
3200 Ohms

\$6⁰⁰

[Genuine Bakelite]

RICHLY beautiful—wonderfully sensitive—highest quality throughout—are these new No. 172 FROST-FONES with genuine maroon bakelite shells and caps. They embody new principles of construction, eliminating lead wires. Have moulded-in terminal block. Shells and caps are highly polished. Easily the most beautiful and finest head-fone on the market.

FROST-RADIO

now includes the new No. 172 bakelite FROST-FONES, the new Nos. 161 and 171 aluminum shell FROST-FONES and FROST-RADIO Tube Sockets, Rheostats, Potentiometers, Switches and Dials, all of highest quality yet priced right because of tremendous production.

Order Them From Your Dealer Today

Your dealer handles FROST-RADIO and can supply you with these new items. Call and see them today, ordering the parts needed for your set. The FROST-RADIO guarantee is your protection.

HERBERT H. FROST, Inc.

154 WEST LAKE STREET, CHICAGO, ILLINOIS.

30 Church Street, New York

*Makers of the famous
Frost-Fones*

STANDARD RADIO RECORD

A new 195 page Radio Record just out! A real necessity. Every radio bug needs a copy.

Only 75c Postpaid

RADIO—Pacific Bldg.—San Francisco

Continued from page 52

to Barklay as he slid over the canyon rim, "The Parson knows these fellows. Thought he might be able to handle them. They'll listen to him when they won't to man or the devil. He—" Further explanation was cut short as he started sliding down the path.

Barklay looked with interest at the unarmed man of whom the sheriff had spoken. He recognized him at once. The Parson was well known throughout the country. In his humble way he journeyed from town to town of the mining section, preaching the gospel as he knew it, ministering to the spiritual wants of the rough men who for the most part made up his congregations. Barklay recalled an instance where the Parson had talked a drunken gang out of the idea of wrecking a town some years previous—how they had listened to him respectfully, and had gone their ways quietly afterward. Too bad that he couldn't be down there now, he thought.

He drew out a pair of binoculars from the car and focused them on the scene below. Through the lens each figure stood out clearly in the firelight. There stood Jackson, strapped to a post, while in a drunken frenzy men capered around him. To one side stood another figure holding a blazing limb. In the background, approaching at a staggering run came another. With a sickening sensation Barklay noted that he carried a can of kerosene.

A sudden yell from behind caused Barklay to turn. Brendt had seized the Parson by the shoulders and was propelling the amazed man toward the car. Barklay wondered if Brendt had suddenly gone crazy, and started after the pair. Brendt threw the door of the car open, talking rapidly as he did so, and pushed the Parson into the driver's seat. Now the Parson nodded comprehendingly. Brendt kicked the starter in, the motor of the machine began its melodious purr. He snapped the three switches of the power box down sharply, pulled the bowl transmitter down from its catch on the ceiling till it hung in front of the Parson. He snapped the door of the car shut. Then Barklay divined the purpose of Brendt and chuckled.

The car was standing almost on the brink of the canyon, on a sharp downward slope, with the radiator pointing toward the mob below.

Rolling forth from the horn beneath the car, in sonorous rebounding volume went the voice of the Parson.

"THOU SHALT NOT KILL."

Down into the canyon rolled the tremendous volume of sound, to strike against the bottom as though driven by the force of sledgehammers. The man with the torch, leaning forward to apply it, sprang backward as though struck. Barklay, watching through

Continued on page 56

Tell them that you saw it in RADIO

AMPLION



England

Canada

Scotland

Australia

Wales

New Zealand

Ireland

So. Africa

Norway

India

Sweden

France

Denmark

Italy

Holland

Spain

Belgium

Japan

WITH the Amplion Loud Speaker the infinite clearness and softness of tone achieves an unsurpassed reproduction welcomed and admired everywhere. The human voice or musical sounds come to you in their true richness, without the slightest distortion, unalloyed — just as they are rendered.

It is hard to believe you are listening to reproduction. Originality is so unmistakably registered in every tone.

The Amplion is made by the world's oldest manufacturer of loud speaking instruments. It is not a head set receiver used as a loud speaker, but a development for radio purposes of a loud speaking device, used exclusively on every ship of the British and other leading navies.

The Amplion requires no battery. You simply attach it in place of head phones. The Amplion is being extensively used in every country mentioned in the border of this announcement.

That it has been adopted as standard by the leading countries of the world is the tribute it has achieved through its brilliant performance.

All models on view at the New York Radio Exposition, Booth 5, at the New York Show — Oct. 6th to 13th.

SIGNAL ELECTRIC MFG. CO.

Sole United States Distributors

Menominee, Michigan

BURNDIPT OF CANADA, LTD.

Canadian Distributors

172 King St., West, Toronto

*The Supremacy of the AMPLION
is the Supremacy
of Actual Performance*

Tell them that you saw it in RADIO

Radio Engineers KNOW

and buy these features

Teleradio

\$5.50

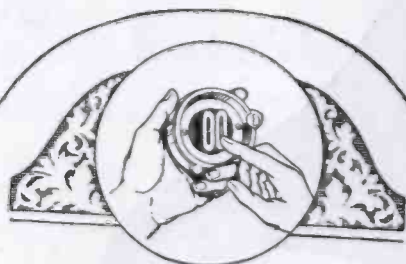

Super-Sensitive

1. A guarantee that less than five per cent variation in resistance ever exists between the coils of Teleradio head sets. The secret of accurate reproduction of faintest signals.
2. Positive adjustment of diaphragm—insures best tonal qualities.
3. Improved self adjustable friction—sleeve—positive position grip.
- 4.—Drawn aluminum case—all metal parts highly nickel polished. Light and durable for the hardest usage.
5. Fabricated head band for unusual comfort and ease.
6. Latest engineering principles and best of materials employed in every detail of construction and manufacture.

If your dealer cannot supply you, write for catalogue and prices.

Jobbers and dealers write for trade prices

TELERADIO ENGINEERING CORP.
484-488 Broome Street
New York City

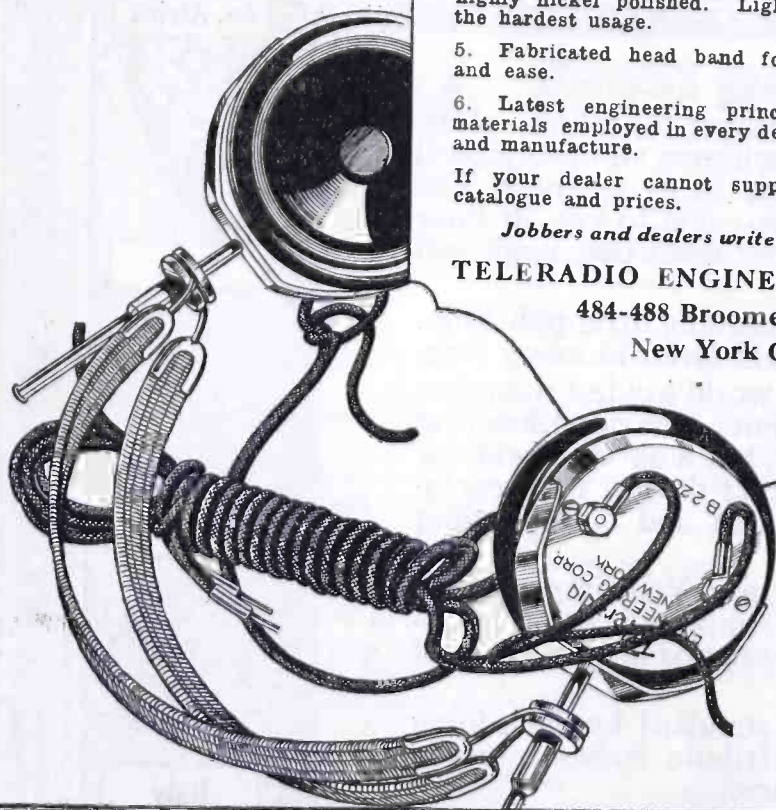

Vernier Condensers	
23-plate	\$4.50
43-plate	5.50
Variable Condensers	
3-plate	\$2.00
11-plate	2.50
23-plate	3.00
43-plate	4.00
Rheostats	
(6 and 30 ohm)	\$1.00
Lightning	
Arrester	\$1.00
Head Phone	
(2,000 ohm)	\$5.50
(2,000 ohm)	6.00
(3,000 ohm)	7.00

Continued from page 54

his glasses, saw the others stiffen in fright. On the steep slope deputies checked their pace for the moment, but the sheriff, comprehending the plan in a flash sprang forward with renewed vigor. Once more the thundering voice rolled forth.

"THOU SHALT NOT KILL."

Then the Parson began to preach. Never in his long career as a man of God had he preached as he did now. Around his opening of "Thou Shalt Not Kill," he built up his sermon. His voice, possessed of a peculiar tonal quality, struck the bottom of the canyon with the force of a battering ram. Coming from the heights above, echoing and rebounding, but with each word as clear as a bell, it struck into the crowd, driving fear into their hearts. Some rolled on the ground in maudlin terror, others ran in fear, others more sober stood their ground. Many of them recognized the voice of the Parson, but it was a voice that they had never before heard. The blazing torch dropped from the hand of the man that held it, the one who had brought the oil had dropped it in flight.

The Parson was warming up to his task. Through the windshield, his face dimly illumined from the lights of the amplifying tubes, Barklay could see the inspiration in his eyes. One moment he pleaded with the men, the next his voice rose in thundering condemnation as he poured his wrath upon them. Barklay moved by some odd sense, opened the door of the car and shoved the glasses into the hands of the Parson. Not ceasing for an instant in his denunciation, the Parson lifted them to his eyes, focusing them automatically. He could make out the faces of the men now, some of whom he recognized. He signaled out various individuals for his targets. Warmed to his task as he was, the Parson possessed a sense of humor and he suppressed a laugh only with difficulty at the expressions of those whom he addressed.

Picture the scene if you can. A drunken mob. A man bound to the stake, expecting death in horrible form. Tumbling down the steep walls of the canyon, guns in hand, the small rescuing party. And over all, the thundering reverberating voice that filled the canyon from wall to wall. Overhead a clouded sky, just enough moon showing to make the scene the more eerie.

And now the Parson saw that his work was done. The sheriff and his men had reached level ground, and unseen had surrounded those remaining of the crowd. Their guns glittered in the firelight. One of them went forward and cut the thongs that bound Jackson.

Then the Parson, being quite human

Continued on page 58

GERMAN HEADPHONES

6000 OHMS

Special Introductory Offer **\$8.50** Per Pair

(Regular Price \$14.50)
WITH HEADBAND AND CORD

Made by Neufeldt & Kuhnke,
Kiel, Germany

THE IDEAL HEADSET FOR DX RECEPTION!

Guaranteed to be superior to any Phone on the market or your money refunded without question.

C. H. RUBY 4719 YGNACIO AVE.
OAKLAND, CALIF.

Tell them that you saw it in RADIO

The New C&W Console Receiver

Completely Self-Contained With Loud Speaker

A Moderate Priced Set that will make Radio Entertainment Permanent in Thousands of Homes.

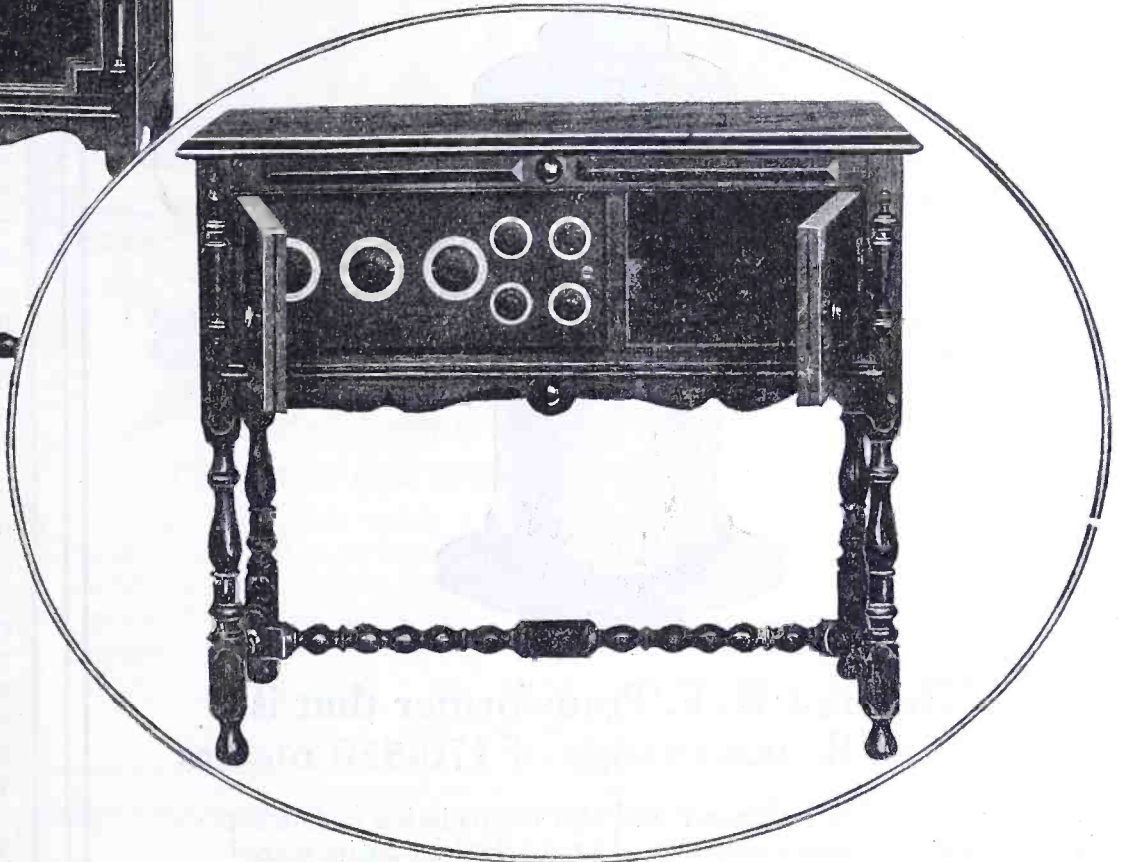
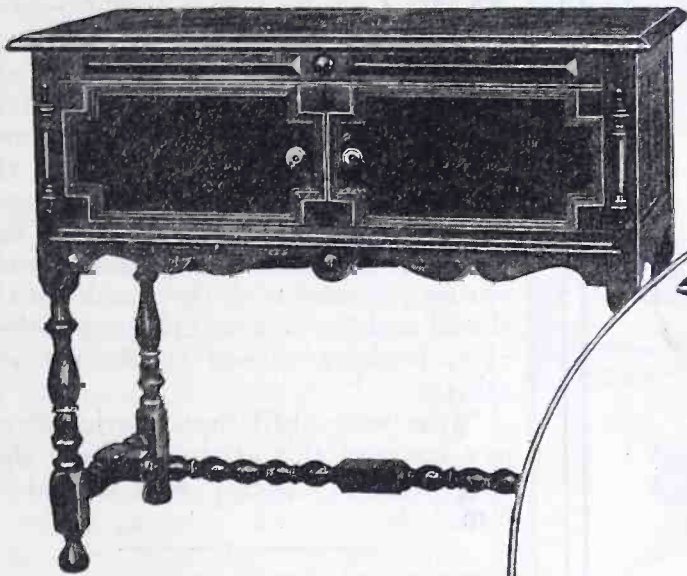

Higher selectivity than any other instrument in its class — louder signals by actual test—this three tube, double circuit Receiver is the last word in radio for the home.

Set is complete with 3UV 199 tubes: 3 large A Batteries: 3 B Batteries and Loud Speaker—simply make antennae and ground connections. Ask your Cutting and Washington Dealer or write for illustrated catalog.



Cutting and Washington Receiver 11A—similar in mechanical design to console model, but of regular cabinet type. This C. & W. Model has enthusiastic users all over the United States. Write for illustrated catalog.

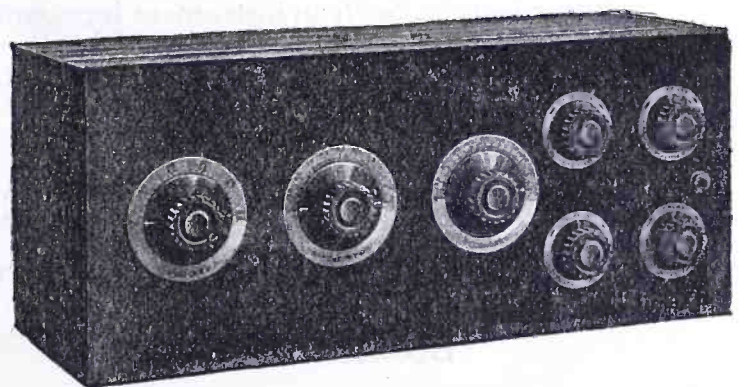

Cutting and Washington Receiver 12A—"Town and Country" model (portable type.) A turn of a switch changes it from single circuit set for outing use, to a double circuit set for use in the home with permanent antennae. Ideal all purpose set.

Dealers: Write for full details of C. & W. Line and Dealer Plan, and copy of interesting book, "The Future of Radio Retailing." No obligation.

CUTTING & WASHINGTON RADIO CORPORATION, Kasota Building, Minneapolis, Minn.

Cutting and Washington

America's oldest manufacturers of commercial radio

Tell them that you saw it in RADIO

RADIO FREQUENCY LABORATORIES, Inc.

announce the development of the

BALLANTINE VARIOTRANSFORMER

(Model 5)



For either
panel or base
mounting

At dealers or
sent postpaid
Price \$9.60

The new R. F. Transformer that is Variable thruout range of 170-550 meters

For the keen amateur and the appreciative broadcast fan, the coming season will be marked by an increased use of radio frequency amplification. And the fixed coil type of transformer—with satisfactory amplification inherently limited to one or two very narrow resonance peaks—will of necessity give place to an instrument better suited for the newly extended schedule of wave lengths. Such an instrument is presented in the BALLANTINE VARIOTRANSFORMER—the only transformer having both primary and secondary windings *continuously variable* to give consistently high amplification at all wave lengths.

"R.F. Amplification with the Ballantine Variotransformer,"
25 pages of theory and practice sent free on request.

BOONTON RUBBER MFG. CO.
424 Fanny Road
Boonton, N. J., U.S.A.

Continued from page 56

closed his sermon with a most un-Parsonlike utterance. "Atta Boy" he said.

And rolling down the canyon echoed the words "Atta Boy."

BARKLAY and Brendt did not do any radio testing that night. In the little mining town to which the sheriff conveyed Red Blake to be securely locked in the local jail, Barklay explained for the tenth time the working of the power box and repeated in dramatic manner the Parson's sermon. And when finally they swung out on the road with the thanks of the sheriff and his men still ringing in their ears, Barklay turned to Brendt and said:

"Just wait until that district attorney hears of this affair. I think that the tables are pretty well turned on him."

PROLONGING TUBE LIFE

Continued from page 22

perature increases as the resistance increases due to the decrease in diameter caused by electron evaporation. As this effect is cumulative, the life decreases very rapidly as time goes on. With constant voltage the power consumption and the temperature decreases about 2 per cent during the life of the tube. With constant power the temperature rises enormously and hence the life is decreased rapidly.

Consequently, so far as tube life is concerned, constant voltage gives the best results, even though it causes diminished electron emission and reduces the tube's output. This voltage should be that recommended by the manufacturer for the particular type of tube in use.

RADIO CONVENTION AT SAN FRANCISCO

The Third Annual Radio Convention will be held at the German House, Turk and Polk Sts., San Francisco, from October 11 to 13, inclusive, together with a radio show, under the auspices of the San Francisco Radio Club. The Secretary, H. A. Tattamham, 316 Richland Ave. (6AUU), San Francisco, will handle all correspondence. The object of the convention will be a get-together meeting of all Pacific Coast Amateurs from the Sixth and Seventh Districts. The old Pacific Plan, which expires on October 31, 1923, will be discussed, and rearranged, so as to conform to the new regulations governing amateur operation. A Sixth District Executive Council will be discussed, and, it is hoped, organized in a manner that will be satisfactory to all concerned, which will bind the Sixth District Amateurs together more strongly than before.

All amateurs and others interested are invited to attend, and all radio clubs which are regularly organized will be asked to send delegates, with proper official credentials for identification. For the benefit of those clubs that do not receive further notification, it is hoped that this will serve as proper notice, although it is hoped all clubs will be advised separately, as well.

RADIO INSTITUTE OF AMERICA

TRAINING IN ALL COMMERCIAL BRANCHES OF RADIO

If you cannot attend the Radio Institute of America in person the same instruction can come to you through our recently inaugurated "HOME STUDY COURSE"—Investigate.

Detailed information free on request.

Conducted by

THE RADIO CORPORATION OF AMERICA



331 Call Bldg.
98 Worth St.

Phone Douglas 3030
Phone Franklin 1144

San Francisco, Calif.
New York City

Tell them that you saw it in RADIO

UNIVERSAL RECEIVING SET

Continued from page 19

Both types of receivers are excellent for the reception of broadcasts from the powerful stations located throughout the country. The three-circuit tuner is more complicated insofar as the novice is concerned and the selectivity often claimed for by the supporters of this type of receiver is generally sacrificed because of the fact that it is harder to manipulate.

The single-circuit tuner is simple to operate and when properly installed is as selective as any other type procurable. The task of designing a receiving set capable of being operated by persons entirely unfamiliar with the technique of radio was mainly borne by the Westinghouse Electric and Manufacturing Company, pioneers in radio broadcasting and owners of the famous Armstrong regenerative patents. Everyone should be willing to grant that this giant concern, as owner of the basic patent, backed by its great research and manufacturing facilities, was in a position to make use of any kind of regenerative circuit they cared to. That was not the most important point involved—there was a public demand to be met “created overnight” and a highly efficient, yet easily operated receiver had to be designed and put into production.

When properly installed and operated both of these receivers will give exceptional results. The single circuit should be used with a one-wire antenna not exceeding 100 ft. in length. In some cases it is desirable to use a single wire 75 ft. long. A much longer antenna can be used with the three-circuit receiver, as will be explained below.

It is common knowledge amongst those well versed in the art that the sensitivity and selectivity of regenerative receivers are dependent on the strength of the received signal impressed on the input of the vacuum tube when the latter is in a regenerative state. In other words, the regenerative receiver is more sensitive and permits a finer degree of tuning when the signal applied to its terminals (grid and filament) is very weak, because a weak signal makes it necessary to work the tube at its best. This effect can be likened to the gyroscope action, in that the faster the weighted wheel revolves the greater the inertia or resistance to being moved out of its plane. In short, the inertia of the tube is greatly increased.

At first thought, one would be prompted to believe that this results in greatly reducing the range of the receiver. That is not so. These weak signals when applied to the tube (which is in a regenerative state) build up to a value nearly representing that possible with a much stronger initial signal. In return for a slight decrease of signal

Continued on page 60

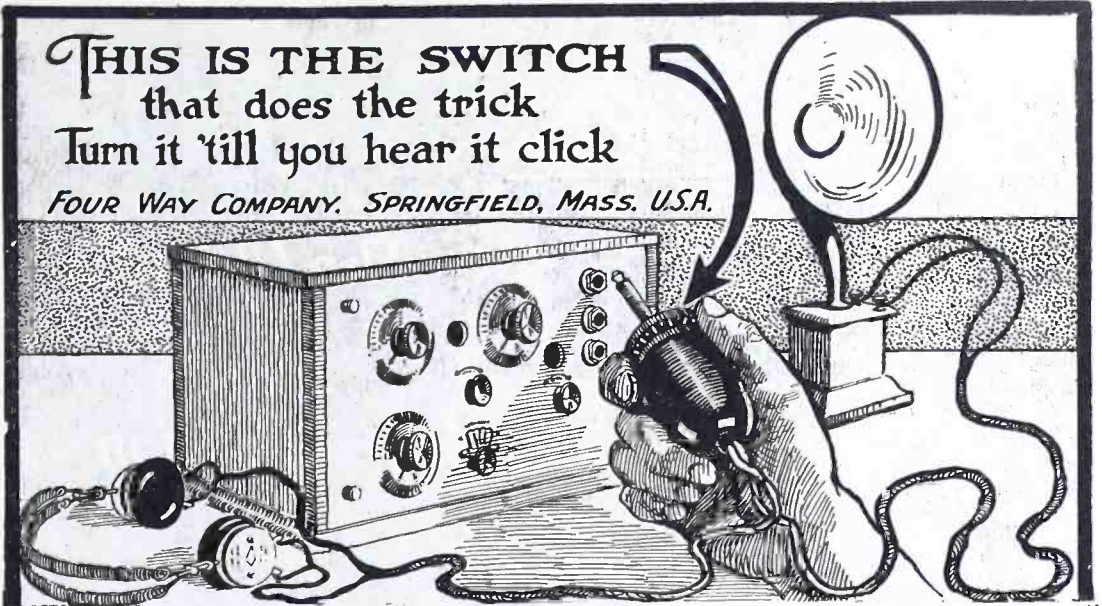

- TURN 1: Head Set
- TURN 2: Loud Speaker
- TURN 3: Both in Series
- TURN 4: Both in Parallel



The latest and greatest improvement in Radio!

A switch plug which makes it possible to tune in through head set and switch in loud speaker by turning dial. Two head sets can be readily attached, or one head set and loud speaker. Both can be used at the same time or either one alone.

\$1.50

FOUR WAY COMPANY
Dept. E, Springfield, Mass.

ACMEDYNE CIRCUIT

as described in minute detail by Mr. Lawrence Cockaday in his article on Tuned Radio-Frequency Amplification in the August "Popular Radio" is employed in the

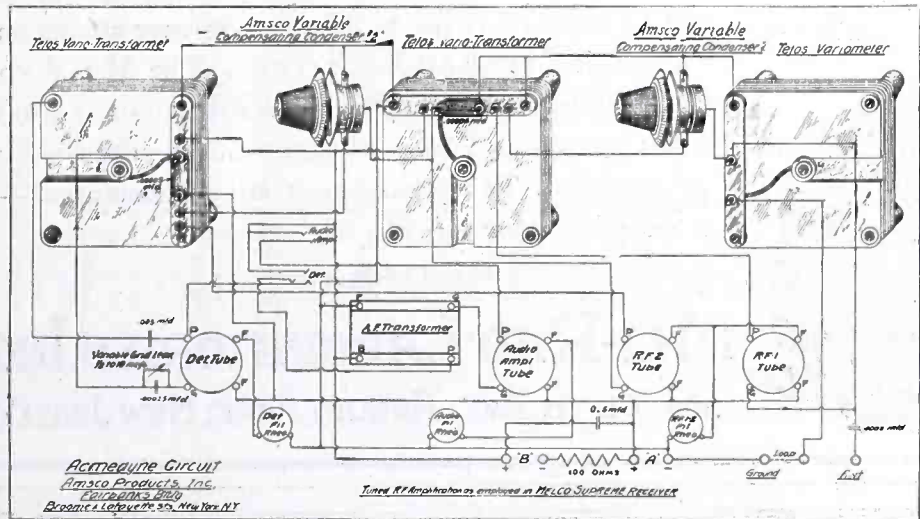

MELCO-SUPREME

The Radio-Frequency Amplifying Receiver that—

Price Only \$125

Complete knock-down parts for Melco-Supreme including drilled engraved Bakelite panel and solid mahogany cabinet
PRICE \$75

Operates with merely a 10 FT. WIRE. Not even a ground necessary.
Offers exceptional **CLARITY** without the slightest loss of tone quality.
Assures unusual program **SELECTIVITY** through its single tuning adjustment.
Affords real **LONG DISTANCE** by covering all Broadcasting ranges from 180 to 610 Meters.

Write for our complete literature illustrating and describing Melco-Supreme in detail, and also our entire line of **AMSCO** Parts.

AMSCO PRODUCTS, Inc.

BROOME and LAFAYETTE STS.

NEW YORK CITY

Tell them that you saw it in "RADIO"

Continued from page 59

MU-RAD ★ RECEIVERS



The Ultimate in Radio Reception

*By this signal from afar off,
Bending like a wand of willow,
Ojéche Mahito, the mighty,
Calls the tribes of men together.*

—THE SONG OF HAWAII, Longfellow



The New
Star in
the Radio
World

GIFTS FROM THE GREAT SPIRIT" said Iron Hawk, the famous Sioux chief, of the Indians' means of communication. The final perfection of this great gift to mankind is radio. The new science attains its ultimate in MU-RAD RECEIVERS. The MU-RAD owner lives in close touch with a vast radius of 4300 miles and more. Time is eliminated. Distance is only geographical. Reception conservatively guaranteed—1000 miles, using only a 2 foot loop aerial.

WRITE FOR LITERATURE

MU-RAD LABORATORIES, INC.

806 FIFTH AVE. ASBURY PARK, NEW JERSEY



LEARN THE CODE

FREE Instruction Circular Giving Complete Details

Subscribe to "RADIO" for one year and we will send you this instruction course free of charge. This offer expires October 30th.
"RADIO"—Pacific Bldg.—San Francisco

strength, which is negligible, a degree of selectivity is obtained which cannot be bettered by any known type of receiving set. The most efficient method of reducing the strength of the incoming signals is to reduce the length and height of the antenna. By shortening the length, less of the passing wave is intercepted and less energy is delivered to the input terminals of the detector vacuum tube.

With a longer antenna, great selectivity can be obtained by using a three-circuit tuner. The energy is transferred from one circuit (primary) to the other (secondary) directly in proportion to their inductive relations and a loss in signal strength is attributed to this arrangement, thereby providing great selectivity even though the original signal picked up is of considerable intensity. By varying the position of the secondary coil in relation to the primary coil any desired strength of signal can be applied to the terminals of the vacuum tube detector. Therefore, it is clear that great selectivity and sensitivity is had with both types of receivers when properly installed and operated.

Obtaining Best Results

The average person makes every effort to get the most he can get out of a radio set, and, in this wild attempt to beat a world record, brings in all of the birds and monkeys of the African jungle. The main adjustment is that which controls the detector tube. By following the directions furnished by the manufacturers and by applying the correct B battery plate voltage as well as detector grid biasing, there will be found a crit-

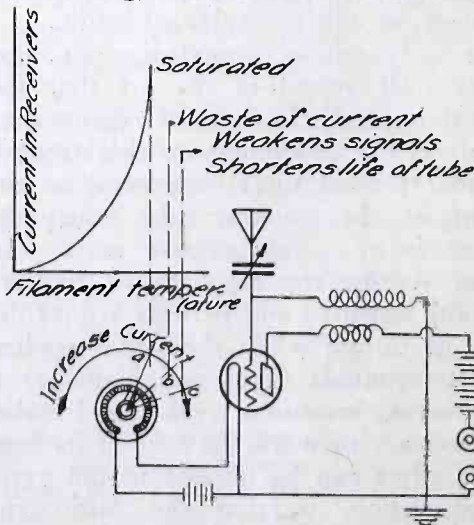

Fig. 5. Effect of Filament Control

ical point of adjustment on the filament rheostat. Beyond this point the signals will not only be distorted but they will be much weaker and the life of the tube as well as that of the battery will be greatly decreased. These are the important points to be considered in the operation of the detector vacuum tube.

As shown in Fig. 5, when the rheostat handle is turned to the right—increasing the current in the filament—the plate

Tell them that you saw it in RADIO

current passing through the telephone receivers increases, first rapidly, then more gradually, until a certain point is reached when a further increase in filament current does not increase the current in the plate circuit. By moving the filament control from *a* to *b*, and even as far as *c*, a considerable amount of battery current is wasted and the life of the filament is greatly shortened. Of course, it is not possible for one to visualize this condition when operating a receiving set. However, by properly operating the receiver it is an easy matter, after tuning in a station, to retard the filament control rheostat handle to the point where the signal just begins to decrease. The best way to gage this is to make use of half of the "tickler" coil in the circuit and bring up the filament until the point of regeneration is reached. This can be ascertained by listening in the receivers for the "thump" or "drummy click" which will be audible when the tube is brought into a state of regeneration. When tuning in, the receiver should not be permitted to remain in the oscillating state, but the tickler should be so operated as to lag a trifle behind the tuning elements. In other words, always bring the tickler up to the point of regeneration to start operation, and then slightly retard it, continually following the tuning element until a station is heard. With the receiver in that position a slight adjustment of the detector filament control will give maximum response.

LETTERS TO THE EDITOR

Continued from page 41

Here is what you need and the approximate cost:

- 2 gross test tubes, size 1x6 in.....\$6.30
- 1 gal. sulphuric acid..... .80
- 1 gal. distilled water..... .20
- A bunch of lead strips 2 in. long by ¼ in. wide (these may be found around most amateur stations or may be purchased at any hardware store.)

The tubes are set in boards in which holes have been drilled ½ in. apart. It is best to make up the battery in banks of 144 cells each, to facilitate in handling. Now here's where you can save the price of an m.g. The plates are old discarded *A* battery plates which you can have for the asking at any battery service station. These are cut (with sharp hack-saw) to a size ¾x5 in.; one negative and one positive plate connected together by means of the lead strips. These connections *must* be welded. This I did with the flame of a small alcohol lamp. Do not solder, as the connection soon corrodes and breaks off.

For insulators I used glass strips until I ran out of them, after which I used rubber strips cut from an old inner tube. These I found to work equally as well as the glass plates and more easily made.

My solution was tested to read 1200—for no reason at all—but was found satisfactory.

These cells when fully charged will produce a trifle over two volts each. The charging was done with a 3-jar electrolytic rectifier connected to 40 cells at a time, more



Natural Re-PRODUCTION Atlas AMPLITONE LOUD SPEAKER

**Letters From
Users Requested**

Far superior in tone," "Surprisingly good results," "the best loud speaker before the radio public," "this most wonderful instrument"---these are typical phrases from letters written us unsolicited by enthusiastic users. What have you accomplished with your Atlas Amplitone? Tell us about it!

M

IRRORS the naturalness of the original production. Actually re-PRODUCES. New principals of acoustics introduced in the marvelous "double diaphragm." Sold by all up-to-the-minute dealers.

Write for the booklet "E". Contains helpful information.

E. F. BALDWIN
Factory Representative San Francisco, Cal.

550 Howard St. San Francisco, Cal.

Distributed in California by

LEO J. MEYBERG CO.
428 Market St. San Francisco, Cal.

Multiple Electric Products Co. Inc.

ORANGE ST. RADIO DIVISION NEWARK, N. J.

or less, according to the juice at hand. The only thing is the cells must not heat.

This battery will work. I have tried several lead-plate batteries, but none of them worked. I have used my battery for about six weeks and have received DX report cards from all over the U. S. and Canada. It gives you real 150-meter juice at very small cost. Will be glad to answer any question pertaining to above. Please enclose stamped addressed envelope. Yours for real C. W.

H. O. MALWITZ, 9DLY,
Box. 3, Brillion, Wis.

The Brandes Products Corporation, Newark, N. J., has started production at their new plant, which is the manufacturing division for C. Brandes, Inc., New York City.

Tell them that you saw it in RADIO

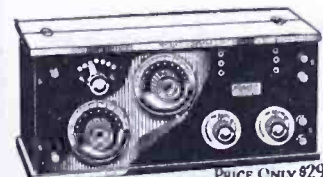

At the low prices shown below you get the efficiency of sets costing three times as much.

These radio frequency receivers pick up stations over 1500 miles away under good conditions—everywhere. Operate either on DRY CELLS or storage battery. Cabinets of solid mahogany and workmanship the finest throughout. Order direct or send for bulletin. For tube outfit, as shown above, headphones only... \$29.50 Four tube outfit for loudspeaker or headphones... 54.50

DEALERS AGENTS—write for proposition quickly—It's a winner.
THE MIDWEST RADIO COMPANY
814 Main Street Cincinnati, Ohio

AERIALS

Continued from page 24

any that we have seen. The selection of a loop for maximum results on a wavelength of 360 meters is as follows:

TABLE II.
Wavelengths of Solenoid-Loops, and Voltage Reception Factors. Loop Size (feet)

No. of Turns	2' x 2'		4' x 4'		6' x 6'		8' x 8'	
	W	VRF	W	VRF	W	VRF	W	VRF
5	200	1200	250	2500	400	4500	500	4500
10	250	2000	450	3100	600	5000	900	5800
15	425	3100	800	3700	950	5400	1300	6300
20	550	4500	1200	4300	1450	5900	1700	6900
25	700	5000	1450	4700	1700	7000	2100	7600

From the table, by interpolation, we find that a 2-ft. by 2-ft. loop of 13 turns will give the necessary wavelength, with a voltage rectification factor (v.r.f.) of 2600; a 4-ft. loop of 7 turns a v.r.f. of about 2800, and a 6-ft. loop of 4 turns, a v.r.f. of 4000. Hence, if it is possible, the 6-ft. loop should be used, since it will give a greater response (as would be expected) than the smaller ones. The spacing of the wires is shown in Table III for the solenoid type of loop. To

TABLE III.
Spacing for Solenoid-Loops

Size, (feet)	Spacing, (inches)	Size, (feet)	Spacing, (inches)
2	0.1	10	3/4
4	1/4	12	1 1/8
6	1/2	15	1 1/2
8	5/8	18	1 3/4

give some idea of the range and best wavelength for loops of various sizes when shunted by a .0005 mfd. (23-plate) condenser, Table IV is given.

TABLE IV.
Best W. L. for Solenoid Loops and W. L. Range with .0005 (23 pl.) Condenser.

Turns	4' x 4'		6' x 6'		8' x 8'		
	Best W L	Eff. Range	Best W L	Eff. Range	Best W L	Eff. Range	
3	250	200-350	3	220	180-400	5	500
4	300	250-400	6	500	400-900	10	900
6	350	300-800	10	700	600-1200	15	1300
10	600	350-1000	20	1400	1000-2000	20	1700
20	1200	900-1800				25	2100

In the design of a loop, contrary to that of an outdoor aerial, the inductance is the determining factor in the natural wavelength, as the shunting condenser is usually large enough to overbalance the effect of the small capacity of the loop. The inductance may be calculated from the dimensions as with any coil used in radio work.

Of the many items that enter into the efficiency of a transmitting or receiving set, the ground is by far the most important. While for receiving, a ground to the house water system is usually sufficient, for transmitting, especially with C. W. sets, the water pipes are inadequate. Just what type of ground to use for a given transmitting set will depend upon the locality, and

Continued on page 68

RADIANT

TRADE MARK
REG. U.S. PAT. OFFICE

TEMPERED PLATES GEARED VERNIER

CONDENSERS

THE greatest condenser trouble—warped plates—is made IMPOSSIBLE in Radiant Condensers. No more readjusting, bending and makeshift supports. Both the rotating and stationary plates are PERMANENTLY FLAT as a straight edge. Flattened under powerful presses, and tempered by a new process, the plates of Radiant Condensers are unaffected by temperature changes. You can identify Radiant Condensers by the radiating rays design on rotary plates. Permanent alignment is "the best condenser buy."

Geared Vernier

Infinitely fine control of this delicate adjustment. Micrometer accuracy without special effort. Neat, smooth-working, trouble-proof gear. Another advantage for the price of just an ordinary condenser.

Write for illustrated booklet and the name of the nearest Heath's Radiant dealer.

Prices

VERNIER TYPE

- 13 Plate including 2 7/8" dial and knob..... \$5.00
- 25 Plate including 2 7/8" dial and knob..... \$5.50
- 45 Plate including 2 7/8" dial and knob..... \$6.50

The Electric Corporation
836 So. Los Angeles St., Los Angeles
Western Radio Inc.
637 S. Hope St., Los Angeles

Distributor for Northern Cal.
Electric Appliance Co.
807 Missouri St., San Francisco

HEATH RAD O & Electric Mfg. Co.

208 First St.
Newark, N. J.

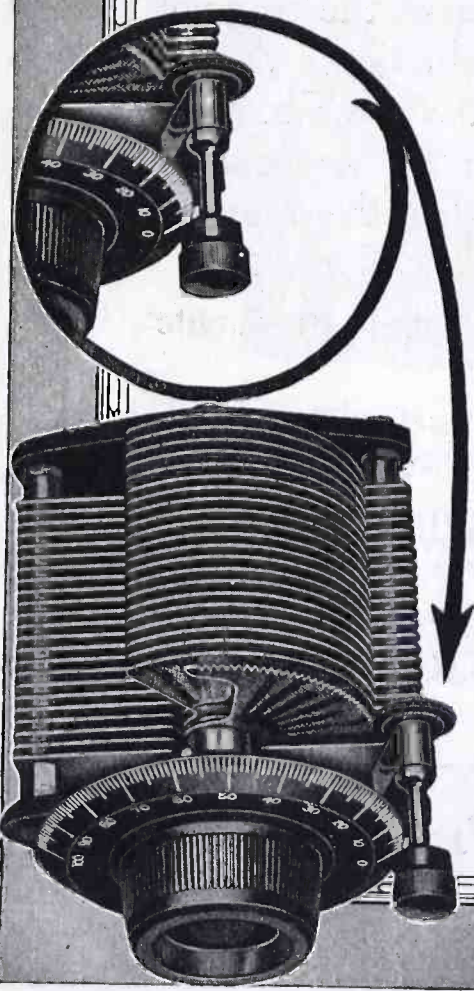

Marle Transformers

Audio and Radio Frequency

Superior Quality Reasonably Priced



Ask Your Dealer

Manufactured by

MARLE ENGINEERING CO.

Orange, N. J.

GOING UP!!

The Lefax Radio Handbook will advance in price to \$5.00 per copy. We have some copies on hand and will dispose of them at the old price of \$3.50. Get yours right now!

"RADIO", San Francisco

Tell them that you saw it in RADIO



A New Pathé Product CURTANTENNA

The Only Variable Loop



Showing Collapsibility and Portability of Curtantenna

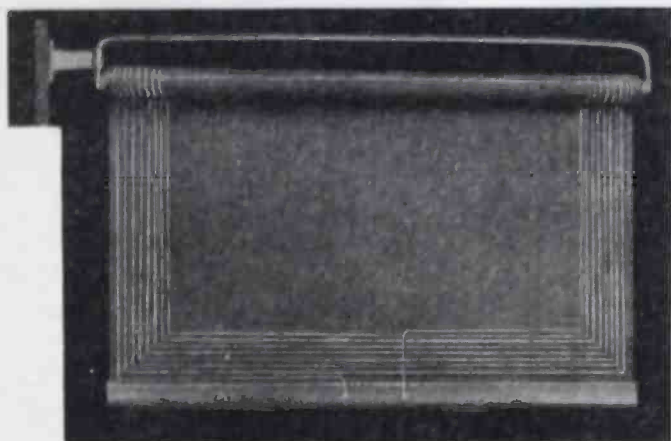

Showing How Curtantenna Can be Varied In Size

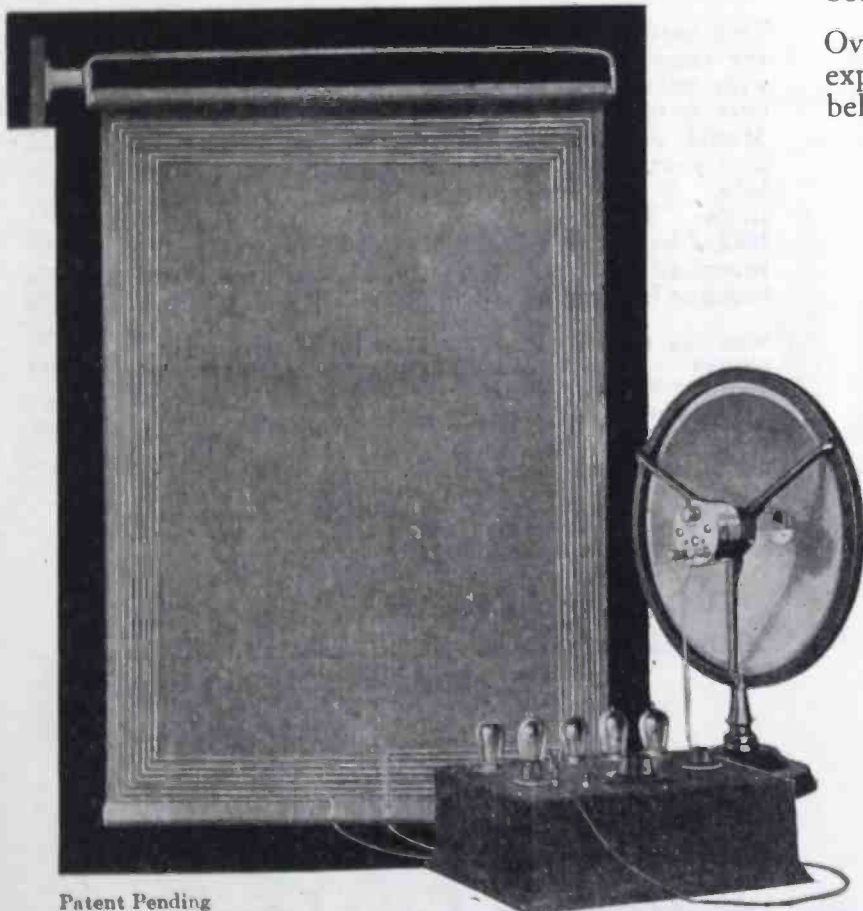

Patent Pending

Showing Curtantenna Fully Extended in Conjunction with Set and Pathé Loud Speaker

A REVOLUTIONARY development in radio aerials for indoor use.

When fully opened is one of the largest and most efficient loops for broadcast reception.

Is instantly collapsible without kinking or tangling the wire.

Ideal for sharp tuning—unsurpassed for distance—reduces static to a minimum. Particularly effective in large cities where several stations are broadcasting at same time. Gives a degree of selectivity hitherto unobtainable.

When closed is as portable as a walking stick.

Comes with wall bracket and swivel or may be attached to any door in house.

Positive in results—very attractive in appearance—easy to handle.

Size can be varied at will.

Over 1500 miles and thirty broadcasting stations have been covered by users of the CURTANTENNA.

Over a quarter of a century of highly specialized experience in the manufacture of scientific devices is behind the Curtantenna.

Price **\$8.50**

On sale at leading radio stores. If your dealer has neglected to stock the Curtantenna, send remittance direct and shipment will be made, charges prepaid, immediately.

Other Pathé products such as the famous Pathé Loud Speaker, Pathé Dials and Pathé Variometers and Variocouplers have already established themselves as standards among users of the best radio material.

Catalogue of Pathé radio products, together with a detailed wiring diagram of a loop receiving set which covered 1500 miles and 30 broadcasting stations using a CURTANTENNA, will be mailed on receipt of 4 cents postage. Address Dept. 187.

Pathé Phonograph & Radio Corporation

20 Grand Ave., Brooklyn, N. Y.

Tell them that you saw it in RADIO



Abroad at Home with a CROSLEY MODEL X-J

PRICE \$65

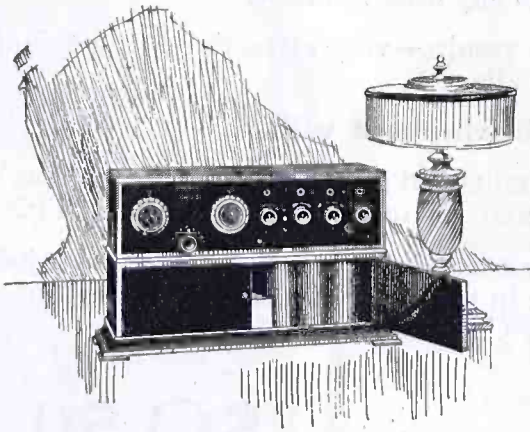

CROSLEY MODEL X-J

A 4-tube radio frequency set, incorporating one stage of Tuned Radio Frequency Amplification, Detector and two stages of Audio Frequency Amplification, with jack to plug in on three tubes for head phones; new Crosley multistats, universal rheostats for all makes of tubes; new condenser with molded plates; filament switch and other refinements of details. A mahogany battery cabinet which makes the set completely self containing may also be had to fit the Model X-J at a cost of only \$16. See illustration above.

See this beautiful receiver at your dealers.

Wonderful opera from New York, love songs from the tropics, dance music from Chicago; stock quotations, stirring speeches, amusing stories from where you will—all these pleasures and utilities are brought truly, clearly, right to your fireside if you own a Crosley Model X-J Radio Receiver.

This beautiful new Crosley 4 tube Model contains the same units as the famous Crosley Model X, with added refinements of detail which make it even better. At bringing in distant stations, the Model X established many records during the past year. Sebring, Fla., continually heard Honolulu. A man writes from Nassau, British West Indies, "First of all on Friday night, June 29, 1923, I heard Honolulu." He goes on to relate that practically all stations in the United States were brought in clear as a bell.

With the Crosley Model X-J even better receptions are assured. We unhesitatingly claim that it is the best radio receiver ever offered, regardless of price.

For Sale By Good Dealers Everywhere

Write for free catalog which shows the complete Crosley line of instruments and parts. In it you will find just the receiver to suit your needs and pocketbook. Crosley Receivers without batteries, tubes and head phones range in price from the efficient 2 tube Model VI at \$28 to the beautiful Console Model at \$150.

CROSLEY MANUFACTURING CO.
1019 Alfred Street Cincinnati, O.

New York Office, C. B. Cooper, 1803 Tribune Building, 154 Nassau Street, Beekman 2061.

Boston Office, B. H. Smith, 755 Boylston Street, Room 316.

Chicago Office, 1311 Steger Building, 28 E. Jackson Blvd., R. A. Stemm, Mgr.

Philadelphia Office, J. H. Lyte, 65 North 63rd Street.

St. Louis Office, Robert W. Bennett Co., 1326 Syndicate Trust Building.

CROSLEY

Better - Cost Less
Radio Products

Tell them that you saw it in RADIO

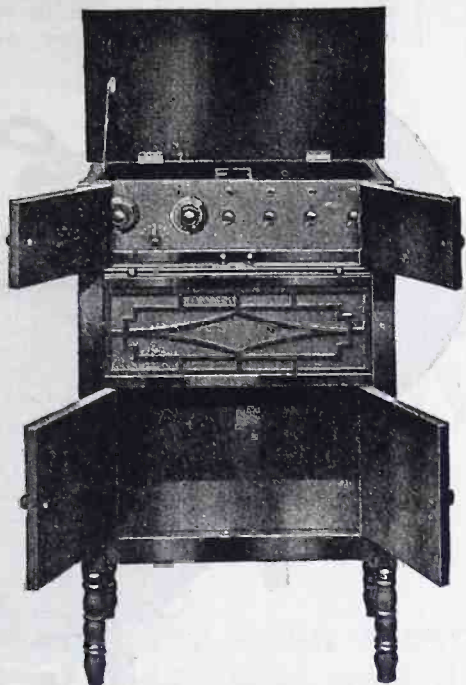
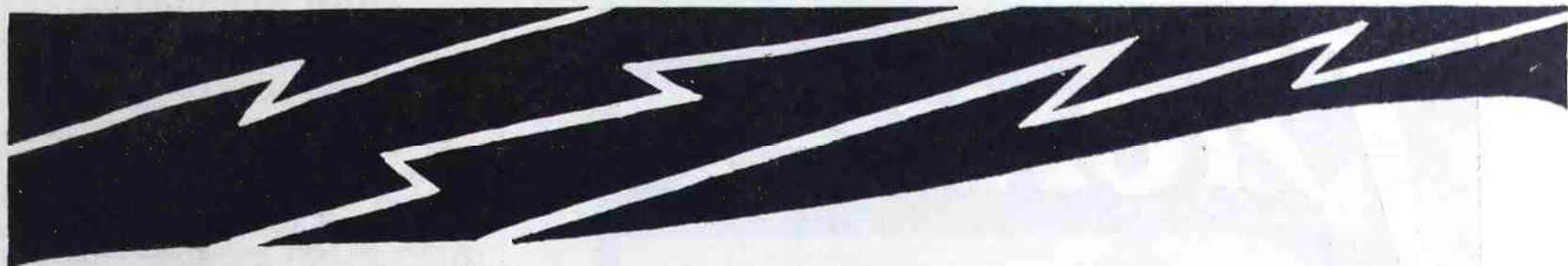

Model XX—Price \$100.

A four-tube set in a beautiful, upright mahogany finished cabinet. The hinged lid and doors give easy access to any part of the receiving apparatus. The lower compartment is for batteries.

Crosley Type "D" Condenser—\$2.25.

The wonderful efficiency of this new condenser has caused its popularity to grow rapidly. It increases the efficiency of your Crosley receiving set, notwithstanding its own conventional form and that it is different from the old interlocking plate type.



New Crosley Socket—50c.

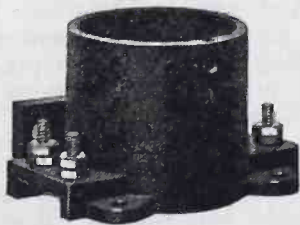

A smaller and neater socket now replaces the old porcelain one. It has the unique feature of base and panel mounting found only in Crosley sockets. (Patent pending.) It fits perfectly and has the highest dielectric qualities.

For Sale by Best Dealers Everywhere
Free Catalog on Request

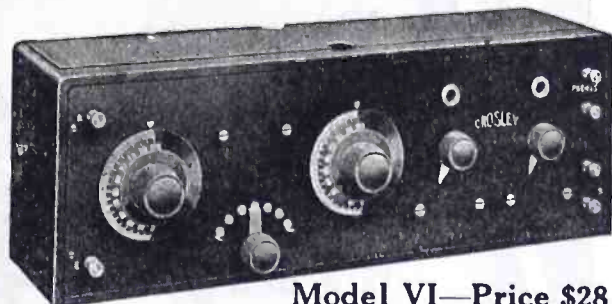

Model VI—Price \$28

This Model contains the stage of tuned radio frequency amplification brought to 100% perfection by the Crosley Co. For its price and size, it gives surprising results in long range reception. Hundreds of testimonials have paid tribute to its efficiency.

New Crosley Multistat—80c.



This multistat, of from 0 to 20 ohms resistance, will take care of all types of tubes with its high and low resistance wire. This unit solves the problem of filament control on different tubes. The smooth running, ball

bearing contact is continued.

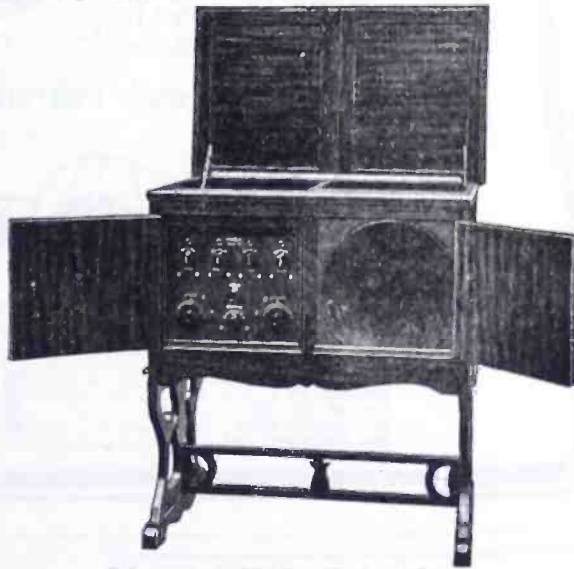

Model XXV—Price \$150

A console cabinet model which is a combination of efficiency and beauty. This is designed for homes and clubs where a complete, long-distance set is required. Equipped with compartment for batteries and loud speaker.

CROSLEY

Better - Cost Less

Radio Products

Tell them that you saw it in RADIO

Pioneer

Distance

—unusual distance—has been gotten by using a Pioneer Variocoupler and a plate and grid variometer.

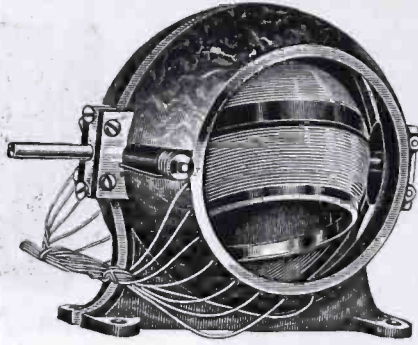

Pioneer Variocoupler \$7.00

Selectivity. 16 taps on the variocoupler gives exceptional close tuning and selectivity. Stations can be cut out and brought in at will. Interference is entirely eliminated.

The instruments have been awarded the highest award by all the testing laboratories.

Made of moulded Bakelite, moulded in our own factory under our own personal supervision.

The hardware is the best obtainable; the contacts are positive and will not become disconnected through use or wear. Instruments are made for table or panel mounting.

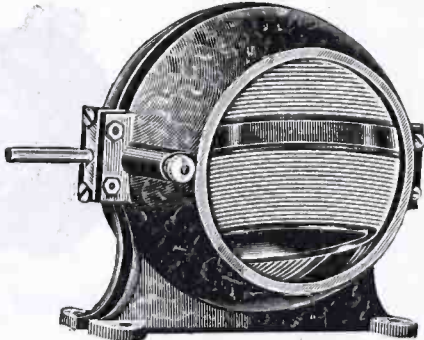

Pioneer Variometer \$6.50

Binding posts on each instrument for ready and quick connections.

PIONEER RADIO CORPORATION

107 Pioneer Avenue

Galesburg, Illinois

Branch Offices:

European Branch Office—London, Eng., 27-28 Anning Street
Gaston E. Marbaix, European Manager

New York City.....	220 Fulton Street
Chicago, Ill.....	33 South Clinton Street
Kansas City, Mo.....	208 Baltimore Building
Minneapolis, Minn.....	705 Plymouth Building
San Francisco, Cal.....	623 Larkin Street

NEW APPARATUS

Continued from page 42

DOUBLE ROTOR TUNING COIL

Of special interest to builders of their own radio sets and experimenters is the new Peerless double rotor tuning coil recently placed on the market by the United Radio Corporation of Rochester, N. Y. The coil requires no other tuning instruments, variable condensers, variometers, or variocouplers in the circuit. Two rotors are mounted



Peerless Double Rotor Tuning Coil

inside of a Formica tube. One controls the wavelength, the other controls the feed-back or intensity of the signals. The circuits are designed to cover all broadcasting wavelengths.

The windings are impregnated with an insulating varnish. Provision is made for mounting on the rear of a panel. Because of its small size and completeness, the coil is well adapted for portable or very compact sets. Experimenters will find many circuits possible by simple changes in connections.

BOOK REVIEWS

"Wireless Course in Twenty Lessons," by S. Gernsback, A. Lescarboua and H. W. Secor. 264 pages, 6x9. Published by Experimenter Publishing Co., New York City. Price \$2.00.

This, the twelfth edition, has been completely rewritten and revised so as to bring it up to date. It gives a simple and brief outline of general principles of electricity, magnetism and radio telegraphy. It then takes up the details of amateur and commercial transmitting equipment, including aerials. The general principles of receiving equipment are likewise discussed with specific reference to detectors, and amplifiers, and various radio applications. Directions are given for learning the code and complying with government requirements. It concludes with a history of radio and the mathematics of wireless telegraphy. The book is well printed and bound and is a good text for the beginner.

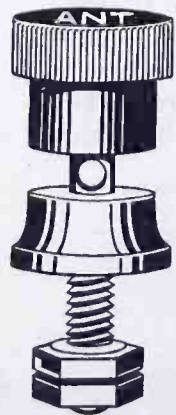

"Read'em" Binding Posts

With knobs that won't come off

Anyone can "read 'em." Irremovable knobs. All popular styles—Antenna, Ground, Fones, A and B Battery plus and minus—abbreviations of different names engraved on knobs. Radio users—ask your dealer for "Read 'em." Dealers—write for our proposition on this big seller. Write Dept. B for liberal profit proposition.

The Marshall-Gerken Co.
Manufacturers
Toledo Ohio

RATHBUN SINGLE-HOLE MOUNTING SUPERIOR CONDENSERS

Die-cast. Light, compact, highly efficient. Proven by 2 years' service. Plain and vernier combination types. Dealers, Jobbers, write!

Rathbun Mfg. Co.
Jamestown, N. J.

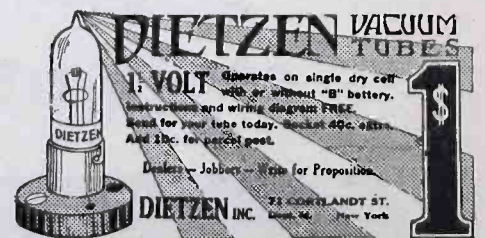

DIETZEN VACUUM TUBES

1 VOLT Operates on single dry cell with or without "B" battery. Instructions and wiring diagram FREE. Send for your tube today. Pocket 49c. Add 10c. for parcel post.

Dealers—Jobbers—Write for Proposition.

DIETZEN INC. 72 CORTLAND ST. New York

Tell them that you saw it in RADIO

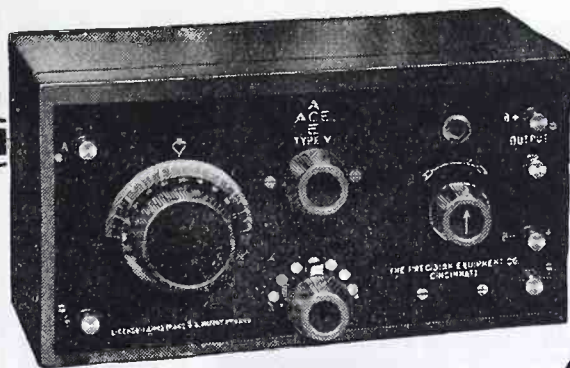

Licensed under
Armstrong U. S. Patent
No. 1,113,149

A Highly Efficient Set at a Moderate Price

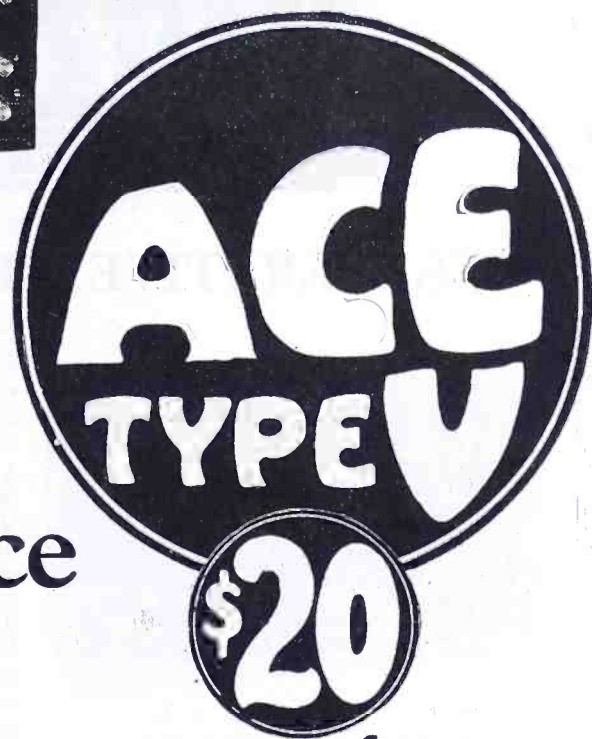

*Armstrong
Regenerative
Receiver*

Here is an inexpensive set that receives signals clear and distinct. It is a long range regenerative radio receiver and under ordinary conditions stations from coast to coast are heard. We have many letters from owners praising the efficiency of the Ace Type V.

The low cost of this set in addition to its remarkable simplicity of operation increases its popularity among radio fans day by day.

A loud speaker can be operated in connection with the Ace Type V by adding an Ace Type 2 B, a new two-stage Audio Frequency Amplifier, which sells for \$20.00. With this addition, music or voice can be heard distinctly all over the room or house.

The modest price of this set makes it possible for everyone to enjoy radio. Don't be without radio entertainment any longer—get an Ace Type V and listen to the world's best musical concerts.

If your dealer cannot supply you, order direct, mentioning his name. Ask for "Simplicity of Radio." Your copy is *Free*.

DEALERS: Write on your letterhead for attractive sales proposition.

The Precision Equipment Company
Powel Crosley Jr., PRES.
1019 Vandalia Avenue, Cincinnati, Ohio



REGENERATIVE RECEIVER No. 102

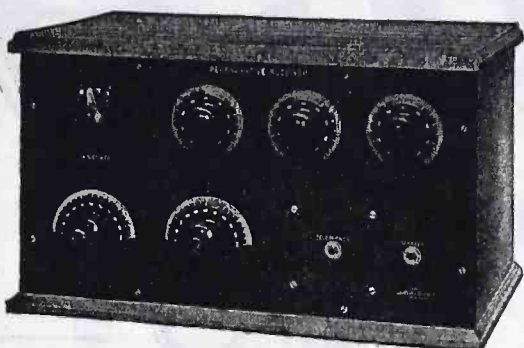

THREE TUBE RECEIVER No. 102
(Licensed under Armstrong U. S. Patent No. 1,113,149)

Chelsea Regenerative Receiver No. 102 is a supersensitive instrument operating on wavelengths of from 100 to over 600 meters. It combines great range and selectivity.

A Regenerative Circuit with two stages of audio frequency amplification is used. Most efficient adjustments are made possible by the use of vernier controls incorporated in the variocoupler and tuning condenser. All binding posts are enclosed in the cabinet eliminating all visible wiring. All insulating material is genuine bakelite, moulded in the Chelsea factory. The cabinet is solid mahogany, beautifully finished with space for batteries. Price \$95.00. Write for Booklet A.

CHELSEA PARTS

The National Chelsea Radio Corporation offers a complete line of parts. These are identical with those responsible for the marvelous results obtained by Chelsea Receivers. For complete description and prices write for Booklet "B."

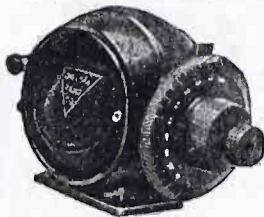

Variometer

The Chelsea Vernier Variometer is the last word in variometer design. It covers an extreme range from 100 to 600 meters, with the closest tuning. Genuine bakelite especially moulded by Chelsea is used throughout. It has no sliding contacts. Furnished complete with dial and vernier.

Variometer No. 80, \$8.00

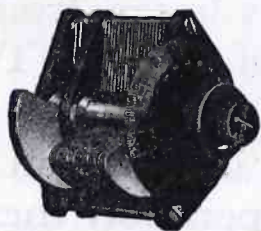

Variable Condensers

The Chelsea Variable Condensers contain only genuine bakelite insulating material. Rotors and Stators are die cast into solid units with perfect alignment of the plates. Spiral connections to rotors. Furnished with from 3 to 45 plates. With or without vernier. Capacities from .00025 to .001 M. F.

Prices from \$2.50 to \$6.75

Write to Dept. 5 for Booklets—"A" for complete receiving sets and "B" for Parts.



METALECTRIC SOLDERING IRON

(the all-metal instrument)

A SOLUTION TO THE SMALL SOLDERING PROBLEM OF THE DISCRIMINATING ASSEMBLER



Renewable tip
UNBREAKABLE CONSTRUCTION—ECONOMICAL OPERATION ON ANY ELECTRIC CIRCUIT. **\$5.50**

from your dealer, or write
Post Electric Co., Mfg'rs. (Fifth Div.) 30 E. 42d St., New York

Tell them that you saw it in RADIO

AERIALS

Continued from page 62

the type, size, etc., of the ground should be largely determined by experiment. In general, in a sandy soil with the moist layer of earth a considerable depth down, a counterpoise will be necessary, but with moist earth near the surface, wires buried a short distance will be sufficient. Sometimes a combination of the two will give the best results, but this must be determined.

Calculations

For those with an aerial that does not fall under Table I, it might be of interest to give the computations necessary to ascertain the capacity. These computations are not very involved and an example will show the application of the formula. The necessary constants k_2 are given in Table V.

TABLE V.
Constants in Computation of Aerial Capacity.

1/4h	k_2	1/4h	k_2	4h/l	k_1	4h/l	k_1	No. of Wires	N
0	0	.55	.228	0	0	.55	.030	2	0
.1	.043	.60	.247	.1	.001	.60	.035	3	.308
.15	.065	.65	.265	.15	.002	.65	.040	4	.621
.20	.086	.70	.283	.20	.004	.70	.045	6	1.18
.25	.107	.75	.300	.25	.006	.75	.051	8	1.66
.30	.128	.80	.318	.30	.009	.80	.057	10	2.05
.35	.148	.85	.334	.35	.012	.85	.063	12	2.37
.40	.169	.90	.351	.40	.016	.90	.069	14	2.63
.45	.189	.95	.367	.45	.020	.95	.075	16	2.85
.50	.209	1.00	.383	.50	.025	1.00	.082	18	3.04

If 1/4h is greater than 1, 4h/l and its corresponding constant k should be used.

$$\text{Then } P_{11} = 4.60 \left(\log \frac{4h}{d} - k_1 \right)$$

$$P_{12} = 4.60 \left(\log \frac{2h}{D} - k_1 \right)$$

Let n = number of wires in parallel.
 d = diameter of wires.
 h = height of wires above ground.
 l = length of each wire.
 D = spacing of wires in parallel, centers.

$$C = \frac{33.916l}{\left[\frac{P_{11} + (n-1)P_{12} - K}{n} \right]}$$

The value of K depends upon the number of wires in the antenna system as follows:

No. of Wires	K	No. of Wires	K
2	0.	8	1.66
3	0.308	10	2.05
4	0.621	12	2.37
5	0.906	14	2.63
6	1.18		

$$P_{11} = 4.60 \left[\log \frac{2l}{d} - k_2 \right]$$

$$\text{and } P_{12} = 4.60 \left[\log \frac{l}{D} - k_2 \right]$$

Suppose we have an aerial of the following dimensions and we wish to know the approximate capacity before erection:

n = number of wires in parallel = 4
 D = spacing of wires in parallel = 2ft.
 d = diameter of wire = for No. 14, .0641 in.
 h = height above ground = 50 ft.
 l = length of each wire = 100 ft.

Continued on page 70

Member
Radio Section

Manufacturers
of Electrical
Supplies



SIMPLIFY YOUR MOUNTING PROBLEMS

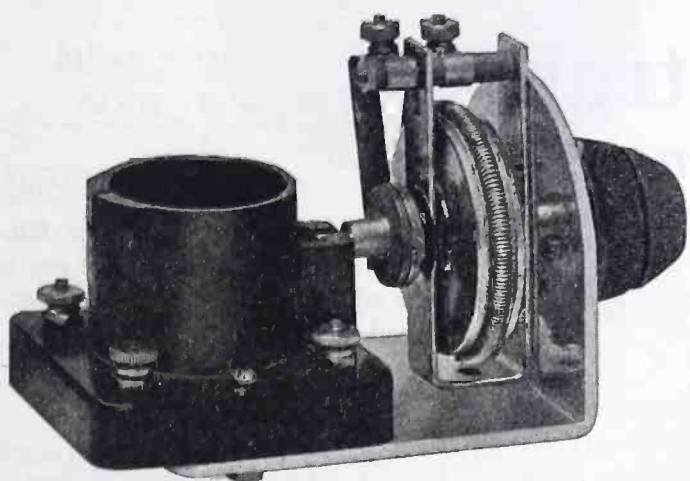

No. 139 Detector Unit (Vernier)..... \$3.00

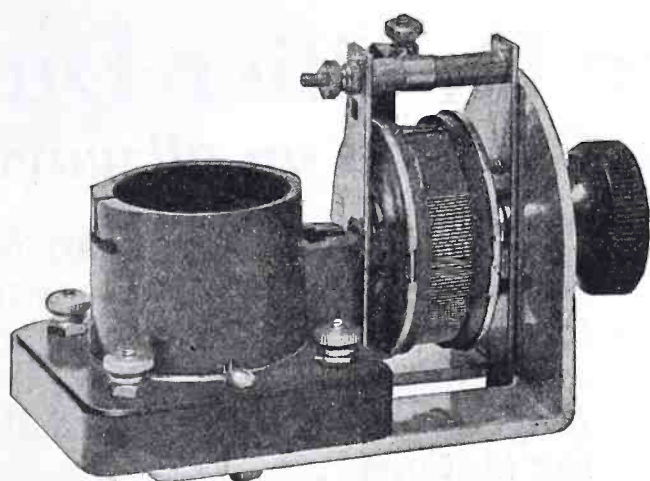

No. 211 Detector Unit..... \$2.40
No. 206 Detector Unit (30 ohm)..... \$3.00

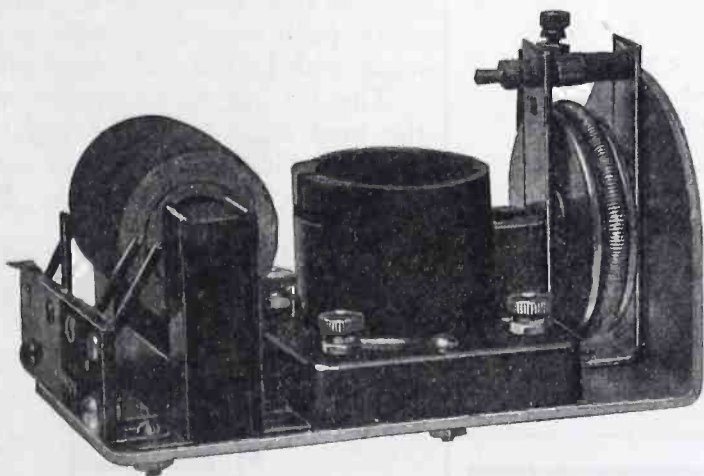

No. 198 Amplifying Unit..... \$7.50

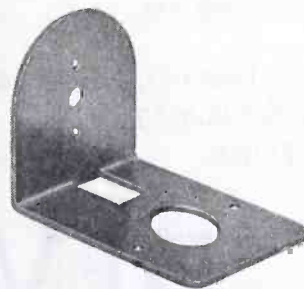

Detector Bracket
..... \$0.30

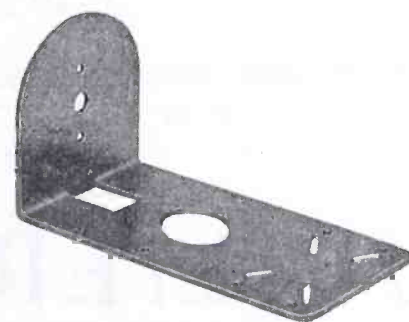

Amplifier Bracket
..... \$0.35

Punched from 3/32-in. aluminum plate. Make your own units. Uses either 4, 30 ohm or Ver. Rheo.

Holes for transformer so arranged that all standard types can be mounted without drilling.

R. MITCHELL CO. :

255 Atlantic Avenue
Boston, Massachusetts

For 47 years Manufacturers of Scientific and other equipment
Look for trade mark on every piece

Jobbers and Dealers write for discounts

Cable Address—Searde-Boston

PACIFIC COAST OFFICE
EXPORT OFFICE

709 Mission St.,
44 Whitehall St.,

San Francisco, Cal.
New York N. Y.

Tell them that you saw it in RADIO

Sharpen Your Tuning

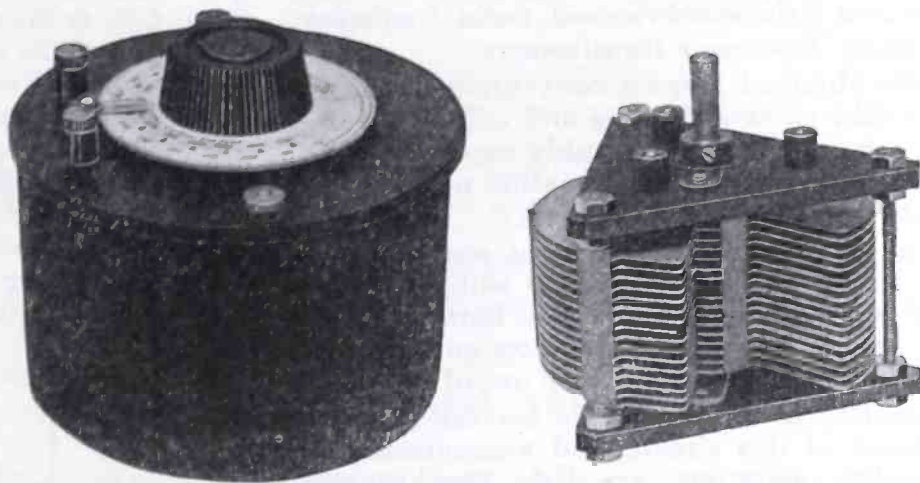

NO OPERATOR of a radio receiving set need be told of the advantage of sharp, precise tuning. It is not always clear, however, how this may be obtained. After a good tuning coil has been chosen look to the CONDENSER for the answer.

Years before radio became a popular pastime, the General Radio Co. was manufacturing low loss, scientifically designed condensers for use in such discriminating laboratories as those of the Bureau of Standards, Naval Radio, General Electric, Westinghouse, Western Electric and the leading educational institutions of the country. The result of these years of research work in our own laboratory has resulted in the design of a condenser incorporating the best features in design and at the same time available at a price substantially lower than other good quality condensers.

Here are some of the important features: Sharp tuning through low loss design using hard rubber properly placed. Heavy brass plates soldered together, keeping capacity constant and greatly reducing danger of short circuiting. Low zero capacity giving wide wave length range. A CONTINUOUS VERNIER formed by a gear and pinion combination. Only one setting required.

Made in three sizes: 250, 500 and 1000 m.m.f., to fit every circuit. Mounted condensers are fitted with calibrated direct reading capacity dial.

Prices, \$3.00 to \$8.50. Send for Educational Pamphlet, "Quality Condensers," and new RADIO BULLETIN 916C.

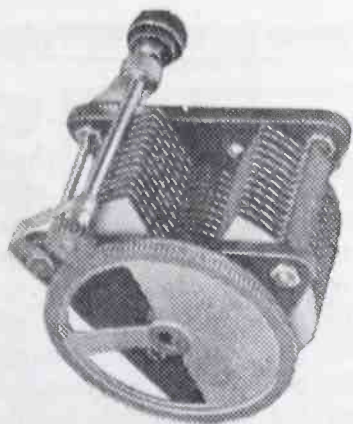

*The General Radio Co.'s
Type 247 Variable Air
Condenser*

5738

GENERAL RADIO CO.

Manufacturers of Electrical and Radio Laboratory Apparatus

Massachusetts Avenue and Windsor Street

CAMBRIDGE

MASSACHUSETTS

Tell them that you saw it in RADIO

Three Tubes Is All You Need

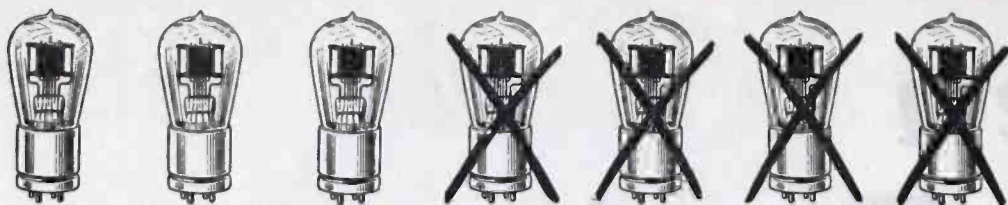

With Erla Synchronized Transformers



Perfect synchronization of Erla transformers assures unequalled range and volume, with no trace of distortion. Cascade \$4. Reflex \$5



One of the most notable improvements of recent years is disclosed in the new Erla synchronized audio frequency transformer. List \$5



Especially constructed for reflex work, the Erla fixed crystal guarantees success. Proof against disturbance through jolt or jar. List \$1



Every Erla fixed condenser is individually tested to the exact capacity shown, an exclusive feature. Made in eleven sizes, 35c to \$1

Transcontinental reception, through a loud speaker, is assured when you tune in with the new Erla Triplex circuit, using three vacuum tubes and Erla synchronized radio frequency and audio frequency transformers.

Results obtained surpass conventional six and seven-tube circuits in range and volume. Moreover, tone quality is remarkably improved, with complete absence of the parasitic noises common to hook-ups less advanced.

For all except the most distant stations, outdoor antenna can be dispensed with, an inside aerial serving equally well. Wet batteries, likewise, are no longer essential, low current consumption enabling satisfactory use of dry cells.

Accounting in large measure for the amazing efficiency of this circuit, and guaranteeing its successful operation, are Erla synchronized radio and audio frequency transformers. For the first time, perfect inter-relation and co-ordination between transformers has been secured in reflex work, producing unequalled amplification without distortion.

A further notable contribution to radio improvement is embodied in the new Erla fixed crystal detector. Providing maximum sensitiveness and purity of reception, with complete freedom from disturbance through jolt and jar, it antiquates the costly vacuum tube for detector purposes.

Detailed working diagrams and descriptions of the Erla Triplex and other advanced Erla reflex circuits are included in Erla Bulletin No. 14, obtainable gratis from leading radio dealers. Or, if your dealer should be unable to supply you, write us direct, giving your dealer's name.

Manufactured by
Electrical Research Laboratories Dept. H
2515 Michigan Ave., Chicago

Coast Representative
Globe Commercial Co.
709 Mission Street
San Francisco

ERLA

Continued from page 70

L is inserted in the aerial circuit, this inductance having a value that will raise the wavelength at least four times that of the fundamental, as determined below, which will allow us to neglect the aerial inductance. The wavelength is then measured with L inserted, and C_a is computed from

$$C_a = \frac{\lambda^2}{(59.6)^2 \times L}$$

L being the value of the inserted inductance in centimeters, C_a desired total capacity of the aerial system, and λ the wavelength in meters.

The fundamental wavelength is determined in a manner similar to that for obtaining the capacity, except that instead of inserting an inductance at L , the lead-in is looped once, and the oscillator coupling coil coupled as loosely as possible to this loop, as in Fig. 3.

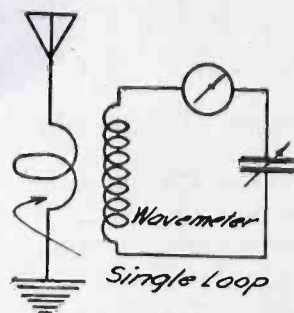

Fig. 3.—Circuit for Measuring Fundamental Wavelength

The fundamental is directly obtained from the value observed on the wave-meter as no computations are necessary. If the oscillator is capable of furnishing sufficient current, a thermo-meter may be inserted in the ground lead to show when the resonance point is reached. Otherwise, the methods of obtaining the resonance point is as outlined in the article on the vacuum tube wavemeter in September RADIO.

Next to be determined is the resistance of the aerial. This is usually measured by what is termed the "artificial aerial method," by which is meant that an artificial aerial is built up with the same inductance and capacity as the outdoor one. From this it will be seen that the determination of the resistance involves determining the inductance as well as the capacity.

The circuit is the same as shown in Fig. 2, but the method of procedure different. A known inductance L is first inserted and the wavelength, λ , determined. Then next a larger inductance, L_1 , generally four times the value of the previous one used, is inserted, and the wavelength λ^1 determined. Calling the capacity of the aerial system C_a and its inductance L_a , we find by substituting in the equation for lumped capacity and inductance that

Continued on page 74

CATALOG E19-112 PAGES FREE

EVERYTHING IN RADIO

One of the largest complete stocks in the world. 40 diagrams of latest Hookups.

DEALERS ALL OVER THE U.S.

Making big profits handling our supplies. 24-hour service. Goods shipped same day order received.



WHOLESALE RADIO DISTRIBUTORS

Dept. N 107 E. 13th St. Kansas City, Mo.

LEARN RADIO

Here's your opportunity. Radio needs you. Win success in this fascinating field. Trained men in demand at highest salaries. Learn at home, in your spare time.

Be a Radio Expert

I will train you, quickly and easily, to design, construct, install, operate, repair, maintain, and sell all forms of Radio apparatus. My new methods are the most successful in existence. Learn to earn

\$1,800 to \$10,000 a Year

FREE Wonderful, home-construction, tube receiving set, of latest design. Write for "Radio Facts" free. Engineer Mohaupt.

American Electrical Association
Dept. 8 4513 Ravenswood Ave., Chicago

Tell them that you saw it in RADIO

The Latest in Radio Sets!

FADA
 NEUTRODYNE
 One-Sixty
\$120.00 Postpaid
 Uses two Stages of Radio and two of Audio.

GREBE
 Latest Models
 CR-12 **\$175.00**
 CR-6 **\$200.00**
 Shipped Postpaid

SEARDE
 Knock-down Sets ranging in prices as low as **\$28.00**.
 Complete instructions go with sets.
 Amplifiers, Tuners, Parts, Etc.

MAGNAVOX

NEW MODELS

COMPLETE NEW LINE

R-3, **\$35.00**; R-2, **\$60.00**; M-1, **\$35.00**; A1-R, **\$59.00**; A2-R, **\$85.00**; A1, **\$27.50**; AC-2-C, **\$55.00**; AC-3-C, **\$75.00**.

ERLA
 Reflex parts and diagrams.
 Regular prices. (postpaid)

4 HOUR MAIL ORDER SERVICE

THREE STORES

WARNER BROS.

THREE STORES

350 Market Street San Francisco 428 Market Street
 Oakland--Twenty-second and Telegraph Avenue

ATHERTON SUPER TRANSFORMER



Patents Pending

The most scientific and highest grade audio frequency transformer manufactured—

AT LAST!

Radio Fans may now hear those long distance stations with absolute clarity and volume by using ATHERTON SUPER AUDIO FREQUENCY TRANSFORMERS. They give you powerful amplification—clear and perfect reproduction—cover all wavelengths—have no resonant peak and they are absolutely distortionless. If you want highest efficiency above all, use these transformers.

THREE RATIOS

5 to 1 for 1st stage
 3.75 to 1 for 2nd stage
 1.45 to 1 for 3rd stage

(Sold by all high grade dealers)

\$6.50

Unrestrictedly Guaranteed

Dealers and Jobbers write for attractive discounts and sales plan.

WOLVERINE MANUFACTURING COMPANY
 603 EAST WATER STREET MILWAUKEE, WISCONSIN
 Pacific Coast Distributors: Cookson & Sullivan, 230 California Street, San Francisco, California.

Amplification perfection

with an audio transformer means PURE TONE QUALITY with MAXIMUM VOLUME.

The AMERTRAN

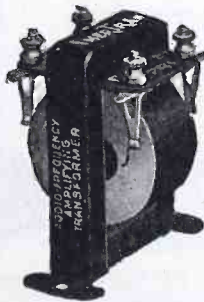

AUDIO TRANSFORMER

is acknowledged by professional radio engineers to be the Standard of Excellence for audio amplification.

The reason for the popularity of the AmerTran among professional radio men is apparent in the Amplification Chart shown in our Circular No. 1005.

Price \$7
 Ask your electrical dealer, or sent carriage charges collect. (Wt. 1 lb.)

Turn ratio, 5:1. Amplification ratio, 30-40 times audibility in the flat part of the curve.

American Transformer Company

Designers and builders of radio transformers for over 20 years.

174 Emmet St.
 Newark, N. J.

Pacific Coast Office
 Rialto Bldg., San Francisco

Tell them that you saw it in RADIO



**"Trans-Inductor
Opens up new possibilities
in Radio-Frequency Amplification
and Selective Tuning**

The Hulbert Transinductor combines volume with clearness to a degree never yet approached by any other means, consists of a wood ball rotor inside a fibre cylindrical stator, both wound for both primary and secondary.

It combines the broad wave-length range of the iron case transformer with the power and clearness of the air-case type.

Its amplifying power is remarkable, permitting us, for instance, to bring in distant signals thru the loud speaker with only one stage of radio frequency.

It permits a finer tuning for any wave-length (150-750 meters) than has yet been accomplished by any other means.

A single 360° dial controls inductance and is especially useful in tuning out troublesome local broadcasting.

It is new, revolutionary; broad, basic patents have been applied for.

It will give your radio receiver a range power, clearness, and control of receiving that will amaze and delight you.

Tell your Dealer to order one or a pair for you. Write for circular. Send dealer's name and address.



SIGNAL Electric Mfg. Co.

Factory and General Offices:
1913 Broadway
MENOMINEE, MICHIGAN

Atlanta, Boston, Chicago, Cleveland, Minneapolis, Montreal,
New York, Pittsburgh, St. Louis, San Francisco, Toronto.

You'll find our local address in your Telephone Directory

**FREE TRIAL
GOTTSCHALK LOUD
SPEAKER---New Models**

*"The Reproducer that has won
a reputation"*

Ask your dealer to demonstrate the Gottschalk against any loud speaker at any price. If your dealer does not stock the Gottschalk, do not accept a substitute but send your order direct to the factory.

5 DAY FREE TRIAL

Ship C. O. D. on five days' trial
Money refunded in full if not
absolutely satisfactory.

SWEET
CLEAR &
MELLOW

Gottschalk Electric and Mfg. Co.
172 Fifth St., San Francisco, Cal.



**Over
1500
Sold
in Past**

Type C, Crystal-
line finish, \$22.00

Type D, smooth
finish, mahogany
or walnut, \$25.00

Complete as illus-
trated with six-
foot cord.

Continued from page 72

$$\lambda = 1884 \sqrt{(L + L_a) C_a}$$

$$\lambda^1 = 1884 \sqrt{(L^1 + L_a) C_a} \quad (a)$$

Eliminating C_a between these two equations and solving for L_a we have

$$L_a = \frac{L^1 (\lambda)^2 - L (\lambda^1)^2}{(\lambda^1)^2 - \lambda^2}$$

which isn't as formidable as it appears, as an example will show. Since we now know the values of L, L^1, λ and λ^1 , and have found L_a , we may substitute these values in the equation (a) for the higher wavelength, thus obtaining the value of C_a . In the above equations the value of the inductances is in microhenries; the wavelength in meters; and the capacity in mfd., with the result in microhenries. Example:

$$L = 100 \text{ microhenries}$$

$$L^1 = 400 \text{ microhenries}$$

$$\lambda = 500 \text{ meters (measured)}$$

$$\lambda^1 = 800 \text{ meters (measured)}$$

Substituting:

$$L_a = \frac{(400)(500)^2 - 100(800)^2}{(800)^2 - (500)^2}$$

Solving for $L_a = 73.5$ microhenries.

Sub. in (a) for C_a

$$800 = 1884 \sqrt{(400 + 73.5) C_a}$$

from which $C_a = .000382$ mfd.

After obtaining the capacity and inductance of the aerial, we are now ready to find the resistance, as shown in Fig. 4. In this circuit L is the equivalent in-

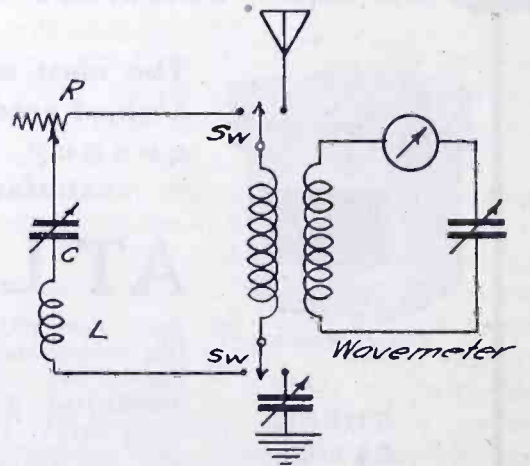

Fig. 4. Circuit for Measuring Aerial Resistance

ductance of the aerial, C is its equivalent capacity, and R is a variable resistance whose various values are known. The coil L is computed as will be given later, while the resistance may be a standard box built for radio work. If a standard is not available, a substitute may be built up by using No. 32 resistance wire wound non-inductively and as criss-cross as possible to cut down the capacity. The resistance may be varied in a manner similar to that of standard boxes. The various values may be ap-

Continued on page 80

SEND NO MONEY **Guaranteed!**
3.98
Money back if they do not satisfy after 5 DAYS TRIAL
SEND no money! Order by postcard and pay postman on arrival. If they do not excel any other phones you ever used regardless of price, return them and your money will be refunded at once.
GUARANTEED ONE YEAR
AMBASSADOR
LONG RANGE PHONES
TOWER MFG. CORP. 98 BROOKLINE AVE., BOSTON, MASS., DEP. 7

FREE write at once for **ILLUSTRATED DRAWING OF ONE TUBE-TRICOIL REFLEX CIRCUIT** that will operate Loudspeaker.
The drawing is non-technical and is so arranged that anyone can build this wonderful inexpensive set.
Construction and Operating Instructions included.
TRI-COIL R.F. TRANSFORMERS SOLD ON MONEY BACK GUARANTEE \$2.00 List at all dealers
BROOKLYN METAL STAMPING CO.
718-728 ATLANTIC AVE. BROOKLYN, N.Y.

Tell them that you saw it in RADIO

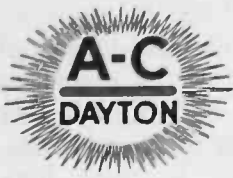

A new A-C DAYTON Product

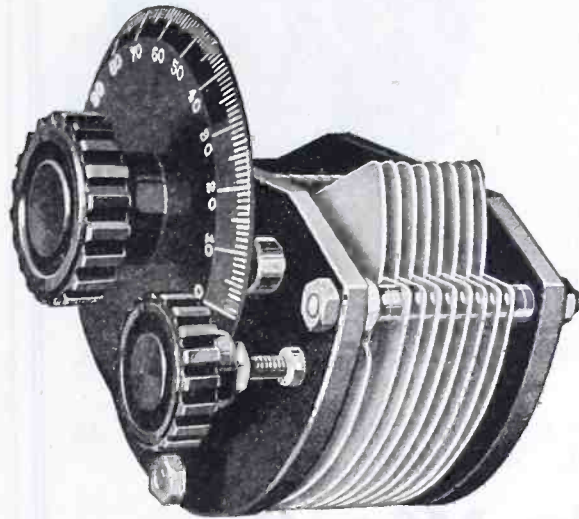

A Vernier Condenser with a Micrometer Adjustment

A New Principle in Vernier Action

The A-C Dayton Vernier Condenser is the product of long laboratory and practical research work. It is not a makeshift, but instead represents well engineered designs.

The principle on which it works is proved and sound and coupled with its great simplicity and accuracy can be termed a *real vernier condenser*.

In the A-C Dayton Vernier Condenser we have actually eliminated all faults heretofore found in Vernier Condensers. This is hard to believe and may sound as an idle boast, but all we ask is a trial for your own conviction.

First, we have absolutely no sliding contacts. This means no more noise so commonly attributed to static. The main condenser shaft is pigtailed,

while the vernier plate is actually anchored (by two studs) and *does not rotate*. The vernier action is obtained by a micrometer screw operating the vernier plate, changing the separation of this plate with respect to the adjacent movable plate.

We claim the accuracy to be fully 300% greater than any other type of vernier and in addition absolutely no chance for any noise. The micrometer screw is allowed *three revolutions* making a change of capacity equivalent to approximately 2 degrees on the main dial. This you can readily see gives a *real vernier* action and can rightfully be called a vernier condenser and is not just a small condenser within a large one.

The vernier plate is made of special spring aluminum and is equivalent to bronze with respect to its spring limits. There is nothing to wear or loosen up and cause trouble, it is fool proof.

Made in two popular sizes

No. 720—.0005 Mfd. Capacity Vernier Variable Condenser, \$3.60
No. 721—.001 Mfd. Capacity Vernier Variable Condenser, \$4.30

Our New 1924 Catalog is now ready. Send 2 cents in stamps for mailing.

The A-C Electrical Manufacturing Co.

DAYTON, OHIO, U.S.A.

Makers of Electrical Devices for over 20 Years

Tell them that you saw it in RADIO

The B.-T. Universal Tuning Unit

There is nothing on the market you can compare with the Bremer-Tully Universal Tuner. It is an entirely new instrument, that gives unequalled selectivity and control on practically all modern circuits.

It replaces coils in Reinartz, Ultra Audion and other regenerative and non-regenerative circuits. In most circuits taps are not required. Also gives remarkable results in Radio Frequency and all Reflex Circuits.

Simple to connect, no soldering; connections made to binding posts, easily changed to any circuit.

Photo diagrams of above, also special Bremer-Tully circuits, in addition to key of windings, furnished. Write today.

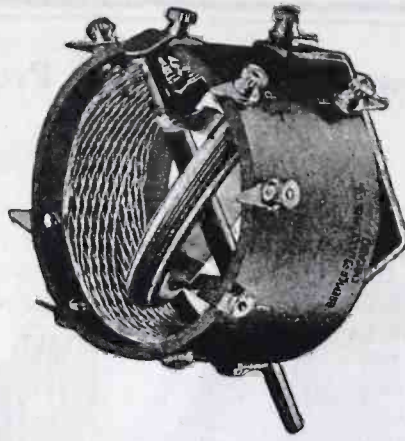

Bremer-Tully Mfg. Co.

536 So. Canal Street

Chicago, Illinois

Continued from page 74

proximated by measuring the length of wire used and computing the resistance from tables, or better still, by actually measuring the resistance with a Wheatstone bridge, available in most high schools now. A total value of 100 ohms should be used, and the finest adjustment for this work need not be over .25 ohms, though in the manufactured boxes the coils go as low as 0.1 ohm. The condenser *C* should be as free from losses as possible, which is also true of the inductances *L* and *L*¹. The wave-meter is shown at *W*.

In obtaining the resistance, the switches are first thrown to the actual aerial, the oscillator loosely coupled and a reading obtained on the meter *M* which will be called *I*. Then the switches are thrown to the artificial aerial, and *R* adjusted until the same value of current, *I*, is obtained as with the actual aerial. The wavelength is also observed, as the resistance will vary with the wavelength. If other values of the resistance at different wavelengths are desired, the inductance *L*¹ or *C*₁ may be varied. As *L*¹ is in both circuits when measurements are taken, it will have no effect on the value of the resistance obtained.

It will be found that the nearer the transmitting wavelength is to the fundamental the greater will be the radiation resistance, i.e., the energy that is usefully used for radio signals. The components of the total resistance, as found above, may be divided into the following components:

- (1) Wasteful—
 - a. Absorption by objects near the aerial as trees, wires, buildings, etc.
 - b. Corona losses on the conductors.
 - c. Leakage in insulators, etc.
 - d. Resistance in aerial and ground.
- (2) Useful.
 - a. Loss due to radiation of signals.

There are various sources of error in the measurement of the resistance of any aerial system, and, even with the most care, results may be obtained which are far from the true value, due to some instrument not behaving as assumed. This is particularly true of the condensers which have been assumed to have zero resistance. Unfortunately this is never true, but with most condensers resistance has a value sufficiently low not to affect the results too much. Since *L* consists of only a few turns, its resistance is low, and need not cause trouble. The value of the resistance of *C* and *L* may be measured, as will be explained later, and added to the resistance found at *R*, if the results are to be accurate. But, with most amateur work, this refinement is not needed. If care is taken, relative values will be obtained which

It's the contact that counts

A CAREFUL examination will show that each contact in Na-ald sockets and adapters is of a wiping nature on a broad surface, and so designed that strong tension is permanent, no matter how often the bulbs may be removed or how much the connecting prongs in the tubes vary. Na-ald sockets are moulded of Bakelite, with uniform cross-section and cure, and other engineering features incorporated to avoid plate to grid losses and to insure that each tube develops its fullest efficiency.

The new Na-ald dials combine rare beauty of design with highest efficiency in use. These dials are moulded from genuine Condensite in such a way that absorption losses are reduced to a minimum. Knobs are so shaped that fingers do not conceal clear numerals and graduation on the bevel of Na-ald dials.

Na-ald Circuit Booklet packed with each Na-ald product

Write for "Why a Bakelite Socket?" and other descriptive literature

Alden Manufacturing Company

Manufacturers of sockets and dials for every radio requirement

Dept. H 52 Willow Street
SPRINGFIELD, MASS.

Cable Address, Aldenco



Na-ald Special Socket No. 499 for U.V. 199 Tubes Price 50c



Two-in-One Socket for W.D. 11 and 200 Tubes No. 450 Price 50c

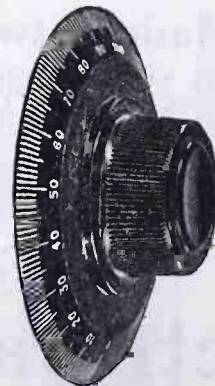

No. 3783—4 3/16-in. Insert 1/4-in. Insert 3/8-in. Dial Price 75c 2 and 3-in. Dials 35c, 3 for \$1.00



Adapter No. 429 for U.V. 199 Tubes, Price 75c



De Luxe No. 400 Price 75c



Small-space, No. 401 35c, 3 for \$1.00



Na-ald W. D. 11 No. 411 Price 75c

Tell them that you saw it in RADIO

will show a great deal in regard to absorption of the waves from the aerial by nearby objects, and remedies taken if possible.

The radiation resistance may be computed very approximately from

$$R=1590 \left(\frac{h}{\lambda}\right)^2 \text{ ohms}$$

in which h is the height in meters, and λ the wavelength considerably greater than the fundamental.

RECENT PATENTS

Continued from page 38

D. G. McCaa, Pat. No. 1,459,786; June 26, 1923. Method of and apparatus for electrical communication.

A receiving system is described that is intended to block out static or other interferences. For this purpose continuous waves are transmitted and modulated with a frequency above audibility. At the receiving end, the detector V_2 is arranged to affect the inductance coils P_1, P_2 so that they produce equal in-phase magnetomotive forces of modulating frequency. The coils S_1 and S_2 coupled to P_1, P_2 are caused to affect equally the telephone P_h , through the intermediary of a double tube V_3 and a transformer T_s . In order to disturb the balancing out effect of coils P_1 and P_2 on the phone P_h a local source of oscillations V_4 is used, which produces beats at audio frequency and in opposite directions in coils S_1 and S_2 , and therefore audible signals in phone P_h .

"Hear it by Radio"
 Denver's Largest Exclusive Radio
 Wholesalers
PARAGON DISTRIBUTORS
 THE ROCKY MOUNTAIN RADIO
 CORPORATION
 1512-1516 Broadway Denver, Colorado

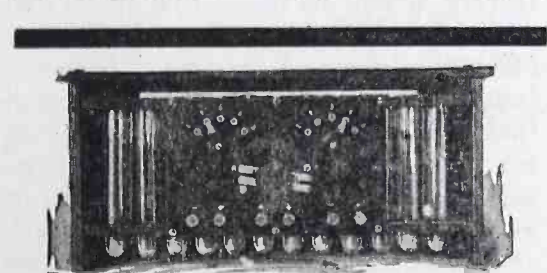

100 Volt Panel (New Type)

KICO Storage "B" Batteries give long service at low cost

Alkaline type, will not sulphate or buckle. Life unlimited. Not harmed by short-circuiting, overcharging, or standing idle. Panel switches afford single cell variations. Easily re-charged from any 110-volt A.C. line by means of small home rectifier. One charge lasts three to six months in detector plate circuit.

Prices without rectifier:		Plain	(With Panels)
16 cell	22 volt...	\$5.50	
24 cell	32 volt...	\$7.25	\$11.75
36 cell	48 volt...	\$9.50	\$14.00
50 cell	68 volt...	\$12.50	\$17.00
78 cell	100 volt...	\$17.50	\$22.50
108 cell	145 volt...	\$23.50	\$28.50
Unmounted rectifier..		\$1.00	
Mounted rectifier...		\$2.50	

SATISFACTION GUARANTEED

All batteries are sold with the privilege of receiving your money back if not satisfied within a 30-day trial. Write for full information on "A" and "B" Batteries.

KIMLEY ELECTRIC COMPANY, Inc.
 2669 MAIN STREET BUFFALO, N. Y.

Whether You "Build Your Own" or Buy Complete Sets—Rely on De Forest

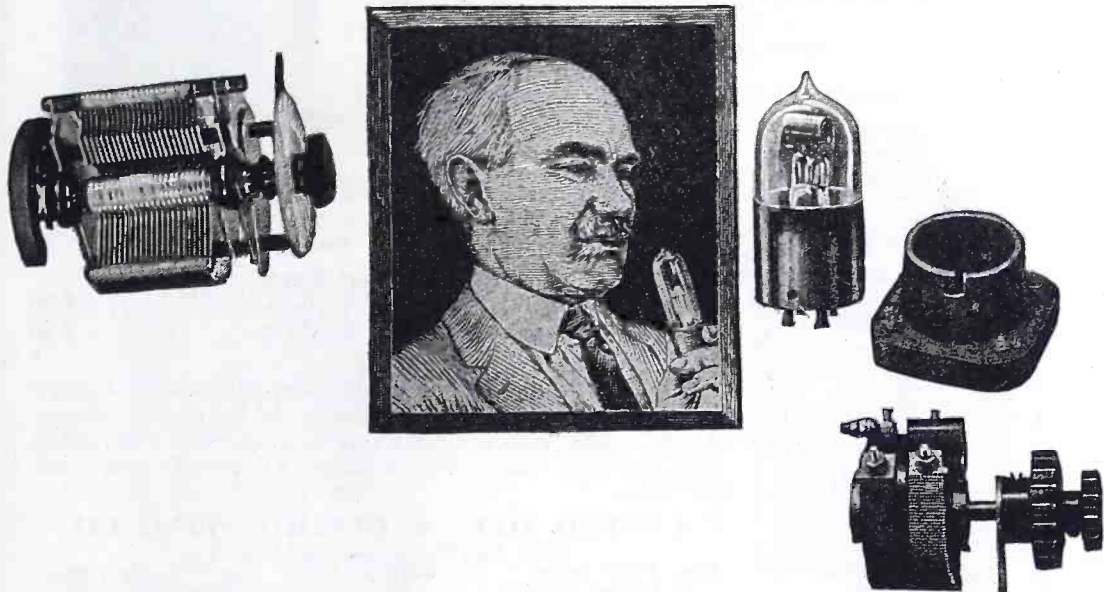

Before anyone else was thinking of radio, nearly a quarter of a century ago, Dr. Lee De Forest was doing the first radio broadcasting.

All during the development of the art the De Forest Company has been making the laboratory tested parts, out of which experts all over the United States made their experimental sets.

When radio became popular the people in general found out that if a part was marked "De Forest"—it worked.

During the "rush months" when radio production couldn't catch up with the demand, De Forest parts were still manufactured with that painstaking care and exactness and knowledge of electrical science which mean the best possible kind of service to the user.

The De Forest name has always been too famous for the De Forest Company to allow anything to go out which was not laboratory tested and guaranteed to function.

Ask the De Forest Agent to show you the laboratory tested De Forest parts. Ask him to tell you about the various hook-ups which are possible. If you are interested in complete sets let him show you the famous De Forest Reflex, whose range on indoor-loop varies from 1,500 to 3,000 miles, according to atmospheric conditions, and which is known all over the country for clearness of reception and unusual ease of control.

Whether you "build your own" or buy complete sets, rely on De Forest—the most famous name in radio.

Send us a postcard for the free De Forest catalog with complete details of sets, parts, and the perfected De Forest dry cell and wet cell audions.

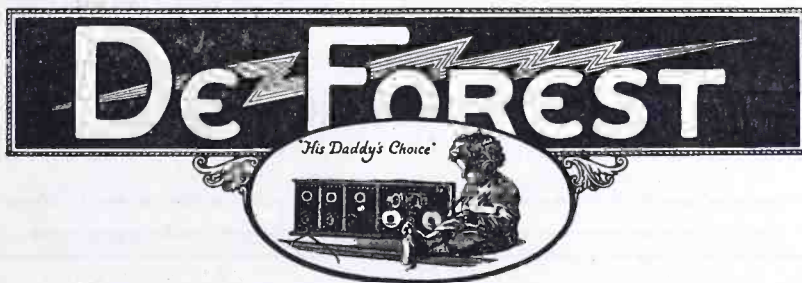

De Forest Radio Tel. & Tel. Co.
 Dept. R-2 JERSEY CITY, N. J.

If located West of Pennsylvania Address

De Forest Radio Tel. & Tel. Co.
 Western Sales Division
 Dept. R-2, 5680-12th St., Detroit, Mich.

De Forest Products are sold only through exclusive agents, direct to the public for your protection. The De Forest Company will be glad to hear from representative dealers in various communities who wish to become exclusive De Forest agents.

Illustrated above are the De Forest Vernier Variable Condenser, \$15.60; the De Forest Combination Audion, \$5.00; the De Forest Tube Socket, 80c; and the De Forest Combination Rheostat and Potentiometer, \$2.00. Prices plus approximately 6% for transportation west of the Rockies.

Tell them that you saw it in RADIO

This "UNITED" Audio Frequency Amplifying Transformer

is a little "gem" of radio engineering—magnetically shielded, Ratio 5 to 1—a wonder-worker in producing loud, clear-toned signals, from any distance. At your dealer's \$4.50.

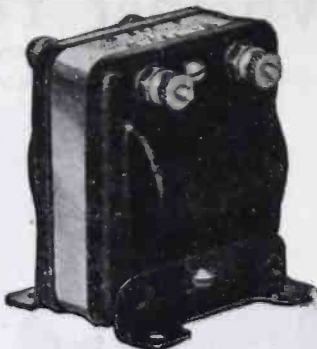

"United" Variable Condensers have a new vernier dial assembly, original with us, that makes fine tuning a joy.

43 plate.....	\$6.50	5 plate.....	\$5.00
23 plate.....	6.00	3 plate.....	4.75
11 plate.....	5.50	Postpaid.	
Price Without Vernier			
43 plate.....	\$4.00	5 plate.....	\$2.50
23 plate.....	3.50	3 plate.....	2.25
11 plate.....	3.00		

Show this ad to your dealer and ask him to supply your needs at the above prices. If he cannot do so, remit to us direct, under our money-back guarantee and give us name and address of dealer you wish to favor.

UNITED MFG. & DISTRIBUTING CO.

9705 COTTAGE GROVE AVENUE,
 New York Office: 50 Church St. New York, N. Y.
 CHICAGO, ILL.
 San Francisco Office: 709 Mission St. San Francisco, Calif.

SHOP PRACTICE

Continued from page 26

less purposes, but among them are the common operations of turning engine cylinders, pulleys, etc.

Speed lathes are operated at quite a high speed, and are so equipped that the tool is held in the hands of the operator, the actual rotation of the work, except as refers to the facility of cutting, bearing no relation to the tool itself. Speed lathes are, primarily, wood lathes, where a high rotative speed is necessary for proper cutting. For turning brass or bronze and some grades of steel and iron, such lathes, equipped with suitable "chucks" which hold the work firmly, can be used with equal facility, as with wood-working, and even more rapid work can be performed on them than can be done with the more cumbersome, though more accurate, engine lathe.

In the construction of radio apparatus, generally, we will be interested in making many small, light parts, such as switch points, knobs, etc. Screw-cutting is more or less of an uncommon operation, as standard dies can be obtained that will cut most of the threads used with much less expenditure of time and labor than can be cut by the aid of such a lathe. The lathe will be found most handy, as well, for winding various inductance coils, and is almost indispensable in winding bank-wound inductances. Therefore, we will rarely find that the screw-cutting lathe is essential, and a speed lathe will serve nicely. On the other hand, a screw-cutting lathe will handle larger and more cumbersome work than the other, and furthermore, if it is necessary to use the screw-cutting feature, it will be found that the actual need for it is really great, and this may offset the increased cost over the speed lathe. It must also be borne in mind that when a screw-cutting lathe is used for general cutting besides screw-cutting, an automatic feeding feature is available, which operates the tool carriage, and enables the turning of accurate cylinders without any effort on the part of the user, other than to set the tool, as required, and to allow it to feed, while a similar operation on a speed lathe would be an extremely hard thing to do. Speed lathes are sometimes equipped with hand-operated tool carriages, which serve fairly well, but generally the screw-cutting lathe is much more desirable than the other type.

Screw-cutting lathes are again classified into two general types, i.e. "standard" and "quick-change." By a standard lathe we mean that the main spindle, to which the work is attached, drives a gear train that in turn operates a long screw, which runs along the front of the lathe, and this screw operates the tool carriage through a system of screws and gears, with a result that the car-

Continued on page 80

The Trinity Loud Speaker



TYPE "A1"
 \$25.00
 21-in. Fiber Horn

The only device of its kind in the Radio field

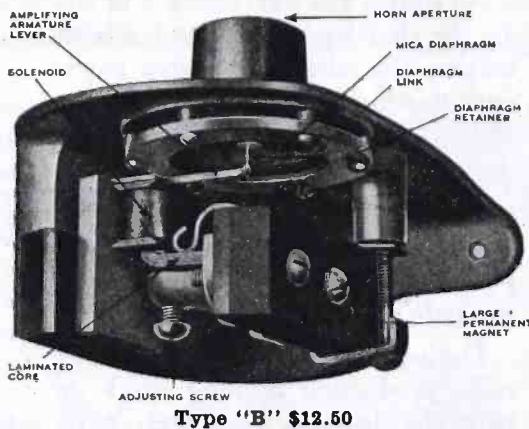

Study the illustration carefully and you will understand why it produces full, clear, natural tones with perfect reproduction of all vocal and instrumental music. May be used with phonograph. No storage battery required.

The Trinity Loud Speaker is an instrument that combines the best qualities of a phonograph reproducer in combination with electro magnetic principles best fitted for radio amplification. Absolutely perfect reproduction of all music and speech without distortion. The volume may be regulated from that required for a room in your home to a tremendous output that can be heard hundreds of feet out of doors by simply increasing "B" battery voltage. No storage batteries required. The instrument is of a heavy duty type and is guaranteed fully by the manufacturers.

Ask your dealer for demonstration—if he cannot we can.

TRINITY RADIO CORP.

446 Tremont Street

BOSTON, MASS.

IMPROVE YOUR SET BY USING THE Welsh Peanut Tube

Strong, velvety tone, no distortion, low initial cost; economical to operate, uses about ¼ amp. Can be operated on storage battery or THREE DRY CELLS. Filament 4 to 6 v. Plate 16½ to 32 v.

Price \$2.00

Special Sockets..... 40c
 Adaptors..... 75c

At your dealer, otherwise send purchase price and dealer's name, and you will be supplied post paid.

Jobbers and dealers write for our special proposition.

Manufactured only by the

WELSH ELECTRIC LAMP CORP.

Boylan Street Newark, N. J.

BEWARE OF IMITATIONS

Tell them that you saw it in RADIO

Last night he could hardly hear the station in his own home town



Tonight the whole world is in his home

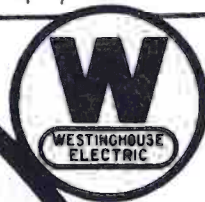
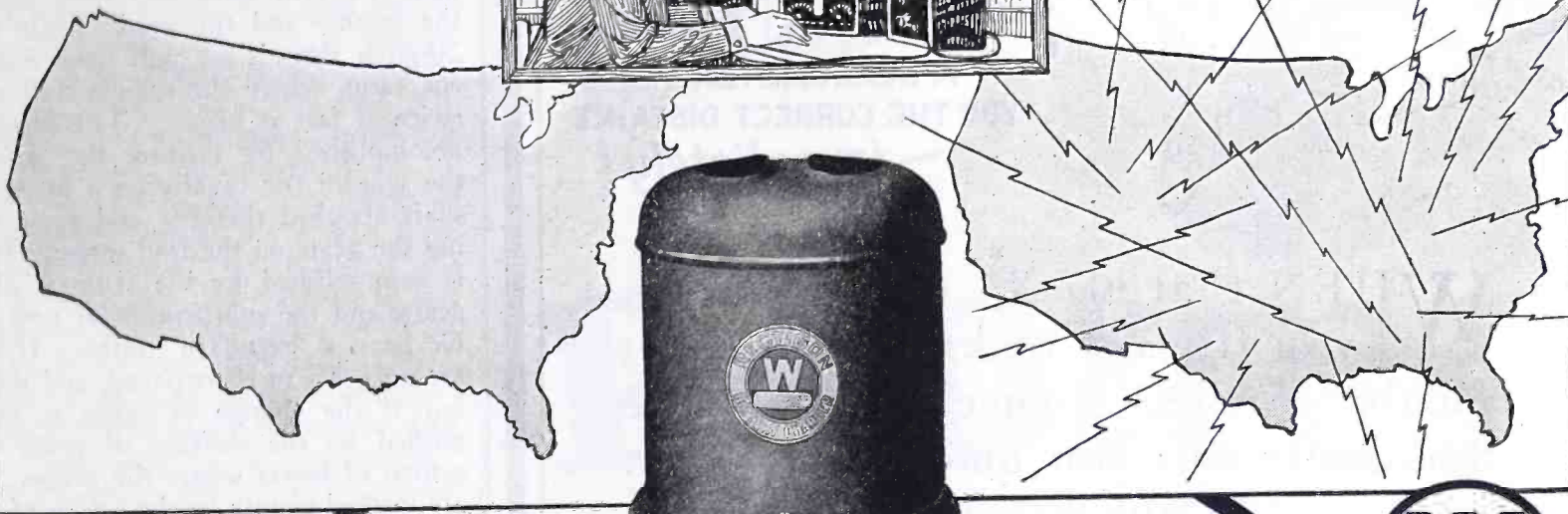

The Rectigon made all the difference

His battery was badly in need of charging. He didn't have time to lug it to a service station, call for it and bring it home again. As a consequence his set wouldn't work right because of "no juice."

The next day he had a Rectigon Battery Charger sent home, called his wife and had her attach it to the run down battery. That night the whole world was in his home because he had a battery full of "pep" to furnish power for his set.

Are you in this man's shoes?
If so, follow in his footsteps.

The Rectigon is a small, inexpensive device made especially for charging radio batteries. It is entirely automatic in operation and as simple to attach as an electric toaster. It is light and portable. The freedom from oil and grease assures against damage to your floors and rugs.

Westinghouse Electric & Manufacturing Company
East Pittsburgh, Pennsylvania

Westinghouse

Tell them that you saw it in RADIO

Continued from page 78

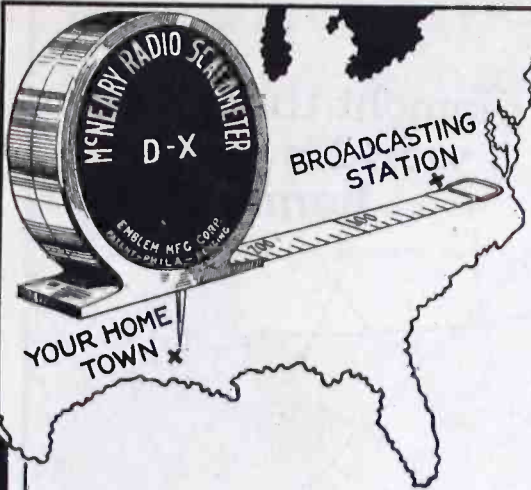

don't guess!
A SCALOMETER TELLS YOU THE CORRECT DISTANCE — immediately!

WHEN that "D X" call comes in, you'll want to know the exact number of miles. No need to guess! The Scalometer tells you quickly--correctly.

With the Scalometer mounted on the official Radio Map at your receiving point—extend the tape to the broadcasting point—and you have in plain type the exact mileage.

Complete

\$1.00

Get the complete set—the Scalometer, the official Radio Map and comprehensive Broadcasting Directory—all for \$1—at your dealers, or write us.

Emblem Mfg. Corporation

251 Middle City Building
 Philadelphia

McNeary RADIO Scalometer
 OFFICIAL RADIO MAP AND BROADCASTING DIRECTORY

riage moves at all times, while in gear, with a direct ratio of motion to the rotation of the work. The process of changing the various gears requires that the gears attached to the "lead screw" (which moves the carriage) be so arranged that they can be shifted, say, where we are cutting threads of 10 per inch, we will have one ratio between the spindle and the work, while for a 20-pitch thread, we will have a different ratio, where the spindle will travel twice as fast as before. This change is accomplished by shifting the gears on the spindle (or usually on a small idler shaft attached thereto) and again shifting the gears on the lead screw. If this is accomplished by the removal of the gears, and the substitution of new ones, we have a "standard" lathe. If there are no gears to be removed, and shifted, but if the change in ratios is accomplished by the shifting of gears by a system of levers where the proper gears are meshed simply by the action of these levers, we have a "quick-change" lathe. The latter gives the operator the choice of any screw threads within the limit of the machine, by means of simply changing the position of the various levers, which are set for the positions marked for the thread desired. In the standard lathe, it is necessary to make this change by the actual removal of the gears in use, and the substitution of the ones desired. This process takes time, and if many different threads are to be cut, the use of the quick change lathe will quickly pay for itself in the time saved. On the other hand, in the usual amateur's shop screw-cutting is rather the exceptional process, and a standard type lathe usually will serve with entire satisfaction.

This size of lathe depends on the purchaser's pocketbook, as well as his needs. A lathe with 7- or 8-in. "swing" (which means that an object 7 or 8 in. in diameter can be turned) is of rather small size, commercially, but usually it will answer all the requirements of the amateur shop. A larger lathe is very much more costly, although a 10- or 11-in. lathe is much to be preferred. Besides the "swing," lathes are also figured as to the length of the object they will handle. For example, a common size is a 12x48-in. lathe. This means that objects up to and including 12 in. diameter, and up to 48 in. in length can be put in the lathe. This does not mean, of course that it is possible to take a steel cylinder of the above size, as the average lathe is not strong enough for such work, but it does mean that pieces of work within these limits can be handled. Lathes capable of handling such large jobs are usually referred to as "heavy duty" types, and are specially built and constructed so they will stand up under

TUBES REPAIRED

We repair vacuum tubes and guarantee them to work like new. Money refunded if not satisfied.

WD 11—WD 12.....	\$3.50	C 300—C 301.....	\$3.50
A. P. & DeForest.....	3.50	201A—301A.....	3.50
UV 201—UV 301.....	3.50	UV 199.....	3.75
5 Watt tubes.....	\$5.50		

No tubes other than those listed above will be accepted.
 Broken Glass Shells replaced—No extra charge

172 Fifth Street **AL. D. BERGEZ CO.** San Francisco, Calif.

Tell them that you saw it in RADIO

enormous strains and loads, which would quickly ruin one of the ordinary type.

If it is not possible to obtain a screw-cutting lathe, it is well to purchase a good "speed" lathe. Most lathes of this type are built for wood-working, but they will serve equally well for light metal-working and coil winding. Owing to their lower price, they may be more easily obtained. It is usually possible to purchase lathe headstocks, tailstocks, counter-shaft and tool rest, separately, and unmounted, from machinery dealers. Such machines are intended to mount on two edgewise wooden planks, which serve as a lathe bed, and generally are intended for wood-working only, but can be used just as well for the light classes of work usual to the amateur radio shop.

Besides a lathe, the other most important machine tool in the shop is the drill press. The type called a "sensitive" drill is the most useful. This is made with either separate drive or built-in motor, and is equipped with a chuck which will take drills from "nothing to 3/8 inches," as the trade term expresses it. There are not the types or styles to choose in drill presses that there are in lathes, but the user cannot go far wrong in the purchase of any of the power-operated types. They cost but little more than the hand-power presses, and a fractional horsepower motor can be obtained with very small expense. In general, the use of the so-called "hand" presses should be avoided, as even the best are clumsy. They all depend for their operation on the turning of a handle, which occupies one of the user's hands, and many of them require, in addition, the use of the other hand to "feed" the drill, thus making it impossible to hold the work except with clamps. If no driving power is available, it would even be preferable to arrange a foot power affair to drive a drill press of the power-driven type, than to bother with the hand-operated ones.

A grinder and buffer is desirable. This may vary from a small grinding wheel screwed to the shaft of a discarded fan motor, to a complete set of two buffing and grinding wheels, which will be driven by a belt from the main shaft, or equipped with a large driving motor. Both of such grinders have their purposes and uses. Small ones are desirable for the sharpening of drills and small tools, but if a job of even moderate size comes up, it will be found to be an extremely slow process to attempt to perform it on a small grinder, and it will become even more tedious on a small buffer. The actual selection of a grinder and buffer is left to the user.

A number of tools will be needed for the lathe, drill and grinder, the most important being listed below. These

*The
Supreme
Insulation*



RADION Panels

are
impervious to
moisture

Moisture is a conductor of radio frequency currents. When a panel or part absorbs moisture from the air it causes short circuits between terminals. These short circuits reduce volume and frequently are the cause of distortion. Tests have proved Radion Panels impervious to moisture. Try them and notice the difference. Send 15c for sample test pieces, 2x3 inches.

18 STOCK SIZE PANELS

Radion being an insulation material especially made for wireless use, has the lowest phase angle difference, lowest dielectric constant, highest resistivity and supreme moisture, gas and acid repelling properties.

AMERICAN HARD RUBBER CO.

11 Mercer St., New York

RADION

Panels - Dials - Knobs - Sockets - Insulators

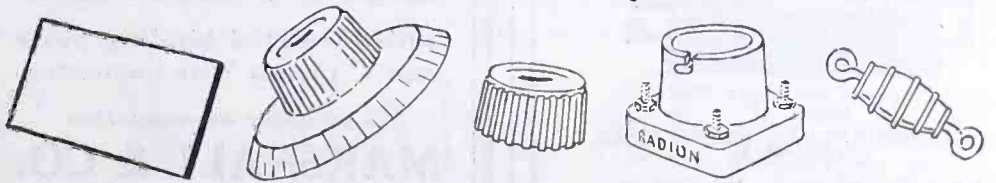

Tell them that you saw it in RADIO

BAKELITE — Condensite — REDMANOL

for Dials

Accuracy of dimension, beauty of color and finish, high dielectric and mechanical strength characterize Radio Dials molded of Bakelite — Condensite — Redmanol.

These properties are permanent; for this material is unaffected by extremes of temperature, does not absorb moisture; will not fade even when exposed to strong sunlight, and neither age nor use causes it to deteriorate.

All the leading makes of dials are molded of this material. Be sure those you buy are made of it.

BAKELITE CORPORATION

Address the Divisions

GENERAL BAKELITE COMPANY - 8 WEST 40th STREET, NEW YORK
CONDENSITE COMPANY OF AMERICA . BLOOMFIELD, NEW JERSEY
REDMANOL CHEMICAL PRODUCTS CO., 636 WEST 22d ST., CHICAGO

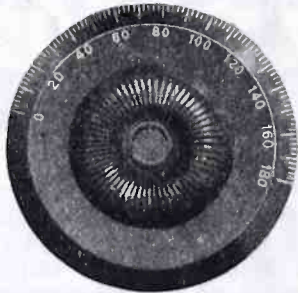
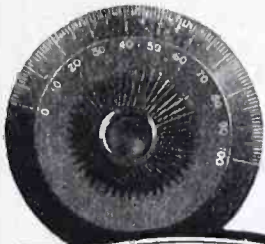

BAKELITE
Condensite
REDMANOL

are the registered Trade Marks for the Phenol Resin Products manufactured under patents owned by BAKELITE CORPORATION

THE MATERIAL OF A THOUSAND USES

may be added to at any time, so it is far better to start with a few and add tools as the work progresses.

TOOLS FOR THE LATHE

- 1 6-in. universal three-jaw chuck, with two sets jaws and key.
- 1 set Armstrong tool holders. (3 holders, one right, one left and one straight.)
- 1 boring tool.
- 1 cut-off tool.
- 1 knurling tool, with at least 4 separate wheels.
- 1 length, self-hardening or high-speed steel for use in the Armstrong holders.
- 1 pair 6-in. outside calipers.
- 1 pair 6-in. inside calipers.
- 1 wood-working spur center.
- 2 ground pointed centers.
- 1 tailstock drill chuck.
- 3 hand "gravers" ground as needed.
- 1 "hand" tool rest.
- 1 hand knurling tool.
- 1 hacksaw.
- 3 lathe dogs, up to 1.5-in. capacity.
- 1 small face plate.
- 1 medium face plate.
- 1 medium, wood-working face plate.
- 1 12-in. steel rule.
- 1 1/2-in. skew chisel.
- 1 3/4-in. skew chisel.
- 1 1-in. skew chisel.
- 1 cutoff tool, for wood working.
- 2 or 3 various woodworking gouges.
- 1 oil can.

The tool equipment outlined above is sufficient for most ordinary work. Some of the more delicate and accurate instruments that are in common use in machine shops have been omitted purposely, as in general, in radio manufacturing, the user is not restricted to the limits of accuracy encountered in more precise machine work, although the use of micrometer calipers, surface gages, etc., etc., will undoubtedly insure greater accuracy in construction and more satisfactory operation.

(To be continued)

HUNT'S UNIVERSAL HAIR-LINE RADIO TUNING DEVICE

PATENT APPLIED FOR

"EURACO PRODUCTS"

(Guaranteed)

Compact — Interchangeable — Accurate
Most Efficient



Price 60 cents per Unit
Mfgs. of

MICA CONDENSERS, GRID LEAKS,
MOUNTINGS

Interesting Proposition for Dealers

European Radio Company

1342 East 22nd Street Brooklyn, N. Y.

NOVO "B" BATTERIES

with insulated binding posts
and 7" Copper Wire Connectors

Pacific Coast Representatives

MARSHALL & CO.

Union League Bldg., Los Angeles, Calif.

Overcomes Body Capacity

Gives micrometric adjustment
outside the field of inductivity.

Tested and approved by amateurs and experts. Enables you to tune distant stations easier and more clearly. Simple as A B C. Installed from outside, no dismantling of your set necessary. Audibility made more natural or less distorted by the fine adjustments obtained. One Hunt's Device handles all dials on set or several sets. Costs only one dollar on guarantee of money refunded if not satisfied. Ask your dealer or order direct from Hunt Co., 484 Shrine Bldg., Memphis, Tenn.

Tell them that you saw it in RADIO



High Efficiency
HEAD SETS

- Army and Navy Type:
2500 ohm, per pair.....\$10.00
3200 ohm, per pair.....\$12.00
- Swedish-American Type:
2200 ohm, per pair..... \$8.00
- Victor Type:
Double pole, single coil, per pair \$6.00
- Keystone Type:
Double pole, single coil, pr. \$5.00

American Electric
COMPANY

CHICAGO, U. S. A.

For 30 Years Makers of Good Telephones



Climatic changes eventually spread a film of oxidization over the surface of plates and spacers. A high resistance is set up to the radio frequency currents. U. S. Tool Condensers are protected against oxidization by a patented chemical process, developed after tireless research and experiment.

U.S. TOOL CONDENSERS

*Plates and Spacers
Chemically Treated
to Prevent Oxidizing*

The greatest enemy of condenser efficiency—oxidizing of plates and spacers—is conquered in U. S. Tool Condensers, as described in the adjoining panel. Years of continual use and exposure leave these condensers unharmed—as perfect as the day they were purchased. Built to maintain a reputation, gained thru years of honest manufacture. Every other feature of these condensers is as thoughtfully evolved. Write for illustrated booklet and the name of the nearest U. S. Tool dealer—TODAY!

U. S. TOOL
COMPANY INC.
114 Mechanic St.
Newark, N. J.

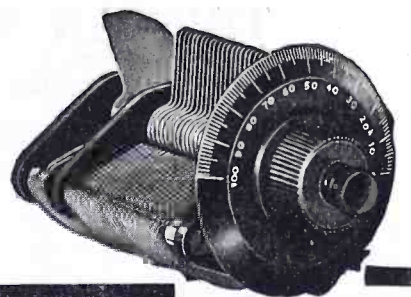

THE CONDENSER SENSATION OF MODERN RADIO



Through the accuracy and dependability of Freshman Condensers, hookups and circuits have been perfected which have completely revolutionized the art of Radio Reception.

These little storers of energy and rectifiers of Radio Current are the very heart of a well-built radio set.

The proper fixed condenser will make all the difference in the world in the reception, clarity and selectivity your set affords.

Capacity	Each	Capacity	Each
.0001	.35	.002	.40
.00015	.35	.0025	.50
.0002	.35	.003	.60
.00025	.35	.004	.75
.0003	.35	.005	.75
.00035	.35	.006	.75
.0005	.35	.008	1.00
.0006	.40	.01	1.00
.0008	.40	.015	1.50
.001	.40	.02	1.75
.0015	.40	.025	2.50

The FRESHMAN is so designed that constant equal pressure is exerted on the condenser plates over the entire area. They are the only condensers that do this and therefore the only condensers that avoid noises, which are due to variable pressure on the plates.

At your dealers, otherwise send purchase price and you will be supplied postpaid.

Chas. Freshman Co. Inc.
Radio Condenser Products
106 Seventh Avenue New York

"ALL-AMERICAN"

*Sets another
World Record!*

THE reception on board the Berengaria, night after night, of the signals from the Drake Hotel, Chicago, during the entire voyage, from New York to Cherbourg, France, a distance of 4000 miles, was a world record achievement for consistent reception. The set used employed "All-American" Amplifying Transformers.

Today another record is being made. Slowly winding its way up into the frozen North is the Bowdoin, on board of which is Captain Donald B. McMillan, on a scientific expedition to the North Pole.

Night after night, up in the Arctic Ocean, he is listening to the world thousands of miles south of him. Again "All-American" Amplifying Transformers are being used, and again new world records are being achieved.

You, too, can set new records with your own set by the use of "All-American" Amplifying Transformers.

Ask your dealer to show you these world record-breaking instruments. They are as attractive as they are efficient.

Book of Successful Hookups sent free on receipt of 2c for postage.

RAULAND MFG. Co.
200 No. Jefferson St., Chicago, Ill.

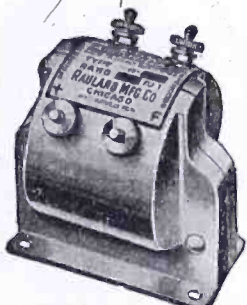
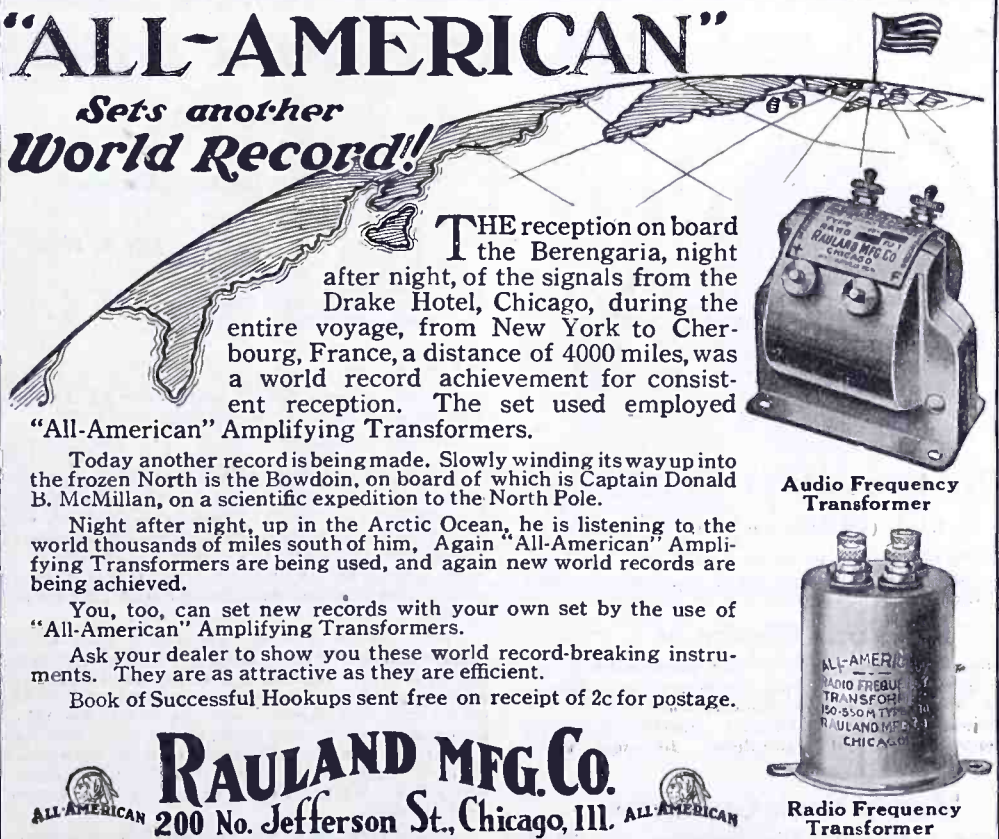

Audio Frequency Transformer



Radio Frequency Transformer

C. W. MANUAL

—Only 25 left.
\$1.00 per copy
"RADIO"
Pacific Bldg.,
San Francisco

Tell them that you saw it in RADIO

At Last
THE GENUINE REINARTZ

Each coil bears a facsimile of John L. Reinartz's signature.

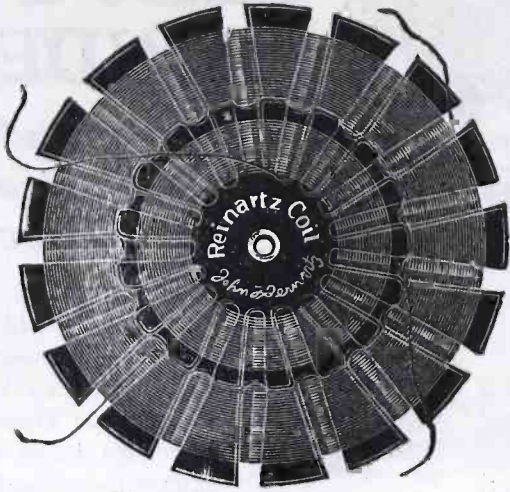

Covers all broadcasting wave lengths now used.

Made under John L. Reinartz's specifications by The Eugene T. Turney Laboratories, Inc., exclusively.
Primary Coil—57 turns—8 taps.
Secondary Coil—45 turns—2 taps.
Diameter 5½ inches. Bakelite cores.
Packed in individual boxes. With new copyrighted Reinartz hookup.
List—\$2.50. Standard package 3 doz.

Jobbers and Dealers write for discounts

TRISTAN SALES CORPORATION

Dept. B

SOLE NATIONAL DISTRIBUTERS

No. 1 Union Square

New York City, N. Y.

REGIONAL REPRESENTATIVES:

Baker-Smith & Co.
741 Call Building
San Francisco, Calif.
Walter I. Ferguson & Co.
208 Baltimore Bldg.,
Kansas City, Mo.

Amalgamated Lamp Co.
1220 West 6th St.,
Cleveland, Ohio

O. P. Smith Co.
205 W. Harrison St.,
Chicago, Ill.
C. L. S. Holmes Co.
601 Boston Block,
Minneapolis, Minn.

INDUCTANCE COILS

Continued from page 31

5 and 7. Thirdly alternate layers, aa^1 and cc^1 , are wound so that parallel turns of one layer fall in *between* parallel turns of the other layer. The total effect is to increase spacing between turns and layers, interpose considerable air dielectric, and thereby decrease distributed capacity and effective resistance of the coil. Table I gives the constants of some of these coils.

TABLE I.
Honey-Comb Coil Constants

No. of Turns	Inductance Milli-Henries	Natural Wave Length Meters	Distributed Capacity m. m. f.
35	0.074	86	30.0
100	0.60	220	22.0
250	4.10	420	12.0

Fig. 10 illustrates the most recent type of such coils. The construction of this coil differs from the above, being based on the theory that most of the distrib-

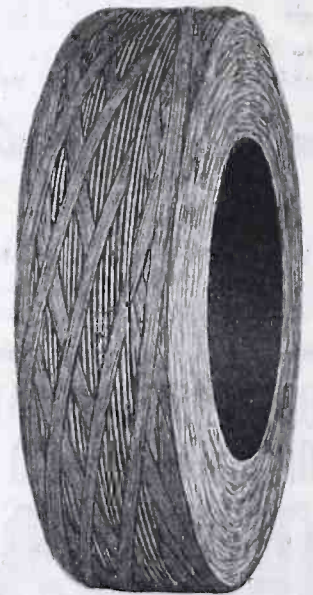
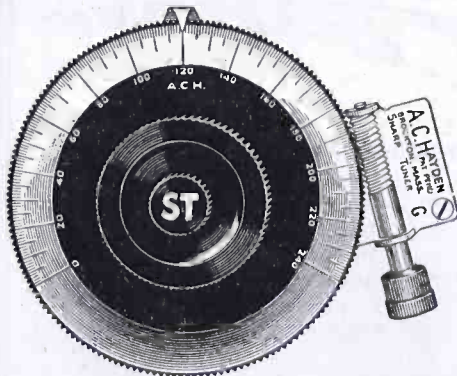

Fig. 10. Remler-Giblin Coil

uted capacity resides between layers, the distributed capacity between the turns in any one layer being very small in comparison. As a result, the turns in each layer are wound close together. In this way more inductance is secured for a given length of wire than if they were spaced. Secondly, the turns are wound in planes perpendicular to the coil axis, thus using a minimum length of wire for one turn. By these means maximum inductance is obtained with a minimum length of wire and the ohmic resistance is thus reduced to a minimum. The increase in distributed capacity due to winding turns of any given layer closely is more than counterbalanced by the decrease in distributed capacity between layers. This decrease is effected by winding layers of cotton yarn of good dielectric qualities between layers, thus spacing the layers. Furthermore, the yarn is wound in lattice fashion, that is, diagonally like the wire in Figs. 8 and 9, so that maximum air dielectric is interposed. The net effect is again to

USE A.C.H. SHARP TUNER DIALS



READ THIS

HOOD RIVER NEWS COMPANY

July 9, 1923.

A. C. Hayden Radio & Research Co.,
Brockton, Mass.

Gentlemen:—

Please send me collect one of your A.C.H. Sharp Tuners with 4-inch Dial by mail C. O. D.

We are owners of Radio K. Q. P. the oldest up-state broad-casting station in Oregon. We have been using your A.C.H. Tuners for over a year having purchased three from the Blue Diamond Electric Co. of this city. We have found them entirely what you claim for them and although we did not like the proposition of having to cut down the shafts of our Variometers and Condenser, we found that the results justified the sacrifice of about half an inch of shaft.

With the aid of these Tuners on a three Circuit Regenerative Set the tuning is so close that signal strength nearly resembles that obtained on a Super Heterodyne Set. We propose to use the 4-inch Dial on a Condenser shunted across a box of special design wound spider-web style, which is not only very directional but also extremely critical, so much so in fact, that the ordinary Vernier Condenser is unreliable. We want the 4-inch A.C.H. Tuner for a ¼-inch shaft.

Please forward at your earliest convenience.

Yours truly,
HUGH G. BALL,

Radio Station Hood River News.

Why the A.C.H. is different

3 in. DIAL (156-to-1) 4 in. DIAL (215-to-1)

Positive movement, no friction to slip, and no back lash in the spiral machine cut worm gear. (Not Moulded.)

Your Choice of

Rough tuning with dial or one thousandth of an inch in either direction with the Sharp Tuner Knob. Both controlled by center Knob ST. Eliminates a vernier condenser. Locks instrument automatically. Dial grounded, reducing body capacity.

Money Back Guarantee

Price A. C. H. 3-inch Dial, complete.....\$2.50
Price A. C. H. 4-inch Dial, complete..... 5.00
Regular fitting 5-16-inch hole, ¼-inch and 3-16 inch Bushings, 5c each extra. 10c for all.

Free Plan with mail orders on request.

A. C. Hayden Radio & Research Co.

Brockton, Mass., U. S. A.

Mail Orders sent prepaid in U. S. A.

Tell them that you saw it in RADIO

decrease the distributed capacity and resistance considerably. Table II gives the constants of coils having the same number of turns as those in Table I. Both these tables give manufacturers' tests. The latter type of winding seems to be a considerable improvement over previous coils.

TABLE II.
Giblin-Remler Coil Constants

No. of Turns	Inductance Milli-Henries	Natural Wave Length Meters	Distributed Capacity m. m. f.	Operating Wave Length Range, with .001 m. f. Condenser
35	.078	87	25.4	128-550
100	.67	217	19.9	380-1550
250	4.2	424	12.1	860-3880

These coils are made in a number of different sizes, each being designated by the number of turns in the coil, having fixed inductances. No dead end losses can therefore exist. Each coil is suitable for operation in a certain band of wavelengths. By this device maximum efficiency in reception is obtained. When different bands of wavelength are to be received the suitable coil is inserted, the design being such as to facilitate easy change of coils. The natural wavelength of each coil is lower than the lowest operating wave for which it is intended. Hence there are no losses due to absorption.

In addition to the electrical advantages these coils have the great advantage of compactness, incorporating a maximum inductance in a minimum space. The form of this type of winding closely approximates the most efficient shape, that is it gives the most inductance for the amount of wire used. The average dimensions of these coils are: inside diameter 2 in., outside diam-

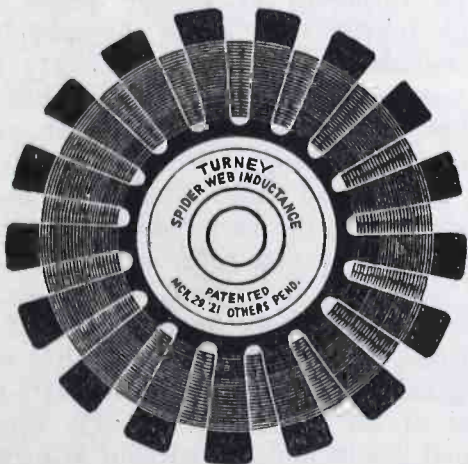
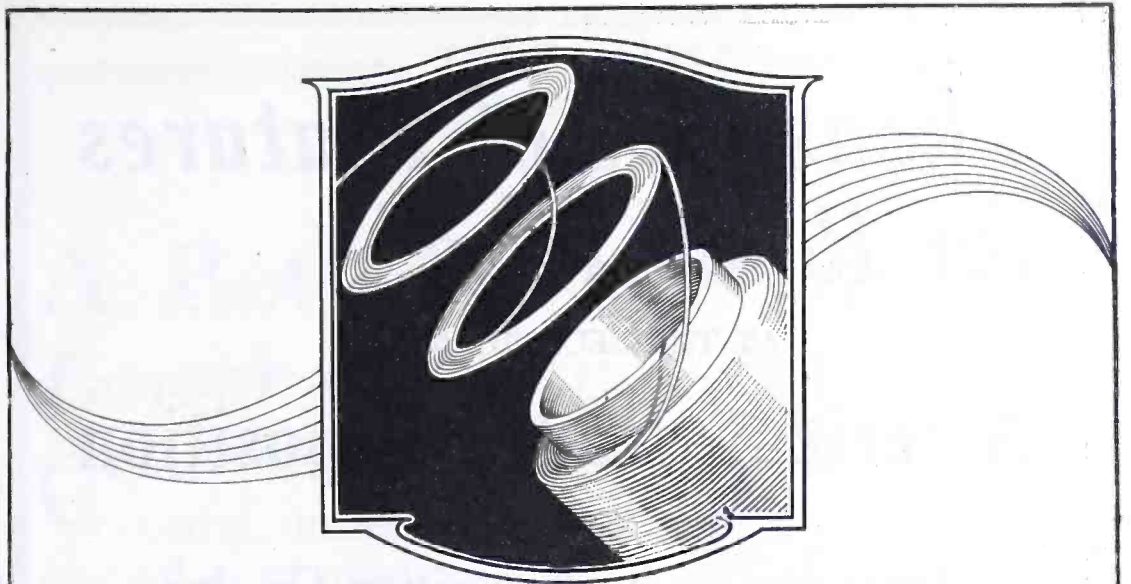

Fig. 11. Spiderweb Coil

eter, 2 1/4 in. to 4 1/2 in., width 1 in. For the same range of inductance a cylindrical coil would vary in size approximately as follows: diameter 3 in. to 5 in., length 1 1/2 in. to 6 in. The saving is obvious.

Spiderweb Coils

Another type of coil which has a very high degree of efficiency is the spiderweb shown in Fig. 11. The coil



Helical Wound Coils

—less distributed capacity, no distortion, and 40% more amplification

ONLY one transformer has or can have Helical Wound Coils, so only one transformer can give you the results you want. That is the Samson HW-A1 Audio Frequency Transformer.

Helical Winding lays a very much less number of turns in each layer than any other method of winding. Consequently there is less electrical pressure between adjacent wires and less distributed capacity.

Test the Samson yourself; prove to your own satisfaction what everyone who has ever tried the Samson has discovered—that it is the most satisfactory audio frequency transformer possible to produce. Ratio: 6 to 1. Price, \$7.00.

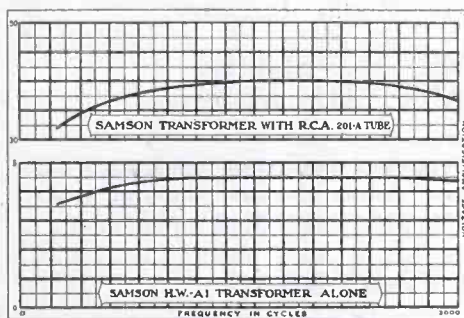

SAMSON ELECTRIC COMPANY
FACTORY: CANTON, MASS.

Sales Offices: Boston, New York, Philadelphia, Pittsburg, Chicago, Cleveland, Detroit, Indianapolis, St. Louis, Minneapolis, San Francisco, Los Angeles, Portland, Montreal, and Toronto.

Samson
HW-A1
AUDIO FREQUENCY
Transformer

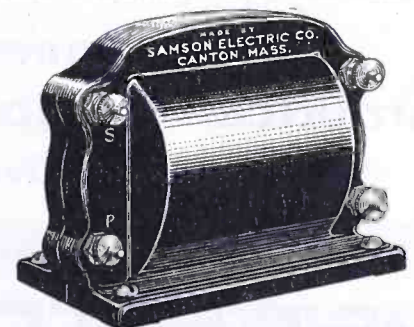

is wound on an insulating form with protruding teeth. It has just enough solid dielectric to support the winding and give it rigidity. The rest of the coil dielectric is air, and dielectric losses and distributed capacity are considerably reduced. The wire is woven over and under alternate teeth. Successive layers of the coil are therefore not on the same side of any given tooth. This increases the spacing between turns and decreases resulting distributed capacity. Table III gives the constants of some of these coils from which it is seen that the distributed capacity and natural wave-

lengths are extremely low. Like the compact multi-layer coils they are made fixed in value, and are used principally in low wave work, namely from 100 to 600 meters. They may of course be made in larger sizes.

TABLE III.
Spider Web Coil Constants

No. of Turns	Inductance Milli-Henries	Natural Wave Length Meters	Distributed Capacity m. m. f.
26	.038	29	.6
36	.066	38	.6
40	30	70	4.6

(To be continued)

Tell them that you saw it in RADIO

Thousands of Features for Radio Fans!

AT THE SECOND ANNUAL

American Radio Exposition

Under the auspices of the

American Radio Exposition Co., Inc.
of New York

October 6-13, inclusive, 1923
(Excepting Sunday)

GRAND CENTRAL PALACE
New York

A Big Amateur Contest

for the best home-built set made by amateurs. Contest is open to all. Sets from all parts of the country, and even from Canada, will be exhibited. Valuable prizes. Write at once for complete details—don't lose any time.

Motion Pictures on Sensational Radio Topics.

Unusual Scenics and Educational Displays, Showing Recent Developments in Radio Industry.

HUNDREDS OF OTHER NOVELTIES
YOU WILL NOT WANT TO MISS

Manufacturers: There still are a few desirable locations left. Wire immediately for particulars. More and better features than last year—booth rates one-third less. Hundreds for leading manufacturers will be represented—you cannot afford to stay out.

J. C. JOHNSON, Gen. Mgr.

American Radio Exposition Co., Inc.
120 Broadway, New York

VACUUM TUBES

Continued from page 28

tion in the energy in the plate circuit which is supplied by the B battery. The incoming signal on the grid is therefore able by the control of this local source of energy to actuate the telephones much more strongly than would be the case if this amplifying property were not present, or the amplified energy in the plate circuit may be applied to the grid of a second tube and amplified again.

Because of this same amplifying property, the principle called "regeneration" may be employed. In this method of using the tube, the incoming energy is used to produce variations in the B battery energy in the plate circuit as described; and then part of this energy variation is taken out of the plate circuit and fed back onto the grid of the same tube where it again produces variations in the plate current which add to the variations previously obtained. In this way a feeble incoming signal may be re-inforced and strengthened to produce a relatively large quantity of sound when it finally is converted into that form of energy. It is by the use of this regenerative action of the tube that stations operating at great distances can be heard with a single tube.

It will immediately appear that a further use of the amplifying property of the tube makes possible the building up of a signal which is barely audible in head telephones, until it is loud enough to furnish music for a large room. To accomplish this result, the energy variation which actuates the telephone in the ordinary detector set is made to pass through the primary winding of a transformer or through a high resistance. The variations of voltage across the high resistance or across the secondary terminals of the transformer are impressed on the grid of a second tube. These voltage variations produce variations in the energy in the plate circuit of the second tube which are much greater than the variations in the plate circuit of the first tube, and which can be converted into sound by means of telephone receivers or can be used to actuate still another tube with corresponding amplification in the plate circuit of the last tube. In this way a signal can be built up without distortion to produce a volume of sound immensely greater than the feeble note you hear in the telephone receivers of your detector set.

Don't forget that the battery in your automobile makes a good source of energy for the filaments, and for a dynamotor for a portable set. Be sure, first, though, that it is a 6-volt equipment, or else rearrange things to fit the voltage it uses.

WANTED—Surplus Radio Material for Cash. Quantities. Communicate stating quantity, description, and price expected. Deal direct with the largest Radio Surplus House in the World. No occasion for a lot of communications through indirect channels. THE R-C OUTLET—Ralph Coen 303 4th Ave., New York City

11 Plate Vernier.....	\$2.20
23 Plate Vernier.....	2.55
43 Plate Vernier.....	3.35
3 Plate Condenser....	.75
11 Plate Condenser....	1.20
23 Plate Condenser....	1.55
43 Plate Condenser....	2.00
.00025 mfd. Bal. Vernier	2.70
.0005 mfd. Bal. Vernier	3.30
.001 mfd. Bal. Vernier	4.00

MONTROSE MFG. CO.
1200 Bedford Ave. Brooklyn, N. Y.

Tell them that you saw it in RADIO

WIRED RADIO

Continued from page 34

impulses jump the gaps and communication is not interrupted even when several miles of the transmission line is down. This feature of the high-frequency telephone system gives it a marked advantage for load dispatching over the conventional wire circuit telephone system.

Communication between Jackson and Battle Creek has demonstrated that even lightning storms, which will interrupt service momentarily on the transmission lines, have no effect upon communication by high-frequency telephony.

The high-frequency apparatus, or the radio units of the system, are located at the various terminal stations. Two antenna wires are strung for a short distance on the towers which support high tension power lines. One of these is a sending antenna and one used exclusively for receiving. The antenna wire is given about 12 feet clearance from the power line wire. The upper or transmitting antenna is connected to the transmitting set and the lower antenna to the receiving set.

High-frequency currents are generated by a 250-watt vacuum tube similar to those used in broadcasting stations. This tube operates on 2000-volt direct current. This high-frequency current flows into the transmitting antenna and instead of being broadcast through the air, it induces, by electrostatic and electromagnetic induction, corresponding high-frequency current in the adjacent power line and this high-frequency energy, superimposed upon the energy transmitted normally by the power line, is carried on the power line to the receiving station, where, by induction, it is led into the receiving set through the receiving antenna. This unit is an ordinary long wave, coupled circuit radio receiver. It is equipped with a detector and one-step amplifier.

The high-frequency currents generated by the 250-watt vacuum tube type oscillator are modulated by a second 250-watt vacuum tube to the grid of which the voice frequencies developed by the microphone are applied. A 50-watt vacuum tube is interposed between the relatively weak microphone circuit and the grid of the 250-watt modulator tube for the purpose of amplifying the voice frequencies.

The Great Western Power Co. of California is now using carrier current radio telephony over its 100,000-volt lines running 150 miles from Big Bend to Oakland. The system is in use primarily as a regular means of communication between the dispatching organization and the generating stations, with an early extension planned to include the principal substations.

Two 250-watt tubes, one as an oscillator and the other as a modulator,



"It Speaks for Itself"

A Better Loud Speaker Lower in Price

COMPARE this wonderful instrument with any other at any price and you will be convinced that the new TRUTONE LITTLE SENIOR has no equal.



The Trutone Little Senior, complete as illustrated

\$ 19.50

Here Is the Complete Trutone Line:

- The SR with Exceptional Volume \$25.00
- The Little SR for Home Reception \$19.50
- Type A for your Head Sets \$8.00
- Type B for any single receiver \$8.00

This loud speaker is not an experiment. Many months of research work have enabled us to build an instrument absolutely correct in its acoustic value. Y not enjoy sweet mellow tones of Radio by adding a TRUTONE to your set? You will find it speaks for itself. TRUTONE loud speakers all talk.

—Has no distortion—brings in signals with greatest volume—has perfectly designed element—and will do full justice to any radio concert. Its appearance is beautiful. Its construction is RUGGED. It is the lowest priced quality instrument on the market.

"Trutonize Your Set and You Will Be Satisfied"

Trutonize your home with the TRUTONE. You can enjoy Radio in the kitchen with the pots boiling. Insist on the TRUTONE from your dealer and you will be satisfied.

FOR SALE BY ALL FIRST CLASS RADIO DEALERS

If your dealer cannot supply you any TRUTONE will be sent to you postage paid upon receipt of price.

Sadler Manufacturing Co.

86 Fourth Street, San Francisco, California

"B" BATTERIES

AN
EVEREADY
PRODUCT

- 43V. Batteries, tapped.....\$5.00
- 22½V. Batteries, Navy Type..... 3.00
- 22½V. Batteries, Commercial Type..... 2.00

Latter two types especially adapted to
Cunningham and Radiotron Tubes.
Postage Prepaid Anywhere in U. S.

ETS-HOKIN & GALVIN

Wireless Engineers

10 Mission Street

San Francisco

Tell them that you saw it in RADIO

The Best Headset



At Your DEALERS
\$5.00

Highest Audibility
Perfect Matching
Greatest Volume

Why Strain Your Ears?

"T-B-H" Head Sets reproduce clearly and naturally. No "Fuzz" or "Tinny" tone. Extremely sensitive.

Aluminum cases—8 Foot cord—Weight 12 oz.
Type 6-A 17500 Turns (2200 ohms) Hard Rubber caps.....\$7.00
Junior 18000 Turns (2000 ohms) Composition caps.....\$5.00

If your dealer does not carry them he will order them for you.

Dealers and Jobbers Write For Discounts

The T-B-H Corporation

Dansville, New York, U. S. A.

DISTRIBUTORS:

The Eastern Specialty Co., Philadelphia, Pa. (Metropolitan District & South Atlantic States.)

Donaldson Radio & Service Station, Kansas City, Mo. (Southwestern States.)

Marie A. Alvarez, Havana, Cuba. (Cuba)

are used in the transmitter with a 50-watt tube for voice amplification. A double unit motor-generator set provides 2000 volts for the plate circuit of the oscillator tubes and 1000 volts on the modulator tube. A 48-volt dry battery is used for the voice amplifier tube. Filaments are lighted by a.c. from the regular supply. A standard regenerative type receiving set is used with two stages of audio-frequency amplification.

The same antenna is used for sending and receiving with a magnetically operated throw-over switch. The antenna is of the T type consisting of a span of wire run under the line conductors for a distance of 900 ft. or more on either side of the power-house where a center tap is brought down. This accomplishes the necessary inductive coupling. No counterpoise is used, the direct ground having proven satisfactory. The best results have been obtained with wavelengths of from 5000 to 6000 meters. The radio has turned out to be a good "trouble shooter," as it indicates trouble before it shows up in any other way on the system. Serious grounds are quickly eliminated and cause no extended interference. But slight atmospheric interference is experienced. Interference from other stations is rare—though an occasional high-power telegraph station is picked up. With the particular wavelength chosen and the sharp tuning possible this is eliminated. No 60-cycle interference is experienced.

The results have been very satisfactory and the system is used regularly in place of the private wire phone which was the only method previously available. It has given much better communication than the wire phone, especially over the longer distances—and has proven subject to much less interference.

The Pacific Gas & Electric Company of California is operating a "carrier current" radio telephone and telegraph system between the Vaca-Dixon Substation and Pit River Power House No. 1. This system utilizes the twin circuit 220,000-volt transmission lines between the two points for a conducting medium, a total distance of 202 miles, and has the sole purpose of directing the operation of the two stations both under normal and emergency conditions.

The system is coupled to the transmission line through a single-wire antenna about 1800 ft. long. This wire is attached to the twin vertical circuit transmission towers at a point on the center line of the tower and at the elevation of the middle crossarm. The main station ground system is also used as a ground for the radio equipment. No counterpoise is used. A wavelength of 6020 meters is used without any interference from the Great Western Power Company.

The transmitting equipment is the regular vacuum tube telephone trans-

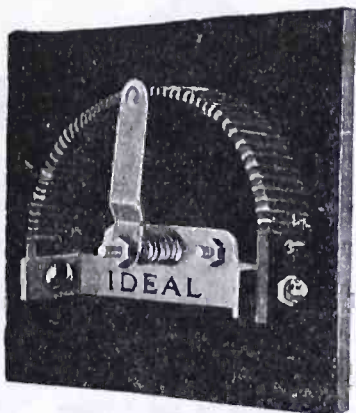

"Ideal" Rheostat Potentiometer

"IDEAL" 6 ohm Rheostat with knob and dial—per 100\$17.50
"IDEAL" 30 ohm Rheostat with knob and dial—per 100 19.50
"IDEAL" Potentiometer with knob and dial—per 100 \$22.00

We manufacture Test Clips, Switch Levers, In and Outside Brass Coil Aerials, Cat Whiskers of Every Description, Phone Connectors to listen-in for 8 parties, Square Copper Nicked Bus Bar Wire Rheostats, Potentiometers of Every Description from 2 to 400 ohms. Made in Composition, Metal, Bakelite Bases.

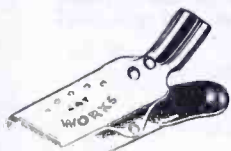

Test Clip for Batteries Per 100—\$3.25



Switch Lever Per 100—\$7.50

"The Marvel" and "The 5 Star Art Work"
Write at once for literature

WE SELL AT WHOLESALE ONLY

COL & W. SPRING CO., INC.

161 Grand Street
New York City

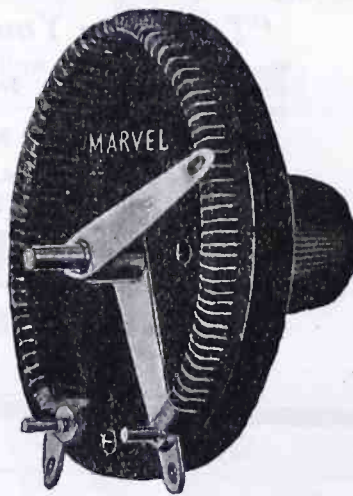

LEARN THE RADIO CODE

in 3 hours or less by the CORYDON SNYDER CODE METHOD

Copyrighted and Patent applied for

ONE PURCHASER SAYS:

"I did not have much faith in your advertisement and when I received your method I was still more doubtful. However, I went at it and in one hour I memorized the Code completely. You certainly have a great method and I wish you the greatest success." (Name upon request)

This home study course sent post paid upon receipt of 50c, stamps or coin. Or, send stamp for particulars, to

Corydon Snyder, 1161 So. Ridgeland Av., Oak Park, Ill.

Tell them that you saw it in RADIO

mission equipment similar to that used by the high-powered broadcasting stations. Four 250-watt and one 50-watt tubes are employed, two of the tubes being used as oscillators and two as modulators with the 50-watt tube as a speech amplifier. The plates of the 250-watt tubes are supplied with a potential of 2000 volts d.c. from a 2-kw. generator. This generator has two commutators, each supplying 1000 volts d.c. and a tap is taken off to supply 1000 volts d.c. potential to the plate of the 50-watt tube. Mounted on the same shaft with the 2000-volt generator is a 1 3/8-kw., 125-volt exciter which also has slip rings for supplying 88-volt, 30-cycle a.c. This 88-volt a.c. is stepped down to 11 volts through a special 800-watt transformer and is used for lighting the filaments of the 250-watt and 50-watt tubes. The generator and exciter are driven by a direct connected 6 3/4-hp., 115-volt d.c. shunt wound motor. This motor derives its energy from the main station storage battery which is unusually large in order to handle the 220,000-volt oil circuit breakers. Normally the battery floats on the charging set and a contactor has been installed in connection with the automatic motor starter which short circuits a portion of the charging generator field rheostat and permits a rise in generator voltage to compensate for the extra load of the radio motor-generator set. Thus under normal conditions of operation no drain is placed on the storage battery. An automatic motor starter is used for control of the motor-generator set, the starting and stopping of the set being accomplished by taking the telephone receiver off or putting it on the hook. The motor-generator set and special 88/12-6-volt transformer were furnished by the General Electric Company.

The receiving equipment consists of a Kennedy 110 receiver which has been modified to make it non-regenerative, and a Western Electric No. 10-A loud speaking outfit using two stages of audio-frequency amplification.

Calling is accomplished by mounting a calling microphone in the horn of the loud speaker which, when the calling circuit is completed, will oscillate and howl in much the same manner that the ordinary telephone will howl when the receiver is placed against the transmitter. This gives a very loud note whose pitch will depend upon the natural period of oscillation of the diaphragms and which is clearly audible in all parts of the station. Ordinarily, it is not necessary to use the calling system as the receivers are always in service and the operator near the set so that the loud speaker simply talks at him and he starts up his set and talks back. The system is arranged for a simplex operation and all that is necessary is to operate a small telephone

FRESHMAN RESISTANCE LEAKS

The largest and most Complete line in the World

Our new construction of all types Variable Resistance Leaks produces a product which we can now guarantee as being scientifically correct, mechanically perfect and built for unusual durability.



Every tube and every circuit requires a different leak resistance. You do not know what value is necessary until your circuit is tested. Freshman Variable Resistance

leaks give an unbroken range of 180 degrees from zero to five megohms.

Base Mounting Type with either .00025 Freshman Condenser **\$1.00**
Without Condenser **75c**



PANEL MOUNTING

Freshman Variable Resistance Leaks

will enable you to get stations you have never heard before. Can be mounted on any panel in a few seconds. When mounted, only the knob shows on the panel. The latest and most essential part of an efficient tube set.

With either .00025 or .0005 Freshman Condenser **\$1.00**
Without Condenser **75c**



FRESHMAN "FIX-O"

Fixed Resistance Leak Combination — 4 in one

Price Complete **65c**

Freshman Condenser .00025 Leak Mounting Freshman Resistance Leak Safe-T Handle



FRESHMAN FIXED

Resistance Leak with Safe-T handle

The only Resistance Leak using no carbon, graphite or lamp black. Guaranteed to remain permanently constant.

Furnished in any value of Resistance from 1/4 Megohm up **30c**



FRESHMAN NOISELESS

Tested Mica Condenser and Leak Mounting

The Freshman Condenser is so designed that constant equal pressure is exerted over the entire area of the condenser plates and the mounting is part of the condenser itself, which makes this new product the only True and Perfect Leak Mounting on the market.

Combination Condenser .00025 and Leak Mounting **40c**

All Freshman Products at your dealers—otherwise send purchase price and you will be supplied without further charge.

Also ask your dealer for our free diagrams of the Neutrodyne, Flewelling and Kaufman Circuits.

Chas. Freshman Co. Inc.
Radio Condenser Products

106 Seventh Ave. New York



\$15.00

F. O. B. Cleveland Type 6 Charges 6 Volt Storage Battery from any 110 Volt 60 Cycle lamp socket at average rate of 6 amperes.



3,250 Hours' Service

From a \$15.00 **F-F BATTERY CHARGER**

"Dear Sir: Find enclosed fifty-four cents for which please send me one set of carbon brushes for an F-F Battery Charger, Type 6.

"This charger has been in use on an average of 25 hours a week for about two and one-half years and the Carbons have never been renewed. The machine is giving very good service. Yours very truly,

"(Signed) Ralph O. Peters.
"1810 Pine St., Boulder, Colo."

This unsolicited report is but one of thousands. Every mail brings additional appreciation for the unusual reliability, and freedom from "grief," enjoyed by F-F owners.

This is the result of ten years' specialization, after making the first satisfactory mechanical battery charger years ago.

You, too, can benefit just as Mr. Peters above, by insisting on the F-F Charger.

There's a type for every need. Buy from your dealer. If he cannot supply you, write for literature or enclose remittance covering express or postal charges on 9 lbs.

It's Free. Write For Bulletin No. 33. Dealers Get the F-F Proposition.

The France Mfg. Co.
10433 Berea Road
Cleveland, Ohio

Western Representative:

EMMETT F. ANNIS

327 Dooly Bldg., Salt Lake City, Utah
67 2nd St., San Francisco, Calif.

Pioneer Manufacturers of Patented Battery Chargers



GUARANTEED REPAIRS

Broken and Burned-Out VACUUM TUBES

W.D.-11 not accepted for repair

Your dealer should know, but if he does not, send direct to

HARVARD RADIO LABORATORIES
Boston 9, Mass.

Tubes returned Parcel Post C.O.D.

Tell them that you saw it in RADIO



Prompt Shipments

A Radiola for every purpose and purse



IT'S early to talk of "shortages" and "slow deliveries," but business is bigger and better every day and all indications point to a demand this fall and winter far ahead of our manufacturers' ability to meet.

In this connection we remind you that our stock of both sets and parts — everything worth while in radio—and plenty of all—is complete, and your mail orders will be taken care of *immediately*.

We pay the postage — send your next order to us and be surprised at our quick action!

COAST RADIO CO., INC.
El Monte California

Introducing the "SR 25"

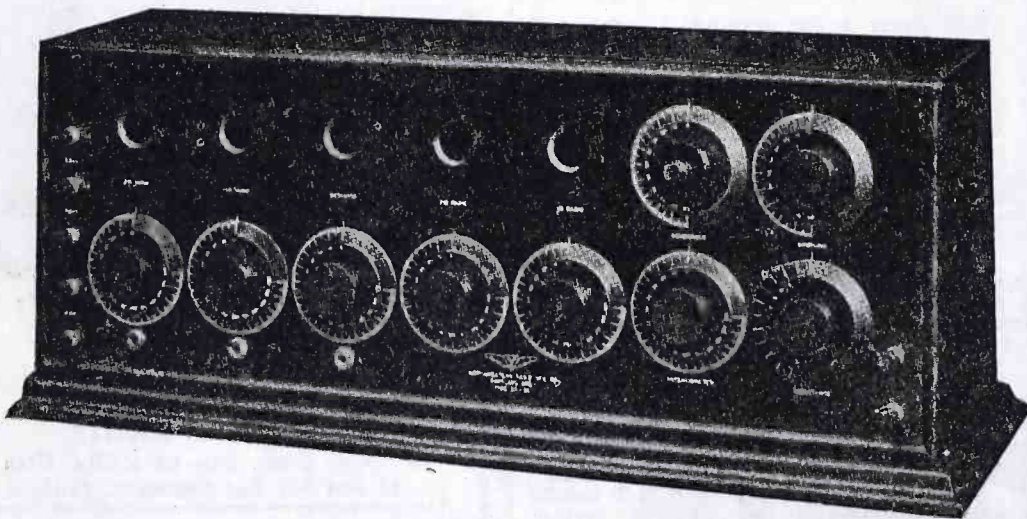

WE INVITE YOUR ENQUIRIES

Hallock and Watson Radio Service

192 Park Street

"KGG"

Portland, Ore.

BROADCAST PROGRAM

A weekly magazine devoted to Western Broadcasting.

5c per copy.
26 issues for \$1.00.

BROADCAST PROGRAM

449 Pacific Bldg.
San Francisco, Cal.

Loud Speaking Crystal Set

AT LAST

You can add a loud speaker to any crystal set by using the STEINMETZ Amplifier costing only \$8.50. Guaranteed to operate on any kind of crystal set regardless of what type it is, or we will refund your money. By using your crystal set with this amplifier music is brought in as clear as a bell and can be heard all over the room. Amplifier uses dry cell tube. Write for our complete catalog and also information on a highly efficient detector and two-stage amplifier at \$22.50.



STEINMETZ WIRELESS MFG. CO.
Manufacturers and Engineers
5705 Penn Ave. Pittsburgh, Pa.

switch which energizes a contactor to connect either the transmitting or receiving set to the antenna, thus permitting talking or listening.

During thorough tests by the Southern Sierras Power Co. of California it was shown that the efficiency of radio transmission between two points on a transmission line is enormously increased by using the transmission line as a "carrier" for the radio communication. It is apparently inadvisable to endeavor to communicate through transformers or open line switches, particularly on long lines (over 100 miles) without the aid of "bypass antennae."

The reception intensity was so great using the "carrier current" radio system over 170 miles of line that the receiver was used with perfect satisfaction in an open room within twenty ft. of a 2000-kva. synchronous condenser in operation. The system was found to be almost entirely free from outside interference and from static. The fundamental and several harmonic notes from the transmission lines were always present, but with the receiving antenna properly arranged gave no appreciable interference.

The General Electric Company has been very active in the development of "carrier current" radio equipment such as to meet the requirements of the power companies, and at the present time is manufacturing standard sets of 50-watt and 250-watt output capacity. The price of the 50-watt set complete with receiver and all equipment necessary to constitute one complete station is approximately \$2000, and that of the 250-watt set about \$6000.

With the engineering resources of the foremost electrical manufacturers of our country working in conjunction with the power companies towards the development and perfection of radio communication methods and equipment applicable to power company needs, as they are now doing, extensive progress can be anticipated. Also, many of the power companies are carrying on their own research investigations along these lines and meeting with considerable success. Amalgamating the efforts of the combined working forces then, it can conservatively be expected that a great stride towards the perfection of a practicable and reliable means of additional communication, suitable for the urgent need of power companies, will no doubt be realized during the ensuing year.

Do you know that in a tungar rectifier that the current passed depends on the secondary voltage of the transformer, as well as the size of the tube? By using a higher voltage a 2-ampere tube will handle as much as 4 or 5 amperes, and a 5-ampere tube over 10.

Tell them that you saw it in RADIO

WANTED—MORE STANDARDIZATION

Continued from page 16

As simple as the tube socket is, no effort has been made to make a standard article out of it. Some are conveniently arranged for panel mounting and others are not. Some make good contact, others are poor. Why do not our manufacturers get together and specify a certain type of contact that will be best suited for a good and permanent connection? Some manufacturers use spring brass and others phosphor bronze.

The writer noted recently that one large manufacturer of panels was attempting to standardize on sizes. This is a commendable move, especially if the cabinet manufacturers would back it up. But as far as the writer knows (and he was consulted in the matter referred to) this manufacturer did not seek the cooperation of others in the field, and, of course, this kind of standardization is usually fruitless.

A great deal could also be said about standardization in transmitting apparatus, but it is not the writer's object to

make a lengthy treatment of this subject. It is simply his desire to impress the readers of RADIO with the importance of a movement of this nature and to solicit their support in bringing it about. If those who buy equipment protest long enough and loud enough our manufacturers will eventually be forced to get around the table and to arrive at some common sense way of remedying the ills mentioned.

Mica-insulated, fixed condensers are most efficient for receiving apparatus.

**RHAMSTINE*
Electric Soldering Iron**



For Home or Laboratory

Specially designed for radio fans and experimenters. Attractively finished in nickel; heating element Nichrome resistance wire; soldering tip; when worn out, can be quickly and cheaply renewed. Complete with 6 ft. cord, two-piece plug, and self-fluxing solder. Used with either D.C. or A.C. Guaranteed one year. And like all Rhamstine* products, quality is combined with low price.

\$2.50 Postpaid Complete with Cord, Plug and Solder

You've always wanted an electric soldering iron; you need one for radio work; and here's your opportunity to get one specially adapted to the purpose. The Rhamstine* name guarantees quality and satisfaction. If your dealer hasn't it yet, send only \$2.50 and we'll send it postpaid; or if you prefer, we'll send it Parcel Post, C.O.D.

Dealers! Send for Prices.

J. THOS. RHAMSTINE*

*Maker of Radio Products

2160 East Larned St., Detroit, Mich.

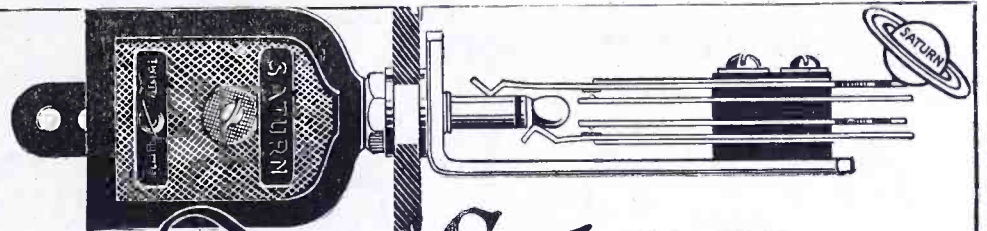

The Saturn

Above The Ordinary "Radio Products"

AUTOMATIC PLUG

Automatically perfect electrical connection. Made or broken with one swift, simple movement. Terminal tips, held in a vise-like grip that tightens the harder you pull on the cords. Lever instantly releases the tips. Each Saturn Plug fully guaranteed.

LIST PRICE, \$1.00

PERFECT JACK

Crowfoot Offset (illustrated in circle below) reduces soldering to utter simplicity. Solder and flux already on blades. Nickel-plated brass bracket, with rounded corners. Spring German-silver blades, Sterling silver contact point.

LIST PRICES

No. 1	Single Circuit	Open	50c
No. 2	Single Circuit	Closed	55c
No. 3	Double Circuit	Closed	75c
No. 4	Single Filament Control		75c
No. 5	Double Filament Control		80c

The Saturn Mfg. & Sales Co., Inc.

48 Beekman Street

New York, N. Y.



A Slight Touch Releases the Tips



NEW "REGAL" PRODUCTS for the 1923-1924 season

NEW "REGAL" AUDIO FREQUENCY TRANSFORMER	\$4.50
NEW "REGAL" DOUBLE ARM INDUCTANCE SWITCH	1.50
NEW "REGAL" VERNIER RHEOSTAT, 30 Ohm	1.25
NEW "REGAL" VARIO-COUPLER	4.50

Regal Inductance Switch

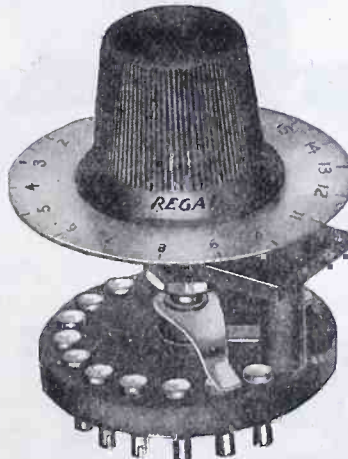

15-point Inductance Switch all in one unit. Beware of cheap imitations. Ask for the Regal. Does away with all drilling of holes in panel. Complete with handsome knob and dial \$1.50

Regal Rheostat

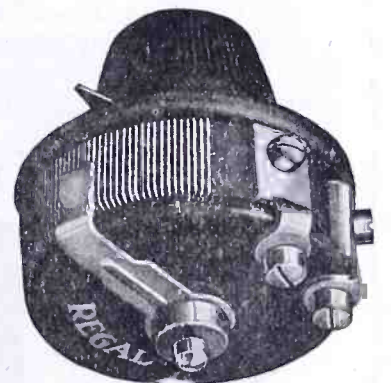

The Big Regal Line is now ready for the trade. If your dealer does not carry Regal products write us direct. Send for catalog No. 22

Exposed resistance wire for sharp sensitive tuning. A fine, dependable, quality instrument.	
6 Ohms	\$1.00
30 Ohms	1.00
30 Ohms Vernier	1.25

AMERICAN SPECIALTY MFG. CO., Bridgeport, Conn.

**BROWNLIE'S
Quick Contact**

Reg. U. S. Pat. Off.



CRYSTAL

A Natural Mineral for your Set
Your Catwhisker contact can move over the entire surface without loss of programme. Fourteen years of crystal making now gives you the world's best product for all uses. Reflex, Radio Frequency and Crystal Receivers.

Manufacturers Orders Solicited.

Price Mounted and Guaranteed 30c

Order From Your Dealer, or Sent Post-paid on Receipt of Coin.

ROLAND BROWNLIE, MFR.
22-24 SAUNDERS STREET
MEDFORD, MASSACHUSETTS

Tell them that you saw it in RADIO

TRANSFORMER LOSSES

Continued from page 32

But from equation (1) we see that 44.2 foot-pounds per minute are equal to 1 watt, hence the expenditure of energy at the rate of 1 watt will raise one pound of water

$$\frac{44.2}{778} \times 1^\circ \text{ F. per minute} = 0.057^\circ \text{ F. per minute}$$

This means that a loss of 1 watt per pound of water produces a rate of temperature rise of 0.057 degrees

Fahrenheit per minute. This is our first step.

Now we must determine what rate of temperature rise is produced when one watt is expended in one pound of iron. The specific heat of iron is 0.11, or 1/9 that of water, since the specific heat of water is 1. This means that it takes 9 times more heat to raise one pound of water 1 degree than it takes to raise one pound of iron 1 degree. That is, the same amount of heat will produce 1/9 the temperature rise in 1 pound of iron that it does in one

pound of water. Therefore since 1 watt raises one pound of water at the rate 0.057 degrees Fahrenheit per minute, one watt will raise 1 pound of iron 9 times that amount, or

$$1 \text{ watt per pound of water raises its temperature at rate of } 0.057^\circ \text{ F. per min.}$$

$$1 \text{ watt per pound of iron raises its temperature } 9 \times 0.057 = 0.52^\circ \text{ F. per min.}$$

We now know that when energy is dissipated in iron at the rate 1 watt per pound its temperature will rise at the rate of 0.52 degrees Fahrenheit per minute. This concludes the preliminary calculation. From our curve we can readily determine the rate at which the temperature of the iron core rises. If we divide this rate at the rate of temperature rise produced in one pound of iron by 1 watt we will obtain the number of watts per pound actually lost in the iron. If now we multiply this value by the weight of the iron core we have the total iron loss.

Let us apply this to the actual case illustrated in the attached graph. The weight of the transformer on which this curve was obtained was 48 lbs. From the curve we see that the total temperature rise in the first ten minutes was 35 degrees Fahrenheit, hence the rate at which the temperature rose was 3.5 degrees Fahrenheit per minute. Since we now know that 1 watt per pound of iron raises its temperature at the rate of 0.52 degrees Fahrenheit per minute, it follows that a rate of temperature rise of 3.5 degrees Fahrenheit per minute is produced by $3.5/0.52$ watts, or by 6.6 watts per pound. This obtained algebraically as follows:

$$1 \text{ watt per lb. gives } 0.52^\circ \text{ F. per min. rise}$$

$$X \text{ watt per lb. gives } 3.5^\circ \text{ F. per min. rise}$$

$$\frac{X \text{ watts } 3.5}{1 \text{ watt } 0.52} = 6.6 \text{ watts per lb.}$$

This gives us the loss per lb. of iron which produced the above temperature rise. Since there are 48 lbs. of iron in the transformer the total amount of energy loss which will produce that same rise must be 48×6.6 , or 316.8 watts, which is therefore the iron loss.

In a similar way the copper loss may be determined by the rise in temperature of the copper. It will be seen that the preliminary calculations are already performed for any kind of test on iron, hence all that the experimenter need do is apply the above results to his tests. The method is simple, requires the use of no expensive measuring equipment and is quite accurate. It will enable the experimenter to determine the efficiency of his transformer very easily, thereby giving him information which he could not otherwise have.

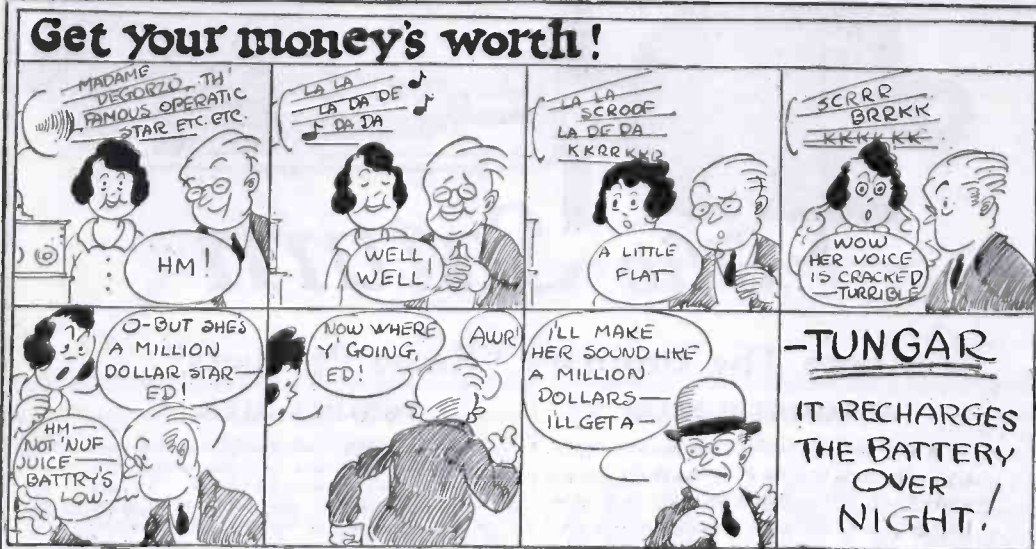

Music's charms cease when batteries fail

Your radio set works best on near and far stations, only when your batteries are delivering ample current.

Storage batteries, tuned up with Tungar, give the fine results which the owner of a high class radio set is justified in expecting from his instrument.

With Tungar—the go-between from house lighting circuit to storage battery—you do not need to move the battery, or buy a new one. Just attach to a lamp socket or a convenience outlet, turn on the current and leave it, any time, day or night.

Tungar is certain, clean and quiet. There are no moving parts to get out of order or to make noise. Its cost of operation is low.

For years motor car owners have used Tungar for charging their automobile batteries. See one at any good electrical shop, or write for literature. Address Section Rd 10.

Merchandise Department
General Electric Company
Bridgeport, Connecticut

Tungar Battery Charger. Operates on Alternating Current.

(Prices east of the Rockies)

2 Ampere Outfits Complete—\$18.00

5 Ampere Complete—\$28.00

Special attachment for charging 12 or 24 cell "B" Storage Battery—\$3.00

Special attachment for charging 2 or 4 volt "A" Storage Battery—\$1.25

Both attachments fit either Tungar

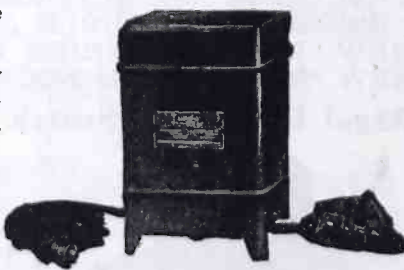

Charge 'em at Home, with

Tungar

BATTERY CHARGER

35A-103D

A GENERAL ELECTRIC PRODUCT

Tell them that you saw it in RADIO



JEWELL LIGHTNING ARRESTER

Approved by Underwriters

The latest regulations of the National Board of Fire Underwriters call for a lightning arrester on every building having an outside aerial.

The Jewell Arrester has passed all the Underwriters' tests and carries their approval.

The case is made of porcelain with a brown finish that harmonizes with interior woodwork. The price is right.

PRICE \$1.10

ORDER FROM DEALER

JEWELL ELECTRICAL INSTRUMENT CO.

1650 Walnut St.

Chicago

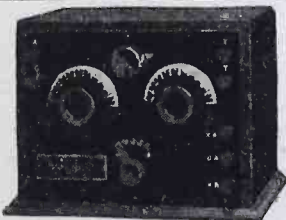

**WOC
TRESCO**

Licensed under Armstrong U. S. Patent No. 1,113,149.

A Long Distance 1,000-mile, 600-meter Range Regenerative Tuner for \$10.00. Add Parcel Post on 6 lbs. New Circuit, Startling Results. Cheaper than Crystal Set. Uses any Aerial. Amplifiers to match set for your loud speakers. Circulars free. Full instructions.

TRESCO
DAVENPORT, IOWA

Telmaco Radio Guide Book

Describes the Best in Radio

20 Circuits in Blue in Catalog

Our new 64-page Catalog No. TCR contains twenty of the most popular radio circuits printed in blue. These include the Hazeltine Neutrodyne, Grimes Inverted, Colpitts, Flewelling, Reinartz, Diode Electrad, Heterodyne, Super-Regenerative and many others. Each article used in circuit is attractively pictured instead of appearing in straight schematic form. Besides containing blue prints, the best in radio is also illustrated and described. Catalog sent postpaid for Ten Cents. Each circuit worth double. Send for your copy today.

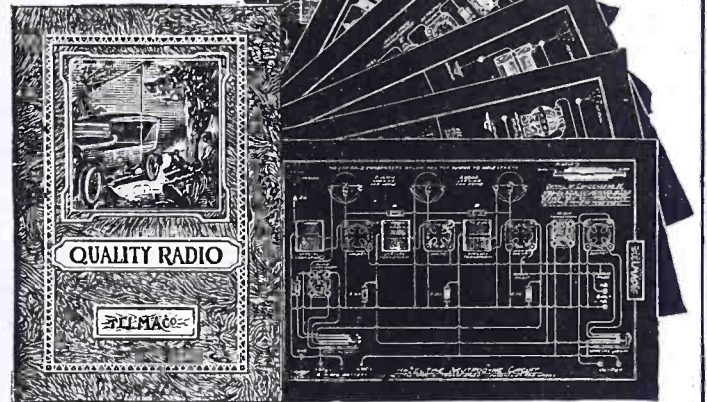

DEALERS! Our New Dealers' Catalog and Price List describes nearly all the better Standard Radio Lines. You should have it. Mailed FREE to all bonafide dealers making request on their business stationery.



Radio Division
TELEPHONE MAINTENANCE CO.
20 So. Wells St., Dept. Chicago, Ill.

TRADE "ESCO" MARK

Quality always has been, and always will be the World's safest investment.

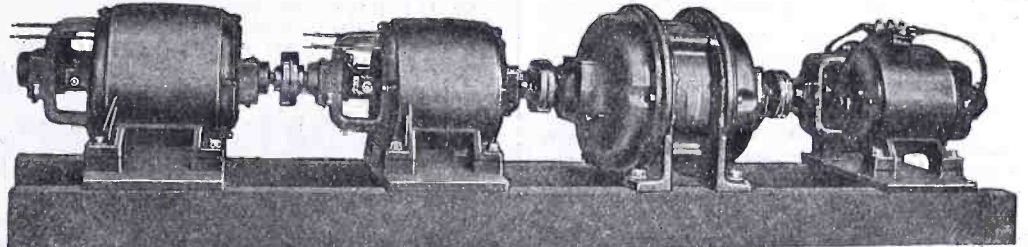

ELECTRO 4 UNIT SET

This is a Special 4 Unit set for Wis. Dep't of Markets—the largest Broadcasting Station in existence. A 10 H. P. 220 V. 60 cyc. 3 phase Motor, two 1600 V. 2000 W. Generators to operate in series, producing 2000 V. 4000 W. and one 12 V. 2000 W. Filament Current Generator. These two, and many other types, used by most prominent educational institutions, various U. S. Govt. Depts. Research Labs., Newspapers, Dept. Stores.

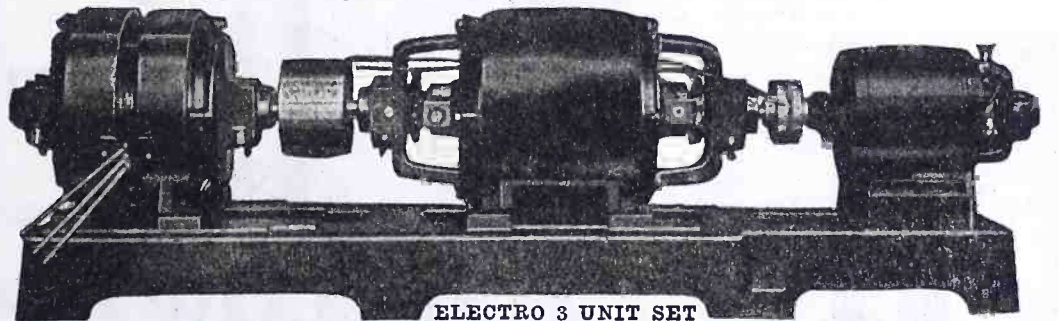

ELECTRO 3 UNIT SET

Sold by Principal Dealers in U. S. and Abroad.

Ask for Bulletin 248

ELECTRIC SPECIALTY CO.
225 South Street Stamford, Conn., U.S.A.
Pioneers in developing quality wireless apparatus

Only 25 Left. \$1 Per Copy
C. W. MANUAL "RADIO"
Pacific Bldg., San Francisco

Tell them that you saw it in RADIO

RADIOADS

A CLASSIFIED ADVERTISING SECTION READ BY BETTER BUYERS

The rate per word is five cents, net. Remittance must accompany all advertisements. Include name and address when counting words.

ADS FOR THE NOVEMBER ISSUE MUST REACH US BY OCTOBER FIRST

EDISON ELEMENTS for STORAGE "B" Batteries. I handle only first grade, full capacity plates. Six to ten cents per pair, postpaid, depending solely upon quantity ordered. A. J. Hanks, 608 Montgomery St., Jersey City, N. J. (6 T. Exp. Oct.)

RADIO WORLD, THE GREAT NATIONAL WEEKLY—published every seven days with all the latest news, developments and pictures of the radio field. 15c a copy. \$6.00 a year (52 numbers), \$3.00 six months, \$1.50 three months. Special to radio readers. Send \$1.00 and we will send you the next eight issues of RADIO WORLD. Pub. Office, 1493 Broadway, New York. (tc)

Vacuum Tube Hospital
We repair and guarantee them.
Agents, Dealers, and Customers Wanted.
George H. Porell Co., Inc.
West Somerville, Mass. (tc)

RADIO GENERATORS—500 Volt 100 Watt \$28.50 each. Battery Charger \$12.50—High Speed Motors. Motor-Generator Sets, all sizes. MOTOR SPECIALTIES Co., Crafton, Penna. (tc)

NEUTRO-TRANS Type 2-A (150-350M), Type 3-A (275-600M) each \$1.25. Either type mounted on 23-plate variable condenser, each \$4.00. Postage paid. Send stamp for catalog.

RAY-DEE-ARTCRAFT INSTRUMENT CO.,
Redlands, Calif.

CLEARANCE SALE. Not a cut price proposition but a genuine clearance sale of a large stock of good radio apparatus that must be disposed of to make room for new lines. The items listed herewith are but a few of the many clearance specials. Be sure to write us today for a complete list of other offerings.

Federal detector and One Step amplifiers, regular price \$52.00, sale price \$26.00. Federal Two Step Amplifiers, regular price, \$58.00, sale price \$29.00. HRA Clapp Eastham detector and one step regular price \$15.50, sale price \$10.00. John Firth Detector Control Cabinet type 20-A, regular price \$27.00, sale price \$8.00. Acmefone receivers with detector and two step amplifier and loud speaker regular price \$80.00, sale price \$40.00.

King Amplitones, regular price \$12.00, sale price \$5.00. 2-5-0 Paragon Transmitters (C. W., Voice, I. C. W.) regular price \$75.00, sale price \$30.00. Meyers Hi-Mu Tubes, RAC3, regular price \$5.00, sale price \$3.00.

4 inch Tuska dials, regular price \$1.65, sale price 60 cents. 4 inch Paragon dials, regular price \$1.75, sale price 60 cents.

All other 60 and 75 cent dials at sale price of 50 cents. These supplies are guaranteed to be in perfect condition. The excess stock is the cause for the sale. You buy these from the largest radio store in the West. Send your orders today to THE RADIO STORE, 560 East Colorado Street, Pasadena, California.

C. W. and RADIO PHONISTS—Our new converters will satisfy your need for a more efficient and durable direct current plate supply. No armatures to burn out. Output from seven hundred to two thousand volts at .4 amperes. Synchronous Motors, Transformers and other parts sold separate. Write immediately. Kimley Equipment Mfg. Co., 290 Winslow Ave., Buffalo, N. Y. (tc)

ARC & SPARK SYSTEMS
Send for Descriptive Circular QRD.
Interesting and Instructive. (tc)
Pacific Radio School 433 Call Bldg., San Francisco

BUILD YOUR SETS WITH QUALITY PARTS and get sure results. Radio Parts Co., Box 56, Unellen, N. J. (Gt-exp. Nov.)

MAKE \$120 WEEKLY IN SPARE TIME.—Sell what the public wants—long distance radio receiving sets. Two sales weekly pays \$120 profit. No big investment, no canvassing. Sharpe of Colorado made \$955 in one month. Representatives wanted at once. This plan is sweeping the country—write today before your county is gone. OZARKA, 814 Washington Blvd., Chicago.

CODE INSTRUCTION THAT INSTRUCTS—Only Two Dollars. Get working knowledge of Code and License One Week. Best reports our Licensed Students; Code mastered in 15 minutes; Ten-word speed in 3 hours. 100 Records and Reports, 12 Districts, One Dime—40 Records Free. Worth of any Method hinges on progress of students. Evidence is offered free and confirmation suggested. Imitation Short Cuts are long cuts to much vexation. Our method is true to title—Users do save much time and a number of previous failures now have license. Dodge Radio Shortkut Dept. R. Mamaroneck, N. Y.

BRANCH MANAGERS WANTED AT ONCE. WOULD YOU LIKE TO TAKE THE MANAGERS CHAIR AND DIRECT SALESMEN IN YOUR TERRITORY, EACH ONE OF THEM BRINGING YOU A GOOD PROFIT?

OUR NEW BUSINESS METHOD IS SO PROFITABLE THAT TERRITORY IS BEING ASSIGNED RAPIDLY. WE ARE GETTING SALESMEN ALL OVER THE COUNTRY AND MUST HAVE YOUNG MEN TO MANAGE THEM.

QUALIFICATIONS NECESSARY:
WE PREFER YOUNG MEN;
MUST HAVE HAD SOME EXPERIENCE ASSEMBLING RADIO SETS, OR HAVE YOUNG MAN AS ASSOCIATE WHO HAS HAD SUCH EXPERIENCE;

MUST BE ABLE TO GIVE REFERENCE.
IF YOU THINK YOU MIGHT WANT THIS PLACE DON'T WAIT, WRITE AT ONCE, SOME ONE ELSE MAY BEAT YOU TO IT.

NATIONAL RADIO SERVICE CO.,
SANTA ROSA, CALIF.

FOR SALE: Ten Watt ACW Transmitter, completely mounted on panel. Brand new R. C. A. equipment. Three meters. One hundred dollars cash. Alfred Higdon, North Fork, Calif.

FOR SALE: Kilbourne & Clark Motor Generator, 2 KW Inductor Type, 500 Cycle.—K. & C. Closed Core Transformer, 2 KW. A. C. Voltmeter and A. C. Ammeter. All in perfect condition, \$150.00 F. O. B. San Francisco. Pacific Radio School, 433 Call Bldg., San Francisco, Calif.

WHEN YOU HEAR A FELLOW, Let Him Know It. Send for prices and samples of our QSL cards. H. H. Olmsted, 3BVT, 1100 Va. Ave. S. W. Washington, D. C.

BIG MONEY AND FAST SALES.—Every owner buys gold initials for his auto. You charge \$1.50, make \$1.44. Ten orders daily easy. Samples and information free. World Monogram Co., Dept. Y., Newark, N. J.

NEW EMERSON MOTOR GENERATOR, 500-watt, 200-watt, \$50.00. M. Magers, 2720 Patee St., St. Joseph, Mo.

RADIO MECHANIC WANTED. NATIONAL RADIO SERVICE ASSOCIATION WANTS RADIO MECHANIC IN EVERY TOWN TO ASSEMBLE A NEW SUPER-RADIO FREQUENCY RECEIVER AND TO GIVE SERVICE ON OTHER KINDS OF SETS. WELL ADVERTISED REGULAR INFORMATION FROM THE ENGINEERING DEPARTMENT IS VERY VALUABLE, BEST OF CHANCES TO GROW UP WITH THE RADIO INDUSTRY. BIG PERCENTAGE PROFIT.
NATIONAL RADIO SERVICE CO.,
SANTA ROSA, CALIF.

MAGNAVOX TYPE R3. Latest nationally advertised reproducers. The factory sealed carton is your guarantee. List \$35. Introductory offer \$25. Radio Central, Dept. P, Abilene, Kansas.

STORAGE "B" BATTERY Lead Type over 2 1/2 AH capacity. Size of elements 2 3/4 x 3/4 x 3/16, in special tube with strap. Shipped dry. Guaranteed. 35c each, postpaid. \$16 for fifty. E. E. Patten, 6709 Carleton Ave., Seattle, Wash.

WE CAN USE MORE SALESMEN. OUR NEW BUSINESS METHOD IS HELPING NEW RADIO SALESMEN TO MAKE QUICK SALES AND BIG PROFITS. WE FURNISH LIVE LEADS AND ASSIST YOU IN CLOSING SALES. EASY TERMS, LONG TIME TO PAY IS MAKING SALES EVERYWHERE. IF NO MANAGER APPOINTED IN YOUR TERRITORY, SEE OUR "MANAGER ADV." ABOVE
NATIONAL RADIO SERVICE CO.,
SANTA ROSA, CALIF.

PROTECT THE HEART OF YOUR RADIO SET

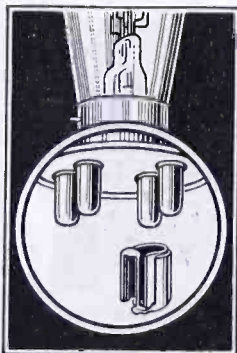

Vacuum Tubes are costly and extremely delicate. B battery or any other excessive current applied for only the fraction of a second to the filament leads will burn out your tubes. You have probably already had this experience and it is apt to happen again at any time. A burnt out tube means money lost—the set out of commission—inconvenience to you.

WHY TAKE THESE CHANCES WHEN RADECO SAFETY FUSES

will absolutely protect your tubes. Applied in an instant to the filament terminals. Will fit any standard tube or go in any standard socket. Fully guaranteed. 50 cts. each. Sent Postpaid. Delay may be costly. Write now. Specify type of tube used.

Dept. 7

RADIO EQUIPMENT COMPANY

630 WASHINGTON STREET, BOSTON, MASS.
New England's Oldest Exclusive Radio House

Distributors of
Many Other Successful Radio Specialties.
Dealers:—Write for our proposition and full details.

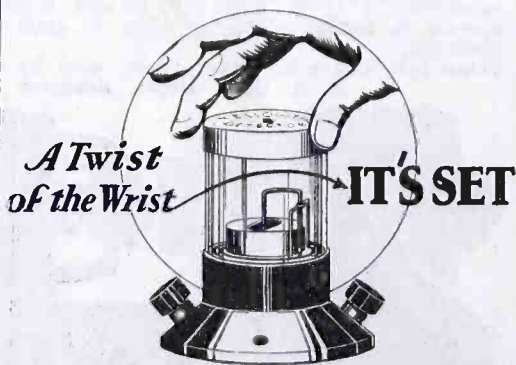

YELLOW TIP MICROMETER ADJUSTING CRYSTAL DETECTOR

Any adjustment made in a moment—fixed instantly! Held indefinitely, until you wish to change, then—"A Twist of the Wrist—It's Set." Ideal for reflex and other circuits. Write for folder and name of your nearest dealer. **\$2**

Wholesale Radio Equipment Company
Exclusive Factory Representatives

34 William Street Newark, N. J.

Dealers and Jobbers—Write for Attractive Proposition

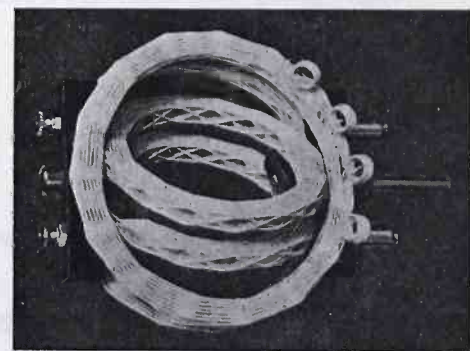

R. M. C. Diamond Weave Variocoupler and Variometer

Due to diamond weave construction and the fact that 7/8 of the total area of windings are supported in mid-air, capacity and dielectric losses are reduced to a minimum in R. M. C. Variometers and Variocouplers. The rotor is continuously variable.

These products may be used in any circuit where a high grade coupler or variometer is required. All metal parts are nickel-plated. Panel mounting requires very small space. Screw holes covered by 2-inch dial.

R. M. C. products are built for the finest sets that can be constructed.

Variocoupler \$4.25
Variometer \$4.25

Write for catalog of other diamond weave coils, and Radio Frequency Transformer.

THE RADIO MANUFACTURING CO.
of Springfield, Massachusetts
Dept. D 97 Dwight Street

Tell them that you saw it in RADIO

FERBEND

TRADE MARK
Wave Trap
PATENT APPLIED FOR

The Original Wave Filter



Stops Interference!

Eliminates interfering stations.
Improves the selectivity of the set.
Eliminates local broadcasting.
Selects between conflicting stations.
Simplifies tuning.
Often increases signal strength.
Reduces howling and squealing.

The WAVE TRAP is mounted on a Formica panel in a beautiful mahogany finished cabinet 6x5x6 and is a high grade instrument throughout, enhancing the appearance of the most expensive sets.

use THE ORIGINAL WAVE FILTER \$8.50 PREPAID

FERBEND

TRADE MARK
Wave Trap
PATENT APPLIED FOR

17 E. SOUTH WATER ST. CHICAGO

Just Out!

The New **RADIO BATTERY**
"EVEREADY" "THREE"

THREE CELLS :: THREE TERMINALS :: THREE PURPOSES
MAY BE USED—

- As an "A" Battery for portable sets having UV-199 Tubes.
- As a "B" Battery for obtaining additional "B" Battery Voltage.
- As a "C" Battery for furnishing negative potential to amplifying Tube Grids.



Eveready "Three" has three Fahnestock Spring Clip Connectors, making it possible to secure 1½, 3 or 4½ volts from the battery. Ask your dealer or write us for circular No. 1025, giving complete information on this NEW Three Purpose RADIO BATTERY. Order Eveready "Three" by catalog number 771. Made by the largest dry battery manufacturers in the world—makers of the famous—

- Eveready Dry Cell Radio "A" Batteries for Dry Cell Tubes.
- Eveready "B" Batteries for all Vacuum Tubes.
- Eveready Storage "A" Batteries for Storage Battery Tubes.

NATIONAL CARBON COMPANY, Inc.
San Francisco, Calif. Los Angeles, Calif.

EVEREADY
Radio Batteries
RELIABLE NOISELESS
—they last longer

The Bull Dog Aerial Mast Seat Fills a Long Felt Want



by enabling any one to install a firm and rigid aerial mast on either a peaked or metal ridge roll type of roof, with the ordinary tools found around the home, thereby eliminating the customary trouble, labor and expense, and supplying neat, substantial construction throughout the entire aerial or antenna. Made in two types. Plain peaked, without hinges, and hinged flanges with holder for "lead-in" support. The hinged type is readily adjustable to any pitch or angle of roof. Equally applicable to flat roofs. A holder for "lead-in" support provided on same base, making direct and simple "lead-in."

Seat for 1½ inch mast, hinged type. \$3.00
Seat for 1½ inch mast, peaked type, plain.. 2.50
Seat for 1 inch mast, peaked type, plain.. 2.00
Seat for 1½ inch mast, flat base type. 2.50

Jobbers and distributors write for discounts. If your dealer cannot supply you, clip coupon and mail with your remittance.

MAST SEAT MFG. CO.

119 5th St. S. E.
Dept. A
Minneapolis, Minn.

Gentlemen: Enclosed is \$.....
Send me Mast Seats to cover remittance.
Kind.....
Name.....
Address.....
City.....
Check, Money Order or Bank Draft.

PEERLESS UNIVERSAL Double Range Tuning Coil

A Complete Tuning Coil—Three Instruments in One
Simple and Economical for Building Your Own Set

150-600 Meters

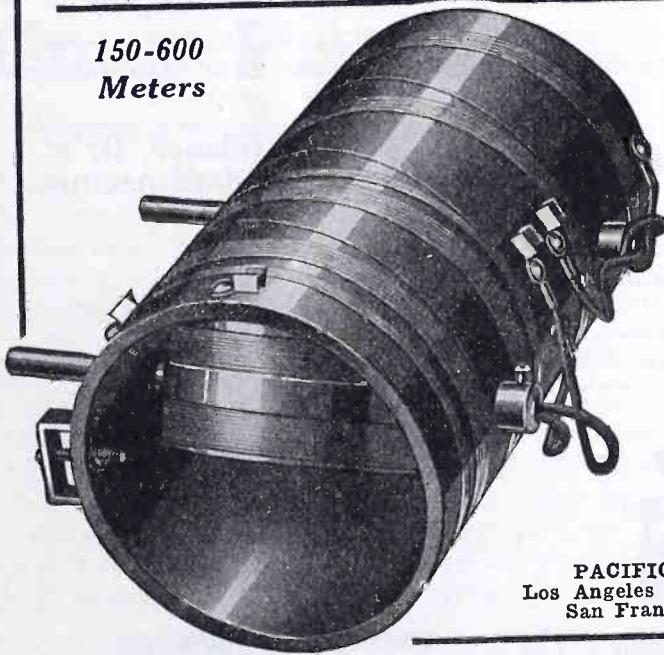

Takes the place of

- Variometers
- Vario-couplers
- Variable Condensers

The price is no more than any of the above units.

United Radio Corp.
Rochester, N. Y.

Distributed by
PACIFIC STATES ELECTRIC CO.
Los Angeles Oakland Portland
San Francisco Seattle Spokane



CARTER
New Inductance Switch
No sliding contacts; panel numbering eliminated; 15 good contacts; adjustable stop pin. Price \$2, including knob-dial.
Coast Dist., Atlantic-Pacific Sales Co., San Francisco.
Carter Radio Co., 201 S. State St., Chicago

RADIO MAILING LISTS	Per M.
12,422 Radio Dealers, U.S. by States	\$7.50
1,614 Radio Mfrs., U.S. by States	\$15.00
1,760 Radio Supply Jobbers, U.S. by States	15.00
260 Radio Stations	4.00
257 Mfrs. complete Radio Sets	4.00
67 Radio Battery Manufacturers	1.50

Ready to send on receipt of remittance
Trade Circular Addressing Co.
166 W. Adams St., Chicago

Tell them that you saw it in RADIO

Coto

"Built First to Last"

Only the Set You Build for Yourself Will Suit You

If you have just half the soul of a real radio fan, a complete, ready made set will pall on you in a week. Build your own! You want radio performance, to be sure, but you want it of your own creation. What so fascinating as to plan, to assemble, to adjust and construct? And finally to get the radio results and the set compactness made possible by this splendid line of distinctive parts—different and better.

Coto for Efficiency and Compactness

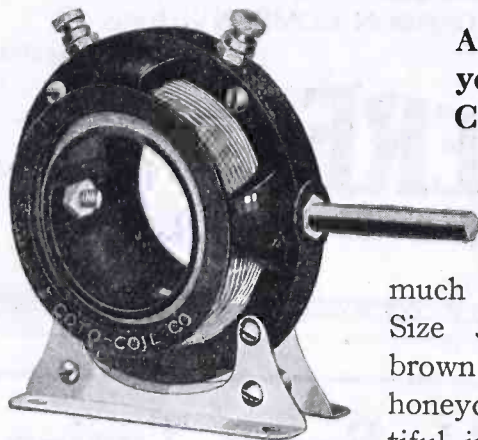

Ask your Dealer to Show you the New Coto Compact Variometer

Especially designed for new wave lengths, 200 to 600 meters and for the much demanded compactness. Size $3\frac{1}{2} \times 3\frac{1}{2} \times 1\frac{1}{2}$ inches. In brown polished bakelite with honeycomb wound stator. Beautiful in action and appearance.

Base or panel mount. Type 8000, \$5.00.

Demand Coto! Get Coto!

JOBBER! DEALER!

The Coto Line has the efficiency, the appearance and the advertising for big selling. Write at once for latest Price and Discount list.

Coto-Coil Co. Providence, R. I. 87 Willard Avenue.

Pacific Coast Branch:
329 Union League Building, Los Angeles, Calif.

Northwestern Branch:
George F. Darling, 705 Plymouth Building, Minneapolis, Minn.

Southeastern Branch:
C. P. Atkinson, Atlanta Trust Co. Building, Atlanta, Ga.

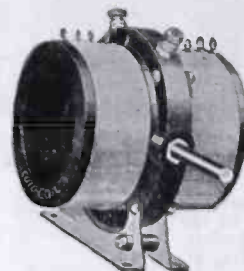

Coto Compact Moulded Bakelite Variocoupler

Twin sister of the Variometer. Size only $3\frac{1}{4} \times 3 \times 3\frac{3}{4}$ inches. Range 200 to 600 meters. Base or panel mount. Type 9000, \$5.50.



The Original Honeycomb Wound Radio Inductance Units

Popular low priced favorites of the amateur and experimenter. Descendants of the Coto Coils that guided the N. C. navy planes across the Atlantic. Sold mounted or unmounted.

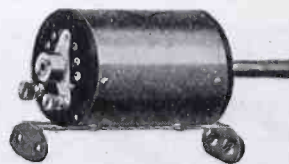

Coto Tapped Radio Frequency Transformer

Efficiently covers the whole broadcasting range because it is tapped. Just work the switch. Type 5000A, \$7.50.

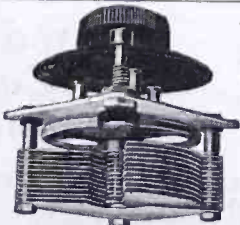

Coto Compact Variable Air Condenser with Vernier
Only $2\frac{1}{2}$ ins. square. Rotor plates soldered to shaft. Stator plates soldered at three points. .0005, \$5.00; .001, \$6.00.



Coto Special Audio Frequency Transformer
Turn ratio of 3 to 1. Coto quality throughout, but made to sell at a popular price. Type 4500, \$2.50.

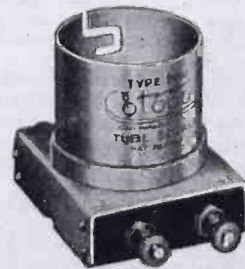

Cotogrip Socket
Has unique double positive grip of tube terminal posts. Best hard rubber insulation. Type 7000, 85 cents.

Tell them that you saw it in RADIO

REMLER

a new and Improved

Variometer



TYPE 500
With Closed Rotor

Price **\$7.50**

With Internal Pigtail Connections.
Wave Length Range 180 to 570 Meters.
Positively Guaranteed.

The Greatest Variometer Ever Produced

A Leader in Appearance and Performance

Three years ago Remler introduced the "moulded Bakelite" Variometer. Since that time the engineers of the Remler Company have made a thorough scientific study of the application of variometers to every phase of radio reception. As a result of this exhaustive study a new and improved variometer, the greatest ever produced, is now offered to the public.

It has the lowest minimum and highest maximum wave length ever obtained in a variometer and the wave length variation is exactly proportional to the reading of the dial scale. It will cover the entire range of amateur and broadcast wave lengths when used with any vario-coupler. When used with a Remler vario-coupler the wave length range is guaranteed to be from 180 to at least 570 meters.

Pigtailed connections are used between stator and rotor resulting in perfect contact and quiet operation. All metal parts are buffed and nicked; green silk wire is used on both stator and rotor. The general appearance and quality of the bakelite molding is the best ever built into a radio item.

If your dealer cannot supply you send the attached coupon direct to us with express or postal money order. Write for complete descriptive circular.

REMLER RADIO MFG. CO.

HOME OFFICE:
248 First St.
San Francisco

154 W. Lake St.
Chicago

30 Church St.
New York City

Remler Radio
Mfg. Co.
248 First St.
San Francisco, Calif.
Gentlemen:

Please send me by return parcel post one new and Improved Remler Variometer Type 500 for which I enclose Seven dollars and fifty cents (\$7.50). If for any reason whatsoever I am not satisfied with this Variometer, I can return it to you express collect and you will refund my seven dollars and fifty cents in full.

Name.....

Address.....

Echophone

ECHOES OF THE WORLD

Echophone Special

\$85.00

Manufactured by The Radio Shop at Sunnyvale
Licensed under Armstrong Pat. No. 1,113,149



No single feature in Radio has attracted the marked interest that the ECHOPHONE INTERCHANGEABLE UNIT has during the past vacation months. To be able to remove from a beautiful home cabinet set the panel of selected, flawless formica mounted with all the controls necessary for perfect radio reception, and slip it into a rough portable cabinet for the automobile or hunting lodge, has placed the ECHOPHONE foremost in the hearts of radio enthusiasts.

ECHOPHONE SPECIAL, the ideal set for use with any make of loud speaker, is made up of the Interchangeable Unit contained in a



beautifully decorated mahogany cabinet constructed to hold both batteries and accessories.

ECHOPHONE STANDARD, which sells for \$75.00, is a narrower cabinet set containing the Interchangeable Unit, but without sufficient capacity to hold the batteries.

The complete ECHOPHONE line contains radio receiving sets ranging in price from \$35.00 to \$198.00.

In all ECHOPHONE sets the same scientific skill has accomplished the elimination of distortion and body capacity effects. Special circuit arrangement makes only two controls necessary, which, with the Vernier, make operation simple and insure perfect tuning.

DEALERS: Write for the ECHOPHONE proposition TODAY
For further information, descriptive literature, illustrated folder or particulars address our nearest branch office

THE RADIO SHOP

General offices and factory, Sunnyvale, California

Branch offices:

Ideal Building
Denver, Colo.

1926 Chestnut St.
St. Louis, Mo.

131-133 Eighth St.
San Francisco, Calif.

914 Flower St.
Los Angeles, Calif.

6 North Michigan Ave.
Chicago, Ill.