

RADIO WORLD

Registered U. S. Patent Office



Air view of newly-developed multiple-unit steerable antenna system at Holmdel, N. J., for improving reception on commercial trans-Atlantic circuits. See page 36.

THE MOST STABLE CAPACITOR YET DEVELOPED

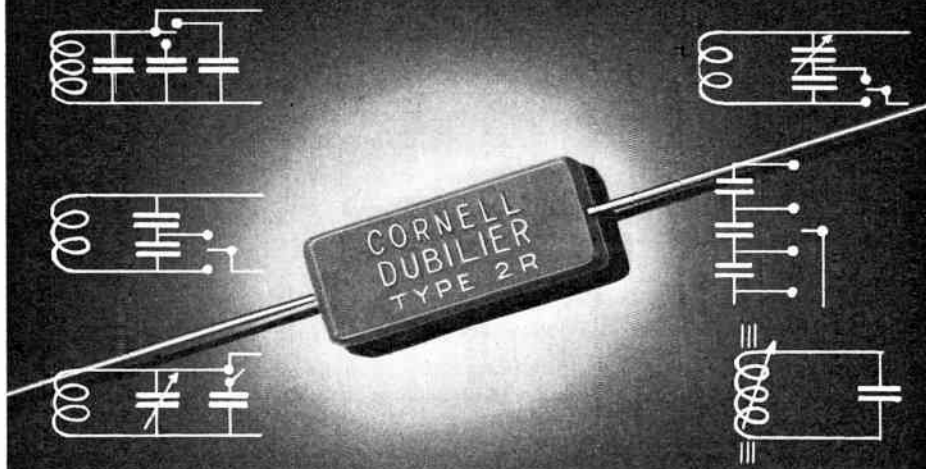

THE C-D "Silver-Mike" THE CONDENSER THAT RESISTS CHANGE

1. Brand *NEW* molded silver-plated mica construction.
2. Remarkably low temperature coefficient: Plus .003% per degree C.
3. Excellent "retrace" characteristics.
4. Practically no capacity drift with time.
5. Exceptionally high "Q" (3,000 to 5,000).
Mechanically protected by low loss Bakelite against physical damage and change in electrical characteristics, due to varying atmospheric conditions.
7. Capacity tolerance well within $\pm 3\%$.
8. Capacitors tested at 1,000 volts, D.C.
Range: 10 mmfd. to 1100 mmfd. (Larger sizes to be made available on specific request).
9. Ideal for use in circuits where the LC product must remain constant under all operating conditions. Specifically designed for use in conjunction with push-button tuning, where accuracy and stability are of paramount importance.
- 10.

CORNELL  **DUBILIER**

1024 Hamilton Blvd.—Cable Address: "CORDU"

CORNELL-DUBILIER ELECTRIC CORP., SO. PLAINFIELD, N. J.

I WILL SEND MY FIRST LESSON FREE

*It Shows How I Train You
at Home in Your Spare Time for a*

GOOD JOB IN RADIO



**J. E. Smith, President
National Radio Institute
Established 1914**

The man who has directed the home study training of more men for the Radio Industry than any other man in America.



**Service
Manager for Four
Stores**

"I was working in a garage when I enrolled with N. R. I. In a few months I made enough to pay for the course three or four times. I am now Radio service manager for the Mc—Furniture Co. for their four stores."—**JAMES E. RYAN, 1535 Slade St., Fall River, Mass.**

**\$40 a Month
in
Spare Time**



"I have a very good spare time trade. At times it is more than I can handle. I make on an average of \$40 per month profit, and that is spare time working week ends and some evenings."—**IRA BIVANS, 102 Diagonal St., Savannah, Ill.**

**Get My Free Lesson on
Radio Servicing Tips**

My sample lesson text, "Radio Receiver Troubles—their Cause and Remedy" covers a long list of troubles in A.C., D.C., battery, universal, auto, T.R.F., super-heterodyne, all-wave, and other types of sets, gives you the probable cause and a quick way to locate and remedy these set troubles. A special section is devoted to receiver check up, alignment, balancing, neutralizing and testing. Get this lesson Free. Just mail coupon.

Clip the coupon and mail it. I will prove I can train you at home in your spare time to be a RADIO EXPERT. I will send you my first lesson FREE. Examine it, read it, see how clear and easy it is to understand—how practical I make learning Radio at home. Men without Radio or electrical knowledge become Radio Experts, earn more money than ever as a result of my Training.

**Many Radio Experts Make
\$30, \$50, \$75 a Week**

Radio broadcasting stations employ engineers, operators, station managers and pay up to \$5,000 a year. Spare time Radio set servicing pays as much as \$200 to \$500 a year—full time jobs with Radio jobbers, manufacturers, dealers as much as \$30, \$50, \$75 a week. Many Radio Experts operate their own full time or part time Radio sales and service businesses. Radio manufacturers and jobbers employ testers, inspectors, foremen, engineers, servicemen, paying up to \$6,000 a year. Radio operators on ships get good pay, see the world besides. Automobile, police, aviation, commercial Radio, loud speaker systems are newer fields offering good opportunities now and for the future. Television promises to open many good jobs soon. Men I have trained have good jobs in these branches of Radio. Read their statements. Mail the coupon.

**There's a Real Future in Radio
for Well Trained Men**

Radio already gives jobs to more than 300,000 people. In 1937 Radio enjoyed one of its most prosperous years. Nearly \$500,000,000 worth of sets, tubes and parts were sold. Over 5,000,000 home Radios were sold—25,000,000 homes (4 out of 5 in the U. S.) now have one or more sets. Over 1,800,000 auto Radios were sold—5,000,000 cars now have radios. Every year millions of sets go out of date, are replaced with newer models. Every year millions of dollars are spent on transmitting equipment, Television developments, etc. The \$30, \$50, \$75 a week jobs have grown from a few hundred 20 years ago to thousands today. And Radio is still a young industry—developing fast.

**Many Make \$5, \$10, \$15 a Week Extra
in Spare Time While Learning**

Almost every neighborhood needs a good spare time serviceman. The day you enroll I start sending Extra Money Job Sheets showing how to do Radio repair jobs. Throughout your training I send plans and ideas that made good spare time money for hundreds. I send Special Equipment to conduct experiments, build circuits, get practical experience. I ALSO GIVE YOU A COMPLETE, MODERN, PROFESSIONAL ALL-WAVE, ALL PURPOSE RADIO SET SERVICING INSTRUMENT TO HELP SERVICE SETS QUICKER—SAVE TIME, MAKE MORE MONEY.

I Give You Practical Experience

My Course is not all book training. I send you special Radio equipment, show you how to conduct ex-



periments, build circuits illustrating important principles used in modern Radio receivers, broadcast stations, loud-speaker installations. I show you how to build testing apparatus for use in spare time servicing from this equipment. Read about this 50-50 method of training—how it makes learning at home interesting, quick, fascinating, practical. Mail coupon.

Money Back Agreement Protects You

I am sure I can train you successfully. I agree in writing to refund every penny you pay me if you are not satisfied with my Lessons and Instruction Service when you finish. I'll send you a copy of this agreement with my Free Book.

Find Out What Radio Offers You

Mail coupon for sample lesson and 64-page book. Both are free to anyone over 16 years old. My book points out Radio's spare-time and full-time opportunities and those coming in Television; tells about my training in Radio and Television; shows you letters from men I trained, telling what they are doing earning. Find out what Radio offers YOU! MAIL COUPON in an envelope, or paste it on a penny post card—NOW!

**J. E. SMITH, President, Dept. 8FM4
National Radio Institute, Washington, D. C.**

**MAIL
COUPON
NOW!**



**GOOD FOR BOTH 64 PAGE BOOK
SAMPLE LESSON FREE**

**J. E. SMITH, President, Dept. 8FM4
National Radio Institute, Washington, D. C.**

Dear Mr. Smith: Without obligating me, send the sample lesson and your book which tells about the spare time and full-time opportunities in Radio and explains your 50-50 method of training men at home in spare time to become Radio Experts. (Please write plainly.)

NAME.....AGE.....
ADDRESS.....
CITY.....STATE.....14X1



QUESTIONS ANSWERED

If you have trouble with your set, send in a detailed account of symptoms, with circuit diagram, and 28c. in stamps or coin, and Radio World's staff will make a diagnosis and report back promptly.

RADIO WORLD

145 West 45th Street New York City

MAILING LISTS



GET OUR FREE
REFERENCE
BOOK and
MAILING
LIST CATALOG
FREE

Gives counts and prices on accurate guaranteed mailing lists of all classes of business enterprises in the U. S. Wholesalers—Retailers—Manufacturers by classification and state. Also hundreds of selections of individuals such as professional men, auto owners, income lists, etc.

Write today for your copy

R. L. POLK & CO.

Polk Bldg.—Detroit, Mich.
Branches in Principal Cities

World's Largest City Directory Publishers
Mailing List Compilers. Business Statistics. Producers of Direct Mail Advertising.

A YEAR'S GIFT FOR HIM

Is your husband, son or nephew interested in radio? Why not send him Radio World for a year? We will send him, at your request, a post card notice telling him of your thoughtfulness in sending a gift that lasts all year!

For \$2.50 a year in the United States he will be reminded of your generosity every time the magazine arrives.

RADIO WORLD, 145 WEST 45th ST., NEW YORK CITY

FREE RADIO AND PARTS CATALOG!



ALLIED'S new Spring Catalog is packed with news for every Ham! 164 pages, all latest Amateur Gear—all leading lines, transmitters, receivers, transceivers; over 12,000 parts, new Kits of all types. 52 new Knight sets. Test Equipment; P.A. Send Postcard today.

ALLIED RADIO CORPORATION
Dept. 16-F-8, 833 W. Jackson Blvd., Chicago



HAMS— FANS!

The 1938 edition of the famous Hammarlund Short Wave Manual is chock full of high and ultra-high frequency receivers and transmitters. No ham or experimenter can afford to be without a copy.

Send 10 cents for your copy now!

HAMMARLUND MFG. CO., INC.

242 WEST 33rd STREET, N. Y. C., DEPT RW-6

A COMBINATION OFFER! RADIO WORLD and "RADIO NEWS" \$3.50

Canadian and Foreign, \$1.50 extra on this offer.

You can obtain the two leading radio technical magazines that cater to experimenters, service men and students, for one year each, at a saving of \$1.50. The regular mail subscription rate for RADIO WORLD for one year is \$2.50. Send in \$1.00 extra, get "Radio News" also for a year—a new issue each month for twelve months. Total 24 issues for \$3.50 and \$5.00 to foreign countries.

RADIO WORLD 145 West 45th Street, N. Y. City

Amazing New Gadgets Speed up YOUR SERVICE WORK

Ghirardi's New Pocket Trouble-Shooters
Save Time • Save Labor • Save Money



These wonder-working "Twin Gadgets" get straight to the bottom of your service jobs—quickly. Instead of servicing by trying out all sorts of experimental tests and remedies, now you can tell—with just a glance at Ghirardi's "Gadgets"—exactly what TESTS to make and what REMEDIES to use for

any trouble symptoms you find. Most useful and ingenious time-savers you ever saw.

HERE'S HOW THEY WORK:

There's nothing to it! Just pick out the card marked with the Trouble Symptom you find in the "sick" receiver. Rip the card around and there you'll see complete instructions for Locating and Repairing the trouble. Use these streamlined servicing short-cuts and stop wasting valuable time "checking" and "tussing." Together, they spot OVER 800 DIFFERENT SET TROUBLES! One for HOME RADIOS, another for AUTO RADIOS—the pair costs only \$1 (\$1.20 foreign), so you can't afford not to have them. Every day without them means money thrown away. Order them the EASY way! Write your name and address on this ad and send it in with a dollar today.

RADIO & TECHNICAL PUBLISHING CO.
45 ASTOR PLACE, NEW YORK Dept. RW-68

These gadgets sent postpaid anywhere
on 5-day Trial basis

50¢ EACH ORDER THEM NOW! \$1 FOR THE PAIR

COIL WINDING; NO COMPUTATION!

SOLENOIDS for all radio frequencies, from the fringe of the ultra highs, to the fringe of audio, may be wound, using popular wire sizes and form diameters, with no computation, yet at 1% accuracy. This is made possible by a series of quick-answer charts constituting "The Inductance Authority," by Edward M. Shiepe, plus an 18 x 20" supplement.

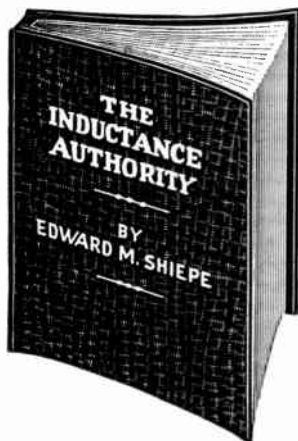

Winding solenoid coils for radio frequencies requires knowledge of the number of turns of any selected type of wire on any sensible diameter to attain an inductance suitable for the tuning condenser and lowest frequency. Hence, with capacity and frequency known, there are two unknowns: (1), the required inductance; (2), the number of turns to establish that inductance. The answers are obtained by consulting "The Inductance Authority," and the supplement. On the large supplement are

plotted the "curves of frequency, capacity and inductance in straight lines, so for a desired low frequency and known capacity the unknown inductance is solved by mere inspection. The number of turns for attainment of that inductance, for all popular tubing diameters and all generally used wire diameters and wire insulations, is read from the inductance-turns charts which are in the bound volume. Coil and set manufacturers, as well as home and shop experimenters, students and teachers freely use this book. The only book of its kind in the world.

Order Cat. INA (price includes bound volume and supplement) postpaid **\$2.00** anywhere on earth.....

Or send \$5.00 for a two-year subscription for RADIO WORLD, regular rate, and this valuable book and supplement will be sent FREE and postpaid anywhere on earth.

Order Cat. PR-IAC.

RADIO WORLD

145 West 45th Street New York City

Refrigeration
1
Text-Book for Home Study
This complete, up-to-the-minute, practical book will teach you quickly how to service all types of refrigerators. Page after page of useful, easy to understand facts. Refrigeration is the big money field you can get into it after studying this textbook. Size 8 1/2 x 11 in. Priced at only \$1.00, postpaid. Send for your copy now.

SUPREME PUBLICATIONS

5729 WEST 18th STREET

CHICAGO, ILL.

SPECIAL 2-FOR-1 OFFER RADIO WORLD

Radio World is \$2.50 a year (12 issues), 25c. per copy. Canada and foreign, \$3.00 yearly. Offers of Radio World and other worthwhile publications for one full year on each (NET):

- RADIO WORLD and SHORT-WAVE and TELEVISION, \$3.50.
- RADIO WORLD and POPULAR SCIENCE MONTHLY, \$3.50.
- RADIO WORLD and RADIO-CRAFT (12 issues), \$3.50.
- RADIO WORLD and RADIO INDEX (monthly, 10 issues), stations, programs, etc., \$3.50.
- RADIO WORLD and EVERYDAY SCIENCE AND MECHANICS (monthly), \$3.50.
- RADIO WORLD and BOYS' LIFE (monthly, 12 issues), \$3.50.
- RADIO WORLD and TRUE STORY (monthly), \$3.00.

Select any one of these magazines and get for an entire year by sending in a year's subscription for RADIO WORLD at the regular price, \$2.50, plus a small additional amount, per quotations above. (Add \$1.50 for extra foreign or Canadian postage for both publications.)

Name

Address

City and State.....

- If renewing an existing or expiring subscription for RADIO WORLD, put cross in square.
- If renewing an existing or expiring subscription for other magazines, put cross in square.

Special Trial Offer for Radio World only: \$1.00 for 5 months, postpaid. Mail order with remittance to Radio World Office. NET.

RADIO WORLD, 145 W. 45th St., New York

Get These Books Now! Take 7 Months to Pay for Them



NOW

this high-powered radio engineering library

sent to you for 10 days' trial—
at a special price and terms

These books cover circuit phenomena, tube theory, networks, measurements, and other subjects—give specialized treatment of all fields of practical design and application. They are books of recognized position in the literature—books you will refer to and be referred to often. If you are a researcher or experimenter—if your interest in radio is deep-set and based on a real desire to go further in this field—you want these books for the help they give in hundreds of problems throughout the whole field of radio engineering.

RADIO ENGINEERING LIBRARY

—especially selected by Radio World's staff of experts
—to give most complete, dependable coverage of facts needed by all whose fields are grounded on radio fundamentals

5 volumes, 3064 pp., 2000 illustrations

1. Glasgow's PRINCIPLES OF RADIO ENGINEERING
2. Terman's MEASUREMENTS IN RADIO ENGINEERING
3. Chaffee's THEORY OF THERMIONIC VACUUM TUBES
4. Hund's PHENOMENA IN HIGH-FREQUENCY SYSTEMS
5. Henney's RADIO ENGINEERING HANDBOOK

Special Low Price and Easy Terms

Bought singly, the five volumes comprising this library would cost you \$25.00. Under this offer you save \$1.50 and, in addition, have the privilege of paying in easy installments beginning with \$2.50, 10 days after receipt of the books, and \$3.00 monthly thereafter. Take advantage of these convenient terms to add them to your library now.

SEND THIS ON-APPROVAL COUPON

McGraw-Hill Book Co., Inc.
336 W. 42nd St., New York, N. Y.

Send me Radio Engineering library, 5 vols., for 10 days' examination on approval. In 10 days I will send \$2.50 plus few cents postage, and \$3.00 monthly till \$23.50 is paid, or return books postpaid. (We pay postage on orders accompanied by remittance of first installment.)

Name.....
 Address.....
 City and State.....
 Position.....
 Company..... R.V.-6-38
 (Books sent on approval in U.S. and Canada only.)

A FREE BOOK FOR EVERYONE IN RADIO

Radio - Craft —complete in everything radio men need, gained popularity and leadership in a few years. Never once has Radio-Craft shortened its stride of editorial progress. Broader in news scope—excellence in illustrations—continued improvement in editorial technique—accuracy in wiring diagrams and schematics—these are the basic ideals upon which Radio - Craft success has been achieved.

To all readers of this announcement the Publishers present a SPECIAL OFFER—A SEVEN MONTHS' SUBSCRIPTION TO RADIO-CRAFT and a FREE COPY of the 1938 RADIO REFERENCE ANNUAL. If you are a regular subscriber, you may also take advantage of this opportunity just the same. The publishers will be glad to extend your present subscription an additional Seven Months, and at the same time, send you a FREE copy of this book.

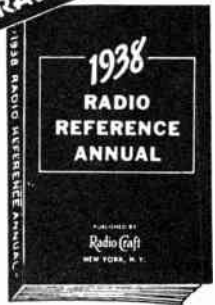

1938 RADIO REFERENCE ANNUAL

SET BUILDING—This particular section of the 1938 RADIO REFERENCE ANNUAL contains a description of a number of important, as well as interesting receivers. They are as follows: A Simplified Converter; A Farm Battery Receiver; An Executive's A.C.-D.C. Desk Set; Handy Book-End Novel Receiver. Other receivers described are: Crystal Set, Portable Battery Receiver, and several others. Each receiver is described accurately, complete with constructional data and parts list.

SERVICING—This chapter is devoted to Radio service instruments in general. Special emphasis is given to a number of the more essential instruments—they are: Service Oscillators, Mixer Circuits, V.T. Voltmeters and an Interference Eliminator.

PUBLIC ADDRESS—For those who find public address their chief interest, here you will find complete design and construction on a P. A. Tuner; a Handy Amplifier; and an Infinite Baffle Loud Speaker.

TEST EQUIPMENT—Radio Service Men who prefer to build their own equipment will find all the construction details necessary for building the following: Condenser Analyzer, Midget Oscilloscope with 1" and 2" tubes; Service Audio Oscillator.

GENERAL INTEREST ARTICLES—A variety of topics have been selected for their interest and importance. These subjects cover—Home Broadcaster; Remote Set Tuning; Carrier-Type Interphone Systems and a number of others.

MISCELLANEOUS—A comprehensive index of important articles which appeared in Radio-Craft during 1937. This section also includes data on recently developed tubes and many other helpful hints and suggestions.

Over 90 illustrations

64 Pages



RADIO-CRAFT

99 HUDSON STREET, NEW YORK, N. Y.

MAIL COUPON TODAY

RADIO-CRAFT R.W. 6-38
99 Hudson Street, New York, N. Y.

Gentlemen: Enclosed you will find my remittance of One Dollar (\$1.00) for which enter my subscription to Radio-Craft Magazine for Seven Months. Send me ABSOLUTELY FREE, and POSTPAID, my copy of the 1938 RADIO REFERENCE ANNUAL.
 New Subscriber Extend present subscription

Name.....
 Address.....
 City..... State.....
 (Send remittance by check or money order. Register letter if you send cash or unused U. S. Postage Stamps.)

RADIO BOOKS

Mathematics of Radio Servicing

Complete home-study training in useful radio mathematics. Explains and interconnects simplified arithmetic and algebra with everyday radio problems. 8 1/2 x 11 in.

Public Address Systems

A practical handbook, full of useful information, well illustrated. Considers in detail various microphones, radio and phono inputs, feed-back, mixing and volume controls, use of vacuum tubes, coupling, loudspeaker placement, DB, and hundreds of other points. Many actual circuit diagrams. Everything about P. A.

Radio Servicing Short-Cuts and Money-Making Ideas

A new and different book that tells how radios can be repaired quickly with the absolute minimum of test equipment. Proves that by actual test 9 out of 10 sets can be repaired with simple tools and ohmmeter. The author, M. N. Beltman, has been in the service work for years and kept data on these important helpful facts. Page after page of practical and money-making ideas applicable to all sets.

Special price, 50¢ each book, postpaid.

SUPREME PUBLICATIONS 3729 W. 13 St.
Chicago, Ill.

CHASSIS-CABINETS PANELS & CANS

STANDARD SIZES ON HAND
SPECIAL SIZES MADE TO ORDER

KORROL RADIO PRODUCTS CO.
350-354 Greenwich St. RW6-38 New York City

BUILD ONE TUBE POCKET SPORT SET

Nothing like it on the market.
No aerial or ground used.

Fully described in November
1937 issue of Radio World.

Complete Kit with Tube and Batteries **\$4.95**

Same as above, but completely wired by us and ready to operate **\$7.95**

SPECIAL INTERRUPTOR COIL ONLY 69¢

Send 3¢ in stamps for diagram.

Mail Orders Filled in 24 Hours

20% deposit with order, balance C.O.D.

DOUGLAS RADIO CO.

PARTS - AMPLIFIERS - TUBES

89 Cortlandt St. New York City

CLASSIFIED ADVERTISEMENTS

7 cents a word. \$1.00 minimum.

HIGH GRADE GOLD, ORE SPECIMENS, rare, beautiful. 50 cents postpaid. Copy, California Mining Journal, mining information, free with order. Sybil Mines, French Gulch, Cal.

WANTED TELEVISION CAMERA AND RECEIVER, disc type, sixty lines or better. Fully described. Box No. 765, Jefferson, Ohio.

HAVE YOU BACK NUMBERS of Radio World, for April, July, September, October, November, December, 1936; February, March, April, June, 1937? If so, please communicate with Radio World, 145 West 45th St., New York, N. Y.

SUGAR DIABETICS—Send for free booklet. Otto Clisky, Leesburg, Florida.

RADIO EXPERIMENTERS AND SET BUILDERS: parts and kits of parts for improved Little Giant R235, six tube R233, Pre-amplifier R228, Portable battery R223, Little Giant R220 and 205 and 6 volt R238. Guaranteed specified parts. Lund Manufacturing Co., Dept. R.W., 43 East Ohio, Chicago.

TREASURE-HUNTING CIRCUITS

By J. E. ANDERSON

Radio devices for locating buried treasure, deposits of ore bodies, etc., open a vast field for potential riches. A detailed discussion by J. E. Anderson appeared in the January, 1938, issue. Send 25¢ for a copy

RADIO WORLD

145 West 45th St., N. Y. City

RADIO WORLD AND POPULAR MECHANICS MAGAZINE—Radio World is \$2.50 a year, and Popular Mechanics Magazine is \$2.50 a year. Popular Mechanics Magazine does not cut rates, but Radio World will send both publications to you for one year for \$3.75. **RADIO WORLD**, 145 West 45th Street, New York City.

TELEVISION

"TELEVISION WITH CATHODE RAYS," by Arthur H. Halloran. Farnsworth and Zworykin systems fully explained. The treatment is mathematical. It is a book for the well-grounded radio man who has vision, the man who wants to be among the first to cash in when the pictures go on the air commercially, but is not for novices. 100 pages or more of supplementary data. Price \$2.75 postpaid including Supplement(s).

RADIO WORLD

145 West 45th Street, New York City, N. Y.

RADIO WORLD

Sixteenth Year

ROLAND BURKE HENNESSY
Editor

H. J. BERNARD
President

HERBERT E. HAYDEN
Advertising Manager

MARTIN POSNER
Technical Editor

PRESTON MACK
Circulation Manager

TABLE OF CONTENTS for JUNE, 1938

A Reliable Tube Tester . . .	10	Electric Fence Control — a New Opportunity	32
<i>That Has Proven Its Worth to a Discriminating Service- man</i>		<i>Based on Principles Service- men Know Well Business Is Growing Fast</i>	
By R. K. Wheeler		By M. N. Beitman	
A Debate on Tracking and Dial Calibration	15	Principles of the Musa . . .	36
<i>Squeals and Non-Squeals Pose Problems</i>		<i>Antenna Array Greatly Im- proves Reception</i>	
A Big Improvement in the 906	16	By C. B. Feldman	
<i>Graphite Coating Inside Enve- lope Affords Stability and Permits Low-Voltage Op- eration</i>		Musa Apparatus	39
Applications of the OA4-G.	19	<i>Circuit Arrangements, Installa- tions, Adjustments and Checking</i>	
<i>New Gas Triode Opens Vast Possibilities Because Requir- ing No Standby Current</i>		By W. M. Sharpless	
How to Wind Short-wave Coils	23	The Musa from the Outside	42
<i>Plug-in Data Given for Stand- ard Diameter and Length</i>		<i>Plant and Location Solutions</i>	
The Finch System of Home Radio Newspaper	24	By L. R. Lowry	
<i>A Detailed Explanation of the Technique</i>		Interference Picked up by Antennas	46
The Cathode Branch in Hum Networks	29	<i>Remedies to Apply Told by Expert</i>	
<i>Insight Into Interference Prob- lem</i>		By Alfred A. Ghirardi	
By Martin Posner		Television Improves Some More	52
Constants for Amplifiers . .	30	<i>RCA Method Clearer, Steadier, Now Equal to Commercial Requirements</i>	
<i>Chart for Resistance-Coupling Applications</i>		Radio University	58
		<i>Questions Answered</i>	
		An Effective Volume Expander	60
		<i>Overcomes Compression in Records and Broadcasting</i>	
		By M. N. Beitman	

Vol. XXXI, June, 1938. No. 3. Whole No. 717. RADIO WORLD, published monthly by Hennessy Radio Publications Corporation, 145 West 45th Street, New York, N. Y. Editorial and executive offices, 145 West 45th Street, New York, N. Y. Executives of RADIO WORLD: Roland Burke Hennessy, editor; H. J. Bernard, business manager; Herbert E. Hayden, advertising manager. Officers of corporation: H. J. Bernard, president-treasurer; Roland Burke Hennessy, vice-president; Preston Mack, secretary. Entered as second-class matter March, 1922, at the Post Office at New York, N. Y., under Act of March 3rd, 1879.

SUBSCRIPTION RATE

Price 25 cents per copy. Subscription \$2.50 per year (12 issues); \$1.25 per six months (6 issues); postpaid in the United States and Possessions; \$3.00 per year, \$1.50 per six months, postpaid in all other countries. Remittance for foreign subscriptions should be by International money-order (postal or express) or draft against or discountable at New York bank.

RADIO WORLD is distributed by the American News Company and its Branches

Over **1500.**
"CASE HISTORIES"
of Receivers

Over **6000.**
"I.F.'s"
of Superhet's

AUTO RADIO
DATA for all
Car Models

Over **25** other
HANDY TABLES
and **CHARTS**



All About
TEST
INSTRUMENTS

All About
TROUBLE
SHOOTING

All About
REPAIRING

2 BOOKS THAT GIVE YOU — ALL THE ANSWERS!

- **Are they Complete?**
You bet they are! They've got all the "417 Things Every Service Man Needs to Know"—and a whole of a lot more!
- **Are they Easy to Use?**
As easy as A B C! Every detail is clearly and thoroughly explained in plain language in thorough Ghirardi style. The books are arranged for quick and easy reference on any aspect of radio service work. They're time-savers!
- **Are they Practical?**
They're for the type of serviceman who isn't afraid to get grease on his smock! The dope you get from them comes straight from the service bench—and that's right where these two books belong!
- **How will they help me?**
In a million and one ways! They'll help you understand all about the latest test instruments and up-to-the-minute repair methods. They'll give you all the servicing data you need for your every day jobs, and for those troublesome hard-to-crack cases you get in too.
- **Are they Guaranteed?**
100%! Your money goes back instantly if for any reason you find them not entirely to your liking (5-day return privilege). You can't lose! You don't risk a single penny! Order them today.

For Every Practical Problem in Radio Service Work—

Ghirardi's two famous servicing books give you absolutely everything you need and want to know about radio service work as it is practised today by the most successful service shops.—**MODERN RADIO SERVICING** is studied constantly by smart service men all over the world to learn all about the latest servicing instruments, latest methods of servicing, and the latest "tricks of the trade." It tells you "how to do servicing."—**RADIO FIELD SERVICE DATA** supplies loads of latest servicing reference data and the Case Histories for over 1,500 receivers at an instant's notice, in the shop or out on the job. It's in loose-leaf form and kept up to date by a regular Supplement Sheet Service, which supplies you with new Case Histories and other valuable servicing data continuously. Of course you can struggle along without these "Ghirardi" servicing books, but you'll do better, quicker service work the moment you get them. You need 'em BOTH! Mail the coupon below—before you turn this page! Sent Postpaid Anywhere!

ALFRED A. GHIRARDI'S MODERN Radio SERVICING & Radio FIELD SERVICE DATA Books

\$6
1,800 Pages
813 Illustrations
for Both Books

MAIL NOW!

RADIO WORLD, 145 W. 45 St., N. Y. City

Here is \$6 for my copies of Ghirardi's MODERN RADIO SERVICING and RADIO FIELD SERVICE DATA. (Including Jan. and June '37 Supplements to the Data Book) postpaid. (\$8.50 foreign).

NAME

ST. & CITY STATE

MONEY-BACK GUARANTEE!

A Reliable Tube Checker

Using the Emission Type of Test

By R. K. Wheeler

WHEN designing any piece of apparatus it is always necessary that compromises be made, to satisfy certain requirements; namely, reasonable cost of finished product, simplicity of operation and not too much sacrifice of efficiency or accuracy.

This is markedly true in the case of tube checkers, where many variations in operation methods are found, with a corresponding variation in cost. Fortunately, in practice a high degree of utility can be obtained at low cost, especially in the case of emission type tube checkers. Emission type checkers admittedly have their shortcomings, but so have all other types regardless of cost, as 100% efficiency can never be attained.

For the consolation of prospective or present owners of emission type checkers, who are somewhat dismayed by the thought that such checkers are not perfect, it might be well to quote a statement in the RCA tube manual, on the subject of tube testing.

A HELPFUL SERVICE

In discussing *all* types of tube checking devices RCA says:

"It is impossible for a tube-testing device to evaluate tubes in terms of performance capabilities for all applications. The tube tester, therefore, cannot be looked upon as a final authority in determining whether or not a tube is always satisfactory. Actual operating test in the equipment in which a tube is to be used will give the best possible indication of a tube's worth. Nevertheless, the tube checker is a most helpful device for indicating the serviceability of a tube."

When enumerating the possible causes of faulty behavior or failure of a tube, the error is often made of assigning each *possible* defect the same weight. This is manifestly wrong, as there are some possible defects that may be seldom or never encountered. To effect a sensible design at reasonable cost, only those defects *likely* to be met should be considered. In actual practice tube failure is nearly always due to lowered emission, or shorts and leakages, and a good emission checker will determine these effects readily.

While there are many commercially-made checkers on the market, available in a wide range of prices, there are many men who gain pleasure and experience by constructing their own equipment.

POINTS TO CONSIDER

There are some points about such practice worthy of close attention. First, the quality of

material used is under control; second, a good understanding of the instrument's operation is acquired; third, the owner need not hesitate to make necessary repairs or desirable alterations.

The checker presented herewith is an emission type, constructed of standard parts, most of which are readily obtainable, and is of more than ordinary flexibility in operation. That it resembles all other emission type checkers goes without saying, since all operate on the same principle, i.e., the correct element is selected as a cathode, other elements being strapped together as anodes, the resulting current through the meter being adjusted so that good tubes will produce about the same meter reading. The sockets are shown in bottom view, numbered according to RMA practice, the associated single-pole, double-throw (SPDT) "element" switches being also numbered to correspond.

EXTENDED USE

The use of individual switches for each tube element permits any terminal to be selected as a cathode, and also allows selection of elements to be used as anodes, thus permitting the checking of separate sections of dual tubes. When tests are made for leakage or shorts the switches allow leakage to be determined to any element while the tube is hot.

A type T-4½ neon bulb is used in the leakage testing circuit, as it is readily obtained, is of small size and good sensitivity. It will be noted that the lamp is shunted with a resistor of .25 meg. This resistor is necessary to reduce the sensitivity of the lamp, otherwise leakage would be shown on an excessive number of tubes which were normal. Since no material is a perfect insulator, there is some degree of leakage present in any tube, and a limit must be placed on the sensitivity of the leakage detector to prevent erroneous conclusions.

REASON FOR CONDENSER

The .5 mfd. condenser in the circuit prevents the flow of rectified current from the tube, but permits the alternating current due to leakage or shorts to pass freely, thus lighting the neon detector. As switches are thrown a single flash will be noted, which is not an indication of leakage, but of charging or discharging current of the condenser.

The 201A tube shown in the circuit is used as a rectifier, so that the same meter used for testing will give some indication of the line voltage, when the DPDT switch is thrown to the "Leakage" position. In the current model

of writer's checker, the meter reads .8 ma when the line voltage is 115 volts, and the primary tap switch is in the proper position. If the constructor does not care to go to the trouble to install this tube, the same results may be obtained by keeping a good tube on hand as a standard, and inserting it in one of the panel sockets when an indication of the line voltage is required.

New tubes will produce a reading of approximately .9 ma, while good tubes that have had some service usually read lower, about .6 to .8 ma. This is because new tubes have an emission somewhat higher than normal for a short time after they are placed in use. After about 100 hours the emission drops slightly, about 10%, to a value which is constant until the tube approaches the end of its life.

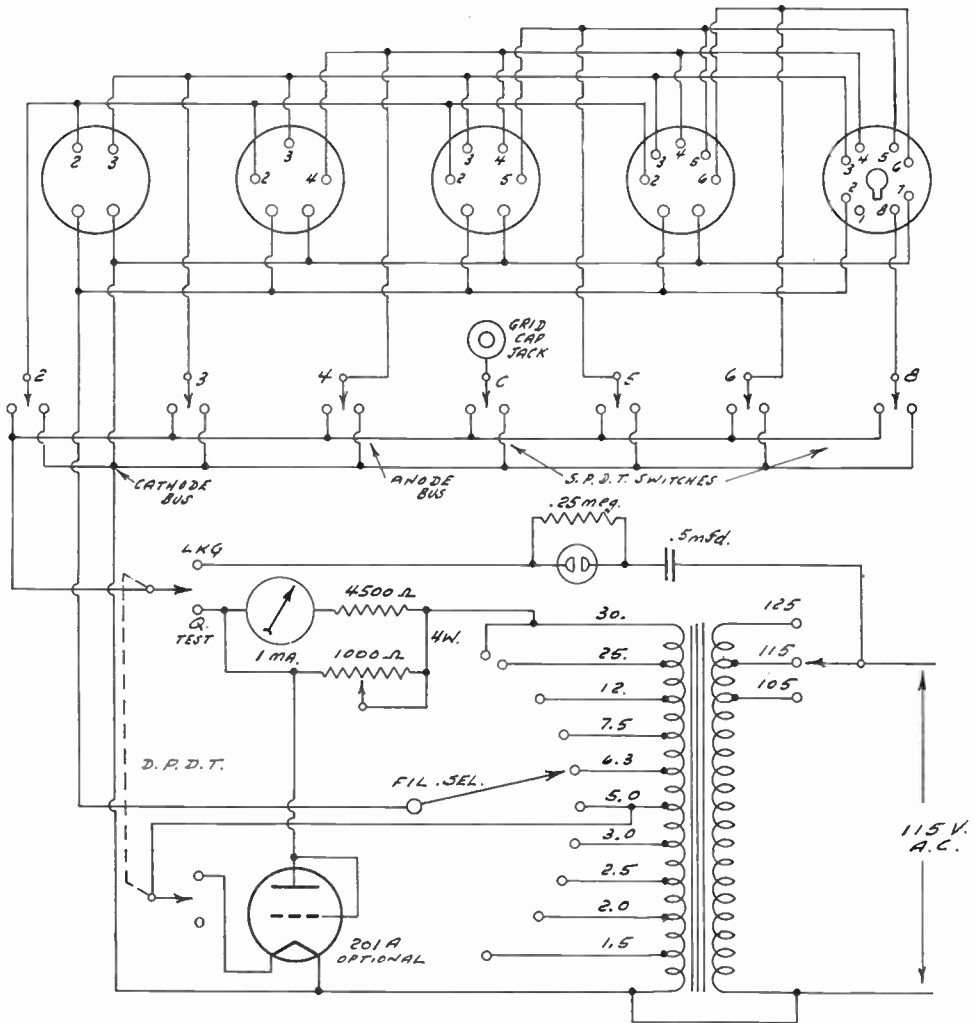

Circuit wiring of the tube checker that has given R. K. Wheeler very satisfactory service. Bottom view of tube sockets is shown. The construction and operation are described in the text.

The meter used is a 2" Triplett 0-1 milliammeter. Center scale or .5 ma is used as a dividing line between good and bad tubes. Since printed "Good-Bad" scales are not always obtainable, a 1/2" line may be drawn at the .5 ma mark, and the balance of the scale colored by hand, if the builder feels this is essential.

If the checker is to be used only for occasional light duty, low-priced wafer sockets may be used. However, if the checker is to have almost constant use, the best sockets obtainable should be used. In writer's opinion the Na-aid "tuning fork" sockets are well suited to this service. The 1,000-ohm potentiometer should

(Continued on page 14)

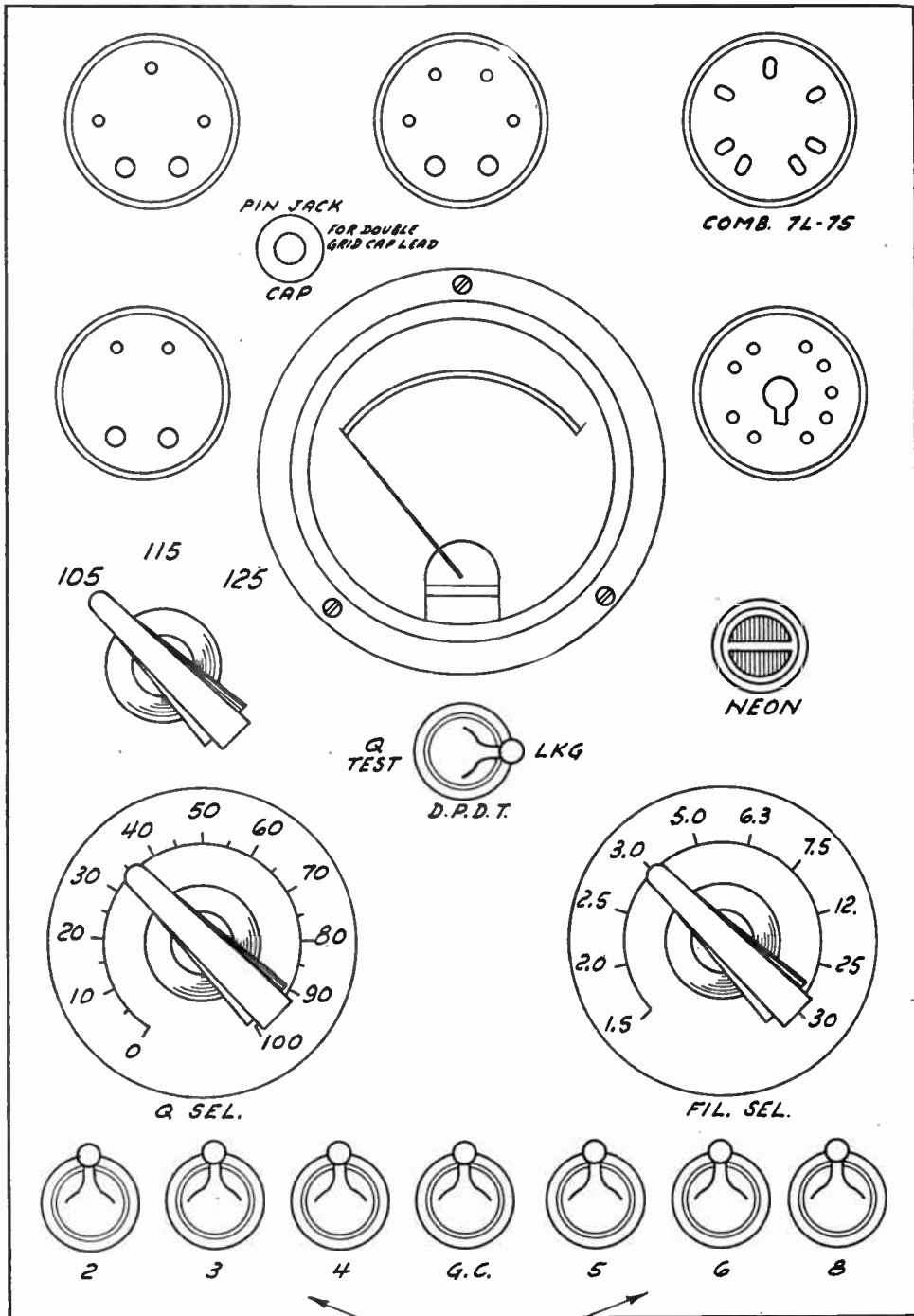

Suggested arrangement of the tube checker panel. The working of the switches is related to the tube chart for this tester printed in the accompanying text.

TUBE CHART

Sw. No. indicates switch to be connected to cathode bus.
Q. Set. indicates the setting of the "Q selector".

2-volt tubes			25 volt tubes			Miscellaneous		
Type	Q Set	Sw. No.	Type	Q Set	Sw. No.	Type	Q Set	Sw. No.
1A4	65	—	25A6	30	8	1V	26	3
1A6	70	—	25L6	22	8	12Z3	14	3
1B4	74	—	25Z5	6	3-4	20	85	—
1C6	62	—	25Z6	10	4-8	22	75	—
1F4	54	—	43	30	5	26	66	—
1F6	64	—	<hr/>			50	66	—
15	70	4	<hr/>			81	82	—
30	68	—	<hr/>			99	90	—
31	70	—	<hr/>					
32	70	—	<hr/>					
33	56	—	<hr/>					
34	70	—	<hr/>					
49	62	—	<hr/>					
<hr/>			<hr/>			<hr/>		
2.5-volt tubes			6.3-volt tubes					
2A3	28	—	6A3	34	—			
2A5	42	5	6A4	56	—			
2A6	42	5	6A6	24	4			
2A7	40	6	6A7	42	6			
2B7	54	6	6B5	58	5			
27	54	4	6B6	50	—			
27 hm	46	4	6B7	54	6			
35-51	50	4	6C6	44	6			
45	52	—	6D6	46	6			
46	50	—	6E6	30	4			
47	50	—	6F7	48	6			
53	28	4	6F5	40	8			
55	60	5	6H6	22	4-8			
56	46	4	6J7	42	8			
57	42	5	6K7	46	8			
58	46	5	6L6	28	8			
59	42	6	6L7	32	8			
82	52	—	6N7	26	8			
G84	72	—	6Q7	40	8			
Wund A	52	5	6R7	40	8			
<hr/>			6X5	20	8			
<hr/>			<hr/>					
5-volt tubes			6.3-volt tubes					
5Z3	38	—	36	42	4			
00A	60	—	37	48	4			
01A	72	—	38	54	4			
12A	50	—	39/44	50	4			
40	70	—	41	42	5			
71A	54	—	42	42	5			
80	50	—	75	36	5			
83	50	0	76	44	4			
83V	10	—	77	42	5			
182A	54	—	78	44	5			
182B	56	—	79	24	4			
183	54	—	84	20	4			
<hr/>			85	46	5			
<hr/>			89	42	5			
<hr/>			<hr/>					
5-volt octal			Majestic types					
5V4	24	8	2Z2	77	—			
5W4	48	8	2S-4S	80	4			
5Z4	38	8	6D7	40	6			
<hr/>			6E7	42	6			
<hr/>			6Y5	20	4			
<hr/>			6Z5	do not check	—			
<hr/>			25S	62	—			
<hr/>			56AS	42	4			
<hr/>			57AS	40	5			
<hr/>			58AS	42	5			
<hr/>			85AS	40	5			

**WHAT'S
IMPORTANT?**

What test equipment does a serviceman really need? Anyone who wants to get a good, hot discussion going need only announce his views on the matter at any gathering of Radioneers, Servicians, Service Engineers, Radio-tricians, Radio Doctors or just plain Tinkerers.

A good rectifier type volt ohm-milliammeter is certainly the prime necessity. The voltage ranges may have much higher sensitivity than the 1,000 ohms per volt which is being considered good. The top resistance range may also be a good deal higher and the current range lower than they have been, in view of the constant increase in number of high-resistance, low-current circuits in the newer receivers.

Next in importance is certainly——?

Well, if it is not a signal generator it is surely a tube tester. Presumably that depends somewhat on the nature of one's business. A store would need a tube checker more than a signal generator, and so might a serviceman, for he could somehow get along without a signal generator, in a pinch, but could he well get along without a tube tester, pinch or no pinch?

(Continued from page 11)

be wire-wound, and of at least 4 watts rating, e.g., the Yaxley M-1M-P. The 2-watt size will not safely carry the current from such tubes as the 83V, 25Z5, etc.

In operation the DPDT switch is thrown to the "Leakage" position and all the element switches thrown to the anode connection (except for such tubes as 5z4, 6x5, etc.) Since one side of the filament is connected to the cathode bus line, leakage between the cathode and filament is checked without further adjustment.

TEST AND QUALITY

Referring to the chart, or tube manual, the tube's cathode is connected to the cathode bus line. Connect each of the other switches singly, checking each element for leakage. With the "Quality" selector at the correct setting, the DPDT switch is thrown to the "Test" position, all element switches connected to the anode bus line, except the cathode switch, which is of course connected to the cathode bus line.

Filament type tubes, which do not have an indirectly heated cathode, are automatically connected to the cathode bus by one side of the filament.

It will be noted that certain tubes, such as the 5z4, 6x5 and others, have the cathode and filament brought out to a common terminal, usually pin No. 3. When checking these tubes, switch No. 8 should be thrown "negative," or to the cathode bus, otherwise the filament, may be overloaded if the "Quality" selector is set at a low figure.

The panel may be of any suitable material. The writer used aluminum. Figures and letters are easily stamped with a set of punches, the panel being finished with crackle lacquer, and the figures filled in with white ink or engraver's wax. A suggested panel lay-out is shown.

CHOICE OF DIFFERENT RESISTOR

All parts are mounted on the panel, the filament transformer directly over the filament tap switch, by machine screws through the panel, with bushings of sufficient length for the transformer to clear the switch and other parts. An engraved plate for the filament switch settings may not be easily obtained, in which case one may be made of sheet metal, the figures stamped by hand, or the figures may be stamped directly on the panel.

A list of control settings is shown for various representative tube types. There may be some variation, due mainly to the transformer, and it may be necessary to make some adjustment of the current through the meter. This can be done by using a different value of series resistor, shown as 4,500 ohms. The resistor may be 4,000 ohms if the meter reading is low, or 5,000 ohms if the meter reading is high. Approximate settings for new tubes brought out may be determined by comparing the characteristics of the new tube with those of tubes already checked and charted. The new tube may then be checked by actual test, and the setting recorded that gives a reading of .9 ma.

No provision has been made to check certain

tubes with abnormal internal connections, such as the 6Z5, 12Z5 and a few others. This would require additional switching for these tubes individually, and since they are seldom encountered, these switches were not installed, it being much simpler to install a new tube of that type to learn if replacement was required. If the user feels he should actually test such tubes an adapter might be constructed, although the writer feels it is hardly worth the trouble and expense.

If all the items necessary to build this checker must be purchased new, the cost will be approximately \$11. However, it should be considered that only high quality parts are to be used, and several desirable features are included, with result that the finished checker will give excellent performance.

RCA Diagrams for 1937 Published in One Volume

A bound volume giving service notes, chassis-layout diagrams, illustrations and complete technical data for each of 85 RCA Victor instruments in the 1937 series has been published.

Entitled "RCA Victor Service Notes for 1937," the 384-page book presents complete information on all RCA Victor home receivers, battery-operated models, phonograph-radio combinations, auto radios, record players, phonographs, amateur receivers, test equipment and antennas. In addition, technical data and diagrams are included for the RCA Victor Electric Tuning mechanism and Armchair Control.

"Original service notes and chassis diagrams on the various instruments have been brought up to date wherever chassis changes have been made," said Edward C. Cahill. "Pictures of all instruments have been included, thus making the book a handy reference for identifying models."

Cornell-Dubilier Publishes Book About Electrolytics

A new book, entitled "Electrolytic Capacitors," in which both radio and electrical men will find authentic information on the theory, construction, characteristics and applications of electrolytic capacitors of all types, and which is replete with the data they have been seeking, has just been published. Its author, Paul McKnight Deeley, is chief engineer of the electrolytic division of Cornell-Dubilier Electric Corporation, world's largest exclusive manufacturer of capacitors. Mr. Deeley is considered the foremost authority on electrolytic capacitors. "Electrolytic Capacitors" is available through the Cornell-Dubilier Electric Corporation, South Plainfield, N. J. Price, \$3.00.

CAPACITY MEASUREMENT

In service practice capacity is measured by the impedance method, whereby the unknown is put in series with a resistor and a voltage.

Second Harmonic of I.F. Stirs Up Quite a Debate

IN the April, 1937, issue appeared an article by H. J. Bernard entitled "Full Analysis of Squeals in Supers." In the July, 1937, issue a letter signed O. H. H. was printed in which the reader set forth that a generator used for close alignment of the i.f., when fed to the antenna circuit for second harmonic effect, was read on the accurate receiver dial as a bit higher than twice the i.f. So if 465 kc was the i-f amplifier frequency, instead of 930 kc being read on the set dial, 935 kc was read. The editor explained to O. H. H. in the same July issue that the signal generator's second harmonic will cause a squeal with the second harmonic of the intermediate frequency produced in the receiver's mixing circuit. In other words, the tracking is not perfect, and the number of cycles it is off is equal to the frequency of the squeal.

WHEELER'S REMARKS

Now comes R. K. Wheeler, one of our contributors, and a serviceman of high attainments, telling what fun he gets browsing through back issues of RADIO WORLD, and commenting on the O. H. H. case as follows:

"I believe you missed the correct answer on this one, which is fairly simple. Assuming that the receiver dial is as accurately calibrated as O. H. H. claims, the error then is in his signal generator. Merely because his signal generator dial is marked 465 kc does not make the output that frequency. The fact that his second harmonic is higher than 930 kc proves it is not.

"This brings to mind the pathetic confidence a large number of radio men have in factory-made instruments. In spite of the numerous excellent discussions in RADIO WORLD in regard to signal generator calibration and harmonic practice, an astonishing number of men accept the calibration of their commercial signal generators as 100 per cent perfect, without ever taking the trouble to check by zero beating against transmitters of known frequency. When they do make such a check and find a discrepancy, many strange explanations, such as that of O. H. H., are evolved to account for the error.

"However, this is no indictment against commercially-made apparatus, as most of it is excellently designed and affords full value for the price paid. The accuracy of the apparatus is usually much greater than the ability of the user."

EDITOR IN SURREBUTTAL

Mr. Wheeler's point, that the signal generator inaccuracy accounts for the difference, correctly describes one possibility, which applies when tracking is good. However, with a receiver dial described as accurate, the signal generator by test could be read to the same accuracy, i.e., checked. Assume then perfect ac-

curacy of the calibrated frequencies. We then have left the only possibility that the intermediate frequency generated is not equal to the frequency of the intermediate amplifier, i.e., tracking is poor.

DIFFERENCE EXPLAINED

When stations do not come in accordance with the frequency markings on the tuning dial it is often said that the tracking is bad, and if they do coincide, that the tracking is good. But there is a difference between "tracking" and "dial calibration."

Suppose that a very accurate signal generator is used and the intermediate amplifier is deemed perfectly aligned. Suppose also that the receiver dial station calibration is accurate. These two suppositions do not guarantee that the tracking is good.

The effect of poor tracking is to reduce the gain to which the r-f signal is subjected and to reduce the signal selectivity. Thus poor tracking means possibility of producing beats with undesired stations and the reception of stations on image frequencies.

It is assumed that the receiver is tuned to the signal frequency as marked on a correctly-calibrated dial, as mentioned above. A "correctly-calibrated dial" does not mean that the signal-frequency marks on the dial refer to the frequency of the tuned input circuit; it means that the local oscillator is at the proper frequency it must have to produce the required i. f. when mixed with the received frequency.

WHAT FOOLED MANY

Now for an apparent anomaly that has misled many. Normally when tuning this receiver you will turn the dial to receive a particular station until maximum amplitude is attained. But this does not necessarily indicate perfect tracking; the maximum amplitude may be a false one, not the highest possible. By a slight departure from the correctly calibrated dial position the amplitude is raised because the r-f end is thereby tuned more nearly to exact signal resonance, though at the same time, since the tuning condenser is ganged, the oscillator is then a trifle off from the frequency perfection requires. Naturally, this lowers the gain as well as the selectivity at the i-f level, because the generated i-f is not exactly equal to the intermediate amplifier frequency. So there arises a compromise condition, a balance of one gain against the other loss, until the false maximum is reached.

Even though useful for build-up at this one setting, the false maximum is not consistent, because as you tune through the dial scale to higher frequencies on the same band, the change in oscillator frequency is so great that no such compensation for false maximum can be accomplished.—EDITOR.

Big Improvement in 906

Graphite Inside Coating on Cathode-Ray Tube Permits Low D-C Voltage Operation, Reduces Spot Displacement and Increases Resistance of One Deflecting Plate

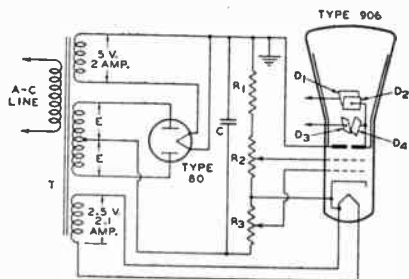

ITEM	400-VOLT OPERATION	600-VOLT OPERATION
RECTIFIER	TYPE 80	TYPE 80
T	110 V./750 V. WITH CENTER TAP (E = 325 V.); FILAMENT WINDINGS AS SPECIFIED.	110 V./900 V. WITH CENTER TAP (E = 450 V.); FILAMENT WINDINGS AS SPECIFIED.
C	1 μ F., 450 V.	0.5 μ F., 600 V.
R ₁	0.25 MEG., 0.5 WATT	0.4 MEG., 0.5 WATT
R ₂	0.15 MEG., 1.0 WA.	0.5 MEG., 1.0 WA.
R ₃	0.015 MEG., 1.0 WA.	0.03 MEG., 1.0 WA.

AN important low-voltage operating condition for the type 906 cathode-ray tube has been established on the basis of a recent improvement in the design of this tube type. This improvement consists in the use of a graphite coating on the inside of the glass envelope. This coating, which is connected to second anode inside the tube, in addition to permitting the tube to operate satisfactorily at comparatively low voltages, reduces the loading effects of the vertical deflection plates, reduces spot displacement due to the use of high resistance between a pair of deflection plates, and decreases reflections of the luminescent trace from the inner walls of the tube.

Reducing reflections from the inner walls of the tube increases the contrast between dark and luminous areas of the screen. Good spot size, good definition, and high sensitivity can be obtained with only 400 volts on the second anode. This new operating condition is important because it enables a three-inch cathode-ray tube to be used with a low-cost power-supply unit. Typical 400-, 600-, 1,200-, and 1,500-volt operating conditions for the type 906 are given in Table I.

EFFECTS OF GRAPHITE COATING

It is of interest to discuss briefly the manner in which the graphite coating improves performance. In an uncoated cathode-ray tube the secondary electrons from the screen, which are emitted because of bombardment by the electron beam, are attracted to the second anode and the deflection plates. The removal of secondary electrons from the fluorescent screen causes the potential of the screen to rise to a value which is somewhat less than the second-anode voltage. A steady screen potential is reached when the number of electrons arriving at the screen equals the number emitted from the screen. Thus, for any static operating condition, the potential difference between screen and second anode adjusts itself to maintain an equilibrium condition between the number of primary and secondary electrons.

Suppose now, that the inside of the glass wall

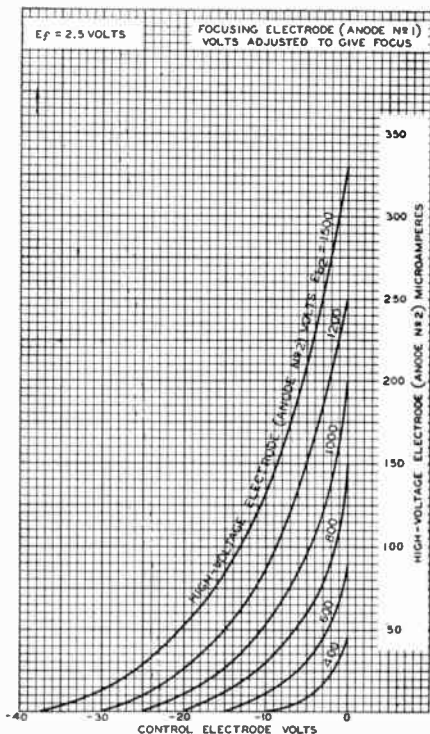
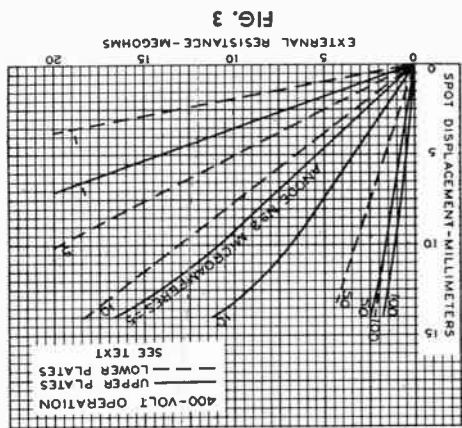
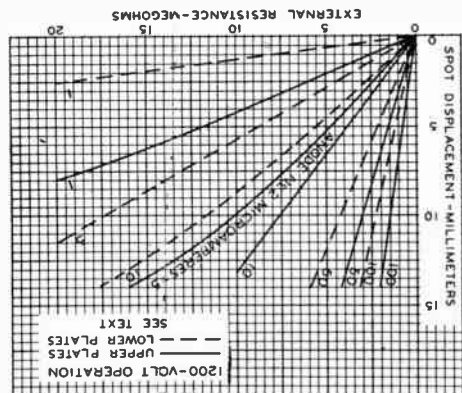
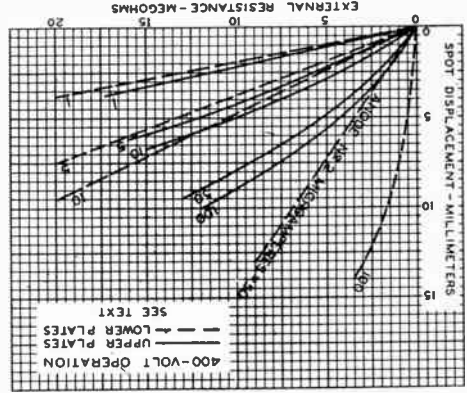
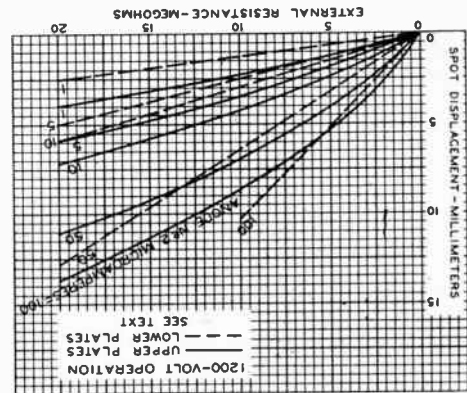

FIG. 1

Power supply unit for the 906, using an 80 rectifier (top). Average characteristics of the 906 for 400, 600, 800, 1000, 1200 and 1500-volt operation are given (lower). The higher voltages afford sharper definition.

is coated with a conducting material, such as graphite, and that the coating is connected to the second anode. Because the coating is closer to the fluorescent screen than the second anode, less potential difference between screen and second anode is required to maintain equilibrium. Thus, for a given second-anode voltage, the potential of the screen in a coated tube is higher than that in an uncoated tube of the same type. The comparatively high screen potential in the coated tube allows the electrons to

value of this second-anode voltage determines the minimum second-anode voltage for satisfactory operation. This value of voltage is less for the coated type 906 than for the uncoated type, because of the relatively small difference in potential between screen and second anode in the coated-type tube. A power-supply unit for low-voltage operation of the improved type 906 is shown schematically in Fig. 1. A type 80 tube is used as a rectifier. A single 1 mfd. condenser of com-



The two curve families at left give the operation characteristics of the coated type, while the two illustrations in column at right cover the uncoated type.

FIG. 3

FIG. 2

strike the screen with low beam divergence and, thus, to produce a well-defined spot. In other words, for equal spot definition, a coated tube requires less second-anode voltage than an uncoated tube of the same type.

POWER-SUPPLY UNIT

When the second-anode voltage on a cathode-ray tube is low, the entire screen may become charged due to impact by low-velocity electrons. When the second-anode voltage is increased, a value of second-anode voltage is found at which the charge on the screen is neutralized by the beam. The

filtering for most applications. In some cases it is desirable to have a spot of better definition than is obtainable under the 400-volt conditions. For such applications, the second-anode voltage may be increased to 600 volts. Typical operating conditions for 600 volts on the second anode are given in Table I. Power-supply data for this operating condition are shown in Fig. 1. The type 80 tube may be used as a rectifier for the 600-volt power-supply unit shown in Fig. 1. Under this low-current condition, operation of the 80 simulates choke-

(Continued on following page)

(Continued from preceding page)
input conditions closely enough to permit the use of 450 volts (rms) per plate.

DEFLECTION-PLATE RESISTANCE

Each pair of deflection plates in a cathode-ray tube loads the circuit connected to the plates. This loading is due to capacitance between the plates and to a flow of current to the plates. The deflecting plates collect secondary electrons from the screen. In the type 906 one plate of each pair connects to the second anode inside the tube. The number of electrons collected by the free plates is less in the coated-type 906 than in the uncoated type, because the graphite coating collects many of the electrons which otherwise would go to the free plates in an uncoated tube.

The pair of plates nearest the fluorescent screen are called the upper plates and are labeled D1 and D2 in Fig. 1; the pair of plates nearest the gun are called the lower plates and are labeled D3 and D4 in Fig. 1.

The deflection-plate current is not constant but depends on the position of the beam. This variable current constitutes a non-linear load on the circuit connected to the plates. The effect of a non-linear load is to distort the trace of an applied voltage. To reduce this effect, the minimum resistance presented by a pair of deflection plates to an external impedance should be much higher than the value of the external impedance.

Approximate values of minimum deflection-plate resistance for different values of second-anode current are given in Table II. These data obtain for the coated- and uncoated-type

906 at the 400- and 1200-volt operating conditions and for the position of the spot corresponding to maximum loading. These data show that the upper deflection-plate resistance of the coated tube is several times that of the uncoated tube. The lower deflection-plate resistances are about the same for both tube types. The high ratio of lower to upper deflection-plate resistance is due to the relative location of these pairs of plates; the upper plates are so disposed as to shield the lower plates.

SPOT DISPLACEMENT

The electron current to the free plates causes another undesirable effect known as spot displacement. The position of the spot on the screen varies with the value of resistance connected between plates. This variation in position is due to the voltage drop across the resistor; the voltage drop, in turn, depends on the current flowing to the free plates.

The relations between spot displacement and external resistance for the 400- and 1200-volt operating conditions are shown in Figs. 2 and 3. The data in Fig. 2 obtain for the coated tube and the data in Fig. 3 obtain for the uncoated tube. The values of displacement shown by the curves obtain when the spot is near the edge of the screen, where maximum displacement is observed. The displacement is less for other positions of the spot. These curves indicate clearly the superior performance of the coated-type 906. The external voltage necessary to position the spot properly can be determined from the given values of deflection sensitivity and spot displacement.

Copyright 1938 by RCA Manufacturing Co., Inc.

TABLE I
Operating Conditions for 906

Heater Voltage	2.5	2.5	2.5	2.5	Volts
Anode No. 2 Voltage.....	400*	600	1200	1500	Volts
Anode No. 1 Voltage (Approx.).....	128	170	345	475	Volts
Negative Grid Voltage	Adjusted to give suitable luminous spot				
Grid Voltage for Current Cut-off (Approx)	-30	-45	-60	-70	Volts
Deflection Sensitivity:					
Plates D ₁ and D ₂ (Upper Plates).....	0.81	0.55	0.27	0.22	Mm-Volt d.c.
Plates D ₃ and D ₄ (Lower Plates).....	0.87	0.58	0.29	0.23	Mm-Volt d.c.

*This operating condition is recommended only for coated type 906.

TABLE II
Minimum Deflection-Plate Resistance of the Type 906

Anode No. 2 Current	400-Volt Operation				1200-Volt Operation			
	Coated Bulb Plates		Un-Coated Bulb Plates		Coated Bulb Plates		Un-Coated Bulb Plates	
Microamps.	Upper ¹	Lower ²	Upper ¹	Lower ²	Upper ¹	Lower ²	Upper ¹	Lower ²
	Megohms							
	Minimum Deflection-Plate Resistance*							
1	110	150	55	150	100	225	50	225
5	55	60	19	55	40	100	20	80
10	35	55	16	35	35	95	14	95
50	16	20	5	15	15	35	4.5	30
100	10	9	2.8	8	8	25	2.5	15

*Approximate. ¹Plates D₁ and D₂. ²Plates D₃ and D₄.

Operation of the 0A4-G

Glow-Discharge Tube Applicable to Carrier-Controlled Systems

THE 0A4-G is a cold-cathode glow-discharge tube of the starter-anode type designed for use primarily as a relay tube in carrier-actuated equipment. The 0A4-G consists of a cathode (K), starter-anode (P₁), and anode (P₂) arranged as shown in the photograph of Fig. 1; socket connections and symbolic representation of the tube are shown in Fig. 2.

In normal operation of the 0A4-G a relatively small amount of energy initiates a glow-discharge between cathode and starter-anode. This discharge produces free ions which assist in initiating the main discharge between cathode and anode. The anode current (I_{a2}), which flows during the cathode-anode discharge, actuates a relay or other device connected in the anode circuit. It is the purpose of this Note to describe the characteristics of the 0A4-G and to show its mode of operation in a typical carrier-actuated system.

BREAKDOWN CHARACTERISTICS

Any one of six different discharges may occur in a gas-triode, depending on the relative potential differences and relative distances between electrodes. The closed curve which describes the voltage conditions necessary for breakdown between any two electrodes in a tube of given geometry is called the breakdown characteristics of the tube.

Consider the test circuit of Fig. 3. A voltage E_{bb_1} is applied to P₁ through a high resistance R_{b1}; a voltage E_{bb_2} is applied to P₂ through a load impedance R_{b2}. From the curve of a typical tube shown in Fig. 4, it will be noted that for values of E_{b_2} less than approximately +285 volts, no discharge is initiated until E_{b_1} is approximately +85 volts. When this value is reached, a discharge between K and P₁ is initiated. This condition is depicted by section A (above zero ordinate) of the breakdown characteristics shown in Fig. 4.

When the anode voltage is increased to +285 volts, a breakdown occurs between cathode and anode. The value of anode voltage required for breakdown between K and P₂ is substantially independent of starter-anode voltage for values of E_{b_1} greater than approximately +18 volts, and less than +85 volts as shown by section B of Fig. 4. Section B, therefore, shows the relation between E_{b_2} and E_{b_1} that is necessary for a cathode-anode discharge when there are no ions to assist the initiation of the breakdown.

INTERCHANGED CATHODE

Section C of Fig. 4 shows the relation between E_{b_2} and E_{b_1} that is required for a dis-

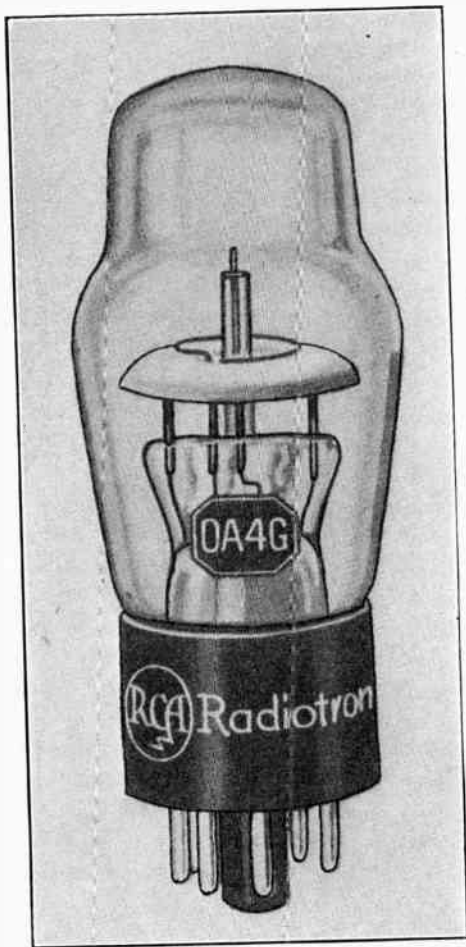

FIG. 1
Appearance of the 0A4-G, with elements plainly shown.

charge between starter-anode and anode when there are no ions to assist the initiation of this discharge. In this discharge, the starter-anode acts as a cathode, so that the slope of section C would be approximately 45 degrees were there no third electrode in the tube. This discharge can occur with positive values of E_{b_1} , because the distance between P₂ and P₁ is less than that between P₂ and K.

Section D shows the relation between E_{b_2}
(Continued on following page)

(Continued from preceding page)

and E_{b1} that is required for a discharge between starter-anode and cathode when there are no ions to assist the initiation of this discharge. It should be noted that this discharge takes place between the same two electrodes as in section A. However, under the conditions of section D, P_1 acts as cathode, because it is negative with respect to K.

Sections E and F show the relations between

discharge to the third electrode is called a transition characteristic.

TRANSITION AND ANODE CHARACTERISTICS

The 0A4-G is designed for operation only in that part of the breakdown characteristics designated by section A (positive anode) of Fig. 4. Although the tube functions in other

BOTTOM VIEW OF SOCKET CONNECTIONS

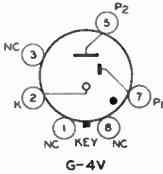

- P₁ = STARTER-ANODE
- P₂ = ANODE
- K = CATHODE
- NC = NC CONNECTION
- = GAS TUBE TYPE

FIG. 2

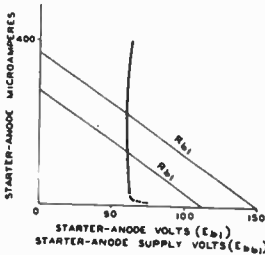

FIG. 5

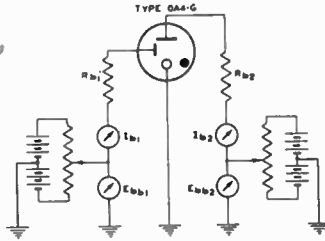

FIG. 3

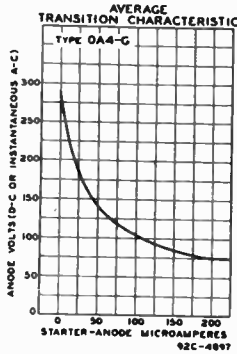

FIG. 6

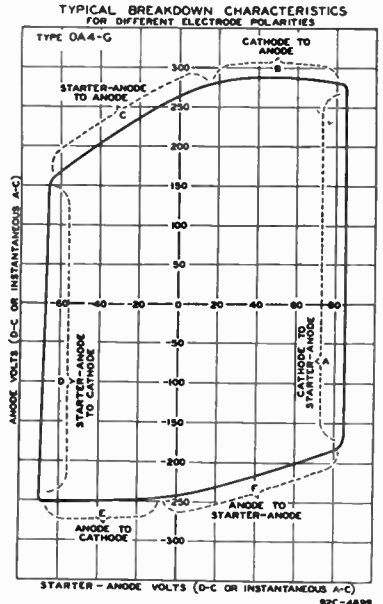

FIG. 4

E_{b2} and E_{b1} that are required to initiate a discharge between anode and cathode and between anode and starter-anode, respectively, when there are no ions to assist the initiation of these discharges. In these cases, as in the previous ones, the first word of the term describing the discharge denotes the electrode acting as cathode.

The breakdown characteristics of Fig. 4 indicate the voltage conditions necessary for breakdown between any two electrodes when there is no assisting discharge current. For example, a discharge between anode and cathode is initiated when $E_{b2} = +285$ volts and $I_{b1} = 0$. When the voltage applied to P_1 is increased so that starter-anode current flows, the discharge between cathode and anode can be initiated at values of E_{b2} less than 285 volts. A relation between the assisting- or initiating-discharge current between two electrodes and the voltage on the third electrode necessary to initiate a

regions, as previously described, its operation in these regions is unstable because of design characteristics. In normal operation, a discharge between cathode and starter-anode assists in initiating a main discharge between cathode and anode.

The relation between starter-anode current and starter-anode voltage is shown in Fig. 5. This curve is obtained by applying various values of E_{bb1} to P_1 through a high resistance (R_{b1} in Fig. 3) and recording I_{b1} ; the starter-anode voltage is then $E_{bb1} - I_{b1}R_{b1}$. The load line R_{b1} intersects the abscissa at values of E_{bb1} of interest. As E_{bb1} is increased above the value at which the $K - P_1$ discharge occurs, I_{b1} increases proportionately and the starter-anode voltage (E_{b1}) remains substantially constant at approximately 60 volts.

Now, for each value of I_{b1} , there is a corresponding value of E_{b2} necessary to initiate the main discharge between cathode and anode.

This relation between I_{b1} and E_{bb2} , the transition characteristic, is shown in Fig. 6. It shows the anode voltage necessary to initiate a discharge between cathode and anode when there is an assisting discharge current (I_{b1}) flowing. For practical purposes, it is convenient to think of the discharge to starter-anode as transferred to the anode when sufficient anode voltage is applied; hence, the name transition characteristic is used to define the relation shown in Fig. 6.

CARRIER-ACTUATED SYSTEM

The transition characteristic approaches the line $E_{bb2} = 70$ volts, the voltage drop across the tube. When the value of E_{bb2} is less than

a-c operated. Under these conditions, the wave form of the voltage impressed on P_1 is shown in Fig. 9. With the proper adjustments, the value of starter-anode voltage is greater than that required to initiate a discharge between K and P_1 for only a part of the interval t . During the small interval ab , the gas (argon) ionizes at an increasing rate; during the interval bc , the rate of ionization decreases; and during the interval cd , the gas de-ionizes at a comparatively slow rate. The process is repeated during successive r-f cycles and the discharge to starter-anode is completed only when the number and amplitude of the peaks are sufficiently great. Thus, to initiate a discharge under a-c

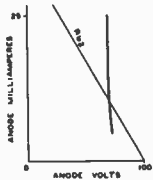
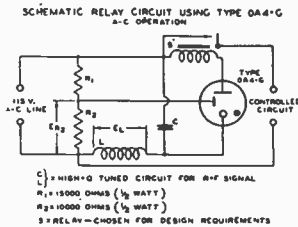

FIG. 7



C) HIGH-Q TUNED CIRCUIT FOR R-F SIGNAL
 $R_1 = 15000$ OHMS ($\frac{1}{2}$ WATT)
 $R_2 = 10000$ OHMS ($\frac{1}{2}$ WATT)
 S RELAY—CHOSEN FOR DESIGN REQUIREMENTS

FIG. 8

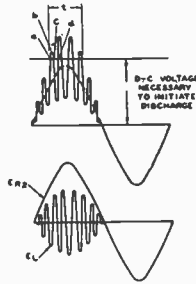

FIG. 9

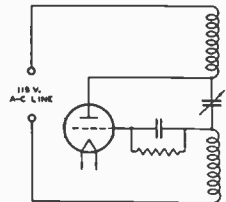

FIG. 10

the voltage drop across the tube, the transfer of the main discharge cannot take place.

The anode characteristic of the tube (Fig. 7) shows the relation between anode current and anode voltage. This relation is obtained by varying E_{bb2} and recording I_{b2} . The anode voltage is then $E_{bb2} - I_{b2}R_{bb2}$. Fig. 7 shows that over the useful operating range the anode-cathode voltage drop remains substantially constant at 70 volts. Operation at anode currents less than 5 milliamperes or greater than 25 milliamperes is not recommended.

An important application of the OA4-G is its use as a relay tube in carrier-actuated systems. The circuit of a typical receiver system is shown in Fig. 8. Low-frequency voltage is applied between anode and cathode through relay S and r-f coil L . A portion of this voltage is also applied between starter-anode and cathode through coil L by means of the voltage divider R_1 and R_2 . Under the conditions shown in Fig. 8, 65 volts peak is applied to P_1 and is in phase with the anode voltage. In addition to this low-frequency voltage, the line carries radio-frequency voltage that is furnished by a remote transmitter.

100% MODULATION

When the resonant frequency of L and C is the same as the frequency of the r-f voltage on the line, a comparatively high r-f voltage is generated across L . The r-f voltage across L is applied to P_1 and P_2 in series with their respective low-frequency voltages.

The radio-frequency voltage is modulated 100 per cent at 60 cycles when the transmitter is

conditions, it is not sufficient that the peaks exceed the value required for d-c excitation; the rates of ionization and de-ionization, the amplitude of each r-f cycle above the value required with d-c applied, and the frequency should be considered. For power-line frequencies of the order of 60 cycles and radio frequencies of the order of 100 kilocycles, it is suggested that $E_{R2} + E_L$ be greater than 110 volts peak.

It should be noted that the low-frequency starter-anode and anode voltages are in phase and that the r-f voltage may be applied during one-half or throughout the entire low-frequency cycle. When the r-f is generated during one-half of the low-frequency cycle, it is possible for the r-f voltage to be applied to the OA4-G during the half-cycle when its anode is negative.

REVERSAL OF LINE PLUG

Under these conditions it is merely necessary to reverse the line plug to either the transmitter or the receiver to obtain proper operation. It should also be noted that during the half-cycle that anode and starter-anode are negative, the OA4-G may be operating in a region corresponding to section D (negative anode) of Fig. 4. On alternate half-cycles, therefore, a discharge between starter-anode and cathode may take place.

From this description, it is seen that the r-f signal need not supply all the power required to initiate the $K - P_1$ discharge. In actual practice, R_2 is adjusted for a value of E_{R2} that is somewhat less than the breakdown value. Then, the r-f voltage need only be enough to

(Continued on following page)

(Continued from preceding page)

supply the difference between the breakdown voltage and the applied low-frequency voltage. In addition, the r-f signal should have sufficient amplitude to compensate for low line voltage. It is recommended, therefore, that provision be made to supply an r-f starter-anode voltage (E_L) of at least 55 volts peak.

Fig. 10 shows the circuit of a typical transmitter. The power line over which the r-f is transmitted also furnishes plate voltage (a-c) for the tube. The distributed constants of the line may have some effect on the amplitude or frequency of the r-f signal. However, these effects can be reduced by inserting a coupling tube between oscillator and power line.

CHARACTERISTICS

Peak Anode Breakdown Voltage (Starter-Anode connected to Cathode)	225 min.	volts
Peak Positive Starter-Anode Breakdown Voltage	70 min	volts
	90 max.	volts
Starter-Anode Current (For transition of discharge to anode at 140 volts peak)	100 max.	micro amperes
Starter-Anode Voltage Drop	60 approx.	volts
Anode Voltage Drop....	70 approx.	volts

MAXIMUM RATINGS AND TYPICAL OPERATING CONDITIONS FOR RELAY SERVICE

Peak Cathode Current..	100 max.	milli-amperes
D-C Cathode Current...	25 max.	milli-amperes
Typical Operation with A-C Supply:		
Anode-Supply Voltage (RMS).....	105-130	volts
A-C Starter-Anode Voltage (Peak)....	70 max.	volts
R-F Starter-Anode Voltage (Peak)....	55 min.	volts
Sum of A-C and R-F Starter-Anode Voltages (Peak).....	110 min.	volts

REFERENCE

Kimball, Charles N., "A New System of Remote Control," *Radio World*, April, 1938.

Copyright, 1938, by RCA Manufacturing Co., Inc.

GREYHOUND COILS ANNOUNCED

Greyhound Equipment Company, specializing in radio and industrial coil windings, with offices and factory at 1720 Church Avenue, Brooklyn, N. Y., has been inaugurated. F. K. Coppel heads the organization, with Sylvan A. Wolin as representative in the metropolitan New York area on domestic and export sales.

First Television Lesson Given in a Classroom

Television's first American test as a medium for classroom instruction was made recently at Radio City when Dr. C. C. Clark gave a lecture-demonstration on the principles and uses of photo-electricity from the experimental television studios of the National Broadcasting Company to more than 200 students facing receivers sixty floors above him in the RCA Building. The demonstration, arranged by Dr. James Rowland Angell, NBC educational counselor, was broadcast over station W2XBS with the cooperation of New York University.

Dr. Clark, associate professor of general science at the university's School of Commerce, was questioned at several points during the demonstration by viewers over a talk-back radio circuit installed for the purpose. Instructor and students were thus linked together in much the same manner as in the classroom. It was clearly evident in the television image that Dr. Clark was listening to the questions, which were delivered in low voices in the distant viewing room.

Motor-Starting Electrolytics Are Announced by C-D

Designed for motor-starting and other a-c applications, the Cornell-Dubilier type ETN dry electrolytic capacitors are hermetically sealed in small aluminum cans and are externally insulated with an impregnated fibre sleeve or container. The low power-factor characteristics of these capacitors and the careful construction, which assures absolute freedom from internal corrosion, are the qualities that make them very useful.

These Cornell-Dubilier capacitors have been designed for operation involving a maximum of 20 starts per hour, each start of 3 seconds duration. They are specially suited for use with fractional horsepower motors of the types used in refrigerators, oil-burners and similar appliances.

Information on these and similar capacitors may be obtained by addressing inquiries to the Cornell-Dubilier Electric Corporation, South Plainfield, New Jersey.

Soldering Irons Added to Stanley Tools Line

Stanley Tools, New Britain, Connecticut, announces a new line of popular-priced "Victor" electric soldering irons. These irons have compressed pure copper tips, brass clad, nichrome heating elements, cool, comfortable hardwood handles, adjustable in length. Made in three sizes: No. 420 at 50 watts, No. 435 at 80 watts and No. 450 at 140 watts, they will operate on either a.c. or d.c.

How to Wind Coils for Plug-in, 10 to 560 Meters

THE chart herewith, together with the illustration, give data on winding short-wave coils and all-wave coils, for a .00014 mfd. condenser, using a coil form of 1 3/8" outside winding form diameter and 2 1/4" long. Plug-in types are considered. The column marked "A" in the table refers to the distance marked "A" in the drawing. The same applies to "B." Coverages are given in wavelengths (meters). To obtain frequencies in kilocycles divide meters into 300,000.

At left in the chart are data for tickler or primary. For a two-winding coil with regeneration the primary is the tickler and antenna is coupled to the grid through a small condenser, preferably 50 mmfd. variable. Without regeneration, the small winding is the antenna primary. Then there is a t-r-f stage thus created and a three-winding coil follows, primary in plate circuit of first tube, secondary in grid circuit of second tube (detector) and tickler in plate circuit of second tube. Then the small winding in left-hand column is primary and the winding described in extreme right-hand column is the tickler.

If any doubt arises, because oscillation is absent, reverse tickler connections.

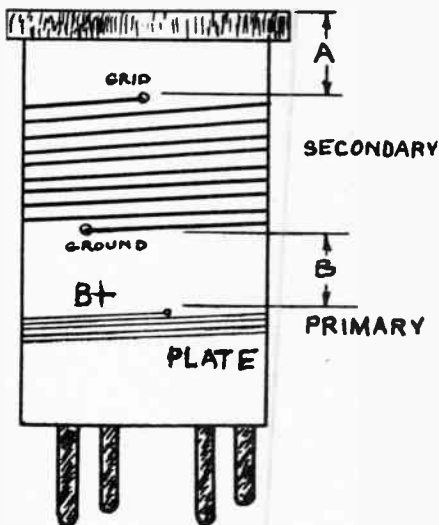

Any round or ribbed coil forms may be used. Diameter, 1 3/8 inch; height, 2 1/4 inches.

Wavelength Covered with .00014 mfd. Condenser

METERS A

TICKLER OR PRIMARY

TURNS	WIRE	B
3 1/2	16 P.E.†	1/4"
8 1/2	"	1/4"
17 1/2	20 P.E.‡	1/4"
38 1/2	"	1/4"
78	28 P.E.	1/8"
160	"	1/8"

SECONDARY

TURNS	WIRE
3	30 D.S.C.
3	"
5 1/2	"
10 1/2	"
16 1/2	"
32	"

In 6 Prong Coils Use This Winding as the Tickler, and the Tickler as Primary. Note *.

TURNS	WIRE
2	30 D.S.C.
6	"
11 1/2	"
24	"
45	"
82	"

*Wind tickler over or between secondary turns

†Space between turns 1/8 inch

‡Space between turns 1/16 inch

The above chart has complete coil data prepared by Allied Radio Corporation for winding four- and six-prong plug-in coils to cover short-wave and broadcast bands with a .00014 mfd. variable condenser. P.E. means plain enameled wire; D.S.C. means double silk covered wire.

DIATHERMY INTERFERENCE FOUGHT

Washington

Legislation to prevent radio interference caused by diathermy apparatus has been submitted to Congress by the Federal Communications Commission. It was stated that such apparatus seriously impairs radio communication

service and is rapidly growing, threatening a large part of the radio spectrum. The proposed legislation, amending the Communications Act, would authorize the FCC to make rules and regulations to prevent interference from diathermy apparatus.

How Radio Newspaper Works

The Finch Home Facsimile Method Explained

A PRIVATE newspaper with any spot in your home as the press room, the world's best editors and reporters on your staff and the radio as your copy boy—this an actual accomplishment—is available today to anyone in the United States possessing an ordinary radio receiving set. No thundering press will deafen you when your newspaper is printed, but instead, equipment contained in a small attractive box, silently will print your "latest edition" while you sleep, completing it in time for reading at breakfast.

The name of this new service is facsimile, "first cousin" of television, since it shares with it some of the same basic principles.

Unlike its more glamorous and well-publicized relation, facsimile steps into broadcasting from other communication fields in which it already has proved its capabilities in a quiet but exceedingly effective manner. For facsimile, as most radio men know, has been in daily commercial use for several years in speeding news-photos back and forth across the country via the telephone circuits and across the Atlantic by short waves.

MASS COMMUNICATION

In spite of the rapid development and use of everyday wire and radio facsimile service, many are unaware of its greater capabilities as a mass communications medium in the broadcasting field. This is largely because of the fact that facsimile transmissions have almost been entirely employed to handle press photos for subsequent newspaper reproduction and in the average layman's mind this is the limitation of the method. Many also confuse television with facsimile and ask why television ultimately will not perform the same duty.

For these reasons the first questions to be answered are "What is facsimile, how does it differ from television, and how does it fit into the radio broadcasting picture?"

Briefly, in non-technical language, facsimile, in its electrical communications sense, involves the conversion of illustrations or other copy, such as printed matter, photographs, line drawings, sketches and etc., into an electrical signal which can be sent over radio or telephone circuits. At the receiver, the signal is automatically converted back into its visible form, appearing as a recorded replica of the original copy. The received copy is permanent and like a printed page can be handled, observed or read whenever desired. It is somewhat as if an amazingly compact printing press, installed at the receiving location were to be remotely controlled by the distant transmitter and in the

process effected the printing of a duplicate of the copy seen at the distant point.

Television involves the conversion of visible aspects of subjects into electrical signals which can be sent to distant points. However, the speed of this conversion is such that ordinary telephone circuits or conventional sound broadcasting equipment cannot handle the signal. Costly co-axial cables with associated high frequency signalling apparatus or special ultra-high frequency radio transmitters and receivers are therefore called in to do this most difficult job.

In addition, there is as much difference in the technique of the two communications mediums as there is between the making of a newspaper and a motion picture. For primarily, where facsimile is concerned only with the transmission and subsequent recording of copies of still subjects such as pictures, and printed pages, television deals with moving objects or persons. The image on the screen of a cathode-ray tube receiver has the basic qualities of a motion picture. The image moves, it is transitional, and when the show is over the screen is black. Since nothing has been recorded, the images will not be seen unless someone watches the screen when they are to be received.

THE FINCH METHOD

Facsimile and television thus perform widely different functions. Each will fit into the communications picture as separate services, having fundamental distinctions as widely divergent as those of the public press and the motion picture.

The more technical phases of facsimile transmission and reception are generally understood by radio and sound engineers. For those who want to know just how radio facsimile transmission is effected, a brief description of the Finch facsimile transmitter now used by the majority of major broadcasters as licensed under the Finch patents will clarify some points in question.

The facsimile transmitter of this type now employed by the broadcasters in their experimental service employs a scanning machine in which copy to be sent over the air is inserted in what is termed the "copy head."

This holds and advances the copy in front of the "scanning head," consisting of a small electric bulb, lens system and photocell. Light from the bulb is focused, as a small spot, on the surface of the paper carrying the copy and the reflected light is picked up by the light-sensitive photo-cell. The scanning head is moved from side to side by an electric motor so that

the spot of light traces a series of parallel paths across the copy which is moved upwards through a distance equal to the diameter of the light spot at the end of each scanning stroke. In this manner, the entire surface of the paper is scanned, line by line, the black, half-tone and white areas reflecting to the photo-cell varying amounts of light ranging from minimum to maximum. These variations in reflected light effect a change in the amount of electric current flowing through the photocell which in turn controls the loudness of a high-pitched

machine to convert them back into their visible equivalents on paper.

THE "HOME NEWSPAPER PRESS"

The Finch "home" facsimile recorder is used for this purpose. It is self-synchronizing, an important advantage, which means that a recorder may be located in one state and the transmitter in another; meaning that the system does not depend upon the local power lines for synchronization. Recorders are made avail-

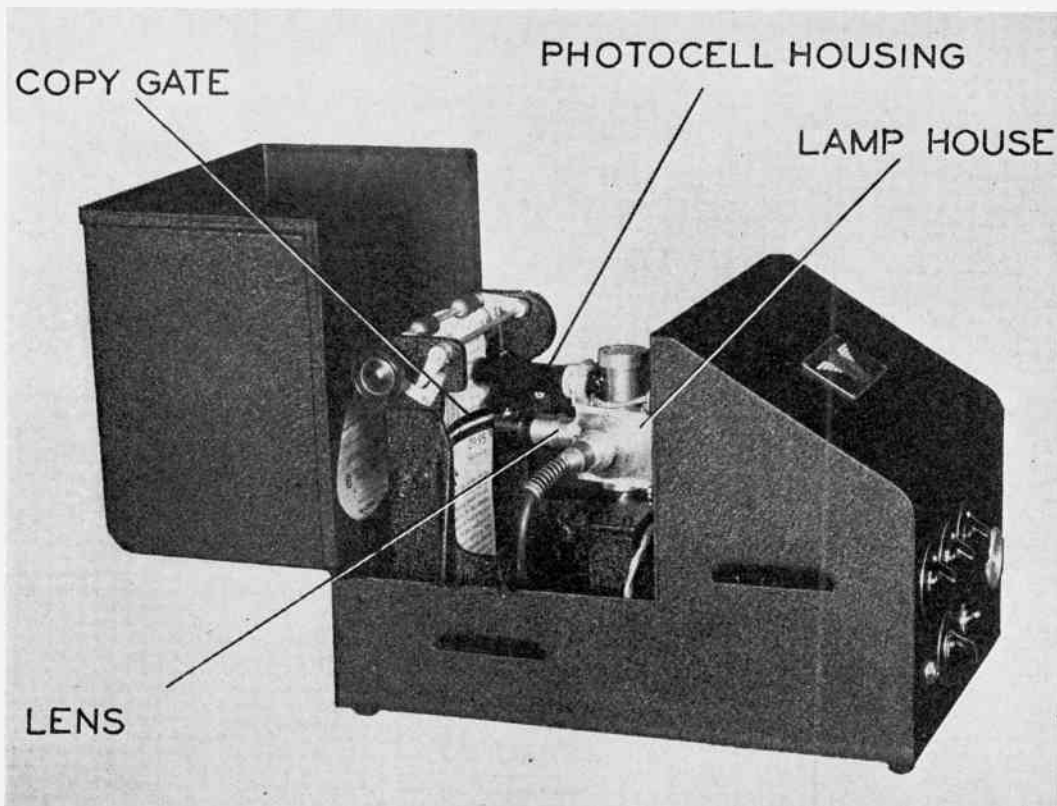

Finch transmitter, with cover hinged back to facilitate loading. All controls are located at convenient position on front panel of unit. The device plugs into any 500 ohm line and works at maximum signal level of zero decibels. It is easily operated and maintained.

whistle-like tone. The tone, called the "facsimile carrier" with its characteristic rising and falling sounds is then applied to ordinary broadcast amplifiers. These deliver it to the radio transmitter in the same manner in which sound broadcast signals are handled. Any conventional receiver tuned to the frequency of the transmitter will then pick up the signal.

However, in order for the broadcaster to utilize these signals he must have a recording

able for a-c or d-c operation, or for battery supply for farm use.

The recording machine in many ways is similar to the scanning instrument. What is termed a "receiving copy head" holds the dry processed recording paper which is fed as a continuous strip two newspaper columns wide from a roll carried in the lower part of the machine. A recording stylus is then moved by a small

(Continued on following page)

(Continued from preceding page)

electric motor from side to side across the surface of the paper, forming marks on the paper corresponding in position and quality to the elements of the copy at the transmitter. When the incoming signal is loudest the line traced is darkest, when it is weakest no trace is formed.

At the end of each of these recording strokes the paper is moved up by an amount equal to

that of the width of each line element. By means of extremely short low-tone signal impulses sent out by the transmitter just before the start of each recording stroke and by the use of a small motor turning over at a predetermined speed the recording stylus moves across the paper in step with the scanning head of the transmitter, recording copy in its proper position. In this manner the recorded copy is built up line by line to appear as a duplicate



To receive illustrated radio news bulletins in the home, the recorder is connected to an ordinary broadcast receiver. The finished facsimile material is recorded by the receiving mechanism upon a continuous ribbon of paper which issues from the rear of the machine. The process is not to be confused with television, which is essentially as impermanent as regular voice transmissions. Facsimile is the first practicable process by which radio leaves a permanent visual record of what it has to say, and the owner of a facsimile recorder may read the daily broadcasts at his leisure or preserve the items for future reference.

of the original. One hundred lines will build an inch of type, or at the operating speed of the present machine a two column newspaper at the rate of five feet per hour. Increasing use of the machine will lead to requisite refinements. It is not impractical to hope for a newspaper of five columns in the near future. This is the tabloid size and the most efficient

speaker circuit is then employed to cut the speaker off during the recording of facsimile broadcasts.

15¢ A WEEK FOR PAPER

The broadcasting station from which facsimile signals are sent is tuned in with a receiver as would be the case if regular sound programs

**MOORE WINS THIRD TERM
AS N. J. GOVERNOR BY 47,000**

VERY LATEST NEWS

**5 KILLED AS PLANES COLLIDE
IN MID-AIR; 2 SAVED BY CHUTES**

SEATTLE, Nov. 3. — Five persons were killed today when two airplanes collided in the air a mile south of Boeing Field. One of the ships was reported to be a U. S. Navy plane and the other a barnstorming ship.

Two Navy fliers saved themselves with parachutes.

RACING RESULTS

AT PIMLICO.

Third—Flying Lance 21.30, 13.00, 7.10; Graeme Croaker 28.10, 14.90; Tilaana 7.30. Off 2:37½.

Scratched—Top Billing, Big Boy Blue, Candy Hero, Fanny That, Equerry, Auxiliary.

AT ROCKINGHAM PARK.

Fourth — Very Busy 16.20, 6.70, 3.50; Long Dave 5.00, 2.80; Evening Time 2.50. Off 2:35.

Scratched—Standard Time.

Fifth—Sanctity 9.10, 4.70, 3.30; Gay Balke 4.10, 3.00; Lady Highness 3.90. Off 3:00.

No scratches.



Here is a sample of experimental recorded facsimile news bulletin. It shows some of the possibilities of home facsimile broadcasting service. The original was cut from a metropolitan newspaper and run through the scanning machine. Via radio facsimile news bulletins, photos, line-cuts, drawings, sketches, cartoons can be transmitted with equal ease.

reading organ the newspaper profession has produced.

The actual home recording machine which can be made to sell under \$50 in mass production is small enough to be housed as a complete unit in a small cabinet approximately a foot square. It may be connected without auxiliary amplifying equipment to the output circuit of any broadcast receiver having a power rating of three watts or more. A switch in the loud

were to be received. The facsimile recorder is switched on and the volume control of the receiver is turned to the point where copy has the desired contrast. The actual recording operation is wholly automatic and requires no attention. Paper costs about 15 cents per week.

The simple statement that recording is automatic may seem relatively unimportant to the average reader, but it is largely the solution

(Continued on following page)

of the automatic recording problem that has made it possible for Finch engineers to pioneer in its present work in opening the "home" facsimile field. For until the development of an automatic machine and inexpensive dry recording paper of wide latitude which requires no liquids for moistening or smudgy carbon transfers for printing, the adaptation of facsimile recording methods to home service seems rather remote.

CONCENTRATED ON AUTOMATIC METHOD

The Finch organization, from the inauguration of early experimental radio facsimile trans-

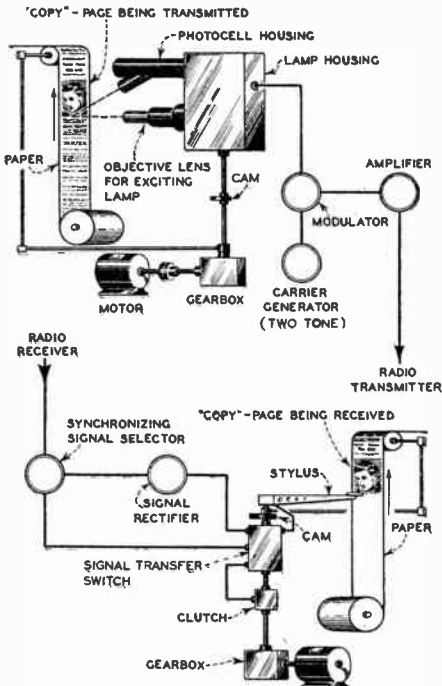

Block diagram of the operation of the Finch system of home radio newspaper service.

missions in 1935 over its own stations has concentrated on the automatic recording problem with the result that the home facsimile machine safely operates without attention throughout long facsimile broadcasting periods. The machine holds a roll of dry processed recording paper which is automatically fed as long as facsimile signals are received. Each roll holds enough paper to provide for a week's recording operations without reloading. Recording paper in a number of different color combinations has been developed, but it is believed that stock on which the facsimile copy appears as black or in half-tones on either a white or orange background will be most popular.

The obvious questions at this point are, "When will facsimile broadcasts occur and what

stations will handle them?" The answer is that during the experimental period and probably thereafter facsimile broadcasts will take place during the early morning hours between midnight and 6 A. M. when sound broadcasting facilities are ordinarily idle. Time clocks will turn the radio receiver and recording motor on and off at specified hours. "Printing" of illustrated world events, news bulletins, with latest news flashes, photographs, market reports, weather maps, cartoons, recipes, and illustrated advertisements of all sorts, will thus be effected in homes while their occupants sleep, the machine being practically silent in operation and entirely automatic in its operation. The result is a complete up-to-the-minute two-column illustrated news bulletin ready to read at breakfast time.

STATIONS GETTING READY

This, to some who are not familiar with facsimile developments, sounds like one of H. G. Wells' prophecies. That it is not attested to by the fact that at present many of the leading major broadcasting stations in the country already have been granted FCC permits and have inaugurated such a service using regular broadcasting frequencies and full power between midnight and 6 A. M. in experimental transmissions to determine public reaction and to obtain basic engineering data for home facsimile services. Stations already licensed on this basis using Finch equipment are: WLW, 500,000 watts, Cincinnati, Ohio; WOR, 50,000 watts, Newark, New Jersey; WGN, 50,000 watts, Chicago, Illinois; WSM, 50,000 watts, Nashville, Tennessee; WHO, 50,000 watts, Des Moines, Iowa; WSAI, 5,000 watts, Cincinnati, Ohio; WWJ, 5,000 watts, Detroit, Michigan; WHK, 2,500 watts, Cleveland, Ohio; WGM, 250 watts, Newport News, Virginia; KSTP, 25,000 watts, St. Paul, Minnesota; WCLE, 500 watts, Cleveland, Ohio; W8XAL and W8XNU, 10,000 watts, both in Cincinnati, Ohio. In addition, other important stations have applied to the FCC and are considering Finch apparatus.

NEW INDUSTRY IMPENDS

When the experimental period has demonstrated the value of facsimile broadcasting service and when publicity and advertising to consumers gets under way, difficulty may be experienced in supplying public demand for home recorders. Because facsimile, like television will inevitably capture the public imagination and when it does another dynamic new industry comparable to sound broadcasting will be born.

FINCH-OWNED AND OPERATED STATIONS

W2XBK	NYC	{ 1,614 kc	
		{ 2,398 kc	
W2XBF	NYC	{ 31,000 kc	(dual-service)
		{ 41,000 kc	under construction
W10XDF	NYC	{ 31,600 kc	
		{ 41,000 kc	
W10XGU	NYC	{ 31,000 kc	(Portable mobile)

The Cathode Branch in Hum Networks

By Martin Posner

Technical Editor

CONSIDERING the complexity of the structure and functions of low-cost mass production tubes, and the numerous consequent opportunities for defects to arise that can cause interference with satisfactory functioning, it must be admitted that on the whole they are remarkable productions. That they can and should be made still better goes without saying, and the better manufacturers fortunately are not content to rest on their laurels.

As an example of these difficulties it is instructive to glance at the possibilities for hum inherent in, say, any good output pentode.

For one thing, the high gain of the tube causes it to make audible a hum voltage which would otherwise remain below the threshold of audibility. Then there are elements in the tube capable of amplifying, such as the screen and suppressor, in addition to the standard control grid; so that power supply filtering and internal isolation adequate for the plate circuit, which of course cannot amplify, need to be much better.

Not only are there are more avenues for the introduction of an audible hum voltage, but the characteristics of these electrical pathways differ. Therefore the portion of hum due to each differs also, and in three ways: (1), voltage; (2), phase; and (3), waveform. Under the

circumstances hum "bucking" or balancing obviously becomes a good deal more complex than the simple balancing out of, say, a hum voltage in the plate circuit by a suitable out-of-phase voltage injected into the grid circuit.

Hum due to the alternating current used for the heater can get into the working tube circuit in several ways. One way is by direct leakage as through the hot glass stem. Another way is by the magnetic field action of the heater current. A third way is by the electrostatic coupling between the heater and an amplifying element, such as a control grid, as in the stem. This is particularly true of tubes having high heater voltage, e.g., 25 volt AC/DC tubes, and shows up worst when the grid circuit impedance is high. A fourth way is by means of the capacitive and resistive paths between heater and cathode. Moreover the heater-cathode path may conduct current better in one direction, so that a rectifying action results.

Since the heater voltage, or at least part of it, is in series with the capacity and resistance of the heater-cathode space, harmonic components of the original fundamental frequency appear, and all these components get into the working circuits as an assorted miscellany of amplitudes, frequencies, and phase relations. Problem: find "the" hum.

Prevention of Mixer Overload

DURING the past months the writer has had an increasing number of complaints from customers relative to poor quality and overloading, when receiving local stations, especially the powerful WLW transmitter, only 100 miles away. In nearly all instances the receivers, although of various makes, were very similar. The receivers were usually of the all-wave type, in the medium price range, and all had a stage of r.f. ahead of the converter, with automatic volume control.

It was readily established that the converter tube was being overloaded, in some cases so badly that local signals blocked the receivers, and reception was had only by tuning off resonance, with resulting bad quality.

In a few instances shortening the antenna was sufficient, although usually causing the converter hiss to become noticeable on out-of-town stations in the broadcast band. Generally, however, the customer had some sort of all-wave antenna, and nothing much could be done along this line.

The best solution, a variable sensitivity control in the cathode circuit of the r-f tube, was not usually acceptable, as the extra control

when brought out in front usually spoiled the panel appearance, by upsetting the symmetry. Most owners objected to having the control in the rear of the chassis.

A solution was finally found that seems to combine all the desirable features required; effective reduction of local signal strength, low cost, unchanged cabinet or chassis appearance, and customer satisfaction.

The cure is simply to shunt a small mica condenser from the plate of the r-f tube to ground. If the receiver is an all-wave job, as is usual, the condenser is connected at the switch, so that it will only be effective on the regular broadcast band.

The smallest capacity possible should be used, usually 50 mmfd., although in some cases 100 mmfd. has been necessary to eliminate the overloading entirely. While this method will also reduce the strength of weaker signals, it is not objectionable, as practically all owners listen only to the stronger stations in the broadcast band. As a rule the gain in the broadcast band, in medium price receivers, is generally much too high, since the set is "pepped up" on the short wave band.—R. K. WHEELER.

Constants for Amplifiers

Using 6C8-G, 6F8-G, 6J5, 6J5-G and 6Z7-G with Resistance Coupling

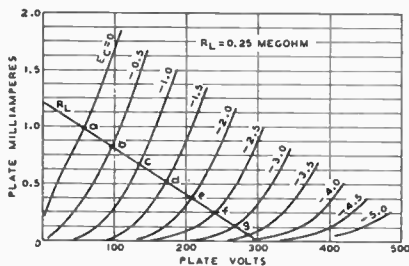

FIG. 1A

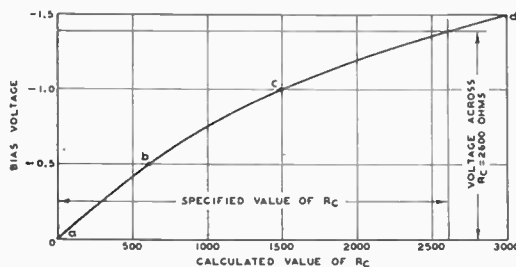

FIG. 1B

RESISTANCE-COUPLED amplifier data for the 6C8-G, 6F8-G, 6J5, 6J5-G, and 6Z7-G are given in this Note. The resistance-coupled data are presented in tabular form for easy reference.

Self-bias operation offers several advantages over fixed-bias operation: (1) the effects of possible tube differences are minimized, (2) operation over a wide range of plate-supply voltages without appreciable change in gain is feasible, and (3) the low frequency at which the amplifier cuts off can be easily changed. Fixed bias operation increases the tendency of an amplifier to motorboat and decreases the compensating action of the plate load resistor.

DIFFERENCE ON A.C.

The values of blocking condenser (C) and cathode-resistor by-pass condenser (C_c) were chosen for an output voltage at 100 cycles of 0.8 the value at 420 cycles. A similar cut-off characteristic at any other low frequency (f_1) can be obtained by multiplying the capacitance values shown by $100/f_1$. [Diagrams printed in

May issue.] On page 31 values of C_c are given for an amplifier with d-c heater excitation. When a-c is used, depending on the character of the associated circuits, the gain, and the value of f_1 , it may be necessary to increase the value of C_c to minimize hum disturbance.

CURVE PLOT

In some applications it is desirable to know the value of bias voltage across a cathode resistor specified in the chart. This can be determined with the aid of a plate family, Fig. 1A. For a particular operating condition, draw the load line corresponding to the values of R_L and E_{bb} of interest, as shown last month. For each point of intersection of the load line and a bias curve (points a, b, c, etc.), calculate a value of bias resistor (R_c). Now, plot a curve (Fig. 1B) showing the relation between calculated values of R_c and corresponding bias voltages. An ordinate erected at the specified value of R_c determines the bias.

Consult last month's diagrams.

Copyright 1938 by RCA Manufacturing Co., Inc.

More Power on Short Waves

Two new 25,000-watt transmitters, enabling American radio programs to penetrate every country of Europe and all parts of South and Central America, have been installed and will go into operation in the immediate future at the National Broadcasting Company's international short-wave station, W3XAL, Bound Brook, N. J.

The new transmitters will operate through four directive beam systems and two non-directive antennas, occupying twenty-four acres at Bound Brook. Plans are under way to sharpen the directive beams so as to concentrate radio energy even more toward European and South American countries covered by NBC's transmissions in six languages.

Electric Fence Control Becomes Big Field

Close Similarity to Radio Technique Opens Sales, Installation and Repair Opportunities to Servicemen—How to Build the Three Leading Types

BY M. N. BEITMAN

Allied Radio Corporation

Safety and Security by Electric Fencing

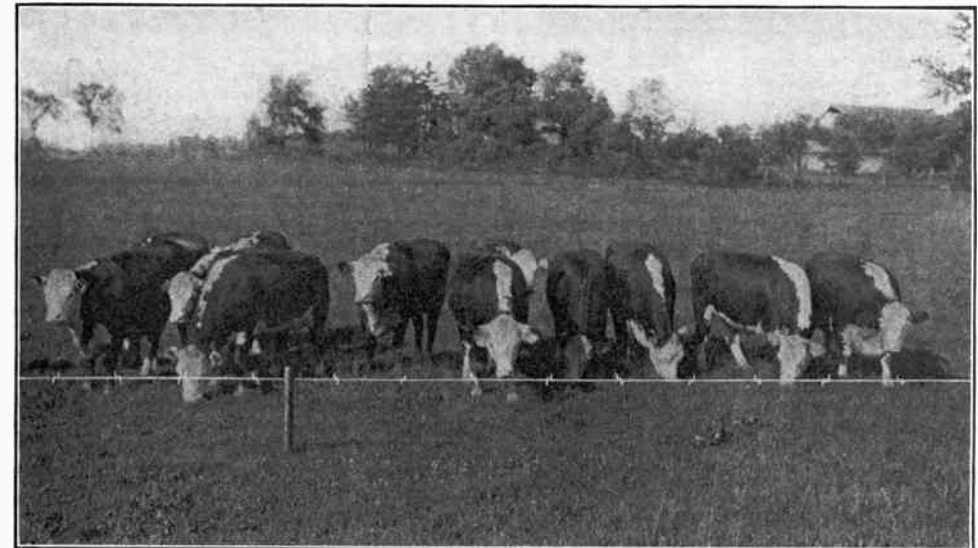
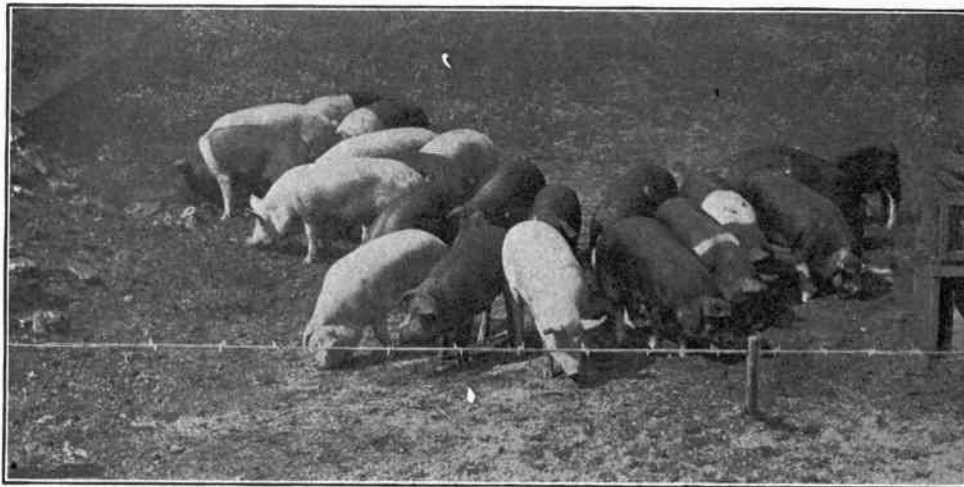

Electric fence control is growing in application and importance. It is attracting servicemen to profitable activities, including sales, installation and repair, since it embodies principles they are fully familiar with in radio practice. The food animals are easily kept within bounds and intruding beasts kept out.

At left is a bunch of meat-type hogs, at right are polled Hereford heifers. The electric fence is in foreground in both instances.

THE electric fence controls are sweeping the country, giving the farmer a better, more economical method of enclosing his fields and offering the aggressive radio service man and experimenter opportunities to make, sell and service this electrical equipment.

The problem of keeping live stock in pasture fields and of preventing wild animals and pests from molesting the live stock and fields has been important to the farmer ever since ancient Roman times. These problems were felt also by the Chinese who made earthen fences with great hardship. In America the split-rail fence is characteristic of the last century. Abraham Lincoln made rail-splitting an historical occupation. With the advance of power lumber-cutting machinery, board fences began to be used,

following the split-rail fences, and next steel-wire fences came into vogue.

All these fences used until this time depended on strength to keep the stock in and keep intruders out. Strong fences called for expensive material and yet were not always effective.

VOLTAGE IS SAFE

In 1874 barbed wire fences were introduced and revolutionized the method of fencing. Instead of depending purely on the strength of the fence, the wire thorn served to provide a painful element to all animals coming in contact. The electric fence has still further reduced the cost of fencing, permitting the use of light stakes spaced up to sixty feet apart and requir-

ing only a single strand of light wire for efficient control.

The object of a fence control unit is to supply effective and yet safe voltage to the insulated wire fence. The return of the unit is connected to a suitable ground. Any animal or person standing on the ground and coming in contact with the fence wire will receive a shock. It is surprising how fast the animals learn to stay away from the painful wire. For the benefit of people passing by, who would not enjoy even this small electric shock, signs warn about the charged fence.

A large variety of fence control units has been placed on the market but essentially all these units are designed for operation on three standard types of electrical power available on

the farm. In the districts where power lines are available, 110-volt a-c units are used. In other places 32-volt units are used for home power plants or 6-volt units are operated from storage batteries or dry-cell batteries.

PULSES OBTAINED FROM D. C.

Since in all units a transformer is used to step up the voltage, the d-c voltage available from the 6- and 32-volt supply first must be interrupted and changed into pulsating d.c. in order to be stepped up by the transformer. In this connection vibrators, swinging pendulum relays, time delay-action condenser-discharge relays, electrical choppers and mechanical choppers are employed. Note the schematic

(Continued on page 35)

6-Volt D-C Model

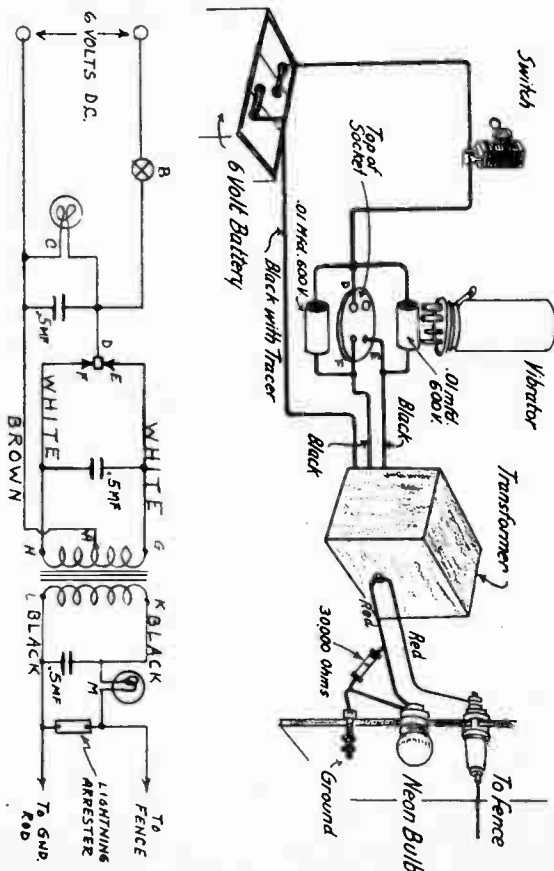

Pictorial diagram and also wiring circuit for a fence-control system using 6 volts d. c., either storage battery or dry cells.

The pictorial diagram illustrates the circuit of the wired 6-volt fence control unit. The kit should be wired in exactly the same way, but a knife switch is used instead of the toggle type, and Fahnestock clips are used for fence and ground connections.

Electric fence controls have been designed to reduce the cost of fencing around pastures, corrals, feeding pens, gardens, etc. But a single wire is used, placed 15 to 18 inches above ground for fencing in sheep, goats, and hogs, or 30 to 36 inches for fencing in cattle and horses. The fence posts may be made of light material and may be spaced 50 feet apart. The wire should be held to the posts by means of insulators. The fence is charged with electrical energy that will effectively shock animals coming in contact with the fence; and yet the special design of the control units makes the voltage entirely safe to man and beast. After the fence is in operation but a short time, the animals will learn to keep away from the wire. The unit may be shut off for days at a time.

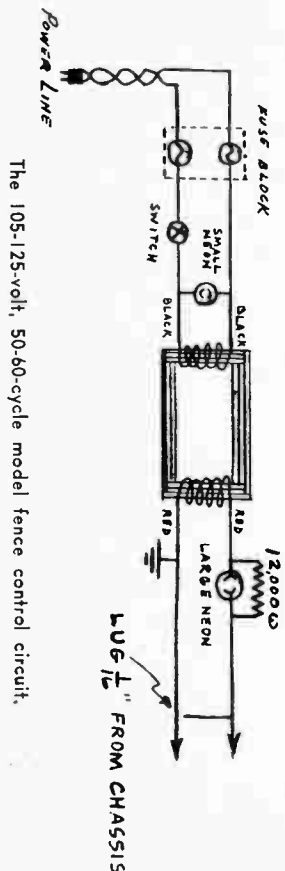

The 105-125-volt, 50-60-cycle model fence control circuit.

RESISTANCE-COUPLED AMPLIFIER CHART

C = BLOCKING CONDENSER (μF)
Cc = CATHODE BY-PASS CONDENSER (μF)

E_{bb} = PLATE-SUPPLY VOLTAGE (Volts)
E_o = VOLTAGE OUTPUT (Peak volts)

R_c = CATHODE RESISTOR (ohms)
R_g = GRID RESISTOR (Megohms)

R_L = PLATE RESISTOR (Megohms)
V.G. = VOLTAGE GAIN

TWIN-TRIODE TYPE 6C8-G (ONE TRIODE UNIT)

E _{bb} ¹	90						180						300						E _{bb} ¹								
	0.1		0.25		0.5		0.1		0.25		0.5		0.1		0.25		0.5										
R _L ²	0.1	0.25	0.5	0.25	0.5	1	0.1	0.25	0.5	0.25	0.5	1	0.1	0.25	0.5	0.25	0.5	1	R _L ²								
R _c ³	3040	3700	4520	6770	7870	8830	12400	15000	16500	2420	3080	3560	5170	6560	7550	9840	12500	15600	2120	2840	3250	4750	6100	7100	9000	11500	14500
R _g ³	2.34	1.48	1.29	0.95	0.81	0.69	0.51	0.43	0.38	2.34	1.84	1.6	1.25	0.95	0.85	0.66	0.5	0.44	3.93	2.01	1.79	1.29	0.96	0.77	0.67	0.48	0.37
C	0.028	0.0115	0.006	0.011	0.0065	0.0035	0.006	0.0035	0.0015	0.026	0.012	0.0065	0.012	0.007	0.0035	0.007	0.004	0.0015	0.037	0.013	0.007	0.013	0.0065	0.004	0.007	0.004	0.002
E _o ³	13	17	19	15	19	21	16	20	25	30	40	45	35	45	50	38	44	51	55	73	80	64	80	90	67	83	96
V.G. ⁴	18	20	21	21	23	23	22	24	24	20	27	23	24	25	26	25	26	26	22	23	25	25	26	27	27	27	28

TWIN-TRIODE TYPE 6F8-G (ONE TRIODE UNIT) ## AND TRIODE TYPES: 6J5, 6J5-G

E _{bb} ¹	90						180						300						E _{bb} ¹								
	0.05		0.1		0.25		0.05		0.1		0.25		0.05		0.1		0.25										
R _L ²	0.05	0.1	0.25	0.1	0.25	0.5	0.05	0.1	0.25	0.1	0.25	0.5	0.05	0.1	0.25	0.1	0.25	0.5	R _L ²								
R _c ³	1650	2070	2380	3470	3940	4820	7860	9760	10690	1190	1490	1740	2330	2830	3230	5560	7000	8110	1020	1270	1500	1900	2440	2700	4590	5770	6950
R _g ³	2.80	2.66	1.95	1.85	1.29	1.0	0.73	0.55	0.47	3.27	2.86	2.06	2.19	1.35	1.15	0.81	0.62	0.5	3.56	2.96	2.15	2.31	1.42	1.2	0.87	0.64	0.54
C	0.06	0.029	0.012	0.035	0.012	0.007	0.0135	0.007	0.004	0.06	0.032	0.0115	0.038	0.012	0.006	0.013	0.007	0.004	0.06	0.034	0.012	0.035	0.0125	0.0065	0.013	0.0075	0.004
E _o ³	11	14	17	12	17	19	14	18	20	24	30	36	26	34	38	28	36	40	41	51	60	43	56	64	46	57	64
V.G. ⁴	11	12	13	13	13	13	13	13	13	13	13	13	14	14	14	14	14	14	13	14	14	14	14	14	14	14	14

TWIN-TRIODE TYPE 6Z7-G (ONE TRIODE UNIT)

E _{bb} ¹	90						180						300						E _{bb} ¹								
	0.1		0.25		0.5		0.1		0.25		0.5		0.1		0.25		0.5										
R _L ²	0.1	0.25	0.5	0.25	0.5	1	0.1	0.25	0.5	0.25	0.5	1	0.1	0.25	0.5	0.25	0.5	1	R _L ²								
R _c ³	1480	1760	1930	3000	3390	3670	5300	6050	6700	930	1100	1210	1820	2110	2400	3240	3890	4360	670	950	1050	1430	1680	1930	2540	3110	3560
R _g ³	2.65	2.02	1.7	1.36	1.1	0.8	0.65	0.61	0.45	3.4	2.6	2.32	1.71	1.38	1.1	0.9	0.703	0.553	3.81	2.63	2.34	1.87	1.46	1.19	0.97	0.72	0.56
C	0.025	0.0115	0.0065	0.01	0.006	0.0035	0.0055	0.003	0.0015	0.028	0.0115	0.007	0.012	0.007	0.0035	0.006	0.0035	0.002	0.028	0.012	0.007	0.012	0.006	0.0035	0.006	0.0035	0.002
E _o ³	8	11	14	12	15	18	14	18	20	18	28	33	28	34	41	32	38	44	38	52	60	50	59	66	55	70	75
V.G. ⁴	21	25	26	28	30	33	31	33	35	26	31	32	35	38	39	39	40	41	31	34	36	38	40	43	42	44	45

THE CATHODES OF THE TWO UNITS HAVE SEPARATE TERMINALS

THE CATHODES OF THE TWO UNITS HAVE A COMMON TERMINAL

¹ Voltage at plate equals plate-supply voltage minus voltage drop in R_L and R_c. For other supply voltages differing by as much as 50% from those listed, the values of resistors, condensers, and gain are approximately correct. The value of voltage output, however, for any of these other supply voltages equals the listed voltage output multiplied by the new plate-supply voltage divided by the plate-supply voltage corresponding to the listed voltage output.

² For following stage (see Circuit Diagrams).

³ Voltage across R_g at grid-current point.

⁴ Voltage Gain at 5 volts (RMS) output unless index letter indicates otherwise.

⁵ At 4 volts (RMS) output.

* Values are for phase-inverter service: See NOTES under RESISTANCE-COUPLED PHASE-INVERTER Diagram.

32-Volt D-C Model

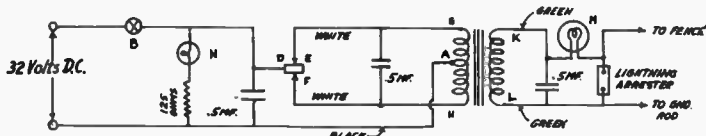

Diagram of electric fence control for 32-volt farm-lighting system.

Connect one side of the 32-volt input line to the center-tap wire of the transformer at A which is colored brown or black. The other side of the line connects to one side of the vibrator socket at B. From other side of this switch run a wire to small socket N and also to vibrator socket at D. The other side of socket N goes to one end of the 125-ohm resistor. The other wire of the resistor goes to the black wire on vibrator transformer. A .5-mfd. tubular condenser should be connected from D to A. Run a wire from E on vibrator socket to G on transformer and from F to H. The two wires at G and H are colored white.

Next connect a .5-mfd. tubular condenser across primary of vibrator transformer from G to H. Another .5-mfd. tubular condenser is wired across the secondary of the transformer from K to L. Run a wire from K to one side of standard socket M and from other side of this socket connect to fence, using insulated wire. Point L on transformer should connect to a good ground which may be a 5- or 6-foot length of pipe driven into the ground. The wire from point L to this ground need not be insulated. Better results can be obtained if the pipe is driven into moist ground. The lightning arrester is connected from ground to wire, going to the fence, and should be located outside of the house.

Screw the pilot light bulb into the socket N and the "short indicator" red bulb M into the standard socket. Connect 32-volt line to inputs as shown on diagram. The bulb N will light up, showing that control is operating. The red bulb will light up only when some part of the fence touches the ground or in rainy weather when the posts are wet.

(Continued from page 33)

diagrams and illustrations pertaining to the different types mentioned.

Some of these units give a continuous shock to the fence, while others are designed to provide an instantaneous shock occurring about forty times a minute. Each system has its own advantages. In case the shock is intermittent there is a possibility that an animal will force its way through the fence during the instant the shock is not present. However, the other system, supplying continuous voltage to the fence, has the disadvantage of requiring greater current for its operation.

TRANSFORMER ALWAYS USED

In all cases the interrupted d-c voltage or the 110-volt a-c voltage is supplied to a suitable transformer which steps up the voltage and places its potential on the fence and ground. The design of the transformer is important to make the unit effective and safe at all times. For example, the six-volt transformers are designed to become saturated on high current requirements on the secondary and thereby have safety limitations. The 110-volt fence-control transformers are of the current limiting type, and have a maximum current available on short circuits of only 8 ma. This value cannot do any harm to man or beast.

(Continued on following page)

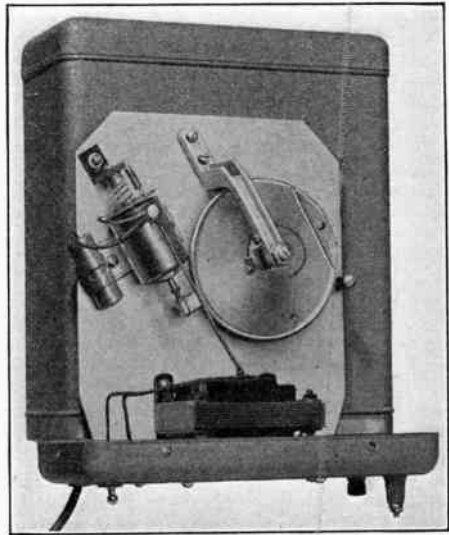

Rear cutout view of the housed assembly, including transformer, .5-mfd. condenser, and fence-charging mechanism.

Principles of the Musa

By C. B. Feldman

Radio Research Department, Bell Telephone Laboratories

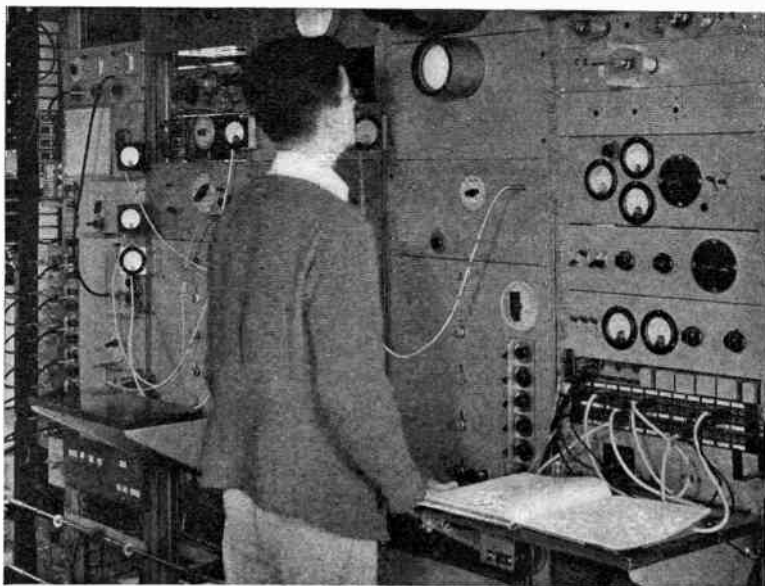

FOR more than a decade point-to-point short-wave radio services have employed directional antennas for both transmitting and receiving. A directional antenna at the transmitter increases the field intensity at the receiving location, while one at the receiver discriminates against noise. The effect of directivity both at the transmitter and the receiver is thus to improve the signal-to-noise ratio of a given circuit, and to permit operation under more adverse transmission conditions than would be possible without them—thus increasing the reliability of the circuit.

Antennas in present use on the longer circuits, such as the route between New York and London, represent about the limit of fixed directivity. Further increase or "sharpening" of the directivity would seriously encroach upon the range of directions over which the wave paths vary in passing from the transmitter to the receiver. Although there is some variation both in horizontal and vertical angle of reception, that in the horizontal plane is usually much

smaller and, as a result, of comparatively little importance.

SELECTIVE DIRECTIVITY

The variation in the vertical plane has already been discussed in the RECORD.* The reasons for it are indicated in Fig. 1. Waves leave the transmitter over a range of vertical angles and thus reach the refracting layers of the ionosphere at various positions and angles. Only those components which reach the ionosphere at less than a certain critical angle are refracted back to earth. Of these only certain ones have directions such that they reach the earth at the receiving location. Even some of these portions of the transmitted wave may be lost by excessive attenuation, but as an overall result there are generally several more or less discrete vertical angles at which the signal may be received.

These angles vary from time to time with variation in height of the refracting layers, and

*Bell Telephone RECORD, June, 1934, p. 305.

(Continued from preceding page)

In many units neon or ordinary filament type bulbs are used to indicate when the unit is operating and also when the fence is shorted. Note these features in the units illustrated.

The radio serviceman and experimenter will find a ready market in every community for fence control units. Not only are these units

useful to the farmer, but they find extensive application for protecting gardens and yards as well as parked automobiles. The assembly and installation of the control units are similar to radio work and with the thousands of units sold at the present time, this field will prove profitable in the future as a servicing medium to those who are enterprising.

if the directivity of the receiver is not broad enough to cover the range of the most prominent signals, there will be times when practically no signal is received even though the field strength is high enough for reception with a properly directed antenna.

Increased sharpness of directivity, however, results in a higher ratio of signal-to-noise, so that if the directivity of the receiver were made very sharp, and some method provided for changing its angle of reception to enable it to be kept pointed at one of the most prominent signals, reception would be greatly improved.

SIGNAL COMPONENTS COMBINED

With a number of such antennas separately directed several signal components could, after

that of antenna 1. Similarly the phase of the signal at antenna 3 is ahead of that antenna 2 by the same amount, and so on for the entire array. As a result the phase of the signal at antenna 2 will lead that at antenna 1 by some angle that may be called θ , while that of the signal at antenna 3 will lead that at antenna 1 by an angle 2θ , and so on for the entire array.

If the receiver is considered to be located at antenna 1, however, it is obvious that the signals from the other antennas also suffer a phase shift in passing over the transmission line from the antenna to the receiver.

SUMMATION SIGNAL

If this phase shift for the signal from antenna 2 is called α , then that for antenna 3 will be

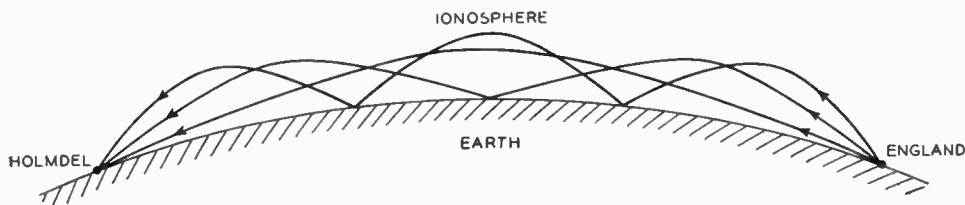

FIG. 1

A simplified conception of the short-wave transmission path between England and America.

proper adjustment for their different transmission delays, be combined in a single receiver. It is just this that the *musa* does—the word *musa* standing for multiple-unit steerable antenna.

The *musa* consists of a number of similar and equally spaced directional antennas laid out along the great-circle direction of the transmitter. These antennas are not sharply directional in themselves, but are designed to receive over the normal range of vertical angles. The reason for the directive action of such an array will become apparent from a study of Fig. 2, where the circles represent the antennas, and the received signal is shown arriving at an angle δ with the ground.

It is obvious that the signal arrives at antenna 2 before it does at antenna 1, or in other words, that the phase of the signal at antenna 2 leads

2α , that from antenna 4 will be 3α and so on. In general, α differs from θ , but it is possible to put a phase-shifting network in the transmission line for antenna 2 to produce a phase shift ϕ of such a value that the sum of θ , α and ϕ will be zero. Similar networks could be put in all the lines—that in the line to antenna 3 being 2ϕ in value, and so on. When this is done the signals from all the antennas will be in phase at the receiver and the combined signal will be equal to their sum.

Since the angle ϕ is equal to the difference between θ and α , and since θ varies with δ , ϕ also will vary with δ . For any one value of ϕ , in other words, the signals at the receiver will be in phase for only one angle of reception. For other angles of reception the signals from the various antennas will be out of phase, and

(Continued on following page)

FIG. 2
The *musa* consists of a number of equally spaced directive antennas with phase-shifting networks in the transmission lines from them.

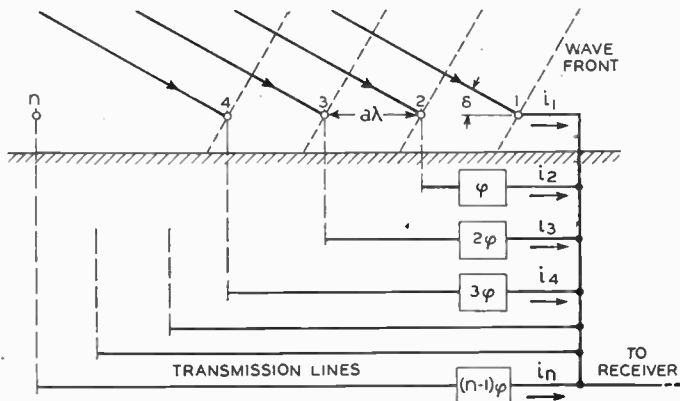

(Continued from preceding page)

their vector sum will thus be less than when they are in phase. As a result, a directional characteristic is obtained, and—other things being equal—the characteristic will be sharper the greater the number of antennas in the array. If with such an antenna array some provision is made for changing the phase-shifting networks in unison, so that when that for antenna

minor ones on each side, but the magnitude of these is comparatively small. There will also be other main lobes, but by the design of the array and the individual antennas these are made to fall outside of the range over which the *musa* is designed to act. The direction of the main usable lobe may be made to vary over the steering range depending on the value of ϕ , and the steering range, in turn, will be larger or

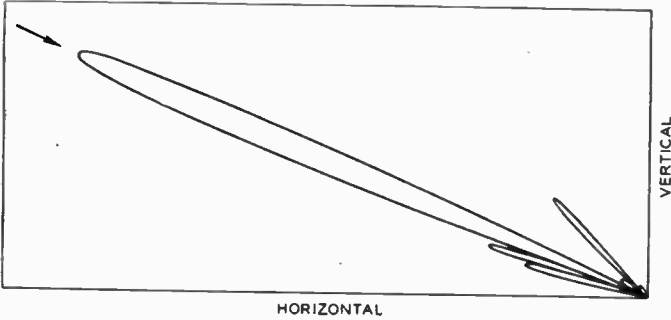

FIG. 3
Receiving characteristic of the experimental *musa*.

2 is changed from ϕ to $(\phi + \Delta)$, that for antenna 3 will be changed to $2(\phi + \Delta)$ and that for antenna 4 to $3(\phi + \Delta)$ and so on, then the angle of most effective reception can be changed merely by changing the values of the ϕ 's.

SIX ANTENNAS

The experimental *musa* now set up at Holmdel consists of six rhombic antennas, and gives a sharp receiving characteristic as indicated in Fig. 3. Besides the main lobe there are several smaller depending on the design of the indi-

vidual antennas and on the distance between the centers of the antennas.

As already pointed out there may be prominent signals arriving in several directions at the same time, and to obtain the maximum receiving advantage all of these signals should be separately received and suitably combined at the receiver. The *musa* readily permits this to be done by providing a number of parallel circuits connected to the same antenna but each having a separate set of phase-shifting networks.

Each of these branch circuits with its phase-shifting networks becomes in effect an inde-

(Continued on next page)

FIG. 4
Simplified block schematic of the *musa* system at Holmdel.

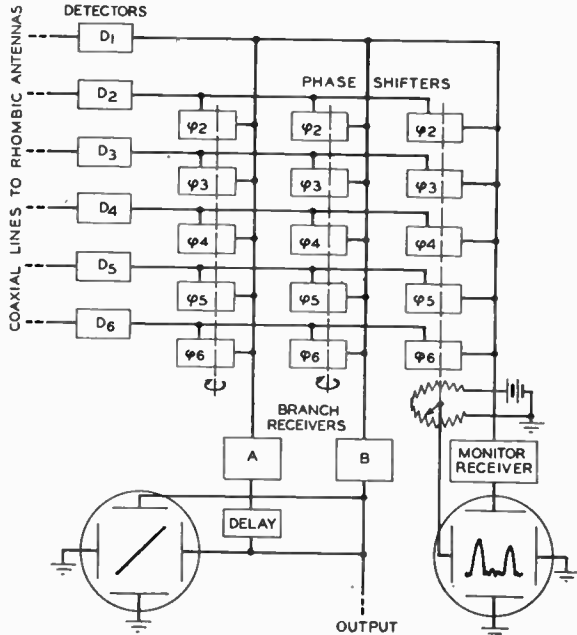

Musa Apparatus

By W. M. Sharpless

Radio Research Department, Bell Telephone Laboratories

THE requirements placed on the musa apparatus differ considerably from those the more ordinary radio receiver must meet, chiefly because of the necessity of combining the outputs of an array of separate antennas in precise phase relationship. The steerability of the musa and the sharpening of its directional characteristic are secured in the experimental system by the use of six separate antennas and high-frequency detectors which feed the receiver through phase-shifting networks. The proper functioning of the system depends on a very accurate control of the phasing of the signals up to their point of combination.

To simplify the experimental equipment of the musa, it was decided to dispense with the selectivity that would have been afforded by high-frequency amplifiers ahead of the detectors, and to employ the simple circuit shown in Fig. 1. The capacitive coupling to the transmission line is a convenient means of matching the low-impedance lines to the high-impedance circuits. Plug-in coils are provided for the tuned circuits to cover the range from 4.5 to 22 megacycles. The first detectors are of the balanced two-tube type which isolates the beat-

ing oscillator from the input circuits, and thus prevents crosstalk between the six inputs, and secures independence of the tuning. This arrangement also prevents two incoming signals that differ in frequency by the intermediate frequency from causing interference in the intermediate circuits that are involved.

LOW-IMPEDANCE FEED

Power from the beating oscillator is supplied to the detectors at low impedance between the cathodes. The transmission lines from the oscillator to each of the detectors are all of the same length so that the six oscillator inputs to the detectors are of the same phase. The six input-circuit controls, together with the coaxial patching cords for connecting the transmission lines to the input circuits, are shown in Fig. 2.

The phase shift along each transmission line should be proportional to the distance to the antenna with which it is associated. To simplify the attainment of this objective, the six coaxial lines are run in a common trench along the axis of the array, so that the physical length of each line is of the correct value. Even

(Continued on next page)

(Continued from preceding page)

pendent musa, and each may be set to receive at a different angle. Since the length of path, as is evident from Fig. 1, is different for each direction of arrival, the transmission delays of the various paths must be equalized, which is readily accomplished by delay networks in the branch paths.

In the experimental musa at Holmdel, three such branch paths are provided as indicated in Fig. 4. The three branch circuits are formed at the outputs of the first detectors for the six antennas of the array, and the three sets of phase shifters in the branch circuits are separately controlled by three dials.

One of the branches, shown at the right of Fig. 4, is used only to explore the angle range to determine the angles at which waves are arriving. Its output is connected to a cathode ray oscilloscope which shows amplitude as the ordinate with phase shift as the abscissa. The plot in the illustration indicates strong signals at two values of ϕ .

The other two branches pass through separate branch receivers, and then one is passed through an adjustable delay network to equalize the transmission delays before the two outputs are combined. The correct delay is indicated by a second oscilloscope as indicated in the illustration. When the delays are properly equalized

the oscilloscope will show only a diagonal line, or compact, elongated figure, as indicated. In this way, the musa may be held at all times on the two most prominent incoming signals, and the sharp directivity of the individual lobes insures the high ratio of signal-to-noise that is desired.

A front view of the experimental musa receiving equipment is shown in the photograph at the head of this article. The high-frequency bay is at the left and the audio-frequency bay at the right. The three middle bays include the branch receivers and the phase-shifting networks, and at the top of one of them are the two oscilloscopes—the larger one, of which only the bottom edge can be seen, being used for monitoring. The number of branches provided is not limited to three, of course, and in a system proposed for commercial transatlantic service, four will be provided.

As outlined in the foregoing, the operation of the musa depends upon the waves being propagated in an orderly manner such as depicted in Fig. 1. Such a ray picture is considerably idealized, but nevertheless experience with the experimental musa indicates that with a few refinements such a receiving system can be expected to increase substantially the reliability of short-wave telephone circuits in the near future.

(Continued from preceding page)

when this is done, the phase shift along each line will not be of the proper amount unless the lines are very accurately terminated to avoid reflection effects. If the input circuits to the receivers are not precisely adjusted, the proper phase will not be applied to the grids of the detectors, and the system cannot be made to function as it should.

To determine the correct adjustment of the input circuits, a test oscillator with an im-

vacuum-tube voltmeter resulted in standing-wave suppression of such an order as to make routine operation of the standing-wave detector unnecessary under ordinary conditions.

The outputs of the intermediate-frequency circuits following the first detectors are divided into three branches, each including its phase-shifting circuits. This branching is accomplished physically by providing a rectangular coaxial bus from the output of each of the six intermediate circuits, and tapping the equip-

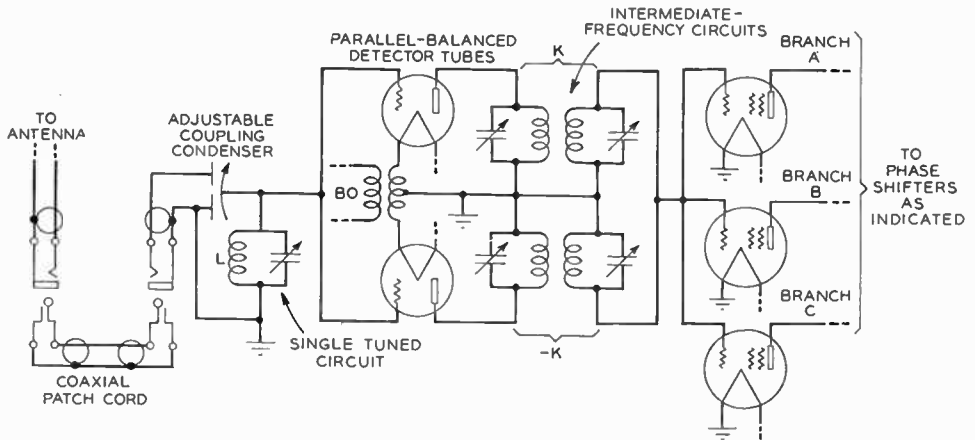

FIG. 1
Simplified schematic of the musa circuit.

pedance equal to that of the coaxial line is plugged into the input jack, and the tuning and coupling condensers are alternately adjusted until a maximum output voltage appears on an indicating meter connected in one of the three branches.

SQUARE LAW VTVM USED

To secure high precision a square-law vacuum-tube voltmeter is employed in which the major part of the current is balanced out and the remainder is read on a microammeter that has a full scale reading of only thirty microamperes. This permits the maximum current to be determined to a high degree of precision.

The ultimate criterion of correct termination is the degree of suppression of standing waves on the transmission line. To insure that setting for maximum current gave the correct adjustment, therefore, a standing-wave detector was installed in the experimental equipment. This detector consists of about sixteen meters of the coaxial line arranged in a coil. This line is terminated in the input circuit to be tested, and fed at the other end by a test oscillator. Six taps are brought out from this coil to the low-capacity switch, and a selector arm connects the taps as desired to an auxiliary receiver of high input impedance. The absence of standing waves is indicated by equal readings at the six positions. It was found, however, that the adjustment for maximum current with the

ment of the three branches to it as shown at the head of this article.

THE PHASE SHIFTS

Phase shifting in the branch circuits is accomplished by a circuit shown schematically in Fig. 3. There are six of these circuits for each of the three branches. The points "a," "b," "c," and "d" have equal voltages to ground but are ninety degrees apart in phase: that of "b" being $+iR$; that of "c," $-iR$; that of "a," $+ji/\omega C$, and that of "d," $-ji/\omega C$. These points connect to four sets of stator plates of two condensers. The rotors of the condensers are mounted at right angles to each other on a common shaft, and are shaped so that the difference in exposure to opposite stator plates is proportional respectively to the sine and cosine of the angle of shaft rotation. Thus, the current in the rotor is constant and of a phase proportional to the shaft angle.

The six phase shifters of each branch are connected to the steering shaft through helical gears with multiple ratios. One of these drives is shown in Figure 4. The individual shafts may be shifted with respect to the main drive when the musa is adjusted. This adjustment is independent of signal frequency. The gains of the phase-shifter circuits may be adjusted independently to compensate for differences in the line losses.

The remaining intermediate- and audio-frequency apparatus does not differ greatly from

other equipment of this type, with the exception of the audio delay networks used in combining the outputs of two branches.

WHERE DELAY IS INSERTED

This delay is inserted in the low-angle branch, and although it could theoretically be provided at intermediate frequency, it is actually obtained electrically in the audio circuits. The delay network is an artificial line of forty sections terminated by its characteristic impedance.

Each section provides a delay of 68 micro-seconds. A switch permits a high-impedance output circuit to be tapped across any section—thus providing a total delay of 2.7 milliseconds adjustable in 0.068-millisecond steps. An equalizing network, designed by P. H. Richardson, equalizes the transmission loss for each step and also equalizes the loss-frequency char-
(Continued on following page)

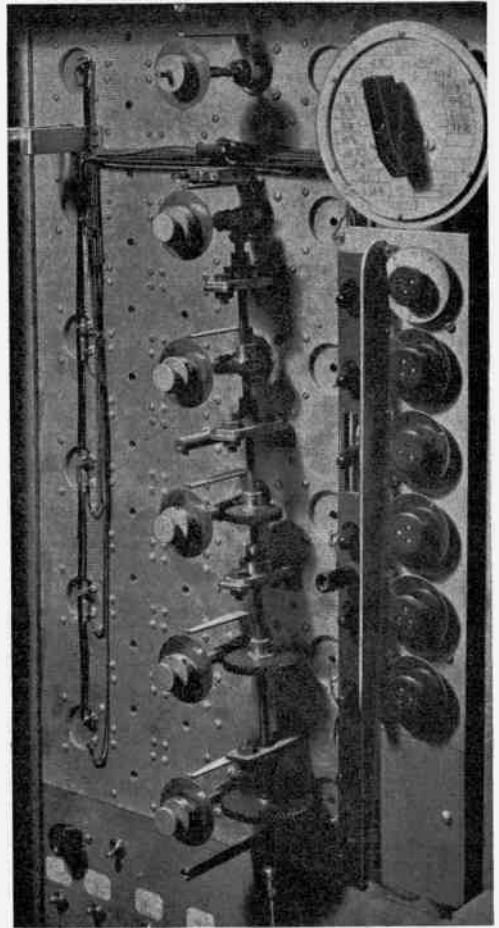
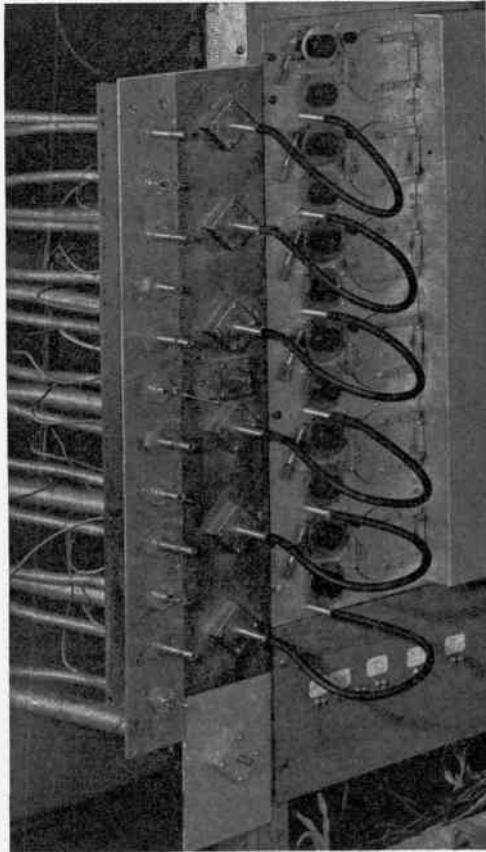
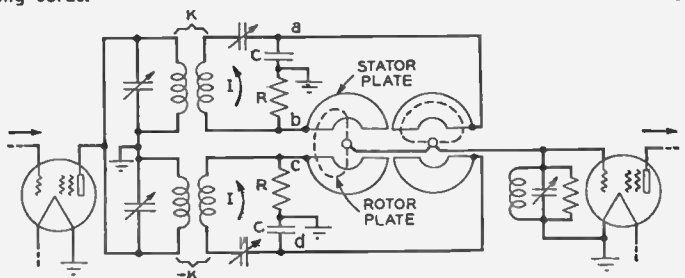

FIG. 2
The transmission lines from the antennas terminate in coaxial jacks and are connected to the input circuits by coaxial patching cords.

FIG. 4
One of the steering drives showing the helical gears and the shafts of the six phase shifters.

FIG. 3
Simplified schematic of the phase-shifting circuit.



The Musa From the Outside

By L. R. Lowry

Radio Research Department, Bell Telephone Laboratories



FIG. 1
The musa terminal building
and the incoming coaxial
transmission lines.

THE array of poles and wires that one would see if flying over the Holmdel radio bic antennas of the experimental musa. These equally spaced antennas, with their individual coaxial transmission lines running underground to the receiver building shown in Fig. 1 comprise the outside plant of the system. Within this building is the musa terminal equipment; and the six coaxial lines may be seen inside the sloping wood casing, on the righthand side, from which one side has been temporarily removed.

The coaxial lines are constructed of sixty-foot lengths of one-inch copper pipe, joined with screw-type unions. The inner conductor consists of a quarter-inch copper tube supported at ten-inch intervals by isolantite insulators. A trench running down the middle of the array carries all six lines; and at each pole one of the lines turns up and runs to the top of the pole where it is connected to one end of the an-

tenna through a coupling unit. A photograph of this coupling unit is shown in Fig. 2, and its circuit schematic is given in Fig. 3. At the other end each antenna is terminated in its characteristic impedance, which takes the form of three spaced resistance units. The arrangement of these units is shown schematically in Fig. 6, and as actually installed, in Fig. 4. The arrangement at each of the five intermediate poles is identical, and is shown in Fig. 4.

SEVERE REQUIREMENTS

Although there is nothing particularly unusual in the antennas themselves, in the coaxial lines, or in the method of coupling, there are a number of requirements of unusual severity that must be met if the array is to act properly as a musa. As has been discussed in a previous article,* the phase differences between

*Second preceding article, this issue.

(Continued from preceding page)

characteristic to make the response flat up to 5,000 cycles.

In this experimental equipment, both linear and square-law detectors are provided for final demodulation, and either may be switched into the circuit as desired.

GAIN EQUALIZED

Automatic gain control for either demodulator is obtained from linear rectifiers, but to secure

as nearly as possible a constant output volume, a different connection is made for each type of detectors employed.

This experimental system was designed for double-sideband reception. Equipment has recently been completed, however, which may be substituted for the double-sideband equipment when single-sideband signals with reduced carrier are to be received. This new equipment may also be employed to select one sideband of a double-sideband signal by the use of crystal filters.

adjacent antennas must be alike; and along each transmission line the phase shift must be proportional to the length.

To meet these conditions the antennas and coupling transformers must be exactly alike, and the coaxial lines must be accurately terminated. Final tests must then be made in order to verify the behavior of the outside plant.

One of the incidental requirements is that the coaxial lines be electrically smooth; in other

larger variations were found. These are believed to be due to a slight irregularity in the line at each joint, which adds a small shunt capacitance. When located at regular intervals, these small capacitances have a cumulative effect at frequencies for which the distance between joints is a multiple of a half wavelength. For the sixty-foot sections of the existing lines and for their actual velocity of propagation, these critical frequencies would

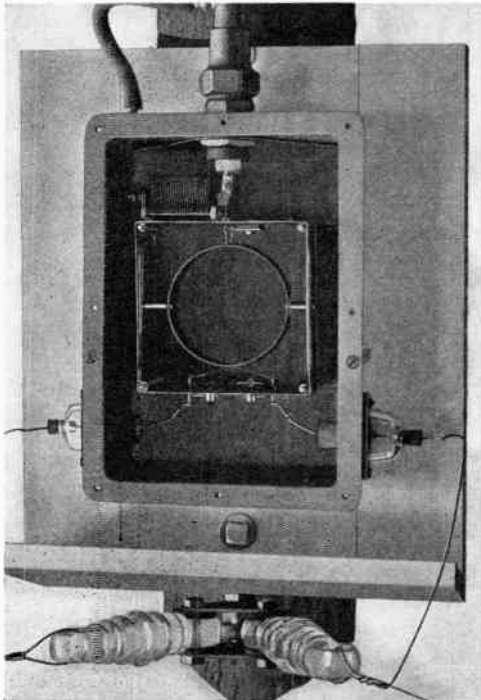

FIG. 2
Coupling unit designed for the musa antenna structures.

words their characteristics—resistance, capacitance, and inductance—must vary uniformly with distance. If they are not smooth, standing waves will be formed even though the lines are correctly terminated, and as a result their impedance will vary with frequency.

SMOOTHNESS TEST

As a test for smoothness, the longest coaxial line—about a thousand meters—was terminated at its remote end by its characteristic impedance and then the near end impedance of the line was measured over a wide range of frequencies. The resistive and reactive components thus obtained are shown in Fig. 5. For most of the frequency range, as will be noticed, the impedance variations are within ± 10 ohms. Variations of this order do not appreciably affect the satisfactory operations of the musa, and are not objectionable.

At 7.7 and 15.4 megacycles, however, much

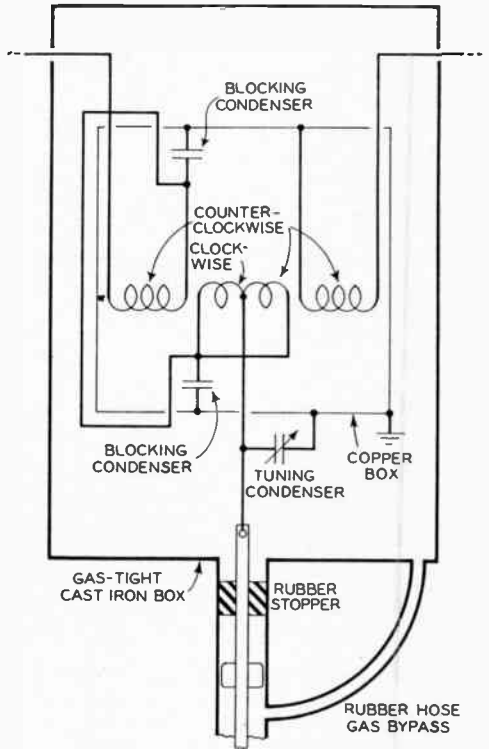

FIG. 3
Circuit schematic of the coupling unit, which is designed to permit checking the continuity of the termination resistance by means of direct current measurements at the terminal building.

be 7.7 and 15.4 megacycles—exactly as found. Since the musa is not required to operate at these two particular frequencies, the regular sixty-foot sections are satisfactory; but if it were to receive at these frequencies, the sections would have to be made of different lengths to avoid this cumulative effect.

UNDER FULL CONTROL

The musa can be controlled over its steerable range and operated in the designed manner without the phase velocity of the transmission lines being known. To be able to determine the angles of the incoming waves, however, the velocity must be accurately determined. The velocity of the existing coaxial line was therefore calculated and also measured. The calcu-

(Continued on following page)

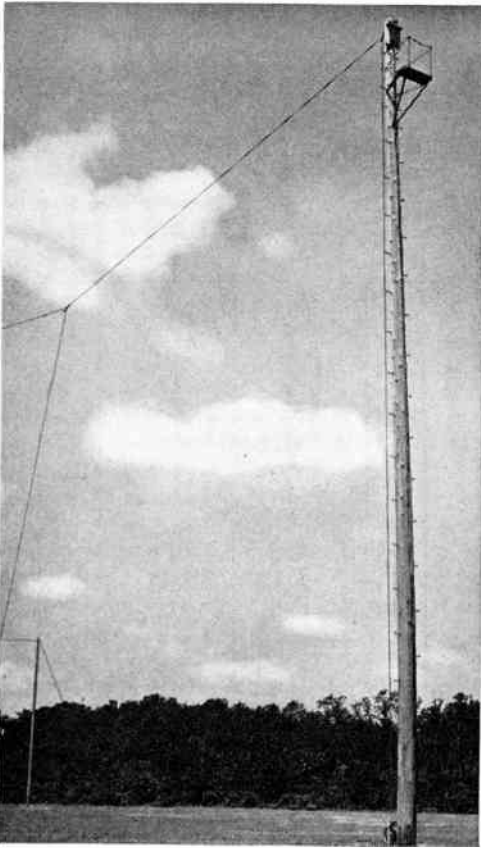

FIG. 4

At their output end each antenna is connected directly to a coupling unit, and at their termination end, the wires of each antenna are connected through three terminating resistances.

(Continued from preceding page)

lated ratio of the velocity of the line to that of light was 0.941; and the measured ratio was

0.933 ± 0.004 . Experience with the system indicates that the value is 0.937.

Measurements were also made at the receiver input of the phase difference between adjacent antennas. At the highest frequency the maximum variation in these measurements including the experimental error, was found to be only 0.4 per cent of the total phase difference between adjacent antennas. Although this variation is satisfactory, experience with the system suggests that the actual variations are considerably less than this. The antenna outputs were found to differ by less than 0.5 db over the working range of frequencies.

VERY LITTLE CROSSTALK

Another requirement for the satisfactory operation of the *musa* is that the coupling, or crosstalk, between adjacent antennas be negligible. Results of measurements on the experimental *musa* are indicated in Fig. 6. The small amount of crosstalk current, 0.0011, measured at the transmission line end of the *musa* and the larger current, 0.161, at the termination end, indicates the unidirectional characteristic of the antenna. To a first approximation, the current in such an antenna increases progressively toward the output end, and under this condition the effective crosstalk current is probably less than 0.081, that is half of $(0.161 + 0.0011)$, and is thus less than ten per cent of the signal current, 1. Antennas at greater spacing, either ahead or behind, contribute relatively nothing. These measurements were made at eighteen megacycles, at which frequency the antennas are proportioned to give maximum radiation approximately end-on. At lower frequencies, the crosstalk is probably less. Since the directional pattern of any antenna is the same for transmitting and receiving, the crosstalk will have less than ten per cent effect when the antenna is receiving.

A further requirement for the *musa* is that the ground on which it is erected should be electrically flat, so that the reflected waves and the direct waves will combine similarly at all parts of the system. This requires that the reflecting plane of the earth should be approxi-

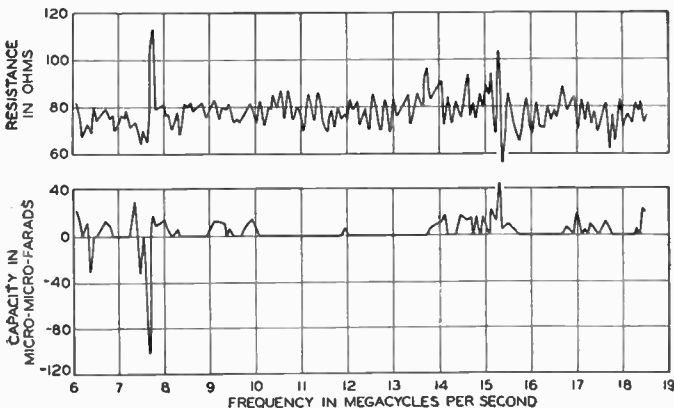

FIG. 5
Resistance component, above, and reactance component, below, of the coaxial transmission lines of the *musa*.

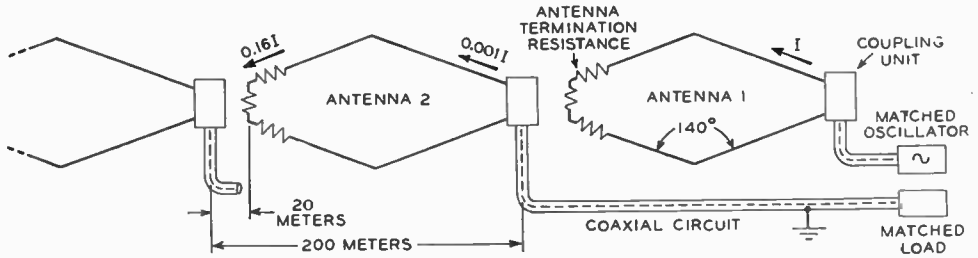

FIG. 6

Values of crosstalk current measured in the experimental must vary at different parts of the antenna as indicated.

mately horizontal. Although the actual surface contour of the ground is not necessarily an indication of the position of the reflecting lay-

er, tests and experience over the last few years have both indicated that the location of the Holmdel site meets this requirement.

Application Rack of Musa System



Rear view of musa rack at Holmdel, N. J. Note the separate boxes for thorough shielding and individual adjustment of the phase-shifting networks. This system is introduced at the receiving end to improve greatly the signal-to-noise ratio. It does this by use of a multiplicity of single antennas arranged end to end along the great circle distance between the transmitter and the receiver. Such an array has been found to have marked selectivity for both the direction and the angle of arrival of waves. This selectivity can be controlled by ganged phase-shifting networks connecting each antenna to the receiver. Thus the effects of fading and noise can be reduced and optimum antenna conditions chosen at will for reception of the strongest and stablest component of the radiated wave.

Interference Factors as Related to Antennas

By Alfred A. Ghirardi

[Herewith is the concluding installment of an extended and expert discussion of interference, reprinted from Alfred A. Ghirardi's "Modern Radio Servicing" by permission of the publisher and copyright owner, Radio and Technical Publishing Company.

In the previous installment the author considered the case where interference, or most of it, was picked up by the antenna, which became excited in either of the following two ways: (1), by direct radiation from the disturbing device; (2), by indirect radiation from the power supply line or some other circuit that has picked up the disturbance.—EDITOR]

THE first condition, that of "direct radiation pickup," is likely to occur if the disturbing device is located in the same building that the antenna installation is in. Even small electrical appliances can radiate disturbances to the lead-in wire if they are near enough to it. In apartment houses, the elevator motors and contactors which are usually in the elevator pent house on the roof radiate very strong disturbances which may be picked up directly by both the aerial and the upper part of the lead-in if they are near enough to it. Such prolific sources as diathermy machines (see May issue), large electric sign flashers, etc., cause the radiation of considerable interference energy which may be picked up directly by radio antennas over an appreciable area.

The second condition, that of "indirect radia-

tion pickup," is perhaps the most common one. The branch circuits of the power supply lines in a building may pick up disturbances, conduct them and re-radiate them to a radio antenna system at some point a considerable distance away either in the same building or in some other building. In rural districts, the elevated power supply line may conduct such disturbances for a considerable distance and re-radiate them to receiving antennas. The same is true for electric surface car lines, etc. Even double re-radiation may occur! A power supply line may conduct disturbances and radiate them to another conductor such as a metal gutter or drain-pipe, a metallic room, a stand-pipe, pipe lines and shafts, etc. The latter conductor in turn may re-radiate the energy to a receiving aerial or lead-in in the vicinity. The possibilities and ramifications of such re-radiation are so complex that they are often responsible for very perplexing interference situations which are encountered. Nevertheless, its importance and prevalence should be understood, for it is often the mysterious reason why an aerial located in a high position ostensibly free from all electrical devices and circuits is very noisy because it happens to be within a zone of disturbance re-radiated by a roof gutter, a metal roof, a metal flagpole, etc., in the vicinity.

INSULATORS IN SERIES

Whenever an aerial is installed, it is good practice to use two or three insulators in series

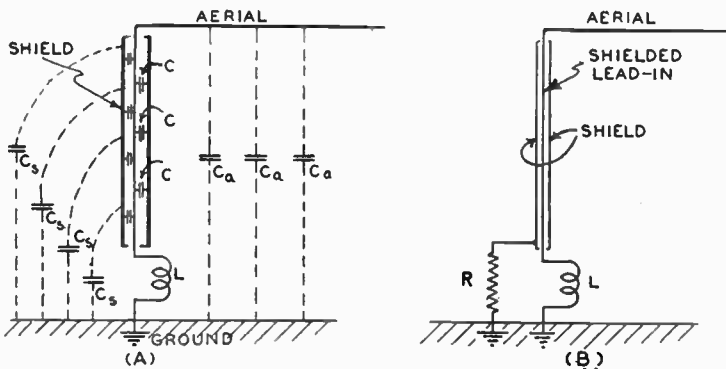

FIG. 4

(A) The various capacities which exist between the aerial, ground, lead-in and shield in a shielded lead-in antenna system. (B) How the lower end of the shield may be connected to ground through a resistance (or choke) to reduce local oscillations of noise current in the shield circuit.

at each end. They should be separated about 12 inches from each other. This brings the end of the aerial wire no closer than 3 feet from its support. This is extremely important when the aerial is suspended from metal supports, such as iron pipe supports, vent pipes, etc., which are either driven into the ground or fastened to the metal frame-work or cornice of the building. These metallic structures may be re-radiating interference from some other source.

It should be remembered that the ordinary inverted *L* or *T* type antenna system consists of three parts. The horizontal portion is the *aerial*; the portion which leads from the aerial to the receiver is the *lead-in*; the portion leading from the set to the ground is the *ground lead*, or more simply, the *ground*. In "doublet" antenna systems there are only the aerial and the lead-in, no "ground" (as such) is used. In the "vertical" antenna there are only the aerial wire and the ground, although strictly speaking, if the aerial is erected very high above the roof, a lead-in will be used to connect it to the receiver.

IMMEDIATE PICKUP

In the majority of cases where interference is experienced, most of the electrical disturbance exists in the immediate vicinity of the building due to electrical devices located therein, or to the electric light and power wiring in the building which radiates interference that has been conducted in from the outside. It is picked up by the lead-in and ground leads, and very often by the aerial as well.

The ground lead, and the ground itself, should come in for a great deal more attention by service men than they usually do. It should be remembered that in all antenna systems (except the loop and the doublet types) the ground lead alone may make quite a fair aerial—especially when the set is installed in an upper story of an apartment house so that the ground lead is high up from the actual earth. (How effective an aerial the usual ground lead makes, may be checked in a minute by disconnecting the aerial lead-in and ground leads from the receiver, connecting only the ground leads to the *Ant.* post of the set instead and tuning for a signal with the volume control full up). As soon as this is realized, the fact that the ground lead will also be affected by all interference radiations from nearby electrical devices, the electric light wiring in the building (and even water and gas pipes if they are acting as re-radiators of disturbance due to their being located close to interference-carrying lighting circuits at some point), follows naturally. The practice of running the ground lead to the plate of an electrical outlet for convenience should certainly be discontinued, for this connects the ground lead of the set directly to the conduit in which the electric light circuit, alive with interference, runs. The set is really then using the main source of the interference as a ground lead—which is certainly not a pleasant condition to picture!

Because of the foregoing conditions which may occur, the "ground" should be given some

attention when noisy reception is experienced. In rural districts, perhaps the best ground is one that is buried outside the house where it is definitely away from all electric light wiring. Obviously, nothing will be gained by sinking a ground close to the point of exit of the electric light circuit, or even the water and gas pipes. A position at least 6 to 10 feet from the building and clear of the foregoing pipes and cables should be selected if possible. Six to ten feet of rod or ordinary iron pipe driven down into the earth, or about fifty feet of bare wire (at least No. 14 gauge or larger) buried in a shallow trench will make a good ground. Of course it is not possible to install such grounds in cities. The only thing that can be done in such locations when interference is experienced is to make a good ground connection (with a ground clamp) to the cold water pipe, or the steam pipe. The higher the connection is made in the building, the noisier the ground will be, for all piping between this connection and the earth will be picking up interference. For this reason, the use of a doublet antenna is very advantageous when conditions of this kind are encountered, for no ground is necessary when it is employed. Therefore, all noise from this source is eliminated by its use.

If the location is "noisy," an indoor aerial is the worst possible type to install, for, the entire antenna system in such cases is located right in the interference zone. Naturally, extremely noisy reception is bound to occur under such conditions.

If an outdoor aerial is employed (an inverted-*L* type is shown here although the same holds true for a *T* type or a doublet) and is installed so that it is *all within the interference zone*, even more noise will result because of its greater pickup of both the signal and the noise due to its greater length. If only part of it is in the interference zone, the signal-to-noise ratio will be improved, for there is now a portion of the aerial which picks up signals but does not pick up interference because it is out of the interference zone.

OPERATION ON ANTENNA

When noise is experienced in an installation of this kind it is very often possible to reduce it somewhat by simply lengthening the aerial portion of the existing antenna (if it is possible to do so) provided the added section is *certain* to be out of the interference zone. Now, since a greater portion of the aerial picks up signals, but comparatively little or no noise, the signal-to-noise ratio is improved. This should really be the first thing to try in cases where the noise is only *moderately* bad. In many cases, this simple expedient will convert noisy reception to satisfactory quiet reception on both the standard broadcast band and short waves. And, although 35 to 60 ft. aeriels are commonly recommended, do not be afraid to try an aerial as much as 100 to 120 ft. long! Of course, lengthening the aerial will increase the capacity between it and the ground. This capacity acts as a small con-

(Continued on following page)

(Continued from preceding page)

denser across the primary coil of the antenna stage in the receiver, and may increase its natural wavelength to an undesired figure. In such cases, a small condenser (which may be an ordinary midget tuning condenser having a maximum capacity of 30 to 90 mmfd.) may be connected in series with the aerial lead-in wire close to the set. Putting this in series with the circuit reduces the effective antenna-ground capacity. Moderate background noise may also be reduced greatly in some cases by the simple expedient of shifting the aerial to a different location, out of the interference zone, when this is possible. This zone may occur above, to one side of, or even below the location of the existing aerial in some cases. The lead-in should be kept free of metal gutters. The service man should not overlook these two simple expedients (lengthening the existing aerial so as to extend it out of the noise zone, and shifting it to a location out of the noise zone) in cases where only a moderate amount of interference is experienced. He should always keep in mind the important fact that the *aerial* portion of the antenna must be erected in a zone which is at least comparatively free of electrical disturbances. Unless it is, no elaborate noise-reducing lead-ins of any kind are going to completely eliminate the noise, for the aerial will still be picking it up.

LEAD-IN PICKS UP, TOO

Assuming that noise pickup by the "ground" has been reduced to a low value and that the aerial has been erected in a noise-free zone, the problem of the lead-in remains. The lead-in can be (and usually is) responsible for a great deal of the noise pickup—especially in apartment house installations where it must run right down for a considerable distance through the thick of the strong interference zone created by electrical appliances and by the network of electric light wiring circuits in the building.

If the aerial can be located in a zone which is reasonably free from man-made electrical disturbances, and if the lead-in can be so arranged that even though it runs through the noise-infested area it does not transfer to the receiver any of the disturbances which it may pick up, then, assuming that the ground is also reasonably free from noise (if it is not possible to get an interference-free ground, a doublet aerial may be used, for it needs no ground at all), satisfactory noise-free reception (so far as the entire antenna system is concerned) should be obtained. Several practical lead-in arrangements which are designed to accomplish this result will now be described.

When we speak of preventing electrical disturbances from affecting a conductor, the first thought which naturally comes to mind is that of electrically *shielding* the conductor from the disturbance by surrounding it with a shield or screen of conducting material. This idea has considerable value when applied to the lead-in of a standard broadcast-band receiver (but it is not satisfactory for short wave or all-wave receivers, as we shall see presently),

and has been used to some extent in receiver installations of this kind where annoying interference has been experienced.

The entire lead-in right from the aerial to the *Ant.* post of the receiver is made of single stranded copper wire which is surrounded by (though insulated from) a low-resistance closely-woven braid of tinned copper which shields it effectively. In the better grades of shielded lead-in the entire conductor and shield is jacketed by a waterproof outer covering of rubber which protects the shield from moisture and corrosion.

INDEPENDENT AERIAL

It is evident that the 20 or more feet of metal shielding (depending upon the length of the lead-in) surrounding the central lead-in wire may act as an independent receiving aerial which will pick up both signals and electrical disturbances (mostly the latter). Furthermore, this 20 or more feet of metal shielding surrounding the central lead-in wire and separated therefrom by rubber insulation (which is a good dielectric having a dielectric constant of about 3) forms a "condenser" of appreciable capacity, C , distributed along the entire length as shown at (A) of Fig. 4. This shielding also has a capacity, C_a , to ground, and the aerial wire has a capacity, C_s , to ground. These are all shown in the illustration. The equivalent electrical circuit which results is shown at (A) of Fig. 5 where A represents the lead-in, S represents the shield and L is the primary of the antenna coil in the receiver. Keeping in mind the fact that signal voltage is induced in the aerial wire and both noise and signal voltage is induced in S , it is evident that we have here two possible oscillating circuits, each one having its own natural resonant frequency determined by its inductance and capacity. One of these circuits consists of the aerial (in which the *signal* voltage is induced), C_a , the "ground," and L , as shown at (C) of Fig. 5. Notice that the *signal* current flows through the receiver coil when it oscillates in this circuit. The other oscillating circuit consists of S (in which the noise voltage is induced), C , A , L , the "ground," and C_s , as shown at (B). Notice that since receiver coil L is also in the path of the noise current which will flow through this latter circuit, the effectiveness of the shield in eliminating noise pickup is greatly reduced. These interfering oscillating currents can be suppressed by grounding the shield at both ends (and at intermediate points along it if possible) so that its entire length will be maintained at as nearly ground potential as possible. Since it is usually very inconvenient to make such a "ground" connection to the top end of the shield in actual installations, most manufacturers of shielded antenna kits resort to a different method of accomplishing the same result. The shield is grounded at the receiver end only, and a high resistance is connected in series with this ground lead (as shown at (B) of Fig. 4). Connecting this resistance in this way has the effect of introducing it directly in series with the oscillating circuit formed by the shield, antenna coil and ground, as shown at (D) of

Fig. 5, and it therefore suppresses the noise currents in this circuit. In some cases, a suitable r-f choke is used instead of a resistor for this purpose (see Fig. 6). Unfortunately, this resistance also reduces the effectiveness of this ground connection to the shield in bypassing the inductive interference currents to ground, but in actual commercial shielded antenna kits some sort of compromise is at-

tempts). Thus it really steps *down* the signal voltage of the aerial and increases the current in proportion (less the losses) so that the signal power may be transmitted through the lead-in at low voltage and higher current (the total signal power would remain unchanged if it were not for the losses which occur in the transformer). Transmitting the signal power at this lower voltage results in less loss in the

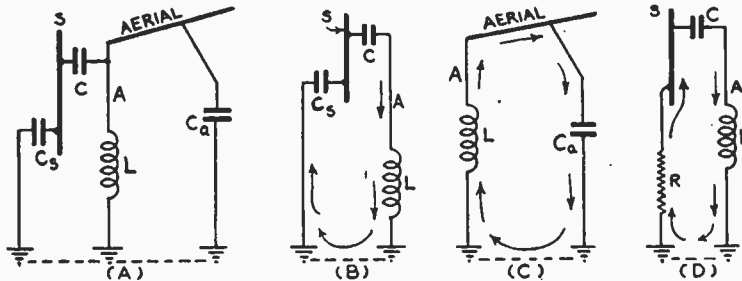

FIG. 5

Equivalent electrical circuits which exist in the circuit arrangements shown in Fig. 4.

tempted between these two conflicting conditions by using a compromise value of resistance or choke.

IMPEDANCE FACTORS

Now if the simple shielded lead-in which we have considered thus far is installed in this way (so that it connects the aerial directly to the input circuit of the receiver) reception will be found to be quite poor. First, since the capacity between the lead-in wire and shield (capacity C in (A) of Fig. 4) is appreciably large for a long length of lead-in, and since the shield is grounded, a considerable amount of by-passing of the high-frequency signal to ground will result. A study of (B) in Fig. 4 reveals that the capacities C and C_s in series really shunt the primary of the antenna coil in the receiver. Since C_s is appreciably large, its shunting effect is appreciable—especially for high-frequency signals. Viewed from another angle, the impedance of a line of large capacity is small, and when it is connected to the relatively large impedance of the aerial at one end and receiver at the other end, the transfer of energy to the receiver will be small.

It will be recalled that, in any system, maximum power is transferred when the impedance of the source is equal to the impedance of the circuit it feeds into (whatever it may be). In our case, the impedance of the aerial is very high compared to the impedance of the shielded lead-in, so that an impedance-matching transformer must be inserted between the aerial and the lead-in line. This transformer may be of the auto-transformer type as shown in Fig. 6, or it may be of the two-winding (separate primary and secondary) type. In either case, the primary winding of the transformer is designed to match the impedance of the aerial circuit to which it connects, and its secondary is designed to match the *lower* impedance of the line (the shielded lead-in to which it con-

nects). Thus it really steps *down* the signal voltage of the aerial and increases the current in proportion (less the losses) so that the signal power may be transmitted through the lead-in at low voltage and higher current (the total signal power would remain unchanged if it were not for the losses which occur in the transformer). Transmitting the signal power at this lower voltage results in less loss in the

EFFECT OF TRANSFORMER

In terms of voltage and current, the antenna transformer reduces the voltage developed in the aerial to a low value and increases the current in proportion. The receiver transformer steps up this voltage again by transformer action and reduces the current. The effect of the ideal shielded lead-in system, then, is to virtually place the radio set up on the roof where the aerial is located, and if the aerial is in a substantially noise-free area, no noise should be heard. In practice, this will be true only if any signal or noise which the shielded lead-in picks up is effectively prevented from affecting the receiver input circuit, and if the transformers are designed correctly to keep the impedances matched. These transformers are really radio-frequency transformers and are ordinarily made of coils wound in either "scramble" or "universal" manner. When purchasing kits of parts for shielded lead-in antennas, the service man should be careful to avoid those types which have excessive losses at certain signal frequencies, and also those whose antenna impedance-matching transformer is im-

(Continued on following page)

(Continued from preceding page)
properly weatherproofed to stand exposure to rain, extreme changes in temperature, humidity, etc., without deterioration.

Since impedance-matching transformers are so commonly used in noise-reducing lead-in systems, it will be well at this point to show why the capacity between the lead-in wire and its shield does not have so much by-pass action when it is terminated by a *low* impedance.

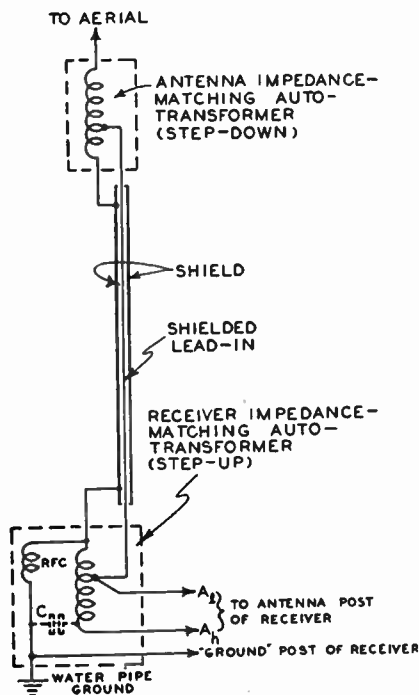

FIG. 6

How impedance-matching transformers are connected at both the aerial and the receiver end of the shielded lead-in.

Consider the circuit shown at (A) of Fig. 7. A high-frequency voltage, E , of 100 volts is impressed across a resistance, R of 10,000 ohms and a capacity, C , whose reactance at the impressed frequency is 10 ohms. The current through R is simply $100/10,000 = 0.01$ ampere, and that through the condenser is $100/10$ equals 10 amperes. It is clear, then, that under these conditions the impedance of the condenser is so *low* compared to that of the resistance (this could also be an inductance) it is connected across, that it takes nearly all of the current that flows from the source of voltage.

Now suppose that the source voltage be stepped *down* by a transformer so that the voltage applied to the circuit is now only 1 volt (as shown at (B) of Fig. 7); the transformer ratio required to reduce this voltage is 100-to-1 (step down). But the impedance is

now reduced according to the inverse square of the transformer ratio, so that the 10,000 ohms now looks like 1 ohm, but the capacity remains the same, because it is connected *after* the transformer. The current through R is now 1 ampere, and that through the condenser is 0.1 ampere. Hence, the *capacity current* is now but a fraction of the *total current*, whereas previously it represented nearly all of the total current.

THE ANTENNA SYSTEM

The same circuit and reasoning applies to the antenna system just described (see Fig. 6). The applied voltage, E , is that generated in the aerial by the signal, R may be considered as the impedance of the aerial, and C is the capacity of the shielded cable. The impedance-matching transformer reduces the voltage applied to C , so that a smaller proportion of the *total current* flows through it. At the receiver end of the line, the reverse takes place, and the voltage is stepped up to the required value. In an actual line, of course, inductance, resistance and capacity are present, so that the conditions are somewhat more complicated than presented here. However, it shows definitely why it is necessary to match the impedance of the aerial to the lower impedance of the shielded lead-in and to match the latter to the higher impedance of the receiver input.

The example presented here did not *match* the impedances, but made them unequal in the opposite sense. This was done to emphasize the effect of varying the impedance connected across a fixed capacity. In fact, though maximum *power* would not be transferred by the system shown here, reflections would occur from one end of the line to the other creating standing waves, and the system would be unbalanced unless the receiver were connected to very definite points along the line. In actual practice, it is essential that the impedances be really matched.

The main difficulty with the shielded lead-in type of noise-reducing system is that the non-adjustable impedance-matching transformers can effectively match the impedances over only a *comparatively narrow band of signal frequencies* (unless variable controls are to be added at the two impedance-matching transformers, which of course is impractical). These transformers can be designed to work fairly efficiently over the limited standard broadcast band of frequencies from 540 to 1,600 kc, and a number of satisfactory units of this kind are on the market. In most of these, the winding which connects to the input circuit of the receiver is tapped (see Fig. 6) so that the full winding (tap A_2) may be used if the set is of the type having a high-impedance input and only part of the winding (tap A_1) is used if the set has a low-impedance input circuit. This makes better impedance matching to both types of receivers possible.

RANGE IS PROBLEM

Unfortunately, the difficulties involved have prevented the development of suitable imped-

ance-matching transformers which will work efficiently over the large range of frequencies covered by the short wave as well as the standard broadcast ranges. Severe line losses drastically cut down the signal intensity if this is attempted. It is for this reason that *the shielded lead-in type of noise-reducing antenna system is suitable when only the standard broadcast band is to be received. It should not be employed if man-made interference picked up by the lead-in is to be minimized when either a short-wave or all-wave receiver is to be used.* In

than the signal is, for then the reserve sensitivity of the receiver (most modern sets have an appreciable reserve) will make up for the increased antenna loss and give adequate volume with a lower background of interference.

The lead-in wire of any inverted-L or T type antenna system (if it is unshielded) picks up signal voltage, especially from nearby broadcasting stations. However, after it is shielded, it becomes merely a power-transmission line serving to connect the aerial to the receiver. If it is a well-shielded lead-in, it no longer

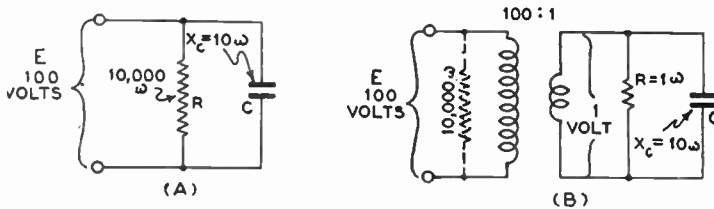

FIG. 7

Equivalent electrical diagrams showing the effect of the impedance-matching transformer on the by-passing action of the lead-in-to-shield capacity of the shielded lead-in.

such cases, one of the other systems which will be described shortly, should be used instead. Even in the case of standard broadcast band reception there is some loss between the receiver and the aerial. For the average case, about 30 to 50 per cent of the induced antenna voltage is lost in the transformers and lead-in. Of course, this loss can be tolerated if the interference is lowered to a far greater extent

picks up any signal. Therefore, in cases where the unshielded lead-in has been picking up an appreciable portion of the total signal received, a decrease in signal voltage will result when a shielded lead-in is substituted for it. To compensate for this elimination of the lead-in pickup, the horizontal portion (aerial part) of the antenna should be made longer than it was when the unshielded lead-in was used.

Some Transformer Effects

The effect of transformer ratios is not always fully appreciated by students.

Assume an alternating-current generator delivering a load to an impedance R . Such a load also may be shunted by a load C , which is undesired, a common case. Since the useful power is that which is supplied to the load R , the current drawn by C produces a power loss in the generator which is of no value whatever in the load circuit. A capacitive load can not be deemed as consuming power, being a wattless load, current and voltage being 90 degrees out of phase, but the condenser does draw current and this current has to be supplied by the generator. If the generator has series internal resistance, nearly always the case, there is heat loss in the generator due to the condenser. Therefore the generator resistance determines the loss.

The loss effect introduced by the condenser is related to the proportion of the total current that it draws, and this is determined by the ratio

of the condenser current bears to the load current.

Assume the case of a 1-to-1 transformer. A given load across, primary or secondary, will draw the same power (less small transformer losses). So if R is 10,000 ohms and C 10 ohms, the two currents at 100 volts are 10 ma and 10 amperes, respectively. In such a case the presence of capacity C produces a big power loss, because it takes a thousand times the current that R takes. Assume the ratio is 100 to 1, primary to secondary, and other values the same, and across the secondary. Now the secondary voltage is one volt and the current through the load R is .1 ma and through C is .1 amp. It is apparent that the proportion of the secondary current remains the same. If a transformer is now connected between the secondary and any subsequent utilization circuit, and given correct impedance relations, the overall transmission efficiency will have been much improved.

RCA Television Reaches Commercial Quality Status

RECENT developments in the RCA all-electronic television system were revealed to members of the press in demonstrations by the Radio Corporation of America and the National Broadcasting Company at Radio City. The demonstrations were designed to show the progress made by the two companies in technical and program experiments during the seven months elapsed since the system was last shown to the press. The former pea-green pictures are now black and white and are clearer, sharper and steadier. The results are satisfactory now for commercial purposes.

While no startling innovations have been introduced in the RCA system during the last year, steady advances have been made toward technical perfection of the medium. David Sarnoff, president of RCA, in reviewing results of two years of experimentation and research in electronic television, said:

"Our experiments with television in the past 18 months have improved the system by increasing its capabilities and efficiency, thus enabling it to move closer to the inauguration of a television service for the American home."

DRAMA BROADCAST

NBC's activities in television at the present time are strictly experimental, Lenox R. Lohr, president of the National Broadcasting Company, pointed out. Since 1936 field-test transmissions have been undertaken periodically by RCA and NBC, under the direction of R. R. Beal, RCA research supervisor, and O. B. Hanson, NBC vice-president and chief engineer.

Four weeks ago a regular schedule of experimental broadcasts of programs especially designed for television was begun. The schedule of five full-hour broadcasts—three afternoon transmissions of test charts and still pictures, and two evening programs of entertainment—will be maintained throughout the month of May.

The most recent demonstration, arranged by C. W. Farrier, NBC television co-ordinator, and consisting of a dramatic production drawn from one of the regular evening programs, was broadcast over W2XBS, in the Empire State tower. The drama, "The Mysterious Mummy Case," was adapted from a Tom Terriss adventure script by Thomas Hutchinson, NBC television program director. Its presentation required three studios and four distinct techniques to portray the misfortunes attendant upon the purchase in Egypt of an ancient mummy case. The main action took place in a live talent studio, but auxiliary media in the form of slides, motion pictures and special television effects were contributed by two other studios.

Five sets were used in the live talent studio

Lower - Priced Units Called Only Barrier to Wide Television

TECHNICALLY speaking, television is a success. This is generally known in the radio field, but like the beginning of radio sound broadcasting and talking pictures, where technical improvements finally resulted in efficient devices, commercial exploitation lags.

The slow development in mass production and distribution of television transmitters and receivers is due to the complexity of the sets now produced and to the high cost of materials necessary to manufacture them. Until a simple unit is produced, available at the popular prices, only a few television receivers will be in operation.

—Wincharger Corporation.

by a cast of nine players. Slides and motion pictures were scanned in another studio, two floors above, and all effects were televised in a special studio nearby.

ACTION SWITCHED TWENTY TIMES

More than twenty switches of action were made from one studio to another during the twenty-five minute performance. All were made in the main control room, adjoining the live talent studio, where both picture and associated sound were monitored.

Picture and sound signals were carried by coaxial cable to NBC's experimental transmitter in the Empire State tower, and there broadcast from a temporary antenna array on the north side of the building to receivers in the metropolitan area. Viewers at the special press demonstrations saw the televised play in receivers located on the 62nd floor of the RCA Building. Pictures were broadcast on a frequency of 46.5 megacycles and associated sound on 49.75 megacycles.

The television images, viewed in a mirror screen at the top of the receiver, were in black-and-white and approximately 7½ by 10 inches in size. No changes in the tentative standards of definition had been made, the picture still being drawn in 441 horizontal lines at the rate of 30 complete pictures a second. Many changes

(Continued on following page)

Tuning Eye Range Increased

ENGINEERS of National Union Radio Corporation have developed a novel cathode-ray tuning indicator tube, the 6AD6G. This tube consists of a circular target, two ray control electrodes, and a cathode, indirectly heated by a 6.3-volt, 150-milliamperere filament. Structurally the tube differs from other tuning indicator tubes previously on the market. It is much smaller—approximately one-half the length of previous tubes—and is based with a metal shell type of base, thus facilitating its use in a clamp behind the dial of a radio receiving set.

Two identical ray-control electrodes are employed with connections to each brought out to separate pins on the base. These control electrodes each produce a shadow pattern on the circular target, and consequently, several varieties of shadow movement are available.

CONTROL TUBE, TOO

A special control tube, actuated from the a-v-c voltage of the receiver, and controlling the 6AD6G, provides for dual range indication with automatic shift from one range to the other.

The special control tube is also a National Union development, the 6AE6G, having a single cathode indirectly heated by a 6.3-volt, 150-milliamperere filament. Around this cathode is a specially-designed grid having evenly-wound grid turns for a portion of its length, while for the remaining portion the grid turns are unevenly spaced. Surrounding this grid are two plates, one opposite the evenly-spaced turns of the grid, and the other opposite the unevenly-

spaced turns. For use as a control tube in conjunction with the 6AD6G tuning indicator tube, one recommended circuit arrangement employs the 6AE6G as a dual range d-c amplifier. The ray-control electrodes of the cathode-ray indicator tube are connected one each to the plates of the control tube. These plates are fed from a positive voltage source through a 1 meg. resistor in each circuit. Application of a-v-c voltage to the grid of the control tube causes the shadow on one-half of the 6AD6G to begin to close, while the shadow on the other half remains essentially stationary. If an even stronger signal is tuned in, and consequently develops more a-v-c voltage, after one shadow has closed completely the second shadow then takes over the function of indication.

ECONOMICAL APPLICATION

For use in low-priced receivers, there is a simple circuit for the 6AD6G, the cathode of which is connected to the screen grid of the i-f amplifier. A resistance is placed in the plate circuit of the i-f amplifier between the high voltage supply and the ground end of the i-f transformer. On the plate side of this resistance, the ray-control electrodes of the 6AD6G are connected. A-v-c voltage of the receiver causes the plate current of the i-f amplifier tube to change in accordance with the signal, and thus the voltage on the ray-control electrodes, with respect to the cathode of the indicator tube, varies and produces a shadow proportional to the incoming signal. This tube represents another development in ray-tube tuning indicators.

(Continued from preceding page)

in the system of transmission, however, has resulted in a steadier image.

The essentials of the RCA all-electronic television system, operated in the New York City area by the National Broadcasting Company, are two: (1) a pick-up tube, the Iconoscope, where the scene before the camera is converted into a series of electrical impulses suitable for radio transmission, and (2) a Kinescope which assembles the transmitted impulses in their proper order to reproduce the original image in the screen of the home receiver.

The Iconoscope contains a light-sensitive plate on which the scene to be televised is focused. A fine jet of electrons sweeps across the plate in a pattern of 441 horizontal lines, thus converting lights and shadows into electrical impulses of corresponding intensities. The plate is completely scanned thirty times a second.

The Kinescope, a funnel-shaped tube about 18 inches long, is the heart of the television receiver. Here a fine ray of electrons, produced in the neck of the tube, is caused to play on a fluorescent screen at the large end of the tube.

Contact of the beam with a fluorescent material on the screen produces a spot of light which varies in intensity according to the strength of the received electrical impulse. Sweeping across the screen in 441 lines, the

beam thus reproduces the lights and shadows that formed the original image focused on the plate of the Iconoscope. Movement of the two beams of electrons is synchronized by special impulses fed into the RCA system.

The present NBC station, W2XBS, has been operated experimentally for ten years. It was established by RCA when comparatively successful broadcasts of low-definition pictures by the older scanning disc method seemed to promise an early television service. It was later realized, however, that this mechanical method would never produce a picture of sufficient detail to satisfy the home viewer; higher speeds were required for finer detail.

Five years ago Dr. V. K. Zworykin, of the RCA laboratories, announced his Iconoscope, the tube that met television's demands for scanning at tremendous speeds. It was the first successful instrument to utilize the electronic method of scanning. Experimental field tests were begun by the National Broadcasting Company in 1936 on a 343-line system. In January, 1937, the standard of definition was raised to 441 lines, now believed to be satisfactory for home entertainment needs. Several series of field tests, undertaken jointly by NBC and RCA, indicate that good 441-line images can be broadcast from station W2XBS over areas within 50 miles of the Empire State transmitter.

RIGHT OR WRONG?

Propositions

1. A grid leak is a resistor inserted between grid and grid return of an oscillator, so that automatic negative bias will be provided, due to the flow of grid current through the resistor.
2. The plate current of triodes, tetrodes and pentodes depends solely on the plate voltage for a given control grid bias, the effect being equal on all three types.
3. So long as the signal input to a vacuum tube does not exceed the negative d-c bias applied to the tube, hence the grid voltage does not swing positive, no grid current will flow, and the tube can be used distortionlessly.
4. Unlike the case of a single-tube oscillator, in a beat oscillator, e. g., an audio beat type, the stability of the beat frequency is at its lowest in the lowest beat frequencies, because even the highest beat frequency is obviously a small percentage of the frequencies of either of the individual oscillators.
5. Acorn tubes are well suited for use as oscillators, detectors and amplifiers at ultra frequencies because of the smallness of elements and of grid-cathode, grid-plate and plate-cathode capacities. Yet the elements are rather close together for increasing the mutual conductance and reducing the transit time of the electrons.
6. When a voltage is induced from a primary into a tuned secondary that, let us say, feeds the grid and cathode of a tube, the secondary circuit is a parallel resonant circuit.

Answers

1. Right. The grid current is produced by the rectification in the grid circuit of the r-f voltage built up by the oscillatory circuit.
2. Wrong. The plate current of triodes does depend directly on the plate voltage, but in the case of tetrodes and pentodes the plate current is practically independent of plate voltage for large values of plate voltage, because the plate resistance automatically rises as the plate voltage rises. This tends to keep the plate current constant. In such tubes the screen, suppressor and grid voltages affect the plate voltage, grid creating the biggest effect.
3. Wrong. Grid current can flow in modern unipotential cathode tubes even if the applied grid bias is a volt negative, due to the effect of the initial potential relation between the grid and cathode and to the initial velocity of the emitted electrons.
4. Right. The lowest beat frequencies give rise to other difficulties besides stability, e. g., the amplitude tends to fall and the wave form tends to become distorted due to one oscillator pulling the other.
5. Right. Naturally these advantages will be nullified unless utmost precautions are taken in keeping the socket, wiring and stray capacities small, and the high-frequency insulation excellent.
6. Wrong. Although apparently the tuning condenser is in parallel with the tuning coil, yet they actually behave as if in series with a phantom generator, just as if the secondary were opened at ground and returned through the generator, represented by the voltage injected by the primary.

Literature Wanted

Readers whose names and addresses are printed herewith desire trade literature on parts and apparatus for use in radio construction. Readers desiring their names and addresses listed should send their request on postcard or in letter to Literature Editor, Radio World, 145 West Forty-fifth Street, New York, N. Y.

F. W. Rohrs, Rosedale Laboratories, Box 385, Baltimore, Md.
 Justin Stenerson, 3165 Decatur Avenue, New York City.
 The Merwin Co., Jensen, Fla.
 Paul Gibbons, 17 Summit St., Newark, N. J.

S. J. Jameson, c/o Sare's Shop, 408 W. Polk, Houston, Tex., prices on better overproduction sets, '37, any make.
 Jefferson County Amateur Radio Ass'n., Sterling Place, W8GYO, Watertown, New York.
 Thomas Powell, 950 N.W. 73rd St., Miami, Fla.
 Clyde L. Duncan, Box 1974, Juneau, Alaska.
 D. Diggins, Tranquille, B. C., Canada.
 G. Mondrush, 16150 Lawton Ave., Detroit, Mich.
 R. J. Robinson, 19 W. Butler Ave., Ambler, Penn.
 John Pappa, 114 N. Massey St., Watertown, N. Y.
 Joseph J. Barry, 37 Camys St., Newark, N. J.
 R. D. Curry, Radio Service Shop, 1622 St. Paul St., Baltimore, Md.
 E. G. Lang, 30 Cleveland Ave., Braintree, Mass.
 Stewart's Radio Service, 419 So. 7th St., Ironton, Ohio.
 W. Topalnitcki, Northern Valley, Alta., Canada.
 W. E. Crooks, Drumhead, Guys Co., N.S., Canada.
 Joseph Sofranko, Potomac Camp, Deer Park, Md.
 Jack K. Clifford, 17 Princeton St., Westfield, Mass.
 C. A. Chevalier, Rt. 1, Box 222, Gulfport, Miss.
 Dominic Capuano, 100-04 Spruce St., Corona, L. I., N. Y.

Hammarlund Manual Has Authentic Data

The 1938 edition of the well-known "Hammarlund Short Wave Manual" contains a wealth of interesting material for the short-wave experimenter. Included in its 32 pages are a number of one-two- and three-tube a-c and battery type short-wave receivers; a short-wave converter, a two stage preselector, an ultra-high frequency superheterodyne and complete power supply data. For the amateur there is a



three-stage modern crystal-controlled transmitter and also an up-to-date five-meter transmitter with appropriate receivers and power supplies for the ham. All apparatus described in this handy experimenters' manual was built and tested in the Hammarlund laboratories.

Four pages are devoted to the short-wave listener and include a large short-wave station list, tuning hints for operating short-wave receivers, and information as to how to obtain verification cards. Profusely illustrated, the book contains more than 50 diagrams and photographs. It has a three-color orange, blue, and silver stiff paper cover and is 6 inches by 9 inches. The price is ten cents.

Radio City Products Has Advanced Tube Checker

Radio City Products Company, 88 Park Place, New York City, announces an advanced tube checker, affording the new dynoptimum test. This device, sold to jobbers at \$16.95, and known as Model 307, tests all tubes under R. M. A. specified voltages and loads. It tests all metal, metal-glass, spray shield, glass tubes, new OZ4 and other cold cathode rectifiers. The manufacturer also sets forth these merits:

Tests all ballast tubes. Separate ballast tubes chart included. Hot inter-element short and leakage test between all individual elements. Hot cathode leakage test. High sensitivity neon indication. Individual tests of each section of full wave rectifiers, duo diodes and all multi-purpose tubes. Accurate calibration checked against our laboratory standard mutual conductance instrument. Accurate line voltage indication directly on meter with smooth power control. Three inch square D'Arsonval meter, 2 per cent accuracy. Direct reading "Good-



Bad" multi colored scale and calibrated reference scale. Simplest operation. Fewer controls than any other approved circuit tube tester.

Parts Show Draws Crowd

The radio parts show was held in Chicago recently under the auspices of Radio Manufacturers Association. Manufacturers, distributors and dealers from all over the country attended. All exhibitors had new apparatus to add to their lines, interest was keen, enthusiasm high, and orders were good, considering the times. Individual organizations held meetings and sponsored lectures for servicemen and dealers, the Institute of Radio Engineers met, and service groups held their own sessions.

Receiving Tube Booklet FREE!

A 16-page booklet, giving the characteristics chart and socket connections of all receiving tubes, is offered *absolutely free* to RADIO WORLD readers. Full data are given on all types, as to use and function, base, socket connections, dimensions, filament or heater voltage; plate; screen, grid voltages; plate and screen currents, a-c plate resistance; amplification factor and ohms load for stated power output. Sixty-three diagrams show socket connections (bottom view). Fill out and mail coupon to get this valuable booklet *absolutely free*.

RADIO WORLD, 145 W. 45th St., N. Y. City

Please send me free booklet on characteristics chart at once to

Name

Street and Number.....

City State.....

1275-B

U. S. Fights for S-W Equality in South America

Schenectady, N. Y.

Stressing the need for a better signal if American short-wave broadcasting is to compete with European stations for reception in South America, Boyd W. Bullock, assistant manager of broadcasting, General Electric Company, stated in an interview that too little thought has been given to the problem of furnishing the people of South America a signal good enough for them to hear if they want to listen to United States programs.

Mr. Bullock debunked the popular idea that short-wave programs, regardless of the power of their transmission, are audible throughout the world. He stated that this belief has resulted from the fact that "ham" broadcasters, using as little as a fraction of a kilowatt of power, have sometimes been heard in distant parts of the world.

FREAK RESULTS DON'T COUNT

"This," he stated, "is not compatible with present broadcast standards, and a consistent signal must be maintained if a real service is to be offered to South America.

"Short radio waves behave much differently from long ones. They seem to start away from the earth immediately they leave the antenna, and return again many miles away. Therefore they skip over large areas. From a given transmitting point different frequencies are required to reach different areas. And different ones are needed for various times of the day."

Asked why some European stations reached South America better than American stations, Mr. Bullock replied that the geographical location of parts of Europe makes it possible to direct from such a location a narrow beam of 15 degrees on Buenos Aires and maintain a strong signal throughout the most populated sections of South America; whereas an equivalent beam from an American station would be as strong at Rio de Janeiro, if directed on that point, but would be inadequate properly to serve the western area of South America.

EQUALITY SOUGHT

Likewise, a 15-degree beam directed on Santiago, Chile, or Buenos Aires would not produce a signal at Rio comparable to, say, a German signal.

"For this reason," added Mr. Bullock, "American stations must use greater power than Germany if a comparable signal is to be

Bills for Government Short-Wave Stations Shelved as a Menace

Washington

LEGISLATION for government operation of short-wave broadcast stations has been postponed by Congress, at least until the next session, following general opposition of broadcasters. Hearings developed strong opposition from the National Association of Broadcasters, networks, and other private broadcasting interests.

President Ethridge of the NAB inveighed against government broadcast competition with private industry and declared that such government broadcasting "suggested the Nazi philosophy" and is "utterly at variance with democratic principles." Congressional leaders stated that bills by Representative Celler of New York and Senators McAdoo of California and Chavez of New Mexico would not be acted on at this session. Sponsors of the legislation urged the proposed U. S. short-wave service to offset foreign radio propaganda, especially to Latin America.

had throughout South America. It is not a problem of counteracting European stations, but rather a question of maintaining a signal approximately as strong as theirs.

"Conditions are such that there are very few frequencies which American stations may use with success in obtaining South American reception. The local stations there destroy the effectiveness of several American stations operating on the same or near the same wavelengths.

POWER AND DIRECTIVITY AS A SOLUTION

"The remaining frequencies which are adaptable for use to South America are near those used by powerful foreign stations, with the result that sideband interference impedes clear reception.

"The only way this problem can be solved, which General Electric's short-wave stations W2XAD and W2XAF are now doing, is to transmit with a power of 50 to 100 kilowatts and use a directive antenna which will concentrate the transmitted energy where it is needed. Vertical as well as horizontal directivity must be accomplished."

S-W RECEPTION IMPROVED

Difficulties in quality reception of short waves are gradually being reduced by superior design of tubes and by using circuit constants that stay put.

G. E. Develops Built-in Antenna

Bridgeport, Conn.

P. F. HADLOCK, engineer of the General Electric radio division, in discussing antennas, pointed out that several years ago, when broadcasting was in its earlier stages, the signal strength of the transmitters and the sensitivity of receivers was considerably lower than at present, and there were fewer stations on the air. He added:

"Because of this, listeners were more eager to pick up far-distant stations and noise-free reception was not thought too important.

CHANGE OF TASTE

"Antennas installed inside the home were clumsy in appearance and inadequate for bringing in distant stations. This made the trend toward outside antennas, which delivered more signal to the receiver, inevitable. This tendency has persisted up to the present because of the popularity of short-wave reception, but currently the trend on the part of radio listeners is to want higher fidelity and greater ease in operation in their receivers, confining their interest largely to the strong domestic stations. In fact, the modern receiver is looked on more as a musical instrument."

General Electric has developed the beam-scope built-in antenna. Correlated with the design of the receiver in which it is installed, it is concealed inside the radio cabinet with no outside connections, and the radio can be moved

to a new location without the rearrangement of any antenna and ground leads.

EFFECTS DISCRIMINATION

It discriminates against undesirable noise interference ordinarily carried to a receiver by the electrostatic portion of the radio signal. The beam-scope receives only the electromagnetic portion of the signal, and is fully shielded against the electrostatic portion.

The new device consists of a self-contained acceptor circuit completely enclosed by a rejector winding, or shield. The winding form is made of a special type of wood, thoroughly impregnated to prevent warping and a loosening of the acceptor winding. The shield or rejector winding consists of many fine wires surrounding the acceptor circuit and connected to the receiver chassis. Termed the "rejector" circuit, the shield is of the Faraday type, shielding the coil electrostatically but not electromagnetically.

ADJUSTED TO RECEIVER

When a receiver is first installed in a home, the beam-scope is rotated and left in the position of minimum noise pick-up. The adjustment is made preferably with the antenna tuned to a weak signal. It is not usually necessary to re-adjust the beam-scope setting once made. The device necessitates no change in the appearance of the cabinet.

Homes with Radios Grow 17 Per Cent. in a Year

Estimated radio ownership in 26,666,500 American homes, not including extra receiving sets in many homes and also sets in automobiles, stores, restaurants, institutions, etc., is reported in a survey of the Joint Committee on Radio Research organized jointly by advertising agencies and broadcasters.

This was an increase of 17 per cent over the previous year and the report estimates that on January 1, 1938, at least 82 per cent of the families of the nation had at least one radio set. The report also includes estimates of radio families by states and counties.

Rider in Larger Quarters; Will Make an Instrument

John F. Rider, publisher, is now located in new and larger offices at 404 Fourth Avenue, New York City.

Mr. Rider promises an instrument and a book with which, he believes, servicemen can quickly solve one of the most baffling and annoying problems encountered in servicing.

RMA Wants No Stations on I.F. Second Harmonic

Washington

Measures to maintain the present 455 kc intermediate frequency for radio receivers, involved in the recent North American treaty negotiated at Havana, have been taken by Radio Manufacturers Association, Inc. Resolutions have been sent to the Federal Communications Commission by the RMA requesting that the 455 kc intermediate frequency be retained and that changes be made regarding the 900 kc and 910 kc frequencies.

There will be problems for radio manufacturers if the second harmonic of the i.f. interferes with a broadcast station frequency, and the RMA is asking that no stations be allocated on the 910 kc frequency, as proposed in the assignment of this frequency to the United States for broadcast purposes.

The RMA also recommended that the 900 kc frequency be assigned to the United States and that Mexico be given the 910 frequency, but if changes cannot be made in the treaty to accomplish this, it is the recommendation of RMA that the FCC make no allocations on the 910 kc channel.

RADIO CONSTRUCTION UNIVERSITY

Answers to Questions on the Building and Servicing of Radio and Allied Devices.

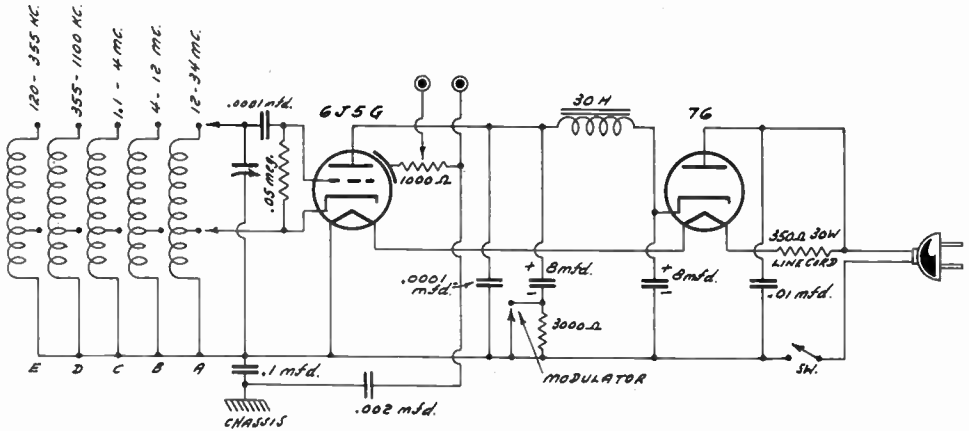

A universal signal generator that operates in five bands from 120 kc to 34 mc. The coils, tuning condenser and direct-reading frequency-calibrated scale are commercially obtainable. An unshorted wire around the 6J5G oscillator provides output coupling. The 76 (or 37) is the rectifier.

OSCILLATOR LINE FEEDING

IN a signal generator of the universal type (a-c/d-c) is it practical to stop the r-f leakage, so that the volume control will be fully effective on all bands? Please show a tested diagram for such a generator.—O. E. F.

It is not practical to prevent the leakage entirely, in fact, it is very difficult to reduce it substantially, unless the makeshift is introduced of having a low oscillation intensity. If this makeshift is to be applied, one way is to ascertain the grid current average for the highest frequency band, and then adjust the plate voltage for the other bands so as to produce the same grid current (not done in diagram). Hence the plate voltage will be reduced and the oscillation intensity likewise. This does not reduce the leakage percentage much, but the original oscillation is low, and the reduction then has a greater apparent effect, and the volume control (attenuator) works much better. The oscillation will not be uselessly low. The coupling to volume control consists of a wire around the oscillator tube, not a short-circuited turn, however. The queer symbol is intended to convey this connection. Having the chassis unconnected to line or tuning condenser frame but a .1 mfd. condenser between condenser frame and chassis, aids in leakage

reduction, and keeps the chassis from being "hot" in an r-f sense. It can be seen that the oscillation is supported to 34 mc, which is extremely high. The use of the B choke, as shown, instead of a resistor, is recommended, as the voltage applied to the 6J5-G plate is then around 150 volts, or about equal to the peak a-c voltage of the 115-volt line. The coils, condenser and frequency-calibrated scale are obtainable commercially.

ELECTROLYTIC CORROSION

IS it not a fact that corrosion can take place in electrolytic condensers? If so will you please state some of the effects?—L. W.

The corrosion that occurs in electrolytic capacitors makes itself apparent by pitting of the anode, the development of growths on the anode surface and the deposition of sludge. There is no definite time at which corrosion may occur. It may start soon after a capacitor has been placed in service. In many cases, when corrosion has actually started, the capacitor may continue to function in a satisfactory manner for long periods of time. In fact there is evidence that in some cases corrosion starts then later stops due to electrolytic action and the anodic film forms over the corroded area. In any event great care must always be exercised to eliminate

from the entire structure of the electrolytic capacitor any impurity or contaminating influence which might result in any corrosive action. Further mention will be made later to the matter of corrosion and its causes.

* * *

B VOLTAGE TOO LOW

TO what would you ascribe the low voltage received by the plates of tubes in a small midget universal receiver? This voltage is around 50 volts, performance is poor, and the grid bias voltage, through self-biasing resistors, is only around one volt, instead of three volts.—E. F. C.

The first thing to suspect is the filter condenser next to the rectifier. Replace this with a condenser known to be good. If there is no rise in d-c voltage, replace the other filter condenser, the one after the filter resistor or B choke. Should neither method help, suspect in this order: the rectifier tube, the power tube and the other tubes.

* * *

BERNARD METER, USING 0-1 MA

CAN you apply the volt-ohm-milliammeter method as devised by H. J. Bernard, and described in last month's issue (May), to a 0-1 milliammeter?—K. E.

The diagram is printed herewith. An eleven-position, single-deck switch is used, and the functions are: 1 = 10 volts d.c.; 2 = 100 volts d.c.; 3 = 1,000 volts d.c.; 4 = low ohms, by the back-up method; 5 = high ohms, using two lower binding posts in diagram, also same position represents one milliampere, using common minus post and second post from bottom; 6 = 10 ma; 7 = 100 ma; 8 = 1,000 ma (one ampere); 9 = 10 volts a.c.; 10 = 100 volts a.c. and 11 = 1,000 volts a.c. One scale is used

for all d.c. (voltages and currents), another scale for all a.c., decimal repetition being applied mentally, and two scales for the respective resistance ranges. The imprinted values are correct, except for the limiting resistors on a-c use, which are only approximate, and will have to be selected by experiment. The 10-volt a-c range particularly has to have a resistor selected thus for calibration purposes. The higher ranges of a.c. run truer to a common sensitivity basis of about one-quarter the d-c sensitivity of 1,000 ohms per volt. More about this circuit will be printed next month.

* * *

PRIVACY ENDANGERED

WHEN a modulated oscillation voltage is fed into the line for carrier system, is there privacy in the conversation, or can anyone hear what is going on?—W.D.

Anyone equipped with a receiver tunable to the frequency of the carrier can tune in at least one side of the conversation, and if the same carrier is used in a two-way system, can hear the whole conversation.

Standard Has Fourteen Replacement Transformers

The Standard Transformer Corporation, 1500 North Halsted Street, Chicago, recently announced a line of fourteen transformers which will service the majority of existing radio sets. Brackets permit these transformers to be mounted in horizontal or vertical position. In addition, they may be used in the conventional half-shell type of mounting. A service guide listing this line of transformers is available by writing the factory for a free copy of Guide RW.

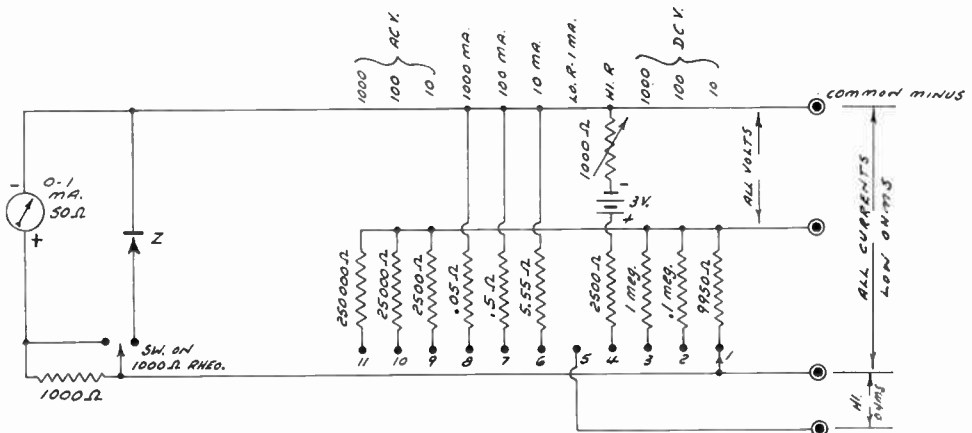

A volt-ohm-milliammeter for d-c and also for a-c volts, using the simplest switch circuit and a 0.1 milliammeter

Two Volume Expanders

Proven Circuits for Quality Reproduction

By M. N. Beitman

Allied Radio Corporation

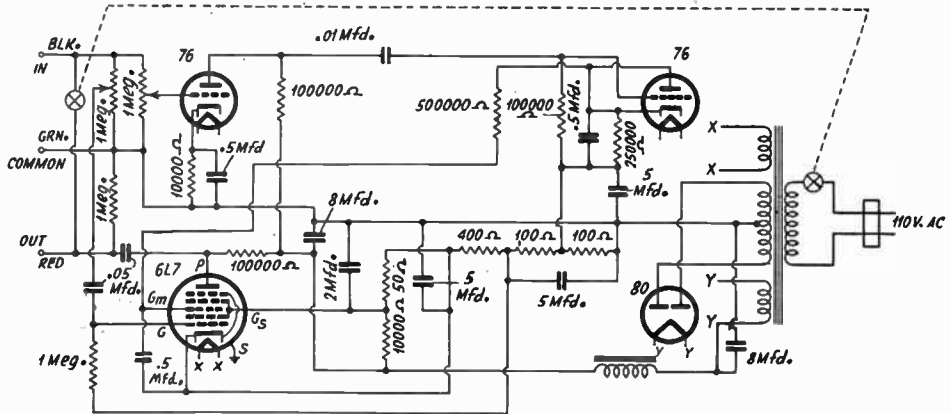

FIG. 1

Diagram of a volume expander as used in a commercial model.

MODERN audio amplifiers and higher-priced radio sets employ volume expanders to restore the true relationship of tone intensity. The discriminating, musically-trained listeners realize by judging a single selection reproduced with the aid of a volume expander the many advantages of this unit.

A symphonic orchestral range is from 4 milliwatts when a single violin is playing softly to a peak of 70 watts with the full orchestra playing the louder passages. This intensity range is about 43 db. The range available in broadcasting is limited by wire lines and the modulation circuit. If high efficiency modulation is to be obtained, average signals must modulate the transmitter as close to 100 per cent as is practical.

In recording, a similar problem is encountered. The succeeding grooves of a record are spaced at definite intervals and the loudest passages must not cut through to the next groove. Now, if the full range is used without any condensation, the weaker passages will be below the noise intensity.

LEVELING EFFECT

To overcome this difficulty, and a similar problem in broadcasting musical selections, logarithmic compression is employed. This method is much better than simply sharply cutting off the extremely loud and soft passages. With this compression method, the average

volume level does not change, but variations in the volume above and below this level are reduced. The objective of the volume expander is to counteract the compression, by changing the volume in the opposite direction, and making the true reproduction possible.

The simplest type of volume expansion circuit would consist of a resistance that will react in a manner to accomplish the objective of volume expansion. Circuits of this type were employed in early Crosley type receivers.

Many of the volume expanders in modern use employ a type 6L7 vacuum tube as an audio amplifier. The expansion action results from the fact that the gain of the 6L7 can be controlled and varied, depending on the applied bias on No. 3 grid. When the bias on this grid is made less negative, the gain of the tube increases. On the other hand, as the bias is increased in the negative direction, the gain decreases.

ACTION DESCRIBED

In the circuit illustrated, this tube is employed. Besides the fact the signal enters the control grid of the 6L7, the signal is also applied to an amplifier and diode type detector, consisting of two type 76 tubes. The circuit of these tubes is so arranged that the potential applied to the No. 3 grid of the 6L7 tube, will be a direct function of the applied signals. This is accomplished by employing the first type 76 tube as a triode amplifier and the second 76

tube as a diode rectifier. One potentiometer controls the actual volume of the circuit, while the second connected to the grid of the first 76 tube controls the degree of expansion.

The circuit of the volume expander illustrated is very simple and the unit itself may be easily constructed. In case a volume expander is used in connection with a phonograph pickup, the pickup itself may be connected directly to the unit.

The output of the volume expander unit is of the high impedance type and may be connected directly to the grid of an audio amplifier tube. This enables the expander to be easily connected to any radio set or amplifier by simply breaking the circuit of the audio stage.

CONNECTIONS TO SET

Detailed information on the proper connection of this unit to radio sets and amplifier is given below.

If the radio set uses a single output tube such as a 45, 47, 48 or other type triode or pentode, the simplest method of coupling for best results is by breaking the grid lead of this tube and inserting the expander in series with the tube. If resistance-capacity coupling is employed, unsolder the condenser at the grid of the output tube. Connect the "in" terminal of the expander through a short piece of insulated wire to this condenser terminal and then connect the "out" terminal of the expander to the grid terminal of the tube.

In the event a push-pull final amplifier is employed, and there is a single triode preceding

this output stage, the same procedure as outlined above may be followed at the grid terminal of this triode amplifier.

If the tube preceding the push-pull output stage is a pentode, or if it is the duo-diode-triode type, a somewhat different procedure must be followed. The expander should then be connected to the plate circuit of the tube.

Unsolder the coupling condenser at the plate terminal of this tube, leaving the resistor still connected. Connect the free end of the condenser to the "out" terminal of the expander unit.

PURPOSE OF CONDENSER

Now take a bypass condenser of at least .1 mfd. capacity and at least 400 volts rating and insert it in the leads from the "in" terminal of the expander. This lead, thus broken by the condenser, should now go over the plate terminal of the tube from which the coupling condenser was unsoldered.

The bypass condenser is used to keep the plate high voltage supply from shorting out to ground and yet allow the audio frequency to pass. The ground or common terminal of the expander is in all cases connected directly to the chassis of the radio receiver or amplifier.

A commercial type volume expander following the general circuit diagram of Fig. 1, is shown in the photograph, Fig. 2.

ANOTHER TYPE

The theoretical possibility of an entirely different type of volume expander circuit is illustrated
(Continued on following page)

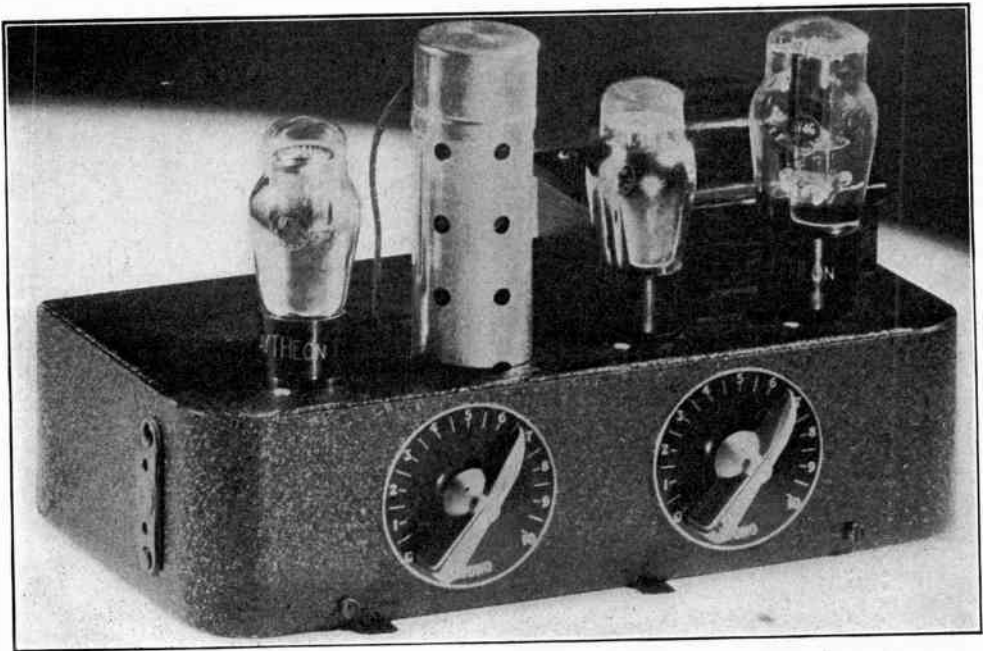

FIG. 2
View of the commercially-made expander.

trated in Fig. 3. Please note that at low signal level the direct and reverse phase signal components as supplied to the type 6F6 vacuum tube are about of the same intensity. This is accom-

out of phase signal. The result is greater amplification. A proper selection of constants gives the correct time delay action required for audio reproduction.

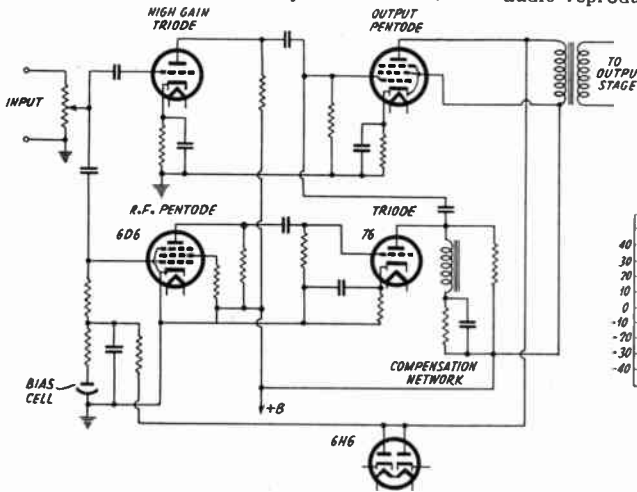
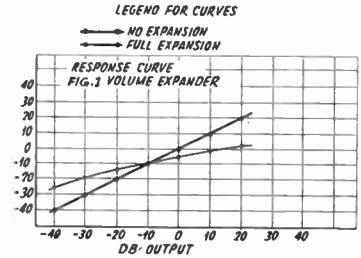

FIG. 3. See-saw type expander at left. Tube at upper left should have a resistor from grid to ground. 6H6 may have cathodes grounded. Curve for Fig. 1 expander below.



plished by selecting the proper components for the type 6D6 tube.

However, as the signal input increases, a different bias is placed on the phase inverter tube and the signal supplied by the straight type 76 triode is considerably greater than the

Volume expanders offer unlimited opportunities for experiment or to develop worthwhile circuit improvements and also give the servicemen opportunities to cash in on the additional business created by volume expander high fidelity reproduction demand.

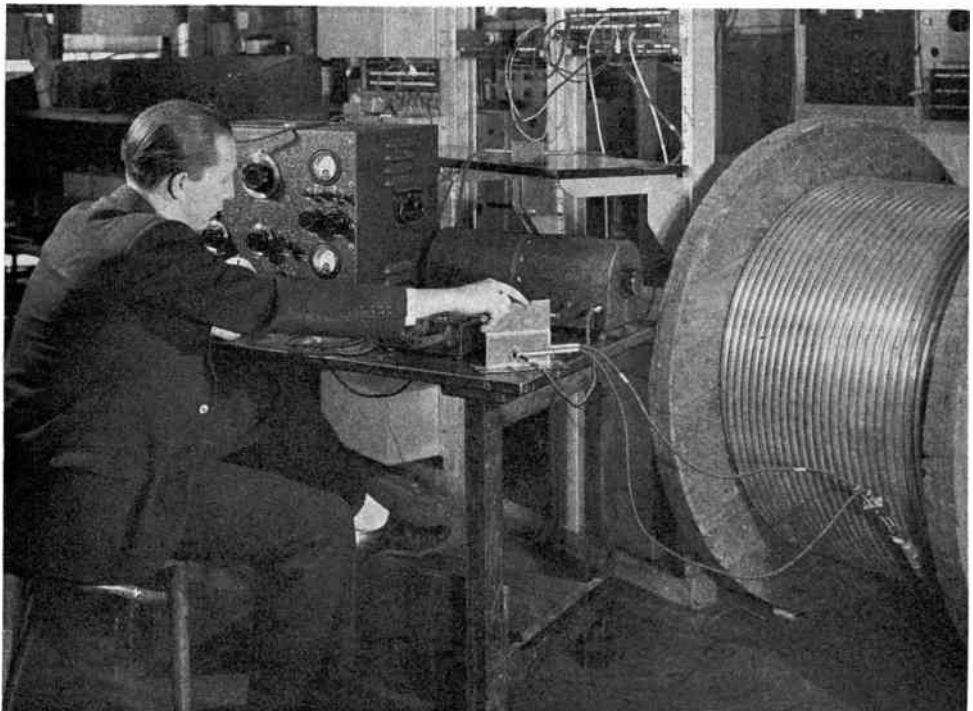

Checking frequency range and phase on coaxial cable at Bell Laboratories.

OHIO VACUUM CLEANERS ON TIME PAYMENTS



Here is a vacuum cleaner made and improved for 29 years by the same company, a cleaner designed for top-most service and long life, powerful enough to get all the hair, lint, thread, etc., the first time it is passed over the rug.

The full size ball-bearing motor develops plenty of suction, and operates for years with little or no attention.

This cleaner has a steel handle finished in chromium with a maroon bag. A rubber handle grip is attached.

Electric-lit device shows-up all litter on the rugs and carpets, and is especially needed in dark places such as under beds. The light is equipped with a switch.

\$59.50

As good as any!
Better than many!
Fill out and mail
Coupon for full
particulars.

Superb for Home Cleaning

The Ohio is built for those who pride themselves on an immaculate home—rugs bright and clean, overstuffed furniture free from dust and moth larvae. Bright clean drapes, mattresses aerated and clean—in fact, all the essential points of good housekeeping. Other features of the Ohio are: easy to empty leak-proof bag; automatic dust shutter; direct air line increases efficiency and prevents clogging; handle lock; soft tread wheels; swivel caster; heavy furniture guard; rubber cord with indestructible plug; restful handle grip, and highly efficient for every dusting and cleaning task.

EVERY NECESSARY CONVENIENCE IS BUILT INTO THE OHIO.

RELIABLE COMPANY,
143 West 45th Street, New York, N. Y.

I am interested in buying the Ohio vacuum cleaner @ \$59.50, on time payments, \$5 down, balance spread over about a year. Please send details.

Please send jobber proposition.

Check off one of above squares

Your Name

Street and Number

City..... State.....

Time switches, seconds or minutes from.....59 cents up
Continuous ringing (locking drop) relay.....59 cents
Yale key operated switch, the key is removable in "off"
or "on" positionSpecial \$1.75

Relays, Solenoids, ALNICO Magnets and other experimental supplies.

BLAN, THE RADIO MAN
64 Dey Street, Dept. 638, New York City

AMATEUR RADIO LICENSES, HOME STUDY COURSE IN CODE AND THEORY

REASONABLE, EFFICIENT and THOROUGH.
RESULTS GUARANTEED.

AMERICAN RADIO INSTITUTE
1430 North Dearborn Parkway, Chicago, Illinois

When writing to Advertisers please
mention that you saw the Advertisement
in RADIO WORLD.



Everything you need in radio. It's all in this new **RADOLEK RADIO PROFIT GUIDE**. Every repair part for every receiver. Newest radio receivers. New 1938 model public address amplifiers, outputs for 5 to 100 watts. New model public address speakers. Test instruments. Technical books. Special equipment. Leading standard brands. Every item guaranteed. It must be right or we make it right.

And everything under one roof. You get what you want promptly, and exactly what you want. Radolek's immense stock plus Radolek's efficient organization insures you fastest service. 25,000 service men depend on this service and benefit by Radolek's lowest prices. Send now for your copy of Radolek's Radio Profit GUIDE. Every repair part for every re-medy.

---RADOLEK---

601 W. Randolph, Chicago, Dept. G-19

Send me the 1938 Radolek Radio Profit Guide FREE.

Name

Address

Service-man? Dealer? Experiment-er?

WITH *Front* OR *Rear*
Illumination

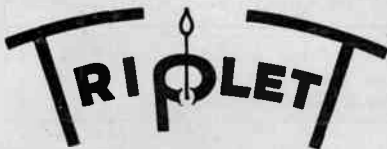

Sensitive and ultra-sensitive electrical indicating instruments. D.C. Moving Coil . . . A.C. the Repulsion Type. Sizes—2" to 7".

Specify TRIPLET for the finest, most up-to-date instruments in appearance, performance and economy.

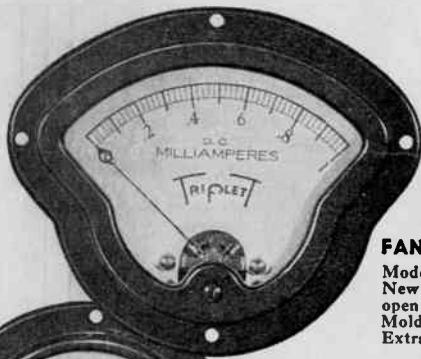

FAN TYPE

Model 529 . . .
New . . . Full open face dial. Molded Case . . . Extra long scale.

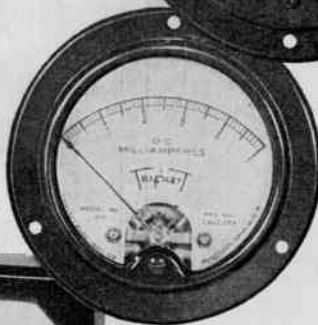

ROUND

Model 321 . . .
(Model 521—5"; Model 221—2") . . . a 3" Round design for flush mounting. Also available in projection mounting and with mirror scale and knife edge pointer.



SQUARE

Model 426—4" instrument with Front Illumination attachment. A beautiful new design. Mounting screws concealed. (Other square models in 2", 3" and 4" sizes.)

SEE THE
NEW TRIPLET 1938-1939 LINE
AT THE
CHICAGO JUNE RADIO PARTS
SHOW BOOTHS 213-15—Henry Avenue



The Triplett Electrical Instrument Co.
276 Hormon Dr., Bluffton, Ohio

Please send me more information on Triplett Model 529; Model 321; Model 426; I am also interested in

Name

Address

City State