

RIDDING SUPERS OF SQUEALS

RADIO WORLD

REG. U. S. PAT. OFF.

BEGINNER'S 4-TUBE SET

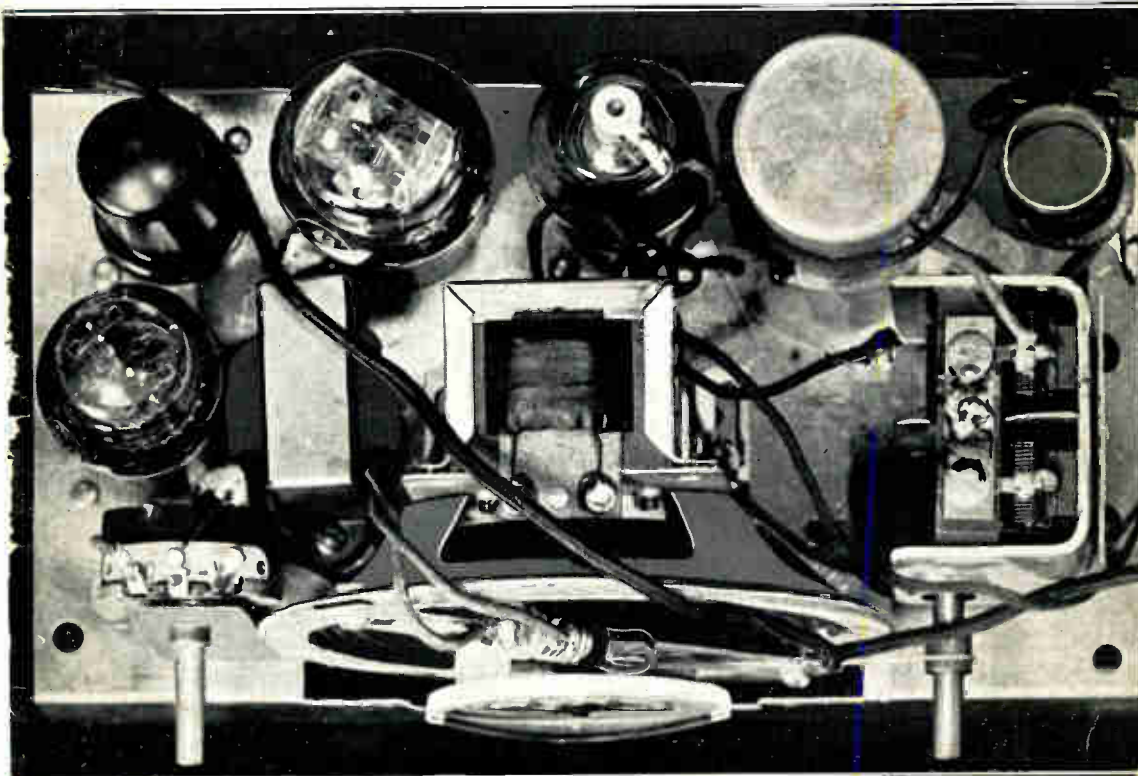

**Here is an easy four-tube set for the beginner. It is a.c.—d.c.
See page 33. Full-size blueprint is on pages 34 and 35.**

CORNELL-DUBILIER CONDENSERS

AVAILABLE AT THE
NATION'S LEADING
DISTRIBUTORS



MILES AHEAD IN PERFORMANCE

The following catalogs giving complete technical data and listing the entire Cornell-Dubilier condenser line available free on request.

- No. 127—Industrial and Transmitting Capacitors
- No. 128—Radio Condensers
- No. 129—Exact Duplicate Replacement Condensers
- No. 130—Power Factor Capacitors
- No. 131A—Radio Servicing Condensers
- No. 132A—Paper Tubular Condensers

CORNELL-DUBILIER CORP.
1024 HAMILTON BLVD.
SO. PLAINFIELD, N. J.

CORNELL  DUBILIER

I'LL SEND MY FIRST LESSON FREE

It Shows How I Train You at Home in Your Spare Time for a

GOOD JOB IN RADIO



**J. E. Smith, President
National Radio Institute**

The man who has directed the home study training of more men for the Radio Industry than any other man in America.

Clip the coupon and mail it. I will prove to you that I can train you at home in your spare time to be a **RADIO EXPERT**. I will send you my first lesson **FREE**. Examine it, read it, see how clear and easy it is to understand—how practical I make learning Radio at home. Then you will know why men without Radio or electrical experience have become Radio Experts and are earning more money than ever as a result of my Training.

**Many Radio Experts Make
\$30, \$50, \$75 a Week**

Radio broadcasting stations employ engineers, operators, station managers and pay up to \$5,000 a year. Spare time Radio set servicing pays as much as \$200 to \$500 a year—full time jobs with Radio jobbers, manufacturers and dealers as much as \$30, \$50, \$75 a week. Many Radio Experts operate their own full time or part time Radio sales and service businesses. Radio manufacturers and jobbers employ testers, inspectors, foremen, engineers, servicemen, paying up to \$6,000 a year. Radio operators on ships get good pay and see the world besides. Automobile, police, aviation, commercial Radio, and loud speaker systems are newer fields offering good opportunities now and for the future. Television promises to open many good jobs soon. Men I have trained are holding good jobs in these branches of Radio. Read their statements. Mail the coupon.

**There's a Real Future in Radio
for Well Trained Men**

Radio already gives jobs to more than 300,000 people. In 1935 over \$300,000,000 worth of sets, tubes and parts were sold—an increase of 20% over 1934! Over 1,100,000 auto Radios were sold in 1935, 25% more than in 1934! 22,000,000 homes are today equipped with Radios, and every year millions of these sets go out of date and are replaced with newer models. Millions more need servicing, new tubes, repairs, etc. Broadcasting stations pay their employees (exclusive of artists) more than \$23,000,000 a year! And Radio is a new industry, still growing fast! A few hundred \$30, \$50, \$75-a-week jobs have grown to many thousands in less than 20 years.

**Many Make \$5, \$10, \$15 a Week Extra
in Spare Time While Learning**

Practically every neighborhood needs a good spare time serviceman. The day you enroll I start sending you Extra Money Job Sheets. They show you how to do Radio repair jobs that you can cash in on quickly. Throughout your training I send you \$500 a year—for hundreds of fellows. My Training is \$500 a year—for hundreds of fellows. My training is famous as "the Course that pays for itself."

I Give You Practical Experience

My Course is not all book training. I send you special Radio equipment and show you how to conduct experiments and build circuits which illustrate important principles used in modern Radio receivers, broadcast stations and loud speaker



installations. I show you how to build testing apparatus for use in spare time work from this equipment. Read about this 50-50 method of training—how it makes learning at home interesting, quick, fascinating, practical. Mail coupon.

Money Back Agreement Protects You
I am so sure that I can train you successfully that I agree in writing to refund every penny you pay me if you are not satisfied with my Lessons and Instruction Service when you finish. I'll send you a copy of this agreement with my Free Book.

Find Out What Radio Offers You
Mail coupon for sample lesson and 64-page book. Both are free to anyone over 16 years old. My book describes Radio's spare time and full time opportunities and those coming in Television; tells about my training in Radio and Television; shows you actual letters from men I have trained, telling what they are doing and earning. Find out what Radio offers YOU! MAIL THE COUPON in an envelope, or paste it on a penny post card—NOW!

**J. E. SMITH, President, Dept. 6MM4
National Radio Institute, Washington, D. C.**

**MAIL
COUPON
NOW!**



**GOOD FOR BOTH 64 PAGE BOOK
SAMPLE LESSON FREE**

**J. E. SMITH, President, Dept. 6MM4
National Radio Institute, Washington, D. C.**

Dear Mr. Smith: Without obligating me, send the sample lesson and your book which tells about the spare time and full time opportunities in Radio and explains your 50-50 method of training men at home in spare time to become Radio Experts. (Please write plainly.)

NAME.....AGE.....

ADDRESS.....

CITY.....STATE.....

*Here's
Proof*

**Service
Manager
For Four
Stores**

"I was working in a garage when I enrolled with N. E. I. In a few months I made enough to pay for the course three or four times. I am now Radio service manager for the M— Furniture Co., for their four stores."—JAMES E. RYAN, 1535 Slade St., Fall River, Mass.

**\$10 Week
in
Spare Time**

"My work has consisted of Radio set servicing, with some Public Address Systems work—all in my spare time. My earnings in Radio amount to about \$10 a week."—WILLIAM MEYER, 705 Ridge Road, Hobart, Ind.

**Earnings
Tripled
By N.R.I.
Training**

"I have been doing nicely, thanks to N. R. I. Training. My present earnings are about three times what they were before I took the Course. I consider N. R. I. Training the finest in the world."—BERNARD COSTA, 201 Kent St., Brooklyn, N. Y.

**The Tested WAY
to BETTER PAY**

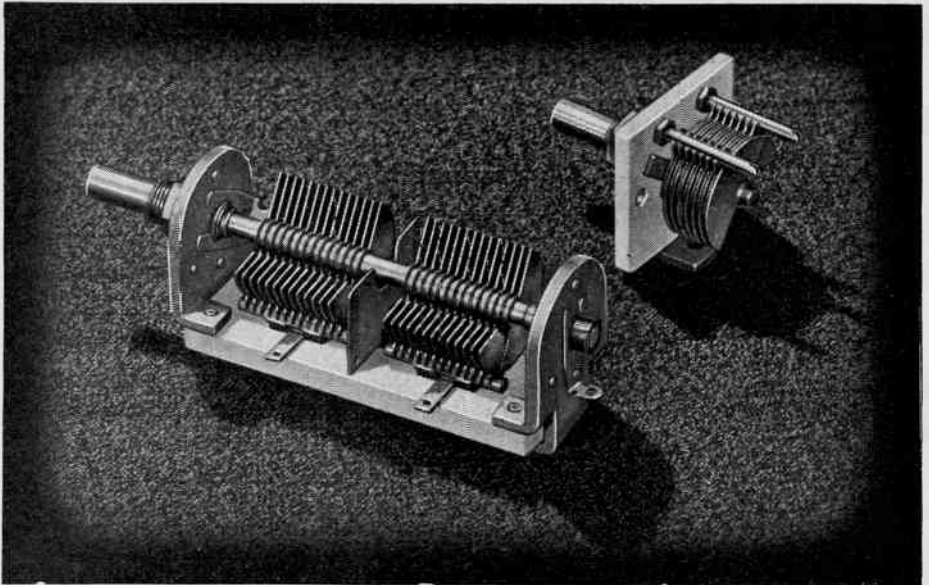

THE NEW "HF" VARIABLE CONDENSERS

A NEW series of ultra-high frequency variable condensers by Hammarlund with a score of advanced, exclusive features that will afford highest efficiency as tuning or trimmer condensers for critical ultra-high frequency work.

Single and dual types have cadmium plated soldered brass plates, and B-100 Isolantite for insulation to insure lowest losses, rigidity, and stability.

In the single unit any one of three different mounting methods may be used. One is a bracket or base mounting; another is a single hole panel mount, and the third is a panel mounting employing spacer bushings which permit complete insulation of both rotor and stator sections. The dual model has single hole panel mounting and base mounting features.

Absolutely noiseless operation is

another feature of these new condensers. For example, the dual model has a split rear bearing with individual noiseless wiping contacts for each section. Rotor contacts can be shifted to several positions via special pins to facilitate wiring with shortest possible leads. Dual model has a special shield with provisions for ground connection.

Single models available in sizes from 15 mmf. to 140 mmf. and a double-spaced 30 mmf. model. Dual sizes range from 50 mmf. to 140 mmf. with also a 30 mmf. double spaced model.

The 140 mmf. single style is only 1-9/16" high, 1-5/16" wide x 1-13/16" long (behind panel) while the 140 mmf. dual is only 1-1/2" high, 1" wide and 3-3/4" long (behind panel). Both models have 1/4" shafts.

The new "HF" condensers are the perfect condensers for your most important work!

Send for a copy of the special "HF" condenser bulletin with further details of these new units. Mail the coupon below.



**FOR FULL
DETAILS**

Hammarlund Manufacturing Co., Inc. RW-10
424-438 W. 33rd St., New York
 Check here for new "HF" condenser bulletin.
 Check here for the 1936 Hammarlund catalog.
Name

Address

**MAIL
TODAY**

HAMMARLUND'S 25TH YEAR

Now—a high powered

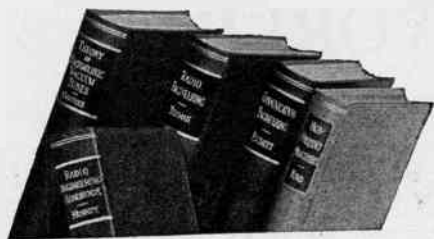

Radio Engineering Library

—especially selected by radio specialists of McGraw-Hill publications

—to give most complete, dependable coverage of facts needed by all whose fields are grounded on radio fundamentals

—available at a special price and terms.

These books cover circuit phenomena, tube theory, networks, measurements, and other subjects—give specialized treatment of all fields of practical design and application. They are books of recognized position in the literature—books you will refer to and be referred to often. If you are practical designer, researcher or engineer in any field based on radio, you want these books for the help they give in hundreds of problems throughout the whole field of radio engineering.

5 volumes, 2891 pages, 2000 illustrations

1. **Everitt's COMMUNICATION ENGINEERING**
2. **Terman's RADIO ENGINEERING**
3. **Chaffee's THEORY OF THERMIONIC VACUUM TUBES**
4. **Hund's HIGH-FREQUENCY MEASUREMENTS**
5. **Hennessy's RADIO ENGINEERING HANDBOOK**

10 days' examination. Special price. Monthly payments \$26.00 worth of books cost you only \$23.50 under this offer. Add these standard works to your library now; pay small monthly installments, while you use the books.

SEND THIS ON-APPROVAL COUPON

McGraw-Hill Book Co., Inc.
330 W. 42nd St., New York, N. Y.

Send me Radio Engineering Library, 5 vols., for 10 days' examination on approval. In 10 days I will send \$3.50, plus few cents postage, and \$3.00 monthly till \$23.50 is paid, or return books postpaid. (We pay postage on orders accompanied by remittance of first installment.)

Name

Address

City and State

Position

Company RW-9-38

YOURS FOR THE ASKING!



The latest Sylvania service booklet is off the press. Send for your FREE copy NOW!

Have you an auto radio installation or servicing business? Then you can't afford to be without this latest Sylvania Service Manual. This handy little booklet is chock-full of valuable information compiled by one of the most expert engineering research staffs in the business. And it's written in your language!

Here are just a few of the important subjects covered: Elimination of motor interference for every make of 1936 car. . . Tube complement chart for practically all models of automobile radio sets, with I.F. peak frequencies. . . Set and Antenna installation hints. . . Power Supply hints, etc. These and hundreds of other problems you will meet in auto-radio installation and servicing are covered in this amazing book.

If this book cost a dollar, you'd pay it willingly. But it doesn't cost a cent! It's yours absolutely free. All you have to do is fill out the coupon below and send it to us. You'll receive your free copy in a few days.

Hygrade Sylvania Corporation. Makers of Sylvania Radio Tubes and Hygrade Lamps. Factories at Emporium, Pa.; Salem, Mass.; and St. Mary's, Pa.

SYLVANIA

The Set-Tested Radio Tube

RW-106

HYGRADE SYLVANIA CORPORATION
Emporium, Pa.

Please send without obligation your new service book, "Auto-Radio Installation and Servicing."
 Experimenter Amateur Call.....
 Serviceman Employed by dealer
 Independent
 Member Service Organization.....

Name

Address

City State.....

Name of Jobber

Address

RADIO WORLD, October, 1936. Published monthly. Vol. XXIX. No. 7. Whole No. 697. Address, 145 West 45th Street, New York, N. Y. Subscription price, \$2.50 per annum (foreign, \$3.00). Single copy, 25c. Published by Hennessy Radio Publications Corporation. Entered as second class matter March, 1922, at the Post Office at New York, N. Y., under Act of March 3rd, 1879.

RADIO WORLD

The How-to-Make-It Monthly—Fourteenth Year

ROLAND BURKE HENNESSY
Editor

HERMAN BERNARD
Managing Editor

HERBERT E. HAYDEN
Advertising Manager

Table of Contents for OCTOBER, 1936

Sound's Status in Radio 7	Oscillator Stabilization 39
<i>Fundamental Principles — Eccentricities of the Ear</i> By M. N. Beitman	<i>Tight Coupling Helps—Compensatory Methods</i> By Brunsten Brunn
Stopping I.F. Oscillation 11	Right or Wrong? 40
<i>Squeals in Superheterodynes Cured</i> By Capt. Peter V. O'Rourke	<i>Ten Challenging Propositions and Answers</i>
Ray Indicator Tube Circuits 16	Service Bureau 42
<i>Proper Connections; Prevention of Overlap; 100- as Well as 250-Volt Operation</i>	<i>Systematic Servicing Recommended</i>
Hunting Riches by Radio 20	Tube Set of Trifling Cost 45
<i>Stern Quest for Fortunes Under Ground</i> By J. E. Anderson	<i>Beginner's Model with Wiring Aid</i> By H. G. Cisin
Infinite VTVM Sensitivity 27	Hearing-Aid Amplifiers 46
<i>Why It Exists—A Revealing Analysis</i> By Herman Bernard	<i>Battery and Universal Models</i> By M. N. Beitman
A Four-Tube Set 33	Improving Tone Quality 48
<i>Universal T.R.F. Receiver with Blueprint</i> By Jack Goldstein	<i>By Using Degenerative Circuits</i>
	Capacity from Harmonics 53
	<i>Measurement Two Ways—Inductance Also Solved</i> By Herman Bernard
	Radio Construction University 56
	<i>Answers to Questions on the Building and Servicing of Radio and Allied Devices</i>

Vol. XXIX, October, 1936. No. 7. Whole No. 697. RADIO WORLD, published monthly by Hennessy Radio Publications Corporation, 145 West 45th Street, New York, N. Y. Editorial and executive offices, 145 West 45th Street, New York, N. Y. Executives of RADIO WORLD: Roland Burke Hennessy, editor and business manager; Herman Bernard, managing editor; Herbert E. Hayden, advertising manager. Officers of corporation: Roland Burke Hennessy, president-treasurer; Roland Burke Hennessy, Jr., vice-president; Herman Bernard, secretary. Entered as second-class matter March, 1922, at the Post Office at New York, N. Y., under Act of March 3d, 1879.

SUBSCRIPTION RATE

Price 25 cents per copy. Subscription \$2.50 per year (12 issues), postpaid in United States and Possessions; \$3.00 per year postpaid in all other countries. Remittance for foreign subscription should be by International money-order (postal or express) or draft against or discountable at New York bank.

RADIO WORLD is distributed by the American News Company and its Branches

Sound's Status in Radio Fundamental Principles—Eccentricities of the Ear

By **M. N. Beitman**

Engineer, Allied Radio Corp.

THE transmission of radio telephony is directly related to sound and, from a purely analytical point of view, radio telephony serves only as a carrier for speech and music to be heard at the receiving end. In this process sound waves are converted to electromagnetic-wave variations and back to sound waves. While these processes of modulation at the radio stations and detection in the radio receivers have received considerable attention, the subject of sound, especially in view of its related importance, has received much less attention.

The physiological and also psychological meaning of sound is a sense entirely within us. It is the actual experience of sensation that we undergo. The physical meaning of sound is the existence of a disturbance in the air or other media consisting of a succession of alternate waves of compression and rarefaction that tend to travel outwardly in all directions away from a vibrating body.

From the physiological definition there would be no sound if there was no one within range to hear. But under the physical definition the smallest periodic vibration of air would constitute sound. We are interested in the creation and perception of sound as well as the actual physical analysis of sound waves.

MUST HAVE A MEDIUM

Sound must be conducted through some medium. In general solids are very good conductors of sound, but porous materials, such as cotton, sawdust, etc., are poor conductors. Liquids are better media for sound than gases. For us, air is the most useful medium for sound conduction.

The velocity of sound in air has been carefully determined. In air at 0° C. the velocity of sound is 1,090 feet per second. As the temperature rises the velocity also increases. This rate of increase is about 2 feet per second per degree Centigrade.

The velocity of sound in many other media has also been determined. In water it is approximately four times as great as in air. A table herewith gives velocity of sound in some common materials. The velocity in any medium is inversely proportional to the square root of the density. A solid having greater weight per unit volume, all other factors being equal, will



FIG. 1

Crowded lines represent condensations, the other lines rarefactions, in this analogy of the effect of sound on a medium.

have lower velocity. Velocity is also directly related the elasticity of the material. The elastic constant of any substance is the degree that substance resists deformation. Soft rubber has a very low elastic constant.

THE VELOCITY FORMULA

The velocity of sound in a solid may be expressed mathematically as:

$$\text{Velocity} = \sqrt{\frac{\text{Elasticity}}{\text{Density}}}$$

Vibrations are transverse or longitudinal. Water waves are transverse to the line motion. There is no forward movement of the water itself, but there is a rising and falling motion as the water wave advances. Any particle of water on the surface will rise and fall, but will move neither forward nor backwards. If the motion of the particle was plotted against time it would describe a curve similar to the wave. The wave itself, of course, results because a great many

(Continued on next page)

VELOCITY OF SOUND IN SOME COMMON MATERIALS

(In feet per second)

Aluminum . . . 16,700	Silver 8,770
Beeswax . . . 2,820	Steel 16,220
Brick 11,960	Tin 8,160
Glass 17,050	Wood:
Iron 16,800	Ash 15,300
Lead 4,020	Elm 13,500
Marble . . . 12,480	Fir 17,220
Platinum . . 8,810	Pine 10,880

(Continued from preceding page)

such particles move up and down in the correct order.

When a body vibrates, the air immediately in front is first compressed and then released. In this way a series of condensations and rarefactions is produced. The crowded lines of the drawing represent the condensations and the others the rarefactions. The train of waves is longitudinal, since it takes place in the direction of propagation. There is but little movement of the air forward since each pulse communicates its energy to the air directly in front.

AMPLITUDE OF VIBRATION

A simple sound wave with no harmonics or overtones present is a sine curve. The vibrating body producing this wave has simple harmonic motion. A curve representing simple harmonic motion may be constructed point by point as shown in Fig. 2. Here a point is considered as moving with uniform velocity around a circle in a counter-clockwise direction. The projection of this point on line A-B vibrates

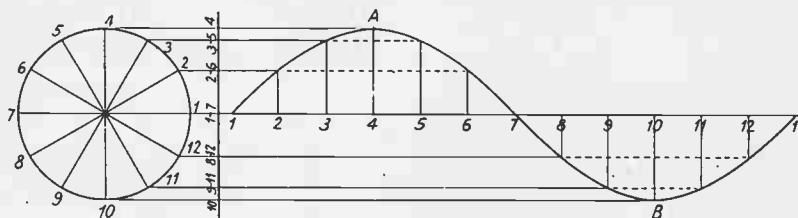

FIG. 2

Sine wave representation. This means a sound wave with no harmonics. The conversion of the graph to a circle subdivided into twelve equal parts or angles is at left.

along this line with simple harmonic motion. If the circle is divided into a number of equal divisions (12 in this case), and an equal number of units are laid off on a horizontal axis, we may consider this horizontal space as time required for the point on the circle to move through one revolution. In this case each horizontal division will correspond to the time taken for the point to pass one division of the circle. By connecting the intersections of the commonly related points a sine curve results.

The amplitude of vibration of simple harmonic motion is the maximum amount of displacement of the point from its position of rest. It is one half the extreme amount of vibration. In the curve of Fig. 2, it is the distance from the axis to points A, or B.

DETERMINATION OF CHARACTER

A cycle is completed when the point returns to its original position. A cycle, therefore, includes two single vibrations, one illustrated as the crest of the curve and the other as the trough.

The period is the time required for the completion of one cycle. It is the period of time which the vibrating body takes between two successive passings of the same point in the

same direction. The number of cycles per second is the frequency.

In considering the sine wave we have taken up only the simplest sound vibrations. Such curves may be produced artificially by means of scientific instruments, but they are rarely found in nature. Usually bodies not only vibrate as a whole but also in parts. This complex vibration creates harmonics or overtones whose frequencies are multiples of the original body frequency and whose amplitudes are considerably smaller than the original fundamental wave.

Any sound wave, no matter how complex, may be shown to be made up of a number of sine waves, one of which is the original wave and the others harmonics of this wave of different amplitudes and phases. The character of any sound depends only on three things: (1) pitch, (2) loudness, and (3) quality.

PITCH AND FREQUENCY

The pitch is the characteristic which enables us to distinguish between notes of various frequencies, the high-, medium- or low-frequency

notes, for instance. Pitch is a direct function of the frequency of the vibration. In simple and complex tones the pitch is usually determined by the fundamental frequency. In some complex tones, however, this is not the case, as shown by recent research.

The second characteristic, loudness, depends on the energy of vibration. However, our ears respond to loudness in logarithmic proportions and not in direct physical ratios. A ten-fold increase of loudness would appear to the average listener only as twice as loud. Signals of equal intensity but of different frequencies usually appear to be of different loudness.

Quality or timber of sound is the character that distinguishes sounds of identical pitch and loudness. Every one knows that the same notes played on a violin and piano equally loud will sound entirely different. This is because while both, being of the same pitch, have the same fundamental frequency, the harmonics present in each greatly differ in number and their relative intensities.

WHAT HAPPENS IN ROOM

To the radio technician, in view of greater everyday application of public address, it is important to understand the behavior of sound in

enclosed rooms. The selection of the amplifying equipment, and the placement of the microphones and speakers, are directly related to the acoustics of the location. Sounds created proceed outwards in spherical waves until they strike the boundaries of the room. Upon striking the walls, sounds are absorbed, reflected, and transmitted in varying amounts, depending on the character of the walls. Sound energy is diminished with each reflection because of the absorption, and this finally results in the sound dying out. Continuous reflection has the advantage of loudness, but always introduces pro-

are obtained when sound rises to a suitable intensity, with no echoes or other distortion, and then dies out quickly enough not to interfere with the succeeding sounds. This is a very hard condition to fulfill, but considerable departure from the ideal is not very objectionable to an average auditor.

In public address installations the acoustical conditions also directly reflect on the feedback difficulties that may be encountered. If some of the sound from the loudspeaker reaches the microphone, either through direct radiation or from reflection from walls, and approaches in

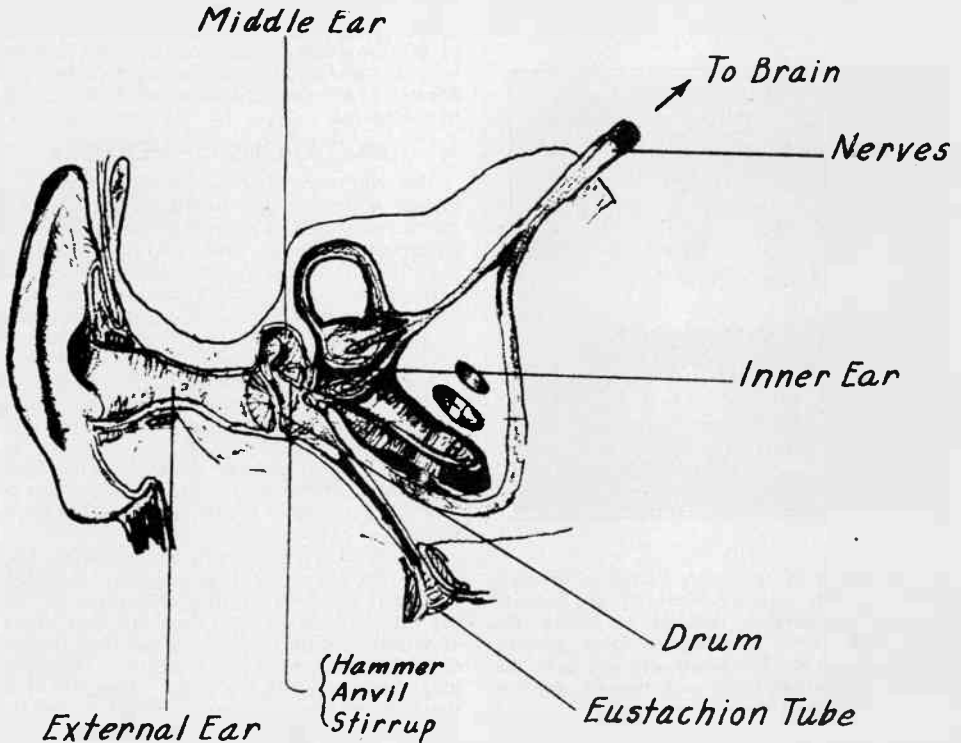

FIG. 3.

Relative positions of the components of the human ear. When the word "ear" is used in this sense it means all shown, not only the lobe that is signified in everyday speech by the word "ear."

longed existence of each sound. This prolongation, or reverberation, is the most common acoustic fault found in auditoriums.

A person talking in an auditorium having a high reverberation time can be understood only with difficulty. Each sound, instead of dying out quickly, persists for some time, so that spoken words blend with their predecessors and set up a sound mixture that produces confusion. This acoustic difficulty may be corrected by the introduction of sound-absorbing materials to reduce the reverberation time.

A HARD CONDITION

In the case of music similar, but less objectionable, effects are produced because of prolonged reverberation. Good acoustic conditions

intensity the level of the direct sound, a "hang-over" or echo effect may be produced. A further increase in intensity of the returned sound may result in a number of oscillations or a continuous, sustained oscillation. These difficulties may be corrected by placing the loudspeakers in a more suitable position, making the speakers more directional away from the microphone, or reducing the overall gain.

THE HUMAN EAR

No discussion of sound would be complete without a consideration of the human ear. The ear is an organ especially adapted to receive sound vibrations and to transform them into nervous impulses.

(Continued on next page)

(Continued from preceding page)

Anatomically the ear is divided into three separate and distinct parts. These parts are so interconnected that sound waves are transmitted from one part to the next. These parts will now be briefly analyzed.

External Ear. This consists of the external parts, including the part we commonly call the ear. There is also a short tube about one inch long along which sounds pass inwards to a sort of a drum.

Middle Ear. This small cavity lies on the other side of the membrane of the drum. By means of the Eustachian tube this cavity is connected with the throat and, thereby, the air

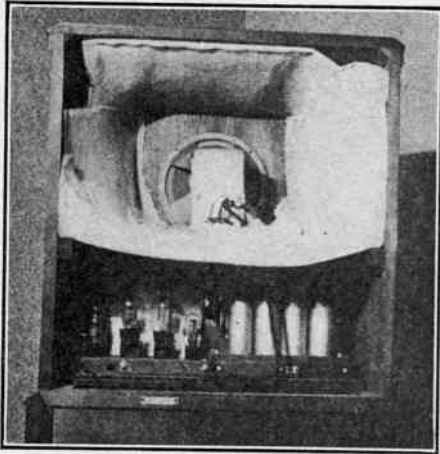

FIG. 4

The tone quality of radio sets housed in old-style highboy cabinets may be improved and cabinet resonance considerably reduced by lining the cabinet with cotton padding or other acoustic absorbing material. The lining also will have the effect of an enlarged baffle and, thereby, improve the low-frequency response.

within is under the same pressure as the air in the external ear. This arrangement releases extreme strains on the membrane between these

two sections. Stretching directly across the cavity of the middle ear is a chain of three very small bones, called the hammer, anvil and stirrup. These bones are bound together and transmit vibrations from the tympanic membrane between the external and middle ear, to the portion of the inner ear known as the cochlea.

Inner Ear. The inner ear receives the ultimate terminations of the auditory nerves and is the essential part of the organ of hearing. Without going into detailed anatomy, the inner ear may be said to consist of a system of small bony spaces and tubes within which lies a membranous labyrinth. Forming part of the lining of the membranous labyrinth are sensitive cells between which are the ending of the nerve fibers. These nerve fibers conduct the impulses to the brain.

LIMITATIONS OF HEARING

The vibrations that can be perceived by the ear lie within certain limits. These limits, of course, are subject to considerable individual differences. Usually the lowest frequency is placed at 30 cycles per second, although some persons respond to vibrations as low as 16 cycles. Below this limit, if any reaction occurs at all, it is due either to pressure sensation or the presence of harmonics.

The high limit of audibility is about 40,000 cycles. Very great variations in this connection exist in different individuals. The ability to hear high-pitched sounds also decreases with age. However, sounds of frequencies higher than about 10,000 cycles are usually overtones and are not missed except by a trained critical listener.

Considerable variation in loudness must occur before the change will be noticed. In general the ear is not a very critical apparatus. It does not discriminate well between different degrees of loudness, fails to notice small percentage of distortion, fills in missing gaps, and possesses tonal gaps and tonal islands. Tonal gaps are the failures found in some individuals to hear well or at all certain frequency ranges. Tonal islands, on the contrary, are special abilities to hear well and discriminate a fine variation of pitch in a certain frequency range.

Cornell-Dubilier to Move to N. J.

Increasing its sales over 300% for the first three months of its 1936 fiscal year, compared to the same period last year, the Cornell-Dubilier Corporation, N. Y. City, manufacturers of the C-D condenser line, have found it necessary to seek additional space far in excess of their New York facilities.

In July of 1934 it was found necessary to move the mica transmitting and molded mica divisions to an additional building at 4380 Bronx Boulevard, and in September of 1935 the laboratories and offices were moved to 4401 Bronx Boulevard.

The Cornell-Dubilier Corporation, after a most thorough search of manufacturing localities and facilities, desired to locate their new

factory in South Plainfield, New Jersey, in the foothills of the Watchung Mountains. The new plant contains approximately 210,000 square feet, 33 acres of land, and, in addition thereto, its own power plant. The entire plant will be devoted to the exclusive manufacture of condensers, and will represent the most modern and up-to-date air-conditioned facilities, says the corporation.

Both the New York plant and the Plainfield plant of the company will be operated during the remainder of the year. The moving of the 1,500 employees and officials, January 1, 1937, will be one of the largest plant removals in the Metropolitan New York area, the management stated.

Stopping I.F. Oscillation

Bad Cases in Two-Stage Systems Cured

By Capt. Peter V. O'Rourke

IN receivers using two stages of intermediate-frequency amplification there is often oscillation at this level for which formal remedies do not always prove effective. Hence some oscillatory i. f. channels were analyzed and it was found that the behavior was largely like that of a single circuit, in that a remedy was applicable at one point to all of them. Therefore the oscillatory channel may be viewed as a feedback loop, in which an audio driver may be theoretically included, because of seepage of r. f. into this tube.

When the oscillation trouble arises, it may be

due to an abundance of chassis room, these coils, if unshielded, may set up fields that interact, and therefore the "remedy" is worse than the ailment.

If one has paper dielectric condensers of high capacity, say, 2 mfd. or more, and these are put across the i. f. cathode biasing resistors the oscillation should disappear. However, this may be regarded as a relatively expensive remedy, especially as in bad cases the capacities may have to be 4 mfd. each. The voltage rating is immaterial. The lowest rating of any paper condenser would be high enough.

Circuit in which the filter of stated values was first tried. The a.v.c. was of the delayed type, derived from the diode shown unconnected. The r.f. choke inductance must be at least as high as indicated. The tube at extreme right is the audio driver.

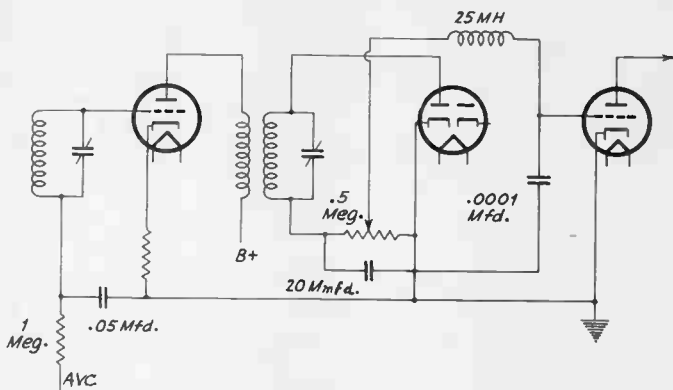

eradicated always by mistuning one or more of the i. f. transformers, but this can not be classified as a remedy, rather as a makeshift, and a poor one at that. For instance, the sensitivity probably will be lower with the two stages (three coils) than if the channel were reduced to one stage (two coils). The same applies to the selectivity. Effectively, then, mistuning is equal to or worse than the reduction to a single i. f. amplifier stage, and there is no sense in having the appearance of two stages but the performance of only one stage.

"REMEDY" WORSE THAN AILMENT

Tying the screens to a common lead may seem to invite oscillation, but it was found that the coupling in a bypassed common screen circuit always was negligible. The limiting resistance is high, usually more than 10,000 ohms, and the bypass capacity is high, usually .1 mfd. or more.

Insertion of r. f. choke coils in the plate returns, bypassing the coils of course, is an aid, but in a rather elaborate set, where there may

Reduction of the B voltage and screen voltage, by permanent insertion of resistors, also bypassed, aids, of course. But if the voltages are inordinately low the movement is again in the direction of killing the effect of the extra stage, that is, performance on a one-stage level, though visually the two stages are present. What does help, even though along the lines stated as having some disadvantages, is to put one resistor of 1,000 ohms or so in series with the B plus feed to the tuner tubes (r. f., oscillator and mixer) and do the same with a separate resistor for the common lead to the i. f. tubes, bypassing each resistor to ground with .1 mfd. Enough B current will flow under some conditions to require that the resistor be 2 watts.

WIDE APPLICATION

Search was made for a simpler and more universally effective method, and it was found at the second detector. Since the whole treatment is that of a feedback loop, the isolation at one point stops the feedback.

(Continued on next page)

(Continued from preceding page)

The basic method is shown in the diagram on page 11, but applies to the duo-diode triode, which may be a 55, 2A6, 85, 75, 6R7 or 6Q7. The 55, 85 and 6R7 have medium-mu triodes, while the others have high-mu triodes, but the principle is the same, and applies also to the duo-diode pentodes 2B7, 6B7, 6B8. Also, the system applies, whether one or both diode plates are used, and whether there is simultaneous or delayed a. v. c. or no a. v. c.

The method consists principally of keeping the radio frequencies out of the audio amplifier, and this is done by inserting a high-inductance r. f. choke, with capacities to ground. It is assumed that the triode is diode-biased, hence the diagrams reflect this condition, but the system may be used no matter how the coupling to the grid is obtained.

The circuit in which the method was first used has a 6H6 tube, only one section of which was used. Then a separate triode, 6C5, was

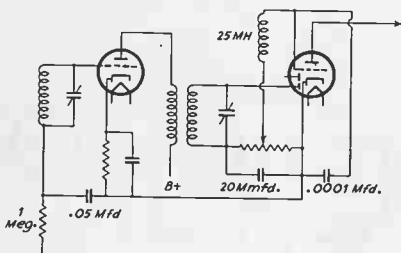

Application of the same filter to a duplex diode triode that also is diode-biased.

direct-coupled to the diode load resistor, the volume control being the arm of a .5 meg. potentiometer. When the capacity across the total of the load resistance was 20 mmfd., the choke 25 millihenries, and the terminating bypassing condenser .0001 mfd., a very bad case of oscillation at the i. f. level was cured.

RETUNING IS REQUIRED

The escape of r. f. through the potentiometer arm happened to be less when that arm was moved completely to the extreme left, for maximum quantity of sound, than at any intermediate position, because of the obstructive effect of the interposed resistance, that between arm and extreme left of the load resistor. This fact in reverse, and one other, afforded two solutions that will be discussed presently.

If the oscillation intensity is still great, the choke may be made larger, or the condensers increased in capacity, although the one permanently across the .5 meg. resistor should not be increased to much more than double the stated value.

One experiment that any one may conduct is to select a choke of high inductance, as prescribed, insert the .0001 mfd. fixed condenser, and then take any variable condenser, connect it in circuit where the 20 mmfd. is shown, and increase the capacity until the oscillation stops.

As soon as the remedy appears to have been perfected, make sure to retune the i. f. coil feeding the detector, all circuits thereof, both if there are two, all three if there are three. The capacity included across the load resistor reflects back on these tuned circuits to a degree, and the retuning must be done so that one does not make the mistake of really introducing mistuning, which is not wanted.

From the position of the rotor of the variable condenser the capacity may be estimated, since the maximum capacity condenser of the variable condenser is assumed known. If it is a straight line capacity condenser, the capacity is proportional to the angular displacement, and the minimum capacity may be neglected for this approximation. Say a 50 mmfd. condenser is three-quarters engaged, then the capacity is $.75 \times 50 = 37.5$ mmfd., and a fixed condenser of 40 mmfd. would be used permanently. Any odd capacity required may be built up by paralleling smaller capacities.

MORE FILTRATION

It is not always easy to find a supply source that stocks the small fixed capacities, but they are obtainable, since leading condenser manufacturers commonly make mica dielectric condensers of less than 50 mmfd.; in fact, Cornell-Dubilier makes them as small as 5 mmfd. If a dozen of these very small condensers are obtained, they may be combined in parallel to constitute any reasonable capacity for the present purpose.

For a little better filtration, although usually more than actually needed, the circuit may be rearranged slightly. It should be understood the i. f. level is at a fixed frequency, so it is not disadvantageous to have some small regeneration present, and it exists in many receivers with two-stage i. f. amplifiers. That is why the lesser filtering circuit was shown, but the change suggested for a more onerous case is to put the choke coil between the return of the secondary and the high side of the load resistor. That is, the circuit sequence would be: diode to one side of the secondary of the last i. f. transformer, other end of the secondary to one side of the 25-millihenry r. f. choke coil and to one side of the 20 mmfd. fixed condenser, other side of that fixed condenser to ground, other side of load resistor to cathode, the .0001 mfd. across the total load resistor.

A LITTLE MORE CAPACITY

If the circuit is arranged that way, the fixed capacity across the load resistor is its self-capacity, which under the circumstance is ratable, plus the capacity resulting from the series connection of the coil's distributed capacity and the first condenser's capacity. If these values are 8 and 20 mmfd., then the capacity additional to the resistor's self capacity is 5.7 mmfd. This is sufficient, even if the potentiometer arm is at zero, no audio signal whatever, a condition never utilized. As the arm is moved to any volume level above zero some extra capacity is introduced due to circuit conditions, or, if not enough, a small capacity is included (20 to 40 mmfd.) as shown in dashed lines.

Of course, there may be conditions which will not be remedied fully by the method outlined, because the feedback is of such a nature that it seems more or less individualized in one stage. The true condition probably is that of the theoretical feedback loop, but the intensity of the feedback is very great. Since the remedy is to short-circuit or open this loop, to destroy

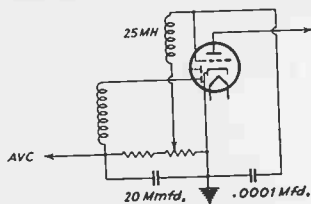

By using less than the full rectified voltage, fixed .05 meg. at left in series with a potentiometer of .5 meg., oscillation often may be curbed. This device may be used in addition to the filter, if necessary.

the impedance presented to the oscillation. Concentration on a particularly offending stage is in order.

CONCENTRATED EFFORT

It then becomes necessary to identify this stage. It does not make any practical difference that the height of the oscillation at this point is due to the presence of a feedback loop. The location may be accomplished by touching the grid of one or another suspected stage, and listening for the distinctive plop. When this is heard the stage is identified, and the biasing resistor in the cathode leg may be increased in value, the bypass condenser across it likewise increased in capacity, the overhead grid lead shielded and sheath grounded to a lug held to the coil shield with a self-tapping screw, the plate lead from this stage also made to consist of shielded wire, with sheath grounded.

Preferably all grounded points are brought directly to the ground post of the set, if fairly adjacent, or to one common point, and a thick bus then run to the ground post. This bus should constitute a wire diameter, of itself as a single lead, or because comprised of numerous strands, much more conductive than the sum of the branch conductivities.

While the cure may not be affected, an improvement is bound to result, and then the general method previously set forth is applied, or, if that has been applied first, the additional precautions certainly should eradicate all the trouble.

Once the oscillation has been removed there will be a remarkable improvement in the operation of the set. The first thing noticed is that the sensitivity to intelligible signals has been greatly increased while the noise has been decreased.

It is characteristic of an oscillatory i.f. channel that noises abound, because the channel is causing the set to operate below the noise level, *less the channel effects and shot effects of the*

tubes are brought forth with considerable volume, and because an oscillatory circuit of that type is subject to all sorts of modulation. The slightest disturbance in the ether will affect the i.f. channel enormously, as well as stray effects in the set, and static of the slightest nature becomes magnified so that most of the reception sounds like machine-gun fire.

AVOIDING A TUNING METER

When there is oscillation the entire channel is a fierce beat-note oscillator, and since the sensitivity to noise is very great, almost any disturbance in the ether is rendered audible, and there are besides the squeals for each station that lays down even a tiny fraction of a microvolt of carrier at the antenna, squeals and squawks between channels, which are quieted when oscillation is removed. The sound of tweet-tweet-tweet as one tunes from carrier to carrier may have its advantage in station-finding, but if so, the advantage must be coupled with a means of removing the beats, as they are not to be present during intended reception of the program. All beat frequency oscillators are thus controllable.

It often happens that, where the automatic volume control is even fairly effective, the carrier of a local station, or of some semi-distant station, will cause a rectified voltage sufficient to bias the controlled tubes additionally negative, so that the squealing stops when the station is tuned in on the nose. Some experimenters therefore do not object to having an i.f. channel that is very sensitive, though not oscillating, hence inter-channel noise is heard. But when the station is tuned in the noise disappears. So they use the system as a rather uncouth one for dispensing with a tuning eye (ray indicator tube) or a tuning meter. It is a fact that the carrier may be tuned in with very high precision this way, but the inter-channel noise must be tolerated then.

ATTENDED BY DISTORTION

Perhaps the viewpoint that there must be some regeneration present of sufficient magnitude to cause the inter-channel noise is not an unsound one. It will be remembered that two years ago the squelch tube was introduced. This consisted of a sharp cutoff type tube, the pentode detector usually, which received the very high voltage between channels, which voltage when rectified made the grid negative, and thus the tube was worked at cutoff between stations. Another way of stating it would be to say that the tube wasn't worked at all, but made not to work, between stations. Hence only when a station was tuned in was anything heard, and this gave the appearance of greatly heightened selectivity, which was not a reality, however.

Some distortion was necessarily introduced into the receiver because of the squelch circuit, for operation could not be at cutoff for a selected condition, and at the best operating point for all other conditions. There had to be in-between values, when though the station was heard, the squelch tube working at too

(Continued on next page)

(Continued from preceding page)

much negative bias for good quality of sound output. Any one with a sensitive ear could notice it. Of course measurements with cathode ray oscilloscope confirmed the aural observation.

While the sensitivity to interference will run high, in an oscillating i.f. amplifier, the practical sensitivity to stations is usually very low. If the station is a weak, distant one the a.v.c. voltage developed may be very small, and especially if there is delay, there may be no a.v.c. for the weak ones, hence with the noise

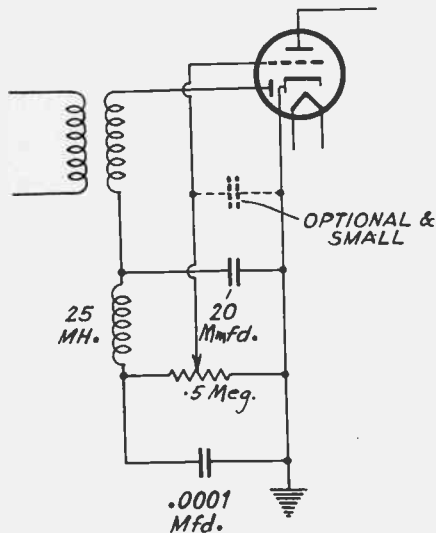

Connections for more complete filtration, if such proves advisable. Usually the extra filtering is not needed.

amplified more than the carrier or modulation, the weak stations may be heard only poorly and distortedly, if at all. Always one must expect a large amount of distortion when the i.f. amplifier is oscillating. Even regeneration introduces a little of that, but if the regeneration is kept low, then the effect on quality is not severe.

The diode-biased tube has been mentioned as one that causes some trouble. The reason is that the negative voltage developed by rectification becomes larger than the amplifier part of the tube, or separate amplifier tube, will stand. Again the plate current cuts off, or is reduced so low that the tube scarcely does more than fulfill the technical assertion that it is conducting. The object is to run sufficient plate current at all times.

A POOR MAKESHIFT

The form of distortion caused by the over-biased triode or pentode is particularly disturbing when strong locals are tuned in, because the speaker seems to choke up and all one's

concepts of tone quality seem to be offended by the performance of the set. The a.v.c. voltage is reduced to a value permitting pleasing reception by detuning slightly at the r.f. level, that is, turning the dial a bit beyond the distortion point, but it should be realized that what one is doing is to tune the set off resonance a bit, and the real object is to have resonance cleanly established. That is why tuning meters are used, or electronic devices.

ONE A.V.C. STAGE A SOLUTION

When the receiver has no a.v.c. the cutoff condition will occur frequently in the amplifier, and the distortion will be amplified in the audio channel. The solution is to introduce a.v.c. and it is recommended that it be simultaneous, that is, taken from the real second detector, and not independently, as for delayed a.v.c. Or, if there is to be some delay, at least one i.f. circuit should be subjected to a.v.c. from the regular detector second. The rest of the controlled circuits may be governed by the separate a.v.c. detector.

It has been found that a.v.c. controlling one stage is sufficient to cure the distortion due to over-biased triode, in all cases where an investigation has been made, but it is not to be assumed that the same will hold true if the amplifier tube that is diode-biased is a pentode such as is conventionally contained in the same envelope as two diode plates (duplex diode pentode). The reason is that such pentodes commonly have a cutoff point nearer zero bias than do the triodes, say, 6 volts compared to 25 volts.

THE COMPLETE RECEIVER

There is printed herewith the circuit diagram of a complete all-wave receiver, showing 6C5 not diode-biased but cathode-resistor-biased in the usual manner. This is done to give another alternative, that is, the elimination of the diode-biasing. It is not recommended particularly that such substitution of coupling be made. The constructor or service man can take this choice. There are points in favor of diode-biasing beyond the fewer parts required. But the distortion complained of does not arise in nearly such a disagreeable form, nor are the limits of operation so narrow, when the reactive coupling is used as shown in the large diagram.

In this circuit the means of stopping i.f. oscillation have not been included, since they are to be adopted only if required, and when the circuit is built it may not need this correction.

The circuit is pronounced on low notes, instead of falling off in amplitude in this region, and the presence of a very high grid resistor in the 6C5 circuit is one reason. This should be one watt. The point is to make this resistor as high as practical, and the practicality is judged by the limitations imposed by blocking, by distortion that appears after some fifteen minutes or so of set operation, and by the life of the resistor. If the troubles arise, a smaller resistor will have to be used, so try 5

meg. At all hazards 2 meg. or more should be used, and this is nearly always feasible.

VARIABLE DELAYED A.V.C.

It was not the intention to get anywhere near the noise level, so an oddity was introduced. This consisted of variable delayed automatic volume control. The a.v.c. rectifier (right) of the 6A6 had its cathode connected to the last i.f. tube, which was a.v. controlled. On weak carriers the delay equals the voltage drop in the cathode resistor of the last 6K7. On other carriers the delay is relatively removed. This is a simple method of obtaining the delay and also it works in the right direction. The method is due to Herman Bernard.

Pilot Lamp Selected On Basis of Current

Since a pilot lamp is shunted by a resistance, usually 20 ohms, and the total current is determined by the rest of the series circuit in which the heaters and the limiting ballast are located, whatever type lamp is used, within reason, does not change the circuit current much, hence does not disturb the voltage much along the rest of the branch. It is therefore on the basis of current, really, that the pilot lamp is to be selected. If a 2-volt pilot lamp as used in battery sets is inserted, resistance around 30 ohms, being across 20 ohms, the effective resistance is around 12 ohms, voltage drop $12 \times .3 = 3.6$ volts; current distribution, .12 ampere through the lamp (if this were possible), .18 ampere through the resistor. The lamp would "go."

The usual 6.3-volt type of pilot lamp will stand the full .3 ampere current, and the 20-ohm parallel resistance causes the net resistance to be around 10 ohms, so around 3 volts are applied to the lamp, and it lights dimly, but sufficiently. The 2.5-volt pilot lamp, good for around .25 ampere, reduces the effective resistance to around 6 ohms, or a drop of 1.8 volts, again causing illumination at less than full brilliance. Fullness causes dazzling, and not much illumination is needed.

It should be remembered that voltage is not the primary consideration. Will the lamp pass the current? The standard type 2.5, 3.3 and 6.3-volt pilot lamps will. Also, if more illumination is required, the 3.3 volt type lamp, capable of passing .2 ampere, may be used. Really only the 2-volt, .06 ampere pilot is ruled out. All the foregoing assumes a 20-ohm shunt resistance.

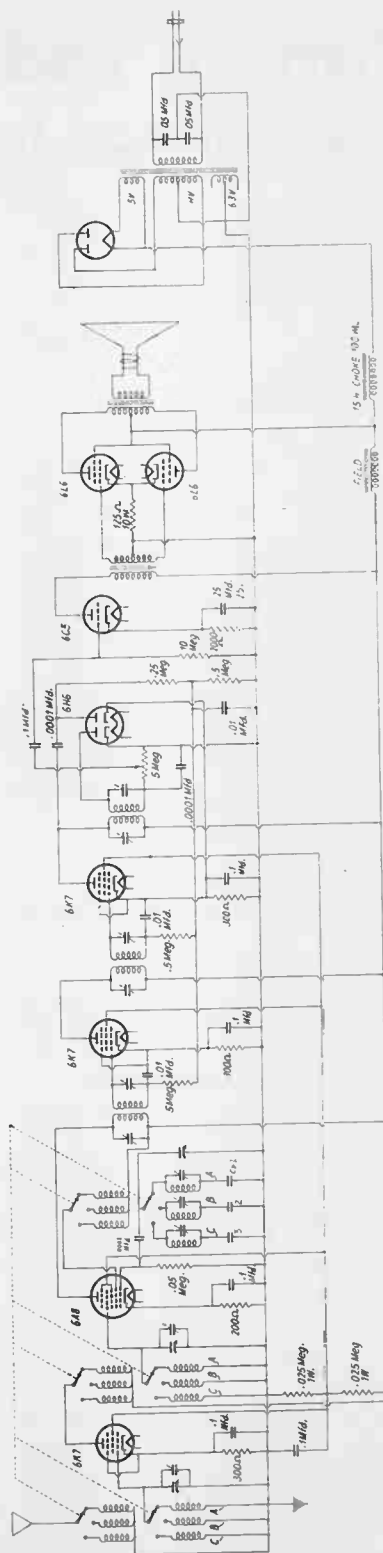

A three-band superheterodyne, using nine tubes, including the new beam tubes, 6L6, in the push-pull output. A is for standard broadcasts, B is for intermediate short waves, and C is for short waves. Cp1 is 350-450 mmfd., Cp2 is .001 mfd. and Cp3 is .003 mfd. Variable delayed a.v.c. is used.

Tuning Indicator Circuits

6E5 and 6G5 for 100- and 250-Volt Operation

THE 6E5 and 6G5 are electron-ray tubes intended for use as tuning indicators in radio receivers. Both tube types have the same external appearance and base-pin connections, but their cut-off voltages are different. This article discusses the characteristics of several practical tuning-indicator circuits that employ these tube types.

Fig. 1 shows the variations in plate current, target current, and shadow angle vs. d. c. grid voltage for the 6E5. Fig. 2 shows these relations for the 6G5. Both tube types have brilliant fluorescent areas when they are operated from either 100- or 250-volt power-supply sources. For 250-volt operation, the 6E5 cuts off at -8 volts and the 6G5 cuts off at -22 volts; for 100-volt operation, the 6E5 cuts off at -3.3 volts and the 6G5 cuts off at -8 volts. A 1-meg. resistor should be connected in the plate circuit of either tube type for 250-volt operation; a .5-megohm resistor should be used in this position when the plate-supply voltage is 100 volts.

250-VOLT OPERATION

Fig. 3 is a typical tuning-indicator circuit for either the 6E5 or the 6G5. Because the a. v. c. circuit is not delayed, the grid of the tuning-indicator tube can be connected to the a. v. c. filter, as shown. The 6E5 should be used in this circuit when the maximum a. v. c. voltage is approximately 8 volts; the 6G5 should be used when the maximum a. v. c. voltage is approximately 22 volts.

However, the fluorescent area of either tube type overlaps when the a. v. c. voltage exceeds the cut-off voltage of the tube. In the event that overlapping occurs, a resistor (R_s) may be connected as shown in order to reduce the maximum a. v. c. voltage to the cut-off voltage of the tube. The value of R_s is easily determined: a strong signal is applied and R_s is adjusted until the shadow angle is nearly zero. If the required value of R_s is low enough to

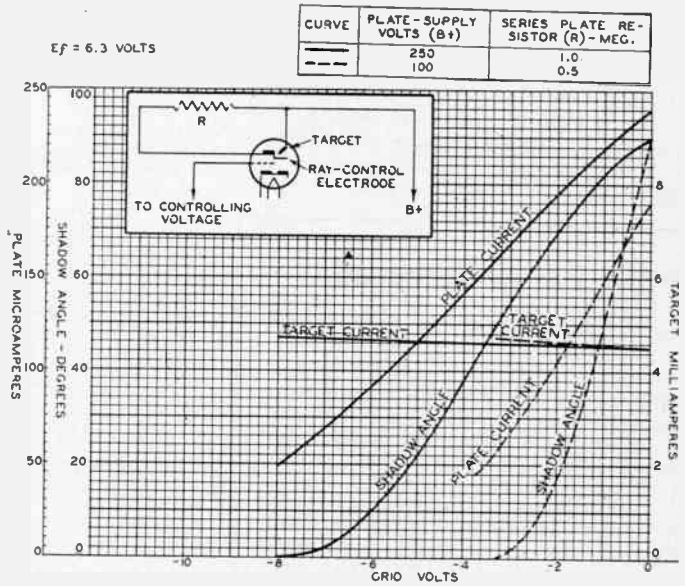

FIG. 1
Variations in plate current, target current and shadow angle, plotted against grid voltage, for the 6E5.

reduce the a. v. c. voltage appreciably, it is desirable to obtain the d. c. controlling voltage for the 6E5 or 6G5 from the audio-diode circuit. Because the audio-diode circuit must be tapped in order that the controlling voltage will equal the cut-off voltage of the tube, a separate a. f. filter is required for the tuning indicator tube. Two electrically equivalent circuits of this type are shown in Fig. 4. Either the 6E5 or 6G5 may be used with these circuits when the maximum diode-circuit voltage exceeds 22 volts; the 6E5 should be used when the maximum diode-circuit voltage is less than 22 volts.

When the a. v. c. system is delayed, the tuning-indicator tube should be actuated through its own filter by the audio-circuit. If the 6E5 or 6G5 is actuated by the a. v. c. voltage in a delayed a. v. c. system, the indicator tube will not operate until the carrier voltage at the diode exceeds the delayed voltage.

The circuit of a typical delayed a. v. c. system, with connections for the tuning-indicator tube, is shown in Fig. 5. In the event that overlapping occurs with this circuit, a resistor (R_s)

may be connected as shown in order to reduce the controlling voltage to the cut-off voltage of the tube. Resistor (R_s) does not reduce the a. v. c. voltage in this circuit.

COMBINATION USE

The 6E5 or 6G5 can be used as a combination second-detector and tuning-indicator tube when it is connected as shown in Fig. 6. The usual values of grid resistor and condenser are

a strong signal applied and then adjusting R_s until the shadow angle is very nearly zero. Thus, for strong signals, the controlling voltage is limited by the setting of the volume control. For weak signals, the volume-control setting is advanced; consequently, the audio output and the controlling voltage of the 6E5 or 6G5 are increased. When the audio amplification of the receiver is low, resistor (R_s) may be added in order to prevent overlapping at advanced set-

FIG. 2
The same relationships as were set forth in Fig. 1 for the 6E5 are given here for the 6G5. It can be seen that the negative grid voltage may be nearly three times as great for the 6G5 as for 6E5. Either tube, however, may be used in any circuit developing more than 8 volts, the 6E5 by tapping.

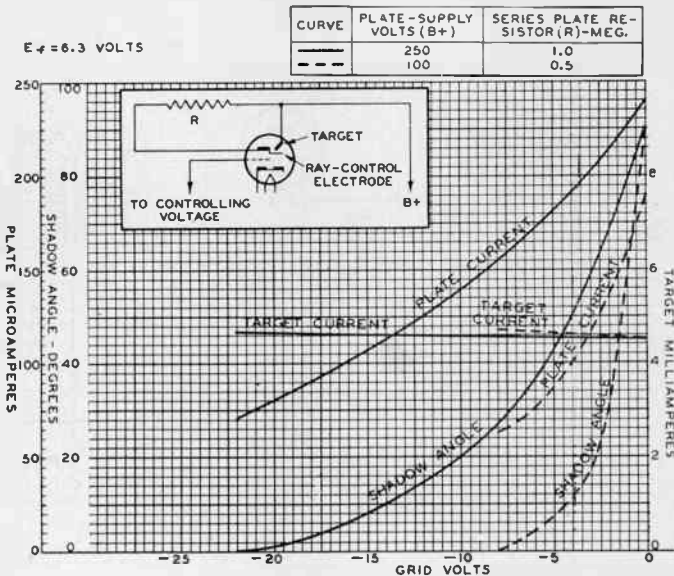

used; the audio voltage is obtained from the grid resistor, as shown. The plate and target circuit is filtered for audio frequencies to prevent the pattern from fluctuating at an audio-frequency rate.

When this circuit is used, the 6E5 or 6G5 should be placed close to the last i-f transformer. With the recommended plate-target resistance, the no-signal shadow angle is less than 90 degrees, because the initial plate-target voltage is adjusted to a low value for good sensitivity. The sensitivity is high for weak signals and decreases with increasing signal strength. An important feature of this circuit is that the edges of the fluorescent area do not overlap, regardless of signal strength, because the dc. plate current remains constant over a wide range of signal voltages. This circuit is of interest for low-priced receivers.

Fig. 7 is a circuit for obtaining high sensitivity on weak signals. The volume control is part of the diode load; the audio signal and the controlling voltage for the 6E5 or 6G5 are obtained from the arm of the volume control. Resistor (R_s) and condenser (C_s) constitute the audio filter for the 6E5 and 6G5. Resistor (R_s) is used to obtain an indication on the 6E5 or 6G5 when the volume control is in the zero-output position.

The value of R_s is determined by setting the volume control for normal audio output with

tings of the volume control. The value of R_s is determined by trial.

TAPPING THE DIODE

As mentioned previously, either the 6E5 or the 6G5 may be used as a tuning indicator when the maximum controlling voltage exceeds 22 volts. Under this condition, it is necessary to tap the diode load at the proper point for each tube type in order to prevent overlapping. When this is done, the ratio of the controlling voltage applied to the 6G5 to that applied to the 6E5 is 22/8. Thus, the 6G5 is always actuated by mere controlling voltage than the 6E5 for the same total diode-circuit voltage. Because of this voltage difference, the shadow-angle change is greater for the 6G5 than for the 6E5, as shown in Fig. 8. In this figure, one ordinate is used for both tube types; the abscissas are in the ratio of 22/8. For example, if the maximum diode-circuit voltage is 30 volts, a 6E5 would be tapped at the 8-volt point and a 6G5 would be tapped at the 22-volt point. When the total diode-circuit voltage is reduced to 7.5 volts, a 6E5 would be controlled by $8/30 \times 7.5 = 2$ volts and the shadow-angle change would be 20 degrees; the 6G5 would be controlled by $22/30 \times 7.5 = 5.5$ volts and the shadow-angle change would be approximately 52 degrees.

The total change in shadow angle from the
(Continued on next page)

(Continued from preceding page)
 zero-signal angle is not the only measure of the sensitivity of these tube types. In actual operation, the tuning dial is rocked about the resonant frequency. For this reason, the rate of change of shadow angle (tuning index) at any point on the shadow-angle curve is a good indication of the facility with which a receiver can be tuned to the carrier frequency from a nearby frequency. Fig. 8 shows the rate of change of shadow angle vs. controlling voltage for both tube types. From these curves, it is seen that the change in shadow angle for small changes

in controlling voltage is greater for the 6E5 than for the 6G5 over the major portion of the operating range. Thus, the tuning index of the 6E5 is greater than that of the 6G5 over a wide range of controlling voltages.

100-VOLT OPERATION

Fig. 9 shows the variation of shadow angle and tuning index vs. controlling voltage for both tube types when the B-supply voltage is 100 volts. One ordinate is used for corresponding curves and the abscissas are in the ratio of 8/3.3, the respective cut-off voltages of the 6G5 and 6E5. These curves show that the total change in shadow angle from the zero-signal

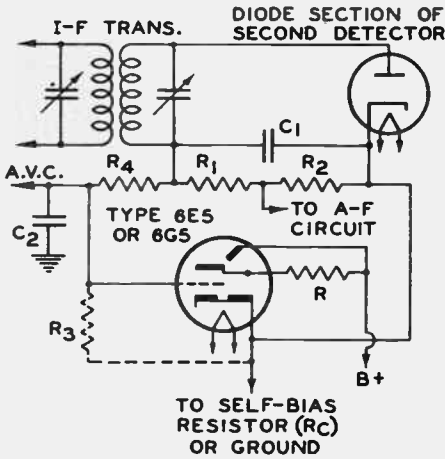

FIG. 3

A typical tuning indicator circuit. The a.v.c. is not delayed, so the grid of the ray tube may be connected to the a.v.c. filter. In dashed lines R_3 is shown, preventing overlapping.

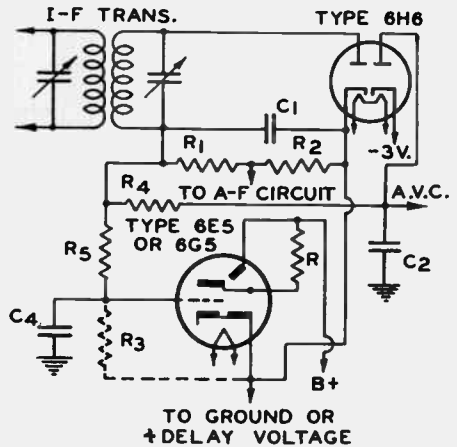
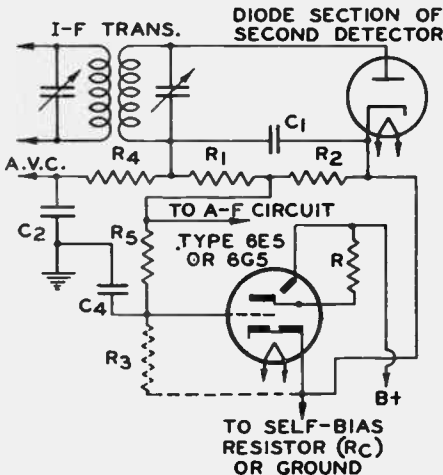
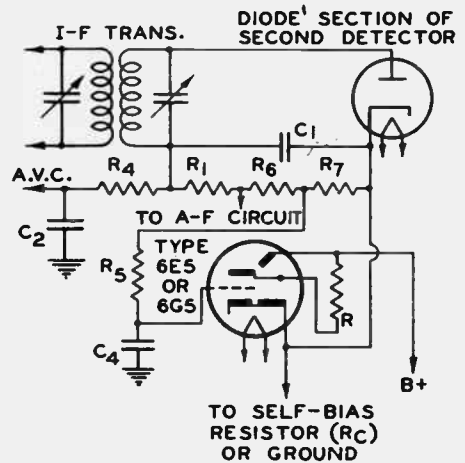

FIG. 5

Delayed a.v.c. R_3 reduces the controlling voltage to prevent overlap.



(a)



(b)

FIG. 4

Tapping of the audio-diode circuit for control voltage equalling the cutoff of the tube requires an audio filter.

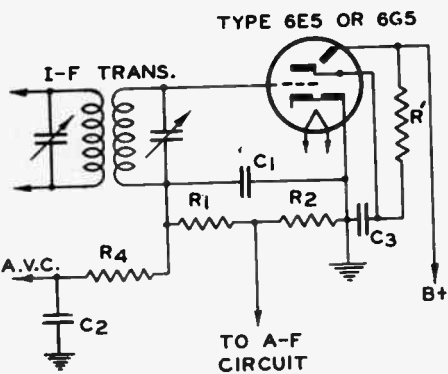

FIG. 6

Either tube as combination second detector and tuning indicator.

angle is greater for the 6G5 than for the 6E5; however, the tuning index is greater for the 6E5 than for the 6G5 over the major portion of the operating range. When the maximum diode-circuit voltage is less than 8 volts, the 6E5 should be used; either tube type may be employed when the maximum diode-circuit voltage is greater than 8 volts.

The difference in cut-off voltage between the 6G5 and 6E5 may determine which of these tuning-indicator tubes will be used in a receiver. Receivers having a large number of

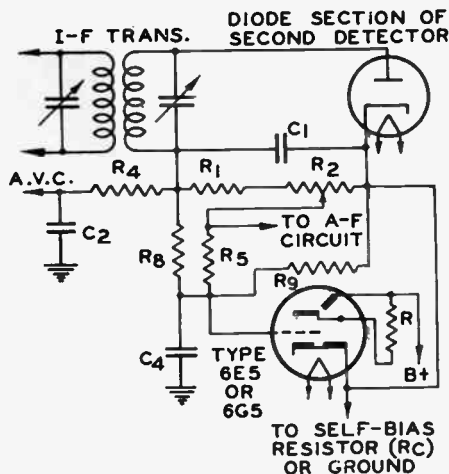

FIG. 7

High sensitivity is obtained for use on weak signals.

tubes under the control of the a. v. c. system usually develop a small voltage in the diode circuit; the 6E5 is generally suited for use in these circuits. The diode-circuit voltage may increase beyond the cut-off voltage of the 6G5 in receivers that have comparatively few tubes under the control of the a. v. c. system; in such cases, either tube type can be used.

Copyright, 1936, by RCA Manufacturing Co.

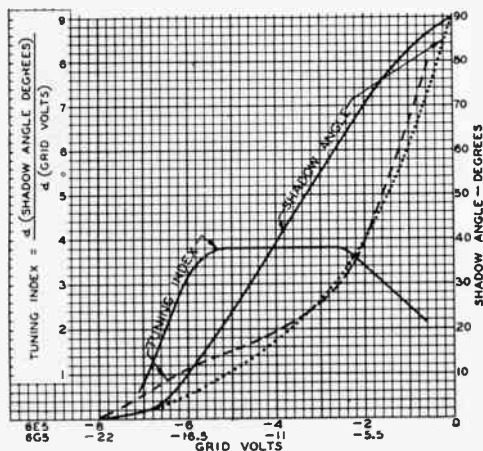
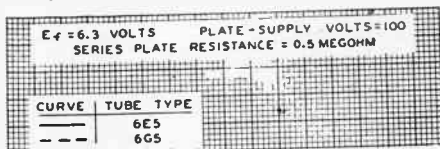
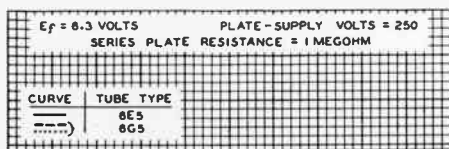

FIG. 8

Tuning characteristics of the 6E5 and the 6G5.

[See page 32 for values of constants for filters.]

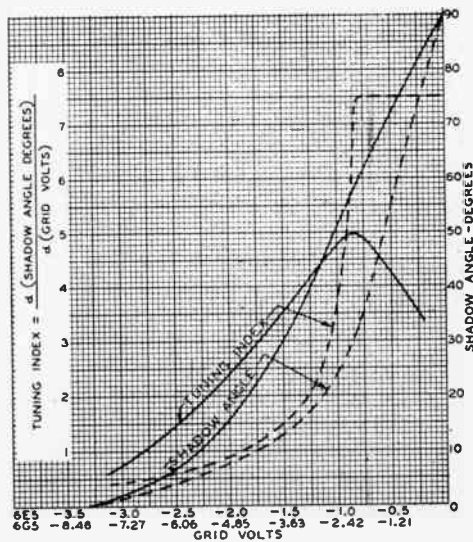

FIG. 9

Hunting Riches by Radio

Stern Quest for Fortunes Under Ground

By J. E. Anderson

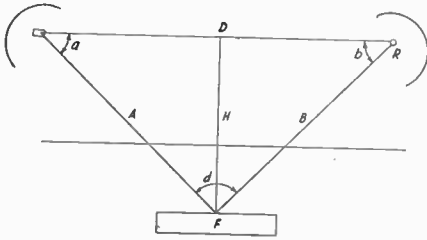

FIG. 17

This illustrates the principle of measuring the depth of a conducting layer in the ground by means of directed short wave transmission and reflection.

A METHOD devised by Conklin employs a large loop which is laid flat on the ground and supplied with high frequency currents from a spark oscillator. By means of two small exploring coils lines of equal magnetic intensities in the field within the large coil are traced and plotted. The contour of these lines is an index to subterranean formation. The two exploring coils act through a rectifier circuit on a direct current instrument.

A straightforward method of locating minerals, based on optical principles, has been devised by Deardorff. The essentials of the method are indicated in Fig. 17. T is a linear high frequency transmitting antenna placed at the focus of a parabolic reflector. The radiator is horizontal but the reflector is placed so that the radiated waves are directed downward along the beam A. R is a receiver of the same design as the transmitter and it is placed so that it can pick up waves coming along the line B. The transmitter and the receiver are placed at a known distance, D, apart. Each is mounted so the reflector can be rotated about the resonant rod as an axis.

F is assumed to be a mineral body that has different electro-magnetic characteristics from those of the surrounding earth. The electrical conductivity may be either greater or less for in either case the waves will be reflected by the body, in some degree at least. In most instances the conductivity will be greater than that of the surrounding earth, and in such cases the body will act toward the waves as a silver mirror acts toward light.

SIMULTANEOUS TURNING

If angle RTF = a , angle TRF = b , and D

The ever-fascinating topic of radio application to geophysical prospecting has been exhaustively examined by J. E. Anderson, radio engineer and former college physics instructor. The data set forth this month are entirely different from those treated last month in the first instalment.

Another instalment will be printed next month—November—and the series concluded the following month.—EDITOR.

is the distance between T and R, then by trigonometry

$A = D \sin a / \sin(\pi - a - b)$ and $B = D \sin b / \sin(\pi - a - b)$, from which the H, the distance between the line TR and the point of reflection, F, can be computed by the formula $H = B \sin a$ or $H = A \sin b$. If T and R are at the same height, H is the depth of the upper surface of the deposit to either of the instruments.

In taking observations it is necessary to turn T and R at the same time for in general the angles a and b will not be equal. They will not be if the reflecting surface is tilted. By attaching a graduated scale to the axis of each of the transmitter and the receiver, both angles can be measured accurately and the distance DF can be computed. Incidentally, this is not quite the depth of the deposit when the reflecting surface is inclined from the horizontal.

The extent of the ore body along the line joining the transmitter and the receiver can be determined to some degree by turning the transmitter, thus sweeping the line TF over it, and by finding the corresponding angle of reflection for each position of the transmitter. If the body is very extensive it may be necessary to move the receiver away from the transmitter and also to move it on the other side of it. Of course the extent as well as the depth of the ore body can be determined by setting up the dual equipment at many different points in the region to be prospected. Lines should be run in both directions, for example, east-west and north-south. The boundaries of any extensive ore body can easily be delineated in this manner.

It will be noticed that the theory assumes that the radio waves used obey the laws of optics. It is a well known fact that they do provided that the length of the wave used is short compared with the dimensions of the reflectors,

both the parabolic cylinders and the ore body. It is not necessary, of course, that the ore body be a perfect reflector. Indeed, any body that is likely to be encountered will depart greatly from a perfect reflector.

DIFFUSE AND LOSS REFLECTIONS

There will be two types of departures. One will be diffuse reflection, such as the reflection from a white surface, and the other will be loss of reflection. The reflection surface might, for example, be only 20 per cent efficient, whereas polished silver is about 98 per cent effective on light. There might also be considerable absorption loss in the non-conducting layers above the ore body. Despite all the possible deviations from ideal optical conditions, the reflected beam will follow optical laws close enough to give very useful information when applied in the manner here indicated.

In order to make the parabolic reflectors effective they can be made of tuned rods similar to the radiating rod and spaced along the parabola one-eighth of a wavelength apart or less. If the frequency used is very high the dimensions of the parabolas need not be great and the entire equipment can be made conveniently portable, or at least easily transportable.

The radiating and receiving rods, as well as the directing rods in the parabolas, will be one half wavelength long, as measured on the conductors themselves. As measured in free space they will be slightly less than half wave. The reason for this is that electric waves travel faster in free space than along the rods. The difference might be of the order of 97 per cent. Hence the tuned rods should be made about 97 per cent of the length of half a wave in free space. Provision should be made for easily tuning each rod whether it is placed at the focus of a parabola or in that parabola.

CHANGING FREQUENCY

The reason why the rods should be tunable is not only that it enables adjusting transmitting and receiving antenna to one particular frequency of the oscillator, but that it permits changing the frequency of the oscillator, still leaving the equipment adjustable to highest sensitivity.

Changing the operating frequency is desirable because the reflecting ability of ore bodies depends on the frequency to some extent. This is also true of optical and heat waves, for a polished silver surface is the best reflector of light whereas a polished copper surface is the best reflector for heat waves.

The different reflecting abilities of different conductors offers a means of determining what the underground ore body is. For any particular radio frequency employed, the received signals will be stronger or weaker according to the nature of the reflector. The frequency of the transmitter can then be changed until the strength of the received signal is greatest. The frequency at which this occurs gives an indication of the nature of the ore body.

There will always be some direct transmission from T to R, even if the best possible

parabolas are used for directing the beams. Besides this direct transmission there will be strays due to diffuse reflection.

CONFUSION AVOIDED

The total stray signal might cause confusion, especially when the desired reflected component is weak because of poor reflecting efficiency in the ore body, much diffuse reflection, much absorption in the intervening strata, and because of great depth. Therefore it is important to counteract as much of the strays as possible. This may be done by conducting part of the energy from the transmitter to the receiver by means of a transmission line. This line should itself be free from radiation, that is, it might be one of the concentric type, or shielded pair, or simply a well twisted pair. It is necessary to apply this bucking signal in the correct phase or it might do more harm than good. Therefore there should be a phase shifting device in the transmission line by means of which any desired phase might be brought about.

INTENSITY CONTROL

Also, there should be an intensity control in the line so that the right amount of bucking signal could be had. The phase changer need only have a range from 0 to 180 degrees, because the phase may be changed 180 degrees by simply reversing the leads.

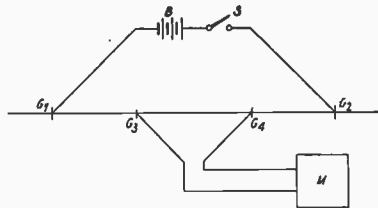

FIG. 18.

This circuit shows how electrical transient currents set up in the ground may be used for determining the thickness of strata below the surface of the ground.

The electrical circuits required for this system are not shown, but they are more or less standard for the frequencies involved. Thus for the oscillator a simple Hartley, or Colpitts, or tuned grid, tuned plate, or Barkhausen-Kurz oscillator can be rigged up, the choice depending largely on the frequency to be employed. The receiver may be a simple regenerative circuit or superregenerative. The least practical power should be used because the less power that is used the less interference will the equipment cause with other services and the easier will it be to manipulate. Medium sized receiving tubes could well be used for the transmitter tubes and the smallest available tubes for the receiver.

METHOD OF TRANSIENTS

An interesting method of exploring earth structures based on the flow of transient electricity
(Continued on next page)

(Continued from preceding page)
cal currents has been patented by Blau. The set-up is illustrated in Fig. 18. Two method stakes, G_1 and G_2 , are driven into the ground approximately one mile apart. Between these stakes is connected a high voltage battery B, the voltage of which should be around 500 volts. It should be variable so that adjustments for different distances and different ground conductivities can be allowed for. In series with the battery is a switch S by means of which the circuit may be made or broken easily.

Two other metal stakes, G_3 and G_4 , are driven into the ground between the first two stakes, and in line with them. The distance between these stakes is more or less arbitrary, but it should be considerably less than the distance between the two stakes first mentioned. The second pair of stakes should be movable so that they may be driven into the ground at dif-

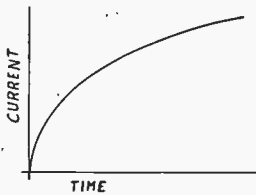

FIG. 19

The manner in which a transient current grows with time when the ground is electrically homogeneous or when there is only one stratum.

ferent positions in the G_1G_2 line and also in lines parallel to this line. A sensitive recording device M is connected to the two inside stakes. This recorder should preferably be an oscillograph which leaves a permanent record.

As long as the switch S is open no current flows. But when it is closed a current begins to flow, and its intensity increases gradually. The change in the current intensity I with time is illustrated in Fig. 19. This figure represents the growth of the current when the soil is homogeneous, or when all the earth strata affected by the battery have the same electrical characteristics. In that case there would only be one layer, electrically.

SIGNIFICANCE OF RIPPLES

When the different strata have different characteristics the growth of the current takes place about as is shown in Fig. 20. The current growth curve contains ripples, one for each rock or soil layer. The height of the ripples, according to the inventor of the method, is proportional to the depth of the rock layers. Each ripple of which the curve in Fig. 20 is made up is a complete transient, like that in Fig. 19, except that it begins at different times, at different current levels, and lasts different times.

The number of ripples recorded will increase

as G_3 and G_4 are moved away from G_1 and G_2 , in either direction and also as the distance between G_1 and G_2 increases.

In case there is a single layer, the time required for the current to build up is given by Ah/R , in which A is a constant, h is the depth of the layer, and R is the resistance of the layer.

Since the height of each ripple is proportional to the thickness, or depth, of each layer, an oscillogram will give a picture of the cross section of the geologic structure below the instruments. By moving the equipment about in the field and getting such pictures at many points systematically, the change in depth and thickness of layers can be traced in the region being explored. Thus it is a simple matter to find structures which are favorable to the deposition of minerals or the accumulation of oil. As is well known, mineral oil and natural gases occur in anticlines or dome-

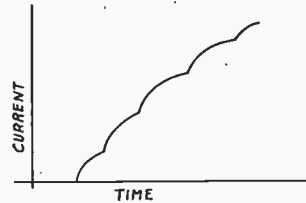

FIG. 20

When the rock strata have different electrical characteristics the transient contains ripples, each ripple being a transient in form. The depth of the transient is proportional to the depth of the layer causing it.

shaped structures of rock, provided there is a porous layer under an impervious layer of which the dome is made. A contour map of any one layer could easily be constructed from data collected with the aid of this method, and such a map would show the presence of anticlines or domes.

A method of exploring the sub-soil for conducting bodies down to considerable depths has been invented by Jakosky. The principle of this method consists of setting up penetrating earth currents between two separated points on the earth's surface and then measuring the resulting magnetic field at many points in the region affected by these currents. The field can be measured either with a bar magnet magnetometer or with a vibrating string magnetometer. The driving electromotive force in the circuit above the surface is either a direct current battery or a low-frequency generator, preferably much less than 100 cycles per second. The voltage required depends on the conductivity of the ground, the distance between the two points, and on the sensitivity of the current meter that is available.

Fig. 21 shows a section of the ground and the electrical circuit. A and B are two metal rods driven into the earth at points separated by 100 to 1,000 feet. Between these two points, above the surface, is connected a circuit consisting of a rheostat R, an ammeter A, and a battery E, or a low-frequency generator. When this circuit is closed above ground it will be completed through the ground. The flow lines of electric current will not be straight from A to B, but will be curved as indicated in the figure, ACB being one of the deeper flow lines. In an electrically homogeneous ground these flow lines will approximately follow a hemisphere.

RESULTANT FIELD

In Fig. 22 the superficial circuit and some of the points of measurement are shown. All

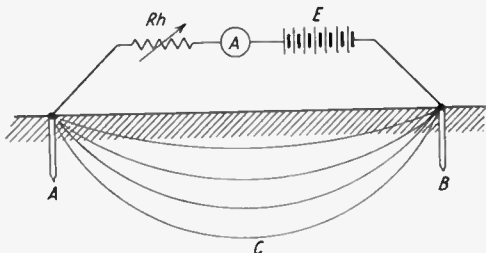

FIG. 21

Cross section of earth showing how ground is energized by means of two electrodes A and B and a circuit above the earth.

the measurements are made as nearly as practical half way between the two earthed electrodes, because here the horizontal component of the field is strongest and here it is also the most nearly uniform. Measurements are first made along the line AB and then along lines parallel to this line on both sides of the median line.

The above-ground circuit, lying on the ground, will set up a magnetic field, which is represented by a circle with its center on the ground. At the point of observation this field is vertical, and its direction is represented by an arrow pointing upward. The underground current in the opposite direction will also set up a magnetic field, and this field is represented by a circle with its center below the surface and with its circumference touching the earth's surface.

At the point of observation the magnetic force due to this field will be horizontal, and it is represented by an arrow pointing to the left. It is the resultants of these two fields that are measured at various observation points approximately half way between A and B. Since the field due to the above-ground part of the circuit can be held constant by holding the current constant, and since the intensity of the magnetic force at the surface due to the underground current will depend on the current dis-

tribution, and hence on deviations from electrical homogeneity, the intensity and direction of the measured component of the field give data from which the location and extent of the underground conductor can be determined.

The intensity of the magnetic field at any point is measured by means of the period of swing to the magnet in the magnetometer. The formula connecting the field strength with the magnet properties is $HT^2M = K\pi^2$, in which H is the magnetic field intensity, T is the time required for the magnet to execute one complete vibration, M is the mass of magnet, and K is its moment of inertia about its center of rotation. This applies to the case when the current used is d.c. When alternating current is used, a vibration magnetometer, or string galvanometer, should be used, and then the intensity is determined from the amplitude of the vibration of the string. The sensitivity of this arrangement may be greatly increased by tuning the string to the frequency used.

FIELD COMPENSATION

No matter where the receiving apparatus is set up the magnetometer will be interfered with by the earth's magnetic field. To eliminate this effect, a compensating coil is used. How this is done is illustrated in Fig. 23. A bar magnet is suspended on a thin wire so that it may swing freely about an axis through its center and at right angles to its length. Concentric with the magnet in its rest position is a compensating coil, shown at the right in Fig. 23. The current in this coil is adjusted until its field at the center of the magnet is just equal to the earth's field at that point, and opposite in direction. The compensating circuit is shown in Fig. 24. A rheostat is provided for adjusting the current through the loop and an ammeter to indicate how much current is required for the compensation. There is also a reversing switch in the circuit for convenience in changing the polarity of the compensating field when that becomes desirable.

Compensation is also required when the energizing current is alternating. If it is not done, the string of the vibration magnetometer

(Continued on next page)

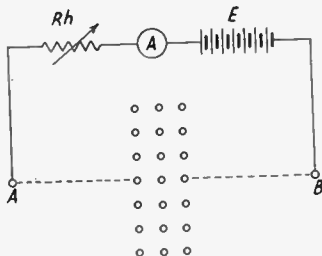

FIG. 22

Plan showing the circuit above the ground and the manner of laying out observation points half way between electrodes.

(Continued from preceding page)

will swing more in one direction than the other. That is, it will be biased.

In Fig. 25 is an illustrative plot showing how the magnetic field is affected by a buried conducting body. On the supposition that the underground currents from A to B flow in the conductor, the secondary magnetic field set up by this conductor will be at right angles to the axis of that body. This is indicated by the short lines at the observation points.

AN INDUCTION METHOD

Another method for locating underground conducting bodies was invented by Jakosky also. Fig. 26 is a section of the earth directly under a region of survey, showing conducting body having an axis OX. SS is the surface of the earth immediately above the body. AB is a Hertzian doublet placed horizontally, or parallel with the line SS in case the surface is sloping. O is a receiving loop placed so that its center

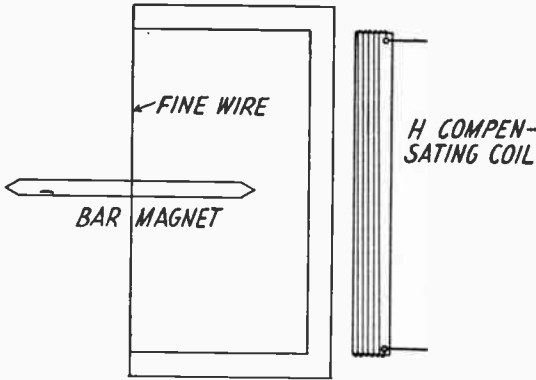

FIG. 23

An outline of the principle of a magnetometer. A magnet is suspended on a wire so that it may turn freely about it as a vertical axis. A compensating coil at right counteracts the earth's field.

is on the line AB, disposed in such direction that it does not pick up any of the energy radiated by AB.

The field B, radiated from AB and cutting the conducting body, induces currents in that body, and these currents set up a secondary magnetic field C, centering about the axis OX. Although the loop cannot pick up any of the energy coming directly from AB, it does pick up the reflected energy from X. The loop O may be turned about a horizontal axis coincident with, or very nearly so, the line of radiator AB. By tilting the plane of the loop until the intensity of the received signal is greatest, it is possible to determine the direction to the

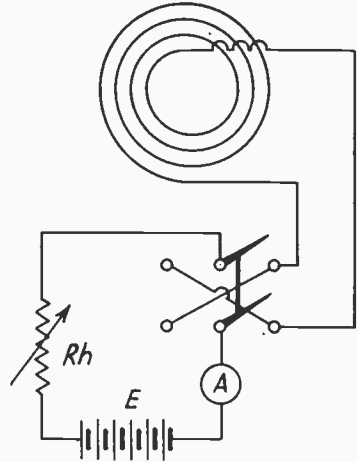

FIG. 24

Details of the compensating circuit. The loop, concentric with the bar magnet, carries a current, controlled by a rheostat. A reversing switch provides a means for changing the polarity of the magnetic field.

nearest point on the axis of the conducting body, for when the signal is strongest the plane of the loop cuts the axis of the body. If the body is elongated and its axis is not parallel with AB, it is possible to increase the strength of the received signals by turning AB as well as the horizontal axis of rotation of the loop O. Since the energizing current in the radiator AB is high frequency, the earth's magnetic field does not affect the accuracy of the measurements.

DETAILS OF RADIATOR

The radiator AB is not a simple rod as shown in Fig. 26. A more detailed illustration of it is shown in Fig. 27. The horizontal wire AB is cut in the middle, or near the middle, and the energy from the high-frequency oscillator is impressed there. To get the highest possible current in the entire length of the radiator, a balanced cross member is put at each end. These two cross members serve to increase the capacity at the ends and therefore to increase the current in the radiator proper. The two cross members will carry some current and this current would result in radiation which would be picked up by the loop O if nothing were done to compensate for the effect. Each cross member is at right angles to the main radiator, which is connected to each at its mid-point. That is, the two portions 2b and 2a are exactly equal. Currents flow in opposite directions in these two ends, and since they are equal, they cancel each other's effect on the loop.

A loop is often used for energizing the earth in place of an antenna of the type in Fig. 27. But a loop is not nearly as effective as a doublet antenna. Therefore, for the same power in the oscillator, explorations may be made to much greater depths when an antenna energizer is used in place of a loop. This is one of the main advantages of the present system.

The oscillator used in Fig. 27 may be any

The forked member FF contains the alignment sights, the line FF being parallel with the plane of the loop. In setting up the equipment at any point the radiator AB and the line FF are aligned by sighting. Although a high degree of accuracy is not required, the alignment should be approximately correct. A scale is provided on the loop for reading its inclination with respect to the vertical.

FIG. 25
Plan of a survey over a possible orebody. A and B are the grounded electrodes. At each intersection, or observation point, the measured field points to axis of the conductor.

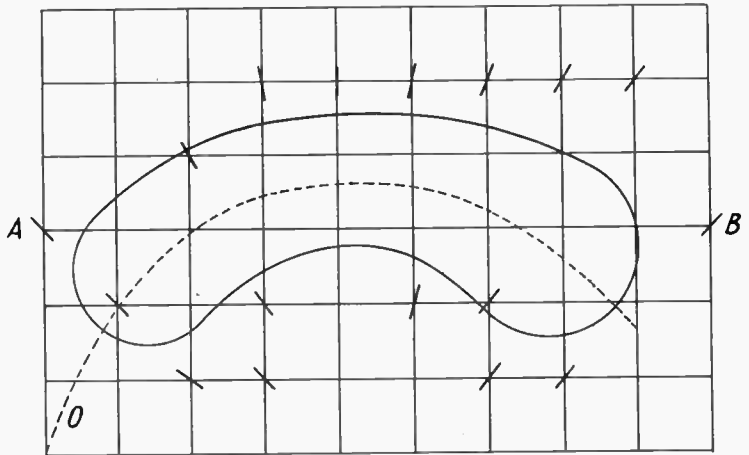

one of several well-known circuits in radio. The type is of no importance but it should be capable of sending out sufficient power to make the system sensitive. Most of the sensitivity of the arrangement, however, may be incor-

The receiver should be quite sensitive, and may be a regenerative Hartley followed by two stages of audio frequency amplification. Naturally, the signal transmitted by AB must be modulated by an audio tone.

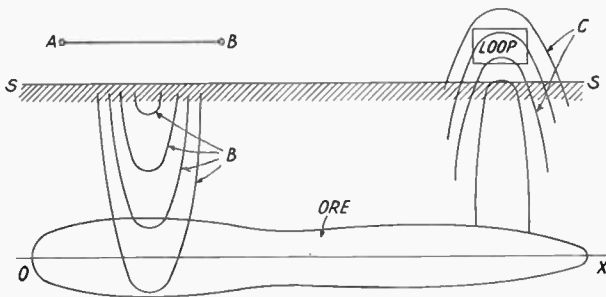

FIG. 26
A cross section of a set-up using a horizontal antenna, AB, to energize orebody OX and a loop 0 for receiving the secondary field from conductor. O is placed so that it cannot pick up signals directly from the antenna.

porated in the receiver rather than in the transmitter.

THE RECEIVER

In Fig. 28 are shown the outlines of the receiver. A loop, which is 0 in Fig. 26, is mounted on a tripod equipped with a ball and socket arrangement for turning the loop in any desired direction. A clamp holds the loop any adjustment effected.

In Fig. 29 is shown the method of taking measurements over a certain region. The field is laid out into squares by means of co-ordinate lines of any suitable separation. Every intersection is an observation point where the loop may be placed. In the figure it is placed at D. The radiating antenna AB should then be aligned so that its line produced cuts through D. When the loop is placed at some other intersection the radiator should be turned

(Continued on next page)

(Continued from preceding page)
 in that direction. This is illustrated by dotted lines.

When the loop has been turned on a horizontal axis so that the signal heard in the ear-phones is strongest, the plane of the loop points directly to the axis of the buried conductor. Thus if the loop is rotated about GG, Fig. 30, until the signal is strongest, the axis of the conducting body and GG are both in the same plane. As was suggested above, GG need not

distance between any two observation points is known, the depth H of the conducting body can be computed in terms of the angles obtained at those points and the known distance. For example, suppose that the distance between two observation points is D feet and that the inclination at the two points is θ_1 and θ_2 , then the depth is computed by $H = D / (\tan\theta_1 + \tan\theta_2)$, which gives H in feet when D is in feet. This computation should be made for many pairs of observation points in order to get a more accurate determination.

FIG. 27
 Details of the radiator AB together with its energizing oscillator. Balanced-end members are put at the extremes of the radiator to increase the radiation into the ground.

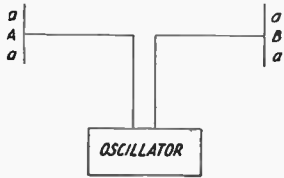

be horizontal if the surface of the earth is sloping but it should be parallel with the surface and practically coincident with the radiator. More accurate readings may be obtained by turning the loop for minimum signal, because minimum is much sharper than maximum. In either case the index which tells of the loop may be arranged so that it points directly to the axis of the ore body or other buried conductor. Fig. 31 shows the loop from another direction. The axis of rotation is G and the angle of inclination is θ . Fig. 32 illustrates how the depth of the conducting body can be determined from observations at the surface. The loop is assumed to have been placed successively at five different locations. At each point a value of θ is obtained. If then the

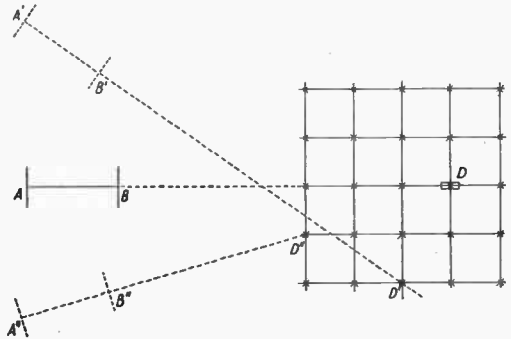

FIG. 29
 A plan showing observation points and the alignment of the radiator at each position of the receiving loop.

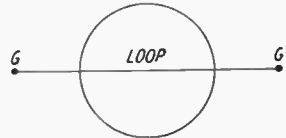

FIG. 30

The loop (right) is rotatable about the line GG, which should be parallel with the surface of the earth and with the radiator line produced. In the vertical view (below) the line is HH.

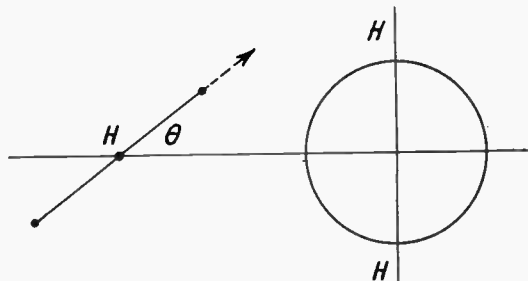

FIG. 31

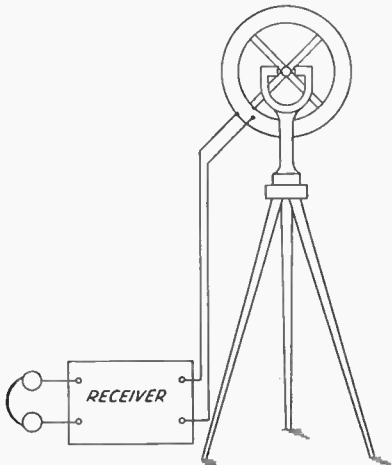
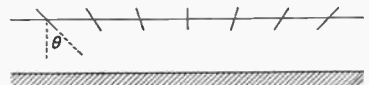

FIG. 28

The receiving loop is mounted on a tripod and is provided with sights for alignment and ball and socket for universal rotation. A sensitive regenerative receiver is connected to the terminals of the loop.



FIG. 32

Infinite VTVM Sensitivity

Why It Exists—Calibration Methods Given

By Herman Bernard

A VACUUM tube voltmeter of the detector type has practically infinite sensitivity. Therefore the sensitivity is not increased by any enlargement of the applied B voltage, in fact, may be decreased by that process; also the inclusion of an amplifier does not increase the sensitivity. This is admittedly unusual doctrine, but it is well supported by the facts.

All tube voltmeters are usually grouped into two classes: detector type and rectifier type. The detector type is a triode, tetrode, etc., so circuited that it does not draw any current from the measured input, hence operates as a plate bend detector. The grid being negative and the input volts limited to amplitudes that will maintain the grid negative, no grid current flows. The rectifier type is the one that does draw current from the measured circuit and is represented by the diode. We are confining ourselves now to the non-current-drawing type, and neglecting the tiny charging current drawn by the input capacity of the tube.

METER SENSITIVITY DEFINED

Since an electromagnetic meter is necessary to measure the plate current, which is related integrally to the square of the r.m.s. input volts, it is clear that if the B voltage is very low there will not be enough current flow to cause a sensible deflection in a 0-1 milliammeter. For instance, with a 30-tube biased by the drop in a negative-leg filament rheostat of 20 ohms, adjusted until 50 milliamperes filament current flowed, at 1.5 applied filament volts, some 12 volts on the plate were necessary to provide nearly full-scale current.

Suppose the plate were returned to the positive filament, so that no external polarization of the plate was introduced, but only the filament voltage drop of around one volt constituted the applied plate voltage, what would happen to the sensitivity of the tube voltmeter? Nothing.

The sensitivity of a meter of any type may be defined in ohms per volt as the reciprocal of the full-scale current in amperes. Suppose the tube voltmeter did draw current from the measured circuit, say, .1 milliampere, or 100 microamperes, the sensitivity would be 1/0.0001 or 10,000 ohms per volt. But if there was no current drawn from the measured circuit, then the sensitivity would be 1/0, or infinity. That is why the statement was made that the detector type tube voltmeter has practically infinite sensitivity, and the slight limitation is due to the charging current of the sum of the grid-cathode and grid-plate capacities, the theoretic-

cal close calibration limit being 10 mc, since at much higher frequencies the calibration may not hold so well, because the charging current becomes ratable. Fair accuracy to 25 mc is readily obtained.

RANGE AND SENSITIVITY

However, with reduced plate voltage we can not get any deflection on a 0-1 milliammeter, which does not mean we can not get any deflection on any electromagnetic meter. Suppose we used a 0-20 microammeter. We would get some sensible deflection. If we used a 0-10

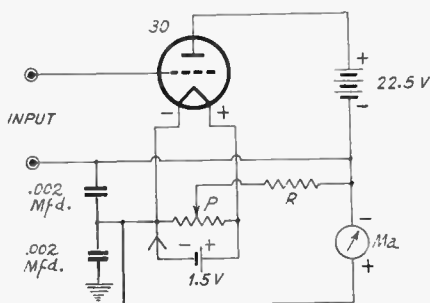

A reflexed type of tube voltmeter that dispenses with a biasing battery. A resistor in the megohm range is put across the input. R is put in series with the meter, between B minus and meter minus, and of such value that 6 ma flow, ma shunted to stand this current. Then the circuit is set up as shown, P 400 ohms up, adjusted to make meter read zero. Then a calibration is run.

or even more sensitive electromagnetic meter we would get all the deflection we needed. Therefore the thermionic, or tube, part of the tube voltmeter has a sensitivity of its own, which is the controlling one, and on which the rating depends, whereas the limitation we are trying to circumvent is that reposing in the electromagnetic instrument.

If we increase or decrease the B voltage, and negative bias proportionately, we do not change the thermionic sensitivity, since we still do not draw any current. If we increase the B voltage and negative bias, to maintain the same general operating point in terms of B current, for instance, 6 milliamperes for a 30 tube with plate voltages of 22.5 volts up, C voltages of 3 volts up, we simply adjust the input voltage

(Continued on next page)

(Continued from preceding page)

range upward. We can measure higher voltages, but we do not alter the sensitivity, unless to reduce it. The sensitivity is not related to the voltage range in the tube voltmeter.

Take the electromagnetic meter. If it has a sensitivity of 1,000 ohms per volt, that applies to full-scale deflection on any range, for the full-scale current is identical on any range, and that current alone defines the sensitivity. The voltage range depends only on the value of the limiting resistor for an electromagnetic meter of given sensitivity.

The same is true of the tube voltmeter so long as the input volts are kept below those that nearly overcome the negative bias, when rectified current will flow in the grid circuit. This current is present even if the grid is slightly negative, and enough negative bias must be supplied to cancel this quiescent current, which is comparable to the dark current in a photoelectric cell.

ACTIVE AND INACTIVE CURRENT

When this current flows the tube acts as a

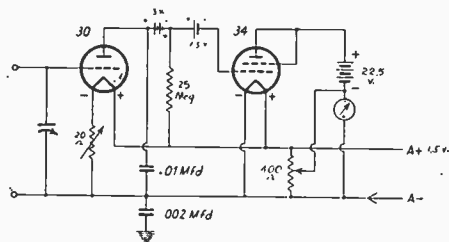

A tube voltmeter, with calibrated variable condenser and amplifier. The potentiometer balances out the dead B current through the electromagnetic meter. A switch may be used for cutting out the variable condenser, present for r.f. measurements as set forth in the July, 1936, issue.

diode and follows a different law. Cancellation of this quiescent current is assumed.

In tube practice the steady current is distinguished from the fluctuating current by calling the steady current the active current and the fluctuating current the reactive current. This does not apply to the tube voltmeter, as there is no reactive or pulsating current, only pure d.c. of various amplitudes, depending on the input volts, although one might call the dead current to be cancelled the inactive current and the live current to be calibrated the active current.

The sensitivity is not increased when the dead current is compensated, but the reliability of the calibration is improved, and somewhat lower voltages may be read. However, whether the voltages to be read are high or low has nothing to do inherently with the sensitivity, because the current drain from the source measures the sensitivity.

It may be recalled that a receiver's sensitivity is measured by determining how low an input-voltage to stated constants will cause rated

output, therefore the sensitivity of a receiver is inversely related to the input volts. That is the standard practice in receiver measurement and rating, and if the same rule were applied to a tube voltmeter, then the sensitivity of the meter would increase, the lower the voltage that can be read. But by definition it does not increase that way, for this is a meter and not a receiver, and we must rate meters the way meters are rated.

Referring again to the full-scale deflection of an electromagnetic meter, we could apply the same principle to the tube voltmeter, because we must be cautious that the full-scale electromagnetic meter reading still keeps the grid effectively negative. Again therefore the same rule that applies to one type meter applies to the other.

AMPLIFIER DIFFICULTIES

Suppose we increase the B voltage more than the relative increase in negative bias. Then more current will flow in the plate circuit and we have perhaps a current that swings a 0.1 milliammeter full-scale. We read higher input voltages nevertheless, but we do not increase the sensitivity, as that is inherent in the tube circuit. Suppose we introduce an amplifier. It is a fact that we may now read lower voltages, because the meter is moved to the output circuit, where sufficiently high B voltage, and appropriate negative bias, again provide sufficient current for the meter. In most instances all we are accomplishing is to bring the current up to a value that produces sensible response in the electromagnetic meter, but if we kept the B voltage down, almost to nothing, and had a related negative bias, still smaller of course, we would accomplish the same end with a more sensitive electromagnetic meter. Hence it is the electromagnetic meter that is the trouble source, and one is needed of much greater sensitivity than the meters one usually has at hand. However low the voltage we might read if an amplifier is included, we could still read as low without the amplifier, if we amplified the electromagnetic meter, so to speak, that is, selected one more sensitive in equal proportion to the amplifier gain, and dispensed with the amplifier.

Another factor in favor of the more sensitive electromagnetic meter is that it is practically non-reactive, and if we are to cover frequencies from a few cycles to 10 mc reliably, and even to 25 mc with good enough accuracy, we could not build an amplifier that would provide equal gain over such a very wide frequency range.

The best that the leading manufacturers of precision instruments have been able to do along that line is to provide for changing the value of load resistors in the resistor-capacity-coupled amplifier, using high values for low frequencies, medium values for medium frequencies, and small values for high frequencies. Other compensations have to be introduced as well.

LOW VOLTAGES IMPORTANT

The objection against the very sensitive electromagnetic meter is its high cost. It might

Mutual Conductance VTVM Merit Figure

That aspect of the tube that is the figure of merit in a vacuum tube voltmeter is the mutual conductance. This is defined as the ratio of small plate current change divided by the grid voltage change of opposite sign, with other voltages constant. In general, it is equal to the amplification factor divided by the plate resistance. The value is expressed in terms of mho, a coined word, ohm spelled backwards. Conductance is thus the opposite of resistance. In tube quantities, millionths of a mho are concerned, called micro-mhos.

Thus the more current the tube passes for stated applied d.c. voltages, the better the tube for VTVM use, since the less sensitive the electromagnetic meter need be for a certain input a.c. voltage, or the lower that input voltage may be for full-scale current.

The amplification factor is not of consequence, since without amplifier the plate is effectively grounded through a condenser.

be cheaper to build the amplifier and use a 0-1 milliammeter than to increase the practical sensitivity by using a more sensitive electromagnetic instrument. The best tube voltmeters do not in general use more than a total of six volts for all purposes of supplying the tube with power and bias, and the needed meter has a full-scale deflection of 20 microamperes. A little more than one volt is encompassed on the lowest range, and series resistance in the input circuit enables increase of range. The low voltages are the problem and the asset in a tube voltmeter.

So when we speak of the amplifier of a tube voltmeter circuit we are referring to something that serves more particularly as a current amplifier, and moreover we introduce the amplifier to encompass the demands of the electromagnetic meter. The thermionic meter itself remains practically unchanged.

MOST VALUABLE DEVICE

Because of the high sensitivity, and the non-reactive performance, the tube voltmeter is so valuable. It is, in fact, considered by many as the most valuable of all test equipment for radio and audio work. As a tube voltmeter therefore it even surpasses the cathode ray oscilloscope.

The circuit selection will depend on the purpose the tube voltmeter is to serve, and an assortment of circuits was printed in last month's issue.

The rectifier type, used in conventional

fashion, draws a little current, and for the low voltage range requires a 0-100 microammeter, at least. The 0-1 milliammeter affords a good calibration for 0-50 volts as the lowest range.

The voltage read on the electromagnetic meter, considering the limiting resistor as a multiplier, is equal to the average of the unknown input, hence the device is direct-reading, in the tube voltmeter sense of being self-calibrating. The r.m.s. is 1.11 times the average. Therefore it is practical to set up a half-wave rectifier type tube voltmeter, say with 50,000 ohms total, including the mean resistance of the conducting diode, and use this to calibrate a detector type.

CALIBRATION METHODS

For a detector type calibration, if one has an a.c. meter of good accuracy, it may be used for a range enabling voltage E to be read at or near full-scale, for greatest accuracy, the

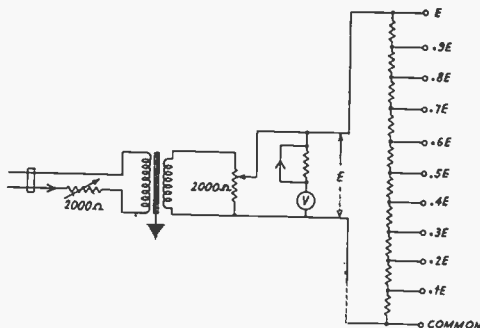

A stepdown transformer connected between the line and the voltage divider at right enables low voltage across the 2,000-ohm potentiometer. This is adjusted to a desired value read on any a.c. voltmeter V , and the output voltage is apportioned in .1-volt steps as shown. The rheostat in the primary leg acts as a vernier.

reduction being accomplished by a stepdown transformer connected to the a.c. line, and augmented by a series rheostat of 2,000 ohms, if the potentiometer draws enough current. If the voltage is reduced to a value that is a multiple of ten, and if ten equal wire-wound resistors are used at the output, the voltage E is divided into ten equal parts, or one volt each between adjoining taps, and ascending orders from one volt to 10, in one-volt steps, from the common.

From the points established, zero to 10 volts, a curve is drawn on cross-section paper, preferably log-log type, and the result will be nearly a straight line. If the detector type tube voltmeter B and C voltages are reduced proportionately, so that the one-volt input produces the same deflection as the ten-volt input formerly did, then the 10-volt curve may be used as the one-volt curve, by dividing by ten. Also, by switching, the range is changeable

(Continued on next page)

(Continued from preceding page)

from one volt maximum to ten volts maximum. The response, or change in d.c. plate current, is proportionate to the square of the r.m.s. input, or the r.m.s. input is proportionate to the square root of the plate current change. To make the meter read only changes, the dead plate current is cancelled, so the meter reads zero at no input.

PEAK TYPE

Peak volts are easily read. A diode may be used. This is practically direct-reading, but not quite, that is, check-up is advisable for a true calibration. However, the result is very

als are connected in the two possible ways. Reversing the connections and averaging the readings is one passable solution, but the departure from sine wave is usually so small that the difference scarcely can be noted when the reversal is made.

It is practical to calibrate at radio frequencies, and if a tuned circuit is used the values will be still more accurate, if one has a means of measuring well the a.c. resistance of the circuit. A certain frequency, say, around 1,000 kc, is fed to the tube voltmeter from a tuned circuit, the a.c. resistance of which is known. Since the inductive and capacitive branches of the tuned circuit cancel as react-

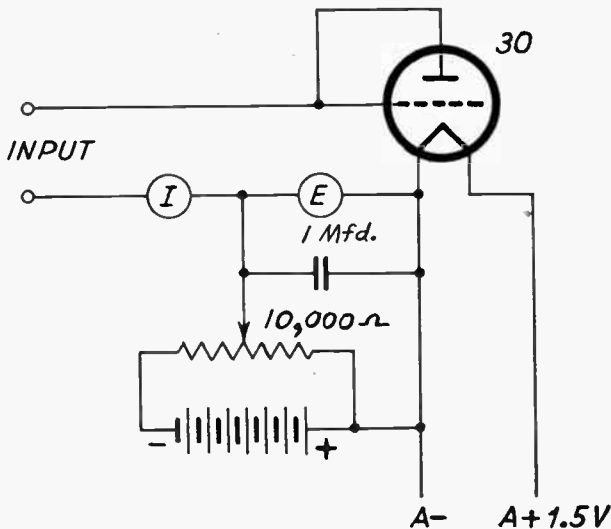

A diode slideback type tube voltmeter measures peak voltages. The electromagnetic meters are of the d.c. type, I a milliammeter or microammeter and E a voltmeter set at suitable range. The tube is merely an indicator, so the voltage is directly read at E, when the potentiometer arm is slid to restore index current.

close if some tiny current is taken as the datum, say, about half way to the first division of the meter, and then the meter reading is mechanically made zero, by closely setting the zero adjuster to make the needle read zero. Then the zero point is used, which has the advantage of eliminating the estimating.

The current meter is I and the voltmeter is E. A 10,000-ohm wire-wound potentiometer is connected across a block of dry cells, if the voltage range is high, or across a single cell, for the lowest range. The electromagnetic voltmeter is set at the range that enables the proper readings. The peak a.c. input to VTVM equals the voltage read on the electromagnetic voltmeter for return of current read at I to zero.

Peak voltmeters are of the slideback type, and include triodes, etc., as well as diodes.

LINE VOLTAGE NEAR SINE WAVE

The line voltage is used throughout the tests suggested, and is accepted as being sine wave, although it usually represents a small departure from sine wave. If there is even order harmonic distortion the peak voltmeter will give different readings when input termin-

ances at resonance, because of equal and opposite amplitude, only the a.c. resistance of the circuit is left, and the voltage is computed by Ohm's law, equalling in volts the resistance times the current, where the current is read on a thermocouple current meter. By reducing the input to the tuned circuit from maximum to the lowest value the thermal instrument and the tube voltmeter will read conjunctively, the full calibration is made.

WAVE FORM ERRORS

All the detector type calibrations are reduced to curves and then the meter scale protracted, if desired, since only the rectifier type current-drawing instrument is fully self-calibrating and independent of the presence of harmonics, whereas the peak type (slideback) is practically self-calibrating, but not independent of harmonics. Hence most tube voltmeters are subject to wave form errors. At radio frequencies, using tuned circuits, these are slight. At audio frequencies they may be serious.

An exception is the full-wave square law detector, free of wave form error, as set forth last month. This will measure small voltages,

also the change is slight, and may be ascribed to stray detection, since the tube is circuited as for best amplification, with voltages apportioned so that the operating point is midway on the straight portion of the characteristic. The differential effect prevails because no tube is truly straight line.

For the 30 tube, assuming B voltage sufficient to produce 6 milliamperes, the negative bias is selected so that just 4 milliamperes flows. The voltage ratio is about 11 to 1. The same current is established no matter what the B voltage, by changing the negative bias accordingly, the change being of course in opposite direction (more positive B, more negative C). This affords operation on the straight part of the characteristic. The current increases practically in every instance of experience, although conceivably could decrease.

The 0-1 milliammeter, if used, is shunted so that 6 milliamperes may be read, then the dead plate current is bucked out, and the shunt removed. A readjustment of the bucking device may be necessary, because of the increased meter sensitivity affording closer adjustment.

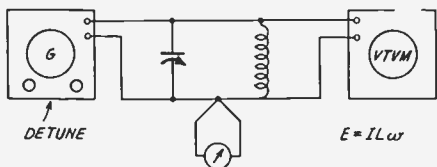

Calibration at a radio frequency has some advantages, as the VTVM reaction present at 60 cycles is practically absent at, say, 1,000 kc. The current I is read on a thermo-electric milliammeter for maximum voltage when the circuit is tuned to the frequency of generator G. Detuning G a little reduces the voltage. The symbol ω equals $2\pi f$, where π is 3.1416 and f is the frequency in cycles.

At 45 plate volts on this tube, negative bias minus 4 volts, the 6 milliamperes will flow, at 2 volts on the filament, or if 1.5 filament volts are used, no filament limiting resistor, the negative bias may be 3.5 volts for 45 plate volts. A change of one milliamperes, that is, from zero reading to full scale, represents an input r.m.s. change of roughly one volt, but calibration is necessary. Two points, near the extremes, would suffice, as on log-log paper the result is practically a straight line.

Any tube voltmeter will measure a.c. volts in any terms. The half-wave diode, in regular fashion, measures the average input volts directly, the peak volts equal 1.5708 times the average, and the r.m.s. equal 1.11 times the average. For converting r.m.s. to peaks for detector types, multiply by 1.414, or peaks to r.m.s. for slideback types, multiply by .707.

The calibration based on first determining the a.c. resistance is rather difficult because of the elusiveness of determination of that resistance, without fine instruments. A method was presented in the July, 1936, issue, and is

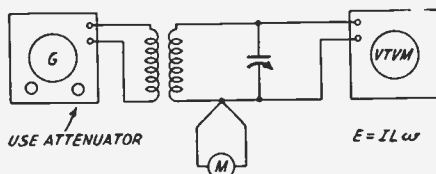

By using a primary and secondary the generator frequency need not be changed, but the generator's attenuator worked instead.

of fair enough accuracy, requiring only a 0-1 d.c. milliammeter. However, methods using a thermo-electric current meter are preferable, especially where the meter is in the inductive branch where the current is much higher, under normal conditions, and therefore the meter does not have to be so sensitive. Hence a 0-50 or 0-100 milliammeter of the thermal type has been suggested.

There are given herewith the circuits for making such measurement with the instrument, and also the formulas are included with the diagrams. In one instance it is practical to use the attenuator of a signal generator, because a transformer couples the generator's output to the tube voltmeter input, the mutual inductive coupling being constant. Methods should be avoided where coupling is made practically directly to the generator, even when through a condenser built into the generator, or where the output resistance of the generator is low, or may be low due to the setting of an attenuator used in making the measurement. The transformer method gets rid of this trouble to a sensible degree.

It has been hinted that the calibration depends on a factor, and that the calibration amounts to a determination of the factor. The type of tube voltmeter being used must be considered, and a table printed last month, classifying the various types, their effects, and their behavior, should be consulted. A curve may be run, using dry cells, to get the general curve contour, assuming 1.58 volts per fresh cell, and then usually the factor to be applied will be a constant. In some instances, as explained last month, the factor is a variable constant.

(Continued on next page)

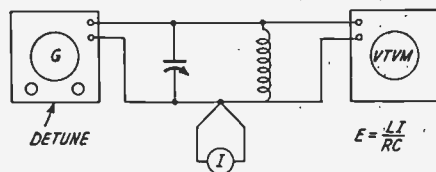

With the thermo-electric milliammeter in the condenser branch, between rotor of condenser and lower post of G, the meter would require nearly fifty times the sensitivity for a certain 1,000 kc voltage measurement, so the inductive branch method is preferable for a 0-50 or 0-100 milliammeter, and is retained. But the formula is for meter moved one step to left.

Capacity of Calibrated Condenser's Leads

IF a calibrated variable condenser's minimum capacity is rather small the capacity of the external leads may be serious, so that the capacity read is only the apparent and not the real capacity; some means would be necessary for remedying this.

It is assumed that the condenser is calibrated for the capacity at the binding posts. Therefore the effect of the capacity of the leads from the post to the unknown condenser have to be considered. This capacity is kept small enough by having these leads short as practical, and also by using the stiff wire, not of too great thickness or diameter, brought out in a line to

the left of the left-hand post and to the right of the right-hand post, then bent around to meet the terminals of the unknown condenser. For calibrated condenser minimum of 15 mmfd. or so such connection products too small a capacity to be ratable. However, the capacity of the leads may be measured, if desired, using the method described in the July, 1936, issue, which was based on fundamental and second harmonic. The generator minimum is measured, then the minimum with the extra leads as used for external capacity measuring connections, and the difference is struck. This is equal to the capacity of the leads.

CALIBRATION OF VACUUM TUBE VOLTMETERS

(Continued from preceding page)

If a complete run is made from known a.c. sources it does not matter if the constant is fixed or variable, because that is taken care of in the calibration, and it applies to the methods set forth this month. Hence the thermal instrument method, perhaps the one to be preferred, since made at radio frequencies, gives you the calibration as soon as the points for the curve are established.

In conclusion perhaps a note on the half-wave rectifier type VTVM is in order. Since each half-cycle is rectified, the question arises, is the output voltage, which is the "average

voltage," equal to $.636E/2$ or to $.636$, where E is the peak of the input voltage? If there is a pulse only once in each cycle, that is, a pulse for the positive alternation only, is not the direct current half that which would exist if there were rectification twice each cycle, one pulse for positive, one for negative alternation, other conditions unchanged, particularly the input volts arranged to be the same for full wave. The answer is that either way the d.c. is $.636$ the peak input, since whether there are one or two pulses takes on the guise of frequency, and the d.c. meter is insensitive to frequency. To accumulate, simultaneous pulses are necessary.

Literature Wanted

Readers whose names and addresses are printed herewith desire trade literature on parts and apparatus for use in radio construction. Readers desiring their names and addresses listed should send their request on postcard or in letter to Literature Editor, Radio World, 145 West Forty-fifth Street, New York, N. Y.

A. N. Loshbaugh, Welch, Okla.
 Floyd Knapp, 1522 Washington St., Long Beach, Calif., on Superheterodynes, General Catalogs.
 Blanco Y Del Valle, Laboratorio Tecnico De Radio, Vallarta 15, Mexico, D. F., Mexico.
 L. C. Warner, Kay Jewelry Company, 985 Main Street, Hartford, Conn.
 R. M. Butler, 5411 Dahlia Lane, Richmond, Virginia.
 Harry Silk, 60 Clinton Street, Paterson, N. J.
 Dave Meyerson, 7 East Gun Hill Road, Bronx, New York.
 F. R. Braune, 2605 Coyle Ave., North Town Station, Chicago, Ill.

SPECIAL CORNELL-DUBILIER CATALOGUE

A special catalogue has been issued by the Cornell-Dubilier Corporation covering the new reduced prices recently announced for their line of "Dwarf-Tiger" condensers. This catalogue lists the entire line of this series, together with catalogue numbers, and shows both the old and new price schedules. The savings shown average over 30%. This catalog, No. 132A, may be obtained from jobbers, or from the Cornell-Dubilier Corporation, 1000 Hamilton Boulevard, South Plainfield, N. J.

CONNECTION OF PRIMARIES

DOES the method of connection of primary and secondary of a radio-frequency transformer make any difference? Yes, the phase is changed 180 degrees by reversal of connections, and there are some slight incidental differences also.

VALUES OF CONSTANTS FOR FILTER CIRCUITS OF ARTICLE ON PAGE 16

$$R = \begin{cases} 1 \text{ meg. for } B+ = 250 \text{ volts} \\ .5 \text{ meg. for } B+ = 100 \text{ volts} \end{cases}$$

$$R' = \begin{cases} .1 \text{ meg. for 250-volt operation} \\ .05 \text{ meg. for 100-volt operation} \end{cases}$$

$$R_1 = .05 \text{ meg. (r.f. filter)}$$

$$R_2 = .2 \text{ meg.}$$

$$R_3 = \text{Determined by test. See text}$$

$$R_4 = \text{a.v.c. Filter Resistor}$$

$$R_5 = R_4$$

$$R_6 + R_7 = 0.2 \text{ meg.}$$

$$R_8, R_9 = \text{Determined by test. See text}$$

$$C_1 = 100 \text{ to } 200 \text{ mmfd.}$$

$$C_2 = \text{a.v.c. Filter Condenser}$$

$$C_3 = .05 \text{ to } 1 \text{ mfd.}$$

$$C_4 = C_2$$

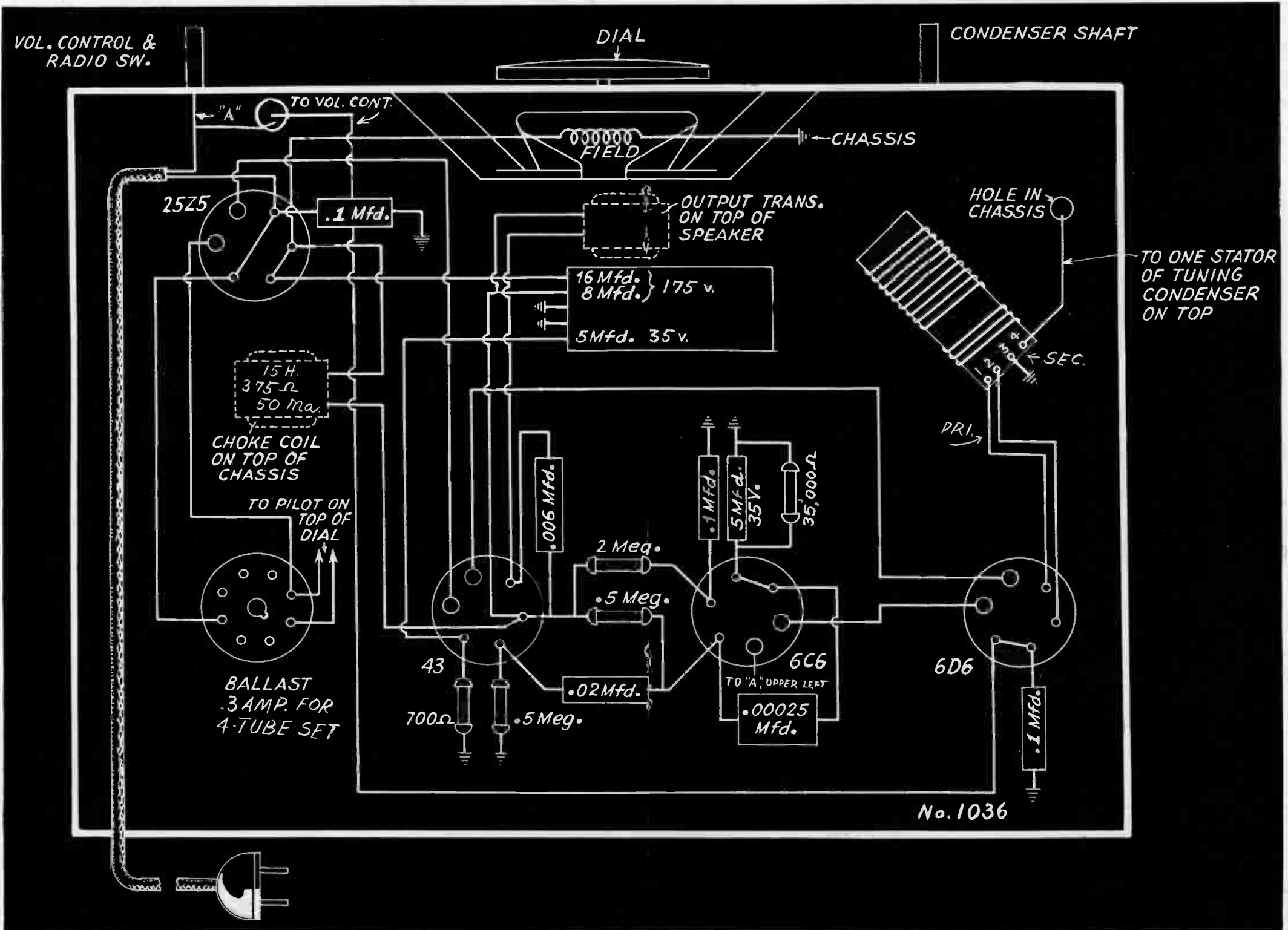

(Continued from page 33)

instead a ballast resistor in a metal tube shell. This ballast drops the line voltage suitably for the heaters and also has an extra resistance inside across which a pilot lamp may be connected.

Probably the most important consideration is that high-gain coils must be used in such a small tuned-radio-frequency set. Such coils have high impedance primaries, in the form of universal-wound coils, and are capacitatively coupled to the secondary, the condenser effect of two turns of wire around the secondary being used. This is equal to about 13 mmfd. The antenna coil is also inductively coupled, so that

be followed as they constitute vital precautions and requisites.

Without the right coils not much may be expected of such a small set. With the right coils the results are acceptable. The secondaries may have 120 turns of No. 32 enamel wire and the primaries may have one millihenry inductance for the antenna coil (inductively and capacitatively coupled) and the other primary have two millihenries, being at right angles to the secondary, capacity coupling alone used. The antenna coil has both forms of coupling, remember.

Next in importance in line with the precautionary idea is to select high-grade low-voltage electrolytic condensers. Two of them are used,

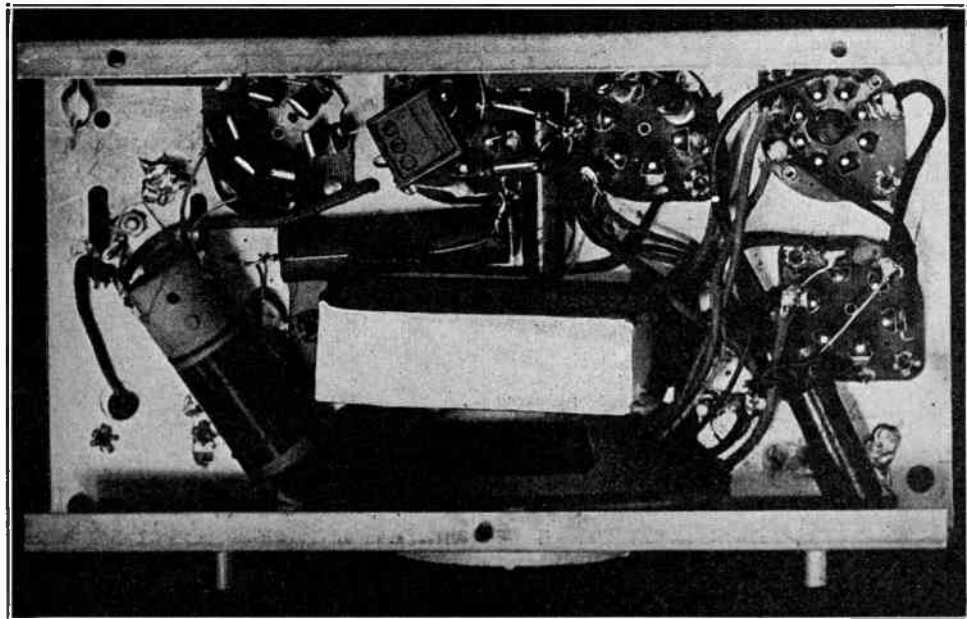

View of the bottom of the wired receiver shows literal parts location. This is not followed in all particulars in Blueprint No. 1036, pages 34 and 35, because for clarity of showing wiring it was impractical to permit superimposition of parts.

the transfer at the low radio frequencies will be good. Only the standard broadcast band is covered.

COILS NOT SHIELDED

To support the necessity for sensitivity there is no shield on the coils. Yet to prevent back coupling, the antenna coil is placed on top of a metal chassis and the interstage coil beneath. These considerations of coil placement should

5 mfd., 35 volts. Good single ones are obtainable at 30c, so there is no need to try to economize, yet if poor ones are bought because a few cents cheaper, here is what happens, in all likelihood. The leakage resistance of the poor condensers is so low that it shunts the biasing resistor and therefore reduces the effective bias. In the case of the 6C6 detector, instead of having a high resistance for bias, has a low resistance, there is very little detection, and re-

See Blueprint No. 1036 covering this circuit, on pages 34 and 35, also top view pictorial wiring on page 37.

Small Set Precautions

Note These Pointers from Expert, Profit Thereby

By Jack Goldstein

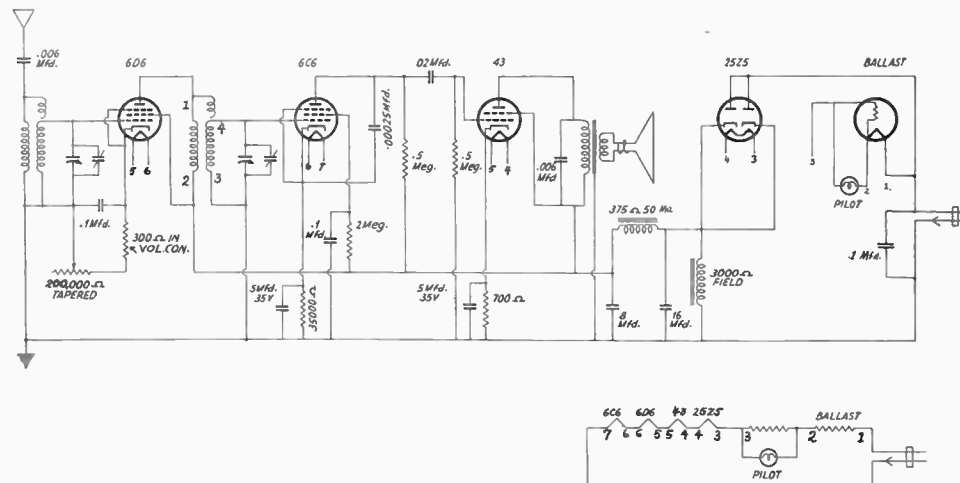

The circuit diagram of the four-tube tuned-radio-frequency set, and detail of the series connection of heaters and ballast. Note that the 6C6 detector heater is connected to one side of the line. This is a standard circuit for a midset set.

VERY satisfactory results may be obtained from a small receiver such as the one illustrated, if certain precautions are taken. The

circuit is one comprising four tubes really, the fifth object that seems to be a tube being (Continued on page 36)

LIST OF PARTS

Coils

- One unshielded high-gain antenna coupler for .000365 mfd. condenser
- One unshielded interstage high-gain coupler for .000365 mfd. condenser
- One B choke, 15 henries up, d.c. resistance not exceeding 375 ohms, and able to stand at least 50 milliamperes
- One 5-inch dynamic speaker for 43 output with built-in output transformer (ohms load 4,500) and 3,000-ohm field

Condensers

- Two .006 mfd.
- One .02 mfd.
- Three .1 mfd.
- One two-gang .00365 mfd. variable, with trimmers
- One electrolytic block consisting of one 16 mfd. and one 8 mfd., both at 175-volt; and one 5 mfd., 35-volt
- One separate electrolytic, 5 mfd., 35-volt

Resistors

- One 200,000-ohm volume control (tapered), with 300-ohm minimum, with switch attached
- One .3 ampere, 4 tube-set ballast with pilot lamp resistor built-in, contained in metal shell, like a metal tube, and similarly based
- One 35,000-ohm
- Two .5-meg.
- One 2-meg.
- One 700-ohm

Other Requirements

- One chassis, 9x5x2 inches
- One dial with pilot-lamp bracket
- Four six-hole sockets and one octal socket
- One pilot lamp
- Two knobs
- Two grid clips
- One a.c. cable and plug
- Four Sylvania tubes: one 6D6, one 6C6, one 43 and one 25Z5. (Ballast, not really a tube, listed as resistor above)

sults are most disappointing. In the power tube circuit the 5 mfd., if poor, provides poor filtration.

REASON FOR POOR DETECTION

Poor condensers will show a reading of about 5,000 ohms on the usual ohmmeter, with 1.5 volt cell, but good condensers will show a resistance around 50,000 ohms under these conditions.

So if 5,000 ohms d.c. resistance is across

ohms for the 6C6 biasing resistor was selected on the assumption of 50,000 ohms resistance of the condenser, therefore the effective resistance is 20,000 ohms, which is entirely satisfactory. The effective value is not critical, and if it turns out to be between 15,000 and 25,000 ohms results will be all right.

Now, the detector circuit has another important aspect. It has been found that the screen voltage for detection must be lower than the plate voltage. Let us consider the effective voltages, meaning those existing at the

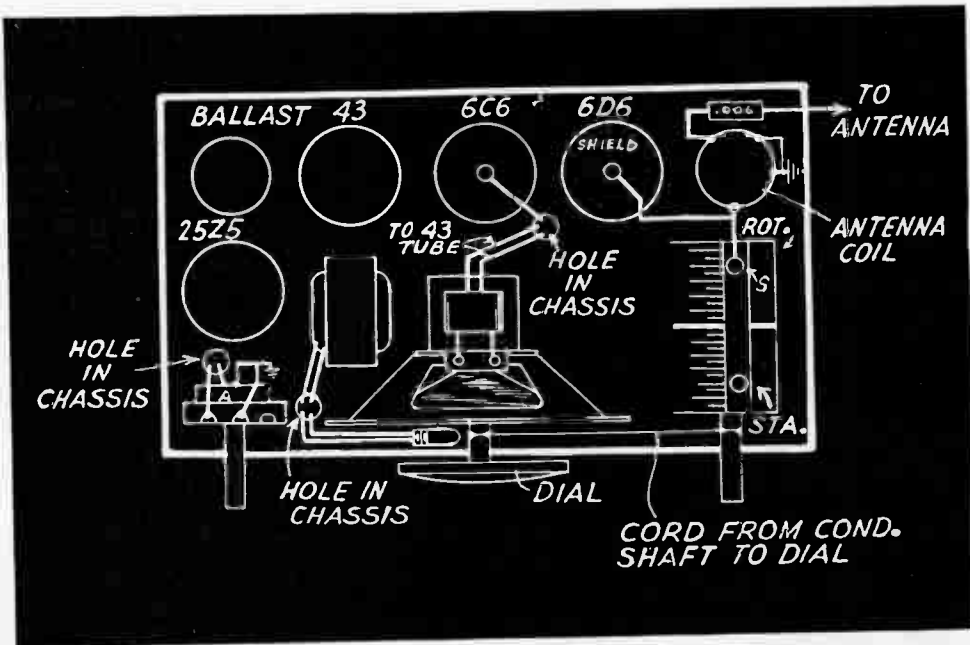

Plan of the top of the four-tube t.r.f. set. This circuit is numbered 1036 in the Radio World series carrying practical "blueprint," for which see pages 34 and 35.

35,000 ohms in the detector biasing circuit, then the effective resistance is less than 5,000 ohms, and not nearly enough. The value of 35,000

plate itself and at the screen itself, at no signal input. The plate current is about three times the screen current, so that if the plate load resistor is less than one-third the ohmage of the screen resistor, then the screen voltage will be less than the plate voltage. Both resistors are assumed to be properly high. This voltage condition will obtain throughout operation, since the two currents are in phase, and the proportion thus holds in the right direction. So the screen voltage-dropping resistor is more than $3 \times .5$ meg., and 2 meg. therefore suffices. Since the resistance is so high, the condenser across it need not be so large, and .1 mfd is sufficient, although higher capacity may be used with somewhat better low-note reproduction. Use paper dielectric rather than electrolytic condensers.

How to Determine What Length Antenna to Use

The antenna length for the four-tube receiver will depend on one's location. For use in cities where there are several broadcasting stations, or more, an indoor antenna, consisting of 20 feet of wire, will prove sufficient.

If one lives in a rural district he may use a longer aerial, even an outdoor one. The longer and higher the antenna, the less the practical selectivity. Therefore where selectivity considerations are not paramount the antenna may be of greater dimensions.

WHY THE DIFFERENCE?

The little set includes speaker, and naturally there will not be sufficient baffle area to enable full realism of low notes, therefore the higher
(Continued on next page)

(Continued from preceding page)

condenser across the screen resistor has been mentioned, also it will be found a .006 mfd. condenser across the primary of the output transformer reduces the accentuation of the high-pitched audio notes. This is to the same point as increasing the low note response relatively. When these two precautions are taken the set will be found to have good audio characteristics, all things considered. The detector plate bypass condenser of .00025 mfd. helps just a little to the same end.

Probably the reader wonders why a condenser of .00025 mfd. is considered large enough at the detector plate, whereas a capacity 24 times as great is used across the primary of the output transformer, and yet both condensers are said to work properly in the desired direction.

In the detector circuit the main purpose of the condenser is to bypass radio frequencies, as none of these is wanted in the audio amplifier (43 tube). The resistance load on the plate is .5 meg., and assuming the operating plate resistance is the same, the condenser is effectively in parallel with .25 meg. The time constant of a circuit is equal to the capacity in microfarads multiplied by the resistance in megohms. The product in this case is $.00025 \times .25$ or .0000625. The frequency in cycles is equal to the reciprocal of the time constant, or $1/0.0000625 = 16,000$ cycles. Since the lowest radio frequency is 530 kc, and the arrangement bypasses frequencies higher than 16,000 cycles, the impedance is extremely low to radio frequencies, practically a short circuit, yet since the audio frequencies above 7,500 cycles are not to be expected or even sought, these are passed, for the impedance to these lower frequencies is high. However, the cutoff not being sharp by any means, there is some attenuation of frequencies even below 10,000 cycles, hence a relative increase of low-note response is present, although not to a marked degree, of course, so far as this particular circuit is concerned.

THE OUTPUT CIRCUIT

Considering, however, the primary of the output transformer, this may be regarded as a resistance for the present discussion, and is a low resistance. The more accurate way of stating the case is to call the impedance to radio frequencies low. It will be remembered that the impedance is that factor that considers all the limitations upon the alternating current, e.g., resistance, which is constant, and reactance, which depends on capacity and inductance. The capacity reactance must be low if the reactance due to the inductance is low, for the desired effect to prevail. Considering, then, the primary as equal to a resistance of, say, 3,000 ohms, time constant would be $.003 \times .006$ or .000018, representing a frequency of $1/0.000018 = 6,000$ cycles. Therefore notes of 6,000 cycles and higher are attenuated, but since the effect is not sharply defined, but spread out, therefore much greater attenuation of higher audio tones is introduced, and the higher in frequency they are the more they are reduced. As stated, reduction of high-pitched notes is necessary in such a circuit.

Detector Heater to Line Bars Modulation Hum

Even in a small set that does not provide possibilities of large baffle area the hum may be considerable, unless proper precautions are taken. The diagram of the four-tube receiver shows a 16 mfd. condenser next to the 25Z5 rectifier, and this or larger capacity should be included. However, 16 mfd. turned out sufficient.

Another consideration in respect to hum has to do with the way the detector heater is introduced into the series circuit. It is imperative that one side of the 6C6 heater be connected to the line, as shown in the diagram, otherwise there may be severe cases of modulation hum. That is the kind of hum absent when no station is tuned in, but heard as soon as the station is heard. It is due to hum in the detector cathode mixing with the station carrier, getting detected and amplified, and being then of course objectionably audible in the speaker.

A further precaution, shown in the diagram, is that a series condenser be connected in the antenna circuit. This is a safety measure, to prevent accidental shorting of the line if the antenna externally should become grounded. No external ground is to be connected to this receiver, neither to the chassis nor anywhere else. There is, however, sufficient automatic grounding through the line, one side of which goes to chassis.

For satisfactory control of the volume the 200,000-ohm rheostat should be tapered. Reverse the terminal connections to the potentiometer if there is great criticalness of adjustment of this control, as then the potentiometer is simply being worked backwards.

SPEAKER BEHIND DIAL

The little speaker has a frequency-calibrated dial in front. A string, with a small spring in series, acts as the belt, so when the condenser shaft is turned, the dial at center is actuated. The string is knotted to the setscrews on the condenser shaft and dial hub. Behind the dial is a pilot light, therefore the dial scale should be translucent.

The metal chassis is standard for such small sets. So is the speaker, which has 4,500 ohms primary impedance, and contains, besides the output transformer, a 3,000-ohm field coil that is connected directly across the line. Additional filtration is supplied by a low-resistance B choke, 375 ohms being the measured value of the one used, and the inductance equalling around 15 henries, but may be less. However, the filter condenser next to the 25Z5 rectifier must be 16 mfd., not less, to avoid hum.

Oscillator Stabilization

Tight Coupling Helps—Compensatory Methods

By Brunsten Brunn

MANY ways have been found for stabilizing the frequency of vacuum-tube oscillators. One of these is to use very close coupling between the plate and the grid windings. If the coupling could be made unity the stability would be complete if it were not for the resistances in the circuit having an effect on the frequency. These, however, are small and it may be said that when the coupling is unity the stability is practically complete. Unfortunately, unity coupling between the grid and plate coils is not easily obtained. It cannot be attained even in audio-frequency transformers, where a high permeability core is used. Still the fact remains that the tighter the coupling between the windings the greater is the stability.

There is one way of getting unity coupling in effect and that is to utilize condensers to aid the mutual inductance. Condensers used for this purpose, however, lead to very complex circuits and there are better ways of getting frequency stability than by unity coupling.

COMPENSATION UTILIZED

It has been shown in technical journals that the frequency of an oscillator can be stabilized by means of reactances in the plate or grid circuit, or in both circuits. One of these methods is the simplest to apply and it always works provided that the frequency is not so high that the tube's interelement capacities play an important part. Of course, it is quite feasible to employ both these methods of stabilization, that is, both tight coupling between the grid and the plate windings and reactance compensation.

In grid circuit stabilization a certain reactance is put in the grid circuit to compensate for any reactance there may be in the plate circuit, or for any reactance of the wrong kind that may be in the grid circuit already. For example, suppose that the oscillator is of the tuned-grid type. There is a condenser in the circuit next to the grid. There is also a grid condenser in most circuits. This condenser is a reactance of the wrong kind, for the proper stabilizing reactance is that of a coil. In this circuit also there is a coil in the plate circuit, the tickler. This should be offset by a condenser in series with it, and it should be of such a value that it tunes the primary to the frequency of the oscillator. Of course, if a condenser is put in series with the tickler, the plate has to be fed through a choke or a resistor. This complicates the circuit.

Instead of putting the condenser in the plate circuit, it may be put in the grid circuit and it will have nearly the same effect. The value would not be the same, however.

WHY CONDENSER DOES TRICK

The reason that a condenser in the grid circuit may be substituted for a condenser in the plate circuit is that a condenser produces the same kind of phase shift no matter where it is placed in series with the signal. Thus the usual grid condenser in a tuned-grid oscillator may be a stabilizer, where as if the plate circuit were treated correctly, the grid condenser would make matters worse, since a coil would be called for.

The tuned-plate oscillator is easily stabilized by means of a coil in the plate circuit and a condenser in the grid circuit. The coil should have the same value as the tuning coil across the condenser. Since the coil is not changed, the stabilizing effect of the plate coil remains the same for all frequencies to which the circuit may be tuned. The grid stopping condenser should have the same value as the tuning condenser, assuming that the primary and secondary inductances are equal. But this requires a variable grid condenser if the frequency of the oscillator is variable. The variable grid condenser could be placed between the grid coil and ground so that a dual condenser could be used for tuning.

NEEDS GRID CURRENT

The grid stabilizing condenser is effective only if grid current flows. There will be grid current, as far as stabilization requirements are concerned, if there is a grid leak directly from the grid to the cathode. If no grid current flows the grid condenser is not required for stabilization. It is possible to operate an oscillator so that no grid current flows provided no grid-cathode resistor is used. But to do so requires careful adjustment of the coupling between the coils, the value of the L/C ratio is the oscillator, the plate voltage in relation to the bias, and also the filament voltage.

There are also several "brute force" methods of improving the stability of the frequency of an oscillator. One is to make certain that the L/C ratio in the tuned circuit is low. With a large condenser and a small coil, even an un-stabilized circuit is fairly constant in frequency. With a large L/C ratio, it is difficult to sta-

(Continued on next page)

Right or

QUESTIONS

- 1—A certain type tube draws grid current unless the grid is biased more than 0.8 volts negative. If this tube is diode-biased in an amplifier following a detector, it always draws grid current.
- 2—A high-gain type of coil is used for increasing the gain on the low radio frequencies, and it is designed with this object in view. Such a coil will increase the selectivity of the circuit at low radio frequencies and decrease at the high.
- 3—An output tube is operated at its optimum adjustment, that is, its plate voltage is the maximum permissible, the load on the tube is designed for greatest undistorted output, the bias resistor has the right value. By adding another tube of the same type in parallel, no other changes, the output of the circuit is greatly increased.
- 4—If a superheterodyne is made to track at two frequencies, say 600 kc and 1,450 kc, it will also track at a frequency about half way between these two provided that the inductance coil in the oscillator bears the correct ratio to the inductance in the radio frequency circuits.
- 5—The output power of a stage of two 45 type tubes is about the same whether they are connected in parallel or a push-pull, and the only advantage of the push-pull circuit over the single-sided one is that the push-pull gives less harmonic distortion for the same total output power.
- 6—The moon and the stars have a pronounced effect on radio reception, especially between 10 and 11 p.m. on cold nights.
- 7—If the intermediate frequency amplifier in a superheterodyne oscillates, there will be one squeal after another as the oscillator dial is turned. It seems that there is a strong squeal at every division of the scale and many squeals in between. If the superheterodyne is provided with a.v.c. the heterodynes will greatly affect the bias on the controlled tubes.
- 8—The Barkhausen-Kurz oscillator operates on an entirely different principle from that of other oscillators, and the frequency is entirely determined by the grid voltage and by the dimensions of the tube.
- 9—The inductance of a radio-frequency coil is a fixed quantity and does not in the least depend on the frequency at which the inductance is measured.
- 10—A condenser is not a pure capacity device, for it has resistance in series, resistance in shunt, and inductance in series with the capacity.

ANSWERS

- 1—Wrong. It draws current only if the bias on the grid is less than 0.8 volts negative. Most of the time there will be a signal on the grid, and this signal will exceed 0.8 volts. Hence the bias on the grid will be more than 0.8 volts negative. This signal bias will be on whether or not a sound is heard because it is caused by the carrier. It is only on extremely weak signals that grid current might flow.
- 2—Wrong. A high-gain coil will increase the gain on all frequencies, and especially on the low frequencies, but it will also decrease the selectivity on all frequencies in the tuning band. The high gain is obtained primarily by tight coupling, and tight coupling always decreases selectivity.

(Continued from preceding page)

bilize even with stabilizing reactances. Still another method is to arrange the circuit so that the product of the plate and the grid resistances is large. A blocking condenser and grid leak help to make the grid resistance high and uniform. This is a strange case where a resistance connected in parallel with another resistance makes the combined resistance greater than the smaller of the two combining resistances. The reason for this is that the unrestricted grid resistances amounts to almost a short circuit, whereas if it is restricted by the blocking condenser and the grid leak it cannot become low.

The plate resistance can be increased in several ways. First is by connecting an external resistor in series with the plate. This has often been called resistance stabilization.

The same effect may also be produced by operating the tube at a filament current much below normal. A tube has successfully been operated with one-third normal voltage across the filaments when the L/C ratio of the tuned circuit was very high and also when the bias on the grid was carefully adjusted so as to make the tube operation at the steepest point of the characteristic. If this adjustment is not made the circuit is not self-starting, but requires external excitation.

Wrong?

- 3**—Wrong. The load is no longer right for the impedance of the two tubes, the bias on the tubes is now much greater and therefore the plate current is less than it would be for two tubes correctly biased, and the plate voltage has been reduced because the drop in the load is now greater. There may or may not be a power gain. The load impedance which was correct for greatest undistorted output for one tube is right for greatest output regardless of quality. Therefore there may be a noticeable impairment of the quality by adding a second tube, not only because of the loading but also because of the overbias.
- 4**—Right. The tracking will be right at about 1,000 kc, or slightly below. If the inductance is not right, the interior tracking point may be closer to either the high frequency or the low frequency tracking points. At points between the two tracking positions that are far apart there will be a great deal of squealing. Nothing can be done by means of the trimmer and padding condensers to overcome this difficulty, for the trouble is in the coil of the oscillator.
- 5**—Right. The output power of two 45's, or any other tubes, is the same whether or not they are in push-pull or in parallel, assuming that the tubes are appropriately and correctly loaded in the two cases. But there is a great difference between the two types of circuit. In the push-pull there is practically no even order harmonic distortion whereas in the parallel circuit there is distortion of all orders. Since the greater part of the distortion occurs in the second harmonic, the push-pull may be driven so as to give more power than the parallel circuit, for the same noticeable distortion.
- 6**—Wrong. No connection has been established between the moon and the stars and strong radio reception. Many attempts have been made to show that the moon has a very strong effect but they have been mostly guesses. There is a strong connection between the sun and radio reception, and since the stars are remote suns there may be a slight vicarious effect due to them, but it has not been proved. There are so many of them that the effects of all of them might add a little to the "solar" effect.
- 7**—Right. If the intermediate amplifier oscillates it generates one frequency and all its harmonics. As the local oscillator dial is turned the frequency changes rapidly, as do its harmonics. The fundamental and the harmonics of the local oscillator frequency beat with the intermediate oscillation and produce strong whistles. Since the heterodynes, whether audible or not, are beats that pass through the filter, they will affect the detector and will set up strong negative voltages on the grids of the a.v.c.-controlled tubes.
- 8**—Wrong. It operates on the same principle as any other oscillator incorporating a vacuum tube having three elements. It differs only in that its grid and plate resistances are low. The grid resistance especially is very low. It is this fact which accounts for the anomalous behavior of the B-K oscillator.
- 9**—Wrong. The inductance depends on frequency because the current distribution changes with frequency. Part of this is due to skin effect and part to the capacity between turns.
- 10**—Right. It is customary to regard a condenser as a pure capacity device and to disregard its resistance and inductance. But the fact is that it has leakage, which is equivalent to resistance across the capacity, and it has series losses, which means resistance in the lead to the plate and in the plates themselves. It has also inductance because of the leads and of the fact that the plates are not concentrated at a point. In good condensers, however, the series and shunt resistance can be neglected.

Sylvania Wins Honors for Safety to Employees

H. W. Zimmer, factory manager of the Emporium plant of Hygrade Sylvania Corporation, is proudly exhibiting Merit and Honor awards won by the Sylvania employes groups in the 1935 Accident Prevention Contest conducted by the Pennsylvania Department of Labor and Industry. Man-hours worked by participating employees during the period of the contest totalled 2,823,550 with only 540 hours of lost time due to accidents.

Honor certificates, indicating no lost time in-

juries, were awarded to a group including the Filament, Stem, Base, and Bulb Departments, who led the record, with 578,343 hours worked, none lost, and to the Finishing Production Development and Engineering group, who worked 438,115 hours without lost time.

Merit certificates, showing an accident frequency rate well below the Pennsylvania average for the industrial group in which Hygrade Sylvania Corporation is classified, were awarded to the Mounting and Unit group and to the Parts Department, and to the Sylvania plant as a whole.

Efforts to attain 100% for all departments are under way.

SERVICE BUREAU

Systematic Servicing Recommended

THE development of a system of servicing has been suggested by Herman Bernard, applicable to practically all receivers, and while the problem is necessarily attended by some serious difficulties, it is not one that should be shirked. At present there exists no regular system of servicing, and each service man has his own method, if any, or it may indeed be only hit-or-miss. However, the idea is sound and should be solved co-operatively. That is, service men may set forth their systems, and thus publicity will be given to various methods, and from the sum of this knowledge and experience a particular method may be developed.

The idea was broached by Mr. Bernard to John F. Rider, who speaks encouragingly of it in the current issue of his house organ, "Successful Servicing."

COMPLETE OVERHAULING

Since the recent birth of the idea I have given it some thought and have come to the conclusion that the proper way to service a set is the one that follows a system whereby the receiver is given a thorough examination. That is, the primary object is not necessarily to get the immediate trouble repaired in the shortest time, but to make a systematic examination and study of the receiver, in the course of which not only will the immediate trouble appear but also any hidden defects, which should be remedied, also. The enhanced reputation that the service man gets for high-grade work is his chief stock in trade and greatest asset, and therefore the complete overhauling is advisable.

After the immediate fault has been repaired and also the weaknesses eliminated, the receiver should be put on test for four hours. This precaution is very valuable, as several receivers have developed defects during the four-hour test. It has been found, also, that a systematic method of servicing, curing latent defects as well as patent ones, has reduced the number of failures that show up on the four-hour-running test. From this it may be imagined, which is true, that some hit-or-miss servicing was attempted experimentally, and found not to be so productive as systematic servicing.

The troubles in a receiver may be grouped into two general classes: those resulting from short circuits and open circuits. Really there is no circuit when the load is open, as a circuit must be closed, but the expression open circuit passes muster in business. Instead of

being entirely open, when there may be no reception, the load may be partly open, or intermittently open and conductive. Also shorts may not be complete, but incomplete, or intermittent, as where a resistor's value becomes alternately normal and much less than what it was originally and should be now.

EDUCATION IS AVAILABLE

Most servicing is done without system and is based on experience of the operator. This experience may not be extensive enough to enable full justice being done in the servicing of the set. Also, the system will not supply all the knowledge that a service man should have, therefore it is also necessary for the service man to have a sound theoretical background, absence of which is his greatest weakness to-day. Splendid courses are given, for instance that of the National Radio Institute, and many fine books are available, particularly Ghirardi's "Modern Radio Servicing," the outstanding volume in the field, so there is no reason why a service man can not be equipped with a fine theoretical basis of his work. It is important, as much so at times as practical experience. Also, Mr. Rider has a series of very informative books on individualized subjects, including the "Hour-a-Day" series and the cathode-ray oscilloscope book, and his manuals are of course the all-revealing sources of receiver information.

Reliance on one's experience alone is a workable basis of operation, even though not the best. A great deal can be accomplished that way. As examples I shall cite a few remedies recently applied.

CITATION OF REMEDIES

A man came in with a set, saying that the rectifier gets red hot. My first suspicion in such a case always is the condenser next to the rectifier, practically always an electrolytic, and when this was cut out of circuit the rectifier did not get red hot. So the condenser was checked on a condenser tester, found to be excessively leaky, practically a short under the circumstances, and was replaced.

But a few days before a woman had come in with the statement that "the large tube" got red but now did not light up any more. A check showed the primary of the power transformer was burned out. The transformer smelled smoky. That smoky smell always means to me a new transformer is needed.

The cause of the trouble was the rectifier tube. One of the plates was shorted to the

filament. If the customer had brought in the set the moment the tube got red hot, turning off the set immediately on noticing the trouble, the remedy would not have been so expensive to her. It made no difference in particular to me that she had erred this way, as my margin on the repair would be the same either way.

PEAK PERFORMANCE GOAL

This parenthetical statement may need some explanation. If just a fault is to be remedied there is often little if any profit in servicing, as so much of the trouble may be due to bad tubes, and tube replacement, while a ratable part of the business, is not nearly enough to live on. You have to take the chassis out of the customer's home, and do some worthwhile work on it, to establish any significant

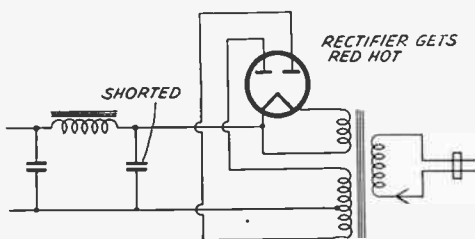

If a rectifier tube gets red hot, a shorted filter condenser next to the rectifier is the author's first suspicion. The other filter condenser shown also is a trouble possibility under these circumstances, as is a short in the rectifier tube.

earning, and the check-up system of thoroughgoing overhauling well justifies the time spent on the set, both from the customer's and the service man's viewpoint.

Whether the service man charges for every visit, or just for actual repairs and replacements, does not alter the advisability of applying a system and letting the customer have the benefit of this better-grade treatment. A weakness caught in time will save the customer money. Also, customers do not as a rule know whether the set is giving all the performance of which it should be capable. Bringing performance up to peak is a repair job of the first order.

Distortion, when very pronounced, is easily noticed by the customer, but may be tolerated for a long while before any move is made to have the set repaired. Soliciting business, by visit or by mail or telephone, is therefore to be encouraged, because quite a few persons, when confronted with the pointed query, will acquiesce in having the set repaired. A little prodding is needed for their sake as well as for ours.

TROUBLE FROM GRID LEAKS

Distortion is often caused by a biasing resistor or grid load resistor that has lost too much resistance, in the power tube circuit, or by the voice coil bobbin being out of align-

ment. Precision jigs needed for perfect alignment of the bobbin are not possessed by service men, as a rule, and the repair can be made sufficiently well with the usual whims, so that the customer is well satisfied. That is, the distortion complained of is eliminated.

The last audio grid leak gives considerable trouble, as it will show up well on the usual point-to-point test, but will fall down when the receiver is operating a while. In fact, the trouble becomes cumulative, the longer the set

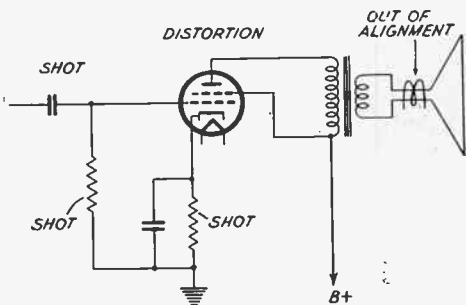

Distortion is frequently caused by a defective leak in the power tube stage. Some grid current may be expected, especially on loud signals, also the voltage across the leak will be much greater in operation than when point-to-point testing is done. Hence the leak may test O.K. yet be defective. Trouble in the biasing resistor or speaker alignment also causes distortion.

plays. This is because the resistor is shot, and when a sufficient voltage appears across it the partial short occurs, and the degree of short may change, that is, the resistance actually becomes variable, which accentuates the distortion. Usually the resistor is of smaller wattage than it should be. There will be some grid current in the power tube circuit and .5 meg. is the maximum for most pentodes, yet 1 meg. to 3 meg. may be called for in the diagram. The low-note response is better with the higher resistance, but the resistor is subjected to quite a strain. I replace with .5 meg., one watt, and seldom have trouble on this score again.

If the biasing resistor is open there will be no signal, but if it is partly shorted—resistance has decreased too much—the overload point is premature, and the plate current may be somewhat too high.

DIAL READINGS AFFECTED

"No signals" may be due to the local oscillator in a super-heterodyne failing to function because the grid leak has lost too much resistance. If the resistance is too low, the losses r.f. voltage are too great, so that the circuit will not oscillate. If it is open the grid-cathode leakage is the only resistance present (including in this the socket and other resistance), and these values are variable from time to time. The open resistor may permit

(Continued on next page)

(Continued from preceding page)

oscillation, but with wobbly signal, classed by the customer as distortion or fading, with accompanying change of dial readings from the original, and from time to time.

If the plate current has been running too high for a long time the primary of the output transformer may become open, another case of "no signals."

USUAL "FADING" CAUSE

Fading is a frequent complaint. This may be due to the open leak in the local oscillator, as the wobbly reception may be classed as fading in the customer's language, as is any form of intermittent reception. The usual cause of fading is an open bypass condenser in the cathode, screen or plate circuit, the values of

trouble. They do not know our language and so can not talk to us as informatively as we would like. If they say the set is dead, all hands know what that is. But for the set that is alive, although not alive enough, that does perform, but performs poorly, they have a variety of ailment descriptions for a particular condition that would require psychoanalysis if not mind-reading to be of any benefit to the service man.

Even though experience does work often as the sole reliance for servicing, system has it all over the symptomatic process. When there is something serious the matter with you a physician gives you a thorough examination.

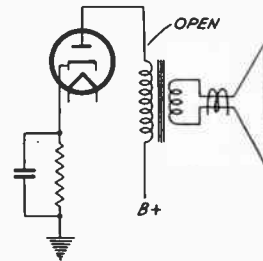
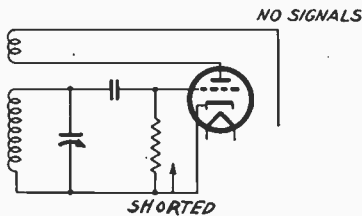

A dead superheterodyne will surely result if the local oscillator stops oscillating, and since resistors may lose their resistance, a shorted or partly shorted grid leak is indicated. If the grid resistor is open, spotty reception classed as fading may result. An open primary (at right) of course, stops reception and is concomitant with a shorted biasing resistor.

.1 mfd. or so as found in most sets. Seldom is fading traceable to conditions in the rectifier tube or filter, although defective filter condensers here sometimes produce a scratchy reception, and failing rectifier tube popping interference.

Factors like those just outlined fall into the classification of utilization of experience alone in the servicing of a set. Cases where such treatment worked have been cited. The customer usually supplied the information used as clue to finding and curing the trouble. But the customers are very unreliable assistants to a service man, because of such different descriptions they give for exactly the same

The reason is that he can not rely on the patient alone for information on symptoms. The patient may describe the pain as being at one place, but the seat of the trouble may be far removed from that place, the sensation being false, or transferred. The physician has to find out for himself, largely, and this is necessary because the patient is not a doctor. The service man also has knowledge, experience and a profession, and his customers are not service men and therefore can not give him much help. The doctor performs his examination according to a system, and his examination includes practically everything, because he can not work reliably on localized suspicion. If anything, he suspects everything, and that is what the service man should do.

—JACK GOLDSTEIN.

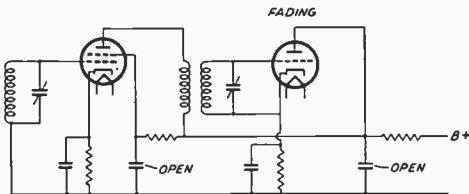

Fading is most often caused by an open or otherwise defective bypass condenser, particularly in cathode, screen and plate return circuits. The filter condensers in the rectifier are not included in this trouble, although popping reception may be due to poor electrolytics or to defective rectifier or power tubes.

Bruno Gets P.A. License

Bruno Laboratories, Inc., are now licensed to manufacture public address equipment under patents owned or controlled by the Western Electric Company, Inc. and the American Telephone and Telegraph Company.

This arrangement widens the sales field of the Bruno Laboratories, Inc., inasmuch as their product can now be used in municipal and government installations or any other institutions where patent infringement protection is necessary. This license specifically covers public address systems including velocity microphones, amplifiers and loudspeakers.

Much from Very Little

The Beginners' Delight, One-Tuber

By H. G. Cisin

Allied Engineering Institute

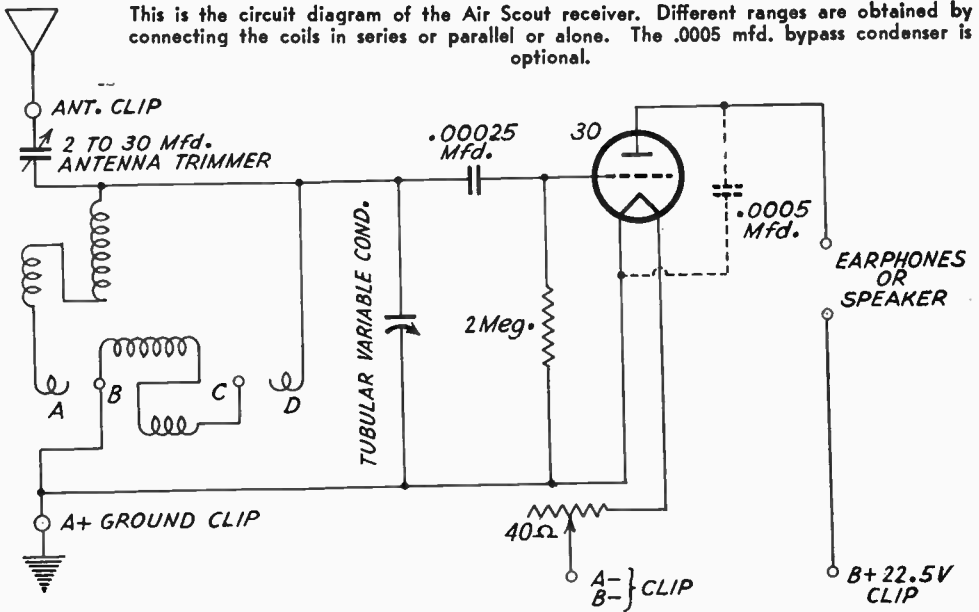

THIS little one-tube receiver should be of interest to beginners in radio experimenting, for it has been designed especially for boys and other novices. The design has been made to meet the demands of those who have not yet learned how to read the conventional electrical symbols universally used for indicating circuit connections. This one-tube set is particularly suitable for a first attempt at building a radio because it has only a few connections and a few parts, and these are very inexpensive. Indeed, the entire cost, including the tube, should not exceed one dollar. Another reason why it is suitable for a beginner is that it is sure to work when the connections have all been made, and the builder does not need to suffer the disappointment of having his first attempt a failure.

For those who can read a circuit diagram drawn with the conventional symbols a diagram is provided herewith. For those who cannot read symbols, a photograph of the panel with the parts laid out is shown in Fig. 2. A full size panel, 8½ x 11 inches, with pictures of the various component parts pasted on the back, also can be used as an aid to the beginner in laying out the parts and wiring them.

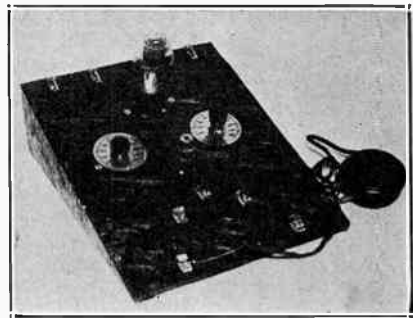

Top view of panel, showing controls and clips

A glance at the circuit diagram will show, as the photograph will confirm, that there are two variable condensers in the circuit. One of these is a small trimmer in the antenna lead, between the antenna clip and the top of the tuned circuit. This condenser helps to adapt the antenna length to the requirements of the frequency to be received and it also helps to increase the selectivity of the circuit.

Hearing-Aid Amplifiers

Battery and Universal Models

By M. N. Beitman

Engineer, Allied Radio Corp.

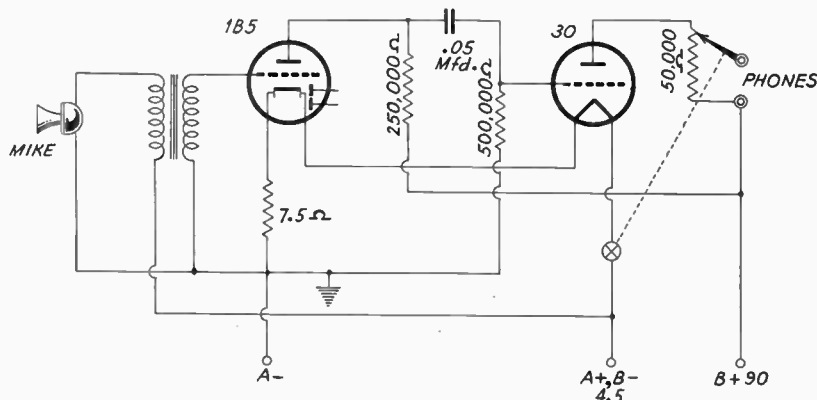

Circuit of the battery model.

THE two circuits of small amplifiers are well adapted to hearing-aid application. Absolutely the minimum of parts is used and the circuits are simple and straightforward. The units are (1) for battery operation, (2) for 110 volts a.c. or d.c. use. A small carbon lapel microphone is used to pick up sound; regular headphones or bone-conducting units may be employed for reproduction. The amplifier will reproduce voice and music clearly and with surprising volume even when the microphone is some distance away from the source of sound. Parts for the construction are standard and are inexpensive. Either of the two amplifier units may be assembled in a convenient carrying case for easy portability.

BATTERY MODEL

The battery model uses two low-filament-drain 2-volt tubes in a resistance-coupled circuit. A type 1B5 tube was found to be best suited for the first stage, since the triode section has an amplification factor of 20. The

diodes are not used. The microphone is transformer coupled to the 1B5 tube input. A small, high-quality microphone transformer should be used, so that light weight and good frequency response can be advantageously combined. The microphone current is obtained from the regular 4.5-volt C battery that is also used to supply filament power.

A type 30 tube is used in the second stage. The filaments of the two tubes are connected in series with a 7.5-ohm voltage-dropping resistor. Two midget 45-volt B batteries are used for plate power. The volume is controlled by a potentiometer in the output circuit.

The B batteries under average conditions will operate for six months without any replacement. The small battery used for operating the filaments will give eight hours of continuous service and about ten hours of intermittent use.

110-VOLT MODEL

The second circuit is designed to operate

LIST OF PARTS

Battery Model

Microphone, single, button lapel type.
Microphone transformer.
Six-prong socket.
Four-prong socket.
Chassis and cabinet.
250,000-ohm $\frac{1}{2}$ -watt resistor.
500,000-ohm, $\frac{1}{4}$ -watt resistor.

Volume control, 50,000 ohms with switch.
.05 mfd. condenser.
7.5-ohm 10-watt resistor.
Tubes: 1A5 and 30.
Hookup wire.
Batteries: two midget 45-volt type, one small $4\frac{1}{2}$ volt C type battery.

Improving Tone Quality With Inverse-Feedback or Filter

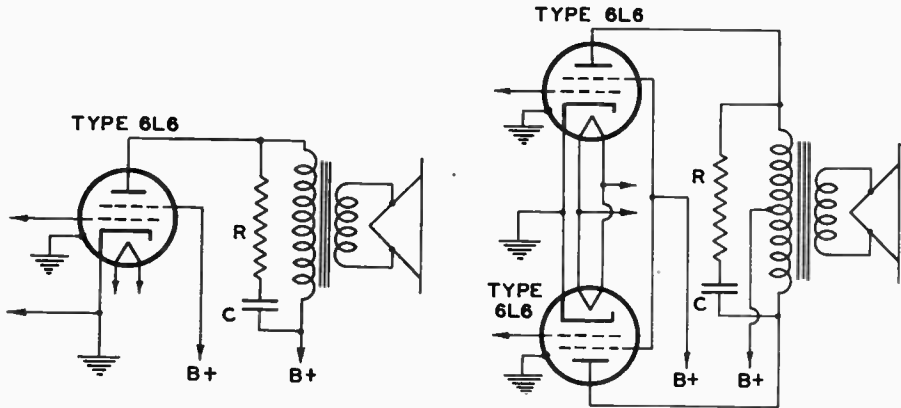

FIG. 1

Resistance-capacity filter for compensating the variable reactance feature of the load. R is the resistor, C the condenser. R equals the load impedance into which output tube or tubes should work.

WHEN power output and distortion characteristics of the final stage of an a. f. amplifier are to be determined, it is customary to replace the loudspeaker by a fixed resistance of suitable value. Actually, a loudspeaker does not present the same impedance to an output tube at all audio frequencies. At the resonant frequency of the speaker, which is usually less than 100 cycles, the impedance of the speaker is high and resistive. At higher frequencies, the impedance of the speaker increases with frequency, because the voice coil has inductive reactance. Unless the variable effects of such a load are reduced by a low-resistance output tube, low frequencies "hangover" and are accentuated by resonance effects in the speaker; high frequencies are accentuated by the rising impedance characteristic of the speaker.

The internal resistance (r_p) of an output tube shunts the plate load (Z_L). When r_p is appreciably less than Z_L , large variations in load impedance do not appreciably affect the output voltage, because the variable load impedance is shunted by the comparatively low resistance of the output tube. Hence, when a low-impedance triode is used in the output stage, the effects of the variable speaker impedance are reduced.

When the internal resistance of the output tube is high compared to the load impedance, the effects of variable speaker impedance may seriously impair quality. This latter condition exists when tetrode—or pentode-type output tubes are used without compensating circuits. This article describes the characteristics of two such circuits: (1) the familiar resistance-capacitance filter, which compensates for high-frequency effects, and (2) inverse-feedback cir-

cuits, which minimize the effects over the entire audio-frequency range.

FILTER AND INVERSE FEEDBACK

Because the load impedance of a dynamic speaker acts like an inductance and resistance in series at frequencies higher than the resonant frequency of the speaker, a suitable resistance-capacitance filter, connected as shown in Fig. 1, can be used to compensate for the variable reactance of the load. Resistance (R) in Fig. 1 is made equal to the load impedance into which the output tube or tubes should work; capacitance (C) is adjusted to give a frequency characteristic which is substantially flat over a desired frequency range.

When R and C are determined in this manner, considerable power may be dissipated in R, especially at the high audio frequencies. For this reason, it may be desirable to increase R and C until a suitable balance between high-frequency compensation and power loss is obtained. The effects of speaker resonance are not reduced by the filter method of compensation.

Inverse-feedback circuits can be used to decrease distortion at the expense of power sensitivity in an a. f. amplifier. Some forms of inverse-feedback circuits cause an increase in the plate resistance of a tube and others cause a decrease in this resistance. In the following discussion, two forms of inverse-feedback circuits are analyzed. The reduction in distortion can be made equal in both forms, although one increases and the other decreases the plate resistance of the tube.

The plate resistance of a tube can be increased or decreased by feeding back to the grid circuit

a portion of the alternating voltage appearing in the plate circuit. Thus, in Fig. 2, when the plate voltage is increased by an amount E by means of switch S , the control grid becomes more negative because of the increased voltage drop across the cathode resistor (R_c); this increase in negative bias reduces the plate-current change. When a signal is applied to the input and the battery (E) is replaced by a suitable load, the effect of the unbypassed cathode resistor is to increase the internal resistance of the tube as measured at the terminals of the load; therefore, the shunting effect of the tube on the load is decreased.

EFFECTS OF DEGENERATION

The a. c. voltage developed across an unbypassed cathode resistor is in opposite phase to the input-signal voltage in a single-tube amplifier; hence, the circuit is degenerative. The

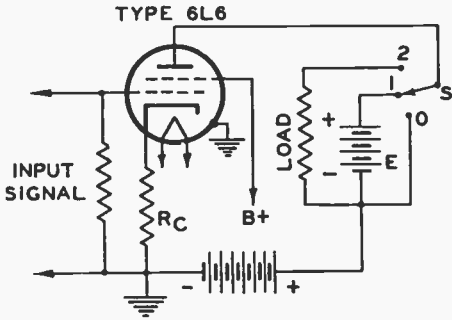

FIG. 2

Distortion is reduced, and so is power sensitivity, by introducing inverse feedback. R_c is the cathode resistor, bypass condenser omitted. Plate resistance is increased.

effects of degeneration in a single-tube amplifier are to reduce the distortion and power sensitivity; the power output is also somewhat reduced due to power dissipated in the cathode resistor. The fractional loss in power output is R_c/R_L , where R_c is the value of the cathode resistor and R_L is the value of the load resistance plus the cathode resistance. The input signal required for rated output with degeneration is approximately

$$E_a = E_o \{ 1 + [g_m R_c / (1 + R_L / r_p)] \}$$

where E_o is the input signal required for rated output without degeneration, and g_m is the grid-plate transconductance of the tube at the operating point. The distortion with degeneration is approximately

$$D_a = D_o / \{ 1 + [g_m R_c / (1 + R_L / r_p)] \}$$

where D_o is the distortion without degeneration. For example, when the bypass condenser was removed from the cathode circuit of a typical single-tube amplifier using a type 6L6 tube, the distortion was reduced to approximately one-half of its former value; the required input signal voltage was doubled, and the power output was reduced by approximately 10 per cent. No other changes in circuit constants

The cathode-resistor bypass condenser should not be removed from over-biased push-pull circuits having a single cathode resistor for both tubes because the alternating plate currents of each tube do not cancel in this resistor; the resulting harmonic components of current cause an increase in distortion. The cathode-resistor bypass condenser may be removed from over-biased push-pull circuits when each tube has its own resistor. However, the advantages of low tube resistance are not obtained.

ENTIRELY COMMON LOAD

When the entire load resistance is common to the plate and the cathode circuit, as shown in Fig. 3, a positive increment in plate voltage causes the same increment in grid voltage. Therefore, the internal resistance of the tube decreases. As in the circuit of Fig. 2, the feedback voltage, which is the entire voltage de-

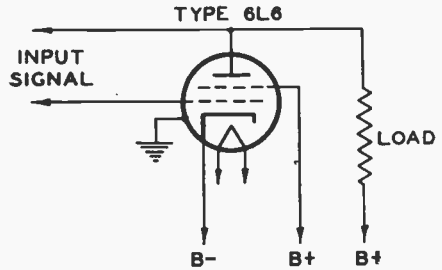

FIG. 3

The load in its entirety is common to the plate and cathode circuits. This method decreases the plate resistance. The output tube is made to act like a low resistance triode.

veloped across the load, is in opposite phase to the input-signal voltage. It follows that this circuit is also degenerative. When the circuit of Fig. 3 is used, the internal resistance of the tube, the distortion, and power sensitivity of the amplifier are reduced; the power output and efficiency are not changed.

The circuit of Fig. 3 alters the normal characteristics of the amplifier in such a manner that the output tube acts as though it were a low-resistance triode. The amplifier has all the advantages of a triode, plus the high efficiency obtainable from a good tetrode or pentode. In addition, the circuit may be made flexible enough to permit the tube characteristics to be changed in steps from those of a tetrode or pentode to those of a low-resistance triode.

The circuits of a practical single-tube and of a push-pull amplifier using partial inverse feedback to reduce the internal impedance of the tube are shown in Figs. 4a and 4b, respectively. Resistors (R_1) and (R_2) and condenser (C) are connected in series; the combination is connected from the plate of each tube to ground. Nearly all the a. c. voltage developed across the load appears across R_1 and R_2 when

(Continued on next page)

Values for Inverse Feedback

For the 6L6 circuits below, where (a) is for single-sidedness and (b) for push-pull, the values of R_1 , R_2 , C and C_1 are as follows:

10% Inverse Feedback

$R_1 = 5,000$ ohms	10,000 ohms
$R_2 = 45,000$ ohms	90,000 ohms
$C = .1$ mfd. up	.1 mfd. up

16.6% Inverse Feedback

8,330 ohms	16,660 ohms
41,670 ohms	83,340 ohms
.1 mfd. up	.1 mfd. up

C_1 = Small capacities, the necessity of which for all cases is determined by experiment. They avoid oscillation due to leakage inductance and shunt capacity of the input transformer.

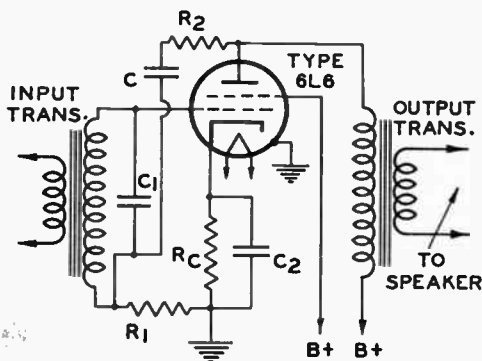

(a)

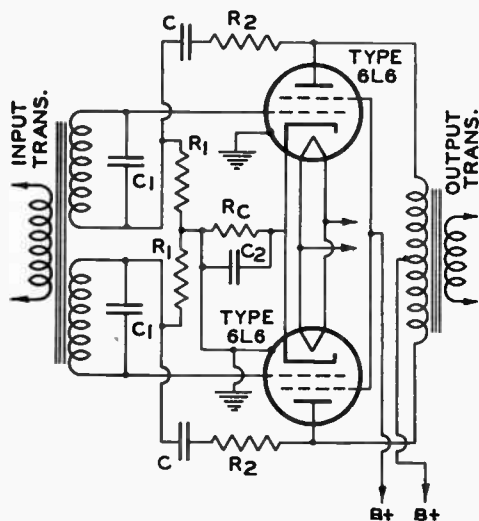

(b)

FIG. 4

Reduced internal impedance of the tube or tubes results from this limited method of inverse feedback. Signal from the plate circuit is fed back to the grid circuit as a series introduction. C_1

compensates for inductive leakage. CR_2 is the feedback branch, R_1 the recipient. C_2 bypasses R_c . Nearly all the a.c. voltage across the load appears across R_1 and R_2 with C and C_1 large.

(Continued from preceding page)

the capacitance of C is high. Of this voltage, that due to $R_1 / (R_1 + R_2)$ is applied in series with the input-signal voltage; this ratio is defined as the per cent degeneration (n). With any per cent degeneration, the tube acts as though its normal internal resistance (r_p) were shunted by a resistance $1 / (n g_m)$, where g_m is the transconductance of the tube.

REQUIRED INPUT SIGNAL

The input signal required for rated output is approximately

$$E_a = E_o \{ 1 + [n g_m R_L / (1 + R_L / r_p)] \}$$

where E_o is the input signal required for rated output without inverse feedback. The distortion with inverse feedback is approximately $D_a = D_o / \{ 1 + [n g_m R_L / (1 + R_L / r_p)] \}$ where D_o is the distortion without inverse feedback. The transconductance of the tube is not changed by the addition of this type of degeneration.

The cathode resistor (R_c) has the same value with and without inverse feedback, because electrode voltages are not changed when this circuit is used. Also, the load impedance into which the tube operates should not be changed when inverse feedback is added. The load resistance that is optimum without degeneration

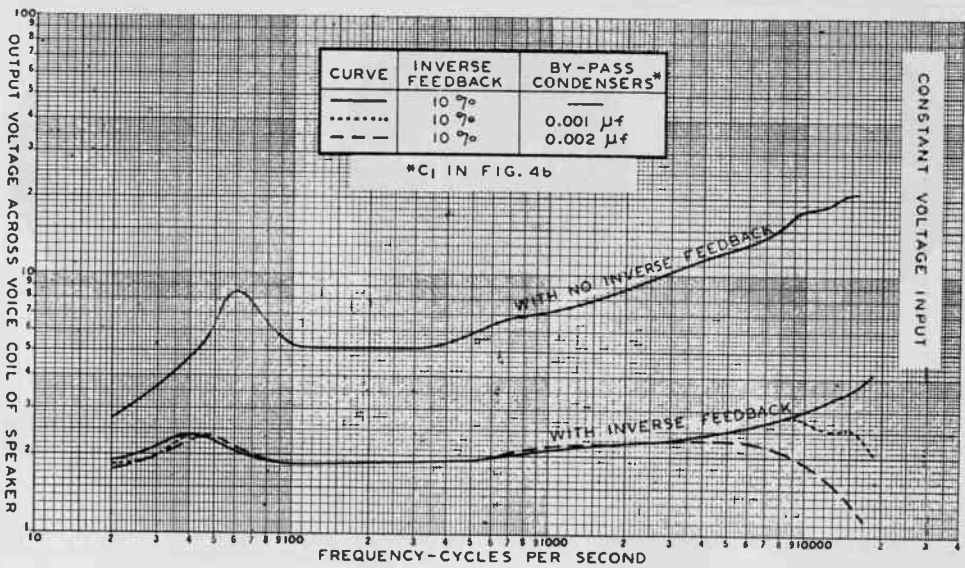

FIG. 5

Frequency characteristics of a typical amplifier, with and without inverse feedback, and with two values of short condensers for the same signal input. Flattening of the characteristic is indicated.

is also optimum with degeneration. Therefore, in order to use inverse feedback in some receivers, it may be necessary only to install R_1 , R_2 , and C .

Although the inverse-feedback circuits of Figs. 4a and 4b offer certain advantages, the following precautions should be observed in the design and use of these circuits in order to avoid the possibility of instability, oscillation, or a marked divergence from expected results.

(1) A conventional resistance-coupled input circuit cannot be used with this type of degenerative circuit, because the input-signal voltage must be in series with the feedback voltage for proper operation.

(2) It may be desirable to connect small fixed condensers (C_1) across each secondary of the input transformer in order to avoid the possibility of oscillation due to leakage inductance and shunt capacitance in the input-transformer circuit. It is advisable to determine by test whether or not these condensers are necessary.

(3) The blocking condensers (C in Figs. 4a and 4b) should be placed between R_1 and R_2 , as shown. When placed between R_2 and plate, the circuit may oscillate because of the capacitance of C to grid.

(4) It might appear that the primary of the output transformer could be tapped at the proper point or that a tertiary winding could be used to obtain the necessary feedback voltage. Attempts to use such schemes may be unsuccessful because of phase shifts due to leakage inductance.

(5) This type of circuit is not suitable for use in amplifiers that are designed for grid-

current operation, because the relatively high values of R_1 cause appreciable grid-circuit distortion.

RESULTS OF OPERATING TESTS

Inverse feedback reduces the power sensitivity of an amplifier. In circuits having this feature it is, therefore, desirable to use an output tube that has high power sensitivity in order to obtain normal power output with reasonable signal voltage. For this reason, the 6L6 tube is well suited for use in this type of circuit. Preliminary tests indicate that the shunting effect on a speaker load by two type 6L6 tubes with 10 per cent. degeneration is comparable to that which can be obtained by two low-resistance triodes in a similar circuit without degeneration. At the same time, the power sensitivity of the 6L6 amplifier is approximately twice that of the triode amplifier and the inherently high efficiency of the type 6L6 tube is retained.

In one test, a push-pull amplifier using two type 6L6 tubes without degeneration was set up under the following typical operating conditions: plate voltage, 400 volts; screen voltage, 300 volts; grid bias, -25 volts; plate-to-plate load, 6,600 ohms. With a peak grid-to-grid signal of 50 volts, the power output was approximately 34 watts at 2 per cent. distortion. When 10 per cent. degeneration was added, using the circuit of Fig. 4b, an output of 34 watts was obtained from the tubes at the grid-current point with approximately 1 per cent. distortion; grid current flowed with a peak grid-to-grid signal of 130 volts. No

(Continued on next page)



FIG. 6

(a)

(b)

(c)

The short impulse signal fed to the amplifier grid circuit.

Output voltage of the 6L6 amplifier, without inverse feedback.

10% inverse feedback made the response flatter, compared to (b).

(Continued from preceding page) changes were made in electrode voltages or circuit constants.

The frequency characteristics of a typical amplifier with and without inverse feedback and with several values of shunt condensers for the same signal input are shown in Fig. 5. These curves indicate that the rise in power output at the resonant frequency of the speaker decreases and the high-frequency response flattens considerably when this form of degeneration is used. The effect of the shunt condensers on frequency response is small, because the secondaries of the input transformer have low impedance.

An interesting set of oscillograms which indicate the damping action of an inverse-feedback circuit are shown in Figs. 6 and 7. A short-impulse signal, shown in Fig. 6a, was fed to the grids of a push-pull amplifier. The output tubes were connected to a loudspeaker

through an output transformer; the voice coil of the speaker was connected to a cathode-ray oscillograph in order to observe and to photograph the wave form of the voice-coil voltage. The slowly decaying output voltage in a 6L6 amplifier without degeneration is shown in Fig. 6b; the more rapid decay with 10 per cent. degeneration is shown at (c). A slight improvement is obtained by using 16.6 per cent. degeneration, Fig. 7 (a). The output of a similar amplifier using low-impedance triodes is shown in Fig. 7 (b).

From these pictures it can be concluded that nearly the same amount of damping can be obtained from type 6L6 tubes with 10 per cent. degeneration as from good triodes without degeneration. However, for approximately the same input-signal voltage and B supply power, about twice the power output can be obtained from two 6L6 tubes as from two good triodes.

Copyright, 1936, by RCA Manufacturing Co., Inc.

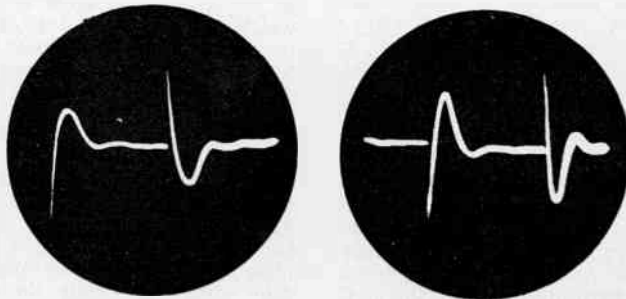

FIG. 7

(a)

(b)

Output voltage when inverse feedback was increased to 16.6%. Difference is small.

Output of low impedance triodes, without inverse feedback compare with (a).

Capacity from Harmonics

Measurement Two Ways—Inductance Also Solved

By Herman Bernard

C_0 is the unknown capacity, e.g., the distributed capacity of the secondary L . C_2 is a calibrated variable condenser at maximum. The high frequency F_h thus established is measured by two settings, F_1 and F_2 , of the low-frequency generator G .

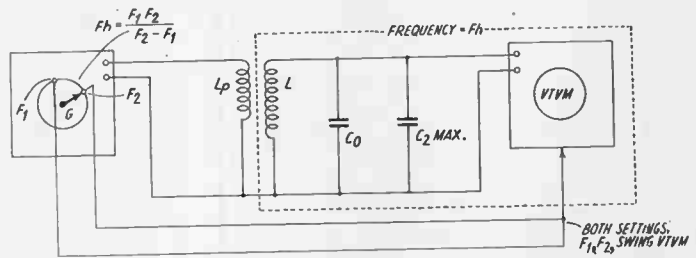

AN harmonic method of measuring small capacities has been developed. The method depends almost exclusively on the accuracy of a calibrated condenser. Two other factors used are frequencies, which attain accuracy somewhat of the order of standard broadcasting stations due to zero-beating, and harmonic orders, the accuracy of which is absolute. However, the frequencies are finally eliminated, the harmonic orders are absolutely accurate, hence the condenser is the only error contributant and should be as accurate as possible.

In the diagram G is a generator, frequency calibrated, but not necessarily with a high degree of accuracy, as the generator inaccuracy will be eliminated. C_p is a few turns of wire used for the capacity effect, for weak coupling of generator G to receiver R . When fundamental or harmonic of G is fed to R , when R is tuned to a station, a zero beat may be established for very high accuracy, audible determination sufficing. S is the speaker from which the response emanates. L_p may be the primary of a built-up transformer, of which L is the secondary the inductance of which is being measured. Then the disturbance of the measurement by the pickup from L_p is zero, because the secondary inductance should be measured in the presence of a fed primary. Otherwise L_p is a turn or two of wire, or more turns if L_p is farther from L . C_0 is the unknown small capacity to be measured, which may be the distributed capacity of L . C_1 is the smaller and C_2 the larger of two capacity settings of the standard. They are shown as two fixed capacities, switched in alternately, because the picture is more simply presented that way. VTVM is a vacuum tube voltmeter, range 0-100 millivolts, so that the coupling between L_p and L , where L_p is an external pickup winding and not the primary of a made-up transformer,

will be weak enough not to disturb the measurement.

NEW HIGH FREQUENCY

We must use two frequencies of the generator to measure approximately the high frequency F_h of the test circuit. Read one generator fundamental that influences the voltmeter. Then read the next consecutive generator frequency that does likewise. The frequency F_h equals the product of the two readings divided by the difference. The approximation is due to the generator inaccuracy but is immaterial, as shall appear.

Now we turn our attention to broadcasting stations receivable well on the set R . Multiply their known frequency by whole numbers until a number is attained that is only a little larger than F_h . Zero beat the generator with this station tuned in on R , by moving G to a little higher frequency than before, and also move the calibrated condenser to somewhat less than maximum capacity. Shut off the set R before adjusting the calibrated unit for maximum deflection and leave the set off henceforth.

The harmonic order of the now accurately known low frequency may be determined by turning the generator to the next consecutive setting that influences the VTVM, dividing the difference between the two low frequencies into the apparent frequency of the second setting, which should be a whole number but if not is made so, and multiplying the accurately known low frequency by this whole number. The answer is F_h , the new high frequency. We have the harmonic order, too.

C_1 IS NOW ESTABLISHED

Now we are prepared to move the calibrated condenser to a new setting, smaller
(Continued on next page)

Special Formulas for R.F. Measurements

This is the fourth and final article of a series by the same author concerning measurements at radio frequencies, principally pure inductance and small capacities. The first article appeared in the July, 1936, issue, entitled "Generator Use Extended," and dealt with measurements of frequencies, percentage modulation, inductance in three ways, mutual inductance, a. c. resistance, Q , and capacities up to the limit of the usual mica dielectric range. One inductance method used fixed frequencies of 138 and 1,380 kc, so L_x in microhenries equalled $1/(C_2 - C_1)$ for 138 kc, or $100/(C_2 - C_1)$ for 1,380 kc. Another inductance case dealt with wavelenths squared, change introduced by including 281.4 mmfd. (more accurately, 281.73 mmfd), so wavelength in centimeters equalled $\lambda_2^2 - \lambda_1^2$. The third case introduced the unknown inductance in series with a known inductance.

In the August issue inductance measurement based on two known fundamental frequencies and two known capacity settings was considered, where L in microhenries equals

$$2,533 (F_2^2 - F_1^2) 10^7$$

$$(C_2 - C_1) F_1^2 F_2^2$$

kilocycles and micromicrofarads considered. Capacity formulas were given also.

Last month, simplification by use of 253.3 mmfd. and 281.73 mmd. for inductance measurements by fundamentals was discussed. A table converting frequencies and wavelengths was printed, also a graph relating frequency kilocycles to wavelengths squared on the one hand, and frequencies squared on the other. These squared terms arise in the formulas.

This month harmonic practice is accurately utilized, with extremely accurate frequency use, absolutely accurate harmonic use, and final accuracy depending principally on the calibrated variable condenser.

All the principal formulas, except series inductance, are special in all four articles, and are not to be found elsewhere. All inductance formulas except series inductance eliminate the effect of distributed capacity on the measurement.

(Continued from preceding page)
capacity, to pick up the next successive VTVM response, and reading the two apparent capacities, we have them, also we have one harmonic order, but the new one is a one higher because the test circuit is higher in frequency now and F_1 is unmolested, so we know both

capacities and both harmonic orders and may apply the formula:

$$C_o = \frac{C_2 n^2 - C_1 m^2}{n^2 - m^2} \quad (1)$$

Where C_o is the unknown capacity C_2 the higher and C_1 the lower capacity of the calibrated condenser, n is the higher and m the lower of the harmonic orders. The capacities are of the same order.

AVOID SOME DIFFICULTIES

Consecutive harmonic orders have been used throughout because consecutive responses avoid some difficulties so n and m are consecutive. However, instead of adding only the number one to the harmonic order found when FH was considered with the accurately known fundamental, we may move the condenser over a greater span, the integral change in harmonic orders being equal to the total number of responses, including the original, less one. If there are five responses, the number to add to or subtract from the original harmonic order is four.

The measurement, which has been recommended for small capacities, also may be readily applied to larger ones, if the other than consecutive harmonic orders are used.

PURE INDUCTANCE

By recasting formula (1) the pure conductance of an unknown coil L may be measured. The inductance formula is

$$L = \frac{n^2 - m^2}{4\pi^2 n^2 m^2 (C_2 - C_1)}$$

The value of $4\pi^2$ is 39.48.

The order of inductance is of the same order as the capacities e.g., L in henries, C_2 and C_1 in farads.

CHECK ON INDUCTANCE

Since the capacity in circuit is known and also the frequency, the inductance method may be checked against the usual formula

$$L = \frac{2,533 \times 10^7}{F^2 C} \quad (2)$$

where L is in microhenries, F in kilocycles and C in micromicrofarads.

TWO NEW SPECIAL TUBES

Two new non-receiving tubes are announced by RCA Radiotron:

The 920 is a twin phototube of the gaseous type. It has two separate units in one bulb and is intended for use with dual sound track motion-picture equipment.

The 1603 is a pentode amplifier designed to have low-noise and low-microphonic characteristics. It is intended for use in high-gain pre-amplifiers.

Step-by-Step Procedure for Formula (1)

For handy operation the technique used in ascertaining an unknown small capacity from formula (1) is tabulated below:

(1)—A circuit is set up, consisting of a signal generator or oscillator, a receiver of standard broadcast band frequencies, a few turns of wire around the output lead of the generator for coupling to the receiver, a pickup coil feeding a coil across a vacuum tube voltmeter, and a calibrated variable condenser also across the voltmeter input. The coil should be of small enough inductance so that a relatively high capacity setting of the calibrated variable condenser will pick up an harmonic of the generator.

(2)—The frequency of the test circuit, consisting of maximum of the calibrated variable, and also the unknown capacity C_0 , across the coil L , is determined approximately. The generator accuracy need not be very high, as the error is not introduced in the result. Set the generator at one position to influence the VTVM, then at the next consecutive position to do likewise, read the frequencies from the generator, subtract the smaller from the larger, divide this difference into one read frequency, and the unknown high frequency F_h equals this dividend multiplied by the other read frequency.

$$F_h = F_1 \left(\frac{F_2}{F_2 - F_1} \right) = F_2 \left(\frac{F_1}{F_2 - F_1} \right) = \frac{F_1 F_2}{F_2 - F_1}$$

(3)—Multiply known local station frequencies by whole numbers, until a number is reached that is somewhat higher than the approximate frequency F_h . Tune in this station on the receiver R , turn the generator to the higher fundamental frequency required for zero beating some generator harmonic with the station frequency. Divide the apparent frequency as now read on the generator into the station frequency, select the nearer whole number, divide this into the station frequency, and the true generator frequency is ascertained. That is how the generator error is eliminated.

(4)—Now the receiver is shut off and the capacity of the calibrated condenser in the test circuit is decreased a little, just enough to produce maximum deflection of the VTVM, which will not likely be full-scale. The test circuit is therefore at an harmonic of the known generator fundamental, but which harmonic order is not known yet. To ascertain this, the new frequency F_H of the test circuit must be found.

(5)—Noting the generator fundamental frequency, turn the generator until its next succeeding dial position likewise actuates the tube voltmeter. Read this approximate frequency from the generator dial. Subtract the lower from the higher generator frequencies, divide this difference into the approximate generator fundamental, use the nearer whole number and the result is the harmonic order of the accurately known generator fundamental ($n = F_h/F_1$).

(6)—Returning to the accurately-known low frequency, which influences the tube voltmeter, read the apparent capacity, and then turn the calibrated condenser to smaller capacity until the next consecutive response in the meter is produced, and again note the apparent capacity setting. The second setting, being of smaller capacity, causes resonance at a higher frequency, and is due to an harmonic order one higher than applicable to the accurately known generator frequency for the higher capacity setting of the calibrated condenser. Thus the two capacity values and the two harmonic orders are known, and from these the unknown capacity C_0 is determined.

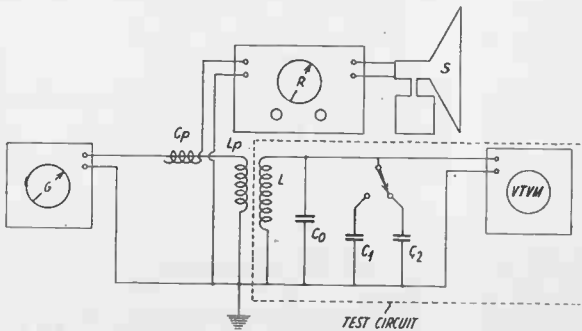

Full setup for measurement. G is the low-frequency generator, C_p is a pickup winding, few turns, for capacity effect, coupling to receiver R ; L_p is inductance pickup coil or primary of a made-up transformer, of which L is the secondary. C_0 is the unknown capacity, C_1 and C_2 are two settings of a calibrated variable, VTVM is the indicator and S is a speaker.

RADIO CONSTRUCTION UNIVERSITY

Answers to Questions on the Building and Servicing
of Radio and Allied Devices.

A.V.C. PEANUT WHISTLE

RECENTLY I added automatic volume control to my receiver. Then a peanut whistle developed. I have checked the tubes for leakage and they are all right. The a. v. c. works fine, but the whistle is a nuisance.—K. W. D.

Increase the resistance in the filter in the return circuits, or the capacity across the present resistors, one controlled stage at a time, until the one is found where the trouble is, and then the remedy is made permanent. The time constant is too low in one or more of these circuits, hence the frequency due to excitation is within the high audio frequency region, and the controlled circuit behaves somewhat as a relaxation oscillator. A higher leak resistance in the local oscillator, if your set is a superheterodyne, also helps sometimes.

* * *

ZERO BEAT PREFERRED

IS it possible to make close frequency calibration of a receiver, using only a generator input, especially to a tuned-radio-frequency set, which I understand is the preferable kind because of absence of danger of spurious responses?—P. L.

No. It is far preferable to zero beat the signal generator with stations of known frequencies, using generator fundamentals or harmonics, and find the receiver settings for zero beats, using the listening method, and also a meter to denote deflection. Thus the frequency, and also the receiver setting corresponding to this frequency, are known closely. The selectivity of the receiver, even if low, then does not introduce an error.

* * *

COMBINED BIASING

IN my set I use a diode-biased triode as driver of a push-pull output stage. Is it all right to use a biasing resistor also, in this driver circuit, so that at no signal there will still be some negative bias, and also twice each cycle, when there would be no bias due to the signal, there will be the steady bias?—K. W. C.

Yes, it is permissible to do this, especially if the steady bias is low, say, around 2 volts. This bias preferably should be obtained from a bleeder circuit in which considerable direct current flows, compared to the current through the cathode circuit of the tube, to insure the steadiness mentioned. If a self-biasing resistor is used, the method is applicable also, but then the

bias at no signal is strictly limited to that which causes no grid current to flow at no signal input. This would be around one volt usually. If the self-biasing resistor is high, then some distortion is introduced, due to the altered curvature of the characteristic, because at no signal there is maximum bias due to this resistor, and at large signal when the plate current is low the bias from the cathode resistor almost disappears.

* * *

DOUBLE-HUMP TUNING

CAN you tell me what causes stations, particularly strong ones, to come in at two places on the dial, both positions close to each other, for all stations? I have tried hard to remedy this serious shortcoming, but have failed.—K. M. S.

This is due to overloading. Usually the trouble arises in the detector. Evidently the manual volume control is at the audio level, perhaps at power tube input, and prior tube or tubes are overloaded, otherwise you would have mentioned that turning down the volume control gets rid of the trouble. The remedy is to select the loudest station receivable, and permanently reduce the input ahead of the detector, by screen or cathode voltage alteration, or otherwise, so that this station comes in at one point only. Then the others can cause no trouble, either. Another solution, which still permits the trouble but enables the remedy to be applied manually, is to move the volume control forward, or add another control, say, of screen voltage. Then the full sensitivity, as may be required for weak stations, is maintained. By the other method there is a permanent reduction of sensitivity. However, all sets should be so circuited and voltage gated that the double humps can not appear.

The trouble you have, of course, is in no way related to image interference in superheterodynes, although there are mechanical aspects of similarity. The dial distance between responses changes with frequency where image trouble exists, and usually the same station seldom is heard twice.

* * *

MEASURING BATTERY RESISTANCE

CAN you give me some handy measurement method for the resistance of a battery.—R. R.

The resistance of a fresh battery of dry cells,

or storage cells, is so long that perhaps you can not expect to measure it with instruments at hand, but with dry batteries particularly the resistance increases with age and use to values readily measured. One method is based on the ohmmeter. Considering the meter and sensitivity and the voltage of the battery, select the proper exact multiplier needed. Then connect the battery in series with the multiplier-meter, with proper polarity. The reading now should be zero for resistance (maximum for current). If the needle is not at the end bar of the scale there is battery resistance current you may be sure. Suppose the meter is a 0-1 milliammeter, the battery is 45 volts, the multiplier, at 1,000 ohms per volt, then is 45,000 ohms, and if the current is read as 20 microamperes, the difference between this and full current deflection current (1,000 microamperes) is divided into the voltage, and the total resistance is thus obtained. Since 45,000 ohms are included in this total, the unknown equals the difference, or 1,800 ohms in this example. Thus,

$$R_b = R_m - [E / (I_f - I_o)],$$

where R_b is the unknown resistance of the battery, R_m is the multiplier resistance required for full-scale meter deflection for the voltage E of the battery, and I_o is the observed current on closing the circuit.

RELATIVE ACCURACY

IN making measurements at radio-frequency levels, based on frequency, capacity and inductance, where one is the unknown and the two others the known, no matter which of the three is unknown, how does percentage error affect the accuracy?—R. W.

The percentage error of known capacity and inductance produces larger percentage error than does the same percentage error of frequency.

STABILIZER

REGARDING the single-sideband short-wave receiver developed by Bell Telephone Labs., described in your September, 1936, issue, please show layout of two-phase motor driving the vernier tuning condenser of the local oscillator through a worm gear, as frequency corrector.—A. L.

The layout is illustrated herewith.

The beat of two modulators drives a two-phase motor that operates until the beat is zero. The speed varies with frequency, so the larger the deviation the more rapid the correction.

METER INDUCTANCE

MEASUREMENTS I intend to make at radio frequencies require a hot-wire ammeter, but since some small inductances are to be included, I would have to know the inductance of the meter, otherwise large error could be introduced.—W. D. C.

Set up a tuned circuit, using calibrated condenser, into which is put a resonant generation, then insert the ammeter, and note the change in condenser setting and frequency required to retune the circuit to resonance, generator unchanged. Compute the inductance. See page 28, August, 1936, issue for formula. A crossed-wire thermoelement, if made with very short heating wires and leads, has a very small inductance and may be usually inserted directly in the circuit without appreciable error.

WHAT RESONANCE IS

CAN you give me some help in the appreciation of resonance? I know that stations come in when the receiver is in resonance with them, but so far I haven't a really good idea of resonance.—K. M. C.

If oscillations of constant amplitude and adjustable in frequency for range of a receiver band are put into the receiver, the generator and the receiver are in resonance when the greatest voltage is developed across the detector input. The generator in practice consists of the station, and it is assumed the carrier alone is considered, without modulation, or that rectification is used, where the radio-frequency voltage causes deflection by a constant factor. Consider that the receiver consists of a single

(Continued on next page)

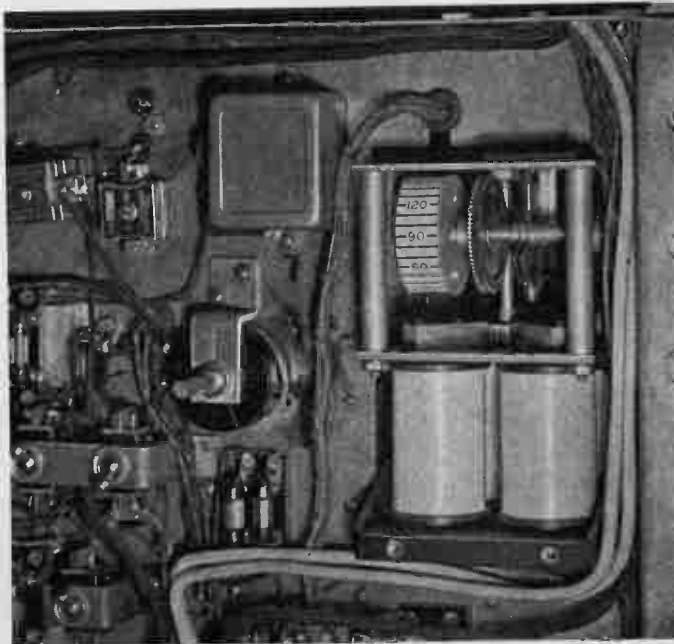

(Continued from preceding page)

tuned circuit, composed of a condenser in parallel with a coil. The condenser offers opposition to the flow of alternating current, due to the condenser's capacity alone, and this is known as the capacity reactance, X_c . It equals $1/(2\pi fC)$ where f is the frequency and C is the capacity. Hence the higher the frequency the lower the capacity-reactance. Also the coil offers opposition to the flow of alternating current, known as the inductive reactance, $X_L = 2\pi fL$. So the inductive reactance increases with frequency. Therefore the two work in opposite directions. The reactances are expressible in ohms. It can be seen therefore that at some frequency the positive reactance and negative reactance are equal, there is no limitation, and the voltage would be infinite, except for the a. c. resistance of the circuit. The condition wherein the reactances cancel is that of resonance. The word that includes the effect of the a. c. resistance along with the reactances is *impedance*.

* * *

OHMS PER VOLT

PLEASE state the rule for the determination of the ohms per volt rating of a voltmeter.—U. D.

The ohms per volt equal the number one divided by the full-scale deflection of the instrument in amperes; in other words, the reciprocal of the full-scale current. Thus, for a meter of 50 microamperes full-scale deflection, since 50 microamperes equal .00005 ampere, the ohms per volt equal $1/.00005$ or 20,000. For a 0.1 milliammeter the ohms per volt equal $1/1,000$ or 1,000.

* * *

6E5 CONNECTIONS

IN the 6E5 tube, is it the target that has the limiting resistor or is it the plate?—K. D. S.

It is the plate, and the object is to limit the plate current and straighten out the visual response in a measure. The full 250 volts are applied to the target. The plate limiting resistor is 1 meg.

* * *

VTVM RANGES

WHAT method may be used in vacuum tube voltmeter practice to enable a practically infinite resistance input for all ranges?—W. D. C.

The method might consist of changing the supply voltages so that they will be suitable for the desired ranges, e. g., increase the negative bias and the positive B voltage on the tube by integral values, the integers equalling the scale multiplication. Example: 0.2 volts, 0.20 volts, 0.200 volts might be worked with 4.5 volts negative bias and 45 plate volts, 45 volts negative bias and 450 plate volts and 200 volts negative bias and 4,500 plate volts, respectively. Of course, these would not be values in practice, but scales would be multiplied by less than 10 each, always the same quantity, however, and applicable to the bias and B voltages as well. Another method is to use the tube voltmeter for

the lowest range as a detector type, then for higher ranges introduce annulling voltages to operate the device as a peak voltmeter, and draw no current, tube operated as indicator, voltages read on a voltmeter across the bias supply. If a little current drain does not matter, high resistances may be used, the higher input voltage being across a total resistance related to the resistance across grid-to-ground circuit by the multiplication factor.

* * *

MORE PEP WRONG WAY

MY superheterodyne has developed a peculiar condition. It is equipped with separate verniers for the oscillator and r. f. stages and I find that the sensitivity is higher by far (about double) when the oscillator is tuned to the lower rather than to the higher frequency, compared to the r. f. level. The circuit coils and padding were designed for the use of higher frequency in the oscillator to establish the difference which is the intermediate frequency. Of course the tracking is far better when the circuit is adjusted as intended, but the sensitivity, as stated, is greater when the vernier is manipulated for lower oscillator frequency. You see, the tracking problem really does not arise, due to the vernier across the oscillator.—K. D. W.

The peculiar condition you set forth is due perhaps to the stray coupling in the receiver. Besides the usual and intended coupling there is this stray coupling of proper phase to reinforce the signal, probably introduce a little regeneration. Either you may adhere to operation by use of the vernier and lower oscillator frequency, or may introduce closer shielding and track as intended, perhaps adding a little regeneration, controllable from the front panel, as the receiver seems able to stand this.

* * *

PREDOMINATING REACTANCE

IOVERHEARD an argument between two radio men about the reactance of a circuit tuned from resonance by increasing the capacity, as to whether the resultant reactance is inductive or capacitive. Which is it?—R. D. G.

The capacitive reactance predominates, when the capacity is increased beyond the resonance point for a parallel tuned circuit. This is obvious when one considers that since the resonant frequency of the circuit containing the condenser is lower, there will be more current through the condenser than through the coil, hence the reactance due to capacity is smaller, or the inductive reactance is higher, as it always is, the lower the frequency. In a series circuit, where maximum current is developed at resonance, instead of maximum voltage, increasing the capacity beyond that creating resonance with some external frequency supply source, reduces the current equally through both condenser and coil (since in a series circuit the same current flows through the members), and the condenser reactance is lower. The whole consideration in both instances is one involving phase.

TWIN-TUBE MULTIVIBRATOR

WILL you please briefly explain the multivibrator and its use with a twin tube?—K. N.

The multivibrator consists of a two-stage resistance-coupled amplifier in which the output of the second tube is injected into the input of the first tube, and the leaks and stopping condensers are of such value as to cause production of a desired audio frequency. The adaptation of the multivibrator to the twin tube is diagramed. The 6N7 metal tube, the 79 approximate equivalent in the glass series, both for 6.3 heater volts, and the 53 for 2.5 volts heater, are in mind, but with small circuit changes the 19 could be substituted for battery use. The instantaneous direction of the current is indicated by the arrows. When the current is rising in the grid circuit of the first section of the tube, through grid leak R_1 , the current is decreasing in the plate leg of that section, through R_3 , on account of the phase inversion of 180 degrees in the tube section. If the plate of the first section is coupled for audio frequencies to the grid circuit of the second section, the direction is the same now, through R_3 , as it was through R_2 , hence it represents a declining value. In the plate leg through R_4 , the opposite holds true, hence there is an increase. So with an increase in this leg, and an increase in the grid leg of the first section, we have equal phase, or zero phase difference, and if the plate of the second section is coupled to the grid of the first section the reinforcement takes place that sets up audio oscillations, although oscillations to 125 kc may be maintained. The frequency is approximately that equal to the reciprocal of the sum of the time constants of the grid circuit elements. These are R_1C_1 for the first section

and C_2R_3 for the second section. The multivibrator is unstable and is rich in harmonics. Instability may be removed by injecting a stable frequency, either higher or lower than the natural frequency of the multivibrator, as the multivibrator will synchronize readily with harmonic or subharmonic, up to the fiftieth. Best results are obtained with harmonic or subharmonic ratios not exceeding 15. Thus a line frequency of 60 cycles may be fed to the second section, where the sine wave is indicated, and the frequency of the multivibrator adjusted to 60/15, 60/14, 60/13, 60/12 etc., or 4,000 cycles, 4,2857 cycles, 4,5384 cycles, 5,000 cycles etc. Or, constants so adjusted, frequency multiples of 60 cycles could be used, for calibrating an audio oscillator from 60 cycles to 9,000 cycles. Even with approximately correct constants, the multivibrator would seek to oscillate at harmonics of the injected frequency. Beyond 9,000 cycles the stability would not be so good, because the ratio is greater than 15, although the change is gradual. The diagram includes an output method.

* * *

TUBE FOR VOLTMETER

FOR the construction of a vacuum tube voltmeter, would you recommend use of a high mu tube, or screen grid tube, or would some other type be preferable?—K. A. C.

It is advisable to use a tube that has a high mutual conductance, possibly ruling out the high mu tubes, and if increased sensitivity is required, use a finer meter. The screen grid tube has some advantages, but at least one extra element is present, and changes in its voltaging may greatly affect any calibration. A triode is preferable, even a power tube of low mu.

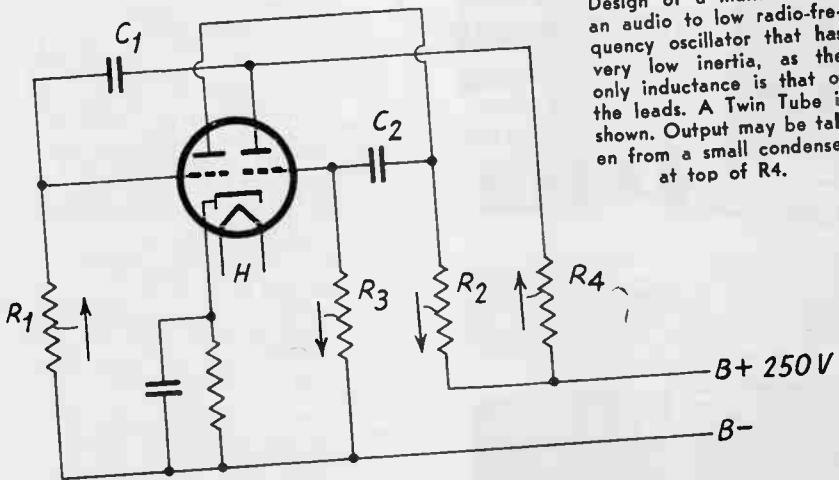

Design of a multivibrator, an audio to low radio-frequency oscillator that has very low inertia, as the only inductance is that of the leads. A Twin Tube is shown. Output may be taken from a small condenser at top of R_4 .

$$f = \frac{1}{C_1 R_1 + C_2 R_3} \text{ APPROX. } C \text{ IS IN Mfd., } R \text{ IN MEG. } F \text{ IS IN CYCLES.}$$

POWERTONE 5-BAND 4-TUBE COMMUNICATIONS RECEIVER

Some of the features found in this masterpiece of engineering are: Band Spread Tuning; Full Sized 4" airplane type dial; Adaptability to operate on either A.C. or D.C.; Elimination of plug-in coils by means of a 5-Band wave switch; Built-in Dynamic Speaker; Use of the new Metal Tubes; and others too numerous to mention. The circuit incorporated is of latest design, and makes use of two of the new metal tubes. They are two 6K7's which are used to provide maximum selectivity and sensitivity. A 43 power pentode used to drive the dynamic speaker, and a 25Z5 tube for rectification purposes.

Band Spread Tuning

Band Spread tuning of all signals is made possible use of a large sized 4" airplane dial. The signal received is spread across the whole dial, thus aiding materially in tuning in more stations and provide better sensitivity.

Complete kit of parts, including pictorial and schematic diagrams, unwired, less tubes and cabinet.....\$10.50
 Wiring and Testing, extra..... 2.50
 4 Matched Sylvania Tubes..... 2.25
 All Metal Crystal Cabinet..... 2.25

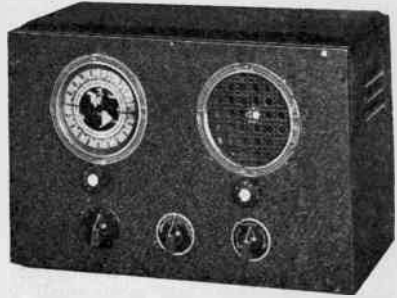

Buddy 2-Tube AC.-D.C. Receiver



"Buddy-2" 2-Tube A. C.-D. C. Receiver Operates on either A.C. or D.C. Makes use of 1-6Y metal tube and 1-12A7 as a combined rectifier and pentode output tube. Furnished with four plug-in coils which tune from 15 to 200 meters. Additional coils to extend the range down to 9½ and up to 2000 meters are available.

Complete kit of parts including pictorial and schematic wiring diagrams, unwired, less tubes, cabinet and additional coils \$4.50
 Wiring and Testing, extra..... 1.25
 2 Matched Sylvania Tubes..... 1.50
 Crystallized Metal Cabinet..... .95
 9½-15, and 200 to 2000 meter coils..... 1.75

Portable 3-Tube Transceiver

Powertone 5 Meter Portable 3-Tube Transceiver
 It is a powerful low current consuming model featuring a unity coupled circuit. Once you have established contact, there is no trouble in maintaining contact when switching to sending and receiving positions. Makes use of 1-30 and 2 type 19 tubes.
 Complete kit of parts including pictorial and wiring diagrams, unwired, less tubes, cabinet and microphone... \$9.50
 Set of 3 matched Sylvania Tubes 1.48
 Portable All Metal Cabinet 1.95
 Wiring and Testing..... 2.50
 R.C.A.-Victor Hand Microphone 1.75



TRY-MO RADIO CO., Inc., 85 Cortlandt Street, New York City
 POWERTONE ELEC. CO., Inc., 179 Greenwich Street, New York City

MAILING LISTS



GET OUR FREE REFERENCE BOOK and MAILING LIST CATALOG FREE

Gives counts and prices on accurate guaranteed mailing lists of all classes of business enterprises in the U. S. Wholesalers—Retailers—Manufacturers by classification and state. Also hundreds of selections of individuals such as professional men, auto owners, income lists, etc.

Write today for your copy

R. L. POLK & CO.

Polk Bldg.—Detroit, Mich.
 Branches in Principal Cities

World's Largest City Directory Publishers
 Mailing List Compilers. Business Statistics. Producers of Direct Mail Advertising.

GENERAL SHORT-WAVE AND PUBLIC ADDRESS MANUAL

This manual includes articles on the construction of short-wave receivers from one to nine tubes, inclusive, and all values between, supers and t-r-f, with the clearest imaginable illustrations, both photographic and draughting. Besides the usual plain circuit diagram there is a pictorial diagram for each circuit. And all the photographs are informative. Portable short-wave sets, design and winding of coils for short waves and broadcasts (intimately illustrated).

List of short-wave stations, with meters and kilocycles and hours on the air; trouble-shooting, and forty other topics, all done well.

The public address section contains data on different systems, how to use them, and offers opportunities to turn public address work to profit. Besides, there are articles on testing and servicing not encompassed by the title of the manual—signal generators, broadcast home and portable set, analyzers, formulas, capacity data. Everything plainly told, simple language, from microphones to speakers.

PRICE 25 CENTS, or send \$1.00 for 4 issues of RADIO WORLD and the manual will be sent FREE postpaid.

RADIO WORLD 145 WEST 45th ST. NEW YORK CITY

CLASSIFIED ADVERTISEMENTS

7 cents a word. \$1.00 minimum.

FOR MODERN RADIO Reception. Use your old aerial. Make your own All-Wave DX system. Simple plan and instructions, 20 cents. OCEANIC ALL-WAVE SYSTEM, 140 West 42nd, New York, N. Y.

SW CRYSTAL SET—4250 mile record. Instructions 18 distance models; "Radiobuilder" year; 25 cents. Laboratories, 151-P Liberty, San Francisco.

40 ACRES—near White River, unimproved, poultry land, \$100; \$5 down, \$5 monthly. Free list and literature. Hubbard, 274 Grossman Bldg., Kansas City, Kansas.

AMATEUR RADIO LICENSES. Resident and correspondence courses. Every graduate a licensed operator. New York Wireless School, 1123 Broadway, New York.

BARGAIN LISTS 6c.—We buy anything. Bi-Cam-Ex, Dept. RW1, 1451 Broadway, New York.

THREE CAMERAS in one. Takes snapshots, moviebooks, 16mm movies. Springmotor driven. Only \$5.00 brand new. Films \$1.00. Send no money. Pay postman. Projectors \$1.00 up. Free lists. Home Movies, Box 32-RW, Easton, Pa.

MAN IN EACH TOWN to plate Auto Parts, Reflectors, Mirrors, etc., by late method. Experience unnecessary. Free particulars and proofs. Write today. Dept. RW-1, Gun Metal Co., Ave. M, Decatur, Ill.

ATTENTION! SERVICEMEN: A catalogue containing 40 most popular Majestic Schematic Diagrams—50c postpaid. Diagrams for any make receiver—40c. Address: Waxman Sales, Inc., 1574 - 56th St., Brooklyn, N. Y. Dept. K.

EDISON STORAGE BATTERIES will save you money. Replace your lead with the Edison. Non-acid. Odorless. Fifteen year life. Liberal unconditional guarantee. Bargains in complete generating plants, motor, etc. Free illustrated literature. "See Jay Battery Company," Dept. RW-1, 82 Sterling Avenue, Yonkers, New York.

You need **2** these books

PRINCIPLES of PUBLIC ADDRESS SYSTEMS

A practical handbook, full of useful information, fully illustrated, written by M. N. Beitman, an engineer and noted authority on audio amplifiers.

Considers in detail various microphones, radio and phonograph inputs, acoustic feedback, mixing and volume controls, use of vacuum tubes, interstage coupling, power amplifiers, output coupling, loud speaker placement, the decibel, P.A. measurements, power level, and other points of importance, including actual circuit diagrams of tested P.A. systems.

MATHEMATICS of Radio Servicing

Introduces and explains the use of arithmetic and elementary algebra in connection with units, color code, meter scales, Ohm's Law, alternating currents, ohmmeter testing, wattage rating, series and parallel connections, capacity, inductance, mixed circuits, vacuum tubes, curves, the decibel, etc., etc., and has numerous examples.

Plainly written and easy to understand. Only useful data included. M. N. Beitman, author. Size, 8 1/2 x 11 in.

Price, 50c each book.

SUPREME PUBLICATIONS

3727 West 13th St., Chicago, Illinois

A COMBINATION OFFER! RADIO WORLD and "RADIO NEWS" \$3.50

Canadian and Foreign, \$1.50 extra on this offer.

You can obtain the two leading radio technical magazines that cater to experimenters, service men and students, for one year each, at a saving of \$1.50. The regular mail subscription rate for RADIO WORLD for one year is \$2.50. Send in \$1.00 extra, get "Radio News" also for a year—a new issue each month for twelve months. Total 24 issues for \$3.50 and \$5.00 to foreign countries.

RADIO WORLD, 145 West 45th Street, N. Y. City

TREASURE SEEKING RADIO CIRCUITS

An 11-page illustrated article by J. E. Anderson, in the September, 1936, issue of Radio World. 25c a copy, postpaid, as long as the limited supply lasts. Or include this as a part of your new short-time or full year subscription.

RADIO WORLD

145 West 45th Street, New York, N. Y.

SPECIAL 2-FOR-1 OFFER RADIO WORLD

Radio World is \$2.50 a year (12 issues), 25c. per copy. Canada and foreign, \$3.00 yearly. Offers of Radio World and other worthwhile publications for one full year on each (NET):

- RADIO WORLD and SHORT-WAVE CRAFT, \$3.50.
- RADIO WORLD and POPULAR SCIENCE MONTHLY, \$3.50.
- RADIO WORLD and RADIO-CRAFT (12 issues), \$3.50.
- RADIO WORLD and RADIO INDEX (monthly, 10 issues), stations, programs, etc., \$3.50.
- RADIO WORLD and SERVICE (monthly), \$3.50.
- RADIO WORLD and EVERYDAY SCIENCE AND MECHANICS (monthly), \$3.50.
- RADIO WORLD and BOYS' LIFE (monthly, 12 issues), \$3.50.
- RADIO WORLD and MOTION PICTURE MAGAZINE (monthly), \$3.50.
- RADIO WORLD and TRUE STORY (monthly), \$3.00.
- RADIO WORLD and LIBERTY (weekly), \$3.00, U. S. only.

Select any one of these magazines and get for an entire year by sending in a year's subscription for RADIO WORLD at the regular price, \$2.50, plus a small additional amount, per quotations above. (Add \$1.50 for extra foreign or Canadian postage for both publications.)

Name
Address
City and State.....

- If renewing an existing or expiring subscription for RADIO WORLD, put cross in square.
- If renewing an existing or expiring subscription for other magazines, put cross in square.

Special Trial Offer for Radio World only: \$1.00 for 5 months, postpaid. Mail order with remittance to Radio World Office. NET.

PRECISION

CONDENSER ANALYZER

Output Meter - Leakage Tester

Complete
with 2 tubes **\$7.40**

A N AMAZING PRICE on a new instrument that *every* service man and home experimenter needs. Not an approximate meter reading but a true capacity bridge that is

DIRECT READING
up to 16 mf.

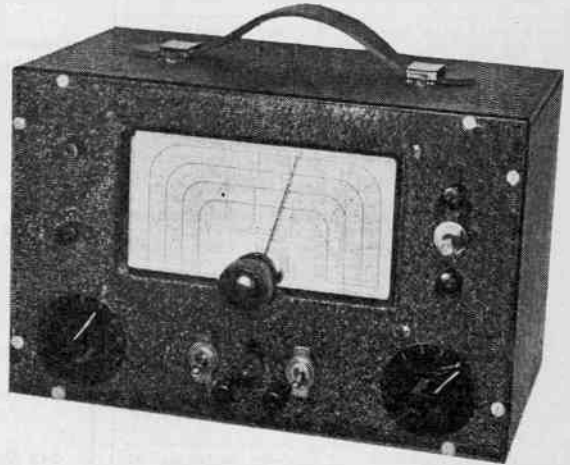
**Tells Everything You Want To Know About a Condenser**

- Is it shorted or open circuited?
- Does it leak and how badly?
- What is its capacity?

T HEN throw a switch and you have a sensitive output meter with shunt voltage adjustment for use with your oscillator when lining up receivers. Three instruments that are indispensable to every serviceman; combined in one small portable case and operating directly from the 110 volt A.C. line. **Model 40 Capacity Analyzer**, in shielded cabinet with carrying handle, wired, calibrated and tested; complete with 2 tubes \$7.40. (Shipping Weight 7 lbs.)

**OUTSTANDING
VALUE!**

Model T-37 SIGNAL GENERATOR

The fastest selling Signal Generator on the market. You can't help but recommend it. Hundreds sold since its introduction three months ago.

Complete
.. only **\$12.40**

- 110 Volts A.C. or D.C.
- 110 kc. — 20 megacycles all on fundamentals.
- Dial is direct reading in frequencies.
- B.F. output may be taken from a high impedance or a low impedance post, in with attenuation present for either.
- Separate audio output at 2 amplitude levels, so that tone may be used for checking public address systems, audio amplifiers in receivers, and speech amplifiers in transmitters.
- Two extra posts on front panel enables leakage tests. Condensers may be checked for leakage, so may tubes, and other normally high resistance currents, otherwise difficult to test.

Model T-37 All-Wave Signal Generator, wired, in shielded cabinet with carrying handle and calibrated, tested; complete with 3 tubes, instructions, (shps. weight **\$12.40** 7 lbs.)

SUPERIOR INSTRUMENTS
Dept. 101, 139 Cedar Street

COMPANY
New York, N. Y.

H.G. CISIN'S NEW 1937

AIR SCOUT JUNIOR DOLLAR RADIO

ONLY KIT OF ITS KIND IN THE WORLD

ONLY
\$ 1

WITH TUBE
SHIPPING WT. 2 LBS
PANEL SIZE
8 1/2" X 11"

KEEN BROADCAST RECEPTION
BATTERIES COST LITTLE AND
LAST A LONG TIME!
EASY TO BUILD



ONLY
\$ 1

WITH TUBE
USES 2 FLASHLIGHT
"A" BATTERIES
+ 1-22 1/2 V "B"
BATT

A REAL RADIO - NOT A TOY
LEARN RADIO BY BUILDING
EARN MONEY BY SELLING
AIR SCOUT JR.

THE BIGGEST DOLLARS WORTH IN RADIO

COMPLETE \$1 KIT CONSISTS OF THESE PARTS

NEW METAL TUBE VARIABLE TUNING CONDENSER LOW DRAIN 30 TYPE TUBE ANTENNA CONTROL TRIMMER FILAMENT RHEOSTAT FIXED MICA CONDENSER 9 FARNSTOCK CLIPS KNOB WONDERFUL NEW PICTURE WIRING DIAGRAM WHEN PASTED UNDER PANEL ELIMINATES GUESS-WORK AND INSURES SUCCESS	2 SPECIAL FIND-ALL COILS* CALIBRATED DIAL GRID LEAK RESISTOR GRID LEAK CONDENSER ROLL OF HOOK-UP WIRE DETAILED INSTRUCTIONS
--------------------------------------------------------------------------------------------------------------------------------------------------------------------------------------------------------------------------------------------------------------------------------------	--------------------------------------------------------------------------------------------------------------------------------------------

AUXILIARY PARTS SOLD ONLY WITH KIT

SINGLE EARPHONE	\$.65	DOUBLE EARPHONES	\$1.40
COMPLETE ANTENNA KIT			.50
2 "A" BATTERIES (FLASHLIGHT)	EACH		.10
22 1/2 VOLT "B" BATTERY			.75
SCREW KIT	\$.10	WOOD PANEL-CHASSIS KIT	35

H.G. CISIN, CHIEF ENGINEER
 ALLIED ENGINEERING INSTITUTE
 98 PARK PLACE, NEW YORK, N.Y. DEPT. R

Gentlemen:

ENCLOSED PLEASE FIND \$ _____
 FOR 1937 AIR SCOUT JUNIOR KIT - AND _____

NAME _____

ADDRESS _____

The EXPERIMENTERS TREASURE HOUSE

Since 1923, we have been catering to the needs of Radio and Electrical Experimenters. From cat-whisker to television tubes, miniature motors, relays from 29c to \$6.50—photoelectric cells, neon lamps from 15c to \$1.50, in fact anything and everything you may need, in stock or know where to obtain for you. We have been shopping agents for well-known schools and institutions for many years, why not for you?

Headquarters for Parts—Since 1923
BLAN THE RADIO MAN, INC.
 C177 Greenwich St., New York, N. Y.
NO CATALOGUE—BUT LOWEST PRICES

WHEN WRITING TO ADVERTISERS
 PLEASE MENTION THAT YOU SAW THE
 ADVERTISEMENT IN RADIO WORLD.

RADIO WORLD AND POPULAR MECHANICS MAGAZINE
 —Radio World is \$2.50 a year, and Popular Mechanics Magazine is \$2.50 a year. Popular Mechanics Magazine does not cut rates, but Radio World will send both publications to you for one year for \$3.75. Radio World, 145 West 45th St., New York City.

1937 RADIO CATALOG



Newest Amateur Equipment at Lowest Prices

You'll find everything you need in ALLIED's big new 1937 Catalog! A tremendous assortment of transmitters, receivers, transceivers. Dozens of new Kits for Set-Builders—new metal tube DX'er, Knight Super-Gainer, new 6-volt All-Wave set, 5 Meter Transceiver and many others. Latest Public Address Systems! Newest Metal-Tube sets! Over 10,000 exact duplicate and replacement parts; tools, test equipment! Everything you want in Radio's Big-Value Book—at lowest prices!

ALLIED SELLS FOR LESS
 We buy in vast quantities, pay less and can sell for less. If you ever find identical brand and quality offered elsewhere for less, Our fresh, clean stocks of highest quality equipment are gathered under one great roof; your orders shipped same day received. It's easy to order from our big Catalog—and you save money. Send coupon now for your copy.

ALLIED RADIO

833 W. Jackson Blvd.
 Chicago, Ill.

Dept. 16-K

Send me your FREE 1937 RADIO CATALOG.

Name

Address

City State

TRANSFORMERS

FOR ALL PURPOSES

for example:

TRANSCEIVER TRANSFORMERS

F-532-B—Microphone and Plate Primaries to Grid Secondary. Uncased, light weight, Net.....\$1.92

F-533-B—Transceiver Output from plate of 33, 38, 41, etc. to 130,1000 or 2000 ohm handset or phones..\$1.00

F-536-B—Similar to F-532-B but for more powerful Transceiver using a 19 as push-pull R.F., 30 as audio driver, and 19 as Class B Modulator.....\$1.85

F-534C—Class B Input, 30 driver to 19 Grids Class B.....\$3.80

F-535-B—Class B Output from 19 Twin to modulate 19. Sec. handles plate current of r.f. stage, impedance approx. 2700 ohms, or any 7 watt stage approx 50 m.a. at 135 volts.....\$1.17



General Replacement Transformers

will be found in our

CATALOGUE No. 51-C

Three examples out of 161:

No. 210—300-0-300 V. 40 m.a.; 2.5 V. 5.5 A; 5V. 2A.....\$1.11

No. 209—330-0-330 V. 60 m.a.; 2.5 V. 8.75 A; 5V. 3A.....\$1.80

No. 1103—Single Plate to Push-pull Grids.....\$3.98



High Fidelity Audio Transformers for Public Address. Broadcast and Amateur Stations will be found in our catalogues No. 70, No. 70-A. Description of all types for microphones, matching, interstage, and output, all fully cased and shielded. Useful diagrams included.

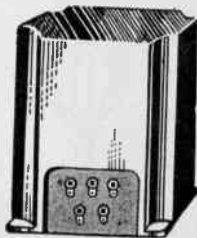

AMATEURS!

SEND FOR CATALOGUE No. 52-C

Contains nearly a hundred stock transformers and chokes for all power phone and C.W. rigs, designed by Boyd Phelps. W2BP-W9BP. Illustration shows FTP-56 which delivers % K.W. and costs \$9.50 net.



Any of the above catalogues free for the asking. If in a hurry, order direct from this ad or see your local jobber. If he does not have these lines tell him he is missing something well worth while.

FRANKLIN TRANSFORMER MANUFACTURING COMPANY

607-609 22nd Ave. N.E., Minneapolis, Minn.



3A 3-Tube

SW Receiver

9½ to 600 meters
A simple and efficient
short wave model, in-
expensive in price but
a wizard in
performance.
Uses three
tubes in a
special ultra-
generative
circuit with
one stage of
audio ampli-
fication and complete built-in
power supply.

- Vernier dial for easy tuning.
- Good volume on all stations.
- Small, compact, and light in weight.
- Operates from your AC or DC house current.
- Black, crackle finish metal chassis, panel and cabinet.

Eilen 3A KIT, of necessary parts, including coils for 9½ to 200 meters, and simple instructions, less cabinet, tubes, B.C. **\$4.95**
 coils, unwired \$1.25
 Beautiful, crackle finish cabinet, extra \$1.14
 Set of MATCHED tubes, extra..... \$1.14
SPECIAL: Complete kit, cabinet, tubes and instructions, less B.C. coils, **\$7.25**
 unwired \$1.50
 Labor for wiring and testing, extra..... \$1.25
 2 Broadcast band coils, extra..... \$1.25

MODEL 3B 3-TUBE BATTERY OPERATED RECEIVER—9½ to 600 meters AN IDEAL SUMMER PORTABLE

Same specifications as model 3A except that it uses 3 of the 2 volt battery operated tubes in a highly efficient circuit as regenerative detector and 2 stage audio amplifier. Same price as 3A.

FREE Large, illustrated catalogue of short wave receivers, transmitters, transmitting apparatus, and accessories. Send stamp to cover mailing costs.

Prompt Service. 20% deposit on C.O.D. orders.

EILEN RADIO LABORATORIES, Dept. RW10, 136 Liberty Street, New York City



BS-5

5-Tube Band switch Receiver

12 to 600 meters
A powerful, sensitive, and selective SW receiver covering the entire wave-length span of 12 to 600 meters in 5 steps.

NO PLUG-IN COILS are used. Simply turn the waveband selector switch and enjoy reception on any wavelength within this range.

Uses two 6D6, one 76, one 49, and one 25Z5 tubes as RF amplifier, electron coupled screen grid regenerative detector, powerful 2 stage audio amplifier with pentode output stage, rectifier, and complete built-in power supply.

HUM-FREE—Hi-fidelity dynamic loudspeaker—Illuminated, airplane type vernier dial—band spread tuning control—automatic headphone jack—extremely smooth acting controls—operates from your AC or DC house current—beautiful, heavy, black shrivel finish chassis and cabinet.

DELIVERS GREAT LOUDSPEAKER VOLUME ON THE GREAT MAJORITY OF SHORT WAVE FOREIGN STATIONS UNDER FAIR CONDITIONS.

PRICE, complete with 5 tubes, cabinet, speaker, wired, ready to use

\$16.95

BS-5 KIT, of necessary parts, including speaker and detailed instructions, 5 tubes, cabinet, unwired..... **\$10.95**

SPECIAL: Complete kit, cabinet, tubes and instructions, unwired..... **\$14.95**
 (If metal tubes are preferred to glass type, add \$1)

AMATEURS: Model BS-5-AB has same specifications as BS-5 except that it has special bandspread circuit for 20-40-80-160 M bands and is equipped with plate voltage cut-off switch. Add \$1.00 to above price.

\$1.00 a month
 is all you need to pay for
LIFE INSURANCE

\$1194.00 of insurance at age 21; \$818.00 at 35. Other ages in proportion in this Old Line Legal Reserve Company that sells without agents and gives the saving to its policy holders. Postal has paid out \$48,000,000 in 31 successful years. It has millions in assets and reserves. Just write a card today with your name, address and exact date of birth and you will get full details and rates for your age by return mail. Insurance is vital! Act promptly while rates are low.

POSTAL LIFE INSURANCE COMPANY
 Dept. RD-180—511 Fifth Avenue, New York

METAL CHASSIS

We can supply chassis for any make receiver, experimental or otherwise.

Inquiries should be accompanied with sketch and complete details enabling us to give quick service as to prices and delivery.

Dept. R.W. 734
KORROL MFG. CO., Inc.
 232 Greenwich St. New York City

"CAPITAL" how and where to obtain capital, fully explained, write for free particulars today. **STAR SERVICE,** Box 333A, Wapakoneta, Ohio.

WHEN WRITING TO ADVERTISERS PLEASE MENTION THAT YOU SAW THE ADVERTISEMENT IN RADIO WORLD.

IRON CORE I.F.

GET in line with the latest developments in G coil design. Use iron-core i.f. transformers and increase selectivity and sensitivity. Results are amazing. Let us prove it with our latest iron core i.f. transformers for 456-470 kc (adjustable within this range), double tuned on top. As much gain and selectivity with one iron-core i.f. stage (two coils), as with two stages (three coils) using ordinary transformers. Shield size 3.5 x 1.5 inches. Price, postpaid. **\$1.15 each.**

Radio design "Noise Silencing Coil Kit" for J. Lamb Circuit O.S.T. one special I.F. 456-470 and special R.F. choke—postpaid.

\$1.50 Both

FREE DIAGRAMS

Enclose stamped self-addressed envelope for free diagrams of t.r.f. and superheterodyne circuits for home construction.

RADIO DESIGN COMPANY

1353 Sterling Place

Brooklyn, N. Y.

WALLY'S

Largest dealer service in the city.
 Cracker-jacks on tough installations and motor noise elimination.

(Authorized All Makes)
AUTOMOTIVE AND MARINE SPECIALISTS
HUDSON TERMINAL GARAGE BLDG.

61 Oey Street, 1 block south Fulton St., New York City
 WOrth 2-9080 WOrth 2-3131

PUBLIC ADDRESS SOUND SYSTEMS

Model 716-D Sound System

Ideal P.A. outfit for a multitude of purposes. Hi-Fidelity output from crystal, velocity or pickup. Perfect control of all inputs for individual or simultaneous operation. Heavy duty parts thruout insure long life and continuous operation.

Complete system with accessories as listed **\$48.50**
Mounted in case **\$3.50**

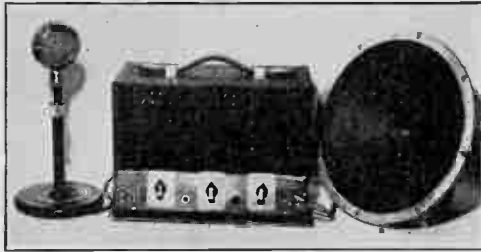

15 WATT, 2 CHANNEL, 2 SPEAKER AMPLIFIER
4 stage high gain dual channel system. Pre-amplification for crystal or velocity mike with low gain input for pickup or tuner. Individual controls for perfect mixing. Field supply for 2 speakers with throwover switch for 1 or 2 speaker operation. 6 tubes: 1 - 75, 2 - 6A6s, 2 - 6B5s push pull, 1 - 83c. 20 watt peak. 40-10,000 cycles within 3dB. Full Range tone control. Heavy gauge steel chassis and screen cover in oven baked crackle. No. 716-D Amplifier, as described: **\$19.95**

Model 716-D Accessories

- Set of 6 matched Raytheon Tubes... **\$5.95**
 - Magnavox 12" Super Dynamic Speaker **4.45**
 - Universal Velocity or Shure #70H Crystal Mike **13.50**
 - Adjustable 6' shock-proof floor stand **5.90**
 - 25 ft. Speaker cable, 25' shielded mike cable **2.25**
- All items may be purchased separately.

Model
717
Hi-Gain
Dual
Channel
Input
20 Watt
Output

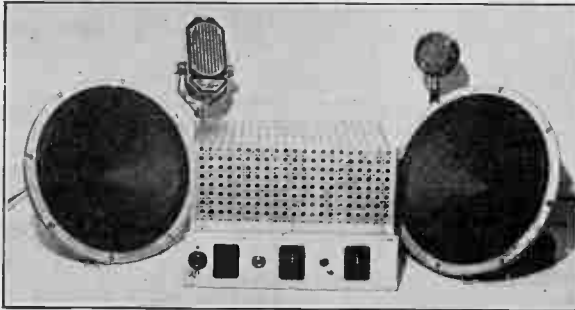

Model
717
Hi Fidelity
Output
1 or 2
Speaker
Operation

20 WATT HIGH GAIN HIGH FIDELITY AMPLIFIER

A complete sound system designed for tremendous volume and real fidelity. Custom-built unit employing 7 of the latest tubes: 1 - 75 2 - 6A6's, 1 - 83v, 2 - 6B5's Push Pull, 1 - 25Z6. 25 watt peak. Frequency response 40,—12,000 cycles within 2dB. Dual channel input. High gain—124dB for crystal or velocity mike. Low gain—90dB for pickup or tuner. Built in speaker field supply for 1 to 4 speakers with selector switch included. Chassis and metal screen cover finished in special oven baked lifetime finish. Dual channel input with individual controls for fading and mixing permit ideal control. Full-range tone control. Power consumption 100 watts. 717 amplifier. 5 stage high gain circuit. As described..... **\$28.50**

QUALITY COMPONENTS MATCH 20 WATT AMPLIFIER

- Items listed may be purchased separately or at complete price marked below.
- 1 Set of 7 Matched Raytheon Tubes. **\$6.95**
 - 2 Magnavox 12 inch Super Dynamics, \$4.45 each..... **8.90**
 - 1 Universal Velocity or Shure Crystal Mike **13.50**
 - 1 6' Adjustable Shock-Proof Floor Stand **5.90**
 - 1 Cable, 25', Shielded for Mike..... **1.00**
 - 2 Cables, 25 ft. each, for Speaker Extensions **2.50**
- Complete System—No. 717 Amplifier. All parts as listed and illustrated. **\$62.60**
Shipped Complete—Ready to Operate

We Also Furnish a 3 Section Case for Mounting } 717 in case **\$69.50**
Amp. and 2 Speakers. }
Specially re-enforced } 716D in case **53.50**

FREE
Information on all PA requirements.

THOR RADIO

65 CORTLANDT STREET NEW YORK

ORDER DIRECT
From
THIS AD. 24 HOUR SERVICE

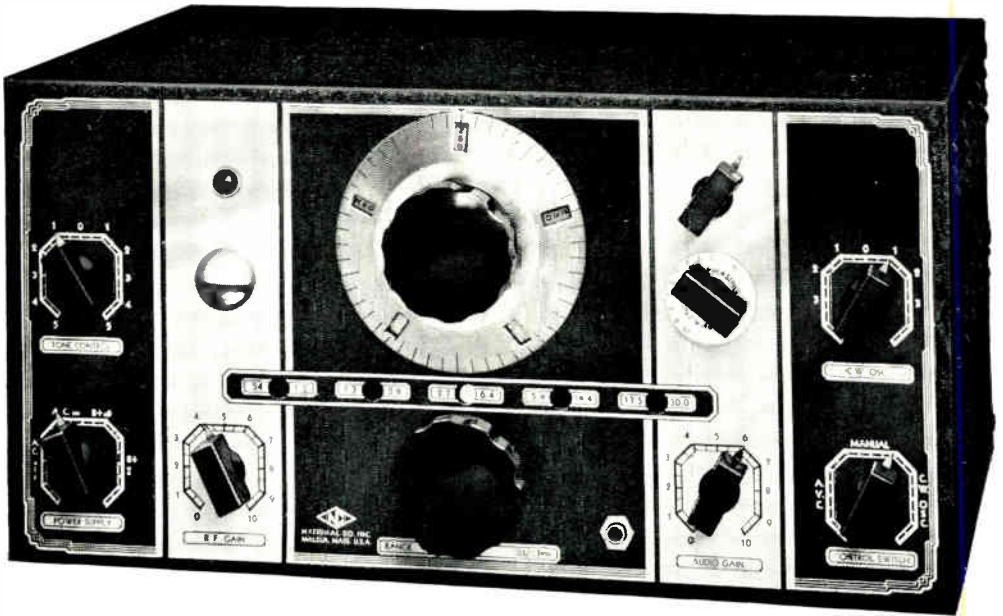

NEW AS TOMORROW!

New in every sense of the word, The twelve tube NC-100 Receiver includes every advanced refinement that could contribute to short wave listening. Unique among its many unusual features is the perfected tuning unit with its Automatic Plug-in Coils, which combine the electrical efficiency of plug-in coils with the convenience of the coil switch. Each of the fifteen H.F. and oscillator coils is enclosed in its own shielded compartment of cast aluminum. A twist of a knob on the front panel brings the desired range into position and plugs it in. Idle coils are isolated, leads are short, losses are low, and calibration

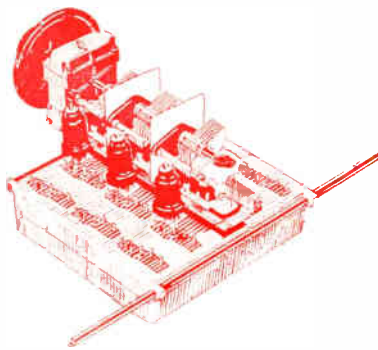

is exact. There are no "dead spots" on the NC-100. Fully worthy of the advanced performance of the Tuning Unit are other details of the super-heterodyne circuit. Thorough use of low-loss insulation and of air-dielectric condensers, together with carefully designed high-Q coils result in exceptionally high signal-to-noise ratio, and high sensitivity. Complete panel controls, ranging from the Micrometer Dial to Cw oscillator tuning control make the operation of the NC-100 a pleasure. See this remarkable receiver at your dealers, or if more convenient write for a completely illustrated folder.

NATIONAL COMPANY, INC., MALDEN, MASS.



D. C. POCKET VOLT-OHM-MILLIAMMETER



MOLDED CASE
3" x 6" x 2" (Approximately)



SELECTOR SWITCH
FOR ALL RANGES



BATTERY, TEST LEADS AND
ACCESSORIES INCLUDED



ACCURACY TO 2%

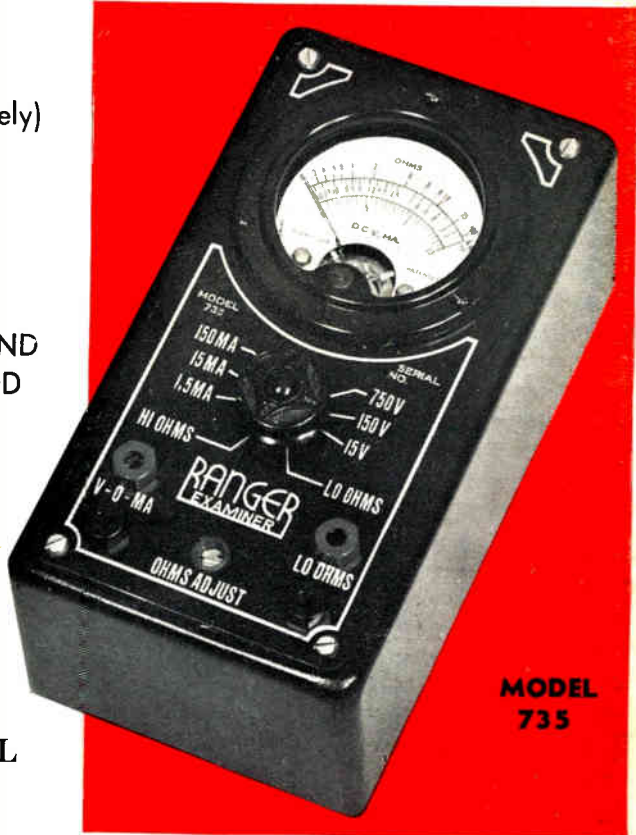

MODEL
735

A PRECISION
INSTRUMENT
AT A SENSATIONAL
PRICE

Model 735 has a Triplett D'Arsonval type precision instrument with easily readable scales. Ranges are 15-150-750 volts; 1.5-15-150 M.A.; 1/2-1000 low ohms; 0-100,000 high ohms at 1.5 volts. Provisions for external batteries for higher resistance measurements. Has selector-switch for all ranges and individual zero adjustment for resistance measurements.

DEALER PRICE **\$10.80**

Sturdy molded black case, 3 1/16" x 57/8" x 21/8" high. Attractive silver and black panel. Battery and test leads with alligator clips are included. Dealer Net Price Complete \$10.80.



READRITE METER WORKS
1027 College St., Bluffton, Ohio

Please send me more information on Model 735 Volt-Ohm-Milliammeter. I am also interested in.....

Name

Address

City State