

MEASUREMENT NUMBER

RADIO WORLD

REG. U. S. PAT. OFF.

15th Year

AUGUST, 1936

25c Per Copy

A BAND-PASS PRE-SELECTOR

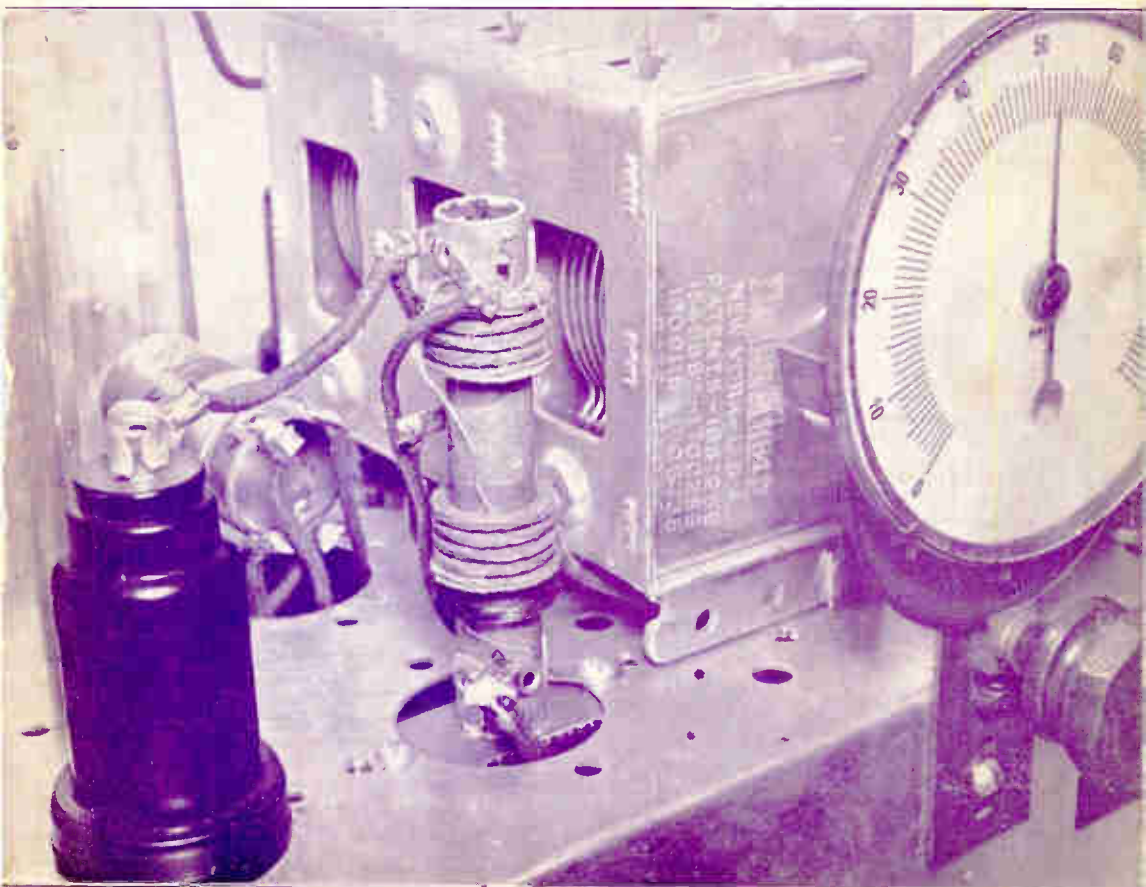

A BAND-PASS PRE-SELECTOR IMPROVES IMAGE SUPPRESSION IN A SUPERHETERODYNE. THE COUPLING DETERMINES THE BAND PASSED. SEE PAGE 45.

FOR

Torrid
Temperatures

DEMAND



Cornell-Dubilier CONDENSERS



Type RHM
Electrolytic

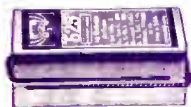

Type DA Paper



Type 9 Mica

When temperatures start climbing and the humidity is equally as high . . . keep your eyes open for condenser troubles!

Cornell-Dubilier engineers have been working on the development of a condenser that is effectively sealed against abnormal summer temperatures and humidity conditions, for more than twenty-six years. That the majority of the leading radio receiver, transceiver and transmitter manufacturers incorporate C-D condensers in their product's assembly is ample proof that the efforts of the C-D laboratories have been successful.

You, too, can enjoy your hobby during the summer months, without the usual aggravating and expensive condenser difficulties . . . by using Cornell-Dubilier condensers.

THE MOST COMPLETE CONDENSER LINE IN THE WORLD!
MICA • PAPER • DYKANOL • WET AND DRY ELECTROLYTIC

Write for Catalog No. 128, detailing in its entirety the C-D condenser line today!

CORNELL-DUBILIER

C O R P O R A T I O N

4343 BRONX BOULEVARD • NEW YORK



J. E. SMITH, President, National Radio Institute
The man who has directed the home study training of more men for the Radio Industry than any other man in America.

Be a Radio Expert

Many make \$30 \$50 \$75 a week

I will train you at home for many Good Spare Time and Full Time Radio Jobs

Do you want to make more money? Radio offers you many opportunities for well-paying spare time and full time jobs. And you don't have to give up your present job or leave home and spend a lot of money to become a Radio Expert.

Many Radio Experts Make \$30, \$50, \$75 a Week

Radio broadcasting stations employ engineers, operators, station managers and pay up to \$5,000 a year. Spare time Radio set servicing pays as much as \$200 to \$500 a year—full time jobs with Radio jobbers, manufacturers and dealers as much as \$30, \$50, \$75 a week. Many Radio Experts operate their own full time or part time Radio sales and service businesses. Radio manufacturers and jobbers employ testers, inspectors, foremen, engineers, servicemen, paying up to \$6,000 a year. Radio operators on ships get good pay and see the world besides. Automobile, police, aviation, commercial Radio, and loud speaker systems are newer fields offering good opportunities now and for the future. Television promises to open many good jobs soon. Men I have trained are holding good jobs in these branches of Radio. Read their statements. Mail the coupon.

There's a Real Future in Radio for Well Trained Men

Radio already gives jobs to more than 300,000 people. In 1935 over 300,000,000 worth of sets, tubes and parts were sold—an increase of 20% over 1934! Over 1,100,000 auto Radios were sold in 1935, 25% more than in 1934! 22,000,000 homes are today equipped with Radios, and every year millions of these sets go out of date and are replaced with newer models. Millions more need servicing, new tubes, repairs, etc. Broadcasting stations pay their employees (exclusive of artists) more than \$23,000,000 a year! And Radio is a new industry, still growing fast! A few hundred \$30, \$50, \$75-a-week jobs have grown to thousands in less than 20 years!

Many Make \$5, \$10, \$15 a Week Extra in Spare Time While Learning

Practically every neighborhood needs a good spare time serviceman. The day you enroll I start sending you

Extra Money Job Sheets. They show you how to do Radio repair jobs that you can cash in on quickly! Throughout your training I send you plans that made good spare time money—\$200 to \$500 a year—for hundreds of fellows. My training is famous as "the Course that pays for itself."

I Give You Practical Experience

My Course is not all book training. I send you special Radio equipment and show you how to conduct experiments and build circuits which illustrate important principles used in modern Radio receivers, broadcast stations and loud speaker installations. I show you how to build testing apparatus for use in spare time work from this equipment. This 50-50 method of training makes learning at home interesting, fascinating, practical.

You Get a Money Back Agreement

I am so sure that I can train you successfully that I agree in writing to refund every penny you pay me if you are not satisfied with my Lessons and Instruction Service when you finish. I'll send you a copy of this agreement with my Free Book.

Find Out What Radio Offers You Act Today

Mail the coupon now for "Rich Rewards in Radio." It's free to any fellow over 16 years old. It describes Radio's spare time and full time opportunities and those coming in Television; tells about my training in Radio and Television; shows you actual letters from men I have trained, telling what they are doing and earning. Find out what Radio offers YOU! MAIL THE COUPON in an envelope, or paste on a postcard—NOW!

J. E. SMITH, Pres., National Radio Institute
Dept. 6HM4
Washington, D. C.



Broadcasting Stations

Employ managers, engineers, operators, installation and maintenance men for fascinating jobs and pay up to \$5,000 a year.

Set Servicing

Spare time set servicing pays many \$5, \$10, \$15 a week extra while learning. Full time servicing pays as much as \$30, \$50, \$75 a week.



Loud Speaker Systems

Building, installing, servicing and operating public address systems is another growing field for men well trained in Radio.



HERE'S PROOF THAT MY TRAINING PAYS



\$80 Monthly in Spare Time

"I work on Radio part time, still holding my regular job. Since enrolling five years ago, I have averaged around \$80 every month." JOHN B. MURPHY, 773 Silver Street, Manchester, N. H.

Makes \$50 to \$60 a Week

"I am making between \$50 and \$60 a week after all expenses are paid, and I am getting all the Radio work I can take care of, thanks to N. R. I. H. W. SPANGLER, 306 Walnut St., Knoxville, Tenn.



Operates Public Address System

"I have a position with the Los Angeles Civil Service, operating the Public Address System in the City Hall Council. My salary is \$183 a month." R. H. ROOD, R. 136, City Hall, Los Angeles, Calif.



This Coupon is Good for One FREE Copy of My Book

J. E. SMITH, President, Dept. 6HM4
National Radio Institute, Washington, D. C.

Dear Mr. Smith: Without obligating me, send "Rich Rewards in Radio," which points out the spare time and full time opportunities in Radio and explains your 50-50 method of training men at home in spare time to become Radio Experts. (Please Write Plainly.)

NAME.....AGE.....

ADDRESS.....

CITY.....STATE.....

An Ideal Receiver!



The Hammarlund "Super Pro"

IN the nation's leading research laboratories, on the air fields, in "ham" shacks, on scientific expeditions, in naval and war departments, coast-to-coast broadcast systems, foreign commercial and government services—everywhere—where the most exacting equipment must be used, Hammarlund "Super Pro's" have been unanimously approved and promptly installed! "Super Pro's" receive such decided acclamation, for they have every grand, important feature demanded by experts—truly the "ideal receiver." One such feature is the electrostatically shielded input. Then there is that uncanny, exclusive Hammarlund five-band switch, remarkably positive and smooth in action. The unique variable selectivity system affords continuous variation from $\frac{1}{3}$ to over 3 times critical coupling. Another feature is the special 12-gang band spread condenser. That cleverly designed "Super-Pro" crystal unit

permits selectivity from a knife-like point for C.W. to a wider degree for practical phone reception. And there are dozens of other outstanding features winning new admiration every moment. The "Super-Pro" reaches new performance standards that you've always wanted! The complete story of this "ideal instrument" appears in a profusely illustrated bulletin. Write for your copy today!

MAIL COUPON FOR FULL DETAILS

HAMMARLUND MFG. CO., Inc. RW-8
424-438 W. 33rd St., New York

- Check here for complete data on the new Hammarlund "Super Pro."
 Check here for 1936 Hammarlund General Catalog.

Name

Address

HAMMARLUND'S 25TH YEAR

RADIO WORLD

The How-to-Make-It Monthly—Fourteenth Year

ROLAND BURKE HENNESSY
Editor

HERMAN BERNARD
Managing Editor

HERBERT E. HAYDEN
Advertising Manager

Table of Contents for AUGUST, 1936

Front Cover Photograph by Herbert E. Hayden

Measuring Filter Capacities 6	The Distributed Capacity Mystery 36
<i>Circuits and Calibration Explained</i> By J. E. Anderson	<i>Measurement Method of High Accuracy</i> By Herman Bernard
Grid Dip Meter Coupling 13	Ways of Reducing Noise 39
<i>Ingenious Immunization Method</i> By Edward M. Shiepe	<i>Filters and Neutralizers Used</i> By M. N. Beitman
Quality From 6F6 as Pentode 16	Transformerless Push-Pull 40
<i>Push-Pull Permits 13 Watts, 5½ Per Cent. Total Distortion</i>	<i>Proven Phase Inverter Circuits</i> By Garrison Edwards
Audio Beat Oscillator Calibration 19	Band-Pass Pre-Selection 45
<i>R. F. Mixing for Steady A. F.</i> By Herbert E. Hayden	<i>Aids in Suppressing Images</i> By Jack Goldstein
New Words for Tube Constants 23	Television Standards Proposed . 48
<i>And What Words They Prove to Be!</i> By Siu Tamara	<i>Report by BMA to Government</i>
Close Measurement of I. F. 24	Vacuum Tube Voltmeters 52
<i>Introducing Facility Few Generators Offer</i> By Capt. Peter V. O'Rourke	<i>Non-Current-Drawing Types</i> By Randall C. Stamford
Makers Carefully Measure Tubes 26	The Simplest Generator 55
<i>Standard and Original Tests Combined</i> By Einar Andrews	<i>Few Parts in Battery Device</i> By Reginald F. Carlson
A New Inductance Formula 28	Wide Range of Super Pro 56
<i>Depends on Capacity Difference and Two Frequencies</i> By Herman Bernard	<i>Technical Features of Hammarlund Set</i> By Lewis Winner
	Radio University 58
	<i>Questions Answered</i>

Vol. XXIX, August, 1936. No. 5. Whole No. 695. RADIO WORLD, published monthly by Hennessy Radio Publications Corporation, 145 West 45th Street, New York, N. Y. Editorial and executive offices, 145 West 5th Street, New York, N. Y. Executives of RADIO WORLD: Roland Burke Hennessy, editor and business manager; Herman Bernard, managing editor; Herbert E. Hayden, advertising manager. Officers of corporation: Roland Burke Hennessy, president-treasurer; Roland Burke Hennessy, Jr., vice-president; Herman Bernard, secretary. Entered as second-class matter March, 1922, at the Post Office at New York, N. Y., under Act of March 3d, 1879.

SUBSCRIPTION RATE

Price 25 cents per copy. Subscription \$2.50 per year (12 issues), postpaid in United States and Possessions; \$3.00 per year postpaid in all other countries. Remittance for foreign subscription should be by International money-order (postal or express) or draft against or discountable at New York bank.

RADIO WORLD is distributed by the American News Company and its Branches

Measuring Filter Capacities

Circuits and Calibration Methods Explained

By J. E. Anderson

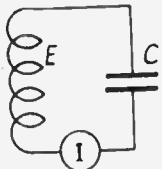

$$C = \frac{I}{E\omega}$$

FIG. 1
A means for measuring capacity depending on Ohm's law. The transformer winding is supposed to have negligible impedance.

MANY different methods of measuring electrical capacity have been developed. In some the unknown capacity is compared with a known standard capacity. Bridges and substitution methods come under this heading. In others the unknown capacity is determined from the reactance effect of the condenser in a circuit. Most direct-reading instruments are based on this principle. In still other methods the unknown capacity is determined in terms of its physical dimensions, such as length and time. These latter are called absolute.

One of the simplest instruments for measuring capacity consists of a source of alternating electro-motive force E of negligible impedance, an a-c milliammeter, and the unknown capacity. The circuit is given in Fig. 1. Since the current in the circuit will be $E/C\omega$, it is clear that if I is the indicated current, the capacity will be given by $C = I/E\omega$. The units are farads, amperes, volts, and radians per second. If the capacity is expressed in microfarads, the current in milliamperes, the voltage in volts, and the frequency is 60 cycles per second, the formula becomes $C = 2.65 I/E$.

Impedance Effect

If the capacity of the condenser is large and the milliammeter comparatively insensitive, this formula is not accurate because the impedance of the voltage source is not negligible.

There may be an appreciable resistance R in the circuit and yet the reactance of the voltage source may be negligible. In that case the circuit may be drawn as in Fig. 2, in which it is understood that all or part of the total resistance is in the transformer winding. The capacity may then be obtained from

$$C = 1/2\pi f \sqrt{(E^2/I^2 - R^2)^{1/2}}$$

If C is expressed in microfarads and the fre-

quency is 60 cycles per second, the formula becomes $C = 2,650/(E^2/I^2 - R^2)^{1/2}$.

It will be recalled that an ordinary voltmeter consists of a sensitive milliammeter in series with a multiplying resistance. Therefore the milliammeter I and the resistance R in Fig. 2 may be regarded as a voltmeter. As such it will not be calibrated in milliamperes, but in volts, and the voltage at any current value I will be $V = IR$. When this relation is substituted in the formula under Fig. 2 it becomes $C = 1/2\pi fR \sqrt{(X^2 - 1)^{1/2}}$, in which $X = E/V$. If the resistance R in the voltmeter is very high, the electro-motive force E will be the reading on the voltmeter when the condenser is shorted, V is the reading on the voltmeter when the condenser is in the circuit. It is clear that X is always greater than unity and that it will be larger the smaller the condenser.

Very Useful Formula

This formula is extremely useful because sensitive a-c voltmeters are now almost universally available. For this reason we shall put the formula in a more convenient form. Suppose the frequency is 60 cycles per second and let the capacity be expressed in microfarads. The formula then assumes the form

$$C = 2,650/R \sqrt{(X^2 - 1)^{1/2}}$$

This holds for a voltmeter of any sensitivity.

Suppose now that the voltmeter has a sensitivity of 1,000 ohms per volt, a very common instrument. Further suppose that it has ranges of 0-5, 0-50, and 0-500 volts. The corresponding values of R are 5,000, 50,000, and 500,000 ohms. Hence we have the three capacity ranges:

Voltage Range	Capacity
0-5	$C = 0.53/(X^2 - 1)^{1/2}$
0-50	$C = 0.053/(X^2 - 1)^{1/2}$
0-500	$C = 0.0053/(X^2 - 1)^{1/2}$

This method of measuring capacity can be

FIG. 2
When the resistance in the circuit is not negligible the capacity can still be measured by the simple circuit if allowance is made for resistance.

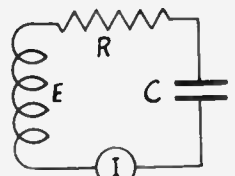

$$C = 1/\omega R \sqrt{(E^2/I^2 - R^2)^{1/2}}$$

$$C = 1/\omega R V \sqrt{X^2 - 1}$$

applied simply with the aid of a circuit like that in Fig. 3. The three multiplier resistors are external and they are connected to one deck of a two-deck, three-stop switch. The three points on the other deck are connected to taps on the secondary of a transformer, the taps being at such voltage points that the meter always reads full scale when the unknown condenser is shorted.

Safety with Sensitivity

This arrangement gives the greatest sensitivity with safety. To allow for line voltage

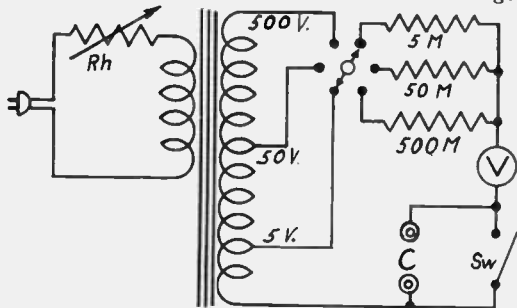

FIG. 3

This illustrates how a high resistance voltmeter can be used for measuring capacity. The applied voltage is adjusted so that the voltmeter reads full scale when the condenser is shorted. See graph for relation between voltage readings and capacity.

variations a high resistance rheostat is put in the primary of the transformer. It is placed here to eliminate as much as possible resistance in the secondary winding.

The scale of the voltmeter can be calibrated in microfarads if desired. Full scale will indicate infinite capacity, or zero reactance, just as full scale in a direct-reading ohmmeter indicates zero resistance. The smaller the condenser in the circuit the lower will be the voltage reading. Only one capacity scale will be required because the three ranges are decimally repeating. The scale might be the middle one. Then to get the capacity on the high voltage setting the reading is divided by 10 and to get the capacity on the low voltage setting the reading is multiplied by 10.

The parts in the capacity meter can also be arranged as in Fig. 5. The formula connecting the two meter readings, the frequency, and the resistance R is $C = (X^2 - 1) \frac{1}{R2\pi f}$, in which $X = I/I_0$ and I_0 is the milliammeter reading when the condenser is not shunted across R and I the reading when it is so shunted.

Danger Lurks Here

This arrangement is somewhat dangerous to use because the current increases as the capacity of the condenser increases. To protect the meter the voltage E should be adjusted so that full scale reading occurs when a specified capacity is connected across R. It will be noticed that the capacity reads from zero up to this maximum value. The variation, however, is not

linear with the deflections. The circuit is most suitable for small condensers.

Measurement by substitution is the most accurate of all methods, but, as a rule, when applied to condensers it is suitable only for very small condensers. In order to make direct substitution it is necessary to have an accurately calibrated standard of the same value as the condenser under measurement. In using substitution methods it is customary to utilize beats between two oscillators for determining the balance point. Fig. 6 shows schematically how substitution may be applied. The frequency of oscillator (1) is fixed, and this oscillator may be that of a broadcast station. It is coupled

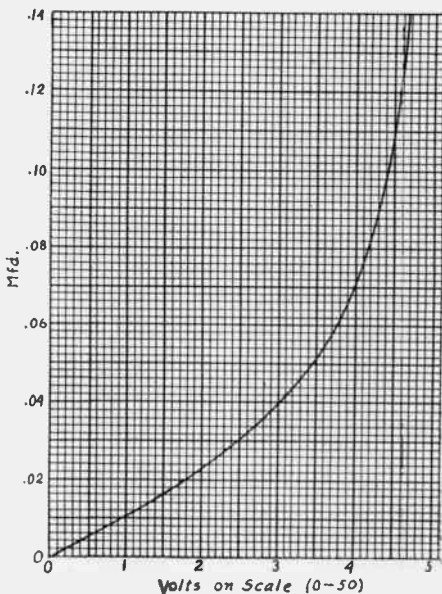

FIG. 4

This curve shows the relation between deflection on a 0-50 volt, 1,000 ohm per volt a-c voltmeter and the capacity in series with the voltmeter and an alternating voltage of 50 volts. The same curve may be used for 0-5 and 0-500 volt ranges by multiplying readings in the first case and dividing them in the second.

loosely to a second oscillator in the tuned circuit of which is a standard calibrated condenser C. Oscillator (2) is tuned to zero beat with oscillator (1) by means of the standard con-

(Continued on next page)

FIG. 5

Sometimes it is convenient to connect the condenser to be measured across the high resistance in the circuit.

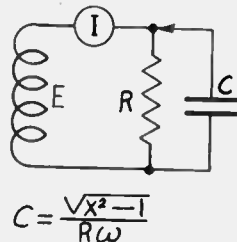

$$C = \frac{\sqrt{X^2 - 1}}{R\omega}$$

(Continued from preceding page)
denser. The capacity reading is noted carefully. Then condenser C under test is connected across the standard. The circuit is now returned to zero beat by decreasing the capacity of the standard. The new reading on the standard should be noted. The capacity of the unknown condenser is equal to the difference between the two readings of the standard. It is clear that this method of measuring capacity holds only if the capacity of the unknown is less than or equal to the total change in the capacity of the standard.

Calibrating a Variable

This method of measuring the capacity of a fixed condenser also may be used for calibrating a variable condenser provided that its maximum capacity is not larger than the total change in the standard. To calibrate a condenser it is only necessary to measure its capacity at all the major scale divisions of the unknown. The middle and the two end points should be included in the measurement. So also should the points 5 and 95 on a 100-degree scale.

The bridge method of comparing condensers is shown in Fig. 7. Two equal resistances R, each of about 1,000 ohms and non-inductive, are connected in series across the secondary of a

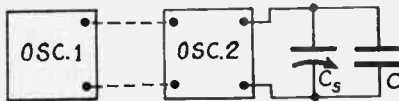

FIG. 6
Two-oscillator system.

transformer which supplies an audible frequency voltage. In shunt with the two resistances are two condensers, a standard C_s and an unknown C. Between these condensers is a decade resistance which by means of a switch may be thrown in series with either C_s or C. Between the switch and the mid-point of the two resistors is a pair of head phones or some other detector of weak audio currents.

Use of Bridge

The bridge is balanced when no sound is heard in the headphones or other sound detector, that is, when no current flows through the bridge. Since the resistance arms are equal the two condensers will also be equal when the bridge is balanced.

In all bridge measurements involving alternating currents two sets of balances must be established independently and simultaneously. One is for the a. c. resistances and the other for the reactances. Both C and C_s will have some resistance, and this may be high when a low audio frequency is used. If the resistances of the two condensers were equal it would only be necessary to balance for the reactances, but in general they will not be equal. The resistance of either condenser may be the larger. Therefore the decade R_x must be arranged so that it can be thrown into either arm so that it may be used to supply the deficiency of resistance in

that arm. In an inexpensive bridge it is not necessary to use a decade resistance, for any variable resistor will serve the purpose. This is because the actual value of the difference in resistance between the two condensers is seldom of any interest.

The bridge in Fig. 7 may be used for measurement by substitution. C then remains fixed and of about the same value as C_s . The condenser to be measured is connected in shunt with the standard and its capacity value is obtained by the difference in two settings of C_s , each representing a balance of the bridge.

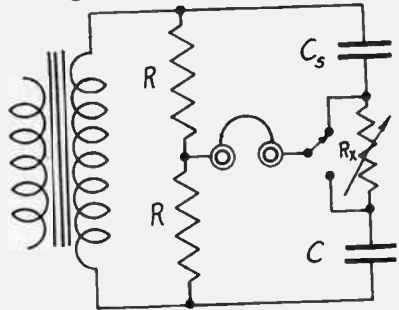

FIG. 7

This is a simple bridge for measuring capacities. If the two resistance arms are equal the two condensers C_s and C are equal when the bridge is balanced. Large condensers can be measured by making R_x/R large, where R_x is the resistance arm opposite C_s and R is the lower resistance.

Unequal Resistance Arms

Sometimes it is necessary to measure the capacity of a condenser that is much larger than the standard. This may be done on a bridge provided the resistance in the two resistance arms are not equal. Let the resistance opposite C_s be R_s and let the resistance opposite C be R. Then one condition for balance is $R_s C_s = RC$. The other condition involves only resistances but it must be satisfied if a sharp balance point is to be obtained. The first balance condition may be written $C = C_s R_s / R$. Thus even if C_s is small comparatively large condensers can be measured provided that we make the resistance ratio R_s/R large. It can easily be made as large as 100, when the unknown condenser would be 100 times greater than the standard.

An absolute method of measuring capacity is illustrated in Fig. 8. A rotating or vibrating switch S alternately connects the condenser C to the battery of voltage V and the milliammeter I. When the switch connects the condenser to the battery, the condenser becomes charged to the potential V. When an instant later the switch connects the condenser to the meter, the charge on the condenser leaks off through the meter and causes a deflection. Each time the switch rotates a quantity $Q = VC$ is transferred from the battery to the meter. If the commutation occurs rapidly enough there will be a steady deflection I. This current is equal to $I = NQ = NVC$, where N is the number of

times per second the switch rotates. Therefore the capacity of the condenser can be computed from the formula $C = I/NV$.

For this principle to give correct values it is necessary that sufficient time be given for the condenser to charge to V volts and also to discharge to zero. Strictly, neither is possible in any finite time, but as there is negligible resistance in the circuit the approach is very close to the ideal even if the value of N is as great as 100.

The drawback in this circuit is that a mechanical switch is required to effect the commutation. Satisfactory switches of this type are not easy to obtain, and even if they are the rate of commutation cannot be measured accurately without cumbersome equipment. Fortunately, a satisfactory electron switch can be arranged in which the commutation rate is as well known as the frequency of the power line.

The electron switch is incorporated in Fig. 9. The plate-cathode circuits of two 37 type triodes are connected in series. Across one the condenser C_x to be measured is connected. A known voltage, measured by E , is applied in the plate circuits of the two tubes. The plate current, if any, is measured by the milliammeter Ma . The two grids are biased independently to the cut-off points by means of batteries.

As long as there is no signal voltage applied to the grids no plate current flows. Provision is made, however, for impressing a voltage of frequency f on the two grids. The two windings supplying the signal voltage are connected in opposite phase so that when the signal makes the grid of one tube less negative it makes the other more negative. Plate current can flow only in that tube in which the signal makes the grid voltage less negative, since both tubes are biased to the cut-off.

Suppose that the phase of the signal is such that the voltage on the grid of the upper tube is more negative. Then the voltage on the grid of the lower tube is less negative, and also less than is required for cut-off. Consequently the lower tube conducts. Since current cannot flow in the upper tube, the effect is that condenser C_x charges up to the voltage E .

During the next half-cycle the phase of the signal voltage is reversed. The upper tube becomes conductive and the lower non-conductive. No current can now flow in the supply circuit and through the milliammeter. However, the charge on condenser C_x discharges through the upper tube. This process is continued as long as the power is on. The condenser charges

(Continued on next page)

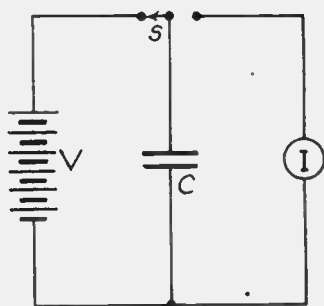
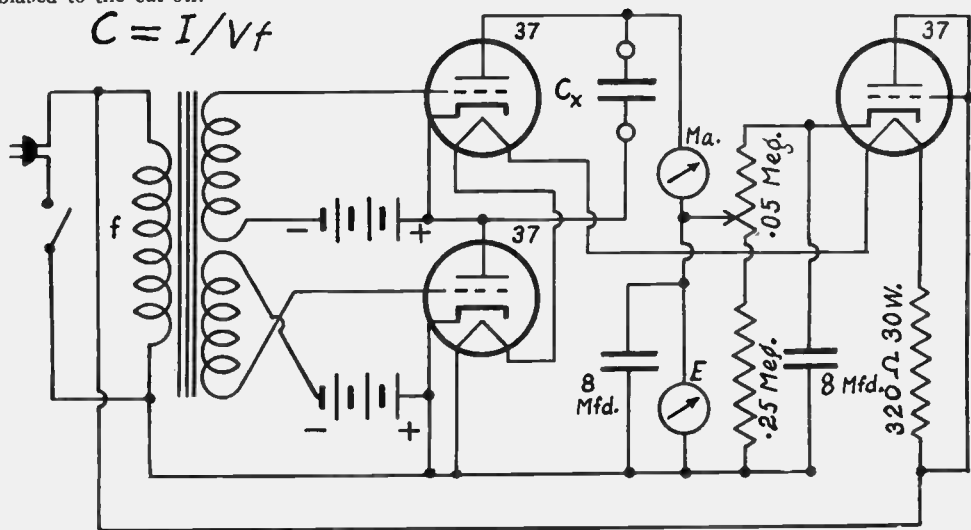

FIG. 8

The charge and discharge method of measuring capacity is illustrated here. This measures the capacity in terms of the voltage of the battery, the number of times per second the condenser is charged and discharged, and the current flowing in the milliammeter.

$$C = I/Vf$$



$$f = 60, V = 16.67, C = I; \quad V = 166.7, C = .1 I \quad (C = \mu F)$$

FIG. 9

Instead of a rotating switch for charging and discharging the condenser a pair of triodes biased to the cut-off may be used. The signal causes one tube to discharge the condenser and the other to discharge it at a rate equal to the frequency of the driving current.

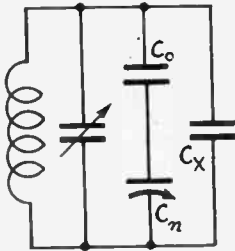

FIG. 10

For measuring minute capacities, less than 1 mmfd., the substitution method may be used as indicated here. A small condenser, C_0 , is connected in series with a large calibrated condenser. Extremely small changes in capacity can be measured by this combination. The minute capacity is connected across the series combination.

(Continued from preceding page)

while the lower tube is conductive and discharges while the upper tube is conductive. The condenser therefore charges and discharges f times per second. Hence the formula given under Fig. 8 becomes $C = I/Vf$, the units being farads, amperes, volts, and cycles per second.

For specific values this formula can be simplified. Suppose the frequency is 60 cycles per

second and that the voltage is 100 volts. Then if C be expressed in microfarads and I in milliamperes, the formula reduces to $C = I/6$ mfd. If the meter is to be used only for measuring capacity, a scale could easily be made so that the deflection gave the capacity directly. This capacity scale would be linear to the extent that the d.c. meter scale is linear.

Direct Reading on Present Scale

If the meter is to be used also for measuring current it would be more convenient to arrange the circuit so that the milliammeter scale



FIG. 11
Appearance of Solar bridge device.

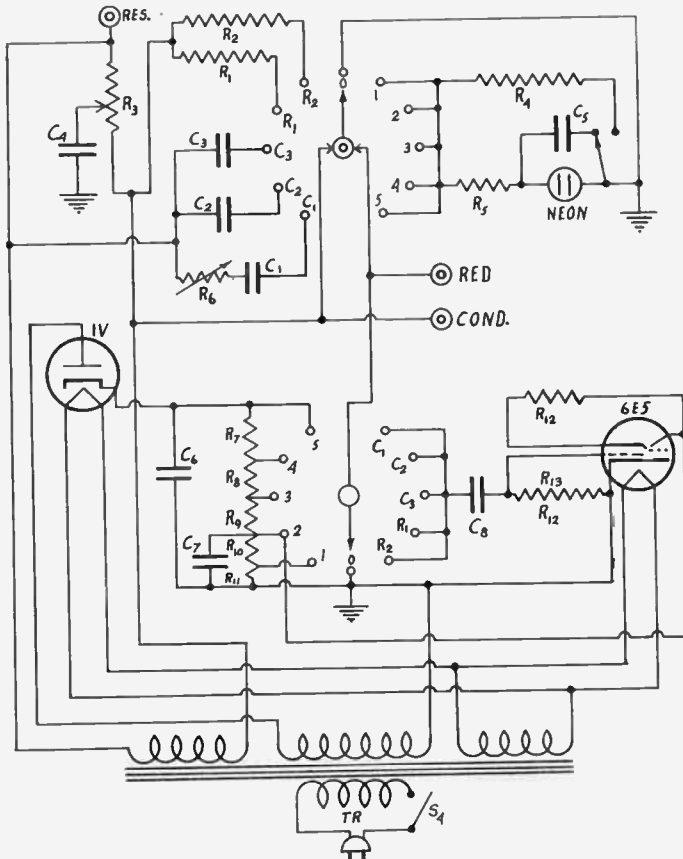

FIG. 12
The circuit of the Solar Capacitor Analyzer. It has a capacity range of from 10 mmfd. to 70 mfd. and a resistance range from 50 to 2,000,000 ohms. It is of the bridge type, and the 6E5 is used as a detector of balance. A neon tube is incorporated in the circuit for the purpose of measuring the leakage through condensers.

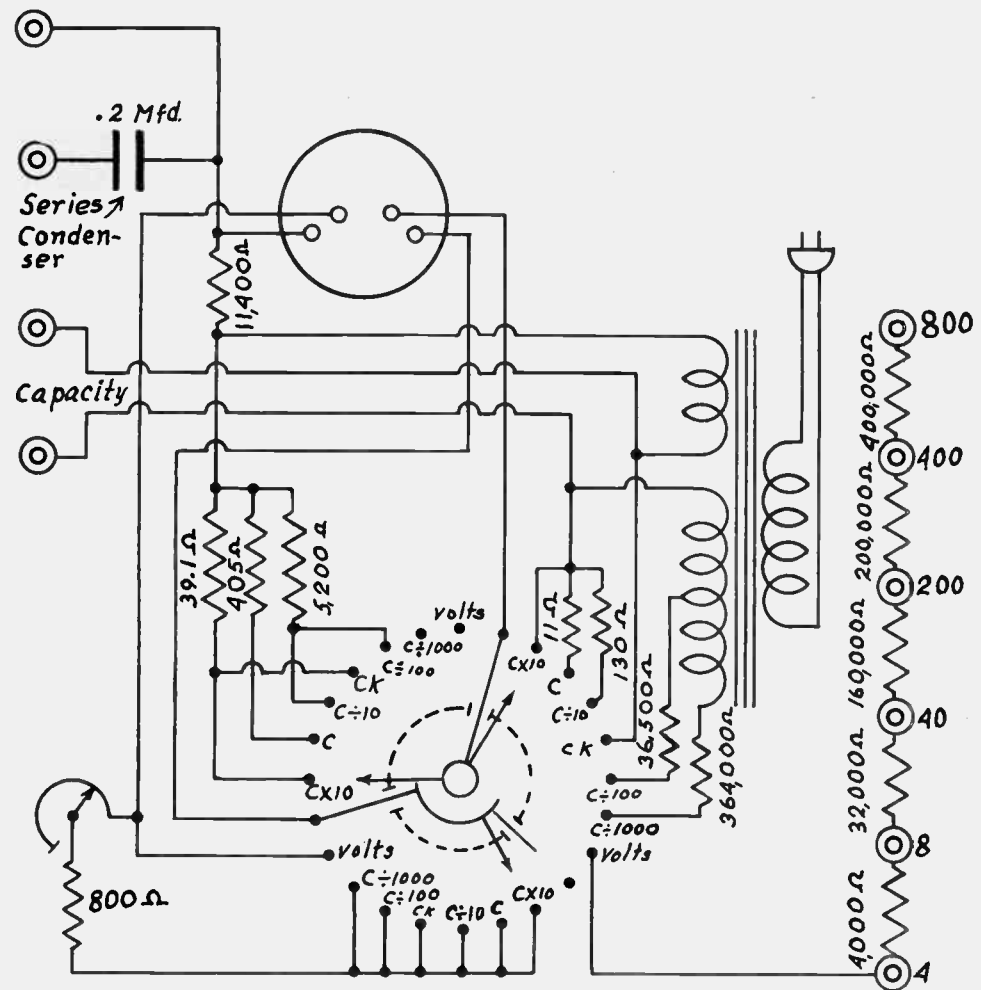

FIG. 13

The Weston capacity meter diagram is given above, and a top view of the instrument at right. This device, as well as others commercially made, will be discussed in detail next month (September issue).



FIG. 14
Top view of the Weston capacity meter. The instrument is direct reading.

gave the capacities directly. This could be done by making the plate voltage 16.67 volts instead of 100 volts. It could also be done by making the frequency 10 or 100. Of course, any deviation from 60 cycles would introduce an uncertainty in the frequency and hence in the result. In places where the line frequency is accurately 50 cycles per second, the plate voltage could be 20 or 200 volts.

In the case of a 60 cycle line a convenient voltage would be 166.7 volts. This would give the simple relation $C = 0.11$. A plate voltage of 16.67 would give $C = I$. This low voltage would cover most low-voltage electrolytic condensers.

Since the current involved is direct, the capacity scale can be extended together with the current scale without any complications.

That is, ordinary resistance shunts will do. If the plate voltage is 16.67 and the frequency is 60, a 100 mfd. condenser could be measured with a milliammeter with a maximum scale of 100 milliamperes. The smallest capacity that could be measured with fair accuracy with this voltage and this frequency is about .05 mfd., for the smallest current that can easily be read on a 0-1 milliammeter is about 1/20 of full scale.

(Continued on next page)

(Continued from preceding page)

It is clear that the same principle can be used for measuring still smaller capacities by using a more sensitive current meter. Suppose, for example, that the meter reads 100 microamperes at full scale and that there are 50 divisions on the scale. The first readable division then represents a current of 0.002 milliamperes. If the plate voltage on the tubes is 166.7 volts and the



FIG. 15

Sprague capacity tester. This will be discussed, with other commercial apparatus, next month.

frequency is 60 cycles, the reading would represent a capacity of 200 mmfd.

If two different plate voltages are to be used, two different grid bias voltages must also be used for the tubes. If a dual range meter is to be built, a switch could be arranged that would insert the proper grid voltage each time the plate voltage was changed. A change in volt-densers of different voltage ratings. For extending the capacity range the simplest change is to put shunts across the milliammeter.

Sometimes it is required to measure extremely minute capacities, such as those between the plate and the control grid of a screen grid tube. They may be of the order of 0.01 mmfd. These are so minute that even the smallest calibrated condensers cannot be used for measuring them accurately. In such cases a large standard condenser may be connected in series with a small known condenser. This combination is put in a tuned circuit which may be tuned to zero beat. The minute condenser to be measured is connected across the tuned circuit. First the circuit is tuned to zero beat without the unknown connected. Then again when it is connected, and the tuning is done with the large calibrated condenser in both instances. The arrangement is shown in Fig. 10. C_a is the calibrated condenser, C_o a small condenser in series with it, and C_x is the minute unknown condenser. Let C_1 be the setting at zero beat of C_a when C_x is disconnected and let C_2 be the setting when C_x is connected. C_a can then be computed by the formula $C_x = C_o^2 (C_1 - C_2) / (C_o + C_1) (C_o + C_2)$.

A numerical example will show how keen this formula is. Suppose that $C_o = 25$ mmfd., $C_1 = 500$ mmfd., and $C_2 = 495$ mmfd. The formula then gives $C_x = 0.011$ mmfd. And still smaller values of C_o can be used, or still larger values of C_a . The limit is really the closeness with which zero beat can be detected, which in turn is limited by the frequency stability of high frequency oscillators.

Padding Directions

The problem is to align the oscillator level of a two-band set on the 60-20 meter range to the r.f. level.

For the present circumstances one may borrow from the author's experience and start with .001 mfd. in series, and use 6,000 kc of generator frequency. The dial will not have to be turned all the way to the end frequency mark, i.e., the plates of the tuning condenser will not be totally engaged, and we simply put in small capacities across the .001 mfd. to increase dial readings, or use less than .001 to decrease them, to coincide response with 6,000 kc on the scale. If we put too little capacity in series, and therefore can not even reach the end frequency, we add to this too-small series condenser some small capacity in parallel, one addition at a time, until we build up to the right value. To .001 mfd. add .00005 mfd. (50 mmfd.) at a time, or put a 100 mmfd. variable across the .001 mfd. and adjust for 6,000 kc.

That is as much as we have to do about padding, except for the fact that the series condenser has reduced the minimum capacity in circuit as well as, though not nearly as much as it has reduced the maximum, but this is easily taken care of by pushing the tickler closer to the secondary, until coincidence is restored, this time at 14,500 kc. The dial is moved to read 1,450 and the tickler adjustment is made.

Ordinarily the reduction at the minimum of tuning condenser is equal to only 2 mmfd., and this is very small, indeed, but some more than this is needed usually, for other reasons. The low frequency end will not be affected ratably by the extra parallel capacity.

An Unusual Set

A manufacturer has brought out an advanced receiver, with full a.v.c.

The circuit also has automatic bass compensation. Ordinarily as music becomes softer and softer, the bass notes become inaudible before the higher tones do. The compensator prevents the volume suppression of bass notes.

The sounding board is shaped like a lyre and made of acoustic wood, enabling the entire sounding board to vibrate freely when low notes are reproduced because of its floating suspension, thus giving the same effect as if the speaker were the size of the board.

The curvilinear speaker cone is shaped something like a morning glory, with the curvature following an exponential curve. The curvilinear speaker has a wider range of frequency response.

The new magnum dial has calibration markings for each tuning range that cover practically a complete circle. In addition to the usual frequency calibrations, the outer circle markings are arranged like the numbers on the face of a clock. The two pointers, together with the clock markings, make time-logging possible. For example, a station may be logged at 4:20 or 11:35 on the outer circles and it will always be tuned in at the same time-reading.

Grid Dip Meter Coupling

New Method of Immunizing Test Circuit

By Edward M. Shiepe

Delta Radio Company

WHEN using a grid-dip oscillator for measuring the inductance of a coil, it is usually found difficult to couple the unknown coil satisfactorily to the oscillator tank inductance.

This difficulty arises from several causes. Mechanical inaccessibility of the oscillator coil may make a direct mutual coupling awkward. Unless special mounting precautions are taken it will be difficult to obtain the same values of mutual inductance and mutual capacitance between the tank coil and the measured circuit. The value of the mutual inductance should be always the same if any attempt is made to compare the Q of different coils. This is because of the well-known phenomenon of double peaks of resonance when close coupling is used. The capacitance between the coils should be held constant. Any variation of this factor on different coils, or for different measurements on the same coil, will require a different value of capacitance for tuning the coil and hence give a different indication of inductance.

Measures at Distance

In Fig. 2A, L_2 is a pick-up coil permanently mounted in relation to L_1 . L_x is the coil for test. The idea is to make L_s , the coil in parallel with L_x , diminish the net inductance of the two to make up for the inductance of the series pick-up coil L_2 . This being done, the condenser C_2 will tune the circuit to the same frequency as it would tune L_x if L_x were connected as in Fig. 1. In other words, Fig. 2 is equivalent to

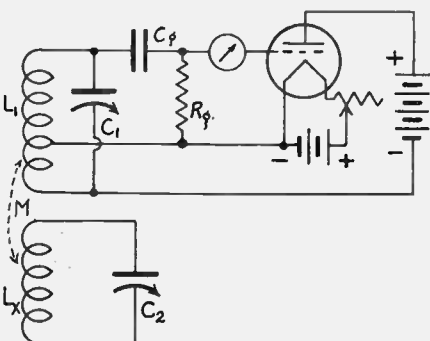

FIG. 1.

The usual circuit for tuning the test circuit $L_x C_2$ to the frequency of the tank circuit $L_1 C_1$, for determining the frequency of $L_x C_2$ and thus enabling computing the inductance of L_x from the known capacity setting of C_2 . Confusion may arise, due to double peaks.

An Ingenious Solution

The author has done considerable original work in connection with radio-frequency inductance measurements. In this article he reveals his method of coupling to a grid dip meter in such a way as to retain accuracy of measurement, and of course avoid double peaks. Moreover, the problem of coupling at a distance from the test circuit is solved at the same time.

Instead of mutually coupling the unknown coil L_x to L_1 of the tank circuit by interlinkage of their fields alone, a permanent pickup winding L_2 is used. L_x is partly known, for instance, a coil for the standard broadcast band. L_s is then chosen so inductance of L_x is reduced by the amount L_s increases the inductance of L_s . (Fig. 2A.) The net effect is little or no change, hence accuracy. The simplicity and ingenuity of the method will be appreciated by those who measure inductance.

—EDITOR

Fig. 1 as far as tuning L_x with C_2 is concerned and it removes all of the objections cited for Fig. 1.

L_x may be removed from L_s and L_s . It may be removed from L_s and L_s . It may be removed from L_s and L_s . (Continued on next page)

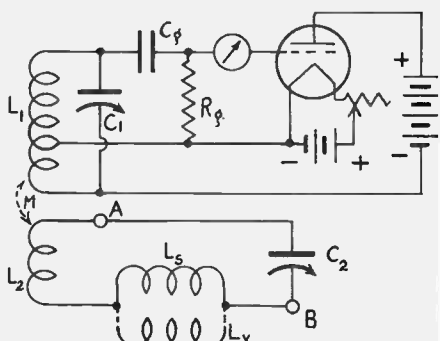

FIG. 2A

The link coil L_2 picks up r.f. to enable measurement of the inductance of L_x . Inclusion of L_s causes the circuit between y and z to behave as if only L_x were in circuit. This is well accomplished by having L_2 be any pickup winding in the test circuit, as long as it is 90% and L_s is 10%.

(Continued from preceding page)
 be mounted on a spinning machine for adjusting its inductance.

To make the total inductance equal L_x , between points A and B (Fig. 2A), it is required that

$$L_x = L_s + \frac{L_s L_x}{L_s + L_x}$$

from which

$$L_x^2 - L_s L_x - L_s L_s = 0 \dots\dots\dots (1)$$

and

$$L_x = \frac{L_s}{2} \pm \frac{1}{2} \sqrt{L_s^2 + 4 L_s L_s} \dots (2)$$

If the last \pm term under the radical sign in (2) were zero, this would make L_x either equal

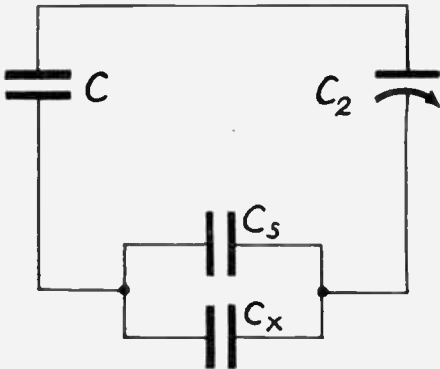

FIG. 2B

The effect of the distributed capacity of L_s (shown as C_x) is small because C is small compared to C_s or to $C_s + C_x$.

to L_s or zero. Larger values of this term would make L_x have one positive and one negative value, mathematically. The negative values have no physical meaning, hence equation (2) should be used with the positive sign only.

Should we express L_s in terms of L_x , we can then plot (2) in terms of L_x and L_s . This is equivalent to taking L_s as the unit of measurement, assigning it a value of one, for instance. In this manner, Fig. 3 was drawn.

Using the Curve

Assume that we are working on the lower end of the curve, say at $L_x = L_s = 2 L_s$. Any variation in the inductance of L_x would produce only a small indication on the measuring device, because of the shunting effect of L_s and the large series effect of L_s . To remove this objection, the utilized ratio of L_s to L_x should be much larger than 1. Take the case of $L_s = 90 L_s$ at which $L_x = 10 L_s$. Here any variation in L_x is hardly affected by the other two coils, relatively.

On the other hand, we should not make L_s too large, because this would increase its distributed capacity to a point where it may become objectionable.

Using the 90-10-1 ratio above, let us design coils for a broadcast band inductance. Say this inductance has a value of 227 microhenries. L_s must be made 9 times this value, or 2,043 millihenries. L_x is then 22.7 microhenries. A honeycomb wound inductance of 2,043 millihenries may have only a few micro-microfarads capacitance if it is properly wound, and it is therefore satisfactory.

The inductance of the oscillator coil may be made the same as that of the measured coil, or 227 microhenries. The pick-up coil should now be mounted close enough to the oscillator coil so that tuning the measured circuit will give a satisfactory response in the resonance indicator.

Using the circuit of Fig. 2A, the measured coil L_x is connected in place and is tuned with the condenser. The value of capacity required is the same as though the condenser were connected directly across the coil L_x alone. This holds for any frequency of the oscillator within the range of the coil-condenser combination. The tuning range may therefore be easily determined using this circuit.

A Word of Caution

When the coils are interconnected in the circuit, care should be taken to insure that L_s , L_s and L_x should have no mutual inductance between them. This can be accomplished by keeping them far enough apart, placing them at right angles, shielding L_s and L_s with the oscillator coil, or by using all three methods.

Fig. 2B shows the circuit of the distributed capacities of the coils with the tuning condenser. The capacity of L_s may be large, but when this is the case, the capacity of L_s is relatively much smaller. The net circuit capacity effectively in parallel with C_s is less than the smaller value. For this reason, also, it is advisable to make L_s small in relation to L_s and L_x .

The curve, Fig. 3, will be found on following page.

[The author will be glad to answer questions about his method. Address him care RADIO WORLD, 145 West 45th Street, New York, N. Y.]

RADIO-FREQUENCY MEASUREMENTS

The July, 1936, issue of RADIO WORLD contained a comprehensive article on how to measure constants in the radio-frequency range. Three ways of measuring inductance; also ways of measuring capacity, Q and percentage modulation, with apparatus at hand. Send 25c for a copy.

RADIO WORLD, 145 W. 45th St., N.Y.C.

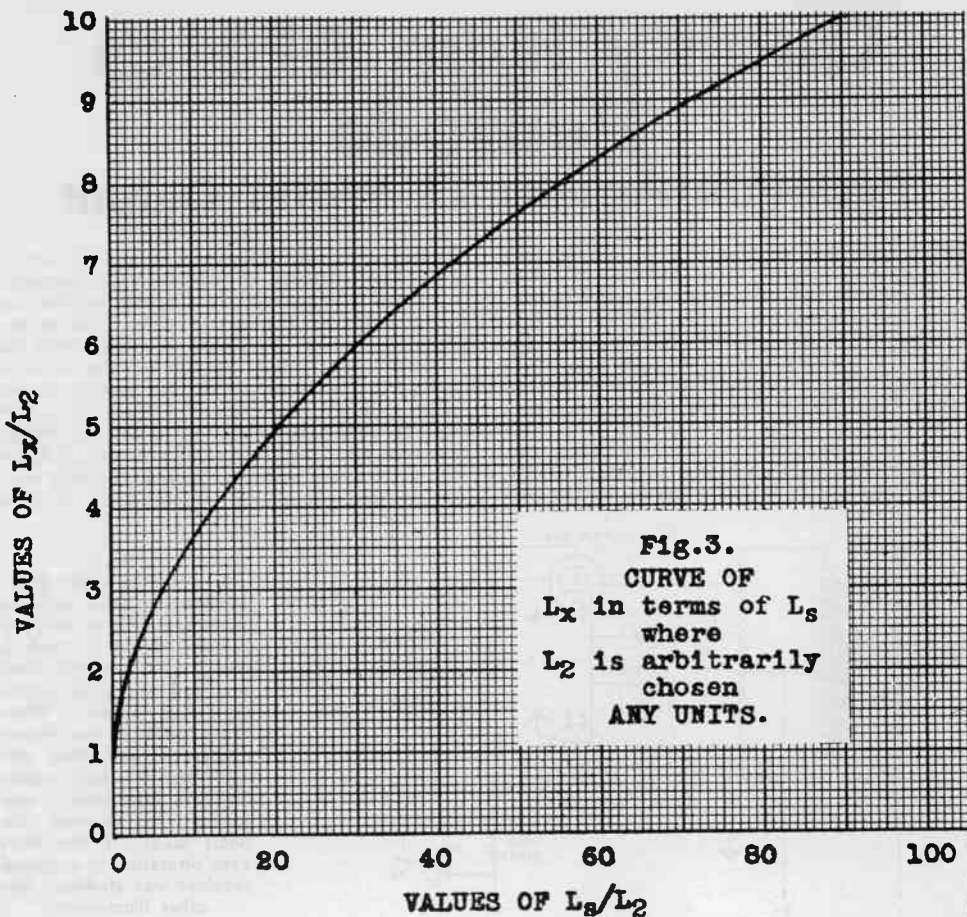

FIG. 3.

Curve of L_x in terms of L_s , applying to article on the preceding two pages.

Photoelectric Lie Recorder Developed

Northwestern University, which devotes considerable effort to studying crime detection in a specially equipped crime detection laboratory, has recently built a lie-detection machine that indicates when the "patient" is lying by careful simultaneous measurements of his respiration, blood pressure, and perspiration. Many tests have been made on students, and these have clearly proved that lies can be detected by this device.

To make tests, delicate recording instruments are needed, especially in the case of measuring perspiration. An extremely sensitive photoelectric recorder, a development of General Electrical Company, is being utilized by the University in Chicago to record the perspiration of the "patient" while he is being questioned.

The photoelectric recorder combines all the advantages of direct-acting recorders with those of the most sensitive indicating in-

struments, by providing a separately excited recording element to do the actual work of making the record. A sensitive indicating instrument controls the position of the recording element so that the record obtained represents the readings of this basic instrument. The loss in the sensitive basic instrument is the only power required from the measured circuit. The link between the basic and recording elements consists of a combined optical system and photoelectric circuit.

The recorder is connected to an electrode placed in the subject's hand. When his answer is a lie, the perspiration in his palm increases, lessening resistance to the electrode. This reaction is reflected on the perspiration recorder, and indicates that the subject was unduly disturbed at that point in the questioning.

The respiration and blood pressure recorders operate simultaneously with the perspiration recorder.

Quality from 6F6 as Pentode

Push-Pull Permits 13 Watts Output

THE selection of the type of output tube to be used in a radio receiver is influenced by technical and economic requirements. For a given power output, the cost of the tube and the cost of the circuits associated with the tube often determine the tube selection; contributing technical considerations are the operating characteristics of the complete a.f. amplifier system.

Two important operating characteristics are: (1) the change in distortion with power output, and (2) the rise in B supply current with power

increase the load resistance to reduce distortion. The efficiency of the tube as an amplifier is increased because of the increase in bias, but the power output may decrease. The screen voltage, however, then may be raised until the maximum dissipation rating of the tube is reached to compensate for the loss in power output. Thus, the bias and load of a 6F6 may be varied to satisfy a variety of design requirements. Such flexibility is not possible with some types of tubes, because the bias voltage is not completely independent of plate

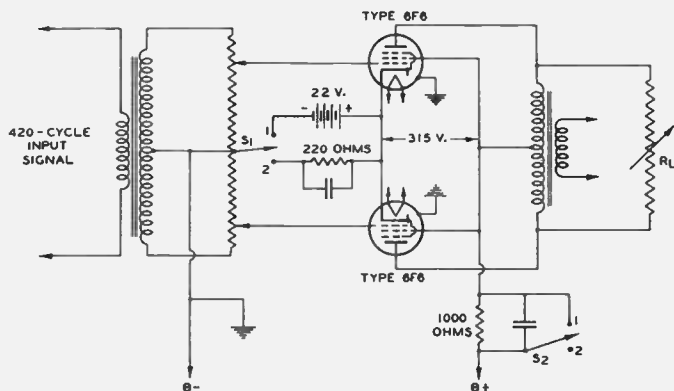

FIG. 1
The circuit used for determination of the optimum plate load for a push-pull circuit. When S_1 and S_2 are thrown upward, fixed bias and zero power supply regulation obtain. When these switches are thrown downward, self bias and 1,000-ohm B supply regulation are introduced. Adjusting R_L changes the ohms load. In the third case operation in a typical receiver was studied. See other illustrations.

er output. The first describes the distortion characteristic of the system and the second imposes a limitation on the maximum permissible regulation of the B supply source.

This article describes an economical push-pull amplifier which uses two type 6F6 tubes connected as pentodes.

This amplifier has important technical features: it can furnish high power out, it has a good distortion characteristic, and the rise in B supply current with power output is small. Complete data for ideal and practical operating conditions are shown in the accompanying illustrations.

Output Tube Characteristics

The shape of the distortion characteristic of a single 6F6 can be varied by choosing suitable values of bias and load. Thus, for a given bias, a value of load can be found for which the distortion characteristic rises slowly at low power outputs and very rapidly at high outputs. For the same bias, a more slowly rising distortion characteristic can be obtained with another value of load.

As the bias is increased, it is necessary to

voltage.

The results of a number of preliminary tests have shown that high output at nominal distortion can be obtained from two type 6F6 tubes with 315 volts on plate and screen and -22 volts on the control grid. A single 6F6 operated with these electrode voltages can deliver 5 watts at 7 per cent total distortion; two tubes connected in push-pull can deliver 13 watts at 5.5 per cent distortion. In either case, negligible control-grid current is drawn at these outputs.

In this article, the characteristics of the push-pull connection will be discussed for three conditions: (1) fixed bias, zero power-supply regulation, and small grid-circuit impedance; (2) self bias, regulation due to a 1,000-ohm power-supply circuit, and small grid-circuit impedance; and (3) operation in a commercial radio receiver of average design.

Operation Without Pre-Amplifier

Two type 6F6 tubes were connected in push-pull, as shown in Fig. 1. Plate and screen voltages were 315 volts and the bias was -22 volts. The control grids were connected to

(Continued from preceding page)

a portion of the receiver is shown in Fig. 2 on preceding page.

It is not necessary to use the phase-inverter circuit of Fig. 2 to duplicate the results. The output tubes may be fed by a single-tube transformer-coupled amplifier, or by a push-pull resistance-coupled amplifier. In either case, results comparable to those reported may be obtained.

Curve for Typical Set

The phase inverter was adjusted by applying to the 6F5 a signal of such magnitude that grid current started to flow in Tube A. The signal input to the 6C5 was then adjusted by means of the potentiometer P until grid current started to flow in Tube B. After this adjustment was made, power output, distortion, and total cathode current were measured for both the practical transformer and the nearly ideal transformer. The tests were carried beyond the grid-current point in order to determine the practical distortion characteristic of the system.

Fig. 3 shows that, in a typical receiver, the distortion increases smoothly from low values at low outputs to reasonable values at high outputs. Under the conditions show in Fig. 2, over 15 watts may be obtained from the system without any discontinuities in the distortion characteristic. These curves also show that the use of a practical output transformer does not reduce the maximum power output and that the total distortion at high outputs is reasonable. The total cathode current is not shown, because the rise was only 4 milliamperes at the 15.5-watt level.

A receiver designed for a maximum output of 15 watts will usually be operated at some lower output level. The distortion characteristics shown in Fig. 3 indicate that low distortion may be expected at these lower outputs and that reproduction will not break up at high outputs. These conclusions were verified by listening tests.

If the output at 5 per cent. distortion is arbitrary defined as a good operating level for this receiver, then the overload characteristic may be defined as the distortion characteristic between the output at 5 per cent. distortion and maximum output, regardless of the output at which grid current flows. For this receiver, the output at 5 per cent. distortion is approximately 9 watts; the overload characteristic, therefore, extends to 15 watts.

Features Listed

The features of the 6F6 output system described in this article are: high output (15 watts) at reasonable distortion, low distortion at low outputs, a smooth distortion characteristic, and negligible rise in d. c. plate current with signal.

Push-Pull Operation

The operating conditions for a push-pull amplifier are tabulated:

Heater Voltage	6.3 Volts
Plate Voltage	315 Volts
Screen Voltage	315 Volts
Control-Grid Voltage.....	-22 Volts
Zero-Signal Plate Current (two tubes).....	84 Milliamperes
Zero-Signal Screen Current (two tubes).....	16 Milliamperes
Plate-to-Plate Load.....	10,000 Ohms
Self-Bias Resistor.....	220 Ohms

(Copyright 1936 by RCA Manufacturing Co., Inc.)

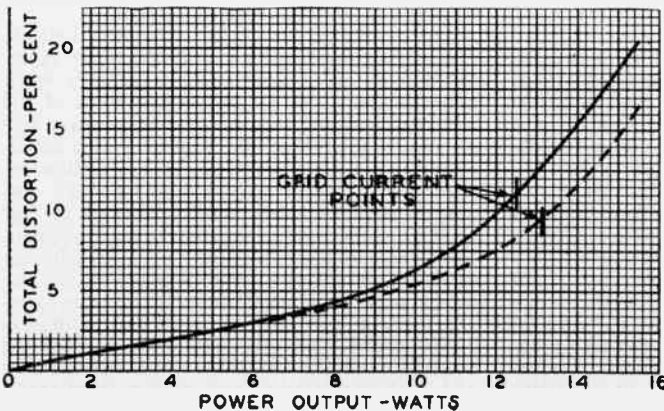

FIG. 3

The solid curve represents practical push-pull attainment in typical receivers, the dashed curve nearly ideal results. In this example the B supply regulation was 850 ohms, the other operating conditions as tabulated at the end of the article. Fig. 2 circuit was used.

R.F. Mixing for Steady A.F.

Beat Calibration for Amplifier Tests

By Herbert E. Hayden

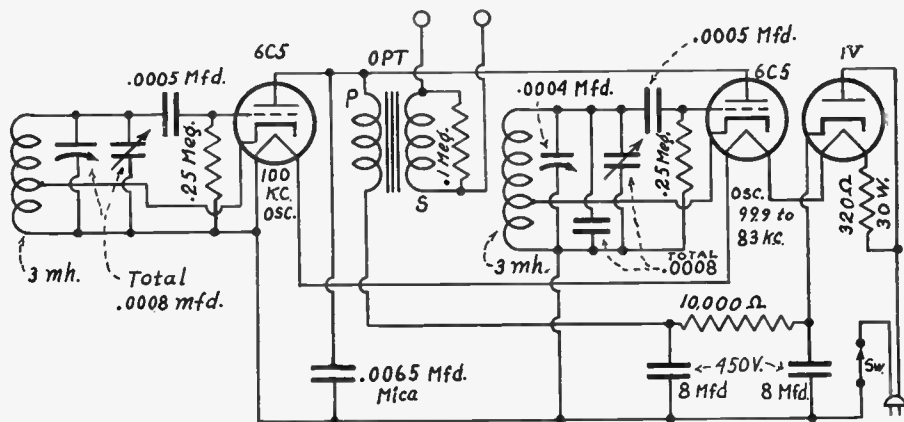

An a.c. operated audio beat note oscillator. The device itself has constant amplitude. A couple of volts across the output transformer secondary (OPT) may be expected. The differences between a fixed r.f. oscillator, 100 kc., at left, and a variably tuned oscillator, 83 to 99.9 kc. (center) produce the audio pitches, 100 cycles to 17,000 cycles.

HEREWITH is a design for a beat frequency audio oscillator, 100 cycles to 17,000 cycles. It may be built with a .00035 mfd. variable condenser and go as low, but not quite as high, perhaps 15,000 cycles.

The condenser actually used was of the same type as found in several commercial radio-frequency signal generators, capacity .0004 mfd.

There is a commercial dial, also, based on putting .0008 mfd. across this variable, whereupon the tuning is from 99.9 to 83 kc. Therefore if a separate 100 kc. oscillator is set up, the resultant beat audio frequencies will be from 100 minus 99.9, or .1 kc, to 100 minus 83, or 17 kc. Multiplying by 1,000 to produce the values
(Continued on next page)

LIST OF PARTS

Coils

Two tapped honeycomb coils, 3 millihenries (commercially obtainable).
One audio-frequency transformer.

Condensers

Two fixed and two variable condensers, or two variables, to attain .0008 mfd. (Cornell-Dubilier IW-5T7 fixed mica condensers, and Hammarlund air padding condensers APC-100 suggested).
Two .0005 mfd. fixed mica condensers (Cornell-Dubilier 5W-5T5).
One .0065 or higher capacity mica fixed condenser (Cornell-Dubilier 3L-5D7).
Two 8 mfd. 450-volt electrolytic condensers in one container (Cornell-Dubilier EG-9808).
One .0004 mfd. variable condenser (General Instrument Co., plates close to the right). This is the only front-panel variable.

Resistors

Two .25 meg. one-third watt resistors (International Resistance Co.).
One 10,000-ohm two-watt resistor (International Resistance Co.).
One .1 meg. one-third watt resistor (International Resistance Co.).
One 320-ohm, 30-watt resistor built into line cord.

Other Requirements

One frequency-calibrated dial, 83 to 99.9 kc, to go on .0004 mfd. variable condenser.
One escutcheon, for dial indication.
Two knobs (one for dial, other for line switch).
Two octal sockets and one UX, four-hole socket.
One panel and one cabinet.
One male plug and line cord (in combination with limiting resistor for heaters, already mentioned).

(Continued from preceding page)
 in cycles we have $.1 \times 1,000$ equals 100 cycles and $17 \times 1,000$ equals 17,000 cycles.

This type of an audio generator has a constant amplitude over its span, and once the calibration is made, or the circuits are adjusted to the frequency-calibrated dial just mentioned, the accuracy depends on the stability of the oscillators. There is a very excellent order of stability, because of the high capacities always across both r. f. oscillators. The oscillation intensity is weak at radio frequencies, but at audio frequencies the resultant is practically the sum of the others, and besides a step-up audio transformer is used, for trebling the amplitude. Primary is in the generator circuit and secondary is used for output. Therefore a high impedance output prevails.

Straightening Out Curve

The transformer tends to upset the constant amplitude. In fact, using a tube voltmeter, the curve of the transformer could be run. For practical purposes the transformer in the generator has a .1 meg. resistor across the secondary. Ordinarily there will not be anything approaching flatness of the operating characteristic of the transformer, because the constructor would be prone to avoid putting in a high-grade and therefore somewhat expensive transformer. The .1 meg. resistors flattens out the response characteristic of the transformer, but may not do it sufficiently, whereupon a lower value resistor would have to be used, and consequent reduction of total output.

Across the secondary a rectifier type a.c. meter may be placed, used at its five-volt range, and the voltage values noted as the generator is turned from one and one terminal audio frequency to the other. If the highs are more accentuated it is practical to put a mica condenser across the secondary to reduce their intensities. The value of capacity is selected by experiment.

Also, the lows may be deficient in amplitude. On the lows the condenser will have substantially no effect, but there is no ready way of building up the lows, only of reducing the highs to the intensities of the lows. Of course, the preferred method is to use a high-grade

Handy Access to All for Audio Standards

It is possible to get audio frequencies from beats with broadcasting stations. Use the standard broadcast band and beat harmonics of a low-frequency generator with these station carriers. Zero beat is established between a frequency-calibrated additional generator's harmonic and one broadcast carrier, then another station is tuned in, generator unmolested, to produce a finite audio beat (not zero). The resultant tone $F_x = n F_g - F_s$, where n is the harmonic order of the generator frequency F_g , and F_s is the frequency of the second station. The formula presupposes tuning the set to a lower frequency for the second setting, otherwise transpose the right-hand member, so $F_x = F_s - n F_g$.

This method was detailed in the January, 1936, issue, pp. 57 and 58, with a tabulation of examples, and additional text, on page 44.

In general, the foregoing would be based on a listening test, audio oscillator turned until the same pitch is duplicated. However, the ear can not be trusted that far. It is much better to combine audio oscillator output with the other beat tone and observe zero beat on an ray indicator tube or a d. c. meter. Resolution to zero, or nearly zero, is the criterion.

transformer, but in its absence the output adjustment may be attempted as explained.

Use of Receiver Diode

Another method is to unhook the input from a diode detector in a set, and put one side of a sensitive current meter (0—.5 ma or better, though 0—1 ma may suffice if two diode plates are paralleled), and connect the other side

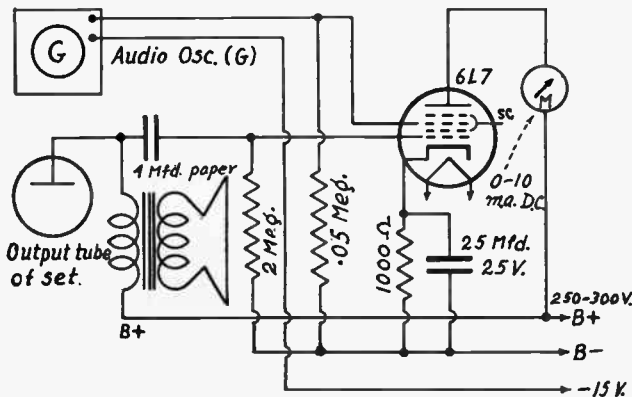

The 6L7 as a mixer, where the tone produced by finite, not zero, beating an harmonic of an extra r.f. generator, not shown, with a broadcast carrier, is put into Grid No. 1, the audio generator, G, to be calibrated supplies frequency to Grid No. 3, and G is adjusted until the meter needle stands approximately still.

of the meter to one side of the secondary of the output transformer OPT, remaining terminal of the audio output to diode plate or plates. Then the current through the diode is read as the generator is turned through its frequency spectrum.

The output is so arranged that the terminals are free, so no danger of short-circuit exists, due to clash of d.c. potentials, some being zero, others negative or positive. The output picks up whatever d.c. potential there is. The circuit is best suited, however, for grid input. If tests are to be made with plate loading, a paper dielectric stopping condenser greater than 1 mfd., the larger the better, should be put between either post and tested circuit. That is to avoid changing the direct current in the plate circuit of a resistive-loaded circuit, where the secondary would present a comparatively low resistance, and greatly reduce the amplifier output, not only by the shunting impedance, but by the resultant increase in bias through a cathode resistor when the plate current was increased.

The self-regulating feature of a cathode-biasing resistor is not uniform enough to atone for the possibility of great reduction of d.c. resistance when the transformer secondary is substituted for or paralleled directly with a high resistance. Also, the impedance load on the plate circuit may not be high enough for high mu tube plates.

The Two R.F. Oscillators

The device is an elementary one. There are two radio-frequency generators, as already explained. These are of the Hartley type, hence the coil is tapped. The total inductance of each coil is 3 millihenries, and these coils are commercially obtainable. The inductance is right, whether the .0004 mfd. condenser is used, or one of approximately the same capacity, but for any save the certain condenser in mind, independent calibration would have to be instituted.

Of the two r. f. oscillators let us consider first the one intended to generate 100 kc.

Set the entire outfit going. Turn the variably tuned oscillator (middle tube circuit) to any setting, and measure the B Voltage drop from plate returns to negative. That means the potential across the left-hand 8 mfd. condenser. Then open the cathode connection of the variably-tuned r. f. oscillator and the voltmeter reading will go up. Put a resistor across the voltmeter, that is, across the left-hand 8

mfd. condenser, of around 10,000 ohms, with a variable resistor of any value around 25,000 or 50,000 ohms, and turn the variable until the voltmeter reads just as it did when the middle tube was functioning. Now the same B current is flowing as before. The reason for this precaution is that a high resistance is in series with the B feed, and the same drop across it should be maintained.

Taking Off the R.F. Voltage

Now put any small coil, like the primary of a broadcast coil, or, if need be, the secondary, or any small r. f. choke, between the left-hand side of the 10-ohm resistor in the B leg of the generator, and plate return. The line must be opened for this insertion. Now disconnect the grounded return of the .00065 mfd. mica condenser, and instead use this condenser lead for output of the intended 100 kc generator. Connect to antenna post of a receiver, and with receiver adjusted for the standard broadcast band tune in a station that operates on a multiple of 100 kc. This is possible nearly in every locality of the United States, particularly as frequencies of 1,300, 1,400 and 1,500 are occupied by many local stations.

Across the coil in this circuit (which coil is exactly the same as the one in the other r. f. oscillator), the total capacity should be .0008 mfd. Therefore if fixed capacities are put in parallel until they nearly total .0008 mfd., or even somewhat exceed it nominally, a small set-screw type air dielectric trimmer may be turned until there is zero beat with the broadcasting station operating on a multiple of 100 kc. The variable may be 50 or 100 mmfd.

The adjustment must be made under the conditions that are to exist in operation. This means that if there is a shield cabinet it must be in place, also that the coil's position must be exactly the same as will be occupied permanently. Moving the coil toward a shield containing iron increases the inductance, and moving the coil away from such a shield reduces the inductance.

Identification Method

So far we have a beat practically zero, at least we should not be able to hear the squeal such as is present, at different audio frequencies, on either side of zero beat. The circuit will be very selective because of the high ratio of capacity to inductance, therefore close zero beat establishment is facilitated.

(Continued on next page)

A high-resistance a.c. voltmeter (rectifier type) may be put across the secondary to measure output volts. Meter is designated V. At extreme right, a receiver diode used for measurement of audio output of generator.

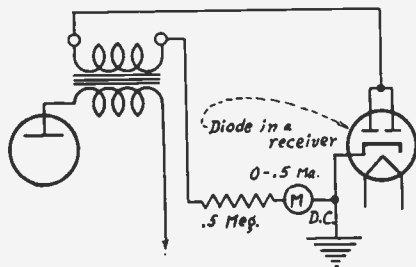
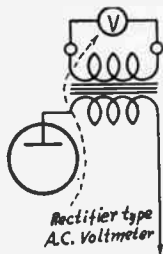

(Continued from preceding page)

If you are so fortunate as to be able to receive two stations, even though one of or both are distant ones, operating on multiples of 100 ks, then the check-up is simplified. We must verify the beat as being due to 100 kc from the generator. Conceivably it could be due to some other harmonic of some other fundamental frequency. But if we can receive other stations of the type just mentioned, we have a good check. Zero beat of course should prevail for all stations operating on multiples of 100 kc.

If we are not so fortunate, at least we know that the responses in the receiver, as we turn its dial, must be 100 kc apart, and if we have some frequency reference, either our own notations of a 0-100 dial, or a set with frequency-calibrated dial, we can note the number of re-

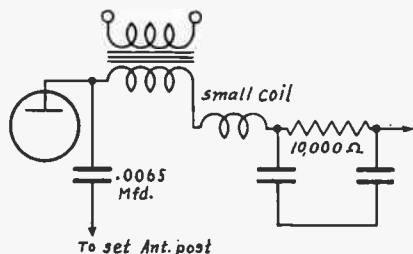

Where the small coil is placed to permit introduction of known radio frequencies, so that beats between oscillator harmonics and stations may be identified. Antenna is connected to a receiver tuned to these stations, one at a time, hence the open side of the .0065 mfd. condenser goes to antenna also.

sponses as the set's frequencies are lowered to the last response, consider these responses as one fewer than they really were, multiply this new number by 100, and see how much we must add (in kilocycles) to the frequency of the station used for first zero beat. This frequency span should be the same as that covered on the set between the two terminal checking points.

The Other R.F. Oscillator

If it is off 20 kc or less, for a real total of six or more responses (five differences or more), starting at 1,400 to 1,500 kc, the true frequency is 100 kc. If responses are more numerous than they should be, decrease the capacity of the trimmer, to the next smaller setting also yielding zero beat with 1,300, 1,400 or 1,500 kc, and try again. If responses were too few, increase the capacity to the next position affording zero beat. The fixed capacities may have to be altered to accomplish the connection, in addition to changing the trimmer setting.

If one has a signal generator, turn it to 100 kc, couple it to the .0065 mfd. condenser as was done in the case of a receiver, and, with phones across the output of the device you are building (at OPT), listen for the response. Use modu-

lation on the signal generator, if possible, to get the approximate position, then remove the modulation and listen on the 'phones for zero beat. Then check this adjustment against a station on a multiple of 100 kc, using a receiver, shutting off the signal generator. The reason is to avoid copying any slight inaccuracy of the generator which, though reading 100 kc, may actually be producing a frequency a little different.

Now shut off the left-hand oscillator and set the middle one going, leaving the compensating resistance across the B line. The output from the .0065 mfd. condenser still is effective, though now for another tube.

Calibrating Your Own Dial

If you are to calibrate your own dial you

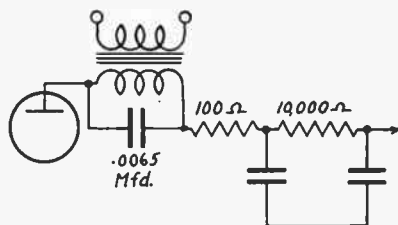

If the oscillations are weak, or seem to be absent, the .0065 mfd. condenser may be connected across the primary of the audio-frequency transformer, as shown, for then the obstruction some a.f. transformers may offer to radio frequencies is removed. The r.f. impedance of an audio transformer may be considerable, especially at low radio frequencies.

may adjust the second oscillator to 100 kc at the minimum capacity setting, remembering to turn the variable condenser to minimum. This is the condenser that has the dial attached. When 100 kc exists in both oscillators the audio output is zero frequency, since the output audio frequency is equal to the difference between the two radio frequencies.

Tenth harmonics may be used against fundamentals of broadcasting stations. Start at 1,000 kc on a receiver, obtaining first from an approximate knowledge, second by verification from the newly-created 100 kc standard. In all instances 1,000 kc is at about the middle of the receiver dial, where condensers of around .00035-.0004 mfd. are used in the set. Now turn the set to lower known frequencies, say, 860 kc is next. Turn the r. f. oscillator until zero beat is attained, and write down the fundamental as 86 kc. That is near the low frequency end of the span to be covered. When tenth harmonics are used, and identified as such, lower frequencies may be calibrated by dividing station frequencies by higher harmonic orders (by 11, by 12, etc.) and an assortment of frequencies is obtained, not even ones, but values that can be communicated to a curve on large cross-section

(Continued on next page)

Winged Words for Tube Constants

By Siu Tamara

IT has come to my attention that the younger generation will have trouble understanding present terminology of tube constants, therefore I suggest clarifications and simplifications. The principal facts desired to be known about a tube, besides price, are (1), the amplification factor, called μ ; (2), the plate resistance, written R_p ; and (3), the mutual conductance, signed G_m . It is not needed to look up the meaning of "bang," or "plop," or "swish," as the sound of each word gives the meaning. This I can not do yet for radio. My original plan is to make up from formulas the words that describe the tube constants.

First, amplification factor, or is how much comes out for how little goes inside. Little difference in plate voltage is divided by little difference in grid voltage. As d is used often for difference, and small d means little difference to me, and as e is for voltage, and ep for plate voltage, so we have, for small difference in plate voltage, the simple word *dep*. Then the difference in small grid voltage is of course *deg*. For all purposes of dividing, use the first vowel of the word divide, found to be i , and any time we want to multiply (not needed now) we may use u , the first vowel in multiply. So to *dep* we annex the i and then the *deg* and instead of the meaningless letter μ or phrase "amplification constant," we have the formula word, *depideg*. It should be remembered by one's self that the plate current must be maintained constant. Since k is for constant and ip for plate current, we may put on *kip* and have *depidegkip*. This becomes a serious word.

Next for plate resistance, which amounts to small difference in plate voltage divided by small difference in plate current, other voltages constant, we have *depidip*, and put on end *kaoe*, meaning constancy of all other voltages, having another serious word, *depidipkaoe*.

Mutual conductance has symbol G_m , too confusing for your countrymen with public enemy work. Also mutual conductance is for triodes, and awkward "control grid-plate transconductance," signed S_m , is for tubes overpopulated with elements. Formula word with fair accuracy could be due to your μ/R_p , or my way, *depidegkipidepidipkaoe*. But to tell more accurately, this conductance is equal to small difference in plate current divided by small difference in grid voltage of opposite sign, other voltages constant. So we have for all the conductances, mutual or trans, the serious word *dipidegkaoe*, easier to remember, besides more accurate. Opposite sign of grid voltage could be shown by reversing *eg* to *ge*, making word instead *dipidgekaoe*.

In conclusion I wish to make grateful acknowledgment to no one for any suggestions or help in this original work on composition of serious tube words by formula symbols.

(Continued from preceding page)

paper, and the dial calibrated in that manner. Data on dial calibration will be found in a signal generator article published last month (July issue, pages 41 and 42).

Now restore the circuit as originally built, that is, connect the .00065 mfd. to ground, remove the r. f. choke and remove the compensating resistor network.

The two radio frequencies are to be combined, the fixed one (100 kc) with the variable ones. To obtain low notes at all it is imperative that this coupling be weak. If it is too strong the lowest frequency of response will be around 500 cycles or perhaps higher. Phones may be left across the output (secondary of OPT), and a test made. Attention is closely paid to whether after some note palpably in the hundreds of cycles there is a sudden drop to silence as the dial is turned toward minimum capacity, as if the tubes had stopped oscillating. Or, looking at the dial, does the first response come in around 500 cycles instead of where desired, at zero on the dial? If so reduce the coupling.

No particular coupling method is shown.

Usually the stray coupling, that due to inductive fields and tiny stray capacities common to both circuits, as well as the line cord and common B bus, are easily enough. If not so in your case, use a smaller capacity than .0065 mfd., or put this condenser across the primary only, and a resistor of 100 ohms or so in series with the common plate return, that is, just ahead of the 10,000 ohms resistor. Do not bypass this 100 ohms on the side of the circuit where the oscillators are.

There is no attenuation provided, because an attenuator that does not greatly alter the output characteristics is very expensive. The usual potentiometer has a variety of objections, including the great load change introduced into the measured circuit at different arm positions. Besides, the high advantage of constant amplitude, afforded by a properly loaded beat frequency oscillator, should be preserved, in the absence of a precision output attenuator network, one of practically constant secondaries. These expensive, precision precautions as to output coupling are not within the scope of the economical audio oscillator that is the basis of this discussion.

Makers Test Tubes Closely

General and Original Methods Used

By Einar Andrews

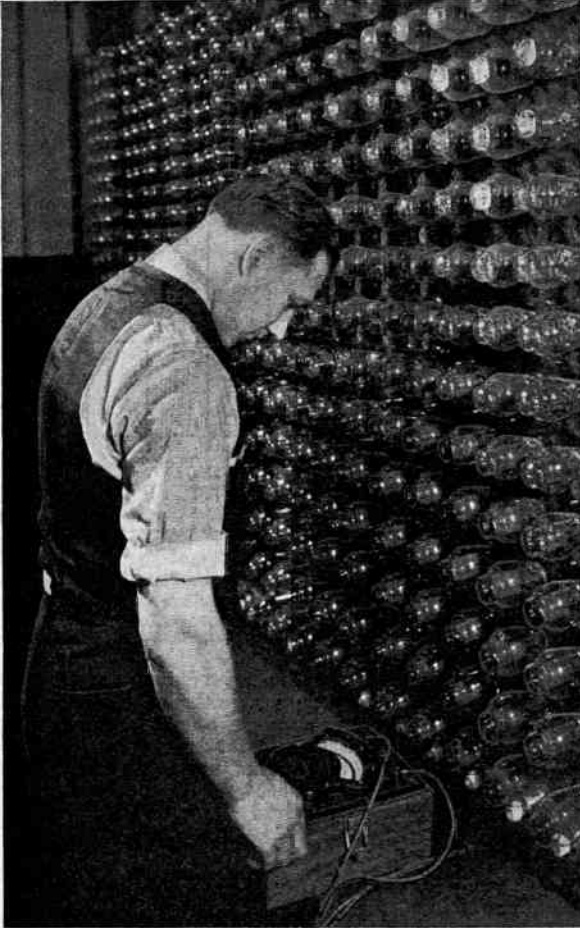

Illustrations from Bell Telephone Laboratories

L. G. Petrovich, of Bell Laboratories, checking operating conditions of 300A vacuum tubes on life tests. This is a new and highly efficient type power tube, manufactured by Western Electric Co.

AFTER tubes have been manufactured they are subjected to rigorous tests. More or less standard methods are used in the tests, although each manufacturer usually has some special technique of his own. The ruggedness of the tubes is tested, occluded gases are driven out, life tests are run, and characteristics taken.

The test for ruggedness consists of suspending the tube under test as a pendulum, displacing the pendulum angle,

and then letting the pendulum swing to a center position, at which point the tube strikes against a stop. The angle of displacement is increased until failure occurs. Breakage may occur in the glass envelope, in the glass insulators inside the envelope, or in any part of the structure. Accidental contact of the plate with one of the other elements is a possible failure.

One of the processes of manufacturing is the driving out of occluded gases. The vacuum pumps carry the exhaustion as far as possible, the "getter" removes the last trace of gas, but if the tube were to be sealed and put into service it would not be long before the vacuum would not be satisfactorily high. Occluded, or hidden, gas molecules gradually become released from the envelope and the internal structures, and these render the tube inoperative. This possibility must be prevented. The usual way is to put the tube in a high frequency induction furnace in which it is heated to a higher temperature than any to which it will rise in normal operation. The heating drives the occluded gases into the open where they may be exhausted by the pump and "got" by the "getter."

Extended life tests are made on large numbers of tubes which have passed the routine tests, which usually are automatic. The object of the life tests is to determine how long the tubes will stand up under specified service conditions, what particular elements will give out first, and to determine what improvements can be made in the tubes to increase their useful life. Often operating specifications are amended as a result of life tests. These are as likely to be favorable as unfavorable. That is, the maximum plate voltage, for example, may be increased by 20 per cent., with a great increase in the output power, without shortening the rated life of the tube. During life tests the specified operating conditions are rigidly adhered to, and frequent checks are made to see that they are being maintained.

Winged Words for Tube Constants

By Siu Tamara

IT has come to my attention that the younger generation will have trouble understanding present terminology of tube constants, therefore I suggest clarifications and simplifications. The principal facts desired to be known about a tube, besides price, are (1), the amplification factor, called μ ; (2), the plate resistance, written R_p ; and (3), the mutual conductance, signed G_m . It is not needed to look up the meaning of "bang," or "plop," or "swish," as the sound of each word gives the meaning. This I can not do yet for radio. My original plan is to make up from formulas the words that describe the tube constants.

First, amplification factor, or is how much comes out for how little goes inside. Little difference in plate voltage is divided by little difference in grid voltage. As d is used often for difference, and small d means little difference to me, and as e is for voltage, and ep for plate voltage, so we have, for small difference in plate voltage, the simple word *dep*. Then the difference in small grid voltage is of course *deg*. For all purposes of dividing, use the first vowel of the word divide, found to be i , and any time we want to multiply (not needed now) we may use u , the first vowel in multiply. So to *dep* we annex the i and then the *deg* and instead of the meaningless letter μ or phrase "amplification constant," we have the formula word, *depideg*. It should be remembered by one's self that the plate current must be maintained constant. Since k is for constant and ip for plate current, we may put on *kip* and have *depidegkip*. This becomes a serious word.

Next for plate resistance, which amounts to small difference in plate voltage divided by small difference in plate current, other voltages constant, we have *depidip*, and put on end *kaoe*, meaning constancy of all other voltages, having another serious word, *depidipkaoe*.

Mutual conductance has symbol G_m , too confusing for your countrymen with public enemy work. Also mutual conductance is for triodes, and awkward "control grid-plate transconductance," signed S_m , is for tubes overpopulated with elements. Formula word with fair accuracy could be due to your μ/R_p , or my way, *depidegkipidepidipkaoe*. But to tell more accurately, this conductance is equal to small difference in plate current divided by small difference in grid voltage of opposite sign, other voltages constant. So we have for all the conductances, mutual or trans, the serious word *dipidegkaoe*, easier to remember, besides more accurate. Opposite sign of grid voltage could be shown by reversing *eg* to *ge*, making word instead *dipidgekaoe*.

In conclusion I wish to make grateful acknowledgment to no one for any suggestions or help in this original work on composition of serious tube words by formula symbols.

(Continued from preceding page)
paper, and the dial calibrated in that manner. Data on dial calibration will be found in a signal generator article published last month (July issue, pages 41 and 42).

Now restore the circuit as originally built, that is, connect the .00065 mfd. to ground, remove the r. f. choke and remove the compensating resistor network.

The two radio frequencies are to be combined, the fixed one (100 kc) with the variable ones. To obtain low notes at all it is imperative that this coupling be weak. If it is too strong the lowest frequency of response will be around 500 cycles or perhaps higher. Phones may be left across the output (secondary of OPT), and a test made. Attention is closely paid to whether after some note palpably in the hundreds of cycles there is a sudden drop to silence as the dial is turned toward minimum capacity, as if the tubes had stopped oscillating. Or, looking at the dial, does the first response come in around 500 cycles instead of where desired, at zero on the dial? If so reduce the coupling.

No particular coupling method is shown.

Usually the stray coupling, that due to inductive fields and tiny stray capacities common to both circuits, as well as the line cord and common B bus, are easily enough. If not so in your case, use a smaller capacity than .0065 mfd., or put this condenser across the primary only, and a resistor of 100 ohms or so in series with the common plate return, that is, just ahead of the 10,000 ohms resistor. Do not bypass this 100 ohms on the side of the circuit where the oscillators are.

There is no attenuation provided, because an attenuator that does not greatly alter the output characteristics is very expensive. The usual potentiometer has a variety of objections, including the great load change introduced into the measured circuit at different arm positions. Besides, the high advantage of constant amplitude, afforded by a properly loaded beat frequency oscillator, should be preserved, in the absence of a precision output attenuator network, one of practically constant secondaries. These expensive, precision precautions as to output coupling are not within the scope of the economical audio oscillator that is the basis of this discussion.

Close Measurement of I.F.

Introducing Facility Few Generators Offer

By Capt. Peter V. O'Rourke

IT is often desired to align an intermediate channel closely at a frequency specified by the circuit designer or the set manufacturer, and yet the run of signal generators will not permit this. For instance, suppose it is required to make the alignment at 456 kc. Perhaps the generator can be read at 455 kc, also at 450 kc and 460 kc, but it would not be practical to set the dial at 456 kc with any certainty.

Of course a difference of one kilocycle is slight, and in point of comparison it is ultimately a case of one kilocycle of the frequency at which the circuit is to be padded, so one out of 600 kc in one instance and one out of 1,450 kc in the other instance, for the standard broad-

end. Now if a small condenser is independently cut in, say, 20 mmfd., and the large one switched out, which may be done with a separate double-pole, double throw switch, the tuning could reach 450 kc, and there would be great bandspread, with registrations one kc apart, instead of 5 kc, and each "one" more greatly spaced from its neighbor than each "five" is spaced from its neighbor on the generator dial itself.

Registration of Frequencies

For the extra condenser a pointer knob is provided, such as manufactured by Triplett, and of course the calibration has to be undertaken. This

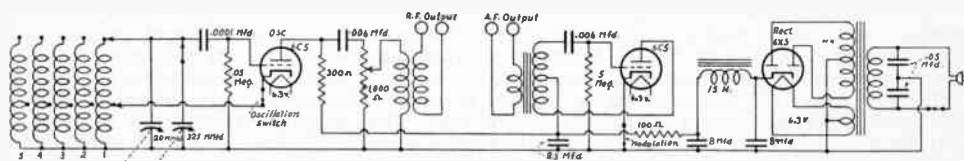

If the high-frequency terminal of any band is in the region in which bandspread is desired, closer readings of intermediate or other frequencies may be attained by mechanically coupling a small condenser to a large one, and independently switching out the large one. This is for a generator one is to calibrate. For a built-up generator, the small condenser would not be mechanically coupled, and the small one could be switched instead of the large one, whereupon bandspread frequencies would be lower than the highest otherwise attainable in the band.

cast band, smaller percentages for higher frequency bands.

Getting Just Right Frequency

But the manufacturers want the sets aligned at just the specified frequency, and while a small difference was cited, a larger one may arise in actual practice. The general problem is addressed to the alignment of frequencies other than multiples of five, since it is assumed the generator has bars of the frequency-calibrated dial 5 kc apart for this range.

A solution may be introduced if the desired bandspread i.f. range for all-wave sets is near the minimum-capacity setting of the tuning condenser, as is true in many generators commercially produced. That arises usually from starting at 100 kc, and using a tuning condenser affording a capacity ratio larger than 10, hence a frequency ratio larger than 3.16, although the calibration of the dial may not necessarily include the full range of generation.

Take as an example a generator that winds up an intermediate-frequency band at 500 kc, remembering that this is the high-frequency

is very easy, because the generator dial itself gives some indication of the frequencies to be expected, and it is necessary only to beat second harmonics of the generator with broadcasting stations, plot a curve with 180 base line divisions, draw a circle on cardboard, use a protractor, and registering each of the points, one kc apart, as read from the curve, write down these frequencies. Due to the large bandspread a small circle is sufficient, also a straight capacity line small condenser could be used, such as Hammarlund MC-20-S.

The first diagram shows a complete, five-band generator, with sine-wave modulation, as the second tube from left is an audio-frequency oscillator. Modulation may be included or omitted, by working the switch the word "Modulation" indicates in the diagram.

Flexible Coupling Used

In this particular instance the small variable is connected mechanically to the main variable, which assumes that the shaft of the larger condenser extends at the rear, so a flexible coupling unit may be included. This is the simplest method

of introducing a separate switch, but it is intended rather for a generator one is to build and calibrate himself, as now the small condenser always is in circuit, and the large one is put in parallel with it, for general use, and taken out of circuit by independent switching, for i.f. bandsread. Coils to cover the five bands with Hammarlund 325 mmfd. midline condenser and the small one straight capacity line in parallel exist commercially.

However, if one is building his own generator or not he may use a three-deck switch, and take care of the small condenser automatically, as suggested in the second diagram. Now either the large or the small condenser is in circuit alone. Consider the switch decks as being A, B and C as marked in the diagram, and the positions of the switch knob as 1, 2, 3, etc., representing bands. The C deck always

the three-deck type, doubling the number of switch positions, and including the small variable as a front-panel-controlled device, the bandsread may be applied to commercial signal generators.

A Word of Caution

A precaution to be observed is that the bandsread should fall in a region where it is wanted, but the fact has been brought out that this is practical with quite a few generators. If conditions are right for the band, the "spread" calibration may be extended to other bands, requiring extra calibration, of course. The system is applicable because the main tuning condenser is not disturbed at all for the bands for which the generator dial was calibrated by the manufacturer, and the only change

If a two-deck switch is to be replaced by a three-deck switch, either in a generator one builds and calibrates, or in a commercial generator already calibrated, the method shown may be applied. On the odd-numbered switch positions usual coverage is obtained, on the even-numbered ones bandsread. Frequencies begin a bit higher for the small than for the large condenser.

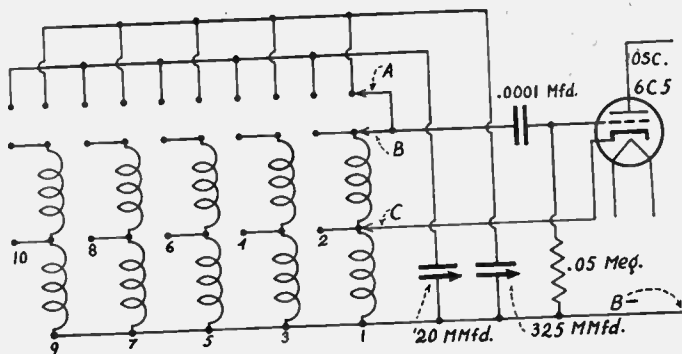

picks up the cathode, as this connection need not be changed at all. The tube grid picks up one coil and large condenser, same coil and small condenser next time.

Odd and Even Numbers

So for the first position, No. 1 on the diagram, we have the large tuning condenser alone in circuit. Next we have bandsread, by using the small condenser alone with the same coil as previously, the spread being for the high-frequency end of the band covered when one was tuning with switch at position No. 1. So No. 2 is high-frequency bandsread for the previous band.

For Position 3 of the switch, the regular tuning obtains for No. 3, the regular band immediately overlapping Band 1, and the large condenser is in circuit, but for the fourth band only the small condenser is in circuit, and so we go again to bandsread. Hence the odd-numbered bands are regular and the even-numbered bands are bandsread.

While the second method, using the three-deck switch, has been discussed mostly from the viewpoint of making and calibrating a signal generator, it is nevertheless true that by supplanting the present two-deck switch with

is to introduce bandsread, no molestation elsewhere.

Although the Hartley circuit is shown, the oscillator may be of any other type. Practically all generators have two-deck switches, and afford room for a three-deck switch, particularly as the three decks may require little more room than two, because closer proximity of the decks may prevail in the substituted three-deck switch.

Poor Contact Trouble

Sounds in a faulty receiver that suggest oscillation in the audio-frequency amplifier, so-called motorboating, sometimes are not due to that cause at all, but to poor contact between rotor of tuning condenser and the potential to which rotor is intended to be connected, usually ground. Mose severe examples concern the local oscillator of a superheterodyne. Some condensers have wipers for aiding contact, and these work free, causing intermittent sounds while tuning, also sometimes after a station is tuned in contact is interrupted. When the contacts are cleaned and made firm the trouble disappears.

Makers Test Tubes Closely

General and Original Methods Used

By Einar Andrews

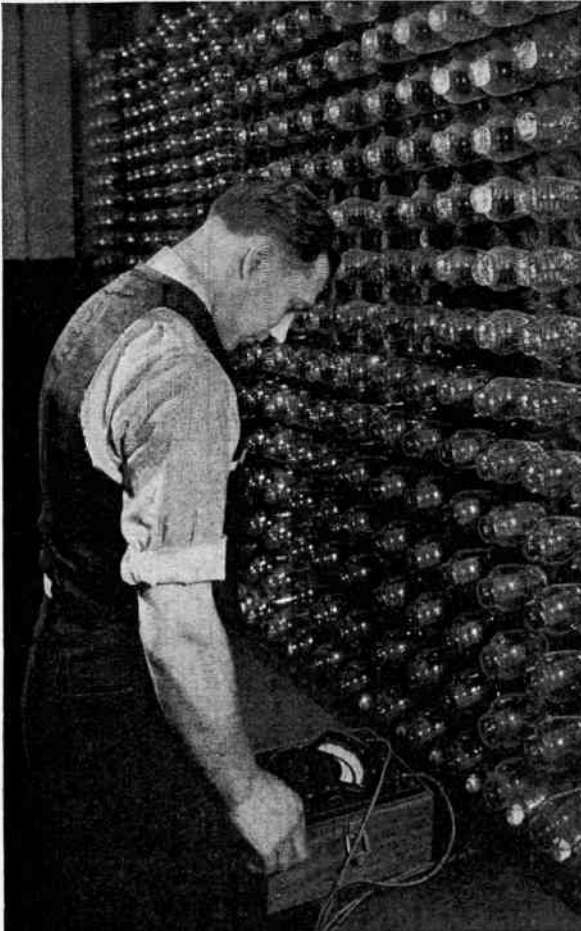

Illustrations from Bell Telephone Laboratories

L. G. Petrovich, of Bell Laboratories, checking operating conditions of 300A vacuum tubes on life tests. This is a new and highly efficient type power tube, manufactured by Western Electric Co.

AFTER tubes have been manufactured they are subjected to rigorous tests. More or less standard methods are used in the tests, although each manufacturer usually has some special technique of his own. The ruggedness of the tubes is tested, occluded gases are driven out, life tests are run, and characteristics taken.

The test for ruggedness consists of suspending the tube under test as a pendulum, displacing the pendulum angle,

and then letting the pendulum swing to a center position, at which point the tube strikes against a stop. The angle of displacement is increased until failure occurs. Breakage may occur in the glass envelope, in the glass insulators inside the envelope, or in any part of the structure. Accidental contact of the plate with one of the other elements is a possible failure.

One of the processes of manufacturing is the driving out of occluded gases. The vacuum pumps carry the exhaustion as far as possible, the "getter" removes the last trace of gas, but if the tube were to be sealed and put into service it would not be long before the vacuum would not be satisfactorily high. Occluded, or hidden, gas molecules gradually become released from the envelope and the internal structures, and these render the tube inoperative. This possibility must be prevented. The usual way is to put the tube in a high frequency induction furnace in which it is heated to a higher temperature than any to which it will rise in normal operation. The heating drives the occluded gases into the open where they may be exhausted by the pump and "got" by the "getter."

Extended life tests are made on large numbers of tubes which have passed the routine tests, which usually are automatic. The object of the life tests is to determine how long the tubes will stand up under specified service conditions, what particular elements will give out first, and to determine what improvements can be made in the tubes to increase their useful life. Often operating specifications are amended as a result of life tests. These are as likely to be favorable as unfavorable. That is, the maximum plate voltage, for example, may be increased by 20 per cent., with a great increase in the output power, without shortening the rated life of the tube. During life tests the specified operating conditions are rigidly adhered to, and frequent checks are made to see that they are being maintained.

Tube characteristics are taken frequently during tests to see how they deteriorate during service. The main thing that accounts for decreased performance with age is the decrease in the electron supply. Oxide coated and thoriated filaments or cathodes have only a definite life. When this has been exhausted there is a sudden extinction of life. However, preceding this demise there is a slow diminution in the performance. Oxide coated and thoriated filaments must be used in order to have a high emission efficiency, or low filament power for a given output.

The 300-A Tube Enables Economy

The new 300-A power tube, developed by Bell Telephone Laboratories and manufactured by Western Electric, reduces the cost of sound-picture and public-address amplifiers. One of the cost-reducing factors is the economy in the rectifier system, made possible in the reduction of the operating plate voltage, compared to the 242-A. Lower maintenance and lower replacement costs are established.

A marked difference exists in the filament power, for the new tube 6 watts per tube, compared to 32.5 watts for the 242-A. Operating plate voltage has been reduced to 325 volts, compared to 800 volts for the other, the plate current is 60 milliamperes, compared to 67.5 milliamperes for the 242-A, while the power output of the 242-A for push-pull at the higher potentials and wattages stated, was 12, compared to 15 for the new tube at the economical supply potentials and wattages.



C. Depew, of Bell Laboratories, testing a tube for shock. The lines on the screen behind the swinging pendulum determine the intensity of the shock.

Disassembled elements of the 300A tube. The grid is in the left hand, the plate in the right. In the background are many of the tubes on life test. The tube is particularly intended for improvement of sound-picture and public-address amplifiers.



A New Inductance Formula

For Measuring the Pure Value of an R.F. Coil, Based on Two Frequencies and Capacity Difference

By Herman Bernard

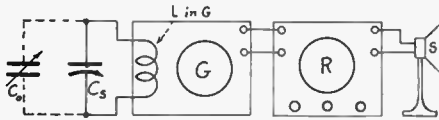

The inductance of a coil L in a generator is measured by connecting a calibrated variable Condenser C_s across the tuned circuit of the generator, and resonating first with one known frequency, then with another. More capacity (C_0) may be introduced without effecting the result. R is a receiver tuned to one, then the other station, for disclosing zero beat with G .

$$L\mu h = \frac{2,533 (F_2^2 - F_1^2) 10^7}{(C_2 - C_1) (F_2^2 F_1^2)}$$

Where $L\mu h$ is the unknown in microhenries, F_2 and F_1 are in kilocycles, and C_2 and C_1 are in microfarads.

THE difficulty of measuring radio-frequency inductances is increased by the presence of the coil's distributed capacity as well as by tube and circuit capacities. If a calibrated capacity is put across the coil, and a test frequency used, the inductance may be computed, but the answer is in terms of apparent inductance. For the calibrated capacity has been increased by the distributed capacity. Therefore we do not know the real capacity.

How great is the error due to using apparent inductance methods can not be determined, because the added capacity is a mystery. If one measures the distributed capacity of the circuit and adds it to the capacity of the calibrated condenser, then of course the result of computation, based on accurately known frequency, will be the real inductance.

The error may be much larger than one would care to tolerate. However, there are methods of inductance measurement wherein the answers are very accurate and represent the true or real inductance, and not the false or apparent inductance.

Basic Formulas

Means were described in last month's issue for measuring distributed capacities, which may be added to calibrated capacities to attain accurate results, but there are still other methods, just as good, and besides handier, that disclose the true inductance. One of them is entirely new.

is advisable to present the basis on which its determination was predicated.

The basic formula is the following:

$$Fkc = \frac{159,160}{\sqrt{L\mu h C \text{ mmfd.}}}$$

To move the inductance into the position of the unknown it is necessary to square the numerator, and square the frequency that will now appear in the denominator:

$$L\mu h = \frac{25,330,000,000}{Fkc^2 C \text{ mmfd.}}$$

The ciphers appended to a number usually are designated as an exponent of ten. Thus, for 1,000,000 one writes 10^6 . If we use the method with the two formulas we then have:

$$Fkc = \frac{15,916 \times 10^4}{\sqrt{L\mu h C \text{ mmfd.}}} \dots\dots\dots (1)$$

$$L\mu h = \frac{2,533 \times 10^7}{(Fkc)^2 C \text{ mmfd.}} \dots\dots\dots (2)$$

Approach to New Formula

Now, it is obvious that if a calibrated condenser is used across a coil, if the *absolute* value of the capacity settings of that condenser alone are considered with frequencies, then the distributed capacity remains a masked factor, and upsets the accuracy. However, the *difference* between absolute values of known capacity may be taken into account, and so may *differences* in frequencies, and products of capacities and frequencies. We thereby investigate inductance by means of dependable ratios rather than by means of absolute values that are not accurately known, but are in fact erroneous.

What we have to do, then, is to change the capacity in circuit by a known amount, this knowledge being derived from a calibrated variable condenser, one of small capacity, say 50 mmfd., for higher accuracy to which differences may be read. The capacity difference must be a known amount, but not any given amount, because the two frequencies to be used for making the measurement will determine how

much the capacity change will have to be, for any setting of the condenser in the generator itself. Note that the generator condenser may be positioned at any capacity, since absolute capacities are not of any consequence. It is the capacity difference that counts.

Method of Procedure

So we set the generator to zero beat, its fundamental with a broadcasting station of known frequency, tuned in on a receiver. Then we connect the calibrated little condenser across the tuned circuit of the generator, and since we have added capacity we must reduce the generator tuning condenser's capacity to allow for the difference, to restore the zero beat.

After noting the first capacity setting of the calibrated condenser we tune in, with the receiver, another broadcasting station of known frequency, and turn the calibrated condenser to greater or less capacity, whichever is required, until we zero beat with the second station. Now we have done everything necessary for applying the formula to solve for the pure inductance of the unknown coil in the generator.

The example of a coil in a generator has been cited, simply because it is a handy example. In practice most measurements would be made in a separate circuit in which the unknown coil is placed, a large variable condenser, not necessarily calibrated, being in parallel with the coil, and the small calibrated condenser also in parallel. The reason for the large condenser, as already stated, is to give wider range or scope. Inductances otherwise too low to enable response are tuned with the large condenser to bring the resonant frequency not only into the broadcast band but to the very frequency of a selected station. If the large condenser is 500 mmfd. the inductance may be as small as 21.5 microhenries, with the uncalibrated variable out of circuit, and the frequency 1,500 kc. With small calibrated condenser now connected at or near its minimum, and generator compensated for it, if the second frequency is 1,400 kc the small calibrated condenser would have to be changed by 100 mmfd.

Now for the Formula

Some indicating device is necessary for the circuit in which the separate coil is being tested, and this preferably would be a vacuum tube voltmeter.

The formula for determination of the pure inductance from the frequencies and capacities follows:

$$L_{\mu h} = \frac{2,533 (F_2^2 - F_1^2) 10^7}{(C_2 - C_1) (F_2^2 F_1^2)} \dots\dots\dots (3)$$

where $L_{\mu h}$ is the inductance in microhenries, F_2 is the higher, F_1 the lower of the two frequencies, C_2 the higher and C_1 the lower of the two capacities. This method does not depend on harmonics.

All subscripts in this article are higher for the higher constants.

Just as a reminder to those not familiar with working 10^7 in a computation, the numerator in the equation equals 25,330,000,000.

This is a method, then, of determining the real inductance, and wholly eliminating the effect of the distributed capacity, moreover a method that does not depend on any particular capacity ratio or any particular frequencies, or on harmonics. Moreover, if any intended measurement proves out of range, as when the inductance is too small for the calibrated condenser and the frequencies by which comparisons are to be made enough capacity may be put across the coil, to lower the frequency within range, and what the amount of this particular capacity is does not matter and need not be known, since the solution in no way depends on it, and does not affect the accuracy.

Other Methods

This is not the only method of measuring the true inductance, but it is a new one and very excellent. Two others were set forth in last month's issue. The first of these had the limitation that two particular frequencies must be used, 138 kc and 1,380 kc, and the second required that wavelengths squared be known.

(Continued on next page)

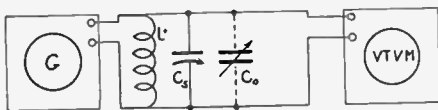

If a generator G of high accuracy is used, then the frequencies are obtained from it, and L may then be an external coil. C_2 is the calibrated condenser, C_1 the range condenser. The formula is the same:

$$L_{\mu h} = \frac{2,533 (F_2^2 - F_1^2) 10^7}{(C_2 - C_1) (F_2^2 F_1^2)}$$

Derivation of Formula (3)

Formula (3) was derived from the following:

$$C_1 = \frac{1}{4\pi^2 L F_1^2}$$

$$C_2 = \frac{1}{4\pi^2 L F_2^2}$$

$$L(C_2 - C_1) = \frac{1}{4\pi^2} \left(\frac{1}{F_1^2} - \frac{1}{F_2^2} \right)$$

$$L = \frac{.02533 (F_2^2 - F_1^2) 10^{12}}{(C_2 - C_1) (F_2^2 F_1^2)}$$

(Continued from preceding page)

However, many who will make measurements of inductance enjoy using several methods, if only to ascertain the degree of coincidence of the solutions. This coincidence depends on the instruments used, that is, how accurately the frequencies and capacities are known.

Since wavelengths squared are quantities nobody can be expected to have available, the formula will be given for wavelengths, which adds a small computation, within anybody's scope.

squares of wavelengths. Hence the generator would have to be calibrated in wavelengths squared, which it never is. However, being calibrated in frequencies always, and sometimes in frequencies and in wavelengths, the generator may be adapted to the simple wavelength requirement by computing the wavelengths of the two frequencies used. The test method now being discussed, which we shall call the wavelength method, *does not depend on harmonics*, but on any two wavelengths. A condenser of 281.4 mmfd. must be put across the unknown



The bank-wound coil, often using Litz wire for the secondary, has succeeding turns wound over preceding ones, in a given order of "retreat." Larger inductance is attained at shorter axial length of winding. Coil diagram of connections is the same as for the single-layer secondaries of the high gain group.

For the case of generator producing 138 kc the formula is

$$L\mu h = \frac{1}{C_2 - C_1} \dots\dots\dots (4)$$

where C_2 is the larger capacity, for picking up the fundamental of the generator, and C_1 the smaller capacity for picking up the second harmonic of the generator. These capacities are read from a calibrated condenser, usual range 50-500 mmfd.

To extend the range to smaller inductances the frequency may be multiplied by 10 and the

coil at one stage of the work. The frequency to which the coil responds due to its natural period is determined, as by putting a known frequency into the coil which in turn feeds a tube voltmeter. Next a capacity of exactly 281.4 mmfd. is connected across the coil, and the new (lower) frequency is measured.

Changing to Wavelengths

Now these frequencies are converted into wavelengths. The formula for this follows:

$$\lambda m = \frac{299,820}{f} \dots\dots\dots (6)$$

The previously illustrated bank-wound coils were of the high-gain, equalizing type. Herewith the low-gain model is shown. The cross-section coil views represent bottom facing the reader, in all diagrams.

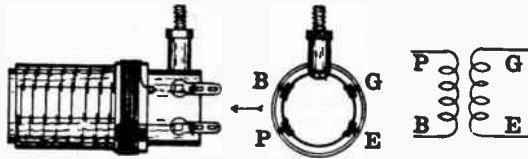

numerator by 100, whereupon the formula for 1,380 kc becomes:

$$L\mu h = \frac{100}{C_2 - C_1} \dots\dots\dots (5)$$

Some Require Harmonics

It should be observed that the method just discussed depends on the use of fundamental and second harmonic of the generator. A more extended discussion of the method appears in last month's issue, in which were presented also details of measuring the distributed capacities of coils, or any other small capacities, using fundamental and second harmonic.

The second of last month's pure inductance methods depends on the difference in the

where λm is the wavelength in meters and f is the frequency in kilocycles.

The original inductance formula, using squared wavelengths, is

$$Lcm = \lambda_2^2 - \lambda_1^2 \dots\dots\dots (7)$$

in which Lcm is the inductance in centimeters (one centimeter equals one one-thousandth of a microhenry, or 1,000 centimeters equal one microhenry). On this score a decimal point was misplaced in last month's issue and the above formula is correct as to the order of L .

Since $\lambda_2^2 - \lambda_1^2$ is the same as

$$(\lambda_2 + \lambda_1) (\lambda_2 - \lambda_1)$$

we may substitute and have

$$Lcm = (\lambda_2 + \lambda_1) (\lambda_2 - \lambda_1) \dots\dots\dots (8)$$

Now we can get along conveniently with a signal generator calibrated in frequencies, although it is always advisable to check the generator frequency against a station of known

curate frequencies are at hand. Zero beat a signal generator with the stations and feed listen on the receiver for zero beats, or watch for them on a meter, if the variable being cali-

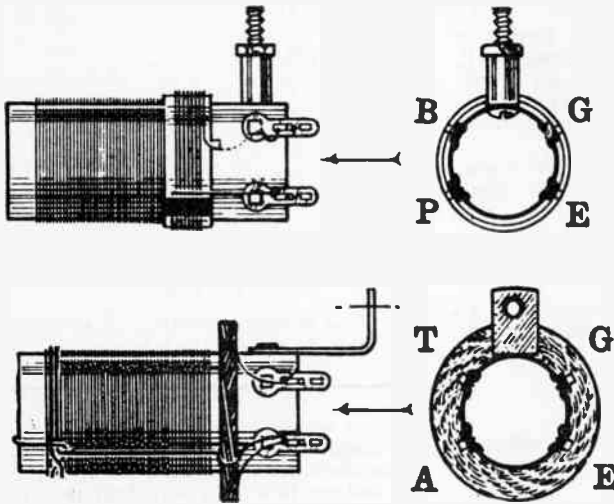

The low-gain coils take this general form. The primary is small and is wound over and insulated from the secondary. The natural period of the primary is higher than the highest frequency to which the tuned secondary responds. The coil connection diagram is the same as for the low-gain bank-wound coil.

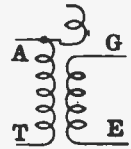

A high-gain antenna coil, with equalizing primary. The natural period, assuming standard antenna self-capacity of .0002 mfd., lies just below the broadcast band. Thus the energy transfer is greater at the low broadcast frequencies, tending to offset the rising characteristic of t.r.f. This is aided by inductive coupling, effective at low frequencies, combined with capacitive coupling, strongest at high frequencies.

frequency. There is no insufficiency of range or latitude. In (8) as in (3) the absolute capacity across the circuit is immaterial. Hence more capacity may be added, until the response is gained, only the same capacity must remain in circuit when the 281.4 mmfd. condenser is "in" and when it is "out," but the measurement depends solely on the difference in capacities on which the measurement is based equalling 281.4 mmfd.

A capacity of just the right amount is obtainable commercially.

Measuring Capacities

If the capacity in circuit—sum of the distributed values of coil, tube, socket, wiring and the uncalibrated variable—is to be measured, this may be done by measuring the inductance, using formula (3), and computing the total capacity for various settings for which ac-

brated is in the generator. If it is outside, use a separate coil, measure its inductance, zero beat a signal generator with the stations, and put generator output into the test circuit: The computations yield the total capacity, but the distributed may be measured separately (July, 1936, issue) and subtracted from the total. The formula for the total capacity is

$$C \text{ mmfd} = \frac{2,533 \times 10^7}{(Fkc)^2 L\mu h} \dots\dots\dots (9)$$

For those desiring to relate capacity to inductance and wavelength the formula is:

$$C \text{ mmfd} = \frac{.2814 \lambda^2}{L\mu h} \dots\dots\dots (10)$$

(Continued on next page)

One of the handiest methods, if one has a system of reading wavelengths, in which generator G could be calibrated, is to measure this difference, determined by first removing C₁, then including it. If C₁ is 281.4 mmfd. then

$$Lcm = (\lambda_2 + \lambda_1) (\lambda_2 - \lambda_1)$$

where Lcm is the unknown inductance in centimeters, λ₂ is the higher wavelength and λ₁ the lower wavelength, generated by G, responses noted in VTVM. If G is calibrated in wavelengths squared then Lcm = λ₂² - λ₁².

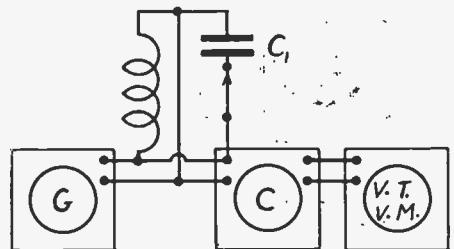

(Continued from preceding page)

where C is the capacity in micromicrofarads, L is the inductance in microhenries and λ is the wavelength in meters.

New Capacity Formula

If formula (3) is investigated further it will be found that an unknown capacity, C, may be measured in terms of the small calibrated condenser and two frequencies, whether C is large or small. It is not even necessary to know the inductance to measure C.

Adhering to higher subscripts for higher quantities, we have the capacity ratio equals the square of the frequency ratio:

$$\frac{C_2}{C_1} = \frac{f_2^2}{f_1^2}$$

There is a certain capacity common to C₂ and C₁ and it is C, the unknown capacity. Therefore

$$\frac{C_2 + C}{C_1 + C} = \frac{F_2^2}{F_1^2}$$

From the foregoing we find the unknown capacity

$$C = \frac{C_2 F_1^2 - C_1 F_2^2}{F_2^2 - F_1^2} \dots\dots\dots (11)$$

Segregation of Capacity

The capacity is the entirety in the circuit being measured, and this may be segregated by measuring the distributed capacity of the coil, tube, socket, wiring, etc., as one value, using the same formula (11), and subtracting the value from the first total. The difference is the value of the intentional tuning capacity, e.g., a particular setting of a variable condenser, hence a large capacity condenser may be calibrated with high accuracy. But when the unknown is large the frequency difference is small and the practical accuracy is not quite so high, unless the inductance is small.

Large capacity differences are preferred for accuracy and large frequency differences might be required. Wide frequency differences are not hard to obtain. We continue to use broadcasting stations as frequency standards, even if we have a generator set at low frequencies,

Derivation of Formula (11)

The derivation of Formula (11) is as follows:

$$C_1 = \frac{1}{4\pi^2 L F_1^2}$$

$$C_2 = \frac{1}{4\pi^2 L F_2^2}$$

$$L(C_2 - C_1) = \frac{1}{4\pi^2} \left(\frac{1}{F_2^2} - \frac{1}{F_1^2} \right)$$

$$L = \frac{.02533 (F_2^2 - F_1^2) 10^{12}}{(C_2 - C_1) F_1^2 F_2^2}$$

L is in microhenries, C is in micromicrofarads and F is in kilocycles.

because we use harmonics of these low generator frequencies. For instance, suppose we have a standard broadcast band receiver set at 660 kc, and we pick up a zero beat near the lowest frequency to which the generator will tune, say it reads 54 kc. We divide 660 by 54 and get 12.22.

That would mean that theoretically the 12.22 harmonic of the generator frequency is equal to the station frequency. But we know that harmonic orders are whole numbers, 1, 2, 3, 4, etc., without limit, therefore since an error obviously exists, and since it is not due to the station, it must be due to the generator, the calibration of which is off. However, a good generator will not be so far off that the nearest whole number dividend will not be the true harmonic order. That is, the real generator frequency is 660/12, or 55 kc, and not 54 kc. So if we introduced harmonics into a tunable system, the consecutive responses in the indicator would be spaced apart by exactly 55 kc.

Known Changes

If we knew one frequency as 660 kc we could move in either direction, adding 55 kc for each

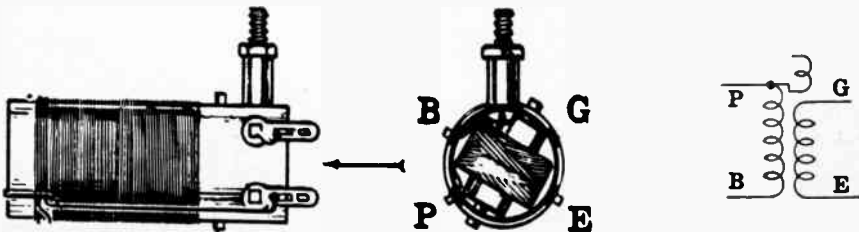

In the high-gain series of coils the interstage transformer also has a high-inductance primary, the universal wound coil inside the solenoid form. Coupling is exclusively capacitive, due to the open-ended wire from primary encircling secondary.

Inductance - Capacity - Frequency Chart

THE chart herewith shows the relationship of inductance, capacity and frequency, so that if any two values are known, the unknown may be read directly from the chart. The accuracy is 1.5 per cent. The ranges are as follows:

Inductance, 10 to 1,000 microhenries. (1,000 microhenries equals one millihenry).

Capacity, 10 to 1,000 micro-microfarads. (1,000 micro-microfarads equal .001 microfarad).

Frequency, 500 to 12,000 kilocycles. (One thousand kilocycles equals one megacycle).

By computation the frequencies may be converted into wavelengths. The wavelength in meters is equal to 299,820 divided by the frequency in kilocycles.

It will be noted that the spaces are not equal for equal steps of changes in inductance or capacity, consequently the distances between the frequency lines are not equal for equal differences in frequency. This is due to the use of cross-section paper plotted according to special rate of change, called logarithmic. Each ten-fold increase is called one cycle (which has nothing to do with the frequency resulting from inductance and capacity combinations). So the paper is plotted for two cycles on each dimension. In the two instances, inductance and capacity, the first cycle is 10 to 10x10, or 10 to 100, and the second is 100 to 10x100, or 100 to 1,000.

When the double logarithmic, or so-called log-on-log, paper is used the "curves" are straight lines. This method of enabling the use of straight lines was devised by Edward M. Shiepe and used first in a supplement to his book, "The Inductance Authority."

The frequencies other than those marked on representative lines may be determined by counting the spaces between such lines, and ascribing to each space a frequency equal to 1/n of the frequency difference between the chosen representative lines. The letter n represents number of spaces

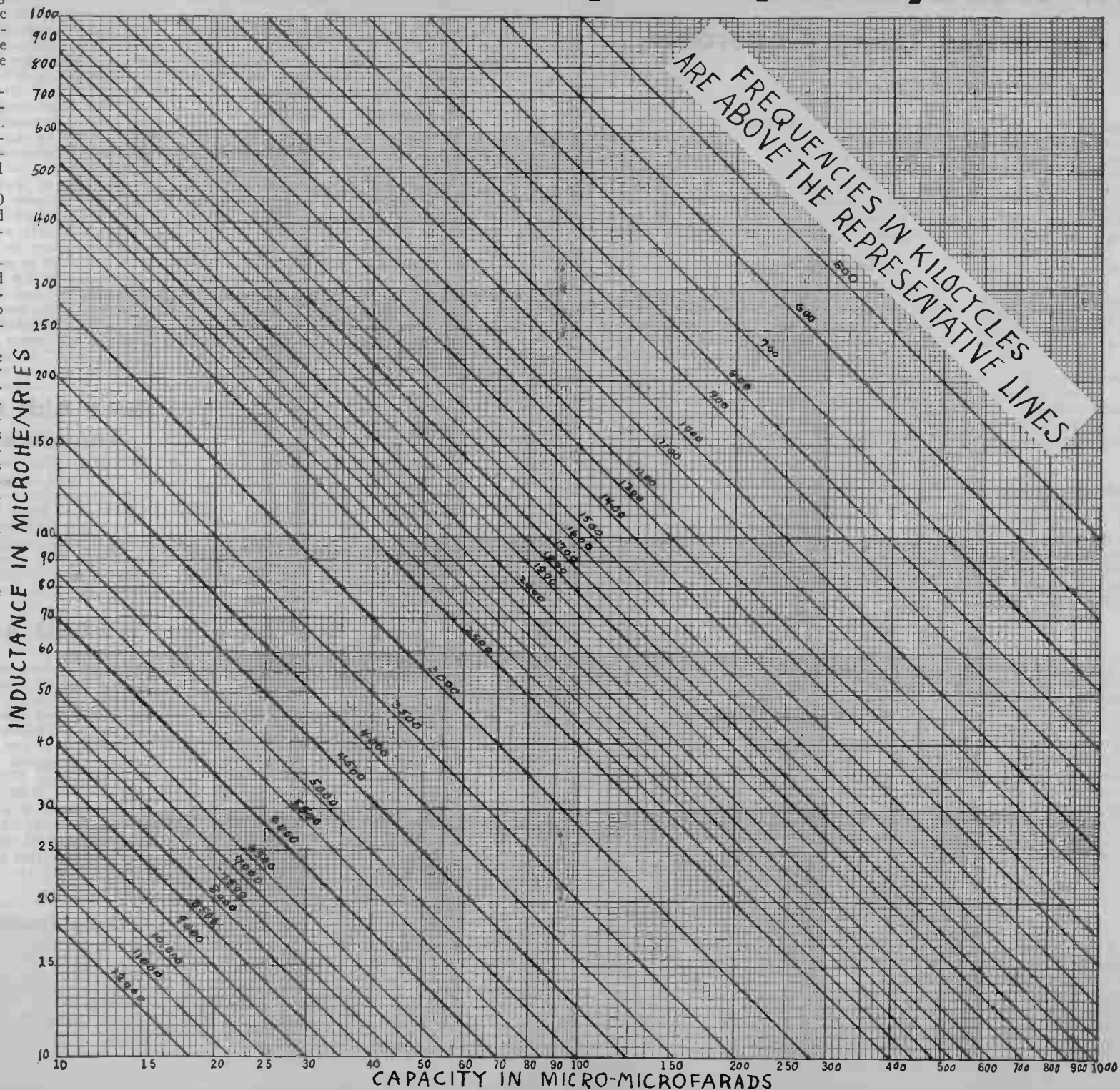

FROM the curve it is possible to tell the total capacity in circuit for known inductance and known frequency, also the total inductance in circuit for known capacity and known frequency, likewise the frequency from known capacity and known inductance. The chart is based on the capacity and the inductance being in parallel. For series connection the results are the same within the accuracy of the chart.

The base or horizontal is called the abscissus, where the capacities are imprinted. The upright or perpendicular plane is called the ordinate, and here the inductance is read. The frequency lines are at right angles to a line drawn through the lower left and upper right-hand corners of the cross-section paper.

To use the chart, locate thereon the values that are known, and follow the line, representing them, until they intersect, then read the unknown. If the capacity is 250 mmfd. and the inductance is 100 μ h, read 250 on the abscissus (base), follow the line upward to read 100 (read at left), and the intersection is 1,000 kc. If the frequency is 500 kc and the capacity is 400 mmfd., read 400 at bottom, go up to the 500 kc line, then to the straight to the left to read inductance, 250 μ h. If inductance is 60 μ h, frequency being 3,500 kc, read 60 at left ordinate (perpendicular) carry line straight to the right to reach intersection with 3,500 kc, and then go straight down, reading the inductance as 33 μ h. (The Greek letter μ , pronounced mu, stands for micro and h for henries.)

The chart has been checked at numerous points, and for these the accuracy proved to be 1.5 per cent.

The chart is useful for all the more important radio frequencies. For instance, the low frequency terminal of the broadcast band is included, because the chart starts at 500 kc. The frequency ratio is 24-to-1.

A New Measurement For Small Capacities, Using Generator

By Herman Bernard

THE determination of any small capacities, such as the distributed capacities of coils, based on differences read from a calibrated condenser, becomes more accurate the more accurately the disclosing capacities can be read. For instance, if one has a condenser of 500 mmfd. maximum and 50 mmfd. minimum, if one can read to, say, 2.5 mmfd., then the accuracy of reading at 500 kc is .5 of one per cent, but at 50 mmfd. it is 5 per cent. Using fundamental and second harmonic of a generator in making a small capacity measurement, naturally one of the deciding readings has to fall in that low capacity region where the accuracy of reading it not very good. This may produce grievous mismeasurement.

The operation for the case of the coil is to gain a maximum deflection in an indicating device, such as a vacuum tube voltmeter, due to resonance of fundamental of the generator and VTVM, then turn the calibrated condenser

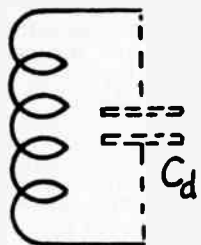

The distributed capacity of a coil is usually represented by the capacity across the terminals. This capacity is shown as C_d . But the effect on performance is greater than the illustrated method represents.

to smaller capacity, until again a maximum deflection, though perhaps less than the former one, results, whereby the second harmonic of the generator is now influencing the VTVM. The apparent capacity ratio is always greater than four, because it would be four if the coil being measured had no distributed capacity, and since the coil must have some, the condenser must be turned an extra bit. Always, of course, the true capacity ratio is four, based on fundamental and second harmonic, but the deviation from four, the expansion of the ratio, is a measure of the capacity of the unknown, which alone causes the expansion.

The formula on which this is based is

$$C_x = \frac{4(C_{\max} - C_{\min})}{C_{\min}}$$

where C_x is the unknown, C_{\max} is the larger of the two capacities (fundamental) and C_{\min} is the smaller of the two capacities (second harmonic) as read on the calibrated condenser. It does not make any difference what the frequency is, so long as fundamental energized the test circuit at the first settings.

The formula may be reduced to the following:

$$C_x = \frac{d}{3} - C_1$$

where C_x is the unknown, d is the difference of the read capacities for the fundamental and second harmonic, and C_1 is the lesser of the two read capacities, previously mentioned as C_{\min} .

Getting Equipment

There is no need to traverse the whole calibrated condenser, since if the true capacity ratio of 4 to 1 is otherwise established, then a much smaller capacity calibrated condenser may be used, say, one of 50 mmfd. maximum, which would have perhaps 6 mmfd. minimum. Since it is too difficult to get fixed condensers that have just the right ratio of 4 to 1, to an accuracy better than one per cent., it is suggested that fixed mica condensers about four times the maximum of the small calibrated variable condenser be obtained, then measured, and when one is found that is four times maximum, or a bit less, note the capacity setting of the small calibrated condenser representing one-fourth of the capacity of the fixed one, and use this position of the calibrated condenser as the reference point.

Now the formula is even simpler:

$$C_x = \frac{d}{3}$$

where C_x is the unknown capacity, d is the difference between the fixed capacity and the small calibrated condenser's position at the reference point.

Operation of Generator

As a matter of practice, then, the generator is turned from its highest frequency until response is gained in the VTVM, when it is known the input circuit to the VTVM is resonant with the fundamental of the generator. Next the fixed condenser is put across the coil as the only external capacity associated with the coil. Next the fixed condenser is switched out and the small calibrated condenser is switched in and until the second harmonic of the generator is picked up. In no instance is the selected generator frequency changed. The capacity setting is read, and the value is subtracted from the capacity value of the reference point. This represents d , or the difference, in the formula.

To work the formula, either multiply by four and then divide by three, or multiply by 1.333. The choice is a matter of personal convenience. Since the number three is recurrent it is indeed

response except the first, and then the frequencies in the receiver would be known to be 660 + 55, 660 + 110, 660 + 165 etc., or 715, 770, 825, etc., for increase of frequency in the indicator system, or 660 - 55, 660 - 110, 660 - 165, etc., or 605, 550, 495, etc. for the opposite direction.

Thus we obtain at first a frequency that is low but accurate and by addition or subtraction register a large frequency difference.

Accuracy is Goal

Since the systems set forth deal with very accurate frequencies, and the only limitation is the accuracy of the small calibrated condenser, to maintain the accuracy for small frequency differences the inductance must be small, as the object is to use up as much of the span of the calibrated condenser as possible.

Since the differences in frequencies are equal for harmonic use, they determine the amount of change to be introduced in the calibrated variable condenser. The calibrated condenser is introduced, at or near "zero" capacity, after zero beat is struck, and the system being measured is tuned to smaller capacity to make up for the distributed capacity of the the calibrated variable, which may be around 8 mmfd. for 140 mmfd. maximum. This is such a slight compensation that there is no peril of missing the harmonic order, although the retuning should be done carefully.

As Low as You Like

If the inductance in the measured circuit is small the frequency difference will be large for a given difference in capacity settings of the calibrated unit, while if the inductance is large the frequency difference will be small. Therefore it may be necessary, for measurement of capacity where large inductance is used, to have a lower frequency than lowest the generator produces. This may be attained by adjusting generator harmonic to zero beat a low-frequency broadcasting station, say, 540 to 600 kc, generator at the lowest frequency that produces this result and then, verifying the true frequency of the generator by the harmonic method already discussed, put any variable condenser at "zero" setting across the generator condenser, leaving generator condenser at the position determined by zero beat, and slowly increase the external capacity to pick up a new beat. Say the same facts prevail as before, generator truly at 55 kc. It was the twelfth harmonic of 55 kc that zero beat with 660 kc, and now that generator frequencies are lower, the harmonic orders are consecutively higher, because the product of generator frequency and harmonic order is always a constant, the station frequency. So divide 660 by the next higher number, 13, then turn to still more capacity, and the next response is due to 660/14, and so on, until you reach a fundamental low enough for the purpose.

So starting with 55 kc we would get 55, 50.761, 47.143, 44, 41.25, 38.823, 36.666, 34.737 and 33 to the twentieth harmonic (660/20 = 33).

Increasing Sensitivity Of Meter is Bugbear

One question that novices constantly bring up, is how to make the meter they have more sensitive. For instance, it is a 0-100 milliammeter, and what they really want is a 0-1 milliammeter, so ask, What can be done to change it in the desired direction? It seems to be pretty well understood that the change can be made in the opposite direction, that is, sensitivity reduced by shunting.

Besides the necessity for a sensitive meter for measurements of circuits in which small current flows, no doubt the commercial aspect is attractive to some, as a 0-1 milliammeter is normally more costly than the 0-100 milliammeter, and if only some secret way could be found to improve the sensitivity, why not apply that method in quantity, and clean up?

Unfortunately for such thoughts, the sensitivity is built into the meter, and if greater sensitivity of the meter is to be attained, the meter has to be rebuilt. That costs more than making a new meter of the higher sensitivity, from the start. So once more there is no pot of gold at the foot of the rainbow.

Three Aids to Recording Announced by Universal

Universal Microphone Co., Inglewood, Cal., has just placed on the market a cutting lubricant, preservative and conditioner. These are, in succession, liquid, wax and salts.

The cutting lubricant is applied before the cutting process, while the wax is coated on afterward. The conditioner's use is twofold, either on new records as a preservative, or on old records as a reconditioner.

W2XAD Adds 1 3/4 Hours

Schenectady, N. Y. W2XAD, short-wave radio station of the General Electric Company, increased its daily schedule of operation by adding 1 3/4 hours. The station now operates daily including Sundays on 15,330 kilocycles or 19.56 meters from 10 a.m. to 3:45 p.m. Eastern Standard Time. Formerly it signed off at 2 p.m. W2XAF, sister station of W2XAD, operating on 9,530 kilocycles or 31.48 meters, will continue to broadcast from 4 p.m. until midnight, EST. The new schedule for W2XAD will give short-wave listeners all over the world an opportunity to hear market and stock reports from that station at 3:30 p.m., as well as from W2XAF at 6:30 p.m.

Closer Tracking With 175 KC

Close tracking of 175 kc oscillator with the prior r. f. tuned circuits is possible because when the oscillator coil has been correctly designed the greatest deviation that need be tolerated is less than 2 kc. This is closer than can be effected when the intermediate frequency is 456 kc,

easy to multiply, because the same product appears on each line, and the only other product of the number one and d, requiring simply writing down d. The author found the 1.333 method more convenient.

A limitation applies, that the frequency to which the test circuit is resonant, with the fixed condenser "in," can not be lower than the lowest frequency to which the generator can be tuned. This is a limitation on the magnitude of the inductance of the coil the distributed capacity of which is to be measured. However, the full range of practical radio-frequency inductances can be measured for distributed capacity in this way.

More Turns, More Capacity?

If the generator's low-frequency terminal is 100 kc, for instance, and the fixed condenser is 200 mmfd. (setting the calibrated condenser at reference point, 50 mmfd.), then the inductance of the coil under measurement may be up to 12.75 milihenries, which is a high order. If the generator goes as high as 25 mcg, then the inductance may be as small as 1 microhenry in the test circuit. The distributed capacity still may be measured.

In connection with the measurement of distributed capacity it is perhaps advisable to make some suggestions so that in using the measurement system set forth one may not run into what seem to be contradictions, and which would invite the assumption the formula does not work.

There is a widespread belief that the more turns you put on a coil, the greater the distributed capacity. It is assumed that the distributed capacity is the sum of the capacities between turns, hence the more turns the greater this capacity. For honeycomb coils it is true that the greater the number of turns, the greater the distributed capacity, but for solenoids, and these are used most extensively in tuned circuits where distributed capacity is important, the number of turns has a negligible effect on the quantity of distributed capacity. What is most important is the form diameter. The larger this is, the greater the distributed capacity. So a coil of a single turn on a given diameter would have a certain distributed capacity, and another coil, with ten turns of the same size and insulation wire on the very same diameter, would have about the same distributed capacity.

Other Factors Considered

Other factors that have something to do with the quantity of distributed capacity are the wire diameter, and the spacing between turns. Large diameter wire produces larger distributed capacity, spacing of the turns will reduce the distributed capacity for any given wire diameter. So to achieve smaller distributed capacity, smaller diameter wire may be used, and spacing may be introduced as well, to the same end.

The reason why distributed capacity is important is that it acts upon the tuned circuit more seriously than would mere presence of the

same amount of capacity externally. If one found a coil had a certain distributed capacity, and a means to remove all of it, and then if a parallel capacity were placed across the coil externally, the effect on the circuit's merit would not be so great.

The only ready, practical way we have of measuring distributed capacity is to ascertain the capacity present across the coil, that is, make the measurement between coil terminals. That total capacity is merely something we measure, and something we refer to as the distributed capacity, but it does not show the effect on the tuned circuit, except as to frequency determination or change, and it impliedly assumes that the inductance throughout the coil is uniform, so-called "current sheet" in inductance. Actually, there is non-uniformity of in-

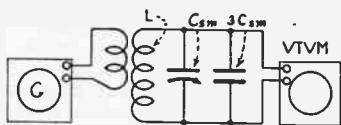

If the problem is to measure the distributed capacity of L, then C_s is turned to maximum, m, becoming C_{sm} , and a fixed condenser of three times C_{sm} is thrown into circuit. Thus the capacity ratio is 4, C_{sm}/C_{sm} , or 4. Generator G_1 used at fundamental pr 4 C_{sm} will respond to the second harmonic at less than C_{sm} when 3 C_{sm} is cut out. The formula:

$$C_x = \frac{4d}{3}$$

where C_x is the unknown distributed capacity, and d is the difference between C_{sm} and the second capacity reading of the standard variable, to resonate with sound harmonic.

ductance along the axis of the coil. The greatest current density is somewhere near the axial middle of the winding, with attenuation toward the ends. The intensity of the field is a measure of the inductance.

With distributed capacity, about which less is known, the same general situation exists, in that the capacity is not uniformly distributed. If, due to the inductance, the current is larger at one place than another, parallel capacity between turns will have an unequally distributed effect.

Actually the total distributed capacity is not the sum of the capacities between turns, which follows from the fact that the total distributed capacity is only negligibly affected by the number of turns; in fact, usually is said to be independent of the number of turns. A full realization of what distributed capacity really is probably has never been achieved.

If the capacity between one turn and its neighbor is not in parallel with the capacity between some other turn and its neighbor, as measurement proves, since the voltage drop across the capacity reactance alone, when measured, is different, then perhaps the turn-to-turn capacities are in series? This we know is not

(Continued on next page)

(Continued from preceding page)

so, because if they were in series, the greater the number of turns, the smaller the total distributed capacity. And yet there is practically no change in distributed capacity as the number of turns is augmented.

Not Same Current, Either

Also, by measurement, the current through the capacity legs of the turns is not the same, therefore again the capacities are not in series. If they are not in parallel, because the voltage drops across the capacity reactance, turn to turn, are not equal, and if they are not in series, because the current through these capacities is not the same, just what is the nature of the connections? It is not the lack of uniform distribution of inductance along the winding with consequent creation of difference of voltage drop across the turn-to-turn capacities, that solves the puzzle, because the capacity differences between turns were measured on a sensitive bridge, merely as capacities, at a frequency for which the inductance was practically zero, and again at higher frequencies where the inductance effect was neutralized in the bridge arm.

It begins to look, then, as if besides having series and parallel circuits, and combinations thereof (and the distributed capacity is not series-parallel, either), we also have some third basic type of circuit connection, about which we knew and even suspected practically nothing.

Has Effect on Q

Whatever the nature of the connection may be deemed to be, the distributed capacity acts to increase a. c. resistance of a radio-frequency coil. That is why we are interested in making measurement, for if the capacity is inordinately large, we have at least one clue to a circuit that did not perform up to par. It is not the effect of distributed capacity on the tuning ratio that matters much, for coils as used ordinarily in sets have a distributed capacity low enough to make it of small consequence in that direction, say, 6 mmfd. for solenoids, or so, for honeycombs or universal wound coils, 10 mmfd. for coils in the millihenry range. We want to keep the distributed capacity low so that we may help in keeping the circuit Q high, the Q being a measure of the merit of a tuned circuit. The thing that keeps the Q of a coil low is the a. c. resistance, the very quantity that distributed capacity increases. All we can do practically, within the scope of usual instruments, is to measure an aspect of the cause, as it shows up capacitatively between the terminals, but we should realize that between turns of the coil events are taking place that are not understood, and the thing we measure is not the hidden, affected part, but the epidermis upon which this hidden part works an influence about which we would like to find out a great deal more.

Other Small Capacities

Aside from distributed capacity of coils, any other small capacities may be measured. First

select a coil, measure its distributed capacity, as it will be in circuit on both occasions, add this to the known value of the fixed condenser, and divide the sum by four. Now we have the reference point for the small calibrated condenser when that coil is used, and it would be used often. From then on the same procedure is applied as already explained.

Comprehensive Book on Communication

MOST up to date of all the comprehensive books on radio theory and practice, "Practical Radio Communications," just published, is the work of Nilson and Hornung, and as its name implies, it stresses the practical side.

Moreover, although a certain amount of mathematics is necessary for any complete and authoritative treatment of the subject, the authors have simplified this very considerably, and offer a treatment that makes no sacrifices yet establishes full revelation. All the latest types of receivers, transmitters and oscillators are set forth, with no neglect either of the traditional information that is still the backbone of any radio discourse. This book is outstanding, and it constitutes a complete, practical course in radio, requiring only the barest minimum of knowledge on the part of the reader. This attitude of taking practically nothing for granted lends to the new volume a tone of detail and completeness that few other radio books possess.

There are more than 750 pages. The printing and blue-flexible cover are remarkably attractive. The book is distinctive in appearance as well as in contents. The publisher is McGraw-Hill Book Co., Inc.

Some Power Tubes Critical as to Load

Some power tubes are critical as to the ohms load required, for if the match is not as specified there will be considerable distortion, especially in the form of strong suppression of the low notes. The tendency seems to be to get away from this rigid requirement.

An example of a critical tube in that respect is the 48. In fact, it is scarcely practical to produce reasonably a speaker that is a proper load for that tube, because the change in plate resistance during operation of the tube is so great. It is the most efficient tube of the old power output series, but this limitation of loading, requiring a practically constant impedance over wide changes in current, is probably too great.

In contrast, the new beam power tube 6L6 is made with such high plate resistance, and therefore with practically constant current characteristic, that there is no critical aspect to the plate loading. However, ohms load is stated in the requirements for operation, and the fact to remember is that there may be considerable departure from the specification, and yet with retention of fidelity.

Ways of Reducing Noise

Filters and Neutralizers Effective

By M. H. Beitman

Engineer, Allied Radio Corp.

RADIO interference in an a.c. set may be picked up by the antenna, the power line, or by both. A variety of methods has been developed to overcome the different types of interference.

To determine whether the interference that results in noise in the radio receiver, is coming from the line or is picked up by the antenna system, it is only necessary to disconnect the antenna from the radio set. If the interference persists obviously the power line is the source of the interference, unless a faulty set creates the noise. The interference coming from the line is due to disturbances set up by nearby electrically operated devices that act as miniature radio stations.

Best Results Close to Source

All electrical equipment using motors with brushes will create interference. Of course, the degree will depend on the amount of sparking and other physical relations. Neon signs, street stop lights, diathermy machines and other electrical machines add their interference. As an attempted solution (and one that fails in most instances) a noise eliminator device in the form of a condenser is shunted across the a.c. line near the radio set and not near the source of interference. Although such a condenser to a certain extent does bypass line interference, usually enough of the interfering signal remains, so that the radio listener fails to note improvement in reception.

Another type of "noise-eliminator" uses a condenser arrangement between the two sides of the line and a common external ground, the unit being placed near the source of the interference.

This method is much more effective and really suppresses interfering noises to a remarkable degree. In general the extent of the filtering action is directly related to the distance between the source of interference and the filter unit. The placing of the filter very close to the source of interference aids greatly in bypassing the undesirable signals and eliminates the possibility of line radiation.

Power Transformer Filter

Filter units for noise suppression using condenser-choke combinations are, of course, best suited for interference elimination. The use of such devices, however, has been limited because the capacity-inductance combination resonates at a certain definite frequency. This results in suppression of noises only of the resonant frequency band.

In general, line noises may be eliminated by using suitable interference filters near the source. The use of filters close to the radio set itself helps the matter very little. It is well, however, to filter the primary of a power transformer, two .05 mfd. or higher capacity condensers in series across the primary, joint of condensers grounded. This often cures tunable hum, also.

A number of improvements have been made during the past few years in the design of antenna systems for reception of radio signals, both standard broadcast and short-wave. A good antenna should have a high signal to noise ratio. This requirement is very nearly filled by a well-designed doublet antenna.

To reduce the pickup of undesirable man-made noises, the antenna itself should be located as far as possible from interfering sources, such as power lines, transformers and other electrical devices.

No Pickup from Leadin

It is usually possible to place the antenna wire itself in an advantageous position, away from sources of interference, but it is usually not practical to do likewise with the leadin wire.

By employing a leadin of the shielded type or of the balanced transposed type, pickup by the leadin system may be eliminated. Although the shielded line is well suited for ordinary broadcast frequencies, such a line cannot be used so successfully for higher frequencies. The transposed leadin may be used on all frequencies and is employed in connection with a doublet antenna.

A doublet antenna consists of two separate antenna wires of equal and suitable length. These wires are suspended in a straight line between two supports and insulated therefrom and between themselves. From the position where the two wires are separated from the common insulator, two separate leadin wires are connected to the two antenna wires respectively. These leadin wires may be twisted, but for best results these wires should be transposed every few feet with the aid of transposition blocks.

Doublet Has Advantages

The pickup of the two different leadin wires will be balanced out in the matching transformer. On the other hand, the pickup of the antenna wires will add up in the transformer.

(Continued on next page)

Transformerless Push-Pull

Phase Inversion Adroitly Accomplished

By Garrison Edwards

PUSH-PULL audio without the use of transformer coupling has gained considerable interest for two reasons, economy and scientific fascination. Good transformers cost much more than the resistors and the condensers needed for transformerless coupling. However, equal quality may be attained by either method. With no transformer, the peril of picking up hum in an a.c. set, due to proximity of the audio coupling transformer to the

On the score of scientific interest, however, the transformation connection is the more inviting, because it introduces novelty and ingenuity, and offers a compelling invitation to the experimenter.

From the Antipodes

The circuit shown on this page accomplishes the push-pull effect without transformer coupling. An Australian radio magazine offered a prize for the most original, best-performing receiver of any kind, and the winner presented a superheterodyne with two degrees of selectivity, one broad for the reception of the regional (local) stations, the other sharp for reception of the national (distant) stations through the regional ones. The audio channel was push-pull, in general according to the circuit herewith.

Note carefully the grounding provision in this circuit, whereby cathode is not directly grounded through the biasing resistor, but there is a .1 meg. resistor in series, before ground is reached. Across the biasing resistor is a large condenser, to avoid degenerative feedback (shown as 25 mfd., 25 volts rating).

Again, on the subject of grounding, the signal may be introduced in parallel, the usual method, across the two horizontal lines extending to the left, but if this is done, and the resistor at left is assumed to be the detector plate load, returned to B plus, the input signal

(Continued on next page)

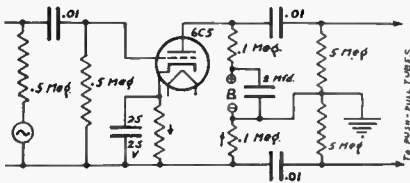

Equal resistors in the plate and cathode legs develop voltage drops that are out of phase and therefore make possible push-pull. The input should be in series (circle at left with sine wave symbol). Arrows show instantaneous direction of signal current.

power transformer, or other such fields, is practically eliminated, but this again brings up the economy question, because if the transformer has a high-permeability shield the same freedom from hum pickup prevails.

(Continued from preceding page)

This action is very similar to the action of a push-pull amplifier.

The doublet antenna, therefore, has the advantage of allowing the placement of the antenna wires themselves away from interference, and by eliminating the leadin pickup increases the signal to noise pickup ratio. An ordinary leadin usually picks up about as much energy as does the intended antenna proper, and does so nearer ground, where the noise fields are often strongest.

A great improvement in elimination of noises of high intensity and short duration is possible by means of the Lamb noise silencer. The noise silencer may be incorporated in any superheterodyne circuit equipped with a. v. c., and operates on the principle of overbiasing the i.f. stage vacuum tube the instant noise develops an assigned threshold voltage. The rectified component of this excessive input supplies the silencing bias.

While the human ear can easily detect noises even of short duration, the ear fails to detect

instantaneous silence because the perception of sound lasts a short while after the source of sound is removed, so the silencing does not create a period of inaudibility.

The installation of automobile radios presents a special problem. The electrical system of the engine and especially the spark plugs causes interference. Spark suppressors and bypass condensers are used to eliminate this source of interference. By enclosing modern radios in metal containers, using close shielding and critical points grounded by bonding, and using suitable filters in the supply voltage leads to the set, the use of spark plug suppressors may be avoided.

Another method used to eliminate noise interference in car radios depends on the principle of inversion. A second interfering signal is introduced exactly out of phase and of the same intensity as the original interference. In this manner the two signals just balance each out and interference is suppressed. The difficulty of this method lies in introducing the correct out-of-phase component.

(Continued from preceding page)

circuit is completed through the .5 meg. grid load and the .1 meg. resistor that is in series with the biasing resistor. Hence there will be inequality, if the load resistors are equal, because there is more signal voltage in one leg than in another, also the phases are opposite, and the push-pull relationship is not truly present, although the method may work satisfactorily.

Series Feed Necessary

The amendment proposes the introduction of the signal in series, and therefore avoids this difficulty, although for grounded cathode tube ahead presents a substitute problem, the introduction of the input signal as a series connection without the use of a transformer!

Hence for practical application, the circuit as shown would be amended, with the .5 meg. resistor at left considered the plate load of the detector, returned to B plus, instead of to the cathode return of the 6C5, and then the plate and cathode load resistors, shown .1 meg. each for a condition of series input, could be made unequal, a tap taken off the plate resistor, so that on test there will be the same amount of a.c. across the output of one section as across the output of the other.

This balance may be measured with a tube voltmeter, across one after another of the two grid leaks at right. Or, if no such voltmeter is at hand, the push-pull tubes that follow may be tested for equality, and the tap arranged so that the same current flows through the plate of one push-pull tube as through the plate of the other, when any audio signal is introduced at the 6C5 input. If the tubes are not alike, a makeshift is to change measure in one push-pull tube, both functioning, then transpose the push-pull tubes, and measure again in the other circuit now, using the same tube as before.

"More Compromising than Promising"

The parallel connection method is considered by the author to be more compromising than promising. In the second diagram, where a diode detector is represented, its load resistor of 0.5 meg. is not grounded. Here it is simple to have the detector cathode above ground, as the detector circuit is complete between cathode and anode. Also, due to series feed the detected signal does not flow through the subsequent load resistors, except after going through the inverter tube, so we have no phase distortion and do not have to resort to any of the tricks of tapping or otherwise trying to compensate in the loads on the inverter.

It is particularly appropriate to use such a circuit in a superheterodyne, because the secondary that serves as input to the detector does not have to be grounded. When a tuned radio frequency circuit is used the grounding of the rotor of the tuning condenser practically requires the grounding of the coil, as filters introduced for segregation introduce some impedance changes that would also require compensation. With a super these difficulties are avoided.

The circuit is true push-pull in the second

example. The arrows on the first diagram designate the direction of current flow at any instant. When the signal voltage is falling in the lower .1 meg. resistor (approaching zero potential of ground) it is rising in the other resistor. These two resistors are separated by the B supply, that is, the lower one goes to grounded B minus and the upper one to B plus.

True Push-Pull

So since extreme upper and lower terminals of this combination of resistors are at opposite potentials at any instant, it is necessary only to observe or maintain equality, which the second diagram shows. Then we have true push-

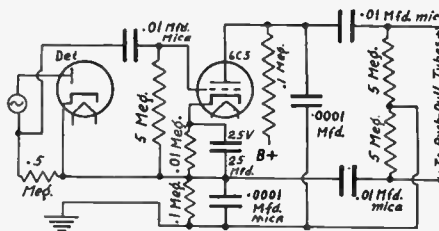

Using a diode detector, wherein the return does not have to be to ground, we have a favorable condition for push-pull. Note that in the amplifier the grid return is not grounded, nor should the output of the preceding tube be grounded, but series input be used, as here. The above circuit fulfills required conditions for true push-pull.

pull and we may couple to the next stage as usual. The stopping condensers and grid leaks are shown, looking into the push-pull circuit, but the rest is not shown, being orthodox. A biasing resistor would go from common cathode or filament to ground, no bypass condenser needed across it, and the output of the push-pull tubes, which may be the power stage, also are conventional.

Under all conditions of true push-pull, the voltage developed across the output is a total, half of which is used for input to one tube and half to the input of the other push-pull tube. Hence the total voltage is 2E and each push-pull tube gets E. This fact is imprinted on three of the diagrams but applies to all.

Distortion is Reduced

It can be seen therefore that the push-pull relationship reduces the realization of signal voltage input 50 per cent, just as a full-wave rectifier yields only half as much d.c. output voltage as does a half-wave rectifier, other factors equal. However, the object of push-pull is quality, not quantity, and besides the sensitivity of a system may be made as high as practical by using more gain at any level, even introducing merely a single more sensitive tube.

For instance, added gain at r.f., i.f., or a.f. (Continued on next page)

(Continued from preceding page)

may be introduced. With modern circuits there is usually plenty of gain, and then some to spare, so that the push-pull circuit is inviting. Besides, it reduces distortion, particularly that due to the even order harmonics, which a truly push-pull circuit balances out. These harmonics are present in the input, that is, really are in the push-pull stage, but they are eliminated from the output, and only the output actuates the next stage, or the speaker.

The proper signal voltage division may be accomplished in other ways, for instance, by taking the full signal output from a diode detector for feeding one push-pull tube, and introducing less than the full rectified output into an amplifier tube, and taking the full output of the amplifier for feeding the other push-pull tube. The general method is used more often by resorting to twin tubes (two equal triodes in one envelope), feeding the full output of one into the grid of the other, but taking off less than the full signal voltage drop in the

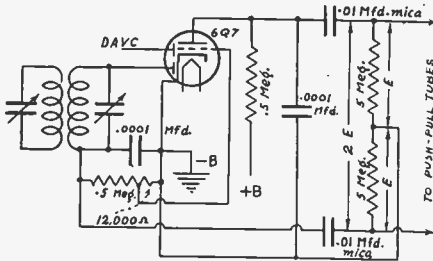

A duo-diode high-mu triode used as detector and phase inverter. Here the voltage inequality to compensate for amplification is introduced prior to amplification. The voltage E put into any one tube is half the total (2E) across the line.

plate leg of the second tube. The factor that determines how much less, is the per stage mu of the amplifier, in the case of the diode, or the second amplifier, in the case of the twin tube. The per stage mu is equal to the mu of the tube as diminished by the loading effect. That is, the full mu of the tube can not be realized in practice. But if the load is a very high impedance, compared to the plate impedance, then the circuit mu may be so close to the tube mu as to justify ignoring the loading effect.

How Tube Mu Enters

In the third diagram, for the reason stated, no attention has been paid to this loading effect. The total resistance load in the diode is 512,000 ohms. The signal voltage developed across this entire resistance is used as input to the lower push-pull tube. Say this is 5 volts. Now, the voltage drop is proportionate to the resistance, so the amount of voltage put into the amplifier is $512,000/12$ or $10/428$ of 5 volts, equals .117 volt. The 6Q7 has a gain

of 43, for the upper push-pull tube so its amplifier will give out $43 \times .117$ or the same voltage as is taken from the diode load resistor for the lower push-pull tube. The proportion of detected voltage here used for input to the amplifier equals the total detected voltage divided by the mu of the tube.

As already outlined, it is not necessary to rely absolutely on the accuracy of the resistors and the attainment of practically the entire tube mu for the per stage mu, for the check-up may be made, based on tube voltmeter use, even if the push-pull tubes themselves are thus used, without calibration, but simply to indicate relative values that are equal.

Good for T.R.F. Sets, Too

Only one diode anode is used for detection proper, the other being intended for delayed automatic volume control, if any a.v.c. is to be used at all. Where high mu triodes or pentodes are used for audio amplification it is usually advisable, if there is a.v.c., to delay it by about ten volts. In fact, a.v.c. may be recommended generally, as then the reception of weak, distant stations is stronger and better, except for the absence of the fading corrective on these particular signals, but this is a theoretical sacrifice anyway. Without the delay the stations might not be heard loudly enough to be enjoyable or even to be rated reasonably as reception. Also, delay helps prevent premature overload of the audio amplifiers. The methods of attaining delay have been discussed in a prior issue,* but for the benefit of those not familiar with them at all, one method is shown later in a complete circuit diagram of a superheterodyne using the inverter stage we have just been discussing.

This inverter stage, by the way, is adaptable to t.r.f. sets, and the method of doing this is shown in a diagram. The solution is to put the "high" side of the tuning system (stator of condenser and equivalent terminal of transformer secondary) to cathode, and put the load resistor between plate and ground. Thereby both coil and load resistor returns are made to the same potential, which is the requirement always, in the absence of special filtering.

The next push-pull circuit also is applicable to t.r.f. sets or supers, because the grounding is right. This circuit has been discussed fully in recent issues[§] and consists of any two separate triodes hooked up as diodes, cathodes independent, or for single tube operation a 6H6, as diagrammed, and properly divides the voltage and the phases.

The Complete Receiver

In conclusion, a few words about the complete receiver may be appropriate. This uses six metal tubes and three glass tubes. For the

*"Delayed A.V.C." by Herman Bernard, February, 1936, RADIO WORLD.

§"Solution of Balanced Detector Problems," by J. E. Anderson; and "Stage to Stage Balance," by Orval C. LaFrance, November, 1935, RADIO WORLD.

6K7's and 6D6's may be substituted, and for the 6A8 the 6A7, whereas the 6Q7 may be supplanted by the 75 and the 6C5's by 76's. No circuit changes are required. (See next page.)

If 2.5 volt tubes are to be used these may be 58's for 6K7's, 2A7 for 6A8, 2A6 for 6Q7, and 56's for the 6C5's, with no circuit changes, only provide the right heater voltage.

The tuner, comprising two r.f. stages and oscillator, is practically standard. The intermediate transformers are of the three-tuned-circuit type, manufactured by Tobe. The volume control is a screen voltage adjuster. A push-pull driver stage is provided for the 45 power tubes, for those who want extraordinarily great volume.

The delayed automatic d.a.v.c. mentioned previously is accomplished as follows: The i.f. carrier is fed to one anode of the duo-diode, represented by upper plate in the diagram, and

d.c. bias before rectification begins in the a.v.c. diode, hence the term delayed a.v.c.

What's the Delay?

The delay is equal to the difference in time between the condition of signal insufficient to overcome d.c. bias, and signal sufficient to overcome d.c. bias. However, although delay is a function of time, the delay is usually stated for such purposes in terms of volts. Here we may say we have about 3.5 volts delay.

Coil Information

The following coil data for one inch diameter, close winding, presuppose aluminum or copper shields, two inch diameter or greater:

R.F. Coil—Secondary, 127 turns No. 32 enamel wire. Two turns of insulating fabric over secondary near one end (bottom, usually). Pri-

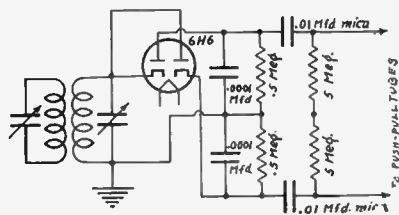
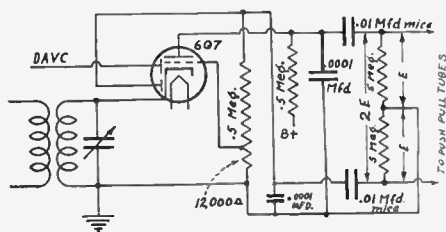

At left, the preceding method is applied to a tuned radio frequency set. The difficulty ordinarily arising because of grounding of the tuned circuit by the condenser rotor is avoided, by feeding the signal between cathode and ground and having the load resistor between anode and ground. At right, a balanced detector that affords push-pull input to the following tubes. This is nicely applicable to supers or t.r.f. sets because of the grounding convenience. The originator is Orval La France.

the return of the coil is through the diode load resistor to ground. However, B minus is not grounded. See center tap of the high-voltage winding of the power transformer, upper right of diagram, and trace this lead down, then to the left until you come to a 100-ohm resistor between B minus and ground.

How Delay Arises

The power tubes' plate current does not flow through this resistor, because the 750 ohm biasing resistor of the 45's goes directly to B minus. However, some 35 ma, due to the other tubes except rectifier, flow through the 100 ohms, so there will be a drop of 3.5 volts. B minus is negative, ground positive, so circuits returned to B minus, where cathodes are grounded, have a negative bias of 3.5 volts at no signal.

When there is a signal, the real detector in the 6Q7 develops a rectified voltage across its load resistor, and since there is a condenser between the two diode plates, and a load on the lower plate (.5 meg.) to B minus, the upper anode may or may not pass current. It is obvious there is a negative bias on the lower diode anode, and with anode negative no rectification takes place. The a.c. voltage of the signal has to be sufficient to overcome this

mary, wound over fabric, 30 turns No. 32 enamel or other fine wire.

Modulator Coil—Same as r.f. coil.

Oscillator Coil—Secondary, 75 turns No. 32 enamel wire. Two turns of insulating fabric over secondary, near one end (bottom, usually). Tickler, wound over fabric, 35 turns No. 32 enamel or other fine wire.

Padding Capacity—Series padder adjusted. Use .0003 fixed mica and 75 mmfd. air dielectric condenser in parallel.

Why Volume Drops on Doublet Use

The ordinary leadin with the inverted L type antenna is as much an antenna as the horizontal wire stretched above the roof, indeed may pick up more energy than the antenna proper. Therefore if one installs a doublet antenna with transposed leadin, the pickup may be less for two reasons: (1) the leadin contributes nothing now, and that is desirable, because the former leadin was very good at bringing in signals from the noise area that is always not far from ground; (2), the doublet itself may have a little less pickup than the L antenna. However, the ratio of signal to noise is increased, and that is what counts.

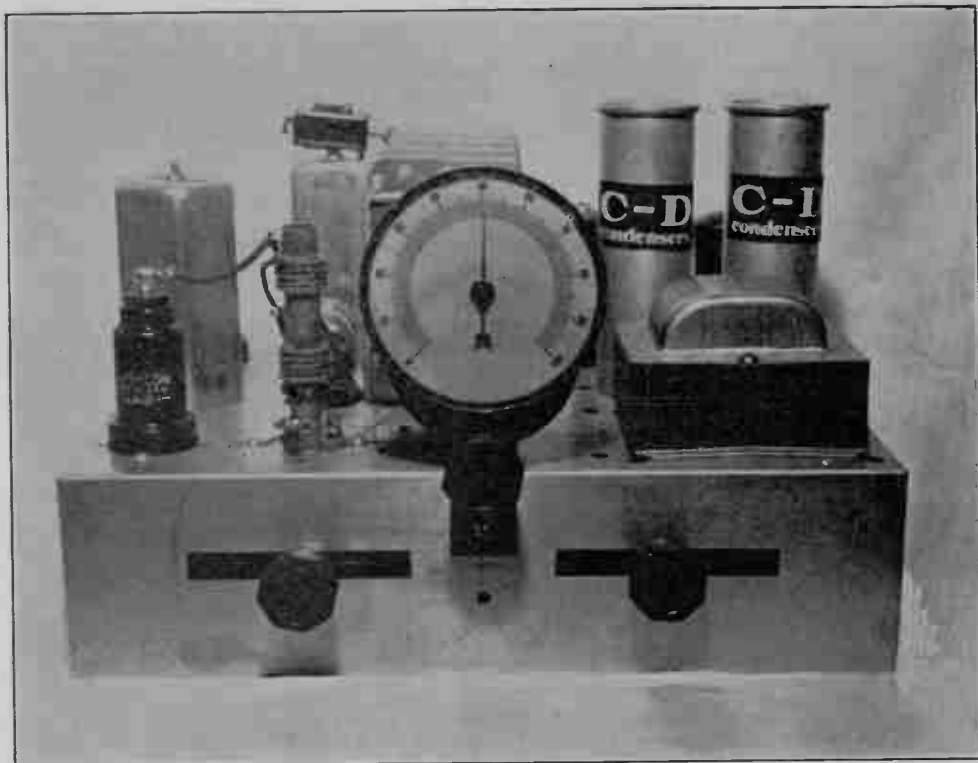

A band-pass tuning arrangement permits greater image suppression, without adding another tube. Front view shows band-pass coil at left.

A Band-Pass Pre-Selector Helpful in Suppressing Images

By Jack Goldstein

Photographs by Herbert E. Hayden

THOSE who desire to include a three-gang condenser in a superheterodyne, instead of a dual, without adding an extra tube, may resort to band-pass tuning of the antenna input stage, whereby the antenna is coupled to the primary of a transformer, the secondary of the transformer is tuned, and an impedance winding, which may be regarded as the second secondary, also tuned, is inductively coupled to the other tuned winding. Thus the three sections of the gang are used, and the benefit that results is improvement of the selectivity, including better image suppression.

Ordinarily there is nothing serious about the image on the standard broadcast band for an intermediate frequency of 456 kc, as used here, or any proximate frequency, and the trouble would be expected only on the short waves of an all-wave set. The lower the wavelength

(higher the frequency) the worse the image trouble becomes.

What the Image Is

The image, as all should know by this time, is a frequency higher by a given amount than the one desired to be tuned in, and is one to which the receiver is sensitive because of the double response nature of a superheterodyne.

The only known way of rejecting images is by improved selectivity.

The frequency where the trouble arises is always higher than the frequency intended to be tuned in, by twice the intermediate frequency. This is the "given amount." Thus, with receiver tuned to 1,600 kc intentionally, the receiver would be less sensitively but

(Continued on next page)

ties for making honeycomb coils, so used commercial products as supplied by coil makers to set manufacturers.

Those desiring to wind solenoids may do so following the data given in last month's issue, where the circuit was shown without the band-pass feature. The distance between nearest parts of the two secondaries in the

found very satisfactory for a one-i. f.-stage construction. He could not line up such an i. f. channel satisfactorily on a station, but had to use a signal generator. So builders are cautioned to use a generator if they want the results to be free of "birdies."

The 200-600 mmfd. condenser is for padding, and is adjusted, as usual, with r. f. circuit set for around 600 kc. It may happen sometimes that the oscillator will not oscillate all over the band, failure showing up at some low broadcast frequency, and if this trouble is encountered, instead of locating the padding condenser between coil one terminal of oscillator coil secondary and ground, put the condenser instead between stator of the tuning condenser and the other terminal of the oscillator coil's secondary.

Personally, the author has never experienced this trouble with this i. f., or anything near it, but did suffer the stoppage with another set, using a much lower intermediate frequency, where the padding condenser was larger in capacity.

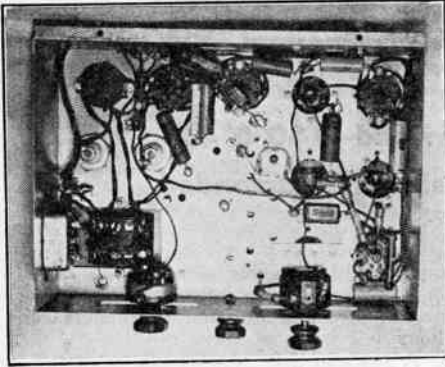

Looking under the chassis we note the set is cleanly wired.

band-pass coil, following last month's winding directions for secondaries, should be $1\frac{5}{8}$ inches.

Signal Strength Less

Noting the loose coupling, one may expect that the signal strength will not be quite so great as with the run-of-the-mine circuit as shown last month. This is true. Double peak tuning as a vice has to be avoided, because if present the selectivity is injured instead of aided. There must be a double peak condition of a mild nature, and to achieve this mildness the loose coupling is important.

Another point to note is that the sensitivity must be less because of the loading effect of the antenna transformer on the grid input winding. There never has been a band pass filter for pre-selection purposes, and the necessary variable tuning aspect, that did not result in reduction of sensitivity. This statement is frankly made, not in derogation of the circuit, because it worked well and cured annoyances for a customer in a congested area of Brooklyn, N. Y., but so that nobody should feel he has blundered about some connection, if there is more volume without the band-pass circuit than with it.

It is for Selectivity

There is more selectivity, and, as usual, we pay for selectivity in terms of sensitivity, if we are not to add tubes or make or introduce regeneration.

The receiver uses iron-core intermediate frequency transformers, which the author has

Metal Tubes Popular; Uniformity Prevails

The production of metal tubes has been going on at a fast pace, and has proved that the tube is popular. At first there was some criticism of the tube, based partly on experiences abroad, although the foreign tube was different. It is true that some manufacturing difficulties were met here, but these did not prove difficult to solve. The characteristics are now uniform in production, the leakage is low, and the performance is marked, especially on short waves.

The inclusion of metal tubes in the i. f. and audio channels is not exactly necessary or of great help, except for those special tubes not represented by any glass-tube equivalent, like the beam power amplifier, 6L6. However, in other instances uniformity of tube appearance more or less, is deemed an advantage in meeting public requirement.

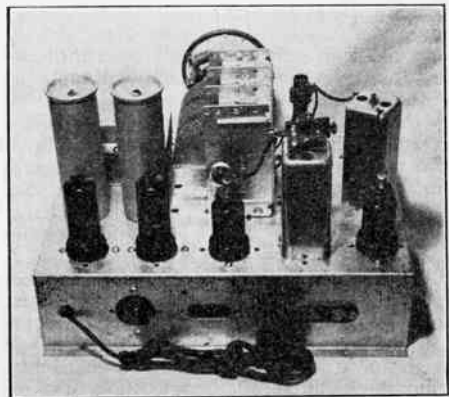

Rear view of the band-pass set.

Television Standards Proposed

RMA Report to Communications Commission Favors 42-90 mc, with 6 mc Channel—Big, New Industry Envisioned—Carrier Range 25 Miles—Sound Channel Provided—440 & 450 Lines, 30 Frames, 60 Fields Recommended

Washington.

Radio Manufacturers Association, Inc., through Albert F. Murray, of its television commission, submitted a report to the Federal Communications Commission on television frequency allocations and related topics. The report follows in part:

The Radio Manufacturers Association consider the following to be important basic television requirements:

1. A single set of television standards for the U. S. A.
2. Frequency channels of adequate width, 6 mc necessary for the transmission of high-definition pictures—pictures which experience has

should be as continuous as possible because of the convenience this affords in tuning, and because this permits the design of simpler, cheaper home television receivers.

5. A space in that experimental region above 120mc for television relaying, pick-up work and expansion. This space is to be shared with other services until that time arrives when, in the opinion of the Commission, definite assignments should be made. Then there will be required the allocation of a continuous band wide enough for a sufficient number of channels for future television service.

Economic and Social Aspects

We turn now from purely technical consideration to facts regarding the economic and social side of television.

In order that television may avoid the difficulties now being experienced in aural broadcasting let us plan at the outset channels of sufficient width and proper arrangement. This means that plans for high-fidelity television, based on the standards suggested by the radio industry, must be laid now. Any other course will later lead to the obsolescence of television receivers.

Today, in the laboratory, high-definition television is a reality. Some who have not actually seen it may naturally be skeptical. It happens that two of the companies in RMA have had the pleasure of demonstrating their high-definition television systems to some of the members of this Commission. It is not necessary, therefore, to offer proof, visual proof, that pictures of satisfactory detail can be transmitted. If this were not the case one RMA member company would not be spending one million dollars to continue laboratory tests in the field.

How will this new art affect our national life? Television, supplementary to, but not taking the place of sound broadcasting, will some day win for itself a place of importance in our national life approaching that of present-day aural broadcasting. We say this because we engineers have observed with keen interest the reaction of individuals to whom we have shown

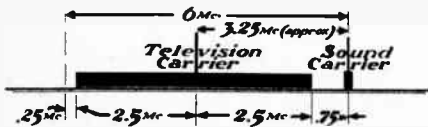

Typical television channel as recommended to the Federal Communications Commission by the television committee of Radio Manufacturers Association, Inc.

shown possess sufficient detail to afford sustaining interest—pictures which will approach the quality of home movies.

A channel 6 mc wide, from the viewpoint of the radio telephone engineer, seems very broad, broad enough for, say, 300 telephone conversations, but if we are to have pictures of satisfactory detail this is the minimum channel width the Federal Communications Commission can assign.

3. Television with its accompanying sound, should be in that portion of the ultra-high frequency spectrum best suited to this service (the 42-90 mc region). This band must be wide enough for a sufficient number of channels to permit the simultaneous broadcasting of a reasonable number of programs in a given territory.

4. The television frequency band, or bands,

television. The groups have been small but sufficiently varied to present cross-section of public opinion. With one accord they have expressed deep interest.

New Industry Envisioned

We believe television, when it reaches the commercial stage, will form the basis of a new industry, an industry producing television equipment in our factories and producing programs in the studios. Thousands of workers will be required to manufacture, distribute and maintain television service in the U. S. A.

Naturally television will some day become the useful and valued servant of a large portion of the American people. The number of our people to be served will be limited by (a) the range of television transmission on ultra-high frequencies, averaging about 25 miles, (b) the initial cost of transmitters, receivers and programs, and (c) the yet unsolved problems of utilizing for transmission the higher end of the ultra-high frequency band.

In asking for the frequency band beginning at 42 mc, we point out that this part of the spectrum is now, and for years has been allocated by the Commission to experimental visual broadcasting. It has been found that in this band the peculiar requirements for television (that is, wire channels and metropolitan coverage) can be met, at least at the lower frequency end. It is logical, therefore, to ask for the continued use of these frequencies. The wisdom of the Commission in designating, five years ago, this particular band for this particular service is shown by the radio industry's recommendations today contained in the following formal report from the RMA.

Lower Frequency Limit

The RMA has previously recommended to the FCC: "... that a continuous band of frequencies from 40 mc to at least the neighborhood of 110 mc be reserved for television service."

The RMA now recommends that the band allocated for television broadcasting should start at 42 mc. (Those companies agreeing: General Electric, Hazeltine, Philco and RCA. Mr. Farnsworth believes that it is satisfactory, but suggests that a frequency of about 60 mc would also be a satisfactory point to start, perhaps even better than 42 mc.)

Reasons for starting television band at 42 mc:

(a) The frequency must be sufficiently high to eliminate multiple transmission paths.

(b) The frequency must be sufficiently high to permit practical designs of circuits to pass the wide frequency bands required for picture transmission.

(c) In the light of present engineering knowledge it appears that a large metropolitan area could be better served with frequencies near 42 mc, than at higher frequencies, because the attenuation increases rapidly with frequency.

(d) With existing transmitter design and existing tube types greater power output for television can be obtained at the lower frequen-

Summary of Proposed Standards

Frequency allocation,	
Lower limit	42 mc.
Upper limit	90 mc
An experimental band starting at	120 mc
Channel width	6 mc
Spacing between television and sound carriers	3.25 mc apprx.
Relation of sound carrier to television carrier	sound carrier higher in frequency
Polarity of transmission	Negative
Number of lines	440-450
Frame frequency	30 per second
Field frequency	60 per second, interlaced
Aspect ratio	4:3
Percentage of television signal devoted to synchronizing signals	Not less than 20%
Synchronizing signal	No recommendation*

*"Serrated" vertical signal favored by RCA.

"Narrow" vertical signal favored by Philco, Hazeltine, Farnsworth, General Electric Co.

cies and relatively lower output at the higher frequencies.

(e) It is believed that better and more economical receiver designs will result when starting the band at approximately this frequency.

(f) It is recommended that television services be started in a frequency band for which there are tried engineering designs. The present lower limit of 42 mc is considered satisfactory.

Some of the above limitations will be modified as the art progresses, but television should not be handicapped by imposing difficult frequency limits during the early stage of its commercial development. For example, as the frequency increases attenuation of the waves increases, and at the same time the possible transmitter power output decreases.

Upper Frequency Limit

It is the recommendation of RMA that the band allocated for television should have its upper frequency limit at 90 mc.

Reason: This is the range tentatively suggested by RMA so as to provide a reasonable number of channels. Single dial receivers can be designed to cover this range.

(Continued on next page)

No 6 Mc Compromise, Summary Sets Forth

The RMA Committee summarized its report as follows:

The television engineers have listed in this report the technical needs of this new art. The radio industry, the Federal Communications Commission, and the American people have a great deal at stake in the future of television. If television development in our country is to continue to lead the world and to proceed to the stage where it offers a satisfactory service for the home, frequency assignments to meet these requirements are a necessity.

As far as channels 6 mc wide are concerned, there can be no compromise.

To make television service worthwhile more than one program must be available in a given urban area and channels must be provided so that there is a possibility of nation-wide coverage in the future.

In view of these facts we respectfully and earnestly urge you, the Commission, to set aside the frequency bands recommended by the radio industry to provide for television broadcasting. The future of this new art is in your hands.

(Continued from preceding page)

RMA recommends that the space above 120 mc be available for television research.

Reason: To provide space for research on remote pick-up, relaying and for future expansion.

Television Channel Width

It is the recommendation of RMA that in allocating channels for television that these should not be less than 6 mc in width.

Reason: It is essential that television have lasting entertainment value. The band width required for picture transmission is directly proportional to frame frequency and to the amount of information to be transmitted. A 6 mc channel permits side bands up to 2.5 mc. A channel makeup, in diagrammatic form, is a part of this report. It shows, reading from left to right:

Guard band25 mc
Lower side band.....	2.50 mc
Upper side band.....	2.50 mc
Guard band75 mc
Sound side bands.....	negligible

Total..... 6.00 mc

The portion of the channel from the television carrier to the sound carrier is fixed by apparatus and performance considerations.

The lower picture sideband is not essential for the transmission of the picture, provided

certain design considerations are taken into account. At present no method is known of designing a practical transmitter for completely eliminating one sideband. It is, however, possible in the transmitter and receiver to favor one sideband and to partially attenuate the other. Future development may indicate how to obtain sufficient reduction in the lower television sideband so as to permit placing the sound carrier of the next lower channel closer to the television carrier of the channel under consideration than that indicated in the diagram. This, however, is a future development which may result from experience with television systems.

Television and Sound Carrier Spacing

It is the recommendation of RMA that the sound and picture carriers be separated by approximately 3.25 mc.

Reason: This is determined by the width of the upper picture side band and the practical circuit selectivity obtainable in the receiver so as to prevent "crosstalk."

Sound Carrier & Television Carrier

It is the recommendation of RMA that in a television channel the sound carrier should be at a higher frequency than the television carrier.

Reason: This permits a better receiver design when using a superheterodyne circuit.

Polarity of Transmission

It is the recommendation of RMA that a decrease in initial light intensity shall cause an increase in the radiated power. This means that negative transmission is recommended.

Reason: Negative transmission permits more efficient use of the transmitter output.

Number of Lines per Picture

It is the recommendation of RMA that for a channel width of 6 mc, and a picture and sound carrier spacing of approximately 3.25 mc, that there should be between 440 and 450 lines per frame.

It is necessary to have this number to approach home-movie picture quality. When this number of lines is reached, the line structure of a picture of average size is no longer conspicuous. Also, this number makes optimum use of a 6 mc channel.

(Note: The highest number of lines used abroad for practical television is 405. This is one of the two British standards for number of lines per frame.)

Frame Frequency

The RMA recommends a frame frequency of 30 per second and a field frequency of 60 per second, interlaced.

Reason: Production of steady images at the receiver requires that the frame frequency be an integral sub-multiple of the power supply frequency.

NOTE: RMA Definition: (a) "The frame

frequency is the number of times per second the picture area is completely scanned." (b) "The field frequency is the number of times per second the frame area is fractionally scanned in interlaced scanning."

Aspect Ratio

It is the recommendation of the RMA that the picture aspect ratio shall be 4:3.

Reason: To conform with existing motion picture practice.

Synchronization Percentage

It is the recommendation of RMA that if the total amplitude of the composite television signal is taken as 100% then not less than 20% shall be used for synchronizing pulses.

Reason: Receivers synchronize satisfactorily on 20% amplitude. Receivers designed to operate on a synchronizing pulse 20% in amplitude will also operate satisfactorily on pulses of greater amplitude.

NOTE: By a composite television signal is meant a signal where the combined video, blanking and synchronizing pulses are present.

Synchronizing Signal

The RMA appreciates the necessity for standards relative to synchronizing but this matter is still in a state of flux. Recommendations on this will be made later, after further field tests.

Besides the report there were submitted RMA's answer to Commission questions, among them the following:

Question: Field intensity required for reliable service.

Answer: Experience indicates that a field intensity of at least 5 millivolts per meter is required to give primary television service in an average residential district.

Question: The relative amount of radio and other electrical interference likely to be encountered.

Answer: Measurements have indicated that electrical interference field intensity of 1 millivolt per meter, or greater, is common in large metropolitan centers and becomes as low as 5 to 10 microvolts per meter in outlying residential districts having very light automobile traffic, and when the receiving antenna is remote from traffic.

Question: The relative amount of noise which may be tolerated in the rendering of service.

Answer: Within the primary service area, approximately the same as that in sound broadcasting.

Question: The operating characteristics of transmitters with respect to external effects and practicability in service for which intended, including frequency tolerances which should be prescribed.

Answer: Television presents no problem in frequency stability different from that of any other type of transmitter operating on comparable frequencies. There is nothing peculiar to television which requires a frequency stability

with greater precision than $\pm .01\%$.

Question: Types of antennas which are available for service for which intended, and their practical limitations, including the best methods of obtaining the most effective use of frequencies.

Answer: The frequencies recommended for the television band are such that antennas can be designed having directivity, both horizontally and vertically.

Question: Receivers available and in process of development, including data with respect to selectivity and practical usefulness for the service for which intended.

Answer: Receivers can be built to operate in accordance with the RMA recommended standards.

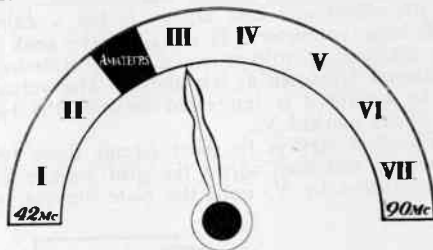

Representative television receiver dial, showing the proposed frequency band, 42 to 90 mc, continuous except for an allotment to amateurs. Eight equal bands of 6 mc are shown, one is for amateurs, leaving seven television channels as dial-enumerated.

You need these 2 books

PRINCIPLES of PUBLIC ADDRESS SYSTEMS

A practical handbook, full of useful information, fully illustrated, written by M. N. Beitman, an engineer and noted authority on audio amplifiers.

Considers in detail various microphones, radio and phonograph inputs, acoustic feedback, mixing and volume controls, use of vacuum tubes, interstage coupling, power amplifiers, output coupling, loud speaker placement, the decibel, P.A. measurements, power level, and other points of importance, including actual circuit diagrams of tested P.A. systems.

MATHEMATICS of Radio Servicing

Introduces and explains the use of arithmetic and elementary algebra in connection with units, color code, meter scales, Ohm's Law, alternating currents, ohmmeter testing, wattage rating, series and parallel connections, capacity, inductance, mixed circuits, vacuum tubes, curves, the decibel, etc., etc., and has numerous examples.

Plainly written and easy to understand. Only useful data included. M. N. Beitman, author. Size, 8½ x 11 in.

Price, 50c each book.

SUPREME PUBLICATIONS

3727 West 13th St., Chicago, Illinois

Tube Voltmeter Applications

No Current Drawn from Measured Circuits

By Randall C. Stamford

ALTERNATING voltages, especially if they are high frequency voltages, are most easily measured by means of vacuum tube voltmeters. There are several types of these. One of the oldest and best known is the so-called slide-back voltmeter. It measures the peak of the alternating voltage wave. The slide-back voltmeter is shown at left above. The voltage to be measured is impressed between the two terminals marked V_x .

The first step is to short circuit these two terminals and then adjust the grid voltage E_g , as measured by V , until the plate current, as

The best tube for use in a slide-back voltmeter is one that has a sharp and definite cut-off. A high mu triode is suitable but a remote cut-off tube like the 58 or 6K7 is worthless.

The large by-pass condenser in the grid circuit is used to insure that all the voltage to be measured is impressed on the grid. The by-pass condenser in the plate circuit acts as a filter and helps to increase the average value of the plate current.

At the right above is the circuit diagram of a direct reading vacuum tube voltmeter. In this case the tube is biased to cut-off or nearly

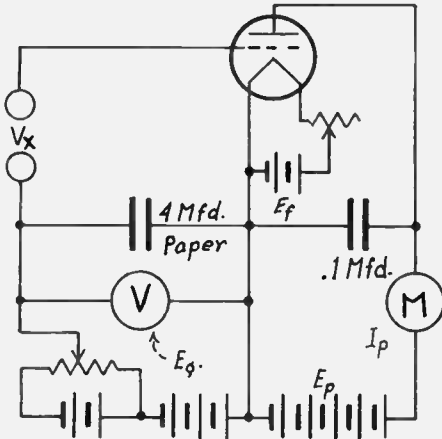

This slide-back peak voltmeter is easy to construct and to use. It is useful in calibrating direct reading instruments. A tube with a sharp cut-off is desirable.

indicated by the milliammeter M , is just zero. The value of E_g required for cut-off is recorded. Let us call it E_1 . Next the voltage to be measured is connected at V_x as stated above. Plate current will now flow because during the positive half cycles of the alternating voltage the grid bias is less than required for cut-off. The bias is increased again until cut-off is just reached.

Type of Tube to Use

Let us call the new value of bias E_2 . The difference between the two bias readings, that is, $E_2 - E_1$, is the amplitude of the alternating voltage impressed at V_x . If the r.m.s. value of the alternating voltage is desired the peak, or amplitude value should be multiplied by .707.

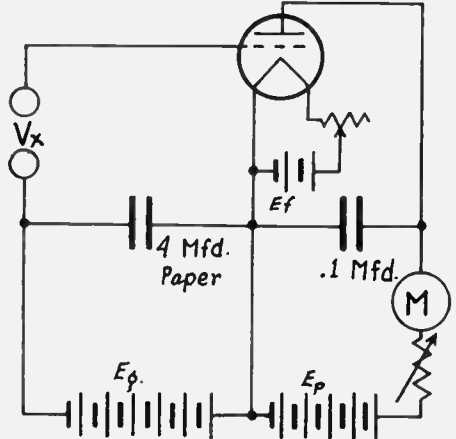

This is a direct reading vacuum tube voltmeter. The tube functions as a transrectifier and the voltage impressed in the grid circuit is read on the plate milliammeter.

so but the bias is left fixed once it has been selected. The alternating voltage to be measured is impressed at V_x . The large condenser across the E_g battery insures that all the voltage is impressed on the grid.

The unknown voltage will cause an increase in the plate current as indicated by the milliammeter M , and the increase will be greater the greater the voltage impressed. The high resistance rheostat in series with the milliammeter serves the purpose of adjusting the scale of the meter.

Range is Controlling

The choice of tube for this meter depends on the voltage range to be measured. If the range is low, say under three volts, a high mu tube

is recommended. If the range is to be very large, say 50 volts, a low mu power tube is indicated. The meter and the voltages E_p and E_s are selected to suit the tube. It is usually possible to select the voltages, the meter, and also the rheostat so that when the amplitude of the highest voltage to be measured is equal to the bias the plate milliammeter reads just full scale. This adjustment takes fullest advantage of the milliammeter as a current indicator. It is seldom that a higher radio frequency voltage than 3 volts need be measured.

Another method of measuring radio or audio frequency voltages by means of a vacuum tube is to compare its effect on the plate current with the effect on this current of a low frequency voltage which can be measured with an a-c voltmeter.

Tube as Indicator

In this case the tube serves only as an indicator of equality. For greatest sensitivity the tube should be biased for greatest detecting efficiency, but if the voltage to be measured is high, the bias may be far beyond the cut-off. In any case, however, the bias must be less than the peak of the unknown voltage for otherwise there will be no plate current. The arrangement is shown in the third drawing. The unknown voltage is impressed at V_x .

By means of a two-pole, double throw switch V_x may be connected in the grid circuit of the tube. By throwing the switch in the other direction a 60-cycle voltage may be substituted. This low frequency voltage is measured with an a-c voltmeter V. There should be a provision for varying the low frequency voltage across V, and this is best done by means of a potentiometer across the transformer winding. One of the leads now going to the voltmeter should go to the slider on the potentiometer. Thus the reading on V can be made any value

between zero and the full voltage of the transformer winding.

Procedure Set Forth

The procedure of measuring an unknown voltage of any frequency is as follows: The switch is thrown to V_x , thus putting the unknown in the circuit. Note the current indication in the plate circuit. Now throw the switch to the low frequency voltage. Adjust the value of this by means of the potentiometer mentioned above until the plate current is the same as it was when the switch was in the V_x position. The reading on the voltmeter V is then equal to the unknown voltage.

This method of establishing the value of a high frequency voltage assumes that its waveform is the same as that of the low frequency voltage. In general this equality of waveform will not obtain. However, both voltages will approach a sine waveform and the error due to differences in the form will be small.

It will be noticed that when the unknown voltage is connected to the grid, the grid is much negative and no grid current can flow. Therefore there will be no drop in the voltage due to loss of power in the voltmeter.

When the grid is connected to the low frequency voltage power is drawn by the voltmeter V, but this does not introduce an error because the low frequency voltage on the grid is actually that indicated by the meter.

A True Potentiometer for D.C.

As a means of varying the bias on the triode its cathode is returned to the slider of a 25,000 ohm potentiometer on the bleeder resistance in the B supply. The voltage range of this potentiometer is wide enough to accommodate most radio frequency voltages that are likely to be met in receivers.

(Continued on next page)

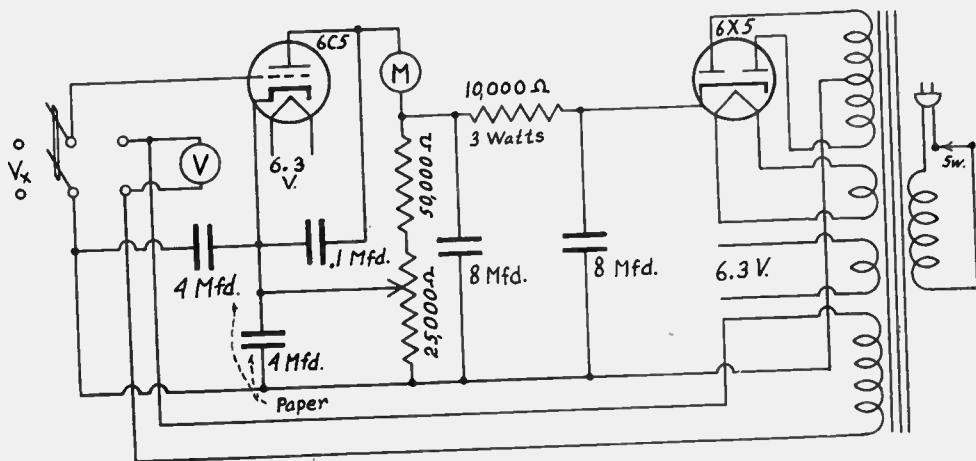

A substitution type of vacuum tube voltmeter. The voltage across V is adjusted to equality with V_x by means of the slider of the triode, the tube being used to indicate equality.

(Continued from preceding page)

At times it is desirable to measure d. c. potentials without drawing any current from the source. For example, the voltage developed across the load resistance of a diode rectifier,

opposition with the unknown. In taking a measurement the switch SW is first put on point (2) and the plate current is noted accurately. A self-bias resistor of 300 or 400 ohms is put in the cathode lead. The object of this bias is to

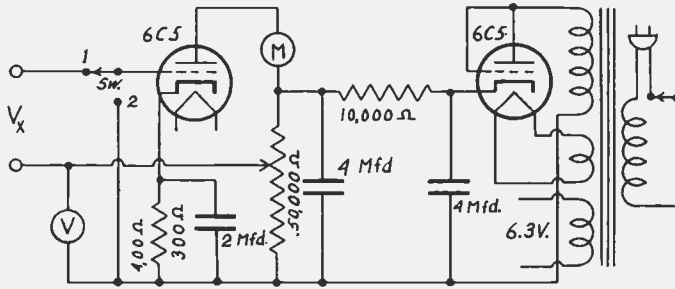

This circuit is a true potentiometer for d. c. That is, it measures d. c. potentials without drawing any power from the source. The unknown is balanced out by a variable voltage, which is measured.

the bias on automatic volume controlled tubes, and the actual bias on the grid of a tube when there is some grid current flowing through a high resistance grid leak. There are no current drawing instruments which can measure these voltages accurately or even approximately. Instruments that would give approximate indications in some instances are expensive and cumbersome.

Just as the vacuum tube is the best for measuring radio frequency potentials, so it is for measuring potentials at direct current. The circuit of a true d. c. potential meter, utilizing a vacuum tube, is shown herewith. The tube illustrated is a 6C5. The B supply rectifier is also a tube of this type. The particular tubes to use is of little importance, but a tube in which the plate current changes rapidly for small changes in the grid voltage is preferable to a low mu tube.

The principle of the potentiometer is as follows: The d. c. unknown is impressed between the two V_x terminals, with the negative toward the grid of the tube. Another d. c. voltage, measured by V and taken from the plate voltage, is impressed in the grid circuit in series-

insure that no grid current flows when the grid is connected to ground and later when the unknown is balanced against the voltage across V.

When the zero setting reading on M has been found, the switch is turned to point (1). The plate current will change. The voltage across V is now changed by turning the knob of the 50,000 ohm potentiometer until the meter M reads exactly the same as it did when the grid was connected to ground. When this point has been found the voltage across voltmeter V is exactly the same as the voltage across V_x . Thus the unknown is read on the meter V.

Range Extension

The voltage range of this instrument is the same as the total voltage across the 50,000 ohm potentiometer. That is, it is equal to the applied plate voltage. The range may be extended, however, with the aid of batteries connected with proper polarity in the lead from the voltmeter to the potentiometer slider. In using this instrument it is important that the negative of the unknown voltage be connected toward the grid. The main purpose of this is to protect the milliammeter.

Amateurs Ask Board for More Space on Air

Washington.

More space on the air is needed by amateur radio operators in the future if they are to be able to most effectively perform such public service's functions as the emergency flood communications work which elicited such high praise from press and public alike last March, witnesses testified on behalf of the amateur service at an engineering conference of the Federal Communications Commission.

K. B. Warner, secretary, and F. E. Handy, communications manager of the American Radio Relay League, national amateur organization, presented detailed arguments asserting the value of the radio amateur both from a technological and emergency communications standpoint, and showed the congestion in the major amateur bands to be so great as to hamper effective operation.

Ross A. Hull, associate editor of "QST," the amateur's magazine, and a recognized authority of ultra-high-frequency work, testified on engineering considerations associated with allocations in this region, and outlined the amateur's work and future needs.

Although representing 92% of the stations in the United States, amateurs have but 7% of the frequencies below 60,000 kilocycles, Handy pointed out. Their congestion is so great that in the 7,000-7,300 kilocycle region, used internationally, there are over 400 stations jammed in every channel. In the 3,500-4,000 kilocycle band, where a great part of amateur emergency communications work is performed, there are 189 U. S. stations per channel on an average. Additional frequencies were requested by the League in both of these bands, as well as in the ultra-high-frequency region.

The Simplest Generator

Few Parts for Battery-Operated Device

By Reginald F. Carlson

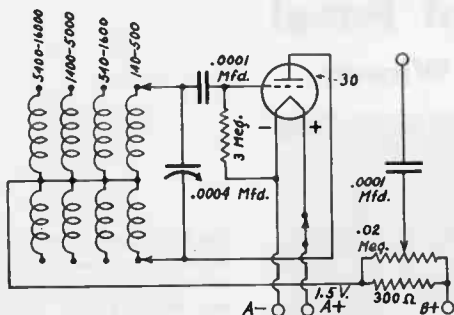

A four band signal generator for battery operation. B plus may be 22.5 volts if B minus is connected to A plus. However, 45 volts are preferable for assurance of oscillation on the smallest coil. The leak-condenser time constant is such as to produce an audible note. Attenuator is effective throughout.

THIS little signal generator "has everything," as follows: all wave coverage, band switch, direct frequency reading dial, attenuator, modulation. Direct frequency reading for any particular dial is possible only with a particular condenser. The coils must be of proper inductance. The attenuator is otherwise known as the radio frequency volume control. Modulation is the sound that is impressed on the generated radio frequency. This should be adjusted so that it is a fairly high pitch, when the tuning condenser is totally enmeshed (plates all the way in) on the highest frequency band. The smaller the leak, or the smaller the grid condenser, or the smaller both, the higher the pitch. Circuit conditions differ. The values stated will afford modulation, probably too low in fre-

quency, so the pitch may be raised as already described.

Battery operation is intended. It is practical to use 1.5 volts directly for the filament excitation, normally intended to be 2 volts. The B voltage may be as low as 22.5 volts, B minus connected to A plus. Then possibly the smallest coil will not oscillate all over the band, but this may not be objectionable to some who would have scant use for the 5,000 to 16,000 kc. range. If the battery voltage is increased to 45, and there is a small battery of this voltage, then there is assurance of oscillation over the full range of the smallest coil, and besides the amplitude is raised for all the frequencies generated, including, by the way, the audio frequency.

The note can be heard plainly even when the r.f. oscillation is put into a set of mild sensitivity.

No trimming capacity is used. If there is a trimmer on the tuning condenser remove it.

Four bands are covered, as imprinted in kilocycles on the diagram. The lowest is 140 to 500 kc and takes care of all necessary intermediate frequencies. The next coil covers the broadcast band. Next comes the intermediate short wave band and finally the foreign short wave band. Since there is no capacity adjustment to be made for any band, the inductance has to be right.

The dial may be affixed to the condenser so that when the plates are totally engaged the escutcheon pointer indicates 140. The set screw is tightened and the position is verified again. When frequencies are checked in operation of the completed device, if the frequency reads too low, then the inductance is too low. If the frequencies read too high the inductance is too high. Inductance may be decreased by removing turns. It may be increased without adding turns by bringing the coil near a piece of iron, or the piece of iron near the coil.

LIST OF PARTS

Four coils to cover four bands, from intermediate frequencies to intermediate high frequencies. These coils are commercially obtainable.

Condensers

One single tuning condenser, .00036 to .0004 mfd. maximum capacity.
Two .0001 mfd. mica fixed condensers (Cornell-Dubilier)

Resistors

One 3 meg. grid leak, one-third watt. (International Resistance Co.)

One .02 meg. potentiometer (Electrad)
One 300 ohm one-third watt (International Resistance Co.)

Other Requirements

One two-circuit, four-position switch.
One on-off switch.
One No. 6 dry cell, 1.5 v (Eveready).
One 22.5 volt small B battery (Eveready).
Four binding posts: one for r.f. output, one for A-, one for A+ and one for B+.
[B minus may be connected either to A- or to A+. For 22.5 volt B battery connect B- to A+, for 45 B volts, connect either way.]

Wide Ranges in Super-Pro Hammarlund Set Has I.F. Selectivity, A.V.C. and Bandsread Adjustable from Front Panel

By Lewis Winner



The condenser gangs being tested for equal capacity of each section at numerous equal angles of displacement, so that precision tuning will result when trimming and padding of circuits are accomplished in the finished set.

IN the Hammarlund "Super Pro" there is the main tuning condenser with its four sections of 180 mmfd. capacity each. The rotor plates are of the midline type, and due to parallel trimmer capacity afford a uniform frequency scale, and a 2 to 1 tuning range. The stators are mounted on Isolantite blocks which are in turn mounted to the shield partitions which form the frame work of the tuning unit. The band spear condenser is mechanically identical to the main tuning condenser.

However, while divided into four main sections, each of these sections has a three-gang condenser, each with separate rotor and stator, equivalent therefore to a 12-gang variable condenser. In this way an appropriate degree of bandsread is obtained in each of the three high-frequency bands.

Non-Critical Tuning

To illustrate, each division of the bandsread dial in the 14.14 mc amateur band covers approximately 4.5 kc. In the 7 to 7.3 and 3.5 to 4 mc bands the coverage is approximately 4 and 5 kc, respectively. These coverages afford comfortable non-critical tuning in the high-frequency ranges without an unnecessary amount of dial twisting. On the two lower frequency bands, this condenser is automatically cut out of the circuit by the band-changing switch.

The selectivity of the intermediate frequency amplifier is continuously variable, by means of a control on the front panel. This control sim-

ultaneously varies the coupling between the primaries and secondaries of the first three i. f. transformers. Since both the primary and secondary of each transformer are tuned, this variation in coupling changes the response characteristic from a single sharp peak in the minimum coupling position, to a wide double-humped curve in the maximum coupling position.

The total range of coupling provided by the front panel control is from approximately one-third optimum in the narrow position to about three times optimum in the wide position. The control being continuously variable, any intermediate value between these two extremes is readily obtainable. Therefore, as the selectivity control operates simultaneously on three transformers in cascade, the change in overall selectivity is tremendous.

At the same time such a wide change in coupling also results in a wide variation in gain, except of course when operating on a. v. c., which may be included or excluded by front panel knob control. The three variable coupling i. f. transformers constitute the input circuits of the three 6D6 i. f. amplifier tubes. A fourth transformer directly behind the first three, couples the output of the third i. f. tube to the control grid of the 6B7 second detector.

Ten Tuned I.F. Circuits

Since the pentode section of the 6B7 second detector amplifies at the intermediate frequency,

there is really a fourth intermediate frequency stage. Its plate circuit is coupled back to its diode plates by means of a fifth, twin-tuned transformer similar in design to the fourth or detector input transformer. The coupling between the primary and secondary of this detector output transformer is also variable by means of a knurled nut on the top of its shield.

Altogether, the intermediate frequency amplifier has ten tuned circuits arranged in five pairs, three pairs of which may have their coupling continuously varied from the front panel, while the coupling of the remaining two pairs may be adjusted from inside the receiver to suit various service conditions met within the field.

All the intermediate transformers, a. v. c. transformers, and the beat oscillator circuit are tuned by means of special Hammarlund air-dielectric variable condensers. This insures stability of both gain and selectivity even under adverse atmospheric conditions.

quiring approximately $5\frac{1}{2}$ turns to cover a complete frequency range. The bandspread dial is calibrated in one hundred equal divisions.

Due to the circuit used for band spreading, readings are almost exactly straight line frequency.

The separate power supply is an entire unit with a dust cover. Two rectifiers are used here, a 5Z3 for the plate voltage and IV for the grid voltage. This unit supplies individual C bias and B voltage. Due to the special filtering system employed, positive humless output is available. This unit is connected to the receiver by way of a special 10-lead cable. The speaker field connections are also obtained from this unit.

[Circuit diagram was published, with other illustrations and text, in last month's issue. The diagram, part 119, should have read "To Speaker" instead of "To 600-ohm Line."—EDITOR.]

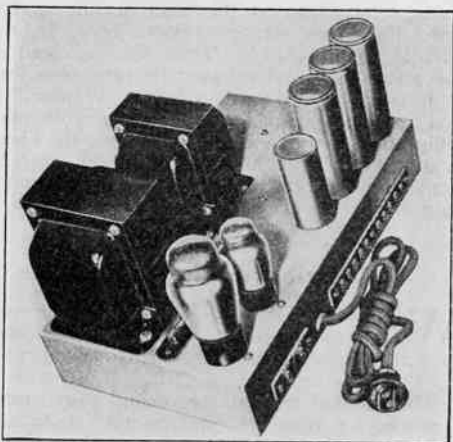

The power supply used with the Hammarlund Super-Pro.

The tuning dials are laminated, translucent celluloid with the scales printed on the center lamination. Each dial is brightly illuminated from the rear affording quick and accurate settings. The main tuning dial has five ranges, as follows:

- 540—1,160 kc.
- 1,160—2,500 kc.
- 2.5—5.0 mc.
- 5.0—10.0 mc.
- 10.0—20.0 mc.

Only one scale is visible at a time. A slotted black mask controlled by the band changing switch knob automatically exposes the scale corresponding to the frequency change for which the switch has been set. Both dials are rotated smoothly and easily by friction drives entirely free from any backlash.

Power Supply is Separate

The knob drives have a ratio of 12 to 1 re-

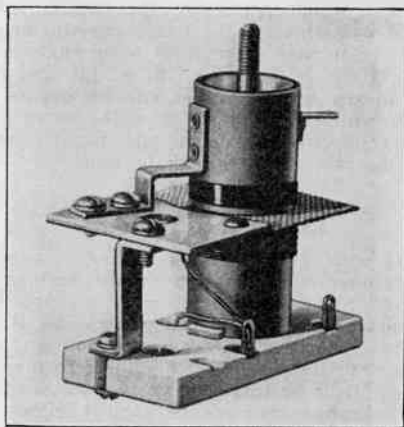

The coils at the r.f. and oscillator level are adjustable as to inductance.

500,000 Watts Sought By KDKA for Clarity

Washington
Application for an increase of power from 50,000 to 500,000 watts for KDKA, world's pioneer radio station and the Blue network outlet of the National Broadcasting Company in Pittsburgh, was made by the Westinghouse Electric and Manufacturing Company, to the Federal Communications Commission.

If the power application is granted, a greatly improved signal will be heard from KDKA. Radio engineers say that the increased power, in conjunction with the new 700-foot vertical radiator just approved by the commission, and now under construction, will provide a broadcast service of the highest quality. The new radiator incorporates features hitherto unused in broadcasting which will provide sky wave suppression of high degree and greatly enlarge the no-fading listening service area,

RADIO CONSTRUCTION UNIVERSITY

**Answers to Questions on the Building and Servicing
of Radio and Allied Devices.**

A.C. Through D.C. Meter

WHEN a d.c. meter is connected to a circuit in which a.c. is flowing, is it not true that the a.c. will not move the d.c. needle, and therefore the d.c. meter does not pass a.c.?—K. M. L.

Many a d.c. meter has been ruined, because the a.c. would not move the needle, but it would pass through the meter nevertheless, so much of it pass through as to produce burn-out. If a.c. is to be used in circuit, and may rise to any quantity, it is safer to bypass the meter with 1 mfd. or so, or, if the meter is of low resistance internally, and the frequency may be low, use a 4 mfd. or more.

* * *

Indicating Systems

TO what extent may indicating systems as recommended for a.v.c. circuits, such as ray control tubes, voltmeters, etc., be applied to circuits in which a.v.c. is lacking?—M. B.

The indicating systems do not do well enough in the circuits not subject to a.v.c. to justify their inclusion, also the necessity for the indication may not be present, either. If, however, measurements are to be made, as for r.f. or i.f. alignment, and the receiver has a diode detector, a sensitive d.c. meter in series with the diode load resistor will give as good an indication as any other method. However, when there is a.v.c., the controlled tube acts as an amplifier, and the need for the very sensitive meter (say, 0-250 microamperes) is dispensed with.

* * *

Line Cord Connections

WHEN a line cord with built-in resistor is used, what is the usual code for connections?—K. W.

Manufacturers of line cords use different methods. The best way is to check. This may be done with a low ohmmeter, or medium ohmmeter, as a resistance around a few hundred ohms is to be expected. Keeping the line cord terminals apart, put ohmmeter between the prongs of the male plug. No reading should obtain. (The line cord is not yet in any circuit). Next remove one ohmmeter connection from one prong, and connect ohmmeter lead to each of the three emerging wires. If the ohmmeter discloses an open circuit for two and a short for one, then the limiting resistor

is connected to the other prong. Remove ohmmeter connection from the prong where it now rests and put it to other prong and repeat the tests of the three leads. Now one will show continuity, as a short, another continuity through some low resistance, and the other will read open. It is the a.c. voltage from this side of the line that will produce rectification, when the alternation is positive, so it is sometimes referred to as the positive side of the line. For some strange reason, however, the lead is usually black. Then the red lead is the return or negative, and the resistance lead is usually covered with asbestos wrapper. If you have no ohmmeter, a 2.5 volt radio pilot lamp and 1.5 volt dry cell may be used. There is a special lamp, .06 ampere, which may be used with the cell, and the cell will last much longer.

* * *

Distributed Capacities

WILL you please give me your formula for measurement of the distributed capacity of a coil, or other small capacities?—E. V.

The method depends on using a generated frequency, putting its fundamental into a test circuit that has an indicator, and then tuning for response from the second harmonic of the generator. Please note that fundamental and second harmonic must be used. The change of reception frequency is produced by lowering the capacity of a variable condenser. The settings are C_2 (higher capacity for fundamental) and C_1 (lower capacity for second harmonic). What the fundamental frequency is makes no difference. The formula is

$$C_x = \frac{C_2 - 4C_1}{3}$$

or may be used in either of the following forms:

$$C_x = \frac{C_2 - C_1}{3} - C_1$$

$$3C_x = C_2 - 4C_1$$

* * *

Practical Q Values

CAN you tell me what is a good Q to find in a commercial coil these days?—T. H.
Coils are built with the object of attaining a Q of at least 10. A Q of 25 it is considered excellent for a commercial coil.

TRADIOGRAMS of the MONTH

Selective Distribution Best, Says Adelman

Current emphasis on the policy of "selective distribution" throws the spotlight on Sales Manager Leon L. Adelman, Cornell-Dubilier Corporation, 4343 Bronx Boulevard, New York City. Mr. Adelman, long known as friend of the American parts jobber, has been a pioneer of this policy in the industry. Under his guidance the Cornell-Dubilier Corporation will closely adhere to it during the coming season.

According to Mr. Adelman, the past tremendous success of the Cornell-Dubilier condenser line can be directly traced to high standards of uncompromising quality and strict adherence to his sales policy. Conclusive proof that the Cornell-Dubilier franchise is very highly desirable and profitable is the fact, that, C-D condensers, the highest-priced condenser line on the market, are meeting in the face of severe cut-throat competition an unprecedented, ever-increasing demand, says Mr. Adelman.

"This means, without a doubt, that the majority of servicemen and amateurs in America really desire a high-quality condenser line, such as Cornell-Dubilier has made available," he added.

Mr. Adelman states that his novel policy of "selective distribution" has made it more and more profitable for the real distributors who are working for the benefit and further advancement of the servicemen and amateurs, to carry the C-D line of condensers. Sales Manager Adelman confidently predicts that the coming 1936 fall season will be the biggest in the history of the company.

New Low-Drain Battery Tubes by National Union

A new line of low-current-drain tubes has been developed by the National Union Laboratories.

"We feel that our engineering staff has achieved one of the outstanding contributions to the art of radio tube manufacture in the development of these new low-drain tubes," said R. M. Coburn, Assistant Sales Manager.

Mr. Coburn states that all types has been designed for operation at 135 volts plate supply and 0.150 ampere filament current, although they may also be used at 250 volts plate supply.

The initial five types of the line have been given type numbers, 6D8G, 6L5G, 6S7G, 6Q6G, and 6N5. All types will be housed in glass bulbs and will use octal bases with the exception of the special tuning indicator tube Type 6N5.

Phono-Radio Portable Announced by Lafayette

A seven-tube portable phono-radio combination, completely self-contained and capable of operation on either alternating or direct current, has been brought out by Lafayette Radio Mfg. Co., 100 Sixth Avenue, New York, N. Y. Known as the Model J-81, this instrument is designed especially for travelers, residents of summer hotels, etc., who want to supplement radio entertainment with selected phonograph records.

A specially constructed Fabricoid covered



carrying case houses the radio chassis, loud speaker, phono turntable, motor and pick-up and a partition for a dozen records. Any 78 r.p.m. record, either 10 or 12 inch, can be played. The loud speaker, protected by a drop door, is located in the front end of the case, and acts as an efficient sound projector. All controls are conveniently located. The entire combination measures $27\frac{1}{2} \times 13\frac{1}{2} \times 10\frac{3}{8}$ inches and weighs 40 pounds.

The radio receiver covers the 18-56, 67-193 and 186-560 meter bands and uses the following tubes: 1-6A8, 1-6K7, 1-75, 1-43, 1-25Z5, 1-2Z3 and 1-50A2MG. A special European model tunes the 18-56, 186-560 and 793-2110 meter bands.

The list price of the Lafayette Model J-81 is \$54.50. Lafayette receivers are distributed by Wholesale Radio Service Co., Inc., of New York, Chicago, Atlanta, and Newark.

New Ranger-Examiner Combination



Readrite Model 640-740.

One of the new Ranger-Examiner line of radio servicing instruments, manufactured by Readrite Meter Works, Bluffton, Ohio, is the Model 640-740 Combination Free Point Tester and Volt-Ohm-Milliammeter. This instrument is adaptable for any purpose in voltage, current or resistance testing, either by direct contact with sockets or by the free point method.

It has a Triplett precision indicating instrument with scale readings of a. c. and d. c. volts, 10-50-250-500-1,000 at 1,000 ohms per volt (2% accuracy on d. c. ranges, 5% on a. c. volts, rectifier type); 1-10-50-250 ma. low ohms scale 0-300; high ohms to 100,000 with provision to increase the scale in 100,000 ohms steps by adding external batteries. Measures low ohms by the backup method without appreciable contact or other errors.

The Free Point Tester has five sockets for handling any type tubes. Panel also includes eight automatic switch type and ten single action jacks.

The sturdy metal case has a black electro-enamel finish. Handle is attached for portable use. Panels are silver and black. Size of case is 11 7/16" x 7 7/8" x 4 1/4".

Triplett Entertains Sales Force, Gives a Preview

The Triplett Electrical Instrument Co. was host to its United States and Canadian sales representatives at a four-day sales conference held in the company's modern, air-conditioned plant at Bluffton, Ohio.

Many principal jobbers also attended the conference on the closing day, which had been designated as "Customers' Day."

A feature of the conference was a preview of new items in electrical measuring and radio testing equipment which will be placed on the market soon by The Triplett Co. Announcement of the new developments has aroused widespread interest among technicians.

New Recorder and Playback

Universal Microphone Co., Inglewood, Cal., has issued a new professional instantaneous recording and playback disc in the following sizes: 8, 10, 12, 13 1/2, 16 and 17-inch sizes, black finish. The highest-priced recording disc, it is the only one on which the cellulose mass is totally free of foreign particles and substances. Continuous recording can be done without dulling or chipping of stylus edge or point, or increase of groove hiss from the beginning to the end of the blank. The frequency response is wider than usual, and the development of the disc is largely made possible through the close cooperation and research work of film technicians.

D.C.-A.C. Converter, 40 Watts Output

The new Carter Converter converts 6, 12, 32 and 110 volts d. c. into 60 cycles, 110 volts a. c. It has an output of 40 watts.

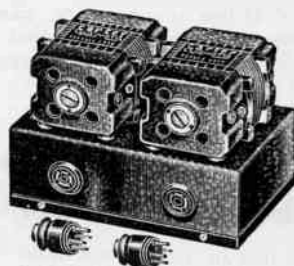

The small size and low cost solve the problem of operating small radio sets and other a. c. devices requiring 40 watts or less in d. c. districts or other places where a. c. is not available.

The Carter Converter is designed for continuous operation and constant output. The case has vents for air-cooling. The armature is dynamically balanced. Special bearings require no oiling. Mounting is on rubber to eliminate noise. The size is 4" wide x 5" long x 2 3/8" high, weight 6 1/4 lbs. It is manufactured by the Carter Motor Co, 369 West Superior St., Chicago, Ill.

Scientifically Engineered Coils

Designed by EDWARD M. SHIEPE

LINK CIRCUIT COILS FOR GRID-DIP OSCILLATOR

These coils consist of a tapped oscillator coil, a pickup coil and a shunt coil to go across the measured coil. The oscillator and pickup coils are wound on the same bakelite form, and the terminals come out to lugs. The shunt coil is on a separate form.

The coils are made to order for any inductance which it is required to measure. Specify oscillator tuning condenser. Per set\$6.50

LONG WAVE AND BROADCAST BAND PRESELECTOR COILS FOR SUPER. 456 kc INTERMEDIATE.

Each of these coils, shown in the accompanying photograph, has one primary and two secondaries. Both secondaries are tuned simultaneously, and have mutual coupling between them. This system gives excellent results, dispensing with one TRF tube and improving both image-suppression and selectivity.

The coils are used with a 3-gang condenser, .00035-.000365MFD, one section of the condenser being for the oscillator coil, shown in the middle of the photograph. The center winding on this coil is the common tickler, the smaller side is the tuned winding for the broadcast band and the larger for the long wave band. Coverage is 200-550 meters (broadcast) and 800-2000 meters (long wave).

The RF coils both have litz duo-lateral wound secondaries, giving the maximum possible gain and selectivity. A four-section, two-position switch is used.

KIT No. 1210. 3 coils as shown, long wave and broadcast bands, with dual oscillator coil, all on 3/4" diam. bakelite.....\$3.76

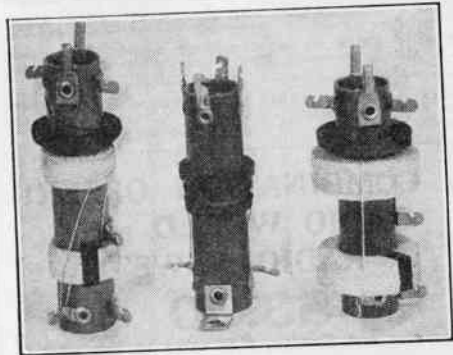

BROADCAST BAND COILS. TRF and Superhet.

Broadcast band coils are of the high-gain variety, supplying maximum gain for minimum number of tubes. These coils have a built-in capacity coupling between primary and secondary, which equalizes the high frequency response. Primaries on antenna coils are designed to tune below the broadcast band with no antenna connected, assuring best results for any antenna.

Secondaries are wound either with spaced enameled wire or are bank-wound with litz. Litz coils give greater selectivity at small extra cost. All coils are enamel-wound unless otherwise specified, and the form diameter is 7/8" for this series. The tuning condenser in all cases is standard, .00035 to .000365 MFD.

2-GANG CONDENSER. COILS UNSHIELDED.

KIT #1020.	One ant. and one rf high-gain	\$0.88
KIT #1021.	Same as No. 1020, except bank-wound litz secondary.....	\$1.20
KIT #1022.	One ant. and one oscillator coil, for 175 or 456 kc. Intermediate frequency.....	\$0.88
KIT #1023.	Same as No. 1022, except bank-wound litz secondary.....	\$1.20

3-GANG CONDENSER. COILS UNSHIELDED.

KIT #1030.	One ant. and two low-gain rf coils.....	\$1.32
KIT #1031.	Same as No. 1030, except litz bank-wound secondary.....	\$1.80
KIT #1032.	One ant., one rf and one osc. for 175 or 456 kc.....	\$1.32
KIT #1033.	Same as No. 1032, except bank-wound litz.....	\$1.80

ALL OF THE ABOVE COIL KITS ARE ALSO SUPPLIED IN SHIELDS. AS SHIELDING ALWAYS REDUCES THE INDUCTANCE OF A COIL, THE SAME COIL CANNOT PROPERLY BE USED BOTH SHIELDED AND UNSHIELDED. DELTA SHIELDED COILS ARE CORRECTED FOR THE EFFECT OF SHIELDING ON INDUCTANCE. THE SHIELDS USED ARE OF HEAVY ALUMINUM, 1 3/4" square by 2 1/4" high. ADD \$0.25 each when specifying shielded coils.

DOUBLY-TUNED IF TRANSFORMERS

DELTA announces a new line of IF transformers of superior design. The coils are wound with litz on seasoned bakelite and are rigidly mounted on Isolantite trimmers. Large inductance to capacity ratios are used to give better gain. The coils come in aluminum shields 1 3/4" square by 3 3/4" high and are fastened to chassis by means of two spade bolts on the bottom. They are individually peaked before shipment.

#2010.	175 kc IF transformer, solid wound, double tuned.....	\$0.90
#2011.	456 kc IF transformer, litz wound, double tuned.....	\$0.93

ADD POSTAGE FOR 2 LBS. ON ALL ABOVE KITS

DELTA RADIO COMPANY

Export Representative:
TECHNICAL PRODUCTS
INTERNATIONAL, N. Y.

135 Liberty Street,
New York, N. Y.
Phone REctor 2-6650

CLASSIFIED ADVERTISEMENTS

7 cents a word. \$1.00 minimum.

AMATEUR RADIO LICENSES. Resident and correspondence courses. Every graduate a licensed operator. New York Wireless School, 1123 Broadway, New York.

GENERAL ELECTRIC 24/750 volt 150 watt battery operated dynamotors, \$25 with filters. Westinghouse 6-15 volt 500 watt generators, \$3.00. 500 watt 500 cycle generators with exciters, \$10 list. Henry Kienzie, 215 Hart Blvd., Staten Island, N. Y.

RAZOR BLADES, 80 double edge blades, 25c, postpaid. Buffalo Products, Buffalo, Minnesota.

MEN AND WOMEN make money in your spare time. Sample with details, 10c. Johnny Sylvia, 117 Jouvette, New Bedford, Mass.

GET \$1.00 EACH for old phonograph records! Instructions, 25c. S. Abbott, University Station, Grand Forks, North Dakota.

SPECIAL PENNSYLVANIA DIAMOND supersensitive DX Radio Crystals, different sizes and kinds. 10 for 50 cents, postpaid. Radio Labs., 13 East Elm, Wilkes-Barre, Pa.

A COMBINATION OFFER! RADIO WORLD and "RADIO NEWS" \$3.50

Canadian and Foreign, \$1.50 extra on this offer.

You can obtain the two leading radio technical magazines that cater to experimenters, service men and students, for one year each, at a saving of \$1.50. The regular mail subscription rate for **RADIO WORLD** for one year is \$2.50. Send in \$1.00 extra, get "Radio News" also for a year—a new issue each month for twelve months. Total 24 issues for \$3.50.

RADIO WORLD, 145 West 45th Street, N. Y. City

When writing to advertisers, please mention that you saw the advertisement in **RADIO WORLD**.

Coil Winding Made Easy

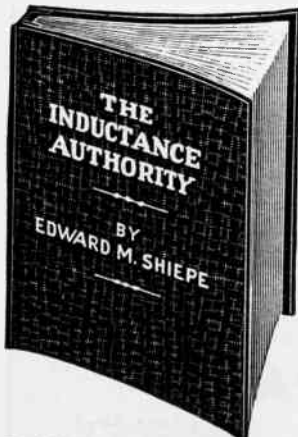

The biggest help anyone can get who desires to wind radio-frequency coils for any frequency from just below the audio range to the fringe of ultra frequencies is to have a book that tells just what inductance is required for the condenser one possesses, and just how many turns of any kind of wire on any sensible diameter are needed to produce that inductance. "The Inductance Authority," by Edward M. Shiepe, gives you all that information, to an accuracy of one per cent. Send \$2.00 and book will be mailed you postpaid; or send \$5.00 for a two-year subscription for Radio World and this valuable book will be sent free.

RADIO WORLD

145 WEST 45TH STREET, NEW YORK CITY



**G R E A T E S T
Book Ever Printed
for Radio Amateurs
and Experimenters
1936 EDITION**

of *'THE RADIO Handbook'*

★ **ALMOST 400 PAGES
ONLY \$1.00 PER COPY**

▲ Many radio books are published, some you'd like to have, others you ought to have, and just a few others you **MUST** have. Here is one of the **MUST** list—"The Radio Handbook," with transmitter and receiver circuits galore, a wealth of fundamental radio information for amateur and experimenter, and what's more, everything authoritative. Imagine! Almost 400 pages, and only \$1, postpaid. Send that dollar now, get the book quickly, and study it slowly, when finished you'll know amateur radio and experimenting, if you don't now. And if you do now, you'll think you didn't after you have.

Send Check, M. O. or Currency to:

RADIO WORLD
145 WEST 45TH STREET, NEW YORK CITY

RADIO WORLD AND POPULAR MECHANICS MAGAZINE
—Radio World is \$2.50 a year, and Popular Mechanics Magazine is \$2.50 a year. Popular Mechanics Magazine does not cut rates, but Radio World will send both publications to you for one year for \$3.75. Radio World, 145 West 45th St., New York City.

WOULD YOU SELL

YOUR INVENTION FOR \$10,000.00?
Cash paid for inventions, also for good ideas.
SHUPITA & KUBSCH . . Whitelaw, Wisconsin

MAILING LISTS



GET OUR FREE
REFERENCE
BOOK and
MAILING
LIST CATALOG
FREE

Gives counts and prices on accurate guaranteed mailing lists of all classes of business enterprises in the U. S. Wholesalers—Retailers—Manufacturers by classification and state. Also hundreds of selections of individuals such as professional men, auto owners, income lists, etc.

Write today for your copy

R. L. POLK & CO.

Polk Bldg.—Detroit, Mich.
Branches in Principal Cities

World's Largest City Directory Publishers
Mailing List Compilers. Business Statistics. Producers of Direct Mail Advertising.

SUBSCRIBE NOW!

RADIO WORLD, 145 West 45th St., New York City. Enclosed please find my remittance for subscription for RADIO WORLD, one copy each month for specified period.

- Two years, 24 issues, \$4.50.
- One year, 12 issues, \$2.50.
- Trial sub., 5 issues, \$1.00.
(50c extra per year for Canadian and foreign postage.)
- This is a renewal of an existing mail subscription (Check off if true).

Name

Address

City

\$1.00 a month

is all you need to pay for
LIFE INSURANCE

\$1194.00 of insurance at age 21; \$313.00 at 35. Other ages in proportion in this Old Line Legal Reserve Company that sells without agents and gives the saving to its policy holders. Postal has paid out \$43,000,000 in 31 successful years. It has millions in assets and reserves. Just write a card today with your name, address and exact date of birth and you will get full details and rates for your age by return mail. Insurance is vital! Act promptly while rates are low.

POSTAL LIFE INSURANCE COMPANY
Dept. RD-144—511 Fifth Avenue, New York

IRON CORE I.F.

GET in line with the latest developments in coil design. Use iron-core i.f. transformers and increase selectivity and sensitivity. Results are amazing. Let us prove it with our latest iron-core i.f. transformers for 456-470 kc (adjustable within this range), double tuned on top. As much gain and selectivity with one iron-core i.f. stage (two coils), as with two stages (three coils) using ordinary transformers. Shield size 3.5 x 1.5 inches. Price, postpaid. \$1.15 each.

TWO-GANG SUPER

One high-gain r.f. and one oscillator coil, both shielded, for .365 mmfd. condenser (requires 200-600 mmfd. padding, not supplied). Both postpaid\$1.25

"FAVORITE" T.R.F. SET

Set of three special shielded coils for Metal-Tube "Favorite" T.R.F. Set described in April, 1936, issue of Radio World. All three, postpaid. \$1.85

FREE DIAGRAMS

Enclose stamped self-addressed envelope for free diagrams of t.r.f. and superheterodyne circuits for home construction.

RADIO DESIGN COMPANY

1353 Sterling Place Brooklyn, N. Y.

Radio World Advertising Rates

	1 time	12 times
Full Page—5/8x8"	\$75.00	\$60.00
1/2 Page—5/8x4" or 2 1/2x8"	37.50	30.00
1/4 Page—2 1/2x4"	18.75	15.00
1/8 Page—2 1/2x2"	9.38	7.50
One inch, single column	5.00	4.00
Agate line	.38	.34
Classified—7c. per word, minimum	\$1.00.	
Color Pages (2 colors):		
Inside front cover		\$90.00
Inside rear cover		90.00
Back cover		90.00

METAL CHASSIS

We can supply chassis for any make receiver, experimental or otherwise.

Inquiries should be accompanied with sketch and complete details enabling us to give quick service as to prices and delivery.

Dept. R.W. 736

KORROL MFG. CO., Inc.
232 Greenwich St. New York City

It DID Happen Here!

AN All-Wave Signal Generator, operating on fundamentals, 100 kc to 20 mc, in five bands, changed by front-panel switching, with modulation present or absent also by front-panel switching, and with an r.f. output attenuator, all housed in a handsome cabinet, and having a direct-frequency-reading dial, coil-switch positions indicating dial bands in frequencies and alphabetically, to sell at \$12.40 net, complete with three tubes, is quite an accomplishment. A few months ago we introduced this Signal Generator, our Model T-37. The price being so low, some persons naturally were skeptical about the generator. Was it accurate? Was it stable? Did it do all the work we said it would do, and do it well?

Perhaps the best answer is that since the introduction of this model many of our old customers, knowing of our careful workmanship and our precision laboratory, purchased one of these generators, and all of them have been greatly satisfied. The generator actually did all we claimed it would do, which was no surprise to these loyal customers, but they still wondered how we could give so much for so small a price. Perhaps others are interested in this same question.

We had been manufacturing an excellent, higher-priced signal generator for about a year and a half, verified the fact there was a good market for signal generators, and decided that if we gaited ourselves to a production run of a few thousand new model generators, the cost of materials and tubes would be reduced so much, although the charge for labor in careful production would not be changed at all, that we could produce the new generator to sell at \$12.40 net, if the entire production were sold. We considered it a sound business undertaking, and the fervid acceptance of the new generator, even during hot weather, vindicates our judgment, and Model T-37 evidently will be sold out before the new season is well under way.

If you have a present or future need for a generator, order our Model T-37 for its reliability, accuracy, sturdiness, attractiveness and fine overall performance. We feel complimented that the price is so low as to cause a sensation, and that the performance of the generator reaches such a high level as to create a second sensation. Who said, "It Can't Happen Here?"

The five bands are: E=100 to 220 kc; D=220 to 660 kc; C=660 kc to 2 mc; B=2 to 6 mc; A=6 to 20 mc.

Model T-37 works on 90-130 volts, a.c. or d.c. The a.c. may be of any commercial frequency.

Two type 37 tubes and a neon tube are used. One of the 37's as Hartley r.f. oscillator, the other as the rectifier. The neon tube is the audio oscillator.

The modulation is about 1,000 cycles.

The purpose of Model T-37 is to enable adjusting the intermediate and radio-frequency amplifiers, 100 kc to 20 mc, at the right frequency.

Posts are included for separate audio output for checking public address systems, audio amplifiers in receivers, and speech amplifiers in transmitters. Filter condenser leakage tests may be made, also.

Model T-37, wired, calibrated, tested; complete with three tubes, in shield cabinet with carrying handle and instructions (shipping weight, 7 lbs.).



SUPERIOR INSTRUMENTS CO.

139 CEDAR STREET, NEW YORK, N. Y. — Dept. W-8.

\$12.40

THOR'S ANNUAL SMASHING SUMMER SALE

Now—while quantities last. All of the famous THOR Kits, Parts and Supplies at unbelievable low prices. Every part, unit and kit in perfect condition and backed by Thor's 16 year old satisfaction guarantee. Take advantage of these reductions now to get the latest and finest in quality merchandise. Only a few of each in stock so get your order in early. First come, first served.

18 ONLY. Famous RGH Jr 2. All wave kits. 15-600 meters. Self-powered AC or DC current. Complete parts including coils, wire, solder and full instructions. Parts mounted on drilled chassis with front panel and dial. Ready to wire.....**NOW 3.95**
Formerly \$6.75
1-6F7, 1-37 tubes, \$1.09 extra.

14 ONLY. Famous RGH 2X short wave converters. Complete converter can be attached to any standard set to cover full short wave range. Built-in coils with band switch and illuminated vernier dial. Completely self-powered. AC only. Uses 1-2A7, 1-80. Complete ready to operate including tubes, metal cabinet and instructions.....**NOW 7.45**
Formerly 9.75

110 ONLY. Genuine Philco aerial kits. Complete high efficiency aerial system. Eliminates noise—increases distance—accommodates 2-4 radios. All parts—wire and transformers **1.79**
NOW
Formerly 7.50

8 ONLY. Famous RGH Super 5 all wave kits. 11-600 meters. AC only. The finest all wave kit on the market with the exclusive front panel coil recess. Uses 1-2A7, 1-58, 1-57, 1-2A5, 1-80, also available for metal tubes. Full electrical band spread. 3 watt output. Illuminated vernier dial. Phone connection. Complete parts including coils, drilled and mounted panel and chassis, wire and instructions.....**NOW 9.95**
Formerly 14.95
Set of 5 matched tubes.....2.45
8" Dynamic Speaker to match...1.99

72 ONLY. Code practice sets. Key and buzzer. Complete in metal case with printed code and instructions. Batteries mounted in case. Blinker light-buzzer and sound connect by 3-way switch. Complete **98c**
NOW
Formerly 1.75

40 ONLY. 4 watt Amplifier. AC only. Uses 1-57, 1-2A5, 1-80. Built-in speaker field supply. Tone and volume control. Input connections for mike tuner or pickup. All heavy duty parts. Black crackle chassis. Complete ready to operate. **3.49**
NOW
Formerly 5.95
Set of 3 matched tubes.....1.21
8" Dynamic Spkr. with output trans... 1.99

28 ONLY. Famous THOR Hi-Fidelity PA5 Amplifier. 16 watt output, using push pull 6B5's, 1-6CG, 1-76, 1-83V. Manual volume and tone control. Speaker field supply built-in. Double inputs for mike, tuner or pickup. Black crackle chassis and cover. Excellent frequency response. One of our best sellers. Ideal for all public address and sound amplification work. Complete, ready to operate.....**NOW 11.55**
Formerly 14.95
Set of 5 matched Raytheon tubes.....3.95
10" Rola Dynamic with output trans. to match...3.45

12 ONLY. 8 watt Amplifier. AC only. Uses push pull 2A5's, 1-57, 1-56, 1-80. Built-in speaker field supply, tone and volume control. Input connections for mike, tuner or pickup. Real quality with a wallop. Black crackle chassis. Complete ready to operate. **7.99**
NOW
Formerly 12.95
Set of 5 matched tubes.....2.04
10" Rola Dynamic with output trans... 3.45

12 ONLY. Famous RGH 4. Prize winner. All wave kits. Highly sensitive circuit. Using 1-58, 1-57, 1-2A5, 1-80. Covers 11-600 meters with exclusive front panel coil recess. Phone connection. Self powered AC only. Complete with metal panel and chassis. Illuminated vernier dial and band spread. Complete, ready to operate.**NOW 7.99**
Formerly 11.75
Set of 4 matched tubes.....1.65
8" Dynamic to match.....1.99

4 ONLY. THOR'S Push Pull 250 Amplifier. By reputation the best in tone reproduction Pure Class A. Using 1-57, 1-58, 2-250, 1-5Z3. All heavy duty oversized parts on black crackle chassis with ventilated cover. Built-in speaker field supply volume and tone controls. Complete.....**14.50**
Formerly 18.50
Set of 5 matched tubes.....3.10
10" Rola Dynamic with output trans...3.45

It is impossible for us to describe in any one advertisement all of the parts available in our stock house of 4 floors. Write us for prices on any radio part manufactured.

Additional technical information on all the above items as well as illustrations of the exact unit may be found in last 4 editions of Radio World. Space does not permit a reprint but items are exactly as described and pictured. This is an unusual opportunity to secure the outfit you want at remarkably low prices, but as quantities are limited and orders filled in the manner in which they are received, we urge you to order NOW. 20% deposit required with each order.

90 ONLY. Genuine Atwater-Kent Model 35. 6-tube battery set. Uses 5-30, 1-31. New 2 watt low drain tubes. Brand new sets. Ideal for farm and boat use. Needs 3 B batteries and 1 A battery. Complete Set **4.95**
NOW
Set of 6 tubes, 2.04.
Speaker to match, 2.45.

ORDER DIRECT FROM THIS AD 24-HOUR SERVICE



167 Greenwich Street, near Cortlandt St.
New York City

Mail orders require 20% deposit all items over 10 dollars. 24-HOUR SERVICE

HURRY!
GET
THIS

FREE

**RADIO
CATALOG**

Anything and everything in radio
—Sets, Parts, Tubes, Kits, Amateur
Equipment, Sound
Amplifiers and Systems.
Whatever you need when
you need it—plus the
fastest, most dependable
service in the field!
Send for this FREE
catalog—the shopper's
guide to radio—used
by fans, amateurs,
experimenters, service
men and dealers.
Shows lowest
Wholesale prices
on standard nationally advertised
radio merchandise. Mail
convenient coupon NOW!



WHOLESALE RADIO SERVICE CO., INC., DEPT. H-11
100 SIXTH AVENUE, NEW YORK

Please RUSH a FREE copy of your big, exclusive radio catalog.

NAME

ADDRESS

TOWN STATE

WHOLESALE RADIO SERVICE CO.
CHICAGO, ILL.
901 W. JACKSON BLVD.

NEW YORK, N.Y. 100 SIXTH AVE.
ATLANTA, GA. 430 W. PEACHTREE ST NW
BRONX, N.Y. 542 E. FORDHAM RD.
NEWARK, N.J. 219 CENTRAL AVE.

TRANSFORMERS

FOR ALL PURPOSES

for example:

TRANSCEIVER TRANSFORMERS

F-532-B—Microphone and Plate Primaries to Grid Secondary. Uncased, light weight, Net.....\$.92

F-533-B—Transceiver Output from plate of 33, 38, 41, etc. to 130,1000 or 2000 ohm handset or phones..\$1.00

F-536-B—Similar to F-532-B but for more powerful Transceiver using a 19 as push-pull R.F., 30 as audio driver, and 19 as Class B Modulator\$1.05

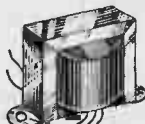

F-534C—Class B Input, 30 driver to 19 Grids Class B\$.80

F-535-B—Class B Output from 19 Twin to modulate 19. Sec. handles plate current of r.f. stage, impedance approx. 2700 ohms, or any 7 watt stage approx 50 m.a. at 135 volts.....\$1.17

General Replacement Transformers

will be found in our
CATALOGUE No. 51-C

Three examples out of 161:

No. 210—300-0-300 V. 40 m.a.;

2.5 V. 5.5 A.; 5V. 2A.....\$1.11

No. 209—330-0-330 V. 60 m.a.;

2.5 V. 8.75 A.; 5V. 3A.....\$1.50

No. 1103—Single Plate to Push-pull Grids\$.98



High Fidelity Audio Transformers for Public Address, Broadcast and Amateur Stations will be found in our catalogues No. 70, No. 70-A. Description of all types for microphones, matching, interstage, and output, all fully cased and shielded. Useful diagrams included.

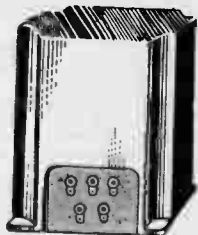

AMATEURS!

SEND FOR CATALOGUE
No. 52-C

Contains nearly a hundred stock transformers and chokes for all power phone and C.W. rigs, designed by Boyd Phelps. W2BP-W9BP. Illustration shows FTP-56 which delivers ¼ K.W. and costs \$9.50 net.



Any of the above catalogues free for the asking. If in a hurry, order direct from this ad or see your local jobber. If he does not have these lines tell him he is missing something well worth while.

**FRANKLIN TRANSFORMER
MANUFACTURING COMPANY**

607-609 22nd Ave. N.E., Minneapolis, Minn.

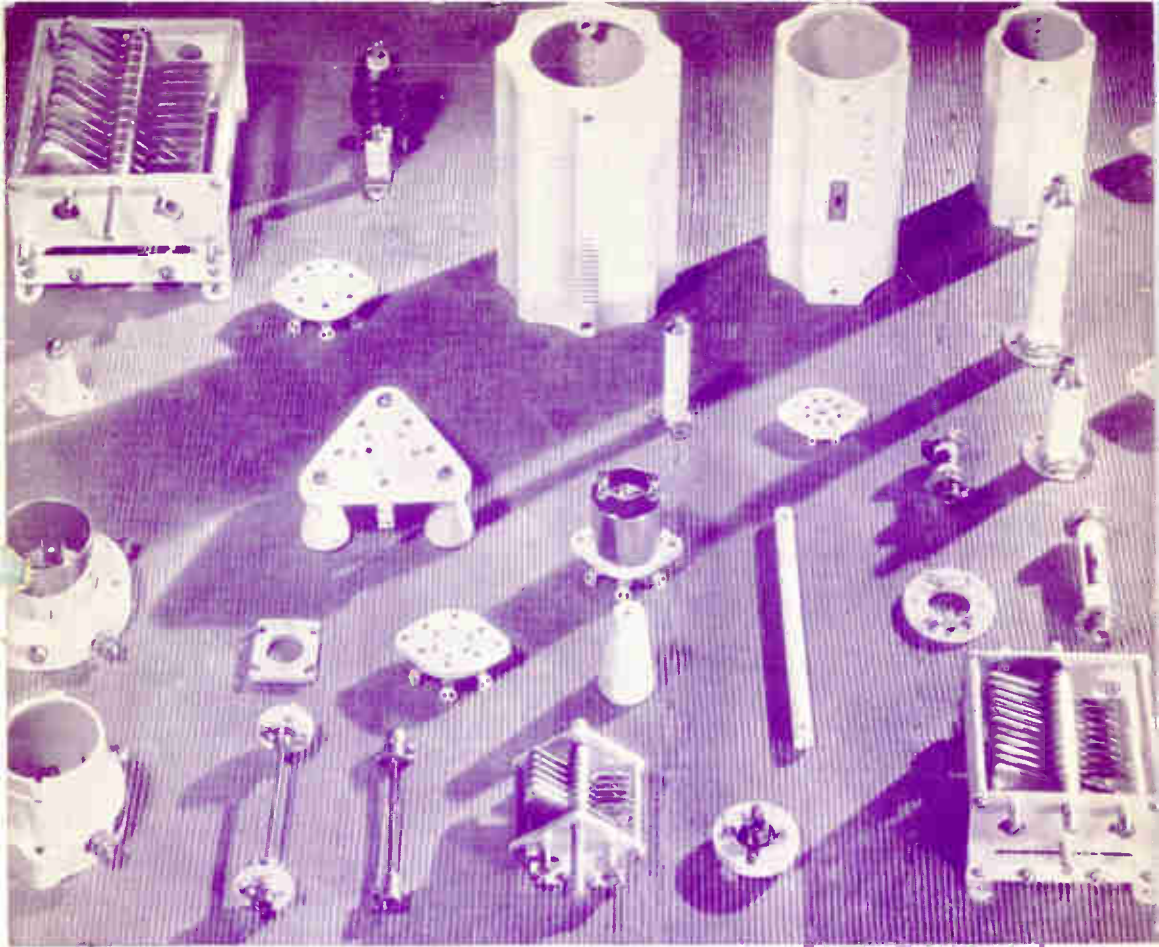

• National offers a thoroughly engineered part for nearly every radio purpose. The entire line cannot be compressed into our twenty-page catalogue, much less a single page. But look over the group above. Transmitting condensers from the little 1000 volt TMS in the foreground to the 12,000 volt TMA at the rear. Low loss ceramic coil forms for every amateur band. Low loss sockets for nearly every tube type, from acorns to power pentodes. Flexible couplings from the little TX-12, which will work around a corner, to the big fellows for heavy condensers, high voltages, and low-losses. Strain insulators, spreaders, lead-ins for the antenna; stand-offs, chokes, dials for the rig. National has what it takes.

NATIONAL



COMPANY

FOUND...THE OUTSTANDING OSCILLATOR OF 1937 MODELS



A SENSATIONAL DEVELOPMENT AT A SENSATIONAL PRICE

This Ranger-Examiner Signal Generator bids fair to revolutionize test equipment in this field. The inside view of the trimmer calibrated coils shows the exclusive development by Ranger-Examiner engineers that gives amazing accuracy and yet makes possible low cost production.

- ★ 110 to 20,000 Kc.
- ★ Direct Reading on Five Bands, all fundamentals.
- ★ Completely shielded.
- ★ Guaranteed accurate to 1% for broadcast and intermediate bands, 3% for Short Wave bands.

Model 557 is sold complete with all batteries and two No. 30 tubes and the five plug-in coils contained in a handsome black leatherette case. Dealer price.....\$18.00

See it at your jobbers.
Write for more information.

All Ranger-Examiner Test Equipment is precision built, quality merchandise, manufactured on a high production basis permitting exceptional values.

Seldom in manufacturing does it occur that a better article is produced at a lower price. . . . But don't take our word, try it out yourself. You will see that the Ranger-Examiner Signal Generator has all the features you demand. It covers the full range from 100 to 18,000 Kc. with the five plug-in coils, all are direct reading and fundamentals; a scale is provided too for graph calculations for those desiring to make charts for reference. It is completely shielded for static and magnetic fields. Attenuation and stability are outstanding features. The signals are strong and either modulated or unmodulated as desired.



READRITE METER WORKS,
827 College St., Bluffton, Ohio

Please send me more information on the Ranger-Examiner.

Name

Address

City State