

THREE WAYS TO GET MORE FROM REGENERATIVE SETS

**RADIO**

REG. U.S. PAT. OFF.

**WORLD**

The First National Radio Weekly — 647th Issue, 13th Year

New, Accurate Method  
of Computing Coil's  
Distributed Capacity

Three PA Systems

**AUG. 18**  
1934

**15¢**  
Per Copy

**IMPROVING  
PERFORMANCE  
OF  
SHORT-WAVE  
RECEIVERS**

**SHORT WAVE—RADIO EQUIPMENT—SERVICE LEADERS**



**Postal Deluxe S.W. Converter**  
Fully described June 30, Radio World; June 2, N. Y. Sun; Radio News, S. W. Radio, S. W. Craft, and Radio Craft. Send for Free Booklet.  
135 W. Liberty St. New York, N. Y.

POSTAL RADIO

**Short-Wave and Public Address Specialists**

Every short-wave receiver or public address system imaginable on display at our new offices in the GREEN EXCHANGE BUILDING.  
You are cordially invited to visit us.  
**PROMPT RADIO SERVICE CO.**  
130 Cedar Street New York, N. Y.

**Brush Up on Short Waves**

ORDER a copy of "The Short-Wave Authority," by J. E. Anderson and Herman Bernard, so you can read the complete exposition of this absorbing topic, and have a ready reference book that solves your short-wave problems. Constructional circuits included. Special chapter on Treasure-Seeking Devices. Great details on superheterodynes and padding. Send no money. Just order book sent C.O.D. at \$3.00. Reliable Radio Co., 145 W. 45th St., N.Y.C.

**Ham & Servicemen's Headquarters**

We carry a complete line of Public Address, Short Wave and Transmitting parts in stock. Largest assortment of Dynamic and Magnetic Speakers in the country.  
**TRY-MO RADIO CO., N. Y. CITY**  
85 Cortlandt St. — 179 Greenwich St.

**An Exclusive Powertone Feature!**  
**—THE "COSMAN TWO"—**

The "Cosman Two" Battery - Operated Short Wave features a coil rack that holds five plug-in coils. This idea eliminates the old fashioned searching for the desired coil. The coils are easily placed in their respective order.

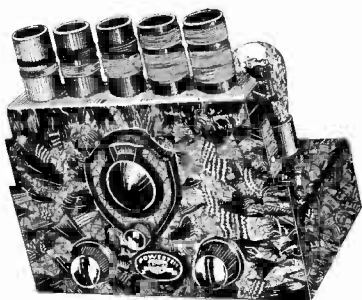

Another remarkable feature is that even though the "Cosman Two" is only a two tube set, it will work a loud speaker at an unusual volume. Foreign stations as well as domestic short waves come in on the loud speaker.

At last loudspeaker reception on two new (2 volt) tubes. Ease of construction is but one of the many new features which is found in this radically new short and long wave receiver. An exclusive idea, makes this one of the many outstanding short wave ideas which are developed for the inexperienced as well as the dyed in wool short wave fans.

- Complete kit of parts (including 4 Bruno junior plug-in coils) 15-200 meters ..... \$5.95
- Bruno Broadcast Coil (200-550 meters) ..... .39
- Kit of R.C.A. licensed tubes, 1-32, 1-33 ..... 1.95
- Wired and tested. Extra ..... 1.00

**PROMPT RADIO SERVICE CO., 130 Cedar St., N. Y. City**

**SHORT-WAVE AND PUBLIC ADDRESS MANUAL**  
**FREE**

192 pages, 400 illustrations, costing \$4,000 to produce. And yet a copy of this manual will be sent to you free if you send \$1.00 for an 8-weeks subscription for RADIO WORLD. Existing subscribers may extend their subscriptions under this offer.

Bound in cardinal red leatherette, this manual includes articles on the construction of short-wave receivers from one to nine tubes, inclusive, and all values between, supers and 1-r-f, with the clearest imaginable illustrations, both photographic and draughting. Besides the usual plain circuit diagram there is a pictorial diagram for each circuit. And all the photographs are brilliantly alluring and informative. Portable short-wave sets, design and winding of coils for short waves and broadcasts (intimately illustrated), list of short-wave stations with meters and kilocycles and hours on the air; trouble-shooting, and forty other topics, all done well.

The public address section contains data on different systems, how to use them, and offers opportunities to turn public address work to profit. Besides, there are articles on testing and servicing not encompassed by the title of the manual—signal generators, broadcast home and portable sets, analyzers, formulas, capacity data. Everything plainly told, simple language, from microphones to speakers.

Send \$1.00 now and get RADIO WORLD for 8 weeks and the manual free. Ask for Cat. PR-SPAM.

RADIO WORLD, 145 W. 45th St., New York, N. Y.

**EARLY SHIPMENT!**  
**PUSH-PULL**  
**AUDIO TRANSFORMER**

Here is an unshielded audio transformer of the highest quality. Both its windings are center-tapped. Hence it may be used as an input transformer coupling from a single plate into two grids in push-pull, or, it may be used as a push-pull interstage transformer coupling push-pull plates to push-pull grids.

This transformer was made up to special order by a company well known for its excellent transformers of all type. This particular transformer has been used in various circuits and also as a replacement transformer in sets, with uniformly satisfactory results.

Type K Push-pull Audio Transformer, \$1.10

**RELIABLE RADIO COMPANY**  
143 WEST 45th ST., NEW YORK, N. Y.

**They Work!**  
**FILTER CONDENSERS**

Here is a dry electrolytic self-healing condenser of 8 mfd. capacity which will give long, hum-free service in power supplies. The condenser is intended for use with an operating voltage of 400 volts, or slightly over, but will withstand a peak voltage of 600.

Type D Condenser, 49c  
**RELIABLE RADIO CO.**  
143 West 45th St. New York, N. Y.

**Subscribers! Important!**

Note subscription expiration date on wrapper containing your copy of RADIO WORLD. If nearing expiration date, please send in renewal so that you will not miss any copies. Subscription Dept., RADIO WORLD, 145 W. 45th St., New York City.

THE ONLY BOOK OF ITS KIND IN THE WORLD. "The Inductance Authority" entirely dispenses with any and all computation for the construction of solenoid coils for tuning with variable or fixed condensers of any capacity, covering from ultra frequencies to the borderlines of audio frequencies. All one has to do is to read the charts. Accuracy to 1 per cent. may be attained. It is the first time that any system dispensing with computation has achieved such very high accuracy and at the same time covered such a wide band of frequencies.

A condensed chart in the book itself gives the relationship between frequency, capacity and inductance, while a much larger chart, issued as a supplement with the book, at no extra charge, gives the same information, although covering a wider range, and the "curves" are straight lines. The condensed chart is in the book so that when one has the book with him away from home or laboratory he still has sufficient information for everyday work, while the supplement, 18 x 20 inches, is preferable for the most exacting demands of accuracy and wide frequency coverage.

From the tri-relationship chart (either one), the required inductance value is read, since frequency and capacity are known by the consultant. The size and insulation of wire, as well as the diameter of the tubing on which the coil is to be wound, are selected by the user, and by referring to turns charts for such wires the number of turns on a particular diameter for the desired inductance is ascertained.

There are thirty-eight charts, of which thirty-six cover the numbers of turns and inductive results for the various wire sizes used in commercial practice (Nos. 14 to 32), as well as the different types of coil wire (single silk, double silk, single cotton, double cotton and enamel) and diameters of  $\frac{1}{8}$ ,  $\frac{1}{4}$ ,  $\frac{3}{8}$ , 1, 1 1/2, 1 3/4, 2, 2 1/2, 3, 3 1/2, 4, 4 1/2, 5, 6, 7, 8, 9, 10, 11, 12, 14, 16, 18, 20, 22, 24, 26, 28, 30, 32, 34, 36, 38, 40, 42, 44, 46, 48, 50, 52, 54, 56, 58, 60, 62, 64, 66, 68, 70, 72, 74, 76, 78, 80, 82, 84, 86, 88, 90, 92, 94, 96, 98, 100.

**"The Inductance Authority"**

By EDWARD M. SHIEPE, B.S., M.E.E.

gives the frequency ratio of tuning with any inductance, when using any condenser the maximum and minimum capacities of which are known.  
The book contains all the necessary information to give the final word on coil construction to service men engaged in replacement work, home experimenters, short-wave enthusiasts, amateurs, engineers, teachers, students, etc.

There are ten pages of textual discussion by Mr. Shiepe, graduate of the Massachusetts Institute of Technology and of the Polytechnic Institute of Brooklyn, in which the considerations for accuracy in attaining inductive values are set forth. These include original methods.

The curves are for close-wound inductances, but the text includes information on correction factors for use of spaced winding, as well as for inclusion of the coils in shields. The book therefore covers the field fully and surpasses in its accuracy any and all mechanical aids to obtaining inductance values.

The publisher considers this the most useful and practical book so far published in the radio field, in that it dispenses with the great amount of computation otherwise necessary for obtaining inductance values, and dispenses of the problem with speed that sacrifices no accuracy.

The book has a flexible colored cover, the page size is 9 x 12 inches and the legibility of all curves (black lines on white field) is excellent.

Send \$4.00 for 84-week subscription for RADIO WORLD and order Cat. PIA sent free, with supplement, post-paid in United States and Canada.

**RADIO WORLD**  
143 West 45th Street New York, N. Y.



ROLAND BURKE HENNESSY  
*Editor*  
 HERMAN BERNARD  
*Managing Editor*  
 OFFICERS  
 Roland Burke Hennessy  
*President and Treasurer*  
 M. B. Hennessy, *Vice-President*  
 Herman Bernard, *Secretary*

# RADIO REG. U.S. PAT. OFF. WORLD

The First National Radio Weekly  
 THIRTEENTH YEAR

Price, 15c per Copy; \$6.00 per Year by mail. \$1.00 extra per year in foreign countries. Subscribers' change of address becomes effective two weeks after receipt of notice.

Entered as second-class matter March, 1922, at the Post Office at New York, N. Y., under Act of March 3, 1879. Title registered in U. S. Patent Office. Printed in United States of America. We do not assume responsibility for unsolicited contributions, although careful with them.

Vol. XXV

AUGUST 18, 1934

No. 23. Whole No. 647

Published Weekly by Hennessy Radio Publications Corporation, 145 West 45th Street, New York, N. Y.

Editorial and Executive Offices: 145 West 45th Street, New York

Telephone: BR-yant 9-0558

## Improving Sets by "Frequency Holding"

### Local Oscillators Should Be Stable, Inductance and "Fixed" Capacity Stay Put

By Leonard J. Press

MAKING "restful" oscillators is one of the problems before the science to-day. The oscillators are "restful" when they don't wobble. That is, when they are frequency-stabilized. A good deal has been accomplished, but little even of what is known has been put into commercial receivers. About the nearest approach to any recognition of the necessity of freedom from drifting was in an ultra-frequency superheterodyne put out for amateurs, where a Hartley oscillator was used, cathode of the 56 tied to a tap on the coil. This gave at least that measure of stability which arises from Hartley circuits when much of the tuning capacity is in circuit.

In signal generators, which are test oscillators accompanied by modulation, or introduction of an audio frequency, experience with the low frequencies, such as found in intermediate channels, shows that there is not much difficulty in repeating the same settings time and again for obtaining the same frequencies. This is sometimes looked upon as frequency stability, but isn't that. The factor that principally changes the required setting of the condenser for generating a given frequency is what is known as the weather. Meteorological conditions would be a better name. Temperature, moisture count most. As they change the inductance changes. Even the tuning condenser capacity changes a bit. When that capacity is large, as on low frequencies, the relative capacity change is slight. Even the inductance does not change much, relatively, hence there isn't much trouble on this account.

#### The Trip to Europe

As soon as the frequencies are heightened the effect of meteorological conditions on the instrument becomes considerable. Even in the broadcast band these effects are noticeable. Several receivers have been under observation for months, under various conditions. All had specially-calibrated dials. All scales were accurate when calibrated. Commercial coils and condensers were used. The required shift in dial position or setting to register the same frequency under various meteorological conditions was quite noticeable. No doubt commercial coils should have better forms, something more in the direction of stone and less in the direction of blotting paper, although some stones will obligingly hold moisture.

A severe test is put on a receiver that has to be sent to Europe. The sea trip puts

This is a short-wave converter of the self-powered type with separate oscillator and modulator. The 15,000-ohm series resistor (lower right) improves frequency stability.

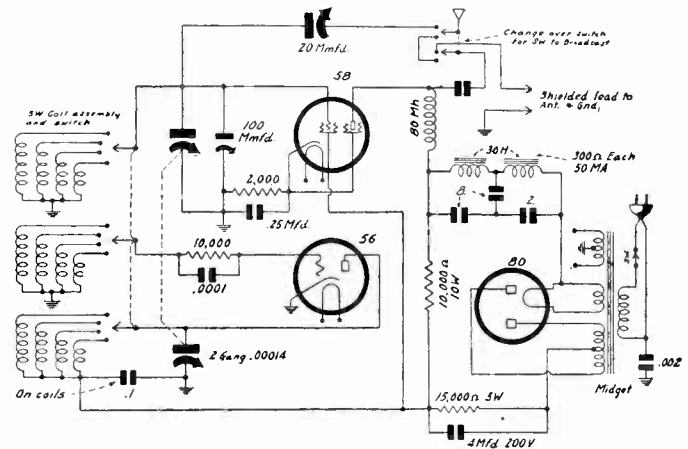

a rigid demand on the coils. Not only the forms, but the very wires are affected. For instance, one manufacturer reports that he changed from enamel-covered to silk-covered wire on his coils, because the enamel sometimes was baked at too high a temperature, resulting in insulation fissures, allowing the moist sea air to attack and corrode the wire. Since he went over to silk he says he hasn't had any trouble.

Only this year have commercial sets appeared that have frequency-calibrated dials that hold in the broadcast band. That is, the change is next to nothing, day after day, night after night, due to better coils.

#### Variations on Short Waves

The short-wave band calibrations are still subject to wide variations, except that these variations are not quite so noticeable, because of the wide jumps in frequencies on the calibration, that is, large frequency difference between bars of the scale. Due to wider-spaced bars, the relative difference is much larger than in the broadcast band, and of course the absolute difference is tremendously larger.

Making calibrations hold on the short-wave band is rendered more difficult due to the large frequency change arising from small physical displacement of turns. If a coil is wound by hand on a small diameter and used in an oscillator, for instance, since the winding may be expanded and contracted readily, by pushing the wire, or at least expanded with no trouble, the frequency

change due to this alteration of inductance is enormous.

Assuming that the coils are wound on an excellent form, one that does not absorb moisture, and is free from residual iron and other injurious foreign substances, we have to pay some attention to the condensers. The tuning condensers will be variable ones, of air dielectric, and meet the requirements. If the condensers have a ball race there may be trouble due to the friction of the ball-bearings causing a thumping modulation or scraping sound above 10 mcg, if the bearings are not snug and well lubricated. This is a possible source of noise in short-wave sets not usually mentioned.

#### The "Semi-Fixed" Condensers

The principal consideration has to do with the semi-fixed condensers, however. It is notorious that compression type trimmers do not constantly provide the same capacity. Set them once and they are a certain capacity then, but what the capacity will be some other time one does not know for sure, not even whether it will be more or less, though less is the general rule, because the spring tends to give under the lasting pressure exerted by it in the compression type instrument. Nevertheless practically all sets, short waves or not, use this type of parallel condenser. It is an adjustable type, usually by a screwdriver, and once set is left thus, hence rated as semi-fixed, but since it changes capacity some doubts may arise as

(Continued on next page)

(Continued from preceding page)

to the propriety of saying it is even semi-fixed.

At the radio-frequency level, which is the frequency of the carrier desired to be tuned in, the effect of the drift of capacity in the trimmers is not so serious, though of course sensitivity is diminished. That is why front-panel manual trimmers are better, particularly those of very small capacity, such as would have little effect on the broadcast band, save at the highest frequencies thereof. Capacities of the order of 10 mmfd. are in mind.

It is recognized that cost enters seriously into the commercial undertakings, but it is also true that home experimenters and others who build sets for themselves or for others, mainly for the pleasure, or perhaps as a business sideline, have a tendency to follow commercial practice. It would be better to forget the big names attached to some commercial sets, and not take for granted that the most appropriate choice has been made for all purposes, when in fact the choice that was made was one of low engineering integrity and required by economic considerations.

**Capacity Must Stay Put**

As stated, at the carrier level of the station the compression type of condenser may be used with least ill effects, but in a superheterodyne certainly the local oscillator should have air-dielectric capacity for parallel and series trimming. The series trimming is more commonly called padding.

Another deterrent is that for the broadcast band the capacity of the series condenser has to be very large, almost ruling out an air-dielectric condenser. For 465 kc intermediate frequency this capacity will range from 350 to 450 mmfd., not entirely out of reason as an air-dielectric condenser, but for 175 kc the series capacity would have to be somewhere around 1,000 mmfd. up. This begins to become prohibitive. Yet the fact remains that some capacity that stays put must be used, otherwise any calibration or peaking will be upset, particularly as the calibration is based on the oscillator frequencies and the intermediate frequency, and if these change, the calibration is "off."

Better than having a compression type condenser would be to select a mica-dielectric fixed condenser of somewhat less than the required capacity and use a small air-dielectric condenser in parallel with it to make up the difference. This is not to say that the mica condenser will not change at all, even if it is of the moulded and vacuum-impregnated type. It is true that some precision fixed condensers are made in somewhat the same way, and they stay put, but in commercial production of fixed condensers of the moulded type the aperture for the plates and mica is the same for all capacities made, hence if this space is not completely filled, and tightly so, the capacity will change a bit due to shifting of the material objects inside.

**Where Inconsistency Enters**

A great deal of fuss is made about air-dielectric condensers across intermediate-frequency coils. It is certainly true that they stay put much better than the compression type, for the same reasons as already stated, the problem being identical and the same. But a point often lost to view is that the change in capacity at this low frequency makes a small difference in frequency, while compression type trimmers are used in the very critical local oscillator, where the same capacity change may change the frequency four times as much. Therefore it is inconsistent to tout air-dielectric intermediates without even more regard for the use of air-dielectric condensers for padding and trimming the local oscillator.

In a receiver designed to cover a wide band of frequencies the padding capacity has to be changed, unless the intermediate frequency is raised for each succeeding band, which would be awkward. The ratio of increase would have to equal the frequency ratio of the tuner. For instance, if for the broadcast band the tuning is from 540 kc to 1,620 kc, the frequency ratio is 1 to 3. Suppose the intermediate frequency is 400 kc. For the next band, to hold the same padding there as was present in the broadcast band, the i.f. would have to be raised to 3 x 400 or 1,200 kc, and if the i.f. were 465 kc for the broadcast band, for the next band it

would have to be 1,395 kc. Using the 400 kc figure as starting point, for simplicity, the i.f. would have to be as follows for four bands: 1 (1), 400; (2), 1,200; (3) 3,600; (4) 10,800. This assumes that the same frequency ratio in the tuner would be preserved for all bands, that is, the condensers would not be changed physically or electrically, only the inductances. This method, which is out of the question as a practical solution, nevertheless is interesting because the same trimming and padding are preserved for all bands.

**Resistance Keeps Changing**

Now, all these changes may take place due to capacity and inductance alterations ascribed to the weather, and yet the system in which they do take place may be stable. Chances are the system is unstable, as the sight of a stable oscillator in a receiver is a rarity indeed. The stability here referred to is the one that designates the tenacity of the oscillator, its ability to generate the same frequency at any particular setting, and not, when left at that setting, change its frequency. That is, assuming the inductance and capacity are held constant, should not the frequency be constant? No, because resistance also affects frequency, and in an unstable oscillator the tube resistance keeps changing. But the frequency will not be constant unless made so by special means. That means would be any that causes the tube to behave like a pure resistance. Another way of looking at it is that the amplitude of the oscillation should be the same at all frequency settings, that is, during the process of tuning from one end to the other of a given band. If a plate circuit meter needle stands still over this span then the oscillator is stable for that band at least. In most oscillators there is a serious dip near the high-frequency end, with oscillation greater or less than over the rest of the tuning, usually less, but possibly varying from greater to less and putting a sharp kink in the curve.

**Use of Series Resistor**

The presence of drift is noticeable in practically all of the tubes and circuits generally used, and getting rid of this trouble constitutes the problem of frequency stability. It may be accomplished, to a greater or lesser degree, by various means, one of which is set forth at some length in an article on service oscillators, printed in "Short-Wave and Public Address Manual." It consists of suitable selection of grid condenser and leak values in a leaky condenser oscillator of any type—Hartley, tuned grid, Colpitts, ultra-audion, etc.

Another method is to use a higher grid leak on pentagrid converter tubes, around 90,000 or 100,000 ohms, and put a fairly high resistance in series with the return of the plate coil, around 25,000 ohms or so. The higher this series resistor, which should be bypassed by a condenser, the greater the stability, because the greater proportion the "pure resistance" of the series element becomes to the total resistance. The tube plate circuit is the variable resistance. But the resistor can be easily made so large that oscillation intensity is too weak. At high frequencies oscillation might stop. Therefore around 25,000 ohms represents a good compromise, with a bypass capacity selected on the basis of watching the plate circuit needle, the condenser being such that the needle is made to stand still, or nearly so, during the 0-100 tuning. This might require an unexpectedly small capacity.

A test for frequency stability independent of meter use is to set the oscillator to beat with an incoming carrier that is crystal-controlled, and listen. The beat should be finite (no zero) and then one listens for an hour or so, if one has the time and inclination, noting whether the audio sound (beat) retains the same pitch, or whether it wobbles all over the map, as the common dynatron does.

**REFLEX FIENDS, TRY THIS**

One of the time-consuming efforts, with plenty of excitement incidental, is experimentation with reflex sets. A fellow who started experimenting with one in 1924 reports that, although he has been at it all the while (with only a little time off for profit-producing work, so he could support his family) that he has almost mastered the problem of stabilizing the circuit. In a reflex stabilization consists of making the set perform almost as well as a standard set that uses, say, one more tube.

Now here is a diagram that may be or used as a trial.

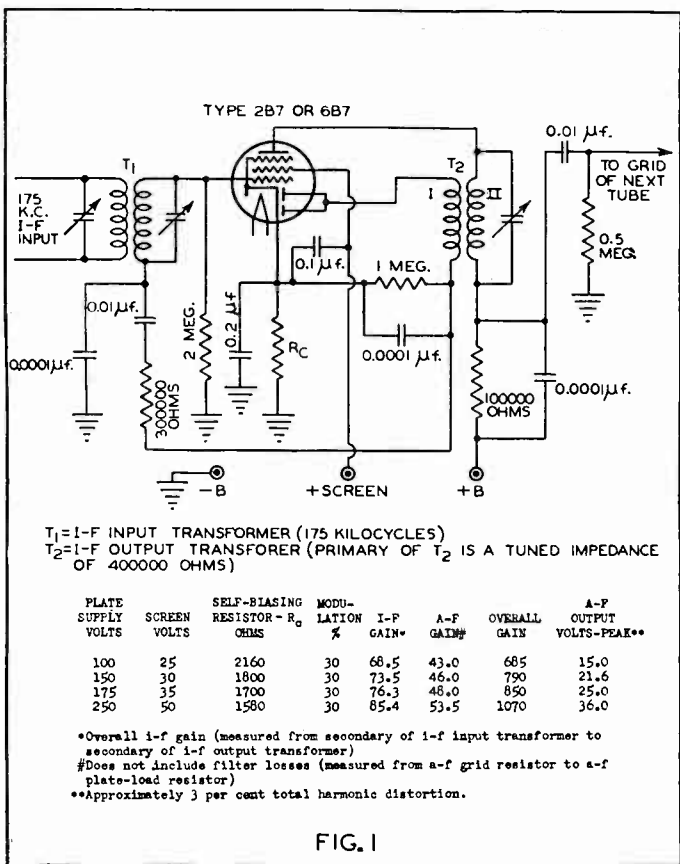



# Three Ideas to Improve Short-Wave Reception

By Harry Willcox

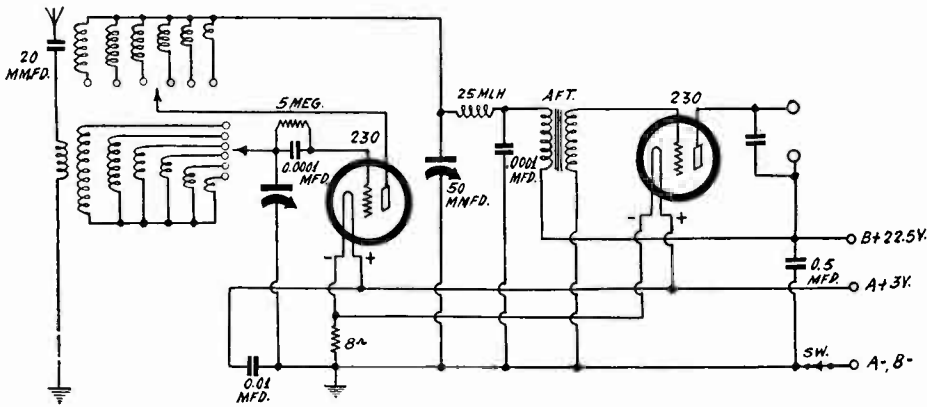

Here is a switch type "detector and one step" for short waves, with leak so high as to injure selectivity at high frequencies. The grid coils should be returned to ground.

FOR so long has the regenerative detector, with one or two steps of audio, been popular that now that the circuit is used for short waves the practices and habits of the broadcast band have been retained. This is not always to advantage.

The circuit became unpopular for broadcasts due to the interference caused by radiation, although as yet the short-wave bands are not apparently deemed so precious that they must be protected in the same way. Still, the day probably will come when the word "bloop" will be applied to this circuit for short waves, just as it was some years ago for broadcasts.

The three practices borrowed from broadcast experience that seem to remain rooted are shown in the diagram, where the grid condenser is 0.00025 mfd., the grid leak 50,000 ohms and the grid returned to positive. The type 30 tube is used, which wasn't

out when the circuit was considered the thing in broadcast reception, but the principles remain the same.

## The Grid Condenser

First let us consider the grid condenser. This naturally is related to the leak resistance, but taking that resistance as found, we have a grid capacity more favorable for low frequencies than for high ones, in fact, a form of modulation may be produced when the radio frequency is very high, known as grid blocking, which consists of stopping and starting of the current through the plate circuit due to the time constant of the grid condenser and leak. It is probably not too much to say that when shifting from one band to another one should change the grid condenser and leak, but that certainly would be awkward. So the lowest values are used consistent with compromised results. The

imprinted values may not be altogether low enough.

The grid condenser therefore well might be smaller, and a value of less than 50 mmfd. is suggested. In fact, if test proves that oscillation still remains at the highest frequencies reached by the tuned circuit, the grid condenser may be lowered in value much below that, the test being, in the presence of oscillation, that the plate current should be as steady as possible through the rotation of the condenser from maximum to minimum for that highest-frequency band. This taking the bumps out of the tube behavior anchors the circuit to more reliable performance.

## The Grid Leak

The grid resistor is important as to its value from the viewpoint just stated, that in conjunction with the grid condenser there should be no combination that will introduce grid blocking, and the resistance should be as low as consistent with good results for another reason. That is that the resistance of the grid circuit itself is high, so the amount of current through the grid resistor will be about the same for the same amplitude of oscillation, whatever value the leak has within reasonable limits, hence a low value of leak is preferable because the power for its service has to come from somewhere. It does. It comes from the cathode, here the filament.

When one considers that with these small tubes there is not much to spare, a measure of conservation becomes alluring. The only purpose of the leak is to cause varying voltage drops across itself due to the grid current flowing through it, the polarities being such that the grid is negative and the other side of the leak positive. This arises from the accumulation of electrons at the grid. They do not leak off fast enough to deprive the grid of all this negative accumulation. That is why the leak for this circuit should not be very low, not hundreds of ohms but thousands, for if the value is too low the intended effect of the leak is lost.

## An Unexpected Trimmer

So the leak is a biasing resistor, and that is all it is intended to be, but it has another effect, and the grid condenser shares this effect. It is an instrument of trimming the circuit. You will find that if you leave everything as it was, and substitute for the 50,000-

(Continued on next page)

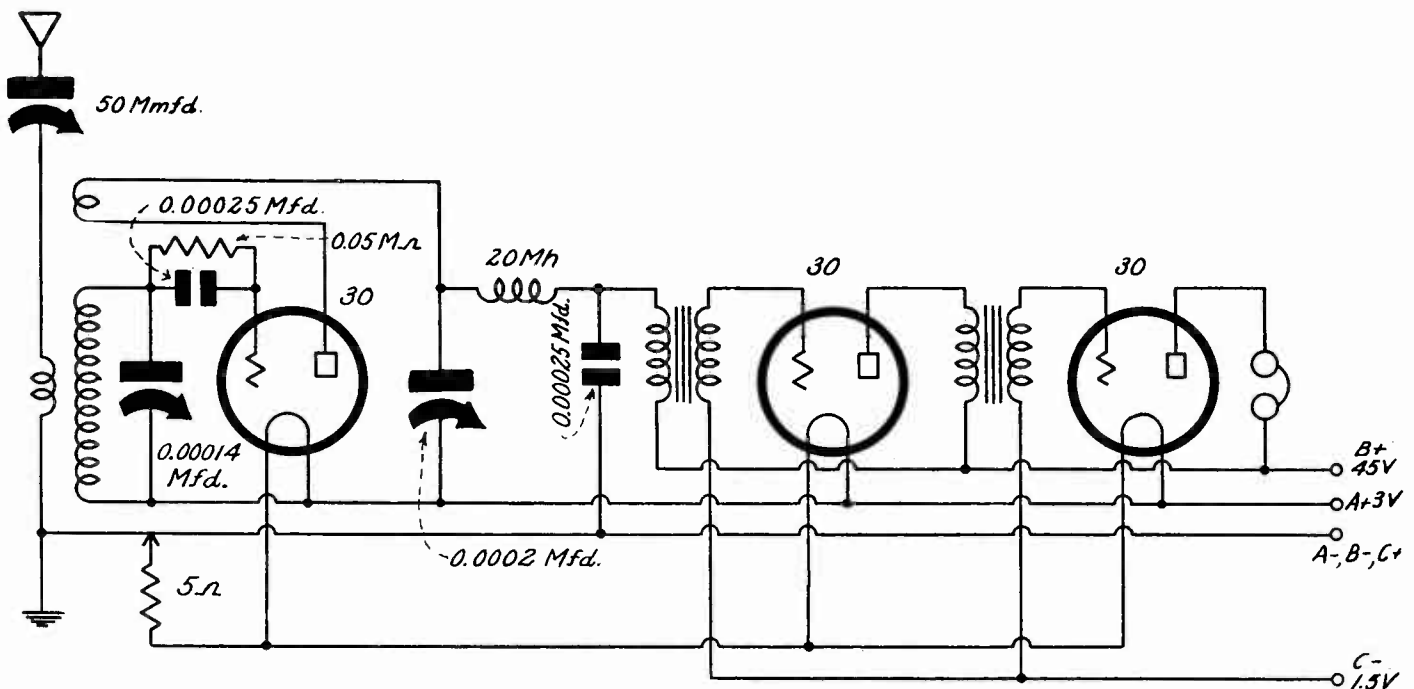

Three suggestions for departing from orthodox practice to improve the operation of a short-wave circuit like this are discussed in the text.

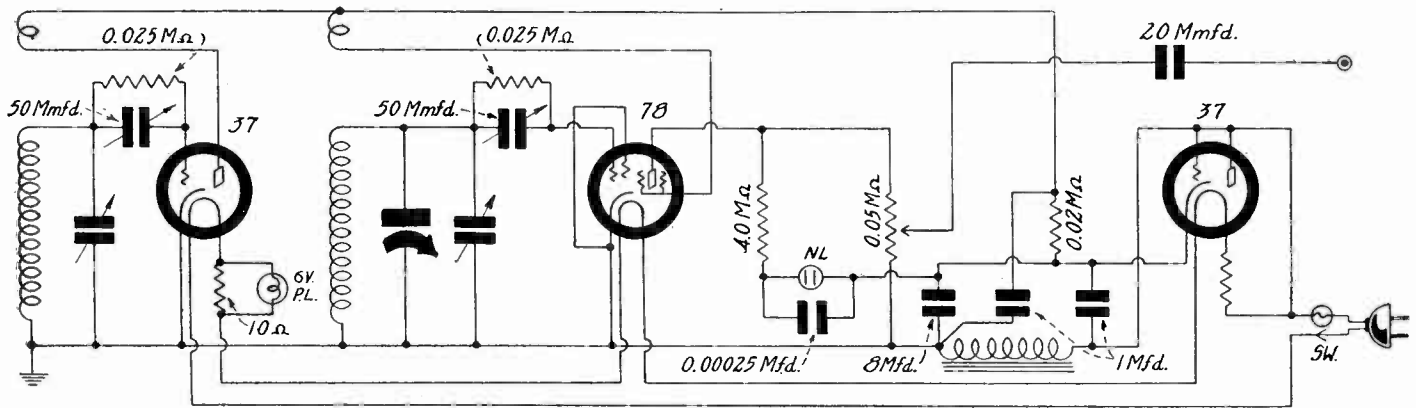

This represents an idea, anyway. See if you can't follow the author in his short article that takes him so far—the production in his mind of a radio-frequency beat oscillator covering 50 kc to 20 mcg, and also to 62 mcg if you feel ambitious. And imagine the broadest band wholly encompassed by a fraction of inch of the dial that records a frequency ratio of only 1,240 to 1.

## Innocent Speculation on R-F Beat Oscillator

By Ralph C. Brush

[The following is a radiost's theorization of the possibilities of an r-f beat oscillator, something not yet on the horizon. There are grains of substantiality in the article, but the author seems to sense both the difficulties and the wide possibilities. If ever the science reconciles the two maybe we shall have something.—EDITOR.]

THE possibilities of a beat radio-frequency oscillator have by no means been exhausted. Beat oscillators now are used for audio frequencies exclusively, but the same principle is applicable to radio frequencies, although the difficulties to be expected are several.

If one desired to construct a radio-frequency beat oscillator he might do so after the pattern shown, introducing any coupling between the two that experience required. None is shown, because if the frequencies are high, as shall appear, and the tubes fairly close together, there will be enough coupling that way, plus the coupling due to wiring, common supply, etc.

Take the left-hand circuit as representing a fixed-frequency oscillator. Take the middle one as representing a variably-tuned oscillator. The tube at right is the rectifier.

### Frequency Values

Since no harmonics are to be used, or desired, the frequency ratio of tuning the middle circuit would be 2 to 1, obtainable from a condenser of 80 mmfd. It makes no difference what the intended frequency range is, it can be covered, and more than covered, provided that the original independent frequencies are made higher than the highest desired for measurement.

Let us assign some values. Suppose we are to construct a signal generator to cover from 50 kc to 20 mcg. The low-frequency end may be forgotten, as that always can be made zero, by zero-beating in the adjustment of the two circuits. It has been said that the independent oscillators should generate frequencies higher than the highest to be measured. The 20 mcg frequency is that highest, so we start a bit higher than that for the lowest frequency of the variably-tuned oscillator. Suppose we select 21 mcg. Then that circuit can be tuned from 21 to 42 mcg. Note that we have established very high frequencies, the reason being that we are foreclosed from lower ones because of confusion arising from harmonics. Any harmonics of 21 to 42 mcg will be higher than 21 mcg so interference possibility from that source is scotched.

After the variably-tuned oscillator is fixed up properly, and the tubes shown will perform at those frequencies, the fixed-frequency oscillation must be established.

### More Than We Bargained For

This may be done in either of two ways. The variable oscillator may be set at 41 mcg and the fixed oscillator at that frequency also, whereupon the smaller capacities of the tuning condenser in the variable circuit would account for the lower test frequencies. We should prefer to uncrowd the higher frequencies, so in the light of condenser plate shapes would select the other method, that of setting the fixed-frequency oscillator at 21 mcg. Now the frequencies covered will be from 21 minus 21, or zero, to 41 minus 21, or 20 mcg, and we have achieved the coverage desired.

But what have we got? More than we bargained for, rest assured. In the first place, there is one dial, and whether the rotation is over an arc of 180 degrees or 270 degrees or even almost 360 degrees, it makes small difference, because over the single scale of the dial we have encompassed a spread of 19.950 mcg. Why, the whole broadcast band would occupy only a small fraction of an inch! An enormous dial would solve the problem, but a construction company would have to erect it, and it would indeed assume the proportions of a building.

Here is something else to think about: Besides the difference frequencies just cited, there would be sum frequencies. The utilized difference frequencies were 50 kc to 20 mcg. The sum frequencies would be from 42 to 62 mcg.

### And Also Some Switching

If we desired to do a bit of switching we might work the circuit as shown for 50 kc to 20 mcg, then cut out the left-hand fixed oscillator and use the other for 21 to 41 mcg, and use the summation by closing the switch again for 42 to 62 mcg. As we start really at zero frequency, but assign 50 kc as a beginning, and wind up at 62 mcg, we have done some traveling. The frequency ratio is more than 1,240 to 1.

## Grid Condenser Affects Tuning

(Continued from preceding page)

ohm leak one of 25,000 ohms or 250,000 ohms, that the frequency of oscillation will change, or, if the circuit is not oscillating, the resonant frequency will change. This is due to the effect of resistance on frequency, as well as the influence different resistors have as a second order effect, in making more or less pronounced the associated capacities on the circuit.

The grid condenser is itself a very serious trimming condenser. It has the same effect as if it were a smaller condenser in parallel with the tuning condenser. The grid condenser is in series in the grid circuit, but the circuit inside the tube may be regarded as a resistance, and in series with the grid condenser, the total series circuit just described shunting the tuned circuit, which it actually does. That is why the equivalent effect of the grid condenser may be expressed as a much smaller parallel capacity.

This may be confirmed experimentally by using different values of grid condenser. The larger the grid condenser, the lower the frequency. That shows that the effect is like that of a capacity in parallel, although, as already mentioned, the true circuit is that of a series chain of resistance and capacity which as a whole is in shunt with the tuned circuit.

Returning the grid to positive in the detector circuit causes the grid current to rise, in fact, there is grid current at no signal. When a signal is introduced this grid current rises proportionately to the amplitude of the signal, or, if there are signal and oscillation or regeneration, then the grid current rises in proportion to the combination. If the grid were returned to ground, by connecting the low end of the secondary to A minus, the circuit would oscillate better at the highest frequencies. The reason is the same as stated before, that it takes power to run the grid leak, and the lowered grid current means less power is taken from the cathode for biasing, leaving more for oscillation and regeneration. Except for reception of unmodulated continuous wave telephony there would be no reason to have the circuit actually oscillating, with the further exception that oscillation would constitute the receiver a non-frequency-determining station-finder.

In conclusion, the suggestions are: (1) that the grid condenser be as much less than 50 mmfd. as is consistent with ability to regenerate at the highest frequency intended to be received; (2), that the grid leak be reduced, and now 25,000 ohms are suggested; and (3), that the grid be returned to negative A.

# Self-Capacity Coupling in R-F Transformers

By Ludwig Essen

son is that the tuning characteristic is different with different coils, hence identical construction is followed.

### Tracking Problem

Tests made showed that when the choke primary was used, put inside the circular coil form of the rest of the winding, at right angles to avoid inductive relationship, that the frequency ratio was a little higher than by the more familiar method. Since there is a difference, if

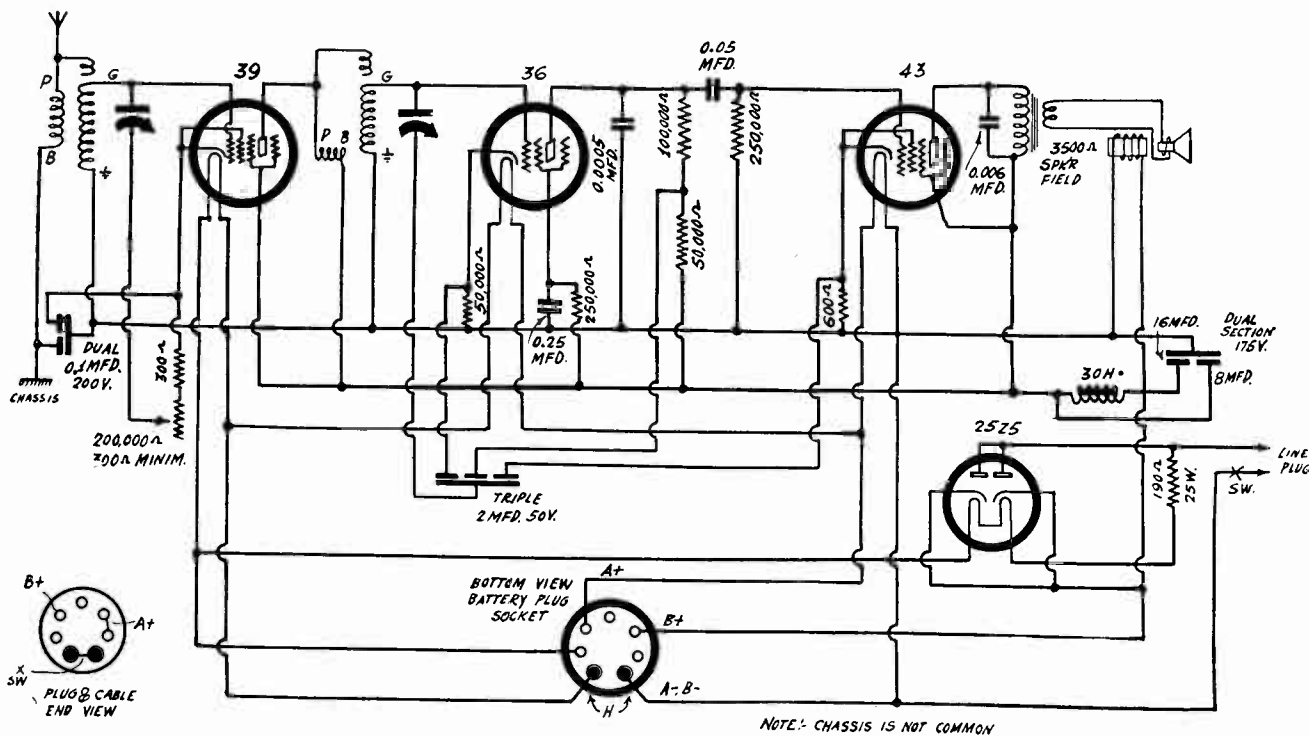

A tuned-radio-frequency receiver using as coupling between choke primaries secondaries the capacity effect of a few extra turns of wire. For such a purpose both coils would have to be the same, as shown, because different types of coils have different tuning characteristics.

THE method of coupling one winding to another by a small capacity, using the capacity between a few turns of wire and the tuned secondary for the purpose, is often used. The primary is likely to be an r-f choke coil. Thus the lower frequencies of the r-f amplifying system, otherwise inclined to be amplified least, are built up. But the capacity coupler must be small. Therefore only a few turns are used, and sometimes only one turn is used. This pickup winding, or small condenser, is inductive-

ly coupled to the secondary, of course, but there is small current through it due to inductance, first because the inductance is so low, second because the winding is intended to be open, and third because the principal flow is through the capacity between that winding and the secondary. In the upper diagram is shown a four-tube universal receiver, with the two radio-frequency transformers using this type of coupling. It should be noted that if this kind of coil is used in one stage it is used in the other stages. The rea-

different types of coils were used the tuned circuits would have another handicap to overcome as to tracking. There is already one handicap, that the tuning condenser sections are not exactly the same at all settings. Another consideration is that in commercial coils of any type the inductances will not be quite identical, although some manufacturers hold to a closeness of less than 1 microhenry out of something under 250 microhenries, which is excellent.

(Continued on page 13)

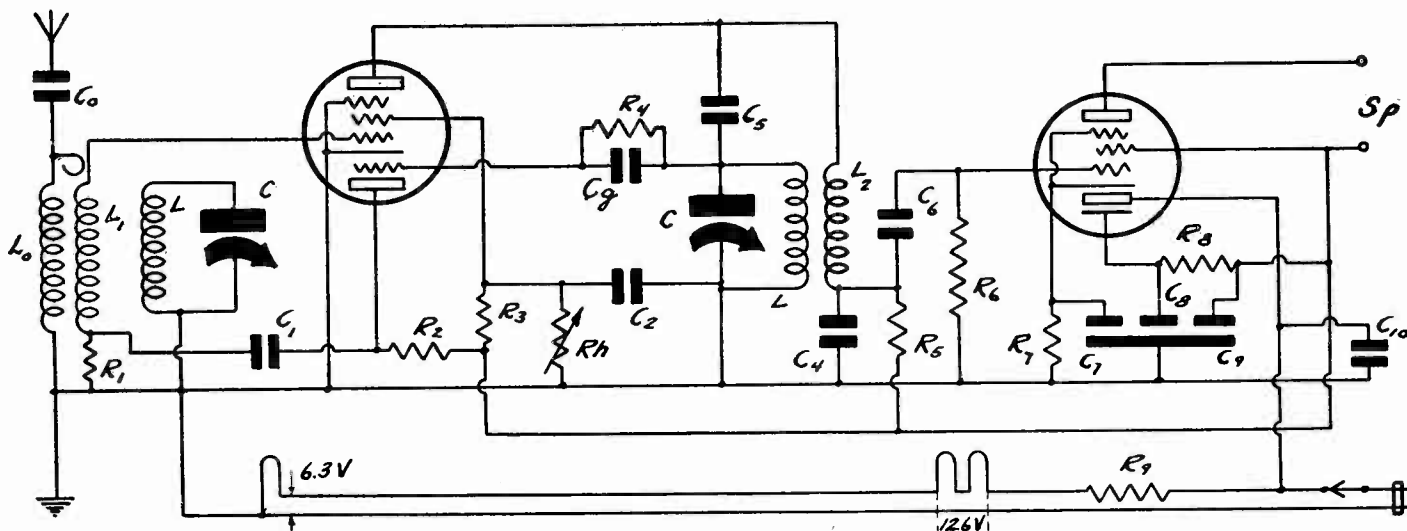

A four-tube set. There are two tubes in the envelope at left and two in the envelope at right. The circuit consists of a stage of t.r.f., a regenerative detector, with feedback controlled by Rh's alteration of the screen voltage, a resistance coupler to the audio amplifier, the diode portion of the right-hand tube serving as rectifier of the line supply.



# A New Way to Compute

## Effect of This Quantity on Losses in Short-Wave Coils—Effi

By Herme

IN considering the construction of home-made short-wave coils the radio-frequency resistance factor is of first importance. It is probably the one thing that counts. All the losses may be described as to their effect in terms of radio-frequency resistance. Those desiring to wind coils on small diameters for a short-wave switching system, particularly a regenerative detector, are referred to last week's issue, dated August 11th, for winding data. The present discussion has to do with theory only. Theory does not mean a dope dream, but past experience applied to a present problem.

One of the first limitations is really a physical one. There have to be so many coils. Where shall they be put? How shall they be arranged? Shall they be shielded? How short can the leads be made? If there is a choice, in favor of which coils should the choice be made as to most favorable location?

### Small Diameters

The necessity for a plurality of coils in a switching system acts as a limitation on the size. The diameter will not be as large as otherwise. In a sense, there must be an acceptance of conditions as they are found, as there will be just so much room, and so many coils must fit into that room.

The lowest-frequency coil may be considered first. Since only short waves are at stake, we may select some frequency around 1,600 kc for starting. If we use plug-in coils we find commercial types already wound for the correct frequency coverage, that is, there is plenty of overlap. It might be said of a few such commercial models that for safety's sake the overlap has been made much greater than we might desire. But if we consider the growingly-popular switch type coils, then we may expect smaller diameters than the 1 to 1½-inch sizes found in commercial mouldings.

The lower the frequency, the greater the required inductance, the more numerous the turns. Therefore if we are to use a common size form for all the coils we shall have a rather long coil for the lowest-frequency band. The distance between terminals of a given winding is known as the axial length. The other important linear measurement is the form diameter, or, more strictly, the form diameter plus the diameter of the wire used, called the winding diameter. The insulation on the wire is not counted as part of the diameter, for it is no part of it but is a function of the spacing or pitch.

### When Coil Is Too Long

The best shape factor for a single winding coil is one where the diameter is 2.45 times the axial length of the winding. Other considerations being equal, more inductance is thus obtained for a given amount of wire. Hence the radio-frequency resistance is less. The factor is usually taken in general practice as 2.5, and even then it is just a reference point, because no small diameter would give us anything like a ratio of 2.5 for the required inductance of some 70 microhenries. In fact, the ratio would be in the opposite direction even if fine wire were used. That is, the axial length would be more than the diameter.

It is fortunately true that the shape factor does not have to be held closely, as the difference in results is small over rather wide variations of this factor, up to axial lengths of winding equal to the diameter. Therefore we strive to turn out a coil that for this band has an axial length not greater than the

In an all-wave mixer like this 24 trimming condensers might be used. Six separate antenna series condensers are shown. The main tuning condensers may have a trimmer — adding three — and each secondary a trimmer, total 27.

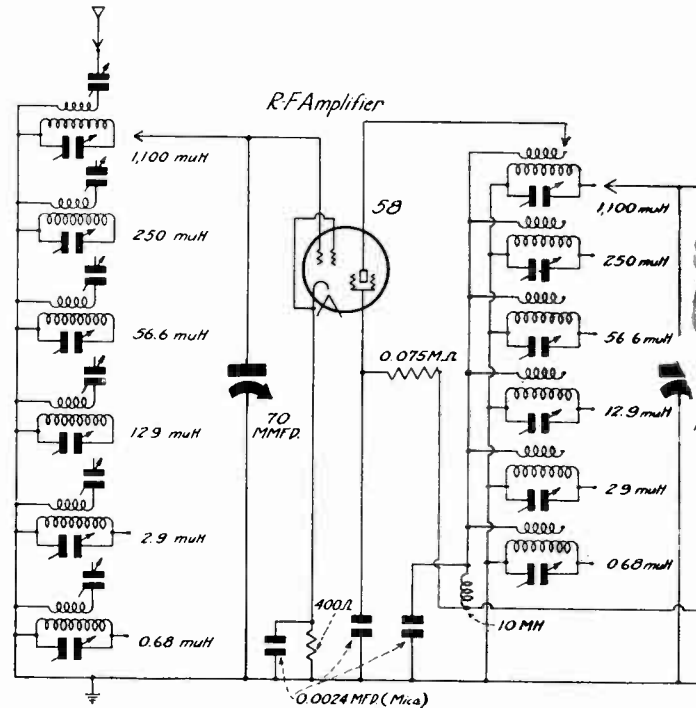

diameter. This can be fairly well accomplished by using No. 32 wire, either enamel covered or single-silk-covered on ½ or ¾-inch tubing. If we did not use fine wire we would have an extraordinarily long coil. For a diameter of ¾-inch we might have an axial length of winding of nearly 2 inches, thus inverting the ratio, making the axial length 2.5 times the diameter, which produces a bad coil.

### Using Larger Wire

The frequency range is an important factor. Here the frequencies are low, the resistance of the fine wire is not material, the oscillation will be pronounced, if the coil is used in an oscillator, even if the wire is No. 32. Besides there is no choice beyond the selection of fine wire, for the reasons stated, unless the diameter is increased. If any prospective builder desires such increased diameter, he may use staggered diameters, starting with 1 inch or more for the low-frequency band, and then using smaller diameters for higher frequencies, though this is seldom done.

The immediate tendency is to increase the wire diameter for higher frequencies, even for the next band, which would start perhaps in the 3-megacycle region. For continued use of the same small diameter, say ¾ or ½-inch, it is not very sound practice to increase the wire diameter much for this next band, again because the coil will become too long to be efficient. You might go up to No. 30 wire, but having No. 32 could well continue to use that.

### High Frequencies

For the next band the wire diameter may be increased to No. 22, while for succeeding bands No. 22 to No. 18 would be used.

If oscillation is desired, but is absent partly or entirely in the band, larger diameter wire is recommended; if the distributed capacity

is too high, smaller diameter wire should be used. Large wire increases eddy-current losses.

For high frequencies, represented by the two bands at this end, spacing is usually employed. This consists of leaving a given amount of space between turns of the winding. A common practice is to space the coil by the diameter of the wire, and this may be done by winding two stretches of wire of the same type side by side and removing one of them after the correct number of turns is put on.

While spacing does decrease the amount of inductance obtainable with a given length of wire put on a form, and thus tends to increase the radio-frequency resistance, spacing reduces the distributed capacity, approximately halving it, for coils of axial length not greater than their diameter. The distributed capacity depends exclusively on the winding diameter and pitch, and, within this ratio of 1-to-1, is free from influence of the number of turns. That is, the distributed capacity for one or two turns would be the same as for 8 or 10 turns. Therefore if the distributed capacity is of any importance, so is the winding diameter, because this diameter largely determines the distributed capacity.

The reason for the importance of the distributed capacity was stated in last week's article on short-wave coils: the distributed capacities between turns being unequal and in the magnetic field where that field is strong, the voltage drop across the capacity becomes high, especially as the capacity is small, hence much energy is present in the unintentional capacity, and the circulating current is reduced.

A general rule, not accurate, is that the distributed capacity in mmfd. is equal to the diameter in centimeters, for close winding, and to half the diameter in centimeters for spaced winding.



# Coil's Distributed Capacity

Efficiency Data for Those Who Wind Their Own Inductances

by Bernard

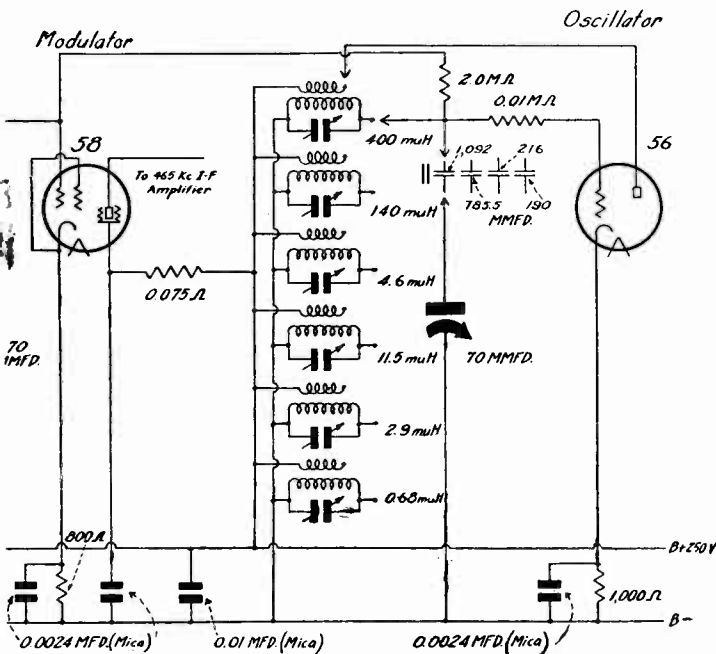

The oscillator at right has a measure of frequency stability, due to the unbypassed 10,000-ohm resistor. This acts as a damper at the low capacity settings of the tuning condenser, and partly corrects the plate current unsteadiness.

current becomes greater toward the center of the coil."

### The Different Capacitances

Discussing methods of computation depending on summing up the charges between turns, he says:

"To sum up the infinitesimal capacitances as such would require one to consider the various capacitances along the coil as being either in series with one another or in parallel with one another. From the discussion given above it was seen that the charge on the coil was greatest and became less at the parts of the coil toward the ends. Thus it can be seen that these capacitances between turns can not be taken as being in series because series capacitances must have the same charge throughout the circuit. They can not be taken as being in parallel because each capacitance then should have the same voltage across it."

### Where Error Creeps In

He says that in any system of computation of the distributed capacity error will creep in if the assumption is made that the capacitances between distant turns are in parallel with those of turns nearer together. The turns that are far apart will have intervening turns that alter the electric field completely from what it would be without any intervening turns. Furthermore, the capacitances would all be unequal and would not permit of treatment as uniformly-distributed constants; the inductance of the separate turns also varies. The central turn may have an inductance of 30 per cent. more than that of an end turn.

### Terminal Lugs Count

Prof. Palermo's formula applies to the coil capacity only. He found that disagreement between measurement and computation by his formula was due to large metal terminals on the coil, so the capacity of the metal terminals would have to be ascertained, and deducted from the measurement, whereupon there would be close coincidence between computation and measurement.

Also, the location of the coil is of some importance, for it relates to the coil's capacity to adjacent objects. He found that this adjacency capacity was least for coils that had a shape factor within that which he followed, e.g., length of winding not exceeding winding diameter.

Until recently there was no completely satisfactory way of determining the distributed capacity, or so-called internal capacity, of a coil, as accepted methods sometimes were based on assumptions not fully borne out, and at best did not always agree with experimental results.

### A New Approach

In the July issue of "Proceedings of the Institute of Radio Engineers" there is an article by A. J. Palermo, of Union College, Schenectady, N. Y., that offers new light on this interesting problem. Prof. Palermo gives the several methods that have been used in the past, and then presents a formula for the determination of the result where computation and measurement closely jibe. The coils considered were for high frequencies. The computed values of distributed capacity ranged from 3.9 to 20.5 mmfd. and the measured values from 3.2 to 21 mmfd., for nineteen coils. He confined himself, consistent with general practice, to coils of having an axial length not greater than the winding diameter. He stated that the distributed capacity, within this form factor, is independent of the number of turns, and that the important considerations are the diameter of the winding and the ratio of pitch to bare wire diameter. The pitch is the distance between wire centers of adjacent turns.

His formula for the determination of the distributed capacity follows:

$$C_o = \frac{\pi D}{3.6 \cosh^{-1} s/d}$$

The meaning of the symbols follows:  
 C<sub>o</sub>=distributed capacity.  
 s=pitch.  
 d=diameter of bare wire.  
 D=winding diameter.  
 cosh<sup>-1</sup>=the inverted hyperbolic cosine (ob-

tained from a table in a book of mathematics).

Single-winding coils are governed by the formula, which also holds, however, for non-circular coils. The circular single-winding coils are called solenoids.

### Much of General Interest

While the article is mathematical, it contains much information of general interest to those not interested in mathematical treatment. For instance, the discussion of the distributed capacity between two turns is very illuminating, especially the treatment relating this capacity to the total internal capacity.

He states that the resistance of the coil is ignored, because deemed small compared to the inductance, and treats of the charging currents from which the distributed capacity is derived in a method that does not meet with his favor, for he says:

"As a matter of fact, the amount of current in the wire varies throughout the coil; it increases in going from the end toward the center of the coil and has its greatest value at the central part. By inserting a non-inductive resistance in the wire at various turns of a single-layer coil, Breit measured the current at various distances from the end of the coil. He found that the current in the wire at the central part could be one and a half times as great as that at the end. This effect is explainable when one considers that the turns of the coil have the greatest inductance per turn at the central part. The end turns have the least inductance. A partial trap effect takes place and the central part of the coil is nearer to resonance than the other parts of the coil, for any definite frequency below the natural period of the coil. Considered from the point of view of circulating current in the path made up of inductance and capacity between two adjacent turns, the circulating

## SUBSCRIBE NOW!

RADIO WORLD, 145 W. 45th St., N. Y. C.

Enclosed please find my remittance for subscription for RADIO WORLD, one copy each week for specified period.

- \$10.00 for two years, 104 issues.
- \$6 for one year, 52 issues.
- \$3 for six months, 26 issues.
- \$1.50 for three months, 13 issues.
- \$1.00 extra per year for foreign postage.
- This is a renewal of an existing mail subscription (Check off if true)

Your name.....  
 Address .....  
 City .....

# Progressive Types of Public Address Systems

By A. L. Hale

obtainable tone quality would be quite acceptable.

## Why Push-Pull Is Used.

Whenever a public address system is built for best possible tone the output is push-pull. It is not that the tone itself is necessarily made much better by any push-pull arrangement, but that the power output of push-pull is greater, and as there are passages of music, and of speech when the talker becomes "inspired" and energetic, when severe demands are made on the output, push-pull is there to meet them. Just how push-pull compares to single-sidedness is a matter of dispute, but the general idea is that push-pull allows four times the power output. Therefore it is well worth while to use push-pull.

Also, push-pull does aid tone to the sole extent of stifling even-order harmonics.

All three diagrams herewith have push-pull output. The first one uses five tubes. A 56 is the first audio amplifier, a 59 used as triode by connecting the two extra grids to the plate, is the second audio tube or driver of the output, which output has grid and cathode at the same potential. That is, without any signal being put in, there is practically no bias on the tube. It is usual to look for negative bias, but here we have zero bias, and therefore we know that the output must be Class B. This is a special form of push-pull, which comes in two kinds, of which one is illustrated, the other being just like a Class A system, except that the negative bias is much higher, and therefore the plate voltage also may be expected to be higher.

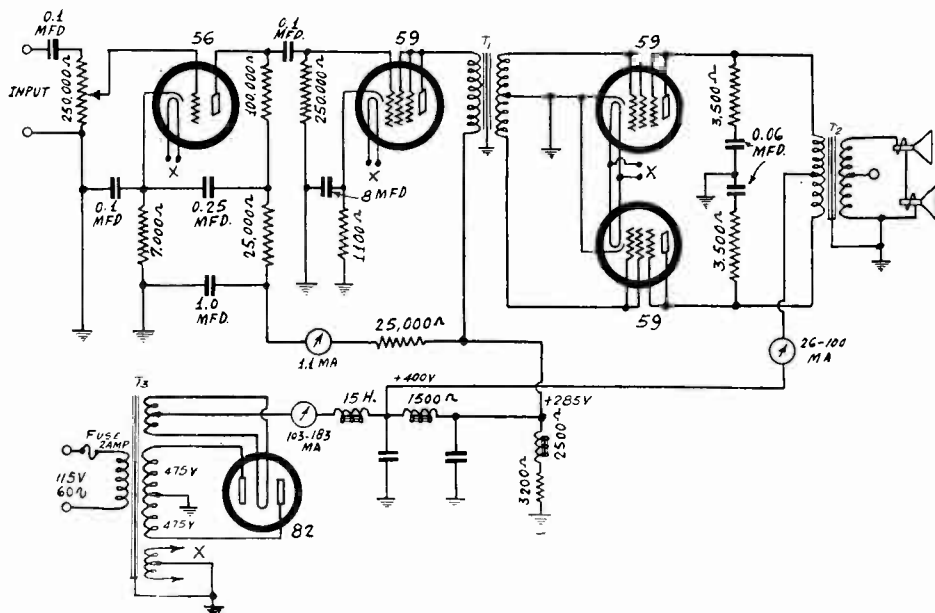

A Class B power amplifier, wherein the 59 used as a triode is the driver of the output.

PUBLIC address systems consisting of only a few tubes can be built with sufficient sensitivity for general purposes. Always to meet the demand for sensitivity, using only a few tubes, hence a low-cost device, the output tubes are pentodes. Thus as few as three tubes are found on occasion, including the rectifier. This makes no doubt the most modest job of all, as there are two stages of audio-frequency amplification, with single-sided output.

If another tube is added, making four, the sensitivity can be raised to such a height

as to meet the requirements of even the microphones of low sensitivity. For instance, condenser microphones and crystal microphones, possessing advantages over the carbon type, have the disadvantage of low sensitivity, and this would have to be atoned for in the amplifier. Of course, it can be done in splendid style.

The single-sided output is found therefore in public address systems of an inconspicuous sort, and the requirement that the tubes be minimum is also indirectly an admission that something less than the best

## What About Class B?

The efficiency of the Class B system is the highest of all, where "all" would constitute Class A, the everyday familiar type, Class AB, where the bias is substantially higher than for Class A, otherwise no change; and Class B, where with special tubes, like the 59's, zero bias is used, or, with Class A tubes for Class B service, extra-high bias negative is introduced. Class C is a special form for frequency-doubling and the like, not used in public address systems.

One objection raised against Class B is that, while its efficiency is high, it handles a power output much greater than required

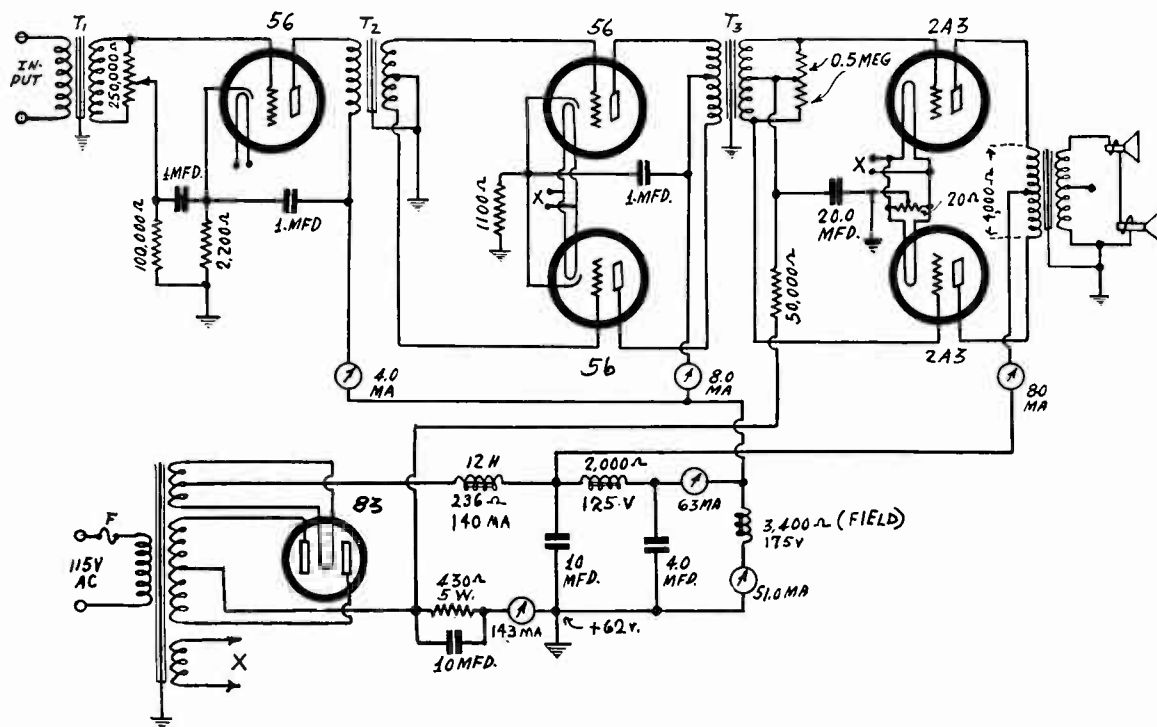

A Class A output power amplifier, using the 2A3's as power tubes. Special attention has been paid to excellent regulation.



# A Multi-Purpose Public Address System

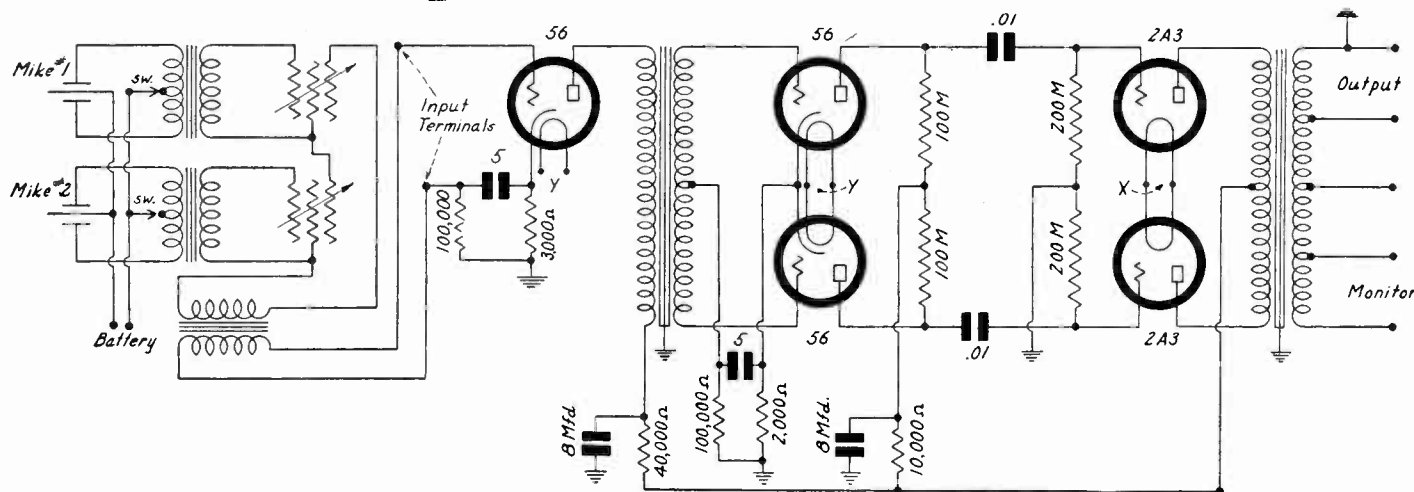

Into this public-address system are built the necessary components for extensive service. Either of two microphones may be connected to the input, or both may be connected, or, if desired, the audio component from a radio set, or the reproduction from a phonograph, may be put in. The volume controls are specialized types known as pads and intended to keep the impedance as constant as practical. The output gives leeway to different types of speakers to match their voice coil impedance, and besides speaker connection there are monitor taps.

for the purposes of a home receiver. Here we are not dealing with a home receiver, therefore may ignore that point. There would be no objection to the greater reserve power, even for home use, unless there was a string to the gain, and that string is that at low volume levels the quality may not always be so good. When the signal becomes appreciable, especially when it is enormous, then the advantage of Class B shows up. Compared to Class A, Class B then wins without a doubt.

Nevertheless Class B output is not met much in power amplifiers such as service men use and rent out, possibly because they have been schooled in the idea that grid current spells distortion, and therefore as there must be grid current in a zero-biased circuit, which becomes positively biased by any signal put in, hence the method may be deemed dubious.

### Special Transformer

Because of the grid current the input transformer has to be special. The general run of transformer will not do, because power is dissipated in the high resistance of the winding. Hence a low-resistance secondary is used, and it would follow that there is a step-down transformation, instead of step-up, to keep the secondary resistance at a minimum. So the triode 59 is a driver in a true and distinct sense, in that it supplies power expended in the coupling medium.

The public address system uses the choke input in the B supply. This means no condenser is across the immediate output of the tube, but a B choke, here 15 henries, intervenes. Then comes the conventional pi-filter.

When using choke input two precautions should be observed. The power transformer's high-voltage secondary should be higher in voltage than ordinarily, for no condenser is next to the rectifier to hold up the voltage. Otherwise the d-c voltage may be 50 volts lower. Choke input compared to the more conventional type. The second consideration is that the choke next to the rectifier should not be on the same core as

the other choke. Usually it isn't, that is, correct conditions obtain, because the second choke may be the speaker field.

### Dual Speakers

Here two speakers are used in series, one more sensitive to high audio frequencies, the other more sensitive to low ones, the combination serving to strike a nice balance, although the two-speaker idea seems to be disappearing from commercial receivers. It never did get very far. As good quality can be obtained from one speaker, although the one-speaker method is somewhat more costly, strange to say, because the single speaker has to be of much better grade than the dual speakers for attainment of equal tonal values.

A compromise type of volume control, or attenuator, is used, the grid of the tube receiving the input being moved up and down a resistance element, potentiometer fashion. For rather low volume levels due to much attenuation there will be some sacrifice of tone, because the resistance actually in the grid circuit becomes too low.

Another tube is added in the second example, to form the audio amplifier that has three a.f., two push-pull. The volume control here is somewhat better, being connected so as to act about as close to a constant impedance as a single unit of the potentiometer type can do, although even the so-called constant-impedance pads are not strictly constant impedance, due to variation in current, hence changes of load conditions.

The power output of the Class B system previously discussed may be considered as 20 watts, though it is rather difficult to give a precise rating, but the second illustration, where 2A3 tubes are used in push-pull for output, does not fall so far below, reaching 15 watts, provided the regulation is good. By good regulation is meant that the current changes only a little with large changes in voltage.

### How Regulation Is Maintained

To achieve such regulation two special precautions are taken. The 83 mercury-vapor rectifier tube is used, which has a

constant drop of 15 volts regardless of the current, and the B voltage feed to the power tubes is taken from the joint of the two B chokes. How low the resistance of the input choke should be may be gleaned from the diagram. The high resistance of the speaker field, which is in parallel with the rectifier circuit, serves to introduce a bleeder current that further steadies the amplifier.

The circuit uses semi-fixed bias, which is one reason for the high output capability. There are, again, two series-connected speakers.

Still another tube is added in the third example, to make a six-tube public address system. Here, it is obvious, the requirements are higher, full provision is made for microphone attachment, using one or two microphones, and special pads are used for attenuators. A 56 receives the input, which is then delivered to a push-pull 56 driver stage, which in turn feeds the 2A3 push-pull output. So we have three stages of audio, the first stage single-sided, the next two push-pull.

### Monitor Output, Too.

The rectifier follows the more familiar pattern of the pi-filter with condenser next to the tube, and the bias is obtained from the drop in the 750-ohm resistor, the resistance of which is well bypassed by a 50 mfd. condenser.

The output transformer is such as to match various types of speakers, according to their voice-coil characteristics, hence is tapped. Also, an output is provided to the listening post of an operator who may be remote from the speaker. This is the monitor service. That is, the operator must be at the amplifier, but the speaker may be far away, connected by a transmission line. He can listen to the reproduction on his own speaker and keep watch on the presence of distortion, governing the controls accordingly. Special precautions have been taken for excellent tone, and the power output has been left at normal, around 10 watts.

None of the foregoing amplifiers is quite sensitive enough for the condenser and the crystal microphones.

# A. V. C. of Small Value in T.R.F., Better in Supers

By Edward Larken

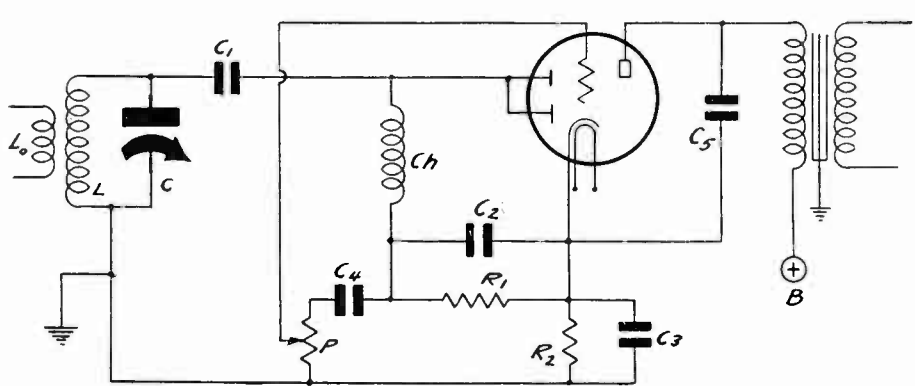

The 55 tube used in the detector and first audio circuit of a tuned-radio-frequency receiver. The object of C1 and Ch is to enable isolation of the diode-anode return to the high (left-hand) side of the load resistor R1.

A TUNED-RADIO-FREQUENCY receiver may have a diode detector, by using a stopping condenser C1 in the first diagram herewith, and a radio-frequency choke Ch, of high inductance, say, 10 mlh or so. That enables the return of the diode-anode circuit to the load resistor on its non-grounded or high side. Otherwise this could not be done, as the LC combination returns to ground, hence the diode-anode would be returned in a manner shorting or precluding an audio load resistor.

C1 may be small, around 0.0001 mfd., the other constants being P, 100,000 ohms up; R1, 500,000 ohms; C2, 20 to 50 mmfd.; R3, 1,000 ohms for an audio transformer load as shown, or for an audio choke plate load, 10,000 ohms if the plate circuit is resistive-loaded; C3 as high a capacity as you can get; C4, 0.01 mfd.

### Selectivity Lowered

The tube is a 55. The two diode plates are tied together, as there is no special use for the extra plate. The audio amplifier triode in this tube is negatively-biased by the drop in R3. To make this bias effective a stopping condenser and

grid leak are used. This condenser is C4. The leak is the potentiometer P.

The only object of putting such a tube in a t-r-f set would be quality, and even then it must be realized that the quality is introduced at the expense of a little selectivity. The reason is that the input would be normally to a detector that draws no current in the input circuit, or draws very small current, whereas the diode here takes power from the tuned circuit for its rectification operation, and this is at the expense of selectivity, because of the equivalent resistance effect.

There would be no particular object in using automatic volume control in a tuned-radio-frequency receiver, and therefore the diode is devoted exclusively to detection. There is some selectivity loss again if a.v.c. is introduced. It is well known that t-r-f sets lacked one thing, that being selectivity. They could be made as sensitive and as powerful as desired, but the curves of a t-r-f set compared to those of a superheterodyne make the t-r-f selectivity look just as bad as it is. Then again for some users much selectivity isn't needed, and the less of it the better the tone quality. For listening

to local stations on a quality set the diode detector might be used even for t.r.f. with great satisfaction.

However, in a superheterodyne it may be advantageous to have a.v.c. The action can be so controlled that very large differences of input voltage (as at the antenna) would make very small difference in the output of the receiver. The a.v.c. circuit acts as a drag on the strong stations, whereas it has little if any effect on the weak ones. So it is obvious that a.v.c. can not be a cure for fading, because a weak station that fades will continue to fade when confronted by a device not affected by weak signals.

### Diode-Biasing of Triode

The a-v-c action may be obtained from a separate tube, as shown below in the next diagram. Part of the voltage at the input to the regular detector (above) is delivered to the grid circuit of the a-v-c tube (below). The plate load resistor on this tube is grounded, but the grid load resistor is returned to B minus, thus the plate is positive, B minus not being grounded. Thus the detector may be any tube. But in the diagram at right the duplex-diode-triode tube is used, and in a t-r-f set an untuned transformer might be used for coupling.

This does not use the self-bias method discussed in connection with the 55 in the first diagram, but uses diode bias. That is, the rectified signal voltage constitutes the bias, and the bias is therefore always large enough. The diode load resistor is the potentiometer R3, about 500,000 ohms, the arm of which goes to grid of the 55 triode. There is another resistor from arm to ground, and if its value is megohms there is no harm, but the resistor serves no particular purpose.

How the connections are made to the controlled tubes is shown. Instead of the coil being returned to ground it is returned through a resistance to the diode's load resistor, on the hot side. Always a resistor is interposed between coil and this negative feed. From coil terminal to ground a condenser is connected. Sometimes an additional resistor is used in the series chain, as R2, to prevent feedback.

### When Grid Current Flows

It is possible that some grid current may flow in the controlled tubes on a very strong signal. Therefore the resistors R3 should not be so very high, around 60,000 to 100,000 ohms being usually sufficient, nor the condensers across them larger than necessary, because then with grid current we have

## Extra Tube for A.V.C. for Non-Diode Circuit

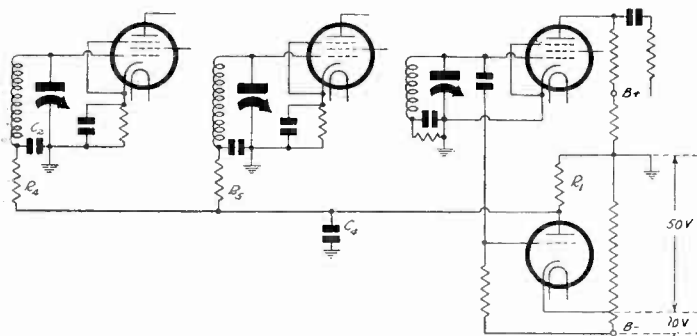

A tube other than a diode may be used as the detector, and automatic volume control introduced by having a separate tube take care of that, as shown at lower right.

## More Usual Way, Using Diode for Both Purposes

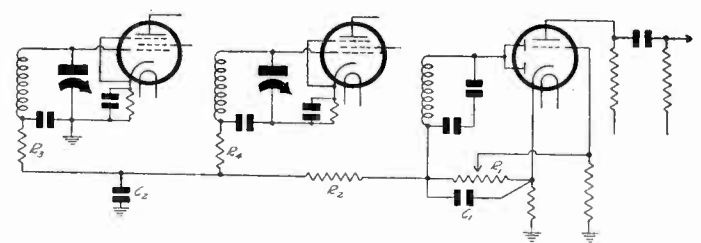

The usual way of working a.v.c., with the resistor-capacity filters to prevent back-coupling, inserted in series with the grid return. The triode of the 55 is diode-biased here.



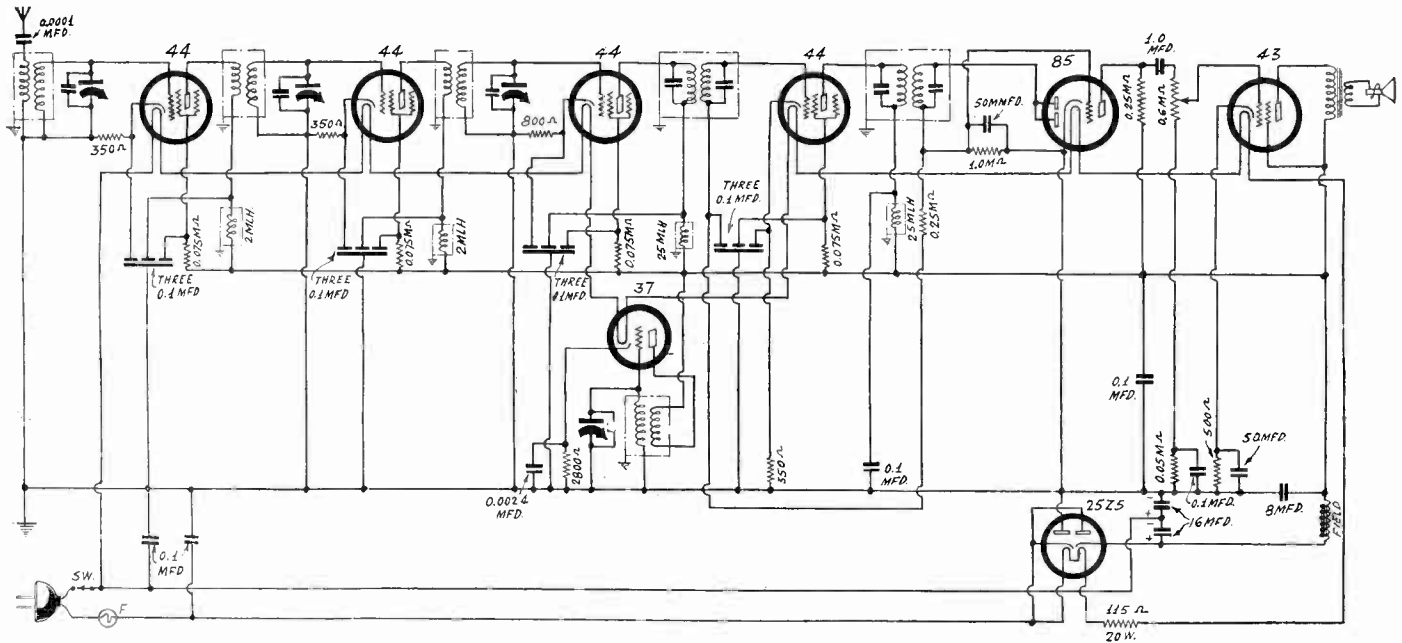

The single intermediate-frequency amplifier tube, fourth from upper left, is subjected to a.v.c., but no other tube is so subjected in the circuit. The first detector could have such control, too, if desired.

leak-condenser action. While this is in the right direction, as further providing negative bias, tone quality may be adversely affected if the constants are too high, due to what amounts to modulation of the r-f tubes by some audio or almost supersonic frequency, occasioned by the time constants in the resistance-capacity network under discussion, when grid current flows.

The final diagram shows the circuit of a universal receiver with a.v.c. used on the single intermediate tube. If more a.v.c. is desired, the grid of the third 44 from the left may be returned to the control circuit, in the same way as the i-f grid return is made, but of course using a separate resistor and condenser for the purpose. That 44 is the separate modulator in the superheterodyne. The 85 demodulator is the same kind of tube as the 55, except that the heater is for 6.3 volts, not 2.5 volts.

#### WHAT ABOUT RHEOSTATS?

The great popularity of the 30 tube in short-wave work caused the big drop in its price. Will rheostats be cheaper for the same reason?

## COIL CAPACITY COUPLING

(Continued from page 7)

The distributed capacity of the choke primary itself will be low, and the more turns on the honeycomb type of coil used for this purpose, the smaller the capacity, as the effect is that of capacities in series. Since there are layers in a honeycomb coil, the rule applying to short circular single-layer coils does not hold. Even if the current distribution is unequal, due to different inductance values between turns and between layers of turns, and also difference of capacity and angle of capacity, the fact is that there is a condition equal to that of series capacity in some place, and thus the total capacity is less than the smallest, hence small at all hazards.

The phrase "angle of capacity" needs some explanation, as it has not occurred before. The peculiar conditions surrounding coil capacity give rise to a capacity effect that is not classifiable in the usual way. That is, one finds in some instances that the capacity between one turn and another is not a series capacity and is not a parallel capacity. Therefore it is some form of capacity about which we

don't know very much, as all united capacities heretofore have been, with rare exceptions, classifiable as series or parallel or series-parallel. Therefore the phrase "angle of capacity" is used to designate some difference in the effect of the capacity, no matter what that difference is, compared to any known relationship of capacities, and includes the mysterious non-series and non-parallel capacity encountered in coils.

If a tube is used as oscillator or regenerator the coil may be different from the antenna coil or from other coils, because the treatment of the oscillator or regenerating circuit may be different.

Ordinarily in superheterodynes the parallel circuit capacity in the oscillator must be higher than that used at the other level, because the frequency curves cross, if padding is excellent.

The tubes used in the lower diagram are a triode pentode and a diode pentode, hence there are two tubes really in each envelope, and the circuit has a t-r-f amplifier and regenerative detector in same envelope, audio amplifier and B rectifier in the second envelope.

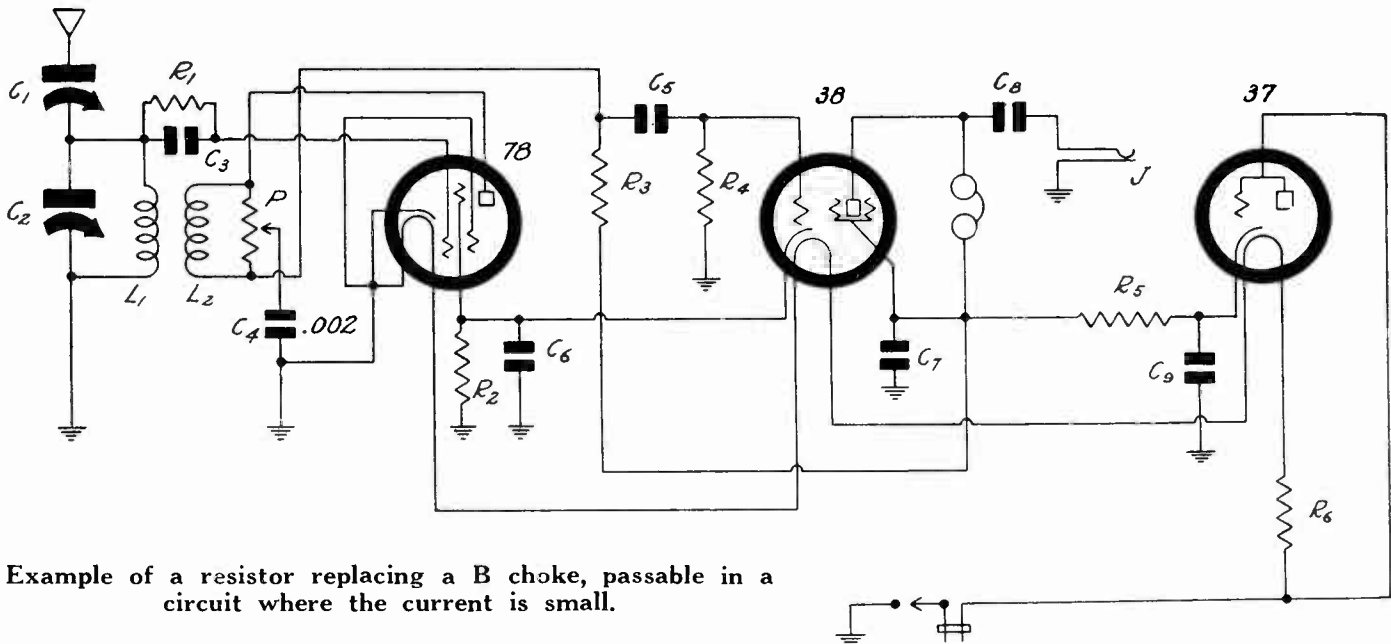

Example of a resistor replacing a B choke, passable in a circuit where the current is small.

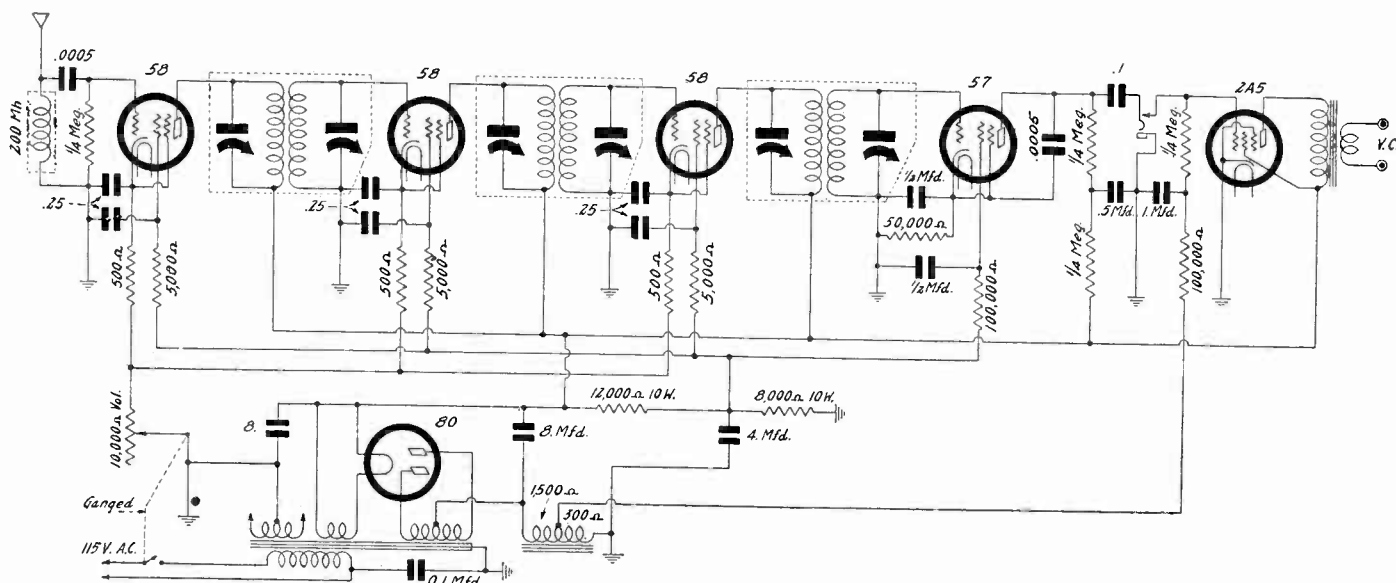

Two three-gang condensers are used in this six-tube a-c-operated tuned-radio-frequency receiver

## Radio University

### Two Triple-Gangs Used

CAN YOU PLEASE show a six-tube circuit that has six tuned circuits for r.f.? The broadcast band is intended. The reason for asking is that I have two three-gang condensers, with shafts extending front and back, and can unite them in the long direction on a drum dial hub.—P. O.

Band-pass tuning can be achieved by using equal primary and secondary, and properly spacing the two windings according to the width of the band. That is, both primary and secondary are tuned. The diagram is printed herewith.

### Microphone Comparison

WILL YOU KINDLY enlighten me with some information in the sound field that has me baffled? What is the meaning of decibels down in comparing a microphone's sensitivity, and to what is the comparison made? Are loudness efficiency and response the same? What is meant by the "burning," "breathing" and "packing" of a microphone?—R. E. P.

The "decibels down" refers to the response of the microphone, compared to some standard, the arbitrary standard of one volt per bar being used generally, the meaning of this to be explained presently. Consider two microphones. The relative loudness efficiency, when these instruments are alternately connected to the grid-filament circuits of a vacuum tube, is a comparative measure of their useful outputs when the instruments are placed successively at the same position in the sound field. It is expressible as the necessary percentage or decibel change in the power output of the vacuum tube using one microphone as a standard in order that the output shall be of the same magnitude as when using the other microphone, equality of the output being judged by listening to a connected telephone receiver or loudspeaker. The response of a microphone is a measure of its electrical output for a specified frequency and pressure on the diaphragm. It is expressible by the ratio of the voltage produced by the microphone between grid and filament, divided by the sound pressure in bars at the frequency on the diaphragm. The result may be expressed in decibels, by multiplying the foregoing ratio by  $20 \log_{10}$ . Burning is rapid resistance fluctuation in a carbon microphone, breathing is a slow resistance fluctuation, and packing is excess mechanical pressure between the points of contact, often resulting from excessive voltages.

### Power Rating

HOW IS IT that the maximum undistorted power output of some particular tube is given as a certain amount, and later circuits are shown, with different voltages, whereby the maximum undistorted power output is considerably more? What is the meaning of "maximum undistorted power output"?—K. L.

The maximum undistorted power output in general means the amount of power than can be obtained with a certain percentage of distortion, usually 5 per cent., and will be different for the same tube, due to difference in load conditions, and also due to difference in applied voltages. Take the case of a triode. The output capabilities are the power output into a resistance load under the condition that there shall be no grid current during the positive part of the grid voltage excitation and that the total generated harmonics with a sinusoidal excitation voltage shall not exceed 5 per cent. The power obtained under these conditions is conventionally called the undistorted power output. The maximum undistorted power output is limited by the safe total plate dissipation. These conditions (load resistance, voltages, total safe plate dissipation) should be stated in determining the undistorted power output. In testing, the load resistance is allowed to vary and that value selected which results in the greatest undistorted output, which in this case may be termed the maximum undistorted power output. Anything is "undistorted" if the distortion does not exceed 5 per cent.

### Negative Resistance

WHAT IS the negative resistance characteristic, and how does it apply to the use of tubes as oscillators?—J. D. C.

Negative resistance describes the fact that as the potential across a device is increased the current through the device decreases. When this condition obtains oscillations are practical at a frequency depending on the resistance and capacity, even without inductance. Thus a neon lamp has such a characteristic, also an argon lamp has it, likewise the sweep oscillator for cathode-ray oscillograph work (885) and the mercury-vapor rectifiers, 82 and 83, have it. The circuit for the neon tubes is to connect a high resistance in series with the lamp (2 meg. suggested) and put a condenser across the limiting resistor. Connect the free end of the resistor and the free terminal of the lamp to around 100 volts d.c. Depending

on the capacity of the condenser and the resistance of the resistor (also somewhat on the voltage) the tube will go out and light up periodically. The periodicity is the frequency of the oscillation. For low frequencies the plan works splendidly and is the basis of the Bernard visual capacity meter, for capacities from about 0.05 mfd. up, almost without limit.

\* \* \*

### Fundamental An Harmonic?

IS IT PROPER to refer to the fundamental as the first harmonic? I thought that harmonics were multiples of the fundamental, hence any harmonic had to be higher than the fundamental.—I. K.

It is permissible to refer to the fundamental as the first harmonic, on the theory that the harmonics are whole-number multiples of the fundamental, and 1, being a whole number, may be included. By stricter application of standardized terminology it would not be so acceptable to refer to the fundamental as the first harmonic, because by definition the fundamental frequency is the lowest component frequency of a periodic wave or quantity. That would exclude the fundamental as a "first harmonic" because where quantities are equal there none is "lowest." Also, by definition, an harmonic is a component of a periodic wave or quantity having a frequency which is an integral multiple of the fundamental frequency. For example, a component the frequency of which is twice the fundamental frequency is called the second harmonic.

\* \* \*

### Images

IS IT TRUE that in a superheterodyne the images become more serious as the frequency is increased and therefore an extra stage of t-r-f may be cut in, to get rid of this interference trouble?—W. S.

That is true. But another reason for the t-r-f stage is that it so happens that the sensitivity of the receiver starts falling off seriously at 10 mcg, so far as the tuner and mixer have any effect on the sensitivity, and due to the tracking considerations they have a large effect. Hence, the extra stage helps to make the response more energetic, but still may leave it far less than what it is for equal input at a few megacycles without the extra stage.

\* \* \*

### Grounding of Oscillator

IS IT NECESSARY to ground a service oscillator that has a shield cabinet? The



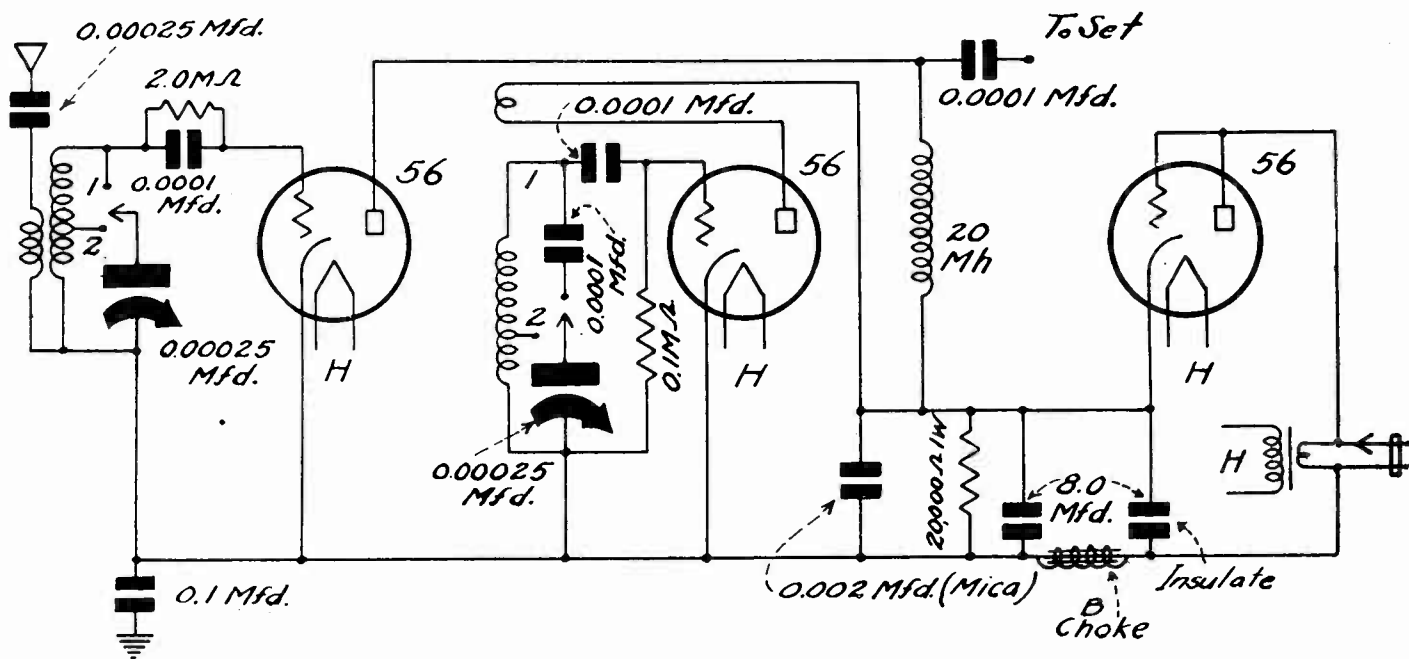

The 56 as a B supply rectifier has grid and plate united.

oscillator I have lacks a ground post, therefore I was wondering.—T. R.

It is not necessary to ground the case. In fact, it is exceedingly difficult to do so. The wire that would be used for connection between ground post of the instrument and external ground would carry current, and might carry enough of it to send out the generated frequency so that a sensitive receiver would pick up the transmission. That is why grounding sometimes is not resorted to, although only through grounding does the effect of the metal cabinet become that of a shield. However, a modified ground condition will exist, as to the cabinet, under most conditions, perhaps what you might call a self-ground. In an instrument like yours has no ground post, that means that if the instrument is calibrated the calibration was made without ground. Usually there is hardly any difference in frequency whether ground is used or not, but if the tuning condenser is of small capacity, or if the maximum is large, minimum capacity is very small, presence or absence of ground will make a ratable difference.

\* \* \*

**Large Audio Bypass**

WHEN I PUT a large bypass capacity across a biasing resistor in the output stage of the set I built the hum increases, so I do not know whether to return to a smaller capacity (0.1 mfd. compared to 16 mfd.) although you always advise large capacity. Of course the general sensitivity is increased by the large capacity, but I wonder whether the increase in hum that goes with it leaves the substitution advisable.—R. E. W.

The reason for the increased hum is that the low frequencies are amplified better, the hum being one of these low frequencies. From your own statement the large capacity is preferable. It particularly permits bringing out the low notes, by removing the negative feedback that is strongest in this region, and in general removes practically all the negative feedback within reason, thus accounting for the increased sensitivity. Yours is a clear case of the B supply not being adequately filtered, and the increased hum is merely the warning to institute the proper improvement in the filter. A large capacity for the first condenser in the direction of the rectifier tube will make for such improvement. Also try reversing the leads to the primary of the output transformer and interrupting the grid return of the power tube with a resistor of 100,000

ohms, bypassing this resistor with 1.0 mfd. The same sort of resistor-capacity filter may be used in the detector plate circuit. When the hum is thus reduced it will be lower than what it is with the 0.1 mfd. condenser across the biasing resistor. Such a device—too small a condenser—is sometimes used in commercial practice to kill hum though tone is sacrificed thereby, being an economical expedient but not an acceptable stroke of engineering.

\* \* \*

**The 56 as B Rectifier**

CAN THE 56 tube be used as B supply rectifier in a short-wave converter? I would like to build such a converter for two bands and would like to know if it is all right to tap the coils.—I. H.

Yes, the 56 may be used and the coils tapped, as the diagram shows. The only other suggestion about the 56 as rectifier of the a-c line current is that the condenser from cathode to line, shown as 8 mfd., may be high enough to cause the tube to burn out sooner than expected, due to the high voltage built up, or charging, when the switch is turned on. This trouble is augmented by the fact that the rectifier is a heater type tube, and, though the current through this rectifier will be small under any conditions, nevertheless in the absence of normal current flow, while the cathode is heating up and the charged condenser is in the critical position, the voltage is high enough to put the tube to a severe test. In case of trouble use smaller capacity here. The grid and plate are tied together to form the anode, instead of plate and cathode, as the grid hasn't enough area for this type of rectification. For diode detection using the 56 the plate-cathode type of anode connection is more suitable. Inductive coupling of the two coil systems is taken for granted in the diagram.

\* \* \*

**Tuning Ratios**

CAN YOU PLEASE give me a brief outline of the ratios of tuning, using usual condensers, or values readily obtainable?—K. H.

The usual ratio for a tuning condenser of a capacity of 0.00035 mfd. to a bit more than 0.0004 mfd. is 3 to 1. That means that the highest frequency is three times the lowest, or the lowest is one-third the highest. In the broadcast band, if the lowest is 540 kc the highest then would be 1,620 kc. Departure from this ratio

would be slight, if present, and in the direction of higher, not lower, ratio. About the same ratio would prevail if the same capacities were used for short waves, although the ratio would triflingly increase, due to the condenser approaching its geometric capacity as the frequency is altered toward infinity. The next most common capacity is 0.00014 mfd. and the tuning ratio would be about 2.5 to 1. For a strict 2-to-1 ratio the capacity should be 80 mmfd. A midget or junior condenser with twelve plates is commercially obtainable that permits this ratio, which is the favored one for systems of oscillation using harmonics for measurement purposes. The foregoing, in its entirety, implies no switching. All the switches have large capacity, therefore reduce the ratio. For instance, a ratio of frequency of 3 to 1 implies a capacity ratio the square thereof, or 9 to 1. If the minimum total capacity in circuit is 40 mmfd. the maximum is right in the light of a 3-to-1 ratio, since the maximum would be 350 plus 20 (the coil, wiring capacity, etc.), and 370/40 is about 9. With a switch of 30 mmfd. the capacity ratio would be 400/70 or 5.7, giving a frequency ratio of not quite 2.4, so you can see the reason for large capacity tuning condenser with switching, for broadcast coverage, to encompass the band. For short waves the lower ratio is desirable and affords better spreadout.

\* \* \*

**Super vs. Regenerator**

WHAT IS the comparison between a superheterodyne and a regenerative set for short waves?—O. T.

The two sets are not far apart in performance. However, the superheterodyne is more acceptable to laymen because much easier to tune. It is likely to be noisier when operated at maximum sensitivity. The regenerative set imposes quite a hardship on those not experimentally versed in feedback control, but the experienced technician has no trouble with it, and therefore may obtain results comparable to those from a super with half the number of tubes and at much less than half the initial cost. There is little advantage in adding t.r.f. to a regenerative detector for short-wave use, as a properly-functioning detector yields as much selectivity as the performance will stand, that is, sidebands may be cut, if desired, and anything more than this is superfluous. Selectivity can be aided or adjusted by the antenna series condenser.

# Station Sparks

By Alice Remsen

ADDITIONS ARE IN ORDER at this time of the year and fall commercials are getting in line; one of the first accounts to start a new series is Enna Jettick shoes, in which Dennis King will be starred, beginning August 22d, and each Wednesday thereafter at 10:30 p. m. Louis Katzman will conduct the orchestra. . . . Crisco is on the air with a dramatic series written by Burr Cook, called "Home, Sweet Home," dealing with the lives of a young couple and their nine-year-old son. You will hear Cecil Secrest, as Fred, the husband, Harriet McGibbon, as Lucy, the wife, and Bill Halop, as Dick, the son. Five times weekly at 2:30 p. m., over an NBC-WJZ hook-up. . . . Wondered what had become of Pat Barnes, last heard of in a series of radio programs from Chicago. Barnes is now the Master of ceremonies with the "Plough, Inc." program, which features Guy Lombardo and his Royal Canadians, each Wednesday at 10:00 p. m. over a WEA-F-NBC hook-up. . . . George Fields and Johnny Welsh, otherwise known as Honeyboy and Sassafras, are making good in a big way on the air with their comedy skit over WEA-F and network every day except Sunday at 12:15 p. m. These boys are old-timers in the entertainment field. . . .

Freddy Martin, who took up the saxophone at the suggestion of Guy Lombardo, is now directing his orchestra on the St. Regis Roof. Freddy is always on the lookout for new talent; a few weeks ago he heard a piano team at a small Virginia roadhouse. One was a former cow-puncher, the other an ex-coal miner. Now the team, Russell and Terry, are featured members of the Martin Orchestra. . . . Martha Mears, who is receiving a big build-up from NBC, has refused offers from Paramount and from the management of "Ziegfeld Follies." Martha prefers to stay in radio. I think she's wise. Martha is young; the pictures and stage will wait for Martha; radio will teach her a great deal. . . . Don Voorhees is becoming quite a good "stooge" for Joe Cook on that House Party show over WEA-F Monday nights. . . . The present radio vehicles of Cliff Edwards, other wise known as "Ukulele Ike," are his first in more than two years. Edwards made a great name for himself when phonograph disks were in the best-selling class; since then he has appeared in many talking pictures, and on the vaudeville stage. He can now be heard each Sunday at 8:00 p. m. over WABC and the Columbia network as the singing M. C. and comedian of the Columbia Variety Hour; in addition the ukulele-strumming singer has his own quarter-hour program each Thursday at 7:30 p. m. . . . Harold Sherman, noted author and psychologist, has a series of programs, each Monday, Wednesday and Friday, at 10:30 a. m., under the sponsorship of the Emerson Drug Company, makers of Bromo Seltzer; WABC only. . . . Everett Marshall will play the title role in a musical version of "Cyrano de Bergerac" on Broadway this coming Fall. Gertrude Nielsen and Vera Van, two Columbia songbirds, are both on a vaudeville tour between broadcasts. . . .

George B. Storer, president of the American Broadcasting System, announces the appointment of Hampton G. Wall, Toledo attorney, as general counsel for the new network. Mr. Wall was formerly a member of the law firm of Fraser, Hiatt, Wall and Effer, of Toledo, Ohio. Mr. Wall has removed his office to New York. . . . Another ABS appointee is Philip F. Whitten, formerly account executive of CBS, and later sales manager of WINS. Mr. Whitten is now sales director of WMCA, the New York key station of the ABS. . . . Evelyn Hayes, songstress of the American Broadcasting System, has canceled her program

## APPLICATION OF ENTERPRISING PURPOSE TO TRANSPOSITION BLOCKS AND LEADS

This is a method proposed for enterprising burglars who must be light weight physically. Of course they are so, mentally, otherwise they wouldn't be burglars.

The idea is that the burglar goes on a Hollywood diet to improve the success of his mission. When his weight is as far below normal as is his mentality, and on a night when the moon is dark, he makes his stealthy way to the roof of a house. He picks out a certain transposed leadin, and using the transmission line as a ladder, each transposition block as a rung, he lightly and stealthily climbs down to the window to which this course leads him. It is considered unfair practice under the Burglars' Code (Section 16A) to use the stand off insulator for support.

Arriving at the window, he removes his jimmy from his left hip pocket and pries open the window, getting inside. Once inside he uses his best judgment.

If he can't afford a jimmy, or the window won't respond to one, he then takes the form of an electron, and enters through the leadin-strips. A step-up transformer then restores him to his normal stature.

In order to work the trick the house must be his own home, all mortgages paid, or no back rent unpaid.

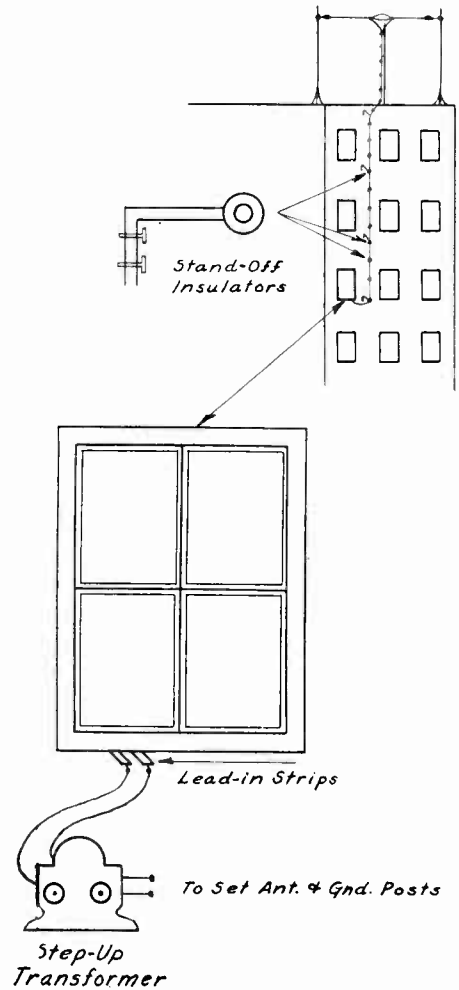

for six weeks in order to sail for London, where she will appear at the Palladium Theatre. She will sing over the BBC stations while abroad. . . . Margie Keeler's debut last week over WMCA and the CBS network excited the interest of movie fan magazine writers. You see, Margie is the little sister of Ruby Keeler Jolson, and so articles and pictures of the clever youngster will appear shortly. . . . The ABS is keeping abreast of the times; they even have the Press-Radio News each night at 7:30 p. m.

There's a future radio star in the making over in Astoria—little Gloria Hiegel; Gloria is less than twelve years old, but she is very ambitious; never misses a broadcast of her favorite singers; she has several—sings right with them too; she'll be heard from soon.

### A THOUGHT FOR THE WEEK

**HAVE YOU HEARD THE GOOD NEWS** about big finance in the radio field? For instance, the Radio Corporation of America made a net income of \$535,855 in the June quarter of this year, whereas for the same period of 1933 there was a net loss of \$790,088, and the net income for the first six months of this year was \$1,771,580, against a loss of \$1,268,211 in the first half of last year.

Then there's the cheering news about the high percentage of rentals in Rockefeller Center, which some folks foolishly have believed to be merely another plan to spend some more of the Rockefeller millions. As a matter of fact, the 80 per cent rentals of space in Rockefeller Center is far and away ahead of the average of any of the recent big real estate projects in the Metropolis, or for that matter, ahead of most of the real estate propositions that have had years of building up.

All of which makes us think there's a good deal of spine and energy in the whole radio structure.

## Quick-Action Classified Advertisements

**LIFE TIME OPPORTUNITY.** Practical money-making schemes, Legitimate, Local, Mail, travel, city, town. Ten cents coin. Bristol Mailing Service, Box 51, Taunton, Mass.

**AGENTS: HUNDREDS OF FAST SELLERS;** blades and soaps for men; also household articles. La France Products, 34 Merchants Row, Boston, Mass.

**HANDY MEN**—Established Vacuum Cleaner Repair Service. Big profits. Write Hudson Specialty Co., 208 48th Street, Union City, N. J.

**LOST KEYS** are returned to you promptly when you use our service. Full Ten Year Service for \$5.20. Only one cent a week. Send your order today. Velva Service Bureau, Dept. B, Box 546, Lima, Ohio.

**PORTRAITS COLORED,** 2c dull prints only. Leon C. Roffe, Laurens, N. Y.

**"THE RADIO HANDBOOK,"** including Television and Sound Motion Pictures. By James A. Moyer and John F. Wostrel, both of the Massachusetts Department of Education. For engineers, designers, operators, service men, experimenters. 886 pages, 650 illustrations, flexible. Price, \$5.00. RADIO WORLD, 143 West 45th St., New York City.

**HENLEY'S "TWENTIETH CENTURY BOOK OF RECIPES, FORMULAS & PROCESSES."** New 1933 Edition. Ten thousand processes, recipes, trade secrets and money-making formulas. For the laboratory, workshop, factory and home. Some subjects fully covered: Dyes, Inks, Waterproofing, Perfumes, Cement, Plating, Glass, Dentifrices, Varnishes, Soaps, Glues, Paints, Adhesives, Enamelling, Hairdressings, Cosmetics, Oils. Price, \$4.00. Book Dept., Radio World, 143 W. 45th St.,

### JOB'S TEARS

Nature's Curiosity—Petrified pearly seeds from Tropic Jungles make necklaces, bracelets, rosaries and novelties. 20c hundred; \$1.00 thousand.

**M. KLEIN,** 1710 West Second Street Brooklyn, N. Y.