

June 15th, 1929

15 Cents

RADIO

REG. U.S. PAT. OFF.

WORLD

The First and Only National Radio Weekly

377th Consecutive Issue—Eighth Year

DC POWER AMPLIFIERS

HOW TO USE OHM'S LAW

WHAT SPEED HAS ELECTRICITY?

TABLE MODEL AC LAYOUT

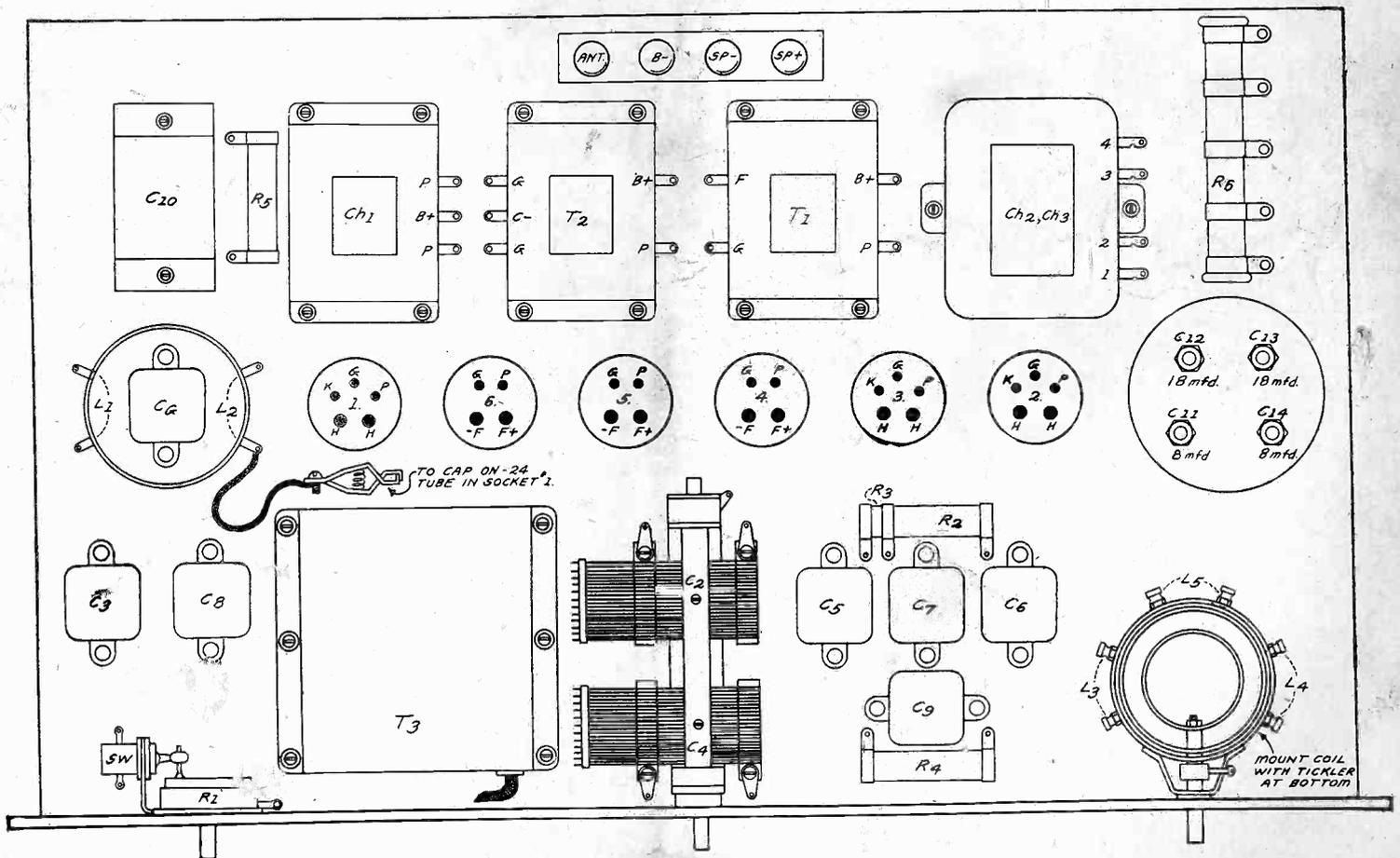

The attractive symmetry of the baseboard of the new 5-tube AC Push-Pull Diamond of the Air. See Article on page 5.

THE FOUR LEGS OF TONE QUALITY

RADIO WORLD, owned and published by Hennessy Radio Publications Corporation, 145 West 45th Street, New York, N. Y. Roland Burke Hennessy, President and Treasurer, 145 West 45th Street, New York, N. Y.; Herman Bernard, Secretary, 145 West 45th Street, New York, N. Y.

HBH Unit

ALL acoustical and radio engineers agree that the balanced armature type of loudspeaker unit is the best, the most sensitive and the most faithful of all magnetic units. But it is only in the HBH unit that superior designing skill, scrupulous care in the selection of the best materials, and extreme accuracy of manufacture have been combined and co-ordinated so as to bring out all the possibilities of the principle of the balanced type unit.

Any magnetic speaker requires a strong permanent magnet for its operation. The strength of the HBH unit is assured by the use of a long magnet of large cross-section, made of specially selected, high coercive-force steel, forged under the lowest heat possible, scientifically tempered in oil and aged.

The making of a permanent magnet requires a highly specialized skill. It must be forged, cut and tempered with as few heatings as possible, and no heating must exceed a certain temperature if the magnet is to retain its strength and permanence. Another important feature of the magnet which enhances its strength and permanence is that NO HOLES ARE CUT IN IT. The magnet is one solid piece of steel and the pole pieces are clamped firmly to the steel by screws in the die cast harness holding the pole pieces and the armature.

The sensitivity and efficiency of the unit are enhanced by the use of laminated, properly tapered silicon steel pole pieces. Eddy current losses are thus reduced to a vanishing minimum and all the force is concentrated on the ends of the armature.

The armature itself is made of carefully annealed soft iron, thus eliminating any residual magnetization and reducing eddy currents and hysteresis losses to a very small percentage of the energy involved in the operation of the unit. The armature is made short and heavy to enhance its effectiveness in translating electro-magnetic energy into sound.

Nobody ever returned an HBH unit because of dissatisfaction with its performance! It stands up and delivers and continues to deliver. You can put 150 volts right through the magnet coils, steadily, without danger of the coil breaking. You don't need any extra power to operate this unit—as you do with dynamics—but get full efficiency at lowest cost and greatest economy.

Put this unit in your cone or cloth speaker in place of the unit now there and marvel at the difference! You will then recognize the technical superiority of this unit in terms of tone value and volume. It produces so much more volume than most other units that it makes distant stations sound like locals.

Order a unit today! Send \$4.00. Try the unit ten days. If not overjoyed, return it for full refund. Otherwise take 90 days to pay the extra \$1.95.

10-day money back guaranty!
90 days to pay in full!

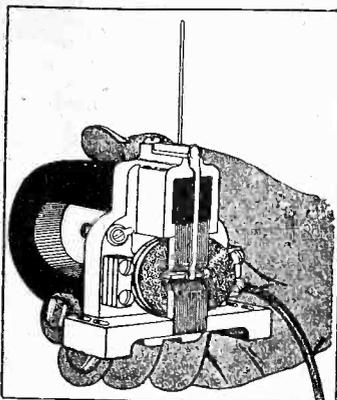

The HBH Unit, representing the most skillful and sturdiest magnetic unit design. Mfgd. under BBL License.

Price \$5.95
Moulded bracket (extra) 45c

Guaranty Radio Goods Co.,
145 West 45th St.,
N. Y. City (Just East of Broadway)

Please ship one HBH Unit only on 10-day money-back guaranty; at \$4.00 down, balance of \$1.95 in 90 days, unless I return the unit in 10 days for full refund of \$4.00.
 Please ship moulded bracket also at 55c.

Name
Address
City
State



Fourteen Circuits
Each Shown in Colored Picture Diagram, Colored Schematic Diagram and Front Panel Layout
Get This FREE Book!

Complete AC electric receivers, with B eliminators included, also AC receivers without B eliminators, also battery operated models, all easy-to-build circuits, using your own parts.

RADIO WORLD, 145 W 45th St., N. Y. City.
(Just East of Broadway)

Gentlemen: Enclosed please find \$1.00 for which please send me Radio World each week for eight weeks (regular price, \$1.20) and besides send me a FREE copy of the 1929 edition of The Radio Blueprint Library of AC and Battery Hookups.

Name
Address
City State

Note: Present mail subscribers may take advantage of this offer by putting a cross in this square. Your subscription will be extended eight weeks.

WHOLESALE RADIO PRICES

In these many years we have been in the Radio Mail Order Business, we have learned from EXPERIENCE how such an organization must be efficiently run in order to GAIN AND RETAIN THE GOOD WILL OF OUR CUSTOMERS. In this, our DETERMINED GOAL, RADIO SPECIALTY COMPANY OFFERS TO SHIP PRACTICALLY ALL ORDERS IN FROM 6 TO 24 HOURS — OFFERS YOU 100% QUALITY MERCHANDISE ON A STRICT MONEY-BACK BASIS IF NOT THOROUGHLY SATISFIED — AND OFFERS YOU ALL MERCHANDISE AT ABSOLUTE ROCK BOTTOM NET PRICES!

Our employees—our executives, are all pledged to handle your every order and inquiry in an intelligent manner. Our RAPID SHIPMENT SCHEDULE MUST BE UNSERVEDLY MAINTAINED! And to this pledge, we owe our daily increasing patronage. It will pay YOU to be numbered among our many thousands of customers! A trial is all we ask.

Buy From Radios
Oldest Mail Order
House

FREE CATALOG

2nd EDITION
JUST PRINTED!



Larger Page Size 8" x 10 1/4"

For Community Set Builders,
Dealers and Agents!

OUR MAMMOTH CATALOGUE CONTAINS THE LARGEST ASSORTMENT OF COMPLETELY ASSEMBLED ALL-ELECTRIC AC RECEIVERS AND GENERAL RADIO MERCHANDISE IN THE COUNTRY! Only the most successful manufacturers' products are listed—such lines as PILOT—SILVER-MARSHALL—CARTER AERO—YAXLEY—TOBE—HAMMARLUND—AMERTRAN—CUNNINGHAM—DONGAN—THORDARSON—MUTER, etc., etc. THE LATEST IMPROVEMENTS IN RADIO ARE LISTED AND THOROUGHLY DESCRIBED IN THIS GREAT CATALOG: A.C. ALL ELECTRIC Sets with self-contained ABC power supply—Public Address Amplifier systems—A.C. Set Converters—A and B eliminators—Dynamic Speakers and Units—Magnetic Speaker Chasses—250 Tube Amplifiers—Airplane cloth Speakers—Push-Pull Power Amplifiers—Electric Phonograph Turn-Tables—Combination Radio and Electric Phonograph Consoles—Speaker Tables—Short Wave Sets and Adapters—Shield Grid Tube Kits—Television Parts. There is also listed CAMERAS—ELECTRICAL HOUSEHOLD APPLIANCES—ELECTRIC VIBRATORS—ELECTRIC TOOLS—COMPLETE WORKSHOPS, etc.

Radio Specialty Co.

100R PARK PLACE, NEW YORK



"RASCO" has it



Vol. XV, No. 13 Whole No. 377
 June 15th, 1929
 15c per Copy, \$6.00 per Year
 [Entered as second-class matter, March, 1922, at the Post Office at New York, N. Y., under Act of March, 1879.]

Technical Accuracy Second to None
 Latest Circuits and News
EIGHTH YEAR

A Weekly Paper published by Hennessy Radio Publication Corporation, from Publication Office, 145 West 45th Street, New York, N. Y.
 Telephone, BRyant 0558 and 0559 (Just East of Broadway)

Electricity's Speed

Can Any Definite Rate Be Assigned to Current?

By *J. E. Anderson*

Technical Editor.

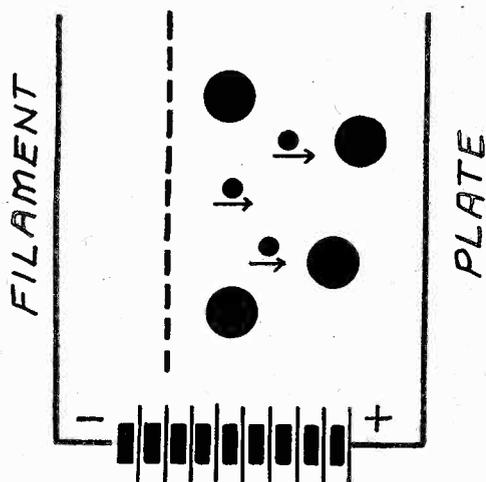

FIG. 1

THE SPEED OF THE ELECTRONS, SMALL DOTS, DEPENDS ON THE VOLTAGE BETWEEN THE PLATE AND THE FILAMENT AND ON THE DISTANCE THEY HAVE FALLEN. IF AN ELECTRON SHOULD STRIKE AN ATOM, HEAVY DOTS, WITH SUFFICIENT SPEED THERE WILL BE IONIZATION AND A BLUE GLOW.

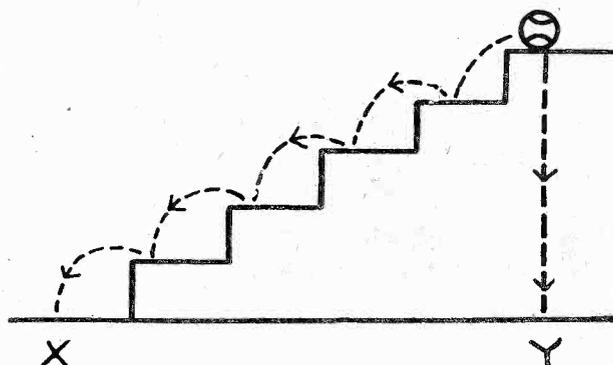

FIG. 2

MECHANICAL ANALOGY OF VACUUM TUBE. IF THE BALL AT TOP FALLS STRAIGHT DOWN IT ACQUIRES HIGH SPEED WHICH MIGHT RESULT IN DAMAGE WHEN IT STRIKES. IF IT FALLS STEP BY STEP IT CANNOT ATTAIN A HIGH SPEED, CONSEQUENTLY NO IONIZING COLLISION CAN TAKE PLACE UNDER SUCH CIRCUMSTANCES.

HOW fast does electricity travel? That question is often asked, and almost as often the answer is that it travels with the speed of light, that is, 186,000 miles per second. The answer is wrong more often than not, for electricity does not necessarily move, and when it does move it does not necessarily move with the velocity of light.

Possibly it is even wrong to speak of electricity moving. Is electricity capable of motion? And this leads to the very old question: "What is electricity?" No one has ever answered that question, so we can't say whether or not it is wrong to say that it can move. Neither can we say how fast it moves, if it does.

Motion of Electro-Magneto Waves

But we do know with reasonable certainty that electro-magnetic waves move, and that they move with the velocity of light. How fast is that? Is it 186,000 miles per second? It may be and it may not. It all depends on where the electro-magnetic waves move, that is, through what medium. But wherever they may move, and through whatever medium, they move with the velocity of light, for light is electro-magnetic waves. But that does not necessarily mean that a light wave, say of a violet color, moves with the same velocity as a radio wave, say one of 1,000,000 cycles per second, through the same medium. Neither does it mean that two radio waves of different frequencies move with the same velocity in the same medium.

Speed Varies

So an answer to the question, "How fast does an electro-magnetic wave move?" can not be given unless the questioner

states the frequency of the wave in question and the nature of the medium through which it moves.

Through empty space an electro-magnetic wave moves with the velocity of 186,000 miles per second, and it seems to be independent of frequency. Through air the speed is slightly less, very slightly, but it is reasonable to suppose that the velocity depends on the frequency.

Through water an electro-magnetic wave moves considerably more slowly than in empty space, and the velocity depends on the frequency. If it did not we would never see a rainbow, because that is produced by the difference in speed of light of various colors, or frequencies, in raindrops. Through glass an electro-magnetic wave moves more slowly than in air, and again the speed depends on the frequency. If it did not, a glass prism would not separate the colors. The same thing applies to crystals, such as the diamond. If the speed of light in a diamond were the same for all frequencies, the crystal would not sparkle in a light.

Radio Waves Like Light

What applies to light waves also applies to radio waves, in so far as conditions can be made the same. If radio waves behave differently, they do so because they differ in frequency from light waves, not because they are waves of a different kind, for they are both electro-magnetic waves.

But an electro-magnetic wave is not electricity. It is only one phenomenon of electricity and magnetism. So knowing the speed of an electro-magnetic wave of a given frequency in a given medium does not involve any knowledge of how fast electricity moves.

If we say that electricity is a quantity of electrons in motion

The Electron Race

How Some Starters Gain More Speed Than Others

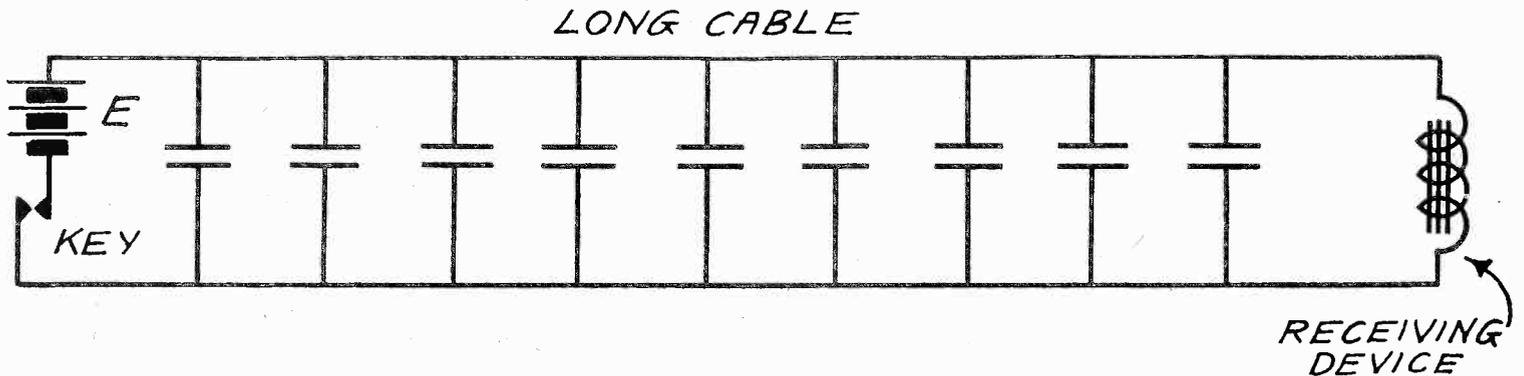

FIG. 3

THE DISTRIBUTED CAPACITY BETWEEN CONDUCTORS OF A CABLE MUST BE CHARGED BEFORE THE RECEIVING DEVICE WILL OPERATE AND THEREFORE SUCH A LINE IS SLOW.

(Continued from preceding page)

we might speak of the velocity of individual electrons. And how fast do they move? They might move with any velocity from zero up to the velocity of light in vacuum, that is, up to 186,000 miles per second.

What determines the speed of an electron? Its speed is affected by electric and magnetic forces to which it is subjected, and the length of time it has been subjected to these forces. Suppose an electron exists alone between two charged conductors which are at a given potential difference. The electric force is the potential difference per unit distance, for example, the force may be 10 volts per centimeter. If the electron is released in this field of forces it will begin to fall toward the positive electrode. As it falls it accelerates, or gains speed, but it cannot gain a speed greater than 186,000 miles per second. In fact, it cannot even reach this speed no matter how strong the electric force, although it can approach it closely.

Collision of Electrons

If there are atoms in the space besides the electrons it may be that the electron in its fall toward the positive plate will hit an atom. Of course, it will stop. If it is not caught by the atom, it will have to start its fall all over again. If the electron is traveling at a great speed when it hits the atom, it might knock out many other electrons that were bound to the atom. These, too, will then start accelerating toward the plate. Light will be emitted when the electron strikes the atom so hard that other electrons are shaken loose. This phenomenon occurs very often in amplifier tubes, resulting in the familiar blue glow.

The blue glow occurs when the voltage between the filament and the plate is very high, and when there are some gas atoms left in the tube. The high voltage will cause the speed of the electrons to be so great that the precipitated electrons can shake other electrons out of an atom during collision. When the voltage is low, the electron never reaches an ionizing or atom-smashing speed between two consecutive collisions.

What occurs might be illustrated with a familiar example. Suppose a round metal ball falls from the top of a tall building. It may not collide with anything in its descent. If it does not, it attains a very great speed by the time it gets to the bottom, and it will undoubtedly smash something. It may even hit so hard that it causes sparks to fly.

Stairway Analogy

But suppose the ball hits a stairway landing once in a while. No damage is done at any point because the ball never gets a chance to acquire a smashing speed. The stairway landings may be compared with the atoms distributed between the filament and the plate, and the ground may be compared with the plate.

In this mechanical example the force causing the ball to fall is always the same, the acceleration of gravity. We would have to go to a larger planet to get a greater force. On Saturn the force would be great enough to give the same ball a smashing speed at every landing. On the moon, or on one of the small planets, the ball could fall all the way to the bottom without gaining smashing speed.

The smashing speed corresponds with the ionizing speed in the vacuum tube, or that speed which the electron must have in order to knock bound electrons from the atom with which it collides.

The blue glow is due to electro-magnetic waves radiated by the atom when it is set into vibration by the collision. Actually it may be the bound electrons remaining with the atom which

vibrate about their center of equilibrium. The color is associated with the atom, for atoms of different substances have different characteristic colors.

If, then, electricity is moving electrons, it has no definite speed, but each electron has a speed depending on the force to which it is subjected and the length of time it has been under the influence of this force without a collision.

Speed of Charging Condenser

By speed of electricity shall we mean the length of time it takes to charge a condenser of given capacity to a given potential difference through a given resistance? The time required is definite, but the time required depends on the capacity of the condenser, the resistance through which the charging current must flow, and on the voltage available for charging. No definite speed can be assigned to a phenomenon so complex. And then the rate of charging the condenser at any instant is not constant. All that can be said is how long it will take when all the conditions are known. If the time elapsed since the charging began is given in addition, the current or the rate of charging at that instant can also be determined. But that does not tell how fast the electricity is moving.

Speed of Electrons in a Circuit

We might mean by speed of electricity the speed with which the average electron moves in a circuit across a given cross-section of a conductor. But why select the average electron? That is a fiction. There is probably no electron which moves at a speed equal to the average. Perhaps there is no convection of electrons in the conductor at all.

Let us assume that electrons do move along the wire in a circuit, and that a current of given intensity flows in that circuit. If the circuit is simple the same current flows in every portion of that circuit. But that does not mean that the electrons everywhere move with the same velocity. A portion of the conductor may have a very large cross-section. Another portion may have a very small cross-section. The same current flows across both, but the speed of the electrons cannot be the same in both. The electrons in the heavy conductor will move very slowly, and in the small conductor very fast.

River Analogy

Let us illustrate with a hydraulic example. Let the circuit be a river through which a definite amount of water flows per second. The rate of flow of water corresponds with the electric current. The water current is everywhere the same, assuming no tributaries or estuaries. In one section of the river the channel is wide and deep, in another it is narrow and perhaps shallow, in still another there may be a waterfall. It is obvious that the speed of the water is different at different sections of the channels. Where the channel is wide, the water is sluggish. Where it is narrow, the water flows more rapidly. And at the fall there is a rush. Yet the current is the same.

The same thing is true in an electric circuit. Where the conductor is heavy, the electron stream is sluggish, where the conductor is fine, the stream is more rapid, and where there is a resistor, the stream rushes.

Potential Analogy

There is a closer analogy between the two cases. In the river where the stream is sluggish there is a very small change of altitude over a given distance. In the electric conductor where

(Continued on page 7)

The New Diamond

245s Used in Push-Pull in AC Screen Grid Set

By Herman Bernard

Managing Editor

The tuner is selective indeed, and this meets a demand ever on the increase, not only because of the desire to separate strong locals not far removed from one another in the frequency spectrum, but also because those who like their DX know they can't receive it before 11 P.M. or later unless strong locals can be tuned out, completely silencing their transmission over a few degrees, say three or four, on the dial. Because of this selectivity it is necessary to tune closely.

Position of Pilot Light

If the optional pilot light is included it may be placed as shown in the diagrams on this page. A 2.5-volt pilot light is now generally available in radio, hardware and electrical stores. Use the upper 2.5-volt winding of the filament transformer. If a 5-volt pilot light is at hand, this may be used, even at half the recommended voltage, because the degree of illumination required is very small. The only object is to make the light shine through the colored window of the lamp bracket, or through the scale of the dial, if a drum dial with attached pilot light is used. Inclusion of a drum in place of the flat type dial would require rearrangement of some of the parts on the baseboard, however.

The condensers in the filter section, C11, C12, C13 and C14, are four Mershons, in one copper can. The two 18 mfd. posts, (Continued on next page)

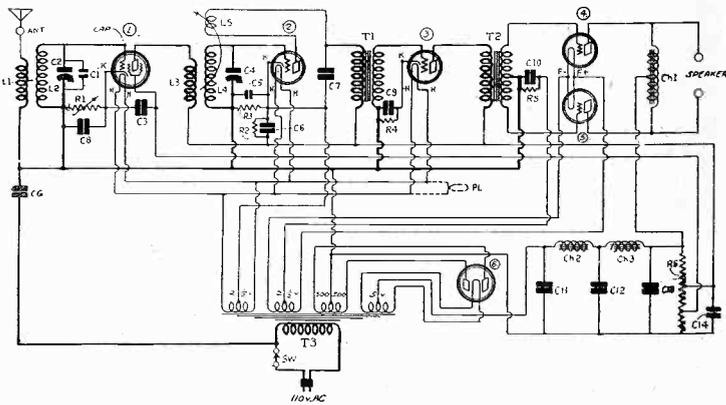

THE PILOT LIGHT MAY BE CONNECTED TO THE HEATER WINDING, 2.5 VOLTS AC. IF A LEAD IS TO BE BROUGHT OUT FOR EXTERNAL GROUND CONNECTION, IT SHOULD BE FROM THE L1 SIDE OF CG. THIS IS MIDTAP OF THE 600-VOLT SECONDARY.

[Part I of this article was published last week, issue of June 8th. Part II, the conclusion, follows.—Editor.]

THE Push-Pull Diamond may be built as a complete table model on a 12x20" baseboard, the layout of parts being as shown on the front cover, or if you have a B eliminator, the receiver alone may be built, with the filament transformer included in the receiver, however. The result in either instance is an AC-operated receiver, with one stage of screen grid radio frequency amplification, regenerated power detector, one stage of single-sided transformer coupled audio, and one stage of push-pull transformer audio.

The suggested output tubes are the new 245s, as these are specially designed for AC operation of the filament, and at 300 volts available from a B supply, 250 for the final plates and 50 to bias the last stage, at this medium voltage about the same undistorted power output is obtainable as from two 210s in push-pull at 350 volts.

If you have a B supply that delivers 180 volts and you desire to use it with the receiver design, the output tubes should be 171A in push-pull, requiring no other change than use of the 5-volt winding of the filament transformer for the final stage alone, with the biasing resistor, R5, still 800 ohms, connected to center-tap of the 5-volt winding. In other words, the three connections of the right-hand 2.5-volt winding in the diagram (bottom winding on the filament transformer) are simply transferred to the 5-volt winding. No hesitancy in accepting this adaptation need be felt. Results are excellent.

The circuit is so framed that if you have a power pack, consisting of one audio stage with B supply, the output tube being 210 or 250, single or push-pull, the final stage in the diagrams on this page may be made single-sided audio, and the stage in the power pack used as the third stage of audio. Ch1 would be omitted, because replaced by the primary of the audio transformer in your power pack. With the exceptions noted, the lower diagram on this page would be followed, because the power pack would supply all B voltages, and the eliminator portion, included in the upper diagram, is not needed.

Use of an External Ground

The front cover illustration shows four binding posts, as some may desire to use an external ground. As stated last week, the ground may be obtained from the AC line, through a fixed condenser, CG, of .02 mfd. capacity. Dispensing with an external ground lead is sometimes a convenience, but those who do not have to run a long lead to a cold water pipe may connect ground to B minus, leaving the condenser CG in the circuit, or, as shown in the lower diagram, may omit CG and connect ground to B minus also. This is a matter of individual choice. In either instance of ground being obtained externally it goes to B minus, and the binding post is so marked.

LIST OF PARTS

- L1, L2—One antenna coil (Cat. AC5).
- L3, L4, L5—One screen grid three-circuit tuner (Cat. SGT5).
- C1—One Hammarlund equalizer, 70 mmfd.
- C2, C4—One Hammarlund dual condenser, each section .0005 mfd. (Cat. MLD23).
- CG, C3, C5, C6, C8, C9—Six Aerovox .02 mfd. fixed condensers.
- C7—One Aerovox .0005 mfd. fixed condenser.
- C10—One Aerovox 4 mfd. bypass condenser.
- C11, C12, C13, C14—Mershon 8-18-18-8.
- R1—One Electrad Royalty variable resistor, 5,000 ohms, with 110 volt AC switch.
- R2, R3—One 20,000 ohm Electrad resistor type B (with 3 terminals).
- R4—One 1,000 ohm Electrad resistance strip.
- R5—One 800 ohm Electrad resistor type B.
- R6—One Aerovox Pyrohm, type A (750, 750, 2,800, 3,000).
- T1—One National A100 audio transformer.
- T2—One National push-pull input transformer.
- T3—One power transformer (Guaranty Radio Goods Co.).
- Ch1—One push-pull output choke (Guaranty Radio Goods Co.).
- Ch2, Ch3—One Silver-Marshall Unichoke 331.
- Ant., Speaker—Three binding posts (B-post optional).
- (1)—One 224 tube; (2), (3), two 227 tubes; (4), (5), two 245 tubes; (6), one 280 tube.
- One 7x21" front panel.
- One 12x20" baseboard with three UY sockets and three UX sockets.
- One flat type dial, with dial pointer.
- Two knobs.
- One roll Corwico Braidite.
- One pilot light, with bracket (optional).

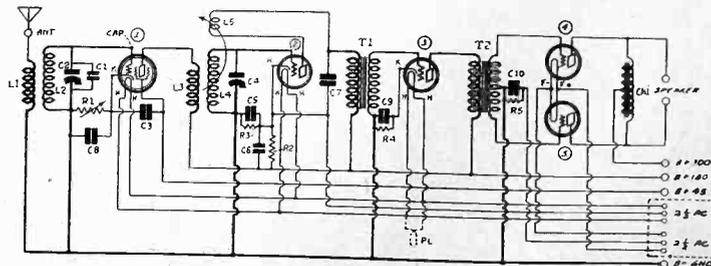

IF AN INDEPENDENT B SUPPLY IS TO BE USED, THIS DIAGRAM MAY BE FOLLOWED. THE CONDENSER CG MAY BE OMITTED, BUT THE FILAMENT TRANSFORMER (DOTTED SQUARE) MUST BE INCLUDED. THE B-LEAD MAY BE CONNECTED TO EXTERNAL GROUND.

The Four Factors

Transmission, Tuner, AF Amplifier and Speaker

By Herbert

THE chief factors affecting quality are (1), the transmission, (2) the tuner, (3) the audio amplifier, and (4) the speaker. This is rather the chronological order than the order of importance. However, it is not safe to assign relative values of importance, since the four elements function inter-dependently in the production or destruction of quality, just as the organs of the body all work together, or if only one fails to function properly, illness results. Poor quality in radio is the equivalent of derangement of one or more of the organs.

For the transmission one must rely solely on the station. Nothing that the receptionist can do, except, perhaps, write a letter of protest to the station, can have any improving effect upon poor transmission. A large number of stations, but a relatively small percentage of the total number of around 600, transmits poor quality, so it is impossible to receive good quality from them. The method of microphone pickup, the type of modulation, the audio amplification, attention to monitoring, and other acts and conditions at the station determine the quality it transmits. All can be remedied, if causing distortion.

The tuner is that part of the broadcast receiver that tunes in the carrier, selecting it alone from among the ninety-six channels in the broadcasting spectrum of frequencies that are 10 kc apart. In the tuner it is easy to avoid distortion, as it is due usually to regenerative effects. If the receiver suffers from involuntary regeneration it will certainly prevent faithful reproduction of the original speech or music, because of injury to the sidebands that carry the higher frequencies of modulation. Stabilization of the receiver by use of grid suppressors, or neutralizing condensers, or other corrective devices, will remedy this distortion, unless the receiver itself is so selective that even with the oscillation suppressed the higher radio frequencies will be absent.

As a rule receivers have not been so selective that serious impairment of the reproduction of the higher audio tones has resulted, but with the demand for selectivity increasing, and with set designers and manufacturers of factory-made receivers desiring to fulfill the requirements of the consumers, it must be expected that more sideband trimming will prevail than ever before. However, so long as this is not carried to the extreme it is pardonable, that is, attenuation of some of the higher frequencies scarcely will be noticeable to the ear.

Since the carrier is 10 kc wide the modulation introduced may be 20,000 cycles. If the carrier is compared to a bird in flight, the wings 10 kc wide, the spread from wing tip to wing tip is 20 kc. It is not necessary, however, to reproduce more than 10 kc; indeed, few receivers are equipped with audio channels that will pass so high an audio frequency. Therefore considerable sideband trimming might take place in the tuner before any difference would be audible, due to the higher cutoff of the audio amplifier.

The detector is regarded as a part of the tuner, because the input to the detector, at the grid-to-filament circuit, is radio frequency current. However, the detector is also an audio tube,

since it contributes some audio amplification. The grid-to-filament circuit receives radio frequency, but detection takes place at this input, while the desired output of the detector tube is audio frequency. The incoming radio frequency has been stripped of its carrier, leaving only the pulsating current that is a copy of the microphone current at the studio. Some radio frequency current gets through the detector tube, but usually it is bypassed by a condenser or choked by a coil in the plate circuit, or choke and condenser are used together, to keep RF out of the audio channel. The importance of maintaining this segregation is to avoid modulation of the current in the audio amplifier by the radio frequency current, for this would cause distortion, too.

Because of its dual function—as the acceptor of RF current and the deliverer of audio current—the detector tube is extremely important. The tendency is to use grid bias detection, because of improved tone quality, because it virtually removes possibility of overloading the detector under normal operation. With higher plate voltages that grid bias detection will stand, and with correspondingly higher negative grid bias, a maximum grid swing equal to that of a medium capacity power tube is practical.

For instance, with AC receivers it is not unusual to operate a 227 tube at a negative bias of 16 volts, obtained through the voltage drop in a biasing resistor, at an application of 180 volts on the plate. Now 16 volts is almost half again as much as the 112A tube will stand when operated at its rated voltages. Because a high negative bias detector tube thus will stand a large signal input, comparable to that which will work a medium power tube up to its limit of undistorted power output, this type of detection has come to be called power detection.

If enough radio frequency amplification is ahead of the detector, only one stage of audio is needed, as the volume then is high enough, and the biasing voltages of the detector and the single audio stage are adequate. For instance, a 16-volt negative bias on the detector would permit, say, eight volts of RF at the detector input, on the theory of halving the applied bias voltage for the purpose of computing the maximum permissible RF input. Therefore a 227 tube and a coupling transformer of a ratio of 1-to-3 (primary to secondary), would permit operation of a 245 output power tube.

The audio amplifier's function is to receive the rectified output of the detector and pass it along to the speaker, increasing the volume without altering the characteristic of the wave form or favoring any particular frequencies or group of them in the audio range. The audio channel can mar the results produced by a good tuner, but an audio channel can not well make up for shortcomings of a poor tuner. If higher frequencies in the audible range are cut off by the tuner, the audio amplifier may be so designed as to give greater amplification in this invaded region, but that is not quality. Instead, it is a makeshift, and usually does not work out even fairly well in practice.

Closest attention should be paid to the audio channel. It

Wire Filaments and Heaters First

(Continued from preceding page)

C12 and C13, are a little nearer the edge. The two 8 mf. sections of the course are farther from the edge. The copper is negative and is to be connected to B minus, which can be accomplished by connection to the bracket used for mounting the copper container on the baseboard.

Individual bias is provided for each stage in the receiver by an independent biasing resistor. The first of these is the adjustable resistor used as volume control. Its maximum is 5,000 ohms. It has a Hart & Hegeman 110-volt AC switch built in. The second is the detector biasing resistor R3. This is physically a section of a 20,000-ohm resistor that has three terminals. Two are the extreme terminals. The third is connected near the B minus end of the resistor, and joins the detector, the cathode. The position of this slider is located experimentally but is usually about $\frac{1}{4}$ -in. from the B minus end. That gives about 2,000 ohms for R3 and leaves 18,000 ohms for R2, since the total resistance between extreme terminals is 20,000 ohms.

R4 is 1,000 ohms and may be a resistance strip such as used for grid suppressor or may be of the higher wattage type, although this is not vital. The front cover illustration shows

it as a higher wattage type, but the resistance strip will do just as well.

R4 is the final biasing resistor. It is 800 ohms, or about half the usual resistance for a single 245 tube. This halving of the resistance is due to the doubling of the plate current in the last stage by the use of the two 245s in series. The bypass condenser C10 should be 4 mfd.

Wiring of the receiver is simplified if the filaments and heaters are connected first, including the rectifier tube, and the tubes tested as to filament voltage. The regulation of the filament transformer is excellent, so that there is a drop of only a small fraction of a volt when one of the three tubes in the tuner is taken out of the socket while the two others are left in place. Many meters will not even respond to this slight change. There is a still smaller change when one 245 tube is removed while the other is left in the socket during tests for filament performance.

R6 is an Aerovox Pyrohm, type A, with taps at 750, 750, 2800 and 3,000 ohms, making a total of five taps, but as only four are used, only four are shown on the front cover. The second 750-ohm tap (1,500 ohms) is used for the 180-volt lead.

Other illustration on front cover.

tors of Quality

Speaker All Vital Organs in the Body of Radio

E. Hayden

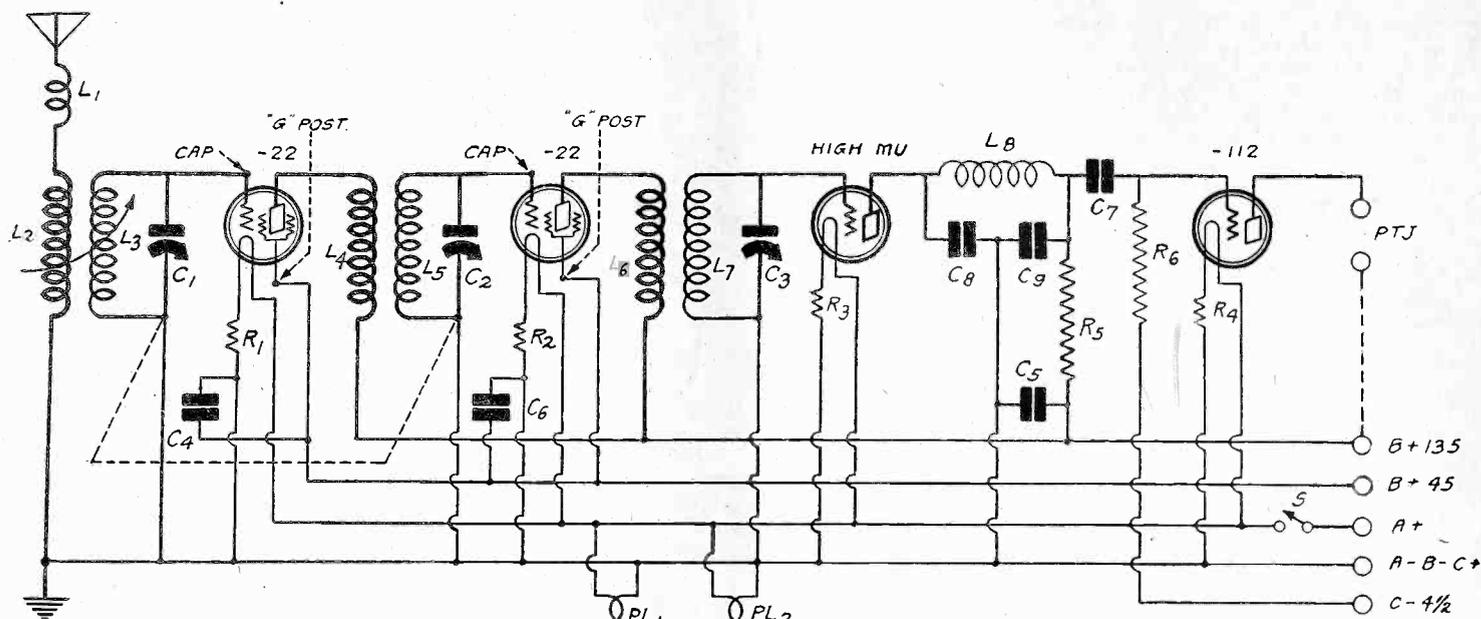

IN THIS BATTERY-OPERATED TUNER AND ONE-STAGE AUDIO THE HIGH MU TUBE IS THE DETECTOR, OPERATED AT 1-VOLT NEGATIVE, THE BIAS BEING THE DROP IN R3. THE APPLIED VOLTAGE OF 135 AT R5 IS REDUCED TO 45 AT THE PLATE. L3 IS THE CHOKE COIL TO KEEP RF OUT OF THE AUDIO CHANNEL. C8 AND C9 AID THIS FUNCTION. THIS FILTER, L3 C8 C9, HELPS PRESERVE QUALITY.

may be resistance coupled, transformer coupled or impedance coupled, or may be a combination of any two or of all three of these, for excellent results are obtainable by all these methods. However, there are no cheap transformers that permit tone quality, no cheap impedance coils either, for the core is expensive, and the required high impedance of both necessitates more wire than was used in the careless days of radio, so the cost mounts. Resistance used in audio coupling should be non-inductive.

If a B supply operated from the convenience outlet, AC or DC, is used, the filtration should be very good, and any biasing obtained through voltage drops in resistors should be safeguarded from undue effects of combining of grid and plate circuits, by placing a suitable bypass condenser across the biasing resistor. No less than .02 mfd. should be used ahead of the last audio biasing resistor in an AC set and the last biaser should have a capacity across it of no less than 4 mfd.

The speaker should be matched to the output tube, or, if not matched, the coupling device should provide this matching. Dynamic speakers have built-in coupling transformers. With high impedance primary and low impedance secondary, since

the plate of the tube has a high impedance and the coupling impedance in the plate circuit should be still higher. However, the voice coil usually has an impedance of 100 ohms or less, hence the transformer takes care of the requirements.

Magnetic speakers also will work well out of the present-day power tubes, either by the choke-and-condenser method of filtered output, or by using a transformer. This type of transformer is a special one, and is designated for magnetic speakers. Other output methods are possible, and one in particular, a single impedance coil connected to push-pull plates, with B plus to center tap, works well into magnetic or dynamic speakers, the tips of the speaker cords going directly to the plates of the two tubes. No direct current will flow through the speaker because the voltages at the plates are equal but opposite, that is, there is no potential difference between the plates. Only the varying component, that is, the audio signal itself, is communicated to the speaker.

When closest attention has been paid to the design of the tuner, the detector that is a part of it, and the audio amplifier, and a speaker is chosen that will make it possible to capitalize on the pains previously taken, the result is wonderful.

When a Line is Slow and When Fast

(Continued from page 4)

along the line with this speed. They start moving slowly when the impulse reaches them, and since this travels with the velocity of light, the electrons start moving in the entire circuit at once, practically speaking.

The desired effect may not reach the other end for some time, especially if the line contains inductance and capacity, and every line does. Some lines contain more than others.

Consider a submarine cable consisting of two conductors. There is considerable capacity between them. In other words, the line is a condenser. It is leaky all the way to the other end, and at that end there is a great leak, constituting the load impedance.

A certain emf is inserted in the line at the sending end. A current begins to flow. How long will it be before the current at the remote end is large enough to perform the work for which it was sent? It may take a second, and if it does, the line is very slow. The condenser must be charged along the entire line before there will be enough voltage across the load impedance to produce enough current to operate the device. Even if it takes a thirtieth of a second the line would be slow.

Submarine signalling over great distances has been very slow

because the lines have been slow to respond. Telephony over such lines has been impossible. Recent improvements brought about by distributing inductance to offset the effect of the capacity have changed this. Telegraphy at high speeds is now possible, and even practical telephony has been achieved over long submarine cables.

They speak of fast lines connecting broadcasting studios with the transmitters, or of fast lines for picture transmission or for high quality voice transmission. When is a line fast? When its characteristics are such that high speed signalling of any nature is possible over it. And good quality voice signalling is very high speed signalling. Of course, the rate at which the words are spoken has nothing to do with the speed of signalling, electrically considered.

A line is high speed if the voltage across the load at the receiving end follows the voltage fluctuations at the sending end even when these fluctuations occur at a very rapid rate, for example, 10,000 cycles per second. If the rapid fluctuations in the voltage do not get to the receiving end, or if they get there greatly attenuated, the line is comparatively slow. A slow line may be speeded up by equalization, particularly by building up the transmission at the high frequency end.

POWER AMPLIFIERS

By J. E. Anderson and Herman Bernard

[Parts I and II of the authors' comprehensive discussion of power amplifiers were published in the June 1st and June 8th issues. Part III is printed herewith. Part IV will appear next week. The entire scope of the power amplifier subject will be covered from week to week for several months.—Editor].

Impedance Coupled Amplifiers

The diagram given in Fig. 11 can be used for assembling different varieties of direct coupled circuits, such as impedance-impedance, impedance-resistance, resistance-impedance, and tuned dual impedance. It is only necessary to substitute the desired coupler for the resistance coupler, of which R6C2R7 is typical. If the coupler comes in assembled form it is connected just as if it were a transformer.

Push-Pull Battery Amplifier

The push-pull amplifier depicted in Fig. 12, differs from the amplifier in Fig. 10 only by the fact that the second stage is push-pull, or symmetrical. Two tubes, (2) and (3), of identical

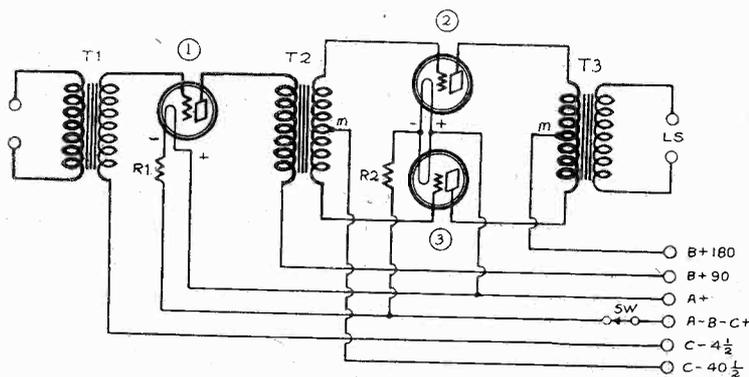

FIG 12

TWO-STAGE, TRANSFORMER COUPLED AUDIO FREQUENCY AMPLIFIER WITH PUSH-PULL OUTPUT STAGE.

characteristics are used in the final stage. This requires a push-pull input transformer T2 and a push-pull output transformer T3, both of which are standard equipment. The plate and grid voltages indicated on the diagram suppose that the first tube in the circuit is a 201A and that the tubes in the second stage are 171A.

By-pass condensers have been omitted from the circuit because the circuit is supposed to be battery operated. Condensers connected as indicated under coupling devices are desirable even if the circuit is powered with batteries.

Non-Reactive Amplifiers

Amplifiers in which neither condensers nor inductance coils of any kind are used are called non-reactive. Sometimes they are called direct current amplifiers, because they will amplify steady and very slowly changing voltages as well as ordinary audio signal voltages. In these amplifiers resistors are used to couple the tubes, and batteries are used to supply the necessary voltages.

The field of application of these amplifiers is somewhat limited. They are used mainly for laboratory measurements. However, they can be used for any purpose requiring a minimum frequency distortion over a very wide range of frequencies, and therefore are used for amplification of television signals in which the frequency range is from about 10 cycles to 50,000 cycles per second.

One type of non-reactive amplifier is built with couplers as in Fig. 7 G. This is the simplest in that a single coupling resistor is used between two adjacent tubes. But this circuit becomes complicated by the necessity of using a separate grid battery, E, for every tube.

Various circuits have been arranged with a view of eliminating the many grid batteries, and one of the most interesting of these was designed by a scientist who uses the pen name of Prof. Joseph Morgan. This circuit is shown in Fig. 13. The outstanding features of the amplifier are the absence of stopping condensers, the arrangement of the coupling resistors and the special application of the voltages. This circuit is non-reactive up to the grid of the last tube, and would be entirely non-reactive if a resistance load were connected in the plate circuit in place of the choke coil Ch, the condenser C and the loudspeaker. For the reception of broadcast signals the circuit as shown is as nearly non-reactive as it can be made.

An amplifier of this kind will not work satisfactorily unless batteries are used to supply the various voltages, and it will work best

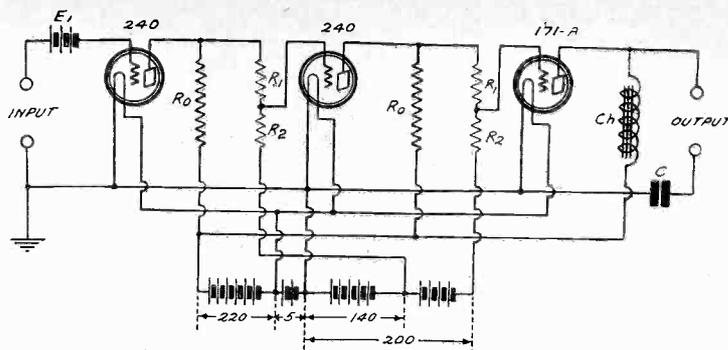

FIG. 13

A RESISTANCE COUPLED AUDIO AMPLIFIER, WITHOUT STOPPING CONDENSERS. THIS IS KNOWN AS THE MORGAN AMPLIFIER.

if they are storage batteries. Neither will it work satisfactorily unless the voltages and the resistances are carefully adjusted. The voltages are indicated on Fig. 13, and the resistors should have the following values: R_0 , .5 megohm; R_1 , .75 megohm; R_2 , 1 megohm. These values are based on the assumption that the tubes indicated are used. The value of battery E1 depends on the strength of the signal impressed. For broadcast reception it need not exceed 1.5 volts, which can be supplied by a single dry cell.

For broadcast reception coil Ch might be any one of many output choke coils having an inductance of 30 henries or more under operating conditions. Condenser C should not be smaller than 4 mfd., and it should be designed for a voltage of at least 400 volts.

Non-reactive amplifiers are often difficult to adjust and to keep in adjustment. The reason is that they amplify steady voltages. Suppose there is a small change in the bias supplied to the first tube. This changes the plate current in the tube, and hence the bias on the second tube. This in turn changes the plate current in the second tube and therefore the bias on the final tube.

While this is exactly the manner in which any amplifier works, circuits containing coils and condensers are not effective at extremely slow changes and therefore changes in the bias values cannot build up. Small changes in the bias on the first tube of a non-reactive amplifier often result in completely paralyzing the final tube, either because of excessive negative or positive bias. Indeed, in some instances even the middle tube will become paralyzed.

The amplifier shown in Fig. 13 is relatively stable and can be used for broadcast reception, or other purpose requiring a minimum of frequency distortion over a wide range. But the stability will be lost if the circuit is powered with a B battery eliminator or with a dry cell battery that is partly exhausted.

The voltage amplification of the circuit in Fig. 13 from the first grid to the loudspeaker is approximately 512 times, or about 256 from the first to the third grids. Since a maximum voltage of 40 volts, peak value, may be impressed on the power tube, a signal voltage of .16 on the first grid will load up the final tube. Such a signal voltage can be obtained from any detector tube or phonograph pick-up.

Ohm's Law

A, B and C batteries were the first energizing sources for power amplifiers, although the undistorted maximum power output was relatively small. The A battery supplied voltage of a low order and current of a relatively high order, and its sole purpose was to heat the filaments of the tubes. The B batteries supplied the plate with high voltage at low current, the C batteries afforded the grid low voltage at no current.

The rated voltage applied to the filament of a tube provides the rated current, since the resistance of the filament is always the same. By Ohm's law the current in amperes is equal to the voltage divided by the resistance in ohms. So, if the voltage across the filament of a 201A tube is 5 volts, and the previously known resistance of the filament is 20 ohms, the current in amperes will be the voltage (5) divided by the resistance (20), or 5/20 or 1/4 ampere. The fractional amperage is usually written decimally thus: .25 ampere.

The resistance of the filament is not stated on the carton or the instruction sheet enclosed therein, but the rated filament voltage, and the filament current flowing at that voltage, are given. Thus a 201A tube is rated as to its filament at 5 volts, .25 ampere.

The application of Ohm's law in one of its three essential forms will give the missing quantity when the two other quantities are known. Thus, as the voltage and the current are known, the resistance is computable. The resistance in ohms equals the voltage divided by the amperage. The resistance in ohms of a 201A tube equals the voltage (5) divided by the current (.25), equals 500/25, or 20 ohms.

The third expression of Ohm's law is for obtaining the voltage when the current and the resistance are known. The voltage equals the product of the current in amperes and the resistance in ohms. Thus, the voltage in the present instance equals .25 (ampere) times 20 (ohms), or 5 volts.

When applying Ohm's law it is necessary to reduce the two known components, whatever they are, to the fundamental

units—ohms, amperes or volts. Subdivisions may be expressed decimally.

From the foregoing a volt may be regarded as an ampere-ohm. The three expressions of Ohm's law are:

$$I = \frac{E}{R}, R = \frac{E}{I} \text{ and } E = IR,$$

where I is the current in amperes, E is the voltage in volts and R is the resistance in ohms.

E stands for the phrase "electromotive force," I for the phrase "intensity of current." For purposes other than formulas, electromotive force is written **emf**.

The electromotive force is that force which causes electricity to move.

The voltage is the emf. measured in volts.

Current is the rate of flow of electricity.

Resistance is the opposition offered to a flow of unvarying current.

Direction of Current Flow

The A battery and the B batteries furnish current and voltage in a battery-operated amplifier. Although current can not exist without voltage, there may be voltage without current, and the C battery is the most familiar example. Resistance may exist without current or voltage.

The current flows through the circuits connected to the A and B batteries from positive to negative. This is in the external circuit or the load. As the circuit is completed through the A and B batteries, inside the batteries themselves the current flows from negative to positive. But the current flows in the same direction in the batteries as in the circuit which the batteries feed, the apparent difference being due to the point of view.

In Fig. 14 the arrows indicate the direction of flow of direct current in a battery-tube circuit. A, B and C designate the three different batteries. The A battery heats the filament, causing electrons to be emitted. The B battery polarizes the plate positively in respect to the negative filament, F—. Tube voltages are always reckoned from F—. The C battery has no designating arrows, because no current flows.

The heavy arrows show the direction of filament current flow, the light arrows the direction of plate current flow. Starting at A—, the negative battery terminal, the current courses through the battery to the positive battery terminal A+, then begins its positive-to-negative route, completed through the filament to A—.

The plate current starts at B minus and flows through the coil L, which may be the primary of an audio transformer, and reaches the plate. Then it flows to the filament in the form of an electron stream, the electrons actually moving against the current. The discrepancy is due to the definition of direction of current, which was laid down before electrons were known. Most of the current passes through the negative filament leg, some of it through the positive filament leg, but eventually all of it reaches A—. Since A— and B— are connected, the plate current is back at the starting point.

Looking again at the heavy arrows denoting filament current and then comparing them with the plate current arrows in the filament, you will see that in the negative filament leg the plate current flows in the same direction as the filament current. The two currents therefore add up. But in the positive filament leg the plate current opposes the filament current, hence reduces the filament current in the positive leg. The negative leg therefore gets hotter than the positive leg.

The two plate current arrows marked X represent the last lap of the plate current's course, along the wire joining A— to B—. Pictorially they carry the eye to the finish line, which is also the starting point, and are not to be read as contradicting the plate current arrow in the A battery.

From the foregoing it is apparent that the plate is positive in respect to the filament. But the plate is negative in respect to B+, since B+ is the voltage source, and the coil L has a resistance to direct current. The plate is therefore negative in respect to B+ by the amount of voltage drop in the Coil L.

The plate also has a direct current resistance which is increased as the C bias is increased. When the plate resistance is known, as well as the resistance of L, the two resistances are added. Since the voltage at B+ is known, the plate current can be computed by Ohm's law.

Theory of DC Eliminator

In about the same class of low maximum undistorted power output as the battery-operated design is the plate supply obtained from the DC convenience outlet. With batteries there is no limit to the amount of plate voltage, except that imposed by economical considerations, but as power tubes of large undistorted power output require high plate voltage and draw heavy plate current, the B battery upkeep cost becomes high when a larger power tube than a 171A is used, especially as the other tubes in the receiver and amplifier will draw plate current also.

In a DC plate voltage supply, the maximum voltage applied to any plate never can exceed the voltage at the source, which

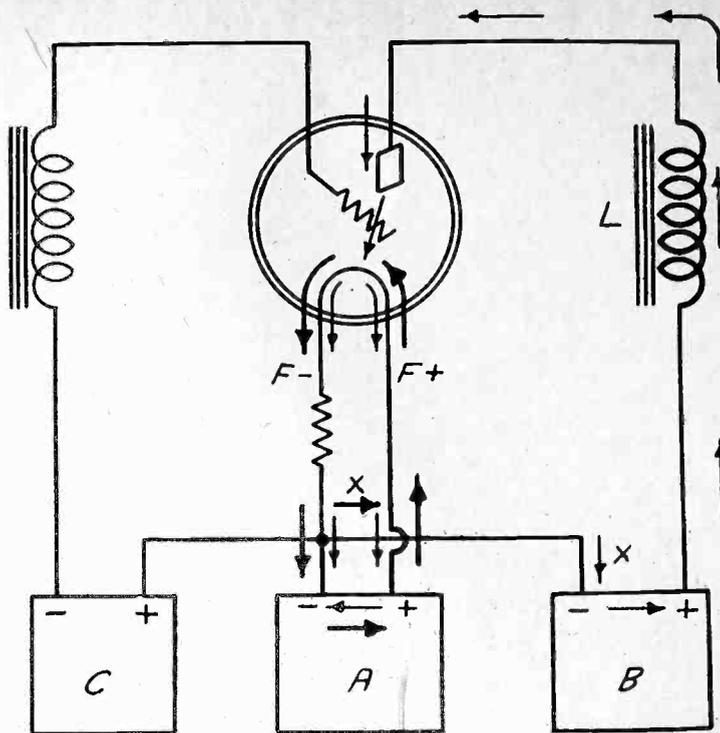

FIG. 14

HOW CURRENT FLOWS IN A BATTERY-POWERED VACUUM TUBE. A, B AND C ARE THE RESPECTIVE BATTERIES. THE LIGHT ARROWS INDICATE PLATE CURRENT, THE HEAVY ARROWS FILAMENT CURRENT. THE TWO ARROWS MARKED X DENOTE THE COMMON CONNECTION OF A— AND B— AND ARE NOT TO BE READ AS CONTRADICTING THE ARROWS IN THE A BATTERY.

is usually 110 volts. In fact, the available maximum is always less than that, due to the voltage drop in the choke coil.

A power supply furnishing A, B and C voltages from the 110-volt DC line is diagrammed in Fig. 15. It is assumed that the voltage at the source is 110 volts and that the choke coil drops 10 volts. As C bias is obtained from the device, the total available plate voltage is reduced by the amount of the maximum C bias. Therefore, with a negative bias of 9 volts for a 112A output tube, there would be 9 volts less than 100 volts on the plate, or 91 volts. If a 45-volt battery is added in series with the maximum output the 136 volts are just right for 9 volts negative bias for the 112A.

The entire 100 volts are dropped across a fixed potentiometer R3 that has suitable taps for providing intermediate voltages and C bias. Assuming the resistance of this potentiometer to increase uniformly on the basis of length, the voltages are proportional to the linear dimensions. From A— to maximum is 91 volts, therefore the 45-volt tap would be about half way between.

A source of filament voltage and current is provided in the supply shown in Fig. 15A.

The current flowing through the potentiometer R3, from 91+ to A—, is only plate and bleeder current. But from A minus to C—9 both the filament current and the other current flow, therefore this section of the potentiometer should be of the "power" type, rated at 30 watts or more. Wattage is the product of voltage and amperage, so if six tubes at .25 ampere each for the filament, are used, the wattage is 9×1.5 , or 13.5 and for the plate current it would be of about .5 watt additional, or a total of 14 watts. It is advisable for a resistor's rated wattage to exceed the wattage needed by about 100 per cent.

The filament voltage and current are obtained directly from the line across which is placed an electrolytic condenser, C1, of large capacity, usually of several thousand microfarads. An electrolytic condenser is one in which the dielectric, that is, the medium separating the plates, is a very thin film of gas. This gas is generated by putting the electrodes or plates in a paste or liquid, which causes the gas film produced by the flow of current through the electrolyte, or solution, to form on the metal plates. Due to the extreme thinness of the gas film and the large surface of the plates, a large capacity is compactly obtained. Electrolytic condensers for this purpose are rated at the voltage at which they are to be used.

The other condensers, C2, C3, C4, C5, C6, C7, may be of the paper dielectric type, known as bypass condensers, and rated for this purpose at 200 volts DC. Their capacity may be 2 mfd., excepting C6, which should be 4 mfd.

Fig. 15A shows only the eliminator, without audio amplifier, but it is assumed that a receiver is powered from this source. The arrows indicate the direction of current flow in the DC

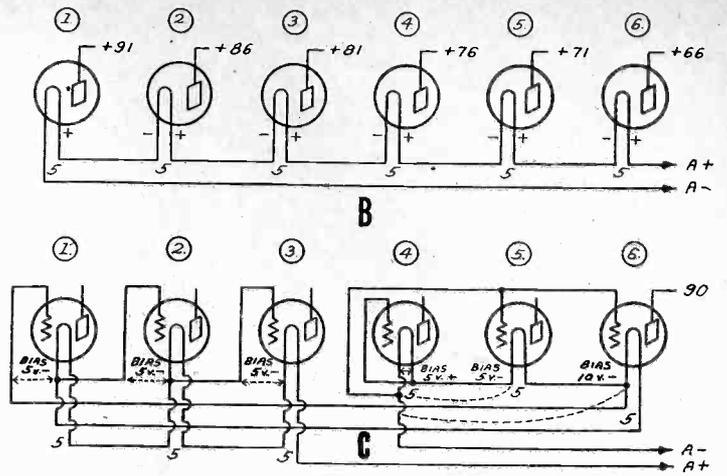
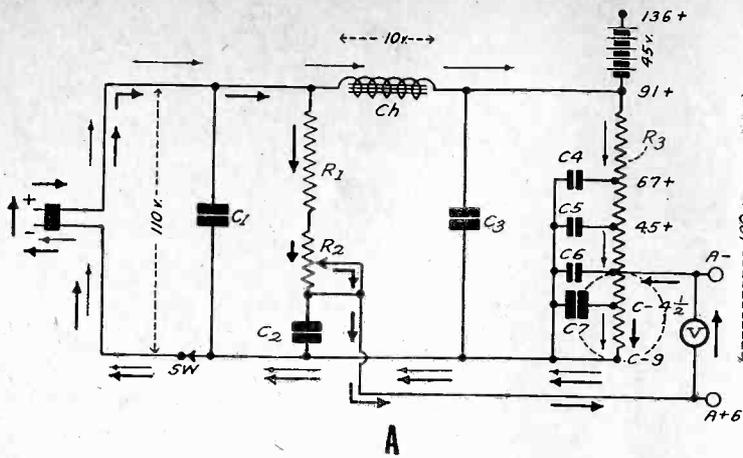

FIG. 15

(A)—DESIGN OF A, B AND C SUPPLY OBTAINED FROM A 110-VOLT DC CONVENIENCE OUTLET. DIRECTION OF CURRENT FLOW IS INDICATED BY THE ARROWS—LIGHT ONES FOR PLATE CURRENT, HEAVY ONES FOR FILAMENT CURRENT. C1 IS AN ELECTROLYTIC CONDENSER OF SEVERAL THOUSAND MICROFARADS. CH. IS A CHOKE HANDLING PLATE AND BLEEDER CURRENT ONLY.

(B)—FILAMENTS OF A RECEIVER CONNECTED IN SERIES. THE EFFECTIVE PLATE CURRENT IS 5 VOLTS LESS FOR EACH SUCCEEDING STAGE.

(C)—ARRANGEMENT OF SERIES FILAMENTS TO GIVE THE TUBES A BETTER DISTRIBUTION OF PLATE VOLTAGES. THE DESIGN SHOWS GRID RETURN CONNECTIONS MADE WITHOUT LOADS, SIMPLY TO OBTAIN BIAS THROUGH VOLTAGE DROPS IN FILAMENTS.

eliminator. The current flows from plus to minus in this supply.

The filament voltage is obtained from the line side of the choke. This prevents the passage of filament current through the choke. There is no necessity for extra filtration of the filament current, the electrolytic condenser smoothing out the generator ripple and other interference. Also, it is desirable to avoid having the choke handle filament current because that current is so high that a large and expensive choke would be necessary. However, the fixed resistor R1, and the adjustable resistor, or rheostat, R2, should be of the power type, which means they should have a high combined rating, about 300 watts, or a current-carrying capacity of 1.5 amperes or more. If they do not, they will get dangerously hot, or burn out entirely. It is always important to determine in any circuit the wattage the resistor or coil is to handle, and as to condensers particularly what voltage they must stand.

Grid bias in the DC eliminator is obtained by moving the A— connection to a point 9 volts higher than the minus point of the DC line. As voltages applied to a tube are reckoned from F minus, the grid returns made to the C-4 and C-9 points will be negative in respect to filament minus by the specified C voltage.

The A voltage output is measured by the 0-10-volt voltmeter, V. This voltage will depend on the resistance of R1 and R2 and on the type and number of tubes used, as all these govern the amount of current. However, the rheostat provides a means for reducing the current, so that when a DC eliminator is designed for six tubes of the .25 ampere filament type, it may be used for receivers that have fewer than six tubes, or, in the event 199 tubes are used in some sockets with a filament drain of only .06 ampere per tube, more than six tubes may be used. If the total current is less than 1.5 amperes the resistance of R1 and R2 must be increased.

Instead of providing a 5-volt filament output, which presupposes there are no filament rheostats, ballasts or Amperites in the receiver, the output may be made 6 volts, the same as that of a storage battery, to meet the same kind of receiver conditions as are generally applicable when storage A batteries are used. This can be done by having the sum of the resistances of R1 and R2 slightly less than otherwise, since the voltage desired on the receiver is now one volt greater.

V must not be used unless all tubes are in the circuit.

Ohm's Law Applied to Fig. 15 A

The only unknown quantities in Fig. 15 A are the values of the resistors R1, R2 and R3. While R3 is a single resistor, that is, a continuous unit from the point marked C—9 to the point marked 91+, electrically it is divided. This division is in two general forms: (1), bleeder-plate current, from 91+ to C—9, and (2), combined filament current and other current carriage, from A— to C—9. R1 and R2 carry filament current alone. There would be another subdivision of (1) for plate current flowing additionally from either intermediate B+ tap.

The voltages and currents are known either by measurement or by computation, after the input voltage is assumed to be 110 volts. It may be 105 volts or 115 volts, as strict adherence to rated 110 volts does not prevail in practice. In some localities, particularly factory neighborhoods, it may be 220 volts. A suitable DC voltmeter will disclose the voltage and also the polarity. If the meter kicks backwards reverse its connection to the line. Whatever the voltage is, the application of Ohm's law is the same. Only the numerical results will differ.

It is desired to provide a 6-volt output to supply the filaments of the tubes to be used. Therefore the voltage drop between, A—

and A+ is 6. The device is to supply up to six tubes of the .25 ampere filament type, therefore the maximum filament current will be 1.5 amperes. Three stages of radio frequency amplification, detector and first audio stage, all 201A tubes, and as final audio tube a 112A, with 91 volts on all plates save the detector, which has 45 volts, will draw about 20 milliamperes, and that figure will be used. By testing each tube individually at the plate and grid voltages to be applied, measuring the plate current of each, then adding the currents, the sum could be obtained experimentally.

The required bias voltages are known, because the tube manufacturer discloses them in the circular contained in the tube carton. For 90 volts on a 201A tube 4½ volts are specified, so 4½ prevail for 91. For 91 volts on the plate of the 112A tube the bias should be 6 volts negative, but we shall assume 9 volts on the theory the 45-volt battery will be added, since too limited an order of undistorted power output is obtained with only the 6 volts bias that the 91 plate volts require.

Instead of adding the extra battery to provide extra plate voltage to support larger bias and greater undistorted output, the voltage could be left at 91 and the last stage made push-pull, thereby approximately doubling the maximum undistorted power output. However, we shall base our problem on 91 volts on a single-sided output at 9 volts bias.

From the foregoing we have all the known quantities of current and voltage, and from these can obtain the values of the resistors, since the resistance in ohms equals the electromotive force divided by the current:

$$R = \frac{E}{I}$$

Let us assume R2 is shorted out of the circuit, since we want a supply for a given radio circuit, using stated tubes, and R2 merely permits the use of fewer tubes or other tubes, even more of them, of lower filament wattage rating. R2 is strictly a limiting resistor, and in general is to be used only when less current is drawn because of different or fewer tubes used. If R2 were omitted, the supply would be lacking in versatility, since with no provision for increasing the resistance to compensate for current decrease, the voltage between A+ and A— would go up, instead of being made to remain the same or made to go down as tubes require. This is because the lower the current through a resistor of given value, the lower the voltage drop, the nearer the A voltage would be to the output voltage (110 volts).

With R2 out of mind for the present, we seek to determine the value of R1. The total voltage is 110, the desired A+ voltage is 6, and the difference is 104. Therefore 104 is E in the formula. The filament current is 1.5 ampere. Therefore the resistance of R1 is computed.

$$R = \frac{104}{1.5} = 69.33 \text{ ohms}$$

We know R1 is 69.33 ohms and must carry 1.5 amperes. Hence the wattage is $69.33 \times 1.52 = 156$ watts. As it is preferable approximately to double the rated wattage of a resistor for an ample margin of safety, we specify R1 should be of the 300-watt type.

As the lowest current desired would be for five 199 tubes and 120 output tube, or $5 \times .06 \text{ ampere} + .12 \text{ ampere} = .42$ ampere, 3.5 volts, we can assign a value to R2 to take care of this situation. The voltage E would be $110 - 3.5$ or 106.5 volts. Hence the total value of R1 and R2 should be $106.5 / .42$, or 253.6. Since R1 has been determined as 69.33 ohms, R2 would have to be 184.3 ohms.

We allowed for 20 milliamperes total plate current. More plate current will flow from the maximum tap (91) than from any

intermediate tap (45 or 67). But the effect here is not enough to require inclusion of this difference in the computation.

R3 itself is connected from 91+ to C-9, or across 100 volts. Therefore it draws current all by itself. What this current is we can not tell yet, because all we know is the voltage drop. We must know the resistance besides, to determine what current R3 alone draws, or the current to determine the resistance of R3. However, the total resistance of R3 is assignable. It should not be low, as it would then draw too much current. The different voltage taps represent proportional points on R3 on the basis of linear length. We can thus make R3 any fairly high resistance, say, 10,000 ohms, and have the taps at the desired points. Now we will know the current drawn by R3 alone.

$$I = \frac{100}{10,000} = .01 \text{ ampere}$$

Hence a 5-watt resistor is ample.

It should be noted that the entire filament current flows in the encircled biasing section of R3, as the heavy arrows reveal. Therefore to determine the resistance of the biasing section we add the filament current to the bleeder and the plate current, or $1.5 + .03 = 1.53$. This is heavy current. A power resistor will be required. The wattage is $9 \times 1.53 = 13.77$ watts, hence a resistor of 25 watts rating is desired. Its resistance:

$$R = \frac{9}{1.53} = 5.88 \text{ ohms for biasing}$$

The $4\frac{1}{2}$ -volt tap is provided by center-tapping the biasing section of R3.

If we desired to compensate for the biasing section because of its 25-watt rating compared with the 5-watt rating of the rest of R3 we could make the rest $10,000 - 5.88 = 994.12$ ohms at 5 watts. Or to avoid that we could have all of R3 rated at 25 watts. Since 5.88 ohms is only about $\frac{3}{5}$ of 1% of the 10,000 ohms, we need not compensate at all for its addition or subtraction.

The 45-volt post is half way between A- and 91+ and the 67+ post half way between 45+ and 91+. The designated B voltages are approximate in all such supplies. In fact, the exact specifications need not be followed, and often can not be, for practical reasons. Also the drop in the audio plate loads has not been deducted, but this would change the figures only slightly. We obtained 69.33 ohms for R1, 184.3 ohms for R2, 10,000 ohms for R3 and 5.88 ohms for the biasing section. In practice these values would be 70 ohms, 200 ohms (since adjustable), 10,000 ohms and 6 ohms, respectively. When .25 ampere tubes are used R2 is shorted out.

Series Filaments

Fig. 15A is for filaments in parallel, the usual method of connecting them. Fig. 15B shows filaments of a receiver connected in series. While by the parallel method the filament currents are added, so that six tubes at .25 ampere draw 1.5 amperes at 5 volts, by the series method the voltages are added while the current remains the same, so that the total voltage required across six 201A tube filaments in series is 30 volts. When resistors are in series the total resistance is the sum of the individual resistances, so six filaments at 20 ohms each taken in series have a total resistance of 120 ohms. As the same current flows through all filaments, the voltage E applied to the series terminals A+ and A- is the product of the current (.25) and the resistance (120) or 30 volts.

The rule is: for parallel connection of equal resistors (e. g., filaments) the currents add up while the voltage is kept the same. For series connection of equal resistors the voltages add up while the current is kept the same. Only equal resistors are considered because unequal ones are not present here. In parallel unequal resistors would require computation by the formula

$$R = \frac{1}{\frac{1}{R1} + \frac{1}{R2}}$$

Where R is the resistance to be ascertained and R1 and R2 are the resistors in parallel. The formula is expressed verbally: The resistance of resistors in parallel is equal to the reciprocal of the sum of reciprocals. When the multiple resistors are equal the formula is the same, but the equation resolves itself into the resistance of one of the equal resistors divided by the total number of equal resistors.

The plate voltages diminish as the filament voltages are added, because the potential at the plate is positive in respect to the negative filament of the same tube. So, as 5 volts are dropped in the filament of tube 1, a 201A tube, the negative filament of tube 2 is 5 volts positive in respect to the negative filament of tube 1. As this reckoning is all in respect to the maximum plate voltage, say 91, the second tube's voltage between F- and the plate is the potential difference between 91 and 5 or 86 volts. Thus if a receiver were built according to Fig. 15A, the plate voltage would be less the greater its need. This could be remedied by rearranging the series chain and also obtaining negative bias from the voltage drops in the filaments. This allows the last tube, 112A, 100 volts less the sum of the drops in the filaments of tubes 4 and 5, or 90 volts. Grid bias is obtained by connection to 10 volts negative (voltage dropped in filaments of tubes 4 and 5), and 5 volts negative for each of the other tubes by connection to the negative filament of the preceding tube. No negative bias could be provided in this way for the first tube in the chain, so the detector tube is

put first, since it takes a positive bias by the leaky-condenser method of detection. Fig. 15C shows the revised series filament connections, with grid loads omitted, although grid return points are shown.

Series filament circuits have no advantage over the parallel filament circuits but have some disadvantages. They can not be used with supplies intended for the usual parallel filament connection.

Difference Between DC and AC Supplies

The difference between a DC and an AC supply of A, B and C voltages and currents, is as follows:

DC	AC
Works from DC line	Works from AC line
Needs no rectification	Needs rectification
Voltage limited	Voltage unlimited
Uses no power transformer	Uses power transformer
Handles modest power	Handles large power
Uses battery-type tubes	Uses AC tubes
Plug polarity fixed	Plug polarity interchangeable

The two types are not interchangeable. Each will work only on the type of current for which it is intended. The AC plug may be inserted in the convenience outlet in either way, but the DC plug must be connected a given way.

It is not economical or otherwise advisable to attempt to change a complete installation of one type to the other type.

Principles of Rectification

In the previous discussion it was assumed that the plate current supply had been rectified before it reached the battery eliminator. This rectification took place at the commutator on the generating machine in the power house and resulted in DC at the convenience outlet.

When the current supply is alternating it is necessary to introduce a device into the circuit which performs the same function as the commutator. That is, it is necessary to use a rectifier which transforms the alternating current into a pulsating, unidirectional current, or a device which passes current in only one direction no matter what the direction of the voltage may be.

There are several forms of rectifier devices in use, such as vacuum tube, gaseous, electrolytic and contact rectifiers.

The vacuum tube, exemplified by the 280 and 281, is perhaps the most familiar. It operates on the principle that an electric current can flow only from the plate to the filament inside the tube, the flow occurring when the plate is positive with respect to the filament.

The gaseous type rectifier, exemplified by the Raytheon BH and BA tubes, works on the principle that electric current between two electrodes in a rarefied gas will flow more freely in one direction than in the opposite one, when one of the electrodes is much larger than the other. In practice one of the electrodes is a point while the other is a conductor having a large surface. Inert gases, such as helium and neon, are used in these rectifiers to prevent chemical action and rapid deterioration.

The electrolytic rectifier depends for its operation on the rapid formation of a non-conducting layer on the surface of one of the electrodes when the current flows between the electrolyte and the conductor in a certain direction, and the rapid breaking-down of this non-conducting layer when the current flows in the opposite direction. Only one of the two electrodes must be made of the metal which forms a non-conducting film, for otherwise current would not flow in either direction. The most common film-forming metal used is aluminum, but there are several metals, chemically related to aluminum, which act in the same way.

The contact rectifiers work in a manner similar to that of the electrolytic, but they do not require an electrolyte. Two dissimilar metals are placed in close contact and an alternating voltage is impressed across the junction. A thin film of a chemical compound is formed on one of the metals, and this film is the rectifying element.

In performance all the different types of rectifiers are essentially the same, but as some of them are more dependable, have longer life, and are more convenient to use, they have become more popular.

Half-Wave Rectifier

An example of the vacuum tube filament type half-wave rectifier is shown in Figs. 16A and 16B. The transformer T which supplies the power contains three windings, a primary which is connected to the power source, a low voltage winding which supplies the filament heating current, and a high voltage winding which supplies the alternating current to be rectified.

For operation it is not necessary that the two secondaries be on the same core. Two entirely different transformers, one for the filament and one for the plate of the rectifier, may be used. Indeed, a battery may be used to heat the filament of the tube. The only purpose of the filament winding is to supply a current which will maintain the filament at a temperature high enough to cause a copious emission of electrons.

[Part IV next week, June 22nd issue]

A Question and Answer Department conducted by Radio World's Technical Staff. Only Questions sent in by University Club Members are answered. Those not answered in these columns are answered by mail.

RADIO UNIVERSITY

Annual subscriptions are accepted at \$6 for 52 numbers, with the privilege of obtaining answers to radio questions for the period of the subscription, but not if any other premium is obtained with the subscription.

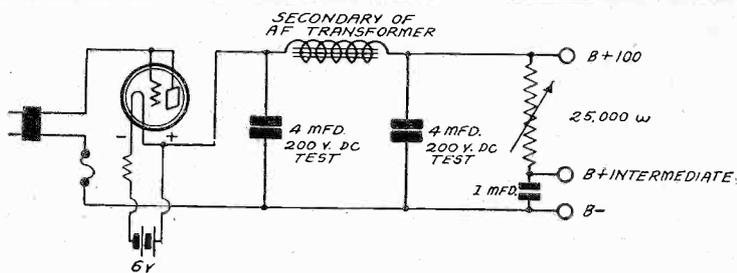

FIG. 758

DESIGN OF A B SUPPLY THAT USES A 201A TUBE AS RECTIFIER AND OMITTS THE POWER TRANSFORMER.

IS IT POSSIBLE to make a B supply, working from the 110-volt AC line, without the use of a power transformer? I have a set that uses storage battery tubes and I am content to retain the storage battery, but I would like to use a B eliminator, at modest output voltage, as I do not require large undistorted power output.—M. M.

Yes, you can connect the 110-volt AC line directly to the plates of a rectifier tube, but can not heat the filament of that tube from the storage battery. Use a separate block of dry cells for the rectifier filament, for instance, if you use a 280 tube. Be sure, however, to insert a fuse of low capacity, as near 1 ampere as you can obtain, putting the fuse in series with one side of the line, ahead of the rectifier tube, of course. Then you can insert the filter chokes and filter condensers and obtain a rectified output of a little more than 100 volts. In fact, if the current drain of your receiver is low, say 15 milliamperes, you can use a 201A tube as rectifier, by joining the grid and plate posts on the socket, and using one side of the filament as B plus, the combined grid-plate, here used as a single plate, being negative. The 201A will not have long life at this drain. See Fig. 758. If the fuse blows put in another and reverse the wall plug.

I HAVE AN AC SET I built myself and it is giving superb performance. I have available three filament voltages—2.5, 5 and 7½. I wonder if the pilot light located in the drum dial can be of the 5-volt type and still be lighted from the 2.5-volt winding? The reason I ask is, I am using push-pull in the last audio, and tax the filament transformer up to the limit on that account, in regard to the 5-volt winding.—J. B. McG.

The 5-volt pilot light will burn brightly enough when heated by 2.5 volts. However, you will probably prefer to use a 2.5-volt pilot lamp, as this type is now generally available, and it is popular in AC circuits. The lamp is obtainable in radio stores, hardware stores and electrical stores. The current drawn of a 2.5 volt pilot lamp is only about .25 ampere, and as the filament winding is usually of low enough resistance to carry several amperes, otherwise is rated to carry a specific higher load, the addition of the pilot lamp's drain is not serious. A 5-volt pilot lamp operated at 2.5 volts draws about .15 ampere.

HAVING built the AC Screen Grid Diamond of the Air, four tubes, I got very good results until the other day, when the first tuning condenser stopped having much effect. Of course the two condensers are ganged, as I am using the prescribed Hammarlund model, but my testing I disconnected the first condenser and there was no difference. Previously when I made this disconnection the signals got much lower and selectivity was reduced. I forgot to state that the reception I am getting now is just the same reduced type as formerly obtainable with the first condenser disconnected.

The trouble is either a break in the leads connecting the stator plates of the first section of the tuning condenser (C1) the coil (L1L2) and the control grid of the first tube, or a break in the first coil (L1L2). Test for continuity with a meter in series with a small battery. When you get no deflection you will have found the open circuit. The diagram is shown in Fig. 759.

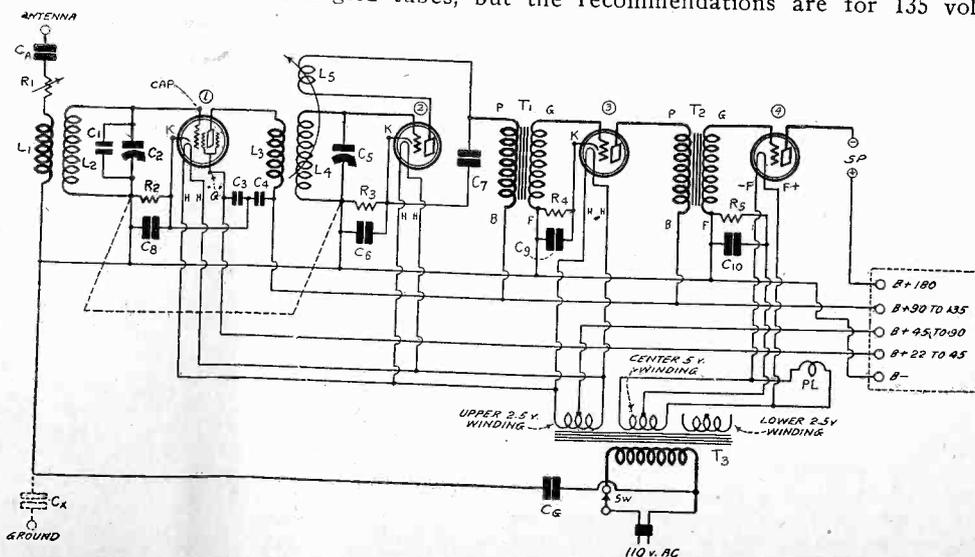

FIG. 759

DESIGN OF THE 4-TUBE AC DIAMOND OF THE AIR, USING ONE SCREEN GRID TUBE. ONE READER'S LOSS OF SENSITIVITY WAS DUE TO AN OPEN IN THE FIRST TUNED CIRCUIT.

I HAVE A JIFFY TESTER that measures the A voltage and current and the B current. By connecting an extra meter, of high resistance, between two posts on the tester, I can read the plate voltage. Is this a means of determining whether the primary of an audio transformer is open? Can I test screen grid tubes with this tester?—B. R.

The Jiffy Tester will tell you whether the audio transformer primary is open, because if it is open there will be no plate current reading and no plate voltage reading. The Tester cuts in at the P post of the socket, so the voltage you read is the net plate voltage, or the applied voltage less the voltage drop in the primary of the audio transformer. The Tester will test a screen grid tube. Use a connecting cable, one end of the cable to the cap of the screen grid tube placed in the Tester socket, and the other end of the cable to the clip that went to the cap when the tube was in the receiver. If you desire an instruction sheet on how to use the Jiffy Tester, write to Guaranty Radio Goods Co., 145 West 45th Street, New York City, and enclose a stamped, self-addressed envelope. The instruction sheet does not cover the screen grid tube test, which has been set forth here, as that test was made possible by an improvement in the design of the Tester made after the instruction sheet was printed.

* * *

I HAVE A BATTERY-OPERATED SET, using storage A and B batteries and dry C batteries. Is there any object in using push-pull as the final stage of audio amplification?—J. M.

Yes. The same advantages, in general, as applying to the use of push-pull in any other audio channel—clearer tone and larger undistorted power output. The volume will not be increased over what you obtain now, but if you provide twice the input to the last stage, you will not overload it, if you do not now overload the single output tube with your present installation.

* * *

MY CHOICE for a receiver is three stages of tuned radio frequency amplification, one stage of resistance coupled audio and one stage of push-pull audio. I am now building such a receiver. But I am in doubt what output tubes to use. I had half decided on a pair of 171A tubes in push-pull, but some friends have encouraged me to use a pair of 245 tubes.—I. D.

You will get good results for either type. The 171As in push-pull will handle without difficulty the volume you will obtain, unless you are using screen grid radio frequency amplification, when, under certain circumstances, such as proximity to high-powered stations, you may run into overload. If your receiver is of the AC type it would be generally preferable to include the 245s in push-pull rather than the 171As, because of less hum and larger maximum power output (handling capacity). Therefore if you can provide the 2½ volts for the 245 tubes from a filament transformer, and apply 250 volts to the plates of these tubes, do so.

* * *

I AM CONTEMPLATING building an eliminator to use with a direct current source from the line. The voltage is 105 volts at the convenience outlet. After the choke coil drops a few volts I'll have only about 100 left, let's say. I would like to use screen grid tubes, but the recommendations are for 135 volts

FIG. 760 GRID BIAS DETECTION, USING A 227 TUBE. THE DETECTOR PLATE CURRENT FLOWS UP THE PRIMARY OF THE AUDIO TRANSFORMER, THEN FROM PLATE, ACROSS GRID, TO CATHODE, THEN TO THE ARROW AND B MINUS.

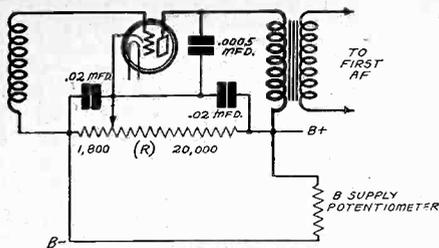

on the plate. Can I use these tubes although I will have available an effective voltage of only 100?—P. L.

Yes. The amplification will be less than otherwise, but the tubes may be used to advantage nevertheless. They will give much more amplification even when thus undervolted on the plate, than will the 201As or equal when those tubes have the rated voltages supplied. Of course, the recommended screen grid voltage of 45 volts would have to be reduced to about 30 volts when the plate voltage is 100. Another method you might employ, to obtain amplification, is to add a 45-volt B battery in series with a 90-volt tap, to obtain the full 135 volts. If you are using more than one screen grid tube, be sure to shield each stage of radio frequency separately. Also in all instances put a bypass condenser from the screen grid post (G post of socket) to ground or F minus. The condenser should be .02 mfd. or higher capacity.

* * *

I HAVE AN OLD SET, using UV, the old style, tubes. These fit in the UV sockets, which have a slot in the collar, to accommodate the pin on the side of the tube base. I recently got a phonograph adapter but can not insert it in the set, because the adapter plug is for the UX type socket. Can I obtain a plug that will make it possible for me to use the pick-up in my set?—H. B.

Yes. You need an adapter to change the UV socket to take the UX plug of the phonograph pick-up. Alden Manufacturing Co. makes one. It is Na-ald Adapter, Cat. No. 299.

* * *

PLEASE LET ME KNOW the difference in performance between the Screen Grid Diamond of the Air and the Screen Grid Universal. I refer to the 4-tube battery models of these receivers.—J. A. E.

The Diamond is highly selective and provides good amplification. The Universal is good on selectivity, but is not as highly selective as the Diamond. But the Universal develops higher amplification. Therefore if you need high selectivity, build the Diamond.

* * *

IS NOT a biasing resistor in the detector circuit of a 227 tube an automatic volume control in itself, since the louder the signal, the greater the plate current, and the greater the plate current the greater the bias, and as this bias moves away from the point of maximum sensitivity the volume declines, hence loud stations are levelled while weak ones are not affected?—W. V. McC.

Such action as you describe takes place, but the control of volume is not complete, although it is automatic. The impulses that strike the grid produce corresponding fluctuations in plate current in a tube. Grid bias detection is provided by the voltage drop in a large resistor, about 50,000 ohms. The plate current in any detector is small. The grid bias detector modulates upward, that is, louder signals increase the plate current. Leaky-condenser detection works just the opposite. But the plate current change, in absolutely quantity, is small, in most instances not nearly reaching .1 milliampere in the detector circuit where negative bias is used and where .3 milliampere is the steady plate current (modulation omitted). So with a 15-volt negative bias for maximum sensitivity, obtained by the voltage drop across 50,000 ohms when .3 milliampere flows, the modulation, introducing the pulsating component, causes a maximum variation of 5 volts. The 5-volt difference will not cause enough change in sensitivity to make the control of volume adequate. Also, the biasing resistor that depends on detector plate current alone cuts down an otherwise larger plate current severely. So the method devised by Prof. Glenn H. Browning of using a lower value (1,800) ohms, and bleeding right through the biasing resistor some independent B current, is preferable. See Fig. 760.

* * *

IN AC SETS it is customary to bias each tube individually by means of biasing resistors. Why can not this method be applied to battery-operated sets? Can a common bias be used? Please show how.—M. T.

In Fig. 761A the method of obtaining negative bias for a receiver powered by a storage battery and a B eliminator is shown. The lead that would otherwise be treated as B minus, that is, the negative lead, is made the maximum C bias. An intermediate C bias is provided. Other intermediate taps would provide other intermediate biases. All the plate current flows through the biasing section. This section is between A— and

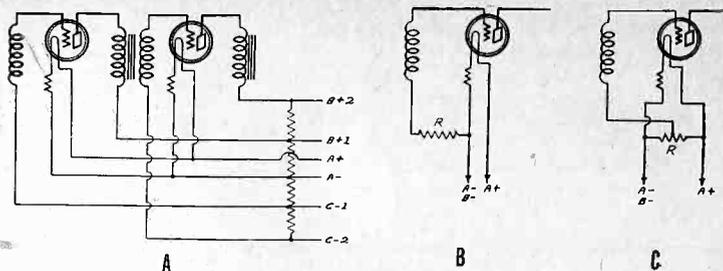

FIG. 761

THE PROBLEM OF OBTAINING C BIAS FROM A BATTERY-OPERATED RECEIVER IS EXEMPLIFIED

B—. The A battery minus connection is therefore lifted from the negative B point to a higher potential. Therefore grid returns made to points negative in respect to A— provide negative grid bias. By-pass condensers should be used, but are omitted to simplify the diagram. In Fig. 761B the resistor R is placed between A minus and the grid return. This reveals, however, that no direct current flows through R, and besides the grid is still returned to A minus. Therefore, no bias results because of the presence of R. There is a little bias due to the voltage drop in the filament resistor. In Fig. 761C the situation obtaining in an AC tube circuit is more closely simulated. Current does flow through R. If the voltage between A+ and A— is 6 volts and R is 120 ohms the current through R is 6/120 or .2 ampere. But the grid return to the filament center (midtap of R) provides zero bias. A resistor interposed between the midtap and the grid return would have no biasing effect, either, for the same reasons outlined in respect to Fig. 761B. Even with a filament type AC tube, like the 226, if separate resistors go from the grid return to midtap, they are in parallel, if fed from the same secondary, hence all tubes get the same bias. Where the filament supply is common to all tubes, as is always the case with an A battery, separate bias through voltage drops through individual resistors in each tube circuit is not possible. In Fig. 761A if the fixed potentiometer at the B supply's output were replaced with a B battery, then connection of A— above B— would provide C bias. But this is exactly how C batteries provide such bias, and they are used, rather than a section of the B battery block, because the C battery provides potential differences in smaller steps.

Join

Radio World's

UNIVERSITY CLUB

And Get Free Question and Answer Service for the Coming 52 Weeks. This Service for Yearly Subscribers Only

Subscribe for RADIO WORLD for one year (52 numbers). Use the coupon below. Your name will be entered on our subscription and University Club lists by special number. When sending questions, put this number on the outside of the forwarding envelope (not the enclosed return envelope) and also put it at the head of your queries. If already a subscriber, send \$6 for renewal from close of present subscription and your name will be entered in Radio University.

NO OTHER PREMIUM GIVEN WITH THIS OFFER

[In sending in your queries to the University Department please paragraph and number them. Write on one side of sheet only. Always give your University Club Number.]

RADIO WORLD, 145 West 45th Street, New York City. Enclosed find \$6.00 for RADIO WORLD for one year (52 nos.) and also enter my name on the list of members of RADIO WORLD'S UNIVERSITY CLUB, which gives me free answers to radio queries for 52 ensuing weeks, and send me my number indicating membership.

Name

Street

City and State

If renewing subscription, put cross here.

'LUCKY STRIKE' ADS TONE DOWN AND WAR IS OFF

Washington.

Due to the change of policy in the programs broadcast by the American Tobacco Company on behalf of its Lucky Strike cigarettes, the National Food Products Protective Association has withdrawn its complaint against 38 stations of the National Broadcasting Company chain that carry the program each Saturday night.

The "tainted testimonials" have been abandoned by the Lucky Strike advertising directors. Prominent persons, including stage folk, athletes and coaches, had been quoted as approving the use of Lucky Strike cigarettes. The contention was that these testimonials were purchased in the open market, and that there were fixed prices, depending on the fame of the professional "testimonialist," there being no sincerity in the indorsement.

This form of "tainted testimonial" has been abandoned by the tobacco company also in its printed advertisements. Pictures of celebrities are shown, but no quotation given.

The Candy Sore Spot

The other sore spot, the one that grieved the food association most, was the slogan: "Reach for a Lucky instead of a sweet." This was felt to be a most unwelcome slap at the candy business, especially as the food association has some testimonials from doctors tending to prove that candy is a wholesome food.

Now this slogan is modified in the broadcast advertising, although flaunted as usual in newspaper and magazine advertisements. In broadcasting only "Reach for a Lucky" is advised, for keeping the body trim and slim, but the invidious injunction against the sweet is out of the aired blurb.

A. M. Kelly, chairman of the National Food Products Protective Committee, wrote a letter to the Federal Radio Commission, withdrawing the complaint without prejudice to renewal. He wrote:

"Public feeling and indignation over the misleading and destructive propaganda contained in the cigarette programs have risen to such a pitch that the tainted testimonials which featured the campaign were forced off the air and the vicious advertising slogan attacking important food industries was modified in the broadcasting program.

"The steps, admittedly, were splendid examples of self-regulation on the part of broadcasting interests.

Says Legislation Is Needed

"Nevertheless, the fact remains that a stupendous effort is still in progress, through the medium of both the printed and the spoken word, urging millions of young women—many of them the future mothers of the nation—to maintain a slender figure by the nicotine method of dieting.

"Just how pernicious and appalling is such advice, expressed through a nationwide \$12,000,000 advertising campaign, is best illustrated by the report published in the New York 'Times,' on May 30th, 1929, giving statistical reports presented at the annual convention of the National Tuberculosis Association meeting in Atlantic City.

"However, as the issue raised by the

Licenses Proposed From Day to Day

Washington.

Senator Couzens suggested that broadcasting station licenses be put on a day-to-day basis, as are many public utilities throughout the country, a method that, he says, tends to keep them on their toes.

The cancellation of such a license, he said, could only be terminated by the Radio Commission after a public hearing. Mr. Couzens said such a provision might be written into his bill for creating a communications department.

About the same time he was making the suggestion to the Senate, the Federal Radio Commission put experimental licensees on an annual basis, instead of continuing them on a temporary basis.

SYKES FAVORS COUZENS BILL

Washington.

Federal Radio Commissioner Eugene O. Sykes told the Senate Committee on Interstate Commerce he favored the principle of a centralized control of wired and wireless communication contained in the Couzens bill.

"I am a very strong advocate indeed of the zone system," replied Commissioner Sykes. "I believe it gives to the Commission, through the commissioner from that zone, a more intimate knowledge of conditions there. The present zone arrangements are working very nicely."

Commissioner Sykes suggested that the Couzens bill should incorporate a proviso which would permit the Commission, after an equalization of the zone assignments of radio facilities required by law, to use unassigned frequencies as it may think best to serve the public.

Regarding a license fee on broadcasting stations, the witness said that he saw no reason why there should not be a tax on so valuable a franchise but questioned the advisability of such a proposal at the present time because radio broadcasting stations are not making money.

latest advertising appeal made in the cigarette campaign is one that demands legislation and not merely regulation, and in view of the modifications already made in the broadcasting program complained of in its petition filed with your body as aforesaid, the National Food Products Protective Committee, withdraws its formal complaint filed with you.

Would Renew if Necessary

"This action is taken without prejudice to its right to renew the complaint in the event that the radio programs of the American Tobacco Company, as now broadcast through some 38 stations, shall exceed their present limitations or otherwise give occasion for further protests on the part of this committee or any of the constituent members thereof."

The petition had asked revocation of the licenses of the 38 stations, some of them among the leading stations of the country.

PROGRAM COST IS ZERO TO ALL, SPONSORS HEAR

French Lick Springs, Ind.

It doesn't cost anybody a cent to have such fine programs on the air as the manufacturers who sponsor them for good-will objectives now provide. So Orestes H. Caldwell told the Association of National Advertisers. He was formerly a Radio Commissioner. He said:

"The public reads with wonderment of the enormous sums paid out to artists and broadcasting stations for a half hour or so on one of the big broadcasting chains. Single program have cost \$10,000 to \$60,000 for one hour.

"Laymen sometimes express surprise at the financial burden thus placed upon the product advertised, and wonder how much the customer pays for all this in the price of the radio-advertised soap or automobile that he buys.

Does Some Straightening

"If the public really fears that it pays a price penalty on the radio-advertised product, it needs to have its economic thinking straightened out. For a little analysis will show that the wonderful programs which now come to us all nightly over the air, free of any cost, are also produced free of any cost to the advertisers who pay the bills—and free of any cost to their customers as well.

"That is, radio entertainment is, indeed, free as air, for it is free to the listener, free to the advertiser whose goods it promotes, and without expense also to the customers who buy those goods.

"Here is a twentieth-century miracle, seemingly almost as much of a paradox as radio itself, yet the economic fact remains that radio programs are financed out of their own savings.

"The secret, of course, is well known to all advertising men. Radio, reaching a vast audience, rapidly builds good-will and an increased volume of sales. This sales volume in turn produces lower selling and distribution costs per unit.

Mr. Waste Alone Pays

"Such reduction in the cost of delivering to you the cake of soap or automobile you buy pays back the cost of programs, artists, station and wire charges, and all—and more besides. Or, looked at another way, you and a million others get your cake of soap plus radio entertainment for the same price as the soap alone would have cost, produced and sold in smaller quantities.

"Thus everybody—advertiser, customer and public—benefits. Nobody pays, except Old Man Waste. Through radio, as with others forms of advertising, the costs of inefficiency in distribution are reclaimed and converted into enjoyment and education for millions. Radio retrieves the wastes which the machinery of commerce creates by substituting more efficient mass merchandising. And out of the economic savings thus accomplished the nights are filled with music."

ARTHUR J. LYONS MOVES

The Tobe-Deutschmann Corporation, of Canton, Mass., has moved its New York headquarters to 136 Liberty Street. Here a showroom will be maintained. The business of this office has been extended under the management of Arthur J. Lyons, Tobe representative in the Metropolitan territory.

ALEXANDERSON TRF PATENT ON TOP, SAYS RCA

Washington.

Insinuations made by a witness before the Senate Committee on Interstate Commerce that the Alexanderson tuned radio frequency patent was anticipated by the German patents seized by the United States Government during the war, and that American decisions in cases sustaining the Alexanderson patent were in suits of doubtful sincerity, were answered by the Radio Corporation of America with denial that cited court records. Col. Man-ton Davis, vice-president and general counsel of RCA, wrote the committee a letter on the subject. His letter was as a reply to testimony given before the committee by Col. J. L. McMullen, of the Judge Advocate General's office of the Army, who appeared in connection with the Couzens bill for the creation of a Federal communications commission. The committee, during the course of these hearings, is inquiring into alleged failure of the Government to assert its patent rights as against those held by the industry, notably the RCA.

Colonel McMullen said that the Schloemilch-Von Bronk patents, seized by the United States from Germany just before the Armistice, "anticipated" the Alexanderson patent of the RCA. He said that the two decisions of the Federal District Courts, upholding the Alexanderson device, were "rather a put-up job" to have the RCA device validated over the other. The Alexanderson patent, he charged, had been upheld "in a sort of left-handed way."

What Letter States

In his letter Colonel Davis declared: "Insinuations were that the Department of Justice had not heretofore been disposed to protect the Government's interests, but that recently there had been a change of policy on this subject.

The witness said he thought the United States had not intervened in the litigation which sustained the Alexanderson patent but that the policy in this respect had recently been changed by the Department of Justice, that he had made a study of these patents and his conclusion was 'that the Schloemilch and Von Bronk patent anticipates the Alexanderson patent.'

Col. Davis referred to enclosures sent with his letter, including Federal court opinions deciding two cases, and photostat copies of briefs showing participation of the United States Government in behalf of the so-called Navy patents.

Col. Davis then continued:

"May I ask your special attention to pages 12-16 of Judge Bodine's opinion in the Splittorf case where after a studious and detailed comparison of the Alexanderson invention and the Schloemilch and Von Bronk patent, the court sustains the Alexanderson patent and winds up by saying that Alexanderson made 'a truly great invention.' May I likewise ask you to examine the photostat copy of the brief filed by the Department of Justice in the Splittorf case? Perhaps this brief may be esteemed an answer to those who, apparently without knowledge of the records they discuss, have criticized the Government of the

Patents Identical, Says Navy Expert

Washington.

For its radio patent holdings, including the Schloemilch-von Bronk tuned radio frequency device, seized during the World War by the Alien Property Custodian, the Department of the Navy paid only \$1,690 to the Custodian, the State Committee on Interstate Commerce was informed by Lieutenant Commander Harold Dodd, in charge of the patents' section of the office of the Judge Advocate General of the Navy.

Testifying in the inquiry into Navy radio patent holdings incident to the hearing on the Couzens Bill, which would create a Federal communications commission, Commander Dodd said the United States Government now holds 55 former German radio patents. Originally, he said, 106 patents were acquired from the Alien Property Custodian, but the number has been decreased by the expiration of patent rights.

The first lot of radio patents, said the witness, was purchased February 6th, 1919, for \$500, at private sale from the Property Custodian. The remainder was acquired, April 10th, 1919, for \$1,190. In this group, he said, was the von Bronk patent, performing the same function as the Alexanderson patent, controlled by the Radio Corporation of America. Basically the patents are identical, he said, and are employed in every receiving set.

Higher Power to KYW Protested by WCFL

Washington.

A protest against possible granting by the Federal Radio Commission of the application for an increased power allotment made by KYW of Chicago, has been presented in a telegram read in the Senate at the request of Senator Dill (Dem.), of Washington.

The telegram was addressed to Senator Dill and signed by E. N. Nockels, general manager of WCFL, Chicago, the Chicago Federation of Labor station, which has heretofore protested that it has not received a fair allotment of time and power from the Commission.

United States, insinuating dereliction in these matters.

No Appeal Taken in U. S.

"May I ask you to examine Judge Thatcher's opinion where the Alexanderson patent and the Schloemilch-von Bronk patent are considered and the Alexanderson patent again sustained?

"The last paragraph on page 9 of Judge Thatcher's opinion discloses that the Edmond case was defended by the Atwater Kent Manufacturing Company and this may be some evidence that the litigation was real and not 'a rather put-up job,' since Atwater Kent as a result of this litigation took licenses and has since been paying royalties under the Alexanderson patent.

"The American litigation referred to was not appealed and is now final. In the Canadian litigation, on the other hand, the Alexanderson patent was sustained by the lower court, which decision was reversed by the Supreme Court of Canada, but jurisdiction of the controversy has been taken by the Privy Council, the highest appellate tribunal in the British Empire, and there this Canadian litigation is still pending, undisposed of."

COURT CAPRICE MADE WGY WIN, IS APPEAL PLEA

Washington.

Counsel for the Federal Radio Commission has filed the Commission's petition for a writ of certiorari, asking the Supreme Court to review the judgment of the Court of Appeals setting aside a decision of the Commission which, in effect, denied the application of General Electric Company for full-time use of the 790-kilocycle channel for its broadcasting station WGY, located at Schenectady, N. Y.

At the time of the Commission's decision, denying the application for renewal on a full-time basis, the position was taken that General Electric Company was not entitled to a hearing unless it applied for a cleared channel assigned to the First Zone. 790-kilocycles had been assigned as a cleared channel to the Far Western States of the Fifth Zone. The Court of Appeals held, however, that public interest, convenience, or necessity warranted renewal on a full-time basis, and directed the Commission to issue such a license.

Upset Reallocation

The Commission says the judgment had the effect of depriving the Fifth Zone of a cleared channel, reducing the total number of such channels to 39; and in part it invalidated the Commission's reallocation embodied in General Order 40 and required by the Davis Amendment, for it upset the designation of eight cleared channels to each of the five zones.

Other features of the case are relied on by counsel for the Commission. It is asserted that the case was moot on February 25th, 1929, the date of the judgment, because the license in question, giving WGY day time use instead of unlimited use of the channel in question, had expired before February 25th.

"Arbitrary and Capricious"

It is also asserted that the Court had no power to receive ex-parte affidavits presented for the first time on the appeal (for there was no hearing before the Commission) as a basis for its judgment on the merits; and that in any case if the Commission erred in refusing a renewal or a hearing on an application which was improper under its rules, the case should have been remanded for a proper hearing, at which all circumstances and facts bearing upon the public interest could be fully developed and considered.

Moreover, the judgment of the Court of Appeals is said to be arbitrary and capricious, based on conclusions of fact which are refuted by undisputed evidence.

If the writ is allowed, this is one of several radio cases which will come before the Supreme Court early in the next term.

A THOUGHT FOR THE WEEK

AS so many electrical and novelty stores handle radio goods—and this goes for the jobbing end, too—that it was rather a silly proposition for the American radio interests to hold their annual convention in Chicago at the same time that the electrical folks were convening in Atlantic City. There's a lack of co-ordination and co-operation somewhere.

H. Pollock, 6239 Langley Ave., Chicago, Ill.
 Herman Pophal, R. No. 2, Box 44, Mausay, Wis.
 R. A. McQuary, 808 Austin St., Plainview, Tex.
 Max Dubowsky, 1360 Lucerne Ave., Fresno, Calif.
 Howell E. Turner, 4483 Guernsey St., Bellaire, Ohio.
 J. M. Cook, 1153 41st St., Milwaukee, Wis.
 Rawls Drug Co., W. J. Rawls, 2200 Second Ave., Dallas, Tex.
 R. Y. Buerger, 144 Elm St., Schenectady, N. Y.
 Gibbs Gas Engine Co., Geo. W. Gibbs, 26 So. Main St., Jacksonville, Fla.
 Herman Mick, 1309 Feazel St., Harrisburg, Ill.
 E. A. Lundberg, 2424 Orchard St., Chicago, Ill.
 Joseph Casey, P. O. Box 1, Melrose, Mass.
 Elmer Krack, 2113 Liberty St., Erie, Pa.
 Paul L. Haertel, 519 N. 5th Ave., Maywood, Ill.
 C. J. McCrea, Box 421, Bedford, Iowa.
 C. W. Fanckboner, P. O. Box 432, Boise, Idaho.
 Mack's Radio Shop, Bridgeport, Ohio.
 A. E. Barton, 170 King Edward Ave., Toronto, Ont., Can.
 Ralph Wallace, 117 Congress St., Portland, Maine.
 The Colossus Co., Inc., P. O. Box 4226, Portland, Ore.
 Geo. W. Tope, Box 159, Gold Beach, Ore.
 Raymond Proffitt, Box 26, Hico, Tex.
 Asa Wingler, 508 No. High St., Salem, Ind.
 J. M. Cleland, Jr., R. R. No. 1, Box 671, Bellingham, Wash.
 Leroy Smeigh, 46 E. South, York, Pa.
 N. Chiafery, 83 Pansy St., Rochester, N. Y.
 M. L. Otis, Lake Superior Dist. Power Co., Ashland, Wis.
 E. J. Fetterhoff, 135 Centre St., Milton, Pa.
 G. C. Blackburn, Otway, Ohio.
 Herbert Nestvogel, 2022 Palmetto St., Brooklyn, N. Y.
 Wright Wilde, 35 McGurk St., New Bedford, Mass.
 L. B. Smith, 9 West Derry St., Hershey, Pa.
 J. P. Silvera, 12 Hiawatha Rd., Toronto, Ont., Can.
 W. C. Campbell, Glendale, W. Va.
 Earl Wolff, 425 Walnut St., Waynesboro, Pa.
 H. P. Carr, R. D. No. 1, Toronto, Ohio.
 Sam Miller, 931 Willow Ave., Hoboken, N. J.
 Frank Willmann, 2302 Potter Ave., Astoria, L. I.
 R. W. Page, R. D. A. Box 105-A, Sanger, Calif.
 E. H. Bailey, Box 22, Artesia, Miss.
 C. E. Layton, 330 East South St., Orlando, Fla.
 John C. Leber, 2308 Delmar Ave., Granite City, Ill.
 C. A. Warhanik, 6052 5th Ave., N. W., Seattle, Wash.
 L. W. Chapman, 491 Park Side Drive, Bay Village, Ohio.
 Edward Yerger, 1220 Green St., Phila., Pa.
 Gilbert Benton, Martins Ferry, Ohio.
 J. G. Jernberg, 127 Lincoln Ave., Wollaston, Mass.
 D. C. Spain, Box 853, Trail, B. C., Can.
 Felix F. Molero, Puerto Madryn, Argentine, S. A.
 S. A. Ryberg, 3657 Dwight, San Diego, Calif.
 John U. Rose, Box 170, Stillwater, N. Y.
 E. A. Peake, 51 E. 68th St., Portland, Ore.
 Robert Clement, 123 Main St., Newport, Vt.
 R. C. Mortimer, McCracken, Kans.
 Jim Rahilly, 2120 Spruce St., Phila., Pa.
 Clarence D. Bussius, 104 17th St., S. E., Washington, D. C.
 Joseph H. Fritsch, 921 72nd St., Brooklyn, N. Y.
 Hydro Radio Club, care A. E. Clark, 59 Murray St., Toronto, Ont., Can.
 Emerson Dietz, 4844 E. 85th St., Cleveland, Ohio.
 R. M. Meier, 1433 Redwood Ave., Akron, Ohio.
 Joseph P. Hughes, 46 East Broad St., Shillington, Pa.
 L. W. Hale, 2610 1/2 E. Madison St., Seattle, Wash.
 A. Platt, 352 48th St., Brooklyn, N. Y.
 Vernon S. Hall, 4217 W. Lafayette, Detroit, Mich.
 Thure M. Ahlquist, 4738 6th St. North, Minneapolis, Minn.
 F. L. Bragg, Gray, Ga.
 Armand Beaudoin, 67 Winter St., Manville, R. I.
 John J. Kovalsky, care Iron City Electric Co., 3577 Bigelow Blvd., Pittsburgh, Pa.
 Geo. Compton, 1476-A Fulton St., Brooklyn, N. Y.
 Albert R. Dorn, 2005 E. Orleans St., Phila., Pa.
 Elvie Thomas, P. O. Box 325, Cottonwood, Ariz.
 Harvey Thompson, P. O. Box 35, Oakfield, N. Y.
 Milton Roseburn, P. O. Box 99, St. Johns Pl. Sta., Brooklyn, N. Y.
 Geo. D. Atkinson, 3004 Madison Ave., Fresno, Calif.
 Walt A. Stang, Stop 8, Lake Ave., Elyria, Ohio.
 W. J. Rose, P. O. Box 147, St. John's Newfoundland.
 H. E. Hurley, Am. Sta. W6CKS, U. S. Veterans' Hospital, San Francisco, Calif.
 R. L. Parsons, 20 12th Ave., San Mateo, Calif.
 N. H. Squire, Box 700, Sonora, Calif.
 Robert Pelton, 1355 W. 10th, Erie, Pa.
 Frank Farbanish, 423 N. Main Ave., Scranton, Pa.
 H. E. Gorratt, 635 Barton Ave., Terra Haute, Ind.
 Oliver Radio Service, 111 E. 7th Ave., Hutchinson, Kans.
 W. J. Roles, 3000 Harrison, Kansas City, Mo.
 Frank E. Biehl, 15 Penelope St., Pittsburgh, Pa.
 C. H. Owens, 5635 Willows Ave., Phila., Pa.
 J. Carroll O'Donnell, 418 Federal St., Pittsburgh, Pa.
 Charles Drewes, 280 Knox Ave., Grantwood, N. J.
 E. H. Damrow, D. C., 209 Jackman Blk., Jamesville, Wis.
 Chas. H. Ray, 611 Circle Ave., Forest Park, Ill.
 Thos. S. Langston, 608 Arch St., Carnegie, Pa.
 W. I. Gilbert, Box 56, Kings Mill, Tex.
 W. B. Blodgett, 1155 National Ave., Milwaukee, Wis.
 Teddy Deitert, 298 High St., Webster, Mass.
 Albert Dollinger, 28 Morton St., Newark, N. J.
 Harold C. Meyer, 1004 N. 11th St. W., Cedar Rapids, Iowa.

Literature Wanted

THE names and addresses of readers of RADIO WORLD who desire literature on parts and sets from radio manufacturers, jobbers, dealers and mail order houses are published in RADIO WORLD on request of the reader. The blank at bottom may be used, or a post card or letter will do instead.

RADIO WORLD,
 145 West 45th St., N. Y. City.

I desire to receive radio literature.

Name

Address

City or town

State

Philip Feintheil, R. D., Mt. Healthy, Ohio.
 Ernest M. Harris, Route No. 1, Charleroi, Pa.
 John G. Hughes, 320 Martin Brown Bldg., Louisville, Ky.
 Francis M. Wherrett, 2714 Edmonson Ave., Baltimore, Md.
 Frank Vinski, 116 No. 9th St., Brooklyn, N. Y.
 Jean Gauvin, 3960 St. Hubert St., Montreal, Can.
 Vernon J. Suche, 4326 Itaska St., St. Louis, Mo.
 S. E. Collins, 155 Furman St., Schenectady, N. Y.
 M. L. Otis, 101 W. 2nd St., Ashland, Wis.
 Adolph Stamper, 1103 Washington Ave., Bronx, N. Y. City.
 W. D. Van Ness, 10 Museum Road, Boston, Mass.
 Wm. S. Sole, Crawford Ter., Union, N. J.
 D. E. Baber, 1256 Lowell, Kansas City, Kans.
 Herman G. Olsen, 1711 Charles St., R. F. D. No. 7, Erie, Pa.
 Paul Bilsland, Box 524, Wenatchee, Wash.
 Miss Bessie M. Dolan, 2200 W. Jockson Blvd., Chicago, Ill., Sta. D.
 Paul C. Seasholtz, P. O. Box 144, Lock Haven, Pa.
 Arthur Fleury, 151 David St., New Bedford, Mass.
 C. L. Jeppesen, Post Office, Waterloo, Iowa.
 Ray Flickinger, 936 Waldman Ave., Flint, Mich.
 Charles Gross, 2905 Grand Concourse, Bronx, N. Y. City.
 Frank J. Orcutt, Radio Sta. W4JO, 2108 W. Church St., Orlando, Fla.
 Edwin C. Watkins, 806 Cornelia St., Flint, Mich.
 W. V. Allen, 417 W. Yosemite, Madera, Calif.
 Ed. Kelley, 381 East Jerome St., San Jose, Calif.
 H. E. Bassford, Jr., 1159 Warnock Ave., Salt Lake City, Utah.
 Ira B. Valentine, Box 22, Squirrel Hill Sta., Pittsburgh, Pa.
 H. Price, 5929 Cadillac, Detroit, Mich.
 H. K. Gibson, 330 S. California Ave., Chicago, Ill.
 Weaver R. Wells, 1312 Willow St., Trinidad, Colo.
 L. P. Gorsuch, 319 No. 2nd Ave., Tucson, Ariz.
 J. C. Ruif, 219 W. Chicago Ave., Chicago, Ill.
 Arthur B. Cooney, Science Dept., Rialto Junior High School, Rialto, Calif.
 Franklin King, 101 Chesterfield St., Virginia Heights, Roanoke, Va.
 J. G. Edmundson, 1009 E. 7th St., Tucson, Ariz.
 G. E. Beck, 2211 E. Houston, San Antonio, Tex.
 Charles G. Kaehms, Box 726, Mayfield, Calif.
 J. E. Anderson, 101 W. 126th St., New York City.
 Mapel Radio Service Co., 2833 Tillman Ave., Detroit, Mich.
 W. P. Dillingham, 1470 Hibbard, Apt. No. 5, Detroit, Mich.
 Harold Redding, P. O. Box 301, Turtle Creek, Pa.
 George E. Fleming, 44-15 43rd Ave., Long Island City, N. Y.
 Mrs. E. Ackerman, 1600 Lucretia Ave., Los Angeles, Calif.
 M. Spooner, Jr., 511 First St., Albany, N. Y.
 O. V. Cheney, Box 343, Hoxie, Ark.
 Hal. Sussman, 74 Osborn St., Brooklyn, N. Y.
 H. C. German, care W. H. Dunning, Navan, Ont., Can.
 E. Hicketier, 2920 35th St., Sacramento, Calif.
 Vernon V. Story, Radio Sta. W4AHQ, Auburn, Ala.
 J. A. Holgate, 1649 1/2 Northampton St., Holyoke, Mass.
 B. R. Farris, 320 N. W. 2nd Ave., Miami, Fla.
 E. R. Holbrook, 1208 70th St., Los Angeles, Calif.
 M. R. Gibson, 16 E. Sixth St., Chattanooga, Tenn.
 S. H. McIntire, 1902 Ann St., Wilmington, N. C.
 Irvin R. Lynch, 2414 Indiana Ave., Columbus, Ohio.
 Wm. F. Warner, 687 Buffum St., Milwaukee, Wis.
 Ivan B. Shaw, Box 509, Yarmouth, N. S., Can.
 Albert C. Weingarth, Jr., 243 So. Ohio St., Los Angeles, Calif.
 Billie Lawson, Hamilton Tire & Accessory Co., 32 High St., Hamilton, Ohio.
 Franz Gaumer, R. No. 2, Wamego, Kans.
 Geo. J. Birchler, 508 Burleigh St., Milwaukee, Wis.
 Arthur K. Holroyd, Apt. B-209, 4619 Chester Ave., Philadelphia, Pa.
 C. Fillmore, N. Hauchett St., Coldwater, Mich.
 Jose A. Sambolin, 10 Salud St., Box 406, Ponce, P. R.
 H. W. Bierhorst, 2741 Wisteria Ave., New Orleans, La.
 H. Carter, 25 Lafayette, Montreal South, Que., Can.
 George Ashley, Box 52, Melbourne, Fla.
 Merle Barker, Rice, Kansas.
 Georg Mertikas, 154 N. Illinois St., Indianapolis, Ind.
 M. George Hassar, 4405 Ashland Ave., Detroit, Mich.
 J. S. Bilanger, Box 62, Arvida, Chicoutimi, Can.

Max Stein, 40 Carmel St., Chelsea, Mass.
 J. Gelston, 90-20 214th Place, Queens Village, N. Y.
 Kenneth P. Selander, 9 Broad St., Plainville, Conn.
 Wm. O. Grafe, 4118 N. Francisco Ave., Chicago, Ill.
 Samuel Watkinson, New Lebanon, N. Y.
 H. L. Fiero, 138-33 97th Ave., Jamaica, N. Y.
 Armando Greco, Av. Montes de Oca No. 1671, Buenos Aires, Argentine, Rep.
 Ben. Dagostin, Sugarloaf, Pa.
 J. Schneider, 104 1/2 So. 3rd St., St. Joseph, Mo.
 Thos. Rossignol, Sanford, Me.
 M. P. Watson, 1917 Frick Bldg., Pittsburgh, Pa.
 T. L. Willis, Staffordsville, Va.
 William E. Mengel, 8 East Green St., Easthampton, Mass.
 P. E. Stone, Box 66, Coaldale, Pa.
 Joseph Kehl, P. O. Box 822, San Francisco, Calif.
 L. L. Berry, 2712 Preston St., Columbia, S. C.
 Jack H. Meyers, 289 King St., Charleston, S. C.
 R. L. Sharp, Vigo Route, Tulia, Texas.
 James McSorley, 251 Maple St., Kearny, N. J.
 Charles Kuhn, Box 301, Orchard Ave., Oakwood, Mo.
 Vincent W. Hdier, 4343 Hirsch St., Chicago, Ill.
 H. Onslow, 2506 No. Orkney St., Philadelphia, Pa.
 Edward Romney, 9 Park Vale, Coolige Corner, Mass.
 Frank Remy, P. O. Box 594, Pleasantville, N. J.
 James Klittner, 141 Morningside Ave., Yonkers, N. Y.
 William F. Bell, Jr., 1524 W. Dauphin St., Philadelphia, Pa.
 F. H. Korber, 502 Lafayette St., Utica, N. Y.
 Radio Service Co., 384 Niagara Falls Blvd., Buffalo, N. Y.
 Robert Pelton, 1355 W. 10th St., Erie, Pa.
 A. F. Abel, 1110 Euclid Ave., Cleveland, Ohio.
 F. G. Hoelzle, 4187 Burgen, St. Louis, Mo.
 A. J. Boehm, 1702 Leister St., N. S. Pittsburgh, Pa.
 G. F. Long, 2701 Monroe Ave., Cleveland, Ohio.
 Raymond Campbell, 2631 Iowa Ave., St. Louis, Mo.
 F. W. Kloss, 2504 N. Alder, Philadelphia, Pa.
 M. J. Young, 619 Cedar St., Allentown, Pa.
 Mahlon M. Lenker, 1002 Ironside Rd., Fairview, Camden, N. J.
 Harry Chassen, 2020 64th St., Brooklyn, N. Y.
 Daniel J. Reid, Payson, Utah.
 Edwin C. Shurig, 5217 Lansdown St., St. Louis, Mo.
 Ralph Carson, Payson, Utah.
 S. B. Ullrich, 45 Williams St., Malden, Mass.
 Dwight C. Aten, 34 Washington Place, care N. Y. U. Bookstore, New York City.
 Acme Finishing House, W. G. Kahler, 352 S. Ann St., Lancaster, Pa.
 H. Steensere, Esq., care Cons. Gas Co., 163rd St. & East River, Bronx, N. Y. City.
 B. Frank Theobald, 515 Packard Bldg., Philadelphia, Pa.
 J. C. Thompson, Samson, Ala.
 Arthur E. Lowe, 1139 Mason St., Victoria, B. C., Canada.
 Frank Copeman, 15 West 37th St., New York City.
 Arthur L. Neyman, 1602 E. 11th St., Shawnee, Okla.
 Robert Jones, 120 Prospect St., Port Chester, N. Y.
 Donald Brasher, 476 N. Grandview, Dubuque, Iowa.
 J. H. Redmond, Athens, Ont., Can.
 Lebay's Home Radio Shop, East Canton, Ohio.
 D. E. Vaughan, Box 5636, State College Sta., Raleigh, N. C.
 L. W. Goodwin, 197 Kent St., Charlottetown, P. E. Island, Can.
 John Karschner, 217 West 28th St., Wilmington, Del.
 M. F. Gunderson, New London, Minn.
 K. O. Weser, Medstead, Sask., Can.
 S. L. Little, Alldritt Garage, 1121 N. W. 29th St., Miami, Fla.
 William L. Wilcox, Water Valley, Miss.
 E. R. Bingham, Middleburg, Pa.
 Ed. Tapper, 1120 Center St., Chicago, Ill.
 Manuel J. Martinez, Box 101, Arcitico, Porto Rico.
 L. F. Reiner, 1328 S. W. 14th St., Miami, Fla.
 Jos. Koselnack, 1913 Jane St., S. S., Pittsburgh, Pa.
 Walter A. Moritz, 2608 Monroe St., Milwaukee, Wis.
 S. J. Clark, care Grand Hotel, Battle Creek, Mich.
 David Lieberman, 1777 E. 8th St., Brooklyn, N. Y.
 Irvin Martin, 1124 4th St., Fairbury, Nebr.
 F. P. Coombe, 242 High St., Morgantown, Va.
 Chas. Hart, Room 204, 218 Main St., Derby, Conn.
 Henry H. Graef, 3110 No. Damen Ave., Chicago, Ill.
 N. T. Turner, R. No. 1, Poteau, Okla.
 L. A. Bloomer, Torrington, Wyo.
 John C. Hudson, 54 Dalton t., Barrie, Conn.
 A. Miller Radio Shop, 414 9th St., Rockford, Ill.
 P. H. Beckman, Redfield, So. Dak.
 Eugene Enteman, care Radio Doctors, Inc., 78 22nd St., Irvington, N. J.
 Elton Kelley, 3327 College, Kansas City, Mo.
 Alfred M. Prior, Glen Park, N. J.
 T. M. Lysle, R. No. 47, Greenville, Pa.
 Wm. Neuman, Radio Laboratory, 85-50 Forest Parkway, Woodhaven, N. Y.

NEW INCORPORATIONS

La Salle Radio and Television Corp., Philadelphia, Pa.—Corporation Trust and Guarantee Company.
 Auto Radio and Electrical Supply Corporation, Freeport, L. I.—Atty. H. C. Evans, 233 Broadway, New York, N. Y.
 State Radio Distributing Co., Newark—Atty. Barney Larkey, Newark, N. J.

LOWER ROYALTY ON SETS SOON, SHOW REVEALS

Chicago.

The radio trade show held at three hotels here for a week was notable for the general rush of set manufacturers to the screen grid tube receiver and to the low-price class. The manufacturers were given to understand that the 7½% license royalty they have been paying on the entire output, including cabinet, will be restricted to the chassis, thus effecting a \$2,000,000 saving. Some manufacturers have priced their new models on this basis, although the formal announcement of the policy change had not been made.

The licensor is the combination of RCA, Westinghouse and General Electric. The reduction is to be made retroactive to April 1st.

The minimum, or the least that the manufacturer must pay, is \$100,000 a year, but no preliminary mention was made of possibility that this, too will be reduced.

The Radio Manufacturers' Association, conducting the show, announced that sales managers from all parts of the country attending the show report that territorial quotas for sets will be doubled, and the demand for receivers so far has resulted in orders exceeding \$95,000,000. Last year about 2,000,000 new receiving sets were manufactured.

The estimate for the season of 1929-30 is 2,800,000.

The show was not open to the public, as it is a trade affair exclusively, enabling manufacturers to exhibit for one another's benefit and to book orders from distributors.

Music Expert Joins NBC as an Executive

Thirty-one years experience in the management of musical stars and the staging of musical events are taken to radio by broadcasting by H. B. Schaad, formerly of the Aeolian Company. His appointment as associate managing director of the National Broadcasting and Concert Bureau was announced recently.

Mr. Schaad was secretary, musical director, and a member of the board of directors of the Aeolian Company. He began his career with the company as office boy. For twelve years he was in charge of activities at Aeolian Hall and for five years was the European representative of the Company. Mr. Schaad has been indirectly associated with radio broadcasting from its first days. It was he who aided the founders of WJZ to obtain talent for its first programs. He has maintained his interest in the new medium and is widely versed in the lore of broadcasting.

LaSalle Is Third To Get Tube License

P. C. Dittman, president of the LaSalle Radio Corporation, Chicago, announces that his company has been granted a license to manufacture and sell LaSalle high vacuum radio tubes under the patents of Radio Corporations of America, General Electric Co., and Westinghouse Electric Manufacturing Co.

Raytheon was first to take out a license and Ce Co. was second.

Churches Seek All Sunday Air

Detroit.

Sunday broadcasting should be solely religious, the Congregational National Council holds. At a meeting it supported the efforts of the Council of Churches of Christ in America in that direction.

Roger Babson, financial writer, said:

"I look forward to the day when the Federation of Churches of our different cities can combine and purchase the time for all day Sunday for one of four great national broadcasting chains and thus outbid secular competitors with their jazz concerts."

STATIONS HAVE MUCH INVESTED

Hartford, Conn.

Addressing the Connecticut Chamber of Commerce, Orestes H. Caldwell said:

"Broadcasting stations alone total \$25,000,000 in plant equipment and at least 7,500 people are employed in the country's broadcasting operations, representing an annual payroll of \$15,000,000.

"Invested in the manufacture and distribution of radio sets, reproducers, tubes and accessories there is now a total of about \$210,000,000, according to careful estimates based upon studies of individual manufacturers' figures.

"These factories and distributing plants employ altogether 100,000 persons, who receive \$200,000,000 annually in salaries and wages. The industry's total annual payroll is \$215,000,000, or a daily payment of two-thirds of a million dollars."

Laws That Handicap Radio Are Feared

Washington.

Caution in legislation on radio is advised by Paul M. Segal and Paul M. P. Spearman, of the legal division of the Federal Radio Commission, in a pamphlet, "State and Municipal Regulation of Radio Communication." The authors state that long, expensive quarrels have accompanied all attempts to control interstate commerce.

"If radio communication is now to traverse the same route," the pamphlet continues, "a vital element in the national development will be handicapped. Radio by its physical nature is the most nationwide of all our commercial agencies. Equally it is the most sensitive to regulation. The guiding principle of attempted local control should be extreme caution."

Photo Transmitted Over U. S. and Ocean

The Radio Corporation of America has announced that the first photoradiogram has been sent from San Francisco to London. The picture was one of Henri Didot, French Consul in Los Angeles, Henry Bancroft-Livingston, British Vice-Consul in Los Angeles, Betty Compson and Bebe Daniels, film actresses.

PHIL MILLER ON HIS OWN

Phil W. Miller, for many years in charge of the radio department in Elliot's drug store in the Cortlandt Street section, has opened a radio store of his own, known as the Neon Radio Corporation, 178 Greenwich Street.

FORTY CLEARED WAVES TO STAY BY 3-to-2 VOTE

Washington.

A resolution presented by Commissioner Eugene O. Sykes to reduce the number of cleared channels from 40 to 35, taking one from each zone, was defeated by the Federal Radio Commission, 3 to 2. Commissioner Sykes and Chairman Robinson voted for the plan. Commissioners Starbuck, Saltzman and Lafount voted against it.

The main provisions of the defeated resolution were:

"First—that seven, instead of eight, frequencies be assigned to each of the five zones.

"Second—That the Commission select one frequency from the eight assigned to each zone under this general order.

"Third—That on each of the five channels thus selected the Commission assign, for simultaneous night operation, not more than two stations located in different zones. That each zone share equally in these assignments."

Wire In Resistors Often Finer Than Hair

In the production of wire-wound volume controls as well as flat wire fixed resistors it is often necessary to work with wires even finer than human hair.

"The reason why we are in position to provide very high resistances in wire-wound units today," states John Mucher, president of the Clarostat Mfg. Co., of Brooklyn, N. Y., "is because of the special alloy wires now available, together with new and improved methods of winding. It is possible to provide resistances up to 3,000 ohms at a very low price, due to remarkable automatic winding machines, together with precise resistance values within 5 per cent.

"The finest work we now undertake is in conjunction with wire-wound volume controls up to 25,000 ohms. Here the wire is about 1½ thousandths of an inch in diameter, as compared with 2 thousandths for the usual human hair. The resistance measures 300 ohms to the foot, and we wind 450 turns per linear inch. So close are the turns that it requires a powerful magnifying lens to note the clean-cut separation between turns, measuring eight ten-thousandths of an inch."

NEW CORPORATIONS

Weber Radio Corporation—Attys. Moers & Rosenschein, 280 Madison Ave., New York, N. Y.
Centralized Radio Corp., Newark, N. J., radio equipment—Atty. Harry A. Friedman, Newark, N. J.

Outing Phonograph and Radio Corporation, New York, phonographs, radios—Corporation Trust Co. of America.

Metro Elec. Co., Chicago, Ill., radio, radio supplies—Corp. Maintenance and Service Co., Dover, Del.

The Radio Electric Finance Company, Wilmington, Del.—Delaware Charter Co.

Vim Radio, Inc., Newark—Attys. Green & Green, Newark, N. J.

SPIEGEL AIDS GINSBERG

Walt Spiegel has joined Brooklyn Radio Service Company in the capacity of assistant to Benjamin Ginsberg. Mr. Spiegel will make his headquarters in the new warehouse and showroom at 1062 Atlantic Avenue, Brooklyn.

New Style DeLuxe Leatherette Carrying Case FREE with each Jiffy Tester!

This combination of meters tests all standard tubes, including the new AC screen grid tubes and the new 245 tube, making thirteen tests in 4½ minutes! Instruction sheet gives these tests in detail.

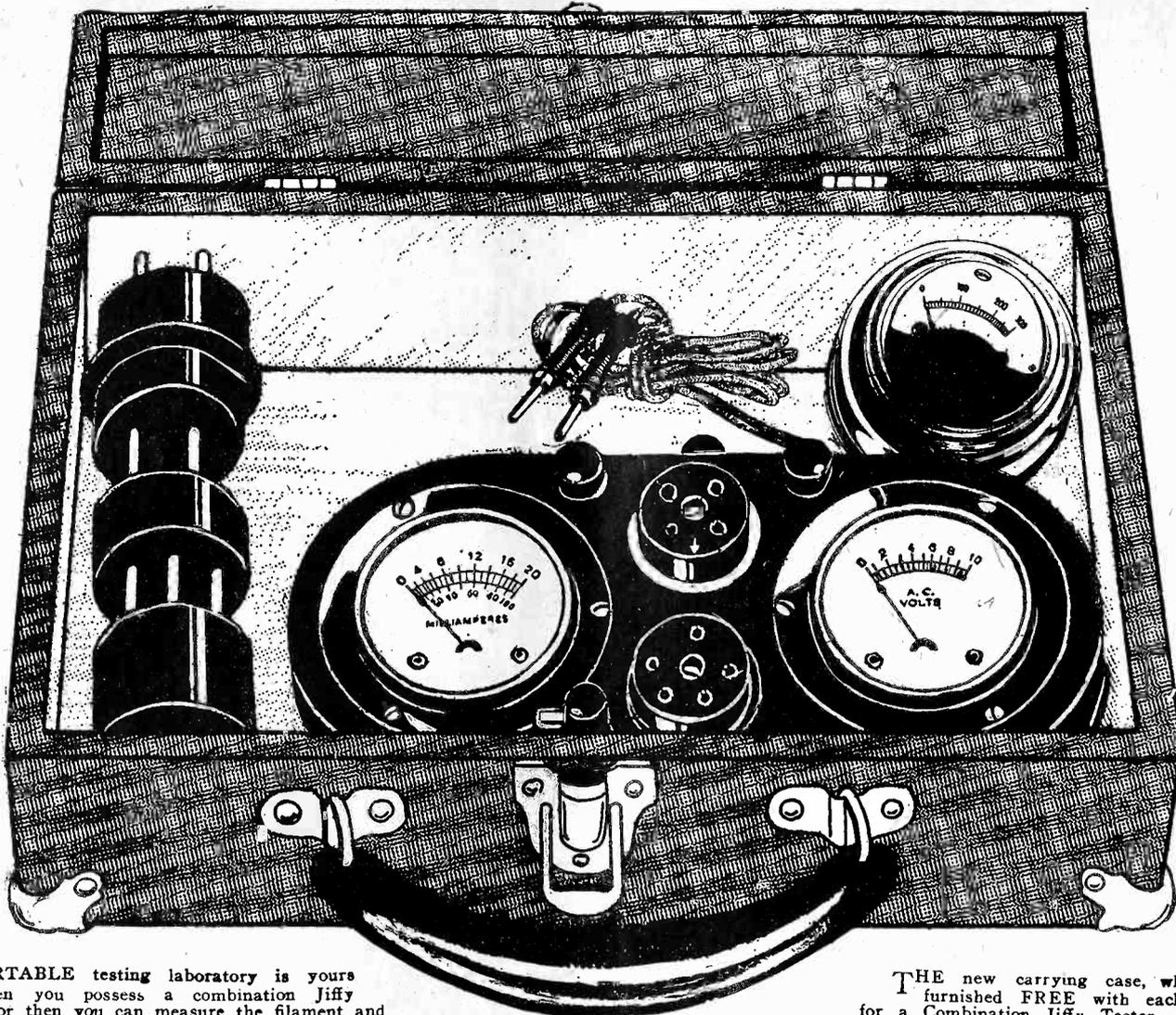

A PORTABLE testing laboratory is yours when you possess a combination Jiffy Tester, for then you can measure the filament and plate voltages of all standard tubes, including AC tubes, and all standard battery-operated or AC screen grid tubes; also plate voltages up to 500 volts on a high resistance meter that is 99% accurate; also plate current.

The Jiffy Tester consists of a 0-20, 0-100 milliammeter, with change-over switch and a 0-10 volt AC and DC voltmeter (same meter reads both), with two sockets, one for 5-prong, the other for 4-prong tubes; a grid bias switch and two binding posts to which are attached the cords of the high resistance voltmeter; also built-in cable with 5-prong plug and 4-prong adapter, so that connections in a receiver are transferred to the Tester automatically. Not only can you test tubes, but also opens or shorts in a receiver, continuity, bias, oscillation, etc. The instruction sheet tells all about these tests.

In addition you can test screen grid tubes by connecting a special cable, with clip to control grid (cap of tube) and other end of special cable to the clip in the set that went to the cap before the tube was transferred to the tester.

THE new carrying case, which is furnished FREE with each order for a Combination Jiffy Tester, contains the entire outfit, including the three meters, cable and plug, and three adapters (one for 4-prong tubes, two for 199 tubes). This case is 10½ x 7¾ x 3½" and has nickel corner pieces and protective snap-lock. The case is made of strong wood, with black leatherette overlay.

To operate, remove a tube from the receiver, place the cable plug in the vacant receiver socket, put the tube in the proper socket of the Tester, connect the high resistance meter to the two binding posts, and you're all set to make the thirteen vital tests in 4½ minutes!

The Combination Jiffy Tester is just the thing for service men, custom set builders, experimenters, students, teachers and factories. Order "Jiffy 500." The price is only \$14.50.

If a 0-600 AC and DC high resistance meter (99% accurate) is desired, so house electricity line voltage and power transformer voltages can be measured, as well as plate voltage, instead of the 0-500 DC voltmeter, order "Jiffy 600" at \$15.50.

GUARANTY RADIO GOODS CO., 145 W. 45 St., N. Y. City. (Just East of Broadway).

- Please ship at once on 5-day money-back guaranty one "Jiffy 500," at \$14.50, consisting of
- (1) One Two-in-One 0 to 10 voltmeter for AC and DC. Same meter reads both. Scale especially legible at 1½ to 7½ volts. This meter reads the AC and DC filament voltages.
- (2) One DOUBLE reading DC milliammeter, 0 to 20 and 0 to 100 milliamperes, with change-over switch. This reads plate current.
- (3) One 0-500 volts high resistance voltmeter, 99% accurate; with tipped 30' cord to measure B voltages.
- (4) One 5-prong plug with 30' cord for AC detector tubes, etc., and one 4-prong adapter for other tubes.
- (5) One grid switch to change bias.
- (6) One 5-prong socket.
- (7) One 4-prong socket.
- (8) Two binding posts.
- (9) One handsome moire metal case.
- (10) One instruction sheet.
- (11) One de luxe carrying case.
- (12) One screen grid special cable.
- If 0-300 DC high resistance 99% accurate voltmeter is preferred to 0-500, put check here. Price is same, \$14.50.
- Same as above, except substitute a 0-600-volt AC and DC high resistance 99% accurate voltmeter (same meter reads both) for the 0-500 DC meter. Price \$15.50.

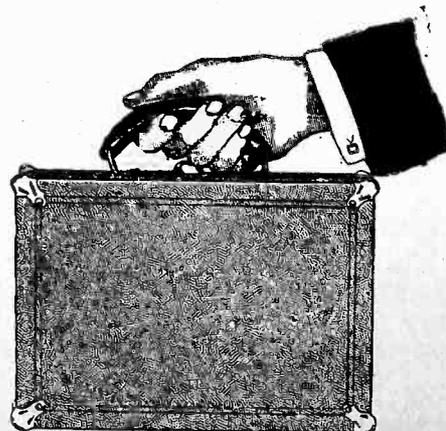

The new de luxe leatherette carrying case is compact and handy. Size 10½" long, 7¾" wide, 3½" deep.

NAME

ADDRESS

CITY STATE

FIVE-DAY MONEY-BACK GUARANTY

"Look for the Green Box"



The Only Tubes with
5-Day Money-Back
Guarantee in Each Box

222 Screen Grid Tube \$3.50

240 High Mu Tube \$1.25

Great for Detector or in audio channels where a resistor or impedance coil is in the plate circuit. Fil. 5 volts DC. plate 90 to 180 volts.

POWER TUBES

250.....\$6.00	210.....\$4.50
171A.....1.50	112A.....1.50

OTHER TYPES

280.....\$2.50	281.....\$3.50
227.....2.25	228.....1.25
261A.....1.00	199.....1.25

KELLY TUBE COMPANY
Walter J. McCord, Manager
57 DEY STREET, NEW YORK CITY
Suite 6 Tel. BARclay 8659

O-600 V. AC and DC
High Resistance Meter

Same Meter Reads Both AC and DC
Accurate to 1 per cent.

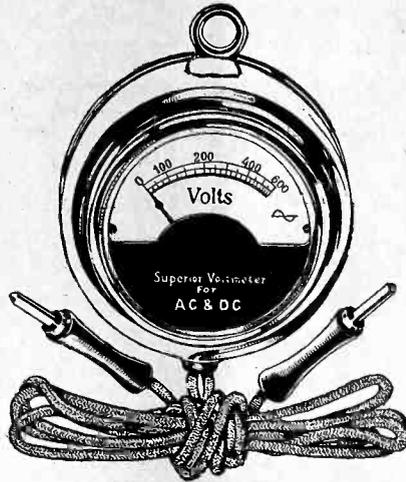

The O-600 volt AC and DC meter (Cat. No. 600) with 3-ft. cord, de luxe tips and hanger \$7.00.

THE output voltages of all B eliminators, the voltage of all B batteries, as well as the house current line voltage, whether AC or DC, and the voltage across power transformer secondaries, can be accurately measured by this meter. The full scale is 0-600 volts, and this same meter measures both AC and DC. Since it is a high resistance meter, of extraordinary range, and accurate to 1% plus or minus, it is advisable to get this meter for your testing purposes, since it is like two meters in one—AC and DC. You can find trouble more quickly without it you can't tell if a power transformer secondary is delivering voltage. 10-day money-back guaranty.

GUARANTY RADIO GOODS CO.,
145 West 45th Street, N. Y. City
(Just East of Broadway)

Please ship at once one O-600 volts AC and DC high resistance voltmeter, accurate to 1% plus or minus (Cat. No. 600); meter equipped with 3-ft. cord, moulded sockets, tips and hanger. [Put cross in proper square below.]

- \$7.00 enclosed
- I will pay postman \$7.00 plus few cents extra for postage.

Name

Address

City State

RADIO WORLD, published every Wednesday, dated Saturday of same week, from publication office, Hennessy Radio Publications Corporation, 145 West 45th Street, New York, N. Y., just east of Broadway. Roland Burke Hennessy, President; M. B. Hennessy, Vice-President; Herman Bernard, Secretary. Roland Burke Hennessy, Editor; Herman Bernard, Managing Editor; J. E. Anderson, Technical Editor; Anthony Sodaro, Art Editor

"WHAT B-ELIMINATOR SHALL I BUILD?"
Send 10c to Dept. RW-4 for this helpful construction book.
175 Varick St., New York, N.Y.
ELECTRAD
INC.

Individual
METERS
For Portable or Panel Use

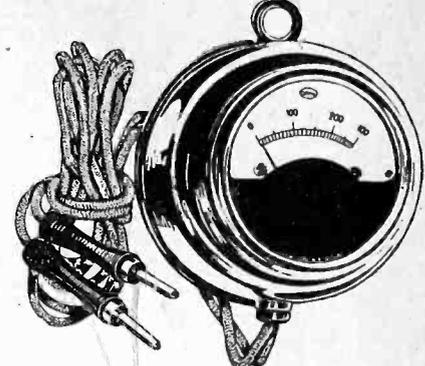

High resistance 0-800 Voltmeter, accurate to 1%. Measures any DC voltage to 300, including B eliminators. Provided with 30" cord, with luxurious jack tips and hanger. Meter full nickel de luxe finish. No. 846F.
No. 847F, same as above, but 0-500 volts, \$6.00

\$4.50

- POCKET AND PORTABLE VOLTMETERS**
- No. 8—For testing A batteries, dry or storage, 0-8 volts DC scale.....\$1.00
 - No. 10—For testing A batteries, dry or storage, 0-10 volts DC scale.....1.00
 - No. 13—For testing A batteries, dry or storage, 0-16 volts DC scale.....1.00
 - No. 50—For testing B batteries, dry or storage, but not for B eliminators, 0-50 volts DC scale.....1.00
 - No. 59—For testing B batteries, dry or storage but not for B eliminators, 0-100 volts DC scale.....1.25
 - No. 40—For testing A and B batteries, dry or storage, but not for B eliminators; double reading, 0-8 volts and 0-100 volts DC scale...1.75
 - No. 42—For testing B batteries, dry or storage, but not for B eliminators; 0-150 volts DC scale.....1.00
 - No. 348—For testing AC current supply line, portable, 0-150 volts.....4.00

- PANEL AC VOLTMETERS**
(Panel meters take 2-5/64" hole)
- No. 861—For reading 0-10 volts AC.....\$2.25
 - No. 862—For reading 0-10 volts AC.....2.25
 - No. 358—For reading 0-6 volts AC.....2.25
- (See No. 348 under "Pocket and Portable Voltmeters.")

- PANEL VOLTMETERS**
- No. 385—For reading DC voltages, 0-8 volts.....\$1.00
 - No. 810—For reading DC voltages, 0-10 volts.....1.00
 - No. 316—For reading DC voltages, 0-16 volts.....1.00
 - No. 326—For reading DC voltages, 0-50 volts.....1.00
 - No. 837—For reading DC voltages, 0-50 volts.....1.00
 - No. 839—For reading DC voltages, 0-100 volts.....2.25
 - No. 842—For reading DC voltages, 0-150 volts.....2.25
 - No. 840—For reading DC voltages, double reading, 1-8 volts, 0-100 volts.....1.50

- VOLTMETERS**
- No. 18—For testing amperage of dry cell A batteries and voltage of dry or storage A batteries, double reading, 0-8 volts, and 0-40 amperes DC.....\$1.25
 - No. 85—For testing amperage of dry cell A batteries and voltage of B batteries (not B eliminators); double reading, 0-50 volts, 0-40 amperes DC.....1.50

- PANEL MILLIAMMETERS**
- No. 311—For reading 0-10 milliamperes DC.....\$1.75
 - No. 895—For reading 0-20 and 0-100 ma. DC....1.50

VOLTAGE REGULATOR

No. 218—For preventing excess voltage on the filament and cathode of AC tubes, by compensating for excess line voltage.....\$3.00

POCKET AMMETER

No. 1—For testing dry cells, 0-50 ampere DC scale pocket meter.....\$.75

Immediate Shipment
GUARANTY RADIO GOODS CO.,
145 West 45th Street, New York City.
Just East of Broadway

Send me the following individual meters (quantity in square):

Cat. No. Cat. No. Cat. No.

Cat. No. Cat. No. Cat. No.

NAME

ADDRESS

CITY..... STATE.....

TEN-DAY MONEY-BACK ABSOLUTE GUARANTY!

Gothic Polo Speaker, \$15.00

Housed in a beautiful Gothic structure of genuine walnut; hand-rubbed to an attractive finish, the Polo driving mechanism and cone combine best quality reproduction with finest appearance. The grille is specially constructed for two-tone effect, so popular in walnut these days. The Polo Speaker in the Gothic housing is an adornment, besides being an outstanding speaker in performance. The design of the cabinet is exclusive. The height is 12 1/2". Shipping weight, 10 lbs. Cat. No. T.M.P.G.....



Guaranty Radio Goods Co.
145 West 45th Street
New York City

PLUG AND CABLE for any SHORT WAVE ADAPTER

May also be used as a 5-Lead Battery Cable and Plug, in conjunction with a 5-prong (AC227) socket.

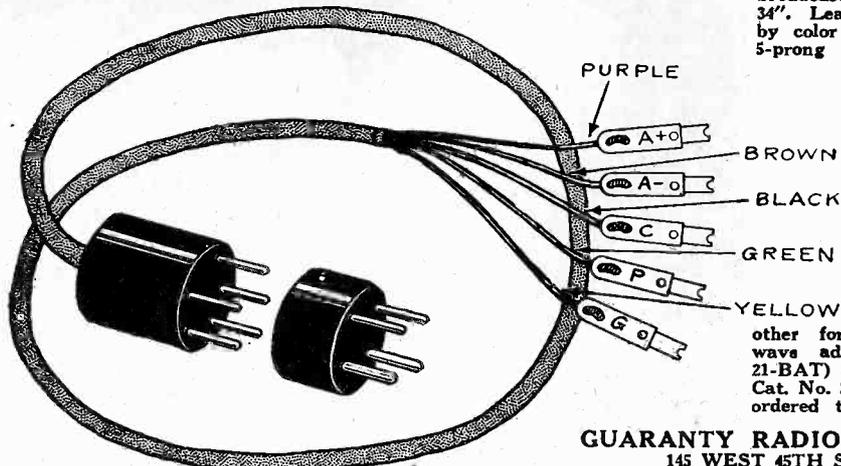

Handiest thing for ANY short-wave adapter. Put detector tube of your present set in socket of any short-wave adapter you build, put plug in detector socket of your broadcast receiver. Cable 34". Leads identified both by color scheme and tags 5-prong plug and 5-lead cable for AC short wave adapter. May be used as 5-lead battery cable plug with UY socket (Cat. No. Z1AC) \$1.50 4-prong extra plug only necessary addition to other for battery short-wave adapter (Cat. No. Z1-BAT) \$0.50. Cat. No. Z1AC and Z1-BAT ordered together \$1.75.

GUARANTY RADIO GOODS CO.
145 WEST 45TH STREET
New York City Just East of Broadway

RADIOLA 18 AC.—All-electric special \$70. Radiola 100 A speaker, special \$21. Act quick. Offer limited. A. S. Cooke, 1304 Pacific Street, Brooklyn, N. Y.

MARVELOUS NEW pick up for phonograph. Only twelve left, all pippins. Money-back 10-day guarantee. Send \$3.75.—P. Cohen, Room 1214, at 143 W. 45 St., N. Y. C.

All Parts for MB-29

as described and specified

by J. E. Anderson

Also

Velvetone 245 P-P Power Amplifier

GUARANTY RADIO GOODS CO.
145 West 45th Street
N. Y. City

Please look at the subscription date stamped on your last wrapper, and if that date indicates that your subscription is about to expire, please send remittance to cover your renewal.

In this way you will get your copies without interruption and keep your file complete. Subscription Department, Radio World, 145 West 45th Street, New York, N. Y.

Quick Action Classified Ads

Radio World's Speedy Medium for Enterprise and Sales

10 cents a word — 10 words minimum — Cash with Order

HOOK UPS made easy. Plug in all parts and connections on a Standardized Radio Hook-up Board. Three tube board, plug in bases, connections \$2.75 post paid. Larger boards. Francis Livingston, owner and inventor, 1594 Humber Street, Memphis, Tenn.

THE CRAFTSMAN Dollar Speaker Filter is guaranteed to relieve speaker of the plate direct current, up to 250 volts. \$1.00 postpaid. Refund if not satisfactory. Attach dollar to This Ad and receive FREE Solid-molded grid-leak, 1 to 3 megohm. Craftsman Radio Products, 351 Halsey St., Newark, N. J.

ARTISTS and Art Students are printing 250 signs or pictures an hour without machinery. Sample and particulars 10c. Straco, 1014 Mulberry, Springfield, Ohio.

ELIMINATE AERIAL. Greater distance, volume, selectivity with "Little Black Box." Rosens Shop, 616 Plant St., Utica, N. Y.

RADIO RECEIVING TUBES, by Moyer and Wostrel, first edition just off the press. No radio service man, experimenter or student of radio should be without this authoritative book on the principles and applications of vacuum tubes. It answers all your questions relating to receiving, amplifying and rectifying tubes. Price postpaid, \$2.50 Radio World, 145 W. 45th St., New York

RADIO INFORMATION

Reliable, prompt, accurate, in every-day language. 25c per question. Radio Information Bureau, 1426 South Clifton Park, Chicago.

REDUCE STATIC: The Phantom increases selectivity, chokes out static. No lightning danger, no aerial, no holes to dig. Completely shielded. Hook up in three minutes. Guaranteed fifteen years. Price \$7.50 postpaid. Brighton Radio Lab., Brighton, Iowa.

ARTISTS and Art Students are printing 250 signs or pictures an hour without machinery. Sample and particulars 10c. Straco, 1014 Mulberry, Springfield, Ohio.

ORIGINAL BALDWIN PHONES, tested and guaranteed, \$3.65, postpaid, Blan, the Radio Man, 89 Cortlandt Street, New York City.

AGENTS AND SALESMEN WANTED

Sell \$5.00 Men's Daily Necessity for 50c. Cost quantities 20c. Sample postpaid 30c. Catalog hundreds household articles free. Mills Sales Co., 901 Broadway, New York.

AGENTS WANTED

CARTER WINDOW WASHER. Exclusive Distributor wanted. **BIG PROFITS.** Cleans, Dries, Polishes, one operation. Territory closing fast. Act quick. **CARTER PRODUCTS**, 985½ Front Street, Cleveland, Ohio.

\$25-\$35 WEEKLY. Easy. Address cards at home. Spare time. Experience unnecessary. Everything furnished. Particulars free. Write today. Rol-Kel Company. Dept. F., Greenfield, Ohio.

RADIOS FOR SALE

RADIO FANS—Would you like to purchase the latest electric Coast to Coast Screen Grid Radio for less than the cost of a battery set? If so address Economy Sales Co., Pa. Ave. Sta., Wash. D. C.

MODEL SHIP for your RADIO. Unusually pretty 16" Santa Maria. Electric light in hollow of composition hull. Nothing to do but paint and rope. Pictured directions for roping. Kit \$7.50. Without light \$6.50. Completely finished \$15. Dr. Irl J. Neal, Mattoon, Illinois.

FARM WANTED

CASH FOR YOUR PROPERTY, farm, business or residence. No matter where located. Free information. International Realty Co., Ford Bldg., Detroit.

WHY WORK for others? Employ agents yourself. Manufacture Toilet Articles, Specialties, etc., at home. 500% profit. \$1 brings complete line. Formco, Box 175, Algoma, Wis.

LATEST KNAPP A-ELIMINATOR. New \$16.00. D. L. Currens, Owensboro, Ky.

SEEDS FOR SALE

ALFALFA SEEDS, hardy common varieties \$8.40, \$10.20, \$12.60, bushel; Grimm variety Alfalfa seed \$18. Scarified sweet clover \$3.90, \$5.20; Alsike or red clover \$15. Bags Free. Send for samples and catalogue. Kansas Seed Co., Salina, Kan.

HAVE AN EXPERT PUT YOUR SET IN SHAPE!

If your receiver or amplifier, no matter of what kind, is not giving proper results, send it to us, prepaid. We will test it FREE and let you know what's wrong, telling you cost of repairs. Our charges are very reasonable. Six years' experience. Loudspeakers and units repaired. Burnt-out coils replaced. Jaynxon Laboratories, 57 Dey Street, New York City.

RADIO FANS: Improve summer reception by using my new method of grounding your set. Cheaply installed, more economical in operation. Full instructions 25 cents. Address Leslie Churchill, Route 3, Batavia, New York.

TRADE—12 Gauge Pump Gun for complete portable radio.—John A. Garriott, Little York, Ind.

RADIO TROUBLE FINDER—Explains and describes 102 possible radio ailments. Fully illustrated. Also list of Radio Broadcasting stations. Our reduced price 50c for a limited time. Anthony's Book Shop, Box 2711 W. P. Station, Cleveland, O.

FLORIDA ORANGES Box containing 80 Sweet Juicy Oranges and 30 Grapefruit: Express paid to your home \$3.75. Address Taylor's Groves, Box 282, Tampa, Florida.

PATENT YOUR IDEAS. Easy terms. Booklet Free. Established 25 years. H. Sanders, Rand McNally Building, Chicago, Ill.

\$5 STARTS YOU in printing business. Five hundred cards printed in three colors. Samples FREE.—Frank B. Ashley, Room 1517, No. 461 Eighth Avenue, N. Y. City.

Recent Issues of **RADIO WORLD**, 15 cents each. Any number published in 1928 available for a short while. Six issues 75 cents, 10 issues \$1.00. Send stamps, coin or money order NOW, before the issues are sold. **RADIO WORLD**, 145 West 45th Street, New York City.

Import Your Own Goods

German Export Magazine published in English offers numerous bargains in latest articles, novelties and new inventions. Also opportunities for obtaining profitable distributing agencies. Sample copy 60 cents postpaid (none free or on memo). Two monthly copies \$1.00. Subscription price \$3.00 per year for 12 monthly copies with special privileges. Square Deal Supply Co., R-246 Fifth Ave., N. Y.

DYNAMIC SPEAKER

Build your own with our castings. Set of machined castings, \$8.00; not machined, \$5.00. Full set blue prints and instructions included. Prices of complete parts on request.

IMPERIAL RADIO SPEAKER CO.
1453 East 174th St., Cleveland, Ohio

RADIO WORLD, published every Wednesday, dated Saturday of same week, from publication office, Hennessy Radio Publications Corporation, 145 West 45th Street, New York, N. Y., just east of Broadway. Roland Burke Hennessy, President, M. B. Hennessy, Vice-President; Herman Bernard, Secretary. Roland Burke Hennessy, Editor; Herman Bernard, Managing Editor; J. E. Anderson, Technical Editor; Anthony Sodaro, Art Editor.

VICTOREEN Super Coils
 Write for Free Blueprints of New Victoreen Circuits
Geo. W. Walker Co.
 2825 Chester Avenue
 Dept. B Cleveland, O.

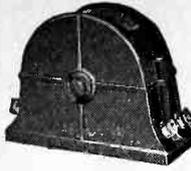

LYNCH METALLIZED
 Standoff—The "Self-Supporting" Resistor. Molded end caps, insuring positive mechanical and electrical contact. Moderate in price. Efficient in operation.
ARTHUR H. LYNCH, Inc.
 1775 Broadway New York, N. Y.
 Write for complete information.

Additional Voltage Taps?
 Is that what you want from that B-eliminator? Simple enough. Just use the **DUPLIX CLAROSTAT** connected to plus B maximum tap and other two terminals will provide two adjustable voltages. Also provide by-pass condensers, and the job is complete.
 Ask your dealer to show you the **DUPLIX CLAROSTAT** and other items of this well-known line. Drop us a line and we'll send you the data.
CLAROSTAT MFG. CO., Inc.
 Specialists in Radio Aids
 291 N. 6th St., Brooklyn, N. Y.

CLAROSTAT

NEWEST BOOK ON VACUUM TUBES
 "RADIO RECEIVING TUBES," by James A. Moyer and John F. Wostrel, first edition just off the press. No radio service man, experimenter or student of radio should be without this authoritative book on the principles and applications of vacuum tubes. It answers all your questions relating to receiving, amplifying and rectifying tubes. It is a complete discussion of tube principles, functions and uses, thoroughly up-to-date.
 In this book the essential principles underlying the operation of vacuum tubes are explained in a non-technical manner as is consistent with accuracy. The book covers the construction, action, reactivation, testing and use of vacuum tubes as well as specifications for vacuum tubes and applications for distant control of industrial processes and precision measurements.
 Price \$2.50
RADIO WORLD
 145 West 45th Street, New York City
 (Just East of Broadway)

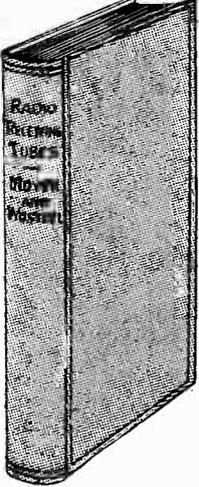

Learn All About
Power Amplifiers
 in
The First Complete Treatise on This Important and Fascinating Subject
 Now appearing serially in **RADIO WORLD**—a fine, big installment each week!
 Written for the novice, but worth any expert's time to read!
J. E. ANDERSON, Technical Editor, and **Herman Bernard**, Managing Editor, are the authors of this splendid exposition of the known facts and previously unknown mysteries of power amplifiers.
 Nowhere else can you get the correlated information, the liberal education, on this subject, for this series traverses a virgin field, blazes the way, and reaches a high goal in instructional literature.
 Service men must know power amplifiers if they are to prosper—indeed, even survive. Custom-set builders must have an equally thorough understanding of the subject. Home constructors, experimenters, students, teachers—all need follow this amazingly skillful, yet simplified, exposition of an absorbing subject.
YOUR OPPORTUNITY!
 The series started in the June 1st issue of **RADIO WORLD**. It will continue for at least three months from then. Send \$1.50 for a three-months mail subscription for **RADIO WORLD** and you will receive **RADIO WORLD** every week for 13 weeks (3 months), and besides receive **FREE** the issues beginning June 1st when the Power Amplifier series started.

SOCKET WRENCH

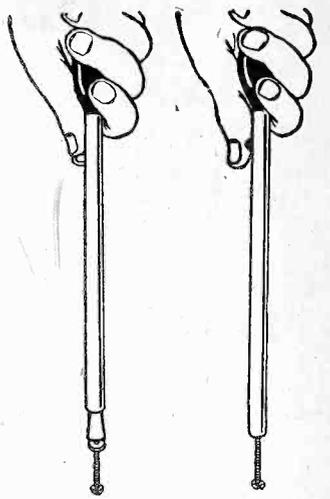

FREE

Push out control lever with knob (as at left) and put wrench on nut. Push down on handle only (at right), then turn nut left or right.
 ONE of the handiest tools for a custom set builder, service man or home constructor is a **BERNARD** socket wrench.
 It consists of a 6 1/2" long metal tubing in which is a plunger, controlled by a knob. The plunger has a gripping terminal (called a socket, hence the name "socket wrench") that may be expanded or contracted to fit 6/32, 8/32 and 10/32 nuts, the most popular sized nuts in radio.
 Use the knob to push out the plunger, press down on the handle to grip the nut, then turn the nut to left for removal or to right for fastening down. Total length, distended, including stained wooden handle, 10". Gets nicely into tight places. Send \$1 for 8 weeks' mail subscription for **RADIO WORLD** and get this wrench **FREE**.
 No other premium with this offer. Present subscriber may extend subscription by stating he is one, and entitle himself to this **FREE** premium, making \$1 remittance.
RADIO WORLD
 145 WEST 45TH ST., N. Y. CITY

DYNAMIC BAFFLE
 Completely built up, for any type dynamic chassis. State what make dynamic you want it for. Case sides, open back. Do luxe finish. Size, 24x24 inches.....
\$12.00
GUARANTY RADIO GOODS CO.
 145 West 45th Street, New York City

PLEASE USE THIS COUPON
RADIO WORLD,
 145 West 45th St., New York City.
 Gentlemen: Enclosed please find \$1.50, for which please send me **RADIO WORLD** each week for 13 weeks, beginning at once. Also send issues beginning June 1st and up to the issue with which my subscription starts, without extra charge.
 Name.....
 Address.....
 City..... State.....
This offer expires July 6th, 1929.

LACAULT'S BOOK
 "Super-Heterodyne Construction and Operation," giving the master's most masterful exposition of the theory, performance and construction of this fascinating type of circuit, is a necessity to every serious radio experimenter. More than 100 pages and more than 50 illustrations. Buckram cover. This book by R. E. Lacault, **FREE** if you send \$1.00 for an 8-weeks subscription for **RADIO WORLD**. Present subscribers may accept this offer. Subscription will be extended.
RADIO WORLD 145 W. 45th St., N. Y. City
 Just East of B'way

FREE!

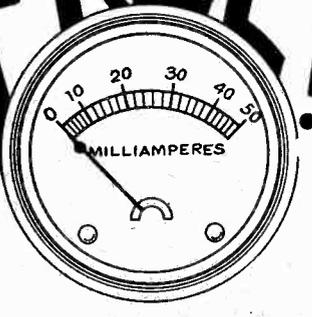

Your Choice of Any One of These Nine Meters FREE!

<input type="checkbox"/>	0-6 Voltmeter D.C.	No. 326
<input type="checkbox"/>	0-50 Voltmeter D.C.	No. 337
<input type="checkbox"/>	6-Volt Charge Tester D.C.	No. 25
<input type="checkbox"/>	0-10 Amperes D.C.	No. 338
<input type="checkbox"/>	0-25 Milliamperes D.C.	No. 325
<input type="checkbox"/>	0-50 Milliamperes D.C.	No. 350
<input type="checkbox"/>	0-100 Milliamperes D.C.	No. 390
<input type="checkbox"/>	0-300 Milliamperes D.C.	No. 399
<input type="checkbox"/>	0-400 Milliamperes D.C.	No. 394

Equip Yourself Now With Necessary Meters!
 To do your radio work properly you need meters. Here is your opportunity to get them at no extra cost. See the list of nine meters at left. Heretofore we have offered the choice of any one of these meters free with an 8-weeks subscription for **RADIO WORLD**, at \$1, the regular price for such subscription. Now we extend this offer. For the first time you are permitted to obtain any one or more or all of these meters free, by sending in \$1 for 8-weeks subscription, entitling you to one meter; \$2 for 16 weeks, entitling you to two meters; \$3 for 26 weeks, entitling you to three meters; \$4 for 35 weeks, entitling you to four meters; \$5 for 44 weeks, entitling you to 5 meters; \$6 for 52 weeks, entitling you to six meters. Return this offer with remittance, and check off desired meters in squares at left.
RADIO WORLD will help you in your radio work, so you will be able to use the meters most valuably. Keep abreast of all the new circuits, intimate details on perfecting existing sets, an set inside track on sensitivity, distance reception, tonal quality, and news of radio, technical and non-technical. Enjoy the writings of Dr. Lee De Forest, McMurdo Silver, J. E. Anderson, Herman Bernard and a host of other radio engineers who contribute their knowledge to you through the medium of **RADIO WORLD**, the first and only illustrated national radio weekly. You can find no magazine that better caters to your needs than **RADIO WORLD**. Short waves? **RADIO WORLD** will tell you all about them. Extremely sensitive broadcast receivers? Their construction and operation are fully discussed with confident regularity. Power supplies—push-pull or otherwise? AC receivers? Seven grid tubes? Large receivers that give a super-abundance of performance—small, economical receivers that give performance out of all comparison to their size? Are you interested in these? Then you're interested in **RADIO WORLD**.
 Present mail subscribers may renew their subscription under this remarkably generous offer. Put a cross in square.
RADIO WORLD
 145 W. 45th St., N. Y. City—Published Weekly.
 All Newsstands, 15c per copy—\$3, six months—\$6 a year

SUBSCRIBERS!
 Look at the Expiration Date on Your Wrapper
 Please look at the subscription date stamped on your last wrapper, and if that date indicates that your subscription is about to expire, please send remittance to cover your renewal.
 In this way you will get your copies without interruption and keep your file complete.
SUBSCRIPTION DEPARTMENT
RADIO WORLD
 145 WEST 45TH ST., N. Y. CITY

RADIO WORLD, published every Wednesday, dated Saturday of same week, from publication office. Hennessy Radio Publications Corporation, 145 West 45th Street, New York, N. Y., just east of Broadway. Roland Burke Hennessy, President; M. B. Hennessy, Vice-President; Herman Bernard, Secretary. Roland Burke Hennessy, Editor; Herman Bernard, Managing Editor; J. E. Anderson, Technical Editor.

Blueprint of the AC Diamond

BUILD this 4-tube receiver, using one 222 tube, two 227 and one 112A (or 171A), and enjoy tone quality, selectivity and ease of control. The official blueprint gives the picture diagram life size, both top and bottom views; also schematic diagram and list of parts. You can use your present B eliminator externally, but the filament transformer is a part of the circuit.

Enjoy the convenience of AC operation, and still have just as selective and sensitive receiver, by building the AC Diamond. If you have 110-volt, 50 to 60 cycle AC house current, then this is the circuit for you. Fine performance. No hum.

Radio World, 145 W. 45 St., N. Y. City (Just East of Broadway)
 Inclosed please find \$1.00 for which send at once official blueprint of the 4-tube AC Diamond.
 30c for the March 23d and 30th issues (1929) describing this circuit.
 \$3.00 for 6 months subscription for Radio World. Send blueprint and two AC Diamond issues FREE.

NAME
 ADDRESS.....
 CITY..... STATE.....

Most Selective Diamond

Follow Blueprint

THIS IS THE BATTERY MODEL

Here is the circuit of circuits—the design that makes a neighboring cleared-channel, high-power broadcaster snap out of audibility at a slight turn of the dial.

No need to worry about the selectivity requirements imposed on receivers by the reallocation.

Volume "to fill the house"—even on distance. Tone quality excellent.

Get the official blueprint of the laboratory model of the new SG 4-tube Diamond, exactly as built by Herman Bernard, the designer.

RADIO WORLD
 145 W. 45th St., N. Y. City
 (Just E. of B'way)
 Enclosed please find \$1.00 for which please send at once the official blueprint of the new highly selective 4-tube screen grid Diamond of the Air battery model.
 60 cents extra for the February 9th, 16th 23rd and March 2nd (1929) issues of Radio World, containing Bernard's articles on the construction of this receiver.
 \$3.00 for 6 months (26 numbers) subscription for Radio World. Send Diamond blueprint and four Diamond issues FREE, in addition to 26 current issues.

Name
 Address
 City State

KELLY TUBES

Prescribed for the

Screen Grid Diamond

One screen grid 422.....\$3.50
 Two 410A at \$1.00 each..... 2.00
 One 412A (for 135 volts)..... 2.00
 or One 471A (for 180 volts)..... 2.00
 Send \$7.50 for set of four tubes for this receiver.
 Specify whether power tube wanted is 412A or 471A

KELLY TUBE COMPANY
 57 Dey Street New York City
 10-Day Money-Back Guarantee

BLUEPRINT of the New, Highly Selective Screen Grid DIAMOND (AC MODEL)

\$1.00

RADIO WORLD
 145 West 45th Street New York City
 Few Doors East of Broadway

Cash in on This Offer Now!

ONE full year's subscription for any **TWO** of the following magazines given to you—**RADIO NEWS** or **SCIENCE AND INVENTION** or **RADIO** (San Francisco) or **BOYS' LIFE** or **CITIZENS RADIO CALL BOOK AND SCIENTIFIC DIGEST** or **RADIO ENGINEERING**.

Select any **TWO** of these four publications, each of which will be sent to you (at only one address, however) each month for twelve months—in other words, 24 issues—if you will send in now your subscription for **RADIO WORLD** for two years (104 numbers) at \$10.00. **RADIO WORLD'S** subscription price for one year is \$6.00, so you gain the extra 2 dollars by taking advantage of the liberal offer for two-year subscriptions; and, besides, you get a subscription for each of the **TWO** other magazines selected from the enumerated list, making a total of 128 numbers for \$10.00.

If you want to select only one from among the four other magazines, you may obtain this one for **TWO** years, so that you will be subscribing for **RADIO WORLD** for two years and for the other magazine for **TWO** years, all for only \$10.00 (both mailed to one address only).

These offers are rightly regarded as among the most liberal ever made, but as they are limited as to expiration date (see notice below) you must act now.

Please use the attached coupon.

SPECIAL TWO-FOR-PRICE-OF-ONE COUPON

RADIO WORLD, 145 West 45th Street, New York City (Just East of Broadway):
 Enclosed please find \$10.00, for which send me **RADIO WORLD** each week for two years (104 numbers), and also send me, without extra cost, each month for one year each of the following **TWO** magazines—total, 24 issues—grand total, 128 numbers:

- | | |
|--|---|
| <input type="checkbox"/> RADIO NEWS | <input type="checkbox"/> RADIO (San Francisco) |
| <input type="checkbox"/> SCIENCE AND INVENTION | <input type="checkbox"/> BOYS' LIFE |
| <input type="checkbox"/> CITIZENS RADIO CALL BOOK, ETC. | <input type="checkbox"/> RADIO ENGINEERING |

If you want one of each, put a cross in a square next to the name of each of the two other magazines. If you want a two-year subscription for **ONE** of the above magazines, with the two-year subscription for **RADIO WORLD** (same grand total of 128 numbers), put two crosses before the name of one magazine.

If you prefer to pay \$6.00 for only one year's subscription for **RADIO WORLD** (52 numbers) and get one of the other magazines for one year without extra cost, put one cross in one square in front of the name of one magazine.

Present **RADIO WORLD** subscribers may renew under this offer. If renewing, put a cross here

Name.....
 Street Address.....
 City..... State.....

THIS OFFER EXPIRES AT NOON ON JULY 30TH, 1929

HAMMARLUND

Dual Midline 23 and Equalizing

CONDENSERS

selected again for their superior qualities and rugged construction by

HERMAN BERNARD

for the

New Push-Pull Diamond

Your Dealer Sells Them



COMPLETE PARTS

for the New, Highly Selective

Screen-Grid Diamond

(Four-Tube Battery Model)

Exactly as Specified by **\$29.00**
 Herman Bernard Net

Guaranty Radio Goods Co.
 145 West 45th Street
 New York City

YOU MUST GET THIS BOOK!

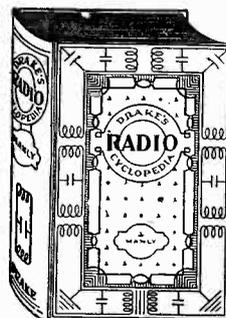

DRAKE'S RADIO CYCLOPEDIA (New Edition)

has been developed to answer the questions of service men, custom set builders and home constructors, of experimenters, students, salesmen and operators of receiving equipment and to allow all these to have instant access to the information they want. The author, Harold P. Manly, has collected and translated into plain English the material formerly obtainable only from dozens of scattered sources.

BOOK IS 2 1/2" THICK, WEIGHS 3 3/4 LBS., 1,025 ILLUSTRATIONS

Each rule, fact, method, plan, layout and diagram is instantly picked out and separated from everything else by placing all subjects in alphabetical order with cross references for every imaginable plan, layout and diagram

1,680 Alphabetical Headings from A-battery to Zero Beat

1,025 Illustrations, Diagrams, Layouts and Graphs
 920 Pages, Each 6 by 9 inches
 240 Combinations for Receiver Layout

OF THE PRINCIPAL ARTICLES
 159 Concern service men, 129 help the set builder, 162 help the experimenter, 155 interest the student, 75 assist in sales work, 73 interest set owners.

GUARANTY RADIO GOODS CO.,
 145 W. 45th St., New York, N. Y. (Just E. of B'way)

Gentlemen: Please mail me at once the new (second) edition of "Drake's Radio Cyclopedia," by Harold P. Manly, just published, with all the latest technical information in it. I will pay the postman \$6.00 plus a few cents extra for postage. If I am not delighted, I may return the book in five days and you will promptly refund my purchase money.

Name
 Address

City..... State.....

5-DAY MONEY-BACK GUARANTY!

DIAMOND Pair

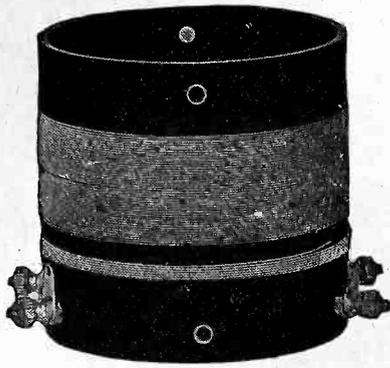

AC5 \$1.50

Highly selective antenna coil for any circuit, and interstage coil for AC circuits. Step-up ratio, 1-to-8. Tunes with .0005 mfd. Model AC3, for .00035 mfd. \$1.75

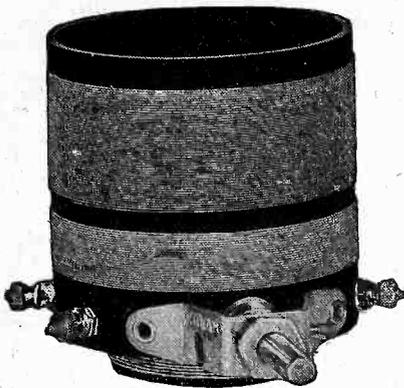

SGT5 \$2.75

Tuner to work out of a screen grid tube. The large primary is fixed and is connected in the plate circuit of the screen grid tube. Tunes with .0005 mfd. Model SGT3, for .00035 mfd. \$3.00

UNIVERSAL Pair

TP5 \$3.00

Interstage coupler to work out of a screen grid tube, where the primary in the plate circuit is tuned, the secondary, in the next grid circuit, untuned. Tunes with .0005 mfd. Model TP3, for .00035 mfd. \$3.25

RF5 \$1.50

Excellent selective antenna coil for any circuit, and interstage coil for any battery operated receiver, excepting output of screen grid tube. Tunes with .0005 mfd. Model RF3, for .00035 mfd. \$1.75

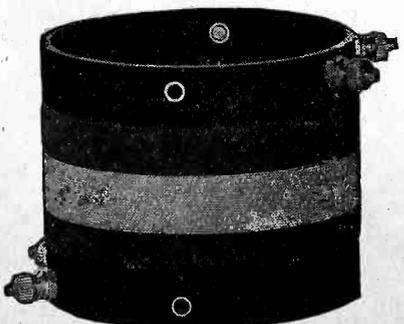

A5 \$1.75

Conductively coupled antenna coil, for maximum pickup, where selectivity is not the main consideration. Continuous winding in two colors. Tunes with .0005 mfd.

Model A3, for .00035 mfd. \$2.00

Screen Grid Coil Co., 143 W. 45th St., N. Y. City

CONE ASSEMBLY WITH DOUBLE MAGNET UNIT

\$6.00



An excellent magnetic type speaker for installation in any cabinet. The unit is a double-magnet Paratone, with two magnet coils, for utmost sensitivity. Each horseshoe magnet is 3/4" thick. The magnet coils are forever protected against dust and other foreign, injurious substances, by special bakelite housings. The pin is reverse drive. The cone frame is metal. The 9" cone is specially treated buckram.

All assembled, with long cord, ready to play. Shipping weight 6 lbs. **\$6.00** (Cat. CAS) Net

The unit alone (cord included). It will operate any type sounding surface, including paper, cloth, wood, etc. Shipping weight 4 lbs. (Cat. UA). **\$3.50** Net

Guaranty Radio Goods Co.

145 West 45th St., New York City

Front Panel and Subpanel for the

Screen Grid Universal

Bakelite front panel alone, drilled. \$2.35
Drilled aluminum subpanel alone, with self-bracketing feature, built-in sockets, extra washers and hardware 3.00
Both front and subpanel together. 5.00

GUARANTY RADIO GOODS CO.

145 West 45th Street, New York City
(Just East of Broadway)

For ANY Tube D.C. or A.C.

AMPERITE automatic filament control increases tube efficiency and lengthens tube life. \$1.10 with mounting (in U. S. A.)

Radiall Company
50 FRANKLIN ST., NEW YORK



AMPERITE

REG. U.S. PAT. OFF.

The "SELF-ADJUSTING" Rheostat

BUILD A 36-INCH CONE—LOWEST COST FOR FINEST TONE!

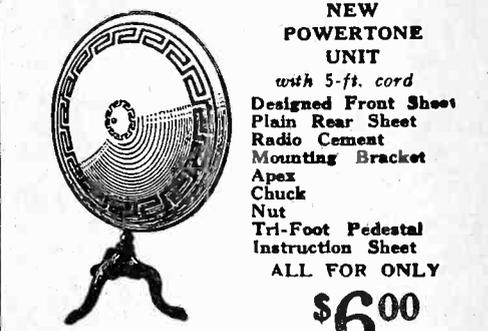

**NEW
POWERTONE
UNIT**
with 5-ft. cord
Designed Front Sheet
Plain Rear Sheet
Radio Cement
Mounting Bracket
Apex
Chuck
Nut
Tri-Foot Pedestal
Instruction Sheet
**ALL FOR ONLY
\$6.00**

24" KIT, SAME PRICE.
Build the speaker. If not overjoyed at results, return the built-up speaker in five days and get ALL your money back!

GUARANTY RADIO GOODS CO.
145 WEST 45TH STREET
N. Y. City Just East of Broadway

**HAVE AN EXPERT PUT
YOUR SET IN SHAPE!**
If your receiver or amplifier, no matter of what kind, is not giving proper results, send it to us, prepaid. We will test it FREE and let you know what's wrong, telling you cost of repairs. Our charges are very reasonable. Six years' experience. Loudspeakers and units repaired. Burnt-out coils replaced. Jaynson Laboratories, 57 Dey Street, New York City.

Twice as Much for Your Money!

Send \$6.00 for one year's mail subscription for RADIO WORLD (52 numbers, one each week), and you will be given one full year's subscription for any one of the following six magazines:

Radio News (monthly)	Radio Engineering (monthly)
Science and Invention (monthly)	Youth's Companion (weekly)
Radio, San Francisco (monthly)	Boys' Life (monthly)

SPECIAL TWO-FOR-PRICE-OF-ONE COUPON

RADIO WORLD, 145 West 45th Street, New York City (Just East of Broadway):
Enclosed please find \$6.00, for which send me RADIO WORLD each week for one year, 52 numbers, and also send me, without extra cost, for one year ONE of the following magazines as indicated:

<input type="checkbox"/> RADIO NEWS	<input type="checkbox"/> RADIO ENGINEERING
<input type="checkbox"/> SCIENCE AND INVENTION	<input type="checkbox"/> YOUTH'S COMPANION
<input type="checkbox"/> RADIO (San Francisco)	<input type="checkbox"/> BOYS' LIFE

[Put a cross in the proper square above. Fill out coupon and send \$6.00. If you are a subscriber for RADIO WORLD or for the other magazine you select, or both, check off squares below. or left.]

Present RADIO WORLD subscribers may renew under this offer. If renewing, put a cross here Name

If renewing for the other magazine you select, put a cross here also Street Address

City State

THIS OFFER EXPIRES AT NOON JULY 30TH, 1929

ARISTOCRAT FLOOR SPEAKER

With Molded Wood Horn of 8 ft. cone travel (exponential type) with baffle and horn motor built in. Extraordinary bargain. **\$20.00**

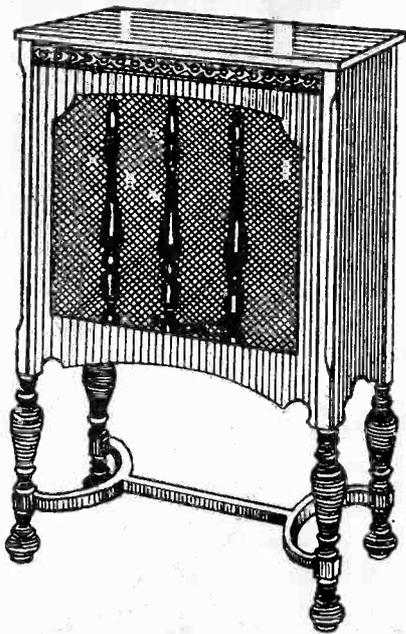

The speaker cabinet is walnut finish, 33" high, 24 1/2" wide, 17 1/2" deep, with carved legs. Golden cloth grille covers front opening. Built inside is No. 595 molded wood horn with baffle and No. 203 driving motor unit that stands 250 volts without filtration. Horn and motor removable. Table alone is worth price asked. Remit with order and we pay cartage on Aristocrat Floor Speaker.

Acoustical Engineering Associates
143 WEST 45th STREET
NEW YORK CITY
(Just East of Broadway)

Aluminum Subpanel for the New, Highly Selective

SG Diamond

Battery or AC Model (specify which)

The best appearance of the New Diamond of the Air results from using the official aluminum subpanel, 10 x 20 inches, with the four sockets built in, and with self-bracketing front. Hardware and insulating washers supplied with each sub-panel. The aluminum sub-panel is exactly the same as the one used in the laboratory models of the battery operated and the AC Screen Grid Diamonds. Holes are drilled for mounting parts, but as this aluminum drills like bakelite you can drill any holes you want.

RADIO WORLD, 145 W. 45th St., N. Y. City.
(Just East of Broadway)

Enclosed please find \$3.00 for which please send one aluminum subpanel 10x20" for the new battery model 4-tube SG Diamond of the Air, with sockets built in, and with self-bracketing front and side and rear supports; also send hardware and insulating washers.

Enclosed please find \$2.35 for which please send 7x21" drilled Bakelite front panel for the new battery model Diamond.

Enclosed please find \$3.25 for the 10x20" aluminum subpanel, etc., for the new AC Screen Grid Diamond.

Enclosed please find \$2.35 for the 7x21" drilled Bakelite front panel for the new AC Screen Grid Diamond.

Enclosed please find \$5.00 for both the aluminum subpanel, etc., and the drilled Bakelite front panel of the battery model.

Enclosed please find \$5.25 for both the aluminum subpanel, etc., and the drilled Bakelite front panel of the AC model.

Name

Address

City..... State.....

AERIAL TUNER

Improves Summer Reception

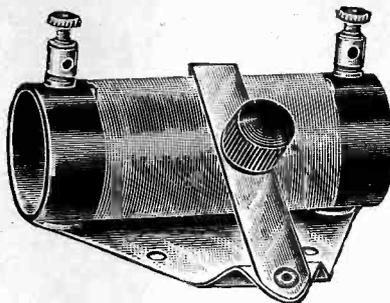

Remove aerial lead from set. Connect aerial instead to one of the binding posts of the Aerial Tuner. Connect the other binding post of the Aerial Tuner to antenna post of your set. Then move the lever of the Aerial Tuner until any weak station comes in loudest. The lever need not be moved for every different frequency tuned in. The Aerial Tuner acts as an antenna loading coil and puts the antenna's frequency at any frequency in the broadcast band that you desire to build up. It makes high wavelengths come in loud as low wavelengths. It helps separate stations and clear up reception. Makes great improvement in Summer reception. Price, \$1.00.

GUARANTY RADIO GOODS CO.
145 West 45th Street
New York City
(Just East of Broadway)

New Diamond (AC or Battery Model)

PARTS FOR THE AC DIAMOND

CA, CG, C7—Three Aerovox .0005 mfd. mica fixed condensers, moulded, @ .25.....	\$0.75
CS, C4, C8—Three Aerovox .006 mfd. mica fixed condensers, moulded, @ .50.....	1.50
C6, C9—Two Aerovox .02 mfd. mica fixed condensers, moulded, @ \$1.00.....	2.00
C10—One Aerovox 4 mfd. condenser.....	2.50
C1—One Hammarlund Equalizer, 70 mfd.....	.40
C2, C5—One Hammarlund Midline double condenser, each section .0005 mfd. (MLD23).....	6.00
R1, SW—One Electrad Royalty volume control (0-5,000 ohms) with 110-volt Hart & Hegeman AC switch built in.....	1.50
R2—One Electrad 900-ohm resistance strip (grid suppressor type).....	.20
R3—One Lynch 50,000-ohm resistor, with clips... ..	.20
R4—One Electrad 2,000-ohm resistance stub.....	.20
R5—One Electrad 2,000-ohm type B resistor (B20).....	.20
T1, T2—Two National A100 audio frequency transformers @ \$5.70.....	11.40
T3—One filament transformer; one winding 2.5 volts at 8 amperes or more, one winding 2.5 volts at 3.5 amperes or more, one winding 5 volts at 2 amperes or more (merchandised by Guaranty Radio Goods Co.).....	6.00
PL—One Yaxley pilot light bracket with green jewel and lamp.....	.55
Ant., ground, speaker —, speaker +, four binding posts @ .10.....	.40
One roll Braiddite wire.....	.30
One 7 x 21-inch front panel.....	2.35
One 10 x 20-inch official AC Diamond aluminum subpanel, self-bracketing, with three five-prong sockets and one four-prong socket built in.....	3.25
Front and subpanel together.....	5.25
Porcelain AC socket, screw plug 3-way plug, cable (lamp cord) and wall plug.....	.75
One dial.....	.98
Two knobs (one for tickler, the other for volume control) @ .20.....	.40
Note: The optional condenser, CX, is .006 mfd. @ .50.....	.50

PARTS FOR BATTERY MODEL DIAMOND

C1—Aerovox .0005 moulded fixed.....	.25
C2—Hammarlund .0005 mfd. Midline.....	3.50
C3, C4—Two Aerovox moulded .006 mfd. @ .50 ea.....	1.00
C5—Hammarlund .0005 mfd. Midline.....	3.50
C6—Aerovox .00025 moulded fixed with clips.....	.30
C7—Aerovox .0005 moulded fixed.....	.25
A1—622 Amperite with mount.....	.85
A2, A3, A4—Three 1A Amperites, three mounts @ .85.....	2.55
R1—50-ohm Frost rheostat.....	1.00
R2—5-meg. Lynch metallized leak.....	.40
T1, T2—Two National A100 audios @ \$5.70 ea.....	11.40
Ant., Gnd., Sp. —, Sp. + posts @ .10 ea.....	.40
PL—Yaxley jewel window bracket .35 with pilot lamp.....	.20
SW—Yaxley No. 10 A battery switch.....	.55
7 x 21-inch front panel.....	.35
10 x 20-inch official battery Diamond subpanel, self-bracketing, with four sockets affixed; subpanel hardware, insulated bushings, washers.....	2.35
Front panel and subpanel together.....	3.00
Two dials with pointers.....	5.00
Two knobs @ .20.....	2.00
One roll stranded Braiddite.....	.40
Hammarlund 70 mfd. Equalizer.....	.30
Four Kelly tubes: one 222, two 201A, one 112A or 171A.....	.40
	7.00

GUARANTY RADIO GOODS CO.
145 WEST 45th STREET
(Just East of Broadway)
NEW YORK CITY

Filament Transformer

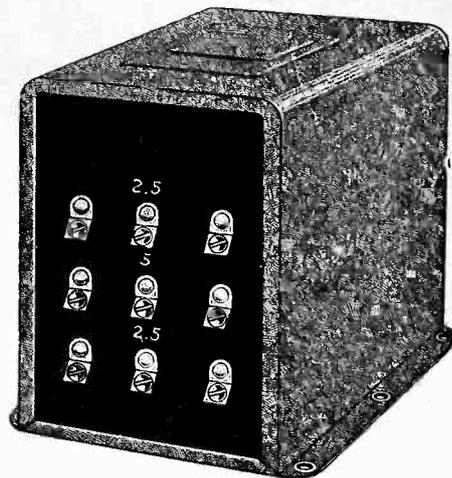

The heater type tube draws 1.75 ampere at 2.5 volts. If several such tubes are used a heavy-duty filament transformer is necessary. The top 2.5-volt winding of this filament transformer easily carries **NINE AMPERES**, or enough current for five heater type tubes. The bottom 2.5-volt winding stands four amperes, or enough current to heat **TWO MORE** such tubes, a total of **SEVEN TUBES!** The power tube, if of the 5-volt type, may be heated from the 5-volt central winding. 5-volt power tubes in push-pull may be heated from this winding.

All three windings are tapped at the exact electrical center. This precision location, made with the aid of an impedance bridge, accounts for absence of hum otherwise caused by the last tube when heated directly with AC. The heater type tubes are indirectly heated by AC, since the filament that glows is fed by AC but communicates heat to the cathode or electron emitter.

The heater type tube is represented by the 227, excellent as radio amplifier and audio amplifier, and the exclusive type of AC detector tube. Also the new AC screen grid tubes, with the same filament voltage and current, are of the heater type.

The transformer is beautifully finished in cracked glossy black, with bakelite front, and comes equipped with 52-inch AC cable with plug. Six riveted mounting holes for baseboard or subpanel. Size, 3 1/4 in. high, 2 1/2 in. wide, 3 in. deep. Shipping weight, 6 lbs.

Cat. F226A, for 50-to-60 cycles, 105-to-120 volts AC, Net Price\$6.00

Guaranty Radio Goods Co.
145 West 45th St.
N. Y. City

All Parts for PUSH-PULL DIAMOND

Mershon Electrolytic Condensers, four-in-one Copper Container

8-8-18-18 mfd. **\$5.76**
List price, \$9.60 Net

10-10-10-10 mfd. **\$4.65**
List price, \$7.75 Net

Filament Transformer, 2 1/2, 5, 2 1/2 v., net\$6.00
Power Transformer, 2 1/2, 5, 2 1/2, 300, 300 v., net.....10.00
S M Unichoke 331, net.....4.80

Guaranty Radio Goods Co.
145 West 45th Street
New York City
(Just East of Broadway)

Recent Issues of RADIO WORLD, 15 cents each. Any number published in 1928 available for a short while. Six issues 75 cents, 10 issues \$1.00. Send stamps, coin or money order NOW, before the issues are sold. RADIO WORLD, 145 West 45th Street, New York City.