

April 27th, 1929

15 Cents

# RADIO

REG. U.S. PAT. OFF.

# WORLD

The First and Only National Radio Weekly

370th Consecutive Issue—Eighth Year

*Sharp Television Pictures 15x18"  
Achieved as Notable Advance  
Toward Regular Home Service*

## VOLUME AFFECTS QUALITY

*What to Expect from a Set;  
Is Number of Tubes the Test?*

## STATIONS WANT PAY FOR POPULARIZING SONGS

*Ten Questions You Should Know;  
Also the Answers to These Queries*

## LACAULT'S POWER AMPLIFIER

*Petition Asks 38 Stations Be Ordered  
Off the Air for Sending "Lucky Strike"  
Advertising*

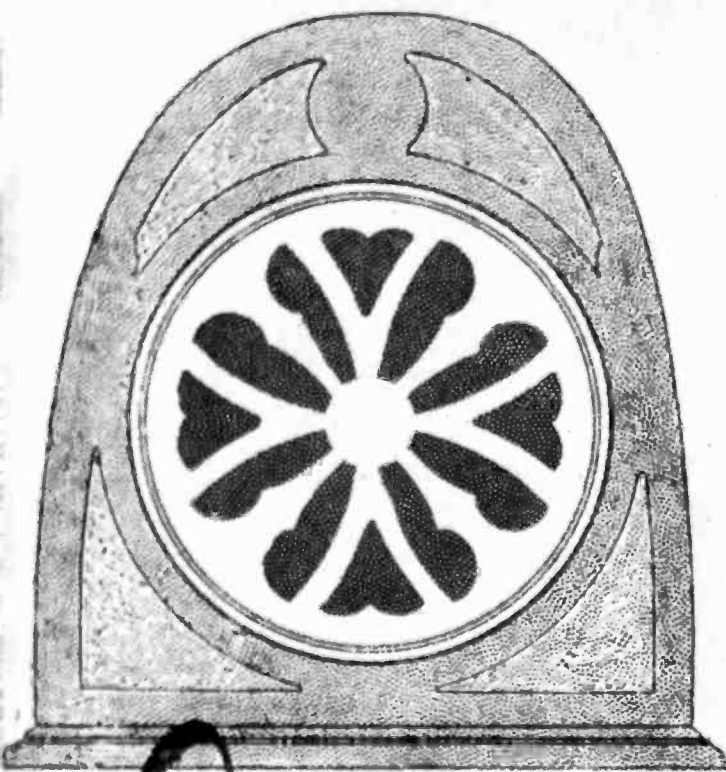

Recently-Discovered Methods of Getting Pure Tone from Phonograph Pick-Ups. See Page 18.

# PACENT Super Phonovox

THE newest and most scientifically accurate and practical pick-up on the market. . . . Plays records through a radio receiver with amazing fidelity and naturalness — and with a tone quality never before equalled. Easily attached—switches instantly from radio to records—absolutely trouble-free. Hear one. At good radio shops everywhere. \$12, \$15 and \$25.

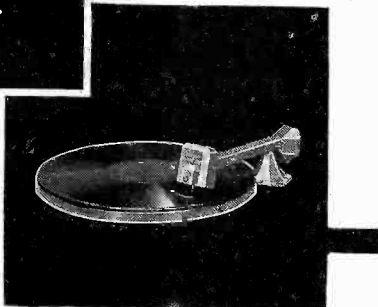

No rubber bearings to wear out and cause variation, perfectly balanced tone arm, hinged head for easy insertion of needle and special 36% English cobalt magnets—are a few Phonovox advantages.

## PACENT ELECTRIC CO., INC.,

91 Seventh Avenue

New York

Pioneers in Radio and Electric Reproduction for Over 20 Years

Manufacturing Licensee for Great Britain and Ireland: Igranic Electric Co., Ltd., Bedford, England  
Licensee for Canada: White Radio Limited, Hamilton, Ont.

## Build the Greatest Circuit—RE 29!

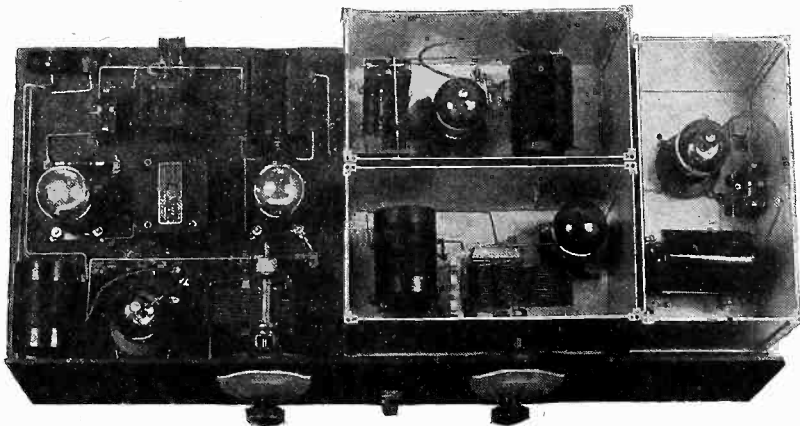

The neat and efficient arrangement of parts in R. E. Lacault's RE29.

### Lacault's Last and Best Receiver!

FOR sheer sensitivity the screen-grid receiver, the RE29, surpassed any circuit he ever tried, R. E. Lacault said, just before his death. So that this extreme sensitivity could be utilized properly, Mr. Lacault spent many trying months until he developed the circuit to a remarkably high point of selectivity, with utter stability. That done, he knew he had a wonderful receiver, one that his large following, eagerly awaiting a screen grid adaptation of his original modulation system, would build with delight and operate with ecstasy! The RE29, successor to a long line of successful Lacault receiver designs, is here. His last circuit,

his best circuit, may now be duplicated by constructors!

THE receiver consists of six tubes (including first audio) in the table chassis and two tubes (a push-pull output) in the B supply and power amplifier. Hence the receiver proper uses eight tubes. Two 281 tubes are used as rectifiers. So well are each independent stage and the group of stages designed that abnormally high amplification prevails. Distant stations "roll in" easily, with volume to spare. The master designer of DX circuits took good care of that!

Build this receiver and the Push-Pull Power Amplifier B supply from the official blueprints.

Send for your free copy of the Builders' Information Sheet today!

## BLUEPRINTS!

BUILD the RE29 and the Push-Pull Power Amplifier B Supply from the official blueprints! The price of the blueprint for the 6-tube receiver RE29 (including first audio) is \$1.50. The price of the Push-Pull Power Amplifier B Supply blueprint is \$1.00. All orders filled promptly. Get your FREE copy of the Builders' Information Sheet TODAY!

All Parts in Stock for Receiver and Amplifier.

Mrs. R. E. Lacault, 1931 B'way, N. Y. City (65th St.)

- Enclosed please find \$1.50 for which please send at once blueprint of the 6-tube RE29 Receiver.
- Enclosed please find \$1 additional for blueprint of the Push-Pull Power Amplifier B Supply.
- 50c for construction article.
- Please send FREE copy of the Builders' Information Sheet on the complete RE29.

Name .....  
Address .....  
City ..... State ..... rw

## DIAMOND Pair

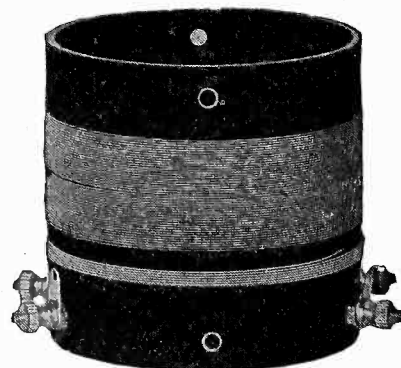

AC5 . . . . \$1.50

Highly selective antenna coil for any circuit, and interstage coil for AC circuits. Step-up ratio, 1-to-8. Tunes with .0005 mfd. Model AC3, for .00035 mfd. . . . \$1.75

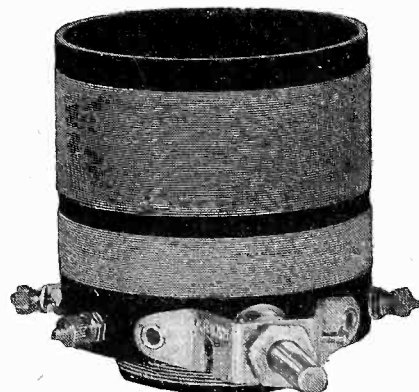

SGT5 . . . . \$2.75

Tuner to work out of a screen grid tube. The large primary is fixed and is connected in the plate circuit of the screen grid tube. Tunes with .0005 mfd. Model SGT3, for .00035 mfd. . . . \$3.00

## UNIVERSAL Pair

TP5 . . . . \$3.00

Interstage coupler to work out of a screen grid tube, where the primary is fixed and the secondary is tuned, in the next grid circuit, untuned. Tunes with .0005 mfd. Model TP3, for .00035 mfd. . . . \$3.25

RF5 . . . . \$1.50

Excellent selective antenna coil for any circuit, and interstage coil for any battery operated receiver, excepting output of screen grid tube. Tunes with .0005 mfd. Model RF3, for .00035 mfd. . . . \$1.75

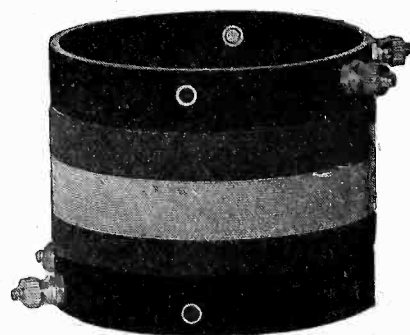

A5 . . . . \$1.75

Conductively coupled antenna coil, for maximum pickup, where selectivity is not the main consideration. Continuous winding in two colors. Tunes with .0005 mfd. Model A3, for .00035 mfd. . . . \$2.00

# YOU MUST GET THIS BOOK!

## DRAKE'S RADIO CYCLOPEDIA (New Edition)

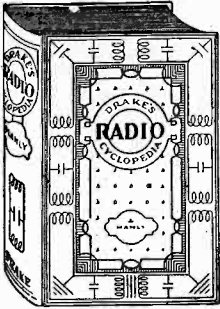

has been developed to answer the questions of service men, custom set builders and home constructors, of experimenters, students, salesmen and operators of receiving equipment and to allow all these to have instant access to the information they want. The author, Harold P. Marly, has collected and translated into plain English the material formerly obtainable only from dozens of scattered sources.

Each rule, fact, method, plan, layout and diagram is instantly picked out and separated from every thing else by placing all subjects in alphabetical order with cross references for every imaginable name under which the information might be classed.

BOOK IS 2 1/2" THICK, WEIGHS 3 1/2 LBS., 1,025 ILLUSTRATIONS.

This alphabetical arrangement lets the experienced worker refer directly to the one thing in which he is interested at the moment without hunting through non-essentials. The needs of the beginner are cared for.

The important articles deal primarily with receiver and reception. They do not stop with the electrical end, but go also into the mechanics of construction. Every new thing in radio is covered in detail.

- 1,680 Alphabetical Headings from A-battery to Zero Beat
  - 1,025 Illustrations, Diagrams, Layouts and Graphs
  - 920 Pages. Each 6 by 9 inches
  - 240 Combinations for Receiver Layout
- OF THE PRINCIPAL ARTICLES**
- 159 Concern service men, 129 help the set builder.
  - 162 help the experimenter, 155 interest the student.
  - 75 assist in sales work, 73 interest set owners.

**GUARANTY RADIO GOODS CO.,**  
145 W. 45th St., New York, N. Y. (Just E. of B'way)

Gentlemen: Please mail me at once the new (second) edition of "Drake's Radio Encyclopedia," by Harold P. Marly. Just published with all the latest technical information in it. I will pay the postman \$6.00 plus a few cents extra for postage. If I am not delighted, I may return the book in five days and you will promptly refund my purchase money.

Name .....

Address .....

City..... State.....

**5-DAY MONEY-BACK GUARANTY!**

# LACAULT'S BOOK

"Super-Heterodyne Construction and Operation," giving the master's most masterful exposition of the theory, performance and construction of this fascinating type of circuit, is a necessity to every serious radio experimenter. More than 100 pages and more than 50 illustrations. Buckram cover. This book by R. E. Lacault, FREE if you send \$1.00 for an 8-weeks subscription for Radio World. Present subscribers may accept this offer. Subscription will be extended.

**RADIO WORLD** 145 W. 45th St., N.Y. City  
Just East of B'way

# LYNCH

Tubadapta improves radio reception and prolongs life of power tubes.

**ARTHUR H. LYNCH, INC.**  
1775 Broadway New York City

Send for free Lynch radio manual

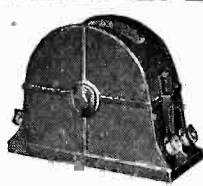

## VICTOREEN Super Coils

Write for Free Blueprints of New Victoreen Circuits

**Geo. W. Walker Co.**  
2825 Chester Avenue  
Dept. B Cleveland, O.

## More Profits To Set Builders

One good radio idea may be worth millions. Barawik has thousands of ideas for radio set builders to make more money. Barawik's Big Radio Book will help you while elections are on and big national events stir the world.



Send for your copy today - NOW.  
**BARAWIK CO.** 1340 Canal Station, CHICAGO, U. S. A.



# Braidite

## HOOK-UP WIRE "THE BRAID SLIDES BACK"

Safe as insulated wire and as convenient as bare wire. You cannot scorch or burn Braidite with a soldering iron. Use Braidite in your next set.

**At All Dealers**  
25 Feet Stranded.....35c  
25 Feet Solid.....30c  
Red, Green, Yellow, Blue, Black  
**FREE** Send us the name and address of your dealer and we will send you a sample package of Braidite FREE. Include 10c for Postage.

**CORNISH WIRE CO.**  
30 Church St. : : New York City

### WHY NOT A TONE BLEND?

If you want real tone quality, try a tone blend of two loudspeakers—a high-pitched horn and a low-pitched cone. Of course you need a VOLUME CONTROL CLAROSTAT shunted across each to control the output and to secure the tone blend.

CLAROSTATS offer a sure way to rejuvenate ANY radio set. Your dealer will tell you how it's done.

**CLAROSTAT MFG. CO., Inc.**  
291 North 6th Street, Brooklyn, N. Y.

## CLAROSTAT

EARN MONEY writing or drawing Jokes, Cartoons, Humor. Experience unnecessary. Vanhookern, Dept. 193-T, Covington, Ky.

# Gothic Polo Speaker, \$15.00

Housed in a beautiful Gothic structure of genuine walnut; hand-rubbed to an attractive finish, the Polo driving mechanism and cone combine best quality reproduction with finest appearance. The grille is specially constructed for two-tone effect, so popular in walnut these days. The Polo Speaker in the Gothic housing is an adornment, besides being an outstanding speaker in performance. The design of the cabinet is exclusive. The height is 12 1/2". Shipping weight, 10 lbs. Cat. No. T.M.P.G.....



**Guaranty Radio Goods Co.**  
145 West 45th Street  
New York City

# Cash in on This Offer Now!

**ONE** full year's subscription for any **TWO** of the following magazines given to you—**RADIO NEWS** or **SCIENCE AND INVENTION** or **RADIO** (San Francisco) or **BOYS' LIFE** or **CITIZENS RADIO CALL BOOK** AND **SCIENTIFIC DIGEST** or **RADIO ENGINEERING**.

Select any **TWO** of these four publications, each of which will be sent to you (at only one address, however) each month for twelve months—in other words, 24 issues—if you will send in now your subscription for **RADIO WORLD** for two years (104 numbers) at \$10.00. **RADIO WORLD'S** subscription price for one year is \$6.00, so you gain the extra 2 dollars by taking advantage of the liberal offer for two-year subscriptions; and, besides, you get a subscription for each of the **TWO** other magazines selected from the enumerated list, making a total of 128 numbers for \$10.00.

If you want to select only one from among the four other magazines, you may obtain this one for **TWO** years, so that you will be subscribing for **RADIO WORLD** for two years and for the other magazine for **TWO** years, all for only \$10.00 (both mailed to one address only).

These offers are rightly regarded as among the most liberal ever made, but as they are limited as to expiration date (see notice below) you must act now.

Please use the attached coupon.

### SPECIAL TWO-FOR-PRICE-OF-ONE COUPON

**RADIO WORLD**, 145 West 45th Street, New York City (Just East of Broadway):  
Enclosed please find \$10.00, for which send me **RADIO WORLD** each week for two years (104 numbers), and also send me, without extra cost, each month for one year each of the following **TWO** magazines—total, 24 issues—grand total, 128 numbers:

- |  |   |
|--|---|
| <input type="checkbox"/> <b>RADIO NEWS</b>                     | <input type="checkbox"/> <b>RADIO</b> (San Francisco) |
| <input type="checkbox"/> <b>SCIENCE AND INVENTION</b>          | <input type="checkbox"/> <b>BOYS' LIFE</b>            |
| <input type="checkbox"/> <b>CITIZENS RADIO CALL BOOK, ETC.</b> | <input type="checkbox"/> <b>RADIO ENGINEERING</b>     |

If you want one of each, put a cross in a square next to the name of each of the two other magazines. If you want a two-year subscription for **ONE** of the above magazines, with the two-year subscription for **RADIO WORLD** (same grand total of 128 numbers), put two crosses before the name of one magazine.

If you prefer to pay \$6.00 for only one year's subscription for **RADIO WORLD** (52 numbers) and get one of the other magazines for one year, without extra cost, put one cross in one square in front of the name of one magazine.

Present **RADIO WORLD** subscribers may renew under this offer. If renewing, put a cross here

Name.....

Street Address.....

City..... State.....

**THIS OFFER EXPIRES AT NOON ON MAY 30TH, 1929**



# New Style DeLuxe Leatherette Carrying Case FREE with each Jiffy Tester!

This combination of meters tests all standard tubes, including the new AC screen grid tubes and the new 245 tube, making thirteen tests in 4½ minutes! Instruction sheet gives these tests in detail.

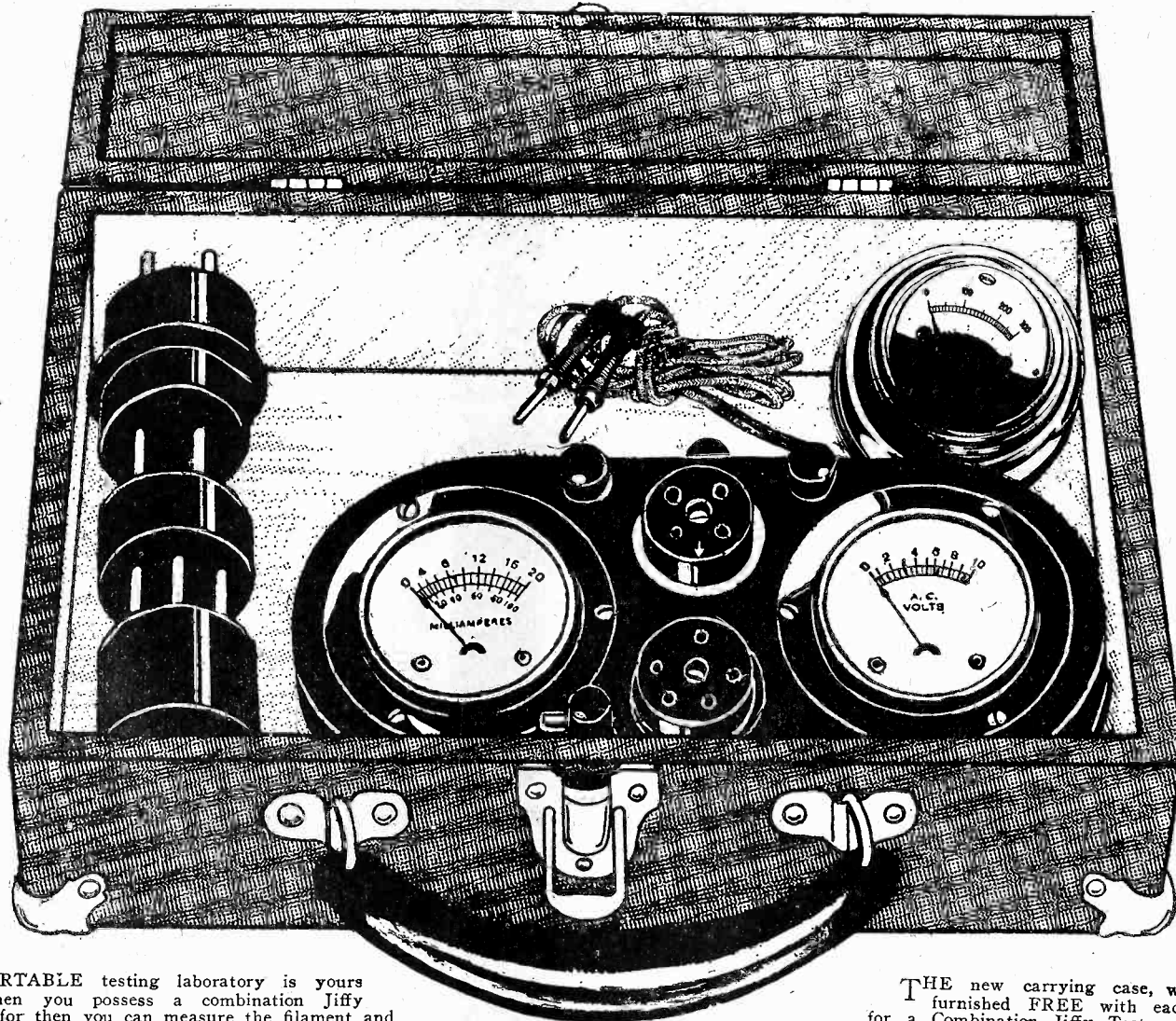

A PORTABLE testing laboratory is yours when you possess a combination Jiffy Tester, for then you can measure the filament and plate voltages of all standard tubes, including AC tubes, and all standard battery-operated or AC screen grid tubes; also plate voltages up to 500 volts on a high resistance meter that is 99% accurate.

The Jiffy Tester consists of a 0-20, 0-100 milliammeter, with change-over switch and a 0-10 volt AC and DC voltmeter (same meter reads both), with two sockets, one for 5-pronged, the other for 4-prong tubes; a grid bias switch and two binding posts to which are attached the cords of the high resistance voltmeter; also built-in cable with 5-prong plug and 4-prong adapter, so that connections in a receiver are transferred to the Tester automatically. Not only can you test tubes, but also opens or shorts in a receiver, continuity, bias, oscillation, etc. The instruction sheet tells all about these tests.

In addition you can test screen grid tubes by connecting a special cable, with clip to control grid (cap of tube) and other end of special cable to the clip in the set that went to the cap before the tube was transferred to the tester.

THE new carrying case, which is furnished FREE with each order for a Combination Jiffy Tester, contains the entire outfit, including the three meters, cable and plug, and three adapters (one for 4-prong tubes, two for 199 tubes). This case is 10½x7¾x3½" and has nickel corner pieces and protective snap-lock. The case is made of strong wood, with black leatherette overlay.

To operate, remove a tube from the receiver, place the cable plug in the vacant receiver socket, put the tube in the proper socket of the Tester, connect the high resistance meter to the two binding posts, and you're all set to make the thirteen vital tests in 4½ minutes!

The Combination Jiffy Tester is just the thing for service men, custom set builders, experimenters, students, teachers and factories. Order "Jiffy 500." The price is only \$14.50.

If a 0-600 AC and DC high resistance meter (99% accurate) is desired, so house electricity line voltage and power transformer voltages can be measured, as well as plate voltage, instead of the 0-500 DC voltmeter, order "Jiffy 600" at \$15.50.

GUARANTY RADIO GOODS CO., 145 W. 45 St., N. Y. City. (Just East of Broadway).

- Please ship at once on 5-day money-back guaranty one "Jiffy 500," at \$14.50, consisting of
- (1) One Two-in-One 0 to 10 voltmeter for AC and DC. Same meter reads both. Scale especially legible at 1½ to 7½ volts. This meter reads the AC and DC filament voltages.
- (2) One DOUBLE reading DC milliammeter, 0 to 20 and 0 to 100 milliamperes, with change-over switch. This reads plate current.
- (3) One 0-500 volts high resistance voltmeter, 99% accurate; with tipped 30" cord to measure B voltages.
- (4) One 5-prong plug with 30" cord for AC detector tubes, etc., and one 4-prong adapter for other tubes.
- (5) One grid switch to change bias.
- (6) One 5-prong socket.
- (7) One 4-prong socket.
- (8) Two binding posts.
- (9) One handsome mo're metal case.
- (10) One instruction sheet.
- (11) One de luxe carrying case.
- (12) One screen grid special cable.
- If 0-300 DC high resistance 99% accurate voltmeter is preferred to 0-500, put check here. Price is same, \$14.50.
- Same as above, except substitute a 0-600-volt AC and DC high resistance 99% accurate voltmeter (same meter reads both) for the 0-500 DC meter. Price \$15.50.

NAME .....

ADDRESS .....

CITY ..... STATE .....

FIVE-DAY MONEY-BACK GUARANTY

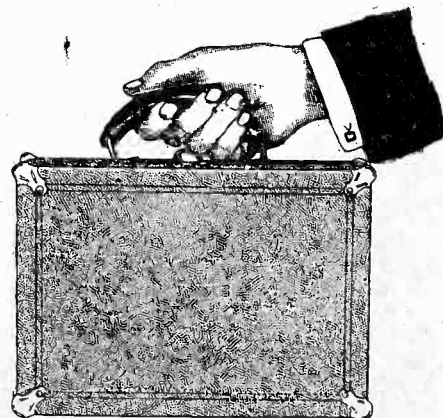

The new de luxe leatherette carrying case is compact and handy. Size 10½" long, 7¾" wide, 3½" deep.

April 27th, 1929

15 Cents

# RADIO

REG. U.S. PAT. OFF.

# WORLD

The First and Only National Radio Weekly

370th Consecutive Issue—Eighth Year

*Sharp Television Pictures 15x18"  
Achieved as Notable Advance  
Toward Regular Home Service*

## VOLUME AFFECTS QUALITY

*What to Expect from a Set;  
Is Number of Tubes the Test?*

## STATIONS WANT PAY FOR POPULARIZING SONGS

*Ten Questions You Should Know;  
Also the Answers to These Queries*

## LACAULT'S POWER AMPLIFIER

*Petition Asks 38 Stations Be Ordered  
Off the Air for Sending "Lucky Strike"  
Advertising*

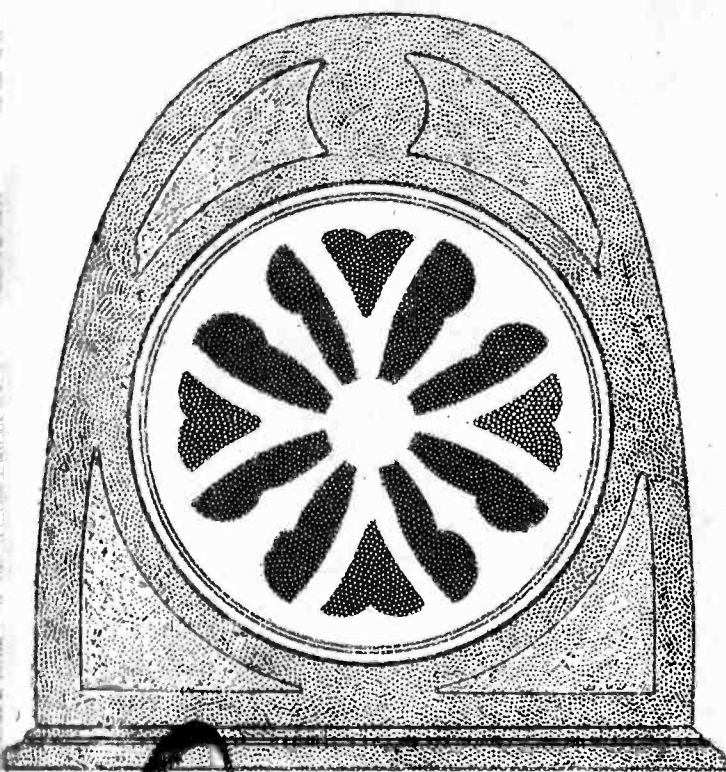

Recently-Discovered Methods of Getting Pure Tone from Phonograph Pick-Ups. See Page 18.



# PACENT Super Phonovox

THE newest and most scientifically accurate and practical pick-up on the market. . . . Plays records through a radio receiver with amazing fidelity and naturalness — and with a tone quality never before equalled. Easily attached—switches instantly from radio to records—absolutely trouble-free. Hear one. At good radio shops everywhere. \$12, \$15 and \$25.

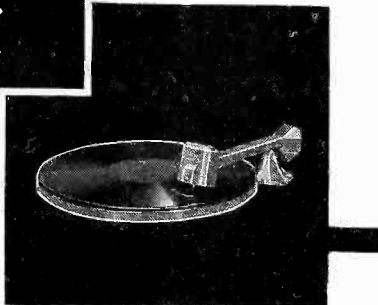

No rubber bearings to wear out and cause variation, perfectly balanced tone arm, hinged head for easy insertion of needle and special 36% English cobalt magnets — are a few Phonovox advantages.

PACENT ELECTRIC CO., INC.,

91 Seventh Avenue

New York

Pioneers in Radio and Electric Reproduction for Over 20 Years

Manufacturing Licensee for Great Britain and Ireland: Igranic Electric Co., Ltd., Bedford, England  
Licensee for Canada: White Radio Limited, Hamilton, Ont.

## Build the Greatest Circuit—RE 29!

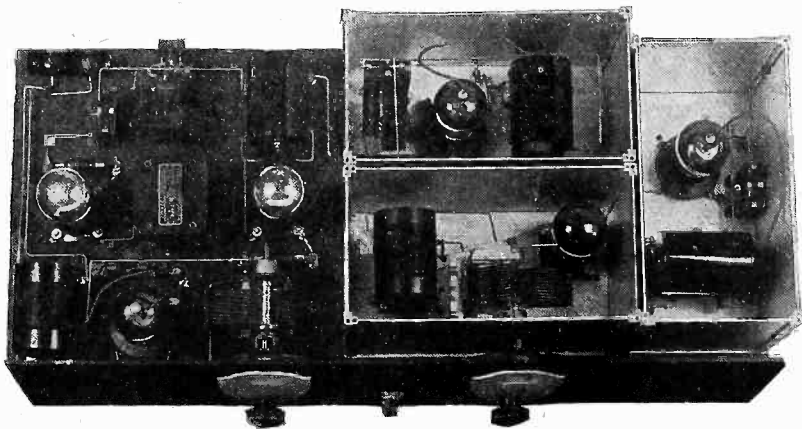

The neat and efficient arrangement of parts in R. E. Lacault's RE29.

### Lacault's Last and Best Receiver!

FOR sheer sensitivity the screen-grid receiver, the RE29, surpassed any circuit he ever tried, R. E. Lacault said, just before his death. So that this extreme sensitivity could be utilized properly, Mr. Lacault spent many trying months until he developed the circuit to a remarkably high point of selectivity, with utter stability. That done, he knew he had a wonderful receiver, one that his large following, eagerly awaiting a screen grid adaptation of his original modulation system, would build with delight and operate with ecstasy! The RE29, successor to a long line of successful Lacault receiver designs, is here. His last circuit,

his best circuit, may now be duplicated by constructors!

THE receiver consists of six tubes (including first audio) in the table chassis and two tubes (a push-pull output) in the B supply and power amplifier. Hence the receiver proper uses eight tubes. Two 281 tubes are used as rectifiers. So well are each independent stage and the group of stages designed that abnormally high amplification prevails. Distant stations "roll in" easily, with volume to spare. The master designer of DX circuits took good care of that!

Build this receiver and the Push-Pull Power Amplifier B supply from the official blueprints.

Send for your free copy of the Builders' Information Sheet today!

### BLUEPRINTS!

BUILD the RE29 and the Push-Pull Power Amplifier B Supply from the official blueprints! The price of the blueprint for the 6-tube receiver RE29 (including first audio) is \$1.50. The price of the Push-Pull Power Amplifier B Supply blueprint is \$1.00. All orders filled promptly. Get your FREE copy of the Builders' Information Sheet TODAY!

All Parts in Stock for Receiver and Amplifier.

- Mrs. R. E. Lacault, 1931 B'way, N. Y. City (65th St.)
- Enclosed please find \$1.50 for which please send at once blueprint of the 6-tube RE29 Receiver.
  - Enclosed please find \$1 additional for blueprint of the Push-Pull Power Amplifier B Supply.
  - 5¢ for construction article.
  - Please send FREE copy of the Builders' Information Sheet on the complete RE29.

Name .....  
Address .....  
City ..... State.....rw

## DIAMOND Pair

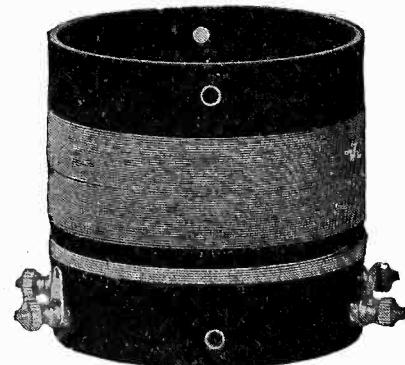

AC5 . . . . \$1.50

Highly selective antenna coil for any circuit, and interstage coil for AC circuits. Step-up ratio, 1-to-8. Tunes with .0005 mfd. Model AC3, for .00035 mfd.....\$1.75

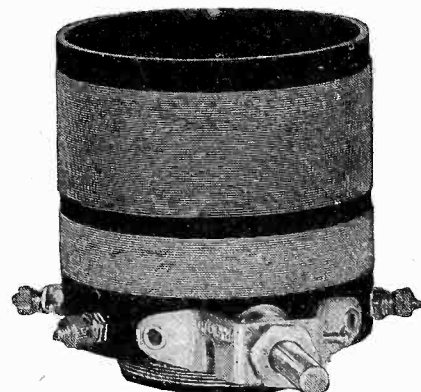

SGT5 . . . . \$2.75

Tuner to work out of a screen grid tube. The large primary is fixed and is connected in the plate circuit of the screen grid tube. Tunes with .0005 mfd. Model SGT3, for .00035 mfd.....\$3.00

## UNIVERSAL Pair

TP5 . . . . \$3.00

Interstage coupler to work out of a screen grid tube, where the primary in the plate circuit is tuned, the secondary, in the next grid circuit, untuned. Tunes with .0005 mfd. Model TP3, for .00035 mfd.....\$3.25

RF5 . . . . \$1.50

Excellent selective antenna coil for any circuit, and interstage coil for any battery operated receiver, excepting output of screen grid tube. Tunes with .0005 mfd. Model RF3, for .00035 mfd.....\$1.75

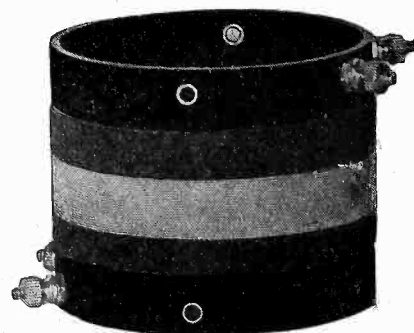

A5 . . . . \$1.75

Conductively coupled antenna coil, for maximum pickup, where selectivity is not the main consideration. Continuous winding in two colors. Tunes with .0005 mfd. Model A3, for .00035 mfd. ....\$2.00

# YOU MUST GET THIS BOOK!

## DRAKE'S RADIO CYCLOPEDIA (New Edition)

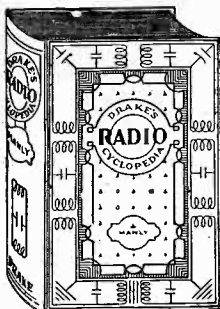

has been developed to answer the questions of service men, custom set builders and home constructors, of experimenters, students, salesmen and operators of receiving equipment and to allow all these to have instant access to the information they want. The author, Harold P. Marly, has collected and translated into plain English the material formerly obtainable only from dozens of scattered sources.

Each rule, fact, method, plan, layout and diagram is instantly picked out and separated from every thing else by placing all subjects in alphabetical order with cross references for every imaginable

BOOK IS 2 1/2" THICK. WEIGHS 3 3/4 LBS., 1,025 ILLUSTRATIONS.

ble name under which the information might be classed.

This alphabetical arrangement lets the experienced worker refer directly to the one thing in which he is interested at the moment without hunting through non-essentials. The needs of the beginner are cared for.

The important articles deal primarily with receiver and reception. They do not stop with the electrical end, but go also into the mechanics of construction. Every new thing in radio is covered in detail.

- 1,680 Alphabetical Headings from A-battery to Zero Beat
  - 1,025 Illustrations, Diagrams, Layouts and Graphs
  - 920 Pages. Each 6 by 9 inches
  - 240 Combinations for Receiver Layout
- OF THE PRINCIPAL ARTICLES**
- 159 Concern service men, 129 help the set builder.
  - 162 help the experimenter, 155 interest the student.
  - 75 assist in sales work, 73 interest set owners.

### GUARANTY RADIO GOODS CO.,

145 W. 45th St., New York, N. Y. (Just E. of B'way)  
Gentlemen: Please mail me at once the new (second) edition of "Drake's Radio Encyclopedia," by Harold P. Marly, just published, with all the latest technical information in it. I will pay the postage \$6.00 plus a few cents extra for postage. If I am not delighted, I may return the book in five days and you will promptly refund my purchase money.

Name .....

Address .....

City..... State.....

**5-DAY MONEY-BACK GUARANTY!**

## LACAULT'S BOOK

"Super-Heterodyne Construction and Operation," giving the master's most masterful exposition of the theory, performance and construction of this fascinating type of circuit, is a necessity to every serious radio experimenter. More than 100 pages and more than 50 illustrations. Buckram cover. This book by R. E. Lacault, FREE if you send \$1.00 for an 8-weeks subscription for Radio World. Present subscribers may accept this offer. Subscription will be extended.

**RADIO WORLD** 145 W. 45th St., N.Y. City  
Just East of B'way

## LYNCH

Tubadapta improves radio reception and prolongs life of power tubes.

**ARTHUR H. LYNCH, INC.**  
1775 Broadway New York City

Send for free Lynch radio manual

## VICTOREEN Super Coils

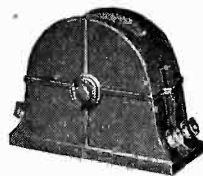

Write for Free Blueprints of New Victoreen Circuits

**Geo. W. Walker Co.**  
2825 Chester Avenue  
Dept. B Cleveland, O.

## More Profits To Set Builders

One good radio idea may be worth millions. Barawik has thousands of ideas for radio set builders to make more money. Barawik's Big Radio Book will help you while elections are on and big national events stir the world.



Send for your copy today - NOW.  
**BARAWIK CO.** 134C Canal Station, CHICAGO, U. S. A.



# Braidite

## HOOK-UP WIRE

### "THE BRAID SLIDES BACK"

Safe as insulated wire and as convenient as bare wire. You cannot scorch or burn Braidite with a soldering iron. Use Braidite in your next set.

**At All Dealers**  
25 Feet Stranded.....35c  
25 Feet Solid.....30c

Red, Green, Yellow, Blue, Black  
**FREE** Send us the name and address of your dealer and we will send you a sample package of Braidite FREE. Include 10c for Postage.

**CORNISH WIRE CO.**  
80 Church St. : : New York City

### WHY NOT A TONE BLEND?

If you want real tone quality, try a tone blend of two loudspeakers—a high-pitched horn and a low-pitched cone. Of course you need a VOLUME CONTROL CLAROSTAT shunted across each to control the output and to secure the tone blend.

CLAROSTATS offer a sure way to rejuvenate ANY radio set. Your dealer will tell you how it's done.

**CLAROSTAT MFG. CO., Inc.**  
291 North 6th Street, Brooklyn, N. Y.

# CLAROSTAT

EARN MONEY writing or drawing Jokes, Cartoons, Humor. Experience unnecessary. Vanhookern, Dept. 193-T, Covington, Ky.

# Gothic Polo Speaker, \$15.00

Housed in a beautiful Gothic structure of genuine walnut; hand-rubbed to an attractive finish, the Polo driving mechanism and cone combine best quality reproduction with finest appearance. The grille is specially constructed for two-tone effect, so popular in walnut these days. The Polo Speaker in the Gothic housing is an adornment, besides being an outstanding speaker in performance. The design of the cabinet is exclusive. The height is 12 1/2". Shipping weight, 10 lbs. Cat. No. T.M.P.G.....

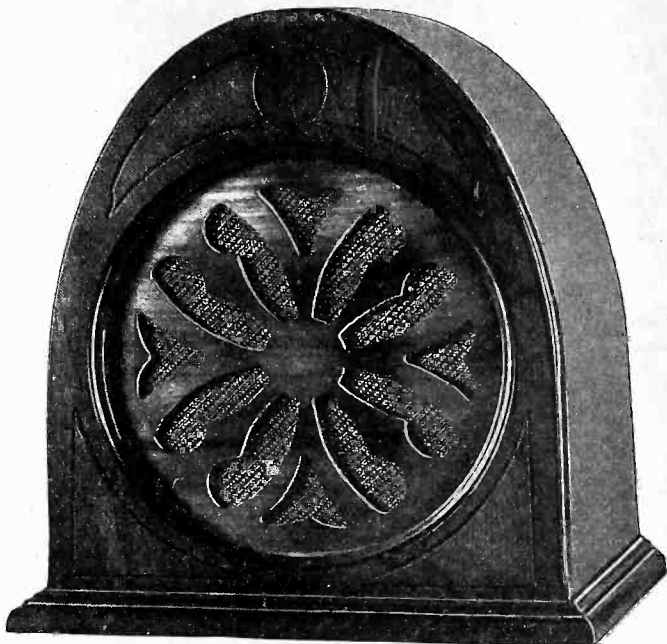

**Guaranty Radio Goods Co.**  
145 West 45th Street  
New York City

# Cash in on This Offer Now!

ONE full year's subscription for any TWO of the following magazines given to you—**RADIO NEWS or SCIENCE AND INVENTION or RADIO** (San Francisco) or **BOYS' LIFE or CITIZENS RADIO CALL BOOK AND SCIENTIFIC DIGEST or RADIO ENGINEERING.**

Select any TWO of these four publications, each of which will be sent to you (at only one address, however) each month for twelve months—in other words, 24 issues—if you will send in now your subscription for **RADIO WORLD** for two years (104 numbers) at \$10.00. **RADIO WORLD'S** subscription price for one year is \$6.00, so you gain the extra 2 dollars by taking advantage of the liberal offer for two-year subscriptions; and, besides, you get a subscription for each of the TWO other magazines selected from the enumerated list, making a total of 128 numbers for \$10.00.

If you want to select only one from among the four other magazines, you may obtain this one for TWO years, so that you will be subscribing for **RADIO WORLD** for two years and for the other magazine for TWO years, all for only \$10.00 (both mailed to one address only).

These offers are rightly regarded as among the most liberal ever made, but as they are limited as to expiration date (see notice below) you must act now.

Please use the attached coupon.

### SPECIAL TWO-FOR-PRICE-OF-ONE COUPON

**RADIO WORLD**, 145 West 45th Street, New York City (Just East of Broadway):  
Enclosed please find \$10.00, for which send me **RADIO WORLD** each week for two years (104 numbers), and also send me, without extra cost, each month for one year each of the following TWO magazines—total, 24 issues—grand total, 128 numbers:

- |  |   |
|--|---|
| <input type="checkbox"/> <b>RADIO NEWS</b>                     | <input type="checkbox"/> <b>RADIO</b> (San Francisco) |
| <input type="checkbox"/> <b>SCIENCE AND INVENTION</b>          | <input type="checkbox"/> <b>BOYS' LIFE</b>            |
| <input type="checkbox"/> <b>CITIZENS RADIO CALL BOOK, ETC.</b> | <input type="checkbox"/> <b>RADIO ENGINEERING</b>     |

If you want one of each, put a cross in a square next to the name of each of the two other magazines. If you want a two-year subscription for ONE of the above magazines, with the two-year subscription for **RADIO WORLD** (same grand total of 128 numbers), put two crosses before the name of one magazine.

If you prefer to pay \$6.00 for only one year's subscription for **RADIO WORLD** (52 numbers) and get one of the other magazines for one year, without extra cost, put one cross in one square in front of the name of one magazine.

Present **RADIO WORLD** subscribers may renew under this offer. If renewing, put a cross here

Name.....

Street Address.....

City..... State.....

**THIS OFFER EXPIRES AT NOON ON MAY 30TH, 1929**

"Look for the Green Box"



The Only Tubes with  
5-Day Money-Back  
Guarantee in Each Box

222 Screen Grid Tube \$3.50



AFTER having tried many screen grid tubes, many specialists have made Kelly 222 their choice. Our 222 stands up! Filament is not critical, but 8.3 volts work best. Plate voltage may be from 90 to 180, but negative bias of 1.5 volts remains the same. The screen grid voltage, G post of socket, may be 22 to 45 volts, depending on how much amplification you want. A working amplification of 60 is easily obtainable (60 mu.).

The plate current is virtually independent of plate voltage in the recommended range, 90 to 180 volts. This aids stability.

The cap at top of the tube is for familiar grid connection.

This tube is for battery or A-eliminator operation.

240 High Mu Tube \$1.25

Great for Detector or in audio channels where a resistor or impedance coil is in the plate circuit. Fil. 5 volts DC, plate 90 to 180 volts.

POWER TUBES

250.....\$6.00	210.....\$4.50
171A.....1.50	112A.....1.50

OTHER TYPES

280.....\$2.50	281.....\$3.50
227.....2.25	226.....1.25
201A.....1.00	199.....1.25

KELLY TUBE COMPANY

Walter J. McCord, Manager  
57 DEY STREET, NEW YORK CITY  
Suite 6 Tel. BARclay 8659

KELLY TUBES  
Prescribed for the  
Screen Grid Diamond

One screen grid 422.....\$3.50  
Two 410A at \$1.00 each.....2.00  
One 412A (for 135 volts).....2.00  
or One 471A (for 180 volts).....2.00  
Send \$7.50 for set of four tubes for this receiver.  
Specify whether power tube wanted is 412A or 471A.

KELLY TUBE COMPANY  
57 Dey Street New York City  
10-Day Money-Back Guarantee

# Most Selective DIAMOND

## Follow Blueprint

THIS IS THE BATTERY MODEL

Here is the circuit of circuits—the design that makes a neighboring cleared-channel, high-power broadcaster snap out of audibility at a slight turn of the dial.

No need to worry about the selectivity requirements imposed on receivers by the reallocation.

Volume "to fill the house"—even on distance. Tone quality excellent.

Get the official blueprint of the laboratory model of the new SG 4-tube Diamond, exactly as built by Herman Bernard, the designer.

RADIO WORLD  
145 W. 45th St., N. Y. City  
(Just E. of B'way)

Enclosed please find \$1.00 for which please send at once the official blueprint of the new, highly selective 4-tube screen grid Diamond of the Air battery model.

80 cents extra for the February 9th, 16th, 23rd and March 2nd (1929) issues of Radio World, containing Bernard's articles on the construction of this receiver.

\$3.00 for 6 months (26 numbers) subscription for Radio World. Send Diamond blue print and four Diamond issues FREE, in addition to 26 current issues.

Name.....  
Address.....  
City.....State.....

## Blueprint of the AC Diamond

BUILD this 4-tube receiver, using one 222 tube, two 227 and one 112A (or 171A), and enjoy tone quality, selectivity and ease of control. The official blueprint gives the picture diagram life size, both top and bottom views; also schematic diagram and list of parts. You can use your present B eliminator externally, but the filament transformer is a part of the circuit.

Enjoy the convenience of AC operation, and still have just as selective and sensitive receiver, by building the AC Diamond. If you have 110-volt, 50 to 60 cycle AC house current, then this is the circuit for you. Fine performance. No hum.

Radio World, 145 W. 45 St., N. Y. City (Just East of Broadway)

Enclosed please find \$1.00 for which send at once official blueprint of the 4-tube AC Diamond.

30c for the March 23d and 30th issues (1929) describing this circuit.

\$3.00 for 6 months subscription for Radio World. Send blueprint and two AC Diamond issues FREE.

NAME.....  
ADDRESS.....  
CITY.....STATE.....

## Aluminum Subpanel for the New, Highly Selective SG Diamond

Battery or AC Model (specify which)

The best appearance of the New Diamond of the Air results from using the official aluminum sub-panel, 10 x 20 inches, with the four sockets built in, and with self-bracketing front. Hardware and insulating washers supplied with each sub-panel. The aluminum sub-panel is exactly the same as the one used in the laboratory models of the battery operated and the AC Screen Grid Diamonds. Holes are drilled for mounting parts, but as this aluminum drills like bakelite you can drill any holes you want.

RADIO WORLD, 145 W. 45th St., N. Y. City.  
(Just East of Broadway)

Enclosed please find \$3.00 for which please send one aluminum subpanel 10x20" for the new battery model 4-tube SG Diamond of the Air, with sockets built in, and with self-bracketing front and side and rear supports; also send hardware and insulating washers.

Enclosed please find \$2.35 for which please send 7x21" drilled Bakelite front panel for the new battery model Diamond.

Enclosed please find \$3.25 for the 10x20" aluminum subpanel, etc., for the new AC Screen Grid Diamond.

Enclosed please find \$2.35 for the 7x21" drilled Bakelite front panel for the new AC Screen Grid Diamond.

Enclosed please find \$5.00 for both the aluminum subpanel, etc., and the drilled Bakelite front panel of the battery model.

Enclosed please find \$5.25 for both the aluminum subpanel, etc., and the drilled Bakelite front panel of the AC model.

Name.....  
Address.....  
City.....State.....

## SOCKET WRENCH

FREE

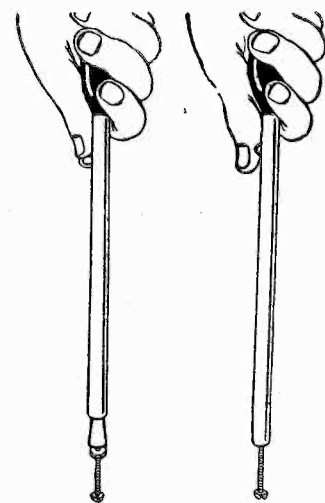

Push out control lever with knob (as at left) and put wrench on nut. Push down on handle only (at right), then turn nut left or right.

ONE of the handiest tools for a custom set builder, service man or home constructor is a BERNARD socket wrench.

It consists of a 6 1/2" long metal tubing in which is a plunger, controlled by a knob. The plunger has a gripping terminal (called a socket, hence the name "socket wrench") that may be expanded or contracted to fit 6/32, 8/32 and 10/32 nuts, the most popular sized nuts in radio.

Use the knob to push out the plunger, press down on the handle to grip the nut, then turn the nut to left for removal or to right for fastening down. Total length, distended, including stained wooden handle, 10". Gets nicely into tight places. Send \$1 for 8 weeks' mail subscription for RADIO WORLD and get this wrench FREE.

No other premium with this offer. Present subscriber may extend subscription by stating he is one, and entitle himself to this FREE premium, making \$1 remittance.

RADIO WORLD

145 WEST 45TH ST., N. Y. CITY

Recent Issues of RADIO WORLD, 15 cents each. Any number published in 1928 available for a short while. Six issues 75 cents, 10 issues \$1.00. Send stamps, coin or money order NOW, before the issues are sold. RADIO WORLD, 145 West 45th Street, New York City.

A COMPLETE CATALOG

containing detailed information on condensers and resistors may be had free on request.



74 1/2 Washington St., Bklyn., N. Y.

THE RESEARCH WORKER

will keep you abreast of developments in radio. It may be had free on request.



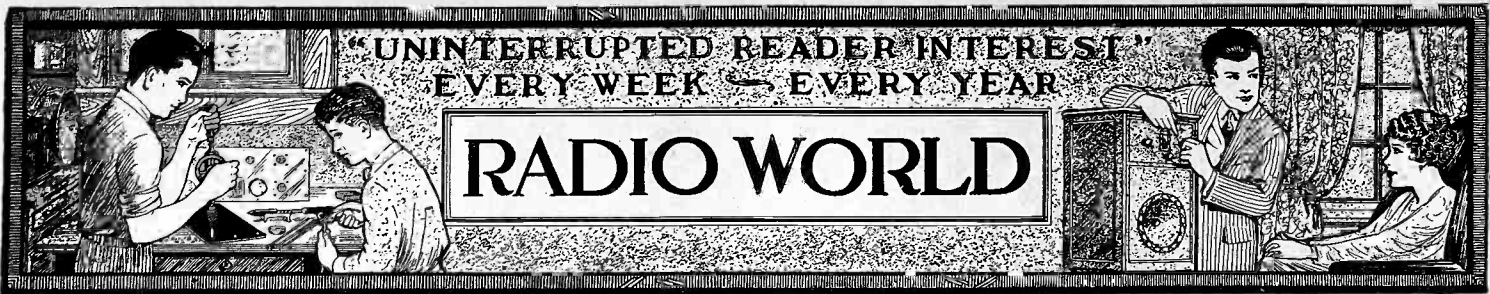

Vol. XV, No. 6. Whole No. 370  
 April 27th, 1929  
 15c per Copy, \$6.00 per Year  
 [Entered as second-class matter, March 1922, at the Post Office at New York, N. Y., under Act of March, 1879.]

Latest News and Circuits  
 Technical Accuracy Second to None

EIGHTH YEAR

A Weekly Paper published by Hennessy Radio Publications Corporation, from Publication Office, 145 West 45th Street, New York, N. Y.  
 Just (East of Broadway)  
 Phone: BRYant 0558 and 0559

# Petition Asks Ouster of 38 Stations for Deceptive 'Lucky Strike' Ads

## JURY OF HAMS TO REPORT ON AIR CONDITIONS

Washington.  
 The Federal Radio Commission has turned to the radio amateurs for information and advice regarding broadcast reception conditions in their localities and in the hope of obtaining data on which future licensing of broadcasting stations may be based. Soon a questionnaire will be mailed to 10,000 amateurs as a test of reallocation effects.

The quality of both the reception itself and the program is to be judged by the jury of 10,000 amateurs, about half the total number of amateurs now licensed. Such problems as number of stations to be licensed, chain broadcasting, cleared channels, interference and distance reception are to be discussed in the answers.

The questionnaire follows:

1.—Comparison of general receiving conditions in your locality based solely on conditions before reallocation of November 11th, 1928, and conditions since that date.

2.—What is your opinion of general receiving conditions in your locality? In answering this keep in mind the number of stations already licensed, the constant demand on the Commission for new stations and for additional power for existing stations.

### More Or Fewer Stations?

3.—In order to give the best possible radio service to the entire country do you consider the number of stations should be increased or decreased?

4.—List in order of preference (based solely on your enjoyment of their programs) call letters of stations that you receive satisfactorily and listen to regularly. Indicate approximately your valuation of programs of various stations, giving best station a rating of 100 per cent. Indicate character of reception as explained in accompanying letter and indicate by letter "D" or "N" whether stations received day or night or both.

5.—List stations that you receive with satisfactory volume but whose programs are such that they do not appeal to you and that you do not enjoy listening to, indicating briefly your objections to their programs.

6.—Chain programs: (a) If you could

## Old World to Get New Waves Soon

Prague.  
 The International Radio Conference held here has succeeded in parceling out the wavelengths among the various European nations. According to the plan adopted nearly all stations in the Old World will have different wavelengths, as the plan differs considerably from that adopted at the Brussels Radio Conference. It is believed that the new plan will help greatly to relieve the chaotic condition of the present broadcast structure in Europe.

Representatives of thirty-six nations, including Soviet Russia, attended the conference. The United States was also represented at the conference, but only in an advisory capacity.

receive but one station would you prefer that to be a local or a "chain" program station? (b) How many stations giving the same chain program can you receive regularly, with entirely satisfactory reception, at the same time, by merely tuning your receiver to the different stations? Give call letters of duplicating stations. (c) Based with regard only to stations that you can receive entirely satisfactorily, would you prefer to have more or fewer of them give chain programs?

7.—Distant reception: List a few of the most distant United States stations received since November 11th, either by loudspeaker or earphones.

8.—Where your receiving conditions are not entirely satisfactory state conditions that limit your reception, such as heterodyne, cross-talk, static, or electrical noises.

### How Many Cleared Channels

9.—Cleared channels: (a) Based on the statement regarding cleared channels or on your own views in case they are not in full agreement with that statement, do you consider that the number of cleared channels should be increased or decreased in order to give best possible reception to the country as a whole? (b) What do you consider should be the power of stations on cleared channels?

10.—State briefly character of programs you enjoy the most and do you consider there is too much advertising by broadcast stations?

11.—Do you object to phonograph or mechanical reproduction being broadcast, and how many people listen to your radio receiver?

12.—The Commission desires to obtain the names of a few listeners in each State who would be willing, on receiving a request from the Commission, to submit a confidential report on the reception of some station or stations from time to time. Would like to have your name placed on such a list?

## USE OF TAINTED 'TESTIMONIAL' CALLED BREACH

Indorsements and Hot Jazz Programs said to be designed to lead young boys and girls to smoke "Luckies" as aid to health and success, contrary to accepted medical view—Stations on NBC chain carrying program charged with violating Radio Law requiring operation in public interest.

Washington.

Revoke the licenses of thirty-eight broadcasting stations that broadcast "Lucky Strike" programs, because misleading or false advertising of the cigarettes is sent over the air!

That is the petition of the National Food Products Protective Association, filed with the Federal Radio Commission.

The association asserts that the "Lucky Strike" advertising stresses the innuendo that cigarette-smoking is beneficial to health, and uses testimonials, bought outright from famous athletes, actresses, etc., and read over the air, together with a "hot" jazz program, all baited to catch the credulity of young boys and girls.

### Cause of Revocation

Broadcasting of programs containing such advertising, where the "tainted testimonials" of popular favorites are made the basis of appeal, is not serving "public interest, convenience and necessity," hence is a cause for license revocation, sets forth the petition, signed by Adrian M. Kelly, for the association.

The program sponsor is the American Tobacco Company, makers of "Lucky Strike" cigarettes.

The stations whose license revocation is petitioned carried a "Lucky Strike" program November 17th, 1928. The program

was sent out by the National Broadcasting Company as a chain feature. Two other instances of objectionable programs are cited and continuous repetition of the offense is alleged.

The stations are listed in the petition as follows:

WSB, Atlanta, Ga.	WFL, Philadelphia
WEBI, Boston	WCAE, Pittsburgh
WGR, Buffalo, N. Y.	WCHS, Portland, Me.
WET, Charlotte, N. C.	KCW, Portland, Ore.
WGN, Chicago	WJAR, Providence,
WTAM, Cleveland, O.	R. I.
WFAA, Dallas, Tex.	KSL, Salt Lake City,
KOA, Denver, Colo.	Utah.
WIO, Des Moines, Ia.	WOAI, San Antonio,
WWJ, Detroit, Mich.	Tex.
WVIC, Hartford, Conn.	KGO, Los Angeles,
KPRC, Houston, Tex.	Calif.
WJAX, Jacksonville,	KPO, San Francisco
Fla.	WGY, Schenectady,
WDAF, Kansas City,	N. Y.
Mo.	KOMO, Seattle, Wash.
KFI, Los Angeles,	KHO, Spokane, Wash.
Calif.	KSD, St. Louis, Mo.
WLAS, Louisville, Ky.	KSTP, St. Paul-Min-
WMC, Memphis, Tenn.	neapolis, Minn.
WTMJ, Milwaukee,	KVOO, Tulsa, Okla.
Wis.	WRC, Washington,
WEAF, New York	D. C.
WKY, Oklahoma City,	WTAG, Worcester,
Okla.	Mass.
WOW, Omaha, Nebr.	

#### Cites Tobacco Company

Licenses were renewed to these stations January 31st last, which was contrary to the Radio Law, the petition sets forth.

Mr. Kelly, the petitioner's chairman, sets forth the formal grounds as follows:

"It is charged by the undersigned that the licenses granted to the above stations are contrary to the provisions of the Radio Act of 1927, which vests in the Federal Radio Commission the authority to grant, modify, or withdraw operating licenses to broadcasters on the principle of public interest, convenience or necessity.

"It is charged by the undersigned that the stations named, over a period of several months, have permitted the American Tobacco Company to employ their facilities for the purpose of broadcasting programs which are contrary to public interest, convenience or necessity.

#### Enumerates Charges

"It is charged by the undersigned that the object of this broadcasting is to transform 20,000,000 adolescent boys and girls into confirmed cigarette addicts by creating a vast child market for cigarettes in the United States; that false and dangerous health claims are made for cigarettes as a substitute for many wholesome foods; that pernicious and harmful diet fads are being encouraged by this broadcasting, which menaces the health and welfare of the future mothers of the nation; that 10,000,000 boys throughout the country are being viciously and deliberately misled by paid testimonials, secured from professional athletes, football coaches and others, definitely suggesting the use of cigarettes as an aid to physical prowess; that the medical opinion of the country is being continuously misrepresented to support the health and medical claims made for cigarettes; that unfair attacks are being made upon some of the country's basic industries in order to increase the market for cigarettes; and that the specific claims made for a particular brand of cigarette advertised on the air are overwhelmingly opposed by established health and medical facts.

"Such radio activities are clearly contrary to public interest, public welfare and public health.

#### Objects to Paid Testimonials

"It is charged by the undersigned that it is not in the public interest that alleged testimonials, for which high prices are reputed to be paid to stage, motion picture and sports celebrities, and to others prominent in the public eye, should be broadcast over a nation-wide network to encourage the use of narcotics among women and children.

"It is charged by the undersigned that it is not in the public interest to allow

a powerful corporation to tell the future mothers of the nation that the way to retain the fashionable figure is not exercise, nor moderation, nor clean living, but rather to smoke more cigarettes.

"It is charged by the undersigned that it is not in the public interest that the growing boys of the country should be told through the radio that cigarette smoking is harmless, and that it is the smart thing to do because leading athletes and popular heroes, whose alleged testimonials are recited in the air, are supposedly confirmed cigarette addicts.

#### Offenses Repeated

"It is charged by the undersigned that such insidious, harmful and untrue propaganda has been broadcast for many weeks past by the American Tobacco Company over a chain of stations hereinbefore named and cited, and that in spite of this fact, these stations were relicensed on January 31st by the Federal Radio Commission as operating in the public interest.

"As a specific example of the type of broadcasting to which these objections are made, the petitioner cites the following sentences from a stenographic transcript of announcement made during a program broadcast by the hereinbefore-mentioned stations on the evening of November 17th, 1928:

"This is the time of the year when football, the great American college game, reigns supreme. About twenty-two years ago, another generation of football enthusiasts were thrilled by the gridiron expert, Walter Eckersaul of the University of Chicago. He is still very active in football . . . Mr. Eckersaul has always realized the value of the physical condition and the importance of maintaining correct weight.

"Nowadays we hear much of the word personality. Probably one of the greatest examples is Irene Bordoni, the French actress. Let me read you what Miss Bordoni says of Lucky Strike cigarettes: 'No, No — sweets are not for me. I smoke a Lucky to keep petite. I cannot afford to eat the French pastries that my countrymen know so well to make. What would my country think if Bordoni were not slim and petite? So I smoke Luckies with that delightful toasted flavor. It rests my tired nerves. It never irritates my throat and always makes me very happy.' There is sound advice to the women of America in what she says about Lucky Strikes. It is good to smoke Luckies if you desire the slender figure which is so much the vogue with the modern woman.'

#### Cites Another Instance

"On December 15th, 1928, the announcer said, in part:

"Modern American music is being acclaimed on all sides. Formost among our pioneers is George Gershwin. He leads an active life, he keeps physically fit, and alert in his mind. Mr. Gershwin says: 'When people ask me how I keep in physical trim, with no excessive weight, my answer is I just smoke a Lucky whenever I crave overrich pastries which fatten; there is nothing to equal that wonderful toasted flavor, so appetizing, yet never interfering with one's appetite for fats.' There is sensible vision in George Gershwin's message about Lucky Strikes.

"Helen Hayes is truly typical of the young dramatic stars; she is pretty, vivacious and with her genuine artistic style will make a great name. She realizes the value of a trim, slender figure. She cannot afford to nibble a fattening sweet. Instead she lights a Lucky Strike and that is undoubtedly one reason she is called

healthy. Here is what she writes: 'Smoke a Lucky; snub a sweet with a disdainful glance. The first time is the hardest, but after you have smoked a Lucky the longing for a sweet disappears in smoke.'

#### Actress's Testimonial

"On February 24th, 1929, the announcer, after quoting Captain Manning, hero of the steamship America, said:

"Irene Franklin writes this letter: 'I love Luckies, they are so good to me. They keep my figure slim and in the best trim. Whenever I crave a sweet I light a Lucky. They also help my throat. No wonder I love Luckies.' Women of America might well profit by this lesson. Why not reach for a Lucky?'

"In support of the charge that the aim of this broadcasting is to create a child market for cigarettes, through its appeal to the young, the attention of the Commission is called to the following facts:

"The audience sought for the program is indicated by the nature of the music offered, consisting of jazz dance compositions of the most vivid type, designed to attract an audience of youth. The aim of the program on the evening of November 17th, 1928, is further shown by the fact that the first testimony adduced for Lucky Strike cigarettes was that of a popular football coach, who sought to impress his boy hearers with the alleged usefulness of tobacco as an adjunct to athletic accomplishment.

"For the other half of the audience, the girls of the country, the tobacco broadcaster provided a testimonial from a popular actress, who urged tobacco as an aid to attaining a fashionable figure.

#### Medical View

"In support of the charge that the health claims set forth for these cigarettes in this radio broadcasting are contrary to established medical findings, the attention of the Commission is called to the following published statement of December 8th, 1928, in the 'Journal of the American Medical Association,' the official organ of the American Medical Association (representing the highest medical opinion in the United States):

"Who would have thought 10 years ago that cigarettes would be sold to the American public actually by insistence on the healthful qualities of certain brands?

"The manufacturers of Lucky Strike cigarettes are promulgating a campaign in which they assert that these cigarettes do not cut the wind or impair the physical condition, and that Lucky Strike satisfies the longing for things that make you fat without interfering with a normal appetite for healthy foods.

"To which the simple reply is: Hooey! The human appetite is a delicate mechanism, and the attempt to urge that it be aborted or destroyed by the regular use of tobacco is essentially vicious.'

"In support of the charge that this broadcasting is a menace to American child life, the attention of the Commission is called to statements from leaders of child welfare, education and training.'

#### Indorsers Mentioned

He then cited the National Child Welfare Association, Boy Rangers of America and American Physical Education Association, who opposed such advertising of cigarettes.

Others similarly referred to as supporters of such opposition were Reformed Church, Methodist Episcopal Church, National Education Association, American Federation of Teachers, American Eu-

(Concluded on next page)

# AC SCREEN GRID TUBE OUT MAY 1 AS THE 'UY224'

The Radio Corporation of American announced that the new four-electrode, AC screen grid amplifier tube, UY-224, will be placed on the market about May 1st.

The new tube is recommended primarily for use as a radio frequency amplifier in circuits especially designed for it, but it may also be used in special circuits as a detector or as an audio frequency amplifier.

The fourth electrode, the screen, makes possible a very high, stable amplification per stage in radio frequency circuits as well as in circuits of lower frequency.

### CHARACTERISTICS

Plate voltage, maximum recommended	180 volts
Negative grid voltage	1.5 volts
Screen voltage, maximum	.75 volts
Plate current	4 milliamperes
Screen current	.....
.....not over 1/3 of plate current	
Plate resistance	400,000 ohms
Amplification factor	420
Mutual conductance	1,050 micromhos
Heater voltage	2.5 volts
Heater current	1.75 amperes
Maximum overall dimensions, Length 5 1/2", diameter 1 13-16 inch.	
Base UY (5 prong).	

The high values of the amplification factor and the mutual conductance indicate that this tube is an exceptionally good amplifier.

## 245 Tube Now \$3.50

The price of the new power amplifier tube, 245, was reduced from \$4.25 to \$3.50 by the Radio Corporation of America. Although this tube was announced during the early part of March, officials of the corporation state that it has already created a demand in excess of preliminary production estimates.

## WLW Bans Singing With Dance Music

Cincinnati, O.

Radio listening is to be made safe for the dialer who wants his dance music pure and undefiled.

Vocal choruses sung by members of dance orchestras broadcast by remote control have been forbidden by WLW. Hereafter, all dance orchestras picked up from points outside the WLW studios must confine their entertainment efforts to dance music and must limit their vocal outbursts to times when they are not on the air.

Ford Billings, director of WLW, says the interdictions of vocal choruses in dance music is designed to please those listeners who abhor the words of popular songs although they enjoy the rhythm and melody.

"Those others, who wish to know the words of current musical numbers, can be satisfied in the number of times the songs are sung by regular vocalists on variety programs," Billings says.

## SHORT WAVES ARE INCREASED

Washington, D. C.

Due to advances in the art of radio communication permitting greater use of channels than heretofore, the Federal Radio Commission issued a general order defining the width of communication channels in the short wave spectrum above 1,500 kilocycles. The width of particular channels depends on the position in the spectrum, that is, upon the absolute value of the frequency, as well as on the type of service to which a given channel is devoted. The effect is to increase the number of high frequency channels by putting some closer together.

Thus a television channel is to be not wider than 100 kilocycles, a relay broadcasting station between 6,000 and 9,600 kc shall be regarded as 20 kc in width, and a commercial telephone channel is to be regarded as 6,000 kc in width.

## Paid Testimonials on Air Opposed

(Concluded from preceding page)

genics Society, Society for the Suppression of Vice, Northern Baptist Convention, American Home Economic Association, Presbyterian Church.

Mr. Kelly continued:

"Beyond the specific charges hereinbefore made by the petitioner and supported by leading medical, health, social service and religious authorities, the undersigned petitioner desires to protest against the use of paid testimonials on the air as contrary to the public interest, dangerous to public health and public morals and inimical to the honest business interests of the country.

"Such testimonials are inherently misleading, when they are not deliberately false, because the radio public is not told that the alleged recommendations of narcotic and other products are bought and paid for in the public market place.

"This petitioner therefore urges that the Radio Commission, acting on the principle of public interest, should require all broadcasters to state specifically, in presenting such testimonials, whether the testimonial has been paid for either in money or by other considerations, and also how much has been paid for each testimonial recited on the air by a broadcast advertiser.

"Radio broadcasting is and should be

more than a mere entertainment service. It is comparable to no other medium of communication with the home. The voice sent broadcast through the air knows no barriers. It invades every home, and it speaks alike to man, woman and child, to the strong and the weak, to the sophisticated and to the innocent. The home lies open and helpless to the intrusion of the spoken word broadcast from a radio station.

"The integrity of broadcasting, already partly destroyed by the testimonial advertising against which the petitioner complains, is vital to the growth and success of this new and great medium of communication.

"The traffic in testimonials is of the most vicious character. Anything and everything may secure endorsement from certain characters prominent in the public eye through services specially organized for this traffic. Standard price lists, carefully scaled in regard to the endorsers' prominence or prestige, are available to any company which seeks support for dishonest or questionable claims.

"The overwhelming opinion of expert advertising authorities supports your petitioner's claim that the use of such paid testimonials over the air is an evil and an offense against public interest."

# ALASKA HEARS "STATES" WELL; BOARD PLEASED

Washington.

At Shungnak, Alaska, within the Arctic Zone, radio programs from stations in all parts of the United States are picked up. Mrs. Inez E. Moore, of the Alaska division of the Bureau of Education, wrote to the Federal Radio Commission.

Expressing gratitude to WENR, Chicago, and WOC, at Davenport, Ia., Mrs. Moore said:

"If it were not for our radio the isolation in this far North would be unbearable."

Mrs. Moore wrote:

"Just a note from far above the Arctic Circle to tell you how much we are indebted to you for the splendid programs we are getting from all parts of the United States. If it were not for our radio the isolation in this far North would be unbearable.

### WENR and WOC Enjoyed

"For awhile we had such splendid programs from WENR (50 kw) of Chicago and also from WOC (5 kw) of Davenport. Have the powers of those stations been lowered?

"We would surely like to have them on the air oftener, for they come in with such clear tones and both stations put on such splendid programs. Many nights this Winter, when we were unable to hear a sound from the Pacific Coast stations we could count on getting WENR or WOC if they were on the air.

"This coming year you will see many mining men in this locality, and they have learned to depend upon our radio; also my radio news bulletins, which I make each night from various news items sent out from those big stations."

Carl H. Butman, secretary of the Commission, replied to Mrs. Moore:

"I am very much pleased to acknowledge your letter advising of the receipt of broadcast programs in the Arctic Circle and complimenting the Commission for its administration. It is reassuring to receive such thoughtful messages because many listeners are impatient and fail to see any desirable results since the reallocation.

"I cannot quite understand why you do not continue to hear station WENR of late, since, as a matter of fact, its power was increased early in the year to 50 kilowatts. The status of station WOC at Davenport remains at 5 kilowatts, and it would seem that that station should be as strong as ever.

### Reception Explained

"With the approach of the Summer months, beginning with April, radio reception becomes worse, due to the increase in static and the fact that during the period from April to September the attenuation of the signals is greater; in other words, they die out more quickly and are consequently not as audible at great distance in the summer as they are in the winter. Practically the same thing happens in daylight, as compared to darkness, as you no doubt know."

### COIL WINDING DATA

RADIO WORLD for March 16th, 1929, contains a table of coil winding data for nine different diameters, for both .0005 mfd. and .00035 mfd. condensers. Send 15c for a copy. RADIO WORLD, 145 W. 45th St., New York, N. Y.—Advt.



# EXPERIMENTAL STATION TESTS FOR TELEVISION

W2XCL, Brooklyn, N. Y., 250 watts, 143.5 meters, is on the air every Monday, Wednesday and Friday between 9.00 and 11.00 p. m. with spoken announcements and musical notes of different frequencies. The purpose of the tests is to determine the quality of the modulation, the ability of the apparatus to handle the wide frequency bands required for television work, and the field strength of the signals in various parts of the metropolitan area.

Owners of short-wave receivers are requested by the Pilot Electric Mfg. Co., owner of the station, to report on their reception of W2XCL, as regular television broadcasting service which the firm contemplates will be entirely for the benefit of owners of such receivers. Comments on the characteristics of the signals may be sent to the company at 323 Berry Street, Brooklyn, N. Y.

## Televisors Ready

"This experimental work will in no way cause interference with regular broadcast programs," said John Geloso, chief engineer of the Pilot company, "as it will be done on a wavelength completely beyond the range of ordinary broadcast receivers.

"We have two highly developed televisors ready to be connected to the radio transmitter proper, but we will not start actual television transmission until we have satisfied ourselves that a considerable number of people can hear W2XCL with good volume and clarity.

We will transmit the images of living people and of actual scenes, and not merely pictures on a photographic film. The latter type of transmission is not truly television; it is what might be called animated radio telephotography."

## Licensed in Two Bands

The Pilot company is one of the few organizations licensed recently by the Federal Radio Commission for experimental visual broadcasting, having been assigned the bands between 2,000 and 2,100 kc (143 to 150 meters), and between 2,750 and 2,850 kilocycles (105 to 109 meters).

Last Summer it built the television apparatus used for a few months at station WRNY.

## Filament Unbalance Often Causes AC Hum

Fans troubled with hum in their AC filament type tubes may find its source in an unbalanced filament circuit. The hum generally occurs in a filament circuit employing a center-tapped transformer winding or a center-tap fixed resistance.

In either instance there is no means provided for compensating for any unbalance in the circuit.

With this in mind, Clarostat engineers developed and produced the new Hum-dinger, an improved center-tap adjustable resistor. This device will eliminate hum in the AC filament type tube and also provide a ready means of grid-biasing by filament voltage drop in A battery circuits. Further information may be had from Clarostat Manufacturing Company, Inc., 291 North Sixth Street, Brooklyn, N. Y.—Mention RADIO WORLD.

## Man's Lightning at 5,000,000 Volts

Schenectady, N. Y.

Artificial lightning, manufactured in the laboratories of the General Electric Company at Pittsfield, Mass., was broadcast by WGY. Synthetic lightning strokes of 5,000,000 volts, the greatest ever manufactured by man, was discharged and the terrific noise carried to the radio listener for the first time.

The demonstration of artificial lightning was heard in the course of a talk by F. W. Peek, consulting engineer of the General Electric Company, who has been engaged for years on the problem of devising means of protecting high voltage lines and electrical apparatus from the assaults of natural lightning. To study best the behavior of lightning he has developed a method of artificially reproducing the natural phenomena and of taming them to do his bidding. In the laboratory at Pittsfield, 5,000,000 volt flashes of lightning were directed at a church steeple in a miniature village.

## WFJC IS 67th NBC OUTLET

WFJC, Akron, Ohio, has been made a permanent addition to the National Broadcasting Company System.

WFJC uses 500 watts and operates on a wavelength of 206.8 meters (1450 kc).

The station is the fifth NBC outlet to be established in Ohio. WLW and WSAI, in Cincinnati, WTAM and WEAR, in Cleveland, are the other 3. The addition of the Akron station brings the total of NBC outlets to 67.

## RIGHT OR WRONG?

[See answers on page 20]

1. —The G. post of the socket connects with the control grid of a screen grid tube.
2. —The current through a conductor, when the voltage is constant, is directly proportional to the resistance of the conductor.
3. —The resistance of a resistor varies with the voltage when the current remains constant.
4. —The resistance of a conductor varies with the current flowing in it.
5. —The wave of a broadcast station is broad when the station comes in all over the dial.
6. —The inductance of an iron core choke coil depends on the alternating current and not on the direct current, flowing in the winding.
7. —The capacity of a condenser does not depend on the voltage impressed on it.
8. —When there is a voltage source in a circuit, current must flow.
9. —A detector tube with grid bias rectifies signals impressed.
10. —A thermo-couple can be used for measuring both direct and alternating current.

# STORMS ALTER FADING EFFECT ACROSS OCEAN

Washington.

A continuous record of fading is being kept by the Bureau of Standards, as set forth in its statement on long-wave transoceanic radio:

"This variability in the signals is the result of changes in the conditions of the upper atmosphere when a part of the waves are believed to be reflected down to the receiving station, where they interfere with the waves coming along the ground.

"In addition to showing the variations in the signals of the individual stations the recorder has also permitted studies to be made of the remarkable differences in fading from two stations situated in the same place when the two signals pass over the same path at the same time but with a slight difference of wavelength.

"By noting the differences of the records made with a loop and with an antenna it has been found possible to follow the rapid changes in the angle at which the reflected wave comes down from the upper air, sometimes even seeming to come from the back.

"The method also permits the study of the effects of magnetic storms on night fading and shows that the severe storms generally produce marked changes, often lasting several days, in the usual fading pattern of certain stations."

## Station Raises Money For Salvation Army

Chicago.

Money from people living in nearly half the States of the Union has been received at WENR as the result of the "stock-selling" campaign inaugurated by Mike and Herman, the station's comedy team, that has just organized the Wild Hootenattie Manufacturing Trust.

Accounts are being kept and audited by members of the Salvation Army in Chicago.

The comedy pair, to bolster up the finances of their mythical organization, decided to sell engraved stock certificates. These certificates are forwarded to every person sending in a dime or more. The station is bearing all the expense. The entire proceeds goes to the Salvation Army. The station's publicity man referred to the plan as "dollars for doughnuts."

## BLAN BUYS 'PHONES

Blan, the Radio Man, 89 Cordlandt Street, New York City, has added to his stock of radio parts and appliances. He aims to be able to supply practically anything obtainable. He has purchased a great part of the remaining stock of original Baldwin phones at a saving which he is passing along to his customers.

## GOTHAM'S CHICAGO OFFICE

The Gotham Engineering and Sales Co., National sales representative for Transcontinental Coil, Inc., of Newark, N. J., announce the opening of a mid-Western sales office under the direction of Fred Garner, at 9 South Clinton St., Chicago.

# STATIONS WANT TO BE PAID FOR PLUGGING SONG

The status of the copyright fee is under investigation by several stations, including two chains, to determine whether an equitable situation exists whereby the composers and publishers of popular music are paid for the privilege they extend of using their songs.

The fight of the broadcasters two years ago against paying any royalty to the publishers for use of the music was abandoned when Congress failed to accept the argument that the stations were doing more for the composers and publishers than the composers and publishers were doing for the stations.

The revenue-producing features of broadcasting in respect to music publishers, composers and musicians generally, has grown into the million-dollar class, and it is estimated that one-third of music's revenue is accounted for by broadcasting.

## Call Situation Changed

Now that broadcasting is established as the outstanding entertainment medium of the world, stations are inquiring anew as to the feasibility of charging copyright owners for using and thus "plugging" the songs. While the attitude of the publishers and composers has been that radio hurts a song more than it helps, and that songs are "done to death" in a few months, stations insist that the present situation has developed the essential value of broadcasting to the popularity of a song, and its consequent profit-making.

The copyright law now protects the publishers and composers, since their works can not be played even in a restaurant without invasion of the copyright, for which privilege virtually all users of the song are required to pay. Some special exemptions have been instituted by the Society of Composers, Authors and Publishers.

Under this law the broadcasters are paying the copyright owners, and so far there has been no indication that a new attempt will be made to change the law. Instead the value of broadcasting to the success of a song will be pointed out, in an effort to have the copyright owner, usually the publisher, pay every time a song is used. Thus there may be a cross-payment proposition, whereby the copyright fee would continue to be paid, but a schedule would be worked out whereby a back-charge would be made by the station to the copyright owner for each rendition.

## Secret Payment Asserted

Some publishers are reported to have recognized the value of broadcasting to the extent of paying for the use of some of their songs, particularly ones newly published, so that the radio market, and incidentally the sheet music market, for the song would be developed. This payment is said to have been made to the performers rather than to the sponsor of a program or to the station itself, as performers sometimes are permitted to choose their own songs.

This is cited as a recognition of the principle that broadcasting is the thing that makes a song nowadays, even though the practice of paying for the use of the song is not indulged in by reputable publishers, and has nothing to do with the Society of Composers, Authors and Publishers.

## Literature Wanted

THE names and addresses of readers of RADIO WORLD who desire literature on parts and sets from radio manufacturers, jobbers, dealers and mail order houses are published in RADIO WORLD on request of the reader. The blank at bottom may be used, or a post card or letter will do instead.

RADIO WORLD,  
145 West 45th St., N. Y. City.  
I desire to receive radio literature.

Name .....

City or town.....

State .....

- Harry McKendary, 175 5th Ave., North Hawthorne, N. J.
- J. H. Mitchell, 205 N. Palafox St., Pensacola, Fla.
- Al. Wesemeyer, 1016 S. Pensacola St., Pascagoula, Miss.
- E. S. Anderson, 136 Firglade Ave., Springfield, Mass.
- H. J. Thurlow, 677 No. 5th St., Saginaw, Mich.
- S. N. Dolch, Eagle Pass, Tex.
- L. A. Morrow, 2103 Mars Ave., Lakewood, Ohio.
- Geo. F. Stoger, 2108-63rd St., Kenosha, Wisc.
- J. Lewis, 1173 Dickerson St., Detroit, Mich.
- Ralph LaSalle, 1180 Atwood Ave., Akron, Ohio.
- Dallas Ruth, Wheelersburg, Ohio.
- Rodney H. Ward, 43 Winter St., Leominster, Mass.
- Howard Armstrong, 706 E. Morris St., Indianapolis, Ind.
- N. S. Bricker, West Gravel Rd., Rt. 1, Bx. 1, Leesville, La.
- W. C. Bond, c/o L. Marshall, Meaford, Ont., Can.
- W. F. Lisman, Gen'l. Elec. Co., Cincinnati, Ohio.
- S. F. Harris, 2212 W. 61st St., Seattle, Wash.
- Chas. A. Wilson, 2248 Michigan Ave., Niagara Falls, N. Y.
- A. B. Levy, U.S.V.R., 225 W. 34th St., N. Y. City.
- Walter Jacquesin, 5040 Plover Ave., St. Louis, Mo.
- C. L. Morris, 426 Lexington, N. W., Grand Rapids, Mich.
- John W. Brown, 34 W. Ridgewood Ave., Ridgewood, N. J.
- Alfred Jesihka, 11 Elbert St., Schenectady, N. Y.
- Irwin Hughes, Whitener, Ark.
- Leslie T. Shubert, 404 W. Hickory St., Kirksville, Mo.
- George E. Gregory, Brackenridge, Pa.
- G. E. Frost, R. No. 1, Woolwich, Me.
- W. B. Farrish, 110 E. Main N, Gainesville, Fla.
- W. J. Mermillion, Box 1354, New Orleans, La.
- Arthur Gaffke, Sta. C, Box 1446, Los Angeles, Calif.
- C. S. Luttrell, Brewer Music Co., 424 Wabash Ave., Terre Haute, Ind.
- R. Kurtz, 170 Schaeffer St., Brooklyn, N. Y.
- Fred B. York, 30 Hancock St., Newburyport, Mass.
- L. A. Rose, 129 Camp St., New Orleans, La.
- Wm. Suhajda, 1911 W. Ohio St., Chicago, Ill.
- F. W. Barnes, Ophir Hall, Purchase, N. Y.
- J. J. Holmes, 403 W. 7th St., Boone, Iowa.
- Albert B. Alcalá, 3121 W. Houston St., San Antonio, Tex.
- J. L. Lackmann & Son, 142 Remsen St., Cohoes, N. Y.
- Louis Tappenbeck, 8128 Sangamon St., Chicago, Ill.
- C. L. Barnhart, 136 Cleveland Ave., Waynesboro, Pa.
- Alfred B. Kendrick, 47 Butler St., Etna Sta., Pittsburgh, Pa.
- O. R. Ackerman, 402 N. 20th St., Forth Smith, Ark.
- C. R. Smith, 1404 Highland Ave., Avon Park, Fla.
- J. T. Guenther, 157 Winslow Ave., Buffalo, N. Y.
- Jos. Wysocki, 665 Seybert St., Hazleton, Pa.
- J. E. Stroebling, 710 State St., Louisville, Ky.
- H. W. Pitzold, 18 Dartmouth St., Boston, Mass.
- Chas. E. Buschman, 1308 Highland Ave., Louisville, Ky.
- Andrew Serenson, Box 34, Thomaston, Conn.
- H. G. Jorgenson, Enderlin, N. Dak.
- W. H. Snodgrass, Box 254, Blunt, N. Dak.
- Wm. J. Taylor, 6301 Fifth Ave., Brooklyn, N. Y.
- Louis Benthein, 320 Carthon St., Buffalo, N. Y.
- Lawrence Dyer, R.F.D. No. 5, Box 161, Glendale, Ariz.
- Ray B. Cotter, 183 Pike St., Weston, W. Va.
- Lawrence Walters, 412 School St., Olean, N. Y.
- John D. Linn, 98 1/2 Madison St., Tiffin, Ohio.
- Vinnie R. Dolch, 106 Wentz St., Tiffin, Ohio.
- Weyeneth Bros., 1113 E. Virginia, Peoria, Ill.
- Paul E. Thorson, 3037 California St., Omaha, Nebr.
- D. C. McFarland, 604 Bankers Trust Bldg., Norfolk, Va.
- Paul Spicer, Weston, W. Va.
- Melvin Stirling, Aroma Park, Ill.
- A. F. Schildhauer, Fairfield Rd., R.F.D.q, Caldwell, N. J.
- C. F. Martin, R.F.D. No. 1, Crossley, La.
- Leland C. Hershner, 3616 "J" St., Lincoln, Nebr.
- O. H. Pederson, 1132 No. Mayfield Ave., Chicago, Ill.

# FIVE STATIONS SEEK CHANGES FROM BOARD

Washington.

Five applications for modification of broadcasting licenses were filed with the Federal Radio Commission. The applications follow:

## EASTERN ZONE:

WBNY, Baruchrome Corporation, New York City, Dr. Sidney N. Baruch, director. This application for modification of station license requests increased power from 250 watts power to 2 1/2 kilowatts, change in frequency from 1,350 kilocycles to 900 kilocycles, and increase in hours of operation from 21 hours to 24 hours.

WRNY, Irving Trust Company, receiver for Experimenter Publishing Company; station transmitter at Coytesville, N. J. This application for consent to involuntary assignment requests the authority to transfer their license of Experimenter Publishing Company to above-named applicant (Irving Trust Company).

## CENTRAL ZONE:

WGBU, Charleston Radio Broadcasting Co., Charleston, W. Va. This application for modification of station license requests the authority to move studio only (street address changed).

## SOUTHERN ZONE:

KFJZ, H. C. Meacham, Fort Worth, Tex. This application for consent to voluntary assignment requests the authority to transfer the license from Henry Clay Allison to H. C. Meacham.

## MIDDLE-WESTERN ZONE:

KWCR, H. E. Paar, Cedar Rapids, Iowa. This application for modification of station license requests increased power from 100 watts to 250 watts power.

## Fessenden Consultant to Majestic Makers

Chicago.

Professor Reginald A. Fessenden, famous radio pioneer and inventor, has accepted the post of consulting engineer for the Grigsby-Grunow Company, of Chicago, manufacturers of Majestic receivers and accessories. His work with the company will be mainly devoted to the development of television apparatus, but because of his long experience in the manufacture of vacuum tubes and in the design of radio receivers he will be consulted as to these, too.

Professor Fessenden's most noteworthy contribution to radio was the discovery of the heterodyne principle and the invention of apparatus to make use of this principle in radio reception. He is also credited with the invention of the condenser microphone as well as many other radio devices.

## NEW CORPORATIONS

- Radio Industries Corporation—Atty. Cuthall, Hotchkiss & Mills, 20 Pine St., New York, N. Y.
- Radel's Radio and Music Stores—Atty. P. S. Glickman, 1501 Broadway, New York, N. Y.
- Leeds Radio Laboratories, batteries—Atty. H. B. Pfeffer, 44 Court St., Brooklyn, N. Y.
- Electrical Condenser Corp., radio apparatus—Atty. B. F. Fanger, 347 Madison Ave., New York, N. Y.
- Pery Radio Corp., apparatus—Atty. J. R. Lippman, 225 Broadway, New York, N. Y.
- American Radio Products Corp., Wilmington—Corp. Service Co.

# What Should You Expect Is the Number of Tubes

By Capt. Peter

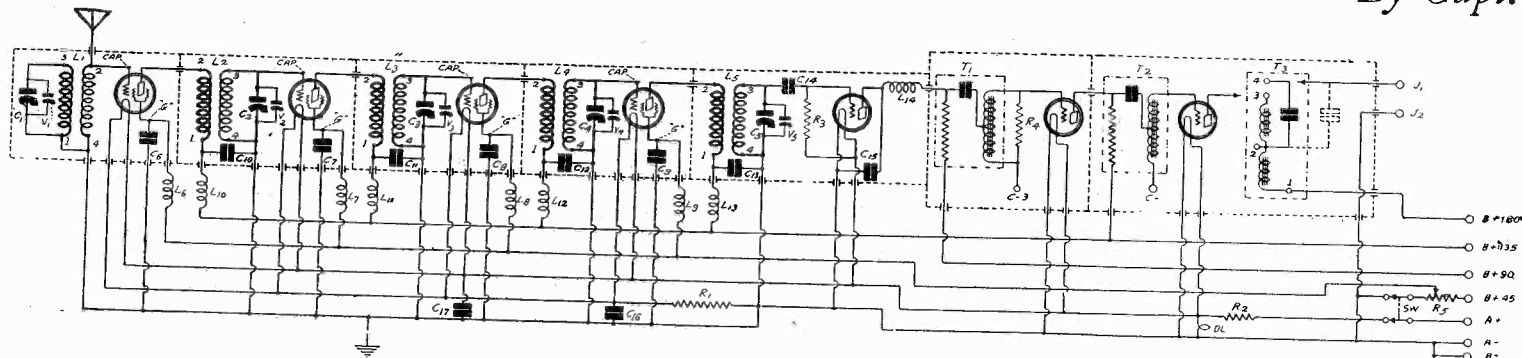

AN EXTREMELY SENSITIVE RECEIVER, THE SARGENT-RAYMENT, WHICH WORKS THE TUBES UP TO THE HILT SO THAT A STATION COMES IN AT VIRTUALLY EVERY DIVISION OF THE DIAL.

HOW much to expect from a radio receiver is something that can be determined best by laboratory measurements, whereby the overall characteristics are determined. These give an accurate picture of the selectivity, tone quality and sensitivity, the three great essentials. The fourth essential is not measurable except by the inspection of a sales sheet, and then only incompletely. It is the appearance.

The outstanding method used by the general public in gauging a receiver is to rate it by the number of tubes. As the general public knows only so much about radio receivers as the manufacturers' advertisements tell them, it must be assumed that the stress laid by manufacturers on the number of tubes in a receiver has made the public use the tube system of rating almost exclusively. However, the number of tubes is no criterion whatever.

As greater confidence has been gained by those behind various circuits and receivers, the home test system has been encouraged, and is being used. This is far better. It enables the prospective purchaser to try out a receiver for five days or so, and determine whether it is what he wants.

### Question of Preference

If he does not want that set it may be no reflection upon the receiver at all, merely an expression of individual taste or preference. If a man wants a great deal of distant reception, for instance, and obtains very little or none at all, he does not get what he wants, although it is usually true that the best tone quality is found in receivers that are no distance-getters. A musically-trained person, with no DX appetite, would be overjoyed to keep the set that the DX hound has rejected. It becomes a question of one model against another model, rather than one make against another, for the similarity of circuits used by set manufacturers, and the almost identical methods of tuning and coupling the stages, result in a fairly even break for all on the question of sensitivity.

### Cost Not Correct Basis

Most of the factory-made receivers, however, are not selective enough for the needs of an urban dweller or a person living near a broadcasting station, although models are being changed, the newer ones being advertised as having greater selectivity. And in 1930 receivers will be still more selective, both the home-

constructed or custom-built type and the factory-made models.

The cost of parts and of complete receivers is another basis of comparison, although one seldom used on any save the high-priced receivers. Much of the cost may be in the furniture rather than in the set.

That price is no criterion of factory-made receivers is borne out by the fact that most manufacturers, when they change a receiver, feature their new model and drop the old one, not even advertising the existence of the old one, so that the "distress merchandise" market is flooded with discontinued models, many of which are fine receivers, the sale of which is hampered, however, by the ducking of service responsibility by the seller.

The whole question, therefore, of what basis of comparison to use in judging a receiver is a complicated one, and soluble best in a laboratory. Yet of the 20,000,000 listeners in the United States, how many have had a laboratory report on the receiver they listen to, or, if they obtained such a report would get any real information from it? Not one-half of one per cent! No indeed! That's 98,000 too many!

To understand the report it is necessary to understand something about radio technique, to or to be instructed sufficiently so that the report would be of some value.

### When Curve is Significant

As for selectivity, a curve could be drawn, and the sharpness of it would be an indication of selectivity, while a broad peak in general would denote low selectivity. By actual operation of a receiver, therefore, and reference to the curve, a person could tell whether a given curve means he can tune out WEAJ, New York, 710 kc, and tune in WGN-WLIB, Chicago, 720 kc. The curve would begin to have some practical significance. Thereafter selectivity of respective receivers could be told in curves and a man would not be put to an actual test in his home of a dozen receivers that attracted his interest.

On the question of sensitivity it would be more difficult to present the correct picture. However, a given field strength in the antenna circuit could be used as a standard, and modulation could be 75 per cent., a fair average. Then the output, at the speaker posts, could be measured in voltage, and compared with the

voltage of the field source. If all receivers and circuits used the same standard system of rating the comparison of sensitivity would be directly numerical.

For quality test the response could be given for numerous points in the audio frequency scale, so that the prospective purchaser or builder would know whether there was any strong discrimination in frequencies (that means distortion). A particular type of speaker would have to be used, but nearly all set manufacturers sell their own speakers, so they could cite the models.

### Why Speaker Figures

The reason for mentioning the speaker is that it must work well out of the output tube and filter of the receiver if the frequency response measurements, made without the speaker in the circuit, are to mean anything. Or the measurements could be given in respect to a receiver used with a given speaker.

The volume can be measured by determining the AC voltage across a speaker of known impedance.

So far no suggestion has been made as to counting the number of tubes in a receiver, and none will be made, since it is folly to assume that the number of tubes is a good basis of reckoning. Take some familiar examples. Suppose you have a high-gain radio-frequency amplifier, consisting of three tuned stages and a tube detector, four tubes in all, on the "radio" side. Then suppose you have two stages of quality transformer coupled audio frequency amplification on the "audio" side.

If you add a radio frequency amplifier, especially a tuned one, you may upset the balance of the entire receiver, creating self-oscillation of so severe a type that no known practical method of suppressing it exists, and thus ruin a fine set.

### Effect on Audio

Or you may add another stage of equally good transformer coupling to the "audio" side, leaving the "radio" channel alone.

The extra drain of the tube may cause the filtration to be poor, since when a filter is operated on the steep portion of its characteristic, as it should be, the effectiveness of the filtration is directly proportionate to the amount of current. When the flat top of the curve is approached, as it may be by overloading the filter, as in adding a tube that draws 10 milliamperes or more, the region is approached where filtration is poor.



# Get from a Given Circuit? the Performance Factor?

O'Rourke

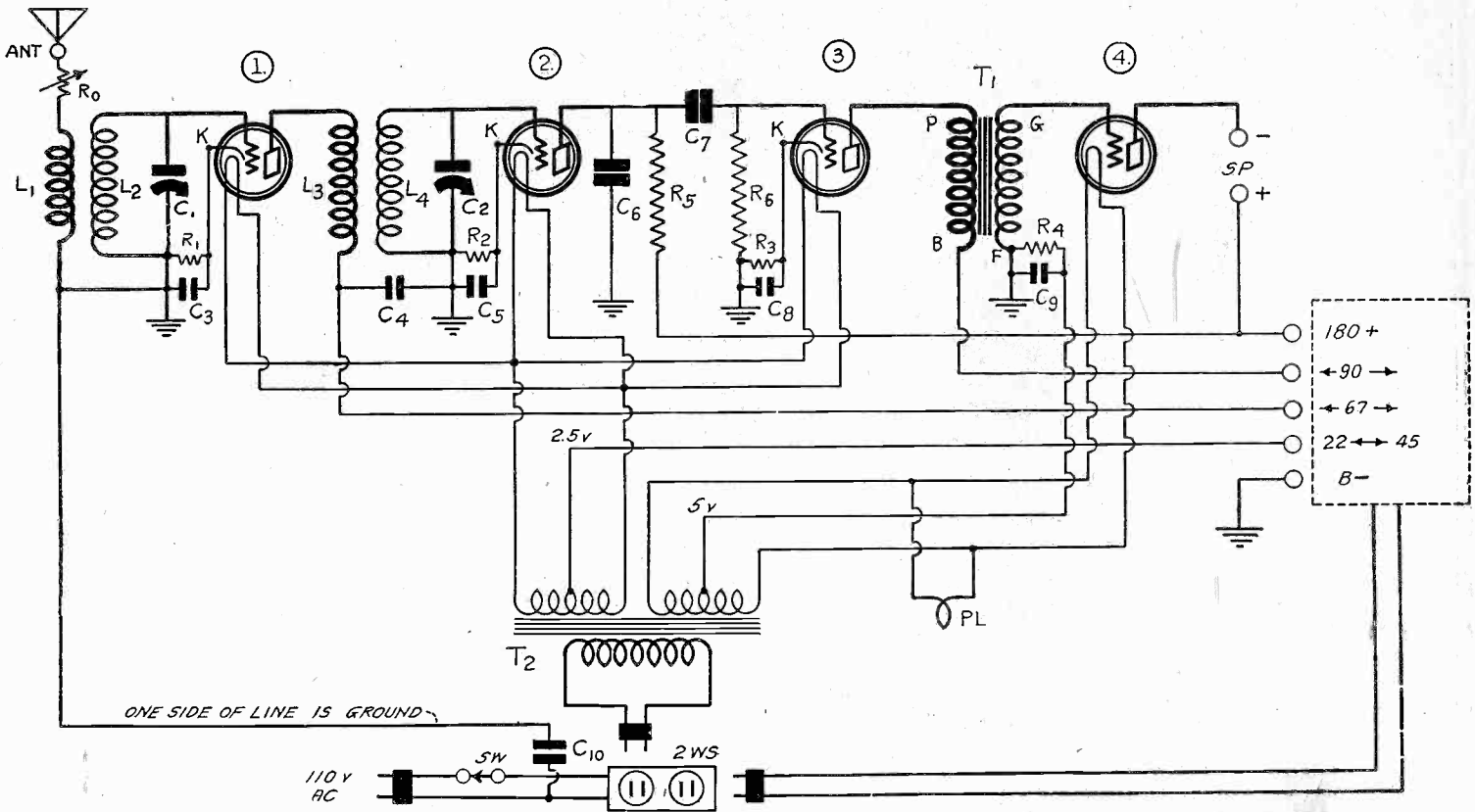

**A MODEST RECEIVER, ONE THAT PRODUCES GOOD QUALITY. IT IS FAIRLY SELECTIVE, BUT NOT ENOUGH SO FOR LARGE URBAN CENTERS, OF IF ONE LIVES NEAR A BROADCASTING STATION.**

ceases to exist. And more than this, the extra stage of audio, unless the circuit is specially designed to make this stage practical, may raise the amplification to such a point that severe distortion will creep in, the last tube will be overloaded, the receiver may motorboat (since motorboating is a function of the amplification) and, again, a fine receiver is ruined.

On the other hand, one may say: "If a receiver has nine tubes including rectifier and is made by a manufacturer who has a circuit using six tubes including rectifier, and the six-tube receiver works well, the nine-tube receiver should be ever so much better, because if a company makes one receiver well it will make all well."

The number of tubes in a receiver, by the way, should not group the rectifier, so this will not be done in the reply.

### The Barrier

The answer to this question is that science itself imposes certain limitations, indeed challenges man to get around its barriers, and one of these barriers is that high amplification will make tubes oscillate, and when you get into the eight-tube class you never can know by any one's reputation that there isn't a great deal of trouble in the set.

Six tubes and rectifier are pretty standard and a good set can be made with these. Seven tubes and rectifier have presented fine opportunities for several manufacturers. But the difficulty of manufacture, service and use increases about as the square of the total number of tubes, after you pass the sixth tube. The biggest problem in radio is the

stabilization of a receiver using more than three tuned radio frequency amplifiers, without loss by neutralization of the very gain sought.

In the audio channel the same holds true: two stages of transformer coupling are standard and easily used, but three stages of transformer coupling requires some excellent design and skill, because of the possible oscillation, e.g., motorboating.

From this it may be assumed that the greater the number of tubes in excess of six (not counting the rectifier), the worse the receiver is likely to be, but that is not so. The difficulty increases frightfully, but, thank goodness, so does man's versatility. It is a fact that extra caution must attach both to the design and construction of a seven, eight or nine-tube receiver, and to the choice of such a receiver by the purchaser.

### Circuit Phenomena

Some circuits lend themselves more readily to stability with a large number of tubes than do others. For instance, a Super-Heterodyne may be made stable without much trouble, although it employs eight tubes. Both in home-constructed and in factory-made examples this will be found true. Likewise, lack of caution even in such a receiver, may bring about instability.

Tuned radio frequency amplification may be developed beyond three stages, expertness of the design bringing about success. A recent example of a very selective, DX and voluminous circuit is the Sargent-Rayment, where each radio stage is shielded, and the leads are cautiously

choked and bypassed so as to get rid of a troublesome source of instability, the high impedance of the common voltage source, e.g., B eliminator. This particular circuit, very popular with home constructors and custom set builders, has brought in a station for almost each division of dial, in many localities, showing it has 10 kc. separation, high sensitivity, high selectivity and volume. But each tuned stage has a trimmer, and the antenna circuit is devoted to an extra precaution against interference, by introduction of a wave trap effect. In other words, a goal was sought, and it was achieved only by careful adherence to the best engineering practice, and the inclusion of parts a set manufacturer (guided strongly by cost) might consider superfluous.

This comes pretty close to the present pinnacle for tuned radio frequency receivers, with as many tuned stages of radio frequency amplification as one would dare use.

On the other hand, it may be said that two tuned stages are the absolute minimum that may be used successfully, the receiver being good for local reception, affording excellent quality, but not coming up to any rigorous requirements for selectivity and sensitivity. One tuned stage is hopeless, two tuned stages are the minimum, three tuned stages the most popular, four bring up special engineering and construction problems, five are likely to be reckless, while six or more are splendid for dreamers and high-hope entertainers, but not for the practical person on whom the circuit designer and the parts and set manufacturers must depend for their own business success.

# Lacault's Parting Advice

By R.

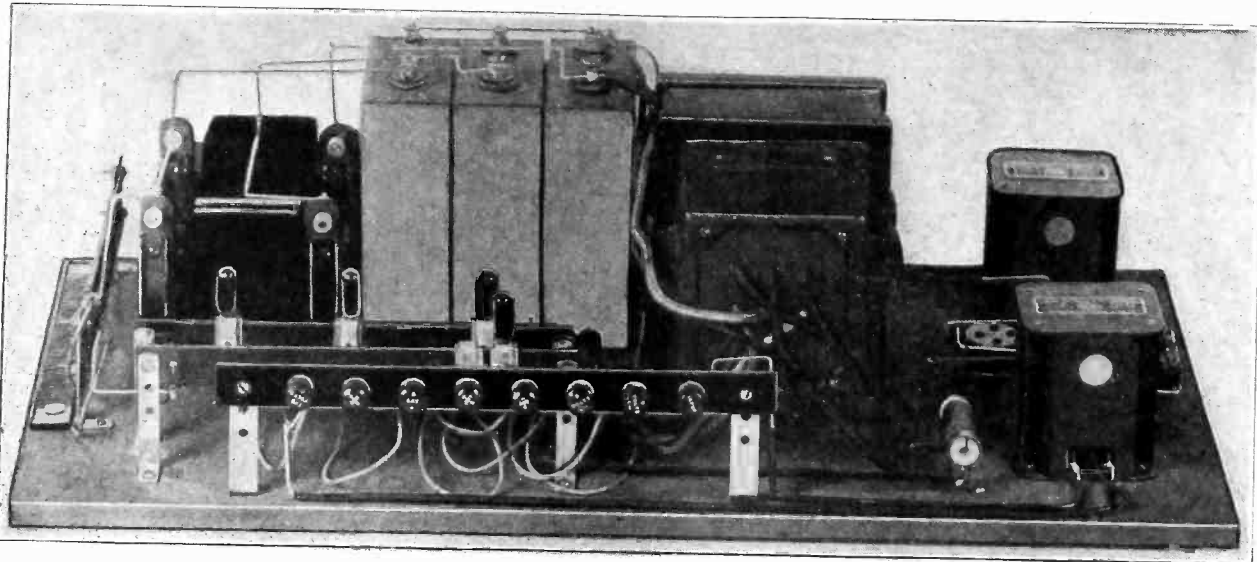

**FIG. 5**  
Front view photograph of the Lacault power pack and push-pull amplifier. The resistor and binding post strips are raised to allow room for the small bypass condensers.

**F**OR building the power supply for the RE29 receiver it is best to procure a hardwood baseboard because the parts are quite heavy and require a strong board for support. Since woodscrews cannot be driven easily into hardwood, a drill or a sharp-pointed tool should be provided for making holes where the screws are to be driven. Of course, these holes should be smaller than the screws. If they are not, the screws will not hold.

The power transformer is so heavy that woodscrews cannot be relied on. Hence, for mounting this transformer four large holes are drilled through the board and the transformer is mounted by means of bolts. If flat-head bolts are used the holes on the bottom side should be countersunk. If any of the other types of bolt is used the holes should be sunk on the under side so that the heads of the bolts come below the surface of the board.

#### Ample Room for Parts

The baseboard is 25¼ inches long and 12 inches wide. This allows ample room for all the parts without any crowding. This not only permits easy access when wiring, but it facilitates circulation of air for cooling the parts.

The actual layout of the parts of the B battery eliminator and the push-pull power amplifier is shown in the illustration. The power supply portion of the unit is shown at the left, looking from the binding post side, and the push-pull amplifier is shown at the right. Some few facts, like small bypass condensers, are not shown in the illustrations, although in the diagram, and of course should be included in the circuit.

The power transformer is an Amertran PF250. It is provided with five leads on the primary side. One lead is for zero, or the grounded side of the line, and the four other parts are for voltages of 100, 110, 115 and 120 volts AC. The lead suitable for the voltage on the line is selected. Usually it is not necessary to provide for switching from one to the other because at any one place the voltage remains fairly constant during service.

#### When Voltage Fluctuates

However, in some places the line voltage fluctuates, and in those cases it is desirable to have a switching arrangement for selecting the proper voltage at any time. This can be done by a simple

four-point switch. If this is used care must be taken to make the wiring safe and consistent with the Underwriters regulations. An approved switch can be obtained.

The two leads of the plug-in cord should be securely connected to the proper terminals on the transformer and soldered. Then they should be wrapped separately with several layers of friction tape and finally taped together.

#### Order of Procedure

In building the power pack and push-pull amplifier the following procedure is recommended. First, place the parts on the board in the proper positions without fastening any down. Mark the position of each with a pencil and locate the holes for the mounting screws. Do this accurately so that all the holes may be drilled at once while nothing is on the board. Remove all the parts, and drill.

Next mount the power transformer. Do not connect anything to the primary leads

of the transformer. When the transformer has been bolted down mount the two sockets for the rectifier tubes. They will be almost in the center of the board.

When this has been done connect the filament leads from the transformer to these sockets. There will be three heavy yellow leads on the transformer. The outside two of these go to the F terminals of the two sockets. Connect the sockets in parallel with heavy leads, such as heavy bus-bar wire.

Next connect the outside red leads from the transformer to the plate terminals of the sockets, one to each. These are the high voltage leads through which flows the AC current to be rectified. The two grid terminals are left blank. Avoid loose uninsulated ends.

#### Condensers Mounted

The next to be mounted are the three high-voltage Parvovolt condensers. They are placed to the left of the transformer, back of the sockets already mounted.

## Volume Control

It is necessary to have a volume control in the RE29, one which is not dependent on detuning. It was Mr. Lacault's intention to insert an automatic control in the power supply, but death overtook him before he could complete this part of the work. However, his laboratory notes clearly indicate what he had in mind. It was a method of automatic volume control based on the automatic variation of the plate voltage applied to the screen grid tubes in the intermediate amplifier. The circuit diagram of this control is shown in Fig. 6.

It consists of a 201A tube, supplied with direct filament from the receiver proper or from the batteries. Two long twisted leads should be run to the set and so connected to the filament circuit that the switch therein controls the filament supply to the volume control tube.

#### Connected Across Speaker

The volume control tube is connected across the loudspeaker terminals. The tube is operated more as a detector than as an amplifier, and therefore a grid battery E is used for biasing. The four microfarad condenser is used to prevent short-circuiting the battery through the loudspeaker and the transformer winding.

A half megohm potentiometer is used to adjust the voltage applied to the grid of the volume control tube. By means of this the volume level may be set at some desired value and the circuit will then maintain that level.

The control tube is supplied with voltage from the 135 volt tap on the power pack. The current required by the two screen grid tubes and the control tube flows through a resistor and a high inductance choke. The voltage supplied to the screen grid tubes depends on the drop in the resistance of the choke and the external resistor. The control tube is biased so that the louder the signal the greater the current. Hence, the greater the signal the greater the drop in the voltage and the lower the voltage applied to the screen grid tubes. Thus an increase in the signal strength reduces the amplification and the volume is automatically maintained at a practically constant level.

#### Get Correct Time Constant

A little experimentation with the setting of the potentiometer, the value of the grid bias and the value of the external resistor is recommended.

In order that the control tube shall not

# to His Great Following

Lacault

Connect the three terminals of the condensers farthest away from the sockets with a piece of bus-bar and then connect the central red lead from the transformer to the same point. Then connect the central yellow lead on the transformer to the unused terminal of the condenser.

We are now ready to mount the two filter chokes. They are placed to the left of the condensers and the sockets. From the post on the first condenser to which the yellow lead has been connected run a bus-bar wire to the nearest terminal of the first choke. This choke is at the back. Insulate the wire with spaghetti. While the insulation is not vital, it is well to take the precaution.

Next run a bus-bar wire from the unused terminal of the middle condenser to the second binding post of the first choke, and continue this lead to the first terminal of the second choke. Insulate the leads. Now run a similar lead from the unused terminal of the third condenser to the second terminal of the second choke coil.

### Wiring Audio Amplifier

At this point leave the B battery eliminator and go to the push-pull amplifier. Mount the two sockets first. Connect the filaments in parallel and run the outside two heavy black leads from the transformer to the filament terminals.

Next mount the two push-pull audio frequency transformers, the output transformer at the back and the input in front. Mount a binding post strip, containing two posts, directly behind the rear transformer on two long angle brackets. Connect up these binding posts and also the grid and plate terminals on the two push-pull transformers and sockets. The middle terminal of the output transformer and the two primary terminals of the input transformers are left unconnected for a while.

Mount the grid bias resistor R to the left of the push-pull input transformer. Connect one side of this resistor to the

- LIST OF PARTS**  
*For Power Pack*
- T1—One Amertran Type PF 250 power transformer.
  - T2—One Sangamo Type B push-pull input transformer.
  - T3—One Sangamo Type D-210 push-pull output transformer.
  - Ch1, Ch2—Two Amertran Type 854 filter chokes.
  - C1, C2, C3—Three Acme Parvolt 1,000 volt, 2 mfd. condensers.
  - C4, C5, C6, C7, C8—Five Acme Parvolt 400 volt, 1 mfd. condensers.
  - C9—One Acme Parvolt 400 volt, 4 mfd. condenser.
  - R—One Electrad Type B 750 ohm grid bias resistor.
- One Carter resistor kit, consisting of three Type F (3,000 ohm) units, one No. 1 (7,400 ohm) tapped unit and one No. 2 (2,900 ohm) tapped unit.
- Four sockets.  
Eleven binding posts.  
One baseboard, 25½x11¾x¾ inches.

center black lead on the power transformer and the other end to the midtap on the secondary of the push-pull input transformer. Mount and connect the 4 mfd. bypass condenser C9 across the resistor.

### Smaller Bypass Condensers

In the circuit diagram of the power pack and the amplifier are some smaller bypass condensers, those not shown in the photographs. They should be mounted in front, allowing plenty of room for the binding post strip and the resistor strips. Mount them so that the terminal lugs are accessible with a soldering iron after the resistor and binding post strips have been mounted. Mount these strips.

Now run a long insulated lead from the midtap of the push-pull output transformer to the second terminal of the second choke coil and to the top of the volt-

age divider, or to the top of the highest resistor strip. Connect all the resistors in series, following the instructions which accompany these strips.

Now connect up the binding posts to the appropriate taps on the voltage divider, and to the small bypass condensers if called for by the circuit diagram of the power pack and amplifier. Note that the P terminal on the primary of the push-pull input transformer is connected to a binding post on the strip and that the other (B) is connected to the 90-volt tap on the voltage divider or to the corresponding binding post.

### Use Rubber-covered Wire

In connecting up the binding posts to the small bypass condensers and the taps on the resistor strip it is best to use flexible, rubber covered wire, because this is easier to handle than bus-bar wire and it is already safely insulated.

While the photographs show only eight binding posts on the strip, an additional post has been inserted in the diagram for the 180-volt tap. A minus 40-volt grid bias post has been provided, although this bias is not used in the circuit. This has been done to provide a bias for —71A type tubes in case it is desired to use the power pack after a receiver using —171 or A171A as the last tube.

The 22 and 45-volt plus binding posts do not have any bypass condensers. Of course, a couple may be introduced, but it is really not necessary, for these posts will be bypassed adequately in the receiver.

When everything else has been finished, and the circuit checked over for any possible omissions and errors, the primary leads on the power transformer should be wired to the cord which leads to the plug.

The completed power pack will give adequate plate power for the RE29 receiver or any other receiver requiring the same plate voltages and currents. The current supplied will be well filtered and free from ripple. The unit will also have a high grade, push-pull power amplifier with output enough to load up any dynamic speaker.

[This concludes R. E. Lacault's four-part article on the RE29 and power packs, written just before his recent death. The other instalments were published April 6th, 13th and 20th.]

## for the RE29

act so rapidly as to level out the low frequency signals as well as the slow fluctua-

tions in volume the values of 4 mfd. and 100 henrys are suggested.

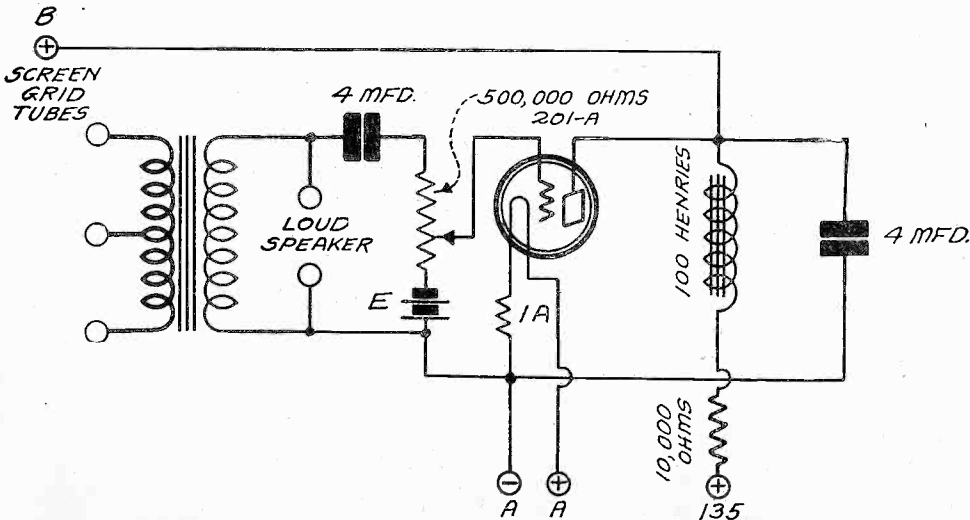

A DIAGRAM OF VOLUME CONTROL CIRCUIT ATTACHED TO THE OUTPUT OF THE PUSH-PULL AMPLIFIER. IT AUTOMATICALLY VARIES THE PLATE VOLTAGE APPLIED TO THE SCREEN GRID TUBES SO AS TO KEEP THE VOLUME CONSTANT.

## Serial Thrillers

### Delight Children

Oakland, Calif.

Radio serials have been found to hold as strong a grip on the boys and girls of today as the old-fashioned movie serial held on the children of fifteen years ago.

This fact is brought to light in letters to KGO from parents, many of whom as children often forgot homework and slipped away to watch Pearl White outwit a gang of crooks.

Now their own children sit before the loudspeaker and with abated breath await the outcome of the terrifying positions authors are prone to wish on serial heroes and heroines.



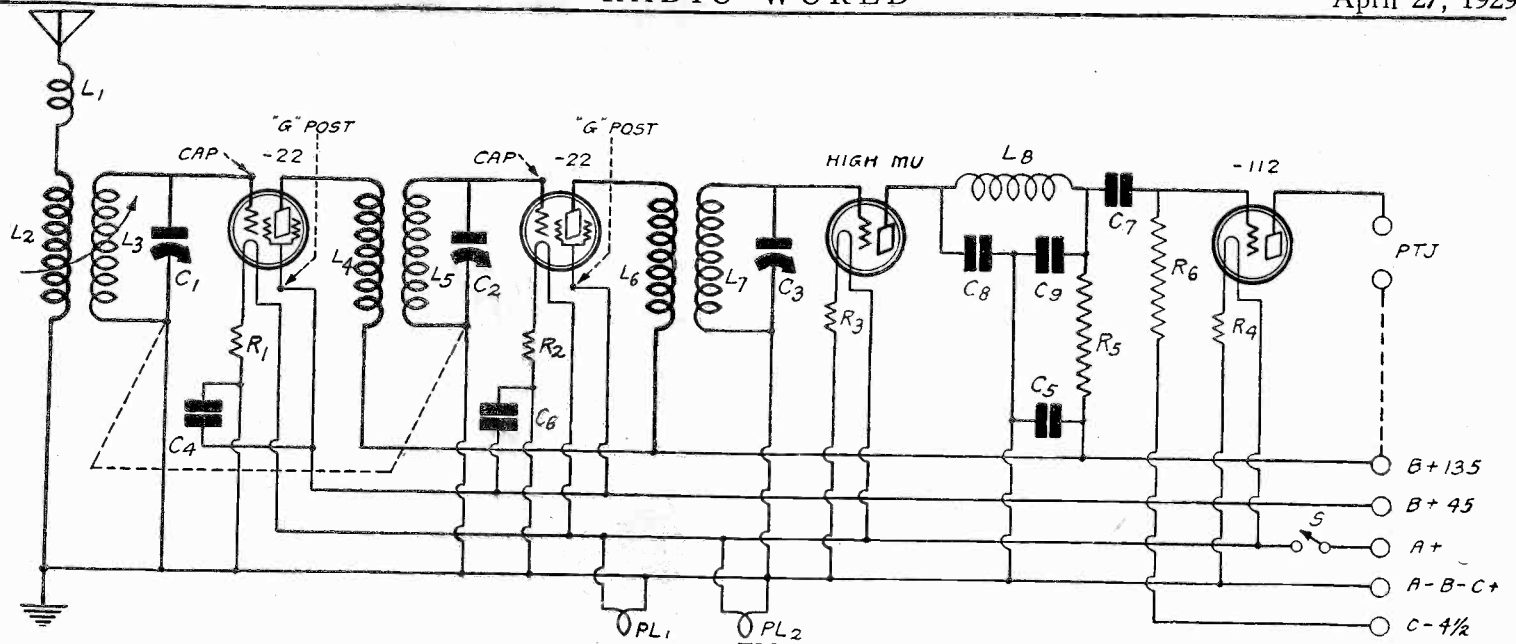

FIG. 743  
A VERY SENSITIVE RECEIVER COMPRISING TWO SCREEN GRID TUBES, THREE TUNERS AND ONE STATE OF RESISTANCE COUPLED AUDIO AMPLIFICATION. CIRCUIT REQUESTED BY CRAIG STEWART.

# Radio University

When writing for information give your Radio University subscription number.

**QUESTION and Answer Department** conducted by **RADIO WORLD**, by its staff of experts, for University members only.

possible. But you can get fair accuracy with ordinary voltmeters.

**WILL YOU PLEASE** publish a diagram of high and low pass filters together with their attenuation characteristics and formulas for determining the critical frequencies.

EDMUND BLAIR,  
Wilmington, Del.

(1)—See Fig. 744 for the diagram. For a discussion of this subject see the March 30th issue of **RADIO WORLD**.

**WILL YOU KINDLY** explain the operation of the radiometer? Does this work on a principle similar to that on which a radio set works?

LEO MERRILL,  
Binghamton, N. Y.

(1)—Fig. 746 illustrates the principle of operation of the radiometer. The vanes are blackened on one side and polished bright on the other. Light is absorbed on the black side and reflected on the other. The difference in the reaction between the air and the vanes causes the rotation. There is no connection between the radiometer and a radio set.

**WILL YOU PLEASE** publish a diagram of a diagram of a four tube circuit using two screen grid tubes, DC on the filaments, and using tuned plate circuits for effective coupling.

(2)—If practical show a circuit having only two tuning controls but three tuned circuits.

(3)—If trimmers are necessary show where they should be put.

ELLWOOD SKOU,  
St. Paul, Minn.

**WILL YOU** please publish a diagram of a circuit comprising two screen grid tubes, three tuners and one stage of resistance coupled audio suitable for operation in conjunction with a push-pull audio amplifier.

(2)—Can such a circuit be operated by a ganged condenser on all three circuit?

(3)—Would you recommend trimmer condensers, or is it possible to omit them?  
CRAIG STEWART,  
Halifax, Nova Scotia.

(1)—See Fig. 743. The first two condensers are ganged, making the circuit two-dial.

(2)—Not very well, unless you are willing to take great care in getting all the tuned circuits equal.

(3)—If all the tuned circuits are put on one control you will need two trimmer condensers. If you gang two of the condensers, as in the diagram, you will need one trimmer.

**DO YOU RECOMMEND** condenser blocks for B battery eliminators or do you prefer individual unit condensers?

(2)—Is there any electrical advantage in using condenser blocks?

JACK ZABRISKI,  
Chicago, Ill.

(1)—While condenser blocks are very convenient, individual units are preferable because if one section breaks down it is not necessary to replace the entire set of condensers.

(2)—There is no electrical advantage in blocks.

**ARE THERE ANY** voltmeters for measuring the high A.C. voltages occurring in the power transformers of B battery eliminators?

(2)—Would it be possible to use an A.C. filament voltmeter for this purpose by using external resistors? If so, please give the values of resistors that should be used to increase the range from 0-8 to 0-1,000.

(3)—Should meters of a high resistance per ohm be used for measuring the high voltages, or will ordinary meters do?

CHAUNCY JONES,  
Amarillo, Tex.

(1)—Yes; there are many such meters available.

(2)—Yes, but the values of the external resistors cannot be given unless the resistance per volt of the filament voltmeter is known.

(3)—It is always best to use a meter that has as high resistance per volt as

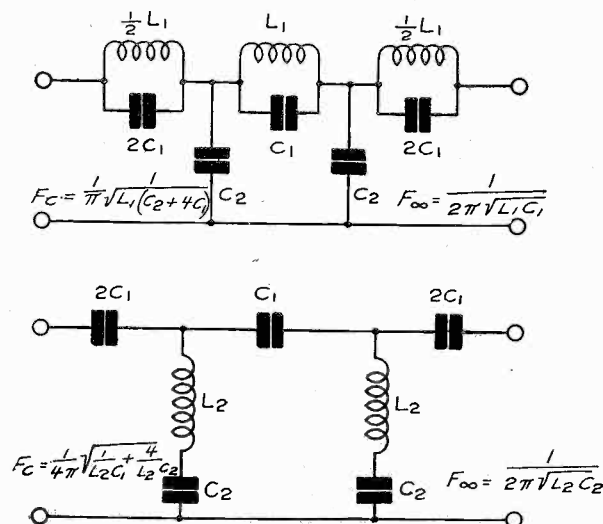

FIG. 744

TWO SECTION LOW PASS (UPPER) AND TWO SECTION HIGH PASS (LOWER) FILTERS WITH THEIR CHARACTERISTICS TOGETHER WITH THE FORMULAS FOR CUT-OFF AND INFINITE ATTENUATION FREQUEN-

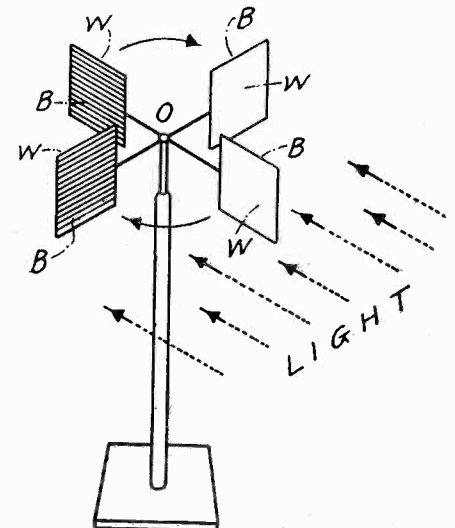
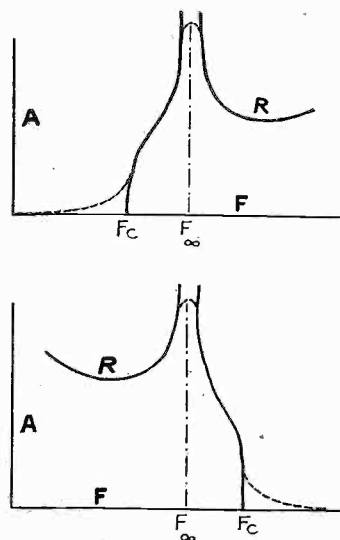

FIG. 746

DIAGRAM OF A RADIOMETER SHOWING THE BLACKENED AND POLISHED SIDES OF THE VANES.

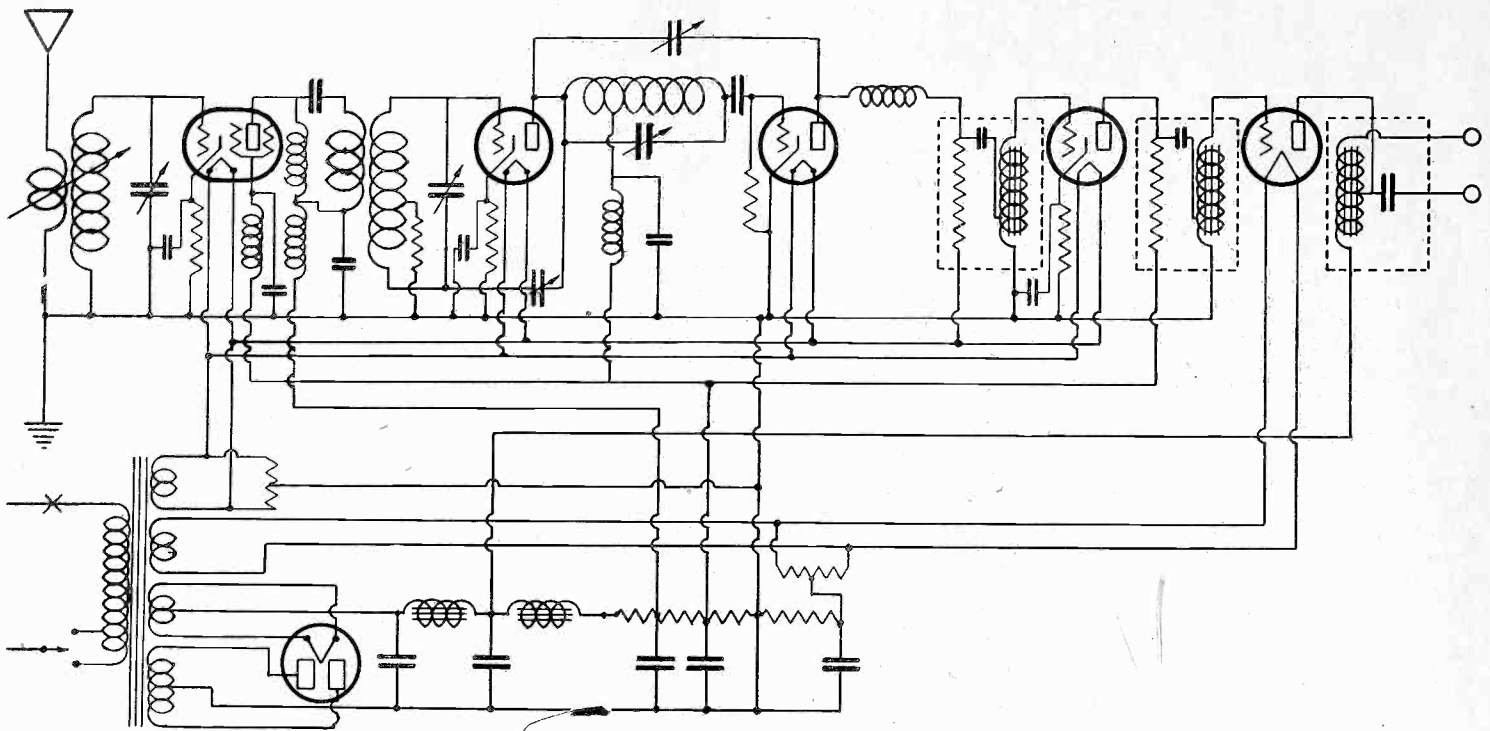

FIG. 745

THE COMPLETE CIRCUIT DIAGRAM OF THE MOORE-DANIELS AC5 RECEIVER. IT EMPLOYS THE NEW AC SCREEN GRID TUBE FOR HIGH SENSITIVITY.

- (1)—See Fig. 747.
- (2)—With one trimmer it is a practical arrangement.
- (3)—The trimmer condenser is connected across Cy. Use a midget of about 70 mmfd.

\* \* \*

PLEASE publish a complete circuit diagram of the Moore-Daniels AC5 receiver. Also let me know where I may get full information on how to build the receiver.

- (2)—Is this receiver as selective as the AC screen grid Diamond?
- (3)—Which would you recommend that I build?

FRANK CLIFFORD,  
Spokane, Wash.

(1)—See Fig. 745 for the complete circuit diagram of this receiver. See April 6th issue of RADIO WORLD for a discussion of the receiver or write the Moore Radio Co., in care of RADIO WORLD.

(2)—The circuit is very selective and sensitive.

## Join RADIO WORLD'S University Club

And Get Free Question and Answer Service for the Coming 52 Weeks  
This Service for Yearly Subscribers Only

Have your name entered on our subscription and University lists by special number. Put this number on the outside of the forwarding envelope (not the enclosed return envelope) and also put at the head of your queries. If already a subscriber, send \$6 for renewal from close of present subscription and your name will be entered in Radio University. No other premium given with this offer.

[In sending in your queries to the University Department please paragraph them so that the reply can be written under or alongside of each query. Write on one side of sheet only. Always give your university number.]

RADIO WORLD, 145 West 45th Street, New York City.

Enclosed find \$6.00 for RADIO WORLD for one year (52 nos.) and also enter my name on the list of members of RADIO WORLD'S University Club, which gives me free information in your Radio University Department for 52 ensuing weeks, and send me my number indicating membership.

Name .....

Street .....

City and State.....

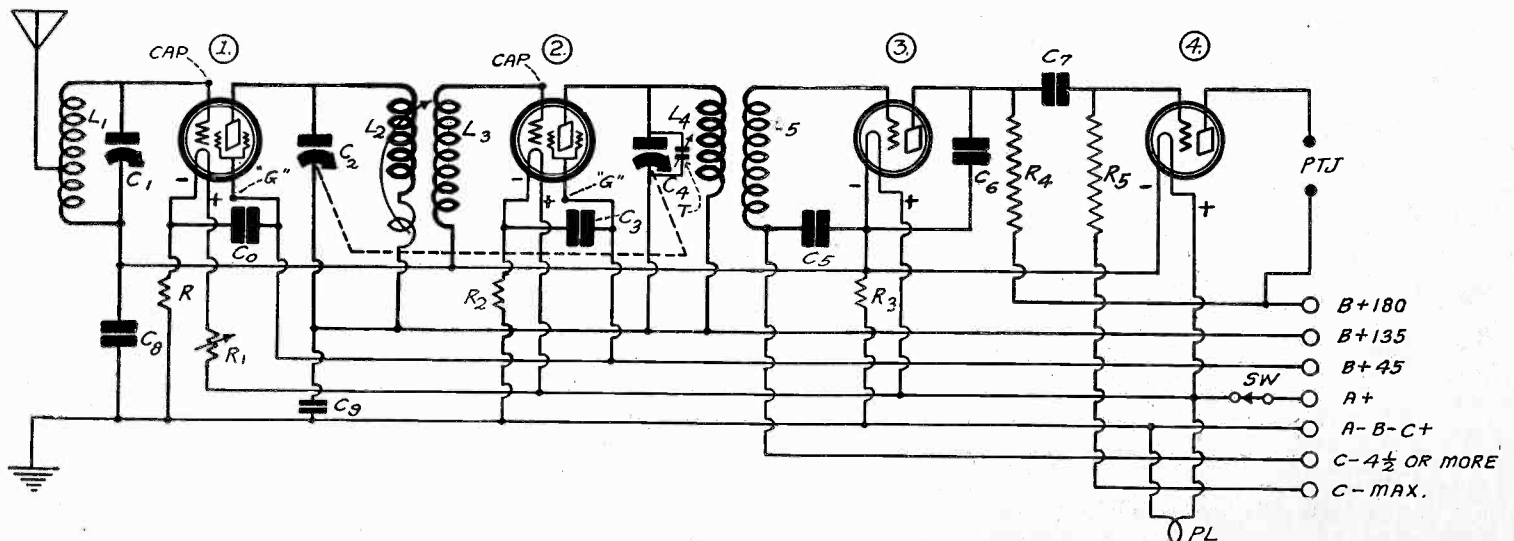

FIG. 747

TWO SCREEN GRID TUBES WITH PLATE TUNING MAKES THIS AN EXCEPTIONALLY SENSITIVE RECEIVER. IT SHOULD BE USED AHEAD OF A POWER AMPLIFIER. REQUESTED BY ELLWOOD SKOU.

# How to Listen In

By Herbert E. Hayden

**T**HERE is an art to listening, as well as to performing. One should hear what there is to hear. Such, however, is not the common happy result.

Some persons imagine they do hear what is not there, wherein an obliging imagination atones for the shortcoming of a radio installation and fills a yearning by contributing nothing to it!

Often persons do not hear what actually is there, or, perhaps, they merely listen to it without hearing it, just as one may see something blankly, without noticing it.

In listening, therefore, not only does an art exist, but it is bound up with a science, as is radio itself. We hear mention of "the art" when the speaker of the evening refers to radio. If he said "the science" we might feel shocked. Truly radio is an art—that is, it is the art of being scientific in the realm of physics—but it is science first and art incidentally. So with the art of listening. It is a science!

## It's Different

We might consider momentarily the legal difference between a delusion and an hallucination. If a person surrounded by intense silence thinks he hears a sound, but the sound is purely fictitious and imaginative, that is a delusion. There was nothing there that could even be mistakenly called a sound. If a person hears an actual note struck, high in pitch, but thinks it is low, that is an hallucination. A delusion is a belief wholly without foundation of any fact whatsoever, whereas an hallucination has some sort of a fact as its basis, however remote or ridiculous.

Now, the untrained listener is never deluded, although he is often hallucinated. There is something there all the time. If he thinks the music being played is jazz, whereas it is Wagner's "Ride of the Valkyries," that is simply an hallucination. Something is being played—even if it's only a game of auction bridge.

In the field of hallucination, however, the listening public runs far astray.

It is impossible to learn from some friend, for instance, whether he is receiving good quality on his radio set. You ask him:

"Well, how do you enjoy the music on your new radio set?"

He replies:

"It's great. Finest set I ever heard. Once in a while the volume is kind of low (when I turn off the set), but otherwise I'm satisfied."

## Real Cause

He doesn't even know that the "low volume" accompanying turning off the set is simply his neighbor's receiver, tuned to the same station, carrying on where the sleeper one left off.

"Do you ever hear any kettle drums in natural tone on your set?" you ask.

"Didn't know kettle drums had any particular tone," he says, by way of picking you up. "Sort of heterogeneous sound, isn't it?"

"Bull fiddles?"

"As my grandfather used to say, 'Fiddlesticks!'"

"Bass viol—no foolin' this time."

"Means the same as bull fiddle to me. I didn't frequency-analyze my set, but it sounds great. At any rate, my wife's satisfied with it, and if you're not, that's the least of my worries. Come over some night—Tuesday will do—and listen for

yourself. If you're one of these expert listeners, as I hear you are, I wish you'd catch the call letters of some of those muffled distant stations."

And so you got to his house. True to dramatic style you find no sound of music as you enter the home, except the musical voice of Mrs. Hostess, greeting you enthusiastically. A bite to eat, a sip, a discussion of the stock market, how television is progressing (these two both the same topic) and finally—

"Well, let's see, or rather, hear what's on the air," from your host.

He turns on the set with a desultory application of thumb-pressure to the toggle. It's an AC receiver with heater type detector tube. A drummy foghorn is imitated for a few seconds, during what you explain is the warming-up process, but the hostess asks if something couldn't be done to stop that nuisance, as the old set (three tubes and six batteries) never made a noise like that, and always worked as fast as spot cash.

No, nothing can be done about it.

## Expert Listens

The host eyes you keenly as some music begins to come in. The hostess eyes you no less keenly. You are an expert listener—you know the tricks of the trade, the rules of the game and the inside discounts—and they want to learn how to behave under circumstances of expert listening.

You look as dumb as anybody can when he is overshadowed by a piece of furniture containing wires, coils and condensers, also eclipsed by a mediocre announcer and "more likewise" by a jazz orchestra. That is, you can not talk "against" an announcer, for there are 1,300 milliwatts undistorted power output against you, and no one knows how many distorted milliwatts! An orchestra is an unfair competitor. You could not even sing against one. There is no competition. The announcer or orchestra wins by default. When the radio is playing one can shine only by being silent.

After a long period of listening, and considerable talking by your host and hostess, none of which was loud enough, thank goodness, for you to understand, the husband obligingly turns off the set and sure enough the equally obliging neighbor is there with the same program, with only a wall between.

"Well, how do you like our set?" asks the wife.

Now for all the teachings of diplomacy!

"I like it," say you, focusing an eye on the furniture effect in which the set is housed. "The only thing I'd suggest—"

"See here, young fellow," and this with no joviality, "you're holding back on us. You don't think that radio receiver is any good at all. Separates one station from another but might as well separate one mad dog from another, for all the real music resulting. Now, come right out with it? Haven't you found this receiver absolutely abnoxious and irritating? Wouldn't you go mad if you had to listen to it night after night, and there've been a hundred thousand sold to people who've stayed sane nevertheless? Tell me the truth, old pal, that's what we want—no salve—just truth."

Well, when a man-to-man demand like that is put up to you, how can you count diplomacy in on the proposition? A man wants to know the truth as it appears to you—searches your soul and your con-

science in the endeavor—pleads with you to help him with the profundity of your relentless wisdom—and what are you to do? Turn him down, after you've eaten most of his food and smoked two of his best cigars and all of his wife's cigarettes? Not if you're a man!

## The Formula

So you tell him:

"If you want to listen to a radio set understandingly you must be able to listen in an auditorium to the same sort of program, just as understandingly, with your eyes shut. If you sit in the lyceum and see six men pulling bows over bull fiddles, you know that bull fiddles are being played, and even if you can't hear one of them, assuming you're deaf to low notes, although this is no accusation. Eyes shut, you can distinguish a piano from a violin. That's too easy. You can tell a cornet from a violin or either from a drum. But how about an oboe? A clarinet? A French horn? A bass viol? A piccolo? A flute? A cornet? An accordion? An organ?"

"Having familiarized yourself with them you will tell them apart like the voices of your children (after they're 13 years old). You will come to know a poor radio receiver that produces a stifled grunt instead of the true zoom of a bull fiddle.

"In your association with music you will naturally acquire some understanding of the fundamentals of acoustics and you will know frequencies, know how to tell them apart, roughly at least. If you have a speaker in the chamber of a console, and the whole contraption has one enormous resonance frequency around 200 cycles, that fact will greet your acute ear, because when a note of 200 cycles is struck you will hear it a hundred times louder than a note of 500 cycles, struck with the same intensity! The box resonance, making the voice sound like that of a man in a barrel after he's completed the irksome walk home from the beach, will leap at you as an intruding annoyance, and won't pass by unnoticed in the desperate zeal for saying a good word for the thing you've brought home in a box and called radio set to the slander of good receivers.

## Speech Not Neglected

"You will listen to a set to determine if the high frequencies are brought out well—the hissing sounds of speech, the E string notes on the violin, with pinkey up near the bridge somewhere. You will know the middles for their proximity to middle A and C that you ought to be familiar with from the tuning whistle that sounds A when you blow into and C when you suck out of it.

"When you get down to 40 cycles you will know you've reached about the lowest listening you can expect to do on a set, because most stations don't send out lower frequencies, most audio amplifiers don't pass lower frequencies and most speakers suppress lower frequencies.

"And when all that and more are accomplished, then you'll be an expert listener, few indeed will be the radio receivers that will give you real delight, you'll be awfully careful to build one that's all that your learning teaches you that you must have, but by then you'll be invited out to so many home dinners—and bring your tools—that you'll wonder if you weren't better off in your innocent childhood."



# Multiple Loudspeakers

Method to Choose Depends on Impedances and Length of Leads

By J. E. Anderson

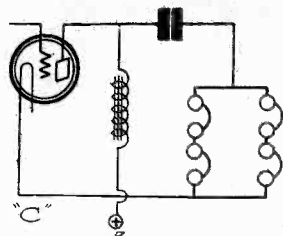
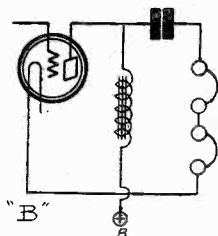
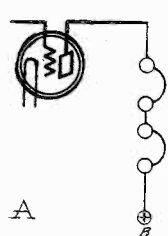

FIG. 1

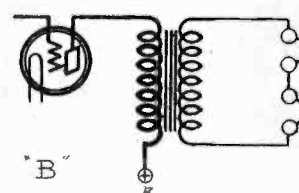
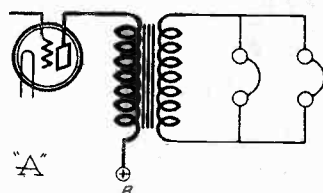

FIG. 2

## Method is Proposed for Operating a Large Number of Reproducers, Where One is in Each Room of a Hotel or Institution — Separate Tube Used for Each Speaker, with Individual Volume Control in Grid Circuit.

It is often desirable to connect two or more loudspeakers to the same receiver. The most natural way of doing this is to connect them in parallel. But that does not always lead to the best results. And when two speakers are so connected for comparison purposes it is quite probable that the better speaker will not show up so well as the other. It depends on the relative impedances of the two speakers.

Another way of connecting them is in series, as shown in Fig. 1A. This is better than the parallel connection because the load on the tube is higher and the quality will be better. But when the series connection is used for comparing two speakers of different design the result is far from conclusive, for again the better speaker may lose the decision.

### Effect of Impedances

When the two speakers are connected in parallel the speaker having the lower impedance will take most of the current and therefore it will appear to be the more sensitive. When the speakers are connected in series, on the other hand, the speaker having the higher impedance will take most of the output power from the tube, and hence that will appear to be the more sensitive.

If the speakers have the same impedance the better sound radiator will appear to be the more sensitive, and that is true for either the parallel or the series connection. If both speakers are of identical construction both will appear equally sensitive for either connection. But there is a great difference in the result just the same.

When the two speakers are in parallel the combined impedance, as it appears to the tube, is only half the impedance of either speaker alone. The load on the tube, therefore, may be much too low to transfer effectively the power from the tube to the speakers. The distortion in the output will be a much higher percentage than when either speaker is used alone, and the total power may be less. This will be true if one speaker matches the impedance of the tube.

### Series Connection

When the two speakers are connected in series the total impedance offered to the tube is the sum of the impedances of the two speakers. If the impedance of

each is less than that of the tube the series impedance may be just right to match that of the tube. This would make the total power output greater than that existing when a single speaker is used. But the probability is that the total impedance would be greater than that of the tube. Then the total power output would be less than maximum, but it will contain less distortion.

The best combination for volume and purity is that which makes the total output impedance equal to twice that of the tube. This condition is brought about if the impedance of each of the two series connected speakers is equal to that of the tube.

The output circuits shown in Fig. 1 A and B are essentially the same. The series condenser offers only a small impedance and the impedance of the choke coil is so large that it does not affect the output impedance offered to the tube. Hence these circuits should be treated in the same way when two or more loudspeakers are connected to the tube.

The circuit in C shows how four speakers should be connected to the tube. They are in series parallel. The combined impedance of these four speakers, if of identical construction, is the same as if only one of them were used. But they can handle four times as much power as before. Of course, it is useless to put four speakers on a tube which can handle only enough power for one tube. When several speakers are used, either at one place or at several different places, a power tube should be used which can handle enough power for all the speakers.

### Connection to Output Transformer

When an output transformer is used between the tube and the speakers the proper connection depends on the impedance of the secondary of the transformer. It is assumed that the primary of the transformer has been wound to take best advantage of the power available in the tube. Exactly the same principles apply to the secondary circuit as if the transformer were not used.

Two speakers may be connected advantageously across the secondary when they cannot be so connected in the plate circuit. If the impedance of the secondary is low it is best to connect the speakers in parallel as shown in Fig. 2A. If

the impedance is high it will be better to connect them in series as in Fig. 2B.

The use of several speakers on one tube raises many other problems which must be met, particularly when some of the speakers are at a distance from the tube and when they are to be turned on and off independently of each other.

The first problem is that of long leads. Two properties of the leads affect the operation, the resistance of the wire and the capacity between the leads. If the leads are very long the shunt capacity and the series resistance will be high. The capacity will detour the high frequencies so that they may not get to the speaker at all. At any rate, they will be seriously attenuated.

The resistance may be so high that it constitutes a considerable portion of the total load resistance. The power expended in this resistance will be lost. Hence the wire chosen for the long leads must be heavy and at the same time the insulation must be such that the capacity is as low as possible, or the leads may be separated widely, wherever possible.

### Independent Control

If many speakers are connected to the same tube and if they are to be controlled at different points, they must be so connected that the turning on and off of any one will not affect the operation of the others. It is obvious that if they are connected in series if one is turned off all in the series will be turned off.

A simple way around this difficulty is to short-circuit a speaker whenever its operation is no longer desired. But that may lead to short-circuiting all the speakers. For example, if all the speakers in one series line should be short-circuited at the same time, all the speakers in the other lines would be short-circuited also.

Even if only one speaker is left on in one of the lines, the others would very nearly be short-circuited. The series-parallel connection which is best from the viewpoint of power transfer is least suited from the viewpoint of independent control.

If only three or four speakers are used they may be connected in series. Then any one may be turned off by merely short-circuiting it. Each time one is turned off the remaining speakers will receive more power. A volume control is required with each speaker.

(To be concluded next week)

# Pure Tone from Pick-ups

## How Scientific Research Overcame Obstacles to Fidelity

By H. B. Herman

Acoustical Expert

ONLY about three years have elapsed since the first electrical pick-up for phonograph records was placed on the market. The first devices offered the public were crude in construction and unscientific in design. Very little was understood about the principles upon which they worked. But the art was new and the public was interested mainly because of the novelty.

Audio amplifiers at that time were not as faithful as they are now and for that reason the defects of the pick-up units were not apparent.

But audio amplifiers were improved to a remarkable degree and the devotees of the electrical pick-up soon recognized that radio reproduction was then much superior to phonograph reproduction, even when both were reproduced on the same audio system. They also noticed that records did not last nearly so long when played electrically as when they were reproduced mechanically. And there was even more needle scratch accompanying the electrical than the mechanical reproductions.

The defects of the electrical pick-ups became obvious, and manufacturers began to experiment, with the object of discovering the causes of the unsatisfactory performance.

### Scientific Design Achieved

The principles of physics involved in the electrical playing of records were carefully studied and applied. Both the electrical and mechanical phases of the subject were studied exhaustively. The result was that pick-up units were improved and developed to a point of efficiency and fidelity not thought possible when the first units were placed on the market.

At this time it can be said truthfully that the fidelity of the electrical pick-ups is greater than the fidelity of the audio systems in modern amplifiers, and that is saying a great deal.

Just what has been accomplished to bring about this improvement? Let us examine some of the major conditions that must be met in order that the pick-up unit be free from needle scratch, frequency distortion, jarring and other disturbances.

### Magnetic System

In the first place, the unit must contain a good permanent magnet. There is no better magnet available than a cobalt steel magnet. Hence this type of magnet should be used in the best units. There should also be a good size coil around the armature. If this coil is too small, the unit will be insensitive and will not respond to the low frequencies. The voltage induced in the coil is proportional to the number of turns on this coil.

### Desirable Features

Extremely light weight is desirable from the viewpoint of permanence of the record. If the unit is very heavy, the needle will engrave the record and ruin it in a few playings. But light weight is not desirable from the point of view of sensitivity and fidelity. If the unit is light, it rides easily over the record, but it also moves with the groove. That is, it vibrates as a whole, and when it does there is very little relative motion be-

unit should be low. That is, that it should come in the bass rather than in the treble. This tends to increase the response of the unit at the low notes and to suppress it at the high.

This is quite in the interest of better quality, because the voltage induced in the coil is greater at the high than at the low frequencies. Thus, placing the natural response peak at a very low frequency builds up the signal where it would be low and suppresses it a little where it would be excessively high. The reduction in the needle scratch follows because this is composed of very high frequencies, not essential to fidelity.

Elimination of response peaks is effected by suitable mechanical damping. Rubber cushions, formerly used, have been eliminated because rubber hardens with use, or with age, and ultimately causes rattling, and shortens the useful life of the unit. Just enough damping is used to prevent free vibration of the armature without reducing the sensitivity of the unit.

### Length of Tone Arm

A desirable feature in any pick-up unit is that the tone arm be as long as practical. If it is short, the needle will not follow the groove at the beginning and the end of a record. The needle will bear against the side of the groove, either on the inside or outside, depending on the placement of the pivot. This shortens the life of the record. When the arm is long, the needle will follow the groove throughout its length without excessive side pressure.

Jarring of the unit, which in every instance results in rattling and reduction of sensitivity, can be eliminated by suitably mounting the armature in the unit. The proper method can be found only by careful experimentation. Some of the better units on the market today have been very carefully designed in this respect.

An important feature is that the unit be designed so that the needle may be inserted and removed easily, in such a way as not to nullify the counterbalancing of the unit. One excellent method is the "fold-back" arrangement used in the new Pacent Super-Phonovox. The unit is attached to the tone arm with a hinge which allows the unit, or the head, to be folded back on the arm, giving easy access to both the needle and the set-screw.

A spring lock holds the unit in place so that the assembly is rigid while in use, and only a slight force is needed to snap the unit into the proper position, or to unlock it.

It is important in a unit that the needle should make the proper inclination with the record. If the needle is vertical, it will cut the groove. If it makes too small an angle, it will not follow the undulations of the record. It has been found by experiment that an angle of about 60 degrees is the best compromise.

### Connection of the Unit

The first units put on the market were provided with a plug for insertion into the detector or first audio socket. This connected the armature coil in series with the primary of one of the audio transformers. However, it did not open the

(Continued on next page)

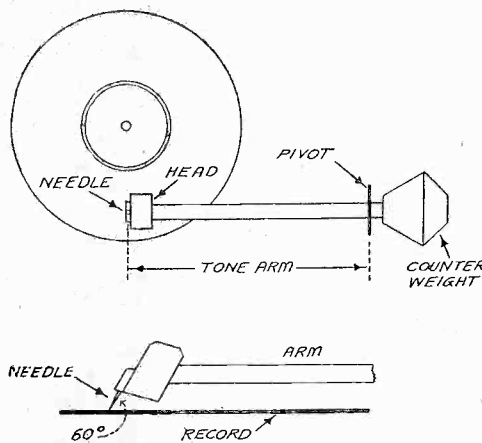

FIG. 1

Upper—Plan of a phonograph record and the electrical pick-up unit, showing the position of the long counterbalanced tone arm.

Lower—Elevation of unit on the record illustrating the proper inclination of the needle to the record. The motion of the record is toward the left.

tween the armature and the field magnet. It is only the relative motion that counts in producing a signal voltage in the armature coil.

Therefore sensitivity and fidelity require a heavy unit. Something must be done to prevent the needle from cutting the record, and one of the simplest and most efficient methods of relieving the record of the load is to counterbalance the unit. If this counterbalancing is properly done, there is no practical limit to the weight of the unit which may be employed, because for every ounce that is added to the unit a weight of equal effect can be added to the counterpoise.

### Center of Gravity

It is not convenient to make the arm holding the counterweight as long as that carrying the unit. For that reason the counterpoise must be considerably heavier than the unit. The pivot on which the arm rests should be placed near the center of gravity of the system, a little closer to the counterpoise than to the unit. If this is not done, the unit will not track the groove in the record at all.

If the pivot is properly placed with respect to the center of gravity, the pressure of the needle against the record will be just right to follow the groove and the undulations without cutting.

When the unit and its counterweight are heavy, the point of the needle tends to remain at the same level, due to the inertia of the unit and the counterweight. If the turntable wobbles, the needle will gouge into the record on one side and the needle will have a tendency to jump out of the groove on the other. Hence a necessary condition is that the turntable be free from all wobble. This condition is met easily by adjusting the turntable carefully on the shaft of the driving motor.

### Eliminating Needle Scratch

As a means of eliminating needle scratch it has been found that the natural period of vibration of the armature in the

# AC Tuner and 1-Stage

## Works Splendidly Into a Modern Power Pack Using New 245 Tube

[An article on a power pack, incorporating a stage of transformer-coupled audio, was published in the April 13th and 20 issues. The output tube was the new 245. The pack was AC operated, and used a 280 rectifier. In the April 20th issue a suggestion was made for an AC tuner and one-stage audio amplifier, to be used in conjunction with the pack. The following article gives additional details about the tuner.—Editor.]

THE "tuner and one-stage" represents a compact receiver, in an 18-inch width, which may be housed in a standard table model cabinet and placed upon the table, or on the baffle block that houses the power pack and dynamic speaker. The receiver also is suitable for installation in a console.

All four tubes in the receiver are type 227, which are of the independent heater type. The AC voltage is received at 110 volts by the filament transformer in the pack, and stepped down to 2.5 volts for the filaments of these tubes. An AC cable lead is run from the 2.5 volt posts of the pack to corresponding posts on the receiver, and from the receiver posts the filament voltage and current are carried to H (heater) posts of the four sockets.

These tubes were used because they are excellent amplifiers and detectors, and because hum is at a minimum. The filament is heated by thermal radiation from the heater.

### Standard Circuit and Parts

Everything in the receiver is as standard as can be. The stages in the radio part are coupled by RF transformers wound for the capacity gang condenser you will use, which may be .00035 mfd. or .0005 mfd. All coils are alike. The primary has six turns, ¼-in. space is left, 48 turns are wound for the secondary, all on a 2½-in. diameter tubing, 2 1-2-in. high. These data are for .0005 mfd. For .00035 mfd. use the same primary, but instead of 48 turns for the secondary, wind 56 turns. The wire is No. 24, single or double silk covered. The factory-made coils of this type are AC5 (for .0005 mfd.) and AC3 (for .00035 mfd.), manufactured by the Screen Grid Coil Company.

The number of turns given is practical, since it takes into account distributed ca-

### LIST OF PARTS

R, SW—One Electrad Royalty volume control, 0-5,000 ohms, with 110-volt AC switch built in.

L1L2, L3L4, L5L6—Three radio frequency transformers for .0005 mfd. or .00035 mfd.

C1, C2, C3 (CT1, CT2, CT3)—One Remler three-section gang condenser, .0005 mfd. or .00035 mfd., with trimmer condensers built in.

R2—One 2,000-ohm. Electrad wire strip resistor.

R1, R3, R4—Three Electrad 900-ohm wire stub resistors.

R5—One Lynch 50,000-ohm fixed metalized resistor with mounting.

R6—One Electrad 1,500-ohm wire wound resistor, type B.

C, C4, C5, C6, C8—Five Aerovox .02 mfd. fixed mica condensers.

C7—One Aerovox .0005 mfd. fixed condenser.

T—One National A100 audio transformer.

One National drum dial, type F, with pilot light PL.

Seven binding posts.

One AC cable, about 10 ft. long.

One convenience 110-volt outlet socket.

One three-way 110-volt socket plug.

One roll of Corwico Braidite wire.

One 7x18" front panel, hard rubber or bakelite.

One 7x17" sub panel, hard rubber or bakelite.

One knob and shaft used as dummy.

Four 5-prong sockets for 227 tubes.

capacity. Theoretical coils call for more turns.

The coils are the only things you can make yourself. Use a bakelite or hard rubber form. All the parts are easily obtainable, and you will have plenty of room to accommodate them. Considerable latitude in the placement of parts is permissible.

A standard layout would be to use a 7x18-in. front panel, with the National dial mounted in the center, so that the tuning knob is 2 in. up from bottom of the front panel. Then the two other holes, one for the volume control switch,

at right, the other for a dummy shaft to engage a knob put at left on the front panel for appearance only, are 2½ in. from either end, also 2½ in. up from bottom.

### Layout of Parts

The ganged condensers run from center to the left. Behind them are placed the first coil and first socket, then the coils and socket alternate, the sockets being in line.

At extreme right enough room will remain for the convenience outlet socket, represented by the small circle with the two parallel slots in it, at right in the diagram, under the cubical three-way plug socket.

The convenience outlet socket is simply a circular one into which AC cable leads may be introduced. These leads are soldered to the phosphor bronze terminals inside the convenience socket after scraping off all the insulation for a stretch of ¼ in. on each lead.

One of the AC cable leads is terminated in this socket. The other AC lead goes to one side of the switch SV, and the other side of this switch is then terminated in the convenience outlet. Thus the switch turns the 110 volts on and off, and access thereto is provided at this convenience outlet built into the receiver. The filament transformer, the power transformer and the AC dynamic speaker may be plugged right into the three-way plug socket that fits into the convenience outlet. If your dynamic speaker is of the DC type, 90 to 110 volts, the field coil should be energized from the rectified output of the B supply, not from the convenience outlet, as that is AC and a terrific hum would result.

The grid bias is negative for all four tubes, but the plate current of each tube flows through no resistor save the one in its own circuit. This avoids reduced amplification and distortion caused by a common impedance. The biasing resistors through which the plate current flows are R1, R4, R5 and R6, and they are chosen to give the correct bias when 90 volts are applied to the plates, but increasing the plate voltage will increase the bias almost correspondingly, so it is safe to increase the plate voltage without fear of overloading due to too low bias.

## Special Adapter Connects Pick-up in the Grid Circuit for Improved Results

(Continued from preceding page)

plate circuit, but permitted a direct current from the B battery to flow through both the unit as well as through the primary of the audio transformer. This was not good electrically.

A better place to connect the pick-up unit is to the grid of a tube; that is, from the grid to the filament or to minus C. Leads are not suitable for this connection. Hence, in modern units, a special adapter is furnished. This is placed between the socket and the tube and the leads from the pick-up unit are connected to special receptacles on the adapter. This makes the proper connection to the circuit and at the same time permits the tube to be used as an amplifier.

Since the unit is connected so that the tube amplifies the signals, it is usually not necessary to connect it to the detector socket. Sufficient volume is obtained by connecting the first audio socket. How-

ever, a volume control is provided the unit, so that if the unit is connected to the detector the volume may be toned down to the proper intensity.

Adapters are available for both DC and AC tubes, and both types are supplied with Phonovox units. If the first audio tube in an AC receiver is of the 226 type, the unit should be connected to the detector socket even if sufficient volume could be obtained when connected to the first audio. The reason is that the adapter makes connection with one side of the filament circuit.

The new Super-Phonovox comes in three different models, the Type 106-A, the Type 106-B, and the Type 106-C Ultra Phonovox. The Type 106-A comes without tone arm and is designed for installation on portables or phonographs having the conventional tone arms. It comprises a Phonovox head with swivel arm, AC and DC wafer adapters, volume

control and instruction sheet. It is finished in bronze.

The model 106-B is provided with counterbalanced tone arm and fold-back hinge, AC and DC wafer adapters, volume control and instruction sheet. This also is finished in bronze.

The model 106-C is the Ultra Phonovox unit which comprises the Ultra head attached to a new counterbalanced tone arm, AC and DC wafer adapters, volume control, an autoplug, instruction sheet and a performance curve showing the response in transmission units plotted against frequency. A motor switch is incorporated in the base of the tone arm which serves as an automatic stop. It is finished in gold. Models 106-B and 106-C can be attached to any motor board with four screws, or if it is not desired that it be attached permanently, it may be mounted on the board without fastening.

[Other illustration on front cover.]



# Volume Affects Quality

Too Low a Level Attenuates Bass and Treble Notes

By Ellwood Snyder

IT HAS BEEN asserted that the frequency fidelity of a radio receiver changes with the volume level. Is there any justification for this assertion?

It is well known that the purity of the output of a receiver depends on the volume, because the greater the volume the greater is the harmonic distortion in the receiver. But it would seem that frequency distortion would be the same no matter what the volume may be, as long as the receiver is able to handle the volume without appreciable harmonic distortion.

There are several factors in a receiver which might change the frequency fidelity as the volume level is changed. One is the effect on the amplification of the changes in the impedance values of apparatuses having iron cores. The permeability of iron changes with the current flowing and therefore the impedances of the transformers or chokes having iron cores will change with the volume level.

## Frequency Discrimination Results

The impedance of a transformer or coupling choke coil is high when the signal current is low. The then amplification will be higher when the signal current is low. But there is very little change in the amplification due to changes in the load impedance, except at the low audio frequency. Hence it is to be expected that the amplification of the low notes would suffer more than that of the high notes as the volume is increased. But this frequency distortion would be small and hardly appreciable.

There may be some other condition which might account for the apparent change in quality as the signal intensity varies. Let us see how the sensitivity of the ear to various frequencies and the overall amplification of the radio receiver mutually affect the result.

Curve A in Fig. 1 gives approximately the sensitivity of the ear. This curve gives the minimum intensity of sound at different frequencies that will produce the sensation of hearing. If the sound from the loudspeaker is such that it falls below this curve no sound is heard.

## Sensitivity of the Ear

The upper curve C is also a limit determined by ear. It represents the pain limit. That is, if the sound is greater than that represented by this curve a sound is not heard but a pain is felt in the ear. All sounds coming from the speaker must have intensities falling between curves A and C.

Suppose the sound at a given volume level that comes from the loudspeaker is such that it can be represented by Curve B. This curve has the same shape as the overall amplification characteristic of a fairly good radio receiver. When the volume of the receiver is turned up, Curve B is lifted toward C but it retains its relative shape. Or we assume that it does, since other effects producing frequency distortion may be neglected. When the volume is reduced the curve B is lowered, but it still retains its shape.

What is the effect on the audibility as the volume is raised and lowered. It is apparent that as the volume is lowered the intersection of curves A and B in the bass region is moved to higher and higher frequencies. Hence when

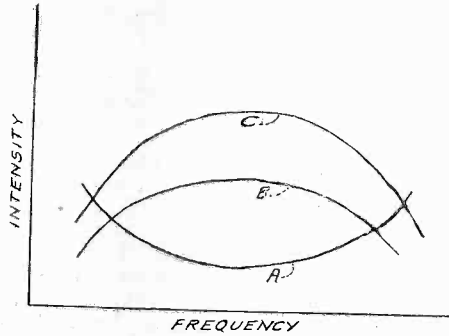

FIG 1.

Curves illustrating how frequency distortion accompanies volume changes due to the curvature of the sensitivity curve A of the ear and the reverse curvature of the radio receiver characteristic B. C is the feeling or pain curve of the ear.

the volume is lowered the bass would disappear first, and the lower the volume the thinner the sound would appear.

## Treble Attenuated

The situation is approximately the same at the upper end of the audible scale. But as the volume is reduced the point of intersection of curves A and B would move toward the lower frequencies. That is, the higher frequencies would disappear from the signal.

As the volume is reduced further, the two points of intersection would approach each other in the middle audio frequencies, and finally only the frequencies lying in the 1,000 to 2,000 cycle region would be strong enough to affect the ear.

It is therefore obvious that the quality of the music and speech heard from the loudspeaker would change materially as the volume is reduced. This effect is due to the inverse nature of the sensitivity curve of the ear, and the amplification curve of the radio receiver and reproducer.

If the response curve of the radio receiver and reproducer could be made to have the same shape as the sensitivity curve of the ear, the sound would have the same apparent quality for all signal intensities.

As the signal intensity is increased toward the pain or feeling limit of the ear, there is not the same relationship. The response curve of the speaker has approximately the same shape as the C curve. Hence all sounds would produce the sense of pain for about the same volume adjustment. But this is of little interest to the radio fan, for nobody would turn up the volume to this point even if the tubes could handle it.

## Straight Response Curve

Certain types of audio amplifiers, such as resistance and impedance coupled, have nearly straight response curves. When the volume of these is increased or decreased, the change in the apparent frequency response is not so great as in the instance of transformer-coupled circuits, because the B curve does not meet the A curve so high or so low. But even if the response curve were absolutely straight the effect still would be present, for the sensitivity curve of the ear re-

mains convex toward the frequency axis. However, there can be nothing better than a straight response curve.

The shape of the curves in Fig. 1 is approximately correct when both the sound intensity and the frequency are plotted on a logarithmic scale, or when the intensity is plotted in transmission units and the frequency is plotted by octaves. But the method used in plotting has nothing to do with the effect illustrated. The fact remains that as the volume is decreased the low and the high frequencies disappear to the ear much sooner than the frequencies in the middle.

If the receiver and speaker are weak on the low notes, a baffle board of large dimensions will intensify the response at the low notes. This effect is clearly noticeable on low intensities. If the volume is so low that the ear fails to perceive the bass, the baffle will bring the low notes out with sufficient intensity to bring them within the sensitivity of ear.

## RIGHT OR WRONG?

[See questions on page 8]

- 1.—Wrong. The G post of socket connects with the screen grid. The control grid comes out in a cap at the top of the tube.
- 2.—Wrong. The current through a conductor is *inversely* proportional to the resistance.
- 3.—Wrong. The resistance of a resistor carrying temperature remains constant as long as the temperature does not change.
- 4.—Right. The resistance of a conductor varies with the current because the current heats the resistor. If the conductor can be maintained at a constant temperature the resistance does not vary with the current.
- 5.—The wave of a broadcast station is not broad. The carrier remains constant at a single frequency. It is the receiver which is not sharp enough to tune the station out.
- 6.—Wrong. The inductance of an iron core choke coil is changed by DC or AC flowing through it, because the permeability of the iron depends on the current flowing in the winding.
- 7.—Right. The capacity of condenser is independent of the voltage and on the charge. In an air condenser the capacity is purely a geometrical property.
- 8.—Right. If the circuit contains a condenser, only alternating current flows. Direct current will not flow because there would be no circuit.
- 9.—Wrong. There is no true rectification, merely distortion. But this distortion results in detection. Rectification is unidirectional conductivity. A detector tube has no conductivity in the grid circuit.
- 10.—Right. But when direct current is measured two readings should be taken, one for each direction of the current through the couple. The average of the two readings is the current value.

# Sharp Television 15x18"

## RCA Group Brings Up Size of Picture Considerably

By Neal Fitzalan

**I**NTENSIVE work in television development is now going on in many large laboratories, and many prominent engineers are working on the problem. Already very encouraging results have been obtained. Some who declined to express any enthusiasm for the future of television only a year ago are now very optimistic as a result of recent demonstrations.

One fact which permitted noteworthy progress in television was the allotment of 100 kilocycle channels to experimental work in television. Previously only 10 kilocycle channels had been available, and satisfactory television was impossible in this narrow band. Now that the band has been widened by a factor of ten, much larger pictures with greater detail are possible.

Previously it was necessary to use only a small number of scanning lines per frame, from 24 to 48, but now as many as 60 lines per frame are used. The speed of transmission has also been increased. Speeds as low as 10 frames per second were used, but now speeds of 20 per second are being used. The increase in the speed has removed the flicker which accompanied television pictures reproduced at the rate of from 10 to 15 per second.

### Speed Sufficient

A speed of 20 per second is sufficient because the flicker disappears at about 16 per second, the speed used in motion pictures before sound pictures arrived, and there was practically no flicker in them. However, the flicker, which depends on the illumination available, increases with a decrease in the illumination. Since the illumination in television is low it is desirable to increase the speed to about 20 per second. It is doubtful, however, whether it is necessary to increase the speed any more, because as the art is developed the illumination will be increased.

The greatest need at present is a wide channel so that high frequencies may be transmitted. The "screen" of the picture is limited only by the frequency band that is available, and the "screen" determines the amount of detail that may be obtained in the reproduced image. When a scanning disc having sixty holes, or any other scanning device producing sixty lines per

picture, is used the detail is nearly as fine as that in newspaper half tone pictures, provided that the reproduced image is not larger than one inch square. If the image is larger than this the same apparent fineness will be obtained if the observer stands at an appropriate distance from the screen on which the image appears.

### Bell System Pictures

The Bell Telephone Laboratories developed a system of television in which 50 scanning lines per picture were used. When the pictures of this detail were thrown on a screen about 18 inches square, the image had sufficient detail to make faces recognizable. The 60-line picture will have considerably more detail than this.

Much work is being done by the Westinghouse Electric and Manufacturing Company, under Dr. Frank Conrad, by the General Electric Co., under Dr. E. F. W. Alexanderson, and by the Radio Corporation of America, under Julius Weinberger. Every phase of television is under investigation and the work in these laboratories is cooperative.

The RCA has broadcast television pictures from its short-wave station 2-XBS for several months, using a 100 kilocycle channel.

The wave of this station is modulated with a television signal consisting of 60 lines per picture, each line being 72 equivalent elements long. Each picture, therefore, contains 4,320 elements. And since there are 20 pictures per second there are 86,400 elements of light and shade every second. This constitutes one sideband of the signal.

### Demonstration Staged

Dr. Alfred N. Goldsmith, vice-president of the RCA, recently gave a demonstration of television reception at his home in New York City, which showed that the art of television has developed near the point where it may be introduced to the public as another form of entertainment.

Several guests assembled about a cabinet containing the television receiver, and they saw on a screen about five inches square the actions of men before the transmitter television three miles away. The demonstration lasted more than an

hour, and during that time the receiver stayed in perfect synchronism without any attention. It was necessary only to adjust the machine to synchronism at the beginning of the demonstration.

During the demonstration Dr. Goldsmith called the man before the television by telephone. The observers at the receiver could clearly see the man pick up the telephone, and by his actions could tell whether his answers to Dr. Goldsmith's questions were "Yes" or "No."

After the demonstration Dr. Goldsmith asked those who had witnessed it whether they thought television had arrived. When they all agreed that it had, he made the astonishing remark that the apparatus used already was obsolete. He said that in the laboratories they had apparatus working which did away with the cumbersome moving parts, or the scanning disc, and which made it possible to project images on a screen 15 by 18 inches.

He declined to reveal the nature of the new devices but stated that they were smaller and simpler to make than the scanning discs. The entire receiver of the future, he said, would not occupy any more room than a present quality radio receiver.

### Special Receiver Needed

While the television is transmitted on short waves, ordinary short wave receivers cannot be used. The tuner of such a receiver is too sharp. It will cut out the detail-carrying high frequencies in the sidebands. The selector of the short wave receiver must be capable of admitting all the sideband frequencies 50,000 cycles on each side of the carrier.

Neither can an ordinary audio frequency amplifier be used to amplify the detected signal. Its transmission band is not nearly wide enough. The very best audio amplifier used in broadcast reception covers only a band of 10,000 cycles, and most of them cover only 5,000 cycles. The amplifier for television signals must cover a band 50,000 cycles wide.

A unique feature of the receiver used by Dr. Goldsmith is that it has no audio frequency amplifier. The signals are amplified at radio frequency and at an intermediate frequency. The output of this amplifier actuates a neon glow tube directly.

# Quick Action Classified Ads

## Radio World's Speedy Medium for Enterprise and Sales

10 cents a word — 10 words minimum — Cash with Order

### AGENTS AND SALESMEN WANTED

Sell \$5.00 Men's Daily Necessity for 50c. Cost quantities 20c. Sample postpaid 30c. Catalog hundreds household articles free. Mills Sales Co., 901 Broadway, New York.

**RADIOLA 18 AC.**—All-electric special \$70. Radiola 100 A speaker, special \$21. Act quick. Offer limited. A. S. Cooke, 1304 Pacific Street, Brooklyn, N. Y.

**ORIGINAL BALDWIN PHONES**, tested and guaranteed, \$3.65, postpaid, Blau, the Radio Man, 89 Cortlandt Street, New York City.

**AMAZING! NEW!** Wondertone, connects between speaker and set. Gives you that rich, vibrant, mellow tone. Practically eliminates hum, static and other noises. \$2.00 postpaid. Literature on request. Wondertone Mfg. Co., 311 Gratiot, Detroit, Mich.

**RADIO RECEIVING TUBES**, by Moyer and Wostrel, first edition just off the press. No radio service man, experimenter or student of radio should be without this authoritative book on the principles and applications of vacuum tubes. It answers all your questions relating to receiving, amplifying and rectifying tubes. Price postpaid, \$2.50 Radio World, 145 W. 45th St., New York.

### RADIOS FOR SALE

**RADIO FANS**—Would you like to purchase the latest electric Coast to Coast Screen Grid Radio for less than the cost of a battery set? If so address Economy Sales Co., Pa. Ave. Sta., Wash., D. C.

**ARTISTS and Art Students** are printing 250 signs or pictures an hour without machinery. Sample and particulars 10c. Straco, 1014 Mulberry, Springfield, Ohio.

**PRINTING**  
500 GUMMED STICKERS 25c  
name and address printed  
**SUNPRINTERS**  
9379 Pryor—Detroit

# New Style DeLuxe Leatherette Carrying Case FREE with each Jiffy Tester!

This combination of meters tests all standard tubes, including the new AC screen grid tubes and the new 245 tube, making thirteen tests in 4½ minutes! Instruction sheet gives these tests in detail.

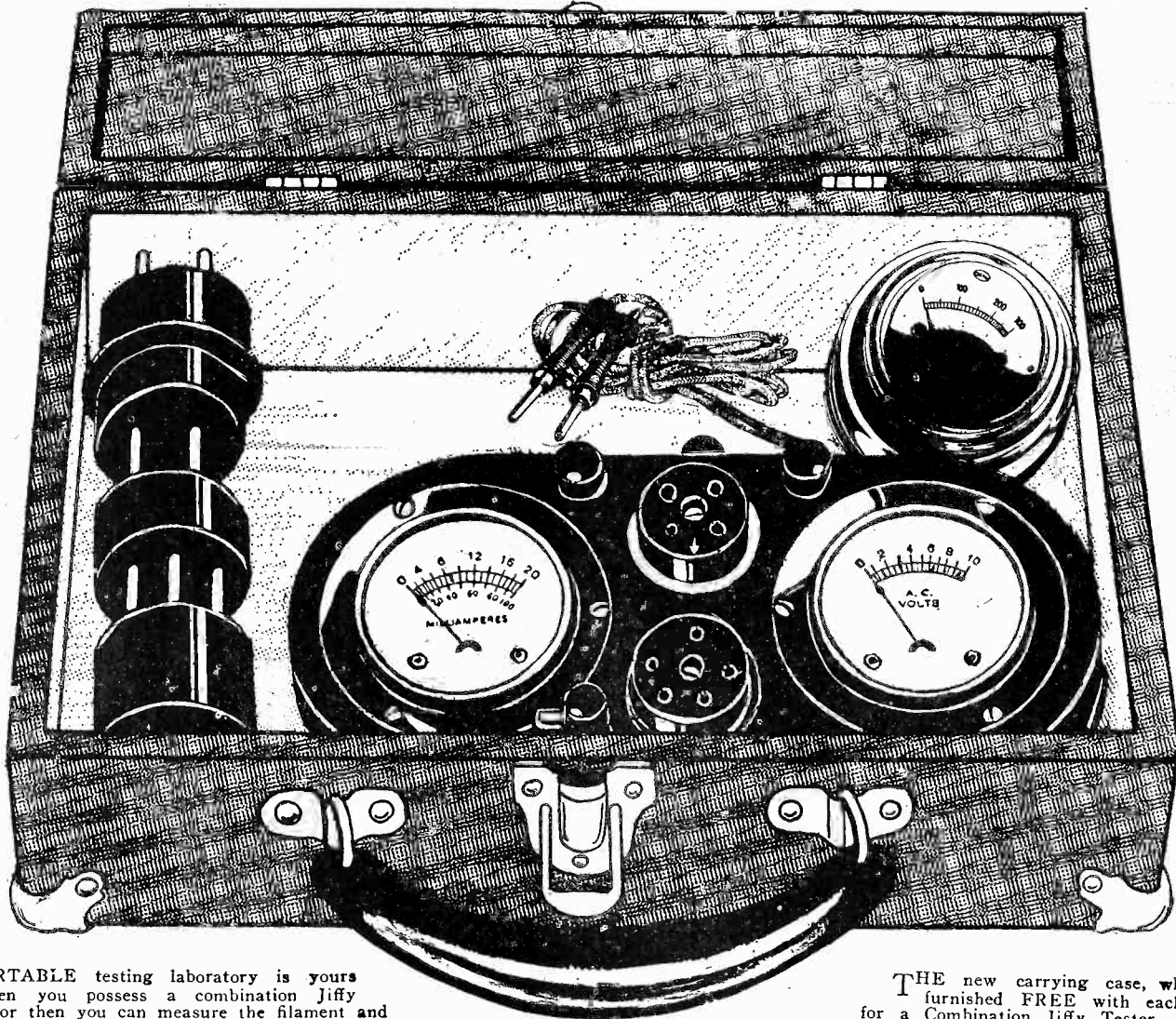

A PORTABLE testing laboratory is yours when you possess a combination Jiffy Tester, for then you can measure the filament and plate voltages of all standard tubes, including AC tubes, and all standard battery-operated or AC screen grid tubes; also plate voltages up to 500 volts on a high resistance meter that is 99% accurate.

The Jiffy Tester consists of a 0-20, 0-100 milliammeter, with change-over switch and a 0-10 volt AC and DC voltmeter (same meter reads both), with two sockets, one for 5-prong, the other for 4-prong tubes; a grid bias switch and two binding posts to which are attached the cords of the high resistance voltmeter; also built-in cable with 5-prong plug and 4-prong adapter, so that connections in a receiver are transferred to the Tester automatically. Not only can you test tubes, but also opens or shorts in a receiver, continuity, bias, oscillation, etc. The instruction sheet tells all about these tests.

In addition you can test screen grid tubes by connecting a special cable, with clip to control grid (cap of tube) and other end of special cable to the clip in the set that went to the cap before the tube was transferred to the tester.

THE new carrying case, which is furnished FREE with each order for a Combination Jiffy Tester, contains the entire outfit, including the three meters, cable and plug, and three adapters (one for 4-prong tubes, two for 199 tubes). This case is 10½ x 7¾ x 3½" and has nickel corner pieces and protective snap-lock. The case is made of strong wood, with black leatherette overlay.

To operate, remove a tube from the receiver, place the cable plug in the vacant receiver socket, put the tube in the proper socket of the Tester, connect the high resistance meter to the two binding posts, and you're all set to make the thirteen vital tests in 4½ minutes!

The Combination Jiffy Tester is just the thing for service men, custom set builders, experimenters, students, teachers and factories. Order "Jiffy 500." The price is only \$14.50.

If a 0-600 AC and DC high resistance meter (99% accurate) is desired, so house electricity line voltage and power transformer voltages can be measured, as well as plate voltage, instead of the 0-500 DC voltmeter, order "Jiffy 600" at \$15.50.

GUARANTY RADIO GOODS CO., 145 W. 45 St., N. Y. City. (Just East of Broadway).

- Please ship at once on 5-day money-back guaranty one "Jiffy 500," at \$14.50, consisting of
- (1) One Two-in-One 0 to 10 voltmeter for AC and DC. Same meter reads both. Scale especially legible at 1½ to 7½ volts. This meter reads the AC and DC filament voltages.
- (2) One DOUBLE reading DC milliammeter, 0 to 20 and 0 to 100 milliamperes, with change-over switch. This reads plate current.
- (3) One 0-500 volts high resistance voltmeter, 99% accurate; with tipped 30" cord to measure B voltages.
- (4) One 5-prong plug with 30" cord for AC detector tubes, etc., and one 4-prong adapter for other tubes.
- (5) One grid switch to change bias.
- (6) One 5-prong socket.
- (7) One 4-prong socket.
- (8) Two binding posts.
- (9) One handsome moire metal case.
- (10) One instruction sheet.
- (11) One de luxe carrying case.
- (12) One screen grid special cable.
- If 0-300 DC high resistance 99% accurate voltmeter is preferred to 0-500, put check here. Price is same, \$14.50.
- Same as above, except substitute a 0-600-volt AC and DC high resistance 99% accurate voltmeter (same meter reads both) for the 0-500 DC meter. Price \$15.50.

NAME .....

ADDRESS .....

CITY ..... STATE .....

FIVE-DAY MONEY-BACK GUARANTY

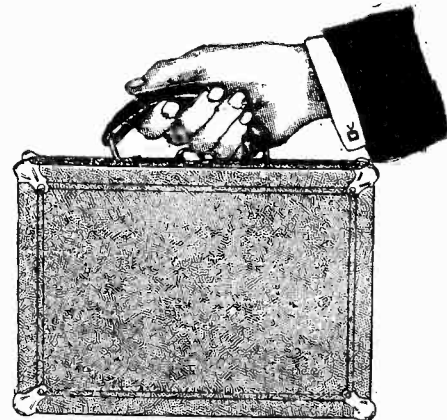

The new de luxe leatherette carrying case is compact and handy. Size 10½" long, 7¾" wide, 3½" deep.



# Choose Your Speaker from This Complete Array!

## EXPONENTIAL TYPE HORNS

Modern acoustical science is striving to equal the performance of a large air column horn with powerful unit, while the horn enjoys its rightful popularity with trained experts. The larger the horn, the better, hence we offer two models: one with 7 3/4 ft. tone travel, the other (where space permits) with 10 ft. tone travel. The material used is patented Racon. Nozzle is standard size.



**Cat. 200**  
**\$7.50 Net**

This horn has a 92-inch air column. No resonance peaks. Front, 18"x18". Depth, 13 1/4". Weight, 5 lbs.



Driving motor, the unit needed to work the air column horns. Standard size thread. Cat. 203. Price, \$3.50 net.

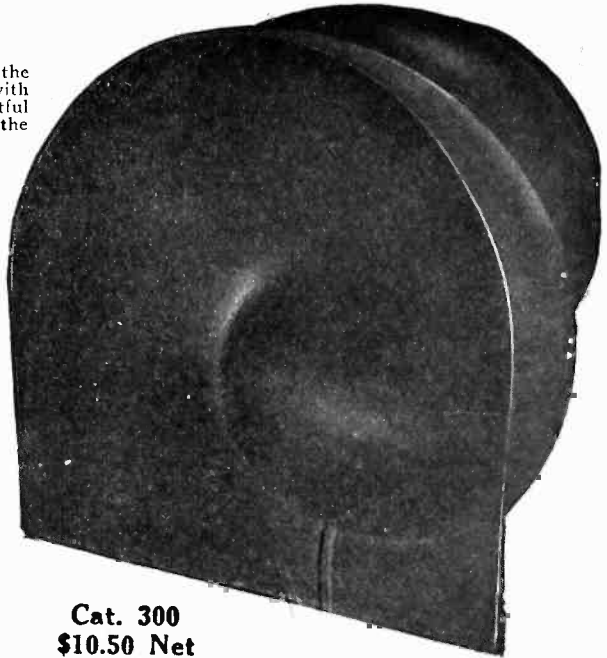

**Cat. 300**  
**\$10.50 Net**

The larger horn is preferable, where space permits. Air column, 120". Front, 18"x18". Depth, 13". Weight, 7 lbs.

## DYNAMIC CHASSES and Baffle

The dynamic speaker is the most popular one by far, and here is your opportunity to get a real fine chassis at a low price. Cat. 110 A.C. operates directly from the 110-volt A.C. (alternating current) lamp socket, to which built-in plug is connected, while the tipped cords go to your receiver output. Dry rectifier and output transformer built in this model.

Those whose place is wired with 110-volt D.C. (direct current) should use Cat. 110 D.C. @ \$17.50 net. Those who have no electricity should use the model that works from a 6-volt storage battery. Cat. 6 D.C. @ \$14.75 net.

At left is illustrated an 18"x18" baffle, Cat. 111, with cane sides and top, for any dynamic speaker. Specify speaker. Walnut 5 ply veneer. Price \$11.00 net.

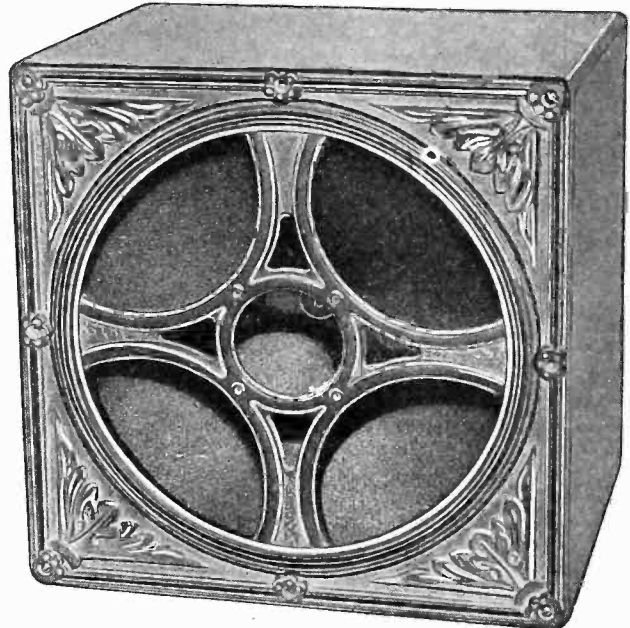

**Cat. 113**  
**Price, \$13.50 Net**

New Model Polo Speaker, with five-ply veneer walnut housing, moulded, decorated metal front piece, and containing Polo Twin Magnet Unit and Textile Cone. All ready to play. Stands 150 volts without filtering. Will work fine from any output tube, from 201A to a pair of push-pull 250s, without rattling.



**Cat. 110 A.C.; Price, \$20.50 Net**

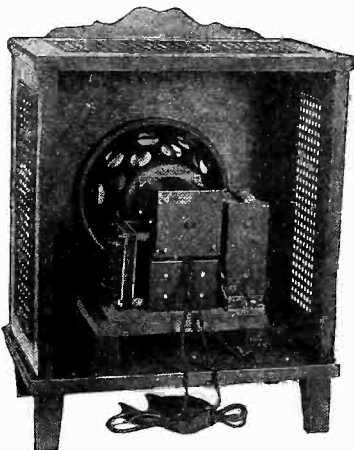

**Cat. 111; Price, \$11.00 Net**

Cat. 110 A.C., shown inside, \$20.50 extra.

### FILL OUT AND MAIL COUPON

ACOUSTICAL ENGINEERING ASSOCIATES,  
143 West 45th Street, N. Y. City  
(Just East of Broadway)

Please send me at once on 5-day money-back guarantee the following (check off):

- |   |   |
|---|---|
| <input type="checkbox"/> Cat. No. 200         | <input type="checkbox"/> Cat. No. 111         |
| <input type="checkbox"/> Cat. 300             | <input type="checkbox"/> Cat. No. 113         |
| <input type="checkbox"/> Cat. No. 110 A.C.    | <input type="checkbox"/> Cat. No. 114         |
| <input type="checkbox"/> Cat. No. 110 D.C.    | <input type="checkbox"/> Cat. 114A            |
| <input type="checkbox"/> Cat. No. 6 D.C.      | <input type="checkbox"/> Cat. 115             |
| <input type="checkbox"/> Cat. No. 300         | <input type="checkbox"/> Cat. 116             |
| <input type="checkbox"/> Please send C.O.D.   | <input type="checkbox"/> Cat. No. 203         |
| <input type="checkbox"/> Remittance enclosed. | <input type="checkbox"/> Please send prepaid. |

Name .....

Address .....

City ..... State .....

**5-DAY MONEY-BACK GUARANTEE**

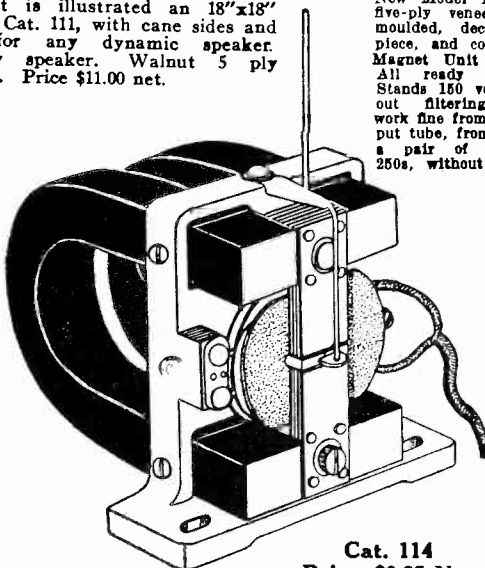

**Cat. 114**  
**Price, \$9.25 Net**

Polo Twin Magnet Unit—weight, 3 1/2 lbs., or twice as heavy as ordinary unit. Twin magnets double sensitivity. This unit gives more volume, clearer tone, and stands the gaff. Supplied with 10-ft. cord. Cat. 114. Tri-foot molded unbreakable metal mounting bracket and apex constitute Cat. 114A @ \$0.75.



**Cat. 115; Price, \$11.50 Net**

Molded 9" spider, unbreakable metal, with Textile cone and felt ring and apex, and Polo Unit mounted on the assembly, which stands on own feet. Cat. 114.

# AN OPEN LETTER

## *To Friends of the Experimenter Publishing Company*

**R**ADIO NEWS, as well as SCIENCE AND INVENTION, AMAZING STORIES, AMAZING STORIES QUARTERLY, YOUR BODY QUARTERLY and the RADIO LISTENER'S GUIDE AND CALL BOOK QUARTERLY have changed hands. All of these magazines are now owned by a corporation headed by Mr. B. A. Mackinnon.

It is the policy of the new organization to very materially improve all of these periodicals and a very definite indication of what may be expected in forthcoming issues may be had from a perusal of the June numbers.

In RADIO NEWS for June you will find sixteen pages more text than were used in our May number. You will find articles on radio subjects by recognized authorities. You will find articles on radio as it applies to the very important development which is coming in the aeronautical field during this year, as well as articles of very great interest on purely aviation lines.

You will find that the editorial policy has been completely changed, and from the present magazine you will see that it is our purpose in the future to be of just as much assistance as possible in the development of any sound idea which will benefit the radio business. We believe that when we describe a particularly good receiver, we should also supply our readers with the information concerning where the parts may be procured and who makes them. We do not believe it is desirable to withhold this information until our readers write us for blueprints, and for this reason all of the technical information from now on is to be contained in the articles themselves. We do not contemplate staying in the blueprint business.

We believe that every reader and every advertiser in RADIO NEWS and all the other magazines published by this Company are keenly interested in our activities, and it is our purpose to keep all of you advised concerning what we are doing. You will find the June issues of the magazines free from any house copy for subsidiary companies owned by the publishers, and in direct competition with other manufacturers and other advertisers. You will also find that a great many of the most reputable advertisers in the business are so well satisfied with the changes in policy in these magazines that contracts are being signed by many of them covering not only RADIO NEWS, but the entire group of RADIO NEWS, SCIENCE AND INVENTION and AMAZING STORIES.

With each succeeding month, we hope to make our magazines better. We shall welcome any cooperation from our readers in the form of comment or criticism.

Cordially yours,

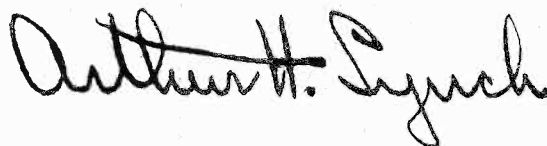

*Editorial Director*