

RADIO *and Television* TODAY

1940

50,000,000 RADIOS IN USE

A STRIKE FOR THE RADIO INDUSTRY!

DECEMBER

Give Your Business a Profit Present

P. R. MALLORY & CO., Inc.
MALLORY



CONDENSERS

Mallory Replacement Condensers have proven to be just like money in the bank for thousands of radio service engineers. Millions are in use! No other line gives such complete and such dependable coverage of every replacement need. F. P. (Fabricated Plate) Capacitors made by Mallory, Mallory Tubular Condensers—now color-coded by voltage, and Fabricated Plate Tubulars Type B B each fill specific needs that are faced every working day. Be sure you can fill these needs quickly and profitably . . . specify Mallory.

VOLUME CONTROLS

Early in 1941, Mallory will introduce the most startling advance ever made in the field of replacement volume controls. This is a completely new Mallory development that has been years in the making. It incorporates features that will revolutionize volume control replacements. Watch this publication for an early announcement. You'll want to be first to see it . . . first to cash in on its many new advantages!



VIBRATORS

Mallory Vibrators have made the same important contributions in the replacement field as they have made to the efficiency of original equipment. When you install a Mallory Vibrator in an auto radio, or other battery operated receiver you know that you have given your customer the finest there is . . . and that you have fully assured customer satisfaction. Millions of Mallory Vibrators in use as original equipment testify that they have to be good.

P. R. MALLORY & CO., Inc.
 INDIANAPOLIS INDIANA
 Cable Address—PELMALLO

Mallory Has Great Things in Store for You in '41

Use **MALLORY** APPROVED PRECISION PRODUCTS

Include VIBRATORS • VIBRAPACKS • CONDENSERS • VOLUME CONTROLS • ROTARY SWITCHES • SINGLE AND MULTIPLE PUSH BUTTON SWITCHES • RESISTORS RADIO HARDWARE

"It's Another RCA Plus!"

"Achievements like the RCA Electron Microscope make RCA Equipment easier than ever to sell!"

TREMENDOUS publicity has greeted the RCA Electron Microscope which extends man's vision far beyond the limits of conventional microscopes—as high as 105,000 diameters! When H. M. Carpenter and Fred Morris visited the great RCA plant at Camden recently, they were quick to see how an achievement like this helps *their* business... and *yours!*

"There," they said, "is one of the greatest RCA advertisements—something no other radio manufacturer can duplicate! Achievements like the RCA Electron Microscope make *all* RCA Equipment better known, more respected... still easier to sell! It's another RCA plus!"

You'll agree that in such achievements lies the prestige of a Name that's a great name to link with your own!... prestige

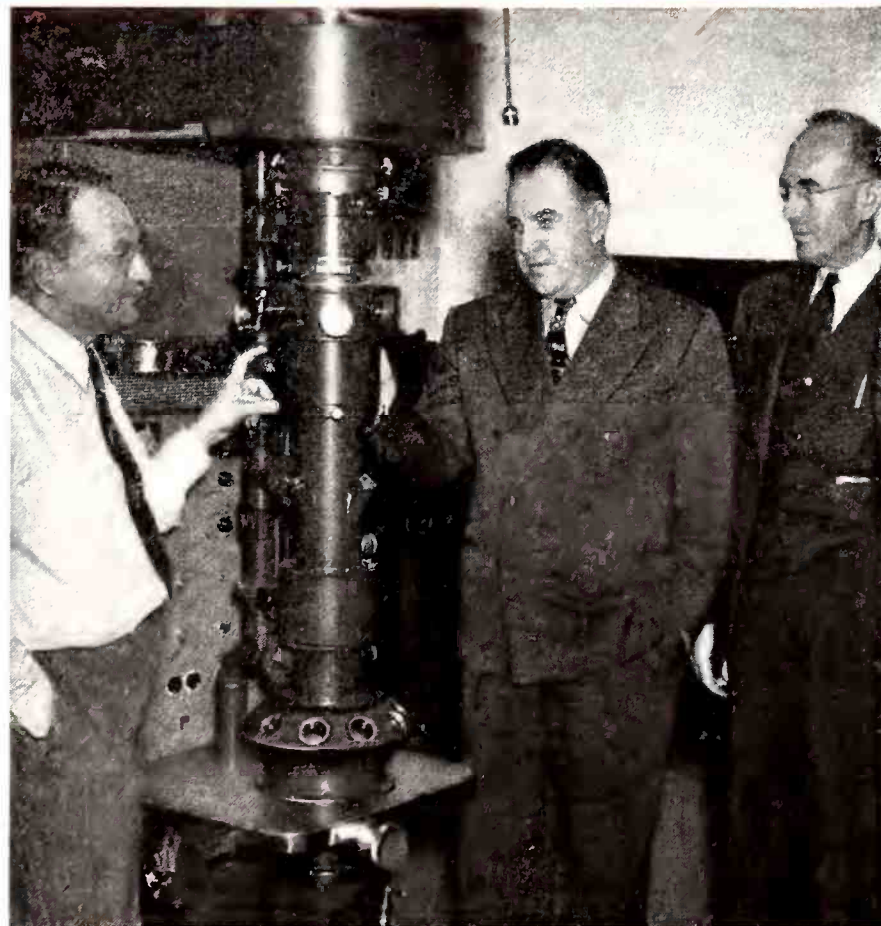

H. M. Carpenter, center, of Thuro Radio Distributors in Tampa, and Fred Morris, right, of the Specialty Distributing Company in Atlanta—two of America's best-known operators—look over one of America's best-known new inventions... the RCA Electron Microscope. At left is Dr. V. K. Zworykin, internationally-famous physicist and Associate Director of RCA Research Laboratories.

that makes RCA Power Tubes, Receiving Tubes, Test Equipment and Amateur Equipment more profit-producing all the time!

Over 380 million RCA radio tubes have been purchased by radio users... In tubes, as in test equipment and accessories, it pays to go RCA All the Way!



WHERE ELSE CAN YOU GET THIS SUPPORT?

Grow with the



TUBE AND EQUIPMENT

FRANCHISE

RCA Manufacturing Co., Inc., Camden, N. J. • A Service of the Radio Corporation of America

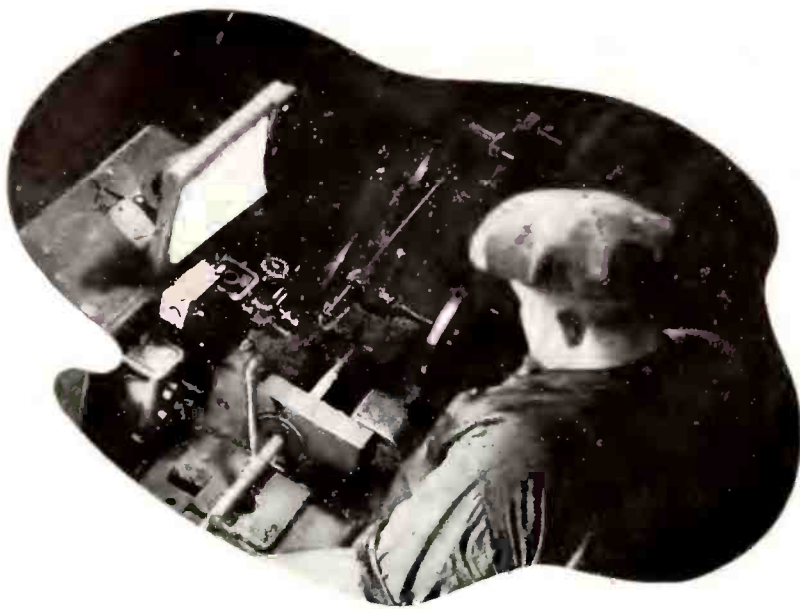

THE LONG and THE SHORT of IT

Cold drawing small tubing is a tedious process — *if you're not a small tubing man.* At Superior, we start with raw stock of about 1" O.D. (seamless and welded)—and draw it practically out of sight, if that is what you need. We know just where to stop to meet your specifications. Every step down is small—a reduction of O.D. through the carefully machined die is made at the same time the wall is reduced by the mandrel. Time after time this operation is performed with intermediate anneals to keep the metal workable. Finally the tubing with Superior high finish is ready for laboratory check.

By concentrating in the small tubing field, Superior has made readily available to all industry a product which has erroneously been called "Specialty Tubing". *It is no specialty when you make it your only business.*

SUPERIOR TUBE CO.

[THE BIG NAME IN SMALL TUBING]

NORRISTOWN, PENNSYLVANIA

EXPORT REPRESENTATIVE
Stupakoff Ceramic & Mfg. Co.
Latrobe, Pa.
U.S.A.

★ *Information about Superior Tubing is found in the booklet illustrated. A copy is yours for the asking.*



Tubing from 5/8" OD down . . . SUPERIOR  Seamless in various analyses. WELDRAWN  Welded Stainless. BRAWN  Welded "Monel" and "Inconel". SEAMLESS and Patented LOCKSEAM Cathode Sleeves.

"FOR FINE SMALL TUBING"

10 ACOUSTICALLY CORRECT REPRODUCERS AND CABINETS

ALL WITH

Bass Reflex

CHOICE OF SPEAKER EQUIPMENT



Equivalent circuit illustrating Bass Reflex principle



"CR" REPRODUCERS

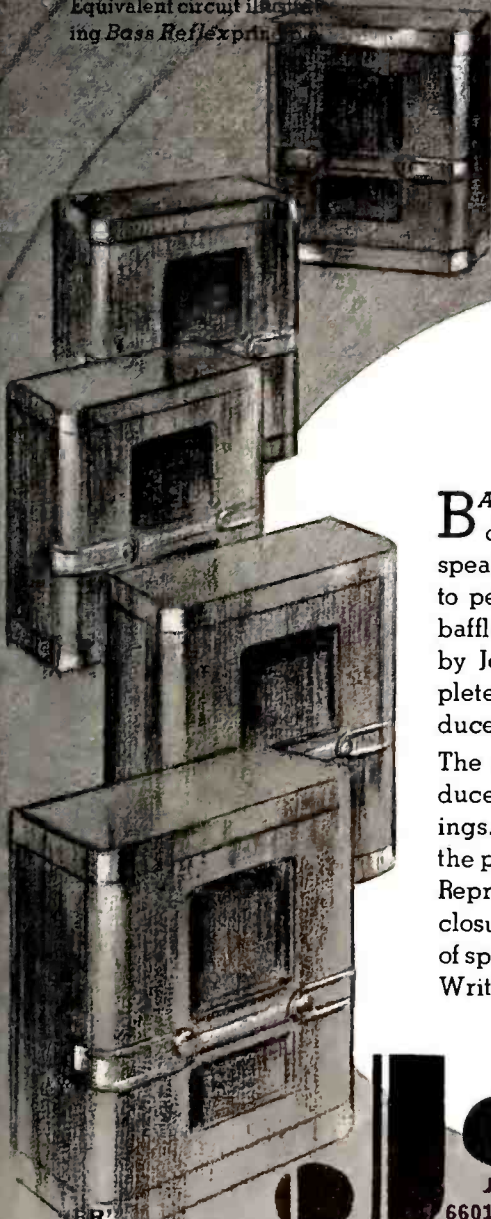

"BR" ENCLOSURES

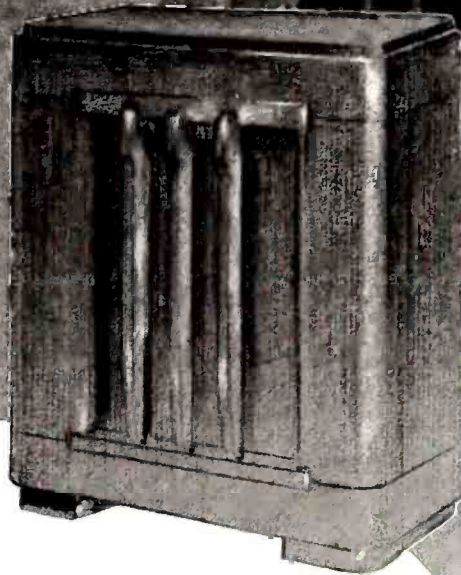

BASS REFLEX gives you *better* sound reproduction because it enables the loud speaker to function with *full* effectiveness, to perform even *better* than with an infinite baffle. This great development, originated by Jensen Engineers, is available in a complete line of acoustically-coordinated reproducers and cabinets for every application. The arresting beauty of the new "CA" Reproducers qualifies them for the finest surroundings. Equivalent performance is provided in the practical, less expensive "MT" Reproducers. Economical "BR" enclosures accommodate your choice of speakers from 8 to 18 inch sizes. Write for complete information.

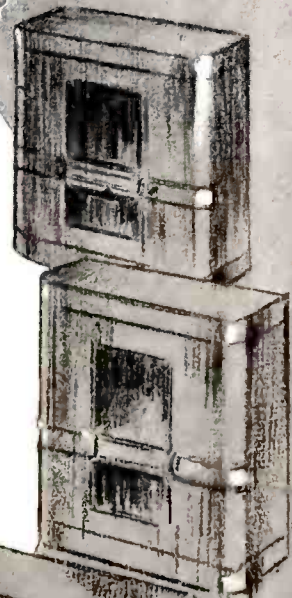

"MT" REPRODUCERS

Jensen

JENSEN RADIO MFG. CO.
6601 S. LARAMIE AVE., CHICAGO

JENNY LIND

might have been a radio star
...and sung to every American!



HUNDREDS of enthralled men and women packed New York's Castle Garden on the night of Sept. 11, 1850, and heard Jenny Lind's first American concert. The next morning, the story of her artistry swept the nation, and Jenny Lind became the most famous singer of the century. But only a few thousands actually heard her sing.

Had radio existed in 1850, every American—the clerk in Boston, the planter in Alabama, the farmer in Illinois, the sailor on a clipper bound for California—would have thrilled to the glorious voice of the Swedish Nightingale. Through broadcasting, her concerts would have reached countless American homes. Through Victor Records, her voice would have been preserved to be enjoyed by music lovers for all time.

Today, radio provides more than musical entertainment for Americans. It gives us vital news as soon as it happens; it keeps us the best informed people. Two great nationwide networks of the National Broadcasting Company, an RCA service, operate 35 hours a day in the aggregate to provide the most interesting radio broadcasting service in the world.

Another vital radio service is performed by R. C. A. Communications, Inc., with its direct transmission to and from foreign countries, and between leading American cities. Radiomarine provides communication with ships at sea. RCA Manufacturing Company designs and builds transmitting equipment, home radio sets and RCA Victrola phonograph-radios, Victor Records, and other radio and sound apparatus. And—that this equipment may constantly be improved—RCA Laboratories continuously pioneer new developments in radio.



RADIO CORPORATION OF AMERICA

Radio City, New York

RCA Manufacturing Company, Inc. National Broadcasting Company Radiomarine Corporation of America
R. C. A. Communications, Inc. RCA Laboratories RCA Institutes, Inc.

20 YEARS OF SERVICE

DELIVERED BY
RAYTHEONS
 IN POLICE
 COMMUNICATIONS



In Operation for 20,000 hours
 ... equivalent to 20 years of service as measured by standard tube guarantees!

That's the record of RAYTHEON Tubes in one of the receiving sets used in the Police Communications System operated by the Sheriff's Office, San Joaquin County, California.

These tubes had to withstand the jarring and jolting of highway police patrol cars driven at high speed. They had to function perfectly at all times, for the briefest breakdown in service might prove disastrous. From every standpoint, they had to be the very best that engineering genius had yet devised. That's why RAYTHEONS were chosen. And they delivered in the most gruelling service imaginable.

This unusual service is typical of the plus satisfaction RAYTHEONS are giving in all types of installations everywhere. And the reason is

that they are the product of the foremost tube engineers ... leaders in their profession who devote their time exclusively to the making of better tubes, and to the pioneering in new radio circuit fields.

Little wonder that servicemen and dealers by the thousands are making money on RAYTHEON replacements. Satisfied customers build your business for you. They tell others ... and that means more customers. Volume grows. So does profit. More profit, too, because of faster turnover on a smaller investment in stock, for you need carry only ONE line. For RAYTHEON makes them all ... and they cost no more! Your RAYTHEON Distributor has an unusual tube deal for you. See him without delay.

Raytheon Production Corp., Newton, Mass.,
 New York, Chicago, San Francisco, Atlanta.



Reading from left to right: Harvey Blackwell, District Supervisor, California Highway Patrol. John E. Warmen, Radio Technician, San Joaquin County Sheriff's Office. Harvey M. O'Dell, Former Sheriff, San Joaquin County. Captain Leland S. Draus, San Joaquin County Detail.



WORLD'S LARGEST EXCLUSIVE RADIO TUBE MANUFACTURERS



Our Warmest Greetings ... for this Christmas and for the years ahead

THIS YEAR, Farnsworth will celebrate its second Christmas of volume sales . . . a celebration happily shared by Farnsworth dealers who have been making splendid pre-Christmas sales and profits.

Before the Farnsworth line reached volume production, in the fall of 1939, some dealers perhaps were doubtful of the future of this new organization which had grown so sensationally. From the very first, however, Farnsworth policies had as their main goal the success and prosperity of Farnsworth dealers. For upon your success, our success depended.

Our thinking has been directed to designing the Farnsworth program *from the dealer's point of view*.

Such policies do not permit sensational merchandising schemes that are so often ruinous to the dealer's

own profit picture. Instead, the Farnsworth merchandising program has been founded upon the basis of fair-minded business practices *with profits to all*. We shall continue these fundamental policies knowing that *Farnsworth* dealers can build up a stable and profitable business year in and year out.

Speaking for every member of the Farnsworth Television & Radio Corporation and for myself personally, we wish to extend our most cordial thanks to the rapidly growing Farnsworth family of dealers for the tremendous volume of Farnsworth business this year; and to tell you that in the months ahead you can look forward to many further Farnsworth developments in new merchandise with striking new features . . . and with unusual profit possibilities.

L. C. Michael
PRESIDENT

FARNSWORTH . . . MAKERS OF RADIO AND TELEVISION TRANSMITTERS AND RECEIVERS,
THE CAPEHART, THE CAPEHART-PANAMUSE AND FARNSWORTH PHONOGRAPH-RADIO COMBINATIONS

DEC 19 1940

RADIO *and Television* TODAY

Defense Agencies Beckon Radio Inventors

The Government is developing a new attitude toward inventors who may have something to offer the Army, Navy or Signal Corps. Radio men with an inventive flair now have a good chance to get a hearing on whether their ideas will fit into the National Defense Program.

All this was outlined by Major General J. O. Mauborgne in his recent address to the Radio Club of America. He reported at least three agencies that may be interested in the efforts of inventors—the National Inventor's Council, the National Defense Committee, and the Signal Corps itself.

Strong Tone in Retail Business

"High gear" is the way to describe general business conditions right now. Dunn & Bradstreet, in the latest report, reveals that "volume is showing a better than normal seasonal increase", and says too that "crowds

were reaching peak proportions earlier than last year . . . shoppers are doing more buying and less looking than usual on their first trips."

In department stores, even before the Christmas rush, sales for the November period in 12 cities are reported by the Federal Reserve System to be 8 per cent over last year.

It is expected that much of the government spending for defense will be felt in payrolls more after the first of the year, when higher wages and increased employment will be fully realized.

Tele Art Moves Ahead

Television developments this month were mostly concerned with the matter of color. CBS tried it out in connection with National Art Week, when a string of American classics in oils and water colors were scanned from slides and reproduced in full color on receiver screens.

GE, too, took a whirl at color when Dr. E. F. W. Alexanderson demonstrated a system using a two-color 24-inch disc about a foot in front of



Leaders all! President L. C. F. Horle of IRE, President J. S. Knowlson of RMA, and Chairman W. R. G. Baker of the National Television Systems Committee, survey radio's bright opportunities for 1941.

EDITOR, Orestes H. Caldwell;
PUBLISHER, M. Clements;
Managing Editor, Darrell Bar-
tee; Merchandising Editor, H.
L. M. Capron; STAFF, E. T.
Bennett, N. McAllister, G. H.
Mayorga, William E. Moulie,
M. H. Newton, R. A. Neubauer,
B. V. Spinetta, R. Y. Fitz-
patrick, 201 N. Wells St.,
Chicago, Ill.; CALDWELL-
CLEMENTS, INC., 480 Lex-
ington Ave., NEW YORK,
N.Y. Telephone PLaza 3-1340.
Copyright 1940. Member Aud-
it Bureau Circulations. Vol.
6, No. 12. December, 1940.

the picture end of the cathode ray tube of his standard receiver. A similar disc revolved before the iconoscope pick-up tube at the transmitter, but otherwise everything was the same as with black-and-white tele.

Meanwhile NBC-RCA transmissions have been resumed, and FCC summarized the general art by reporting that a unified system is being speeded by a total of \$8,000,000 to be spent by some two score individuals and firms authorized by FCC to experiment.

More of That FM Progress

FM was seen to march stoutly ahead this month, as the FCC granted seven more construction permits for FM stations. The total for authorized commercial transmitters is now 25. The new permits will offer service to Connecticut and Rhode Island, about half of Massachusetts, a section of southeastern New York state, part of Tennessee, and the Pittsburgh, Chicago and New York metropolitan districts. Nashville, Tenn., became the first Southern city to adopt FM for police communication.

Dealers in central New York state made a sales event out of the debut of General Electric's station W2XOY at Schenectady. They got together ahead of time and got the technical dope. The opening itself was staged at Proctor's Theater with "Hollywood Premiere" effects and drew overflow crowds of 3,500.

Ben Gross, Stromberg's well known representative in the New York and New England areas meanwhile described FM as "something real for the



Howard Gates, who has had a full 21 years of experience in radio, is the new president of Majestic Radio & Television Corp., Chicago. See page 33.

dealer to sell his old customers and to thousands of new ones . . . 15,000,000 of them in the next 3 to 5 years . . . with the average unit of sales at least 3 times the present."

Radio Listening Soon to Peak

Just ahead of radio men now, are the most important radio listening months of the whole year. This is probably of first interest to servicemen, but it also indicates to salesmen just when the peak of the radio listening appetite occurs.

These figures were assembled by noting the average hours listened per day during each month. Counting 100 per cent as the peak. Ten months are rated as follows:

January	99	June	71
February	100	July	61
March	95	October	74
April	91	November	88
May	77	December	94

This data comes from the National Radio Index of the A. C. Nielsen Co., marketing experts of Chicago.

Many Small Tubes Make Up Tele Screen

Dr. A. N. Goldsmith, consulting engineer, New York City, has invented a new television system using a number of small low-priced cathode-ray tubes combined in multiple arrangement for the production of a large image, instead of the present method of a single expensive cathode-ray tube. Dr. Goldsmith is a member of the National Television Standards Committee.

His invention provides ingenious electrical circuits by which each small

cathode-ray tube scans only a small section of a large screen. Dr. Goldsmith believes that such small cathode tubes may be made almost as simply and inexpensively as the ordinary home lighting bulb, once their production has been started. Such small tubes are freed of the strains present in the large tubes, and are expected to last a greater number of hours. By combining these small bulbs a total screen of any desired dimensions can be obtained. Each small tube produces its part of the image in such perfect harmony with the others that the eye is said to be unable to detect where the image segments join.

Parts Show 1941 Coming Up

Some of the early plans for the 1941 Radio Parts National Trade Show were made last month when the Board of Directors of the Radio Parts Manufacturers National Trade Show, Inc., met at the Stevens Hotel in Chicago. The show will be held June 10 to 13 inclusive at the Stevens. The first three days will be special for the jobbing trade; on the 13th the exhibition will open to the radio trade in general.

Three officers of the Show company were reelected: A. A. Berard, president; H. E. Osmun, vice-president; and J. J. Kahn, secretary-treasurer. Herbert W. Clough was elected to the Board of Directors to represent the Western Division of the Sales Managers Club, and he began his term of office at this meeting.



Crosley Corp.'s vice-president and general sales manager Robert I. Petrie, reported at the firm's big convention this month that 1,600 radio dealers had been added to Crosley organization.



"Sales of 75 million records this year and 100 million in 1941," estimated Tom Joyce of RCA, in speech, Dec. 3, to Sales Executives Club, New York City.

Recorded Musical Greetings from Dealer

An aggressive idea for sending novel Christmas greetings to the most important customers is being used by Jack Winer of Dynamic Radio, 1895 Broadway, New York City. He sells home recorders and blanks, so he's having several hundred recorded greetings made up with professional talent offering a lively tune in which the lyrics have to do with "Season's Greetings from Dynamic Radio."

The stunt was not an expensive one, as 6-in. blanks were used, and mailing was not a problem. Playing time for the records was about 1½ min.



Harry J. Deines has been advanced by General Electric Co. to the position of manager of advertising and sales promotion for the radio dept. He has been with GE since 1930.

Radio's "Strike" on the Front Cover

The industry has played its sales game so thoughtfully and so skillfully through the months of 1940, that we now enjoy the "strike" that you see on the front cover of this issue. The year 1940 winds up with all previous radio records going down before it. The totals for this year on home sets, auto radios, tubes, records, etc., are all represented in the goal that everybody's been trying for; you can see that the effort of 1940 was very well-aimed.

Gains in some branches of the industry were of course more spectacular than in others and to get a line on what actually happened the final figures in each branch will be published in good time. Big gains made this year by the broadcasters will also be presented.

Much of the volume increase in radio sales was recorded during the latter part of the year after the buying power of the nation had begun to feel a strong lift. Here we have the big challenge for radio men in 1941.

FM Faces Polarization Problem

A new hurdle to frequency-modulation reception has arisen in the divergence of engineering practice regarding polarization of transmitting antennas. Most of the earlier FM stations, led by Major Armstrong's Alpine, N. J., transmitter, use horizontal polarization. Certain of the recent transmitters, such as WOR, New York; Rochester, N. Y., Chicago, Ill., and Milwaukee, Wis., have installed vertical polarization, claiming that this simplifies listeners' installations, since a wire dropped out of an upstairs window gives excellent pickup. Vertical antennas would also facilitate future automobile FM sets, whereas horizontal antennas would be awkward on cars.

While for nearby reception with a strong field, the direction of polarization makes little difference, it is in suburban areas where signal strength is weak that the present divergent systems cause serious difficulties.

TWO ANTENNAS NEEDED

For example a horizontal doublet at Greenwich, Conn., 28 miles from New York, picks up all N. Y. FM stations except WOR. To hear WOR a separate vertical doublet is required, but using this, NBC's horizontal transmission is then spoiled. Attempts to devise a combination antenna, have resulted in noise and crosstalk. The only way a listener can hear all N. Y. FM stations satisfactorily is by switching antennas at the same time he switches stations, a requirement which is not going to be popular with laymen. Discriminat-



"In radio since 1921," is proud record of D. Wald, of DeWald Radio, who has just added 4-lb. "Companionette" to his complete line. See page 29.

ing householders will also complain about having two or more awkward doublets high above their roofs.

So definite is this polarization effect in FM reception even at considerable distances, that at a point like Greenwich, Conn., about midway between two transmitters on the same channel—WOR vertical, and Meriden, Conn., horizontal—either station's program can be brought in clearly without interference, by merely swinging a doublet antenna into vertical or horizontal position.



Now they're ready to plan the 1941 Parts Show, these directors of the Radio Parts Manufacturers National Trade Show, Inc. Left to right, H. E. Osmun (Centralab), vice-pres.; H. W. Clough (Belden), new director; Ken Hathaway, managing director; K. C. Prince, legal counsel; A. A. Berard (Ward Leonard), president; and seated, J. J. Kahn (Stancor), secretary-treasurer.



Directly above, GE offers an AM-FM model JFM165, 12 in. speaker, for \$175.



Above, right, the A-94 Recordio from Wilcox-Gay, 10 tubes, 2 bands, changer.

There's a brand new force at work in the radio business. It is a development which gathers importance every business day, and actually means more profits for the man who sells sets.

From all sides and all along the line, the American public is now being treated to new fidelity and accuracy of sound reproduction. For the first time—in the newspapers, in magazines, in radio reviews—the popular attention is being focussed on new degrees of reality in movie sound.

The new "Fantasia" produced by Walt Disney has shown what can be accomplished when the sound man gets carte blanche to carry out present-day possibilities of his medium. And Warner Brothers in "Santa Fe" now follow up with a new high-fidelity sound system which produces added realism.

New principles of sound recording promise still further richness of overtones and bass.

RADIO'S PART

Meanwhile, frequency modulation undeniably sets new standards in radio realism, with absence of background noise. The "high-fidelity" stations in the 1800-1600 kc band have long been testing the full reach of quality receivers. And in the regular broadcast band, both transmitters and receiving sets have recently been given fullest extensions of artistic reproduction.

With the buying public thus made

thoroughly conscious of high fidelity sound and quality reproduction, it is time the radio trade employed anew every means to demonstrate and sell *quality* radios.

And now, with an unparalleled industrial activity ahead, the market for quality radios is opening up in every bracket of purchasers.

A WIDE APPEAL

Many radio dealers have already taken hold of this new opportunity. Sales arguments and store demonstrations are being geared to this new market. Finer cabinet styles and the "guts" of the big receivers are being popularized by these retailers. Some of the ideas are reported herewith.

"If you hear a voice in an adjoining room, you can tell instantly



Right, top, the Westinghouse WR-484 2-band automatic combo, 12 in. speaker.

Center, the Console Grande by Sonora. KXF-95, 5 watt output, 6 push buttons.

Below, right, FM, standard, and short wave Stromberg-Carlson with labyrinth.

Directly below, the Philco 616P with photo-elec. pickup, mystery control.



New fidelity in sound reproduction has claimed the attention of millions and they'll want it in radios

whether it is coming from a radio, or whether someone is present and speaking. This has been going on for nearly 20 years. In a way, it serves to illustrate what radio has lacked in fidelity, and it indicates that the most innocent ear can detect faithful reproduction."

These are the words of a veteran radio dealer, who was speaking of the immediate sales prospects for quality radios. His view is that the appeal of the finer radio instruments applies to a lot more people than just the

ones with the musical flair and the trained ear.

This dealer has a floorful of combinations—really expensive jobs—and he's giving his prospects credit for tonal discrimination. He's talking up FM, and demonstrates it whenever possible because he finds that there's a great deal of interest in it. However, when he has to choose between demonstrating AM and playing a record, he plays the record because he says that few of the daytime programs are good bets for this purpose. He points out that in demonstrating records, he is able to exhibit good music as well as good reproduction, and this helps a great deal in the general impression he makes on his prospect.

DEMONSTRATION TIPS

One thing that this retailer likes about the "quality" business, besides the high unit profit and the chance to feature performance rather than price, is the fact that people don't try to chisel so much on the matter of demonstrations. When they are shopping for a midget, they may accept the set for a home trial, and keep it for an indefinite time without the feeling of guilt. "They wear it out, bang it around, and decide that they don't want it." But buyers of quality goods are "more thoughtful of the dealer's time, and most of them are serious to start with."

DISPLAY HINT

Another dealer, whose business is a radio-music one of long standing, depends on store atmosphere, a system of interwoven displays, and the use



This RCA automatic V302 has Tone Guard, 15" speaker. Sheraton style, \$300

of technical features in his sales talks.

He keeps his quality radios in scattered groups. In handling a prospect, he will very likely usher her around the usual strings of sets, while he delivers a preliminary set of sales points. Then he often exhibits pleasure at the customer's reactions, and escorts her to a room or a corner which has the "plush" atmosphere. She gets the idea of "special handling" and relaxes in an easy chair in a good mood, for further demonstrations of a personalized nature.

For the purpose of stirring up miscellaneous interest and inquiries, combinations in this store are spotted around among the other products displayed for sale. It has been found that a handsome combination will
(Continued on page 26)

The Crosley 31BF here is a recorder, too; concert speaker, 8 push buttons.



Left, top, the 8-tube Emerson automatic No. 372, 12 in. speaker, \$199.95.

Center, the Kensington style Panatrop with 11 tubes, by Brunswick.

Below, left, Adam Secretary type Magnavox; FM, recorder, optional. \$395.

Directly below a 3-band job, 11 tubes, 12 in. speaker, Farnsworth BK112, \$275.



FRONT





Grace Line

UNCLE SAM SHIPS MORE RADIOS

NEW MARKETS IN LATIN AMERICA FOR U.S. RADIO PRODUCTS

Certainly radio is one of the important links in the hemisphere chain which is now being forged to bind the United States closer to the countries of Central and South America.

The radio products made in this country—the receiving sets and the radio tubes and parts designed by the alert engineers of the United States—will get extra attention from our neighbors to the South. These countries have not developed their radio markets as fully as we have, and there remains a big sales job ahead. The fact is, there are only about 4,000,000 radio families in the combined areas of 20 leading Latin American republics. Whose total population amounts to over 127,600,000.

The process of building and selling

radios for foreign users is of interest to U. S. dealers and distributors as well as manufacturers. It means that radio products in general have a tendency to become more sturdy and more tough, because of the designers' efforts to build units that will withstand the extreme climatic conditions of other continents. Also, the development of radio cabinet styles to suit foreign tastes has had its effect on U. S. styles themselves.

PROGRAM LINK

The U. S. broadcasters are taking action which is expected to have a powerful effect on how the people abroad regard the whole subject of U. S. radio. All three of the networks—CBS, MBS and NBC have

recently enlarged the number of programs available to Latin American listeners, and an improved program service to these countries has lately been one of the chief concerns of U. S. broadcasting leaders.

A perfect example of how this influences the sale of sets is seen in the announcement last week by the Cuban Minister of Education, to the effect that radio will now be installed in every public and high school in the country. The step was taken so that Cuban youngsters may listen daily to the CBS "School of the Air" series, now being broadcast in Spanish on all Cuban stations.

The U. S. makers of sets are making their bid for the Pan-American business against a background of gen-

eral export trends which appear to be extremely favorable. Our total exports to the 20 Latin American republics, according to figures from NBC's International Division are 52.1 per cent up for the first six months of this year compared with the same period in 1939. The half-year total for 1940 is \$378,497,215—a figure which should be attractive to any U. S. business man.

RADIO SALES FEAT

As for radio's part in this picture, here are the dollar values for total radio sets, tubes, loudspeakers, parts and other set accessories, exported to the five "buyingest" Latin American countries for the first 9 months of this year: Brazil, \$1,194,211; Argentina, \$1,017,390; Mexico, \$978,258; Chile, \$479,551; and Cuba, \$427,456.

When you count the number of receiving sets alone, the rank of the Pan-American countries is changed because some of them insist on doing their own assembly work. Chief buyers of U.S. sets for the 9-month period this year are Mexico, 43,480; Brazil, 36,191; Chile, 23,216; Cuba, 18,762; and Venezuela, 15,442.

In the majority of the countries named above in both sets of figures, the buying of U.S. radio products is running ahead of last year.

U.S. radio men will want to remember that the Union of South Africa, too, has been an important market. Fact is, that country has already bought \$747,639 worth of radio products from us this year. The number of sets already sold there is 23,613.

Of course this and other British-controlled countries are apt to change their import regulations over night.

FOREIGN BUYERS

as seen by RMA Export Chairman

W. A. Coogan, chairman of the RMA Export Committee and manager of foreign sales for Hygrade Sylvania Corp., declares that "though most of the European sales volume has been lost, our radio export figures are almost identical to last year . . . some markets outside of the war areas are now buying radio materials in larger volumes than ever before."

Mr. Coogan, who has travelled widely in the foreign markets, observes that U. S. set manufacturers are getting greater sales volume in Latin America, with most of our companies who maintain their own export divisions offering new radios constructed and designed particularly to cope with the atmospheric conditions encountered in tropical climates. He points out too that large volumes of sets and parts are still being shipped to South Africa, Hawaiian Islands, Philippine Islands, New Zealand and India.

An example is the very recent action taken by Canada. Radios, phonographs and appliances were included in a long list of products whose importation is now prohibited.

AMERICAN SOLIDARITY

In respect to hemisphere defense and economic developments, it has been said that the United States should take the initiative in establishing unity in the Americas. This should be a challenge for U.S. radio men, because there is no better way to advertise the American way of life than via radio. And no better way for our Latin neighbors to hear about it, than through U.S. receivers.

Musical Standing of Radio Men

(From the president of the National Association of Music Merchants)

Editor, RADIO TODAY:

The position of the radio-music merchant in his community is quite an outstanding and important one, for music always plays a commanding part in entertainment of any nature. There is hardly a function that is not dependent on music as a background, and the local music merchant is called upon constantly for assistance in almost every public entertainment.

INSPIRES ACTION

He has been the source of inspiration for music in the schools as an educational medium, for it is he who has called the attention of the school authorities from one end of the country to the other to the many advantages of music. The result has been the establishment of music departments under the various State Boards of Education. Every high school of any

size in our State now has a music department and a band director, and this movement is extending now to the grammar schools. Magnificent new music departments have just been completed and equipped with radio, phonograph combinations and recording machines, also pianos and musical instruments at many school centers here..

What is true for Louisiana is also true of many other states—all inspired and helped by music merchants who realize, not only the cultural benefits and pleasures of music, but also the outstanding educational advantages of it. I could write a book about this.

And now finally about radio itself. No home is complete without a radio and I imagine there are but few without it; however, the tendency today is towards the small and cheap variety, which is having a bad effect on the profits of the industry.

PLACE OF MUSIC DEALERS

I am quite sure that the music merchant has not made this picture and is in no way responsible for it, but this situation is due to the fact that the manufacturers have been placing dealers in small corner drug stores and other outlets, who maintain no service departments and who handle only the very small units. Our own business would not furnish any such index to the consumption of radio. Our average unit sale would be much higher and I feel sure that this is true of all music stores. They have pioneered the radio and were it not for them, recorded music now used in connection with radio combinations would still be in its toddling clothes, and I sometimes wonder if the manufacturers ever stop to think about the vital importance of the music merchants to them.

(Signed) PAUL S. FELDER

Philip Werlein, Ltd.
New Orleans, La.

Triplett Executives Hosts to Foreign Visitors

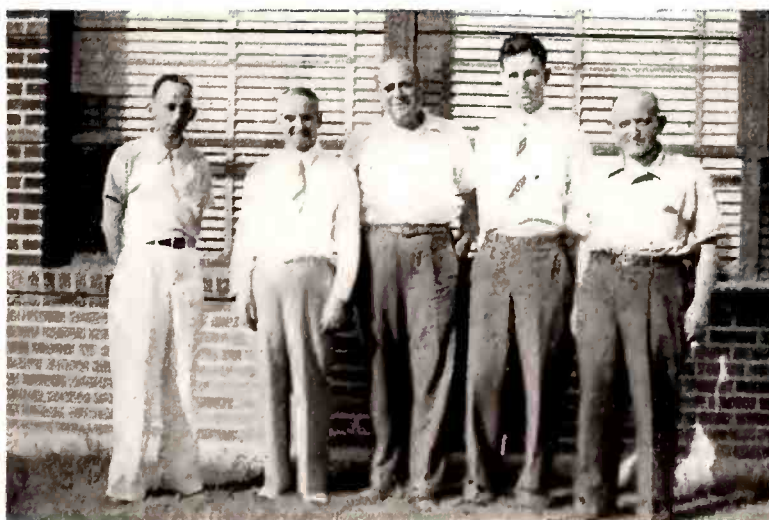

From Mexico way, come guests to the Triplett Electrical Instrument Co., Bluffton, Ohio. Left to right, Senor Olaguibel; R. L. Triplett; Senor Mabardi, Triplett rep in Mexico; N. A. Triplett; and Senor Margules. This photo appeared in last month's "Radio Today," but the gentlemen were incorrectly identified.



PLAN FOR

The dealer should now be up to his neck in direct mail, phone calls, extra plans for window displays.

CLEANING OUT STOCK AND MAPPING SALES FOR NEXT MONTH

The greatest holiday season that retailing has ever known is now almost at an end.

From such a vast movement of merchandise there must remain a corresponding residue of slow, or non-moving units.

It is also inevitable that in the next three months radio sales will be substantially less than in the last three months. Competition will be much keener next month. It will be keener among radio dealers, among whom cut-price advertising will herald the clean-out efforts of manufacturers' surplus production as well as of dealers' own slow-moving stock. And there will also be keener competition with department and furniture stores, who will be enticing the public to buy at their White Sales, Houseware Sales, Furniture Sales and Pre-Inventory Sales.

To hold radio sales volume, as well as to get stock in good shape, every dealer should go into January with very definite plans for action.

CUT THE SLOW ONES

First, of course, is the need for an accurate physical inventory, and an analysis of recent sales as the starting point for the January sales drive.

Then you will realize that any given model will not be more saleable than it was during December, and all slow or non-moving models should be marked down, as drastically as necessary to quickly move them.

In determining the extent of these price reductions, three factors must be kept in mind.

First, the new prices must be sufficiently attractive to induce sales interest when compared with the prices of other models and of manufacturers' surplus production.

Second, they must be so attractive as to compete successfully for public interest with the "Sales" advertising of department stores' annual and semi-annual sales events.

Third, they must be low enough to induce *immediate* buying action, lest further reductions will be necessary later.

SALES ENTERPRISE

Most dealers complain as much about their lack of store traffic as any other factor in their business.

And because of this, price reductions alone are not to be relied upon to move any given quantity of merchandise.

Coupled with prices which are right, must go *consistent* and *energetic* selling effort.

Many dealers, particularly those in metropolitan areas, feel they cannot afford to buy the waste circulation of their large local papers, and so do little newspaper advertising.

The most effective means for the

local or neighborhood dealer to offset the large newspaper drives used by his major competitors during this period, are personal telephone solicitation, selected direct mail, and attractive window display.

THE BEST APPROACH

Telephone solicitation, this season, cannot produce results comparable to the effort and expense involved, if it is merely perfunctory, or if it is not consistent.

Such phone solicitation should be an interesting and attractive selling presentation of a specific model.

If you keep at this, as thousands of dealers have done, and are doing, the results will be as surprising to you, as they have been to all those who say 'phone selling doesn't work!

RESULTS VIA MAIL

Direct mail, too, may be made to produce results which are far beyond those commonly believed possible.

Ordinary folders only, indiscriminately mailed, may be expected to produce results of a very ordinary nature.

Mailings should be done on a personal basis, with the message short, interesting and to the point. Let it strike the eye forcibly and favorably.

Arouse interest and maintain repetitive effect by regular, frequent mailings over a period of 4 to 10 weeks, and watch the results jump to surprising points.

On a 10-piece mailing to 1000 selected names, such methods have been known to produce 100 sales, 300 service jobs and 100 good prospects within the 10-week mailing period.

That's an outstanding pay-off on an excellently done job—but even half

JANUARY ACTION

Make an inventory analysis of your recent sales, and decide which models are the "slow" ones.

Cut the prices on these units to where they compete with your neighbors, who are probably planning special sales of their own.

Back up your offers with energetic sales effort appropriate to 1941—direct mail, phone calls and fresh window displays.

START OF NEW YEAR

such results would still be *very* worthwhile.

And when it comes to window displays, which are the "eyeways" to your store, remember they must be attractive, and *tell a story* if they are to be effective in producing sales.

If price is the story you want to tell, don't infer it, don't let your prospect guess at it, but *tell it*. And tell it in a way which will not only attract, but will even demand attention, stop passersby, get over the "bargain appeal," and create the urge to buy. If you are building your sales appeal around style, performance, the pride of ownership, do it positively.

BUILD NEW "EYEWAYS"

A little originality to make your window stand out from its competitors will pay big dividends in results. Light, color, action, will attract the eye, but if your window does not tell a *selling* story, little good results.

In the months just ahead, some dealers may wait in their stores for business to come to them. They may be very disappointed. Smart dealers will be fighting hard, to tell the story of radio first, and their own sales story second. Business will continue to be good for these dealers.

Dealer Likes Store Full of Combos

When a customer walks into the Hippodrome Music Shop in New York City, he is confronted by an exceptionally large stock of radios, on the floor and on the tricky shelves. Complete variety of merchandise is probably the long suit of the shop, but the truth is that every set shown (except those on the shelves) is a radio-phonograph-combination.

Ed Burton is the proprietor, but a lot of the selling is done by Nat Leeds, and Mr. Leeds believes that combinations are the timely profit-makers for the rest of 1940 and maybe for next year. Table models, consoles and chairsides are all there, with eye-catching variety in cabinet styles. The place bristles with microphones; a good number of the instruments are recorders, too. Variety in prices is provided also because the Hippodrome stocks quite a supply of "dumped" models for the folks who can't pay top prices.

Such a mass of "wanted" merchandise has a lot of sales advantages, Mr.

Lee's points out, because you can always show your customers, old and new, that you have something which will make them a little more satisfied.

A Plan for Happily Selling All Prospects

One of the big radio retailers in the Middle West is now using an exceptional plan on home follow-ups, whereby customer satisfaction is re-emphasized. Features of the store's system are as follows:

When a customer buys a radio for \$50 or more, whether at the store or not, the salesman is required to call at his home to see that all is okay. If he fails to do this, and trouble occurs, he is required to pay 2 per cent to the service department.

When the service department gets a repair job that runs high, it is reported to the salesman. The customer is phoned about the charge, and is confronted with the idea of a new set. When servicing is done in the home, the repair charge is deducted from the cost of a new set.

In cases where a salesman is unable to close a sale at the store, he offers the set on trial. If the prospect still hesitates, his name and address is taken, and he is called whenever the store has a sale which makes the set price more attractive to the prospect.

Watch This Year 'Round Radio Market

The very small "personal" battery portable, heralding the "pocket radio" of the near future, has created new selling opportunities for alert dealer organizations to do a real merchandising job.

Though a tremendous latent demand exists for portables they still have to be sold.

Dealers who are doing a sound and consistent merchandising job, report they are 12-month sellers, with a mid-summer peak demand.

Replacement batteries too are not only making their contribution to dollar sales, but also keep the dealer in contact with the user, thus offering new selling opportunities.

Far from being a "necessary evil" as many dealers characterize them, compacts this year can be sold at a better profit, can be "sold up" easier than for many years.

Compacts and portables will represent about 60 per cent of the units sold, and 30 per cent of the dollar value during the next few months.

No dealer can afford to "play down" so important a part of the radio business, and smart dealers are using compacts and portables as stepping-stones to consoles, combination and other sales.

Here's a resourceful window with ideas galore. It features the "personal" radio, includes photos of them in use in various places, along with pictures of broadcast events, shows a miniature Pullman berth to rear, and a ship model at center. At Lyon & Healy's, Chicago.



RADIOS FOR '41

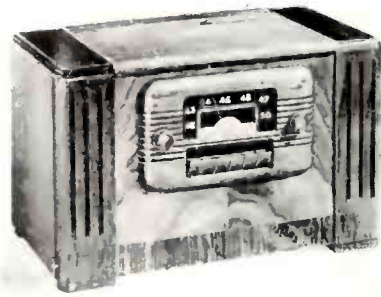

The young lady at the right is using the 11-tube, 5 spread band Philco 788T Tropic, \$150.



needs for AC operation. Large illuminated, 3-colored slide-rule dial. Cathode ray tuning eye. P.M. dynamic speaker. Phono-telev. plug connection. Also available in AC-DC, with built-in loop antenna. Electromatic Distributors, Inc., 88 University Pl., N.Y.C.—RADIO TODAY.

S-W FM Interpreter

★ Attachment for use with standard receivers through phono-jack, making the set adaptable to FM reception. Provides automatic push-button tuning for 6 stations, 2 knobs for station selection and on-off. 9 tubes, 110 v., 60 cycle current. Extra jack for phono-pickup. \$50. Walnut cabinet. Stewart-Warner Corp., 1826 Diversey Pkwy., Chicago, Ill.—RADIO TODAY.



Recordio Jr.

★ Recordio Jr., a portable radio, phonograph and recorder combo, weighs less than 20 lbs. 78 r.p.m. single speed recording. Plays 12 in. records. Built-in antenna, needle holders, high output mike with snap holders inside case. Snap-on cover and strong handle, airplane style luggage covering. \$39.95. Wilcox-Gay Corp., Charlotte, Mich. RADIO TODAY.



Emerson table combo.

★ No. 403, Phonoradio, 18th C. table model in 2-toned mahogany. 5 tubes, AC superhet, Standard Amer. Bdcsts. & police. Electro dynamic speaker. Inclosed super-loop Phono has crystal pickup, self-starting constant speed motor and plays 12 in. records. \$29.95. Also available for AC-DC at \$39.95. Emerson Radio & Phono Corp., 111 8th Ave., N.Y.C.—RADIO TODAY.



Sentinel 233Q

★ Listing at \$24.95 (with batteries) is Sentinel's solid walnut wood chest radio, a 4-tube battery-operated superhet. Built-in loop aerial, A. V. C. Lid operated on-off switch. Tunes 535 to 1600 kc. 9½ in. x 4½ in. x 5 in. Sentinel Radio Corp., 2020 Ridge Ave., Evanston, Ill.—RADIO TODAY.



Weston D-39

★ Concert grand, 3-band (broadcast and shortwave) superhet table models in walnut woods and ve-



Fada piano radio

★ 24 Kt gold plate miniature replica of baby grand combined with 1941 Fada radio is Model 182G. 5-tube, AC-DC superhet. Covers American Broadcast and state police bands. 4½ in. dynamic speaker. Weighs 7½ lbs. Non-tarnishable, solid metal. \$49.95. Fada Radio & Elec. Co., 30-20 Thomson Ave., L. I. City, N. Y.—RADIO TODAY.

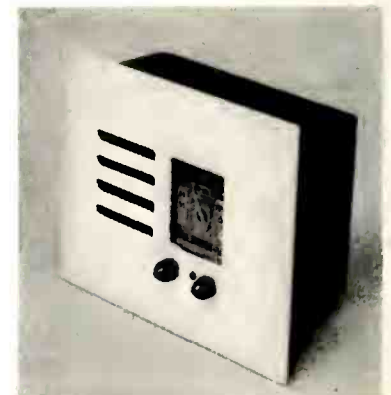

Flush-Wall radio

★ Model 5P radio built into the wall contains 5-tube Philco or equivalent, comes with hinges, steel box (3¾ in. deep) antenna and plain or white panels (8¾ in. x 11¼ in.). Special color panels extra. \$29.95. Flush-Wall Radio Co., 57 State St., Newark, N. J.—RADIO TODAY.



20 years ago radio was like this. RCA research and engineering have played an important part in radio's great advance during the past two decades. Not the least of RCA's contribution has been the combining of radio and the phonograph—to bring your customers today's great RCA Victrola.

"JUST WHAT WE ASKED FOR!"

—say dealers about RCA Victor promotion celebrating Broadcasting's 20th Birthday

ANNIVERSARY OFFER

features new 1941

RCA Victrola
with Exclusive Tone Guard



RCA VICTROLA V-205

Feature-packed to sell! 9 tubes! • Gentle-Action Automatic Record Changer! • 12-inch Electrodynamic Speaker! • Exclusive RCA Victor Tone Guard! • Stabilized Electric Tuning! • 12 Watts Output! • Magic Loop Antenna!



EVER SINCE the great 40th Anniversary RCAVictrola promotion of two years ago, dealers everywhere were after us for another. This promotion, celebrating Broadcasting's 20th Birthday, was our answer—and dealers everywhere are enthusiastic about it. For it's booming the sales of RCA Victrola Model V-205... it's capitalizing on the intense public interest in phonograph-radios... it's upping dealers' profits! Push this great trade-in offer at every opportunity—and it will push your profits skyward!



Trademarks "RCA Victor" and "Victrola" Reg. U. S. Pat. Off. by RCA Mfg. Co. Inc.

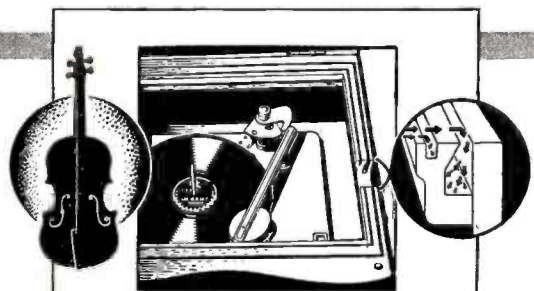

EASILY, EFFECTIVELY DEMONSTRATED!
RCA VICTROLA TONE GUARD

Scientifically shaped slots suppress unwanted mechanical noises. Play a record with the lid of the instrument open. Close the lid—immediately mechanical noises are sealed in silence.

RCA
Victrola

Combines Record and Radio Entertainment
A Service of the Radio Corporation of America

QUALITY

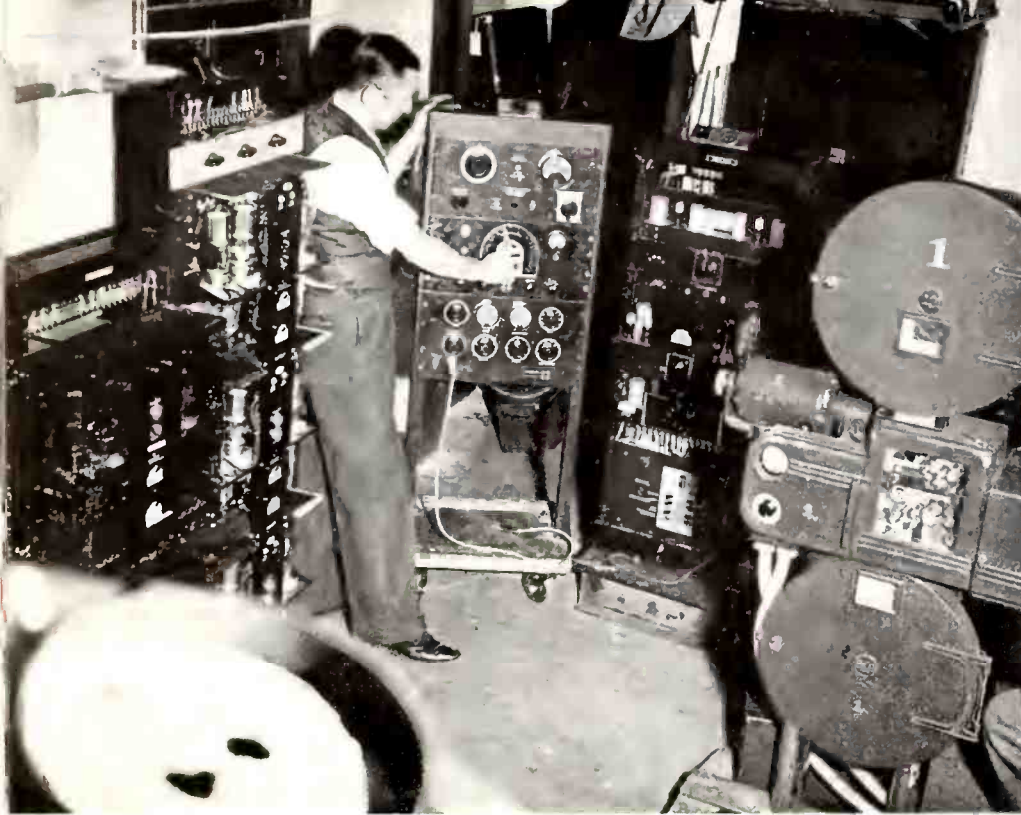

Special amplifiers and 4-track sound film projector at right used in "Fantasia."

High-fidelity, three-dimensional sound in Walt Disney's movie shows advantages and possibilities to sound men

New thrills are in store for your ears—this is forecast by the phenomenal success of Walt Disney's new production "Fantasia" with "fantasound" reproduction of the music.

Fantasound is a system of (1) automatically controlling the apparent source of sound in the theatre and (2) expanding the range of sound intensity. The "dimensional" or perspective effect gives sound a new life; the buzz of a bee moves across the screen and into the wings of the stage, the audience has the impression of being "immersed" in the orchestra, the violins appear to move from left to right

while the sounds of the woodwind section, which were on the right, now come softly through the wings at the left of the stage.

TREND TO FIDELITY

Thus the present trend of high fidelity and increased effectiveness of sound and radio is opening up new markets for PA men. Better and more elaborate equipment will be demanded in auditoriums, schools, churches, etc.

The principle of fantasound is that of separately recording three different versions of the sound. That is, the

string section of the orchestra would be recorded at a level considerably above the background of the rest of the instruments, on soundtrack A; another section, the woodwinds for example, would be similarly transcribed on track B; and so would the complete orchestra as it is normally picked-up by the mikes without any extra emphasis placed on particular instruments, be recorded on track C. These recordings are then matched together with a fourth "control" track on the same strip of 35 mm. film. The sound recorded on each of the first three tracks may be any part or all of the original sound and is usually a portion of the sound to which it is desirable to give particular emphasis.

The "control" track or fourth track, which has been mentioned, is an ordinary sound-on-film recording consisting of three frequencies which are not in harmonic relation. In the fantasia film, the three control frequencies used are 250, 630, and 1500 cycles per second. Each of these three frequencies, through its recorded volume, controls a particular sound track.

CONTROL VOLTAGES

These control frequencies are amplified and then separated by filter networks. The three amplified signals are rectified to form the DC control voltages. These varying DC voltages control the bias on the 106-watt amplifiers, thereby regulating the volume, just as AVC does in a radio.

The three control frequencies are recorded along with a playback of the three original musical tracks in such sequence and volume level that the desired effects of stereophonic and moving sound are realized. For example, if it is desired to "move" a sound from left to right across the screen, and the 250-cycle note controls the left speaker

Block diagram of the "Fantasia" sound system with a reproduction of the four track sound film shown at the left.

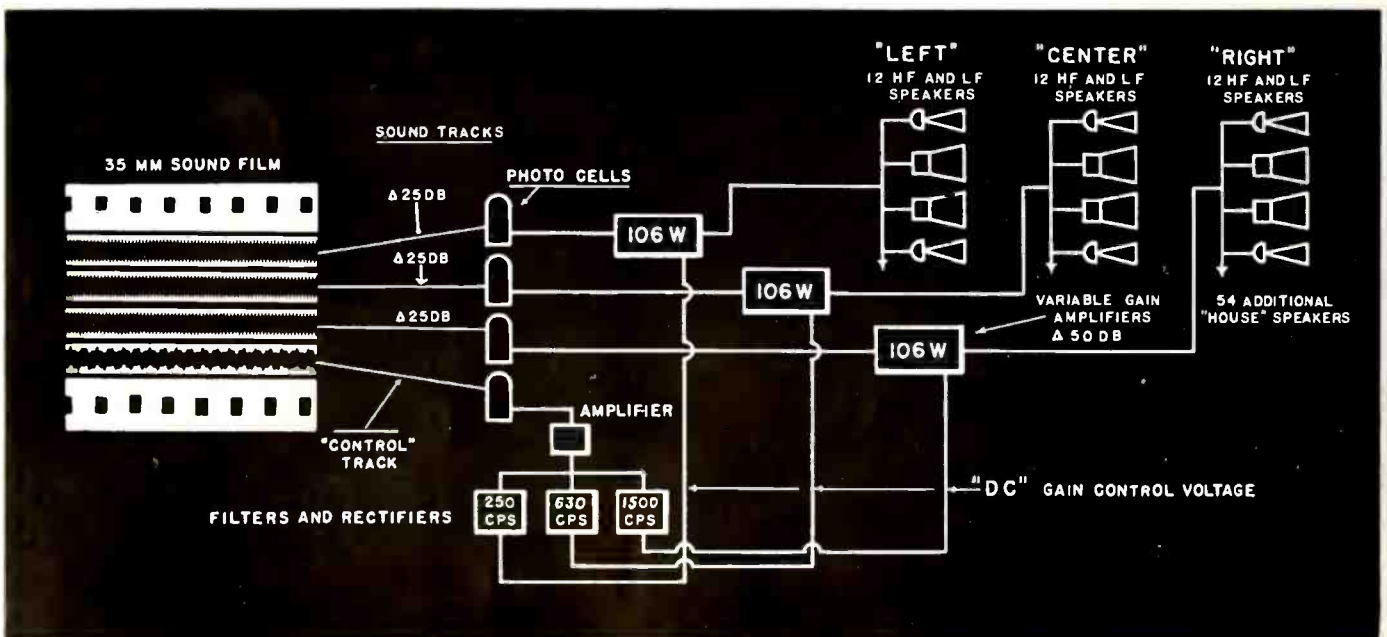

N SOUND

group, 630 cycles the center group, and 1500 cycles the right group, the procedure is as follows: The center and right hand speaker groups will run at low volume with the background music due to the high level of the two control frequencies, 630 and 1500 cycles. The left amplifier and speakers will operate at normal level corresponding to a low level 250 cycle control tone. The sound on the "left" track will appear on the "center" track while the 250-cycle signal is increasing in level on the control track to cut down the volume of the left amplifiers. At the same time, the 630-cycle note is decreasing in amplitude to let the center speakers carry the normal level of the sound which a moment before was on the left. The volume of the center speakers is then decreased while the same sound appears on the "right" track and the 1500-cycle note decreases in level to allow the right hand speaker group to come up to normal volume with the original sound.

90 SPEAKERS

These changes from one speaker group to another are not noticeable by the audience; only the total effect of a moving sound is apparent. A sound may be "moved" from right and left toward the center, or from the center out to both sides, etc.

The three-stage speaker banks consist of 8 low-frequency and 4 high-frequency units each. The remaining 54 speakers of the 90 total are placed around the walls of the theatre. These speakers are divided into two groups and are connected to the right and left stage speaker banks.

Normally silent, the house speakers serve to alter the reverberation time of the theatre and create the illusion of "surrounding" the audience with sound. These "house" speakers are

manually controlled as to the point in the show when they are connected with the stage units.

75 DB VOLUME RANGE

The normal recording range of volume on the original sound track is about 25 DB while the dynamic range of the amplifiers is 50 DB. The total dynamic volume range of the system, under the control of the fourth track, is 75 DB, which more nearly represents the range of a symphony orchestra (which may be 100 DB.)

The block diagram of the system shows an actual strip of sound film, the photocells, control, amplifier and speaker equipment.

For emergency use, a regular sound-track is also printed on the picture

(Continued on page 23)

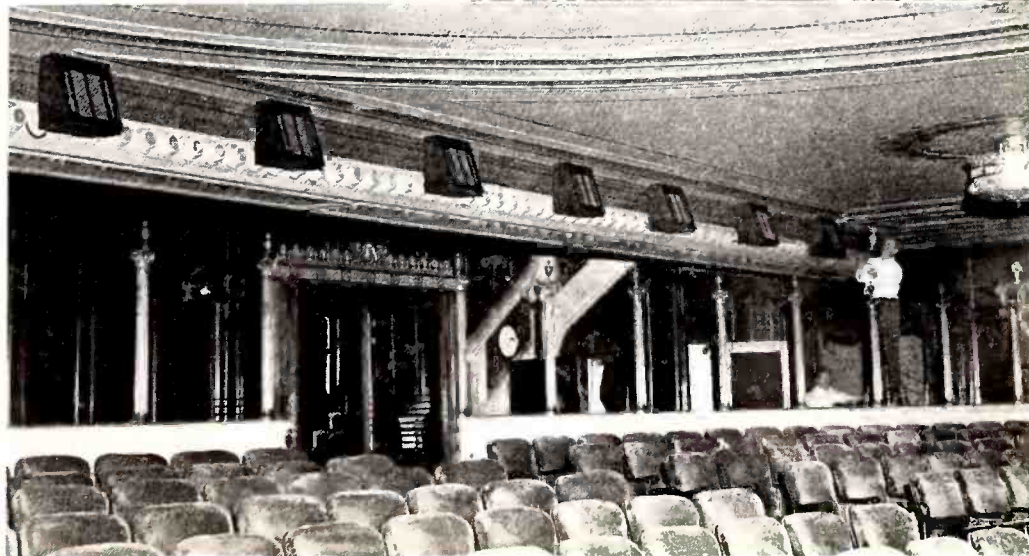

Top. One of the "house" speakers being installed in Broadway Theatre, New York.

Center. Some of the auxiliary "house" speakers across the back of the theatre. These are connected to proper stage banks and serve to surround the audience with sound.

Left. Main stage speaker banks. Compare size to man at left. Each bank connects to separate amplifier channel with 106 watts output. Note high frequency units on top of the L. F. horns.



QUALITY IN SOUND



Special amplifiers and 4-track sound film projector at right used in "Fantasia."

High-fidelity, three-dimensional sound in Walt Disney's movie shows advantages and possibilities to sound men

New thrills are in store for your ears—this is forecast by the phenomenal success of Walt Disney's new production "Fantasia" with "fantasound" reproduction of the music.

Fantasound is a system of (1) automatically controlling the apparent source of sound in the theatre and (2) expanding the range of sound intensity. The "dimensional" or perspective effect gives sound a new life; the buzz of a bee moves across the screen and into the wings of the stage, the audience has the impression of being "immersed" in the orchestra, the violin appears to move from left to right

while the sounds of the woodwind section, which were on the right, now come softly through the wings at the left of the stage.

TREND TO FIDELITY

Thus the present trend of high fidelity and increased effectiveness of sound and radio is opening up new markets for PA men. Better and more elaborate equipment will be demanded in auditoriums, schools, churches, etc.

The principle of fantasound is that of separately recording three different versions of the sound. That is, the

string section of the orchestra would be recorded at a level considerably above the background of the rest of the instruments, on soundtrack A; another section, the woodwinds for example, would be similarly transcribed on track B, and so would the complete orchestra as it is normally picked-up by the mikes without any extra emphasis placed on particular instruments, be recorded on track C. These recordings are then matched together with a fourth "control" track on the same strip of 35 mm. film. The sound recorded on each of the first three tracks may be any part or all of the original sound and is usually a portion of the sound to which it is desirable to give particular emphasis.

The "control" track or fourth track, which has been mentioned, is an ordinary sound-on-film recording consisting of three frequencies which are not in harmonic relation. In the fantasound film, the three control frequencies used are 250, 630, and 1500 cycles per second. Each of these three frequencies, through its recorded volume, controls a particular sound track.

CONTROL VOLTAGES

These control frequencies are amplified and then separated by filter networks. The three amplified signals are rectified to form the DC control voltages. These varying DC voltages control the bias on the 106-watt amplifiers, thereby regulating the volume, just as AVC does in a radio.

The three control frequencies are recorded along with a playback of the three original musical tracks in such sequence and volume level that the desired effects of stereophonic and moving sound are realized. For example, if it is desired to "move" a sound from left to right across the screen, and the 250-cycle note controls the left speaker

group, 630 cycles the center group, and 1500 cycles the right group, the procedure is as follows: The center and right hand speaker groups will run at low volume with the background music due to the high level of the two control frequencies, 630 and 1500 cycles. The left amplifier and speakers will operate at normal level corresponding to a low level 250 cycle control tone. The sound on the "left" track will appear on the "center" track while the 250-cycle signal is increasing in level on the control track to cut down the volume of the left amplifiers. At the same time, the 630-cycle note is decreasing in amplitude to let the center speakers carry the normal level of the sound which a moment before was on the left. The volume of the center speakers is then decreased while the same sound appears on the "right" track and the 1500-cycle note decreases in level to allow the right hand speaker group to come up to normal volume with the original sound.

90 SPEAKERS

These changes from one speaker group to another are not noticeable by the audience; only the total effect of a moving sound is apparent. A sound may be "moved" from right and left toward the center, or from the center out to both sides, etc.

The three-stage speaker banks consist of 8 low-frequency and 4 high-frequency units each. The remaining 54 speakers of the 90 total are placed around the walls of the theatre. These speakers are divided into two groups and are connected to the right and left stage speaker banks.

Normally silent, the house speakers serve to alter the reverberation time of the theatre and create the illusion of "surrounding" the audience with sound. These "house" speakers are

manually controlled as to the point in the show when they are connected with the stage units.

75 DB VOLUME RANGE

The normal recording range of volume on the original sound track is about 25 DB while the dynamic range of the amplifiers is 50 DB. The total dynamic volume range of the system, under the control of the fourth track, is 75 DB, which more nearly represents the range of a symphony orchestra (which may be 100 DB).

The block diagram of the system shows an actual strip of sound film, the photocells, control, amplifier and speaker equipment.

For emergency use, a regular sound-track is also printed on the picture (Continued on page 23)



Top. One of the "house" speakers being installed in Broadway Theatre, New York.

Center. Some of the auxiliary "house" speakers across the back of the theatre. These are connected to proper stage banks and serve to surround the audience with sound.

Left. Main stage speaker banks. Compare size to man at left. Each bank connects to separate amplifier channel with 106-watt output. Note high frequency units on top of the L. F. horns.

Block diagram of the "Fantasia" sound system with a reproduction of the four track sound film shown at the left.

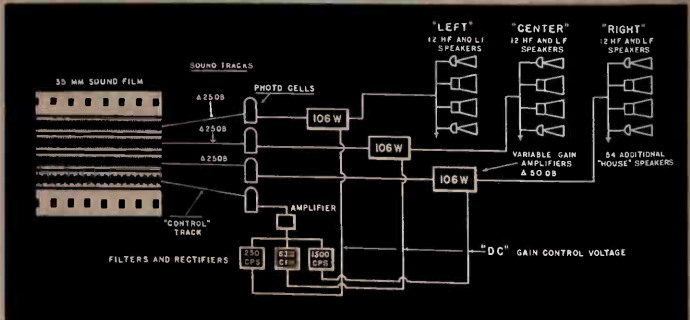

HOW DEALERS DO IT

"Radio Census" Gets New Contacts

Here is an idea for dealers operating in cities having two or more broadcast stations.

Map out a sales campaign whereby listeners are catalogued by making the "RADIO CENSUS." Each household is personally visited and the housewife asked if the radio is on, to what program tuned, and asked to mention several favorite programs. No query is made regarding which station is favorite, to avoid unnecessary blood being shed between rival broadcasters.

In the course of conversation, information is sought as to the year the present radio was purchased. The canvasser then consults his quotation book and marks on a card the trade-in value for the householder's future reference. Radio stations and sponsors will thank you for the tabulated comments on favorite programs and the stations which are tuned in at varying parts of the day. Dealers can then catalogue the city by sections and promising patrons may be selected for a callback or phone followup.

The plan also provides a slant on the used radios available and the average age. Canvassers can catch at a glimpse the financial status of the family, their need for an extra radio in the house, interest or lack of it in phonograph and recording devices

and antenna equipment. It must be stressed through newspapers and direct mailing that the Radio Census is solely for the purpose of maintaining a closer three-way relationship between store, radio station and individual radio listener.

Leave a New Set, While Fixing Old

L. L. Kelsey of Stewart-Warner tells how recently he visited a dealer who was "worried sick" because he had 22 radio sets on his service bench promised to his clients within 48 hours. Kelsey asked how many new radios the dealer had in these homes on demonstration while he repaired the old sets, and was surprised to learn that the dealer didn't have any.

Kelsey pointed out that if the dealer left new sets on demonstration the service department could take plenty of time for repairs. Also the extra time afforded would give the family an opportunity to get "wedded" to the new set and so would in many instances convert such a service call into a new sale!

Keep an Eye, or a Chain, on Your Personal Sets

Naturally, a radio dealer is anxious to display his new "personal" receivers out where the customers can paw them around. But it gives the store

a new problem, because the camera-sized sets are being filched by the dozen. Most of the thefts are being reported in the big bad cities like New York and Chicago, where the pre-shrunk receivers are being hidden under coats and hustled out of the store before the merchant can say \$20.

RADIO TODAY has looked into the matter and has some rather violent data to report. For instance one jobber says that it's the dealer's own damned fault. "God knows that radio buyers are scarce enough! The salesman should be at the side of the prospect every minute!"

One dealer snapped crossly that "I don't have that kind of trade at my store." We reminded him that the thievery was in progress at some of the flossiest shops in Manhattan, and can only hope that somebody didn't walk out with a couple of sets while he was exhibiting his optimism.

TRAPS ARE BAITED

Other dealers have taken steps to make it tough for the robbers. One store has a photo cell outfit which starts an uproar whenever a customer picks up one of the tiny sets. One of the biggest stores in New York uses a fancy chain to keep the radio identified with the counter. And some of the retailers are using the shoulder straps which come with the radios, to buckle them down to display fixtures.

In one case, a radio man reported that he had always been forced to keep an eye on his midgets, and that this was nothing new for him. He displays the smaller sets in a spot near his office, and he is not to be fleeced by any vandal of ordinary skill. Another device: attach a small bell to the radio so that the sticky-handed fellows will be accompanied by a rousing ting-ling while they make for the door. The latter plan has saved one dealer a perfectly good RCA, that we know of.

Still another suggestion, which perhaps belongs to the less serious section of the annals of crime, is just to encourage the bums to steal the radios. Then you report the matter to the police and the newspapers, and you get reams of free publicity for your new type radio. Before you know it, the "personals" are in the same class as gems. Small, but terrific.

Oh, yes. We may as well report the remarks of the embittered dealer who has a large store and hires eight or ten salesmen for it. "I think," he muttered, "that most of the sets are stolen by my own salesmen, but of course you can't quote me on it!"



Football displays will be unseasonal after New Year's Day; then you can do stunts like this with other sports. It's a modernistic trim at Goldblatt's, Chicago.



MAKE a place for the YEAR BOOK
in your 1941 advertising budget.

RADIO'S ONLY COMPLETE TRADE DIRECTORY AND YEAR-ROUND BUYERS' GUIDE

WHILE you are making provision in your budget, you can make sure of having your advertisement appear alongside your free directory listing if you make your space reservation NOW.

Positions are assigned in the order of their receipt by us. Don't jump to the conclusion that there's "lots of time." There's not. Orders are coming in now. The 1940 Year Book was 40% greater than in 1939. On the basis of orders already on hand, the 1941-42 Year Book will be the largest ever published.

Each previous edition of this annual directory has been a complete sell-out as far as the choice positions are concerned. That's because the selling power of the directory is known and appreciated by many advertisers who use it year after year.

We repeat: provide for it in your schedule and, if possible, make your reservation now.

Published annually in March as an
integral section of RADIO TODAY



Covers the purchasing power of the
radio and electronic field, including:

- ▲ Executive, engineering, purchasing and sales heads of ALL manufacturers in the radio and electronic field.
- ▲ ALL jobbers of parts, accessories, servicing equipment, sets, sound systems, recorders, etc.
- ▲ Operating engineers or technicians of all U.S. broadcast stations and recording studios.
- ▲ Handpicked lists of dealers and service dealers, sound specialists, auto radio installers, etc.
- ▲ Heads of U.S. government communication and recording services - Weather, Forestry, Coast Guard, F. B. I., Army, Navy, Air services, etc.

If you need further information NOW—

Telephone New York City (PLaza 3-1340) or Chicago (Randolph 9225), or wire us collect.





Above, the new quarters of a Minneapolis, Minn., parts jobber, L. J. Bonn, who estimates his volume for this year around \$165,000. The firm has a branch in St. Paul, and has gradually expanded after opening with a few lines back in 1931. Bonn's new methods of stocking and displaying are shown in main floor scene, right.



PARTS SALES STRATEGY



At left is the short wave receiver display at front entrance. Extra "cleanness" in these main floor sections is due to Bonn policy of keeping all the slower items in basement.



At the right is Bonn's "Bargain Basement" where obsolete or overstocked items are spread out, after being taken off inventory. Bonn got quantity and variety here by buying a bankrupt stock. Idea has helped greatly to move dead items, and keep upper floors in extra good shape.

QUALITY IN SOUND

(Continued from page 19)

film. This emergency track uses the regular sound equipment of the theater when it is required.

The special equipment was built for Fantasia by RCA. Twelve more units will soon be operating in theatres all over the country, and plans call for still more sets of apparatus.

Sound men can learn a lot from the methods used by motion picture engineers to achieve realism as well as trick effects. Smaller scale adaptations of the multiple channel idea can be used for plays and other auditorium sound jobs.

A possible system would use three separate amplifiers and speaker groups arranged on the stage to give much the same perspective of sound as used in Fantasia. The gain controls of the three amplifiers are then arranged for easy control by the operator. In the type of play where action takes place at the right and left sides of the stage, pickup at these points and amplification through speakers placed in the same relative position will create new realism in the performance.

Perspective speakers must be placed far enough apart to be effective; the farther the better.

HOW TO DO IT

Practice in operating the controls will show a lot of effects that can be obtained. Action moving from one side of the stage to the other can be followed by spacing the mikes at left, center and right and adjusting the gain of the amplifiers in the proper order and time. Off-stage sound effects especially, will be realistic when they are heard from the proper quarter.

If the directional characteristic of the sound is required only a few times during a performance, a single amplifier could be used by switching the speakers to correspond with the position of the mikes. The volume of the channels should be reduced to zero before the speakers are switched to prevent "thumping." Another alternative would be to use individual attenuators in each speaker circuit, thereby cutting in and out the horn associated with the place of action on the stage.

The public attention that is being given to this type of sound will also focus more strongly on PA systems that do not have corresponding reproduction quality and versatility. The public is being educated to quality reproduction in high-fidelity stations and in FM broadcasting, and now is the time for PA men to sell the jobs that carry out this new trend.

Kaar Names Neely

Kaar Engineering Co., Palo Alto, Calif., has appointed Norman B. Neely, technical sales representative, as exclusive representative for southern California and Arizona. Kaar manufactures a complete line of police and communications radio equipment. One of the specialties of the Neely organization is contact with state, county and municipal governmental agencies.

Here's the one you have been waiting for!



This "different" Meissner Portable

PHONO-RECORDER

can bring YOU extra profits!

Whether you are a Jobber, Dealer-Serviceman or Sound Technician, this new Meissner Portable Phono-Recorder should be the means of putting extra money in your pocket!

Its outstanding high quality, professional appearance and operation, fidelity of recording and reproduction, facility and flexibility in handling all sizes of records up to 12"—plus its additional features including its use as an auxiliary P-A System for small groups, make its demonstration and sale almost a matter of form in many widely variant fields.

Housed in an attractive airplane-luggage case, only 16" x 17" x 7", this instrument is readily handled on any kind of job. Contains built-in, high-quality audio amplifier, complete with tubes; space for crystal mike and power cord inside case; record storage space conveniently placed inside demountable cover. Operates directly from any 110-volt, 60-cycle power line. Sturdy 6" dynamic speaker furnishes full volume output on reproduction or P-A use, without distortion.

Fully equipped with complete control equipment for making high-grade recordings—Volume Control, Tone Control, Selector Switch for Recording, P-A and Reproduction, Normal and Overload Indicators; provided with first quality magnetic cutting head and wide-range crystal pick-up. Furnished with combination hand-and-stand crystal microphone.

Nothing has been overlooked to make this unit the real leader of the field in quality performance! And yet the price has been held to an encouragingly low level—only \$59.50 list, subject to usual Jobber and Dealer discounts!

Write for Your Free Copy of the New Meissner General Catalog!

ADDRESS DEPT. T-12



Thanks—
Mr. Philco Dealer

—for a year of record-breaking
Radio and Phonograph sales
... the 12th Straight Year of
Philco Leadership!

—for a year of record-breaking
Refrigerator sales ... achieving
an Increase of Over 300%

Yes, 1940 was Great...
1941 will be Greater!

PHILCO ALL YEAR 'ROUND F

HOME RADIO • PHONOGRAPHS • TELEVISION • AUTO RADIO • RAD

BIG NEWS

NOW ON ITS WAY TO YOU

Philco Announces New Radio and Phonograph Models for January to June Promotion!

The past year has been the biggest year in Philco Radio history. More sales, more advertising, greater promotions than ever before. And, right on the heels of this profitable year, Philco brings you a sensational series of brand-new models to keep your radio profits BOILING after January 1st... to keep your sales UP right through the Winter and Spring.

These additions to the 1941 Philco line are not just new models but amazing PROMOTIONAL values, designed to help you cash in on the tremendous popularity of Philco's great 1941 inventions.

You need "HOT" VALUES in the Winter and Spring. And they are ready for you... the greatest promotional items ever offered in radio giving you the opportunity for the biggest January to June you have ever known!

Right now, your Distributor is at a special Philco meeting... getting the news about the sensational new radio models. He is telling the great Philco story... that will bring you big business for you from the very beginning of the new year! So prepare yourself for a greater radio year in 1941.

GREAT REFRIGERATION PROGRAM SPURS PHILCO ALL YEAR 'ROUND PLAN!

Thanks to your confidence and support, Mr. Philco Dealer, Philco Refrigerator sales for the past year showed an *increase of over 300%*... the greatest record of sales growth in the industry.

The sensational 1941 Philco Refrigerators now on the way to your distributors and shortly to be announced to the trade will give you new evidence of the power and ingenuity of Philco engineering and merchandising.

These refrigerators are new and different, chock full of exclusive features that lift Philco out of the crowd... saleable features in every price bracket that only Philco dealers will have to sell.

An advertising and promotional program worthy of this great refrigerator is now in the works. It is a typical Philco campaign, dominating, forceful, practical.

Philco All Year 'Round, in 1941, is a policy of vital importance to every Philco dealer. Radio and refrigeration are now linked together in a mutual profit program that makes the Philco franchise the most valuable in the appliance field.

*In Radio and Refrigeration, it's Philco in 1941!
...Get the Story from your Philco Distributor.*

PROFITS ALL YEAR 'ROUND

ES · PARTS · REFRIGERATORS · AIR CONDITIONERS · DRY BATTERIES

Thanks— Mr. Philco Dealer

—for a year of record-breaking
Radio and Phonograph sales
... the 12th Straight Year of
Philco Leadership!

—for a year of record-breaking
Refrigerator sales ... achieving
an Increase of Over 300%

Yes, 1940 was Great...
1941 will be Greater!

BIG NEWS NOW ON ITS WAY TO YOU

Philco Announces New Radio and Phonograph Models for January to June Promotion!

The past year has been the biggest year in Philco Radio history. More sales, more advertising, greater promotions than ever before. And, right on the heels of this profitable year, Philco brings you a sensational series of brand-new models to keep your radio profits BOILING after January 1st... to keep your sales UP right through the Winter and Spring.

These additions to the 1941 Philco line are not just new models but amazing PROMOTIONAL values, designed to help you cash in on the tremendous popularity of Philco's great 1941 inventions.

You need "HOT" VALUES in the Winter and Spring. And they are ready for you... the greatest promotional items ever offered in radio... giving you the opportunity for the biggest January to June you have ever known!

Right now, your Distributor is at a special Philco meeting... getting the news about these sensational new radio models. He is hearing the great Philco story... that will mean big business for you from the very beginning of the new year! So prepare yourself for an even greater radio year in 1941.

GREAT REFRIGERATION PROGRAM SPURS PHILCO ALL YEAR 'ROUND PLAN!

Thanks to your confidence and support, Mr. Philco Dealer, Philco Refrigerator sales for the past year showed an increase of over 300%... the greatest record of sales growth in the industry.

The sensational 1941 Philco Refrigerators to be announced to your distributors and shortly evidence of the power and ingenuity of Philco engineering and merchandising.

These refrigerators are new and different, chock full of exclusive features that lift Philco price bracket... saleable features in every have to sell.

An advertising and promotional program worthy of this great refrigerator is now in the works. It is a typical Philco campaign, dominating, forceful, practical. Philco All Year 'Round, in 1941, is a policy of vital importance to every Philco dealer. Radio and refrigeration are now linked together in a mutual profit program that makes the Philco franchise the most valuable in the appliance field.

*In Radio and Refrigeration, it's Philco in 1941!
...Get the Story from your Philco Distributor.*

PHILCO ALL YEAR 'ROUND FOR PROFITS ALL YEAR 'ROUND

HOME RADIO · PHONOGRAPHS · TELEVISION · AUTO RADIO · RADIO TUBES · PARTS · REFRIGERATORS · AIR CONDITIONERS · DRY BATTERIES



CAP SAYS:—

H. L. M. CAPRON
Merchandising
Editor

Mark Twain once said "Everyone talks about the weather, but no one does anything about it."

That's pretty much like the evils in the radio business.

Recently I talked with half a dozen dealers in a small city on this much-talked-about subject. Every dealer told me what was wrong, disclaimed any responsibility himself, and named one of the other six as the "horn and tail" guy.

As far as I could see, they were *all* good fellows, trying to do an honest, clean job, and make a decent living.

But *all* were paying more attention to the *other* fellow than they were to running *their own* business the way they *should* run it.

That goes for manufacturers too, who will copy and follow one another almost blindly.

If men, and companies, dealers and manufacturers, only had enough *confidence* in themselves, and courage to do what they know is right, and let the "devil take the hindmost" our industry would be a lot different—quickly.

It *can* be done, for others have done it, but then, perhaps they *wanted* to do it more than the radio industry does.

QUALITY SETS IN FAVOR

(Continued from page 11)

scarcely ever destroy the unity of any floor grouping, particularly if the units concerned are of a musical nature. Certainly people "will never get interested in combinations unless they are exposed to them."

TECHNICAL TALK

"I like to sell these sets with the back panel off," says this radio man. "Even if the prospect does not understand what you are saying about tone ranges, speakers, and circuits, your language and your easy familiarity with them are impressive."

(He has found, however, that people *do* know something about speaker sizes. This feature of the radio, at least in this dealer's experience, is popularly regarded as an index of its tonal ability.)

A speaking acquaintance with the various period cabinet characteristics is important in this business, of course, and this radio man can get very glib about some period fundamentals which he has found very easy to master. While he has been around period cabinets he has observed them thoughtfully and carefully and has done some "home work" on the subject.

"It's a mistake to imagine, though," he declares, "that all of the 'musician' types of prospects are fussy about cabinets. Some of the long-haired, more informal types don't give a damn about how the cabinet looks or how it will fit into their studios

... they want high fidelity and little else."

Additional sales methods are reported by a dealer who says that "I demonstrate and describe the big sets in a way that makes them sound like they would cost \$500. Then when I tell the prospect the price around \$200, after the sales talk is further along, it is a pleasant surprise."

A classical or semi-classical record—a really good recording of an interesting selection—is used in demonstrations here. At this store, the

most-used one is the Hungarian Rhapsody No. 2.

This dealer does a flourishing business in records, and he says that record buyers often become buyers of quality sets. It happens like this: A customer hears a new record of a symphony and wants to buy it. But he says that "I'm just afraid that it won't sound decent on my old record player." Then the record is played on a combination in which the customer might reasonably be interested, and the dealer has the beginnings of a contract.

That all the better radios be kept in an absolutely neat and polished condition is specially important, this retailer advises.

Philco Sets Radio Records

Philco Corp. has recently been busy with breaking records in production, promotion and gross sales.

One event was the production of the company's 15,000,000th radio, which was presented to Philadelphia Mayor Robert E. Lamberton, by Philco vice-president in charge of production George E. Deming, with appropriate ceremonies. The event was described as "a production achievement made possible by extensive engineering and research."

Later, the firm's advertising manager, Ernest B. Loveman, announced Philco's most ambitious Christmas advertising and merchandising campaign in its history. Ads in leading magazines and newspapers and a new Christmas display were included.

Further news was made by executive vice-president Larry E. Gubb, who reported that Philco's gross sales for the first 10 months of this year were 24 per cent over last year. Mr. Gubb revealed that sales of combinations were nearly 5 times as great as last year, and that refrigerator sales had nearly tripled.



Dealer and manufacturer discuss Farnsworth sales plans for quality radios. Jerome Murphy, left, M. Steinert & Sons, Boston, and I. C. Hunter, Capehart division sales manager.

ALL THESE 24 BIG ISSUES



AND RECEIVE *Free* A COPY OF THIS
MUCH-NEEDED RADIO TRADE DIRECTORY!

PUBLISHED ANNUALLY,
THE RADIO YEAR BOOK
AND TRADE DIRECTORY
IS BOUND INTO RADIO
TODAY AS AN INTEGRAL
SECTION OF THE MARCH
ISSUE.

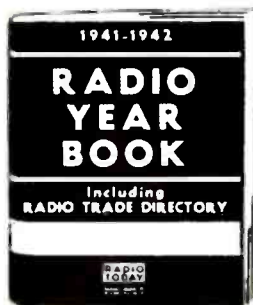

IF YOU ACT PROMPTLY,
YOU MAY START YOUR
SUBSCRIPTION WITH RA-
DIO'S TWENTIETH ANNI-
VERSARY ISSUE. QUAN-
TITY STRICTLY LIMITED.

Here is your biggest value in radio trade papers. For less than 1¢ a week you can keep up to date on all important developments in the radio industry — news, merchandising ideas, servicing methods, new products, etc. — in radio's outstanding magazine.

You need BOTH—RADIO TODAY and RADIO YEAR BOOK

The 1941-1942 RADIO YEAR BOOK and TRADE DIRECTORY is a well-known buyers' guide. It tells you Who makes What.

It is the ONLY directory available anywhere in the industry which gives you the names and addresses of Manufacturers of ALL products used by radio service men.

The Year Book's available information does not stop with the directory. It gives you also:

All American Broadcasting Stations and leading Short Wave Stations of the World—Television Stations—Built, building and planned—Frequency Modulation Stations in operation and authorized.

Your subscription to RADIO TODAY insures your receiving a copy of the 1941-1942 RADIO YEAR BOOK and TRADE DIRECTORY. Information is now being compiled. Copies will be mailed in March, when it will be published as a section of RADIO TODAY.

DON'T DELAY . . . MAIL THIS COUPON TODAY

RADIO TODAY, 480 Lexington Ave., New York, N. Y.

Enter my subscription for 2 years, including the Radio Year Book and the 20th Anniversary Number.

I am attaching \$1 in full payment. (Foreign—\$2.)

Name

Company

Address

City State

NEW RADIO MODELS



Zenith Poketradio

★ A 4-tube superheterodyne is model 4K600, featuring Litz wound Wavemagnet, 6 tuned circuits and core tuned I. F. transformers. Opening cover turns on set. 3½ in. P. M. dynamic speaker. 540-1600 kc. Weighs 4 lbs., 9 oz., 3¾ in. x 4¼ in. x 7¾ in. \$19.95 fob factory. Zenith Radio Corp., 6001 Dickens Ave., Chi., Ill.—RADIO TODAY.

Emerson Phonoradio

★ Model 397, AC superhet automatic combo covering standard American and police broadcasts. 5 tubes, 12 in. electro-dynamic speaker, inclosed super-loop. Automatic record changer, 10 and 12 in. records, crystal pick-up. 18th C. walnut cabinet. Emerson Radio-Phono Corp., 111 8th Ave., New York, N. Y.—RADIO TODAY.



Sonora "Gems"

★ Three new "Teeny Weenies" 4 tube AC-DC plastic table models feature P.M. dynamic speaker, built-in antenna. Come in 3 color-schemes, KF-121, green-maroon combination, KF-127, tan-green, KF-123 (shown) maroon-tan. Sonora Radio and Telev. Corp., 2626 W. Washington St., Chicago, Ill.—RADIO TODAY.

General Telev. No. 696

★ Plastic table model available in ivory or walnut, features a new patented Syncro-tenna (Wavescope) and Polytrol resistor system. 6 tubes, AC-DC superhet, 5 in. dynamic speaker. Telev. and phono. connector. Standard Amer. broadcast and police. General Telev. & Radio Corp., 1240 N. Homan Ave., Chicago, Ill.—RADIO TODAY.

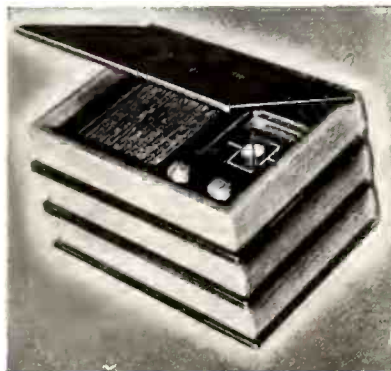

Sentinel book radio

★ Model 238V book radio with 5 tubes AC-DC superheterodyne circuit. Built-in loop aerial, A. V. C. Tunes standard broadcast band. Case bound in maroon-colored simulated leather. 10½ in. x 7¼ in. x 5¾ in. \$19.95 Sentinel Radio Corp., 2020 Ridge Ave., Evanston, Ill.—RADIO TODAY.



Dynavox port. phono

★ Deluxe amplified portable electric phonograph, model 501, with grained Fabricoid case in black and other colors. Crystal pickup. 110-120 v., AC. \$39.50. Dynavox, 55 E. 11th St., N. Y. C.—RADIO TODAY.



Admiral "camera" radio

★ Self-powered superhet bantam portable 27-G4, has powerful miniature P.M. dynamic speaker, Aero-scope, iron core I.F. coils, A.V.C. 4 miniature multi-purpose tubes 2 flashlight and 1 B battery. Ebony Lumerith plastic case with simulated snake skin trim. 8¼ in. high 4½ in. wide, 4 in. deep. \$14.95. Also available for 5-tube AC-DC battery operation. Continental Radio & Television Corp., 3800 W. Cortland St., Chicago, Ill.—RADIO TODAY.

GE auto radio

★ GE, model JA-64, 6-tube superhet radio of gray wrinkle enamel incorporates the touch-tuning feature. New stations easily set up. Manual tuning knob and illuminated slide rule dial. Chassis and 6 in. electrodynamic speaker are built in single unit. Variable antenna adjustment. General Electric Co., 1285 Boston Ave., Bridgeport, Conn.—RADIO TODAY.



Echophone receiver

★ "Commercial" Model EC-1, AC-DC compact type receiver. Turning range continuous from 545 kc to 30.5 mc. Electrical band-spread tuning. Headphone speaker switch; beat frequency oscillator, permits code reception. 5 in. P. M. speaker. \$19.95. Echophone Radio Corp., 201 E. 26 St., Chi., Ill.—RADIO TODAY.

Emerson Names Schasseur for Latin America



Robert Schasseur

Robert Schasseur, long-time Emerson distributor in Paris, France, has now been named Emerson's traveler for Central and South American countries.

An 8-month tour is planned for the new representative. He will visit established Emerson distributors and work on outlets in new territories. His first stop will be Mexico and he will end his itinerary at Rio de Janeiro, Brazil, where he plans to spend a month to six weeks.

DeWald "in Radio Since 1921"

In reproducing the early trademarks of concerns that have long been active in the radio business, under the heading "Names that Shine in Radio History" in our 20th Anniversary Number in November, the DeWald Radio Manufacturing Corporation, 436 Lafayette St., New York, was inadvertently omitted through an engraver's error.

The DeWald corporation, under the direction of President David Wald, has been continuously in business since 1921, without any corporate adjustments whatsoever. This long active history as a pioneer radio manufacturer has led to the slogan which appears on the DeWald letter-head: "Quality Since 1921".

Radio Leaders at Charity Event

More than 1,200 leaders in the radio, musical instrument, refrigeration and allied fields attended the \$100-a-couple Twelfth Annual Radio Dinner Nov. 24 at the Waldorf-Astoria, New York City. The dinner was part of the 1940 campaign of the New York and Brooklyn Federation of Jewish Charities. A 3-hour performance by stars of stage, screen and radio followed the dinner event.

Henry Benjamin, Samuel Kassover and H. M. Stein are honorary chairmen of the radio division of the Federations.

Associate chairmen who serve with Mr. Smith and Max Kassover are: Benjamin Abrams, Abe Bloom, William Brand, Samuel Salzman and Irving Sarnoff.

Motorola Appoints Idaho Jobber

Billmeyer, Inc., Fifth and Center Sts., Pocatello, Idaho, are now the distributors for Motorola car and home Radio in the middle and southern part of Idaho, the entire state of Utah, the southern part of Wyoming and in five counties along the eastern border of Nevada.

Philco Auto Set Sales to New High

Sales of Philco car receivers in the first ten months of 1940 added up to \$6,878,909 at factory selling prices, according to James T. Buckley, president of Philco Corp.

The 1941 line of Philco automobile radios was introduced in September and unfilled orders already total approximately \$2,000,000 at factory selling prices . . . we expect further increases during the next several months," Mr. Buckley stated.

In the past ten years Philco has made and sold more than 3,300,000 auto sets.



TRIPOLET
MODEL 1620

Combining simplicity of operation with absolute flexibility, Triplet's new lever switching permits individual control for each tube element yet test procedure is simple and quick. The switch setting shown above will permit tests of 45 commonly used different type tubes without change of positions of the levers. Many tubes require only two lever switch settings—more than half, only three settings.

Model 1620 also features four additional "quick change" non-obsolete features, including the above switching section. RED • DOT Lifetime Guaranteed Instrument panel may be returned

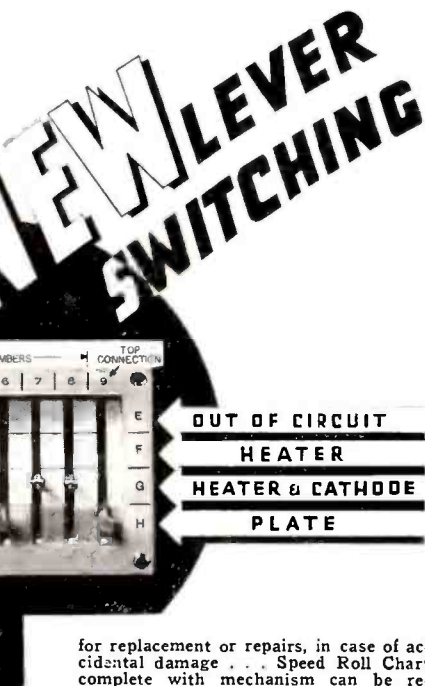

OUT OF CIRCUIT
HEATER
HEATER & CATHODE
PLATE

for replacement or repairs, in case of accidental damage . . . Speed Roll Chart complete with mechanism can be replaced, in the case of new factory releases, by removing only four screws from front of panel . . . New socket panel to meet future radical tube changes which present spare socket cannot accommodate will be available at nominal charge upon return of old panel . . . Switching section with power supply also can be replaced should unanticipated changes make it necessary. Gracefully proportioned wood case, natural finish. Beautiful two-tone brown-tan sloping panel; polished metal chrome trim with inlaid color.

Model 1620 Counter Tube Tester **\$37.84**
Dealer Net Price



MODEL 1612

Impressive Counter Tube Tester . . . RED • DOT Lifetime Guaranteed Instrument with 6" GOOD-BAD SCALE . . . Illuminated Speed Chart . . . Sockets include Loctals, Bantam Jr. and new Midgets. Provides for tubes with filament voltages from 20 steps from 1.4 to 117 volts. Dealer Net Price \$29.84

MODEL 1270

Model 1270 is an advanced electrical circuit analyzer that shows the wattage consumption, amperes and line voltage of all household appliances including electric ranges under actual operating conditions.
Dealer Net Price . . \$29.83



For full cooperation with the National Defense Program, Triplet engineering and production facilities are being rapidly expanded to continue the service and delivery to which our trade is accustomed.

WRITE FOR CATALOG . . . SECTION 1912 HARMON DRIVE
THE TRIPOLET ELECTRICAL INSTRUMENT CO.
Bluffton, Ohio

NEW SOUND EQUIPMENT

Products for higher fidelity and greater coverage with your PA and sound installations.



Erwood portable P.A.

The Rostrum system as it is called contains one portable case with amplifier, speaker, mike and controls, etc. Removal of cover gives access to illuminated reading platform. Erwood Sound Equip. Co., 223 W. Erie St., Chi., Ill.—RADIO TODAY.

P & B relays

★ New line of radio relays for AC and DC use may be had in 10,000 ohm resistances for high sensitivity in plate circuits. Antenna change-over and keying relays have polystyrene insulation. Complete line is described in new catalog with list prices. Potter & Brumfield Mfg. Co., Princeton, Indiana—RADIO TODAY.

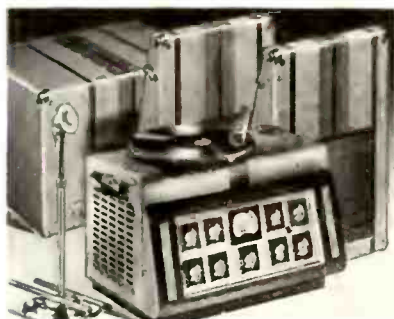

Allied sound system

★ Fifty-watt master system for large installations has 6 input channels, electronic mixing, inverse feedback, fuse protected speakers, silencer jacks, illuminated panel. Universal output impedances. Four mike, 2 phono inputs with individual controls. Allied Radio Corp., 833 W. Jackson Blvd., Chicago—RADIO TODAY.



Astatic FP pickups

★ Permanent sapphire stylus, feather weight contact of 1 ounce, curved off-set tone arm, are features of new phono pickup. Reduced weight of the vibrating system increases record life. Models FP-18 and FP-38 list at \$16.50. Astatic Microphone Labs., 830 Market St., Youngstown, Ohio.—RADIO TODAY.

RCA photo tube

★ Increased sensitivity to light sources predominating in blue is characteristic of the 929. Tube has sensitivity of 45 microamps per lumen from tungsten filament operating at 2870° Kelvin. Anode volts, 250. RCA Mfg. Co., Harrison, N. J.—RADIO TODAY.

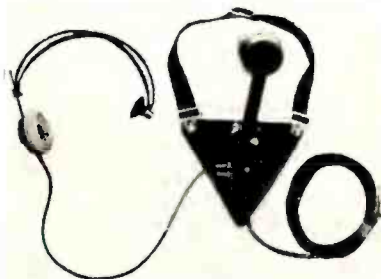

Universal mike

★ The new Universal dynamic breastplate type of microphone is designed for operators of wired music systems. It will be available in carbon and crystal as well as dynamic. Comes with Universal single or double headset in high or low impedance. Universal Microphone Co., Inglewood, Cal.—RADIO TODAY.

Sprague wire wound resistors

★ New type of insulation on resistance wire makes possible more compact resistors in high ranges. Insulation is moisture-proof and is not damaged by even red heat. New units known as Koolohms. Sprague Products Co., North Adams, Mass.—RADIO TODAY.



University "Bull" speaker

★ Model 4XR loudspeaker designed for 100 w. continuous audio output. Reflex projector is acoustically equivalent to 6 ft. exponential horn. Ruber tire rim. Four 25 w. Model PAH high efficiency break-down proof drivers. Completely waterproof. Complete incl. 4 PAH units, 4XH multiple horn, dust cover, mounting bracket less flat platform, \$255. University Labs., 195 Chrystie St., N. Y. C.—RADIO TODAY.

Turner contact mike

★ Magnetic pick-up for musical instruments, model MM has novel clamp for securely attaching it to violins, banjos, guitars, etc. without tools. Has continuously variable volume control built in. High impedance—works into grid circuit. Finished in brown enamel; 3¼ x 1½/16 wide. List, complete with 25-foot cable, \$12.50. Turner Co., Cedar Rapids, Iowa.—RADIO TODAY.



Lafayette amplifier

★ Model 462-T amplifier provides identical performance on car-battery or AC line. 30 W. output. 4 input channels. Tapped output from 2 to 500 ohms. Phono equipment has rim-driven turntable and crystal pickup. Lafayette Radio Corp., 100 Sixth Ave., N. Y. C.—RADIO TODAY.

"The Reps" Add New Members

Four new members have been added to "The Representatives", the national organization of manufacturers representatives. These are Carl A. Stone, 1406 S. Grand Ave., Los Angeles, Calif., George H. Pierce, 618 Girod St., New Orleans, La., Ernest L. Wilks, 7935 Eustis St., Dallas, Tex., and T. C. Ruhling, 304 Burt Bldg., Dallas.

Membership of this organization is now almost 200 and growing fast. Any factory rep handling two or more parts lines, who has been so engaged for one year or more is eligible for The Reps and should apply to the secretary, David Sonkin, 220 E. 23rd St., New York City.

Two members of the group now have new addresses: John Keefe, 721 Market St., Camden, N. J. and Fred C. Kennedy, 23 University Ave., St. Paul, Minn.

Emerson Tubes Get a Sales Booster

Now available from the distributors of Emerson Radio & Phonograph Corp., 111 Eight Ave., New York City, is a new display card for Emerson tubes, lithographed in full color, suitable for counter or window. It shows glass, bantam and metal tubes, plus vigorous sales messages on tube quality.

Emerson has announced the addition of a number of new tubes to its line, to fit replacement needs of the trade. These include 7A4, 7A5, 7E6, 7E7, 7F7-7G7/1232, 7J7, 12B8GT, 25B8GT, 32-L7GT.

Turner in Big Expansion

The manufacturing facilities of The Turner Co., makers of microphones at Cedar Rapids, Iowa, have been greatly expanded. Extensive additions have been made to the company's machine shop facilities, to take care of the fast increasing volume of business which the firm now enjoys.

An additional flash from Turner is that it is now licensed to manufacture vibrators for car and other portable radios under James patents 1,940,496 and 2,113,726. The firm will start deliveries Jan. 1, 1941.

McCanne Shows Values of Staticless Radio

Dramatic demonstrations of FM are being conducted at various meetings by the Stromberg Carlson assistant general manager, Lee McCanne. Two shows of feature interest were recently held for the Rotary Club of Wilmington, Del., and for the 700 members of the Forman's Club, Eastman Kodak Co., Rochester, N. Y.

Jobber Branches Out

Dymac, distributors of Buffalo, N. Y., have opened a new branch at 504 W. State St., Olean, N. Y.

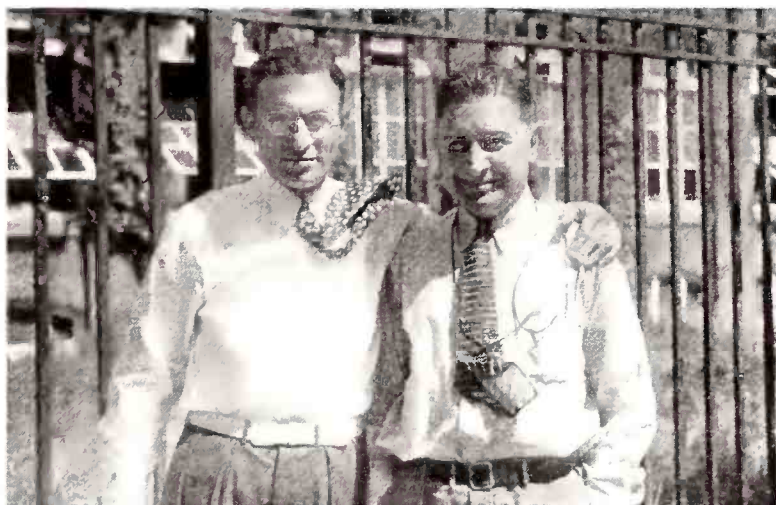

Here's a pair of veteran radio men—Charley Golenpaul of Aerovox, left, and Austin Lescarbourea, public relations expert and scientific writer. More should be said about the long-time record of Aerovox, certainly the name should have been included among "Names That Shine in Radio History" in the 20th Anniversary issue of "Radio Today" last month.

RCA Personal Catches Up with Demand

RCA Victor now reports that its Personal radio has at last achieved distribution throughout the country after unprecedented demand had retarded its advance on new markets for

several months."

As dealers and distributors report exceptional interest in the radio as a gift item, and the novelty of the set continues to attract widespread publicity, RCA gives it an additional boost via color ads in the December issues of leading magazines.

VELOCITY **AMPERITE** **P. G. DYNAMIC**

2 GREAT MIKES!



AMPERITE VELOCITY
with exclusive **ACOUSTIC COMPENSATOR**

Actually a combination Velocity-Dynamic, having best features of both types.

Model RBHk, hi-imp: (RBMk, 200 ohms); LIST \$42.00
Model RBSHk, hi-imp: (RBSk, 200 ohms); LIST \$32.00



ELIPSOID PICKUP PATTERN

Features new superior **UNI-DIRECTIONAL elipsoid pickup pattern.**
ELIMINATES FEEDBACK TROUBLE. HAS FLAT RESPONSE.

Model PGH, hi-imp: (PGL, 200 ohms); 40-10,000 CPS,..... Chrome LIST \$32.00
Model PGAH, hi-imp: (PGAL, 200 ohms); 70-8000 CPS,..... Chrome LIST \$25.00

AMPERITE KONTAK MIKE

Puts musical instruments across. Beautiful results with any amplifier, record player, and most radio sets.

MODEL SKH (hi-imp)..... LIST \$12.00
MODEL KKH, with hand volume control, LIST \$18.00
Plug extra..... LIST \$1.50

AMPERITE WRITE FOR FREE SALES AIDS
561 BROADWAY
NEW YORK



NEW REFRIGERATORS

The homes in your community can now get the benefit of an interesting series of new services, offered by the 1941 refrigerators. These services—the ability of the boxes to perform new tasks for the housewife—are reaching a new high and they're giving the retailer of refrigerators something solid to talk about.

The new models are the kind which outmode the old ones, and fit smartly into the "food trends" of the day. They can be presented as the up-to-the-minute center of the modern kitchen, with their different kinds of cold, and their room for everything.

All these features, of course, cannot be offered at rock-bottom prices, but the buying power of the public is now so stoutly on the uptrend that this hurdle will not worry the enterprising dealer.

Most of the manufacturers are really helping the dealers to get this sales job under way. They have organized consumer advertising campaigns on a new scale, and they are offering sales helps that get down to business.

Some of the newest lines to be shown are described here. They will be followed in future issues by sales-points summaries of models being shown later this month.

GALE SIX

The No. 1 refrigerator to be shown for 1941 by Gale Products, Galesburg, Ill., is a six footer model GS658. It's a unit in the popular price bracket, with twin freezers (for ice cubes and frozen foods), extra capacity sliding meat drawer, glass utility shelf, twin vegetable fresheners, etc.

The Gale boxes all have the hermetically-sealed "Mechanical Iceberg" units. And one of their new developments is a "fluid cooled" static condenser which is said to cool during

The top box in Stewart Warner's line of Standard models, No. 801 at \$159.95.



Crosley's "Super Shelvador" is shown here on the Deluxe "8" model DM841.

the "Off" cycle. There's no fan—no moving parts.

Chrome-plated grilles, massive doors, rounded tops are the features of the Gale cabinet styling. The door handles and the trim inside show a lavish use of polystyrene plastic.

GIBSON FEATURES

Nine models are being marketed in 1941 lines of the Gibson Electric Refrigerator Corp., Greenville, Mich. There are five types, including the Conventional Freez'r Shelf, Deluxe Freez'r Shelf, Super Freez'r Shelf, and apartment house. Prices range from \$89.95 to \$219.95.

With emphasis on the Freez'r shelf feature, Gibson makes a point of extra freezing capacity and special chilling accommodations. In addition, the features are Defrostajar, Twin Fresheners, gliding shelves, tilt bin, etc.

The first model for 1941 to be shown by Gale Products, the six-foot GS658.

This company uses the Scotch Yoke sealed mechanism, and declares that "this principle floats power from the motor to the piston, resulting in almost unbelievable quietness."

CROSELY SELLERS

Introduced by the Crosley Corp., Cincinnati, are four 6-foot models and two 8-foot ones, besides the apartment house units. The line features a new patented Super Shelvador, which has Dulux-finished steel shelves with removable bottoms in place of the wire ones formerly found in the well known Crosley Shelvador. Extra convenience and space thus offered inspires the Crosley ad theme, "Food to the Front."

Two of the Crosley models, a six and an eight in the "DM" series, have the "Moist-Kold" feature, with refinements.

More sales points of this line include an improved Freezor-cold evaporator, extra large cold-storage meat chest, clear-vision crisper of increased size, new temperature control panel, Fiberglas insulation, one-piece all-steel cabinets, a newly refined Electro-saver, etc.

Stewart-Warner Corp., Chicago, has eight models in the 1941 line, four Standard units, and four Dual Temp ones. One of the latter group was shown in the November issue of RADIO TODAY.

SW features a moist-cold compartment and a "Freezing Locker." Sterilamp, illuminated 16-point cold control, "space-making" shelves, vapor sealed, all-steel cabinets, etc., are offered. The evaporator is a space-saving type which does not take up the storage room.

Standard models range in list prices from \$101.95 to \$159.95. The tags on the Dual Temps run from \$189.95 to \$259.95.

Representing the Gibson Super Freez'r Shelf line, SF-691 priced at \$199.95.

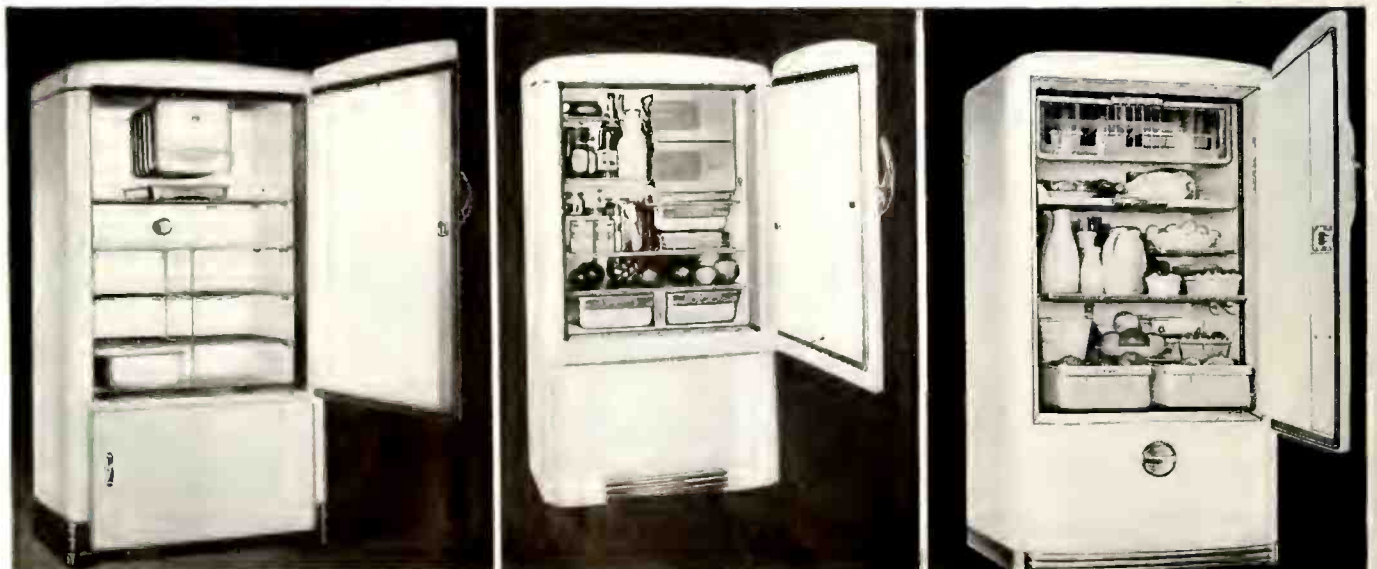

BOOM IN BOXES

For the first 10 months of this year, the sales of refrigerators to dealers and distributors amounted to 2,347,157, compared with 1,682,372 for the same period last year, an increase of nearly 40 per cent.

The latest monthly total for this year is for October, when 82,019 units were sold, according to reports from National Electrical Manufacturers Association, who combines the figures from 13 companies. In the same month last year, sales amounted to 57,715.

Howard Gates Is New President of Majestic

The new president of Majestic Radio & Television Corp., 2600 W. 50th St., Chicago, whose name is Howard Gates, and whose appointment has been announced by Majestic treasurer Elmer C. Upton, has had 21 years of experience in engineering and building radio sets. During this period he has held key posts with Zenith, Gates Radio, and Colonial Radio.

Mr. Gates for the past 4 years has been at Detrola Radio Corp., as vice-president in charge of engineering, which position he now leaves to become president of Majestic.

Walter G. Scott, acting president and a director of the firm, who had been retained during the company's period of reorganization, has resigned. Other directors include Allen B. Du Mont, Curtis Franklin, Parker McMahon, Rex Parkin, Paul Raiborn, and Mr. Upton.

Crosley Convention Sees More Business in '41

Crosley Corp. held its annual distributor convention at the Taft Theatre, Cincinnati, Dec. 2 and 3rd, with more than 200 jobbers on hand for an attractive presentation of Crosley refrigerators, radios, washers, ranges and ironers.

The big meeting opened with a welcome by Powel Crosley, Jr. and Ray-

mond C. Cosgrove. Other executives of the company to appear included Robert I. Petrie, vice president and general sales manager; J. F. Crossin, R. J. O'Connor and W. T. Wallace. L. Martin Krautter, with Roy S. Durstine and H. G. Little, of Crosley advertising counsel, told about promotion plans.

As the new products were shown and the big ad campaign behind them was explained, guests and convention leaders saw excellent business prospects for 1941. Mr. Petrie reported in his address that during the past 60 days more than 1,600 radio dealers had been added to the Crosley organization.

Mr. Cosgrove, as vice-president and general manager of Crosley's manufacturing division, described the new Crosley organization for the jobbers. He said, "We have developed a sales organization, headed by Mr. Petrie that is second to none in the business . . . the changes that we have been making are about complete . . . we are coming to this convention with the strongest setup of any that I know of in these kinds of businesses."

Callahan Joins Burton Browne

Burton Browne Inc., Chicago advertising agency has revealed the appointment of J. C. Callahan to head its Public Relations division. Mr. Callahan has supervised the advertising for many firms including Zenith, Colin B. Kennedy, Transformer Corp. of America, Home Appliance Division of Fairbanks Morse, and Majestic.

Opportunity for Radio Man in New Jersey

Samuel Siegal, of Siegal's Home Appliances, Watchung Ave. at North Ave., Plainfield, N. J., has announced that he will now offer for rent a radio concession in his store. Rent will be \$50 per month for the place in Siegal's large corner outlet, which is an established home appliance location.

Standard Sales New Home

Standard Sales Co., Spokane, Wash., Crosley distributor in the "Inland Empire," has moved into its new headquarters at 1219 W. First Ave.

FREE! New Turner Mike Catalog—Showing Way to New Sales and Profits

Including such favorites as

Turner 99 Dynamic

The toughest, most reliable and efficient mike in the entire Turner line, and the first choice for professionals who insist on the most for their money. No. 99 is demanded by internationally famous manufacturers for their finest equipment. The \$29.50 list price is right, and discounts assure real profits on a mike with no returned-goods headaches. Read all about 99 in the new Turner Catalog—the sure way to cash in!



Turner Hand-D Microphone

TRIPLE-PURPOSE

- Hang It
- Hold It
- Mount on desk or floor stand

Fills the job of several mikes, cutting your inventory. Specially engineered response for voice or music. Positive contact slide switch permits off-on operation without fatigue. With 7 ft. cable, using removable connector. Rich brushed chrome finish.

9X—CRYSTAL, List...\$22.50
9D—DYNAMIC, List...\$25.00



Turner BX "Challenger" Mike

Tops in low cost, high-performing units, ideal for P.A., recording or amateur work. Styled to sell on sight, and designed to stay sold. Attractive bronze enamel finish. With 7 foot cable.

BX—CRYSTAL, List...\$9.95
BD—DYNAMIC, List...\$12.50



Send for Your Catalog NOW

Crystals Licensed Under Patents of The Brush Development Co.

TURNER COMPANY 913 17th St. NE
Cedar Rapids, Iowa
Exported thru Ad Auriema, 116 Broad St., N. Y. City
Cable Address: Auriema, N. Y. City. All codes used.

New Short Wave Thrills



HOWARD "BAND EXPANDER" TUNING!

"Band Expander" tuning on HOWARD International Receivers electrically S-P-R-E-A-D-S short wave bands sixteen times. The dial diagram shows the ordinary crowded 25 meter band and illustrates the increased band range. All models have "Fly-Wheel" Tuning Controls, "Eye-Angle" Dial, and RF Stage for world-wide reception and high image ratio. The sensational new HOWARD International Receivers are profit producers! Send for information today!

America's Oldest Radio Manufacturer

HOWARD RADIO COMPANY

1731-35 Belmont Av., Chicago, Ill. - Cable Address: HOWARDCO, USA

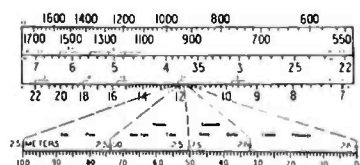

SERVICING FOR FIDELITY

How to make extra profit by improving tone quality and response with new parts.

High fidelity, quality, frequency response, and tone range are terms that are coming before the listening public in ever increasing doses. FM has been talked about, demonstrated and proved its reproducing qualities to an increasingly critical public. All of which points toward the serviceman's opportunity of selling high quality parts that will improve the tone range and quality of sets brought in for service.

The quality of reproduction that is possible from any receiver depends upon the quality of the parts used, especially in the audio section. Speaker, tubes, transformers, have to be good in themselves and must be properly matched to each other.

Chassis must be rigid, cabinets well braced, rf and other parts solid and not subject to vibration with normal operating conditions. Alignment must be perfect, tuning condenser, coils and speaker free from dirt. When these things are in tip-top shape, the correct electrical conditions can be established that will insure the best quality.

SPEAKER DELIVERS

The speaker has the job of vibrating the air at the intensity and frequency of the electrical power supplied to it. To do this job, its fundamental design must be such as to reproduce frequencies in the audible range equally well.

The modern high quality electrodynamic and PM dynamic speakers have been carefully designed so that the weight of the voice coil and cone, the compliance or springiness of the cone suspension, and the magnetic structure work together. This com-

pliance of the cone edge support is an important factor in the reproduction of "lows," while it is less important at the higher audio frequencies. A large diameter cone is required to reproduce the low notes. The mass or weight of the moving parts of the speaker (voice coil and cone) limit the high frequency response, but in order to prevent the generation of harmonics due to vibration of the cone itself, a fairly heavy cone is used. The facts indicate that it is not possible to produce a speaker having perfect response at both the low and high ends of the audio range.

SELLING PERFORMANCE

This is very much the case, and speakers are a compromise of the desirable qualities. The usual console set uses a 10 or 12 inch speaker which gives moderately good reproduction on the lows and middle register. Smaller speakers give a better high frequency response because of their light cones, thus the absence of "lows" in the small table sets and compacts. Because the average listener reacts more favorably to the low frequency response of a set, the single large speaker is usually satisfactory. Extension of the high range of reproduction would mean an additional speaker of small diameter. Adding a "hi" speaker is a very good "special job."

When one of the older sets comes into the shop for service, and observations show that a new modern speaker would really perk-up the response, install one and let the customer hear the difference. This procedure should only be attempted with regular cus-

tomers when it is obvious that a new speaker will improve the set and you have suggested a trial with the new speaker.

BAFFLE IMPROVEMENTS

Another cause of poor performance in some sets is the baffle effect of the cabinet. The purpose of a baffle is to increase the length of the sound path from the front of the cone to the rear

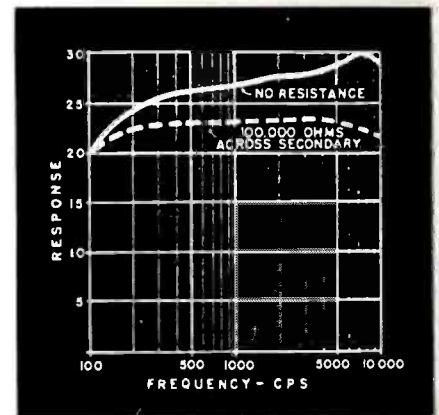

Response of older audio transformers can be smoothed out by adding shunt resistor to secondary.

and prevent cancellation of the two sounds which are 180 degrees out of phase. If the baffle is large enough to delay the sound from the back by $\frac{1}{2}$ wave length, the front and rear sounds will then be in phase and aid rather than oppose one another. The wave length at 100 cps is about 11 feet. This would require a baffle 11 feet square ($11\frac{1}{2}$ from speaker center to any edge). Such a baffle size is not practical for home receivers even when "folded" into a cabinet, and other means are used to secure good low frequency response.

If the open back of the cabinet is closed, the objectionable "cabinet resonance" is eliminated and more lows will come through, if the resonant frequency of the speaker is less than the open cabinet resonant frequency.

PHASE INVERTER

The graph, at left, shows the relative responses for an open back, closed back, and "phase inverter" type of cabinet. The open cabinet resonance "hump" is apparent as well as the extended low frequency response of the other two types.

The phase inverter cabinets are

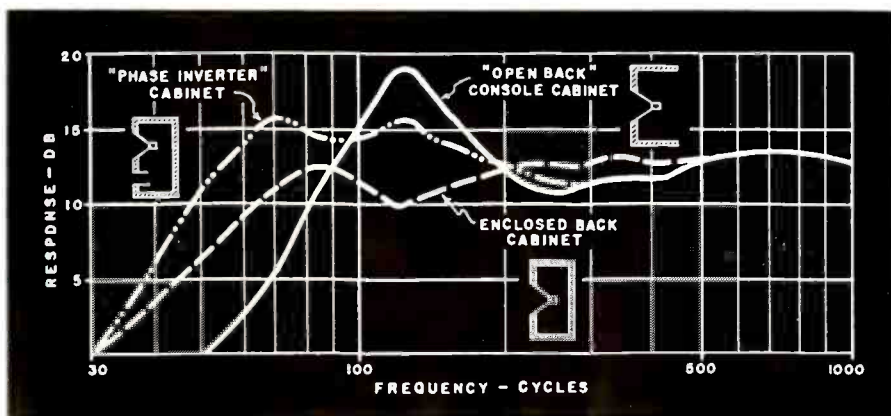

Comparison of frequency response characteristics for three different types of speaker housings. Note the resonant hump for the typical open back cabinet at approximately 120 cps. All improvement by other two types is below 500 cps.

modifications of the closed back type. The design is such that sound from the back of the cone comes through the opening in the front of the cabinet in phase with the normal sound.

The tubes in any set vitally affect the quality of reproduction. Push-pull tubes in particular can create distortion if they are not balanced, that is, they are not similar enough electrically. If one tube has a higher transconductance than its partner, distortion will result because the voltages from the two tubes will not be equal in magnitude.

Three types of distortion which may be in an amplifier are amplitude, frequency and phase distortion.

DISTORTION IN AMPLIFIERS

Amplitude distortion is the most common type and is due to operation on the non-linear portion of the tube characteristic. This type of distortion can be corrected by adjustment of the bias for the tubes so that correct operation is obtained, and limiting the driving voltage if necessary.

Where a special job is to be done,

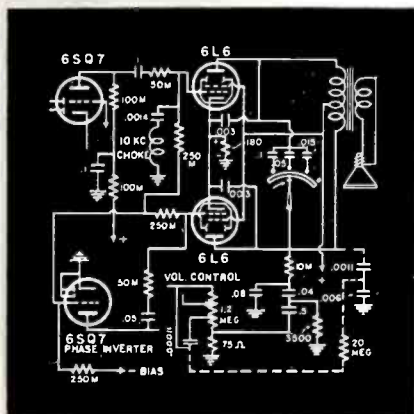

Circuit of the audio end of Emerson 365 showing 10 kc. trap and feedback.

measure the line voltage in the customer's home and if it is quite different from that in your shop, adjust the bias for correct operation under its usual operating conditions.

An average difference of 5 volts in the AC line would easily change the plate voltage by 25 volts and thus throw the bias off by several volts. As stated before, this procedure is not for the run-of-mill jobs, but only where the maximum quality is to be obtained.

The correct bias condition can be determined by several methods. The easiest is probably direct comparison with data on the particular tube type. Where the plate voltage is not the exact figure given in tube manuals, a satisfactory bias voltage is found by interpolation of the recommended operating condition.

Thus, if the actual plate voltage is half way between two recommended values, the bias can also be assumed to be half way between the two given voltages. If you want to be more fussy, use an oscilloscope across the voice coil while driving the amplifier at full volume from an audio oscillator and adjust the bias until the output wave has exactly the same shape as

the input wave, usually sine shaped. Too low or too high a bias will flatten off the tops or bottoms of waves.

FLAT TRANSFORMERS

Older types of audio transformers do not have the flat frequency response of new models. Better core materials and winding methods have improved response to a remarkable degree. Changing to these high fidelity units will make a better satisfied customer, and at the same time increase your "per job profit."

Where the additional cost of new transformers is not warranted, response of the old units can be improved by shunting the secondary with 100M or 125M resistor, if this is not already incorporated. A graph on page 34 shows the relative effect of adding the shunt resistor. If the secondary is push-pull, put the same value resistor across each half of the secondary.

Feedback is another one of the means you can use to improve quality in some of the older sets. Positive feedback (introducing part of the plate voltage into the grid circuit so that it is in-phase with the grid voltage; regeneration) is seldom used because the amplifier becomes unstable. Negative feedback (degeneration; the reverse of positive feedback) is being employed in modern audio amplifiers to smooth out peaks in the response characteristic and reduce distortion.

FREQUENCY DISTORTION

Frequency distortion, the second of the three types, is largely reduced by negative feedback. If the amplifier tends to amplify the highs more than the lows, feedback will level this out because more of the highs will be canceled in the grid circuit. Feedback can best be used only with high gain stages, because of the loss of output which occurs.

The feedback voltage may be applied to the grid of the output tube or to the cathode of the preceding driver tube.

Phase distortion is not a problem in audio amplifiers.

OTHER SOURCES

Other sections of a receiver can also cause distortion trouble. The align-

ment of radio or intermediate transformers may be such that the bandwidth is insufficient.

If the IF transformers are too "sharp" for good quality, stagger the alignment of primary and secondary so that the wider band audio signals can get through without being cut off. This type of alignment work should preferably be done with a 'scope and wobulator. The peak should be as "flat" as possible. Avoid too large a "dip" in the center as the lows will suffer.

Audio howls, hum and microphonics all detract from good quality. Trace out feedback causing howling, shield the high gain audio tubes to prevent hum and rubber-mount parts causing microphonics.

Serviceing for fidelity can be profitable business. The first few may be hard to sell, but results will speak for themselves in advertising what you can do.

Audio Filter in Emerson Models 365, and 372

The special audio system used in these two models has emphasized bass and a 10 kc. audio filter to eliminate best notes from two adjacent station frequencies.

The filter is a series resonant coil and condenser connected from the 6L6 grid to ground. The trap thus offers a low impedance path to ground for 10 kc. notes.

The base response is improved by feedback to the volume control circuit through the R-C filter from the plate of the 6L6. A shunt tone control is used across the output transformer. Degeneration in the cathode circuit of the 6L6's results from the un-bypassed cathodes resistor, and thus reduces distortion.

Permeability Tuning in Philco Model 788

A new 11-tube short wave receiver just announced by the Philco Co. has eight tuning bands, five of which are "spread" bands in the short wave region. Broadcast and two regular short wave ranges are covered by the conventional ganged tuning condenser;

(Continued on page 39)

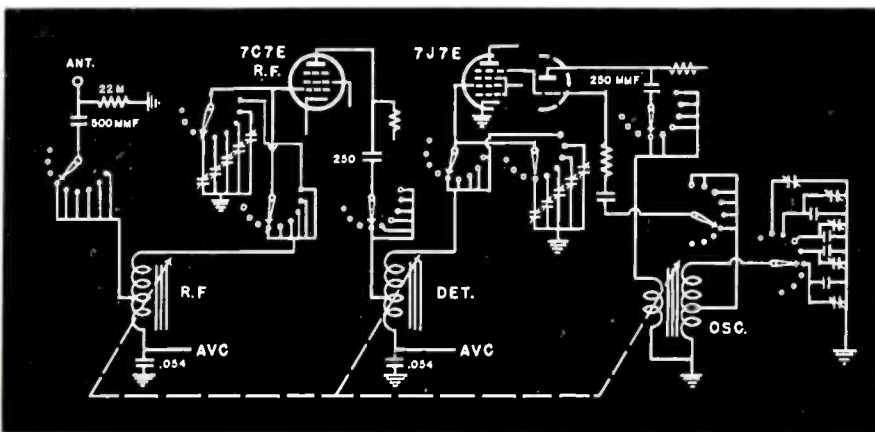

Partial circuit of the permeability tuner used in Philco model 788 for band-spread tuning on 5 short-wave ranges. Tuned trimmers and rotary switch select the range. Iron cores are moved in the three coils by separate dial system.

NEW EQUIPMENT



Sprague filter

★ Multiple section, inductance & capacity filter, LF-2, for use on sources of radio interference. For installation at the power outlet of interfering device drawing up to ½ amp. \$3.50 list. Sprague Prods. Co., North Adams, Mass.—**RADIO TODAY.**

Stanley plastic hammers

★ Complete line of soft faced hammers use tough plastic heads. Come in variety of head styles. Useful for working on chassis; will not mar surface. Stanley Tools, New Britain, Conn.—**RADIO TODAY.**

RCA tubes

★ A new miniature tube, 3S4 is a pentode power amplifier with 2.8 and 1.4 volt filament. Drain is .050 ma. at 2.8 volts. 180 milliwatt output. Five new transmitting tubes 815 beam power push pull pentode, 826 triode, 866 rectifier, 1625 12.6-volt pentode, 1626 a 12.6-volt triode. RCA Mfg. Co., Harrison, N. J.—**RADIO TODAY.**



Eagalite button

★ Illuminated push button provides for illuminating name, house no. and button through small lamp inside. Operates on all bells and chimes from 6 to 14 volts, higher voltages upon request. Complete with bulb, brown, \$1, ivory, \$1.25 Eagle Elec. Mfg. Co., 59-79 Hall St. Brooklyn, N. Y.—**RADIO TODAY.**



Philco equip. stand

★ A test equipment stand built of heavy gauge sheet metal, baked on blue enamel finish. Any number of them can be bolted together to accommodate additional instruments. Signal generators shown in top and VTVM circuit tester below. Philco Corp., Tioga & C Sts., Phila., Pa.—**RADIO TODAY.**



Belden wire

★ Corona-resistant wire is suitable for high voltages carried in cathode ray tube television circuits. Transmission cable 8219 is shown. Special rubber compound, Pyro-Glaze seal and braid of Belden Fiberglas protect it against heat and corona. Wire is white and has outer diameter of .200 in. Belden Mfg. Co., 4689 W. Van Buren St., Chicago, Ill.—**RADIO TODAY.**

Consolidated wire

★ Servicemen are now able to secure Hi-Temp rubber covered hookup wire. It has full Underwriters approval. Safe for temperatures up to 75 degrees C. Exceptionally flexible, solid and stranded. Offered in wide variety of colors. Consolidated Wire & Assoc. Corps., 516 S. Peoria St., Chi., Ill.—**RADIO TODAY.**

Thordarson transmitters

★ Six new kits now available cover 20 to 80-watt fone and CW transmitters, for fixed, portable, and mobile use. Five and ten meter units are among the group. Parts for 20-watt unit list at \$22.50. Thordarson Electric Mfg. Co., 500 W. Huron St., Chicago, Ill.—**RADIO TODAY.**

Raytheon tubes

★ Four new tubes just announced include 6SD7GT semi-remote cutoff pentode for RF and IF amplifiers; 6U6GT beam power amplifier; 7L7 lock-in type sharp cutoff pentode; 7N7 lock-in type twin triode with separate cathode leads. Raytheon Production Corp., 55 Chapel St., Newton, Mass.—**RADIO TODAY.**

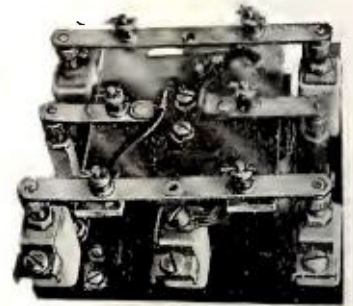

Ward-Leonard relay

★ Heavy duty break-in relay used in phone transmitters for push-to-talk operation. Lucite cross arm carrying the contact fingers, Isolantite blocks mounted on Bakelite base support contact posts. All contacts are rated 25 amps. Ward-Leonard Elec Co., Mt. Vernon, N. Y.—**RADIO TODAY.**

JFD cable racks

★ New wall racks that hold five spools of assorted dial cable and cord have 6-inch rule stamped on the rack for convenient measurement. Spools may be ordered in 25, 50, 100, and 250-foot capacities. Stock 9A25 has two spools of bronze cable, heavy and light, and three sizes of linen cord; net, \$2.76 with rack. J.F.D. Mfg. Co., 4111 Ft. Hamilton P'kway, Brooklyn, N. Y.—**RADIO TODAY.**



Ohmite Cordohm

★ Tapped line cord resistor for AC-DC sets are made in variety of sizes for 4 or 5-tube sets. Line cord resistor is tapped for pilot light. Heat is radiated outside the set prolonging part life. Ohmite Mfg. Co., 4835 Flournoy St., Chicago, Ill.—**RADIO TODAY.**

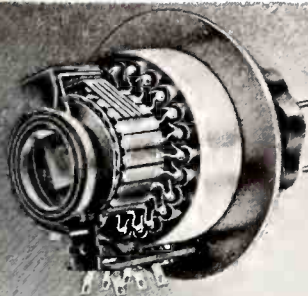

ATTENUATORS
2 sizes, 20- and 30-steps.



INSULATED METALLIZED
Also Type BW Wire Wound
Insulated. 1/2-, 1- and 2-Watts.



HIGH VOLTAGE
Metallized type. 5 sizes.



METALLIZED CONTROLS
Volume-Tone-Poten-
tiometer, Metallized &
Wire Wound.



**HIGH
FREQUENCY
POWER RESISTORS**
Metallized type. 10 sizes.
1/3 to 150 watts.



**PRECISION WIRE
WOUND RESISTORS**
12 sizes.

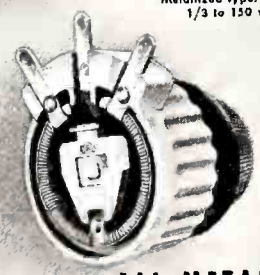

**ALL-METAL
RHEOSTATS**
2 to 100 Watts.

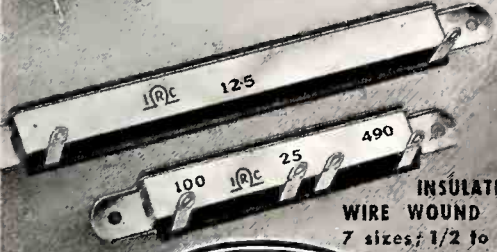

**INSULATED
WIRE WOUND RESISTORS**
7 sizes; 1/2 to 20 Watts.



**POWER
WIRE WOUND RESISTORS**
Cement Coated—53 sizes,
fixed and variable types.

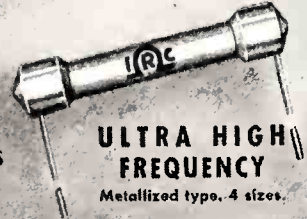

**ULTRA HIGH
FREQUENCY**
Metallized type. 4 sizes.



... Specialists in

RESISTORS and CONTROLS Since 1921

ALL SHAPES—TYPES—SIZES

Every IRC Resistor or Control is backed with all the highly specialized facilities of a large, internationally-known organization that has pioneered the leading fixed and variable resistance developments, and which has thought only resistance's, researched only resistances, and made only resistances for more than 19 years. It is our firm belief that the utmost in quality and dependability can come only through intense specialization such as this.

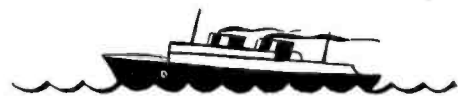

OFRECEN PROTECCION EXCEPCIONAL CONTRA TODAS INFLUENCIAS DEL CLIMA

Por haber sido ingenierados con objeto de quedar protegidos contra toda clase de condiciones climatológicas, las RESISTENCIAS y CONTROLES I.R.C. presentan lo mejor con respecto a funcionamiento continuo y exención de fallas, dondequiera que se usen. Su diseño científico, unido a la construcción que incorpora características exclusivas dándoles perfecta protección, hacen que estos productos trabajen irreprochablemente bajo todas condiciones de servicio.

NUEVO CATÁLOGO EN ESPAÑOL:

Este nuevo catálogo I.R.C. impreso en español le será enviado a Vd. prontamente a su solicitud. Señores Fabricantes, Radiotécnicos, Aficionados, Radiomecánicos y Distribuidores! Este librete les servirá a Vds. de guía para sus requisitos de resistencias y controles de calidad, que han de corresponder a todos los usos de la radiotécnica moderna.

INTERNATIONAL RESISTANCE COMPANY

401 N. BROAD ST., PHILADELPHIA, PA.

"FARR BETTER SERVICE"

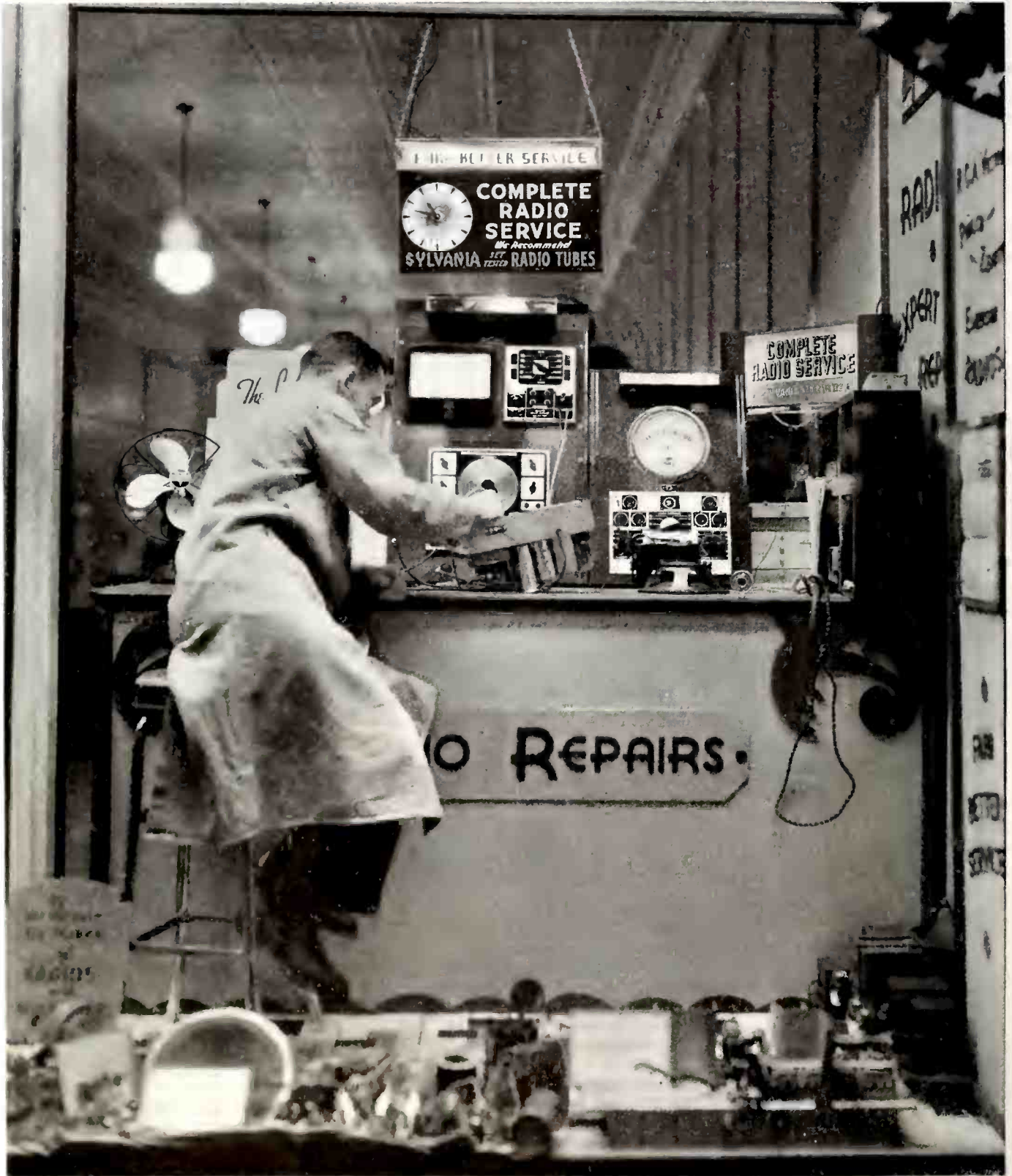

Servicemen who bring their benches, instruments, and methods out where passers-by can observe them, create confidence among customers as well as build up an "expert" reputation. Mort F. Farr, 7044 Garrett Rd., Upper Darby, Pa., has done a swell job with this idea. In the window are two RCA model 80 chassis, the one on the right intact, while the left hand set is knocked down to show the large

number of parts. This window proved itself by copping third prize in an "unusual and interesting display" contest held by local merchants.

Farr handles Philco, Emerson, RCA, and Zenith sets, Victor records, and Sylvania tubes. The racked test equipment is Precision. Neat raised block-letter signs boost store appeal. Note the professional touch added by a shop coat.

SERVICE NOTES

(Continued from page 35)

540 to 1720, 2.3 to 7.2 mc., 7.2 to 22 mc. The five band spread ranges, 9.4 to 9.9, 11.4 to 12.0, 14.8 to 15.6, 17.3 to 18.2, 20.9 to 21.9 mc., are logged on a separate dial. Tuning is accomplished by moving iron cores through the RF, Det., and Osc. coils. The five bands are selected by conventional rotary band switch which parallels trimmers across the coil. As may be seen in the circuit diagram, only one coil for each stage is used on all five bands, the particular range being selected by a switch and parallel trimmers. The three coils are mounted in line. Mechanically, the tuner consists of a threaded shaft mounted in ball bearings which moves a carriage with the three iron cores. It is similar to a lathe feed screw and tool carriage action.

Pen-sized Oscillator for Servicemen

A new and useful instrument for servicemen just introduced is called the Pen-oscil-Lite. It is being manufactured by the General Test Equipment Co., 213 Crosby Ave., Kenmore, N. Y. This device is about the size of large fountain pen. It has a rounded bakelite end piece which holds a short metal prod. The other end has a plunger button for turning the instrument off and on. A single pen type flash-light cell is used to operate the oscillator and each cell will last for several months under normal use.



The oscillator is a high frequency audio buzzer. The square wave of voltage developed by the unit has a great many harmonics in the radio spectrum so that it can be used as an all wave oscillator. The device is very handy for quick testing of sets that are dead. The signal can be applied at important points from the speaker to the antenna to locate faulty stages or parts. When testing audio sections it is only necessary to ground the case of the Pen-oscil-lite through a 0.1 mfd condenser and touch the prod to the circuit. All RF and IF circuits can be checked by touching only the tip to the wiring. The output is highly directional and is rapidly attenuated with distance, so that the signal can be put where it is wanted and the strength controlled by moving closer or farther away from the circuit. The note is modulated at about 500 cycles so that it is readily distinguished.

Photo-relay Jobs for Servicemen

There are many opportunities for the radio and service man to expand his activities through the application and installation of photo-cells for customers in his community. A guide-book for such expansion into new fields for which the radio man is exclusively



Well-arranged and equipped service shop of James A. McRoberts, Long Island City, N. Y. McRoberts advertises his "modern instruments to carefully adjust your radio" and gets plenty of business, too.

equipped, is this new compilation "Photo-relays, their Theory and Application" by F. H. Shepard, Jr. The book is copyrighted by John M. Coffeen, vice-president Allied Control Co., 227 Fulton St., New York, and is priced at 25 cents a copy.

Topics covered include photoelectric phenomena, amplifiers, glow discharge tubes, light sources, applications, fundamental circuits, controls, and miscellaneous uses.

Mr. Shepard was formerly in charge of the Special Electronics Division of RCA and has been doing consulting

work in this line for a number of years. He has also collaborated in the publication of several books and articles on the subject. The present book is therefore authoritative and will be of interest to practical readers.

* * *

1941 edition of "The Red Book of Instrument Value," giving specifications and illustrations of Webber service instruments, has been released by Earl Webber Co., 4348 W. Roosevelt Rd., Chicago, Ill.

AS CHIEF CONDENSER BLOWER OUTER OTTO OOMPH WAS A FLOPPEROO

Ever since Otto Oomph was a boy, he suffered from a strange disease. Smashophobia, the doctor called it—the horror of breaking things—but there was nothing to be done about it. When he broke a Christmas tree ornament one year, poor Otto cried for two days. When he grew up, he wouldn't shoot as much as a clay pigeon and denting the fender of his car would make him sick.

Eventually, however, Otto became an electrical expert. That got him a job in the Sprague laboratories and Otto was really happy for the first time—that is, until someone made him Chief Condenser Blower Outer in the Test Division.

Now, voltage in the electric chair at Sing Sing is 1,200 volts. In contrast, controllable AC voltages in the Sprague lab run as high as 7,200 (and much higher in the special high voltage lab) for here is where Sprague condensers really get "the works." They are torn apart, tortured and blasted, not only to see how good they are, but how to make 'em better. WHAM! Poor Otto jumped six feet when a can condenser, deliberately loaded with supercharge to determine its breakdown point, exploded in a cage.

BAM! SNAPPETY-CRACK. Otto shivered as another condenser gave its life under 4,000 volts of D.C. . . .

CLICKETY-CLICK as AC refrigerator starting condensers were switched tortuously on and off 150 times an hour.

SIZZ-SIZZLE and SISS as vapor streams played on condensers to prove their moisture-proof ability.

In a massive oven, dozens of units were undergoing life tests at 200° F. Elsewhere, Television condensers were telling their story under 3,000 to 10,000 volts of DC; tiny electric razor condensers were getting

the equivalent of 14 years of the hardest kind of use; and, almost every minute some condensers gave up the ghost and another fact was added to the science of constructing condensers that excel in the rough and tumble usage of the field.

"I can't stand it—I can't stand it," wailed Otto at last, weeping over the remains of an 8 mfd. 450 V. Atom midget dry.

"Gosh, Otto," consoled an engineer. "What you worrying about? That condenser is only rated at 450 V. We had to smack it with a surge of almost 700 V. before it went.

"Sure," sobbed Otto. "But I can't stand this business of busting things. It ain't fair to treat such swell condensers so downright mean. It makes me sick. I— I wanna quit."

And quit Otto did.

'Twas a year before we heard from him again and then he wrote:

"Dear Boss: Maybe you think I was silly to quit, but it just isn't my nature to bust things up. I'd go home and dream about condensers on those torture racks—the finest condensers in the world just waiting to be blown up if it took all the power in Massachusetts to do it.

"But all's well that ends well. I'm in the radio service business and doing fine. I use Sprague Condensers—and boy, are they real! Not a blow-out in a carload. No failures from moisture—or anything else in fact. I realize it's because of the work you guys are doing in the lab, but I still say blowing up condensers is a helluva job for a sensitive man like me.

Love and Kisses,

OTTO OOMPH"

SPRAGUE PRODUCTS COMPANY
North Adams, Mass.



SERVICE NOTES

General Electric Portables JB-508, 513

New portable models in GE line include the combination spring wound phonograph unit, circuit of which is shown, and JB-513 portable radio.

JB-508, and JB-513 have identical radio circuits. The only changes are in the addition of the crystal pickup and Radio-Phono selector switch which are included in the circuit diagram of JB-508 below.

Batteries may be replaced in the two radio models without removal of the loop antenna from the chassis. On the phonograph, 508 model, the motorboard is removed (hand crank must be removed first). The two "B" units are placed in the bottom sections, terminals inward. The "A" unit goes in on top with socket toward the clamp block. Battery complement is one Eveready 747 and 2 Eveready 482 or equivalents.

Since the sets must be aligned out of the cases, it is important to place the batteries, loop antenna and chassis in the same relative positions occupied in normal use.

455 KC. IF ALIGNMENT

With the volume control full on, connect the test oscillator to the flexible leads from the loop antenna and adjust IF trimmers for maximum output at 455 kc. Use as weak a signal as possible.

To align the RF end, leave the test oscillator connected to the leads from the loop. Tune receiver to minimum capacity position and test oscillator to 1700 kc. Adjust the trimmer on the cut (oscillator) gang section for peak output. Tune receiver and oscillator

to 1500 kc. and adjust the trimmer on the antenna section for maximum output.

Voltage readings on the diagram are for 120-volt AC line operation and measured to ground.

Metal Cabinet Given to Servicemen

A storage cabinet for volume and tone controls is being given to servicemen with the purchase of the stock of 18 controls, 6 switches, and 5 special shafts at \$14.97 net, by International Resistance Co., 401 N. Broad St., Phila., Pa. The cabinet is 14½ x 7½ x 4¼. Three drawers at the right end give ample space for the switches, shafts, and other spare parts. A hinged front cover may be removed when the cabinet is used on the bench. It is now being featured by IRC jobbers.

Interchangeable Tube Chart From Hytron

GT	Metal	GT	MG	GT	Metal	GT	MG
1A7GT	1A7G	6X5GT	6X5G	6X5GT	6X5G	6X5MG	
1A8GT	1A8G	6X6GT	6X6G	6X6GT	6X6G	6X6MG	
1A9GT	1A9G	6X7GT	6X7G	6X7GT	6X7G	6X7MG	
1B6GT	1B6G	6X8GT	6X8G	6X8GT	6X8G	6X8MG	
1B7GT	1B7G	6X9GT	6X9G	6X9GT	6X9G	6X9MG	
1B8GT	1B8G	6X10GT	6X10G	6X10GT	6X10G	6X10MG	
1B9GT	1B9G	6X11GT	6X11G	6X11GT	6X11G	6X11MG	
1C6GT	1C6G	6X12GT	6X12G	6X12GT	6X12G	6X12MG	
1C7GT	1C7G	6X13GT	6X13G	6X13GT	6X13G	6X13MG	
1C8GT	1C8G	6X14GT	6X14G	6X14GT	6X14G	6X14MG	
1C9GT	1C9G	6X15GT	6X15G	6X15GT	6X15G	6X15MG	
1D6GT	1D6G	6X16GT	6X16G	6X16GT	6X16G	6X16MG	
1D7GT	1D7G	6X17GT	6X17G	6X17GT	6X17G	6X17MG	
1D8GT	1D8G	6X18GT	6X18G	6X18GT	6X18G	6X18MG	
1D9GT	1D9G	6X19GT	6X19G	6X19GT	6X19G	6X19MG	
1E6GT	1E6G	6X20GT	6X20G	6X20GT	6X20G	6X20MG	
1E7GT	1E7G	6X21GT	6X21G	6X21GT	6X21G	6X21MG	
1E8GT	1E8G	6X22GT	6X22G	6X22GT	6X22G	6X22MG	
1E9GT	1E9G	6X23GT	6X23G	6X23GT	6X23G	6X23MG	
1F6GT	1F6G	6X24GT	6X24G	6X24GT	6X24G	6X24MG	
1F7GT	1F7G	6X25GT	6X25G	6X25GT	6X25G	6X25MG	
1F8GT	1F8G	6X26GT	6X26G	6X26GT	6X26G	6X26MG	
1F9GT	1F9G	6X27GT	6X27G	6X27GT	6X27G	6X27MG	
1G6GT	1G6G	6X28GT	6X28G	6X28GT	6X28G	6X28MG	
1G7GT	1G7G	6X29GT	6X29G	6X29GT	6X29G	6X29MG	
1G8GT	1G8G	6X30GT	6X30G	6X30GT	6X30G	6X30MG	
1G9GT	1G9G	6X31GT	6X31G	6X31GT	6X31G	6X31MG	
1H6GT	1H6G	6X32GT	6X32G	6X32GT	6X32G	6X32MG	
1H7GT	1H7G	6X33GT	6X33G	6X33GT	6X33G	6X33MG	
1H8GT	1H8G	6X34GT	6X34G	6X34GT	6X34G	6X34MG	
1H9GT	1H9G	6X35GT	6X35G	6X35GT	6X35G	6X35MG	
1I6GT	1I6G	6X36GT	6X36G	6X36GT	6X36G	6X36MG	
1I7GT	1I7G	6X37GT	6X37G	6X37GT	6X37G	6X37MG	
1I8GT	1I8G	6X38GT	6X38G	6X38GT	6X38G	6X38MG	
1I9GT	1I9G	6X39GT	6X39G	6X39GT	6X39G	6X39MG	
1J6GT	1J6G	6X40GT	6X40G	6X40GT	6X40G	6X40MG	
1J7GT	1J7G	6X41GT	6X41G	6X41GT	6X41G	6X41MG	
1J8GT	1J8G	6X42GT	6X42G	6X42GT	6X42G	6X42MG	
1J9GT	1J9G	6X43GT	6X43G	6X43GT	6X43G	6X43MG	
1K6GT	1K6G	6X44GT	6X44G	6X44GT	6X44G	6X44MG	
1K7GT	1K7G	6X45GT	6X45G	6X45GT	6X45G	6X45MG	
1K8GT	1K8G	6X46GT	6X46G	6X46GT	6X46G	6X46MG	
1K9GT	1K9G	6X47GT	6X47G	6X47GT	6X47G	6X47MG	
1L6GT	1L6G	6X48GT	6X48G	6X48GT	6X48G	6X48MG	
1L7GT	1L7G	6X49GT	6X49G	6X49GT	6X49G	6X49MG	
1L8GT	1L8G	6X50GT	6X50G	6X50GT	6X50G	6X50MG	
1L9GT	1L9G	6X51GT	6X51G	6X51GT	6X51G	6X51MG	
1M6GT	1M6G	6X52GT	6X52G	6X52GT	6X52G	6X52MG	
1M7GT	1M7G	6X53GT	6X53G	6X53GT	6X53G	6X53MG	
1M8GT	1M8G	6X54GT	6X54G	6X54GT	6X54G	6X54MG	
1M9GT	1M9G	6X55GT	6X55G	6X55GT	6X55G	6X55MG	
1N6GT	1N6G	6X56GT	6X56G	6X56GT	6X56G	6X56MG	
1N7GT	1N7G	6X57GT	6X57G	6X57GT	6X57G	6X57MG	
1N8GT	1N8G	6X58GT	6X58G	6X58GT	6X58G	6X58MG	
1N9GT	1N9G	6X59GT	6X59G	6X59GT	6X59G	6X59MG	
1O6GT	1O6G	6X60GT	6X60G	6X60GT	6X60G	6X60MG	
1O7GT	1O7G	6X61GT	6X61G	6X61GT	6X61G	6X61MG	
1O8GT	1O8G	6X62GT	6X62G	6X62GT	6X62G	6X62MG	
1O9GT	1O9G	6X63GT	6X63G	6X63GT	6X63G	6X63MG	

Some confusion exists on the subject of just what tubes are interchangeable among the four classes available. The Hytron Corp., 75 Lafayette St., Salem, Mass., has compiled the following table for quick reference.

In general the GT tubes will replace tubes of other types of construction in the same horizontal line. Certain high gain RF and second detector tubes require a shield when the GT replaces a metal tube. Tubes requiring a special shield are marked*. Glass and metal tubes of the same electrical type may be generally interchanged except for certain high gain RF and audio tubes. The changing of classes of tubes in IF stages may involve re-alignment.

Radio Via the Briny Deep

To improve the signal delivered to metropolitan New York listeners, NBC's Red Network outlet, WEAJ is employing a new transmitter and antenna system on a peninsula of northern Long Island, thus providing a direct salt-water route for its programs to this area. Being an excellent conductor of radio waves, the salt water path promises to greatly improve reception. The high steel buildings of New York handicap the pickup of direct radiations of the antenna, thus the emphasis on ground waves. Directional radiation is also being accomplished by two quarter wave antennas, one of which acts as a partial reflector. The ground system will consist of 120,000 feet of copper ribbon, radiating in 500 foot lengths from the bases of the antenna towers.

Rimco's model 701 radio dynalyzer is illustrated and described on new data sheet of Radio Instruments Mfg. Co., 1131 Terry Rd., Jackson, Miss.

GENERAL ELECTRIC JB-508

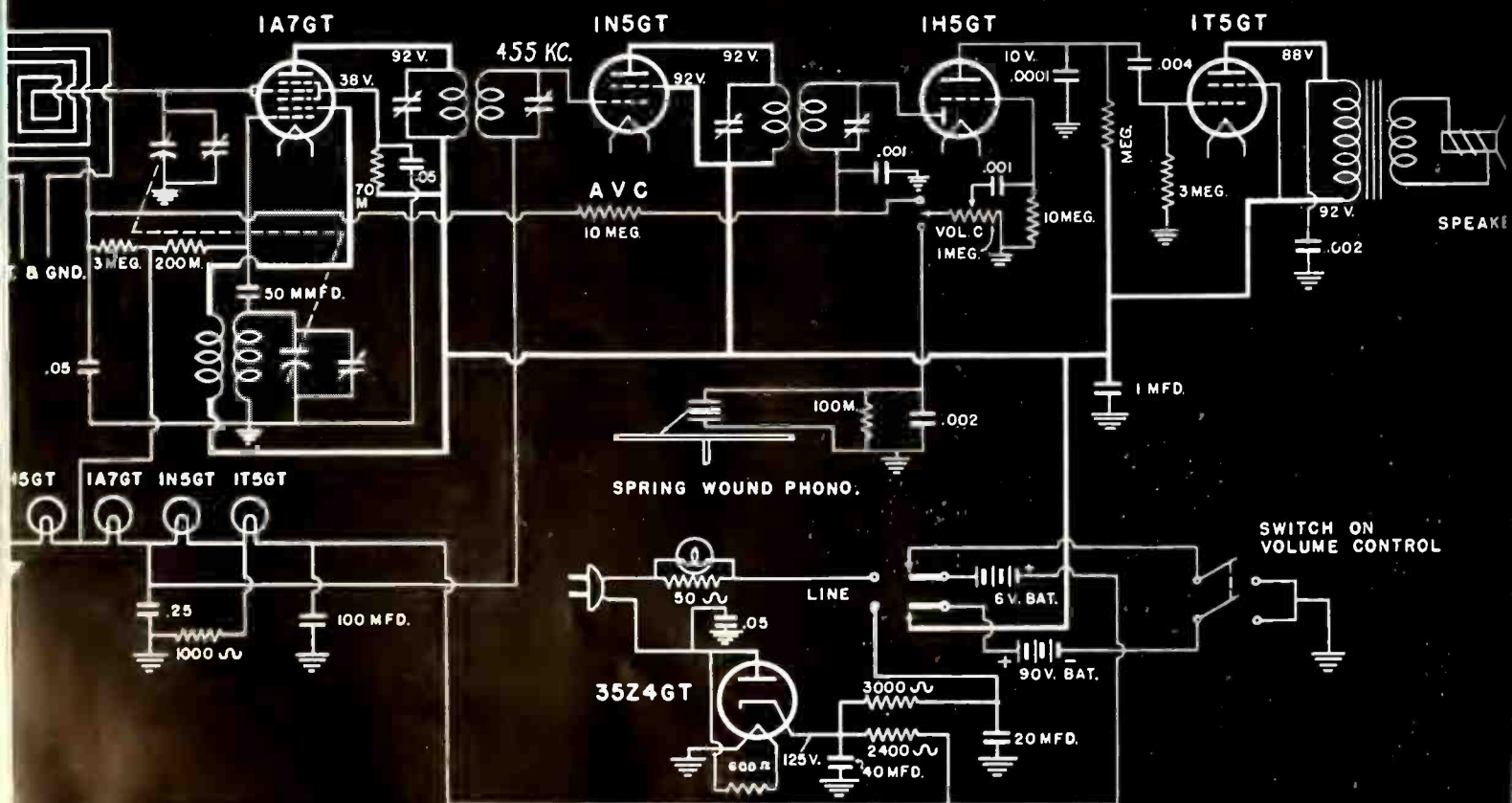

Jensen Builds Largest Soundroom

Having nearly ten times the enclosed volume of the next largest similar structure, the new "free-space" soundroom of the Jensen Radio Manufacturing Company at Chicago, is nearing completion. According to Hugh S. Knowles, Jensen Vice-President and Chief Engineer, the new soundroom will permit a more accurate determina-

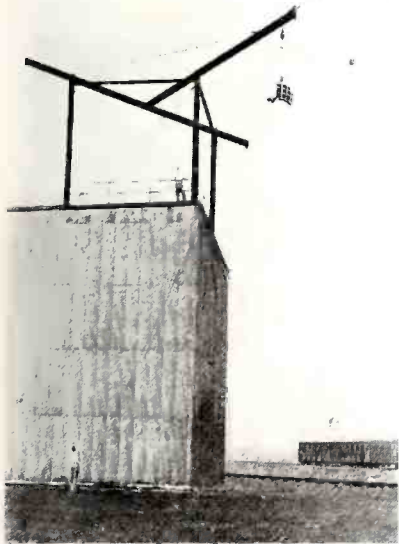

Exterior view of largest sound test room at Jensen plant. Photo shows outdoor test on "K" horn.

tion of the response and directional characteristics of loudspeakers at low frequencies and will greatly facilitate precision acoustical measurements as shown in the photograph where the performance of one of the new 60-cell type "K" Horns, equipped with 2 type X permanent magnet driver units, is being determined.

Unique Rider Text Has Divided Pages

"The Meter at Work" is the title of the newest text book by John Rider, 404 4th Ave., N. Y., N. Y. A special treatment of the text and diagram

reference material makes this book easier to study, easier to work with. Each page of the book is split so that the text material occupies the lower two-thirds and a reference diagram the other third. With this arrangement, the reader can easily refer to the diagram mentioned in the text by turning the upper parts of the pages until the correct diagram is found.

BOOK REVIEW

Elements of Acoustical Engineering

by Harry F. Olson, E. E., Ph. D.

Published by D. Van Nostrand Co., Inc.
250 Fourth Ave., New York, N. Y.

An understanding of modern acoustics is becoming more of a necessity for sound and service men. This new text by the Acoustic Research Director of RCA covers the elementary theory, as well as the general details of loud speakers, horns, mikes, architectural acoustics, speech, music, and hearing.

Mathematical treatments of speakers, mikes, etc., are given along with general facts. The book is exceptionally well illustrated with graphs, diagrams, and sketches.

The action of pieces of sound apparatus is made clear by showing the equivalent electrical circuit. The mechanical, acoustical and electrical comparison in the early part of the book makes the understanding of this relation easier.

The chapters on speakers cover the types of driving systems, frequency characteristics of the various designs and sizes of cones, and the action of various baffles, including the closed cabinet, phase inverter, and acoustic labyrinth.

Of special interest to sound men is the chapter on horn-type speaker systems. The basic types of microphones are covered in a special chapter with data about their response, etc.

Servicemen will find the data on phonograph pickups, hearing aids, and testing of loud speakers extremely useful.

These are but a few of the subjects covered in the book. The price is \$6. This is a good book to have in your technical library.



● Keeping one jump ahead of the radio workers' growing and changing requirements, Aerovox steadily adds to its already remarkably complete line of condensers of all types.

And to aid you in picking those new items off the jobber's shelves, Aerovox now "flags" new items for you. Yes, sir! Each new-item carton carries a vivid red label on front and sides (see above). You can't miss these new things in condensers. Since such items are not as yet cataloged, the list price appears on the sides of label. A tear-off re-order ticket insures the continued stocking of the item.

It's just another example of that merchandise-mindedness which makes Aerovox the household word among those who make a living out of radio.

● Ask for CATALOG . . .

Your jobber can give you the latest edition containing all Aerovox items right up to date. Ask for it. Also ask about a free subscription to the monthly Research Worker. Or write us direct.





KEN-RAD

DEPENDABLE RADIO TUBES

Dealers and servicemen will find Ken-Rad Radio Tubes their best choice because of liberal sales and adjustment policies, plus tubes of known quality.

KEN-RAD TUBE & LAMP CORPORATION, OWENSBORO, KENTUCKY
Export Dept., 116 Broad St., New York, U.S.A. Cable Address: Minthorne, New York



Eureka!
He's done it again!

Homer G. Snoopshaw, B.R.S. (Battery Replacement Specialist), once more comes through in his capacity as Replacement Adviser in Bud's Radio Shop.

After studying this troublesome mail-order Dynamic DeLuxe for only four days, he is able to state emphatically that the correct battery for this portable is Burgess No. 4GA42. A call to the Burgess Distributor and the customer is satisfied and on his way.

How could Homer's employer possibly get along without him?*

*By getting a free copy of the Burgess replacement guide from his local distributor, or writing direct to the Burgess Battery Company, Freeport, Illinois.

BURGESS
The Complete Replacement Line

POWER for any Emergency

with **PINCOR**
GOLD CROWN Power Plants

These rugged, heavy duty, gasoline engine driven generators provide low cost power anywhere, anytime, for electrical machinery, standby emergency service, field and construction work, portable radio equipment . . . charging batteries . . . lighting homes, boats, trailers, etc. Output up to 15 KW; A.C. or D.C.; standard or special voltages; air or water cooled; gasoline, kerosene or natural gas operation. Send for new catalog and prices today.

PIONEER GEN-E-MOTOR CORP.
Dept. R-2-5, 466 W. SUPERIOR ST., Chicago, Ill.
Export Address: 25 WARREN ST., N. Y., N. Y.
Cable: SIMONTRICE, New York

RECORDS AND

Disc Sales in 17-Year Record

Record sales during the month of October set a new 17-year high, according to news from RCA Victor.

In all classifications, total volume topped every similar period since 1924. Much of the increase was due to lively activity in the Red Seal division where "album sets are going like single records", officials reported.

In particular, "The Heart of the Symphony" album has set new highs, in its early sales.



One of RCA Victor's newest record promotions, the Player-Pak. The luggage-type container is easily portable when customer buys. It includes player, album, needles, extra album, booklets, all for \$9.95. Designed specially for window and counter display.

Columbia's New Record Catalog

A completely re-styled record catalog of 315 pages has been published by Columbia Recording Corp., 1473 Barnum Ave., Bridgeport, Conn. The volume has a new and special way of giving complete information on rec-

Wax Worth Watching

EDDIE DUCHIN and his orchestra playing Down Argentina Wav, with VC by The Earbenders—Columbia 35774.

WILL BRADLEY and his orchestra, featuring Ray McKinley, playing Celery Stalks at Midnight—Columbia 35737.

FOUR KING SISTERS singing Don't Go in the Lion's Cage Tonight—Bluebird B10930.

ARTIE SHAW and his Gramercy Five playing Cross Your Heart—Victor 26763.

TOMMY TUCKER and his orchestra playing Papa's in Bed With His Britches On, with VC by Amy Arnell—Okeh 5861.

INK SPOTS singing Java Jive—Decca 3432.

ANDREWS SISTERS singing Sweet Molly Malone—Decca 3440.

XAVIER CUGAT and his orchestra playing Adios—Victor 26794.

WAYNE KING and his orchestra playing Falling Leaves—Victor 26785.

ords, artists, music and prices, with fool-proof cross-indexing and a simple system of reference.

The cover has 3 colors. The book retails through dealers for 25c.

Recordio Offers Year-'Round Disc Promotion



A new sales promotional kit, for 1941 use by Recordio dealers, is forthcoming from Wilcox-Gay Corp., Charlotte, Mich. It offers a record blank, a seasonal sticker and an envelope to those who want to use home recorders on any of the important holidays, including Christmas, Thanksgiving, Valentine's Day, etc. Stickers are packaged 6 to an envelope, to be sold at 5c.

Phono-Motors Now Packaged



The complete line of Even-Speed" phono-motors, made by the Alliance Mfg. Co., Alliance, Ohio, is now available in individual cartons for the radio service trade. The step is taken because of the fast growing replacement market for these motors, and it offers jobbers and dealers easier handling, easier storing, and display features.

Recoton's New Needle Pack Ready

Calling attention to "the increased public attention to records, and the interest in better needles," the Recoton Corp. 178 Prince St., New York City, is ready with newly packaged needles. The Recoton Flat Shank steel cutting

RECORDERS

needle, which has been sold in packs of 10, now comes in a smart new envelope of 5. This and other packaging stunts on the company's many products are described in complete literature available from Prince St.

"Off the Records" to Get Buyers Interested

A new record-reviewing service for record stores and record departments to send out to customers has been started by The Record Reviewers, 2440 Lakeview Ave., Chicago. Combined reviews of Columbia, Decca and Victor records are issued monthly in a publication *Off the Records*, which is sold to dealers on a syndicated basis. Only one store in each city may buy it.

Off the Records is edited by Edgar N. Greentree, nationally known record critic.

Boosting Record Sales



Bonnie Baker and Orrin Tucker, two of the popular artists who make best-selling discs for Columbia Recording Corp., are shown here with new dealer display.

For School Market

Two new RCA folders, "Special Victor Records for Use in Schools" (Form IS2785) giving the many types avail-

able for use in schools from elementary through college, and "Victor Records for Integrated Units of Learning" (IK2944) listing records to be used in grades 1, 2, and 3. Both these folders are available on a reasonable price plan. RCA Mfg. Co., Educational Dept., RCA Victor Div., Camden, N. J.

Photo-Electric Stopper



A new display for the "record playing on a beam of light" idea. From Philco Corp.

Howard "Since 1918"

Howard Radio Company, 1731 Belmont Ave., Chicago, points out that it has the privilege of carrying the title "America's Oldest Radio Manufacturer" having manufactured radio parts since 1918. These parts, such as condensers, tubes, tube-sockets, controls, and phono-plugs, were the vital components for the start of the great radio industry. Howard Radio Co. has been manufacturing radio receivers since 1920.

In 1919, the company manufactured tube sockets, dials, switches, condensers, multi-terminal plugs, and vacuum tubes. These tubes were unusual in their design at the time, having a built-in metal shield, a practice that was not to be generally adopted until fifteen years later, according to D. McKenzie, advertising manager.

Sentinel Plays Santa to Distrib Salesmen

Distributors' salesmen have been awarded an impressive batch of prizes, by Sentinel Radio Corp., at the end of a big contest staged "as a good will gesture to the men in the field, and to help maintain the great sales pace of the 1941 Sentinel line". Christmas turkeys, sports jackets, luggage, wrist watches, cash prizes, were among the awards.

Standing in the contest was determined by the sale of models which had each been designated as worth certain numbers of points. Totals were reported by Sentinel distributors.

Tie To G. I. Motors Changers, Recorders for Phonograph \$\$\$

YOU can count on distinctly superior operation from every General Industries motor, record-changer and home-recording assembly. . . . And besides, you get modern streamlined design and fine finish—up-to-date simplicity of operation—labor-saving speed of installation and modern, assembly-line low cost. All help your sales of new sets, your volume of refitting and rebuilding.



New GI-C120 automatic streamlined record changer; capacity, ten 12" or twelve 10" records. One lever sets for either size records or manual playing. High-quality tangent-tracking crystal pickup. Enclosed motor. Cycling switch.



New GI-R70 simplified home-recording unit. Includes cutting arm with concealed feed-screw, high-impedance crystal pickup, weighted turntable, special rim-drive extra-power motor.



New, Light Rim-Drive Motors

Precision-built. Sturdy. Evensped. Positive alignment of turn-

table, idler and drive. We are the world's largest manufacturer of phonograph motors—make a full line. . . . Order test changers, recorders, motors—check them for superior performance. State voltage and frequency of current. New Catalog, prices, on request. Write TODAY.

The GENERAL INDUSTRIES CO.

Dept. 38 ELYRIA, OHIO
Order your Play-back and Cutting Needles from
The General Phonograph Mfg. Co., Putnam, Conn.



SOLVED! CASE #6794



Eureka! He's done it again!
 Homer G. Snopshaw, B.R.S. (Battery Replacement Specialist) once more comes through in his capacity as Replacement Adviser in Dea's Radio Shop.

After studying this troublesome multi-order Dynamic Deluxe for only four days, he is able to state, emphatically that the correct battery for this portable is Burgess No. 42-Ags. A call to the Burgess Distributor and the customer is satisfied and on his way.

How could Homer's employees possibly get along without him?

BURGESS
 The Complete Replacement Line

POWER for any Emergency



with **PINCOR**
GOLD CROWN Power Plants

These rugged, heavy duty, combine engine driven generators provide low cost power, operation, storage, for electrical machinery, standby emergency service, field and construction work, portable radio equipment, charging batteries... lighting homes, boats, trailers, etc. Output up to 15 KW. A.C. or D.C. standard or special voltages; oil or water cooled; portable, 100 lbs. or more; or non-portable, 200 lbs. or more. Send for new catalog and prices today.

PIONEER GEN-E-MOTOR CORP.
 Dept. R-2, 44 W. Superior St., Chicago, Ill.
 Export Address: 75 WABSEN ST., N. Y., N. Y.
 Cable: SIMONPREE, New York

RECORDS AND RECORDERS

Disc Sales in 17-year Record

Record sales during the month of October set a new 17-year high, according to news from RCA Victor. In all classifications, total volume topped every similar period since 1924. Much of the increase was due to lively activity in the Red Seal division where "album sets are going like single records", officials reported. In particular, "The Heart of the Symphony" album has set new highs in its early sales.



One of RCA Victor's newest record promotions, the "Player-Pak". The luggage-type container is easily portable when customer buys. It includes player, album, needles, extra album, booklets, all for \$9.95. Designed specially for window and counter display.

Columbia's New Record Catalog

A completely re-styled record catalog of 315 pages has been published by Columbia Recording Corp., 1473 Barnum Ave., Bridgeport, Conn. The volume has a new and special way of giving complete information on rec-

ords, artists, music and prices, with foot-proof cross-indexing and a simple system of reference. The cover has 3 colors. The book retails through dealers for 25c.

Recordio Offers Year-Round Disc Promotion



A new sales promotional kit, for 1941 use by Recordio dealers, is forthcoming from Wilcox-Gay Corp., Charlotte, Meck. It offers a record blank, a seasonal sticker and an envelope to those who want to use bonus recorders on any of the important holidays, including Christmas, Thanksgiving, Valentine's Day, etc. Stickers are packaged to an envelope, to be sold at 5c.

Phono-Motors Now Packaged



The complete line of Even-Speed phono-motors, made by the Alliance Mfg. Co., Alliance, Ohio, is now available in individual cartons for the radio service trade. The step is taken because of the fast growing replacement market for these motors, and it offers jobbers and dealers easier handling, easier storing, and display features.

Recoton's New Needle Pack Ready

Calling attention to "the increased public attention to records, and the interest in better needles," the Recoton Corp., 175 Prince St., New York City, is ready with newly packaged needles. The Recoton Flat Shank steel cutting

needle, which has been sold in packs of 10, now comes in a smart new envelope of 5. This and other packaging stunts on the company's many products are described in complete literature available from Prince St.

"Off the Records" to Get Buyers Interested

A new record-reviewing service for record stores and record departments to send out to customers has been started by The Record Reviewers, 3410 Lakeview Ave., Chicago. Combined reviews of Columbia, Decca and Victor records are issued monthly in a publication *Off the Records*, which is sold to dealers on a syndicated basis. Only one store in each city may buy it. *Off the Records* is edited by Edgar N. Greenleaf, nationally known record critic.

Boosting Record Sales



Bonnie Baker and Orrin Tucker, two of the popular artists who make best-selling discs for Columbia Recording Corp., are shown here with new dealer display.

For School Market

Two new RCA folders, "Special Victor Records for Use in Schools" (Form 152785) giving the many types avail-

able for use in schools from elementary through college, and "Victor Records for Integrated Units of Learning" (152844) listing records to be used in grades 1, 2, and 3. Both these folders are available on a reasonable price plan. RCA Mfg. Co., Educational Dept., RCA Victor Div., Camden, N. J.

Photo-Electric Stopper



A new display for the "record playing on a beam of light" idea. From Phonio Corp.

Howard "Since 1918"

Howard Radio Company, 1731 Belmont Ave., Chicago, points out that it has the privilege of carrying the title "America's Oldest Radio Manufacturer" having manufactured radio parts since 1918. These parts, such as condensers, tubes, tube-sockets, controls, and phono-plugs, were the vital components for the start of the great radio industry. Howard Radio Co. has been manufacturing radio receivers since 1920.

In 1919, the company manufactured tube sockets, dials, switches, condensers, multi-terminal plugs, and vacuum tubes. These tubes were unusual in their design at the time, having a built-in metal shield, a practice that was not to be generally adopted until fifteen years later, according to D. McKenzie, advertising manager.

Sentinel Plays Santa to Distrib Salesmen

Distributors' salesmen have been awarded an impressive batch of prizes, by Sentinel Radio Corp. at the end of a big contest staged "as a good will gesture to the men in the field, and to help maintain the great sales pace of the 1941 Sentinel line". Christmas turkeys, sports jackets, luggage, wrist watches, cash prizes, were among the awards.

Standing in the contest was determined by the sale of models which had each been designated as worth certain numbers of points. Totals were reported by Sentinel distributors.

Tie To G. I. Motors Changers, Recorders for Phonograph \$\$\$

You can count on distinctly superior operation from every General Industries motor, record-changer and home-recording assembly... And besides, you get modern streamlined design and fine finish-up-to-date simplicity of operation—labor-saving speed of installation and modern, assembly-line low cost. All help your sales of new sets, your volume of re-thing and re-building.



New GI-C120 automatic streamlined record changer, equipped for 12" or 10" records.

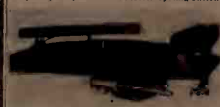

New GI-R70 simplified home-recording unit, includes cutting arm with concealed feed screw, high-impedance crystal pickup, weighted turntable, special rim-drive extra power motor.



table, idler and drive. We are the world's largest manufacturer of phonograph motors—make a full line. Order steel changers, recorders, motors—check them first superior performance. Name voltage and frequency of current. Catalog, prices, on request. Write TODAY.

THE GENERAL INDUSTRIES CO.
 Dept. 38, ELVIRA, OHIO
 Order from Phonobank and Catalog handles from The General Phonobank, Inc., Dept. Phonobank, Canton

DISTRIBUTOR DOINGS

What the Parts Jobbers Want

At recent meetings of radio parts distributors, held in Chicago, Detroit, Minneapolis, Kansas City, Harrisburg, Pa., and Springfield, Mass., very similar trade topics were discussed, revealing, according to NRPDA executive director Arthur Moss, that most of the problems encountered are national in scope.

"The only way in which the problems can be solved, is through the help of all jobbers regardless of their location. If each member will actively cooperate with the other jobbers in his territory on these general problems, solutions can and will be found very quickly. Every parts distributor must realize that alone he is helpless against trade practices which if unchecked become national problems affecting all jobbers", declared Mr. Moss.

TRENDS IN DISTRIBUTION

As questions leading to the greatest discussion at all meetings, parts jobbers should view with alarm the following growing tendencies.

- a. The elimination of cash discounts.
- b. The lowering of trade discounts.
- c. The charging of excise taxes on the invoices of manufacturers to the jobber.
- d. The competition of set manufac-

turers, using their much lower costs, to enter the legitimate parts jobbing field.

By resolutions passed at sectional meetings NRPDA went on record to the effect that:—

a. A jobbing discount of 60-10 with suggested resale of 40 per cent is essential to the parts distributor to cover expenses and leave a small net profit.

b. A lowering of list prices on standard brands would prove very detrimental because an increase in unit sales, if any, could not make up for the loss in dollar volume or dollar gross profit.

UPSET RESALE POLICIES

c. Manufacturers should improve the quality of jobbing parts and give merchandising helps, such as meetings for dealers and servicemen addressed by their technical factory representatives.

d. The great differential in prices between manufacturer and jobber permits the manufacturer to upset standard resale policies. Jobbers do not want lower prices but feel that set manufacturers entering the jobbing field should maintain recognized jobbing lists and discounts. Parts manufacturers are urged to help accomplish this for otherwise the entire parts distributor picture will soon be undermined. The business of the parts distributor is entirely dependent on recog-

inition of this factor. They do not have any other means of making a profit.

e. We recognize that manufacturers' costs have gone up, but so have the jobbers'. If such wide differentials are not justified between jobbing and manufacturer prices then certainly the jobber should not be further penalized by elimination of cash discounts, shorter discounts, and excise taxes. If these can be justified the jobber prefers the list price be raised to take care of them. The parts jobber can not absorb these extra costs.

f. That a cash discount is solely given as an incentive to pay bills within the stipulated period. A cash discount is only fair to those concerns who so run their business that they are able to take it. A cash discount helps create a better credit picture. The good jobber should not be penalized for the poor one.

TUBE POLICIES

The following matters were taken up at all meetings for discussion, and the opinion of the jobbers is given:—

a. The practice of some manufacturers in having different policies in different sections of the country was evident.

Selling dealers direct or creating a dealer-jobber on the grounds of necessity in a particular territory was condemned. What one manufacturer does in one territory is done by another manufacturer in another territory with the result that all jobbers are affected on their lines. NRPDA takes the stand

Filters
Record Scratch
Through Floating Point

NEW NATIONALLY ADVERTISED

Fidelitone

FLOATING POINT PHONOGRAPH NEEDLE

Three to six months average service from each needle . . . Retail for 50c.

Made by the world's oldest and largest makers of long-playing needles . . . Ask your Parts Distributor or write for full details.



PERMO PRODUCTS CORP.
6415 Ravenswood Ave., Chicago
Manufacturing Metallurgists

PERMO POINT

Oxford

. . . The Finest in
Small Speakers



One of the most widely used replacement speaker is OXFORD Model 5V-L. Furnished in all standard fields from 450 ohms to 2750 ohms. Also available with single or universal output transformer.

Model 5V-L - - List \$2.00

Precision built to exacting requirements OXFORD Electrodynamic and Permug speakers ranging from 2" to 14" will fill the bill no matter what the application. OXFORD is tops in quality and outstanding value. Sold through leading radio parts jobbers everywhere.

Write Dept. RT-4 for descriptive BULLETIN No. 400.

OXFORD-TARTAN
RADIO CORPORATION

915 W. VAN BUREN ST. • CHICAGO, U. S. A.

Clarion Public Address Executives in Seattle



Mapping more sales of sound equipment in the northwest area—left to right, H. L. Shortt, pres., Transformer Corp. of America (the Clarion executive stopped in Seattle during a nation-wide tour); Bert Harris and Ed Mickelson, Seattle Radio Supply Co.; and R. C. James, Jr., Northwestern representative for Clarion.

that only the right kind of distribution is justified in any territory.

b. Tube type markings in many instances are not satisfactory and easily rubbed off.

c. That the withdrawing of price protection by manufacturers is not in the best interest of the tube industry and that price protection should be afforded to distributors and dealers as in the past. Price protection for all practical purposes would eliminate "Buy-in deals" and "loading campaigns." We believe that the tube manufacturer should replace tube for tube rather than a percentage allowance on their billings to distributors in lieu of the manufacturers' guarantee. The allowance made on the invoice is in dollars whereas the distributor makes replacement in units. This works to the disadvantage of the distributor as the 3 per cent is not sufficient to cover the distributor.

Sonora Picks Hamburg to Head Promotion



Herbert S. Hamburg

Announcement of the appointment of

Herbert S. Hamburg, to head up the promotional activities of Sonora Radio & Television Corp., Chicago, has been made by Joseph Gerl, Sonora president. Mr. Hamburg has had an extensive experience in sales work, recently with Art Publishing Co., and previously with Reliance Mfg. Co. and Triangle Electric. His appointment at Sonora is part of the firm's steadily expanding sales program.

Gilfillan to Rebuild Burned Plant

News from Gilfillan Bros., Los Angeles, whose plant at 1815 Venice Blvd., was destroyed by fire Nov. 31, is that the factory will be rebuilt immediately. Co-owner S. W. Gilfillan, who estimated the damage to be about \$600,000, declared that a new plant at the same site will be started as soon as the debris can be cleared away. Company officials estimated that about 70 per cent of the loss was covered by insurance.

Roye Agency Takes on Bud Products

Announcement has been made of the appointment of Roye Sales Agency, 11 Warren St., New York City, as sales representatives for Bud Radio, Inc., Cleveland. The Roye brothers, Marvin and Oscar, will cover metropolitan New York area, and will carry a complete stock of Bud products. They are also sales reps in the area for Operadio Mfg. Co., J. W. Miller Co. and Hallcrafters.

Rep Moves

Ernest K. Seyd, manufacturers representative formerly located at 39 Robin Road, West Hartford, Conn., now has a new address—Andover, Conn.

new*

* Webster defines "new" as: "Lately made. Lately discovered. Renewed. Different." All of these descriptions apply to the Rider Books listed below. They have all been recently published. They all bear on lately discovered developments or currently revived subjects—and they are *all different*—in approach, handling and even in physical make-up. Order the ones you need—TODAY.



new MAKE-UP OF BOOK

Embodies a new feature exclusive to Rider Books. Pages are split so that the upper parts (containing diagrams and charts) can be turned without disturbing the lower parts of the pages (containing text). Obvious advantage in the reading and study of "Meters at Work." Only \$1.25.

OUT NOV. 30th—ORDER YOURS TODAY

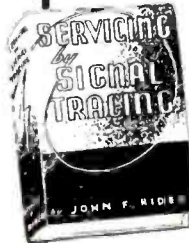

new SERVICING TECHNIQUE

Servicing by Signal Tracing is being used by an ever increasing number of professional radio servicemen for locating troubles in every conceivable type of radio communication system. It is the most fundamental method—free from limiting factor heretofore encountered. 360 pages—188 illus.—\$2.00.

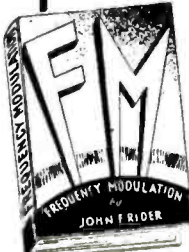

new DEVELOPMENT IN RADIO

Frequency Modulation is not just a coming thing—it is here! This book explains transmission and reception of F-M signals—discusses the new F-M sets. 136 pages—Illustrated—\$1.00.

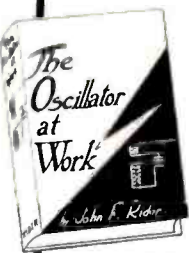

new EXPLANATION OF THEORY

Know all about Oscillators. Get your money's worth out of them. Know how to test them—repair them. Protect the investment you have in oscillator equipment and make any future investment in the light of the

knowledge this book gives you. 256 pages—167 illus.—\$1.50.

JOHN F. RIDER PUBLISHER, INC.

404 Fourth Avenue, New York City
Export Division Rocke-International Elec. Corp.,
100 Varick St., New York City Cable: ARLAB

Read RIDER BOOKS

SALES HELPS

Jensen Offers New Eye-Catcher

A full-size counter display sample of the new Jensen J4P-51 Concentric Dual Extended-Range high-fidelity speaker is now offered as a new attention-getter for distributors. It comes from Jensen Radio Mfg. Co., 6601 S. Laramie Ave., Chicago.

Test Equipment Seller by RCA

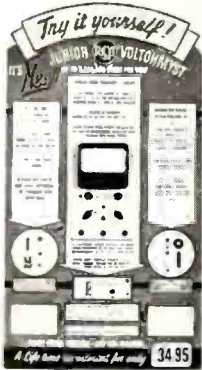

Newest display rack for the RCA Junior VoltOhmyst has a special sell itself feature. Mounted on the brilliant yellow, red, blue and black board are

GREENOHMS for that extra OVERLOAD FACTOR

200-watt adjustable Greenohm. Note clean-cut construction.



Wire-wound. Unique cold-setting inorganic cement coating.

Wire unimpaired in production. No corrosion. No weakening.

Maximum heat conduction and radiation.

10, 25, 50, 80, 100, 160, and 200 watt ratings. Fixed and adjustable.

★ Inorganic cement coating. You can spot them in better-grade amplifiers, transmitters, oscillographs and other assemblies that must stand up. ★ Ask for Greenohms. ★ Or write us direct for latest data: Clarostat Mfg. Co., Inc., 281 N. 6th St., Brooklyn, N. Y.



"It Pays to Display," says Motorola, who offers this big Xmas display package. Life-size Santa, 2 Xmas trees, 2 streamers, 6 price cards.

a transformer and rectifier, a high value resistor and bias cell, a low resistance coil winding, and a leaky condenser. With three leads from the volt-ohmyst, the customer can perform many tests normally required in radio servicing.

Sylvania Has New Airliner Display



A timely new display in eight colors for the winter windows of Sylvania radio servicemen and dealers, has been announced through its jobbers by Hy-

grade Sylvania Corp. There's a catchy outline of a giant tube, with a TWA cockpit scene shown inside, all are designed to fit into the intense public interest in aircraft just now. It stands 40" high; for use on counters there is a miniature companion piece one foot high.

"Different" Displayer



A new 5-set display piece for auto radio, accenting "world's largest manufacturer." Philco also has a 2-set one.

SPENDING 15% TO 20% TOO MUCH ON TELEGRAMS?

Find out by letting Postal Telegraph check your communications files! This free analysis has achieved *sensational* savings for others. Uncovers waste, then provides easy-to-follow, *permanent* plan to stop it!

For free telegraph cost analysis—with absolutely no obligation to you. Address: Mr. H. A. Davis, Postal Telegraph, 253 Broadway, New York City.

WIRE COLLECT:

Postal Telegraph

INDEX TO ADVERTISERS

	Page
AEROVOX CORP.	41
AMPERITE CO.	31
BRACH MFG. CORP., L. S.	47
BURGESS BATTERY CO.	42
CLAROSTAT MFG. CO., INC.	46
FARNSWORTH TELEV. & RADIO CORP.	6
GENERAL INDUSTRIES CO.	43
HOWARD RADIO CO.	33
HYGRADE SYLVANIA CORP.	Cover 4
INTERNATIONAL RESISTANCE CO.	37
JENSEN RADIO MFG. CO.	3
KEN-RAD TUBE & LAMP CORP.	41
MALLORY & CO., INC., P. R.	Cover 2
MEISSNER MFG. CO.	23
OXFORD-TARTAK RADIO CORP.	44
PERMO PRODUCTS CORP.	44
PHILCO RADIO & TELEV. CORP.	24, 25
PIONEER GEN-E-MOTOR CORP.	42
POSTAL TELEGRAPH	46
QUAM-NICHOLS CO.	47
RADIO CORP. OF AMERICA	4
RAYTHEON PRODUCTION CORP.	5
RCA MFG. CO., INC.	1, 17
RIDER, JOHN F.	45
SPRAGUE PRODUCTS CO.	39
SUNDT ENGINEERING CO.	48
SUPERIOR TUBE CO.	2
TRIPLETT ELEC. INSTRUMENT CO.	29
TURNER CO.	33
UNIVERSITY LABORATORIES	48
WILCOX-GAY CORP.	43
WOODALL CO., THE W. P.	Cover III

While every precaution is taken to insure accuracy, we cannot guarantee against the possibility of an occasional change or omission in the preparation of this index.

NEW BOOKLETS

Circular, printed in green and black, concerning Stromberg-Carlson's new line of radios. Stromberg-Carlson Tel. Mfg. Co., 100 Carlson Rd., Rochester, N. Y.

48-page catalog covering all types of private inter-communicating systems including wiring diagrams and installation data is Bulletin No. 103 (available in bound or looseleaf form) of the Conn. Tel. & Elec. Corp., Meriden, Conn.

An 8-page bulletin, "Radio Interference Elimination for Public Utilities" issued by Sprague Prods. Co., North Adams, Mass., describes the causes and cures of radio interference on power transmission and distribution lines. Copy will be sent free to bona fide radio servicemen, upon request.

A folder dealing with Rimco Dynalyzer has just been put out by The Radio Instr. Mfg. Co., Inc., 428 W. Capitol St., Jackson, Miss.

A GE folder No. GEA-3480, has been released on FM communication equipment—receivers and 25-w. transmitters. General Elec. Co., Schenectady, N. Y.

A 20-page booklet issued by the Port-o-Matic Corp., 50 E. 77th St., N. Y. C. presents its line of radios, phonographs and combinations in consoles and portables.

Fifth edition of Stancor Famanual just announced by Standard Transformer Corp., 1500 N. Halsted St. Chicago, Ill. Twelve transmitters and six amplifiers are included in constructional articles. Available at distributors or direct for 15 cents.

Complete line of photo electric cells shown in new Bradley Labs., 82 Meadow St., New Haven, Conn., booklet. Luxtron cells are of the voltage generating type, sensitive and stable.

A 16-page booklet by RCA Mfg. Co., Camden, N. J., covers the types and applications of their various photo tubes. Characteristics and typical circuits are shown. Available at distributors.

New catalog of heavy duty polarized power plugs and sockets just released by Howard B. Jones, 2300 Wabansia Ave., Chicago. With 2 to 12 contacts, connectors designed for 5000 volts at 25 amps.

Radio capacitor bulletin 185A covers 1941 line of Cornell Dubilier Elec. Corp., S. Plainfield, N. J. All types of radio condensers are included. Available at distributors or direct.

New line of motor starting capacitors of small size use "size adjuster" to fit old housings. New catalog with complete details may be had from P. R. Mallory & Co., Indianapolis, Ind.

Ward Products Corp., 1523 E. 45th St., Cleveland, Ohio, will supply on request a guide WA-107 of 1941 auto antenna installation positions for all 1941 cars and data on the universal antenna E3-68.

JIM QUAM Says



Every year at this time we try to say it in some new and different way but when we get all through trying, we find there are no better words than that simple, old-fashioned greeting:

**A Merry Christmas
and a
Prosperous New Year**
from
The Whole Quam-Nichols
Organization

QUAM-NICHOLS CO.

33rd Place & Cottage Grove
CHICAGO

1674 Broadway
NEW YORK



BRACH Antennae

Automobile
Home — All types
F-M Systems
Television
Police • Marine
Multiple Systems
Complete Kits
Accessories

Made by World's Oldest and Largest
Manufacturers of Radio Aerial Systems

L. S. BRACH MFG. CORP.

55 DICKERSON STREET
NEWARK, N. J.



WHERE TO LOOK FOR NEW SALES AND BIGGER PROFITS!



CARILLONS • MUSICAL TOWERS

New Big Profit Outlet—Live wire sound men can cash in on the big demand for tower and bellry chimes. Sunco Carillons are sold and installed by qualified dealers exclusively. Sales Leads! We advertise regularly in 10 leading church publications that cover an audience far in excess of one quarter million readers. These exclusive features mean more profits—easier, quicker sales: Micro-tuning to 1/5000 of 1% permits playing of any harmony, same as on a piano. Speakers handle deepest tones at full power. Covers area 2 miles in diameter. Many special carillon records available. READ THIS: If you have an established sound business with commercial listing, and are looking for a new profit outlet—Write us at once!

SUNDT ENGINEERING COMPANY
4763 Ravenswood Ave., Chicago, Illinois

Sell & Use LITTELFUSES

WRITE FOR CATALOG

Get this new catalog free. Shows complete line of Littelfuses for radio, transmitters, rectifiers, meters, instruments. FUSE MOUNTINGS—all kinds. When you want fuses—LITTELFUSE! See your jobber or write:

LITTELFUSE INC.
4763 RAVENSWOOD AVE. CHICAGO, ILL.

New University

***Super *Power *Bull *Speakers**

Introducing:
A Complete new line of "Bull" Speakers.

Featuring
Breakdownproof Diaphragms — Waterproof Assembly—Highest Possible Reflex Efficiency — Super Power Acoustic Output—Non Resonant Construction.

100 watts; Model 4 X R "Standard Bull" Speaker. (with quadruple driver)

50 watts; Model 2YR "Baby Bull" Speaker. (with dual driver)

Write for details

University
100 CHITRE STREET NEW YORK, N.Y. CABLE UNIVERSITY

WHAT READERS SAY

Dealer Inter-relates Platform Planks

Editor, RADIO TODAY:

We are interested in merchandising as well as service problems and your "Business Platform" on page 22 (September issue) is not only timely but is forcefully to the point and should be of great interest to every legitimate retail dealer.

We appreciate the value of each "plank" and would like to see some very active and open discussion of some of the pros and cons. Such discussions would definitely bring hitherto hidden facts out into the open and would go a long way toward helping out this generally deplorable situation.

We have been practically crowded out of merchandising because of the extent to which the evils in "plank No. 6" have developed. Most of the other planks, it seems to us are dependent on this one. For instance, we believe that "Creative Selling" is a normal function of the retailer; in his window, on his floor, and in the home; but we can't afford to do the creative work and have the sales go through "Plank No. 6" channels. "Plank No. 9" is a point well taken as service does not accompany the sales that go through "plank No. 6 channels." This reflects to the detriment of the name of the product and its manufacture if the customer is not satisfied.

(Signed) C. W. FARRINGTON
Farrington Radio Co.
Arlington, Mass.

A Designer Writes Out Loud

Editor, RADIO TODAY:

Should the radio industry adopt some striking new cabinet form and material?

1. Form? Yes, and I believe it is the only solution to the problems. By form, I mean new and concentrated exploitation of the seven elements of visual perception; line, color, value, texture, volume, area, and space.

2. About every practical material has been used for small units, but wood is here to stay for large items. Nothing can ever equal the comfortable feeling which woods, in different finishes, lend to any atmosphere. Also, wood is ideal for the tonal quality it lends to acoustical phenomena. Lastly, the economy and endurance of cabinets in the home as they are made in production today, are as good as they were in the old days of the best cabinet-maker's art.

Should "furniture" models with remote control be promoted? Yes, but I think their volume will be limited because of the cost of authentic furniture and the number of people in the market for them. Also, I think it is criminal when a radio is "hid" in an item that was designed to have true doors and drawers.

Are chairside models, with their

handiness of control, and double usefulness as convenient furniture—the radio sets of the future? Again yes, but limited, because they are only enlarged table-models set on the darkness of the floor. If they contain a large set, people don't think they are getting much of a "package" for the price.

EARL GAGEN
4328 Kenmore Ave.
Chicago, Ill.

Platform Support From Hollywood

Editor, RADIO TODAY:

Your "ten points" are just simply horse sense. The executive who would try to justify any other platform should be excluded from the companionship of reasonable men.

If the radio industry would follow these ten points there would be no pressing problem for dealers today—at least none of any consequence.

From my own standpoint I think that the multiplicity of models and the terrific pace of obsolescence thereof is the greatest single headache. In my opinion this factor is the greatest creator of sales resistance, forcing the consumer to buy BELOW his or her capabilities with the idea that he will not lose as much on a jalopy as on a worthwhile item, when it goes out of date next month—and believe me brother, the consumer is aware of, and afraid of, just this.

(Signed) H. D. HATFIELD
Hollywood, Calif.

Thoughtful Note on Television

Editor, RADIO TODAY:

Here is my impression of the way people are thinking about television in South Carolina.

All of our customers are very enthusiastic over the idea of television—in fact every one that we come in contact with wants to know when we will be able to get it in this part of the country. However, we have not noticed any decline in radio sales and everyone is assured that when television does reach us the public will be able to purchase the video attachment for the late model radios.

We have included "and Television Service" in our company name because we do not want to be caught napping. We wish to establish the idea to the public that we are keeping abreast of the latest developments in television and that we will be able to give them expert service when it arrives. This is explained to everyone who asks, as we do not want to create a false impression that we are selling or servicing television yet; instead we are preparing to give them the best when it arrives.

W. H. Herring
Columbia, S. C.

Every 3rd Serviceman Answered!

**RADIO TODAY LISTS
PRODUCE 9,600 REPLIES
FOR HICKOK**

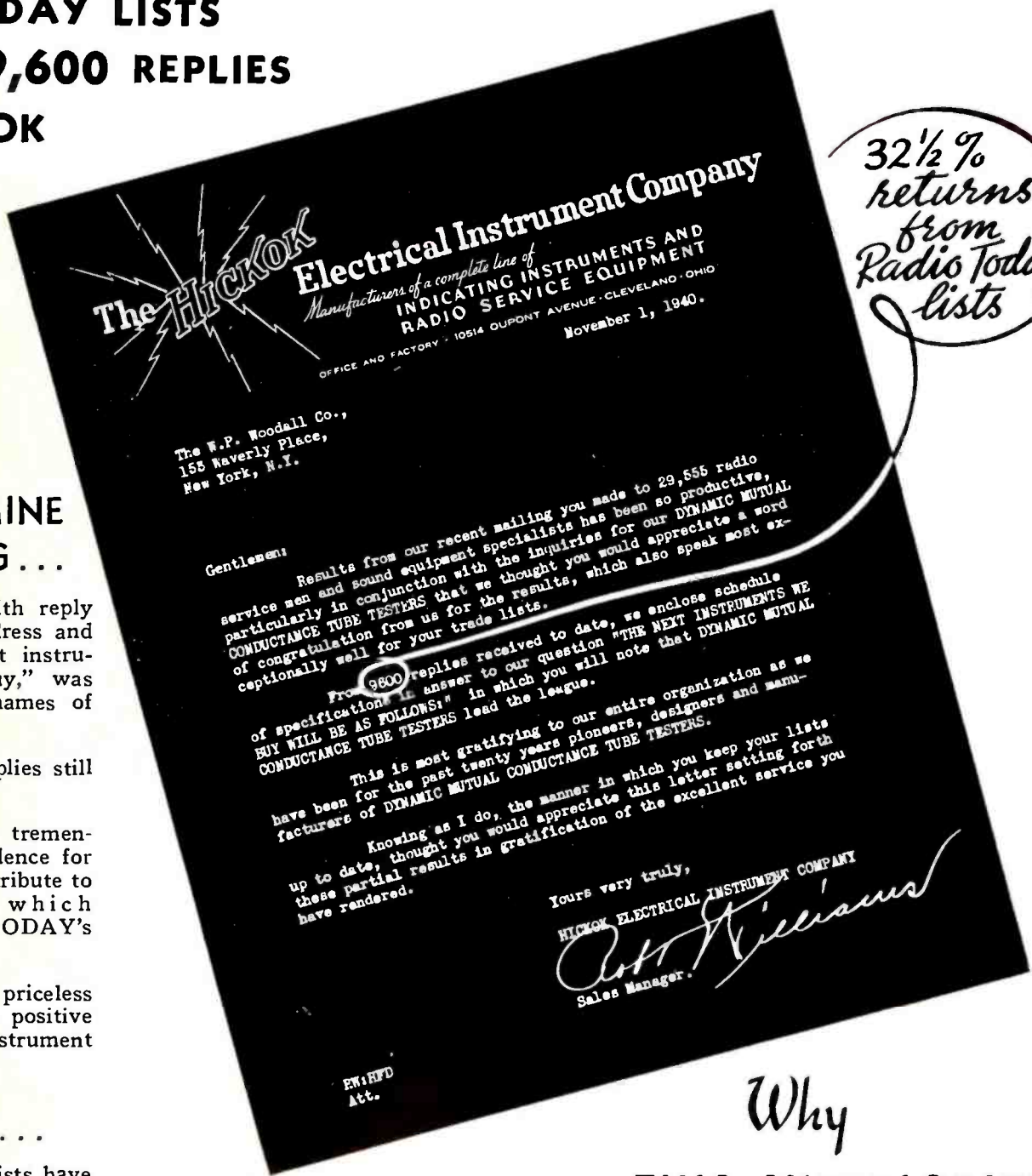

32½% returns from Radio Today lists

LET'S EXAMINE HIS MAILING...

Hickok catalog, with reply card for name, address and statement of "next instruments we will buy," was mailed to 29,555 names of radio servicemen.

9,600 answered—replies still coming in.

Response taken as tremendous vote of confidence for Hickok, as well as tribute to Woodall Service, which manages RADIO TODAY's mailing list.

Gave Hickok a priceless prospect list, plus positive data on trend of instrument buying.

Proving that...

RADIO TODAY lists have a distinctly higher level of buying power.

Higher degree of accuracy, plus selectivity.

Exceptional results were obtained without inducements; with no appeal to cheapness or price.

AND what about the cost? Actually, the cost is insignificant in view of the results that are plainly possible.

RADIO TODAY is constantly spending money to MAKE its lists, and KEEP its lists, the finest in radio—to make them PAY YOU.

Why THIS SUPERIORITY?

Your distributors — your salesmen — would SELL MORE with this kind of lead-producing sales promotion. That is why smart radio sales managers are doing a two-fisted selling job — using RADIO TODAY mailing lists and RADIO TODAY advertising pages.

The
F. P. WOODALL COMPANY
155 WAVERLY PLACE, NEW YORK

Operating and managing
the direct mail services
of RADIO TODAY



480 LEXINGTON AVE., NEW YORK