

RADIO TODAY



NO CROWD TOO LARGE - NO GROUP TOO SMALL - FOR MODERN P. A.!

"SELLING SOUND" in this issue

APRIL

OUT IN FRONT!

WITH
FEATURES TO STIMULATE BUYING
PRICE TO STIMULATE SALES



PEP UP YOUR Spring SALES WITH THIS Sensational MODEL F-65BT

TOUCH TUNING — Instantaneous variable capacitor type, positive, trouble-free with six buttons tuning in five stations and the sixth button providing for manual control. 6 G-E Pre-tested Tubes, a Power Output of 5 watts and a 12-inch Stabilized Dynamic Speaker provide ample volume and exceptional clarity, definition and realism of tone. This model features the new G-E Louver Dial which enables easy tuning from any position, standing or sitting — without distorting the cabinet. Two Bands, Automatic Volume Control, Automatic Tone Compensation, I.F. Wave Trap, Visual Volume Control, Visual Tone Control, and Tone Monitor Circuit Design.

FIRST TIME A G-E
TOUCH TUNING RADIO
FOR LESS THAN \$99.95

GENERAL  **ELECTRIC**

MAN, OH MAN! WHAT A BOOK!

The **Second** (1938) Edition of the
MALLORY-YAXLEY
Radio Service Encyclopedia



*The
 Greatest
 Time-Saver
 a Service Man
 ever had*

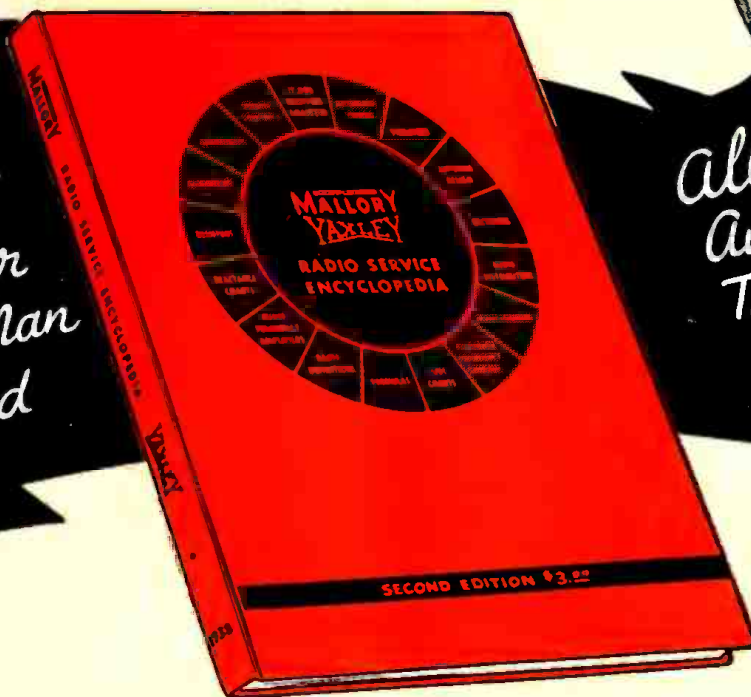

*All
 Automatic
 Tuning Systems
 Completely
 Analyzed*

17,000
 RECEIVERS
 ANALYZED

TUBE
 CHARTS

AUDIO
 AMPLIFIER
 DESIGN & USE

ALIGNMENT

RESISTORS

ANTENNA
 DESIGN

VOLUME
 CONTROLS

CONDENSERS

Use
P. R. MALLORY & CO. Inc.
MALLORY
 REPLACEMENT
 CONDENSERS...VIBRATORS

Use
YAXLEY
 REPLACEMENT
 VOLUME CONTROLS

Mister, it's a B O O K . . . beyond your fondest dreams. If you thought the First "MYE" was "hot", you'll say this Second Edition "tops" everything! 17,000 receivers analyzed (5000 more than in the First Edition). 336 pages of handy, concise information. (There were 216 in the First Edition.) Chuck full of substantiated radio service data never available before.

It gives the answer to EVERYTHING a service man wants to know "in one book . . . on one page . . . on one line"

Vibrators . . . Transformers . . . Audio Distribution . . . Condensers . . . Rectifiers . . . Antenna Design . . . Resistors . . . Formulas . . . plus the last word on radio's newest and most vital subjects.

Complete Automatic Tuning Information

With over 100 illustrations . . . with schematics . . . trouble shooting charts. Audio degeneration . . . the new profit avenue modernizing old type receivers. Alignment and the use of the Oscilloscope for "high fidelity" servicing. Tube charts . . . covering every type . . . every make.

The time you save on the first job in which you use it will more than pay for your copy. And the way to make it profitable for you is to begin using MYE today! See your distributor now! His supply is limited.

P. R. MALLORY & CO., Inc., INDIANAPOLIS, INDIANA
 Cable Address—Pelmallo

NEW SPACE COOLER MAKES DRAMATIC DEMONSTRATION!

ONLY
\$159⁵⁰ LIST
F.O.B. FACTORY



High quality "package" unit eliminates all engineering problems.. Just plug it in.. No water pipes to connect.. No wiring to install.. Fits on window sill.. Demonstrates itself.. A new APPLIANCE!



THE NEW Johnson Space Cooler is a compact, self contained electric refrigeration plant which circulates air over cold coils where it is cooled, cleaned, de-humidified—then distributed throughout the room. It provides the refrigerating equivalent

of 650 lbs. of ice per day! Fits on any window sill. (Width 27". Window sealing-panels are furnished.)

Show it. Simply take it to a prospect's home or office. Plug it in. And let it sell itself!

Nothing that you handle makes a more convincing demonstration. The housewife in her kitchen, the professional man in his office, the

patient in the sick room gets sold—quick—on a unit that gives *real* relief from heat and humidity!

The Johnson Space Cooler is the product of Johnson Motors, builders of the world famous Sea-Horse Outboard Motors, Briggs household refrigerators and other products of high quality. More than five years in refrigeration, with many notable developments to its credit, have given Johnson a perfect background for this latest achievement.



DEALERS, DISTRIBUTORS

Send for full details, discounts and merchandising plans. The season is **HERE**. Every day means extra profits.

JOHNSON MOTORS • REFRIGERATOR DIVISION
2040 MONMOUTH BLVD., GALESBURG, ILLINOIS

JOHNSON
Space Cooler

GET GOING RIGHT NOW . . WRITE, WIRE FOR DETAILS

When Scientific Research and

Life Itself

Depend on Radio Tubes—

**the Bowdoin-Kent-Harvard
Arctic Expedition**

used **RAYTHEONS!**

Up in the cold, bleak Arctic—radio communication is all-important—the life-line to any scientific expedition.

Radio tubes *must* work efficiently—*must* be of sturdy construction to withstand the rigors of cold climate, the vibrations of the ship, the jarring of dog sleds.

The custom-built radio receivers used in the recent Bowdoin-Kent-Harvard University Expedition to the Arctic were completely equipped with Raytheon tubes—another reassuring tribute to Raytheon engineering, quality and dependability.

Radio servicemen and dealers save on unprofitable call backs and build good-will by using these same Raytheons.

Use Raytheons for *your* replacements and enjoy greater permanent tube profits.

RAYTHEON

CHICAGO • ATLANTA • NEW YORK • NEWTON, MASS • SAN FRANCISCO
"WORLD'S LARGEST EXCLUSIVE RADIO TUBE MANUFACTURERS"

CROSLLEY dealers are making sales NOW with this story!

THE HANDIEST REFRIGERATOR EVER BUILT

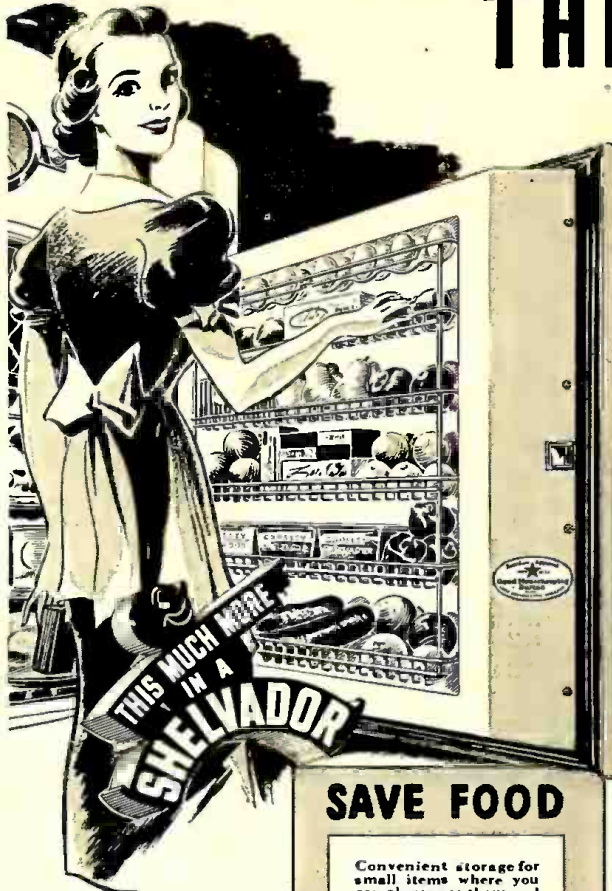

Here's a refrigerator in which a woman can get at things easily. Nothing gets lost. The shelves in the door permit storing of small items so ingeniously that you can actually get MORE FOOD in the Shelvador than in ordinary refrigerators of equal size.

CROSLLEY SHELVADOR

A refrigerator is a little room from which an ingenious device extracts heat, providing safe food storage temperature. To do so costs money. Hence skillful placing of food is necessary to use all that cooled space. The Shelvador efficiently fills all space—eggs, fruit, butter, bacon, and covered dishes, in the door shelves; bulkier foods on the cabinet shelves. When you open the door foods are instantly findable, and you close it promptly. Safe box temperature is maintained and little current used. And the orderly storage makes true the statement that you can "put more food in the Shelvador."

with built-in RADIO

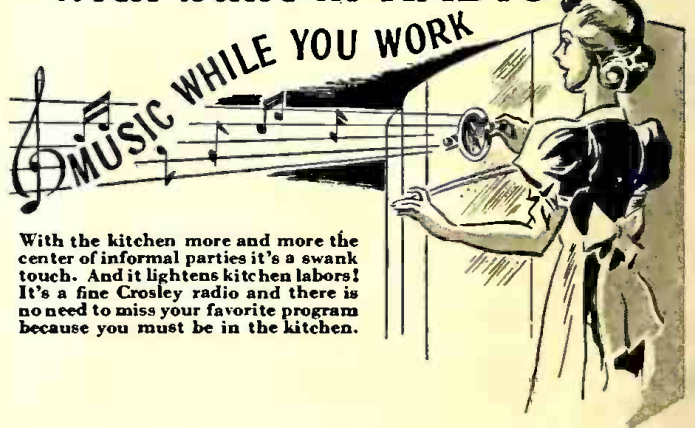

With the kitchen more and more the center of informal parties it's a swank touch. And it lightens kitchen labors! It's a fine Crosley radio and there is no need to miss your favorite program because you must be in the kitchen.

All refrigerators are good—all look alike—all have the same selling appeal. The buyer's dollar will come easiest to the one that has more to offer than the rest. With the Shelvador and built-in Radio, Crosley dealers have a powerful customer attraction and sales-closer that is creating business now.

THE CROSLLEY RADIO CORPORATION - - CINCINNATI
 POWEL CROSLLEY, Jr., President
 Home of "the Nation's Station"—WLW—500,000 watts—
 70 on your dial

SAVE MONEY

These Effective Ways!

SAVE FOOD

Convenient storage for small items where you can always see them and easily reach them, saves many a leftover that might be forgotten and wasted.

SAVE CURRENT

New sealed Electro-saver unit shows highest operating efficiency. Running periods are short. This saves wear on motor. Temperature control permits economical cooling.

SAVE STEPS

Many features like Quick Release ice cube tray, crisper, removable shelf sections, covered jars for leftovers, and the Stora-drawer for non-refrigerated storage, save many steps and time.

SAVE UP-KEEP

Amazing new glass wool insulation proves most practical and efficient of all insulation. Dulux finish and chrome hardware make cleaning easier.

THEY MUST HAVE TUBES-
and **PHILCO** is naturally
FIRST CHOICE!



PEOPLE can and do put off buying new radio sets . . . but they can't keep peace at home while putting off the purchase of needed replacement tubes.

They *must* have tubes . . . and now with the baseball season coming on . . . and big sports broadcasts constantly scheduled . . . better daylight reception becomes as important to the men as to the women . . . and tube sales are in the making!

Make sure that you get your share of those tube sales by having a complete stock of PHILCO Tubes on hand. PHILCO is the name they all know, the name they all respect, the name that appears on more radio sets than any other name!

Make Spring a clean-up time for weak tubes! Go after the replacement market with the tube that is first choice with over ten million radio owners — the tube that bears the PHILCO name!

PHILCO
TUBES

The Easiest Tubes in the World to Sell



" I'VE GOT
JUST WHAT YOU NEED
to make sales "

THE buying public's confidence in Commercial Credit Company and familiarity with our time-payment financing plan can be a good-will credit on your ledger . . . a big help at the point of sale.

Many of your prospective customers have had other purchases financed through us. We exercised diplomacy as well as thoroughness in investigating their credit. Our collection system has been courteous and considerate as well as efficient.

When you offer them Commercial Credit Company financing, you find ready acceptance of terms.

Commercial Credit Company supervision of credits and collections is an asset on the merchandising side, too. It helps to eliminate bad credits . . . allows you to concentrate on sound sales to your great advantage. Prompt remittance of your money increases your rate of capital turn-over.

Call on me. I am one of 205 local managers, ready to finance all the sound sales you can make. The great resources of Commercial Credit Company . . . unaffected by changing local conditions . . . are behind me.



REFRIGERATORS • RADIOS
RANGES • HEATING AND AIR
CONDITIONING EQUIPMENT

COMMERCIAL CREDIT COMPANY

COMMERCIAL BANKERS



HEADQUARTERS BALTIMORE

CONSOLIDATED CAPITAL AND SURPLUS OVER \$64,000,000

Serving Manufacturers, Distributors and Dealers Thru More Than 205 Offices in the U. S. and Canada

To Millions
RADIO
 brings the
PRICELESS
GIFT OF
MUSIC

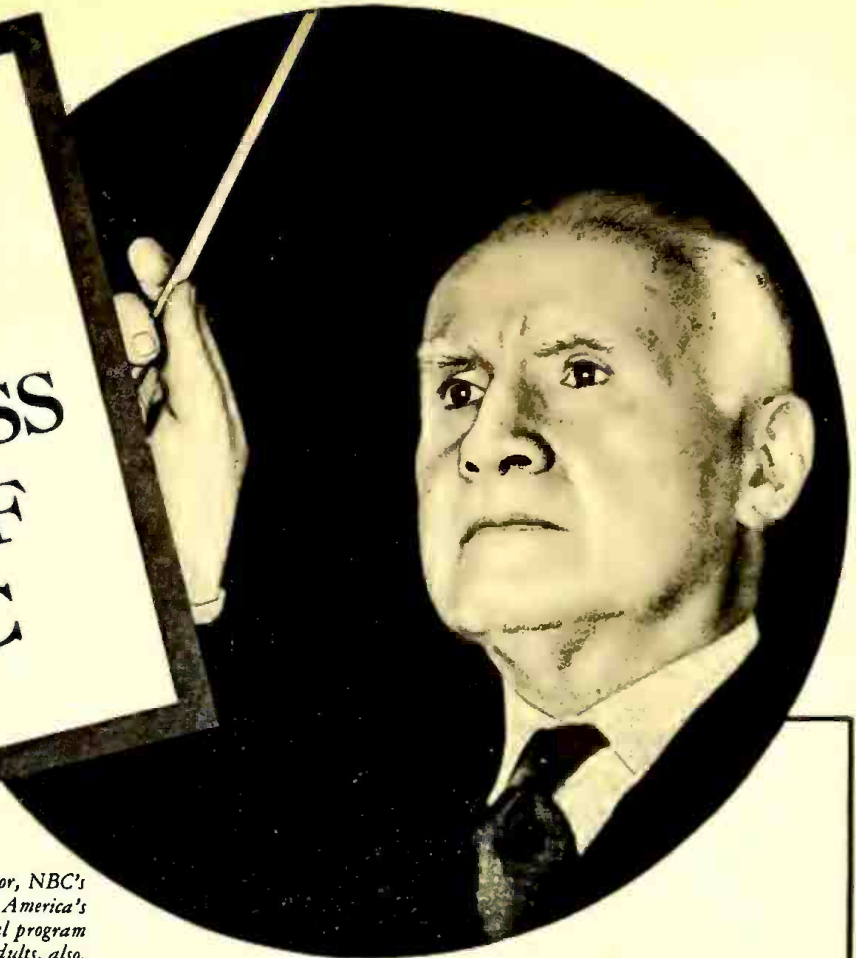

DR. WALTER DAMROSCH, conductor, NBC's exclusive "Music Appreciation Hour," America's most widely-listened-to musical educational program for school children. Very popular among adults, also.

RCA further promotes music culture and the music industry by cooperating with NATIONAL MUSIC WEEK—May 1 to 7—You, too, can profit by helping "Foster Local Music Talent"

AUTHORITIES have declared radio to be the greatest single factor in the promotion of music. RCA again assumes leadership in this enterprise through NBC's whole-hearted participation in this Fifteenth Annual Celebration of National Music Week, which will be officially inaugurated by the Magic Key program on Sunday, May 1st.

Such worthwhile musical services are not new with RCA . . . For, through Dr. Walter Damrosch, on NBC's "Music Appreciation Hour," RCA has for many years contributed to the growing musical enjoyment of countless men, women and children throughout the country. Into their homes, from the Metropolitan Opera stage and through the NBC Symphony Concerts directed by Arturo

Toscanini and other famous conductors, RCA has brought the world's most magnificent music. Every Sunday, RCA's popular Magic Key program brings them superb musical entertainment from all parts of the world.

Radio Dealers...Support National Music Week

It will pay every radio merchant to stand behind National Music Week. This worthwhile promotion will greatly stimulate public desire for fine music. And to enjoy it, people will buy fine radios, phonograph-radios and phonograph records. This will help radio merchants...So be sure to cooperate wholeheartedly with your local musical organizations and broadcasting stations in *fostering local musical talent!*

RCA presents the "Magic Key" every Sunday, 2 to 3 P. M., E.D.T., on the NBC Blue Network.



RADIO CORPORATION OF AMERICA
 RADIO CITY • NEW YORK

RCA MANUFACTURING COMPANY, INC.
 NATIONAL BROADCASTING COMPANY

RADIOMARINE CORPORATION OF AMERICA
 RCA INSTITUTES, INC.

RCA COMMUNICATIONS, INC.

Staff—

DARRELL BARTEE
G. H. MAYORGA
N. McALLISTER
M. H. NEWTON
R. NEUBAUER
B. V. SPINETTA
VINTON K. ULRICH

LEE ROBINSON
Sales Manager



ORESTES H. CALDWELL
Editor

M. CLEMENTS
Publisher

Copyright 1938
Caldwell-Clements, Inc.
480 Lexington Ave.
New York, N. Y.

Tel. PLaza 3-1340

Vol. IV, No. 4.

MEMBER AUDIT BUREAU OF CIRCULATIONS

NATIONAL MUSIC TUNE-UP

★ Opening event of the big National Music Week celebration, May 1-7, is set for 2 p.m. on Sunday, May 1. C. M. Tremaine, secretary of the Music Week committee, will interview RCA's David Sarnoff, committee chairman, on the Magic Key program on the NBC Blue network.

Other network features will follow during the week, to mark the period as a nation-wide stimulation of local music talent. As the National Association of Music Merchants points out, "The Richest Child Is Poor Without Musical Training."

INTRODUCING THE NARAR

★ The National Association of Radio and Appliance Retailers got under way March 21 when some fifty dealers from the eastern half of the nation met in New York City to line up all U.S. dealer groups under one banner. Members of the new organization are to be the various radio and appliance associations and leagues, with special provision made for individual dealers in areas where no such group exists. The purpose is to clean up the trade and to give the dealer a national voice.

The officers elected were Russell A. Atkinson, Brooklyn, N. Y., president; Homer C. Davis, Philadelphia, vice-president; W. H. Frederick, Wilmington, Del., recording secretary; Ralph Wegner, Fort Wayne, Ind., treasurer, and B. H. Poucher, Philadelphia, executive secretary. Mr. Poucher's offices are now in the Architects Building, 17th at Samson St. Regional vice-presidents and various committees will be named later. The next meeting is scheduled for July, in Chicago.

The association went on record as favoring (1) stabilization of prices, (2) the sale of radio and appliances through established dealer outlets and the elimination of discount

houses, cooperative buying groups, corporation buying and utility purchasing, (3) control of production, (4) uniform trade-in allowances, (5) the labeling of merchandise for manufacturer identification, (6) the elimination of cruises, spiffs, prizes, etc., (7) the use of a police policy among its members, (8) the elimination of misleading ads, (9) the exchange of ideas and ideals, (10) cooperation with other similar associations, and (11) special support for manufacturers and distributors who cooperate with the association.

FAVORED FLASHES

★ A big section of the American public flatly prefers to get its news from the radio, rather than from the newspapers, according to figures revealed in Fortune Magazine's Survey of Public Opinion. Of the persons

contacted, 23.5 per cent said that their main source of news was the radio, while 45.2 per cent said they depended upon newspapers, mostly. Radio's popularity in this field is therefore an amazing thing, since it is only a youngster as compared with the newspaper, and radio's long suit is supposed to be entertainment, anyway.

Among those who said that they preferred radio as a news source, the reasons were given as follows:

	Per cent
Gets news more quickly.....	23.4
Less time to find what's going on.....	19.5
More interesting, entertaining.....	11.9
Just don't read newspapers.....	7.5
Radio fairer than newspapers.....	6.9
Radio more complete than papers.....	6.6
Newspapers more confusing.....	4.3
No mistakes on radio.....	3.3
Work and listen at same time.....	2.8
Easier.....	1.6
Cheaper.....	1.2
All other.....	5.3
Don't know.....	.6

PARTS SHOW EXTRA

★ Progress in the planning of the Radio Parts Manufacturers National Trade Show, at the Stevens Hotel in Chicago, June 8-11, indicates that the event will this year have extra features, extra interest, extra scale.

The Show management reports that attendance will break all records. With two months yet to go, more booths have already been contracted for than were occupied at the show held last June.

Representatives of the trade from Canada and foreign countries will have their own headquarters on the exhibition floor. Another new wrinkle is the formation of a Personal Service Bureau, which will take advance registrations and will act as a sort of hospitality center during the show.

Recently announced also is a new feature—a display built around the story of the radio station donated to the inhabitants of Pitcairn Island. Eighteen companies made donations, and will be represented in the display.



C. E. Carpenter, Philco tube manager, presents \$5,000 first prize in recent mystery contest.

SARNOFF REPORTS FACSIMILE UNDERWAY

★ "Various broadcasting stations will shortly commence experimental transmission by facsimile of news bulletins and pictorial material to a limited number of receivers in their local areas," said David Sarnoff, president of RCA, at a stockholders' meeting, April 5. "The RCA Manufacturing Company is now building facsimile transmitters and several hundred receivers which have been ordered for this purpose. The fundamental technical problems of facsimile have been solved, and the immediate question is largely that of determining useful and self-supporting services for the medium."

National Broadcasting Company earned a net profit of \$3,700,000 in 1937, said Mr. Sarnoff. NBC's gross was \$41,000,000, about 36 per cent of RCA's gross of \$113,000,000.

"AMERICAN RADIO LEADS WORLD"—PALEY

★ In a report to the public and CBS stockholders over the air, April 5, William S. Paley, CBS president, asserted that the only basis for Federal regulation of broadcasting was to prevent radio stations from interfering with or overlapping one another, and declared that regulation should be limited to "the bare necessities of the case," chiefly that all broadcasters "should maintain freedom, fairness and non-partisanship of the air."

He added that under the private competitive system existent in the



The new vice-president in charge of sales for Detrola Corp.—James J. Davin. He'll handle both radios and refrigerators.



George A. Scoville, Stromberg-Carlson, general manager, teams with Sales Manager Lloyd Spencer in putting over April sales drive.

United States broadcasting had been used more effectively for the "entertainment, the information and the education of a whole people than it has under any other plan of operation in the world."

SPORTS AHEAD

The following preliminary listing of big-time sports broadcasts will give the dealer a place to start on promotions among this special group of fans. Whether or not these broadcasts are listened to via auto sets does not influence the fact that any radio advertising which the dealer does in connection with the lists, will very likely be read.

April 23	... Chesapeake Stakes NBC
April 29-30	... Penn Relays CBS and NBC
May 7	... Kentucky Derby CBS
May 14	... Preakness NBC
June 1	... English Derby NBC
June 9-11	... National Open Golf Champ.	... CBS
June 10-11	... Wimbledon Tennis NBC
June 22	... Schmeling-Louis Bout NBC
June 27	... Poughkeepsie Regatta CBS and NBC
July 6	... All Star Baseball Game CBS and NBC

COMPOSERS TO HEAR MUSIC OF FUTURE

★ Radio-tube musical development and amplified musical instruments will have a unique demonstration at the Town Hall Club, New York, May 5, under the auspices of the League of Composers.

This organization is backed by such musical leaders as Leopold Stokowski, Mrs. Otto H. Kahn, Paul D. Cravath, Artur Rodzinski, Mrs. Arthur M.

Reis, Marion Bauer, Aaron Copland, Rudolph Ganz, Albert Stoessel and others.

Dr. Orestes H. Caldwell, editor of RADIO TODAY, will preside as chairman of the evening's program and interpret the demonstrations which are designed to show musicians and composers the possibilities of the new electronic pianos and organs, amplified musical instruments, and radio-tube music sources.

Benjamin F. Miessner will discuss electronic instruments, Leon Theremin will present space-controlled music, and Joseph Schillinger will demonstrate the Hammond organ.

Other devices will be exhibited.

FOR "SELLING SOUND,"— PAGES 27-51, THIS ISSUE

The second installment of "Selling Sound," issued semi-annually by RADIO TODAY, is included in the latter pages of the issue now in the reader's hands.

Designed as a complete informational guide to the active new field of sound re-inforcement and public-address, the current section of "Selling Sound" includes:

New trends in sound distribution; industry stabilizing; big 1938 sales promised. How to select the right microphone, amplifier and speaker. Acoustic considerations. Amplifier ratings. Contact-mike opportunities. Decibel levels. Complete specifications of sound systems. New developments in sound equipment. News of the sound business.



C. T. McKelvy is in charge of sales for the new Seeburg Radio Corp., soon to make a big radio announcement.

KNIFING THE RECESSION

Nothing sells like selling—here's a blast of ideas for your attack on a dull season



Caro Miller of L. Hart & Son Co., San Jose, Calif. F. J. Degroot (and wife) of Sanborn, Iowa. A. J. Davis of Waukesha, Wis. D. Tofallos of 9th Ave., NYC. C. Llewellyn of Los Angeles, Cal. T. J. Byron, also of Los Angeles.

Pictured above are the dealers who had a hand this month in our coast-to-coast collection of vigorous selling methods.

Promote a stock of small colorful kitchen model radios to be pushed as ideal Mother's Day gifts, lightening the burden of her working hours. With each radio give a small memo pad, ostensibly to be used for radio recipes and a list of various morning programs with the hour and the station where each may be heard.

Dust off the trade-marks of manufacturers and give them a chance to register with your customers. Spot them on appropriate sets against colorful backgrounds and remember that old ones may be as interesting as newer emblems.

Knock at the door of your customer's most likely neighbor, when you deliver a set, as if by mistake. Among people who live in flats and bungalow courts, this does not seem far-fetched. Apologize for your mistake, but start a sales talk and angle for an invitation to return as soon as you have installed the set you came to deliver.

Fasten a series of large sheets of paper together, to represent an enormous book with the binding at one end. Spot it in the center of your window, opened to a page upon which is lettered the features of a new

model. Either a foot-light or a spotlight may be used to seize attention for the sales message.

Encourage the practice of your salesmen taking new table models home with them, one by one. Suggest that more intelligent selling will result from a thorough testing of each receiver under local conditions. Experiences collected from such tests can be worked into sales arguments.

Ask customers whether they know the difference between a megacycle and a motorcycle. To encourage listening to Continental broadcasts, explain that the short wave proposition is really very simple; use an authoritative yardstick of radio wave bands, common sense and non-technical talk.

Choose a feature model to show in mass display. Conduct the stunt so that the prospect will get the definite idea that you have stocked the number by the dozens; convey the impression that you have only the utmost confidence in the job—its quality and its coming popularity.

Make a list of all the dramatic serials on the air, under the head of "What will happen next?" Be sure

that you are familiar with the broadcast stories yourself, and get your prospects interested in the plots. Introduce the programs briefly in demonstration periods, if necessary.

Get up a mailing piece which features the sales and engineering phrases used by manufacturers in 1938. Be sure that you have the latest, and that you tell them a little something that prospects were not able to get, in the way of explanation of these phrases, from other sources. Don't be so general that the prospect won't feel the urge to come into the store.

Tell your assistants that your store must be kept slick as a whistle from front to back. See that the whole establishment has a "first class" atmosphere that will influence the mood of the salesmen as well as the customers. Publicize the idea that the day of the junky radio sales and service shop is gone.

Re-check the lighting in your windows, and see that your displays introduce your store to the public as a clean shop. If your competitor wishes to fill his window full of special prices, teach him a lesson by keeping special price signs out of your window, but meet him in values.

Establish yourself as a factor in your local celebration of National Music Week, May 1-7. See that your store is headquarters for information, and work with all organizations, such as music clubs, schools, choral groups, etc., and make sure that the broadcast schedules are passed around. Use the slogan "Foster Local Music Talent" and accent work among younger persons of your community.

Get the dope on how many of your prospects are moving on the official moving day, May 1. Suggest that you will move the old set out on the appointed day, and if possible take a look at the new address and suggest what 1938 receivers would fit into the new surroundings.

Make up your own list of news broadcasts which concern the Austrian situation, for a group of prospects which will obviously have a special interest. Also, cash in on the intense interest in broadcast news on the war in Spain and the conflict in China.

Take advantage of the fact that major league baseball begins April 18. Use the sports schedule as the basis for tube check-ups among sport fans, and see that they have enough personal radios among them. Get in, too, on the listener interest in airings of the Kentucky Derby, Penn Relays, Wimbledon tennis matches, the Max Schmeling-Joe Louis bout on June 22, golf tournaments, etc.

Distribute mailing pieces in a circular form, as a new promotion on records. Include lists of new recordings, and dope on most-popular tunes. Invite people to hear the records, and be sure to list the new record-playing instruments offered by manufacturers. Introduce record fans to new orchestras by suggesting that they listen to the radio programs of the artists concerned.

Tell your customers that they "need to have the winter weather" taken off their radio antennas, for best reception in the Spring. Suggest that the winter months may have left the aerial in an unfortunate condition, so that you have a chance to make repairs or to talk up the advantages of a newer and better type of antenna.

At the right Miss Bette Cooper, who was named "Miss America 1937," but who snubbed the razzle-dazzle connected with the award, and went home to finish school. Back home, one of her pals is a personal Philco.

Record of Handling of Radio Listed Below No 2100

Bought from League Hardware Co Price \$89.50

Date of Purchase June 2, 1935

Make Cresley Number 6845 Model Cobenet

Sold to James S. Whipple

Address 608 Lawrence St

Date Sold June 17, 1935

Remarks _____

Use your old sales records as "leads" for replacement and extra-set prospects. Customers of three years past, or longer, are usually ready for another purchase or for a service inspection and tube-and-antenna check-up!

Call your staff together and tell them that the marketing authority. Mrs. Christine Frederick, has issued the statement that women buy 60 per cent of the radios. Exchange notes and experiences on selling women and outline the sales which make up a better merchandising approach to that sex.

Check over all your old and new customers to find where they need extra sets. Keep records on which of them have radios in the kitchen, dining room, bed room, sewing room, play room, daughter's room, son's room, nursery, game room, maid's room, chauffeur's room, garage, workshop and attic. See that your sales staff believes that every comfortably equipped home should have at least as many radios as there are people in the household.

Exhaust the prospects for small radios in the industrial sections of your community. Explain to factory managers that radios are needed for power house engineers' personal use—point out that a number of radio stations are now giving frequent time signals which are invaluable for checking clocks and blowing factory whistles on the dot.

Start a campaign—on small radios particularly—among business houses. Explain to store keepers that a radio set is a business asset in attracting customers and holding them while they look and buy. Check up on these places in your town; barber shops, restaurants, candy stores, gas stations, offices, factories, shoe-shine parlors, beauty shops, drug stores and cigar stores.



★ ANNOUNCEMENTS in the auto radio field this Spring have added up to a special merchandising proposition for dealers.

Radiomen have listened to flashes about Mototone, Safety Tuning, Motoset, Bel Monitor, Synero-Tuning, Sportsman, Acoustimatic, Magic Voice, Commander, Acoustrol, Eliminode, Acoustinator, and other trade developments.

They watched the automotive manufacturing industry stage a highly successful promotion on used cars. They realized that most of the new owners were prospects for sets or service.

They received from 23 major manufacturers in the auto radio field a series of powerful merchandising helps. They noticed that the new display and demonstration devices had taken on new appeal, new color.

Records of cars

The next step, then, is the execution of a new sales campaign for the current months which will dramatically take into account all these new elements in the business.

For one thing, there is the matter of the dealer's getting a list of all likely car-owners in his area. Accurate and up-to-the-minute lists of car radio prospects come (1) from the regular lists of home radio and appliance customers, (2) from an exchange of information with automotive outlets in the community, (3) from newspapers which carry news about newcomers, (4) from connections with auto clubs and whatever drivers' schools there happen to be in the community, (5) from records of special demonstrations, and (6) from reports of auto shows.

Auto drivers get the big broadcasts these days at just the touch of a button.

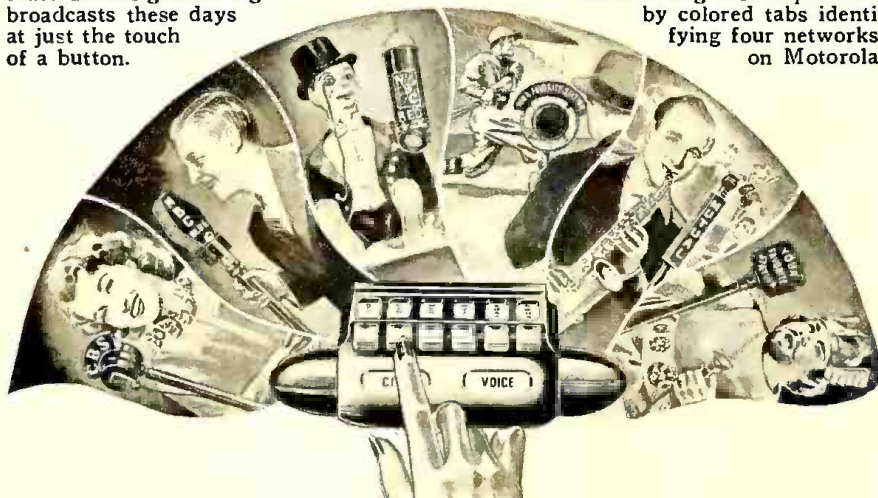

More tuning ease is provided by colored tabs identifying four networks, on Motorola.

SPRING SELLS AUTO RADIO

All the names collected from these sources are carefully approached with sales material on such 1938 features as push-button convenience, simplicity of installation, new angles on styling, developments in noise suppression, advantages of custom-built equipment, and the great variety and appeal to be found in the new auto aeriels.

Making them buy

Armed with all the names and addresses and phone numbers which are worth a Spring approach, the dealer then considers a likely appeal for each party. This often depends upon what the prospects' Springtime driving plans are, what they like to listen to on their auto radio, and how fussy they are about the appearance of their car.

Here's where the new roto newspapers, paper napkins, giveaway pencils, post cards, blotters, pass-out folders, thermometer name plates, book matches, handbills, etc., come

into the picture. All these have been styled for 1938 and rushed out in masses from manufacturing headquarters.

Demonstration tricks

One of the new wrinkles in demonstration of car radio is the use of a parked car, in front of the dealer's store. The radio is turned on, tuned to a show that will attract average passers-by, and the car is plastered with stickers which will hook the stunt up with the dealer's name and store. Because the car is not occupied, and because it has extra decoration as well as a lively broadcast to be heard, people will stop to look and listen. This device is being recommended by several manufacturers, who supply the dealer with the stickers.

Other showings will occur in the usual manner in the store, while the dealer uses demonstration boards which give the customers a chance to try new tuning devices themselves.

In some cases, dealers prefer to show off their new models under actual driving conditions, and encourage the prospect to take a ride. In instances where the customer has some special interest in the elimination of interference, this procedure seems to be a good bet. Matters of noise suppression are finally settled.

Cover the town

There are still some gas stations and some auto service establishments which do not sell auto radios, and these are spots for the radio dealer to see that the patrons of these places hear about his merchandise. By hooking up with these stations and spotting demonstrators among them, the radio man reaches a driving public which is of important size and buying power.

Hardware stores, machinery shops, implement houses and other non-radio outlets also deserve this sort of attention, as they will materially like the number of people who are introduced to the new auto-radio models.

Selling broadcasts

A popular idea among dealers is the use of some form of broadcast schedule along with auto-radio advertising in folders, cards or booklets. Because the motoring public is predominantly male and because auto radio listeners in general have proven themselves to be sport fans, the network coverage of sports events is an important factor.

COLLECTING MONEY TODAY

Keeping close contact with customers. Watching credits.

★ "THE servicemen who look like the greatest little go-getters often turn out to be the lousiest credit punks in the business," says a New York parts jobber who has the problem of collecting from servicemen.

"The ones who put up the biggest front are apt to be mostly front," he declares, and adds that "the sleepier they look the better they manage their business, as a rule."

To this jobber, the recession did not mean a tightening of credit terms among servicemen, but simply a policy of more personal contact. The buyers are not meeting their obligations as regularly and as promptly as they formerly did, and this moves the jobber to desert his formal credit procedures, and to concentrate on individual investigations.

"In dull times, I give my servicemen every chance to pay, and if they show good faith, I go easy. But if they start to be cagey and hard to talk to, I nail 'em."

New trends

Further investigation among the parts distributors in Ohio, Connecticut, Washington, Massachusetts and New Hampshire reveals that servicers are generally further behind than usual, and that parts wholesalers are, as a rule, tightening their terms. However, the survey shows that the majority of them are not suffering from bad debts, the average being around 3 per cent and many of the jobbers reporting "negligible" or "very small."

The idea of more personal contact as a solution to current problems is a popular one, and jobbers are likely to say, if asked about special collection methods used today, that "we just keep after them in a nice way."

One of the main difficulties is described by a jobber in these words: "Most servicers have approached the work through their interest in the technical aspects and not with an eye for business administration. They are not as a rule enthusiastic about business routine or bookkeeping and it naturally follows that their credit position, as a general thing, is apt to be precarious most of the time."

This distributor points out that "periods of recession tend to benefit

servicemen because their customers are holding back from getting new sets and are more willing to undertake repairs and replacements. Many servicemen report better business for the January-April period this year, than for the same months last year."

Which accounts are OK?

What they look for in selecting serviceman accounts can be summarized as past payment records, moral standing, ability to work, value of store and stock, trade references, potential profitable volume, and loyalty to one jobber.

A New York parts jobber says sharply that "the collection problem is the reason that I'm not out today contacting my servicemen."

"The good ones are taken care of, and the lousy ones will come to me. Collections in general are rotten today, and a jobber executive spends as much time on them as he does on selling."

This jobber asks payments on the teeth of each month, and his accounts must make some kind of an effort at that time, or he starts to get tough. He finds that many servicemen try to play one jobber against another, and he often runs into cases where accounts are slow

because they are on the books of several distributors and therefore can't keep up with any one of them. In such instances, jobbers phone each other for a friendly exchange of credit information.

For this wholesaler, about 2 per cent of the total volume must be marked off as bad debts. He finds that on major service equipment, about half of the manufacturers handle the paper themselves. But this does not relieve the dealer of all effort on the account, because he will lose his commission on the sales if the serviceman defaults.

He never gets too tough on servicemen unless the girl at the 'phone tells him that the boss is "out," when he knows that such is not the case.

A careful check

What this jobber does is to keep a sharp eye on the shop activity of slow accounts. He watches for evidence that the dealer was able to buy merchandise from others and he maintains an acquaintance with the personnel so that he knows practically everything that happens. If the serviceman-dealer has some slow accounts himself, the jobber offers some appropriate and tactful advice on collection technique.



"Hard-boiled collection methods should be the last resort," declares radio jobber Yates Hoag of Utica, N. Y., who drew this picture.

NEW MUSICAL



Phonograph with Philco

★ Table type phonograph radio combination. Crystal type pick-up—full-floating motorboard. Plays 10 or 12-inch records. Uses Philco receiver chassis. Cabinet of walnut veneers and contrasting avodire wood. Size 20 x 14 x 13 1/4 inches. Model 16 TP—list \$79.50. Radiobar Co. of America, Erle Ave. & K St., Philadelphia, Pa.—RADIO TODAY.

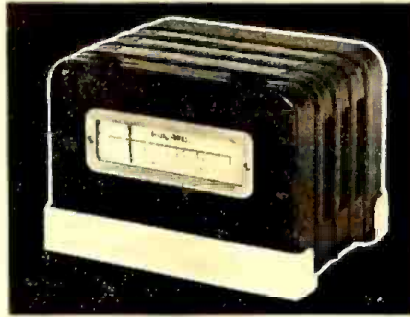

Howard table set

★ AC-DC type receiver using TRF circuit. Finger-tip tuning made possible by illuminated wheel controls projecting through top of cabinet. Uses 4 tubes and has beam power output. Dynamic speaker unit. Cabinet of steel felt laminated. Felt lamination eliminates resonance. Available in opalescent bronze, black, ivory, and cardinal red with contrasting trim. Model 200. Howard Radio Co., 1731 Belmont Ave., Chicago, Ill.—RADIO TODAY.

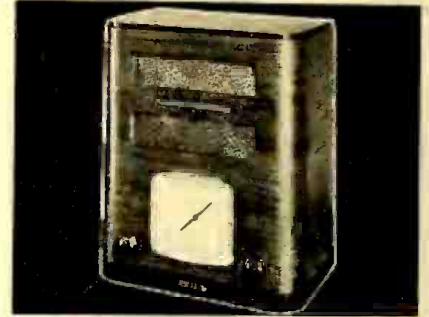

RCA farm receiver

★ 4-tube 6-volt receiver for farm use. Superhet circuit. Tunes 540-1,720 KC. Output of 7 watts. PM dynamic speaker unit. Vernier dial with 8-1 ratio. Cabinet of walnut veneer. Model 94BT-6—list \$29.95. Model 94BT is the same set designed for aircell operation—list \$19.95. RCA Mfg. Co., Front & Cooper Sts., Camden, N. J.—RADIO TODAY.



6-tube receiver

★ AC operated dual-band receiver tuning 540-1,730, 5,600-18,000 KC. Power output of 5 watts—6 1/2-inch dynamic speaker. Floodlighted cone type dial. Push-button tuning for 6 stations—adjusted from front of set. Glowing bulls-eyes indicate band. Tone control. Walnut cabinet. Size is 10 1/4 x 19 x 8 3/4 inches. Model AZ-196—list \$59.95. Emerson Radio & Phonograph Corp., 111 Eighth Ave., New York, N. Y.—RADIO TODAY.

Arvin push-button tuning

★ Adapter unit for converting the Arvin models 22A, 23, and 42 for push-button operation. Automatically tunes in 6 stations. Motor operated mechanism attaches to side of set. Push-button control clamped to steering column or instrument panel. Model ET—list \$17.95. Noblitt-Sparks Industries, Columbus, Ind.—RADIO TODAY.

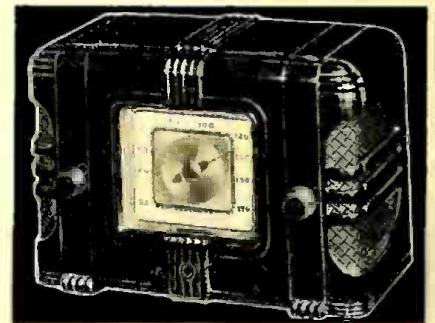

Grebe Challenger

★ Tuned radio-frequency table type receiver for AC-DC operation. Beam power output tube—5-inch dynamic speaker. Full-vision illuminated dial with 2-color scale. High "Q" coils. Plastic cabinet in ebony, walnut, ivory, jade, and red. Size 7 x 10 x 5 1/4 inches. Standard model tunes broadcast band—long wave band also available. Challenger 5. Grebe Mfg. Co., Inc., 119 Fourth Ave., New York, N. Y.—RADIO TODAY.

Cowl type antenna

★ One-piece brass, heavily chrome-plated auto radio antenna for cowl mounting. Set-screw adjustment permits lowering of rod. Equipped with 34-inch low-loss shielded lead-in. List \$3.85. Hahn-McPherson Labs., Hatboro, Pa.—RADIO TODAY.



Self-contained amplified piano, affording concert-grand volume and quality from minipiano cabinet. Built by Hardman-Peck Piano Company under B. F. Miessner electronic-piano patents. Compact and inexpensive, yet giving full range of artist.

MERCHANDISE



Knight receiver

★ 5-tube AC superhet receiver with push-button tuning for 4 stations. Manual tuning utilizes dial with magnifying glass to provide large, clear station calibrations. Octal glass type tubes, automatic volume control, dynamic speaker. Plastic cabinet—11 x 7 x 7 inches. Available in ivory, walnut, or black. Allied Radio Corp., 833 W. Jackson Blvd., Chicago, Ill.—**RADIO TODAY.**

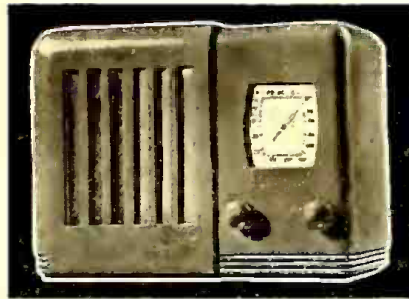

Admiral receivers

★ 5-tube (including plug-in resistor) AC-DC tuned radio frequency receiver. Tunes 2 band: 175 to 550 and 800 to 2,000 meters. Full-vision type dial. 5-inch dynamic speaker. Undistorted power output of 1½ watts. Cabinet of brown or ivory bakelite. Set measures 8¾ x 6¾ x 4¾ inches. Model 516-5C. Model in upper right-hand corner is a 5-tube AC superhet with push-button tuning. Other models not illustrated are 6-volt 6-tube dual-band farm receiver, and 6-tube table type phonograph combination. Continental Radio & Television Corp., 3800 Cortlandt St., Chicago, Ill.—**RADIO TODAY.**

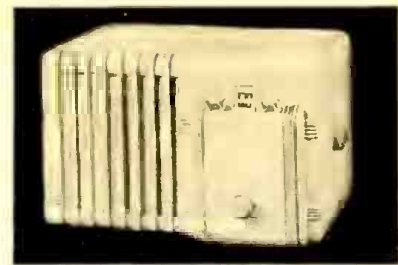

Auto radio P.B. unit

★ Push-button tuning unit for use with any auto radio. Push-button control can be attached to steering column or instrument panel. Manual control fastened to or below instrument panel. Tuning mechanism uses a 6-volt motor and selects up to 5 stations. Mechanism housed in case approximately 4½ x 3½ x 3 inches. Attaches to set or fire wall. F. W. Stewart Mfg. Corp., 340 W. Huron St., Chicago, Ill.—**RADIO TODAY.**



DeWald combination

★ AC-DC radio and AC phonograph unit in table cabinet. Employs RCA synchronous motor and magnetic pick-up. Plays up to 12-inch records. Power output of 2 watts using beam power tube. Full range dynamic speaker. Tunes broadcast band and police calls. Walnut cabinet measures 13¾ x 8½ x 9¾ inches. Model 531—list \$49.95. Pierce Airo, Inc., 436 Lafayette St., New York, N. Y.—**RADIO TODAY.**

Gilfillan receiver

★ AC operated superhet using 5 glass tubes. Tunes broadcast band. AVC — dynamic speaker. Pentode power output stage. Radio log dial. Mahogany cabinet. Model 5G8. Gilfillan Bros., Inc., 1815 Venice Blvd., Los Angeles, Calif.—**RADIO TODAY.**

The new high-fidelity "local" receivers become fine musical instruments for fine homes. Here's McMurdo Silver's Orpheon, announced first in February. Note "jewel-box" tuner beside listener. Flat under-rug cable connects with speaker.

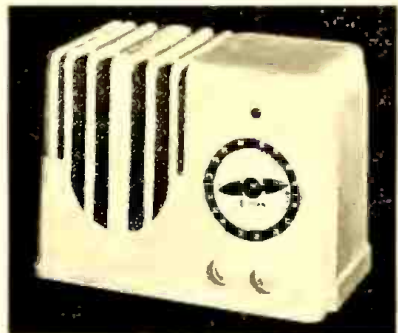

Fada Coloradio

★ 5-tube (including plug-in resistor) AC-DC T.R.F. table type receiver. Tunes broadcast band and police calls. Beam power output tube. Series 450. In walnut—list \$12.95 FOB factory, ivory \$15.95 FOB. Fada Radio & Electric Co., 30-20 Thomson Ave., Long Island City, N. Y.—**RADIO TODAY.**

Tiny electrolytics

★ Metal-can electrolytic condensers with insulating jacket. Pig-tail leads provide support. Available in 4, 8, 12, 16, 24, 30, 40 mfd in voltage ratings of 100, 250, 450. Dandee electrolytics designed for use where space and cost are prime factors. Aerovox Corp., 70 Washington St., Brooklyn, N. Y.—**RADIO TODAY.**

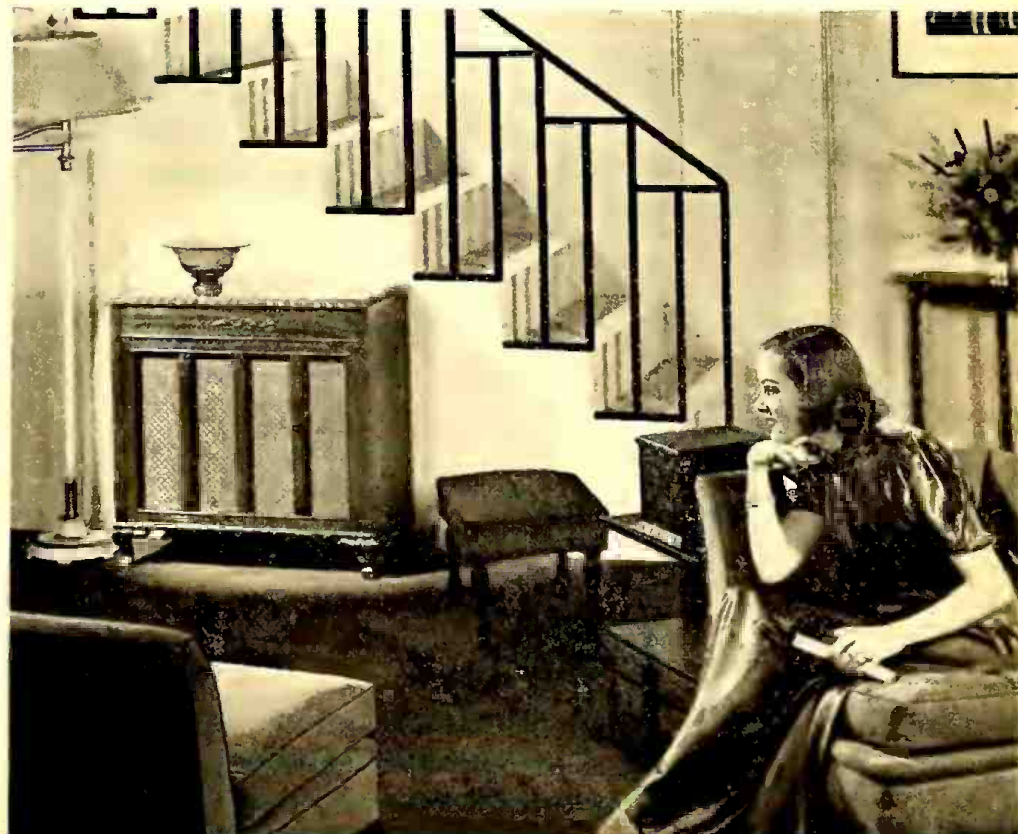

"TUNE UP" RADIOS FOR SUMMER

Eliminate interference, replace antennas and tubes

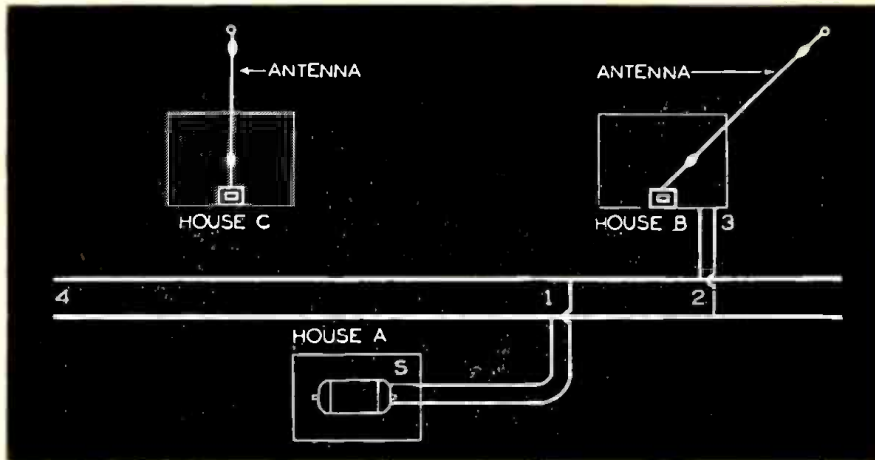

How man-made interference is transmitted from nearby dwelling, through power lines and through antenna interaction.

★ *IN more than one hundred broadcasts over nationwide networks of NBC, CBS and Mutual, O. H. Caldwell, editor of RADIO TODAY, has given practical advice to radio listeners on getting their sets in best condition to receive the great program offerings on the air. The following is an extract from one of these coast-to-coast broadcasts, and may be quoted by radio men as newspaper text or on the air, in any way that will benefit radio reception.*

* * *

To determine whether the noise arises inside the radio set or comes in on the antenna, the simplest test, of course, is to disconnect the antenna while the radio set is still turned on. If the noise continues with little change, with the antenna disconnected, the trouble is somewhere in the set. Tubes may be at fault. This may be tested out by trying new tubes in place of the old ones, one by one, to see if the noise disappears.

If, however, the interference is found to come into the set only when the antenna is connected to the set, the position and condition of the antenna should be looked into.

No better than antenna

Do not be satisfied with a short indoor antenna if you want good, clear interference-free reception. Instead use an outdoor antenna and see that your antenna is up as high as

possible, where it has a chance to pick up a strong "signal" from the broadcasting station, while at the same time picking up a minimum of interference and man-made static from the wires and appliances in the house. If a short antenna is merely run around the picture molding of the room (as is so often most convenient to do), such an antenna may bring in sufficient volume, but it also brings in considerable interference induced from the network of electrical wires in the house, electrical appliances, etc. So that at times the amount of "radio noise" picked up by the antenna, and heard in the set, may be very disturbing. Such interference may be reduced or eliminated at its

source by applying condensers or choke-coils at the offending appliances. To do this work, an experienced radio serviceman should be called in.

In, on the other hand, the antenna is mounted high above the house or runs off from the house, high above the ground, the antenna will get a minimum of noise and a maximum of broadcasting. The intensity of the noise will then be so far below that of the broadcast signal, that the noise will not be noticeable. So in this way, by means of a high antenna, one usually puts an end to interference from local electrical causes in the house, and at the same time brings in clearer, louder signals from the broadcast station, greatly improving the quality of reception.

The wire leading down from such a high antenna to the radio set may pass right through the interference area of the electric wiring and electrical appliances. To avoid this the new scientific twisted-pair lead-in may be used. This shields the antenna from interference which would otherwise reach the antenna wire and be carried into the set. Many good antennas are on the market which improve reception on both the broadcast channels and short-waves.

Above all else the answer to clear, interference-free reception is an adequate antenna, installed as high as possible and far away from the house wiring and appliances.

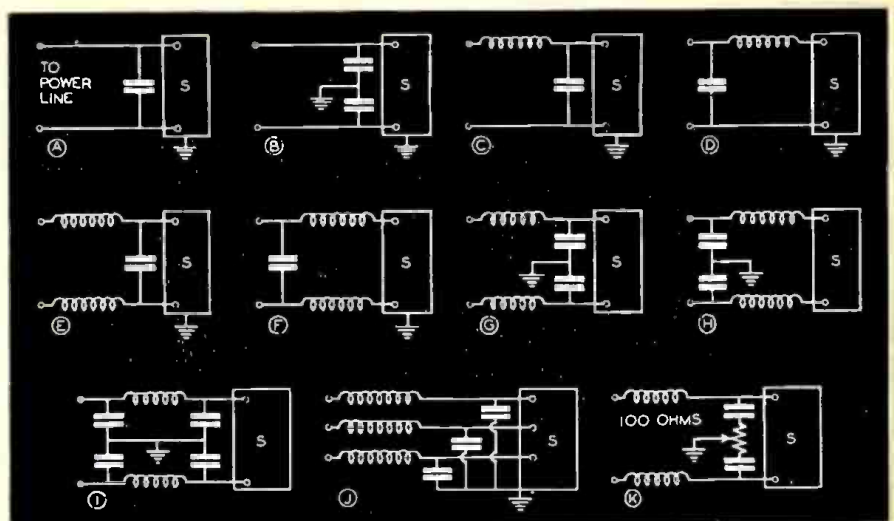

Methods of installing condensers and chokes to cut out interference.

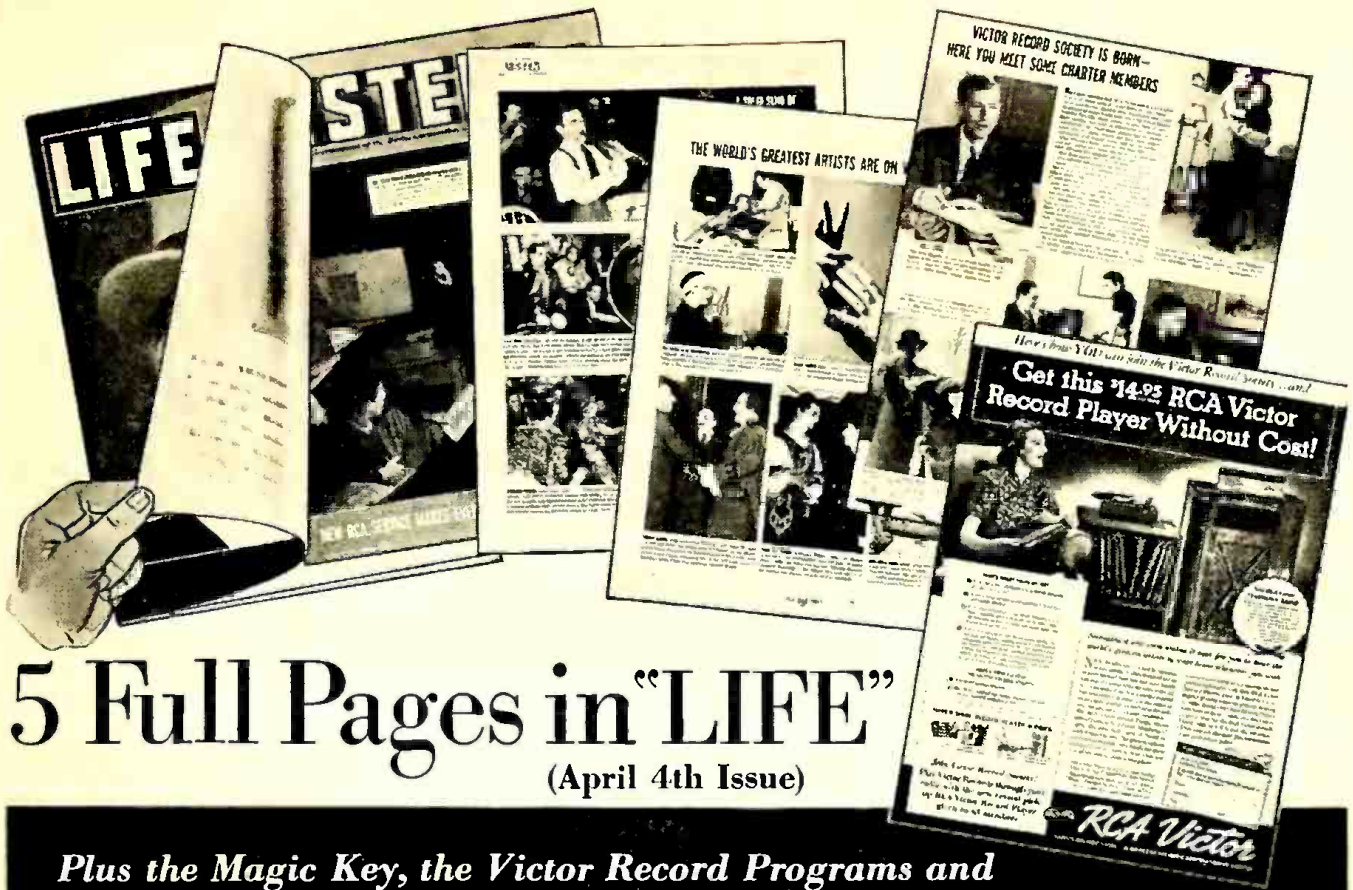

5 Full Pages in "LIFE"

(April 4th Issue)

Plus the Magic Key, the Victor Record Programs and other outstanding mediums... will sell your customers the

VICTOR RECORD SOCIETY

RCA Victor's "Magazine within a Magazine" in "Life" April 4, 1938, tells 14,000,000 readers about new Victor Record vogue

Everywhere Americans are eager to join the Victor Record Society! They proved it in the sensationally successful Wilmington trial. And—right now—they're proving it in every section of the country!

That's the reason why RCA Victor is devoting the entire next issue of "Listen" to the Victor Record Society. On April 4th, 1938, five exciting, colorful pages in "Life" will blast this important news to millions

of music lovers all over America.

And that's just one part of a \$500,000 Campaign which includes the Magic Key, the Victor Record Programs, National Magazines and Newspapers.

Your biggest business-building chance in years!

Even before the Victor Record Society started, Victor Record sales had soared 575% above '33. Now—with this sensational new sales-making plan—you're offered the greatest single profit-making opportunity in years! So don't wait! Start cashing in now! See your distributor at once for full information and sales helps!

RCA VICTOR RECORD PLAYER—R-93-B
Plays Records Through Any Modern AC Radio!



This is the RECORD PLAYER Victor Record Society members receive at no cost. Plays records with full tone of the radio. Can be played from armchair. No getting up to change records. List price \$14.95. See your distributor.

Over 325 million RCA radio tubes have been purchased by radio users... In tubes, as in radio sets, it pays to go RCA All The Way.

Listen to the "Magic Key of RCA" every Sunday afternoon at 2:00, E. S. T., over the NBC Blue Network.



RCA Victor

**RADIO'S
GREATEST
VALUE**

A SERVICE OF THE RADIO CORPORATION OF AMERICA

NEW THINGS

Latest news of radio products from the manufacturers



Utah speakers

★ 3½-inch dynamic speakers featuring PM and electrically excited fields. Will handle five watts. 3½-ohm voice coil. Frequency range of 200 to 8,000 cycles. EE model has 450-ohm field requiring 3 to 6 watts excitation. Utah Radio Products Co., 820 Orleans St., Chicago, Ill.—RADIO TODAY—see also advt. p. 51.

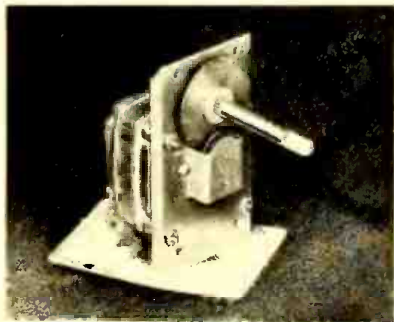

Push-button tuning motor

★ Dependable, low-cost motor for push-button tuning. Self-aligning, oilless bearings guarantee permanent shaft alignment and noiseless operation. Thermostatic protection. Measures only 2¼ x 2¼ x 1¼ inches. Mounting and gear assemblies to specification. Model R. Alliance Mfg. Co., Alliance, Ohio.—RADIO TODAY.

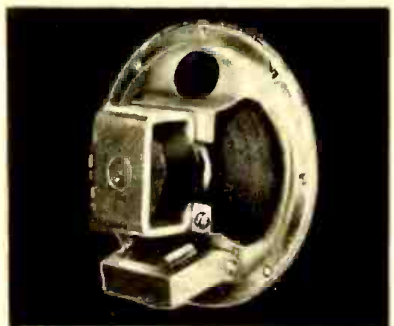

Jensen replacement speakers

★ Low-cost line of speakers for replacement purposes. Made in 5, 6, 8-inch sizes. Fixed or adjustable impedance transformers, wide assortment of field coil resistances. Series "S." Jensen Radio Mfg. Co., 6601 S. Laramie Ave., Chicago, Ill.—RADIO TODAY.

Tobe weatherproof filterette

★ Weatherproof noise filter unit for outdoor installation on police call relays. Eliminates noise occurring from flashing lights used in police recall systems. Unit is contained in weatherproof, cast iron housing for of inductance and capacity to prevent the feedback of interference to the electric power supply line or its distribution along the wiring between the relay and the call lamp. Tobe Deutschmann Corp., Canton, Mass.—RADIO TODAY.

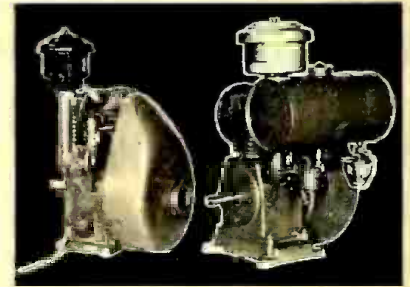

Lauson engines

★ Air-cooled four-cycle gas engines of compact dimensions. Ratings of ½, ¾, and 1 H.P. Ball bearings. Extremely light weight. Dust-sealed magnetos, oil bath air cleaners. Lauson Co., New Holstein, Wis.—RADIO TODAY.

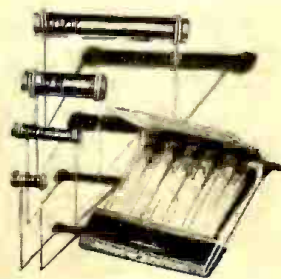

Ceramic condenser

★ Fixed condenser with temperature coefficient designed to compensate for temperature changes in radio set. Available in temperature coefficient from -0.0060 to 0. Capacitances from 10 to 1,000 micro-mikes are available. Small mass permits following of ambient temperature with minimum of lag. Described fully in Bulletin No. 20. Centralab 900, E. Keefe Ave., Milwaukee, Wis.—RADIO TODAY—see also advt. p. 51.

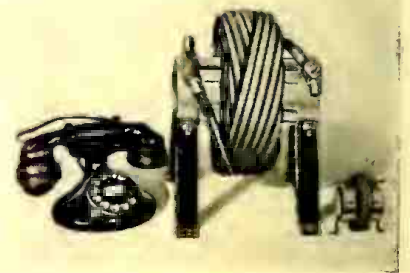

Heavy-duty R.F. choke

★ Duo-lateral type choke for radio interference filtering. Rated at 150 amps DC. 12-inch diameter winding of No. 1 B & S gauge flexible cable. Used in installations such as large flashing signs. J. W. Miller Co., 5917 S. Main St., Los Angeles, Calif.—RADIO TODAY.

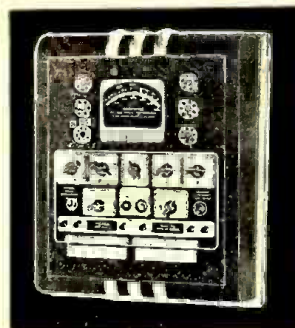

Mutual conductance tube tester

★ Counter and portable type tube checkers employing dynamic mutual conductance test principle. Uses square meter with translucent illuminated dial. Indicates tube value in microhms and "good, bad, doubtful." Sufficient plate current to check emission. Checks gas content and open and shorted elements. Models T-54-P and T-54-C—net \$49.80. Hickok Electrical Instrument Co., 10514 DuPont Ave., Cleveland, Ohio—RADIO TODAY.

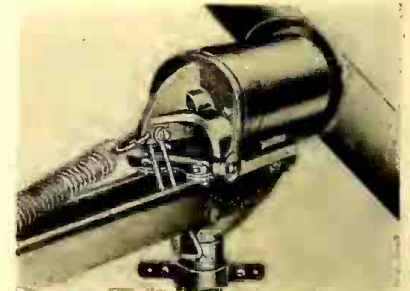

Hy-tower charger

★ Wind-driven battery charger made entirely of steel except for propeller and generator end plates. Non-arcing collector ring. "Slip-the-wind" governing principle. Vibration and tail vane fluttering eliminated. Parris-Dunn Corp., Clarinda, Iowa—RADIO TODAY—see also advt. p. 53.



MEANS PROFIT TO YOU!

...because you can now obtain valuable merchandise awards with the purchase of

RCA RADIOTRONS!

THE Radiotron Trading Post Catalog contains more than 200 of the finest merchandise awards chosen from the Grade "A" stocks of reliable manufacturers. Items for your home, your office—gifts for your wife, mother and children—or for your own personal use.

Ask your Radiotron Distributor for a copy of the Radiotron Trading Post Catalog. Choose the awards you want...and they are yours—ABSOLUTELY FREE—with the purchase of RCA Radiotrons.

MODERNIZE YOUR SERVICE SHOP

with RCA Test Equipment. Ask your local RCA Radiotron Distributor how you can obtain the many pieces of RCA Test Equipment, as well as Public Address Systems, FREE with the purchase of RCA Radiotrons.



RCA Presents the Magic Key every Sunday, 2 to 3 P.M., E.S.T. on the NBC Blue Network.



Radiotrons

RCA MANUFACTURING CO., INC., CAMDEN, N. J. • A SERVICE OF THE RADIO CORPORATION OF AMERICA

OVER 325 MILLION RCA RADIO TUBES HAVE BEEN PURCHASED
by radio users . . . in tubes, as in radio sets, it pays to go RCA ALL THE WAY.

SEASONAL APPLIANCES

ASSISTANCE IN SELLING SMALL LINES

★ For the sales personnel of appliance stores in Washington, D. C., the Electric Institute of that city conducted a sales course which has flagged the attention of the industry. The course presented detailed information for selling electric mixers, percolators and coffee makers, roasters, waffle irons, sandwich grills, toasters, hot plates, casseroles, chafing dishes, electric irons, heaters and electric fans.

To begin with, the Institute summarizes the reasons why people buy:

1. Comfort and convenience.
2. Safety and protection.
3. Gain and economy.
4. Satisfaction and affection.
5. Pride of ownership.

For each appliance the course first describes fundamental structure, moves on to "how to sell" suggestions of a specific nature, and lists "customer-catchers."

For a brief sample of how small appliances are dealt with in this course, we quote from the section on electric fans:

"While fans are distinctly a seasonal item whose main function is to circulate the air in hot weather, they do have other uses. In winter a fan

will help distribute the heat in a room if placed where it will blow air into the radiator.

"Set in the kitchen window, a fan will ventilate the kitchen. Drawing the fresh air in will tend to expel the stale air and odors. For ventilating a closet—to freshen the air or to expel the odor of moth preventatives, set a fan so that it will blow air into the closet.

"When clothes must be dried indoors, a fan placed to circulate air around and through the wet garments will speed up the drying process. When used in conjunction with a heater, the drying time will be shortened even more. Whether for drying purposes or for room heating, a fan placed before a radiant heater will distribute the heat more generally throughout the room than is possible with the heater alone.

"The current taken by fans is usually expressed in amperes. The household fans have, on the average, motors of from 0.5 to 1 amp. The operating cost for these fans would be around one cent for four hours' operation."

Managing director of the Institute is J. S. Bartlett. Presentation of the sales course was under the personal supervision of Miss Bernice Burns of the Institute's Home Economics staff.

Governair room coolers

★ Air conditioners designed for cooling, ventilating, cleansing, circulating, and dehumidifying. Come in three models: ½, ¾, and 1 H.P. First model has reciprocating type compressor, extended surface type condenser, centrifugal air blower, welded steel frame, Freon refrigerant, roller bearing casters. Capacity rated as 6,400 B.T.U. per hour. Cabinet finished in natural black walnut. Governair Corp., 603 W. Main St., Oklahoma City, Okla.—RADIO TODAY.

Press Kloth

★ A patented process pressing cloth, of heavy cotton material, specially treated and prepared to resist water. As hot iron is applied, the steam created by water lying on the surface of the Kloth penetrates the Press fabric and a professional steam press is the result. Iron slides freely; no "press" shine. Parris-Dunn Corp., Clarinda, Iowa—RADIO TODAY.

★ *Marshall Wells Co.*, Crosley distributors in the Spokane, Wash., area, were recently hosts to 117 dealers at

a 3-day showing of *Shelvadors* and *Mystic Ovens*. Guests predicted a big year in 1938 at the banquets and displays at local hotels. Crosley district manager *P. W. Bailkowsky* was on hand.

★ *Norge* has opened its first big promotion drive of the year by featuring "the ability of its smallest *Rollator* compressing mechanism to power three *Norge* refrigerators while running only one-third of the time in a 70-degree room." Drive includes greatly enlarged space in leading magazines, newspaper ads in 75 key cities, etc.

★ The *Pleasantaire* factory in Brooklyn, N. Y., is now booked up on orders for its portable room cooler through late April and is accepting orders for early May, according to news from president *Richard F. Roper* of *Pleasantaire Corp.*, 1623 Connecticut Ave., Washington, D. C.

★ Sales headquarters for the new *Steem Electric* iron have been established at 11 W. 42nd St., New York City.

RECEIVER KIT

★ New *Browning 83* receiver kit has been designed so that the set can be assembled easily by radiomen or even the novice in a short time. While designed primarily as a chassis for modernizing old radio sets, it is also well-adapted for use in the country or while vacationing. A 6-volt model suitable for this purpose is available in addition to the standard AC model.

The accompanying picture shows the *Browning 83* mounted in trailer. All-wave reception extending up to 22,000 KC is provided. Receiver is assembled with a screw driver, pliers, and soldering iron. Adjustment problems reduced to a minimum—no signal generator is needed.

The tuner unit is completely assembled and aligned before shipment. Complete instructions and full-scale wiring diagrams are furnished. Another feature of this receiver kit offered by



Howard J. Tyzzer is now chief engineer of the household radio division of Crosley Radio Corp. With Crosley since 1933, he's been in radio for 27 years, and has several inventions and patents to his credit.



Browning Labs. is that the builder can incorporate minor changes in or additions to the circuit. Noise suppression, volume range expansion, etc., are easily added since spare holes are provided.

Executioner

(OF IMPERFECT TUBES)

Read how "the crusher" helps enforce Sylvania's "no repair" policy.



A switch is thrown...a motor hums...giant metal "teeth" start to grind—and it's *goodbye to imperfect tubes!*

That's how "the crusher" works. Now we'll tell you *why*:

To insure uniform, high quality...Sylvania tests each tube scores of times—for materials...for construction...for performance. And

thanks to a strict "no repair" policy—any tube that fails *even one* of these tests is sent to "the crusher"...*completely destroyed!*

Never a "dud"... never a second-quality Sylvania tube. For Sylvania—in accordance with this rigid policy—*destroys* defectives instead of repairing them. Remember this when you buy.

SYLVANIA

SET-TESTED RADIO TUBES

HYGRADE SYLVANIA CORPORATION
Emporium, Pa. • Also makers of the
famous Hygrade Lamp Bulbs

DYNAMIC ANALYSIS OF FILTERS

Theoretical analysis of how R, C, and L are used for filtering and by-passing in the power, AF, and RF sections of a radio set

By VINTON K. ULRICH
Service Editor, RADIO TODAY

★ In recent conversations with servicemen, it has been apparent that there are many who are not fully acquainted with the characteristics of resistors, condensers, and inductances. So before going into the actual procedure of Dynamic Testing, there will be a brief outline of basic radio principles, showing how R, L, and C behave at various frequencies and in combination with one another.

A condenser (paper) has an infinite resistance to DC voltages and a finite reactance (AC resistance) to AC voltages. The reactance of a condenser varies with frequency; at low frequencies the AC resistance is high, while at higher frequencies the AC resistance may be low enough to consider the condenser as a short circuit (although it actually has some reactance).

Reactance vs. frequency

An ordinary AC voltmeter on a 60-cycle line will readily show how the AC resistance of condensers varies with the size. The circuit is shown in Fig. 1. If the condenser is 1 mike, it has about 2,500 ohms reactance (AC resistance). If connected in series with a 150 volt AC meter on 110 volts having 150,000 ohms internal resistance, the added resistance would have practically no effect and meter would read approximately 110 volts. A .01 condenser has 250,000 ohms reactance at 60 cycles, so if connected in series with the voltmeter, the combined resistance and reactance would give less than half-scale reading on the meter. This is the principle used in meter

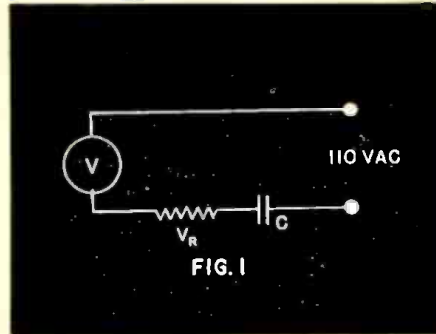

Fig. 1—A condenser in an AC circuit acts as a resistor which changes with frequency.

type capacity indicators. The fact that a condenser has an AC resistance is readily shown by the above illustrations. (In this and other illustrations in this article, phase relationships are being disregarded so as not to complicate the discussion.)

As far as frequency is concerned, the reactance of the condenser varies oppositely to the frequency as shown below:

1 microfarad condenser (approx.)		
6 cycles.....	25,000	ohms
60 cycles.....	2,500	ohms
600 cycles.....	250	ohms
6,000 cycles.....	25	ohms
60,000 cycles.....	2½	ohms
600 kilocycles.....	¼	ohm

This characteristic can be easily shown by using a high sensitivity AC voltmeter in series with a .01 condenser across the output of a receiver when a 400-cycle note is being supplied from the signal generator. Higher readings will always be obtained on 400 cycles than on 60 because the reactance of the condenser is less on 400 cycles. If the serviceman will think of a condenser as an AC re-

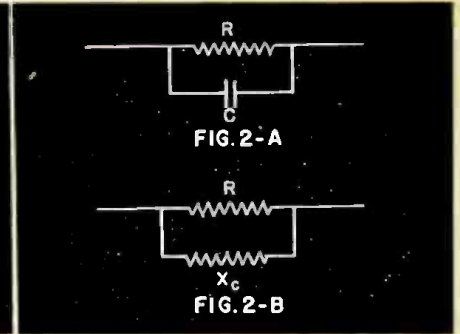

Fig. 2—The capacitive reactance of a condenser is equivalent to an AC resistance.

sistance or reactance having an ohmic value, it will be easier to understand circuit operation. Of course, the serviceman must bear in mind that if he changes the frequency, the reactance will change.

In Fig. 2-A a condenser and a resistor in parallel are shown to illustrate the case where a by-pass condenser is used across the cathode resistor. This condenser can be replaced by a reactance or AC resistance in parallel with the cathode resistor as shown in Fig. 2-B (speaking in terms of AC, not DC). If this condenser had about 10 mikes capacity, it would represent 250 ohms at 60 cycles and 25 at 600 cycles. If the cathode resistor were 2,500 ohms, then at 60 cycles, approximately 90 per cent of the AC current would pass through the condenser. And at 600 cycles 99 per cent of the current would pass through the condenser.

As all servicemen know, or should, a by-pass condenser is used for the purpose of shunting the AC current to ground so as to eliminate the AC voltage present. Or looking at it another way, if only 1/10 of the AC current flows through the cathode resistor, the AC voltage across the resistor will be reduced to 1/10.

Similarly in an I.F. or R.F. amplifier a 300 to 1000 ohm cathode resistor is shunted with a .1 condenser. At 600 KC this condenser will have a reactance of 2½ ohms. This 2½ ohm reactance or AC resistance is practically a short circuit across the cathode resistor as far as R.F. currents are concerned, although it has no effect on the DC bias. In most circuits even a .01 condenser would be okay since it has a 25 ohm reactance at 600 KC, which is less than 1/10 of the usual I.F. bias resistors.

As the frequency increases it is pos-

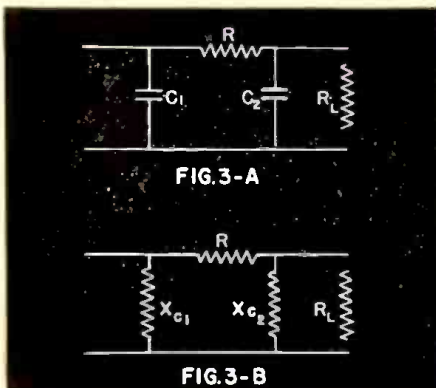

Fig. 3—Equivalent circuit of a simple resistance-capacity filter, using condensers.

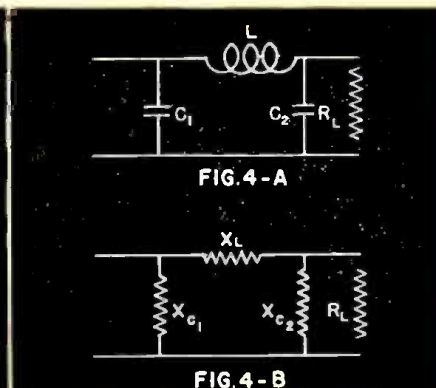

Fig. 4—An inductance offers a resistance to AC currents which changes with frequency.

sible to use smaller and smaller by-pass condensers, since with increasing frequencies the reactance decreases.

In all by-pass and filtering circuits, it is the ratio of capacitive reactance to the resistance that counts. If the resistor is decreased in value, and the same degree of filtering is needed, then a larger condenser must be used. This is one of the bases of the dynamic method of servicing.

What the radio servicemen are interested in, is whether or not there is enough by-passing action in the circuit. What the actual value of the capacitor is, does not matter in the least. (This does not apply to tuned circuits). In fact some very large condensers, due to their method of construction, have a much higher R.F. reactance than their capacity would indicate. That is why electrolytics and inductivity wound paper units are not used in R.F. circuits.

And the only way to tell if a condenser is properly working on R.F. is test it on R.F., which to the serviceman means in the radio set. In dynamic testing we are developing a test which will show whether or not the condensers are working satisfactorily at their operating frequencies. And then on A.F. or even 60 cycles, there is the leakage factor in electrolytic condensers. A unit which may be okay in one circuit, may have too much leakage for another. Again the best way of determining if the unit is okay is to test while circuit is in operation which is dynamic servicing.

Audio decouplers

In Fig. 3-A the circuit is that used in many resistance-coupled audio amplifiers. Often the resistor and C-2 combination is called an audio filter or audio decoupler. C-1 is the condenser in the main filter. Since the reactance of C-1 is usually a fraction of the resistance R, the power supply filtering is greatly improved. Usual values are C-2, 1 mike; R, 20,000 ohms. The equivalent AC circuit is shown in 3-B. C-1 by-passes the largest part of the AC ripples to ground. C-2 also has a low AC resistance (2,500 ohm reactance at 60 cycles) and compared to the load resistance R-L, so it also by-passes some AC ripple.

But more important, condenser C-2 provides an audio filtering. In this case the filter may be looked upon as operating from right to left. Because condenser C-2 has a 2,500 ohm (60 cycles) reactance in comparison to 20,000 for R, the greatest part of the audio currents present are by-passed to ground through C-2. In this way, the audio currents are eliminated before they can get back to the power supply unit. Naturally the value of R is made as great as possible without causing too great a DC voltage drop across itself. If the load R-L is so great as to require that R be rather small in order to avoid a large DC drop, then the condenser C-2 must also be made larger.

R.F. filters

This same type of circuit is found in the screen and plate circuits of R.F. and I.F. amplifiers in some types of receivers. For instance some sets use a 5,000 ohm plate series resistor and .1 by-pass condenser. At 600 KC the condenser has a reactance of about 2½ ohms. This is a ratio of 2,000 to 1. Consequently approximately 1/2,000 of the voltage feeds back across R and the 1,999/2,000 is by-passed by C-2.

In the resistance-capacity filter circuits, the capacitive reactance varies with frequency while the resistance remains constant. In Fig. 4-A an inductance is used instead of the resistor. For R.F. it would be an R.F. choke, while for audio it would be a large iron-core choke.

In previous paragraphs it has been pointed out that the reactance (AC resistance) of a condenser decreases with an increasing frequency. Just the opposite is true with an inductance. To DC the inductance offers no resistance (except the DC ohmic value). As the frequency increases the AC resistance of the inductance increases. Therefore inductances are used in circuits to carry DC current while offering a resistance to AC currents.

Inductance filtering

In Fig. 4-B, the inductance has been replaced by its equivalent reactance or AC resistance. If the inductance had 13 henries, the reactance at 60 cycles would be equal to 5,000 ohms. The condenser C-1 might have 8 mikes which would give it about 300 ohms reactance. The division in the AC currents is similar to that occurring with a resistor. At 600 cycles the capacitive reactance would have decreased to 30 ohms and the inductive increased to 50,000 ohms. This indicates that if the circuit works okay at the lowest

audio frequency, it will work even better at the higher frequencies. Therefore tests would be made at the lowest frequency at which circuit must work.

In an R.F. circuit the inductance might have a value of 10 millihenries and the condenser about .1 mfd. The ratio of inductive to capacitive reactance will be on the same order as that discussed in the preceding illustration.

Chokes of both the R.F. and A.F. type are used chiefly to avoid having a large DC drop. If the DC drop is negligible, a resistor is usually employed to reduce cost and space.

It should be kept in mind that in every illustration given above, the item that is most important is the reactance or AC resistance of the circuit elements. Or sometimes the term impedance is used—impedance being the vector combination of resistance and reactance. And since it is the AC resistance that counts, tests must be made over the normal range of AC frequencies at which the unit must operate. That is the basis of dynamic servicing or testing.

tone control by inverse feedback

★ Now that inverse feedback or degeneration is becoming better known it is being used in a variety of ways. It is used to reduce distortion and to compensate for frequency discrimination in amplifiers. Newest use is to provide a variable frequency response characteristic in a tone control circuit.

Accompanying circuit is used in the more powerful Thordarson amplifiers. Two controls are used—one for high end and the other for the low. Unlike most tone controls, these controls can either raise or lower the response at their own end of the band.

(To next page)

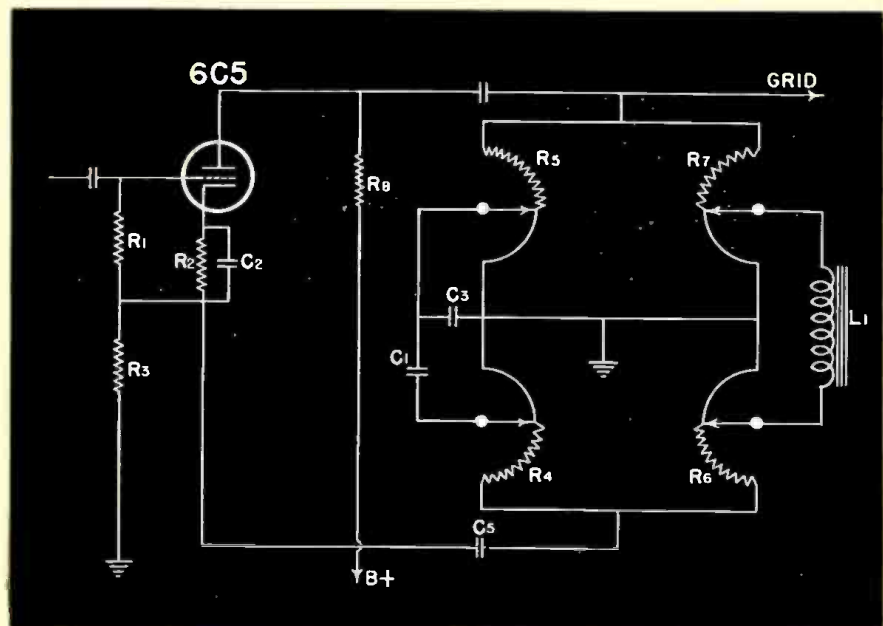

Inverse-feedback is used to provide a variable frequency characteristic. Two sets of ganged controls provide variation as required.

MORE SERVICE NOTES

(From preceding page)

Mechanically the two controls are somewhat unusual. Half of the control is zero resistance. If the pointer of the upper control is on the resistance element, then the pointer of the lower control is on the short-circuiting element and vice-versa. For normal setting the pointers are at the mid-point of the control just resting on the zero-resistance element.

Thus for normal setting the arms of the four controls are grounded. When the contact on R-6 is advanced toward C-5, L-1 is grounded at the top end and connected across R-3 through C-5. This means, that for low frequencies, the combination of R-3 and C-5, L-1 provides a lower impedance. As a result the degeneration caused by R-3 in the cathode circuit is decreased on low frequencies, giving a boost in the low response.

Similarly if the arm on R-4 is moved down to C-5, the cathode circuit degeneration is decreased for the higher frequencies giving a resultant boost in the highs of the amplifier.

The paralleled impedance of R-5 and R-7 form the grid return for the following tube and if C-1 or L-1 is moved toward the grid end of the following tube, high or low frequency attenuation results.

If the contact on R-7 is moved toward the grid end, then L-1 is connected from ground to grid. Since the impedance of L-1 is less at low fre-

quencies than high, the low-frequency response is decreased. And likewise when C-1 is at the grid end of R-5, the impedance is less at high frequencies. In fact it acts like the usual tone control in a radio set, causing high-frequency attenuation.

C-3 was added to increase the high frequency attenuation since the value of C-1, although correct for high frequency boost, did not provide enough high frequency attenuation. R-2 and C-2 provide the normal operating bias for the 6C5 tube.

Since the grid return through R-1 is connected to the "cold" end of the bias network, R-3 is the DC return for the plate current. C-5 is provided to eliminate the DC flow through the choke, since the DC resulted in noisy operation because the DC current was actually passed through the contact arm of R-6.

ADMIRAL 8K & 8KU

★ Eight tubes are employed in the Admiral 8K receivers. The 8K is designed for American use and tunes on three bands. The 8KU is for European service and has a long-wave band instead of the police band.

Set uses a pre-selector antenna stage on the broadcast band. On the other bands the set uses a 2-gang condenser circuit.

The tube-line-up and circuit of the receiver is conventional. A phase inverter is used for the push-pull output stage. Note that the 75 tube gets its bias from a tap on the 76 cathode bias resistor.

Alignment frequencies and trimmer locations are shown on the chassis layout diagram.

SETTING UP PUSH-BUTTON SETS

★ Servicemen setting up push-button sets having more buttons than there are stations providing consistent reception, should explain to the customer that there will be times when some of the stations will not provide satisfactory reception. For in many locations only some six or eight stations provide consistent reception, while in remote areas this number may dwindle to two or three.

Consequently when the customer pushes the button for a station that may be fading or have insufficient signal to be heard, the radio set is often blamed.

Some servicemen set up the receivers only to those stations that provide consistent, quality reception and leave the remaining buttons blank. While this may be easiest from the dealer's point of view, we feel that every button should be used—otherwise the customer may feel that he is getting only part of the receiver's full performance. If only eight out of sixteen buttons are used, to the layman it may appear that

(Continued on page 26)

ADMIRAL MODELS 8K & 8KU

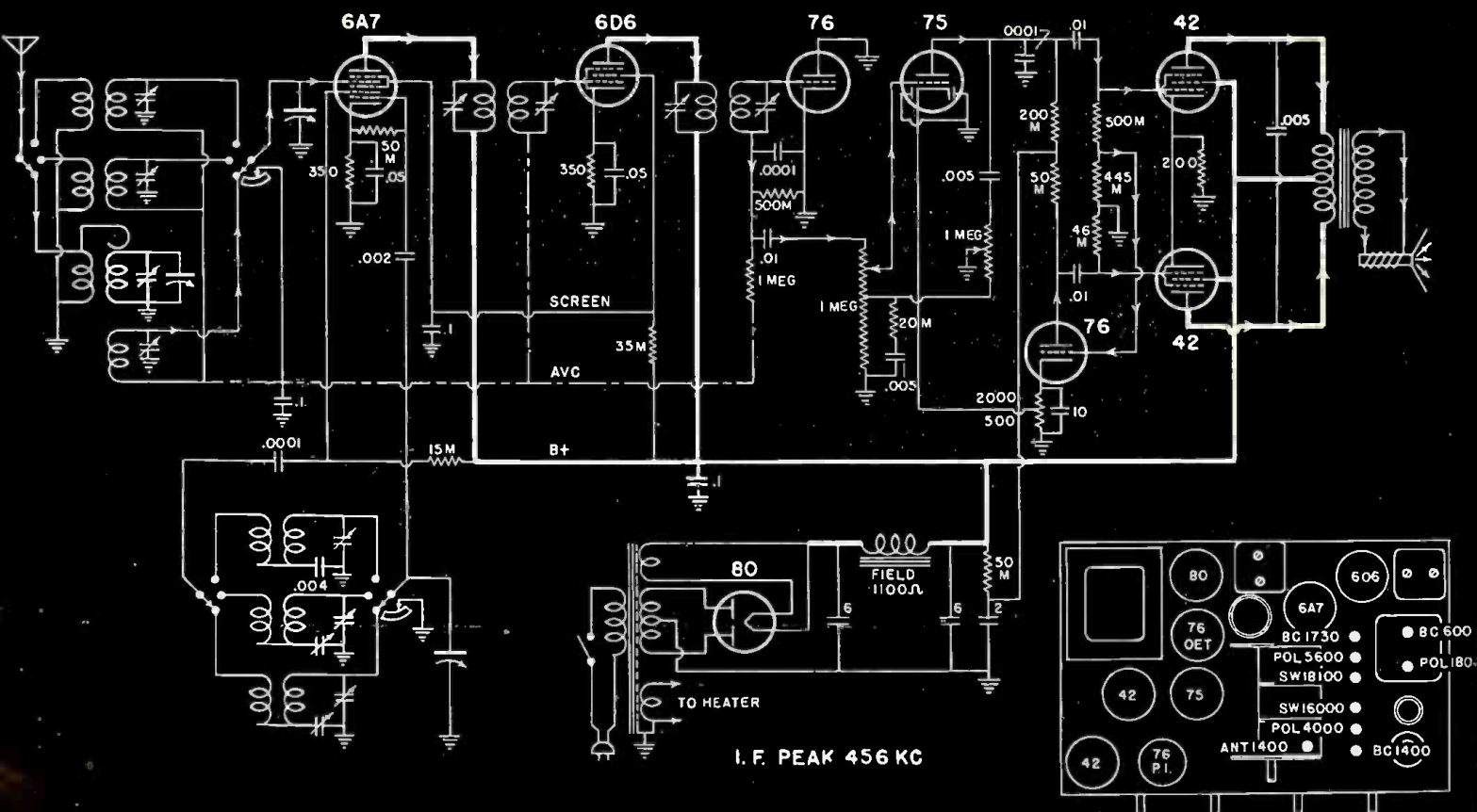

The article below appeared in last month's issue of this publication. If you failed to read it, dig out last month's copy and do so.

THE SERVICE-INSTRUMENT RACKET

Rockets that Are Ruining Radio—VIII
 Inferior test equipment marketed by false claims. Cheap designs sacrifice usefulness in effort to lower costs

THE APPEARANCE of test equipment which has included the radio service field in the past few years has been a most interesting one. Many agencies have been busy developing new instruments. Not only does the service man need a better instrument, but the manufacturer needs a better instrument. The service man needs a better instrument to get the most out of his work, and the manufacturer needs a better instrument to get the most out of his work. The service man needs a better instrument to get the most out of his work, and the manufacturer needs a better instrument to get the most out of his work.

connected to a generator as discussed provided a much signal that the set was immediately overloaded even at the minimum output when the generator was turned on. Where the generator was turned on, the frequency to which the set was tuned dropped. The audio output decreased. When the signal was turned in to the set, the AVC voltage dropped at the same time, probably because of the loading of the generator tubes. Even with the signal generator set for minimum voltage, the receiver developed 2 to 3 volts AVC bias.

1—frequency AC voltmeters
 Condenser-type voltmeter multipliers are used in some AC voltmeters. While the multiplier can be made accurate on some ranges, it is not accurate on other ranges. A condenser-type multiplier is not accurate on other ranges.

Trimmers in test oscillators
 High-quality stable trimmers in test oscillators are not to be considered since they do not have the short-circuiting of ordinary test trimmers. In fact, many high-grade laboratory test oscillators are so designed that they are not subject to the effects of trimmer failure. The trimmer is not subject to the effects of trimmer failure.

Voltmeter calibration
 Voltmeter calibration is a most important factor in the accuracy of test equipment. The accuracy of test equipment is a most important factor in the accuracy of test equipment.

Here's the answer to this problem:

WESTON Model 772 Super-Sensitive Analyzer



20,000 ohms per volt, 50 microampere WESTON meter, broad ranges to meet every service test requirement. AC accuracy 3% at all frequencies from 60 to 7000 cycles, and temperatures from 30° to 110° F. No condenser type of multipliers. Resistor accuracy better than 1%. Maximum voltage in ohmmeter 15 volts on 30 megohm range. (It's WESTON Guaranteed)

WESTON

Model 776 (hand-calibrated) Oscillator



An Oscillator that holds its accuracy. Accuracy 1/4% on broadcast and IF bands, 1% on short wave bands. No padders or trimmers used—no dead spots. Low loss coils—controllable output from 1 microvolt to 1 volt—constant 50% modulation—hand-calibrated dial. (It's WESTON Guaranteed)

Buy the instruments which are bought and used by the manufacturers, the scientific laboratories, the engineering schools and Government bureaus. They know instrument accuracy and dependability... For fifty years they have standardized on WESTONS!

WESTON Instruments

Weston Electrical Instrument Corporation
 597 Frelinghuysen Avenue, Newark, N. J.
 Send complete information on WESTON Radio Instruments.

NAME.....
 ADDRESS.....
 CITY..... STATE.....

SERVICING

only half of the set is being used.

To overcome the possibility of repeat service calls, the serviceman should explain that the local stations will always be good, but that the more distant stations will not always provide satisfactory reception. Also it should be strongly emphasized that it is not the fault of the set—either the chassis or the push-button mechanism, but is due to atmospheric conditions and the distance.

WARPING, "SHEATHING," CHECKING

★ Warping of cabinets is caused chiefly by moisture entering the edges and inside surface of the hardwood lumber. This can be prevented by using waterproof glue and by "sealing" the edges of the panels—although probably 50 per cent of the sets in use today do not have such sealing or filling.

When moisture enters it may also cause "sheathing" at the finish—a condition in which the surface veneer splits away from the cabinet proper, particularly at the edges of panels or slabs.

This is quite different from "checking" of the varnish finish caused by exposure to hot and cold. Cabinets left in a freezing temperature are likely to show this checking or cracking of the varnish in small squares or hexagons, due to shrinkage of the varnish surface.

SERVICE TIPS

RCA model M-34 No volume control action

★ This complaint accompanied by weak signals is usually caused by an open i-f coil winding. Go over the soldered connections in the i-f transformers with a hot iron as the joints may be held together only by resin with no electrical contact being made.

Silvertone model 1506 Dead

★ Look for an open voltage divider or an open i-f transformer primary. There is a .01 mfd. condenser between the plate and grid of the 47 tube. Make sure that this condenser is not shorted. If there is little or no reception above 1200 Kc. try a new type 24 tube.

Majestic model 70 Intermittent reception

★ The nuts on the power pack terminal strip should be tightened with a pair of pliers. Start with the bottom strip by removing the top one first and when the lower ones are all tight put the top one back into place and thoroughly tighten the top ones.

Mojestic model 90 Tunable hum

★ In many cases the antenna choke connected from the antenna post to ground will give trouble. This is true when the antenna has

been accidentally given a high voltage charge such as lightning, etc. Replace this choke to remedy the difficulty. An ohmmeter test will not disclose the trouble in every case.

Motorola models twin Dead on high eight, dual six frequencies

★ First try replacing the oscillator tube. If a buzzing noise is audible from the vibrator pack, with the volume control turned off, tighten the screw which holds the vibrator pack in the housing. This is located at the bottom of the set and also holds the cover of the set on. A poor ground connection of the vibrator causes the trouble.

PHILCO WIRING DIAGRAM BOOKS

★ New Philco R.M.S. wiring diagram books are published in two volumes for more convenience. Volume one contains 200 pages and contains wiring diagrams (schematics), parts layout drawings, and parts list, for every Philco built by the company through 1936. Volume two which has 176 pages has the same information for the 1937 and 1938 receivers. Alignment data has also been included.

The books are bound in loose-leaf form with 9 x 12 fabricoid binders. The treatment of the information is similar to that used in the Philco service notes. Priced at \$1.25 per volume. Philco Radio & Television Corp., Tioga and C Sts., Philadelphia, Pa.—**RADIO TODAY.**

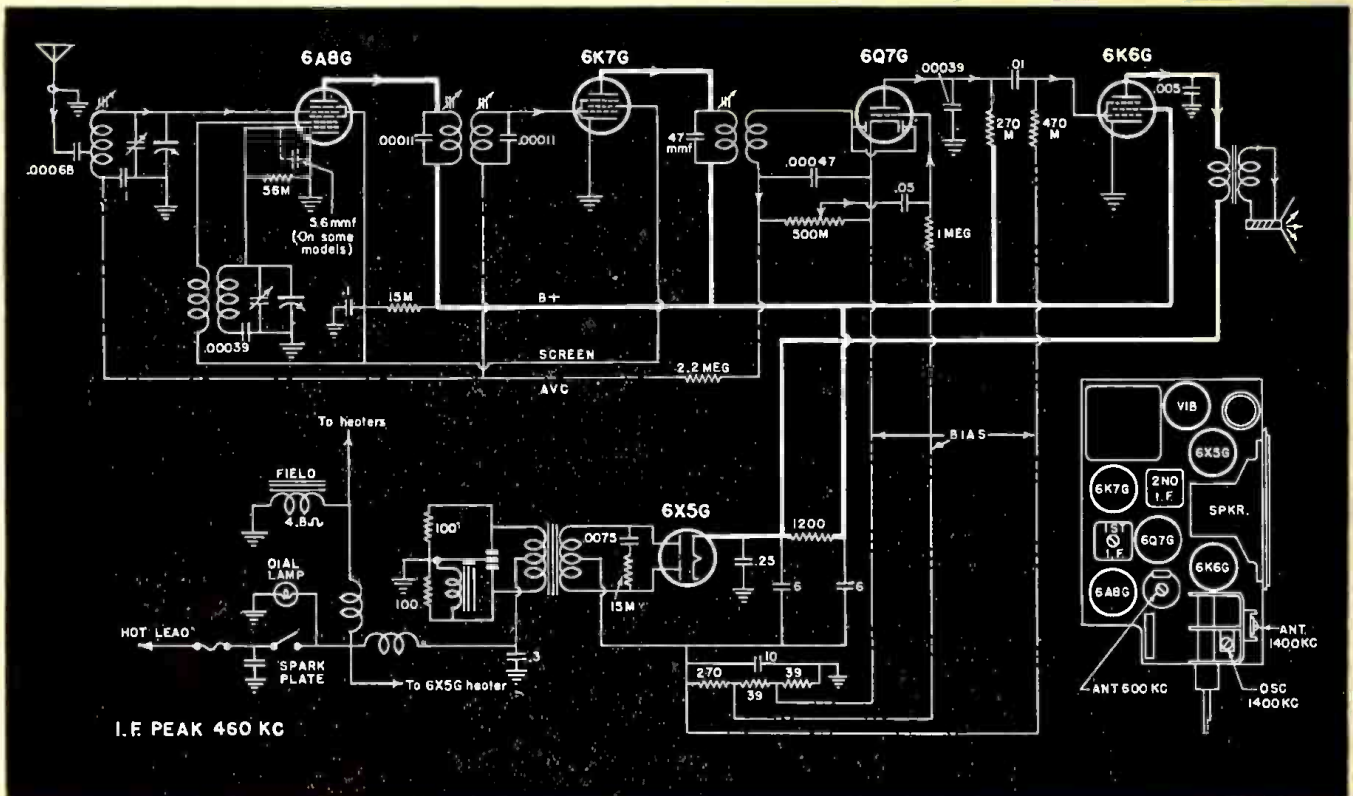

RCA-Victor 8M 5-tube auto radio set. Note the use of fixed bias from the negative return of power supply circuit.

Selling Sound

PUBLISHED SEMI-ANNUALLY AS A SECTION OF "RADIO TODAY"

THOUSANDS OF INQUIRIES PROVE IT

**WEBSTER
CHICAGO
SOUND
EQUIPMENT
is the line to
Sell**



NEW ONE-CASE PORTABLE SYSTEM
14 Watt.....Model PA-714

Everything in Sound

The new Webster-Chicago catalog is off the press — may we send it to you without obligation? . . . Just write us.

- Portable Systems
 - Fixed Systems
 - Mobile Systems
 - Inter-Office Communicat- ing Equipment
 - Systems for Institutions, large and small
 - Systems for Factories and large and small businesses
 - Reproducers of all Kinds
 - Turntable Motors
 - High Fidel- ity Pickups
 - Microphones
- Also a complete line of Parts and Accessories



NEW MOBILE SYSTEM
30 Watt.....Model MP-532

Webster-Chicago received many thousands of direct inquiries during the past year as a result of advertising and publicity. The inquiries came from large and responsible business firms and institutions, as well as from individuals and small firms, illustrating the broad general interest in the phenomenal development of Sound.

Webster-Chicago has carefully built its business during 13 years of experience to design the right kind of sound merchandise for today's market. Sound Systems that are built right, sold right at the right prices and stay sold. Furthermore, Webster-Chicago sound equipment is backed by national advertising with sustained local help for the individual go-getter.

Distributors and dealers make money with Webster-Chicago. . . . Write for any information on merchandise, sales policies or service policies without obligation.



Manufactured under license arrangements with Electrical Research Products, Inc., subsidiary of Western Electric Co. Inc. and American Telephone and Telegraph Co.

WEBSTER - CHICAGO

AMPERITE

offers
"ADJUSTABLE RESPONSE"
 (HIGHER OR LOWER PITCH WITH THE SAME MICROPHONE)

... made possible by
THE ACOUSTIC COMPENSATOR
 (pat. pend.)

PUSH UP TO INCREASE HIGHS, PUSH DOWN TO INCREASE LWS



Here is an improvement of great value at no extra cost! Exclusive with Amperite, the Acoustic Compensator gives you these advantages:

- (1) With the flip of a finger, you can now lower or raise the response of the microphone—without introducing any peaks or other undesirable effects: (Not a volume control. Gradually changes operation of the microphone from constant velocity to constant pressure.)
- (2) Permits adjustment of the microphone for most desirable response for close talking or distant pickup.
- (3) Makes the system immediately adjustable to any "taste," room condition, or equipment.

MODELS RBHK, RBMk, with Acoustic Compensator, Frequency range 40 to 11000 CPS. Output, -65 db. Complete with switch, cable connector and 25' of cable . . . \$42.00 LIST. Chrome, \$43.00 LIST
 MODELS RBHn, RBMn, without acoustic compensator, \$42.00 LIST

IMPROVES ANY "LOW-COST" INSTALLATION ON 4 COUNTS!

P. A. Men, you can improve those "price" jobs by using the popular Amperite Model RAH (or RAL). You will get better results because (1) it is excellent for both speech and music; (2) has flat response without undesirable peaks; (3) reduces feedback; (4) stands up under rough handling, changes in temperature, pressure or humidity. . . . Frequency range 60 to 7500 cps. Output, -68 db.

MODEL RAH (Hi-imp.) with 12' of cable. MODEL RAL (200 ohms) with 8' of cable. . . . ONLY \$22.00 LIST

NEW LOW-PRICED CONTACT MICROPHONE . . \$12.00 LIST

The success of our Model KTH (\$22.00 List) has created a demand for a popular-priced Amperite Contact Microphone. The new model listed below can be used on most radio sets made since 1935 and on all P.A. systems. It "makes an ordinary violin sound like a Strad" . . . gives a small piano the tone of a Grand. And yet, there is no distortion. No unnatural effects. No "fingering noises." Installation is simple . . . no changes in strings or instruments . . . attached without tools.

Operates with either high or low gain amplifiers. Has frequency response of 40 to 9000 cps. Output, -40 db. 20' of cable.

MODEL SKH (Hi-imp); SKL (200 ohms) \$12.00 LIST
 SKH or SKL with foot-operated volume control \$20.00 LIST
 Professional Model KTH (or KTL) \$22.00 LIST

"TOPS IN MIKES"

Station KVOL, of Lafayette, La., writes us, unsolicited: ". . . the Amperite mikes have been in service here for almost three years, and have proven themselves to be "tops" in mikes. They have broadcast in the rain and in the hot sun. They have even been dropped, but they always came through in fine shape . . ." The Amperite Studio Velocity Model SR80n now has -56 db output. Frequency range 40 to 15000 cps. Triple shielded, fitted with switch, (optional), cable connector, and 25' of cable.
 MODEL SR80n (200 ohms); \$80.00 LIST
 MODEL SR80Hn (Hi-imp.); \$80.00 LIST

Sales Aids for the P. A. Man Amperite offers the following co-operation to P.A. Men.

- (1) FREE Window Decal advertising your Sound Service. Size 5 1/4 x 9 1/4, finished in 4 striking colors.
- (2) FREE Window Display, 11 x 17.
- (3) Special Sound Equipment Letterheads. Samples and prices on request.
- (4) FREE use of cut for printing business cards, etc.

Write for these valuable sales helps, and new Illustrated Bulletins, today!



AMPERITE 6. 561 BROADWAY, N. Y. U. S. A.

CABLE ADDRESS
 ALKEM, NEW YORK



VELOCITY

AMPERITE

MICROPHONES

Business is
stabilizing,
leaders say.

Selling Sound

SECTION

Products
in demand
by public

★ To afford readers an authoritative picture of the trends and prospects in the sound business during the coming year, the editors invited industry leaders to express frankly their own views on the current situation in sound.

"We look for 1938, despite the present recession, to set a new mark for the sale of sound equipment, as parts jobbers are more and more appreciating the value of the larger unit sale inherent in sound-equipment merchandising," declares John Erwood, vice-president Webster-Chicago. "More recognition and emphasis must be placed upon improving the ultimate performance of sound equipment for the consumer. This makes it imperative that equipment be chosen on a system basis rather than individual component parts.

"There is a definite trend in jobbing organizations for the creation of sound departments, specializing in the sale of sound equipment, and their activity is being extended more and more towards cooperative work with dealers. This cooperative promotional activity is the logical approach to meeting mail-order competition. Jobbers and dealers must take more advantage of the sales promotional material furnished by the larger manufacturers of sound equipment. Many sales lost to mail-order competition could have been saved had contact been made at the right time."

Legitimate channels

"We are very optimistic about the possibilities of the public address business," comments H. A. Wilson, Operadio sales manager. "The present trend seems to indicate that the business as a whole is being definitely stabilized, and that this equipment is more and more going through the legitimate jobber-dealer channels.

"We have found that in general our best outlets have been the radio-parts distributors. These distributors, awaking to the possibilities of the sound business, are in many cases organizing special sound departments with a trained sound man in charge. The exception to this rule is found in very few of the larger cities where the sound business has grown to such proportions that it has been profitable for a sound specialist (and by this we mean a real sound expert) to organize a sound distribution company.

"Reports from our customers and field representatives indicate a rapidly growing interest in quality equipment and in large permanent installations, and we honestly believe that with general conditions improving, the year of 1938 should be the best year that the sound equipment industry has ever known."

Distributor essential

"The sound business is peculiar in that the unit sale is large and the net profit comparatively small," observes S. Ruttenberg of Amperite. "As a result the P. A. man never gets into a position where he can afford to carry a stock large enough to take care of his requirements. When he does need material it is usually in a hurry.

"A live distributor is therefore in an excellent position to be of service to the P. A. man. The distributor can usually obtain credit whereas most P. A. men have no credit rating. A P. A. man who knows his business should not have any trouble what-

SEE BIG 1938

ever competing with mail-order houses because he has the distinct advantage of direct contact and the chance to demonstrate."

Profitable if handled properly

"The average P. A. man, after having weathered a very severe set-back in business during the winter months, is extremely optimistic over the prospects for this Spring and Summer," says Hubert L. Shortt, president Transformer Corp. of America. "Even at this writing, we find a definite change in sentiment. Men, who in some measure depend on the sale of sound equipment for a living, have already planned their Spring campaigns. And that, in my opinion, is the secret of success in the P. A. business. It's simply the old story of the early bird getting the worm.

"Too many would-be sound specialists like to see the business roll in, without the necessity of sales-promotion expenditures and good old hard work. Successful organizations know only too well that this condition never exists. To make any business profitable today you must be alert, active and ready to gain every advantage.

"Despite the recession, P. A. has and will continue to progress. Our organization looks forward to a very successful year in P. A. because: Sound re-enforcement is now a necessity; it is gaining in popularity; the potentialities are unlimited; equipment performance is very good, and prices are the lowest ever."

Create consumer interest

"Sound re-enforcement has no visible limits today. Indeed, sound has become as much of a necessity in modern business as it is in the entertainment world. Few industries offer as many opportunities to their sales agencies as does sound. The market is rich, fertile, and ready for the cultivation. Each new day uncovers some new use, some heretofore unthought-of field, ripe for sound installations." These are the views of A. W. Pletman, president, Wholesale Radio Service Company.

"In such a market growing with gusher-town speed, that man is foolish who, having sound equipment to sell, stops to worry too much about competition. He is like the runner who leads the pack until, foolishly turning to see where the rest are, he stumbles and loses the race.

"Competition, of course, cannot be overlooked. Fundamentally, every merchandiser of sound equipment must have quality units at competitive prices. However, price and quality alone will not create a demand for sound re-enforcement. First, there must be a need for this equipment. Today, this fundamental is an established fact. Second, the prospective user must know about your organization and your services. Also, he must be shown why sound equipment is a necessity in his business.

"The sound business made some of its most important gains during the 'depression' years. The market was at that time, and still is, increasing at a fast pace. The trend of the sound business curve is still upward. That is why we say, 'look for a big year in 1938.'"

BETTER SOUND JOBS!

Importance of acoustics in getting quality sound reproduction — Problems of sound pick-up.

★ For some years the public has listened to the average sound-reinforcing system of which the quality of reproduction has been greatly inferior to that of the average radio set in the home. The reasons for this were poor sound equipment and failure on the part of the sound-man to apply the fundamentals of acoustics to his installations to insure a successful job. Today we have better equipment which, if installed and used intelligently, will result in better sound installations.

It should be realized at the outset that there is something more to a good sound job than merely delivering the equipment, connecting it and showing the customer how to use it. Each installation is *individual* because of the acoustic conditions present at the microphone and in the space where the loudspeakers are located. These conditions are different for each job and must be recognized.

It is well to keep in mind always that the objectives of a successful sound system are: (1) to reproduce sound, such as speech, music, records or radio, faithfully; and (2) to distribute this faithful reproduction sufficiently well and loud enough for the entire audience to hear *comfortably*.

Acoustic considerations

To attain these objectives a fundamental knowledge of acoustics is therefore essential on the part of the sound technician. An understanding of

the acoustics of the space in which the sound originates and in which it is reproduced is very necessary. A knowledge of the characteristics of the loudspeaking system itself is also essential.

Concerning the acoustics in which sound is picked up or in which it is reproduced, four factors are of concern: Reverberation, echo, resonance and diffraction.

Reverberation and echoes

Reverberation is caused by reflection and is characterized by the persistence of sound after the source of sound has ceased to emit. When the time of reverberation in the space where the microphone is located is great enough to cause one sound to hang over and become mingled with succeeding sounds it is practically impossible to improve conditions by the use of a public address system. In such a case it will be necessary to place sound absorbing material in the space. The effect of absorbing material on reducing the time of reverberation depends upon the amount used and its disposition.

Echo usually occurs in large buildings or in large open spaces surrounded by buildings, trees or other obstacles which interfere with the reproduced sound rather than with the source of sound. There are cases, particularly in auditoria having large curved wall-space or ceilings, from which localized echoes occur. The speaker's voice or extraneous sounds

from the audience may be reflected from one or more of these surfaces to focal spots where the volume of sound is consequently great. Therefore, it is important that the microphone is not placed at one of these spots.

The points of localized echo are also particularly troublesome when they occur in the space occupied by the audience. Under these conditions not only is the sound intensity too great, but the character of the sound is altered and very often badly confused. The avoidance of such difficulties is a matter of test and involves a rearrangement of the loudspeakers. They should not be aimed at hard flat or curved reflecting surfaces.

Resonance or peaked output becomes important in connection with the placing of the microphone. Detrimental effects generally result from attempts to conceal the microphone by placing it in some form of small enclosure. The subject of auditorium resonance was discussed in the September, 1937, issue of *SELLING SOUND*, page 31, and a practical method of dealing with it was described.

Sound diffraction

The troubles introduced by diffraction are only rarely encountered. They occur when sound is reflected from regularly spaced reflectors or passed through regularly spaced openings. Loudspeakers operating in a large field surrounded by an open-work board fence are a source of this trouble as well as regularly-spaced flat-sided columns in auditoria. This trouble is found in distinct areas, particularly at the outskirts of the audience where the sound is badly distorted.

Considering the characteristics of the system itself, it should be such that reproduction is faithful, which is requirement number one. The second requirement—that it deliver its reproduction loud enough for the entire audience to hear comfortably and enough above noise for good intelligibility—bears on the psychology of hearing. There must be co-ordination between hearing and seeing, or illusion. The illusion should be such that the majority of the audience is conscious of only one source of sound, and that that sound emanates from the speaker himself. This effect is accomplished by mounting the loudspeakers in a group over the speaker's location.



With summer and fine weather coming, outdoor gatherings of all kinds offer opportunities for sound jobs. For concerts, good quality is essential.

Too much amplification!

When the voice of a speaker is amplified too much, apparent distortion results. If the speaker is talking in a conversational tone his voice contains a larger percentage of low frequencies than when he raises his voice to a high level. If the output level of the system is so high that instinct tells the audience that the speaker should be shouting, the system appears to make his voice sound quite heavy and somewhat unnatural. This is a common fault in system-operation and has done much to retard the acceptance of sound reinforcement by the general public. This is trivial to one who places loudness before quality and illusion. The sound-man's job is to have his customers use their systems properly thereby maintaining a high standard of reproduction. Pleasing results are what lead to more installations!

Microphones

One of the important factors which will improve many a sound-job is the use of the proper microphone. The suitability and the limitations of the several types should be understood and kept in mind. These instruments have been developed and improved to the point where the sound-man need only select the proper type for the pick-up and install it properly to do a good job. The choice depends upon the acoustic conditions at the sound-collecting point in the space where the sound is being reproduced, and upon the nature of the pick-up. The essential characteristics of the various types follow.

A universal microphone with one set of fixed characteristics does not adequately satisfy the many problems of sound collection. For example, directional and non-directional microphones have definite applications, while non-uniform response over a limited range may be best suited for pick-up under certain conditions. Weight and size may be important considerations in some cases, while in others high output may be more desirable than other characteristics.

Wide-angle pick-up

Generally speaking, natural reproduction requires a microphone that has no peaks of its own. For wide-angle distortionless pick-up, the moving coil or dynamic microphone of spherical shape, having a flat circular acoustic screen in front of the diaphragm gives a smooth response and has a high ratio of output level to weight of the instrument. The impedance is low, which means that a long lead can be used. Several types of rochelle salt crystal microphones are available. The spherical non-directional type has a high impedance and should be arranged to operate directly into a vacuum tube.

For semi-directional pick-up, which must be resorted to when acoustic interference prevails, such as street

noise, electric fans, etc., a velocity or the spherical-shaped dynamic microphone can be used. In the latter case the acoustic screen is removed and an annular disc or baffle is fastened over the front of the mike. Semi-directional microphones, both of the direct and diaphragm-actuated crystal types are also available.

Directive pick-up

For directive pick-up, which has been found to be desirable in instances where it is necessary to improve the ratio of direct to reflected sounds, or to discriminate against undesired sounds, the uni-directional and bi-directional microphones have been found useful. This transmitter has particular application in cases where the sound to be collected originates in front of the instrument and undesired sounds in the rear. It is also useful in controlling acoustic feedback.

Bi-directional pick-up is accomplished through the use of the ribbon microphone which collects sound from the front and back and none from the sides. This type is also very useful in reducing feedback. Ribbon microphones, however, may give trouble when used out-of-doors in a strong wind unless shielded by a windbreak. These instruments have low impedance.

For announcing, a microphone designed for such work should be used. These mikes discriminate against the lower voice frequencies and provide maximum response at the higher frequencies, and thus improve intelligibility.

The lapel microphone is designed for the lecturer, demonstrator, the specialty act, etc., where freedom of movement by the wearer is important. These are small and very light and discriminate against the low voice frequencies.

For footlight installations for stages, the microphones should be approximately 12 feet apart.

Avoid reflecting surfaces

In placing any mike it is important that no highly reflecting surfaces be located between the speaker and the microphone in such a manner that sound from the reflecting surface is thrown back directly at the microphone. Distortion from this cause is characterized by a hollow quality. The use of a sound-absorbing material on the floor or the reflecting surface will eliminate this difficulty. In general, reverberation from walls or from the acoustic properties of sets and stages, becomes more serious proportionately as the microphone is removed away from the source of sound.

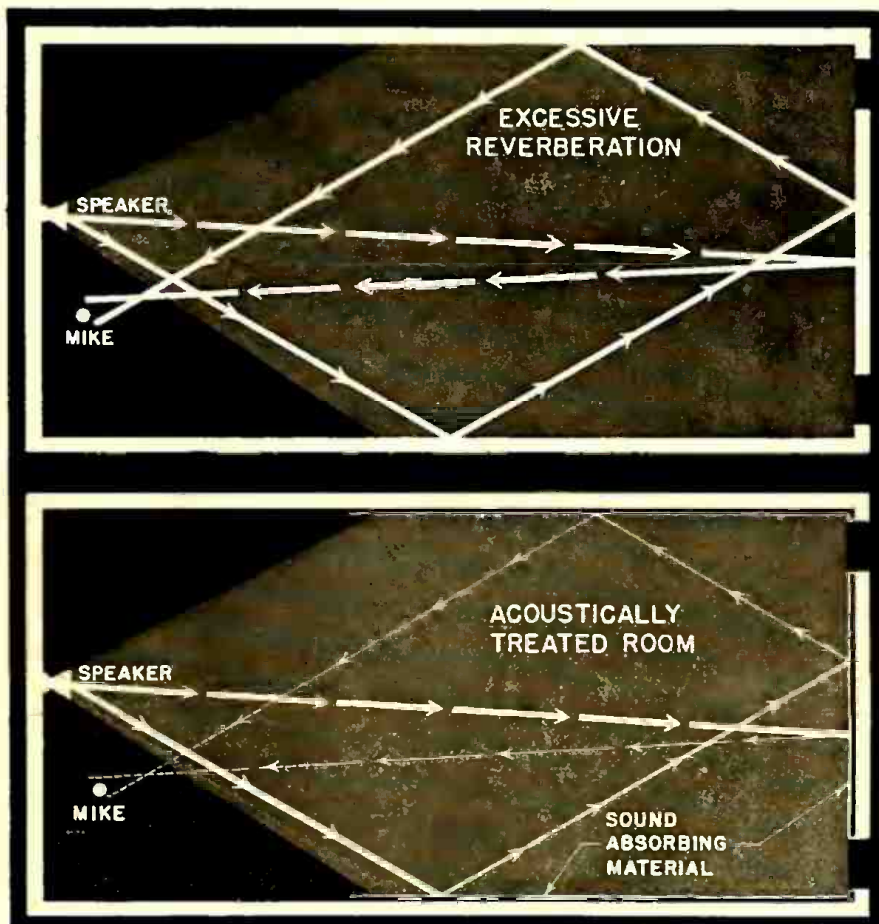

Top chart illustrates excessive reverberation. Note how sound beams hit wall and bounce off without losing any volume because the walls do not absorb any of the sound. Bottom chart shows how sound absorbing material reduces the reflected sound wave and at same time reduces possibility of feedback to microphone.

AMPLIFIERS AND SPEAKER SYSTEMS

Sound amplification and distribution problems

★ Important factors in selecting an amplifier for a sound system are: (1) ability to show the required gain over the desired frequency range, and (2) ability to deliver the required amount of power without overloading. It should be free from hum. Complete amplifier specifications are listed on pages 42-44 and an explanation of them appears on page 38.

The response-frequency characteristic of the amplifier will indicate its gain over the frequency spectrum. These curves are available to the sound-man from the manufacturer. Some speech amplifiers are usually designed to work from a definite impedance and any great change from that value is apt to cause frequency discrimination at the input transformer and thus change the frequency-response characteristic.

Universal input impedances

A desirable feature which will eliminate the possibility of this trouble is the universal impedance input circuit. Amplifiers are now available with universal input transformers which permit any type of microphone or transcription equipment to be used interchangeably so that the best condition of impedance match is maintained without the use of external transformers or matching pads. With the wide variety of microphones and record pick-ups now used, and the probability that the variety will increase, input circuits should have great flexibility to be completely adaptable.

Concerning amplifier power, which is also cited in the article previously mentioned in *SELLING SOUND*, it is usually well to have a reserve power of ten to fifteen percent more than is actually required. Sometimes additional loudspeakers will be purchased for the installation and this reserve will be sufficient to operate them.

Extreme fluctuations of power supply voltage are often encountered in remote localities such as rural communities and resorts. Here some simple and inexpensive means of compensation will be required. The primary winding of the power transformer of the amplifier should be tapped to provide this compensation. If a more elaborate control is needed an autotransformer panel, equipped with a voltmeter and having a switch for varying the voltage supply to the amplifier should be used.

Stabilized feedback amplifiers are now available which have other very desirable points and are not expensive. The use of this new equipment should indicate the sound man's ability to keep abreast of the new and latest types of equipment.

Amplifier frequency response

In the past the overall frequency characteristic of a sound system could only be altered, to correct acoustic defects in the space where the sound is reproduced, by adding external equalizers or by changing the characteristic of the amplifier. This latter operation is the work of an engineer.

Amplifiers are now available with an adjustable response characteristic which permits either the low or high ends of the characteristic to be attenuated with the result that the overall response can be adjusted to compensate for auditorium resonance or other acoustic defects. Through the use of equalizers it is possible to improve many existing sound installations. Dialogue equalizers will add crispness and intelligibility to speech by elimination of the unnecessary low frequencies. A high-pass filter will provide compensation for exaggerated low-frequency response or rumblings inherent in some microphones. The elimination of the low frequencies in high-power installations, in those cases where they are not needed, increases the available power output from the loudspeakers. Low-pass filters may be used to suppress noise due to needle-scratch from transcription equipment.

Loudspeakers can be divided into two general classes: (1) the directive type, such as horns, and (2) the non-directive or cone types which are usually mounted in cabinets or on baffles. The properties of each type should be understood and used to advantage.

Directive speakers

We all know that a horn is a sound projector. It is therefore useful for transmitting sound over comparatively great distances. With it sound can be directed to specific areas at sufficient volume to over-ride interfering noises. Furthermore, loudspeakers having directive properties have advantages which can be used to secure good overall results from a sound system when the time of reverberation seems excessive for ordinary speech and music. If, in using a horn, the first surface the sound strikes is highly absorbent, such as the audience area, the effect will be to reduce the reverberation time because the direct sound is higher in level than the reflected sound. It is therefore possible by careful use of the directional properties of horns to so distribute sound as to raise the intensity-level in the audience area and thus avoid some of the more severe interferences or reflections that would occur if non-directive loudspeakers were used.

Avoid reflections

At the same time the directive speaker may seriously exaggerate an acoustic fault if it is not properly controlled. It should not be aimed at ceilings or walls from which there is a possibility of high-intensity reflections. In general horns should be mounted as high in the air as consistent with the architecture to direct the sound

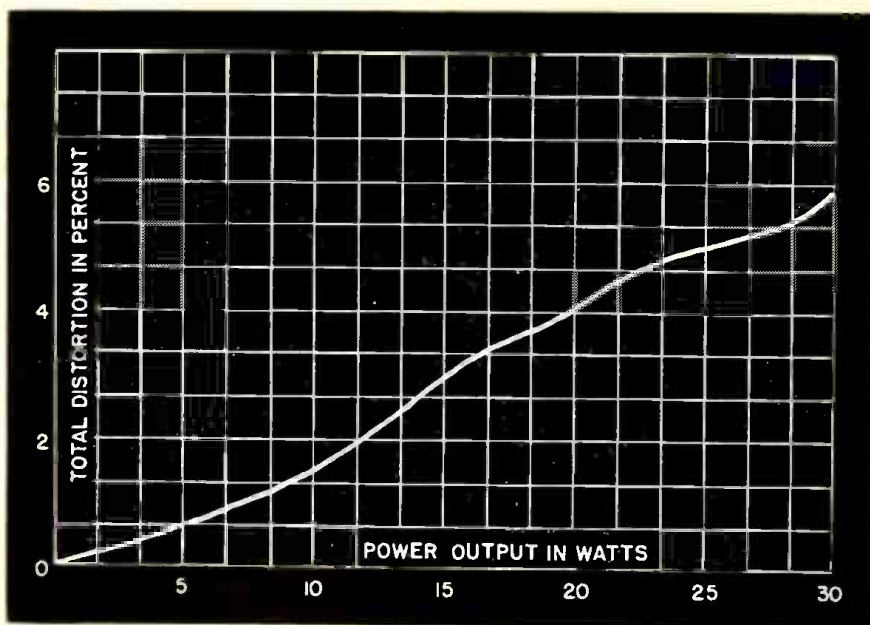

Distortion in sound amplifiers should be held to a level. Curve above is for a 25-watt amplifier. At outputs much greater than the rated, distortion becomes extremely high.



This storm-proof marine type cone speaker made by Atlas Sound is well suited for all outdoor applications. Unit worked okay after rigid test shown above.

downward to the audience area, thus reducing the intensity of sound reflected from the ceiling.

The low-frequency response of a horn is dependent on the length of the air-column. To obtain low frequency response the horn becomes exceedingly long and heavy.

Cone speakers

The objections to weight and size of horns are overcome by the cone loudspeaker. Assuming a good cone unit is employed, it must be properly mounted to give good results. Cabinets and baffles should be large. Even these speakers are directional with respect to the high frequencies. They should be so mounted that the listener will be in the high frequency beam, so, obviously, the speaker should be mounted level with the head of a seated listener. The use of vanes to distribute the high frequencies is helpful. Most vanes are designed to spread the beam in the horizontal plane only.

In order to reproduce the low frequencies, the cone should be large and the speaker should be mounted on a large baffle, or in a large cabinet or closet. Care should be taken so that the baffle or any parts cannot rattle. If the cost of the large 18" speaker is prohibitive, the use of two smaller speakers will improve the low-frequency response. These may be mounted side by side in the same baffle or cabinet, and they must be correctly phased.

Phasing speakers

When two speakers are correctly phased both cones will move in the same direction when the voice coils are excited. A simple way to observe this motion is to connect an ordinary 1½ volt dry cell across the two voice-coils connected either in series or in parallel. Observing that the direction of movement of both cones is the same as the battery is connected and disconnected will indicate that the speakers are correctly phased.

For the deluxe installation, the acoustic-labyrinth type of speaker is very desirable. The use of this type overcomes certain objections to mounting speakers in cabinets with result-

ing poor low-frequency response. Also, the use of a horn coupled to the back side of a cone loudspeaker, gives high efficiency and smooth response at the low frequencies. Acoustic networks and "infinite baffle" housings are now used to improve the low-frequency response of dynamic speakers. This is a comparatively inexpensive method of improving response.

Permanent magnet dynamic loudspeakers are especially suitable for centralized radio and for school systems as well as other applications where electrical field excitation is not readily available or expedient.

Educating customer

After the job is done and the installation has been turned over to the customer, the sound-man can still do things to improve conditions, and, incidentally help his reputation as a good sound-man. He should make sure the customer understands how to operate the system properly. He can persuade him not to use too much volume. The customer may need to be

educated! If the sound-man cannot get a contract for service and maintenance, he can make sure the customer is given the information he needs. It will help both in the end.

The sound-man should go back to the job once in a while to see if the customer is still satisfied and to make a check of the system operation. The customer may want to try some new tricks involving additional equipment, and technical advice at this point may put over the sale.

Let's have better sound installations!

DECIBEL CHART

★ On page 35 of this issue appears a chart designed for converting decibel levels to powers or to voltages for specific load resistances. Also the voltages and powers can be converted to decibels. Zero decibel is set at .006 watts, which is the most common standard used in sound.

Three sets of scales are employed to extend the range of the chart. When using the chart, the same scale must be used for any one calculation.

Commonly used load resistances are shown on the chart—these are used when converting decibel levels to volts and vice-versa. An example indicated by dotted lines is shown on the right side of the chart and labeled (a). Always be sure to employ the proper load resistance.

Conversion of decibels to watts is accomplished by using the *DB vs. POWER* line. An example shown in dotted lines on the left is labeled (b).

The data for this chart was supplied by G. M. Giannini, of Transducer Corp., who is offering additional copies of this chart, suitable for framing, without charge. Requests should be addressed to the company at 30 Rockefeller Plaza, New York, N. Y.

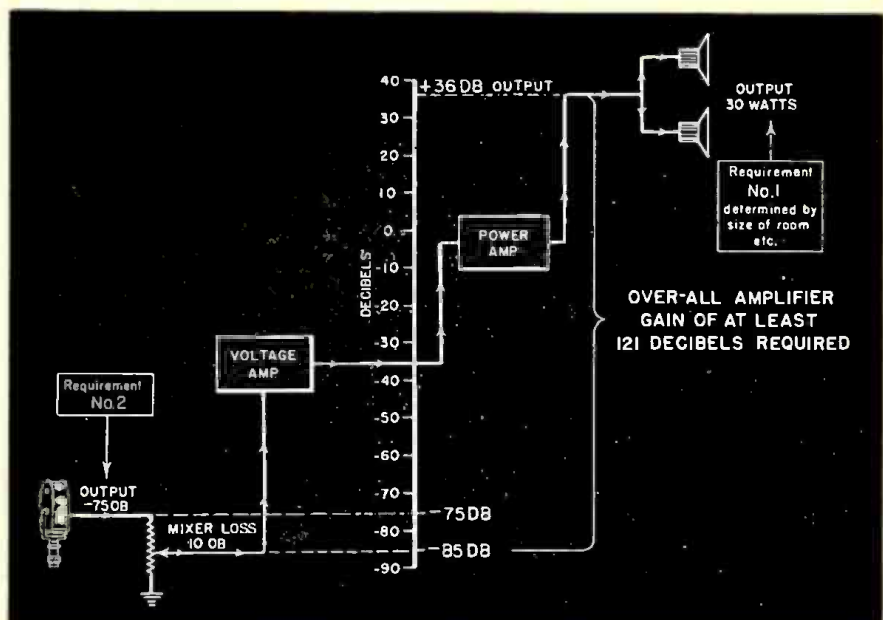

Power output of a system is determined by acoustical conditions while the input level is determined by the type of mike used. From these two requirements the amplifier gain is calculated in terms of decibels.

HOW TO SELL "SOUND"

An experienced sound specialist tells ways to locate and close sound sales. Rentals important

★ Sound today is perhaps one of the most complicated phases of the radio business, as those in it are finding out. In the first place, little or no consumer advertising has been done, and in the second place the consumer understands in many cases nothing regarding the equipment, outside of it being called a "loud speaker system." Perhaps this lack of knowledge on the public's part is the greatest obstacle in making sales, as the consumer is always "afraid of being taken" when buying equipment.

Reports of sales now being made show that "sound" is no baby any longer but is an established radio industry in its own. Present-day equipment has been perfected tremendously over that offered two years ago, and is more compact, reliable and streamlined to fit in with any surroundings, whether a church, or a tavern.

The radio dealer who does not have a man devoted to sound equipment, at least part of the time, is placed at a decided disadvantage from the start. By association with the installations and equipments, such a specialist soon learns the limitations and peculiarities, knows the prospect field, and can talk intelli-

gently regarding phases of equipment when required. It is practically impossible for each salesman to know all the whys and wherefores concerning sound, since so many new different advances are realized each week, hence it is best to let one person concentrate exclusively on sound equipment.

Sales thru rentals

The rental field which the dealer enters at the start, is quickly over-looked in favor of sales when the going gets tough. Yet it is through the rental approach that ultimate sales of sound equipment are made in 75 per cent of the cases. The prospect rents the equipment, soon learns the convenience and labor-saving possibilities, and then wants to purchase it. Yet many dealers exist on the hit and miss of giving a demonstration, telling the price, and using some persuasion. Then in the event the sale does not materialize, they drop the prospect cold.

Even if the prospect buys equipment elsewhere, the serviceman can get business again. The equipment will need servicing at some time, new tubes, and in case of a pickup, new

records. Take for example, this case that actually happened:

One soundman gave a bid of \$175 for equipment specified on the bid. Another bid \$150 and got the business. This particular church at the time requested an amplifier with two speakers and a microphone. This being a 15-watt amplifier was ample for their hall. But spring came and the equipment was of no use on the outside due to incorrect baffles, and output.

Friend dealer who was left cold on the sale had kept sending this church postcards advertising sound rentals, sales and service, and was able to turn in a few profitable rentals on this basis. His cost was nominal, not more than six or seven cents postage for coverage of this church, and other amusement places through systematic monthly mailings.

Churches, schools, "bingo"

Many churches and schools today are buying equipment not in the least suited for their future requirements. True, additional microphones may be added, as well as speakers, but the output peak is always there, and in nine cases out of ten, the church or school will not buy additional accessories, leaving an opening for the rental soundman, for certain requirements which can not be covered by the initial equipment.

At the present time "bingo" games are popular and to a certain extent replacing lotto. One of the main reasons being that bingo is played faster and consequently produces more revenue for the sponsor of the affair. Almost any hall, no matter how small, the smaller ones, incidentally the easier, can be sold by pointing out that any overflow can be accommodated by the use of an additional speaker with microphones connected to the system for calling back games. This is more efficient than any buzzer or telephone system and also easier for the soundman to install.

Spring has come, summer is approaching, so don't forget all of the festivities among the churches and schools, and the factory employees'

(To page 48)

SPECIAL CAR MAKES 7000-MILE TRIP TO DEMONSTRATE SOUND

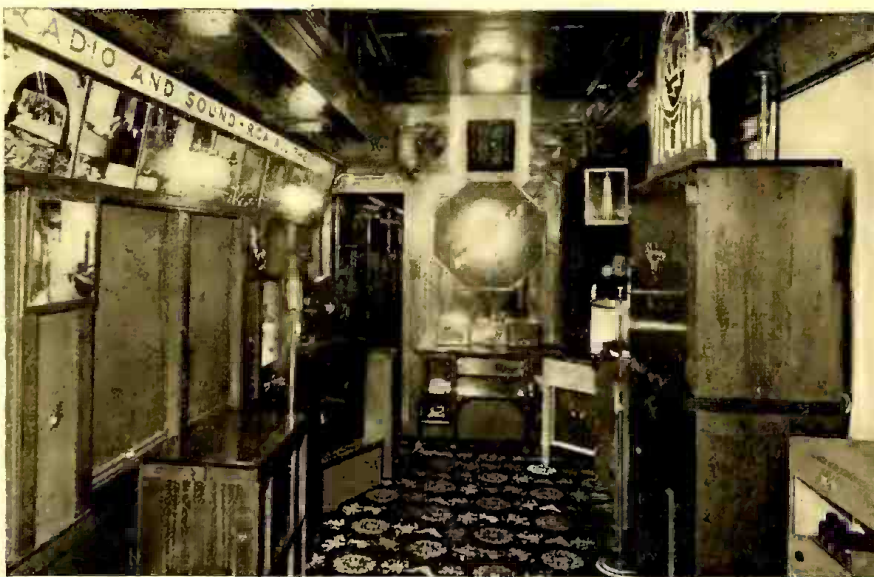

Sound equipment gets a private car and hundreds of architects, engineers, builders, educators, entertainment operators, industrialists, etc., hear the story of PA's efficient usefulness. RCA's \$35,000 sound exhibit, in this special Pullman, travels 7,000 miles and stops in 24 key cities for demonstrations of 1938 amplification.

DECIBELS EXPRESSED IN VOLTS & WATTS

For matching microphones, amplifiers, and speakers

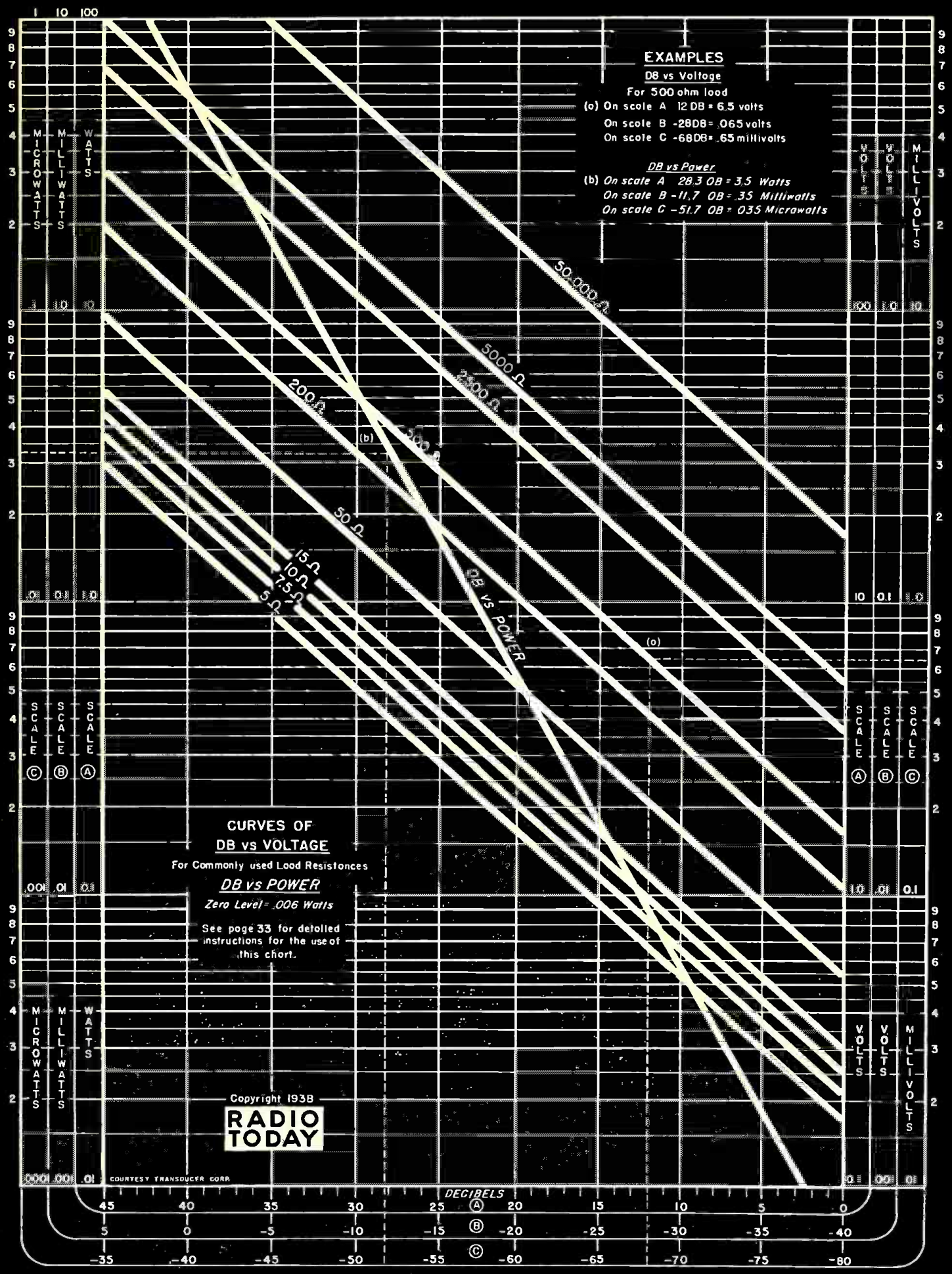

"CONTACT MIKE" OPENS NEW FIELDS

Picks up vibrations direct from instrument. New commercial opportunities

★ NEW possibilities in musical reproduction and "sound selling" are opened up by the "contact microphone," which reproduces the vibrations of any instrument or object on which it is placed. This reproduction is accomplished, moreover, without introducing any annoying peaks, and life-like results are given throughout the entire frequency range, explains Sam Ruttenberg of Amprite.

An idea of the reproduction quality of the new contact mike can be gained from the fact that it was used recently by the Philadelphia Symphony Orchestra to reinforce a mandolin solo. The unit is flat within ± 2 db from 40 to 9,000 cycles per second. Its operating principle is magnetic.

Although the violin is one of the most versatile instruments, its use has been reduced to practically large symphony orchestras where enough violins to give the necessary dynamic power can be afforded. Violinists therefore learned to play the more demanded saxophones. The reason for the unpopularity of the violin in dance orchestras is due to its limited power output. Sound engineers removed this objection by giving the violinist amplification—and yet he must be pushed to try it—to experiment with it. Patience and tact must therefore be exercised by the sound man in dealing with musicians. Stokowski compares this lack of interest in sound amplification on the

part of musicians, as follows: "If a gold mine were found or a subterranean sea of petroleum discovered, it would be quickly developed. But a means whereby every man can hear music with overwhelming beauty and elegance is neglected and left unused."

New magic for violins

With the aid of the new contact microphone a \$50 violin can be given the tone and volume of one costing several thousand dollars. It also gives the violin the dynamic power of the brasses. A few violins can give a small orchestra the effect of a symphony. A "hot" violinist can obtain effects unobtainable by any other instrument. Instead of decreasing, the use of amplification will increase the employment of violinists—their more powerful instruments will increase their usefulness and field.

Classical guitar players find it difficult to obtain volume. Their power of interpretation is limited. The contact mike gives the guitar the volume and depth of a piano. And incidentally a small piano can be made to sound like a concert grand. When the contact unit is attached to the piano of a dance band, the piano becomes more audible and gives the band more fullness—especially when the floor noise level is high.

An unusual and fortunate use of the contact microphone is in helping the deaf to enjoy playing or hearing

musical instruments. This is accomplished by attaching a contact unit to practically any musical instrument, feeding it into a low gain amplifier or radio set and then to an ear phone or "bone-conductor."

Another rather unusual use that was accidentally discovered is in making sound effects for radio and movie studios. Granulated sugar dropped on a piece of paper placed over the contact mike, will give the effect of rain. Talking very close and into the unit was found to be the best and easiest way to obtain a "telephone voice." Pounding the chest with the contact unit against it, gives the illusion of galloping horses's hoofs, etc.

Recording of a piano has always been difficult—especially when special rooms are not available. By putting a single contact microphone on the sound board of the piano, better recording can be obtained than with any regular type of microphone. Of course outside noises will not be picked up.

Home applications

Not limited to the professional field, servicemen will find the contact unit a very easy sale in any home where an instrument is played. Attach the unit to a musical instrument such as a violin, ukulele, piano, etc., connect it to the radio and request the musician to play with the contact unit connected. The better tone and volume of the instrument will be immediately noticeable. A demonstration is all that is usually necessary to close the sale. It is an extra sale since it does not compete with anything else the serviceman sells. When the unit is taken off, the instrument will sound rather flat.

Practically any number of contact mikes can be connected in parallel and fed into one input. In other words, a unit can be attached to each of twenty-five instruments and all fed into one amplifier. In many cases, the musician prefers to have a separate amplifier for his own instrument. A compact low-gain amplifier with a speaker on it is placed next to the musician, giving a perfect illusion of the music coming only from the instrument.

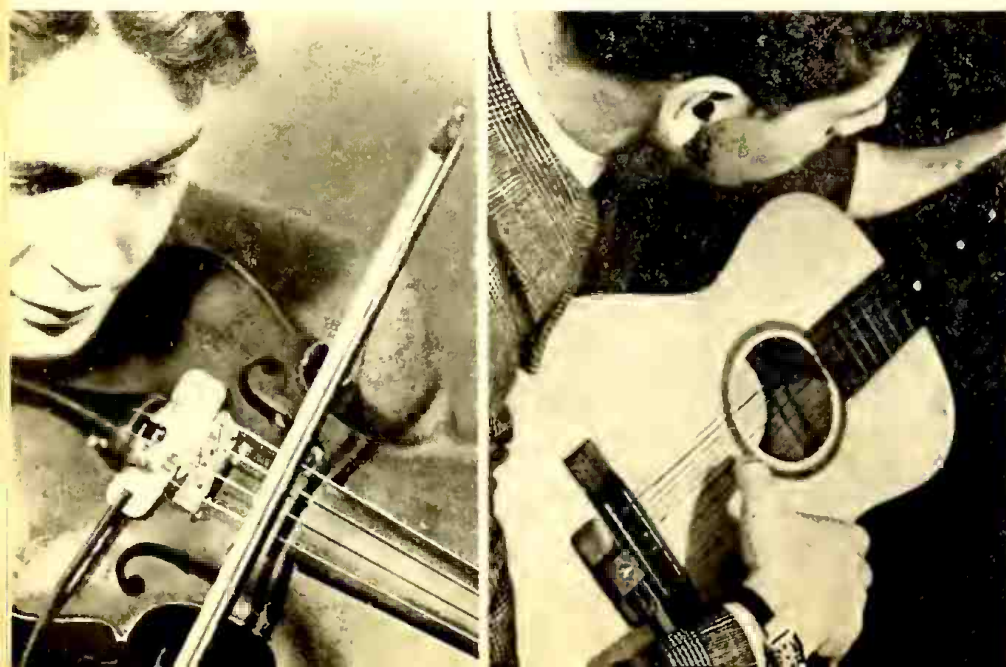

Webster Electric Sound Equipment

...the Standard for Better Distributors



This Three-Toned, Streamlined Mobile System is Typical of the Entire Line!

● Progressive, forward-looking distributors are taking on sound equipment—and they are standardizing on Webster Electric Sound Equipment—the line which offers the greatest opportunities for capturing this expanding market!

Webster Electric Sound Equipment is quality plus. It has the greatest eye appeal. Its tone quality is unsurpassed. It is truthfully rated. It is built in all the sizes required to cover the portable and semi-portable market.

The Mobile Amplifier illustrated above is typical of the line. It is truthfully rated at 20 watts

with only 5% harmonic distortion. It is designed for 6-volt storage battery or 110 volt A.C. operation. It is finished in silver, black and red and can be supplied with all the component parts for a complete mobile system.

Write for full details of the Webster Electric policy which fully protects the distributor, and also, for complete details of the entire Webster Electric line.

Licensed by Electrical Research Products, Inc., under U. S. Patents of American Telephone and Telegraph Company and Western Electric Company, Inc.

WEBSTER ELECTRIC COMPANY, RACINE, WISCONSIN, U. S. A.

ESTABLISHED 1909 • Export Dept.: 100 Varick St., New York City • Cable Address: "ARLAB" New York



A New Pick-Up

Here is a new Pick-Up made of solid, hand-rubbed walnut—a finish and design that will enhance the appearance of modern cabinets. It is fitted with the new crystal cartridge.



A New Crystal Pick-Up Cartridge

This new cartridge (Pat. applied for) is unique in its design and superlative in performance. Entire assembly is enclosed in flexible molded rubber.



Teletalk

Teletalk is the outstanding electronic inter-communication system. The only system which includes models to meet every office communication need.



Webster Electric

PORTABLE AND SEMI-PORTABLE SOUND SYSTEMS • ELECTRONIC INTER-COMMUNICATING SYSTEMS • ELECTRIC PHONOGRAPH PICK-UPS • TRANSFORMERS AND FUEL UNITS FOR OIL BURNERS

WHAT AMPLIFIER RATINGS MEAN

Facts that will help the sound man select his equipment

★ As new amplifiers continue to appear on the market the prospective customer and P.A. man find it increasingly difficult to compare ratings and values. Since equipment for checking amplifiers is not generally available, and even if it were comparative tests would be a lengthy procedure, the customer must rely entirely upon the manufacturer's ratings. These ratings, although generally authentic, are often based upon different standards of measurement, and in order to compare any two amplifiers, it is extremely important that the various ways of rating amplifiers be understood. The amplifier specifications on pages 42 & 44 have been compiled so as to list the data on a basis suitable for comparison.

Normal vs. max. power

At present the term "power" may be defined in a number of ways and it is important in comparing amplifiers that the different methods of power rating be understood. The terms "normal power" and "peak power" are misleading to the layman and to add further to the confusion some amplifiers are listed as capable of useful output over a certain power range. If the output of an amplifier is listed as 8 to 15 watts, the lower power of 8 watts is the normal output, and the wave form flattens abruptly for higher outputs, even though the amplifier may be capable of 15 watts of highly-distorted power. In all cases the normal rating is the true output of the amplifier, states S. Douglas Fortune of Thordarson Elec. Mfg. Co.

Practically any amplifier is capable of an output of twice its normal value. Fig. 1A shows the sine wave output

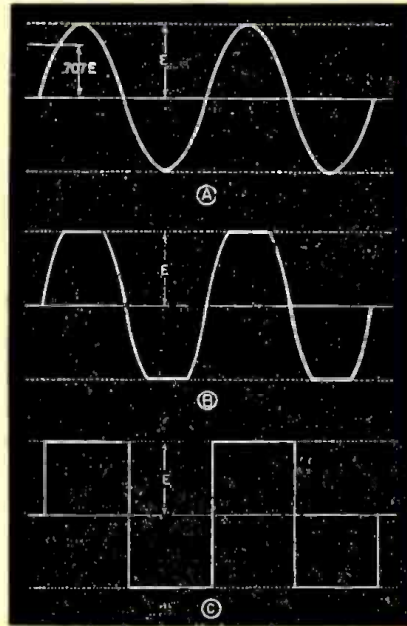

Fig. 1—Waveform of various outputs.

of an amplifier. The effective value of the peak value E is $.707E$, and the power output varies as $(.707E)^2$ or $\frac{1}{2}E^2$. If now the amplifier be overdriven so that Fig. 1C is the result, the effective value is very nearly E , so that the power varies as E^2 which is twice the normal value of $\frac{1}{2}E^2$. The distortion in a square wave is extremely high.

Sometimes the value of "peak power" for a given amount of distortion is listed. For instance an amplifier may be rated at 20 watts normal and 25 watts peak. This peak rating usually contains from 10 to 15 per cent distortion. Although this method is somewhat more conservative than

the previous method of peak power rating, it does give the power rating with a flat topped wave, which is similar to that of Fig. 1B. In comparing power rating it is important to place all values of peak power secondary to the normal rating which is the true output of the amplifier. Naturally, the greater the peak power for a given normal power, the lower the distortion will be when overloading takes place.

"Distortion" as well as "power" may be interpreted in a number of ways. Some manufacturers lacking the facilities for actually measuring distortion list the total amplifier distortion as that given by the tube manufacturer. The distortion figure listed by the tube manufacturer in no way accounts for practical limitations encountered in actual design or variation normally encountered in tube characteristics. Distortion figures may be accepted as authentic only if a distortion set of tubes, such as in chart on page 32.

"Undistorted" output

Some manufacturers list the output of their amplifiers as "undistorted power." Distortion under 5 per cent is usually considered negligible and an amplifier with 5 per cent distortion may be considered as having "undistorted output," although the term has been applied so loosely that it may now mean an output with practically any amount of distortion, and it should not be assumed that an amplifier with "undistorted power output" has necessarily less than 5 per cent distortion. In the amplifier specifications on pages 42 & 44, the distortion at normal rated output is given.

(To page 46)

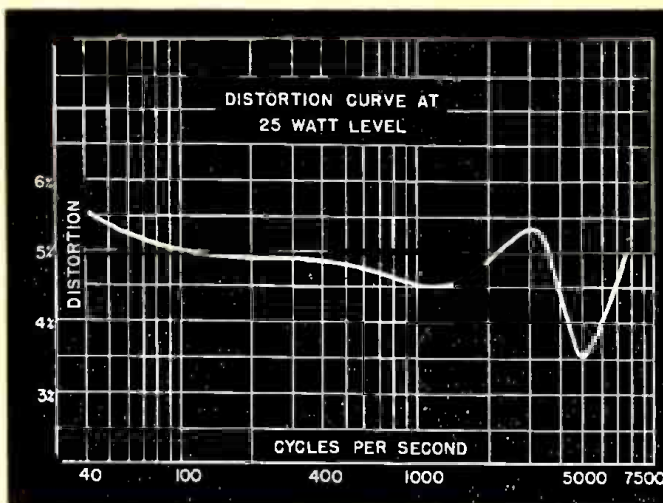

Fig. 2—Distortion vs. frequency characteristics of a typical amplifier at rated output.

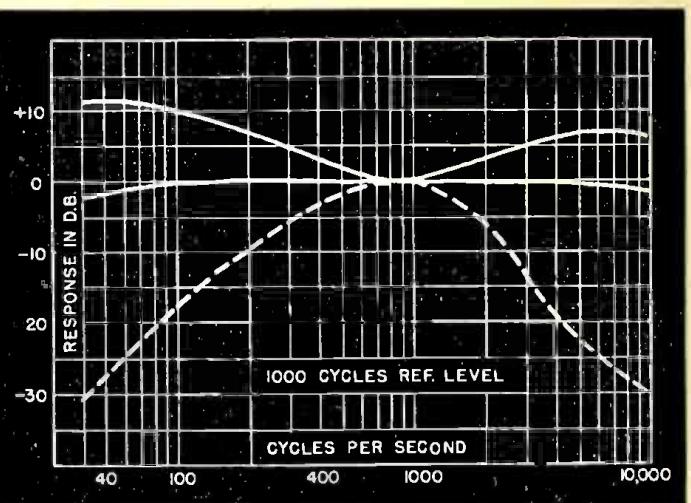

Fig. 3—Normal amplifier frequency response is center curve. Other curves show effect of tone controls.

Sound Amplification *IS* Big Business...

**WILL BRING
YOU
BIG PROFITS!**

RCA PRESENTS
AN AUTHORIZED
DEALER PLAN
FOR
COMMERCIAL
SOUND



COMMERCIAL SOUND SECTION • RCA MANUFACTURING CO., INC.
CAMDEN, N. J., U. S. A.

This booklet contains the RCA Authorized Dealer Plan for Commercial Sound. It is chock full of ideas and plans for sales stimulation. Your RCA distributor will give you full details.

Again RCA gives you a large profit opportunity . . . offers you a well organized merchandising plan . . . tried and proved selling plans . . . sales promotion aids . . . engineering assistance . . . powerful national advertising

PLUS the Most Complete Line of Sound Equipment in the World —Priced in Your Interest!

Selling sound is big business! And if you're not in it you're passing up juicy profits every day! For your field of prospects is wide and varied. And the prices of RCA Commercial Sound Equipment make your every sale well worth while! Installations range in price from \$80 to \$10,000 and up.

RCA offers you a valuable franchise—another important link in the RCA All The Way chain. Take advantage of this offer! If you do nothing more, investigate the plans that have been made for your profit. You have nothing to lose—everything to gain. Your RCA distributor has full details. Get in touch with him NOW!

An Almost Limitless Field of Prospects

For your convenience, some of these are listed below

- | | |
|-------------------|-------------------|
| Night Clubs | Beer Gardens |
| Country Clubs | Department Stores |
| Churches | Auction Rooms |
| Government Depts. | Theatres |
| Hotels | Dance Halls |
| Resorts | Amusement Parks |
| Hospitals | Public Schools |
| Industrial Plants | Colleges |
| Business Offices | Airports |
| Roadside Stands | Bus Stations |



As a franchised dealer, this sign identifies your store as RCA Sound Headquarters.

RCA presents "Magic Key" every Sunday, 2 to 3 p. m., E. S. T., on the NBC Blue Network.



Commercial Sound

RCA MANUFACTURING COMPANY, INC. • CAMDEN, N. J.
A Service of the Radio Corporation of America

NEW SOUND ITEMS



25-watt amplifier

★ Amplifier with multi-stage inverse feedback. Power output of 25 watts with 2½ per cent distortion. Frequency flat within 1½ DB from 50 to 10,000 cycles. Webster-Chicago Model 2L-25. Webster Co., 5622 Bloomingdale Ave., Chicago, Ill.—**RADIO TODAY**—see also advt. p. 27.

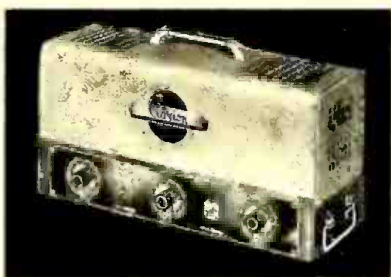

Clarion 30-watt sound system

★ Fixed type sound system having 30-watt output with 7 per cent distortion. Uses two 12-inch speakers with flare baffles. Gain of 131 DB with 1 meg input resistance. Uses 6L6 tubes. Inverse feedback, luminous glo dials. Multi-impedance output transformers. Transformer Corp. of America, 69 Wooster St., New York, N. Y.—**RADIO TODAY**—see also advt. p. 43.



Power amplifiers

★ Booster type amplifiers for use with any sound system. Beam power output stages with inverse feedback. Built-in driver stage. Facilities for electrically excited speakers. Available in 25-watt and 60-watt outputs. Modern-styled cases. Allied Radio Corp., 833 W. Jackson Blvd., Chicago, Ill.—**RADIO TODAY**.

Talking door interphone

★ Wired type interphone for use in providing communication with visitor at the door. Eliminates need of going to door for peddlers and salesmen. Housewife can find out who is there without opening door. Uses 3-tube amplifier and PM speakers. Consumes no current when not in use. Requires no drilling in door, just fastens to inside of door. List \$29.95. Regal Amplifier Co., 16 W. 17th St., New York, N. Y.—**RADIO TODAY**—see also advt. p. 47.

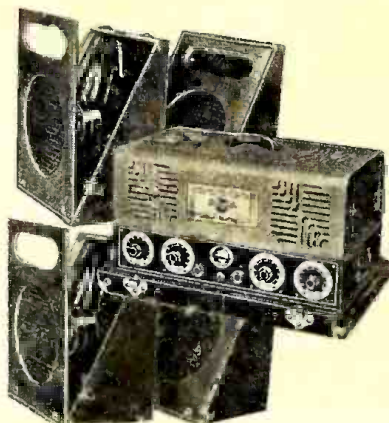

Lafayette sound system

★ 70-watt sound system with 100-watt peak output. Push-pull parallel beam power tubes. Automatic volume control or volume expansion. Mixing and fading facilities for 4 input channels. Four heavy-duty PM speakers, two mikes supplied. Housed in 3 carrying cases. Wholesale Radio Service Co., 100 Sixth Ave., New York, N. Y.—**RADIO TODAY**—see also advt. p. 49.



Velotron microphone

★ No voltage velotron microphone. Output level of —50 DB. Bidirectional characteristic. Substantially free from peaks. Can be used with runs up to 1,000 feet. Requires no matching transformer—works into grid of tube. Units may be used in parallel. Available in high, medium and low-pitch types. List \$22.50 less cable. Bruno Labs., 30 W. 15th St., New York, N. Y.—**RADIO TODAY**.

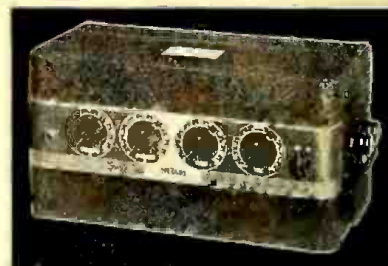

Operadio amplifier

★ 35-watt sound amplifier. Three input channels—electronic mixer. Distortion of only 5 per cent. Can be used with all types of mikes. Gain of 134 DB. Non-resonant equalizer used as tone balancer for high and low frequencies. Base type mounting—can be bolted to standard 19-inch rack. Supplies field to 2 speakers. Operadio Mfg. Co., 13th St., St. Charles, Ill.—**RADIO TODAY**—see also advt. p. 41.



Vocograph mobile amplifier

★ 30-watt sound system for use on AC or 6-volts DC. Beam power output tubes. Built-in AC power pack. Changeover accomplished by flip of a switch. Complete accessories available. Model 30-M30 amplifier—list \$109. Vocograph Sound System, 164 N. May St., Chicago, Ill.—**RADIO TODAY**—see also advt. p. 48.



Bogen mobile amplifier

★ Universal type mobile amplifier for 6-volts DC or 110 AC. Conversion accomplished by changeover switch. 28-watts undistorted output. Universal mike input. Tapped output impedances. Electronic mixing. Stand-by switch for saving battery consumption. Crystal type pick-up. Model C28—list \$132.50. Phono assembly—\$49.50. David Bogen Co., 663 Broadway, New York, N. Y.—**RADIO TODAY**—see also advt. p. 47.

(Continued on page 43)

**AT LAST...
WHAT YOU'VE ALL
BEEN LOOKING FOR**

Remote VOLUME CONTROL

**MODEL 414
PORTABLE P.A. UNIT
14 WATTS**



- ★ **ADJUST VOLUME FROM ANY POINT IN THE AUDIENCE**
- ★ *Without* **GOING BACK TO AMPLIFIER**
- ★ *Without* **MOVING AMPLIFIER WITH YOU**

MODEL 410—PORTABLE P. A. UNIT ...



14 Watts
Has same features as Model 414, but is smaller, more compact. Ideal for carnivals, side-shows, concessions, etc. Heavy duty 8 in. h permanent magnet dynamic speakers mounted in separate carrying case. Moderately priced.

MODEL 172—MOBILE P. A. SYSTEM ...

25 Watts
A mobile P. A. system that combines AC-DC in ONE CASE. Instantly available for either voltage without removal of packs. Latest dynamic type microphone specially designed for Sound Truck work. Unaffected by wind and adverse climatic conditions. Modern, streamlined appearance. Provisions for Remote Volume Control, Headphone and Meter Monitoring.



Export Division: 145 W. 45th St., New York City

● A development in P. A. equipment as revolutionary as the self starter on an automobile. Remote volume control from any point within hearing range. Get full details now about Model 414, and this **GREAT** New Selling feature.

PLUS THESE GREAT FEATURES:

PROTECTED RECESSED ILLUMINATED CONTROLS ... FULL 14 WATTS OUTPUT; HIGH GAIN ... BEAM POWER TUBES ... CATHODE DEGENERATION ... 3 CHANNEL INPUT ... 12" HEAVY DUTY PERMANENT MAGNETIC DYNAMIC SPEAKERS ... PROVISIONS FOR HEAD PHONE AND METER MONITORING ... PROVISION FOR PAGING SWITCH CONTROL ESPECIALLY DESIGNED FOR BEAM POWER TUBES ... SMALL, LIGHTWEIGHT, COMPACT ... WITHOUT SACRIFICING TONE QUALITY ... ATTRACTIVE TWO-TONE GRAY CARRYING CASES.

See How Remote Volume Control Works!

—MAIL THE COUPON!—

OPERADIO MANUFACTURING COMPANY
Dept. R.T. 4, St. Charles, Illinois

Please send me complete data on the REMOTE VOLUME CONTROL feature of Model 414 Portable P. A. Unit.

Name

Street Address

City.....State.....

Model 410 Portable P. A. Unit Model 172 Mobile P. A. System

OPERADIO MANUFACTURING COMPANY ST. CHARLES ILLINOIS

AMPLIFIER AND SOUND SYSTEM SPECIFICATIONS

Compiled by Radio Today

Amp. model No.	S. S. model No.	Amp. list price	S. S. list price	Rated watts	% distortion	Max. watts	Gain		No. of inputs	No. of mixers	No. of tone controls	No. of tubes	Output		Line watts	Power source	Speakers		Type	Phono turntable		
							DB	Input resist					Tubes	Class			No. & Type	size				
Allied Radio Corp., 833 W. Jackson Blvd., Chicago, Ill.—"Knight"																						
B12110	B12111	\$ 25.00	\$ 49.50	10	7%	11	70	200 ohms	2	2	1	3	1-6L6G	AB ₁	45	AC	1-8"	EE	Carb.	No		
B12100	B12101	29.50	84.50	10	7	11	110	2 Meg.	2	2	1	5	1-6L6G	AB ₁	60	AC	1-8"	EE	V	No		
B12120	B12121	59.95	149.95	20	3	25	115	2 Meg.	4	3	2	8	2-6L6G	AB ₁	150	AC	2-12"	PM	V	No		
B12130	B12131	70.00	165.00	25	3	30	120	2 Meg.	4	3	2	8	2-6L6G	AB ₁	160	AC	2-12"	PM	V	No		
B12140	B12141	95.00	205.00	40	5	55	124	2 Meg.	6	6	2	14	2-6L6G	AB ₂	180	AC	2-12"	PM	V	No		
B12160	B12161	112.50	297.50	60	5	70	130	2 Meg.	6	6	2	16	2-6L6G	AB ₂	225	AC	4-12"	PM	V	No		
	B12118		150.00	18	5	25	115	2 Meg.	2	2	1	6	2-6N7G	B	NS	6V D.C.	2-12"	EE	C	Yes		
	B12119		170.00	18	5	25	115	2 Meg.	2	2	1	6	2-6N7G	B	NS	110V A.C.	2-12"	PM	C	Yes		
B12170	B12172	120.00	210.00	25	5	32	120	2 Meg.	4	3	2	9	2-6L6G	AB ₁	84	6V D.C.	2-12"	PM	C	Yes		
B12171		105.00		25	3-5	30	120	2 Meg.	4	3	2	9	6L6G	AB ₂	160	110V A.C.				Yes		
Amplifer Co. of America, 37 West 20th St., New York, N. Y.—"ACA Gold Medal Amplifiers"																						
15A		120.00		15	5	25	110	1 Meg.	NS	2	3	8	6L6G	A	85	AC		EE*	C-D-V	No		
25A		175.00		25	5	30	110	1 Meg.	NS	2	3	8	6L6G	A	95	AC		EE*	C-D-V	No		
35A		225.00		35	5	42	110	1 Meg.	NS	2	3	8	6L6G	AB ₁	100	AC		EE*	C-D-V	No		
50A		310.00		50	5	60	110	1 Meg.	NS	2	3	12	6L6G	AB ₁	120	AC		EE*	C-D-V	No		
70A		395.00		70	5	90	115	1 Meg.	NS	2	3	12	6L6G	A	130	AC		EE*	C-D-V	No		
15E		150.00		15	3	22	125	1 Meg.	NS	2	3	8	6L6G	A	85	AC		EE*	C-D-V	No		
25E		200.00		25	3	32	125	1 Meg.	NS	2	3	8	6L6G	A	95	AC		EE*	C-D-V	No		
40AB		250.00		40	3	50	125	1 Meg.	NS	2	3	12	6L6G	AB ₁	100	AC		EE*	C-D-V	No		
50E		330.00		50	3	60	125	1 Meg.	NS	2	3	12	6L6G	AB ₁	115	AC		EE*	C-D-V	No		
80E		420.00		80	3	92	125	1 Meg.	NS	2	3	NS	6L6G	AB ₂	150	AC		EE*	C-D-V	No		
24A	24S	95.00	310.00	24	2.5	30	112	1 Meg.	NS	2	2	6	6L6G	AB ₁	95	AC	2-12"	EE	C-D-V	No		
32A	32S	115.00	465.00	32	3	40	133	1 Meg.	NS	2	2	7	6L6G	AB ₁	115	AC	2-12"	EE	C-D-V	No		
64A	64S	175.00	770.00	64	5	72	136	1 Meg.	NS	2	2	10	6L6G	AB ₁	130	AC	4-12"	EE	C-D-V	No		
96A		115.00		96	6	110	35	1 Meg.	NS	NS	NS	8	6L6G	AB ₁	95	AC		EE*	C-D-V	No		
128A		150.00		128	6	150	38	1 Meg.	NS	NS	NS	12	6L6G	AB ₁	150	AC		EE*	C-D-V	No		
12D	12S	80.00	195.00	12	5	19	120	1 Meg.	NS	2	2	5	6F6G	A	85	AC	1-12"	EE	C-D-V	No		
18D	18S	85.00	245.00	18	5	22	135	1 Meg.	NS	2	2	6	6F6G	AB ₁	95	AC	1-12"	EE	C-D-V	No		
20A	20S	90.00	310.00	20	5	30	102	1 Meg.	NS	2	1	7	5V4G	AB	100	AC	2-12"	EE	C-D-V	No		
25B	25S	100.00	370.00	25	6	30	94	1 Meg.	NS	2	1	6	6N7G	B	110	AC	2-12"	EE	C-D-V	No		
40A	40S	120.00	460.00	40	5	50	105	1 Meg.	NS	2	1	9	5V4G	AB	120	AC	2-12"	EE	C-D-V	No		
50B	50S	145.00	490.00	50	6	60	97	1 Meg.	NS	2	1	9	6N7G	B	130	AC	4-12"	EE	C-D-V	No		
*PM Speakers supplied on Universal and 6V D.C. systems only. †Available at increased cost.																						
Audio Development Co., 4347 France Ave., Minneapolis, Minn.																						
28A		\$ 44.50		12	NS	NS	125	2 Meg.	2	2	1	6	2-6V6	AB ₁	NS	AC				No		
29A		69.00	\$144.00	23	NS	NS	126	2 Meg.	3	2	1	7	2-6L6	AB ₁	NS	AC	2-10"	PM	C	No		
30A		69.00		17	NS	NS	128	2 Meg.	3	2	1	7	2-2A3	AB ₁	NS	AC				No		
31A		88.50		33	NS	NS	128	2 Meg.	3	2	1	9	4-2A3	AB ₁	NS	AC				No		
32A		58.00		10	NS	NS	120	2 Meg.	2	2	1	7	4-25L6	AB ₁	NS	DC				No		
Bell Sound Systems Inc., 61 E. Goodale, Columbus, Ohio																						
412	PA412	\$ 60.00	\$129.50	12	2 3/4	18	124	5 Meg.	3	2	1	7	2-6V6G	AB ₁	90	AC	2-10"	PM	C	No		
424	PA424	75.00	187.50	24	2	34	130	5 Meg.	4	3	2	7	2-6L6G	AB ₁	120	AC	2-12"	PM	C	No		
435	PA435	125.00	259.00	35	2	42	132	5 Meg.	4	3	2	8	2-6L6G	AB ₁	130	AC	2-12"	PM	C	No		
460	PA460	185.00	418.50	60	2	80	140	5 Meg.	5	6	2	15	4-6L6G	AB	185	AC	2-13"	PM	C	No		
408	PA408S	44.50	94.00	8	5	10	102	5 Meg.	2	1	1	5	2-6F6G	A	75	AC	1-10"	PM	C	No		
D-24	M-24	115.00	230.00	24	2	34	130	5 Meg.	4	3	2	7	2-6L6G	AB ₁	{102 120	6V D.C. 110V A.C.	2-12"	PM	C	Yes		
407	PA407S	NS	69.50	7	7	10	90	5 Meg.	2	2	1	3	1-6L6G	A	70	AC	1-10"	EE	{Handtype Carb.	No		
David Bogen Co., Inc., 663 Broadway, New York, N. Y.—"Supreme Fidelity"																						
C6	CP6VT	\$ 32.25	\$ 71.50	6	5	9	123	1/2 Meg.	2	2	1	4	1-6L6G	AB ₁	73	AC	1-8"	EE	SV	No		
C10	CP10VT	47.50	79.00	10	5	12	125	1/2 Meg.	2	2	1	5	2-6V6	A	88	AC	2-10"	PM	SV	No		
C12	CP12VT	55.75	98.50	12	5	14.6	128	1/2 Meg.	2	2	1	6	2-6N6	A	112	AC	2-11"	EE	SV	No		
AD10		47.25		6	5	7.2	122	1/2 Meg.	2	2	1	7	2-25L6	A	52	AC	DC			No		
AD16	ADP10	72.50	136.00	10	5	11.8	124	1/2 Meg.	2	2	1	11	4-25L6	A	100	AC	DC	2-10"	PM	V	No	
SM6		45.25		6	5	14	123	1/2 Meg.	2	2	1	4	1-6L6	A	83	AC				No		
C15	CP15VT	75.75	132.75	15	5	20	128	1/2 Meg.	4	2	1	8	2-6N6	A	125	AC	2-10"	EE	SV	No		
CX15	CPX15VT	75.75	158.50	15	5	20	128	1/2 Meg.	4	2	1	8	2-6N6	A	125	AC	2-12"	EE	PM SV	No		
CX12-15	CP12-15	70.75	115.00	15	5	22	124	1/2 Meg.	2	2	1	7	2-6V6	AB ₁	80	{6V DC 110V A.C.	2-10"	PM	SV	No		
CX18	CPX18V	93.50	189.50	18	5	25	125	1/2 Meg.	4	2	2	10	2-6N6	AB ₁	125	AC	2-12"	EE	PM V	No		
CX30	CPX30V	123.70	224.00	30	5	42	131	1/2 Meg.	4	2	2	12	2-6L6	AB ₁	175	AC	2-12"	EE	PM V	No		
C28	CP28VT	132.50	202.50	28	5	36	115	1/2 Meg.	2	2	1	6	2-6L6	AB ₁	165	{6V DC 110V A.C.	2-12"	PM	SV	No		
C30	CP30VT	95.60	184.50	30	5	42	122.5	1/2 Meg.	4	2	1	8	2-6L6	AB ₁	175	AC	2-12"	EE	PM SV	No		
CX70		189.50	70*	3.8	100	124.5	1/2 Meg.	6	4	2	17	4-6L6	AB ₁	290	AC				No			
C100		126.00		100	5	130	17	15-50 ohms	1	None	None	7	4-6L6	AB ₂	300	AC				No		
PM12	PM12	159.50	159.50	12	5	14.5	128	1/2 Meg.	2	2	2	6	2-6N6	A	113	AC	1-10"	PM	None	Yes		
PM12	PM12VT	159.50	189.00	12	5	14.5	128	1/2 Meg.	2	2	2	6	2-6N6	A	113	AC	1-10"	PM	SV	Yes		
*Two 35 watt channels.																						
McMurdo Silver Corp., 2900 So. Michigan Ave., Chicago, Ill.—"Masterpiece"																						
3B		\$ 49.00*		20	3	25	NS	1 Meg.	1	-----	-----	3	4	2-6L6G	AB ₁	85	AC	AC-DC	1-15"	EE	None	No
Pre-Amp 1B		17.50		1	15	53	1 Meg.	2	2	-----	-----	3	6J5G	A	75	AC	-----				No	
2B—Volume expander. 2-6F8G Tubes. 0 to 35 Db. Expansion controlled by potentiometer. List price \$12.00. Average gain as amplifier +15 Db. As expander—10 Db.																						
*Price includes speaker.																						
Miles Reproducer Co., Inc., 812 Broadway, New York, N. Y.—"Milea"																						
M-02-2	21E	\$79.50	\$189.50	20	NS	20	120	1/2 Meg.	3	3	1	6	6L6	A	120	AC	2-10"	PM	C-V	No		
M-02-3	12	195.00	725.00	60	NS	60	125	1/2 Meg.	4	4	1	11	6L6	A	160	AC	8-12"	PM	C-V	NS		
M-02-5	20B	85.00	230.00	26	NS	30	115	1/2 Meg.	3	3	1	5	6A6	B	NS	6VDC	2-12"	PM	C-V	No		
M-02-6	20	120.00	470.00	52	NS	60	115	1/2 Meg.	3	3	1	9	6A6	B	NS	6VDC	6-12"	PM	C-V	No		
M-02-7	27	62.50	175.00	15	NS	15	115	1/2 Meg.	3	3	1	6	25L6	A	NS	DC	2-12"	PM	C-V	No		
AC-DC No. 1		62.50	175.00	6	NS	8	NS	1/2 Meg.	3	3	1	6	25L6	A	NS	AC-DC	2-12"	PM	C-V	No		
AC-DC No. 2		120.00	230.00	15	NS	15	NS	1/2 Meg.	3	3	1	9	25L6	A	NS	AC-DC	2-12"	PM	C-V	No		
Montgomery Ward & Co., W. Chicago & N. Larr, Chicago, Ill.—"Airline"																						
3014	3012	\$31.95	\$ 55.95	15	7	18	120	2 Meg.	3	3	1	7	6F6G	AB ₁	85	AC	1-10"	PM	Choice	No		
2925	2929	42.95	72.95	25	5	40	115	2 Meg.	3	3	1	9	6L6G	AB ₁	150	AC	1-12"	PM	Choice	No		
3240	3241	54.95	89.95	40	5	55	125	2 Meg.	3	3	1	9	6L6G	AB ₁	175	AC	2-12"	PM	Choice	No		
3560	3561	59.95	115.00	60	5	90	125	2 Meg.	3	3	1	13	6L6G	AB ₁	250	AC	4-12"	PM	Choice	No		
3600	3601	79.95	129.00	100	5	210	120	2 Meg.	3	3	1	15	6L6G	AB ₁	400	AC	4-12"	PM	Choice	No		
2803V																						

NEW THINGS

(Continued from page 40)



P.M. dynamic horn unit

★ Permanent magnet speaker unit with efficiency equal to electrically excited units. Will handle 25 watts continuously and 50 watts peak. Hard drawn duralumin diaphragm. Alnico magnet. Weather-proof design. 15 ohm voice coil at 1,000 cycles. Weight 8¾ pounds. Model P.A.—list \$40. University Labs., 191 Canal St., New York, N. Y.—**RADIO TODAY.**



Mobile sound system

★ Combination 6-volt and 110 AC sound system. PM dynamic speakers to reduce battery drain. Turntable has separate power switch—crystal pick-up. Three input channels electronically mixed. Conversion accomplished with connecting cables. Model M-24. Bell Sound Systems, Inc., 61 E. Goodale St., Columbus, Ohio—**RADIO TODAY**



Sound truck power plant

★ 300-watt 110-volt 60-cycle AC power plant for use in sound trucks. Also supplies 25 amps DC at 6 volts for battery charging. Speed 1,800 r.p.m. Self-cranking when used with storage battery. Remote control starting available. Shielded ignition and radio filter. Weight 125 pounds. Model 21A. Special muffler available to reduce exhaust noise. Kato Engineering Co., 727 S. Front St., Mankato, Minn.—**RADIO TODAY.**



C. I. S. E. Plan

- 1- FACTORY PURCHASING POWER.
- 2- COMPETITION-DEFYING PRICES.
- 3- MOST COMPLETE LINE OF QUALITY P.A. EQUIPMENT.
- 4- EXCLUSIVE TERRITORY... SOLD ONLY THROUGH C.I.S.E. AGENTS.
- 5- FREE ENGINEERING AND CONSULTING SERVICE.

Have you heard the news?

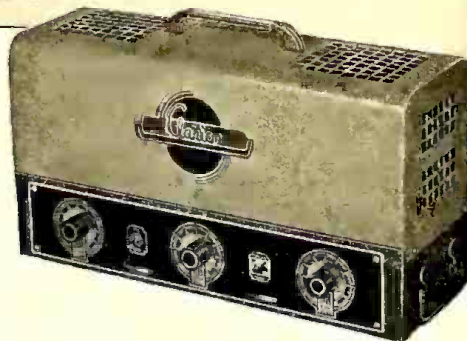

The C.I.S.E. Plan has revolutionized sound distribution. Organized late in '37 to give the sound business back to the sound specialist, the Plan caught on instantly. It abolished cut-throat selling, meager profits, all the old confusion rampant in the P.A. field.

Sound men were wild with enthusiasm. Here was what they needed! Here was a plan enabling sound specialists to buy *direct from the factory*. Here was a way to sell sound equipment on an even basis with every distributor and manufacturer in the land.

The flood of requests for charter membership was so tremendous that only now are we in a position to consider further applications. Do you want to join the C.I.S.E.? Would you like to enjoy the untold benefits, the prestige and protected profits this Plan offers you?

Then mail the coupon today. It is your application for membership in the C.I.S.E. The new Spring listing of Clarion highest-quality sound equipment is ready—prices lower than ever before. But—only C.I.S.E. agents are authorized to handle Clarion sound equipment. You can be the official distributor in your territory . . . if you hurry. *Mail this coupon now!*

TRANSFORMER CORPORATION OF AMERICA

C.I.S.E.

CLARION INSTITUTE
OF SOUND ENGINEERS
69 WOOSTER ST., N.Y.C.

CLARION INSTITUTE OF SOUND ENGINEERS
69 WOOSTER STREET, NEW YORK CITY

Please send me an application form immediately. I want to belong. This, in no way obligates me, of course. RT-4

Name.....

Address.....

City..... State.....

PASTE COUPON ON PENNY POST CARD

SELLING SOLO

AMPLIFIER & SOUND SYSTEM SPECIFICATIONS—Cont.—Compiled by Radio Today

Table with columns: Amp. model No., S. S. model No., Amp. list price, S. S. list price, Rated watts, % distortion, Max. watts, Gain (DB, Input reslt), No. of inputs, No. of mixers, No. of tone controls, No. of tubes, Output (Tubes, Class), Line watts, Power source, Speakers (No. & Type), Type, Phone turn table. Includes sections for Peerless Radio Co., Radolek Co., RCA Mfg. Co., Sundt Engineering Co., Thordarson Electric Mfg. Co., Transformer Corp. of America, United Sound Engineering, Vibracloc Mfg. Co., Volu-Tone Co., The Webster Co., Webster Electric Co., Wholesale Radio Service Co., and Lafayette.

CODES—NS—Data not supplied. EE—Electrically excited field. PM—Permanent magnet field. C—Crystal. Carb—Carbon. D—Dynamic. SC—Sound cell. SV—Static velocity. V—Velocity.

NEW THINGS

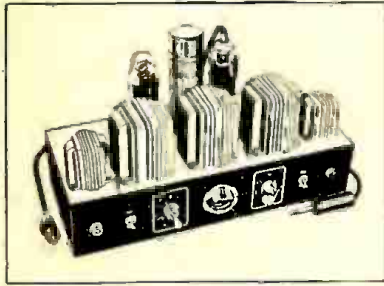

Volume range expander

★ Electronic type of volume range expander. Adds brilliancy to record reproduction by increasing the loud passages and softening the low passages. Inserted between pick-up unit and amplifier. Adds approximately 20 DB to amplifier gain when desired. List \$65. Amplifier Co. of America, 43 W. 20th St., New York, N. Y.—RADIO TODAY.

Hand microphones

★ Military type hand microphones with carbon or crystal units. Mike fits into palm of hand. Spring-lever type switch is optional. Anti-noise close-talking models also available. Finished in black morocco grain with bright polished grille. List \$15 to \$31.50. Shure Bros., 225 W. Huron St., Chicago, Ill.—RADIO TODAY.

Custom carrying cases

★ Complete line of carrying cases for speakers, amplifiers, phonographs, automatic record changers, test instruments, speaker baffle cases, etc. Made of heavy plywood with fabricoid covering, heavy-duty carrying handles and bumpers to protect corners. Custom Auto Trunk Co., 300 W. 19th St., New York, N. Y.—RADIO TODAY.

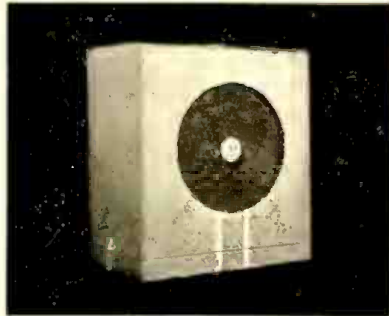

Infinite baffle mounting

★ Infinite baffle cabinet for improving bass response of speaker unit. High-frequency deflector baffle spreads out high frequencies. Sound Systems, Inc., 6545 Carnegie Ave., Cleveland, Ohio—RADIO TODAY.

32-watt amplifier

★ Beam power amplifier with 32 watts output—total harmonic distortion of 1 per cent. Gain of 75 DB. Direct input to grid of 1st amplifier—100,000 ohms. Output

impedance of 500. Model 37A. Seairland Products Co., 20 E. Jackson Blvd., Chicago, Ill.—RADIO TODAY.

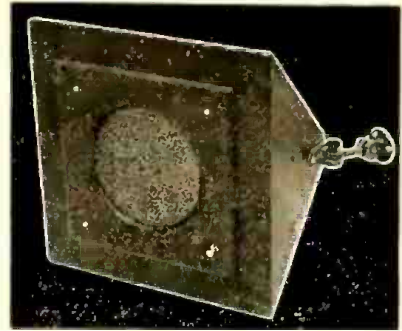

Vibraloc reproducer

★ Sound reproducer designed for all purposes. Acoustically designed case provides better tone range and fidelity. Sound waves diffused for better coverage. List with mounting fixture—\$25. Vibraloc Mfg. Co., 3691 Mission St., San Francisco, Calif.—RADIO TODAY—see also advt. p. 47.

Molanode capacitors

★ Electrolytic capacitors for filtering and by-passing. Housed in metal containers with mounting lugs. Units may be insulated by use of mounting washer. Bracket mounting also available. Voltage ratings from 25 to 450. Capacitances from 5 to 50 mikes. Magnavox Co., Ft. Wayne, Ind.—RADIO TODAY.

AMPLIFIERS

By THORDARSON

Built by Audio Experts for Audio Experts

*The Amplifier
of "Tomorrow"
in*

- PERFORMANCE
- APPEARANCE

See Your Jobber or
Write Factory for
Catalog No. 600-C

THORDARSON ELECTRIC MFG. CO.
Amplifier Division
500 W. HURON ST. CHICAGO, ILL.



MICROPHONE SPECIFICATIONS compiled by Radio Today

Model No.	List Price	Type	Directional Char.	Mounting	Freq. Range		Output			Cable Length	Model No.	List Price	Type	Directional Char.	Mounting	Freq. Range		Output			Cable Length																																	
					Cycles	+ or - DB	DB	Ohms impeded.	Model No.							List Price	Type	Directional Char.	Mounting	Cycles		+ or - DB	DB	Ohms impeded.	Cable Length																													
Amperite Co.—561 Broadway, New York, N. Y. RBHn \$42.00 Vel B-D St 40-11M NS -65 2M 25 RBMn 42.00 Vel B-D St 40-11M NS -65 200 25 RBHK 42.00 Vel B-D St 40-11M NS -65 2M 25 RBMK 42.00 Vel B-D St 40-11M NS -65 200 25 RBBHn 42.00 Vel B-D St 40-11M NS -68 2M 25 RBBn 42.00 Vel B-D St 40-11M NS -68 200 25 RSHn 32.00 Vel B-D St 60-8M NS -68 2M 12 RPSn 32.00 Vel B-D St 60-8M NS -68 200 8 SR80Hn 80.00 Vel B-D St 40-15M NS -56 2M 25 SR-80n 80.00 Vel B-D St 40-15M NS -56 200 25 RAH 22.00 Vel B-D St 60-7½M NS -68 2M 12 RAL 22.00 Vel B-D St 60-7½M NS -68 200 8 S-1 15.00 Sv B-D St 80-7M NS -52 Static 12 7JH 22.00 Vel B-D Lpl 60-7½M NS -70 2M 25 7J 22.00 Vel B-D Lpl 60-7½M NS -70 200 25 HAM 22.00 Vel B-D Dk 60-7½M NS -68 2M 12 HAL 22.00 Vel B-D Dk 60-7½M NS -68 200 8 HDH 22.00 Vel B-D Hd 60-7½M NS -68 2M 12 HDL 22.00 Vel B-D Hd 60-7½M NS -68 200 12 KHL 22.00 Mag NS NS 40-9M NS -40 2M 25 KTL 22.00 Mag NS NS 40-9M NS -40 200 25 SKH 12.00 Mag NS NS 60-6M NS -40 2M 20 SKL 12.00 Mag NS NS 60-6M NS -40 200 20 ACH 25.00 Vel B-D St 60-7½M NS -70 2M 25 ACL 25.00 Vel B-D St 60-7½M NS -70 200 25 †Available in chrome finish at \$1.00 extra.											Brush Development Co., 3311-25 Perkins Ave., Cleveland, Ohio B-1 \$26.50 Cry N-D St 5000 Flat -66 .005 Mfd NS 50-200-2000 20 BR2S 29.50 Cry N-D St 5000 Flat -66 .005 Mfd NS 30-300-2000 None BL-1 30.00 Cry N-D Lpl 5000 Flat -72 .01 Mfd NS 30-300-2000 20 AR-43 75.00 Cry N-D St 5000 Flat -60 .005 Mfd NS 30-300-2000 20 AR-26 75.00 Cry N-D St 5000 Flat -66 .02 Mfd NS 30-300-2000 20 R-34 75.00 Cry N-D St 10,000 Flat -67 .0035 Mfd NS 30-300-2000 20 BT-4 90.00 4-Cry N-D Floor 5000 Flat -66 .01 Mfd NS 30-200-2000 20 R-22 65.00 Cry N-D St 8000 Flat -70 .003 Mfd NS 200 None Carrier Microphone Co.—525 So. Commercial St., Inglewood, Calif. 300-V NS Vel B-D Opt 30-10M NS -65 50-200-2000 20 618-D NS Dyn U-D Opt 40-10M NS -65 30-300-2000 None 103-D NS Dyn N-D St 50-8M NS -70 30-300-2000 20 105-D NS Dyn U-D St 50-8M NS -70 30-200-2000 20 500-A NS Cond N-D St 40-11M NS -30 200 None Electro-Voice Mfg. Co.—324 Colfax Ave., South Bend, Ind. V-1 \$25.00 Vel B-D St 40-10M NS -68 †Optional 8 V-2 35.00 Vel B-D St 40-10M NS -67 †Optional 20 V-3 50.00 Vel B-D St 35-12M NS -66 †Optional 20 V-4 75.00 Vel B-D St 30-12M NS -64 †Optional 20 K-20 19.50 Vel B-D St 45-8M NS -68 †Optional 8 K-21 24.50 Vel B-D St 40-8M NS -66 †Optional 8 K-22 29.50 Vel B-D St 40-8M NS -64 †Optional 8 5 5.00 Carb U-D St 50-7.5M NS -45 200 None 75 7.50 Carb U-D St 40-7.5M NS -45 200 6 100 10.00 Carb U-D St 40-7.5M NS -45 200 6 201D 15.00 Carb U-D Hd 60-5M NS -42 200 6 L-6A 25.00 Dyn U-D St 40-10M NS -58 †Optional 20 L-6B 27.50 Dyn U-D St 40-10M NS -58 †Optional 20 †Impedances of 50, 200, 500 ohms or direct-to-grid.											M1-4001-B 44.35 Vel N-D Lpl 80-7M NS -80 250 30 M1-6225-A 11.50 Carb N-D Dk 50-6.5M NS -63 250 None M1-6226 26.50 Dyn N-D Pipe 100-8M NS -68 250 6 M1-6228 29.95 Dyn N-D Pipe 100-8M NS -68 40,000 30 Radio Receptor Co. Inc.—251 West 19th, New York, N. Y. 7A \$60.00 Dyn U-D St 50-9M NS -69 30 None 7B 45.00 Dyn U-D St 100-5M NS -61 30 None 7C 29.00 Dyn U-D St 100-5M NS -69 30 None Searland Products Co.—20 E. Jackson Blvd., Chicago, Ill. S-8 NS Dyn U-D St 50-9M NS -59 30 None A-9 NS Dyn U-D St 100-5M NS -51 30 None L-10 NS Dyn U-D St 100-5M NS -61 30 None Shure Bros.—225 W. Huron St., Chicago, Ill. 700A \$25.00 Cry S-D Sw 30-10M 3 -52# 5 Meg† 7 701A 25.00 Cry S-D St 30-10M 5 -52# 5 Meg† 7 702A 25.00 Cry N-D St 30-10M 5 -52# 5 Meg† 7 703S 27.50 Cry S-D Dk NS -46# ½ Meg† 7 720A 39.50 Cry U-D St 30-10M 5 -54# 5 Meg† 25 750A 25.00 Cry U-D Hd 30-10M 5 -74# 5 Meg† 7 760A 30.00 Cry U-D Hd NS -49# 5 Meg† 7 70H 22.50 Cry S-D NS 30-10M 7½ -44# 5 Meg† 7 70S 25.00 Cry S-D Dk NS -44# ½ Meg† 7 76A 25.00 Cry S-D Lpl NS -52# 5 Meg† 25 85A 45.00 Sc N-D St 30-10M 3 -65# 5 Meg† 7 3B 5.50 Carb S-D St 30-5M 10 -42# 200 ohms† None 5B 10.00 Carb S-D St 30-7M 10 -42# 200 ohms† None 10B 10.00 Carb S-D Hd 30-5M 10 -42# 200 ohms† 6 †Impedance is value of terminal resistance to be used. †Open circuit level is given in DB below 1 volt per dyne per sq. centimeter.											Transducer Corp.—30 Rockefeller Plaza, New York, N. Y. MK20 \$19.50 Dyn U-D St 90-9M 5 -55 200-50,000 None TR5 27.50 Dyn U-D St 150-8M 5 -45 200-50,000 25 MK30 27.50 Dyn U-D St 30-10M 4 -55 200-50,000 25 MK35 34.50 Dyn Adjust St 25-10M 3 -52 200-50,000 25 TR6 39.50 Dyn U-D St 100-8M 5 -40 200-50,000 25 MK40 39.50 Dyn Adjust St 25-10M 3 -50 200-50,000 25 MK60 59.50 Dyn Adjust St 25-12M 2 -45 Any 25 MK90 90.00 Dyn Adjust St 25-12M 1 -45 Any 25 The Turner Co.—Cedar Rapids, Iowa 30-30 \$22.50 Cry NS St 30-8M 4 -52 500,000 8 30-BT 24.00 Cry NS St 30-8M 4 -52 500,000 8 77 29.50 Cry NS St 30-10M 3 -54 500,000 8 2X 50.00 Cry NS St 30-12M 1½ -65 500,000 8 83-B 25.00 Cry NS Lpl 100-8M 7 -60 500,000 8 VT-73 25.25 Cry NS St 100-6M 10 -50 500,000 6 T-9 19.50 Cry NS St 50-6M 7 -53 500,000 8 DB-50 22.50 Cry NS St 50-7M 5 -50 500,000 8 38 22.50 Cry NS St 40-7M 4 -56 500,000 8 24 22.50 Cry NS St 50-6M 7 -50 500,000 8 24-G 22.50 Cry NS St 100-6M 8 -49 500,000 8 31 22.50 Cry NS * 30-10M 5 -60 500,000 20 24-B4 25.50 Cry NS Hd 100-6M 8 -49 500,000 8 88 32.50 Dyn NS St 40-10M 3 -60 500,000 8 *Suction Cup.											Western Electric Co.—195 Broadway, New York, N. Y. 630A NS Dyn N-D † 35-10M Flat -89* 20 NS 635A NS Dyn S-D † 35-10M Flat -89* 20 NS 618A NS Dyn S-D † 35-10M Flat -82* 28 NS 600A NS Carb S-D † 35-10M 7 -44* 200 NS †Floor, desk, hand or suspension. *Open circuit below 1 volt per bar.										

CODES: NS—Information not supplied. Carb—Carbon. Cry—Crystal. Dyn—Dynamic. Sv—Static velocity. Vel—Velocity. B-D—Bi-directional. N-D—Non-directional. S-D—Semi-directional. U-D—Uni-directional. B&S—Ball & socket. Dk—Desk. Hd—Hand. Lpl—Lapel. St—Stand. SW—Swivel.

AMPLIFIER RATINGS

(From page 38)

Most distortion curves are run at 400 cycles and at this frequency the only distortion encountered is that associated with the non-linear characteristics of the tubes. There are several other sources of distortion which show up at other frequencies, the most serious of which is the low frequency distortion which may be introduced by a poorly designed output transformer. This distortion is due to the non-sinusoidal magnetizing current of the output transformer which causes a distorted voltage to appear across the primary.

The condition is further aggravated by the use of high plate resistance tubes, and it is not uncommon to find beam power amplifiers which have an undistorted low frequency output of only 20 per cent of the normal rating. This low frequency distortion is par-

ticularly objectionable since all harmonics fall in the audible range. This type of distortion may be reduced by the addition of inverse feedback, and by the use of an output transformer which has adequate primary inductance. Fig. 2 shows the distortion curve of a typical high-quality amplifier from 40 to 7500 cycles; this curve was run at rated output of 25 watts.

Frequency response whenever mentioned is usually stated quite specifically. However, on checking the response curve, the scale should be noted since the response of a poor amplifier may look unusually good if a large scale is used. The frequency response of some amplifiers is capable of variation at will, providing low or high compensation. Fig. 3 shows the response curves possible with a well-known make of amplifier.

The db which is used in the measurement of gain is often a rather unsatisfactory unit, since the db is primarily a power ratio and the gain of

an amplifier may be varied several db by changing the input impedance (load). In some instances manufacturers use an input impedance equal to the value of resistor across the input circuit. Since 5 megohms is the most commonly used resistor, gain measurements based on this value will be unusually high. An input impedance of 100,000 ohms seems to be the most commonly used value, although any input impedance may be used provided that the value is specified.

The tube complement will usually give an indication of the input impedance used in computing the gain. In comparing gain, reference should be made to the same input impedance. If an amplifier has a certain gain when referred to a 100,000 ohm input impedance, the gain will be increased by 10 x log of 5,000,000 or 17 db if the gain is computed from a 5 megohm input. In the specifications listed on pages 42-44, the input resistance used for measuring the gain has been specified.

CS

"MAGIC PHONE"

The Intercommunicator
that PERFORMS and SELLS!



Model SP2 (illustrated) provides dependable two-way communication between master and remote station, with variable Vol. Control and excellent tone. No tricky controls. No unproved features. Sold to the trade at a sensible list price. 1 Master and 1 Remote station with 50 ft. of cable. Uses 6 1/2" P.M. SPEAKERS List Price **\$22.50**

Model SP2-P, same as Model SP2, but has privacy control on remote station. Features: Privacy at remote station and eliminates background noises at master station List Price **\$24.50**

ACT NOW

Send in for illustrated folder. Active Jobbers and Sales Agencies write in for protected territories. Systems to meet any requirement.

Manufactured by

Comun-A-Phone Systems, Inc.
1175 Broad St. - - - Newark, N. J.

TRANSDUCER

leads again with A NEW DYNAMIC BALL SHAPE MIKE

Transducer pioneered the streamlined dynamic microphone field with the famous 'Bullet' models. Now, added to this great line of quality leaders is the new Ball Shape 'Bullet' dynamic, model MK35. The same care in design and manufacture which has put Transducer 'Bullets' out front have been applied to the new Ball type. See it! Hear it! Put it through its paces! Free catalog of the entire 'Bullet' line on request. Write... New Decibel Matching Chart suitable for framing given to every purchaser of Transducer 'Bullet' Microphones!



Model MK 35 Priced from
\$19.50 to \$90.

'BULLET' MICROPHONES
Made only by
TRANSDUCER CORPORATION
30 Rockefeller Plaza, New York, N. Y.



Pioneer dynamotors

★ Complete line of dynamotors for providing a high DC voltage from low voltage batteries. Units for sound systems, police radios, aircraft, and broadcast purposes. Pioneer Silver Band units have high efficiency, low commutator ripple and excellent regulation. Pioneer General-Motor Corp., 466 W. Superior St., Chicago, Ill.—RADIO TODAY.



Precision multi-meter

★ Multi-range AC-DC meter unit designed for wall or rack mounting. Has remote control range selector unit for easy use. Selector unit fits in recess on wall unit when not in use. Six-foot cable connects selector unit and meter. Unit has a 9-inch meter. AC-DC voltage ranges 0/10/50/150/500/1,500 volts at 1,000 ohms per volt. DC current range 0/1/10/50/150/500 mils/10 amps. Ohmmeter with 4 scales—center reading of 20/800/8M/80M ohms. Five decibel ranges —10 to 59 DB. Precision Apparatus Corp., 821 E. New York Ave., Brooklyn, N. Y.—RADIO TODAY.

BOGEN SOUND SYSTEMS

"ALWAYS FIRST
WITH THE LATEST"

In Response to Numerous Requests We Announce the New
Medium Powered

BOGEN MODEL CX18
DE-LUXE AMPLIFIER—18 WATTS

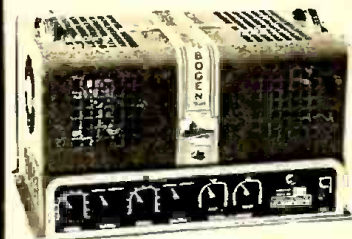

FEATURING
THE EXCLUSIVE ELECTRONIC TONE
CORRECTOR (not a compensator)

The superiority of this new tone circuit is so great that many sound engineers of radio broadcast stations and nationally known industrial organizations, specified and purchased the larger model CX30 amplifier in order to obtain the ELECTRONIC TONE CORRECTION feature even though they only required 10 or 15 watts of power for a particular installation.

Now, with the CX18, you can feature this new and outstanding development in all your smaller P.A. installations.

Ask your local Distributor for a demonstration. Descriptive literature upon request.

DAVID BOGEN CO., INC.
663 Broadway, New York, N. Y.

PIONEERS IN PUBLIC ADDRESS DEVELOPMENT

UNIVERSAL RECORDERS

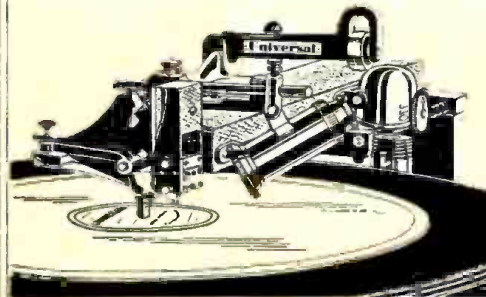

● Complete line of wax and instantaneous recording machines, professional model (as illustrated), school and college model, aluminum recorder and a portable model. Blank discs, needles, styli and accessories.

Recording Division **UNIVERSAL MICROPHONE CO., Ltd.** 424 WARREN LANE
INGLEWOOD, CALIF.

S E L L I N G S O C I E T Y

VOCAGRAPH " "

LOWER PRICES

make Sound
easy to sell!

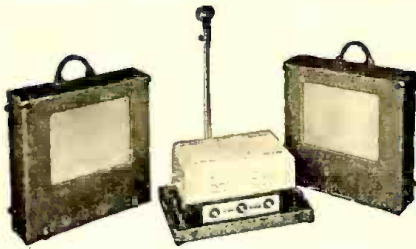

Don't let sales slip through your fingers. VOCAGRAPH low prices and money-back guarantee of performance will close the deal every time. Compare these values and ask your distributor or write the factory for engineering data on the complete line.

TWELVE WATTS—\$17.70

Push-pull '42 output. High gain for use with velocity or crystal mike. Full-range tone control. Output impedance 4 and 8 ohms. For use with P.M. speakers. Complete, fully portable with crystal microphone, speaker, and carrying case, only \$47.40.

TWENTY WATTS—\$26.10

Three channel input. High gain for crystal, velocity, etc., mikes. Push-pull beam power output. Impedance selector for 2, 4, 8, 166, 250 and 500-ohm output. Fully portable with crystal microphone, dual speakers, and carrying case, only \$70.80.

THIRTY WATTS—\$39.90

Three channel input. Beam power push-pull output. Variable impedance selector. Extreme fidelity with Colortone frequency compensator. 135 Db gain. Fully portable with dual speakers, folding floor stand, carrying case, etc., only \$99.00.

FREE—Sound Rental Sign



VOCAGRAPH SOUND SYSTEMS
162-C N. MAY ST., CHICAGO, ILL.

Free from your distributor, a large sign advertising your "Sound Rental Service." See him for this business builder or enclose 10c with this coupon.

HOW TO SELL "SOUND"

(From page 34)

picnics. In selling these installations emphasize that any announcement can be directed to the entire area with ease, and also the favorite radio programs can be reproduced through the loud speakers. It is a simple matter to take a lead from any radio transformer and plug into the phonograph, or if this is not feasible to place a microphone in front of the radio speaker.

A strong selling point besides the above on Saturday and Sunday affairs, is that ball games can be aired, or if this is not desirable or possible, owing to the games not being broadcast on these days, ball scores can be announced by innings.

Sell "announcements"

Pointing out how easy it is to locate someone, find the parents of a wandering lass, and provide continuous musical entertainment by means of recordings or the radio or both, gives you an inside edge into these functions.

You can also show that the cost of the rental of the system can be met and bettered by mentioning merchants' names over the system at



Robert Barr will sales-manage the Vocagraph sound division of Electronic Design Corp.

thirty-minute intervals as sponsoring this service. This may sound difficult but it was done last year in many cities.

And don't forget the high schools—baseball and track. Everyone likes to know what is going on—a sound rental will bring earnings besides giving yourself some nice publicity. Wherever people congregate sound equipment is needed. At the theatre for the hard of hearing; outside the ticket window for announcements and in bowling alleys for their tournaments now going on.

"TOKFONE"—The 1938 Sensation!

PEP • PUNCH • PRICE



TOKFONE, Jr.
Master Station

"TOKFONE" JUNIOR

Consisting of Master,
Remote Station and
50 ft. of wire.



TOKFONE, Jr.
Remote Station

\$10⁷⁵

The Biggest Buy in
Communication Systems

NOTHING CAN TOUCH IT!

GET YOUR SHARE!

..CRASH THIS FERTILE MARKET!

If you're in a position to "CASH-IN" with FAST MOVING-LOW PRICED intercommunication systems then you owe it to yourself to get in touch with REGAL—NOW!

• Note These Facts! •

OTHER TOKFONE SYSTEMS—adaptable to meet all requirements—from 2 to 40 stations—beautifully hand-rubbed cabinets—NO PREFERENCES—NO TRICKS—No Makeshifts—All New Merchandise—Special Units if Necessary—Manufactured in our own factory.

We also Manufacture P.A. Equipment in the following sizes: 6, 12, 15, 30, 60 Watt—Amplifiers—Parts used are: Aerovox-Thordarson—I.R.C.—Parmet-Rola—Clarostat-Eby and Holyoke—Nothing but the best.

SEND FOR CATALOG SHOWING COMPLETE LINE!
REGAL AMPLIFIER MANUFACTURING CORP.

14 WEST 17th STREET

Cable address
"Ramcoamp"

NEW YORK CITY



Centered between the two workmen at lower left is an inter-phone doing a job

'PHONES IN CONSTRUCTION WORK

★ A live-wire radio firm in Florida has discovered that intercommunication systems are needed on construction jobs, and has had good success with installations made for local builders. Flagler Radio Co., Inc., Miami, started out on this work when a huge electric display sign was being built for National Distillers.

The size of the sign, which is illustrated herewith, and the extremely complicated nature of its structure, made it necessary for workmen to keep in touch with each other. Constant communication made the work safer and faster, according to president R. H. Lehfeldt, of Flagler Radio.

"As connections were made to the flasher they were checked with the men working on the face of the sign," reports Mr. Lehfeldt, "and the use of

an IC system became invaluable as a time saver."

Flagler's later went to work at the construction site of the new DuPont building in Miami. "This building is 18 stories high. In the superintendent's office we installed a master station, and every third floor, a speaker. This was necessarily a high power job, to cover three stories at this high noise level, but it works perfectly and saves a tremendous amount of 'running around' looking for men."

"Tokfone" systems, made by Regal Amplifier Mfg. Corp., New York City, are being used by Flagler.

★ A detailed and illustrated description of an inexpensive centralized school sound system is presented in a new bulletin prepared by Wright-DeCoster, Inc., St. Paul, Minn. Suggestions on proper installation of all types of school systems are included in this release. No. A 18; the bulletin and diagram will be sent free.



D7T High Imp. LIST \$2250
D7 Low Imp. LIST \$2200

The NEW "CLIPPER" DYNAMIC

Another American Moving-Coil Microphone, Featuring

- HIGH OUTPUT—SMALL SIZE
- RUGGEDNESS—FIDELITY
- TRIM—EFFICIENT DESIGN
- LONG LIFE—STABILITY

D7 and D7T Microphones come complete with 12 1/2' R/S cable and Amphenol plug. Chrome finish. 5/8-27 Connector. Over-all height, 2 1/2". Diameter, 1 1/4". Net Weight, 8 1/2 ounces.

Request Catalog No. 27 for Complete Details.

AMERICAN MICROPHONE CO., Inc.
LOS ANGELES, CALIF.

Lafayette TAKES THE HEAD- ACHE OUT OF P.A.

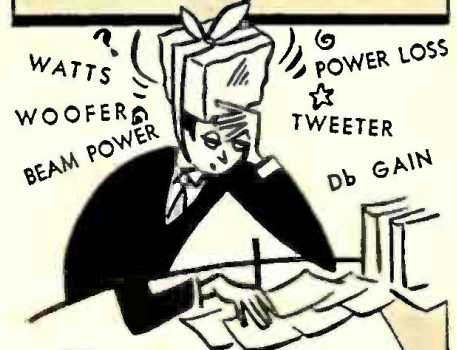

WHEN you buy LAFAYETTE P. A. you can forget the technicalities. Lafayette systems are co-ordinated at the factory, which means you get a complete P. A. system, modern, smoothly styled and ready for operation. There are no "extras" to pay for. Every Lafayette system comes complete down to the last plug and baffle. No headaches when it comes to paying, either! The Lafayette quoted price is the final price.



A SYSTEM FOR EVERY PURPOSE

In our new Spring Catalog you will find page on page of P. A. systems — the finest ever built. Amazing values from the smallest indoor to giant super-power installations. Remember, there's a Lafayette Sound System for every purpose and they're all priced right!

FREE!

Send for this great new catalog. It gives all the details about the money-making advantages of Lafayette P. A., receivers and cameras in a special new photography section. Mail the coupon now!



MAIL THIS COUPON NOW!

WHOLESALE RADIO SERVICE CO. INC.
NEW YORK, N. Y. • CHICAGO, ILL. • ATLANTA, GA.
100 SEATH AVENUE 901 W. JACKSON BLVD. 235 PEACHTREE STREET
BOSTON, MASS. • BRONX, N. Y. • NEWARK, N. J. • JAMAICA, L. I.

100 SIXTH AVENUE, NEW YORK, N. Y.
RUSH FREE CATALOG No. 71-97 DB

NAME _____
ADDRESS _____
CITY _____ STATE _____

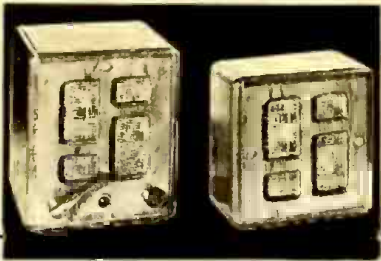

"COMMUNI-CALL"

This 2-way loud speaking system enables you to sell **only** **GENUINE PACKAGED** **\$2500** intercommunication.

- Comes complete—nothing else to buy.
- No critical adjustments to make.
- Operates on either AC or DC current.
- 50 feet of underwriters' cable.
- All foreign and line noises eliminated.
- Latest circuit and RCA licensed tubes.
- Simple, efficient and economical.
- "Talk-back" without switch on outlying stations.
- Clear, distinct reproduction of normal speaking voice.
- Beautiful cabinets, hand-rubbed piano finish.
- Master stations equipped with volume control, pilot light and talk-listen switch.
- Wide market—adaptable to needs of homes, offices, factories, restaurants—wherever instant communication is needed with individuals or groups.
- Also available—a 6-station selective system, interconnected by plugs without installation expense, wire splicing, etc.

We have a **PROFITABLE, WORK-ABLE** proposition for jobbers and dealers. Wire or write today.

CHICAGO SOUND SYSTEMS CO.
160 E. ILLINOIS ST. CHICAGO, ILL.
ESTABLISHED 1930

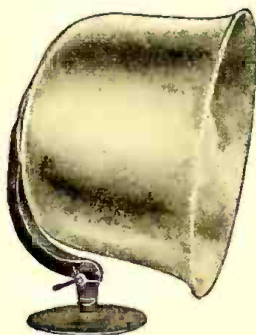

☆ **NEW** ☆
ATLAS
"STORM
PROOF"
MARINE
HORN
\$10.29
(Dealers Net)

If you are Selling Sound . . .

Don't overlook the new Atlas 100% "Storm-Proof" Marine Horn for cone speakers. This horn opens a new market for you in installations where weather conditions are the big problem. The new revolutionary method of inverted speaker mounting offers positive protection against mechanical damage to the cone speaker. A sturdy cast mounting bracket is available for sound truck or surface mounting. Floor stand available for portable applications.

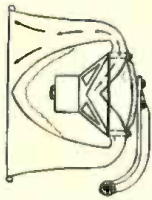

Showing radical new principle in exponential baffle design, with protected speaker cone and acoustical treatment to absorb back pressure.

- WX-8 Horn only for 8" speakers. List **\$17.50**
- WX-12 Horn only for 12" speakers. List **\$30.00**

Write for New Catalog!

New 1938 Spring & Summer Catalog F-38 brings you the newest P. A. developments. Baffles, Enclosures, Microphone Stands, P. M. Units, and other accessories. Send for this helpful catalog now.

ATLAS SOUND
CORPORATION
1453 39th STREET, BROOKLYN, N. Y.

"SOUND" SHORTS

★ As a part of general company expansion, *John Meck, Electronic Design Corp.* president, has announced the appointment of *Robert Barr* as sales manager of their *Vocograph* sound systems division. The *John Meck-Bob Barr* team first worked together when both were executives in the *Clough-Brengle Co.*, some time ago.

Vocograph has also doubled its production facilities in order to keep up with jobber requirements on the 1938 "Hushed Power" sound line. Further, two new field representatives have been appointed: *Henry P. Segal*, Gardner, Mass., to cover the New England states, and *James Vawter*, Buffalo, N. Y., to cover New York state.

★ *Communicating Systems, Inc.* 130 W. 56th St., New York City, have announced that the company will start selling home television receivers as soon as program service is available from broadcasters. These will sell as low as \$125 for 3-in. picture size; cathode ray type systems will be used in a design worked out by chief engineer *Lewis W. Parker*.

★ *Universal Camera Corp.* has developed some new high speed automatic processing machinery for its movie film, and is therefore announcing a price reduction in processing charges to the consumer. *Univer* says that "the new arrangement has several important advantages, because with a portion of the processing charge included in the retail price of the film, both the dealer and distributor are able to increase their volume and profits."

MICROPHONE MERCHANDISER



★ A display piece which takes up a minimum of counter space and yet presents a variety of microphone styles has been prepared for distributors by *Transducer Corp.*, 30 Rockefeller Plaza, New York City. It consists of a metal base finished in black crackle, fitted with chrome stand-rod to which actual mikes are attached. Sales copy says simply, "Bullet Microphones Streamlined for Sound Reasons." Shipped with the merchandiser are four *Bullet* dynamic models, including a new spherical style.

Now! BALLAST REPLACEMENT

made **AMAZINGLY SIMPLE**

- Servicemen, with only 4 standard types of *Amperite AC-DC Regulators* you can replace 90% (over 100 types) of AC-DC Ballast Tubes now in use! Consult your jobber.
- *Amperite Regulators* are equipped with a patented *Automatic Starting Resistor* to prevent untimely burnouts and save pilot lights.
- New Low Price on *Amperite AC-DC Regulators*: \$1.00 LIST

Amperite Replacements for 2V Battery Set ballasts \$1.25 list



AMPERITE
AUTOMATIC REGULATORS



LIST PRICE **\$25.00**
Complete With Mounting Fixture

FIDELITY! TONE RANGE! DISTORTIONLESS POWER! BEAUTY OF DESIGN and EASE OF INSTALLATION! IT'S ALL THERE IN A VIBRALOC . . .

Studio or Stadium coverage with the same reproducibility . . . "if you're doubtful . . . we've got the proof . . . just write."

Patented Acoustical features incorporated in the new *VIBRALOC REPRODUCER* reveal, for the first time, brilliant definition in tone blending at any volume level. The usual beam or searchlight effect is not present in the *VIBRALOC* method of sound distribution, resulting in freedom from reflection distortion and other acoustical troubles.

Locking mechanical vibrations at the source of audio sound distribution eliminates disturbance of the original wave form, permitting movement, into free space, minus pressure re-shaping or the effects of resistance to coil movement.

Order Direct Until Your Jobber Is Stocked.

JOBBERS!! DEALERS!!

Exclusive Territories Available! Catalogs & Proposition Upon Request.



sell
collect
then pay

That's how the Tung-Sol Consignment Plan works for dealers who can qualify. Yes, Tung-Sol, without any premium for financing, places a stock of tubes in the dealer's care...the dealer sells them...deducts his profit...and pays once a month for those sold. A simple, clean-cut plan that assures full profit from every tube sale. Capital usually tied up in tubes is released for other profitable investment;— and the dealer is protected from losses due to slow turnover—reduction in price, obsolescence and cut-price competition. The best quality tubes, backed by a sound merchandising policy—a combination that will put your tube department on a money-making basis.

If, as a reputable dealer, you are interested in increasing your tube profits you'll undoubtedly want complete details—Write our sales office nearest you.



Dept. C.

TUNG-SOL

Tube Flow Radio Tubes

TUNG-SOL LAMP WORKS, INC.

Radio Tube Division

SALES OFFICES: ATLANTA • BOSTON • CHICAGO • DALLAS
KANSAS CITY • LOS ANGELES • DETROIT • NEW YORK
GENERAL OFFICES, NEWARK, N. J.

**ANOTHER
SCOOP!**
by



**TWO
NEW 15" HIGH
FIDELITY SPEAKERS**

- Type G15 - 25
- 15 INCH ● 30 WATT PEAK
- 20 WATT ● High Fidelity
- List Price \$24.50 complete with Transformer



- Type H15 - 25
- 15 INCH ● 45 WATT PEAK
- 30 WATT ● High Fidelity
- List Price \$28.50 complete with Transformer

These two new speakers present a triumph in precision engineering and offer audible proof of Utah's unexcelled ability in the speaker field.

Both types show brilliant response from 50 to over 8,000 cycles without the use of tweeters, cut off networks, etc.

The "Life-Tone" quality of both G15 - 25 and H15 - 25 is beyond comparison!

Write for details.

Visit us at the Radio Show, Room 561, Stevens Hotel, and Booths 113 and 115, Marconi Boulevard, Radio Parts City, Stevens Hotel, June 8, 9, 10 and 11.

UTAH RADIO PRODUCTS CO.
CHICAGO, U. S. A.

BUENOS AIRES — UCOA RADIO PRODUCTS CO.

"16 YEARS OF LEADERSHIP"

Selling SOCO

AMERICA'S No. 1 MOVIE CAMERA



Richard Arlen, star of Columbia's "No Time To Marry."

With F.3.5 Lens.. \$19.95

UniveX mass distribution methods—which have made UniveX movie cameras and projectors the largest selling in the world—now bring accessories to the point where everybody can afford them! Here's your opportunity to build a real volume accessory business on a small inventory and keep customers coming back to your store again and again!

Quality Movie Accessories

When you sell a UniveX Cine "8" your customer also saves on accessories—for UniveX high quality accessories are available at the lowest prices in all movie history! *Feature them!*

UniveX Projector Only motor-driven 8 mm. projector under \$26. Fifteen important features **\$14.95**

UniveX Titrer Specially designed for UniveX Cine "8". Title cards and lettering kit included **\$2.50**

UniveX Exposure Meter Insures proper exposure under all light conditions **\$1.95**

UniveX Exposure Meter Case **35¢**

UniveX Film Viewer & Editor Enables you to properly edit your own movies. 1/5 the cost of other devices . . . **\$1.95**

UniveX Splicer For any 8 mm. film. Makes strong splices quickly. Complete with cement **\$1.00**

Telescopic View Finder Insures perfect focusing. Compensates for Parallax on close-ups. Fits any model UniveX Cine "8" **\$1.95**

Prices Higher Outside United States

UNIVERSAL CAMERA CORP.
Dept. 73, 32 W. 23rd St.
New York City

FREE BOOKLET

Send me free booklet "How To Take and Show Movies." Also catalogue of UniveX Cine Accessories.

Name _____

Address _____

City _____ State _____



SELLING MORE RECORDS

TALKING TO MUSIC LOVERS

★ A good many record salesmen are still embarrassed about what they consider to be a fatal lack of knowledge of classical music. However, the record companies are regularly furnishing material which fills any such gap; appropriate notes accompany releases on new classical recordings and give the record merchandiser the useful and interesting facts.

Here is a sample of background material, furnished in this case in connection with Columbia Masterworks' April release of Alfred Wallenstein's "Sinfonietta" recording of Mozart's Symphony No. 25.

"Alfred Wallenstein was born in Chicago. Before the age of ten he was already devoting himself to the cello. At fourteen, he went to Europe alone to study. Still in his teens he toured with such artists as Schumann-Heink, Maud Allen and Pavlowa. From 1922 until 1929 he was leading cellist with the Chicago Symphony Orchestra. At the personal request of Toscanini, Wallenstein came to New York as first cellist of the New York Philharmonic-Symphony. He left that post to take over the musical directorship of Station WOR and devote himself entirely to conducting. With this release he now becomes an exclusive Columbia recording artist.

"In the past few years Alfred Wallenstein has gained a tremendous reputation for himself because of his well-known weekly 'Sinfonietta' and 'Symphonic Strings' nation-wide broadcasts. In these programs one is almost certain to find music that is seldom heard, for Wallenstein frequently includes rarely played music. Recently he drew from obscurity and broadcast Mozart's Symphony No. 25."

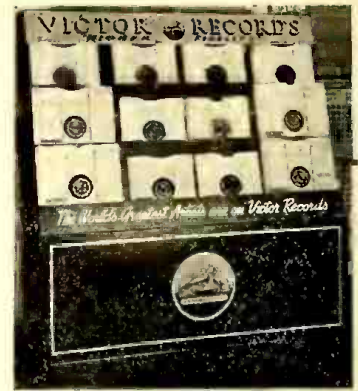

Practically a complete record department in itself, this unit is designed for display, selling counter and stock-room service. It's an all-steel affair in red, black and gold, from RCA-Victor.

WAX WORTH WATCHING

★ **ANDREWS SISTERS** singing *Ti-Pin-Tin* and *Where Have We Met Before*—Decca 17003.

DICK ROBERTSON and his orchestra playing *Drop a Nickel in the Slot* and *You Went to My Head*, both with VC by Dick Robertson—Decca 1706.

LEO REISMAN and his orchestra playing *Mariachie* (rumba) from the MGM film "Girl of the Golden West" with VR by Felix Knight, and *Para Vigo Me Voy* (rumba)—Victor 25804.

FRANK LUTHER, arranging and producing the complete story in song (with orchestral accompaniment) of *Snow White* and the *Seven Dwarfs* on three records—Decca 1700-01-02.

RED NORVO and his orchestra playing *There's a Boy in Harlem* with VC by Mildred Bailey, and *How Can You Forget* with VC by Terry Allan, both from "Pools for Scandal."—Brunswick 8089.

TOMMY DORSEY and his orchestra playing *Jezebel* from Warner Bros. film of the same name, and *Bewildered*, both with VR by Jack Leonard—Victor 25795.

DUKE ELLINGTON and his orchestra playing *Srrouch and If You Were in My Place*, both with VC by Ivy Anderson—Brunswick 8093.

MAXINE (Vocadence) Sullivan, with Claude Thornhill and his orchestra singing *Dark Eyes* and *It Was a Lover and His Lass*—Victor 25810.

AL DUFFY FOUR playing *Ciribiribin* and *Maria Ah Maria*—Decca 1683.

LEWIS "RED" EVANS and the Boys playing *Thanks for the Memory* (two parts), from the Paramount film "Big Broadcast of 1938," with vocal refrain by "Red" Evans—Victor 25783.

"The World's Best Value"

KADETTE RADIOS

INTERNATIONAL RADIO CORPORATION, ANN ARBOR, MICHIGAN, U.S.A.

NEW BOOKLETS

★ "Move to the Mountains—Yet Stay at Home" is the title of a new folder issued by Johnson Motors, Refrigeration Division, Galesburg, Ill., illustrating and describing the new Johnson Space Cooler.

★ "Ain't It The Truth" is the title of a special folder issued by Aerovox Corp., 70 Washington St., Brooklyn, N. Y., featuring the company's radio noise eliminators. Cover has a lively cartoon style.

★ Now available from Triplett Electrical Instrument Co., Bluffton, Ohio, are new price sheets Nos. 47T and 47-I. Changes in these issues include additional information, price changes, and announcement of new instruments.

★ Completely new 12-page catalog giving the details on the entire line of IRC Standard Resistors and Volume Controls, has been released by International Resistance Co., 401 N. Broad St., Philadelphia, Pa. Added to the regular IRC products are seven new items. Copies from jobbers or direct from IRC.

★ Relays, timers and thermostats are covered in detail in a new technical catalog just issued by Struthers Dunn, Inc., 139 N. Juniper St., Philadelphia, Pa. Free copies will be sent to those requesting catalog D and mentioning RADIO TODAY.

★ Cornell-Dubilier catalog flyer No. 154-A lists two new C-D products, the type BR "Beavers," tiny etched-foil dry electrolytic filter capacitors, and the type 2R silver-plated mica capacitors. Address requests to Cornell-Dubilier Electric Corp., South Plainfield, N. J.

★ A folder titled "Third Year for Pleasantaire Conditioning" has been released by Pleasantaire Corp., 1623 Connecticut Ave., Washington, D. C. It contains description, specifications and sales chances for the Model B2000 room cooler.

★ A feature folder on new Precision instruments, series 860 and series 510, is available from Precision Apparatus Corp., 821 E. New York Ave., Brooklyn, N. Y.

★ "It Performs Like Magic!" is the title of a new folder released by Commun-a-phone Systems, Inc., 1175 Broad St., Newark, N. J. Magic-Phone intercommunicating systems are described and illustrated.

★ New JFD 1938 catalog features auto radio cable replacing tools, fittings, shafting and casing, antennas, insulators, tuning wrenches, noise suppressors, etc. Illustrations also show assortments of woven fabric dial belts for all home sets, packed in steel kit boxes. Many other home set and auto radio accessories are pictured and priced. J. F. D. Mfg. Co., 4111 Fort Hamilton Parkway, Brooklyn, N. Y.

ADDISON AUTOMATIC TOUCH TUNER



MODERNIZE Your Present Radio Inventory with the Outstanding Development of the Season—Touch Tuning.

EASY TO INSTALL . . .
No Special Tools Required.

Adaptable to ANY Superheterodyne Radio—Works perfectly on all models—No Dial Manipulation is necessary. Action is instantaneous.

LIST PRICES
Model
5 Button—\$5.50
6 Button—\$7.00
7 Button—\$8.50
8 Button—\$10.

Write for complete details and Special Distributor and Dealer discounts.

Manufactured and Guaranteed by

ADDISON RADIO MFG. CO., INC.
3017 CARROLL AVE. CHICAGO, ILL.

PARRIS-DUNN NEW HY-TOWER AGAIN YEARS AHEAD

*in Design
Performance
Durability*

NEW GENERATOR AIR COOLED
NEW COLLECTOR RING
NEW SHOCK ABSORBER SPRING
NEW PIVOTING POINT
NEW ALL STEEL FRAME
NEW TEAR DROP TAIL VANE

RETAINING FOUR LEGGED ALL STEEL TOWER

HY-TOWER New 1939
steel built Hy-Tower charger. New patented pivoting point with shock absorber governing control eliminates vibration.

10 FEET TALL

The Proven "slip the wind" governing principle that made Hy-Tower famous the world over is retained and

is Approved by
AMERICA'S LEADING RADIO MANUFACTURERS

New
Main Frame, compact, all steel, lighter — stronger — indestructible.

New
Improved life-time, full floating, self-adjusting, carbideless, non-arcng collector ring.

New
Heavy Duty Shielded Air-Cooled Three-Brush Generator with new patented rear pivot shock absorber mounting.

WRITE OR CABLE TODAY FOR COMPLETE INFORMATION

PARRIS-DUNN CORP.
CLARINDA Dept. RT-391 IOWA



On the Shelves of BUENOS AIRES

• In that Metropolitan store on the Calle Rivadavia 869 Mr. Francisco Fernicola, the proprietor, is enthusiastic, for he writes, "They ask for them . . . these servicemen and amateurs . . . and come back again and again for other Centralab parts. Naturally, I must agree with them that they are the best."

In the Argentine, Brazil, Sweden, France, Australia . . . the fame of Centralab parts persists.



Smooth controls, permanent resistors, positive selector switches, perform their miracles in myriad languages in all parts of the globe.

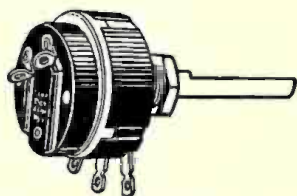

Manufacturers, servicemen and amateurs everywhere . . . SPECIFY CENTRALAB.

Get the Centralab Volume Control Guide

Centralab

Milwaukee, Wis.

Division of Globe Union, Inc.

BRITISH CENTRALAB, Ltd.
Canterbury Road, Kilburn
London, N.W.6, England

FRENCH CENTRALAB CO.
118 Avenue Ledru-Rollin
Paris XI, France

NEW THINGS

(From page 18)



Mallory vibrators

★ Line of replacement vibrators featuring 8 contacts. For farm and auto receivers. Positive starting, easy installation. Freedom from lead breakage, freedom from broken reeds. Complete listing in bulletin E-551. P. R. Mallory & Co., 3029 E. Washington St., Indianapolis, Ind. RADIO TODAY—see also advt. p. 1.



Hi-voltage electrolytic

★ Dry electrolytic condenser with 585 DC volt continuous rating. Peak rating of 700 volts. Self-healing after breakdowns. Designed for use in amplifiers having high voltages. Super-Volt manufactured by Dumont Electric Co., Inc., 514 Broadway, New York, N. Y.—RADIO TODAY—see also advt. p. 59.



6-volt Winchargers

★ Heavy-duty 6-volt wind driven generator which starts charging in a 6-mile an hour breeze. Supplies 22 to 25 amps. 8-foot propeller. Auto-type brake. The Low-wind type starts in 4 mile wind. Output of 12 to 14 amperes. Designed especially for the southeast part of U. S. where wind velocity is low. Wincharger Corp., Sioux City, Iowa.—RADIO TODAY.

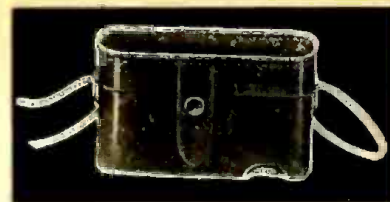

Univex camera case

★ Jiffy case for Univex minicam. Brown case that permits instant shooting without removal of camera. Viewfinder, shutter release and winding knob accessible when open. Complete with shoulder strap—list \$1. Universal Camera Corp., 32 West 23rd St., New York, N. Y.—RADIO TODAY—see also advt. p. 52.



Marion meters

★ Line of meters having D'Arsonval movement with 2 per cent movement. Sapphire jewel pivots. Sealed against dust. Bakelite cases. Model 54S illustrated. Case dimensions—4 3/8 x 4 3/16 inches. Mounts in 2 3/4-inch hole. Marion Electrical Instrument Co., Manchester, N. H.—RADIO TODAY.



Tom Thumb radio

★ 4-tube AC-DC T.R.F. receiver. Dynamic speaker, illuminated dial. Self-contained antenna. Size 7 x 4 1/2 x 3 3/8 inches. List \$9.95. Automatic Radio Mfg. Co., Inc., 122 Brookline Ave., Boston, Mass.—RADIO TODAY.

Vertical antenna

★ All-wave, non-directional vertical antenna mast. Consists of 4 sections of steel tubing telescoping one within another. Extends to 24 feet. Mounted on sturdy wood insulator which is attached to a steel ground post. Designed for use with RCA Magic Wave coupling unit and transmission line. Premax Products Div., Chisholm-Rider Co., Niagara Falls, N. Y.—RADIO TODAY—see also advt. p. 55.

It's VERTICAL

A New Steel ANTENNA

NEW!
Easy to Erect!
Hot Seller!

GOES up in small space—gives world-wide reception. Built of tubular steel, telescoping to 6' length. Premax Lock permits erection up to 24'. Na guys! No Overhead Wires. Comes complete with 4-section mast, insulator unit and steel ground post. Write today for bulletins and discounts. Lists \$10. Order a sample.

Premax Products
Division of Chisholm-Ryder Co., Inc.

3846 HIGHLAND AVE.
NIAGARA FALLS, N. Y.



Remote radio tuner

★ Remote push button tuner for use with any radio set. Electric motor drive permits setting stations at any frequency. Handles up to 7 stations. Supplied with 20-foot cable. Housed in compact wooden case. List \$16.75. Addison Radio Mfg. Co., 3017 Carroll Ave., Chicago, Ill.—**RADIO TODAY**—see also advt. p. 53 and 56.

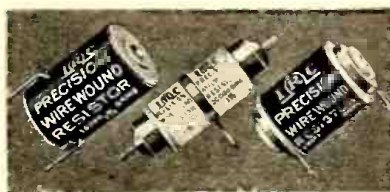

Precision resistors

★ Wire-wound precision resistors. Types WW-5, WW-6, WW7, WW-8, WW-9 are intermediate sizes for flexible mounting, also providing as in WW-5 high ohms non-inductively wound on a small form. WW-8 and WW-9 are center-tapped, inductively wound to save space. WW-12, WW-13, WW-14 have both terminals at 1 end. Tolerances up to 1/10 of 1 per cent. International Resistance Corp., 401 N. Broad St., Philadelphia, Pa.—**RADIO TODAY**—see also advt. p. 58.

Fixed power resistors

★ Power resistors with choice of coating for various operating conditions. Inorganic cement used when overloads are incurred. May be operated at red heat without danger. Varnished-coated type used for maximum protection in humid locations or where acid vapors are



PRESTO RECORDING CORP.
New York, N. Y.
Gentlemen:
We wish to thank you for the lead on a prospective purchaser of a Presto Recorder . . . the writer immediately called and closed the sale. We are forwarding our order for two more machines . . .

TAKEN from a dealer's letter written one week after he took on the Presto line.

He is one of the growing organization of Presto dealers who now receive over 400 factory leads each month on radio stations, schools, advertising agencies, industrial concerns and individuals who are considering the purchase of Presto sound recording equipment.

You owe it to yourself to get information on the sound recording business . . . a business that has almost doubled in the past year in spite of current business trends.

Send for free bulletin "How to Sell the Presto Sound Recorder." It tells the whole story.



Auto Radios For 1938 by TRAV-LER

These new 7-Tube Trav-Ler models have full 8 watts power output. Sensitivity is 1.5 microvolts at one watt output. Has full A.V.C. and three-gang variable condenser. Has the very latest features including iron core coils.

TRAV-LER RADIO

7-TUBE AUTO SET with external 8 in. electro dynamic speaker—Model 711—Price. \$59.95

7-TUBE RADIO with self-contained 6½ in. electro dynamic speaker—Model 710—Price \$49.95

The Trav-Ler Electric Automatic Tuning Unit is simple and accurate. No drift or backlash—instantly set up from the driver's seat without tools—any station on any button—6 buttons—motor driven. Mounting holes provided for easy installation. Price \$17.95

TRAV-LER RADIO & TELEVISION CORP. 1938

1921 1036 WEST VAN BUREN ST., CHICAGO, ILL.
AC AND AC-DC HOME SETS AUTO SETS BATTERY SETS

PRESTO RECORDING CORPORATION
137 WEST 19th St.
NEW YORK, N. Y.

ADDISON

Automatic Push Button TUNERS

For the Car—ELECTRIC TOUCH
TUNING; ACCURATE, SIMPLE

For the Home—REMOTE TOUCH
TUNING AT ANY DISTANCE

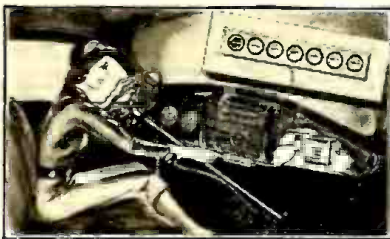

Complete safety tuning.
Instant control. 10 KC.
separation. No drift.
Automatic muting. Dial
pointer moves with but-
tons. Simple to install.
Fits any radio.

LIST

\$14.50

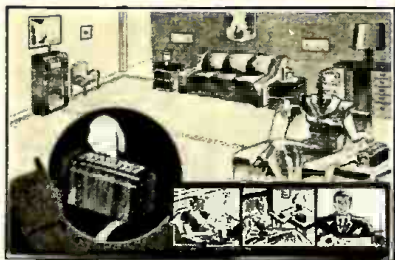

LIST

\$16.75

Tune any of 7 favorite
stations and adjust vol-
ume, all from any conven-
ient location. Accurate,
clear, no drift. 10 KC.
separation. With 20 ft.
flat remote cable and in-
structions.

Write for full details and special dealer
and distributor discounts.

ADDISON RADIO MFG. CO., INC.

3017 Carroll Avenue, Chicago, Ill.

present. Varnish coated units in
5 and 10 watts, cement in 10 and
20 watts. Clarostat Mfg. Co., Inc.,
285 N. 6th St., Brooklyn, N. Y.
—RADIO TODAY.

Sprague midget electrolytics

★ Small etched-foil electrolytic
condensers. "Atoms" are available
in standard sizes and voltages. 8
mfd. 450 volts measures ¼-inch di-
ameter by 1½ inches—list 60 cents.
Hermetically sealed—yet protected
against blow-ups. Designed for re-
placement work in all types of sets.
Sprague Products Co., North
Adams, Mass.—RADIO TODAY.

Multi-coupler antenna system

★ Master type all-wave antenna
system for use where multiple radio
outlets are needed. Ideal for apart-
ment houses—also suited for homes
where more than 1 radio is used.
Provides noise reduction on all fre-
quencies. One antenna operates 10
to 25 sets. Unit consists of antenna
transformer and multi-coupler unit
for each radio outlet. Easy to in-
stall—designed for outside wiring.
Amy, Aceves & King, Inc., 11 West
42nd St., New York, N. Y.—RADIO
TODAY—see also advt. p. 59.

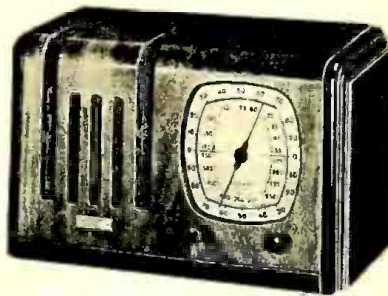

Sky-Chief table sets

★ 6-tube AC-DC superhet with
beam power output tube. Tunes
broadcast and state police bands.
Two-tone walnut veneer cabinet.
Dial of recessed type with double
gold-color scale. Model 38-2—list
\$24.95.

5-tube AC-DC superheterodyne
with self-contained aerial. Has dy-
namic speaker. Walnut cabinet.
Model 38-1—list \$14.95. Sky-Chief
Radio Corp., 44 W. 18th St., New
York, N. Y.—RADIO TODAY—see also
advt. p. 62.

RADIO SERVICEMEN OF AMERICA NOW HAS 27 CHAPTERS

★ RSA reports that the mem-
bership has tripled in the last
ninety days. Four new chapters
have affiliated making the total
chapters now operating twenty-
seven.

The influence of the RSA to-
wards the betterment of existing
evils in the radio service industry
is becoming more apparent each
day.

Applications are on file from
ten more local associations located
in every section of the country.

We are in the process of mail-
ing free of charge to all of our
members the second of a series of
advance technical information.
The first issue of our house organ,
The Radio Serviceman, was mailed
to our members in February and
the second mailing is going for-
ward in the next few days.

New Hampshire—The members
of the New Hampshire Chapter
RSA met at a dinner on March 1st
in Hudson and elected the follow-
ing officers: Chairman, George J.
Craig; vice-chairman, Ray Gal-
lagher; secretary, Ray Rogers;
and treasurer, George P. Lefebvre.

New Bedford—One of the new-
est local organizations to join the
RSA is the Whaling City Chapter
located in New Bedford, Mass. The
following officers were elected to
guide the chapter for the year:
President, Fred Fiske; vice-presi-
dent, J. A. Sumner; secretary,
James L. Shepley; and treasurer,
Walter England.

Regular meetings are held on
the third Wednesday of every
month in the Labor Temple at
New Bedford.

Interstate—The Interstate
Chapter met on March 15th at the
Midwest Timmerman Building,
Dubuque, Iowa, and the business
part of the meeting was opened
by a discussion on the formulation
of a list of slow pay customers
which could be operated as credit
information bureau for the benefit
of all the members. The motion
adopted such a list was carried
over until a following meeting in
order that more discussion may
be had.

Nashville—One of the newer
chapters to join the RSA is the
Nashville Chapter. They are just
getting started on the work under
the able leadership of Mr. Frank
Clark and R. Thomas.

Boston—The Boston Chapter of
RSA were guests at a lecture held
in The Norfolk House Centre on
March 21st, at which time Mr.
Connor of the Sylvania Tube Cor-
poration spoke to the members.

The chapter is slowly but surely
correcting many of the evils of the
service industry which have been
prevalent in the Boston area.

Oklahoma City—Oklahoma City
Chapter reports through its secre-
tary, L. G. Dearing, that they are
contemplating a membership drive

There is **MONEY** in **MODERNIZING** old sets

with the **ULTRA NEW**

BROWNING 83

DX reception—4 overlapping bands.—
High fidelity—Exceptional signal to
noise ratio—AC or battery-operated
and quickly convertible.



Bringing old receivers up-to-date with the Browning 83
is a tremendous field and a real profitmaker for the
service man. Millions of obsolete chassis are reposing
in fine old consoles, bookcases, secretaries and other
pieces of furniture—all worthy of a modern set.

Browning 83 enables you to give your customer a cus-
tom-built set which you build from our specifications.
A real market for your time! A big outlet for parts!
Send coupon today.

RT1

BROWNING LABORATORIES, INC.
750 Main Street, Winchester, Mass.

Send free circuit diagram and descriptive literature.

Name

Street

City and State

in the near future which should result in doubling the membership of the chapter.

New Jersey—Meetings are held semi-monthly on Tuesdays at the Hotel Douglas in Newark. Technical meetings are scheduled for April 12th, 26th and May 10th. Al Fasanello of 187 Highland Ave., Newark, is secretary.

RSA reports the election of the Board of Directors as follows:

Second district: L. G. Dearing, 1116 N. Walker, Oklahoma City, Oklahoma.

Fourth district: T. P. Robinson, 2712 N. Henderson Avenue, Dallas, Texas.

Fifth district: E. H. Bertelsen, 2344 38th Street, Rock Island, Illinois.

Seventh district: Howard S. Watts, 918 E. 6th Street, Duluth, Minn.

Eighth district: Lee Taylor, 1352 Catalpa, Chicago, Illinois.

Ninth district: Joseph A. Cole, 13065 Camden Avenue, Detroit, Michigan.

Tenth district: Donald H. Stover, 9 S. Galena Avenue, Freeport, Illinois.

Twelfth district: Albert J. Theriault, 2712 W. 25th Avenue, Cleveland, Ohio.

Thirteenth district: Gerard G. Larkin, 1375 Pennsylvania Avenue, S.E., Washington, D. C.

Fifteenth district: Carl A. Rauber, Somerville, N. J.

Sixteenth district: Kenneth A. Vaughan, 312 Market Street, Johnstown, Pa.

Seventeenth district: George A. Duvall, 8005 3rd Avenue, Brooklyn, N. Y.

Eighteenth district: Henry M. Lutters, 758 E. 230th St., Bronx, N. Y.

Nineteenth district: John T. Rose, 5 S. Duane Avenue, Endicott, N. Y.

Twentieth district: None.

NY SERVICEMEN STUDY BUSINESS COSTS

★ At the May 9 meeting of the Radio Servicemen of America, to be held at 8 p.m., Hotel Victoria, New York City, a feature will be the discussion of the cost of making service calls, led by A. E. Rhine, A. E. Rhine Engineering Service. Based on his own practical experience of 18 years in servicing, Mr. Rhine will show what the actual cost per hour to the serviceman is, how to compute this cost, and why all charges and estimates should be made only after this cost is known.

Charles Yokum of Weston Electrical Instrument Corporation will discuss the application of instruments to servicing work.

★ Harry Gerber, 49 Portland St., Boston, Mass., sales representative for *Aerovar* condensers and resistors in the New England area, last month celebrated the beginning of his 15th year of his affiliation with the firm.

★ *T. Lundahl*, head man of *Technical Appliance Corp.*, 17 E. 16th St., New York City, returned recently after a tour among jobbers and manufacturers in Detroit, Milwaukee, Chicago, Terre Haute, Indianapolis and Rochester. Lundahl is active in a national campaign to get the public conscious of the need for a post-winter check-up on antennas. In the field, he found the best sales jobs being done by those who are using every sales and service contact as an "opener" for antenna sales and service.

★ Now effective is a price reduction on T-J-U Dykanol capacitors, announced by *Cornell-Dubilier Electric Corp.*, South Plainfield, N. J. The step was taken mostly because enlarged production facilities were made possible following increased demand for these capacitors from the U. S. Army, Navy and Signal Corps.

★ *Ward Leonard Electric Co.*, has appointed *Charles D. Southern*, 30 W. Rudisill Blvd., Ft. Wayne, Ind., as sales representative for WL radio products in the entire state of Indiana.

★ *Paul M. Bryant* has resigned the post of assistant to the president of *Zenith Radio Corp.* to become executive vice-president of *Pervel Corp.*, 11 West 42nd St., New York City.

KNOBS!

Quality knobs, molded of Bakelite, Durez, Plaskon or Beetle. Standard 1/4" shaft. Set screw or spring mounting. Standard colors: Black, ivory and walnut. Other colors made to order.

RADIO KNOBS—Touch Tuning Knob No. 1760. Patented assembly method. Made either with a recess for station calls, as shown, or plain. 31/64" diameter; 9/16" high.

No. 1750, touch tuning knob, plain top, push on self locating; 31/64" diameter; 9/16" high.



Actual size



No. 1400
Dia. 11/16"
Hgt. 13/32"

Actual size



No. 1450
Dia. 11/16"
Hgt. 13/32"

Actual size

POINTER-BAR-LEVER-CONTROL KNOBS—For use on instruments, meters, controls, switches, valves, stoves, timers, rheostats, X-ray, radio, intercommunication, sound amplifying and other products.



No. 2110, illustrated, especially adapted for intercommunicating systems. 1 5/8" long overall; 19/32" high; 11/16" dia. at large end. Metal insert. Pat. app. No. 2100, 2 1/2" long overall; 5/8" high; 11/16" dia. at large end. Metal insert. Pat. app.

HARRY DAVIES COMPANY

MOLDERS OF PLASTICS
1428 N. Wells St., Chicago, Ill.
Consult Us on Your Moulding Problems

Send for illustrated catalog of other stock items

GIVE ALL TUBES A COMPLETE TEST

on P.O.E. Testers
POWER OUTPUT PLUS EMISSION

Model 1504
Dealer Price . . \$62.33

Now Equipped With PLUG-IN TYPE RECTIFIER

(exclusive Triplett feature)

Model 1504 Combines in One Tester the Following Servicing Instruments

1. Power Output Test for All Amplifying Tubes.
2. Emission Test for All Tubes.
3. Free Point Tester.
4. Neon Short Test.
5. Separate Diode Test.
6. D.C. Voltmeter.
7. D.C. Milliammeter.
8. A.C. Voltmeter.
9. Ohmmeter.
10. Condenser Test for Shorts.
11. Electrolytic Condenser Leakage Test.
12. Decibel Meter.



TUBE TESTER

Model 1502 —DEALER PRICE . . . \$40.33

Model 1503* —DEALER PRICE . . . \$51.33

*Same as 1501 less Free Point Tester

The Triplett Electrical Instrument Co.
194 Harmon Drive, Bluffton, Ohio

Please send me more information on—
 Model 1504 Model 1502 Model 1503

Name _____
Address _____
City _____ State _____



**YOU'LL NEVER
LOSE A
CUSTOMER**

*by giving him
the best.*



**INSULATED
Metallized TYPE BT
RESISTORS**

Almost any piece of carbon is a resistor . . . but a really good resistor, scientifically designed to meet every requirement of Radio, is something else again.

IRC Resistors may cost a little more to buy . . . But they actually cost far less to use in all replacement work. There's no come-back when you use IRC's. They never let you down . . .

*"They Stay
Put!"*

**INTERNATIONAL
RESISTANCE COMPANY**

401 N. Broad St., Philadelphia, Pa.

MOTOROLA CONTINUES HOME SETS

O. H. Caldwell,
Editor, RADIO TODAY:

I am very happy indeed to answer your inquiry regarding the Motorola home-set line for the coming season. I want to state very definitely to you that Motorola will have a line of home-set receivers for this coming season.

It is true that we have somewhat revamped our organization, the reason being that we have changed our plans for the issue of a home-set line for this coming season from the original plan that we had last Fall.

We sincerely believe that the plans that we have in mind in regard to the 1938-39 Motorola home-set line will meet with extreme interest on the part of the retail dealer. We sincerely believe that in the issue of our new line we will overcome many evils that have caused dealer suffering in home sets the last few years.

Statements as to our specific plans will be outlined in our trade paper ads starting in the May issues.

We are looking forward with extreme interest for a very progressive line of home-set receivers this coming season.

With kindest personal regards, I remain,

Yours very truly,

P. V. GALVIN, *President,*
Galvin Manufacturing Corp.

NOTICE!

To RADIO TODAY's subscribers who are waiting for their 1938-1939 RADIO YEAR BOOK:

Because of the many changes in the manufacturing branch of radio there has been a delay in the completion of the current RADIO YEAR BOOK which includes the official radio trade directory. The YEAR BOOK is now in production and will be mailed to subscribers within the next 2 or 3 weeks.

RADIO TODAY

480 Lexington Avenue New York, N. Y.

JOBBERS

★ *Stewart Warner* has announced that a new factory branch will be opened at 1001 York St., Indianapolis, Ind., to serve the entire state of Indiana. It will operate under the name of *Stewart-Warner Distributors Co.*, will occupy a part of the new SW factories in Indianapolis, and, complete with a big service department and display quarters, will distribute both radios and refrigerators. Appointed sales manager for the new firm is *Fred Ahrbecker*, a highly successful executive who for the past two years has been sales manager for *Central Distributing Co.*, former SW jobbers in the area.

★ *Majestic Radio & Television Corp.*, Chicago, recently announced the appointment of two new exclusive distributors on the West Coast. In the San Francisco area, *Majestic* products will be distributed by the well-known *George H. Eberhard Co. Watson & Wilson* will act as *Majestic* distributors in the Los Angeles area.

★ Announcement has been made by *John Meck*, president of *Vocagraph Sound Systems*, that complete stocks are now available at ten distributing centers, including Atlanta, Ga.; Los Angeles, Calif.; San Francisco, Calif.; Gardner, Mass.; New Orleans, La.; Kansas City, Mo.; Miami, Fla.; Pittsburgh, Pa.; Norfolk, Va.; and Baltimore, Md. He states that upon completion of this plan, a sound dealer or distributor will be able to secure any model in the *Vocagraph* line within 24 hours.

★ *Radio and refrigeration engineer*—RADIO TODAY has just learned that one of the best known radio and refrigeration engineers in the industry is now available. He has been identified with the industry for many years, occupying important executive posts. Anyone interested can reach him by addressing Box 199, care of RADIO TODAY.



It's true, what they say about Dixie Radio Co.—they're in a good mood. Ben Krell, head man, and Earl Beaudry, sales manager of the Columbia, S. C., jobber firm are standing at the left. In the front row you'll recognize Charles Golenpaul, Aerovox sales manager. Earl Dietrich, of Raytheon Production Corp., snapped the picture on his recent trip south.

★ In recognition of notable work among jobbers, **L. K. Wildberg**, president of **The Radiart Corp.**, Cleveland, has announced that **Keneth C. Burcaw** will now be sales



"Ken" Burcaw of Radiart

supervisor for the firm throughout the western part of the country. "Ken" was cited for good work in "solidifying Radiart's distribution of its vibrators and, in a whirlwind campaign, establishing leading jobber outlets for the company's 1938 line of auto aerials." He was recently married.

★ **L. L. Kelsey**, Stewart-Warner manager radio division, has announced the appointment of **Burwell Calahan** as special representative on auto radios with headquarters in Detroit, at 15501 Woodrow Wilson Ave. Mr. Calahan is a veteran in radio and for the past three years served as manager of the radio division of United Motors Service, and previously Atlanta branch manager for General Motors Radio. He brings a background of more than 15 years experience in radio.

★ **James J. Davin**, popular sales executive, has been appointed vice-president in charge of sales of the **Detrola Corp.**, with headquarters at Detroit. "Jim" Davin, as he is known to thousands of jobbers and dealers from coast to coast, needs no introduction to the trade, for he has been identified with radio and allied activities for more than 20 years. Recently he was sales promotion manager of the General Household Utilities Corp., and there is no phase of merchandising or sales promotion that is not an open book to the new Detrola vice-president. According to the plans of "Jack" Ross, president of Detrola, the company will sponsor an intensive campaign to build up a nation-wide jobber and dealer organization for Detrola radio receivers and refrigerators, under the direction of "Jim" Davin.

Now is the Time to Install the New "MULTICOUPLER" ANTENNA SYSTEM

Live wire radio men are getting into the new field of installing master aerials during the dull season.

Master antennae are not limited to apartment buildings. Private residences offer a big field.

Install the new all-wave, noise reducing antenna system, employing our latest developments.

Get in on this business now. We furnish standard installation specifications free. If you have a particular problem, let us help you. Write NOW for complete details.

AMY, ACEVES & KING, Inc.
11 West 42nd Street, New York, N. Y.
Consulting Engineers — Specialists in Antenna Systems — Licensor of leading set and antenna equipment manufacturers.



A Amazing Improvement in Electrolytic Condensers

FREE
10 Tubulars with every kit of 10 popular electrolytics.

DUMONT engineers produced and patented the world's first electrolytic condenser in common use today. Same engineers, after five years' research now produce **FIRST SUPER HIGH VOLTAGE Electrolytic**. Reheals if overloaded or punctured. This patented feature is found only in **DUMONT Condensers**. Used by U. S. Government—a real test of quality. Used in highest priced radio receivers, yet sold at very attractive price. Try some today and be convinced. **FULLY GUARANTEED for 1 YEAR.**

Manufactured by

DUMONT ELECTRIC CO., Inc.
514-516 Broadway, New York
WRITE FOR CATALOGUE AND NAME OF NEAREST JOBBER

WORLD'S LEADING MANUFACTURERS OF PRECISION CONDENSERS

IT'S THE BEDSIDE RADIO THAT'S BROKEN

Customers don't like to pay big money to repair small inexpensive sets. All you can charge is cost plus a small profit for this type of work. You can't afford to come back to make good a job failure. Use dependable **Ward Leonard Replacement Parts** that stand up and keep your job profits.

WARD LEONARD ELECTRIC CO.
40 SOUTH STREET, MOUNT VERNON, N. Y.
Please send me Circular 507.

Name
Address
City State
Jobber's Name



Cash in on Changers for Good Profits INSTALL THIS UNIT

GETTING business—and good business—with radio-phonograph combinations, is all the reason you want for using General Industries Record-Changer Units. You'll find them highly satisfactory profit makers.

Ready assembled, easy to install, General Industries Changer Units enable you to price your sets in the popular bracket that brings steady demand. Self-starting governor-controlled Flyer Motor. Simple, accurate, dependable, foolproof changing mechanism.

Order a Sample for Testing

Model "M," latest improved type, plays and changes eight 10-inch or seven 12-inch records. Model "K" plays and changes seven 10-inch records, plays 12-inch records changed by hand. Please specify exact voltage and frequency of current you use.

The GENERAL INDUSTRIES CO.
3838 Taylor Street, Elyria, Ohio

GENERAL Changers Sell More Sets

ANY MOVIE STARS AMONG YOUR CUSTOMERS?

★ As a big help to merchandisers of home movie outfits, Univex is taking part in a national Home Movie Test, along with Warner Bros. and Picture Play Magazine. Screen tests in Hollywood will be awarded to those home movie fans who enter the best 8 mm. film of themselves, shown in various poses. Consolation prizes, 75 of them, will also be awarded. Judges will be Bette Davis and Errol Flynn, working with Warner Bros. executives.

GIANT BLUE PRINT

★ A counter display for the Ward Leonard antenna change-over relay is being furnished to jobbers and dealers free, from company headquarters at Mt. Vernon, N. Y. The 6 x 9 card is done in "blue print" style with white lines showing the circuit hook-up, and provision is made for the user to mount his own relay from stock.

MONSTER CARTONS

★ Giant display cartons, exact replicas of the Tung-Sol radio tube containers, are now offered to dealers for showroom, counter or window trim use. These are reproduced in full color, and they come from Tung-Sol Lamp Works (radio tube division), 95 Eighth Ave.,

Newark, N. J., or from jobbers. Also a metal sign lithographed in five colors and coated with Deluxe



varnish is being offered to dealers by Tung Sol. The sign is 17 x 11 inches and has a punched flange for mounting; it features tube testing and is illustrated with tubes.

MAKING AIR CONDITIONING HISTORY



WITH A FULL-SIZED
UNIT THAT SELLS
AS LOW AS

\$175

• Your customers don't want inefficient air-conditioning. Better not sell any unit than sell an unsatisfactory one. Because Koolroom is a 5-purpose air conditioner it should be your choice to build your air conditioning business. For in one complete unit we give you an air conditioner that is plus powered . . . to cool, to dehumidify, to ventilate, to clean and to circulate air. There are nine models in

the Koolroom line from a 1/3 ton capacity model at \$175.00 to a 5-ton capacity model at \$1350.00 (prices slightly higher west of Rockies). Write today for the Koolroom franchise in your community.

KOOLROOM DIVISION
of Indian Products Corporation
2342-D INDIANA AVE. CHICAGO, U.S.A.
Cable "Trailco Chicago"

*They live Longer—
that's all!*

**CORNELL-DUBILIER
Capacitors**



SHO-GRAM

RADIO PARTS CITY
 STEVENS HOTEL, CHICAGO
 JUNE 8, 9, 10 AND 11, 1938

FLASH! FROM RADIO PARTS CITY

President, B. N. SHURE Shure Brothers
 Vice President, A. A. BEBARD Ward-Leonard Electric Co.
 Secretary-Treasurer, ARTHUR MOSS Solar Mfg. Corp.
 Director, H. E. OSMUN Centralab
 Legal Counsel, E. C. PRINCE

RPM6-38NTS 87 CU CHICAGO ILLINOIS
 WILL C YOUAT,
 THE RADIO PARTS SHOW, NEXT JUNE

YOU'LL FIND ALL THE LATEST DEVELOPMENTS IN RADIO PARTS AND APPARATUS AT THE NATIONAL RADIO PARTS TRADE SHOW AT THE STEVENS HOTEL IN CHICAGO. DON'T FORGET - THE SHOW OPENS ON WEDNESDAY, JUNE 8, AND WON'T CLOSE TILL SATURDAY NIGHT, JUNE 11. NO SHOW ON SUNDAY.

NO MATTER WHAT YOUR POSITION IN RADIO YOU CAN'T AFFORD TO MISS THIS AMAZING EXHIBITION. PLAN TO STAY THE FULL FOUR DAYS BECAUSE THERE WILL BE SOMETHING FOR EVERYONE EVERY MINUTE OF THE SHOW PERIOD.

TECHNICAL LECTURES ---

An Outstanding Program Arranged by a Special Committee of Radio Servicemen of America! Speakers of National Prominence Will Discuss Subjects of Vital Interest and Importance to Radio Servicemen. A Committee of the Chicago Section, IRE, is Planning an Engineering Session.

BUSINESS SESSIONS ---

WEDNESDAY, June 8 — 10:00 a. m.
 Board of Directors, Radio Servicemen of America
 THURSDAY, June 9 — 10:00 a. m.
 Sales Managers Club
 The Representatives
 National Association of Radio Parts Distributors.

Already A Bigger Show Than Last Year!

THE ONLY EXHIBITION OF RADIO PARTS AND ACCESSORIES IN 1938
 Sponsored by RADIO MANUFACTURERS ASSOCIATION and SALES MANAGERS CLUB
 and operated by

PERSONAL SERVICE BUREAU ---

Let Our Personal Service Bureau Handle Your Perplexing Problems! We Will Make Hotel Reservations for You, and Will Give Information about Stores, Theaters and Amusements, Points of Interest in and around Chicago, Broadcasting Stations, and Finally, Arrange Your Departure by Train, Plane, Bus, or Auto. Also, Let Our Personal Service Bureau Make Your Show Registration Now to Avoid the Last Minute Rush!

RADIO MUSEUM DISPLAY ---

Three Big Show Cases Filled with more than 150 Pieces of Old-Time Radio Apparatus! Most of this Exhibit, Collected by McMurdo Silver, Will Be Sent to the Smithsonian Institution in Washington, D. C., After It Is Displayed at the Parts Show.

RADIO PARTS MANUFACTURERS NATIONAL TRADE SHOW
 53 WEST JACKSON BOULEVARD CHICAGO, ILLINOIS

SKY-CHIEF announces

- Fewer models—Higher list prices
- Longer discounts for profitable sales

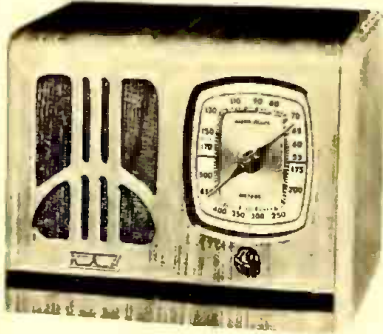

OUTSTANDING VALUE **\$14.95**

- Model 38-1—Powerful 5 Tube Set
- Handsome two-toned Air-Flow walnut veneer cabinet covered in Fabricoid—Blue, Green, Red, White
- Natural Tone Dynamic Speaker
- Gold color illuminated 5-in. tuning dial
- Works on either AC or DC current
- Self-contained aerial
- Beam power audio output

DISTRIBUTORS and DEALERS—write for catalog and wholesale prices on complete line.

SKY-CHIEF RADIO CORPORATION
44 West 18th St. New York, N. Y.

AMPERITE offers "ADJUSTABLE RESPONSE"*

... made possible by
THE ACOUSTIC
COMPENSATOR

(pat. pend.)

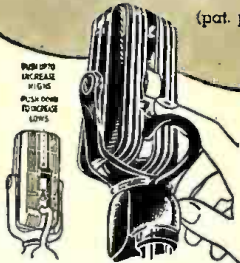

*Higher or lower pitch with the same microphone.

With the flip of a finger you can now (1) lower or raise the response of the microphone. . . (2) adjust the microphone for most desirable response for close talking or distant pickup. . . (3) adjust the system to any "taste", room condition, or equipment.

MODELS RBHk, RBMk, with Acoustic Compensator. frequency range 40 to 11000 cps, output, -65 db., complete with switch, cable connector and 25' of cable. \$42.00 LIST

NEW LOW-PRICED CONTACT "MIKE"
Model SKH (hi-imp); SKL (200 ohms) \$12.00 LIST

MODELS RAH-RAL, excellent for speech and music. Reduce feedback. \$22.00 LIST

Write for Complete Illustrated Bulletins and Valuable Sales Helps.

AMPERITE Co. 561 BROADWAY, N. Y.
Cable Address: Alkem, New York

AMPERITE *velocity* MICROPHONE

TRADE FLASHES

★ *Walter A. Coogan*, export manager for Hygrade Sylvania, returned recently from a 3-months business trip to 15 commercially important countries on the continent where radio tubes are sold. Mr. Coogan, a top figure in export circles, reports improved prospects for European business during the rest of the year, although trading has been hurt by munition spending, unstable governments, general jitters and a business recession. He reports Scandinavia to be the bright spot abroad. Mr. Coogan noticed a tendency in imports toward quota systems, and otherwise observed that television development was slow except in London.

★ *W. W. Watts*, vice-president of *Wincharger Corp.*, Sioux City, Iowa, gives an optimistic report on farm radio business: "We can very definitely confirm the fact that rural trade has not been as adversely affected by the business recession as has city business. We have not laid off a single person from our factory or office and are running at almost the same capacity we were during the middle of the winter. Contrary to reports I get from many other businesses, our business during March on all units is considerably ahead of last year."

★ *The Addison Radio Mfg. Co., Inc.*, manufacturer of automatic tuning units for both home and auto-radio sets, is building up a nation-wide organization. *Adolph Blanc*, identified with radio for many years, is president of the company, and *Frank O'Hara*, who has been an active figure in radio for a long time, is general sales manager. *John Koppel*, 60 E. 42nd St., New York, representative of the company, is establishing many important sales outlets for the company's products.

★ *The Burgess Battery Co.* has elected *Dan W. Hirtle* president and *Dr. C. F. Burgess* chairman of the board of directors at a recent annual meeting of the board.

★ *Joe Gerl*, president of *Sonora Radio & Television Corp.*, Chicago, has just announced appointment of *Don M. Fetterman* as chief engineer of Sonora radio division. Mr. Fetterman is well known in engi-



Mr. Fetterman joins Sonora

neering circles, possesses extensive experience in the field of radio design. He was formerly with *Continental Radio & Television Corp.*, and, prior to that, with the *Wells-Gardner Co.*, both of Chicago. Under the vigorous leadership of President Gerl, a veteran in radio, Sonora has just acquired extensive new quarters and is actively engaged in the production of its new 1939 models. A complete line, including bakelite midgets, table and console models, farm and auto receivers, is projected and will be released shortly. Engineer Fetterman promises unusual new features in operating and circuit design. Dominant emphasis will be placed on tone quality and power output, to uphold Sonora's slogan of twenty-four years' standing—"Clear as a Bell." Unique cabinet designs have been worked out and are already in production. First models will be released early in April, with the complete line promised shortly thereafter.

★ *D. R. Bittan Sales Co., Inc.*, manufacturers' representatives, have moved to new offices at 53 Park Place, New York, N. Y.

A GOOD NAME GOES A LONG WAY



Customers buy quicker when you recommend Ken-Rad Tubes. They know Ken-Rad Tubes give better radio reception.

KEN-RAD TUBE & LAMP CORP.
OWENSBORO, KY.

★ KEN-RAD ★

DEPENDABLE RADIO TUBES

★ *John S. Garceau* has been named advertising and sales promotion manager for *Crosley Radio Corp.*, according to an announce-



Crosley names John Garceau

ment by executive vice president *Lewis M. Crosley*. Mr. Garceau has been an advertising executive since 1921, and has performed ably in key positions in the radio, appliance and air conditioning fields. For the past two years he has been advertising and sales promotion manager for the radio, home laundry and refrigeration divisions of *Fairbanks-Morse*, and is now regarded as one of the most widely known executives in the industry.



Mr. Goldberger of Precision

★ *H. T. Roberts*, vice-president and sales manager of the *J. P. Seeburg Corp.*, Chicago, has just announced that *C. T. McKelvy* will direct all sales activity of the *Seeburg Radio Corp.*, a subsidiary. At present, Mr. McKelvy assists Mr. Roberts in the sales division of the parent firm, which now enjoys the largest volume in its history, running over 100 per cent ahead of last year.

Very soon, Seeburg Radio will introduce a new radio development announced as having revolutionary acoustical and design features. The new product will get the same intensive promotion which has made Seeburg products leaders in the coin-operated field for nearly 40 years.

C. T. McKelvy needs no introduction to the radio-music industries, having been associated with a number of top firms in the field for over 20 years. He has developed exceptional knowledge of manufacturing, marketing and trade cooperation, which insures his notable success as a Seeburg executive.

★ *T. B. Weaver* has joined *Parris-Dunn Corp.*, Clarinda, Iowa, to head a new department recently organized by the company to manufacture and sell *Pres Kloth*. The new product is a cotton fabric specially designed so that housewives may give a professional steam press to clothing and fabrics of all kinds. Mr. Weaver, after long research and experiment, developed *Pres Kloth*.

★ Added to the staff of *Precision Apparatus Corp.*, 321 E. New York Ave., Brooklyn, N. Y., is *Gerald N. Goldberger*, as engineer in charge of research and new products development. He has been a technical consultant for Precision for the past year and a half, and has had a wide experience, formerly, in the broadcasting, television, sound picture and medical fields.

★ *Earl L. Hadley* has been appointed manager of the advertising and sales promotion dept. of the appliance division on *Fairbanks-Morse & Co.*, according to general manager *W. Paul Jones*. For several years Mr. Hadley was advertising director for *Grigsby-Grunow*,
(To page 64)

JANETTE ROTARY CONVERTERS



For Converting DIRECT to ALTERNATING Current

● Built in capacities from 110 to 3250 volt amperes—with or without all wave filters. Dynamotor construction—economical to operate—ruggedly built for years of trouble-free service—used or recommended by the largest manufacturers of sound apparatus—in use in all countries of the world—Send for price and data bulletins 13-1, 13-25.

Janette Manufacturing Company

556-558 West Monroe Street Chicago, Ill. U. S. A.
BOSTON - NEW YORK - PHILADELPHIA - CLEVELAND - MILWAUKEE - LOS ANGELES
DETROIT - SEATTLE

TOPSTREEM

"Come 7"



1. Maximum Pickup.
2. "Knee-Action" mounting.
3. Reasonable Prices.
4. A model for EVERY car.
5. Rustproof Monel Metal.
6. Chromium & Exclusive Zinolyte Plating.
7. Licensed & Manufactured under Patent No. 105067.



Sales Offices in all Principal Cities
For descriptive list price folder, see your nearest jobber or drop us a postal.

TOPSTREEM, INC.
1811 S. LYNDALE AVE., MINNEAPOLIS, MINN.

Complete Electric Plants

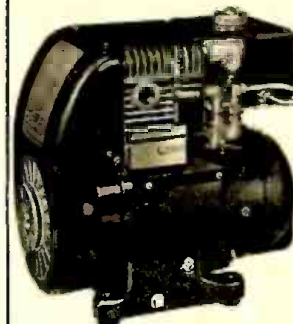

NEW
1938
MODELS
SIZES
350 to 5000
WATTS

COMPLETE POWER UNITS

Operating A.C. Radio, PUBLIC ADDRESS SYSTEMS, SOUND CARS, MOTION PICTURE EQUIPMENT, and RADIO TRANSMITTERS. Also furnish Power for Lights, Water Systems, Refrigerators, all Household Appliances for FARMS, CAMPS, LAKE HOMES, or STANDBY SERVICE. For use anywhere Power Line Current is not available.

A PLANT FOR EVERY PURPOSE

110 Volt A.C., 6, 12, 32 and 110 Volt, D.C. as well as Combination A.C.-D.C. Units. Anyone can Operate. COMPLETE, READY TO RUN.

WRITE FOR DETAILS ON DEALERS' PROPOSITION AND TERRITORY

D. W. ONAN & SONS
590 Royalston Ave., Minneapolis, Minn.

JIM QUAM Says



Half the fun in watching some slick magician pull the Ace of Spades out of your vest pocket is in knowing that it just wasn't there regardless, and that there isn't any magic about the whole thing anyway.

There's no magic about Quam speaker quality either. We don't get that kind of performance by waving a wand. It's taken months and years of sweating and a generous pile of greenbacks to bring Quam Speakers to their present state of perfection—and we're not through yet by a long shot! It might surprise you to see the work going on in our laboratory, but you can hear the results every time you listen to a Quam Speaker.

See our exhibit—210 Bell Street, Chicago Radio Parts Show.

QUAM-NICHOLS CO.
33rd Place & Cottage Grove CHICAGO 1674 Broadway NEW YORK



Everything you need in radio. It's all in this new **RADOLEK RADIO PROFIT GUIDE**. Newest repair part for every receiver. Newest radio receivers. New 1938 model public address amplifiers, outputs for 5 to 100 watts. New model public address speakers. Test instruments. Technical books. Special equipment. Leading standard brands. Every item guaranteed. It must be right or we make it right.

And everything under one roof. You get what you want promptly, and exactly what you want. Radolek's immense stock Plus Radolek's efficient organization insures you fastest service. 25,000 service men depend on this service and benefit by Radolek's lowest prices. Send now for your copy of Radolek's Radio Profit Guide. It will help you make more money.

---RADOLEK---
601 W. Randolph, Chicago, Dept. D-18
Send me the 1938 Radolek Radio Profit Guide FREE.

Name

Address

Service man? Dealer? Experimenter?



Earl Hadley goes to FM

(From page 63)

More recently he has been an executive of the Chicago agency, *Henri, Hurst & McDonald, Inc.*, handling Fairbanks-Morse appliance advertising.

R.M.S. RADIO COURSE

★ That the radio industry, and the men in it, could profit from radio education is the belief of Robert F. Herr, manager of Philco's parts and service division, and is also the prime reason for the special course in radio education for dealers and servicemen announced this week by Philco in conjunction with the Radio Manufacturers' Service and the National Radio Institute.

This course in modern radio theory and practice was especially designed for people engaged in the radio industry, and is open to the 27,000 dealers and servicemen affiliated with Philco and Radio Manufacturers' Service.

This course in radio education is being offered at a price about one-half the regular cost. To make the offer even more appealing, there is given with the course at no extra charge the new Model 044 Philco Audio Signal Generator.

Commenting on the motive behind such an unprecedented offer for radio study, R. F. Herr said: "The radio industry for some time has been conscious of a need among many servicemen for a more thorough knowledge of basic radio principles.

"The complicated radio circuits of today and the approach of television in the future present to these servicemen a problem which can be solved only by a definite and supervised course of study."

The course is primarily designed for three types of persons in radio work: (1) the type of serviceman who was once well-grounded in radio theory, but who has grown rusty and become out of touch with new developments; (2) the type of serviceman whose only radio knowledge has been gained from his practical work and who has little or no understanding of basic radio principles; (3) the dealer and salesman who will find that they are better equipped to sell their wares when they more fully understand what they are selling.

• INDEX • TO ADVERTISEMENTS

	Page
ADDISON RADIO MFG. CO., INC.	S3, 56
AMERICAN MICROPHONE CO., INC.	49
AMPERITE CO.	28, 50, 62
AMY, ACEVES & KING, INC.	59
ATLAS SOUND CORP.	50
BOGEN CO., INC., OAVIO	47
BROWNING LABS., INC.	56
CENTRALAB	54
CHICAGO SOUND SYSTEMS CO.	50
CINAUTOGRAPH CORP.	Cover III
COMMERCIAL CREDIT CORP.	6
COMUN-A-PHONE SYSTEMS, INC.	47
CORNELL-BOUBILIER ELEC. CORP.	60
CROSLY RADIO CORP.	4
OAVIES CO., HARRY	57
DUMONT ELECTRIC CO., INC.	59
ELECTRONIC DESIGN CORP.	48
GALVIN MFG. CORP.	Cover IV
GENERAL ELECTRIC CO.	Cover II
GENERAL INDUSTRIES CO.	60
HYGRADE SYLVANIA CORP.	21
INTERNATIONAL RADIO CORP.	52
INTERNATIONAL RESISTANCE CO.	58
JANETTE MFG. CO.	63
JOHNSON MOTORS	2
KEN-RAD TUBE & LAMP CORP.	62
KOOLROOM DIV., INOIAN PRO. CORP.	60
MALLORY & CO., INC., P. R.	1
ONAN & SONS, O. W.	63
OPERAIO MFG. CO.	41
PARRIS-OUNN CORP.	53
PHILCO RADIO & TELEV. CORP., Tube Div.	5
PREMAX DIV., CHISHOLM-RYOER CO., INC.	55
PRESTO RECORDING CORP.	55
QUAM-NICHOLS CO.	64
RADIO CORP. OF AMERICA	7
RADIO PARTS SHOW	61
RAOOLEK	64
RAYTHEON PRODUCTION CORP.	3
RCA MFG. CO., INC., Comm'l Sound.	39
RCA MFG. CO., INC., Radiotron Div.	19
RCA MFG. CO., INC., RCA-Victor Div.	17
REGAL AMPLIFIER MFG. CORP.	48
SKY-CHIEF RADIO CORP.	62
THORARSON ELEC. MFG. CO.	45
TOPSTREEM, INC.	63
TRANSOUCCOR CORP.	47
TRANSFORMER CORP. OF AMERICA	43
TRAV-LER RADIO & TELEV. CORP.	55
TRIPLETT ELEC. INSTRUMENT CO.	57
TUNG-SOL LAMP WORKS, INC.	51
UNIVERSAL CAMERA CORP.	52
UNIVERSAL MICROPHONE CO., LTO	47
UTAH RADIO PRODUCTS CO.	51
VIBRALOC MFG. CO.	50
WARO LEONARDO ELEC. CO.	59
WEBSTER-CHICAGO	27
WEBSTER ELECTRIC CO.	37
WESTON ELEC. INSTRUMENT CORP.	25
WHOLESALE RADIO SERVICE CO., INC.	49

While every precaution is taken to insure accuracy, we cannot guarantee against the possibility of an occasional change or omission in the preparation of this index.

5 REASONS WHY

it's easy to sell

CINAUDAGRAPH

Permanent Magnet Speakers



Gymnasium and auditorium installation



Memorial tower chime reinforcing installation



An elaborate installation on a private estate



Church using argan and tower chimes reinforcement

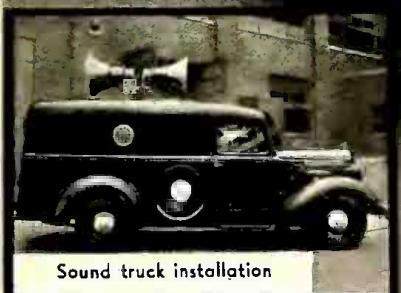

Sound truck installation

Here's the best sales ammunition you could have to help you sell sound equipment. In America's great cathedrals, in gymnasiums, skating rinks, private estates, on sound trucks and many other locations where sound amplification is used, you'll find Cinaudagraph Permanent Magnet Speakers. (See illustrations for several outstanding Cinaudagraph installations).

That tells you what Cinaudagraph performance is like! That explains, better than all the claims, better even than a list of construction details, why it's easy to sell Cinaudagraph Speakers. The line is complete (5 to 8 inch), the line is competitively priced, the line SELLS.

Wherever you find sound at its best today, you will also find Cinaudagraph. Get in on the extra profits to be had from the specified line of speakers. Write for interesting literature that tells why you can make MORE MONEY selling Cinaudagraph Permanent Magnet and Electro-Dynamic Reproducers.

C I N A U D A G R A P H C O R P O R A T I O N

SPEAKER DIVISION... STAMFORD, CONN.
EXPORT DEPT... 100 VARICK ST., N. Y. C.

Motorola

AMERICA'S
FINEST
AUTO RADIO

★ INVITES COMPETITIVE
COMPARISON..

NO OTHER
AUTO RADIO HAS
ALL THESE FEATURES
AT THIS PRICE..

\$39⁹⁵

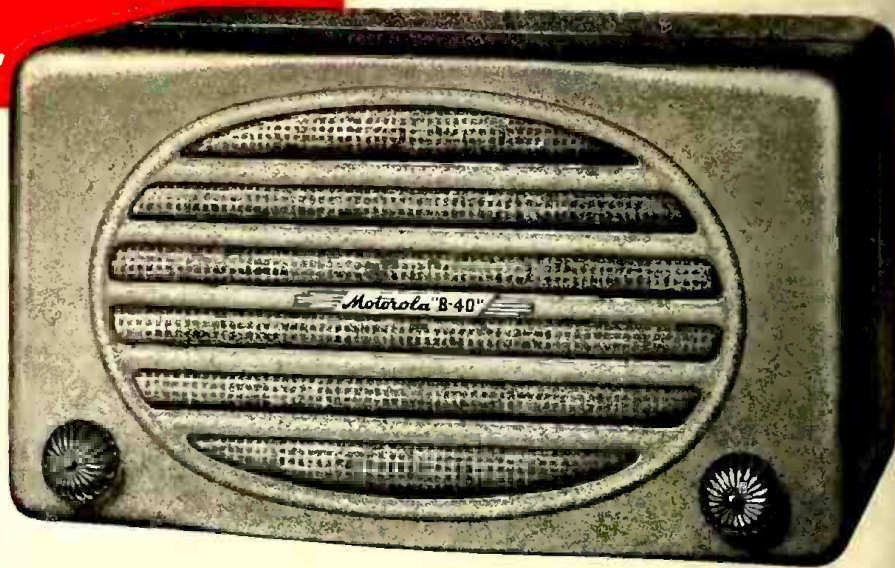

Model "8-40" Motorola

★ **AUTOMATIC TUNING** . . . Can be set for any number of stations.

★ **CONTROLS** . . . that Fit into the Instrument Panel and Match the Styling of Any Car at no extra cost.

★ **STABILIZED CIRCUITS** . . . All Trimmer Condensers and Coils are completely stabilized against Temperature or Humidity Drift, instead of relying on Broad Tuning to eliminate drift.

★ **6 TUBES** . . . to provide the Sensitivity absolutely essential for satisfactory Auto Radio performance.

★ **3 GANG CONDENSER** . . . With Tuned RF Stage, which increases Sensitivity, improves Selectivity, rejects tweets, birdies, and Code interference.

★ **SENSITIVITY** . . . Equal to the highest priced auto radio (1 Microvolt for 1 Watt).

★ **SELECTIVITY** . . . 10 KC separation with no cross talk.

★ **TONE and SENSITIVITY CONTROL**

★ **6½" ELECTRO-DYNAMIC SPEAKER**

Custom Panel Controls

to Match All Cars

NOW

—SELL THE RADIO PEOPLE WANT TO BUY!

GALVIN MANUFACTURING CORPORATION • CHICAGO