

SERVICE DEALER

MAY

1956

50 c



and *ELECTRONIC SERVICING*

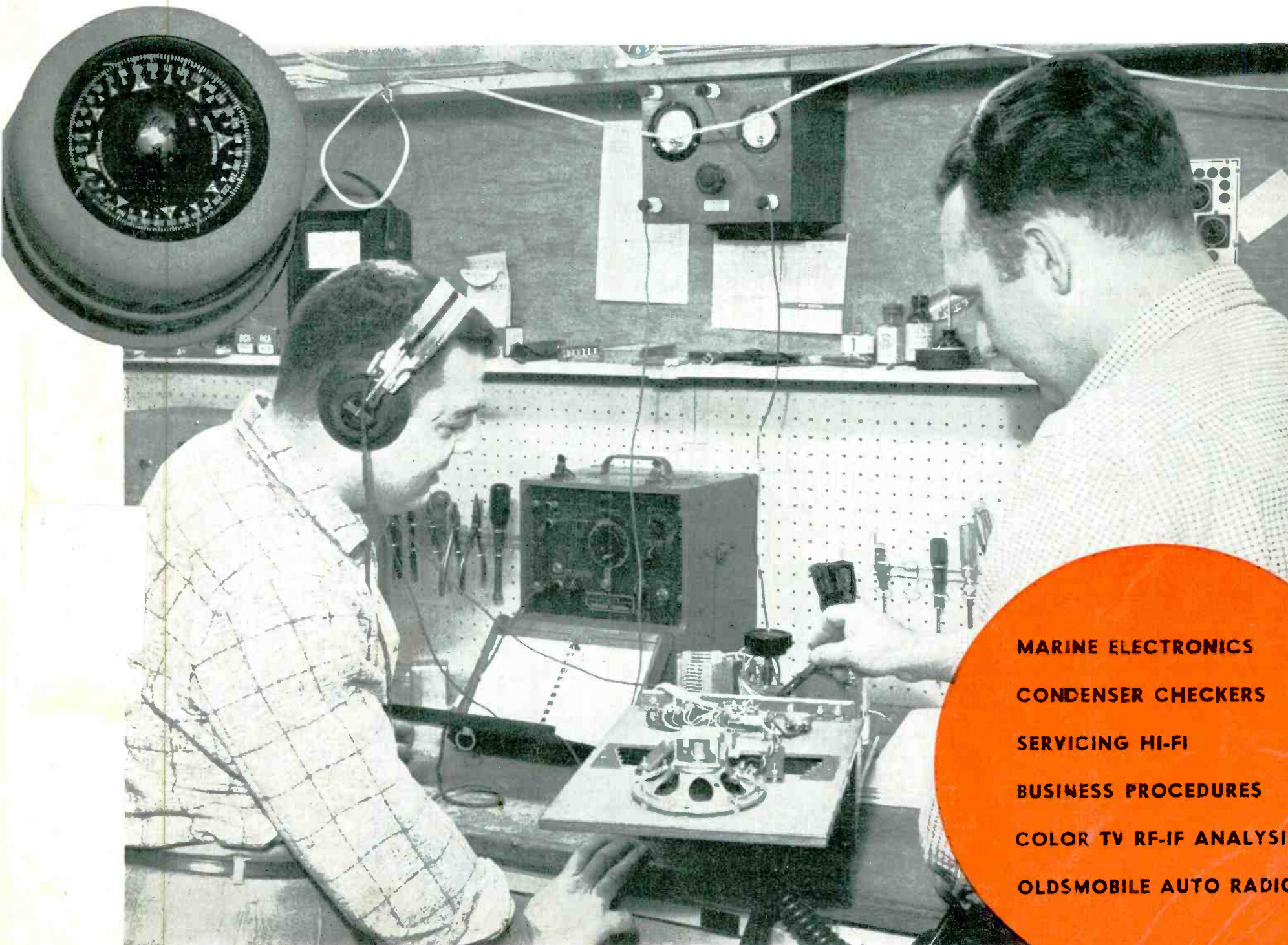

MARINE ELECTRONICS
CONDENSER CHECKERS
SERVICING HI-FI
BUSINESS PROCEDURES
COLOR TV RF-IF ANALYSIS
OLDSMOBILE AUTO RADIOS

your source of finest TV and Radio Tubes is

first in transistors... **RAYTHEON**



Raytheon's pioneering in the research, development and production of Transistors has resulted in many important "firsts" — firsts that give Raytheon an unchallenged lead in the field. Here are some of these firsts:

FIRST in commercial production. Raytheon was the first company to commercially produce and sell junction transistors. These first transistors set high performance standards as they revolutionized the hearing aid industry.

FIRST in RF Transistors. Raytheon scored another important first by leading the way in RF Transistors, too. The first commercially produced RF Transistors — Raytheons — are revolutionizing the portable radio industry, and are being used in computers and communication equipment. Many major manufacturers of portable radios use these Raytheon RF Transistors and all "hybrid" portables use either Raytheon Transistors, Raytheon Subminiature Tubes or a combination of both.

FIRST in PNP Silicon Transistors. Raytheon alone makes a line of PNP Silicon Transistors that fills the need for transistors that will operate at high temperatures.

FIRST Major Manufacturer to Break the Dollar Barrier. A most important first to you — Raytheon is the first major supplier to achieve such high production and product acceptance of their transistors that one of the line could be priced at less than a dollar — Raytheon quality transistors range in price from 99¢.

At Raytheon more than 100 engineers and scientists, plus nearly 1400 other employees are devoted to a single task — the design, development and production of the finest and best in transistors and diodes. To help them work more efficiently, and to meet increasing production schedules Raytheon recently added facilities totaling three acres of engineering and manufacturing space to its Semiconductor Division.

Raytheon Tube Distributors from coast to coast stock and recommend Raytheon Transistors.



ACTUAL SIZE

This huge plant (3 acres of floor space) has just been added to Raytheon's Semiconductor Division — to help meet the ever increasing demands for Raytheon Transistors.

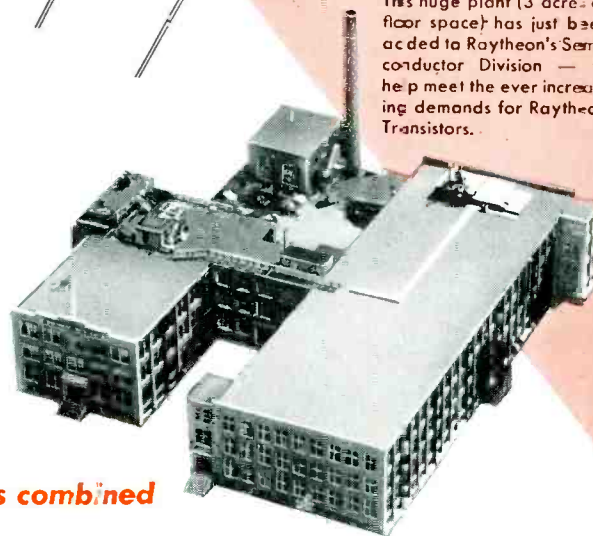

RAYTHEON TRANSISTORS

more in use than all other makes combined



RAYTHEON MANUFACTURING COMPANY

Receiving and Cathode Ray Tube Operations

Newton, Mass. • Chicago, Ill. • Atlanta, Ga. • Los Angeles, Calif.

Raytheon makes all these: } Receiving and Picture Tubes, Reliable Subminiature and Miniature Tubes, Semiconductor Diodes and Transistors, Nucleonic Tubes, Microwave Tubes.

EDITORIAL STAFF

Sanford R. Cowan	Publisher
Samuel L. Marshall	Editor
Oscar Fisch	Assistant Editor
Charles W. Gardner, Jr.	Editorial Production Manager
San D'Arcy	Contributing Editor
Robert T. Dargan	Contributing Editor
Paul Goldberg	Contributing Editor
Elbert Robberson	Marine Communications Editor
Lawrence Fielding	Hi-Fi & PA Editor

BUSINESS STAFF

Advertising Sales

New York and East	Richard A. Cowan Jack N. Schneider James J. Stillman 67 West 44th Street New York 36, N. Y. MUrray Hill 7-2080
Chicago and Midwest	Jim Summers 400 North Michigan Ave. Chicago 11, Illinois SUperior 7-1641
West Coast	Ted E. Schell 2700 West 3rd Street Los Angeles 57, Calif. DUnkirk 2-4889

David Saltman Advertising Production Mgr.

CIRCULATION

Harold Weisner	Circulation Manager
Carol J. Binderman	Ass't Circulation Mgr.
Mady Weinbaum	Circulation Processing

SERVICE DEALER and ELECTRONIC SERVICING (formerly Radio-TV Service Dealer) is published monthly by Cowan Publishing Corp., 67 West 44th Street, New York 36, New York, MUrray Hill 7-2080. Subscription Price: \$3.00 one year, \$5.00 two years in the United States, U.S. Possessions, Canada and Mexico. Elsewhere \$1.00 per year additional. Single copies 50¢. Second Class Mail privileges authorized at New York, N. Y.

POSTMASTER: SEND FORM 3579 TO SERVICE DEALER and ELECTRONIC SERVICING, 67 WEST 44th STREET, NEW YORK 36, N. Y.

SERVICE DEALER



and **ELECTRONIC SERVICING**

VOL. 17, NO. 5

Member

MAY, 1956

EPA

FEATURE ARTICLES

- The Marine Electronics Business**, by Elbert Robberson 8
How to get started and make progress in this ever expanding field.
- Condenser Checkers, Part 1**, by Steve Travis 10
How various types of condenser checkers perform their tasks of testing various types of condensers.
- The Service Dealer and Hi-Fidelity**, by Lawrence Fielding 12
Hi-Fi is a natural for the Service Dealer. This article points up why this is so and how it can be accomplished.
- Fundamental Business Procedures**, by Edward J. Thompson 14
Proper business methods and procedures pay dividends in fewer losses and greater profits.
- Color R.F.-I.F. Section Analysis**, by Bob Dargan and Sam Marshall 16
Overall analysis of the *rf-if* sections used in various color receivers.
- Auto Radios for 1956 Oldsmobiles**, by Andrew V. Doppie 20
Installation and service suggestions pertaining to auto radios designed for 1956 Oldsmobiles.
- Service Dealer's Complete Manufacturer's Schematics** 25-28
Crosley 1956 receivers.
- Guest Editorial**, by Walter C. Bieda, Sr. 29
The relationship between personal appearance and the impression it leaves.
- Proper Billing Pays**, by San D'Arcy 30
Discussion of business forms; how they impress the customer and lead to better customer-service dealer relationships.

CIRCUIT AND SERVICE FORUM

- The Answer Man**
- Philco TV 332, automatic tuning failure 22
- All sets, 6AU4-GT failure 22
- Sylvania TV, halo-light flickering 22
- Video Speed Servicing Systems**
- Philco TV 353 35
- RCA KCS72 37
- The Work Bench**
- GE 21T30 "J" line, horizontal frequency trouble 44
- Zenith 22T20, horizontal frequency out of range 45

DEPARTMENTS

- Ad Libs** 2 **Buyer's Directory** 41
- Rider Speaks** 6 **New** 42
- Trade Flashes** 18 **Advertisers' Index** 53
- New Test Equipment** 40

FRONT COVER

Improved compass by Marine Compass Co., and E. S. Ritchie & Sons Inc. Shop foto by Elbert Robberson.

Entire Contents Copyright 1956, Cowan Publishing Corp.

COWAN PUBLISHING CORP., 67 West 44th Street, New York 36, N. Y.

SERVICE DEALER and ELECTRONIC SERVICING • MAY, 1956

3+3=410

when you use
the **NEW**



SHURE RK-56

LIST PRICE \$22.95 including technical data, replacement chart and 5" x 3" x 1/4" plastic box.

REPLACEMENT CARTRIDGE KIT

as a companion to the RK-54

The 3 CARTRIDGES in the RK-56 Kit provide dependable, quickly-installed replacements for 218 cartridges of seven manufacturers.

When used with the RK-54 Kit (where 3 cartridges replace 192) you will have profitable replacements for 410 of the most frequently used phono cartridges!

Here is broadest coverage for the lowest investment.

The RK-56 Kit contains:

Cartridge	Application	Type	OUTPUT LEVEL		Needle Force	Net Weight	Response To
			MG	78			
WC10	Extended range, Improvement- Replacement cartridge for 132 3-speed, plastic-cased cartridges, crystal or ceramic, single needle or turnover.	CERAMIC	.78v	1.0v	7 grams	7 grams	12,000 cps
W70	All-Purpose Single-Needle cartridge. For Webster C and CX series.	CRYSTAL	3.0v	3.8v	10-15 grams	16 grams	5,000 cps
W72	Dual-Voltage 3-speed Turnover cartridge for Webster FX and Astatic LQD series cartridges.	CRYSTAL	4v or 2v ^{1/2}		8-12 grams	7.5 grams	5,000 cps

¹Model W72 has a slip-on capacitor furnished as an accessory. With the capacitor, output is 2 volts without the capacitor, output is 4 volts.

Available at your Shure Distributor . . . or write to Shure for complete information on this new profitable replacement kit.

SHURE

The Mark of Quality

SHURE BROTHERS, INC.

222 Hartrey Avenue • Evanston, Illinois

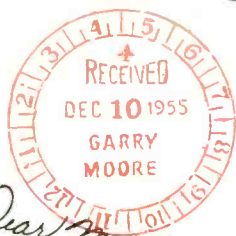

Dear Mr. Moore:

3447 N. Oakland Ave.
Milw. 11, Wis.
Dec. 9, 1955

On your morning show you say that CBS tubes are the best and I'll buy that! I've always had tube troubles and no matter how expensive an instrument we owned its performance was mediocre. Maybe we were too critical but a television picture is either good or it is not. When our picture tube gave up the struggle our serviceman at the Ace Electric Co. installed a CBS picture tube. We are delighted with the ultra bright and shadow clear picture we are receiving.

I wanted you to know that we are glad we took your advice and believe me when the time comes to buy a new set it will be a CBS if they make them. (Do they?)

Sincerely
Mrs. Ruth Svensson

CBS-HYTRON

Danvers, Massachusetts

A DIVISION OF COLUMBIA BROADCASTING SYSTEM, INC.

HERE'S PROOF

**your
customers
want
CBS tubes**

Since Garry Moore has been selling CBS tubes over the CBS Television Network, most service technicians have had women customers ask them for CBS tubes. And not just once in awhile.

Every day more and more women are requesting CBS tubes. We hear stories like Mrs. Svensson's often.

It all adds up to these important facts. You build good will . . . cut callbacks . . . and profit more when you install CBS tubes . . . the tubes with the Good Housekeeping Guaranty Seal.

Is your caddy well stocked with CBS tubes?



Show her the CBS carton with the Good Housekeeping Guaranty Seal. See Garry Moore sell your expert service over the CBS Television Network.



S. R. COWAN

Reminiscing—and Looking Ahead

In 1929, when I was selling advertising for "Radio Engineering" (then the "top" magazine in the field), McGraw-Hill announced they would launch a competitive publication to be named "Electronics." McGraw-Hill said that "Electronics" would cover "all kinds and types of equipment actuated by electronic tubes, even radios." In those days the staff of "Radio Engineering" considered our contemporary presumptuous for implying that the then booming radio broadcasting and receiver business would eventually be but a small segment of the overall, but then nebulous, electronics field. Time has proven that we, not McGraw-Hill, were wrong. Today the radio-TV manufacturing business, even if you add to it all the money spent by commercial sponsors for radio broadcasting and telecasting, is lower in dollar volume per annum than just one phase of electronics manufacturing and servicing, to wit; the military guided missile program. Believe it or not, one West Coast manufacturer has its own service department wherein 17 technicians are employed full time solely on the job of calibrating the firm's test equipment. Scores of other servicemen working in that plant use the test equipment to service the electronically controlled machinery. Not all electronic service departments are as large as the one cited, but this serves to prove the point.

But today, mellowed by over a quarter century of experience, I am inclined to believe that the servicing of installed electronic and commercial communications equipment is a very important business just as is the servicing of home and auto radios and TV sets. Thousands of radio-TV servicemen, although presently engaged solely in servicing radios and/or TV sets concur, and it was due to their recommendation that we have broadened the editorial scope of "Service Dealer" to include "Electronic Servicing."

We reiterate what has been said previously as a word of caution. Today the law stipulates that radio-TV servicemen cannot service certain equipments such as 2-way and ship-to-shore radio transceivers unless they hold an FCC issued radio-telephone ticket. These tickets, or

Ad Libs

licenses, issued free by FCC to those who qualify, are 1st, 2nd and 3rd class, and the type of industrial communications servicing one intends to do determines which class ticket must be held. We'll have articles on this subject, with complete explanations, in future issues.

Welcome Aboard!

Two new editors' names appear on the masthead of this issue. Elbert Robberson, now our Marine Communications Editor, has for over 25 years been recognized as *the* authority in his field. His articles in "Yachting" on marine communications equipments are considered as "classics" by boat owners. We promise this: the articles Mr. Robberson writes for SERVICE DEALER and ELECTRONIC SERVICING will, over a period of time, cover every facet of marine communications and electronic device selling and servicing and will prove interesting to every serviceman who reads them, regardless of whether or not the serviceman does boat radio or boat electronic equipment servicing.

Likewise plaudits to Mr. Lawrence Fielding, our new Hi-Fi and PA Editor. He has been in radio for 15 years and for the past 10 years has been "top brass" with one of the foremost audio equipment manufacturers. He knows all phases of Hi-Fi and PA design and selling, both from the manufacturer's view as well as from the seller's. Thus, Mr. Fielding's department in SERVICE DEALER and ELECTRONIC SERVICING will not be premised on wishful thinking. Instead it will cover practical and proven successful aspects in an effort to get "their share" of Hi-Fi or PA business for those servicemen who, heretofore, have been on the "outside looking in."

N.Y. State Survey

A Governor's committee is at present engaged in evaluating the TV service situation in New York State with a view to possible legislation to correct any of the evils that may exist. Wherever the fault may lie, we hope they will come up with the answer.

[Continued on next page]

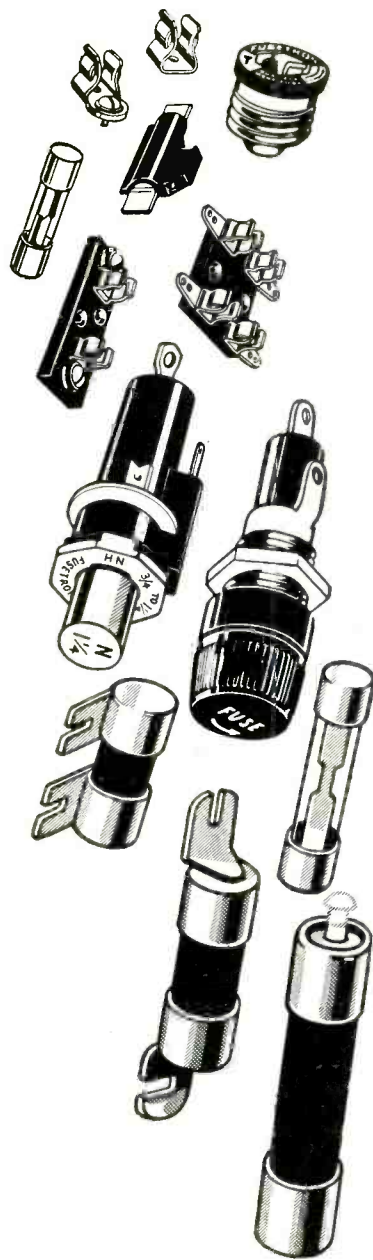

Makers of a complete line of fuses for home, farm, commercial, electronic, automotive and industrial use.

BUSS FUSES

A complete line to meet all your fuse requirements . . .

You'll find the type and size fuse you need, quickly and easily, by turning to BUSS. The complete BUSS fuse line includes: standard, dual-element (slow blowing), renewable and one-time types — in sizes from 1/500 amp. up . . . plus a companion line of fuse clips, blocks and holders.

BUSS fuses are dependable and "trouble-free"

To assure you of top quality and proper operation under all service conditions — BUSS fuses are electronically tested. A sensitive device automatically rejects any fuse not correctly calibrated, properly constructed and right in all physical dimensions.

That's why BUSS fuses give you protection against costly trouble. They help reduce unnecessary repairs and replacements by safeguarding users' equipment when there is trouble on the circuit. And BUSS fuses help you avoid costly and time wasting callbacks by eliminating needless blows.

But most important, by helping you avoid "kicks" and complaints — BUSS fuses are helping guard you against loss of your most valuable business asset — customer good will.

For more information on BUSS and FUSETRON small dimension fuses and fuseholders, write for bulletin SFB.



BUSSMANN MFG. CO.

UNIVERSITY AT JEFFERSON,



(Div. of McGraw Electric Co.)

ST. LOUIS 7, MO.

AD LIBS

[from previous page]

Rider Spoke in April

You'll recall I said, when we recently arranged with John F. Rider to have his "Rider Speaks" page run as a regular feature, it was mutually agreed that he would be allowed to select his own subjects and present his views *carte blanche*. Because I was traveling around the country these past months, it was not until the April issue came off the press that I knew what subject matter had been covered in it by Mr. Rider. Now, having read it, I heartily concur with his views. Further, I urge all readers of this journal to re-read Mr. Rider's April page for it contains a wealth of sound reasoning and the reader's future can be affected by his subtle prognostication.

Starting A New Era

This issue starts us on our 17th year as a radio-TV serviceman's technical publication. The new title and format of the magazine may startle you. In view of this, we welcome your comments, suggestions and criticisms, so send 'em in! We want you to believe that we consider you as a part of our staff just as we consider ourselves as being a part of your enterprise.

Random Notes

The other day a serviceman sent us his subscription order and this particular one caused a mild furor in the circulation department. The order was on a subscription order form which appeared only in our May and June 1940 issues. Took the fellow quite a while to decide about subscribing! On the other hand, it's gratifying to know that there are servicemen who have kept their copies of *Service Dealer* for 16 years.

New York City saloon-owners are currently being told in newspaper advertisements specifically directed to them by a local TV discount house that it will rent them a Color TV receiver for \$1.00 a day. That part of the advertisement does not cause us alarm, but one other part does. I refer to the paragraph which reads: "It is cheaper to



Philco breaks National Campaign to replace "Tired" Picture Tubes



Don't let a
"Tired" Picture Tube
spoil half of your TV enjoyment



Now, Get a better picture than ever before!
PHILCO Star Bright 20/20
ALUMINIZED PICTURE TUBE
Bond plus Warranty

Regardless of the make or model of your TV set, you will get the best picture ever when you change to the Philco Star Bright 20/20. And it's the only TV picture tube made that gives you double protection with both bond and warranty.



Bonded to be built with all new picture making parts, to the same rigid standards as tubes in newest Philco TV sets. Plus full year warranty.

Authorized Philco Service Dealer now. Ask about his insurance for your old picture tube.

Millions of TV Set owners get the call to action—to
phone you immediately for a new picture tube

TV Guide, Saturday Evening Post, newspapers and TV commercials are ready to break the big replacement story and sell the Philco Star Bright 20/20 Aluminized Picture Tube for you. Be sure to have stock on hand when your phone starts ringing. Then you'll be ready to move into the homes of television owners and cash in on the greatest campaign of its kind ever to hit the public.

Invest in your future in Color TV Service and equip your shop FREE during the fabulous

**PHILCO SHARE
AND PROFIT**
Dividend Opportunity

That's right, you can earn FREE color and B/W Test Equipment and Parts and Accessories by concentrating your radio and TV parts on Philco. With each purchase you get SHARE and PROFIT stamps, redeemable for the dividends of your choice at your Philco Distributor. They build EXTRA 100% PROFITS because they cost you nothing. See your Philco Distributor now for full details.

Now, an Exclusive Double Edged Selling Tool...

Bond plus Warranty

ON EVERY

PHILCO®

Star Bright 20/20



Sharon Kay Ritchie
Miss America 1956

SUPER ALUMINIZED! CLEAREST, MOST LIFELIKE PICTURE POSSIBLE

Regardless of the make or model of a TV set, a Philco Star Bright 20/20 Aluminized Picture Tube gives your customers a clearer, brighter, more lifelike picture than ever before... and builds confidence in you.

PHILCO PICTURE TUBE BOND

Bonded by a leading Indemnity Co. to be built with all new picture making parts, to the same rigid standards of tubes in the newest Philco TV models.

PHILCO PICTURE TUBE WARRANTY

Covers the picture tube for one full year. Combined with the new Philco bond, it offers the purchaser guarantees never before matched in television history.

Yes, Philco gives you a double-edged selling exclusive to boost your replacement tube business. In addition to the one year warranty, the Philco Star Bright 20/20 Aluminized Picture Tube is BONDED to have all new picture making components. This bond protects your customers against counterfeit tubes and assures a picture tube that's built to the same rigid standards as those in original TV receiving equipment. The Philco Star Bright 20/20 is the only picture tube made that is backed by such a bond.

PHILCO CORPORATION

ACCESSORY DIVISION

PHILADELPHIA 34, PA.

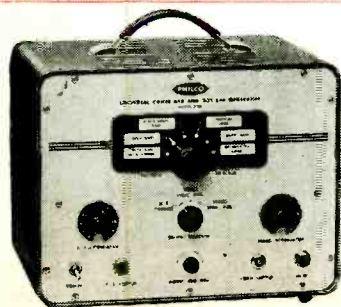

Philco puts you in the color service business with this one compact instrument

PHILCO Universal COLOR BAR and DOT BAR Generator

It's new... highly efficient... designed to provide the widest possible variety of functions in the minimum amount of space. PHILCO MODEL 7100 is used to

completely trouble-shoot circuits associated with color reproduction and make accurate convergence adjustments in any color television receiver on the market.

rent a Color TV set rather than buy one." We believe that Service Dealers should rent radios and TV sets (just as they should rent PA outfits). A profit can be made on such rental transactions and frequently sales result from rentals. But to tell prospective Color TV set buyers in high-pressure advertising that they should NOT buy an item because it will cost less if rented, in our opinion, is negative and very low-strata merchandising. It creates a doubt as to the product's merit and value. Many millions of dollars have been invested in Color TV development. To have this huge investment jeopardized—to have derogatory and snide aspersions cast on Color TV by a "price butcher" of this discount house's ilk, is in our opinion untenable. Were we the sales manager for a Color TV set manufacturer we would refuse to sell our merchandise to such a discount house because it has proven to be a mere opportunist, not a sound merchandiser.

Refuse No Jobs

Many servicemen have declined service jobs on Geiger Counters, photo-flashers and other electronic devices because, not having had any experience with them, or a source from which to obtain technical guidance, they believed it wiser not to "get involved." To prevent the bypassing of such profitable jobs SERVICE DEALER and ELECTRONIC SERVICING recently published articles on servicing Geiger Counters and radiation detectors. We now have in preparation articles on servicing electronic photo-flash units as well as a myriad of other electronic devices. The techniques, schematics and pertinent facts required by a radio-TV serviceman to enable him to do this type of extra-curricular work have never before been published by any serviceman's magazine.

If, in future, you are ever offered a service job on any type of electronic device about which you are not already familiar, *don't decline the job!* Accept it and communicate with our Answer Man at once. He will get to you immediately the information you need. There is no charge for such reader service. It's our policy to help you do every possible or potential job in every phase of electronic equipment servicing.



BEST FOR COLOR TEST!



MODEL 617
3" OSCILLOSCOPE

The most for your scope dollar. Flat-face CRT gives edge-to-edge accuracy... laboratory precision *plus* field ruggedness. And at your electronic jobber, it's just... \$269.50.

There's just one way to test the new color TV sets... WITH NTSC COLOR PATTERN. That's what Hycon's Model 616 Color Bar/Dot Generator offers... *all* standard colors, sequences and patterns easily selected and graphically shown *in actual color* right on the control panel. For color TV, get ready... GET HYCON!

"Where Accuracy Counts"
Hycon ELECTRONICS, INC.
A Subsidiary of Hycon Mfg. Company
321 SOUTH ARROYO PARKWAY
PASADENA, CALIFORNIA

MAIL,
please,
for Catalogs
616 and 617

HYCON ELECTRONICS, INC. Dept. W
P.O. Box 749 Pasadena, California
Please send me the new model 616 and 617 catalogs.

Name _____

Address _____

City _____ State _____

RIDER SPEAKS

FROM where we sit, and judging from what we have picked up here and there, the hi-fi component manufacturers might well give some consideration to making a few changes in the design of the components they produce.

There is a need for some form of standardization among the components offered to the hi-fi enthusiast. As far as the service technician is concerned, his services will be needed whether or not standardization ever becomes a reality, but the electronic parts distributor or the sound equipment distributor who deals in high-fidelity components is very much concerned with the continued sale of the elements that make up the system, from the tuner or turntable to the speaker. He is also concerned with any possible sales volume.

The problem seems to be the development of a mental block on the part of the individual interested in assembling and installing a hi-fi system. He believes there are undue difficulties involved; that the costs are higher than they should be; that once such a system is assembled it is forever "frozen" to the components initially selected; that any change in the system is tantamount to forming a new system; that acquiring "furniture" to house the equipment is a detailed, tiring affair; that finding people to make the installation is difficult. In substance, some people are becoming frightened by the com-

plexities they conjure up in their minds, and slowly but surely are becoming discouraged from buying components.

We are fully mindful of the fact that a variety in hi-fi components is necessary to sales because the different likes of different people must be satisfied. We are mindful of the fact that manufacturers of these units cannot make identical components with similar performance characteristics. Such thoughts are farthest from our mind, but at the same time we feel that more attention can be paid by the manufacturer to those simple factors which might make the selection, assembly and installation of a hi-fi system easier, if they desire to increase sales, let alone maintain the sales level.

In line with the above, we think that a form of standardization in the physical dimensions of many units of like function (even if unlike in performance) is required. (This does not include the speaker, of course.) We think that removing as many of the variables as possible, involved in the housings of components in furniture would be conducive to more sales. We realize that furniture cannot be standardized, but even if the outside appearance of a cabinet is subject to variables in order to conform with the decor of a room, the inside space for the components of a system might well become standard.

What forms can this standardiza-



JOHN F. RIDER

tion take? Consider, for example, the problem of interconnection between components. The types of connectors used should be alike. If the design of two systems is such as to afford two outputs, the two output connectors should be alike; if the output system calls for three, four, or more outputs, all systems identical in number of outputs should use similar connecting means. A move of this type, while it is not a major change, would afford maximum interchangeability with minimum difficulty.

Consider record changers and turntables. There are many brands on the market, and there are many types of mechanism, but there isn't any reason why the bases on which these devices rest should not be of uniform size, so that the opening in which record changers or turntables can be mounted in a piece of furniture would be the same size.

Standardization tends to remove the individuality in a product but we do not believe it applies to the suggestions being made here. One of the most progressive steps ever taken in the electronics industry was the standardization of the octal socket. It didn't affect the different types or the materials of which they could be made, nor did it limit any manufacturer in presenting the selling points of his product or the number of tube types. What it did was to minimize variables and afford the the utmost flexibility to the user.

**RADIART COMMUNICATION VIBRATORS
IN 6 VOLT AND 12 VOLT SERIES**

Here is the ABSOLUTE answer to every communication vibrator replacement...
because NOW... you are ABSOLUTELY CERTAIN of the proper vibrator
replacement for EACH original type! And QUALITY you can depend
upon because of superior engineering... long lasting
dependable service because of quality controlled
manufacture which means MORE
performance hours per dollar!

**These 10 Types Offer Proper Replacement
For Original Communication Equipment**
Here is a 6 volt vibrator for EACH 6 volt operation
and a 12 volt vibrator for EACH 12 volt operation!

Old Number	New Number	
	6 volt	12 volt
5515	5715	6715
5518	5718	6718
★	5721	6721
★	5722	6722
★	5725	6725
5605	5805	6805
5620	5820	6820
5621	5821	6821
5622	5822	6822
★	5824	6824

THE RADIART CORPORATION
CLEVELAND 13, OHIO
VIBRATORS • AUTC AERIALS • TV ANTENNAS
ROTORS • POWER SUPPLIES

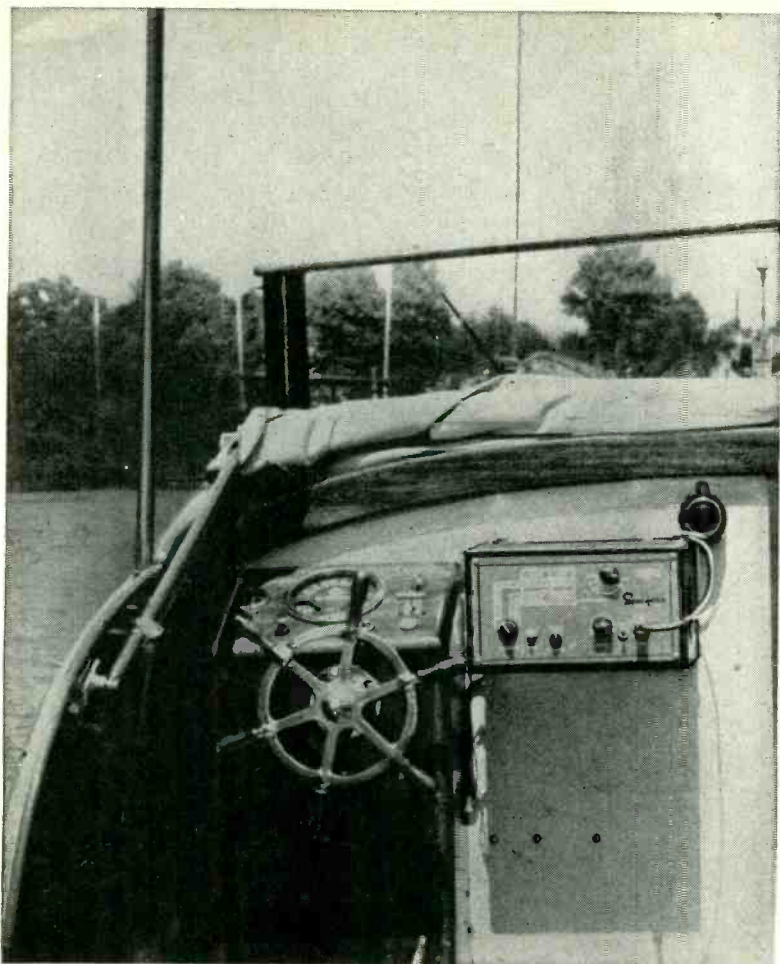

▶ Sonar telephone available as portable or fixed station.

IMAGINE you are out in a small boat. The water gets rough, or fog closes in, or the engine dies. Right then, you become a red-hot prospect for marine-electronics equipment. You'll want a radiotelephone, a direction finder, and a depth indicator. Thirty-million people could get in this exact situation today, and their number is climbing.

"Not around here," you might say.

But boating is not limited to seaports any more—it abounds around Louisville and Las Vegas, as well as Long Beach, and the sound of the outboard fills the

land. Its devotees spent a billion dollars last year. You don't need a computer to spell out the conclusion—here is a market worth looking into! And it isn't overcrowded—yet.

The secret of success in this field is *service*. Give boatmen the specialized attention they need, and they'll travel miles for it.

Unfortunately, you can't just put up a sign and be in business. Not safely, anyway. This is not like home-radio service, where a mistake has no great importance. In marine electronics one wrong connection can sink

This article begins a series on various types of electronic equipment that can be sold, installed, and serviced by competent service dealers. Information on the various installation and service techniques will follow.

The Marine Electronic

the ship! So here is a guide to a safe launching, and a course that will keep you securely in the channel.

Variety of Equipments Involved

First, let's see what the marine-electronics field involves. Once it was a strictly seawater activity, mostly concerned with *wireless*, which actually had more wire than anything. Today you'll work with packages as smooth and neat as an A&P coffee grinder. Foremost among these is the two-way radiotelephone. These range from pocket-size citizen's-band outfits, through battery-operated marine-band portables that can be used on any boat bigger than a one-man Kayak, up to many-hundred watt powerhouses that will talk hundreds of miles.

These sets have from 4 to 10 pre-tuned channels, selected by the skipper, who just turns a knob on the front panel. Prices range from a little over \$200 to well over \$1000. It is customary for the sales agency to install the equipment, which involves putting in wiring, and tuning up receiver and transmitter channels.

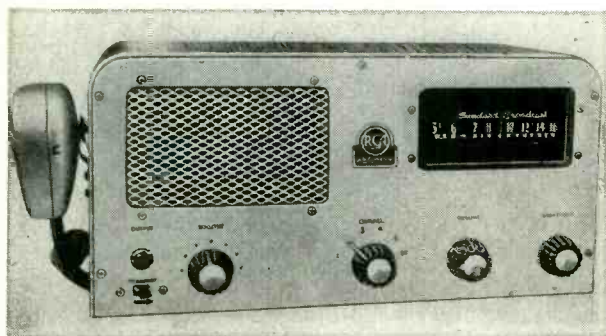

▶ Radiomarine telephone with broadcast receiver.



▶ Ray Jefferson telephone and hailing speaker.

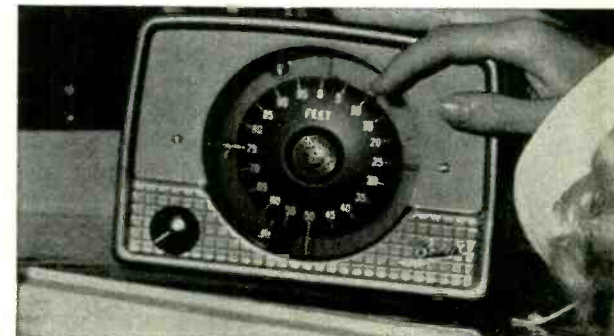

▶ Bendix depth indicator for water under keel.

by **ELBERT ROBBERSON**
Marine Electronics Consultant



Business

They also usually furnish the antenna, which retails at upwards of \$50.00, and the frequency-control crystals, listed from about \$40.00 up per set. Installation of a ground plate on the boat's bottom may also fall to the radio-service agency, although this job is sometimes taken care of by the owner's favorite shipyard. But it can be seen that every radiotelephone sale is a fairly important transaction.

Second to the telephone is the radio direction finder, which is simply a carefully engineered receiver using a highly directive loop antenna. These have reached the stage of development where they can be carried in almost any boat, and will help a skipper grope home using bearings on broadcast stations, as well as airways and marine beacons. A set that can be used for direction finding costs from \$50.00 up. The dealer's responsibility may end when he hands the set to the customer, or it may extend to wiring it into the boat, testing and calibrating the set for bearing errors, and then giving a short course of instruction in its use, which services may involve a fee of \$50.00. (Continued on page 51)



▶ Raytheon radar indicator.

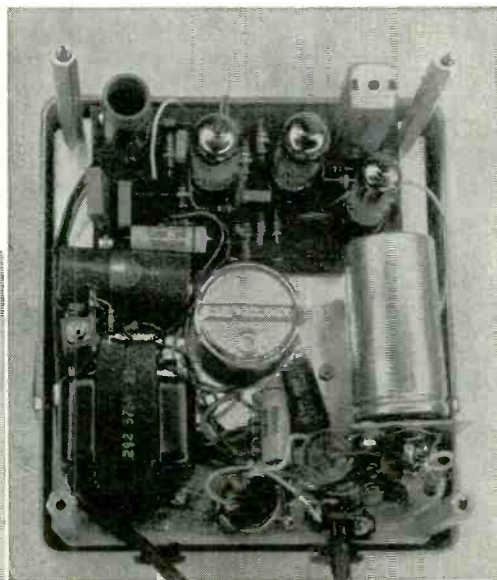

▶ Raytheon DE-122 echo depth sounder. 0-120' range; 5% accuracy.



▶ Guest direction finder.

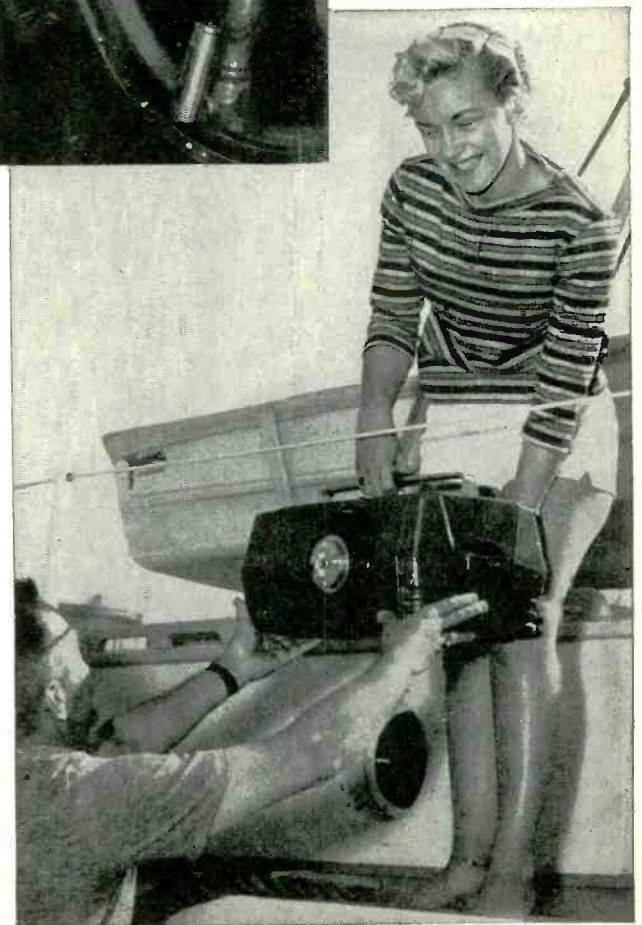

▶ Bendix gas-engine power plant. 1000 W.-115 Vac.



Cornell-Dubilier Model BF-70 capacitance-resistance analyzer.

Condenser Checkers

PART 1

by STEVE TRAVIS

This article presents a description of various makes and models of condenser checkers, and a simplified discussion of their circuits.

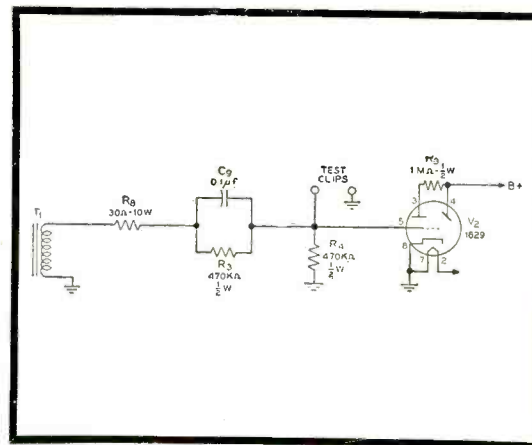

Fig. 1—Partial short-test schematic.

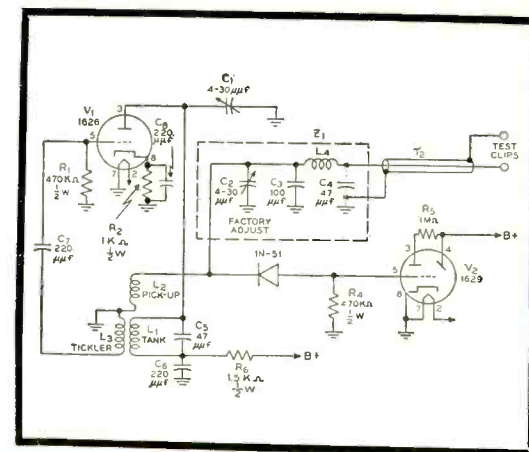

Fig. 2—Partial open-test schematic.

TIME is money. Servicemen are interested among other things in making money. So, when the question is asked, "What can we do to get those jobs off the bench faster?" the alert serviceman usually perks up his ears. One answer to this question is to provide one's self with up to date equipment. Everybody knows how indispensable a volt-ohmmeter is. Many technicians consider a scope absolutely necessary. Flyback checkers have saved technicians considerable time.

Condenser failures in TV receivers rank high among the most common causes of troubles. How can we quickly and definitely locate open, shorted or leaky condensers? How can we check power factor, capacitance value, and intermittent operation? Modern condenser checkers give us the answer.

One simple unit for checking of condensers is the Sprague Model KT-1. This unit checks capacitors for shorts, opens and intermittents without removing them from the circuit. Any capacitor within the range of 30 *uuf* to 2000 *uf* may be easily checked for these defects even though in parallel with a resistance as low as 60 ohms.

Short Test

Fig. 1 shows the basic circuit used for the short test of a condenser. An ac voltage is supplied by the secondary of a power transformer. When the test clips are connected together or shorted the voltage at the grid of the "eye" tube is zero, and is indicated by a maximum opening of the "eye." When the test clips are opened, a bias voltage appears at the grid of the "eye" tube causing the "eye" to close. Even if a resistance of only 60 ohms appears across *R4*, enough bias is developed to activate the magic eye. It is for this reason that in-circuit tests of capacitors can be made.

In making a short test the switch in the lower left portion of the panel (see illustration) is placed in the SHORT position and the test clips are connected to the terminals of the capacitor to be tested. The PRESS-TO-TEST switch is pushed down. If the "eye" remains completely open (no change of shadow angle as the switch is activated) the capacitor is shorted and should be replaced. If the "eye" closes (even slightly in the case of large capacitors in parallel with small values of resistance) the

Sprague Tel-Ohmike Model TO-4.



Heathkit checker Model C-3.



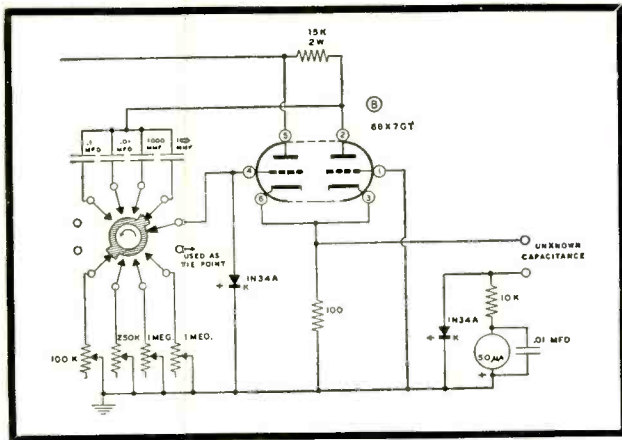

Fig. 3—Partial schematic of capacity meter.

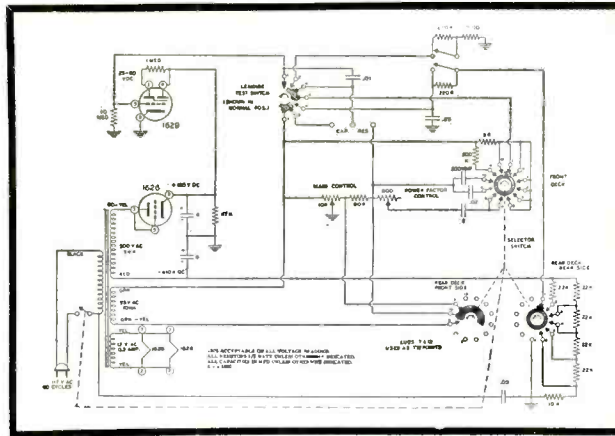

Fig. 4—Heathkit Condenser Checker Model C-3.

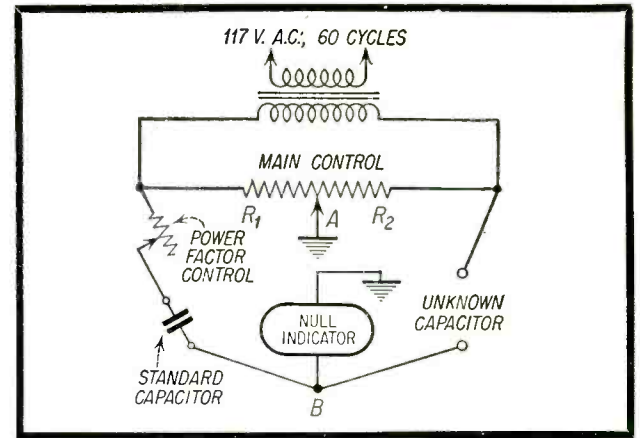

Fig 5—Simplified Wien Bridge circuit.

capacitor is not shorted. The capacitor can, at this time, be tapped sharply. If the "eye" flutters, the capacitor is intermittent and should be replaced.

Open Test

In using the Sprague Model KT-1 the switch is placed in the OPEN position. The clip leads are connected to the terminals of the capacitor under test, or left connected from the short test. The test cable T2 and the impedance Z1 of Fig. 2 constitute a quarter wave transmission line operating at the same frequency as an oscillator circuit in the unit. The frequency is approximately 20 mc. A useful property of a quarter wave line, utilized in this test, is that the impedance connected to the output end of the line is reflected back reciprocally to the sending end. Thus, if the output is shorted the input end "sees" an open circuit.*

In operation, if the test clips are open or are connected to an open capacitor, the sending end, coupling coil L2, "sees" a short circuit (zero voltage), and the

"eye" remains open indicating the connected condenser is open. Any good capacitor connected to the clips results in a voltage across L2 which is rectified by the 1N51 crystal. A resultant *dc* voltage is impressed upon the grid of the "eye". This *dc* voltage causes the "eye" to close in proportion to its magnitude. A small capacitor causes a small closure, while a larger capacitor causes the "eye" to close completely. If the "eye" closes (the capacitor must be larger than 200 *uuf* to completely close the "eye") the capacitor is not open.

Here again the capacitor can be tapped sharply. A flutter of the "eye" indicates an intermittent condition.

A Capacity Measuring Meter

It is often desirable and sometimes necessary to be able to measure the capacitance value of a particular condenser. Means of doing this can be accomplished easily with such a unit as the Heathkit direct reading capacity meter, Model CM-1. The circuit for this unit is shown in Fig. 3. The unknown capacitance is connected in series with a germanium crystal, a 1N34, shunted by a meter circuit. The measurement of

capacity is accomplished by rectifying a square-sided pulse and measuring the average value of the rectified *dc* voltage on a meter. The meter is calibrated in capacitance corresponding to the *dc* voltages impressed across it. The impedance of the meter circuit in conjunction with the unknown capacity determines the shape and consequently, the average value of the rectified voltage.

The oscillator circuit of this unit employs a 6BX7 tube in a cathode-coupled multivibrator circuit. The frequency of the multivibrator depends upon the capacitance switched into the circuit, and varies from about 80 cycles to 80 kc. A 100 ohm cathode resistor provides the common impedance necessary to maintain the oscillator in operation and is also the source impedance of the pulse used for the measurement of the capacitance. The range switch selects the value of the feed-back capacity and the series calibrating potentiometer. These values establish the pulse repetition rate and therefore the maximum capacity that can be read on any range.

A more elaborate instrument for measuring capacitance and performing additional tests is found in the Heathkit

Model C-3 condenser checker. This unit provides a means of capacitance measurement on four scales covering from 10 μf to 1000 μf . At the same time *dc* leakage test polarizing voltages are made available from 25 volts in five steps to a maximum of 450 volts. Also, resistance measurements covering two ranges, 100 ohms to 50,000 ohms and 10,000 ohms to 5 megohms, can be accomplished.

The Heathkit Model C-3 tester makes use of an *ac* powered bridge circuit employed for both resistance and capacitance measurements. The schematic diagram for the unit is shown in Fig. 4. This circuit resolves itself into the more simplified one shown in Fig. 5, which is known as a line frequency Wien Bridge. It can be noted that the main control is a potentiometer with its variable arm grounded. By rotating the control, the resistances, R1 and R2, in the two legs can be increased or decreased. A standard comparison condenser is connected into a third leg and the fourth leg of the bridge contains the unknown condenser. By adjusting the main control, which is calibrated in capacitance, the

[Continued on page 46]

Cornell-Dubilier Bridge BF-60.



Sprague Kwik-Test Model KT-1.



Simpson In-Circuit checker 383.

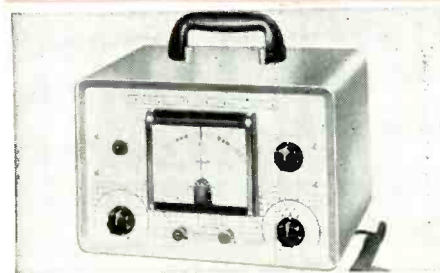

Heathkit Capacity meter CM-1.



The Service Dealer and HI-FIDELITY

by LAWRENCE FIELDING

Introducing a new series on Hi-Fi for the professional electronic serviceman. It is the writer's aim to make the servicing of this equipment mostly quantitative

THE term "high-fidelity", as well as its contracted and capitalized small cousin Hi-Fi, has suddenly become a household word for millions. True, many individuals who use the term would be rather hard-pressed to give an acceptable definition of high-fidelity, if asked. Nevertheless, the phrase has become a part of our daily conversation.

Regrettably, the entire subject has taken on all the outward appearances of a real "fad", and, as is true with all fads, a great many misconceptions exist in the mind of the general public. Uncontrolled, and often misleading advertising in mass media such as newspapers and nationally distributed magazines tends to amplify these misconceptions. It's not

unusual to visit a customer's home in the course of a television service call and have him extol the virtues of his recently acquired, \$20.00 "guaranteed" Hi-Fi children's phonograph.

It is the general purpose of this new series of articles to arm the reader with sufficient, sound information to intelligently appraise the merits (or, in many cases, the demerits) of so-called high-fidelity systems. To do this we must first become acquainted with some generally accepted definitions of high-fidelity and, at the same time, perhaps, dispel some popular notions concerning your place in this new mass-market industry. Next, in the series of articles to follow, we hope to change the ap-

Fig. 1—Typical hi-fi installation assembled from individually manufactured components, commercially purchased. Such a system can cost as much as \$2000.

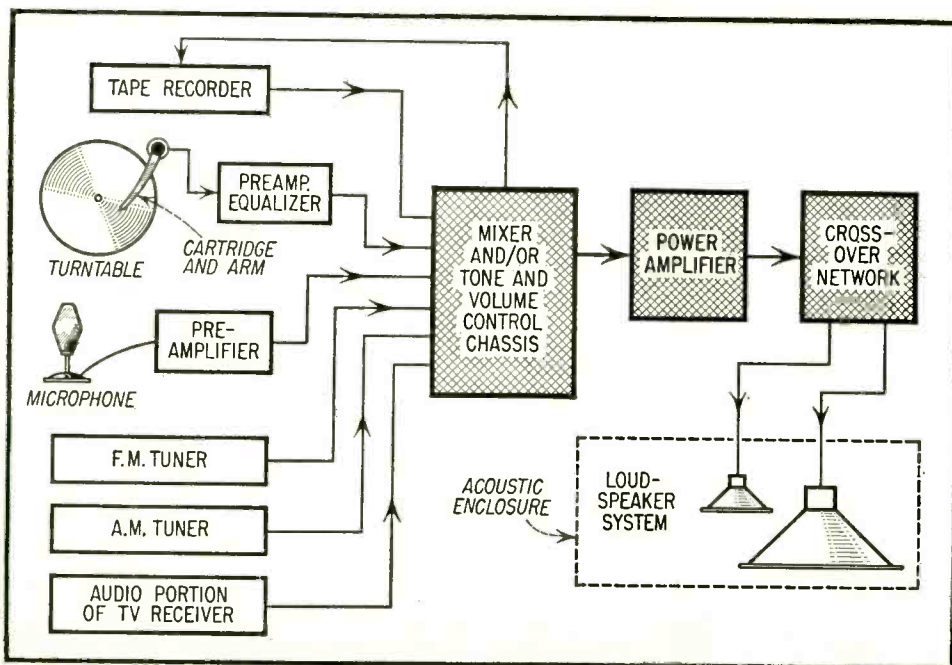

will it be this...



...or this ↓

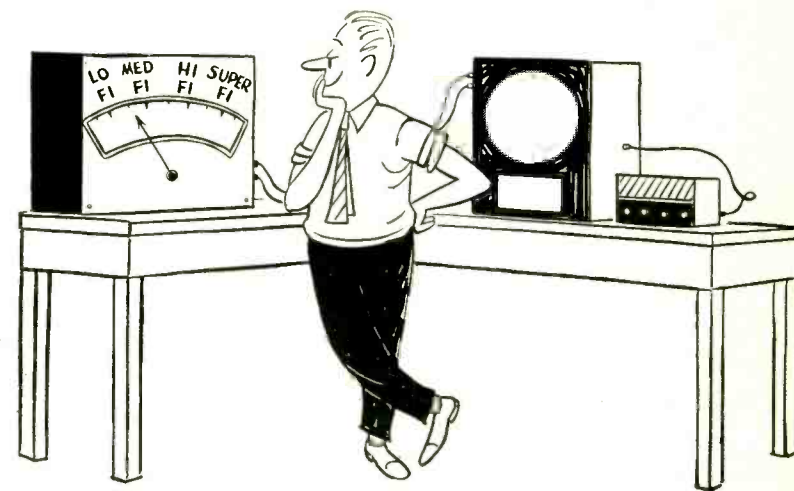

proach to high-fidelity servicing from an opinionated art, to a calculated science.

Hi-Fi Defined

Before going any further, let's establish a working definition of high-fidelity. Most manufacturers of this type of equipment have, as their ultimate goal, the design, development and production of a set of components capable of reproducing sound which is indistinguishable from the original, live sound. Almost anyone intimately associated with this work will be quick to admit that we have not, as yet, reached this goal. Therefore, the term high-fidelity must be thought of as a relative term. Perhaps we should have labeled such equipment *higher-fidelity*—that is, higher than the fidelity achieved by table-model *ac-dc* radios, or higher than the fidelity of sound that "bounces" out of an open-backed, pre-war console. In any case, remember that there is no fine dividing line between high-fidelity and "low-fidelity." In fact, if this science should ever reach its ultimate goal, we would probably do just as well to drop the adjectives altogether and label such

products as having "fidelity", or complete faithfulness to the original sound.

At this point the question naturally arises, "Who's to say if a particular system or set of components comes as close as possible to reproducing life-like sound?" Who, indeed, but a technically competent serviceman, properly equipped to *measure* the performance of a given system and to *interpret* his measurements in judging the performance of *any* high-fidelity system.

The Serviceman's Double Dilemma

The concept of high-fidelity probably grew in the minds of many engineers simultaneously, back in the middle thirties. These men were engaged in the new miracle of making motion pictures that "talked." Extremely rugged amplifying and reproducing systems were in use in those days. Many of them were capable of reproducing excellent sound in motion-picture theaters. Undoubtedly, some of these engineers, after a hard day in the sound-studios would go home and listen to their table-model radios or phonographs and wonder why the sound they heard was so inferior to the sound

hey worked with at the studio. They began to experiment, to build and to rebuild, using principles borrowed from the industrial and public address sound equipment manufacturers. The word spread very slowly at first, so that before the war there were at best, perhaps, only two or three companies devoted exclusively to the manufacture of sound equipment capable of reproducing reasonably life-like music and speech in the home. Most early owners of this equipment were sufficiently technically minded to do their own servicing if the equipment became faulty.

As is true in almost every field of electronics, World War II advanced the science very rapidly, so that in the late nineteen-forties, high-fidelity began to take on the aspects of a young and growing industry. The rest is history. Today, a leading small manufacturer in this industry (and, by the way, most of the manufacturers are small by comparison with other "luxury item" industries) will turn out about 75,000 component items this year. *Who services all this equipment?* Very often that job is handled either directly by the manufacturer or by a few, scattered large retail outlets who maintain major service-organization set-ups. Up to the present time, the thousands of owner-servicemen all over the country just haven't played a major role in this field. *Why?* It's true that the number of service calls per high-fidelity installation has been relatively low *up to now*. That is because the equipment is as new as the infant industry and is usually fairly conservative in design. But, make no mistake about it! High-fidelity equipment uses the *same* capacitors, transformers, tubes and resistors that you've been replacing in other electronic equipment ever since you've been in business. These components do not have "infinite life" built into them, despite the quality of sound reproduced by the equipment containing them. And remember, too, that not all parts of a high-fidelity system are electronic. Turntables and record-changers have motors to drive them. So do tape-recorders. Needles have a way of wearing out rapidly, at the expense of the unsuspecting record collector. The list of future work is endless. When all this equipment begins to give way,

[Continued on page 48]

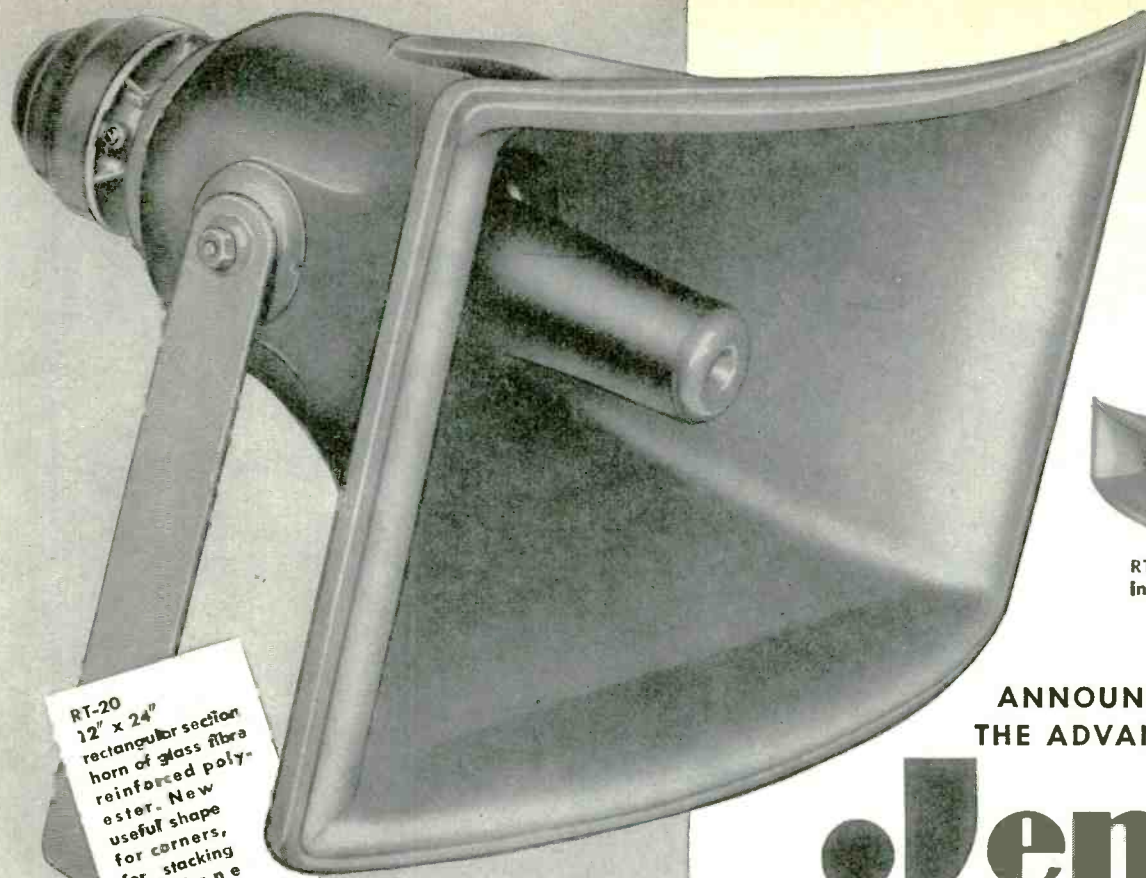

RT-20
12" x 24"
rectangular section
horn of glass fibre
reinforced poly-
ester. New
useful shape
for corners,
for stacking
in plane
or circular
arrays.

RT-20's
in plane array



RT-20's
in circular array

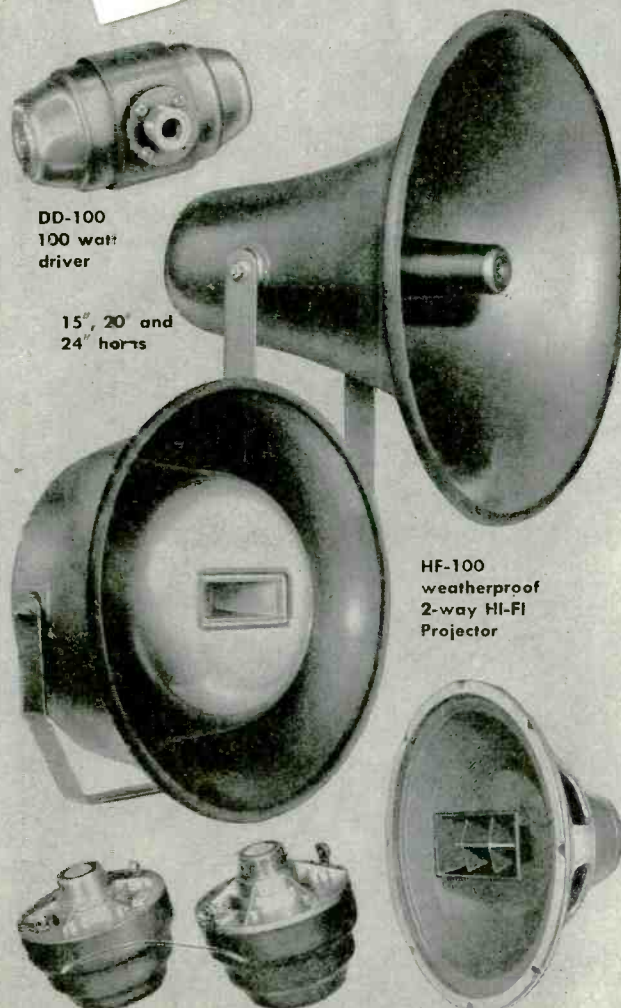

DD-100
100 watt
driver

15", 20" and
24" horns

HF-100
weatherproof
2-way HI-FI
Projector

D-30 and D-40
30 and 40 watt
drivers

Four 12" and 15"
2-way and 3-way
speakers

ANNOUNCING THE ADVANCED **NEW**

Jensen

**PROFESSIONAL
SERIES** LOUDSPEAKERS

FOR INDUSTRIAL, COMMERCIAL, INSTITUTIONAL,
CIVIL DEFENSE, AND MILITARY SOUND SYSTEMS

If sound is your business, here is big news for you . . . a complete new line of loudspeakers to meet for the first time every sound system need for both entertainment and efficient, effective communication. From a fraction of a watt to 1600 watts or even more . . . for high fidelity or high efficiency coverage . . . for distributed or concentrated source projection . . . indoors or out—there is a Jensen Professional Series loudspeaker that will do the job *better, more dependably, and more economically* than ever before. Just as an example, the new Hypex Lifetime Driver Units are *guaranteed indefinitely against failure under normal use!*

Three years of product design and a background of nearly 30 years of field experience and manufacturing know-how come to you in Jensen Professional Series loudspeakers. We can't begin to illustrate or describe all the items here—nor tell you about all the new features for convenience and performance which we've built into them. Catalog 1070 tells the whole story, including valuable information on sound system design. Send for your free copy today.

Jensen MANUFACTURING COMPANY
6601 S. Laramie, Chicago 38, Illinois

Division of The Muter Co. • In Canada, Copper Wire Products, Ltd. Licensee

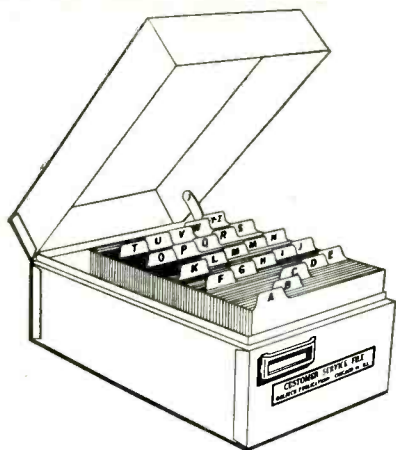

Fundamental Business Procedures . . .

by EDWARD J. THOMPSON



THERE'S an old saying in our business: "You don't have to be crazy to be a serviceman, but it sure helps!" In like vein one might say: "Servicemen are not required by law to use business forms or business-like methods . . . but . . . by failing to do so they're inviting failure." If you don't subscribe to this theory, look at the record! The Department of Commerce maintains an excellent statistical record of business failures and successes. These records prove conclusively

Left: (top to bottom) Figs. 1, 1A, 2, 3

Below: Fig. 4—Parts guarantee form.

that 11 out of 13 newly established business enterprises that start out with properly maintained records have been successful. In contrast 4 out of 5 newly established businesses which did *not* use and maintain proper business forms from the outset failed in less than 10 months. If I were engaged in the radio, TV or electronic service business, even as a part-timer—I'd hate to buck such odds.

Cost of business forms

What will a comprehensive set of fundamentally needed business forms cost? . . . and, how much of a return can be expected to offset the investment? Well, looking at it from the most conservative and pessimistic angle possible I'd say that an initial outlay of from \$9.55 to \$14.00 is required and that amount should come back to the investor on the first 10 or 12 jobs he does. Then for his dividend he can expect upwards of \$80.00 more. On the other hand a \$20.00 initial outlay for business forms will provide the serviceman with a real fine set of material and its cost will come back in relative proportion many many times. Stated another way, the average full-time radio-TV serviceman will handle 1,200 to 1,600 repair jobs a year. Some part-timers will do upwards of 400 a year. But try as you will, you can't use up more than 5 cents worth of printed forms on any single job and as a matter of fact the average job will only require 2 to 3 cents worth of printed forms purchased from your parts distributor.

What basic forms should a serviceman have and use? Opinions on this will vary, but I'm entitled to my ideas so I'll express them. In doing so, I'll use throughout, as illustrations, the various stock printed forms that are produced by Oelrich Publications of Chicago. These are carried as stock-items, for over-the-counter sale, by practically every radio-electronics parts distributor in the country.

First thing I'd buy is the #705 "Customer Service File System" which lists at \$6.95 and comes as a file

A description of various business forms available that tie in with the ordinary run of business procedures followed in a typical serviceman's day.

box complete with 500 3" x 5" cards. See Fig. 1. Each card gives you a complete service history on any unit serviced—shows the nature of the complaint, the price charged, job number, date serviced, parts replaced, etc. It also shows warranty expiration dates on pix and regular tubes, parts, etc. If you happen to have your own small file box all you need are the No. 704 Customer Service Cards themselves. 500 cards printed maroon on white, cost \$2.50.

Next, if I did both radio and television servicing, I'd buy (even if I were a very small-operation independent part-time serviceman) two pads of Oelrich's #209 "Radio Service Work Sheets" (Fig. 2) and two pads of their #212 "TV Service Shop Reports, (Fig. 3)—(each pad has 50 duplicate sets of data sheets so I'd start with a supply that would let me handle the first 100 jobs). If I only did radio servicing and no TV servicing I'd only get the #209's. Both of these forms sell for \$.95 per pad—a \$3.80 outlay—and they do a "selling job" for you, as each can be shown to the customer as a completely itemized job record, (and you'll have the duplicate for your files.) Here's an instance where invaluable customer good-will can be obtained—and your prestige raised—simply for an investment of less than \$.02 per job. (If you tacked \$.50 extra onto the labor charge you'd get it from the customer without a quibble because you used such an ethical approach. Being evasive or keeping information from a customer is the best way to make him suspicious . . . and a "suspicious" customer will quibble about charges and is never a really pleased customer.

Now I'd add to my business-operations stock a #111 "Parts and Service Guarantee Book" that lists for \$2.00 (see Fig. 4). The book of 100 two-section parts and service guarantees help you keep a record of your parts warranty obligations and eliminates having a customer misunderstanding as to what a parts or service guarantee covers. In my opinion it's a most impressive way to convince the customer that he's dealing with a reputable serviceman! Servicemen have told me that by

merely showing they use such guarantee forms to potential customers they frequently get jobs that otherwise would go elsewhere.

Up to this point I've shown four basic business form "musts" that would require an outlay of \$12.75 even if the serviceman bought the file box, or only \$8.30 if he had his own file box. Naturally a service shop or serviceman would want his name imprinted on every form so if we add the outlay of \$1.25 for a rubber stamp and pad it gets us up to the original \$14.00 investment I first mentioned, or \$9.55 if he had his own box.

Now if I were a serviceman I'd want a supply of Oelrich's #107 "TV Job Tickets" and their #108 "Radio Repair Tags." See Figs. 5 and 6. (Of course you don't need the #107's if you don't do TV servicing.) These "Job Tickets" are on a manila tag stock, numbered, come 100 to a pad and cost but \$1.60 per book. As their names imply the "Job Tickets" perform several functions. Rubber stamp your name on the bottom right section, tear it off and present it to the customer as his claim check. The upper [Continued on page 43]

Below: Figs. 5 and 6—Job ticket forms.

RADIO AND TELEVISION

TUBES TESTED FREE

PROVIDED THAT NEEDED REPLACEMENTS ARE PURCHASED AT TIME OF TEST, OR IF TUBES TEST O. K.

A SERVICE CHARGE OF 10¢ PER TUBE WILL BE MADE IF OUR TEST SHOWS ONE OR MORE DEFECTIVE TUBES AND CUSTOMER DECLINES TO PURCHASE AT LEAST ONE NEEDED REPLACEMENT.
OUR TUBE TESTING SERVICE IS PROVIDED SO THAT OUR CUSTOMERS CAN DETERMINE THE TUBE OR TUBES THAT REQUIRE REPLACEMENT SO THAT THEY CAN PURCHASE CORRECT REPLACEMENTS. THIS SERVICE IS NOT INTENDED OR PROVIDED FOR AMATEUR SERVICEMEN.

TUBE SALES ARE FINAL

ALL TUBES SOLD ARE GUARANTEED ON A REPLACEMENT BASIS ONLY AND NO CASH REFUNDS WILL BE MADE.

ESTIMATES

RADIO \$1.00
TELEVISION \$4.00
PHONE \$1.00

AN HONEST AND ACCURATE ESTIMATE REQUIRES CONSIDERABLE ANALYSIS TIME BY A SKILLED TECHNICIAN AND OUR ESTIMATE CHARGES ARE BASED ON AVERAGE CASES. THE ESTIMATE CHARGE IS MADE ONLY WHEN CUSTOMER DECIDES AGAINST HAVING HIS UNIT REPAIRED. IN MOST CASES OUR ESTIMATES ARE ACCEPTED AND NO CHARGE IS MADE FOR ESTIMATE BECAUSE WE FURNISH THE TIME SPENT IN MAKING THE ESTIMATE AS PART OF THE TIME REQUIRED TO PROPERLY SERVICE THE UNIT AND CONSEQUENTLY WE CHARGE FOR THAT TIME AS PART OF OUR LABOR CHARGE. IN MANY CASES WE CANNOT MAKE AN ESTIMATE OF TV SERVICE COSTS BECAUSE THE DEFECT IS OF AN OBSCURE AND COMPLEX NATURE THAT REQUIRES MANY HOURS TO LOCATE AND WE RESERVE THE RIGHT TO DISCUSS TO MAKE AN ESTIMATE IF WE FEEL IT CANNOT BE DONE IN A REASONABLE PERIOD OF TIME.

BEST BUY IN SCOPES



new!
Simpson
COLORSCOPE
MODEL 458

Compare the new Simpson Colorscope Model 458 with any oscilloscope on the market. It is an advanced, seven-inch, high-gain, wide-band scope especially designed for color-TV service. Ideal for black and white, too.

100% RESPONSE at 3.58 mc color-burst!

DUAL bandwidth—narrow or wide!
FLAT FREQUENCY RESPONSE, within 1 db to 4.5 mc!

RISE TIME less than 0.05 microsecond (wide band)!

FULL RANGE compensated vertical attenuator!

Price with shielded input cable, **\$22995** manual...

Four accessory probes available for extra utility!

See Your Distributor for details or write—



SIMPSON Electric Company
WORLD'S LARGEST MANUFACTURER
OF ELECTRONIC TEST EQUIPMENT

5200 W. Kinzie St., Chicago 44, Illinois
Phone: ESfebrook 9-1121
In Canada: Bach-Simpson Ltd., London, Ont.

COLOR R.F.-I.F. Section Analysis

by **BOB DARGAN** and
SAM MARSHALL

From a forthcoming book entitled
"Fundamentals of Color Television"

THE section comprising the *rf* tuner, the video *if* stages and the video detector (or detectors if two are used) shall be called the RF-IF Signal Section; for it is in this section that the composite *rf* and *if* signals are processed before being fed into the separate chrominance, luminance, sound, and sync sections. In some receivers a stage of video amplification is included before this division is effected.

Classification of Composite Signal Section Types

Block diagrams of various systems used are shown in Fig. 1. In (A) we observe a system using a single detector followed by a video amplifier stage, the output of which feeds separate chrominance, luminance, sound and sync input circuits. Fig. 1B shows a dual detector system in which the luminance signal is recovered in one detector, and the sound and chroma signals in another. In Fig. 1C we illustrate another type of dual detector receiver in which the luminance and chrominance signals are recovered in one detector and the sound signal in the other.

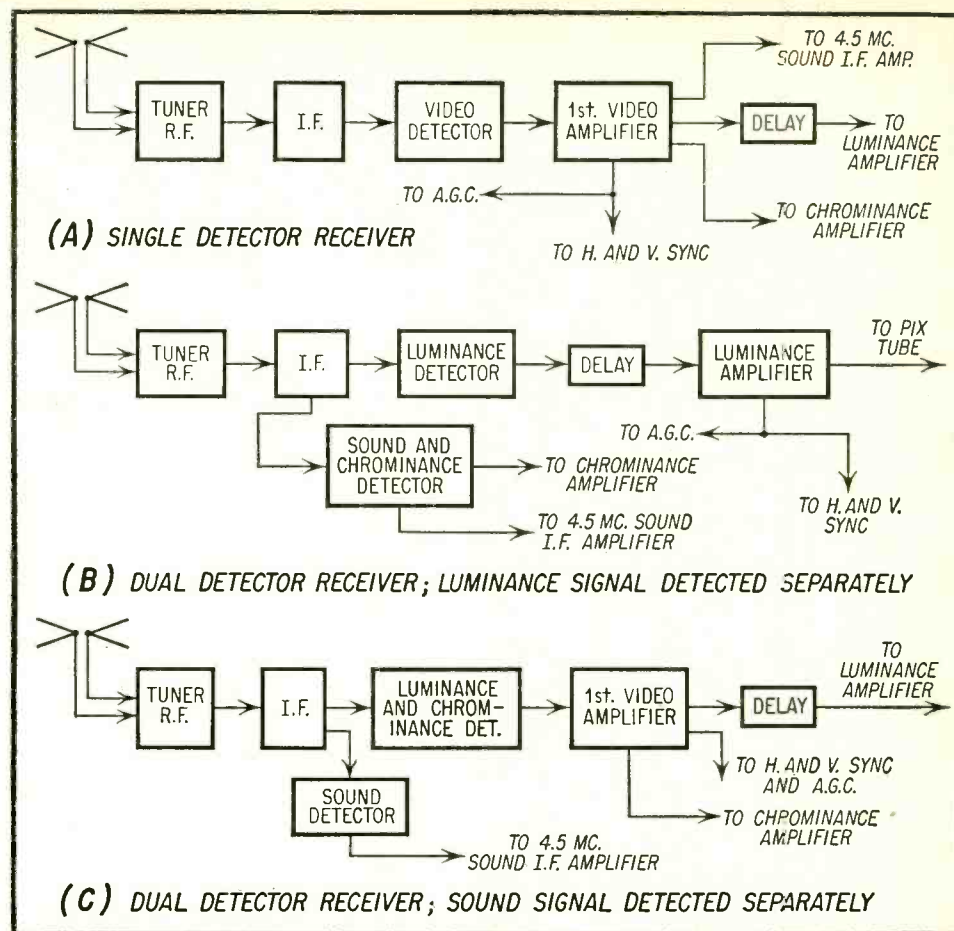

Fig. 1—Various types of RF-IF sections employed in color television receivers. Notice that these receivers are categorized into three groups as shown in the figure.

Tuner Considerations

Tuners used in color TV receivers are essentially the same as tuners used in monochrome receivers except for more rigid adherence to component values and operating specifications. These specifications include:

1. Bandpass characteristics of tuner

2. Linearity of circuit operation
3. Impedance match between transmission line and tuner
4. Local oscillator frequency stability

Let us first consider bandpass characteristics. Whereas response variations of plus or minus 3 db over the *rf* pass band are generally acceptable in monochrome

Fig. 2—Comparable acceptable tuner response curves for color and B&W.

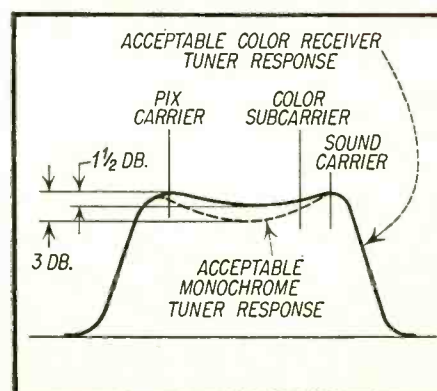
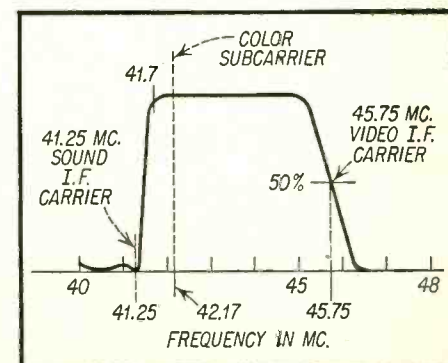

Fig. 3—Ideal video IF response curve showing levels for various carriers.



tuners, the maximum deviation in color receivers is plus or minus 1.5 db. See Fig. 2. Adherence to a flat bandpass characteristic is desirable for proper color fidelity. In fact, if the color carrier amplitude is reduced too much the color signal will be lost entirely.

A flat bandpass tuner characteristic over the complete range of channels received is instrumental in preventing changes of overall relative amplitude between the luminance and chrominance signals as they progress from the tuner input to the picture tube input. Should there be an attenuation of either signal with respect to the other, readjustment of the chroma control becomes necessary to restore the original amplitude relationships. The elimination of this readjustment, when switching from one channel to another, is one of the goals that color set designers are striving for; and a flat bandpass characteristic in a tuner is a means toward attaining that goal.

The second item, under "tuner considerations", referring to linearity of circuit operation, is important in that any condition giving rise to cross-modulation (or detection) in the tuner due to non-linearity of circuit operation can result in serious color degradation and impaired monochrome reception. Under these conditions any stray signal pickup falling in the *rf* range can modulate the incoming color signal, thereby producing undesirable effects such as streaking, herringbone patterns, confetti, etc. For this reason, required tuner operating voltages must be closely adhered to, and *rf* tubes designed to insure

[Continued on page 24]

Fig. 4—Typical video IF response curve for narrow band receiver.

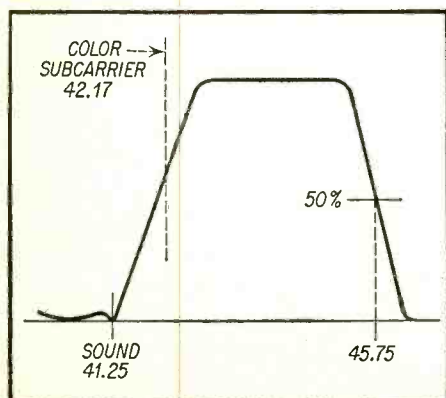

how long would it take you to solve this service problem?

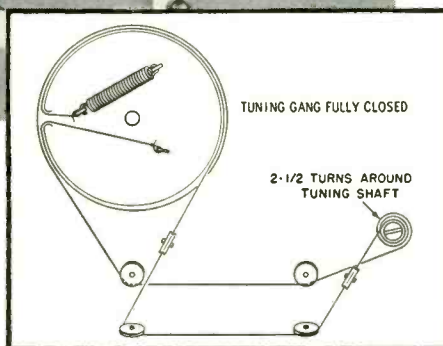
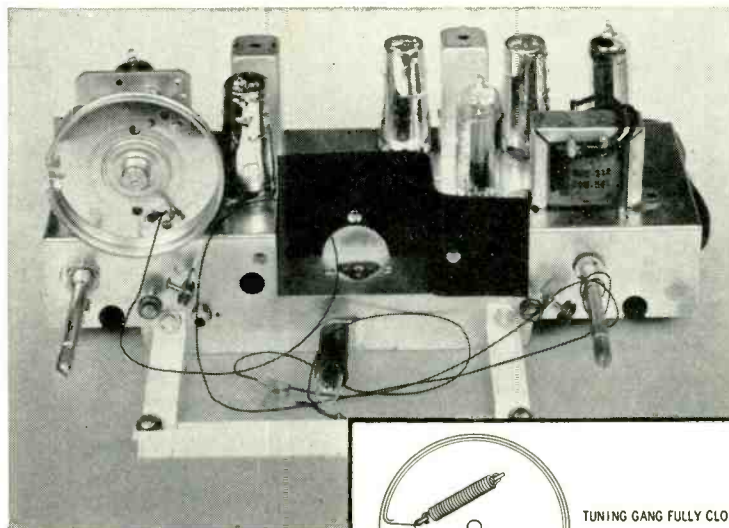

SYMPTOM:

Note the photo: The dial cord obviously needs repairing

It might be possible to replace or re-string the dial cord without a diagram, but why waste valuable time trying to figure out the correct way? With a PHOTOFAC Folder by your side, you save time. Here's why:

In just seconds, you refer to the Dial Cord Stringing Diagram in your PHOTOFAC Folder. It shows the one right way to re-string the cord. You don't waste time puzzling over why the dial pointer moves the wrong way, why the gang doesn't turn, why there's jamming or skipping. You solve this nuisance service problem in a few minutes with PHOTOFAC's help. It's just one of the important time-saving features found in PHOTOFAC—the world's finest service data.

what's your service problem?

THESE EXCLUSIVE PHOTOFAC FEATURES* HELP YOU SOLVE ANY PROBLEM FASTER, EASIER, BETTER—HELP YOU EARN MORE

PHOTOFAC gives you complete coverage on over 20,000 TV, Radio, Amplifier, Tuner and Changer models. And PHOTOFAC is a *current* service—keeps you right up with late model production—brings you these exclusive features:

FULL SCHEMATIC COVERAGE

1. Famous "Standard Notation" uniform symbols are used in every schematic. Diagrams are clear, large, easy to read and handle.
2. Wave forms and voltages are shown right on the schematic for fast analysis.
3. Transformer lead color-coding and winding resistances appear right on the schematic.
4. Schematics are keyed to parts lists and to parts on chassis photos.

FULL PHOTOGRAPHIC COVERAGE

5. Exclusive photo coverage of all chassis views is provided for each model; all parts are numbered and keyed to the schematic and parts lists for quicker parts identification and location.

ALIGNMENT INSTRUCTIONS

6. Complete, detailed alignment data is standard and uniformly presented in all Folders. Alignment frequencies are shown on radio photos adjacent to adjustment number—adjustments are keyed to schematic and photos.

TUBE PLACEMENT CHARTS

7. Top and bottom views are shown. Top view is positioned as seen from back of cabinet. Blank pin or locating key on each tube is shown. Charts include fuse location for quick service reference.

TUBE FAILURE CHECK CHARTS

8. Shows common trouble symptoms and tubes generally responsible for such troubles. Series filament strings are schematically presented for quick reference.

COMPLETE PARTS LISTS

9. Detailed parts list is given for each model. Proper replacement parts are listed (with installation notes where required). All parts are keyed to chassis photos and schematics for quick reference.

FIELD SERVICE NOTES

10. Each Folder includes time-saving tips for servicing in the customer's home. Gives valuable hints for quick access to pertinent adjustments, safety glass removal, special advice covering the specific chassis, etc.

With PHOTOFAC by your side, you solve your service problems in just minutes... you service more sets and earn more daily



MONEY BACK GUARANTEE!

Got a tough repair? Try this—at Howard W. Sams' own risk: see your Parts Distributor and buy the proper PHOTOFAC Folder Set covering the receiver. Then use it on the actual repair. If PHOTOFAC doesn't save you time, doesn't make the job easier and more profitable for you, Howard W. Sams wants you to return the complete Folder Set direct to him and he'll refund your purchase price promptly. GET THE PROOF FOR YOURSELF—TRY PHOTOFAC NOW!

free



Send for Sams' INDEX TO PHOTOFAC FOLDERS—your guide to virtually any receiver model ever to come into your shop; helps you locate the proper PHOTOFAC Folder you need to solve any service problem on any model. You'll want this valuable reference guide. Send coupon now.

*These are only a few of the 32 features found exclusively in PHOTOFAC—the world's finest service data

HOWARD W. SAMS & CO., INC.

Howard W. Sams & Co., Inc.
2209 E. 46th St., Indianapolis 5, Ind.

- Send FREE Index to PHOTOFAC Folders
 I am a Service Technician

Name _____

Address _____

City _____ Zone _____ State _____

"LOWEST IN RETURNS"



"Tung-Sol Tubes are lowest of all in returns because they're made to deliver in excess of the requirements of leading independent set makers."

ts TUNG-SOL®
Magic Mirror Aluminized
PICTURE TUBES

TUNG-SOL ELECTRIC INC., Newark 4, N. J. Sales Offices: Atlanta, Columbus, Culver City, Dallas, Denver, Detroit, Melrose Park (Ill.) Newark, Seattle.

The Radio Corporation of America opened an extensive advertising and promotion campaign in Chicago to tie in with the start of station WNBQ's all-color local telecasting, it was announced by R. H. Coffin, Vice President, Advertising and Sales Promotion.

"Chicago Goes Color" will be the theme of the coordinated campaign to be conducted jointly by RCA, NBC station WNBQ and the RCA Victor Distributing Corp., which distributes RCA Victor products in the Chicago area.

"As of next Sunday station WNBQ will become the world's first station to telecast all its local live programs in compatible color," Mr. Coffin said. "We believe this is an extremely important milestone in the rapid progress of color television and we are giving it our complete support."

• • •

RETMA reports that cumulative retail sales of television receivers during January and February 1956 amounted to 1,144,767 compared with 1,274,198 sets sold during the corresponding period a year earlier. Radio set sales during the first two months of this year, excluding auto sets, totaled 986,073 compared with 794,989 radios sold during the same period last year.

In February, 576,282 television receivers and 1,093,506 radios were manufactured compared with 588,347 TV sets and 1,078,624 radios produced in January. February 1955 production of television receivers had totaled 702,514 and radio output had been 1,089,724 units.

Television sets manufactured with UHF tuning facilities totaled 78,956 in February, while 2,660 TV receivers containing FM circuits were produced, RETMA said.

Picture tube sales in February totaled 898,063 units valued at \$17,136,695 compared with 892,385 tubes worth \$17,016,391 sold in January. Sales in February 1955 had totaled 859,529 picture tubes worth \$17,119,568

Receiving tube sales showed 37,754,000 tubes with a value of \$30,756,000 sold in February, compared with 40,141,000 tubes worth \$31,314,000 sold in January. Manufacturers' sales of receiving tubes had totaled 38,526,000 units with a value of \$28,108,000 in February 1955.

• • •

James M. Skinner, Jr., was elected President of Philco Corporation and William Balderston was re-

t r a d e

elected Chairman of the Board of Directors, at the organization meeting of the Company's Board Friday, April 6.

James H. Carmine, who previously expressed a wish to retire as Philco President at the conclusion of his term in office, will continue as an active member of the Board of Directors and Finance Committee, and will serve as a special consultant on sales and merchandising.

• • •

The manufacture of television receivers has been suspended by Stromberg-Carlson, a division of General Dynamics Corporation, it was announced by Robert C. Tait, President.

The decision to suspend the production of television receivers was reached after more than a year of careful study, and after a fact-finding survey of the field by an independent research organization, Mr. Tait said. The decision was actuated by an increasing demand on Stromberg-Carlson's facilities as a designer and producer of electronics equipment for manifold industrial and government applications, he explained.

• • •

J. P. Brocki has been appointed television service manager of the TV and broadcast receiver division of Bendix Aviation Corporation, it was announced by H. C. Morgan, divisional general sales manager.

Brocki has been on the staff of the division for ten years. Previously he was assistant service manager, and foreman of TV test and inspection.

In his new position he will supervise the activities of the service and parts department.

• • •

The National Electronic Distributors Association joined the citizens of the Ellenville community in a tribute to Harry, Joe and Lou Resnick, founders and owners of Channel Master Corp.

The TV antenna and accessory manufacturers were presented with a bronze plaque by Mr. Aaron Lippman, Board Chairman of the Association, in recognition of "their personal integrity and their unflinching efforts to advance the interests of the Electronics Industry and in appreciation of their enthusiastic support of our mutual objectives."

• • •

General Cement Mfg. Company of Rockville, Ill. is now acting as national distribution agency for Stackpole Resistor Division of the Stackpole Carbon Com-

flashes

pany in Ardmore, Pa. Stackpole replacement components will be packaged under the name General Cement-Stackpole, and are available to servicemen through electronics parts distributors.

• • •
"Color schools" are being planned by the Radio and Television Division of Sylvania Electric Products Inc. to show the correct way to service Sylvania color television sets, which are to be unveiled later this year.

To open the nationwide training program for servicemen, a one-week, 60-hour course will be held in Buffalo in late Spring. Mr. Merriam, Service Manager, said the school will be tailored especially for service managers of Sylvania distributors and will include lectures and actual work on the Sylvania color chassis, with defects being introduced into the circuitry and servicemen being shown techniques for correcting them.

Following this, the Division plans a one-week, 60-hour course on color service for dealer service men and independent service contractors, also to be held in Buffalo. Afterward, local color clinics will be scheduled for dealer servicemen throughout the country, running 12 and 24 hours in duration.

• • •
An entirely new line of television receiving tubes which will reduce series-string heater power 25 percent—thus easing design problems in the trend to smaller sets—has been developed by the General Electric Tube Department.

These tubes will draw 450 milliamperes of heater current and are designed to meet series-string circuit requirements of portable television receivers. G.E. production facilities are ready to turn out 450-milliamperer versions of any or all of the some 50 popular 600-milliamperer controlled warm-up types as required. The company expects that the 600-milliamperer series-string line of tubes, also originated by G.E., will continue to be used in the larger television sets.

• • •
R. J. Yeranko, Director of The Magnavox Service Department announces that Ray S. Guichard joins the Magnavox Service Department staff as Assistant Service Manager responsible for the administration of the Spartan Division service operations.

Guichard comes to Magnavox from Capehart-Farnsworth where he has been Director of Publications and Training of the Service Department since 1947.

The Spartan Division service operations will be carried on from the Magnavox Fort Wayne office.

Howard W. Sams & Co., Inc., Indianapolis electronic engineering and publishing firm which does an annual sales volume approaching four million dollars celebrates its tenth birthday this month, marking the growth of the company from a twelve-man nucleus to its present staff of over two hundred persons—eighty-four of whom have been with the company five years or more.

The event will be featured by a Service Awards Dinner at the Meridian Hills Country Club April 18th, at which fifteen persons will receive Ten Year Service pins. Eight of the twelve founders are still with the company.

• • •
The modern automobile, replete with safety features and long rear fins, is bringing about a revolution in automobile antennas, according to Ben Snyder, head of Snyder Mfg. Co., one of the world's largest manufacturers of auto radio and television antennas and automobile accessories. Snyder, one of the pioneers in rear deck antennas for automobiles, said the trend is accelerating to such an extent that manufacturers of autos will be using nothing but rear-deck antennas by 1958.

• • •
Shure Brothers, Inc. has recently moved into a new building located at 222 Hartrey Avenue, Evanston, Illinois. The new plant is situated just north of the Chicago city limits.

• • •
A record attendance of electronic engineers and scientists is expected to assemble in Washington for the seventh of a series of three-day technical meetings on electronic component parts and materials which opens on Tuesday, May 1, in the auditorium of the U. S. Department of Interior.

The theme of the 1956 Electronic Components Symposium is "Components—Accomplishments and Trends" and will feature addresses by top-level industry and government officials as well as papers by leading electronic experts from manufacturing concerns and federal agencies, the Radio-Electronics-Television Manufacturers Association announced.

• • •
Kenneth H. Brown has been appointed service manager of the television-radio division, Westinghouse Electric Corporation, G. C. Larson, assistant general manager, announced recently.

Mr. Brown was formerly service manager with the
[Continued on page 50]

"HIGHEST IN PROFITS"

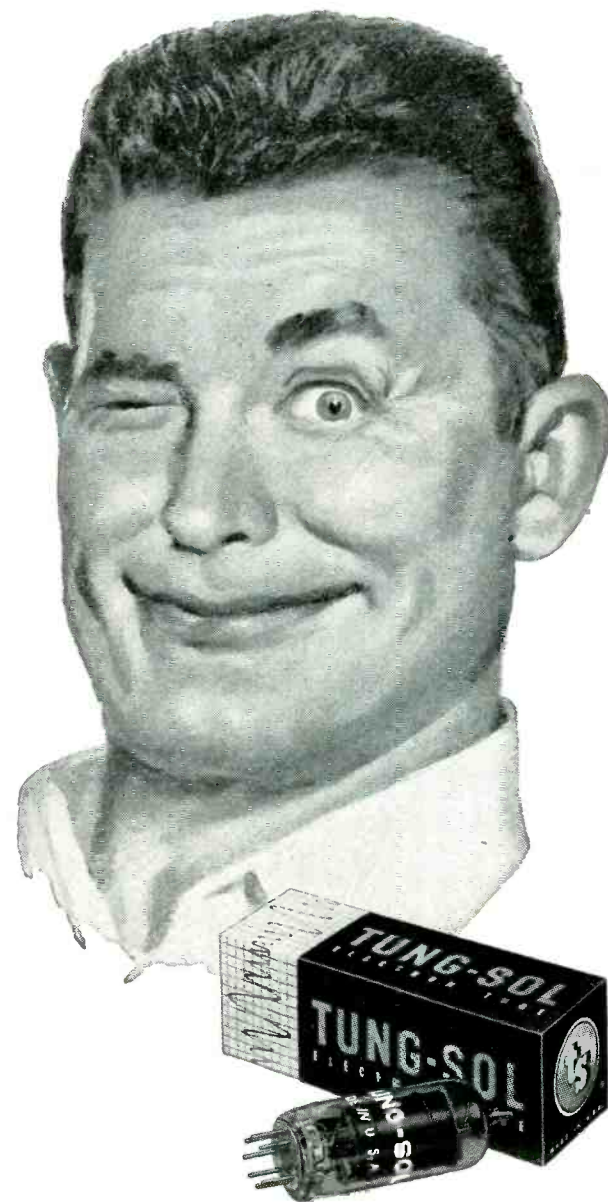

"I can depend upon Tung-Sol Tubes to stay installed. Instead of wasting time and money on callbacks, I'm out servicing new business."

ts TUNG-SOL®
Blue Chip Quality
RECEIVING TUBES

TUNG-SOL makes All-Glass Sealed Beam Lamps, Miniature Lamps, Signal Flashers, Picture Tubes, Radio, TV and Special Purpose Electron Tubes and Semiconductor Products.

Merit

FIRST IN EXACT REPLACEMENT.

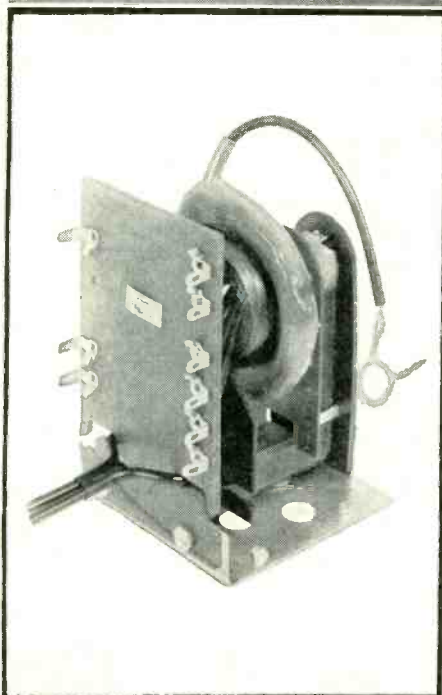

HVO-47 FOR EXACT REPLACEMENT in ANDREA, ARVIN, DUMONT, HOFFMAN, KAYE, HALBERT, PACIFIC MERCURY, PACKARD BELL, SILVERTONE, STROMBERG-CARLSON, TECH-MASTER . . . another in the complete Merit line of exact and universal transformers, yokes and coils. Merit is the only manufacturer of transformers, yokes and coils who has complete production facilities for all parts sold under their brand name.

Merit

MERIT COIL & TRANSFORMER CORP.
4427 N. CLARK ST., CHICAGO 40, ILL.

Auto Radios for 1956 OLDSMOBILES



by
**ANDREW V.
DOPPLE**

Auto Radio Serviceman
Frank A. Reeve Co.

Beginning a series of articles on auto radio installation and service on various makes of 1956 automobiles.

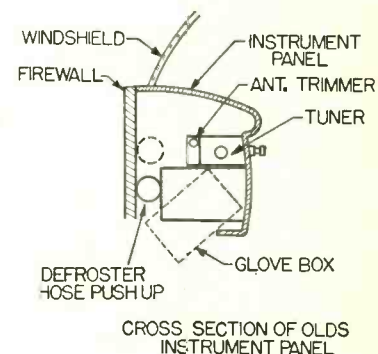

Fig. 1—Tuner mounts in glove box.

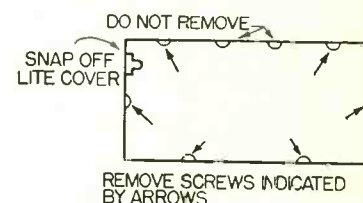

Fig. 2—Location of box screws.

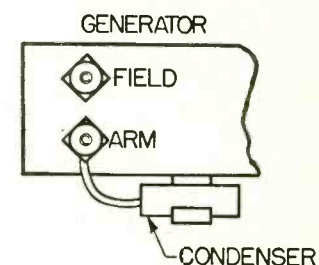

Fig. 3—Generator condenser.

OLDSMOBILE offers two 1956 models in their auto radio line for Custom installation. One, part #983334, is their De Luxe seven-tube set, including rectifier, with manual tuning and five push buttons. The other, part #983336, is an eight-tube super de luxe job with electronic tuning and five push buttons. Both receivers are supplied by Delco, a division of United Motors Service (G. M. Co.). Each receiver comes in two units, one containing the complete tuner section, plus amplifiers and the other, containing the speaker and power supply.

Installation

The tuner unit mounts in the center of the instrument panel, directly above the glove box as shown in Fig. 1. Removal of the glove box presents the only difficult problem, but is rather easy if a few simple instructions are followed. Open the glove door and remove the six Phillips-Head self-tapping screws, as shown in Fig. 2. Do not remove the two

screws holding the glove box door catch. Remove the glove box lite cover (snaps off) and bulb. Now push the box forward as far as possible and push the flexible depositor base up and out of the way (do not disconnect). At the same time push the glove box down, and it will fall to the floor.

The tuner unit is now accessible. Remove the front controls with a small screwdriver also the mounting nuts, using a 5/8" deep socket wrench. Disconnect the three-prong plug from the speaker unit, (held in place by Phillips self-tapping screw). Disconnect the green and black wires which are held together by two push-in type plastic connectors. Remove the antenna lead-in; then, with a 7/16" wrench remove the bolt holding the tuner to the mounting bracket, on the side facing the steering column. Push the unit forward, until the controls clear the mounting holes. Tilt the set down in back and out.

Disconnect the green "A" supply wire. Current is supplied to the set through

the tuner unit from a fuse holder marked "radio" located directly under the steering column. The fuse is a 7/2

Oldsmobile DeLuxe Model 983334 12 volt Delco auto radio.

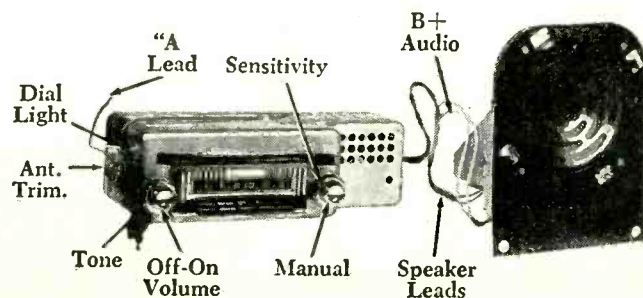

Oldsmobile Super DeLuxe Model 983336 Delco auto radio.

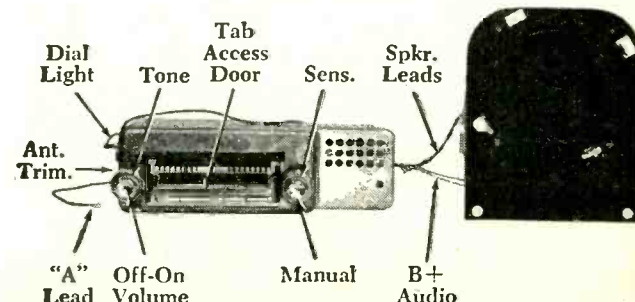

amp., type AGW. The speaker-power unit mounts directly behind the grille at the right end of the instrument panel. Four bolts hold the unit to the mounting bracket. Use a 7/16" wrench for removal.

Two antenna types are available. One is manually operated and the other is an electrical push-button control job. Both mount on the left front fender.

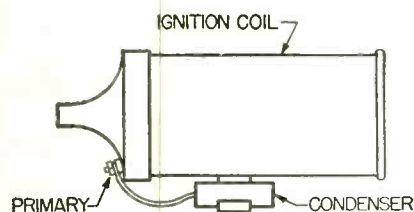

Fig. 4—Ignition coil condenser.

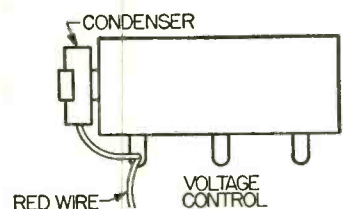

Fig. 5—Voltage control condenser.

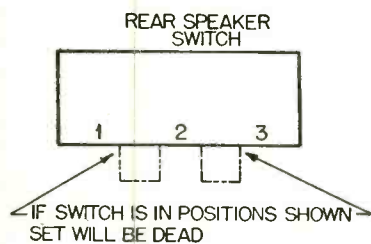

Fig. 6—Speaker switch details.

All 1956 Oldsmobiles have special resistor type spark plug and coil wires and no other suppression is necessary at the distributor. Condensers are mounted at the following points: (1) "A" terminal (brown wire) of the generator (see Fig. 3), (2) the primary terminal of the ignition coil (Fig. 4) (3) the positive (red wire) terminal of the generator-voltage control. (Fig. 5).

The super de luxe receiver, #983336 is identical to the above except for the addition of a 12AU7 tube for the operation of the automatic tuning feature.

Service Suggestions

The antenna trimmer condenser is located on the tuner unit at the rear on the side toward the steering column.

[Continued on page 39]

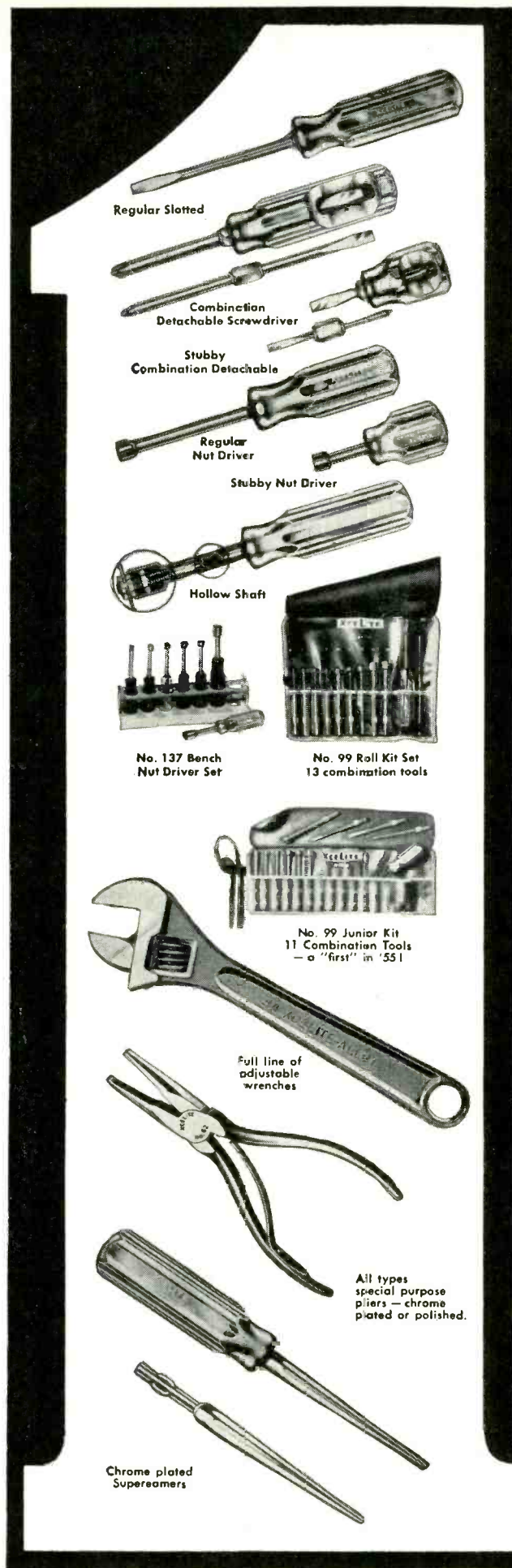

XCELITE

BRINGS YOU THE FINEST TOOLS *FIRST!*

FIRST with plastic handle screwdrivers. First to use amber color. First with man-size handles!

FIRST with square bladed screwdrivers.

FIRST with alloy steel blades in all screwdrivers. First to standardize on S.A.E. 6150 chrome vanadium.

FIRST to introduce nut drivers with plastic handles.

FIRST to draw-form nut driver sockets instead of broaching.

FIRST to use colored nut driver handles to signal size.

FIRST with small pocket clip screwdrivers.

FIRST with reversible combination Phillips and regular screwdrivers.

FIRST with detachable reamers.

FIRST with complete screwdriver — nut driver — reamer kits — new and better ones every year.

FIRST with ...

well, see for yourself at

BOOTH 225

Chicago Parts Distributors Show

"Originators — not imitators"

XCELITE, INCORPORATED

DEPT. R, ORCHARD PARK, NEW YORK

In Canada — Charles W. Pointon Ltd., 6 Alcina Avenue, Toronto, Ontario

The ANSWERMAN

Inquiries Sent To The Answerman Will Be Acknowledged Only If Accompanied By Radio-TV Service Firm Letterheads Or Similar Identification.

**Dictate Reports
Accurately-Promptly!**
make your car, boat or plane
a "rolling office"
with **ATR**
INVERTERS

for changing your storage
battery current to
A.C. Household
ELECTRICITY
Anywhere
... in your
own car!

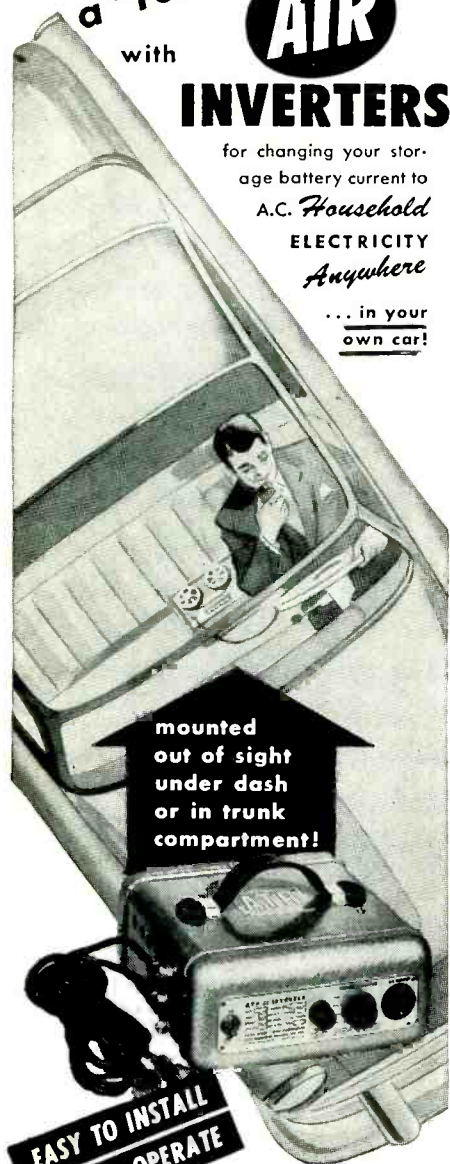

**EASY TO INSTALL
EASY TO OPERATE**

ATR INVERTERS

especially designed for operating
standard 110 volt A. C. . . .

- TAPE RECORDERS
 - DICTATING MACHINES
 - WIRE RECORDERS
 - ELECTRIC RAZORS
- for
- EXECUTIVES
 - OUTDOOR MEN
 - SALESMEN
 - REPORTERS
 - PUBLIC OFFICIALS
 - FIELD INSPECTORS
 - POLICEMEN
 - DOCTORS
 - FIREMEN
 - LAWYERS, ETC.

See your jobber or write factory

✓ NEW MODELS ✓ NEW DESIGNS ✓ NEW LITERATURE
"A" Battery Eliminators, DC-AC Inverters, Auto Radio Vibrators

ATR AMERICAN TELEVISION & RADIO CO.
Quality Products Since 1931
SAINT PAUL 1, MINNESOTA, U. S. A.

BY RTSD TECHNICAL STAFF

Dear Mr. Answerman:

I have a Philco TV-332 chassis with an automatic tuning system. I am having a little problem with it and wonder if you can suggest a solution.

The customer's complaint is that the remote feature of this system works sometimes, and sometimes not. Occasionally the tuner does not stop on station.

The unit is completely new to me and I don't exactly know how to tackle it, or where to start. Is it possible that the gear train is binding somewhere?

R. P.

Chicago, Ill.

Philco automatic tuning systems have worked very well and ordinarily have not experienced any binding in the system. I don't believe this is your trouble. I think that more than likely a small amount of grease or dirt has gotten down into the contacts of the stepper unit switch as shown in Fig. 1. The contacts on the stepper unit switch should be cleaned out with carbon tet

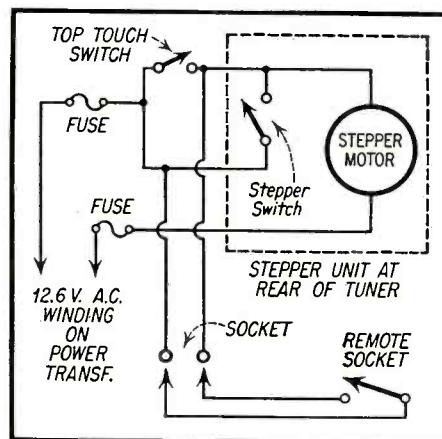

Fig. 1—The automatic touch tuning circuit used with the Philco TV-332 chassis.

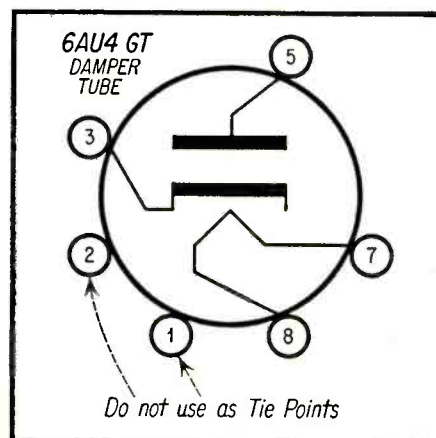

Fig. 2—Pins 1 and 2 should be avoided as tie point terminals on 6AU6-GT tubes.

or contact cleaning fluid as used for TV tuners. Of course if the contacts have become carbonized it is necessary to remove the burned spot. The carbonization should be cleanly removed and then the contacts washed to remove any possible oil or dirt.

Dear Sir:

I have noticed in several new TV sets that there has been a number of 6AU4-GT damper tube failures. I have been unable to come up with a good reason for this tube becoming defective so frequently.

Is it possible that there has been a bad run of these tubes?

E. H.

San Francisco, Calif.

It is not believed that the cause of repeated damper tube failures is necessarily due to the tube itself.

Some TV receivers, unfortunately, make use of the unused terminals on the damper tube socket as tie lugs. Recommendations by tube manufacturers with respect to this is that the damper tube socket not be used for such connections or tie points because it increases the possibility of breakdown in the socket between the damper tube

high potential pins and anything connected to the vacant socket terminals. It has been noticed in some of these cases that arc-over has occurred across the socket, as well as through the socket material. Often there is evidence of the arcing on the socket in the form of a black carbonization between the pins with which it is occurring. It is suggested that such tie points be removed when repeated damper tube failure occurs. Generally it is indicated in most tube manuals that pins 1 and 2 on the socket as shown in Fig. 2 should not be used.

Mr. Answerman:

I have a Sylvania TV receiver that is causing me a little concern. The "Halolight" flickers when the set is in operation and my customer objects to it. Not being too familiar with this unit I am at a bit of a loss to know exactly what to do. I actually do not have a copy of the circuit diagram so I am further handicapped.

Any suggestions or hints you can give me as to why the Sylvania "Halolight" may be blinking and what to do about it will be of considerable assistance to me.

C. L.

Newark, N. J.

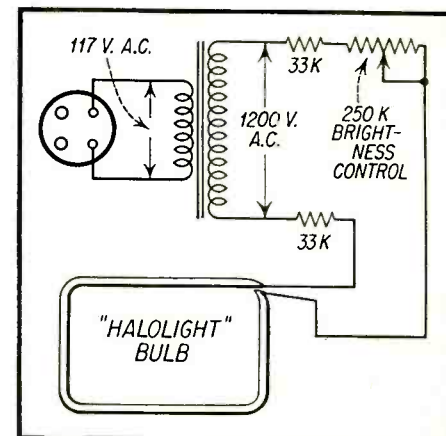

Fig. 3—"Halolight" circuitry showing components. Note brightness control.

Although there is seldom trouble with this feature as applied to the Sylvania TV receivers, any number of things may have occurred to bring about the condition.

First, it is suggested that the transformer voltage be measured. As shown in Fig. 3, this voltage should be around 1200 volts *ac* for most receivers, except the 24 inch picture tube size which requires about 1800 volts. It is possible that the transformer has failed and is furnishing inadequate or improper voltage.

The next check to be made is of the two current limiting resistors, 33K ohms, and the series brightness potentiometer which is 250K ohms. It may be that one of these series resistors or the brightness potentiometer has become defective, or has increased in value. Perhaps the best method of testing these resistors is to substitute new ones in place of the existing ones.

If the blinking persists reduce the value of one of the 33K ohm resistors to about 27K or perhaps a little lower. It is very possible that the "Halolight" tube has aged and requires an increase in applied voltage to keep it lighted. A caution that should be observed in reducing the value of these resistors is that if they are made too low in value the dissipation rating of the components may be exceeded.

If the above change does not correct the bulb flickering the bulb itself should be examined. In the manufacture of these bulbs many times the required amount of mercury is deposited in the tube and it is generally visible as a small drop rolling around in the bulb if held up to the light. When a mercury drop is not found rolling around inside the tube it often indicates that there may be insufficient mercury in the tube and the tube requires replacement.

Another point about the tube is that it should be checked out of the metal light shield. If the tube lights when held in the hand (this can be done without being exposed to a shock hazard if the bulb is gripped away from the end terminals) then the terminals should be examined and covered with a few windings of cambric tape over the sleeves at each end. The plastic material may be cracked or defective and not providing proper insulation.

PRECISION

presents...the New Model E-420
DOT and BAR GENERATOR
for Color Convergence - Linearity Patterns



YES!
The NEW Model E-420
is compatible for Color
and Monochrome TV.

It is the one Dot and Bar Generator that offers at a reasonable price, every desirable feature for color convergence and linearity testing.

Model E-420 Deluxe (illustrated): In custom-styled, blue-grey, hooded steel cabinet and four-color, satin-brushed aluminum panel with contrasting dark-blue control knobs. Dimensions 13 x 11½ x 6½ inches. Complete with tubes, output cables and comprehensive instruction manual.

Net Price: \$150.00

Model E-420 Standard: Electrically identical to above, but in standard black ripple finished cabinet with black anodized aluminum panel. Case dimensions 10½ x 12 x 6 inches. Complete with tubes, cables and manual as above.

Net Price: \$145.00



● it's a
WHITE DOT generator



● it's a
VERTICAL BAR generator



● it's a
HORIZONTAL BAR generator



● it's a
CROSS HATCH PATTERN generator



● it has
VARIABLE DOT SIZE and NUMBER



● it has
VARIABLE 'V' and 'H' BAR WIDTH and NUMBER



● it provides
DIRECT VIDEO OUTPUT

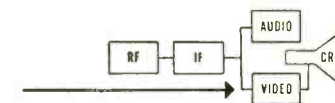

● it provides
MODULATED TV CHANNEL OUTPUT

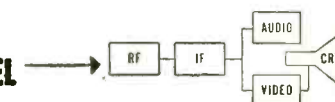

PRECISION Apparatus Company, Inc.

70-31 84th Street, Glendale 27, Long Island, New York

Export: Morhon Exporting Corp., 458 Broadway, New York 13, N.Y., U.S.A.
Canada: Atlas Radio Corp., Ltd., 50 Wingold Ave., Toronto 10, Ontario

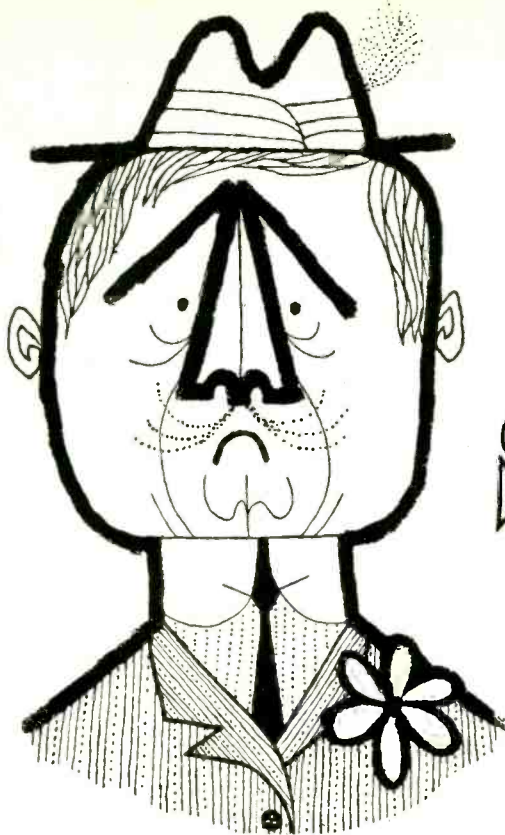

SAD?

because you
weren't able
to get your

1956 *Radio Electronic* MASTER

Sorry you were disappointed. In many areas, there just weren't enough MASTERS to meet the demand.

But — cheer up. If you act fast, we can help you get your industry-wide buying guide. We've located several distributors with extras on hand.

And what's more . . . you'll only pay the \$2.95 distributor price instead of the regular \$7.50.

So send your coupon now . . . first-come — first-served.

1450-Page Buying Guide . . . helps you shop before you buy. The supermarket pages of The MASTER enable you to compare specs and prices first — then buy and save.

Right in Your Customer's Home . . . you can sell direct from The MASTER's pages. Watch it pay off in extra sales!

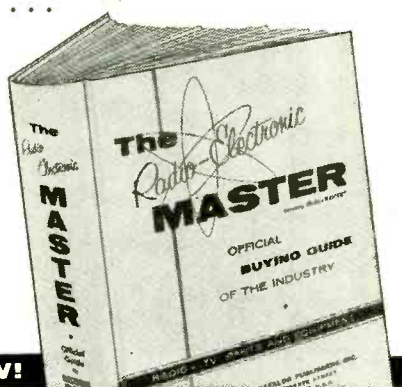

- 100,000 items
- Complete descriptions
- Specifications—Prices
- 11,000 illustrations
- 8 x 11", 6 lbs.
- 350 mfrs.

MAIL COUPON NOW!

UNITED CATALOG PUBLISHERS, INC., 110 LAFAYETTE ST., NEW YORK 13, N. Y.
Here's my \$2.95. Please rush me the 1956 MASTER, Official Buying Guide of the Electronic Parts and Equipment Industry.

Name.....

Address.....

City..... Zone..... State.....

SD-5

COLOR RF-IF

[Continued from page 17]

linear operation for the range of signals received must be used.

The third item, "Impedance match between transmission line and tuner," is an important consideration because unless this match is maintained, standing waves will be introduced in the antenna circuit. Under conditions of mismatch the amplitude relations between the luminance and chrominance signals will not remain constant for the various channels tuned in, thereby producing the effects just discussed.

The final consideration, "Local oscillator frequency stability," refers to the ability of the oscillator in the tuner to arrive at an operating frequency in 30 seconds after turn-on, and its ability to maintain that frequency with negligible drift during the subsequent use of the set. One of the important consequences of oscillator drift which shows up in a color receiver reflects in the wideband character of the *if* bandpass (4.2 *mc*), and the steep slope of the bandpass in the vicinity of the sound *if* notch. (See Fig. 3). Drifts of 200 or 300 *kc* would produce negligible sound-in-picture interference in the usual narrow band black and white receiver. However, this amount of oscillator drift in a color receiver will bring the sound *if* carrier well up the steep slope of the curve and produce annoying sound beat patterns. These beat patterns will consist of both 4.5 *mc* sound information and a 920 *kc* beat. This 920 *kc* beat is produced by the interaction of the sound *rf* carrier and the *if* color subcarrier in the video detector. The beat frequency degrades the monochrome and color portions of the picture, giving rise to a fine herringbone

color pattern. Obviously, keeping the sound signal attenuated will keep the 920 *kc* beat invisible.

Video I.F. Considerations

When comparing video *if* system requirements for color receivers with those of black and white receivers the first significant point that presents itself is the greater video *if* bandpass required in color TV. Taking into consideration that the color subcarrier is located 3.58 *mc* above the picture carrier, and that an additional .5 *mc* must be added for upper color sideband information, (plus about .1 *mc* to allow for variations in *if* tuning), it becomes evident that the video *if* bandpass must be able to accommodate a bandpass up to 4.2 *mc*.

This bandpass is much greater than that required for monochrome receivers. On this score alone, the circuits used in color TV will be found to be somewhat different from those used in monochrome receivers. Fig. 3 illustrates a typical video *if* bandpass characteristic for a color receiver, and points up the 4.2 *mc* response range. This curve is drawn for a video *if* pix carrier frequency of 45.75 *mc* and a corresponding sound *if* carrier frequency of 41.25 *mc*.

Notice that the amplitude of the video *if* carrier (as in monochrome receivers) is adjustable to 50% of the maximum value of the curve to compensate for the vestigial sideband nature of the transmitted signal.

Proceeding to the color *if* subcarrier, we observe that at this frequency the response is on the flat part of the curve. This flatness is maintained for .5 *mc* above the color subcarrier to accommodate the color video sideband signals from 3.58 to 4.08 *mc*.

[Continued on page 32]

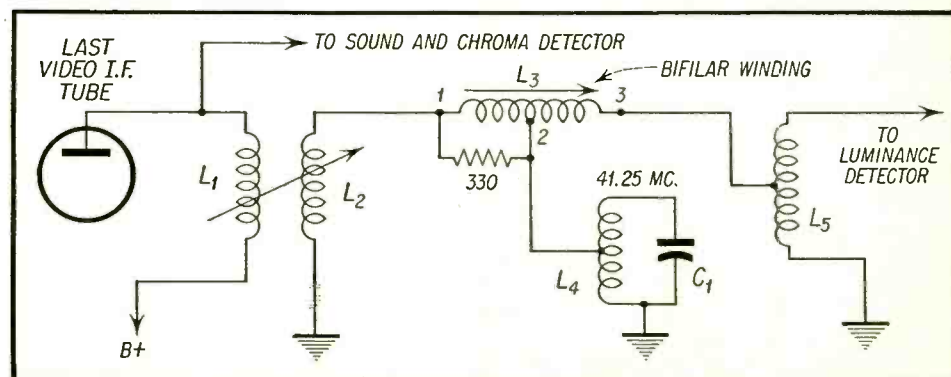

Fig. 5—Bifilar T trap circuit provides high rejection of the sound I.F.

HEIGHT CONTROL - This control increases the overall height of the picture. When making this adjustment it is sometimes necessary to also correct the Vertical Linearity to obtain a picture that is correctly proportioned.



Misadjusted Height

VERTICAL LINEARITY - This control increases or decreases the height of the upper portion of the picture. Readjustment of the Height Control may be necessary after adjusting the Vertical Linearity.



Misadjusted Vertical Linearity

AGC LEVEL CONTROL - This control when misadjusted may cause a picture to be overcontrasted, or to show vertical or horizontal jitters, picture pull, or buzz in the sound. If readjustment seems necessary, the control can be readjusted by one of the methods given under "AGC Level Control".

NOISE GATE CONTROL - With this control, it is possible to obtain improved picture stability in the presence of electrical interference (noise). To adjust, first turn the control completely counter-clockwise where its effect is minimized. Then advance the control clockwise only far enough to stabilize the picture. If the control is adjusted on a signal of one strength, it may require readjustment when a signal of different strength is received, or when the setting of the Area Switch is changed. The final adjustment of this control should be made on the strongest signal received. The limiting factor in this adjustment is the loss of sync stability or the introducing of buzz into the sound.

BUZZ CONTROL - See Sound Alignment

ION TRAP MAGNET - See Ion Trap Magnet Adjustment

REAR VIEW ADJUSTMENTS

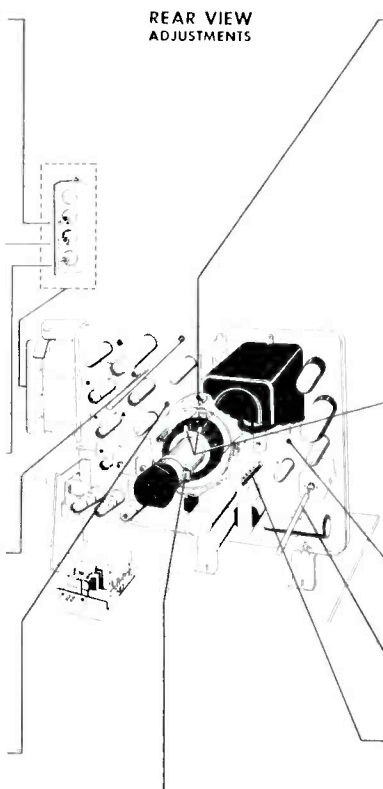

DEFLECTION YOKE ADJUSTMENT - The deflection yoke must be positioned as far forward as possible on the neck of the picture tube. To do this, loosen wing nut on the top of the yoke shield and push the yoke snug against the bell of the picture tube. At the same time, rotate the yoke to left or right as required to make the picture parallel with respect to top and bottom of window frame. Be sure to hold the yoke in position while tightening the wing nut.



Picture Tilted

CENTERING MAGNET ADJUSTMENT - If the picture is off center and/or has neck shadow as shown in the illustration below, rotate either or both centering magnet levers until the picture is centered on the screen and is free of all neck shadow. Then readjust the Ion Trap.



Off Center and Neck Shadow

HORIZONTAL DRIVE - With a screwdriver inserted through the small hole just below the Horizontal Output Transformer, adjust the Horizontal Drive Trimmer for maximum picture width.

HORIZONTAL FREQUENCY CONTROL - See Horizontal Frequency Adjustment

FOCUS - On the terminal board located below and to the right of the deflection yoke, move the blue lead from one lug to another until the sharpest picture or sharpest horizontal lines are obtained. Note that the position of the lead may need to be changed if a replacement picture tube is installed.

AGC LEVEL CONTROL ADJUSTMENT

CAUTION - Unlike most AGC adjustments, the AGC control cannot be adjusted in the usual manner by setting it to the position where the picture just begins to overload. Because the Contrast Control in the present sets is located in the output circuit of the video amplifier, a different method of setting up the AGC control must be used. Note, however, that the setting is somewhat critical. If the control is advanced too far, the picture may not only be overcontrasted, but the sync portion of the video signal may be compressed or clipped, and thus cause an unstable sync, vertical or horizontal jitters, picture pull, and/or buzz in the sound. If it is not advanced (clockwise) far enough, the video detector signal will be too low and cause a weak contrasted picture.

The AGC Control is preset at the factory and signal handling capabilities of the AGC circuit is good enough that it should rarely, if ever, have to be reset when the receiver is installed in the home.

However, should the control be inadvertently turned, or if the picture shows signs of a misadjusted AGC Control, it can readily be checked by one of the methods below. The method using an oscilloscope is the best and most satisfactory way.

WITHOUT AN OSCILLOSCOPE

Step	Receiver Tuned to	Contrast Control and Noise Gate set to	Adjustment of AGC Control
1	Medium to strong TV signal. Weak signal cannot be used.	Contrast set full clockwise so that Area Switch is in "Fringe" position. Noise Gate Control fully counter-clockwise.	Rotate AGC control to fully counter-clockwise position and note position of slot in shaft.
2	"	"	Advance AGC control slowly clockwise to where the picture shows the first sign of overload (drift or jitter in picture or loss of sync), and note the position of the slot.
3	"	"	Estimate the amount the control shaft was rotated from the full counter-clockwise position. Back the control off approximately 45% to 50% of this distance.
4	"	"	Recheck the receiver on all stations to make sure there is not only adequate contrast, but also that there are no signs of overload. If in doubt, repeat steps 1 thru 3, and/or favor the setting of the AGC control that reduces the contrast range.
5	"	"	Reset the Noise Gate Control, if necessary.

HORIZONTAL FREQUENCY ADJUSTMENT

The Horizontal Frequency Control is the extension on the brass screw in the top of the Horizontal Oscillator coil (L117) which is located below the Horizontal Output tube. The extension shaft permits the adjustment of the control, when necessary, to compensate for any change due to aging of the tubes or components in the circuit which would shift the oscillator frequency beyond the range of the Horizontal Hold Control.

Step No.	Receiver Tuned to	Set Horizontal Hold Control	Adjust Horizontal Frequency Control
1	TV station signal	Fully clockwise.	Adjust clockwise or counter-clockwise until picture locks in. Be sure that Noise Gate Control is not advanced too far.
2	"	"	Adjust counter-clockwise (out of can) until picture goes out of sync.
3	"	"	Adjust slowly clockwise until picture just locks or syncs in.
4	"	Center of range.	When the Frequency Control is properly adjusted, the range of the Horizontal Hold Control is such that when the tuner is switched off and back onto a station, the picture will pull in and lock when the control is set near either end of its range.

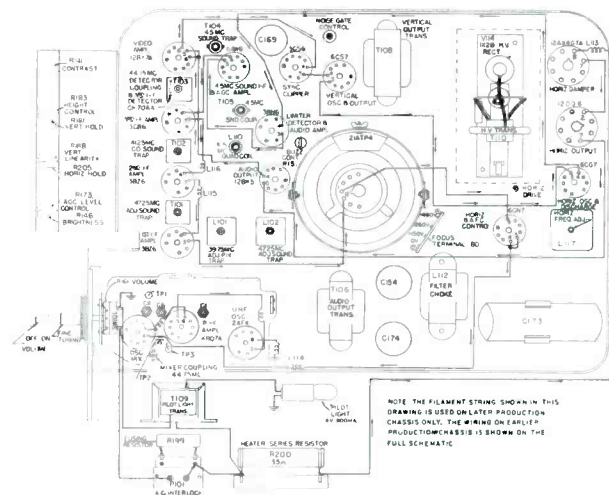

Bulletin No. 494 TUBE SIDE OF CHASSIS (Tube and Alignment Locations and Tube Filament Wiring)

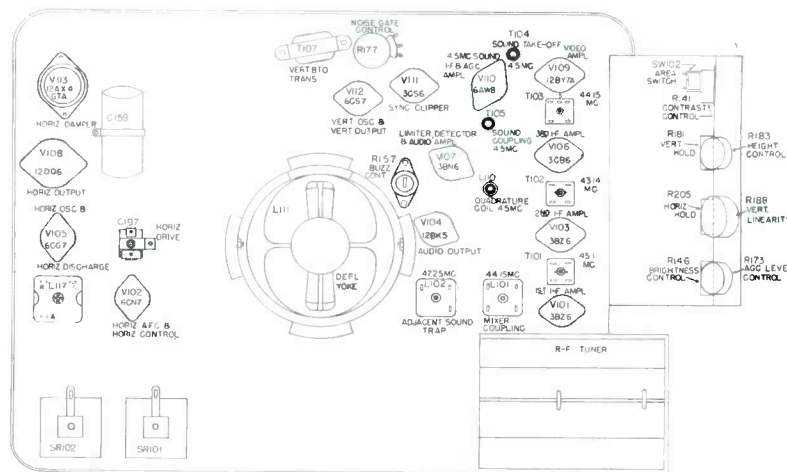

WIRING SIDE OF CHASSIS 472 & 473 (Tube and Alignment Locations)

SOUND ALIGNMENT

The 4.5 mc. trap slug of L109 must be aligned first, regardless of which procedure is used for the remainder of the alignment (Procedure A or B).

Step No.	Channel Set to	Signal Generator Connected to	Scope Connected to	Adjust
1.	Any unused channel	Lug 5 of T103 and chassis. Set generator for 4.5 mc. 400 cycle AM signal (modulated 30% or greater).	High side (thru detector probe) to high side of contrast control, or blue lead on the top lug of terminal board located on tube side of chassis adjacent to T102. Low side of scope to chassis.	Back out each slug of T104. Then adjust slug on clip side of T104 until first null is reached, indicated by minimum height of pattern on scope screen.

Proceed with the remainder of the Sound Alignment, using either a signal from a TV station as a Procedure A, or alignment equipment as in Procedure B.

PROCEDURE A (With signal from station)

Step No.	Channel Set to	Adjust	Remarks
1.	Strong signal	L110 (Quadrature coil) for maximum sound output. 2nd peak from open end of coil is the correct peak.	Set Buzz Control (R157) approximately 90° from clockwise stop.
2.	Weak signal	T104 (slug on wiring side of chassis) and T105 for maximum sound output.	Keep signal below limiting. If the signal in the area is too strong to obtain these peaks, remove the antenna from the receiver.
3.	Weak signal	Buzz Control (R157) for minimum noise hash.	This signal should be weak enough to allow noise (hash) to come thru along with the sound.
4.	Strong signal	L110 (Quadrature coil) for maximum sound output.	Limit the volume control setting so that this peak can be heard.
5.	Weak signal	Repeat step 3.	Same as for step 3.

SCHEMATIC CHASSIS 472 (CODE B) and 473 (CODE B)

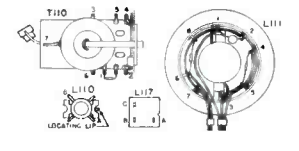
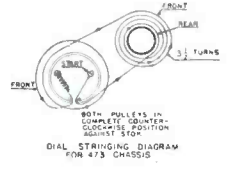
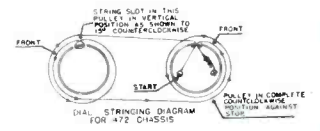
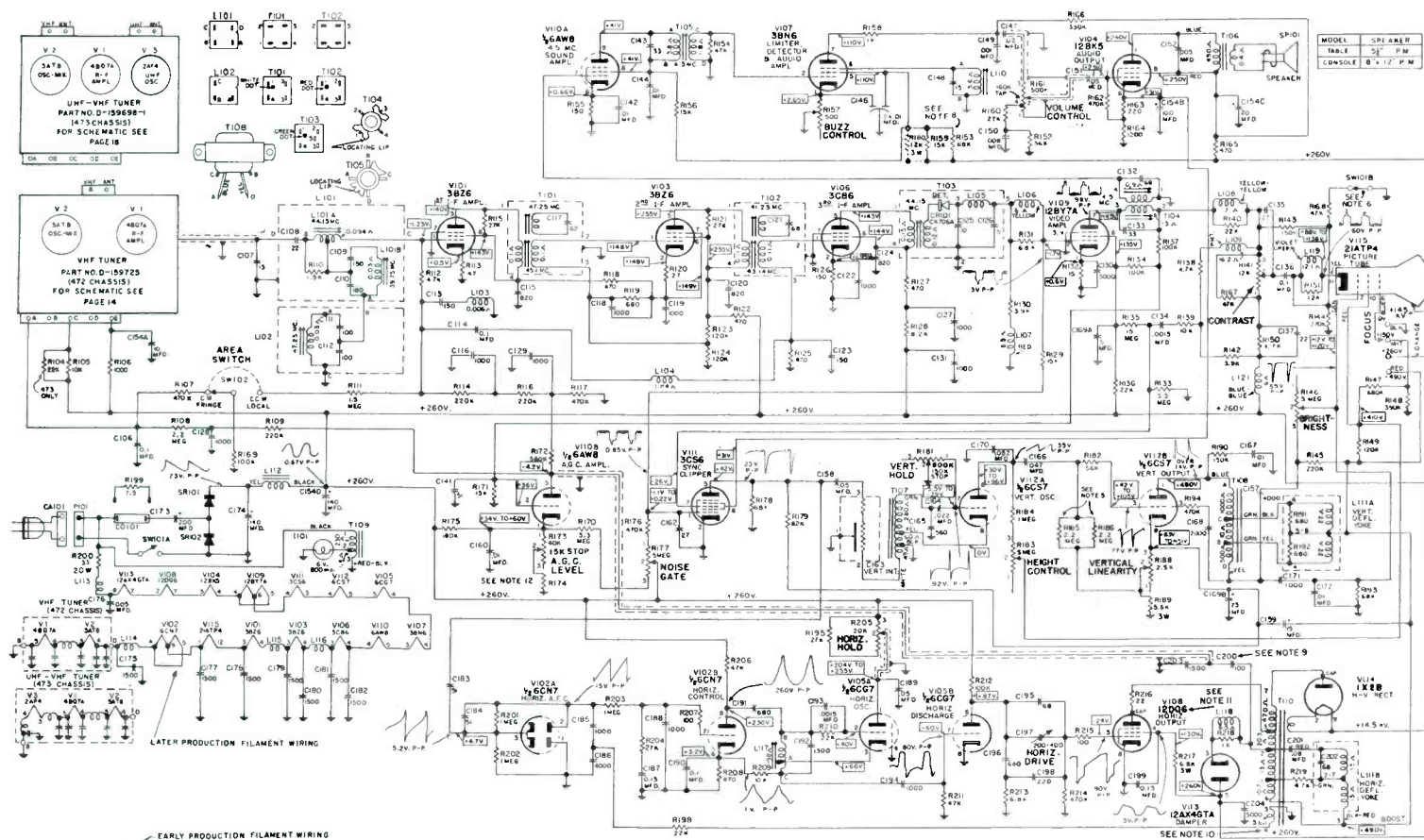

TO ADJUST THE ION TRAP MAGNET Set the Brightness control completely counter-clockwise, then advance slightly clockwise (less than 1/4 turn). Slide the trap forward or backward on the neck of the tube and at the same time rotate trap clockwise or counter-clockwise until a raster appears, then adjust for maximum brightness. If no raster is obtained with this setting of the Brightness control, advance the control slightly clockwise and repeat adjustment of the trap until a raster appears. The final setting of the trap should be made with the Brightness control set to the maximum position with which good line focus can be obtained. If neck shadow is encountered, or if the picture is off center, correction should be made with the centering magnet on the back cover of the deflection yoke. Never use the Ion Trap to correct neck shadow. Always set the trap to the position where maximum brightness is obtained. After any adjustment of the deflection yoke or centering magnet the Ion Trap should always be checked and readjusted for maximum brightness.

UHF - VHF TUNER
(Part No. 159698-1)

VHF TUNER
(Part No. 159725-1)

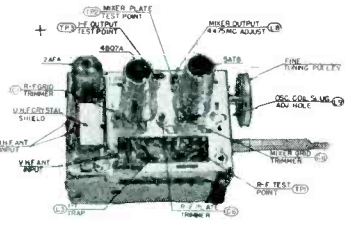

COMBINATION VHF-UHF
13-Position Turret Tuner, Part No. 159698-1

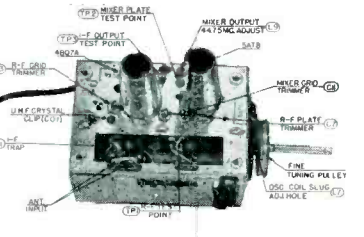

VHF TURRET TUNER Part No. 159725-1

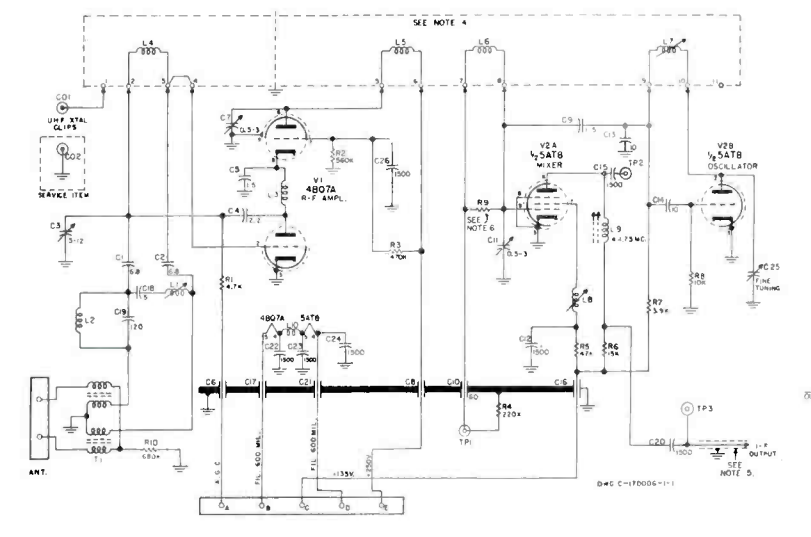
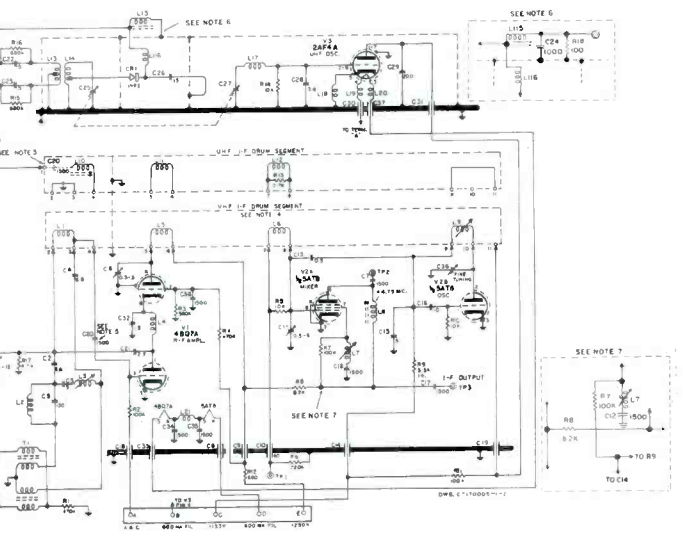

BLOCK DIAGRAM

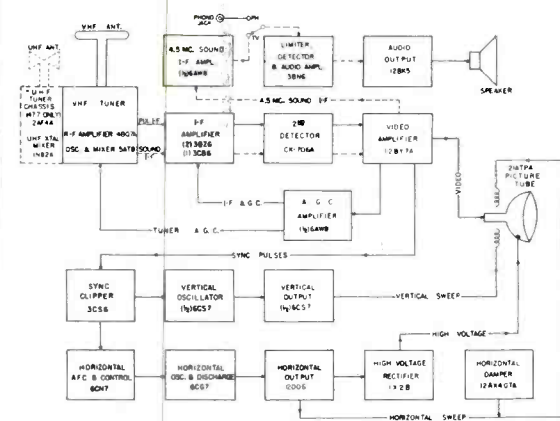

SPECIFICATIONS

POWER SUPPLY: 117 volts, 60 cycle, a.c.
POWER CONSUMPTION TV, 155 watts VHF
 Phono, 120 watts Models
 TV, 160 watts VHF-UHF
 Phono, 125 watts Models
AUDIO POWER OUTPUT: 1.7 watts maximum.
ANTENNA INPUT IMPEDANCE: 300 ohms balanced.
FREQUENCY RANGE: 54 to 88 mc. & 174 to 216 mc.
 (Channels 2 thru 13)
 470 mc. to 890 mc. (Channels 14 thru 83)
INTERMEDIATE FREQUENCY:
 Video Carrier -- 45.75 mc.
 Sound Carrier -- 41.25 mc.
 Inter-carrier Sound -- 4.5 mc.
DEFLECTION: Electromagnetic.
FOCUS: Electrostatic.
ION TRAP: Single Permanent Magnet.
HORIZONTAL SCANNING FREQ: 15,750 c.p.s.
VERTICAL SCANNING FREQ: 60 c.p.s.
FRAME FREQUENCY: 30 c.p.s.
SCANNING: Interlaced, 525 lines.
SPEAKER: 8" x 12" PM.
VOICE COIL IMPEDANCE: 3.2 ohms @ 400 cycles.

HEIGHT CONTROL - This control increases the overall height of the picture. When making this adjustment it is sometimes necessary to also adjust the Vertical Linearity to obtain a picture that is correctly proportioned.

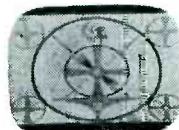

Misadjusted Height

VERTICAL LINEARITY - This control increases or decreases the height of the upper portion of the picture. Readjustment of the Height Control may be necessary after adjusting the Vertical Linearity.



Misadjusted Vertical Linearity

AGC LEVEL CONTROL - This control when misadjusted may cause a picture to be overcontrasted, or to show vertical or horizontal jitters, picture pull, or buzz in the sound. If readjustment seems necessary, the control can be readjusted by one of the methods given under "AGC Level Control"

NOISE GATE CONTROL - With this control, it is possible to obtain improved picture stability in the presence of electrical interference (noise). To adjust, first turn the control completely counterclockwise, where its effect is minimized. Then advance the control clockwise only far enough to stabilize the picture. If the control is adjusted on a signal of one strength, it may require readjustment when a signal of different strength is received, or when the setting of the Area Switch is changed. The final adjustment of this control should be made on the strongest signal received. The limiting factor in this adjustment is the loss of sync stability or the introducing of buzz into the sound.

BUZZ CONTROL - See Sound Alignment

ION TRAP MAGNET - See Ion Trap Magnet Adjustment

REAR VIEW ADJUSTMENTS

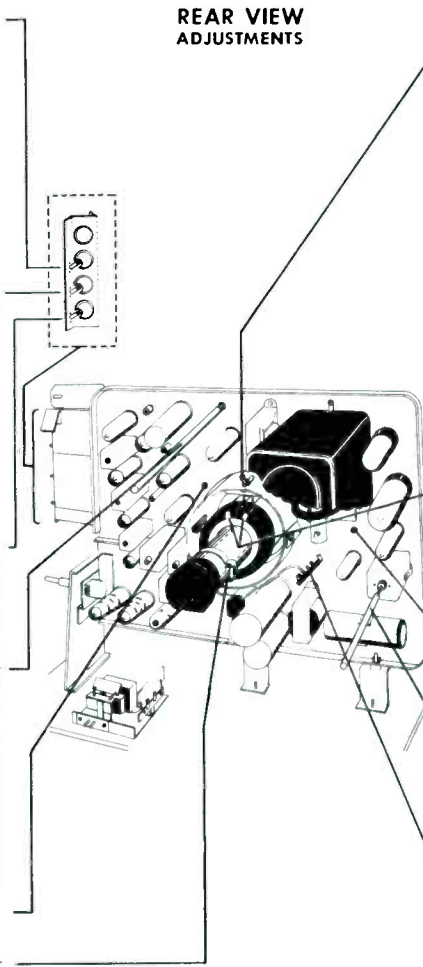

DEFLECTION YOKE ADJUSTMENT - The deflection yoke must be positioned as far forward as possible on the neck of the picture tube. To do this, loosen wing nut on the top of the yoke shield and push the yoke snug against the bell of the picture tube. At the same time, rotate the yoke to left or right as required to make the picture parallel with respect to top and bottom of window frame. Be sure to hold the yoke in position while tightening the wing nut.



Picture Tilted

CENTERING MAGNET ADJUSTMENT - If the picture is off center and/or has neck shadow as shown in the illustration below, rotate either or both centering magnet levers until the picture is centered on the screen and is free of all neck shadow. Then readjust the Ion Trap.



Off Center and Neck Shadow

HORIZONTAL DRIVE - With a screwdriver inserted through the small hole just below the Horizontal Output Transformer, adjust the Horizontal Drive Trimmer for maximum picture width.

HORIZONTAL FREQUENCY CONTROL - See Horizontal Frequency Adjustment

FOCUS - On the terminal board located below and to the right of the deflection yoke, move the blue lead from one lug to another until the sharpest picture or sharpest horizontal lines are obtained. Note that the position of the lead may need to be changed if a replacement picture tube is installed.

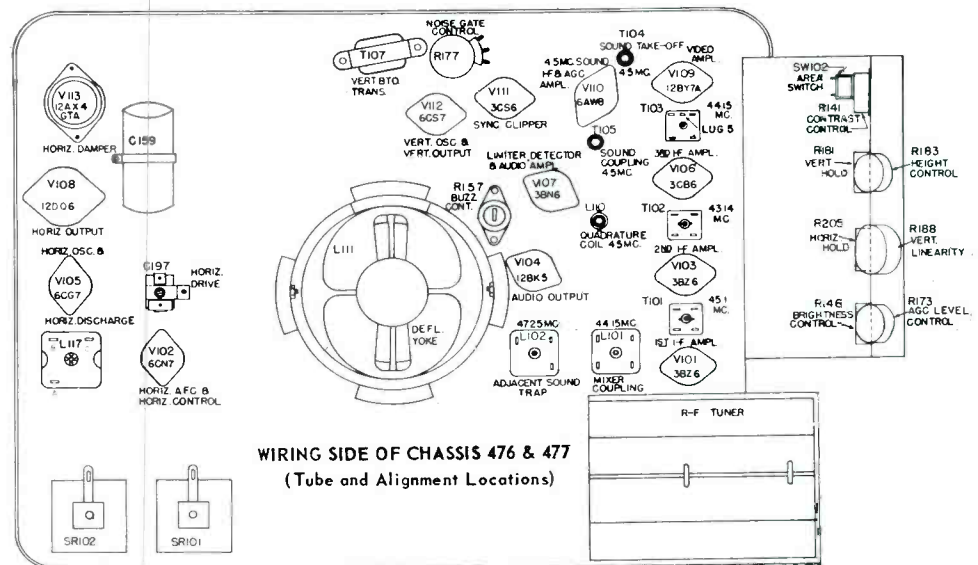

WIRING SIDE OF CHASSIS 476 & 477 (Tube and Alignment Locations)

ALTERNATE OSCILLATOR ALIGNMENT

In the tuners used on chassis 476 and 477, there is an oscillator adjustment for each channel. When the receiver is installed, the oscillator should be adjusted for each channel on which a station is operating in the area.

Set the Channel Selector to the channel that is to be adjusted. Turn the Fine Tuning control to as near the center of its range as will permit the slug to be adjusted. The oscillator trimmer slug is to the right of the channel selector shaft, and is accessible thru a hole in the front of the tuner after the tuner knobs have been removed. Use a non-metallic screw driver and adjust the oscillator trimmer slug until the proper tuning point is in the center of the Fine Tuning Range.

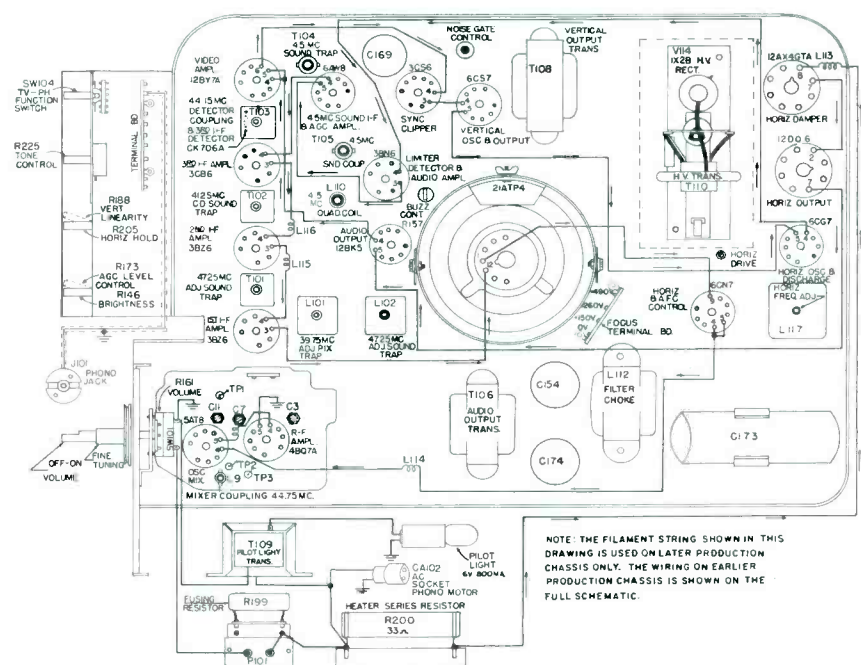

TUBE SIDE OF CHASSIS (Tube and Alignment Locations and Tube Filament Wiring)

NOTE: THE FILAMENT STRING SHOWN IN THIS DRAWING IS USED ON LATER PRODUCTION CHASSIS ONLY. THE WIRING ON EARLIER PRODUCTION CHASSIS IS SHOWN ON THE FULL SCHEMATIC.

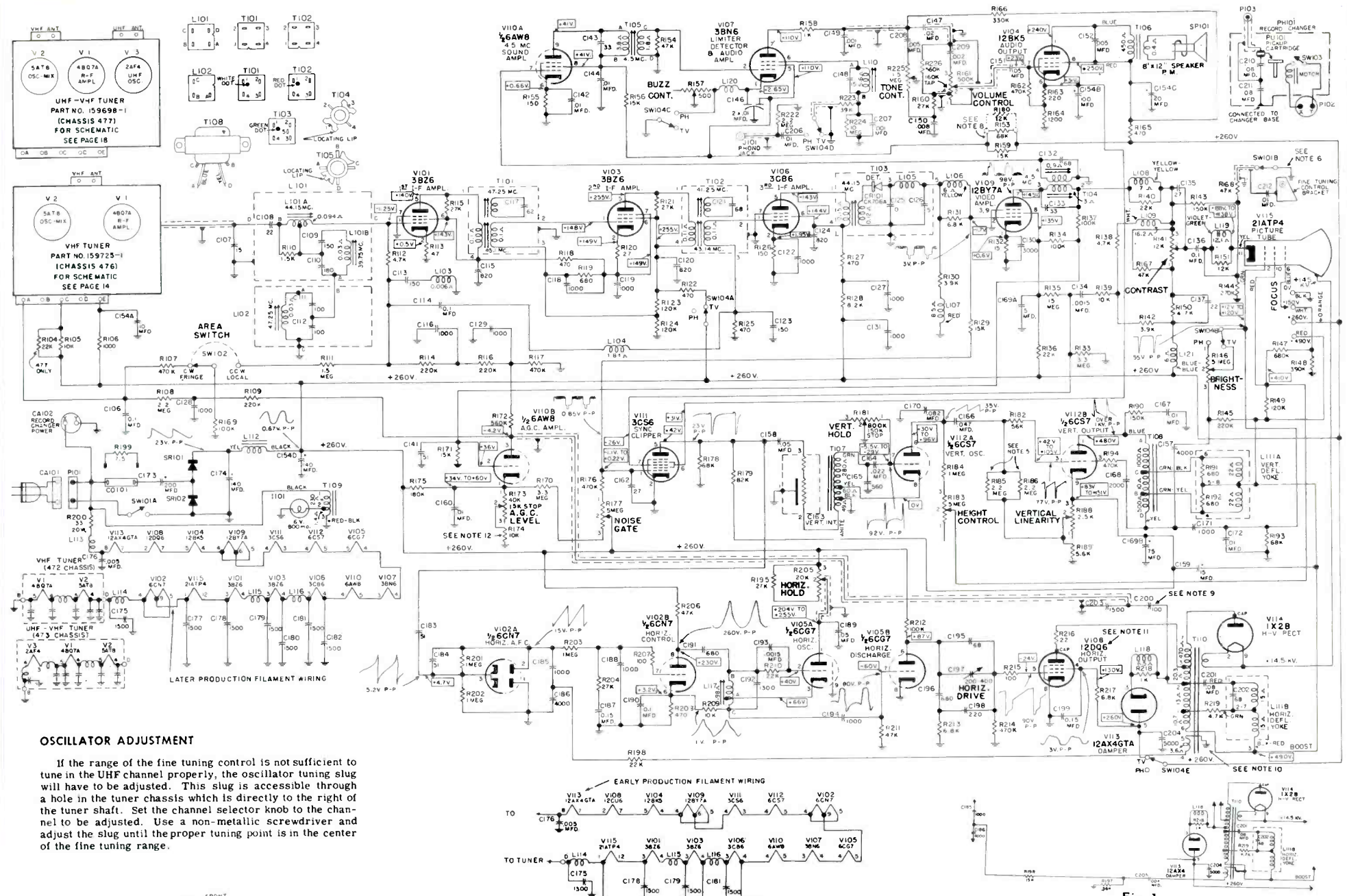
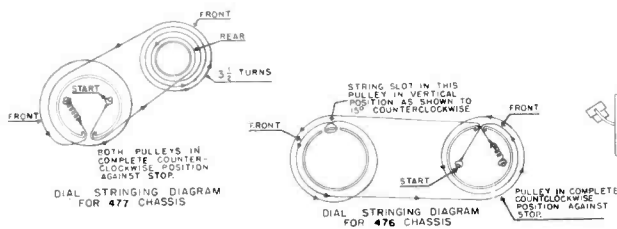

Fig. 1

OSCILLATOR ADJUSTMENT

If the range of the fine tuning control is not sufficient to tune in the UHF channel properly, the oscillator tuning slug will have to be adjusted. This slug is accessible through a hole in the tuner chassis which is directly to the right of the tuner shaft. Set the channel selector knob to the channel to be adjusted. Use a non-metallic screwdriver and adjust the slug until the proper tuning point is in the center of the fine tuning range.



NOTES

- All voltages measured with an electronic voltmeter connected from socket lead to chassis. Some voltages are variable and voltages shown were measured with a normal picture on the picture tube and the contrast and brightness control set for 60 volts peak to peak on the cathode (pin #11) of the picture tube. Socket voltages tolerance 10%. Input signal 6000 microvolts, minimum for these readings. Area switch in local position. SW104 in TV position.
- Supply voltage, 117 volts 60 cycle A. C.
- K-1000
- All capacitance values in mmf. and all resistance values in ohms unless otherwise noted.
- R185 or R186 will be clipped off on some chassis.

- SW101B is open when SW101A is closed.
- Terminals of T104, T105 and LC10 are viewed from coil side.
- On some chassis R153 and R159 are replaced by R180, 12K ohm, 3 watt resistor (Part No. B-170773-3).
- On some chassis C200 (100 mmf) may be replaced with two capacitors connected in parallel:

158215-2	47mmf, 10%, 3 kv.
and 158215-32	82mmf, 10%, 3 kv.

 or

158215-3	68mmf, 10%, 3 kv.
and 158215-56	56mmf, 10%, 3 kv.

This change of parts is made on some chassis in order to increase picture width. It is not used on all chassis and is not designated by a code letter change.

- There were a few pilot run chassis 476 Code A and 477 Code A which were wired as shown in Figure 1. The differences between these and later production chassis are (1) the bottom winding of the transformer, (2) the value of R198, and (3) the use of R197 and C205.

All service replacement transformers are like those used in the later production. Therefore, when installing replacement transformers, remove C197 and C205, change R198 to a 22K resistor and connect the bottom winding of the transformer as shown in the complete schematic.

- Tube type 12DQ6 is used in later production chassis instead of 12CU6. It is also recommended to use the 12DQ6 as a replacement horizontal output tube in any Crosley chassis where a 12CU6 was originally used. The new type 12DQ6 tube was created because the standards for the 12CU6 proved to be inadequate. These standards allowed too wide tolerances with the result that some manufacturers were making lower output 12CU6's while other manufacturers were making 12CU6's with higher output. In many instances, a low output 12CU6 can not be used in a circuit that requires a higher output tube. In the 12DQ6 the standards are adequate to specify a tube which is the equivalent of the high output 12CU6, but with narrow tolerances, to avoid another problem of interchangeability.
- On later production chassis R173 AGC Level Control is Part No. 170501-1; it is the same as 159863-1 but without the 15K stop. For replacement purposes, use whichever control is currently available.

GUEST EDITORIAL

by **WALTER C. BIEDA**

Chief Service Engineer, TV Division, Sylvania Elec. Prod. Inc.



EDITOR'S NOTE: Walter C. Bieda, Sr., Chief Service Engineer for the Radio and Television Division of Sylvania Electric Products, Inc., is a man with many hobbies ("ham" radio, sound movies, boating, organ playing) but with one overriding major interest: helping the radio and television serviceman. NATESA recognized this recently with a special citation honoring him as "Truly a friend of independent service."

THE television and radio serviceman is a "doctor"—and will be more successful if he acts and looks the part.

He's called into the home to diagnose a "sick" television set or radio; he may operate there or in his shop. He has a wealth of technical information at his fingertips because of professional training and experience, just as a physician has. As important, the TV and radio serviceman deals in an area that is mysterious to the layman, the same as a doctor.

But a few servicemen fail to live up to the level they should . . . and it hurts their business, as well as hurting the whole profession.

When you get right down to it, the respect you command from your customers determines whether you'll be called back and whether your customers will come to you when they're ready to buy a new set. Commanding respect is greatly a matter of psychology.

How does a doctor dress? A lawyer? The answer is plain: with white shirt, tie, suit. How do their offices look? Clean and well-ordered, if they're good men—

for they know that orderly surroundings engender respect from their patients and clients.

Here lies a lesson for the serviceman.

A neat, clean shop is part of the lesson, for many television and radio work-rooms look like the day after a hurricane. It's important also to have a fool-proof system for finding sets that have been repaired and are being picked up by the customer; having to wait irritates the set owner, and hearing the clerk mutter that he can't find the merchandise doesn't help your shop's reputation.

Then there's the matter of house calls.

A serviceman can't always wear shirt, tie and suit. Doing roof jobs, or other dirty work, he'd quickly ruin his clothes. But one dealer outfits his servicemen in neat uniforms, with the firm name tastefully imprinted on the jackets—and you'd be amazed at the impression that makes on customers. A neatly-clad serviceman appearing at a housewife's door is sure to make a better impression than one whose outfit is too casual or even downright messy.

One serviceman carries a clean pair of gloves in his kit and does it for just one purpose: when he's ready to move the customer's set in the home, to get at the chassis, he puts on the gloves so he won't leave finger marks on the cabinet. Small item? Sure—but it pays off by leaving a good impression.

Another idea that's been used successfully is for the serviceman to carry a small rug or mat, to protect the home-owner's rug or floor from dirty parts or tools. Too often, placing tools or set parts on a light colored rug leaves a smudge of dirt, and that disturbs the housewife more than many servicemen realize.

Taken separately, these ideas don't sound important, and you might shrug them off. They aren't important, when you consider how small the effort required; but they are important in shaping the impression you leave with the housewife. That impression may well determine whether you're called back—or whether, if you're a dealer, you get an order when the set owner is ready to buy a newer model.

Your doctor has a bedside manner. You can cultivate a "tele-side" manner, using tact and patience with customers—and it will pay off for you.

help your heart fund



help your heart

Here's The ANTENNA YOU CAN MAKE MONEY Installing

designed for 1 man... 7 minute installation

NEEDS ONLY A HAMMER TO INSTALL

GENUINE *Color Beam*
\$14.95 COMPLETE LIST

YOU MAKE \$600 ON ANTENNA SALE ALONE

 Exclusive with **WINEGARD**

ANY ANTENNA THREE YEARS OLD SPOILS THE TV PICTURE

*designed for **BLACK and WHITE** and **COLOR**

Available at Leading Parts Distributors Everywhere or Write

Winegard Company
Burlington, Iowa

For Pamphlet "How to Make Money on One Man Antenna Installation."



Antenna boxed—completely assembled—attached lead-in



Raise main crossarm.



Snap secondary crossarms in place.



Nail up mounting bracket.

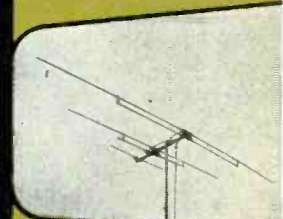

Drop lead-in wire.



Attach lead-in to TV set—special clip snaps on.

for service and lab. work

Heathkit PRINTED CIRCUIT OSCILLOSCOPE KIT FOR COLOR TV!

① Check the outstanding engineering design of this modern *printed circuit* Scope. Designed for color TV work, ideal for critical Laboratory applications. Frequency response essentially flat from 5 cycles to 5 Mc down only 1½ db at 3.58 Mc (TV color burst sync frequency). Down only 5 db at 5 Mc. New sweep generator 20-500,000 cycles, 5 times the range usually offered. Will sync wave form display up to 5 Mc and better. Printed circuit boards stabilize performance specifications and cut assembly time in half. Formerly available only in costly Lab type Scope. Features horizontal trace expansion for observation of pulse detail — retrace blanking amplifier — voltage regulated power supply — 3 step frequency compensated vertical input — low capacity nylon bushings on panel terminals — plus a host of other fine features. Combines peak performance and fine engineering features with low kit cost!

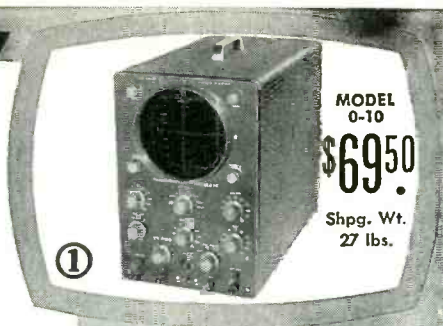

MODEL
O-10
\$69.50

Shpg. Wt.
27 lbs.



MODEL
TS-4
\$49.50

Shpg. Wt.
16 lbs.

Heathkit TV SWEEP GENERATOR KIT ELECTRONIC SWEEP SYSTEM

② A new Heathkit sweep generator covering all frequencies encountered in TV service work (color or monochrome). FM frequencies too! 4 Mc — 220 Mc on fundamentals, harmonics up to 880 Mc. Smoothly controllable all-electronic sweep system. Nothing mechanical to vibrate or wear out. Crystal controlled 4.5 Mc fixed marker and separate variable marker 19-60 Mc on fundamentals and 57-180 Mc on calibrated harmonics. Plug-in crystal included. Blanking and phasing controls — automatic constant amplitude output circuit — efficient attenuation—maximum RF output well over .1 volt—vastly improved linearity. Easily your best buy in sweep generators.



Every Serviceman's Profit-Maker Team...



Service Aids and Your G-C Distributor!

G-C—MAKERS OF
SPRA-KLEEN
STOPS TELEVISION
AND RADIO CONTROL NOISES

ELIMINATES NOISE due to dirt, dust and corrosion on electrical contacts.

JUST SPRAY ON... convenient power spray can does the job in a wink. No need to dismantle chassis.

CLEANS AND LUBRICATES contacts, controls, relays, switches and other sliding electrical contact devices in one operation.

SAVES TIME AND MONEY—gets the job done fast—long lasting—full 6 ounces. No. 8666



POOF!
THERE GOES
NOISE

GENERAL CEMENT MFG. CO.
919 Taylor Avenue • Rockford, Illinois

FREE COPY... G-C Catalog. Send postcard today!



G-C
Chemicals



G-C
Alignment
Tools



G-C
Hardware



G-C
Service
Aids



TV-radio service work is faster, easier, more profitable... when you use G-C Service Aids. You'll find thousands of them at your G-C parts distributor.
SEE US... BOOTH 590—ROOM 612—PARTS SHOW



ATTRACTIVE 2-COLOR COVER OF BOOK

Proper Billing

The presentation of the bill to the customer and its effect on customer relations.

by SAN D'ARCY

initial parts of the serviceman-customer relationship as outlined above. Instead we will cover the final phase—that time when the bill is presented—which frequently is the moment when serviceman-customer relationships are either solidified or broken. It's a truism that: "A satisfied customer is your best advertisement" so let's see how "bill presenting time" can be reached, and concluded, to everyone's satisfaction.

When a bill is presented to a customer a serviceman can either win the customer's respect and future business or he can get into the customer's "doghouse."

With this in mind we called on several service shops and several part-time servicemen and asked them to show us how they presented their bills to customers. The procedures used by some made a very favorable impression, while others were quite the opposite.

WHEN a customer walks into a service shop with a radio set under his arm and describes his "problems" to the serviceman—or when a customer phones a serviceman and asks him to "come out and see what's wrong with my radio (or television) set"—quite obviously two conflicting psychological happenings occur, to wit: 1)—the serviceman hopes first that he will be given the job, and second, that he'll make a profit on it—and, 2)—the customer hopes first that he won't be asked to pay too much money for the repair job, and second, that when the work is done he'll get satisfaction for his investment.

In this treatise we do *not* intend to discuss any of the sales or merchandising angles which take place during the

Fig. 1—(Left) Poor form. Fig. 2—(Center) Fair form. Fig. 3—(Right) Good form.

PAYS!!

We do not intend to embarrass any service shop by showing its billing method. Instead we'll show you how some use a system that in our opinion is very bad indeed, how others use a bill that is only passing fair, and finally how others use an order form which is highly effective. Incidentally, we learned that the latter is a stock form pad called "TV-Radio Service Order" type TVR-100 which is printed by Electronic Publishing Company, Inc., of Chicago and which is sold over-the-counter for a very nominal sum by practically every parts distributor.

First, glance at *Fig. 1*. Here, in our opinion, is a very bad method of billing. Now look at *Fig. 2* and you'll see a printed form that is slightly better than that shown in *Fig. 1*. Now look at *Fig. 3* and you'll see a "Form" that is better than either of the other two, but which still is far from perfect. Finally, glance at *Fig. 4*, which is the TVR-100 Order Forms sold by distributors. Here, in our opinion, is a well-executed "Order Form" that "has everything." *Fig. 5—A and B* shows what is printed on the back of the original and second sheet of the TVR-100 forms, which are done in triplicate.

As stated above, the TVR-100 forms come in pads with triplicate sheets. The original is white, the second or duplicate sheet is yellow, and the third, or office record triplicate is pink.

Figs. 5A, 5B
Printed material on
back of
TVR-100.

GUARANTEE OF TUBES AND PARTS
All tubes, parts and materials placed in your set for no reason on the reverse side of this order are of best quality and are guaranteed for a period of 90 days from the date set was delivered or repaired in the house, provided all charges have been paid in full.

We cannot, however, assume responsibility for failure of any other components that may become inoperative during this period. This Guarantee does not cover damage resulting from accidents, fire, theft, neglect or abuse by the owner.

GUARANTEE OF PERFORMANCE
Upon completion of the work specified on the front of this order, we guarantee that your set has been restored to its normal performance. If there is any reason for dissatisfaction, however, we must be notified within 48 hours after set is delivered or repaired. We cannot guarantee immediately after a longer period due to the possibility of wear or damage to part of the set failing or becoming inoperative.

OUTSIDE INTERFERENCE
Liability for external interference caused from other TV receivers, automobiles, electrical phenomena, appliances, diathermy, streetlights, short wave, FM receivers or transmitters, etc., cannot be assumed by us.

BACK OF ORIGINAL (White Copy)

Fig. 4—TVR-100 Order Forms by Dave Rice.

In preparing his TVR-100 Order Forms, Dave Rice, of Electronic Publishing Company was far-sighted. First of all, he protected the service shop by stipulating exactly what tube, part, and performance guarantee is given on a finished job. (This also makes a favorable impression on the customer). All customers get the original copy, or white sheet which has the guarantee on its reverse side. However, in cases where the serviceman has had to "pull" the set, by using the second, or yellow sheet of the order form, he,

[Continued on page 34]

BACK OF DUPLICATE (Yellow Copy)

Sonotone's 2-model line simplifies cartridge replacement!

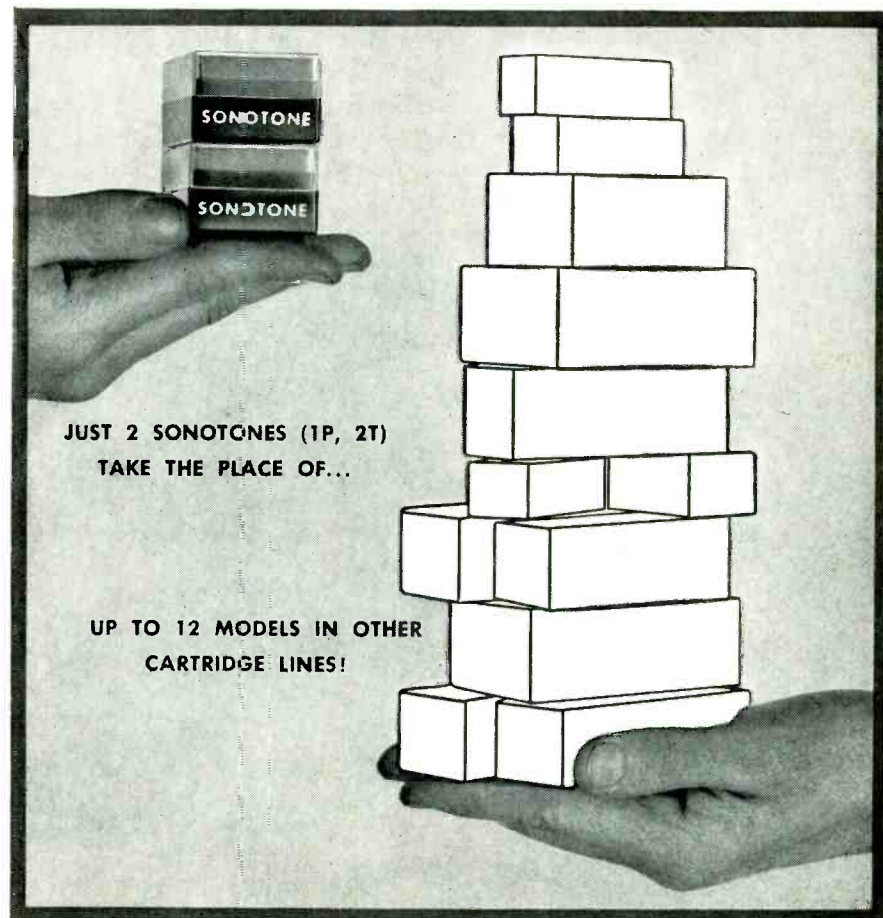

*You finish jobs faster, please customers more,
when you standardize on Sonotone Ceramics*

Why juggle a handful of different cartridges, when it's so much easier and faster to stick to just *two*? Sonotone single-needle 1P and turnover type 2T are all you need for over 90% of quality replacement jobs.

These two Sonotone cartridges fit practically any arm. They're quick to install. And remember, Sonotone cartridges are *more* than replacements. They'll give *better* response than original equipment...enhancing your reputation for quality work.

New standard of the phono industry

More than half the quality phonographs made today by leading manufacturers, you'll find one of these Sonotone cartridges. All the more reason why you should standardize on Sonotone.

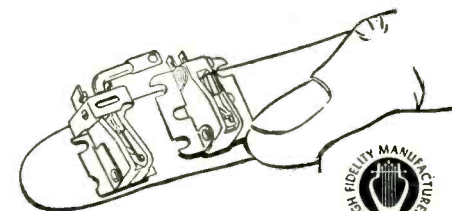

SONOTONE CERAMIC CARTRIDGES

ELMSFORD, N. Y.

In Canada, contact Atlas Radio Corp., Ltd., 50 Wingold Avenue, Toronto

COLOR RF-IF

[Continued from page 24]

In the vicinity of the sound *if* carrier the response curve drops sharply into a notch at 41.25 mc. This sharp drop is accomplished by traps especially designed for this purpose, and is necessitated by the fact that the rejection of the sound carrier in the video *if* section must be kept high (about minus 40 db) in order to prevent formation of the 920

kc beat previously referred to.

Due to the complexity of design of a wide band *if* system some receivers are using a relatively narrow band *if* with a response such as that shown in Fig. 4. Although this *if* response appears to deliberately sacrifice chroma signal, this loss of signal level is compensated for in the chroma section of the receiver. The end result of this compensation produces relative luminance/chrominance amplitude ratios which correspond to those present in the original transmitted signal.

Traps

In addition to the conventional series resonant and absorption type traps found in monochrome receivers, elaborate traps are used in color receivers for the more exacting task of signal rejection in color video *if* sections.

One of the newer type traps, called a "bifilar T" trap, is designed to produce the effect of high attenuation with steep sloping sides, as shown in Fig. 5. In this circuit L_2 is coupled to L_1 . The coil L_3 is a bifilar winding where winding 1-2 is interwound with winding 2-3 to produce unity coupling. The 330 ohm resistance in combination with L_3 provides a negative resistance effect which is opposite to the equivalent resistance of the resonant trap circuit C_1, L_4 . The explanation of this negative resistance effect is beyond the scope of this article. The resultant high Q of the trap provides a 32 db rejection of the sound *if* in the luminance channel.

Another type of trap circuit is shown in Fig. 6. Where fringe conditions are such that the sound reception is weak, it may be desirable to adjust the amplitude of the sound *if* carrier for a better compromise between adequate sound response and the 920 kc beat interference signal. The circuit shown in Fig. 6 allows for this adjustment.

In analyzing the trap action we observe that the trap is made up of three branches. The first branch, L_1-C_1 is predominantly inductive, because C_1 is large enough to be negligible in this application. It is present only to prevent short-circuiting the *agc* voltage. The second branch C_2-C_3 is capacitive. The third branch R_1-R_2 is resistive. In effect, the inductive branch L_1 is in parallel

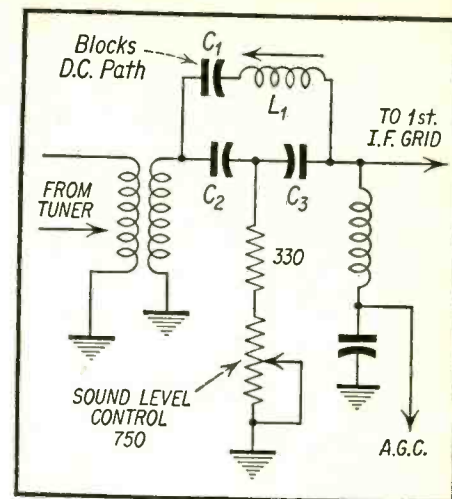

Fig. 6—Sound level control used in adjustable trap circuit.

with the capacitive branch C_2-C_3 , thereby providing a parallel resonant circuit which presents a high impedance to the sound *if* frequency.

The phase relations in the inductive and the capacitive branch are essentially equal and opposite at the sound *if* frequency. However, the phase in the capacitive branch may be altered by the resistance connected between the junction of C_2 and C_3 and ground. Variation of this resistance, and hence the phase, will control the effectiveness of the trap action. Thus, when an increase in sound transfer is desired, R_1 may be adjusted for this purpose.

As in the tuner, similar precautions with respect to nonlinear circuit operation must be observed in the *if* section, otherwise cross-talk and an improper passband will result. For this reason special *if* amplifier tubes such as the 6DC6 and 6BZ6 with remote cutoff and high sensitivity characteristics have been developed and are being used.

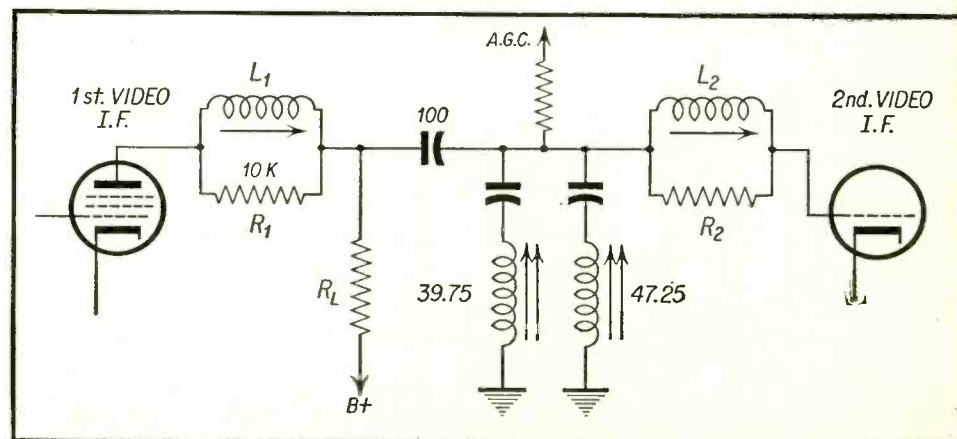

Fig. 7—Series resonant tuned circuit used in I.F. stages of color TV receiver.

Now Available! NEW...

VACO

Hollow Shaft NUT DRIVERS in Color

Nothing else like them anywhere! Choice of 28 types and sizes! New plastic kit at right contains 7 most popular drivers in self-standing bag for service work or bench use.

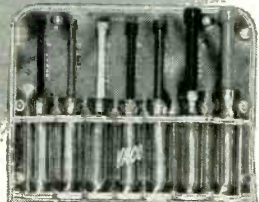
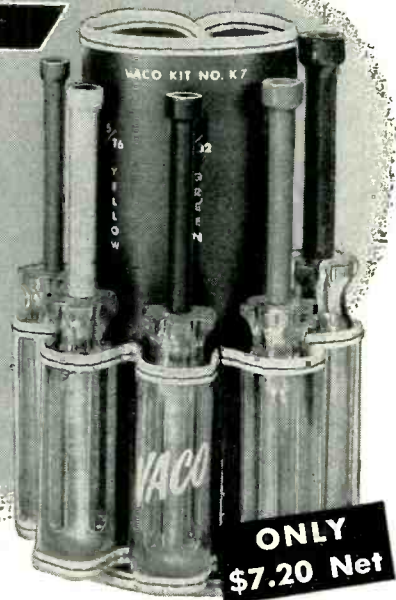

No. K7 Self-Standing Service Kit
Stands Up! Hangs Up! Folds Up!

Stands upright for easy accessibility. May be hung flat on wall or may be folded. Each driver fits in individual holder marked for size, color.

Check These 6 Important VACO Features

NEW! Each size color-keyed!

NEW! All-hollow shafts

NEW! Extra large VACO Comfordome Handles!

NEW! Extra hard long wearing sockets!

NEW! Shafts insulated from handle to tip!

NEW! Available in 4 shaft lengths and 7 Hex sizes!



THIS COUPON WORTH \$1.20

Coupon only valid for use as stated below. Not valid in states where prohibited.

Name..... R. T.
Street.....
City..... Zone..... State.....

VACO PRODUCTS COMPANY
317 E. Ontario St., Chicago 11, Ill.
In Canada: Vaco-Lynn Products Co., Ltd., Montreal 1, Que.

Take this coupon to your jobber. It is worth \$1.20 when filled in and used to purchase one VACO K7 Kit. If your jobber cannot supply you, write direct.

The wider bandpass of the *if* section is effected by the use of overcoupled interstage transformers and the use of four or five stages of video *if* employing stagger tuning. Crystal detectors are generally used because they are more linear than their vacuum tube prototypes, and because they are small enough in size to be housed in the *if* cans, thereby eliminating stray pickup interference.

Bifilar coils in interstage coupling offer many desirable features as compared to conventional single tuned coils. In a

bifilar-wound transformer both primary and secondary are wound together, thus affording almost unity coupling. This allows the use of the primary winding in the plate circuit of the driver tube and the secondary winding in the driven tube. The cost of the coupling capacitor and grid resistor usually used in stagger tuned systems is thereby saved. A single powdered iron core effects the necessary tuning.

As an added advantage, bifilar coil usage results in improved noise immunity. This takes place as follows. Con-

ventional *if* circuits contain relatively high values of grid resistors. Because of this an incoming high level noise pulse can result in a grid bias with an amplitude high enough to cut off the tube. This will drive the picture tube toward the black level producing black spots or "holes" which give rise to *annoying trailing white tails* wherever these "holes" appear on the picture screen. With bifilar coils the grid circuit impedance is practically zero, so that even if a noise signal is present, the corresponding pulses will not give rise to grid bias, and will not produce the effect just described.

Another type of *if* amplifier coupling circuit employed in color TV receivers, as shown in Fig. 7, is one in which the plate coil is connected in series with the output capacitance of the tube to form a series resonant circuit. The resonant frequency of the latter is adjusted to the desired value so that the voltage drop across *L1* is a minimum and the voltage transfer to the next stage (as developed across *RL*) is a maximum. At any frequency other than the resonant frequency, the impedance is very high, so that where an unwanted signal is concerned the greatest voltage drop appears across *L1* and the voltage transfer to the next stage (as developed across *R2*) is a minimum. The purpose of resistor *R2* is to reduce the *Q* of the coil so that a desired bandpass is effected.

Application of this method of coupling may be employed in the grid circuit by connecting a coil *L2* in the manner shown in Fig. 7. In this case the grid signal load consists of *L2* in series with the parallel traps tuned to the adjacent channel sound (47.25 *mc*) and the adjacent channel pix (39.75 *mc*).



THEN AFTER YOU TEST THE TUBES
BY TAPPING THEM WHAT HAPPENS THEN.

PAYS ITS WAY every day

**TESTS and
REPAIRS
TV PICTURE
TUBES**

**Makes Customers Happy
—Creates New Profits**

Servicemen now earn new servicing dollars in minutes and build satisfied customers—with B&K Deluxe Portable CRT 400.

Spots and corrects picture tube troubles in a few minutes, right in the home, without removing tube from set! Restores emission, stops leakage, repairs inter-element shorts and open circuits. Grid cut-off reading indicates picture quality customer can expect. Life-test checks gas content and predicts remaining useful tube life. Cuts operating costs, eliminates tube transportation. Also saves money on TV set trade-in reconditioning. Profits start the very first day.

Send for Bulletin 104-D



DELUXE CRT 400 with 4½" Plastic Meter

Weighs only 5 lbs. mounted in rugged, luggage style, carrying case covered with handsome, durable leatherette.
Size: 11 x 7½ x 5". Net \$54.95



**CATHODE
REJUVENATOR
TESTERS**



ECONOMY CRT 200

Every serviceman can cash in on picture tube repairs with this low priced quick profit maker. Performs most of the functions of the CRT 400. Has 3" meter. In leatherette carrying case.
Size: 11 x 7½ x 5". Net \$39.95
Weighs 5 lbs.

**PROVEN IN
THE FIELD
EVERY DAY
BY OVER
20,000
SERVICEMEN**

Made by the Makers of the DYNA-QUIK Tube Tester

B & K MANUFACTURING CO.
3726 N. Southport Ave. • Chicago 13, Illinois



**MILLIONS
SOLD**

**BECAUSE IT'S
Antenn-gineered**

by **Snyder**
PHILADELPHIA

3-D Directronic

**TV INDOOR
ANTENNA**

**\$9.95
LIST**

**SELLS
FOR 7.95**

**BLACK
WHITE
COLOR
-FM-
VHF
UHF**

SNYDER
MANUFACTURING CO.
PHILADELPHIA • LOS ANGELES • TORONTO

PROPER BILLING

[from page 31]

the serviceman, gets a "responsibility release," as is shown in Fig. 5 B. Likewise, in cases when a repair job is done and the customer wants to defer payment, the serviceman can, if he wishes, make delivery and then, he asks for the customer's signature on the "Promissory Note" portion of the second sheet. When this is done (and it is absolutely legal) the serviceman is fully protected and can collect his fee without being required to pay court or lawyers' fees if he ever has to take legal action at some future date.

Often a service bill for \$30 or \$40 can work a hardship on a customer and he would like to pay off the obligation in two or three monthly payments. The "Promissory Note" portion of the TVR-100 form handles cases like these very effectively, and here again, is done in such a way as to make a favorable impression on the customer.

For example, by getting the customer's signature in the space of the lower left corner, the customer's "release" is an invaluable adjunct and provides a certain degree of protection to the service firm.

As to the original, or face side of the Order Forms, these are complete in every detail. By using a completely itemized form such as this, both the serviceman and customer have a complete record of the transaction itself. Now visualize yourself as a customer—wouldn't you rather get a bill like this on a TVR-100 form—as contrasted with the one shown in Figure 1?

Finally, insofar as good business practice is concerned, service shops using these forms, can save themselves much money each year in maintaining tax records. In certain states and cities there are local taxes that must be collected from customers and then be accounted for by the service shop operator. We estimate that the cost of using TVR-100 forms will add only a penny or two to the cost of any job. Without doubt that small investment will come back, not only in keeping tax payment records in order, but much more so from the favorable impression you will make upon your customers.

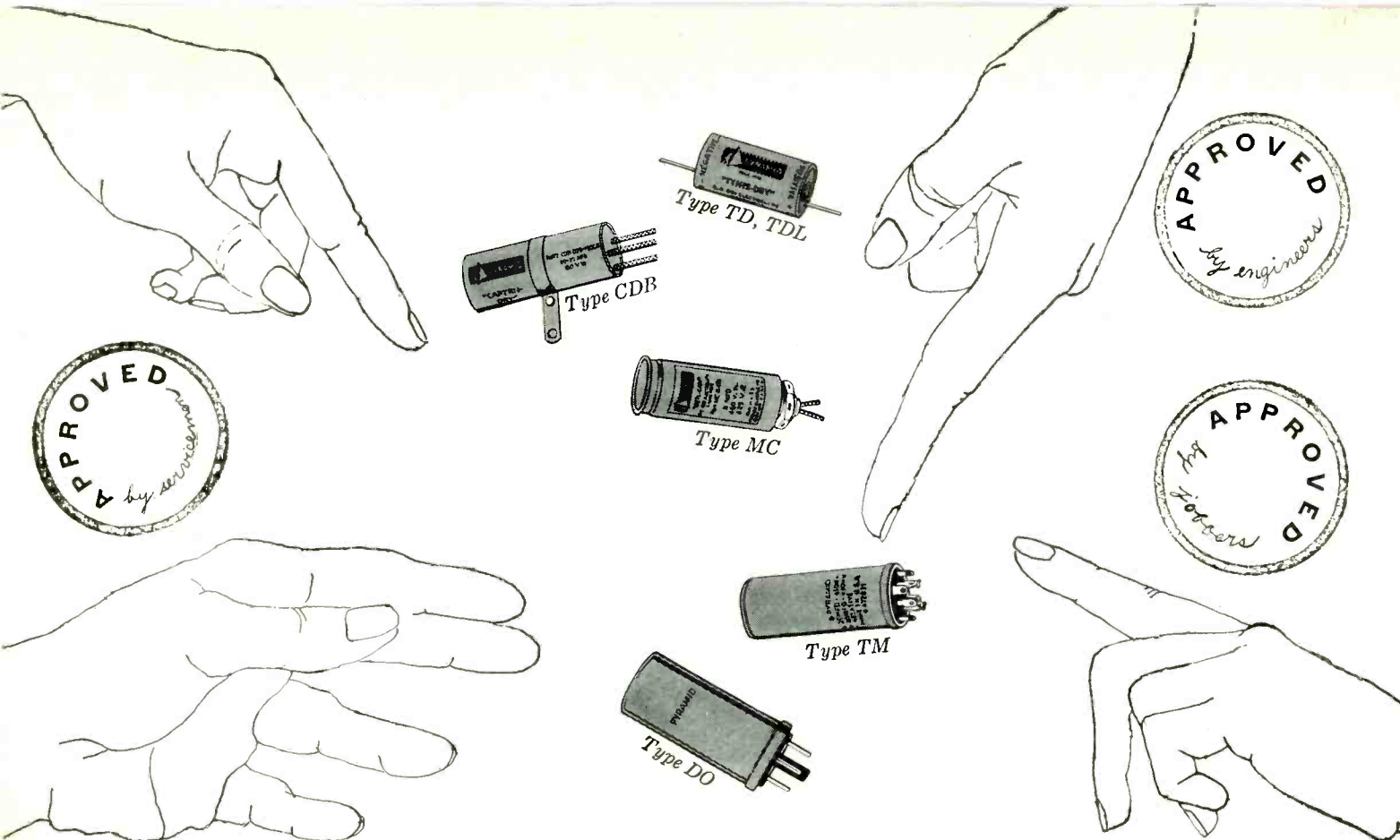

YOU CAN'T ARGUE WITH ACCEPTANCE

The most complete line of twist mount
dry electrolytic capacitors

Proven quality, 100% inspected, accurate
replacement, prompt delivery

Better than any claims we could make is the unqualified and enthusiastic acceptance by engineers and servicemen alike. These are some of the features on which this acceptance is based:

Aluminum containers provide maximum protection against moisture.

Low leakage, long shelf life.

Designed for 85° C. operation.

Complete with metal and bakelite mounting plates.

Easy to mount.

Extremely compact—yet highly dependable. Pyramid capacitors are listed in Sams' Photofacts and Counterfacts.

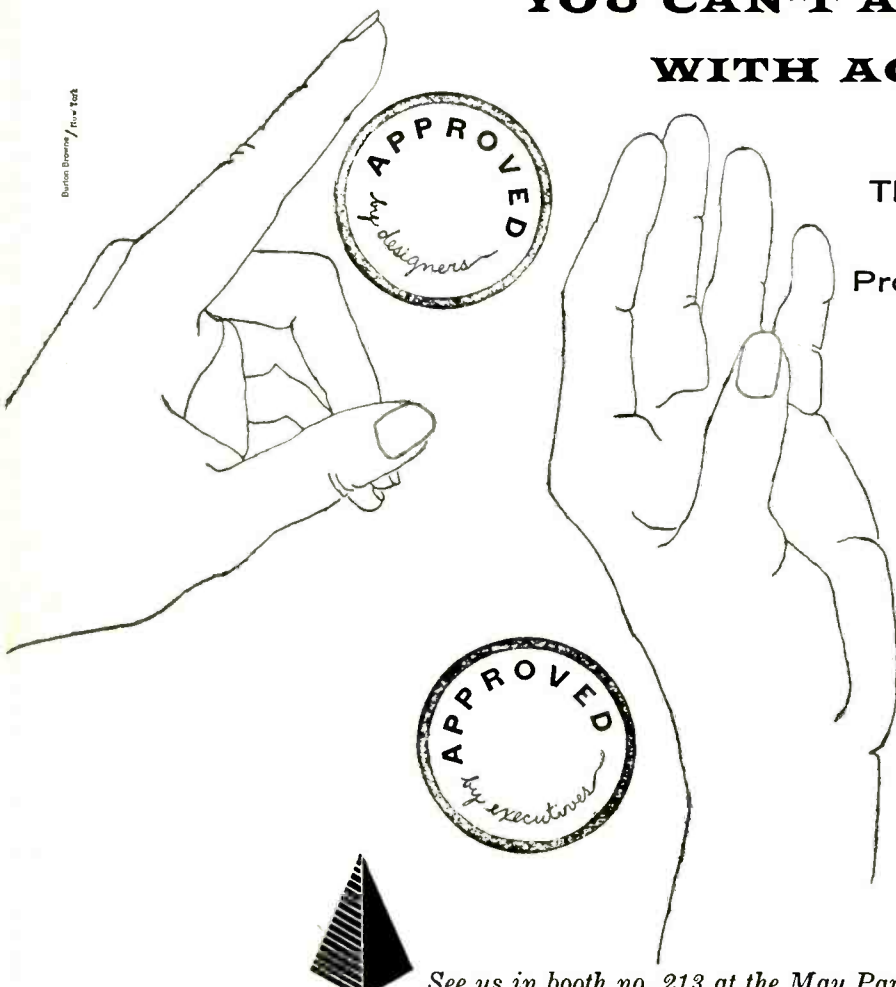

See us in booth no. 213 at the May Parts Show

PYRAMID ELECTRIC COMPANY

1445 Hudson Blvd., North Bergen, N. J.

to
be
SURE!

buy
VOKAR

the original-
equipment
VIBRATOR



Leading manufacturers of original-equipment auto-radios specify Vokar vibrators as components for installation on the production-line. Why? They're sure Vokar quality never varies — will always contribute to top performance demanded of today's radios.

You too can depend on Vokar vibrators—for sure starts, longer life, silent operation. For all replacement jobs, buy Vokar Imperial or Quality Brand vibrators to be sure of satisfied customers.

Now is the time to stock up on 12-volt vibrators—ONLY TWO VOKAR IMPERIALS ARE NEEDED TO FILL ALL REPLACEMENTS!

VOKAR—preferred by leading manufacturers of auto-radios.



VOKAR

VOKAR CORPORATION
DEXTER 2, MICHIGAN

Mfg: Philco Chassis No. TV-354

Card No. PH 354-1

Section Affected: Audio

Symptoms: Mechanical hum emanating from components such as yoke, vertical output transformer, or power transformer.

Reason For Change: To improve, reduce or eliminate mechanical hum.

What to do:

Install rubber grommets at the item causing the hum. If it is associated with the yoke, install rubber grommets under the CRT support brackets. The cabinet side and top is acting as a sounding board for the buzz transmitted through the metal brackets.

If the vertical output transformer is causing the hum install the grommets under the mounting brackets of the transformer.

If the power transformer is the cause of the hum due to loose laminations correct by tightening cover and core holding screws.

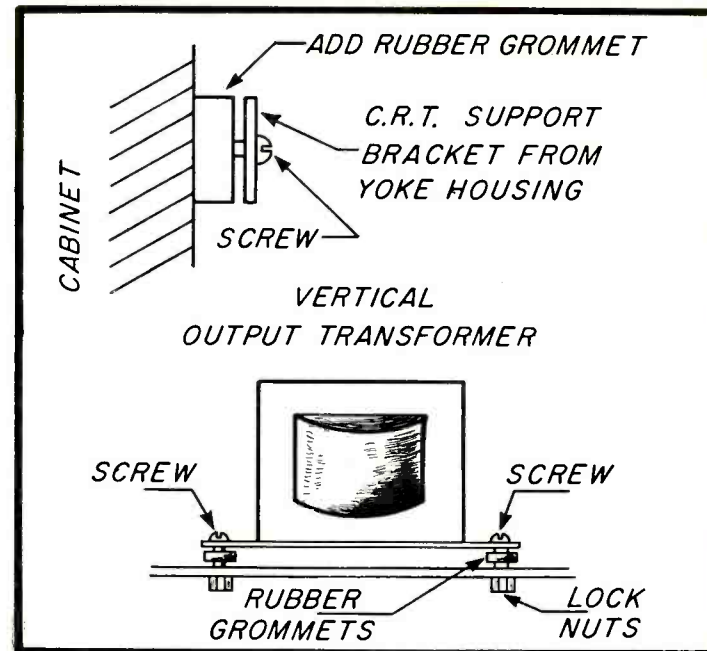

Mfg: Philco

Chassis No. TV-354

Card No. PH 354-2

Section Affected: Pix

Symptoms: Trailing edges in certain portions of the picture due to undesirable oscillation.

Reason For Change: To improve the transient response of the video amplifier stage.

What to do:

Replace: X10, 240 microhenry coil with a 400 microhenry coil.

R70, 22 ohm resistor with a 33 ohm resistor.

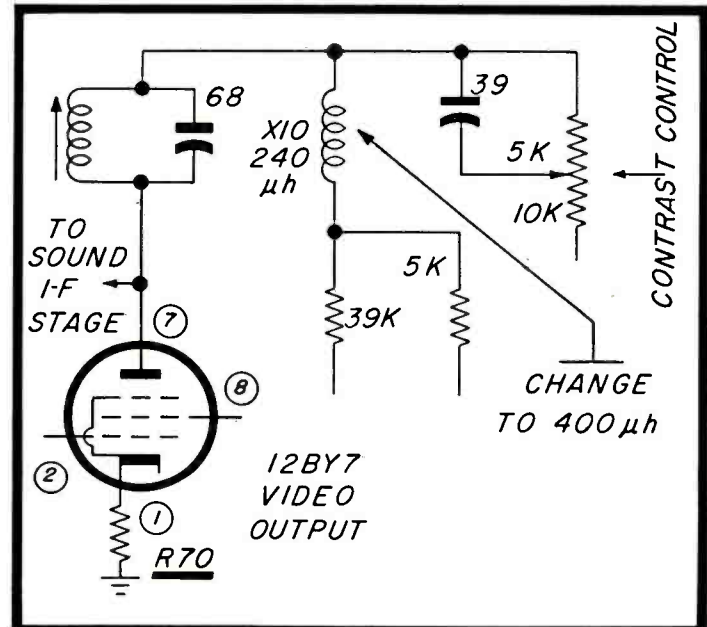

Mfg: Philco

Chassis No. TV-354

Card No. PH 354-3

Section Affected: Audio

Symptoms: No sound or distorted sound

Cause: Component failure. The cathode resistor has increased in value or opened.

What to do:

Replace: R6, 270 ohm resistor. This resistor should be 2 watts.

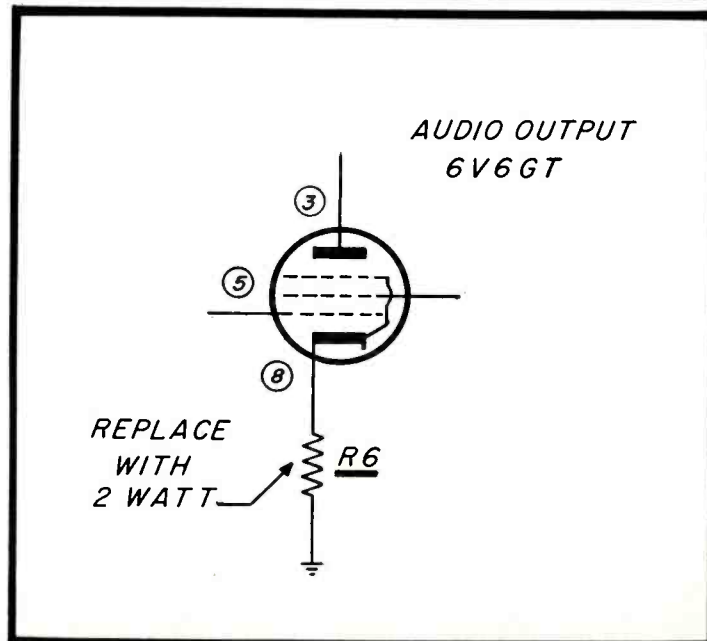

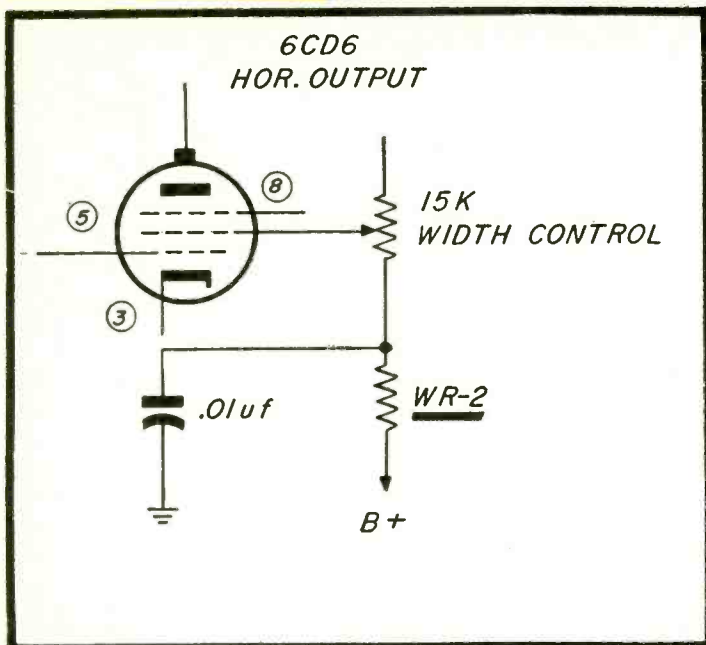

Mfg: Philco

Chassis No. TV-354

Card No. PH 354-4

Section Affected: Raster and Pix

Symptoms: Insufficient width and poor horizontal linearity.

Reasons For Change: To improve circuit and make available a greater range of width control with better horizontal linearity.

What to do:

Change: WR-2 from 8200 ohms, 7 watts to 6500 ohms, 7 watts.

Note: This has been incorporated in chassis after run 6.

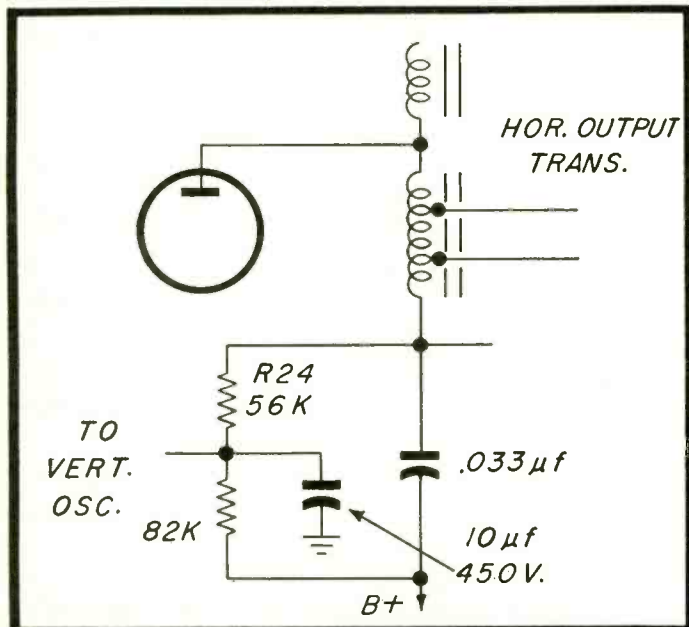

Mfg: Philco

Chassis No. TV-354

Card No. PH 354-5

Section Affected: Pix and Raster

Symptoms: No vertical deflection

Cause: Component failure. Resistor R24 burned open or increased very high in value. This resistor can also be the cause of vertical shrinkage if it increases in value as the receiver warms up.

What to do:

Change: R24, from 56K to two resistors, 33K and 22K in series each having a wattage dissipation rating of 2 watts.

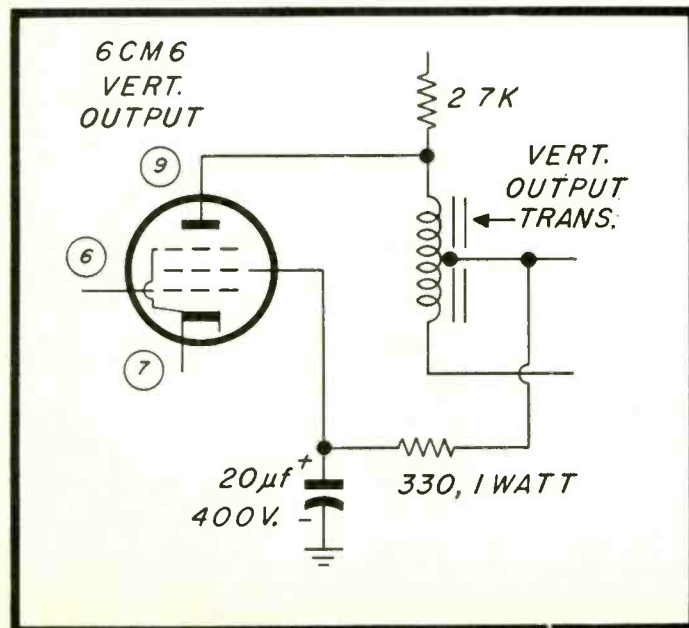

Mfg: Philco

Chassis No. TV-354

Card No. PH 354-6

Section Affected: Pix and Raster

Symptoms: Vertical shrinkage and squeezing at bottom of picture.

Reason For Change: To increase decoupling of B plus supply, provide additional filtering and effectively make the screen 10 volts higher.

What to do:

Add: 330 ohm resistor, one watt and 20 μ f condenser, 400 volts.

Note: Under low line voltage conditions or in a hot climate the bottom of the picture may shrink up during the first three hours of operation. This is very frequently due to an increase in resistance in the yoke as its temperature increases.

If shrinkage still persists change yoke to part No. 32-9689-1.

If shrinkage is still objectionable change Vertical Output Transformer to 32-8686 from 32-8667.

35% More
CRYSTAL-CLEAR
at NO EXTRA Cost!



... in answer to public demand ... the NEW KRYLON GIANT CAN—the biggest can of Crystal-Clear protective coating on the market (16.2 oz.) ... the greatest value ever offered your customer ... replacing the 12-oz. can, now discontinued. PRICE REMAINS THE SAME, \$1.95 list. What a value ... sales-builder ... profit-maker! Order today! (Krylon 6-oz. line remains the same, 98c list.)

SPRAY ENAMELS

Yes, Krylon spray enamels also in the NEW GIANT SIZE, (16.2 oz.)—same price, \$1.69 list. Again, 35% MORE spray enamel at NO EXTRA COST! (6-oz. size 98c list) 17 colors

DULLING SPRAY

A "must" for every photographic, movie, and TV studio! Minimizes bothersome high-lights ... simplifies lighting arrangements ... saves preparation time. Giant can, \$1.95 list.

Zinc Chromate METAL PRIMER Spray provides excellent bond for bare metal surfaces. Spec. MIL-P-6889-A, Type 1; Aviation supply stock No. R 52P 20405. Giant can, \$1.95 list.

Krylon-Houghton RUST VETO Spray protects metal surfaces against corrosion ... resists oxidation ... displaces moisture. Giant can, \$1.95 list.

STENCIL INK Sprays for stenciling, marking, coding, etc. ... increases life of stencils ... speeds up work—cuts down costs! 7 colors. HIDE-A-MARK cover cost makes containers re-usable ... economical. Dries rapidly. Giant can, \$1.69 list.

ORDER FROM YOUR JOBBER OR WRITE

KRYLON, Inc., HARRISTOWN, Pa.

KRYLON—THE BRAND WITH THE DEMAND

Choose from these

JACKSON

3

Service Engineered

TUBE TESTERS

1 Famous
Model 648P
Dynamic
\$109.50 net

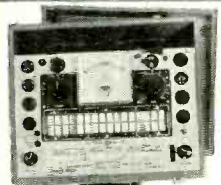

Fastest Dynamic Tube Tester made, yet it's fully flexible for all receiving types, new and old. The set-up time is actually less than the warm-up time of the tube. Provides fast, accurate shorts tests. Metered plate current shows tube condition. Meter calibrated in Good-Bad as well as Percent of relative micromhos. Automatic Line Voltage Indicator, Life Line Indicator, Noise Test, plus a husky filament transformer with voltages for even the newest types make this an outstanding service tester.

2 Low-Cost
Forty-Niner
with Plug-In
Accessories

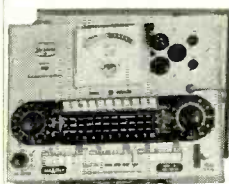

\$49.95 net, Accessories extra

A good, basic tube tester, with plug-in accessories for performing a wide variety of additional tests. Accessories may be added any time, permit testing tubes for filament current and high resistance shorts, as well as checking selenium rectifiers. Lever action shows which pins are connected. Sensitive shorts test. Line Voltage Indicator. A tremendous value.

3 New,
Portable
Dynamic
Model 561
\$89.95, net

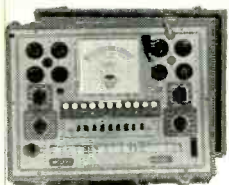

Employs famous Jackson Dynamic principle, applying separate voltages to each tube element. High voltage power supply for most accurate tests. Improved switching system gives simplified, fast operation. Filament voltages for the very latest TV types. Fully portable case finished in harmonizing gray and green, tough plastic fabric. Built-in roll chart, with free replacement service for one year.

Test Data on New Tube Types
for All Jackson Testers Appears
Monthly on Page 65 of PF Reporter

For more information, write:

JACKSON
ELECTRICAL INSTRUMENT CO.

Service Engineered Test Equipment

16-18 S. PATTERSON BLVD., DAYTON 2, OHIO
In Canada: The Canadian Marconi Company

Mfg: RCA

Chassis No. KCS-72

Card No. RC 72-1

Section Affected: Pix and sound

Symptom: No picture, No sound or weak sound.
Brightness Okay.

Cause: Component Failure. Transformer T105
shorted primary to secondary

What to do:

Check: For a positive voltage on *agc* line;
if so:

Replace: IF transformer, T105

V106
6CB6
1st. PIX
I-F AMP.

V107
6CB6
2nd PIX
I-F AMP.

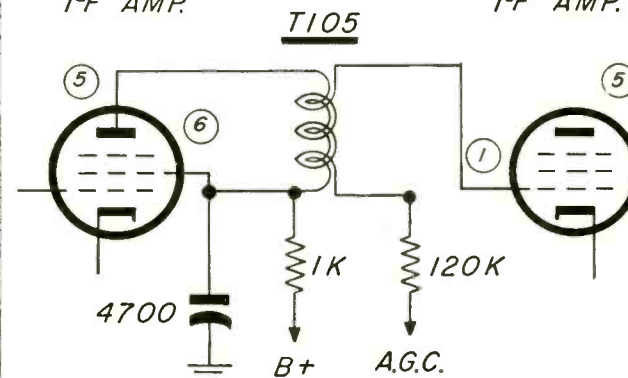

Mfg: RCA

Chassis No. KCS-72

Card No. RC 72-2

Section Affected: Pix and Sound

Symptoms: No picture or sound on channel.
Snow off-channel

Cause: Component failure. Open C136, 220 μ f
condenser

What to do:

Replace: C136, 220 μ f condenser, 22000 volt
rating.

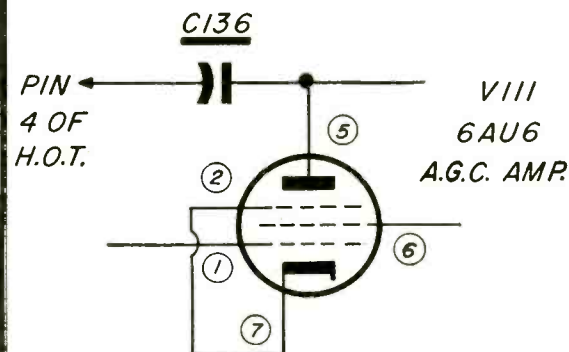

Mfg: RCA

Chassis No. KCS-72

Card No. RC 72-3

Section Affected: Pix and raster

Symptoms: No brightness or raster. High volt-
age normal.

Cause: Component failure. Condenser C158, .1
 μ f shorted.

What to do:

Check: Voltage variation at pin 2 of picture
tube socket.
Replace: C158, .1 μ f condenser.

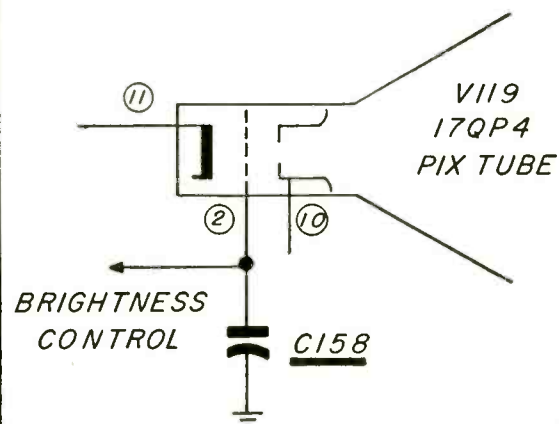

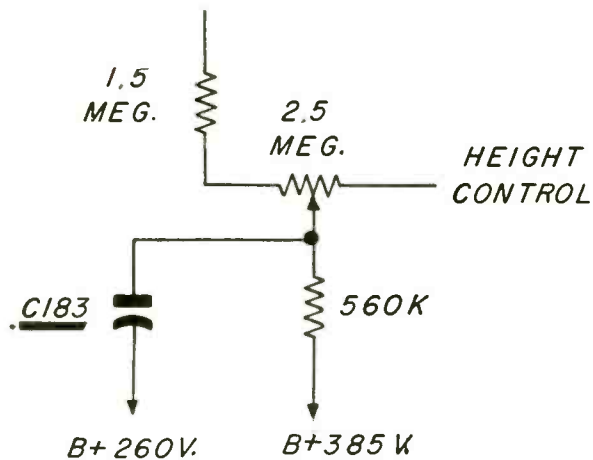

Mfg: RCA

Chassis No. KCS-72

Card No. RC 72-4

Section Affected: Pix and raster

Symptoms: Insufficient vertical deflection. Low voltage on plate of V113, 6J5 vertical oscillator tube.

Cause: Component failure. Condenser C183, .1 μ f shorted.

What to do:
Replace: Condenser C183, .1 μ f.

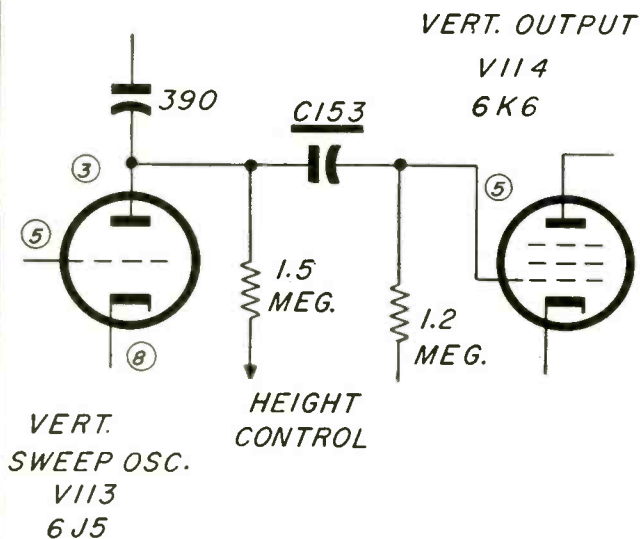

Mfg: RCA

Chassis No. KCS-72

Card No. RC 72-5

Section Affected: Pix and raster

Symptoms: No vertical deflection

Cause: Component failure. Open C153, .1 μ f condenser.

What to do:
Replace: Condenser C153, .1 μ f.

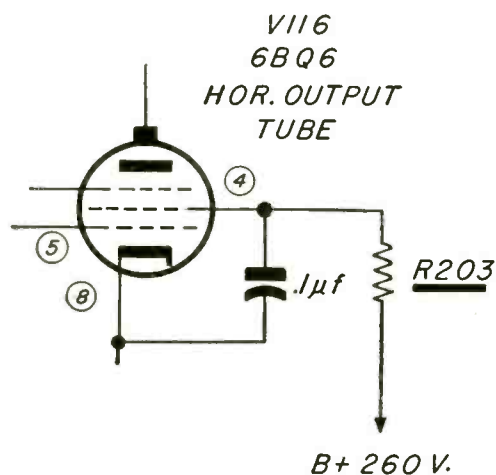

Mfg. RCA

Chassis No. KCS-72

Card No. RC 72-6

Section Affected: Pix and raster

Symptoms: Insufficient width. Width may shrink during operation.

Cause: Component failure. Screen dropping resistor has changed to higher resistance value or changes with operation. (R203)

What to do:
Replace: Resistor R203, 6.8K ohms, 2 watts.

FREE

news of the month

Cornell-Dubilier's "THE CAPACITOR" is keeping over 100,000 readers abreast of the latest electronic techniques and practices. Condensed, meaty-reading articles that will make your job easier and your service better. FREE—12 times a year—mailed right to your home. Join C-D readers' club—a subscription is yours FREE for the asking.

A service of
CORNELL-DUBILIER
world's largest manufacturers of capacitors

GET ON THE LIST
FOR CORNELL-DUBILIER'S
"CAPACITOR"—YOURS

FREE

Editor—"The Capacitor"
CORNELL-DUBILIER ELECTRIC CORP.
Dept. RS-56, South Plainfield, N. J.

—Yes Sir! Put me down for a FREE
Subscription to Cornell-Dubilier's
"THE CAPACITOR"

name _____
please print

address (home) _____

city _____ zone _____ state _____

my occupation or
job title is _____

AUTO RADIO

[from page 21]

Tune the set to a weak station between 600 and 1000 kc and adjust the trimmer for the loudest signal. This is very important and too often overlooked.

If the set is dead (no sound from speaker), and if the car is equipped with a rear speaker, be sure that someone hasn't accidentally moved the speaker switch to a neutral position (see Fig. 6). This is a common occurrence and many complaints have been traced to this source. Shorted antenna leads contribute a large percentage of complaints of intermittent and noisy reception. Substitute a test antenna. Always try the OZ4 by substitution (located in speaker unit). By removing the glove box and the tuner mounting bolts, the unit can be lowered far enough to remove the cover and tube replacement can be made on the spot.

Note: Be sure to ground the unit properly with jumper wire when testing this way.

If the set is over-sensitive to car accessories, etc., that is, if a clicking noise is heard in the speaker when applying the pedal or when directional signals are being used, antenna pickup may be suspected. To eliminate, this source of trouble, re-route the antenna lead.

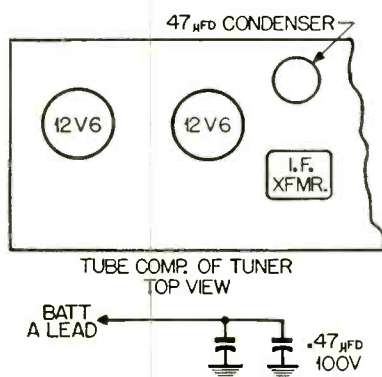

Fig. 7—Location of .47 uf condenser.

If the set blows fuses instantly, and it is not the fault of the vibrator, check the .47 μ f 100 volt "A" battery bypass condenser located in the tube compartment of the tuner section. See Fig. 7.

If you get complaints of ignition noise, be sure that some mechanic hasn't replaced one or more of the ignition wires with regular wires. If the set hums excessively, try another vibrator.

Excitingly new

"LIVING SOUND" IS YOURS TO ENJOY
WITH NORELCO *F.R.S.*

FULL RESONANCE TWIN-CONE SPEAKERS

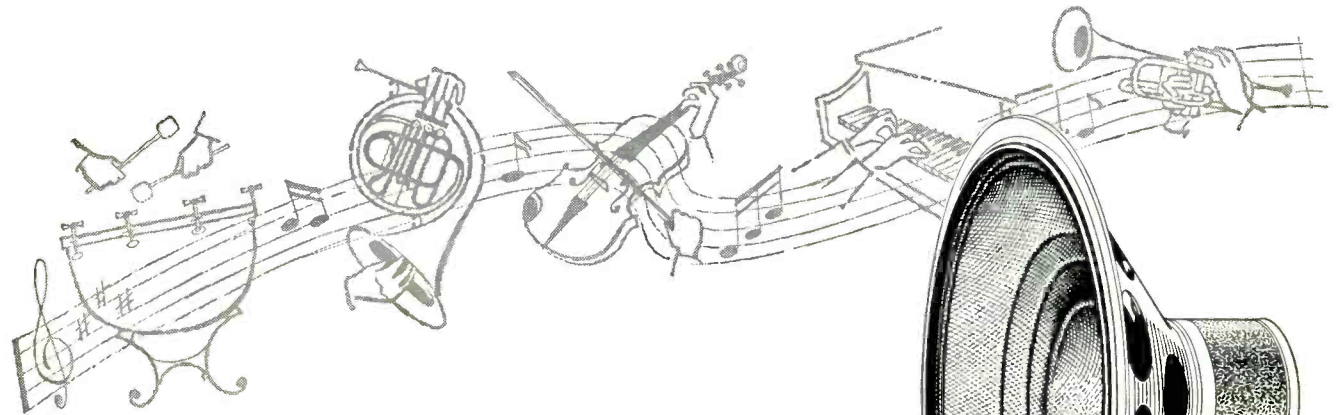

High fidelity and tonal qualities associated with expensive multi-unit speaker systems— are similarly produced with new Norelco FRS Twin-Cone Speakers.

Norelco's exclusive Twin Cones are made from specially selected and matched materials— operated from the same magnet and voice coil— some covering an extremely wide range up to 20,000 c/s. Norelco's twin-cones are always in phase and operate in harmony—providing the same degree of efficiency under all conditions.

Unequaled manufacturing precision and quality is inherent in all Norelco speakers. All component materials—including magnets, wire and even cone materials—are manufactured and assembled by Philips to suit a specific speaker design.

Many sizes in standard impedances are available from your dealer or send to Dept. E5 today for more details. Norelco FRS speakers are priced from \$59.98 to \$9.90 audiophile net.

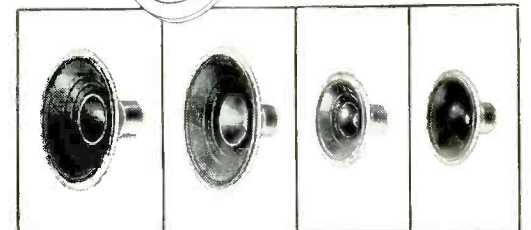

Add to... and improve any sound system!

with *Norelco*

*FULL RESONANCE SPEAKERS



NORTH AMERICAN PHILIPS CO., INC., 100 East 42nd Street, New York 17, N. Y.

SERVICE DEALER



and **ELECTRONIC SERVICING**

NEW TEST EQUIPMENT

HICKOK RECTANGULAR METERS

Newly developed 4 1/8" rectangular meters permitting maximum length of scale to an accuracy of 1 1/2% are now available in *ac* and *dc* models. Identified as Models 68 and 69, these meters are made for semi-flush panel mount applications and are supplied with or without illumination feature. An external zero adjust is provided in all cases. Two mounting stud locations are available for special applications.

(Check 501 on inquiry card for more information)

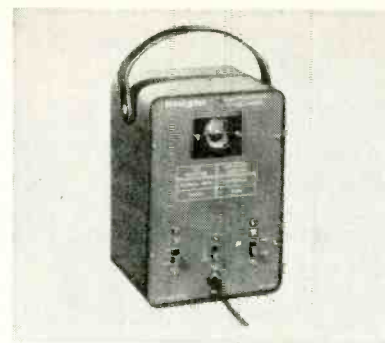
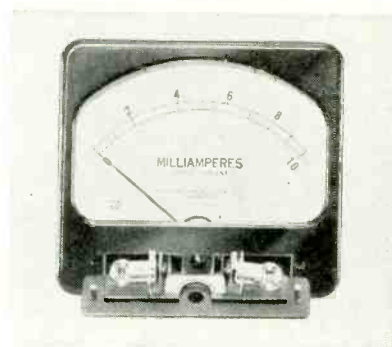

CAPACITOR CHECKER KIT

Allied Radio Corporation announces the release of a new capacitor checker that tests capacitors for opens or shorts while the capacitors are still wired in the circuit.

The test for opens can be made on any capacitor of 20 mmf or greater capacity, even if the capacitor is in parallel with a resistance as low as 50 ohms. The test for shorts can be made on any capacitor up to 2000 mfd, even when shunted by 20 ohms.

(Check 505 on inquiry card for more information)

3 1/2" RECTANGULAR METER

Phaoston announces a new line of 3 1/2" Rectangular Custom Meters.

Their metal cases will not chip, shatter or warp. In addition, they provide anti-magnetic shielding to the meter movement to provide more lasting accuracy to the advertised 2% full-scale calibration (which is really calibrated to 1% of full-scale deflection). The scales are large and clear so that they can be read at 8 feet.

(Check 506 on inquiry card for more information)

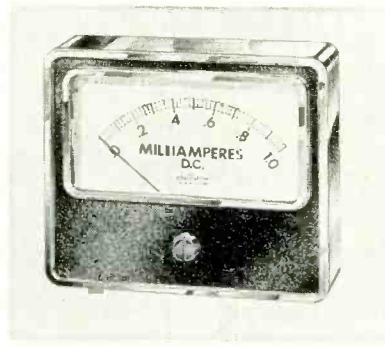

WESTON ADAPTER

A new plug-in Adapter which greatly extends the use of the Weston Model 749 Miniature AC Clamp Volt-Ammeter has just been introduced by the Weston Electrical Instrument Corporation. This compact adapter has plug receptacles on either side; one of which reduces the scale range of the Model 749 by a factor of 10, permitting low current measurements. The receptacle on the other side is for reading the ampere scale directly (1:1).

(Check 502 on inquiry card for more information)

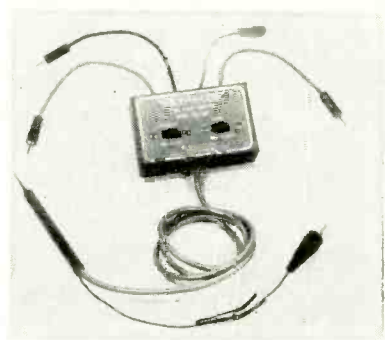

WIN-TRONIX SYNC ADAPTERS

Winston Electronics, Inc. has announced the Model 915/960 Sync Adapter for producing sync pulses when used with the Model 820 Sweep Circuit Analyzer. The sync pulse outputs from the adapters are injected into sync circuits for trouble shooting by signal substitution. This instrument converts the saw tooth waves of the Model 820 to sync pulses at either the horizontal or vertical frequency. Either positive or negative pulses may be obtained.

(Check 507 on inquiry card for more information)

FLOOR STAND FOR TUBE TESTER

A new Floor Stand for use with the DYNA-QUIK Tube Tester is now made available by B&K Mfg. When combined with the B&K Dyna-Quik Model 500 chassis, this unit makes an integrated, one-piece permanent tube tester and vendor.

The Dyna-Quik "500" quickly and accurately tests over 95% of all popular TV tubes in use today for dynamic mutual conductance, shorts, grid emission, gas content, leakage, and life expectancy.

(Check 503 on inquiry card for more information)

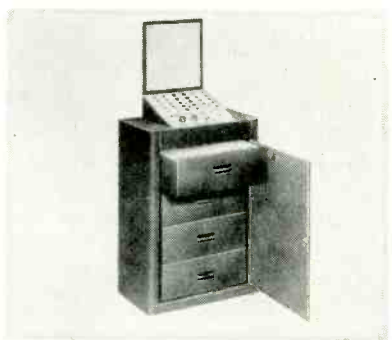

DONNER SINE WAVE GENERATOR

The new Donner Model 1200 Sine Wave Generator produces pure sinusoids from 1 cps to 1 mc in 6 decade ranges. Stable amplitude, freedom from drift, and high calibration accuracy are insured by a fully regulated power supply and generous negative feedback.

The Donner Model 1200 has application wherever high-quality sine waves are essential, as in communications, audio, and laboratory testing.

(Check 508 on inquiry card for more information)

TRICRAFT TUBE ANALYZER

Tricraft Products announces an inexpensive tube checker which is compact and rugged enough to take it day in and day out in the service kit. It checks all standard octal, loktal 7 and 9 pin miniature tubes for emission, gas, shorts, opens, microphonics and filament continuity. (Also picture tubes). All elements checked independently. Obsolete proof. No circuit changes necessary to check new tubes as they are developed.

(Check 504 on inquiry card for more information)

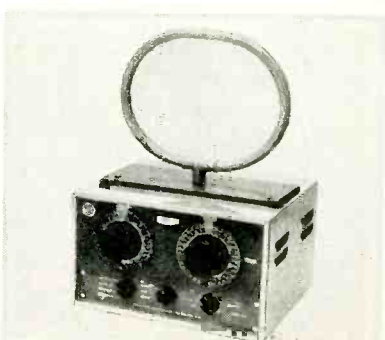
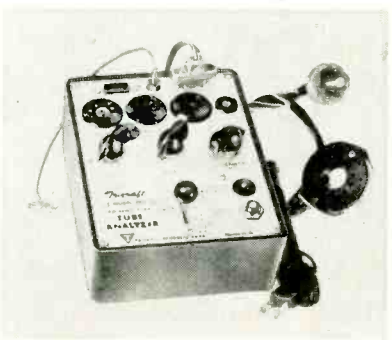

KAAR DIRECTION FINDER

The new Kaar 238 Direction Finder with simplified controls allows positive and direct operation because it is completely controlled from the front panel.

Front loop panel control, with vertical compass rose, assures smooth, easy operation so necessary for accuracy. It allows eye-level mounting; helps the operator take bearings more rapidly; and permits orienting the direction finder in any position on the boat.

(Check 509 on inquiry card for more information)

(Free Literature Request Form Appears on Page 41)

AMPLIFIERS—(Audio, Hi-Fi, P. A.)

Allied Radio Corp. 100 N. Western Ave., Chicago 80, Ill.
Blender-Tongue Labs, Inc. 526 North Ave., Westfield, N. J.
Bogen & Co., Inc., David 29 Ninth Ave., New York 14, N. Y.
Transvision, Inc. 360 North Ave., New Rochelle, N. Y.

ANTENNAS

American Phenolic Corp. 1830 S. 54th Ave., Chicago 50, Ill.
Channel Master Corp. Ellenville, New York
Clear Beam Antenna Corp. Canoga Park, Calif.
Cornell-Dubilier Electric Corp. South Plainfield, New Jersey
Finney Company, The 4612 St. Clair Ave., Cleveland 3, Ohio
General Cement Mfg. Co. 919 Taylor Ave., Rockford, Ill.
Hi-Lo TV Antenna Corp. 3540 N. Ravenswood Ave., Chicago 13, Ill.
Holloway Electronics Corp. Fort Lauderdale, Fla.
JFD Manufacturing Co., Inc. 6127 16th Ave., Brooklyn 4, N. Y.
Phileo Corp. Philadelphia 34, Pa.
Radiart Corp. 3455 Vega Ave., Cleveland 13, Ohio
Radio Merchandise Sales, Inc. 2016 Bronxdale Ave., New York 60, N. Y.
Snyder Mfg. Co. 22nd & Ontario Sts., Philadelphia 40, Pa.
Technical Appliance Corp. Sherburne, New York
Telrex, Inc. Asbury Park, N. J.
Walco Electronics Corp. 3602 Crenshaw Blvd., Los Angeles 16, Cal.
Winegard Company 3000 Scotten Blvd., Burlington, Iowa

ANTENNA ACCESSORIES

Alliance Manufacturing Co. Alliance, Ohio
American Phenolic Corp. 1830 S. 54th Ave., Chicago 50, Ill.
Blender-Tongue Labs, Inc. 526 North Ave., Westfield, N. J.
Channel Master Corp. Ellenville, New York
General Cement Mfg. Co. 919 Taylor Ave., Rockford, Ill.
I. E. Manufacturing Co. 325 N. Hoyne Ave., Chicago 12, Ill.
JFD Manufacturing Co., Inc. 6127 16th Ave., Brooklyn 4, N. Y.
Jontz Manufacturing Co. 1101 E. McKinley Ave., Mishawaka, Ind.
Kenwood Engineering Co. 265 Colfax Ave., Kenilworth, N. J.
Mosley Electronics 8622 St. Charles Rock Rd., St. Louis 14, Mo.
Mueller Electric Co. 1583 E. 31st Street, Cleveland 14, Ohio
Phileo Corp. Philadelphia 34, Pa.
Radiart Corp. 3455 Vega Ave., Cleveland 13, Ohio
Radio Merchandise Sales, Inc. 2016 Bronxdale Ave., New York 60, N. Y.
South River Metal Products Co., Inc. South River, New Jersey
Superelex Electronics Corp. 6 Radford Place, Yonkers, N. Y.

BATTERIES

Burgess Battery Co. Freeport, Illinois
RCA, (Tube Div.) Harrison, New Jersey

BOOKS & MANUALS

Cisin, Harry G. Amagansett, N. Y.
Cowan Publishing Corp. 67 West 44th Street, New York 36, N. Y.
Electronic Publishing Co. 180 N. Wacker Drive, Chicago 6, Ill.
Rider, John F., Publisher 480 Canal Street, New York 13, N. Y.
Sams, Howard W. & Co., Inc. 2201 E. 46th Street, Indianapolis 5, Ind.
United Catalog Publishers 110 Lafayette Street, New York 13, N. Y.

BUSINESS ORDER FORMS

Electronic Publishing Co. 180 N. Wacker Drive, Chicago 6, Ill.
Oelrich Publications 4308 N. Milwaukee Ave., Chicago 41, Ill.

BUYER'S DIRECTORY OF ADVERTISED PRODUCTS

● This department is an additional service to our readers and advertisers. It is not intended to cover all products in all categories, nor is it intended to cover all products made by any manufacturer.

● The classifications are broad. Under each is listed the name and address of only those manufacturers who have, in the recent past, or who are currently advertising these particular products in this publication.

● This service is not a part of the advertiser's contract. The listings may change in future issues. Every reasonable precaution is taken to avoid errors and omissions.

CAPACITORS

Aerovox Corp. New Bedford, Mass.
Astron Corp. 255 Grant Ave., East Newark, N. J.
Centralab, Div. of Globe-Union 900 E. Keefe Ave., Milwaukee 1, Wisc.
Cornell-Dubilier Electric Corp. South Plainfield, New Jersey
Erie Resistor Corp. Erie, Pa.
Illinois Condenser Co. 1616 N. Throop St., Chicago 22, Ill.
Planet Sales Corp. 225 Belleville Ave., Bloomfield, N. J.
Pyramid Electric Co. 1445 Hudson Blvd., North Bergen, N. J.
Syracuse Products Co. 71 Marshall Street, North Adams, Mass.

CHEMICALS, SPRAYS, LUBRICANTS

Electronic Chemical Corp. 813 Communipaw Ave., Jersey City 4, N. J.
General Cement Mfg. Co. 919 Taylor Ave., Rockford, Ill.
Great Eastern Mfg. Co. 165 Remsen Ave., Brooklyn 12, N. Y.
Krylon, Inc. Ford & Washington Sts., Norristown, Pa.
Quietrol Co., Inc. Spartanburg, South Carolina

Superelex Electronics Corp. 6 Radford Place, Yonkers, N. Y.
Telematic Industries, Inc. 16 Howard Ave., Brooklyn 21, N. Y.
Walco Electronics Corp. 3602 Crenshaw Blvd., Los Angeles 16, Cal.

CHOKES, COILS & TRANSFORMERS (RF)

Acme Electric Corp. 468 Water Street, Cuba, New York
Chicago Standard Transformer Corp. 3501 Addison Street, Chicago 18, Ill.
Merit Coil & Transformer Corp. 4427 N. Clark Street, Chicago 40, Ill.
Miller, J. W. Company 5917 S. Main Street, Los Angeles 3, Cal.
Superelex Electronics Corp. 6 Radford Place, Yonkers, N. Y.
Triad Transformer Corp. 4055 Redwood Ave., Venice, Cal.

CHOKES, COILS & TRANSFORMERS (Audio and Line Freq.)

Acme Electric Corp. 468 Water Street, Cuba, New York
Chicago Standard Transformer Corp. 3501 Addison Street, Chicago 18, Ill.
Delco Radio (Div. of General Motors Corp.) Kokomo, Indiana
Merit Coil & Transformer Corp. 4427 N. Clark Street, Chicago 40, Ill.
Perma-Power Company 4721 N. Damen Ave., Chicago 25, Ill.
Triad Transformer Corp. 4055 Redwood Ave., Venice, Calif.

CHOKES, COILS & TRANSFORMERS (Deflection & Focusing)

Acme Electric Corp. 468 Water Street, Cuba, New York
Chicago Standard Transformer Corp. 3501 Addison Street, Chicago 18, Ill.
Great Eastern Mfg. Co. 165 Remsen Ave., Brooklyn 12, N. Y.
Merit Coil & Transformer Corp. 4427 N. Clark Street, Chicago 40, Ill.
Perma-Power Company 4721 N. Damen Ave., Chicago 25, Ill.
Ram Electronic Sales Co. Irvington, New York
Superelex Electronics Corp. 6 Radford Place, Yonkers, N. Y.
Triad Transformer Corp. 4055 Redwood Ave., Venice, Calif.

CONNECTORS, PLUGS

Blender-Tongue Labs, Inc. 526 North Ave., Westfield, N. J.
Cannon Electric Co. P. O. Box 275, Los Angeles 31, Calif.
Eby Sales Co. of N. Y. 130 Lafayette Street, New York 13, N. Y.
General Cement Mfg. Co. 919 Taylor Ave., Rockford, Ill.
Mosley Electronics 8622 St. Charles Rock Rd., St. Louis 14, Mo.
Radio Merchandise Sales, Inc. 2016 Bronxdale Ave., New York 60, N. Y.

FUSES

Bussmann Mfg. Co. University and Jefferson, St. Louis 7, Mo.
Littelfuse, Inc. 4751 N. Ravenswood Ave., Chicago 40, Ill.

HARDWARE

General Cement Mfg. Co. 919 Taylor Ave., Rockford, Ill.
I. E. Manufacturing Co. 325 N. Hoyne Ave., Chicago 12, Ill.
Kenwood Engineering Co. 265 Colfax Ave., Kenilworth, N. J.
Mueller Electric Co. 1583 E. 31st Street, Cleveland 14, Ohio
South River Metal Products Co., Inc. South River, New Jersey
Walco Electronics Corp. 3602 Crenshaw Blvd., Los Angeles 16, Cal.

MICROPHONES, Stands & Accessories

American Microphone Co. 370 S. Fair Oaks Ave., Pasadena 3, Cal.
Atlas Sound Corp. 1446 39th Street, Brooklyn 18, N. Y.
Shure Bros., Inc. 222 Hartrey Avenue, Evanston, Ill.

[Continued on page 47]



MODEL RE-1

MULTIPHASE "Rejuva-Tube"

CRT REJUVENATOR

Brings "Dim-Outs" Back to Life
SENSATIONAL MONEY MAKER

Complete Kit \$49.50 Factory Wired \$59.50

Condensed Instructions Printed Inside Case Lid
Write for Manual on Rejuvenation with the "Rejuva-Tube"

*Patent Pending

SEE US AT MAY PARTS SHOW
CONRAD HILTON HOTEL
DISPLAY ROOM 660A

No Guesswork with Rejuva-Tube!

- Only Device That Meters Cathode Activity During Rejuvenation
- Tells Exactly When Rejuvenation Should Stop —
- Prevents Damage to Cathode Emitting Surface
- Built-in Current Limiter Eliminates Possibility Of Accidental Cathode Ribbon Burn-Outs

COMPARE THESE FEATURES

Tests — Repairs TV Picture Tubes Without Removing Tube From Set

- Compact, light-weight and easy to use.
- Complete Tester: detects open or shorted elements and leakage as high as 3 megohms between elements.
- Highest quality lab instrument construction.
- Special metered circuit removes "particle" shorts between heater and cathode.
- Checks cathode emission and grid cut-off characteristics.
- Predicts approximate life-expectancy of tube—identifies gassy tubes.



DEALERS! Now you can sell those "dim-out" trade-ins at a good profit, and back them up!

SERVICEMEN! Sell rejuvenation service. Fully 80% to 90% of picture tubes that have gone dim in service can be quickly reactivated to furnish up to years of "bright as new" service!



Central Electronics, Inc.

1247 W. Belmont Ave.

Chicago 13, Illinois

SERVICE DEALER



and **ELECTRONIC SERVICING**

NEW PRODUCTS

RF NOISE FILTER

Astron Corporation has announced the development of a new miniaturized *rf* noise suppression filter, style #AF1108. Containing 14 toroids and 8 capacitor sections, the AF1108 features a noise suppression range of .15 to 1000 megacycles. Its rugged construction enables it to withstand great amounts of shock and vibration as well as elevated operating temperatures. The unit is small and light and can be custom-engineered without shape limitations.

(Check 517 on inquiry card for more information)

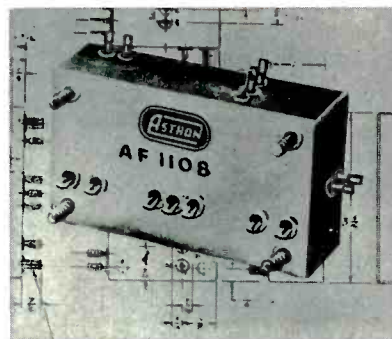

DEFLECTION YOKES

Ram Electronics Sales Co. has released 2 new 90° television deflection yokes, the Y90F12/47 and the Y90F19/43. They incorporate the latest design features to eliminate early problems of pin-cushioning and edge-to-edge focusing and a vinyl insulator between horizontal and vertical coils for longer life. These yokes are replacements for yokes in the sets made by 37 different TV manufacturers, from Admiral to Zenith.

(Check 515 on inquiry card for more information)

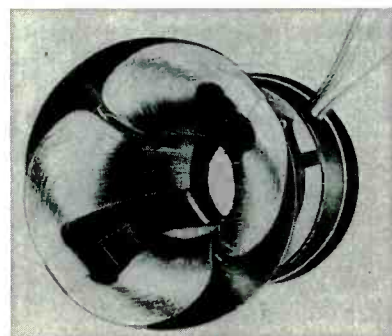

WORK CLOTHING LOCKERS

Change-O-Matic, a new type of locker system, has been introduced by the Change-O-Matic Corporation. It acts as a soiled uniform container, supplies clean uniforms quickly and replaces old fashioned clerk and counter distribution. A compact steel cabinet of either ten or sixteen compartments, it provides an individual locker for each employee while utilizing a minimum of valuable floor space.

(Check 511 on inquiry card for more information)

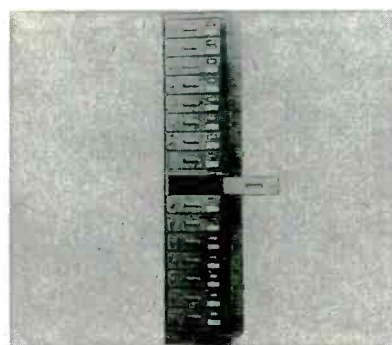

MINIATURE TRIMMER CAPACITOR

JFD has introduced a new, unique type of Trimmer Piston Capacitor. There are two models, each designed to meet the extremely critical, exacting requirements of automation and printed circuitry. The overall lengths of both models are exceptionally minute: model VC9G measures 9/16", while model VC10G is 5/16". They both employ glass dielectrics and invar silver-plated rotors. They are now available at low cost.

(Check 514 on inquiry card for more information)

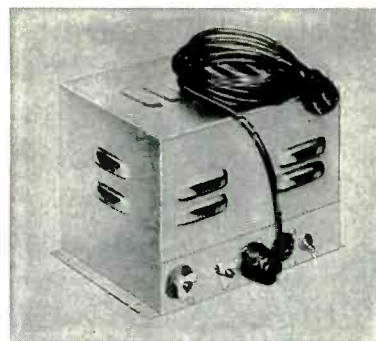
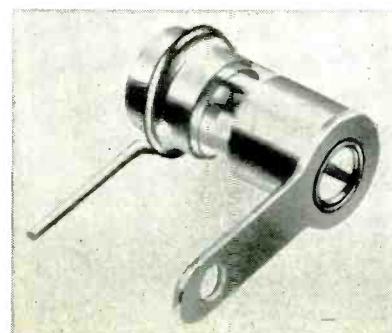

FIXED/MOBILE POWER SUPPLY

The James Vibrapowr Company announces the addition of model C-1450 to its line of communications power supplies. It operates from 6 or 12 volt vehicular ignition systems or from regular 117 volt 60 cps. ac lines. It can supply *dc* output up to 250 volts at 100 *ma* for receiving and dual output of 500 volts at 175 *ma* and 250 volts at 75 *ma* for transmitting. When operated from a 117 volt *ac* source, it also supplies up to 10 amps. at either 6 or 12 volts.

(Check 518 on inquiry card for more information)

REMOTE CONTROL UNIT

A new low cost, attractively designed, completely new remote control tuner has been developed and manufactured by International TV Remote Control Company. The "it" tuner allows the viewer to switch channels and even fine-tune the television picture automatically from anywhere in a room. It can be installed in three minutes right in the home. The unit will attach to all major television sets without connecting wires or using tools.

(Check 513 on inquiry card for more information)



MINIATURE RESISTOR

A new, silicone-sealed ceramic shell type resistor is now in production at Reon Resistor Corp. The miniature precision power unit, compact and self supporting, is resistant to humidity and salt spray military tests. Ideal for terminal board or printed circuit mounting, the ceramic shell offers uniform outer dimensions and is unaffected by abrasion and rough handling. Unusual stability is achieved by special design and maximum environmental protection.

(Check 510 on inquiry card for more information)

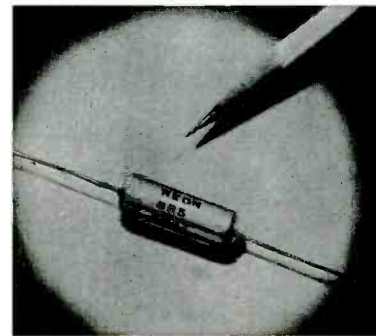

AEROSOL CAN

Krylon, Inc. announces the largest seamed aerosol can ever made commercially for its spray enamels and coatings. It is a 17.8 ounce aerosol can at the same price as Krylon's former 12 ounce size. The consumer will get 35% more of the acrylic plastic and the spray enamels at no extra cost. The container will give the consumer slightly more than a full pint of paint for less cost than a traditional pint can of paint plus the cost of a paint brush.

(Check 512 on inquiry card for more information)



ATR INVERTER

American Television and Radio Co. announces its new line of 6 and 12 volt inverters. This group of ATR Inverters is especially recommended for use with standard *ac* operated tape or wire recorders, dictating machines, radios, amplifiers, and similar electronic equipment. These Inverters also come equipped with four-point voltage regulators which make possible the correct output voltage for minimum to maximum loads.

(Check 516 on inquiry card for more information)

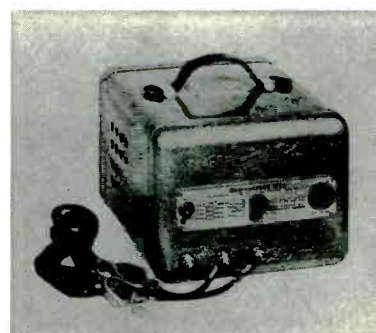

(Free Literature Request Form Appears on Page 41)

BUSINESS PROCEDURES

[Continued from page 15]

right portion tears off and has a $\frac{1}{4}$ " hole through it so it can be slipped onto a set's volume control shaft for easy identification. The third section is filled in as work is done by the serviceman and gives you the preliminary facts needed so your completely itemized bill can subsequently be made up. These "Job Tickets" take guesswork out of billing and should also be used as an inventory control guide. (For example, each night or once a week check off from the "job records" the number of tubes, by type or other components used that day, or week, and you'll know how many replacements should be bought from your distributor to maintain a level inventory.)

In the Oelrich line of printed business forms for servicemen there are a dozen or more other types of forms that are not being covered in this treatise because of space limitations. Every service firm owner or independent serviceman should look the items over at their distributor's store and decide for himself which of these would be worth having.

Sales aids—Sign Cards

Next I would recommend two more steps for servicemen to take. First, that all service firms and service dealers look at Oelrich's "Business Sign Kit 800" which consists of 25 different merchandising messages (some of which are shown as Fig. 7). The kit sells for only \$2.50. These 25 signs, attractively printed on wood-simulated cards, each $5\frac{1}{2}$ " x $10\frac{1}{2}$ " are designed not only to be decorative, but also to call the customer's attention to products and services you offer which are frequently overlooked. A sign maker would charge much more than \$2.50 for any single sign found in Kit 800 and yet the whole batch of 25, which sell for a pittance, can act as effective, dignified silent salesmen.

Finally, remembering that most customers carefully examine bills that are submitted to them, and, knowing from experience that it doesn't pay to trust to memory when writing down charges for replacement items used on any job, if I were a serviceman I'd always have handy a copy of the latest "Radio-Electronic Master" (see Fig. 8) which is

represented as the official buying guide of the industry by United Catalog Publishers, who issue it periodically. You'll find every parts distributor continually referring to and using the "Master" because it describes products completely and gives the *list price* for each.

Isn't it logical that when a customer questions a price you've used he will be completely satisfied when you open your copy of the "Master"—show him the item and its published list price? If you charged *less* than published list price you'll be a "hero" and if it is your policy to charge actual list, then you're proving that you're not a "phony price" chiseler.

Remember, the "Radio-Electronic Master" contains thousands of listings, all indexed and cross-indexed for easy reference. The parts distributor pays United Catalog several dollars for each copy and practically all distributors make it a standard practice to give a "Master" free of charge to all of their better customers. I have no idea as to what dollar volume of business you transact each year with your distributor, but I venture the guess that if you do any appreciable amount he will be only too happy to give you a copy of the "Master" in the hope that it will cement your good-will toward his firm.

The New NO-NOISE TUNER TONIC
with PERMA-FILM

Cleans, lubricates, restores all tuners including water type.

Won't change or affect capacities, inductance or resistance. Won't harm insulations or precious metals, nor attack plastics. For television, radio and FM. Eliminates all noise, oxidation and dirt indefinitely.

Non-toxic, non-inflammatory, insures trouble-free performance.

Net to servicemen **\$3.25**

Extra economical because a small amount does the job!

"NO NOISE"
Volume Control and Contract Restorer with Perma-Film

Cleans, lubricates, protects... Net to not a carbon-tet solution. Still service- available in the new 6 oz. men **\$2.25**
spray can.

2 oz. bottle \$1.00 Net to servicemen Also available in 5 oz. bottles and quart cans.

At your nearest distributor

ELECTRONIC CHEMICAL CORP.
813 Communipaw Avenue, Jersey City 4, N. J.

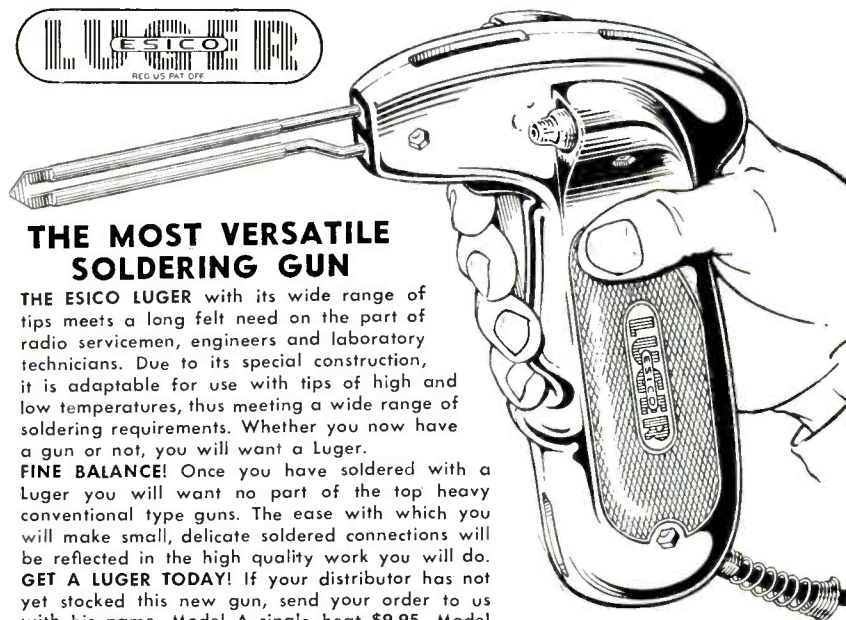

THE MOST VERSATILE SOLDERING GUN

THE ESICO LUGER with its wide range of tips meets a long felt need on the part of radio servicemen, engineers and laboratory technicians. Due to its special construction, it is adaptable for use with tips of high and low temperatures, thus meeting a wide range of soldering requirements. Whether you now have a gun or not, you will want a Luger.

FINE BALANCE! Once you have soldered with a Luger you will want no part of the top heavy conventional type guns. The ease with which you will make small, delicate soldered connections will be reflected in the high quality work you will do.

GET A LUGER TODAY! If your distributor has not yet stocked this new gun, send your order to us with his name. Model A single heat \$9.95. Model B, dual heat \$11.95.

ELECTRIC SOLDERING IRON CO., INC., 5856 W. Elm, Deep River, Conn.

SAVE TIME! MONEY! CUSTOMERS!

INCREASE SALES! PROFITS! GOOD WILL!

DECREASE LOSSES... ERRORS... COMPLAINTS... with

OELRICH Business Forms & Sales Aids

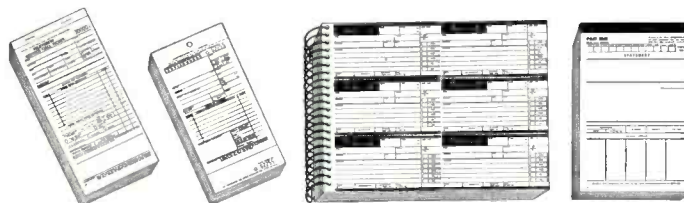

DESIGNED SPECIFICALLY FOR RADIO-TV SERVICE

Twenty-Eight items that can earn extra profits, organize business FOR YOU while at the same time favorably impressing your customers and eliminating misunderstandings. You can't afford to be without them. Buy in small quantities at low cost. Ask your jobber about them today!

OVER 800 JOBBERS TO SERVE YOU!...

Our products are distributed coast to coast... look for our big red display unit on your jobber's sales floor. Solve many of your business problems by including our forms and sales aids in your business plans.

SEND FOR FREE CATALOG

.....

• OELRICH PUBLICATIONS
• 4308 N. MILWAUKEE AVE. • CHICAGO 41, ILL.

PLEASE SEND FREE CATALOG

.....

Name _____

Address _____

City _____ Zone _____ State _____

EICO 84 Withers St., Brooklyn 11, N. Y. D-5

SAVE ME 50% on precision instruments—
send **FREE CATALOG** on EICO's 46 models
in factory-wired and kit form.

My Name.....
Address.....
City..... Zone..... State.....



NEW! COLOR

and Black-&White
DC to 5 MC LAB & TV
5" OSCILLOSCOPE

#460
Factory-wired
and tested **\$129.50**
Also available as kit **\$79.95**

• Features DC Amplifiers!

Flat from DC-4.5 mc, usable to 10 mc. VERT. AMPL.: sens. 25 rms mv/in; Z 3 megs; direct-coupled & push-pull thruout; K-follower coupling bet. stages; 4-step freq-compensated attenuator up to 1000:1. SWEEP: perfectly linear 10 cps-100 kc (ext. cap. for range to 1 cps); pre-set TV V & H positions (30 & 7875 cps); auto. sync. ampl. & lim. PLUS: direct or cap. coupling; bal. or unbal. inputs; edge-lit engraved lucite graph screen; dimmer; filter; bezel fits std photo equipt. High intensity trace CRT. 0.06 usec rise time. Push-pull hor. ampl., flat to 400 kc, sens. 0.6 rms mv/in. Built-in volt. calib. Z-axis mod. Sawtooth & 60 cps outputs. Astig. control. Retrace blanking. Phasing control.

BEFORE you buy ANY instruments—get the **FACTS** on the money-saving, high-precision EICO line. Fill in coupon for **FREE** catalog & name of your nearby distributor.

EICO 84 Withers St., Brooklyn 11, N. Y.
Prices 5% higher on West Coast

THE FIRST

Meter Designed for
General TV Servicing

a professional instrument
designed for testing a
T.V. ABOVE and BELOW
chassis!

THE VIDEO
PROBE METER!

Saves TWO HOURS PER
DAY when used in shop
for under chassis work.

\$31.50 Model VI

With the attachable pick-up loop, (where sufficient signal is available) the Probe Meter can detect and indicate radiation of signal thru I.F. and video amp tubes. (Simply slide loop over tube being tested.) Where internally shielded tubes are encountered, remove tube and insert probe tip into grid pin of socket. Indicates gain per stage.



DEALERS
NET PRICE

\$31.50

Can accurately trace and indicate the following T.V. circuits,—(from tuner to pix tube) R.F., I.F., Det., Video, Sync., local osc., Hz. osc., Hz. Drive, audio output, sound I.F. (Signal tracing radios).

**EXCELLENT FOR TRACING AND COMPARING
COLOR T.V. CIRCUITS.**

ADDITIONAL FEATURES

Voltmeter, 0-500 V. D.C. 20,000 Ohms/volt
Fully Guaranteed

If your dealer cannot supply you, order direct
full purchase price refunded if not satisfied.

DEALERS, REPS. & DISTRIBUTORS WILL
RECEIVE IMMEDIATE ATTENTION.

Research Inventions & Manufacturing Co.
617 F St., N. W., Washington 1, D. C.

THE WORK BENCH

Unusual Service Problems And Their Solutions

by **PAUL GOLDBERG**
Service Manager

THIS month's installment concerns horizontal *afc* problems. A knowledge of horizontal oscillator and *afc* circuitry and operation is a great aid in solving such problems.

GE 21T30 "J" line

The receiver was turned on and it was noted that the picture was out of horizontal frequency range. Tubes V107-12AT7, and V112-12AJ7, the horizontal phase detector and horizontal oscillator and discharge tubes, were replaced individually but had no effect. See Fig. 1.

The diagram was then analyzed. The horizontal phase detector or *afc* tube, V107B, compares the received sync pulse with the pulse fed back from the horizontal discharge circuit. If there is a difference in frequency or phase between these two

signals it results in a *dc* corrective voltage which is directed to the control grid of the horizontal reactance tube V112A.

The horizontal pulses flowing from the phase splitter V110A, are coupled to the cathode of the phase detector. A sample of the horizontal waveform from the discharge tube V113A is fed to the plate of the phase detector and hence modulates its plate current. The horizontal reactance tube V112A acts as a variable resistance which is connected in series with C260 across the horizontal tank circuit. The combination of this capacitance and variable resistance results in a variable reactance, and produces a variable frequency. As the *dc* output from the phase detector changes amplitude or polarity, the reactance tube plate resistance changes accordingly. A positive voltage causes the

tube to conduct more heavily thus lowering the resistance between the condenser C260 and ground. This increases the effective capacitive reactance of C260 across the oscillator tank circuit and causes a lowering of its natural frequency. By the same token a negative grid corrective voltage will result in a higher natural resonant frequency of the tank circuit.

The horizontal oscillator is of the Hartley type. Feedback occurs by a return tap to the grid tank coil from cathode.

Knowing these facts, a voltage check was first made at pin #1 of V112B, the horizontal oscillator. It measured correctly at about 175 volts. The voltage at pin #6 of V112A also measured correctly at about 195 volts. Before setting up the scope for waveform checks a last voltage check was made at pin #7 of V112A. This is the *dc* corrective voltage check. The voltmeter instead of reading about -10 volts, which is a normal reading, measured zero volts.

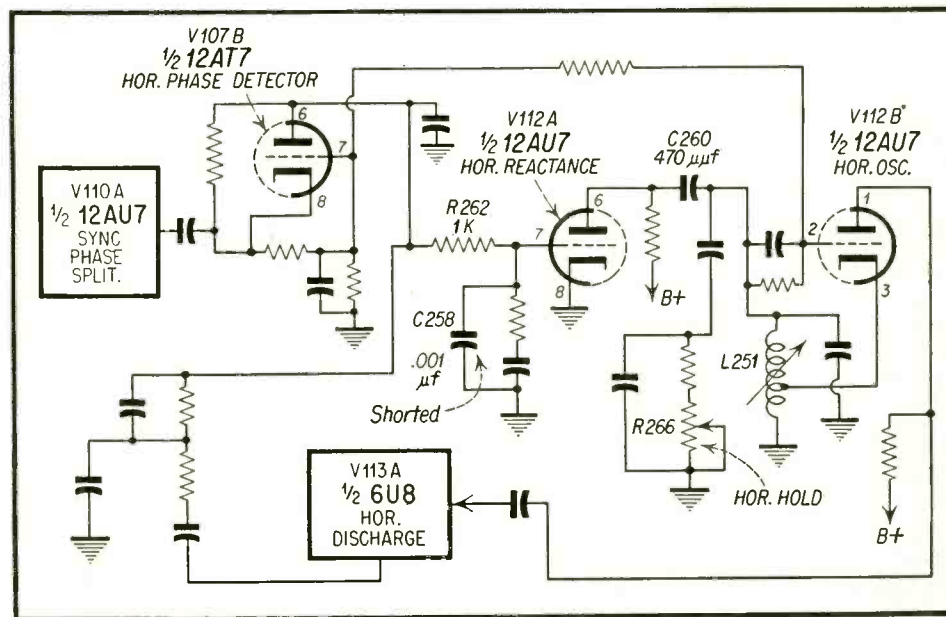

Fig. 1. Partial schematic of General Electric Model 21T30, "J" Line. This is an example of an automatic frequency control circuit which makes use of a triode type of phase detector in combination with a reactance tube. A separate horizontal discharge tube is employed. Cause of trouble was shorted C258.

This Month's Problem:

The author analyzes two cases involving trouble in horizontal *afc* circuits.

DON'T JUST SAY CAPACITORS

Ask For Sprague By
Catalog Number

Know what you're getting
get exactly what you want.
Don't be vague insist on
Sprague. Use complete radio-
TV service catalog C-610.
Write Sprague Products Com-
pany, 71 Marshall Street,
North Adams, Massachusetts.

SPRAGUE

WORLD'S LARGEST CAPACITOR MANUFACTURER

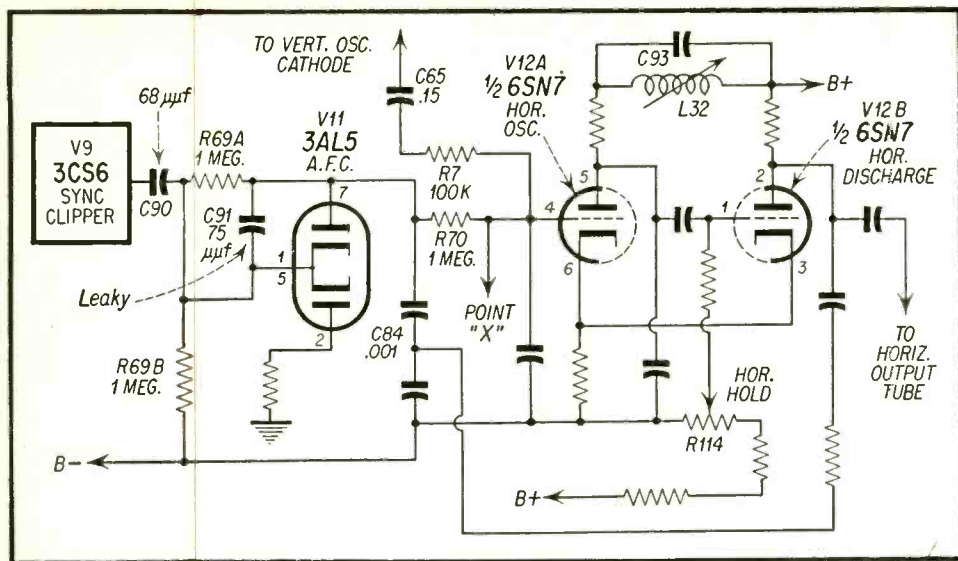

Fig. 2. Partial schematic of the Zenith Model 22T20. This illustrates a type of automatic frequency control circuit which makes use of dual diode for phase detection. Note that in this case the correction voltage is applied directly to the horizontal oscillator, without making use of a reactance tube. A separate discharge tube is used here also. Cause of trouble was leaky C91.

A resistance measurement was then taken from pin #7 of V112A to ground. The ohmmeter read zero ohms. Condenser C258, (.001 μ f), was then clipped out of the circuit and measured for leakage. It was found to be shorted completely. Following the replacement of this condenser the horizontal oscillator slug adjustment L251 was adjusted and the receiver now functioned properly.

Zenith 22T20

The receiver was turned on and it was observed that the horizontal frequency was far out of range. The *afc* tube, V11 (3AL5) and V12 (6SN7) the horizontal oscillator and discharge tube were replaced individually but had no effect.

The diagram was then analyzed. The cathodes of V11 obtain sync information from the sync clipper through C90, (68 μ f). A sample of the horizontal sawtooth voltage is obtained from the plate of the discharge tube and applied to the plates of the 3AL5 tube through the .001 μ f condenser, C84. The sawtooth divides equally between the diodes. When the sawtooth is in phase with the sync pulse, each diode conducts equally and the difference of potential across the one megohm load resistors R69A and R69B is zero and no change appears at the grid (pin #4) of the horizontal oscillator. If line fluctuations cause the horizontal oscillator frequency to change, one diode will conduct more than the other and a difference voltage at the grid of the 6SN7 will pull the oscillator back into phase.

Components R7, (100K) and C65 (.15 μ f) form a stabilizing anti-hunt circuit. This circuit introduces a small parabolic voltage from the cathode of the vertical oscillator which cancels the effect of the parabolic voltage appearing in the B+ applied to the plate of the horizontal oscillator.

The horizontal oscillator is a cathode coupled multivibrator which is stabilized by the tuned circuit L32 and C93 in the plate circuit of the oscillator tube.

Knowing all the facts, (including the fact that all the tube filaments in this receiver were in series) pin #4 of V12A was clipped out of the circuit at point "X", in order to sectionalize the trouble in either the circuitry of V11 or V12. (Ordinarily V11 (3AL5) could be pulled out of the socket as a check, but this could not be done because a series filament receiver was involved).

The receiver was again, turned on and it was noted that the horizontal frequency, although not holding, naturally, was now back in range. It was deduced therefore that the trouble was in the 3AL5 circuit. Point "X" was next resoldered and a quick resistance check was made of all components in the *afc* circuit. When R69A was measured, it was found to be 1000 ohms. Noting that C91 was directly in parallel with R69A, (one megohm), C91, (75 μ f) was clipped out of the circuit and measured. It was found to measure about 1000 ohms. When a new 75 μ f condenser was installed the receiver functioned properly.

Star Performers on Your Service Team...



Television Hardware and
your TELCO Distributor

BRINGING YOU THE ALL NEW

RATCHET CHIMNEY MOUNT

FAST INSTALLATION... simply thread strap thru ratchet bolt and tighten.
REALLY HOLDS... ratchet bolt design never lets go. FITS MAST UP TO 1 1/4" DIAMETER.
LONG LASTING zinc plated and dicromate dipped for double weather proofing.
No. 9218 Ratchet mount with 24' galvanized straps.
No. 9219 Ratchet mount with 24' stainless steel straps.

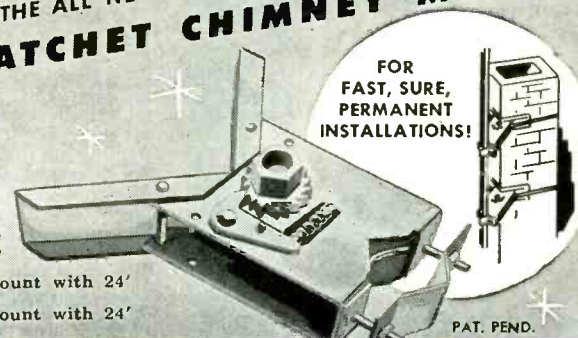

FOR FAST, SURE, PERMANENT INSTALLATIONS!

PAT. PEND.

TELEVISION HARDWARE MFG. CO.

Division of General Cement Mfg. Co

919 Taylor Avenue, Rockford, Illinois

FREE COPY... TELCO Catalog. Write for yours now!

TELCO
HARDWARE



Everything for fast profitable TV installations—stand-offs, mounts, towers, arrestors, all accessories. The complete line is at your nearby TELCO distributor.

SEE US . . . BOOTH 590—ROOM 612—PARTS SHOW

Facts About Self Service Tube Testers

- Testers are put in drugstores, service stations, dept. stores, etc.
- Customers do the actual checking
- Customer pays cooperating merchant for tubes purchased
- 2,000 new testers are being placed each month!
- Testers have taken over 40% of tube sales in many places
- Tester owners report average profit per tester of \$90 monthly

\$34.50 PUTS YOU IN THE PROFITABLE "SELF-SERVICE" TUBE BUSINESS! THIS IS THE "GENERAL PLAN":

- No wiring for you to do. We ship panel with tube chart, signs, tube trays, window banners, and EVERYTHING but the cabinet.
- In one day, you make the cabinet; and "earn" \$110.
- We furnish suggested cabinet drawings.
- We help you get started—we give you advertising material, selling tips, tell you how to do it. We even show you how to increase your service business!
- Send \$34.50 for each tester. Pay \$45 balance at \$15 per month, FROM YOUR PROFITS, the next three months!

Don't delay. There are only a limited number of top locations in your area. Get yours before they're gone.

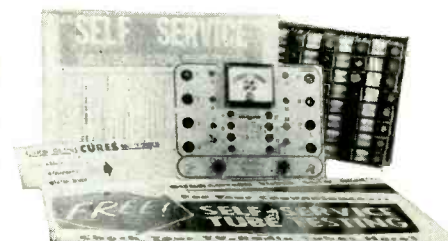

GENERAL ELECTRONIC RESEARCH COMPANY
P.O. BOX 223
WHITEWATER, WISCONSIN

KENCO KATE SAYS
**"NO
 INSTALLATION
 PROBLEMS
 when you use
 KENCO
 MOUNTS"**



Patented Kenco Eave Mounts



Easily mounted on hanging rafters or trim boards of eave. Eliminates need for drilling into brick or masonry walls. Ideal for buildings with extended roofs. Hot dip galvanized.

Available in 3 sizes:
 Model # 122 22" Eave Mount
 Model # 128 28" Eave Mount
 Model # 148 48" Eave Mount

OTHER KENCO PRODUCTS:
 All-Position Mounts; Parapet Mounts; Sky Struts; "Snap-In" Wall Brackets; "Snap-In" Chimney Mounts; Z-Type Chimney Mounts; Lag Screws and Hardware.

KENWOOD ENGINEERING CO., INC.
 Kenilworth, New Jersey

for all your
**Exact Replacement
 TV TRANSFORMERS**

**Specify
 Stancor**

FREE
 STANCOR TV Transformer Replacement Guide listing over 8000 models and chassis of 117 manufacturers... also STANCOR Auto Radio Replacement Guide with replacement data on over 540 auto radios of 40 manufacturers. Available from your distributor or by writing Chicago Standard.



**CHICAGO STANDARD
 TRANSFORMER CORPORATION**
 3586 Elston Avenue • Chicago 18, Illinois

CONDENSER CHECKERS

[from page 11]

four arms can be balanced as far as their impedances are concerned. When balance is accomplished the voltage across the bridge, from point A to point B is zero. This is indicated with a null device such as a meter or an electronic "eye". A power factor control is employed in further adjusting for balance when measuring electrolytic condensers. In the Heathkit Model C-3 indication of bridge balance or null is observed by means of a magic "eye" electron beam indicator tube. At balance the "eye" is open to its maximum angle.

Electrolytic condensers have a certain amount of internal resistance in series with their capacitance. To completely balance the bridge it is necessary to also balance this internal resistance with a resistor in series with the standard condenser. This resistor is known as the power factor control on all units. As electrolytic condensers are only found in the higher capacity values, the control only functions on the higher and extended ranges of the Heathkit unit as can be noted in Fig. 4.

Power factor percentage is a measure of the energy loss in a condenser. In filter applications a high power factor percentage decreases the effective capacity. When measuring the capacity of electrolytic condensers the power factor control as well as the main control should be adjusted for a null indication. The power factor percentage is then taken at the same time.

In measuring resistances with the Heathkit Model C-3 tester either of two resistors, 2k or 200k are switched in position in the bridge instead of the standard condensers. The fourth arm then contains the unknown resistance and the scale of the main control is read, having been calibrated in ohms as well as capacitance values. When balance or zero voltage is indicated by the null indicator the ohms value is read directly on the main control scale.

After the capacity value has been determined with this unit a leakage test for quality can be quickly made. The

selector switch is set to one of the five polarizing voltages made available. The leakage switch is then changed to the leakage test position and the action of the electron beam indicator tube observed. If the shadow angle closes suddenly and then returns to normal a

satisfactory condenser is indicated. Leakage is indicated by the degree of closing angle on the electron beam tube. A partially closed "eye" or a fluttering condition indicates a leaky condenser. If the "eye" closes entirely or overlaps, the condenser is shorted.

[To Be Continued]

SERVIS-ADES
 by
TELE-SCOPIC PRODUCTS, INC.
 215 W. 33rd St. • New York 1, N.Y.

Send checks or money orders only

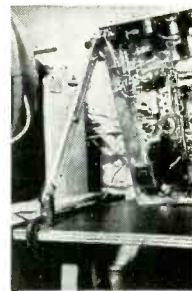

**ADJUST-
 ABLE
 3rd ARM**

FOR HOLDING
 CHASSIS IN
 POSITION ON
 WORK BENCH

\$5.50 each

CHASSIS HOLDERS
 FOR HANDLING CHASSIS
 WITHOUT CUTTING FINGERS \$1.00 pair

**DON'T JUST SAY
 CAPACITORS**

Ask For Sprague By
 Catalog Number

Know what you're getting
 . . . get exactly what you
 want. Don't be vague . . .
 insist on Sprague. Use Com-
 plete radio-TV service cata-
 log C-610. Write Sprague
 Products Company, 71
 Marshall Street, North
 Adams, Massachusetts.

SPRAGUE®

WORLD'S LARGEST
 CAPACITOR MANUFACTURER

As easy to use as a pencil

**WALL
 INDUSTRIAL
 SOLDERING IRONS**
give you

More
 BTU's . . .

Faster
 HEAT . . .

Higher HEAT
 CONTINUITY

Exclusive
 THERMOSTATIC ACTION . . .
 Guaranteed for the life of the iron!
 Prevents excessive tip burning!

than **ANY OTHER**
 soldering irons of equal tip size

Proved 4 times faster on the production lines of America's leading electronics firms. Complete range of sizes . . . scientifically designed . . . individually tested . . . for easier, surer precision work or heavy duty soldering. Operate on 110-120 volts, AC or DC! Model 18T illustrated, \$6.25 list.

Write for FREE Catalog



WALL MANUFACTURING CO.
 Grove City, Pennsylvania
 OVER 20,000,000 SOLDERING PRODUCTS SINCE 1864

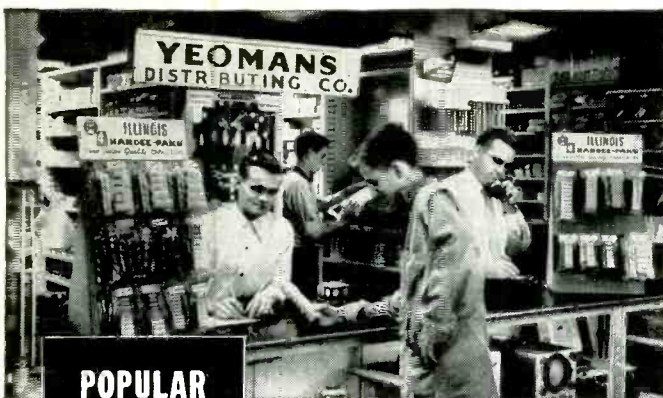

**POPULAR
WITH
SERVICEMEN**

ILLINOIS "HANDEE-PAK" CAPACITOR KITS

Servicemen go for the new ILLINOIS "HANDEE-PAK" Capacitor Kit assortments because they take up little room in the service kit—are easily identified and since they are hermetically sealed in polyethylene bags, the capacitors are always factory fresh and clean! Each PAPER CAPACITOR KIT is made up of 10 assorted new Type ITC Ceramic Cased Paper Capacitors of the capacity and voltage ratings most used by servicemen. The ELECTROLYTIC KITS consist of 5 popular types.

LOOK FOR THEM ON THE NEW JOBBER COUNTER RACKS

New ILLINOIS "HANDEE-PAKS" are available at most better jobbers—carry a few "HANDEE-PAKS" in your service kit. They are the ultimate in packaging, convenience and reliability.



ILLINOIS CONDENSER CO.
1616 N. THROOP STREET CHICAGO 22, ILLINOIS

Nearly EVERYBODY BUYS SELECT-O-VISION for *COMPLETE TV Remote Control

"Nothing Defaces
Your Set."

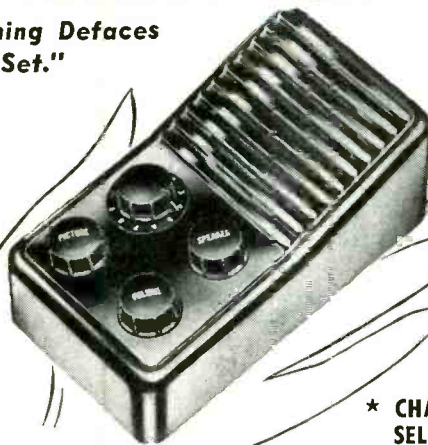

* CHANNEL
SELECTOR

* Dual Control
* Speaker Selector
* Picture Control
* Volume Control
* On & Off Control

PERSONAL SPEAKER

brings audio into the palm of your hand.

Many excellent territories still open for dealers and distributors.

Write, Wire or Call and learn how you too can
INCREASE PROFITS

Mfr. By **MALIN ENTERPRISES**

2209 Michigan Avenue Santa Monica, Calif.

BUYER'S DIRECTORY OF ADVERTISED PRODUCTS

[Continued from page 41]

PHONOGRAPH NEEDLES

Jensen Industries, Inc. 342 S. Wood Street, Chicago 12, Ill.
Permo, Inc. 6415 N. Ravenswood Ave., Chicago 26, Ill.
Recoton Corp. 52-35 Barnett Ave., Long Island City 4, N. Y.
Walco-Electrovox Co., Inc. 60 Franklin Street, East Orange, N. J.

PHONOGRAPH PICKUPS & CARTRIDGES

American Microphone Co. 370 S. Fair Oaks Ave., Pasadena 3, Cal.
Electro-Voice, Inc. Buchanan, Michigan
Shure Brothers, Inc. 222 Hartrey Avenue, Evanston, Ill.
Sonotone Corp. Elmsford, New York

POWER SUPPLIES (Converters & Inverters)

American Television & Radio Co. 300 East First St., St. Paul 1, Minn.
Electro Products Labs, Inc. 4501 N. Ravenswood Ave., Chicago 40, Ill.
Porna-Power Company 4721 N. Damen Ave., Chicago 25, Ill.
Vokar Corporation Dexter 2, Michigan

RESISTORS & CONTROLS

Aerovox Corp. New Bedford, Mass.
Centralab, Div. of Globe-Union 900 E. Keefe Ave., Milwaukee 1, Wisc.
Ciarostat Mfg. Co., Inc. Dover, New Hampshire
Delco Radio, Div. of General Motors Corp. Kokomo, Indiana
Erie Resistor Corp. Erie, Pa.
International Resistance Co. 401 N. Broad St., Philadelphia 8, Pa.

SEMI-CONDUCTORS

CBS-Hytron 100 Endicott Street, Danvers, Mass.
Federal Telephone & Radio Corp. 100 Kingsland Road, Clifton, N. J.
General Electric Co. Schenectady, New York
Philco Corp. Philadelphia 34, Pa.
RCA, (Tube Div.) Harrison, New Jersey
Raytheon Mfg. Company Newton, Mass.
Tarzian Inc., Sarks 415 N. College Ave., Bloomington, Ind.
Tung-Sol Electric, Inc. 95 Eighth Ave., Newark 4, N. J.

SERVICING AIDS

Allied Radio Corp. 100 N. Western Ave., Chicago 80, Ill.
American Phenolic Corp. 1830 S. 54th Ave., Chicago 50, Ill.
Belion Manufacturing Co. 4647 W. Van Buren St., Chicago 80, Ill.
Blondie-Tongue Labs, Inc. 525 North Ave., Westfield, N. J.
Columbia Wire & Supply Co. 2850 Irving Park Road, Chicago 18, Ill.
Electric Soldering Iron Co. Deep River, Conn.
Electronic Publishing Co. 180 N. Wacker Drive, Chicago 6, Ill.
General Cement Mfg. Co. 919 Taylor Ave., Rockford, Ill.
Mail Tool Company 7740 South Chicago Ave., Chicago 19, Ill.
Oelrich Publications 4308 N. Milwaukee Ave., Chicago 41, Ill.
Quietrol Co., Inc. Spartanburg, South Carolina
Ram Electronic Sales Co. Irvington, New York
Tele-Scopic Products, Inc. 215 W. 33rd Street, New York 1, N. Y.
Ungar Electric Tools, Inc. P. O. Box 312, Venice, Calif.
United Catalog Publishers 110 Lafayette Street, New York 13, N. Y.
Vaco Products Co. 317 E. Ontario Street, Chicago 11, Ill.
Wen Products, Inc. 5806 Northwest Highway, Chicago 31, Ill.
Xcelite, Inc. Thorne Ave. and Bank St., Orchard Park, N. Y.
Yeats Appliance Dolly Sales Co. 2133 N. 12th Street, Milwaukee 5, Wisc.

SPEAKERS

Atlas Sound Corp. 1446 39th Street, Brooklyn 18, N. Y.
Delco Radio, Div. of General Motors Corp. Kokomo, Indiana
Jensen Mfg. Company 6601 S. Laramie Ave., Chicago 38, Ill.
North American Philips Co., Inc. 100 East 42nd Street, New York 17, N. Y.
Oxford Electric Corp. 3911 S. Michigan Ave., Chicago 15, Ill.
Philco Corp. Philadelphia 34, Pa.
Quam-Nichols Company Marquette Rd. & Prairie Ave., Chicago 37, Ill.
University Loudspeakers, Inc. 80 S. KENSICO AVE., White Plains, N. Y.

SPEAKER ENCLOSURES

Jensen Mfg. Company 6601 S. Laramie Ave., Chicago 38, Ill.
Transvision, Inc. 460 North Ave., New Rochelle, N. Y.
University Loudspeakers, Inc. 80 S. KENSICO AVE., White Plains, N. Y.

TEST EQUIPMENT & INSTRUMENTS

American Scientific Development Co. 334 S. Main St., Fort Atkinson, Wisc.
B & K Manufacturing Co. 3731 N. Southport, Chicago 13, Ill.
Central Electronics, Inc. 1247 Belmont Ave., Chicago, Ill.
Electronic Instrument Company (EICO) 84 Withers Street, Brooklyn 11, N. Y.
Electronic Test Instrument Corp. 13224 Livernois Avenue, Detroit 38, Mich.
General Electronic Research Co. Whitewater, Wisc.
Heath Company, The Benton Harbor, Michigan
Hickok Electrical Instrument Co. 10533 Dupont Ave., Cleveland 8, Ohio
Hycon Electronics, Inc. 320 S. Arroyo Parkway, Pasadena, Calif.
Jackson Electrical Instrument Co. 16 S. Patterson Blvd., Dayton 2, Ohio
Moss Electronic Distributing Co., Inc. 38 Murray Street, New York 7, N. Y.
Phaotron Company 151 Pasadena Ave., South Pasadena, Calif.
Philco Corp. Philadelphia 34, Pa.
Precision Apparatus Co., Inc. 70-31 84th Street, Glendale 27, L. I., N. Y.
Proscope Co., Inc. 44-05 30th Ave., Long Island City 3, N. Y.
Radio City Products Co., Inc. Centre & Glendale Sts., Easton, Pa.
Research Inventions & Mfg. Co. 617 F Street, N. W., Washington 1, D. C.
Seco Mfg. Co. 5015 Penn Avenue South, Minneapolis, Minn.
Simpson Electric Company 5200 W. Kinzie Street, Chicago 44, Ill.
Superior Instruments Co. 2435 White Plains Rd., New York 67, N. Y.
Telematic Industries, Inc. 16 Howard Ave., Brooklyn 21, N. Y.
Teletest Instrument Corp. 31-01 Linden Place, Flushing 34, N. Y.
Tripllett Electrical Instrument Co. Bluffton, Ohio
Weston Electrical Instrument Corp. 614 Frelinghuysen Ave., Newark 5, N. J.
Winston Electronics, Inc. 4312 Main Street, Philadelphia 27, Pa.

TOOLS

Electric Soldering Iron Co. Deep River, Conn.
General Cement Mfg. Co. 919 Taylor Ave., Rockford, Ill.

Buyer's Directory continued on page 50

SPECIAL OFFER TO OUR READERS!

By special arrangement with John F. Rider Publisher, Inc., SERVICE DEALER and ELECTRONIC SERVICING now brings you a COMPLETE diagram service to help you do a faster, easier servicing job!

**ALL COMPLETE! ALL FACTORY
PREPARED! ALL FACTORY
AUTHORIZED!**

✓ Just \$1.25 for COMPLETE SERVICING INFORMATION on any TV receiver . . . any year, any make, any model . . . from 1946 on!

✓ Just 75¢ for COMPLETE SERVICING INFORMATION on any radio . . . any year, any make, any model . . . from 1941 on!

**TAKE ADVANTAGE OF THIS SPECIAL
OFFER . . . MAIL THE COUPON TODAY!**

COWAN PUBLISHING CORP.

67 W. 44 Street, New York 36, N. Y.

Please RUSH me the the following diagrams:

TV DIAGRAMS @ \$1.25 EACH

CHASSIS #	MAKE	MODEL #

RADIO DIAGRAMS @ 75¢ EACH

CHASSIS #	MAKE	MODEL #

MAKE CHECKS & MONEY ORDERS PAYABLE TO
COWAN PUBLISHING CORP.

(For all New York City orders, please submit additional 3% sales tax.)

Name _____

Address _____

City _____ State _____

**By popular demand, the serviceman's most-wanted book,
Video speed Service Systems Vol. 1. is now also available
in a low cost PAPER BOUND COVER EDITION**

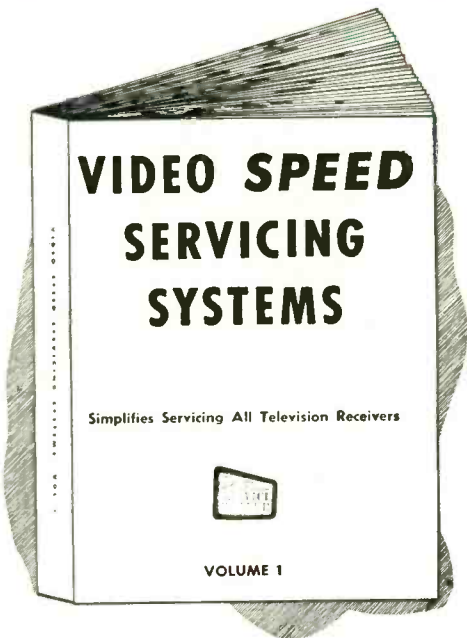

**TAKE
YOUR
CHOICE**
← **New Hard Paper
Cover Bound Edition**
\$2.95
Postpaid
**Cloth-Covered
Ring Binder** →
Edition
\$4.95
Postpaid

(New York City Residents, add 3%
to cover city sales tax)

Distributors—Order your supply
now. Service Dealers, order from
your distributor. If he can't
supply you, order direct by mail
from us.

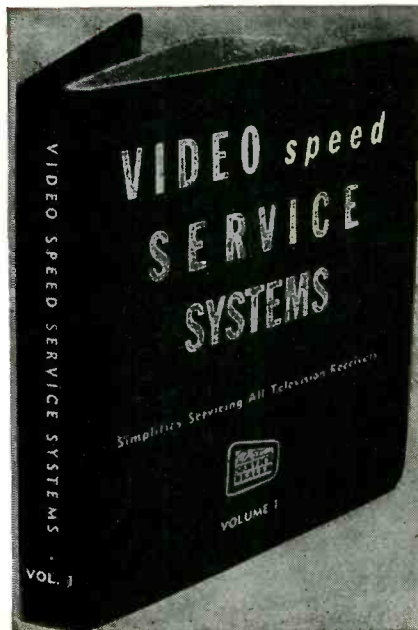

Has the identical contents of the Ring
Binder Edition but the price is only
\$2.95

Facts About Video speed Service Systems :

CONTENTS:

A compilation of specific receiver service repairs, "bugs", chronic troubles, field circuit changes, manufacturers' production revisions, etc. The compilation enables the service technician to pin-point what is wrong with any given TV set and to correct the fault in the shortest possible time.

SOURCES:

The material was obtained directly from manufacturers, distributors' service departments, TV service organizations, and top TV Service-dealers throughout the country. Furthermore—all material has been checked carefully to assure dependability and accuracy.

USES:

The VSSS data sheet for any particular TVset maker's model or chassis number gives: 1—the section of the set affected; 2—the symptom; 3—the cause of complaint; 4—the solution, in simple, understandable and usable form.

Video Speed Service Systems is guaranteed to simplify servicing all TV sets. Contains over 600 service items representing over 2500 of the most serviced TV models now in use. Over 25 different manufacturers' lines are covered. Almost 15,000 copies of VSSS have been sold at \$4.95. Every technician needs a copy.

CUT OUT AND MAIL

COWAN PUBLISHING CORP., 67 WEST 44TH STREET, NEW YORK 36, N. Y.

Please send me postpaid Video speed Service Systems Vol. 1 in Paper Bound Edition for \$2.95 . . . or Hard Cover Ring-Binder Edition for \$4.95. My check for \$..... is enclosed. If you reside in New York City add 3% to cover city sales tax.)

Name

Address

City Zone State

HI-FI

[from page 13]

many servicemen will find themselves totally unprepared, both technically and psychologically, to bid for their fair share of this source of income.

The Hi-Fi Enthusiast

Lack of technical training on the part of service personnel is due, in part, to the rapid expansion of the field in so short a period of time. There is also another, perhaps more subtle reason for the inactivity of servicemen in this potentially lucrative field. Because the early enthusiasts were primarily technical people, it became universal practice to publish a good deal of technical data concerning high-fidelity equipment. This practice has persisted to the present day. As a result, many high-fidelity customers have had to acquaint themselves with technical terms, some of which are more familiar to them than to their prospective servicemen. Not all high-fidelity enthusiasts fall into this classification, but those who do can make things pretty rough on the uninitiated service dealer who is, perhaps, a bit rusty on his decibels, equalization curves, Fletcher-Munson effect and variable speaker damping. These terms, and many more, constitute the language of high-fidelity. In order to instill confidence in a customer, a service dealer must not only speak that language, but must thoroughly understand the concepts behind the terms used.

The second major potential customer is at the other end of the scale, compared to our "engineering-minded" friend described above. This fellow knows absolutely nothing about electrons and cares even less. However, bear this in mind. This latter fellow is fast becoming the majority consumer of high fidelity components. He requires even greater understanding in trying to cultivate his friendship and win his confidence. *This fellow is a music lover!* There are more and more of them joining the ranks of high-fidelity equipment owners every day. This is the fellow, who, when asked on the telephone to state the nature of his complaint, will, nine times out of ten reply, "It just doesn't sound right!" What you, the serviceman, say and do

at that critical point can determine once-for-all whether or not you've added another customer to your list. Believe me, arriving at his home, listening for a moment, and then telling the customer that it sounds just *fine* to you is the *worst possible* thing to do. This constitutes the "opinionated art" approach we mentioned before. You'll have to forget that approach if you ever hope to get your share of this up and coming Hi-Fi business.

A very specific and important purpose of this series of articles will be to alter that approach to one of scientific analysis, measurement, test and interpretation. We will not abandon the use of our ears completely in favor of test equipment any more than we would think of shutting our eyes to the symptoms displayed on a TV screen. Instead, we hope to show you how proper use of test equipment (much of which is already on your work-bench) can, together with your sense of hearing, enable you to prove to your customers *positively* that his equipment is either *not* performing according to specifications, or, in many cases, that it *is!* In any case, there won't be any debate about it, or any cupping of the hand over the ear in an attempt to measure hum, distortion, or "right-soundingness."

Of course, in order to use test equipment in the audio field, it is necessary to know the function of every element of a high-fidelity system. A few simple tests by a trained technician can usually determine whether an electronic part of the system is operating correctly or not. So, our second purpose will be to acquaint the reader at some point in each article with the normal or expected behavior of each element of the system. By learning to recognize correctly functioning equipment, systems requiring trouble-shooting stand out quite readily.

In one sense, this can prove to be simpler than any service work you've done to date. Remember that most high fidelity equipment in service today is put together very much like a block diagram. That is, several components operate in what might be called a series-parallel arrangement, as shown in *Fig 1*, for example. In such installations, isolation of the defective block is very simple and will be the subject of our first technical article next month.

Seen the Saw?

INDISPENSABLE FOR RADIO-TV

CUTS 2 x 4's
IN SECONDS.
CUTS
1/2" STEEL.

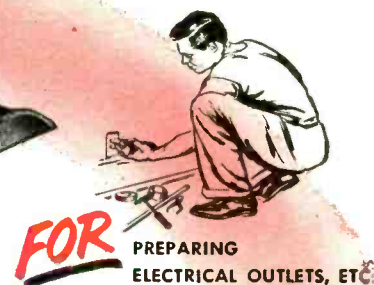
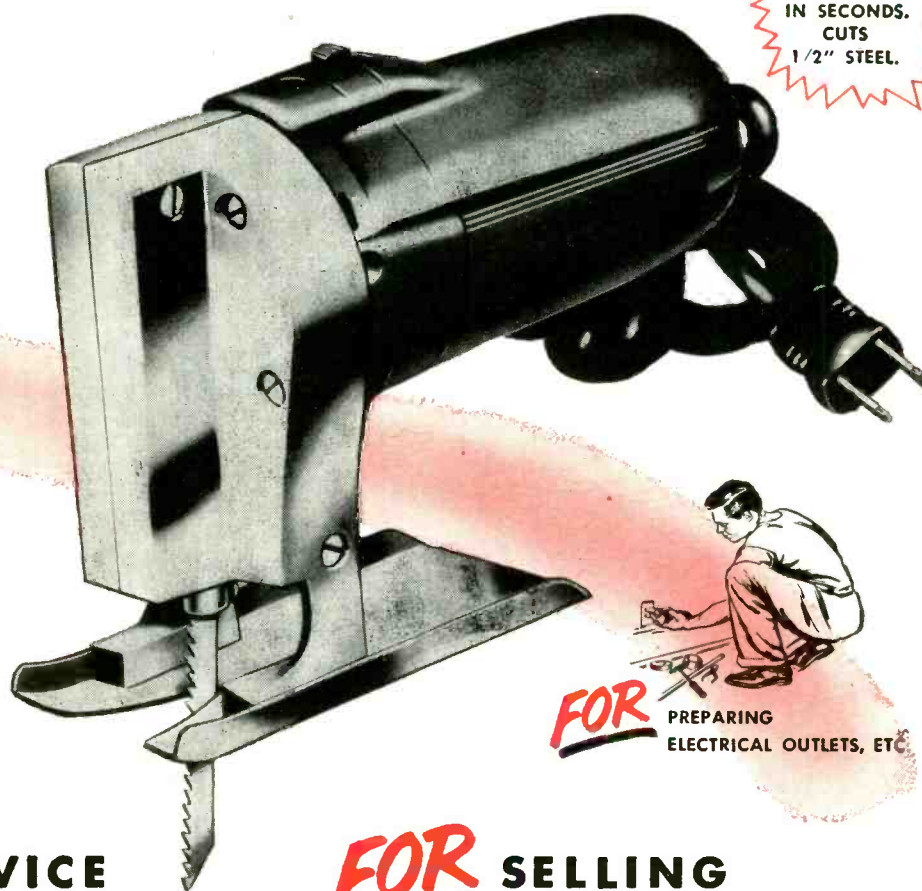
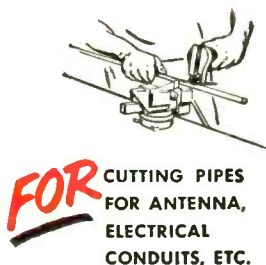







FOR SERVICE

FOR SELLING

Like other WEN tools, this new Power Saw is compact, handy, efficient, ideal for the Service Man. Has powerful AC/DC Universal motor. Delivers 2650 - 3/8" strokes per minute. Cuts wood, plastics, metals, composition, hard rubber, etc. Acts as jig, rip, crosscut, band, hack, coping, scroll or keyhole saw. Interchangeable blades. Air stream blows dust off work.

This is the hottest selling item in electrical power tools today. It's being snapped up by professionals and amateurs alike wherever shown. And no wonder—for this saw does the work of 8 saws—more swiftly, smoothly and safely than tools costing twice as much. EVEN CUTS HEAVY LUMBER—STEEL PLATE. Price complete with 3 blades. Only \$29.95 LIST

THERE'S PERFORMANCE AND PROFIT IN EVERY WEN PRODUCT

"Quick-Hot" ELECTRONIC SOLDERING GUNS			ELECTRIC SANDERS—POLISHERS			POWER SAW
#199 K  KIT \$9.95	#288  \$9.95	#199  \$7.95	#202  \$13.95	#303  KIT \$16.95	#404 HEAVY DUTY  KIT \$19.95	#505  \$29.95

— ALL OPERATE ON 110-120 VOLT A.C. — 60 CYCLE —



WEN

PRODUCTS, INC.

5808 NORTHWEST HIGHWAY, CHICAGO 31, ILL.
(Export sales, Scheel International, Inc., Chicago)



Radio - TV Hi Fi-Audio Communications Electronics

SERVICEMEN

SERVICE DEALER

and **ELECTRONIC SERVICING**

is **YOUR** magazine.

Subscribe to it now. Reap its benefits!

Now every serviceman engaged in every phase of radio-TV
and Industrial Electronics servicing will find:

SUBSCRIPTION RATES: 12 Issues \$3; 24 Issues \$5 (In the U.S.A., U.S. Possessions, Canada and Mexico). Elsewhere add \$1 per year.

COWAN PUBLISHING CORP.

67 W. 44 St., New York 36, N.Y.

NEW

RENEWAL

Sirs: I remit herewith \$..... Enter a subscription for..... years as follows:

Name.....

Address.....

City..... Zone..... State.....

Name of firm.....

Firm's business address.....

City..... Zone..... State.....

CHECK YOUR CLASSIFICATION

- Independent Radio-TV Serviceman Owner
 Radio-TV Service Organization Employee
 Retail Store having Service Department Service Mgr.
 Industrial Electronic Service Firm Student

If some other type of company describe:.....

IF STUDENT, Name of School.....

A TYPICAL ISSUE COVERS

- Latest TV Installation and Maintenance Techniques for VHF and UHF
- Auto Radio Installation and Service
- Mobile Communications, 2-Way Radio, Ship-to-Shore Radio Installation and Service Techniques
- Industrial Electronics Equipment Servicing Data
- Advanced Data on New Circuitry
- Production Changes and Field Service Data on Receivers
- New Tubes
- New Test Equipment, Operation and Application Data
- P.A. Installation and Service
- Hi-Fi Installation and Service
- New Developments, Such As Transistors, Color, UHF, etc.
- News of the Trade
- Service Short Cuts and Shop Notes
- Explanation of Difficult Circuits
- M'fgr's Complete Line of TV Schematics
- Video Speed Servicing Systems

BUYERS DIRECTORY OF ADVERTISED PRODUCTS

[Continued from page 47]

Ohmite Manufacturing Co. 3640 W. Howard Street, Skokie, Illinois
 Philco Corp. Philadelphia 34, Pa.
 Krauter & Co., Inc. 583 16th Avenue, Newark, N. J.
 Mail Tool Company 7740 S. Chicago Ave., Chicago 19, Ill.
 Tele-Scopic Products, Inc. 215 W. 33rd Street, New York 1, N. Y.
 Ungar Electric Tools, Inc. P. O. Box 312, Venice, Calif.
 Vaco Products Co. 317 E. Ontario St., Chicago 11, Ill.
 Walsco Electronics Corp. 3602 Crenshaw Blvd., Los Angeles 16, Cal.
 Wen Products, Inc. 5806 Northwest Highway, Chicago 31, Ill.
 Xcelite, Inc. Thorne Ave. and Bank St., Orchard Park, N. Y.

TUBES—CRT & RECEIVING

Barry Electronics Corp. 512 Broadway, New York 12, N. Y.
 CBS-Hytron 100 Endicott St., Danvers, Mass.
 Ceo Electronics Co. Columbia Ave. and 18th, Irvington 11, N. J.
 Delco Radio, Div. of General Motors Corp. Kokomo, Indiana
 Federated Television Mart 513 Rogers Ave., Brooklyn 25, N. Y.
 General Electric Co. Schenectady, N. Y.
 Philco Corp. Philadelphia 34, Pa.
 RCA, (Tube Div.) Harrison, N. J.
 Raytheon Mfg. Company Newton, Mass.
 Tung-Sol Electric, Inc. 95 Eighth Ave., Newark 4, N. J.

VIBRATORS

American Television & Radio Co. 300 E. First Street, St. Paul 1, Minn.
 Cornell-Dubilier Electric Corp. South Plainfield, New Jersey
 Delco Radio, Div. of General Motors Corp. Kokomo, Indiana
 Radiart Corp. 3455 Vega Ave., Cleveland 13, Ohio
 Vokar Corporation Dexter 2, Michigan

WIRE—CABLE—HARNESSES

American Phenolic Corp. 1830 S. 54th Ave., Chicago 50, Ill.
 Bolden Manufacturing Co. 4647 W. Van Buren St., Chicago 80, Ill.
 Columbia Wire & Supply Co. 2850 Irving Park Road, Chicago 18, Ill.
 Eby Sales Co. of N. Y. 130 Lafayette St., New York 13, N. Y.
 Federal Telephone & Radio Corp. 100 Kingsland Road, Clifton, N. J.
 Jersey Specialty Co. Burgess Place, Mountain View, N. J.

TRADE FLASHES

[Continued from page 19]

Bendix Television Division at Towson, Maryland. Previously, he was sales engineer with the Raytheon Manufacturing Company, Inc.

He attended Denver University, and is a graduate of Capital Institute of Engineering. He later spent eight years with the U. S. Navy and was honorably discharged with the rank of chief fire controlman.

The current issue of New Jersey Business Magazine, in an article "Meet Mr. Antenna," is featuring the story of Michael D. Ercolino, electronics scientist whose antenna inventions made possible TV reception as we enjoy it today.

A resident of Ocean Township, New Jersey, Ercolino is regarded a foremost authority on antenna principles.



Making reference to Ercolino's nick-name "Mr. Antenna," the article states:

"Whenever there is talk about the electric light, one almost inevitably thinks of Thomas Alva Edison. When radio is the conversational topic, the name Guglielmo Marconi comes to the fore. Likewise, the name of Michael Ercolino is synonymous with antennas."

MARINE ELECTRONICS [from page 9]

The next most popular item is the depth finder, which is an automatic radar-like mechanism that bounces an ultrasonic "beep" off the bottom and measures the time in transit in terms of

depth of water in feet or fathoms. It will also detect fish. Unit cost runs from the neighborhood of \$200.00 up, and the installation bill may go from a few dollars up to several hundred, depending

upon the amount of shipfitting required to accommodate the transducer to the hull of the boat.

Radar, Loran, and other more complicated aids to navigation are not ordinarily handled by beginning operators, but there is still a possibility of breaking into this service if you can work up a convincing record of reliability in complex jobs. These projects run into the kind of money it would be nice to collect a couple of times a year.

If all of the above seems exotic, there is still a great bulk of marine work to be done in just adapting shore-side electronic gadgets to operation on a boat. The man who has advanced to the stage of luxury of owning a yacht may not wish to step back to such primitive discomfort as scraping off his whiskers with a sliver of steel. Yet his electric shaver won't work from the boat battery. Some smart serviceman can fix him up with an electronic converter that will chew up his 6, 12, or 32 volts *dc* and spit out 110-volts *ac*. Converters will produce any power desired from 50 watts on up, so almost any *ac*-operated device an owner may want can be used aboard his boat.

It may seem odd that a man will go to the trouble of buying a boat to get away from the annoyances of everyday life, and then turn around and bring most of them aboard his boat—but it is done! Accordingly, where large fleets of boats are gathered, TV dipoles are almost as prevalent as the sloop sailing rig; and the high-fidelity rumble of open-diapason organ pipes drowns out the hungry seagull. Installing high-grade broadcast, short wave, TV and Hi-Fi equipment on boats is a specialty any service agency would do well to learn about.

In the field of small, fairly simple devices, there are electronic "sniffers" to detect the presence of explosive gas in a boat's bilge, automatic steerers to hold the boat on course, electronic tachometers for the engines, and electronic detectors to find things dropped overboard. There are even electric swizzlers for mixing drinks. A small shop could enter this field since it doesn't require much investment—just knowledge.

The Technical Side

Sell a midget radio, and the buyer can

THE BOOK YOU NEED TO PRICE WITH SPEED... for profit

quick check for 60,000 prices
Profit-making time-money-phone call-saver. 200 pocket-sized pages. Replacement parts listed by manufacturer, product and part number. up-to-date charging information. Completely revised 4 times a year.



"Very useful to me" - Conway, Penna.

"Been able to find every item" - Frankfurt, N.Y.

"Nice to have all prices" - Kincaid, Pa.



"It's a perfect book" - Teasdale, Ont.

and the perfect partner
DAVE RICE'S OFFICIAL TV-RADIO SERVICE ORDER BOOK
For TV, Radio, Phono or Hi-Fi service. provides separate listings for:

Picture tubes, receiving tubes, parts and components, serial numbers, labor and state and local taxes. 5 1/2" X 8 1/2" — 50 sets of triplicate orders—carbons bound in at parts distributors or send check to

ELECTRONIC PUBLISHING CO., INC.
180 NORTH WACKER DRIVE • CHICAGO 6, ILLINOIS
DIGEST: \$2.50 per copy.
ORDER BOOK: \$.75 each or \$6.50 per dustproof box of 10.

Your Partner for Profitable Installations . . .

TELCO VHF-UHF ANTENNAS and your TELCO Distributor!

BRING YOU THE MASTERLINE
TELCO CONICAL ANTENNA
ALL ALUMINUM!

ALUMINUM CROSS ARM—high Tensile Alloy.
UNBREAKABLE INSULATOR—made of Styron.
DOWELED ELEMENTS—doweled with 6" dowels, 3/8" diameter, closed end aluminum elements.
DOUBLE LIFE AGAINST RUST . . . zinc plated and dicromate dipped insures long-lasting protection.
CROSS BAR ASSEMBLED . . . insures fast installation.
ALL CHANNEL COVERAGE engineered for peak reception.

No. A-8700-8S	8-Element 1-Bay
No. A-8700	10-Element 1-Bay
No. A-8702-8S	8-Element 2-Bay
No. A-8702	10-Element 2-Bay

FOR VHF

TELCO ELECTRONICS MFG. CO.
Division of General Cement Mfg. Co.
919 Taylor Avenue, Rockford, Illinois

FREE COPY . . . Telco "Supermarket" Catalog. Send postcard today!

Telco Roto-Indoor Antenna No. A-9263
Telco Deluxe Corner Reflector No. A-8984
Telco UHF 10-Element Golden Yagi No. A-320

With such a wide variety of TELCO Antennas to choose from, you can be sure of profitable installations regardless of distance or location. Your nearby TELCO distributor will be glad to show you the complete TELCO line.

SEE US . . . BOOTH 590—ROOM 612—PARTS SHOW

NEW PROFIT MAKER... Electenna

AUTO RADIO REPLACEMENT ANTENNA

Here's sales potential! Millions of car owners will welcome new Electenna... first and only replacement antenna that installs fast, using present mounting and wiring. Boosts radio reception; up to 100% gain over standard 54" antenna fully extended. Beautiful design, chrome finish. Short height avoids damage.

Retails profitably for you at **\$5.95**

COILTENNA
Coil only without antenna. Easily installed. Gives same improved performance. Packed in colorful self-service counter display container. Retails at only \$3.95.

Dealers! Jobbers! Write today!

ELECTENNA DISPLAY BOARD
Large, colorful counter display given to dealer does outstanding self-service selling job!

Another Quality Product of **Electrend** Electronic Division
PRODUCTS CORPORATION
St. Joseph, Mich.

Advertisers' Index

American Television & Radio Co.	22
B & K Manufacturing Co.	33
Barry Electronics Corp.	52
Bussmann Manufacturing Company	3
CBS-Hytron	2
Central Electronics, Inc.	41
Chicago Standard Transf. Corp.	46
Cornell-Dubilier Elec. Corp.	38
EICO	44
Electrend Products Corp.	51
Electric Soldering Iron Co.	43
Electronic Chemical Corp.	43
Electronic Publishing Co.	51
General Cement Mfg. Co.	30, 45, 51
General Electronic Research Co.	45
Heath Company	30
Hycon Electronics, Inc.	6
Illinois Condenser Co.	47
Jackson Elec. Instrument Co.	37
Jensen Manufacturing Co.	13
Kenwood Engineering Co.	46
Krylon, Inc.	36
Malin Enterprises	47
Merit Coil & Transformer Corp.	20
North American Phillips Co., Inc.	39
Oelrich Publications	43
Perma-Power Company	52
Permo, Inc.	43
Philco Corporation	4, 5
Precision Apparatus Co., Inc.	23
Pyramid Electric Company	34
RCA Batteries	Cover 4
Radiart Corporation	7
Raytheon Manufacturing Co.	Cover 2
Research Inventions & Mfg. Co.	44
Sams, Howard W. & Co.	17
Shure Brothers, Inc.	1
Simpson Electric Co.	16
Snyder Mfg. Co.	33
Sonotone Corporation	31
Sprague Products Company	44, 46, 52
Triplet Elec. Instrument Co.	Cover 3
Tung-Sol Electric, Inc.	18, 19
United Catalog Publishers	24
Vaco Products Co.	32
Vokar Corporation	35
Wall Manufacturing Co.	46
Wen Products, Inc.	49
Winegard Company	29
Xcelite, Inc.	21

a **VOM** ... plus a **VTVM** when you need it.

DOUBLE USE... HALF THE PRICE

TRIPLETT MODEL 631—In one year accepted as the standard **COMBINATION VOM-VTVM**

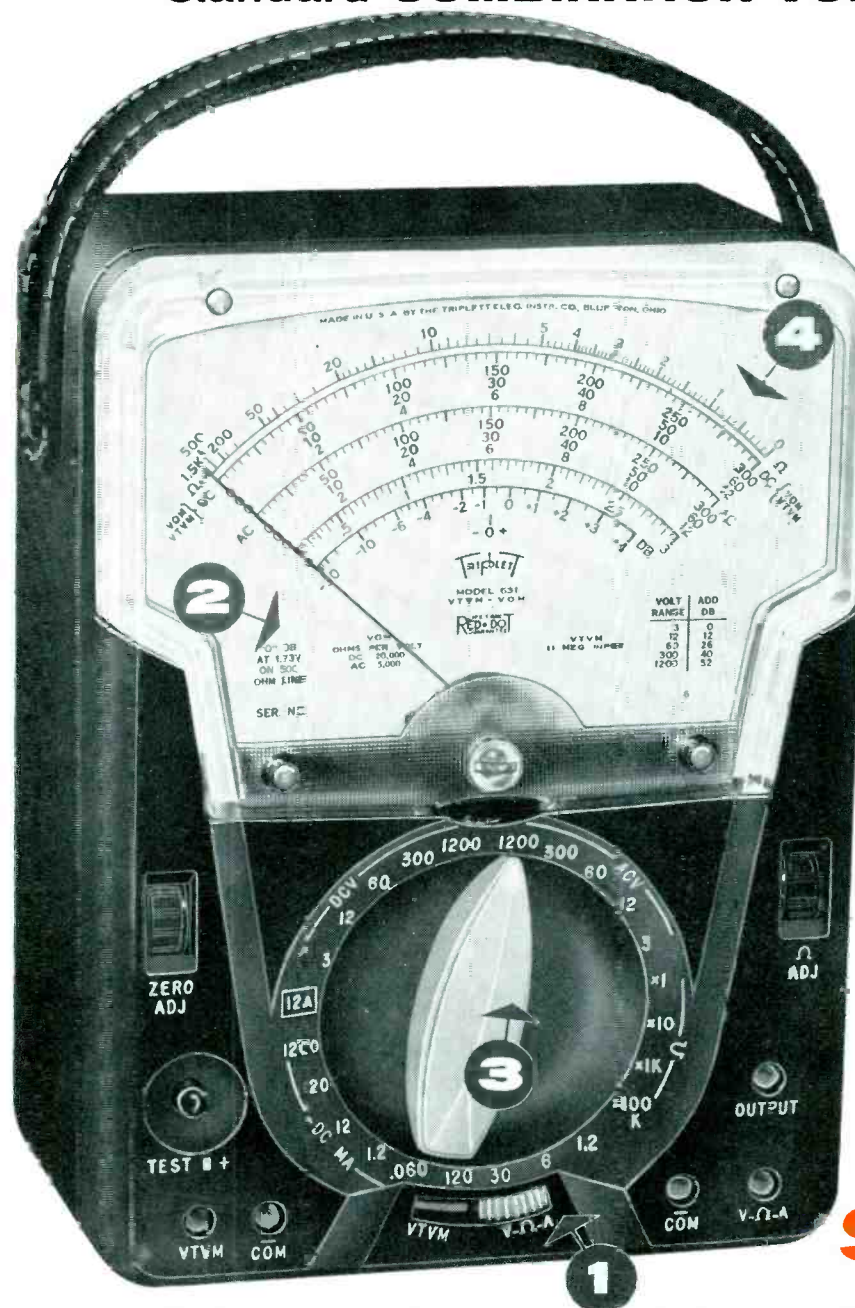

Battery operated

- 1** Just flip the switch.
- 2** Standard sensitivities as used in servicing manuals.
- 3** 34 ranges—with the famous Triplet single knob control.
- 4** Extra long scales—unobstructed visibility.

\$59.50

By using the Volt-Ohm-Mil-Ammeter for all general testing (90% of your testing) and the Vacuum Tube Voltmeter only when you need it, you have the advantage of a VTVM with extremely long battery life. Batteries are used only about one-tenth as much as in the ordinary battery-operated VTVM. Features: Ohms, 0-1500-15,000 (6.8-68 center scale. First division is 0.1 ohm.)

Megohms: 0-1.5-150 (6,800-680,000 ohms center scale.) Galvanometer center mark "—0+" for discriminator alignment.

RF Probe permits measurements up to 250 MC. \$7.00 net extra.

Featured by leading electronic parts distributors everywhere.

**SEE US IN BOOTH No. 320
AT THE MAY PARTS SHOW**

TRIPLET

TRIPLET ELECTRICAL INSTRUMENT COMPANY • 52 years of experience • BLUFFTON, OHIO

Triplet's design and development facilities are available for your special requirements for meters and test equipment.



Full sail ahead for profits

WITH RCA RADIO BATTERIES

With portable radios sailing into the big-time as they grow smaller and lighter and more economical to operate, the battery business is getting bigger and more profitable. You can ride the crest of this booming market by stocking and merchandising RCA Radio Batteries. The selling power of the RCA monogram helps you win sales faster and easier. It's the name customers look for and want more than any other brand. What's more, with RCA's business-building promotional material you're ship-shape for a season of smooth and easy profits.

RCA has a comprehensive line of batteries to meet the needs of practically every portable on the market, including the transistorized sets. See your RCA Distributor today. He's ready now to help you chart your course to bigger profits with RCA Batteries and RCA promotional material.



RADIO BATTERIES

RADIO CORPORATION OF AMERICA HARRISON, N. J.

Support National
Radio Week,
May 13-19

SERVICE DEALER
and ELECTRONIC SERVICING

COWAN PUBLISHING CORP., 67 West 44th Street, New York 36, N. Y.