

Radio-Television

**SERVICE
DEALER**

TV-AM-FM-RADIO-ELECTRONICS

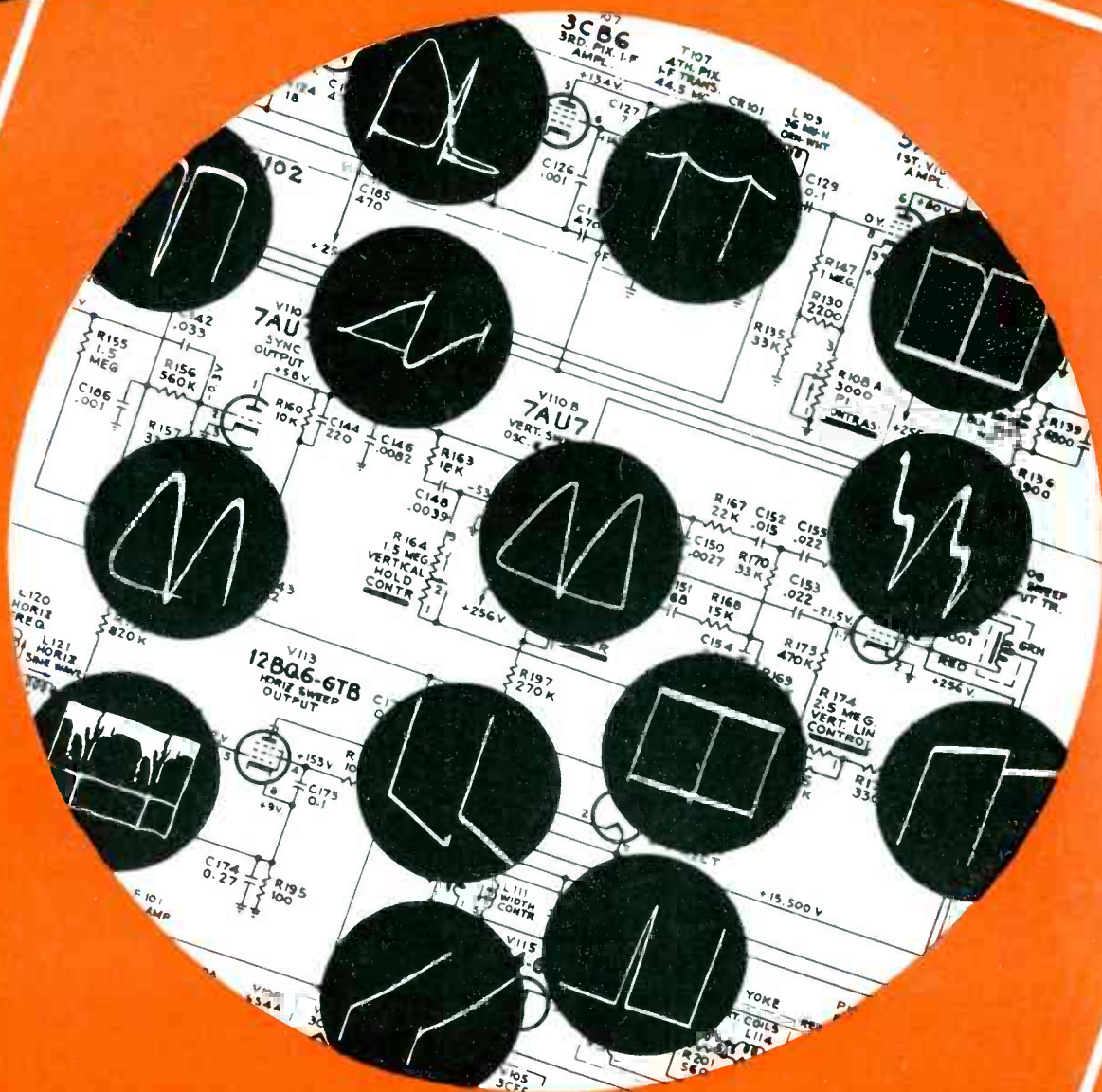

Scopes Speed Up Servicing

See Table of Contents

ANTHONY C JANKOWSKI
18705 KELSO AVE
CLEVELAND 10 OHIO

JAN 14 1956

“This portion of the Garry Moore Show is brought to you *in behalf of radio and television service-dealers* who use and recommend CBS Tubes.

“That’s the way you’re introduced. Later, I focus right on you — like this:

“... television sets require trained service-dealers to keep them in good condition. And believe me, a qualified service-dealer *is a trained technician*. He has spent a lot of time and effort studying electronics, and a substantial amount of money for technical equipment.”

Garry Moore
**sells
your
service**

while he sells
CBS Tubes*



Garry
Moore
*famous CBS
Television Star*

“See how CBS-HYTRON works side by side with you. The easy way for you to cash in is to use and recommend CBS Tubes. Because I keep reminding my listeners there are no better tubes made than CBS Tubes — and they have the Good Housekeeping Guaranty Seal.”

You’ll build profitable customer confidence and sales when you recommend CBS Tubes . . . the tubes with the Good Housekeeping Guaranty Seal.



*On the CBS Television Network.

CBS-HYTRON, Danvers, Massachusetts . . . A DIVISION OF COLUMBIA BROADCASTING SYSTEM, INC.



EVERY SERVICE FIRM OWNER IN THE U.S.A. Receives SERVICE DEALER Monthly

Member **EPA** — Circulation Statement sent on request

COWAN PUBLISHING CORP., 67 West 44th Street, New York 36, N. Y.
Telephone MURray Hill 7-2080

VOL. 17, NO. 3

MARCH, 1956

EDITORIAL STAFF

Publisher

SANFORD R. COWAN

Editor

SAMUEL L. MARSHALL

Editorial Production

CHARLES W. GARDNER, JR.

Contributing Editors

ROBERT T. DARGAN

PAUL GOLDBERG

OSCAR FISCH

SAN D'ARCY

Cover by

MIKE LOYER

BUSINESS STAFF

Advertising Department

RICHARD A. COWAN

JACK N. SCHNEIDER

JAMES STILLMAN

Production Manager

DAVID SALTMAN

Circulation Manager

HAROLD WEISNER

Ass't Circ. Mgr.

C. J. BINDERMAN

BRANCH ADVERTISING OFFICES

West Coast:—TED E. SCHELL, 2700 W.
Third St., Los Angeles, Calif. DUmkirk
2-4889

Mid-West:—JIM SUMMERS, 400 N.
Michigan Ave., Chicago 11, Ill.
SUperior 7-1641

FEATURE ARTICLES

- | | |
|--|----|
| Transistor Tester | 9 |
| Describing a new piece of test equipment that will soon become standard equipment for the practicing radio and TV serviceman. | |
| Practical Scope Servicing, by Allan F. Kinckiner | 10 |
| A description of elusive troubles that were located with the aid of the cathode ray oscilloscope. | |
| Troubles Involving Defective Detector Crystals and Leaky Vertical Filter Condensers, (A Work Bench Feature) by Paul Goldberg | 17 |
| Color Sync Analysis, Part 4, by Bob Dargan and Sam Marshall | 18 |
| Discussion of the reactance tube and its operation; also the general operation of the APC (Automatic Phase Control) Loop. | |
| A New Idea In Tube Testers, by Herman Hoffman | 22 |
| Description of an unusual and versatile tube tester which permits it to be used as a piece of test equipment for many important circuit tests. | |
| Servicing AM-FM Tuners, by Steve Travis | 24 |
| Analysis of 1956 AM-FM tuners together with unusual features and circuitry. | |
| There Is Profit In Mechanized Control, by Robert H. Stockman | 26 |
| Description of a very efficient method of registering and controlling various store transactions. | |

CIRCUIT AND SERVICE FORUM

- | | |
|--|----|
| The Work Bench | |
| Philco TV 350, intermittent overload | 17 |
| Philco RF-38, Deflection CPI, unsymmetrical raster | 17 |
| The Answer Man | |
| CBS-Columbia Chassis No. 921-14, narrow pix and overdriven | 21 |
| Motorola TS-534Y, Horizontal pulling | 21 |
| Crosley Chassis 431-2, bars and interference on channel 5 only | 48 |
| Westinghouse V2342, No Raster, no pix, high voltage O.K. | 49 |
| Video Speed Servicing Systems | |
| DuMont RA312, 313 | 37 |
| Stewart Warner 21-9300 Series | 39 |

DEPARTMENTS

- | | | | |
|-------------------------------|----|----------------------------|-------|
| Editorial | 2 | Complete Mfr's. | |
| Rider Speaks | 6 | Schematics (Philco) | 29-36 |
| Association News | 14 | New Components | 42 |
| Trade Flashes | 28 | New Test Equipment | 44 |
| | | Advertising Index | 64 |

RADIO-TELEVISION SERVICE DEALER is published monthly by Cowan Pub. Corp., 67 West 44th St., New York 36, N. Y. Subscription price: \$1.00 per year in the United States, & U.S. Poss. Elsewhere \$1 per year additional. Single Copies 25c. Second Class mail privileges authorized at New York, N. Y. Copyright, 1956, Cowan Publishing Corp. Tel.: MU 7-2080.

POSTMASTER: SEND FORM 3579 TO RADIO-TELEVISION SERVICE DEALER,
67 WEST 44th ST., NEW YORK 36, N. Y.



EDITORIAL... by S. R. COWAN PUBLISHER

Pots and Pans

We get it from the "Underground" that some "Public-Spirited" TV set manufacturers, interested in saving the customer a few cents on the receiver, are contemplating the use of potentiometers without back covers.

What a wonderful shelter those pots will be for all the accumulated dust, roaches, miniature mice, and other assorted denizens of the undersides of chassis. True, the customer will pay a few cents less for the receiver, but little does he know that he is letting himself in for a periodic cost of at least \$10.00 or more for cleaning out the accumulations of filth that are bound to occur. Get your vacuum cleaners ready boys.

Pots and Convergence

Recently a few cases of color receiver mis-convergence were experienced by our staff and other color TV servicemen which involved potentiometers that had become "noisy" due to such conditions as grit accumulation, and operation at currents beyond the rated capacity of the controls.

Those servicemen who know what a tedious job it is to converge a color TV receiver will join me, I know, in "congratulating" those penny-wise and pound-foolish individuals responsible for another ripe situation for "call-backs" and "closer" customer-serviceman relations. To those who are as yet uninitiated in the gentle art of convergence, trying to converge a color receiver at the present state of the art with a noisy convergence control is like trying to thread a needle in a barrel going over Niagara Falls with St. Vitus to the bargain.

The Wrong Slant

Our few remaining blood corpuscles invariable get into a dangerous boil when a member of our own clan screams hysterically for the whole world to listen everytime a serviceman is found to be dishonest. He usually whoops it up to a point where it assumes proportions far in excess of its import; in fact to a point where he has the public believing that all servicemen are crooks, all except himself.

I'm not a betting man but I'll wager two bits (that's my limit) that if we were to compare the

ethics of the Radio-TV Serviceman with the ethics of individuals in other callings and professions, like the plumber, the electrician, the auto mechanic, the dentist, the doctor, the lawyer, the politician, etc. we'd come out pretty high on top; although I will admit we'd come out pretty low income-wise.

"National Television Servicemen's Week."

Again this year the US Chamber of Commerce listed the period March 5th-10th as "National Television Servicemen's Week." Supporting the project, RCA's Tube Division carried promotional campaigns in national consumer magazines, and on radio and TV stations. RCA tube distributors also made available a magnificent brochure which explained the underlying and sound reasons behind the "National Television Servicemen's Week" project. It was a worthy endeavor!

Servicemen everywhere know that they need all the public relations support that can be rendered on their behalf by any and all manufacturers, especially those with advertised names that are household words. Just as the public is cognizant of the importance of high professional ethics and standards which are accorded to doctors and lawyers—so can radio-TV servicemen eventually earn a high place in public esteem. The sooner that day arrives the better it will be, not only for set owners needing service, but also for the servicemen who render it. Mutual respect inevitably brings mutual benefits.

Radio Use Holds Steady

According to A. C. Nielson Co., reputable statistical and fact-finding organization, almost 9 million homes were using radios for entertainment regularly during December and that frequently, in October and November some top-ranking radio shows reached as many as 2.8 million homes. The Nielson report also stated that over any given weekend at any given hour there are as many as 3 to 4 million car radios in use. Stated another way—radio is far from dead or dying. Despite TV's terrific increase, radio usage is still an important factor and the service potential is not to be looked at with snide glances.

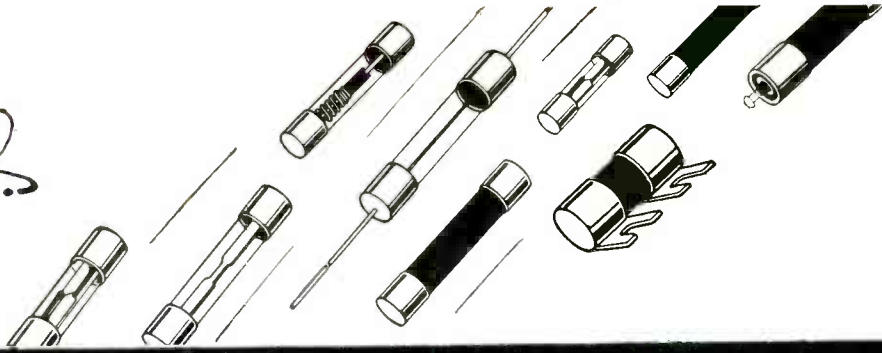
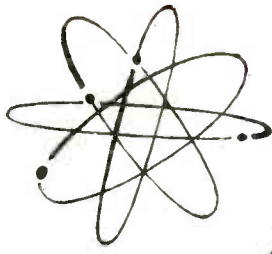

dependable BUSS FUSES can help safeguard the good name of your Product or Service

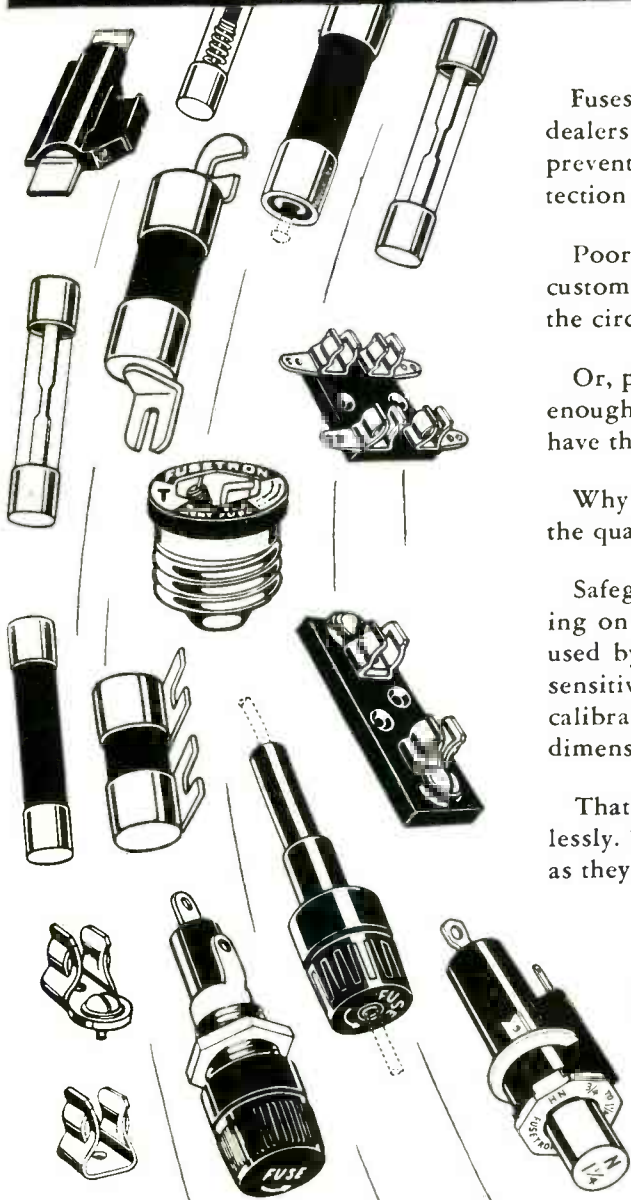

Fuses may be considered a small item by many service dealers and manufacturers—however, BUSS quality fuses can prevent endless trouble by giving dependable electrical protection under all service conditions.

Poor quality fuses can blow needlessly and shut down your customers' equipment — even though no trouble exists on the circuit.

Or, poorly made fuses might *not* shut down the circuit quick enough when there is an electrical fault — and your customers have the expense of replacing needlessly burned out parts.

Why chance having these troubles mistakenly blamed on the quality of your product or service?

Safeguard against loss of customer good will by standardizing on "trouble-free" BUSS fuses. Each BUSS fuse, normally used by the Electronic Industries, is electronically tested. A sensitive device automatically rejects any fuse not correctly calibrated, properly constructed and right in all physical dimensions.

That's why BUSS fuses blow only to protect — never needlessly. Thus they help safeguard your good name — as surely as they protect users.

Makers of a complete line of fuses for home, farm, commercial, electronic, automotive and industrial use.



356

BUSSMANN MFG. CO.

(Div. McGraw Electric Co.)

University at Jefferson St. Louis 7, Mo.

ONLY **RAYTHEON** PICTURE TUBES .

CORONA INHIBITOR

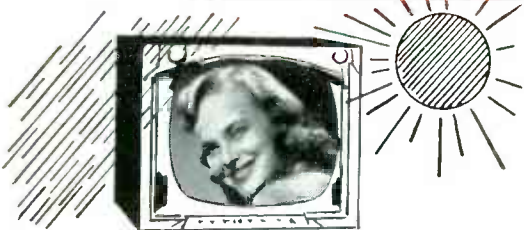

This Raytheon development insures brightness rain or shine. Ordinary tubes lose up to 10% of their brightness on humid, damp days. Not so, Raytheon Picture Tubes. Tests prove *no loss of brightness* even under a water spray on the high voltage contact — thanks to *Corona Inhibitor*.

CROSS-CHECK CONTROL

DAILY QUALITY CONTROL SUMMARY

Date: 11/29/51

# Tested	100	# OK	95	% Defective	5%
----------	-----	------	----	-------------	----

Tube Type	Serial #	Defect	Oper.	Pack Shift	Comments
170P6	62	0			
210P6A	79	1			

Lot Fabrication: Passed

Tube Type	Serial #	Defect	Oper.	Pack Shift	Comments
170P6	62	Loose Base	IS	1st	Major Reject

\$ Defective: 5, Non-OK: 5, Pass: 95, Hold: 0, Short: 0, Priv: 0, Sat: 0

Mount Line			
Good	Defective	% Defective	
Focus Assembly	-	-	-
Cathode Assembly	-	-	-
Finished Mount	50	0	0%
Disposition:	Passed		

Raytheon Picture Tubes are *right* when you get them, thanks to **RAYTHEON'S CROSS-CHECK QUALITY CONTROL**. This comprehensive Raytheon quality control method includes daily tests made on tubes for pressure, base torque and outside coating adhesion. Engineering controls check screen color and brightness and tube life under both ideal and extremely adverse conditions. And, most important of all, a substantial percentage of every day's production is actually *unpacked and retested for physical appearance and electrical characteristics* before quality control headquarters will permit release of a single tube for shipment.

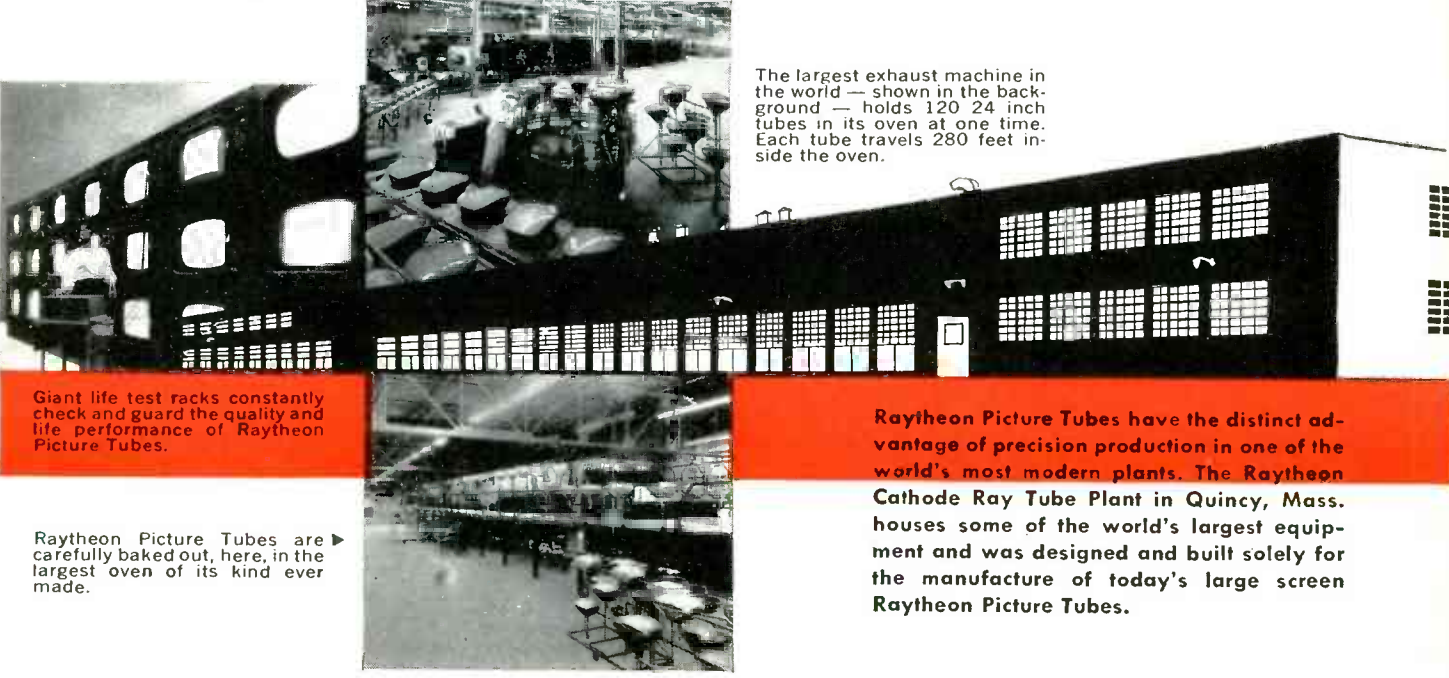

Giant life test racks constantly check and guard the quality and life performance of Raytheon Picture Tubes.

The largest exhaust machine in the world — shown in the background — holds 120 24 inch tubes in its oven at one time. Each tube travels 280 feet inside the oven.

Raytheon Picture Tubes are carefully baked out, here, in the largest oven of its kind ever made.

Raytheon Picture Tubes have the distinct advantage of precision production in one of the world's most modern plants. The Raytheon Cathode Ray Tube Plant in Quincy, Mass. houses some of the world's largest equipment and was designed and built solely for the manufacture of today's large screen Raytheon Picture Tubes.

give you these major advantages

**ALUMINIZED
with**

Lumilac

LUMILAC — a lacquer especially blended and used exclusively by Raytheon — is the secret of the superiority of Raytheon Aluminized Picture Tubes. This amazing lacquer produces an extra smooth, unbroken surface for the pure aluminum coating, yet leaves no gas-producing residues which could impair cathode emission and shorten tube life.

The result — all the benefits of aluminized tubes, sharper picture, superior contrast, high light output — *plus excellent tube life.*

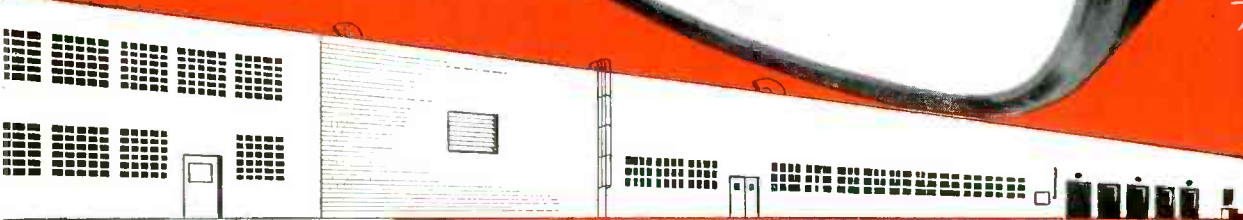

RAYTHEON MANUFACTURING COMPANY

Receiving and Cathode Ray Tube Operations

Newton, Mass. • Chicago • Atlanta, Ga. • Los Angeles, Calif.

Raytheon makes all these

Receiving and Picture Tubes, Reliable Subminiature and Miniature Tubes, Semiconductor Diodes, Power Rectifiers and Transistors, Nucleonic Tubes, Microwave Tubes



Excellence in Electronics

RIDER SPEAKS



IS a shortage of TV service technicians in the making? This may seem a strange question to ask when we know there is no shortage at the present time. But it can happen, and it is interesting to reflect on the situation that can conceivably create it.

The want ads in newspapers and in the national technical publications have for quite some time pin-pointed the shortage of formally trained engineering personnel. They are sorely needed by the manufacturers of specialized electronic devices. All kinds of inducements are being offered to get men to quit one job and take another—even if the ads do not say this in so many words. Industry representatives are visiting engineering schools and signing up men in their third year for jobs after graduation. That such efforts are being made is not surprising, nor is it to be criticized; the men are needed.

There was a time in the not too distant past when engineers were sought as trainees for maintenance work on special electronic devices being manufactured for government, industry and business. After a while the practice was discontinued because it was found to be too difficult to utilize engineers in this fashion; the attractions offered by the design field were too powerful to be ignored and the men changed jobs. It was only natural therefore that industry started looking toward the TV service technician as the likely prospect to train for specialized electronic maintenance.

The effort is slowly but surely bearing fruit. Representatives of industry are visiting schools that teach television servicing, interviewing men who have demonstrated certain capabilities. Strong bids are being made to attract these men to work in industry as maintenance men, laboratory technicians, research assistants, etc. Not only have the men lent a willing ear, but the training offered them is proving very attractive because it is tied in with a *career*.

It is reasonable to assume that it is somewhat difficult to persuade the owner of even a small TV service shop to close his doors and go to work for industry. The individual with a family and children in school is not inclined

to relocate himself and the family, although this is not a factor for the men who are employees of service shops and do not have children. For that matter many of the jobs being offered do not call for a change of locale. It's not a question of lack of loyalty to the service shop employer but simply a question of economics, and the vision of the almost limitless horizon of industrial applications of electronics.

Even the shop owner is not immune to temptation. He too is subject to the forces of economics: he too is concerned with financial improvement. The discouragement arising out of bad publicity is not readily forgotten and if, for any one of a number of reasons, business is not as good as it should be it doesn't take too much to swing a man from one side of the fence to the other.

The TV servicing industry has lost many competent men, and it will lose more. Maybe the number of men who have gone to industry has not reached major proportions, but it is no secret that many TV receiver manufacturers are finding it somewhat difficult to implement their color TV service training programs because they cannot find all the men they are seeking.

We have read the forecasts of the sales volume of the television servicing industry in the years to come and they are figures that command respect. However, it is understandable that the individual suffering a decline in servicing income at the moment is not too ready to think in terms of improvements in the future. The reason for the decline is not the important thing in his mind. He is concerned with the present.

Schools are mindful of the needs of industry and are stepping up the pace in inaugurating all sorts of courses that eventually will produce electronic technicians. Among these are television service technicians, but we just can't help

but wonder if the students, given the choice between television servicing and industrial electronics, will not be more inclined to choose the latter.

Given a suitable number of teachers (and they certainly are hard to get) and given the required amount of time (and it will consume several years at the least), the schools may turn out all the men required by the industrial electronics, business electronics and home electronics equipment manufacturers. But it can't be taken for granted, because, as has been mentioned time and again in the press, instructor personnel is in short supply. Maybe the teacher is a dedicated man, but an automobile costs him just as much as it does the engineer working for industry—and he has much less left from his pay envelope after he buys one. So industry looks more attractive as a place of employment than the school.

The value of training in the radio and television servicing arts has been stressed for many years, and the recommendation to members of the servicing industry has been to attend association training series, manufacturers' lectures as much as possible to gain greater technical stature. Such lectures were well attended prior to World War II, but after the war the attendance fell to a discouraging level and many organizations as well as manufacturers discontinued them.

Yet we find that many of the younger men who have been in the servicing business since the end of the war have, during the past two years, paid great heed to the attractions being offered by the specialty electronic equipment manufacturers seeking trained personnel. A significant number have left the ranks of the service technicians and returned to school for formal education. The baccalaureate degree is their objective because of what it offers in the form of a career.

So much for the problem. What about the answers? Nothing is going to eliminate the competition that exists and will become even more acute, between what we consider the industrial and business electronics equipment manufacturer and the home electronics

[Continued on page 47]

the fastest selling
ROTORS

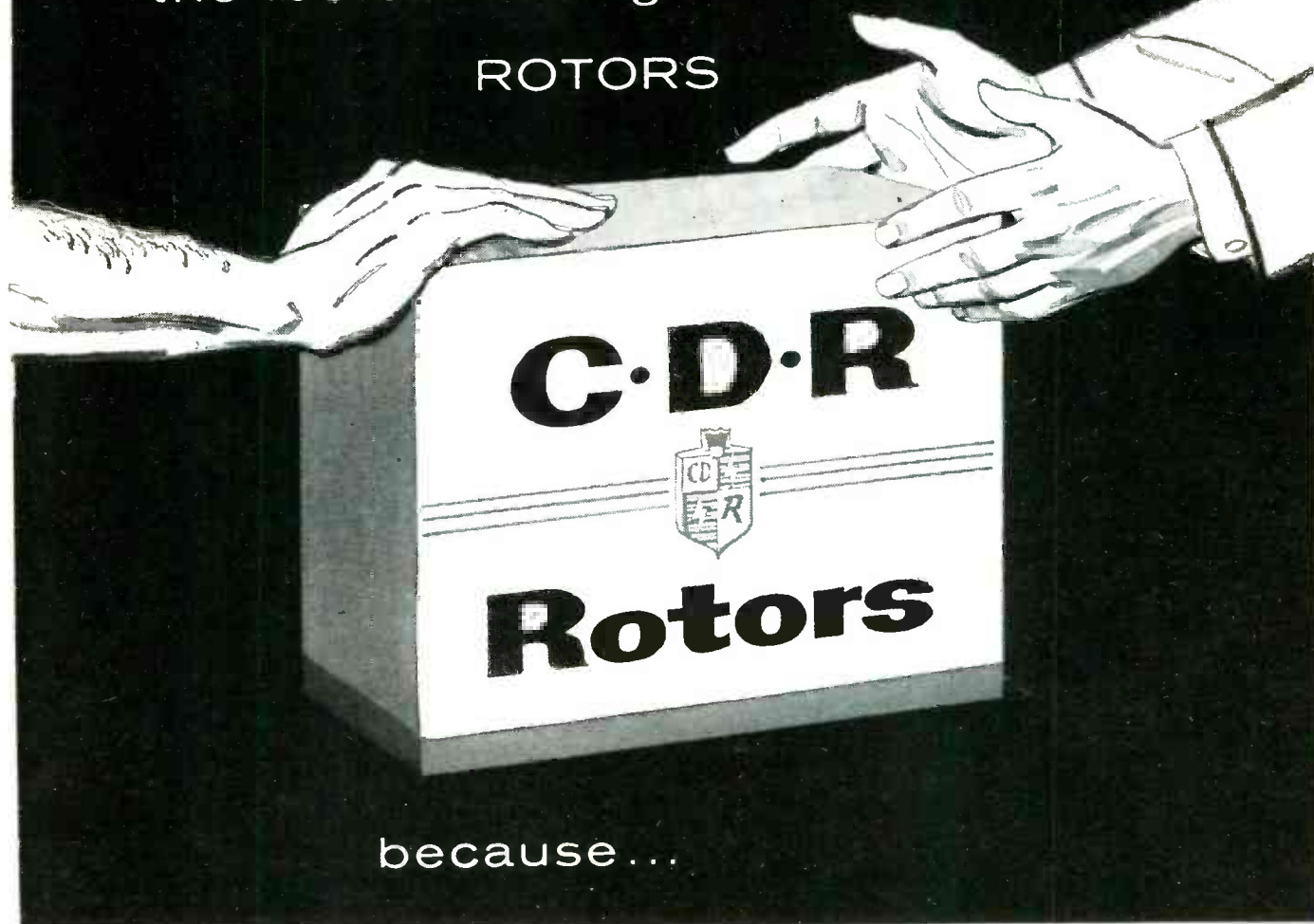

because...

- ✓ Pre-Sold to millions every week on TV
- ✓ The Most Complete Line... A Model for Every Need
- ✓ Superior Engineering... they're Tried-Tested-Proven

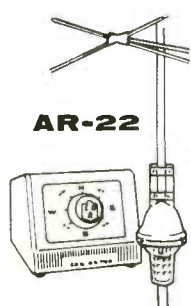

AR-22

Completely AUTO-MATIC version of the TR-2 with all the powerful features that made it famous.

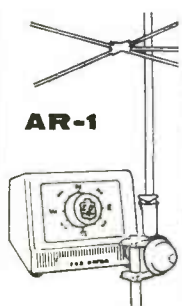

AR-1

Completely AUTO-MATIC rotor, powerful and dependable. Modern design cabinet. 4 wire cable.

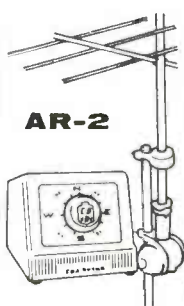

AR-2

Completely AUTO-MATIC rotor with thrust bearing. Handsome cabinet, 4 wire cable.

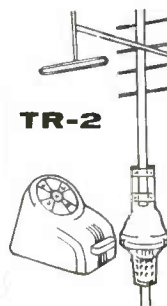

TR-2

Heavy-duty rotor with plastic cabinet, "compass control" illuminated perfect pattern dial, 8 wire cable.

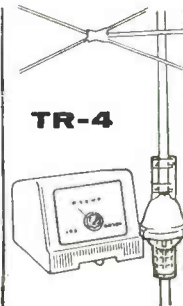

TR-4

Heavy-duty rotor, modern cabinet with METER control dial, 4 wire cable.



TR-12

Combination value... complete rotor with thrust bearing. Modern cabinet with meter control dial, uses 4 wire cable.

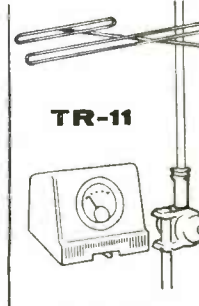

TR-11

Ideal budget all-purpose rotor, new modern cabinet featuring meter control dial, 4 wire cable.



CORNELL-DUBILIER
SOUTH PLAINFIELD, N. J.



THE RADIART CORP.
CLEVELAND 13, OHIO

**MR. SERVICE DEALER! INVEST IN ...
YOUR FUTURE IN TV COLOR SERVICE
AND EQUIP YOUR SHOP *FREE!***

DURING THE FABULOUS
PHILCO
SHARE *and* PROFIT
DIVIDEND OPPORTUNITY



That's right! This is the year to equip for color and by concentrating your radio and TV Parts and Accessory purchases on Philco, you can earn **FREE** Philco color and B/W Test Equipment and Parts and Accessory Dividends . . . all at no extra cost! **SHARE** and **PROFIT** dividends go to work for you immediately . . . building **EXTRA 100%** profits because they cost you nothing. Sell them for full profit or put them to work in your own shop. Make your business prosper like never before! Now is the time to equip yourself for color servicing . . . **FREE**. See your Philco Distributor for details.

NO LIMIT TO WHAT YOU CAN EARN
Order your Parts and Accessories, then pick the dividends you need. Stock up on genuine Philco Parts and Accessories and earn the dividends of your choice through valuable **SHARE** and **PROFIT** stamps you receive with each purchase. **SHARE** and **PROFIT** stamps are redeemable at your Philco Distributor's for the dividends of your choice.

**PHILCO PUTS YOU IN THE COLOR
SERVICE BUSINESS WITH ONE COMPACT INSTRUMENT**
**PHILCO UNIVERSAL COLOR BAR AND
DOT BAR GENERATOR Model 7100**

It's new . . . highly efficient . . . designed to provide the widest possible variety of functions in the minimum amount of space. **PHILCO MODEL 7100** can be used to completely trouble-shoot circuits associated with

color reproduction and make accurate convergence adjustments in any color receiver made. In conjunction with your present monochrome equipment, it gives you complete color service facilities!

PLUS OTHER VALUABLE *FREE* DIVIDENDS LIKE THESE

- Store Aids and Fixtures
- Dealer Store Identification Signs
- Your Choice of Parts and Accessories
- 6 HP Lauson Outboard Motor



PHILCO CORPORATION
ACCESSORY DIVISION PHILADELPHIA 34, PA.



SHOWN in the upper right hand corner is the new G.E. portable transistor tester expected to be a boon for radio and television service technicians. This instrument was designed by Semiconductor Product application engineers at Electronics Park, to fill the need for a device to determine quickly if a transistor is usable in an electronic circuit. About the size of a pocket radio, it may be used to check all junction transistors for short circuits, opens, leakage, and current gain.

To simplify use of the instrument, the meter has two scales. The lower scale, used for determining leakage, is divided into three large sections by different colors. The green section indicates no significant leakage and a usable transistor while the yellow section indicates a borderline unit and the red section, high leakage and therefore an unusable transistor. The upper scale is used for checking current gain. This is accomplished by pushing a button on the tester deck and noting the amount of "needle jump." For convenience, separate plug-in sockets for NPN and PNP type transistors are incorporated on the face plate of the transistor tester.

According to G. E. engineers, transistors should only be checked on instruments specifically designed for that purpose. General purpose instruments, such as ohmmeters or common vacuum tube volt meters have been found impractical because they either do not give the information needed unless special involved



TRANSISTOR TESTER

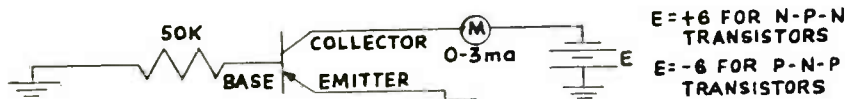

Fig. 1.

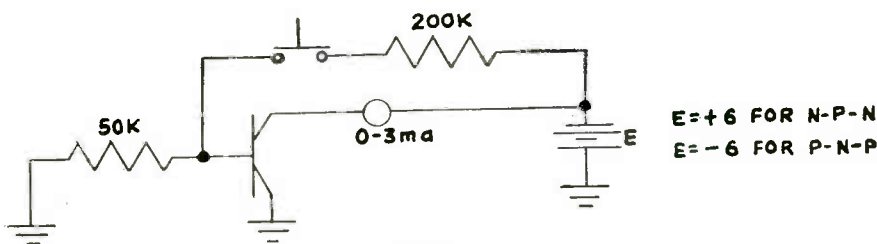
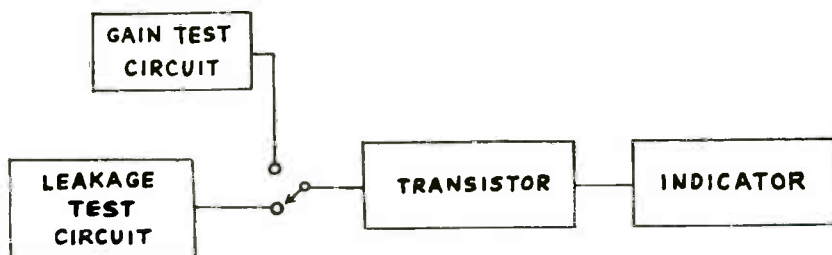

Fig. 2.



BLOCK DIAGRAM OF NEW G-E TRANSISTOR TESTER

Fig. 3.

circuitry is also attached to each transistor or they cause too much current to flow through the transistor thereby damaging it.

Figure 1 of the schematic is a simple circuit used to check the collector current that flows when the emitter is grounded and no signal is applied to the base. This current is a function of the temperature, the resistivity of the germanium, and most important, becomes quite large if there is contamination on the surface of the germanium, or if the transistor has been damaged by a short circuit. This obviously is a portion of the circuit used in the transistor tester.

Figure 2 shows a circuit, also a portion of the transistor tester by which current gain is checked. A small current is put into the base of the transistor allowing the current amplifier, the incremental change in collector current, caused by a change in base current to be checked.

The manner in which leakage (Fig. 1) and gain (Fig. 2) are separately checked is indicated in the block diagram of Fig. 3. When the "PRESS FOR GAIN" button is not depressed the instrument is ready to read "Leakage." When this button is depressed the instrument reads "Gain."

PRACTICAL SCOPE SERVICING

Unusual Troubles Are Generally Brought to Light by Unusual Methods of Detection.
And, There's Nothing Like a Scope to Effect These Unusual Methods of Detection.

by **ALLAN F. KINCKINER**

THE enthusiasm with which a servicer accepts the scope as the primary shop test tool goes far in amortizing its initial cost. This enthusiasm should require no selling. The scope is a must in any shop where time is a precious commodity.

Following are some service jobs where the scope vindicated certain suspected circuits and conclusively pointed to the fault in others less suspect.

Bendix 205L, complaint—no raster

Through scope tracing it was found that the horizontal oscillator was supplying a 70 volt pulse of acceptable shape to the grid of the 6BG6; a little low but not so bad. Pulse tracing through a high voltage capacitor divider probe to the damper plate indicated a pulse of about 800 volts, about 40% low. Next, a voltmeter reading of the boost across the damper showed about

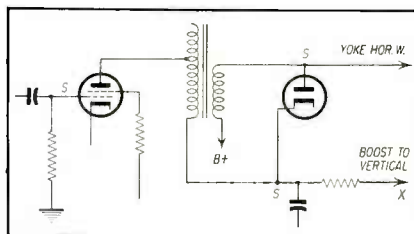

Fig. 1a—With a condition of "no raster", normal scope readings at points "S" indicate Bendix horizontal circuit is OK. Fault due to overload at point X.

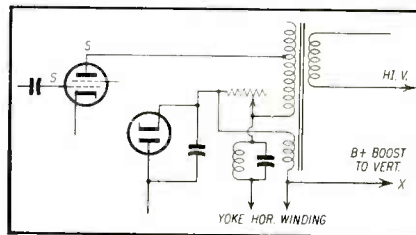
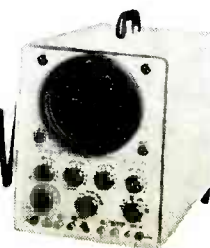

Fig. 1b—Similar symptoms to 1a. Scope readings at points "S" vindicate horizontal circuit in Motorola receiver.

10 volts boost. The previous checks vindicated the horizontal circuit clear up to the damper, and with the big pulse on the damper plate the damper should have shown a larger boost. Scoping at the damper cathode proved the boost condenser OK. Apparently the boost was overloaded, and the vertical circuit was doing the overloading. With new tubes in the vertical circuit, the trouble was still there. Further scope tracing showed that the vertical circuit was not oscillating. Subsequent checking proved an open feedback condenser in vertical oscillator, replacing it brought the set back to normal. This same condition has been experienced in some Motorolas where a faulty 12BH7 will load the boost and kill the raster. See Figs. 1a and b. Here scope tracing conclusively pinpointed the trouble where it originated.

RCA KCS 47—Weak reception

Recently on several RCA KCS 47 chassis it was noted that the sets seemed slightly weak and would not overload when the *age* switch was set to fringe. This overloading is normal at our location. Using the scope as a primary tool.



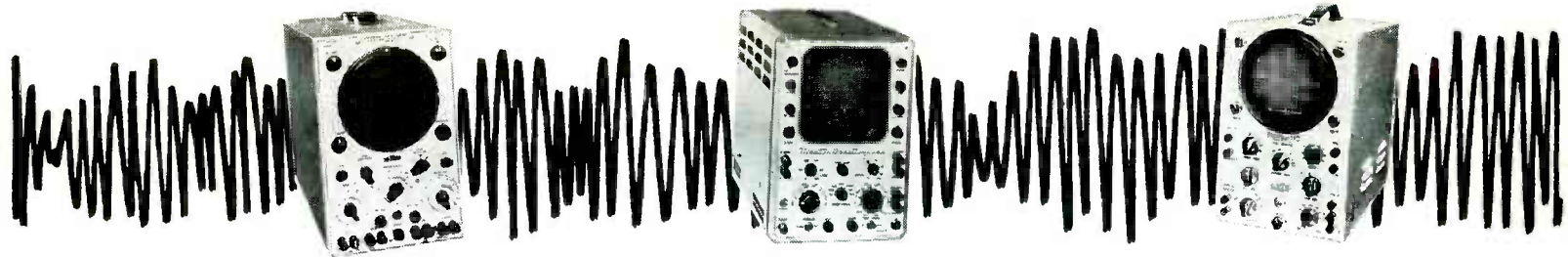

but this time with a high sensitivity demodulator probe the lack of gain across a 6CB6 tube was noted. Replacing the tube brought the set up to par. Strangely enough the old tube had passed as OK on several different tube checkers.

Motorola TS 95—Hard on 6BQ6's and blowing fuses

The set, hard on 6BQ6 tubes, had a blown fuse. Before replacing the fuse the circuit was checked for a short and

pulses were normal but the sampling pulse was too high. Further checking revealed an open .01 μ f condenser from point x to ground. This condenser integrates the pulse as taken from the horizontal transformer, and decreases its amplitude to about 25 volts.

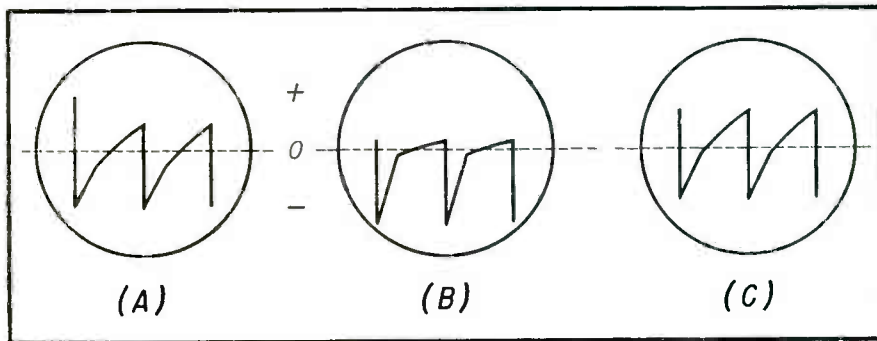

Fig. 2—(A) Normal and (B) abnormal waveform observed on Motorola TS 52. (C) observed on Motorola TS 95 did not have enough negative peaking.

Admiral

Consider the case of spurious oscillation in a vertical output transformer used in an Admiral, the set had breathing in the top quarter of its raster. Scope tracing the vertical showed no fault up to the plate of the 6S4, there with the pulse expanded on the scope a wiggle was noted on the vertical trace, trouble was apparently in the vertical output transformer or in the yoke. Hooking in a new transformer cleared the trouble in the set and on scope waveform.

Motorola TS 52—Intermittent raster

Aside from the Syncroguide where the scope is necessary for proper adjustment, several jobs come to mind where the scope was the only tool enabling repairs in a reasonable time. For instance, in a Motorola TS 52 the raster would appear only part of the time. On checking horizontal waveforms, only the pulse at the multivibrator output plate was of improper shape, the saw tooth portion being too flat with respect to the trailing edge. It was theorized that excessive peaking of the pulse was bracing off the 6BQ6 tubes. The trouble was suspected in the pulse forming circuit. Replacing the 680 μ f condenser (it forms the saw) corrected the trouble.

none was found. A millimeter was used in place of the fuse and read a current of 115 mils with the set working, a normal reading should be about 90 mils. Scope tracing the horizontal oscillator showed all waveforms normal except at the output. At that point the pulse was almost all sawtooth with very little of reverse peaking. Careful inspection turned up a solder short across the pulse forming resistor. Clearing the short, brought the current down to a normal 90 mils, and the set was OK.

Oddly enough neither set exhibited poor linearity as might be expected though each set gave bigger brighter pictures after the faults were corrected. See Figs. 2a, 2b, and 2c.

Admiral Series 22—No raster

The raster would appear only when the 6AL5 was removed. Experience suggested a leaky condenser feeding one plate of the 6AL5; or an open condenser feeding the free cathode; or a positive voltage at point x (Fig. 3). Voltmeter readings indicated no leakage voltage. So the scope was put to use and curve tracings were taken with the following results. The pulse at the cathode was 20 volts negative; the pulse at the plate was 20 volts positive; but the pulse at point x read over 100 volts. The sync

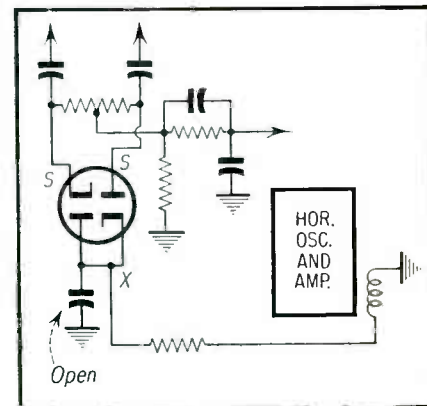

Fig. 3—Admiral 22: Normal scope readings at points "S", and wrong reading at point "X".

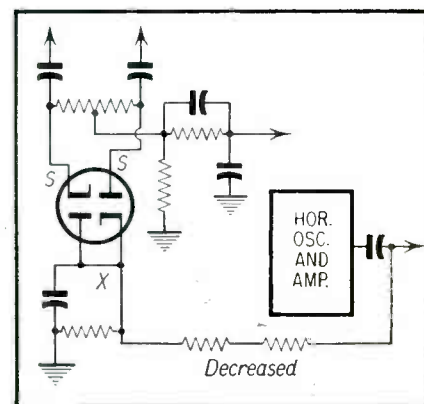
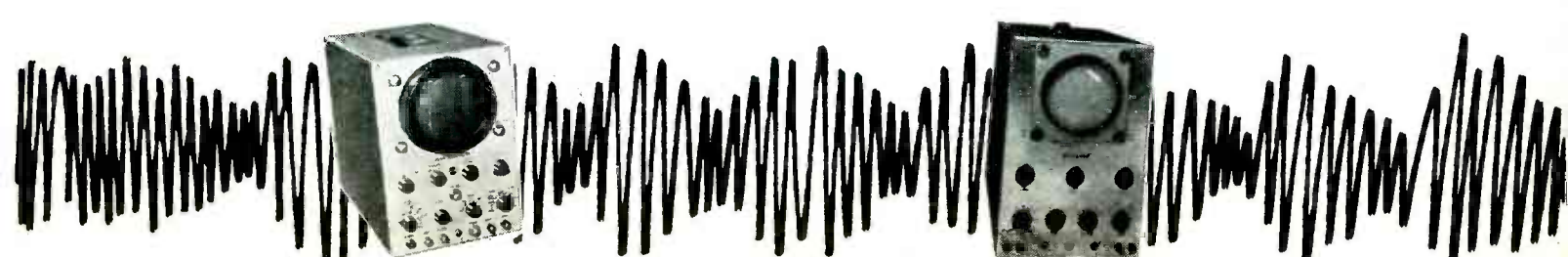

Fig. 4—Motorola TS 95: Normal readings at points "S", and wrong reading at point "X".

Motorola TS 95—Critical horizontal hold

In this set the horizontal hold was very critical and only possible with some foldover. Removing the phase detector tube revealed no foldover when the pix would hold even momentarily. Scope



at

AMPHENOL

7 major
quality
checks

ASSURE SUPERB
CABLE PERFORMANCE

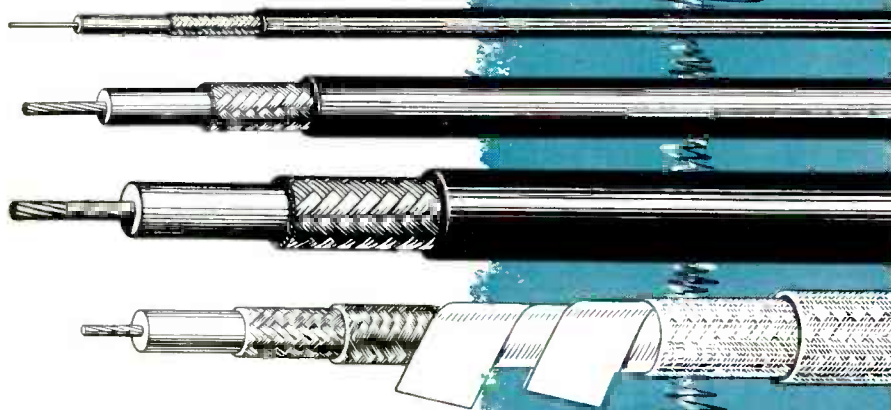

7 major quality checks, on the line and in the laboratory assure the top performance of dependable AMPHENOL coaxial cable.

- 1 Center conductor: lab check of mechanical and electrical characteristics.
- 2 Dielectric: rolling micrometer checks dimensions during extrusion.
- 3 Finished Core: micrometer checked again before jacketing.
- 4 Shielding: checked after braiding for percentage of coverage, loose ends, tightness.
- 5 Jacket: inspected 100% during extrusion.
- 6 Complete cable: special lab check of every run, electrically and mechanically.
- 7 Complete cable: every foot extruded is run through automatic machinery for final dimensional check.

Constant inspection and testing during manufacture, the use of fine materials, modern equipment, skilled workmen: all are combined at AMPHENOL. Specify and insist upon AMPHENOL coaxial cables!

✓ CHECK WITH YOUR AMPHENOL
DISTRIBUTOR FOR EVERY CABLE NEED

AMERICAN PHENOLIC CORPORATION
chicago 50, illinois
AMPHENOL CANADA LIMITED toronto 9, ontario

AMPHENOL

tracing revealed an oversized pulse at point x (Fig. 4). This pulse is taken from the top of the yoke, dropped through two 150K resistors in series. The resistors had decreased down to about 15K ohms each. Replacing them brought the set back to tip top shape and also increased the size and brightness along with horizontal stability.

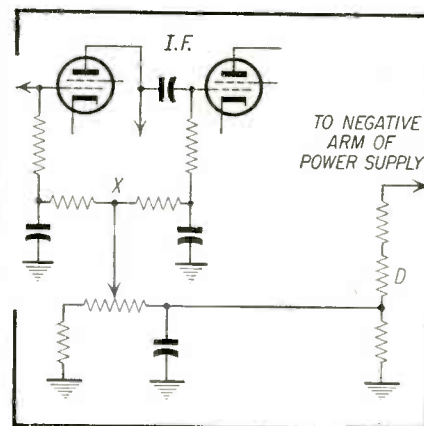

Fig. 5—Very small noise pulse at point "X" observed with scope, was traced to noisy resistor (marked "D") located in power supply voltage divider.

RCA 721—Changing picture contrast

The picture contrast kept changing. Scope tracing revealed the trouble was ahead of the video detector. Disconnecting the tuner output and feeding the *if* with a generator proved the trouble to be in the *if* section. Next all voltages feeding the *if* were checked and a pulse of .1 volts of no specific frequency was found on the bias bus. Further checking turned up a noisy resistor in the negative arm of the power supply. See Fig. 5.

Motorola 15C1—H.V. and raster

This set had a low high voltage and about an inch wide raster. Pulses up to the damper yoke connection of the horizontal transformer were OK. The trouble was traced to a broken lead of the horizontal transformer at this point. See Fig. 6. Open chokes in anti-ringing filters in Admirals and Philcos produce corresponding conditions. See Fig. 7.

G.E. 16C, 17C—Pix goes negative

This receiver showed oscillation in the video amplifier with pix going negative and/or big blurs in pix. Using the scope through a low impedance demodulator probe on the final video *if*, the waveform was found normal. Regular probing of detected signal proved
[Continued on page 62]

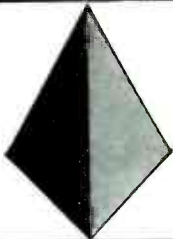

NO. 57

PYRAMID

technical

bulletin

THERE IS MORE TO A CAPACITOR THAN ITS DESIGN FORMULA:

$$C = \frac{K D}{A}$$

Pyramid's production and life tests of their capacitors are among the most stringent in the industry. Production test for voltage breakdown, capacitance, power factor, insulation resistance and seal are performed on 100% basis. In consisting of life, temperature and immersion cycling, vibration, and corrosion where applicable. These serve to guarantee that the capacitors you purchase are consistently as represented to be.

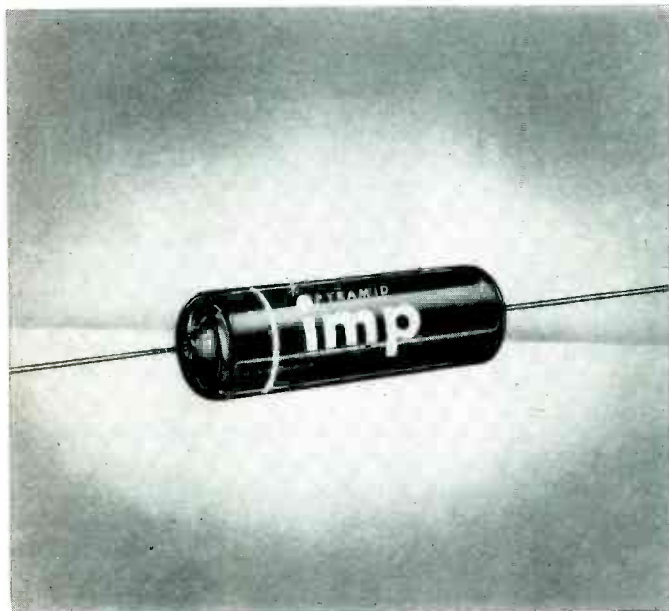

Pyramid capacitors also owe their exceptional performances to the type of materials used in their manufacture and the production methods which Pyramid engineers have devised. For example, in the new Pyramid IMP capacitor, a new, exclusive plastic molding technique was developed which bonds casing, impregnated element, and tinned copperweld leads into one compact assembly capable of withstanding severe physical abuse. In addition, this unit is heat and moisture resistant withstanding the RETMA humidity-resistance test to a remarkable degree. In another capacitor, type MT metallized paper units, vacuum impregnation is employed and the ends of the capacitor are sealed with plastic. Then, as a final step, the entire unit is completely coated with a highly moisture resistant wax. It is production techniques such as these which, in conjunction with high quality papers, impregnants (such as Halowax, Mineral Oil, or Silicone Base Synthetic Oil), and metals, that account for the excellent stability and long life that Pyramid capacitors exhibit.

Pyramid capacitors, particularly electrolytic capacitors, are specifically designed for long shelf life. To achieve this goal requires that the various materials and chemicals used in the manufacture of these units possess a high quality and long term stability. Another contributing factor to long shelf life is the care which is taken to provide maximum protection against the corrosive effects of chemicals in the atmosphere. This necessitates a container which is well insulated against the intrusion of moisture, i.e., one which is air tight and hermetically sealed.

* * * * *

The number of different types of capacitors that Pyramid manufactures is extensive. Included in this line are the following:

1. Electrolytic capacitors, type TD, with each unit sealed in a metal tubular case. Available in single sections, dual sections, and triple sections.
2. Electrolytic capacitors in screw base metal containers, type MC. Available in single and dual sections.
3. Twist-Mount electrolytic capacitors, type TM. Available in single, dual, and triple sections. Different sections may have different working voltages.
4. HI-TEMP Twist-Mount Electrolytic capacitors, type TWH. Designed for 100°C operation.
5. Dry Electrolytic capacitors in wax-filled, impregnated cardboard tubes, type CDB. Available in single, dual, and triple sections. Sections may possess individual leads or share a common negative terminal.
6. Plug-in Electrolytic capacitors, type DO, provided with 4 pins on standard octal base.
7. High-capacitance, low voltage electrolytic capacitors, type PFB.
8. Molded tubular paper capacitors, type IMP.
9. Miniature tubular paper capacitors. Type 85LPT.
10. Ceramic-cased tubular paper capacitors, type CT.
11. Bathtub-Type Oil-Paper Capacitors, types PDM, PDMT, PDMB.
12. Metal-tubular Oil-Paper capacitors, types PTIM, PTDMV, 4PTIM, 4PTIMV, 7PTIM.
13. Small-base oil-paper capacitors, types PKM, PKMF, PKMS, PKMT, and PKMB.
14. High-voltage oil-paper capacitors, types PLM, PLMF, PLMS, PLMU, PLMR.
15. Kraft-tube metallized paper capacitors, type MT.
16. Metal-can metallized paper capacitors, types MP GK, MP GM.
17. Metal-tube metallized paper capacitors, types MPTIK, MPTIM.
18. "Glasseal" subminiature paper tubular capacitors, and many others.

Pyramid capacitors are competitive in price because of the modern production methods that are employed throughout every phase of capacitor production. Whenever possible, automation techniques are being applied so that more uniform high quality may be achieved. Much of Pyramid's success is due also to the aggressiveness of Pyramid engineers in pioneering new products.

PYRAMID ELECTRIC CO.



North Bergen, New Jersey

FOR COMPLETE DATA SEND FOR ENGINEERING BULLETIN—FORM IMP-2

SEE US AT BOOTH 586
AT THE I. R. E. SHOW

PYRAMID IS THE BIG NAME IN CAPACITORS AND SELENIUM RECTIFIERS TODAY!

**25% more
POWER**

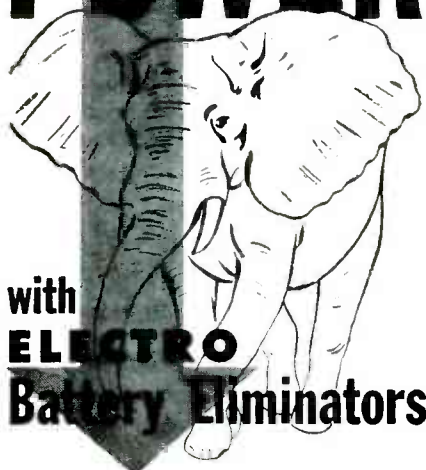

with
**ELECTRO
Battery Eliminators**



**6/12-volt DC Power Supply . . .
operates all 6 & 12-volt auto radios
Same price range as Kits!**

Heavy duty control transformer offers better regulation and withstands overloads for long service. Electro application of larger selenium rectifiers, combined with EPL patented conduction cooling increases rectifier power rating at lowest operating cost. Rugged, high quality construction, superior filtering, wide application. **\$39⁹⁵**

**Only Electro offers actual proof
with performance charts**

DC Output Voltage	Amperage Output		% AC Ripple
	Continuous	Intermittent	
0-8	0-10	20	5
0-16	0-10	20	5

**Model "NF" DC Power Supply
0-28 volts up to 15 amperes**

Less than 1% ripple at top load. Intermittent loads up to 25 amperes. Acclaimed in industry for its unmatched performance and construction at this price. **Certified performance. \$195⁰⁰**



**SEND TODAY FOR
DETAILED BULLETINS!**

110-55

ELECTRO PRODUCTS LABORATORIES

4501-R N. Ravenswood Ave., Chicago 40, Ill.

Rush bulletin on

Electro "D-612" Electro Model "NF"

Name _____

Company _____

Address _____

City _____

Province _____

ASSOCIATION

By Sam Marshall

Television Service Association (TSA of Detroit, Mich.)

A group of approximately 175 TSA members and associates recently gathered at a dinner to pay homage to Lawrence (Larry) Howard of Radio Electronics Television Schools (RETS). Larry has been a great asset to all of the TSA projects. He could always be depended upon to lend both sound thinking as well as hard work to the many TSA programs. More recently he put long hours with the licensing committee in working what we think is an outstanding model ordinance to uplift and regulate the Television service industry in Metropolitan Detroit.

Federation of TV-Radio Service Associations of Penna.

At its regular monthly meeting held January 22, 1956 at the Harrisburger Hotel, Harrisburg, Pennsylvania, the following new Federation officers were sworn in by committee chairman, Mr. Milan Krupa, of Wilkes-Barre: Chairman: Bert A. Bregenzer, Vice-Chairman: Wm. Morrow, Secretary: Leon J. Helk, Recording Secretary: Ray Blackworth, Treasurer: L. B. Smith.

Northeast TV Service Dealers Association, Phila., Penna.

N.E.T.S.D.A. is now publishing a monthly newspaper which covers the local and national advancements of each association, also a condensed column on new trends and products in the service and sales industry. Edited and published by Ray Fink and Byron Frank.

Philadelphia Radio Service Men's Association, Inc.

The Federation of Radio and Television Servicemen's Association of Pennsylvania will set up a licensing program April 1st, 1956. Bert Bregenzer, who was re-elected chairman, said local chapters will license servicemen in their areas.

The birth of a national group for radio and television service associations outside of the present National Alliance of Television and Electronic Service Associations will probably become a reality soon, according to a statement by Murray Barlowe, president of the Radio-Television Guild of Long Island.

Radio TV Guild of L. I.

At the December Executive Commit-

tee Meeting held at the new meeting place of the Guild, (559 Front Street, Hempstead) it was unanimously agreed to use this location as a permanent Guild Headquarters.

At this meeting it was suggested to use the same building, if and when it becomes permanent Guild Headquarters, as a Television Service Clinic to which members could bring difficult problems for consultation with other members. This idea was so enthusiastically absorbed by the men in attendance that before the evening was over practically everyone agreed to donate one thing or another to the proposed clinic. Jack Wheaton was placed in charge of the Committee for the Clinic with Ralph Raynor and Bob Henderson in charge of setting up the room set aside for the actual clinic.

Radio and TV Association of Santa Clara Valley (Calif.)

A reduced rate on initiation fees was voted last month as RTASCV's membership drive was slammed into high gear.

Turning an eye on some 200 radio-television dealers and service dealers in the Valley who do not hold Association membership, members voted to cut the \$60 initiation fee to \$35 as an incentive to build the organization's rolls.

Radio Television Technicians Guild, Boston, Mass.

The Radio Television Technicians Guild of New England announces the registration of all its members as registered technicians. All members are pledged to abide by the Guild's Code of Ethics and Servicing Standards. They are given a registration certificate to be displayed in their place of business.

It is felt that this registration program will insure the public of fair business practices and reflect credit upon the Electronic Service Industry and the Guild.

Due to the great success of the first Electronic Convention of the Radio Television Technician Guild of New England, the Guild is now formulating plans to hold its second convention sometime in the fall.

Federation of Radio Service Ass'ns. of Penna.

The FRASAP are making extensive plans to put into operation, April 1st,

NEWS

the Federation licensing plan. This plan sponsored by the Federation, but to be administered through the local association will license television and electronic technicians. Each shop throughout the State will be assigned a number. All applicants for license will be required to have passed a technical examination together with the requirements of a minimum amount of test equipment necessary to perform service before acquiring a license. All technicians, whether members of an association or not will be eligible for a license. This is just one more project in the Federation's drive to protect the public and lend stature to its local associations. A News Letter and various other projects will help to make this program a possibility.

Certified Electronic Technicians Association (New York City)

The above organization was inaugurated by a group of servicemen from among the first graduates of the RETMA Advanced TV Techniques Course. Its first periodical, Vol. 1, No. 1 is dated Feb. 1956, and includes a message from the President, Ed Tilin, and other worthy features that go to make up a good association news outlet.

TELSA (Connecticut)

Many of us are overloaded with used TV sets in this area and would like to unload them. Any ideas or helpful suggestions would be appreciated.

F. E. Silverman
Hartford Chapter

National Alliance of TV and Electronic Service Ass'ns (NATESA)

NATESA announces an annual convention of the TV-Radio and Electronics Service Industry to be held in Chicago, Ill. on Sept. 14 to 16 inclusive.

In an open letter to the Executive Director of the National Electronic Distributors Association (NEDA), Frank J. Moch, President of NATESA takes to task the contents of an Editorial which appeared recently in the NEDA Journal. The sum and substance of the controversy is that NEDA, which is against licensing, makes certain claims, the validity of which are attacked by Mr. Moch.



Complete SERVICE DATA

AT UNBELIEVABLY LOW COST!

RIDER MANUALS — THE ONLY FULLY FIELD-TESTED, FACTORY-APPROVED SERVICE DATA — IS AVAILABLE TO YOU AT AN INCREDIBLE PER CHASSIS COST OF 8¢...EIGHT CENTS! AT A PER-MODEL COST OF ONLY 2¢...TWO CENTS PER MODEL!

TV 17 is ready!

LIMITED PRINTING — GET YOUR COPY NOW.

- ★ Completely current with receiver production.
- ★ Complete 1956 lines of RCA, Philco, Admiral, etc.
- ★ All production runs and changes.
- ★ Over 35 manufacturers covered.
- ★ Coverage: August 1955-December 1955.
- ★ Latest 21" color TV.
- ★ Really COMPLETE servicing information.

Only \$24.00

FACTORY SKILL and FACTORY KNOWLEDGE become yours when your service information source is Rider Manuals. . . . Not only do you get *most for your money*—but you get information which covers *all the production runs* that may come to your bench.

RIDER'S SPECIALIZED AUTO RADIO MANUALS

Complete data on all auto radios, for any make car or truck purchased between 1948 and 1954! Soft Cover, 8½ x 11", illus.

- #5001-A: Ford, Lincoln, Mercury. Only \$3.00
- #5002-A: Buick, Cadillac, Oldsmobile. Only \$3.00
- #5003-A: Chevrolet, Pontiac, GMC & Chevrolet trucks. Only \$1.80
- #5004-A: Chrysler, DeSoto, Dodge, trucks, Plymouth. Only \$3.00
- #5005-A: Henry J., Hudson, Kaiser-Frazer, Nash, Packard, Studebaker, Willys. Only \$3.00
- #5006-A: Motorola auto radio installation car or truck made between 1948 and 1954. Only \$3.00
- #5007-A: Automatic, Firestone, Montgomery Ward, Spiegel radios for all makes of cars. Only \$3.00

RIDER'S SPECIALIZED TAPE RECORDER MANUAL, VOL. I

Fact-filled pages on every recorder made by the 12 most prominent manufacturers from 1950 through 1954. All details of operation, adjustments, trouble diagnosis, servicing, etc. Soft Cover, 288 pp., 8½ x 11", illus.

- #6001. Only \$4.50

RIDER'S SPECIALIZED HI-FI AM-FM TUNER MANUAL

An informative, factory-accurate manual covering the 20 most popular brands of AM or FM hi-fi tuners made between 1950 and 1955. Gives you comparative specifications, characteristics, all information on adjustments and servicing, etc. Soft Cover, 192 pp., 8½ x 11", illus.

- #7001. Only \$3.50

TV FIELD SERVICE MANUALS: WITH TUBE LOCATIONS

edited by Harold Alsborg

A practical series of tube location handbooks, plus discussion of trouble symptoms, adjustments, etc. Each volume has 7 years coverage, starting with 1947. Soft Cover, spiral binding, 5½ x 8½", illus.

- VOL. 1: Covers sets by Admiral, Affiliated Retailers (Artone), Aimeco (AMC), Air King, Air Marshall, Allied Purchasing, Andrea, Arvin, Automatic.
- #155. Only \$2.10
- VOL. 2: Covers Bendix, Caphart, CBS-Columbia, Crosley, Dumont.
- #155-2. Only \$2.40
- VOL. 3: Covers Emerson, Eada.
- #155-3. Only \$2.10
- VOL. 4: Covers GE, Hallcrafters, Hoffman.
- #155-4. Only \$2.40
- VOL. 5: Covers Motorola, Philco.
- #155-5. Only \$2.40

RIDER MANUALS AND THE FAMOUS LINE OF ECONOMICAL RIDER BOOKS ARE AVAILABLE AT YOUR PARTS JOBBER. LOOK FOR THE RIDER BOOKSELLER.



FREE CATALOG ON REQUEST

If your jobber does not sell Rider Manuals order them from us.

JOHN F. RIDER PUBLISHER, INC.
480 Canal Street, New York 13, N. Y.

In Canada:
Charles W. Pointon, Ltd.
6 Alcina Ave., Toronto, Ontario
Prices approx. 5% higher.



NEW CHASSIS PUNCHES

A complete line of precision punches, featuring Walsco-Pioneer "Taper Wedge" design to speed more accurate hole punching... any size, any shape.

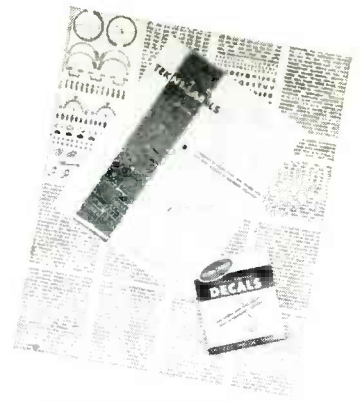

NEW TEKNI-LABELS

A complete line of handy title and design decals for speedy labeling of electronic equipment.



CHEMICALS

A complete line of chemical specialties, including cements, solvents, and contact cleaners in bottles and handy spray cans.



HARDWARE & SERVICE AIDS

A complete line of essential small component hardware, packaged in reusable plastic boxes. Dial cord, feed-thru bushing, and other valuable service aids.

NEW PHONO-RECORDER DRIVES & BELTS

The first, complete line of vital replacements for all major phonographs and tape recorders. Packaged in convenient kits or sold separately.



If it makes servicing
faster, easier,
more profitable...
you'll find it in the

COMPLETE **WALSCO** LINE



ELECTRONICS CORPORATION

A SUBSIDIARY OF *TelDatagraph* CORPORATION

3602 Crenshaw Blvd.
Los Angeles 16, Calif.

Overseas Representative
Ad Auriema, Inc.
89 Broad St., New York 4, N.Y.



ALIGNMENT TOOLS

A complete line of tools for every servicing job.

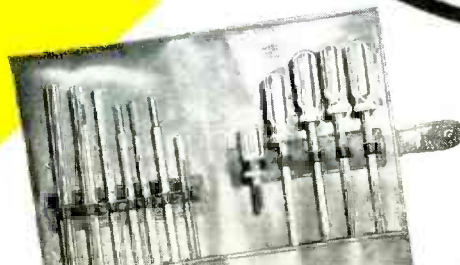

Canadian Representative:
Atlas Radio Corp., Ltd.
50 Wingold Ave., Toronto, Can.

THE WORK BENCH

Unusual Service Problems And Their Solutions

by Paul Goldberg

This Month's Problem:

**Defective crystal detector
Leakage in vertical condenser, modulating horizontal sweep.**

THIS month's installment concerns two odd troubles involving Philco television receivers.

PHILCO TV 350

The receiver was turned on and it was observed that the receiver's picture would overload intermittently, about once every five or ten minutes. This receiver has a three position *age* switch; strong, normal, and fringe. The receiver was set at the normal position because it would overload continually on strong position and would remain snowy on fringe positions.

Every once in a while the picture would turn completely negative, but then just as quickly it would snap back to normal. The 1st and 2nd *if* tubes, 6DE6's were replaced individually, but had no effect. The 6BZ7, *rf* amp., which is also connected to the *age* line was also replaced, but had no effect. The 6AT6 and 6CS6 were also replaced because of their connections to the *age* circuitry, but had no effect on the trouble.

Voltage checks were next attempted, but as soon as the test probes touched any point in the *age* system during the period of overload, the picture would snap back to normal. At this point the diagram was studied. It was noted that this receiver used a 1N64 crystal for diode detection.

Crystals permit the use of a higher load resistance since the detector shunt capacity is less when crystal detectors are used. When a tube is used as a detector the shunt capacity is higher because of the interelectrode capacity of the tube as well as the surrounding wiring.

It might be also well to note that the internal resistance of a crystal compared with that of a diode tube is lower so that its detection efficiency is increased since it permits a large percentage of the total signal voltage drop to appear across the load. The forward resistance for current flow from cathode to positive anode is approximately 50 ohms. The backward resistance for cur-

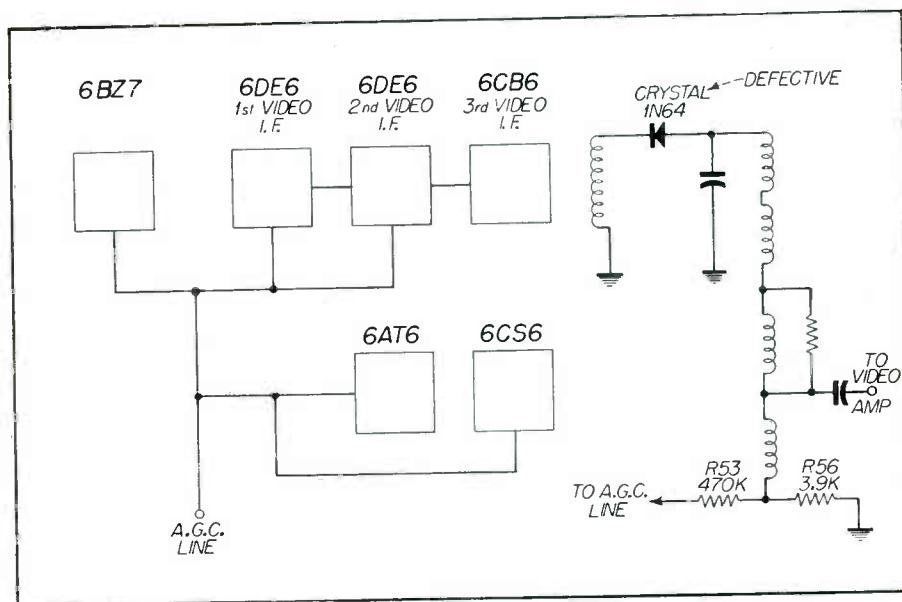

Fig. 1—Partial block diagram of Philco TV 350. Note that undue opposite current flow in crystal can disrupt *age* action.

rent flow in the inverse direction is about .5 megohms. In other words, the resistance ratio of most crystals runs about 10,000 to one.

Another advantage of the crystal is that the possibility of hum pickup is eliminated since no heater is involved. The maximum peak inverse anode voltage is about 50 volts while the crystals average anode current is about 22.5 ma. The principal disadvantage of the crystal seems to be its lower inverse resistance compared to the diode tube.

Knowing all these facts the 1N64 crystal was clipped out of the receiver and resistance checked with an ohmmeter. It measured about 50 ohms cathode to anode and about 100,000 ohms in the inverse direction. This is about 2,000 to one instead of 10,000 to one. A new crystal was then installed (1N64) which had a resistance ratio of one meg to 50 ohms, which is even better than average (20,000 to one). The receiver was then checked continually for two days and did not overload at any time. When a crystal reads 100,000

to 50 ohms it will draw more than the usual current in the opposite direction. Thus the voltage drop across R56 will be negative on 1/2 cycle and a small amount positive on the other 1/2 cycle. R56 serves not only as a load resistor for the 1N64 but as a point where *age* voltage is tapped off by R53. The overload occurs therefore because of the lowering of the *age* (less negative) bias voltage due to a defective crystal.

PHILCO RF38, DEFLECTION CPI

The receiver was turned on and it was noted that the bottom of the raster at the sides tended to be smaller. (Refer to Fig. 2). This symptom usually means yoke trouble. An exact replacement yoke was therefore installed but the trouble remained. The diagram was then studied.

It seemed that a defective component was affecting the horizontal sweep at the bottom of the raster. Hum sneaking into the horizontal sweep section could cause this trouble, we believed. Thus

[Continued on page 60]

COLOR SYNC

In this installment the theory and operation of the Reactance Tube and its associated circuitry is dis-

PART 4

by **Bob Dargan and Sam Marshall**

from a forthcoming book entitled "Fundamentals of Color Television"

UP to this point in our discussion of the Color Sync Section we have analyzed two of the five basic blocks comprising this portion of the color TV receiver, these being the Color Burst Gate and Phase Detector circuits. It will be recalled that the output of the color burst stage provides a color burst signal which is the only direct link to the phase of the subcarrier signal developed at the transmitter. Since the various hues contained in the chroma signal are established at the transmitter with reference to the subcarrier phase, the reference phase of the local 3.58 mc oscillator, which establishes the demodulation axes of the chroma signal, must at all times have a fixed relationship with the color burst phase if the correct hues are to be recovered.

The second block in this system, the Phase Detector, is the circuit in which the color carrier reference signal developed by the local 3.58 mc oscillator is compared against the incoming color burst. As a result of this comparison a dc correction voltage is developed at

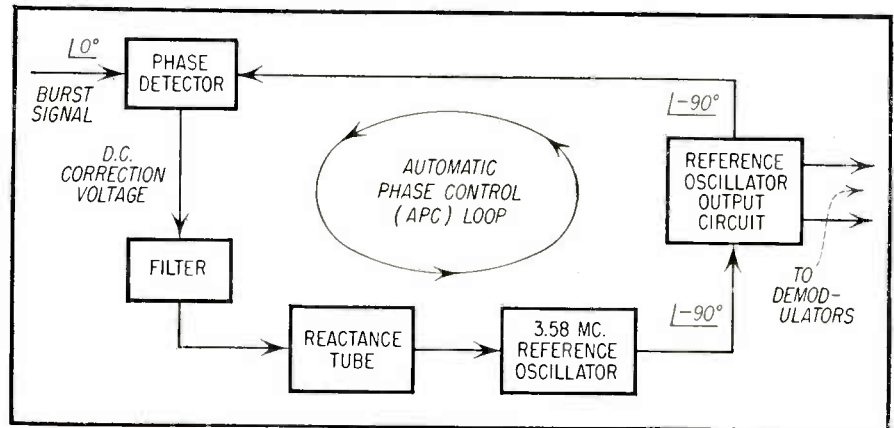

Fig. 1—Block diagram of APC loop.

the output of the phase detector. This voltage is zero if the color carrier reference signal is in quadrature with the color burst signal. If the signals are not in quadrature, positive or negative correction voltages are developed at the phase detector output, the polarities of these voltages depending on whether the phase difference between the burst and reference signals is more or less than 90°.

The third block in the overall analysis of the color sync section is the reactance tube. Fig. 1 indicates that the correction voltages developed at the output of the phase detector are applied to a Reactance Tube. The latter has the property of converting a dc bias

applied to its grid into an equivalent change in inductance or capacitance across its output plate circuit. Inasmuch as the latter is in parallel with the crystal of the local 3.58 mc oscillator, this change in inductance or capacitance tends to bring the oscillator into quadrature phase with the burst signal phase.

Reactance Tube Operation

It is well known that in a circuit containing capacitance and resistance the current leads the voltage drop across the capacitance by 90°, and leads the applied voltage by some value slightly less than 90°, depending on the resistance in the circuit as shown in Fig.

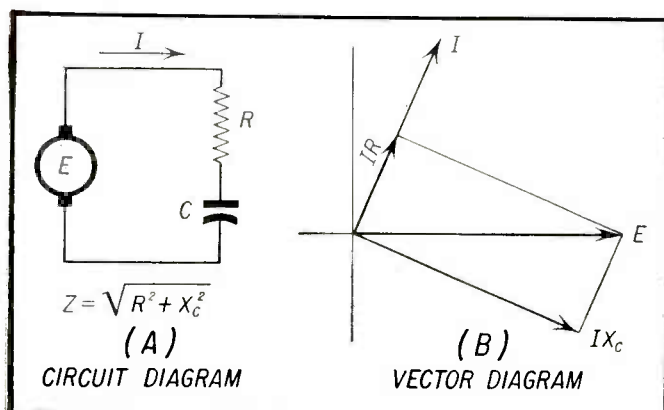

Fig. 2—Voltage and current relationships in a circuit containing resistance R, and capacitance C.

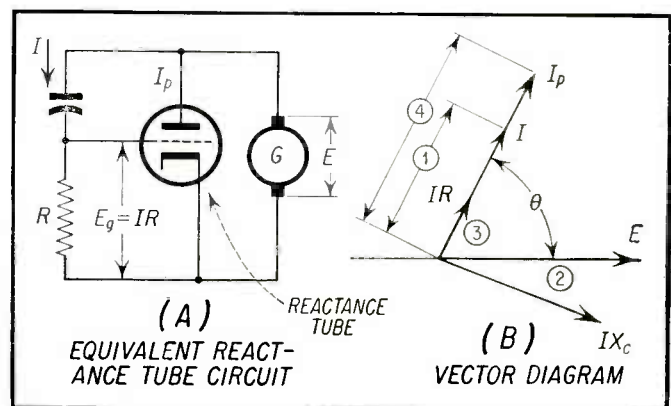

Fig. 3—Voltage and current relationships in a circuit which is mostly capacitive.

ANALYSIS

cussed. Also discussed is the need for, and operation of the automatic phase control (APC) loop.

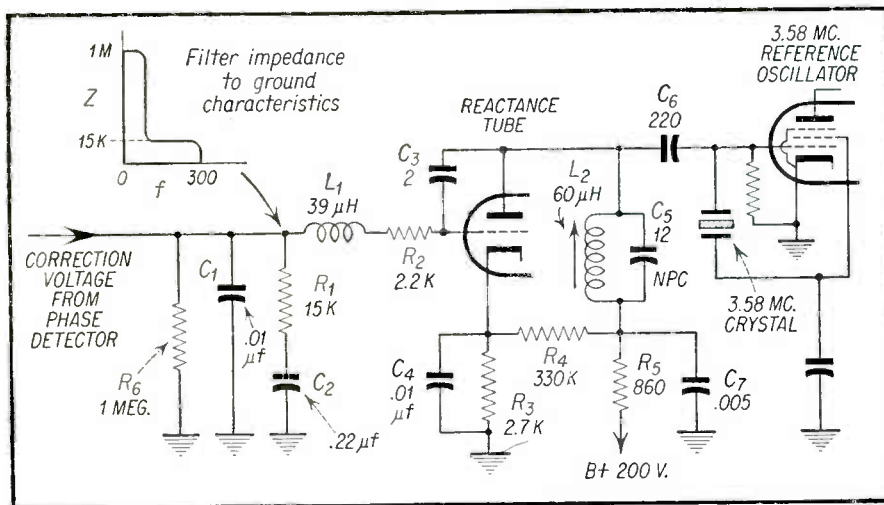

Fig. 4—Typical reactance tube circuit used in color TV receiver.

2. Thus, if the net reactance in a circuit is capacitive the current leads the applied voltage. Conversely, if the current in a circuit leads the applied voltage, the circuit reactance is said to be capacitive, just as though the circuit element were to all intents and purposes an equivalent condenser.

This principle is used in a reactance tube circuit in the following manner. Consider a circuit connected as in Fig. 3A in which the frequency of the generator G and the values of R and C are such that the capacitive reactance of C is very much higher than R . In practice this value is approximately 10 times the value of R , so that the phase angle ϕ approaches 90° . Under these conditions the following sequence of events takes place.

1. The existence of E across R and C results in a current I which leads E by almost 90° . Current I is shown as vector 1 in Fig. 3B, and E is shown as vector 2.

2. The voltage drop IR becomes the grid voltage E_g , and is in phase with I . Grid voltage E_g therefore leads E by almost 90° . The voltage drop IR is shown as vector 3 in Fig. 3B.

3. The plate current I_p resulting from E_g is in phase with I and therefore leads E by almost 90° . The plate current I_p is shown as vector 4 in

Fig. 3B.

Thus we have a condition where the current in a circuit is made to lead the applied voltage across the circuit. From our previous discussion we have shown that such a circuit is capacitive, and as applied to Fig. 3A, the generator G sees the equivalent of a capacitance connected across it.

The equivalent capacitance of such a circuit is given by the formula:

$$C_{eq} = G_m \times R \times C$$

where: G_m is the mutual conductance of the tube.

It is evident that by varying the mutual conductance G_m of the tube, the equivalent capacitance C_{eq} can be increased or decreased. One method by which a tube's mutual conductance may be varied is to vary its "C" bias. This is essentially what happens when the correction voltage varies the grid bias of the reactance tube.

If we substitute a crystal oscillator in an APC loop for the generator G , it is evident that the plate circuit of the reactance tube will be in parallel with the crystal. If the frequency of the oscillator is the same as the frequency of the incoming burst signal, and the phases of both signals are in quadrature, no correction voltage will be developed at the output of the phase detector. Any change in frequency or

phase will be transmitted to the phase detector, which in turn will develop a corresponding correction voltage designed to change the capacitance of the reactance tube in such a way as to bring the oscillator in frequency and in phase with the burst signal. Under these conditions, the quadrature relationship between burst and the 3.58 mc reference phase is constantly maintained.

Automatic Phase Control (APC) Loop

The system just described, which comprises the phase detector, reactance tube, and reference 3.58 mc oscillator, is known as an automatic phase control (APC) loop. The need for an APC loop of this nature is necessary in color receivers in order to maintain a high degree of synchronization between the phase of the color burst signal and the phase of the reference oscillator under all conditions of receiver operation. If this synchronization is not maintained the phase of the reference oscillator will not be correct and will result in demodulation of the chroma signal along incorrect axes, thereby resulting in the reproduction of incorrect colors.

Various conditions arise during reception that tend to disrupt this synchronization. Among these are:

1. Changes in reference oscillator frequency produced by variations in temperature, humidity, etc.

2. The phase and frequency of the incoming burst varies with different stations. Thus, when switching from station to station (assuming that the burst signal is maintained within the 11 cycle limits of the subcarrier frequency set by the FCC) the burst frequency may vary as much as 22 cycles between stations.

3. Spurious noise signals produced by thermal fluctuations in the receiver components may modulate the burst signal waveform enough to cause fluctuation of the reproduced chroma signal.

The APC loop action is one in which first the frequency and then the phase difference between burst and reference is rapidly reduced until both signals

are locked together in frequency and phase. Actually, the oscillator signal during this action lags the burst signal by a constant small value of time which is referred to as the maximum (static phase error) allowable limit for acceptable color fidelity. The time taken to produce this sequence of events is called, "stabilization time," and generally is designed for a maximum duration of one second.

It should be obvious by this time that the operation of an APC loop depends on certain interrelated operating characteristics. These are:

1. Phase detector sensitivity.
2. Reactance tube sensitivity.
3. Hold-in range.
4. Static phase error.

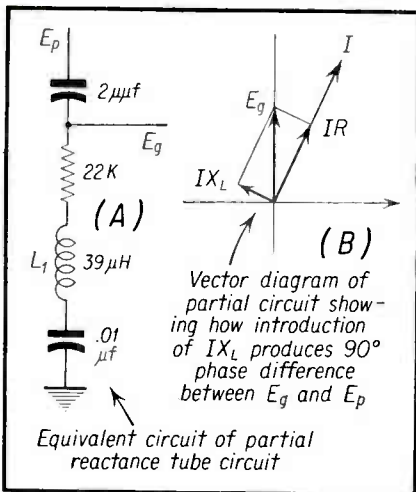

Fig. 5—Introduction of L1, 39 microhenrys, produces phase shift in Eg, so that final phase shift between Eg and Ep is exactly 90°. This method is used almost universally in all receivers.

Phase detector sensitivity μ is a measure of the instantaneous voltage output E of the phase detector for a given phase difference ϕ between burst and reference signals. Phase detector sensitivity may be expressed as:

$$\mu = E/\phi$$

Reactance tube sensitivity B is a measure of the change in oscillator frequency Δf for a given change in control grid voltage on the reactance tube ΔE . It may be expressed as:

$$B = \Delta f/\Delta E$$

Hold-In-Range f_c is expressed as the maximum frequency difference between burst and reference which may be corrected by the APC loop. It may be expressed as:

$$f_c = \mu B$$

Static phase error ϕ (mentioned previously) is the phase shift between reference and burst caused by a system in which the controlled oscillator is constantly attempting to attain impedance characteristics of the filter in-

chronization with the incoming burst. It is the price paid by the system for the APC action taking place, and may be expressed as:

$$\sin \phi = \frac{\Delta f}{f_c}$$

From the above expressions it is evident that the functions of the phase detector, the reactance tube, and the reference oscillator are closely interwoven.

APC Filter

The spurious noise signals referred to in a previous paragraph which produce phase modulation of the color burst signal manifests itself as "streaking" or "confetti" on the picture tube screen. Such noise may be reduced by reducing the overall bandwidth of the system. This is accomplished by utilizing an R-C filter network between the output of the phase detector and the input of the reactance tube as indicated in Fig. 1. It must be borne in mind that this noise reduction is obtained at a cost of reduced hold-in range, increased static phase error, and increased stabilization time.

A useful formula which ties up the three important out-of-sync operating characteristics of the APC loop is as follows:

$$f_p = \frac{1}{2} \sqrt{T_s} (f_B)^{3/2}$$

where:

f_p is the out-of-sync pull-in range

T_s is the stabilization time in seconds

f_B is the overall bandwidth of the loop

This equation tells us that the pull-in range is proportional to the square root of the stabilization time and the three-halves power of the loop bandwidth. In a well-designed system where the noise bandwidth is chosen at 100 cps, and the maximum stabilization time is set at 1 second, a maximum permissible difference of 500 cycles per second is allowable between the burst and reference signal frequencies.

Of special significance is the fact that the APC loop must be considered in its entirety when examining its many functions. Thus, if one were to ask why a very low pass filter is not used at the output of the phase detector for better dc filtering, the answer lies in the above equation. Here we see that it is necessary to preserve some ac band-pass in order for the entire APC loop to function as an effective frequency corrective circuit.

Reactance Tube Circuit Analysis

A reactance tube circuit which is representative of the type used in all color TV receivers is shown in Fig. 4. In this circuit R6, C1, R2, and C2 comprise the noise filter network. The impedance that up to 100 cycles or

thereabouts the noise signal sees a shunt resistance of 1 megohm. At 100 cycles the shunt impedance becomes 15K. Above 300 cycles the filter is practically a short circuit to the noise signal.

An analysis of the course of the signal from the reference oscillator to the reactance tube indicates that this signal (neglecting for the moment the effect of L1) is fed through C6 into the R-C voltage divider C3 and R2. This voltage divider is returned to ground through C1. The purpose of L1 is to make the voltage drop across R2 lead the applied voltage by exactly 90°. In this manner the plate current will also lead the applied voltage by,

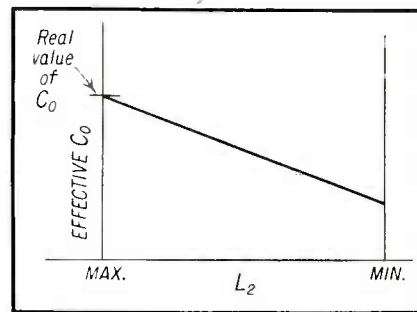

Fig. 6—Variation of L2 varies Co, which is the total capacitance across the crystal. This includes the effect of the reactance tube when the latter is operated at zero bias.

90° and the tuning effect across the oscillator tank will be truly capacitive.

The manner in which L1 produces a relationship between Ep and Eg which is exactly 90° is shown in Fig. 5. This is in contrast to the almost 90° relationship of Fig. 3. In Fig. 5 we observe an equivalent circuit at (A) and its corresponding vector diagram at (B). Note that without L1 the resultant voltage E would be equal to IR. However, with L1 producing IXL, the voltage at the grid Eg, which is now made up of the resultant of IR and IXL, is now exactly 90° out of phase (in quadrature) with E as shown in (B).

The tuned circuit L2-C5 provides a means for adjusting the frequency of the parallel tank circuit consisting of the 3.58 mc crystal and L2-C5. In practice this adjustment is made by feeding a color bar signal into the chroma amplifier of the receiver. With the correction voltage from the phase detector shorted out by shorting C1, (making the grid voltage on the reactance tube zero), the slug of L2 is adjusted until the color bars appearing on the picture tube screen are almost stationary. Under these conditions the frequency of the reference oscillator approaches that of the incoming color burst signal. On removal of the short

[Continued on page 62]

The ANSWERMAN

Inquiries Sent To The Answerman Will Be Acknowledged Only If Accompanied By Radio-TV Service Firm Letterheads Or Similar Identification.

by **RTSD**
Technical Staff

Dear Answerman:

In a CBS-Columbia chassis 921-14 the following conditions are observed:

The picture is narrow on both sides by about four inches, the picture is overdriven or negative in appearance and there is a vertical sync buzz noticeable in the audio.

The following steps were taken in trying to service this receiver:

I have checked all tubes, substituted for the horizontal output transformer, width coil, and the yoke. I also checked the transformer and yoke with a flyback checker and found them to be normal. The voltages seem to be close enough to that designated in the service literature except that the -15 volts at the plate of the 6U8 *agc* amplifier tube is low. Aside from this I have not been able to find anything that will correct the condition.

Can you offer a few suggestions as to what to do now?

S. N.

Los Angeles California

Apparently you have overlooked something in your testing. Since there are two definite symptoms to work with, narrow picture and overdriven picture it seems reasonable to believe that the trouble is in the deflection system somewhere due to the fact that this system is in a position to introduce both difficulties. It is also possible that there are two difficulties in the chassis but it is unlikely. A goodly portion has been eliminated by substitution which should make it somewhat easier.

Many of the components in Fig. 1 can be responsible for the trouble. An increased screen feed resistor, a leaky screen bypass condenser, an open cathode bypass condenser, a defective drive trimmer, a leaky coupling condenser, a leaky charging condenser, a leaky boost condenser, etc., can produce reduced width and the resultant overdrive. With this number of condensers to check it is obvious that one of the new in-circuit capacitor checkers would be quite handy.

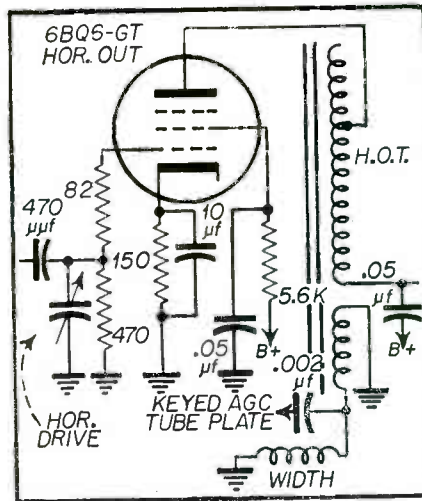

Fig. 1—CBS-Columbia horizontal output circuitry.

The overdrive is due to the *agc* system which obtains its keying voltage pulse for the 6U8 *agc* tube at a special winding of the horizontal output transformer. If the drive on the transformer becomes reduced the pulse at the special winding and coupled to the *agc* tube is likewise reduced. The result of an insufficient pulse being supplied brings about the generation of a smaller negative bias when the *agc* tube conducts and this incorrect *agc* voltage permits the overamplification of the signals in the *if* circuits and the overdriven condition.

In further considering the insufficient drive on the horizontal output transformer it would be very desirable to know whether the oscillator is providing the required amplitude of pulse, 60 volts peak to peak, to the grid of the horizontal output tube. This points up the desirability of being able to measure peak to peak voltages with a voltage calibrator and an oscilloscope or with a VTVM. It is suspected that the grid drive signal will be determined to be of correct amplitude and that the cathode resistor, R315, has increased in resistance from 150 ohms to a much higher value.

This exact case was witnessed in which the cathode resistor had gone to about 1300 ohms introducing all the

above mentioned symptoms. With such a large resistance in the cathode circuit too much *dc* voltage is dropped across it, biasing the tube very heavily. A much smaller portion of the grid signal permits tube current to be pulsed, developing less deflection signal in the plate circuit with a resultant reduced drive on the deflection transformer, reduced width and the other symptoms.

Dear Sir:

I have a case of horizontal pulling in a Motorola TS-534Y chassis that is causing me difficulty. I am sure it is not tubes as I have substituted new ones in the set and the same condition remains, perhaps a little better, but still there. The voltages are close to normal; at least there are no voltages that are off by an appreciable amount. The vertical lock-in action is good. Please advise.

L. B.

Washington, D.C.

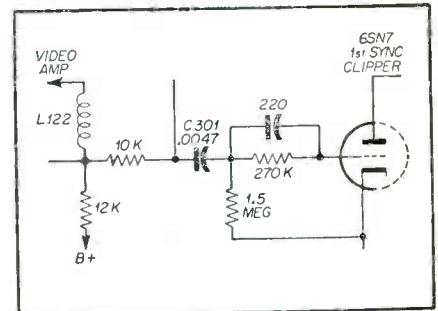

Fig. 2—Horizontal pulling in a Motorola TS-534Y chassis.

If you note the partial schematic of Fig. 2 you will find that there is a coupling condenser, C301, .0047 μ f, connecting the video signal from the video amplifier to the 1st sync clipper, a 6SN7 tube. This condenser also blocks *dc* voltage from being applied to the grid and disrupting the biasing of the sync clipper. Should the condenser develop an internal leak, and should a small amount of *dc* current pass through the condenser, the bias on the clipper tube would be altered to such an extent that proper clipping is impossible. Video information will be conducted through

[Continued on page 48]

A NEW TUBE

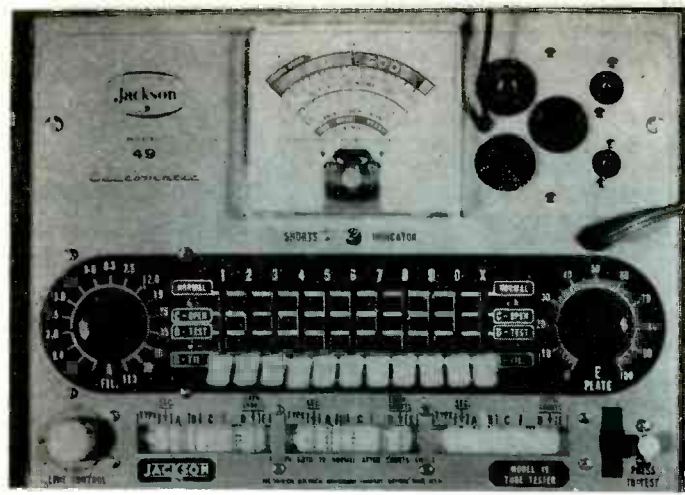

Fig. 1—Photo of basic tube tester, Jackson 49.

by **HERMAN HOFFMAN**

A NEW idea in tube checkers has made its appearance in the test equipment field. Recognizing that the serviceman, like any other citizen, has a healthy respect for his pocketbook, the Jackson Electrical Instrument Company has designed an instrument which combines low cost with unusual versatility. It consists basically of a conventional tube checker, with provisions for the convenient addition of accessory panels. Accessories are available for the following functions:

1. Testing selenium rectifiers.
2. Checking heater current.
3. Testing for high resistance shorts.
4. Checking 4, 5, 6, and 7 prong tubes, and sub-miniature 7 and 8 pin tubes.
5. Checking picture tubes.

The basic unit is the Jackson Model 49 Tube Tester, a photograph of which is shown in Fig. 1. A schematic of the unit is shown in Fig. 3. A study of this schematic will show that this is a conventional type of tube tester equipped to handle the testing of all tubes encountered in ordinary every day servicing. By eliminating all the circuitry so frequently found in tube testers for the purpose of making special tests, the manufacturer has been able to produce a basic low cost, portable, unit with high utility value, since it can cope with the vast majority of tube testing problems encountered in the serviceman's daily routine.

Now for the unique characteristic of the tester. Referring to Fig. 1, it will be noticed that there is a blank panel at the left of meter movement. This panel is easily removed by turning a retaining screw a quarter of a turn and then simply lifting the panel out. Any one of the accessory panels may then be placed in the space made available by

the removal of this panel. Fig. 2 shows the appearance of the unit with the Selenium Rectifier Tester added.

If the serviceman is interested only in the tube testing functions, he simply does not purchase any of the accessories. Should he desire to add other functions to the capabilities of the tester, he may simply purchase the particular accessory he desires. The first step in preparing the basic unit to receive the various accessories is to install the Model P49-B plug-in unit. A photograph of this unit is shown in Fig. 4a. Its schematic is shown in Fig. 4b. The installation is quite simple and is accomplished as follows:

1. In Fig. 3, the wires connecting points 1B with 2B, 3B with 4B, 5B with 6B, and 7B with 8B are clipped out, leaving open circuits at these points. A drawing is supplied to identify these points easily.

2. The leads from the female connector shown in Fig. 4 are then soldered to the various "B" points indicated.

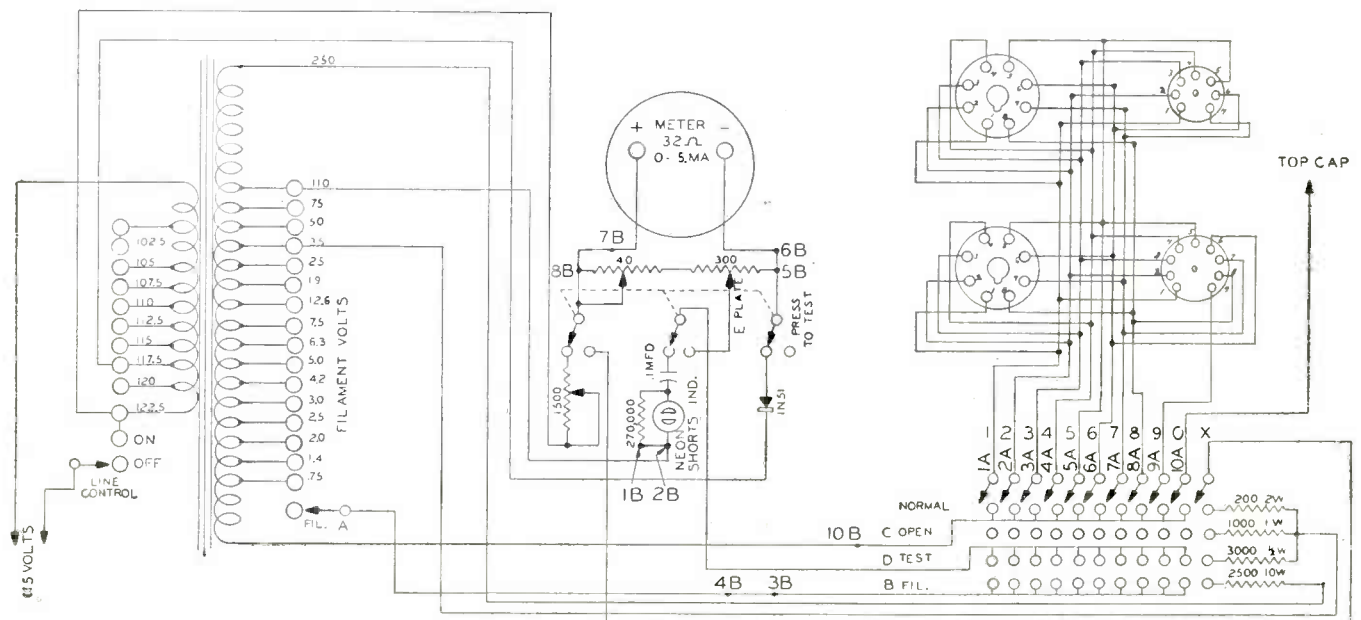

Fig. 3—Circuit diagram of Jackson Model 49 tube tester.

IDEA IN TESTERS

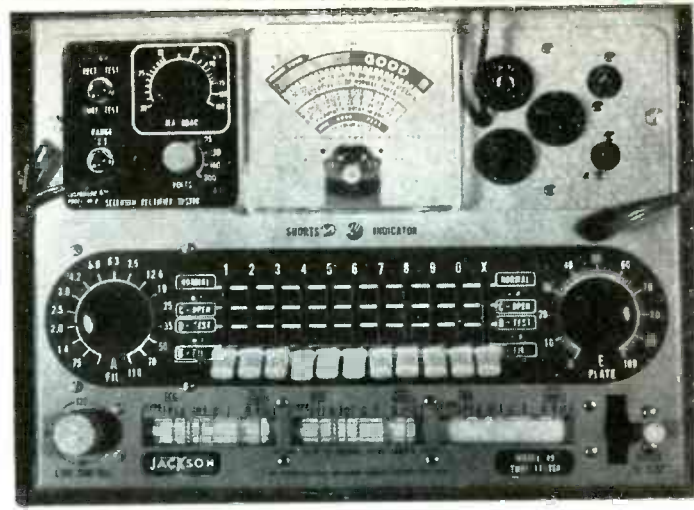

Fig. 2—Basic unit with selenium tester in place.



Fig. 4a—Accessory kit Mod. 49B.

Thus the yellow-red lead in Fig. 4 is indicated as going to point 1B. This point is identified in the same way, 1B, in Fig. 3, the schematic of the basic unit.

Once this has been done, the basic tube tester may be used either with or without accessories, by simple plug-in action. If no accessory is desired, the male jumper plug shown in Fig. 4 is simply plugged into the female connector. This action simply closes the circuits which were opened in the first step of the installation, thus restoring the basic unit to its original condition. The accessories are provided with similar male plugs. If it is desired to add one of the accessories, it is simply a matter of removing the jumper plug, and inserting the plug of the accessory units place.

The Selenium Rectifier Tester

A photograph of the Selenium Rectifier Testing accessory is shown in Fig. 2. Fig. 5 is a schematic of the same unit. It is designed to test selenium rectifiers rated from 25 to 300 volts with current ratings of from 20 to 650 ma. Once installed, it may be left in place permanently without disturbing the tube testing function of the basic unit.

In operation the circuit is arranged to apply an ac voltage to the rectifier

under test and measure the *dc* current output. When S1 is depressed it places the meter in the circuit to measure the *dc* current output. Switch S3 is a range switch for the meter. It is shown in the X1 position in the schematic. In this position R1 and R2 act as a shunt for the meter. In the X10 position, R3 is inserted as an additional shunt. Switch

SCHEMATIC - P49-B

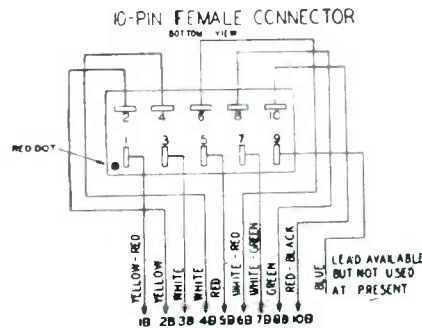
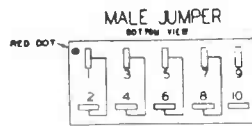

Fig. 4b—Schematic of accessory kit Model 49B.

S2 selects the voltage to be applied to the rectifier. Resistor R4 adjusts the milliamperes load on the rectifier. One of the scales on the meter face indicates the condition of the rectifier as good

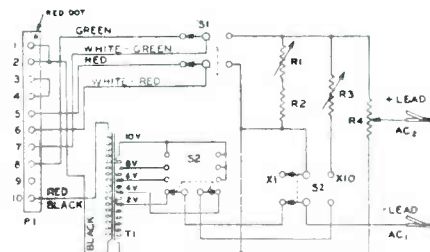

Fig. 5—Schematic of selenium rectifier tester Model 49R.

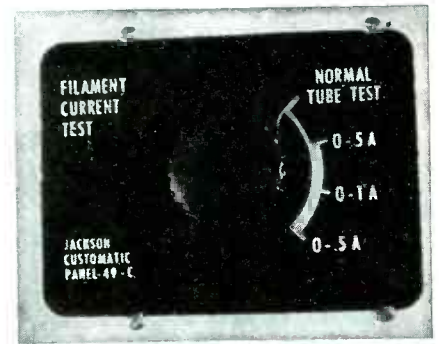

Fig. 6a—Heater current tester, Model 49C.

if the needle deflects to the green position or bad if the needle comes to rest in the red portion.

Heater Current Tester

The Model 49-C accessory tester is used for measuring heater currents up

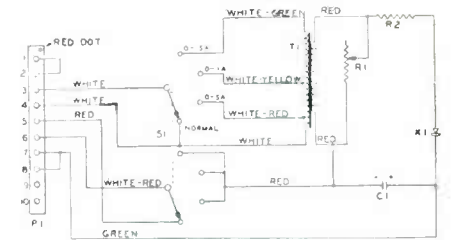
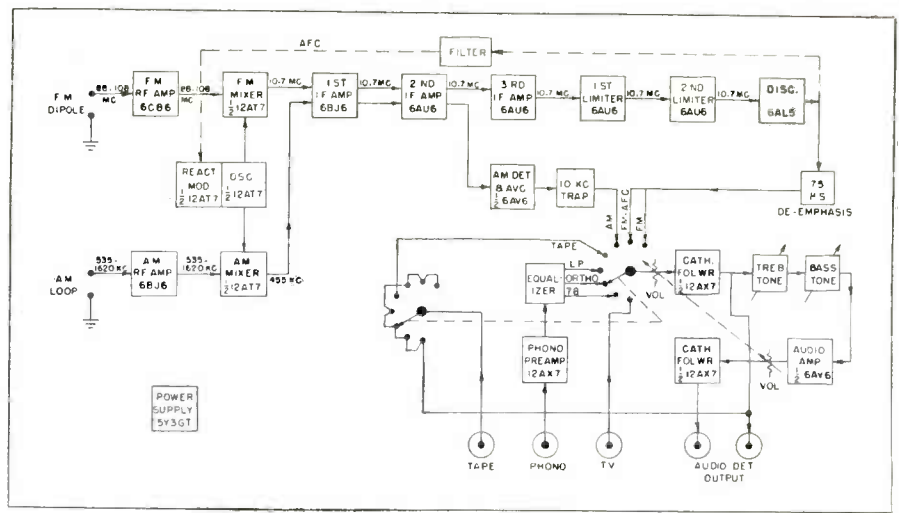
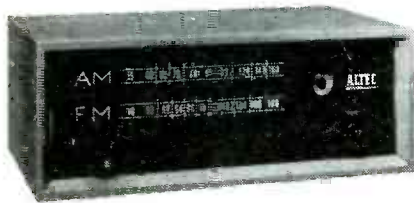
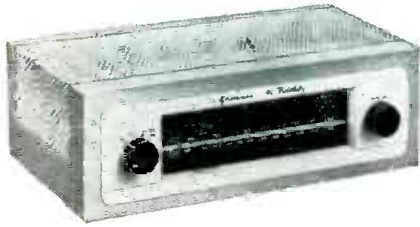
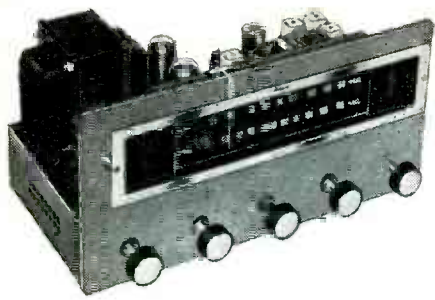

Fig. 6b—Schematic of heater current tester Model 49C.

to 5 amps. Such information is useful, particularly in series string circuits, where too large a deviation from the rated current may seriously affect both the life and the operating characteristic of other tubes in the string. Warm-up time may also be checked. Fig. 6a is a photograph of this accessory panel and Fig. 6b is its schematic. As with the other accessories, the tube tester function of the basic unit remains undis-

[Continued on page 58]



SERVICING AM-FM

by **STEVE TRAVIS**

THERE are two basic types of AM-FM tuners, available, the basic tuner and a more elaborate version with many additional features. The basic tuner contains only those portions necessary to provide AM and FM reception, and is desirable when existing equipment contains a preamplifier and an amplifier with tone and loudness controls already incorporated.

When AM and FM circuits are combined into a single basic unit the result is generally something similar to the system shown in the block diagram of Fig. 1 without the added features of the phono preamplifier, equalizer and tone control circuits. As shown in Fig. 1, the AM section of the AM-FM tuner employs a tuned *rf* stage ahead of the mixer to provide adequate image and *if* rejection, reduce cross modulation, and raise the signal level at the converter input to minimize undesirable converter noise.

Examining the AM-FM portion in this block diagram it can be noted that the same oscillator tube is employed for both AM and FM. Through the use of temperature compensated components and stabilizing circuits the oscillator stage for FM operation is made quite stable. In many other receivers separate oscillator tubes are used.

A common *if* strip is employed in Fig. 1 and the AM signals at 455 *kc* are separated in the second *if* amplifier stage through the use of a conventional AM detector. The amplification of AM signals is more easily accomplished with the 455 *kc if* frequency than is possible at the much higher FM *if* frequency of 10.7 *mc*. Thus, it is commonly found that AM-FM tuners use an extra stage of amplification for FM signals.

Some AM-FM tuners employ a separate channel for the AM signals and a separate channel for the FM signals with only the self contained power supply and the audio output provisions common to both circuits.

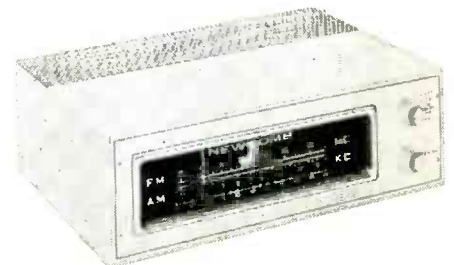
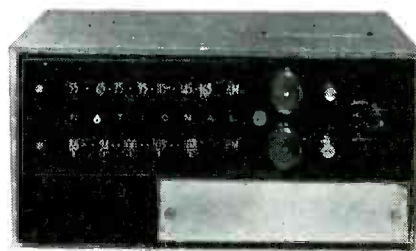

THE WORK BENCH

Unusual Service Problems And Their Solutions

by Paul Goldberg

This Month's Problem:

Defective crystal detector

Leakage in vertical condenser, modulating horizontal sweep.

THIS month's installment concerns two odd troubles involving Philco television receivers.

PHILCO TV 350

The receiver was turned on and it was observed that the receiver's picture would overload intermittently; about once every five or ten minutes. This receiver has a three position *age* switch: strong, normal, and fringe. The receiver was set at the normal position because it would overload continually on strong position and would remain snowy on fringe positions.

Every once in a while the picture would turn completely negative, but then just as quickly it would snap back to normal. The 1st and 2nd *if* tubes, 6DE6's were replaced individually, but had no effect. The 6BZ7, *rf* amp., which is also connected to the *age* line was also replaced, but had no effect. The 6AT6 and 6CS6 were also replaced because of their connections to the *age* circuitry, but had no effect on the trouble.

Voltage checks were next attempted, but as soon as the test probes touched any point in the *age* system during the period of overload, the picture would snap back to normal. At this point the diagram was studied. It was noted that this receiver used a 1N64 crystal for diode detection.

Crystals permit the use of a higher load resistance since the detector shunt capacity is less when crystal detectors are used. When a tube is used as a detector the shunt capacity is higher because of the interelectrode capacity of the tube as well as the surrounding wiring.

It might be also well to note that the internal resistance of a crystal compared with that of a diode tube is lower so that its detection efficiency is increased since it permits a large percentage of the total signal voltage drop to appear across the load. The forward resistance for current flow from cathode to positive anode is approximately 50 ohms. The backward resistance for cur-

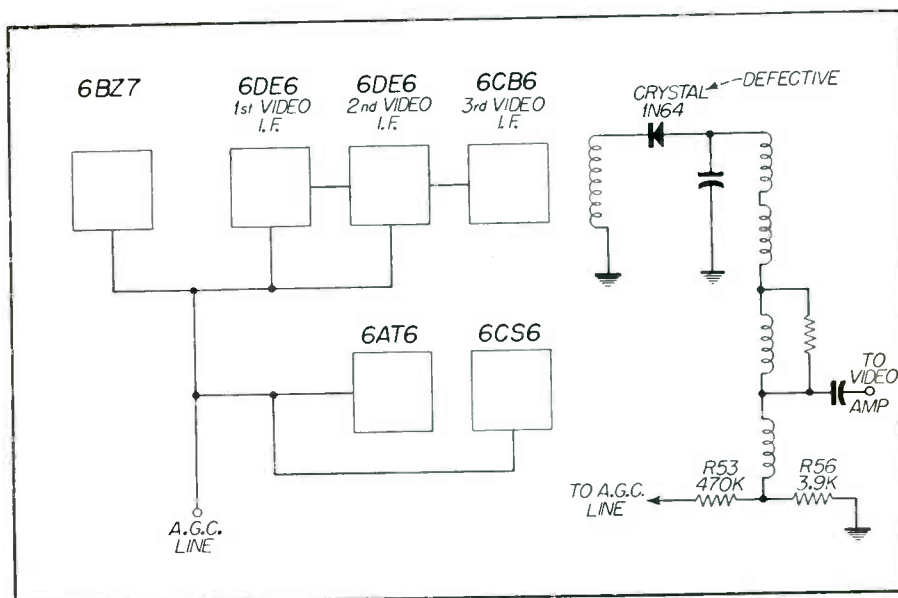

Fig. 1—Partial block diagram of Philco TV 350. Note that undue opposite current flow in crystal can disrupt *age* action.

rent flow in the inverse direction is about .5 megohms. In other words, the resistance ratio of most crystals runs about 10,000 to one.

Another advantage of the crystal is that the possibility of hum pickup is eliminated since no heater is involved. The maximum peak inverse anode voltage is about 50 volts while the crystals average anode current is about 22.5 ma. The principal disadvantage of the crystal seems to be its lower inverse resistance compared to the diode tube.

Knowing all these facts the 1N64 crystal was clipped out of the receiver and resistance checked with an ohmmeter. It measured about 50 ohms cathode to anode and about 100,000 ohms in the inverse direction. This is about 2,000 to one instead of 10,000 to one. A new crystal was then installed (1N64) which had a resistance ratio of one meg to 50 ohms, which is even better than average (20,000 to one). The receiver was then checked continually for two days and did not overload at any time. When a crystal reads 100,000

to 50 ohms it will draw more than the usual current in the opposite direction. Thus the voltage drop across R56 will be negative on 1/2 cycle and a small amount positive on the other 1/2 cycle. R56 serves not only as a load resistor for the 1N64 but as a point where *age* voltage is tapped off by R53. The overload occurs therefore because of the lowering of the *age* (less negative) bias voltage due to a defective crystal.

PHILCO RF38, DEFLECTION CP1

The receiver was turned on and it was noted that the bottom of the raster at the sides tended to be smaller. (Refer to Fig. 2). This symptom usually means yoke trouble. An exact replacement yoke was therefore installed but the trouble remained. The diagram was then studied.

It seemed that a defective component was affecting the horizontal sweep at the bottom of the raster. Hum sneaking into the horizontal sweep section could cause this trouble, we believed. Thus

[Continued on page 60]

COLOR SYNC

In this installment the theory and operation of the Reactance Tube and its associated circuitry is dis-

PART 4

by **Bob Dargan and Sam Marshall**

from a forthcoming book entitled "Fundamentals of Color Television"

UP to this point in our discussion of the Color Sync Section we have analyzed two of the five basic blocks comprising this portion of the color TV receiver, these being the Color Burst Gate and Phase Detector circuits. It will be recalled that the output of the color burst stage provides a color burst signal which is the only direct link to the phase of the subcarrier signal developed at the transmitter. Since the various hues contained in the chroma signal are established at the transmitter with reference to the subcarrier phase, the reference phase of the local 3.58 mc oscillator, which establishes the demodulation axes of the chroma signal, must at all times have a fixed relationship with the color burst phase if the correct hues are to be recovered.

The second block in this system, the Phase Detector, is the circuit in which the color carrier reference signal developed by the local 3.58 mc oscillator is compared against the incoming color burst. As a result of this comparison a dc correction voltage is developed at

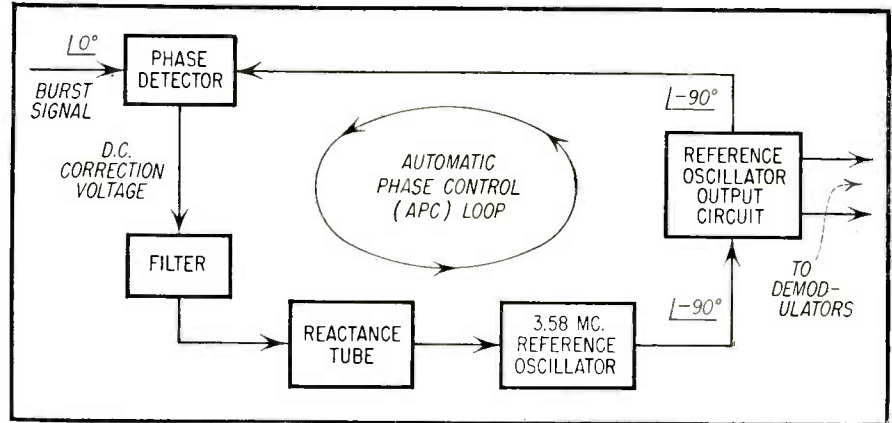

Fig. 1—Block diagram of APC loop.

the output of the phase detector. This voltage is zero if the color carrier reference signal is in quadrature with the color burst signal. If the signals are not in quadrature, positive or negative correction voltages are developed at the phase detector output, the polarities of these voltages depending on whether the phase difference between the burst and reference signals is more or less than 90°.

The third block in the overall analysis of the color sync section is the reactance tube. Fig. 1 indicates that the correction voltages developed at the output of the phase detector are applied to a Reactance Tube. The latter has the property of converting a dc bias

applied to its grid into an equivalent change in inductance or capacitance across its output plate circuit. Inasmuch as the latter is in parallel with the crystal of the local 3.58 mc oscillator, this change in inductance or capacitance tends to bring the oscillator into quadrature phase with the burst signal phase.

Reactance Tube Operation

It is well known that in a circuit containing capacitance and resistance the current leads the voltage drop across the capacitance by 90°, and leads the applied voltage by some value slightly less than 90°, depending on the resistance in the circuit as shown in Fig.

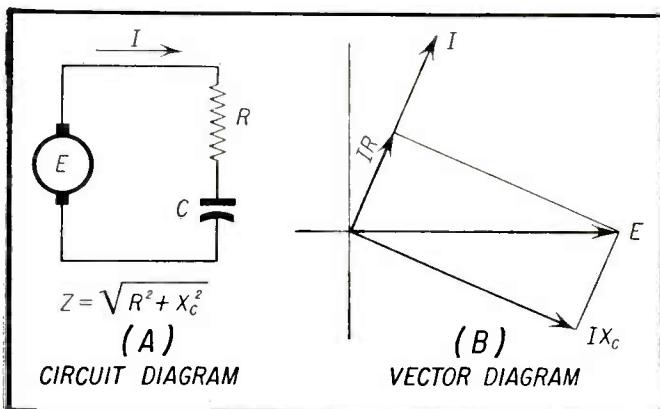

Fig. 2—Voltage and current relationships in a circuit containing resistance R, and capacitance C.

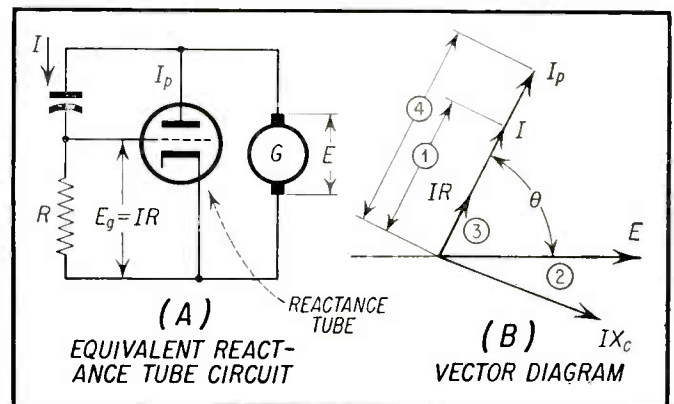

Fig. 3—Voltage and current relationships in a circuit which is mostly capacitive.

ANALYSIS

cussed. Also discussed is the need for, and operation of the automatic phase control (APC) loop.

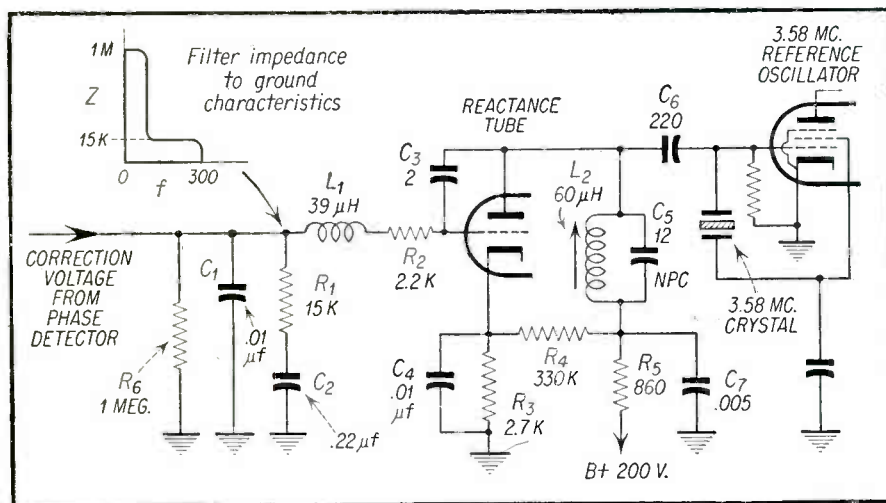

Fig. 4—Typical reactance tube circuit used in color TV receiver.

2. Thus, if the net reactance in a circuit is capacitive the current leads the applied voltage. Conversely, if the current in a circuit leads the applied voltage, the circuit reactance is said to be capacitive, just as though the circuit element were to all intents and purposes an equivalent condenser.

This principle is used in a reactance tube circuit in the following manner. Consider a circuit connected as in Fig. 3A in which the frequency of the generator *G* and the values of *R* and *C* are such that the capacitive reactance of *C* is very much higher than *R*. In practice this value is approximately 10 times the value of *R*, so that the phase angle θ approaches 90° . Under these conditions the following sequence of events takes place.

1. The existence of *E* across *R* and *C* results in a current *I* which leads *E* by almost 90° . Current *I* is shown as vector 1 in Fig. 3B, and *E* is shown as vector 2.

2. The voltage drop *IR* becomes the grid voltage *E_g*, and is in phase with *I*. Grid voltage *E_g* therefore leads *E* by almost 90° . The voltage drop *IR* is shown as vector 3 in Fig. 3B.

3. The plate current *I_p* resulting from *E_g* is in phase with *I* and therefore leads *E* by almost 90° . The plate current *I_p* is shown as vector 4 in

Fig. 3B.

Thus we have a condition where the current in a circuit is made to lead the applied voltage across the circuit. From our previous discussion we have shown that such a circuit is capacitive, and as applied to Fig. 3A, the generator *G* sees the equivalent of a capacitance connected across it.

The equivalent capacitance of such a circuit is given by the formula:

$$C_m = G_m \times R \times C$$

where: *G_m* is the mutual conductance of the tube.

It is evident that by varying the mutual conductance *G_m* of the tube, the equivalent capacitance *C_m*, can be increased or decreased. One method by which a tube's mutual conductance may be varied is to vary its "C" bias. This is essentially what happens when the correction voltage varies the grid bias of the reactance tube.

If we substitute a crystal oscillator in an APC loop for the generator *G*, it is evident that the plate circuit of the reactance tube will be in parallel with the crystal. If the frequency of the oscillator is the same as the frequency of the incoming burst signal, and the phases of both signals are in quadrature, no correction voltage will be developed at the output of the phase detector. Any change in frequency or

phase will be transmitted to the phase detector, which in turn will develop a corresponding correction voltage designed to change the capacitance of the reactance tube in such a way as to bring the oscillator in frequency and in phase with the burst signal. Under these conditions, the quadrature relationship between burst and the 3.58 mc reference phase is constantly maintained.

Automatic Phase Control (APC) Loop

The system just described, which comprises the phase detector, reactance tube, and reference 3.58 mc oscillator, is known as an automatic phase control (APC) loop. The need for an APC loop of this nature is necessary in color receivers in order to maintain a high degree of synchronization between the phase of the color burst signal and the phase of the reference oscillator under all conditions of receiver operation. If this synchronization is not maintained the phase of the reference oscillator will not be correct and will result in demodulation of the chroma signal along incorrect axes, thereby resulting in the reproduction of incorrect colors.

Various conditions arise during reception that tend to disrupt this synchronization. Among these are:

1. Changes in reference oscillator frequency produced by variations in temperature, humidity, etc.

2. The phase and frequency of the incoming burst varies with different stations. Thus, when switching from station to station (assuming that the burst signal is maintained within the 11 cycle limits of the subcarrier frequency set by the FCC) the burst frequency may vary as much as 22 cycles between stations.

3. Spurious noise signals produced by thermal fluctuations in the receiver components may modulate the burst signal waveform enough to cause fluctuation of the reproduced chroma signal.

The APC loop action is one in which first the frequency and then the phase difference between burst and reference is rapidly reduced until both signals

are locked together in frequency and phase. Actually, the oscillator signal during this action lags the burst signal by a constant small value of time which is referred to as the maximum (static phase error) allowable limit for acceptable color fidelity. The time taken to produce this sequence of events is called, "stabilization time," and generally is designed for a maximum duration of one second.

It should be obvious by this time that the operation of an APC loop depends on certain interrelated operating characteristics. These are:

1. Phase detector sensitivity.
2. Reactance tube sensitivity.
3. Hold-in range.
4. Static phase error.

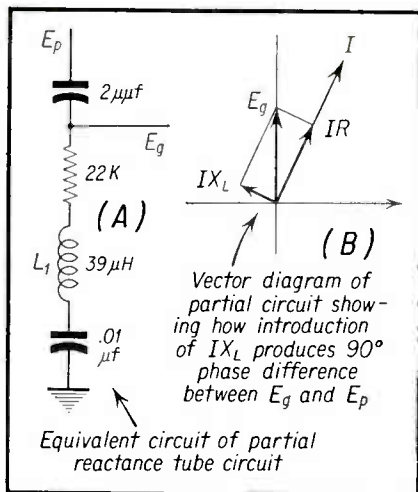

Fig. 5—Introduction of L_1 , 39 microhenrys, produces phase shift in E_g , so that final phase shift between E_g and E_p is exactly 90° . This method is used almost universally in all receivers.

Phase detector sensitivity μ is a measure of the instantaneous voltage output E of the phase detector for a given phase difference ϕ between burst and reference signals. Phase detector sensitivity may be expressed as:

$$\mu = E/\phi$$

Reactance tube sensitivity B is a measure of the change in oscillator frequency Δf for a given change in control grid voltage on the reactance tube ΔE . It may be expressed as:

$$B = \Delta f/\Delta E$$

Hold-In-Range f_c is expressed as the maximum frequency difference between burst and reference which may be corrected by the APC loop. It may be expressed as:

$$f_c = \mu B$$

Static phase error ϕ (mentioned previously) is the phase shift between reference and burst caused by a system in which the controlled oscillator is constantly attempting to attain impedance characteristics of the filter in-

chronization with the incoming burst. It is the price paid by the system for the APC action taking place, and may be expressed as:

$$\sin \phi = \frac{\Delta f}{f_c}$$

From the above expressions it is evident that the functions of the phase detector, the reactance tube, and the reference oscillator are closely interwoven.

APC Filter

The spurious noise signals referred to in a previous paragraph which produces phase modulation of the color burst signal manifests itself as "streaking" or "confetti" on the picture tube screen. Such noise may be reduced by reducing the overall bandwidth of the system. This is accomplished by utilizing an R-C filter network between the output of the phase detector and the input of the reactance tube as indicated in Fig. 1. It must be borne in mind that this noise reduction is obtained at a cost of reduced hold-in range, increased static phase error, and increased stabilization time.

A useful formula which ties up the three important out-of-sync operating characteristics of the APC loop is as follows:

$$f_p = \frac{1}{2} \sqrt{T_s} (f_b)^{3/2}$$

where:

f_p is the out-of-sync pull-in range
 T_s is the stabilization time in seconds
 f_b is the overall bandwidth of the loop

This equation tells us that the pull-in range is proportional to the square root of the stabilization time and the three-halves power of the loop bandwidth. In a well-designed system where the noise bandwidth is chosen at 100 cps, and the maximum stabilization time is set at 1 second, a maximum permissible difference of 500 cycles per second is allowable between the burst and reference signal frequencies.

Of special significance is the fact that the APC loop must be considered in its entirety when examining its many functions. Thus, if one were to ask why a very low pass filter is not used at the output of the phase detector for better *dc* filtering, the answer lies in the above equation. Here we see that it is necessary to preserve some *ac* band-pass in order for the entire APC loop to function as an effective frequency corrective circuit.

Reactance Tube Circuit Analysis

A reactance tube circuit which is representative of the type used in all color TV receivers is shown in Fig. 4. In this circuit R_6 , C_1 , R_2 , and C_2 comprise the noise filter network. The impedance that up to 100 cycles or

thereabouts the noise signal sees a shunt resistance of 1 megohm. At 100 cycles the shunt impedance becomes 15K. Above 300 cycles the filter is practically a short circuit to the noise signal.

An analysis of the course of the signal from the reference oscillator to the reactance tube indicates that this signal (neglecting for the moment the effect of L_1) is fed through C_6 into the R-C voltage divider C_3 and R_2 . This voltage divider is returned to ground through C_1 . The purpose of L_1 is to make the voltage drop across R_2 lead the applied voltage by exactly 90° . In this manner the plate current will also lead the applied voltage by,

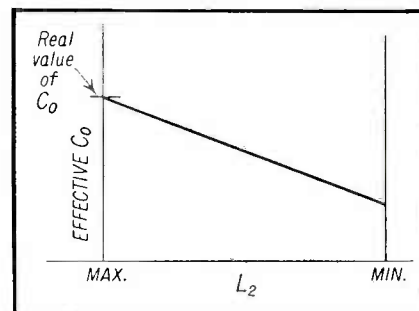

Fig. 6—Variation of L_2 varies C_0 , which is the total capacitance across the crystal. This includes the effect of the reactance tube when the latter is operated at zero bias.

90° and the tuning effect across the oscillator tank will be truly capacitive.

The manner in which L_1 produces a relationship between E_p and E_g which is exactly 90° is shown in Fig. 5. This is in contrast to the almost 90° relationship of Fig. 3. In Fig. 5 we observe an equivalent circuit at (A) and its corresponding vector diagram at (B). Note that without L_1 the resultant voltage E_g would be equal to IR . However, with L_1 producing IX_L , the voltage at the grid E_g , which is now made up of the resultant of IR and IX_L , is now exactly 90° out of phase (in quadrature) with E as shown in (B).

The tuned circuit L_2 - C_5 provides a means for adjusting the frequency of the parallel tank circuit consisting of the 3.58 mc crystal and L_2 - C_5 . In practice this adjustment is made by feeding a color bar signal into the chroma amplifier of the receiver. With the correction voltage from the phase detector shorted out by shorting C_1 , (making the grid voltage on the reactance tube zero), the slug of L_2 is adjusted until the color bars appearing on the picture tube screen are almost stationary. Under these conditions the frequency of the reference oscillator approaches that of the incoming color burst signal. On removal of the short

[Continued on page 62]

The ANSWERMAN

Inquiries Sent To The Answerman Will Be Acknowledged Only If Accompanied By Radio-TV Service Firm Letterheads Or Similar Identification.

by **RTSD**
Technical Staff

Dear Answerman:

In a CBS-Columbia chassis 921-14 the following conditions are observed:

The picture is narrow on both sides by about four inches, the picture is overdriven or negative in appearance and there is a vertical sync buzz noticeable in the audio.

The following steps were taken in trying to service this receiver:

I have checked all tubes, substituted for the horizontal output transformer, width coil, and the yoke. I also checked the transformer and yoke with a flyback checker and found them to be normal. The voltages seem to be close enough to that designated in the service literature except that the -15 volts at the plate of the 6U8 *age* amplifier tube is low. Aside from this I have not been able to find anything that will correct the condition.

Can you offer a few suggestions as to what to do now?

S. N.

Los Angeles California

Apparently you have overlooked something in your testing. Since there are two definite symptoms to work with, narrow picture and overdriven picture it seems reasonable to believe that the trouble is in the deflection system somewhere due to the fact that this system is in a position to introduce both difficulties. It is also possible that there are two difficulties in the chassis but it is unlikely. A goodly portion has been eliminated by substitution which should make it somewhat easier.

Many of the components in Fig. 1 can be responsible for the trouble. An increased screen feed resistor, a leaky screen bypass condenser, an open cathode bypass condenser, a defective drive trimmer, a leaky coupling condenser, a leaky charging condenser, a leaky boost condenser, etc., can produce reduced width and the resultant overdrive. With this number of condensers to check it is obvious that one of the new in-circuit capacitor checkers would be quite handy.

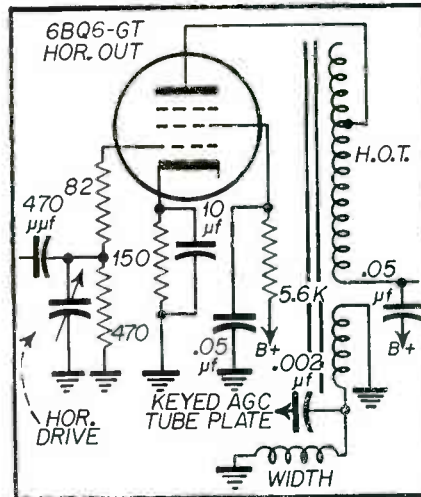

Fig. 1—CBS-Columbia horizontal output circuitry.

The overdrive is due to the *age* system which obtains its keying voltage pulse for the 6U8 *age* tube at a special winding of the horizontal output transformer. If the drive on the transformer becomes reduced the pulse at the special winding and coupled to the *age* tube is likewise reduced. The result of an insufficient pulse being supplied brings about the generation of a smaller negative bias when the *age* tube conducts and this incorrect *age* voltage permits the overamplification of the signals in the *if* circuits and the overdriven condition.

In further considering the insufficient drive on the horizontal output transformer it would be very desirable to know whether the oscillator is providing the required amplitude of pulse, 60 volts peak to peak, to the grid of the horizontal output tube. This points up the desirability of being able to measure peak to peak voltages with a voltage calibrator and an oscilloscope or with a VTVM. It is suspected that the grid drive signal will be determined to be of correct amplitude and that the cathode resistor, R315, has increased in resistance from 150 ohms to a much higher value.

This exact case was witnessed in which the cathode resistor had gone to about 1300 ohms introducing all the

above mentioned symptoms. With such a large resistance in the cathode circuit too much *dc* voltage is dropped across it, biasing the tube very heavily. A much smaller portion of the grid signal permits tube current to be pulsed, developing less deflection signal in the plate circuit with a resultant reduced drive on the deflection transformer, reduced width and the other symptoms.

Dear Sir:

I have a case of horizontal pulling in a Motorola TS-534Y chassis that is causing me difficulty. I am sure it is not tubes as I have substituted new ones in the set and the same condition remains, perhaps a little better, but still there. The voltages are close to normal; at least there are no voltages that are off by an appreciable amount. The vertical lock-in action is good. Please advise.

L. B.

Washington, D.C.

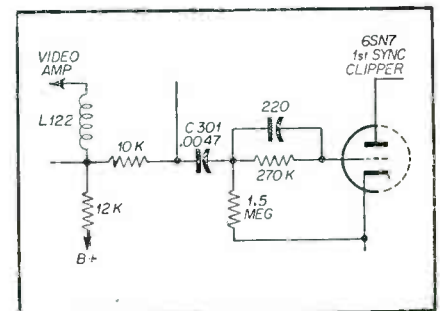

Fig. 2—Horizontal pulling in a Motorola TS-534Y chassis.

If you note the partial schematic of Fig. 2 you will find that there is a coupling condenser, C301, .0047 μ f, connecting the video signal from the video amplifier to the 1st sync clipper, a 6SN7 tube. This condenser also blocks *dc* voltage from being applied to the grid and disrupting the biasing of the sync clipper. Should the condenser develop an internal leak, and should a small amount of *dc* current pass through the condenser, the bias on the clipper tube would be altered to such an extent that proper clipping is impossible. Video information will be conducted through

[Continued on page 48]

A NEW TUBE

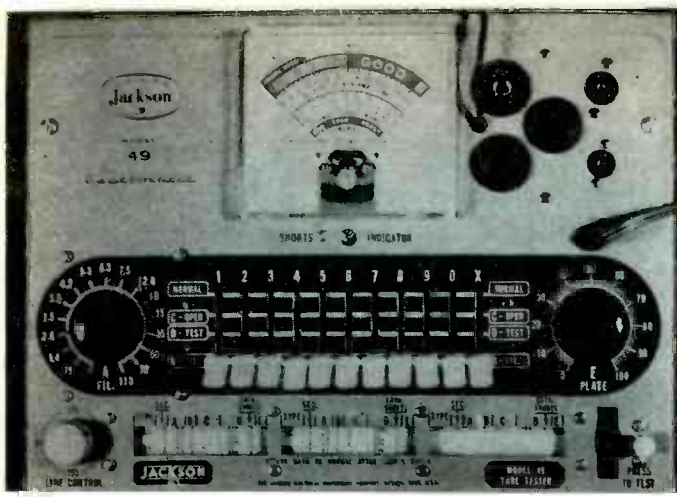

Fig. 1—Photo of basic tube tester, Jackson 49.

by **HERMAN HOFFMAN**

A NEW idea in tube checkers has made its appearance in the test equipment field. Recognizing that the serviceman, like any other citizen, has a healthy respect for his pocketbook, the Jackson Electrical Instrument Company has designed an instrument which combines low cost with unusual versatility. It consists basically of a conventional tube checker, with provisions for the convenient addition of accessory panels. Accessories are available for the following functions:

1. Testing selenium rectifiers.
2. Checking heater current.
3. Testing for high resistance shorts.
4. Checking 4, 5, 6, and 7 prong tubes, and sub-miniature 7 and 8 pin tubes.
5. Checking picture tubes.

The basic unit is the Jackson Model 49 Tube Tester, a photograph of which is shown in Fig. 1. A schematic of the unit is shown in Fig. 3. A study of this schematic will show that this is a conventional type of tube tester equipped to handle the testing of all tubes encountered in ordinary every day servicing. By eliminating all the circuitry so frequently found in tube testers for the purpose of making special tests, the manufacturer has been able to produce a basic low cost, portable, unit with high utility value, since it can cope with the vast majority of tube testing problems encountered in the serviceman's daily routine.

Now for the unique characteristic of the tester. Referring to Fig. 1, it will be noticed that there is a blank panel at the left of meter movement. This panel is easily removed by turning a retaining screw a quarter of a turn and then simply lifting the panel out. Any one of the accessory panels may then be placed in the space made available by

the removal of this panel. Fig. 2 shows the appearance of the unit with the Selenium Rectifier Tester added.

If the serviceman is interested only in the tube testing functions, he simply does not purchase any of the accessories. Should he desire to add other functions to the capabilities of the tester, he may simply purchase the particular accessory he desires. The first step in preparing the basic unit to receive the various accessories is to install the Model P49-B plug-in unit. A photograph of this unit is shown in Fig. 4a. Its schematic is shown in Fig. 4b. The installation is quite simple and is accomplished as follows:

1. In Fig. 3, the wires connecting points 1B with 2B, 3B with 4B, 5B with 6B, and 7B with 8B are clipped out, leaving open circuits at these points. A drawing is supplied to identify these points easily.

2. The leads from the female connector shown in Fig. 4 are then soldered to the various "B" points indicated.

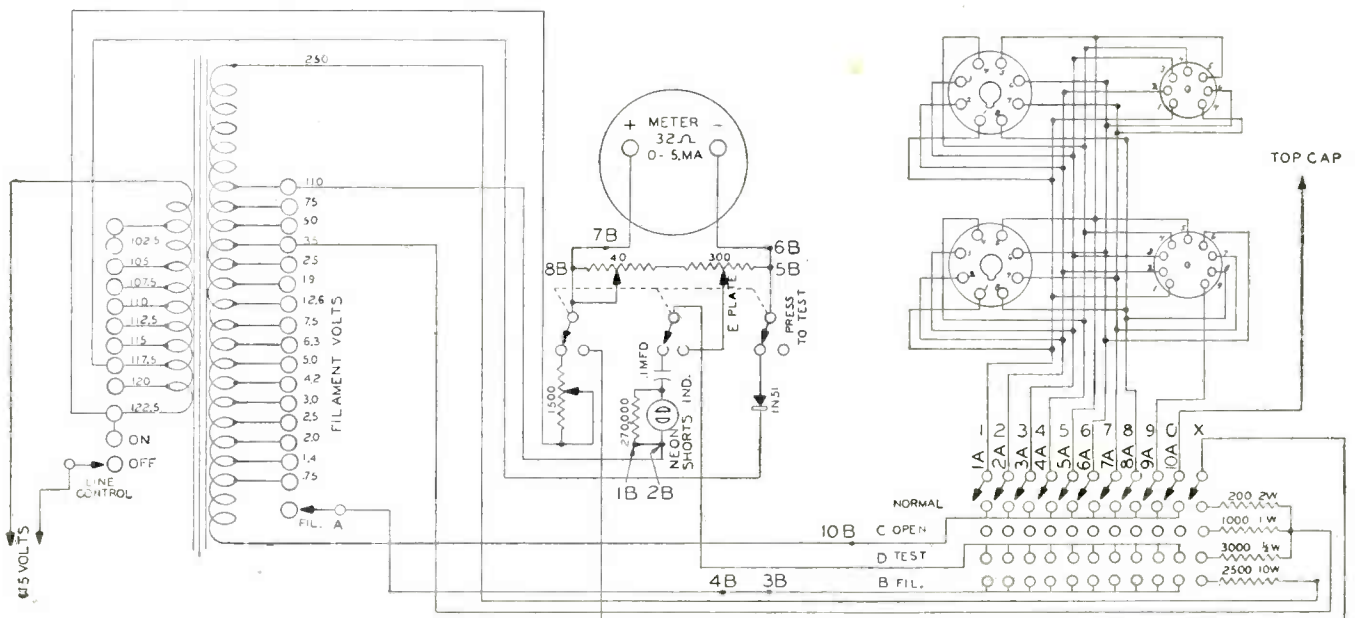

Fig. 3—Circuit diagram of Jackson Model 49 tube tester.

IDEA IN TESTERS



Fig. 2—Basic unit with selenium tester in place.

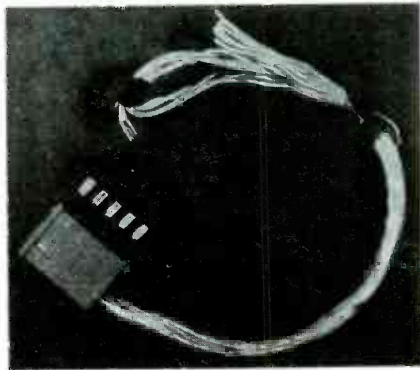

Fig. 4a—Accessory kit Mod. 49B.

Thus the yellow-red lead in Fig. 4 is indicated as going to point 1B. This point is identified in the same way, 1B, in Fig. 3, the schematic of the basic unit.

Once this has been done, the basic tube tester may be used either with or without accessories, by simple plug-in action. If no accessory is desired, the male jumper plug shown in Fig. 4 is simply plugged into the female connector. This action simply closes the circuits which were opened in the first step of the installation, thus restoring the basic unit to its original condition. The accessories are provided with similar male plugs. If it is desired to add one of the accessories, it is simply a matter of removing the jumper plug, and inserting the plug of the accessory units place.

The Selenium Rectifier Tester

A photograph of the Selenium Rectifier Testing accessory is shown in Fig. 2. Fig. 5 is a schematic of the same unit. It is designed to test selenium rectifiers rated from 25 to 300 volts with current ratings of from 20 to 650 ma. Once installed, it may be left in place permanently without disturbing the tube testing function of the basic unit.

In operation the circuit is arranged to apply an ac voltage to the rectifier

under test and measure the *dc* current output. When *S1* is depressed it places the meter in the circuit to measure the *dc* current output. Switch *S3* is a range switch for the meter. It is shown in the *X1* position in the schematic. In this position *R1* and *R2* act as a shunt for the meter. In the *X10* position, *R3* is inserted as an additional shunt. Switch

SCHEMATIC - P49-B

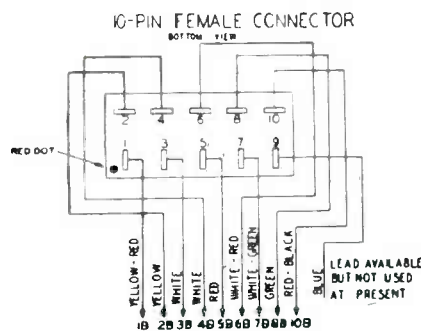
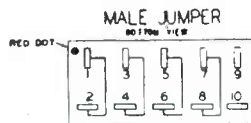

Fig. 4b—Schematic of accessory kit Model 49B.

S2 selects the voltage to be applied to the rectifier. Resistor *R4* adjusts the milliampere load on the rectifier. One of the scales on the meter face indicates the condition of the rectifier as good

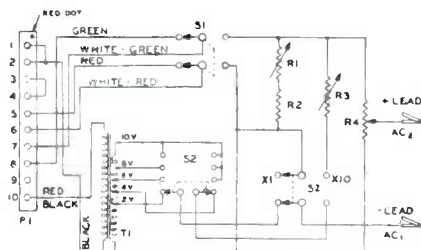

Fig. 5—Schematic of selenium rectifier tester Model 49R.

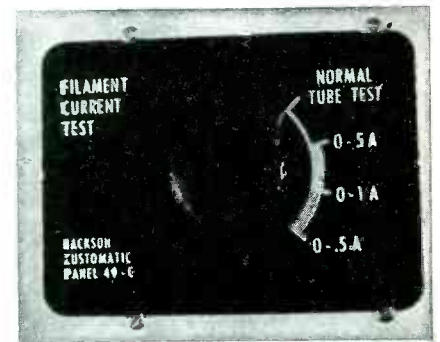

Fig. 6a—Heater current tester, Model 49C.

if the needle deflects to the green position or bad if the needle comes to rest in the red portion.

Heater Current Tester

The Model 49-C accessory tester is used for measuring heater currents up

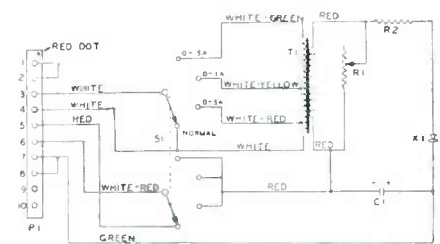
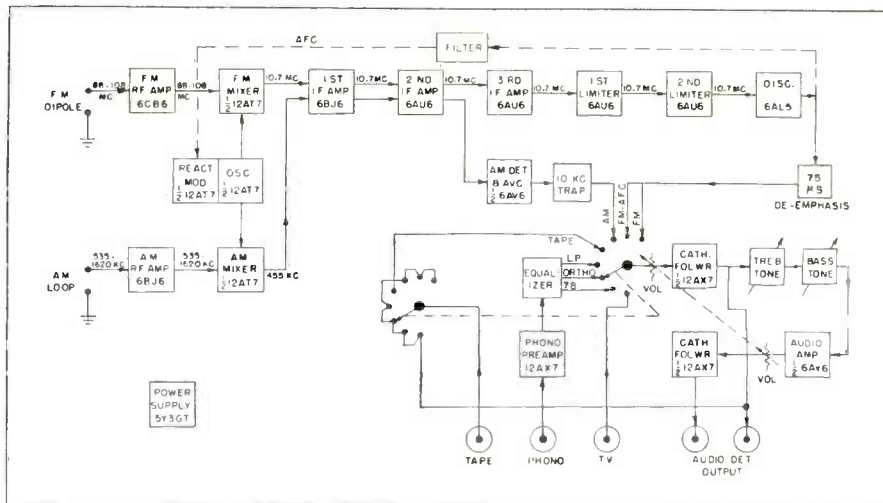
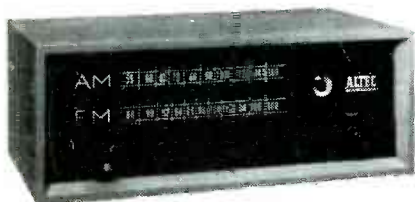
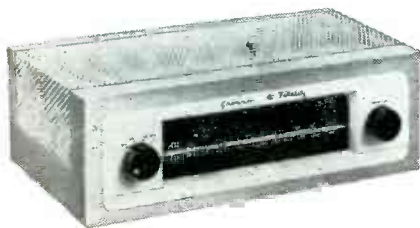
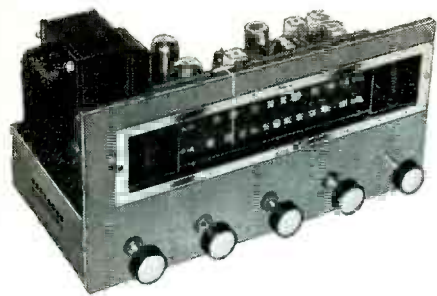

Fig. 6b—Schematic of heater current tester Model 49C.

to 5 amps. Such information is useful, particularly in series string circuits, where too large a deviation from the rated current may seriously affect both the life and the operating characteristic of other tubes in the string. Warm-up time may also be checked. Fig. 6a is a photograph of this accessory panel and Fig. 6b is its schematic. As with the other accessories, the tube tester function of the basic unit remains undis-

[Continued on page 58]



SERVICING AM-FM

by **STEVE TRAVIS**

THERE are two basic types of AM-FM tuners, available, the basic tuner and a more elaborate version with many additional features. The basic tuner contains only those portions necessary to provide AM and FM reception, and is desirable when existing equipment contains a preamplifier and an amplifier with tone and loudness controls already incorporated.

When AM and FM circuits are combined into a single basic unit the result is generally something similar to the system shown in the block diagram of Fig. 1 without the added features of the phono preamplifier, equalizer and tone control circuits. As shown in Fig. 1, the AM section of the AM-FM tuner employs a tuned *rf* stage ahead of the mixer to provide adequate image and *if* rejection, reduce cross modulation, and raise the signal level at the converter input to minimize undesirable converter noise.

Examining the AM-FM portion in this block diagram it can be noted that the same oscillator tube is employed for both AM and FM. Through the use of temperature compensated components and stabilizing circuits the oscillator stage for FM operation is made quite stable. In many other receivers separate oscillator tubes are used.

A common *if* strip is employed in Fig. 1 and the AM signals at 455 kc are separated in the second *if* amplifier stage through the use of a conventional AM detector. The amplification of AM signals is more easily accomplished with the 455 kc *if* frequency than is possible at the much higher FM *if* frequency of 10.7 mc. Thus, it is commonly found that AM-FM tuners use an extra stage of amplification for FM signals.

Some AM-FM tuners employ a separate channel for the AM signals and a separate channel for the FM signals with only the self contained power supply and the audio output provisions common to both circuits.

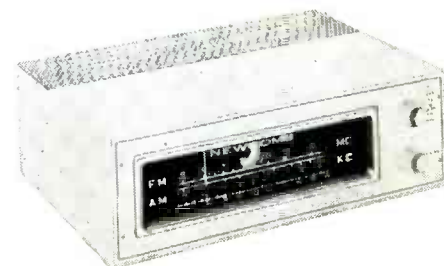
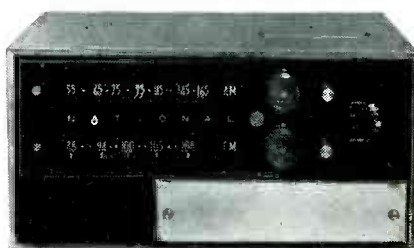

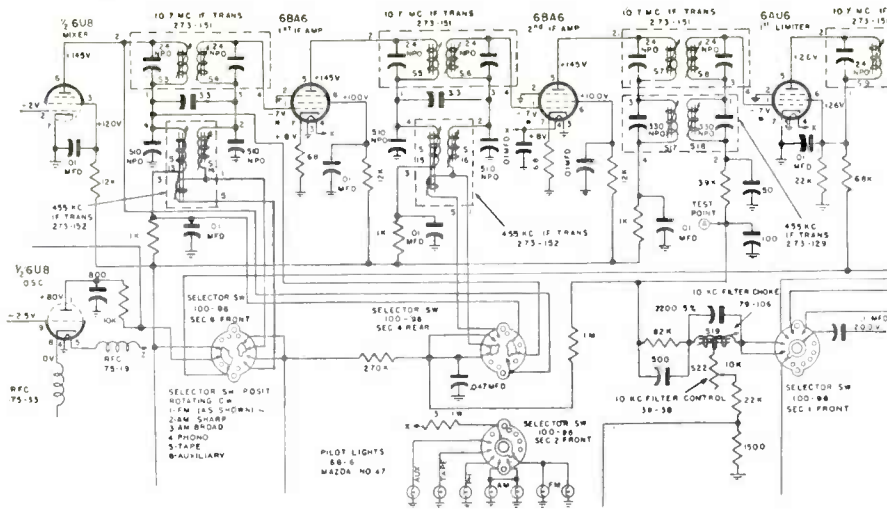
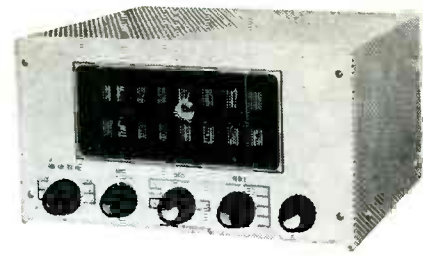

Fig. 1—(upper left hand page) Block diagram of RCA AM-FM tuner.

Fig. 2—Partial schematic of Pilot AM-FM tuner AF-860 IF stages.



TUNERS

AM-FM Tuners Incorporating Additional Features

More than 50% of the AM-FM tuners made available are of the more elaborate design. Such a tuner is the one shown in block diagram form in Fig. 1.

Besides functioning as a radio receiver a tuner may also be used as the control center of the high fidelity system. In this case the tuner should include a preamplifier for low level magnetic pick-up, as well as an equalizer, tone control, audio amplifier and cathode follower circuit. The record player may then be plugged into the tuner as well as the other accessories such as a tape recorder, television receiver, etc. The tuner then permits any of the different signals to be made available through selection with a front panel switch. The selector switch chooses the particular signal information that is to be handled.

In the particular example shown in Fig. 1 two output jacks are provided, one supplying the audio from the audio

detector previous to the tone control circuits, and one jack supplying the signals after they have been passed through the tone and amplifier circuits. The detector output taken from a point previous to the tone controls provides a flat response regardless of the tone control positions. This jack is useful for recording the output of the tuner or phonograph while monitoring. The tape recorder jack is connected so that it serves as an input to the recorder for all positions of the function switch except playback.

Characteristics of AM-FM Tuners

Sensitivity is a characteristic of the AM portion of an AM-FM tuner which is defined a little differently than in FM tuners. Good sensitivity to be found in AM tuners is in the order of 5 microvolts or better with 1 volt audio output. Distortion in AM-FM tuners should be well below 1% on both AM and FM reception.

[Continued on page 50]

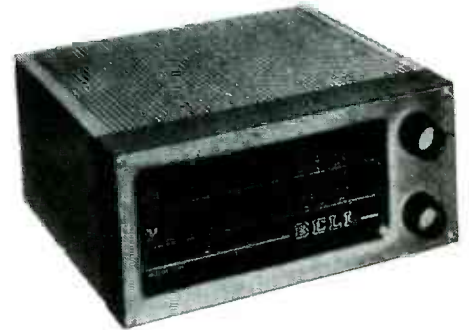

There Is IN MECHANIZED CON

ROBERT H. STOCKMAN,
Owner
by **Stockman's Radio & Television
Service**
Greenwood, South Carolina

In this atomic age anyone who shakes his head with suspicion at "new-fangled" ideas usually finds himself on the outside looking in. This applies to business methods as well as research.

THE rapid growth of the radio and television service industry during the past five years has compelled individual operators to take a hard look at their management methods. I am speaking not so much of inventory control and technical processes as I am of office and credit management, two business problems that are given a wide berth by most of us.

I am bringing this subject up in order to give you a detailed description of a mechanized bookkeeping system that has been outstandingly successful for us. By simply comparing your own system with our machine methods, you

will possibly see room for improvement, no matter how long you have been using your present system.

We became acutely aware of the need for mechanical control when we were swamped by the paper work that followed in the wake of an increase in volume. On the surface, it might appear that an increase in paper work would be welcomed if it followed increased sales. We agree; there are no complaints from us about the "troubles" caused by increased sales. However, it does not follow that old-fashioned bookkeeping methods must be used. As a matter of fact, an owner should con-

sider a mechanized system when it becomes apparent that bookkeeping is taking too much of his time as well as the time of other selling personnel.

We streamlined our bookkeeping by installing a modern charge-posting cash register. This machine is constructed to accumulate totals of nine separate types of transactions. Here is the way the system works:

A consecutively numbered sales slip (Fig. 1) is made out in duplicate on all cash and charge repair work. When the work is completed, the original goes on the radio or television set and the duplicate is spindled on a "work com-

Stockman's Radio & Television Service
Sales, Installation and Repair
SERVISE AT THE SALES
Dial 9-2191
Greenwood, S. C. May 18 1956
Name: R. B. Rowe
Address: 1264 Aike
All Repair Work Cash on Completion
of Work. If Custom's Not at Home, Please
Present This Bill at Store or Mail Check.
You Will Not Receive Another Copy. Call
When This Original
1 1264 Aike 2/15
Repair & Adjustment 1.00
Tax 6/15
6/19
216 - 61 - 006.1911 A
DN: 5253

Name: J. W. Johnson
Address: 219 Ashland St. City: City
1 1 216 - 55 - 023.5611 A
2 2 216 - 59 - 023.5611 A
3 3 216 - 59 - 048.1611 A
4 4 216 - 60 - 048.1611 A
5 5 216 - 60 - 025.008 A
6 6 216 - 60 - 023.1611 A
7
8
9
10
11
12
13
14
15
16
17
18
19
20
Stockman's Radio & Television Service
-048.1611 A
-025.008 A
216 - 60 - 023.1611 A
THIS IS YOUR RECEIPT
(MAY 18 1956)

DAILY STATEMENT
(*) READ Register Control Totals on This Form
DATE: May 16
1 * Department I 216 - 435 - 123.68
2 * Department II 216 - 445 - 068.78
3 * Department III 216 - 455 - 045.67
4 * X 216 - 465 - 003.95
5
6 TOTAL SALES (Add) 842.08
7
8 * Cash Sales 216 - 505 - 196.29
9 * Received On Account 216 - 475 - 025.50
10 Total Cash Received 821.79
11 * Paid Out (Subtract) 216 - 485 - 005.50
12 CASH CALLED FOR BY REGISTER 216.29
13 Cash in Drawer 216.19
14 ~~Draw~~ or Short 10
15 Previous Acct. Receivable Total 900.00
16 * Today's Charges (Add) 216 - 515 - 045.79
17 TOTAL 945.79
18 * Today's Rec'd on Acct. (Subtract) 216 - 495 - 025.50
19 TOTAL 920.29
20 Adjustments
21 PRESENT ACCT. REC. TOTAL 920.29
22 * Today's Previous Bal. Pickup Total 216 - 545 - 057.50
* INDICATES MACHINE TOTAL
* 216 - 545 - 057.50

At left is a machine-validated sales slip. In the center is a customer's ledger card. Customer receives the receipt which shows total sale, previous balance owed, and new balance; date and serial number print automatically. At right is the "Daily Statement of Business" which is used in balancing each day's records. The machine-printed figures cannot be altered.

Profit

TROL

pleted" file provided for this purpose.

If the customer pays cash when he picks up his set, the duplicate is taken off the "work completed" file and validated on the cash register. The salesperson simply lines the slip up on the "printing table" of the machine after the sale has been added on the register and a validation of the amount collected is printed on the slip, which is then spindled on a "Cash" file. As the slip is added by the register, a machine-printed receipt is automatically made for the customer.

If the customer wishes to have the work charged, his individual ledger card (Fig. 1) is removed from the tray and the transaction is posted in his presence. The sale is completely itemized on the cash register; then the salesperson "picks up" the previous balance owed by the customer and records the total amount charged, using the "Charge" key. When a total is taken, the machine prints on the ledger card the total amount owed to-date. As this takes place, the register automatically prepares a full receipt for the customer, showing not only total sale but previous balance owed and new balance now owed. In effect, the charge customer gets a statement of account every time he makes a purchase.

Sales of new or used radio or television sets are described on the bill of sale form, also shown in Fig. 1. If sold for cash, the sale is recorded on the machine as a cash sale. If the sale is to be charged and carried by the store, the transaction is posted to a ledger card immediately.

This appears to be a simple operation, and it is. There are several important advantages of handling transactions in this manner.

First, we have positive assurance that all transactions are added correctly. This is a protective feature that needs no elaboration. In addition to protecting us, automatic addition also protects



(Above) The bookkeeper posts a transaction. The machine accumulates totals of nine types of transactions.

the customer against any unintentional error in our favor.

Second, customers accounts are always posted to-date. Moreover, complaints are completely eliminated because the customer is the auditor of his own account.

Third, all of our transactions can be completely audited, if necessary. The machine-printed figures on our sales slips and ledgers make this possible. A detail tape within the machine furnishes a complete history of each day's transactions in the order in which they occurred.

Fourth, the register automatically accumulates these sales figures into separate totals as the sale takes place. At the end of the day the machine furnishes me information in minutes that would not be available to me for days under any other set-up.

Payments on Account

When a customer pays on his account, the transaction is posted to the ledger card by the register. The machine-printed receipt showing the old balance, the amount of the payment, and the new balance is given to the customer as his record of the payment.

A local bank finances some of our paper, but this does not interfere with machine control. Payments received for the bank's accounts are recorded in the same way except that no ledger card is involved. Payments received for the bank's accounts are listed on the back of our "Daily Statement" form and subtracted from the machine's "Re-

ceived on Account" total to arrive a correct total of our own "Received on Account" payments.

When we balance at the close of each day's business, the register's nine totals are printed on the "Daily Statement" form shown in Figure 2. Note that sales are separated into (1) Taxable Sales, (2) Non-Taxable Sales, (3) Labor, and (4) Sales Tax. (Non-taxable sales are sales of merchandise to other dealers).

Transactions are separated into (1) Cash Sales, (2) Charge Sales, (3) Money Received on Account, and (4) Petty Cash Paid Out. There is also a grand total of all money received by the store.

What Are The Results?

The most important result of our machine system is that it has eliminated the time-consuming detail work required in our old system. In addition, the errors that frequently occurred in our old system have been completely eliminated. In my opinion, the machine saves the full time of at least one person. By that I mean if we did not have the machine, we would be forced to add another bookkeeper to take care of the increased volume.

If your store system has not kept pace with the selling and technical side of your business, it would be a wise move to go over each transaction in detail—survey the entire store—to see if your system can be mechanized. Believe me, the results will be profitable.

MECHANIZE

WITH

Mall
TOOLS

Speed Control Clutch \$15.95

Reciprocating Saw \$14.95

Metal Nibbler \$17.95

MODEL 143T DRILL \$42.00

POWERS ALL OF THESE ATTACHMENTS

Screwdriver \$10.95

Auger Set \$5.50

Mechanic's Drill Set \$7.25

Tool Balancer \$23.95

Equip your shop for **MECHANIZED SERVICE** for as little as **\$138.50.**

Mechanization of your radio and television shop with MALL Tools can save you time and money. And, the lightweight, powerful and flexible MALL 143T (1/4") drill is the answer. This perfectly balanced drill, with the trigger switch lock, is equally perfect in wood or metal. It is a virtual powerhouse around which many useful attachments can be driven. Mechanize your shop and increase productivity now with MALL Tools.

MAIL THIS COUPON TODAY

MALLTOOLCO PORTABLE POWER TOOLS
GASOLINE-ELECTRIC-AIR

7749 South Chicago Ave., Chicago 19, Illinois
O. K! tell me about MALL Tools for the Radio and Television field.

Name _____

Address _____

City _____ State _____

RT-1-306

TRADE FLASHES

General Electric has come to the aid of ear-weary cab drivers and other two-way radio users by removing the distracting chatter of radio calls intended for others. An improved electronic system designed to eliminate the annoying chatter was announced recently by Harrison Van Aken, general manager of G. E. Communication Equipment. G. E. engineers have licked the problem by incorporating simple electronic tone selecting equipment in standard two-way radios, Van Aken explained. The tones turn the mobile radio receivers on individually, thus allowing a dispatcher to communicate with any radio-equipped car or truck without bothering all other radio-equipped vehicles in the network.

Electronic technicians and service dealers who subscribe to Hoffman Electronics Corporation's Service Data will now receive, at the end of the year, a bound indexed book containing schematics, parts list, tuner data, and general service notes on all sets released throughout the year. Under this offer, being made for the first time by Hoffman, a subscription to the firm's tech data, which is mailed direct to the subscriber at the time of each new set release, will entitle the subscriber to receive the extra set of service information for his shop file.

Subscribers to technical service literature issued by the Radio and Television Division of Sylvania Electric Products Inc., whose numbers doubled last year, are reminded of the necessity of signing up for the 1956 issues. E. W. Merriam, Service Manager, said, "The advantages of receiving up-to-date technical data regularly are, of course, apparent to all servicemen. Many times when we receive a request for a competent serviceman, we refer to our subscription file in giving the customer the name. By doing this, we feel that we are helping servicemen, the customer, and ourselves." One year's subscription to the technical service literature is available for \$2.00 from the factory's Service Department, 254 Rano St., Buffalo 7, N. Y.

Storm damage to television antennas resulting in heavy insurance claims is receiving a great deal of attention on the part of fire insurance companies. These companies are becoming alarmed because extended coverage endorse-

ments on their policies have been written to include television antenna installations. In many states insurance companies have eliminated liability for the antenna under a \$50 deductible clause. In other states, insurance policies require an additional premium to cover the antenna. Thus the selection of an antenna is becoming increasingly important to the householder.

Construction of a new plant to manufacture surface-barrier transistors will begin shortly at Concord, N. H., it was announced by the Sprague Electric Company of this city. The new building will occupy 20,000 sq. ft. adjacent to the Concord Airport on a site now held by the Concord Regional Development Corporation. It is expected that production will be well under way by fall of 1956. The surface-barrier transistors, which Sprague was recently licensed to produce under Philco patents, are the only transistors currently available for use in high-speed electronic computing machines. Their ultra small size, very low power consumption and remarkable dependability have resulted in a continually increasing demand not only for business computers but for military applications such as circuitry in missile guidance and weapons control assemblies.

A new "package" of television components that will insure better reception at a reduced cost in color as well as black and white receivers was unveiled recently by Standard Coil Products Co., Inc., 2085 North Hawthorne Ave., Melrose Park, Ill., the world's largest manufacturer of electronics components. The new Standard "package" consists of a tuner, I.F. strip, sync generator and delay line and was introduced by Linus Ruth, who heads the color development laboratory of the Los Angeles research division of Standard Coil. Mr. Ruth made the presentation at a special TV color symposium held at the Melrose Park plant and attended by more than 40 color engineers representing all major mid-western television manufacturers.

A gold-plated volt-ohm-milliammeter was presented to Ray R. Simpson, founder of Simpson Electric Company, at a testimonial dinner recently at the Chicago Athletic Club. The dinner commemorated Simpson's 50th year in
[Continued on page 43]

Mfr: Du Mont Chassis No. RA 312/313

Card No. DM 312-1

Section Affected: Raster

Symptom: No raster

Cause: Open resistor

What To Do:

Replace: R292 (1.5K) and/or open.
Check: Yoke for leakage.

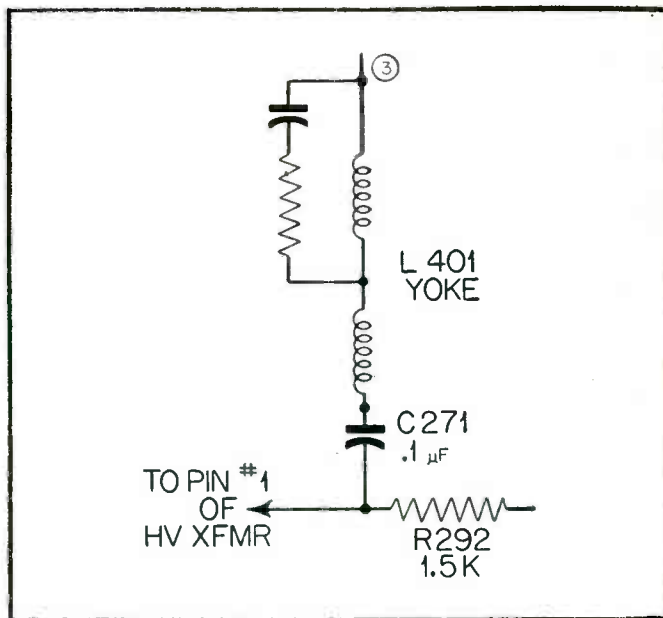

Mfr: Du Mont Chassis No. RA 312/313

Card No. DM 312-2

Section Affected: Raster

Symptom: Top half of raster brighter than bottom half. Also possible loss of vertical size.

Cause: Open boost capacitor

What To Do:

Replace: C287A (20 μf) and/or C289 (20 μf).

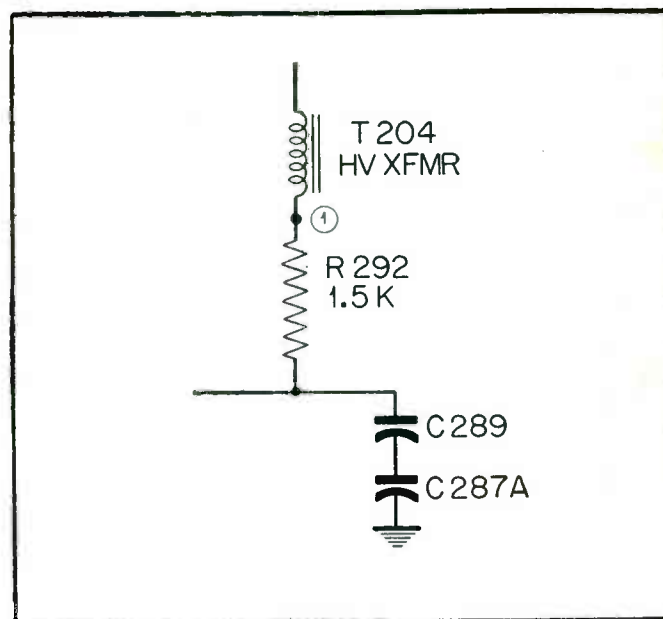

Mfr: Du Mont Chassis No. RA 312/313

Card No. DM 312-3

Section Affected: Pix and sound

Symptom: Poor sync, buzz in sound, weak video

Cause: Leaky condenser

What To Do:

Replace: C229 (2.2 μf).

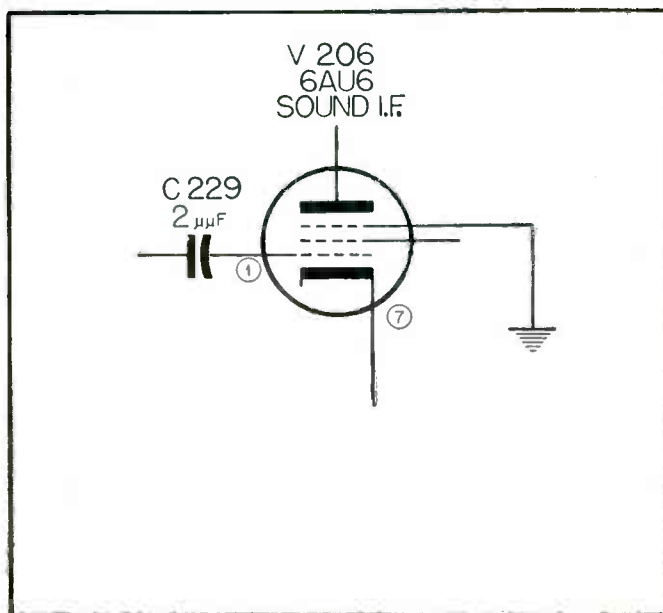

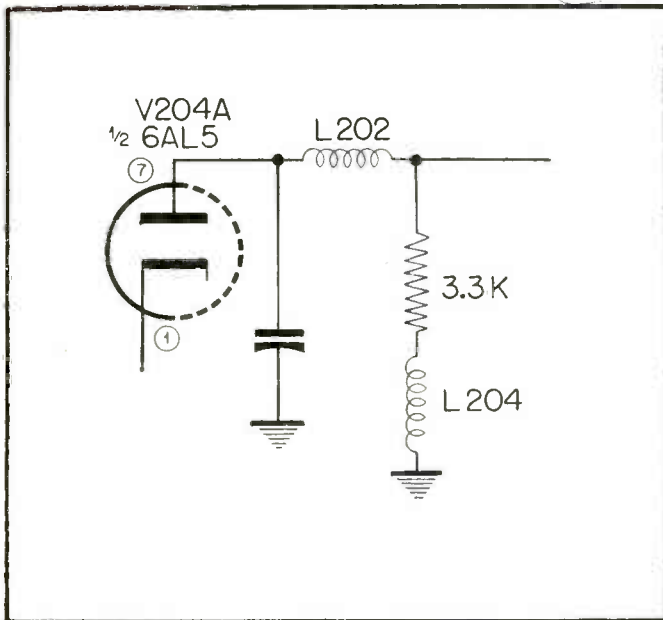

Mfr: Du Mont Chassis No. RA 312/313

Card No. DM 312-4

Section Affected: Pix

Symptom: Video smear

Cause: Open choke

What To Do:

Replace: L204; or repair.

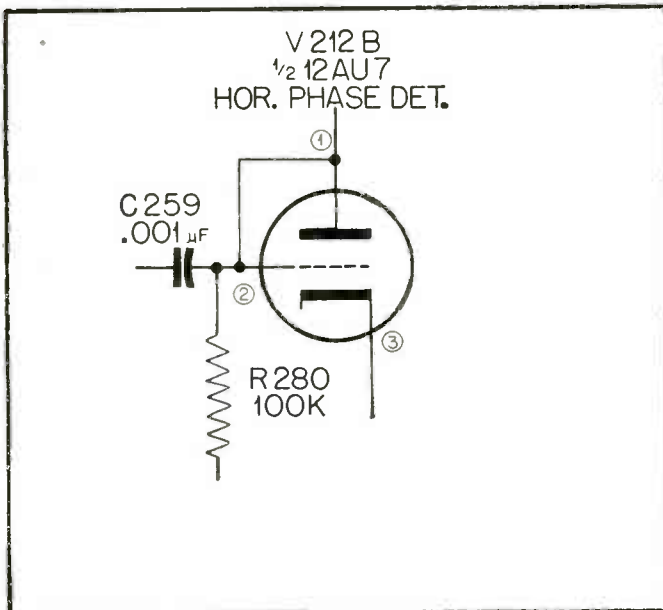

Mfr: Du Mont Chassis No. RA 312/313

Card No. DM 312-5

Section Affected: Raster

Symptom: No raster; no high voltage

Cause: Shorted condenser

What To Do:

Replace: C259 (.001 μ f).

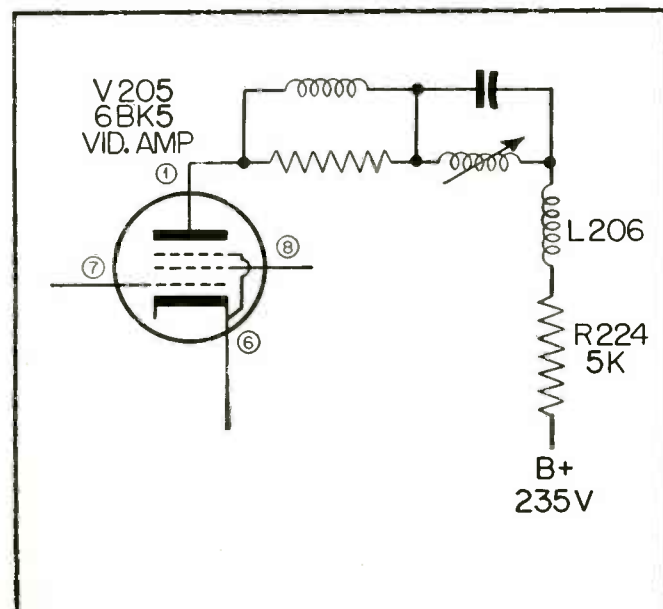

Mfr: Du Mont Chassis No. RA 312/313

Card No. 312-6

Section Affected: Pix

Symptom: Weak, negative pix

Cause: Open choke

What To Do:

Replace: L206; or repair.

Mfr: Stewart Warner Model No. 21-9300 Series

Card No. SW 9300-1

Section Affected: Raster

Symptom: Intermittent or no vertical height. Vertical linearity control and 390 ohm resistor burned out.

Cause: Shorted 6AH4 vertical output tube

What To Do:

Replace: Vertical linearity control, also 390 ohm resistor, also 6AH4 vertical output tube.

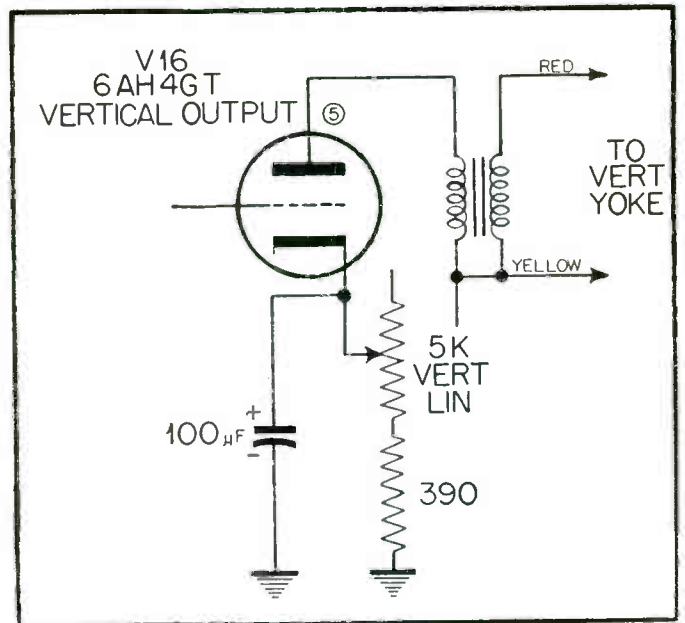

Mfr: Stewart Warner Model No. 21-9300 Series

Card No. SW 9300-2

Section Affected: Sync

Symptom: Horizontal instability

Cause: Open by-pass condenser

What To Do:

Replace: .22 μf bypass condenser connected between pin 8 of 6BQ6GT and ground.

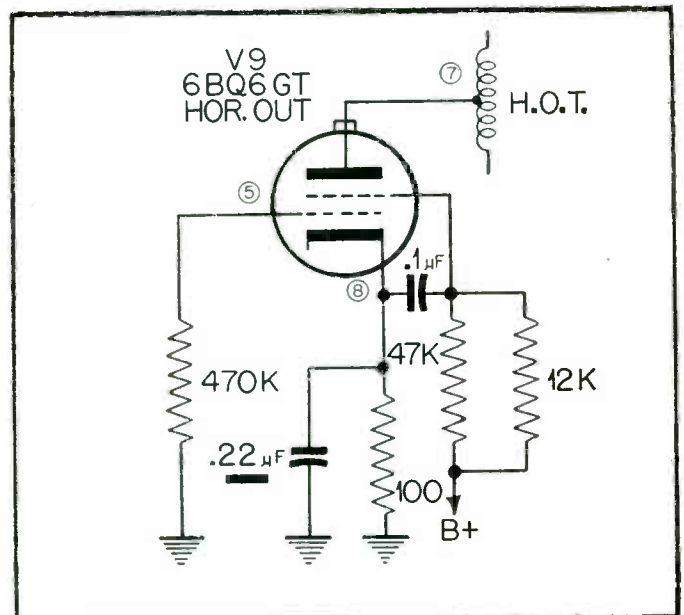

Mfr: Stewart Warner Model No. 21-9300 Series

Card No. SW 9300-3

Section Affected: Sync

Symptom: Pix loses sync after a short time

Cause: Unstable capacitor

What To Do:

Replace: 200 μf capacitor connected between terminal "F" of syncroguide transformer and pin 4 of V8B, horizontal oscillator.

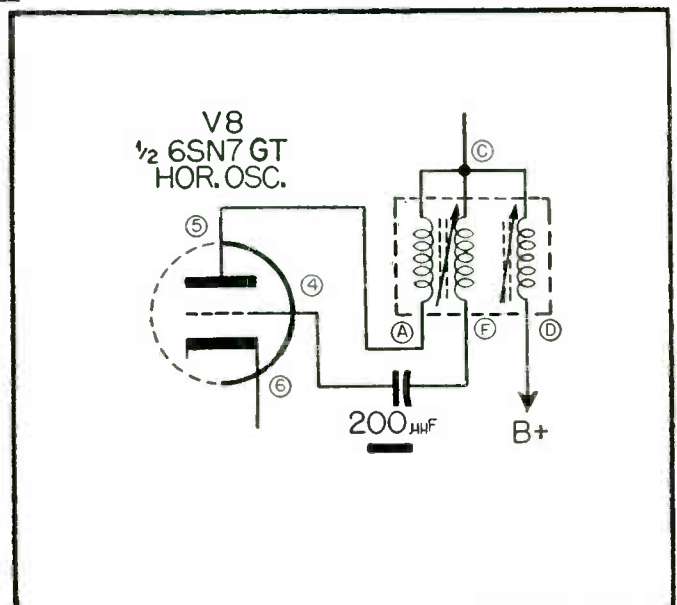

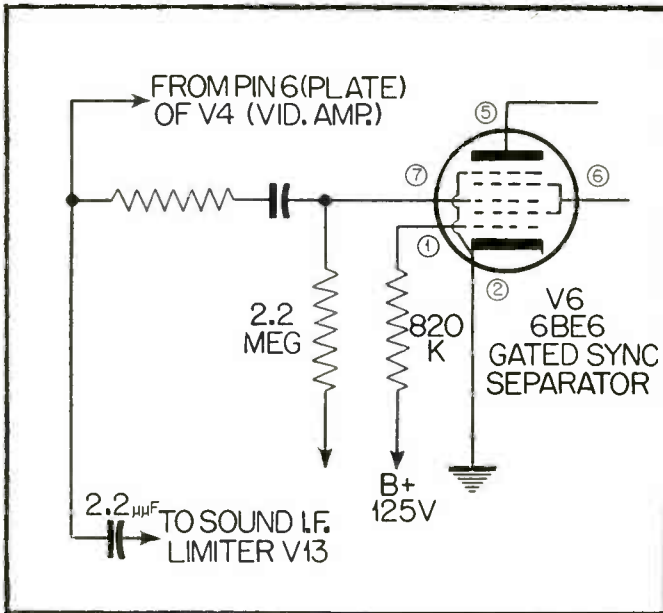

Mfr: Stewart Warner Model No. 21-9300 Series

Card No. SW 9300-4

Section Affected: Sync

Symptom: Loss of horizontal sync and weakening of vertical hold.

Cause: Open condenser

What To Do:

Replace: .047 μ f condenser connected between pin 7 of 6BE6 sync separation and 18K resistor.

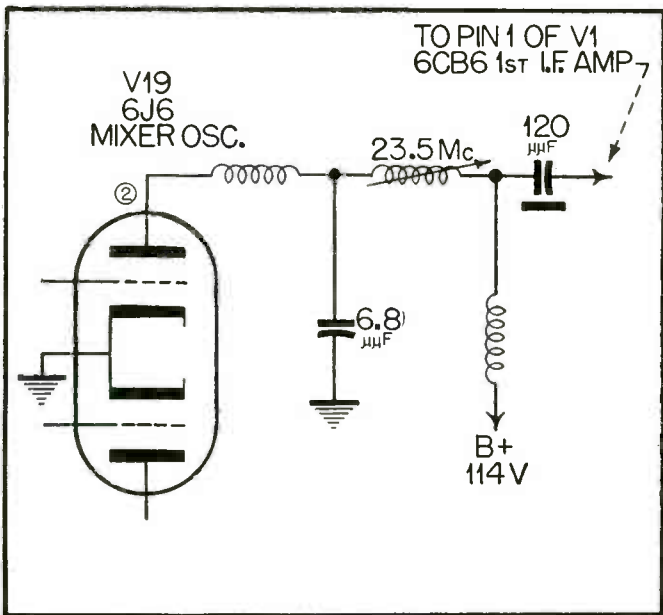

Mfr: Stewart Warner Model No. 21-9300 Series

Card No. SW 9300-5

Section Affected: Sound and pix

Symptom: Loss of sound and pix on one or more channels

Cause: Shorted condenser

What To Do:

Replace: 120 μ f condenser connected between plate of V19-6J6 mixer-oscillator, and pin 1 of V1-6CB6 1st if amp.

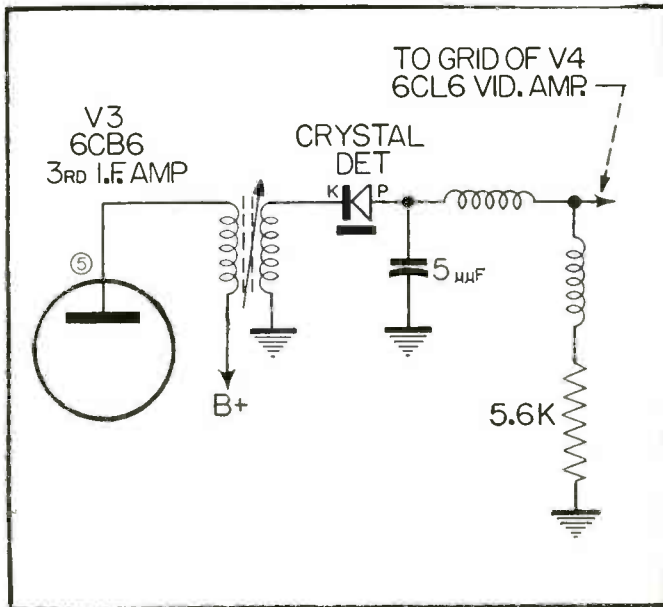

Mfr: Stewart Warner Model No. 21-9300 Series

Card No. SW 9300-6

Section Affected: Sync and pix

Symptom: Loss of sync and blurred pix. AGC may fail as contrast control is increased.

Cause: Defective crystal detector

What To Do:

Replace: Crystal detector.

how long would it take you to solve this service problem?

SYMPTOM:

Loss of horizontal hold. Hold control will not pull the picture into synchronization. Sound is normal.

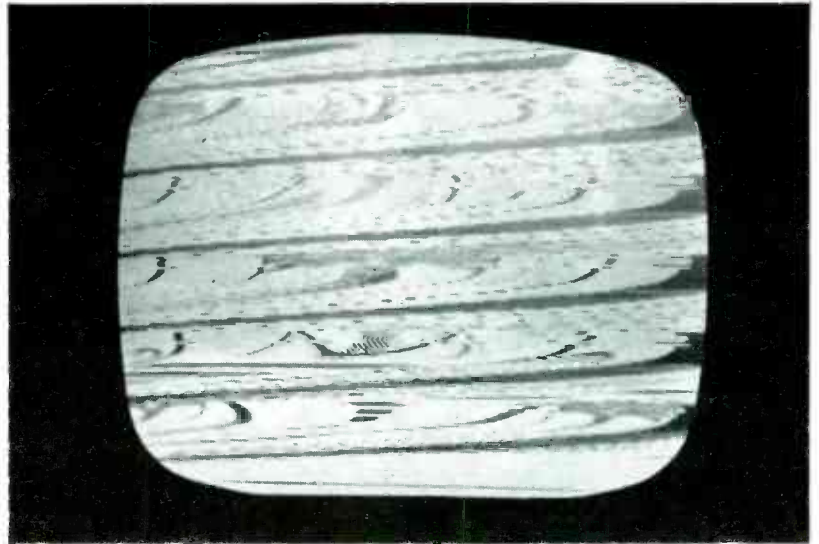

There's no telling how long it might take to solve this problem with hit-or-miss methods—it's been known to take hours. With a PHOTOFACT Folder by your side, the job takes just minutes. Here's why:

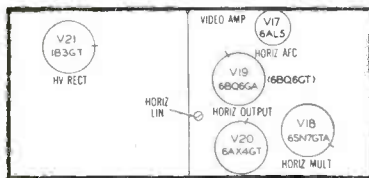

In just seconds, you locate the tubes most likely to cause this symptom by referring to the Tube Placement Chart* and Tube Failure Check Chart* you'll always find in the same place in each PHOTOFACT Folder.

In this case the trouble wasn't caused by tube failure, so...

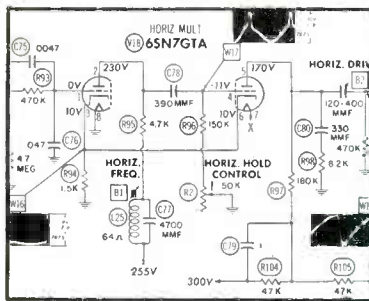

In just seconds you refer to the Horizontal Circuit on the Standard Notation Schematic* featured exclusively in all PHOTOFACT Folders. Circuits are always laid out in the same uniform manner. The Horizontal Circuit is always located in the lower center of the schematic. In a matter of minutes you check waveforms and voltages—they're right on the schematic. And in those same few minutes you find the answer to the problem in this case history. The waveform at W17 and the voltage reading at Pin 4 show a leaky coupling capacitor C78. Yes, you have your answer in just minutes!

C74	270	500	RCM20A2.71K	S1470	D6-27
C75	.0047	400	RCP10M4472M	S14700	D6-47
C76	.047	200	RCP10M2473M	BPD-05	DF-50
C77	4700	500	47X543	1464-0047	
C78	390	500	RCM20B391J	1469-00039	D6-39
C79	.1	400	RCP10M4104M	P488N-1	DF-104
C80	330	500	47X570	1469-00033	D6-33

And PHOTOFACT, through its accurate Parts Listings*, instantly gives you a choice of the proper replacement required to accomplish the repair. You save even more time!

From start to finish, you solve your service problems in just minutes... you service more sets and earn more daily with PHOTOFACT by your side!

*One of 32 features found exclusively in PHOTOFACT—the world's finest service data



MONEY BACK GUARANTEE!

Got a tough repair? Try this—at Howard W. Sams' own risk: see your Parts Distributor and buy the proper PHOTOFACT Folder Set covering the receiver. Then use it on the actual repair. If PHOTOFACT doesn't save you time, doesn't make the job easier and more profitable for you, Howard W. Sams wants you to return the complete Folder Set direct to him and he'll refund your purchase price promptly. **GET THE PROOF FOR YOURSELF—TRY PHOTOFACT NOW!**

free



Send for Sams' INDEX TO PHOTOFACT FOLDERS—your guide to virtually any receiver model ever to come into your shop; helps you locate the proper PHOTOFACT Folder you need to solve any service problem on any model. You'll want this valuable reference guide. Send coupon now.

HOWARD W. SAM'S & CO., INC.

Howard W. Sams & Co., Inc.
2209 E. 46th St., Indianapolis 5, Ind.

Send FREE Index to PHOTOFACT Folders
 I am a Service Technician

Name _____

Address _____

City _____ Zone _____ State _____

NEW COMPONENTS

In requesting more detailed information on these products, please check the code number of the product on the convenient coupon on page 63, and send it, along with your company letterhead or business card, to New Products Dept., SERVICE DEALER, Suite 510, 67 West 44th St., New York 36, N.Y.

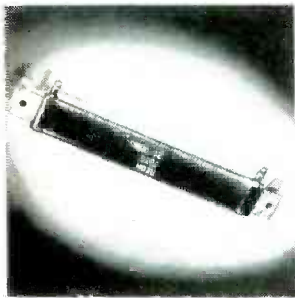

Reon Resistors

Reon's new "M" series miniature ($\frac{3}{8}$ " O.D.) and "SM" sub-miniature series ($\frac{1}{4}$ " O.D.) have been developed to readily fill the need for a lead mounting in printed circuitry or crowded chassis requirements. It was announced today by Reon Resistor Corp. An optional pigtail construction features "R"-radial, "A"-off center axial, or "C"-central axial. For details, check C30.

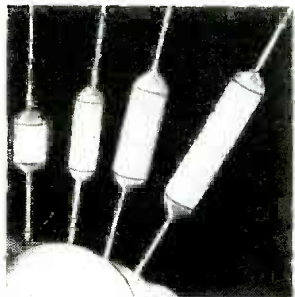

CD Capacitor

Designed specifically to meet the unique electrical requirements and dimensional limitations of extremely small equipment, a new subminiature series of Tantalum capacitors, Type NT, has just been developed by the Cornell-Dubilier Electric Corporation. These new subminiature capacitors are available in a wide selection of ratings and sizes down to the most minute dimensions. For details, check C31.



Luxo Lamp

In normal use, the heat given out by the shade of an incandescent Luxo Lamp is small and does not cause any problems for the serviceman. On certain types of very close work, it may be desirable to use an inner reflector. With an inner reflector the Luxo shade remains amazingly cool. The inner reflector also concentrates the light in a smaller area. For details, check C32.

Cornell-Dubilier Filters

A new series of "Quietone" PI Filters in tubular cases has just been made available by the Cornell-Dubilier Electric Corporation. These metal-cased, hermetically-sealed tubular type filters afford high insertion loss values for the suppression of radio noise. They are made to the smallest possible sizes and minimum weight for the stated ratings and attenuation characteristics. For details, check C33.

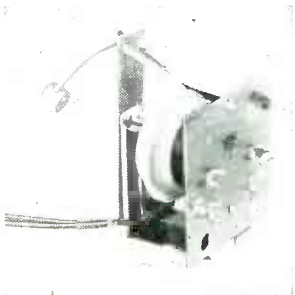

Ram Flyback Transformers

The X126 and X127 are new flyback transformers which are being released by the RAM ELECTRONICS SALES CO. The X126 is an autotransformer-type flyback which is used in 66-70 degree horizontal deflection angles systems and delivers from 13 to 15 kv. The X127 (illus.) may operate both in the 66-70 and 90 degree systems and is capable of delivering from 15 to 19 kv. For details, check C31.

Wen Soldering Kit

The new Wen Model 199 home utility soldering kit provides the serviceman or householder with an efficient soldering gun and several components which enable it to do a variety of cutting, soldering, and other tasks. For details, check C35.



Xcelite Plier

A new Xcelite plier has the compactness of needle nose pliers plus narrow end-nippers for flush or other cutoff work in miniature and sub-miniature chassis. Just introduced to the electronics and allied industries, it is the No. 62 Transverse Cutter. A spring return permits using just the thumb and a finger in close quarters. For details, check C36.



GC Trol Line

"Trol-Gun" and "Trol-Kleener" are the new radio-television cleaner and lubricator for eliminating noisy volume controls introduced by General Cement Mfg. Co. Though volume controls are the duo's principal application, they can be used on push buttons, switch contacts and tuners, and will not harm finishes of wood, acetate, metal and the like. For details, check C37.



TM No-Fog

Tele Matic Industries has incorporated an anti-static agent into a novel device to ensure cleaner, clearer pictures. NO-FOG neutralizes the electrostatic charge indefinitely. It is a colorless, odorless liquid, which when sprayed on the tube or mask and wiped with a clean dry cloth, leaves an invisible insulation against static. For details, check C38.



B-T Cable Stripper

Blonder-Tongue Laboratories announces the Model S-1 Rotary Stripper for coax cables and other non-metallic tubing up to $\frac{1}{2}$ " diameter. This new installation tool is especially useful for stripping coaxial and other shielded cable for TV, audio, industrial and electrical purposes. For details, check C39.

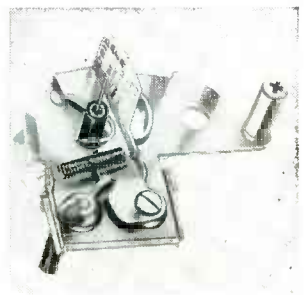

TRADE FLASHES

[from page 28]

the electrical instrument business. Leading figures in the electronic service and industrial instrument field honored the 66-year-old innovator and inventor.

General Dry Batteries, Inc., Cleveland, announces that it has set up eleven warehouses across the country to insure fast service for its battery customers. Locations of the warehouses are: Atlanta, Georgia; Boston, Massachusetts; Cleveland, Ohio; Dallas, Texas; Denver, Colorado; Dubuque, Iowa; Los Angeles, California; Memphis, Tennessee; Portland, Oregon; San Francisco, California; and Silver Spring, Maryland. All battery shipments will now be made within 48 hours from these warehouses, according to J. J. Langlois, sales manager of General Dry. He said the new warehouses will greatly facilitate shipping factory-fresh batteries to the firm's customers.

Westinghouse is planning to produce color television receivers starting sometime in mid-year. E. J. Kelly, general manager of the firm's television-radio division here, announced recently. "We have designed a small compact receiver with the largest screen, employing a 22-inch rectangular all-glass color tube." Mr. Kelly said. "This permits housing in a small package size enabling production of color sets in table models." The color table sets, to be available in compact versions, will be not much larger than most present-day 21-inch black-and-white receivers, Mr. Kelly indicated.

The first commercial transistorized portable two-way radio has been announced by Daniel E. Noble, vice president of the Communications and Electronics Division, Motorola Inc., pioneer in the field of portable and mobile radio communications. The new line of "Handie-Talkie" radiophones includes 42 different models. Designed to operate from two to five days without a battery change, the new radiophones were introduced in two basic series: the "H" series for maximum portability and the heavy-duty "P" series for longer range communications.

Morris Sobin, president of Olympic Radio & Television Inc., has announced the purchase for cash of all of the outstanding stock of David Bogen Co., Inc., 29 Ninth Avenue, New York, N. Y. The purchase marks the initial step in Olympic's over-all plan of expansion. [Continued on page 45]

Simpson...the most Complete Line of VOM's

Select the one that fits your needs!

MODEL
260
world's most popular!

Over half a million Model 260's have been sold to date! 20,000 Ohms per volt. You'll find it wherever quick, accurate, electrical checks are needed. It's so handy, so dependable, so sensibly priced! Ask your jobber. Price, including Adjust-A-Vue Handle, only ... **\$38.95**

Carrying Cases from **\$6.75**

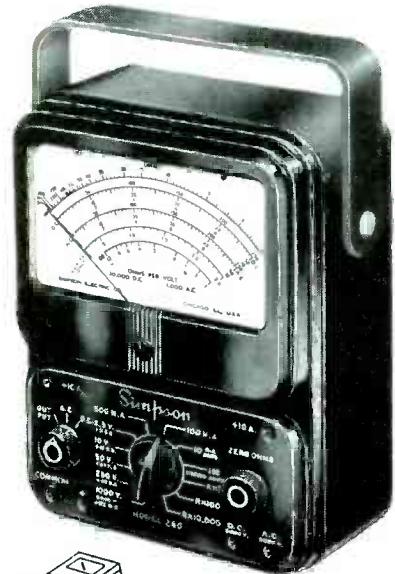

MODEL **262**

Deluxe!



the new VOM with a 7" meter

20,000 Ohms per volt DC and 5,000 Ohms per volt AC sensitivity ... 33 ranges ... compact 7" case with Adjust-A-Vue Handle ... **\$59.50**

Carrying Case ... **\$ 9.95**

NEW!

- ➔ **MIDGETESTER** Model 355—New shirt-pocket size Volt-Ohmmeter **\$29.95**
- MODEL 240**—Small VOM; 14 ranges; up to 3000 volts AC or DC **\$26.35**
- MODEL 230**—Small VOM; 12 ranges; up to 1000 volts AC or DC **\$24.95**
- ROTO RANGER** Model 221—25 Separate meters at turn of a switch **\$75.00**
- LABORATORY STANDARD**—For instrument calibration. Price on application.

MODEL **269**

100,000 Ohms per volt!



Most sensitive VOM

available! A Volt-Ohm-Microammeter with a big 7" meter in a compact 7" case ... 33 ranges ... Adjust-A-Vue Handle ... **\$88.00**

Carrying Case ... **\$ 9.95**

Simpson ELECTRIC COMPANY

World's Largest Manufacturer of Electronic Test Equipment

5200 W. Kinzie St., Chicago 44, Ill. • ESTebrook 9-1121
In Canada: Bach-Simpson, Ltd., London, Ontario

NEW TEST EQUIPMENT

In requesting more detailed information on these products, please check the code number of the product on the convenient coupon on page 63, and send it, along with your company letterhead or business card, to New Products Dept., SERVICE DEALER, Suite 510, 67 West 44th St., New York 36, N.Y.

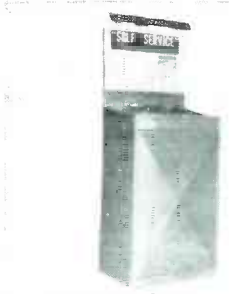

ASD Merchandiser

American Scientific makes available a self-service tube merchandising plan with a direct tie-up with the serviceman. In this case the serviceman installs the self-service tube tester and makes the deal with the proprietor of the establishment in which it is installed. Name and phone number of serviceman is printed on cabinet. For details, check M30.

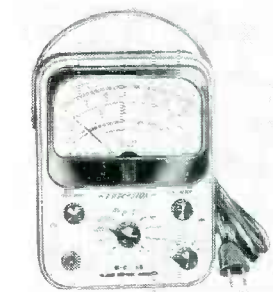

Precision Volt-Ohmmeter

Precision Apparatus Co., Inc., announces the addition of the Model 68, a new vacuum tube volt-ohmmeter. The model 68 is an AC-operated wide-range general purpose electronic test set equipped with a 5 1/2" wide-angle PACE meter of $\pm 2\%$ accuracy and 1 1/2 multipliers and shunts of both wire and deposited film types. For details, check M31.



Superior Multimeter

The new Model TV-60 Allmeter, a complete all-purpose 20,000 ohms per Volt Multimeter, has a recessed 6 1/2 inch 40 Microampere meter with mirrored scale that assures accuracy and easy-reading, announces the Superior Instrument Company. Extra services include an accurate direct-reading Capacity meter, a Kilovoltmeter, an R. F. Signal Tracer and an Audio Signal Tracer. For details, check M32.



Century's CRT Testivator

Century's new CRT Testivator can be used to test cathode emission, open elements, and indicates shorts and leakage between elements. Engineered and precision made with quality components to give dependable and accurate service. For details, check M32.



Hickock Tube-Tester

Known as the model 539B, this instrument is built with latest Dynamic Mutual Conductance Circuits and provides 6 micromho ranges: 60,000; 30,000; 15,000; 6,000; 3,000; 600 micromhos. In addition, a rectifier diode range and a voltage regulator (VR) range are provided. The 600-micromho range is especially suited for more accurate testing of subminiature type tubes. For details, check M34.

Superior Tester

According to the Superior Instrument Co., New York, N. Y., their new Model TV-12 tube tester is not a "rehashed" model. This radically new tester will check tubes under dynamic conditions very closely simulating the manner in which they would function in a receiver or amplifier. It will also test all Transistors produced to date. For details, check M35.



Phaotron Meter

Produced to the highest quality standards for maximum performance and convenience, this Phaotron unit is a completely self-contained, ready-to-use precision portable instrument. A recent addition to the Phaotron line of products, it has been acclaimed as one of the finest portable instruments of its kind. For details, check M36.

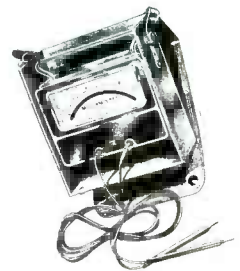

CG Transistor Tester

A fast comparative check on PNP and NPN transistors is now provided by a new, completely self-contained, portable transistor tester, Model TR-2, manufactured by CG Electronics Corporation. The unit features 4" meter with two ranges that allow the operator to read Alpha, Beta, and Ico directly. For details, check M37.

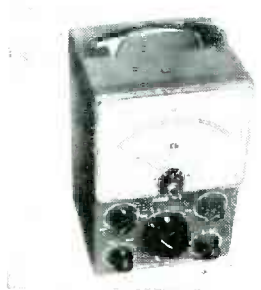

Teletest "CapaciTester"

The revolutionary, new CapaciTester, made by TeleTest Instrument Corp., is now available to electronic equipment manufacturing and service technicians for immediate delivery. The CapaciTester is the first instrument capable of in-circuit testing all types and capacities of coupling condensers for leakage up to 40 megohms. For details, check M38.

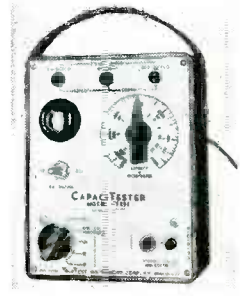

Heathkit Audio Generator

This new Heathkit Model features step-tuning from 10 cps to 100 kc with three rotary switches that provide two significant figures and multiplier. Less than .1% distortion. Frequency accurate to within $\pm 5\%$. Output monitored on a large 4 1/2" meter that reads voltage or db. Both variable and step-type attenuation provided. Meter reads zero-to-maximum at each attenuator position. For details, check M39.



TRADE FLASHES

[from page 43]

pansion and diversification. David Bogen Co., Inc. produces a complete line of hi-fidelity equipment, television boosters, short-wave receivers, centralized sound systems, transcription players, baffles and inter-communicating and public address systems, all of which supplement the present television, radio and electronic products of Olympic. Founded in 1932, Bogen has broad distribution throughout the United States and Canada.

A professional quality, medium priced tape recorder with new engineering developments of interest to the entire recording industry was announced recently for Keystone Camera Co., Boston, by Robert C. Berner, vice president and director of sales. Mr. Berner reported that the Keystone instrument is the first to utilize magazine loading of tape, which eliminates threading and adjusting. He predicted that "before long, this unique and simple method of playing tape will be utilized by every manufacturer of tape equipment and by those firms who are entering the already grown pre-recorded tape market."

Joseph Frank, President of Astron Corporation, East Newark, New Jersey, manufacturers of capacitors and RF noise interference filters, announced that his company has bought all of the outstanding stock of Skottie Electronic Corporation, Inc., of Peckville, Pennsylvania. The purchase includes the plant buildings and production facilities. Skottie is a manufacturer of ceramic capacitors, producing a complete line of disc types and tubular units in a wide range of values. They supply also subminiature units designed specifically for transistorized and printed circuits.

Retail sales of television receivers established a new record in 1955, the Radio-Electronics-Television Manufacturers Association reported. Sales of radios, excluding automobile receivers, increased by nearly half a million from the level of 1954, it added. During the past year, 7,421,084 TV receivers moved through retail outlets compared with 7,317,034 sets sold a year earlier, the previous record year. December sales totaled 933,467, RETMA reported, compared with 591,366 in November and 1,093,702 TV receivers sold at retail in December 1954. Sales of radios, excluding automobile sets, totaled 6,921,384 in 1955 compared with 6,430,743 sold a year earlier. It was reported by RETMA that 1,388,801

Give customers "hi-fi satisfaction" —profitably!

THE BRILLIANT NEW "3" SERIES SONOTONE CERAMIC

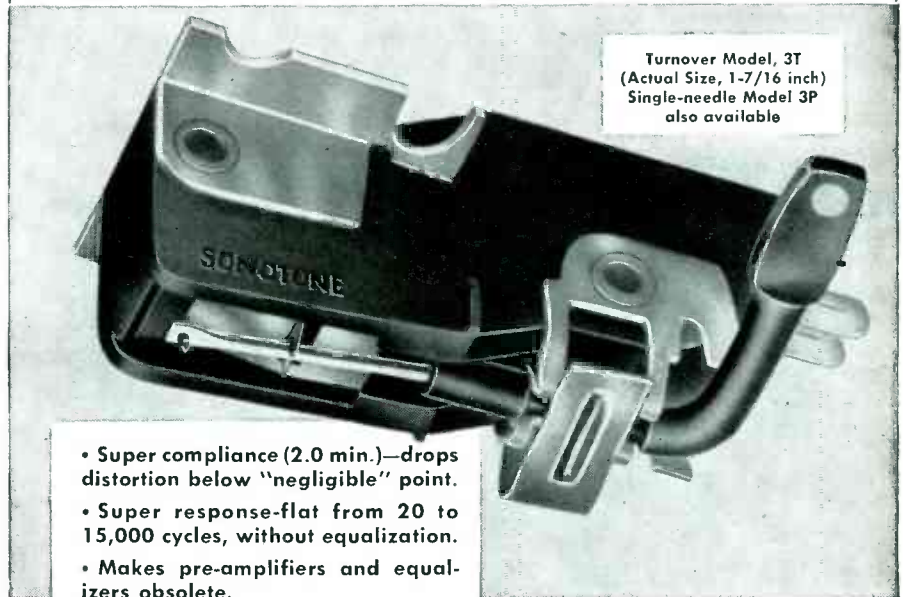

- Super compliance (2.0 min.)—drops distortion below "negligible" point.
- Super response—flat from 20 to 15,000 cycles, without equalization.
- Makes pre-amplifiers and equalizers obsolete.

If you've followed the development of ceramic cartridges since Sonotone pioneered them in 1946, you know of their enormous advances.

Now Sonotone presents the "3" Series, which sets utterly new standards of performance and opens the door to profitable "hi-fi" business for you.

The Sonotone "3" Series ceramic cartridge can be used as a replacement in nearly any phonograph circuit. It delivers a brilliance and clarity of sound which will be noticed and commented upon by delighted customers. Because these cartridges deliver a whopping 0.5 volts (roughly 50 times as much as most velocity types), they do not need preamplification and equalization circuits. And naturally the non-magnetic structure eliminates motor hum.

There are two basic models, a turnover (3T-S) for all record speeds and a single-needle model (3P-1S) for 33 and 45 rpm records. They have standard $\frac{1}{2}$ or $\frac{5}{8}$ inch mounting centers and fit any of the widely used tone arms. Prices begin at \$12.50 list (sapphire needles).

Use the brilliant new Sonotone Series "3" on your next replacement job. You'll find yourself on the way to profitable "hi-fi" business.

SONOTONE®

CORPORATION, ELMSFORD, N. Y.



Write Department CD-36 for free cartridge replacement chart.
In Canada—Atlas Radio Corp. Ltd., 50 Wingold Ave., Toronto.

radios moved through retail stores in December compared with 865,602 sold in November. During December 1954, 1,158,588 radios had been sold.

The world's most modern sight, sound and communication system is being installed in the Marriott Motor Hotel, world's largest drive-in hotel, now under construction in Arlington County, Va., just outside the nation's capital. Signing of a contract for leasing of a complete Stromberg-Carlson sound, radio and television system for the motor hotel was announced jointly by J. W. Marriott, founder and President of Hot Shoppes, Inc., which is building the

hotel, and Harris Myers, contract sales manager of the Special Products Division of Stromberg-Carlson, a division of General Dynamics Corporation.

So successful was the first "National Television Servicemen's Week," observed in 1955 as a salute to American radio and television dealers and service technicians, that RCA quickly recognized the demand of the trade to perpetuate this historic event in the interests of the radio-TV industry. Subsequently, RCA registered officially with the Chamber of Commerce of the United States the second annual "National Television Servicemen's Week."

This sincere acclaim by RCA to dealers and service technicians is especially significant in the view of the many complex technical advances made during the past year, and the increasingly heavy commercial demands placed on this group of American businessmen. To promote "National Television Servicemen's Week" in 1956, the RCA Tube Division has organized a progressive campaign based on sound experience and solid, time-tested ideas. This merchandising program is yours—it will be promoted for you by RCA in national consumer magazines, and on radio and TV stations from coast to coast to call immediate public attention to your indispensable services. "National Television Servicemen's Week," in conjunction with the support of your RCA Tube Distributor, will help you build lasting business success through better public relations!

A Magnavox color television service school for The Magnavox Company's midwest dealers and authorized servicing agencies opened in Chicago January 23 at the Washburne Trade School. Under the personal direction of Charles Kayhart, company service training director, a series of five day sessions is scheduled in which practical color set setup and installation training is emphasized. Wayne Kichna, Carl Gates and Vernon Brown of the Magnavox field engineering staff will conduct the classes, which are limited to small groups.

A pair of new PNP alloy-junction germanium transistors CBS types 2N180 and 2N181, has been developed by CBS-Hytron, a Division of Columbia Broadcasting System, Inc. These transistors are for general purpose low-frequency use and feature a wide variety of applications because of the collector dissipation of 150 mw for the 2N180 and 250 mw for the 2N181. An additional feature is their ability to maintain high amplification at high current levels, thus lending themselves to medium power applications such as the output stage of a portable radio receiver. Typical applications are: Class A amplifiers, driver for PP class B stage, microphone or phono preamplifier, and low-frequency flip-flop circuit.

Nearly 7.5 million television receivers were shipped to dealers during 1955 to establish a new record, the Radio-Electronics-Television Manufacturers Association reported recently. During the last year, 7,421,978 TV sets moved into the hands of dealers, RETMA reported, compared with 7,161,362 in 1954, the previous high year. Shipments during five-week December totaled 800,192 compared with 634,742 in four-week November and

Now Available! NEW...

VACO[®]

Hollow Shaft NUT DRIVERS in Color

Nothing else like them anywhere! Choice of 28 types and sizes! New plastic kit at right contains 7 most popular drivers in self-standing bag for service work or bench use.

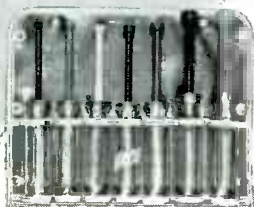

**No. K7 Self-Standing Service Kit
Stands Up! Hangs Up! Folds Up!**

Stands upright for easy accessibility. May be hung flat on wall or may be folded. Each driver fits in individual holder marked for size, color.

Check These 6 Important VACO Features

NEW! Each size color-keyed!

NEW! All-hollow shafts

NEW! Extra large VACO Comfortome Handles!



NEW! Extra hard long wearing sockets!

NEW! Shafts insulated from handle to tip!

NEW! Available in 4 shaft lengths and 7 Hex sizes!

THIS COUPON WORTH \$1.20

Coupon only valid for use as stated below. Not valid in states where prohibited.

Name..... R. T.
Street.....
City..... Zone..... State.....

VACO PRODUCTS COMPANY
317 E. Ontario St., Chicago 11, Ill.
In Canada: Vaco-Lynn Products Co., Ltd., Montreal 1, Que.

Take this coupon to your jobber. It is worth \$1.20 when filled in and used to purchase one VACO K7 Kit. If your jobber cannot supply you, write direct.

1,014,227 TV sets shipped to dealers in December 1954.

A contest that teaches entrants the main selling points of modern TV sets, while giving them a chance to win one of the latest models, is an unusual feature of a TV set promotion that started Sunday, Feb. 26, in the Chicago Tribune. Leading manufacturers co-operating with the Tribune in this promotion include Admiral, Crosley, General Electric, Motorola, Philco, RCA, and Westinghouse. Contests will invite readers to use skill and judgment in choosing the most important selling points or features of TV sets now on the market. Readers will be invited to study this list of features, and to rank them in order of their greatest appeal to prospective buyers described in each problem. The Tribune has invited the 1700 appliance dealers in the Chicago area to participate in the promotion. Details of the contest and promotion have been provided to all dealers, either by letter or through personal contact.

RIDER SPEAKS

[from page 6]

equipment manufacturer for maintenance personnel. Certainly not in the foreseeable future. There just aren't enough trained men to go around and satisfy all needs.

Industry knows this and is training its own people, but training alone is not enough. If the TV receiver, tape recorder, hi-fi equipment, record player, auto radio and radio receiver manufacturer who envisions an expansion of home electronics equipment is interested in having an adequate army of maintenance personnel, he (collectively speaking) must do something about making servicing of these equipments a year-round job. It must be a means of earning an income that compares favorably with other sources of revenue that require continuous training.

If the industrial and the business electronics equipment manufacturers present their requirements in terms of careers for the men who go to work for them, the home electronics equipment manufacturers will have to do likewise. The RETMA has embarked upon a training program, working as closely as possible with the private and municipal schools of the nation, hoping in this way to build a roster of technically competent maintenance personnel. This is a worthwhile effort and our close association with it has been most interesting. It is a progressive step, especially the program of accreditation. Having inaugurated it the RETMA can't let go any more. This is good.

But it is not the entire answer. The accreditation program is fine for the

64% of the top Engineers

PREFER AND USE

HICKOK

DYNAMIC MUTUAL CONDUCTANCE TUBE TESTERS

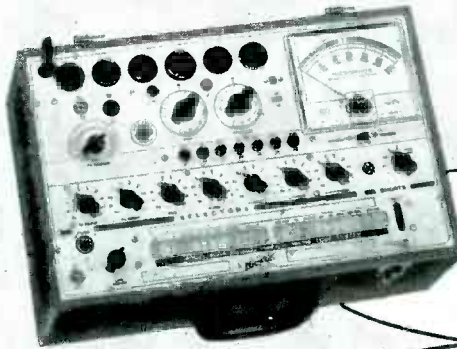

MODEL
600A

World's most popular
Tube Tester

"... that 600A is certainly unbeatable! I have sold 4 for you by just letting service centers use mine for part of one day."

Harold F. Tolles, St. Johns, Mich.

"I purchased a 600A last Fall and have found it to be one of the best investments in test equipment that I have ever made."

R. Lytwyn, Nytl Electronics

All tube testers manufactured today fall into four major classifications.

If you use vacuum tubes in your profession, and if you ever intend to purchase a tube tester please write today for the 28 page book of Tube Tester Facts and learn the advantages of each classification in order that you will be able to more efficiently select for your requirements.

This detailed, illustrated and descriptive book also contains circuit diagrams and formulas.



THE HICKOK ELECTRICAL INSTRUMENT CO.

10533 DUPONT AVE. • CLEVELAND 8, OHIO

Gentlemen:

Kindly send me free of charge your new 28 page book of Tube Tester Facts.

NAME _____

COMPANY _____

STREET _____

CITY _____ ZONE _____ STATE _____

INCREASE YOUR TUBE PROFITS

\$90.00 A MONTH*

... AND GET EXTRA SERVICE CALLS!



This tester with tube stock permits customers to:

- Test their own tubes
- Buy replacement tubes from you
- Identify you for service needs

You have an extra store wherever you put this self-service tester.

TO FIND OUT:

- How to put a tester in a store
- How many tubes to stock and types
- How to buy and mark up tubes
- How easily this rugged tester works
- How to finance a "route"

Mail this ad or a postcard now to address below.

*Names and addresses of full-time servicemen earning this income with this tester on request.

TV 20-S Console Model
Complete \$189.50 at Jobbers.

Developed and Manufactured by
AMERICAN SCIENTIFIC DEVELOPMENT CO.

334-336 S. Main St., Ft. Atkinson, Wisc.



TELCO TELEVISION HARDWARE AT YOUR DISTRIBUTOR

WRITE for your TELCO Catalog or ask your supplier. FREE!



TELCO CHIMNEY QUICK MOUNT
One-piece style for fast installing.
No. 8005



TELCO DELUXE CHIMNEY MOUNT
All aluminum, with stainless strap.
No. 8001



TELCO TV STAND-OFF
Wood-screw type, 3 1/2" long.
No. 8027



TELCO DUPLEX STAND-OFF
Inline wood-screw type, 7 1/2".
No. 8225



TELCO UNIVERSAL LIGHTNING ARRESTOR
UL-approved; for all lead-ins.
No. 8642



TELCO TELEVISION ROLL-AROUND
Fits under most sets for easy moving.
No. 8957

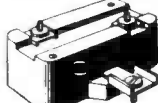

TELCO UHF-VHF LIGHTNING ARRESTOR
UL-approved; 300- & 450-Ohm lines.
No. 8640



TELCO RATCHET TYPE CHIMNEY MOUNT
For masts to 1 3/4" dia.; fast, sure.
No. 9218

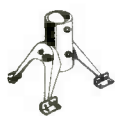

TELCO NO-GUY ROOF MOUNT
Cast iron base; 1 1/2" dia. masts.
No. 9060



TELCO HEAVY DUTY RIDGE MOUNT
For flat or any-angle roof; 1 3/4" mast.
No. 8630

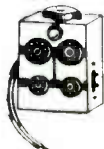

TELCO TUBE CHECKER
Series filament and continuity tests.
No. 9270



TELCO TV LEAD-IN TUBE
Universal style, up to 14" wall.
No. 8958

TELEVISION HARDWARE MFG. CO.

Division of General Cement Mfg. Co. 914 Taylor Avenue • Rockford, Illinois

man who is in the servicing business, but the problem of keeping him in the servicing business is equally important. The inducements to stay in the home electronics equipment servicing business must be as strong as the inducements to leave it.

Men must be attracted to home electronics servicing. They must find it profitable. They must have the opportunity to grow. It must be a year-round activity. There must be a reason for attending schools teaching home electronics equipment servicing (now exemplified by TV servicing). All receiver manufacturers should be promoting the need for service—not just a few. The same applies to the manufacturers of other electronic devices sold to the public. Many manufacturers consider reference to the need for service negative selling. This seems foolish in the light of past experience. Consumers are certainly aware that all the electronic equipments they have purchased in the past have required servicing.

Many receiver manufacturers have spent great sums of money to help train technicians. The money was well spent and more will have to be spent, in fact continued effort is needed to assure the manufacturer that the talent he has helped create is available when needed.

John F. Rider

ANSWER MAN

[from page 21]

the clipper tube in too great a proportion, eventually affecting the horizontal oscillator and distorting the picture with pulling. This is most likely what has occurred to bring about the above condition and should be one of the first items to examine in instances of horizontal pulling.

Dear Answerman:

A Crosley chassis 431-2 exhibits bars and interference on channel 5 only. I know the trouble is originating in the chassis because with the same antenna other receivers work fine. Channel 5 is not very strong in this particular location but I don't believe this actually enters into the problem. The lines noticeable in the picture are objectionable enough that the customer wants me to do something about them but I don't know what can be done.

Is there anything that I might try so as to eliminate this condition?

E. M.

Port Washington, N.Y.

This interference sounds very much as though it is originating at the video detector circuit. There is a type of

how long would it take you to solve this service problem?

SYMPTOM:

Loss of horizontal hold. Hold control will not pull the picture into synchronization. Sound is normal.

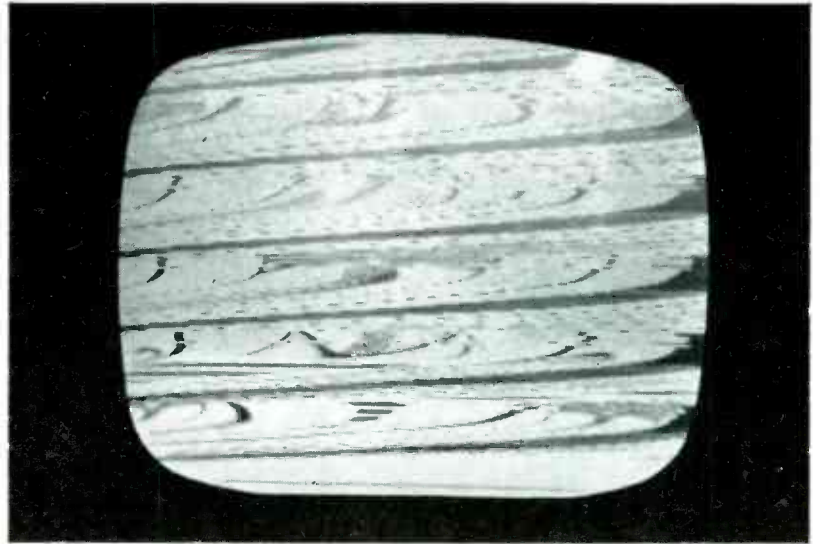

There's no telling how long it might take to solve this problem with hit-or-miss methods—it's been known to take hours. With a PHOTOFACT Folder by your side, the job takes just minutes. Here's why:

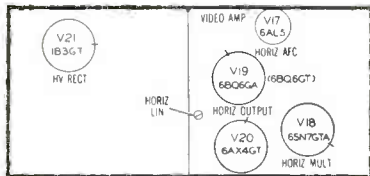

In just seconds, you locate the tubes most likely to cause this symptom by referring to the Tube Placement Chart* and Tube Failure Check Chart* you'll always find in the same place in each PHOTOFACT Folder.

In this case the trouble wasn't caused by tube failure, so...

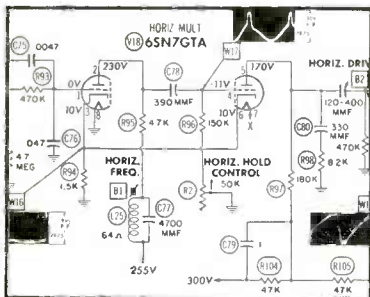

In just seconds you refer to the Horizontal Circuit on the Standard Notation Schematic* featured exclusively in all PHOTOFACT Folders. Circuits are always laid out in the same uniform manner. The Horizontal Circuit is always located in the lower center of the schematic. In a matter of minutes you check waveforms and voltages—they're right on the schematic. And in those same few minutes you find the answer to the problem in this case history. The waveform at W17 and the voltage reading at Pin 4 show a leaky coupling capacitor C78. Yes, you have your answer in just minutes!

C74	270	500	RCM20A271K	S1270	D6-270
C75	.0047	400	RCP10M4472M	SI4700	D6-472
C76	.047	200	RCP10M2473M	BPD-05	DF-50
C77	4700	500	47X543	1464-0047	
C78	390	500	RCM20B391J	1469-00039	D6-390
C79	.1	400	RCP10M4104M	P488N-1	DF-104
C80	330	500	47X570	1469-00033	DF-330

And PHOTOFACT, through its accurate Parts Listings*, instantly gives you a choice of the proper replacement required to accomplish the repair. You save even more time!

From start to finish, you solve your service problems in just minutes...you service more sets and earn more daily with PHOTOFACT by your side!

*One of 32 features found exclusively in PHOTOFACT—the world's finest service data

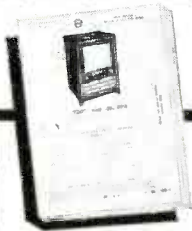

MONEY BACK GUARANTEE!

Got a tough repair? Try this—at Howard W. Sams' own risk: see your Parts Distributor and buy the proper PHOTOFACT Folder Set covering the receiver. Then use it on the actual repair. If PHOTOFACT doesn't save you time, doesn't make the job easier and more profitable for you, Howard W. Sams wants you to return the complete Folder Set direct to him and he'll refund your purchase price promptly. **GET THE PROOF FOR YOURSELF—TRY PHOTOFACT NOW!**

free



Send for Sams' INDEX TO PHOTOFACT FOLDERS—your guide to virtually any receiver model ever to come into your shop; helps you locate the proper PHOTOFACT Folder you need to solve any service problem on any model. You'll want this valuable reference guide. Send coupon now.

HOWARD W. SAM'S & CO., INC.

Howard W. Sams & Co., Inc.
2209 E. 46th St., Indianapolis 5, Ind.

- Send FREE Index to PHOTOFACT Folders
 I am a Service Technician

Name _____

Address _____

City _____ Zone _____ State _____

NEW COMPONENTS

In requesting more detailed information on these products, please check the code number of the product on the convenient coupon on page 63, and send it, along with your company letterhead or business card, to New Products Dept., SERVICE DEALER, Suite 510, 67 West 44th St., New York 36, N.Y.

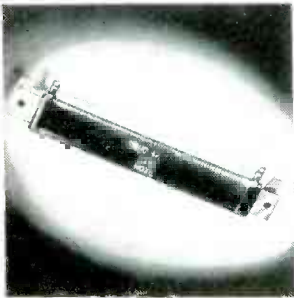

Reon Resistors

Reon's new "M" series miniature ($\frac{3}{16}$ " O.D.) and "SM" sub-miniature series ($\frac{1}{16}$ " O.D.) have been developed to readily fill the need for a lead mounting in printed circuitry or crowded chassis requirements. It was announced today by Reon Resistor Corp. An optional pigtail construction features "R"-radial, "A"-off center axial, or "C"-central axial. For details, check C30.

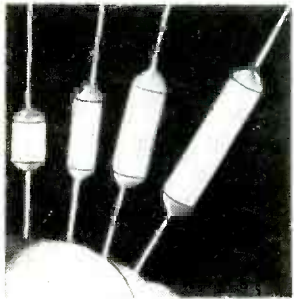

CD Capacitor

Designed specifically to meet the unique electrical requirements and dimensional limitations of extremely small equipment, a new subminiature series of Tantalum capacitors, Type NT, has just been developed by the Cornell-Dubilier Electric Corporation. These new subminiature capacitors are available in a wide selection of ratings and sizes down to the most minute dimensions. For details, check C31.



Luxo Lamp

In normal use, the heat given out by the shade of an incandescent Luxo Lamp is small and does not cause any problems for the serviceman. On certain types of very close work, it may be desirable to use an inner reflector. With an inner reflector the Luxo shade remains amazingly cool. The inner reflector also concentrates the light in a smaller area. For details, check C32.

Cornell-Dubilier Filters

A new series of "Quietone" PI Filters in tubular cases has just been made available by the Cornell-Dubilier Electric Corporation. These metal-cased, hermetically-sealed tubular type filters afford high insertion loss values for the suppression of radio noise. They are made to the smallest possible sizes and minimum weight for the stated ratings and attenuation characteristics. For details, check C33.



Ram Flyback Transformers

The X126 and X127 are new flyback transformers which are being released by the RAM ELECTRONICS SALES CO. The X126 is an autotransformer-type flyback which is used in 66-70 degree horizontal deflection angles systems and delivers from 13 to 15 kv. The X127 (illus.) may operate both in the 66-70 and 90 degree systems and is capable of delivering from 15 to 19 kv. For details, check C34.

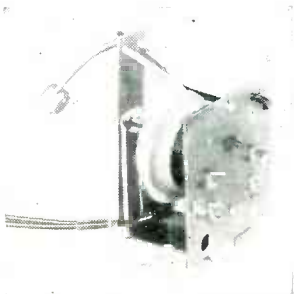

Wen Soldering Kit

The new Wen Model 199 home utility soldering kit provides the serviceman or householder with an efficient soldering gun and several components which enable it to do a variety of cutting, soldering, and other tasks. For details, check C35.



Xcelite Plier

A new Xcelite plier has the compactness of needle nose pliers plus narrow end-nippers for flush or other cutoff work in miniature and sub-miniature chassis. Just introduced to the electronics and allied industries, it is the No. 62 Transverse Cutter. A spring return permits using just the thumb and a finger in close quarters. For details, check C36.



GC Trol Line

"Trol-Gun" and "Trol-Kleener" are the new radio-television cleaner and lubricator for eliminating noisy volume controls introduced by General Cement Mfg. Co. Though volume controls are the duo's principal application, they can be used on push buttons, switch contacts and tuners, and will not harm finishes of wood, acetate, metal and the like. For details, check C37.



TM No-Fog

Tele Matic Industries has incorporated an anti-static agent into a novel device to ensure cleaner, clearer pictures. NO-FOG neutralizes the electrostatic charge indefinitely. It is a colorless, odorless liquid, which when sprayed on the tube or mask and wiped with a clean dry cloth, leaves an invisible insulation against static. For details, check C38.



B-T Cable Stripper

Blonder-Tongue Laboratories announces the Model S-1 Rotary Stripper for coax cables and other non-metallic tubing up to $\frac{1}{2}$ " diameter. This new installation tool is especially useful for stripping coaxial and other shielded cable for TV, audio, industrial and electrical purposes. For details, check C39.

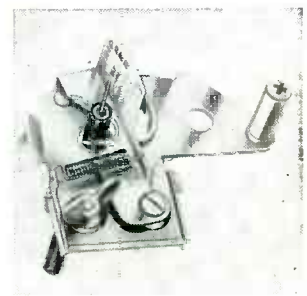

TRADE FLASHES

[from page 28]

the electrical instrument business. Leading figures in the electronic service and industrial instrument field honored the 66-year-old innovator and inventor.

General Dry Batteries, Inc., Cleveland, announces that it has set up eleven warehouses across the country to insure fast service for its battery customers. Locations of the warehouses are: Atlanta, Georgia; Boston, Massachusetts; Cleveland, Ohio; Dallas, Texas; Denver, Colorado; Dubuque, Iowa; Los Angeles, California; Memphis, Tennessee; Portland, Oregon; San Francisco, California; and Silver Spring, Maryland. All battery shipments will now be made within 48 hours from these warehouses, according to J. J. Langlois, sales manager of General Dry. He said the new warehouses will greatly facilitate shipping factory-fresh batteries to the firm's customers.

Westinghouse is planning to produce color television receivers starting sometime in mid-year. E. J. Kelly, general manager of the firm's television-radio division here, announced recently. "We have designed a small compact receiver with the largest screen, employing a 22-inch rectangular all-glass color tube," Mr. Kelly said. "This permits housing in a small package size enabling production of color sets in table models." The color table sets, to be available in compact versions, will be not much larger than most present-day 21-inch black-and-white receivers, Mr. Kelly indicated.

The first commercial transistorized portable two-way radio has been announced by Daniel E. Noble, vice president of the Communications and Electronics Division, Motorola Inc., pioneer in the field of portable and mobile radio communications. The new line of "Handie-Talkie" radiophones includes 42 different models. Designed to operate from two to five days without a battery change, the new radiophones were introduced in two basic series: the "H" series for maximum portability and the heavy-duty "P" series for longer range communications.

Morris Sobin, president of Olympic Radio & Television Inc., has announced the purchase for cash of all of the outstanding stock of David Bogen Co., Inc., 29 Ninth Avenue, New York, N. Y. The purchase marks the initial step in Olympic's over-all plan of expansion. [Continued on page 45]

Simpson...the most Complete Line of VOM's

Select the one that fits your needs!

MODEL
260
world's most popular!

Over half a million Model 260's have been sold to date! 20,000 Ohms per volt. You'll find it wherever quick, accurate, electrical checks are needed. It's so handy, so dependable, so sensibly priced! Ask your jobber. Price, including Adjust-A-Vue Handle, only ... **\$38.95**

Carrying Cases from **\$6.75**

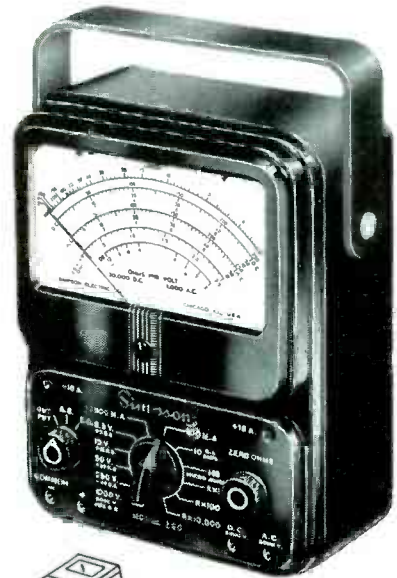

MODEL **262**

Deluxe!



the new VOM with a 7" meter
20,000 Ohms per volt DC and 5,000 Ohms per volt AC sensitivity ... 33 ranges ... compact 7" case with Adjust-A-Vue Handle ... **\$59.50**
Carrying Case ... **\$ 9.95**

MODEL **269**

100,000 Ohms per volt!



Most sensitive VOM available! A Volt-Ohm-Microammeter with a big 7" meter in a compact 7" case ... 33 ranges ... Adjust-A-Vue Handle ... **\$88.00**
Carrying Case ... **\$ 9.95**

NEW!

- ▶ **MIDGETESTER** Model 355—New shirt-pocket size Volt-Ohmmeter **\$29.95**
- MODEL 240**—Small VOM; 14 ranges; up to 3000 volts AC or DC **\$26.35**
- MODEL 230**—Small VOM; 12 ranges; up to 1000 volts AC or DC **\$24.95**
- ROTO RANGER** Model 221—25 Separate meters of turn of a switch **\$75.00**
- LABORATORY STANDARD**—For instrument calibration. Price on application.

Simpson ELECTRIC COMPANY

World's Largest Manufacturer of Electronic Test Equipment

5200 W. Kinzie St., Chicago 44, Ill.

• ESTebrook 9-1121

In Canada: Bach-Simpson, Ltd., London, Ontario

NEW TEST EQUIPMENT

In requesting more detailed information on these products, please check the code number of the product on the convenient coupon on page 63, and send it, along with your company letterhead or business card, to New Products Dept., SERVICE DEALER, Suite 510, 67 West 44th St., New York 36, N.Y.



ASD Merchandiser

American Scientific makes available a self-service tube merchandising plan with a direct tie-up with the serviceman. In this case the serviceman installs the self-service tube tester and makes the deal with the proprietor of the establishment in which it is installed. Name and phone number of serviceman is printed on cabinet. For details, check M30.

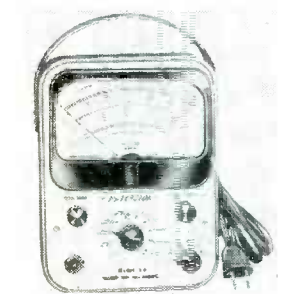

Precision Volt-Ohmmeter

Precision Apparatus Co., Inc., announces the addition of the Model 68, a new vacuum tube volt-ohmmeter. The model 68 is an AC-operated wide-range general purpose electronic test set equipped with a 5 1/2" wide-angle PACE meter of $\pm 2\%$ accuracy and 17 multipliers and shunts of both wire and deposited film types. For details, check M31.



Superior Multimeter

The new Model TV-60 Allmeter, a complete all-purpose 20,000 ohms per Volt Multimeter, has a recessed 6 1/2 inch 40 Microampere meter with mirrored scale that assures accuracy and easy-reading, announces the Superior Instrument Company. Extra services include an accurate direct-reading Capacity meter, a Kilovoltmeter, an R. F. Signal Tracer and an Audio Signal Tracer. For details, check M32.

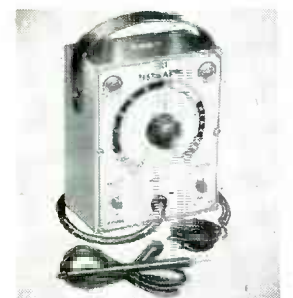

Century's CRT Testivator

Century's new CRT Testivator can be used to test cathode emission, open elements, and indicates shorts and leakage between elements. Engineered and precision made with quality components to give dependable and accurate service. For details, check M32.



Hickock Tube-Tester

Known as the model 539B, this instrument is built with latest Dynamic Mutual Conductance Circuits and provides 6 micromho ranges: 60,000; 30,000; 15,000; 6,000; 3,000; 600 micromhos. In addition, a rectifier diode range and a voltage regulator (VR) range are provided. The 600-micromho range is especially suited for more accurate testing of subminiature type tubes. For details, check M34.

Superior Tester

According to the Superior Instrument Co., New York, N. Y., their new Model TV-12 tube tester is not a "rehashed" model. This radically new tester will check tubes under dynamic conditions very closely simulating the manner in which they would function in a receiver or amplifier. It will also test all Transistors produced to date. For details, check M35.



Phaostron Meter

Produced to the highest quality standards for maximum performance and convenience, this Phaostron unit is a completely self-contained, ready-to-use precision portable instrument. A recent addition to the Phaostron line of products, it has been acclaimed as one of the finest portable instruments of its kind. For details, check M36.



CG Transistor Tester

A fast comparative check on PNP and NPN transistors is now provided by a new, completely self-contained, portable transistor tester, Model TR-2, manufactured by CG Electronics Corporation. The unit features 4" meter with two ranges that allow the operator to read Alpha, Beta, and Ico directly. For details, check M37.



Teletest "CapaciTester"

The revolutionary, new CapaciTester, made by TeleTest Instrument Corp., is now available to electronic equipment manufacturing and service technicians for immediate delivery. The CapaciTester is the first instrument capable of in-circuit testing all types and capacities of coupling condensers for leakage up to 40 megohms. For details, check M38.



Heathkit Audio Generator

This new Heathkit Model features step-tuning from 10 cps to 100 kc with three rotary switches that provide two significant figures and multiplier. Less than 1% distortion. Frequency accurate to within $\pm 5\%$. Output monitored on a large 4 1/2" meter that reads voltage or db. Both variable and step-type attenuation provided. Meter reads zero-to-maximum at each attenuator position. For details, check M39.

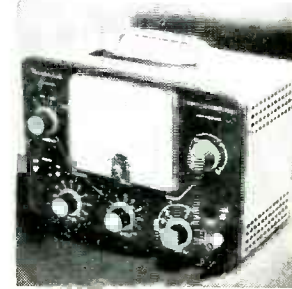

TRADE FLASHES

[from page 43]

pansion and diversification. David Bogen Co., Inc. produces a complete line of hi-fidelity equipment, television boosters, short-wave receivers, centralized sound systems, transcription players, baffles and inter-communicating and public address systems, all of which supplement the present television, radio and electronic products of Olympic. Founded in 1932, Bogen has broad distribution throughout the United States and Canada.

A professional quality, medium priced tape recorder with new engineering developments of interest to the entire recording industry was announced recently for Keystone Camera Co., Boston, by Robert C. Berner, vice president and director of sales. Mr. Berner reported that the Keystone instrument is the first to utilize magazine loading of tape, which eliminates threading and adjusting. He predicted that "before long, this unique and simple method of playing tape will be utilized by every manufacturer of tape equipment and by those firms who are entering the already grown pre-recorded tape market."

Joseph Frank, President of Astron Corporation, East Newark, New Jersey, manufacturers of capacitors and RF noise interference filters, announced that his company has bought all of the outstanding stock of Skottie Electronic Corporation, Inc., of Peckville, Pennsylvania. The purchase includes the plant buildings and production facilities. Skottie is a manufacturer of ceramic capacitors, producing a complete line of disc types and tubular units in a wide range of values. They supply also subminiature units designed specifically for transistorized and printed circuits.

Retail sales of television receivers established a new record in 1955, the Radio-Electronics-Television Manufacturers Association reported. Sales of radios, excluding automobile receivers, increased by nearly half a million from the level of 1954, it added. During the past year, 7,421,084 TV receivers moved through retail outlets compared with 7,317,034 sets sold a year earlier, the previous record year. December sales totaled 933,467, RETMA reported, compared with 591,366 in November and 1,093,702 TV receivers sold at retail in December 1954. Sales of radios, excluding automobile sets, totaled 6,921,384 in 1955 compared with 6,430,743 sold a year earlier. It was reported by RETMA that 1,388,801

Give customers "hi-fi satisfaction" —profitably!

THE BRILLIANT NEW "3" SERIES SONOTONE CERAMIC

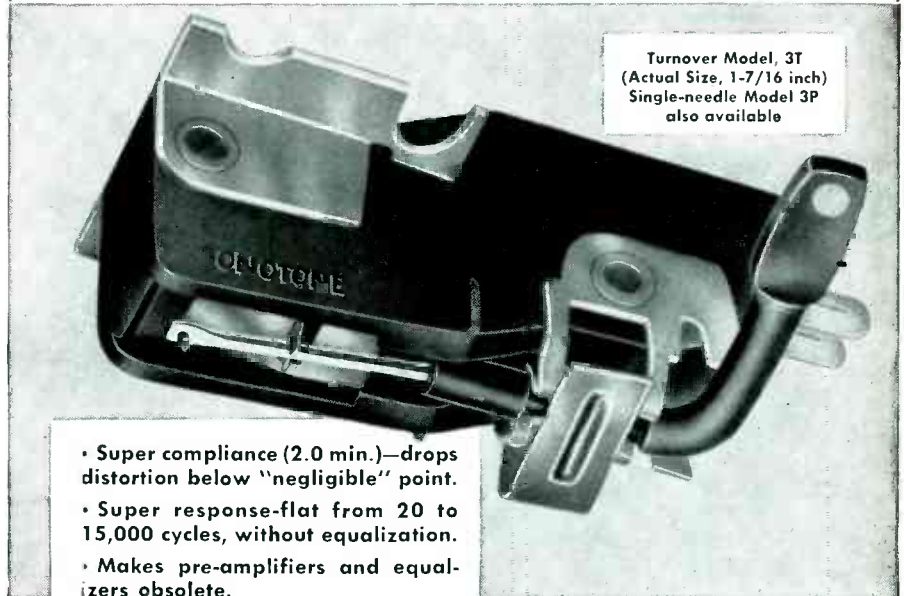

If you've followed the development of ceramic cartridges since Sonotone pioneered them in 1946, you know of their enormous advances.

Now Sonotone presents the "3" Series, which sets utterly new standards of performance and opens the door to profitable "hi-fi" business for you.

The Sonotone "3" Series ceramic cartridge can be used as a replacement in nearly any phonograph circuit. It delivers a brilliance and clarity of sound which will be noticed and commented upon by delighted customers. Because these cartridges deliver a whopping 0.5 volts (roughly 50 times as much as most velocity types), they do not need preamplification and equalization circuits. And naturally the non-magnetic structure eliminates motor hum.

There are two basic models, a turnover (3T-S) for all record speeds and a single-needle model (3P-1S) for 33 and 45 rpm records. They have standard $\frac{1}{2}$ or $\frac{5}{8}$ inch mounting centers and fit any of the widely used tone arms. Prices begin at \$12.50 list (sapphire needles).

Use the brilliant new Sonotone Series "3" on your next replacement job. You'll find yourself on the way to profitable "hi-fi" business.

SONOTONE®

CORPORATION, ELMSFORD, N. Y.



Write Department CD-36 for free cartridge replacement chart.
In Canada—Atlas Radio Corp. Ltd., 50 Wingold Ave., Toronto.

radios moved through retail stores in December compared with 865,602 sold in November. During December 1954, 1,158,588 radios had been sold.

The world's most modern sight, sound and communication system is being installed in the Marriott Motor Hotel, world's largest drive-in hotel, now under construction in Arlington County, Va., just outside the nation's capital. Signing of a contract for leasing of a complete Stromberg-Carlson sound, radio and television system for the motor hotel was announced jointly by J. W. Marriott, founder and President of Hot Shoppes, Inc., which is building the

hotel, and Harris Myers, contract sales manager of the Special Products Division of Stromberg-Carlson, a division of General Dynamics Corporation.

So successful was the first "National Television Servicemen's Week," observed in 1955 as a salute to American radio and television dealers and service technicians, that RCA quickly recognized the demand of the trade to perpetuate this historic event in the interests of the radio-TV industry. Subsequently, RCA registered officially with the Chamber of Commerce of the United States the second annual "National Television Servicemen's Week."

This sincere acclaim by RCA to dealers and service technicians is especially significant in the view of the many complex technical advances made during the past year, and the increasingly heavy commercial demands placed on this group of American businessmen. To promote "National Television Servicemen's Week" in 1956, the RCA Tube Division has organized a progressive campaign based on sound experience and solid, time-tested ideas. This merchandising program is yours — it will be promoted for you by RCA in national consumer magazines, and on radio and TV stations from coast to coast to call immediate public attention to your indispensable services. "National Television Servicemen's Week," in conjunction with the support of your RCA Tube Distributor, will help you build lasting business success through better public relations!

A Magnavox color television service school for The Magnavox Company's midwest dealers and authorized servicing agencies opened in Chicago January 23 at the Washburne Trade School. Under the personal direction of Charles Kayhart, company service training director, a series of five day sessions is scheduled in which practical color set setup and installation training is emphasized. Wayne Kiehna, Carl Gates and Vernon Brown of the Magnavox field engineering staff will conduct the classes, which are limited to small groups.

A pair of new PNP all-junction germanium transistors CBS types 2N180 and 2N181, has been developed by CBS-Hytron, a Division of Columbia Broadcasting System, Inc. These transistors are for general purpose low-frequency use and feature a wide variety of applications because of the collector dissipation of 150 mw for the 2N180 and 250 mw for the 2N181. An additional feature is their ability to maintain high amplification at high current levels, thus lending themselves to medium power applications such as the output stage of a portable radio receiver. Typical applications are: Class A amplifiers, driver for PP class B stage, microphone or phono preamplifier, and low-frequency flip-flop circuit.

Nearly 7.5 million television receivers were shipped to dealers during 1955 to establish a new record, the Radio-Electronics-Television Manufacturers Association reported recently. During the last year, 7,421,978 TV sets moved into the hands of dealers, RETMA reported, compared with 7,161,362 in 1954, the previous high year. Shipments during five-week December totaled 800,192 compared with 634,742 in four-week November and

Now Available! NEW...

VACO®

Hollow Shaft NUT DRIVERS in Color

Nothing else like them anywhere! Choice of 28 types and sizes! New plastic kit at right contains 7 most popular drivers in self-standing bag for service work or bench use.



ONLY \$7.20 Net

No. K7 Self-Standing Service Kit Stands Up! Hangs Up! Folds Up!

Stands upright for easy accessibility. May be hung flat on wall or may be folded. Each driver fits in individual holder marked for size, color.

Check These 6 Important VACO Features

- NEW! Each size color-keyed!
- NEW! All-hollow shafts
- NEW! Extra large VACO Comfortome Handles!
- NEW! Extra hard long wearing sockets!
- NEW! Shafts insulated from handle to tip!
- NEW! Available in 4 shaft lengths and 7 Hex sizes!



THIS COUPON WORTH \$1.20

Coupon only valid for use as stated below. Not valid in states where prohibited.

Name..... R. T.
 Street.....
 City..... Zone..... State.....

VACO PRODUCTS COMPANY
 317 E. Ontario St., Chicago 11, Ill.
 In Canada: Vaco-Lynn Products Co., Ltd., Montreal 1, Que.

Take this coupon to your jobber. It is worth \$1.20 when filled in and used to purchase one VACO K7 Kit. If your jobber cannot supply you, write direct.

1,014,227 TV sets shipped to dealers in December 1954.

A contest that teaches entrants the main selling points of modern TV sets, while giving them a chance to win one of the latest models, is an unusual feature of a TV set promotion that started Sunday, Feb. 26, in the Chicago Tribune. Leading manufacturers co-operating with the Tribune in this promotion include Admiral, Crosley, General Electric, Motorola, Philco, RCA, and Westinghouse. Contests will invite readers to use skill and judgment in choosing the most important selling points or features of TV sets now on the market. Readers will be invited to study this list of features, and to rank them in order of their greatest appeal to prospective buyers described in each problem. The Tribune has invited the 1700 appliance dealers in the Chicago area to participate in the promotion. Details of the contest and promotion have been provided to all dealers, either by letter or through personal contact.

RIDER SPEAKS

[from page 6]

equipment manufacturer for maintenance personnel. Certainly not in the foreseeable future. There just aren't enough trained men to go around and satisfy all needs.

Industry knows this and is training its own people, but training alone is not enough. If the TV receiver, tape recorder, hi-fi equipment, record player, auto radio and radio receiver manufacturer who envisions an expansion of home electronics equipment is interested in having an adequate army of maintenance personnel, he (collectively speaking) must do something about making servicing of these equipments a year-round job. It must be a means of earning an income that compares favorably with other sources of revenue that require continuous training.

If the industrial and the business electronics equipment manufacturers present their requirements in terms of careers for the men who go to work for them, the home electronics equipment manufacturers will have to do likewise. The RETMA has embarked upon a training program, working as closely as possible with the private and municipal schools of the nation, hoping in this way to build a roster of technically competent maintenance personnel. This is a worthwhile effort and our close association with it has been most interesting. It is a progressive step, especially the program of accreditation. Having inaugurated it the RETMA can't let go any more. This is good.

But it is not the entire answer. The accreditation program is fine for the

64% of the top Engineers

PREFER AND USE

HICKOK

DYNAMIC MUTUAL CONDUCTANCE

TUBE TESTERS

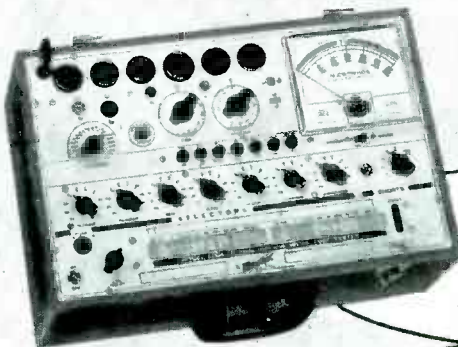

MODEL 600A

World's most popular Tube Tester

"... that 600A is certainly unbeatable! I have sold 4 for you by just letting service centers use mine for part of one day."

Harold F. Tolles, St. Johns, Mich.

"I purchased a 600A last Fall and have found it to be one of the best investments in test equipment that I have ever made."

R. Lytwyn, Nytyl Electronics

All tube testers manufactured today fall into four major classifications.

If you use vacuum tubes in your profession, and if you ever intend to purchase a tube tester please write today for the 28 page book of Tube Tester Facts and learn the advantages of each classification in order that you will be able to more efficiently select for your requirements. This detailed, illustrated and descriptive book also contains circuit diagrams and formulas.

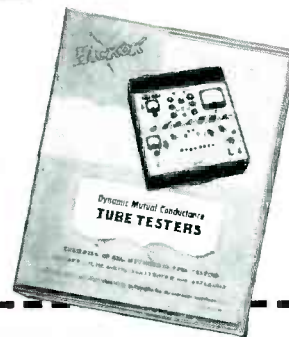

THE HICKOK ELECTRICAL INSTRUMENT CO.

10533 DUPONT AVE. • CLEVELAND 8, OHIO

Gentlemen:

Kindly send me free of charge your new 28 page book of Tube Tester Facts.

NAME _____

COMPANY _____

STREET _____

CITY _____ ZONE _____ STATE _____

INCREASE YOUR TUBE PROFITS

\$90.00 A MONTH*

... AND GET EXTRA SERVICE CALLS!



This tester with tube stock permits customers to:

- Test their own tubes
- Buy replacement tubes from you
- Identify you for service needs

You have an extra store wherever you put this self-service tester.

TO FIND OUT:

- How to put a tester in a store
- How many tubes to stock and types
- How to buy and mark up tubes
- How easily this rugged tester works
- How to finance a "route"

Mail this ad or a postcard now to address below.

*Names and addresses of full-time servicemen earning this income with this tester on request.

TV 20-S Console Model
Complete \$189.50 at Jobbers.

Developed and Manufactured by

AMERICAN SCIENTIFIC DEVELOPMENT CO.

334-336 S. Main St., Ft. Atkinson, Wisc.

TELCO

TELCO TELEVISION HARDWARE AT YOUR DISTRIBUTOR

WRITE for your TELCO Catalog or ask your supplier. FREE!



TELCO CHIMNEY QUICK MOUNT
One-piece style for fast installing.
No. 8005



TELCO DELUXE CHIMNEY MOUNT
All aluminum, with stainless strap.
No. 8001



TELCO TV STAND-OFF
Wood-screw type, 3 1/2" long.
No. 8027



TELCO DUPLEX STAND-OFF
Inline wood-screw type, 7 1/2".
No. 8225



TELCO UNIVERSAL LIGHTNING ARRESTOR
UL-approved; for all lead-ins.
No. 8642



TELCO TELEVISION ROLL-AROUND
Fits under most sets for easy moving.
No. 8957

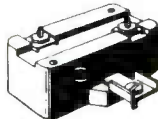

TELCO UHF-VHF LIGHTNING ARRESTOR
UL-approved; 300- & 450-Ohm lines.
No. 8640

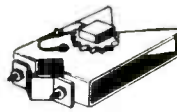

TELCO RATCHET TYPE CHIMNEY MOUNT
For masts to 1 1/4" dia.; fast, sure.
No. 9218

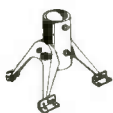

TELCO NO-GUY ROOF MOUNT
Cast iron base; 1 1/2" dia. masts.
No. 9060



TELCO HEAVY DUTY RIDGE MOUNT
For flat or any-angle roof; 1 1/2" mast.
No. 8630

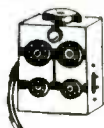

TELCO TUBE CHECKER
Series filament and continuity tests.
No. 9270



TELCO TV LEAD-IN TUBE
Universal style, up to 14" wall.
No. 8958

TELEVISION HARDWARE MFG. CO.

Division of General Cement Mfg. Co. 914 Taylor Avenue • Rockford, Illinois

man who is in the servicing business, but the problem of keeping him in the servicing business is equally important. The inducements to stay in the home electronics equipment servicing business must be as strong as the inducements to leave it.

Men must be attracted to home electronics servicing. They must find it profitable. They must have the opportunity to grow. It must be a year-round activity. There must be a reason for attending schools teaching home electronics equipment servicing (now exemplified by TV servicing). All receiver manufacturers should be promoting the need for service—not just a few. The same applies to the manufacturers of other electronic devices sold to the public. Many manufacturers consider reference to the need for service negative selling. This seems foolish in the light of past experience. Consumers are certainly aware that all the electronic equipments they have purchased in the past have required servicing.

Many receiver manufacturers have spent great sums of money to help train technicians. The money was well spent and more will have to be spent, in fact continued effort is needed to assure the manufacturer that the talent he has helped create is available when needed.

John F. Rider

ANSWER MAN

[from page 21]

the clipper tube in too great a proportion, eventually affecting the horizontal oscillator and distorting the picture with pulling. This is most likely what has occurred to bring about the above condition and should be one of the first items to examine in instances of horizontal pulling.

Dear Answerman:

A Crosley chassis 431-2 exhibits bars and interference on channel 5 only. I know the trouble is originating in the chassis because with the same antenna other receivers work fine. Channel 5 is not very strong in this particular location but I don't believe this actually enters into the problem. The lines noticeable in the picture are objectionable enough that the customer wants me to do something about them but I don't know what can be done.

Is there anything that I might try so as to eliminate this condition?

E. M.

Port Washington, N.Y.

This interference sounds very much as though it is originating at the video detector circuit. There is a type of

interference, due to the third harmonic of the video *if* carrier that is radiated by the video detector circuit and picked up at the antenna. The third harmonic of 26.4 mc is 79.2 mc and this frequency falls well within the channel 5 frequencies of 76 to 82 megacycles. Thus, this third *if* harmonic can cause difficulty in channel 5 reception if it is radiated in any great amount of strength.

When the difficulty is being experienced the video detector tube, in this case the 6AM8 tube, should be shielded as this will help reduce the radiation originating inside it.

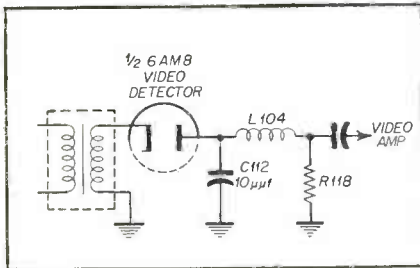

Fig. 3—Partial schematic of Crosley chassis 431-2.

There is also a component in the video detector circuit which, when defective (open) does not generally disrupt the presentation of a good picture. The purpose of this condenser is to filter the *if* frequencies thus reducing the third harmonic also. As can be noted in Fig. 3, C112, a 10 µf condenser is used from the plate of the video detector to ground. If this condenser is open or possibly missing it will bring about the described symptoms. This is probably the cause of the interference in this problem which is most prevalent under relatively weak signal conditions.

Dear Answerman:

I have been working on a Westinghouse chassis V2342 that has been

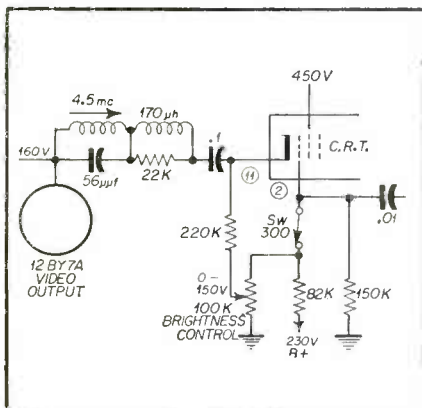

Fig. 4—Brightness control circuit of Westinghouse V2342.

causing me a bit of a problem. My difficulty is no picture or raster. I have sufficient high voltage and the picture tube filament is lit. I have fooled with the beam bender, substituted another one, and tried almost everything I can think of but I can't get a raster or picture. I have even substituted another picture tube and had the identical results, so I feel sure there is something wrong in this particular chassis, but I can't solve the problem. The proper voltages are present at the picture tube socket as indicated by the schematic. What am I overlooking?

N. A.
St. Louis, Mo.

Since the picture tube and the beam bender have been eliminated and the high voltage has been measured and found correct the trouble is more than likely associated with the controls and components of the CRT elements and the various voltages applied.

Most important is the voltage provided to the cathode, as can be noted in Fig. 4. This voltage should be measured, perhaps with one of the CRT socket adapters which can be connected at the socket exposing terminals for just such measurements. Using such an adapter the grid to cathode voltage can be measured as this is one of the important control voltages. This voltage

PAYS ITS WAY every day

**TESTS and
REPAIRS
TV PICTURE
TUBES**

**Makes Customers Happy
—Creates New Profits**

Servicemen now earn new servicing dollars in minutes and build satisfied customers—with B&K Deluxe Portable CRT 400.

Spots and corrects picture tube troubles in a few minutes, right in the home, without removing tube from set! Restores emission, stops leakage, repairs inter-element shorts and open circuits. Grid cut-off reading indicates picture quality customer can expect. Life-test checks gas content and predicts remaining useful tube life. Cuts operating costs, eliminates tube transportation. Also saves money on TV set trade-in reconditioning. Profits start the very first day.

Send for Bulletin 104-D



DELUXE CRT 400 with 4½" Plastic Meter

Weights only 5 lbs. mounted in rugged, luggage style, carrying case covered with handsome, durable leatherette. Size: 11 x 7½ x 5". Net \$54.95



CATHODE REJUVENATOR TESTERS

ECONOMY CRT 200

Every serviceman can cash in on picture tube repairs with this low priced quick profit maker. Performs most of the functions of the CRT 400. Has 3" meter. In leatherette carrying case. Size: 11 x 7½ x 5". Weights 5 lbs. Net \$39.95

PROVEN IN
THE FIELD
EVERY DAY
BY OVER
20,000
SERVICEMEN

Made by the Makers of the DYNA-QUIK Tube Tester

B & K MANUFACTURING CO.
3726 N. Southport Ave. • Chicago 13, Illinois



new!

portable

FIELD STRENGTH METER



OPERATES ANYWHERE!
...
NO AC LINE NEEDED
...
LIGHTWEIGHT
...
RECHARGEABLE BATTERY



Simpson

MODEL 498-D

The extra versatility you get in a Model 498 helps get jobs done faster. Covers all channels, UHF and VHF. Excellent for fringe areas. Measures relative field strength from 50 microvolts to 0.5 volts with continuously variable sensitivity. Also provides a 15-second tuner substitution test for servicing TV. Complete Standard Coil UHF-VHF tuner. Model 498-D operates from any one of four sources: (1) 117 ACV line; (2) internal storage battery (recharge by self-contained charger or your auto battery); (3) automobile battery; (4) external battery.

Model 498-A (117 ACV only)
with shoulder strap **\$14850**

Model 498-D (117 ACV and 6.3 DCV)
with shoulder strap,
less battery **\$15550**

No. 5721 Storage Battery, 12 amp
hour capacity **\$950**



See Your Electronics Parts Distributor, or write . . .

SIMPSON ELECTRIC COMPANY
WORLD'S LARGEST MANUFACTURER OF
ELECTRONIC TEST EQUIPMENT
5200 W. Kinzie St., Chicago 44, Illinois
Phone: Estebrook 9-1121
In Canada: Bach-Simpson, Ltd., London, Ont.

should vary with the brightness control being rotated and under normal conditions adjusts from about zero to 150 volts with the brightness control. More than likely this voltage will not vary with the control rotation but will be found to be somewhere around 50 volts or higher. It might be as high as 160 volts or it might be adjustable from 80 to 150 volts. Under these circumstances the CRT is biased beyond cutoff and can't conduct and provide a raster. This condition would be brought about if the .1 μ f condenser shorts or develops a leak. Unless the voltage is checked with the rotation of the brightness control it may be assumed that because there is voltage at this point that the circuit is normal. Most likely the .1 μ f condenser is leaking causing a positive voltage to be applied to the cathode that is biasing the tube out of conduction.

A point of further interest is the employment of the switch SW300 in this circuit. Switch SW300 functions in conjunction with the on-off switch. It works in such a manner that when the on-off switch is closed applying power to the receiver, SW300 is open and vice versa. This permits the elimination of the bright spot on the CRT immediately after the receiver has been switched off. At this time the deflection circuit ceases functioning and SW300 shorts grid ± 2 to B plus voltage of 150 volts. The positive potential as applied to the grid immediately removes the space charge of electrons and prevents the bombardment of the phosphor and the production of the spot on the picture tube.

AF-FM TUNERS

[from page 25]

AM SHARP and AM BROAD IF Selectivity

Cross talk and monkey chatter is caused by the sidebands of adjacent channel stations beating with the desired signals. This type of interference is in the nature of high-pitched, unintelligible sounds, and can be reduced by narrowing the *if* bandpass. Since this feature would only be desirable during those periods when the interference is occurring, a means of switching circuits would be advantageous. The *if* bandpass then can be made sharp to reduce the interference and broad for greater fidelity when the interference is not present.

A tuner using this feature is the Pilot AM-FM tuner (see Fig. 2) where positions for AM SHARP and AM BROAD *if* bandpass reception are among the positions found on the function switch. In the AM SHARP posi-

to be SURE!

buy
VOKAR

the original-
equipment
VIBRATOR



Leading manufacturers of original-equipment auto-radios specify Vokar vibrators as components for installation on the production-line. Why? They're *sure* Vokar quality never varies — will always contribute to top performance demanded of today's radios.

You too can depend on Vokar vibrators—for sure starts, longer life, silent operation. For all replacement jobs, buy Vokar Imperial or Quality Brand vibrators to be *sure* of satisfied customers.

Now is the time to stock up on 12-volt vibrators—**ONLY TWO VOKAR IMPERIALS ARE NEEDED TO FILL ALL REPLACEMENTS!**



VOKAR—preferred by leading manufacturers of auto-radios.

VOKAR

VOKAR CORPORATION
DEXTER 2, MICHIGAN

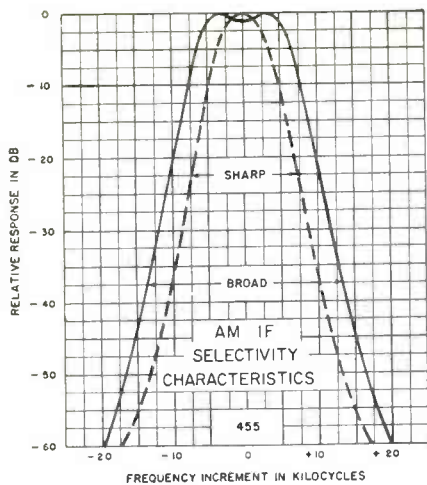

Fig. 3—Sharp and broad frequency responses obtained with Pilot model AF-860.

tion the *if* selectivity is at a maximum for separating stations which are close together in frequency, as can be noted in Fig. 3.

The bandpass for the AM SHARP position is about 6 *kc* wide while in the AM BROAD position the bandpass is about 14 *kc* wide. The broad bandpass in the AM BROAD position is accomplished by making use of a switch to short a winding of several turns on the *if* transformer as can be noted in Fig. 2. This broadens the *if* bandpass by loading the transformer because of the shorted turns introduced into the circuit.

An interesting feature of this tuner is the *if* circuitry where both the AM or FM *if* signal is amplified in the same tube. Following two stages of *if* amplification the AM signal is detected in the grid-to-cathode circuit of the first limiter tube. From this point it is coupled through a 10 *kc* filter and applied to a function switch which couples the

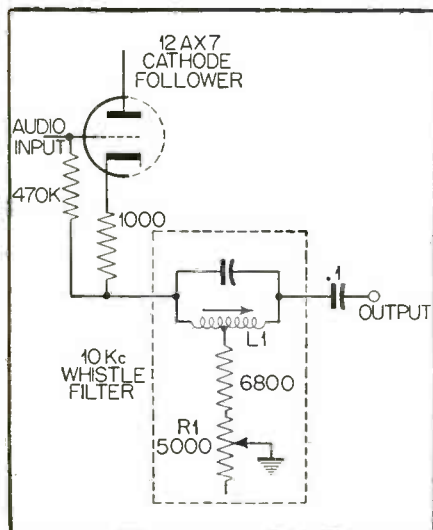

Fig. 4—10 *kc* whistle filter used in the National "Criterion".

audio voltages through a .1 μ f condenser to a cathode follower (not shown in this figure).

It is interesting to note that the FM and AM tuned *if* circuits are connected in series. Connecting these circuits in this manner does not appreciably attenuate either the AM or FM signals. The shunt capacitance associated with the AM tuning coils is large enough to constitute an effective short circuit for the FM signals of 10.7 *mc* *if* frequency. On the other hand the coil in the tuned circuits for the FM signals is of very low impedance with respect to the AM signals of 455 *kc*. Thus, the two circuits and systems can be used in a common arrangement without any diffi-

culty.

The 10 *KC* Whistle Filter

Very frequently, in AM-FM tuners receiving AM broadcasts, a 10 *kc* whistle is heard as the tuning progresses from one station to the next. The whistle is the result of the two adjacent broadcast channel carriers beating together in the second detector, producing a 10 *kc* beat note. This 10 *kc* note is the frequency difference between adjacent AM broadcast channels. This interference is strongest midway between the two stations.

Another source of a similar type of interference is a high pitched whistle

don't be a circuit juggler..

use **STANCOR EXACT REPLACEMENT FLYBACKS**

You just remove the old flyback and install the new one . . . No circuit changes are necessary . . . Even the leads are the proper length for quick, easy installation.

FREE: STANCOR TV Transformer Replacement Guide listing over 8000 models and chassis of 117 manufacturers . . . available from your distributor or by writing Chicago Standard.

CHICAGO STANDARD TRANSFORMER CORPORATION
 3511 ADDISON STREET • CHICAGO 18, ILLINOIS
 Export Sales: Roburn Agencies, Inc., 431 Greenwich Street, New York 13, N. Y.

for service and lab. work

Heathkit
PRINTED CIRCUIT
OSCILLOSCOPE KIT
FOR COLOR TV!

① Check the outstanding engineering design of this modern printed circuit Scope. Designed for color TV work, ideal for critical Laboratory applications. Frequency response essentially flat from 5 cycles to 5 Mc down only 1½ db at 3.58 Mc (TV color burst sync frequency). Down only 5 db at 5 Mc. New sweep generator 20-500,000 cycles, 5 times the range usually offered. Will sync wave form display up to 5 Mc and better. Printed circuit boards stabilize performance specifications and cut assembly time in half. Formerly available only in costly Lab type Scope. Features horizontal trace expansion for observation of pulse detail — retrace blanking amplifier — voltage regulated power supply — 3 step frequency compensated vertical input — low capacity nylon bushings on panel terminals — plus a host of other fine features. Combines peak performance and fine engineering features with low kit cost!



MODEL
0-10
\$695.00
Shpg. Wt.
27 lbs.



MODEL
TS-4
\$495.00
Shpg. Wt.
16 lbs.

Heathkit TV

SWEEP GENERATOR KIT
ELECTRONIC SWEEP SYSTEM

② A new Heathkit sweep generator covering all frequencies encountered in TV service work (color or monochrome). FM frequencies too! 4 Mc — 220 Mc on fundamentals, harmonics up to 880 Mc. Smoothly controllable all-electronic sweep system. Nothing mechanical to vibrate or wear out. Crystal controlled 4.5 Mc fixed marker and separate variable marker 19-60 Mc on fundamentals and 57-180 Mc on calibrated harmonics. Plug-in crystal included. Blanking and phasing controls — automatic constant amplitude output circuit — efficient attenuation—maximum RF output well over .1 volt—vastly improved linearity. Easily your best buy in sweep generators.

Heath
COMPANY
A SUBSIDIARY OF DAYSTROM, INC.
BENTON HARBOR 29, MICH.
WRITE FOR FREE CATALOG
...COMPLETE INFORMATION

caused by the horizontal deflection system radiation of television receivers radiating harmonics of their 15.75 kc fundamental deflection frequency into the surrounding area. Horizontal deflection radiation interference of this nature is very common. It usually appears at a number of points (harmonics of the 15.75 kc fundamental) across the dial, sometimes falling directly in the bandpass of some AM broadcast station. In contrast the 10 kc whistle appears usually during tuning of stations and is not generally experienced when the station is properly tuned in.

To reduce 10 kc interference a filter or trap may be installed to block the 10 kc beat note from appearing at the speaker. This circuit, comprising *L1* and *R1* with their associated components, is shown in Fig. 4. Its relative position in an overall block diagram may be noted in Fig. 1. The trap has the purpose of attenuating the frequencies at 10 kc as can be observed in Fig. 5 and attenuation up to 80 db is obtainable.

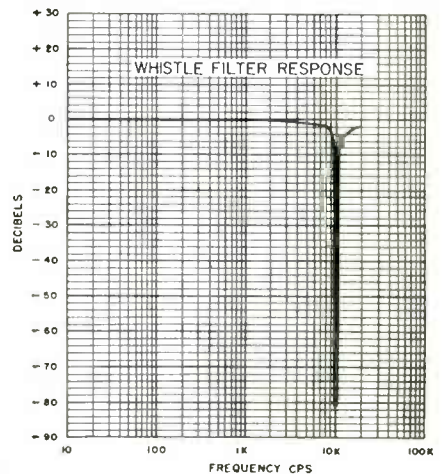

Fig. 5—Audio frequency response due to 10 kc whistle filter.

Generally, this circuit never requires adjustment. Should alignment somehow become necessary an audio generator and an oscilloscope with high sensitivity, or a VTVM, may be used to perform the correction. The signal generator, accurately set at 10 kc, is connected to the top of the volume control. Coil *L1* and resistor *R1* are then set for a null point on the indicating device.

Hum Balance

One very important aspect with respect to high fidelity tuners in comparison with ordinary radio receivers is the hum level. Generally, the amount of audible hum from a radio is high, much higher than is tolerable from a good AM-FM tuner. The hum level from a tuner to be used with a high fidelity system should be in the order of

G-C RADIO-TELEVISION PRODUCTS
AT YOUR DISTRIBUTOR
WRITE for your G-C Catalog or ask your supplier. FREE!

<p>G-C TEST SOCKET ADAPTER KIT Complete, for all tests. No. 9250</p>	<p>G-C VINYLITE CEMENT Great adhesion; many uses; 2 oz. No. 58-2</p>	<p>G-C RADIO-TV SERVICE CEMENT High grade adhesive. No. 30-2</p>	<p>G-C SPRAY-KLEEN Contact Cleaner No. 8666</p>
<p>G-C 300-OHM LINE TOOL Slot, strip, cut twin leads. No. 9220</p>	<p>G-C DUAL SHEET METAL PUNCH Two punches—3/8" x 1 1/2" No. 9260</p>	<p>G-C DUAL TUBE PIN STRAIGHTENER For both 7 and 9 pin tubes. No. 9092</p>	<p>G-C TV CHASSIS SUPPORTS Tilt chassis safely. No. 9176</p>
<p>G-C ECONOMY TEST LEADS Tenite 5' prods, 50" leads. No. 9190</p>	<p>G-C ALIGNMENT KIT Roll case and 9 matched alignment tools. No. 5023</p>	<p>G-C K-27 PRINT-KOTE Pressure spray silicone resin. No. 14-6</p>	<p>G-C SPRAY DE-OX-ID Cleaner for radio, TV controls. No. 19-6</p>

GENERAL CEMENT MFG. CO.

914 Taylor Avenue • Rockford, Illinois

By popular demand, the serviceman's most-wanted book, Video speed Service Systems Vol. 1. is now also available in a low cost PAPER BOUND COVER EDITION

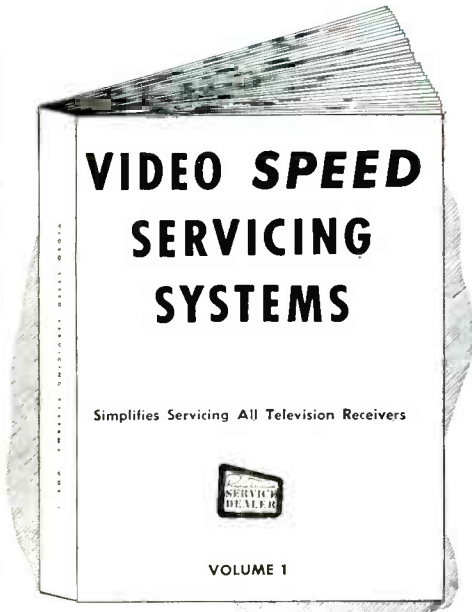

Has the identical contents of the Ring Binder Edition but the price is only \$2.95

TAKE YOUR CHOICE

← New Hard Paper Cover Bound Edition

\$2.95
Postpaid

Cloth-Covered Ring Binder Edition **\$4.95**

Postpaid

(New York City Residents, add 3% to cover city sales tax)

Distributors — Order your supply now. Service Dealers, order from your distributor. If he can't supply you, order direct by mail from us.

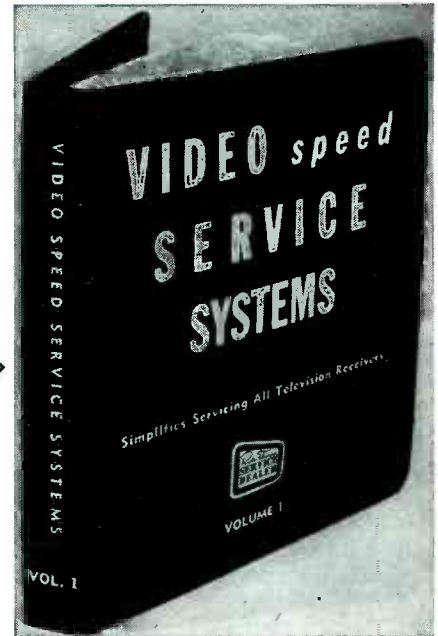

Facts About Video speed Service Systems :

CONTENTS:

A compilation of specific receiver service repairs, "bugs", chronic troubles, field circuit changes, manufacturers' production revisions, etc. The compilation enables the service technician to pin-point what is wrong with any given TV set and to correct the fault in the shortest possible time.

SOURCES:

The material was obtained directly from manufacturers, distributors' service departments, TV service organizations, and top TV Service-dealers throughout the country. Furthermore — all material has been checked carefully to assure dependability and accuracy.

USES:

The VSSS data sheet for any particular TVset maker's model or chassis number gives: 1—the section of the set affected; 2—the symptom; 3—the cause of complaint; 4—the solution, in simple, understandable and usable form.

Video Speed Service Systems is guaranteed to simplify servicing all TV sets. Contains over 600 service items representing over 2500 of the most serviced TV models now in use. Over 25 different manufacturers' lines are covered. Almost 15,000 copies of VSSS have been sold at \$4.95. Every technician needs a copy.

CUT OUT AND MAIL

COWAN PUBLISHING CORP., 67 WEST 44TH STREET, NEW YORK 36, N. Y.

Please send me postpaid Video speed Service Systems Vol. 1 in Paper Bound Edition for \$2.95 . . . or Hard Cover Ring-Binder Edition for \$4.95. My check for \$..... is enclosed. (If you reside in New York City add 3% to cover city sales tax.)

Name

Address

City Zone State

NORELCO
**F.R.S.* SERIES
FULL RESONANCE
TWIN-CONE
SPEAKERS



Now available to the trade

World wide enthusiastic acclaim for Norelco radios is a tribute to the excellence of these speakers. These precision-made full-resonance speakers are made by famous Philips of the Netherlands.

Available in sizes from 12 to 5 inches. Prices of Twin-cone **FRS** speakers range from \$59.98 to \$9.90 audiophile net.

CONE:

Materials are selected and treated for each speaker size providing maximum resonance for the physical characteristics of both power and dimensions of each speaker.

VOICE COIL:

Specially hand wound for each speaker type—assuring maximum overall efficiency.

MAGNET:

Distinctive steel alloy with preferential crystal orientation to provide highest magnetic power. Each speaker magnet is individually aligned—thus damping distortion, increasing efficiency and extending the frequency response.

In all **FRS** speakers, the high range cone is of special design and makes it possible to obtain a smooth response curve, extending a full octave above 10,000—up to 20,000 cycles. Speaker designs provide energy transmission almost independent of frequency.

ADD TO... and improve any sound system with *Norelco*®
***FULL RESONANCE SPEAKERS**



Write today to Dept. E3 for brochures and prices of these unique speakers.
North American Philips Co., Inc.
 100 E. 42nd Street
 New York 17, N. Y. E-3

60 db down or better with a signal 100% modulated. Cathode-to-heater leakage in tubes can frequently occur, contributing to the presence of hum in a tuner. This is specially of concern when cathode bias is employed as it may result in hum being injected across the cathode resistor.

Some tuners have provisions for cancelling residual hum in the audio system. The circuit generally consists of a potentiometer connected across the filament windings for the audio circuits. The center arm of the control is usually grounded, and by adjusting it the hum induced by the filament can be balanced out or reduced to a minimum. However, before adjustment is ever attempted the ac power plug should be reversed to determine whether it will correct the hum condition.

Figure 6 shows one type of hum balance control which permits adjustment for the audio amplifiers. In the circuit shown a small dc positive potential is applied to the filaments equal to the normal potential difference between the cathode and filament. Under these conditions the possibility of cathode leakage is minimized. At the same time this circuit provides a means of balancing the filament circuit impedances for a minimum of induced 60 cycle voltage.

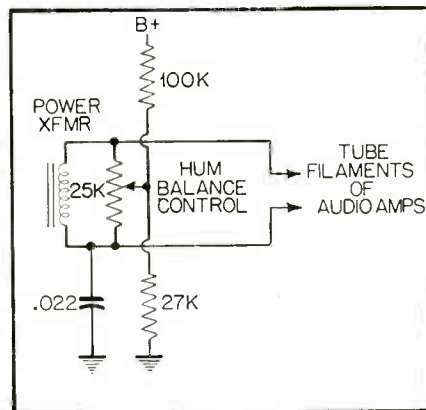

Fig. 6—Hum balance circuit used in some AM-FM tuners.

In making the adjustment for hum balance the antenna is generally disconnected and the volume control advanced to full volume. The hum balance potentiometer is then rotated to the point of optimum hum cancellation as heard from the speaker system. Of course, a scope can be employed for a more definite, visual indication.

Meters For Tuning

Accurate tuning of stations is facilitated by observing a visual movement of some type of indicator, either a meter or a tuning eye. This is particularly desirable for FM tuning. An unusual cir-

Choose the right Pliers for faster, better work!

Fine or Sturdy, Long or Short Points ...KRAEUTER makes them

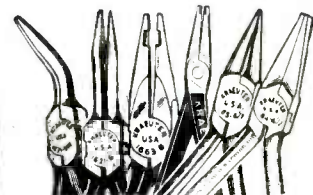

- 1631 — 5½" curved snipe nose
- 1621 — 6" snipe nose
- 1663 — 6" cutters ¼" from tips
- 71 — 8" cutters at tips of jaws
- 85 — 4½" round nose, round jaws
- 84 — 4½" flat nose

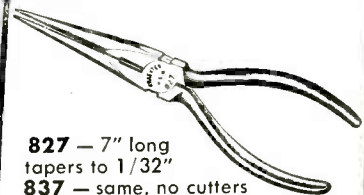

- 827 — 7" long tapers to 1/32"
- 837 — same, no cutters
- 826 — 6", 1/32" points
- 836 — 6", no cutters
- 825 — 5", 1/32" points
- 835 — 5", no cutters
- 83 — 4½", 1/32" points, no cutters

These extra-fine needle point, full polished pliers are used by the skilled electronics technician for delicate, precision wiring.

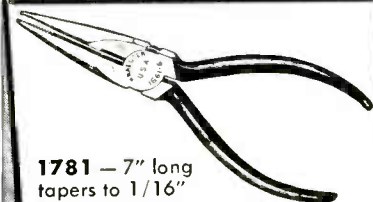

- 1781 — 7" long tapers to 1/16"
- 1771 — same, no cutters
- 1661 — 1/16" points
- 1671 — 6", no cutters
- 1641 — 5", 1/16" points
- 1643 — 5", no cutters

Standard chain nose pliers for general wiring. Polished heads, blued handles.

Your electronics distributor stocks these and other Kraeuter needle nose, diagonal, electrician's side-cutting, slip-joint, and radio-TV pliers.

KRAEUTER
 Newark, N. J.
 Fine Tools — Since 1860

cuit that enables the tuning of AM stations as well as FM stations is found in the Pilot chassis AF-850 and AF-860. (Fig. 2). These tuners make use of a meter movement connected as shown in Fig. 7.

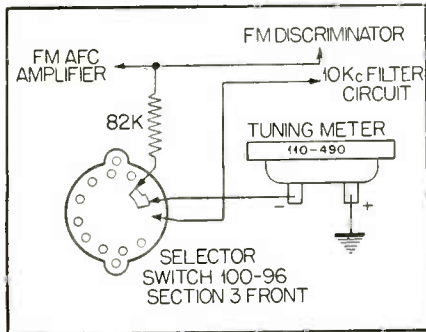

Fig. 7—Meter circuit for AM-FM tuning in Pilot model AF-860.

For the FM tuning indications as the tuning passes through a station the pointer will deflect to one side, reach a peak and reverse its motion, pass through the center of the scale, reach another peak on the opposite side of center scale, again reversing its motion and returning to center scale. The movement that takes place is a response to the normal *dc* potentials obtained from an FM discriminator circuit as the tuning progresses through a station. The correct tuning position is between peaks. At this point the rushing noise that is heard between stations will have disappeared and the signal will be reproduced with no distortion or background noise. Once the FM station has been properly tuned in, advancing the *afc* control will lock the oscillator frequency so as to hold the station in tune.

On AM tuning, the pointer will deflect towards the right when a station is tuned in and the point of maximum deflection to the right corresponds to proper tuning. It can be noted in Fig. 2 that the voltage used as an operating potential for the meter for AM tuning is obtained at the junction in the 10 *kc* filter of the 22K and 1500 ohm resistors. This potential is negative and varies in amplitude directly as the strength of the signal.

Many high fidelity tuners furnish a tuning eye of the 6E5 or 6AL7 variety to permit obtaining positive tuning through the indications of the eye. In this instance the eye is usually operated in conjunction with both AM and FM reception. Along with this there also is often made available a reference or logging scale so that the station may be located and tuned in with considerable ease and speed.

The 6AL7 electron ray indicator as used in AM-FM tuners provides a double indication of two rectangular fluorescent patterns side by side. In the

from the VOICE OF AUTHORITY IN SWEEPS...

SPOT and FIX TV FAULTS FAST!

FREE RAM BOOK SHOWS HOW!

Typical latest field-proven servicing data you'll find in your RAM book:



FAULT: "Ringing."
CAUSE: Incorrect value of balancing R-C network across one-half of H. Yoke winding.
(A): H. Yoke current wave-form. Obtained by connecting scope across 10-ohm resistor inserted in series.



FAULT: Picture compression and stretching.
CAUSE: Capacitance value of boost capacitor (connected to linearity coil) too low.
(B): H. Yoke current wave-form. Leaky boost capacitor could cause similar effect.



FAULT: Picture stretching at left and compression at right.
CAUSE: 0.02 mf boost capacitor (connected to linearity coil) used instead of 0.1 mf capacitor.
(D): H. Yoke current wave-form.

For over 10 years, RAM has specialized and pioneered in sweeps exclusively. RAM designs them, makes them, counsels TV set manufacturers on them, field-services them, educates Servicemen on them — leads the industry.

No one but RAM can bring you such proven data — as shown here and in the RAM Manual. In manufacturing know-how and field experience, you can depend on RAM for...

THE VOICE OF AUTHORITY IN SWEEPS

Send coupon today — get the BEST information from the FOREMOST manufacturer now!



RAM ELECTRONICS SALES CO. • Irvington, N. Y.
Canadian Sales Division: Telequipment Mfg. Co., Ltd., Ontario
Export Dept: Dage Corp., 219 E. 44 St., New York, N. Y.

TELCO TELCO VHF-UHF ANTENNAS

Cover the Mass Market — 109 Styles Available For Every TV Installation

WRITE for your TELCO Catalog or ask your supplier. FREE!

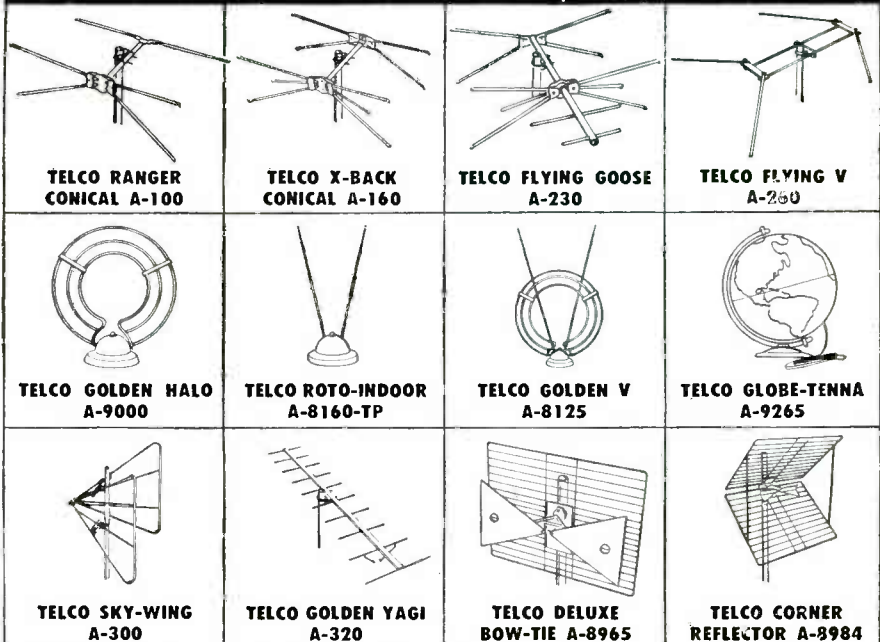

TELCO ELECTRONICS MFG. CO. • Division of General Cement Mfg. Co.

914 Taylor Avenue • Rockford, Illinois

JONKEN LEG SETS NET PRICES

(Order by Model Number
See Opposite Page)

TAPERED LEGS

(Set of 4, with 2 in 1 leg mounting brackets,
screws and your choice of glides or casters.)

BAKED BLACK ENAMEL

Model	Lg Hgt.	Price
BB-5	5"	\$5.25
BB-6	6"	5.25
BB-9	9"	5.50
BB-12	12"	5.75
BB-14	14"	5.75
BB-16	16"	6.10
BB-22	22"	6.65
BB-24	24"	6.65
BB-26	26"	6.90
BB-28	28"	6.90

SATIN BRASS

Model	Lg Hgt.	Price
SB-5	5"	\$5.95
SB-6	6"	5.95
SB-9	9"	6.25
SB-12	12"	6.60
SB-14	14"	6.60
SB-16	16"	6.95
SB-22	22"	7.60
SB-24	24"	7.60
SB-26	26"	8.00
SB-28	28"	8.00

SATIN CHROME

Model	Lg Hgt.	Price
SC-5	5"	\$5.95
SC-6	6"	5.95
SC-9	9"	6.25
SC-12	12"	6.60
SC-14	14"	6.60
SC-16	16"	6.95
SC-22	22"	7.60
SC-24	24"	7.60
SC-26	26"	8.00
SC-28	28"	8.00



1" SQUARE STEEL LEGS

BAKED BLACK ENAMEL

Model	Lg Hgt.	Price
ISS-5"	5"	\$5.05
ISS-6"	6"	5.05
ISS-9"	9"	5.30
ISS-12"	12"	5.75
ISS-14"	14"	5.75
ISS-16"	16"	5.90
ISS-22"	22"	6.10
ISS-24"	24"	6.10
ISS-26"	26"	6.25
ISS-28"	28"	6.25

SATIN BRASS

Model	Lg Hgt.	Price
IS-5B	5"	\$5.90
IS-6B	6"	5.90
IS-9B	9"	6.20
IS-12B	12"	6.30
IS-14B	14"	6.30
IS-16B	16"	6.60
IS-22B	22"	7.00
IS-24B	24"	7.00
IS-26B	26"	7.50
IS-28B	28"	7.50

SATIN CHROME

Model	Lg Hgt.	Price
IS-5C	5"	\$5.90
IS-6C	6"	5.90
IS-9C	9"	6.20
IS-12C	12"	6.30
IS-14C	14"	6.30
IS-16C	16"	6.60
IS-22C	22"	7.00
IS-24C	24"	7.00
IS-26C	26"	7.50
IS-28C	28"	7.50

Price includes set of 4 legs, mounting brackets,
screws and your choice of glides or casters.

schematic diagram provided, Fig. 8, the negative voltage from either the FM demodulator circuit or the negative *ave* voltage is switched to the elements of the electron eye tube. In either case, since the potentials are negative, the tuning is performed for the narrowest or shortest height on the fluorescent pattern. When selecting a station the tuning indicator should be rocked back and forth to obtain the narrowest possible bar on the tuning indicator which is the optimum setting. The distinct advantage of using an electronic eye such as this is that it provides a positive indication and presents a very high impedance to the circuit into which it is connected. Therefore, it can be connected without too much loading of the associated circuits.

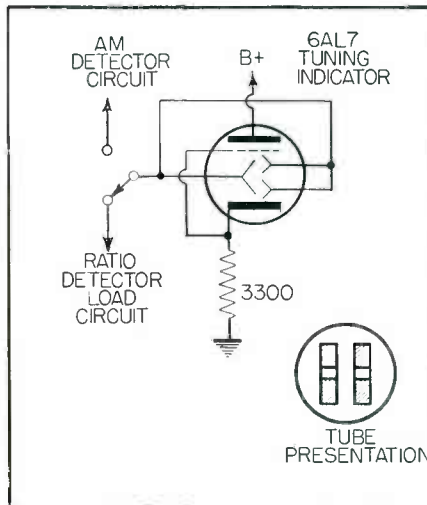

Fig. 8—Electronic tube circuit used in Stromberg-Carlson AM-FM tuner for tuning.

Binaural Broadcasting

Binaural or dual channel broadcasting involves the employment at the studio of two microphones properly positioned from each other during the origination of the programs. The two signals are radiated in the form of both AM transmissions for one, and FM transmissions for the other. When decoded in the home and applied to two speakers spaced about 7 feet apart a very close approximation of the original sounds is obtained with a stereophonic sense of depth and realism.

A very unique feature with respect to binaural reception is found in the National "Criterion" AM-FM tuner. This tuner has a function switch which when placed in the binaural position enables the AM and FM portions to be operated simultaneously and independently with individual tuning and volume controls. Two jacks are provided as low impedance outputs from the AM and FM sections respectively. They are

Merit

FIRST IN EXACT REPLACEMENT.

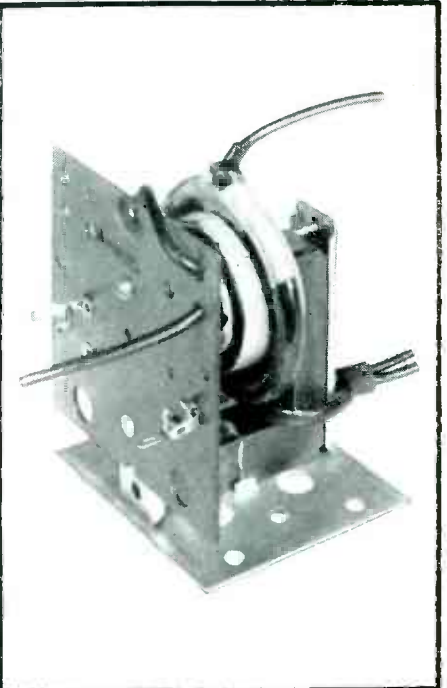

HVO-45 FOR EXACT REPLACEMENT IN WESTINGHOUSE covers 13 chassis. Another in the complete Merit line of exact and universal transformers, yokes and coils. Merit is the only manufacturer of transformers, yokes and coils who has complete production facilities for all parts sold under their brand name.

Merit

MERIT COIL & TRANSFORMER COMPANY
4427 N. CLARK ST., CHICAGO 40, ILL.

IN THE SHOP



TELE-CHECK

A PORTABLE PICTURE TUBE AND YOKE ASSEMBLY complete with 6-ft extension leads to service all T.V. Sets.

Flexible assembly permits each component to be used separately.

Available as a complete unit, or without 5AXP4 tube.

A MUST FOR EVERY SERVICEMAN LOCALIZE THE TROUBLE ON THE FIRST CALL INVALUABLE FOR BENCH WORK

Model CR-99—complete with tube Net \$39.95
Model CR-98—kit without tube Net \$24.95

IN THE HOME



10 service short cuts with TELE-CHECK. Name of nearest distributor.

Name

Address

Fig. 6

TeleMatic

TELE-CHECK

A PORTABLE PICTURE TUBE AND YOKE ASSEMBLY complete with 6-ft extension leads to service all T.V. Sets.

Flexible assembly permits each component to be used separately.

Available as a complete unit, or without 5AXP4 tube.

A MUST FOR EVERY SERVICEMAN LOCALIZE THE TROUBLE ON THE FIRST CALL INVALUABLE FOR BENCH WORK

Model CR-99—complete with tube Net \$39.95
Model CR-98—kit without tube Net \$24.95

IN THE HOME



TELEMATIC INDUSTRIES, INC.
16 Howard Ave., Bklyn. 21, N. Y.

intended to be used with two independent amplifier and speaker systems for binaural reception. This is possible in such cities as New York where binaural broadcasts have been offered by such stations as WQXR.

TUBE TESTER

[from page 23]

turbed by the addition of this accessory, so that it is not necessary to remove it when routine tube testing is done.

Referring to Fig. 6b and tracing the connections back to the basic circuit in Fig. 3, it will be seen that the heater current is made to the primary of T1 in Fig. 3. Switch S1 is a spring return type of switch, and its position determines how many turns of the primary are used. By this means three different meter ranges are provided, namely 0-5A, 0-1A, and 0-5A. The secondary circuit is connected through the plug to the meter of the basic unit. X1 of course rectifies the ac, and C1 filters it since dc is required to actuate the meter movement. The face of the meter is provided with the necessary scales for reading the heater current.

High Resistance Short Tester

Figure 7a is a photograph of the Model 49-N High Resistance Shorts Accessory Tester. Fig. 7b is its schematic. It makes possible the measurement of internal resistances of up to 2 megohms between tube elements.

Co-ordinating the schematic of Fig. 7b with that of Fig. 3 shows that the only change made in the basic circuit by the addition of this accessory is the ad-

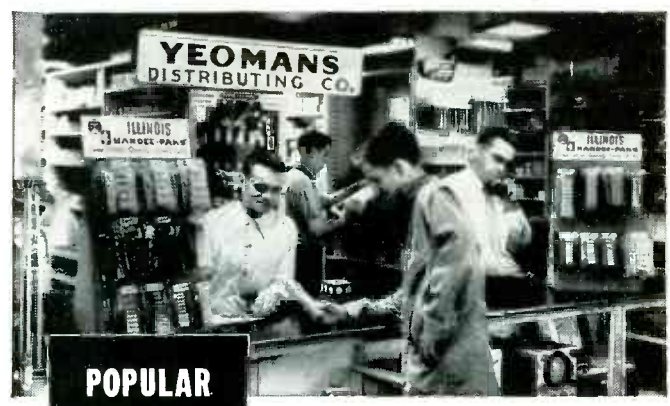

POPULAR WITH SERVICEMEN ILLINOIS "HANDEE-PAK" CAPACITOR KITS

Servicemen go for the new ILLINOIS "HANDEE-PAK" Capacitor Kit assortments because they take up little room in the service kit—are easily identified and since they are hermetically sealed in polyethylene bags, the capacitors are always factory fresh and clean!

Each PAPER CAPACITOR KIT is made up of 10 assorted new Type ITC Ceramic Cased Paper Capacitors of the capacity and voltage ratings most used by servicemen. The ELECTROLYTIC KITS consist of 5 popular types.

LOOK FOR THEM ON THE NEW JOBBER COUNTER RACKS

New ILLINOIS "HANDEE-PAKS" are available at most better jobbers—carry a few "HANDEE-PAKS" in your service kit They are the ultimate in packaging, convenience and reliability.



ILLINOIS CONDENSER CO.
1616 N. THROOP STREET CHICAGO 22, ILLINOIS

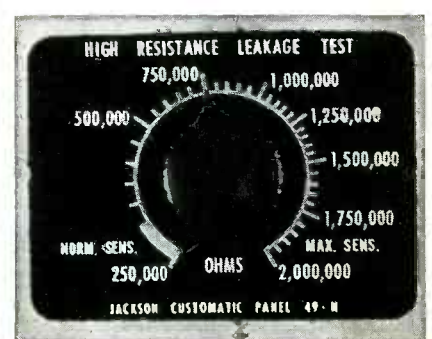

Fig. 7a—High resistance, shorts tester, Model 49N.

dition of a variable resistor in series with the 270,000 ohm fixed resistor which shunts the neon tube short indicator. The variable resistor is adjusted until the neon indicator begins to glow. The dial is calibrated to read the ohmic value of the inter-element leakage resistance at this point.

**35% More
CRYSTAL-CLEAR
at NO EXTRA Cost!**



In answer to public demand... the NEW KRYLON GIANT CAN—the biggest can of Crystal-Clear protective coating on the market (16.2 oz.)... the greatest value ever offered your customer... replacing the 12-oz. can now discontinued. PRICE REMAINS THE SAME, \$1.95 list. What a value... sales-builder... profit-maker! Order today! (Krylon 6-oz. line remains the same, 98c list.)

SPRAY ENAMELS

Yes, Krylon spray enamels also in the NEW GIANT SIZE, (16.2 oz.)—same price, \$1.69 list. Again, 35% MORE spray enamel at NO EXTRA COST! (6-oz. size 98c list) 17 colors

DULLING SPRAY

A "must" for every photographic, movie, and TV studio! Minimizes bothersome high-lights... simplifies lighting arrangements... saves preparation time. Giant can, \$1.95 list.

Zinc Chromate METAL PRIMER
Spray provides excellent bond for bare metal surfaces. Spec. MIL-P-6839-A, Type 1; Aviation supply stock No. R 52P 20405. Giant can, \$1.95 list.

Krylon-Houghton RUST VETO
Spray protects metal surfaces against corrosion... resists oxidation... displaces moisture. Giant can, \$1.95 list.

STENCIL INK Sprays for stenciling, marking, coding, etc. Increases life of stencils... speeds up work—cuts down costs! 7 colors. HIDE-a-MARK cover coat makes containers re-usable... economical. Dries rapidly. Giant can, \$1.69 list.

**ORDER FROM YOUR JOBBER
OR WRITE
KRYLON, Inc., Norristown, Pa.**

KRYLON—THE BRAND WITH THE DEMAND

Accessory Tube Socket Panel

Figure 8a is a photo of the Model 49-A Accessory Tube Socket Panel. The use of this panel makes possible testing of 4, 5, 6, 7, and subminiature 7 and 8 pin tubes. The installation in this case differs from that of the previous accessories. It is accomplished as follows:

1. The leads from the original socket panel are unsoldered at the points

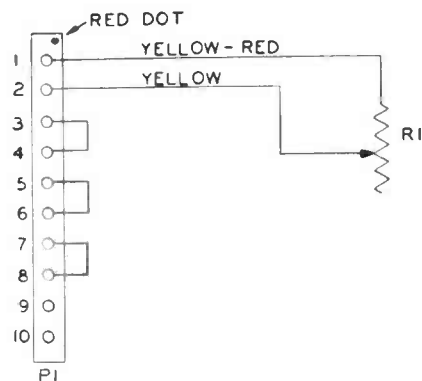

Fig. 7b—Schematic of high resistance, shorts tester.

marked 1A through 10A in Fig. 3. A perspective drawing is provided with the accessory kit to simplify the location of these points.

2. An 11 pin female connector with leads is provided with the kit. These leads are now wired to the points 1A through 10A as indicated in Fig. 8b. This prepares the tester to receive either socket panel by plug-in action.

3. The original tube socket panel is now lifted from its position at the right of the meter, after turning the retaining

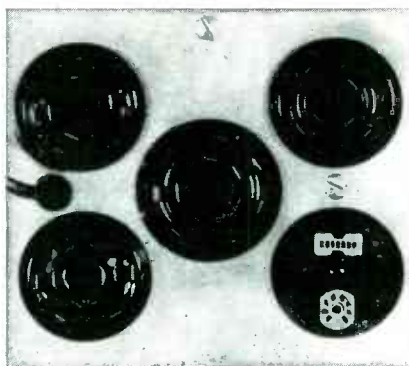

Fig. 8a—Accessory tube socket panel, Model 49A.

screw, a quarter turn. The loose hanging wires, (from step 1), are now soldered to the pins of an 11 pin male connector. Connections are made so that the wire colors will correspond for both male and female connectors.

4. The accessory socket panel comes equipped with an 11 pin male connec-

FREE



**news of
the month**

Cornell-Dubilier's "THE CAPACITOR" is keeping over 100,000 readers abreast of the latest electronic techniques and practices. Condensed, meaty-reading articles that will make your job easier and your service better. FREE—12 times a year—mailed right to your home. Join C-D readers' club—a subscription is yours FREE for the asking.

A service of
CORNELL-DUBILIER
world's largest manufacturers of capacitors



Editor—"The Capacitor"
CORNELL-DUBILIER ELECTRIC CORP.
Dept RS-36, South Plainfield, N. J.

Yes Sir! Put me down for a FREE Subscription to Cornell-Dubilier's "THE CAPACITOR"

name _____ please print

address (home) _____

city _____ zone _____ state _____

my occupation or job title is _____

**New! COLOR
& BLACK & WHITE
LAB & TV SERVICE
5" SCOPE**



**KIT
\$79.95
Factory
Wired
\$129.50**

#460

- Flat from DC to 4.5 mc to reproduce 3.58 mc sync burst and oscillator signals in color TV sets.
- V amplifier direct-coupled and push-pull thru-out; gradual roll-off beyond 4.5 mc, useful at 10 mc.
- High V sensitivity: 25 mv/in.
- Choice of direct coupling (DC) or capacitive coupling (AC).
- 4-step frequency-compensated attenuator in both AC and DC positions.
- Built-in calibrator permits peak-to-peak voltage measurement.
- Automatically syncs anything visible on the screen.
- Pre-set TV V & H sweep positions (30 cps & 7875 cps).
- Edge-lit lucite engraved graph screen with dimmer control; filter; standard bezel fits standard photographic equipment.
- 5UP1 CRT.

Prices 5% Higher on West Coast
Write for Name of Distributor
& FREE New 1956 CATALOG D-3



84 Withers St. • Bklyn 11, N. Y.

**NOW IN STOCK AT YOUR NEIGHBORHOOD
DISTRIBUTOR—ORDER NOW!**

©56

**The New NO-NOISE
TUNER TONIC**

with PERMA-FILM

Cleans, lubricates, restores all tuners including wafer type.

Won't change or affect capacities, inductance or resistance. Won't harm insulations or precious metals, nor attack plastics. For television, radio and FM. Eliminates all noise, oxidation and dirt indefinitely.

Non-toxic, non-inflammable, insures trouble-free performance.

Net to servicemen **\$3.25**

Extra economical because a small amount does the job!

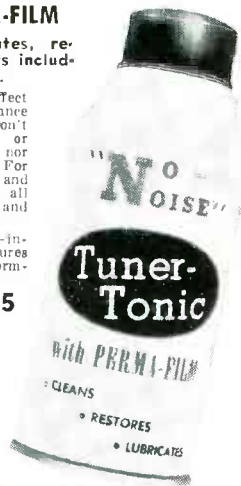

Volume Control and Contract Restorer with Perma-Film

Cleans, lubricates, protects. Net to **\$2.25**
not a carbon-tet solution. Still service-
available in the new 6 oz. men

2 oz. bottle \$1.00 Net to servicemen
Also available in 8 oz. bottles and quart cans.
At your nearest distributor
ELECTRONIC CHEMICAL CORP.
813 Communipaw Avenue, Jersey City 4, N.J.

11-Pin Connector - Bottom View

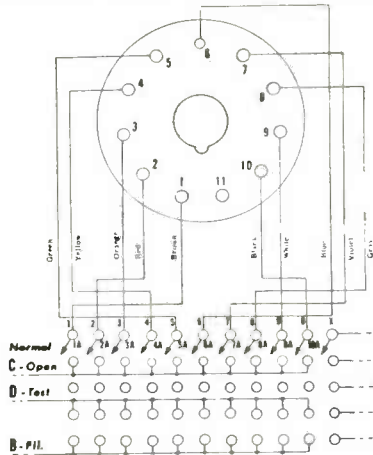

Fig. 8B—Schematic of accessory tube socket panel.

tor. Either socket panel may now be installed by simple plug-in action.

Testing Picture Tubes

An easily constructed adapter for the purpose of checking picture tubes is one in which an 8 prong octal plug is connected to a duo-decal socket by means of a harness. The harness should be long enough to allow the picture tube to be checked without removing it from the receiver cabinet.

WORKBENCH

{from page 17}

the 6SN7, 6CD6, 6BY5 were replaced individually but had no effect. If 60
[Continued on page 62]

**DON'T
JUST SAY
CAPACITORS**

Ask For
Sprague
By Catalog
Number

Know what you're getting . . .
get exactly what you want.
Don't be vague . . . insist on
Sprague. Use complete radio-
TV service catalog C-610. Write
Sprague Products Company,
71 Marshall Street, North
Adams, Massachusetts.

SPRAGUE
WORLD'S LARGEST
CAPACITOR MANUFACTURER

FOR OVER

**30
YEARS**

EBY



**HELPS YOU
SIMPLIFY
SERVICING**

WITH A COMPLETE LINE OF

**TELEVISION
HARNESSES
AND
EXTENSIONS**

EBY manufactures all types of harnesses and extensions to facilitate servicing of all makes T.V. Receivers. Complete Service Kits for individual T.V. receivers are also available. Write for descriptive literature.

All EBY Products are fully stocked in New York for immediate delivery.

Write for new catalog

EBY SALES CO. of N. Y.
130 LAFAYETTE ST.
NEW YORK 13, N. Y.

**The NEW YEATS "Shorty"
STATION WAGON & PANEL
PICK-UP APPLIANCE DOLLY**



Only 47" tall, this new Yeats dolly is designed for TV and appliance men who make deliveries by station wagon or panel delivery. No need to detach appliance for loading . . . the YEATS "Shorty" will slide into your vehicle with ease. Has same aluminum alloy frame, 30 second strap ratchet and caterpillar step glide as the standard size YEATS dolly! See your dealer today!

YEATS "Everlast" COVERS & PADS



SEND postcard for full information on our complete line TODAY!

YEATS appliance
dolly sales co.

2133 N. 12th St.

Milwaukee 5, Wis.

More Professional Servicemen Subscribe To "SERVICE DEALER" Than Any Other Technical Magazine Because Its Feature Articles and Regular Departments Have Proven To Be The Most Helpful, Accurate and Timely. 24 Issues Cost Only \$2.



You may subscribe if you are a:

- ★ Serviceman employed by a Service Organization.
- ★ Serviceman employed by a radio/TV Dealer.
- ★ Serviceman employed in industrial electronic service firms.
- ★ Independent serviceman who does not have a business establishment.
- ★ Employee of a Distributor.
- ★ Student enrolled in accredited Radio/TV Schools, Colleges, etc.
- ★ Hobbyists or experimenter.

A TYPICAL ISSUE COVERS

- Video Speed Servicing Systems
- Rider's "TV Field Service Manual" data sheets
- Latest TV Installation and Maintenance Techniques for VHF and UHF
- Auto Radio Installation and Service
- Advanced Data on New Circuitry
- Production Changes and field service data on receivers
- New Tubes
- New Test Equipment, operation and application
- Hi-Fi Installation and service
- New developments, such as transistors, color, UHF, etc.
- News of the trade
- Service Short Cuts & Shop Notes
- Explanation of difficult circuits

"Service Dealer" does not have field subscription salesmen calling on the trade. You must order your subscription direct from us or from your magazine agency.

Subscription rates: \$2.00 for 2 years \$1.00 for 1 year

RADIO-TV SERVICE DEALER

67 W. 44 St., New York 36, N.Y.

NEW RENEWAL

Gentlemen: Here is \$2.00 for which enter my 2 year subscription. (This rate applies in USA only. Elsewhere add \$1 per year)

Name

Address

City Zone State

Name of firm Owner Employee

Firm's business address.....

City Zone State

Your Position or Title.....

Check whether firm is: Service Organization or Dealer having Service Dept.

If some other type of company describe:.....

IF STUDENT, Name of School.....

cycles was sneaking into the horizontal sweep section the raster's sides would be "S" shaped. Nevertheless all the filters were bridged with new ones individually. When C705, 10 μ f, was bridged the trouble disappeared. The raster snapped back to normal. Condenser C705 was then replaced with a new 10 μ f and the receiver functioned normally. The defective C705 allowed the vertical saw-tooth voltage to sneak into the horizontal sweep section and

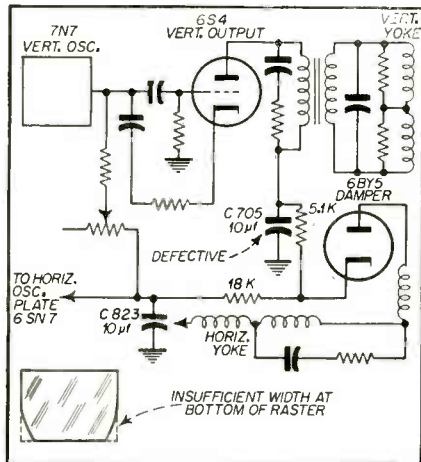

Fig. 2—Partial schematic of Philco RF 38, Deflection CPI vertical output circuit.

modulate the horizontal sweep voltage to some degree. However, the fact that

C823 was still functioning properly in its strategic position in the circuitry prevented the further *defection* of the raster.

COLOR

[from page 20]

across C1 the APC action will take effect and the bars will lock into sync.

Referring to Fig. 6, as we vary L2, notice that at the outset, where L2 is a maximum, the effective value of C_o is its real value. As we reduce L2 the effective value of C_o gets smaller and smaller. Thus, we observe that L2 provides a means for changing the effective value of C_o and therefore the tuning of the crystal.

PRACTICAL SCOPE SERVICING

[from page 12]

it to be normal. When the probe was touched to the first video amplifier grid (Fig. 8) the trouble cleared. All parts between detector and grid were tested or replaced with no results. Finally a 15 μ f condenser (about equal to the probe capacity) was wired from first video grid to ground and the set played perfectly.

RCA KCS 62, KCS 82—Raster shrinks and becomes dim

Sets would play normal for about twenty minutes, following which the raster would shrink and become dim. The set was allowed to cool off, and scope wave form drawings were made while the set was operating normally.

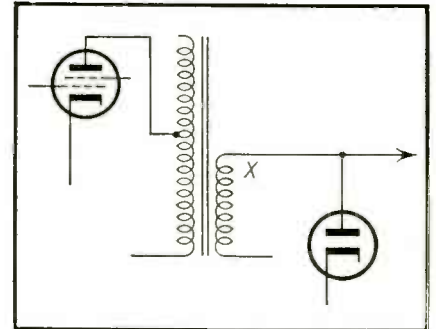

Fig. 6—Break in lead or choke shown at "X" will give rise to conditions observed in text.

The set was allowed to run until the trouble recurred. Scope readings were then compared. It was noted that the horizontal pulse amplitude at the output grid decreased by 30%. Since the pulse decreased much less at the side of the coupling condenser, the condenser was changed but without effect. A careful visual inspection showed that the

SPECIAL OFFER TO OUR READERS!

By special arrangement with John F. Rider Publisher, Inc., RADIO-TV SERVICE DEALER now brings you a COMPLETE diagram service to help you do a faster, easier servicing job!

ALL COMPLETE! ALL FACTORY PREPARED! ALL FACTORY AUTHORIZED!

- ✓ Just \$1.25 for COMPLETE SERVICING INFORMATION on any TV receiver . . . any year, any make, any model . . . from 1946 on!
- ✓ Just 75¢ for COMPLETE SERVICING INFORMATION on any radio . . . any year, any make, any model . . . from 1941 on!

TAKE ADVANTAGE OF THIS SPECIAL OFFER . . . MAIL THE COUPON TODAY!

Radio-TV Service Dealer, 67 W. 44 Street, New York 36, N. Y.

Please RUSH me the following diagrams:

RADIO DIAGRAMS @ 75¢ EACH		
CHASSIS #	MAKE	MODEL #

TV DIAGRAMS @ \$1.25 EACH		
CHASSIS #	MAKE	MODEL #

MAKE ALL CHECKS & MONEY ORDERS PAYABLE TO Radio-TV Service Dealer
(For all New York City orders, please submit additional 3% sales tax.)

Name
Address
City State

.47 μ f condenser was dressed near the drive trimmer and was leaking oil or soft wax on the trimmer. Replacing the trimmer and repositioning the .47 μ f condenser effected a permanent cure.

RCA Sets using direct drive—narrow width

The raster had snapped down to two or four inches wide. A routine scope check indicated that the pulse feeding the 6BG6 grid was much too high in frequency and low in amplitude. These

TUBES

These are *not* used tube bargains. All CECO tubes are factory fresh. Prices are as low as quality permits. Write today for free tube list. You'll be glad you did.

CECO ELECTRONICS CO.
Columbia Ave. at 18th
Irvington 11, N. J.

**DON'T JUST SAY
CAPACITORS**

Ask For Sprague By
Catalog Number

Know what you're getting . . . get exactly what you want. Don't be vague . . . insist on Sprague. Use complete radio-TV service catalog C-610. Write Sprague Products Company, 71 Marshall Street, North Adams, Massachusetts.

SPRAGUE
WORLD'S LARGEST CAPACITOR MANUFACTURER

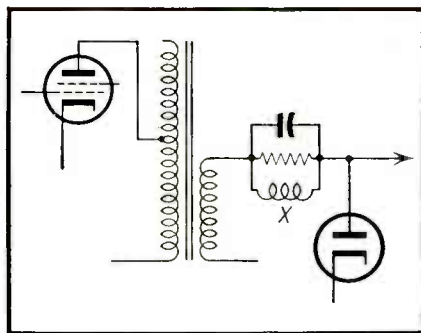

Fig. 7—Break in lead or choke at "X" in the above figure gives rise to conditions discussed in text.

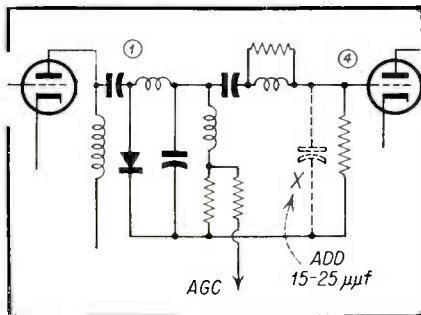

Fig. 8—Adding capacitor as shown cleared up video oscillation. All points between 1 and 4 scoped OK with video amplifier out of set. Use smallest value of capacitance (without affecting detail) to clear up trouble.

sets use the synchroguide horizontal oscillator system. When further checking showed the *dc* voltages did not change in proportion to the frequency, the trouble was diagnosed as shorted turns in the oscillator transformer, or an open in the 180 μ f feedback condenser. Tack soldering a new condenser in the circuit made the set play OK. After the set played for several hours the condenser was permanently wired in. The interesting condition here is that while the frequency is too high to match the yoke inductance for wide deflection, it still builds up plenty of high voltage in the horizontal transformer, only in the direct drive circuit is this possible.

SHOOT TV TROUBLE FAST!

With H. G. Cisin's Copyrighted RAPID "TV TROUBLE SHOOTING METHOD"

Without experience or knowledge, this guaranteed new method of servicing TV sets enables you to DIAGNOSE TV troubles as rapidly as an expert. **NO THEORY—NO MATH**—you can locate all faults in record-breaking time, regardless of make or model. "TV TROUBLE SHOOTING METHOD" is the most valuable aid to TV servicing ever written. Be a TV Trouble Diagnostician. Increase your present earnings. Open your own Profitable Business or get a high-paying skilled job.

It's all in this book . . . Nothing more to Pay—Nothing else to Buy Alphabetically listed there are 85 picture troubles, over 58 raster and 17 sound troubles and by this unique copyrighted method you know EXACTLY WHERE the trouble is; plus step-by-step instructions, including 89 RAPID CHECKS, enabling you to find the faulty part.

13 IMPORTANT PRELIMINARY CHECKS NEED NO INSTRUMENTS! Of the 89 Rapid Checks, **OVER 65 ALSO REQUIRE NO INSTRUMENTS!** Rapid checks include emergency checks for distorted pictures, defective tubes including PIX tube, plus 57 others. **ALL EXPLAINED IN SIMPLE LANGUAGE, PERFORMED WITHOUT INSTRUMENTS. MANY CHECKS USE THE PICTURE TUBE AS A GUIDE.**

H. G. Cisin, the author, is the inventor of the AC/DC midset radio. He licenses RCA, AT&T, etc. He has also trained thousands of technicians now owning their own prosperous TV service organizations or holding highly paid TV positions. His years of experience are embodied in this remarkable new TV TROUBLE SHOOTING METHOD. **Guaranteed. Money Back in 5 Days if Not Satisfied!**

ABSOLUTELY FREE with each order: H. G. Cisin's newest book "TV & RADIO TUBE SUBSTITUTION GUIDE." Gives direct replacements of set and picture tubes. Most valuable servicing aid! **ACT NOW**—get both books postpaid at cost of only one! **\$1** Post-paid

RUSH COUPON NOW!

H. G. CISIN, CONSULTING ENGINEER.
Amagansett, N. Y. (Dept. D-2)
Enclosed find \$1. Rush both books.

Name _____
Address _____
City _____ Zone _____ State _____

Only TOP-QUALITY brands of STANDARD BRAND TUBES

NEW . . . FIRST QUALITY. Each tube carries a ONE YEAR GUARANTEE. Latest datings, no rejects, no rebrands or reworked bargains.

Name Brand
6AF4A98
Replaces 6AF4

WHILE THEY LAST!

6S17	50c	6SL7	63c
6AK5	49	6SN7	66
6AC7	50	6VGGT	56
6AG7	49	12AT7	79
6AL5	45	12SH7	62
12BH7	72	6AU6	54
12AX7	72		

Act Fast — WHILE THEY LAST! FILTER CONDENSERS

250 mfd—150V	120 mfd—150V	50 mfd—25V	39c
Fresh Paper Packs			
20 mfd—25V	20 mfd—25V	Fresh Paper Packs	39c
140 mfd—300V	200 mfd—150V	5 mfd—300V	30
6 mfd—150V	Fresh Paper Packs		39c
100 mfd—300V	200 mfd—200V	40 mfd—200V	30c
Fresh Paper Packs			
80 mfd—300V	40 mfd—250V	100 mfd—50V	10
mfd—450V	Fresh Paper Packs		39c
120 mfd—150V	FOR LATEST TV REC.	Fresh Paper Packs	29c
40 mfd—350V	40 mfd—350V	20 mfd—350V	20
mfd—350V	Fresh Paper Packs		39c
40 mfd—450V	40 mfd—450V	80 mfd—25V	CAN
			49c

GOV'T SURPLUS 6AG551c

NAME BRAND SELENIUM RECTIFIER
350MA99c 500MA \$1.39
No Order Too Small. Merchandise shipped within 24 hours of receipt of order. 25% deposit required with order. F.O.B. Brooklyn.

FEDERATED TELEVISION MART, INCORPORATED

513 Rogers Ave., Dept. RS, Brooklyn 25, N. Y.

Please use this coupon promptly to obtain more technical information on antennas, test equipment and components — simply check the key numbers below . . .

NEW PRODUCTS DEPT. ROOM 510
RADIO TELEVISION SERVICE DEALER
67 West 44th St., Send me more information on these items. My letterhead or business card is enclosed.
New York 36, N. Y.

<input type="checkbox"/> C30	<input type="checkbox"/> M30
<input type="checkbox"/> C31	<input type="checkbox"/> M31
<input type="checkbox"/> C32	<input type="checkbox"/> M32
<input type="checkbox"/> C33	<input type="checkbox"/> M33
<input type="checkbox"/> C34	<input type="checkbox"/> M34
<input type="checkbox"/> C35	<input type="checkbox"/> M35
<input type="checkbox"/> C36	<input type="checkbox"/> M36
<input type="checkbox"/> C37	<input type="checkbox"/> M37
<input type="checkbox"/> C38	<input type="checkbox"/> M38
<input type="checkbox"/> C39	<input type="checkbox"/> M39

This Offer Expires May 1, 1956. March, 1956

Name _____
Firm (please enclose company letterhead or business card) _____ my position _____
Business Address _____
City _____ Zone _____ State _____

Only the 5 TOP-QUALITY brands of
STANDARD BRAND TUBES

AT SENSIBLE PRICES!

- RTMA Guarantee
- 1st quality only
- No private brands
- No rebrands or rewashed bargains
- Individually boxed
- Brand New
- No rejects

FREE! Newest handy air-mail order form for your ordering convenience.—Free!
• Lists ALL popular TV & radio types.
• Makes mail-ordering a real pleasure.
• Orders over \$25.00 (with remittance) postpaid

0Z4	.50	6AT6	.55	7G7	1.15
1AX2	1.00	GAT8	1.10	7H7	.85
1B3GT	.80	8AU4GT	1.05	7J7	1.35
1H5GT	.80	6AU5GT	1.25	7K7	1.20
1L4	.85	6AU6	.70	7L7	1.15
1L6	1.10	6AU7	.90	7N7	.95
1LA4	1.00	6AV5GT	1.22	7Q7	1.00
1LA6	1.00	6AV6	.55	7R7	1.30
1LB4	1.00	6AX4GT	.85	7V7	1.30
1LC5	1.00	6AX5GT	.75	7W7	1.30
1LC6	1.00	6BA5	.65	7Y4	.70
1LD5	1.00	6BA7	.80	7Y4	1.00
1LE3	1.00	6BC4	1.60	7Z1	.70
1LG5	1.00	6BC5	.70	12A4	.85
1H4	1.00	6BC7	1.25	12A5	.70
1LN5	1.00	6BD5	1.40	12A5	.75
1N5GT	.95	6BD6	.75	12A7	.95
1Q5GT	1.15	6BE6	.70	12A7	.65
1R4	1.00	6BF8	.70	12A7	.80
1R5	.85	6BF8	.70	12AV6	.55
1S4	.90	6R6G	1.80	12AV7	1.00
1S5	.70	6BH6	.80	12AW6	1.00
1T4	.80	6BJ6	.85	12AX4GT	.90
1T5GT	1.05	6BK5	1.00	12AX7	.80
1U4	.75	6BK7A	1.10	12AZ7	1.75
1U5	.70	6BL7GT	1.15	12AZ7	.90
1V	.95	6BN6	1.15	12B4A	.85
1V2	.70	6B6GTA	1.4	12B4A	.85
1X2B	.95	6DQ7A	1.20	12BA6	.65
2AF4A	1.40	6BX7GT	1.25	12BA7	.95
2D21	1.00	6BY5G	1.30	12FD6	.75
2X2	.50	6BZ7	1.25	12BE6	.70
3A3	1.10	6C5	.50	12BF6	.65
3A4	.85	6CB5	4.50	12BH7A	.95
3A5	.75	6CB6	.70	12BK5	1.00
3AL5	.85	6CD6G	1.80	12BQ6GTB	1.40
3AU6	.70	6CFR	.90	12BY7A	.95
3AV6	.50	6CG7	.85	12BZ7	1.00
3BC5	.80	6CG7	.85	12C06	1.40
3BN6	1.05	6CM6	.85	12C7GT	.85
3BY6	.75	6CS8	.75	12SC7	.80
3CB6	.80	6CU8	1.40	12S17	.75
3CF6	.90	6D6	1.15	12SKGT	.75
3LF4	1.20	6DF5	.85	12SL7GT	1.00
3Q4	.85	6FG6	.85	12SN7GTA	.80
3Q5GT	1.00	6H8	.75	12S07GT	.70
3S4	.80	6J18	3.95	12SK5	.75
3V1	.85	6J5	.50	14A4	1.00
4T07A	1.00	6J6	.70	14A5	1.50
4BZ7	1.35	6J7	.95	14A7	.85
5AM8	1.05	6K6GT	.70	14AF7	1.00
5AN8	1.10	6K7	.90	14B6	.85
5AQ5	.75	6KR	1.25	14C7	1.00
5AS8	1.10	6L6GA	1.30	14E6	1.20
5AT8	1.10	6L6M	1.7	14E7	1.30
5AY8	1.15	6N7	1.20	14F7	1.00
5AW4	1.15	6Q7	1.00	14F8	1.30
5AZ4	.60	6SA	.65	14H7	1.00
5I6	.90	6SGT	1.10	14I7	1.00
5T4	1.75	6SA7GT	.85	14O7	.95
5U4G	.80	6SC7	.90	14R7	1.30
5U4GB	.70	6SF5	.75	14S7	1.25
5U8	1.10	6SF7	.95	14W7	1.35
5V4G	.95	6SG7	.95	19BG6G	2.00
5V6GT	.70	6SH7	.95	19T8	1.20
5W4GT	.70	6SJ7M	.75	25AV5GT	1.30
5X4G	.80	6SKGT	.75	25AX4GT	1.10
5XR	1.05	6SL7GT	1.00	25BK5	1.00
5Y3GT	.35	6SN7GTA/B	.80	25BQ6GTB	1.40
5Y4G	.65	6SQ7GT	.70	25CD6GA	1.80
5Z3	.90	6SR7	.75	25CU6	1.35
5Z4	1.25	6T8	1.05	25L6GT	.70
6A8GT	1.10	6U8	1.05	25W4GT	.75
6AB4	.65	6V3A	1.30	25Z5	.80
6AC5GT	1.18	6VRGT	.65	25Z6GT	.65
6AC7	1.10	6V6M	.30	35A5	.70
6AD7G	1.35	6W4GT	.70	35B5	.70
6AF4	1.90	6W6GT	.90	35C5	.70
6AF6G	1.20	6X4	.50	35L6GT	.65
6AG5	.75	6X5GT	.55	35W4	.45
6AG7	1.35	6XR	1.00	37Z5	.70
6AH4GT	.85	6Y6G	.95	37Z5	.45
6AH6V	1.00	7A5	.95	41	.85
6A15	1.75	7A6	.80	42	.75
6AK5	.75	7A7	.85	43	.85
6AK6	.80	7A8	.80	50A5	.70
6AL5	.60	7AG7	1.00	50B5	.70
6AL7GT	1.65	7AH7	1.00	50C5	.70
6AM4	1.55	7B5	.80	50L6GT	.65
6AN8	1.15	7B5	.70	50X6GT	.90
6AN4	1.80	7B6	.80	50Y6GT	.80
6AN5	3.50	7B7	.80	50Y7GT	.80
6AN8	1.20	7R8	.90	70L7GT	1.55
6A05	.70	7C5	.80	80	.80
6A06	.60	7C6	.80	117L7GT	.65
6AQ7GT	1.20	7C7	.80	117N P7	2.50
6AR5	.75	7E7	1.20	117Z3	.70
6AS5	.75	7E7	1.20	117Z4GT	1.15
6AS6	2.25	7F7	.90	117Z6GT	1.15
6AS8	1.20	7F8	1.20		

You may include in your order types not listed. We stock over 1000 types including Diodes, Transistors, transmitting and Special Purpose types.

CASH PAID for excess tube inventories. Must be new, boxed and clean. WRITE!

TERMS: 25% with order, balance C.O.D. All merchandise guaranteed. F.O.B. N.Y.C.
BARRY ELECTRONICS CORP.
Dept. 5D
512 Broadway, N. Y. 12, N. Y.
Walker 5-7000

Advertising Index

American Phenolic Corp.	12
American Scientific Development Co.	48
B & K Manufacturing Co.	49
Barry Electronics Corp.	64
Bussmann Manufacturing Co.	3
CBS-Hytron	Cover 2
Ceco Electronics Co.	63
Chicago Standard Transformer Corp.	51
Cisin, H. G.	63
Cornell-Dubilier Elec. Corp.	7, 59
Eby Sales Co.	60
EICO	60
Electronic Chemical Corp.	60
Electro Products Labs, Inc.	14
Elektronic Bargain House	56, 57
Federal Telephone & Radio Corp.	Cover 3
Federated Television Mart	63
General Cement Mfg. Co.	48, 52, 55
Health Company	52
Hickok Elec. Instrument Co.	47
Illinois Condenser Co.	58
Jackson Electrical Instrument Co.	64
Kraeuter Company	54
Krylon, Inc.	59
Mall Tool Company	28
Merit Coil & Transformer Co.	57
North American Phillips Co. Inc.	54
Philco Corporation	8
Pyramid Electric Company	13
Radiart Corporation	7
Ram Electronic Sales Co.	55
Raytheon Manufacturing Co.	4, 5
RCA Tube Dept.	Cover 4
Rider, John F. Publisher	15
Sams, Howard W. & Co.	41
Simpson Electric Co.	43, 50
Sonotone Corporation	45
Sprague Products Co.	60, 63, 64
Telematic Industries, Inc.	58
Vaco Products Co.	46
Vokar Corporation	50
Walsco Electronics Corp.	16
Yeats Appliance Dolly Sales Co.	60

DON'T JUST SAY CAPACITORS

Ask For Sprague By Catalog Number

Know what you're getting . . . get exactly what you want. Don't be vague . . . insist on Sprague. Use complete radio-TV service catalog C-610. Write Sprague Products Company, 71 Marshall Street, North Adams, Massachusetts.

SPRAGUE

WORLD'S LARGEST CAPACITOR MANUFACTURER

JACKSON INSTRUMENTS
make more profits

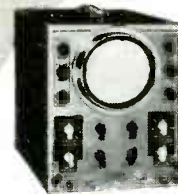

Model CRO-2
Wide Band Oscilloscope
\$22500 Dealer Net.

Flat within 1 db, 20 cycles thru 4.5 mc.* Maximum deflection sensitivity .018 r.m.s. volt-per-inch. Incorporates Horizontal Sweep Expansion, Sweep Polarity Reversal, big 5-inch CR tube, Linear Sweep Oscillator 20 cycles thru 50 kc.

*NOTE: Scopes down 3 db at 4.5 mc. are actually down 30%!



Model TVG-2
Television Generator
\$25995 Dealer Net.

Complete television Signal Generator for VHF, IF, color. Sweep Oscillator 20 kc. thru 216 mc. all on fundamentals. Sweep width 0 thru 18 mc. Marker Oscillator 4 mc. thru 216 mc. Separate Crystal Oscillator.

NEW!

Model 49 Tube Tester

with Plug-In Accessories

\$4995

Dealer Net.



Accessory Testers as low as \$6.95.

Brand new, fully flexible tube tester with plug-in accessories for making other tests. Lever action and big 4 1/2" meter, plus speed chart for rapid testing. Accessories for measuring Heater Current, High Resistance Shorts to 2 megohms, and checking selenium rectifiers now available, others soon.

Available from Leading Distributors

JACKSON

"Service Engineered" Test Equipment
16-18 S. Patterson Boulevard Dayton 2, Ohio
In Canada: The Canadian Marconi Co.

TOP performance for TV anywhere!

Federal's "ALL-STAR" LEAD-IN TEAM

*Urban, fringe or distribution system . . .
heat, rain, dust, snow, ice, salt spray,
polluted air . . . whatever the conditions
you'll find a winner in these dependable
Quality-Controlled Cables by "FTR"*

North, East, South, West . . . wherever there are TV customers . . . Federal's "All-Star" Lead-in Team can be depended upon to deliver *championship performance* . . . !

These six popular types are outstanding examples of the quality, ruggedness, efficiency and long life built into every foot of Federal Cable. Whatever the run requirements or local weather conditions the Federal "All-Stars" will score high in satisfaction . . . with you and your TV customers.

Federal lead-ins can be installed with utmost confidence, because they are engineered and manufactured by a *pioneer* cable maker . . . and "Certified by a World of Research" . . . through the International Telephone and Telegraph Corporation.

Check the high points of Federal's "All-Star" Lead-in Team . . . then get in touch with your Federal Distributor. Always specify "Federal" . . . keep those TV installation profits instead of paying them back in call-backs!

*"America's leading producer of
solid dielectric cables"*

Federal



A DIVISION OF



High Volume-Low Price TV Lead-in

TV-1190



Economical and Efficient

TV-1190—300-ohm heavy-duty lead-in with 90 mil. web. Has 7/#28 copper strands. Economical and highly efficient. Insulated with Federal-developed "silver" polyethylene for long life. Also available in brown.

TV-2000



Another Low-cost Leader

TV-2000—300-ohm dumbbell-shaped lead-in with 55 mil. web. Has 7/#30 copper strands. A high-value, low-cost type for the average installation. Cinnamon-brown color is protection against ultra-violet.

"Quality-Controlled" TV Lead-in & Cable

TV-1182



Heavy-duty Type

TV-1182—300-ohm deluxe type heavy-duty long life lead-in with 7/#28 copper strands, 100 mil. web. Available in "silver" or brown polyethylene. Resists weather, heat, sun. Very low line loss in fringe areas.

TV-1184



Quality plus Economy

TV-1184—300-ohm dumbbell-shaped, standard, economy type lead-in with 7/#28 copper strands, 70 mil. web, for urban areas with no unusual conditions. Cinnamon-brown color is highly effective in resisting ultra-violet.

Community TV Lead-in

59/U
Type



Secondary Lead-in

59/U Type—73-ohm coaxial lead-in. Highly efficient as a Community TV pole-to-house tap-off. Meets all needs wherever a high-grade installation is a must. Ideal for use with unbalanced input TV receivers.

Rotor Lead-in

TV-1188



TV-1188—Rugged, dependable, long-life rotor lead-in. Weather-resistant. Insulated with "silver" vinyl. Three 7-strand conductors of .0121 AWG soft bare and one conductor of .0121 AWG tinned soft bare.

For data on other types, write Dept. D-485A

Federal Telephone and Radio Company

A Division of INTERNATIONAL TELEPHONE AND TELEGRAPH CORPORATION
COMPONENTS DIVISION • 100 KINGSLAND ROAD • CLIFTON, N. J.

In Canada: Standard Telephones and Cables Mfg. Co. (Canada) Ltd., Montreal, P. Q.
Export Distributors: International Standard Electric Corp., 67 Broad St., New York



"BACKGROUND QUIETNESS"

...for new "front-end" performance!

A MAJOR ENGINEERING FEATURE OF RCA RECEIVING TUBES

Known for their ability to hold tube noise to surprisingly low levels—and produce a cleaner TV picture for the customer—RCA Receiving Tubes are making even more friends with servicemen the country over.

Take a few of the improvements that contribute to background quietness in the famous "front-end" tube—the RCA-6BQ7A: Gold-plated grids reduce reverse grid current; extra heater-to-cathode insulation lowers leakage current and reduces hum; larger grid and cathode connectors minimize "induced" grid noise. . . . features that can give new "front-end" performance!

For increased "background quietness" and a cleaner picture, always replace with RCA Receiving Tubes—and say goodbye to costly callbacks.



RECEIVING TUBES
RADIO CORPORATION OF AMERICA