

SEPTEMBER, 1952

Radio-Television SERVIC DEALER

MAY 27
MUSIC
CHESTER J. BRESHER
21 10 57
30



The Professional Radio-TVman's Magazine

IN THIS ISSUE:

Horizontal Deflection Circuit Theory
Your Hi-Fi Market, Part I
Is D-C Restoration Necessary?
TV Sync Circuits, Part I
Broad Band Yagi Antennas

AM-FM-TV-SOUND

ACTUAL SIZE

New CBS-HYTRON

Germanium Diodes

Guaranteed Moisture-Proof!

GENERAL PURPOSE TYPES

1N48

1N51

1N52

1N63

1N64

1N65

1N69*

1N70*

1N75

1N81*

*JAN TYPES

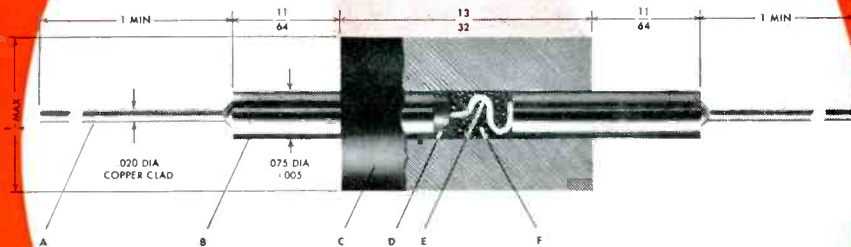

Mechanical Specifications

- A. .020" copper-clad wire
- B. Nickel-silver "clip-in" pin
- C. Glass-filled plastic case
- D. Germanium crystal soldered directly to base
- E. .005" tungsten cat whisker
- F. Moisture-resistant impregnating wax

WHY CBS-HYTRON GERMANIUM DIODES ARE BETTER RECTIFIERS

1. **MOISTURE-PROOF** . . . eliminates humidity and contamination problems
2. **SELF-HEALING** . . . self-recuperating from temporary overloads
3. **SUBMINIATURIZED** . . . only 1/2 inch long, 1/4 inch in diameter
4. **SOLDERED WAFER** . . . omission of plating eliminates flaking
5. **LOW SHUNT CAPACITY** . . . 0.8 μf d average
6. **SELF-INSULATING CASE** . . . mounts as easily as a resistor
7. **EXCEPTIONAL LIFE** . . . 10,000 hours minimum under rated conditions
8. **NO FILAMENTS** . . . low drain, no hum

Vital germanium wafer in a CBS-Hytron diode is *guaranteed moisture-proof*. Sealed against deadly moisture . . . fumes . . . and contamination, a CBS-Hytron diode keeps moisture where it belongs . . . out! First, by a chemically and electrically inert impregnating wax. Second, by a glass-filled phenolic case. With *moisture-proof* CBS-Hytron germanium diodes, you can be sure of maximum trouble-free life.

Superior techniques also permit CBS-Hytron to omit plating of the germanium wafer. Soldering is directly to the base. Thus flaking is eliminated and quality improved. Universal design of CBS-Hytron diodes follows Joint Army-Navy specifications. "Clip-in" feature gives you versatility, ruggedness, and electrical stability. Flexible pigtailed of copper-clad steel welded into sturdy nickel pins also insure you against damage by soldering heat.

Check the eight important-to-you reasons why CBS-Hytron *moisture-proof* germanium diodes are better rectifiers. Send today for complete data and interchangeability sheets. Specify CBS-Hytron *guaranteed moisture-proof* diodes for superior, trouble-free operation.



SALEM, MASSACHUSETTS

THE WORLD'S FIRST BROAD BAND YAGI!

CHANNEL MASTER'S
new **futuramic**



The first antenna ever built that combines . . .

- Broad band coverage *with the*
- High gain and directivity of the Yagi

*Designed for service TODAY and TOMORROW --
in these 3 booming VHF markets:*

Horizontal
Polar Pattern

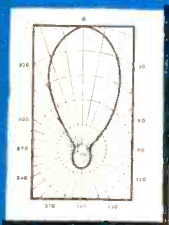

**BOOM
BRACED**

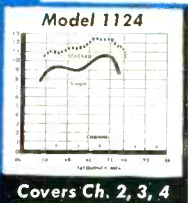
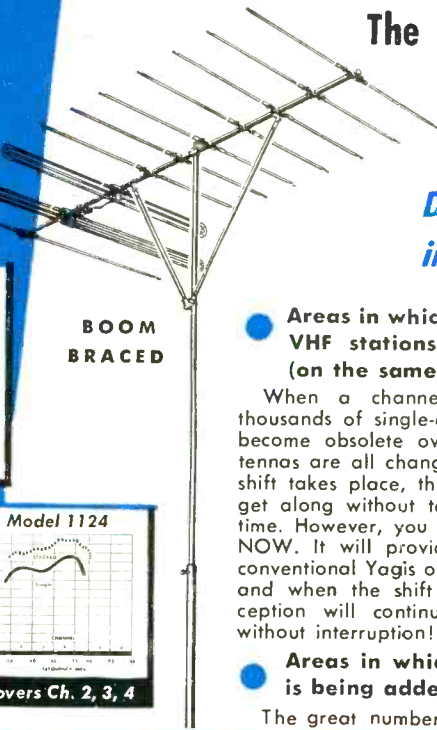

- Areas in which the FCC has ordered VHF stations to change channels (on the same band).

When a channel-shift takes place, the thousands of single-channel Yagis in use will become obsolete overnight. Unless such antennas are all changed on the same day the shift takes place, the set owner will have to get along without television for a period of time. However, you can install the Futuramic NOW. It will provide better reception than conventional Yagis on the present channels — and when the shift occurs, this superior reception will continue on the new channel without interruption!

- Areas in which a new VHF station is being added to the present one.

The great number of single-channel Yagis

now in use will not bring in the new channel. If an additional Yagi is installed, it will have to be tied into the present installation with separate leads and a switching system. However, ONE Futuramic will do the job of BOTH antennas — at lower cost — with better results on both channels.

- Areas served at present by two or more VHF stations (on the same band).

In such areas, the installation man has had to compromise between conventional broad band antennas, and separate Yagis for each channel. Only the Futuramic will give you the full advantages of both. It combines highest gain and sharpest directivity with simple, economical installation.

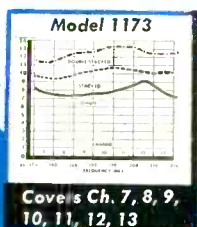
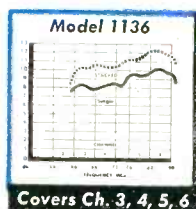
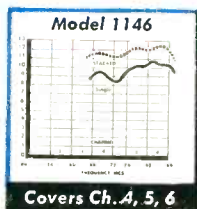
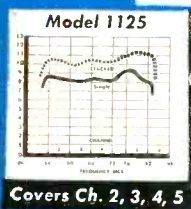

Model No.	Channels Covered	List Price
1173	7, 8, 9, 10, 11, 12, and 13	\$20.83
1124	2, 3, and 4	\$40.97
1125	2, 3, 4, and 5	
1136	3, 4, 5, and 6	
1146	4, 5, and 6	

SHATTERS all performance records!

- Channel for channel, the Broad Band Futuramic will outperform any conventional SINGLE-CHANNEL Yagi.
- On each of its specified channels, one single Low Band Futuramic will outperform any 4-bay conical or fan array.
- A single High Band Futuramic will outperform any 2-bay conical or fan array on every channel from 7 to 13.
- A high-low Futuramic combination is the most sensitive array ever devised for all-channel VHF reception.
- And the Futuramic uses Channel Master's famous Z-Match system for maximum stacking gain.

Write for complete technical literature.

CHANNEL MASTER CORP.

ELLENVILLE, N. Y.

Now

A SELENIUM RECTIFIER TESTER

The **ONLY** instrument ever designed to provide The Four Essential Tests for Selenium Rectifiers used in radio and TV receivers:

- 1 Opens**
TESTS 2 Shorts
FOR 3 Forward Conductivity
4 Reverse Leakage

Never before has this been possible with a single, popular-priced instrument!

New

Model 100-A

GALVANIC

SELETESTER

SPECIFICATIONS AND FEATURES:

- Eliminates the totally inadequate substitution and ohmmeter tests which frequently cause damage to other expensive components.
- Checks rectifiers in half-wave circuits without unsoldering leads.
- No guesswork . . . simple one-directional scale provides immediate positive reading of both forward and reverse.
- Non-obsolete . . . will test all presently-made radio and TV power supply selenium rectifiers, and any that may be made in the future.
- Large, easy-reading 4 5/8" D'Arsonval-type rect. meter.
- Power requirements: 117 volts, 60 cycles AC.
- Dimensions: 5 1/2" x 4" x 10".
- Shipping weight: approximately 6 pounds

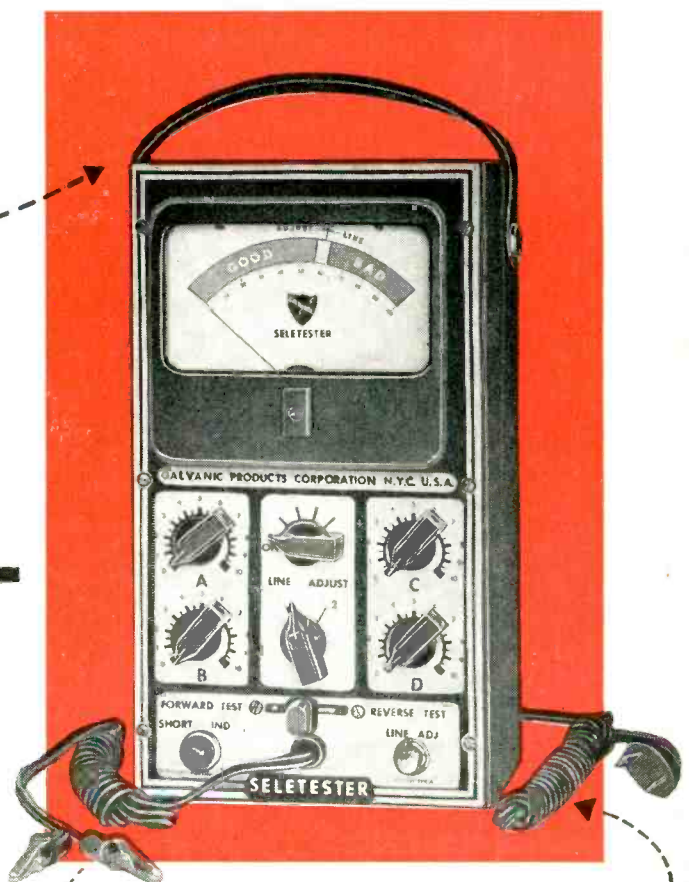

Model 100-A Seletester, complete with 3 ft. test leads, insulated alligator clips, 6 ft. line cord, detailed instruction manual.....\$39.95 net



Ask your local Radio Parts Distributor for a demonstration of the Seletester, or write directly to factory for detailed literature.

GALVANIC PRODUCTS CORPORATION

110 East Hawthorne Avenue

Valley Stream 12, N. Y.

EDITORIAL

by S. R. COWAN

Our New HI-FI Audio Department

This issue contains the first installment of our new department which will cover every phase of building, installing and servicing high fidelity audio systems. Years of research and preparation lie behind the venture. Dozens of angles and outlines were analyzed before an acceptable and we believe fool-proof, program was decided upon.

Hi-Fi audio reproduction for the mass market is a relatively new art. In May 1947, the publisher of "Service Dealer" launched a magazine called "Audio Engineering." It was a smash success from its inception and still is regarded in highest esteem as the authority in the field of audio engineering progress. We mention this merely to establish the fact that the specialized art of publishing in the audio field is not new or experimental as far as "Service Dealer's" staff is concerned.

High fidelity audio hobbyists, from now on, will provide radio servicemen and service dealers with a tremendously profitable share of their expenditures. Unlike short-wave and amateur radio hobbyists, comparatively few audiophiles and music lovers enjoy building and installing their own equipment, and hardly any of them have the skill or inclination to service their own equipments when a fault occurs or a modification is desired (as it frequently is).

Hi-Fi audio reproduction and quality sound distribution is, as stated before, a new art. Radio technicians, thoroughly trained in radio circuitry, will find that Hi-Fi audio, like television, requires know-how that can only be gained from newly acquired learning and practical experience itself. To that end our new department is aimed.

The financial rewards to those who engage in Hi-Fi installing and servicing will justify their participation. Hi-Fi enthusiasts and music lovers are known to be liberal spenders, and they are usually very well informed about their hobby, too. The many thousands of audio hobbyists and the millions of dollars worth of high fidelity installations that are already in use are collectively bringing new converts into the field hourly. That's where our market lies.

Our new department will give you in interesting form all the fundamental information needed. It will keep you abreast of new developments, installation and servicing techniques, as well as the latest equipments and components. It will guide you in the developing of prospects and sales, too. Custom Hi-Fi audio is "just a-borning." We urge you to get on the bandwagon now while it is picking up momentum. Don't risk having the play taken away from you by some enterprising competitor. Give Hi-Fi a whirl and it will give you a handsome profit.

We might warn you that you might also become infected to the point where you'll join the ranks of Hi-Fi fans. If you do, you may rest assured of one result—you will thoroughly enjoy the experience.



Sanford R. Cowan
EDITOR & PUBLISHER

Samuel L. Marshall
MANAGING EDITOR

COWAN PUBLISHING CORP.
67 WEST 44TH ST.
NEW YORK 36, N. Y.



Vol. 13, NO. 9

SEPTEMBER, 1952

Editorial	3
Trade Flashes	4
Horizontal Deflection Circuit Theory <i>by Frank Defina</i>	17
The how and why of horizontal deflection circuits.	
Your Hi-Fi Market, Part I, <i>by Charles D. Graham</i>	20
Beginning a series of articles on servicing, maintaining, and selling hi-fi equipment.	
Is D-C Restoration Necessary? <i>by Matthew Mandl</i>	23
Pros and cons on the need for d-c restoration.	
TV Sync Circuits, Part I, <i>by Leonard Lieberman</i>	26
Start of a series on operation and servicing of sync circuits.	
Circuit and Service Data of CBS Chassis 817, 817-1, 820, and 820-1.....	28
Shop chart illustrating important service data of these chassis.	
Broad Band Yagi Antennas <i>by Harold Harris & Harry Greenberg</i>	30
How a Yagi may be designed to render broad band service.	
Coupling Matching Transformers To Constant Voltage Lines, <i>by Larry A. Stineman</i>	33
Suggestions and techniques every serviceman will appreciate.	
New Tubes	34
Sylvania—6X8. RCA—6CL6. Haledy—TT-1 Cold Cathode Tube.	
Circuit Court	35
DuMont RA 160-sync. Motorola Model 17K10E area selector switch. Magnavox 105 Series—video detector.	
Shop Notes	37
Zenith Model 20H20—17": insufficient vertical height. Admiral 24D1: vertical jitter. Sentinal: horizontal linearity adjustment. Removing dirt or scale in variable condensers. Interlock cord. Westinghouse V-2162: loss of sync.	
Trade Literature	38
New Products	40
Index of Advertisers	56

SANFORD L. CAHN, Advertising Director HARRY N. REIZES, Advertising Manager
DAVID SALTMAN, Production Mgr. NATHAN BOYCE, Circulation Mgr.

TED E. SCHELL, 2700 West 3rd St., Los Angeles 5, Calif., Dunkirk 2-4889
RADIO-TELEVISION SERVICE DEALER is published Monthly by Cowan Pub. Corp., 67 West 44th St., New York 36, N. Y. Subscription price: \$2 per year in the United States, U.S. Poss. & Canada; elsewhere \$3. Single Copies: 25c. Reentered as second class matter Sept. 25, 1950 at the Post Office at New York, N. Y. under the Act of Mar. 3, 1879. Copyright 1952, Cowan Pub. Corp.

VITAL BOOKS FOR THE TV Service Technician

"Servicing TV in the Customer's Home"

Saves you time, work and chassis-hauling on outside TV service calls. Shows you how to make successful repairs on the spot using these methods: employing VTVM and capacitor probe to trace down trouble; "tube-pulling" to diagnose trouble by observing audio and picture effects; performance tests through analysis of test pattern; adjustment techniques developed for field servicing. Saves time, avoids chassis removal. 96 pages, 5 1/2 x 8 1/2".
ORDER TC-1. Only \$1.50



"Making Money in TV Servicing"

Tells how to start and operate a profitable TV service shop. Covers: overall planning, initial investment, selecting location, finances, budget control, work control, overhead, service charges, purchasing, operating and personnel problems, service contracts, customer relations, collections, advertising, etc. Written by a successful authority in the TV service field—sound, practical advice. 136 pages, 5 1/2 x 8 1/2".
ORDER MM-1. Only \$1.25



"Television Antennas" New 2nd Edition

A complete treatment of TV receiving antennas, based on actual field experience. Shows how to select proper antennas for given locations; explains how to install and solve troubles. Chapters on: antenna principles; construction; analysis of all commercial types; full installation data and short-cut hints; TV antenna problems and trouble-shooting. Fully illustrated. 224 pages, 5 1/2 x 8 1/2".
ORDER TAG-1. Only \$2.00



"Television Tube Location Guides"

VOL. 3. Shows tube positions and functions in hundreds of important TV sets. Helps save servicing time. Often, looking at the picture or listening to the sound, provides the clue to the trouble. Frequently, a tube failure is the cause. This guide, with its clear, accurate tube placement and function diagrams, makes trouble diagnosis and tube replacement quick and easy, without removing chassis. 192 pages. All



new diagrams continuing coverage from Vol. 2.
ORDER TGL-3. Only \$2.00
VOL. 2. Over 200 pages of tube placement diagrams not included in Vols. 1 and 3.
ORDER TGL-2. Only \$2.00
VOL. 1. Over 200 pages of diagrams not in Vols. 2 and 3. ORDER TGL-1. Only \$1.50

"Photofact Television Course"

A full, easy-to-understand explanation of TV principles, operation and practice. Covers Cathode Beam Formations and Control, Beam Deflection Systems, Beam Mod. and Synchron.; analyzes CR tubes, camera tubes, voltage supplies, saw-tooth generators, sync. circuits, control functions, antenna circuits, RF input tuning, IF systems, AGC, DC restoration, etc.; with full bibliography and glossary. 208 pages, 8 1/2 x 11".
ORDER TV-1. Only \$3.00



HOWARD W. SAMS & CO., INC.

Order from your Parts Jobber today, or write direct to Howard W. Sams & Co., Inc. 2209 East 46th Street, Indianapolis 5, Ind.

My (check) (money order) for \$..... enclosed. Send the following books:

- TC-1 MM-1 TAG-1
 TGL-3 TGL-2 TGL-1 TV-1

Name.....

Address.....

City..... Zone..... State.....

TRADE FLASHES

A "press-time" digest of production, distribution, and merchandizing activities

Tube Sales Rise

Sales of both television picture tubes and radio-TV receiving tubes in June were above those of May, the Radio-Television Manufacturers Association reported recently.

TV picture tubes sold to equipment manufacturers in June totalled 285,975 and were valued at \$5,871,483. These sales represented an increase over both May of this year and June, 1951. Total picture tube sales, including those to distributors, to the U. S. Government, and for export, were 376,943, valued at \$8,029,864.84, in June.

During the first half of 1952, a total of 2,393,980 TV picture tubes were sold, of which 1,845,309 went to equipment manufacturers. These figures compare with 2,888,295 total unit sales and 2,552,757 sales to manufacturers in the corresponding 1951 period.

Sales of receiving tubes in June increased from the previous month but declined from June 1951. Sales totalled 24,365,462 units, valued at \$18,279,016, compared to 23,636,484 tubes valued at \$17,037,274 in May. In June 1951, 27,667,099 receiving tubes were sold.

For the first six months of this year 160,183,526 tubes were sold compared to 215,902,325 in the first half of 1951.

A breakdown of the June report showed that 21,572,686 receiving tubes of the entertainment type were sold plus 2,792,776 of the allied or non-entertainment type. A total of 15,770,335 tubes were sold for new equipment, 5,187,557 for replacements, 930,001 for export and 2,477,539 to government agencies.

Radio-TV Production Drops

Production of both radio and television receivers in the first six months of this year declined substantially under the output of the corresponding 1951 period, the Radio-Television Manufacturers Association reported recently.

RTMA estimated the industry's output of radios at 40 per cent under the first half of last year. TV production declined 33 per cent below last year's six-month figure.

The report showed the manufacture of 4,838,343 radios in the first half of this year compared with 8,007,905 in the same 1951 period. The TV output was estimated at 2,318,236 sets as against 3,457,519 in the first half of last year.

A breakdown of the six-month radio production report showed 1,331,877 home sets, 685,085 portables, 1,543,877 auto sets and 777,504 clock radios. Home sets with FM facilities totaled 222,988 in the six-month period. In addition, 57,483 TV sets with FM circuits were produced.

In June, a five-week reporting period, 361,152 television receivers and 874,253 radios were manufactured.

DuMont Predicts 700-800 New TV Stations

Television coverage of the 1956 presidential political conventions and campaigns by a total of from 700 to 800 new TV stations from coast to coast and a large increase in the number of new receivers by that time was forecast recently by TV scientist and manufacturer Dr. Allen B. Du Mont.

By 1956, Dr. Du Mont said, the Federal Communications Commission will have approved 800 new stations in addition to the 109 now on the air and the number of TV receivers can be expected to increase from the current figure of approximately 18 million to upwards of 50 million.

Bersche Key Speaker at NEDA Convention

H. F. Bersche, Manager of Renewal Sales for the Tube Department, Radio Corporation of America, will be the key speaker at the Third Annual Convention and Manufacturers' Conference sponsored by the National Electronic Distributors Association to be held in Atlantic City, N. J., September 22 through 25.

In his lecture, "New Electronic Frontiers," Mr. Bersche plans to discuss such electronic developments as Ultra-High-Frequency television, microwave relay, and industrial TV, as well as new electronic devices—currently undergoing intensive research—which are on the verge of becoming realities. He will also empha-

More POWER to you...

with the Radiart TV Booster

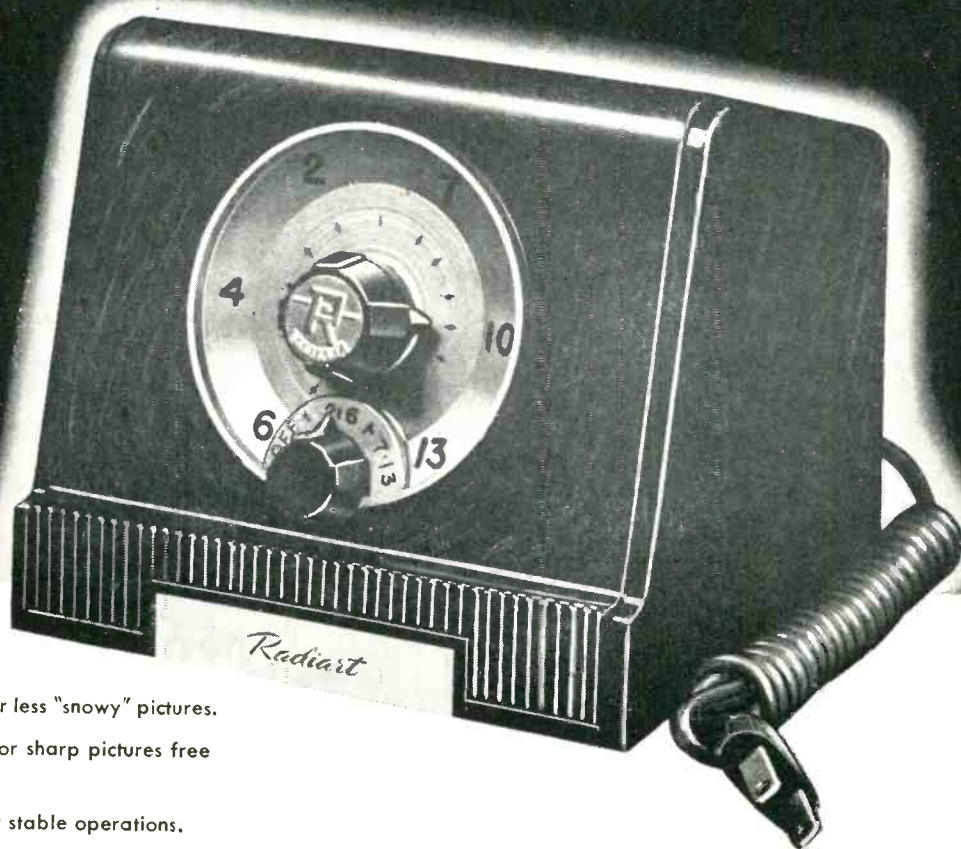

- ★ High signal-to-noise ratio for less "snowy" pictures.
- ★ Wide band amplification for sharp pictures free from "smear".
- ★ Complete neutralization for stable operations.
- ★ Large, handsome dial face for easy reading.
- ★ Operates on 115 V. A. C., 60 cycle current.
- ★ **Attractively styled cabinet with mahogany grained polished finish . . . matching the rotor control cabinet . . . together making the TV TWINS . . . the ideal combination for the MOST in TV reception.**

Here's the power boost needed to get the MOST from any TV set! It improves the picture because it increases contrast . . . minimizes ghosts, snow and interference and actually STRENGTHENS the signal! Easily installed — simple in operation — a welcome addition to any home.

The Perfect Partner to the CDR Rotor...they go together



THE RADIART CORPORATION CLEVELAND 13, OHIO

VIBRATORS • AUTO AERIALS • TV ANTENNAS • ROTATORS • POWER SUPPLIES



TUBE AND TOOL CARRYING CASE
Holds 137 tubes — plus all regular tools.

FLASHING SERVICE DISPLAY
A 6-color display featuring your ability to "Clear Up The Picture."

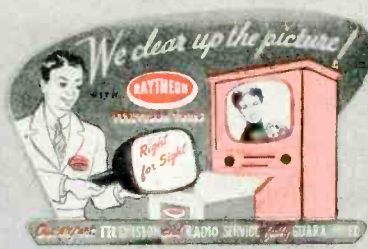

GUARANTEED
TELEVISION... RADIO SERVICE
RAYTHEON
TELEVISION AND RADIO TUBES

PLEXIGLO ILLUMINATED SIGN
A bright and colorful service selling sign.

To help you increase your profits...
To help you work more efficiently...



has made these useful
NEW SALES AND SHOP AIDS
AVAILABLE TO YOU!



POLITICAL WINDOW STREAMER
You can use this effectively from now 'til November.



ILLUMINATED TEST PATTERN CLOCK
A Telechron motored beauty.



DISPLAYS
Colorful displays that sell your service.

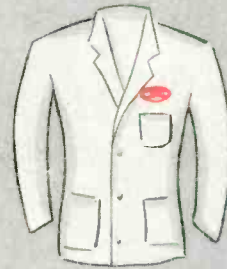
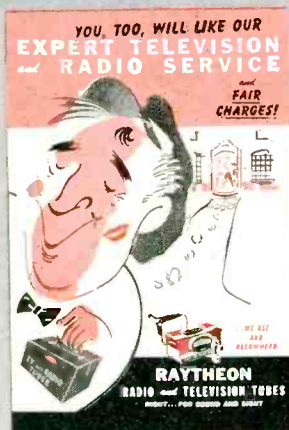

SHOP JACKETS and COATS
Expertly designed, sturdy, long wearing, comfortable garments. Full length or jacket style.



SCOTCH TAPE AND DISPENSER
3/4" Scotch Acetate Tape bearing your name. Handy Dispenser.

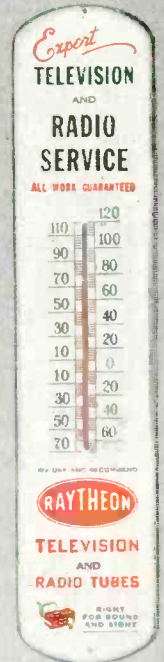

OUTDOOR THERMOMETER
A heavy gauge, jumbo size (8" x 39") outdoor unit.



Write for FREE BOOKLET!

It's chock full of these and many other useful shop aids and sales promotion items that are musts for every service dealer — imprinted stationery, job tags and record cards, ad mats, post cards, shipping labels, decals, etc. Some are free, others available at less than cost. Ask your Raytheon Tube Distributor for them or write for booklet to Department G.



RAYTHEON MANUFACTURING COMPANY

Receiving Tube Division
Newton, Mass., Chicago, Ill., Atlanta, Ga., Los Angeles, Calif.
RAYTHEON MAKES ALL THESE:

RECEIVING AND PICTURE TUBES • RELIABLE SUBMINIATURE AND MINIATURE TUBES • GERMANIUM DIODES AND TRANSISTORS • NUCLEONIC TUBES • MICROWAVE TUBES

RADIO-TELEVISION SERVICE DEALER • SEPTEMBER, 1952

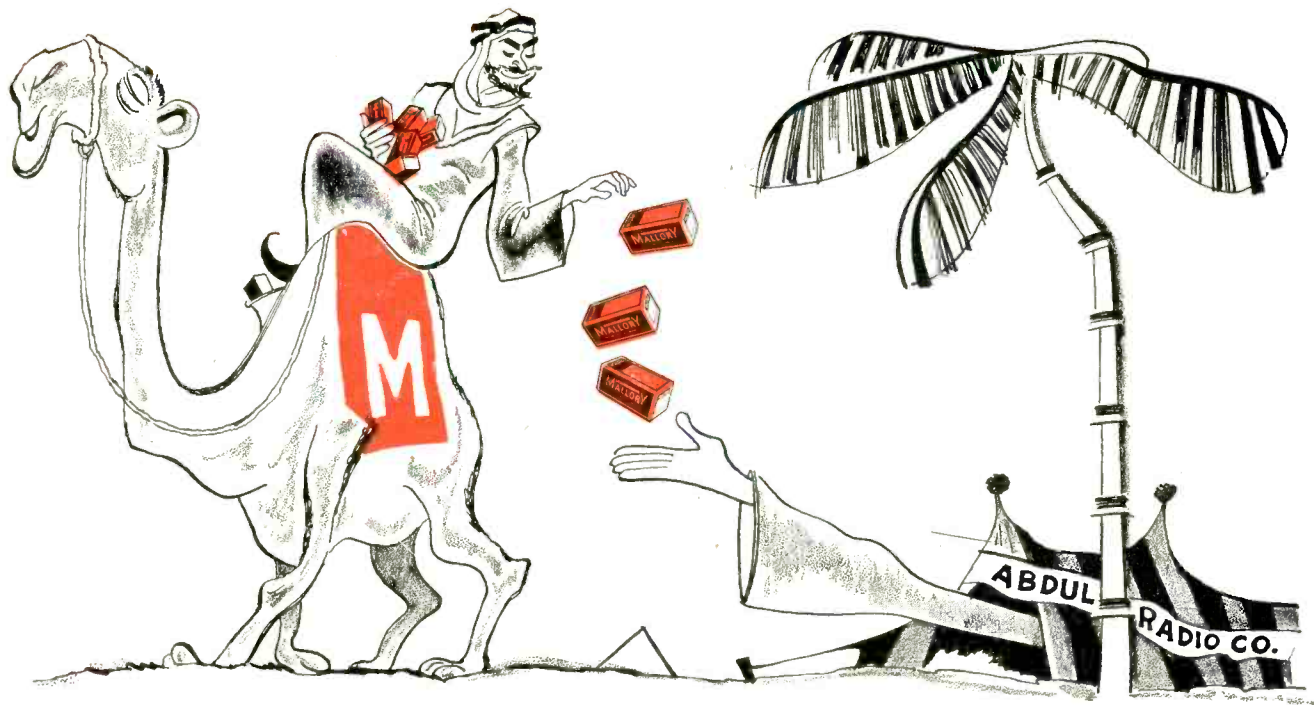

Preferred by Servicemen everywhere . . .

MALLORY VIBRATORS

There are three big reasons why servicemen prefer Mallory vibrators over all other brands combined. They count on Mallory vibrators for long dependable service because they give . . .

- 1— Slow contact impact for minimum wear
- 2— High contact pressure for low resistance
- 3— Fast contact break for reduced arcing, pitting

That combination—available only from Mallory, with its patented, tuned mechanism—means real performance for you and your customers. That's why more Mallory vibrators are used as original equipment than all other makes combined. Put these features to work for you. When you order vibrators . . .



Service 47 Radio Makes With ONE of Mallory's Special Vibrator Deals

Ask your distributor about these Mallory specials. They help keep your inventory down. You can service 47 radio makes with the 6 Mallory vibrators in one of these deals. And you get a handy parts cabinet at no additional cost when you buy at your regular discount price. Call your distributor today for details.

Make Sure! Make it Mallory!

P. R. MALLORY & CO., Inc.
MALLORY

CAPACITORS • CONTROLS • VIBRATORS • SWITCHES • RESISTORS
• RECTIFIERS • VIBRAPACK* POWER SUPPLIES • FILTERS

*Reg. U. S. Pat. Off.

APPROVED PRECISION PRODUCTS

P. R. MALLORY & CO., Inc., INDIANAPOLIS 6, INDIANA

single test — double check



new

Simpson

MODEL 485

synchronized crosshatch pattern generator

You control your own broadcast test pattern for initial installations and linearity adjustment calls with the Simpson Model 485. Newly developed Model 485 provides a synchronized signal, modulated on the carrier frequencies of channels 2 through 6, which can be tuned and sent through the receiver under test — anywhere, at any time! The vertical and horizontal sync pulses provide means by which the pattern is locked in on the TV receiver. Since this is a transmitted TV signal, it is not necessary to check against a broadcast pattern. Linearity is double checked with a single test — no call back to cut service profits.

Dealer's net price, including special output cable for 75 and 300 ohm terminations, only \$147.50. Ask your jobber for full information or write —

SIMPSON ELECTRIC COMPANY

5200 West Kinzie Street, Chicago 44, Illinois
CO 1-1221

BURTON BROWN ADVERTISING

Another reason why Simpson is world's largest manufacturer of test equipment

size how they relate to the electronic distributing industry and the extent to which they are affecting, and will continue to affect, the distributor market. Mr. Bersche reveals that he will stress too just what the new advancements in electronics mean to electronic distributors, in terms of potential renewal sales in future years.

National Electronics Conference

The eighth annual National Electronics Conference will convene Sep-

tember 29, 30 and October 1, 1952 at the Sherman Hotel, Chicago.

The greatly expanded technical program offers 99 papers covering a broad field of Electronic Research, Development, and Industrial Application and is supplemented by over 75 exhibits by manufacturers and institutions foremost in the electronics field.

On the social side, the conference sponsors three luncheons featuring prominent speakers, an evening banquet, and a full three day social pro-

gram for the ladies. Two evenings are available for viewing the exhibits or visiting any of the famous entertainment spots which are only a few steps from the Hotel Sherman.

The conference is sponsored by the American Institute of Electrical Engineers, Illinois Institute of Technology, Institute of Radio Engineers, Northwestern University, University of Illinois with Purdue University, University of Wisconsin and the Society of Motion Picture and Television Engineers participating.

Advance registration may be made by writing to National Electronics Conference, Inc., Karl Kramer, Executive Secretary, 852 East 83rd Street, Chicago 19, Illinois.

Sprague Poster Improves Public Relations

"Why Doesn't My Set Stay Fixed?" — the television set owner's question that frequently embarrasses Service Technicians — is answered clearly and convincingly in a new window display poster just prepared for service shop use by the Sprague Products Company, 71 Marshall Street, North Adams, Massachusetts.

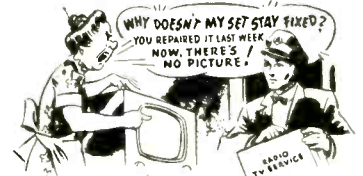

HERE'S YOUR ANSWER, MR. AND MRS. SETOWNER!

900 times out of a thousand, when this happens — don't blame your service technician!

The repair to your television receiver made several days ago or even several months ago probably had no relation to the new trouble that developed today.

Actually, there are more than 300 electrical parts in even a small table model television receiver. Trouble in any one of them might cause the picture or sound to disappear or to be received poorly.

Take your automobile for instance. Tuning up the motor today is no guarantee against a tire blowout tomorrow!

Such a thing is easier to understand because most of us are more familiar with automobiles than with today's highly complicated TV and radio sets. But such unconnected troubles occur in TV and radio nevertheless — and because they are

so hard to explain in non-technical terms, it is always embarrassing to your service technician when they do.

His continued business existence is based on gaining the full confidence of you and other set owners like you. He isn't in business to "rip you or to overcharge you." His success is based on doing each and every job to the level best of his ability, at a fair price for his skilled labor. It is only when you patronize the shop that feature "bargains" at ridiculously low prices that you need worry. Good radio and TV service can't be bought on the bargain counter! Set owners who recognize this aren't likely to get "gypped."

Sincerely yours,

Harry Galt

SPRAGUE PRODUCTS COMPANY
71 Marshall Street, North Adams, Mass., U.S.A.



WORLD'S LARGEST MANUFACTURER OF ELECTRIC CONDENSERS

Designed as a public relations service to promote a better understanding between TV setowners and repair technicians, the new poster is a follow-up to the now famous "Are Servicemen Gyps?" message that received wide acclaim from the service trade earlier this year.

The new poster briefly explains to the setowner that the repair to his TV receiver made several days or even months ago probably had no relation to the new trouble that devel-

FIRST IN
1946

First and Foremost...

... year after year

RCA TV Deflection Components

- FIRST** ... with commercial components for the pulse-operated "fly-back" circuit.
- FIRST** yoke with powdered-iron core.
- FIRST** yoke using "saddle coil" construction.
- FIRST** horizontal-output and high-voltage transformer with high-efficiency Ferrite core.
- FIRST** yoke with distributed "Cosine" windings.
- FIRST** auto-transformer for higher-efficiency vertical-deflection circuits.
- FIRST** yoke with molded plastic housing.
- FIRST** high-efficiency horizontal-output transformer with layer-wound coils.
- FIRST** horizontal-output and high-voltage transformer of the "Universal Type."

It pays to use the best . . . and RCA TV Components are best by design.

TMK. ®

FIRST TODAY
AND TOMORROW



RADIO CORPORATION of AMERICA
ELECTRONIC COMPONENTS

HARRISON, N. J.

TRIO ANNOUNCES SENSATIONAL NEW **ZIG-ZAG** ANTENNA

Patent Pending

★ **Higher Gain than any Yagi!**

Plus

★ **All-Channel VHF Performance!**

Here's the greatest advance in TV antennas since TRIO'S introduction of the dual channel yagi! The sensational new TRIO ZIG-ZAG antenna is basically a multiple element yagi type antenna on each channel, yet one 2-bay antenna — and in some models a single bay antenna — covers all VHF channels!

This sensational antenna has sharper directivity and higher front-to-back ratio. It provides snow-free pictures, and fade-free sound even in the most remote fringe areas.

Tremendous forward gain is accomplished without long, bulky, arrays that operate on only one channel. With the new fringe area model ZIG-ZAG antenna, one bay provides tremendous gain on all low channels, 2 thru 6, and the other bay provides similar high gain on channels 7 thru 13.

HOW THIS AMAZING ANTENNA WORKS

Trio ZIG-ZAG antennas utilize a new principle whereby an array is composed of a series of elements, one or more of which is resonant on any one channel while the remaining elements, which are non-resonant on that channel, provide parasitic voltages having the proper phase relative to the direct voltage. These act as very efficient directors and reflectors. All elements are directly connected to the feed-line.

The various models, listed below, are designed to provide a simple installation for all areas, from metropolitan to extreme fringe. Two bay models, like the single bay models, are operated with a single 300 ohm lead-in to the set, with less than a 3:1 standing wave ratio.

8 MODELS FROM WHICH TO CHOOSE:

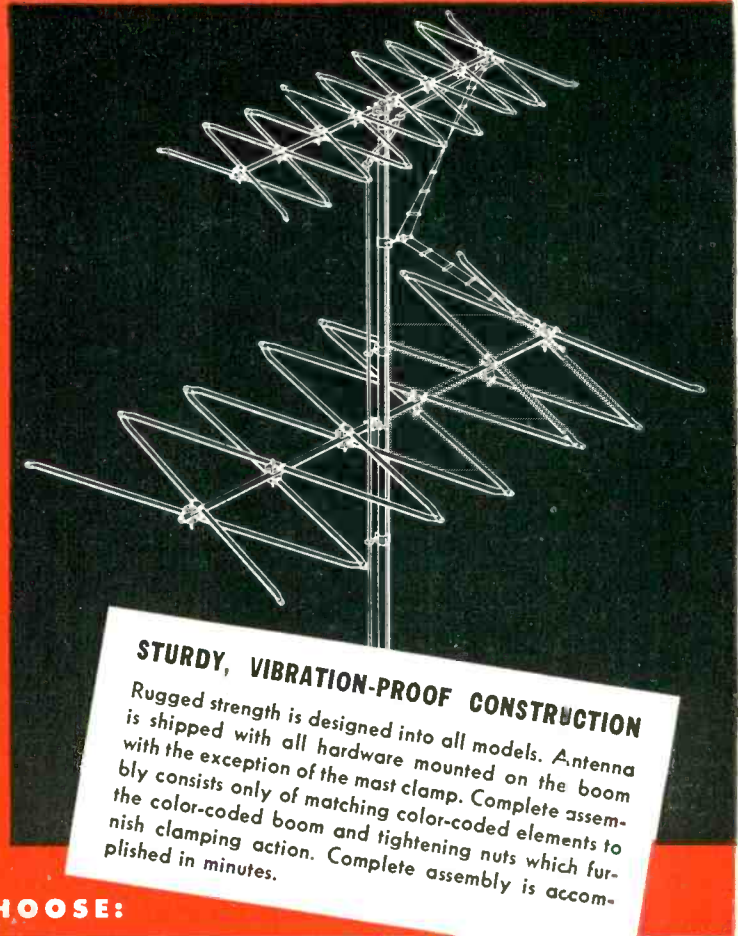

STURDY, VIBRATION-PROOF CONSTRUCTION
Rugged strength is designed into all models. Antenna is shipped with all hardware mounted on the boom with the exception of the mast clamp. Complete assembly consists only of matching color-coded elements to the color-coded boom and tightening nuts which furnish clamping action. Complete assembly is accomplished in minutes.

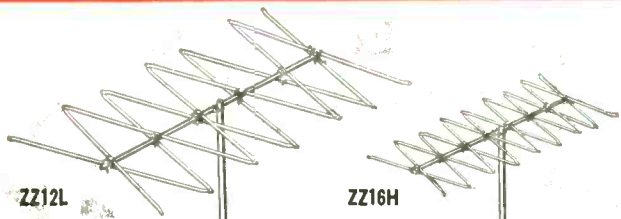

ZZ12L

ZZ16H

FOR EXTREME FRINGE RECEPTION — ZZ16H provides over 14 DB voltage gain as compared with a resonant reference dipole on Channels 7 thru 13; and ZZ12L provides gain of 12 to 14 DB on Channels 2 thru 6. Gain of the ZZ12L is 12 DB on Channels 2 and 3 and is 14 on Channels 4, 5 and 6. These models have narrowest forward lobe and highest front-to-back ratio and should be used in areas where co-channel interference is a problem.

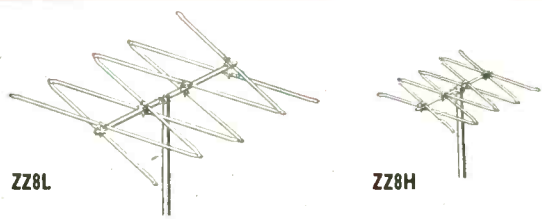

ZZ8L

ZZ8H

FOR NORMAL FRINGE RECEPTION — Where maximum gain is not necessary, these models are ideal. The ZZ8H for Channels 7 thru 13 and the ZZ8L for Channels 2 thru 6. Voltage gain is 9 DB on Channels 2 and 3 and 11 DB on Channels 4 thru 13. These models have patterns comparable to a well designed multi-element single channel yagi.



WRITE FOR CATALOG

ZZ6L

ZZ6H

FOR NEAR FRINGE RECEPTION — These models provide a voltage gain of 8 to 9 DB on Channels 2 thru 13. These models have pattern and gain comparable to a cut-to-channel yagi. ZZ6L covers Channels 2 thru 6. ZZ6H covers Channels 7 thru 13.

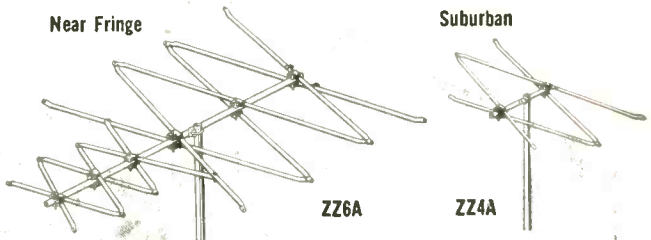

Near Fringe

Suburban

ZZ6A

ZZ4A

SINGLE BAY ALL-CHANNEL RECEPTION — Model ZZ4A is a single bay antenna providing adequate gain and directivity on all channels, 2 thru 13, in suburban areas. Model ZZ6A is also an all-channel single bay antenna providing greater gain for near fringe use.



TRIO MANUFACTURING COMPANY • GRIGGSVILLE, ILLINOIS

The TRIO ROTATOR

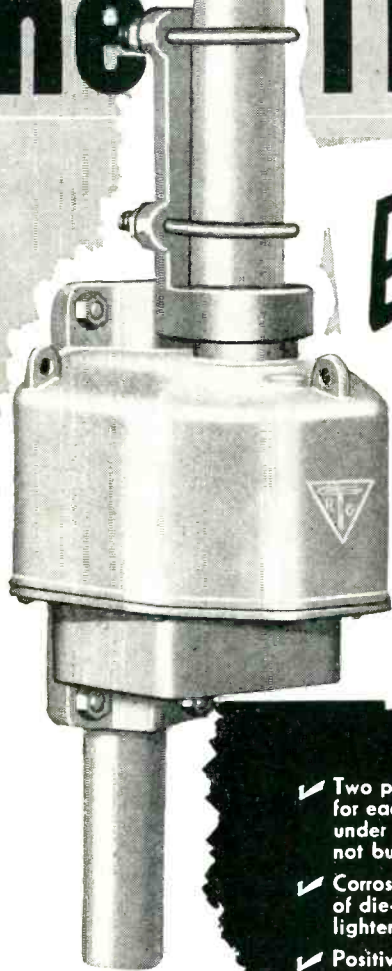

Easy to Sell!

It's easy to sell a product with as many plus features to talk about as the TRIO ROTATOR. In design, in construction, appearance; it is by far the outstanding TV antenna rotator in the market today!

Stays Sold!

In addition to providing a powerful sales story, the features listed below are your assurance of complete customer satisfaction: Assurance that the TRIO ROTATOR will give dependable performance year in and year out — in all kinds of weather!

- ✓ Two powerful 24 volt motors used — one for each direction of rotation. Each motor under load only fraction of time — will not burn out!
- ✓ Corrosion resisting, weatherproof housing of die-cast aluminum for greater strength, lighter weight, perfect alignment of parts!
- ✓ Positive electrical stops at ends of 360° rotation prevent damaging or twisting of leads!
- ✓ Will support heavy TV arrays — even in 80 MPH winds!
- ✓ Permanently lubricated with special grease that functions perfectly in high and low temperature extremes!
- ✓ Ball-bearing end thrusts on all shafts, including motor! Main shaft vertical load carried on large oversized "Oilite" self-lubricating bearing!
- ✓ All motors, shafts and gears mounted on a rugged, one-piece casting for true alignment and longer life!
- ✓ 1 1/16" diameter tool steel main shaft and mast holder will withstand 4500 inch pounds bending moment!
- ✓ Rotator and mast holder fits any pipe size up to 2" OD!
- ✓ Precision built to extremely close tolerances!



Smartly Styled

DIRECTION INDICATOR

The TRIO Direction Indicator is housed in a sturdy plastic cabinet of graceful lines. It is a beautiful instrument that will blend harmoniously with any furniture style.

Utmost ease in selecting the desired antenna direction is provided by a new "finger tip" control that operates at a light touch and the easy-to-read dial face that clearly and instantly indicates the exact antenna position.



FULLY TESTED BEFORE SHIPMENT

Each TRIO ROTATOR is thoroughly factory tested to the equivalent of 3 months of constant operation. This, plus an additional torque test guarantees each unit to be perfect in every detail of assembly.

The TRIO ROTATOR's sound design and construction has been proven by three years of extensive field testing under every extreme of weather.



TRIO Manufacturing Company
GRIGGSVILLE, ILLINOIS

BUSS FUSES

**Help Protect Your Product . . .
Your Profit . . . Your Reputation**

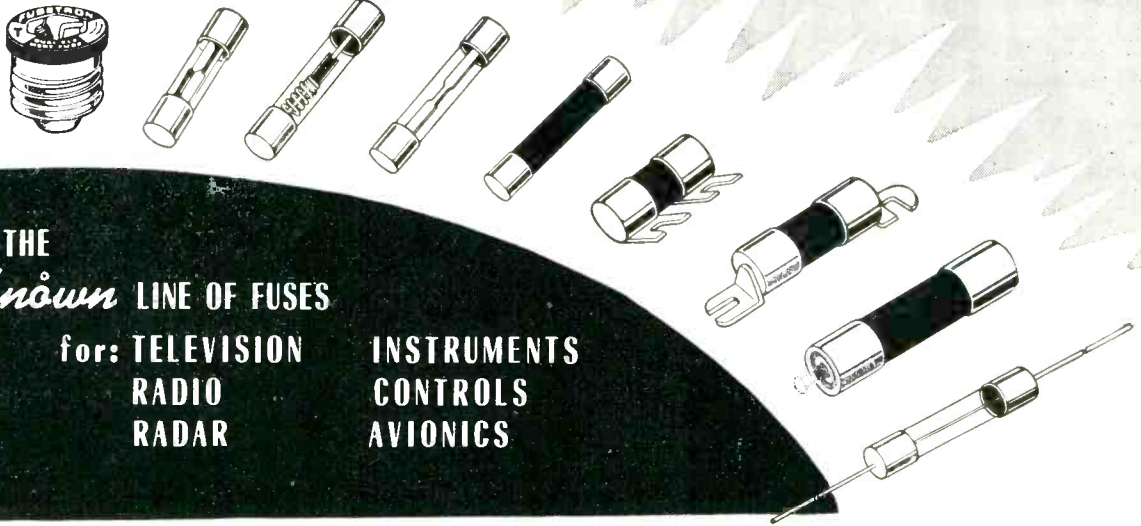

THE
Known LINE OF FUSES

for: TELEVISION INSTRUMENTS
RADIO CONTROLS
RADAR AVIONICS

38 year's service to American homes, farms and industry is behind every fuse that bears the BUSS trademark. Your customers have confidence in BUSS . . . they know the BUSS name represents fuses of unquestioned high quality.

To maintain this high standard each and every BUSS fuse is tested in a highly sensitive electronic device that rejects any fuse that is not correctly calibrated — properly constructed and right in physical dimensions.

It's easy to select a BUSS fuse that's *right* for your fuse application. The complete BUSS line includes: Dual Element (Fusetron slow blowing type fuses), Renewable and One-Time types — available in all standard sizes, and many special sizes and designs.

THE BUSS TRADE-MARK HELPS INSURE YOUR PROFITS AND GOOD-WILL —

Since BUSS is the *Known* line you will never be bothered with kicks and comebacks because people won't blame troubles they have on fuses you furnished them.

Thus the BUSS Trade-Mark protects your profits and goodwill.

For More Information
CLIP THIS HANDY COUPON NOW . . .

... Plus
**A COMPLETE LINE OF FUSE CLIPS,
BLOCKS AND HOLDERS**

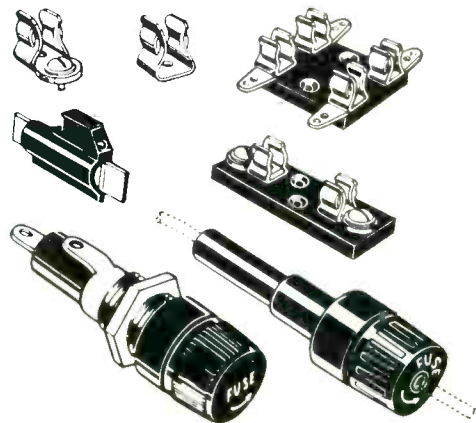

BUSSMANN Mfg. Co. (Division of McGraw Electric Co.)
University at Jefferson, St. Louis 7, Mo. SFB

Please send me bulletin SFB containing complete facts on BUSS small dimension fuses and fuse holders.

Name.....

Title.....

Company.....

Address.....

City & Zone.....State..... 952

BUSSMANN MFG. CO., Division McGraw Electric Company
University at Jefferson St. Louis 7, Mo.

oped today. Following an explanation of the complexity of a modern TV receiver, the set owner is led to an understanding that good service cannot be bought at bargain counter prices.

These large window-size posters with a cartoon at the top are available free at your local Sprague distributor or direct from the Sprague Products Company for 10c to cover the cost of handling and mailing.

Sylvania Moves Into Woburn Plant

The Electronics Division of Sylvania Electric Products Inc. has begun moving into its new headquarters at the company's recently constructed plant at 100 Sylvan Road, Woburn. The shift of headquarters and most manufacturing operations from the division's plant at 70 Forsyth Street, Boston, involves the movement of 80 tons of machinery, tools and equipment and is expected to take about four weeks.

The Woburn plant will be headquarters of the administrative, sales, engineering and manufacturing staffs of the division, as well as the site of the principal manufacturing operations.

G. E. Provides More UHF Stations

Equipment for a high-power television station to operate in the new ultra-high-frequencies will be shipped by the General Electric Company here to Springfield, Mass. in December, it was announced recently. It will be Springfield's first television station.

Frank P. Barnes, G-E broadcast equipment sales manager, said the new station, with call letters WWLP, will operate on channel 61. He said the company is the only manufacturer currently producing a high-power transmitter for the ultra-high-frequencies.

Audio Fair

The Audio Fair, 1952, slated to open October 29 at the Hotel New Yorker, will run for four days instead of three as in previous years, closing November 1, and will represent the greatest number of manufacturers of high-fidelity sound equipment ever to participate in a single exhibit, according to announcement of Harry N. Reizes, Fair Manager.

Held annually in conjunction with the yearly Convention of the Audio Engineering Society, the Audio Fair is open to the public and admission is free to all persons with an interest in the reproduction of sound, hobbyists and professionals alike.

Displays include working demonstrations of the latest speakers, am-

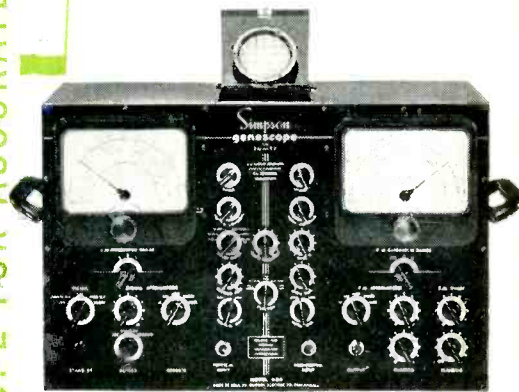
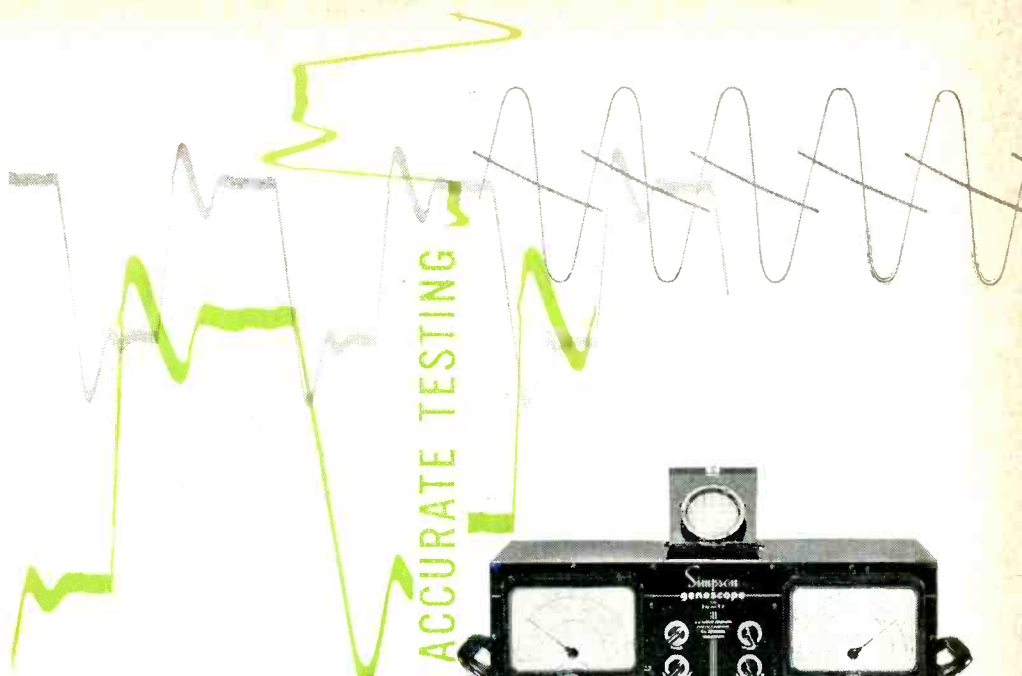

approved by
service managers of:

- admiral*
- zenith*
- motorola*
- emerson*
- hoffman*
- hallicrafters*

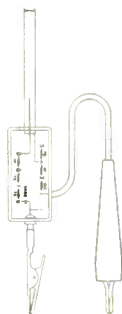

SIMPSON MODEL 480 GENESCOPE FOR ACCURATE TESTING

- All the necessary signal sources for alignment of FM and TV receivers • Includes the Simpson High Sensitivity Oscilloscope and high frequency crystal probe for signal tracing • Independent, continuously variable attenuators and step attenuators for both AM and FM units offer complete control of output at all times • 0-15 megacycle sweep is provided by a noiseless specially designed sweep motor based on D'Arsonval meter movement principles • The exclusive Simpson output cable (illustrated) includes a variable termination network, quickly adapted to provide open, 75 or 300 ohm terminations — the addition of a pad provides attenuation and isolation • Use of appropriate resistors across certain terminals will provide any other termination required. A .002 MFD blocking condenser can be added on any termination for use on circuits containing a DC component • The FM generator output voltage is constant within .2 DB per MC of sweep.

dealer's net \$395.00

SIMPSON ELECTRIC COMPANY
5200 W. Kinzie St., Chicago 44, Illinois • Phone: COlumbus 1-1221 • In Canada: Bach-Simpson, Ltd., London, Ont.

BURTON BROWNE ADVERTISING

TECHNICAL ARTICLES WANTED

on TV, AM RADIO, FM RADIO, PHONO MECHANISMS, HI-FI AUDIO, AUTO RADIO, TEST EQUIPMENT, ANTENNAS

pertaining to their

Theory, Installation, Application, Service and Maintenance

submit manuscripts to Managing Editor

RADIO-TELEVISION SERVICE DEALER

67 West 44 Street

New York 36, N. Y.

This instrument provides complete sweep and marker frequencies

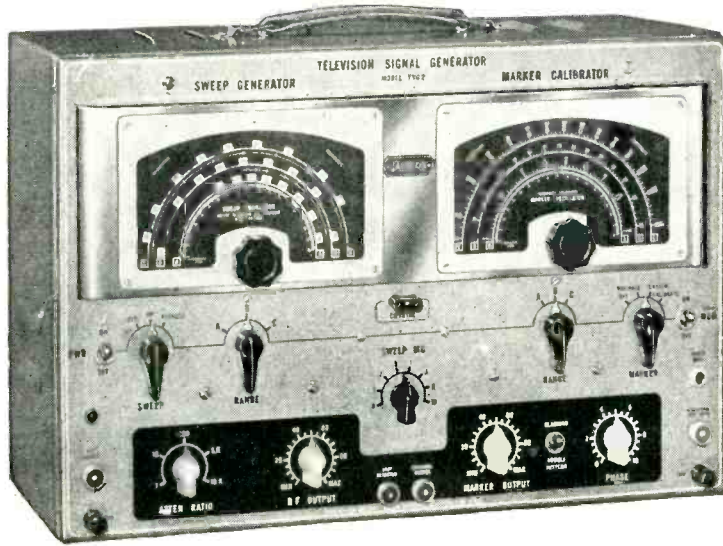

Jackson Model TVG-2 Television Generator

Both industrial and service technicians the world over use the Model TVG-2. Years of experience have proved that Jackson Signal Generators STAY accurate. Just ask the "ole timer" who owns one.

Continuously variable sweep frequencies over all TV and FM bands . . . Reversible single response pattern with base line or double pattern . . . Adjustable sweep width from 100 KC thru 18 MC . . . Marker Calibrator continuously variable from 100 KC thru 216 MC . . . Separate Crystal Oscillator for use either as a marker or calibrator . . . Video Modulation Jack provides for picture or pattern

modulation . . . Marker Calibrator IF frequencies all on highly stable fundamentals . . . RF Output completely controllable with variable and step attenuator . . . Multiple shielding of attenuators and circuits insures low leakage . . . Complete Sweep and Marker Generators in one beautiful instrument . . . Styled to match the famous Jackson Model CRO-2 Oscilloscope.

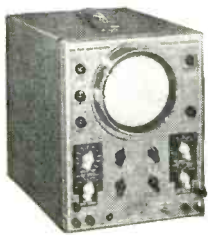

MODEL CRO-2
OSCILLOSCOPE

**Two Other Fine
Jackson Instruments**

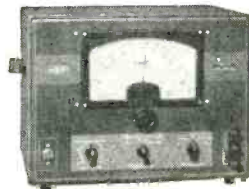

MODEL 655
AUDIO OSCILLATOR

5-inch oscilloscope having a vertical sensitivity of .018 RMS v.p.i. and band width flat within 1.5 db from 20 cycles thru 4.5 Mc. Linear saw-tooth sweep oscillator 20 cycles thru 50 KC per second in 5 steps. A standard voltage provided for determining unknown Peak to Peak potentials of all waveforms. Has reversible vertical polarity and return trace blanking.

Sine-wave 20 cycles to 200,000 cycles. Less than 5% harmonic distortion between 30 cycles and 15,000 cycles. Frequency calibration accurate within 3% or 1 cycle. Hum level down more than 60 db of maximum power output. Output impedances of 10, 250, 500, 5000 ohms or Hi Z resistive output.

See your electronics distributors for more information, or write

plifiers and record playing equipment, as well as all the other components that go to make up sound reproducing systems. Although the majority of the Fair's exhibits emphasize the ease and economy with which high-fidelity music can be achieved in the home, many displays are built around professional equipment, such as recorders and public address and broadcast systems. In view of the Fair's acceptance by the audio industry as the ideal occasion for introducing newly developed equipment, manufactured exhibits will feature many devices displayed for the first time for public observation.

Theme of the 1952 Audio Fair will be *Audio Today and Tomorrow*—and already exhibitors are competing behind the scenes in the planning of displays based on this idea. Old-timers in the audio field will revel in the nostalgia afforded by goose neck speakers, quarter-pound magnetic pickups, and cylinder-type records—at the same time sharing the delight of today's audio hobbyist in such innovations as binaural tape recording, amplifiers virtually without distortion, and modern LP recordings and pickups which approach the ultimate in sound reproduction.

Walsco Offers Free Vacations

Walter L. Schott, president, recently announced Walsco's plan to celebrate the sale of its 1,500,000 TV antenna. The 1½ millionth antenna to roll off the production line will be placed in a regular carton, together with 4 free vacation certificates . . . two all-expense vacations for the dealer or installer who *buys* the lucky antenna, and the other two for the jobber or jobber salesman who *sells* it.

The lucky buyer and seller of Walsco's 1½ millionth antenna will be allowed to select any vacation spot in America for a full week, all expenses paid by Walsco. The winners will travel aboard the new, luxurious TWA Super Constellation to and from their destination.

Jack Carter, Walsco sales manager, emphasized that "this is not a contest . . . there is nothing extra to buy." He only cautioned dealers and installers to carefully inspect each Walsco antenna carton. The free vacation certificates will be attached to the 1,500,000th antenna. The antenna cartons will all be tightly sealed and unmarked.

Color Television Discussion

Developments in color television will be discussed during sessions of [Continued on page 48]

JACKSON ELECTRICAL INSTRUMENT CO.
"Service Engineered" Test Equipment DAYTON 2, OHIO In Canada: The Canadian Marconi Co.

Rauland Tubes give you a prettier profit picture



Rauland picture tubes are first choice of an ever growing number of service dealers and men. First, because of the completeness of the Rauland replacement line.

Second, because you get the benefit of acknowledged leadership in picture tube engineering. Rauland research has developed more picture tube improvements since

the war than any other company.

You get quality you can count on, too. Rauland production employs machines unique in the industry—many of them designed by Rauland engineers and built in Rauland's own plant.

And finally, you get assurance of customer satisfaction beyond

what any other line can give you. Installation and adjustment of Rauland tubes is faster and better. The Indicator Ion Trap gives you the surest known protection against ion burn and shortened tube life.

Specify Rauland—deliver Rauland—and assure yourself of pleased picture tube customers.

THE RAULAND CORPORATION



Perfection Through Research

4245 N. KNOX AVENUE • CHICAGO 41, ILLINOIS



*Long Life—Low Maintenance
No Comebacks with the*



New **300 OHM
TRANSMISSION CABLE**
by **BELDEN**

To You,
Belden's Golden Anniversary
Means
—product performance that
can come only from a "know-
how" that has grown through
actual service since the
inception of Radio.
—an ability to co-oper-
ate in pioneering new
wires to meet or antici-
pate industry's grow-
ing needs.
In the years that
follow
This Belden
Program Is—
— TO BE
CONTINUED

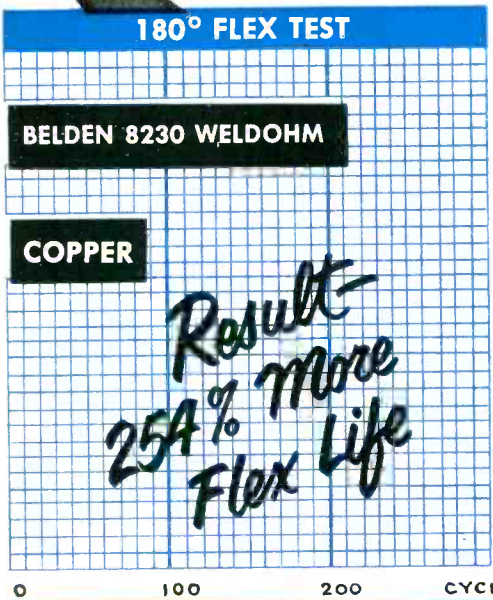

No. 8230



**COPPER-
SHEATHED
20-GAUGE
STRANDED STEEL WIRE**

Brown Polyethylene—Resists Weather and Oxidation

The new Belden Weldohm, 300-ohm Transmission Cable is the greatest advancement in television installation since television began.

Reducing TV lead-in conductor breakage to a minimum is easy. The new Belden Weldohm Cable has overcome the breakage point by 162%, that's 1½ times the strength of pure copper wire.

In actual test, Belden Weldohm Cable will withstand 254% more whipping or severe flexing than the average installation of 300-ohm copper lead-in wire.

There is no difference in the electrical characteristics between an all-copper conductor and the Belden Weldohm copper-coated steel wire. The web is 72 mils of 100% virgin polyethylene.

Replace with Belden Weldohm or make your next new installation with Weldohm and avoid expensive loss of time and labor.

Specify Belden—Weldohm Transmission Cable.

Belden Manufacturing Co., 4639 W. Van Buren St.
Chicago 44, Illinois



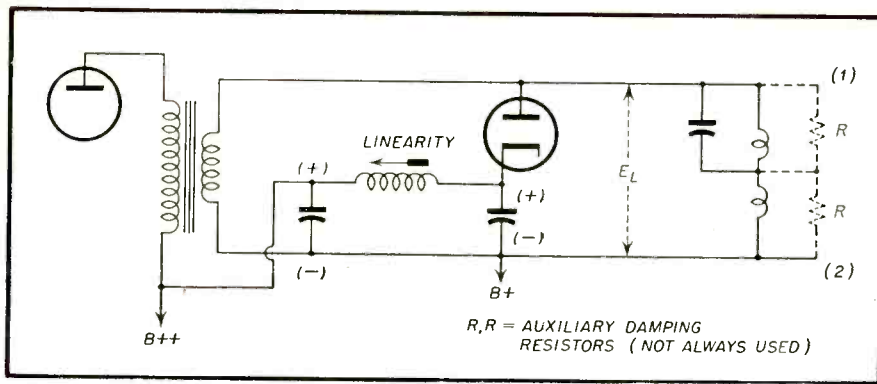

Fig. 6—Damper tube circuit.

Now, $E_L = .01 \times 120,000 = 1200$ volts and, since the grid of the horizontal amplifier tube has suddenly been driven by the negative spike of the drive voltage, the magnetic field in the transformer collapses rapidly, producing the retrace voltage E_L which is of opposite polarity to the trace voltage E_L . The deflection coil current also reverses as shown by the dashed arrows of Fig. 1. The reversal of deflection coil current snaps the picture tube electron beam from the right side of the screen to the left side. The spot "flies back," so to speak, and it is from this that the system name of "fly-back" is obtained. The inductive kick of voltage due to the sudden collapsing of the transformer circuit

magnetic field is responsible for the high voltages obtained.

Because the primary of the output transformer has about 3.5 times as many turns as the secondary, the "kick-back" voltage is stepped up to $3.5 \times 1200 = 4200$ positive volts on the plate tap of the transformer. (In practical circuits because of damper tube action, leakage inductance effects and unpredictable resonance effects, the voltage on the plate of the tube may become of the order of 6000 volts.) Despite this high voltage on the tube plate, the tube does not conduct because during retrace time the grid voltage of the tube is highly negative.

The sudden change of voltage E_L

from 120 volts to -1200 volts (A to B, Figs. 3 or 4) not only produces retrace but it also triggers off a resonance condition. The stray capacitances of the entire deflection circuit composed of the stray capacity of the yoke, transformer, wiring, and etc., can be thought of as a lumped capacitance which may be represented as C_s of Fig. 1, which shunts the inductance of the deflection coil. The inductance and C_s together constitute a tuned circuit which in our example can be made to resonate at approximately 100 kc/s. The flyback voltage, which reaches a peak of -1200 volts, shock-excites this resonant circuit, producing a 100 kc/s voltage (Fig. 3 or 4) that oscillates about the desired sweep voltage axis and gradually dies down to the desired sweep voltage due to losses in the circuit which damp out the oscillations, but this takes an appreciable amount of time. The oscillatory voltage in turn causes the sweep current (Fig. 2) to oscillate about the desired sweep sawtooth. These current oscillations would cause extremely severe horizontal foldover regions on the picture tube face, and would be unusually severe on the left-hand side of the screen.

Some means of heavily loading the deflection coil circuit at the right time must be found so that a true sawtooth of current is made to flow through the deflection coil. Relatively low-ohmage resistors could be placed across the deflection coil, as is done in vertical deflection coil circuits, thus heavily loading and damping the oscillations. Doing this would cause high tube currents, require larger power-supplies, necessitate paralleling two or more output tubes, etc., and would make a TV set more cumbersome, more expensive, and uneconomical to manufacture and operate. To obviate these and other disadvantages, damper tube circuits are employed. (Parenthetically, it might be well to note here that in those circuits where resistors are used across the deflection coil, it should be understood that they supplement and aid the damper tube circuit to rapidly attenuate the oscillations of the deflection voltage and current. These resistors are of higher ohms value than those which would be used if oscillation-damping depended solely upon resistance loading.)

Damping tube circuits serve to provide two functions in a modern TV receiver:

1. To act as variable damping re-

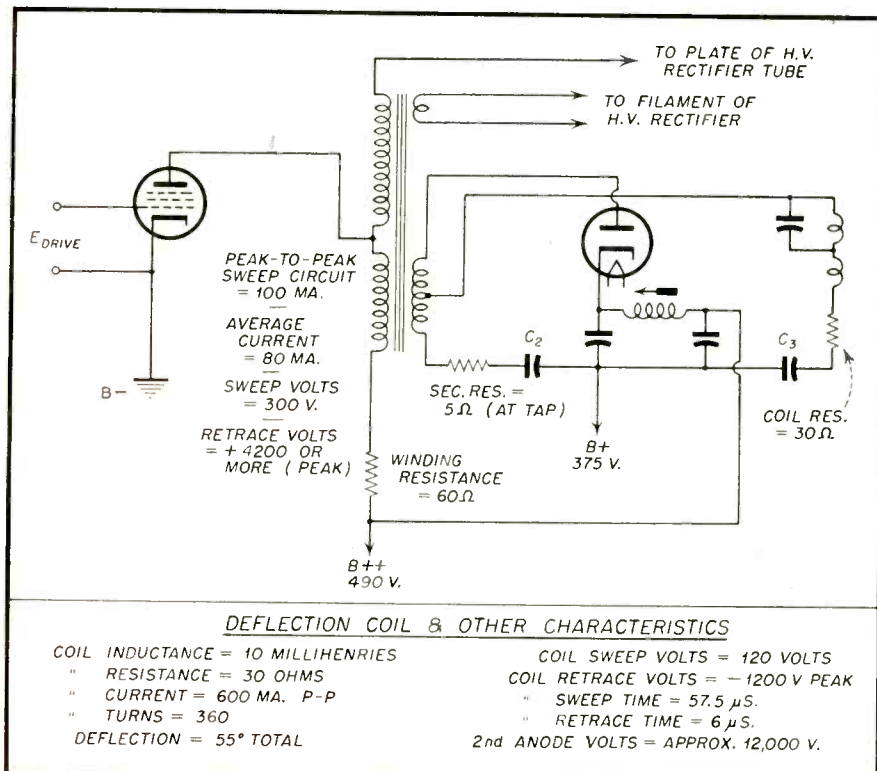

Fig. 7—Complete circuit with a variation showing the damper tube tapped higher on the secondary than the deflection coil.

[Continued on page 54]

Your Hi-Fi MARKET

PART I

by CHARLES B. GRAHAM

Beginning a series of articles on installing, maintaining, and selling Hi-Fi equipment. While most of the material covered in these installations will be of a technical nature, some of it will cover the merchandizing angle in order to prepare you adequately for Your Hi-Fi Market.

TODAY, as more and more set manufacturers move into the growing high-fidelity market, is the time for alert service organizations and technicians to get their own custom-building programs started. The 1951 sales volume of high-fidelity assemblies was over 13 million, and this year it should go to between 15 and 20 million installations. Many experts believe that before long the radio set will no longer be produced except in small table models. It is a fact that RTMA figures show standard sets losing ground steadily as TV sales continue. This trend will be accentuated with the upswing of UHF.

Another indication (beyond the introduction by Pilot, Hallicrafters, and Stromberg-Carlson, etc. of their hi-fi lines) is the trend recently noted by RTMA of most set makers to larger speakers and heavier magnets.

But TV, while it will continue to remain the bread-and-butter item in areas where it is already established, will not satisfy the demands of those enthusiasts (estimated at half a million, nationally) who are daily becoming more hi-fidelity conscious. The bug has been implanted for a number of years, largely by consumer publications, and the seeds are bearing fruit for the service dealers who can sense customer demand.

Many of us think of some particular eccentric, or "bug" who once wanted a hi-fi setup, and who has soured us on the breed, or at best caused us to look on them as a group apart from ordinary people. The fact is, though, that high-fidelity enthusiasts are found everywhere you find people who take their music seriously. They look



(Photo Courtesy Electronic Workshop)

Fig. 1—Custom built high-fidelity set-ups can please the home owner who likes modern or traditional furnishings. The corner baffle uses an Altec-Lansing 15" speaker. The turntable accommodates a Pickering arm for LP records and a Shure arm for 78 rpm's. The amplifier used is a Waveforms.

and act just like other people. And they represent real market possibilities.

In future installments of this series we will go into the ways and means already used by service-dealers to merchandise high-fidelity. We'll take up methods of securing customers using them to advertise our merchandise and go into the details of assembly and installation of hi-fi systems. But most important for those who have been concentrating on TV until now or improving their radio servicing without paying much attention to high-fidelity, we will go into such de-

tails of the technical end of it as should be required to provide a basis for installing and servicing the high-quality audio systems which are available today.

Let's take a look at this stuff—high fidelity—just what is it, anyway? "That's easy," somebody will say. "It's playing back, getting out of a system exactly what went into it."

Oh yeah? Have you ever tried making a 12" circle of heavy paper sound like one hundred and ten (not unusual for a major symphony orchestra) instruments including, say, eight double basses, six trombones, and assorted drums? We can list a few of the more obvious causes of "non-fidelity" on a later page after we've come to some sort of agreement as to what "high-fidelity" is.

A while back we said, "It's getting back out exactly what you put into a sound reproducing system." Obviously, impossible! That would be complete fidelity, or perfection. This is not an advertisement so we can forget phrases like, "It's just like being *right there!*" and, "You can close your eyes and just *see* the orchestra." High-fidelity means "a relatively high degree of fidelity." It has been defined by the FCC in setting up standards for FM broadcast stations as, "Linear amplification of the input sound from 40 to 15,000 cps within 2 db." There are further specifications having to do with the 75 microsecond pre-emphasis which is used to provide a better signal-to-noise ration (when the receiver *de-emphasizes* correspondingly) and with the permissible deviations. But this definition will serve as a workable standard.

However, the day has passed when any radioman thinks of wide frequency response only when talking about high-fidelity. Today the art has progressed to the point where he must also be concerned with the system's *intermodulation distortion* and *transient response* as well as *harmonic distortion*.

Harmonic Distortion

As most servicemen are aware, *harmonic distortion* (which until recently was the distortion intended when using the term "% of distortion") refers to the introduction of certain new or additional waves where before there were none. ¹An amplifier or amplifying system with harmonic distortion of, say, 5% would generate harmonics (multiples) of the original input wave which would equal one-twentieth the amplitude of the original. The percentage of harmonics generated increases as the amount of power being generated increases, so that the nominal harmonic distortion figure is usually related to the nominal maximum output—10, 20 or more watts.

The *exact* amplification of a tone or series of tones is not supposed to include *any* harmonics which were not in the input signal; but practical amplifiers don't work that way.

Linear amplification of the overtones (harmonics), produced by musical instruments and present in the actual input signal, is desirable. These overtones are what give each instrument much of its character and differentiate the sounds of the various instruments from each other.

Fig. 2. shows two typical notes, one as played on the flute, which has a rather clear, simple, pure tone, and the other as played on the violin which has a much more complex sound. It will be seen that the flute note, the fundamental of which is about 800 cycles, has only one significant overtone. On the other hand the violin note is rich in overtones, having at

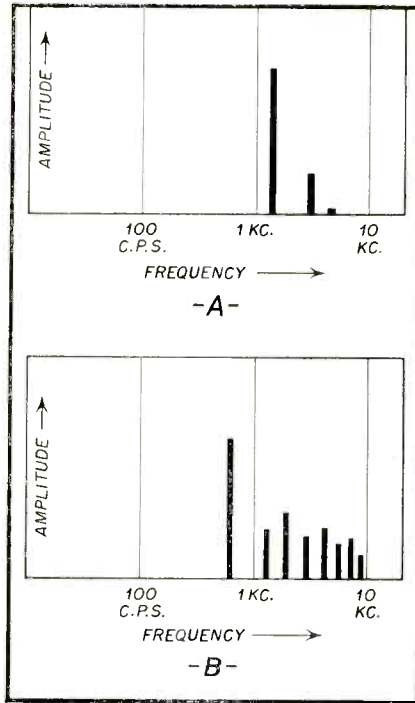

Fig. 2—(A) A typical flute note. Fundamental and 1st overtone are the only significant contributions to the tone. (B) Violin note has many overtones (harmonics), therefore sound is rich and complex.

least eight. Notice that the wave shapes of various tones vary considerably from one instrument to another, thus even further changing the characteristic "sound" of the instruments.

Intermodulation Distortion

When one realizes that each of these overtones can, on being amplified generate its *own* harmonics through harmonic distortion, the need for low harmonic distortion is seen. However, since these added sounds will all be exact multiples of actual musical notes the total sound is not nearly so displeasing as are the products of our newer and fancier problem—*intermodulation distortion*. (Called IM, for simplicity.)

IM distortion is the result of sum and difference-frequency signals being produced by the original signals. This in turn produces brand new, unpleasant notes. If a 100 cycle organ tone and a 5000 cycle flute note are amplified simultaneously the output due to intermodulation distortion will contain not only 100 cycles and 5000 cycles, but 4900 and 5100 cycle tones. These tones, not being multiples of either original tone, will sound unpleasant. If there is IM distortion of the order of 10 or 20%, then the IM products, the 4900 and 5100 tones, will be a very noticeable fraction of the amplitudes of the desired tones, and will be audible. Thus we need systems which produce even smaller percentages of IM distortion than of harmonic distortion.

Transient Response

Transient Response is partly a measure, of among other factors the flatness of frequency response of a system. Sharp wave fronts, generated by instruments like the snare drum and cymbals will suffer noticeably, and the sounds reproduced will not be crisp if the transient response is poor. Also, poor transient response can produce sounds unlike anything sent into the system when a component, such as the pickup, microphone, or speaker continues to emit waves started by one pulse even though it is time to produce the next. In loudspeakers this is called "hangover", and is worst, of course in cheap speakers, and at low frequencies, where the excursions of the speaker cone are greatest.

In general, there is a rough correlation between the harmonic and IM distortion figures for an amplifier. Depending on the method of measurement this varies from about 3/1 to 4/1. There was a time when 5% harmonic distortion at rated output was regarded as acceptable. Today this is regarded as a fair PA amplifier rating. Thus 1 or 2% harmonic distortion, and 3 to 5% IM distortion are maximums, at rated outputs, for reasonably good quality amplifiers. In a later article of this series we will go into more detail on the meanings of these ratings and the methods of testing distortion.

Power

The power capabilities of the components of a high-quality system are also of importance. A table receiver which delivers one or two watts to the speaker is normal, and provides plenty of power for its purpose. But most of that power is above 150 or 200 cycles, and there is no reserve left for the sudden demands made by

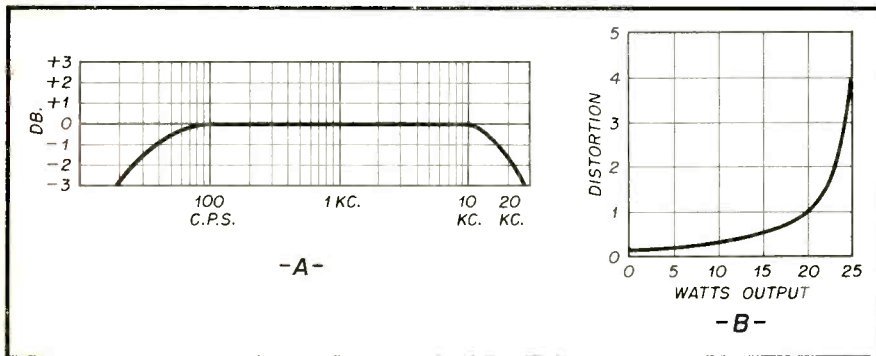

Fig. 3—(A) Zero db equals 18 watts. Power curve indicates that amplifier is within 1 db from 45 cps to 18 kc. (B) This curve shows amplifier which has less than 1% distortion at 18 watts.

a clash of cymbals, heavy drum beats, or the other rapid rises in volume. Although the latter occur only for a few milliseconds, they make all the difference between realism and sounding flat.

Since, most of the power in music is contained in the frequencies from 150 cycles down, a high-quality amplifier must be able to deliver 10 to 30 watts of relatively undistorted power for short periods.

Recently, due largely to the efforts of a number of transformer manufacturers, the practice of rating amplifiers as to *power capability* is coming into more common practice. A typical high quality amplifier spec sheet states "20 watts from 50 to 10,000 cycles, and down no more than 2 db at 20 and 20,000 cycles." Power curves at the rated output and at some medium figure are often shown, and provide a much more accurate idea of the real performance capabilities than the old frequency response curve, which usually was made at a watt or less. See Fig. 3.

As a reaction to the notion that wide frequency range alone would make music sound real, there has been much talk recently about restricted frequency range.² Tests have been made on various types of audiences which indicate that small changes in band width are not easily noticed. This, coupled with the fact that until this decade wider range was usually accompanied by plenty of distortion, had soured many manufacturers and designers on wide frequency range. The principle was discovered (and it unquestionably applies in most cases), that a *balanced* frequency range coming out of the loudspeakers, even if it is not so wide, sounds better than a system delivering much wider range only in one direction, up or down.

Phase Distortion

Phase Distortion (phase shift) is important in this day of high-feedback amplifiers, and it can be checked by square wave inspection. A later chapter will go into the details, but it will suffice here to say that low phase shift not only near the audio range, but throughout the entire amplified region is necessary.

Many of the questions we will touch upon have been argued by the best engineers in the world for several years, with little agreement in many cases. Generally these questions have no final or definite answers, and we will not take sides.³ For the sake of having something to work with in the series it will be necessary to make a number of arbitrary decisions as to the specifications which approach

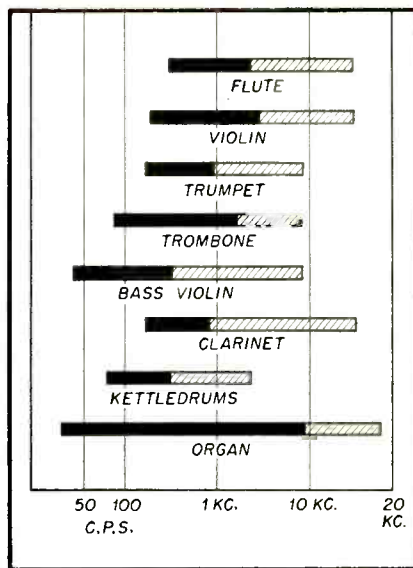

Fig. 4—Approximate frequency ranges covered by musical instruments. Fundamental notes are shown in black. Total sound may include harmonic overtones up to the shaded portion of each bar.

complete reproduction (best *fidelity* approach to the original) and which are still within the realm of practicality, from an economic standpoint.

For a system which qualifies as one of high fidelity it must be something like this:

1. Total distortion, IM and harmonic of the amplifier should be less than 3% at all frequencies in the audio range, and at all power outputs, up to its rated output.
2. The frequency response should be within ± 3 db over the range to be reproduced, and might fall off gradually, especially as it goes up, without any peaks in the ultrasonic region.
3. The power rating should be at least 10 watts for a small system in a small room, and from 20 to 30 watts at least, in larger installations.
4. The amplifier should reproduce square waves with little tilt or rounding within the audible range. (This indicates satisfactory phase-shift and transient response to at least 10 times the frequencies of the square waves employed.)
5. The range to be reproduced should be at least 60 to 10,000 cycles for a minimal system, and 40 to 16,000 cycles if the very best program material (top LPs, live local FM broadcasts, and original tapes made on professional recorders) is to be used. See Fig. 4.

It should be noted that the amplifier if it conforms to these requirements, will not perceptibly impair the fidelity of the system. In this case the program material, the pickup instrument (tuner, phono cartridge or re-

corder head and preamp), and the loudspeaker will contribute most of the distortion present. It would be unwise to carry an amplifier beyond these specifications with most of today's pickup and reproducing devices.

Finally, we can list a number of the more apparent causes of poor fidelity as compared to the original program. In succeeding installments we will discuss those over which we presently have any degree of control.

1. The *amplifier* may be incapable of handling the necessary power without distortion. (As discussed briefly above—many chapters could go into this alone but at least one will be devoted to it as completely as space allows.)

2. Amplifier and pickup devices cannot or do not properly compensate for, or *equalize* the program material.

3. The loudspeaker (and/or pickup) does not have wide enough frequency response for recreation of the program material.

4. The loudspeaker, though having wide enough frequency response, and although as smooth as is economic, cannot handle the power required for realistic reproduction, particularly at the low frequencies. It breaks up, or just doesn't move enough.

5. The reproduction is *monaural*, one-eared; it must compress into 60 or so db of dynamic range (variation from loudest to weakest) that which in reality may be 90 or so db also, the reproducing room is of a different size, shape, and differently lined from the studio or pickup hall.

Numerous other causes exist, but most of them are even further outside our potential control than those mentioned in *point 5* above. Consideration of the more obvious things touched on in this installment will keep us busy for many months.

Hi-Fidelity V has been knocking at the door for a long time. It has gained great acceleration from the home magazines, consumers groups, magazines and from record reviewers in a wide variety of publications. The greatest number of people who have thus had their interest aroused are still waiting to be satisfied. You have given them radio, and in many cases TV, you can now give them hi-fi audio.

¹ Amplification of the overtones (also called harmonics) which musical tones include.

² Regarding frequency response range of amplifiers, it should be noted that there is considerable variation of opinion among engineers as to whether or not it should be "flat from d.c. to 200,000 cps, ± 1 db," or flat from about 40 to 14,000, with fairly rapid attenuation outside that band.

³ "Triodes vs tetrodes" comes in round four!

[To be continued]

Is D. C. Restoration NECESSARY?

by **MATTHEW MANDL**

(Author of *Mandl's Television Servicing*)

A NUMBER of television receivers manufactured during the past year have omitted the d-c restorer circuit. Actually, a d-c restorer would not be necessary if direct coupling were used between video amplifier stages and between the last video amplifier and the picture tube grid. With direct coupling, the d-c level of the composite video signal is not altered. When, however, a coupling capacitor is used, the d-c level is lost and therefore the characteristics of the video signal can be changed to a considerable extent. The d-c restorer is then used to re-establish the d-c level and thus maintain the proper average background and illumination of the transmitted scene. Thus, the omission of the d-c restorer with capacity coupling can alter the picture background to a considerable extent in some scenes. For many scenes, however, the lack of d-c restoration is hardly noticeable. For this, and other reasons, there are arguments for omitting the d-c restorer circuit from television receivers, but there are also strong reasons advanced for its inclusion. Inasmuch as most textbooks and articles have stressed the importance of the d-c restorer, technicians have wondered why some manufacturers are leaving it out of their new receivers. The circuit itself is simple and can be incorporated in a receiver by using just a few parts. In fact, the vacuum tube need not be used but a germanium crystal can be employed instead.

D-C Restorer Merits

In order to understand the differences which exist, let us briefly review the merits of the d-c restorer. This will be of material aid to the technician in diagnosing contrast and brilliancy troubles and thus avoid confusing the symptoms which appear on occasion because of the lack of d-c restoration. This aids in evaluating whether or not such a circuit

The recent vintage of TV receivers has produced a number of sets without d-c restorer circuits. In this article the author discusses the pros and cons of d-c restoration, and indicates how it may be added if desired.

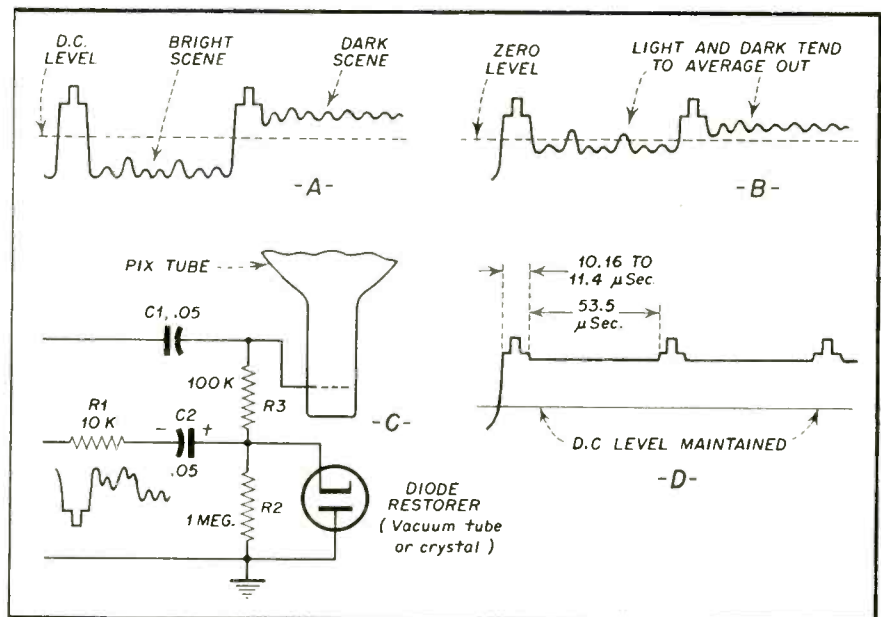

Fig. 1—(A) Original waveform of scene containing d-c level. (B) Same signal with d-c level removed. (C) simple d-c restorer circuit. (D) D-C level is maintained with a d-c restorer.

should be installed in a receiver which does not have it. There have been occasions where viewers have noticed differences in new receivers without a d-c restorer as compared with their old one which has such a circuit. On other occasions, however, the difficulties were caused by contrast and brilliancy control defects.

In Fig. 1A, a composite video signal is shown in which the first portion indicates a bright scene while the second section indicates a dark line trace. The d-c level which is derived from the video detector is the reference point above and below which the

signals vary in amplitude. If a coupling capacitor is used to transfer signal energy to a subsequent stage, the d-c level would be lost because the composite video signal now assumes the characteristics of alternating current. In such an instance there would be a zero level of voltage and above this the signal would have a plus polarity while below it would have a negative polarity. When this occurs the signal will tend to average itself out along the zero level line.

This, then, will tend to decrease the negative levels as well as the positive levels of signal. This is shown at B of

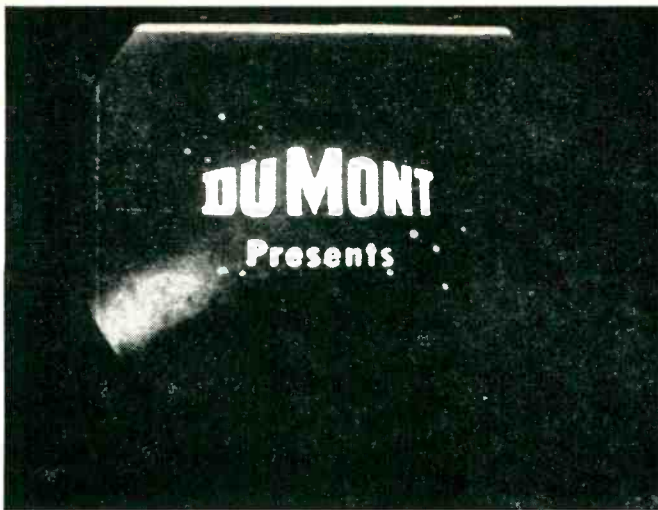

Fig. 3—Background is black and lettering is white.

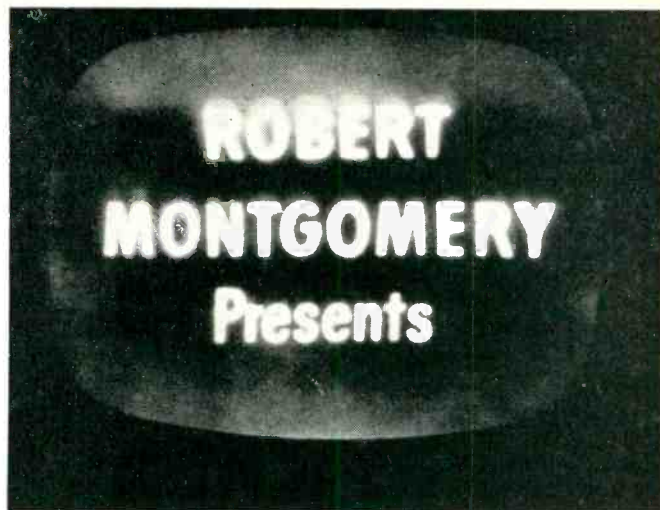

Fig. 4—Scene without use of d-c restoration.

Fig. 1. If the transmitted scene is a bright one, it would tend to pull the signals toward the zero reference line and thus darken that area. With the dark levels, it would tend to pull those toward the zero reference line and then tend to lighten the levels. At the same time the levels of the sync tips would no longer be of similar amplitude. This means that retrace lines would become visible for some scenes if the brightness control and contrast control setting were not adjusted to maintain good blanking.

The d-c restorer is a simple diode of either the vacuum tube or germanium crystal type as shown at *IC*. A sample of the composite video signal is impressed across the circuit and the diode conducts for the peak of the sync signal. This charges the capacitor *C2*. During a decline of the sync tip level such as occurs during signal information, the d-c restorer tube does not conduct and the charge across *C2* will now appear across *R2*. This alters the bias on the picture tube and thus establishes a d-c reference level of constant amplitude. This comes about because the charge on *C2* is constantly being replenished by the incoming sync pulses which cause conduction of the restorer tube.

Operation Without D-C Restorer

If a coupling capacitor is used without d-c restoration most scenes will not appear sufficiently different to the viewer to cause him to note the absence of d-c restoration. As a matter of fact, a number of engineers claim that the average viewer would never notice the lack of a d-c restorer if he were not acquainted with the symptoms on the screen. Some viewers, however, have noticed the difference in some transmitted scenes. This is particularly true if the televised scene

is that of a dark room with only small articles or objects visible. Thus, for instance, if an actor is walking through a dark room with a lighted candle, with d-c restoration the transmitted scene would be black with the candle light being white. Without d-c restoration, however, the room does not assume total blackness, but rather a dark gray and in some instances a light gray. This comes about because the constant line-by-line trace of a black or dark scene requires a constant level of video signal information. With d-c restoration this level is maintained as shown at *D* of Fig. 1.

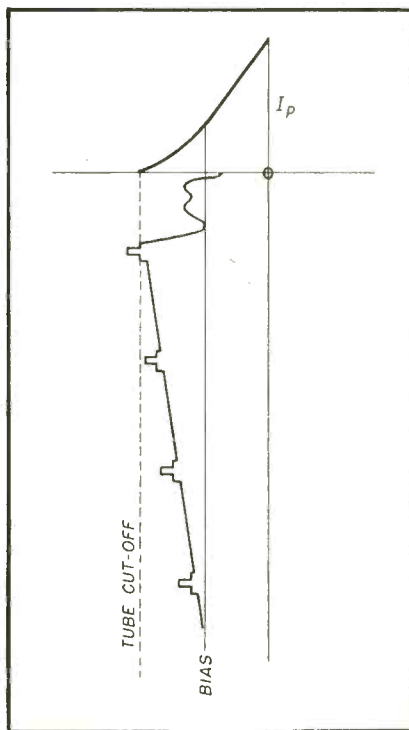

Fig. 2—Without d-c restorer, "C" bias is not always at cut-off when the sync pulse arrives.

This represents several horizontal line scans of the transmitted scene. To represent a very dark area or a black area, the video signal would have to remain near the blanking level as shown. Inasmuch as horizontal blanking is approximately 10 micro-seconds, while a horizontal line scan is approximately 53.5 micro-seconds, it means that the video signal must remain fairly constant line after line. Thus, a relatively long scan is maintained and this is only interrupted periodically by the horizontal sync signal.

If a coupling capacitor is used, the long duration blanking level represents a d-c component rather than an a-c component. Thus, the capacitor is unable to maintain a constant output voltage without periodic changes to replenish the energy drawn from it. As shown in Fig. 2, the initial peak amplitude of the signal would place a charge upon this capacitor but since no rate of change is present the capacitor would slowly discharge. This would mean a gradual decline of the level which is supposed to be maintained at the blanking or cut-off portion of the picture tube. The decline of the signal level could occur to the point where it would equal the fixed bias on the picture tube. Thus, instead of the scene appearing black because the signal is reaching cut-off, it will be gray because the signal has established itself around the bias line.

If the signal level is interrupted occasionally by an image such as a column of white or some other light object, the capacitor is charged for each line trace and will maintain a blanking level. Under such a condition the scene will really appear black and the d-c restorer would not be missed. This brings about the curious condition where the scene can be gray if only

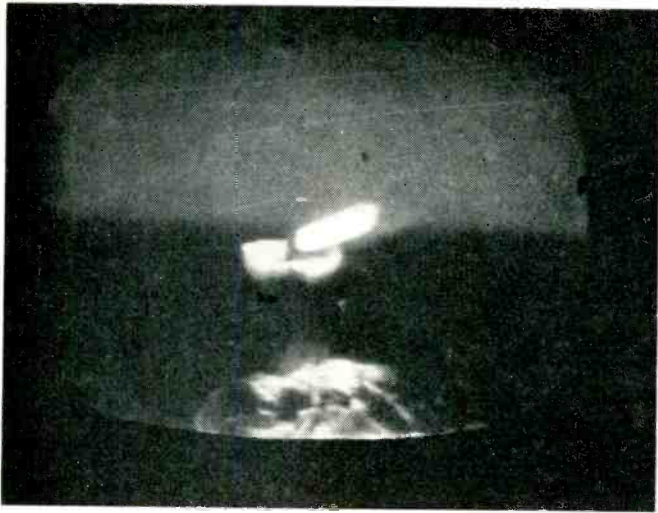

Fig. 5—Black and white scene without d-c restorer.

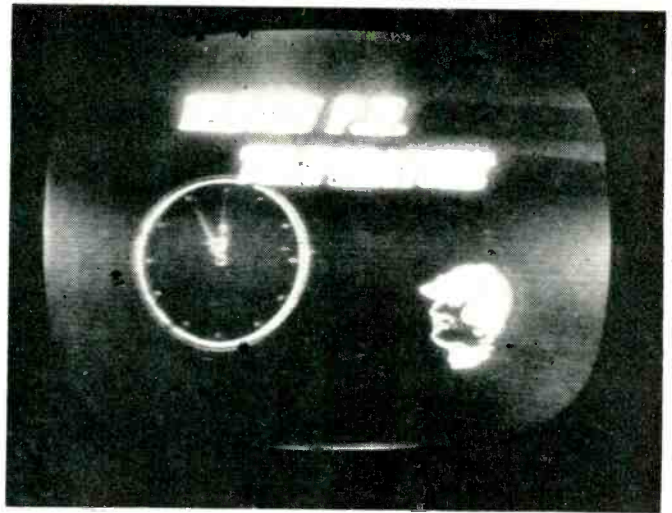

Fig. 6—Another scene without d-c restoration.

one or two small objects are visible, while the scene would appear black if a fairly large light object were present in the picture.

Typical Illustrations

These factors are shown in some photographs which have been taken from a receiver with a d-c restorer and another receiver which utilizes capacity coupling but does not have a restorer tube. *Fig. 3* shows a scene in which the background is black while the lettering is white. A gray shaded portion is present at the bottom left, and this is the scene as transmitted. The picture is of a receiver outside its cabinet and on the work bench. The room was darkened to emphasize the blacks, whites, and intermediate shades of gray. Note the white horizontal portion of the raster before the black background trace is begun at the top of the scene. This receiver has a d-c restorer and this scene is identical to that which would be received if

direct coupling were used.

In *Fig. 4*, a similar scene is shown on a receiver which does not utilize d-c restoration for reinsertion of the d-c level which was upset by the coupling capacitor. You will note that the initial scan at the top of the screen cannot produce black because the coupling capacitor is unable to furnish d-c output. As soon as white letters appear in the scene, however, there is a periodic change of signal information and the charge and discharge of the capacitor now maintains a black level. Thus, the background and on occasion retrace line but soon after the last line of lettering, the capacitor discharges because there no longer is a rate of change in the incoming signal. The background again becomes dark gray instead of black.

In *Fig. 5*, a lighted candle is shown in a dark room. Here the entire background should be black. Instead, how-

ever, the top half of the picture is dark gray because the type of signal which is present is as shown in *Fig. 1D*. The constant level of the signal is not reproduced by the coupling capacitor with the results as shown in *Fig. 2*. This causes the gray background and on occasion retrace line will also be visible because the blanking is pulled below the picture tube cut-off. As soon as the downward trace arrives at the point where the lighted candle is shown the signal information again has changes in amplitude. Inasmuch as this now resembles a.c., the capacitor will transfer such information to the picture tube. The scene now assumes the proper illumination and background. As shown in *Fig. 5*, the lower half of the picture is now black. If a d-c restorer had been used, the entire background would have been totally black.

Many viewers would not realize that

[Continued on page 53]

Fig. 7—Scene without d-c restorer being used.



Fig. 8—Scene using a d-c restorer.

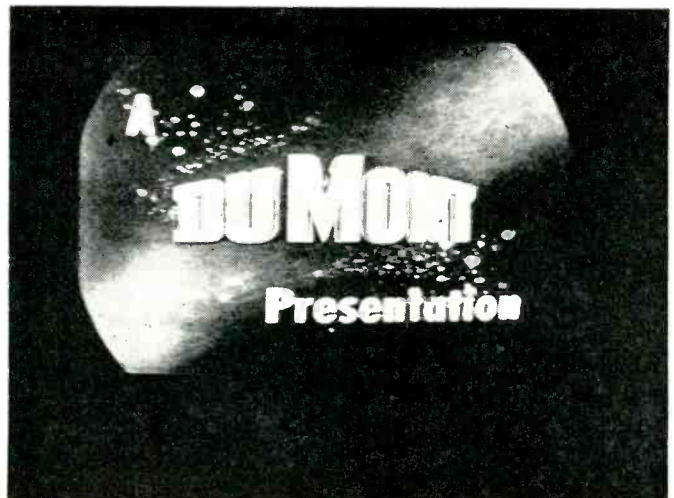

TV SYNC CIRCUITS

PART I

By LEONARD LIEBERMAN

Beginning a series on TV sync circuits, their operation and servicing, by the writer who is currently engaged in taking you through all the sections of a TV receiver in a similar manner.

THE section of the TV receiver which gives the serviceman his greatest headaches is the sync circuits. At the same time it is also the source of set trouble to which the customer is most sensitive. The average customer will tolerate poor video response, noise in the pix, noise in the sound, etc. But, when the pix shows a tendency to "hook", roll vertically, tear out horizontally or shift from side to side, then there is an agonizing cry "get the serviceman down here quickly." The reason for this is rather obvious, while the customer can accustom himself to poor pix or poor sound, when the sync goes bad, he has nothing to watch.

Sync separation circuitry is the least standardized commercially. Where the other sections fall into two or three categories, the sync circuits vary considerably. Sync separators makes use of just about every tube characteristic to accomplish their purpose. They use plate saturation, cut-off bias, grid current flow, cathode drivers, cathode followers, etc.

The sync pulses are required so that each line and each field will be scanned by the CRT's electron beam in the same sequence that they are scanned by the camera tube at the transmitter. The term "sync circuit" is applied to those tubes and associated components which do the following jobs:

1. Separate the sync pulse from the video information; sometimes called: sync stripping, or sync separation, or sync clipping.
2. Amplify the sync pulse.
3. Insure that all the sync pulses are the same amplitude; sometimes called, sync leveling.

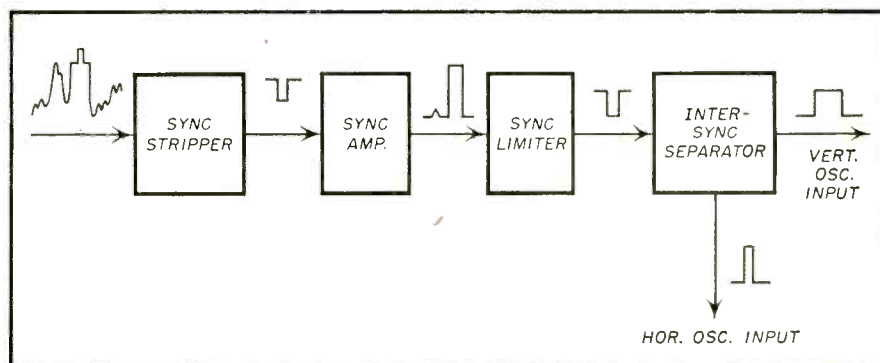

Fig. 1—Basic block diagram of sync section.

4. Separate the vertical pulses from the horizontal; sometimes called: intersync separation.

5. Supply the vertical and horizontal oscillators with sync pulses of such polarity that they will trigger the oscillators.

Fig. 1 is a block diagram of these functions. Let us examine each block separately. In some sets we will find a separate tube for each function and in others several functions being per-

formed by a single tube. The basic operation, however, still remains the same.

Sync Stripper

The term "sync stripper" is more nearly descriptive of this stage than the more generally used "sync separator." The reason for this is that sync stripper describes the circuit action exactly. What this stage does is strip the video information from the composite video signal, leaving only the sync pulses to be amplified. The general description of the stage operation is as follows: The composite video signal is taken off at some point after the video second detector. The rectified signal is fed to an amplitude discriminator. By amplitude discriminator is meant a tube which will respond only to the sync portions of the composite signal. The output of this tube now contains only the sync pulses. (Fig. 2). The sync take-off point can be the video second detector load resistor (Fig. 3a); the a-g-c rectifier (Fig. 3b); the video amplifier plate circuit (Fig. 3c); or the d-c restorer diode (Fig. 3d). The sync

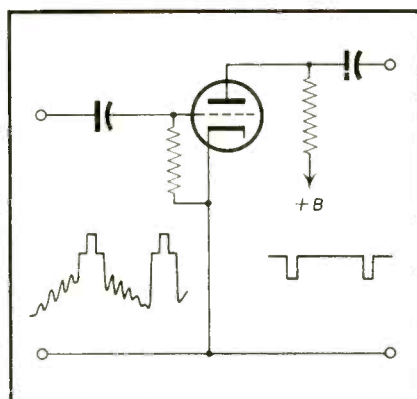

Fig. 2—Sync-stripper circuit.

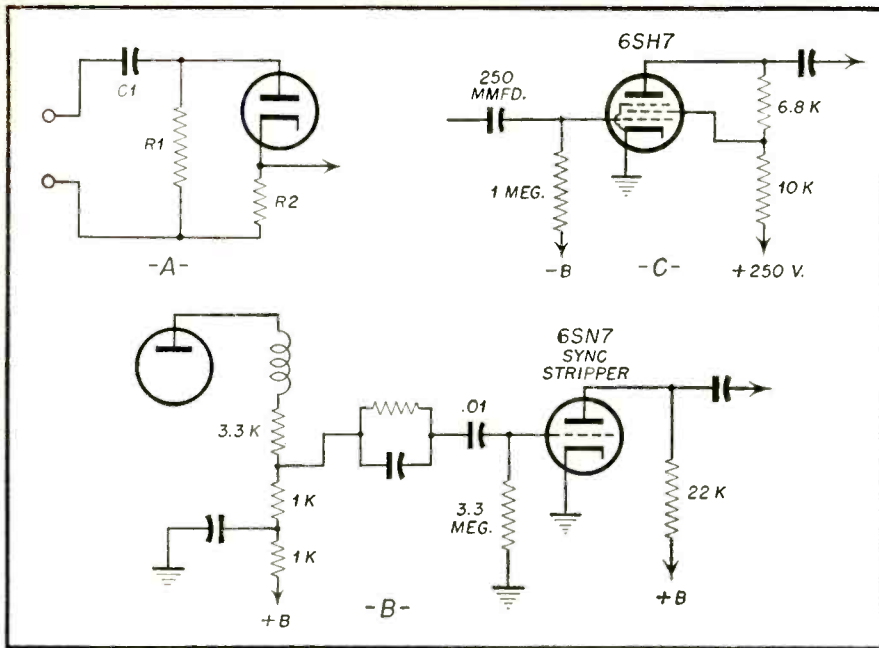

Fig. 4—Various types of sync strippers. (A) Diode stripper. (B) Triode stripper. (C) Pentode stripper.

stripper can be a diode (Fig. 4a), a triode (Fig. 4b) or a pentode (Fig. 4c).

The action of the diode sync stripper (Fig. 4a) is quite simple and is the most basic of the stripper circuits. The first composite signal arriving at the input will cause the diode to conduct. This conduction will cause C1

to charge up to the peak value of the signal; that is the top of the sync pulse. The RC time is such that C1 discharges approximately 25% in the time of one line (63.5 usec). Thus, when the next sync pulse arrives, the tube conducts for the time of the pulse. This conduction current causes a voltage to appear across R2 which

corresponds to the sync pulse.

This diode action is sometimes used in pentode multiple purpose sync tubes. Used thusly, the grid and cathode are so biased that the grid current flows during the time the sync pulse is active, that is the grid acts as the plate of the diode. As a result of the change in grid voltage the tube plate current is varied so that the tube rectifies (strips) the sync signal and amplifies it as well (Fig. 5).

Triode and pentode sync strippers more generally operate on the basis of tube-cutoff characteristics (Fig. 6). This type of tube operation is the one most commonly used. The requirements for this operation are:

1. That the tube have a sharp cut-off.
2. That the sync signal be of a large enough amplitude to extend the

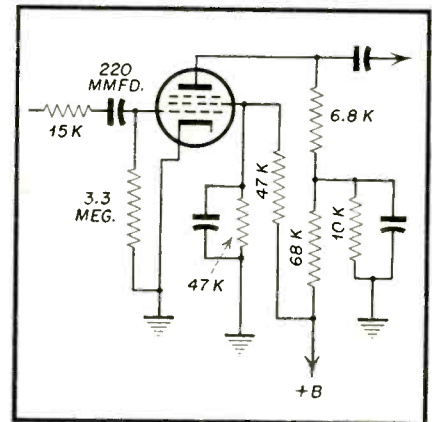

Fig. 5—Multi-purpose pentode stripper.

grid bias from cut-off to zero volts.

3. That the signal input has the sync pulse in the positive direction.

4. That the sync pulse amplitudes be approximately the same.

5. That the sync level of the transmitted video signal in the area be constant. By sync level is meant the percentage of sync to the overall signal. (Fig. 7).

The last named item is unfortunately something which the serviceman can do nothing about. It has been the author's experience to observe in many parts of the country that the sync level at the transmitters do not always conform to F.C.C. requirements. He has found some areas where there is a violent sync level fluctuation. In one case, he measured this fluctuation to be from 10% to 40% of the composite signal level. If you are having sync trouble on practically all sets in your area, it would be advisable to look into the question of

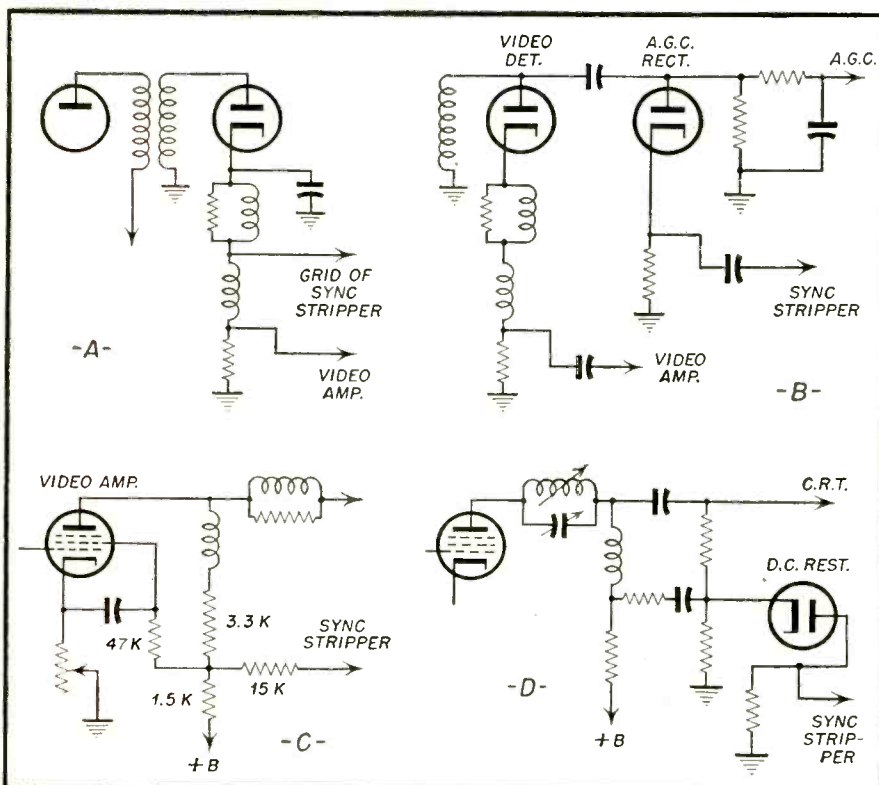

Fig. 3—Sync take-off points. (A) Video detector. (B) A-G-C rectifier. (C) Video amplifier plate. (D) D-C restorer.

[Continued on page 46]

CIRCUIT & SERVICE DATA

of

CBS CHASSIS 817, 817-1, 820 and 820-1

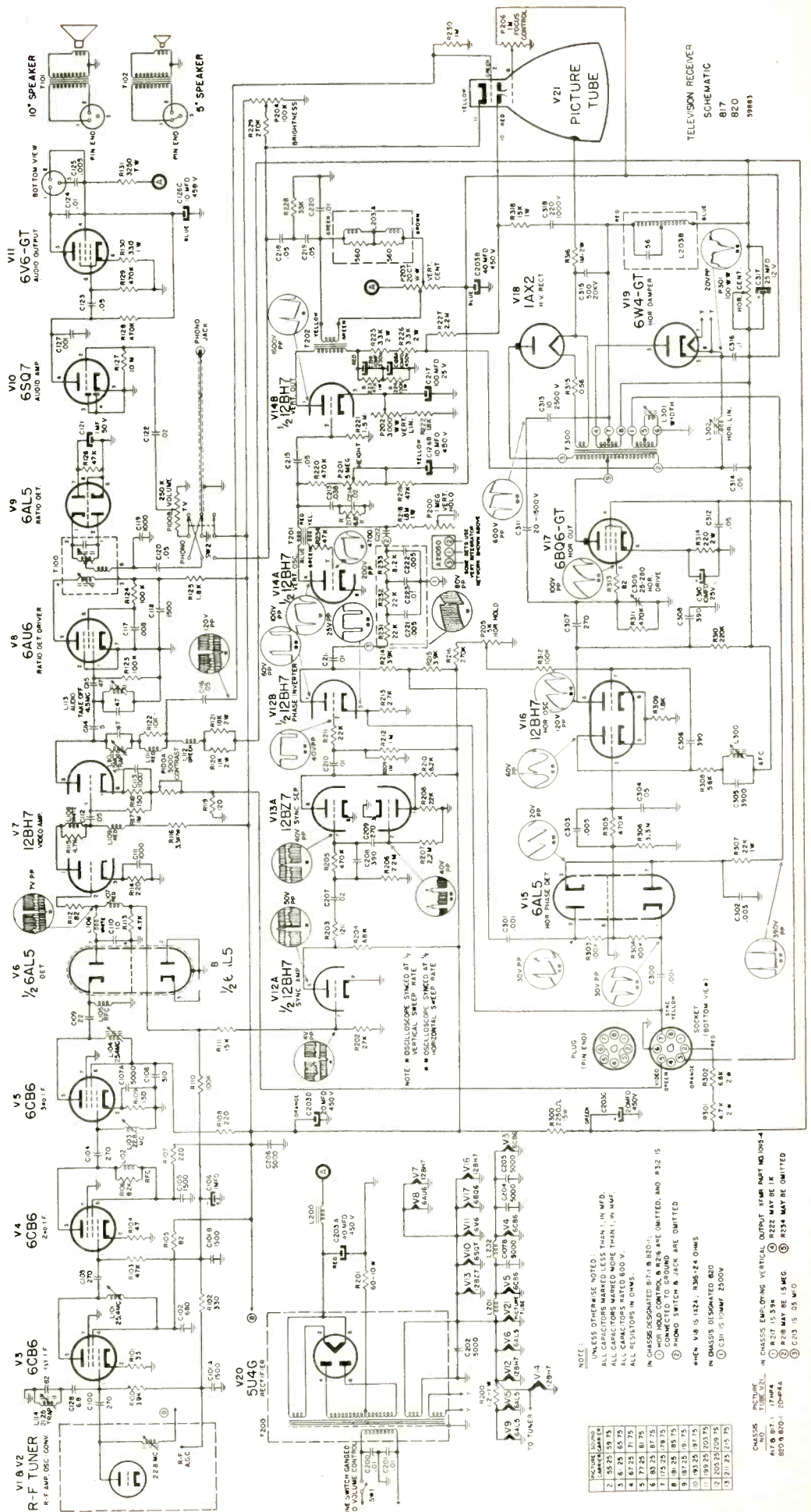

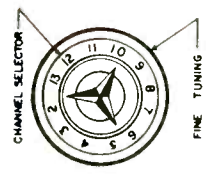
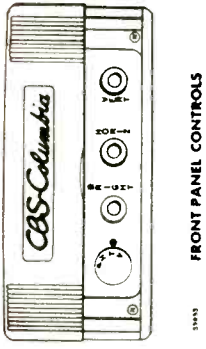
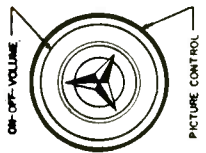
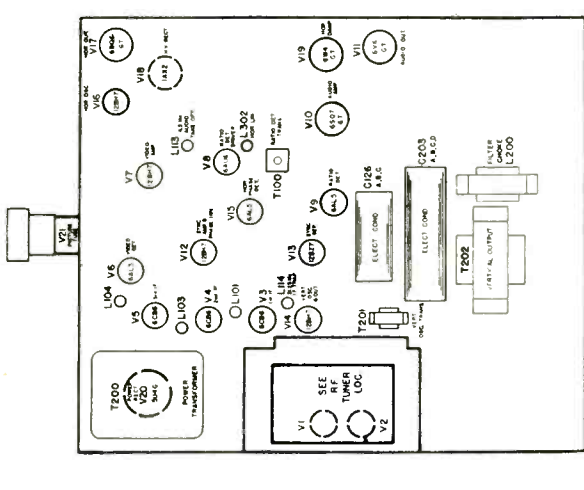
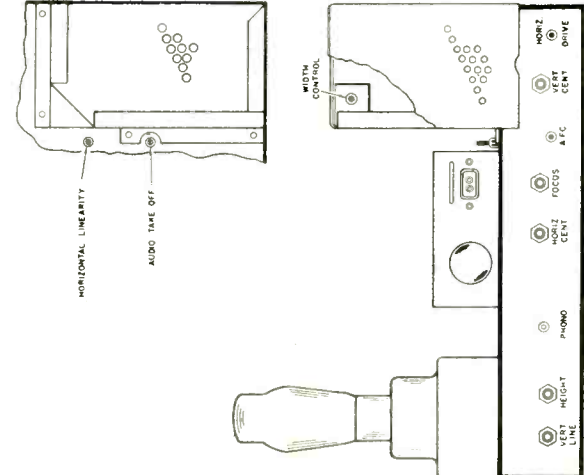
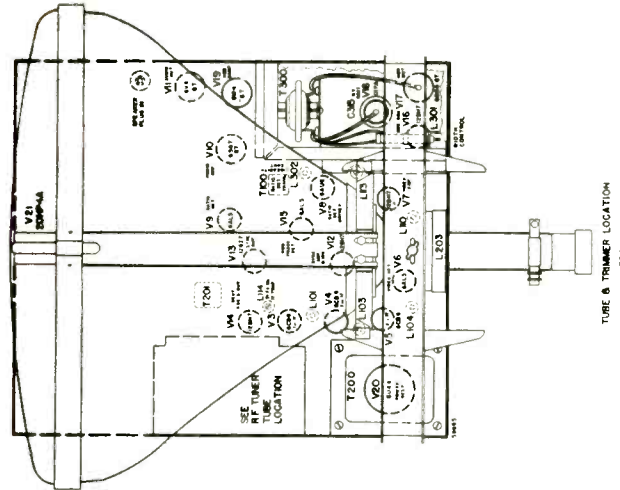
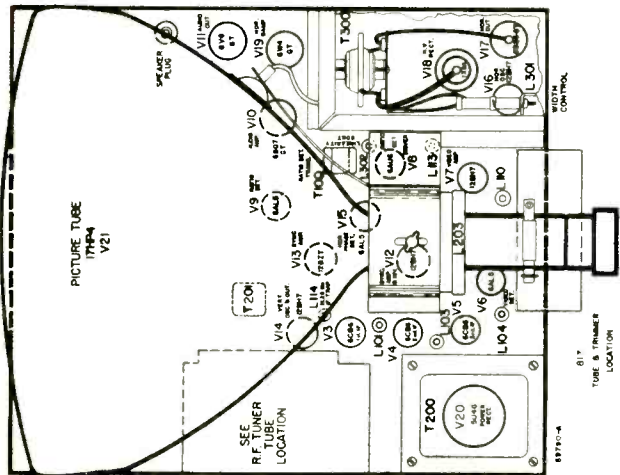

FRONT PANEL CONTROLS

CHANNEL SELECTOR

FINE TUNING

RESISTANCE MEASUREMENTS ON 817, 817-1, 820 and 820-1 CHASSIS

TUBE LOC.	TUBE TYPE	1	2	3	4	5	6	7	8	9
V1	6BC5	150K	0	0	0	25K	25K	0	0	0
V2	6X4	33K	47	0	0	23K	23K	0	0	0
V3	6CB6	188K	56	0.3	0	23K	23K	0	0	0
V4	6CB6	0.2	150	0.2	0	23K	23K	0	0	0
V5	6AL5	25K	4.7K	200	0	31K	1M	0.05K	0	0
V6	6CB6	100K	0	0	0	25K	125K	0	0	0
V7	6AU6	0	0	0	0	0	0	47K	0	0
V8	6AL5	0	0	0	0	0	0	0	0	0
V9	6AV6GT	0	0	0	0	20K	29K	0	0	330
V10	6AV6GT	0	0	0	0	0	0	0	0	0
V11	6AV6GT	0	0	0	0	0	0	0	0	0
V12	12BH7	31K	0.5M	2.7K	0	0	0	0	0	0
V13	12BZ7	20K	2.2M	0	0	0	0	0	0	0
V14	6AL5	215K	1.5M	3.3K	0	0	0	0	0	0
V15	6AL5	150K	1.5M	3.3K	0	0	0	0	0	0
V16	12BH7	35K	3.8M	1.8K	0.0	0.0	0.0	0.0	0.0	0.0
V17	6BQ6GT	XX	0	X	36K	470K	X	0	150	204K
V18	12A	XX	X	204K	X	26K	X	204K	204K	XX
V19	6W4G	X	X	26K	X	100	X	26K	XX	XX
V20	504G	X	X	26K	X	100	X	26K	XX	XX
V21	12HP4	Pin 1: 0; Pin 2: 1M; Pin 10: 200K; Pin 11: 370K to 270K; Pin 12: 0; Pin 13: 0								

NOTE: Resistances measured from Pin to ground with Phenac-TV Switch, if any, in TV position.

X: Indicates that pin is used as terminal post for another part of the chassis.

XX: Indicates that pin is used as terminal post for another part of the chassis.

1: Varies with contrast (picture) setting.

2: Varies with brightness setting.

3: Varies with linearity setting.

4: For 820 and 820-1, Pin 1=25; Pin 5=25; Pin 8=0; other readings as given above.

5: Varies with vertical alignment setting; reading given is nominal.

6: Varies with horizontal alignment setting; reading given is nominal.

7: Varies with hold setting.

8: On 820 and 820-1, Pin 8=0.

9: For vertical output transformer marked PC10152-1 only; if vertical output transformer is marked PC10115, the following resistances apply:

TUBE SOCKET VOLTAGES ON 817, 817-1, 820, 820-1 CHASSIS

TUBE LOC.	TUBE TYPE	1	2	3	4	5	6	7	8	9
V1	6BC5	-1	0	0	6.2 ac	105	105	0	0	0
V2	6X4	150	0.5	0	6.2 ac	-2.5	-4	0	0	0
V3	6CB6	-0.4	0.6	6.0 ac	0	120	120	0	0	0
V4	6CB6	0	1.0	6.1 ac	0	120	120	0	0	0
V5	6AL5	0	0	0	6.3 ac	0	0	-0.4	0	0
V6	6CB6	90	-0.4	2.0	6.3 ac	6.3 ac	16.5	15.5	3.5 ac	0
V7	12BH7	0	0	0	0	0	0	0	0	0
V8	6AU6	-0.5	0	0	6.3 ac	120	50	0	0	0
V9	6AL5	0.5	-0.5	5.5 ac	0	0	0	0	0.75	0
V10	6AV6GT	0	0	0	0	0	0	0	0	0
V11	6AV6GT	0	0	200	270	0	0	75	6.3 ac	0
V12	12BH7	60	20	20	0	0	0	14	-0.4	0
V13	12BZ7	50	-0.8	0	0	0	0	90	-0.9	0
V14	6AL5	450	-0.1	26	0	0	0	150	-50	0
V15	6AL5	450	-0.1	26	0	0	0	150	-50	0
V16	12BH7	200	0	15	3.3 ac	6.3 ac	120	3	15	0
V17	6BQ6GT	-17**	0	0	145	-17	0	6.3 ac	15	0
V18	12A	320**	0	0	595	0	0	310	525	525
V19	6W4G	360	0	0	310	320	320	320	320	320
V20	504G	Pin 1: 0; Pin 2: 3 to 6; Pin 10: 515; Pin 11: 40 to 150; Pin 12: 6.3 ac								
V21	12HP4	Pin 1: 0; Pin 2: 3 to 6; Pin 10: 515; Pin 11: 40 to 150; Pin 12: 6.3 ac								

NOTE: All voltages measured with V. T. M. from pin to ground with line selector switch in TV position.

** Above voltages apply only when vertical output transformer is marked PC10152. If vertical output transformer is marked PC10115, the following voltages apply.

CABINET PARTS REPAIR LIST

PART NAME	MODEL 17718 CHASSIS 817	MODEL 17M18 CHASSIS 817	MODEL 17C18 CHASSIS 817	MODEL 20T18 CHASSIS 820	MODEL 20M18 CHASSIS 820	MODEL 20A18 CHASSIS 820
Cabinet	A60168-1	A60165-1	A60170-1	A60169-1	A60166-1	MODEL 20H28 CHASSIS 820
Trapdoor, Cover	A4497	A4498	A4499	A4497	A4497	A60166-3
Trapdoor, Base	A4498	A4498	A4498	A4498	A4498	A60166-3
Safety Glass	A62290	A62277	A62368	A62353	A62351	A60166-3
Mask	A62367-1	A62367-1	A62367-1	A62367-1	A62367-1	A60166-3
Beck Cover	A62354	A62354	A62354	A62354	A62354	A60166-3
Speaker	57PM	57PM	57PM	57PM	57PM	A62360
Knob, Channel Selector	A39242-1	A39242-1	A39242-1	A39242-1	A39242-1	A62360
Knob, Volume	A39240-3	A39240-3	A39240-3	A39240-3	A39240-3	A62360
Knob, On-Off/Volume	A39241-1	A39241-1	A39241-1	A39241-1	A39241-1	A62360
Knob, Pic-Control	A39239-3	A39239-3	A39239-3	A39239-3	A39239-3	A62360
Knob, Floor-TV Switch	A39249	A39249	A39249	A39249	A39249	A62360

REAR CHASSIS CONTROLS

BOTTOM VIEW

800 SERIES

BROAD BAND YAGI ANTENNAS

by **HAROLD HARRIS** and **HARRY GREENBERG**

(Engineering Dept., Channel Master Corp.)

The article presents a basic discussion of broad band Yagi antenna design, and describes a unique system of accomplishing this purpose.

THE lifting of the freeze by the FCC will mean that television will be available to thousands of families that could not get it in the past. It means many other things too. It means that people receiving television at present, will probably receive more stations in the future—and it means that in thirty specific cases, problems will arise when stations which are now on the air, must move to different channels. Despite the fact that there will be many new stations on the air, fringe areas will be with us always. Some areas which are now in the primary service zone of present transmitters will fall into the fringe areas of new stations.

All of the foregoing is to indicate, in part, the tremendous antenna problem which lies ahead, and our concern here is with VHF only. Although the Yagi antenna, due to its excellent gain and directivity, has become one of the most widely used types in the country, it has one severe limitation—its narrow band width. There have been a few Yagi types on the market which have been able to operate on two channels, but by far the greatest number have been confined to one channel operation. This limitation will be underlined with great emphasis when a single channel area such as Schenectady, New York, must change frequencies from channel 4 to channel 6. Viewers in this area, which depends chiefly upon Yagis, will find that their present antennas will not work satisfactorily *after* the shift is completed. Servicemen in the area will undoubtedly be flooded with antenna-

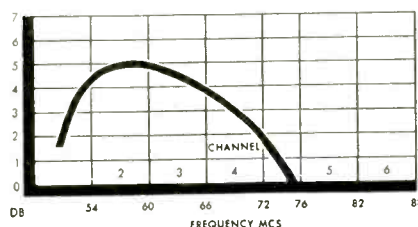

Fig. 1—Gain curve of Channel 2 antenna

change calls when the shift is a—who change their antennas too early from channel 4 to channel 6 will not be able to get satisfactory reception *before* the change is completed.

This situation, created by a change of frequency, is only one type of problem. In other areas, like those in which new stations will be added to present ones on the same band, the Yagi that has been supplying reception will no longer suffice. Thus it will be seen that in the VHF world of the future, the Yagi antenna, as we know it, cannot perform its function adequately. What obviously is needed is an antenna having the outstanding gain directivity, and structural characteristics of the Yagi, and yet having the band-width to cover several channels.

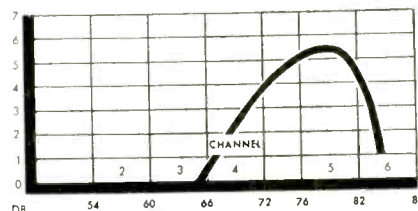
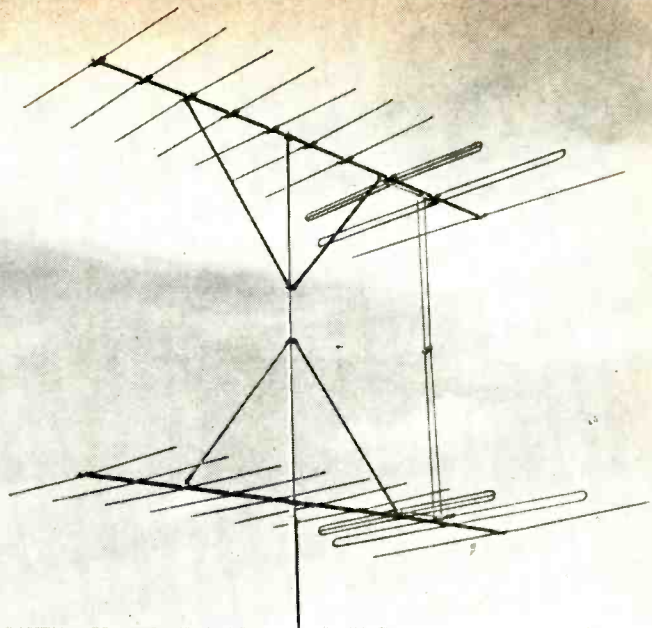

Fig. 2—Gain curve of Channel 5 antenna

Based upon the above analysis, the Channel Master Corporation undertook to develop a practical broad band Yagi antenna—an antenna which would work satisfactorily in the present and which would provide reception for channels which changed or which were added in the future. They called this laboratory undertaking “Project Futuramic,” and the result is a Yagi antenna which will work up to four channels on the low band and across the entire high band. This “Futuramic” Broad Band Yagi holds its impedance across the entire band for which it is designed, has a higher front-to-back ratio than conventional Yagis, plus outstanding gain.

Before entering into a detailed description of the more unique parts of the “Futuramic” Yagi antenna, it would be helpful to review some of the characteristics of parasitic antenna systems. The first type with which we are concerned, is the folded dipole with single reflector. The gain curve of this antenna is shown in Fig. 1. It can be seen that in this case, our dipole and reflector combination is peaked at channel 2. This combination of dipole and reflector falls off very sharply on the low end and more gradually on the high end. Now, let us consider a folded dipole with single director. This type of combination can supply slightly higher gains than the folded dipole with reflector, but its characteristics differ in two respects. First, its band width is not as great, and secondly, it drops off sharply at the high end and more gradually at the low end (Fig. 2).

The photograph on the right illustrates a stacked low band antenna of the type described in this article. Notice the boom braced supports for greater strength.



Let us superimpose these two gain curves and the result is shown in Fig. 3. Our solution begins to take shape. Here we have a situation where we have a folded dipole with reflector for channel 2 which covers up to channel 4 with moderate gain—and then we have a folded dipole with director cut to channel 5 which also covers channel 4 with moderate gain. However, our problem is to develop a resonant dipole system which can hold up across the band from channel 2 to channel 5 so that we can take advantage of the reflective and direct systems. The use of the conventional single dipole is impossible because it cannot hold up over this wide band of frequencies. The problem is to use two dipoles for either end of the band,

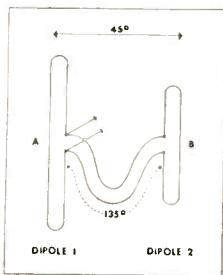

Fig. 5—System with one dipole tuned to Channel 2 and one to Channel 5.

phase them in such a way so that they will each contribute their two peaks, still maintain resonance in-between, and, therefore, hold a fairly constant impedance across the entire band under consideration.

In addition to the problem of holding a constant impedance, it would be desirable to have a dipole system, which would also have gain, considered as a separate system and which could contribute significantly to the directivity of the array. The characteristics of such a dipole system are shown in Fig. 4. If we can combine

the characteristics of this dipole and the characteristics of the reflective and directive system shown in Fig. 3, we are on our way to achieve our end, which is a high-gain, broad band Yagi with outstanding directivity characteristics.

In Fig. 5, we have drawn a two-dipole system connected by a network.

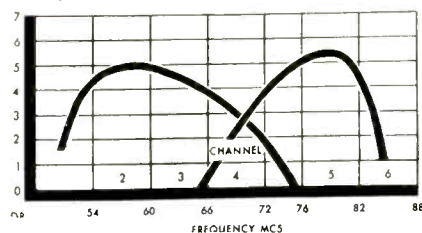

Fig. 3—Composite gain curve of Figs. 1 and 2.

The dipoles are spaced 45 degrees from each other in space and tied together with a harness which makes their electrical phasing 135 degrees apart. Dipole 1 is tuned to the lower end of the band and dipole 2 is tuned to the higher end of the band which we are covering. Let us assume that a signal is coming from direction A. The signal from direction A hits dipole 2, 45 degrees after it hits di-

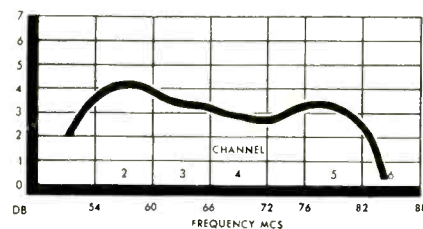

Fig. 4—Gain curve of basic two-dipole system without parasitic elements.

pole 1. This signal is then fed back from dipole 2 through the network which causes it to lag an additional 135 degrees. Therefore, since it has

dipole 1 to 2, and an additional 135 degrees travelling back through the network, it arrives at dipole 1, 180 degrees out of phase with the original signal. This 180 degree phase difference causes the signals to be cancelled at the feed points of the system, if they are emanating from direction A, which in this case would be the back of our system.

So far, we have seen how these two dipoles act to reject signals from the rear. Let us now assume that a signal is coming from direction B. The signal from direction B hits dipole 2, 45 degrees earlier than it hits dipole 1. However, it is then delayed 135 degrees in the network which feeds it

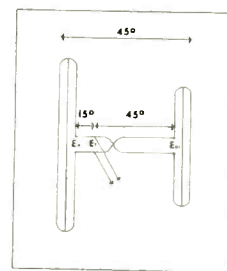

Fig. 6—How spacing is accomplished in the "Futuramic" Yagi. Dipoles are 45° apart in free space. Feed points are 15° in front of 1-f dipole.

to dipole 1. As a result, the signal from dipole 2 is delayed 135 degrees minus 45 degrees, and arrives at the feed points of dipole 1 only 90 degrees out of phase with the signal which has travelled to dipole 1 through free space. This phase difference of 90 degrees means that 1.4 more signal is contributed at that point by this system than if a single dipole were used alone. Therefore, we have described a two-dipole network which not only has gain in itself, but which also has directivity since its

gain is in a forward direction and it rejects signals from the rear.

In the "Futuramic" Yagi, the conditions of being 45 degrees apart in free space and 135 degrees apart in phasing, are shown in Fig. 6. The feed points are forward of the low frequency dipole by 15 degrees through a length of twin lead. The higher frequency fold is fed through a length of twin lead 45 degrees long. However, this piece of twin lead is transposed so that instead of the effective length being 45 degrees, it is 180 degrees, it is 180 degrees minus 45 degrees—that is, 135 degrees. The explanation of this twin tuned dipole system will refer to the vector diagrams, Fig. 7 and Fig. 8.

Let us first consider how this system works at the low frequency end of the band. Let E_T be our reference voltage at the terminals of the entire system. Therefore, E_A , the voltage at the lower frequency fold, lags this voltage by 15 degrees since it is fed through a 15 degree length of line. The voltage at the higher frequency fold, E_{B1} , would normally lag E_T by 45 degrees, since it is fed by a 45 degree network. This is shown on the vector diagram and it can be seen from this that E_{B1} , and the voltage at the small fold, lags the voltage E_A at the large fold by 30 degrees. However, the voltage at the higher frequency fold is also changed in phase by 180 degrees due to the fact that the line is transposed. This voltage, which is the actual voltage at the smaller fold, is shown by the vector E_{B2} .

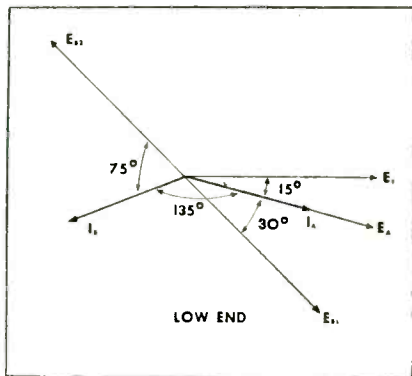

Fig. 7—Vector diagram showing l-f operation of the antenna.

We must now bear in mind that the voltage-induced current in the fold is the signal with which we are concerned. Since we are considering a case where the signal is of the frequency to which the low frequency fold is cut, this fold is resonant. Therefore, the current and voltage are in phase. The current vector I_A is shown to coincide with E_A . However,

CHANNEL SHIFTS			
AREAS	Stations	Present Channels	Proposed Assignments
Chicago	WBKB	4	2 *
Pittsburgh	WDTV	3	2 *
Cleveland	WXEL	9	2 *
	WNDK	4	3 *
Milwaukee	WTMJ-TV	3	3 *
Cincinnati	WLWT	4	4 *
	WKRC-TV	11	7 *
	WCPO-TV	7	12 *
Providence, R. I.	WJAN-TV	11	10 *
Atlanta, Ga.	WLTV	8	11 *
Norfolk-Portsmouth-Newport News, Va.	WTAR-TV	4	3 *
Louisville, Ky.	WAVE-TV	5	3 *
	WHAS-TV	9	11 *
Birmingham, Ala.	WBRC-TV	4	6 *
Albany-Troy-Schenectady, N. Y.	WROB	4	6 *
Columbus, Ohio	WLWC	4	5 *
Rochester, N. Y.	WHAM-TV	3	4 *
Memphis, Tenn.	WMGT	4	5 *
Dayton, Ohio	WLWD	5	5 *
	WHIO-TV	13	7 *
Syracuse, N. Y.	WSYR-TV	5	7 *
Grand Rapids, Mich.	WOOD-TV	7	7 *
Wilmington, Del.	WDEL-TV	7	12 *
New Haven, Conn.	WMHC-TV	6	6 *
Johnstown, Pa.	WJAC-TV	13	6 *
Davenport, Ia.-Moline-Rock Island, Ill.	WOC-TV	5	6 *
Lancaster, Pa.	WGAL-TV	4	3 *
Huntington, W. Va.-Ashland, Ky.	WSAZ-TV	5	3 *
Bloomington, Ind.	WTTV	10	4 *
Ames, Ia.	WOI-TV	4	5 *

Asterisks indicate where stations are shifting channels on the same band, and where Channel Master's Futuramic Yagi can be used. This situation occurs in 26 out of the 30 channel shifts proposed by the FCC.

Proposed channel shifts of TV stations in various sections of the country—present and proposed assignments.

at the lower frequency, the higher frequency fold is a capacitive reactance. And in a capacitive reactance, the current can lead the voltage up to 90 degrees. In the case under consideration, the system is designed so that the current leads the voltage by 75 degrees as shown by the vector I_B indicating the current in the smaller fold. If we now refer to our vector diagram, we see that the currents in the two folds are 135 degrees apart—and since we physically spaced the two folds 45 degrees in space, we have fulfilled our conditions described above for maximum gain and directivity in our two-fold system.

Let us now consider the case where the signal being received is the higher frequency, the one to which the small fold is resonant. Our voltage vectors will all be the same as described in the previous considerations. However, in this case, the current in the smaller fold is in phase with its voltage as shown by I_B which coincides with E_{B2} . The larger fold, cut to the lower frequency, acts as an inductive reactance—and in this case, the current lags the voltage by 75 degrees as shown by the vector I_A . It will now be seen that once again our currents I_B and I_A are 135 degrees apart. It will readily be understood that since these vectors rotate in a continuous man-

ner as the frequency changes, this 135 degree relationship is maintained for all frequencies between the low and the high to which the two dipoles are tuned respectively. This twin tuned dipole system is the heart of the "Futuramic" Yagi. The problem now remains to combine this system with a

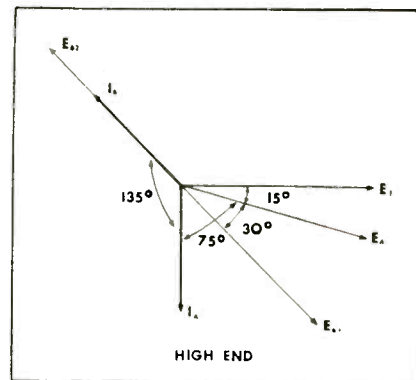

Fig. 8—Vector diagram illustrating h-f operation of the antenna.

number of parasitic elements which will increase the gain.

Since the addition of more than one reflector does not contribute materially to gain, the twin tuned dipole system was designed to give its maximum gain at the low frequency, so that this maximum gain, combined

[Continued on page 52]

Coupling

MATCHING TRANSFORMERS TO CONSTANT VOLTAGE LINES

by **LARRY A. STINEMAN**

(Chief Engineer, Merit Coil & Transformer Corp.)

IN coupling to 70.7 volt, and 141.4 volt, and other constant voltage lines, or from a 70.7 volt line to a 141.4 volt line or vice versa, we offer these suggestions:

Referring to Fig. 1, matching transformers for constant voltage lines have a multiple tapped primary, and a tapped secondary winding for 4, 8 or 16 Ohms. In accordance with RTMA standards* the primary winding is so constructed that with the lowest tap connected across the constant voltage line the full rated secondary power output for which the transformer was designed is obtained. Each successive or higher tap then provides a reduction in power in steps of 3 DB (or a reduction in power as measured in watts of one-half). The primary taps are labeled and instruction sheets provided so that connections can be easily made for various desired power output values without further calculations. However, any type universal matching transformer, having a high impedance tapped primary coupling to a voice coil, may be used to couple to constant voltage lines, provided the power rating of the transformer is not exceeded.

Now the relation;

$$\text{Power} = \frac{(\text{Constant Line Voltage})^2}{\text{Impedance Tap}} \quad (1)$$

Or transposed;

$$\text{Impedance Tap} = \frac{(\text{Constant Line Voltage})^2}{\text{Power}} \quad (2)$$

can be used in most cases to provide the answer to most questions that may arise.

Example:

How to use a matching transformer rated at 10 watts

To find the proper primary tap for connection to a 70.7 volt line to obtain full output.

Substituting in equation (2):

$$\text{Impedance Tap} = \frac{(70.7)^2}{10} = \frac{5000}{10} = 500 \text{ ohms}$$

To reduce the power 3 DB (or to 5 watts).

Substituting in (2);

$$\text{Impedance Tap} = \frac{(70.7)^2}{5} = \frac{5000}{5} = 1000 \text{ ohms}$$

Example:

How to determine a power rating

Finally, if a transformer is used which matches a 2000 Ohm primary to a voice coil, then the power obtained from coupling the primary to a 141.4 volt line will be;

$$\text{Power} = \frac{(141.4)^2}{2000} = \frac{20000}{2000} = 10.0 \text{ Watts}$$

It is assumed that the transformer is of large enough capacity to handle this amount of power, otherwise distortion will occur at the lower frequencies.

By using one of the higher primary taps a 70.7 transformer can be used on a 141.4 volt line. Suppose the output rating of the transformer is 20 watts; the 70.7 volt tap would be 250 ohms as given by equation (2). To obtain this output at 141.4 volts, the required impedance tap would be;

$$\text{Impedance Tap} = \frac{(141.2)^2}{20} = \frac{20,000}{20} = 1000 \text{ ohms}$$

Thus, in connecting to constant voltage lines, either the required impedance tap or the resulting power may be easily calculated by using one of the simple equation given above

*These units are designed in accordance with the following RTMA specifications:

- Load Impedances:** These transformers shall be designed to operate into load impedances of 4, 8, or 16 ohms. The manufacturer shall designate for each secondary tap the load impedance for which it is designed.
- Input Voltages:** These transformers shall operate from 70.7 volts, or one or more of the speaker-distribution-line voltages in a series derived by the successive multiplication or division of 70.7 volts by the square-root of 2. (For labeling purposes, two significant figures may be used.)
- Input Power:** The power taken from the line by each primary tap when the transformer is properly terminated in its rated load impedance shall fall in a series based on one watt and proceeding upward and downward in 3 db steps. The manufacturer shall designate for each primary tap the power in watts drawn at the standard input voltage for which the transformer is designed.

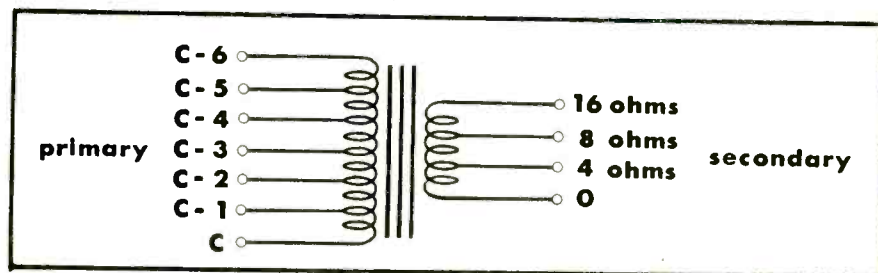

Fig. 1—Typical matching transformer schematic.

NEW TUBES

Sylvania—6X8

A miniature 9-pin medium-mu triode and sharp cutoff pentode contained in one envelope, designated 6X8, is now in production at the Radio Tube Division of Sylvania Electric Products Inc.

The tube is designed as a combined mixer and oscillator in television receivers using an intermediate frequency of approximately 40 mc. Characteristics of the pentode section



	Triode Section	Pentode Section
Plate Voltage	100	250 Volts
Suppressor		Connected to Cathode at Socket
Screen Voltage	100	150 Volts
Cathode Bias Resistor	40	200 Ohms
Amplification Factor	6900	750,000 Ohms
Plate Resistance (approx.)	5800	4600 Ohms
Transconductance		
Control Grid Bias (approx.) for Plate Current of 10 uap	-10	-10 Volts
Plate Current	8.5	7.7 Ma
Screen Current		1.6 Ma
Control Grid Circuit Resistance		
Fixed Bias	0.1	Heqohm Max.
Cathode Bias	0.5	Heqohm Max.

Fig. 1—6 x 8 characteristics.

of the Sylvania 6X8 are similar to the Sylvania Type 6AG5. The triode section is comparable to one section of the Sylvania Type 6J6. Except for a common cathode, application of the 6X8 is similar to the Sylvania 6U8.

The pentode mixer section of the 6X8 provides low grid No. 1 to plate capacitance as compared with a triode mixer. This low grid No. 1 to plate capacitance reduces feedback problems often encountered in mixers when using an i-f in the vicinity of 40 mc. The low output capacitance enables the tube to work into a high impedance plate circuit resulting in higher mixer gain.

The Type 6X8 is also well suited for use as a mixer in am-fm receivers. The pentode may be used as a pentode or triode connected mixer depending on the desired signal to noise ratio.

RCA—6CL6

A new power pentode of the 9-pin miniature type, designated as the 6CL6 and designed especially for use in the final video-amplifier stage of television receivers, has been announced by the RCA Tube Department.

Designed in miniature as the equivalent of the metal type 6AG7, the 6CL6 has very high transconductance, low interelectrode capacitances, and high output-current capability. These features make possible the design of wide-band video circuits having a voltage gain of 40 to 45. Providing high plate current at low plate voltages, the 6CL6 can supply sufficient peak-to-peak output voltage to drive large picture tubes with high efficiency and low amplitude distortion.

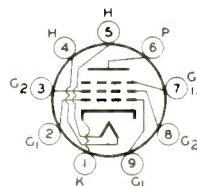

Socket connections—bottom view.

Characteristics:	
Plate Voltage	250 volts
Grid No. 3	Connected to Cathode at Socket
Grid-No. 2 Voltage	150 volts
Grid-No. 1 Voltage	-3 volts
Peak AF Grid-No. 1 Signal Voltage	3 volts
Zero-Signal DC Plate Current	30 ma
Max.-Signal DC Plate Current	31 ma
Zero-Signal DC Grid-No. 2 Current	7 ma
Max.-Signal DC Grid-No. 2 Current	7.2 ma
Plate Resistance (Approx.)	0.15 megohm
Transconductance	11000 umhos
Grid-No. 1 Voltage (Approx.) for plate current of 10 uap	-14 volts
Load Resistance	7500 ohms
Total Harmonic Distortion	8 per cent
Max.-Signal Power Output	7.8 watts

Fig. 2—6CL6 characteristics.

Separate base-pin connections for grid No. 3 and cathode permit the use of an unbypassed cathode resistor to provide degeneration without encountering parasitic oscillations which would otherwise occur if grid No. 3 were connected to the cathode within the tube.

Haley TT-1 Cold Cathode Tube

The Haley TT-1 is a cold cathode triode tube with an external electrode. The tube does not contain a filament—thereby eliminating the usual filament current drain found in hot tubes. With the absence of heater filament action, it is able to perform instantaneously without any warm up.

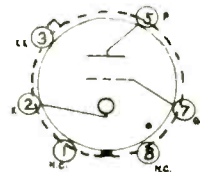
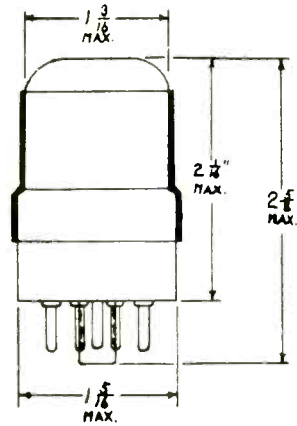

Socket connections—bottom view
Pin 1—no connection. Pin 2—cathode. Pin 3—External electrode. Pin 5—anode. Pin 7—starter anode.

Peak Anode Breakdown Voltage (Grid tied to CATHODE—no external electrode voltage)	Approx. 190 volts
Peak Negative Starter Anode Breakdown Voltage	65 volts
External Electrode Voltage	0 - 160 volts (depending upon application)
D.C. Anode Extinction Voltage	Approx. 75 volts
Starter Anode Current (For transition of discharge to anode at 120 volts peak)	Approx. 1 microampere
Anode Voltage - Drop	Approx. 55 volts
Ionization Time	10 micro-seconds
De-ionization Time	9 - 10 milliseconds
Ambient Temperature	-60° to +75° C

Fig. 3—TT-1 characteristics.

No deterioration takes place while it is waiting to operate (hot tubes will eventually fail by heater burn out or loss of emission deterioration, circuitry designed with the TT-1 will have an unlimited long life expectancy (up to forty years).

Associated with the operation of the TT-1 is a characteristic red cathode glow which can conveniently be utilized for indicating purposes.

The elimination of filament transformers, plate transformers and complex power supply simplifies design. The TT-1 operates directly from a-c or d-c lines, and is unaffected by temperature.

Circuits employing the Haley TT-1 result in an amplification of 2 1/2
[Continued on page 56]

CIRCUIT COURT

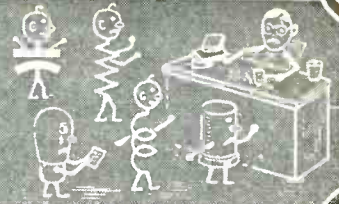

Du Mont RA 160—Sync

This Du Mont model utilizes a sync circuit (Fig. 1) not usually seen in commercial sets. In most sets, the composite sync (horizontal and vertical) is usually stripped from the video, clipped, limited then separated and fed into the horizontal and vertical oscillators, respectively. In the circuit under consideration, each sync system has its own amplifier, clipper and limiter string. The outputs are then fed to the respective oscillator circuits.

For ease in description, the horizontal and vertical circuits will be considered separately. The inputs to V212A, the sync amplifier and V212B, the vertical clipper are directly coupled to the video amplifier output circuit. They also share a common grid resistor, R228. The signal appears at both grids and across R228. Let us first consider V212A.

Due to the direct coupling, the grid of V212A is positive. The cathode resistor, however, is of a large value, 180K. As a result, the slightest cathode current will develop such a positive voltage across the resistor that the grid to cathode bias is at virtual cut-off.

When a signal appears across R228, the tube will still be in this virtual cut-off condition. C260 will charge up to the full peak value of the sync pulses. The RC time constant of R266 and C260 are such that the voltage at the cathode of V212A will have dropped to the level of the blanking pedestal after the end of the horizontal sync pulse. In this way, the tube bias is such that only the horizontal pulse will cause it to conduct. This arrangement serves four purposes:

1. the video information is stripped from the sync.
2. the tube remains cut-off during the period of the vertical pulses, thus only the horizontal pulses are amplified in the output.
3. the circuit automatically compensates for variations in signal strength of the received signal.
4. Noise pulses at times other than sync time, cannot get through.

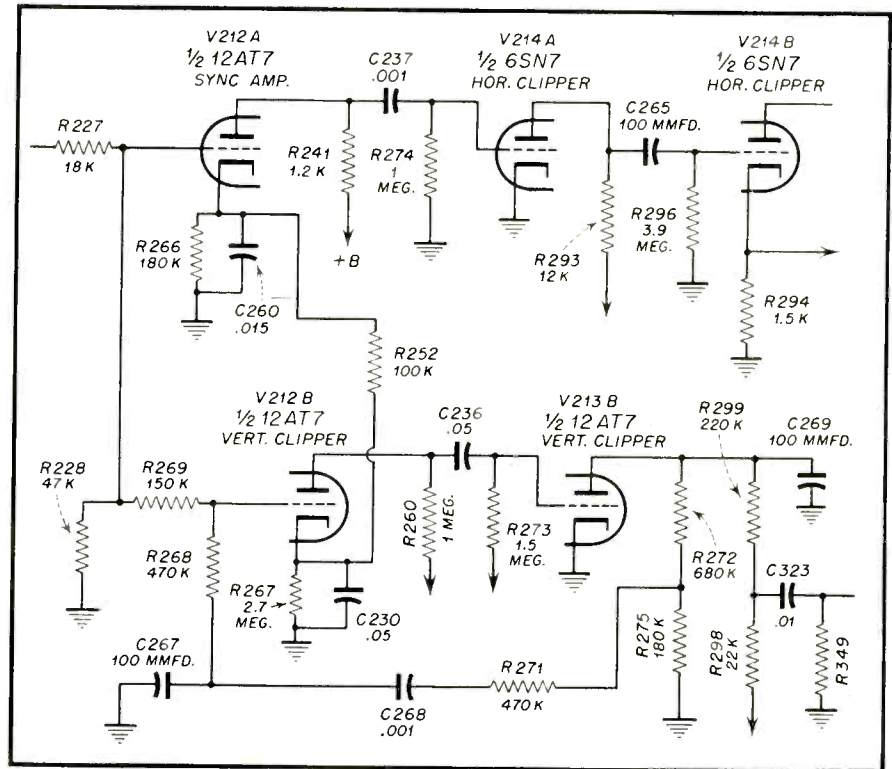

Fig. 1—Partial schematic of Du Mont RA 160-sync

The pulse at the plate of V212A is then fed to two successive stages which further clip and limit the pulse. The purpose of this is to clip any noise pulses which may be on the blanking pedestal or on the sync pulse itself. The output is taken off V214B as a cathode follower and is fed to the Hor. a-f-c tube.

The vertical system operates in a similar manner. The variations in the vertical circuit are there mainly to eliminate the horizontal pulses from the vertical system. The signal is fed to the grid through R228. At this point, we find an unusual use of tube input capacity. R228 and the input capacity act as an integrator. The result of this integrator action is that the input to V212B is a sawtooth similar to the input to the vertical oscillator.

By means of cathode cut-off voltage, this pulse is separated from the video signal. It is then fed to another

clipper stage. V212B has a very low tube conduction as a result of the value of the cathode and plate resistor. This, plus the fact that the average bias developed as a result of the sawtooth pulse, led to the use of the biasing voltage present at the cathode of V212A. This bias is coupled to the cathode of V212B by isolating resistor R252. The RC time of R267 and C230 is such that the horizontal and noise pulses are filtered out.

As stated previously, the output of V212B is fed to V213. This tube, as a result of connecting the grid resistor to 145V, draws some grid current. With this type of operation, the tube bias is close to zero. The input signal then goes from cut-off to plate saturation eliminating any noise pulses which may be higher than the sawtooth pulse. This also cuts off any video or horizontal pulse serrations which might have been passed by V212B. From the plate of V213 the

pulse is taken off a voltage divider network of $R298$ and $R299$. It is then put through a differentiating network consisting of $C323$ and $R349$ to shape the pulse. When the pulse is properly shaped, it is then fed into a regular integrating network and into the vertical blocking oscillator.

Motorola Model 17K10E Area Selector Switch

This model put out by Motorola has a 3-way area selector switch mounted on the rear chassis pan apron. The markings are "Local", "Suburban", "Fringe". Examination of the schematic (Fig. 2) shows that this switch is essentially an a-g-c control switch.

The video detector, a 1N60 germanium diode works into a load resistor, $R15$, $R14$ and $C17$ act as an average-type a-g-c and in the "Local" position develop the complete a-g-c voltage. In the "Suburban" position of the switch, $R18$ and $R19$ in series are shunted across $C17$. Their series resistance is approximately 2 megs. They are put effectively in series with $R14$ to ground and cause the a-g-c voltage across $C17$ to decrease.

In the "Fringe" position, $R19$ is shorted out. This leaves only $R18$ across $C17$. It also causes a much greater drop in the voltage developed at the a-g-c buss.

In addition to the change in a-g-c voltage, the switch performs another operation which tends to make fringe reception better. This change makes the set less susceptible to noise pulses in the "Suburban" and "Fringe" positions. This is accomplished with a modification of the video amplifier grid circuit. The grid resistor is

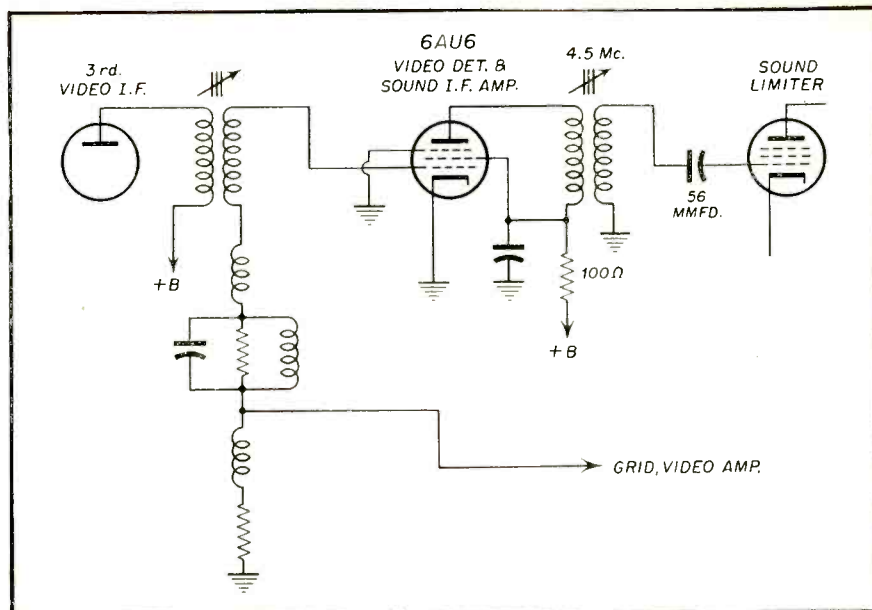

Fig. 3—Partial schematic of Magnavox 108 Series

brought directly to ground in these switch positions. As a consequence, the input resistance is reduced with the result that less amplifier bias is developed. With less bias there is a tendency to compress the tops of the sync pulses. This compression tends to eliminate any noise pulses which might be riding on top of the sync pulses. It also insures that no signal will be fed the sync amplifiers which are of greater amplitude than the sync pulses and which might falsely trigger the sweep oscillators.

Magnavox (105 Series)— Video Detector

This set has a circuit about which there has been much discussion among engineers and which might appear in a number of sets in the near future. This circuit involves the use of multi-

grid tubes in the video detector circuits. In this set it is a pentode but a triode can also be used. Intercarrier buzz is the reason for this type of circuit. It is generally agreed that the sound take-off should be prior to the video amplifier. Taking the sound signal off at the detector tends to reduce the possibility of sync compression occurring. There is, however, a drawback to this in that an extra sound amplifier stage is required. In this circuit, the multi-grid tube acts as a video detector and as sound amplifier.

In order to understand the operation of this circuit, it would pay to briefly review what happens in a detector. When an r-f or i-f envelope is fed to a detector and there is a fixed frequency at the detector a mixing action takes place. As a result of the heterodyning action another i-f signal can be formed. In the TV i-f signal, this condition is present. There is a fixed frequency (the picture carrier) and 4.5 mc away there is another frequency (the sound carrier) which is being varied. The consequence is that at the detector output we have a demodulated AM signal (video signal) and a 4.5 frequency-modulated sound signal. See Fig. 3.

Let us now examine the operation of the Magnavox circuit in detail. The 6AU6 cathode is grounded and the grid is connected to the last i-f transformer. With this connection, there is grid current flow from the grid through $L16$, $L17$, $L18$ and $R31$ to ground at each positive cycle of the i-f amplifier. There is, as explained previously, a 4.5 mc signal present at

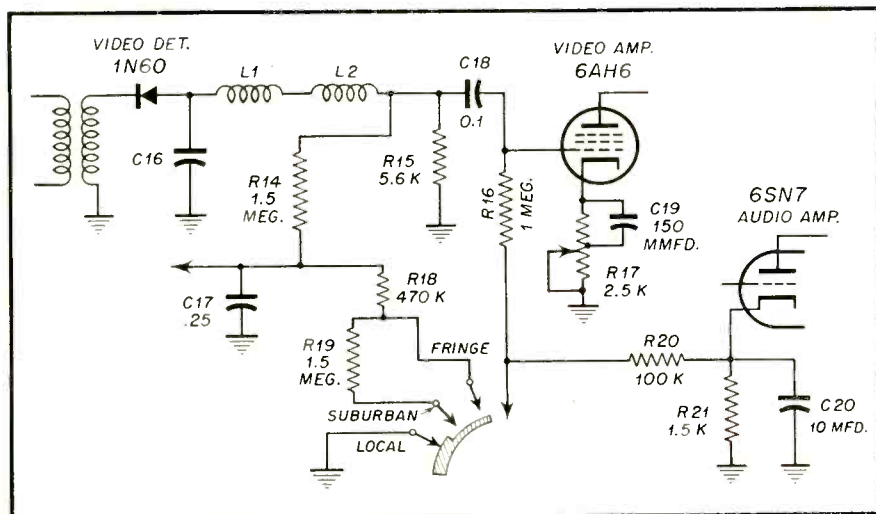

Fig. 2—Partial schematic of Motorola 17K10E

[Continued on page 56]

SHOP NOTES

Write up any "tricks-of-the-trade" in radio servicing that you have discovered. We pay from \$1 to \$5 for such previously unpublished "SHOP NOTES" found acceptable. Send your data to "Shop Notes Editor."

Zenith Model 20H20-17" Insufficient Vertical Height

If the Picture size of Zenith Model 20H20 17" receiver is normal when first tuned on then narrows in a few minutes, check vertical size circuit.

Putting in a new 6BL7 tube gives a normal picture for a few minutes then the picture will narrow again.

This circuit has a 3.3 meg. 1/2 Watt resistor coming from the size control which changes from 3.3 meg. to approx. 60 meg.

Sometimes this resistor will check normal but changes after a few minutes use. Consequently if suspicious of resistor change it on general principles. It may save a lot of time trouble-shooting later.

*C. F. Elgasser, Jr.
San Diego, Calif.*

Admiral 24D1-Vertical Jitter

Symptom: Vert. Jitter, hold OK, top 2" of pix slightly compressed, Vert. Osc. buzz very strong in sound, trouble starts after about 2 hrs. of operation and is intermittent.

Buzz completely gone when killing Vert. Osc. or output. Level reduced when shorting pin 1 or removing 1st pix i-f tube. Scope shows vert. osc. pip on screen and B plus or Video i-f stages, all by-pass and B plus filter Cond. check OK. At this point you start pulling your hair, if there is any left.

Solution: change Vertical output Transformer, although resistance checks do not reveal shorted turns.

*Submitted by:
Eric J. Ritter
Chicago, Ill.*

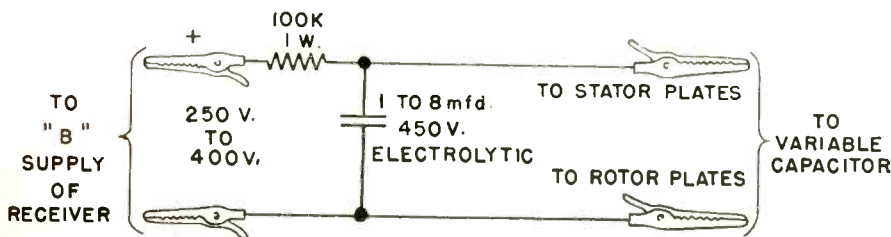

Fig. 3—Set-up for removing scale in variable condensers.

Sentinel-Horizontal Linearity Adjustment

A simple, fast, and accurate method, which does not require a station test pattern for adjustment of horizontal linearity is being successfully used by Mr. Marvin Miller of Miller TV Service, 3135 W. Main St., Springfield, Ohio.

Mr. Miller's device, shown in Fig. 1, consists of a 6-8 volt 150 ma pilot light #44, with two clip leads. Here is the way it works.

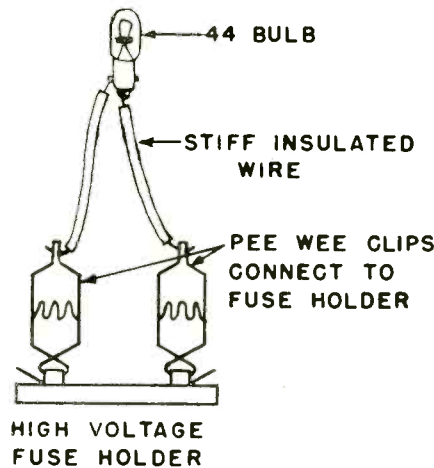

Fig. 1—First method.

1. Remove the high voltage fuse from its holder in the high voltage cage.
2. Clip a lead from the pilot light to each terminal of the fuse holder.
3. Adjust the horizontal linearity control for minimum pilot light brightness.

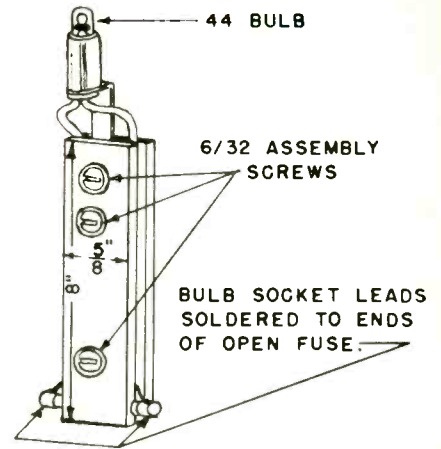

Fig. 2—Second method.

The above system is just as accurate as the 150 ma meter method recommended in the latest Sentinel Service Manuals—many servicemen feel that the pilot light brightness method is easier to use.

An easy way to make a tool that will snap into the fuse holder is to use two strips of bakelite about 8" by 5/8" and fastening an open fuse in one end, and a pilot light holder in the other as illustrated in Fig. 2. This unit raises the light above the edge of the high voltage cage for easier viewing.

A 200 ma bulb can be used—it gives less light and reduced glare, also at minimum current the light almost goes out.

*Sentinel Radio Corp.
Service Dep't.*

Removing Dirt or Scale In Variable Condensers

In many cases, when variable tuning capacitors have become noisy or their plates have shorted due to dirt and scale collecting between the plates, the capacitors can be repaired by applying high voltage to their plates. See Fig. 3.

Crosley Service Dep't

Interlock Cord

An electric shaver cord from the Remington shaver will fit most of your television interlocks and is free from short hazard.

*Glen D. Kemerer
Live Oak, Calif.*

Westinghouse V-2162, Loss of Sync

Westinghouse V-2162 Chassis. Complaint: after on 1/2 hr. set completely loses horizontal sync. Remedy: turn off set, and immediately check keyed a-g-c winding on the width coil. It will check open, however, if allowed to cool, the coil will check continuity.

TRADE LITERATURE

Servicemen and Jobbers who have used the Littelfuse *Official TV Fuse Guide* before and those who want an aid to faster and easier fuse replacement copy just off the press.

The Official TV Fuse Guide is printed on a durable enamel stock and punched at the top so that it can be hung on a nail in the Repair Shop. It lists the brand name, model numbers and corresponding fuse requirements on all makes and models, starting with the very first sets made and ending with those now on the market.

The Official TV Fuse Guide and Automotive Fuse Guide are available through Jobbers or by writing direct to Littelfuse, Inc., 1865 Miner St., Des Plaines, Illinois.

* * *

Electronic Instrument Co., Inc., 84 Withers Street, Brooklyn 11, New York, designers and manufacturers of the famous EICO test equipment, have just released the news of the publication of the new EICO 1952 Catalog. Handsomely printed in red, blue, black and white, this new 8-page Catalog covers all the 22 Kits and 25 Wired Instruments which now comprise the complete EICO line.

The Catalog contains large illustrations and complete descriptions of technical specifications, prices and recommended applications of all the EICO Vacuum Tube Voltmeters, Oscilloscopes, Sweep Generators, Signal Generators, Tube Testers, Volt-Ohm-Milliammeters, Battery Eliminators, High Voltage Probes, Radio Frequency Probes and Crystals.

For a free copy of this valuable new catalog, write directly to EICO.

* * *

By the addition of only 9 types of C-D twist-prong electrolytic capacitors to stock, service men will be able to service at least 134 additional TV set models that have been marketed during the past year.

This is revealed in the new edition of the Cornell-Dubilier *TV Capacitor Replacement Guide, TVR-7A*, just published and available to servicemen free of charge through local C-D distributors.

The new TV Guide lists 1149 TV set models of 73 manufacturers, as

compared with 1015 TV set models of 68 manufacturers listed in the original C-D Guide published a year ago.

The Guide is arranged to enable the service man to locate the correct replacement capacitor with a minimum of time and effort.

* * *

To acquaint its customers and prospects with the size and extent of its manufacturing facilities, General Cement Manufacturing Company, Rockford, Illinois, has just published a 16-page illustrated brochure. Called "*The Story of G-C*", this new booklet shows the part played by this firm in supplying thousands of electronics components to the radio-television industry and other fields. Free copies of the brochure may be obtained by writing direct to General Cement Manufacturing Company, 919 Taylor Avenue, Rockford, Illinois.

* * *

Counter Catalog C-823, listing the most popular "bread - and - butter" items for the service trade—Atom and Twist-Lok Electrolytics, Telecap Black Beauty Molded Tubulars, Ceramite Disc Ceramics, Bulplate High Voltage Ceramics, and the new Universal Doorknob Ceramic—is now available from the Sprague Products Co., 71 Marshall St., North Adams, Massachusetts.

Both net and list prices for each item are clearly tabulated, thus avoiding discount mathematics for jobber's countermen. The easy-to-read, 12 page catalog is printed on heavy paper and punched at one corner so that it can be tied to the counter for ready use by customers while waiting to be served. Copies of this new catalog are available to jobbers upon request to the manufacturer.

* * *

A new eight page *brochure* describing the firm's extensive facilities for the production of electronic parts and equipment has been issued by the Insuline Corporation of America, 36-02 35th Avenue, Long Island City, N. Y. Copies are available free of charge.

* * *

Two new booklets on mobile communications antennas have been published by Ward Products.

Every antenna and accessory for mobile use is included in the new mobile catalog. For each model, there is a complete description and specifications. The entire book is plastic bound between sturdy covers for easy reference.

"*How to Specify Mobile Antennas*" is the title of a new booklet for the mobile user. It describes the popular base, whip and spring combination, states some of the factors involved in purchasing them, and gives a complete description of how these components are produced.

Free copies of each of these booklets can be obtained from radio parts distributors or direct from Ward Products Corp., Division of The Gabriel Co., 1523 East 45th Street, Cleveland 3, Ohio.

* * *

TV Troubleshooting And Repair Guide Book, a new publication of John F. Rider Publisher, Inc., 480 Canal Street, New York 13, N. Y., is now available at the publisher's distributors.

The television receiver is broken down into sections and the troubles that the service technician may encounter in these various sections, are fully discussed. Author Robert G. Middleton, Senior Engineer with Precision Apparatus Co., Inc., writes with the experience born of many years lecturing and demonstrating the use of test equipment as applied to TV receiver servicing.

There are ten informative chapters in *TV Troubleshooting And Repair Guide Book*: Receiver differences and waveforms; handy hints in visual alignment procedures; troubleshooting sync circuits; locating sweep troubles; faults in video amplifiers; checking high-voltage power supplies; test equipment kinks; troubleshooting in the home; receiver buzz; causes and cures; external interference.

The many troubleshooting charts included in the book further aid in the rapid location of faults and their repair.

Completely indexed, and containing 204 8 1/2" x 11" pages in a heavy durable cover, the book is now available at Rider distributors. It is priced at \$3.90.

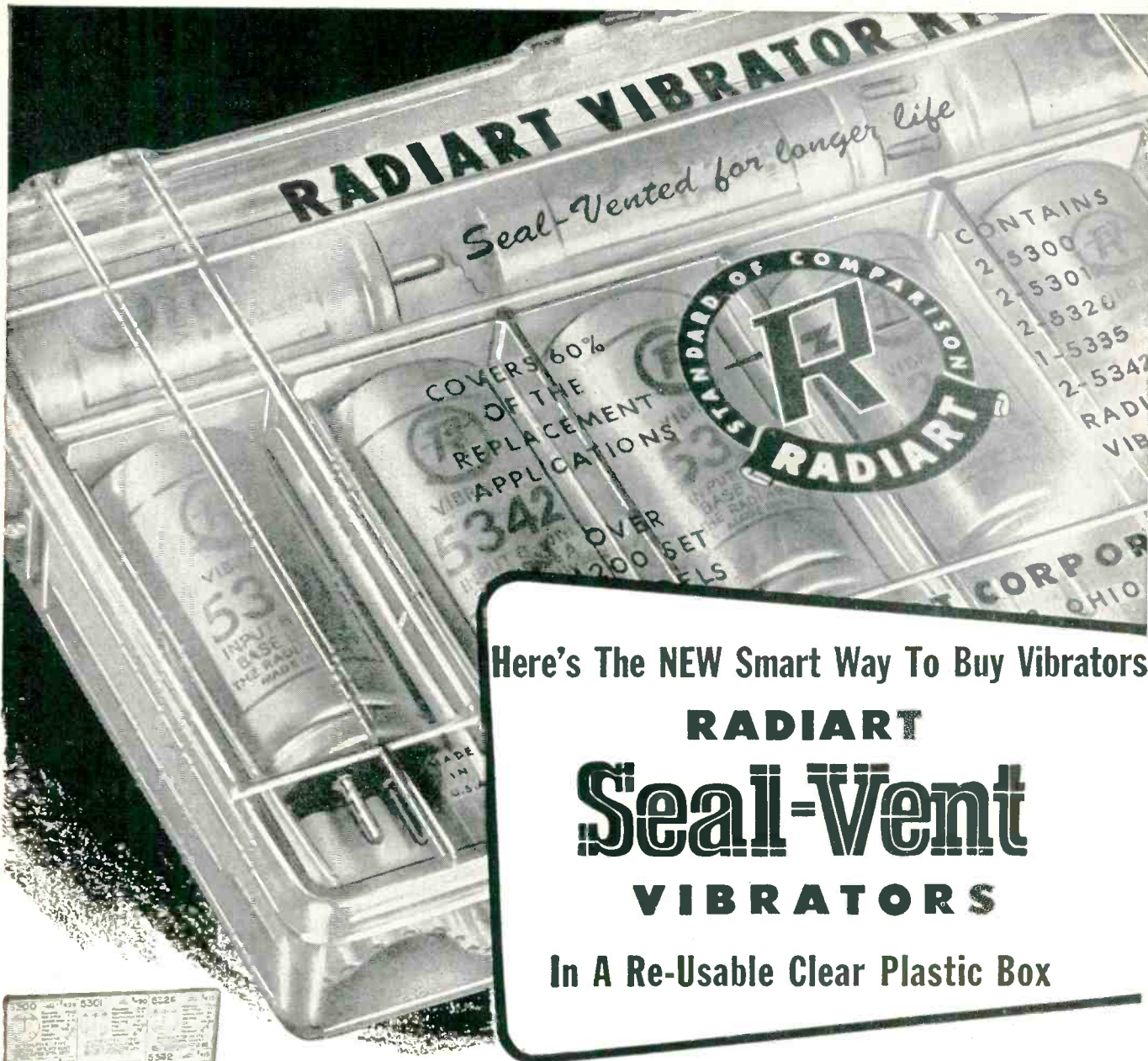

Here's The NEW Smart Way To Buy Vibrators

RADIART
Seal-Vent
VIBRATORS

In A Re-Usable Clear Plastic Box



this is the way it looks fully packed



here is the re-usable box with dividers for a hundred uses at home or work

★ The BEST Vibrator Money Can Buy

★ A "BONUS" for You in the Re-Usable Plastic Box

★ Save Time — Buy the ONE KIT that Gives You the Five Types that Serve 60% of the Replacement Requirements

Here's another PLUS for you from Radiart — the RADIART VIBRATOR KIT! In this handsome plastic box with sturdy dividers and a hinged cover are these 9 vibrators . . . all yours for the price of the vibrators alone! You get these 5 basic types that serve 60% of replacement applications . . . 2-5300 . . . 2-5301 . . . 2-5326 . . . 2-5342 and 1-5335. These are all the famous quality . . . with the sensational SEAL VENT. Original quantities are limited . . . so make sure of yours by seeing your RADIART jobber NOW!



THE RADIART CORPORATION CLEVELAND 13, OHIO

VIBRATORS • AUTO AERIALS • TV ANTENNAS • ROTATORS • POWER SUPPLIES

NEW PRODUCTS

SELENIUM RECTIFIER TESTER

An entirely new instrument for testing Selenium Rectifiers, as used in radio and television receivers, is announced by Galvanic Products Corporation of Valley Stream, New York. The Selester, Model 100A, as this unit is known, is said to be the first instrument specifically designed for this application. It is claimed to be the only meter providing means for making the four required and prescribed tests for: (1) Forward Resistance, (2) Reverse Leakage Current, (3) 'Opens' (4) 'Shorts'.

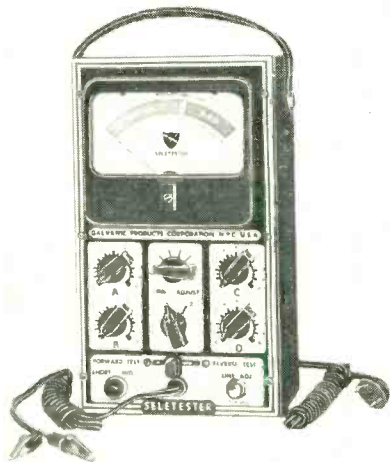

Compact and portable, the Selector measures 5½" wide x 4" deep x 10" high, thus taking a minimum of valuable shelf space. Case is heavy gauge, black, wrinkle-finish steel. Has leather carrying handle. Weights approximately 6 pounds. Model 100A comes complete with 4 ft. test leads, fully insulated alligator clips, 6 ft. line cord and detailed instruction manual. Input, 117 volts, 60 cycle A.C. Price . . . \$39.95 net. For additional information, write to Rectifier Division, Galvanic Products Corp., 110 East Hawthorne Avenue, Valley Stream, New York.

WIRE-WOUND DUAL CONTROLS

P. R. Mallory & Co., Inc., Indianapolis, announces the addition of a 2 watt wire-wound front control section to round out their current line of selective assembly dual concentric Midgetrol carbon TV volume controls.

Known as the "WK" series, the new wire-wound control sections are available in 10 resistance values ranging from 750 to 7000 ohms in tapped and untapped types as required. They may be employed in conjunction with any of the previously announced "UR" carbon rear control sections to fabricate a dual concentric volume control of exact replacement characteristics.

Appropriate assembly fittings consisting of an inner shaft, a phenolic spacer, a special coupling cup and a shaft end are supplied with each "WF" control section. Concise, clearly illustrated instructions permit quick and easy assembly without special tools or soldering.

Over 90% of all TV and automobile radio set dual volume control requirements can be met by combinations of these controls. Authorized Mallory Distributors are now featuring the Mallory Midgetrol, dual concentric volume control and accessory parts.

NEW HYPASS CAPACITORS FOR MOBILE RADIO USE

Two new capacitors, one specifically designed to eliminate automotive radio noise and the other to filter power-line, filament, and control circuits, have been added to the line of Sprague Hypass feed-through capacitors.

Type 48P18 is rated at 0.5 mf, 50 volts d-c working, and 40 amperes through current. It provides effective filtering of troublesome voltage regulator noise in mobile radio installations when installed in series with the battery and generator armature leads to the voltage regulator.

Another Sprague Hypass capacitor, Type 80P3, is designed to filter and by-pass harmonics and spurious r-f currents in transmitters, radio, and TV receivers. A bulk-head mounting bracket permits through-chassis mounting for complete circuit shielding and isolation. Type 80P3 is rated at 0.1 µf, 600 volts d-c working, 20 amperes through current, and may be used at potentials up to 250 volts, 60 cycles a-c.

Complete details on these and other Sprague Hypass Capacitors are available on request to Sprague Products Co., 71 Marshall Street, North Adams, Mass.

VOLTAGE BOOSTER

To solve the problem of annoying fluctuations in TV picture size due to drops in line voltage, I.D.E.A., Inc., Indianapolis, has designed a new voltage booster which maintains a 117 volt power supply regardless of line voltage variations from 90 to 130 volts. The new booster, called the Regency VB-1, can also be used to get peak performance from any electrical device drawing 350 watts or less.



Since the Regency VB-1 is an automatic transformer with tapped primary, it can be used with equal efficiency in high voltage areas to decrease line voltage.

The new VB-1 voltage booster is made by the makers of the well known Regency TV picture signal booster. It will list for \$19.95. For further information and literature write I.D.E.A., Inc. Regency Division, 7900 Pendleton Pike, Indianapolis 26, Indiana.

BRACED YAGI ANTENNAS

Multi-element television yagi antennas, said to feature excellent electrical characteristics and an unusual bracing device, have been developed by RMS (Radio Merchandise Sales, Inc.), manufacturers of antennas and electronic accessories for television.

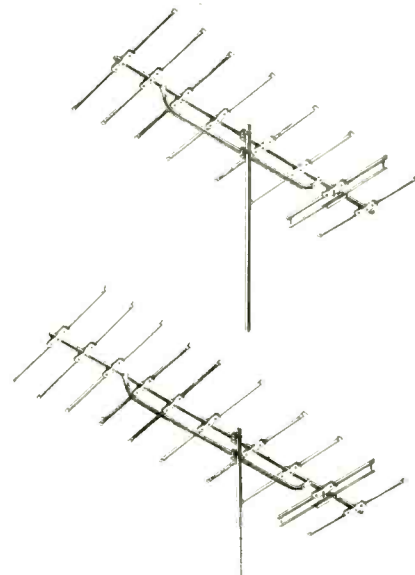

The steel brace included with low band models of these antennas, runs horizontally below the crossarm, and its steel-formed brackets grip securely around the major portion of the crossarm circumference. The crossarm and brace are provided with their own U-Bolt attachments, and when assembled to the mast provide structural rigidity necessary to keep the antenna free of rocking and swaying off the azimuth.

In both the 8 element and 10 element models, the addition of elements has caused excellent increase in gain; and a narrowing of the forward directional pattern. For this reason, security of attachment to the mast is the critical consideration in the installation of these antennas, and the new RMS bracing structure is said to give this assurance.

CROSSHATCH GENERATOR

With the new Simpson Crosshatch Pattern Generator, horizontal and vertical linearity, hold, height, width and drive adjustments may be made easily and quickly when transmitter test pattern are not available.

The Simpson Model 485 provides a synchronized signal, modulated on the carrier frequencies of channels 2 through 6, which can be tuned and sent through the receiver under test. When the receiver has been properly adjusted, the signal will show equally spaced lines in vertical, horizontal or crosshatch patterns on the picture tube.

All patterns are locked in place with synchronizing pulses exactly the same as the sync pulses in transmitted wave-forms making it unnecessary to double check against actual transmitted test pattern.

The exclusive Simpson output cable includes

FREE
 Your vacation may come
 in this WALSCO
 carton...

1,500,000th
WALSCO
 TV ANTENNA

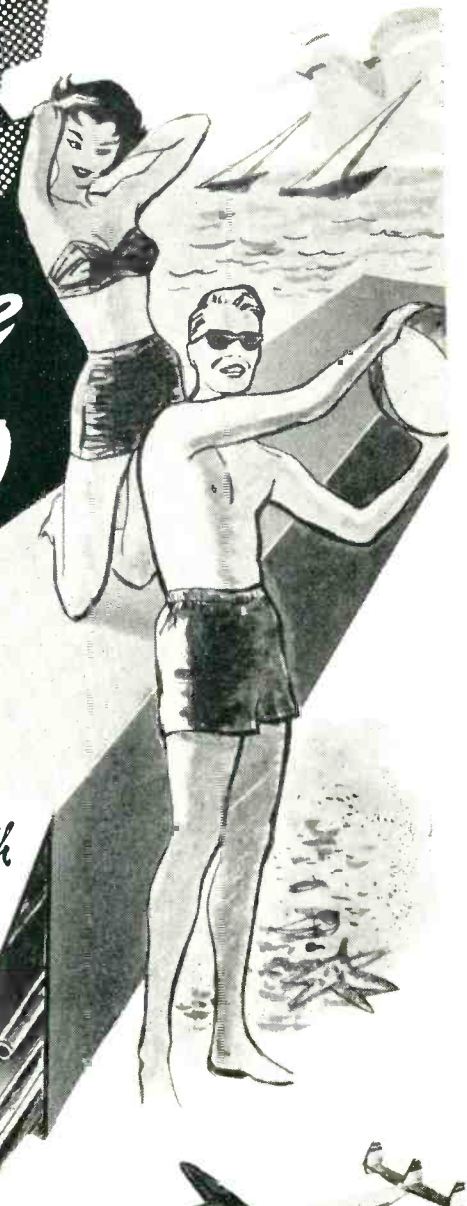

The next quality antenna you buy, be sure to ask for WALSCO. You may be purchasing the lucky 1½ millionth antenna to be produced by WALSCO. Attached to it, you will find the winning certificate. Mail the certificate to WALSCO and you receive 2 tickets and all expenses to any vacation spot in America. Everything will be FREE. You will travel via luxurious TWA Constellation. WALSCO will arrange a thrilling vacation for you and your companion for one full week.

Travel FREE via
 luxurious TWA
 Constellation to any
 vacation spot in America...
all expenses paid!

This is not a contest... nothing extra to buy. Just watch for the 1,500,000th WALSCO antenna. Your jobber may have the lucky antenna right now. It will come in a regular carton, with no special markings.

**Ask your jobber for WALSCO... it's America's quality antenna.
 And you may win a fabulous FREE vacation for two.**

WALSCO

Walter L. Schott Co.

3225 Exposition Place
 Los Angeles 18, California

Overseas Representative

Ad Auriema, Inc.

89 Broad St. New York 4

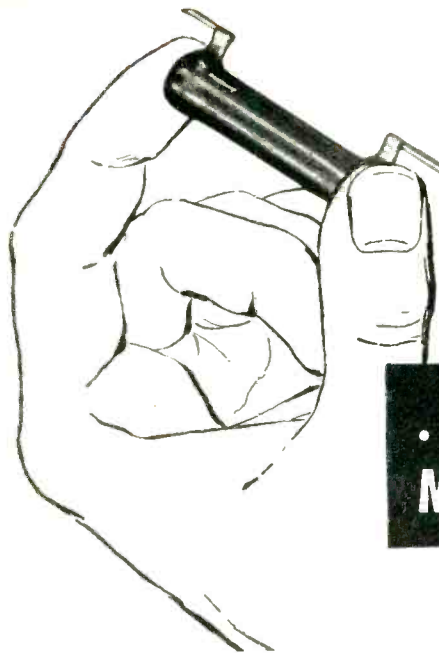

OHMITE *resistors*

**... for that EXTRA
MARGIN OF SAFETY!**

Customers judge your service by the results they get. If a radio or TV repair job fails to stand up, they blame *you*, not the parts you used.

Don't jeopardize your business reputation with "just-as-good" replacement parts. OHMITE resistors provide an extra margin of safety. You can depend on these quality resistors—wire-wound or composition—to give years of trouble-free service.



OHMITE MANUFACTURING COMPANY
4846 Flournoy Street, Chicago 44, Illinois

Send for stock catalog

*Be Right
with...*

OHMITE®

DEPENDABLE RESISTANCE UNITS

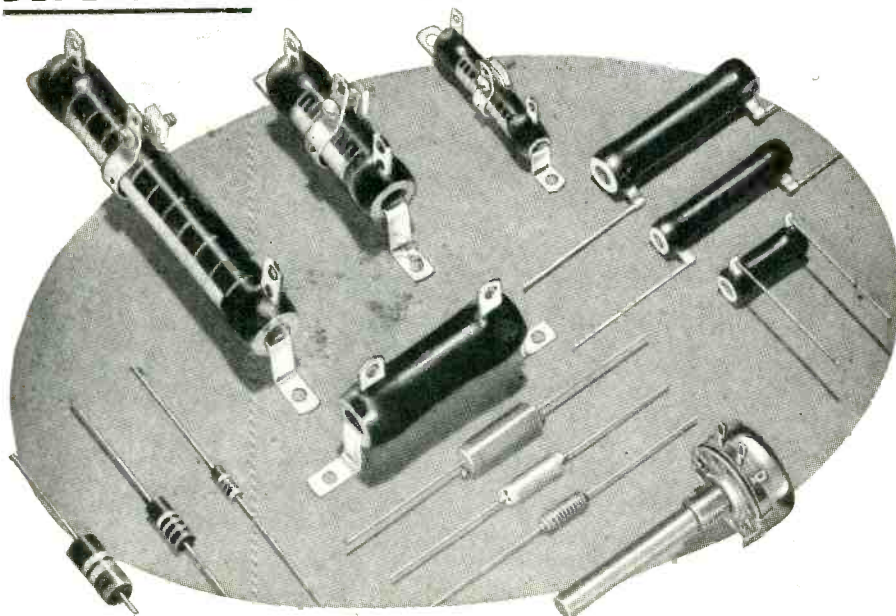

a variable termination network which is quickly adapted to provide 75 or 300 ohm terminations.

Model 485 is housed in a gray hammer-oid finished case with heavy leather handle for greater portability. Line voltage is 105-125 volts AC, 60 cycles; 45 watts. The new Simpson Model 485 crosshatch generator is 11- $\frac{3}{8}$ " wide; 8- $\frac{3}{8}$ " high; 9- $\frac{1}{4}$ " deep and weight 11- $\frac{1}{2}$ lbs. Dealer net price, including special output cable and operating manual, is \$147.50.

WIDE-BAND, HIGH-GAIN SCOPE

The Instrument Division of the Allen B. Du Mont Laboratories, Inc., 1500 Main Avenue, Clifton, N. J., announce the Type 303-A oscillograph designed specifically for the study of pulses and other high-speed phenomena. The new instrument is a wide-band, high-gain cathode-ray oscillograph. In addition to the conventional qualitative analysis, the Type 303-A is equipped with circuits for the precise quantitative measurement of both time and amplitude.



Nomin bandwidth of the new Type 303-A is 10 megacycles, with a transient response of 0.033 μ second. Owing to the gradual fall-off of the Y-axis frequency response characteristic signals as high in frequency as 20 megacycles or more may be usefully displayed.

Internal circuits provide square-wave voltage standards of 0.1, 1.0, 10, and 100 volts with an accuracy of better than $\pm 5\%$, for amplitude calibration, and sinusoidal timing markers of 0.1, 1.0, 10, and 100 μ seconds, at an accuracy of better than $\pm 3\%$.

A truly useful display of low-level pulses is assured, since the deflection factor of the vertical amplifier is 0.1 peak-to-peak volt per inch with 1.5 inch of undistorted vertical deflection for unidirectional signals is available and 3 inches for symmetrical signals.

TV ANTENNA KITS

TV installation men are enthusiastic about the convenience and economies which they obtain as a result of making "package installations" with Channel Master Antenna Kits. Because all necessary components for average installations are included with each kit, dealers and distributors find that they always have exactly the right quantity of mounting accessories on hand. They no longer find it necessary to build up surplus inventory of mounts, hardware, and other accessories.

On "over-the-counter" antenna sales, one quick sale includes both the antenna and all the necessary accessories. The dealer need not consume his time and profit by "picking orders" of low-dollar-volume accessories.

In addition to the antenna, each kit contains: a floor mount, screw eyes, guy ring

NOW...

Quality Matched

TV REPLACEMENTS BY

DU MONT

COMPLETE INFORMATION ON REQUEST

REPLACEMENT SALES
Cathode-ray Tube Division
Allen B. Du Mont
Laboratories, Inc.
Clifton, New Jersey

DEFLECTION YOKE . . .

Type Y2A1 with distributed winding provides edge-to-edge focus. Built to withstand conditions of high temperature and humidity. Short overall length.



FLYBACK TRANSFORMER

Type H1A1 - with universal mounting bracket. Mount it on its side or bottom. "Matched" for use with the Type Y2A1 Deflection Yoke. Ferrite core insures high efficiency.

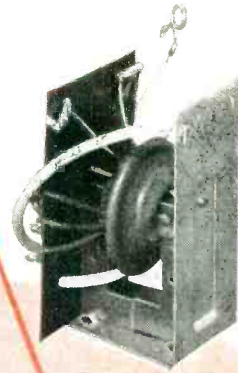

WIDTH AND LINEARITY COILS . . .

For use with H1A1 and Y2A1 and complete the "universal" deflection system. Designed to withstand heavy pulses required to sweep wide angle picture tubes. Utilize adjustable iron cores.



ORIGINAL TELEVISION PARTS . . .

A complete line of replacement television parts incorporated in Du Mont Telesets. Ask your local distributor for cross-reference literature, or write. Look for the package with "original television part," your only guarantee of fitness.

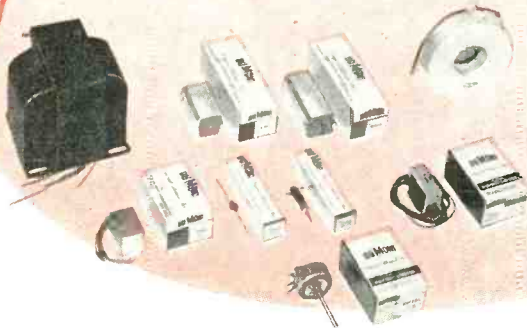

TELETRONS . . .

Quality standard of the industry. Electromagnetic, low-voltage electrostatic focus, and exclusive Selfocus. Complete line of popular sizes.



THE ORIGINAL

Television
tube caddy

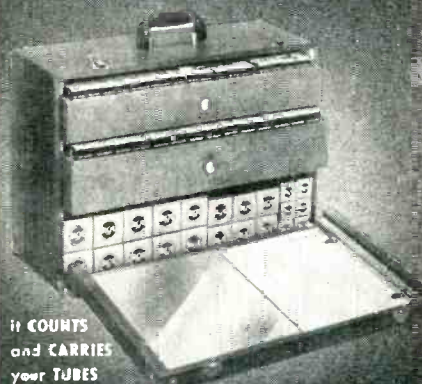

It COUNTS
and CARRIES
your TUBES

**CARRIES EASIER
LOOKS NEATER
PAYS FOR ITSELF**

The Customer only knows what she sees. She probably wouldn't know a rectifier from a resistor, and couldn't read a meter. But she can read the writing on a wall—and on her floor when you set your tools down.

Servicemen who carry the Tube Caddy make the right impression. No "fishing" a tube out of the bottom of a tool kit. Every tube has its place. The customer recognizes systematic efficiency—the kind that builds confidence, and makes your business grow through recommendations from one customer to another.

Tube Caddy. Holds up to 249 tubes.
20x13½ x 9 in. . . Net to Dealer

\$13.50*

Tube Caddy Jr. Holds up to 143 tubes.
15½ x 13x8 in. . . Net to Dealer

8.95*

*Higher on West Coast
Also TV Cabinets, Wall Baffles
Ask your jobber today or write

ARGOS PRODUCTS CO.
312 D MAIN STREET • GENOA, ILLINOIS

APC

Craftsmanship in Cabinets

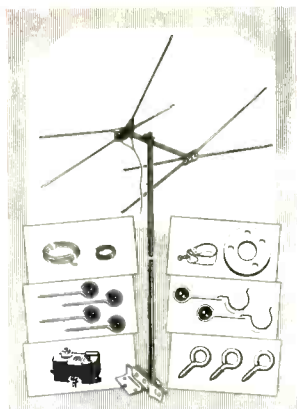

and clamp, swaged mast, stand-off insulators, lightning arrester, twin lead, and guy wire. These kits not only include everything necessary for a complete installation, but because all component parts are included as a "package" sale, the total cost is lower than if all the items were to be purchased separately.

HIGH GAIN YAGI

VEE-D-X is now in production on the new "Long Long John" twelve-element single channel Yagi. It was announced by The La Pointe-Plascomold Corporation. This new antenna is the successor to the Long John eight-element Yagi.

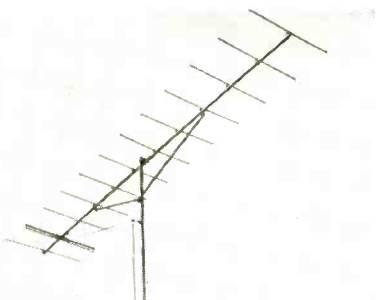

Both high and low channel models of the VEE-D-X Long Long John feature "rigidized" construction, with V shaped boom braces and reinforced element stampings. Other features include pre-assembled construction, 6 mc band width, and high front-to-back ratio. Both Long Long John models may be stacked by using the regular Long John phasing harness.

All high channel Long Long John list for \$18.50. Models LLF-2 and 3 list for \$41.95. Models LLF-4 and 5 list for \$36.98. Models LLF-6 list for \$31.95.

VACO MERCHANDISER

A new, Vaco "Vari-Board" for displaying screw drivers is announced by Vaco Products Company (well-known manufacturers of break-proof, shock-proof plastic handle screw drivers), 317 East Ontario Street, Chicago 11, Illinois.



This display (illustrated in photograph below) is constructed of multiple punched-out masonite and measures 24" x 24" with 4 movable, self-anchoring wood shelves 1" thick, 6" deep and 11" wide with individual holes for each driver.

In use, the Vaco "Vari-Board" accommodates regular stock assortments furnished with it or special screw driver assortments may be displayed simply by hooking other Vaco shelves into the punched-out holes as desired. Moreover, where a large wall space is to be used for a screw driver display, 24" and 12" boards may be combined either side by side or top and bottom to make complete display combinations.

AUTO RADIO ANTENNA MERCHANDISER

A completely new and redesigned display board for its line of auto radio aerials is now being offered to dealers throughout the country by Snyder Manufacturing Company of Philadelphia.



The display board is mounted on a heavy wood base and is designed for counter exhibit. Attractive in appearance, the display gains attention through its use of red, blue and Day-Glo green colors.

The display board itself is free, the only charge being for the aerials. Choice of any set of 4 aerials may be made, including one 4-section cowl, one 3-section cowl, one top cowl and one fender mount. Each board with set of aerials is individually packed.

Details and catalogs on the Snyder auto aerials and display may be obtained by writing to Snyder Mfg. Co., Philadelphia 40, Pa.

ALIGNMENT SCREWDRIVER

An exceptionally long alignment screwdriver, measuring 12 inches, has been brought out by the Insuline Corporation of America, Long Island City, N. Y. Made of flexible bone fiber with screwdriver blades at both ends, the new tool is especially useful for service work on deep and complicated television chassis. Containing no metal, it protects the service technician against possible shock and at the same time it cannot cause any accidental short circuits in tight wiring.

The new tool carries the catalogue number 6159. Distribution is through regular jobber channels.

TVI FILTER

Telematic Industries, Inc., Brooklyn, New York has designed two low pass line filters to eliminate diathermy interferences above 70 cycles that enter a TV receiver through the a.c. line.

WT-29, a tunable hi-freq line filter with a variable frequency range of high attenuation in the diathermy spectrum prevents diathermy frequencies from entering a TV set via the a.c. line.

TV SERVICING

is easier than you think

How many times have you asked yourself this question: "What can I do to make my servicing job easier?" Chances are you ask it every time you get a "stickler" in the shop. But have you ever stopped to consider that *all* your servicing . . . from the real headaches to the simplest repair . . . can be easier than you ever thought possible if you GET THE COMPLETE SERVICING INFORMATION ON A RECEIVER BEFORE YOU START TO REPAIR IT. Let's take a closer look to see why. *All* servicing data must originally come from the receiver manufacturer. He made the product, so he knows all about it. His information is not based on a single receiver but on hundreds, which are sampled. If you are using this kind of information, servicing is easy; but if you are using abridged data — information which does not originate with the set manufacturer — you do *not* have all the data required to do easy — permanent — prestige-building servicing.

Here's a typical example: For Stewart-Warner model 9122-A the set manufacturer prepared the equivalent of 35 pages (8½ x 11") of servicing data. The complete data is published in Rider TV Manuals Vol. 8 and in Rider TV Tek-File pack 12. The reason was that the production runs covered seven different codings (from A to G) plus 16 important changes in the receivers. Some of these changes were made to eliminate such actions as component resonance in the I-F system . . . horizontal sync instability . . . and the possibility of arcing in the high voltage system. Other changes were in tubes and parts. But *all* of the changes are vitally important to you when you're faced with a repair on this Stewart-Warner model. This is only one case in thousands of why it is absolutely necessary for you to have the complete, official, manufacturer-prepared servicing information for every set you repair.

There are two ways for you to get complete, official, factory prepared servicing information. One way is to write the set manufacturer directly. However, this takes time when you

need it most: While the customer's set is in the shop. So the easy way is to buy this data in complete published form. This means Rider Servicing Data! For 22 years Rider Servicing information has been the only publishing source for factory authorized and prepared servicing information: Exactly as issued by the manufacturer who made the set . . . organized into indexed, easy-to-follow style. In Rider Servicing Data you get all of the manufacturer's troubleshooting test patterns . . . schematics of all his productions . . . stage by stage alignment curves . . . clear, enlarged chassis views . . . the manufacturer's circuit changes . . . circuit explanations . . . voltage data, disassembly information and much, much more. For example: Rider Servicing Data has shown scope waveforms in TV receivers ever since the first TV receiver was made!

And Rider Servicing Data now has these important new features: manufacturers' trouble cures and guaranteed replacement parts listings. The manufacturers' trouble cures are standard (3 x 5") index cards, called Rider Handies, containing vital manufacturer-issued permanent trouble cures plus production changes. Each Handy is identified with a manufacturer and receiver model. With Rider Handies you save countless hours of diagnosis and repair time . . . because Handies contain the data you *must* have to make permanent repairs on many receivers. The replacement parts listings are included in the latest Rider Servicing Data. All these replacement parts must meet the physical and electrical performance ratings of the original equipment.

To meet your individual requirements, Rider TV Servicing Data comes in two forms. The Manual form; volumes covering the complete data on receivers manufactured during a certain period, and Tek-File form; separate packs containing complete data for specific models.

The TV Manual form has nine volumes covering more than 4,200 models of television receivers. Each vol-

ume has over 2,000 (8½ x 11") pages of servicing data with an index covering the contents of all volumes. Each volume is attractively bound in a permanent hard cover. The Manual form is ideal for shop use and as a permanent reference.

The Tek-File form now covers more than 2,200 models. Each Tek-File pack contains complete data for several of the most popular models . . . the ones you are called to work on every day. (Contents are clearly marked on the cover of each pack.) These models are bound in handy, standard file folders for easy home and shop use. In each Tek-File pack you get a special coupon. 15 of these coupons plus a small handling charge entitles you to a permanent, hard-cover manual binder for Tek-File shelf use. Or if you prefer, each coupon is worth five cents toward the purchase of any Rider book. Note: Get your free Tek-File indexes covering the contents of all packs at your jobber's. If he doesn't have them, write us.

For the complete servicing facts on *radio*, get Rider Radio Manuals. In 22 volumes Rider Radio Manuals give you the complete, factory-authorized, official AM, FM radio servicing data for receivers manufactured over the past 22 years! Plus complete data on auto radios, record changers, tuners and recorders. Everything is organized and indexed to make radio servicing easy.

DON'T BE SWITCHED

Remember, Rider Manuals and Tek-Files are the *only* source for complete published servicing data. If your jobber doesn't have them, DON'T BE SWITCHED! If he doesn't have Rider Manuals, write to us . . . we'll tell you where to get them. If he doesn't have Rider Tek-Files, write to us . . . we'll fill your order directly. (Please include your jobber's name.) Why not prove to yourself that Rider Servicing Data really makes servicing easy. Try one Rider TV Tek-File pack *at our risk!* Try a pack for the next receiver you repair . . . if you don't agree that it makes your servicing easier than anything you've ever used RETURN THE PACK TO US WITHIN SEVEN DAYS AND WE'LL SEND YOU A FULL REFUND! So act now . . . you have absolutely nothing to lose! John F. Rider, Publisher, Inc., 480 Canal Street, New York 13, N. Y. West Coast Office: 4216-20 W. Jefferson Blvd., Los Angeles, California.

ATR

For
AC CURRENT ANYWHERE



STANDARD AND HEAVY DUTY INVERTERS

For Inverting D. C. to A. C. . . .
Specially Designed for operating A. C. Radios, Television Sets, Amplifiers, Address Systems, and Radio Test Equipment from D. C. Voltages in Vehicles, Ships, Trains, Planes and in D.C. Districts.

ATR ✓ NEW MODELS
✓ NEW DESIGNS
✓ NEW LITERATURE

"A" BATTERY ELIMINATOR
AC-DC INVERTERS
AUTO RADIO VIBRATORS

See your jobber or write factory

AMERICAN TELEVISION & RADIO Co.
Quality Products Since 1931
SAINT PAUL 1, MINNESOTA-U. S. A.

TV SYNC CIRCUITS

[Continued from page 27]

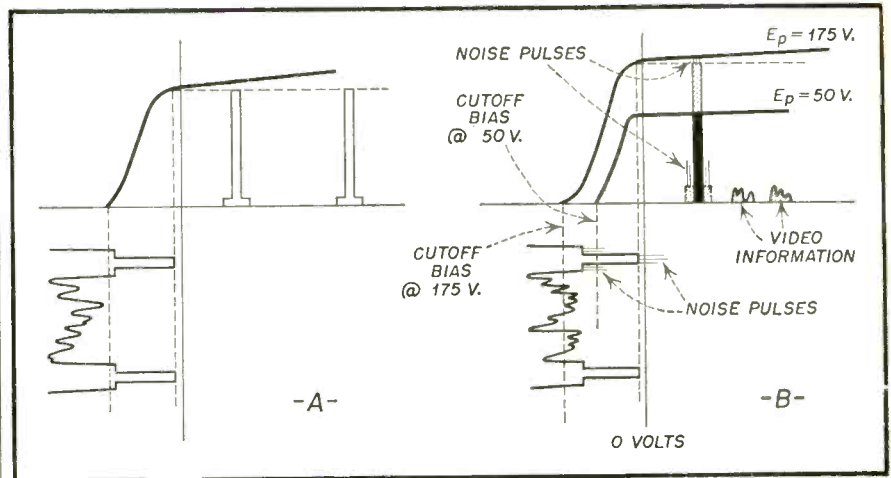

Fig. 6—(A)—Biasing to cut-off only. (B) biasing to cut-off and reducing plate voltage. Solid bar indicates I_p pulse with bias and low plate voltage.

the transmitted sync level with your local TV station engineer.

The other requirements of sync stripper action are, however, inherent in the set design. They will be discussed in order. The tube must be of the sharp cut-off type, otherwise, the video information will not be cut out in pictures containing a large amount of black information. This could result in some waveform distortion and also false triggering of the sweep oscillators.

The reason for the requirement for the sync portion of the signal to extend the grid bias from cut-off to at least zero volts is that in this manner the output of the stripper can be kept constant. A constant output is obtained by clipping due to plate saturation, grid current flow above zero volts, and negative grid bias cut-off. Another advantage gained by this positive limiting operation, is the elimination of any noise pulses riding on top of the sync pulse. This positive

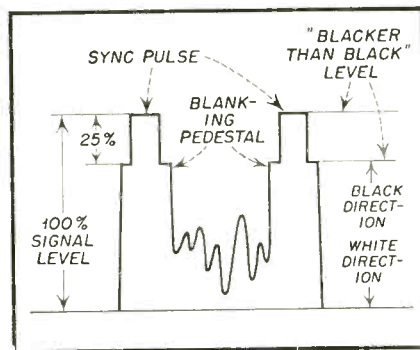

Fig. 7—Sync level standards.

The sync portion of the picture should be of an amplitude large enough so that with the bias set properly, only the sync information extends beyond cut-off. It should also extend to or beyond the zero voltage point. This condition is sometimes met by causing the stripper bias point to be varied by the signal strength (see diode action in pentodes, above). It is more often met by reducing the plate voltage (if the stripper is a triode) or plate and screen voltage if it is a pentode. (Fig. 6).

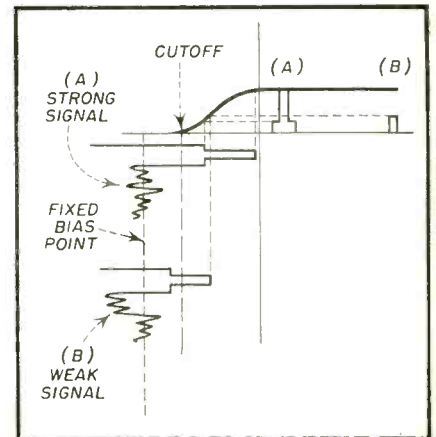

Fig. 8—Effect of fixed bias with weak and strong signal reception.

limiting action is sometimes performed in the stripper and sometimes in a following limiter stage.

The third requirement is self-explanatory, since, if the sync were in the negative direction the sync pulses would be cut off. Fig. 8 shows why the bias level should be that of the weakest signal received. If this bias were permanently fixed with a strong

G.E. TELLS YOUR CUSTOMERS!

National advertising sponsored by General Electric gives public the facts about the important service rendered by a skilled, highly-trained industry.

This ad, now running in LIFE and COLLIER'S, will help 35,000,000 readers to understand and respect the television serviceman and his work.

As a manufacturer of high-quality tubes and parts, General Electric has an important stake in your business, and is anxious to see a greater appreciation of your experience and abilities.

For extra copies of this LIFE-COLLIER'S ad write General Electric Company, Tube Department, Schenectady 5, New York.

AMERICA'S NEWEST "PROFESSION" KEEPS 18 MILLION TV SETS HEALTHY!

EIGHTEEN MILLION new "patients" is a tremendous responsibility for the television service industry—an industry that had only 2,000 sets to take care of just five short years ago. The phenomenal growth of TV has challenged every resource of service shop and individual technician. Television itself embodies new electronic principles which had to be learned by over 51,000 servicemen, most of whom were radio specialists. Manufacturers did everything they could to make it easy for these men to become the highly-qualified TV experts they are today. Schools and courses were established . . . new test equipment parts were distributed to every TV area. But the real responsibility for acquiring

TV know-how rests with the serviceman. As a group, these technicians have done an unprecedented job of meeting the service needs of the "TV epidemic". They have built for themselves an important new industry based on one ideal: to safeguard a billion-dollar owner investment in TV.

Your TV serviceman deserves your full respect and confidence. He has invested over \$3,000 in special test and other equipment in servicing sets. He is technically trained and experienced . . . familiar, by constant study, with latest television improvements. Call your favorite TV serviceman whenever you want your set put in top working order. He will always do his best to serve you promptly and at a fair, reasonable cost!

This advertisement is published as a tribute to the television servicemen of America by the Tube Department of the General Electric Company, Schenectady, N. Y.



LONG, TOUGH TRAINING—FOR EVERY TV TECHNICIAN. Months of study, and intensive practical experience, are only the start of your serviceman's training. He must know intimately the circuit of every make of TV. He must keep posted on all design change. No professional man in a field is obliged to read and study more continuously.

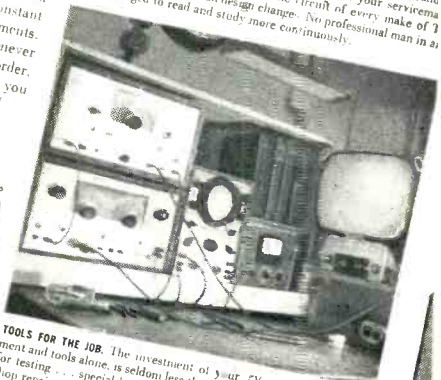

TOOLS FOR THE JOB. The investment of your TV technician in equipment and tools alone, is seldom less than \$3,000! Precision instruments for testing . . . special hand-tools . . . bench equipment for major TV shop repairs . . . these are pluses he must add to the customary business man's investment in shop and trucking facilities.



OPERATION TELEVISION—RIGHT IN THE HOME. When your TV serviceman removes your TV chassis from its cabinet, ask him to show you the myriad tubes, coils, and other parts, inter-connected by an "orderly maze" of wiring! Only highly-skilled hands can safely probe for faults, make repairs—usually on the spot—that restore the picture and sound to normal. His tools and equipment are as complete for their purpose as the contents of a doctor's kit. Aided by his specialized training, your serviceman diagnoses TV troubles, and restores your set to "health", in the least time and at the least cost to you.



ON CALL RIGHT THROUGH THE DAY. Morning, afternoon, or evening, a phone call finds your TV serviceman ready to respond. Serving a community that relies on him, he makes every possible effort to live up to this responsibility. His charges—which reflect the actual time he spends serving you plus any necessary tubes and replacement parts—are your best investment in television satisfaction.

★ THIS ADVERTISEMENT IS PUBLISHED AS A TRIBUTE TO THE TELEVISION SERVICEMEN OF AMERICA BY THE TUBE DEPARTMENT OF THE GENERAL ELECTRIC COMPANY



VIKING speakers by Jensen

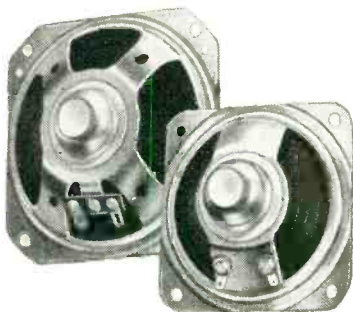

low cost replacement
speakers by Jensen . . .
makers of the World's
Finest Loudspeaker—
the G-610 Triaxial

Jensen

JENSEN MANUFACTURING COMPANY
DIVISION OF THE MUTER COMPANY
6601 S. LARAMIE AVENUE • CHICAGO 38, ILLINOIS

Viking speakers—
manufactured with the
same engineering and
production skills which go
into every Jensen product—
are designed especially for
low-cost replacement and
utility applications. The
Viking line includes 12
models from 3½" to 12"
with 4" x 6", 5" x 7" and
6" x 9" ovals, all P.M.
An accessory bracket,
designed especially for the
Viking series, solves
chassis and transformer
mounting problems.

BURTON BROWNE ADVERTISING

signal in mind, such as in Fig. 8a,
when a weak signal comes along, the
results are as shown in Fig. 8b.

TRADE FLASHES

[Continued from page 14]

the 1952 Radio Fall Meeting, accord-
ing to Virgil M. Graham, Chairman
of the Radio Fall Meeting Commit-
tee. The technical conference will be
held Oct. 20-22 at the Hotel Syracuse,
Syracuse, N. Y., under sponsorship of
the Radio-Television Manufacturers
Association's Engineering Depart-
ment.

A symposium on the National Tele-
vision System Committee's television
receiver developments, arranged by
the Professional Group on Broadcast
and Television Receivers of the In-
stitute of Radio Engineers, will be
held on Oct. 21. The papers will range
from "General Considerations in the
Design of a Color Television Re-
ceiver" to specific phases of operation
in color television sets.

Other sessions during the three day
meeting will include papers on ultra
high frequency television, electron
tube quality control, electronic de-
vices, including transistors, and gen-
eral information on television.

On Monday evening, Oct. 20, the
Syracuse Technology Club and the
Syracuse Section of the IRE will hold
a meeting. The Radio Fall Meeting
dinner will be held on Oct. 21.

World Standardization on Tube Bases

Action on a program for promot-
ing the interchangeability of electron
and radio tubes manufactured in most
countries of the world will be taken
at the international session in The
Netherlands.

Virgil M. Graham, director of tech-
nical relations of Sylvania Electric
Products Inc., said the meeting of the
International Electrotechnical Com-
mission (IEC), opening at Scheven-
ingen on September 3, would clear
the way for putting into effect the
proposals for standardizing the base
dimensions of tubes.

Raytheon Holds Meeting for Servicemen

Over 250 service dealers in the Bos-
ton area recently attended the popu-
lar and informative Raytheon "How
to Interpret What You See" technical
meeting at the Hotel Kenmore in
Boston.

The principal speaker was Mr. Ken-
neth Kleidon of the Belmont Service

the
bottom won't
drop out!



The bass response—
weakest feature in most
fine sound systems—
is custom engineered
into Jensen Back-Loading
Folded Horn cabinets.

In this universal design,
a long folded flare path,
expanding on the Hypex*
formula, gives superior
bass response—even
when placed on a sidewall.
In a corner, walls act
as extensions of the horn.

Available in mahogany
and blonde for both
15" and 12" speakers.

Ask your jobber or
write for 1020 brochure.

*Trade Mark Registered

Jensen

JENSEN MANUFACTURING COMPANY
DIVISION OF THE MUTER COMPANY
6601 S. LARAMIE AVE. CHICAGO 38, ILLINOIS
IF CANADA:
COPPER WIRE PRODUCTS LTD., LICENSEE



BURTON BROWNE ADVERTISING

Department assisted by Mr. George St. Andre, New England Service Manager for the Belmont Radio Company, manufacturers of the Raytheon television set line.

The meeting was sponsored by three of the leading Boston Parts distributors, DeMambro Radio Supply Company, Electrical Supply Corporation and Lincoln Electronic Supply Corporation. The meeting was organized by Arthur E. Akeroyd, Representative for the Raytheon Tube Line in the New England area.

Jensen Announces Servicemen Contest

Announcement of a \$5000 contest for radio-television servicemen was made by Karl Jensen, vice president of Jensen Industries, Inc., well known phonograph needle manufacturer. Scheduled to start September 1st and to run to the end of the year, the novel contest offers cash prizes to servicemen sending in the most empty Jensen needle packages during that four-month period.



The contest, called "Win a Grand" from its top award of \$1000, features a total of 187 cash prizes, which Jensen feels will draw a sizable number of entrants from the nation's service field. A full advertising and direct mail promotion campaign has been planned to spread the word in the trade, and radio parts distributors are being asked to distribute contest literature and entry blanks which require a sentence completion.

Belmont Changes Name

The directors of Raytheon Manufacturing Company, Waltham, Mass., at a recent meeting voted to change the name of its television manufacturing subsidiary, Belmont Radio Corporation, to Raytheon Television and Radio Corporation, it was announced by C. F. Adams, Jr., president of Raytheon.

In announcing the change, Mr. Adams stressed that the present man-

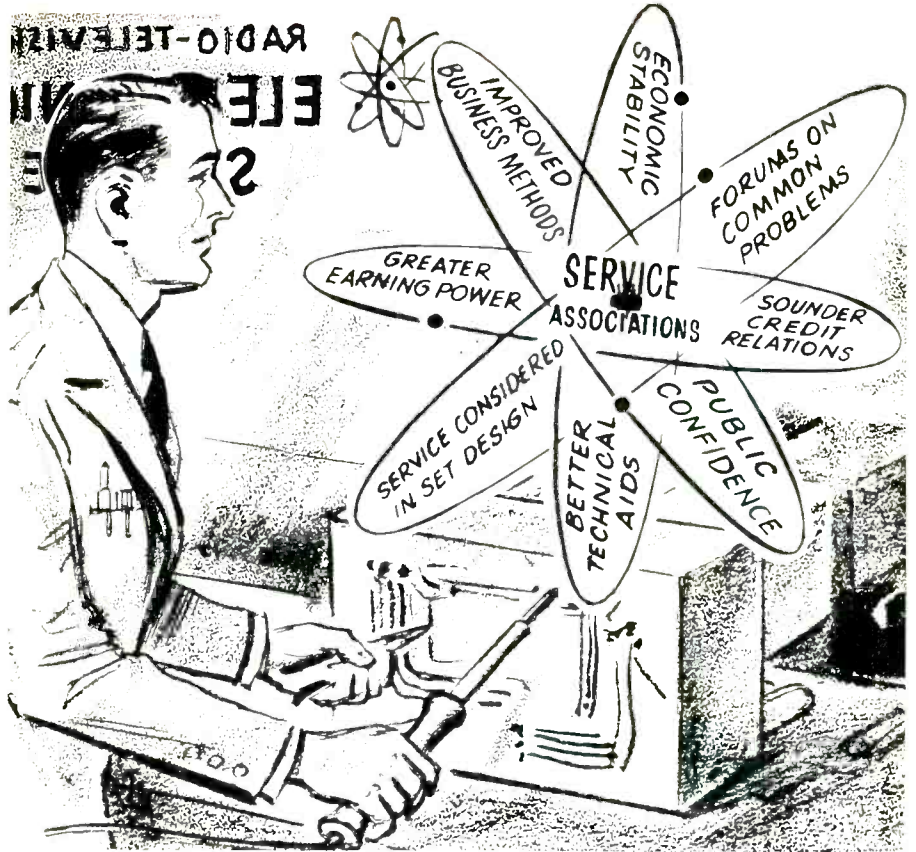

THE MODERN ELECTRONIC TECHNICIAN HAS A NEW VIEWPOINT!

A changing attitude on the part of the radio and television service technician is the thing that is pulling the electronic service profession out of the doldrums. He is learning that he cannot call himself a success, as an individual, until he can look around and see other technicians who have assets he can admire or compare with his own. As long as there are too many in his profession operating without scruples, and trying to get along under a "hand to mouth" economic operation without adequate testing instruments and other technical aids, there is not much to measure one's success by.

His interest and attendance at the local service association meeting shows that the modern Electronic Technician is beginning to look beyond the "tip of his soldering iron." Through these associations, he is rapidly gaining recognition, not only in his own community, but also in the vast electronic industry, as being an essential link between the manufacturer and consumer.

In addition to getting valuable technical "know-how" from non-commercial sponsored lectures and demonstrations, he is finding out how to make his business bring a fair return on his rather large investment in training, experience,

and testing instruments. He is also learning how to be fair to both his customers and himself by keeping his "know-how" and test equipment up-to-date and not resorting to price cutting for his service in diagnosing trouble.

As technicians gain that feeling of mutual respect and esteem among themselves by regarding each other as business associates instead of raw competition, their most valuable asset—technical "know-how"—will no longer be obscured. The technician's interest in matters which affect his economic welfare will lead him and the entire service industry to greater economic stability.

The time and money you devote to your service organization is not an expense—it is an investment in your future that will be paid back many, many times.

Our 25th Year

SUPREME

Testing Instruments

"SUPREME BY COMPARISON"

TUBE TESTERS • SIGNAL GENERATORS
PANEL METERS • MULTI-METERS
OSCILLOSCOPES

Supreme, Inc., Greenwood 3, Mississippi

SYLVANIA
PRECISION

FREE!

The following manufacturers' products are cataloged in the 128 page Instrument & Test Equipment Section.

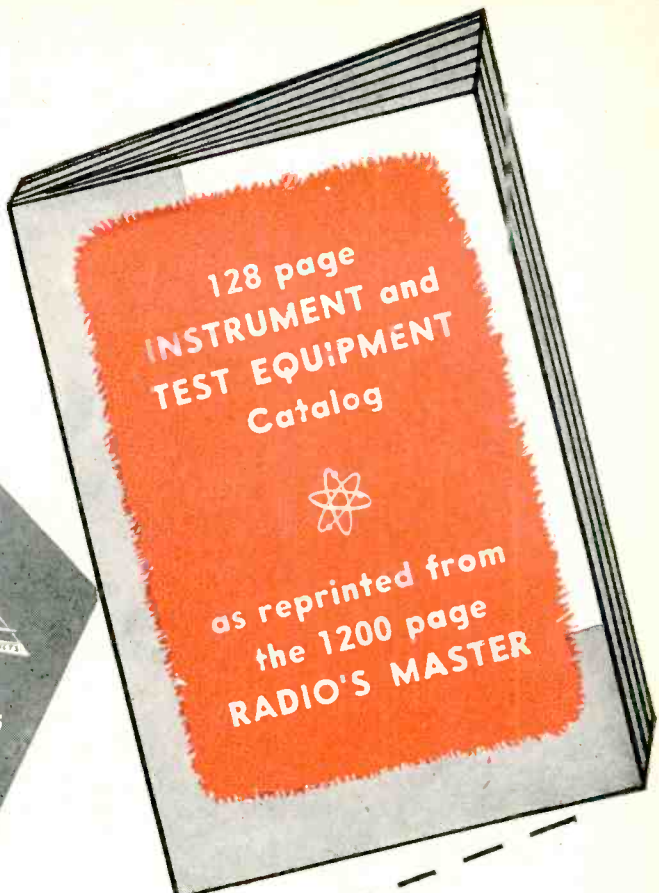

RADIO-TELEVISION SERVICE DEALER subscribers can receive, without cost or obligation, a complete 128 page catalog section on Test Equipment and Instruments, as reprinted from the 1200 page RADIO'S MASTER, the Industry's Official Buying Guide.

This section catalogs in detail the products of the leading Instrument and Test Equipment manufacturers—all in 1 handy booklet. It is complete with descriptions, specifications and illustrations as written by each manufacturer. You will find this large catalog section extremely helpful and a handy reference.

This FREE offer is made possible by a special arrangement between RADIO-TELEVISION SERVICE DEALER and the publishers of RADIO'S MASTER. Be sure to get your copy . . . just mail coupon NOW.

These manufacturers do not catalog test equipment in Radio's Master. Separate catalog sheets will accompany each booklet.

- Clippard Instrument Lab.
- Dumont Laboratories, Inc.
- Galvanic Products Corp.
- Heath Company
- National Union Radio Corp.
- Oak Ridge Products
- Panoramic Radio Products
- Transvision, Inc.



GET YOUR FREE 128 page CATALOG

RADIO-TELEVISION SERVICE DEALER
67 WEST 44th STREET, N. Y. 36, N. Y.

Please send, without cost or obligation, the 128 page Instrument and Test Equipment Catalog as reprinted from Radio's Master.

Name.....
 Address.....
 City..... Zone..... State.....

SERVICEMEN!

Have You Entered THE BIG

Jensen \$5,000.00

Cash Prize Contest?

SEE YOUR *Jensen* NEEDLE DISTRIBUTOR
TODAY FOR DETAILS AND ENTRY BLANKS.

NEW! MOSLEY WALL-THRU

For TV, FM and Amateur Transmission Line

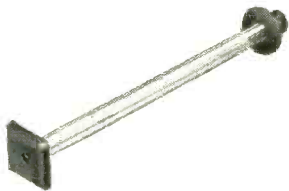

Cat. No. 625

List Price \$1.95

Cat. No. 625-PK

WALL-THRU, complete with
MOSLEY Universal TV Lead-
in Socket and Plug.

List Price \$3.00

- Fits Any Wall Up To 13" Thick!
- Completely Weather-Proof!
- For Standard Flat 300 Ohm Line or RG-59/U Co-ax Cable!
- MOSLEY Lead-In Socket Can Be Mounted Direct To Inside Plate!
- Precision Molded Polystyrene End Plates!
- Easily, Quickly Installed!

MOSLEY ELECTRONICS

2125 LACKLAND ROAD OVERLAND 14, MISSOURI

Your One Complete Speaker Source

UTAH REPLACEMENT SPEAKERS

Export Dept. Rocke International Corporation, N. Y. C.

RADIO PRODUCTS CO., INC.

HUNTINGTON, INDIANA

A WHOLLY OWNED SUBSIDIARY OF NEWPORT STEEL CORPORATION

will extend back to Spaulding Ave., giving the Stancor plant frontage on four city streets. The left wing, fronting on Kedzie, which with the other new wing is of single story construction, provides shipping and receiving docks as well as additional storage space.

Speer Resistor Moves Plant

The Speer Resistor Division of Speer Carbon Company has completed the moving of their manufacturing facilities from St. Marys, Pennsylvania, to the new plant in Bradford. Eight production lines are now in operation at Bradford.

I. C. S. Announces TV Course

A new course for television technicians has been announced by the International Correspondence Schools of Scranton, Pennsylvania.

John C. Villaume, acting dean of the faculty at I.C.S., describes the course as being designed "to acquaint manufacturing and sales engineers, broadcast engineers, students and technical workers in this field with all components of transmitting and receiving equipment in both mono chrome and color."

BROAD BAND YAGIS

[Continued from page 32]

with the single reflector, produced both excellent gain and directivity on the low end of the channels under consideration. It should be borne in mind that the potential gain of the twin tuned dipole system alone, is over 3 DB. The parasitic directive system does not suffer the limitation in number of elements that a parasitic reflective system does. Therefore, it was possible to add seven directors which provided very strong gain at the higher frequencies. The result of the somewhat stronger directive system is that the antenna tended to have a slightly sloping gain characteristic increasing with frequency. This, of course, is desirable since it tends to keep the actual voltage fed to the receiver at a constant level.

It was found that significant stacking gains could be achieved by using Channel Master's well-known Z-Match System. In this system, the impedance of each bay is dropped, and then transformed up to approximately 600 ohms at the center feed point. The two 600 ohm impedances in parallel gave a total impedance of 300 ohms for the stacked array. The reduction of impedance was accomplished by removing the center bar of

the lower frequency folded dipole. Additional structural strength was obtained by the use of boom bracing.

D.C. RESTORERS

[Continued from page 25]

the incorrect shading is caused by their receiver and does not represent the true scene which is transmitted. For this reason most viewers would not note the absence of d-c restoration unless they had become accustomed to it and noticed the difference when a new set was purchased. Without d-c restoration an entirely black scene would not be received. Thus, between scenes when the station blanks out, the entire screen would be gray instead of totally black.

Fig. 6 shows another scene which should have a black background. Note the trailing black which appears at maximum intensity after white lettering or other objects. Fig. 7 also shows the black background for white lettering only. On the other hand, notice the correct balance of whites and blacks in Fig. 8 which shows the true scene with a receiver having direct coupling. The lettering is against the proper background with its diagonal light shading as originally transmitted.

Reasons for Omitting D-C Component

The claims for omission of the d-c restorer are based on several factors. One is that inasmuch as the average viewer is unaware of the subtle differences which exist, the d-c restorer would not be missed. If the black background appears gray, the viewer would have no means of ascertaining whether or not the scene were transmitted as it appears on the screen.

Another argument advanced is that overmodulation often occurs at the transmitter. This is particularly true if a switch is made from a studio scene to one on motion pictures. The tendency would be for overmodulation of the motion picture scene unless correction were made at the transmitter in terms of level, shading, etc. Thus, with d-c restoration the contrast may appear overly dark during a film commercial or other filmed scene. This may require the viewer to readjust contrast and brilliancy controls to get normal contrast and background. When the scene shifts back to the studio program, the brilliancy may be too high and the picture may appear slightly washed-out. The viewer would then be compelled to readjust contrast and decrease brilliancy.

Without a d-c restorer the overly dark scene would have a dark gray

level and necessity for readjustment of brilliancy and contrast controls would not be as urgent. For this reason it is claimed that even though the background is averaged out to some extent, it becomes less troublesome for the viewer because contrast need not be reset.

The purists, however, argue that this is alleviating the symptoms without correcting the original defect. The contention here is that the receiver should faithfully reproduce the televised scene regardless of whether it is transmitted correctly

or incorrectly. Such individuals argue that it is up to the transmitting station to assure good transmission rather than to rely on the omission of an essential circuit for correcting a defect originating at the station.

Both arguments are well founded and it is certainly not a matter of strict economy for the manufacturer to omit the d-c restorer circuit. Restoration can be added to most receivers by the simple inclusion of a resistor, capacitor, and a germanium crystal. In fact, this can be done by a technician if the viewer notices the

Especially Designed for Radio & TV!

LYNN *Lightning*
 SOLDERLESS WIRE
 TERMINAL
 REPAIR KIT

NO. 2195
 SERVICE KIT

Now you can get a positive, trouble-free connection on every terminal... as fast as you can close your hand. No messy soldering or waiting for an iron to heat! With a Lynn *Lightning* service kit you just strip primary wire from 10 to 22 gauge with handy, combination stripping and crimping tool... select the proper terminal... then *crimp* it on. Every job quick, clean, professional-looking! Kit comes complete with crimping tool, 10 different types of terminals in 11-bin, clear plastic box. Only **\$8.50**

Two New Television Screw Drivers

Reach hard-to-get-at spots with the new Vaco AT 510 non-metallic, fiber shank driver for critical tuning and aligning work... the 10" blade gives you all the length you need. Adjust the new type focalizers with specially designed Vaco Beryllium-copper drivers... non-magnetic, yet nearly as hard as steel for adequate torque without interference with the Ion trap field. Full information on other aligning tools, nut setters and special radio tool kits on request. Write for FREE catalog.



317 E. Ontario St., Chicago 11, Ill.
 In Canada: Vaco-Lynn Products Co., Ltd.
 204 Laurier Ave. W., Montreal B, Que.

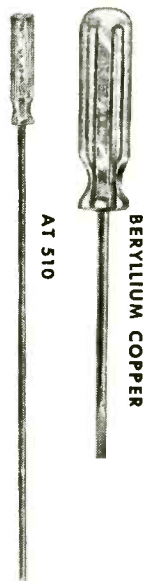

ONLY *Copperweld* RADIO and TV PRODUCTS

Offer the **EXCLUSIVE ADVANTAGES** of
Copperweld's Molten-Welded Construction



Result—**UNMATCHED DEPENDABILITY AND OVERALL ECONOMY**

Write today for further details.

COPPERWELD STEEL COMPANY • Glassport, Pa.
SALES OFFICES IN PRINCIPAL CITIES

Copperweld **GUY STRAND
ANTENNA WIRE • GROUNDING WIRE
GROUND RODS AND CLAMPS . . .**

also **HOOK-UP WIRE, TWIN-LEAD AND COAXIAL CABLES,
AND MANY OTHER ELECTRONIC WIRE PRODUCTS**

THIS IS IT! THE RELAY WITH *Interchangeable Coil* FOR A WIDE RANGE OF RADIO APPLICATIONS

GUARDIAN Series 200

Interchangeable
COIL and CONTACT
Switch Assembly

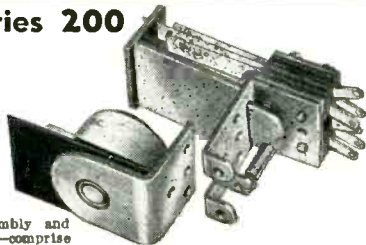

Two basic parts—a coil assembly and a contact switch assembly—comprise this simple, yet versatile relay. The coil assembly consists of the coil and field piece. The contact assembly consists of switch blades, armature, return spring and mounting bracket. The new Guardian Midget Contact Assembly which is interchangeable with the Standard Series 200 coil assembly, is also available in either single pole, double throw; or double pole, double throw.

CONTACT SWITCH ASSEMBLIES

CAT. NO.	TYPE	COMBINATION	
		Single Pole	Double Pole
200-1	Standard	Single Pole	Double Throw
200-2	Standard	Double Pole	Double Throw
200-3	Contact Switch Parts Kit		
200-4	Standard	Double Pole	Double Throw
200-M1	Midget	Single Pole	Double Throw
200-M2	Midget	Double Pole	Double Throw
200-M3	Midget Contact Switch Parts Kit		

13 COIL ASSEMBLIES

CAT. NO.	A.C. COILS*	VOLTS	CAT. NO.	D.C. COILS	VOLTS
200-6A		6 A.C.	200-6D		6 D.C.
200-12A		12 A.C.	200-12D		12 D.C.
200-24A		24 A.C.	200-24D		24 D.C.
200-115A		115 A.C.	200-32D		32 D.C.
			200-110D		110 D.C.

*All A.C. coils available in 25 and 60 cycles

GUARDIAN  **ELECTRIC**
1606-K W. WALNUT STREET CHICAGO 12, ILLINOIS

A COMPLETE LINE OF RELAYS SERVING RADIO AMATEURS

lack of d-c restoration and desires correction.

Whether or not the technician takes the affirmative or negative stand in this respect, it is to his advantage to recognize the differences which exist so he can, on occasion, install the restoration circuit should the customer desire it. He can also remove it if he believes it would be to the advantage of the viewer. Some technicians have claimed that they are not bothered as frequently by complaints of changes in brilliancy and contrast after removal of the d-c restorer. They state that removal will level the average background and thus eliminate the false complaints which arise from viewers when the transmission is not kept at a proper level for the various scenes.

Many technicians, however, firmly believe it should not be omitted and will wire one into the circuit when the receiver comes into the shop for major repairs. The decision is up to you. Knowing all the facts should help you decide on the stand you wish to take. The writer has watched two receivers side by side—one with and the other without restoration. If you have two such receivers on your workbench make your own comparisons. It may convince you that its inclusion makes for better all-around reception.

HOR. DEFLECTION CIRCUIT THEORY

[Continued from page 19]

sistors for the fast reduction of oscillations.

2. To remove the oscillatory energy and convert it to charge condensers whose charge voltage is made to series aid the B+ power-supply thereby obtaining a higher voltage power source, called, appropriately enough, B₊₊. This higher d-c voltage supplies the horizontal output stage, and quite often supplies several other stages of the receiver, helping those stages to provide greater output than when usual B+ is supplied.

Figure 5 is a modified version of Fig. 1 and it shows how a diode tube might conceivably be connected in a circuit. The diode would conduct when E_t is positive on the high side of the deflection coil and the tube would conduct most heavily at the peak of the shaded first oscillatory half-cycle shown in Figs. 3 and 4. During retrace time the high side of the deflection coil is negative with respect to cathode of the damper tube,

NOW *The Brilliant*

**ALL-CHANNEL
Q-TEE**

has
**RUGGEDIZED
CONSTRUCTION**

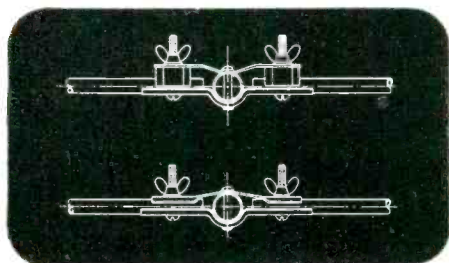

For positive element support under the most severe conditions, the Q-Tee is now supplied, at no extra cost, with special reinforcing brackets, making the Q-Tee the strongest antenna for its weight ever made. (See below)

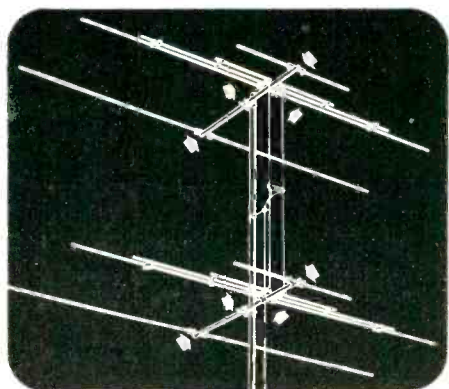

plus every desirable feature
in an all-channel antenna

First antenna to employ printed circuit filters. Provides higher average gain than other broad band antennas over all channels. Better front-to-back ratio with perfect 300 ohm match and lower standing wave ratio. Easily installed and serviced. Better rooftop appearance. Available in three series - Q-Tee Single Bay for primary areas; Q-Tee Double for near-fringe areas; Q-Tee Quad for fringe areas. The Single Bay . . . lists for only **\$7.75**

VEE-D-X

THE LaPOINTE-PLASCOMOLD CORP. SD-9
ROCKVILLE, CONNECTICUT

Send me complete information on the Q-Tee.

NAME

ADDRESS

CITY..... ZONE..... STATE.....

which is the same as saying that the plate of this tube is negative with respect to its cathode, and therefore would not conduct. The damper tube will conduct through the total sweep time in this circuit.

The damper tube plate current, when it flows, produces a heating effect in the tube, which means that a power waste is occurring. A booster circuit is used which captures as much as possible of this power before it is wasted and converts it to power which can be used to supplement the B+ power-supply.

When E_L is such that *point 1* is positive with respect to *point 2*, which happens during sweep time, the damper tube conducts (cathode to

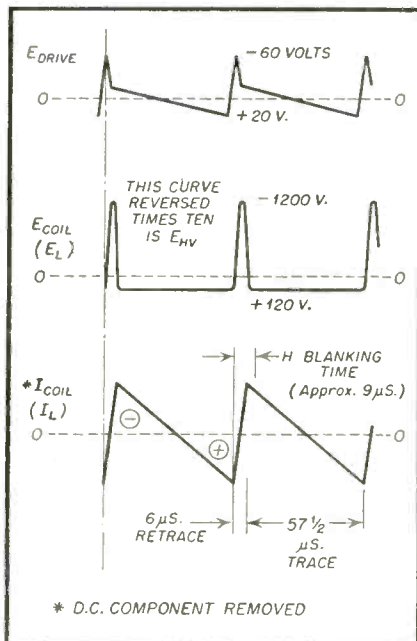

Fig. 8—Wave Shapes of E and I in Fig. 7

plate) charging the condensers as is shown in Fig. 6. As the condensers become charged the diode current diminishes. When *point 1* becomes, or tends to become, highly positive as is the case at time C of Figs. 3 or 4, the damper tube conducts most heavily, and thus accomplishes two quite desirable things:

1. The oscillatory voltage is quickly damped at the proper time.
2. The condensers are quickly charged.

The condensers are charged at a 15,750 c.p.s. rate and consequently need not be of a high capacity rating.

Circuits of the type diagrammed in Fig. 6 leave a d-c component superimposed on the deflection coil current which would mean that the picture would be off center. Electrical centering controls provide a d-c current of

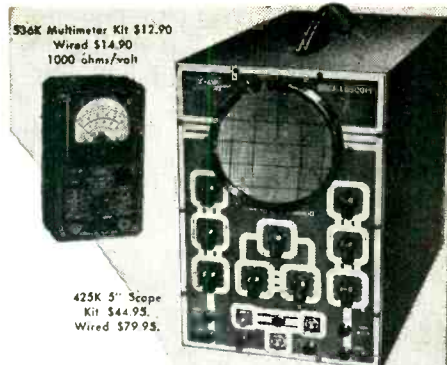

YOU BUILD

EICO

**KITS
IN ONE
EVENING-**

**but they
last a lifetime...
and you save
50%!**

22 Kits and 24 Instruments —
the Industry's most complete
line of **MATCHED
TEST INSTRUMENTS!**

Over ¼-million EICO Instruments are now in use the world over! That's the proof of EICO's leadership in **Value to the Serviceman!**

For latest precision engineering, finest components, smart professional appearance, lifetime performance and rock-bottom economy — see and **compare** the EICO line at your jobber's today **before you buy any higher-priced equipment!** You'll agree with over 100,000 others that only EICO Kits and Instruments — no other — give you the industry's greatest values at lowest cost.

Write NOW for
**FREE latest Catalog
D-9.**



625K Tube Tester
Kit \$34.95.
Wired \$49.95.



221K VTVM Kit \$25.95.
Wired \$49.95.



565K Multimeter Kit \$24.95.
Wired \$29.95.
20,000 ohms/volt.



320K Sig. Gen.
Kit \$19.95. Wired \$29.95.



360K Sweep Gen.
Kit \$34.95. Wired \$49.95.



1040K Battery Elim.
Kit \$25.95. Wired \$34.95.

**Laboratory
Precision
at Lowest Cost**

Prices 5% higher on West Coast.

EICO

©1952 **INSTRUMENTS & KITS**
ELECTRONIC INSTRUMENT CO., Inc.
84 Withers Street, Brooklyn 11, N. Y.

FASTER STURDIER

Lower Installed Cost

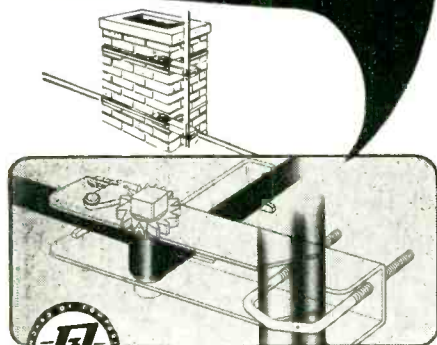

SPEE-DEE

CHIMNEY MOUNT

Model AK 85 The fastest-installed chimney mount ever devised for TV antennas! Rugged in design—simple to install. Simply thread strapping through ratchet, around chimney and back through ratchet—wind up ratchet tight—and the job's done! Heavy gauge, zinc-plated steel with large "U" bolt for up to 1 3/4" O.D. mast and full length galvanized steel strapping.

THE RADIART CORPORATION
CLEVELAND 13, OHIO

1953 ALLIED CATALOG



**236-PAGE
BUYING GUIDE**

**Complete
Up-to-Date**

FREE!

**EVERYTHING IN RADIO, TV
AND INDUSTRIAL ELECTRONICS**

Service Technicians, Engineers: You'll want the latest ALLIED Catalog. It's complete, authoritative—packed with the world's largest stocks of test instruments, amplifiers, P.A. systems, tubes, parts, tools and accessories. Save time and money at ALLIED. Send today for your FREE 236-page Catalog.

FREE—SEND FOR IT!

ALLIED RADIO

ALLIED RADIO CORP., Dept. 26-J-2
833 W. Jackson Blvd., Chicago 7, Illinois

Send FREE 1953 ALLIED Catalog

Name _____

Address _____

City _____ Zone _____ State _____

equal amplitude and opposite polarity to the aforementioned d-c component to bring about proper picture centering. When d-c blocking condensers like C₂ and C₃ are in the circuit as in Fig. 7, mechanical centering may be used. Fig. 8 depicts the waveshapes of voltage and currents of the circuit shown by Fig. 7.

Adding additional turns to the output transformer for a high voltage winding by autotransformer action provides for a high voltage which reaches a positive peak value at the same time that the inductive kick-back takes place. One or two turns of well-insulated wire wound around the iron core of the horizontal output transformer suffices for supplying power at 15.750 c.p.s. to the HV rectifier tube filament.

Slightly before retrace starts and slightly after trace starts the grid of the picture tube is driven negatively enough by the negative-going voltage of the transmitted horizontal blanking pulse so that the picture tube spot is extinguished.

A subsequent article will deal with the techniques and devices used for locating and shooting troubles in horizontal deflecting and associated circuits.

NEW TUBES

[Continued from page 34]

million or more. The required grid current is less than 1 micro-ampere, which presents no loading problem to any existent circuit. Input impedances of up to 100 megohms are typical.

The Haledy TT-1 is applicable to various electronic, mechanical, and electric controls and products, as well as timing circuits, indicating circuits and memory circuits.

CIRCUIT COURT

[Continued from page 35]

the grid. This signal modulates the tube's plate current. The plate impedance is a tuned 4.5 mcs tuned circuit. This tuned circuit causes the plate circuit to show a high impedance to the 4.5 mc signal and a low impedance to all other frequencies. As a result only the 4.5 mc signal is amplified. The secondary of this tuned circuit feeds this amplified signal to the grid of the sound limiter through a 56 mmf condenser.

\$1.00 to \$5.00 PAID

"for SHOP NOTES"

Write up any "kinks" or "tricks-of-the-trade" in radio servicing that you have discovered. We will pay from \$1 to \$5 for such previously unpublished "SHOP NOTES" found acceptable. Send your data to "Shop Notes Editor," RADIO-TELEVISION SERVICE DEALER, 67 West 44 St., New York 36, N. Y. Unused manuscripts cannot be returned unless accompanied by stamped and addressed return envelope.

AD INDEX

Allied Radio Corp.	56
American Television & Radio Co.	46
Argos Products Co.	44
Bussmann Manufacturing Co.	12
Belden Manufacturing Co.	16
Channel Master Corp.	1
Copperweld Steel Co.	54
DuMont, Allen B. Lab., Inc.	43
Electronic Instrument Co., Inc. (EICO)	55
Galvanic Products Corporation	2
General Electric Company	47
Guardian Elec. Mfg. Co.	54
Hytron Radio & Electronics Co. Cover 2	
Jackson Electrical Instrument Co.	14
Jensen Industries, Inc.	52
Jensen Manufacturing Co.	48
LaPointe-Plascomold Corp.	55
Mallory, P. R. & Co., Inc.	7
Mosely Electronics	52
Ohmite Manufacturing Co.	42
Radiart Corporation	5, 39, 56
Rauland Corporation	15
Raytheon Manufacturing Co.	6
RCA Tube Dept.	9, Cover 4
Regency	Cover 3
Rider, John F. Publisher, Inc.	45
Sams, Howard W. & Co. Inc.	4
Schott, Walter L. Co.	41
Simpson Electric Co.	8, 13
Supreme, Inc.	49
Transvision, Inc.	51
Trio Manufacturing Co.	10, 11
Utah Radio Products Co., Inc.	52
Vaco Products Company	53

Regency

HIS CHOICE IS

LARGEST SELLING VHF BOOSTER . . . AT ANY PRICE!

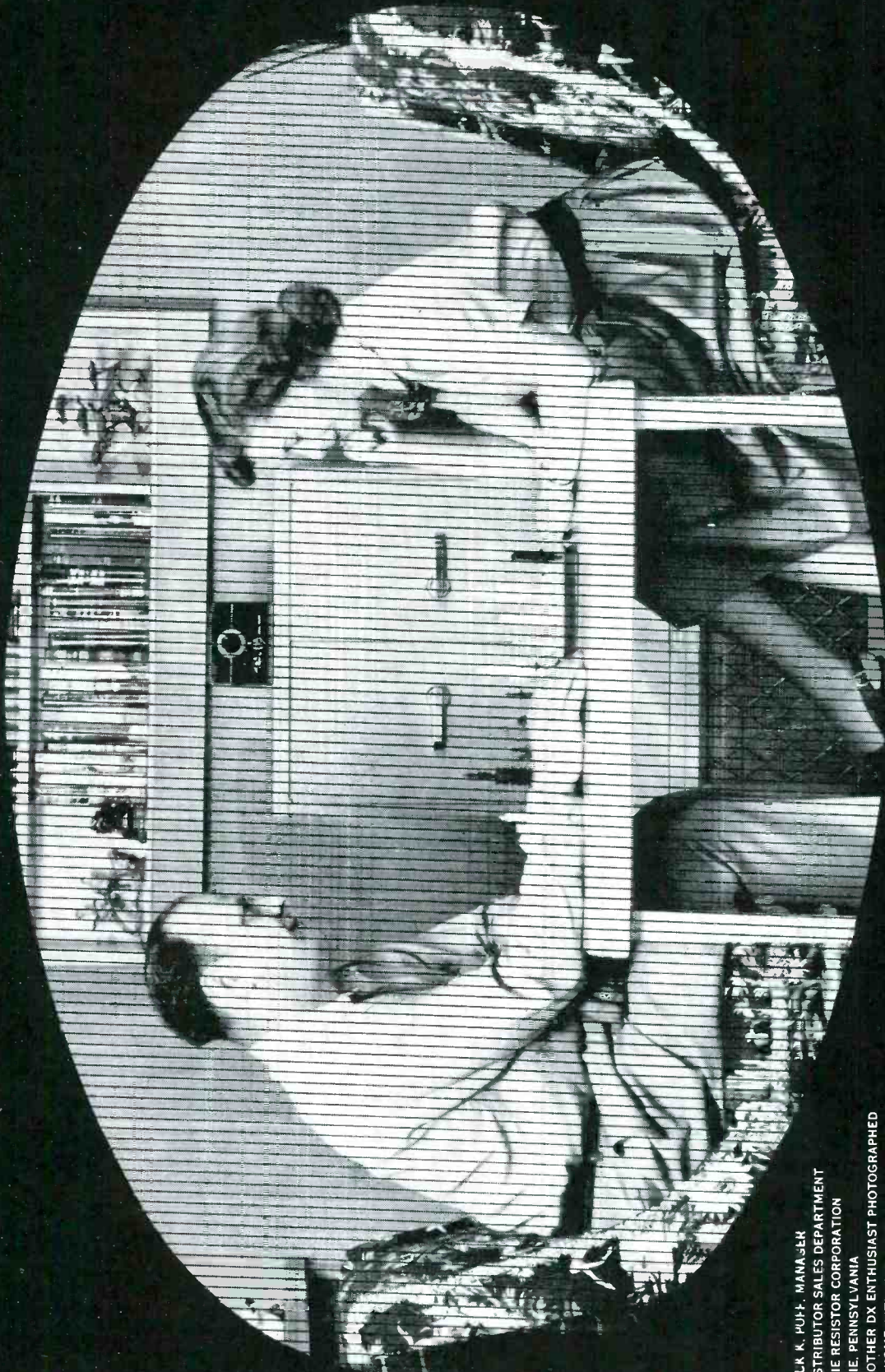

JACK K. PUFF, MANAGER
DISTRIBUTOR SALES DEPARTMENT
ERIE RESISTOR CORPORATION
ERIE, PENNSYLVANIA
ANOTHER DX ENTHUSIAST PHOTOGRAPHED
AT HOME WITH MRS. POFF

BURTON BROWNE ADVERTISING

ALSO MAKERS OF THE

Regency

UHF CONVERTER

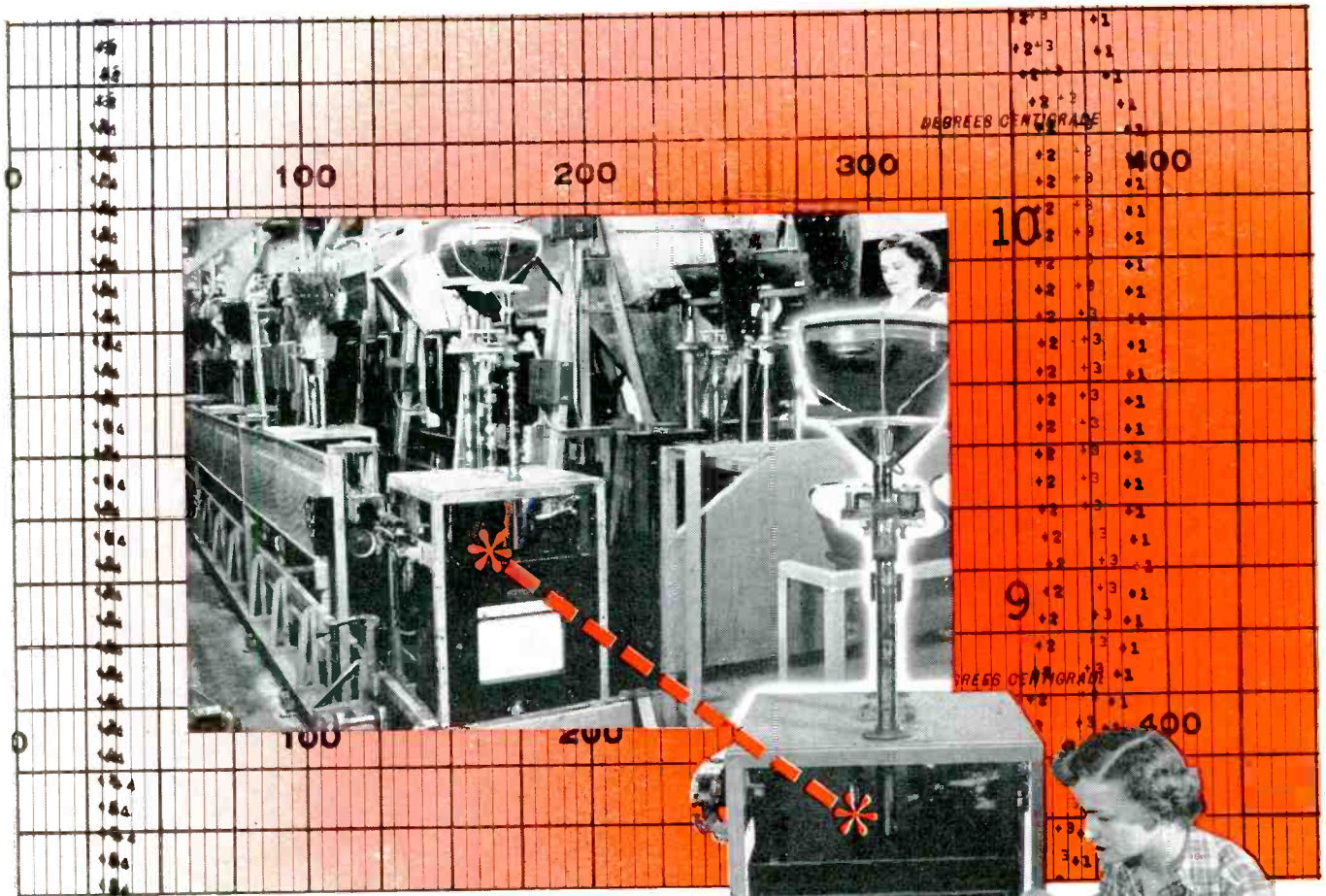

The guinea pig that
"runs a fever"

to bring you better picture tubes

IN THE straight-line exhaust systems used at RCA picture-tube plants, each picture tube rides through a long oven on its own "exhaust cart." As the tube passes through this oven, the envelope is freed of gas by baking it at high temperatures.

These high temperatures must be carefully controlled for each picture tube type, and held to rigidly prescribed limits, in order to avoid setting up harmful strains in the glass, especially at the faceplate and wall of the tube.

Here is where the "electric guinea pig" comes in. The "guinea pig" actually consists of a sample tube, with five thermocouples attached to its outside surfaces. These thermocouples are connected to an instrument known as a recording pyrometer. At intervals during the day, this "guinea pig" travels through the oven, and emerges with a complete and accurate "fever chart" for the particular tube type in production. In this manner, temperature deviations are quickly spotted . . . and promptly corrected.

This is another example of the care exercised in the manufacture of RCA picture tubes. Through constant vigilance, RCA closely guards its own reputation for quality . . . and yours as well.

With RCA Receiving Tubes, as well as RCA Kinescopes, TOP-QUALITY CONTROL makes the difference.



RADIO CORPORATION of AMERICA
ELECTRON TUBES
HARRISON, N. J.

TMKS. ®