

DECEMBER, 1951

Radio-Telev.
**SERVICE
DEALER**

ACME RADIO SERVICE
1584 MAIN ST
GREEN BAY WISC
214 OCT 58 50L-161



The Professional Radio-TVman's Magazine

IN THIS ISSUE:

Troubles in Television RC Networks
Looking For Trouble? No. 7
Soldering Wires to MIP Type Plugs
LHF Converters
Men of Radio, Part 10
The Femme Touch
Here's How & Why

AM-FM-TV-SOUND

INSIST on this label...

Replace with
the **Exact**
original equipment

Thomas
PHOTOTRON
TELEVISION
PICTURE TUBE

Thomas Electronics Inc., Passaic, New Jersey, U. S. A.

Replacement **16CP4A** Tube Chart

GROUP 1	LENGTH	ENVELOPE	DEFLECTION ANGLE	ION TRAP	CAPACITANCE (µuf)	TYPE FACE PLATE
16AP4	21½	M	52	D	M	Clear
16CP4	21½	G	52	D	M	Clear
16CP4A	21½	G	52	D	2000	Grey
16LP4	22¼	G	52	S	2000	Clear
16LPA	22¼	G	52	D	2000	Grey
16ZPA	22¼	G	52	D	2000	Clear
16ZPA	22¼	G	52	D	2000	Grey

... it's your guarantee* of quality.

It means you're replacing a picture tube with the exact original equipment...chosen by these 20 manufacturers (and many more!) because of proved superior performance.

This means less time-killing tube call-backs: more profit

for you in each replacement! So, insist on this label... and get the best — THOMAS!

*Every THOMAS Phototron picture tube is guaranteed for 6 months from the actual date of installation: regardless of how long the tube remains on your shelf.

Contact your jobber or distributor for the complete THOMAS Phototron line... or write THOMAS direct.

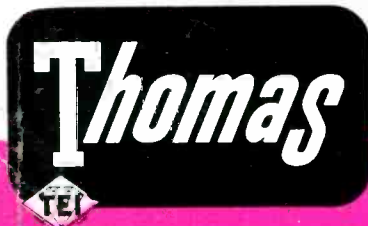

Phototron picture tube

ELECTRONICS Inc. PASSAIC, NEW JERSEY

Export Rep: Joseph Plasencia - 401 Broadway, New York, N. Y.

Canadian Rep: Charles W. Pointon - 1926 Gerrard St. E., Toronto, Ontario

In Volume Controls, too ... fast, sure fit is important

In a survey of hundreds of servicemen, the importance of fast, sure installation was emphasized time after time in connection with volume controls. If you want a control that lets you do the job fast . . . and do it right . . .



Make Sure! Make it Mallory!

When you use the Mallory Midgetrol*, you get a combination of features that can't be matched.

First, you get a permanently fixed, tubular brass shaft that can be adapted for split-knurl or flatted type knobs in a few seconds by inserting one of the steel shaft ends supplied in every package. This means utmost convenience without sacrificing the stability of permanent, two-point shaft suspension.

Second, you get the convenience of AC switch design that permits secure attachment, *without*

removing the control housing. Positive indexing assures proper position.

Third, you get exceptionally accurate resistance values and taper curves.

Fourth, you can be sure of years of quiet, satisfactory service life through extremes of humidity and temperature.

Make it Mallory and make sure! Ask your distributor to show you the time-proved Mallory Midgetrol with the new features that make installation faster and simpler than ever.

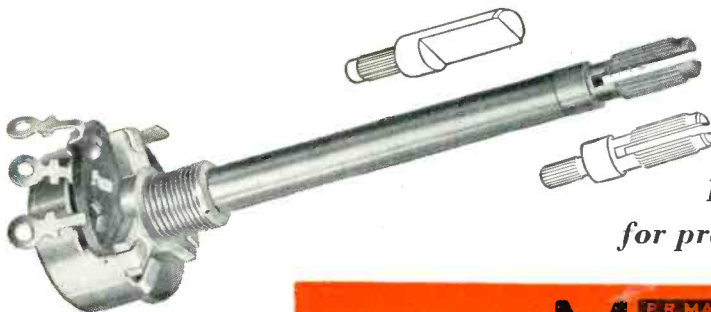

*Depend on your Mallory Distributor
for precision quality at competitive prices*

Single Section Control Illustrated

Dualconcentric Mallory Midgetrols can be made up easily by combining factory-assembled front and rear sections of desired resistance values. Ask your Mallory Distributor for details!

*Reg. U. S. Pat. Off.

P. R. MALLORY & CO., Inc.
MALLORY

CAPACITORS • CONTROLS • VIBRATORS • SWITCHES • RESISTORS •
RECTIFIERS • VIBRAPACK* POWER SUPPLIES • FILTERS

*Reg. U.S. Pat. Off.

APPROVED PRECISION PRODUCTS

P. R. MALLORY & CO., Inc., INDIANAPOLIS 6, INDIANA

There Are **36,292,000** Automobiles In The U.S.A.

18,100,000 of Them Have Radios...

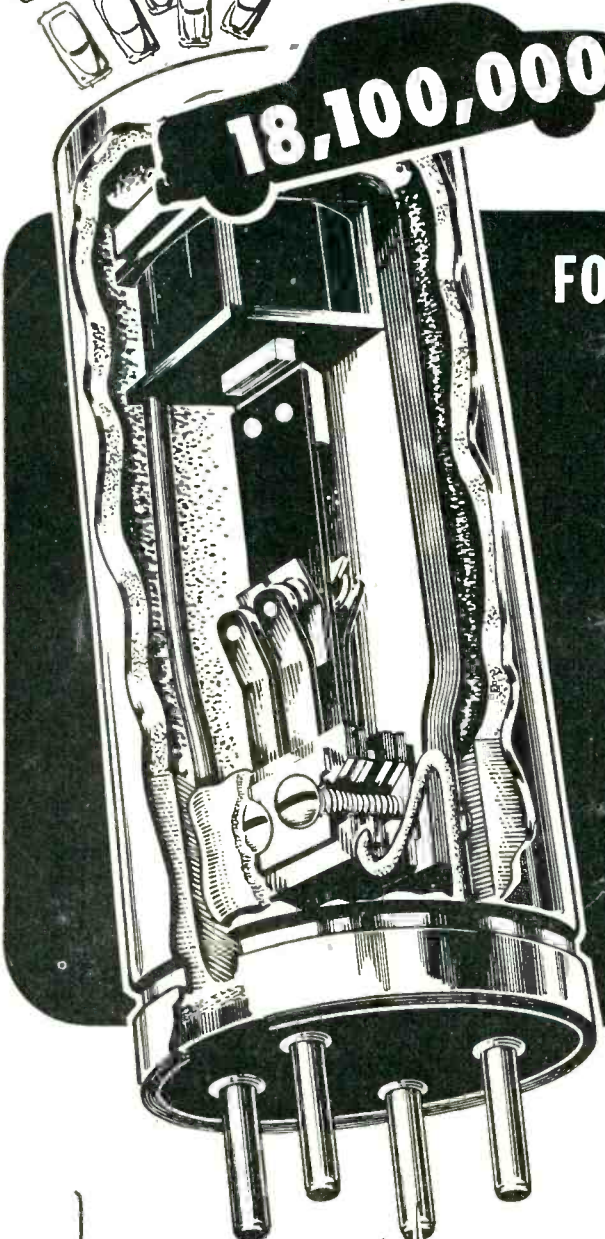

FOR *Each* OF THESE 18,100,000
 RADIOS THERE IS A
Correct
RADIART
REPLACEMENT
VIBRATOR

This Is Big Business For You...

These 18,100,000 automobile radios require vibrator replacement at one time or another. Good servicemen everywhere install and recommend RADIART VIBRATORS in EVERY CASE... because there is a correct Radiart replacement vibrator... to ORIGINAL SPECIFICATIONS... for most every need! No "guess work"... no "next best type"... Radiart gives your customers the best... assuring you they'll keep coming back... always satisfied. Jobbers everywhere carry all popular types in stock... or can get quickly any number wanted from the 86 precision engineered types manufactured.



AND... TWO-WAY MOBILE COMMUNICATIONS... REPRESENTS BIG VIBRATOR REPLACEMENT BUSINESS!... Continuous-duty service in taxicabs, police cars, etc. - frequently 'round-the-clock' - means 3 to 6 vibrators replaced per year... See your jobber for the latest issue of RADIART FORM F 781 for complete listings... or write direct to -



THE RADIART CORPORATION CLEVELAND 2, OHIO

VIBRATORS • AUTO AERIALS • TV ANTENNAS • ROTATORS • POWER SUPPLIES
 RADIO-TELEVISION SERVICE DEALER • DECEMBER, 1951

EDITORIAL

by S. R. COWAN

We're Hysterical!

TV Channel 13 (N.Y.) has a new commercial sponsor who offers for a buck a copy a book on TV servicing. The chap who spiels the commercial tells TV listeners that if they buy this book they'll never have to call in a professional TV serviceman or pay high service fees to have their sets repaired or adjusted because by simply following the instructions given by the book anyone at all can do any necessary TVset repair or adjusting job without a bit of difficulty. What a laugh! How ridiculous (or hungry for a commercial sponsor) can a TV station get?

As we see it, Channel 13, if it is responsible for the sale of many copies of the video repair book, will help the professional TV service business boom because in all likelihood anyone who buys a copy of the book will 'louse up' his TVset so badly he'll have to call in a Pro to undo the mess he'll get himself into. But seriously, TV servicing is so complex that even experienced experts run into difficulty on occasion and it's tough enough to have to repair a set that goes haywire of its own accord without having to unscramble a mess that some novice tinkerer caused.

Color TV Shelved For Now

Our last issue went to press on the day that Defense Mobilizer Charles E. Wilson issued the Directive ordering production of color TVsets stopped. So, this is the first chance we've had to reiterate what we've said so often, i.e., that color TV is a hurdle we won't have to face for some time. That is, color TV by means of the incompatible method. However, research and development work on color TV is not being stopped entirely, and there is every reason to believe that in time the FCC will again be asked to give its approval to color TV casting by a compatible method. When that day arrives *color will be here* to stay, and make no mistake about it! Meanwhile, we of the service profession would be wise to learn all we can about the subject, and so, from time to time, even though color TV is something for the future, you'll see articles on it in this magazine. The TV service profession has learned, just as medical men have learned, that from an educational point of view one must always strive to keep ahead of, and not merely abreast of the new developments, techniques, etc., that are being advanced in our art.



Sanford R. Cowan
EDITOR & PUBLISHER

Samuel L. Marshall
MANAGING EDITOR

COWAN PUBLISHING CORP.
67 WEST 44TH ST.
NEW YORK 18, N. Y.



VOL. 12, NO. 12

DECEMBER, 1951

Editorial	3
Trade Flashes	4
Sync Pulses, <i>by San D'Arcy</i>	12
Troubles in Television RC Networks, <i>by Matthew Mandl</i>	17
Servicing procedures used in tracing down RC network faults	
Looking for Trouble? No. 7, <i>by Cyrus Glickstein</i>	19
A service jaunt through an Admiral Model 21B1 receiver	
Soldering Wires to MIP Type Plugs	22
How to properly solder leads to MIP type plugs explained with the aid of illustrations.	
UHF Converters, <i>by Allan Lytel</i>	23
Construction and design of the Stromberg-Carlson UHF converter	
Men of Radio, Part 10, <i>by William R. Wellman</i>	25
Final installment on this popular series	
The Femme Touch, <i>by Elsie Kraft</i>	26
A humorous and revealing story of how the wife of a service technician learned how to "pay for her keep."	
Circuit Court	27
Admiral TV Tuner 94C37-1. Zenith Receiver Chassis 20J21	
Association News	28
Here's How & Why, <i>by Chet Jur</i>	29
An explanation of the Cosine Wound focus coil	
Trade Literature	30
Shop Notes	31
G.E. 800, 810 Series—repairing horizontal transformer. Cheater Cord. RCA-9X-561, 9X-562, (RC 1079B, RC 1079D)—hum reduction. Crosley 1951 Receivers—to reduce hum or buzz: preventing corona or arcing on glass portion behind metal bell of 16 or 19-inch metal picture tube.	
New Products	32
Circuits:	
Basic circuit used in differentiator networks	17
High pass filter used in sync lock circuit	17
RC filter network after horizontal oscillator	18
Basic integrator circuit	18
RC filter in vertical oscillator circuit	18
Composite signal consisting of video signal and sync pulses	19
Partial schematic of Admiral 21B1 showing sync section	20
Antenna switching on Stromberg-Carlson UHF converter	23
Block diagram of Stromberg-Carlson UHF tuner	24
Circuit diagram of Stromberg-Carlson UHF tuner	24
Partial schematic of Admiral TV tuner 94C37-1	27

SANFORD L. CAHN, Advertising Director HARRY N. REIZES, Advertising Manager
DAVID SALTMAN, Production Mgr. CHARLES LO CICERO, Circulation Mgr.
BRANCHES: H. A. METZGER, 230 S. Wells St., Chicago, Ill., Webster 9-2666
TED E. SCHELL, 112 West 9th St., Los Angeles 15, Calif., VAndike 8921
RADIO-TELEVISION SERVICE DEALER is published Monthly by Cowan Pub. Corp., 67 West 44th St., New York 18, N. Y. Subscription price: \$2 per year in the United States, U.S. Poss. & Canada: elsewhere \$3. Single Copies: 25c. Reentered as second class matter Sept. 25, 1950 at the Post Office at New York, N. Y. under the Act of Mar. 3, 1879. Copyright 1951 Cowan Pub. Corp.

PHOTOFACT Users Write Our Best ADS!

Hundreds of unsolicited letters tell what the world's finest Radio & TV Data means to Service Technicians



Norman H. Otto
726 Cherry Ave.
San Bruno, Calif.

"The extent of your PHOTOFACT service amazes me more and more at each publication. Your new P.F. Index is very handy."

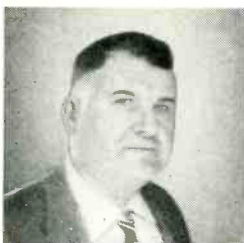

E. A. Randall
4710 Annette St.
New Orleans, La.

"I have all PHOTOFACT Folders and use them quite often. Your circuit diagrams help plenty and save a great deal of time. I have been in service work since 1934."



Harry Larrison
1723 Oakwood Ave.
Akron, Ohio

"In my opinion, PHOTOFACT is to radio and TV servicing what the five cent cup of coffee was to the American scene of yesterday—and this isn't idle praise, but cold facts, proved by the needs of everyday servicing."

NOW! GET THE PROOF FOR YOURSELF!

FREE

We'll Send You a FREE Photo-
fact Folder on any postwar re-
ceiver listed in the PF Index.

Learn for yourself—at our expense—how PHOTOFACT pays for itself by earning bigger repair profits for you! Ask for a FREE Folder covering any postwar AM, FM or TV receiver listed in the PHOTOFACT Cumulative Index. Examine it. Put it to work at your bench—then judge for yourself!

WRITE FOR FREE FOLDER TODAY!

HOWARD W. SAMS & CO., INC.
2201 East 46th Street • Indianapolis 5, Indiana

TRADE FLASHES

A "press-time" digest of production, distribution,
and merchandizing activities

September Tube and TV Pix Tube Sales Increased Over August

Sales of receiving tubes in September increased substantially over those of August, the Radio-Television Manufacturers Association reported. September sales totaled 27,946,193 compared with 23,761,253 tubes sold in the preceding month.

The September sales brought to 280,795,338 the number of receiving tubes sold in the first nine months of 1951.

A breakdown of the September tube sales report showed 16,176,604 tubes sold for new sets, 7,363,721, for replacement, 2,836,988 for export and 1,568,880 to government agencies.

Increased sales of television picture tubes to TV set manufacturers were also reported in September. It was also noted that tubes rectangular in form and 16 inches and larger in size made up 97 percent of the month's sales.

September sales to set manufacturers totaled 294,951 units valued at \$6,138,517, 98 percent of which were rectangular tubes. This compares with August sales of 210,043 units valued at \$4,327,234. Sales during the first nine months of 1951 amounted to 3,146,173 tubes valued at \$78,852,954.

Radio and TV Production Down

Radio and television set production dropped five and 21 percent, respectively, in the first nine months of 1951 compared with the corresponding period of 1950, the Radio-Television Manufacturers Association reported.

Production of radio receivers in the January-September period totaled 10,077,478 as against 10,638,800 in the same 1950 period. TV set output fell from 5,028,200 sets in the 1950 period to 3,970,857 in the first nine months of this year.

RTMA's estimates, which include production by members of the Association and non-members, showed a total of 5,133,033 home radios, 1,096,770 portables and 3,847,675 auto sets produced during the first nine months of 1951.

September production, covering a five-week period, was estimated at 337,341 TV sets and 1,100,246 radios.

This compares with 843,800 TV sets and 1,335,500 radios manufactured in the same 1950 month. Radios with FM facilities were estimated at 84,842. In addition, 15,803 TV sets containing FM audio circuits were produced.

Sylvania Television Award Winners Announced

The seventeen men and women comprising the Sylvania Awards Committee of Judges upset several award traditions at the Announcement Dinner Nov. 8 at the Hotel Pierre in New York.

They named two comedians Sid Caesar and Imogene Coca as the best actor and actress in television. They honored the talks of the Chicago Zoo Curator Martin Perkins as the program most suitable for children and they were unable to give their grand award to any program since they found none measuring up to their ideas of a truly outstanding entertainment.

Their lustiest cheers went to the hundreds of unsung camera crews and directors responsible for bringing to the screen such public events as the United Nations sessions, the Kefauver hearings, the MacArthur homecoming and the imaginative coverage of major sports events.

Du Mont Promotes Inputuner Sales

A campaign to bring to existing TV set owners the added entertainment value of fine FM musical programs, is announced by the Electronic Parts Department of Allen B. Du Mont Laboratories, Inc., East Paterson, N. J. Du Mont Inputuner conversions are being offered to several thousand TV set owners through their servicemen-dealers, with a trade-in allowance on their present tuners.

"For a limited period only," states Ed B. Hinck who heads up Du Mont TV component sales, "we are offering a trade-in allowance to and through our distributors on every TV tuner replaced by a Du Mont Inputuner. We hope to bring a brand new conception of home entertainment through service dealers before the general public, for with the Du Mont Inputuner in place of the usual set tuner, the owner can now have the equivalent of a fine

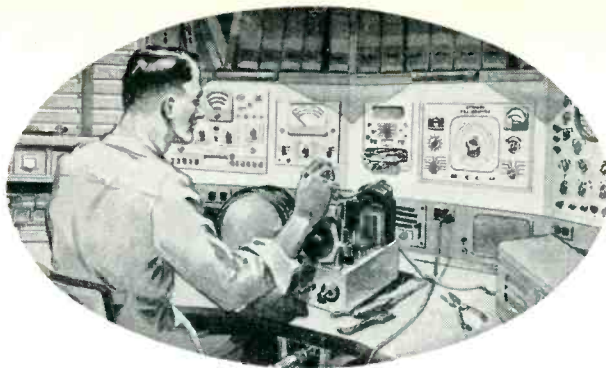

GIANT WINDOW-SIZE
REPRINTS OF THIS
MESSAGE

are yours for the asking.
Please send 10¢ to cover
handling and postage.



ARE SERVICEMEN GYPS?

Every so often, some national magazine sounds off about radio-television servicemen.

"Servicemen are a bunch of gyps," is the general theme. "They'll clip you if you don't watch out."

They might just as well write the same thing of doctors, lawyers, storekeepers, auto mechanics—or anyone else. There are gyps in every line. Actually, the percentage in radio is far lower than in most.

The average serviceman—and I have met thousands during 30 years in radio parts manufacture—is a hard-working, straight-shooting individual. Rather than gyp customers, he is far more likely to spend more time on a job than he knows he will be paid for—simply as a matter of personal pride in doing things right.

The other evening, a friend's TV set went bad. A serviceman called for it in his truck and returned it in good working condition within 48 hours. His bill came to \$10 for service plus \$2.68 for replacement parts.

My friend argued that this was too much—yet he would never dream of complaining to the medical specialist who charged him \$10 for a 15-minute office visit; the lawyer whose bill for writing a simple will was \$75; or the garage man who, as my friend laughingly admits, charges \$5 for "just raising the hood" of his car.

In a very large Eastern city the Better Business Bureau received fewer than 1,000 complaints about service in a year. Most of the complaints came from folks who expected first-class reception in doubtful fringe areas; who tried to operate their sets without suitable

antennas, or who had bought sets "wholesale" or at ridiculously low prices from cut-rate dealers who could offer little or no service.

Actually, it takes almost as long to become a good serviceman as it does to train for any other profession. Beyond this, it calls for regular study to keep up with the constant stream of new developments. Also, it requires a surprisingly big investment in test instruments, manuals and other shop equipment. The modern radio or TV receiver is by far the most intricate piece of equipment the average person ever owns or uses.

Servicemen are not fly-by-night businessmen. Ninety-nine out of 100 radio-television servicemen run their businesses properly. The other one per cent—the gyps—can usually be spotted a mile away. Nine times out of ten, they are the shops that feature "bargain" prices and ridiculously liberal service contracts. And their victims are generally set owners who expect to beat the game by "getting something for nothing."

Good television sets or good TV service are not things to be bought on a "bargain counter" basis. Set owners who recognize this aren't likely to get gyped.

Instead, they'll find that they get more real value for their television entertainment dollars than for almost any other dollars they spend!

Harry Nathan

PRESIDENT

SPRAGUE PRODUCTS COMPANY

North Adams, Mass.



PIONEERS IN DEPENDABLE CAPACITORS
AND RESISTORS FOR RADIO AND TELEVISION SERVICING



**THIS MAN IS YOUR
MOST VALUABLE
BUSINESS ASSET!**

A satisfied customer—the keystone of any successful business! You endanger customer good will when you use “just-as-good” replacement parts on your repair jobs. Use quality OHMITE components—known the world over for dependability among servicemen, amateurs, and design engineers—and you can be sure of customer satisfaction every time. It’s just good business!

OHMITE MANUFACTURING COMPANY

4846 Flournoy St., Chicago 44, Ill.

Be Right with **OHMITE®**

RHEOSTATS • RESISTORS • TAP SWITCHES



Write
FOR
STOCK
CATALOG

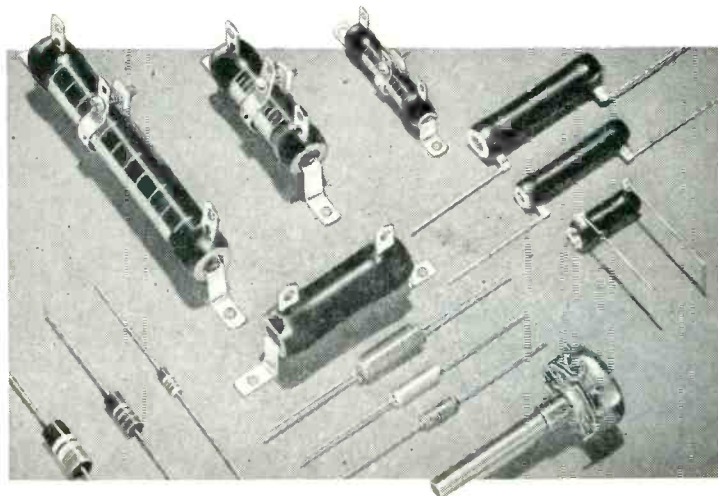

FM receiver in addition to an improved TV set, thus doubling the value of the TV investment.

VEE-D-X Announces Identification Letter Change

Windsor Locks, Conn., Nov. 1—In order to assure accuracy in ordering and to prevent errors in filling orders on the new VEE-D-X “Rocket” Booster, it has become necessary to change the Model No. from OS to RB, it was announced by Fred A. Hess, Sales Manager of the LaPointe Plascomold Corporation.

It would be appreciated if all those concerned would make note of this change and act accordingly (eg: to order a “Rocket” Booster for channel 6, order RB-6).

Jensen Name Now Identified With Viking Loudspeaker Line

Formerly a “Jensen” private brand line for low cost replacement purposes, Viking loudspeakers are now being identified by the phrase “Viking by Jensen” according to an announcement by Ralph P. Glover, Product Mgr. of Jensen.

The brand, already a leading replacement item, will be given extensive publicity in service dealer publications and in dealer literature. Presently included are 12 models from 3½” to 12” sizes, and with 4 x 6, 5 x 7, and 6 x 9 ovals, all PM. A bracket set is available which provides flexible facilities for chassis and transformer mounting. The line is attractively boxed in individual cartons and goes to the distributor in standard packages of 5 units.

Standard Coil Appoints New General Sales Manager

Louis Martin has been appointed to the newly created post of General Sales Manager of Standard Coil Products Co. Inc. of Chicago, Los Angeles and Bangor, Michigan according to an announcement by Robert E. Peterson, Vice President in charge of sales.

Mr. Martin comes to Standard Coil from General Instrument Corporation where he was General Sales Manager of the Elizabeth and Sickles Divisions. He will direct all sales operations for Standard Coil Products Co. Inc. from their main office, 2329 North Pulaski Road, Chicago 39, Ill.

Workshop Plans New Lab

A new antenna laboratory will be erected by the Workshop Associates, Division of The Gabriel Company, it was announced today by Gardiner G. Greene, Gabriel Vice-President in charge of Electronic Divisions. To be located in Natick, Massachusetts, the laboratory is scheduled for completion

[Continued on page 10]



for greater speed and
accuracy of TELEVISION INSTALLATIONS
in any locality use the new

Simpson

MODEL 488

TV FIELD STRENGTH METER

In addition to location of maximum signal areas, the Simpson Model 488 Television Field Strength Meter is also ideal for antennae orientation, comparison of antennae systems, adjustment of TV signal boosters and checking antennae and lead-in installations to list but a few of the many functions available . . . THE 50 MICROVOLT FULL SCALE RANGE IS AN OUTSTANDING FEATURE FOR THOSE CONCERNED WITH FRINGE AREA INSTALLATIONS WHERE MAXIMUM EFFICIENCY MUST BE ATTAINED . . . The 500, 5,000 and 50,000 microvolt ranges extend the usefulness of the Simpson Model 488 into areas of higher signal strength. The large 4½-inch modernistic meter is easily read from a considerable distance and all controls and connections are arranged for greatest accessibility. Model 488 is housed in a beautiful gray hammerloid finished case for greater portability. LINE VOLTAGE: 105-125 volts, 50-60 cycles. SIZE: 8" x 11" x 8½".

WEIGHT: 11½ lbs. Shipping weight 15 lbs.
DEALER'S NET PRICE, including operating instructions and shoulder strap . . . \$89.50

SIMPSON ELECTRIC COMPANY

5200 WEST KINZIE STREET, CHICAGO 44, ILLINOIS

Phone: COLUMBUS 1-1221

In Canada: Bach-Simpson, Ltd., London, Ontario

CONSERVE
CRITICAL
MATERIALS

HERE'S THE POWER RESISTOR THAT NEEDS NO DE-RATING

IRC PWW's Carry Full Wattage in **ANY** Range!

What is the function of this type of resistor?
To handle POWER!

Power rating of many power resistors is derated sharply—as much as 75%—in the higher resistance values—to prevent voltage breakdown between winding turns and resultant turnouts.

IRC PWW's need no derating because of resistance value! These rugged, full size power wire wounds carry full wattage rating—even in the highest stock resistance values—without failure. Ample core sizes produce larger heat-radiating surface areas and the special rough, dark coatings dissipate heat fast—so IRC PWW's operate at lower temperatures. Low temperature processing preserves fine wires and prevents turns of windings from shifting—reduces likelihood of hot spots and voltage breakdowns.

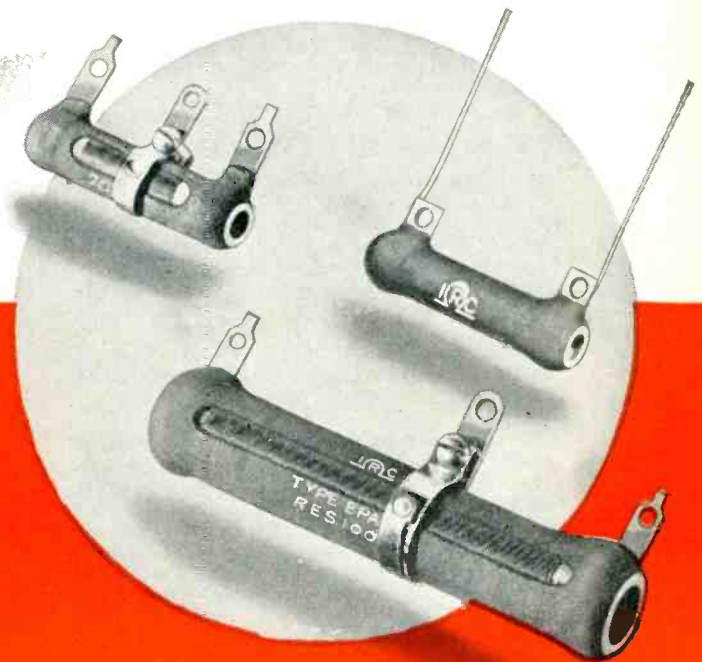

THERE JUST ISN'T A BETTER POWER WIRE WOUND FOR CONTINUOUS OPERATION AT FULL RATED POWER FOR LONG, DEPENDABLE, TROUBLE-FREE PERFORMANCE . . .

You can get fixed and adjustable IRC PWW's in a full range of power ratings, resistance values, sizes and terminal types . . . adaptable to any rig or use. In adjustable types, contact is made by a metal band which can be positioned anywhere along the resistor. By using additional bands, various taps can be obtained—permitting the resistor to be used as a voltage divider. Tolerances: Fixed types—standard tolerance $\pm 5\%$ for 50 ohms and over, $\pm 10\%$ below 50 ohms. Adjustable types—standard tolerance $\pm 10\%$.

For exacting, heavy-duty applications—high-voltage bleeders, bias supply, grid and filament-dropping resistors—leading technicians and industrial users have specified IRC PWW's for more than 15 years.

COMPARE IRC PWW's WITH ANY OTHER POWER RESISTOR

Feature by feature, IRC PWW's *prove* their superiority over ordinary resistors. PWW's give balanced performance in every characteristic. Here's why...

Rugged Steatite Winding Forms. Carefully selected steatite tubes have superior mechanical strength, withstand sudden variations in temperature, are impervious to moisture.

Adjustable Bands. IRC Adjustable PWW's are fitted with adjustable bands specially designed to maintain constant pressure. Bands feature a stainless steel spring with a silver contact button, which is oxidation free and cannot corrode to cause open circuits or high resistance at point of contact.

Uniform, High-grade Alloy Windings. Unusually rigid specifications govern resistance value, diameter, elongation, and weights. Resistor elements are wound with uniform spacing and tension, and wire is secured to terminal electrically and mechanically.

Special Heat-dissipating Cement Coatings. IRC's exclusive dark, rough coatings are used for 3 specific reasons: (1) They can be processed at lower temperature, which does not harm the wire windings or cause them to shift. (2) The rough surface provides a larger area for faster heat radiation. (3) The porous cement coatings do not trap moisture which might cause windings to corrode.

Full Size for Cooler Operation. Ample size is essential to fast heat dissipation. Because IRC PWW's are full-size units, they operate at much lower temperatures. This cooler operation assures long life for the resistor, and also safeguards critical components mounted nearby.

UNIQUE LUG-AND-LEAD DESIGN GIVES FLEXIBILITY IN MOUNTING

An exclusive feature of IRC 10- and 20-watt Power Wire Wound Resistors is the combination lug-and-lead terminal for flexibility in mounting. In tight space applications, lugs may be cut off without disturbing lead, and in other installations the leads may be removed. Leads are a full 1 $\frac{3}{4}$ " and all terminals are hot tin dipped for easy soldering.

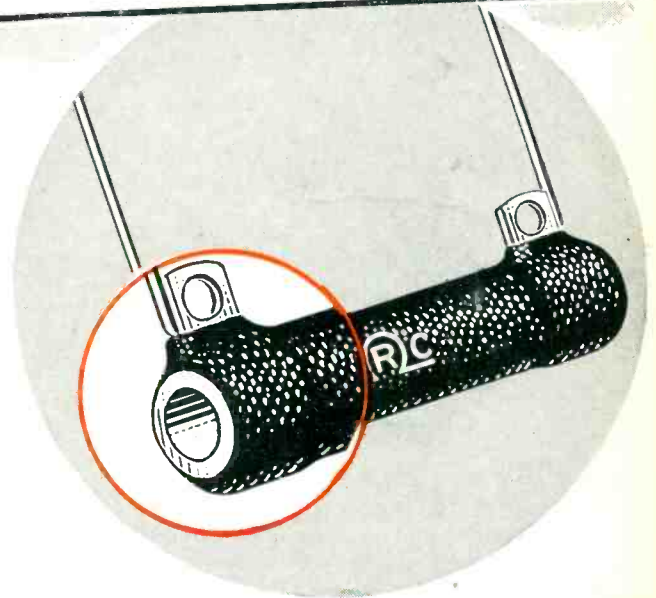

**INTERNATIONAL
RESISTANCE COMPANY**

401 N. Broad Street, Philadelphia 8, Pa.

Wherever the Circuit Says ~~~~

In Canada: International Resistance Co., Ltd., Toronto, Licensee

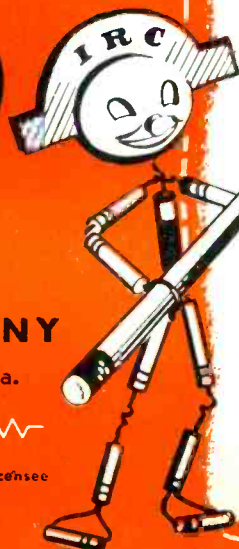

SEND TODAY

**INTERNATIONAL
RESISTANCE
COMPANY**

413 N. Broad St., Phila. 8, Pa.

Please send me full information on IRC Fixed and Adjustable Wire Wound Resistors,

NAME.....

COMPANY.....

ADDRESS.....

J. F. ARNDT & CO., ADV. AGENCY

RCA LIGHTNING ARRESTERS

Listed by Underwriters Laboratories, Inc.



TYPE 215XI

For Outdoor Installation

\$125 Suggested List Price

TYPE 214XI

For Indoor Installation

\$110 Suggested List Price



Now — amazing new conductive rubber elements insure lasting protection

THAT'S RIGHT . . . the resistance elements in the new, improved RCA Lightning Arresters are made of *rubber* . . . a remarkable, new *conductive rubber* that is *non-corrosive and impervious to moisture* . . . to provide *lasting protection* to TV and FM installations. Now you can install an RCA Lightning Arrester *and forget it*.

What's more—the unique construction of RCA Lightning Arresters makes them the *easiest* to install. No stripping, cutting or splicing of transmission line

necessary. Just mount, unscrew cap, insert transmission line in slot, replace. Easy as that!

Type 214XI, for indoor installation. Comes complete with ground strap to fit any 1/2" to 2" pipe. **Type 215XI**, for outdoor installation, can be installed on wood, brick, stone, or cement surfaces. Both types accommodate standard 300-ohm twin-lead without upsetting the electrical characteristics or continuity of line.

ATTRACT NEW BUSINESS with the RCA Lightning Arrester Flasher Display—Put this arresting 12" x 15" two-color sign in window—or on counter with kit of 10 RCA Lightning Arresters—and make sales quick as lightning. Comes complete with cord and socket. See your RCA Parts Distributor today for full details.

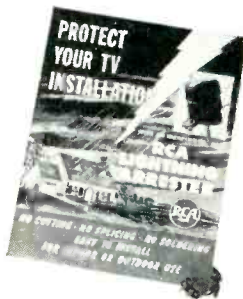

RADIO CORPORATION of AMERICA
ELECTRONIC COMPONENTS HARRISON, N. J.

→ Continued from page 6

in mid-1952.

The laboratory site consists of a 46 acre tract approximately twenty miles from Boston. The building will be two stories with a modern glass brick front. The roof will be specially designed for outdoor antenna work. Electrical engineering, mechanical engineering, model shop, and a drafting department will all be located in the laboratory, together with all engineering offices for the Workshop Associates.

Boston Distributor Wins RCA'S VoltOhmyst Contest

Max Cramer (left), of Hatry and Young, Inc., Boston, receives an RCA WV97A Senior VoltOhmyst meter, first prize in a product-information contest staged by the RCA Tube Department during the recent NEDA Show in Cleveland. A witness to the



presentation is Jim Owens, Manager of RCA's Test Equipment Group. Second Prize, an RCA WV77A Junior VoltOhmyst meter, was won by Samuel Abelson, of the Radio Equipment Corp., Buffalo. The contest involved a drawing among contestants who established eligibility by answering correctly basic questions concerning RCA Test Equipment.

Sylvania Appoints C. J. Luten

C. J. Luten has been appointed editor of SYLVANIA NEWS, commencing with the November, 1951 issue, according to an announcement by Terry P. Cunningham, Director of Advertising of Sylvania Electric Products Inc. Mr. Luten succeeds Robert A. Penfield as editor-in-chief of the NEWS. Mr. Penfield, who edited the 21-year-old Sylvania service dealer magazine since 1947, has been promoted to the position of Advertising and Sales Promotion Supervisor.

Erie Resistor Develops New Package

Erie Resistor Corporation of Erie, Pennsylvania has developed an ingenious "Breakaway" package consisting of two drawer trays and a sleeve.

[Continued on page 40]

WHEN YOU NEED A FUSE —THINK OF BUSS...

Fuse Headquarters for the Electronic Industries

**TELEVISION • RADIO • COMMUNICATIONS
CONTROLS • AVIONICS • INSTRUMENTS**

A complete line of fuses is available. Made in Dual-Element (Slow blowing), Renewable and One-Time types. Sizes from 1/500 ampere up.

And a companion line of BUSS Fuse Clips, Fuse Blocks and Fuse Holders.

Behind each fuse or fuse mounting are 37 years of know-how in building products of unquestioned high quality, the world's largest fuse research laboratory and the world's largest fuse production capacity.

Each BUSS Fuse Electronically Tested.

To assure proper operation in the field, each and every BUSS fuse is tested in a highly sensitive electronic device that rejects any fuse that is not correctly calibrated — properly constructed and right in physical dimensions.

**BUSS Fuses are made to Protect —
not to Blow.**

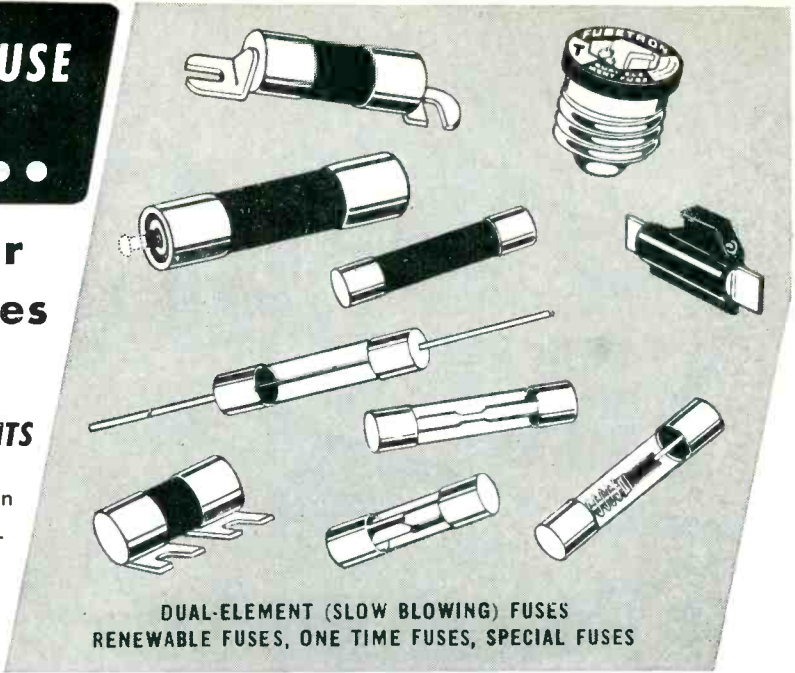

DUAL-ELEMENT (SLOW BLOWING) FUSES
RENEWABLE FUSES, ONE TIME FUSES, SPECIAL FUSES

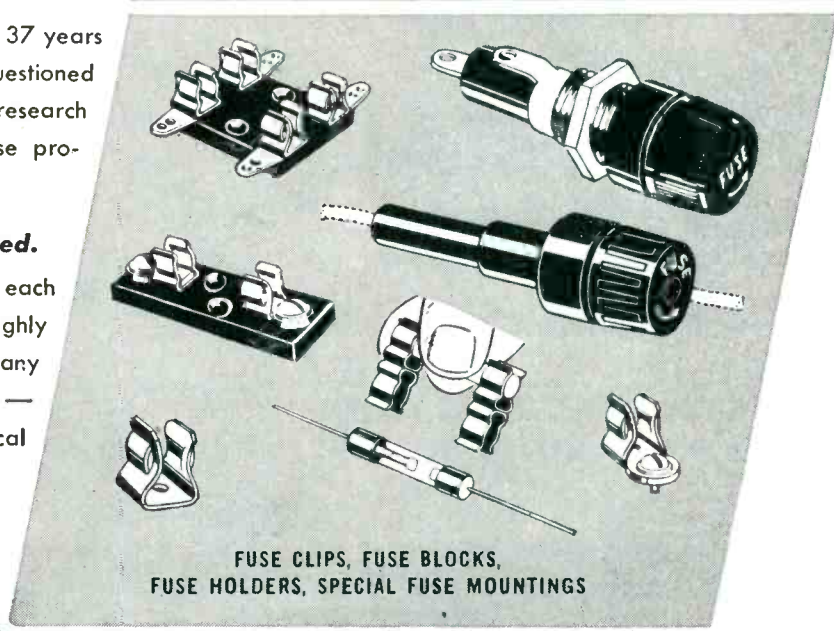

FUSE CLIPS, FUSE BLOCKS,
FUSE HOLDERS, SPECIAL FUSE MOUNTINGS

**The BUSS Trademark
can help in SALES
or SERVICE**

The name BUSS is recognized as standing for fuses of unquestioned high quality. Millions and millions of BUSS fuses in daily use in Homes, Buildings, Automobiles, T-V, and other Electronic devices and in Industry have built for BUSS a reputation for quality and an acceptance enjoyed by no other fuse manufacturer.

That is why BUSS Fuses protect your profits and goodwill as surely as they protect the user.

USE THIS COUPON — Get All the Facts

BUSSMANN MFG. CO., St. Louis, Mo.
Division of McGraw Electric Company
MANUFACTURERS OF A COMPLETE LINE OF FUSES
FOR HOME, FARM, COMMERCIAL AND INDUSTRIAL USE.

BUSSMANN MFG. CO., University at Jefferson St. Louis 7, Mo. (Division McGraw Electric Co.) SD-1051

Please send me Bulletin SFB containing complete facts on BUSS Small Dimension Fuses and Fuse Holders.

Name _____

Title _____

Company _____

Address _____

City _____ State _____

Snyder
PHILADELPHIA

YEARS AHEAD

Directronic

MOTORLESS
TV AERIAL SYSTEMS

360° ELECTRONICALLY SWITCHED BEAM

GIVES SAME CLEAR PIX AS MOTOR
DRIVEN AERIALS AT $\frac{1}{3}$ THE COST

SIMPLE FLICK OF SWITCH
CLEARS PICTURE **INSTANTLY**
NO WAITING

OPENS BIGGEST
REPLACEMENT MARKET
IN **TV** HISTORY

MAIL THIS COUPON TO-DAY!

SNYDER MFG. CO. C
22nd & Ontario Sts., Phila. 40, Pa.

Please send me free copy of authoritative
booklet **TENNA TIPS** on Directronic and
all other types of aerials, plus catalogs.

NAME _____
ADDRESS _____
CITY _____ ZONE _____ STATE _____

NO MOTORS OR
MOVING PARTS

NO ROOF
ORIENTATION

NO ELECTRIC
POWER

NO GHOSTS

SYNC PULSES

by San D'ARCY

License bills covering servicemen and dealers are the present-day hot topic in many key cities. However, unless a license law is drafted properly, and with the participation of the service fraternity itself, it cannot benefit the public, and it most certainly will be detrimental to the service field. Too much legislation, especially the wrong kind, is worse than no legislation at all.

Of all the proposed license bills we have read so far only that one in process of promulgation for New York City warrants consideration and support by the service fraternity. The others have faults and weaknesses that make them impractical.

Labor unions and receiver manufacturers' distributors are now the chief objectors to the N. Y. C. bill as now worded, and both of these groups are opposed purely for captious and selfish reasons. RTMA cannot sway unions, but it should interfere with the distributors. In thousands of cases where dealers or servicemen have been accused of malpractice the basic cause of complaint points right to the distributor level where, because of present-day business methods, the distributor did not make an immediate exchange of a defective tube or part covered by the manufacturer's warranty. RTMA can correct this quite easily.

Standards are needed by the phonopickup cartridge and needle manufacturers—or chaos will result at the service and jobber levels. Here again RTMA has the power to correct a fast expanding evil. Right now there are about 120 different types and styles of phono needles. Some of the designs are real wacky—the brain children of idealistic but impractical engineers.

How can jobbers or servicemen carry replacement stocks of several hundred different types of cartridges and needles? They can't! As a matter of fact, the industry's best authorities agree that RTMA should appoint a committee to review the situation and restrict the set manufacturers to a nominal number of cartridge styles and needle designs. Were such a committee set up, it would, within a year or two, be able to restrict the "playboy engineers" to a choice of 20 or 25 styles and cartridge types at most. Then needles and cartridges would cost less, the available ones would be better, the

[Continued on page 38]

1921 ~~~~~ 1951

Large-sized Clarostat compression-type adjustable resistor of the early 'twenties

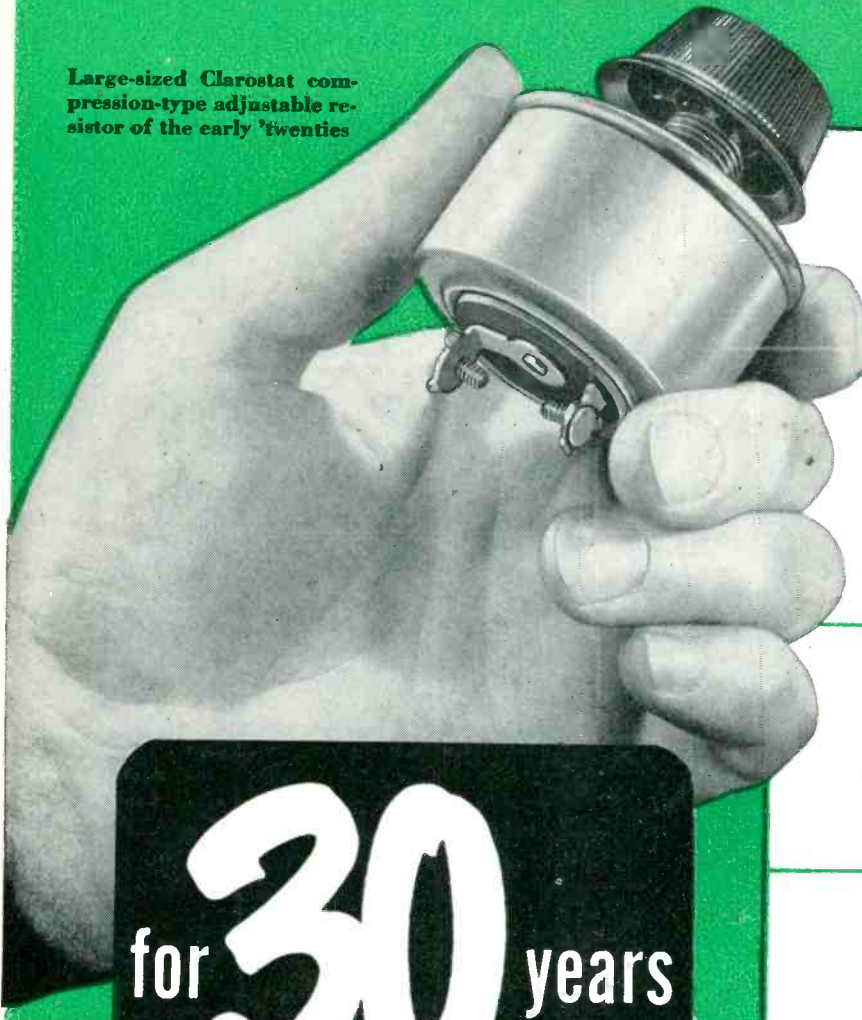

for **30** years

"the house of Resistors!"

It was in the early 'twenties. Socket-power radios needed voltage control to be practical. And Clarostat came up with the RIGHT answer—the original Clarostat compression-type adjustable resistor. Since then, over three decades, Clarostat has come up time and again with the RIGHT resistor, control and resistance device. That's specialization—and it's yours when you ask your Clarostat distributor for Clarostat resistors, controls and resistance devices. •Latest catalog on request. •Be sure you use Clarostat's servicing data—TV Replacement Control Manual, etc.—available from your distributor.



Controls and Resistors

CLAROSTAT MFG. CO., INC. • DOVER, NEW HAMPSHIRE
IN CANADA: CANADIAN MARCONI CO. LTD., MONTREAL, P. Q., AND BRANCHES

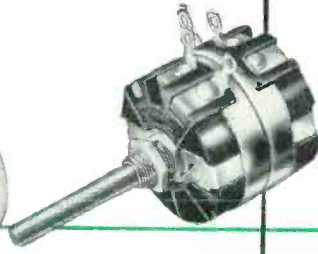

Wire-wound potentiometers and rheostats.

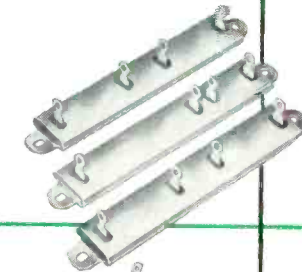

Metal-clad wire-wound molded resistors.

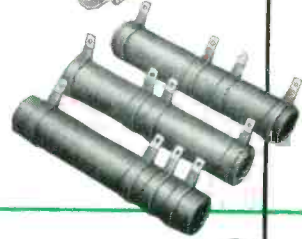

Greenohms — inorganic-cement-coated power resistors.



Voltage-dropping and voltage-regulating ballasts.

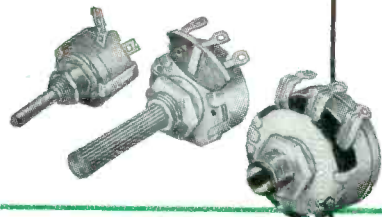

Choice of controls — no bigger than a dime! — 1/8" — 1 1/8" dia.

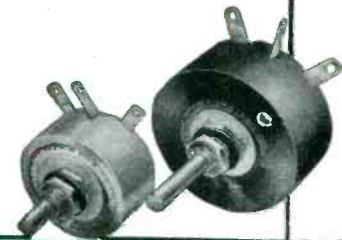

25- and 50-watt power rheostats for roughest going.

Introducing...

THE MAGIC OF MODEL M

"The Magic of Model M" . . . a new trend for TV antennas! And Walsco introduces the first antenna with chromate-coated Magnesium cross-arms. Structural strength is almost equal to steel, and yet is 1/3 lighter than aluminum. Once you install, that's all! No costly call-backs that eliminate your profit. Chromate-coating assures positive corrosion resistance. Elements are made of high-conductivity, super-strength aluminum alloy, reinforced with Swiss "Permalum." Guaranteed sturdier, more dependable under severest weather conditions. Equipped with famous Walsco "signal director" and unbreakable insulator. Same high standards of Walsco crystal-clear TV reception.

* NEW
WALSCO
TV ANTENNA Model M

Once you install... that's all!

WALTER L. SCHOTT CO., 3225 Exposition Place, Los Angeles 18, Calif.

Branch: Chicago 6, Ill.

M*

M

Structural strength
almost equal to steel

M

One-third
lighter than aluminum

M

Chromate-coating for
positive corrosion resistance.

AVAILABLE AT PARTS JOBBERS EVERYWHERE

Model 4090 M—Single Bay — List \$ 9.25

Model 4092 M—Dual Array — List \$19.85

Model 4094 M—4 Bay Stack — List \$44.50

All prices without mast.

Walsco quality earned its reputation

WALSCO

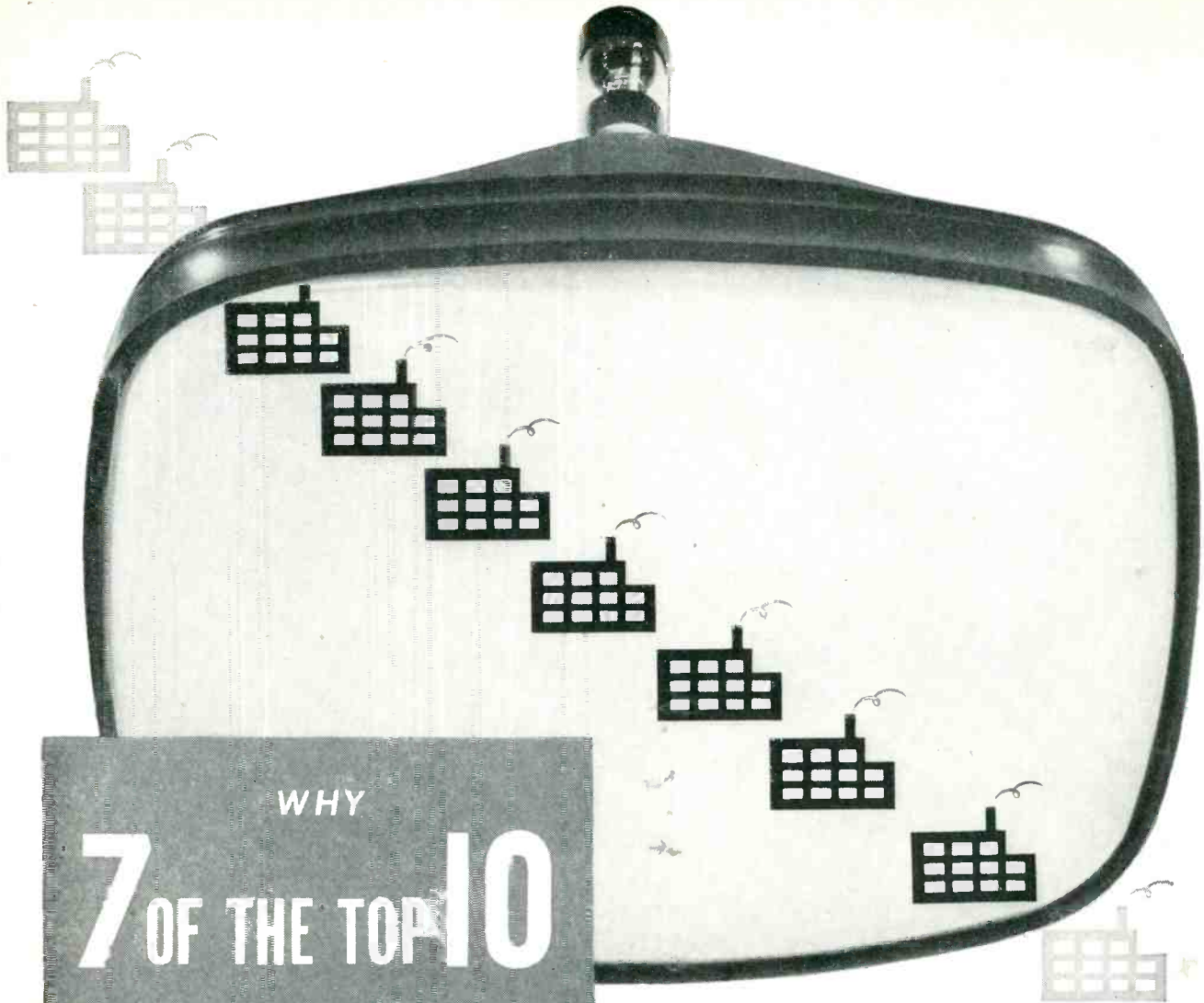

WHY
7 OF THE TOP 10
 TELEVISION SET
 MANUFACTURERS USE
SYLVANIA
 PICTURE TUBES

The important reasons behind the steadily increasing demand for Sylvania TV Picture Tubes are: (1) high quality performance, (2) broad national recognition.

Sylvania's picture tube experience includes leadership in 4 specialized fields . . . all basic to TV picture tube production. These are *radio, electronics, lighting, and phosphors.*

A Sylvania tube engineer, for example, invented the famous Ion Trap now generally adopted, under special Sylvania license, by other leading picture tube makers.

Sylvania's 25 years of lighting research, including advances in phosphors and filamentary wire techniques and coatings, has also contributed to the outstanding clarity and long life of Sylvania picture tubes.

Popular TV show tells millions

Set owners are being kept informed of Sylvania's leadership by the big, popular television show, "*Beat the Clock*," on CBS-TV. Every week this program emphasizes Sylvania's unique background and the fine quality of all Sylvania products, thus assuring you of an enthusiastic acceptance of Sylvania Tubes used as replacements in the sets you service.

To help you choose the right Sylvania Tube for each service job see your Sylvania Distributor now for your free SYLVANIA TV TUBE SELECTOR, a handy wallet folder which explains the differences between more than 100 types of picture tubes. Sylvania Electric Products Inc., Dept. R-2312, Emporium, Pa.



SYLVANIA



RADIO TUBES; TELEVISION PICTURE TUBES; ELECTRONIC PRODUCTS; ELECTRONIC TEST EQUIPMENT; FLUORESCENT TUBES, FIXTURES, SIGN TUBING, WIRING DEVICES; LIGHT BULBS; PHOTOLAMPS; TELEVISION SETS



*How come you
sell so many
picture
tubes,
Sam?*

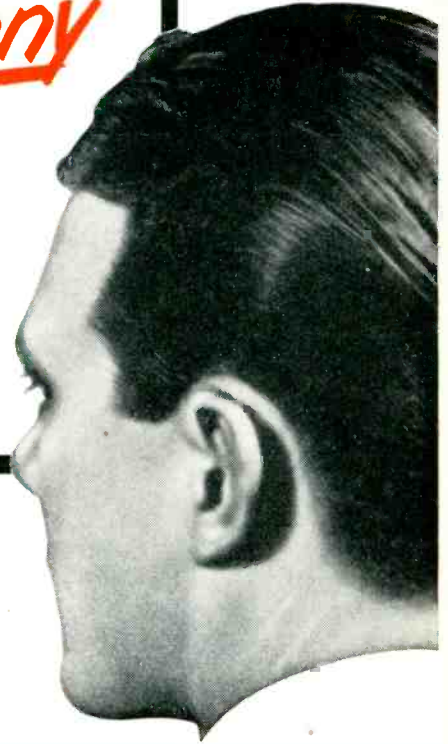

"I'm using the CBS-Hytron Easy Budget Plan, Joe. My CBS-Hytron distributor gave it to me."

"Tell me more."



"Well, CBS-Hytron's Plan helps me sell TV picture tubes and service to many a customer who just doesn't have \$50 cash. My customer now pays for the job painlessly a few dollars a month. Yet I get my cash right away."

"Fine! How does it work, Sam?"



"Simple. I introduce my customer to the finance company authorized by CBS-Hytron. The finance company does the rest . . . acts as my credit department . . . arranges all details. My customer gets his tube and I get my cash — at once."



"That's swell, Sam! I've sure been losing sales I shouldn't. I need that CBS-Hytron Easy Budget Plan. CBS-Hytron tubes are tops, too. Thanks for the tip. I'll see my CBS-Hytron distributor today."

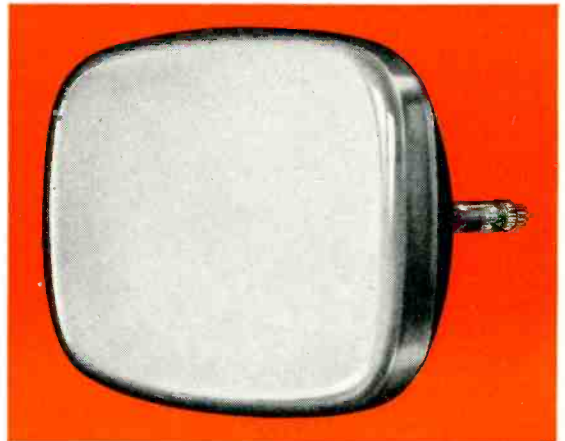

SAVE THE SALE No need for *you* to miss a single profitable picture-tube sale . . . just because your customer does not have the cash. Get the details on this original CBS-Hytron service for you. See *your* CBS-Hytron jobber . . . or mail this coupon . . . today!



MAIN OFFICE: SALEM, MASSACHUSETTS

HYTRON RADIO & ELECTRONICS CO.
SALEM, MASSACHUSETTS

Please rush me details on the CBS-Hytron Easy Budget Plan.

NAME.....
(Please print)

STREET.....

CITY.....STATE.....

Troubles In Television

RC NETWORKS

by MATTHEW MANDL

(Co-Author: Television and FM Antenna Guide)

Presenting a basic discussion of R-C filter networks used in many applications in radio and T-V receivers. Servicing procedures to be followed for tracking down faults in these networks are outlined. Circuits discussed are: differentiator, integrator, a-g-c, ratio detector, and de-coupler networks of various types.

IN television receivers there are a number of instances where innocent looking resistor-capacitor combinations form very important filter networks. When these become defective their influence on circuit behavior is far different than one might expect when by-pass capacitors or voltage dropping resistors go bad. For this reason they present special problems to the servicing technician. Thus, familiarization with their function and recognition of the symptoms they produce, when they develop troubles, will save considerable time because isolation of the offending R-C combination will be facilitated.

Horizontal High-Pass Filter

The horizontal sweep systems in television receivers are a common source of troubles because most of them contain a sync lock circuit, as well as the "kick-back" high voltage forming stage.

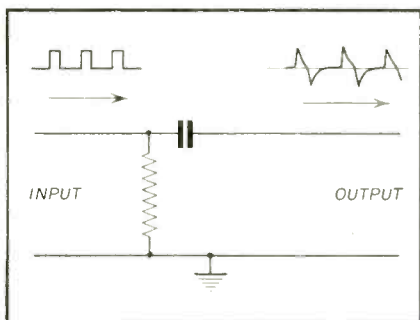

Fig. 1. Basic circuit used in differentiator networks.

The inclusion of such circuits in a crucial sweep system multiplies the possibilities of circuit or parts failure as well as slippage out of adjustment in terms of linearity, lock, and sweep width. One of the important cogs in all horizontal sweep systems is the "high-pass" filter network shown in Fig. 1. This capacitor-resistor combination is also referred to as a "differentiator" and its purpose is to pass the high frequency components of the horizontal sync and keep all lower frequencies (including 60 cps sweep), out of the horizontal sweep circuit. Besides this, it derives from the horizontal signal a straight leading edge for precise timing of horizontal sweep as shown in the illustration.

This R-C combination resembles the conventional coupling capacitor-grid leak circuit except that the time constant is considerably shorter. Ordinarily the capacitance value of the capacitor is made large so that the low frequency components will not be diminished unduly because of the high reactance in series with such signals. Lower frequencies in audio amplifiers are diminished because of the increasing reactance for decreasing frequency. With a high-pass filter of the differentiator type, however, the capacitor is made smaller to provide a deliberate increase in series reactance for the lower frequencies.

Thus, only the high frequency components of the pulse pass through the circuit. Because of this, the circuit pro-

vides a high reactance for any 60 cps pulses and cuts them down proportionately. Such a circuit is shown in a typical sync lock in Fig. 2 (Capehart CX-33 Chassis).

This differentiator circuit provides a steep edge for good sync stability and tends to reduce lower frequency noise pulses which might disturb the lock system. If a sine-wave producing oscillator is employed in the sync lock circuit, another differentiator type of R-C network is also used as shown in Fig. 3.

This is typical for all the "Sync-lock" circuits using the Hartley oscillator. Here, low plus "B" is applied

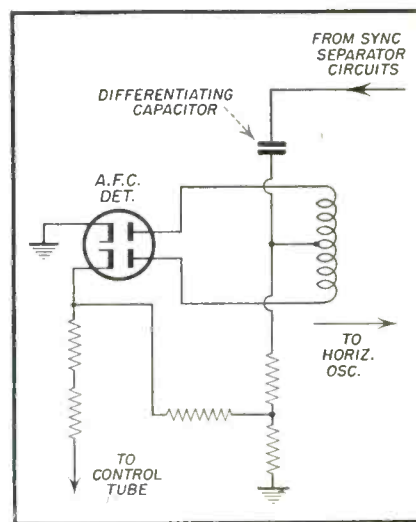

Fig. 2. High pass filter used in sync lock circuit.

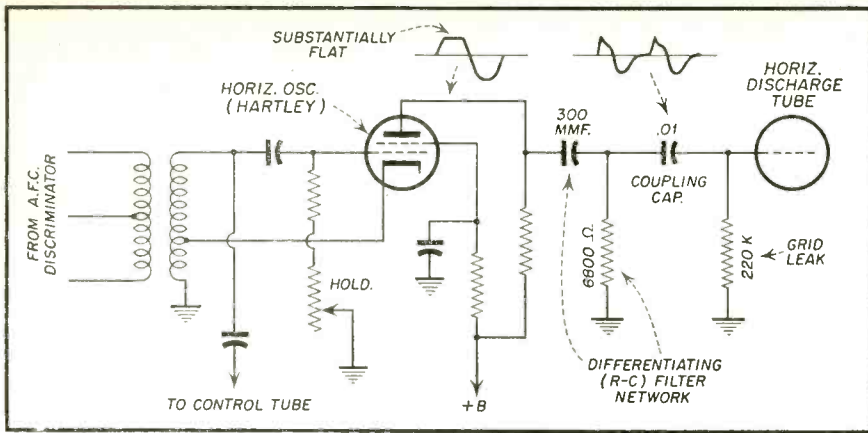

Fig. 3. R-C filter network after horizontal oscillator.

to the oscillator plate so the tube saturates and clips the top of the sine-wave output to level it off. The differentiator circuit derives a straight edge so that a properly timed and shaped signal can be applied to the discharge tube which forms the sweep sawtooth. Again, defects in this circuit could upset timing, sweep stability, and proper amplitude of sawtooth (effecting width) as well as linearity. Both resistor and capacitor can be checked with the ohm scale of a VTVM.

For the resistor, replace any which is off value by more than 10%. In the case of the capacitor, use the $R \times 1$ megohm scale and replace any capacitor which indicates a leakage resistance of less than 500 megohms. Disconnect both the resistor and capacitor when checking. When the $R \times 1$ meg scale of the VTVM is used, make sure that hand resistance is not influencing the reading. Keep fingers away from test probe metal ends to avoid false readings.

Vertical low-pass filters

In the vertical sweep system another

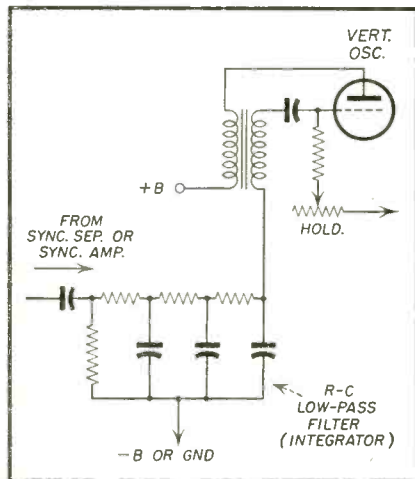

Fig. 5. R-C filter in vertical oscillator circuit.

filter network is used, though in this instance more elaborate in circuit structure. This is a "low-pass" filter and the basic R-C combination is shown in Fig. 4. This is also called an "integrator" circuit. This filters out the higher frequency components of the 60 cycle sync pulses and at-

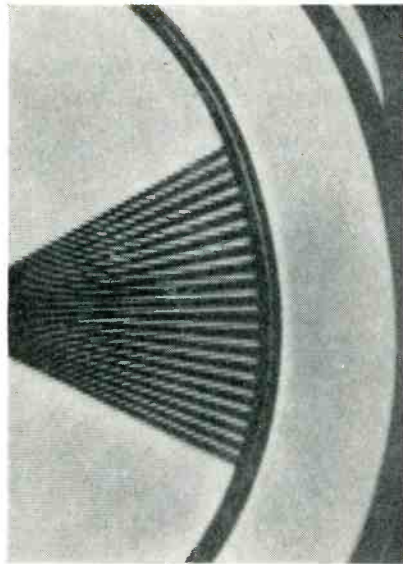

Fig. 7. Loss of interlace that occurs as a result of faulty filters. Notice lacy appearance of horizontal wedges, often referred to as a "moire" effect.

tenuates all higher frequencies, including 15,750 horizontal sweep and high frequency noise pulses. When the vertical blocks of the composite video signal come along, the charge across the capacitor will increase and fire the vertical oscillator (blocking oscillator type or multi-vibrator). A typical circuit such as used in television vertical systems is shown in Fig. 5, and consists of a combination of resistors and capacitors for more adequate filtering.

This circuit is important because the charge from equalizing pulses must not build up while the vertical

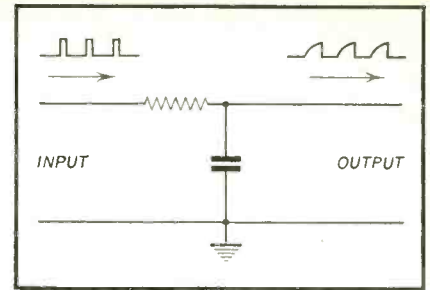

Fig. 4. Basic integrator circuit.

blocks do increase the edge as shown in Fig. 6.

This building-up of the firing levels for the vertical oscillator must be very exact in timing. Component failures or changes of values in any of the parts will not only effect sync stability but will effect "interlace" as shown in Fig. 7. As shown in this illustration, loss of interlace will cause the horizontal wedge of a station pattern to assume a "lacy" appearance. This is also referred to as "moire" effect. Servicing procedure for the integrator network follows that outlined for the other R-C circuits. The ohm scale of the VTVM is useful for checking both resistor values and the leakage of capacitors. Capacitors can, of course, be checked in a capacitor checker if one is available, though as a rule it is not the capacity which causes a resistor to become defective, but rather the leakage resistance which occurs.

AGC R-C Filter

Another resistor-capacitor combination is incorporated in the a-g-c feed line to the r-f and i-f stages as shown in Fig. 8.

The purpose of these resistors and capacitors is to by-pass the signal components from the negative a-g-c voltage so that only pure d.c. will be applied as bias. The number of such resistors and capacitors depends on

[Continued on page 46]

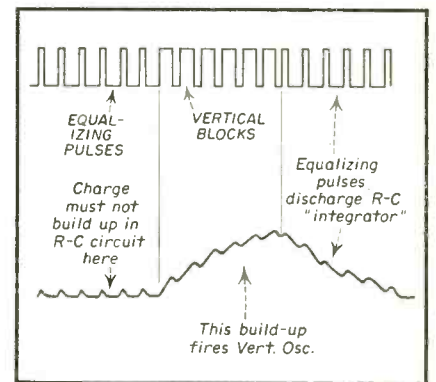

Fig. 6. How pulses build up firing level of vertical oscillator.

LOOKING FOR *Trouble?*

No. 7

by **Cyrus Glickstein**

(Instructor, American Radio Institute)

TO play this game, just assume the defective TV receiver is on the bench for servicing. You can join in the step-by-step hunt for the trouble by answering the questions. Answer each question before going on to the next. There may be more than one correct answer to a question. If so, indicate all correct answers. Answers and discussion follow.

Type of Set: Admiral, Model 21B1. Transformer low voltage supply, fly-back high voltage supply, intercarrier sound.

Trouble: Pix keeps tearing horizontally. It tears for an instant, goes back to normal, tears again, and so on. The picture holds still vertically. Sound, contrast, and brightness seem normal.

1. As usual, the first step in looking for trouble is to try to locate the defective section. First, appropriate controls are checked—horizontal hold, vertical hold, contrast, channel selector and fine tuning. On all the active channels, the fine tuning is adjusted for the best combination of picture and sound. The contrast is rotated through its range. However, the picture continues to tear horizontally while holding still vertically. Adjusting the horizontal hold control cannot prevent the tearing. When the vertical hold control is rotated a little to one side, the pix slowly rolls downward. When the vertical hold is rotated a little in the reverse direction, the pix rolls slowly upward. On the basis of these checks, the trouble most likely is located in:

- a) Horizontal AFC circuit (Sync discriminator)
- b) Sync section (Sync separator, sync amplifier, Sync inverter)
- c) Integrating circuit (input to

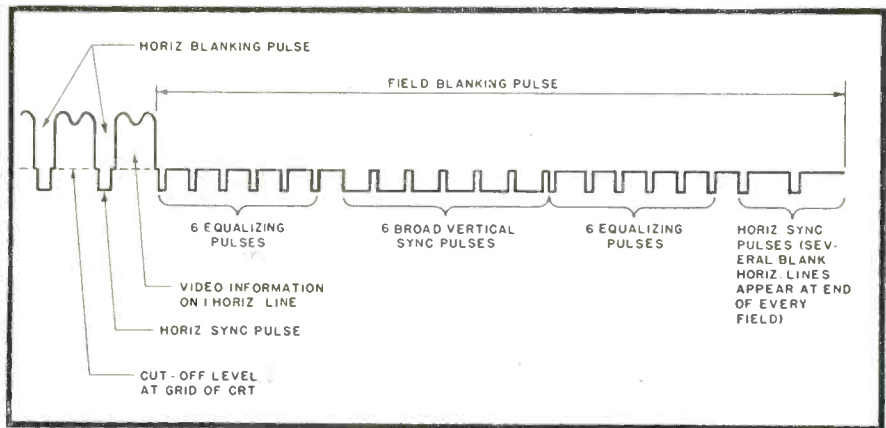

Fig. 1. Composite signal, consisting of video information, horizontal and vertical sync pulses, and blanking pulses. Composite signal appears at plate of last video amplifier, and is fed to control grid of CRT. (Polarity of signal is reversed when it is fed to cathode of CRT.)

vertical osc.)

d) Video strip (video i.f., video det., video amp.)

e) Low voltage supply

2. Trouble is indicated either in the sync section or in the video strip. In all TV receivers, the complete signal, including video information, blanking pulses and sync pulses, appears at the plate of the last video amplifier stage (Fig. 1). The complete signal is fed to the picture tube grid (or cathode, depending on the design). In most sets, part of the signal is taken off from the plate circuit of the last video amplifier and fed to the sync section. There, the sync pulses are separated from the video information, amplified and passed along to the vertical oscillator and horizontal AFC (automatic frequency control) circuits for synchronizing action.

Since the sync pulses in the receiver being checked are apparently not coming into either the vertical or

horizontal sweep circuits, it is possible they have been lost in either the sync section or the video strip. The simplest way to determine if good sync pulses are present at the end of the video strip, just before the composite signal is fed to the sync section, is:

- a) Use VTVM in video strip
- b) Use scope on video and sync circuits to check for correct wave-forms.
- c) Check the sync pulses by examining the picture on the screen of the pix tube
- d) Use a signal generator and measure the gain of the stages in the video strip
- e) Check the negative voltage on the grid of the video detector

3. The controls of the receiver are adjusted so that the vertical blanking, equalizing and sync pulses are visible on the screen. This is done by turning the brightness up, contrast down somewhat, and adjusting the vertical

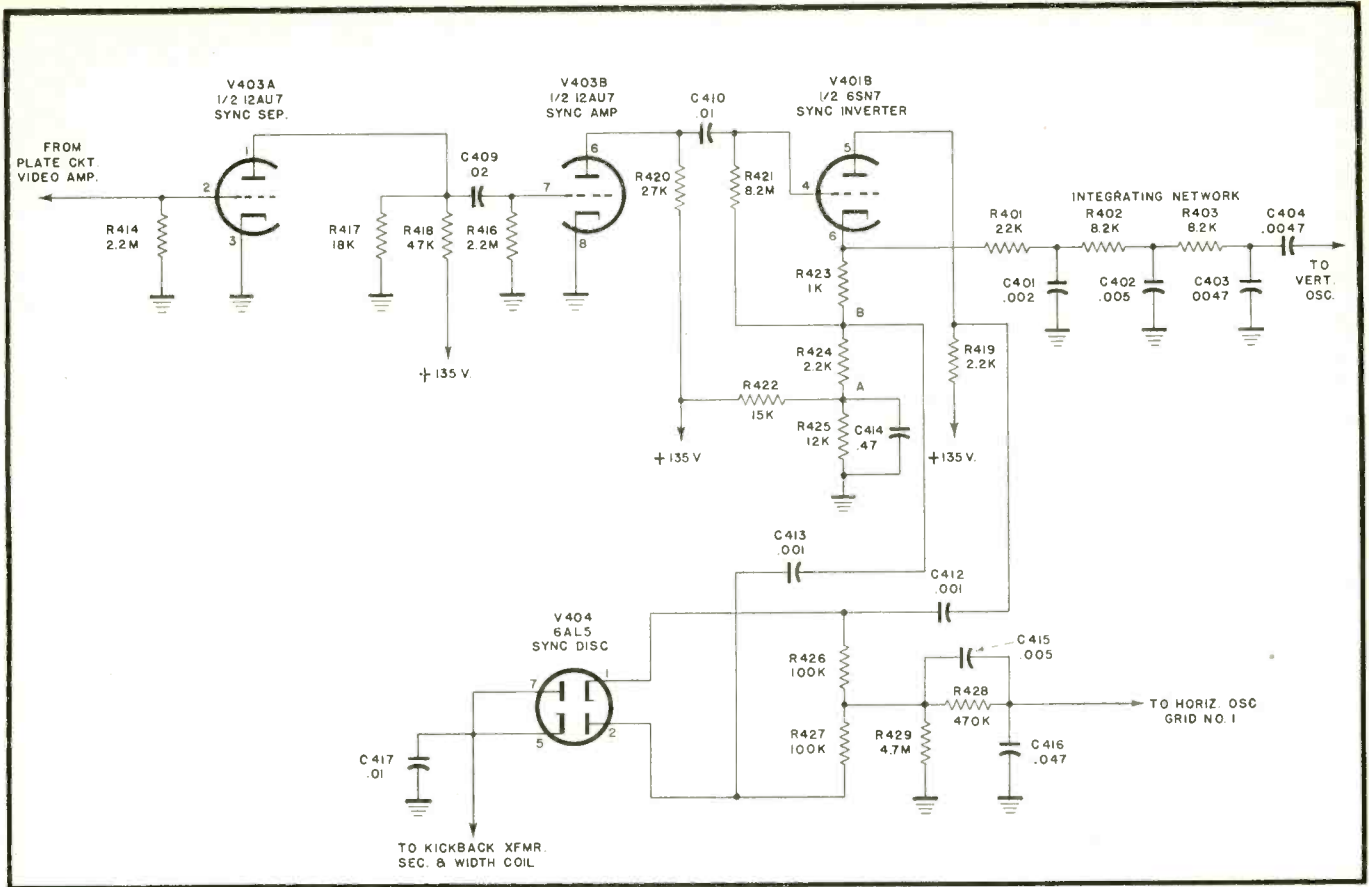

Fig. 3. Partial schematic of Admiral 21B1, showing sync section.

hold control so that the picture rolls downward slightly. The blanking period between fields then becomes visible (Fig. 2) and the vertical sync and equalizing pulses, if present, become visible. When this is done to the receiver under test, the blanking pulses are blacker than any black portion of the picture and the sync pulses are the blackest part of the screen. This indicates that sync pulses of the correct amplitude are present at the control grid (or cathode) of the CRT, just before the signal is fed to the sync section. The trouble therefore appears to be in the sync section, Fig. 3. The following tubes are changed—12AU7, V403. Sync sep. and sync amp.; 6SN7, V401B. Sync inverter; 6AL5, V404. Sync discriminator. No improvement.

A scope is used as the quickest means to localize the trouble to a defective stage in the sync section. The following patterns are seen at the indicated check-points, Fig. 4. On the basis of the observed wave-forms, the following circuit is defective:

- a) Sync separator stage, 1/2 (12AU7), V403A
- b) Sync amplifier stage, 1/2 (12AU7), V403B
- c) Sync phase inverter, 1/2

- d) Integrating circuit
- e) Horizontal sync. discriminator, 6AL5, V404.

4. The scope check indicates trouble in the sync phase inverter stage, 1/2 (6SN7), V401B. The following voltage checks are made:

The following resistance readings were obtained:

Rk (to ground)	56 K
Rg " " "	8 Meg.

Point A	"	10 K
Point B	"	55 K
Rp (plate to +135 v. point)		2 K

On the basis of the above voltage and resistance readings, the trouble is:

- a) C410 shorted (coupling condenser to grid, pin 4, of sync phase inverter, V401B, 1/2 (6SN7))
- b) C413 leaky (coupling condenser from point B of cathode of sync phase inv. to hor. sync disc., V404, 6AL5)
- c) C403 shorted (in integrating circuit)
- d) R423 open (1 K resistor in cathode circuit)
- e) R424 changed value (2.2 K resistor in cathode circuit)

ANSWERS & DISCUSSION

1. b and d

Under normal conditions, when the vertical hold control is rotated to one side, the picture should start to travel down slowly on the screen. This occurs when the vertical sweep frequency is made too high. Therefore the incoming field does not finish at the same instant as the receiver's vertical sweep. Since the vertical sweep is faster than the incoming field, it finishes sooner. Some of the

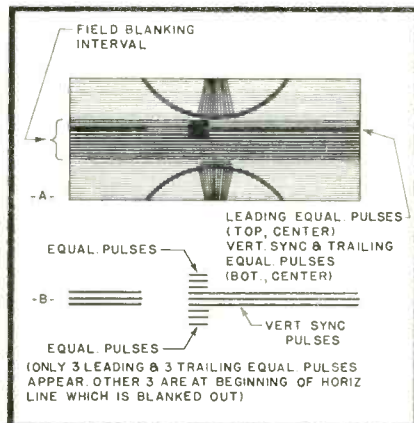

Fig. 2. Controls adjusted to inspect field blanking pulses, vertical sync pulses, and equalizing pulses on the screen of the picture tube.

first field is left over for the second vertical sweep cycle. Part of the second incoming field is left for the third sweep, and so on. There is more and more field left on each succeeding sweep, giving the impression of a picture moving down the screen, Fig. 5. Again, under normal operation, when the vertical hold is rotated in the opposite direction, nothing happens for a certain angle of rotation. Then the picture suddenly goes out of sync. The pix does not appear to move upward slowly. The upward motion, if any, is very rapid. There seems to be a number of pictures, one superimposed on the other and each displaced vertically from the other. The explanation for this action is rather simple. Normally, the vertical sweep frequency in the receiver is set slightly lower than the field frequency by correctly adjusting the vertical hold control. As a result, the incoming vertical sync pulses trigger the vertical oscillator just before the oscillator completes its natural cycle. In this way, the sync pulses control the frequency of operation, as they are supposed to do. Just as soon as the vertical hold control is set so the sweep frequency is slightly higher than the incoming vertical pulses, the picture goes out of sync and appears to move down the screen as described above. The sync pulses under such conditions have no effect in controlling the frequency. On the other hand, when operation is normal and the vertical hold is rotated so that the sweep frequency is reduced somewhat, the picture still remains in sync. The sync pulses still trigger the sweep before the oscillator would normally finish its cycle on its own. However,

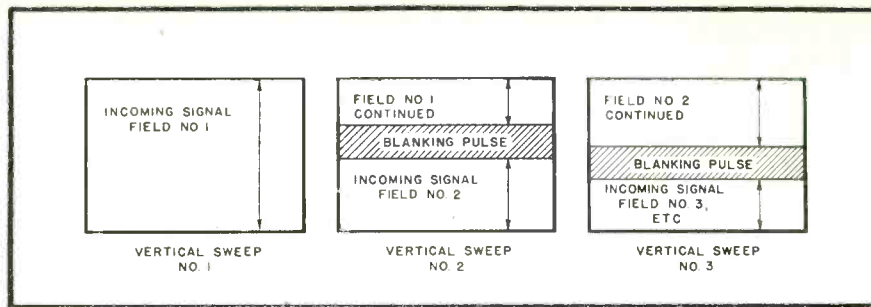

Fig. 5. Vertical sweep frequency higher than incoming field frequency. More and more field is left for the next vertical sweep, making picture appear to move downward. Blanking appears a little further down on each succeeding sweep.

if the vertical hold is rotated still further so that the sweep frequency becomes very low, the picture goes out of sync suddenly. The negative voltage on the grid of the vertical oscillator becomes too large to be overcome by the incoming sync pulses.

In other words, under normal conditions, the vertical hold control can be turned in one direction and the pix starts to move downward slowly, just as soon as the vertical oscillator frequency is made slightly higher than 60 cycles. However, when the vertical hold is turned in the opposite direction, there will be an angle of rotation when nothing happens and the pix remains in vertical sync. Then as the vertical hold is rotated still further in that direction the pix suddenly goes out of sync. This happens only after the vertical oscillator frequency is made considerably lower than 60 cycles.

In some receivers the vertical oscillator is unusually stable and can remain fairly well in sync by itself, even when no sync pulses are fed to

the oscillator. Therefore, the mere fact that the picture is not moving vertically does not necessarily mean the vertical oscillator is receiving sync pulses. Where there is horizontal sync trouble the vertical oscillator should also be checked to help diagnose the trouble. This can be done simply by rotating the vertical hold control. If the vertical hold setting is very critical—a slight movement in one direction making the picture drift downward on the screen and a slight rotation in the other direction making the pix move up the screen slowly, then it can be assumed that no (or too small) vertical sync pulses are coming in to trigger the vertical oscillator.

On the basis of the action of the controls, then, in the receiver under test, it appears that both the horizontal and vertical sync pulses have been lost. Now, it is possible that two separate troubles—one in the integrating circuit and one in the horizontal sync discriminator circuit—have caused the loss of these pulses. However, it is not customary to assume the presence of two separate troubles in radio and TV servicing, unless all of the more usual possibilities have been eliminated. The common procedure is to look for one defect which accounts for the observed trouble. Most likely, the loss of the vertical and horizontal sync pulses has occurred either in the sync section or the video strip. Even though the picture information seems more or less normal, it is possible to lose the sync pulses in the video strip if a stage is driven to saturation or cutoff, so cutting down on the amplitude of the sync pulses. An incorrect video i-f response curve or poor video amplifier frequency response can also cause low amplitude or distorted sync pulses. A defect in the low voltage supply would show up in other operations of the

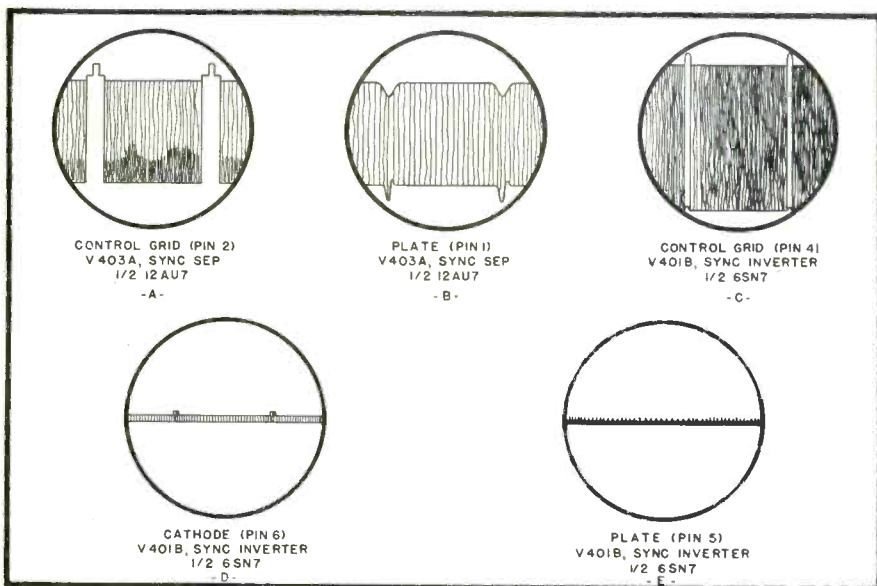

Fig. 4. Waveforms observed on oscilloscope.

[Continued on page 44]

SOLDERING WIRES

to MIP type plugs

These operations, of interest to all technicians, which appeared on page 137 of the *Amphenol Engineering News*, is being reprinted in these columns as a service to our readers through the courtesy of the American Phenolic Corporation.

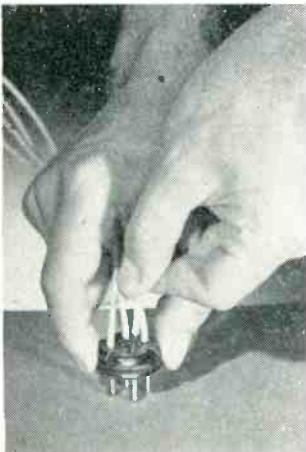

Fig. 1. Plug is faced mating face down.

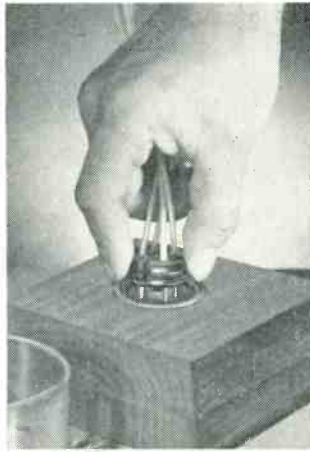

Fig. 2. Felt pad is used to hold flux.



Fig. 3. Prongs and leads are immersed in pot.

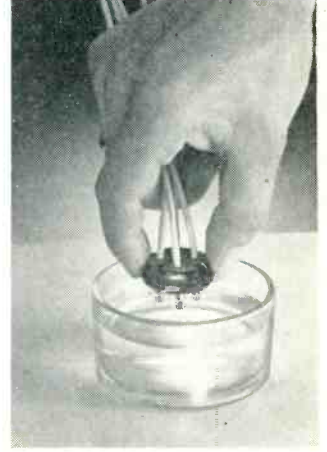

Fig. 4. Soldered prongs are dipped into alcohol.

USERS of molded-in-pin plugs often meet difficulty in soldering leads into these plugs. The use of proper technique will overcome these problems.

All leads should be stripped $\frac{5}{8}$ " when the PM8 is used and $\frac{3}{4}$ " on other PM plugs. The long stripping dimensions are necessary because there must be space left to permit the escape of air from the prong during the soldering. The bare wire must be pre-tinned before insertion into the plugs.

1. If the plug is placed mating face down and the wires then inserted and

held as shown, they will be in proper position for the next operation.

2. Although any type of dish may be used for flux, it is advisable to use a felt pad in the dish to hold the flux and prevent excessive deposits during the fluxing operation. The dish shown has a center well to accommodate a pilot stud which is present on some of the PM type plugs. Note that the wires are still held in the same position as in step one. Touch the prongs of the plug to the saturated felt pad so that only the ends of the prongs are fluxed.

Since the prongs of these plugs are "blind end prongs" prior to molding they do not have plating on the internal surfaces. It is necessary to use a flux other than rosin and alcohol to get the proper cleaning action for soldering. Saf-T flux in liquid form can be procured from the Saf-T Flux Company, Post Office Box 94, Collegeville, Pennsylvania. It is non-corrosive and has an excellent cleaning action.

3. After fluxing, the prongs and leads are immersed in a solder pot. The pot should be set to operate at a temperature of 550° F. and should contain 50/50 or 60/40 solder. Note again that the wires are still held in the same position as in the first two

operations. Do not dip the prongs deeper than $\frac{1}{8}$ " into the molten solder.

4. Hold the prongs in the solder a few seconds and then quickly dip into a dish of alcohol. The alcohol dip will provide a cleansing action and remove the residue of flux from the prongs.

5. The cap is then slipped over the wires and pushed over the plug so that the dimple in the cap is in alignment with the keynote in the plug.

6. Cock the cap so that the flange is resting on the shoulder of the socket, then set the socket on the work table as shown and snap the cap in place with the heel of the hand.



Fig. 5. Cap is slipped over wires and pushed over plug.

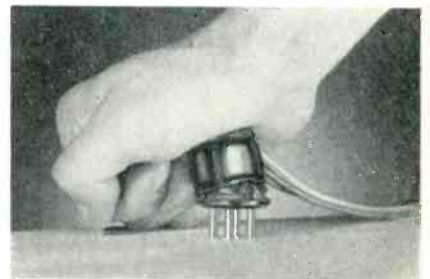

Fig. 6. Cap is snapped over plug with the heel of the hand.

UHF CONVERTERS

by ALLAN LYTEL

(Author of forthcoming book, "UHF Fundamentals")

MANY v-h-f TV manufacturers have tackled the problem of u-h-f TV with a view to conversion of the present sets for the new band. Among the many commercial organizations seeking information concerning operation and characteristics of the u-h-f band has been the experimental transmission by RCA and NBC in the Bridgeport, Connecticut area. This station operates from 529 to 535 megacycles and has been used to demonstrate operation of television in this new band.

The exact placement of the u-h-f band does not appear to be settled at this writing; the lower limit will be either 470 or 500 megacycles. (The final utilization of the band from 470 and 500 megacycles has still to be decided upon by the FCC.) The upper limit will be 890 megacycles; thus the new channels will be from 14 to either 78 or 83.

One of the complete commercial u-h-f converters is the Stromberg-Carlson model shown in Fig. 1. This unit is 8 x 4 x 6 inches and is covered in green leatherette. As shown there are two controls and this model is designed to feed a signal at the frequency of either Channel 5 or 6 to the v-h-f tuner input. The near control is used for tuning the u-h-f band and the rear control is the selector switch. Operation of the selector switch may be seen from Fig. 2. Power for the v-h-f TV receiver is obtained from an outlet on the converter chassis. The converter itself has a line cord as the power input source.



Fig. 1. Stromberg-Carlson VHF tuner.

In this article, which is one of a series on UHF converters, the author discusses the construction and design of the Stromberg-Carlson unit. With the imminence of UHF transmission it would be wise for the serviceman to read and save these articles for handy service reference.

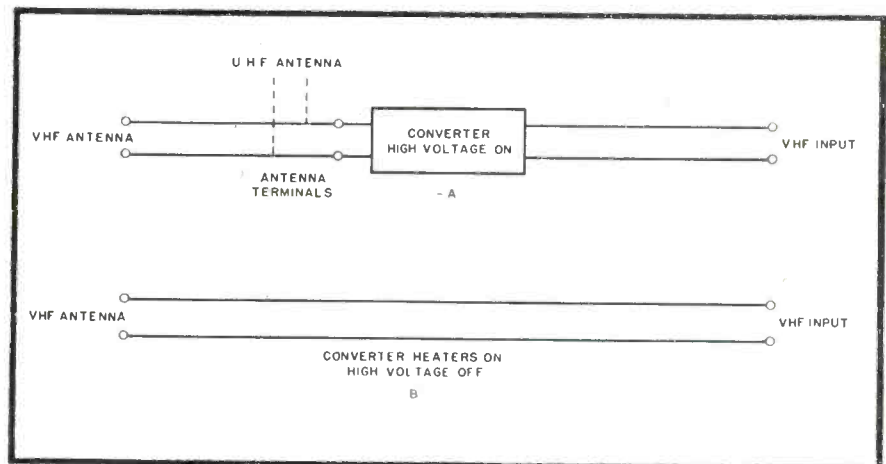

Fig. 2. How antenna connects to both converter and receiver in various switch positions. In position A antenna connects to converter. In position B antenna connects to receiver. In position C power on both units is off.

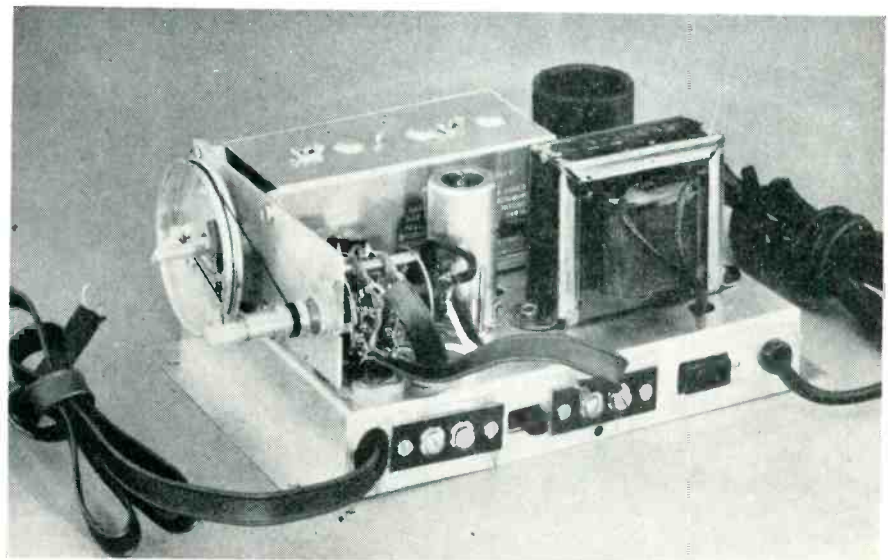

Fig. 3. Open view of converter chassis.

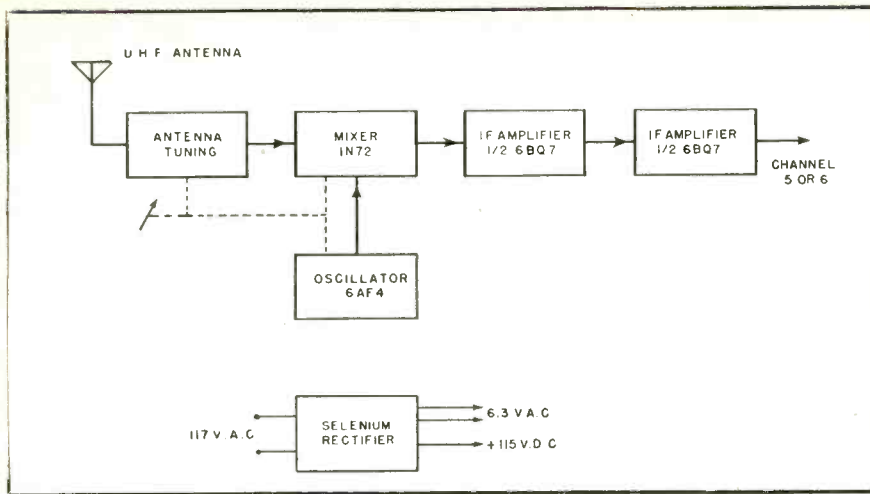

Fig. 4. Block diagram of Stromberg-Carlson UHF tuner. Note use of selenium rectifier.

In position *A*, *Fig. 2*, which is the u-h-f position on the selector switch, the converter output (either Channel 5 or 6), is applied directly to the v-h-f receiver which is tuned to the proper channel. There are three possible antennas which may be used for the u-h-f signal source in the position. First, and probably best, an external antenna cut for the u-h-f band may be used; Second, the built-in antenna for u-h-f may be used; or last, the same antenna used for v-h-f may also be the input for the u-h-f stations. Also, in this position of course heater and plate voltage is applied in both the converter and the receiver.

In position *B*, the v-h-f position, the normal v-h-f antenna is connected through the converter to the receiver. High voltage to the converter is off but the heater supply is still connected to reduce the warm-up time or instability due to warm-up drift.

In position *C*, both units are turned off. From this it may be seen that this converter, and others like it, need only two steps to be placed in operation. The v-h-f antenna is connected to the converter chassis (and a separate u-h-f antenna may also be connected to the converter if needed) and the receiver line cord is plugged into the converter chassis after which the converter line cord is plugged into an outlet.

Figure 3 is a view of the chassis with the cabinet removed. From left to right along the front apron are the following: leads to the v-h-f receiver tuner input (this is the converter output), the input for the v-h-f antenna, the selector switch for either Channel 5 or 6, terminal strip for a separate u-h-f antenna (where needed), the power source socket for the receiver line cord, and last, the line cord for the converter itself. On the opposite side of the chassis is the Mallory-Ware 3 section tuning unit.

Figure 4 is the block diagram and the schematic is in *Fig. 5*. A 3 section tuning unit is used with crystal mixer and a 6AF4 oscillator. The 6AF4 is an Acorn tube and the 6AF4 is a miniature version of this tube designed for u-h-f oscillator service. A 6BQ7 is used as a two stage i-f amplifier connected in cascade.

The tuning elements are inductively padded which is an aid in securing the proper tuning range. An amplifier tube is not used in the r-f stage, the output from this stage of tuning is applied to the tuned mixer stage with its 1N72 crystal mixer. High voltage for the oscillator is applied in shunt with the tuned circuit through *R-1* and *R-2* in series. The *C-6* capacitor is a feed-through type which is also used in the hot water supply. Self grid bias is obtained through the grid resistor *R-3*; a normal bias is -5 volts.

Mixer output at either Channel 5 or 6 is fed into grid at pin 7 of the i-f amplifier. The plate amplified output is coupled to the cathode of the other tube section. Since its grid is at ground potential, this second section of the tube acts as a grounded grid amplifier. Cathode ground return is through *L-11* and *L-10*. Switch *M-3* shifts the i-f tuning 6 megacycles; and since the tuning unit has a bandwidth of 12 megacycles there is no loss of tracking with this switch in i-f frequency.

Oscillator design is a serious problem in this frequency range. A special
[Continued on page 40]

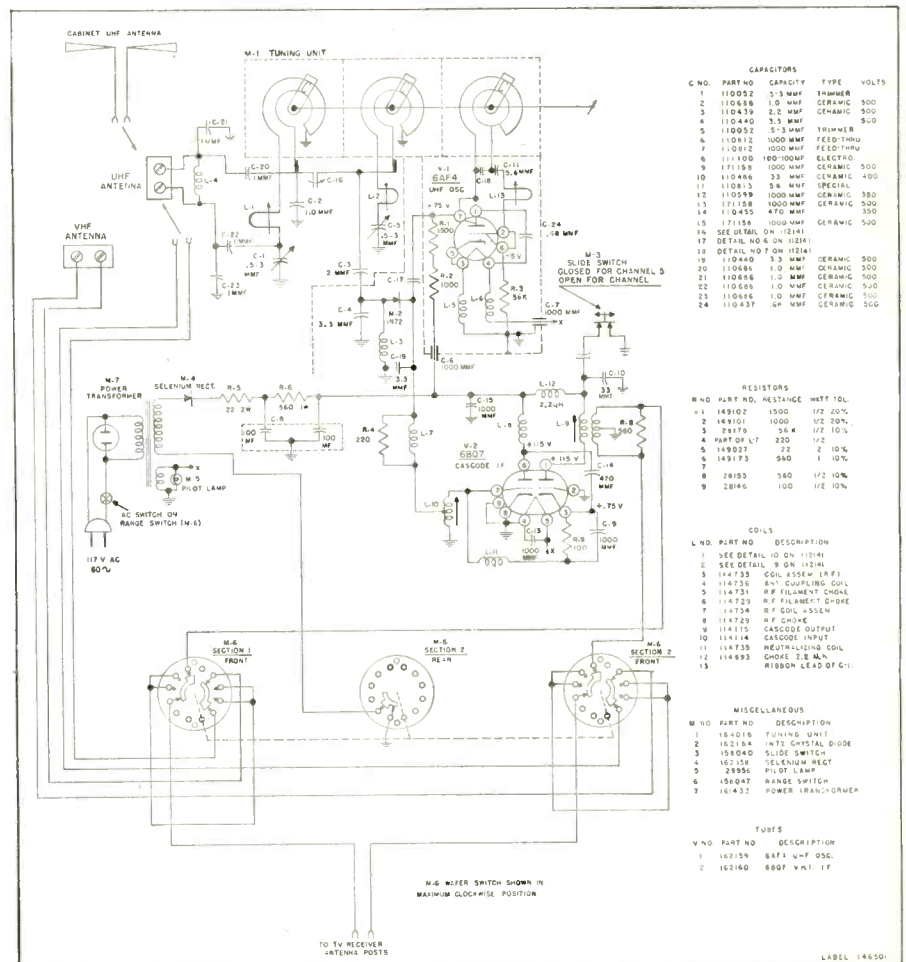

Fig. 5. Circuit diagram of Stromberg-Carlson tuner.

MEN OF RADIO

PART 10

by WILLIAM R. WELLMAN

This is the final installment of this most excellent series. We are gratified at the many favorable letters received praising our efforts to bring to the serviceman the background history of his art, thereby enriching him both culturally and technically.

FARNSWORTH finally obtained a position as member of a survey crew, working in connection with a drive to raise funds for the Salt Lake City community chest. His meeting with George Everson and Leslie Gorrell, who were in charge of the drive, was most fortunate. His enthusiasm and knowledge soon impressed both Everson and Gorrell, who offered to assist him in financing his invention. Everson, by the way, later wrote a biography of Farnsworth: "The Story of Television". At the start, a partnership was formed, with Farnsworth holding a half interest, the remainder being divided between Everson and Gorrell. Everson invested about six thousand dollars in the project, in the hope that this amount would cover the cost of constructing a working model of the system.

Months passed, during which time the preliminary model began to take shape, but at length it became evident that many difficulties stood in the path of success and not the least of these was the need for additional capital. Farnsworth had been far too optimistic in his estimate of the funds needed; the original fund was running low and financing on a much larger scale was needed if the project was to be carried to ultimate success. At this juncture an encouraging finding was reached; several studies that had been initiated with the purpose of determining the practicability of the scheme concurred in the opinion that the system was not only original but perfectly feasible as well. Incidentally, all of the foregoing had taken place before the inventor had reached the age of 21.

With the knowledge and firm conviction that Farnsworth's system was workable, Everson set out to obtain more adequate financing and was successful. A laboratory was set up in



(Courtesy RCA Laboratories)

Dr. Vladimir K. Zworykin

San Francisco and here construction of the first all-electronic television system proceeded. In time, the first camera tube was completed; this was a project of considerable magnitude in itself for much of the actual work on this device as well as the manufacture of cathode ray tubes, special amplifiers and many other units was performed in the small laboratory available. That the system was completed at all is a tribute to the genius and determination of Farnsworth and his associates, for they obviously did not have at their command the extensive resources of present-day industrial laboratories, but were forced to operate on a rather limited monthly budget. But by the late 1927 the complete transmitter and receiver had been set up and the first image was sent over a wire line.

Next problem was the improvement of clarity and definition of the images, largely through improved scanning methods and an increase in the number of lines scanned per image.

It was determined that 400 lines was about the minimum for good definition, as compared to the 40 lines then being used in mechanical scanning methods. One of Farnsworth's principal problems was the low sensitivity of the dissector tube. As this was an inherent quality, satisfactory output could be obtained only through the use of suitable amplifiers. This led to his development of a unique method of amplification based upon the well-known principle of secondary emission. Special tubes having a multiplicity of anodes were constructed. Electrons, released from a cathode struck the first anode, releasing several secondary electrons; these in turn bombarded the second anode where several more were released. Total current flow in the tube was the sum of the original electron emission from the cathode plus the secondary emission from all of the anodes. The principle is well known and rather widely used today in the electron multiplier.

First licensing for use of the Farnsworth television patents occurred in 1931, when the Philco Corporation entered into a contract with Farnsworth and his backers. The contract provided for removal of the laboratory and its staff to the Philco headquarters in Philadelphia. Here, preparations were made for experiments in the transmission of pictures via radio instead of over wire lines. In 1934, after several years of experimental work at the Philco plant, Farnsworth set up a separate laboratory in Philadelphia.

By 1937, through a series of successful demonstrations and several licensing agreements between his organization and various British and German firms, Farnsworth had attracted a great deal of attention as a

[Continued on page 42]

THE FEMME TOUCH

by ELSIE KRAFT

(Kraft T.V. & Radio Shop, Stroudsburg, Pa.)

We know you'll enjoy this bit of literature by the spouse of one of our radio-TV service dealers. Written in a free and entertaining style, it relates how "Madam" Serviceman makes herself extremely useful in the shop.

WHEN Hank opened his radio and television repair shop a few months ago, he was merely tolerant of the idea that I stay at the shop full time with him. After we scrubbed and painted our store, purchased and assembled the necessary furniture and fixtures, and lined and decorated the windows, Hank thought he'd better send me back home during the day, lest the neighborhood males who usually hang around a repair shop wouldn't put in an appearance, seeing me around, and he'd never get to talk shop. But a dial cord fixed all that.

The first week, incidentally I was still around to make the boss's lunch, set up the ledgers and wash windows, when the first dial cord replacement came in. It was a tricky little thing and I watched amusedly as Hank just about had it right, after half an hour of fiddling, when it ups and jumps off the little pulley it was supposed to ride on. More fiddling and fuming on his part got it back where it had been the third inning of the All-Star game, and here it was the traditional 7th-inning stretch; so the man did likewise. While he's up, he says, "Got any coffee?" After we downed that with yesterday's streisel buns, he went back to his little puzzle.

Now we were down to the part where you hook the tiny spring, with our giant fingers that seem all thumbs, back onto the dial cord drum, and hope she turns the dial—I'm in the act too now, but don't know just when I was hired. Heads bent over it, my page boy flopping in his face, Hank says, "Hold onto this, while I pull the spring with the long-nose." After three pulls and time out to locate the spring that jumped away under the counter, we hooked it on. Let's hope we didn't foul up on that home-made diagram, and she'll turn the dial, or

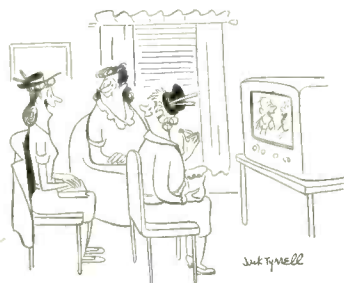

"Remember—before television—how we used to do our housework?"

Madam Customer will be stuck with one station for the natural life of her Philco, and we'll be out a customer.

Anxiously we turn the dial post—the little red pointer is moving gayly back and forth as we turn. Success! We had promised the job for 5 P.M. and it's only 3. We're nicely out of that one. But are we? I check it back and forth again. I thought something was wrong! When we turn the dial up-hill for the high frequency stations, our friend the pointer goes down to the tiny stations, and vice versa. By now Hank figures I'm in this thing over my head so it's my ball-game.

About an hour and an Alka Selzer later, I look over my glasses and say, "I've got it." I slide the chassis back in the cabinet, put the knobs and screws back on so it looks like a radio, give it a wipe with my little dust cloth, and set it aside on the bench with finished jobs.

Enter Madam the Customer! Much more hep on radios and what makes them sing than little me, and incidentally much bigger. This lady, though she lives alone, isn't one to call in any old service-man when her set goes on the fritz. No Sir! She pulls it out herself, puts the tubes in a paper bag and trots to the hardware

store to have them tested. She knows every tube is good and tells you so. She knows all that's wrong with it is the dial cord, which she tried to fool with herself. I know how she feels, having spent several hours in solitary confinement with the same Philco.

Well, sir, she dials it back and forth about eight times each way, to make sure it rides its rail perfectly before she gets out the alligator wallet. She looks at me and says, "I think it's slipping around the 70's. I'm slipping in my early thirties, but don't tell her that. She urges me (dares is more like it) to dial it without slipping. I have to agree that it slips just the tiniest bit in the 70's. Hank snickers from his position on the back bench. Not having dial cord in the place, due to newness of same, I had said blithely to Hank when the job came in, "So what! it looks like fishing tackle, what she has left in it; there's a tackle shop down the street," and had loaded her very dry Philco with a string of the best nylon bass line. And now the fish were yelling, "Sucker".

So here we are with this fishing tackle that keeps slipping—only when she tries it, I tell myself. I think fast—"Madam," says I, "It must be this new nylon dial cord the salesman put over on me. You know how everyone wants their slips sewn with nylon thread, it's the same in this business. Nylon wears like iron, but it slips. If you'll be good enough to wait a few days till I can get in the old type we will be very happy to replace the dial cord for you." She beamed, I screamed (inwardly). Here I was right where I started three hours and four dial cords before.

Well, sir, I'm the dial cord man now, among other things such as

[Continued on page 42]

CIRCUIT COURT

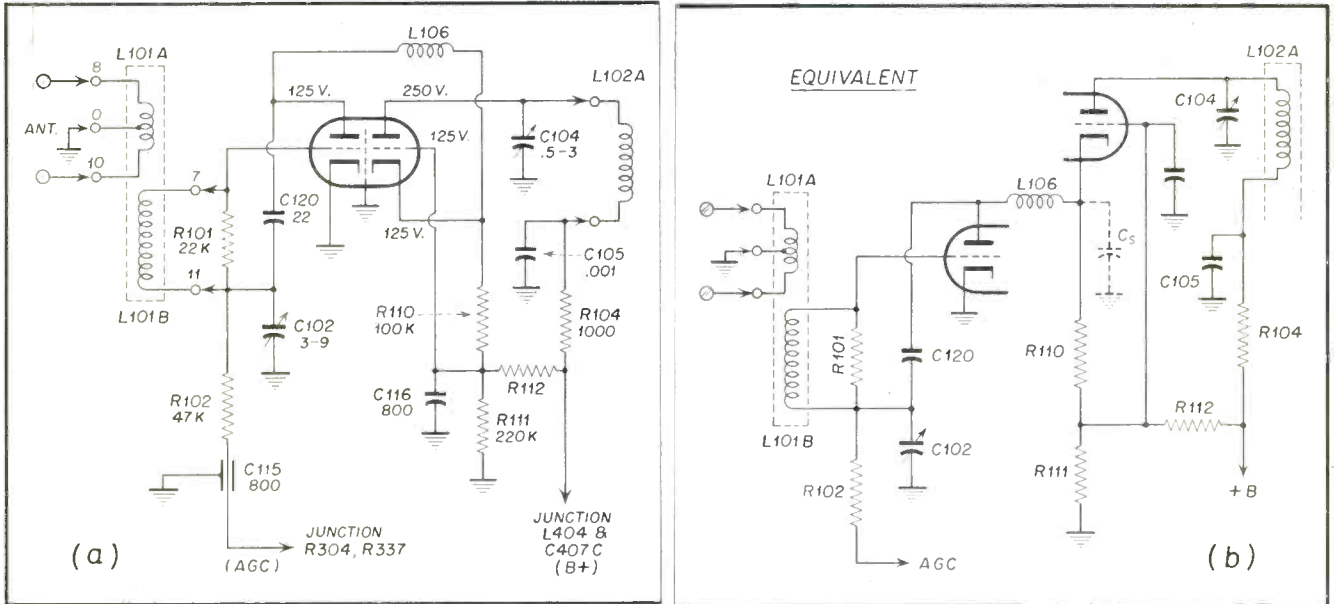
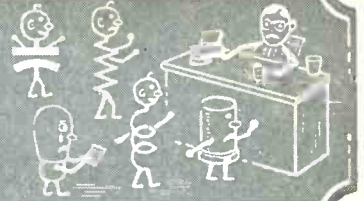

Fig. 1. Partial schematic of Admiral TV tuner 94C37-1. This tuner utilizes a 6BQ7 connected in a cascode amplifier. A simplified schematic of this circuit is shown on the right (b) for use with the explanation given in the text.

The Admiral TV Tuner 94C37-1

This tuner uses a new type triode in an unusual amplifier circuit. Triode types which we used until now had low noise figures and also low gain. Pentodes which have a high gain, have a high noise figure. The trend commercially, until the use of the development that this analysis will discuss, has been toward the pentodes. Its purpose was to increase the sensitivity of the receiver, in order to push fringe area reception further and further from the transmitting antenna.

The new type amplifier, under discussion, an example of which is shown in Fig. 1 has an exceedingly low noise figure. Its internal construction permits circuit design which the tube characteristics of previously used triodes had made extremely critical.

This type of circuit is called a *cascode* amplifier. The advantages of this circuit are that we have the low input to output impedance features of a triode and the high output impedance (meaning high gain) of a pentode. The disadvantage of using this circuit is that neutralization is required to prevent degeneration of the higher frequencies.

In the Admiral circuit, we find the plate of the first section of the triode directly connected with a cathode of the second section, so that the total tube current of the entire tube flows through both sections. The negative bias on the second section is obtained by means of the network of *R110*, in conjunction with the bleeder resistors *R111*, *R112*. This network tends to keep the grid and cathode of the second section at the same d-c potential.

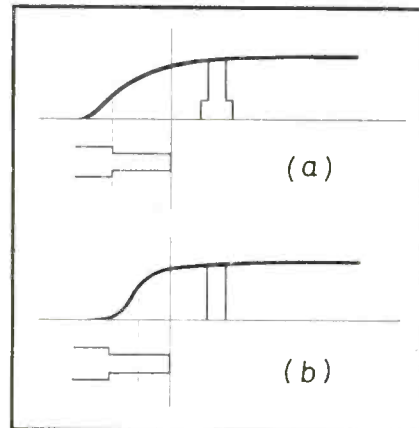

Fig. 3. Sync clipping action that takes place in 6BE6 circuit of Zenith sync clipper and limiter.

The appearance of the signal across *R110* then furnishes the bias.

The r-f signal is applied to the grid of the first section through the antenna coil *L101*. The dynamic resistance of the second section acts as the plate load for the first section. In this manner, the signal coming out of the first section is amplified. The signal then appears across *R110* between cathode and grid and is further amplified by the second section. It then appears across the plate load circuit of the second section *L102* and is then applied to the converter.

Zenith TV Receiver Chassis 20J21

Illustrated in Fig. 2 is an interesting sync clipper and limiter circuit using a 6BE6. In order to overcome the usual sync problems such as noise, video in the sync; and in order to obtain constant sync input under most signal conditions, use is made of the 6BE6. Its characteristics are used so as to apply a sliding bias which is proportional to the signal input. By sliding bias, we mean a bias which varies instantaneously with the strength of the received signal.

In this circuit, a negative going sig-

[Continued on page 40]

ASSOCIATION NEWS

Local, State, and National Associations are urgently requested to send in news of their activities so that we may print them in these columns.

NETSA ACTIVITIES

THE National Electronic Technicians and Service Dealers Association held its annual meeting in the Hotel Stacy Trent in Trenton, New Jersey on November 11, 1951. Mr. E. W. Merriam, Service Manager for the Radio Television Manufacturers Association, was guest speaker who gave an outline on his proposed projects to promote the paper presented by the National Electronic Technicians and Service Dealers Association at the Chicago meeting to the Radio Television Manufacturers Association's Service Committee. At the completion of Mr. Merriam's talk, the score or more delegates present from the various Chapters presented a series of questions to Mr. Merriam who tried to answer as many as possible. A series of requests and demands were also given to Mr. Merriam to present to the Radio Television Manufacturers Association's Service Committee at their next meeting. The National Electronic Technicians and Service Dealers Association's delegates then voted to give all the cooperation necessary to Mr. Merriam in helping him to promote a concrete program for the servicing industry.

The National Electronic Technicians and Service Dealers Association's delegates voted to hold a National meeting of the various heads or representatives of servicing associations throughout the country for May 1952, at which time, representatives of the Manufacturers, Distributors, Broadcasters, and Sales Representatives will be requested to attend. A definite date and location has not been selected as yet, but will be after a survey is made among all Radio and Television Technicians and Service Dealers' Associations in the U.S.A. A National code of ethics was adopted by the body and will be presented for vote and ratification by all Chapters. *Federation of Radio Servicemen's Association of Pennsylvania*

The Federation of Radio Servicemen's Association of Pennsylvania

held their last meeting in Scranton, Pa. on October 21, 1951, at which time, delegates from all Chapters were present. In addition, there was representation from the Southern Penn. Radio and Television Technicians' Association of York, headed by their President, Mr. Sheffer, who presented their application for membership to the State group which was voted upon and accepted. This makes the tenth Chapter in the State Federation. The 50 Point recommendation as prepared by delegates of the Federation that were presented to the Radio Television Manufacturers Association, the National Electronic Distributors Association, and the set distributors as-

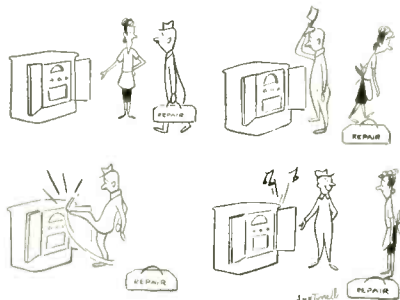

sociation, were thoroughly covered at this meeting.

Each year, as in the past four years, the Federation appoints a committee to arrange for a statewide vote in all Chapters to select the individual, organization, or the publication who has made an outstanding contribution to the servicing industry. For this, the Federation awards its annual plaque. The committee appointed this year is the delegation from Altoona. The nomination for officers for 1952 is being handled by the committee of delegates from Luzerne County (Wilkes-Barre). The new speaking schedule for 1952 will include John Rider, nationally known publisher, Capelhart-Farnsworth, Howard W. Sams, Motorola, etc.

Luzerne County Of Radio Servicemen's Association

The Radio Servicemen's Associa-

tion of Luzerne county is as usual carrying on with a full line of business and social activities. On Wednesday, September 26, 1951, Motorola presented an interesting lecture and demonstration on Motorola TV receivers, in the Hotel Sterling, Wilkes-Barre. Last Tuesday, September 18th Mr. A. G. Petrasak, from the RCA Tube Department presented a splendid lecture on UHF, Better Business Methods, and a thorough discussion on the various circuits in the RCA Television receiver. This lecture was extremely well received and was one of the series arranged for by the State Federation. It is hoped that another invitation will be extended to Mr. Petrasak for a return engagement. Two weeks prior on September 4, 1951, the General Electric Supply Co., presented a lecture on its receivers in the Kings Inn. Lecturers were Bill White from General Electric Supply Co., and Fred Miller from General Electric Corp. Due to lack of accommodations, and a very large turnout, this lecture will again be presented in a room capable of accommodating a large crowd. The local Association is looking forward to the future lectures which have been arranged by the State Federation and is at present doing its part in promoting licensing. *Associated Radio And Television Servicemen of New York*

Max Leibowitz, president, has arranged for a series of articles in the local daily newspapers on the need for licensing, also supplied a story entitled "Here's A Law To Protect You" to the TV Guide whose circulation in New York runs into many thousands. On November 12, Mr. Leibowitz appeared as a guest on a program on WCBS-TV Channel 2 in New York City, at which time, he presented the servicemen's views on licensing. Oak Ridge Products Co. will supply many pieces of test equipment for the Associated Radio and Television Servicemen's Association of New York's Club Room. A committee has

(Continued on page 38)

HERE'S HOW & WHY

by CHET JUR

(Sales Engineer, Merit Transformer Corp.)

Describing a new type of focus coil which may be used to great advantage by the servicing technician in improving overall picture clarity. At the same time it provides a means by which he may increase his sales receipts.

WHEN a television serviceman repairs a set, his function is to restore it to normal correct operation . . . not to re-engineer it in any way. Yet, new design units may at times be available which, with a minimum of labor and cost, can be installed and will lead to considerably better performance.

A case of this type is the introduction of the "cosine" wound, edge to edge focus type deflection yoke. This newly developed deflection yoke was designed to meet the need of better focusing on the larger picture tubes.

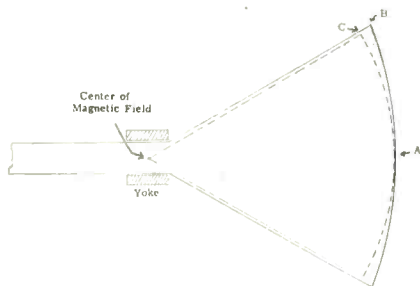

Fig. 1. Distortion due to the curvature of the tube face.

Many types of distortion exist as a result of the complex magnetic field which is present about the deflection yoke, but some produce more effect on the picture than others and compensation or correction must be introduced to counteract the undesirable effect.

One type of distortion is due to the difference in the curvature of the tube face and the curvature of the magnetic field developed by the yoke. This is illustrated in Fig. 1. As can be seen at point "A" in Fig. 1, the curve of the tube face and the magnetic field coincide, but as we move away from this point, the two curves begin to separate and at points "C" and "B," there is some distance between the curves. It is apparent that the bigger the tube, the greater the distance between "C" and "B," therefore, the greater the area out of focus on the picture tube face.

The second type of distortion which must be considered is the deformation

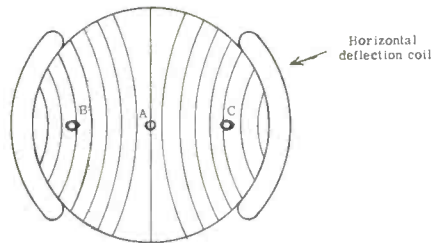

Fig. 2. Distortion of the electron spot due to a non-uniform magnetic field.

of the electron spot as it moves from left to right across the tube face. This is illustrated in Fig. 2.

In this illustration, the lines from top to bottom represent the magnetic field developed by the horizontal deflection coils. This field increases in strength as the spot moves from "A" to "B" to point "C." Therefore, the spot starts in a strong magnetic field at point "B," moves into a gradually weakening field which is weakest at "A," and back through an increasingly stronger field with maximum

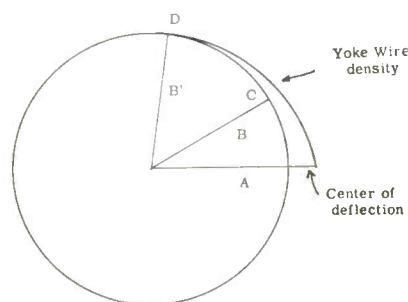

Fig. 3. Density of wire distribution of the cosine yoke.

strength at "C." This causes the spot to change in shape from a perfect circle to an oval, depending on whether the focus of the beam is adjusted for best focus at point "A" or point "C."

Both types of distortion are corrected by winding the deflection yoke to compensate for these conditions. This is done in the newly designed "cosine" type deflection yoke.

The horizontal coils on the yoke are distributed over a much greater portion of the circumference of the yoke with the density of wire distribution determined by a cosine relationship between a line drawn along the center of deflection (horizontal) and a line indicating any point of deflection on the curve of the yoke. This is illustrated in Fig. 3.

It can be seen that "A"/"B" is greater than "A"/"C" so the density

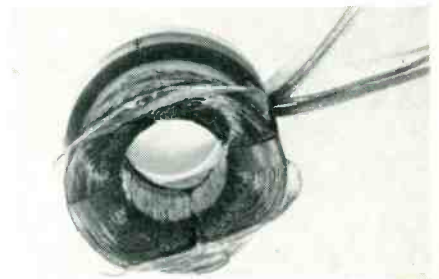

Cosine wound, edge to edge focus yoke.

is greater at point "C" than at point "D." Now the magnetic field as illustrated in Fig. 2 is more uniform across the face of the tube and the electron spot is less distorted. By adjusting the focus at point "A" (Fig. 2), the picture is still in focus at point "B" and "C." Also, the curve of magnetic field strength as illustrated in Fig. 1 is distorted to move closely parallel the curvature of the picture tube face and the distance from "B" to "C" in Fig. 1 is kept to a minimum.

Since this type of deflection yoke was not available before early 1951, there are many large tube television sets in use which could be improved by using the "Cosine" yoke.

It is available on the market individually boxed or in kit form with matched components.

TRADE LITERATURE

TV And Electronics As A Career, a new book by Ira Kamen and Richard H. Dorf, published by John F. Rider Publisher, Inc., 480 Canal St., New York 13, N. Y., is now available at the publisher's distributors.

Engineering, broadcasting, manufacturing, servicing, parts and receiver distributing, sales representation, retailing, and electronics in the armed forces are discussed by the authors, and the following top authorities, who wrote on their special fields. J.R. Poppele, vice-pres., WOR-TV, W. R. Peterson, ass't. mgr., Electronics Div., Admiral Corp., W.H. Bohlke, mgr., Custom Service Div., RCA Service Corp.

In addition to the chapters covering the various phases of the electronics industry, there are included appendices on pay scales for broadcast personnel and TV service branch personnel, electrical engineering curriculum, and educational institutes in the U.S. teaching radio, television, and electronics.

All the why's and wherefore's of the electronics industry are explained for the newcomer embarking on a career, and the electronics "oldtimer" desiring to switch to another field of specialization within the industry.

Written in an easy-to-read style, *TV And Electronics As A Career* contains 325 pages with 136 illustrations in a cloth binding. It is priced at \$4.95.

* * *

RCA tube distributors are offering dealers and servicemen a *three-ring leatherette binder* at no extra charge when they purchase RCA Victor service data literature costing them \$10 or more.

The binders are intended for the filing of individual RCA Victor service data booklets. However, the purchase price of such literature when bought in bound volume form will also be counted toward a bonus binder.

RCA Victor service data available to all servicemen includes bound volumes of technical and servicing information covering all RCA Victor radios, phonographs, and television receivers produced from 1923 through 1950; individual booklets on RCA

Victor's "Million Proof" television receivers and early 1951 TV receivers; and individual booklets on the company's 1950 radios and phonographs.

* * *

A new wall chart of *Impedance Mismatch and Line Loss versus Line Impedance and Line Length* has just been announced by *Newcomb Audio Products Co.* 6824 Lexington Ave., Hollywood 38, California. It is available free to sound specialists and audio installation engineers. Ask for chart 105.

* * *

General Cement Mfg. Company, 919 Taylor Ave., Rockford, Ill. announces their new No. 155 *Catalog* which is available to all radio and TV service dealers.

* * *

Oxford Electric Corporation, manufacturers of Oxford speakers, announces its new *catalog* is available for the industry.

Completely illustrated in three colors, the catalog lists all information on the complete Oxford line which includes permanent magnet speakers, electro dynamic speakers, and speakers for TV replacement, auto radio replacement, public address intercoms, and outdoor weatherproof applications.

Complete data is given on the Oxford line ranging from 2" to 15" units. Copies of the catalog are available without obligation from Oxford Electric Corporation, 3911 South Michigan Avenue, Chicago 15, Illinois.

* * *

Aimed at the humorous as well as the serious side of the average TV serviceman, a cartoon booklet entitled "*Blue Book TV Servicing*" has been prepared and published by *Bendix Television and Radio* for free distribution to all members of the electronic trade throughout the United States. An initial mailing of the booklets to 40 thousand TV and radio retailers has already begun. Requests for additional free copies will be handled within two weeks immediately after the first general mailing has been completed.

"*Blue Book of TV Servicing*" contains on its 40 pages the chief "do's and don't's" or tips to the TV service-

man about getting along harmoniously with the customers he visits. Each point of servicing conduct has been illustrated by cartoonist Yardley of the Baltimore Sun papers and Pathfinder news-magazine. Printed in two colors, The Blue Book is of convenient size for easy reading, and promises to be one of the most popular novelty booklets found in the TV business.

* * *

A new *TV control replacement manual supplement* is now being offered to TV servicemen through *Clarostat* jobbers. The new supplement is another service offered by Clarostat through its jobbers to aid the serviceman in his service field.

The *Clarostat Mfg. Co., Inc.*, Dover, New Hampshire, manufacturers of controls and resistors, issued a manual last Spring listing 343 set listings covering nearly 1500 TV models, 105 Standard controls with 5,705 applications, and 222 RTV or Exact-Duplicate controls with 3,451 applications.

The new supplement will give a continuation of RTV numbers listing the manufacturers part that they are used to replace.

* * *

"*Masterpieces in Miniature*" is the title of *Bulletin 951* just released by *Tetrad Co., Inc.*, Los Angeles, producers of copper wire windings and the specialized electronic components in which they are used. In line with current trends, the bulletin emphasizes miniaturization.

Illustrated are hermetically sealed miniature transformers, solenoids, radar deflection yokes, radar peaking coils, pulse transformers, universal windings and television horizontal output transformers, focus coils, and radar tuning and peaking coils. Also shown are special coils made to customer design. Illustrations are included showing winding stages of "Charactron" deflection coil developed by Consolidated-Vultee Aircraft Corp.

Copies of Bulletin 951 may be had by writing Tetrad Co., Inc., 4921 Exposition Blvd., Los Angeles 16, Calif.

* * *

Highlighting the trend toward miniaturization and elimination of

[Continued on page 40]

SHOP NOTES

Write up any "tricks-of-the-trade" in radio servicing that you have discovered. We pay from \$1 to \$5 for such previously unpublished "SHOP NOTES" found acceptable. Send your data to "Shop Notes Editor."

G. E. 800, 810 Series-Repairing Hor. Trans.

General Electric 810 and other 800 series TV sets, using the old G. E. transformer. Usually only the upper winding is shorted internally, resulting in little or no High Voltage and is evidenced, by no light in the 1B3 tube.

It is found that replacement of this transformer and the replacement type requires quite a few changes. To effect quick and economical repair, remove the upper winding, by removing two screws, and lift up laminations and slide coil off. Obtain an old RCA type transformer and remove the outer

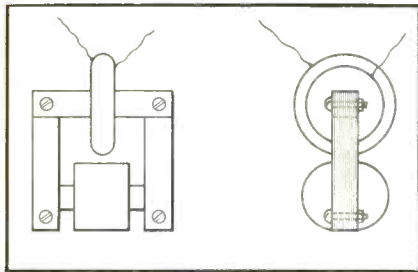

Fig. 1. Front and side views of G.E. transformer.

coil. Coil can be cemented in place of old coil (even though it is a very loose fit) after a few turns of poly, tape is wrapped on laminations. See Fig. 1.

If, after coil is in, high voltage is not present, reverse coil.

Submitted by
Edward Connolly
Brooklyn, N. Y.

Cheater Cord

With so many TV service calls "home-handled" by simply discovering and replacing a sick tube—we have found the following most useful method for getting power to the set with the safety-back removed.

Two connectors were removed from a Cinch molded socket and soldered to the ends of a replacement power cord. Two pieces of insulating tubing slipped over the connectors eliminated short possibilities. The connectors can

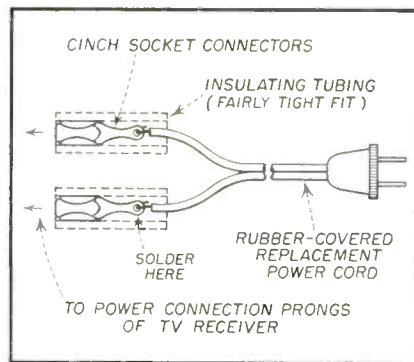

Fig. 2. Utilizing cinch connectors in cheater cord.

be spread out or pinched up with long-nose pliers to fit the power connector prongs of most TV receivers regardless of spacing. See Fig. 2.

A fuse holder (auto radio type) in the line, or a fused socket is a worthwhile addition.

Submitted by
C. W. Bacon
Fair Lawn, N. J.

RCA - 9X561, 9X562 (RC 1079B, RC 1079D) Hum Reduction

Due to the excellent bass reproduction of these instruments, the precautionary lead dress should be closely observed for minimum hum in the output.

A shield has been added to capacitor

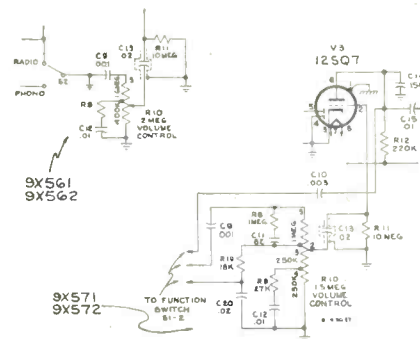

Partial Schematic Diagrams
Models 9X561, 9X562, 9X571, 9X572

Fig. 3. Hum reduction in RCA receivers.

C13 and is connected to common wiring. The outside foil polarity of capacitors C9, C12 and C13 should not be reversed. The correct polarity is indicated in Fig. 3.

In some chassis a .025 μ f capacitor has been used as a substitute for the .02 μ f capacitor C13.

Service Dept.
Radio Corp. of America

Crosley 1951 Television Receivers To Reduce Hum or Buzz:

1. Make certain that electrolytic capacitor (C120) has a good ground connection by soldering a wire from the chassis to one of the ground lugs on the capacitor. This should be done on all sets contacted in the field to prevent trouble developing as the set ages. Later production sets have the capacitor grounded in this manner.
2. Make certain that the sections of the electrolytic capacitor (C120) are properly connected as shown by the schematic.
3. If the shield in back of the contrast control has been removed, be sure to replace it.
4. On sets equipped with a resistor-capacitor unit (Part No. W-149881), dress the coupling capacitor (C122) as far as possible away from the resistor-capacitor unit.
5. If necessary, remove the resistor (R141).
6. Adjust the ratio-detector transformer (T102) secondary for minimum hum or buzz, while the set is tuned to the station. Only a slight adjustment is required. If the screw is turned too far, the result may be weak or distorted audio output.
7. Check overall alignment according to the service information bulletin.

Preventing Corona Or Arcing On Glass Portion (behind metal bell) Of 16 or 19-inch Metal Picture Tube.

1. To retard the accumulation of dust collecting on the glass area behind the metal bell of the picture tube, this area was sprayed with silicon lacquer. In some cases this lacquer was hydroscopic, permitting moisture to be absorbed which resulted in corona or arcing. When this condition is experienced, thoroughly clean all the silicon lacquer from the tube with acetone.

Crosley Service Dept.
Division AVCO Mfg. Corp.

NEW PRODUCTS

DEFLECTING YOKE

FOR 20" & 21" PICTURE TUBES

Tube Department, Radio Corporation of America, Harrison, N. J. offers the new RCA-211D1 Deflecting yoke for use with the new rectangular kinescope 21AP4 as well as with other rectangular picture tubes having a horizontal-deflection angle of about 66°.

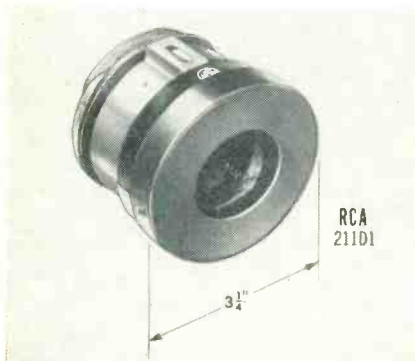

The 211D1 has been designed to provide good side and corner resolution without making any sacrifice in the ability of the yoke to give reproduction of horizontal and vertical lines with very little departure from straight.

This new yoke can be used with the RCA Horizontal-Deflection-Output and High-Voltage Transformers 224T1, 225T1, 227T1, and 228T1 depending on the focusing method and the voltage requirements of the picture tube used.

8-ELEMENT YAGI

The development of a new Vee-D-X antenna for more powerful single channel fringe area reception was announced today by the La-Pointe Plascomold Corporation.

A single-bay 8-element Yagi, the "Long John" (Model LJ), produces 41% more gain than the best 5-element Yagi and is equal in gain to any 5-element stacked array, it was stated. Higher front-to-back ratio eliminates co-channel interference, yet the LJ has the same wide-band width as the famous Vee-D-X JC.

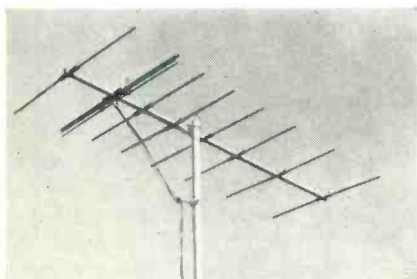

The "Long John", Vee-D-X engineers reported, was produced as a result of increasing demand throughout the trade for a single-bay antenna that produced as much gain as a stacked Yagi array, yet was lower in cost,

easier to install, and better in appearance. The LJ is manufactured with standard Vee-D-X pre-assembled construction and is provided with a reinforced boom on the low channels for extra sturdiness.

The development of this revolutionary new antenna is part of the Vee-D-X research program for constantly improving long distance TV reception.

UHF CONVERTER

P. R. Mallory & Co., Inc., Indianapolis 6, Indiana, will make available a new Mallory UHF converter which will make it possible for conventional VHF television receivers to receive UHF programs. The new converter is entirely self-contained including the built-in UHF antenna. It may be connected to a VHF television receiver in a matter of minutes providing UHF reception quickly, conveniently and without sacrificing reception of VHF channels. No changes need be made in any part of the television receiver. Two conveniently positioned front panel controls provide smooth, continuous tuning of all UHF channels, a-c control of the VHF receiver as well as the converter, and a quick means of antenna selection to permit normal operation of the VHF set when desired.



The converter employs three tuned circuits in the r.f. and oscillator sections to provide tuning characteristics similar to those normally expected from the better low-frequency tuners. In addition, the over-all performance of the unit is improved greatly by means of a built-in i-f amplifier employing a 6BA7 twin-triode connected in a low-noise circuit. Two designs will be available, one having an i.f. of 127 megacycles for use with VHF receivers employing a Mallory six-turn Inductant; the second incorporating an i.f. output at VHF Channel #5 or #6 for use with VHF receiver employing switch type tuners. The over-all stability of the unit is such that it may be employed successfully with either inter-carrier or conventional VHF television receivers.

HORIZONTAL OUTPUT AUTO-TRANSFORMER

A new high efficiency replacement and conversion TV autotransformer has just been released by RAM Electronics Sales Co. The RAM NO54 requires less driving power than a true transformer and yet provides ample high voltage and sweep for tube sizes up to 21" rec-

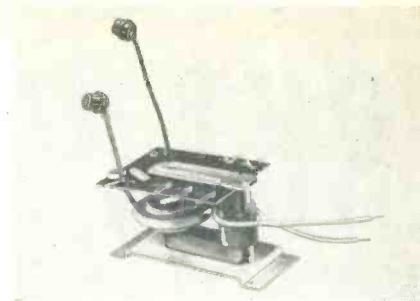

tangular. It is designed to be used with the RAM YTOF30, a 30 millihenry Ferrite Cosine Yoke.

In sets using selenium-rectifier voltage-doubler circuits with 250 volts B+ supply, the XO54 produces 13.5 KV with a boost voltage of 430 volts; with standard power supplies, it produces 15 KV with a boost voltage of 500 volts.

The RAM XO54 has excellent regulation and linearity and needs no special coils. Its new high-permeability ferrite core combined with special precision-pattern windings result in outstanding efficiency.

RAM makes a complete line of Test-Pattern Tested components for Color and Monochrome Television. For further details, write directly to RAM Electronics Sales Co., 7 South Buck-out St., Irvington-on-Hudson, New York.

PHONO PICKUP CARTRIDGE

The newly perfected Astatic L-12-U phono-graph pickup cartridge, employing a condenser harness which slips on or off the terminals to change output from a high of 4.0 volts to a low of 1.2 volts at 1,000 c.p.s. will serve as an ideal replacement for more than 125 different standard 78 RPM cartridges now in use, it was announced by William J. Doyle, general sales manager.

A second new feature of the Astatic dual-output cartridge is a needle chuck limiting principle which restricts motion of the chuck both radially and lengthwise. Purpose is to prevent dislocation of the chuck and to protect against crystal breakage from rough handling and when changing needle, it is said.

The L-12-U cartridge is furnished with the tiny condenser harness in position on the terminals. Installed in that manner, output is high. Slipping off the condenser raises output.



The range of the new cartridge is to 5,000 cycles. Minimum needle pressure is one ounce, weight of the cartridge 19 grams. The housing is stamped steel.

Complete installation instructions and a listing of all cartridges which the L-12-U will replace are furnished with each unit.

LIGHTNING ARRESTER

Milton S. Roth, Sales Manager of Cleveland's Radiart Corporation, announces the introduction of a new lightning arrester, with the unveiling of Radiart's Model TA5. This lightning arrester completely eliminates the necessity of

JUST DIAL THE TYPE...

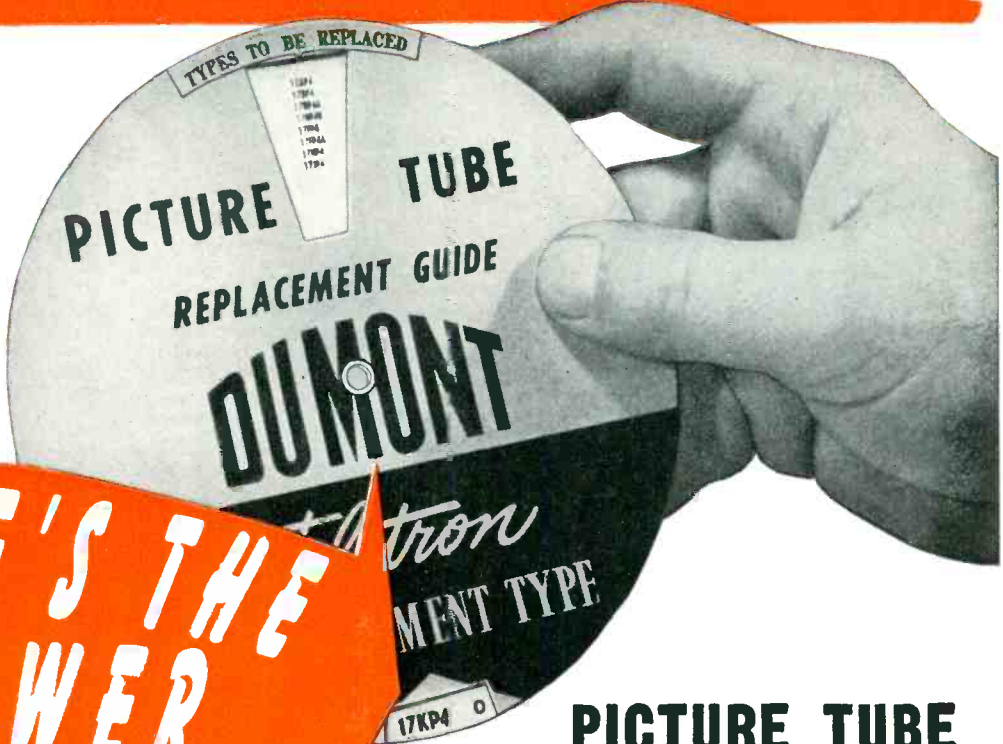

HERE'S THE ANSWER

PICTURE TUBE REPLACEMENT GUIDE

No thumbing through pages and comparing characteristics to arrive at the correct replacement — merely turn the dial to the desired tube type and PRESTO! there's the correct replacement type. These Du Mont TV Picture Tube Selectors are available through your Du Mont Teletron distributor. Get yours today.

DATA

Designation	Length	Base	Control	Max. Anode	Full Screen
17K94	10 1/2"	9	1	15.5 KV	10"
17K95	10 1/2"	9	1	15.5 KV	10"
17K96	10 1/2"	9	1	15.5 KV	10"
17K97	10 1/2"	9	1	15.5 KV	10"
17K98	10 1/2"	9	1	15.5 KV	10"
17K99	10 1/2"	9	1	15.5 KV	10"
17K9A	10 1/2"	9	1	15.5 KV	10"
17K9B	10 1/2"	9	1	15.5 KV	10"
17K9C	10 1/2"	9	1	15.5 KV	10"
17K9D	10 1/2"	9	1	15.5 KV	10"
17K9E	10 1/2"	9	1	15.5 KV	10"
17K9F	10 1/2"	9	1	15.5 KV	10"
17K9G	10 1/2"	9	1	15.5 KV	10"
17K9H	10 1/2"	9	1	15.5 KV	10"
17K9I	10 1/2"	9	1	15.5 KV	10"
17K9J	10 1/2"	9	1	15.5 KV	10"
17K9K	10 1/2"	9	1	15.5 KV	10"
17K9L	10 1/2"	9	1	15.5 KV	10"
17K9M	10 1/2"	9	1	15.5 KV	10"
17K9N	10 1/2"	9	1	15.5 KV	10"
17K9O	10 1/2"	9	1	15.5 KV	10"
17K9P	10 1/2"	9	1	15.5 KV	10"
17K9Q	10 1/2"	9	1	15.5 KV	10"
17K9R	10 1/2"	9	1	15.5 KV	10"
17K9S	10 1/2"	9	1	15.5 KV	10"
17K9T	10 1/2"	9	1	15.5 KV	10"
17K9U	10 1/2"	9	1	15.5 KV	10"
17K9V	10 1/2"	9	1	15.5 KV	10"
17K9W	10 1/2"	9	1	15.5 KV	10"
17K9X	10 1/2"	9	1	15.5 KV	10"
17K9Y	10 1/2"	9	1	15.5 KV	10"
17K9Z	10 1/2"	9	1	15.5 KV	10"

CODE KEY

RD - Round
 BT - Brouncker
 C - Cathode Ray Pilot
 G - Green Ray Pilot
 X - External Conductive Coating

NOTES

- All Du Mont Teletron replacement types have the standard 5 pin J-socket base.
- All Du Mont Teletron replacement types have the same length and control magnets, except the Type 17K9A which employs a double field magnet.
- When ordering a magnet for other than a replacement tube, please specify the number of turns in magnet winding of 1/2 inch for each 17K9 series tube or below the required number of turns.

THE SELF FOCUS TELETRON

Several advantages may be realized by using the Self Focus Teletron for replacement. Operation is easier, less costly, and not affected by changes in anode voltage or beam current variations.

To replace the Self Focus Teletron for a tube in which a PMU is being used, simply remove the PMU and install the correct tube.

Unique structure of the Self Focus Teletron permits picture quality by eliminating defects associated with conventional face tube designs.

If a focusing and/or scan control and/or deflection coil is required, maximum minimum voltage should be 5 volts.

Cathode-ray Tube Division
 ALLEN B. DUMONT LABORATORIES, INC.
 750 Bloomfield Avenue, Clifton, N. J.

Electrical characteristics of each replacement type are shown on the rear of the Selector when the type is dialed. This is the information necessary for those conversion jobs that spell profits for you.

ASK YOUR DU MONT DISTRIBUTOR

CATHODE-RAY TUBE DIVISION
 ALLEN B. DUMONT LABORATORIES, INC.
 CLIFTON, N. J.

TRADE MARK



stripping wires. In the TA5, sharp-toothed cup washers pierce the insulation to make permanent electrical contact with the wire leads of the transmission line. Molded of genuine Bakelite, the unit is permanently sealed against temperature changes and humidity. It will fit anywhere, can handle jumbo or standard twin leads, and does not unbalance the line.

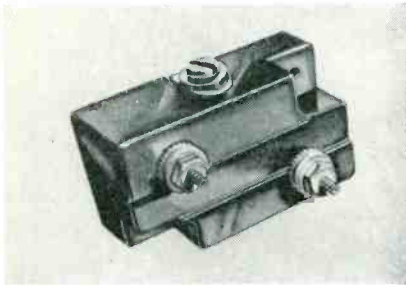

The TA5 is characterized by low internal capacity and high internal resistance, thus insuring no loss of signal, and a "leaking off" of static charges. Radiart's lightning arrester has been thoroughly tested and approved by the Underwriter's Laboratory. For more information, contact the Radiart Corporation, Cleveland 2, Ohio, or your nearby Radiart distribu-

SUB-MINIATURE CONTROL

A new, improved sub-miniature control known as Series 48A is announced by Clarostat Mfg., Co., Inc., Dover, New Hampshire, manufacturers of resistance devices. The new control is an improved version of the Series 48 controls introduced in 1948.

Measuring only $\frac{5}{8}$ " in diameter, the Clarostat Series 48A is available as either a single or dual unit. The body depth of the single unit is $\frac{7}{16}$ ", while the double unit measures $\frac{53}{64}$ ". Bushing is $\frac{1}{4}$ " long, beyond which the shaft extends $\frac{1}{2}$ ". The shaft may be obtained as a flattened, or slotted tube. Standard shaft is $\frac{1}{8}$ " round of soft metal. The body of the new control is durable bakelite.

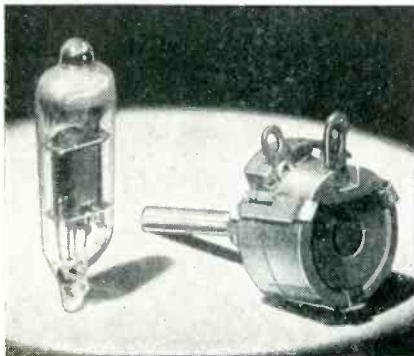

Series 48A is available in either tapered, or linear resistances. The linear ranges are from 1000 ohms to 5 megohms. Tapered resistances run from 5000 ohms to 2.5 megohms.

HORIZONTAL OUTPUT KIT

The Merit Coil and Transformer Corp., are now shipping to jobbers the new #1000 TV Kit which contains three major components for conversion, replacement and improvement of set reception.

The components are, the HVO-7, a 77J-1 type of flyback which can be mounted over and under the chassis, horizontally, vertically, or on the side wall of the hi-voltage cage; one MWC-1, a wide-linearity coil with AGC winding which matches the HVO-7; and one MDF-70 Cosine Wound Deflection Yoke for edge to edge picture focus for use on approximately 10,000,000 large picture tube sets.



Included with the Kit are these helpful information sheets; a technical data sheet on the components, a sheet which explains the hows and whys of the Cosine Yoke and the Merit Conversion Procedure Sheet.

An individual, corrugated shipping wrapper and a DayGlo sign for counter display of the kit are features designed to aid the jobber to easy and fast sales.

5-ELEMENT TWIN-DRIVEN YAGI

A new antenna designed for the extreme fringe areas is announced by Technical Appliance Corporation, Sherbourne, N. Y., manufacturers of TACO antennas and TACOPLEX Master Antenna Distribution System. The new antenna is known as the Super 980 and is a 5-Element Twin-Driven Yagi design.

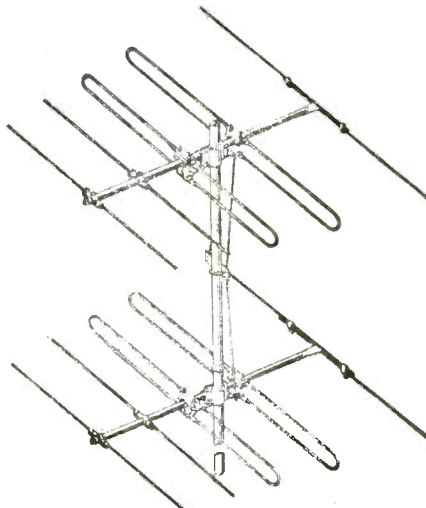

Tuned for any one of the low-band channels, the Super 980 features a gain greater than the well-known 4-Element Twin Driven design. The antenna consists of three parasitic elements, two directors, one reflector, and two driven elements. The driven elements are folded-dipoles connected in parallel with a terminal impedance matching the 300 ohm twin lead line.

A sharp degree of directivity eliminates most noise and reflected signal pickup providing clearer, stronger pictures. High front-to-back ratio is helpful in areas affected by co-channel interference.

Rigid construction assures dependable service under the most adverse weather conditions. Antenna comes completely factory assembled in the TACO Jiffy-Rig manner and is readied for installation in a matter of a few minutes. Depending upon the installation requirements, the 5-Element Twin-Driven Yagi is available as a single bay, or stacked array.

PARAPET MOUNT

Kenwood Engineering Co., Inc. of Kenilworth, N. J. announces a new revolutionary parapet mounting bracket designated as Model #106 for antenna masts up to $1\frac{1}{2}$ " in diam-

eter. It consists of a sturdy frame with four claw-like members which clear the coping and extend to the wall. These claws are made of heavy gauge steel placed on edge to give powerful clamping action. At the lower end of each claw is a hardened cone point set-screw which gives positive anchorage to the wall. A novel eccentric or cam at each side of the frame can be adjusted to give positive vertical support on tile or stone copings, regardless of contour. The mount is shipped

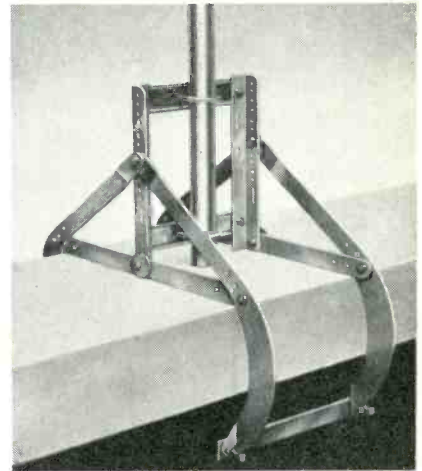

completely assembled for quick installation on walls up to $13\frac{1}{2}$ " in thickness. Hot dip galvanizing is used to provide permanent rust protection. Model #106 Parapet Mount is individually packaged and shipped complete with all hardware.

CRT TESTER

This new miniature CRT TESTER makes it possible to determine the condition of the CR tube in a television receiver without removing it from the cabinet or chassis.

It is necessary merely to remove the back from the receiver, and disconnect the socket from the CR tube. The socket of the CRT Tester is then attached to the CR tube, and the toggle switch is turned on. After allowing approximately 30-45 seconds for the cathode of the CR tube to reach operating temperature, the push button is depressed. If no reading is



obtained on the meter, the tube is dead. A reading below .2 ma. indicates a tube too weak for further use. A tube reading from .2 to .4 ma. will produce a usable picture in a properly operating TV set. A reading above .4 indicates a good tube. Some good tubes, especially new ones, will give a reading above 1 milliamper, which is excellent.

It will be noticed that, with older tubes, the meter will climb steadily if the button is held down. This merely indicates that the cathode takes a longer time to heat up, but the final reading will be the true one. During the process of testing, it is advisable to tap

Golden Opportunity

to prepare for better pay jobs in

Television Servicing

for men in
radio-electronics

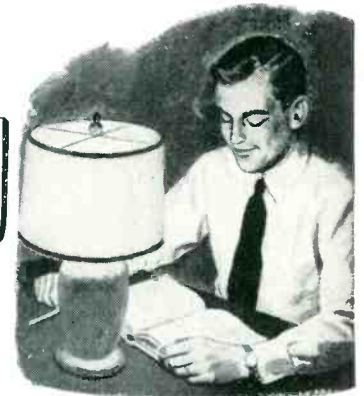

YOU STUDY AT HOME

In your spare time, you learn pre-tested "How-to-do-it" techniques with "How-it-works" information in easy-to-study lessons. The course is based on the experience of the RCA Service Company in servicing thousands of home television receivers.

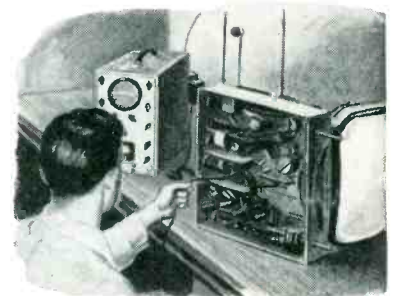

YOU KEEP WORKING ON YOUR JOB

Because you work in the radio-television-electronics industry, your job provides the laboratory work of the course. There are no kits, parts or equipment to buy. Self-employed independent radio and television servicemen are eligible for enrollment.

No vocational field offers more opportunities for "career" jobs and good pay than television—America's fastest growing industry. The demand for TRAINED and EXPERIENCED TV SERVICEMEN is growing. There is a big shortage of such men now and will be for several years to come.

PLENTY OF GOOD JOBS OPEN TODAY

Radio-Television jobbers, dealers and service companies offer lifelong opportunities with excellent salaries for qualified service technicians. Manufacturers of television receivers are looking for men with good service training as inspectors, testers and troubleshooters. Many experienced servicemen go into business for themselves. Others hold their regular jobs and earn extra money servicing TV receivers in their spare time.

Radio-electronics manufacturers busy with defense equipment contracts offer excellent job opportunities for men with a television technician background. Servicemen called into military service are further reducing the supply of skilled TV servicemen available for civilian activities. Think what television servicing offers *you* in terms of a lifetime career and financial security.

RCA INSTITUTES Home Study Course in TELEVISION SERVICING—

A Service to the Industry

Because of the critical shortage of TRAINED and EXPERIENCED TV SERVICEMEN, RCA Institutes is offering this highly specialized and practical home study course as a service to the working members of the radio-television-electronics industry. Its object is to train more *good* servicemen and to help make good servicemen *better*.

Never before has this course been available to anyone outside of RCA. It is now offered to *you*, through RCA Institutes, one of America's oldest and most respected technical training schools. The course covers most major makes and types of TV receivers. Available exclusively to men in the radio-television-electronics field. Not offered to the general public, or under G.I. Bill.

The cost is low . . . only \$9 a unit for 10 units or \$90 total, on an easy pay-as-you-learn plan. At successful completion of the course you earn an RCA Institutes certificate that can lead straight to a better job at higher pay.

RCA Institutes conducts a resident school in New York City offering day and evening courses in Radio and TV Servicing, Radio Code and Radio Operating, Radio Broadcasting, Advanced Technology. Write for free catalog on resident courses.

SEND FOR FREE BOOKLET. Find out complete details of the RCA INSTITUTES Home Study Course in TELEVISION SERVICING. Don't pass up this opportunity to prepare yourself for a money-making career in the television industry. Illustrated booklet explains all the features of the course. Mail coupon in an envelope or paste on a penny postcard—NOW!

MAIL COUPON NOW!

RCA INSTITUTES, INC.
Home Study Department, RSD-1251
350 West Fourth Street, New York 14, N.Y.

Without obligation on my part, please send me copy of booklet "RCA INSTITUTES Home Study Course in TELEVISION SERVICING." (No salesman will call.)

Name _____ (Please Print)

Address _____

City _____ Zone _____ State _____



RCA INSTITUTES, INC.
A SERVICE OF RADIO CORPORATION of AMERICA
350 WEST FOURTH STREET, NEW YORK 14, N.Y.

gently around the neck and base of the CRT tube, to see if a change occurs in the meter reading, indicating a short or open in the electron gun.

The meter in the CRT TESTER is protected by a 1/200 ampere fuse, located on the back of the meter. The fuse may be reached by removing the 4 front panel screws, and lifting the panel. Caution! Replace Only With 1/200 Ampere Fuse.

This CRT Tester is covered by the usual 90 day parts and workmanship warranty.

DEFLECTION YOKES

Two new deflection yokes, with cosine distributed windings designed to provide anti-astigmatic focusing, over the entire television tube picture area, were announced by the Standard Transformer Corporation, Chicago.

DY-8 and DY-9 newest components in the Stancor TV replacement line, are both 70°, ferrite core deflection yokes with coils wound



on nylon bobbins, according to Gilbert C. Knoblock, Stancor general sales manager.

DY-8 has a horizontal inductance of 8.5 MH and DY-9 has a horizontal inductance of

13.5 MH, Knoblock said, and these carefully selected values cover replacement requirements of hundreds of TV models.

Stancor Bulletin 387, describing both deflection yokes in detail, is now available, and both units are now in stock for immediate delivery.

RESISTANCE DECADE BOX

Just released by the Electronic Instrument Co., Inc. 276 Newport Street, Brooklyn 12, N. Y., designers and manufacturers of the famous EICO complete line of instruments and kits, the new Model 1171 supplies resistance valued from 0 to 99,999 ohms with 1/2% precision.

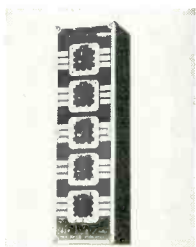

Another outstanding feature of this instrument is its new separate Comparator Position which, with its binding posts, permit instant, easy substitution of an actual equivalent component for the resistance value indicated on the decade box.

The Model 1171 has 5 separate switches, with 10 positions on each. All integral resistors have 1/2% accuracy.

Of rugged and simple internal construction, the Model 1171 is housed in a sturdy heavy-gauge quality steel case and bears an impressively handsome 3-color etched rub-proof panel. Dimensions are: 3 1/2 x 12 x 3".

For further information on Model 1171 and the rest of the complete EICO line, write directly to Electronic Instrument Co., Inc.

MULTIPLE RECEIVER ANTENNA COUPLERS

Known as the Tele-Plex TV Couplers, the new JFD couplers deliver full signal strength to two, three or four sets using the same antenna. Each unit has built into it the popular JFD UL approved "Little Giant" lightning arrester to protect the home and the TV set against lightning damage.

The new JFD Tele-Plex Couplers solve the trade-in problem on old TV sets by keeping both sets at home at minimum cost and to mutual profit of both dealer and set owner. Making use of the existing antenna installation, the couplers install in minutes and do not require any booster, or electric current or attention.

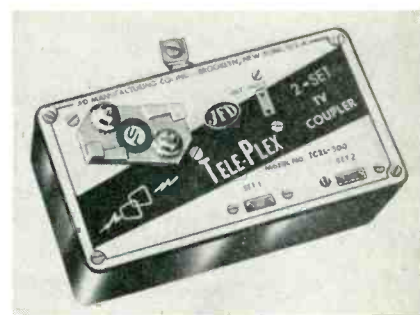

Housed in sturdy, compact, light-weight instrument cases, the JFD Tele-Plex TV Couplers can be attached out of sight on back or inside of the TV cabinet or on the wall or baseboard.

Three models to meet most impedance requirements make up the Tele-Plex line. Model TC2L-300 couples two 300 ohm sets to a 300 ohm antenna. Model TC4L-300 couples four 300 ohm sets to a 300 ohm antenna. Model TC4L-72 couples four 72 ohm sets to a 300 ohm antenna.

A colorful descriptive brochure covering the entire JFD Tele-Plex line is available from the manufacturer upon request.

ANTENNA KITS

Two new TV antenna kits have been announced by the Ward Products Corporation. Called Ward Installation Kits, they make available, in a single package, all the components required for a TV antenna installation.

For local installations, there is the single stack package, Model TV-105 and, for fringe areas, the double stack Model TVS-103. Each package includes a conical antenna, mast, lead-in, stand-offs, pipe strap, base, and other installation material. The double stack package has an additional antenna bay and mast.

For example, several ways were pointed out in which Ward Installation Kits cut installation costs. First, there is no chasing for loose parts, and the lead-in is already cut to length. Since each package is a complete installation in itself, shrinkage is virtually eliminated. The single package is easier to handle, too, and tends to automatically balance inventory by keeping all materials in the proper quantities. Also, cost per installation is easy to compute from the price of a package. These advantages, have been noted by many installers and have helped them to markedly increase their profits.

Ward is featuring the kits as a way to "stop hidden costs and make plus profits". They are now available through radio distributors everywhere and free literature can be obtained from Ward Products Corporation, 1523 East 45th Street, Cleveland, Ohio.

Mr. Serviceman:

YOUR CERAMIC CONDENSER STOCKING PROBLEMS ARE NOW SOLVED WITH THE INTRODUCTION OF THIS UNIQUE ERIE RESISTOR

"Breakaway" PACKAGE

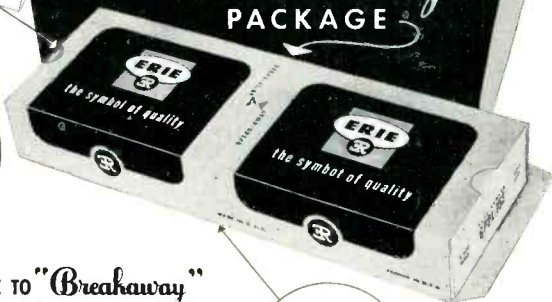
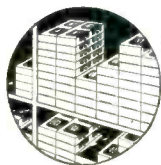
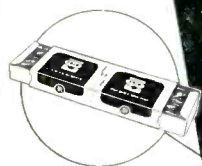

NOW IS THE TIME TO "Breakaway" FROM LESS EFFICIENT METHODS OF STOCK KEEPING AND MERCHANDISING OF CERAMIC CONDENSERS. THIS EXCLUSIVE NEWLY DESIGNED PACKAGE BY ERIE RESISTOR PROVIDES FOR:

- * Easy stacking on shelves
- * "At a glance" inventory control
- * Quickly dispensing one or several polyethylene bags containing 5 ceramic condensers of the same capacity (note: Trays slide from either end of package)

Complete package consists of a perforated outer sleeve and two trays each containing 25 Ceramicons. The package will "Breakaway" along the perforated edge thus making two "half boxes," each a neat box of 25 which your larger dealers and industrial customers will find ideal for keeping their stock of Ceramicons clean and orderly.



Electronics Division
ERIE RESISTOR CORP., ERIE, PA.
LONDON, ENGLAND • TORONTO, CANADA

Now...a NEW Junior VoltOhmyst* ...the WV-77A

For all regular measurements and specialized measurements as illustrated.

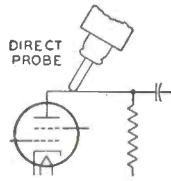

MEASURES AC VOLTS...such as signal voltage or plate of af tube.

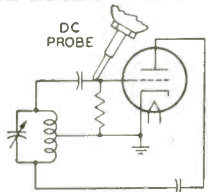

MEASURES DC VOLTS... such as oscillator grid bias. One-megohm resistor in probe prevents circuit loading.

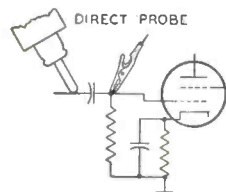

MEASURES RESISTANCE... such as leakage in coupling capacitor up to 1000 megohms.



Check these important features...

- ✓ Accurate laboratory calibration.
- ✓ Meter electronically protected against burn-out.
- ✓ Metal case shielding... extra stability in rf fields.
- ✓ Sturdy 200-microampere meter movement.
- ✓ Carbon-film 1% multiplier resistors... dependability plus.
- ✓ Zero-center scale... for discriminator alignment.
- ✓ Frequency response flat from 30 cps to approximately 3 Mc.
- ✓ High ac input resistance for greater accuracy.
- ✓ Constant dc input resistance... 11 megohms on all scales.
- ✓ Negative feedback circuits for greater over-all stability.
- ✓ Ohms cable always positive... for quick leakage measurements of electrolytic capacitors.
- ✓ Polarity reverse switch... eliminates cable switching.
- ✓ ± 3% over-all accuracy on +dc scales, and ± 5% on ac and -dc scales.

Available from your RCA Test Equipment Distributor

Just one probe cable and one slip-on probe handle all measurements.

An all-electronic ac-operated vacuum-tube volt-ohmmeter by RCA ONLY \$47.50.

Includes DC probe, AC direct probe and cable, ground lead, and alligator clip.

The RCA WV-77A VoltOhmyst* provides the extra features you have tried to find in an inexpensive VTVM. Using the famous Volt-Ohmyst electronic bridge circuit, 200-microampere meter movement, and carbon-film multiplier resistors, the WV-77A incorporates features you would expect to find only in more expensive instruments. Sturdily built... calibrated against laboratory standards... and backed by a 12-month warranty... the WV-77A has the durability, versatility, and accuracy to please discriminating customers such as service technicians, engineers, amateurs, and military personnel.

As a DC Voltmeter it measures dc from 0.05 volt to 1200 volts in five ranges. Uses 1-megohm resistor in isolating probe; probe has less than 2-uuf input capacitance. Has 11-megohm input; useful for measuring high-resistance circuits such as oscillator, discriminator, and avc.

As an AC Voltmeter it measures ac from 0.1 volt to 1200 volts rms in five ranges.

Uses high-impedance diode tube as signal rectifier. Frequency range is more than adequate for measurement of power line, audio, and ultra-sonic frequencies.

As a wide-range Chmmeter the WV-77A measures resistance from 0.2 ohm to 1 billion ohms in five ranges. Requires only 1.5-volt battery as burn-out protection in measuring such low-power elements as battery-type tube filaments.

The all-new RCA WV-77A VoltOhmyst comes completely equipped with probes and cables as illustrated. For complete details, see your RCA Test Equipment Distributor today... or write to RCA, Commercial Engineering, Section 55LX, Harrison, N. J.

Accessories Available on Order

The WG-289 High-Voltage Probe and WG-206 Multiplier Resistor extend the dc range of the WV-77A to 50,000 volts.

The WG-264 Crystal-Diode Probe extends frequency range of the WV-77A to 250Mc.

*Reg. U. S. Pat. Off.



RADIO CORPORATION of AMERICA
TEST EQUIPMENT
HARRISON, N. J.

WORLD WIDE ACCLAIM!!

By Thousands of
Service Technicians
Using This New
**RCP MODEL 807
COMBINATION
TUBE & SET TESTER**



This advance design combines all of the features of new Model 323 Free Point Dyn-optimum Tube Tester with a complete modern multitester set and condenser tester.

\$76⁹⁵

Has unique advantages of burnout protection. Power Supply has fuse protection and meter has fuse protection.

RCP's reputation for value in combination tube and set testers is not only nation wide but world wide. Thousands and thousands of the 800 series testers are in use. New Model 807 is the best of all in performance and value.

Tube Tester—identical to Model 323. Condenser tester tests paper-mica and electrolytic condensers for leakage.

MULTITESTER RANGES:

DC VOLTMETER—0-10-50-500-1000-2500.

AC VOLTMETER—0-10-50-500-1000-2500.

DC MILLIAMMETER—0-10-100-1000.

DC AMMETER—0-10.

DECIBEL METER—8 to +15, 15 to 29, 29 to 49, 32 to 55.

OHMMETER—0-500-5000 ohms, 0-0.1-1-10 megohms.

Housed in handsome hand-rubbed carrying case with test leads—batteries, etc.—complete, ready to operate. Size 12½ x 12¾ x 4¾ inches. Weight 12¼ lbs.

See this powerful combination tube and set tester TODAY! Available at your distributor. Insist on RCP instruments. Write for Catalog RD-11.

RADIO CITY PRODUCTS CO., INC.

152 West 25th St.  New York 1, N. Y.

ASSOCIATIONS

[from page 28]

been appointed to select nominees for new offices for 1952.

Radio Servicemen's Association Of Trenton, New Jersey

In order to promote a more progressive and active program within the association for the benefit of its members, a series of technical and business lectures have been arranged for and will be held in the studios of the local broadcasting stations. Gibson Grandly of Trenton has been appointed Chairman of the new membership committee and already good results have been obtained. Membership is now open to all Radio and Television technicians and service dealers in the Metropolitan area of Trenton.

Long Island Television And Radio Technicians Guild

The Long Island Television and Radio Technicians Guild president, Eugene Laper had appointed a nominating committee to select officers for 1952. A series of lectures are being arranged for by the Educational Committee on Television and Radio servicing as a business. The Long Island Television and Radio Technicians Guild has decided to make a bigger effort to take a more active part in the Empire Federation and in the National Electronic Technicians and Service Dealers Association.

Kingston Radio Servicemen's Association

The officers of the Association under leadership of their President, Raymond E. Trumpait will undertake a campaign to visit all technicians and service dealers in the area to obtain additional membership. A program of a series of lectures and social events are being scheduled for 1952.

Philadelphia Radio Servicemen's Association

The Philadelphia Radio Servicemen's Association is preparing a program of public relations to be carried directly to the homes of the thousands of customers serviced daily by Philadelphia Radio Servicemen's Association members. The magazine committee is now completing the mailing list which will include most of the four thousand members in the State Federation and the officers of a hundred or more individual Radio and Television Technicians and Service Dealers Associations throughout the country. The Philadelphia Radio Servicemen's Association News which is the voice of the local servicemen will, therefore, be available to all those interested.

Copies can be obtained by writing to Mr. Stan Myers, 1643 S. Wilton Street, Philadelphia 43, Pa.

Mid-State Radio Servicemen's Association Of Harrisburg

The Association and its membership have attended a series of technical lectures sponsored by R.C.A. in September, General Electric in October and Raytheon in November. The Raytheon lectures were one of the finest that we have received in a long time. In addition to the hundred or more members who were present, there were scores of invited technicians from Harrisburg and surrounding areas. In December we will have John Rider. Due to this series of interesting and educational talks, we have managed to increase our membership.

Lackawanna Radio Technicians Association

The Lackawanna Radio Technicians Association has just completed part of its series in the State Federation's technical meetings. The men are contemplating a new advertising and publicity campaign for its entire membership through newspapers and radio ads. The election of new officers at the last meeting and the committee heads will again promote an active program for the Lackawanna technicians.

Blair County Association Of Radio Service Engineers

Through the promotion of our technical talks to the technicians in the surrounding area, our membership committee obtained in the past six months over thirty-five new members. Our delegates to the State Federation brought us a series of additional business and technical programs which we hope to round out the balance of the year, a publicity campaign to promote the association emblem and the public is now under advisement.

SYNC PULSES

[from page 12]

music loving public would benefit, and common sense servicing could be managed without technicians needing a course at M.I.T. just to change a phono needle or cartridge.

As a passing thought, RTMA would be wise in reviewing the TV picture tube situation too. Here again standards and restrictions as to number of types are needed. Well over 100 different kinds of C-R tubes are produced by major tube manufacturers who have had to kow tow to the whims of engineers. One jobber recently told us that he needs a warehouse 87 times as large as his store just in order to



"Say, Bill! Have you subscribed to Rider's NEW monthly TEK-FILE service? It's the hottest thing to ever hit the servicing field. It's just like carrying Rider TV Manuals around in my pocket."

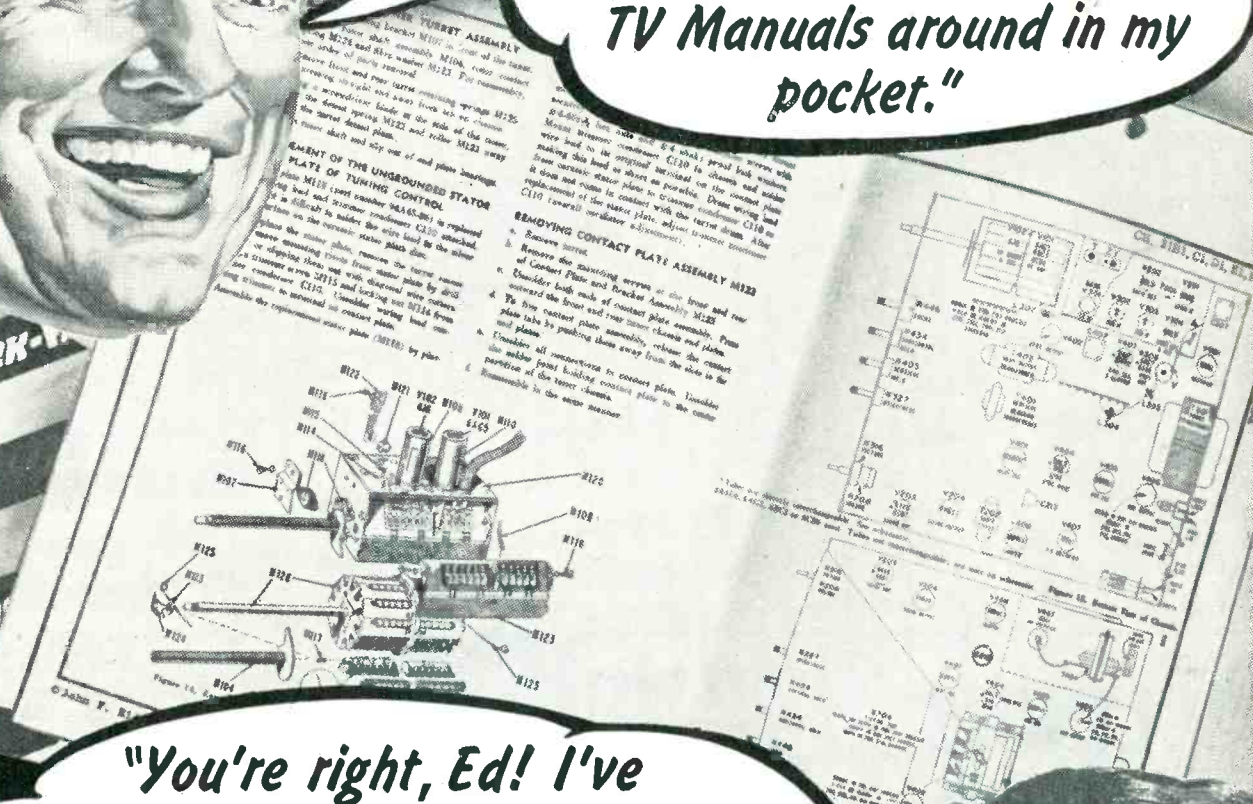

"You're right, Ed! I've never seen so much really useful TV information....and each manufacturer's data is individually bound in separate file folders. An average of 160 pages for only \$2.00! All production runs are covered—and the data matches the set I'm working on!"

Listen friends: take a tip from Bill and Ed—ask your jobber for Tek-File, today!

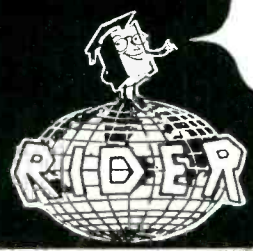

**JOHN F. RIDER Publisher, Inc.
480 Canal Street, New York 13, N. Y.**

carry a representative stock of replacement picture tubes. This same jobber contends he could handle a proper C-R tube inventory in 8,000 square feet of space if only 30 TV tube types were made, and that his overhead would be reduced so much that he could do justice to the thousands of other items that must now be neglected because of store space limitations.

Harry Kalker, *prexy of Sprague Products Co.*, is currently running full page advertisements in radio trade journals explaining how unjustly maligned is the radio-TV service profession, and how the public misjudges the integrity of radiomen as compared to other professional men whose stock in trade is Know-How. Other manufacturers have made the same sort of educational effort from time to time, and more should do it in the future.

TRADE FLASHES

[from page 10]

The sleeve is perforated in the center, so that it may be easily broken apart. Each half then makes a complete drawer tray unit, containing an assortment of 5 different capacity Erie

Ceramicons, with 5 of each capacity in separate polyethylene bags. The 25 Ceramicons make a practical assortment for the retail dealer and the service man.

UHF

[from page 25]

tube is used with a special low capacity socket and careful selection of heater chokes permits operation throughout the range. It is a property of u-h-f oscillators to have certain frequency portions at which the tube stops oscillating. These portions are known as holes in the tuning range. This circuit provides complete operation over the entire range and is thus free from holes. Warm-up period for the oscillator varies with tubes and is about one minute after the plate voltage is applied if the heaters are first warmed up.

Other features of this unit are the balanced output, through L-9 and the wafer switch and the power supply. A self-contained supply is used both to simplify connections to the receiver and prevent loading the power supply of the v-h-f receiver.

TRADE LIT

[from page 30]

weight for use in military equipment, *Triad Bulletin 451*, recently released, announces the addition of miniature transformers for portable equipment, voice frequency audio components, power transformers (combined plate and filament), filament transformers and filter reactors.

Use of the 380-1500 cycle line frequencies for power equipment permits notable reduction in size of transformers and reactors; new developments in core materials and new winding and impregnating technique permit further reduction.

Copies of Bulletin 451 containing detailed specifications, illustrations and prices may be obtained by writing *Triad Transformer Manufacturing Co.*, 2254 Sepulveda Blvd., Los Angeles 64, California.

CIRCUIT COURT

[from page 27]

nal is taken off the voltage divider network R49, R61 and R75 in the grid circuit of V6, which is the video amplifier. This signal is fed to grid 1 of the 6BE6. The normal operating bias of this tube is thus determined by the size of the signal. The amount of signal taken off from R49 of the network can be regulated by adjustment of R75. This allows for conditions in the fringe area, where more sync is desired. Under normal conditions the biasing signal is approximately 2 volts peak-to-peak. This establishes a bias on grid 1 in the order of -2 volts. We then take off the amplified pulse from the plate of V6 and feed it through C18 and R55 to grid 3 of the 6BE6. This signal is approximately 40 volts peak-to-peak and is positive going. Thus grid 3 tends to act as the signal grid and grid 1 acts as a d-c bias grid. The net result, for weak and strong signal inputs, are shown in *Fig. 3a and 3b*. The plate of the 6BE6 runs at approximately 25½ volts positive. In this manner, we get clipping of the tops of the sync pulse and we also have the bottom portion of the blanking pulse cut off as it will generally occur below the cut-off level. (see *Fig. 3a and 3b*)

On some weak signals, there might be a tendency for disturbance of the sync by noise imposed on the blanking

ILLINOIS ELECTROLYTIC CAPACITORS

of "Time Tested Quality"
for every electronic application

Seventeen years of production experience, making millions of quality capacitors, has created this complete, outstanding ILLINOIS CONDENSER line. There's a full Jobber line of capacitors for every TV and radio replacement purpose; capacitors for the entire electronics industry—capacitors that meet the highest standards of dependability.

This engineering and manufacturing experience enables ILLINOIS CONDENSER COMPANY to meet every demand for new capacitor types, whether for peace or defense applications.

Write for catalog or tell us your needs. There is an ILLINOIS ELECTROLYTIC CAPACITOR exactly suited for the job—a capacitor of "Time Tested Quality".



ILLINOIS CONDENSER CO.
1616 NORTH THROOP STREET • CHICAGO 22, ILL.

EXPORT DIVISION: 15 Moore St., New York 4, N. Y., U. S. A.
CABLE ADDRESS: "MINTHORNE"



Competence

is the word for Model 3432

Take it at face value, and you can't be wrong! The big, BIG no-glare illuminated dial, the fine control Output Attenuator, the wide frequency range, improved shielding to control radiation, and other performance features—all proved for action and accuracy. Give it the bench test—you'll find more competence packed in its handsome metal case than any test oscillator you ever used. It's double-copper shielded and individually calibrated against precise crystal standards. It is competent every step of the way.

Extra-Large Dial
Seven long 330° scales for easy reading at any spot on the dial. All Illuminated—no glare. Top scale is 16" long. Dial has 10 to 1 ratio vernier tuning.

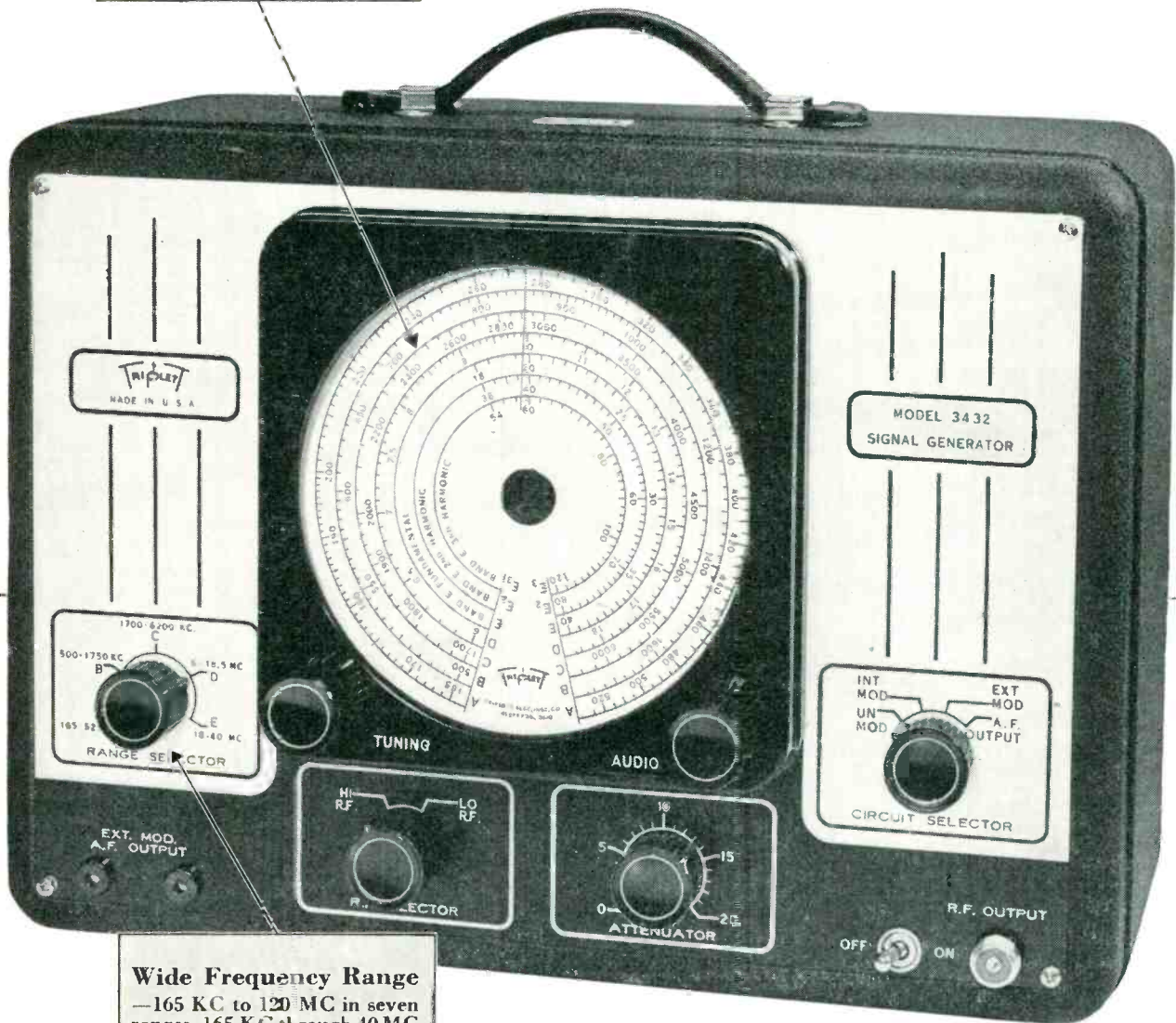

Wide Frequency Range
—165 KC to 120 MC in seven ranges. 165 KC through 40 MC fundamentals; through 120 MC by strong harmonics.

ONLY \$79.50 at your Distributor
(Price subject to change)

FOR THE MAN WHO TAKES PRIDE IN HIS WORK

Triplet

TRIPLET ELECTRICAL INSTRUMENT CO., BLUFFTON, OHIO, U. S. A.

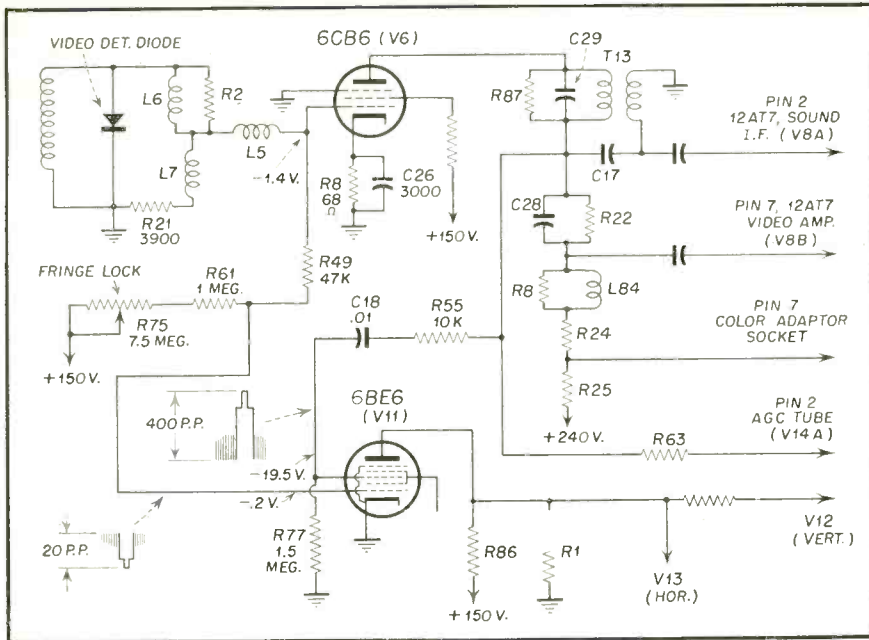

Fig. 2. Partial schematic of Zenith 20J21 receiver.

pulse only. The amount of noise interference as a result of this can be considered negligible, compared to systems which due to incomplete clipping allow noise on the sync pulse itself to ride through and falsely trigger the sweep circuits. On strong

signals, the biasing point is set at a more negative level so that cut-off occurs above the blanking pulse level. The plate circuit, however, still clips the top of the sync pulse. Occasionally, strong noise pulses appearing on the sync pulse going into grid 1 will tend

to drive the tube momentarily to bias below cut-off. While this will cause a stoppage of sync pulses to the horizontal and vertical oscillators for the period of a few lines, the fly-wheel action of the oscillators will keep them at approximately the correct sweep frequencies until the sync clipper starts conduction again.

The d-c voltages in the circuit are obtained by conventional methods. The plate voltage of the 6BE6 is kept low by means of the bleeder network R86 and R1 between ground and +150. The second and fourth grids are kept at a low voltage by means of the load resistor R79 a 39K resistor going to +150. The bias on the third or signal grid is obtained by grid leak action through R77, a 1.5 meg. resistor. This bias is in the order of -19 volts. The cathode is grounded.

FEMME TOUCH

[from page 26]

simonizing the company truck, etc. I get two bucks and more for every dial cord I replace, and I've learned a trick or two since the fishing tackle episode. Armed with a diagram book of every dial cord ever threaded, three weights of genuine "Nylon" dial cord, and my ever loving Scotch tape, I look forward to Hank's "I've got a job for you honey."

A little trick I've picked up is to thread your cord through your pulleys, around your posts, thither and yon as the diagram shows, and when you get to the point where you have to stop and look at the diagram again, or stop to fiddle with the spring, which still jumps around a few dozen times on me, Scotch tape your cord down onto the chassis as far as you are on both lines when you are ready to call "Uncle". This will hold your cord exactly as it was strung, without slipping, until the fiddle work has slipped into place. Then remove the Scotch tape and hope she rides the rail.

I was going to tell you about the time I pasted a very healthy picture of Dagmar onto a stray picture tube I thought was just taking up room, but I have to go now.

MEN OF RADIO

[from page 25]

leading television pioneer. One result was a patent license arrangement with the American Telephone and

Insure BETTER Television Service to Your Customers! ... Exclusively Designed



HIGH VOLTAGE AND ELECTROLYTIC TUBULAR TELEVISION CAPACITORS

Especially Engineered for Television Circuits by INDUSTRIAL CONDENSER CORP.

The economical quality line for replacement. Industrial Condenser Corp., manufacturers of Capacitors exclusively brings you highest quality for the particular requirements of Television at exceptionally attractive prices! Special Capacitors are Pyroteen impregnated for low power factor, high insulation resistance, high operating temperatures. Oil, Pyroteen, Wax and Electrolytic Capacitors. Finest materials throughout.

Ask Your Jobber for our Attractive Prices Today!

Or write for Bulletin 1095. Industrial makes quality Capacitors for Television, Radio, every electronic and industrial application—all types.

Send for Complete Catalog

INDUSTRIAL CONDENSER CORP.

3243 N. CALIFORNIA AVENUE CHICAGO 18, ILLINOIS
Sales offices in principal cities.



Modern plant built by Industrial Condenser Corp., for manufacture of Capacitors only.

Address Change...

Subscribers to SERVICE DEALER should notify our Circulation Dept. at least 5 weeks in advance regarding any change in address. The Post Office Dept. does not forward magazines sent to a wrong destination unless you pay additional postage. We cannot duplicate copies sent to your old residence.

RADIO-TELEVISION SERVICE DEALER, 67 West 44th St., New York 18, N. Y.

Telegraph Company, formally signed on July 22 of that year. The inventor then had at least 150 patents to his credit, although he was only 31.

Dr. Vladimir K. Zworykin

By that time, competition between Farnsworth and Zworykin, of RCA, began to be evident and inevitable. Zworykin had developed the iconoscope camera tube which, although more sensitive than the dissector, was judged to be somewhat inferior in definition. While Zworykin was responsible for the principle of interlaced scanning, Farnsworth had straight-line scanning to his credit, as well as the use of the saw-tooth wave form.

With the purchase of the Capehart Company in 1939, the Farnsworth group actively engaged in the manufacture of home receivers. Later that year, RCA decided that the Farnsworth patents were vitally important to them, and Farnsworth and his financiers felt that an RCA licensing arrangement was desirable. Accordingly, an agreement was entered into whereby Farnsworth was to be paid continuing royalties for the use of his patents; this was probably the first time that RCA had acquired patents under such an arrangement.

Final perfection of the television camera tube, plus considerable research in the reception field was the contribution of Dr. Vladimir K. Zworykin, of RCA. Dr. Zworykin was born in Mourom, Russia, in 1889. He received part of his education at the Leningrad Technological Institute, under Boris Von Rosing, who devised a method of modulating the electron stream of the cathode ray tube. During this period Zworykin came to a full realization of the potentialities of cathode ray tubes and it is certain that from his work he gained a great deal of inspiration that later influenced his efforts in the field of television.

For a period following his studies in Russia, he was engaged in X-ray research in Paris, and at the beginning of World War I returned to Russia to serve as an officer in the Russian Army Signal Corps. At the end of the war he came to the United States and for a time worked as a bookkeeper at the Russian Embassy. He became a citizen of this country in the legal minimum of time, and shortly joined the research staff of the Westinghouse Electric and Manufacturing Company. Later he became associated with the Radio Corporation of America as Director of the Electronic Research Laboratory.

Within a few years after his arrival

in this country, Dr. Zworykin became interested in photoelectric emission; in fact, in 1926 he was awarded a doctorate by the University of Pittsburgh based upon a thesis describing the limitations of the then existing photocells and methods of improvement. His monumental work: "Photocells and Their Application" appeared in 1932 and is still a classic.

Between 1924 and 1929, Zworykin developed the iconoscope tube, but the patent on this device was not issued until December of 1938, due to interference proceedings. That the iconoscope was far more sensitive than Farnsworth's dissector tube,

there can be little doubt. A comparison of the amount of light required to actuate both tubes is in the ratio of 400 to 1; in other words, using standard 35-millimeter film the dissector needed 400 times as much light as the iconoscope. On the other hand, the dissector provided improved clarity, as has been noted earlier. The orthicon and the image orthicon, developed by Rose and his associates, of RCA, provided an even further reduction in the amount of light needed. The image orthicon will pick up a satisfactory image when the illumination is only 1/500th that needed to operate the iconoscope; to put it in

"CONICAL-V-BEAMS" *REGISTERED TRADE MARK

Keep in Step WITH ANTENNA PROGRESS

-INSTALL *Telrex*
"CONICAL-V-BEAMS"

for finer TV performance in every type of signal area!



Near or far, you can rely on Telrex "Conical-V-Beams" for full audio and video bandpass, high gain and high signal to noise ratio. Telrex quality of construction assures a lasting installation, full customer satisfaction and a minimum of service callbacks. Don't settle for less than the best! Check with Telrex on your next antenna requirements. Write for latest catalogs.



TELREX MODEL 8X-TV Famous for high gain. Will out-perform any other type antenna. "If the 8X-TV does not provide a usable signal, TV reception is impractical."

"CONICAL-V-BEAMS" are produced under Re-issue Patent No. 23,346

THE SKILL TO DESIGN...
THE FACILITIES TO PRODUCE...
THE ABILITY TO DELIVER

CANADIAN AND FOREIGN PATENTS PENDING



AMERICA'S STANDARD OF COMPARISON

Telrex INC.

CONICAL-V-BEAMS

ASBURY PARK 5, NEW JERSEY

other terms, the image orthicon will permit picking up television scenes with as little light as that provided by a candle.

Though there is little question but that Zworykin invented a more sensitive television camera tube than did Farnsworth, there still remains the problem of who first conceived and developed the idea of such a tube. As we have already learned, Farnsworth first thought of the principle about 1921 and his first demonstration took place about 1927. Dr. Zworykin claims, in an article written by him for Encyclopedia Americana, that he invented the iconoscope in 1923 and that it was "the earliest in conception of all practical television pickup tubes". In the same article he goes on to say that the image dissector was invented by Farnsworth in 1928.

Zworykin's intensive research in electronic optics led to the invention of the electron microscope, capable of magnification of more than a hundred times greater than that of the best optical microscope. It is now a versatile tool of science, serving in hundreds of laboratories throughout the world.

TROUBLE?

[from page 21]

receiver as well as in the sync action.

2. ^c Under normal operation, the vertical sync pulses are not seen on the screen since they appear during the blanking interval between fields. However, it is simple to set the receiver to observe the vertical blanking and sync pulses on the screen of the picture tube by a few adjustments. 1) Turn up brightness. 2) Turn down contrast so the picture is greyish. 3) Rotate the vertical hold so the picture moves down slowly along the screen. Under such conditions, the blanking interval between fields which is usually not seen, becomes visible, Fig. 2. Also visible are the vertical sync and equalizing pulses. The blanking level should be darker than any section of the picture, since it is more negative compared to any picture information, Fig. 1. In the same way, the vertical sync and equalizing pulses should be the darkest parts of the screen since they represent the most negative parts of the signal coming to the screen. If the sync pulses are not darker or

if they are not visible, Fig. 6, it means the sync pulses are lost before they come to the picture tube. In such a case, the trouble would be indicated in the video strip rather than the sync section. On the other hand, if the

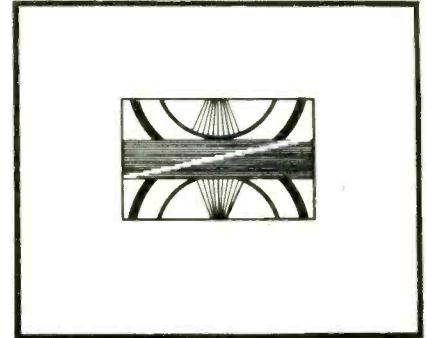

Fig. 6. Loss of vertical sync pulses in video strip. This is indicated by a) blanking pulses which are not darker than any other video information in the picture, and b) equalizing and sync pulses which are barely visible.

observed pulses are blacker than all other parts of the picture, Fig. 2, it indicates that sync pulses of the proper amplitude are coming in to the picture tube. The video strip must

THIS IS IT! THE RELAY

WITH *Interchangeable Coil*
FOR A WIDE RANGE OF RADIO APPLICATIONS

GUARDIAN Series 200

Interchangeable
COIL and CONTACT
Switch Assembly

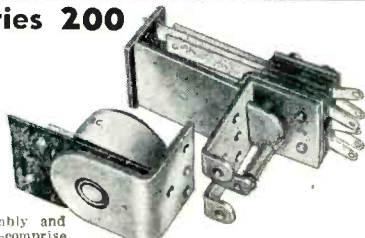

Two basic parts—a coil assembly and a contact switch assembly—comprise this simple, yet versatile relay. The coil assembly consists of the coil and field piece. The contact assembly consists of switch blades, armature, return spring and mounting bracket. The new Guardian Midget Contact Assembly which is interchangeable with the Standard Series 200 coil assembly, is also available in either single pole, double throw; or double pole, double throw.

CONTACT SWITCH ASSEMBLIES

CAT. NO.	TYPE	COMBINATION	
200-1	Standard	Single Pole	Double Throw
200-2	Standard	Double Pole	Double Throw
200-3	Contact Switch		
200-4	Parts Kit		
200-M1	Standard	Double Pole	Double Throw
200-M2	Midget	Single Pole	Double Throw
200-M3	Midget Contact Switch	Double Pole	Double Throw
		Parts Kit	

13 COIL ASSEMBLIES

A.C. COILS*		D.C. COILS	
CAT. NO.	VOLTS	CAT. NO.	VOLTS
200-6A	6 A.C.	200-6D	6 D.C.
200-12A	12 A.C.	200-12D	12 D.C.
200-24A	24 A.C.	200-24D	24 D.C.
200-115A	115 A.C.	200-32D	32 D.C.
		200-110D	110 D.C.

*All A.C. coils available in 25 and 60 cycles

GUARDIAN ELECTRIC

1606-P W. WALNUT STREET

CHICAGO 12, ILLINOIS

A COMPLETE LINE OF RELAYS SERVING RADIO AMATEURS

HICKOK



Model 215

Latest Design VACUUM TUBE VOLTMETER

features:

- Accurate Peak-to-Peak measurements
- Portable, shock-resistant case
- Large 5", easy-to-read meter
- Zero-Center scale

INCLUDES:

- Exclusive, New Single-Unit AC-DC Probe

DC VOLTMETER

Volts: 0-1200 in 7 ranges
Input Resistance: 10 megohms

OHMMETER

Design Center: 10 ohms
Readability 0.2 ohm to 1000 meg.

Provides the sensitivity and ranges for quick, accurate measurements of sine or complex waves of electronic devices. Test leads are included. Write for full details today.

AC VOLTMETER

AC, RMS: 0-1200 in 7 ranges
AC, Peak-to-Peak: 0-3200 in 7 ranges
Frequency Characteristics: 40 cps to 3.5 MC, and to 250 MC with crystal probe
Input Impedance: 30 meg. shunted by 150 uuf with dual-probe furnished.

THE HICKOK ELECTRICAL INSTRUMENT COMPANY
10533 Dupont Avenue • Cleveland 8, Ohio



SAVE Up to \$1.00 each.

**Form a Group,
Service Dealers**

Subscribe to "RTSD"—

"The Professional Radio-Television man's Magazine"— published monthly. All articles are exclusive and timely. Practically every issue is worth what an entire 1 year subscription costs.

The more in a group the bigger the savings. 6 men in a group save \$1.00 each; 4 men groups save \$.75 per man. Present "RTSD" subscribers may participate in or form a group with co-workers, or even competitors. Still active subscriptions are automatically extended 1 year. Start a Group today! The timely and exclusive technical data appearing in future issues of "RTSD" will make this the best investment you ever made. The special Group Rate offer may be withdrawn at any time—so hurry.

Use This Coupon For Convenience

(The coupon below can be used for from 1 to 6 subscription orders. Use it today!)



TEAR OUT — MAIL TODAY

RADIO-TELEVISION SERVICE DEALER
67 West 44th Street, New York 18, N. Y.

Please enter 1 year subscription orders for the names given below. Our remittance is enclosed.

NOTE: If you do not wish to tear this order blank out, just print or type the information on a single sheet of paper, following the style given. Each subscriber's occupation must be clearly described.

	In U.S.A. & Canada	Foreign Rates
<input type="checkbox"/> One 1-year subscription	\$2.00	\$3.00
<input type="checkbox"/> Two 1-year subscriptions, each	1.75	2.75
<input type="checkbox"/> Three 1-year subscriptions, "	1.50	2.50
<input type="checkbox"/> Four 1-year subscriptions, "	1.25	2.25
<input type="checkbox"/> Five 1-year subscriptions, "	1.10	2.00
<input type="checkbox"/> Six 1-year subscriptions, "	1.00	1.50

Name
Address

Describe Title or Position and Type of Business

State whether a New Subscriber or Renewal Order

Name
Address

Describe Title or Position and Type of Business

State whether a New Subscriber or Renewal Order

Name
Address

Describe Title or Position and Type of Business

State whether a New Subscriber or Renewal Order

Name
Address

Describe Title or Position and Type of Business

State whether a New Subscriber or Renewal Order

Name
Address

Describe Title or Position and Type of Business

State whether a New Subscriber or Renewal Order

Name
Address

Describe Title or Position and Type of Business

State whether a New Subscriber or Renewal Order

how to choose a high fidelity loudspeaker

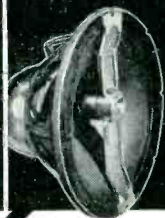

Jensen
WIDE RANGE



G-610
TRIAXIAL
3-WAY
SINGLE-UNIT
DIRECT RADIATOR
TYPES (5"-15")

"Genuine Jensen Wide Range" means much more than wide frequency range—it means superior performance all the way—in every attribute that makes for enhanced listening pleasure: 1. Wide Frequency Range . . . 2. Balanced Frequency Response . . . 3. Smooth Response . . . 4. Wide Angle Distribution . . . 5. Low distortion . . . 6. Good Efficiency . . . 7. Adequate Power-Handling Capacity.

Whatever the cost or size, a choice from the Genuine Jensen Wide Range series insures a maximum of performance to today's new high fidelity standards.

Write for free booklet—"Let Music Come to Life"—it includes a listing of Genuine Jensen Wide Range loudspeakers.

Jensen

MANUFACTURING COMPANY
Division of the Muter Company
Export Department at the Factory
6601 S. Laramie • Chicago 38, Illinois

BURTON BROWNE ADVERTISING

therefore be O.K. and any loss of sync must be due to a defective condition beyond this point—that is, in the sync section.

Use of a VTVM in the video strip will give no important information concerning the presence of sync pulses. It is not necessary to apply a scope to all the video and sync circuits to obtain the desired information. The same information can be obtained by simply applying the scope to the plate of the video amplifier stage. It can then be determined if good sync pulses are present at this point. A signal generator would not give the desired information concerning sync pulses in a simple gain check. Checking the negative voltage on the grid of the video detector would be rather difficult since video detectors are generally diodes, which, needless to say, have no grids.

3. ^c

The input to the grid of the sync phase inverter, V401B, 1/26SN7, is O.K. Practically no output is observed on the cathode or plate of this stage.

4. •

The change of value of R424 accounts for the incorrect voltage and resistance readings. The high cathode voltage (+103 v.) is caused by the tube current going through the large amount of cathode resistance. This is added to the approximately 60 v. of cathode voltage resulting from the voltage dividing effect of connecting R425, 12K, and R422, 15K, in series across +135 v. (Fig. 3). The other cathode resistors are returned to the point between these two resistors, point A. As a result of this voltage divider, +60 v. is measured on the cathode when the tube is out of the socket. Since the grid resistor, R421, 8.2M, returns to point B, there is also +60 v. measured on the control grid when the tube is out of the socket. Under normal conditions, the control grid voltage is less positive than the cathode (+25 v.) This occurs because the large positive sync pulses coming in on the grid draw grid current and charge C410, the .01 μ f, coupling condenser. C410 then discharges through R421, the grid return, to provide grid leak bias during the intervals between pulses. The top of R421 becomes negative compared to the bottom end. However, because of the large increase in cathode resistance, the tube cannot operate normally.

A shorted coupling condenser, C410, would make the control grid voltage more positive than the cathode of the sync inverter stage. It would also reduce the resistance reading from the control grid to a much lower figure

than the observed reading. If C413 were leaky, this would cause a positive voltage to appear on the grid (pin 1) of the horizontal oscillator. A substantial positive voltage on this grid would cause the tube to conduct heavily and probably prevent the oscillator from operating. This would cause a blank screen, since the receiver uses a flyback high voltage system. In addition, a leaky C413 would not explain the abnormally high voltage measured at the cathode of V401B.

A shorted C403 in the integrating circuit would not produce the high cathode voltage. An open R423 would cause a higher than normal cathode voltage but the reading on the control grid would then be only +60 v., rather than the observed reading. None of these other possible troubles would account for the observed resistance readings from cathode to ground or from point B to ground.

R-C NETWORKS

[from page 18]

the number of stages to which the a-g-c voltage is fed. Usually a series resistor precedes each grid to which a-g-c is applied and such a resistor is always accompanied by the necessary filter capacitor to ground. The capacitors must have sufficient capacity to filter out not only the high frequency components of the video signal, but also the lower frequencies which include vertical and horizontal sync pulses.

When any one of the capacitors become shorted it will, of course, ground the a-g-c voltage. This means that none of the tubes would be getting controlled bias and the a-g-c function is lost. Besides this, overloading will occur with the stronger television stations and the picture may become excessively contrasty or dark, and may even turn negative. If capacitors open, inadequate filtering may result and picture contrast levels vary. An open resistor would, of course, also remove a-g-c from stages following the resistor.

The components can again be easily checked with a VTVM, and a voltmeter can be placed from the AGC line to ground. When a VTVM is placed across the line a negative voltage should appear when a station is tuned in.

Ratio Detector R-C Filter

Another important filter network is used in the ratio detector of the television sound section. In contrast to the discriminator type of detector

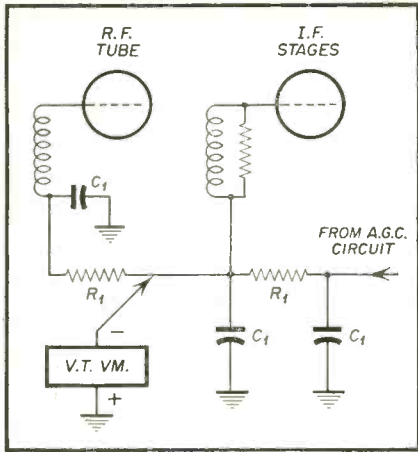

Fig. 8. Filter network in a-g-c systems.

where a limiter is used to clip noise and AM signals, the ratio detector uses a long time constant filter as shown in Fig. 9. Inasmuch as low voltage is present the resistor gives little trouble, though ageing will affect the leakage resistance factor of the capacitor. When this occurs the capacitor is no longer able to filter the

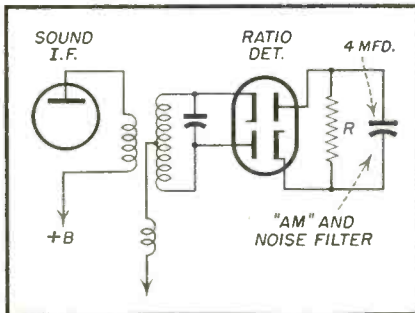

Fig. 9. Noise suppression network in FM detector.

noise components and these will appear from the loudspeaker. A defective ratio detector noise filter network will also increase the tendency for inter-carrier buzz. Any such capacitors having an appreciable leakage should be replaced by a new one. Electrolytic type of capacitors do not have as high an initial resistance as the paper or mica type, and some new electrolytic types have a leakage resistance as low as 200,000 ohms when ohmmeter test prods are applied. When reversing the test prods a different ohmic reading will be obtained because the electrolytic capacitors pass more current through them in one direction than in the other.

Leakage resistance also depends on the size of the capacitor. In general, however, they should be replaced if their ohmic reading is less than 100,000 ohms. As with other capacitors

AEROVOX Twist Prong Base ELECTROLYTICS



GREATER SELECTION OF VOLTAGE, CAPACITANCE AND SECTION COMBINATIONS . . .

• Don't improvise! With Aerovox Type AFH (85° C. for TV) twist-prong base electrolytics you can select just that combination of voltages, capacitances and sections required. In singles, duals, triples and quads. Over 200 different numbers to choose from.

Prongs extend down through mounting washer and are

twisted to hold capacitor in place. All connections to terminals except the cathode attached to container. Metal or fiber washers supplied for grounded or insulated can.

Ask your jobber for Aerovox Type AF electrolytics. Consult Aerovox listings for the exact combination you need.



CAPACITORS • VIBRATORS • TEST INSTRUMENTS

For Radio-Electronic and Industrial Applications

AEROVOX CORPORATION, NEW BEDFORD, MASS., U. S. A. • Sales Offices in All Principal Cities
Export: 41 E. 42nd St., New York 17, N. Y. • Cable: AEROCAP, N. Y. • In Canada: AEROVOX CANADA LTD., Hamilton, Ont.

Fringe Areas!

Brach Air General gives more gain than a stacked yagi, on every TV channel!

Tested... best performance. Strongest construction. Air General, Brach TA-450 is the only antenna tested to give you highest gain... withstand high winds, and ice loading. Has non-hygroscopic high-impact insulators; rugged triangular construction; quick rig assembly... and other exclusive features. Guaranteed highest DB gain on all channels... better than any yagi. Order today!

FREE Send for new booklet, "How to get the most out of fringe area installations" by Ira Kamen, leading TV antenna authority.

Brach MANUFACTURING CORP.
200 Central Ave., Newark 4, N. J.

Be Safe! Be Sure!

with a FULL-SIZED VEE-D-X ARRESTER

COSTS NO MORE THAN A MIDGET

2 WIRE RW-200	4 WIRE RW-204
\$125 LIST	\$150 LIST

2-WIRE RW-300 \$200 LIST

For extra heavy duty. An air gap plus resistors provide double protection.

THE LaPOINTE-PLASCOMOLD CORP.
Windsor Locks, Conn.

IT'S SENSATIONAL!

**CLEAR BEAM'S
NEW ALL-CHANNEL
RHOMBIC**



Electronically Engineered for
**LONG DISTANCE
(DX) RECEPTION**
and Unusually
SHARP DIRECTIVITY
Over the Entire TV Spectrum

**Clear Beam
TV ANTENNAS & ACCESSORIES**

100 PROSPECT AVE., BURBANK, CALIF.
ROckwell 9-2141 CHArleston 0-4886

**PERFORMANCE
Not Size
IS WHAT COUNTS**

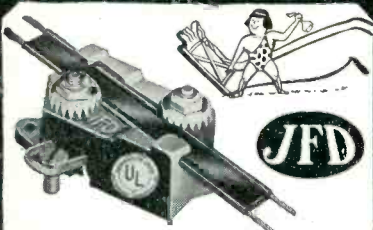

**"LITTLE GIANT"
LIGHTNING
ARRESTER**

**PROTECTS
Against Lightning Hazards**

No. AT 105 \$1.25 LIST
For ribbon-type and oval
jumbo twin lead.

ONLY JFD Lightning Arresters offer you these
exclusive patented features...

1. Strain-relief Retaining Lip prevents pulling or straining of lead against contact points.
2. You actually see positive contact made with lead-in wire.
3. No wire stripping or cutting.

Write for Form No. 84 showing the damage
lightning can do to a Television Installation.

JFD MANUFACTURING CO., Inc.
6125L 16th AVENUE, BROOKLYN 4, N. Y.
FIRST in Television Antennas and Accessories

these should be disconnected from the circuit when checking for leakage.

Decoupler R-C Filters

A very common R-C network is the "decoupler" type shown in Fig. 10. The purpose for this capacitor and resistor combination is to isolate all amplifier stages from another by preventing the common coupling which would occur because of the power supply feed line. This type of network is found in almost every stage of a television receiver where plus "B" is applied to the plate circuit. The decoupler capacitor and resistance combination are always below the load resistor, or below the tuned resonant circuit. In video amplifiers the decoupler circuit also improves low frequency response. At high frequencies the decoupler capacitor has a low reactance and shunts any signals which might appear across the decoupler resistor. At low frequencies, however, the reactance of the decoupler capacitor becomes high and shunts less and less signal from across the decoupler resistor. This means that at low frequencies the decoupler resistance is added to that of the load resistance and a larger signal voltage drop oc-

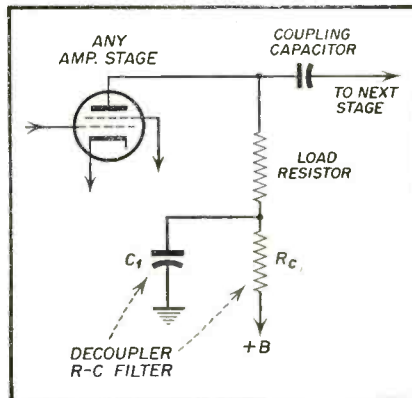

Fig. 10. Typical decoupling network.

curs. The same reasoning applies in the audio amplifier section and helps improve bass response.

If the decoupler capacitor opens there will be a decrease in low frequency output and interaction between stages may result. If the decoupler capacitor shorts it will usually overheat or burn out the decoupler resistor. Thus, a burnt-out decoupling resistor indicates the need for checking the associated capacitor for a shorted condition. Leakage and resistor values can be ascertained as previously detailed. A decrease in low frequency components in the video signal will cause trailing smears to appear to the right of medium or large size objects on the picture tube screen.

**IF YOU HAVEN'T RECEIVED
YOUR COPY OF THE NEW
1952 SOUTH RIVER
CATALOG**

on the World's Finest
Antenna Mounting Materials
just mailed to all
Jobbers, Dealers and
Service Men,

write

**SOUTH RIVER METAL
PRODUCTS CO., INC.**
South River, New Jersey

**\$1.00 to \$5.00 PAID
"for SHOP NOTES"**

Write up any "kinks" or "tricks-of-the-trade" in radio servicing that you have discovered. We will pay from \$1 to \$5 for such previously unpublished "SHOP NOTES" found acceptable. Send your data to "Shop Notes Editor," RADIO-TELEVISION SERVICE DEALER, 67 West 44 St., New York 18, N. Y. Unused manuscripts cannot be returned unless accompanied by stamped and addressed return envelope.

AD INDEX

Aerovox Corporation	47
Brach Manufacturing Corp.	47
Bussman Manufacturing Co.	11
Clarostat Mfg. Co., Inc.	13
Clear Beam Antennas	48
DuMont, Allen B. Lab., Inc.	33
Erie Resistor Corp.	36
Guardian Elec. Mfg. Co.	44
Hickok Elec. Instrument Co.	44
Hytron Radio & Electronics Co. (Div. of CBS)	16
Illinois Condenser Co.	40
Industrial Condenser Co.	42
International Resistance Co.	8, 9
Jensen Manufacturing Co.	46
JFD Manufacturing Co.	48
LaPointe-Plascomold Corp.	47
Mallory, P. R. & Co., Inc.	1
Ohmite Manufacturing Co.	6
Radiart Corporation	2
Radio City Products, Inc.	38
RCA Tube Dept.	
RCA Electron Tubes	Cover 4
RCA Test Equipment	37
RCA TV Components	10
RCA Institutes, Inc.	35
Regency Div., I.D.E.A., Inc.	Cover 3
Rider, John F. Publisher, Inc.	39
Sams, Howard W. & Co., Inc.	4
Schott, Walter L. Co.	14
Simpson Electric Company	7
Snyder Manufacturing Co.	12
South River Metal Products Co.	48
Sprague Products Co.	5
Sylvania Electric Products Co.	15
Telrex, Inc.	43
Thomas Electronics, Inc.	Cover 2
Triplett Elec. Instrument Co.	41

HIS CHOICE IS

Regency

CHARLIE GOLENPAUL
EMINENT DISTRIBUTOR SALES MANAGER
AEROVOX CORPORATION
PHOTOGRAPHED IN HIS HOME

LARGEST SELLING BOOSTER
AT ANY PRICE

BURTON BROWNE ADVERTISING

THE QUALITY OF RCA TUBES IS UNQUESTIONED



Extra Performance

as a matter of course...with RCA tubes

The RCA-developed "A" frame construction—used in 6 of the metal type r-f amplifiers—is one of the many improvements that contribute to the extra performance of RCA tubes.

The "A" frame—shown in red—consists of a top member, two vertical members, and a bottom cross member. The ribbed uprights are welded to the cross member... the feet of the uprights are welded to the grounded metal header. In effect a truss, this rigid "A" frame acts as the supporting member for the tube elements. Its increased resistance to vibration reduces the possibility of electrode displacement due to wear on the holes in the mica spacers... and thereby

plays an important role in reducing microphonics and maintaining uniform tube characteristics.

In addition to imparting rigidity to the tube elements, the top and bottom members of the "A" frame serve as shields. The two ears of the top member add to its effectiveness in reducing grid-to-plate capacitance... the tab on the lower member—which extends down to the stem—provides additional shielding between grid and plate leads.

The extra performance built into RCA tubes accounts for their high quality, long life, and dependability. They cost no more. Why not use them for your daily tube requirements?

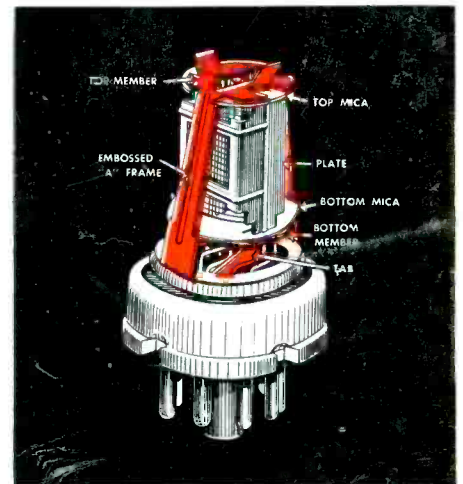

Keep informed—keep in touch with your RCA Tube Distributor



RADIO CORPORATION of AMERICA
ELECTRON TUBES
HARRISON, N. J.