

Radio
**SERVICE
DEALER**

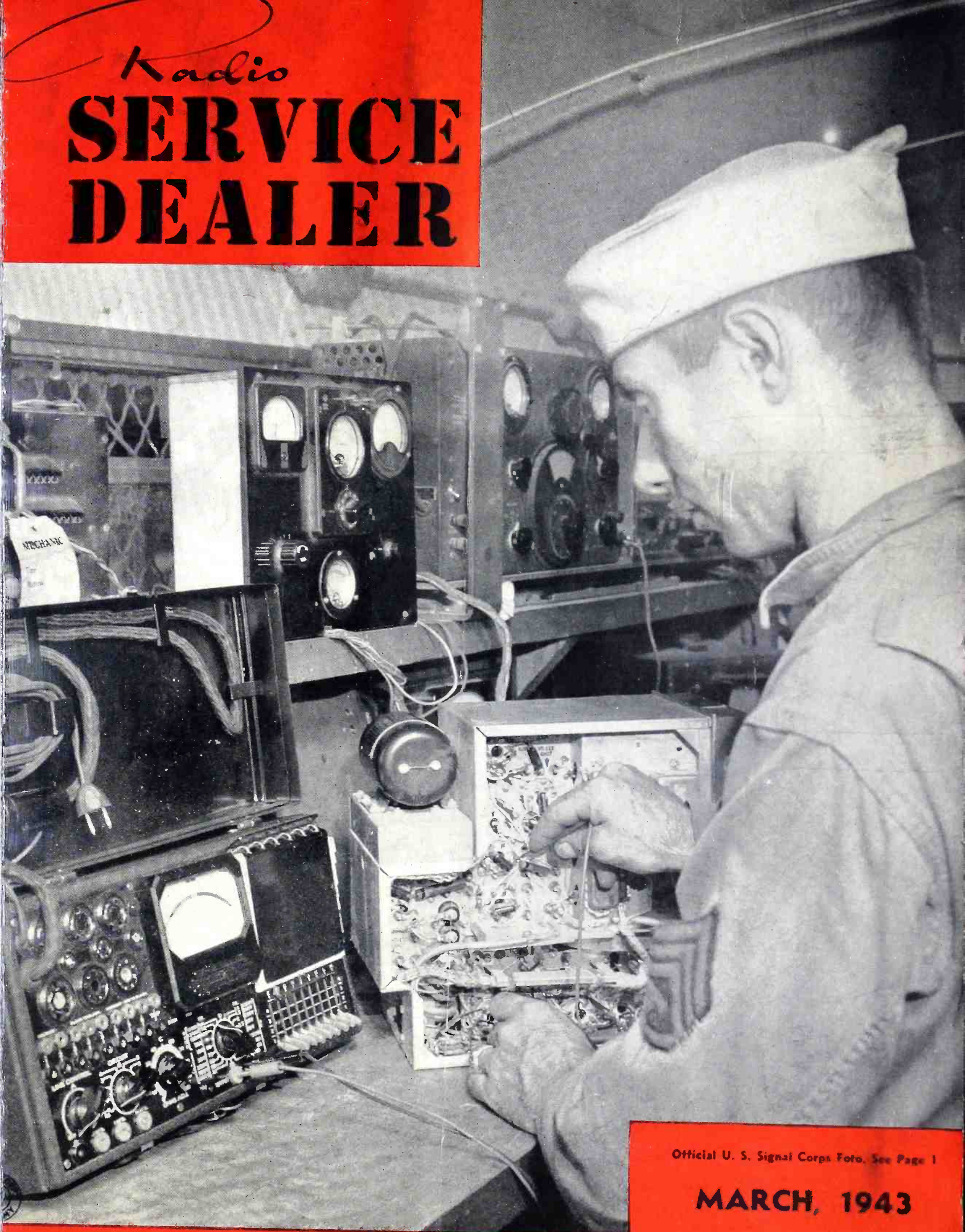

Official U. S. Signal Corps Photo. See Page 1

MARCH, 1943

RADIO-ELECTRONIC MAINTENANCE MEN



IMPORTANT NOTICE

to Radio Service Engineers,
Dealers and Hams
Who Are Entering the Service
of Our Armed Forces

A critical shortage of radio test equipment is seriously handicapping repair work in the civilian radio field.

Do not store your radio test equipment for the duration. It will only deteriorate and become obsolete.

Be patriotic. Sell your meters, signal generators and other test equipment so that it will be able to function efficiently where it will do the most good.

Now is the time when your test equipment will bring a fair price, and the money you receive, invested in War Bonds, will help you when the Victory comes.

If you do not know some one who needs your test equipment, list your inventory with your Mallory distributor. He will help you dispose of it to real advantage.

If you do not know his name, get in touch with us.

P. R. MALLORY & CO., Inc., INDIANAPOLIS, INDIANA

P. R. MALLORY & CO. Inc.
MALLORY



Approved Precision Products

Radio SERVICE-DEALER

SOUNDMAN AND JOBBER

Reg. U. S. Pat. Off.

Vol. 4, No. 3 ★ March 1943

Member of Audit Bureau
of Circulations



PUBLISHER
SANFORD R. COWAN

Advisory Editor
M. L. MUHLEMAN

Contributing Editors
JOHN H. POTTS **JOHN F. RIDER**
"On Leave" Major
U. S. Sig. Corps

News Analyst
A. N. BELKNAP

Circulation Manager
R. ALAN



Executive & Editorial Offices
132 West 43rd St., New York

Ad Index

Aerovox Corporation	34
Paper Tubular Condensers	
Allied Radio Corp.	35
New Buying Catalog	
Astatic Corporation, The	33
Radio Plugs, Sockets, Connectors	
Brach Mfg. Corp., L. S.	24
Antennas & Radio Parts	
Burt, W. R.	36
Tubes Wanted	
Centralab	34
Resistors, Switches, Capacitors	
Cinaudagraph Speakers, Inc.	31
"Mallard" Speakers	
Clarostat Mfg. Co., Inc.	35
Stabilized Element Controls	
General Industries Co., The	36
Replacement Phono-motors	
Guardian Electric Co.	32
Relays	
Hallicrafters	32
Communications Equipment	
International Resistance Co.	9
Volume Control Contest	
Ken-Rad Tube & Lamp Corp.	26
Radio Tubes	
Lafayette Radio Corp.	33
Replacement Parts & Kits	
Logan, Nelson	30
Tubes Wanted	
Mallory & Co., Inc., P. R., 2nd Cover	
A Patriotic Appeal	
Meissner Mfg. Co.	27
Radio Training Kits	
Polymet Condenser Co.	34
Replacement Condensers	
Racon Electric Co.	4
Horns, Trumpets & Speakers	
Radio Servicemen of Amer., Inc.	34
Brandex & Service Notes	
Raytheon Production Corp. 4th Cover	
Replacement Tubes	
RCA Mfg. Co., Inc. 3rd Cover	
"What Is Electronics"	
Rider, John F.	25
Rider Books & Manuals	
Simpson Electric Co.	15
Meters & Instruments	
Sprague Products Co.	13
"Trading-Post" & Condensers	
Standard Transformer Corp.	30
Replacement Transformers	
Triplett Elec. Co.	35
Instruments	
U. S. Treasury Dep't.	10
War Savings Bonds	
Utah Radio Products Co.	7
Radio Parts	
Weston Elec. Instru. Corp.	3
The Standards Are Weston	

Contents

Editorial	2
Watch The Kyser Case!	
Some Causes of Radio Noise	5
By John H. Potts	
Locating Intermittent Troubles	11
By H. F. Gulliver	
Technical Service Portfolio—XXVIII	16
Meters & Meter Substitutes	
Shop Notes:	
Oscillator Coil; repairing burned out sections	21
Substitute Signal Tracer; for testing rf-if sections	21
Crosley; Service suggestions on filters and resistors	21
General Electric 32-RLP; record-player adjustments	21
RCA—15-BP Series; tube burnouts in early models	21
Montgomery-Ward "Airline" 14 WG-808; freq. shift	21
Fada Model 119; gain data	23
Resistor Voltage-dropping Table	23
Salvaging Old A-B Batteries	23
Substitute for Aerial Wire	23
2 v. Power Supply Operates 1.4 v. Tubes	23
Converting Power Transformers Into Outputs	23
Model "L" Porta-Powr; repair, adjustments	23
Skyrover Model 519; gain data	23
Train For Civilian Defense	22
Victory Line Standards	27
Book Review:	
The Inductance Authority	27
The Stroboscope	28
Post-War Electronic Developments.	31

Cover Picture

(Official U. S. Signal Corps Photo)
During field maneuvers Sgt. Balsamelo tries a new tester in radio maintenance work. The "shop" is mobile, otherwise it is typical of any well equipped service bench. However, the apparatus repaired is quite different from that used by civilians. The Signal Corps still needs men. More on this subject appears on page 22.

Entire Contents Copyright 1943 by Cowan Publishing Corp.

All rights reserved—no part of this magazine may be reproduced in any form, by any means, or translated into foreign languages without permission in writing from the publisher.

RADIO SERVICE DEALER, published monthly at 34 N. Crystal Street, East Stroudsburg, Pa., by the Cowan Publishing Corp., Executive and Editorial Offices at 132 W. 43rd Street, New York, N. Y. Subscription rates—United States and Possessions, \$2.00 for 1 year, \$3.00 for 2 years; elsewhere \$3.00 per year. Single copies 25c. Printed in U.S.A. Entered as Second Class Matter October 3, 1941, at the Post Office at East Stroudsburg, Pa., under the Act of March 3, 1879.

Radio Service-Dealer, March, 1943

Watch the Kyser Case!

● Kay Kyser, famous band leader, was placed in class 1-A by his draft board. He appealed for deferment and is supported by no less than the Office of War information. OWI submits that Kyser is a necessary man who can do more as a morale builder while a civilian than as a soldier. We admire Kyser greatly, as a comic and musician, but, we believe that if his radio mike were taken away from him his capacity for building morale would diminish to the near vanishing point.

Kyser's mike has not been taken from him yet, but millions of his potential listeners have been. Yes, if OWI, or OPA wants to study this contention they will find in short order that over 10 million radio sets are no longer operative because, in most cases, radio service-dealers cannot get to the homes because OPA withholds the gas to do it with.

We smile to ourselves at the stupidly hesitant stand of OPA regarding radio. On March 8th the acting chief counsel of the OPA gasoline ration section replied to our appeal for supplemental gas (as covered in the February editorial) as follows: *We are giving our consideration to the entire problem of repair of nonportable radios but at the present time our ruling that household radios are entertainment devices is still controlling.*

Again, and a thousand times again for OPA's benefit, do we acknowledge and agree that household radios are entertainment devices. And we contend that radio is much more because it provides news, vital news, and even alarms, which in time of air-raid might be factors of invaluable importance to morale. Give Kyser his radio and take receivers from civilians and you have two conflicting attempts on the part of Washington bureaus that would be laughable if they weren't so serious. Perhaps we should approach OWI and ask support in our efforts to make OPA use commonsense. Not a bad idea! We just got a news release that Elmer Davis plans regular 15 minute broadcasts to keep the populace aware of developments. Right now in too many radioless homes you can hear the expression, "Where's Elmer?"

Service Manpower Shortage

● Twenty-four months ago our files contained the names of approximately 60 thousand men who were engaged in some phase of radio repairing. 30 thousand were either independent servicemen or dealers who operated service departments, the balance were part-timers, not basically engaged in the radio industry. Twelve months ago the migration away from radio began. Then our files contained the names of 20 thousand service-dealers and but a handful of part-timers. The migration to war-industry and higher paying jobs continued. Now, our records, and they are probably the most accurate in existence, indicate that less than 11 thousand Dealers (who do their own servicing) and Independent Service Organizations still remain in business. There are some 4 thousand part-timers hanging on, but they are the old, once full-time

employed servicemen who still want to keep a finger in the pie. The old experimenter-type part-timer is gone. He just couldn't get by on substitution work, having insufficient ability.

The average service-dealer establishment used to consist of 2.6 men, including the owner. Now the average is down to 1.4 men per shop. So, we find there are about 16,000 trained radio technicians in civilian life here in the U.S.A. and approximately 50 million still operative receivers for them to keep in repair. That leaves a theoretical 3,507 sets-per-man to maintain annually, or over 15 sets per man per day. If the pre-war normal supply of exact-replacement tubes and parts were still available, it would be relatively easy for a radio serviceman to "work on" 15 jobs daily and repair them even if the normal average number of toughies came into the shop. But, without the normal supply of replacement tubes and parts, an overwhelming job faces the servicemen. He must now spend hours repairing, by substitution and revision methods, a job that would ordinarily take but a few minutes.

Radio repairing, as it now manages to survive, constitutes what is probably America's greatest underpaid "lost manpower hours" industry. The nation owes present-day radio repairmen a debt of gratitude for they are serving at great personal sacrifice, putting in many hours for little money, when they could easily say, "To hell with it all! There ain't no gratitude, and all we get are squawks from customers who feel that we've jacked prices." Such is far from the case. Repairers are pitching in to do their bit on the home front, and the slight inconvenience they cause customers by making 'em wait their turn for set repairs is slight penalty in times like these. Any set owner who doesn't agree should try to fix his own set without replacement parts and tubes.

Some Jobbers Are Hoarding

● Perhaps we haven't given this subject the correct heading. It might have been better stated that "some jobbers are refusing to make sales to servicemen who haven't high priorities because they, the jobbers, are stupid and behind-times."

Jobbers who have taken advantage of PD-1X forms find that they can replace sold merchandise to a very great extent. Let us repeat, PD-1X forms are beginning to work. Any jobber who refuses to sell such common items as clips, capacitors or transformers without a high priority is merely kidding himself out of profit, turnover and business. And he is helping Hitler by freezing stocks that are worthless unless being used. If a jobber hoards stock, refusing to sell without a high priority, should find a "Victory" line available in a few months, he will have been the victim of his own selfishness. For such men we have no sympathy. 50% of the jobbers operating a year ago have folded. 50% of those still operating are high-binders seeking priority business. Buy from those who cooperate by using PD-1X and watch the opportunists hang themselves by super shrewdness.

**FOR ELECTRONICS
MEASUREMENTS, TOO,**

the Standards are Weston

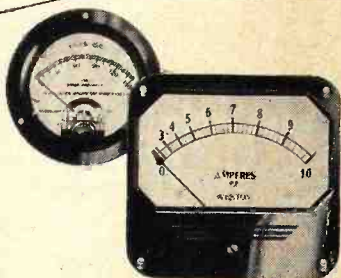

Panel Meters for Electronic applications

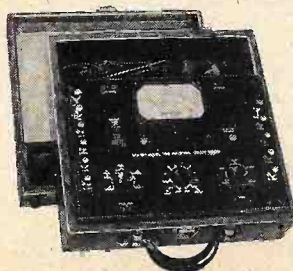

Electronic Circuit Testers



Ultra-Sensitive Laboratory Portables

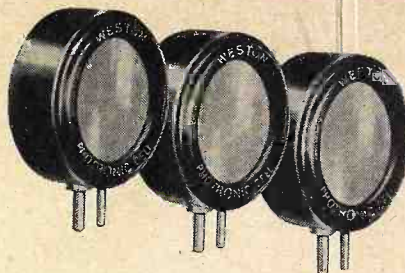

***Photronic (photo-electric) Cells**



Electronic Tube Checkers



Sensitive Relays

In the field of electronics, too, the measurement tools bear the name most familiar to you. For just as WESTON pioneered fundamental electrical measurement, as well as the special measurement needs of radio, so WESTON has provided simple, precise instruments and devices for the problems encountered in electron-

ics research, production and control. Weston Electrical Instrument Corporation, 597 Frelinghuysen Avenue, Newark, New Jersey.

**PHOTRONIC — A registered trademark designating the photoelectric cells and photoelectric devices manufactured exclusively by the Weston Electrical Instrument Corporation.*

Laboratory Standards . . . Precision DC and AC Portables . . . Instrument Transformers . . . Sensitive Relays . . . DC, AC, and Thermo Switchboard and Panel Instruments.

WESTON

Specialized Test Equipment . . . Light Measurement and Control Devices . . . Exposure Meters . . . Aircraft Instruments . . . Electric Tachometers . . . Dial Thermometers.

FOR OVER 54 YEARS LEADERS IN ELECTRICAL MEASURING INSTRUMENTS

Radio Service-Dealer, March, 1943

They're In Control!

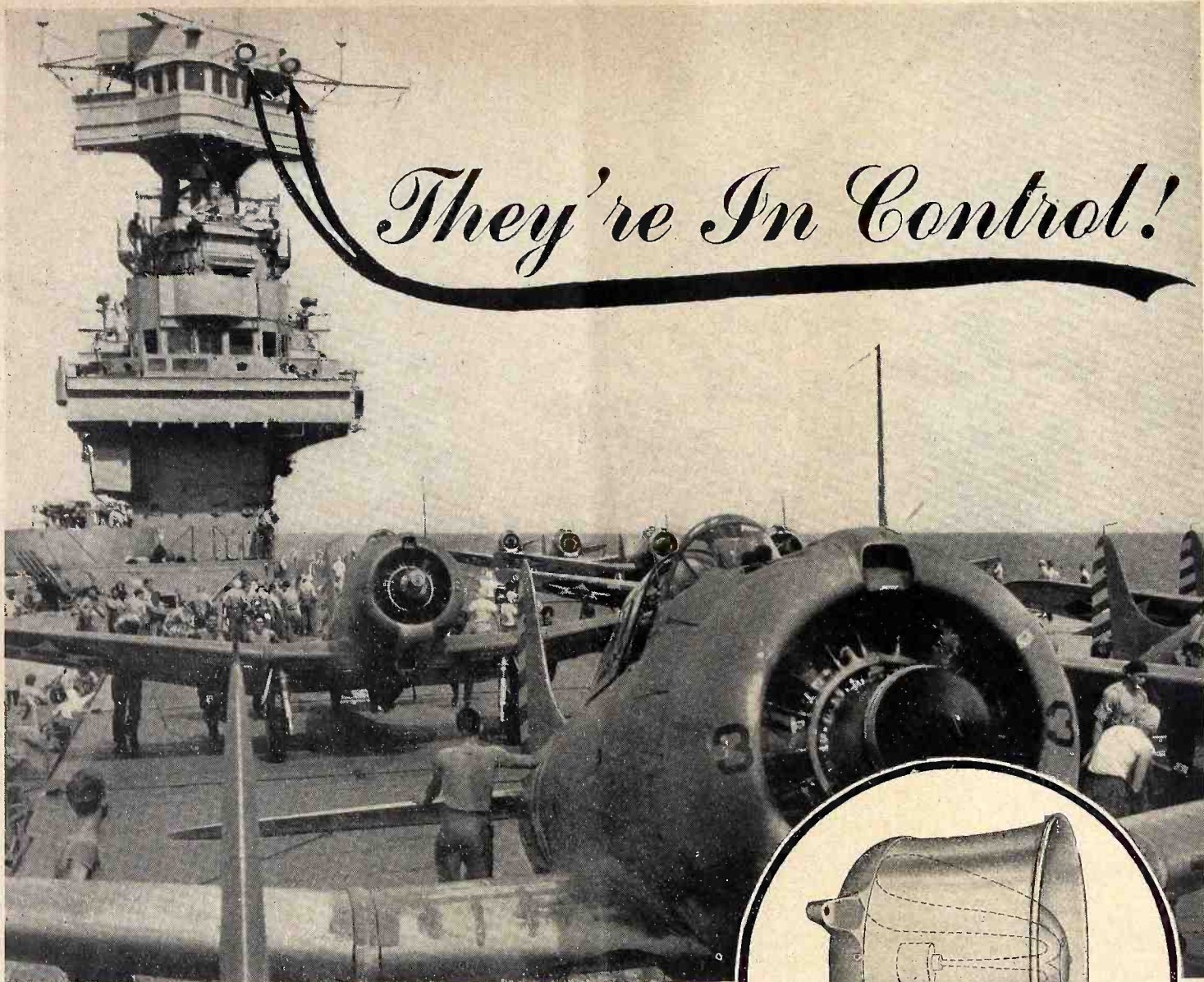

Official U. S. Navy Photo

When our Battle Force has an important job to do, out go the "Flat-tops". Aboard these carriers RACON Speakers carry commands to the entire crew. RACONS are on the 'island' which is the battle control center—and all through the ship's innards. For big jobs, where thousands of lives are at stake—upon which even Victory itself might depend—our Navy relies on aircraft carriers and RACONS. Both are efficient and dependable.

The entire war is not carried on at sea, nor are RACONS to be found only on carriers. RACONS are used on all types of Navy, Coast Guard and Maritime Commission ships—also by the Air Force and Army, in War Plants and Training Bases.

Wherever there is need for dependable public address and sound distribution systems RACONS are in the forefront. There is a RACON for every conceivable application. Our production facilities can meet your requirements. Write to us today. Ask for our latest, free catalog.

RACON ELECTRIC CO., 52 East 19th St., New York, N. Y.

RACON

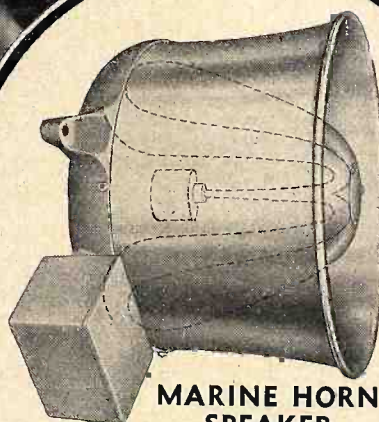

MARINE HORN SPEAKER



RE-ENTRANT TRUMPETS

Here are but two of the many RACON Speakers. The Marine Horn Speaker (used on the "Flat-tops" illustrated) is of the re-entrant type, for marine and general p-a applications. Available in several sizes, from 5 to 50 watts, they may be used as loudspeaker or as microphone. (Approved by the Bur. of Marine Inspection, Dep't of Commerce.) RACON Re-entrant Trumpets occupy small space but afford a long horn that carries highly concentrated sound efficiently over long distances. Several sizes available. Send for the new RACON Catalog.

Some Causes Of RADIO NOISE

OF all the troubles which afflict radio reception, none is quite so annoying to the general public as noise. Such ailments as limited frequency response, excessive distortion or poor sensitivity, which may be immediately apparent to the trained radioman, are often passed unnoticed or accepted philosophically by the average set owner—so long as the set continues to operate. But let even minor background noises interfere with reception and a hurry call goes out for a serviceman. Often these noises are due to causes external to the set and occasionally the serviceman brings the set to the shop for a fruitless search for the cause, which lies elsewhere. Sometimes the fault is in the chassis components, but is difficult to localize. In either case, a good deal of time can be saved by considering the most likely causes of the trouble and applying some short-cut elimination methods to localize the defect.

Diagnosis by Substitution

In investigating any complaints of noise a most useful test instrument is a small combination line-and battery-operated portable radio, which may be brought into the customer's home and operated under the same conditions as the receiver in question. If the portable test set operates satisfactorily when the customer's antenna and ground are connected to it, then these items may be eliminated as possible causes. If noise appears in the test set when it is plugged into the line supply, but not when operated from batteries, then the cause is localized in the line supply. Thus two major causes of noises may be quickly checked. An additional advantage of this substitution method, which will be appreciated by all who have had to deal extensively with noise com-

by **John H. Potts**

plaints, is that a comparison test of this sort is convincing to the customer, who normally finds it very difficult to understand that all troubles which afflict reception need not necessarily arise in the receiver itself.

If no portable test set is available, a quick check of the antenna and connecting wires may be made by simply detaching the antenna and ground from the receiver and touching a finger to the antenna post so that your body acts as the antenna. If the noise then disappears, we know of course that the trouble must be associated with the antenna and ground system.

External Sources of Noise

Let us look into some of these external sources of noise. In *Fig. 1*, we show a typical antenna and ground system. Some of the elements shown, such as the lightning arrester and lead-in strip, are not so often used nowadays, and oc-

asionally we shall find the ground connection omitted, notably when a-c/d-c sets are concerned. Each junction point of each component of this network is a possible source of noise. At the antenna, the point at which it connects to the lead-in is a frequent offender, as are adjacent antennas which may sag and touch each other—a condition often encountered in apartment-house installations. The time-honored test for troubles of this character is to reach out the window and jerk the lead-in wire, while listening to possible repercussions in the ailing receiver. This, of course, doesn't work when the lead-in is anchored at the roof, as it should be but so often isn't.

The air-gap type of lightning arrester, designed for outdoor use, seldom causes any trouble. Usually this type is fitted with a petticoat cover which sheds water so the sole precaution required is to make certain the joints are properly made at its terminals. A good practice is simply to bare a portion of the lead-in wire and wind around the terminal before continuing to the receiver. This keeps the lead-in in one piece.

The lead-in strip should preferably use screw connections rather than clips. The riveted connections of the latter are frequent causes of noise. Any strip which shows wear

Fig. 1. A typical antenna and ground installation

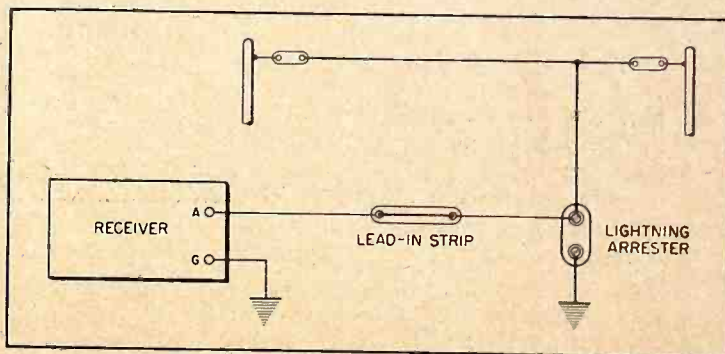

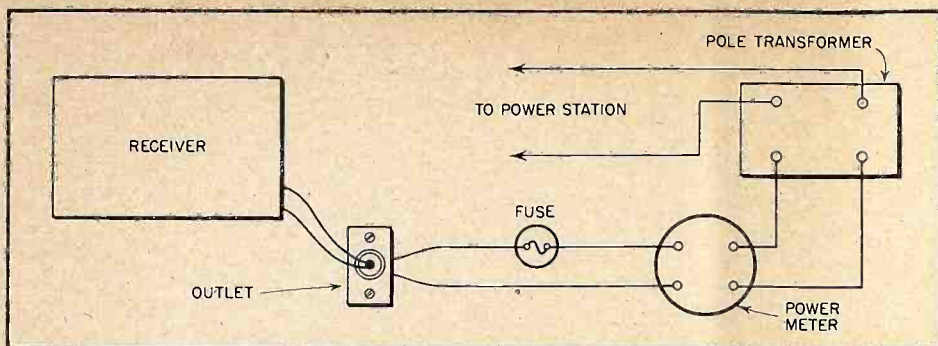

Fig. 2. Noises originating in the power line circuit may usually be localized at some point in the circuit shown.

should be replaced. Strips should be fastened in place with saddle staples or the equivalent—never by tacking through the metal or rivet holes. Any interfering metal weather-stripping should be carefully removed; noise has often been caused by intermittent contact to such metal strips, especially when jagged cuts have been made in the stripping without taking the precaution to smooth the edges before installing the lead-in strip. A much better arrangement, which is trouble-free, is to drill a hole through the wall and insert a porcelain bushing. The hole should be slanted downward from inside the wall to outside, so that moisture will not run down the wire into the room.

Ground-Power Line Noise

The ground clamp is another frequent cause of noise, especially when one of the copper-plated strap types is employed. It is one of the misfortunes of the service industry that the adjustment holes in these straps are so spaced that they cannot possibly fit any of the radiator pipes to which they are usually connected. Thus they quickly become loose and cause noise. It is well worthwhile to replace each and every one of these with a metal clamp which can be fitted to the pipe by means of a thumb-screw adjustment. Even these leave much to be desired, in that the screw metal is too soft to dig into the pipe as intended, but they are far better than the straps. The latter are intended for connection to water pipes, usually of small diameter and always inconveniently located.

In the power line circuit, as pictured in Fig. 2, we need to consider more than just the plug connection to its receptacle. In most states, the responsibility of the power companies ends when they bring their lines to the meter; thereafter it's up to the customer to see that everything is as it should be. And before we get

too deeply into this, remember that only a licensed electrician is permitted to work on power lines, according to most local laws. However, this will not preclude the unlicensed from making such investigations as are necessary to localize troubles, provided care is taken not to disturb circuits or circuit components.

The first point of attack, for noise localization in such circuits, is the junction of the power plug to the receptacle. A loose wire on the plug is a common cause, and should be checked as a routine procedure on every service call. For some reason, the screws are seldom firmly tightened when the power cord is lengthened or changed by an inexperienced person, and even the experienced sometimes slip up at this point.

Old receptacles often have poor

contacts, which have become spread out from long-continued use. Usually the customer attempts to overcome this by bending the prongs of the plug, with the result that an additional fault is introduced. It is not difficult to remove the face plate over the receptacle and tighten the contacts, if not too far gone. The sole precaution needed is to remove the line fuse before going to work on the contacts. This precaution should never be neglected; it is far too easy for a screwdriver or a pair of pliers to slip and go places where they were never intended. And short circuits are dangerous.

Often fuses are replaced by the housewife, occasionally resulting in an arcing contact in the fuse box, which causes noise. And, in older houses using cartridge fuses, corrosion at fuse contacts is a frequent cause of trouble.

Beyond the fuse box we enter the meter, which should never be tampered with. And, from the meter to the pole transformer, it is up to the public utility company to see that a noise-free line is supplied. However, it is good to be able to say definitely that the trouble has been localized to this area. One favorite method (employed by the public utilities) of checking the power line connections from the pole transformer to the meter is to knock the wires with a long broomstick while listening to re-



"The set ain't bad, but personally I want a Television-FM job and a 2 year service guarantee or I ain't trading."

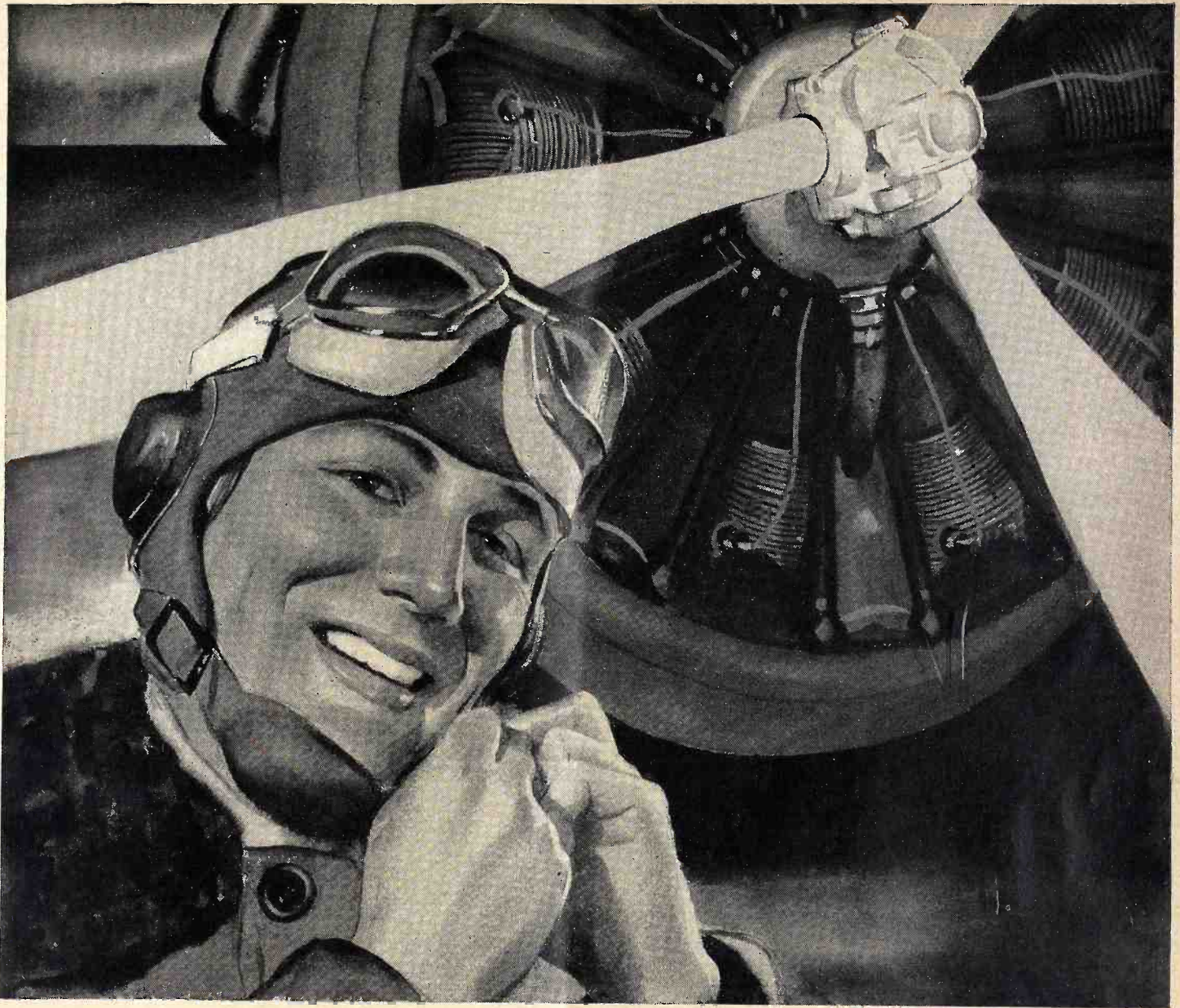

"TELL 'EM WE COULDN'T DO WITHOUT THE PARTS THEY'RE GIVING UP"

"Yeah, the folks back home are helping us plenty by giving up those radio and communication parts. See—over those hills! There's a bridge there. We just bombed hell out of it—cutting off an enemy tank column. With inadequate communications, we couldn't have done it!"

COMMUNICATIONS are vital in this war of rapid movement—where success demands "co-ordination" of widely dispersed units.

When a swift PT boat gets its radio orders to torpedo an enemy transport . . . when a bomber drops its eggs over a submarine base . . . when an allied tank column, keeping in contact by radio, speeds over Sahara's sands . . .

Utah Parts are playing their role in this war of communications.

Soldiers of production build dependability into those parts at the Utah factory. Utah engineers plan it in the laboratories . . . as they pore over blueprints far into the night.

Constantly, research is going on at Utah . . . new and better methods of production are being developed . . . to help keep the ears of the armed forces open. Tomorrow—when peace comes—this research and experience will be reflected in the many civilian products being planned at the Utah Laboratories. Utah Radio Products Company, 810 Orleans Street, Chicago, Ill. Canadian Office: 560 King Street West, Toronto. In Argentine: UCOA Radio Products Co., SRL, Buenos Aires. Cable Address: UTARADIO, Chicago.



PARTS FOR RADIO, ELECTRICAL AND ELECTRONIC DEVICES, INCLUDING SPEAKERS, TRANSFORMERS, VIBRATORS, UTAH-CARTER PARTS, ELECTRIC MOTORS

Radio Service-Dealer, March, 1943

ception. Any noise resulting will be heard in the radio and indicates a poor connection along the section of the line being checked.

In any power line circuit testing, it is handy to have available a long power cord, say 100 feet or so, with a receptacle at one end and a plug at the other. This may be used to jump the circuits believed to be affected and thus localizes power line troubles by a process of elimination.

Common Household Appliance Noises

The fact that common household appliances, such as vacuum cleaners, electrical refrigerators, oil burners, etc., can cause noise disturbances is well known and needs no discussion other than to mention that filters must, of course, be fitted to the offending appliances and not to the receiver, if they are to be effective. Further, it will be found that suitable filters are not always cheap. The recommendations of the manufacturers of the appliances in question should always be sought and followed, particularly when major household units, such as oil burners, are under consideration.

Not so well known is the fact that small appliances, such as electrical heating pads, bottle heaters and irons are frequent offenders. In the case of heating pads, the source of the trouble is in the thermal switch which shuts off the current when the temperature has come up to a certain value and turns it on again automatically when it drops too low. Occasionally a point is found where the contact goes intermittently on and off at a rapid rate, and severe noise results. With bottle heaters and irons, especially the latter, the noise is caused again by poor contacts, usually the plug which connects to the iron. This type of plug usually has a limited life and generally is replaced by the housewife, with consequent poor connections. When not replaced, the sparking at the contacts becomes excessive in time, with the expected results. Other

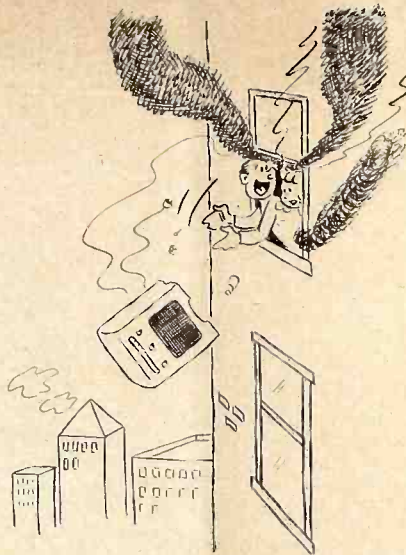

"Don't worry dear, I'll save the radio."

heaters, such as those used for tropical fish tanks, which operate on a thermal switching system, likewise cause considerable interference and often over a considerable area, perhaps 100 to 200 feet. We call specific attention to these latter appliances because, in shutting off suspected appliances one by one to localize the trouble, occasionally some of these less obvious appliances are overlooked.

Component and Circuit Noises

As in external sources of trouble, noises in the receiver itself are fundamentally caused by defective contacts, resulting either from mechanical breaks, electrical overloads, or corrosion. In some instances all three of these causes may contribute to the final result. Thus, in transformers, we find that moisture enters the windings, causes electrolysis due to galvanic action, corrosion occurs and a mechanical break is the ultimate result. It has been found that, in tropical climates or in places where high humidity and salt water are present, the life of transformers, either power, or audio, will seldom exceed a year or so unless the windings are thoroughly impregnated against moisture. This fact is not generally realized by the radio servicing industry. Too often the fault is laid to the use of acid fluxes or soldering, because the appearance of the wire at the point where corrosion occurs is similar to that which results from the use of such acids. Actually, this may be caused by galvanic action—an electric current which results when dissimilar metals are joined. The lead-tin solder itself, in contact with copper, can cause this current. Without moisture at the contact, the effect is negligible. But when the junction of the

dissimilar metals becomes damp, particularly with salt water, active corrosion occurs. This can be seen in an examination of the chassis grounds of many receivers; the bluish-green hue of corroded copper is often evident. Here the contact is against steel alloy and is accelerated by the larger exposed surface. In many of the better commercial test instruments, it will be noted that all soldered contacts are coated with a reddish, transparent lacquer. This is generally Glyptal, which is made by the General Electric Company, and which serves to keep moisture from the soldered point. Before this protective coating is applied, the joint is carefully cleaned with alcohol.

Most power transformers are wound with enameled wire, and this type of insulation is not very effective in the presence of moisture. Thus thorough impregnation of all windings with a moisture-resistant compound is essential for satisfactory life. For best results the transformer should be potted in a case, and the case in turn should be hermetically sealed against moisture. It is important not only that the seams of the case be watertight; the terminals must be so designed that moisture cannot enter any eyelets or other means of fastening the terminal to the terminal board, and thus get into the windings. In many cases the wire acts like the wick of a kerosene lamp, the moisture is picked up by its insulation and travels along into the winding. Suitable compounds for potting transformers are made by Mitchell-Rand, Irvington and others. They should have high thermal conductivity so that heat generated in the windings is dissipated. Particular attention should be devoted to proper potting of transformers of all types which are to be used on marine radio installations. The characteristic sputtering noise of a defective transformer is more frequently encountered in such installations than in

(Continued on page 24)

\$1.00 PAID FOR SHOP NOTES

Write up any "kinks" or "tricks-of-the-trade" in radio servicing that you have discovered. We will pay \$1 in Defense Stamps for such previously unpublished "SHOP NOTES" found acceptable. Send your data to "Shop Notes Editor," RADIO SERVICE-DEALER, 132 W. 43rd St., New York City. Unused manuscripts cannot be returned unless accompanied with stamped and addressed return envelope.

Be 100% with your

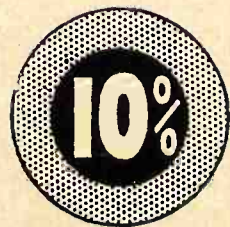

Buy WAR BONDS

There's Still Time to Qualify in the



"Here's How"

VOLUME CONTROL

Contest



SHARE IN \$500.00 WAR BONDS!

Closing Date April 10th

Yes, there's still time to put yourself in the running for one of those FIVE \$100 U.S. War Bonds, as announced in last month's issue of this magazine. *But there's no time to lose!*

If you saw the original notice and have been putting it off . . . well, this is the LAST CALL! Contest closes and entries must reach IRC by April 10.

If you have overlooked this "golden" and patriotic opportunity . . . if you are a radio man living within the United States . . . if you would like to have one of those \$100 Bonds inscribed with your name and delivered to you, the field is still wide open and you stand as good a chance as anyone!

HERE'S WHAT TO DO

IRC feels that radio service men today are doing a fine job in keeping the Nation's radios functioning in the face of unprecedented difficulties. Often unable to get exact duplicate replacement and repair parts you would ordinarily require for the job in hand, you are showing amazing resourcefulness.

All right—write IRC an informal, simple letter telling in your own words—

How you were able to replace a volume control and get the radio set working satisfactorily—when you couldn't obtain the volume control you would ordinarily have considered necessary for that particular make and model of radio.

Please be specific. Name the make and model instrument you were working on. Tell what the VOLUME CONTROL trouble was. Describe exactly what you did, and why: whether you made certain mechanical changes in the substitute control to adapt it to the set, and/or certain electrical changes in the circuit.

BONDS for IDEAS

It's your factual story that counts in this contest—not your spelling, your "literary style" or anything else. What we're after is a straightforward account of a VOLUME CONTROL problem you ran up against, and how you licked it. *Your* story, unexciting as it may seem to you, may be the very one to cop one of those awards!

PRIZES WILL BE AWARDED

by an impartial board of three—Joseph Kaufman of the National Radio Institute, William Moulie of "Radio Retailing Today" and IRC's Chief Engineer Jesse Marsten. The judges' decision as to the five winning entries will, of course, be final and if in their opinion winning ideas of equal merit are presented, duplicate awards will be made.

RADIO INDUSTRY TO BENEFIT

Though all ideas entered in this contest become the property of IRC, contestants have the satisfaction of knowing that their worth-while ideas will be passed along to the entire service profession. Thus, while you extend a hand to others, they too will help you to keep radio sets in operation that might otherwise be retired from service and become lost jobs for you.

HAVE YOU WON A BOND ALREADY?

Some VOLUME CONTROL jobs you have already done may be good enough to win a \$100 Bond, if you write us about it NOW.

DON'T PASS UP THIS CHANCE!

Remember, you have as good a chance to win as the next fellow. Fill out that coupon right now! Write your letter tonight! Don't put it off—and later kick yourself for passing up an opportunity. A \$100 bond would sure come in mighty handy at maturity, wouldn't it? O.K.—*let's go!*

Uncle Sam's Men, Too

If you're now in Government service, in or out of uniform, you're eligible in this contest too. Maybe the job you have in mind was done before you went into the Service.

CLIP THIS—FILL IN—SEND IN WITH YOUR ENTRY

INTERNATIONAL RESISTANCE COMPANY
401 N. Broad St., Philadelphia, Penna.

RSD

• Gentlemen: Here is my entry in your \$500 U.S. War Savings Bond Contest.

MY NAME _____

COMPANY _____

ADDRESS _____

CITY _____ STATE _____

MY REGULAR DISTRIBUTOR IS _____

Tomorrow's

SALES CURVES
ARE BEING
PLOTTED . . .

Today

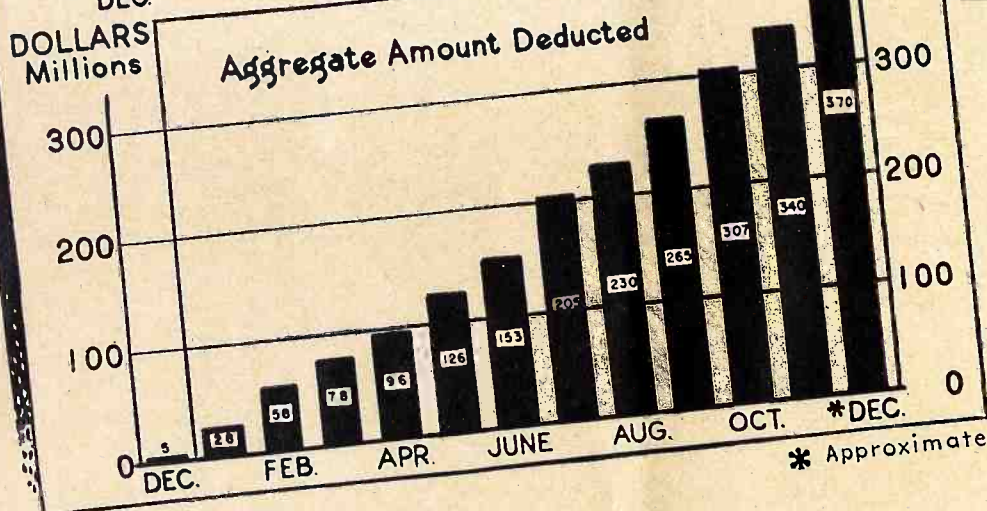
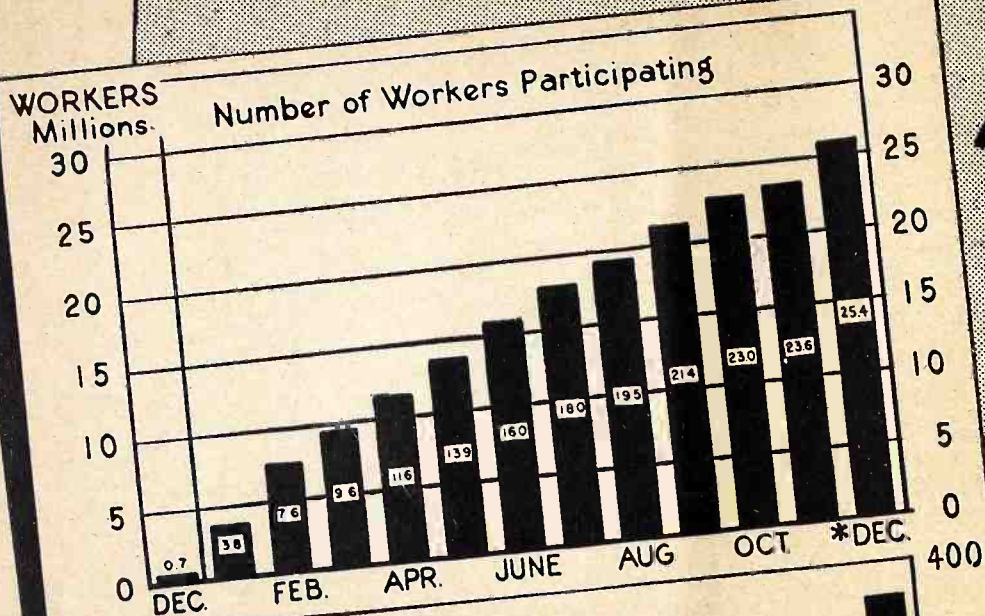

THESE CHARTS SHOW ESTIMATED PARTICIPATION IN PAYROLL SAVINGS PLANS FOR WAR SAVINGS BONDS (Members of Armed Forces Included Starting August 1942)

STUDY THEM WITH AN EYE TO THE FUTURE!

There is more to these charts than meets the eye. Not seen, but clearly projected into the future, is the sales curve of tomorrow. Here is the thrilling story of over 25,000,000 American workers who are today voluntarily saving close to FOUR AND A HALF BILLION DOLLARS per year in War Bonds through the Payroll Savings Plan.

Think what this money will buy in the way of guns and tanks and planes for Victory today—and mountains of brand new consumer goods tomorrow. Remember, too, that War Bond money grows in value every year it is saved, until at maturity it returns \$4 for every \$3 invested!

Here indeed is a solid foundation for the peace-time business that will follow victory. At the same time, it is a real tribute to the voluntary American way of meeting emergencies that has seen us through every crisis in our history.

But there is still more to be done. As our armed forces continue to press the attack in all quarters of the globe, as war costs mount, so must the record of our savings keep pace.

Clearly, on charts like these, tomorrow's Victory—and tomorrow's sales curves—are being plotted today by 50,000,000 Americans who now hold WAR BONDS.



Save with
War Savings Bonds

This space is a contribution to America's all-out war effort by

RADIO SERVICE-DEALER

LOCATING INTERMITTENT TROUBLES

By H. F. Gulliver

NOTE: Some months ago when Mr. Gulliver, a successful mid-western radio service-dealer, offered to write for us a series of exclusive articles covering the present day problems that confront professional technicians, we accepted the offer with some trepidation.

Usually, professional radio servicemen "know their stuff technically" but they seem to lack the ability to present their views in a manner that allows their contemporaries to derive benefit therefrom. Happily Mr. Gulliver's several articles have been "on the beam." The large volume of favorable comment from "RSD" readers so attests, ED.

AN intermittent radio may be described as any receiver which operates normally most of the time, but which stops, cuts down in volume, or gets noisy or distorted some of the time. Too often these receivers have been money losers for service establishments, taking a great deal of time and too often coming back for free re-do jobs. However, intermittents can be money makers if a definite plan of servicing them is followed. This discussion will attempt to set forth a definite plan of attack.

In general, our plan for servicing sets is to locate the section of the receiver which is not operating normally, and then isolate the trouble within this section. With noisy intermittents however we depart from this procedure to a certain extent, as is explained later.

Observation and experience seem to indicate that all intermittent troubles may be roughly grouped into four general types and a slightly different test procedure seems to work best for each. The four general intermittent categories are:

1. *Cuts down or out, no accompanying noise or disturbance. (May cut gradually or quickly.)*
2. *Cut out or down, but cutting is simultaneous with noisy condition, such as snapping and frying sounds. May be noisy at times without the volume varying.*
3. *Cuts out or down, with heterodyne whistles.*
4. *Intermittent hum or intermittent distortion, no actual cut-out.*

Two Systems of Testing

There are two accepted methods of testing for intermittents. In one, a signal is fed into the antenna and measured as it progresses through the receiver. This is termed "signal tracing." The alternate is to feed a signal into the receiver at various places, observing whether it emerges from the loud speaker. This latter system is spoken of as "signal injection." Both systems have advantages. A combination of the two systems will probably be preferred by most servicemen.

Requirements—Equipment Needed

The first and most important requirement of test equipment for servicing intermittents, is that it must not accidentally, and temporarily, cure or hide the trouble before it is definitely located. We must have test equipment which is very lightly coupled to the circuit under test, and which neither draws power from the circuit under test, or applies power to it. The signal generator used must be capable of supplying a signal about equal in strength and modulation %, to that which is usually received, and in the case of signal injection equipment, the sig-

nal to be injected must be of equal strength to the average received signal, at the point where it is to be injected.

Signal tracing equipment now on the market fills the requirements very well. The RF, audio and d.c. electronic voltmeters incorporated are coupled lightly, take no appreciable power from the circuit under test and do not apply a voltage across the circuit under test.

Injection equipment now on the market is not so complete or good. However the February issue of RADIO SERVICE-DEALER described apparatus ("The Multivibrator For Intermittents") which can be constructed for a very small sum and which does the job very well, leaving signal tracing equipment available for general bench work.

Since we do not want to start the set operating accidentally, (after it has cut out), the sound procedure is to attach the test terminals before turning the set on. This may not always be necessary, but in general is good practice. If the test leads are soldered on before the receiver is placed in operation, there is the added advantage that the set chassis may be picked up for inspection, shaken or turned over to promote the intermittent operation without danger of the test leads becoming shorted or coming loose.

Type 1. Intermittents

When the set just cuts down or out without any unusual noises, we have no indication, by mere listening, of just where the seat trouble may be located. To make our discussion more real, let's consider a

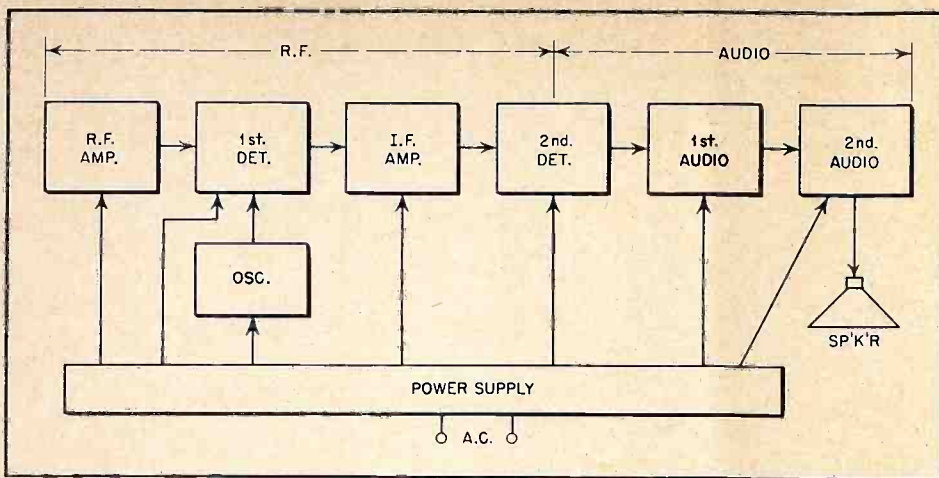

This is the same circuit as Fig. 1. However, here it is illustrated in "block style".

radio as shown in Fig. 1. This is a rather common, modern type of circuit. Fig. 2 shows the same set in block style, indicating the various sections of the receiver. It is our theoretical problem and purpose to isolate the trouble into one of the sections in Fig. 2.—(if it is easier to locate a needle in a small stack of hay, than in a large one we may also assume that it will be easier to locate trouble in a small portion of a set than in the entire radio).

Let us assume that the set under test, periodically loses strength,—fades—and then soon regains normal volume. We may first divide the set into two convenient parts, RF in the first half and audio in the last half. The point where the division should be made is just after the diode detector, ahead of the volume control.

A measurement must be made of the audio voltage present, when the set is normal, and when it cuts down. If the audio voltage drops, the trouble must be in the first half of the set, or the first four blocks of Fig. 2. If no drop is noted, we then must look for the trouble in the last three blocks. By starting approximately in the middle of the receiver, we have eliminated several blocks with the first test. Actually, we may make several tests at one time, three to five with common test equipment. In one test (one period when the set cuts down), we may trace the trouble definitely into one or two sections.

"Tracing Signals" for Trouble Source

As an illustration of signal trac-

ing procedure, let us suppose that we have the set of Fig. 1 on the bench for test. We have available signal tracing equipment consisting of a .005 to 25 tuned RF vacuum tube voltmeter (TRFVTVM), covering 100 to 1750 Kc, and a .3 to 25 TRFVTVM good from .6 to 15 Mc. Then we have a 2.5 to 500 DC, VTVM, and also a .1 to 500 audio VTVM.

To prepare the receiver for the first test period, we may connect the audio meter to point 4 in Fig. 1, so that the audio voltage may be measured where it first appears. The sensitive TRF meter may be connected to point 2, the input of the first detector. The less sensitive TRF meter may be hooked to point 8, the plate of the IF tube. The DC meter may connect to the AVC at point 6. A modulated signal is fed into the antenna of the receiver from a suitable signal generator. The intensity of the signal should be equal to that of the average station normally received. All meters are tuned and set on appropriate scales. When the receiver cuts out, we observe which meters drop. Let us say that all meters drop. Since we had meters hooked to points 2, 4, 8 and 6, the trouble must be ahead of point 2, which was nearest the antenna. Or the trouble might be common to all circuits. Such a trouble could be a failure of the B voltage. We now know that the trouble must either be in the loop or section 1 of the receiver, or in the common voltage supply.

To prepare for the second test

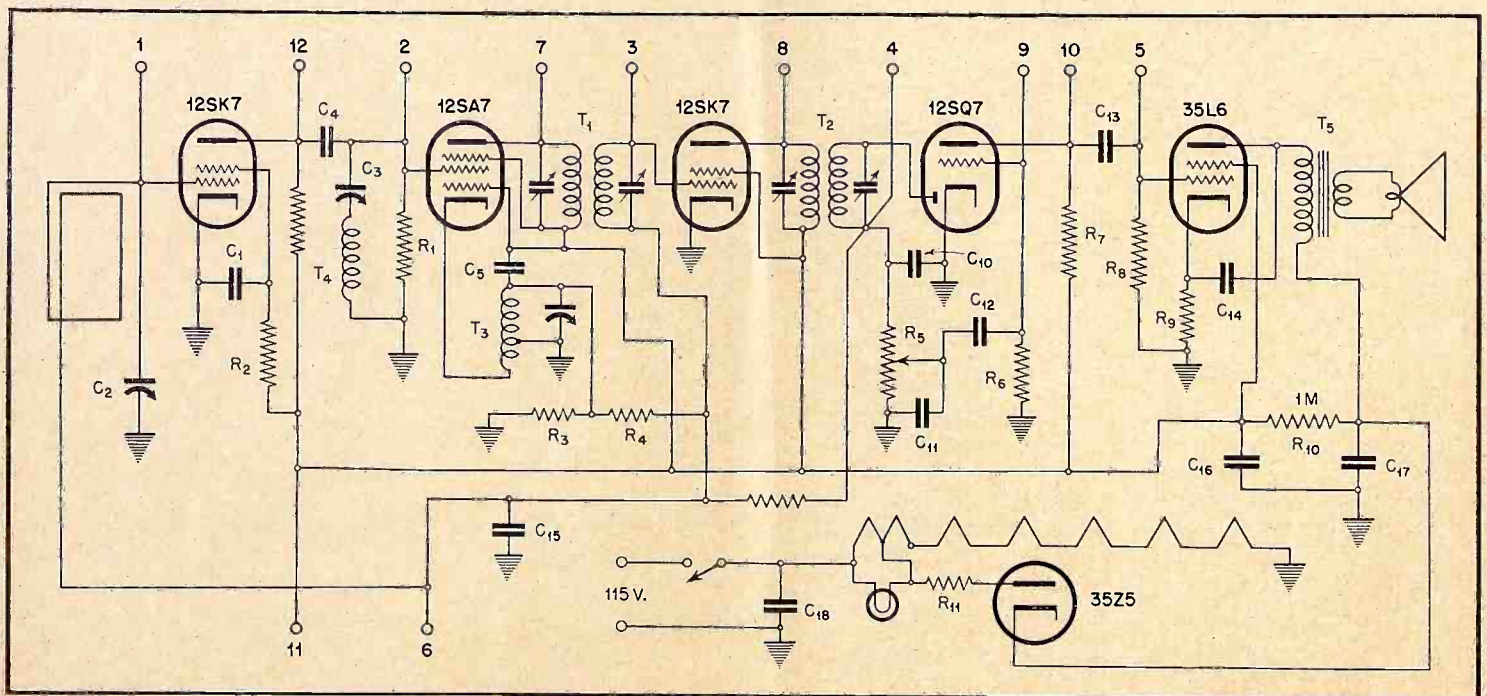

This is a typical, present day radio receiver circuit.

The SPRAGUE TRADING POST

EXCHANGE — BUY — SELL

TUBES AND PARTS FOR SALE—Have many types of new home radio receiving tubes that are slow sellers. Also overstock of new parts, etc. Will swap for other tubes, etc. that I need or will sell wholesale. Send your list and I will mail mine. All letters answered. Dolan Radio Service, 187 Union St., Randolph, Mass.

VOLTOHMMETER TO SWAP—Will trade Weston Model 564 volt-ohmmeter; also Hallcrafters Sky Buddy S19R, good as new; also two auto radios in good condition. Want good capacitor analyzer or what have you? Charles H. Wallace, 532 Foster Rd., Princess Bay, S. I., New York.

WILL BUY—Veedolyzer, traceometer, or chanalyst in good condition. Have for trade or sale a Model 15 Scott all-wave receiver in perfect condition. D. M. Clutter, 28 Maplewood Pl., Athens, Ohio.

RCA VOLTOHMYST JR. WANTED—Must be in good condition. Will pay cash. Have for sale Giant Racon units. National Sound Eqpt. Co., 625 Main St., Worcester, Mass.

MANUALS FOR SALE—Riders Manuals Nos. 1 to 12 (except No. 2) in first class condition. \$60. Lee H. Peabody, 1319 S. Osage, Sedalia, Mo.

LIST PRICE FOR TUBES—Will pay list price for the following tubes (in original cartons) any quantity: 35Z5; 50L6; 12SA7; 12K7; 12SK7. Greenwald Specialty Co., 58 S. Royal St., Mobile, Ala.

HAVE TUBES, METERS AND SPEAKERS—also keys, filter blocks and cabinets. Want 8 mm. projector and films. G. Sanikofsky, 110 Wilson St., Brooklyn, N. Y.

WANTED—2½ meter transceiver, portable or stationary. Will trade for same, or will buy. Charles Halas, 1229 So. Wisconsin Ave., Berwyn, Ill.

WANTED—6 foot steel relay rack for standard 19" panels. Richard Berry, Service Engineer, Thomas A. Edison, Inc., 110 Arlington St., Boston, Mass.

TRADE TUBES FOR RECORDS—I'll pay cash or trade tubes and parts for old phonograph records (in new condition) — your whole stock or white elephants. Yates M. Hoag, RD1, Utica, N. Y.

WANTED IN A HURRY — A signal generator suitable for set or receiver aligning; also small AC-DC volt-ohmmeter. Jerry Havard, Burke, Texas.

WANT TO BUY—AC-DC multi-test-

er or a pocket volt-ohm milliammeter signal generator and tube checker. State condition and price. A. V. Larson, 822—4th St., Madison, Minn.

WILL TRADE—books, mikes, and many other items including photo equipment for oscilloscope, f-m receiver, condenser tester, photo equipment or what have you. Joseph Zielinski, 1637 Blackhawk St., Chicago, Ill.

INSTRUMENTS, ETC. FOR SALE—Meissner analyst; tube tester; Kray-O-Meter; C-B signal generator; condenser tester; manual; v-o-m and socket selector; radio course; radio books; electrolytic condensers; tubes, resistors, etc. Would like to sell all to one person. Write for details. W. Kay, 319 Main St., Niagara Falls, N. Y.

CHANALYST TO TRADE—Will trade RCA-Rider Chanalyst in brand new condition for an oscilloscope and vacuum tube voltmeter (A-C and D-C) or will buy same for cash. J. A. Silvestro, 2009 Roanoke St., West Hyattsville, Md.

WILL TRADE—Will trade three National coils 20-80—and a 40-meter band spread; also a National 2-gang tuning condenser for these coils and a coil socket. Need a Chanalyst or a good signal generator. Benj. W. Flemming, 1123 Bayard St., Baltimore, Md.

WANTED FOR CASH—Superior or other makes of multi-testers, signal generators, vacuum tube voltmeters, and channel analyzers. Give details. Hobart Radio Service, 4259 Washington St., Roslindale, Mass.

TUBES TO SWAP OR SELL—Have plenty of the following tubes to sell for cash or trade: 12SA7, 50L6, 12SK7, 12SQ7; 35Z5, 5Y3, 6K7, 6A8, 6F6, 6H6, 6Q7, 6x5, 25L6, 35L6, 35Z3, 48, 32, 34. What have you? Hoepfners Radio Shop, 1613 W. 4th St., Davenport, Iowa.

TUBES AVAILABLE—What am I offered for 150 assorted tubes in the following types: 1C7G, 1D5G, 1F7G, 1H6G and 1J6G? Will swap 150 Delco type 4 prong vibrators, or sell @ 40c each. I need a small bench metal lathe with back gears, Jacob's chuck and tail chuck. Forest Radio & Appliance Service, 148-150 Forest Ave., Buffalo, N. Y.

MANUALS WANTED—Rider's Manuals Nos. 8 to 13 for cash. Also want RCA Jr. Volt-ohmyst and pocket volt-ohmmeter. Al's Radio Shop, 2027 W. Division St., Chicago, Ill.

Your own ad run FREE!

The "TRADING POST" is Sprague's special advertising service designed to help radio servicemen obtain the things they need, or to dispose of things they do not need during the shortages of these war-time days. Send in your ad today! We'll run it in at least one of the five leading radio magazines in which the TRADING POST appears—at no cost to you, and providing only that the ad seems to us to fit in with the TRADING POST plan. "Emergency" ads will receive first attention. Keep your copy short. Write clearly. Address your ad to: SPRAGUE PRODUCTS COMPANY, Dept. RSD-33, North Adams, Mass.

TUBES AND RADIOS TO TRADE—Philco table models PT3, PT96, and 321T; also Zenith 6G601 and 7G605. Also have some much wanted numbers in tubes on same deal. Write for details. We want solid shellac scrap records. Will allow 5c per pound against 40% off of Western list on above radios. The Emporium, Radio Dept., San Francisco, Cal.

WANTED—Superior model 1280 set tester or model 1250 multi-tester. State price and condition. John O'Reilly, 1823 White Plains Rd., Bronx, New York, N. Y.

FOR SALE OR TRADE—Used Wurlitzer 12" and 16" record coin-operated phonographs; also RCA portable recorder MI-12701 complete with mike. Could use new radio tubes of the needed types, Rider Chanalyst, or late test instruments. Tomalino Radio Service, Glendive, Montana.

WANTED—Triplet signal generator; Solar condenser checker, Model BQC; and a late model tube tester. John Chulick, P. O. Box 55, Winters, Calif.

VOLTOHMYST WANTED—Will pay \$35 for good used Volt-ohmyst, Jr. or \$55 for senior model. J. N. Gilbert, 2805 Ontario St., Knoxville, Tenn.

WILL SELL OR TRADE—Hammar-

lund Comet Pro receiver; also Peak pre-selector, both in good condition. Want 3" oscilloscope, late model tube tester, and new radio tubes. E. W. Edwards, 4740 Johnson Ave., Hammond, Ind.

EQUIPMENT FOR SALE—Having sold business and joined the Navy, I offer: One Solar capacity analyzer and resistance bridge Model CB-1-60, 110 volts, 60 cycle, complete with leads. Also offer one Hickok tube tester, model AC-51; also one Sangamo portable watt-hour meter type F, 5 amps, 115 volts, 60 cycles. L. A. Maples, 76 Chestnut Ave., Danville, N. Y.

WANTED—One Volt-Ohm-Milliammeter. Will pay cash. Require this immediately. G. C. Carlson, Austin, Pa.

WANTED—Superior Channel-Analyzer in perfect condition. Will pay good price for a good instrument. Joseph K. Pepper, Box 66, Mt. Holly Springs, Penna.

FOR SALE OR TRADE—Weston tube tester IV—120 v. tubes, V-O-MA meters; Hickok tube tester and ma meters; radio chassis, parts, precision resistors and shunts. Need amplifier, also 8" or 10" circular saw. Make offer. Satisfaction guaranteed. C. Demeter, 933 Emma St., Elizabeth, N. J.

TC TUBULARS . . . "Not a

Failure in a Million!"

Sprague TC Tubulars are the best-known by-pass condensers in Radio today—because they're the most dependable. Test voltage, 1200; working voltage, 600. They cost little—they do a big job—they will not let you down. Famous Sprague inner-seal moisture protection and many other features make them tops for any job. Sold by Sprague distributors everywhere. Ask for them by name!



SPRAGUE PRODUCTS CO.
North Adams, Mass.

SPRAGUE CONDENSERS AND KOOLOHM RESISTORS

Obviously, Sprague cannot assume any responsibility, or guarantee goods, services, etc. which might be exchanged through the above advertisements.

Radio Service-Dealer, March, 1943

period we will connect our DC meter to the plus B common terminal at 11. The sensitive TRF meter is the only other instrument suitable for use in section 1 since the RF voltages are low, so we will connect it to point 12, directly on the plate lead of the RF tube. We place the set in operation and wait for it to cut out. When it cuts we observe that the B voltage is constant, and so is the TRF meter. We are now able to definitely say that the trouble lies between points 12 and 2. Knowing that the trouble is located in such a small area of the receiver, the problem of definitely locating the defect becomes more simple. Our first suspicion would be directed at C_4 . When the set cuts out C_4 , it might be bridged with a new condenser of similar capacity, to see if the signal is restored. C_4 is the most likely cause of the trouble. However if C_4 doesn't seem to be defective, and if the wiring is visually "OK," we have remaining, the grid resistor R_1 , and the wave trap C_3-T_4 . Disconnecting the wave trap will not make the set inoperative, but will tell us whether the set still cuts out without it. In the event the set still is intermittent without the trap in operation, the grid resistor may be at fault, or the 12SA7 tube may be bad. A new tube can be substituted. If the trouble still persists, only the resistor or socket remain as potential source of complaint, and only very rarely would a resistor cause such a trouble. This extended discussion is presented to demonstrate the elimination process which can so well be employed when the trouble has been isolated into a certain small section of the receiver.

When the trouble is believed to emanate from one of several component parts, our problem becomes complex—resolves itself into a fundamental and theoretical knowledge of how and why each of these parts operate. Since these is scarcely room in a series of articles of this kind to go very deeply into the theory involved, we must assume that our readers know such things as the proper operating voltages of tubes, theory of resonant circuits, IR losses, etc., etc.

Substitutes for Signal Tracers

Possibly you are one of those who are not fortunate enough to own a signal tracing instrument. Think nothing of it! Within arms' length in your shop is a good substitute. For use in intermittent tracing we need only an indicating instrument, something indicating relative signal

This circuit, using a Loctal type tube, is suitable for checking RF.

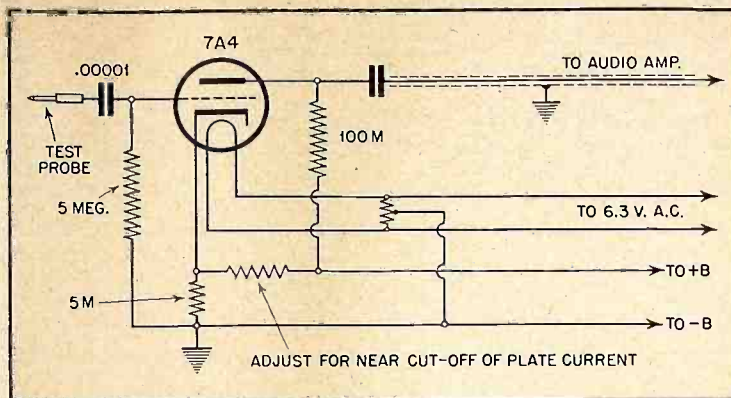

strengths. This instrument must be receptive to the broadcast band and intermediate-frequency in the receiver under test. Since any receiver is sensitive to the BC band, and most receivers now use 456 Kc for the IF., we may use another radio for the test instrument. The sound from the loud speaker may substitute for a meter. Keep in mind that the coupling to the receiver under test must be very light to avoid detuning effects. A nearly open, and variable postage stamp type trimmer is convenient. It may be well to short out the AVC on the receiver used as a test instrument.

For instance, if the receiver shown in Fig. 1 were to be used as a test instrument, for broadcast band, a test lead from point 1 would be used, with the series condenser as close to the set under test as possible. For checking 456 Kc IF circuits, a similar lead from point 2 would be em-

ployed. It must be remembered that for best results the two IF frequencies must be identical. When testing the last IF stage, the signal delivered by the set under test, may be too large to use unless a very small coupling condenser is used between it and the test instrument.

Another type of instrument for indicating RF, and listening to same, may be constructed by adding a grid bias detector to any high gain audio amplifier. While this is not as sensitive as other systems it has considerable value in the absence of more elaborate equipment. Fig. 3 shows the circuit for such a device, using a loctal type tube. This tube works best if located out on the end of a cable, next to the set under test. Another very nice tube to use for this purpose is a Micro-tube, about the size of a dial light. It is small enough to fit in a very small probe.

(Continued on page 31)

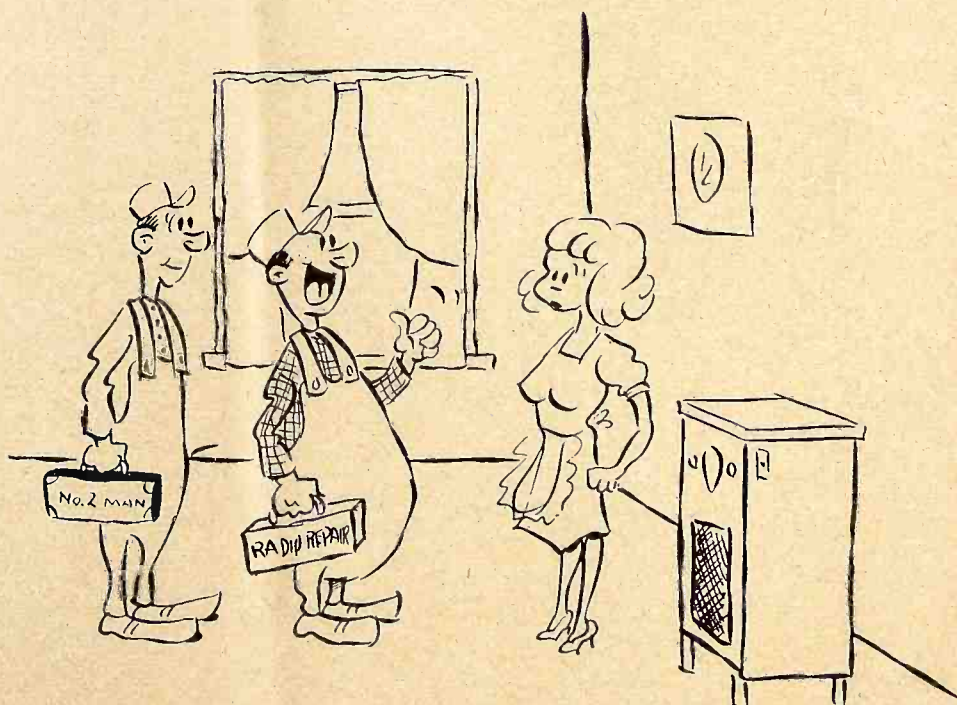

"He repairs the damage I do while repairing the damage already there!"



TOUGH CUSTOMERS

These men who fight for America . . . we knew them as just boys a few months ago. Now they're the toughest fighting men in the world. Call it the American love of freedom and justice, if you will, that makes them fighting mad. Or let's say simply that they don't like bullies. This much you can count on—they're going to drive a hard bargain with America's enemies.

For the big job they've got to do, they deserve the finest tools that American skill and ingenuity can contrive. We at Simpson are proud and glad to give our best . . . to match their fight with work . . . to produce Simpson Instruments in unprecedented numbers . . . and to wish them Godspeed with every working hour.

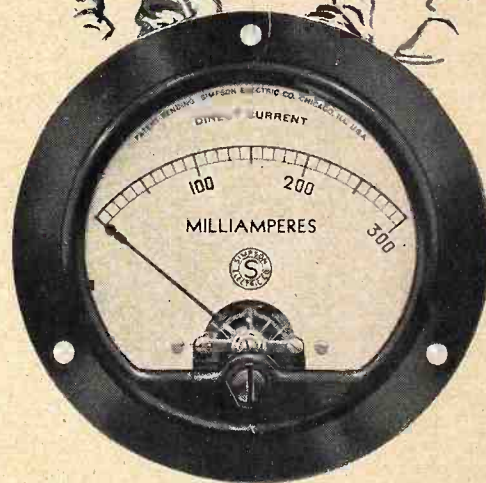

SIMPSON ELECTRIC COMPANY
5200-5218 Kinzie Street, Chicago, Illinois

Simpson

INSTRUMENTS THAT STAY ACCURATE

Buy War Bonds and Stamps for Victory

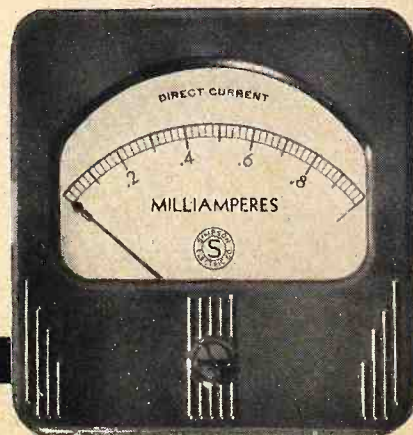

TECHNICAL SERVICE PORTFOLIO

SECTION XXVIII

METERS And Meter Substitutes

WAR conditions have created such a critical shortage of meters of all types that even old, damaged instruments are now in demand for use in the production of war apparatus. As a result, the chances of getting a replacement for a meter which has "gone West" in service are very, very slim—in fact, it's going to be pretty difficult even to get a minor repair made. Even in peace times meter repair men were never plentiful, because most men skilled in this sort of work were permanently employed in meter factories, and there never were many companies making meters. Because meters were delicate instruments, manufacturers have never encouraged the unskilled to attempt to fix their own, no matter how simple the job. And, unless one's nerves are steady and fingers deft, it is just as well to leave the job for someone else. But these are not ordinary times—the problem of keeping going under difficulties faces all of us, in or out of the Armed Forces—so we've got to tackle jobs which ordinarily we wouldn't consider touch-

ing. We are going to find that all meter repairs are not difficult; that perhaps the trouble which may now be facing you is relatively simple to fix. And, if it can't be fixed, it is still possible to substitute another meter, or even a substitute for a meter, and thus keep going.

In this article we are going to talk about d-c meter movements only, because this type is used almost universally for practically all radio servicing. You will find such a meter in your tube checker, your volt-ohmmeter, analyzer and other additional equipment you may have on hand.

For a-c measurements, usually a copper-oxide or tube rectifier serves to convert the alternating voltage to direct current, so that it may be measured by the meter.

Moving Coil Movements

Of the d-c meter types, the moving coil, or D'Arsonval movement is now employed in all good test equipment. In this type of meter, the current to be measured passes through a rectangular coil which is pivoted between the poles of a permanent magnet, as shown in *Fig. 1*. The pointer, which is attached to the moving coil, swings over the calibrated scale when the coil moves. The degree of coil movement is proportional to the current through the moving coil, consequently the pointer deflects greater for higher currents. Note that all meters really measure current, though some may be calibrated in terms of volts. The only real difference between a milliammeter and a voltmeter is that the latter has a resistance in series with

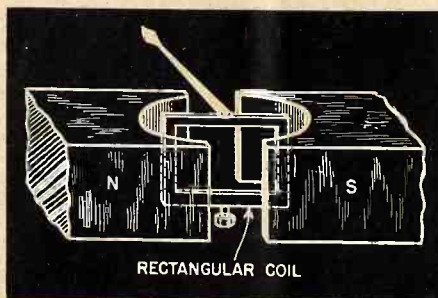

Fig. 1. Skeleton view of moving coil d-c meter.

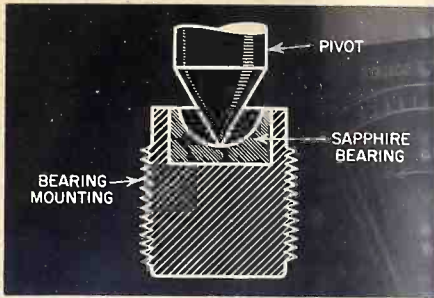

Fig. 2. A sectional view of the bearing and pivot used in a high-grade moving coil meter. The lower bearing, which is shown, is threaded for adjustment.

the coil which limits the amount of current which can pass through the coil when a given voltage is applied. Another adjustment is made in terms of the applied voltage, rather than the current going through the meter coil.

The restoring spring, which is coiled around the point where the pointer is attached to the moving coil, greatly resembles the mainspring of a watch. Its purpose is two-fold; it serves to bring the pointer quickly back to its starting position when the current is removed, and it also brings the pointer promptly to its starting position when current is applied. In these operations it overcomes any slight friction which occurs in the bearing on which the moving coil is pivoted. When you look at the delicate pivot and coil of a sensitive meter, it is hard to realize that there is really a relatively tremendous pressure on the bearings of a meter. But if you examine the pivots under a microscope you will see that they resemble the shape shown in Fig. 2, and are pointed so that only the tiny area of the point rests on the bearing. If we convert the pressure exerted on this tiny pivot point to the customary reference of pounds per square inch of bearing surface, we are apt to find that the force exerted on the bearing is of the order of thousands of pounds per square inch. That is why a jewel of the hardness found in the sapphire is generally employed in such bearings. And the materials and hardening processes used in making pivots which will stand up under this strain are carefully guarded secrets in the better meter factories. Since the normal strains under which the pivots and bearings operate are tremendously increased when a meter receives a hard jolt

or is carelessly subjected to the vibration which results when it rides on the hard floor of a service truck, it is not strange that many meters become damaged and inaccurate as a result. And troubles from this cause cannot be fixed by the unskilled worker, or without replacement parts.

One result of such abuse is to cause the pivot points to become blunt or deformed. Then, when current passes through the moving coil, the pointer no longer swings freely over its arc. Rather, it shows a tendency to stick at some points. This is particularly evident when sufficient current is applied to cause full-scale deflection of the pointer, and then the current is gradually reduced. If the current is held steadily at some fixed point, and the meter face is gently tapped, it will be found that the pointer assumes a new position, as shown in Fig. 3. This is due to the tapping, which serves to overcome some of the friction in the deformed pivot and thus allows the pointer to move nearer its proper position. In a perfect bearing and pivot, this tapping has no effect, because there is no appreciable friction which is not overcome by the restoring spring. Actually, in most of the lower-priced meters now on the market, particu-

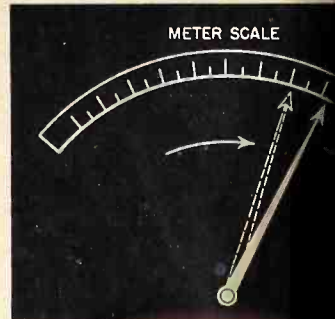

the current held

larly the more sensitive meters, 50 to 200 microamperes, require a certain amount of friction to be dependent, but this should not be more than a single scale division. The reason is that a stronger spring should not be used to overcome the friction because the current through the coil is small, and the flux density in the gap wherein the moving coil functions is limited. In the more expensive meters a larger and more powerful magnet, of cobalt steel or similar, provides greater flux density so that a stronger restoring spring may be employed and therefore friction in the bearings is minimized. Present-day meters owe their ruggedness to

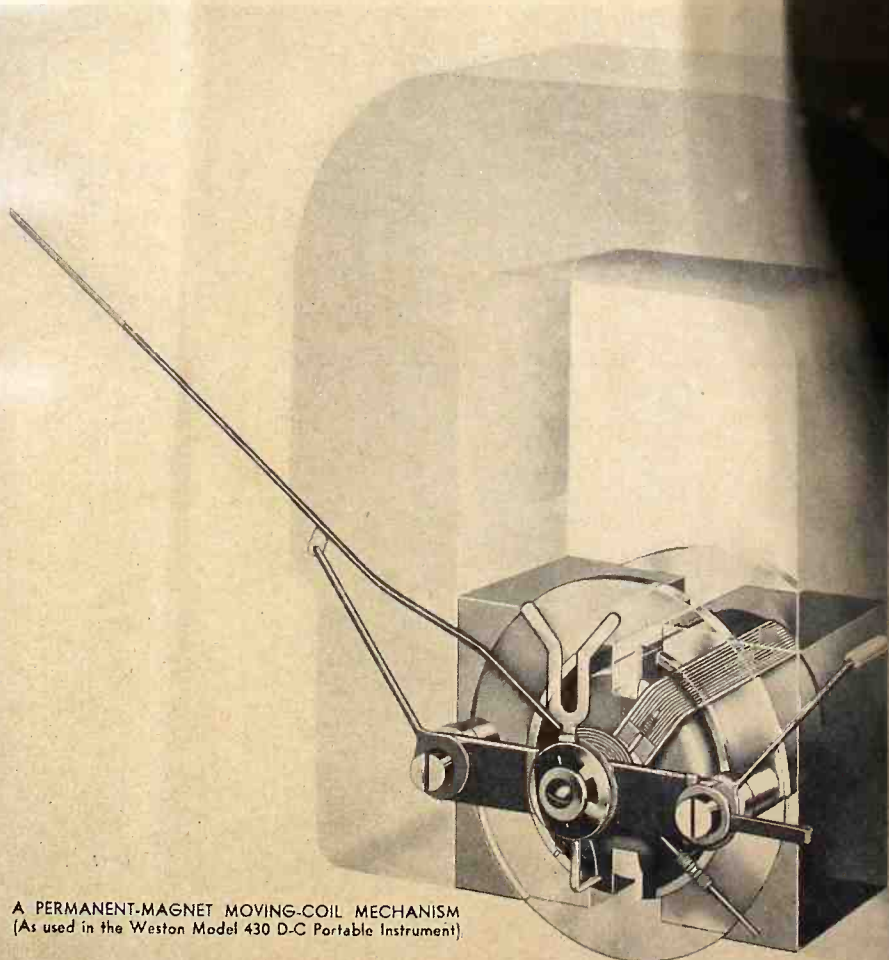

A PERMANENT-MAGNET MOVING-COIL MECHANISM (As used in the Weston Model 430 D-C Portable Instrument)

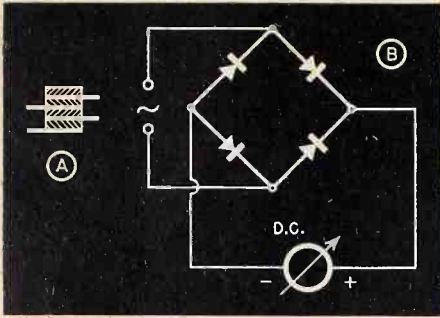

Fig. 4. The full-wave copper oxide rectifier, so widely used, is small and often has terminals arranged as in (A) above. The schematic circuit in which it is used is shown in (B).

these new magnets, without which it would not be practical to design a sensitive meter for radio service work.

Minor Repairs

The type of friction just described had best be left untouched by the inexperienced, but there are other cases of friction which can be taken care of without difficulty. Often a meter pointer will be driven off scale accidentally, due to momentary overload. The effect is a bent pointer, which may rub against the scale at some point in its deflection, thus causing sticking or inaccuracies in its indication. This trouble may quite easily be corrected by disassembling the meter and straightening the pointer. To take the meter apart, remove the three screws placed equidistant around the rear periphery of the case. In some makes, notably Weston, one or more of these retaining screws is sealed in place with wax. Usually this is done with the top screw. The wax may be readily removed by carefully heating with a soldering iron, or may be pried out with a sharp-pointed tool. Then the screw may be removed.

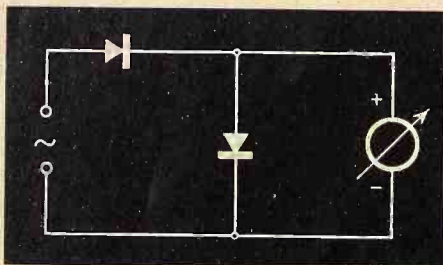

Fig. 5. By shunting a rectifier element across the meter coil as shown, better rectification is obtained, particularly when a series resistor is used to increase the range of voltages which may be measured.

After removing the screws, the meter may be pried free from the front portion of the case. Do not attempt to twist the movement out—you may damage the zero adjusting screw on the meter window. If the meter is laid face down, it will be found that the assembly may be most easily removed from its case.

The pointer is extremely light, and must be *very carefully* handled. It is best to use tweezers when adjusting the pointer or straightening bent portions. The meter should rest on the table while adjustments are being made. *Never* attempt to hold the meter in one hand while manipulating the tweezers with the other, especially if you are inexperienced. After adjustments have been made, lift the meter and blow gently across its face so the meter pointer deflects in its normal direction. Watch to see if the pointer touches the dial or any part of the assembly as it moves over the arc. When certain that it is free from any rubbing contact, reassemble. Make certain that the zero adjusting screw in the dial glass lines up with the fork provided for zero adjustment, then replace the screws. This procedure should be followed in any adjustments of the meter.

If the glass face of the meter becomes broken, it may be easily replaced provided a replacement glass can be obtained; but this is not always easy. In an emergency, a celluloid face may be used, made from the same type of material as is used for "unbreakable" crystals in watches. Your local jeweler can probably get this for you, or can cut a piece to fit. Don't attempt to use the meter without some protection of this sort—otherwise dust will get into the movement and the meter will become inaccurate and unreliable in action.

Troubles in which the moving coil is involved are usually hard to fix. However, if the coil opens and the meter becomes inoperative (which is likely to occur in hot, humid climates, particularly when a sensitive meter with a large number of turns of fine gauge wire on its moving coil is concerned, examine the coil carefully to make certain the break has not occurred near a terminal. If it has, then it may readily be fixed by cleaning the wire and resoldering. Cleaning off the enamel insulation, if necessary, is done by dipping the end of the wire in alcohol, then holding it in a Bunsen burner flame, after

which the charred insulation may readily be removed between a thumb and finger. Use a fine-pointed, clean, tinned iron in resoldering, cleaning the joint after soldering with alcohol, to remove excess rosin flux.

Converting Ammeters—Galvanometers

If the nature of the trouble is such that no repair can be made, it is often possible to adapt another meter to the job at hand. It is not generally known that ammeters, which have but little application in radio testing, may easily be converted to milliammeters which, while none too sensitive, may be used for quite a variety of radio testing. If you happen to have a spare d-c ammeter with a range of 1 to 25 amperes, its sensitivity may be increased to give full scale deflection for about

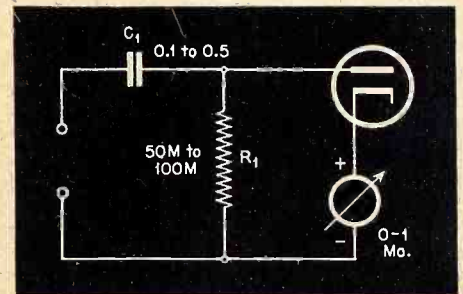

Fig. 6. A simple diode provides efficient half-wave rectification and enables a-c measurements to be made with a d-c meter.

15 to 20 milliamperes by simply removing the shunt, which is placed across the meter terminals. In some cases, it will be necessary to disassemble completely the magnet assembly to get at this shunt, but, once removed, it will be found that sensitivity of the order described above has been obtained. This meter may be calibrated against another milliammeter and a corrected scale marked in on the regular scale, or, for a neater job, a graph may be plotted giving the current in milliamperes for the corresponding ampere calibration with the shunt. Of course, if you can find someone who will swap a good d-c milliammeter for your useless ammeter, this is the simpler way out. But you won't find many in the radio service business who are interested in ammeters.

A burnt-out thermo-galvanometer makes an excellent and sensitive d-c meter. All that is necessary to make this conversion is to disconnect the wires from the thermocou-

ple elements, which are arranged in zig-zag form to make a bridge arrangement, and to reconnect these wires to the regular meter terminals. Such meters have a full-scale sensitivity of 400 to 700 microamperes and thus may be readily converted into 1000 ohms-per-volt meters, either d-c or, in conjunction with a copper-oxide rectifier, for a.c. too. You will find, however, that such meters are poorly damped—that is, it takes some time for the pointer to come to rest. Further, the moving coil is of very low resistance—this means low torque, consequently a weak spring must be used and poor damping action results. But it is better—much better—than nothing. In fact, the writer used such a meter for test purposes for many months, with excellent results.

Shorts in Rectifiers

Mention of copper-oxide rectifiers brings to mind the fact that these handy little gadgets can likewise cause a lot of meter troubles. It is not unusual for one section of such a rectifier to become shorted. If a bridge type of rectifier is employed, as shown in Fig. 4, the result is only partial rectification, the meter reads low, and the pointer may vibrate when an element fails. The rectifier, if of the type shown in Fig. 4A, may be checked by measuring the resistance between adjacent terminals. The ohmmeter test prods should be reversed after the first reading between the same terminals and the difference in reading noted. One reading should be considerably higher—from 10 to 50 times—than the other, if rectification is taking place. That, as you know, is the principle of their operation—much greater opposition to the flow of current in one direction than in the other.

If there is little or no difference in the ohmmeter readings when testing any section of the rectifier, it may be possible to use two of the remaining good sections in a different type of circuit, which is nonetheless efficient. This is shown in Fig. 5. This type of rectifier circuit, though relatively new, has come into rather general use in medium-priced service test equipment. Its principle of operation is as follows: The series copper-oxide rectifier element passes current freely when the polarity. Consequently the meter reads higher when the current is of the proper polarity. Because some

current also flows through the meter when the polarity is reversed, due to the fact that the copper-oxide rectifier does not have infinite resistance in its theoretically non-conducting polarity, this current bucks that flowing in the direction of low resistance and tends to reduce the efficiency of the rectifier and lower the reading. To overcome this fault, one section of the copper-oxide rectifier is shunted across the meter as shown (in some designs, the shunt rectifier is placed ahead of the series rectifier so that it shunts both the meter and series rectifier). In either form of connection, the bucking current passes freely through the shunt rectifier, so that but little goes through the meter. Thus but little bucking action results. When the flow of current is in the opposite direction (that is, when the polarity of the a-c wave reverses), the series rectifier allows current to pass freely but the shunt rectifier offers a high impedance to shunt current losses. Thus more efficient rectification results, with a minimum of rectifier elements required.

The V-T Rectifier

If it is necessary to replace the copper-oxide rectifier, a half-wave vacuum tube rectifier may be employed, as shown in Fig. 6. When using a vacuum tube rectifier, it is not necessary to add a shunt rectifier in the manner just described, in order to increase the rectification efficiency, because the vacuum tube rectifier has practically infinite impedance to current polarized in the non-conducting direction. Therefore a single unit as shown serves the

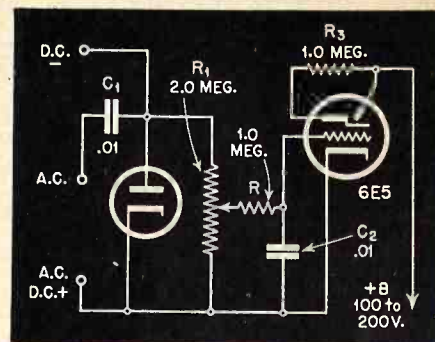

Fig. 7. With this circuit, both a-c and d-c voltages may be measured without a meter.

purpose. Any diode, such as a 6H6, or any triode connected as a diode, serves the purpose.

So far we have discussed only the possibility of utilizing a meter, either in repaired or altered form, to measure voltage and current. When the nature of the trouble is such that the meter cannot be repaired, one alternative is available in the form of the "magic eye." This device has already found favor as an indicator of current and voltage in its well-known application in the Rider Chanalyst, where its stability, ruggedness and general utility are generally realized. If we make use of the characteristic of this type of tube by which the eye closes when a d-c negative bias of the order of 4 to 6 volts is applied to the grid, we find that a ready means of indicating approximately the values of voltages under test. By means of an added rectifier, a-c measurements may also be made, as with any d-c meter. And, by adding a calibrated multiplier, or simply by calibrating a high-resistance potentiometer,

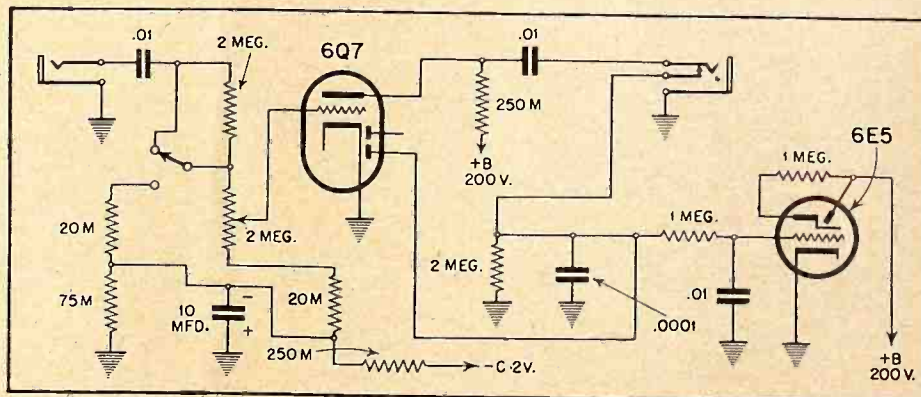

Fig. 8. The audio channel of a signal tracer may be calibrated to read a-c voltages over a wide range.

TECHNICAL SERVICE PORTFOLIO

SECTION XXVIII

METERS And Meter Substitutes

WAR conditions have created such a critical shortage of meters of all types that even old, damaged instruments are now in demand for use in the production of war apparatus. As a result, the chances of getting a replacement for a meter which has "gone West" in service are very, very slim—in fact, it's going to be pretty difficult even to get a minor repair made. Even in peace times meter repair men were never plentiful, because most men skilled in this sort of work were permanently employed in meter factories, and there never were many companies making meters. Because meters were delicate instruments, manufacturers have never encouraged the unskilled to attempt to fix their own, no matter how simple the job. And, unless one's nerves are steady and fingers deft, it is just as well to leave the job for someone else. But these are not ordinary times—the problem of keeping going under difficulties faces all of us, in or out of the Armed Forces—so we've got to tackle jobs which ordinarily we wouldn't consider touch-

ing. We are going to find that all meter repairs are not difficult; that perhaps the trouble which may now be facing you is relatively simple to fix. And, if it can't be fixed, it is still possible to substitute another meter, or even a substitute for a meter, and thus keep going.

In this article we are going to talk about d-c meter movements only, because this type is used almost universally for practically all radio servicing. You will find such a meter in your tube checker, your volt-ohmmeter, analyzer and other additional equipment you may have on hand.

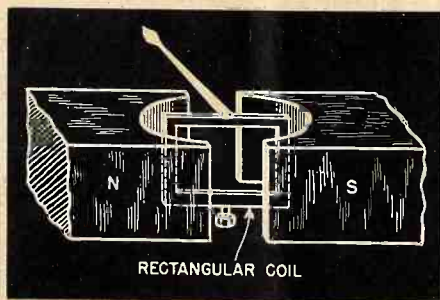

Fig. 1. Skeleton view of moving coil d-c meter.

For a-c measurements, usually a copper-oxide or tube rectifier serves to convert the alternating voltage to direct current, so that it may be measured by the meter.

Moving Coil Movements

Of the d-c meter types, the moving coil, or D'Arsonval movement is now employed in all good test equipment. In this type of meter, the current to be measured passes through a rectangular coil which is pivoted between the poles of a permanent magnet, as shown in *Fig. 1*. The pointer, which is attached to the moving coil, swings over the calibrated scale when the coil moves. The degree of coil movement is proportional to the current through the moving coil, consequently the pointer deflects greater for higher currents. Note that all meters really measure current, though some may be calibrated in terms of volts. The only real difference between a milliammeter and a voltmeter is that the latter has a resistance in series with

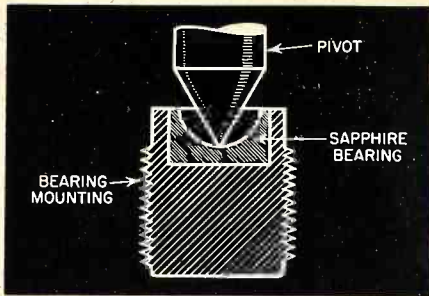

Fig. 2. A sectional view of the bearing and pivot used in a typical high-grade moving coil d-c meter. The lower bearing, which is shown, is threaded for adjustment.

the coil which limits the amount of current which can pass through the coil when a given voltage is applied. And the calibration is made in terms of the applied voltage, rather than the current going through the meter coil.

The restoring spring, which is coiled around the point where the pointer is anchored to the moving coil, greatly resembles the mainspring of a watch. Its purpose is two-fold; it serves to bring the pointer quickly back to its starting point when the current is removed from the meter and it also brings the pointer promptly to its ultimate reading when current is applied. In these operations it overcomes any slight friction which occurs in the bearings on which the moving coil is pivoted. When you look at the delicate pointer and coil of a sensitive meter, it is hard to realize that there is really a relatively tremendous pressure on the bearings of a meter. But if you examine the pivots under a microscope, you will see that they resemble the shape shown in Fig. 2, and are pointed so that only the tiny area of the point rests on the bearing. If we convert the pressure exerted on this tiny pivot point to the customary reference of pounds per square inch of bearing surface, we are apt to find that the force exerted on the bearing is of order of thousands of pounds per square inch. That is why a jewel of the hardness found in the sapphire is generally employed in such bearings. And the materials and hardening processes used in making pivots which will stand up under this strain are carefully guarded secrets in the better meter factories. Since the normal strains under which the pivots and bearings operate are tremendously increased when a meter receives a hard jolt,

or is carelessly subjected to the vibration which results when it rides on the hard floor of a service truck, it is not strange that many meters become damaged and inaccurate as a result. And troubles from this cause cannot be fixed by the unskilled worker, or without replacement parts.

One result of such abuse is to cause the pivot points to become blunt or deformed. Then, when current passes through the moving coil, the pointer no longer swings freely over its arc. Rather, it shows a tendency to stick at some points. This is particularly evident when sufficient current is applied to cause full-scale deflection of the pointer, and then the current is gradually reduced. If the current is held steadily at some fixed point, and the meter face is gently tapped, it will be found that the pointer assumes a new position, as shown in Fig. 3. This is due to the tapping, which serves to overcome some of the friction in the deformed pivot and thus allows the pointer to move nearer its proper position. In a perfect bearing and pivot, this tapping has no effect, because there is no appreciable friction which is not overcome by the restoring spring. Actually, in most of the lower-priced meters now on the market, particu-

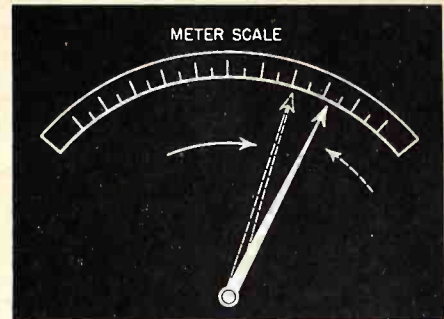
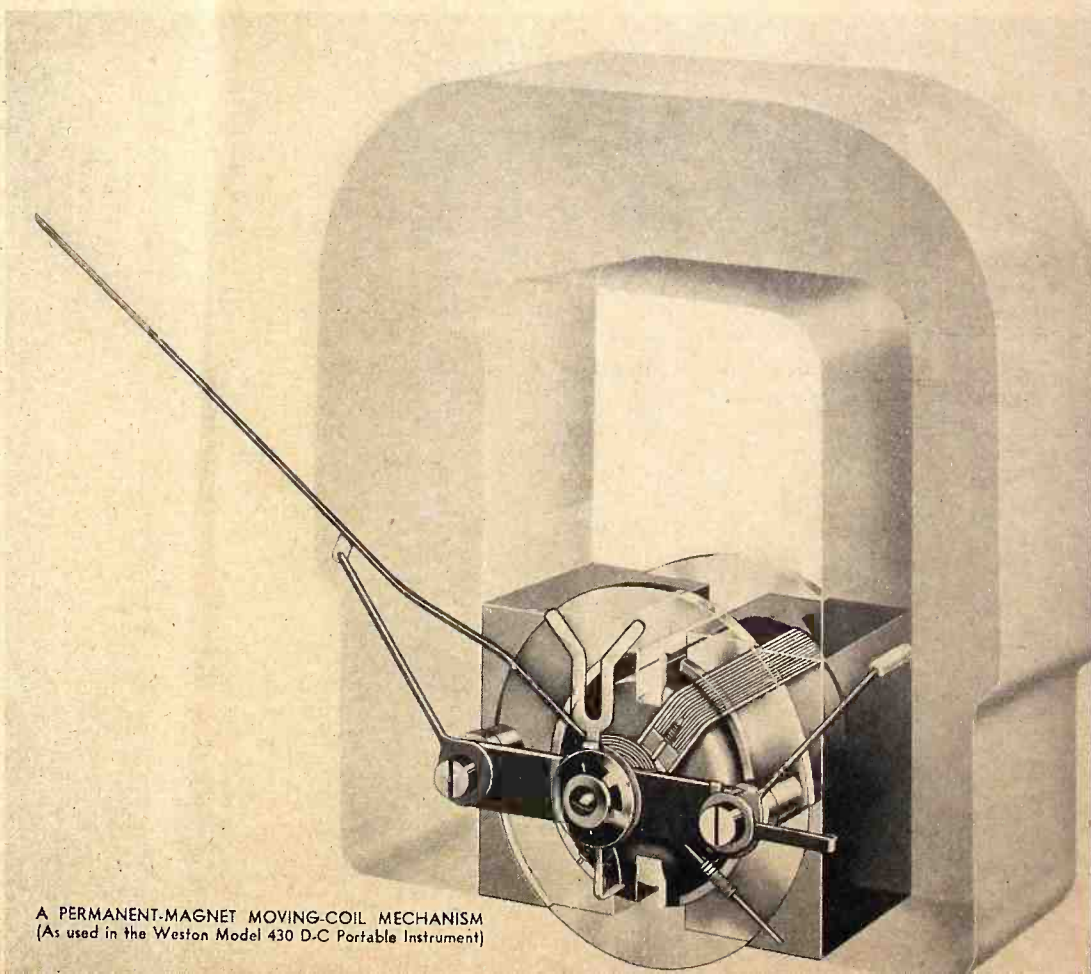

Fig. 3. Friction causes the meter pointer position to change when the meter face is tapped, though the current through the meter is held constant.

larly the more sensitive types of 50 to 200 microamperes, full scale, a certain amount of friction is evident, but this should not be more than a single scale division. The reason is that a stronger spring cannot be used to overcome the friction because the current through the coil is small, and the flux density in the gap wherein the moving coil functions is limited. In the more expensive meters a larger and more powerful magnet, of cobalt steel or alnico, provides greater flux density so that a stronger restoring spring may be employed and therefore friction in the bearings is minimized. Present-day meters owe their ruggedness to



A PERMANENT-MAGNET MOVING-COIL MECHANISM (As used in the Weston Model 430 D-C Portable Instrument)

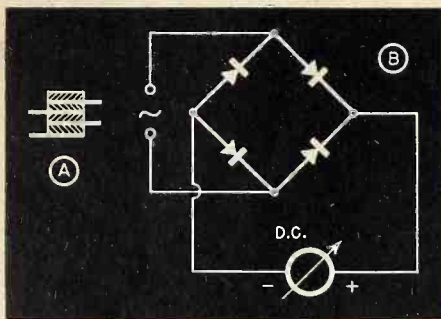

Fig. 4. The full-wave copper oxide rectifier, so widely used, is small and often has terminals arranged as in (A) above. The schematic circuit in which it is used is shown in (B).

these new magnets, without which it would not be practical to design a sensitive meter for radio service work.

Minor Repairs

The type of friction just described had best be left untouched by the inexperienced, but there are other cases of friction which can be taken care of without difficulty. Often a meter pointer will be driven off scale accidentally, due to momentary overload. The effect is a bent pointer, which may rub against the scale at some point in its deflection, thus causing sticking or inaccuracies in its indication. This trouble may quite easily be corrected by disassembling the meter and straightening the pointer. To take the meter apart, remove the three screws placed equidistant around the rear periphery of the case. In some makes, notably Weston, one or more of these retaining screws is sealed in place with wax. Usually this is done with the top screw. The wax may be readily removed by carefully heating with a soldering iron, or may be pried out with a sharp-pointed tool. Then the screw may be removed.

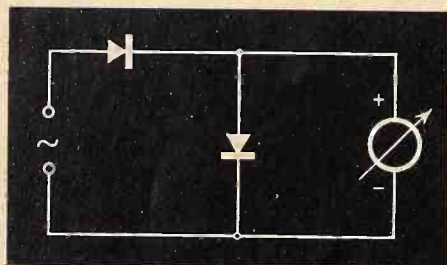

Fig. 5. By shunting a rectifier element across the meter coil as shown, better rectification is obtained, particularly when a series resistor is used to increase the range of voltages which may be measured.

After removing the screws, the meter may be pried free from the front portion of the case. Do not attempt to twist the movement out—you may damage the zero adjusting screw on the meter window. If the meter is laid face down, it will be found that the assembly may be most easily removed from its case.

The pointer is extremely light, and must be *very carefully* handled. It is best to use tweezers when adjusting the pointer or straightening bent portions. The meter should rest on the table while adjustments are being made. *Never* attempt to hold the meter in one hand while manipulating the tweezers with the other, especially if you are inexperienced. After adjustments have been made, lift the meter and blow gently across its face so the meter pointer deflects in its normal direction. Watch to see if the pointer touches the dial or any part of the assembly as it moves over the arc. When certain that it is free from any rubbing contact, reassemble. Make certain that the zero adjusting screw in the dial glass lines up with the fork provided for zero adjustment, then replace the screws. This procedure should be followed in any adjustments of the meter.

If the glass face of the meter becomes broken, it may be easily replaced provided a replacement glass can be obtained; but this is not always easy. In an emergency, a celluloid face may be used, made from the same type of material as is used for "unbreakable" crystals in watches. Your local jeweler can probably get this for you, or can cut a piece to fit. Don't attempt to use the meter without some protection of this sort—otherwise dust will get into the movement and the meter will become inaccurate and unreliable in action.

Troubles in which the moving coil is involved are usually hard to fix. However, if the coil opens and the meter becomes inoperative (which is likely to occur in hot, humid climates, particularly when a sensitive meter with a large number of turns of fine gauge wire on its moving coil is concerned, examine the coil carefully to make certain the break has not occurred near a terminal. If it has, then it may readily be fixed by cleaning the wire and resoldering. Cleaning off the enamel insulation, if necessary, is done by dipping the end of the wire in alcohol, then holding it in a Bunsen burner flame, after

which the charred insulation may readily be removed between a thumb and finger. Use a fine-pointed, clean, tinned iron in resoldering, cleaning the joint after soldering with alcohol, to remove excess rosin flux.

Converting Ammeters—Galvanometers

If the nature of the trouble is such that no repair can be made, it is often possible to adapt another meter to the job at hand. It is not generally known that ammeters, which have but little application in radio testing, may easily be converted to milliammeters which, while none too sensitive, may be used for quite a variety of radio testing. If you happen to have a spare d-c ammeter with a range of 1 to 25 amperes, its sensitivity may be increased to give full scale deflection for about

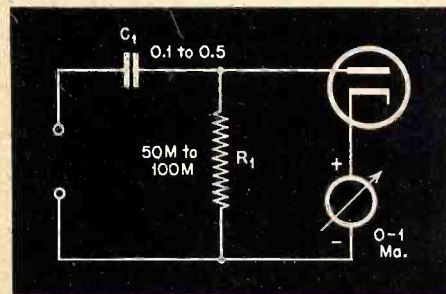

Fig. 6. A simple diode provides efficient half-wave rectification and enables a-c measurements to be made with a d-c meter.

15 to 20 milliamperes by simply removing the shunt, which is placed across the meter terminals. In some cases, it will be necessary to disassemble completely the magnet assembly to get at this shunt, but, once removed, it will be found that sensitivity of the order described above has been obtained. This meter may be calibrated against another milliammeter and a corrected scale marked in on the regular scale, or, for a neater job, a graph may be plotted giving the current in milliamperes for the corresponding ampere calibration with the shunt. Of course, if you can find someone who will swap a good d-c milliammeter for your useless ammeter, this is the simpler way out. But you won't find many in the radio service business who are interested in ammeters.

A burnt-out thermo-galvanometer makes an excellent and sensitive d-c meter. All that is necessary to make this conversion is to disconnect the wires from the thermocou-

ple elements, which are arranged in zig-zag form to make a bridge arrangement, and to reconnect these wires to the regular meter terminals. Such meters have a full-scale sensitivity of 400 to 700 microamperes and thus may be readily converted into 1000 ohms-per-volt meters, either d-c or, in conjunction with a copper-oxide rectifier, for a.c. too. You will find, however, that such meters are poorly damped—that is, it takes some time for the pointer to come to rest. Further, the moving coil is of very low resistance—this means low torque, consequently a weak spring must be used and poor damping action results. But it is better—much better—than nothing. In fact, the writer used such a meter for test purposes for many months, with excellent results.

Shorts in Rectifiers

Mention of copper-oxide rectifiers brings to mind the fact that these handy little gadgets can likewise cause a lot of meter troubles. It is not unusual for one section of such a rectifier to become shorted. If a bridge type of rectifier is employed, as shown in Fig. 4, the result is only partial rectification, the meter reads low, and the pointer may vibrate when an element fails. The rectifier, if of the type shown in Fig. 4A, may be checked by measuring the resistance between adjacent terminals. The ohmmeter test prods should be reversed after the first reading between the same terminals and the difference in reading noted. One reading should be considerably higher—from 10 to 50 times—than the other, if rectification is taking place. That, as you know, is the principle of their operation—much greater opposition to the flow of current in one direction than in the other.

If there is little or no difference in the ohmmeter readings when testing any section of the rectifier, it may be possible to use two of the remaining good sections in a different type of circuit, which is nonetheless efficient. This is shown in Fig. 5. This type of rectifier circuit, though relatively new, has come into rather general use in medium-priced service test equipment. Its principle of operation is as follows: The series copper-oxide rectifier element passes current freely when the polarity. Consequently the meter reads higher when the current is of the proper polarity. Because some

current also flows through the meter when the polarity is reversed, due to the fact that the copper-oxide rectifier does not have infinite resistance in its theoretically non-conducting polarity, this current bucks that flowing in the direction of low resistance and tends to reduce the efficiency of the rectifier and lower the reading. To overcome this fault, one section of the copper-oxide rectifier is shunted across the meter as shown (in some designs, the shunt rectifier is placed ahead of the series rectifier so that it shunts both the meter and series rectifier). In either form of connection, the bucking current passes freely through the shunt rectifier, so that but little goes through the meter. Thus but little bucking action results. When the flow of current is in the opposite direction (that is, when the polarity of the a-c wave reverses), the series rectifier allows current to pass freely but the shunt rectifier offers a high impedance to shunt current losses. Thus more efficient rectification results, with a minimum of rectifier elements required.

The V-T Rectifier

If it is necessary to replace the copper-oxide rectifier, a half-wave vacuum tube rectifier may be employed, as shown in Fig. 6. When using a vacuum tube rectifier, it is not necessary to add a shunt rectifier in the manner just described, in order to increase the rectification efficiency, because the vacuum tube rectifier has practically infinite impedance to current polarized in the non-conducting direction. Therefore a single unit as shown serves the

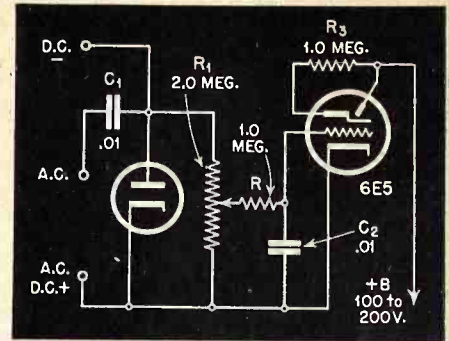

Fig. 7. With this circuit, both a-c and d-c voltages may be measured without a meter.

purpose. Any diode, such as a 6H6, or any triode connected as a diode, serves the purpose.

So far we have discussed only the possibility of utilizing a meter, either in repaired or altered form, to measure voltage and current. When the nature of the trouble is such that the meter cannot be repaired, one alternative is available in the form of the "magic eye." This device has already found favor as an indicator of current and voltage in its well-known application in the Rider Chanalyst, where its stability, ruggedness and general utility are generally realized. If we make use of the characteristic of this type of tube by which the eye closes when a d-c negative bias of the order of 4 to 6 volts is applied to the grid, we find that a ready means of indicating approximately the values of voltages under test. By means of an added rectifier, a-c measurements may also be made, as with any d-c meter. And, by adding a calibrated multiplier, or simply by calibrating a high-resistance potentiometer,

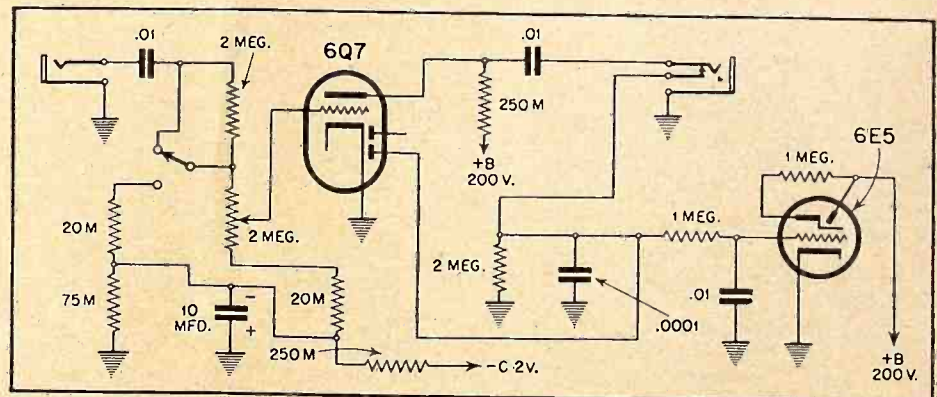

Fig. 8. The audio channel of a signal tracer may be calibrated to read a-c voltages over a wide range.

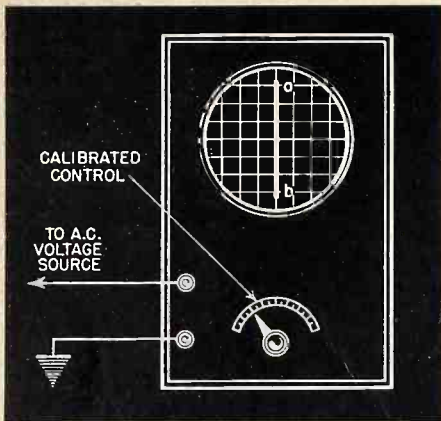

Fig. 9. The 'scope may be calibrated for a wide range of a-c voltages. A reference level is chosen, such as the line a-b, and the input voltages required to produce this level are marked on a card placed under the vertical amplifier control pointer.

placed in its input circuit, a wide range of voltages may readily be measured. For greater sensitivity, an amplifier may be added. This arrangement is applicable in any form of test instrument as a substitute for the d-c meter. To be sure, in such applications it has its faults. We need not expect the accuracy of a good meter, nor its convenience and ease of operation. But we are considering methods of meeting emergencies, of getting results when no other means are readily available. As such an expedient, the "magic eye" often fills the bill. And, it has advantages in that it cannot be ruined by accidental overload, as is the case with some meters.

"Magic Eyes"

A simple application of the indicator tube for checking a-c and d-c voltages over a wide range is shown in Fig. 7. The input potentiometer is calibrated by placing a card under the hex nut which hold the control

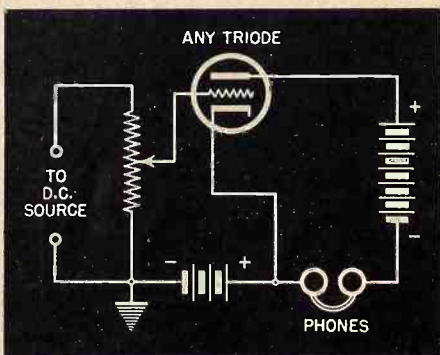

Fig. 10. Headphones, and this circuit, may be employed for checking voltages.

against its mounting (panel or other support) and the position of a pointer, fastened to the potentiometer shaft is noted for various applied input voltages, either a-c or d-c, using a borrowed meter in shunt across the source. Each major point is marked on the card and intermediate points are obtained by dividing the distance between points into five divisions. A calibration for voltages above 5 volts is obtained at each major point by noting the position of the knob pointer at which the indicator eye just closes. This can be determined to a high degree of accuracy and is substantially independent of variations in power supply voltages over reasonable limits. It is advisable to apply more than 250 volts across the potentiometer, but an additional resistance may be placed in series with the "high" end of the potentiometer to increase the range, if desired. When a 2-megohm potentiometer is employed (other values above 0.5 megohms may be employed) a 2-megohm series resistor will double the upper range. Note that this device should be used *without* a ground. This is because the positive voltage in the apparatus being checked must be applied to the cathode of the 6E5, and, since the positive voltage is seldom grounded in radios, we might cause a crossed ground, or short circuit, when connecting this magic eye circuit to the circuit under test if the magic eye cathode were grounded and connected to positive, while the ungrounded negative of the magic eye circuit is connected to a grounded negative in the source of voltage being tested.

In Fig. 8 the audio channel of a typical signal tracer (Rider Chanalyst) is shown. A shielded cable, terminating in a pin jack at one end and a phone plug at the other is connected to the input jack of this channel. When the pin jack probe point is connected to a point where an a-c potential exists, the ground of the channel being connected to the ground of the apparatus under test, this a-c voltage is impressed on the grid of the amplifier tube, rectified by one of its associated diodes, and the resulting output voltage actuates the 6E5. Using the components shown, it is possible to measure voltages over a range extending from 0.2 volts (approximately) to 100 volts, with the toggle switch in the position shown, and to 1000 volts, rms, when the toggle is switched to

the 20,000 ohm resistor and thus placed a shunt divider in the circuit. The phone jack in the output circuit enables headphones to be plugged in and the channel to be used for listening to the audio signal picked up by the probe when connected to various points in the audio section of an operating radio receiver. Also, this method may be employed to listen for noise or hum in components of the amplifier or power supply.

Oscilloscopes

By calibrating the vertical amplifier control of a cathode ray oscillograph, as indicated in Fig. 9, it is possible to measure a-c voltages over a wide range, just as has been described for the magic eye device,

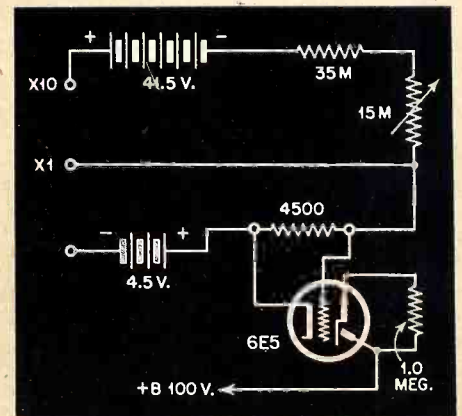

Fig. 11. How an indicator tube may be used to replace a meter in a typical ohmmeter circuit.

shown in Fig. 7. The method of calibration is the same, a reference height being chosen on the screen. The cathode ray scope of course has the added advantage of indicating distortion. For high d-c voltages, the displacement of a spot on the calibrated screen may be used to indicate the magnitude of the voltage. In such cases it will be necessary to connect directly to the deflecting plates of the 'scope, and therefore the sensitivity will be low. Care should be taken not to adjust the spot for a sharp focus on the screen, or to use high intensity illumination, or the screen will be burned. It is better to keep the horizontal sweep in operation to spread the spot and thus avoid the dangers of concentration. On the whole, it is not considered practical to use the oscillograph in

(Continued on page 27)

Card 1

OSCILLATOR COIL

(Repairing Burned Out Sections)

When the primary of an oscillator coil of the type shown burns out a satisfactory repair can be made by connecting a 10,000 ohm resistor across the terminals of the primary; and a .00025 condenser from the anode grid side of the resistor to the junction of resistor, padder and low side of the oscillator secondary. The oscillator trimmer and padder must be re-aligned.

The same repair may be effected in other types of coils by dispensing with the oscillator grid condenser and shifting the grid resistor to the low side of the secondary.

Submitted by Wade Gass

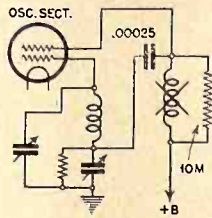

Card 2

SUBSTITUTE SIGNAL TRACER

(For Testing r-f/i-f Sections)

When proper test equipment is not at hand a satisfactory signal tracer can be adapted for the receiver under repair by making the changes in circuit indicated herewith.

Break the circuit at the high side of the volume control or other diode resistor at A. Ground the circuit at B. Break the circuit at C. Connect a 50,000 ohm resistor between A and C. Connect a probe through a small condenser to the diode. The detector and audio section act as a signal

(Continued on Card 4)

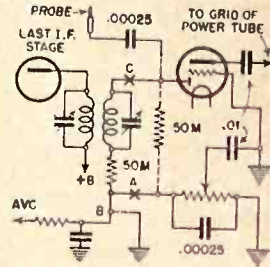

Card 3

CROSLY SERVICE SUGGESTIONS

(Regarding Filters and Resistors)

When ordering ballast tubes always advise if substitute A.C.-D.C. line cord will be acceptable instead.

Multiple section voltage dividers and filters for Crosley sets are difficult to obtain. It is suggested that whenever practical only the defective section should be replaced, rather than the entire unit.

Card 4

tracer for the remainder of the circuit.

It is first necessary to determine by a disturbance test if the audio section is in working order.

Submitted by Wade Gass

Card 5

RCA 15-BP SERIES PORTABLES

(Tube Burnouts in Early Models)

Frequently the 3Q5 and 1H5 tubes burn out in early models. The cause is an accumulated charge in the 200 mfd filament cond. C12, discharging through the 3Q5 filament and the 20 mfd capacitor C17 to ground, when the set has been working on a-c and is switched to battery, or on and off quickly. To remedy, ap-

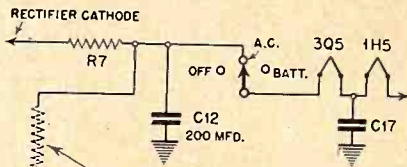

NOTE: DO NOT USE A LOWER VALUE RESISTOR, OR FILAMENT VOLTAGE WILL BE REDUCED TOO MUCH.

(Continued on Card 7)

Card 6

MONTGOMERY-WARD "AIRLINE" 14WG-808

(Frequency Shift)

When you encounter shifting in the lower frequencies, sometimes a complete instrument checkup will indicate that everything in the circuit is perfectly okay, and yet the frequency shift remains.

Generally the trouble is caused by the 6SA7 tube which may also check "ok." Simply replace and use another 6SA7 tube.

Submitted by K. P. Kuenzel

Card 7

ply a bleeder to discharge the C12 capacity. As illustrated, connect a 25,000 ohm 1/2 watt resistor from the end of Candohm R7 nearest the loop antenna to the resistor frame, which is grounded to chassis. This resistor is located on top of the chassis, above the tubes. Do not use a resistor of less than 25,000 ohms or filament voltage will be reduced too much.

Submitted by R. W. Cutts

Card 8

GENERAL ELECTRIC 32-RLP

(Record-player Adjustments)

When the mechanism fails to eject records properly the fault may be due to a bent rocker arm (fig. 9 of service notes) or the rocker arm may be binding at the motorboard. Another source of trouble could be the ejector pin (52) which might need adjustment. Generally warped records cause the mechanism to fail to eject records properly.

"Wows" in this model record player can be caused by a bent record spindle or by a flat on the motor drive wheel. Check these carefully. (69 and 60)

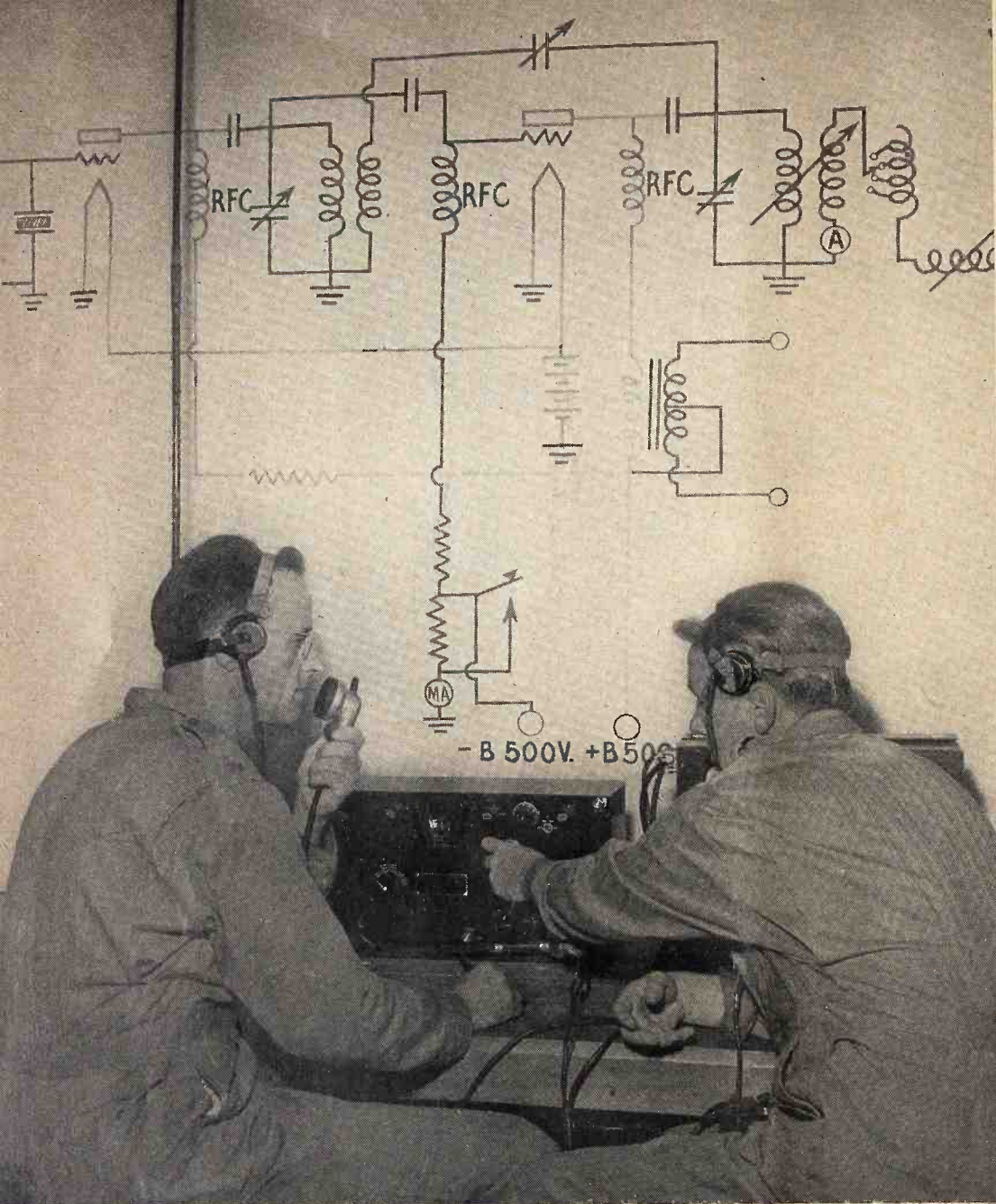

Technicians Needed By The Military

COMMISSIONS AND RATINGS OFFERED TO INSTRUCTORS

AMONG the most urgent needs of new officer personnel in the United States Navy is for professional technicians in engineering fields, the Director of Naval Officer Procurement, Chicago, has announced.

Perhaps first in the list are graduate electrical and radio engineers, those mainly between 21 and 50 years who have followed electrical engineering since their graduation, and who have a knowledge of ultra-high frequencies, electronics, and television. Those more familiar with power engineering likewise may find

a place in the Navy which is interested in these men in ages up to 50 years. Electrical engineers are needed especially in the Navy's fields of radio and detection devices. Men with radio or communication engineering degrees may qualify for officers commissions as well. Waivers for minor physical defects often are obtainable.

A Petty Officer rating is offered to men with sufficient experience in radio to instruct classes in Radio Theory, Practical Operation, Code, or Maintenance.

The Navy has schools in several parts of the country to instruct enlisted men in radio, and it is for these schools that instructors are needed. Many men selected will go through a refresher course at the Naval Aviation Service School at East 87th and Anthony Avenue, Chicago, where they will be instructed in use of the radio equipment used by the Navy.

In some cases men with B. S. degrees in mechanical or other engi-

neering subjects and who have had experience in radio and electrical work may qualify for officer assignments in radio or electrical lines. Usually, however, degrees in engineering other than electrical tend to fit the applicant for other duty. For instance, Navy activities in ordnance, construction, and ship operation use mechanical, civil, and chemical engineers. Here again physical waivers often are possible and the age range is usually between 30 and 45 years or beyond those two limits in some cases.

Another special officer procurement program under way is for college teachers of physics, or chemical, diesel, electrical, mechanical, and radio engineering at Naval Reserve Midshipman Schools. Private school and junior college teachers and others qualified to teach those subjects in colleges also are being sought.

Either Ensign W. W. Hall, Room 300, or Mr. M. G. Miller, Room 1184, both in the Board of Trade Building, Chicago, will answer all requests for information.

★

Train for Civilian Defense!

(Official U. S. Signal Corps Photo)

The importance of a complete system of independent radio communications in the event that enemy attack or sabotage puts our normal communication system out of commission is very real.

To meet this need the Office of Civilian Defense, the Federal Communications Commission and the Defense Communications Board have created the War Emergency Radio Service.

"Like all other civilian defense activities, this highly important war emergency service must be manned by volunteers," said George S. Van Schaick, director of the OCD, Second Region, yesterday. "For this vital service we call upon the young men and women throughout the country who hold licenses as amateur radio operators. Radio service men and even persons who have little experience in the field may be eligible. They are given proper training. Any citizen, male or female, over the age of 16 is eligible for training for this service.

Any one interested should go to the nearest bureau of the Civilian Defense Volunteer Office or police station house for information and instruction.

Shop Notes

Data presented as "Shop Notes", contributed by service-dealers as a result of practical experience, is carefully considered before acceptance. We believe it correct but we assume no responsibility as to results.

FADA MODEL 119

Card 1

(Gain Data)

Ground of Signal Analyzer and Signal Generator to chassis. No external to ground. Generator's high side lead through .1 mfd conds. to yellow wire on loop.

ANT.	1.	600KC
6SA7 GT grid	26.	600KC
6SA7 plate	280.	Osc. freq. 1056KC
6SA7 plate	60	I.F. freq. 456KC
6SK7 GT grid	38	I.F. freq. 456KC
6SK7 plate	1250	I.F. freq. 456KC
6SQ7 GT diode plate	1700	I.F. freq. 456KC
AVC	7	volts D.C.
6SQ7 GT audio plate	5.75	volts 400 cps
25L6 GT grid	5.25	volts 400 cps
25L6 plate	57.	volts 400 cps

Submitted by Robert Boudreaux

RESISTOR VOLTAGE-DROPPING TABLE

Card 2

(For tube heaters in AC-DC sets)

		120 VOLT LINE																
VOLTAGE DROPS		1	2	3	4	5	6.3	10	12.6	15	25	50	55	75	100	110	117	120
R@3amp.	RESISTANCE STRING	3.333Ω	6.666Ω	10Ω	13.333Ω	16.666Ω	21Ω	33.333Ω	42Ω	50Ω	83.333Ω	100Ω	109.333Ω	250Ω	333.33Ω	366.6Ω	390Ω	400Ω
	VOLTAGE DROPS	1	2	3	4	5	6.3	10	12.6	15	25	50	55	75	100	110	117	120
R@1.5amp.	RESISTANCE STRING	6.666Ω	13.333Ω	20Ω	26.666Ω	33.333Ω	42Ω	66.666Ω	84Ω	100Ω	166.666Ω	183.333Ω	250Ω	333.33Ω	366.6Ω	390Ω	400Ω	400Ω
	VOLTAGE DROPS	1	2	3	4	5	6.3	10	12.6	15	25	50	55	75	100	110	117	120

Submitted by L. H. McMurray

SALVAGING OLD "A"- "B" BATTERIES

Card 3

(Obtaining extra life)

If the "A" side seems bad peel off cover. Generally acid corrosion has eaten away a wire or two. If so, clean up and make repairs. Follow same procedure with "B" side. Don't throw away any side that is good.

Often you can salvage a good "A" side of one battery and a good "B" from another. These can usually be combined to afford some extra service until a new A-B battery can be obtained.

Submitted by R. L. Hester

SUBSTITUTE FOR REGULAR AERIAL WIRE

Card 4

Real aerial wire is hard to obtain. Try disassembling some old unusable power or output transformers. From some you can usually unwind and salvage long enough strands of enameled copper wire to serve as aerials for BC receivers. Be careful not to snarl the wire and don't stretch it too tightly.

Submitted by R. L. Hester

2 VOLT POWER SUPPLY TO OPERATE 1.4 VOLT TUBES

Card 5

The output of a 2 volt Porta Powr unit can be reduced so it will operate and not burn out sets employing 1.4 volt tubes. Put a 7 to 10 ohm wire-wound resistor in series with the "A" supply to reduce the voltage. Tapped resistors should be used to simplify adjustments. The amount of resistance required depends upon the number and ampere rating of tubes in the set.

Submitted by R. L. Hester

SALVAGING DEFECTIVE POWER TRANSFORMERS

Card 6

(Converting Them Into Outputs)

If the primary of a 110 volt power transformer is burned out or shorted you can salvage and repair the unit and then use it as an output transformer provided it will fit into the space available and you can find a way of fastening the mount.

Connect the plate or plates to the plate winding of the transformer and the voice coil to the filament winding.

Submitted by R. L. Hester

MODEL "L" PORTA-POWR PACKS

Card 7

(Repair and Adjustment)

These converters sometimes fail after long or continuous service, or they will only operate receivers during night time. Reason: power pack output has dropped to 1 or 1½ volts, which is insufficient for 2 volt tube operation. Cause: oxide rectifier has become defective.

Solution: the "A" voltage can be increased by shunting a 7 to 10 ohm tapped resistor across the filter choke. Adjust resistor until test shows that 2 volts output is being delivered.

Submitted by R. L. Hester

SKYROVER MODEL 519 (Gain Data)

Card 8

Ground side of signal analyzer and generator to a-c switch. Be sure the instruments used for tests are not grounded to earth. Set analyzer to 600KC and the generator and receiver should be tuned to give the peak on the gain meter, if the instru. has one.

The attenuator on the generator is decreased until the gain reads 1. From then on all readings are to be regarded as so many points above or below the ant. reading of 1. (Note: rack gang conds. on all list except the far osc. reading.)

ANT. (loop)	1.	through .0002 conds.	600KC
12A8 GT osc. mod. grid	.5		600KC
"	plate	540. osc. freq.	1056KC
"	"	30. I.F. "	456KC
12K7 GT I.F.	grid	2.4 I.F. "	456KC
" I.F.	plate	425. I.F. "	456KC
12Q7 GT diode	plate	350. I.F. "	456KC
AVC	12	volt d-c.	
1st A.F.	plate	5.5 volts 400 cps	
35L6 GT	grid	4.70 " " "	
"	plate	38. " " "	

Submitted by Robert Boudreaux

PROUDLY IN THE
Nation's Service



As in the First World War, BRACH radio and electrical equipment is once again proving its excellence and dependability under the most exacting conditions...the products of 36 years' experience in "QUANTITY-plus-QUALITY" manufacture.



L. S. BRACH MFG. CORP.
World's Oldest and Largest Manufacturers of Radio Aerial Systems
55-65 DICKERSON STREET • NEWARK, N. J.

Radio Noises

(Continued from page 8)

most others which servicemen meet.

Localizing Circuit Trouble

In localizing noise troubles in a receiver, the usual method is to try the volume control first. With the receiver operating, the volume setting is increased and reduced in turn. If the noise level changes, then all stages and components fol-

lowing the volume control are immediately eliminated as possible sources of the trouble. If the noise level is unchanged, the fault must originate in some circuit following the volume control, or in the power supply. Thus a simple test of this character quickly eliminates a large number of components as possible causes and aids in isolating the real cause. When the trouble is in stages preceding the volume control, removing tubes one by one, in turn, serves to isolate further the trouble. Thus if the noise ceases when the mixer tube is removed, we know that stages

following the mixer are not affected. Note that we cannot say that the trouble is in the mixer circuit simply as a result of this test; we only know that it is not in other stages. It might be in the oscillator, in the power supply, in the antenna coil, or in some other associated circuit. Further tests along established lines, using either signal tracing or more formal methods, will isolate the defective component. Remember, though, that noise is always the result of a defective mechanical or electrical contact. A possible exception is that caused by excessive gas in a radio tube, but this usually manifests itself in the form of a hiss.

One practice which is frequently followed in trouble shooting for noise is to tap each suspected component. It is really amazing how often this method gives misleading results. One will tap a tube, ever so gently, and find a ready noise response, only to discover, on further test, that other tubes respond likewise. It is better, in such instances, to resort to more heroic methods; massage the chassis none too gently with the fists. The intermittent contact will then often be completely broken (if that is the cause) and will then be easier to locate.

Another test which uncovers a common cause of noise is rotating the gang condenser while the antenna and ground connections are removed. Often noise and occasionally oscillation result from corrosion occurring where the brass forks make contact with the variable condenser rotors. The cure is simply to remove, clean and tighten the tension of these forks.

Troubles occurring in controls are often corrected by cleaning with carbon tetrachloride. The same cleaner is often applied to other contacting surfaces, such as socket contacts, springs, tube prongs, etc. There is no question as to its effectiveness in removing noise due to corrosion at such points. Not so well known is the fact that carbon-tet itself can cause corrosion if slopped indiscriminately over parts. While this solvent dries rapidly, it should be remembered that it must be used sparingly or the benefits derived will be followed by further trouble, due to the carbon-tet, in the near future.

Much has been stated about the need for avoiding the use of solder fluxes, particularly of the acid type. It has been generally assumed that this is all that need be considered. However, any flux, even rosin, can attack metal. The function of the flux is

attack the metal is would not clean it. So it is important to clean off any excess rosin after soldering, if a permanently satisfactory contact is to be assured. This is best done with alcohol. Care must be taken, however, that the alcohol is carefully applied, as it will damage the color coding of resistors if allowed to flow freely over such coded surfaces. The completed joint should be coated with transparent lacquer, as previously described, to prevent moisture from causing trouble. These precautions are most necessary when the apparatus is subjected to unusual operating conditions; in normal home use we need not observe such soldering care . . . it takes too much time and is not quite so important.

Troubles similar to those occurring in power and audio transformers are also frequently uncovered in r-f and i-f coils, especially when concentrated windings of the universal type are employed. Again the cause is generally moisture entering the windings, causing intermittent breakdown of insulation, corrosion at contacts or breaks at terminals. Any long-continued hot, humid spell in Summer causes an immediate increase in failures of these components. More careful impregnation of windings is essential, and when it is possible to repair the defect, it is a good idea to dry the windings thoroughly and immerse the transformer in an impregnating compound until all bubbles cease. A good many suitable compounds are available; select one which will not appreciably affect coil Q. The type of impregnant suitable for audio transformers will not be satisfactory, as a general rule.

The power switch, particularly if the type used on volume controls is used, often causes noise. Some of the older sets used fuses set in mountings which corroded, causing noise. These points should not be overlooked in hunting down the source of complaint.

Defective contacts in electric light bulbs used in mounted receptacles and table lamps also cause noise. Often the bulb is screwed in loosely and makes intermittent contact. Occasionally such troubles may be noted when walking over a floor, particularly when an electric light bulb mounted in a ceiling receptacle in a cellar below becomes loose. Another source of noise due to contact between dissimilar metals occurs when conduit is ungrounded and improperly anchored so that it rubs against gas or water pipes placed adjacent to it.

Some Things are REALLY Scarce Right Now*



*(Especially Radio Servicemen's Time)

THERE is only one practical way to offset the present shortage of labor—that is to ration the time you do have available.

Study your bench-time just as you check the consumption of any other rationed item. Make sure the latest methods are being employed—that testing instruments and Rider Manuals are being used on every job. For, the dependable servicing information in the thirteen Rider Manuals will lead you quickly to the cause of failure—supply you with the facts that speed repairs.

Stop wasting time "guessing out" defects; today it's your patriotic duty to work with system and assurance.

Reach for one of the thirteen Rider Manuals before you begin every job. In doing so you'll conserve manpower, parts, time and civilian sets—all critically scarce right now.

RIDER MANUALS

Volumes XIII to VII	\$11.00 each
Volumes VI to III	8.25 each
Volumes I to V, Abridged	\$12.50
Automatic Record Changers and Recorders	6.00

OTHER RIDER BOOKS YOU NEED

The Cathode Ray Tube at Work	
Accepted authority on subject	\$3.00
Frequency Modulation	
Gives principles of FM radio	1.50
Servicing by Signal Tracing	
Basic method of radio servicing	3.00
The Meter at Work	
An elementary text on meters	1.50
The Oscillator at Work	
How to use, test and repair	2.00
Vacuum Tube Voltmeters	
Both theory and practice	2.00
Automatic Frequency Control Systems	
—also automatic tuning systems	1.25
A-C Calculating Charts	
Two to five times as fast as slide rule.	
More fool-proof, 16 pp. 2 colors	7.50
Hour-A-Day-with-Rider Series—	
On "Alternating Currents in Radio Receivers"—	
On "Resonance & Alignment"—On "Automatic Volume Control"—On "D-C Voltage Distribution"	90c each

JOHN F. RIDER PUBLISHER, INC.

404 Fourth Avenue • New York City

Export Division: Rocke-International Electric Corp.
100 Varick Street New York City. Cable: ARLAB

RIDER MANUALS

SPEED REPAIRS — AND VICTORY

MALLORY GETS 2nd STAR

»» P. R. Mallory & Co., Inc., Indianapolis, Indiana, was advised on February 3, by Admiral C. C. Bloch, Chairman of the Navy Board for Production Awards, that it had been granted a renewal of the Army-Navy "E" Award for an additional period of six months, dating from December 31, 1942. This renewal grants Mallory the right to add an additional white star to its pennant.

Mallory was the first company in Indianapolis to receive the Navy "E" pennant and flag of the Bureau of Ordnance. These were awarded in December of 1941 by Secretary of Navy Knox.

On July 18, 1942, notice of the re-

newal of this award was announced. This permitted the company to add its first white star to the Army-Navy "E" flag which had supplanted the former Navy "E" pennant and Bureau of Ordnance flag.



CROSLEY SERVICE HELPS

»» To keep Crosley radios in operation for the duration, the Crosley Service Department announces that it has compiled a new list of replacement parts which are available in limited quantities.

Additional lists will be issued from time to time and it is believed they will be of great assistance in solving service parts problems.

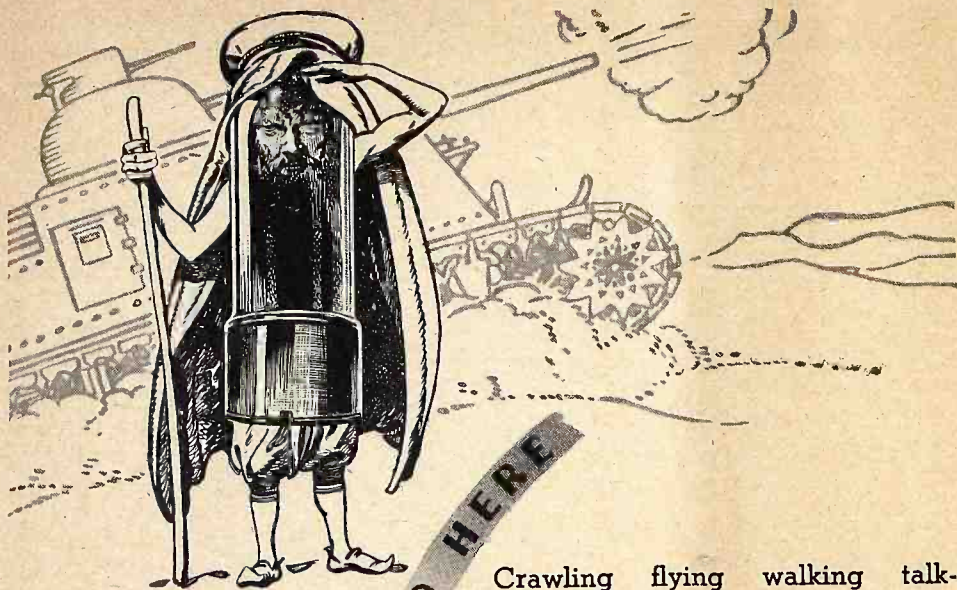

Crawling flying walking talk-
 ing overseas underseas here
 there and everywhere Radio
 Tubes perform Instant sending
 instant receiving clearly surely
 — that's Ken-Rad That's what
 the armed forces are getting
 Today the boys on the fighting
 fronts come first Later there will
 be tubes for you and your radio

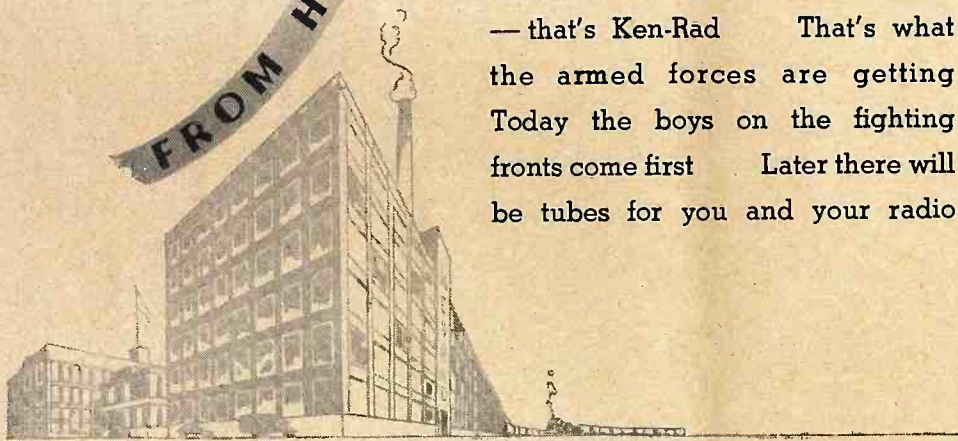

KEN-RAD

RADIO TUBES • INCANDESCENT LAMPS • TRANSMITTING TUBES

OWENSBORO • KENTUCKY

“Victory” Line Standards Set

The first standards for “War Model” replacement parts designed to keep home radio sets running in spite of wartime shortages, have just been completed, the American Standards Association announced March 2nd. This work, done at the request of OPA after consultation with WPB, indicates Washington’s interest in keeping civilian radio sets

operating at a good level of efficiency. ASA has tried to compile a simplified line of parts sufficient to service an estimated 90 per cent of modern home receivers in use today.

Production of parts to these new standards will, it is expected, be scheduled by manufacturers to start in April; and the parts will be covered by price ceilings.

The list of replacement parts which is deemed adequate for servicing the great majority of home receivers shows but nine paper condensers, nine electrolytic condensers, eleven values of volume controls, six

power transformers, two chokes, two interstage audio transformers, one driver audio transformer, and three output audio transformers.

The complete list of parts and their values was published in the February issue of RADIO SERVICE-DEALER, pages 24-25. Only the slightest changes have since been effected, although the list, at that time, was merely tentative. Now manufacturers must await materials allocations from WPB, and the availability of facilities so production can be started.

★

Book Review

THE INDUCTANCE AUTHORITY, by Edward M. Shiepe, B.S., M.E.E., 50 pages, 9½ x 12 inches, published by Gold Shield Products, New York, N. Y. Price \$2.50.

This book, composed principally of charts, dispenses with the usual paper work necessary for computing the physical characteristics of solenoid coils for tuning with variable or fixed condensers of any capacity, from the ultra-high frequencies to the borderline of audio frequencies. An accuracy of 1 percent is claimed.

There are 38 charts, of which 36 cover the number of turns and inductive results for the various wire sizes used in commercial practice, as well as different types of insulation covering. Each turns chart for a given wire size has a separate curve for each of 13 form diameters from ¾” to 3 inches.

The forepart of the book contains 10 pages of explanatory data related to the use of the charts. Included as an insert is a straight-line inductance - capacity - frequency chart, measuring 17” by 22”, with a range of 5 to 50,000 kc.—M.L.M.

★

KEN-RAD TUBES SUCCESSFULLY WITHSTAND HARD ARMY USE

»» An associate of the Ken-Rad Tube & Lamp Corporation, Owensboro, Kentucky, has received a letter from a staff sergeant in the headquarters company of an Army outfit that has been on maneuvers for several months in the United States. The letter says in part:

“During maneuvers headquarters company used about 56 radio tubes in their receiving and sending sets. In those three months the tubes took an awful beating. After maneuvers headquarters company tested all their radio tubes and of the 56, for all their rugged treatment, only one was bad. P. S.—They were all Ken-Rad Tubes.”

Meters And Meter Substitutes

(Continued from page 20)

this manner, for d-c voltages, though, for a.c., it is very useful and effective.

Headphones

Another emergency substitute for a meter is found in the use of headphones in conjunction with an amplifier, as shown in Fig. 10. The amplifier is made up in accordance with the circuit shown, connecting the phones in the ground lead to avoid danger of accidentally getting high voltage across one's head. The plate voltage should be kept low as an additional safety precaution, 22 to 45 volts being adequate. The grip bias voltage is adjusted until connecting the test prods to a d-c source of $1\frac{1}{2}$ volts or so gives a barely audible click, with the potentiometer adjusted to maximum. The voltage is then increased and the potentiometer is readjusted until a click of the same magnitude is heard, and this point is marked on a card slipped under a pointer attached to the shaft of the potentiometer, in the same manner as was described for the amplifier circuit of Fig. 7 and Fig. 9. The calibration is continued for a number of voltages over a wide range. If a 2-megohm potentiometer is used, voltages up to 250 volts d.c. may thus be checked. A lower or higher resistance potentiometer may be used. If too low resistance, the ohms-per-volt rating drops and the load on the voltage source increases. If too high, the control won't stand up long. In making tests with this arrangement, it is necessary to make and break the circuit to produce the clicks. This is easily done by simply tapping the wire against the "high" side of the circuit under test. Very small voltages may be measured in this way, if desired. Alternating voltages may also be checked, but the measurements will be pretty rough.

An application of the indicator eye to an ohmmeter is shown in Fig. 12. Actually, what this amounts to is a method of checking continuity, since it is not intended that accurate measurements be made in this way. Of course, it would be possible to make a calibration for the degree of closure of the magic eye, in much the same manner

as was done for the amplifier and cathode ray oscillograph controls. But we do not feel that this is practical to do. There are plenty of occasions when it is merely necessary to know whether a circuit or component is open or shorted. And this simple arrangement supplies the answer.

★

NOW CAPTAIN KRICH

»» Paul R. Krich, Executive Vice-President of Krich-Radisco, Inc., well known Newark, N. J., parts distributors, has just been promoted to the rank of Captain in the Army Air Forces.

RADIO KITS designed by Meissner for Accurate Radio Training

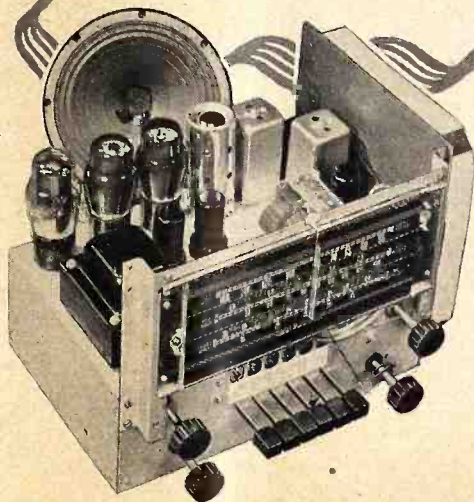

9 TUBE STANDARD KIT—

Designed for faster training of advanced radio students. 3 band AC superheterodyne. Automatic push button tuning. Push-pull audio. 6" speaker. Connections for phonograph, television and FM. Frequency range 185 to 550 meters, 40 to 136 meters, $12\frac{1}{2}$ to 40 meters. Model No. 10-1195. Complete kit with tubes, special school net price \$48.90 (cabinet for 9 tube kit \$6.90).

6 TUBE KIT—

Engineered for more complete basic training. Frequency range 540 to 1620 kc. (53 to 16 meters) on 2 bands. Operates on 110-120 volts 50-60 cycle AC, or 110-120 volts DC. Beam power output. 6" speaker. 4 panel controls. Kit complete with tubes. Model No. 10-1197. Special school net price \$19.10.

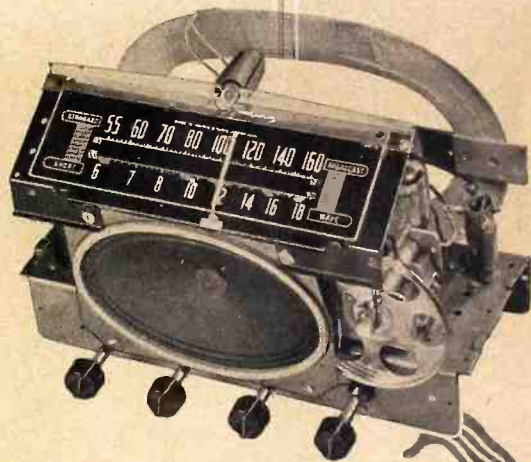

See your Meissner distributor or write for complete catalog!



Meissner

MOUNT CARMEL, ILLINOIS

"PRECISION-BUILT PRODUCTS"

GRAND BECOMES MFR'S REP.

»» Jack Grand, one of radio's pioneers has become a member of the sales representative firm of Burlingame Associates, 69 Murray Street, New York City.

Mr. Grand takes up his duties with the firm originally founded by Bruce Burlingame, now on a leave of absence due to his activity with the armed forces. The firm has been carried on in his absence by Charles Sargeant, sales engineer, and William Adams, in charge of service and the repair of test equipment.

BUY WAR SAVINGS STAMPS



Copyright 1943.
Cowan Pub. Corp.

INSTRUCTIONS

THIS stroboscope disc may be used to check the speed of any recording or reproducing turntable at either 78.26 r.p.m. or 33 $\frac{1}{3}$ r.p.m.

Cut out and mount on stiff cardboard, or on a 10-inch phonograph record, using rubber cement or any other adhesive that will not shrink the paper. Do not use ordinary paste.

If the disc is mounted on a phonograph record, make sure that the record spindle hole is truly centered; if it is off-centered, thus causing a "wow" or variation in musical pitch, it will affect the accuracy of the stroboscope disc, resulting in a backward and forward movement of the segments, even though the turntable speed may be constant.

By the same token, care must be exercised in cutting out or punching out the center hole for the stroboscope disc. The white dot is the exact center, the black area the portion to be removed. A scribe compass will do the job nicely.

In using the stroboscope, it is preferable that a normal load be placed on the turntable, so that operating conditions are simulated. In checking the speed of a record-player turntable, for instance, check the speed with the pickup needle traversing the outer grooves of a 10-inch record placed on the turntable underneath the stroboscope disc -- or the outer grooves of the record on which the stroboscope

disc is mounted, as the case may be.

With the turntable in motion and the stroboscope disc in place, cast the light from a neon tube directly on to the rotating disc segments. The neon tube must be energized from a 60-cycle source. If the turntable speed is exactly 78.26 r.p.m., the inside segments will appear to be stationary; if the speed is 33 $\frac{1}{3}$ r.p.m., the outside segments will appear stationary. A backward and forward motion of the segments will indicate a variation in turntable speed; a backward or forward motion will indicate that the turntable is running below or above the required speed, and should be adjusted until the proper series of segments appear stationary.



No tubes — no parts — no help, but “RSD” will surely relieve your headaches

« More leading independent radio service-dealers subscribe to “RSD” than to any other publication devoted to radio-electronic maintenance. The reason is simple: *only* “RSD” meets the present-day needs of servicemen for timely technical data to help them repair radios faster, more efficiently and at lower cost — especially without exact duplicate parts or tubes. Most Signal Corps instructors subscribe to “RSD”. Send us *your* subscription order today and let “RSD” relieve *your* headaches during the months to come.

MONEY-BACK GUARANTEE: We have always guaranteed that any subscriber not entirely satisfied with his “RSD” subscription investment need only ask for a refund in full, which will be cheerfully given. Not a single request for a refund has been received in three years.

TEAR OUT AND MAIL TODAY

RADIO SERVICE-DEALER
132 West 43rd Street, New York City, N. Y.

Sirs: Here is my check (or money order) for \$... Enter my subscription order to RSD for the next issues. (12 issues cost \$2.—24 issues cost \$3.)
(Canadian and Foreign subscriptions are \$3 annually.)

Name (print carefully)

ADDRESS

CITY STATE I am OWNER
 SERVICE MGR.
 SERVICEMAN

FIRM NAME

IS YOUR FIRM A: SERVICE-DEALER JOBBER MANUFACTURER

IF IN SOME OTHER BUSINESS, TELL WHAT IT IS:

NEW POTENTIOMETER HAS STABILIZED ELEMENT

»» Important developments in the processing of resistive coatings have resulted in potentiometers and rheostats claimed to be virtually on a par with

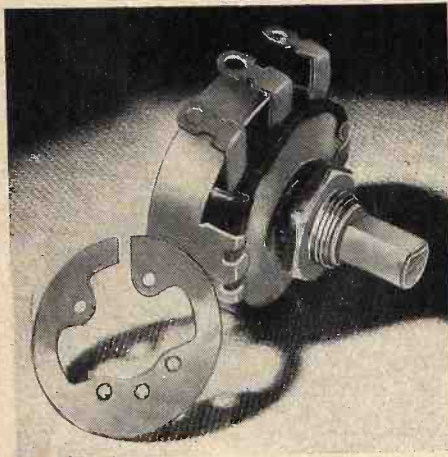

Clarostat's New Resistor

wire-wound units in matters of resistance permanence, immunity to climatic conditions and wearing qualities.

Clarostat Series 37 controls employ the new stabilized element developed after years of intensive research and exhaustive tests. This element takes the form of a resistive coating on a bakelite base, being practically as smooth and hard as glass.

Controls incorporating the new stabilized element were quietly introduced to the trade many months ago, to get the reaction of users out in the field. Accurate resistance values, even after months of continuous usage under adverse conditions, have been noted. Leading instrument makers now use these controls in place of former wire-wound units even for relatively low resistance values. For further information on the new stabilized elements controls write Clarostat Mfg. Co., Inc., 285-7 N. 6th St., Brooklyn, N. Y.

SOLENOID CONTACTOR CONTROLS

»» Among five types of approved solenoid contactor units announced by Guardian Electric Manufacturing Company, Chicago, the B-5 series illustrated, has a contact rating of 50 amperes continuous and operates on 24

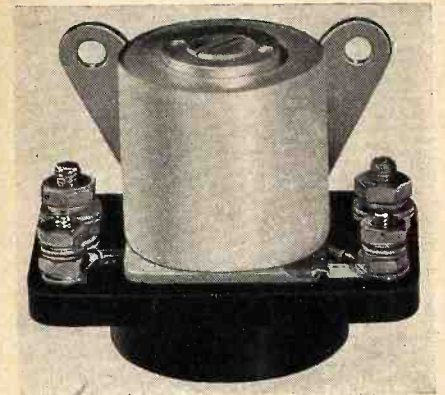

Guardian B-5 Solenoid Contactor

volts D.C., producing a coil current of 210 milliamperes. It has double pole, single throw, normally open contacts. Weighs 11.2 ounces.

The B-5 Solenoid Contactor, like the balance of the series, is built to U. S. Army Air Force specifications and can be adapted for numerous applications of heavy current control in aircraft and other products.

Unit is said to resist acceleration and vibration over 10 times gravity, that it operates in any position and is so constructed that it may be disassembled with pliers and screwdriver. Metal parts are plated to withstand 200-hour salt spray test. Full details obtainable by writing to Guardian Electric, Dept. B-5, 1637 West Walnut Street, Chicago, Illinois.

Safeguard your
"GUARANTEE"
 USE **STANCOR**



STANDARD TRANSFORMER
 • CORPORATION •
 1500 NORTH HALSTED STREET . . . CHICAGO

WAR MEMO:

The aims behind the War Bond Payroll Savings Plan are worth repeating over and over:

1. To help pay the stupendous production costs of winning this war.
2. To siphon into production channels that portion of America's *current income* which would otherwise flood the Nation with inflationary cash.
3. To create individual backlogs of financial security for use during the industrial readjustment after the war.
4. To create a Nation-wide saving habit which will serve the interests of both Capital and Labor after the war.



★ ★ ★ ★ ★

Keep after that "10% of gross payroll goal"! Buy War Bonds to the limit yourself—encourage your employees to do likewise!

USED TUBES WANTED

Until new tubes are available I will buy, sell or trade good second hand tubes. Send me a list of what you have on hand and your price. Nelson Logan, Mitchell, South Dakota.

**OUR MEN NEED
 ★ BOOKS ★**



**SEND
 ALL YOU CAN SPARE**

Good books, in good condition, are wanted by the 1943 VICTORY BOOK CAMPAIGN for men in all branches of the service. Send yours to the nearest collection center or public library.

Are You Moving?

Notify RSD's circulation department at 132 West 43rd Street, New York City of your new address 2 or 3 weeks before you move. The Post Office Department does not forward magazines sent to a wrong address unless you pay additional postage. We cannot duplicate copies mailed to your old address. Thank You!

Post War Electronic Developments

»» Vast developments being made in the radio industry as a result of equipping American and Allied armed forces with radio equipment "better than the enemy's" will make available many new electronic products for the police communication officer in the post-war period, it was explained recently by Herbert DuVal, Jr., General Electric radio engineer, before the 9th Annual Conference of Associated Police Communication Officers.

Among such developments is a circular-type antenna which gives a higher field strength for a given transmitter power, both for station and mobile use. Another development is a resonant in-

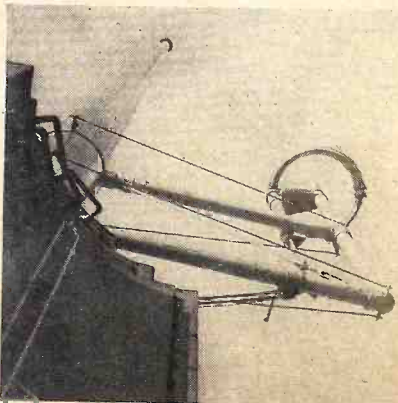

The New G-E Circular FM Antenna

verter to replace dynamotors and vibrators. "Present vibrators have to break the full-load current of the apparatus whereas the new resonant inverter has electrical and mechanical resonant circuits such that vibrator contacts break only during periods when the current through the contacts is zero," Mr. DuVal explained. "Such a unit requires very little maintenance and should give service longer than dynamotors or present vibrators, the latter being unsatisfactory for high-current interruption."

The most important job of the police communication operator at this time, Mr. DuVal pointed out, is in the care and maintenance of his apparatus. Now also is the time for police communication officers to help the radio industry and the F.C.C. by formulating plans to use super-high frequencies in the post-war period to relieve congestion now existing on police radio and other frequencies.

★

PARTS CATALOG

»» It is announced that Radio Warehouse Market of 362 Wooster Ave., Akron, Ohio, has prepared a catalog of all radio items available from that source at this time without delay or priorities. The catalog will be sent free to service-dealers.

Radio Service-Dealer, March, 1943



THE "MALLARD" — one of Cinaudagraph Speakers' achievements—designed to meet War standards. The finished Mallard is an unenclosed, moisture-impervious speaker — some have been tested under water and recommended wherever outdoor installations are required.

Cinaudagraph Speakers, Inc.

3911 S. Michigan Ave., Chicago

"No Finer Speaker Made in all the World"



Locating Intermittent Troubles

(Continued from page 14)

The bias on this type instrument must be adjusted to near cut off for the plate current, when no RF signal is being applied.

Still another type of instrument suitable for work with RF is the untuned variety of vacuum tube voltmeter, which may also be used for audio or DC. These instruments

however are frequently not sensitive enough to be valuable in the first circuits of the receiver, and in some cases the scales are not extended enough for the high RF or audio voltages which may be encountered. They do have one advantage. They are more accurate than any of the tuned variety of RF meter.

Injection Type of Test

Consider again the same radio, Fig. 1, and the original intermittent problem. This time we will use injection equipment to locate the intermittent part. The injection equip-



Listening Posts!

You will find Hallicrafters Communications Equipment working three shifts at our Country's "Listening Posts" . . . searching the airways for illegal programs and espionage messages.

Hallicrafters Communications Equipment is engineered to "take it" on this constant operating . . . there are no rest periods, no time out, it's constant performance!

WORLD'S LARGEST EXCLUSIVE MANUFACTURER OF SHORT WAVE RADIO COMMUNICATIONS EQUIPMENT

The Hallicrafters Equipment you can buy—when communications equipment may again be sold for Civilian use—will incorporate all of the endurance and top quality performance you will ever demand.

Illustration—typical view of Hallicrafters Communications Equipment is a monitoring (listening in) station—somewhere in the U.S.A.

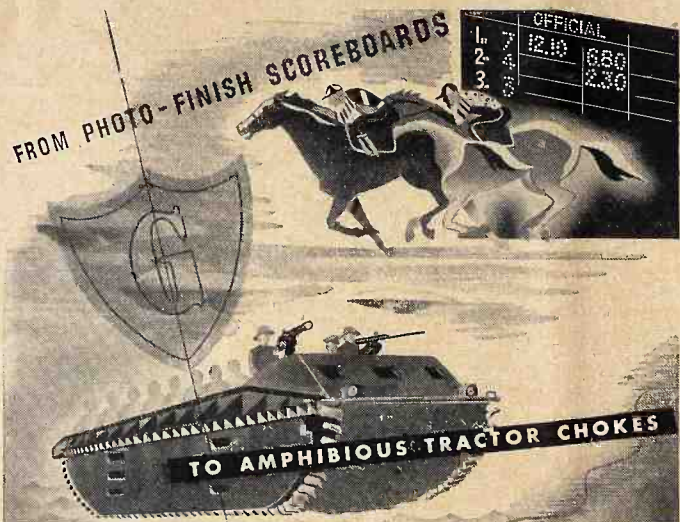

RELAYS BY GUARDIAN MEET ALL CONTROL NEEDS . . .

★ Whether the principle is electronic or magnetic . . . whether the job requires a tiny A.C. relay or a heavy-duty D.C. solenoid . . . whether time delay or instantaneous action . . . there is usually a "Relay by Guardian" to meet the "specs" on most applications . . . from animated electric signs to electric chokes for the Army's amphibious tractors.

A Midget Relay . . . for tight places . . .

The tiny series 195 relay shown at the right weighs less than an ounce, but it's a cocky and energetic little-bantam . . . full-of-life and fight . . . in a small way, of course—but plenty sufficient for its job in aircraft, radio and other applications where small size and lightweight are at a premium. Write for Bulletin 195.

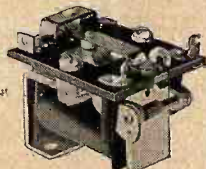

Series 195 Relay

GUARDIAN ELECTRIC
1637 WEST WALNUT STREET CHICAGO, ILLINOIS
A COMPLETE LINE OF RELAYS SERVING AMERICAN WAR INDUSTRY

ment, we shall say, consists of something similar to the multivibrator and associated equipment described in the February issue of "RSD". We have five leads available, but we might have any convenient number. The more leads used, the quicker the job may be completed.

As in the signal tracing system, we will hook leads to *points 2, 4 and 8*. Then in addition, leads will be hooked to *point 7 and point 1*. (*Point 1* is the loop.) The signal into each lead is adjusted to provide the same level from the speaker. Now, the signal is injected into the loop, and only this one is allowed to stay on, until the set cuts down. Then a signal is switched into *point 2*. In our case a signal is heard so we know that the set is functioning from that point to the speaker. This routine places the trouble in *block 1* of *Fig. 2*, or the coupling circuit. It may be possible to further inject signals within the block, or it may be necessary to switch to tracing and measuring equipment to definitely locate the trouble.

Audio Troubles

When working with audio circuits, the same general procedure is followed, using either injection of tracing, except that the audio VTVM is used for measuring purposes. Since the multivibrator furnishes audio as well as RF signals, it is used equally well for audio and RF injection.

Next month Mr. Gulliver discusses noisy intermittents and departs from standard procedure with some rather interesting test procedure, which will be of interest particularly to the more advanced serviceman.—ED.

★

WHY WIRE IS SCARCE

»» "The war needs are consuming increasingly vast quantities of copper wire, and it is vital that domestic users prolong the life of their electrical equipment by careful handling of electrical cords and wires," says H. W. Clough, vice president of the Belden Mfg. Co., Chicago, a leading manufacturer of electrical wires and cordage, now producing electrical wiring for airplanes, tanks, ships, and army communications equipment.

In contrasting domestic wiring uses with war needs, it is disclosed that it takes the copper equivalent of all the lamp cords in 400 average homes to meet the monthly welding cable requirements of one shipway building merchant vessels; it takes the copper from over 800 electric shaver cords to wire an army truck; a medium bomber needs the copper from over 1,000 electric toaster cords.

Death of I. R. Baker Shocks Radio World

Members of the radio, television and electronics industries mourned the loss of one of its best liked pioneers in the death of Irvin Ray Baker, 39, of Haddonfield, New Jersey. Mr. Baker, formerly head of RCA's Broadcast Transmitter Sales and latterly advancing the development of electronic applications to war industries, died at work February 9th of a cerebral hemorrhage.

Mr. Baker attended Gettysburg College. He had become interested as a boy in what was then known only as wireless. After he received his BS degree, he continued his studies to receive another degree in Electrical Engineering. He entered the employ of the General Electric Company, in 1927. There he was placed in charge of operations of the famous Schenectady broadcasting station—WGY—one of the first in the nation. In 1929 he joined the Radio Corporation of America; within a few years his qualities of leadership and pioneering knowledge led to his appointment as head of broadcast transmitter sales at the RCA Camden plant. When the war came, Mr. Baker devoted most of his time to research into the use of high frequency radio current to speed war production.

Mr. Baker is survived by his wife, Eleanore, and a month old son, Robert Roland. The funeral was held on Friday, February 12, at Gettysburg, Pa.

RCA TO TRAIN CO-ED RADIO TECHNICIANS

» » A comprehensive program designed to turn out trained women radio technicians will be undertaken by the RCA Victor Division of the Radio Corporation of America, F. H. Kirkpatrick, the Company's director of personnel planning and research announced.

Comprising the first girl's training school of its kind in the electronics field, the engineering cadettes will earn as they learn at Purdue University in Lafayette, Indiana. Classes will begin around May 1st. A group of from 80 to 100 girls, between the ages of 18 and 22 will be selected from the Company's own plants and from colleges and universities. Basic requirements are two years of college study with satisfactory grades, some competence in mathematics, good health, and an interest in technical radio work.

The curriculum provides for two terms of 22 weeks each. The cadettes will be given courses of study designed especially to qualify them for immediate assignment on test and quality control work on the electronic, sound, and radio equipment which RCA is building for the armed forces. The schedule calls

RADIO PARTS HEADQUARTERS!

Quick Deliveries!

Why waste time and money? Lafayette has complete stocks of radio, sound and electronic parts and equipment.

Just one order to Lafayette secures everything you need . . . two big warehouses for faster deliveries!

RADIO KITS DESIGNED FOR TEACHING REQUIREMENTS or made up to your own specifications.

TECHNICAL BOOKS in radio, sound, electronic and associated fields. Order from Lafayette's complete stocks. Lowest prices and immediate deliveries.

FREE — 130 page indexed catalog . . . your quick reference guide to everything you need in radio, sound and electronic equipment. Write for your **FREE COPY** today. Address 901 West Jackson Boulevard, Chicago, Illinois. Dept. 3K3

LAFAYETTE RADIO CORP.

901 WEST JACKSON BOULEVARD, CHICAGO, ILL. • 265 PEACHTREE STREET ATLANTA, GA.

"Making BETTER Connections"



★ The successful functioning of radio equipment between ground stations, planes, ships, tanks and other machines of war depends upon the uninterrupted flow of communication through radio plugs, sockets and connectors. The manufacturing of these important parts has been entrusted, in part, to The Astatic Corporation, its organization and facilities. Production, on a volume basis, is now under way, supplying concerns holding government contracts for radio equipment. Inquiries from qualified manufacturers given prompt attention.

ASTATIC

IN CANADA:
CANADIAN ASTATIC, LTD
TORONTO, ONTARIO

THE ASTATIC CORPORATION

YOUNGSTOWN, OHIO



COMPACT CAPACITY

● Priorities and rationing notwithstanding, you can still get high-grade electrolytic capacitance in these Type PBS condensers. Compact dimensions. Sturdy cardboard-case construction. Adjustable metal mounting flanges, for single or stacked mounting. Separate polarity-indicating colored leads. Dependable condensers in every way—at low cost.

● See Our Jobber . . .

Order these handy PBS Aerovox electrolytics from him. Ask for latest "Victory" catalog. Or write us direct.

AEROVOX CORPORATION
 NEW BEDFORD, MASS., U. S. A.
 In Canada: AEROVOX CANADA LTD., Hamilton, Ont.
 EXPORT: 100 Varick St., N. Y., Cable 'ARLAB'

We have available a supply of RCA Victor service notes for 1938, 1939, and 1940. If you would like a set—over 200 pages of detailed service data—send 45c in cash to cover postage and handling.

"BRANDEX"—a guide to concealed service data on "private brand" sets can be had for 25c per copy. It is cross-indexed for Brand-name, Manufacturer outlet, Identification marks, etc. Hurry before the supply is exhausted. Once they are gone there won't be any more.

RADIO SERVICEMEN OF AMERICA, Inc.
 RSA Press & Supply Service
 414 Dickens Ave., Chicago, Illinois

for 40 hours per week of classroom work or supervised study.

Those selected will be paid a salary and, according to Mr. Kirkpatrick, will be considered "employees-in-training." All their university expenses will be paid by RCA. The cadettes will live on the Purdue campus and will have the same status as other undergraduate students. They will also be encouraged to participate in sports and social activities on the campus.

The plan also provides for the assignment of an RCA personnel official, Miss Frances M. Tallmudge, former Associate Dean of Women at Antioch College, as a full-time resident advisor to the cadettes at Purdue University.

★

NEW INTER-COMM

»» Illustrated is the Super-Chief model inter-communication system announced by the Talk-A-Phone Mfg. Co. of Chicago.

The amplifier delivers five watts and operates units up to 3000 feet from one another. Each station has its individual volume control. Up to 80 stations may be used and each can, by means of the "Conference Traffic Control," hold a private conference without interrup-



tion or eavesdropping from other stations outside of the conference group. When one of the conference group is being called, he is signalled by a light so that he knows that the call is waiting. Working in conjunction with the Traffic Control is the "Busy Signal Light." This light is illuminated when the line on another station is busy and remains lighted until that station is clear.

The Super-Chief uses finger-tip push-button control and a "Hold-O-Matic Switch," which is nickel silver plated and of the self-cleaning constant pressure type to assure quick positive action.

For a catalog on Inter-comm and paging systems write Talk-A-Phone Mfg. Co., 1219 W. Van Buren St., Chicago.

★

RENEW YOUR "RSD" SUBSCRIPTION TODAY. 12 Issues \$2.00

FOR VICTORY BUY
 United States War
 Bonds and Stamps

POLYMET
CONDENSER CO.
 699 EAST 135th ST.,
 NEW YORK, N. Y.

JOBBER & DISTRIBUTORS

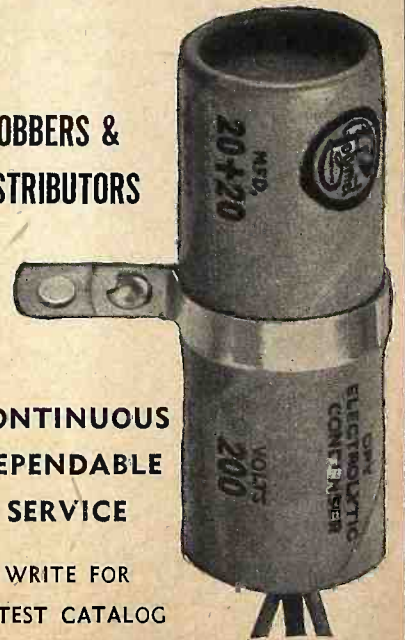

CONTINUOUS DEPENDABLE SERVICE

WRITE FOR LATEST CATALOG



Old Man Centralab
 reminds you to always "specify Centralab" when ordering parts.



FIXED RESISTORS



CERAMIC CAPACITORS



VOLUME CONTROLS



WAVE CHANGE SWITCHES



TOGGLE SWITCHES

Centralab

DIVISION OF GLOBE UNION, INC.
 MILWAUKEE, WIS.

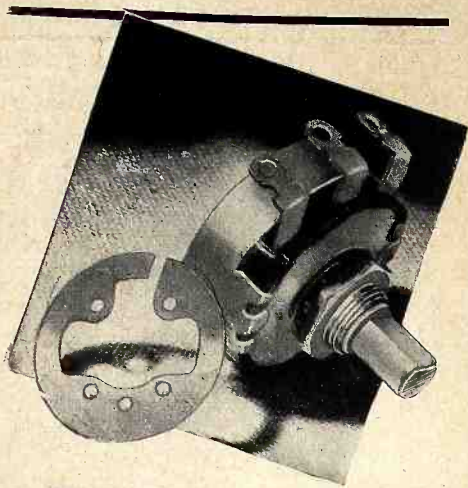

STABILIZED!

★ Have you tried those Clarostat Type M or composition-element controls with the new stabilized element? If not, a brand new experience awaits you. Remarkably accurate resistance values first and last; extreme immunity to humidity, temperature and other climatic conditions; minimized wear; exceptionally quiet operation. ★ Ask your jobber.



CLAROSTAT MFG. CO., Inc. • 285-7 N. 6th St., Brooklyn, N. Y.

TRIPLETT Combat Line INSTRUMENTS



TRIPLET MODEL 626
with long 5.60" scale

This illustration is 1/2 actual size. Note broad scale and minimum panel space required.



A WORD ABOUT DELIVERIES
Naturally deliveries are subject to necessary priority regulations. We urge prompt filing of orders for delivery as expeditiously as may be consistent with America's War effort. TRIPLET ELECTRICAL INSTRUMENT CO., BLUFFTON, O.

SOLENOID CONTACTOR AIRCRAFT CONTROL

»» Guardian Electric, Chicago manufacturer of relays and electrical control assemblies, announces production of five types of approved solenoid contractor units built to U. S. Army Air Force specifications for remote control of electrically actuated aircraft armaments, instruments and devices. Among these, the B-4 type illustrated, originally designed for airplane starting mo-

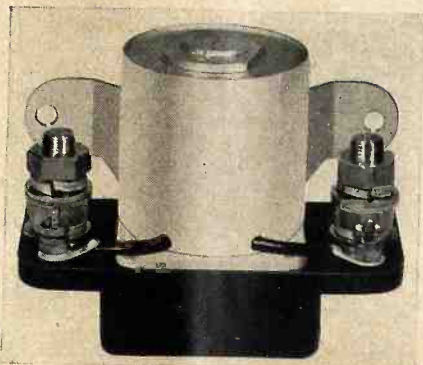

tors, may be used for other applications of heavy current control.

The B-4 Solenoid Contactor operates on 24 volts producing a coil current of 300 milliamperes. Contacts are rated at 200 amperes at 24 volts D.C. Unit has double pole, single throw, normally open contacts. It is claimed that unit resists acceleration and vibration over 10 times gravity and operates in any position. May be disassembled with pliers and screwdriver. Metal parts are plated to withstand 200 hour salt spray test. Weight of unit, 31 ounces. Descriptive circular and full details available from Guardian Electric, Dept. B-4, 1637 West Walnut Street, Chicago, Illinois.

★

EVEREADY UPS KLEINSMITH

»» C. O. Kleinsmith, for the last two years Manager of the Eastern Division of National Carbon Company, Inc., has been appointed General Sales Manager of the "Eveready" Division of the company, it is announced by J. M. Spangler, Vice President in charge of sales.

★

UNIVERSAL SWITCH

»» Universal Microphone Co., Inglewood, Cal., has announced the distribution of its standard microphone switch SW 141, available in quantity orders to government contractors and sub-contractors. The assembly is housed in plain plastic case with hanging eye at the top.

SW 141 switch is complete with cable strain relief construction, may be used as a press-to-talk type, or the locking button may be used on the "on" position.

Lightweight, compact, durable, the switch can be adapted for various communications devices for mobile units. It was specifically designed and engineered for use on cord assembly CD 318, as well as cord CD 508, but also has other applications. It has been built to specifications of the Army Signal Corps and approved by that office.

JUST OUT! NEW ALLIED 1943 BUYING GUIDE FOR EVERYTHING IN RADIO AND ELECTRONICS

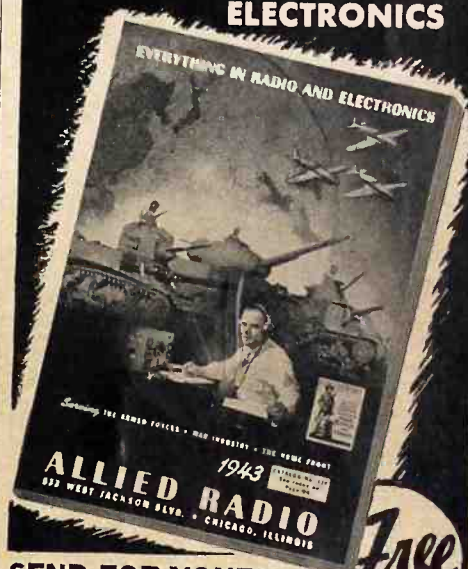

SEND FOR YOURS
...NOW!

Free

The latest streamlined 1943 Catalog of everything in Radio and Electronics. Get all your needs quickly from this ONE dependable central source of supply . . . over 10,000 items for the Armed Forces, for Radio Training, for Research Laboratories, for War Industries and for Service Replacement. Our large complete stocks speed delivery. Our experienced staff is ready to help you. Send for your new Allied Catalog today . . . it's FREE!

SEND FOR THESE VALUABLE NEW BOOKS!

RADIO DATA HANDBOOK
No. 37-754

Formulas, charts and technical data25c



RADIO CIRCUIT HANDBOOK
No. 37-753

Practical data and schematic diagrams. 10c

DICTIONARY OF RADIO TERMS
No. 37-751

Simple definitions of radio terms . . . 10c



SIMPLIFIED RADIO SERVICING
No. 37-755

Short cuts in trouble-shooting 10c

WRITE FOR QUANTITY QUOTATIONS

ALLIED RADIO CORP., Dept. 35-C-3
833 W. Jackson Blvd., Chicago, Ill.

Please send following books (. . . c enclosed)
 FREE No. 37-754 No. 37-751
1943 Catalog No. 37-753 No. 37-755

Name

Address

City State

★ ALLIED RADIO ★

GENERAL INDUSTRIES *Smooth Power* MOTORS



NOW CARRYING ON FOR
VICTORY

Originally designed for powering phonographs, and then record changers and home recorders, G. I. Smooth-Power Motors are now serving on many fronts for purposes not dreamed of two or three short years ago. There they are making records for efficiency and reliability as they had done for thirty years before Pearl Harbor. When G. I. Motors are again available to the trade, they will be found even exceeding the performance that made them standards of excellence in peacetime days.



THE GENERAL INDUSTRIES CO.
Dept. 17 · Elyria, Ohio

\$1.00 PAID FOR SHOP NOTES

Write up any "kinks" or "tricks-of-the-trade" in radio servicing that you have discovered. We will pay \$1 in Defense Stamps for such previously unpublished "SHOP NOTES" found acceptable. Send your data to "Shop Notes Editor," RADIO SERVICE-DEALER, 132 W. 43rd St., New York City. Unused manuscripts cannot be returned unless accompanied by stamped and addressed return envelope.

MR. TUBE DISTRIBUTOR!! WE OFFER:

- \$1.40 net each for type 2A3
- 1.50 net each for type 2A4C
- .80 net each for type 5Z3
- .65 net each for type 6C6
- .75 net each for type 6SC7GT
- .50 net each for type 45
- .50 net each for type 75
- 2.50 net each for type 2051

Prices are net f.o.b. your city. TUBES MUST BE IN CLEAN MANUFACTURER'S INDIVIDUAL CARTONS.

The above is only a partial list of our requirements. Write for offer on 25 additional types. If You Can Supply 10 to 99 tubes—Please write us.

If You Can Supply 100 to 499 tubes—Please WIRE US COLLECT.

If You Can Supply Over 500 tubes—Please PHONE US COLLECT.

We will forward 25% certified deposit with order, and you can express C.O.D. for balance due you.

Other types needed include Glass tubes in the following: 1N5, 5V4, 5Y3, 6X5, 25A7, 30, 47, 58, 80, 1B5, 1Q5, 5W4, 5X4, 5Y3, 6A6, 6F5, 6F6, 6H6, 6L6, 6SF5, 6U5/6G5, 7F7, 25L6, 42, 57, 79 and 83, and others.

W. R. BURTT

(Ph. 45412)

308 Orpheum Bldg. Wichita, Kansas

PEP TALKS SPEED PRODUCTION

» Seeking to inject greater interest on the part of its employees into speeding up production of war materials, Thordarson Elec. Mfg. Co. of Chicago found a way to generate more individual enthusiasm.

Thordarson transformers are being turned out for use in the new Scott Radios, the receiving sets used on U. S. merchant ships, because they do not



E. H. Scott describes his receiver to Thordarson production line workers.

send out energy waves to invite destruction from lurking submarines.

Thordarson officials felt that if the workers who make these transformers for the Scott receiver could see what it looked like and hear of how many lives of U. S. seamen it was saving, they would have a more personal interest in their production lines. The aid of E. H. Scott, inventor of the receiver, was sought to carry out the plan. Mr. Scott brought one of his receivers to the Thordarson plant where he explained and demonstrated its life saving value.



MALLORY PROMOTES ELECTRONICS

» To promote a better understanding of electronics and its significance in the future of industrial development, P. R. Mallory & Co., Inc., has scheduled a series of four lectures by Dr. Paul R. Heyl to be given in Indianapolis on March 1 and 29, May 3 and June 7.

The lectures will develop the history, theory and practical applications of electrons, and indicate the progress which the science of electronics has made in gaining control of nature's forces for employment by mankind. Dr. Heyl is one of America's foremost physicists, for many years known throughout the country for his work with the U. S. Bureau of Standards. Recently retired from the Bureau, he has been retained as consultant for Mallory.

Although the lectures are planned primarily for the Mallory engineering, sales and production personnel, a number of individuals from manufacturing plants, colleges, high schools, broadcasting stations, training schools for the armed forces and other interested organizations in the central Indiana area have been invited. Reprints of all lectures will be available.

"Every dime and dollar not vitally needed for absolute necessities should go into WAR BONDS and STAMPS to add to the striking power of our armed forces."

—President Roosevelt

EVERYBODY
EVERY PAYDAY

10%

IN WAR BONDS

★ ★ ★ ★ ★ ★ ★ ★
**New Goal for
Payroll Savings Plan!**

Along with increased war production goals go increased costs . . . extra billions which must be raised, and raised fast, to win this war.

That means we must raise our sights all along the line, with every firm offering every American with a regular income the chance to buy more War Bonds. YOUR help is asked in encouraging employees to put at least 10 percent of their pay into War Bonds every payday, through the Payroll Savings Plan.

For details of the Plan, approved by organized labor, write, wire, or phone Treasury Department, Section T, 709 12th St. N. W., Washington, D. C.



U.S. WAR SAVINGS BONDS

This space contributed to
America's All-Out War
Program by
RADIO SERVICE-DEALER



WHAT IS ELECTRONICS?

... and what does it mean to the radio serviceman and tube equipment distributor?



You've been hearing a lot about the "Electronics Industry" lately. Maybe you've been puzzled about the aura of mystery surrounding it. Perhaps you've even done a little wondering as to where such a development leaves you, and why.

Actually, "Electronics" is neither altogether new nor mysterious. Just as "wireless" grew into Radio with all of its ramifications in the fields of communications, and entertainment, so is Radio now expanding into "Electronics."

"Electronics," then, is simply a term for the newer applications of the basic radio-electronic circuit utilizing the well-known Radio Tube and its derivations.

Thus, in considering the latter, it is well to remember that the "Magic Brain" of any Electronic device is a tube—and

that the fountain-head of modern tube development is RCA. Remember, too, that development of a new tube, or a new application for an old one, stands as a new opportunity for the men to whom *no* tube or the circuit designed for its operation is altogether new. *This means you.*

The whole history of Radio has been one of rapid growth. New developments have constantly created new business and markets—and the best of these have fallen naturally to those who have specialized in the basic principles behind them all. Certainly they should continue to do so now.

Thus, to the RCA Tube and Equipment Distributor and Serviceman, "Electronics" means that Radio again stands on the threshold of another of its beginnings—one which may prove to them to hold the greatest possibilities of all!



RCA RADIO-ELECTRONIC TUBES

RCA Victor Division, RADIO CORPORATION OF AMERICA, Camden, N. J.

BUY U. S. WAR BONDS EVERY PAYDAY

INSTANT ACTION

WITH

Raytheon Tubes!

... when anti-aircraft batteries go into action it must be instant action. There can be no delay!... communications for firing orders must work and they do with RAYTHEON tubes consistently doing their duty with our armed forces.

When you see a difficult job well done you will usually find that RAYTHEON tubes have been chosen to perform the task.

The unfailing performance qualities embodied in Raytheon tubes are the reason engineers who demand accuracy, stamina, and long life, specify Raytheons.

RAYTHEON PRODUCTION CORPORATION

NEWTON, MASS.
LOS ANGELES
NEW YORK
CHICAGO
ATLANTA



RAYTHEON
RADIO TUBES

DEVOTED TO RESEARCH AND THE MANUFACTURE OF TUBES FOR THE NEW ERA OF ELECTRONICS