

MAY 1942

Radio
**SERVICE
DEALER**

This Month

AIRCRAFT "SHAKE TEST"

See Page 18



WAR RESTRICTIONS ON TUBES

See Page 5

INSTALLING TELEVISION ANTENNAS

See Page 6

ANALYZING OPA PRICE REGULATIONS

See Page 7

A SLANT ON COLLECTIONS

See Page 8

DESIGN OF OHMMETERS

See Page 11

NEW CIRCUIT COURT

See Page 15

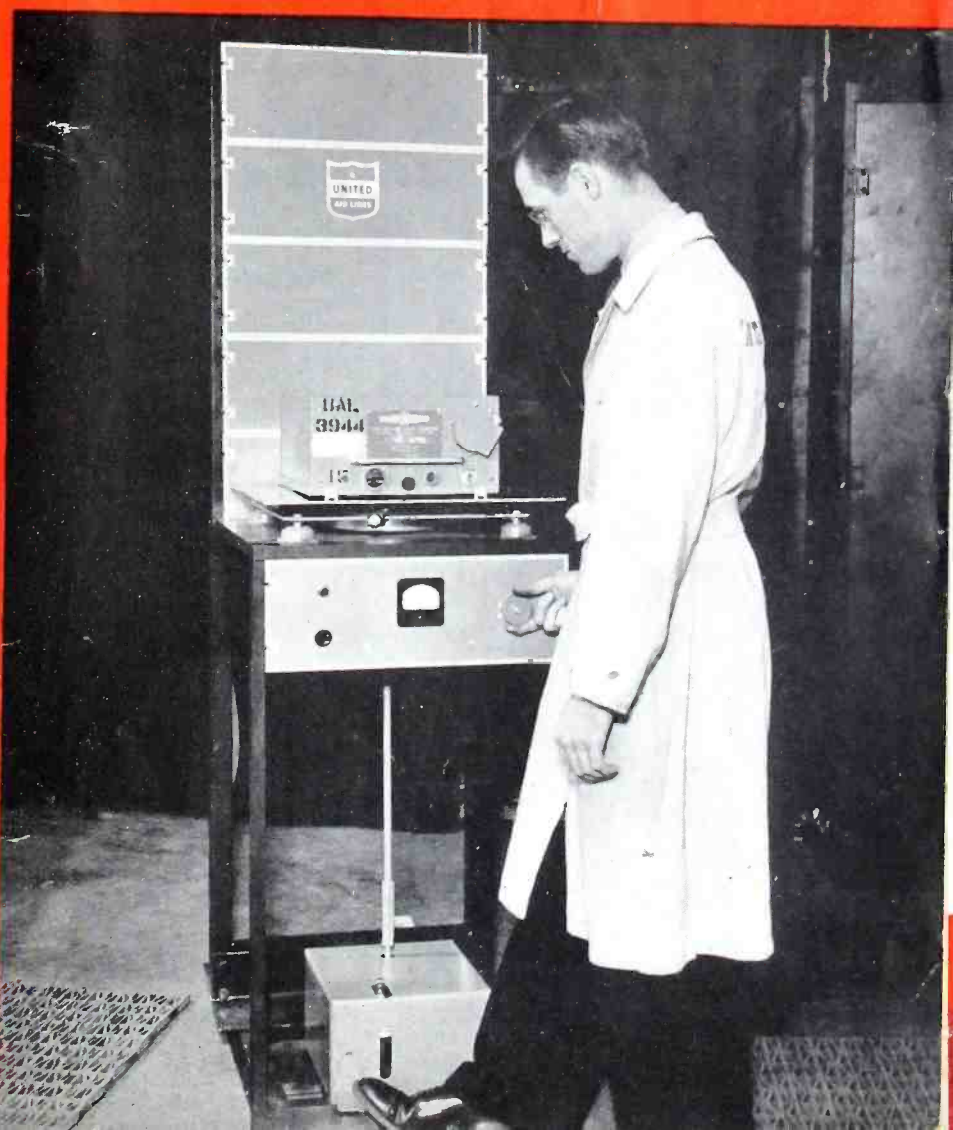



The Home Front Needs Good Reception

“Keep ’em listening!”

Despite restricted production and material shortages, as a radio service engineer, we urge you to “keep ’em listening!”

We know how essential a home front job you perform. And, you know you can depend on Mallory for practical help in meeting the brain-racking radio service problems imposed by current shortages and restricted production.

Although we are up to our ears in wartime production, we haven’t forgotten your needs for one instant.

We are making every effort to provide adequate supplies of Mallory Approved Precision Parts. Our research laboratories are working night and day, coping with the present, anticipating the future. Problems induced by material shortages have, in many cases, resulted in engineering adaptations that mean real progress in good servicing.

And we are getting a fine demonstration of how beautifully the Mallory policies of standardizing parts and simplifying lines have operated to aid servicemen.

You can depend on Mallory and Mallory Distributors for real help, while you work to “keep ’em listening.”

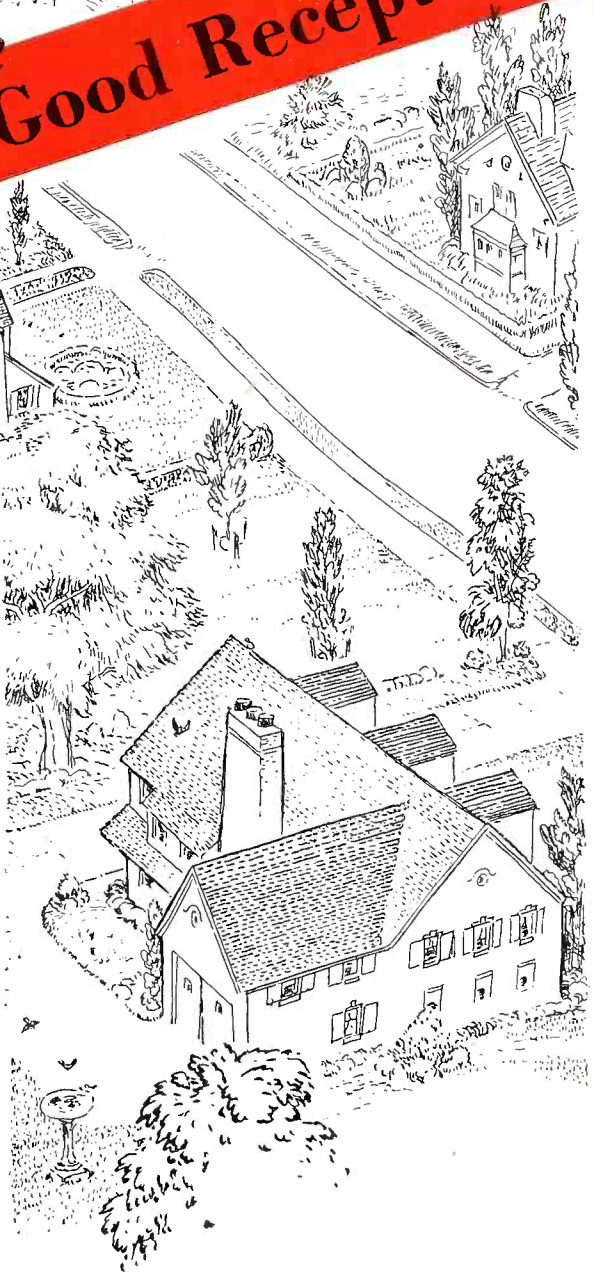

P. R. MALLORY & CO., Inc.
INDIANAPOLIS INDIANA
 Cable "Pelmallo"

P. R. MALLORY & CO. Inc.
MALLORY
Approved Precision Products

Radio

SERVICE-DEALER

SOUNDMAN AND JOBBER

Reg. U. S. Pat. Off.

Vol. 3. No. 4 ★ May 1942

Ad Index

Contents

Aerovox Corporation 30 Condensers	Editorial:
Amperite Corporation 32 Ballast Tubes	The Moose Tightens 3
Centralab 31 Resistors, Controls, Switches	War Restrictions on Radio Tubes .. 5 By John H. Potts
Clarostat Mfg. Co., Inc. 25 Wire-wound Resistors	Installing Television Antennas 6
General Electric Company 27 Tubes	OPA Price-Fixing Order Analyzed .. 7
Insuline Corp. of America 32 Industrial Equipment Catalog	A Slant On Collections 8 By B. V. Selle
Mallory & Co., Inc., P. R. ... 2nd Cover Replacement Parts	Technical Service Portfolio—XVIII: Design and Maintenance of Ohmmeters 11
Meck Industries, John 30 Sound Equipment Catalog	Circuit Court:
Ohmite Manufacturing Co. 25 Resistors & Calculator	Belmont 7D22: A-F Regeneration 15
Polymet Condenser Co. 27 Condensers	G.E. 40: A-FM Combination 16
Racon Electric Co. 2 Horns, Trumpets, Speakers	Crosley 72 CA: Tone Control 17
Radio Equipment Co. 23 "Service Flat Rates"	RCA 15X-36X: Oscillator-Converter ... 18
Radolek Company 31 Parts Catalog	Shop Notes:
Raytheon Production Corp. ... 4th Cover Raytheons Prove Stamina	Emerson GB-441: Replacing 6SS7 Tube 19
RCA Manufacturing Co., Inc., 3rd Cover Chanalyst-Converter	Making a Radio Cleaning Dust Blower 19
Rider, John F. 23 Rider Books & Manuals	Stewart-Warner 1942 Models: How to Order Correct Replacement Parts and Speakers 19
Schott Co., Walter L. 32 Radio Servicing Products	RCA Output Transformers: Changes in Color Coding 19
Ward Leonard Elec. Co. 32 Relays, Resistors, Rheostats	Discontinued Sylvania Tube Types: What Substitutes to Use 19
Weston Elect. Inst. Co. 4 High & Ultra High Frequency Test Equip.	List of Tube Types ordered out of production April 27 by War Pro- duction Board 21
Whedbee, Farnk E. 25 Business Record Service	The RadioFront 20 By Karl A. Kopetzky
	My Log 22 By San D'Arcy
	RSA News 26

Executive & Editorial Offices
132 West 43rd St., New York

★
PUBLISHER

SANFORD R. COWAN

Contributing Editors

JOHN H. POTTS JOHN F. RIDER

News Analyst

KARL KOPETZKY

3911 S. Michigan Ave., Chicago, Ill.

Circulation Mgr.

Office Mgr.

R. ALAN

H. BRUN

RADIO SERVICE DEALER, published monthly at 34 N. Crystal Street, East Stroudsburg, Pa., by the Cowan Publishing Corp., Executive and Editorial Offices at 132 W. 43rd Street, New York, N. Y. Subscription rates—United States and Possessions, \$2.00 for 1 year, \$3.00 for 2 years; elsewhere \$3.00 per year. Single copies 25c. Printed in U.S.A. Entered as Second Class Matter October 3, 1941, at the Post Office at East Stroudsburg, Pa., under the Act of March 3, 1879.



RACON is doing an "all out" job for every sound equipment user. Yes sir! You'll find RACON PRODUCTS at Army bases and training centers, working hard for Uncle Sam in all kinds of weather and climates. At sea, the Navy and all leading Steamship lines use RACON's too, because they meet extremely rigid specifications and are dependable when lives are at stake. In the air, on planes, dirigibles and blimps, and at airports (Commercial and Government owned)—where stamina and peak efficiency under every condition must obtain—there too are RACON's. Not least in importance are the many Police, Utility, Civilian Defense, Air-Raid Corps and Industrial War Production p-a installations where RACON's are used exclusively.

There's a reason for RACON's predominant leadership. RACON's cost no more than other brands yet they have many exclusive, patented features. And delivery schedules are dependable. Soundmen and Jobbers—specify RACON's—there is a unit for every type of sound installation. Full particulars are contained in our new catalog. Send for your free copy today.

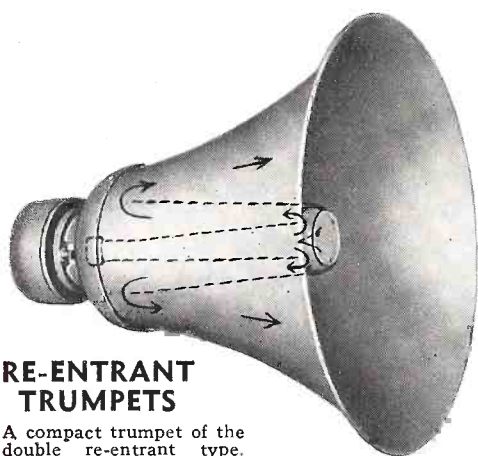

RE-ENTRANT TRUMPETS

A compact trumpet of the double re-entrant type. Occupies but a small space, nevertheless has a long air column enabling it to deliver highly concentrated sound of the greatest efficiency over long distances. Base and inside cone arm made of aluminum castings, outside bell of heavy gauge aluminum spinning, center section of RACON ACOUSTIC material to prevent resonant effects. Available in 6', 4½', 3½', and 3' air column units.

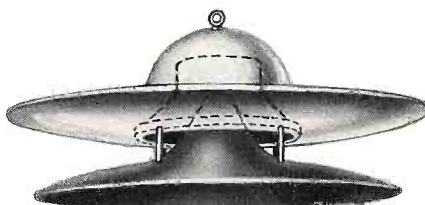

RADIAL CONE SPEAKERS

Types for high fidelity, giving even intensity sound projection over a circumference of 360° radially. Upper deflector made of heavy gauge aluminum, cone covering of steel, and lower deflector of RACON ACOUSTIC material storm-proofed for all weather conditions. Models for 5"—6"—10"—12" cone speakers.



RACON P. M. HORN UNITS

Operating capacity 12-15 watts, peak 25 watts. Other P.M. units available from "baby unit" of 5 watts to "bull unit" with an operating capacity of 50 watts. Efficiencies of the highest order obtainable with the finest magnetic material and steel utilized.

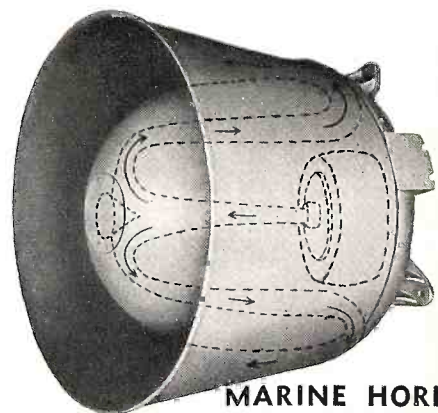

MARINE HORN UNIT SPEAKERS

Re-entrant type speakers using horn type units for marine and general P-A applications—may be used as loudspeaker or as a microphone. Miniature and regular sizes approved by the Bureau of Marine Inspection and Navigation, Department of Commerce, for marine work. In all sizes, miniature, midget, regular and bull, handling from 5 to 50 watts. Illustrated is the Bull Marine, using RACON unbreakable bell and center section.

RACON ELECTRIC CO. 52 EAST 19th ST. NEW YORK, N. Y.

THE NOOSE TIGHTENS!

FEWER TUBE TYPES

NEARLY 350 TYPES of tubes, many of prime replacement status, are no longer being manufactured for any but National Defense requirements. The complete list, in reference form, is printed on page 21 in this issue. Other such drastic changes or manufacturing curtailments effected will be published in future issues. We fear there will be too many for comfort.

OPA FIXES PRICES

In comprehensive fashion the new Maximum Price Regulations, as they apply to radiomen, on and after July 1st, are explained in this issue. The penalties for violating the new law are severe. After reading and following our interpretations of it no Service-Dealer should be placed in jeopardy.

HINTS THAT HELP

Captain John F. Rider, Signal Corps, U. S. Army, well known as the publisher of Rider Manuals, states in the current issue of his house organ *Successful Servicing* that "for the duration publication of this organ will be suspended to help conserve paper." The "sign-off" issue contains three excellent recommendations with which we are in hearty accord.

They are: (1) that radio servicemen seeking commissions in the Signal Corps should immediately brush up on all phases of basic radio theory, starting with Ohm's law and a study of the manner in which vacuum tubes work, because when these men enter the army they will have to follow prescribed training methods regardless of their previous experience and ability as professional technicians. (2) that it would be worthwhile for all servicemen who plan to continue as such to learn more about the uses, applications and limitations of their present test equipment as henceforth, with some replacement tubes and parts about to become unavailable, much circuit revising must be anticipated and at least less time will be required to accomplish any given repair job. (3) that in view of the impending shortage of man-power it might be advisable to start training some young ladies of above-average mentality in the art of radio servicing. RSD now numbers amongst its subscribers many female Service-Dealers who seem to be rather successful in their efforts to do efficient repair work or to direct and manage their servicing organizations.

SWAP YOUR SURPLUS

Help conserve the Nation's resources by putting into immediate use every idle instrument and all surplus components.

Many servicemen owned instruments and a stock of parts, tubes, etc., but now have no use for same because they have joined the armed forces or have entered some other line of endeavor. Many practicing servicemen now own duplicate or equivalent sets of test equipment, some of which they can easily spare. Put idle equipment to work! Are you overstocked on some replacement parts and in need of others not obtainable? Start swapping! First see what sort of deal can be arranged with your jobber. Or, if you want us to, RADIO SERVICE-DEALER will start a "Swap Department" where an inter-exchange of commodities can be advertised as being "available" or "wanted."

ADVERTISED BRANDS

Again we urge our readers to buy only reputable, advertised parts and tubes. The market is being flooded with salvaged stuff, taken from junk heaps or reject piles. Generally these reclaimed items look as good as the hard-to-obtain legitimate parts they are supposed to supplant but in actual practice they are worthless. They are sold without a guarantee that really backs 'em up. They break down in short order necessitating loss-accruing repeat repairs and they induce customer dissatisfaction. Last, but not least, reputable parts manufacturers who still maintain contact with you through advertising do so as a tangible indication that they plan to serve your best interests, come what may, until that happy future day when we will all again enjoy "business as usual."

HIGH FREQUENCIES

30,000 KC.

Ultra HIGH FREQUENCIES

HERE ARE THE INSTRUMENTS FOR YOUR MEASUREMENT NEEDS!

*50 kc to 33 mc
fundamental
frequencies*

WESTON Model 776 OSCILLATOR

For testing broadcast and intermediate frequencies... in vacuum tube circuits. Accurate within 1/2 of 1% on broadcast bands—1% on short wave bands. Has large 330° hand calibrated dial. WESTON AAC (Automatic Amplitude Control) circuit assures uniform output level regardless of frequency (no trimmers or padders used.) Triple shielding eliminates leakage.

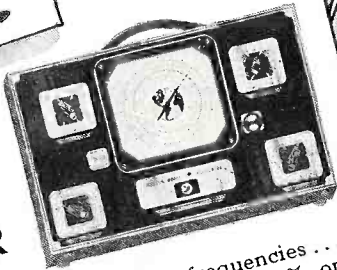

*22 mc to 150 mc
fundamental
frequencies*

WESTON Model 787 UHF OSCILLATOR

For testing transmitters and receivers—stationary and mobile—AM and FM types operating in high frequency bands. Inductive tuning system provides fundamental frequencies with higher resonant circuit voltages and broad tuning range. High order of stability and reset-ability over entire frequency band. Reads 40 kc. per division at 40 mc. Modulation frequencies 400-1300 and 3000 cycles. Compact, Portable, battery operated.

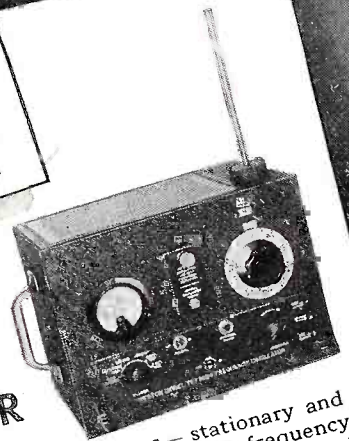

*For potential
measurements over
broad frequency
ranges*

WESTON Model 669 Vacuum Tube Voltmeter

For measuring voltages in vacuum tube circuits where frequency is a factor. Has low input capacity of 5 microfarads with 6" leads. All ranges operate direct to measuring tube grid, providing a maximum input resistance and impedance device. Loading effect on circuit under test is only that of the tube itself, as no grid resistors are used on 0-1.2-3-6-8-12-16 volts ranges. Phone jacks provided for making audible tests. Ranges 0-12-30-.60-80-120-160 volts full scale with multipliers.



*For your panel
and built-in
needs*

WESTON Thermo-Ammeters

WESTON improved design of heating elements provides extreme accuracy on high frequencies (frequency error less than 2% up to 65 mc). Available as ammeters and milliammeters in ranges for all transmitters including portables. Also a complete line of ultra-sensitive portable instruments for high frequency laboratory measurements. ... for complete information on these and other WESTON instruments see your local WESTON representative, or write Weston Electrical Instrument Corporation, 605 Frelinghuysen Avenue, Newark, New Jersey.

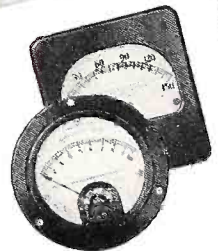

Laboratory Standards... Precision DC and AC Portables... Instrument Transformers... Sensitive Relays... DC, AC, and Thermo Switchboard and Panel Instruments.

WESTON

Specialized Test Equipment... Light Measurement and Control Devices... Exposure Meters... Aircraft Instruments... Electric Tachometers... Dial Thermometers.

FOR OVER 51 YEARS LEADERS IN ELECTRICAL MEASURING INSTRUMENTS

WAR RESTRICTIONS ON RADIO TUBES

by John H. Potts

EFFECTIVE April 27th, the manufacture of 349 of the 710 types of radio tubes available for civilian use was prohibited for other than national defense applications. Thus, in one single order of the WPB, one of the greatest problems of the radio industry has been substantially minimized. For the types of tubes affected by this order are not the ones popularly used, but rather those which are obsolete, or which differ in but minor respects from others still available. For the serviceman and dealer, this order means that fewer types need now be stocked; consequently less capital need be tied up in inventory. And, far from putting receivers out of service, the need for replacements of prohibited types may be met by substitution of better, readily obtainable types, often with greatly improved receiver performance.

Although in some cases minor changes may be required in the circuits, sockets, or perhaps the total number of tubes employed in the receiver, in general these changes will be few and require but little time or expense to make. Thus, far from resulting in hardship, the effect of this limitation order is likely to be beneficial both to the trade and to the set owner.

To some extent, of course, limitations have already been in effect. Where there were formerly, for instance, several manufacturers of metal tubes, now but two make such types—in fact, only one manufactures the complete line of available types and many types have become scarce due to priorities. Substitution of GT types, with a simple metal shield slipped over the glass envelope, has been the practice in many stores to meet the demand for hard-to-get types, such as the popular 6K7. And, as we glance over the list, we note that the proportion of GT-type tubes which have been prohibited is decidedly small. One striking point which will be noted is the classification of a number of ballasts as tubes on the list. Curious, isn't it, since it was the government which first insisted that such ballasts were not tubes and should never, never be spoken of as such. Not,

of course, that there wasn't good reason to object; during the depression you'll recall that there were plenty of ten-tube, ten-dollar sets of which six of the ten tubes were ballasts. The air and the business has been a lot cleaner since such practices were eliminated.

Available Substitutes

But let's run over the list of discontinued tubes. (See "Shop Notes"—page 21 in this issue.) First is the OOA, the 5-volt caesium-gas-filled detector tube which was so popular way back in the '20's, but has been virtually extinct for over a decade. We won't miss it; it was critical to operate and belongs to the era of regenerative, storage-battery operated receivers long since past. The OZ3 may be replaced

take up those of the *a-c* and *a-c/d-c* types which are of more immediate interest to all in the trade.

First of the types which we want to consider now are the 2.5 volt tubes. You will note that the 3A3H is out. The substitute is a 2A3, using a center-tapped 20 ohm resistor across the filament and returning all plate and grid circuits to this point—this includes the bias resistor, of course, if one is used. Next on the list is the 2A7S—use the 2A7, with a shield, if necessary (sometimes it isn't). The 2B6 requires special attention, see next month's issue for this, but the rest of the 2.5 volt family listed may be readily replaced with 6.3 volt types as indicated. The filaments?—just run them in series and connect across the line, as shown in Fig. 1. You can use a resistor cord to limit the current to 0.3 amperes. The proper value for the number of tubes in the string may be determined from Table 1.

Some discussion of Table 1 is in order. The resistance values given are based on the use of 0.3 ampere, 6.3 volt tubes with a nominal line voltage of 117. This line voltage is the "design center" called for in all receiver design work where the tubes may be operated over a range from 110-125 volts, approximately. The values of *R* given were determined by calculating the resistance required to limit the current in a 117 volt circuit to 0.3 amps. By Ohm's law, this is $117/0.3$ or 390 ohms. The resistance, when operating, of a 6.3 volt, 0.3 amp. tube is equal to $6.3/0.3$ or 21 ohms. Thus for each such tube placed in series with *R* (see Fig. 1), the resistance of *R* may be reduced by 27 ohms.

If a 25 volt, 0.3 amp. tube is placed in the string, it may be assumed to replace four 6.3 volt types, in calculating the value of *R* required. For the 12.6 volt tubes, care is required in that the current rating is usually 0.15 amps. instead of 0.3 amps. Therefore the resistance of the tube is not twice, but four times as great as that of the 6.3 volt, 0.3 amp types. However, since the current is reduced by one-half, the wattage dissipation requirements in the

TABLE 1

No. of Tubes	Series Resistance Required (Ohms)
1	369
2	348
3	327
4	306
5	285
6	264
7	243
8	222
9	201
10	180

The table above shows the resistance (corresponding to *R* in Fig. 1) required to limit the total circuit current to 0.3 amperes when the line voltage is 117. The values of *R* given should be held to within $\pm 5\%$.

with either an OZ4 or OZ4-G, by substituting an octal socket or adapter. The O1A and O1AA are two more of the long-obsolete 5 volt types—they can be replaced by 1.4 volt types in rural districts where there are still a few of the old-timers in operation. More about them later. The 1A1 is a ballast, and so are all the other alphabetical types starting and ending in the numeral 1. The 1.4 volt types, and other battery-type tubes listed, will be considered in detail next month. Now we want to

resistor R remains the same as for an equivalent number of 6.3 volt 0.3 ampere tubes in the filament string.

What we have said above applies likewise to loktals. Although these tubes are nominally rated to operate at 7 or 14 volts, the current rating is slightly higher at these voltages so that the resistance of such tubes is practically the same as for 6.3 volt types of comparable heater current ratings. Loktals may be obtained with characteristics which approximate those of tubes which are more difficult to obtain, or which are on the prohibited list and, by substituting a loktal socket, it will often be possible to effect satisfactory operation without further changes.

However, it will be found that considerable thought has been given by Government officials to simplifying the matter of making substitutions. Many, for instance, will wonder why the popular 5Y3-G has been prohibited. But this tube may be quite readily replaced by the 5Y4-G, which plugs right into the same socket. While some changes in socket wiring are required (see your tube handbook) these take but a moment. The 5Y4-G may likewise be substituted for the 5W4 and 5W4-G, changing the socket connections as mentioned above, and, while the current required for the heater is 2 instead of 1.5 amps (for the 5W4),

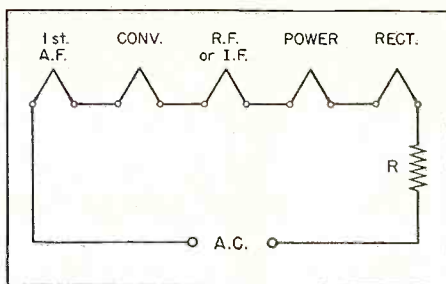

Fig. 1. In making substitutions, keep the audio, mixer and r-f or i-f tubes in the order shown. This keeps hum at a minimum.

any power transformer which has been properly designed can accommodate this slight increase without undue strain.

Similarly, the elimination of the 5Z4-G causes no hardships. The 5Z4 is still on the market. And, if the latter becomes hard to get, the 5V4-G can be plugged right in the same socket, with no changes whatsoever. In fact, the 5V4-G is really a swell rectifier; low voltage drop, more output and it's a heater type which won't overload condensers by getting into operation before the tubes draw plate current.

While the 5T4 is out, it may be replaced by the 5U4-G which, however, requires 3 amps. instead of the 2 amps. required by the 5T4. Otherwise, these

are the same. It might be well to check the filament voltage when making such substitutions; a 50% increase in filament current is not negligible by any means.

The axe has fallen on the 6X5 and 6X5-G, but the 6X5-GT is still available; smaller and therefore easier to handle and stock.

Rectifier Types

Skipping over to the 25 volt rectifiers, which constitute such a large proportion of tube replacements, note that the 25Z5 remains unaffected, and may be employed to replace the 25Z5MG, the 25Z3, the 25Z4 and 25Z4-GT, with a socket change required for the latter. While the 25Z6G is out, the 25Z6GT is not, and may be substituted without any changes whatsoever.

It should be mentioned that 25 volt rectifiers which have similar characteristics to 35 and 50 volt types may be substituted for the latter, if necessity requires—but take care that the socket connections are similar—by simply increasing the series resistance R in the circuit of Fig. 1. And by the same token, it is possible to reduce the resistance of R and substitute a tube with a higher voltage rating.

Next month the problems involved in the more difficult replacements will be considered in detail and a tabulation of equivalents will be supplied.

INSTALLING TELEVISION ANTENNAS

WITH the advent of several television transmitters on the air, particularly in New York where there is now a choice of WNBC (NBC), WCBW (Columbia) and WABD (Du Mont), the installation of a satisfactory antenna becomes somewhat more involved than when there was just a single transmitter to be tuned in. In this connection the Du Mont service department issues the following suggestions based on several years of experience:

Erect the television antenna in the clear wherever possible, as high and far back from the street as possible, so as to minimize both auto ignition interference and that from electrical equipment.

Antennae over 15' high should be securely guyed. Mount securely on chimney or wall. The dipole (both rods) or antenna should be equal to one-half the wave length of the signal to be received, for best results.

Frequencies assigned to present New York television transmitters, together with desirable dipole characteristics, are as follows:

Station	Frequency in M.C.	Length of Dipole	Length of Reflector
WNBT	50-56	100"	112"
WCBW	60-66	90"	96"
WABD	78-84	72"	76"

The foregoing does not imply that a separate antenna is required for each station. It has been found that in most sections of the New York metropolitan area a satisfactory signal can be picked up from all three stations on an antenna tuned to WCBW's frequency—a 90" dipole (45" each rod) with reflector. However, in some outlying sections it may be necessary to erect a second antenna tuned to WABD's frequency—72" dipole (36" each rod) to pick up all three transmitters until such time as WABD's power is raised to normal strength.

When the receiver is located at a

considerable distance from the transmitter, better pickup and directional properties are required. A second dipole with both arms connected together, parallel with and $\frac{1}{4}$ wave length behind the pickup dipole, (see diagram), is necessary to reflect the

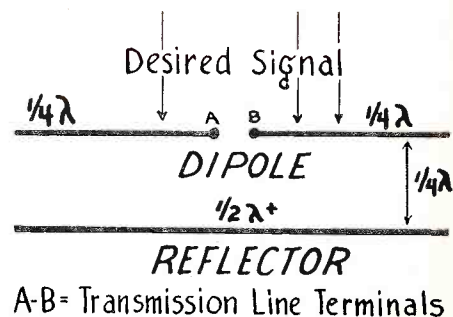

signal back and aid the signal strength materially. Such a reflector will often help materially in reducing

(Continued on page 24)

OPA PRICE-FIXING ORDER ANALYZED

IN no uncertain terms Uncle Sam has wielded the "big stick." The General Maximum Price Regulations order issued by Office of Price Administration on April 28th, 1942 defines what maximum prices you, we and all other businessmen may charge hereafter for services rendered or commodities sold. We analyze here how the regulations apply to the radio repair industry.

Quoting from the OPA Order, "on and after July 1st, 1942, all retail services having to do with installation, maintenance, repair and distribution of commodities must be priced no higher than the highest levels charged in March 1942." Note the wording '*retail services*'! As explained in the Order, a radio service-dealer who repairs a defective receiver renders a *retail service* . . . while doctors and barbers are classified as professional men who render *personal services*, i.e., *services to the person*, not to the thing (like a radio). Thus men like barbers, or doctors are exempt from the Maximum Price Order restrictions, but radio service-dealers must abide by the new price-fixing law.

COST PRICES ARE CONTROLLED TOO

There is some satisfaction in the new OPA order as it protects all service-dealers and jobbers against price increases too. After May 11 they will not have to pay any more to a manufacturer for parts than they did when prices were highest during March. The Order reads: "Beginning May 11, manufacturer and wholesale prices, and the prices for wholesale services must not exceed the highest March levels for each seller."

The OPA order goes on to explain that after May 11th manufacturers may not change (upward) their list prices to a level higher than was in effect during March and they may not endeavor to obtain a greater net sum for their merchandise by the expedient of reducing discounts. In other words, on May 11th prices will be forced down to or must stay at no higher levels than were actually used by a seller during March. A seller can ask lower prices, if he so desires, but we doubt if the price of any item will go below March levels.

HYPOTHETICAL CASES TO GO BY

Many government Orders or Regulations are worded in a manner that tends to confuse all except "Philadelphia lawyers." Thus, a clear and understandable interpretation of this newest

Drastic Regulations Now Affect All

Radio Service Dealers and Parts Jobbers

and far-reaching OPA Regulation, particularly with regards to helping you determine what your "highest March prices" were, is in order. Hypothetical cases will be cited to show you how much you can price your services, or merchandise, at after July 1st basing the prices on transactions of similar nature handled by you during March.

Case 1. Suppose during March you replaced defective volume controls in several different receivers owned by different customers. Customer "A" needed a new control which you installed at the list price of \$1.75 plus \$2.50 for Labor while Customer "B" needed a new control which you installed at its list price of \$2.00 plus \$2.75 for Labor. Should your records show that during March the highest price you charged for Labor when installing *any type* of volume control was \$2.75, then after July 1st you must not charge any customer more than \$2.75 for Labor on a replacement volume control installation. You may charge less if you wish.

Case 2. Suppose during March you sold 30 type 12SK7 tubes. (They list at \$.95 each.) If you charged some customers \$.80 or \$.85 for tubes of this type and if you charged only one customer full list price, then, after July 1st you may charge any and all customers as much as \$.95 for any and all 12SK7's you may sell because the OPA Regulation allows you to use as a ceiling the maximum price obtained for that particular commodity in *any* single transaction handled during the month of March. On the other hand, if during March you did not obtain more than \$.85 from any customer who happened to purchase a 12SK7, then after July 1st you must not charge any customer more than \$.85 for a tube of that type.

Case 3. Here is the method whereby March levels may be determined on Labor charges. Assume that during March you did a lot of different repair jobs and on some of these you charged as much as \$6.00 per hour while on others you only earned as little as \$2.50 per hour. The new Law allows you to charge no more than \$6.00 per hour for any repair job you may do

after July 1st. You may quote or take less per hour if you wish.

Case 4. Assume that after July 1st you find it necessary to do some sort of job, or replace some item that by peculiar quirk you had no transactions on during March. This will happen frequently to service-dealers because of the technical nature of the business. The OPA order provides for the contingency in this fashion, "if there was no actual delivery of a particular article (or service) during March, 1942, the seller may establish as his maximum price the highest price at which he *offered* the article for sale during that month. This permits the use of a list price if no *completed* sale occurred in March. However, to cover articles that were not sold during March and had no offering price the seller must establish as his maximum price the highest price he charged in March for the *most nearly similar article*. In cases where a seller did not deal in the same or similar commodities or services during March, he must base his maximum price on the highest price charged during March by his most closely competitive seller of the same class. The seller here must not use the prices of a more pretentious store in a better neighborhood. He must find a store as nearly like his own as possible."

Case 5. It was the established policy of many service-dealers to render a "Free Estimate" or "Free Checkup" prior to and during March 1942. (The new Maximum Price Regulation does not actually mention or cite such cases and does not promulgate rules that must be observed hereafter. We are trying to get a ruling from OPA on the subject.) Meanwhile, according to our interpretation of the new law, it does not prohibit such service-dealers from inaugurating now, or after July 1st, a new policy whereby they may establish base minimum "estimate fees" or "inspection fees" provided their basic prices are very similar to and no higher than those charged by their nearest competitor. (Reread *Case 4* above to see why we come to this conclusion pending a definite ruling.) Meanwhile, we again urge all service-

(Continued on page 23)

A SLANT ON COLLECTIONS

B. V. SELLE WRITES TO JOHN F. RIDER

"Dear Mr. Rider: For many years I have been a radio serviceman. I've had my ups and downs. I've learned the hard way—from actual experience. I've paid for my mistakes and thought that other servicemen might want to have some of my views on the general subject of being a radio serviceman, especially on the business aspect of making a profit on every job done."

Sincerely yours, Burt Selle

DURING my 16 years in business I have seen many competitors come and go. Those who failed were not necessarily incompetent technicians. In fact, most were better-than-average in technical ability but lacked business ability. Sure, I've been confronted with tough technical problems. I solved most in due time. And I've had some tough business management problems that had to be studied carefully before I got the right answer. When confronted with a management problem I generally gave it the same sort of diagnostic treatment that I would a technical stickler because were I to deliver a job to a customer not knowing whether or not I was taking a loss on it, it would be like returning an unfixed set to a customer, only more so.

As I see it, a serviceman is like a shoemaker. He's just a businessman with certain basic expenses that must be met. He should not take or handle business in anything less than a satisfactory and profitable manner. He should know what his monthly and daily overhead is. He should know how much per-working-hour he must get paid in order to live. He must provide a sinking fund as a cushion in case there is a depression period. He must provide for the day when his equipment will become obsolete and need replacing.

My toughest problem was not that of ascertaining my minimum monthly overhead. I did find it difficult to learn how to manage my business in such a way that I could know in advance that I would not have to take a loss on any job. And like other servicemen, I wanted to find a customer-relationship pattern that would strengthen the rest of my business set-up. Here are the 8 basic phases of business I feel servicemen should have the answers to:

1. Determine a basic minimum labor charge for services rendered

INTRODUCING B. V. SELLE

Recently the Elyria (Ohio) Chronicle-Telegram published the following story:

The Federal Bureau of Investigation today has a new device for the coding and deciphering of secret messages as the result of work done by an Elyria man, Burton V. Selle, who yesterday turned his invention over to the U. S. government.

The idea for the device, which scrambles the words of any message into a jumble even more incoherent than the double talk of the Hut Sut song, came to Selle as far back as 1933, but in those peaceful depression days he saw little practical use for his brain child.

Selle, who has been in the radio field for 16 years and now operates the Factory Radio Service Co. at 308 Depot street, Elyria, originally designed the device for use with radio transmission, although it can be adapted for many phases of government work.

so that profits will be realized not only on physical labor but also on cash investment represented by inventory and equipment.

2. Find a means of determining the total cost of any given job prior to actually contracting to do the work. Unexpected contingencies must be anticipated.

3. Find a sensible method of presenting the price estimate convincingly so the potential customer will be satisfied to say 'go ahead with the job' and you'll know that he won't try to welch when the bill is presented.

4. Find a method that will facilitate collecting cash-on-the-line when the job is completed and delivery made.

5. Find the right way of refusing to give credit to a customer when credit is not justified, or if extending it would reduce profits or possibly jeopardize goodwill and future business relationships.

6. Find the right way to extend credits to the right type of customer when it is advisable to work on extended terms.

7. Establish a means whereby charge accounts will pay promptly.

8. Learn how to deal with delinquents in a reasonably satisfactory manner. In general,—know my legal rights.

I believe only a few servicemen ever had courage enough to ask for *and get* a decent living wage, whether or not he was the owner of the business or just an employee. No business or profession takes more out of a man than radio servicing. It is a mild form of skull-duggery. Brain cells must be constantly crammed full of new technical developments. New equipment is constantly needed. Customers have never been taught that servicing is a profession, not a mere hobby.

OVERHEAD MUST BE DETERMINED

There are many variables. Every serviceman must learn for himself just what his basic overhead is. If anything, he should figure on the *high* side, especially now that costs are rising by leaps and bounds. If you *used* to spend \$5 a month for gas and oil, you have every right to figure that *from now on* your gas and oil costs will be nearer to \$7 a month. If you *used* to pay \$25 a week for an assistant it would be wiser to face the issue squarely and figure that right now you can't get an assistant to work for less than \$35 a week. (It costs your assistant more to live and you've got to pay a part of his increased overhead). By the same token, if you were formerly satisfied with \$50 a week you'll have to revise your estimates because now-a-days you simply can't get along on that amount. You'll need at least 25% more just to maintain the same living standard you formerly enjoyed. Consider this as part of Problem 1.

In estimating the total cost of a job before submitting a quotation to the customer, never forget the *contingency angle*. Make him understand that there may become apparent, after you have started trouble-shooting, some defect or defective part not considered at the moment the price quotation is given. Take time and trouble to stress this angle and you provide a cushion for yourself. Neglect this angle and you may take a loss on much work done. If you don't take an actual loss you may at least lose a percentage of anticipated profits.

Phase 3 is almost part of phase 2, except that here you can lay down a written estimate sheet for the customer to sign. It should be itemized as thoroughly as possible. It acts as a contract or binder between parties whereby you get a "green light" and the customer gets an actual receipt for the

(Continued on page 10)

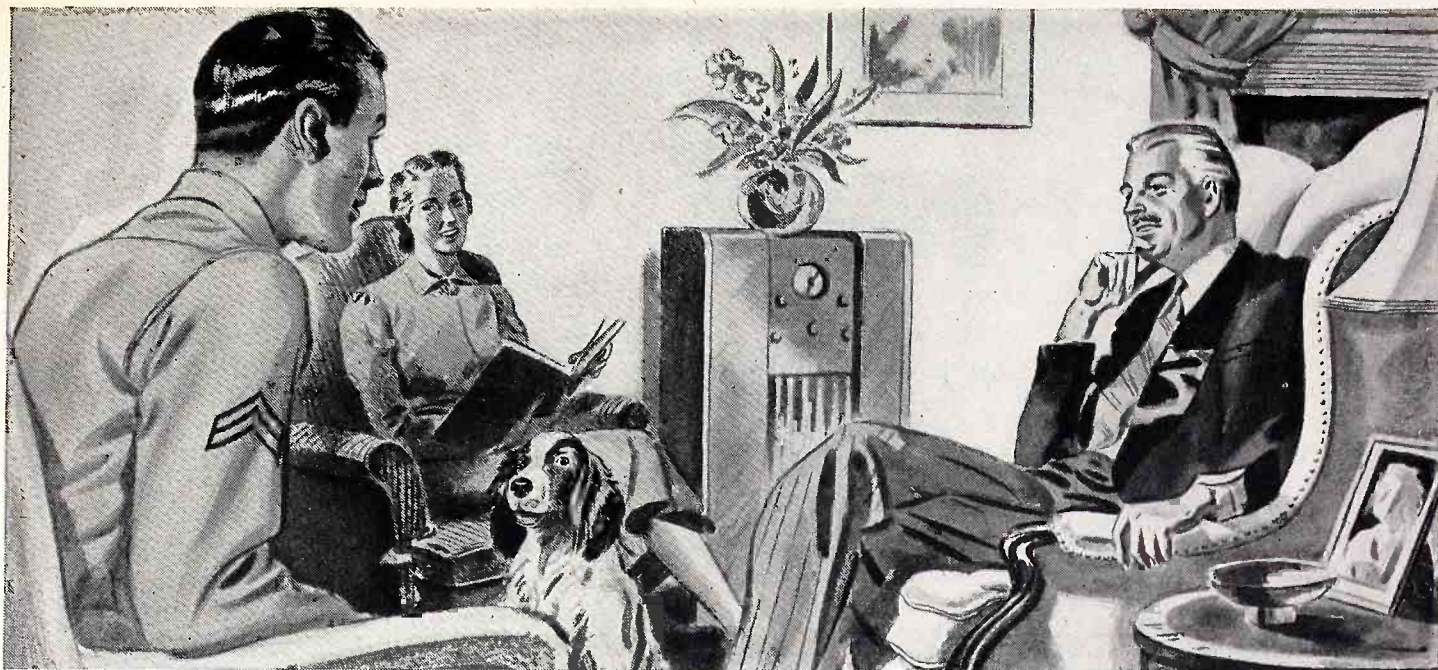

WHAT ABOUT RESISTORS AND CONTROLS FOR THE HOME FRONT?

A Statement Regarding the IRC War Effort and Its Effect on Normal Production

As a natural consequence of unquestioned leadership in its field, IRC has been called upon to provide fixed and variable resistors for war requirements to an extent which has absorbed a large part of its production capacity. This war demand has steadily increased and has exceeded all expectations. Naturally, this is a tremendous responsibility that we cannot neglect.

Nevertheless, we have by no means forgotten the important requirements of service men and jobbers. We have wanted for some time to make a definite statement concerning our ability to supply replacement parts. This has been impossible since there was no means of knowing the extent of the war demands, and no definite provision has been made to insure a supply of critical materials for radio servicing requirements.

The national authorities in charge of this most difficult task of allotting critical materials for the greatest good of our Nation fully recognize the importance of radio repair and maintenance but, up to now, urgent war production has rightfully had priority over all else. As soon as these authorities decide upon definite plans for the allotment of materials for replacement parts, we shall relay these plans to you.



Meanwhile, we state definitely:

That IRC realizes fully the importance of keeping the Nation's old radios in perfect working order during the emergency.

That IRC thoroughly recognizes its obligation to keep jobbers and service men supplied with dependable replacement parts.

That IRC pledges itself to fulfill its obligation to the utmost, within the limits permitted by authorization of critical materials.

If deliveries have at times been slow, or if you have found an occasional unit missing from jobbers' stocks, we know that you will understand. You will realize that any failure to deliver goods on the home front is only because we have recognized that there *must* be no failure to deliver them on the war front.

Obviously, all replacement parts production will be faced with many difficulties arising from the war. Through participation in the "Production Requirements Plan" now being expanded to cover replacement parts, plus full utilization of our greatly enlarged manufacturing facilities, IRC hopes to be in a position to handle all legitimate requirements.

The home front has not been forgotten.

We'll do our level best to meet its needs!

INTERNATIONAL RESISTANCE COMPANY 401 NORTH BROAD ST. PHILADELPHIA, PA.

A SLANT ON COLLECTIONS

(Continued from page 8)

merchandise he entrusts to your care.

GET CASH ON DELIVERY

Having gotten the customer sold to the point where you know you have the job, and a profit . . . you have to lay it on the line to your customer so that he will know definitely that he will be expected to lay cash on the line at the time the repair job is delivered. In ordinary transactions the bill will not be too high for the average customer to meet, if he knows in advance approximately what he is to be charged. Assuming that we have an average or low-price repair job at hand, a casual statement to this effect will generally work: "Mr. Jones, I'll have the job finished in three days. I'll drop you our regular notification card so that you can arrange to have delivery made at a convenient time." For my own purposes I have found a very effective card. It is reprinted here as *fig. 1* for your examination. Use this idea if you want to.

Usually when my customers receive a card like this they phone to tell me when it will be convenient for them to have the set returned. While on the telephone, I find it worthwhile to stall for a moment, explaining that I am getting their card before me, and in casual manner I quote from the card giving the make of the set, outline of work done, and then I carefully mention that the cost was so-much, or so-much, and that delivery will be made promptly at the time agreed upon. And when I make delivery as promised I expect my customer to make his cash delivery in like manner. There should be no hitch. But if there is a hitch, as has happened, then I protect my interests.

Assuming a maid comes to the door and is willing to accept the repaired set and she tells me that the Madame isn't home and no money has been left. Do I leave the set and accumulate an account receivable? Or do I refuse to leave the set and figure a repeat visit? A case like this is a "contingency," where unexpected additional overhead comes in, and has been taken care of when working on phase 2. You, and no one else must determine how you will want to handle cases like this. But, let me stress again . . . unless, in your original estimate you have provided for such losses in time and effort, you'll never make a success in the servicing business. But, back to the problem! If that sort of thing happens to me, and if I weren't positive from past experi-

(Continued on page 30)

Dear M^{rs} Trotter Date Nov. 23 19 41

Your Grunow

Radio has been repaired and restored to proper working order, and is ready for you to call for. If you wish to have us deliver, please Phone 3155 and inform us as to the day, time, and place you will be present to accept delivery.

The cost of repairs came to \$ 8.95 including labor, material and tax.

Thank you. Sincerely Your Radioman

Burt Selle

PLEASE NOTE: All labor and material sold only on a strictly cash basis, unless you already have a charge account in good standing with this company. We will be glad to assist you to open a charge account with us, if you will ask to fill out a credit application form. CREDIT TERMS: 1. Cash down, balance payable within 10 - 30 days.

STORE & SHOP HOURS: Monday to Thursday 9:00 A.M. to 6:30 P.M. Friday to 7:30 P.M. Saturday 8:00 A.M. to 9:00 P.M. Sunday by appointment only.

REMEMBER. NO PARKING WORRIES. WHEN YOU COME TO BURT'S

Fig. 1. Post Card That Gets Results.

I hereby inform you fully of my financial condition. AMOUNT \$ INFORMATION

FULL NAME _____ Married or Single _____

Residence _____ How Long _____ Rent _____ Board _____ Mortgage _____ Paid per month \$ _____

Previous Address _____ How Long _____

Home Phone No. _____ Business Phone No. _____

Employed by _____ Address _____

Employed as _____ How Long _____ Name of Superior _____

Pay Day _____ Salary _____ Other Income _____ Total Income _____

Description of Real Estate Owned _____

Located at _____ Amt. Mortgages \$ _____

Are you liable as Guarantor or Maker on a loan? _____ If so, for what amount? _____

Credit References: (Give 3 Merchants, Firms, or Loan Companies with whom you have had credit)

NAME AND ADDRESS	AMOUNT	AMOUNT OWING NOW

My total indebtedness does not exceed \$ _____

Description of self: Color _____ Age _____ Height _____ Weight _____ Color Eyes _____ Color Hair _____

Date _____ Signature _____

DO NOT WRITE BELOW THIS LINE

Sources: How did you happen to come to us? (Give all sources mentioned)

If purchasing, describe article: Selling Price \$ _____ Trade-in \$ _____ Cash Down \$ _____ Amt. to Finance \$ _____

Time Received	Notified	Date Customer to Call	A.M.	P.M.
Account Number	X	X	X	X
Date Will Pay				
Date Made	J	J	J	J
Amount	C	C	C	C
Rate				
Schedule	I	I	I	I
Security				
Approved by	L	L	L	L
Line of Credit				
PB Bal.				

Fig. 2. Typical Credit Application Form.

TECHNICAL SERVICE PORTFOLIO

SECTION XVIII

DESIGN AND MAINTENANCE OF OHMMETERS

GOOD test apparatus for radio servicing is becoming increasingly scarce, due to priorities and the conversion of many test equipment manufacturing plants to war work. For the same reasons, it is difficult to get such apparatus repaired within a reasonable time, when the need arises. And often, when a serviceman finds himself with a defective essential test instrument, it means tough sledding until the instrument is back on the job again. In fact, there are cases where it will simply mean that he'll have to shut up shop in the interim. This is particularly true when one loses the services of the ohmmeter, without which it is practically impossible to do any trouble shooting efficiently. Of course, if a schematic of the instrument is at hand, repairs can be effected without great difficulty. But instruction books and schematics often become mislaid, and are seldom available if the apparatus is purchased second-hand, as so many are going to be. There will usually be little point

in writing the manufacturer for schematics; most are so harassed getting out war production that such services can no longer be handled in the "business as usual" manner. So to smooth the way of those who must fix their own equipment, without benefit of schematics, we are outlining here the fundamentals of the design of our most important piece of equipment; the ohmmeter. Also we are covering many advances which have been made in recent years, some of which have received relatively little attention.

SERIES-TYPE OHMMETER

The fundamental circuit of the series-type ohmmeter, which is in general use in the service industry, is shown in *Fig. 1*. The resistance R_1 is so chosen that it limits the current in the circuit to full-scale deflection of the meter when the terminals $X-X$ are joined. The greater the sensitivity of the milliammeter M , and the higher the battery test voltage used, the higher the value of resistance which can be measured. If a 1 ma meter is employed and the battery voltage is 4.5, the total circuit resistance required to limit the current to full-scale deflection of the meter may be determined by Ohm's law, as follows:

$$R = \frac{E}{I} = \frac{4.5}{.001} = 4500 \text{ ohms}$$

Note that R is the total circuit resistance, not just the limiting resistor R_1 . In most cases, of course, other components which make up the total circuit resistance, such as the internal

resistance of the meter, and of the battery, are negligible. But when a high resistance meter is employed, or when the battery is old and the ohmmeter is used on a scale which draws considerable current, we must take these other resistances into account. In general, the meter resistance will not exceed 300 ohms, and is generally considerably less, except when movements of high sensitivity are employed. The battery resistance will ordinarily be of the order of 0.1 ohm when fresh, depending on its size, and may run to an ohm or more when old.

RECALIBRATION

The center scale reading of the ohmmeter, on the particular scale in use, (in the case of a multi-range type), is equal to the total circuit resistance of the ohmmeter, assuming that the battery voltage is up to normal. Just why this is so we may see from a single test. Considering the circuit of *Fig. 2*, when the terminals $X-X$ are joined the meter deflects to full scale under

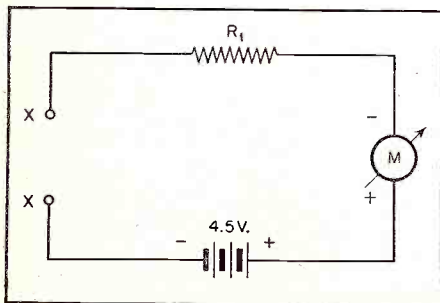

Fig. 1. Fundamental Ohmmeter Circuit.

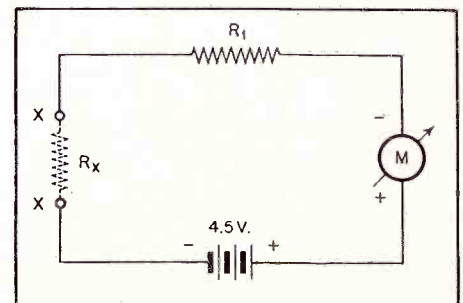

Fig. 2. Connecting a Resistor Reduces Current.

proper operating conditions. Now we know by Ohm's law that, to reduce the current in a circuit by one-half, we must double the circuit resistance. Therefore when we connect a resistance R_x , equal to the circuit resistance of the ohmmeter, across the terminals $X-X$, we double the resistance in series with the battery and accordingly the current is halved and the meter reads half-scale. It is important that this be realized, because it enables us to tell by a glance at the ohmmeter center-scale calibration just what the total circuit resistance is for any given range. Thus we can more readily determine what values of resistance are required when replacements are necessary. In some cases the center-scale calibration will not be in the mechanical center of the scale, due to the fact that the electrical and mechanical centers may differ. In such cases, the electrical center, equal to one-half the current or voltage full-scale calibration, should be used.

Some means for compensating for battery depreciation is included in practically all ohmmeters. One method is shown in Fig. 3A. The variable resistance R_a is placed in series with R and the value of the latter is decreased correspondingly. Then, when the terminals $X-X$ are joined, if the meter does not provide full-scale deflection due to a drop in battery voltage, the circuit resistance is reduced by decreasing the resistance setting of R_a . Thus, if a total circuit resistance of 4500 ohms is required for full-scale deflection with a 4.5 volt battery, the circuit resistance will have to be reduced to 4000 ohms to maintain the same current in the circuit when the battery voltage has fallen to 4 volts. But, if the meter is to read accurately, we have shown that the total circuit resistance should be equal to the center scale calibration of the meter. When

the circuit resistance is reduced to 4000 ohms, the meter will read half-scale when a 4000 ohm resistance is connected across its terminals, yet it is calibrated at this point as 4500 ohms. Thus the reading is in error in proportion to the drop in battery voltage. It is because of this fault that this type of zero adjustment is no longer used in modern ohmmeters. However, those who have such types will still find them useful for general trouble shooting where accuracy is not essential, such as in continuity testing for shorts and opens.

A better method for battery voltage compensation is shown in Fig. 3B. Here the adjustable resistance R_a is placed in series with a limiting resistor R_L and together they are shunted across the meter. In this circuit, the current, with a fresh battery, is kept about 20% greater than full-scale deflection of the meter. The shut circuit, composed of R_L and R_a serve to bypass the excess current around the meter. As the battery voltage decreases, the current in the circuit decreases proportionately. Then the resistance of the shunt is increased by adjusting R_a so that less current is bypassed around the meter and therefore more passes through the meter so that full scale deflection is restored. The advantage of this circuit is that the change in total circuit resistance required to cause a considerable change in current is small, because the circuit resistance change is confined to the meter circuit, which will seldom be greater than a few hundred ohms. Since the circuit current is proportionately greater than is employed when the meter is unshunted, the center scale calibration is likewise lower than is employed in the circuit of Fig. 3A. In general, we may expect the center scale calibration to be about 20% less than when the meter is unshunted.

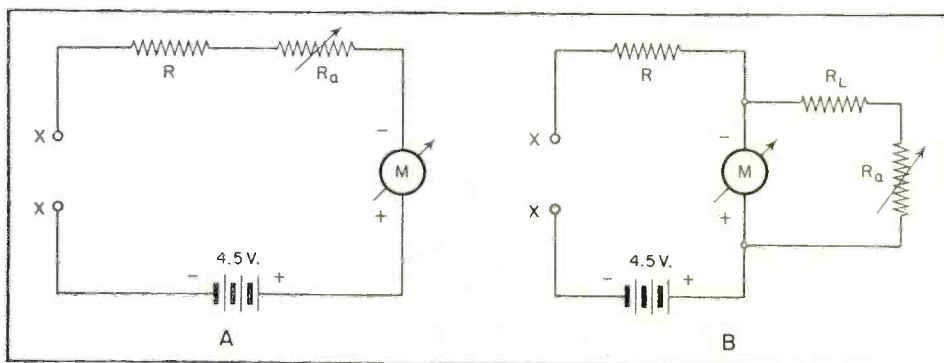

Fig. 3. (A) Series Resistance Method of O Adjustment. (B) Meter-Shunting Method.

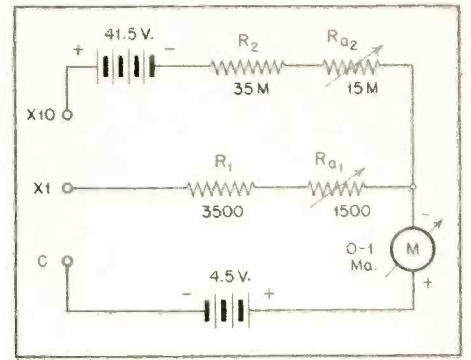

Fig. 4. A Simple, two-range Ohmmeter.

TWO-RANGE OHMMETERS

In Fig. 4 the circuit of a two-range ohmmeter is shown. If a 1 ma meter is used, a 4500-ohm center scale calibration will usually be employed. Accordingly, the total circuit resistance will have to be 4500 ohms and a 4.5 volt battery will be required to bring the circuit current up to 1 ma for full scale deflection of the meter when the test terminals are joined. This adjustment of current is made by varying R_a1 . If the battery voltage decreases, R_a1 is reduced accordingly. For the high ($X10$) range, terminals C and $X10$ are employed. The resistances $R2$ and R_a2 are respectively 10 times greater than R_a1 and $R1$, so that the circuit resistance may be increased by a factor of 10, and the 41.5 volt battery, in series with the 4.5 volt one used for the low range, multiplies the test voltage by 10 also, so the circuit current may be brought up to 1 ma. The ohmmeter will, on this scale, read accordingly 45,000 ohms at half-scale deflection and is therefore 10 times as sensitive as on the low range. One feature of this design is that the adjustable resistors R_a1 and R_a2 , once set to provide full-scale deflection on each range, need not be adjusted when switching from one range to another. Otherwise this circuit is subject to the same limitations mentioned in discussing the circuit of Fig. 3A.

MULTI-RANGE OHMMETERS

In Fig. 5, we have the circuit of a modern, high grade multi-range ohmmeter. A great many instruments of various manufacture are designed in this manner. Although the circuits employed are similar, the individual values of resistors used vary with the meter resistance and the current in each circuit as well as that required for full scale deflection of the meter. However, if we know the meter sensi-

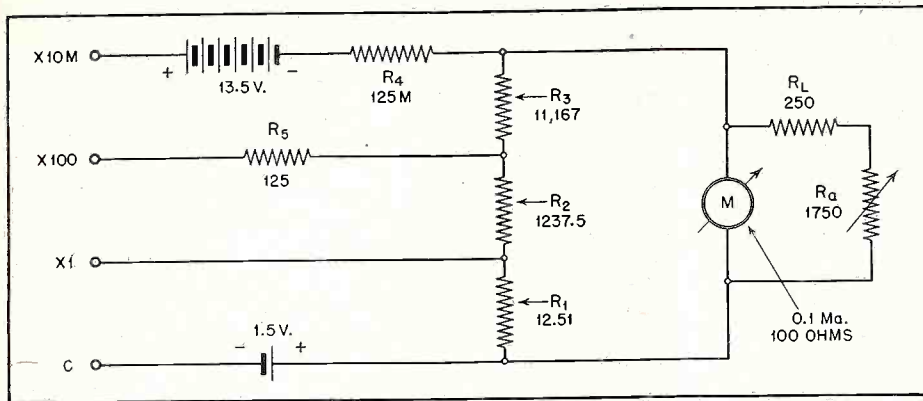

Fig. 5. A Modern, multi-range Ohmmeter Design.

tivity (in ohms-per-volt, as a volt-meter; or in milliamperes or micro-amperes for full scale deflection, as a micro-ammeter) and the internal resistance of the meter, we may readily figure out the resistance values required. The meter sensitivity is generally easy to determine, since it is often listed in the manufacturer's catalog, most ohmmeters being designed to be used also as voltmeters. If it is a 1000 ohms-per-volt instrument, we know the meter must be a 1 ma instrument; for a 20,000 ohms-per-volt movement, the meter would have to be 20 times as sensitive, accordingly the movement required would be a 50 microampere type.

COMPUTING RESISTANCE VALUES

The internal resistance of the meter is equal to the value of resistance shunted across the meter which will reduce the full-scale reading by one half. We could, of course, shunt a variable resistance across the meter and adjust it until the meter read half scale, then disconnect the shunt and measure its value with some other instrument, but this presupposes that we have another ohmmeter at hand. It is more likely to be easier to get a resistance whose value is known and which is somewhere near the estimated internal resistance of the meter and use it

as a shunt. When so used, the amount of current passing through the shunt will be equal to the reciprocal of the ratio of its resistance to that of the meter. For example, if we place the meter in a circuit in series with sufficient resistance to produce full scale reading and then connect a shunt resistance across the meter, the meter reading will be reduced. Let us assume the reading is reduced one-third when the resistor used as a shunt is 100 ohms. Then the current through the 100-ohm shunt will be equal to one-third that of the total current in the circuit, the remaining two-thirds of the current must flow through the meter. If two-thirds the current flows through the meter and only one-third through the shunt, then the meter must have one-half the resistance of the shunt. So the meter resistance, in this case, would be 50 ohms.

The required values of resistances in the circuit of Fig. 5 may be figured out along somewhat similar lines. Let us assume that our meter resistance is 100 ohms and its sensitivity 0.1 ma, as shown on the diagram. We want to use a 1.5 volt battery for the test circuit, and to be able to use this battery until its voltage drops to 1.25 volts. As the battery, when fresh, may read as high as 1.6 volts, we must be able to adjust the meter shunt circuit, com-

posed of RL and Ra , so the meter current will be 0.1 ma over this range of battery voltages. In practice, it is usually customary to assume that the battery voltage will normally be 1.5 volts and to make the initial calculation on that basis. If we allow for a 20% shunting of the meter at 1.5 volts, we can reduce the amount of this shunting to 10% or less as the battery voltage drops below 1.5 increase the shunt when the battery is at its initial fresh value of 1.6 volts. For the 20% shunt, the resistance of RL and Ra , in series, should amount to 5 times the resistance of the meter, or 500 ohms. RL is made 250 ohms so that the shunt could be reduced to this value, if required, although unnecessary. This generous margin is employed to enable a wider tolerance in the value of resistor chosen. If it should happen to be 200, or even 400 ohms, it would serve the purpose.

When the circuit current is 0.12 ma, which is the value obtained at the nominal battery voltage of 1.5 when a 20% shunt is employed, the circuit resistance necessary is equal to $1.5 / .00012$ or 12,500 ohms. Accordingly, the resistance required to reduce the reading by one-half, or the center scale calibration, would likewise be 12,500 ohms. Usually this is made 12.5 ohms, in multi-range work, with the provision of multiplying by 1000 when using the scale employing this range. For the X1 range, the current in the shunt circuit $R1$ of Fig. 5, would be 1000 times that in the meter circuit, for the X100 it would be 10 times and for the X10,000, the battery voltage is increased and the series resistance likewise, until the current is the 0.12 ma.

The first calculation of the resistance values in the multi-range circuit is made for the X1 range. This is shown in Fig. 6. Here we have redrawn the circuit to show the resistors in use for the range given. The total current in the circuit is equal to that

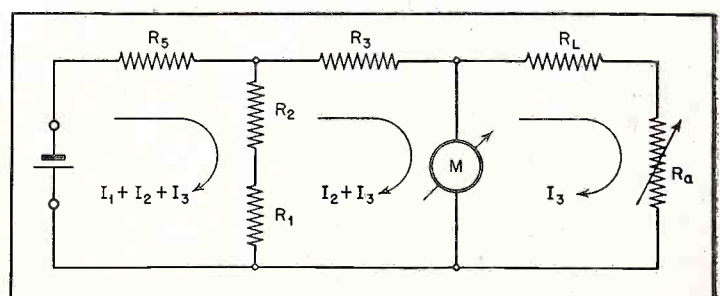
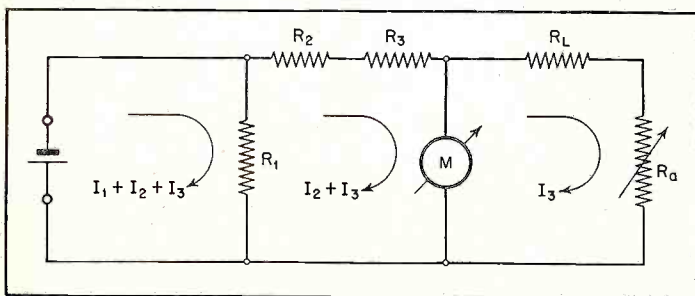

Figs. 6 and 7. Analyzing the Current Distribution in the Ohmmeter Circuit Ranges Shown in Fig. 5.

which passes through $R1$ plus the current passing through the meter plus the current through the shunt. These currents are designated as $I1$, $I2$ and $I3$ respectively. If the battery voltage, E , is 1.5, the resistance, R , representing that of $R1$ when shunted with the series combination of $R2$, $R3$, and the meter and its associated shunt resistors, is equal to 12.5 ohms, the value of center-scale calibration under consideration. The total circuit current E/R is equal to $1.5/12.5$ or 120 ma. The relative values of the resistance in Fig. 6 is proportional to the current in each circuit.

The total current is composed of $I2$, the meter current and $I3$, the shunt current. $I2$ plus $I3$ equals 0.120 ma. Since the shunt resistance passes 1/5th the current of the meter, its resistance must be 5 times the meter resistance, or 500 ohms. The combination of meter and shunt resistance will therefore equal 83 ohms. The total circuit resistance required to limit the current in the circuit to 0.12 ma when the battery is 1.5 volts is $1.5/.00012$ or 12,500 ohms. Subtracting the meter circuit resistance from this value leaves 12,417 ohms. The current in $R1$ is equal to 120 ma less the current in the meter circuit. This is equal to $120 - 0.12$ or 119.88 ma. Dividing 1.5 by .11988 gives us 12.51 as the resistance of $R1$.

For the X100 range, let us refer to

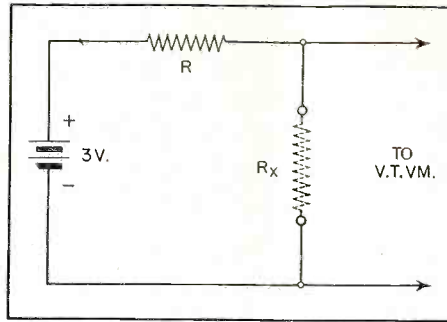

Fig. 8. The V-T Ohmmeter Circuit Is Simple.

Fig. 7. We know that the effective circuit resistance must be 100 times 12.5 or 1250 ohms. Also we know that the meter circuit resistance should be 9 times that of the shunt divider circuit composed of $R1$ and $R2$, in order to reduce the sensitivity by 1/10th, since the normal circuit resistance is 12,500 ohms. So we make $R1$ plus $R2$ equal to 1250 ohms and $R3$ plus the meter circuit resistance equal to 9×1250 or 11,250 ohms. However, the shunt resistance of $R1$ plus $R2$, when shunted by 11,250 ohms is approximately 1125 ohms, instead of the required 1250 ohms. To make up the difference, $R5$ is added, equal to 125 ohms. The effective circuit resistance thus becomes 1250 ohms, as required for this range. $R2$ is determined by subtracting 12.51 ($R1$) from 1250 ($R1$ plus $R2$) and becomes 1237.5 ohms. $R3$ is obtained by subtracting

the meter circuit resistance, 83 ohms, from 11,250, equal to 11,167 ohms.

It will be noted that, when the terminals C and $X100$ are joined, it is necessary to readjust Ra to a different position from that used in the $X1$ position. This is due to the fact that the battery is then placed in series with a total circuit resistance (for the meter circuit) of less than the 12,500 ohms used on the $X1$ range. This is because $R2$ is no longer in series with the battery, as was the case when connected as in Fig. 6.

For the X10,000 range, the analysis is similar to that of the circuit of Fig. 3B, and need not be again described in detail.

THE MODERN V-T OHMMETER

A modern development in ohmmeter circuits is the vacuum-tube ohmmeter, such as is represented by the Rider RCA Voltomyst. While the circuit of the vacuum tube part of the instrument is rather complex, that of the measuring network itself is relatively simple. This is indicated in Fig. 8. The measuring terminals are designated as $X-X$ across which the resistor under test is placed. Initially the terminals $X-X$ are open-circuited, so the battery voltage is applied through the resistor R to the input circuit of the d-c vacuum-tube voltmeter, which is designed to give full-scale deflection for 3 volts (Continued on page 27)

Fig. 9. The Rider RCA Junior Volt-Ohmyst is a Multi-range V-T Ohmmeter and Voltmeter

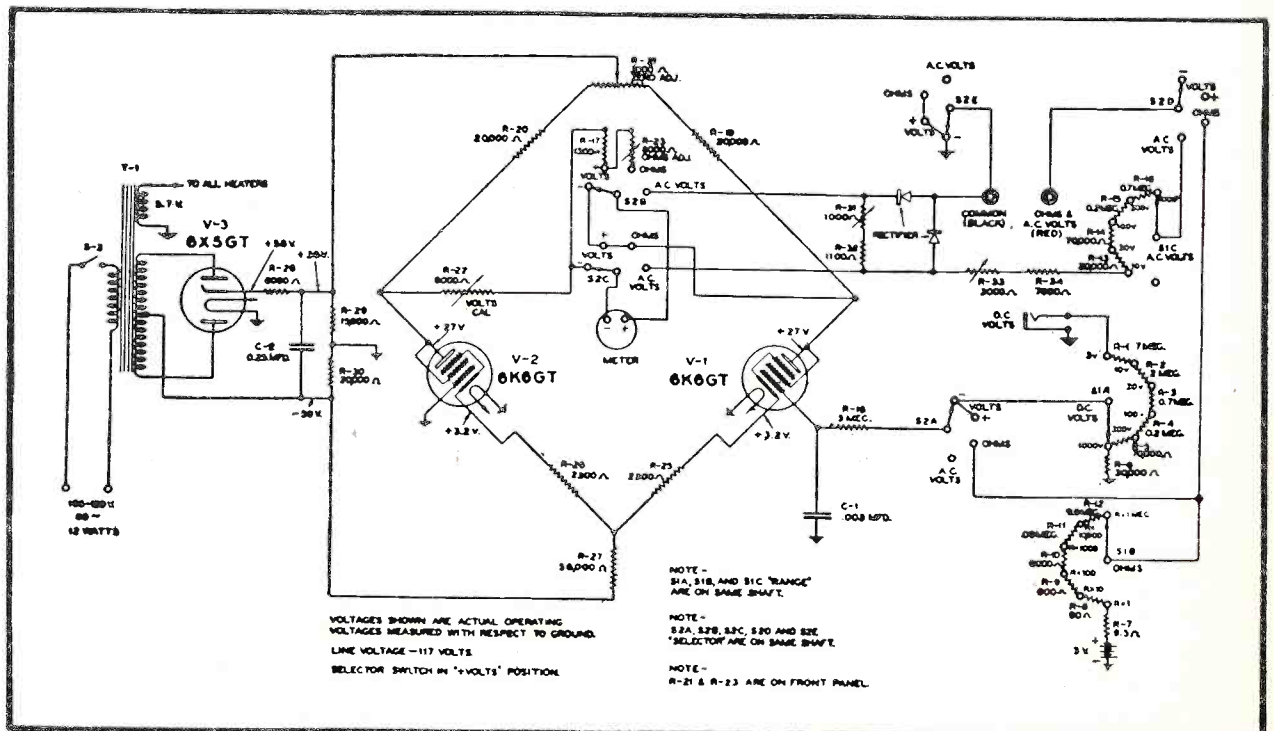

Schematic by Courtesy of RCA Mfg. Co., Inc.

across the unbypassed resistor $R9$ in the cathode circuit of the 6S7G and supports the low-frequency voltage on the grid of this tube.

Note that an equalizer $R7-C16$ is in series with the volume control and the grid of the 6S7G.

A 35Z5GT half-wave rectifier supplies the shunt-connected, 4000-ohm speaker field as well as the tube voltages. A two-section resistance-capacity filter is used, with the plate of the beam-power tube being fed from the output of the first section.

LATEST MUSAPHONIC (FIG. 2)

The final *General Electric* contribution to improved receiver design is to be found in their latest Model 40, a radio-phono combination with frequency modulation. The complete circuit is shown in Fig. 2.

Oscillator-Converter: The a-m broadcast section is of conventional design, but the f-m section is far from conventional. Referring to the oscillator-converter circuit, the first 6SG7 acts as a conventional r-f amplifier when operating in the s-w or b-c bands. However, in order to obtain optimum gain, the above tube becomes the first converter of a double or cascade converter when operating in the f-m band.

This cascade converter consists of the two 6SG7 converter tubes and a 7Q7 oscillator, with their associated circuits. The tuning condensers for the two converters and oscillator are low-capacity sections and ganged together. The antenna tuning circuit consisting of $T5$ and $C3$ tunes the f-m band from 42 to 50 mc; the second converter tuned circuit consisting of a portion of $T6$ and $C29$ tunes from 23.15 to 27.15 mc; while the oscillator tuned circuit consisting of $C5$ and a portion of $T7$ tunes from 18.85 to 22.85 mc. The oscillator voltage is capacity coupled to the grid of the first converter tube through $C7$. This produces, by heterodyne action, a signal to which the plate circuit of this first converter is tuned. The first converter tube also provides a gain of unity for the oscillator frequency. Accordingly, oscillator voltage is also applied to the grid of the second 6SG7 converter which produces in its plate circuit the i-f frequency of 4.3 megacycles.

To illustrate the action; consider an f-m signal of 42 mc to which the receiver is tuned. The oscillator frequency for this setting of the tuning control is 18.85 mc and it heterodynes in the first converter with the 42-mc signal to form 23.15 mc (42-18.85). The 23.15-mc signal in turn, beats with the oscillator signal in the second converter to produce the 4.3-mc intermediate frequency.

The i-f Amplifier: The i-f amplifier operates in dual capacity in that it will function either at the 455 kc required for the broadcast and s-w bands or at 4.3 mc required for the f-m band, without the need of switching transformers except at the primary of the first i-f stage. When the i.f. is operating at 455 kc, the primary and secondary coils of the 4.3-mc section of $T1$ and $T2$ are such a low impedance that they can be considered as shorted across; while when operating at 4.3 mc, the primary and secondary trimmers of the 455-kc section of $T1$ and $T2$ are such a low impedance that they effectively short out this portion of the transformer. Thus the frequency at which the i.f. is operating is applied across the proper section of the dual transformers and is amplified by the i-f tubes.

Cascade Limiter: The limiter circuit consists of two resistance-coupled 6SH7 tubes in series. Each limiter operates at zero initial bias and low screen voltage. Both grid circuits are designed for self-biasing and the use of capacity-resistance networks provides enough time delay to retain the grid bias between signal peaks. The action of the limiter is such that as soon as a signal is applied to the grid of the tube the grid draws current. This grid current charges up the condenser $C51$

across the grid resistor $R19$ and at the same time establishes a bias through current drain in the resistor. The circuit is so designed that negative signal swings are all beyond plate-current cutoff and positive signal peaks are cut off by plate-current saturation. The value of the first limiter capacity-resistance network $C51-R19$ is so chosen (33 mmfd-100 M) as to limit peak noise amplitudes. This arrangement leaves the second limiter with the very much simplified task of reducing the remaining noise to the desired level.

Station Silencer: This circuit operates on amplitude-modulated noise signals to produce squelch or quieting of the audio amplifier. Since the noise limiter circuits only operate when an f-m carrier is present, noise between stations will ride through with undiminished amplitude. This amplitude modulation appears in the last noise limiter plate circuit and develops a voltage across $R35$. This voltage is rectified by one diode of the 6SQ7 and then applied to the first audio grid circuit of this tube provided the switch $S6$ is open. This rectified d-c voltage is sufficient to completely bias off this audio tube so that no signal is passed. When a sufficiently strong f-m signal is received so that the noise limiters operate with satisfactory signal strength, the noise or amplitude signal is reduced so low that the

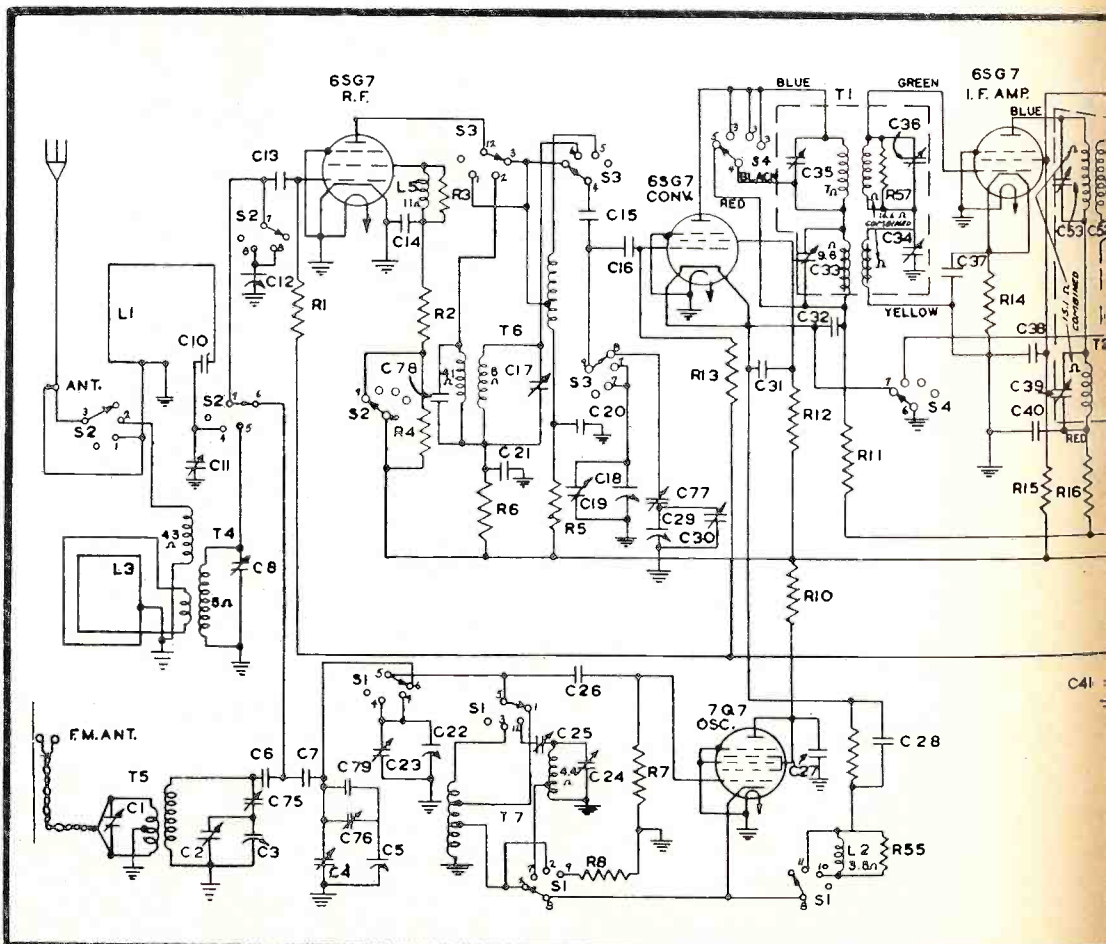

Fig. 2. Schematic of G. E. Model 40

proper bias is restored to the 6SQ7 a-f amplifier and the audio signal is then passed on. This squelch voltage can be manually removed by closing switch S6 so that weak f-m stations that have considerable noise present can be received if desired.

Audio Channel: The 6SQ7 functions as the a-m detector and as the first a-f stage for a.m., f.m. and phono, the selection of the desired service being made by means of switch S4. The treble tone control C66-R44 shunts the plate circuit of the triode section of this tube, while the bass control, varied by steps, is accomplished by switch S5 associated with the volume control. Bass response at the lower settings of the volume control is automatically accentuated by means of inverse feedback from the speaker voice-coil circuit to the volume control, with the inverse voltage being developed across R29.

The phase inverter is a simple triode, this being a section of the 7K7, the diodes of which are employed in the f-m discriminator circuit. This inverter is of the voltage-divider type, with one-half the output audio voltage appearing across R41, and the other half in opposite phase, across R42. Both of these resistors have a value of 82,000 ohms, while R39 which provides the grid bias, has a value of 3300 ohms.

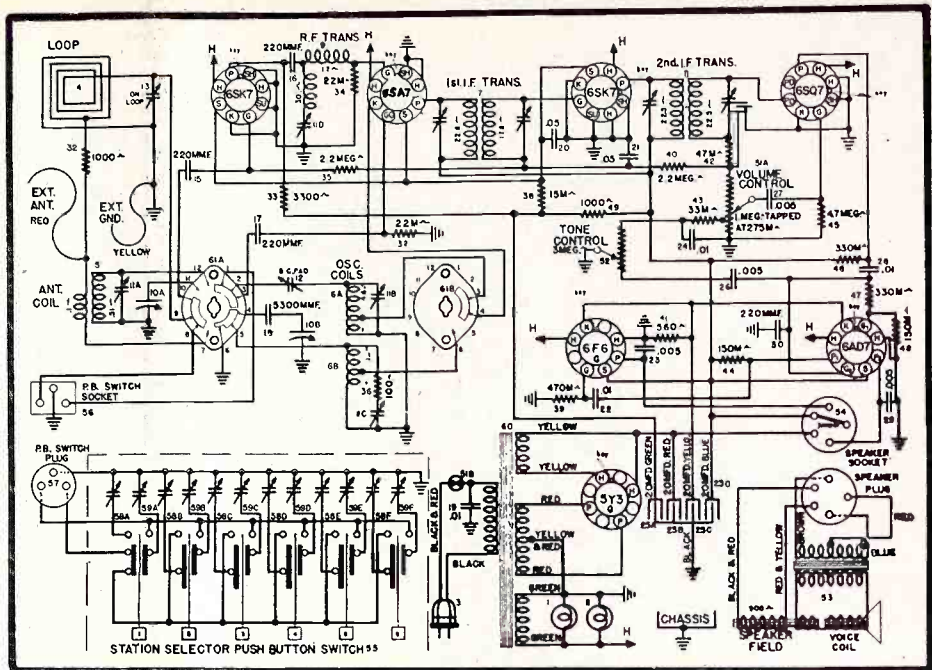

Fig. 3. Crosley Model 72CA. Note variable bass-treble tone control.

Since the grid return is to the point between R39 and R42, rather than to ground, the gain of the triode is not sacrificed.

While inverse feedback is present in a small amount, it is not of such a degree as to substantially reduce the effective plate impedance of the output

beam-power tubes. Hence a corrective filter R52-C70 is used across the primary of the output transformer to improve the frequency characteristic. As a means of preventing high-frequency transients, 1000-ohm resistors R47 and R51 are connected in series with the power-tube grids.

CROSLY MODEL 72CA (FIG. 3)

Crosley's late Model 72CA, Chassis 80, is a 7-tube a-c, 2-band job with auxiliary push-button tuning in the b-c band. The ranges are 540 to 1600 kc and 4.7 to 18 mc, with the r-f stage effective in both bands. Maximum power output is 6.5 watts.

The schematic is shown in Fig. 3. Range switch is shown in p-b position, with broadcast loop 4 in use. The next clockwise rotation disconnects the p-b assembly and connects in the variable gang condensers 10A-10B. The last switch position disconnects the high end of the loop and connects the short-wave antenna coil 5 in circuit. In this position the loop functions as a capacity antenna, but, in addition, an external antenna may be used, as indicated by the (red) lead. Also in this position, the lower end of the primary of the s-w antenna coil is grounded for operation through switch contact 7 and the second switch sector which makes contact with the grounded lug 6. In the other switch positions the primary of the s-w coil is left open so as not to short out either that portion of the loop serving as a "primary" or the external antenna, if one is used.

The 6SK7 r-f stage is resistance coupled to the mixer, but an r-f booster coil (9) is included in the grid circuit of the 6SA7. The same circuit car-

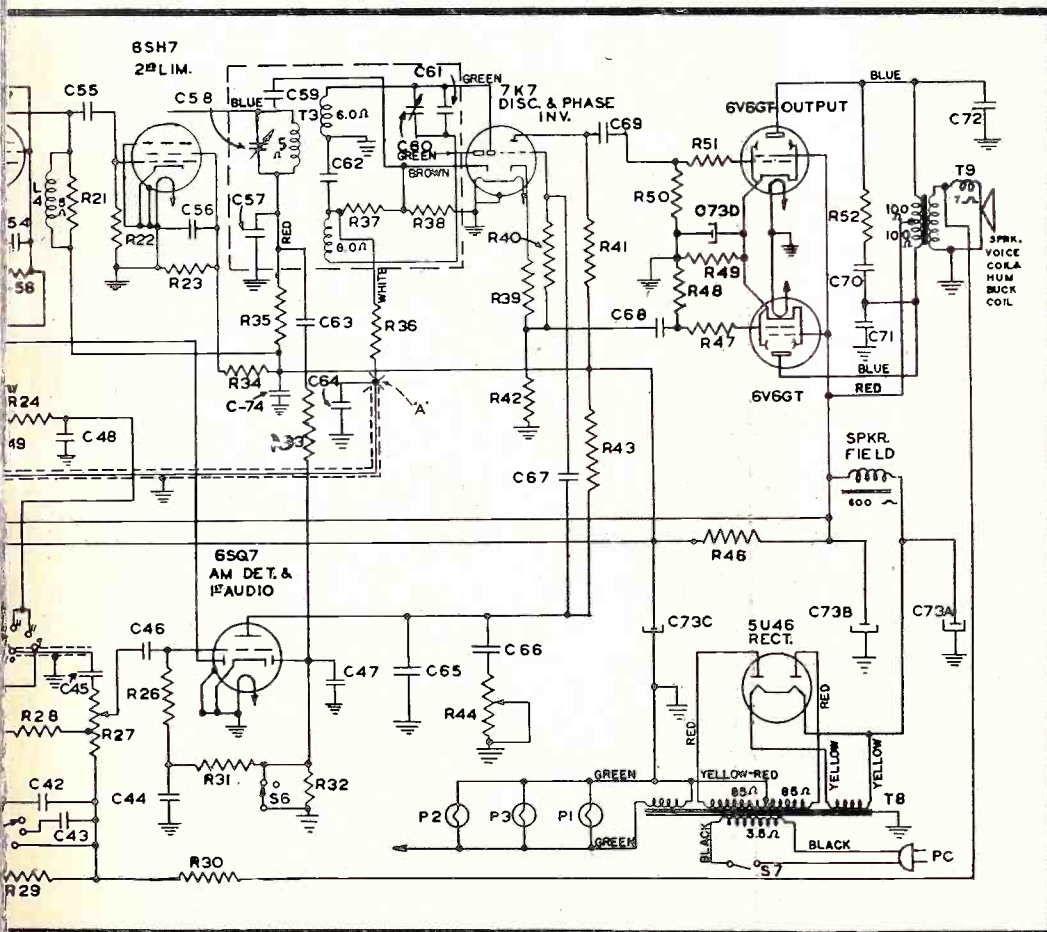

lic' A.M. and F.M. combination.

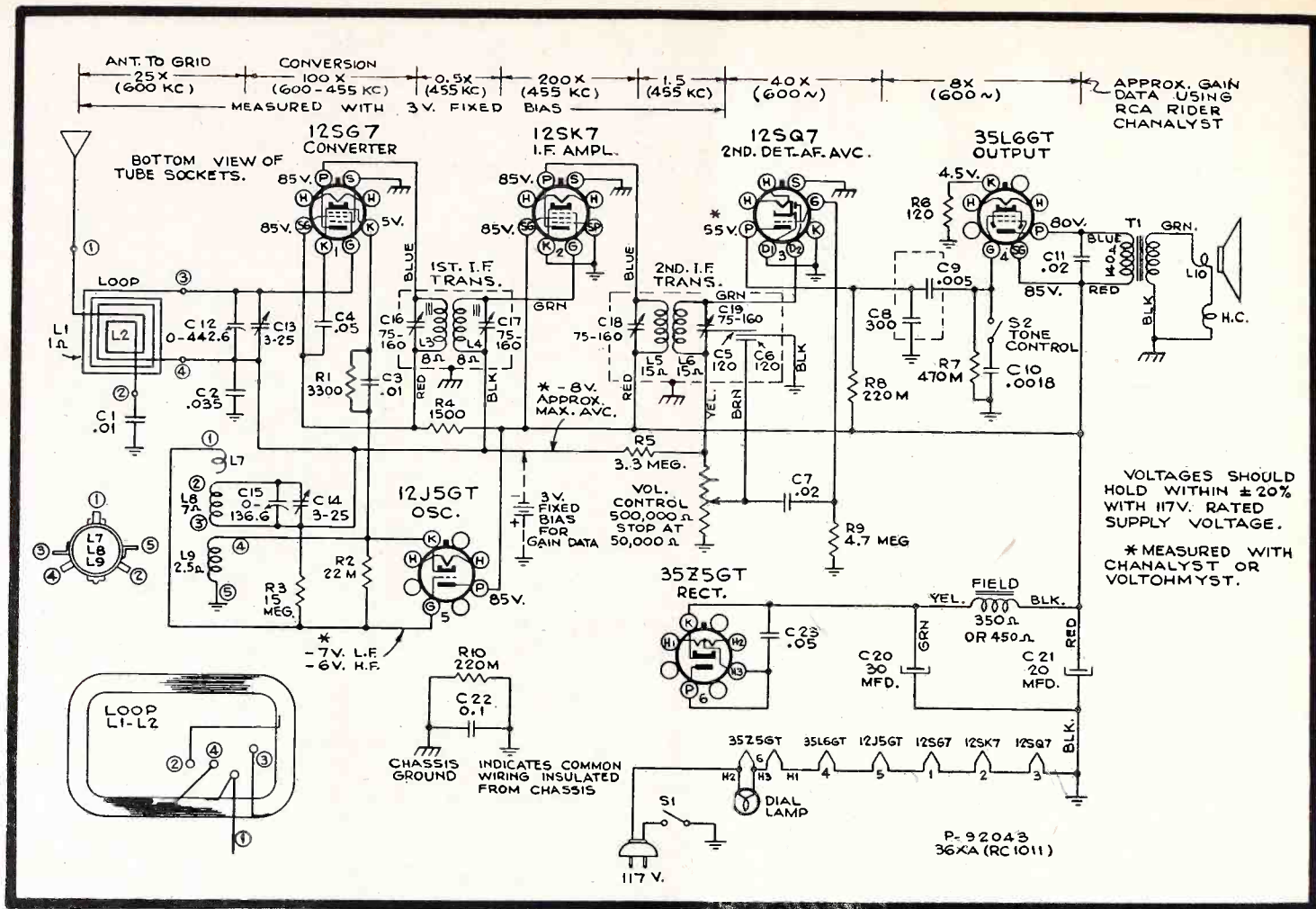

Fig. 4. Schematic of RCA 15X, 36X with separate oscillator and converter.

ries the series-connected wave trap which is adjusted by means of trimmer 11D.

The i-f circuits are conventional. The 6SK7 i-f tube and the 6SK7 r-f tube rely on the avc circuit for their initial bias, cathode resistors not being used.

The volume control is of the compensated type, providing a rising bass at low volume settings. Associated with this circuit and the output of the 6SQ7 a-f amplifier is the tone control 52 with its arm grounded. This arrangement provides a graduated response from bass (with high's bypassed to ground) to treble (with the low's bypassed around condenser 24.)

This receiver is one of the few incorporating a 6AD7 triode-pentode in the audio system. The pentode section in conjunction with the 6F6 forms the push-pull output stage. The triode section serves as the phase inverter and derives its grid voltage from the output of the 6SQ7, the voltage being obtained from the divider formed by resistors 47 and 48.

Filtering in the power-supply circuit is provided by sections 25A-B-D of the electrolytic, the speaker field, and the 1000-ohm resistor 49. Section 25C of the electrolytic serves as the bypass for the cathode resistor 41 common to

the output pentodes.

RCA's 15X & 36X (FIG. 4.)

RCA has leaped over the finish line with a neat ac-dc chassis (No. RC-1011) in two cabinet versions, one plastic and one wood. Though there are 6 tubes, as may be seen in the schematic of Fig. 4, a separate oscillator is used instead of the expected tuned or untuned r-f stage.

High conversion efficiency is obtained through the use of a 12SG7 in the mixer stage. Here, again, the oscillator voltage is injected into the cathode circuit of the mixer. Bias is obtained by the drop across resistor R1, and oscillator voltage is developed across the oscillator cathode coil L9 through which the 12SG7 cathode is grounded. Grid bias for the oscillator tube is established across the grid leak R2, while the open-end coil L7 serves as the grid condenser.

It should also be observed that a portion of the oscillator grid voltage is applied to the avc bus through the 15-meg resistor R3. This provides an initial or delay bias for the converter and r-f tubes.

The upper end of the volume control to the stop point, which represents 50,000 ohms, serves as the i-f filter in conjunction with sections C5 and C6 of

the i-f transformer trimmer C19.

Degeneration is applied to the 35L6GT output tube by the simple means of leaving off the cathode resistor bypass condenser. A shunt-condenser tone control is incorporated in the grid circuit for those who want the high's toned down.

★

RADIO "SHAKE TEST"

See Front Cover

HERE is the United Airline's newly designed vibration generator for testing aircraft radio equipment under conditions considerably in excess of those encountered in flight. H. N. Wilcox of United's communications laboratory, who developed the device, is shown putting a radio receiver through a typical test. An air-operated generating unit (below) actuates the test table to which the radio set is attached (above).

The layman can hardly appreciate the stress factors and strain imposed upon radio equipment used in aviation, tank, jeep and other military endeavors. Ordinary types of receivers and components simply cannot be used because upon radio's optimum efficiency may depend many thousands of lives.

Shop Notes

EMERSON GB-441 6SS7 Replacement

Card 1

As an indication of what can be done in a strict emergency, but not suggested as normal procedure; I was unable to obtain a 6SS7 tube for replacement in an Emerson GB-441. As an alternative I used a 12SK7 (not a 6SK7) which also has a 150-mil heater. This was made possible by the fact that the tube heaters are series-connected, the effect of the 12SK7 merely altering the voltage drop.

Submitted by Warren P. Schreiber

DUST BLOWER

Card 2

An excellent dust blower for cleaning radios can be made from an old truck tire air compressor (which you can pick up from a junk yard for a few dollars) a motor, about 8 feet of windshield wiper tubing, and the tip from an automatic pencil for the nozzle. A paint brush can be added to loosen the dust.

To keep dust from blowing around the shop, an exhaust fan can be made from any electric fan mounted face in to a piece of furnace pipe. The end of the pipe should be outside the shop or terminated in a dust-collecting sack.

Submitted by Pehm Radio Service

STEWART-WARNER 1942 SPEAKERS

Card 3

How to Order Correct Replacement Part

Speakers for Stewart-Warner 1942 Receivers were obtained from several companies. Speakers bearing the same part number are directly interchangeable, regardless of supplier, but the service parts such as cones and output transformers for a given speaker are not interchangeable with those for a similar speaker obtained from a different manufacturer.

Before ordering cone and voice coils or output transformers for the models listed below, check the prefix letter before the number stamped on the speaker frame. The prefixes commonly used are "R", "M", "O", "U", "C", and "CR". If in doubt as to the proper part number for a cone

Continued on Card 4—>

or output transformer, include the part number of the speaker on the order and *Be sure to show the prefix.*

This table shows the receiver models which used more than one type of speaker and the service parts for the various speakers:

Receiver Model	Speaker Number	Order Cone and Voice Coil Number	Order Output Number
206DAS	R-500918 or R-500920	R-500331	R-500921
206DBS			
206DCS			
206EAS	O-500918 or O-500920	O-501475	O-501474
206EBS			
206ECS	M-501245 *CR-501245	M-501305 CR-501247	M-501304 CR-501246
208BK			
208CK			
12-4D1	R-500886 *CR-500886	R-500913 CR-502011	R-500912 CR-502012

* On some "CR" speakers the prefix is not shown but the speaker can be identified as such by the distinctive olive-gray color of the frame.

RCA OUTPUT TRANSFORMERS

Cards 5-6

Changes in Color Coding

In some production, the color code of leads on the following transformers is changed. When installing, check the drawing number stamped on the transformer and refer below for color code.

ORIGINAL COLORS

Stock No.	35774	37350	35056	33444	37899	14534	36098
Dwg. No.	94106-1	89681-3	89681-2	83517-3	94193-1	83517-1	94117-1
Pri. Start	Red	Red	Red	Red	Red	Red	Red
Pri. Tap	Black			Red-Black	Red-Black	Red-Black	
Pri. Finish	Blue	Blue	Blue	Red	Black-Red Ter.	Red	Red
Sec. Start	Bus	Green-Red Tr.	Black	Black	Yellow	Black	Bus
Sec. Finish	Bus	Brown	Black	Black	Black	Black	Bus

ALTERNATE COLORS

Stock No.	35774	38994*	35056	33444	37899**	14534	36098
Dwg. No.	94106-2	97610-2	97610-1	97604-2	97604-1	83517-1	97611-1
Pri. Start	Blue	Blue	Blue	Brown	Brown	Red	Blue
Pri. Tap	Red	Red	Red	Red	Red	Red-Black	Red
Pri. Finish	Red-Black	Red	Red	Blue	Blue	Black	Black
Sec. Start	Bus	Black	Black	Bus	Black	Black	Black
Sec. Finish	Bus	Green-Red Tr.	Green-Red Tr.	Bus	Green-Red Tr.	Black	Black

* Stock No. 38994 supersedes No. 37350.

** Stock No. 37899 supersedes No. 14534.

DISCONTINUED SYLVANIA TUBE TYPES

Card 7

Listed here are tubes which have been withdrawn from the Sylvania Tube List. Information is shown for each type as to whether or not an interchangeable tube is available, or if a type can be substituted by some small change. Although these tubes have been withdrawn from regular factory stocks, your Sylvania Jobber may have them in his stock and they should be used until substitutions are needed.

Type 1F6. There is no direct interchangeable type, but Sylvania type 1F7G can be used by removing the 1F6 socket and installing an octal socket, following the 1F7G base diagram for wiring connections. In some cases it may be necessary to reverse the filament connection for satisfactory performance.

Type 1T1G. No available tube can be used as a direct replacement, but the type 1R1G can be used by shunting a 50 ohm resistor across the filament at the socket.

Type 1A6G. No available tube can be used as a direct replacement, but type 1J6G can be substituted provided the tube is used for operation on a filament voltage of 2.0 volts. This substitution does not require any socket or wiring changes. If a ballast tube or resistor is used in the set it should be changed to accommodate the additional 120 ma. filament drain of the 1J6G.

Type 6A4/LA. No available tube can be used as a direct replacement.
Type 6AB7/1853 (Metal). This tube has no directly interchangeable type. The Lock-In type 7H7 can be used in most cases by changing the socket and rewiring to accommodate the 7H7.

Courtesy "Sylvania News"

DISCONTINUED SYLVANIA TUBE TYPES

Card 8

Type 6AE5GT/G. No available tube can be used as a direct replacement.
Type 6AF6G. No available tube can be used as a direct replacement.
Type 6AG7 (Metal). No available tube can be used as a direct replacement.

Type 6L6 (Metal). This tube can be directly replaced by the 6L6G where space permits and where external coupling is not a factor.

Type 6SK7 (Metal). Type 6SK7GT/G can be used as a direct replacement. In some cases an external shield, properly grounded, may be necessary.

Type 6SQ7 (Metal). Type 6SQ7GT/G can be used as a direct replacement. In some cases an external shield, properly grounded, may be necessary.

Type 12SK7 (Met.) Type 12SK-7GT/G can be used as a direct replacement. In some cases an external shield, properly grounded may be necessary.

Type 12SQ7 (Met.) Type 12SQ-7GT/G can be used as a direct replacement. In some cases an external shield, properly grounded may be necessary.

Type 20B6G. No available tube can be used as a direct replacement.

Type 40Z5/45Z5GT. Has no direct interchangeable type, but the 35Z5GT can be used without any changes in the socket, provided a resistor is placed in the power line to increase the voltage drop 10 volts. The resistor should be a 68 ohm, 2 watt unit.

Type 45Z3. No available tube can be used as a direct replacement.

Type 884, 885. No available tube can be used as a direct replacement.

Courtesy "Sylvania News"

The RADIOFRONT

KARL A. KOPETZKY

Tube Production Curtailed

BY now every serviceman knows that the production of certain tubes has been prohibited for the duration. The list is as long as your arm, but the effect will not be noticeable for some time to come. Then it will hit servicemen like a bolt from the blue. Here are just a few tubes in the list that struck a responsive note.

Gone are the 5Y3G's which were so popular in the Philcos and Zeniths. Ditto the 6E6's which were the "magic eyes" of many a set. No more are the 6N6's which were output tubes for the Crosley and auto radios. Hams will mourn the passing of the 6V6G and the 6B6GX's which were favorite oscillator and amplifier tubes. The mid-gut mixers, 12SA7G and the 12SK7G have been curtailed also, to be joined by the 1232 television and the 1852 and 1853 FM tubes. The '24, an oldtimer, with which 10% of the sets still remaining in the field are equipped, is prohibited; as is the 25L6 and the 25L6G for the AC-DC sets. The Sparton outputs, 182B/482B and the 183/-483 have been banned, but can be replaced with a '45 by changing over the transformer to 2.5-volt operation. So it goes. We won't know radio by the old terms any more, and you will be required to use your ingenuity to replace these banned tubes when they have been burned out. That's where your training will come in handy.

Records

We were amazed to see the following sign in a radio store. "Bring in your old records. No matter what their condition, we will buy them." Later our favorite platterbug gave us a clew in a card received from a well-known record house. It seems that radio stores must turn in an old record for every three new ones they sell. Hence the offer to buy the old platters. Shortage of shellac. This is but a forerunner of things. Time will see you turning in one burnt-out electro-condenser for every one you sell, or one burnt-out battery in exchange for a new one. So give the matter some thought, and begin to assemble a stockpile of old parts; they will be worth their weight in new ones, literally.

Washington Shift

Word comes from the Capital that Chief Robert C. Berner, who had com-

THANKS, FELLOWS!

Many thanks for your turn-out for information on vacancies in the Army and Navy for radio-men. There were so many replies that I couldn't answer them all personally. They have been forwarded to the proper people who will write you fellows direct. All production expediting jobs are now filled.

K.A.K.

plete charge of all civilian radio, has been supplanted by L. H. Peebles and that a division of the WPB known as the *Communications Branch* has been set up. Under Mr. Peebles, a new officer, Mr. Frank H. McIntosh, will be *Radio Section Chief*. Not that Mr. Berner didn't do a bang-up job; just that with the limitations on manufacture, there is no longer the necessity to maintain the staff and the men to administer to radio. Further, the *Communications Branch* of the WPB has been moved to new quarters adjacent to the FCC and will be in close contact with the *Defense Communications Board*.

Expect More Restrictions

On May 18 price ceilings become effective. This extends not only to new radios and phonographs, but also to tubes, parts, refrigerators, light bulbs, flashlights, electrical appliances, etc. Distributors' price ceilings become effective a week earlier. The ceiling is the highest selling price in March, 1942. All wholesalers and retailers will be automatically licensed by the national regulation on May 11, and will have to register at a later date to be announced by *OP Aman Henderson*. Become familiar with the new regs. They are interpreted elsewhere in this issue.

As soon as *WPB Chief Nelson* has the war production situation well in hand (and that is expected to be before this fall), he will start on the consumer goods. To be expected, is some sort of action with regard to replacement parts. It is well known that the manufacturers of parts are being hard pressed for units for the War, and that the civilian replacement parts business is making serious inroads into this picture. More and more of the manufacturers are telling their cus-

tomers (jobbers and servicemen), that they are unable to make any promises on the delivery of parts. And more and more the servicemen are being thrown back on their own resources. Just how long this situation can keep up is anyone's guess. But it is our guess that Henderson will step in and limit, if not temporarily stop, the production of civilian parts. He has already done something in the matter of tubes.

Next on the list are condensers. There is no reason why their number should not be decreased. There are too many types in too wide a range. The serviceman will have to have more than a bowing acquaintance with Ohms Law to be able to make repairs in the future, to make up required units out of the smaller number of condenser values which will be available.

Also we will not have the wide range we have become accustomed to in the matter of "working voltages." Condensers can well be limited to a few "most used" types without upsetting the picture beyond all recognition. And that is just what is bound to happen.

Next there is the matter of the "exact-replacement" transformers. Not only has the past seen much waste here, but a burnt-out transformer can be repaired and re-inserted in a set. The use of the renewed transformers will by itself save a lot of copper so vital to our War Success. We believe the days of the "exact-replacement" transformer are numbered.

In the matter of coils and speakers, the "renewing" of the used parts is far wiser to the replacement system. True it is that we have not been educated in the matter of using "renewed" and repaired parts, but we will get used to that, as everything else.

The temper of the people is rising, and their patience with those whose sole object is to keep themselves going at the cost of the Ultimate Success is fast waning, if not diminishing to the vanishing point.

It will therefore behoove every serviceman to take careful stock. Too many have been going along as usual, hoping that the lightning would not hit them. It will. And suddenly!

Choose your radio literature carefully

With the serviceman's pocketbook becoming somewhat leaner, or more particular, as the case may be, he will
(Continued on page 31)

Shop Notes

"War Production Board Limitation Order L-76—Effective April 27, 1942

The Following Tube Types Are Not To Be Manufactured

Except on a Preference Rating A-1-J or Higher**

00A	95	4A1	6C7	6S6GT	12C8GT	25Z6G
OZ3	V99	4A6G	6C8GT	6SE7GT	12E5GT	27S
O1A	X99	5	6D5G	6T5	12J5G	29
O1AA	117E4GT	5T4	6D5MG	6T6	12J7G	31
LAL	117L7GT	5V3G	6D6G	6T7G	12K7G	25A5LT
1A1/5E1	117M7GT	5W4	6D7	6U5	12K8GT	35L6G
1A5G	117Z6G	5W4G	6D8	6V4G	12Q7G	35RE
1A7G	117Z6GT	182B/482B	6E4GT	6V5G	12S7GT	35S
1B1	1N1	183/483	6E6	6V6G	12SA7G	35Z3LT
1B4	1N5G	401	6E7	6V6GX	12SC7GT	35Z5G
1B4P	1N6G	485	6E8G	6V7G	12SK7G	35Z6GT
1B4P/951	1N6GT	950	6F5MG	6W5G	12Z5	40
1B7G	1P1	1232	6F7S	6W6GT	14	45A
1B8GT	1P5G	1852	6G5	6X5	14A4	46A1
1C1	1Q1	1853	6G7	6X5G	14A7	46B1
1C4	1Q5G	5X3	6G7S	6X6G	14B6	48
1C5G	1R1G	5Y3G	6H4G	6Y3G	14B8	49
1D1	1R4	5Z4G	6H5	6Y5	14C5	50C6G
1D2	1S1G	5Z4MG	6H6G	6Y5G	14E6	50L6G
1D4	1T1G	6	6H6MG	6Y5GT	14E7	50Y6G
1D7G	1T4GT	6A4	6H7S	6Y5S	14F7	50Z6G
1E1	1T5G	6A4/LA	6H8G	6Y5V	14N7	50Z6GT
1E2	1U1	6A5G	6J5G	6Y6	14Y4	50Z7G
1E4G	1W1	6Z6X	6J5GX	6Y6GT	15	51
1E5G	1Y1	6A7S	6J6GT	6Y7G	17	51S
1E5GP	1Z1	6A8MG	6J7MG	6Z3	18	52
1E5GT	2	6AB5	6K6G	6Z4	20	55
1E7G	2A3H	6AB6G	6K6MG	6Z5	22	55S
1F1	2A7S	6AC5G	6K7MG	6Z6MG	24	56AS
1F7GH	2B6	6AC6G	6L6GT	6Z7G	24S	56S
1F7GV	2B7	6AC6GT	6L6GX	7	25A6	57AS
1G1	2B7S	6AD5G	6M6G	7A7LM	25A6G	57S
1G4G	2E5	6AD5GT	6M7G	7B5LT	25A7G	58AS
1G5GT/G	2G5	6AD6G	6M8GT	7B6LM	25AC5G	58S
1G6G	2S/4S	6AE5G	6N5	7B8LM	25B5	64
1G6GT	2W3	6AE5GT	6N5G	7C5LT	25B6G	65
1G7GT/G	2W3GT	6AE6G	6N6	7D7	25B8GT	68
1H5G	2X3G	6AE7GT	6N6GT	7G7	25D8GT	69
LJ1	2Y2	6AF5G	6N6MG	7N5	25L6	70
LJ5G	2Y3	6AF6GT	6N7G	7R7	25L6G	70A7GT
1K1	2Y4	6AF7G	6N7GT	8	25N6G	70L6GT
1K4	2Z2	6AG5GT	6P5G	9	25RE	75S
1K5G	2Z2/G84	6AG6G	6P6	WD11	25S	79
1K6	3	6AH5G	6P7G	WD12	25X6GT	82V
1K7G	3B8GT	6AL6G	6P8G	WX12	25Y4GT	85AS
1L1	3C5GT	6B6	6Q6	12A	25Y5	87S
1L5G	3LE4	6B7S	6Q6G	12A5	25Z3	88S
1L5GT	3Q5G	6B8GT	6Q7MG	12A8G	25Z4	89
1LB6	3S5	6C5G	6R6G	12B6	25Z4GT	
1LC5	4	6C5MG	6S5	12B7	25Z5MG	

*This list to be amended from time to time.

I'M scared. I don't think Honey will sue me and I don't think they can arrest me for what happened. My conscience is clear. Hope Honey sees it my way too.

Jerry, my partner, is really the guy who should be blamed. If he'd only take all the outside calls I wouldn't be in this jam and Honey wouldn't have a hole in her dress and a burned spot on the other side of her lap. After all, like most servicemen, I'd rather stick to the bench because I get a kick out of signal tracing, even when I quickly learn what's wrong with a set after a few finger pokes here and there. In just a moment I'll explain why I'm in a jam with Honey and then you'll know how she got hot pants.

Hyman Blum is a pretty good customer. Today he phoned at noon to tell Jerry that the RCA Personal he bought for his son Chauncey won't play even though he tried a couple of

new flashlight batteries. Jerry should have guessed that the Minimax had gone dead. After all, the bloody set has been perking fine since we sold it to Hymie last Summer. No battery will work forever. But Jerry, he tells nobody nothing. *Make 'em pay for information* is his motto. "Don't do anything free and they'll respect you more and pay you more," he always says. Ah well!

So, on the phone Jerry told Mr. Blum he'd run over later in the day and then he turned to me and said, "You handle it, Perce, I've got ducats to the ball-game." And off he went.

I stood there trying to figure out who's screwy and what I'd have to charge Blum for a new battery after driving out there two miles. Then the phone rang again. It was Topper Hopp, who by peculiar coincidence lives right around the corner from brother Blum. Seems that the RCA

111K we sold him last year ain't getting the right stations when tuned by push-button. Figuring that I'd best kill two birds with one trip, now that tires are hard to get, I arranged a date for late afternoon. Then I ground out a batch of stuff that's been getting in my hair lately. Had to wait for some shielded wire and parts so long I thought the sets would rot before I could get to work on 'em.

Well, about four-thirty, I started rolling. Made sure I had a new battery and tube kit with me just in case. Nothing to the Bum job. Just the battery gone dead. Could have finished up with it in 8 seconds flat. Instead, after I put in the new Mini, I wiped off the set to give her a shine, tested the tubes, tightened the hinge spring, checked for "ear distortion on high volume" and "eye sensitivity on sharp tuning," then asked for four and a half smackeroos. Got my dough without a hitch. I suppose that if I had simply replaced the dead battery I could only have gotten three bucks at best. Then I walked around the corner to Topper Hopp's house. A neat little wig-wam it is, too.

The door opened soon after I rang the bell and Honey Hopp let me in. She's topper's only and favorite child. And my oh my, what a child! About 20, I'd say, with teeth like pearls, a smile like T-H-A-T, hair like Turner's, eyes like Colbert's, legs like Dietrich and a buxom bosom like that gal Lake. But what's the use? I still prefer to sit on my fanny working at the bench although once in a while it is nice to get out and meet *such* interesting customers. Kinda relaxing, you know!

As Honey seemd to be home all alone, I figured it was worthwhile for me to put on an act just to impress her. Out came my analyzer, and for lack of something better to do while stalling, I plugged my old soldering iron into the wall socket. Just about then I thought I had two strikes on Jerry, even if he was at the ball park and I in the parlor of the Topper Hopp's.

For Honey's benefit, I elucidated about resistors, coils and chokes. Then down on my knees I went, and right into the back of the set, with Honey standing right close, almost cheek to cheek, watching to see what was happening. I explained to her that this particular RCA 111K was one of the

(Continued on page 27)



I couldn't turn around in a hurry. It's difficult to explain how you got a shiner.

OPA PRICE FIXING ORDER

(Continued from page 7)

dealers to cease making free inspections except on such minor items as tube testing.

Case 5 cont'd. Service-dealers who during March had in effect and displayed signs quoting "fixed minimum prices" for services cannot after July 1st increase those minimum scales to levels higher than were in effect during March. However, as cited in *Case 1*, the new law does not prohibit you from charging, for any service, a price equal to the highest level established for that service during March. It is possible that your minimum price scale for recentering a speaker cone is \$1.00. If during March you never did any such repair job for less than \$1.50 after July 1st you may not increase the advertised minimum scale price over \$1.00 but you may refuse to accept or do any such work for less than \$1.50, or for a higher figure, if during March you obtained a higher fee for recentering someones speaker cone.

YOU ARE LICENSED FROM NOW ON

You may say to yourself, "who will checkup on me and why should I worry about following all these new OPA regulations?" The answer is clearly give on page 8 of the Maximum Price Order. This deals with bookkeeping and records that *must* be maintained and which *must* be accessible to government auditors at all times. We quote, "In July, 1942 all wholesale and retail sellers of commodities and services are automatically licensed by the Administrator. There will be no physical evidence of the license issued immediately. Nevertheless, the provisions of the price control law are applicable, which means that a licensee who violates the regulation may, after warning by OPA, have his license suspended by court action. A national registration of every retail and wholesale outlet will be undertaken in the near future. Each store must be registered separately. Forms will be issued by OPA."

Continuing, the Regulation reads, "with reference to the posting of 'ceiling prices' . . . the order requires the article itself or the shelf, box, rack or counter be marked, or a price list posted for public inspection. Maximum price is to be stated as 'Ceiling Price \$—.' or 'Our Ceiling \$—.'"

In connection with proper pricing of services and marking of commodity prices one other OPA regulation, that dealing with firms which operate more

(Continued on page 25)

THEY DON'T GET RID OF THEM NOW They Bring Them To You To Fix!



—And some of them are "honeys"—five, eight, even ten years old! But it's your patriotic duty to keep those old babies working when there are no new sets being made.

There's only one way to handle this extra volume, and that's by repairing more sets, per hour, per man, by means of increased efficiency. And the thirteen volumes of Rider Manuals will give you just that.

RIDER MANUALS

Volumes XIII to VII \$11.00 each
 Volumes VI to III 8.25 each
 Abridged Volumes I to V \$12.50
 Automatic Record Changers and Recorders ... 6.00

FOR EARLY PUBLICATION

Inside the Vacuum Tube—complete elementary explanation of fundamentals of vacuum tubes.
 A-C Calculation Charts—146 charts covering A-C calculations from 10 cycles to 1000 mc.

OTHER RIDER BOOKS YOU NEED

The Cathode Ray Tube at Work \$3.00
 Frequency Modulation 1.50
 Servicing by Signal Tracing 3.00
 Meter at Work 1.50
 Oscillator at Work 2.00
 Vacuum Tube Voltmeters 2.00
 AFC Systems 1.25

HOOR-A-DAY-WITH-RIDER SERIES—on "Alternating Currents in Radio Receivers"—on "Resonance & Alignment"—on "Automatic Volume Control"—on "D-C Voltage Distribution" 90c each

JOHN F. RIDER PUBLISHER, Inc.

404 Fourth Avenue New York City
 EXPORT DIVISION: Rocke-International Elec. Corp.,
 100 Varick Street, New York City. Cable: ARLAB

JUST OUT

RIDER MANUAL VOL. XIII

1672 PAGES \$11.00

Not just a Convenience—a Necessity!

ORDER NOW! Avoid Disappointment

that may result by putting off buying until
"tomorrow."



**YOU NEED RIDER MANUALS
TO "CARRY ON"**

FLAT RATES

Eliminate labor losses
Reduce price arguments
Make estimating easier

SIMPLIFY YOUR SERVICE PRICING!!

Compact vest pocket volumes containing complete flat rates for radio service work from A to V. Includes instructions on pricing procedures showing examples, storage charges, disposal of instruments and guarantee. If your jobber doesn't have it, send 25c for a prepaid copy.

Specify the Schedule you want.

Schedules for

\$1.00
\$1.25
\$1.50
\$1.75
\$2.00
\$2.25
\$2.50
\$2.75
\$3.00
\$3.25
\$3.50

per hour

RADIO EQUIPMENT CO.

1215 Nicollet Ave. Minneapolis, Minn.

Every serviceman should carry one.

INSTALLING TELEVISION ANTENNAS

(Continued from page 6)

or eliminating "ghosts" or multiple images.

Metal structures and large buildings in the path of the signal will reflect transmitted waves and cause multiple images or "ghosts" on the television screen. These "ghosts" can be quite annoying, and should be eliminated by rotating or changing the location of the antenna, or by the use of reflector rods. Sometimes such reflector waves can be converted into an asset especially in the city where low buildings are sandwiched between high buildings. Often it is possible to pick up the reflected signal below the line-of-sight, or to turn the dipole completely away from the line-of-sight in eliminating "ghosts" and picking up a reflected signal with better results than on a direct pickup.

The dipole connects with the television by means of a satisfactory transmission line. Twin-conductor is satisfactory in most localities, if the length is under 75 to 100'. Such transmission line should have an impedance of 72 ohms. It must be noted that twin-conductor cable causes some loss of signal strength — approximately 20% for lengths from 100 to 200', but this may be overlooked in favorable locations. A coaxial cable will provide a signal of greater strength to the receiver, especially if a long length is involved.

When signal level is weak, the contrast or the sensitivity control, or both, must be turned on "Full," which may result in picking up considerable interference. Small white spots and flashes similar to a snow storm on the screen and indeed terms "snow in the picture," indicate a weak signal pickup.

Installation crew should preferably consist of two men, one on the roof to rotate the antenna and locate its best position, the other watching the television screen results. These two men should be in constant communication to speed up a satisfactory installation. Some means of telephonic communication will greatly help.

All of which should not be taken to mean that the television installation is difficult or uncertain. With the greater television transmitting power now used, the pickup problem is considerably simplified. In fact, the installation may be as simple as placing the dipole on a clothes-tree near to the set, and adjusting the direction and angle until best results are obtained. Or again, at a considerable distance, the dipole with reflector may be laid on the raft-

ers in the attic of the country residence, aimed approximately at the transmitter, and satisfactory signals obtained immediately. It is all a matter of distance from the transmitter, locality, sensitivity of the television receiver, the dipole setting, and perhaps a bit of good luck in getting the best lineup quickly.

★

NATIONAL UNION AIR-RAID ALARM

National Union Radio Corporation of Newark, N. J. announces its new AR-101 Air-Raid Alarm available through its distributors. Designed to work on any A.V.C. type of radio set, table model or console, AC-DC or battery operated, the Alarm is set off by your local "alert" broadcasting station which is on the air 24 hours a day.

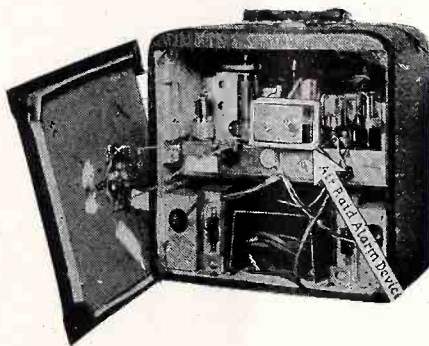

When the radio station goes off the air at the first indication of an air-raid, the Alarm automatically goes on, creating a loud, penetrating signal in your radio which will automatically warn you that an air-raid "alert" alarm has been ordered.

This unit is complete in a compact metal case, ready for immediate installation and operation.

★

NEW INSULINE CATALOG

A new, descriptive 20 page catalog of electronic parts and equipment manufactured by the Insuline Corp. of America, 30-30 Northern Blvd., Long Island City, New York, has just been announced as being available to all manufacturers, government officials and jobbers who apply for same on their business stationery.

★

ELECTRONIC GADGETEERING

"From now on we shall see a rapid development of electronic gadgeteering, which means the non-radio application of radio technique," states Charley Golenpaul, jobber sales manager for Aerovox Corporation.

"I believe the era of electronic gadgeteering is now opening up in a big way. The ban on amateur radio

communications is not going to leave the enterprising 'ham' twirling his thumbs. Many are already or will soon be in our armed and technical services. Others will find wartime radio jobs. Those remaining on the home front are going to put their experience, equipment and ambition to work on new and startling applications in the home, shop, factory and elsewhere, far removed from customary radio practice.

"I suppose most radio men have heretofore been too busy with radio proper to find extra time and energy for non-radio or electronic gadgeteering possibilities. However, many of them now are going to use their 'rigs' and parts for new functions. I can visualize some pretty interesting developments—light-beam telephones for conversing over considerable distances; automatic photo-electric garage-door openers; photo-electric switches turning lights on and off with darkness or daylight; checking the stoking of furnaces or boilers by the chimney smoke; various comparators or instruments for comparing and matching colors and shades; checking solution concentrations and chemical studies by conductivity means; and so on.

"As a starter, electronic gadgeteering can be based on well-known elementary principles and basic circuits long known to radio and electrical workers. The Aerovox Research Worker already has released considerable data on the subject, and our engineers are working up further and more specific data to be released through our monthly bulletin and also through the radio and electronic press generally.

"Radio parts jobbers are going to nurse this electronic gadgeteering trend along. The more enterprising jobbers will doubtless be on the lookout for installations in their territory, and will try to get the details wherever possible so as to pass such practical information on to others. I appreciate the reticence of industrialists to part with such information, more so in these wartime production days, but wherever possible such information should be made generally available in a helpful exchange of ideas.

"Make no mistake about it, the temporary suspension of 'ham' communications may well turn out to be a boost. It will generate a lively interest in electronic gadgeteering. And when 'ham' communications are resumed again with the return of peace, I venture to predict that electronic gadgeteering will comprise a greater field for radio parts, particularly the quality of extra-heavy-duty components, than all amateur radio activities put together. Furthermore, many a 'ham' will find an interesting way of making real money out of his hobby, and that's something."



★ Looking for that toughest thing in power resistors? Well here it is—Clarostat Greenohms. Just try these green-colored power resistors. Compare them with others. They stand overloads without flinching. Last and last. Yet cost no more.

Quality resistance wire wound on heat-resistant ceramic tube. Special inorganic-cement coating will not crack, peel, flake, even under severest heat shock. Fixed and adjustable. 10 to 200 watts. Note sturdy construction throughout—rugged mounting lugs, rigid terminals, positive sliding contact. Wide choice of resistance values.

★ Ask Our Jobber . . .

He'll gladly show you Clarostat Greenohms. Try them on your very next job. You'll find them the toughest thing in resistors.



Clarostat Mfg. Co., Inc.
285-7 N. 6th St., Brooklyn, N. Y.

**COMPLETE
BUSINESS RECORD
SERVICE**

★ Providing all Records for Federal, State, and Sales Taxes, Social Security and Workman's Compensation Reports. Complete System includes Permanently Bound Record Book and PREPARATION of Federal Income Tax Returns for TWO YEARS. \$12.50 Postpaid.

Frank E. Whedbee
Seabrook, Maryland

OPA PRICE FIXING ORDER

(Continued from page 23)

than one establishment, is worth noting. The General Maximum Price Regulation permits the charging of different prices for the same article in different stores under common ownership even if they are located in the same neighborhood. Each store is regarded as "an individual seller" and may charge no more than the highest prices obtained for any commodity sold by that particular store during March, 1942.

INSTALL BOOKKEEPING SYSTEM

If any service-dealer failed in the past to maintain a fairly accurate set of business records, he now finds himself in a very ticklish spot. We urge all such service-dealers to communicate with their nearest OPA office at the earliest possible moment, and without fail. They must also immediately install and maintain a comprehensive business record system. Otherwise they must immediately get out of business and stop servicing. Even a part-time serviceman must maintain business records from now on or quit servicing.

VIOLATORS GO TO JAIL

In conclusion we strenuously call your attention to the penalties which may be imposed upon any service-dealer who fails to abide strictly by the price-fixing regulations. We quote the OPA orders's closing paragraph, which reads, "Penalties that the Emergency Price Control Act provides for violation of the Administrator's regulations, orders, etc., include fines of not more than \$5,000 or one year's imprisonment, or both; civil suits for treble damages; and revocation of the seller's license for not more than 12 months." Ignorance of the law is no excuse for violation of it.



MRS ELECTIONS

Master Radio Servicemen, Inc., of Northern Kentucky and Greater Cincinnati, elected new officers at their last meeting. The new officers are: President, *E. C. Helmers*; 1st Vice President, *W. M. Stephenson*; 2nd Vice President, *William Halpin*; Treasurer, *Ray S. Rohrer*; Secretary, *Bob Pepper*.

MRS has a mutual assistance agreement with WCKY, the station providing them with two spot announcements each day.

The organization recently inaugurated a guarantee plan wherein the work of each member is backed up by the group.

2 Handy Aids for Resistance Problems Today!

New OHMITE Quick Reference Catalog 18 FREE



Gives up-to-date information on the wide range of Ohmite stock resistors, rheostats, chokes and switches used in all types of applications. Helps you select the right units for each job easily, quickly. Send for Catalog 18 now — it's Free.

Handy OHMITE Ohm's Law CALCULATOR



Figures ohms, watts, volts, amperes — quickly, easily. Solves any Ohm's Law problem with one setting of the slide. All values are direct reading. No slide rule knowledge necessary. Size 4 1/8" x 9".

Yours for only 10c. At your Jobber or send coupon.

OHMITE MANUFACTURING CO.
4846 Flournoy St., Chicago, U.S.A.

Send Free Catalog 18.
 10c in coin enclosed. Send Ohm's Law Calculator.

Name _____
Address _____
City _____ State _____
R.S.D. May-'42

Be Right with OHMITE
RHEOSTATS · RESISTORS · TAP SWITCHES



"Cooperation is not sentiment, it is an economic necessity"—Steinmetz

USE IT,—AND PROSPER!

THE new RSA "corrective Service-form" announced in these pages last month brought such overwhelming response that it seems advisable to answer some of the more pertinent questions here, to accommodate the wishes of a large number of inquirers.

If you will refer to last month's RSA News for the illustration of this business management pricing form you will notice that it is designed to lend itself to almost every one's method of operation.

By separating the form at the center you will also have an attractive statement-form. You may use this part for your monthly statements or, if yours is the habit of billing the "Doctors way," use this space to say,— "For Services Rendered." You can also use this space to list merchandise sold.

To use the line "Customers description of Trouble,"—make it show exactly that. It is your protection against unlimited responsibility on jobs of limited service. You all know the story: when a customer comes back with his radio shouting, "You fixed it!—Look at it now!—It's worse than before!" Well,—if you will fill in this line appropriately, (Customers description of Trouble) either by word or number in accordance with the number system of the "Record of Professional Services" you will always have a strong defense position against unjust guarantee or adjustment claims. To cite an instance,—if you corrected hum during the repair in question, and had it correctly recorded in the "Complaint-line" as either "Hum" or "No. 2," The customer cannot very well make his story stand up against yours if he tries to blame you for something else, such as noise or intermittance. As far as you are concerned in this particular case, you corrected hum. Your guarantee concerns itself with hum only. Guarantee the set against this trouble for the specified time, but don't let customers take advantage of you by holding you responsible for something which was not of your doing. A judicious use of the line "Customers description of Trouble" will save you many an hour, many a dollar, and many a customer whose good-will might be lost otherwise.

Now, to go to the next section headed "Radio and Phono Checkup." We incorporated this section to better enable you to collect a decent service fee. It is primarily designed for use on home calls, but it is equally useful in the shop. By giving a written record of your findings in accordance with the specific checkup features a particular set may call for, you will quite definitely have something to show for the fee you want to collect. It is recommended that you use such symbols as *G* for good; *P* for poor; *F* for fair; *N* for noisy, and so on, to designate your findings. Perhaps you have a better system; if so, use it. The important thing to keep in mind is, that you give the customer proof that a

columns marked "components" and "time." Those who prefer the straight "corrective system" may use these columns for their own shop records or not at all.

Our experience has shown that it is good psychology to direct your Salestalk along the "corrective" line, without putting too much stress on Parts and Time.

It is also excellent psychology to use a large size service-form such as ours to give emphasis to the scope of operation. Remember, when you do a good repair job you do a *big* job. A good sized bill-form will make it appear even bigger. It's in your favor. Try it!

You may obtain these "Corrective" forms with your imprint by addressing the RSA Press & Supply Service, 414 Dickens Avenue, Chicago, Illinois. We apologize for the delay in filling some orders last month. We were swamped with orders. Now we are able to fill any order within a week or ten days. It is with pride and gratification that we say: "Thanks for your initial response and grand reception." And to those servicemen who as yet have not availed themselves of the prestige which membership in the RSA can give your business, we say: Join now—let the world know that you are an RSA man!—Use this form!—Wear the RSA pin!—Show your RSA card!—Display the RSA insignia wherever you can!

★

ATTENTION—RSA DIRECTORS!

A Board Meeting has been called for June 7th to 9th, to be held at the Stevens Hotel in Chicago. All Directors are urgently requested to be present in person, or make suitable arrangements for proxies. This meeting is the most important in years. Plan now to attend.

★

Interstate Chapter:

The April 28th Meeting, held at the Blackhawk Hotel in Davenport, Iowa, was really a gala affair. It could have been called "Navy Night." After a 6:30 dinner President Gordon introduced Ensign J. R. Lindeman, Jr., of the Radar Procurement Office, Chicago, the principal speaker and R. M. Nelson, R. C. Anderson, and C. E. Hanks, also Navy men from the Tri-Cities. Navy pictures were shown. These elicited favorable response from the more than 50 servicemen present who

(Continued on page 28)

WANT A \$1. DEFENSE STAMP?

★ The stuff that usually helps are the practical "Shop Experiences"—the short-cuts and solutions to the problems you and other servicemen solve in your daily work. Such "Shop Notes" are mutually valuable and in order that they will come to the attention of all of our servicemen readers, we are offering a \$1. Defense Stamp for such previously unpublished "Shop Notes" or "kinks" that you send in and that we find acceptable for publication.

Here's a chance for all of you to earn and learn at the same time! Dig out those special shop notes and tricks of yours now and mail them in to "Shop Notes Editor", RADIO SERVICE-DEALER, 132 W. 43rd St., New York City. Sorry, unused manuscripts cannot be returned unless accompanied with stamped and addressed return envelope.

service of definite consequence was rendered. This checkmarked "Check-up" does just that. It should thus be clear that an appropriate service fee is quite fair and in order.

The "corrective" section headed "Record of Professional Services," was discussed at length in last month's introduction article and should not require further clarification. The response we had to this feature clearly indicates that there is substantial agreement in the purpose and practicability of this system of billing for services. We wish to add however, that those servicemen who, because of habit, desire to co-ordinate a "Parts and Time" billing with the "corrective" system can do so by using the vertical

SERVICE PORTFOLIO

(Continued from page 14)

input. Since a 3 volt battery is employed, the VTVM normally reads full scale, because the input circuit of the tube voltmeter has practically infinite resistance and therefore there is no measurable current in the circuit and consequently no voltage drop across R . But when an unknown resistor, R_x is connected across the measuring terminals, a drop in voltage occurs since the voltage is then divided by R_x . The VTVM measures this voltage drop and is calibrated to indicate the relative resistance in ohms for varying values of R_x . For additional ranges, other values of R are employed. A feature of this type of instrument is that extremely high resistances can be measured. Further, it is unnecessary to readjust the zero setting when switching from one range to another. A complete circuit diagram of the Rider RCA Junior Voltohmyst is shown in Fig. 9.

In any ohmmeter, care should be taken to replace the batteries frequently, even though the instrument has not been used much. Also, guard against exposure to heat and moisture. And, as with any type of meter, be careful not to drop it or submit it to heavy jolts, which abuse causes the meter pointer to stick. Take care of your instruments and they'll take care of you.

★

MY LOG

(Continued from page 22)

few jobs of this model that was shipped with a 33,000 ohm grid leak in the oscillator circuit, and that those babies won't oscillate on push-button tuning in localities where the line voltage runs low, as it does here in Shortville. You see, you've gotta use a 56,000 ohm grid leak instead.

Well, as I said before, Honey was standing close, watching over my shoulder. She is so much like Veronica, I didn't dare turn around in a hurry. It's too much trouble explaining why you're wearing a shiner.

Just as I was sliding the chassis out, I guess Honey decided to relax. Evidently she sat down. She didn't stay down long. She must have lit on my soldering iron. Wow! What a yelp she gave!! Scared me stiff!!! And then when I tried to help her by patting the part of her dress where it was smoldering she sort of got provoked a bit more. What she said to

KEEP A BALANCED TUBE STOCK ALWAYS ON HAND

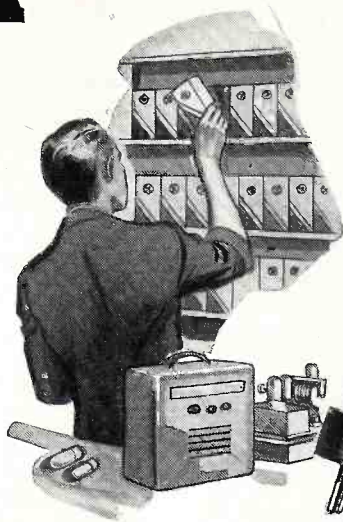

Win Customer Goodwill
With Quick Service



KEEP 'EM PLAYING

WITH



Electronic

RADIO
TUBES

FAMOUS FOR
LONG LIFE AND
FINE RECEPTION

GENERAL  ELECTRIC

PROTECT that 40%

Now more than ever the jobber and service man must protect the standing which he has built. Condenser replacements account for about 40% of all radio repair jobs. Dependable condensers are therefore essential to the building of the utmost in customer satisfaction and in holding your clientele.

CONTINUOUS DEPENDABLE SERVICE

For 21 years the manufacturers of POLYMET ELECTROLYTIC and BY-PASS CONDENSERS have striven to improve quality and service. Add to this a liberal and reasonable mark-up and the fact that no fly-by-night "bargain catalogs" can undersell you on POLYMET. You're protected, your customer is satisfied, your profits and volume increase. We're conserving vital defense materials by limiting sizes to those most universally used. These will serve practically every need, replacing larger electrolytics when proper capacity and voltage are used.

Complete listing of available types and prices will be forwarded upon request.

POLYMET CONDENSER CO.
699 E. 135TH. ST., NEW YORK, N.Y.



me can't be printed. I did the next best thing. Yes sir! I made a strategic retreat. Grabbing my tools, the hot iron and chassis, I rushed back here. Gee, I wonder if Honey is really mad at me for putting the iron where I did,

or for trying to put out the fire? Time will tell. And in the meantime, I wonder, can she sue me for a new dress. If she claims I injured her feelings, can they arrest a guy for an accident like that?

now know what inducements the Navy offers to men in the Radar division.

Dr. Z. V. Harvalik, professor at St. Ambrose College, and Honorary member of Interstate Chapter also gave a brief address describing the National Defense Course already given at the college and outlining the courses planned for the future and the requirements. Also introduced during the evening were three well-known supply house managers, M. W. Berberet (Midwest Timmerman), Max Laity (Tri-City) and Joe Kehoe (Lofgrens).

Oscar W. Olson, Secretary-Treasurer

★

Chicago Chapter:

Our meeting on the night of April 22nd had featured speakers officers from the U. S. Signal Corps. Major Stefaniak and Lieutenant Cox stressed the urgency for all types of radiomen to line up with the National War Effort, either directly in the armed service or in a civilian capacity. They outlined the types of position and rates of pay for both classifications.

General discussion followed the talks of the military men and Joe Rose of the service section of RMA told those present that the men who remain in the repair business will probably get parts, tubes, and other essential units for some time to come. Buss Jimieson further amplified his remarks by advising that jobbers are finding it difficult to obtain parts they order, yet, he believed that the men who are entering government service are leaving a sufficient overflow of material that should help to keep present servicing activities at their present levels.

Plans are underway to insure the continued activity of the local RSA chapter even though some key men are leaving to work for Uncle Sam. A new service form was presented at the meeting and met with approval by many members.

Lowry E. Easley, Publicity

★

Fremont Chapter:

The following officers were elected at our last meeting: Ralph Eversole of Fremont, Chairman; Donald Burns of Woodville, Vice-Chairman; William Brown of Toledo, Secretary; and Robert Uhl of Tiffin, Treasurer. Many new members have joined and the renewal percentage is high. After election of officers Bernard Gallar ran a party. Ralph Witter of Old Fort won the door prize.

Robert M. Uhl, Secretary

Boston Chapter:

The meeting held on April 14th featured a Smorgasbord Dinner after which Ray Wyman spoke on "More Gain in I-F and R-F Amplifiers." Have you anything to sell or swap? Lot's of activity in this regard around here.

H. Leve, Secretary

★

Wichita Chapter:

Our 3rd annual election was held April 8th at our regular meeting place, the Knotty Pine Room of station KFBI with the following results: Art Koop, President; Raymond Engstrand, Vice-President; Mack Lovern, Secretary and yours truly—

R. A. Swan, Secretary

★

Danville Chapter:

The last meeting's attendance was the most gratifying in a long time. Mr. Clinton Sandusky, well known Danville business man was the featured speaker. Our Bowling team, last week, beat some of the toughest competition in the League. The government sponsored Radio School, now in the third of its 16 week course, is being attended by Goth, Kirk, McArdle and Stapp, all RSAmens. Earl Dong makes the headlines by being the first to use a bicycle for transportation.

The Danville "Servicemen's Dirt"

★

DUVALL WITH SIGNAL CORPS.

George F. Duvall, our National director for district No. 17, is now with the U. S. Signal Corps, in the Office of Captain Dever Harden, Room 607, at 39 Whitehall street, New York City.

George will be glad to interview any radio serviceman that will pay a visit to the office. He has the authority to rate and hire radio men for this office. Every member of our organization owes it to himself to find out exactly what the Signal Corps has to offer to real radio servicemen. Have a chat with George Duvall. A pleasant surprise awaits most of you.

★

Spitalny Now Instructor

Max Spitalny, until recently Editor of the Metropolitan New York Chapter's "Bulletin" and actively engaged in recruiting men for Civilian Technical Corps has been ordered to report to the Signal Corps, U. S. Army, Ft. Monmouth, N. J. where he will act as civilian radio instructor.

★

LETTER FROM ENGLAND

Edward H. Gordon, President of the Interstate Chapter, has shown us an interesting letter from Knoel L. Crag-

in who's now with the CTC in England. Knoel was formerly with the Iowa Ramblers Orchestra and the Merrill Radio Service, Oelwein, Iowa. Here's a part of what he had to say:

"Having a fine time here and sure like it. The people are swell and the country is beautiful. The grass is still green (Dec. 12th) though the nights are quite cold, and there's rain and fog, but that's okay as it keeps the Jerries at home.

"Have not seen one bit of war so far, and I didn't see anywhere near as much bomb damage as I expected the three times I've visited London — which is a great place.

"The work I'm doing is certainly different from anything I did at home. You boys 'ain't seen nothin' yet."

"How are the new broadcast sets? Can the manufacturers get transformer iron, or are all the sets ac-dc by now?"

★

Lehigh Valley Group:

On April 13th, the Lehigh Valley Radio Service Association held its fifth anniversary meeting. This was a real honest-to-john birthday party. Officers of five years back were reinstated, the records of that period were turned over to them, and they held a meeting like those transacted in that "mid-victorian" era. Til Reichard, secretary of that time, still seems to be bellowing forth with his lusty Pennsylvania Dutch accent.

A Bill Phaker "Take It or Leave It" program was put on. The 64c winners were Carl Williams, Curtis Seasholtz and John Repa.

Precedents were broken when two beautiful birthday cakes were brought in resplendent with candles and icing. Someone handed Carl a piece of cake and a plate of ice cream. Well, to make a long story short, he'll be out some time in June, and we don't mean Carl.

The regular LVRSA meeting held on May 4th at the Hotel Allen, Allentown, passed the following resolution:

Resolved that: Any Member in good standing enlisted or inducted into United States Military Service shall remain a member in good standing, without further payment of dues, until 90 days after discharge from such service.

R. W. Reidy, a new member with a lot of good ideas to stimulate interest in our association, was appointed to the Program Committee. After all business was completed, a Round Table Forum was held, each member putting a question in a box and some other member or members answering it. This stunt was very effective.

Ray E. P. Abbott, Sec'y

DE LUXE INDUSTRIAL MODEL ACOUSTI-BOOTH ANNOUNCED BY BURGESS

A new wooden Acousti-Booth, finished in attractive walnut color, is announced by the Burgess Battery Company, Acoustic Division, 2825 W. Roscoe St., Chicago, Ill. This new booth is part of the line of wooden booths being developed to enable the company to supply industrial users without priorities or other restrictions. These booths conserve steel for national defense because no critical materials are used in their construction.

The walls and ceilings in the new Model 210 Acousti-Booth are constructed of heavy reinforced birch plywood panels, filled with a thick blanket of sound-absorbent material. The inside walls of the booth consist of a heavy perforated plywood facing, which protects the sound-absorbent material. This combination of perforated plywood and the sound-absorbent material which it protects is a patented Burgess development. These acoustic panels blot up factory noise and create a remarkable "zone of quiet" in the booths.

The Model 210 Acousti-Booth is supplied attractively finished in walnut, with light wood interior. It may also be obtained unfinished to permit finishing to suit your requirements. A shelf is provided for the telephone instrument and for taking notes. Overhead electric light fixture with pull-chain provides ample illumination. Outside dimensions are 30 inches wide by 79½ inches high by 38 inches deep. The front opening is 24 inches wide. Approximate shipping weight is 225 lbs.

★

RCA HELPS WAR EFFORT

An annual saving of 207,667 pounds of paper—enough to fill eight railroad cars—has been achieved by the RCA Manufacturing Company under a program instituted several months ago to standardize and curtail promotion literature and mailing pieces, according to D. J. Finn, Advertising Manager.

"RCA Victor has surveyed every use to which paper has been put with an eye to saving every pound possible as a contribution to the war effort," Mr. Finn said. "The savings have been made possible by standardizing all types of literature, by reducing sizes, and by numerous changes in house organs."

"In the latter case," Mr. Finn said, "page sizes have been reduced in several instances, the number of pages has been cut and the frequency of issue during the year has been curtailed. These savings are in addition to those made as a result of the curtailment and elimination of commercial production."

MECK "SINGING STRINGS"

A "Singing Strings" amplifier for providing resonant power for string instruments and providing increased volume, either for solo or orchestral work, without the harshness of "heavy playing."

Model M-1 Amplifier System is made up of matched units, employing a



specially designed amplifier, loud-speaker, and acoustical carrying case. Two input jacks are provided, allowing two instruments to be played at one time through the amplifier system. If desired, a crystal or dynamic mike can be used with one electrified instrument for accompaniment. The unit may be used with any modern electric instrument or in conjunction with a contact pickup for electrifying any string instrument. It is completely self-contained in a lacquered, aerocord carrying case with ivory plaskon handle. By John Meck Industries, 1313 W. Randolph St., Chicago.

★

Sylvan A. Wolin has been appointed Jobber Sales Manager of Solar Manufacturing Corporation, Bayonne, N. J., manufacturers of capacitors.



SYLVAN A. WOLIN

Mr. Wolin is well known to the radio jobbing trade. For several years he has been Sales Promotion Manager of Solar and also assistant to Wickham Harter, General Sales Manager.

New Service Guides and Manuals

1942 REPLACEMENT VIBRATOR GUIDE RELEASED BY MALLORY

A comprehensive new guide covering the types of replacement vibrators used in 1942 cars and battery operated home receivers has just been released by P. R. Mallory & Co., Inc., Indianapolis, Ind. and is available to service-dealers through jobbers.

The brochure contains the original part number and recommended Mallory replacement vibrator type for over 170 different auto radio models. Six pages are devoted to important data showing how to most easily and efficiently install receivers in 1942 model cars. A chart gives the location of special grounds and points to be by-passed for noise elimination. Forty-seven illustrations show how to accomplish the by-passes and where the condensers should be positioned for best results.

In addition the guide gives many case histories and describes an excellent new trouble-shooting procedure method which enables a serviceman to most easily locate sources of trouble.

★

1942 EDITION OF SPRAGUE INTERFERENCE ELIMINATION MANUAL READY

A new Manual of Radio Interference Elimination has just been announced by Sprague Products Company, North Adams, Mass., makers of Sprague Condensers, Koolohm Resistors, and various items of test equipment. The booklet is available either direct or through Sprague jobbers at a net price of 25c.

The new Manual has been revised and brought fully up to date. From a study of noise-reducing antennas, to the work of locating and remedying all types of man-made radio noises, it is complete.

The Manual tells service-dealers how to locate noise-making devices, and how to determine exactly what corrective filters are required before such units are purchased or any permanent installation made. Described and illustrated are the correct filter circuits and parts required to reduce noise from electrical devices such as fluorescent fixtures, single or polyphase motors, DC generators, alternators, switches, thermostats, sign flashers, arcing devices, oil burners, gas engines, vibrating contacts, mercury vapor lamps and many others. In addition, the Manual tells radio service-dealers how to go about building profitable interference elimination business.



**TO Replace
DISCONTINUED
WETS....**

Despite shortages of this, that and the other material, Aerovox continues to meet the essential requirements of servicing. Through engineering ingenuity closely geared to field conditions, plus exceptional production foresight and facilities, Aerovox still has a suitable replacement condenser for almost every need. In dry electrolytics to replace discontinued "wets", for instance:

Type GL metal-can dry electrolytic, Type F prong-base, and Type PRU handy AC-DC universal replacement with spade lugs, are meeting almost 90% of all electrolytic jobs. And don't overlook those other popular Aerovox replacement types—Dandees (PRS) midget metal-case electrolytics; PBS cardboard box type; PR tubular electrolytics, etc.

Ask Our Jobber . . .

Put your wartime replacement needs up to him. He'll help you out with suitable Aerovox types. Ask for latest catalog—or write direct.

AEROVOX
CORPORATION
NEW BEDFORD, MASS., U. S. A.
In Canada: AEROVOX CANADA LTD., Hamilton, Ont.
EXPORT: 100 Varick St., N. Y., Cable 'ARLAB'

NEW CATALOG
OF SOUND AMPLIFYING SYSTEMS
AUDIOGRAPH Sound Systems represent the latest in Public Address equipment—a complete line plus pre-tested accessories.
NEW LOWER PRICES
Outstanding quality and performance at prices that help you meet any competition.
WRITE FOR YOUR FREE COPY
AUDIOGRAPH
THE FIRST NAME IN SOUND
John Mack Industries—1313 W. Randolph Street, Chicago, U. S. A.

UNIVERSAL MIKE BUYS STAMPS

The Employees' Club of the Universal Microphone Co., Inglewood, Cal., besides individually buying U. S. defense bonds and stamps, also uses them as grand prizes in their weekly raffle.



NEW BLACKOUT BULB

Important changes in Blackout bulb specifications are announced by the Wabash Appliance Corporation, Brooklyn, N. Y., whose silver-lined Blackout bulb, placed on the market in early January, was put through exhaustive blackout tests in actual city-wide blackouts in practically every State. Specification changes are based on the results of these tests, as well as on various official recommendations.

The most important specification change is in color of light from blue and red to the deep orange recommended by the Office of Civilian De-



fense. Other changes are in size which is smaller, in reduced current consumption to 15 watts, in elimination of the former built-in reflector, and in the improved type of heavy black silicate coating to prevent light leakage.

The deep orange light that the new unit provides, is said to be ample to permit room occupants to see each other plainly, as well as furniture, doors and windows. The bulb will fit any household socket, and will list at 45c.



EMERSON ENTERS PARTS BUSINESS

Complete Line of Parts Available—The Emerson Radio and Phonograph Corporation, New York City, announces a complete line of quality replacement radio parts for servicing all makes of sets on the market.

Comprehensive in scope, the line-up of Emerson parts includes receiving tubes, ballast tubes, radio pilot lights, flashlight bulbs, condensers of all types, resistors, resistance line cords, shielded i-f transformers, varied phonograph equipment, speakers, transformers, volume controls, drive belts,

etc. To facilitate merchandising many of these parts, Emerson has designed various kits, such as a volume control kit, drive belt kit, resistor kit, condenser kit, etc. Each kit contains an assortment of popular values most generally used in servicing. For instance, the resistor kit contains twelve different values that are used in the majority of sets on the market.

Emerson parts are individually packaged in an attractive 2-color carton designed for effective shelf-display and sales appeal. An attractive descriptive catalog illustrating and listing prices on all parts is available to service-dealers through Emerson distributors, or by writing to Jack Geartner, Jobber Sales Manager, 111 8th Ave., N.Y.C.



R.C.P. EXPANDS

Radio City Products Co., Inc., manufacturers of the RCP line of test instruments, announces removal of its plant and offices to new and larger quarters at 127-133 West 26th Street, New York City.



A SLANT ON COLLECTIONS

(Continued from page 10)

ence with the customer that my dough would be coming promptly, I wouldn't hesitate for a moment. I'd simply refuse to leave the set, explaining that (and you can use a 'hurt tone or expression') it was too bad that the Madame and I missed connections but that the set was ready and would be redelivered at some later date by pre-arrangement, or if the customer wanted to call, it would be ready. Very few garages, butchers or toy stores deliver repaired cars, pork chops or Parchesi games to their customers on a deferred payment basis, and there's no reason why your customers should expect you to be an exception just because you are dealing with brain-power and transformers. Train 'em, or lose money on them. Take your choice.

WHEN CREDIT IS WANTED

Of course we haven't yet considered the case where right from the start the customer wants extended credit or deferred payment. Here again you have to rely upon business ability. I find it satisfactory to tell the average customer that while it isn't my general policy to do repair business on a time-payment basis, I will be happy to do so if they can submit satisfactory credit references. Such credit-reference forms are available at finance companies, most stationary stores, or from big corporations at a most nominal figure. The customer who has to fill-in a page of intimate financial and personal data will generally find it a lot more

expedient to revise his plans and agree to pay cash on delivery. In other words, try to use a very thorough credit questionnaire form like *fig. 2*. When a form like this doesn't discourage a customer, let them fill in the form, take it to your bank, or to the customer's bank, or go to a regular credit agency in your vicinity. For a nominal sum you'll be able to get a bona-fide credit report. As you have to lay out cash for credit information be sure that you receive some cash deposit in advance to at least protect your outlay. Bad credit reports mean refused jobs. Don't gamble on some one else's credit with your hard-earned money.

Where extended credit is given and the customer becomes delinquent in making payments you run into a rather dangerous phase of business management. I use on my statemets a successful phrase. It reads: "If you have already made the remittance referred to above, please ignore this monthly statement of your account. Thank you." That *thank you* and reminder works wonders for me. Very few of my accounts run past due date.

Outright delinquents are headaches for all servicemen. The smaller your business, the shorter your margin of profit, the worse the headache becomes. Most of us servicemen are honorable in our dealings with our customers and we hope for like treatment in return. But when we don't get it, and when the customer is just an outright gyp, we have no choice but to resort to Law. Most states and cities have laws that protect small businessmen. In New York City, for example, there is a Small Claims Court where bills of less than \$100 can be sued for upon application for a Summons from the Court Clerk. You simply explain your complaint to the Clerk and pay \$1.25 fee for having the Summons served. Then you must appear in the Court at the time indicated on a card that the Court sends after service has been effected. The Judge will represent you as though he was your lawyer. If you win the case all cost will be charged against the Defendent. All you can lose is your \$1.25 provided you were justified in bringing the suit in the first place. Always try to avoid legal procedure. Use nice, but forceful efforts of another nature until you are convinced that nothing but legal action will avail. Collection agencies will represent you on a straight commission basis if you want to resort to them. By the same token, many lawyers will take a civil case of this nature on a contingency basis . . . meaning they will take a part of their fee from you and a part will be assessed against the customer.

ADDENDUM

Recently, a radio serviceman in New York City was arrested by a customer charged with "petty larceny" because he refused to return to the customer a set which he had "inspected" and for which inspection he claimed an "estimate fee" of \$1.00 which the customer refused to pay. The serviceman contended that a "minimum inspection, or estimate fee charge" sign appeared prominently in his store. The customer denied this. The case came to trial and the criminal charge was dismissed. The result might not have been the same had the customer brought civil action claiming damages on the grounds that the serviceman was unlawfully withholding property not rightfully his to hold.

It costs money, it takes time to inspect a receiver and estimate what the fault is. Servicemen who say they do estimating free may do so free to the customer but they mustn't forget that they are doing it at a definite expense to themselves and not *free of cost*. I advocate a reasonable minimum charge for every service rendered. I can't afford to do otherwise. My business is managed so that the customer knows in advance that he must pay for any services, and when he gets my receipt for a set that may be left for inspection he protects me against legal action because, printed clearly on the receipt is the statement that there is a fixed minimum inspection charge which must be paid before the merchandise will be returned.

★

RADIOFRONT

(Continued from page 20)

do well to consider the radio literature he reads, carefully. Aside from text books and catalogs, which are his "tools of trade," the serviceman should read those periodicals which do him the greatest service in his chosen profession. Let us consider some of the radio monthlies.

One very old publication recently, in glamorous fashion, showed a graph portraying the future as *it* says it will be. The graph looked like a very bum bobby-pin, bent wide apart. The rising part of the graph showed the increase in business due to sales and the greater interest in war news. The downward part purported to show what was going to happen when the curtailment of radio sets and the expected curtailment of radio parts went into effect. What a black and misleading picture

(Continued on page 32)



Old Man Centralab

reminds you to always "specify Centralab" when ordering parts.



FIXED RESISTORS



CERAMIC CAPACITORS

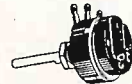

VOLUME CONTROLS



WAVE CHANGE SWITCHES



TOGGLE SWITCHES

Centralab

DIVISION OF GLOBE UNION INC.
MILWAUKEE, WIS.

BOOST
Service Profits
**LOWEST PRICES....
FASTER DELIVERY at
RADOLEK**

Radolek stocks replacement parts to repair any radio—every type of tube, transformer, speaker, condenser, volume control, resistor, auto radio accessory—everything you need at rock bottom prices. And too, Radolek understands service problems—gets your order to you in double-quick time. Order from Radolek for complete satisfaction!

RADOLEK REPAIR SERVICE

Let Radolek repair your damaged or burned out transformers, coils, speakers, test apparatus, etc. Guaranteed equal to new. Write for prices.

FREE!

BIG NEW RADIO SERVICE GUIDE!

Buying from Radolek means Greater Values, Better Service and More Profits. Send today for the big FREE Radolek Service Guide.

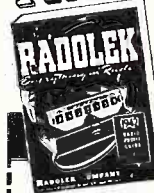

SEND TODAY! PASTE ON A POST CARD

RADOLEK CO., Dept. SD-66
601 W. Randolph St., Chicago, Ill.

Please send the Big FREE Radio Service Guide.

Name

Address

DEALER SERVICEMAN SOUND ENG.

SAVE AT RADOLEK

New Catalog

GIVES PICTURE STORY OF
**INSULINE'S ENLARGED
MANUFACTURING FACILITIES**

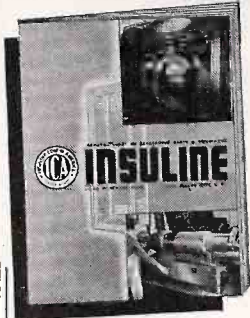

Free to Mfrs.
and Jobbers

The
**JOBBER
Too**

Fits into this Picture

- The jobbers who have worked with INSULINE during the past 22 years are not to be forgotten now . . .
- We believe that there's a need for the Jobber of Electronic Products and Parts as a bridge between the Manufacturer and Purchaser of Defense Materials—More of this business should go thru jobbers!
- INSULINE is in a position to cooperate. This is shown in our New 12-page Industrial Catalog—a complete story of our facilities and products. Write for this Catalog NOW!



INSULINE CORP. OF AMERICA
30-30 NORTHERN BLVD.
LONG ISLAND CITY, N. Y.

WALSCO

**Products for
Better Radio Service**



A complete line of chemicals and adhesives such as

- Noise eliminating compounds
- Friction production liquids for dial drives (No-Slip)
- Speaker Cements
- Thermo-plastic Adhesives

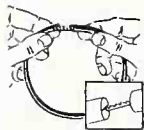

Dial Cables and Cords of all descriptions. The WALSCO UNIBELT, a universal dial belt that fits any radio, comes open, will not slip or stretch.



**WALSCO STAPLE
DRIVER**

automatically staples radio, intercom.; telephone, and other wires. Does wiring jobs twice as good and in half the time.

Write for free catalogs No. 42-D, and Unibelt reference chart.

WALTER L. SCHOTT CO.
5266-70 W. PICO BLVD.
LOS ANGELES CALIFORNIA
OFFICES IN NEW YORK AND CHICAGO

RADIOFRONT

(Continued from page 31)

to paint for the trade! (Possibly the editor thought he could "impress" WPB officials). This worthy publication forgot completely that servicemen possess a great amount of self-assurance and ingenuity. Count on it that the serviceman will find a way to make his repairs . . . if he has to use thumb tacks and baling wire to do it. The picture of the industry practically folding up is not true. And a magazine which paints such a picture is doing the serviceman a great disservice because it shakes his faith in his profession without just cause. Even now there are 10- to 15-year-old receivers in operation because servicemen know their stuff.

Another magazine (generally partial to "ham-activities") has forsaken the serviceman entirely. Although claiming well over 15000 readers in the servicing classification, it tacitly implies that the *business-like* serviceman is gone for the duration. Nothing could be further from the truth. Are all auto repairmen going haywire? No! They are doing their best with what they have—and radiomen can do likewise.

Another magazine devoted "entirely to the serviceman" filled its paper with a brand of lotus-smoke which was in the form of opinions by "leaders in the field." One "leader's" opinion struck us particularly funny. It said in effect that his "XYZ Co." was seeing to it that all its customers (the jobbers) were getting their parts promptly. Let it be known that the "XYZ Co." is on the way towards being taken over by Uncle Sam for non-fulfillment of its Government Contracts. What chance do you think the customers will have? That's right, exactly none.

So servicemen, pick yourself a good monthly magazine which tells you the truth fearlessly, even if it hurts you. Get a periodical which tells you what is what, and what you can do to make money in the service fields, one that tries to help a serviceman solve his real problems, technical or otherwise.

Stick to your game, servicemen, and it will follow as night does day that you will pull through this War and find yourself more firmly fixed, in a better business position, and with a customer's list which eventually will spell success with a very enormous s. Meanwhile you can take satisfaction in this thought: good radio reception helps keep the nation informed quickly about world-wide events and can in a real emergency contribute to the country's defense. Keep 'em playing in the Armed Services and in American Homes!



4 STANDARD TYPES

of Amperite Regulators replace over 400 types of AC-DC Ballast Tubes now in use.

Amperites are real REGULATORS . . . have patented Automatic Starting Resistor which prevents initial surge and saves pilot lights . . . Ask Your Jobber.

AMPERITE

THE *Simplest*

WAY TO REPLACE

BALLASTS

WRITE FOR REPLACEMENT CHART

AMPERITE CO. 561 BROADWAY, NEW YORK, N. Y.

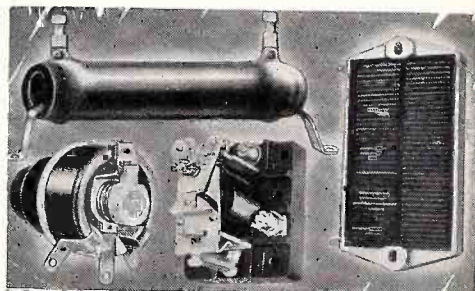

RELAYS RESISTORS RHEOSTATS

The oldest and most complete line for use in commercial, police, fire department and government radio and signal work. Proven dependability and conservative ratings. You are not experimenting when you install Ward Leonard items . . . you know they are right.

**WARD LEONARD
RADIO SPECIALTIES**

WARD LEONARD ELECTRIC COMPANY
46 South St., Mount Vernon, N. Y.

Please send me Circular 507 covering Relays, Resistors and Rheostats.

Name

Street

City and State

Call Signal

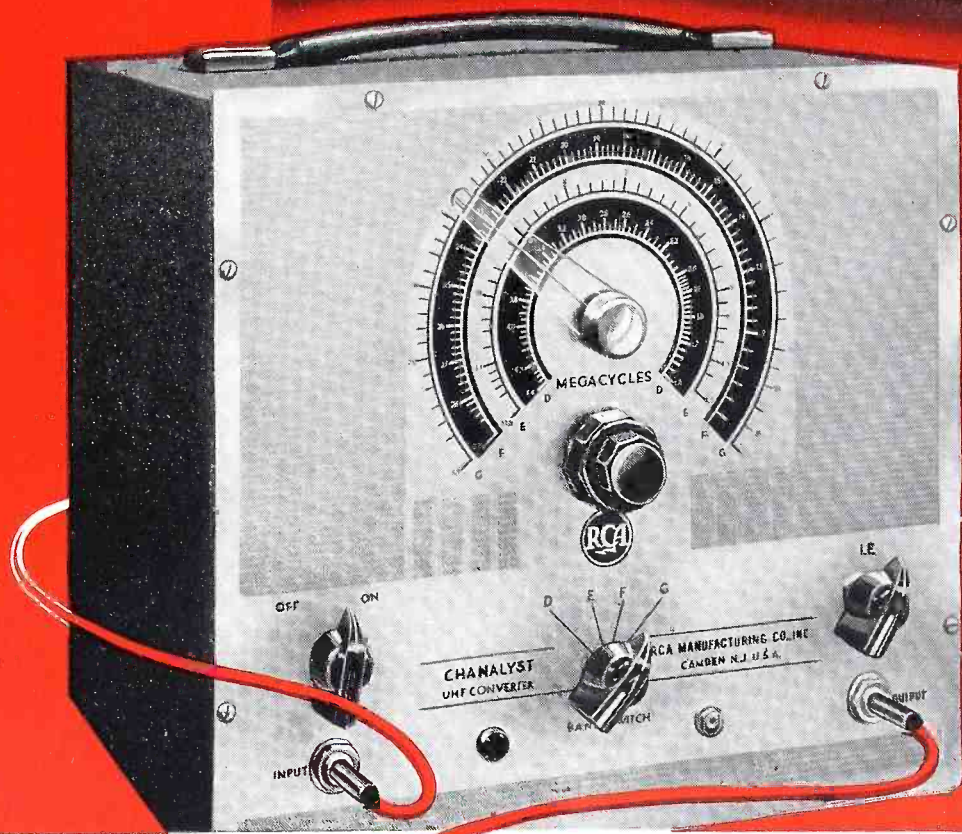

Stock No. 164

Price, including lead for coupling with RCA Rider-Chanalyst, and special test cable and probe . . .

\$55⁰⁰ net

RCA Chanalyst CONVERTER

for Military Applications of Signal Tracing UP TO 80 MEGACYCLES

By combining this new Chanalyst UHF Converter with your RCA Rider-Chanalyst, the horizon of your radio servicing is extended into the high frequencies to include such important services as F-M, Facsimile, Television, Aviation, Marine and Police Radio, as well as a host of others. Your present signal tracing methods can now be applied to the most modern devices used in these UHF services, placing you in a position to take advantage of the ever-increasing demand for competent technicians in this fast-growing field.

The RCA Chanalyst Converter reduces the higher frequencies (up to 80 megacycles) to values within the range of your RCA Rider-Chanalyst. From this point on, the procedure is exactly the same as that used at standard frequencies. You use exactly the *same* controls on your Chanalyst to make the *same* tests, the *same* measurements, and in exactly the same manner as before. *There is no new technique to learn!*

The new probe used with the Chanalyst Converter almost completely isolates instrument effects from the circuit under test. You can probe high frequency circuits without detuning them beyond the extent of ONE-HALF OF ONE MICRO-MICROFARAD. This allows unprecedented freedom of operation while the receiver is functioning.

Panel height and decorative features of the Converter match those of the Chanalyst. In every respect, it is an ideal companion piece—a necessity for the modern service dealer—a real opportunity for greater profits.

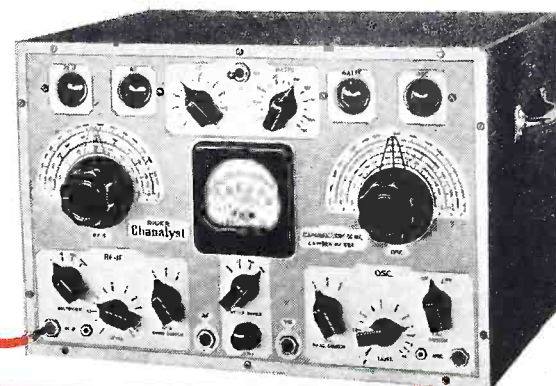

OVER 4,000 SATISFIED USERS are saving time, money and effort through Signal Tracing servicing with the RCA Rider-Chanalyst.

MINIMIZE EQUIPMENT OBSOLESCENCE . . .

the Signal Tracing Way

Not only does the RCA Rider-Chanalyst speed up your work and simplify difficult jobs—equally important, it is designed for minimized obsolescence. No better proof of this is needed than in the new Chanalyst Converter which enables you to handle UHF work—keeps you ahead of competition—saves you the cost of complete new equipment.



Test Equipment

RCA MANUFACTURING CO., Inc., Camden, N. J. • A Service of the Radio Corporation of America





**RAYTHEONS PROVE
THEIR STAMINA
ON THE NAVY'S NEW PT BOATS**

Bouncing over the waves at nearly a mile a minute our new PT boats are the fastest fighting craft afloat today. This breath-taking speed takes its toll of both men and equipment . . . RAYTHEONS prove their stamina by being able to function under this grueling test. The crew of a PT boat are selected with extreme care . . . they must be physically fit to stand up under the strain of constantly pounding the water, sudden turns and cramped quarters. RAYTHEONS too must take this punishment and deliver peak performance . . . the same dependable performance they have been giving to servicemen everywhere. Successful servicemen and dealers realize the advantage of RAYTHEON replacement tubes to protect their profits, turnover and the goodwill they have built up in their communities. With all their plus advantages, RAYTHEONS cost no more . . . Insist on RAYTHEONS for your next tube order.

Raytheon Production Corporation — New York, Chicago, Los Angeles, Atlanta, Newton, Mass.

NOTICE! If you have not obtained RAYTHEON'S interchangeable Tube Chart, it is important to get one of those cards at once from your RAYTHEON jobber. Speeds up radio repair service and simplifies your tube stock by elimination of a large number of types.



**RAYTHEON
RADIO TUBES**

WORLD'S LARGEST EXCLUSIVE RADIO TUBE MANUFACTURER