

# ELECTRONIC TECHNICIAN

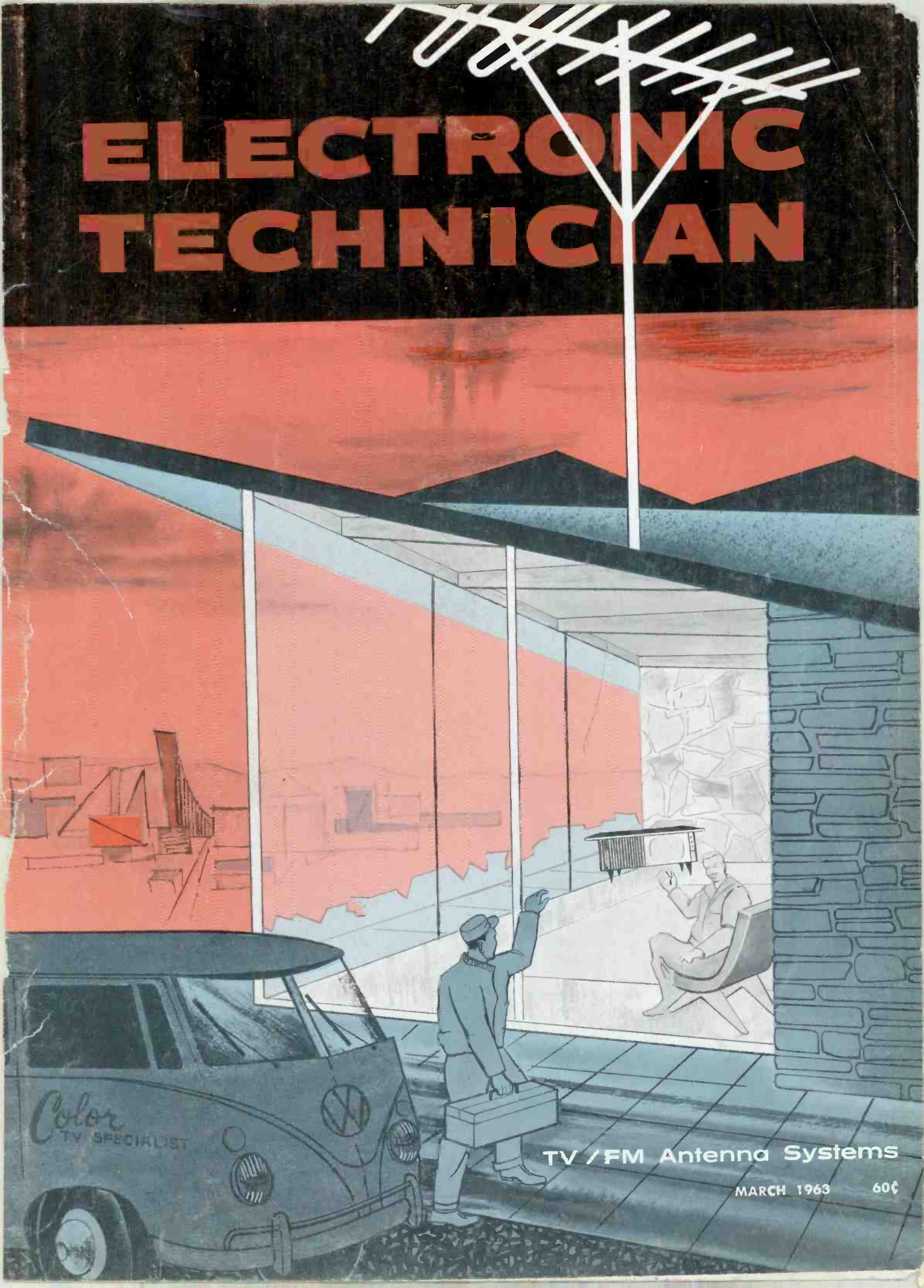

TV / FM Antenna Systems

MARCH 1963 60¢

**In COMPONENTS** if it's news, expect it first from IRC

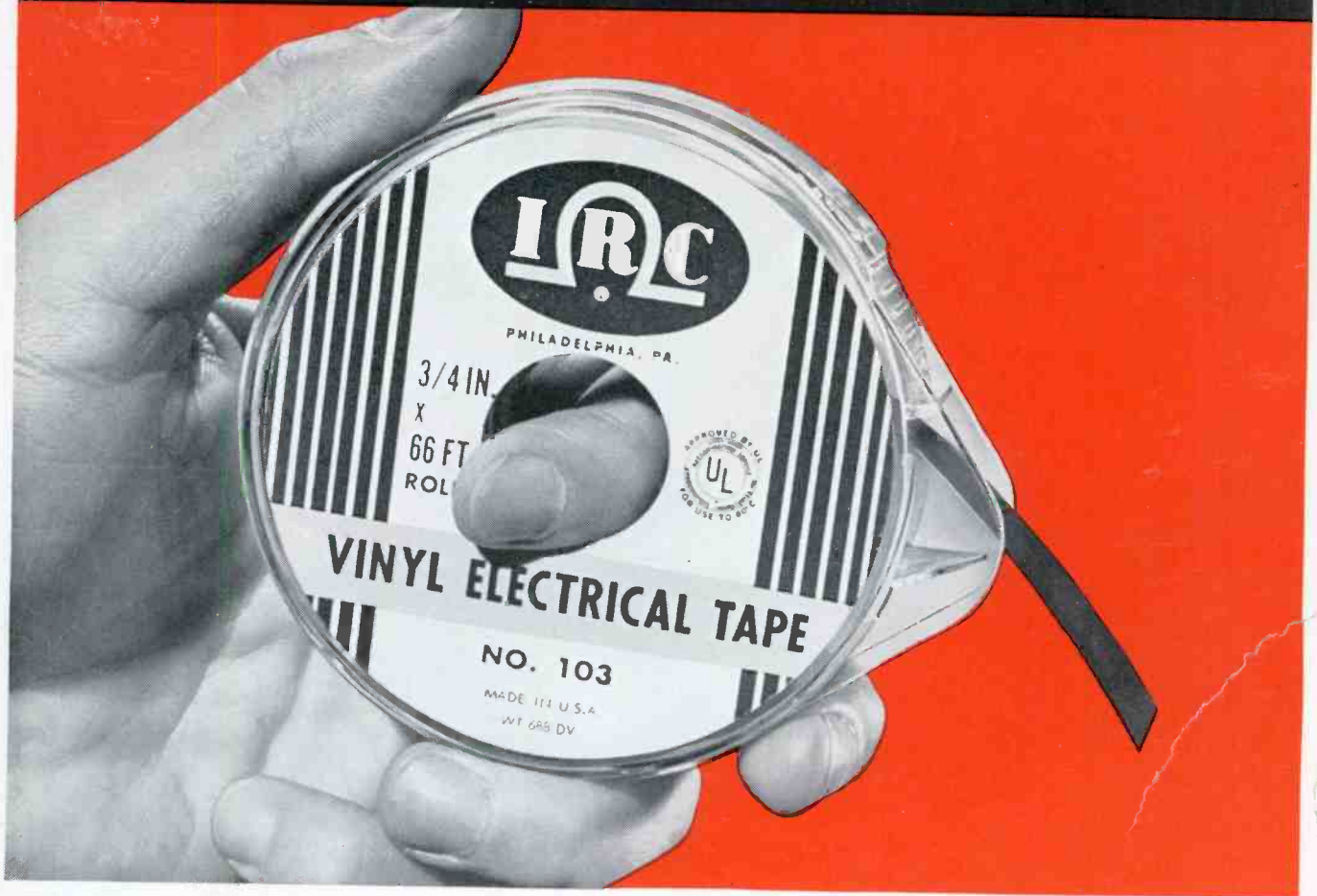

## **NEW... IRC Vinyl Electrical Tape** **Fast, safe one-hand insulating**

New IRC Type 103 Vinyl Electrical Tape has everything a good tape should have . . . and then some.

- 2 to 18 times better dielectric strength than other tapes.
- Seals and insulates in one fast tape-and-tear operation . . . saves tape and time. UL approved as a single insulation for wire splices.
- Saves space in confined areas . . . ends "twice-around" wraps with bulky tapes.
- Provides a tight insulated plastic seal . . . resistant to abrasion, water, acids, alkalies, corrosion and aging.
- Gives a neater wrap . . . adheres readily to irregular surfaces and contours.
- Makes an excellent wrap for insulating tools.

### **TAPE-AND-TEAR DISPENSER**

For fast, one-hand taping IRC Vinyl Electrical Tape comes to you in a sturdy tape-and-tear dispenser. It keeps tape clean and prevents stretching. Cutting blade is shielded for your protection. Dispenser is loaded with 66 feet of  $\frac{3}{4}$ " tape . . . ready for instant use.

Also available in cellophane wrapped rolls:

$\frac{3}{4}$ " wide by 20 feet long

$\frac{3}{8}$ " wide by 20 feet long

$\frac{3}{8}$ " wide by 36 yards long

Ask for IRC Vinyl Electrical Tape at your Electronic Parts Distributor.

International Resistance Co., Philadelphia 8, Pa.



--- for more details circle 28 on post card

# SENCORE

## SIMPLIFIES COLOR SERVICING

### NEW! CA122

### COLOR CIRCUIT ANALYZER

A simple approach to a complex problem

Here is an instrument that is designed to eliminate the guesswork in color TV servicing. A complete analyzer that provides all required test patterns and signals for testing from the tuner to the tri-color tube. Additional analyzing signals for injection at each stage including audio, video and sync, brings to life a truly portable and practical TV analyzer for on the spot service; virtually obsoleting other analyzers with the advent of color. Sencore's simplified approach requires no knowledge of I, Q, R-Y, B-Y, G-Y or other hard to remember formulas. The CA122 generates every signal normally received from the TV station plus convergence and color test patterns.

The CA122 offers more for less money:

**TEN STANDARD COLOR BARS:** The type and phase that is fast becoming the standard of the industry. Crystal controlled keyed bars, (RCA type) as explained in most service literature, offer a complete gamut of colors for every color circuit test.

**WHITE DOTS:** New stabilized dots, a must for convergence, are created by new Sencore counting circuits.

**CROSS HATCH PATTERN:** A basic requirement for fast CRT convergence.

**VERTICAL AND HORIZONTAL BARS:** An added feature to speed up convergence, not found on many other color generators.

**SHADING BARS:** Determines the ability of the video amplifier to produce shades (Y Signal) and to make color temperature adjustments. An important feature missing on other generators.

**COLOR GUN INTERRUPTOR:** For fast purity and convergence checks without upsetting color controls. Insures proper operation of tri-color guns, preventing wasted time in trouble shooting circuits when CRT is at fault.



A must for color . . .

a money maker for black and white TV servicing

**ANALYZING SIGNALS:** RF and IF signals modulated with any of the above patterns for injection into grid circuits from antenna to detector. IF attenuator is pre-set for minimum signal for each IF stage to produce pattern on CRT thus providing a check on individual stage gain. Sync and video, plus or minus from 0 to 30 volts peak to peak, have separate peak to peak calibrated controls for quick checks on all video and sync circuits. Crystal controlled 4.5 mc and 900 cycles audio simplify trouble shooting of audio circuits.

**NEW ILLUMINATED PATTERN INDICATOR:** A Sencore first, offering a rotating color film that exhibits the actual color patterns as they appear on color TV receivers. Locks in with pattern selector control.

You'll pay more for other color generators only.

Dealer Net. . . . . 187.50

### NEW! PS120 PROFESSIONAL WIDE BAND OSCILLOSCOPE

A portable wide band 3 inch oscilloscope for fast, on-the-spot testing. An all new simplified design brings new meaning to the word portability . . . it's as easy to operate and carry as a VTVM. Though compact in size, the PS120 is powerful in performance: Vertical amplifier frequency response of 4 MC flat, only 3 DB down at 7.5 MC and usable to 12 MC, equips the technician for every color servicing job and the engineer with a scope for field and production line testing. AC coupled, with a low frequency response of 20 cycles insure accurate low frequency measurements without vertical bounce. Sensitive single band vertical amplifier; sensitivity of .035 volts RMS for one inch deflection saves band switching and guessing. Horizontal sweep frequency range of 15 cycles to 150 KC and sync range from 15 cycles to 8 MC (usable to 12 MC) results in positive "locking" on all signals. New exclusive Sencore features are direct reading peak-to-peak volts — no interpretation; dual controls to simplify tuning; lead compartment to conceal test leads, jacks and seldom used switches. Rear tilt adjustment angles scope "just right" for easy viewing on bench or production line. Size: 7" w x 9" h x 11 1/4" d. Weight: 12 lbs.



A must for servicing color TV in the home . . . lowest priced broad band scope. All hand wired — all American made

**SENCORE**, ADDISON, ILLINOIS

... for more details circle 41 on post card

Dealer Net. . . . . 124.50  
(with low cap. probe)

Kit. . . . . 74.50

Prices effective January 1, 1963

Tarzian offers  
**FAST, DEPENDABLE  
TUNER REPAIR  
SERVICE (ALL  
MAKES)**

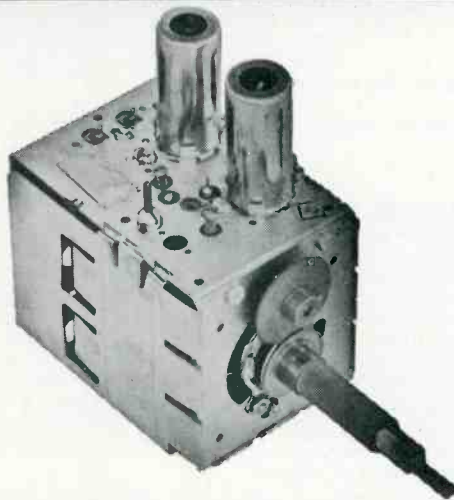

It just makes sense that a manufacturer of tuners should be better-qualified, better-equipped to offer the most dependable tuner repair and overhaul service.

Sarkes Tarzian, Inc. pioneer in the tuner business, maintains two complete, well-equipped Factory Service Centers—assisted by Engineering personnel—and staffed by specialized technicians who handle **ONLY** tuner repairs on **ALL** makes and models.

Tarzian-made tuners received one day will be repaired and shipped out the next. Allow a little more time for service on other than Tarzian-made tuners.

Tarzian offers a 12-month guarantee against defective workmanship and parts failure due to normal usage. And, compare our cost of \$9.50 and \$15 for UV combinations. There is absolutely no additional, hidden charge, for **ANY** parts except tubes. You pay shipping costs. Replacements on tuners beyond practical repair are available at low cost.

Ⓜ Tarzian-made tuners are identified by this stamping.

When inquiring about service on other tuners, always give TV make, chassis and Model number. All tuners repaired on approved, open accounts. Check with your local distributor for Sarkes Tarzian replacement tuners, replacement parts, or repair service.

 **SARKES TARZIAN, INC.**  
*Bloomington, Indiana*

MANUFACTURERS OF TUNERS . . . SEMICONDUCTORS . . . AIR TRIMMERS . . . FM RADIOS . . . AM/FM RADIOS . . . AUDIO TAPE . . . BROADCAST EQUIPMENT

**ONLY  
\$9.50  
INCLUDING**

**ALL PARTS  
(except tubes)  
and LABOR**

**24-HOUR SERVICE  
1-YEAR WARRANTY**

**TWO SERVICE CENTERS  
TO SERVE YOU BETTER**

**See your distributor, or use the  
address nearest you for fast fac-  
tory repair service**

537 South Walnut St.  
Bloomington, Indiana  
Tel: 332-6055

10654 Magnolia Blvd.  
North Hollywood, Calif.  
Tel: 769-2720

**WORLD'S LARGEST  
ELECTRONIC TRADE  
CIRCULATION**

# ELECTRONIC TECHNICIAN

**RON KIPP** Publisher  
**TOM COOPER** Editorial Director  
**VICTOR L. BELL** Editor  
**JACK HOBBS** Managing Editor  
**WARREN CREWS** Associate Editor  
**ALEX ORR** Assistant Editor  
**JERROLD PATTERSON** Assistant Editor  
**EARL HINTZ** Production Manager  
**MAGGIE KANE** Advertising Production  
**JIM GHERNA** Art Director  
**JERRY WHITTLESEY** Circulation Manager  
**ETHEL NASH** Circulation Fulfillment

March • 1963

Vol. 77 • No. 3

## CONTENTS

Letters to the Editor .....	22
Technical Digest .....	29
Test Instruments for Bench and Caddy .....	32
ET Viewpoint .....	39
TV/FM Fringe Antenna Installations .....	40
Standards and Test Procedures for Master Antenna Systems .....	43
<i>by Vic Nicholson</i>	
Solving 'Tough-Dog' Oscillation and Regeneration Problems .....	46
<i>by George P. Oberto</i>	
The LPV Antenna .....	49
Increase Your Income on TV Service Calls .....	50
<i>by Lon Cantor</i>	
A Closer Look at TV/FM Transmission Lines .....	52
<i>by Roland Miracle</i>	
FM Stereo Antennas .....	55
<i>by Paul Faler</i>	
Guide to Master TV Antenna Systems .....	56
What UHF Means to the Technician .....	57
<i>by Jack Beever</i>	
'Tough Dog' Corner .....	60
<i>by Darrell W. Lingbeck, Audry A. Pizanie and R. E. Vogan</i>	
Shop Hints .....	62
<i>by Frank J. Kish, Leonard Blechman, John Blazek, James Weldon and Nobel C. Travis</i>	
New Products .....	64
New Books .....	84
News of the Industry .....	85
Coming Events .....	88
Free Literature .....	92
Advertisers Index .....	94



AN OJIBWAY  
PUBLICATION

**OJIBWAY PRESS, Inc.**

Ojibway Building  
Duluth 2, Minn

AREA CODE 218 727-8511

**Sales Offices:**

**NEW YORK:** Ron Kipp, 480 Lexington Ave., New York 17, N. Y. TN 7-0011

**CHICAGO:** William Klusack, 221 N. LaSalle St., Chicago 1, Ill. CE 6-1600

**CLEVELAND:** Arnold T. Suhart, 6207 Norman Lane, Cleveland, Ohio. YE 2-6666

**LOS ANGELES:** Boyd B. Garrigan, 1145 W. Sixth St., Los Angeles 17, Calif. HU 2-2838



Copyright 1963 by Ojibway Press, Inc., Duluth 2, Minn. Reproduction and reprinting prohibited except by written authorization of the publication.  
If you have a change of address or a question about your subscription, write: ELECTRONIC TECHNICIAN, Circulation Department, Ojibway Building, Duluth 2 Minnesota. BE SURE TO SEND ALONG THE ADDRESS LABEL FROM YOUR MOST RECENT ISSUE.

## TEKFAX ..... 16 PAGES OF LATEST SCHEMATICS

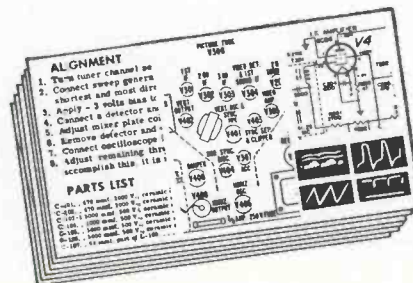

- DELCO: Chevrolet Radio, Model 985431
- GENERAL ELECTRIC: TV Chassis, QX Models M502XBN, EB, VY, 3XBN, EB and VY
- MONTGOMERY WARD: FM Multiplexer, Model WG-399A
- SONAR: CB Model "G" Transceiver
- WESTERN AUTO: TV Chassis, Models 2DC1300B, 02B, 01B and 03B
- WESTINGHOUSE: AM/FM Tuner/Amplifier V-2515-6

# MAKING ROOM AT THE TOP



## AC VTVM & AMPLIFIER #250

**NEW** EICO ENGINEERING ACHIEVEMENT Kit \$49.95 Wired \$79.95

Phenomenally good AC VTVM, bound to make room for itself at the top of the professional market. 12 ranges from 1 mv to 300 V full-scale, 10c-600kc  $\pm 0$  db response, 10 megohms input impedance,  $\pm 3\%$  of full scale accuracy. At the flick of a switch, the internal wide-band amplifier is available for external use. Provides 8c-800kc  $\pm 0$  db response, 5 VRMS output, 5 kilohm output impedance, gain control, noise -40 db. Regulated power supply, frame grid tubes.

**AC VTVM #255** Kit \$44.95 Wired \$72.95

All the precision VTVM facilities of the #250, less the external use of the wide-band amplifier.

# LETTERS TO THE EDITOR

## Dumont 274 Manual

Editor, ELECTRONIC TECHNICIAN:

I read in your January Letters to the Editor column that Mr. MacDonald needs a Dumont 274 manual. I have such a manual and would be more than glad to let Mr. MacDonald have it since it is no longer of any use to me.

I find your magazine very interesting and educational. I think it is a credit to the service industry. Keep up the good work.

GEORGE S. LEWIS

Cleveland, Ohio

Editor, ELECTRONIC TECHNICIAN:

In your January issue of ELECTRONIC TECHNICIAN Mr. S. C. MacDonald, Jr., Providence R. I. stated he was in dire need of an operations Manual for a Type 274 Du Mont Scope. I am enclosing a copy of this manual for his needs. I do not think a man should be without an operation manual just because he does not know how to spell his last name.

JAMES P. McDONALD, JR.

Dallas, Tex.

• Thanks to Mr. McDonald for the manual. We have forwarded it to reader MacDonald.—Ed.

Editor, ELECTRONIC TECHNICIAN:

Thank you very much for your assistance in getting a 274 Du Mont Scope Manual and Mr. McDonald's letter—he certainly has a sense of humor.

I have renewed my subscription for three more years—wouldn't be without it.

WM. S. C. MACDONALD, JR.

East Providence, R. I.

## CRT-5A

Editor, ELECTRONIC TECHNICIAN:

I take ET and have for many years. I was reading the letters to the editor, and happened to see a request for service information on the Hollywood Instrument CRT-5A. The instrument was made in Royal Oak, Michigan not far from me and is out of business. This may not be what you wanted to hear, but is all I know about it. Sorry, Mr. Guillory, if I'm not much help.

GENE ELLIS

Pontiac, Mich.

## ARMED TO THE TEST LEADS FOR THE TRANSISTOR GAME

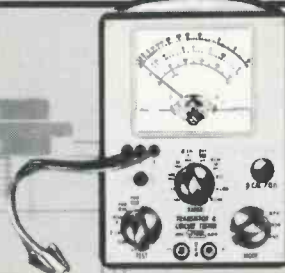

## TRANSISTOR AND CIRCUIT TESTER #680

Kit \$25.95 Wired \$39.95

Measure ICEO, ICBO &  $dc\beta$  directly,  $ac\beta$  indirectly, without charts or special settings—plus all dc volts, currents, and resistances needed to service transistor equipment. 50  $\mu A$ , 3 1/2" face meter movement provides sensitivity and scale length necessary for accurate measurements. Built-in 20,000 ohms/volt VOM facilities let you work on transistor equipment with minimum equipment tie-up.

## SITTING DUCKS FOR THIS SNOOPER



## IN-CIRCUIT CAPACITOR TESTER #955

Kit \$19.95 Wired \$39.95

Leave those capacitors where they are! Without unsoldering:

- check for shorts (even in the presence of as little as 1 ohm shunt resistance)
- check for opens (determine the presence of as little as 5mmf in the circuit), and to confirm open indication . . .
- measure capacitance with  $\pm 10\%$  accuracy between 0.1 mf and 50 mf
- measure RC product, convertible into dissipation or power factor.

### Also New From EICO:



Battery Eliminator and Charger #1064 Kit \$43.95 Wired \$52.95



AC Bench Supplies Model 1073—Kit \$35.95 Wired \$47.95 Model 1078—Kit \$42.95 Wired \$54.95



AC Volt-Watt Meter #261\* Kit \$49.95 Wired \$79.95

\*Formerly designated as #260.



For complete catalog of over 106 EICO kits and wired units—hi-fi, test equipment, citizens radio, ham gear—plus name of nearest distributor, write to dept. ET-3

EICO ELECTRONIC INSTRUMENT CO., INC., 3300 NO. BOULEVARD, L.I.C. 1, N. Y. Export Dept, Roburn Agencies Inc. • 431 Greenwich St., New York 13, N. Y.

Add 5% in the West

See us at IRE Booth #3101

• • • for more details circle 22 on post card

## New Heavy Duty RFI Suppression Kit For Mobile Radio



**R**ADIO HAMs, fleet owners, and CB operators can now enjoy clearer, more readable, less tiring mobile communications at longer effective ranges.

Sprague's new Type SK-1 SUPPRESSIKIT provides effective R-F Interference suppression—at moderate cost—up through 400 megacycles. Designed for easy installation on automobile, truck, or boat engines with either 6-volt or 12-volt generators, the Suppressikit makes possible high frequency interference control by means of Sprague's new, extended range, Thru-pass® capacitors.

The components in the SK-1 Suppressikit are neatly marked and packaged, complete with easy-to-follow installation instructions. All capacitors are especially designed for quick, simple installation.

The generator capacitor is a heavy-duty unit rated at 60 amperes, and will operate at temperatures to 125°C (257°F). This means you'll have no trouble with an SK-1 installation in the terrific temperatures found "under the hood" on a hot summer's day. There's no chance of generator failures from capacitor "short outs," as with general purpose capacitors. The Thru-pass capacitors for use on voltage regulators are also rated at a full 60 amperes.

The Deluxe Suppressikit is furnished complete with an 8-foot shielded lead on the generator capacitor which can be trimmed to necessary length for any car or small truck, preventing R-F radiation from armature and field leads.

Containing only 5 easy-to-install capacitors, the Deluxe Suppressikit is a well-engineered kit. The net price is a little higher than that of many thrown-together kits, but it saves you so much time and aggravation it's well worth the slight extra cost.

For additional information on the Type SK-1 Suppressikit, see your Sprague Electronic Parts Distributor.

65-341 R2

MARCH 1963

## Sprague TWIST-LOK® Capacitors give you 2 tremendous advantages over all other twist-prong electrolytics



**1**

**The right size, the right rating, for EVERY replacement job**

No need to compromise or improvise...the TWIST-LOK Line includes over 1690 different capacitors . . . It's the industry's most complete selection of twist-prong type capacitors, bar none!

**2**

**Exclusive, improved cover design for greater dependability**

Type TVL Twist-Lok Capacitors are now more dependable than ever! Sprague's new cover design provides a truly leak-proof seal and permits capacitors to withstand higher ripple currents.

### Compare internal construction of TWIST-LOK to ordinary 'Lytic!

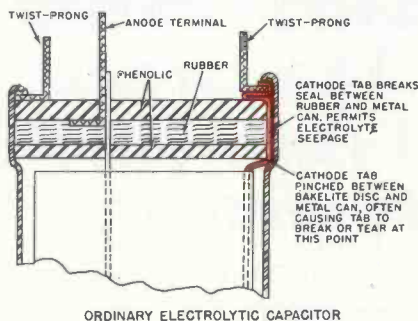

ORDINARY ELECTROLYTIC CAPACITOR

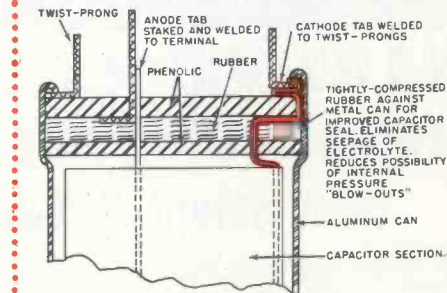

SPRAGUE TWIST-LOK® ELECTROLYTIC CAPACITOR

Get your copy of Sprague's comprehensive *Electrolytic Capacitor Replacement Manual K-106* from any Sprague Distributor, or write to Sprague Products Company, 65 Marshall St., North Adams, Mass.

WORLD'S LARGEST  
MANUFACTURER OF CAPACITORS



... for more details circle 44 on post card

Available from all authorized ARCO distributors



# Arcolytic®

## 1401 Values... The largest selection of exact replacement twist-mount & tubular electrolytics

■ 99.99% high purity aluminum foil electrolytics at no extra cost! ■ Choose from stock any single, dual, triple or quadruple capacitance - voltage combination for replacement in television, radio, and other electronic equipment ■ Made to withstand high ripple and high surge voltages ■ Designed for 85°C high temperature operation ■ Greater shelf and operating life because only premium grade ingredients are used ■ Built and tested to meet EIA Specification RS-154 ■ Individually packaged with mounting plates for your convenience ■ Unconditionally Guaranteed.

# ARCO electronics inc.

ELECTROLYTIC DIVISION

Community Drive, Great Neck, New York • HUinter 7-0500

Branches:  
Dallas 7  
Los Angeles 35

## LETTERS

### TO THE EDITOR

Editor, ELECTRONIC TECHNICIAN:

The Hollywood Instrument CRT-5A was made by the Consolidated Radio and Tel. Co. and were located at 45 Aston Place, New York, N. Y. They have been out of business about 20 years.

The Radio Troubleshooter's Handbook, by Alfred A. Ghirardi however, has information on page 619 that I am quite sure would help him.

WILLIAM E. DONOVAN

Milton, Mass.

• *Are there any other Hollywood Instrument Companies?*—Ed.

### CD Helps Stocking

Editor, ELECTRONIC TECHNICIAN:

Your Circuit Digests are very helpful; when looking at each new schematic I can determine what new tubes I should order.

JOSEPH WIACK

Brick Town, N.J.

### Oldtimer

Editor, ELECTRONIC TECHNICIAN:

I have been reading your magazine since its inception, and its predecessor publications, for many years. I've always enjoyed it—keep up the good work.

NORMAN HARPER

Charleston, Mo.

### Don't Build It - Buy It

Editor, ELECTRONIC TECHNICIAN:

I have read with interest 2 articles on your Shop Hints page this month dealing with a problem which seems to plague servicemen everywhere.

They deal with the problem of obtaining power in the back of a TV set for instruments such as solder guns, tube testers, VOMs, service lights, etc.

It may interest your readers to know of a device which we manufacture which solves such problems safely, and with no strain. It is called a Cheater Cube.

IRVING ROZAK

R-Columbia Products Co., Inc.  
2008 St. Johns Avenue  
Highland Park, Ill.

• *Mr. Rozak also pointed out on an enclosed sheet that the connections*

ELECTRONIC TECHNICIAN



## Time for a new look at silicon rectifiers

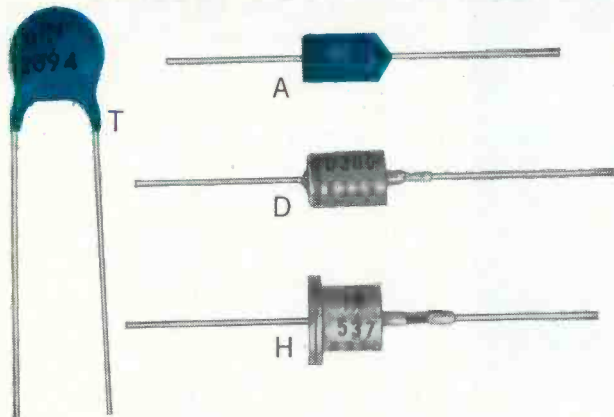

SILICON RECTIFIERS—750 ma @ +50°C

PRV	T	A	D	H
50	1N2090	A50	D50	1N536
100	1N2091	A100	D100	1N537
200	1N2092	1N2069	1N3193	1N538
300	1N2093	A300	D300	1N539
400	1N2094	1N2070	1N3194	1N540
500	1N2095	A400	D400	1N1095
600	1N2096	1N2071	1N3195	1N1096

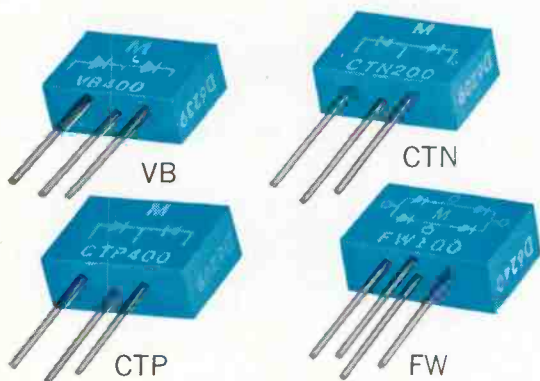

PACKAGED RECTIFIER CIRCUITS

PRV	750 ma @ +50°C			1.5 amp @ +50°C FW
	VB	CTN	CTP	
50	VB50	CTN50	CTP50	FW50
100	VB100	CTN100	CTP100	FW100
200	VB200	CTN200	CTP200	FW200
300	VB300	CTN300	CTP300	FW300
400	VB400	CTN400	CTP400	FW400
500	VB500	CTN500	CTP500	FW500
600	VB600	CTN600	CTP600	FW600

The silicon rectifier industry moves at such a rapid pace that you may not be aware of some recent developments.

Take *hermetic sealing* for example. Many technicians feel that the "top hat" rectifier is the only safe one to use . . . probably because it's the original MIL type (1N536, etc.). This is the Mallory "H" type. It's a fine rectifier and we sell thousands of 'em. If you really *need* hermetic sealing, you should check the Mallory "D" series. It's smaller than the "H" and actually has *better characteristics at a lower price*.

But are you sure you really *need* hermetic sealing? The Mallory "A" series (axial leads) and "T" series (parallel leads) actually withstand *four times* the humidity cycling of the MIL test. They're both epoxy encapsulated and are available in all ratings up to 600 PRV at lower cost than either the "D" or "H". You shouldn't confuse the Mallory "A" or "T" rectifiers with those made by other people, though. No kidding, we use a *superior* encapsulating system. If you need *quality*, you'll be ahead with Mallory.

So, whenever you need 750 ma from 50 to 600 PRV, decide on the style and price that fit your requirements. Your Mallory Distributor has *exactly* the right rectifier for you.

**Multi-rectifier circuits.** Instead of hooking up a number of rectifiers to make a doubler, full-wave center-tap or full-wave bridge, you can now get Mallory *pre-packaged circuits*. Cost is less than that of separate rectifiers. And convenience and reliability are far greater, because you have fewer solder connections to make, fewer parts to stock and handle. We make them in ratings up to 600 PRV.

**Reliability.** Lots of people think "reliability" applies only to military electronics. But Mallory doesn't think so. We think the service technician needs reliable components, too. We'd like to say our silicon rectifiers were 99.99% reliable. But we can't. In order to quote 99.99%, one must have a *failure somewhere*. The fact is, that during 1962 we didn't have a *single* failure. Saying 100% reliability sounds like bragging . . . so we won't say it.

You might be interested to know that every single Mallory silicon rectifier gets a complete electrical check at *full* temperature and *full* load THREE SEPARATE TIMES. Time consuming? You bet! But there is absolutely no question about quality.

Mallory Silicon Rectifiers are available through your Franchised Mallory Distributor . . . see him for other Mallory products, too . . . batteries, capacitors, controls, switches, resistors and vibrators. In fact, see him for *all* of your electronic requirements.

*the key to  
over 1,200  
profitable  
cartridge  
replacements*

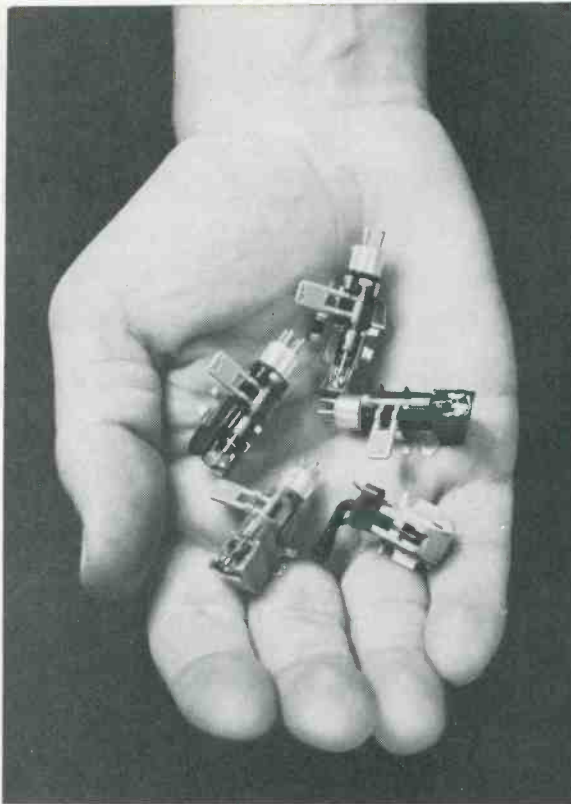

# SONOTONE CARTRIDGES

When you rely on Sonotone cartridges, you're always in the best position to increase your replacement profits.

1. You tie up less capital in inventory, because fewer cartridges replace more models.
2. You always have the right replacement. Sonotone cartridges have been specified as original equipment in more than 14,000,000 phonographs — that's the number of genuine direct replacements you can make with Sonotone.
3. You have more satisfied customers. Replace with Sonotone and the improvement in performance is dramatic. Sonotone cartridges feature ceramic transducers—no problem from magnetically induced hum. They're designed to track at the optimum tracking forces for record changers. Needles can be replaced with ease thanks to unbreakable nylon, snap-in-snap-out type needle assembly.

*5 new Sonotone cartridges—excellent replacements for more than 1,200 phonograph models*

**Model "2TA."** Ceramic mono cartridge, an improved version of the famous Sonotone "2T Series." New needle assembly, plus increased compliance and lower tracking force, make it ideal for both stereo and mono records.

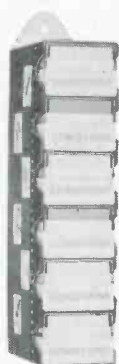

**MODEL "916-TA."** This low cost stereo ceramic cartridge employs some of the basic design features of the audiophile-accepted Velocitone Series. New universal tonearm terminal plug for easy replacement in quality models.

**MODEL "9TA."** Ceramic stereo/mono cartridge features low stylus mass and high compliance. New universal tonearm terminal plug for fast easy replacement. For deluxe models.

**MODELS "16T-A" AND "18T-A."** Two budget priced stereo cartridges with wide channel separation and smooth flat response over the high fidelity range. New universal terminal plug for fast replacements.

*Your most profitable cartridge replacement is Sonotone. Call your distributor today.*

## SONOTONE CORPORATION

ELECTRONIC APPLICATIONS DIVISION • ELMSFORD, N. Y.

In Canada: Atlas Radio Corp., Ltd., Toronto • Cartridges • Speakers • Tape Heads • Microphones • Electron Tubes • Batteries • Hearing Aids • Headphones  
- - - for more details circle 42 on post card

## LETTERS

### TO THE EDITOR

*shown in our shop hint drawing were unsafe. The connections should, of course, be covered with spaghetti and taped.—Ed.*

#### Needs Schematic

Editor, ELECTRONIC TECHNICIAN:

We have been told that you could furnish a Schematic for the following electric eye unit

Detect-O-Ray Model L 162 C  
made by:

Detect-O-Ray Co.  
2622 North Halstead Street  
Chicago 14, Ill.

If you can supply this information or advise us where we might obtain it we would certainly appreciate it.

HENRY W. WOOD

Birmingham, Ala.

• Can any of our readers help Mr. Wood?—Ed.

#### Wants Technical Lexicon

Editor, ELECTRONIC TECHNICIAN:

I think your magazine is a must for any technician. I would like to see, in addition to the many useful helps already published by you, a list and definitions of the latest electronic terms.

THOMAS J. WILLIAMS

Minneapolis, Minn.

#### Wants FCC Law-Theory Column

Editor, ELECTRONIC TECHNICIAN:

I enjoy your magazine very much, especially the tough dog corner.

I also agree with Mr. Lawson's letter (Jan. 63) about a column on the FCC commercial license, regarding Theory & Law.

JOSEPH H. MCCONOGHY, JR.

Downingtown, Pa.

#### Testimony

Editor, ELECTRONIC TECHNICIAN:

Many thanks for the trouble you went to securing the schematic for the TV relic I have on the bench. It is good to know people like you and to be associated with you in the electronic field.

If ET desires a testimonial I'd be delighted to give one. Also I am extending my subscription 3 more years. ET is the most practical publication for the electronic field.

NAT JACOBY

Los Angeles, Calif.

ELECTRONIC TECHNICIAN

*even the  
picture tube  
is  
revolutionary...*

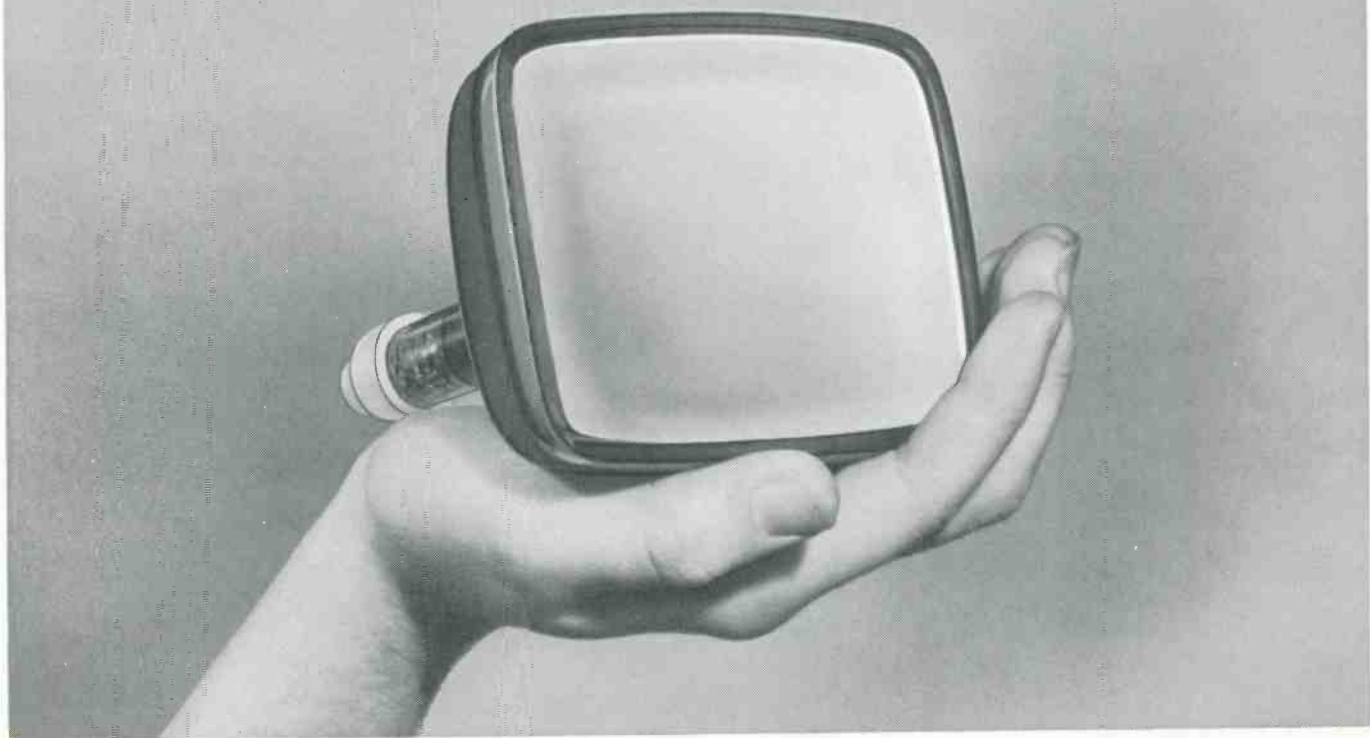

**SONY MICRO-TV—THE TELEVISION OF THE FUTURE**



There are many remarkable firsts in the new 25-transistor SONY Micro-TV. Not the least of them is the unique picture tube, designed, engineered and manufactured by SONY. Only by using 70° deflection—the first on a commercial set—with a phenomenally low drain gun and radically new phosphors, was SONY able to bring you unbelievable picture quality. Yet Micro-TV is hardly larger than your phone, and weighs a scant 8 lbs. Another SONY first is the use of snap-out circuit boards which permit you to send them directly to our service centers for the replacement of a defective component. Micro-TV operates on rechargeable battery pack as well as 12v auto/boat power and AC. **\$229.95.** Rechargeable battery pack, accessories extra.

**SONY**<sup>®</sup>  
RESEARCH MAKES THE DIFFERENCE

**SONY CORPORATION OF AMERICA**  
580 Fifth Avenue, New York 36, N.Y.

Regional Offices  
Western: 627 South Towne Ave., Los Angeles 21, Calif.  
Central: 4959 W. Belmont Ave., Chicago 41, Ill.

Send me more information on the SONY MICRO TV.

NAME \_\_\_\_\_

STORE \_\_\_\_\_

ADDRESS \_\_\_\_\_

CITY \_\_\_\_\_ ZONE \_\_\_\_\_ STATE \_\_\_\_\_

Sony Corp. of America, Dept. 580 Fifth Ave., New York 36, N.Y.

for more details circle 43 on post card

Now in stock at your distributor

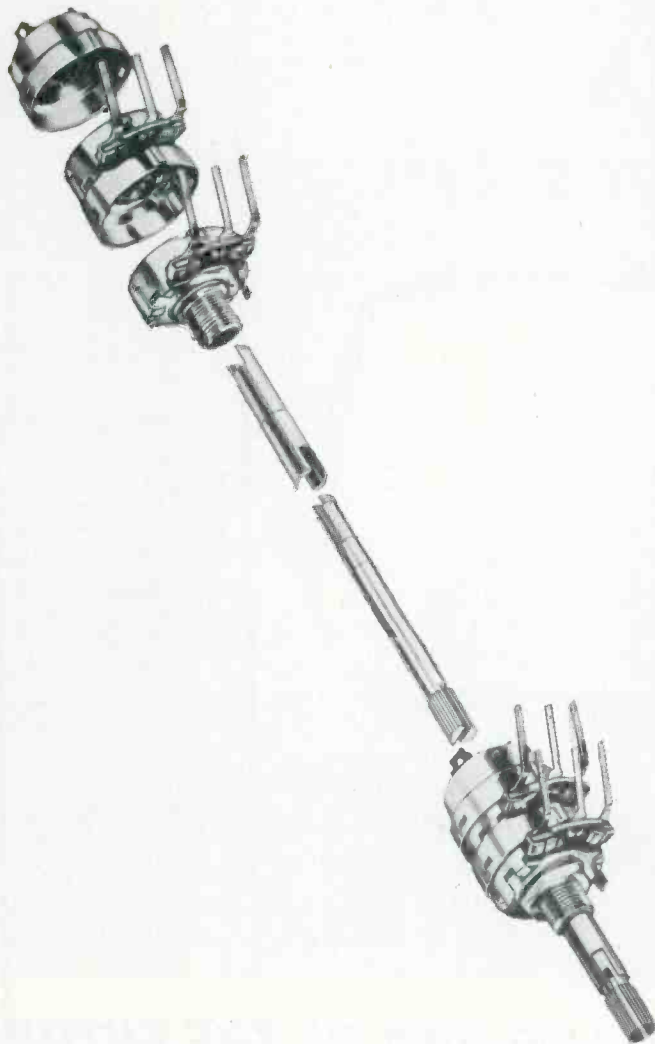

# THE NEW FASTATCH® II

**FROM CENTRALAB**  
**GIVES YOU** *complete  
instant exact replacement con-  
trol coverage for dual concentric,  
single, and matched twin controls.*

Fastatch II gives you convenient and simple control assembly. Any control can be permanently assembled in seconds—no shaft cutting—no complicated alignment—no twisting. Just snap together and install. Your Fastatch II product will be identical to the manufacturer's original control. Check these FASTATCH II features:

- No shaft cutting . . . Exact replacement shafts are available for every application regardless of length or termination.
- Shaft won't loosen or pull out—permanent locking construction.
- Universal terminals replace all three types of printed circuit, wire-wrap and hole type terminals.
- No backlash on duals and twins.



## NEW FASTATCH® II FRK-100 KIT

Everything needed to assemble an infinite variety of controls in seconds.

- 36 assorted front and rear controls in the 27 most popular resistance values
- 40 universal shafts
- 8 switches
- Current cross-reference guide
- Heavy-gauge steel cabinet.

B6308

**Centralab**  
ER

THE ELECTRONICS DIVISION OF GLOBE-UNION INC.  
902B East Keefe Avenue • Milwaukee 1, Wisconsin  
In Canada: Centralab Canada Ltd., P.O. Box 400, Ajax, Ontario

--- for more details circle 17 on post card  
ELECTRONIC TECHNICIAN

# MANUFACTURERS TECHNICAL DIGEST

## MAGNAVOX

### AM/FM Radio Chassis R201—Service Notes

Motorboating on AM operation: Add capacitor C230 (5pf 25 v) from the emitter of Q204 in IF section to chassis ground.

Insufficient high frequency response on AM: Change resistor R210 from 1.2K to 2.2K and capacitor C508 from 5000 pf to 2200 pf. These components are in the 10 kc filter network.

Improper voltage regulation of —36 v supply: Change resistor R502, in series with Zener diode SD501, from 6.8K to 4.7K.

Motorboating on all functions: Caused by oscillation in 1st preamp stage in audio preamp module. Add resistors R401 and R402 (4.7K) in series with capacitors C403 and C411 respectively, to chassis ground. Also, remove capacitors C407 and C415 (1000 pf) connected between pins 8 & 9 on PC401 and PC402 respectively.

## PHILCO

### Chassis 12N51, 12N51A, 12N51X and 12N52—Production Changes

12N51 Run 9 — VOS Perma-Circuit Panel was changed to Run 6 (blue dot). Panel changes were as follows: Resistor R16, vertical oscillator plate circuit, was changed from 1.5 MΩ to 2.2 MΩ. Resistor R43, horizontal oscillator cathode was changed from 1200 ohms to 1100 ohms 5%. Reason To improve horizontal oscillator performance.

12N51A Run 7—was changed to Run 5 (green dot). Panel change involved resistor R43, horizontal oscillator cathode circuit, which was changed from 1200 ohms to 1100 ohms 5%. Reason: To improve horizontal performance.

12N51X Run 4—was changed from Run 3 to Run 4 (yellow dot), part no. 54-5794-15. Panel component changes were the same as Run 7 of the 12N51 chassis. 12N52 Run 4—was changed from Run 4 to Run 5 (green dot), part no. 54-5794-15. Panel component changes were the same as Run 7 of the 12N51 chassis.

## RCA

### Color Chassis CTC12—Chroma Board Layout

The new chroma board layout with signal paths for

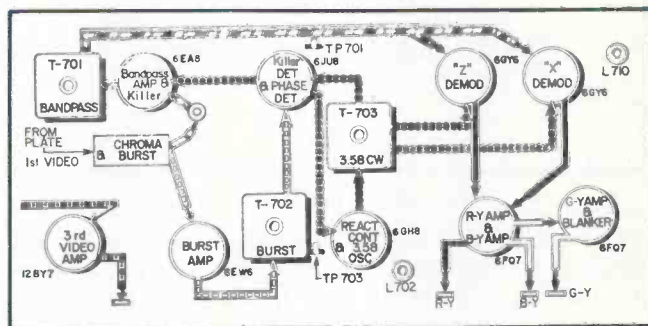

Chroma board layout of RCA CTC12 color chassis

video, color, color control and killer control signals is illustrated here. The video signal from the delay line is fed through the third video amplifier stage to the cathodes of the kinescope.

Color and burst signals are taken from the plate of the first video amplifier and fed to the color take-off coil. The color signal as chroma is amplified in the bandpass amplifier and fed to the demodulator tubes. Output of the "X" and "Z" demodulators is fed to the color video amplifiers from which the color video information is fed to the kinescope grids. The burst signal is fed through the keyer tube to the phase and killer detectors. The killer detector tube allows the bandpass amplifier to pass signals only when burst is present and the 3.58 cw oscillator is in correct syne with burst.

The phase detector compares the phase of the 3.58 MC cw signal with burst phase. If this is incorrect, a correction voltage is produced which is applied to the color oscillator control grid to correct phase. The 3.58 cw signal is also given the proper phase shift and applied to the suppressor grids of the "X" and "Z" demodulators.

## WESTINGHOUSE

### Chassis V-2438—Keyed AGC Circuit

The keyed AGC circuit in this chassis uses a triode (½ 6CL8) as a coincidence amplifier. Two signals must be applied at the same time before the tube will conduct. The two signals are the horizontal sync portion of the composite video signal—applied to the grid of the AGC tube—and a large positive pulse from the fly-back transformer—applied to the plate. The circuit is shown here.

By connecting the tube's cathode to 135 v and the

# MANUFACTURERS TECHNICAL DIGEST

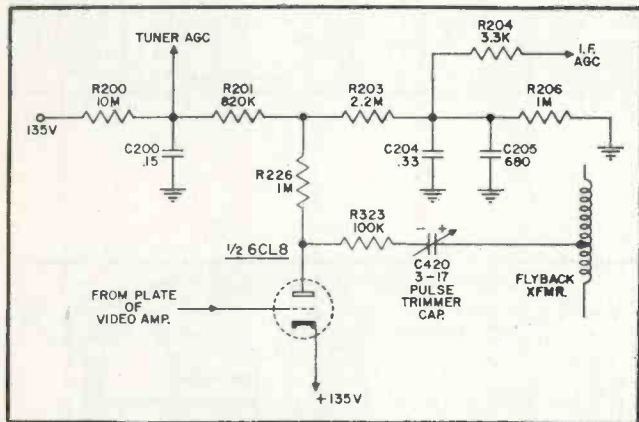

Westinghouse Keyed AGC circuit

grid to the plate circuit of the video amplifier, the triode is cut off. When a horizontal sync pulse is applied to the AGC tube's grid, it is brought out of cut-off. Before the tube conducts, however, it must have B+. This is supplied by a large positive pulse which is capacitively coupled from the flyback transformer. Plate voltage, therefore, is supplied at the rate of 15,750 cps.

The horizontal sync pulses applied to the AGC tube's grid and the large positive pulse applied to the plate are both 15,750 cps. Since the sync pulses control the phase of the pulses from the flyback transformer, the condition of coincidence is satisfied. When these signals are applied to the tube simultaneously, it conducts.

When the tube conducts, the pulse trimmer capacitor charges. When the sync pulses are absent, the tube cuts off. Capacitor C420 discharges thru R203 and R206 to ground producing a negative voltage drop across these resistors. This negative voltage is quite high and must be reduced to a level of  $-1$  to  $-5$  v before it can be used to control the gain of the set.

To reduce the negative voltage to a useable level, R200, R201, R203 and R206 are connected between +135 v and ground. This is a simple series circuit in which current flows from ground through the resistors to the +135 v source and produces a voltage drop across each resistor. When the AGC pulse trimmer capacitor discharges, current flows from the capacitor thru R203 and R206 to ground. This current flow opposes the current flow produced by the 135 v across the four resistors. The resultant AGC voltage will be negative when the incoming signal is strong enough to overcome the positive voltage on the line.

The AGC voltage varies in value according to the amount of incoming signal strength. A strong signal at the video amplifiers' plate is coupled to the AGC tube grid. This decreases the AGC tube bias, allowing it to conduct more heavily. The increased current causes a larger negative voltage to appear on the AGC line, which is used to decrease the RF amplifier and IF stage gain.

The pulse trimmer capacitor C420, is mounted on the side of the flyback transformer cage. Adjusting it changes the horizontal pulse amplitude applied to the AGC tube plate. This varies the amount of AGC tube conduction and hence the voltage.

The control is adjusted with an insulated screwdriver. Select the strongest channel in the area, turn the trimmer until the picture begins to bend at the top. Then back the trimmer off slightly until the bend disappears.

The AGC time constant permits fairly rapid changes in AGC voltage and reduces airplane flutter.

## ZENITH

### Color Chasis—Black and White Tracking

If a color set is to have good black and white tracking, it must produce black and white pictures within the normal usable range of both the contrast and brightness controls. The three screen grid adjustments, the B and G gain, the screen bias adjustments, plus the brightness and contrast controls, are used for adjusting black and white tracking. During this procedure, the voltages on the cathodes, control grids, and screen grids of the picture tube guns are adjusted to produce black and white pictures throughout the usable range of the brightness and contrast controls.

To adjust, tune in a monochrome picture that displays an adequate range of light levels, light and grey objects, dark objects, etc. Set the brightness and contrast controls for a normal picture.

1. Set the CRT Bias and the three Screen adjustments to minimum (fully counter-clock wise).
2. Set the B/W switch to Set-Up position. In this position the vertical sweep is removed to facilitate adjustments.
3. Advance each screen adjustment to produce a white horizontal line of medium brightness through the center of the screen.

In some instances, the Red, Green, and Blue lines may not completely overlap to form a white line due to the removal of the vertical sweep and necessary vertical convergence waveforms. In such cases, adjust the three screen controls for Red, Green and Blue lines of approximately equal intensity. If one or more of the screen adjustments fail to produce a line, leave that particular screen setting (s) at maximum. Advance the CRT bias setting to produce a line of medium brightness for that particular Screen adjustment (s). Adjust remaining screen adjustments for a white line, or lines of approximately equal intensity.

4. Return the B/W Switch to "Normal" position.
5. Alternately adjust the Blue and Green Gain adjustments to produce a normal black and white picture.

Check over-all black and white tracking throughout the normal brightness and contrast range. Accuracy of Screen adjustments is important. If difficulty is encountered in obtaining good black and white tracking, picture tube drive connections should be checked and altered, if necessary.

### IF YOU CHANGE YOUR ADDRESS

Notify us at 1 East First Street, Duluth 2, Minn. Please allow 6 weeks for the change.



**TUBE TESTER 88, \$69.50 NET**—locates all tube faults quickly, accurately with patented Seco grid circuit test that checks tubes 11 ways—also cathode emission test.

**DELUXE POWER SUPPLY RPS-5, \$69.50 NET**—transistorized zener-regulated circuit maintains constant voltage over wide load fluctuation without overshoot—up to 30 V DC and 150 ma.

**REGULATED TRANSISTORIZED SUPPLY RPS-2, \$26.95 NET**—constant voltage—adjustable 0-25 V. Bias tap—0-100 ma.

**TRANSMITTER TESTER 510B, \$48.95 NET**—reads both positive and negative modulation peaks on 0-120% scale—also RF output in 0-5 watts and 0-400 ma. For Handy-Talkies tool!

**REGULATED TRANSISTORIZED SUPPLY RPS-4, \$36.95 NET**—constant voltage—meter ranges 0-1.5, 0-15 and 0-30 V DC—reads load in 0-30 and 0-150 ma. Taps for simultaneous biasing.

**TRANSISTOR AND TUNNEL DIODE ANALYZER 250, \$74.50 NET**—complete transistor lab in one compact unit—even has VOM! Analyzes semi-conductors in or out of circuit—no set-up data needed.

**ANTENNA TESTER 520A, \$49.95 NET**—reads Forward Power and Reflected Power directly in watts! Antenna efficiency reads in: SWR from 1:1 to 8:1, per cent, or GOOD-POOR. For 50 ohm coax.

## New Look in Test Equipment



The look is bold, professional, functional. Handsome black cases, lustrous brushed aluminum panels, wide easy-to-read meters—"matched set" appearance and quality. It comes to you now from Seco. See the "New Look" display of Seco test equipment at your electronic distributor's and at the May Parts Show in Chicago. Look for the red velvet!

**SECO ELECTRONICS, INC.** 1211 South Clover Drive,  
Minneapolis 20, Minnesota  
Subsidiary of Di-Acro Corporation,  
Lake City, Minnesota

--- for more details circle 40 on post card

## SWEEP GENERATOR

For Manufacturer's brochure of this equipment circle 400 on post card.

*Knight RF Sweep Generator at \$44.59, kit*—It's surprising how many service shops are skimming by without a sweep generator. To do the right kind of a job, no service shop should be without one. Money should not be the fly in the ointment either; witness this fine inexpensive kit by Knight. All the TV and FM sweep work can be handled with this unit and a few crystals. For a wider variety of work, the shop should be equipped with a (almost equally valuable) signal generator.

The construction of this unit is definitely not for the totally inexperienced. If you're new to this business, forget it—the Knight con-

struction manual doesn't tell you how long to cut every wire nor how much insulation should be removed from it. The construction time over similar kits is thus greatly speeded up after you get the idea. Although the kit was well packaged, we could find very little reasoning for packaging some of the components together in various boxes and bags. After this became apparent it caused no trouble.

The unit performed well after construction, except that the 0 to 13 Mc sweep claimed by Knight was not achieved with this particular unit. After about 11 Mc the sweep became slightly distorted and the unit would not sweep



beyond 12 Mc. An electronic output regulator maintains the sweep amplitude within 1 db to as high as 0.15 v. The horizontal sweep voltage for the scope is about 5v. Two marker crystal sockets for the built-in marker oscillator are provided to allow quick, convenient switching between any two commonly used frequencies.

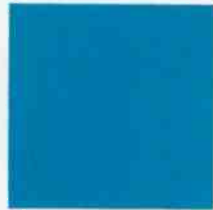

# TEST INSTRUMENTS for Bench and Caddy

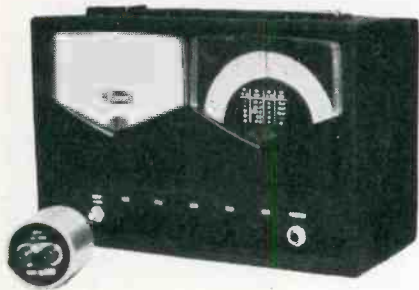

*Benco (Blonder-Tongue Labs) Field Strength Meter, Model FSP-3, at \$405*—Technicians who go in for fringe and near fringe area antenna installations will find that a good portable field strength meter simplifies a significant portion of the work. We have used this meter in preliminary surveys on actual antenna installations and it has served us well as "eyes" and "ears." Antenna installations were made to receive TV and FM stations up to

## FIELD STRENGTH METER

For Manufacturer's brochure of this equipment circle 401 on post card.

130 miles away. The meter makes the difference between *knowing* what you are doing and groping around blindly in a hit-or-miss fashion.

This unit is versatile — designed as FS and wattmeter. Both sound and video channels for all VHF TV stations are calibrated and clearly marked on the tuning dial. It is completely transistorized and ruggedly constructed. The self-contained eight Mallory (or equivalent) RM12R batteries provide up to 180 hours of continuous operation, or about 3 hours a week for a year. The unit can be powered with a 12-v car battery by connecting a 150Ω½-w resistor in series.

The FSP-3's basic meter scale is 0-100μv and is extended to read 0-3 v by attenuator buttons. By pressing the 10 db button the range is extended to read 0-300μv. This

is multiplied by a factor of 10 for each 20 db button (total of 4) pushed "in," giving a maximum range of 0-3 v when all 20 db buttons are "in." Alternatively, the 10 db button can be left "out" and the 0-100μv basic range can be extended by a factor of 10 for each 20 db button pushed "in," giving a maximum range of 0-1 v when all 20 buttons are "in."

The meter comes with a comprehensive operating and maintenance manual. This manual details many other essential uses for the instrument in addition to its work as FS meter. It can be used, for example, as an excellent TVI and RFI locator—hand carried or mobile. Carrying case optional at \$56. The unit measures 5¼ x 11¼ x 7¾ in. and weighs 10 lb.

More Bench and Caddy  
On Page 34



# EYE-OPENER!

"Watch what happens..."

when I flick the switch..."



## Unique new Telstar Instant Home Demonstrator by Channel Master sells boosters by the hundreds ...and you can get it free!

Turn "snow" into "dough"! Sell Channel Master's outstanding Telstar Boosters—hundreds of them—during routine service calls.

Channel Master's Telstar Instant Home Demonstrator gives startling, dramatic "split-second proof"...that Telstar Boosters step up TV and FM gain. It puts into your hands the kind of powerful selling tool—a "house-to-house," before-and-after comparison test—that you've never had but always needed.

Want to know how you can get an Instant Demonstrator free!... For full facts... call your Channel Master Distributor now!

Now there are 2 TELSTARS—both with built-in lightning protection!

1. Improved, easy-to-install TELSTAR TV/FM Booster (Model 0023A) with 4 set coupler.
2. New Telstar FMX for FM/STEREO (Model 0025) with 2 set coupler.

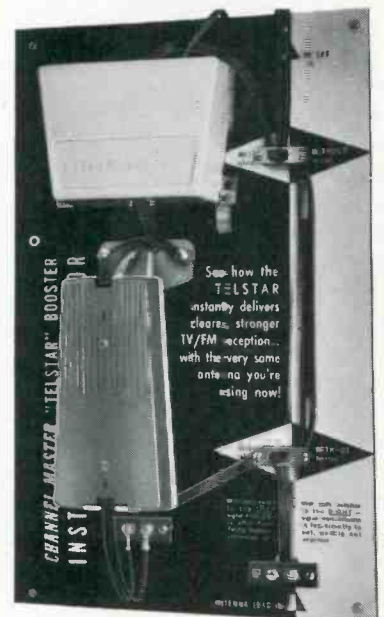

Fast, easy, light, compact! Comes pre-wired with booster already mounted—ready for instant use in customer's home. No climbing up on masts—no time-consuming hookups.

... for more details circle 18 on post card

### CHANNEL MASTER CORP.

ELLENVILLE, NEW YORK



*Don Bosco Lab set Stethotracer model PHD-100 at \$140.* — The Lab set Stethotracer is the basic pen-size Stethotracer amplifier with several attachments. The unit is turned off and on by sliding the

## STETHOTRACER

*For Manufacturer's brochure of this equipment circle 402 on post card*

pocket clip on the case. A sub-miniature jack just below the clip feeds an ear phone (supplied) or may be connected to a scope or VTVM through a special adapter.

One direct probe, two attenuator probes (20 and 40 db) and a demodulator probe are a part of the standard equipment. In the lab set, several additional attachments are included. Among these are: A vibration pickup, to detect minute mechanical vibrations; an output adapter which connects the unit to a scope, VTVM or recording in-

strument; a microwave demodulator which demodulates frequencies from 300 Mc to 10 Gc; a monophonic tape head to monitor moving magnetic sheet or tape; a miniature microphone covering the range of speech and an input adapter which allows the output of any other device to be fed to the input of the unit through a standard phone plug.

The unit is extremely versatile and should find many uses in the TV technicians' caddy as well as on the bench.

# TEST INSTRUMENTS for Bench and Caddy *Continued*

## VOM — MODEL 120

*For Manufacturer's brochure of this equipment circle 403 on post card.*

*Precision model 120 VOM at \$44.95* — Troubleshooting transistor circuits has proved to be a real problem to technicians still using old equipment. The very low voltages encountered with transistor circuitry is one of the biggest reasons. To counteract this problem, the model 120 incorporates a special 60 gr.  $\mu$  a or 0.3 v scale. In all, there are 59 ac and dc ranges incorporated into the meter. Maximum readable voltage is 6000 v either ac or dc. With an optional probe the unit is capable of measuring 30 kv.

A mirrored scale is also featured in the meter scale to reduce the possible parallax when reading the meter. A transit position is provided in the function switch which shorts

the meter and provides increased damping when the instrument is not in use. A polarity reversal switch eliminates the necessity of switching leads for positive and negative dc voltages.

The scale is color coded, to simplify reading the scale, with red, black and blue figures. The meter is a 5¼ in., two percent, 50  $\mu$  a D'Arsonval type. One percent multipliers and shunts are used throughout the unit giving it an over-all three percent accuracy. A db scale is also included on the meter scale.

Banana type plugs are used on the test leads supplied with the instrument to insure long jack life. The meter is available with a wide



variety of accessories including a retractable snap-on stand, extra duty probes for higher voltages and leather carrying case.

### Note That Price

The price of the B&K Color Generator model 850 featured in Test Instruments for Bench and Caddy for February was listed as \$195.95. The price should read \$199.95.

## Fringe Money

With the advent of more TV stations, more powerful TV stations and more sensitive receivers the average technician has let a lot of antenna business slip from his grasp. With the present popularity of FM even more money is slipping away. People living in areas with one, two or perhaps no FM stations in the immediate vicinity are unaware of the potential of enjoyment they have. We feel it is up to the TV service dealer to inform the customer of what he is missing and how you can help him.

Stations both FM and TV more than 100 miles distant are no longer out of reach. Although it is improbable that FM stereo can be received at such distances, good FM monophonic and TV signals can be received. The profit from the sale of an antenna and the installation, with the potential sale of more TV sets, color and associated Hi Fi equipment can hardly be sneezed at.

In many areas offering only two broadcast stations the service dealer sells sets for more than \$300—the cost per channel, \$150. If you're in the fringe of another area offering different programs it should be easy for you to sell a good antenna system. An antenna system costing \$100 which brings in three more stations (for about \$33 per channel) should be soft sell!

In talking with an executive with one of the large antenna manufacturers recently we heard a couple of ideas which are worthy of passing on. "If I had a shop,"

he said, "I'd put a map of the area on the wall and mark on it all the TV and FM stations within a 100 mile radius. When customers came in I could explain that with a good antenna installation they could receive all of these stations.

"I'd buy a demonstrator antenna which would fit most of my applications in the area so I could prove it before getting into some rare areas where reception wasn't good. I think I'd even offer free demonstrations."

Antennas and antenna preamplifiers have come a long way since the early days of TV when a large antenna was not an uncommon sight. If you aren't making the most of this business in your area now, you may be missing the boat.

Our emphasis in this issue is on antennas. Beginning in this issue a two part article will show how to make a good installation in various fringe areas. It's not too difficult and the rewards are ample. We used antennas built by several leading manufacturers in real fringe test installations. The results were excellent and we've formed a new appreciation for the quality and engineering in the antennas and their associated components.

If you're looking for a way to fight the DIY tube testers at the local drug store and the discount houses' "cut-throat tactics," quit complaining and offer some services that they can't offer. Help the customer to more enjoyment and yourself to a healthier business by using your antenna technical knowledge.

## Play Now, Pay Later

In many areas, spring means an increase in both service and sales. Most technicians are looking forward to this, but too few are thinking about the slump that always occurs as the days get shorter and hotter.

Unless you've made enough money this past year to be able to take an all-summer vacation, you'd better plan your summer business program right now.

If you haven't already broken into the PA/or intercom business, this summer might be a good time to do it—if the sales potential is not good in your area, you should investigate the possibilities in renting PA

systems. Check with schools, churches, lodges and other social organizations—summer outdoor activities will always go over better if a good sound system is used. You'll have the same prospects for indoor functions in the winter.

Plan a transistor radio repair campaign; set up a battery headquarters—don't worry about the discount houses. Quality, guaranteed merchandise can still be sold.

But most important, don't wait until the time is ripe—plan now.

# TV/FM Fringe Antenna

■ The problems encountered in fringe type antenna installations are numerous, and many technicians have been discouraged from making these installations. To help technicians understand some of the difficulties that may be encountered in installing fringe type antennas, the editors of *ELECTRONIC TECHNICIAN* have made several installations in and around Duluth, Minn.

Although there is probably no other area with all the problems found in Duluth, we feel the technician will be able to solve the problems in his own area by applying the methods used for the various systems here.

## Considerations

To judge whether any of your customers are candidates for a fringe antenna installation, you will need to weigh several factors: 1. The distance of the closest stations not normally picked up in your area. 2. The signal strength of these stations. 3. Interference problems which might arise from local stations. 4. The necessary expense to achieve satisfactory results. 5. Whether stations already in the area are programming sufficiently different to warrant receiving the additional stations.

Of course, if the goal is to reach more FM stations, then the programming is almost always varied enough to justify more stations. In "fringe only" installations, the goal may be to improve monophonic FM reception or B/W TV reception to multiplex or color standards. In these cases it is almost always easy to justify a more elaborate antenna installation unless interference or other problems are too great.

A general layout of Duluth is shown in Fig. 1. The city is built

on a cliff sloping toward the lake, with the center of town being the low point. Transmitting towers for the two local channels (3 and 6) are situated about halfway across the length of the town on the cliff's peak. Channel 6 broadcasts color programs regularly. Both stations put out a strong signal over most of the area.

The Minneapolis—St. Paul area, approximately 130 miles south of Duluth, has five TV stations: Channels 2, 4, 5, 9, and 11. A little to the east of this area, Channel 13 is broadcasted from Eau Claire, Wis. Because of the proximity of the weak signals on the low band to the strong signals from local stations, it was at first considered only practical to try to pick up channels 9 and 11. As a bonus, we found that we could also receive channel 13 without a rotor.

At the same time, however, we wanted to pick up all the FM stations in that area. Only two FM stations are normally available here, one in Duluth, another about 30 air miles to the east in Wisconsin.

## Solutions to the Problem

Several possible solutions were offered by leading antenna manufacturers. Robert M. Flemming of Winegard felt that a preamplifier on the antenna system would probably be overloaded by the strong local signals. The solution he offered was a pair of stacked 13 element Yagis for channels 9, 11 and 13; another antenna specially designed for fringe FM reception; and a third antenna to receive the local low-band channels to insure good color reception.

L. H. Finneburgh, of the Finney Co. offered a similar solution. One notable exception, however, is that

he suggested using the high-band antenna for local reception as well as for fringe signals; he also suggested using a specially designed FM antenna for fringe FM reception. This may be possible in other installations depending on the positions of the distant and local stations relative to the antenna.

Since the antenna is cut to the high band channels, there is little danger of overloading the set on local signals. Too strong a signal at the set may cause difficulty in receiving weaker signals, even at the other end of the TV band. To a large part, this depends on the design of the receiver.

Both Channel Master and JFD thought broadband antennas might be best, in an attempt to receive all the channels possible. The Channel Master installation uses stacked antennas with a rotor. Both systems use transistor preamps which are easily overloaded on strong local signals. Eliminating overload problems sometimes requires elaborate filtering; this will be discussed in part II.

Jerrold-Taco's Dan O'Connell and A. E. Kushner presented the most extensive plans; stacked Yagis for 9 and 11, with a high band amplifier; stacked Yagis for channel 5, with a channel 5 amplifier; and stacked Yagis for channel 4, with a channel 4 amplifier. No attempt was made in this system to receive FM.

All the systems were used at different locations, which presented problems peculiar to that area, to set up as many obstacles and different situations as possible.

## Probing For the Proper Antenna Location

When it is resolved that it may be possible and feasible to install

# Installations

fringe antennas in your area, a survey will be necessary. A good field strength meter will prove very helpful, here. To date, most of our tests have been conducted with a Blonder Tongue (Benco) portable unit.

Generally speaking, if it is possible to obtain a  $100 \mu v$  signal at the antenna terminals, reception of the station is practical. A booster will be necessary, however, to obtain a snow-free picture and good color reception. The set up shown in Fig. 2 is the method used to check the signal strength. Although an actual survey in terms of  $\mu v$  per meter is possible with dipoles cut to proper length, a survey to determine the feasibility of an installation can most easily be accomplished with the antenna considered best for the job.

The antenna should be assembled, installed on a mast and moved to various locations and heights until the maximum signal is obtained. As a rule of thumb, the signal strength is usually doubled each time the antenna height is doubled. On occasion, however, an increase in antenna height decreases the signal strength. It should not be assumed that raising the antenna will better the signal; all the points within a practical range of mast or towers should be checked and several different locations should be checked to insure against installing the antenna in a dead spot. Dead and hot spots are not uncommon.

Of course, while probing vertically and longitudinally, the antenna should also be rotated for maximum signal strength. Don't guess at the direction of the station; even if you're right you may find that this is not the area with the strongest signal. Fringe antennas have a

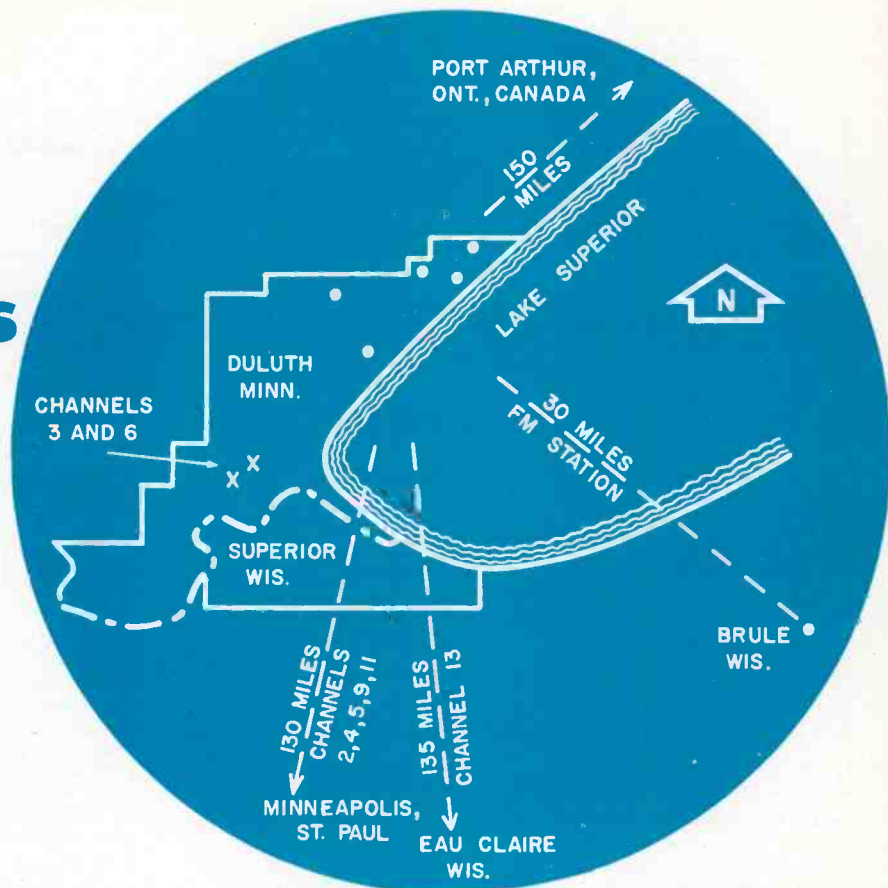

Fig. 1—Map of Duluth area showing the five receiving antenna locations and two local TV stations.

very narrow "angle of pick up" and must be aimed very carefully.

## Installation

There are many different ways to mount a TV/FM antenna. Aside from the various house type mounts, there is the tower mount. The tower, when erected from the ground is undoubtedly the best method. Guying is not usually necessary when the tower does not have to be over 50 ft. high.

The type of twin lead you select will depend on the particular installation. But in every case it should be highest quality of its kind. Although tubular filled or hollow twin lead is a very low loss type, it may be impractical to install in some installations using weathertight preamplifiers. Further, when a mast mounted preamplifier is used the losses introduced in the feed line are of less importance than when no booster or a set mounted booster is used.

In particularly noisy installations, or locations which require minimal pickup of other broadcast signals, coaxial cable should be used. Al-

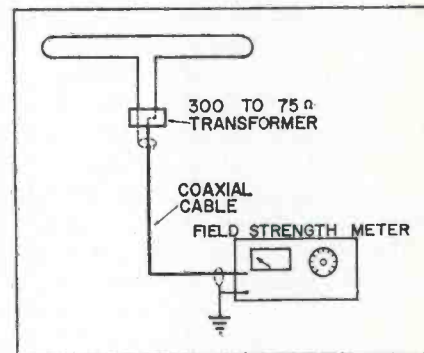
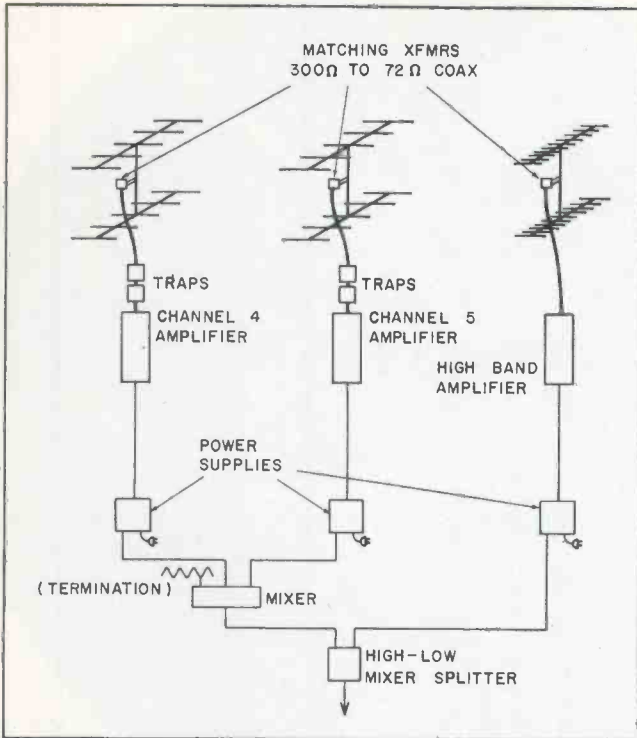

Fig. 2—Hook-up used for making preliminary field strength measurements.

though the cable run still must be kept as short as possible, using standoffs will not be necessary.

It will probably be necessary to hold a meeting with prospective customers to determine some of their viewing and listening habits. For example, if the household has only one TV set and plans on no more, your problems will be minimized. Only one outlet will be required. On the other hand, if more than one TV set is used in the house at the same time provisions will be necessary to feed both sets. If a broadband antenna using a



Jerrold-Taco installation utilizes stacked arrays for each fringe channel.

rotor is employed, then obviously there will be trouble when one viewer wants to watch the broadcast from a station in one direction and the other viewer wants to watch a station in the other direction. Two separate antenna installations or separate antennas may be required to solve such problems.

FM receivers must also be considered in such installations, of course. If the FM tuner is fed directly from the TV antenna, it may be necessary to use a filter or buffer to keep the TV signal out of the FM tuner. Even though the TV signal may not be audible in the tuner, it may cause noise and improper limiting on weak signals. The direction of the FM stations relative to the TV stations must also be considered. ■

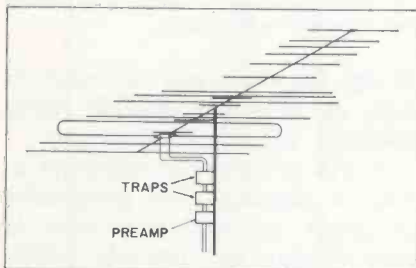

JFD unit. A single broadband antenna with traps and a transistor preamp.

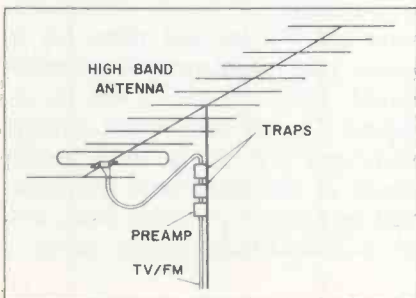

A Finney installation uses high-band antenna for local and fringe stations.

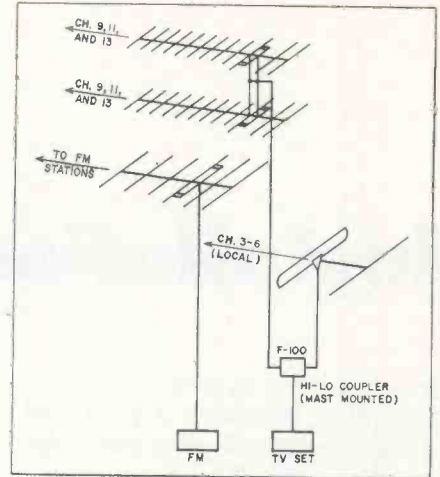

The Winegard installation utilizes no preamplifiers. All antennas (except stacked Yagis) are separated about 5 ft. Separate leads are used for FM and TV signals.

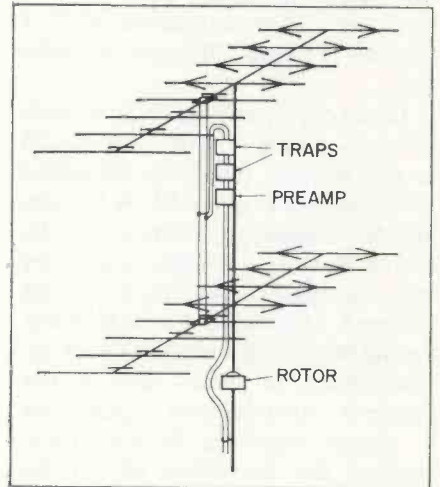

Channel Master installation uses stacked broadband antennas and a transistor preamp. A rotor was used in an effort to pick up other fringe stations.

## CHART I

### DO

1. Run the lead-in straight over the shortest possible route from antenna to set.
2. Use wall or window feed-through insulators.
3. Ground the antenna mast to earth with No. 4 AWG aluminum wire and use a feed-line lightning arrester grounded to mast.
4. Form drip-loops at all connections and points of entry.
5. Twist twin-lead about one turn every 18 in.
6. Guy all masts that extend 10 ft. in height.
7. "Probe" for best antenna location. Use a field strength meter, if possible.
8. Orient antennas for best reception. A guess is rarely good enough.
9. Dress twin-lead on opposite sides of the mast when two lines are used.
10. Spray and tape antenna terminals after connecting feed-line.

### DON'T

1. Parallel lead-in to electrical conduit, down spouts, heating ducts, water pipes or other metallic objects.
2. Pinch lead-in windows, doors, etc.
3. Make right angle bends in the lead-in.
4. Run lead-in parallel to the ground for any great distance.
5. Coil lead-in wire behind the TV or FM set. Cut all excess lead-in from the system.
6. Use "bargain" twin-lead. Thin-web, small diameter conductors, reclaimed copper and Poly isn't economical at any price.
7. Pinch lead-in too tightly in stand-offs.
8. Run two lines on one stand-off.
9. Install long unsupported transmission line runs.
10. Ignore manufacturers' instructions.

■ Master antenna test procedures and test equipment have become important in recent times. Important because today's systems are confronted with increasing demands for better quality pictures, more channels, and additional services—including FM stereo and Pay TV. Whether the system is large or small, the end product must have no visible picture or sound degradation from antenna site to receivers.

#### Picture Quality Standards

It is necessary to establish performance criteria for judging a system. These standards must be expressed in terms of relationships and these relationships are expressed in db.

How do we express a "good" picture in db? A "good" picture must have the proper amount of signal, and the proper *kind* of signal. It is easy to state the proper amount of signal in db with respect to a given reference. The proper kind of signal can also be expressed in db since it can express the ratio between the signal's desired component and the undesired components.

Obviously, if the proper amount and kind of signal exists at the most distant receiver on any leg of the system, it may be concluded that this portion of the system is in good working order. How do we express in db the factors which make up this picture?

(1) The first factor is the amount of signal—both video and audio. This can readily be expressed in db. This should be from 6 db below 1000  $\mu\text{V}$  at any receiver in fringe areas to 10 db above 1000  $\mu\text{V}$  in metropolitan areas.

(2) The video signal should be at least 40 db above any system-introduced noise component.

(3) Cross modulation components should be at least 50 db below the desired video carrier.

(4) Amplitude variations within any channel should be less than 2 db from P-P.

(5) Reflections or ghosts should be 20 db or more weaker than the desired signal.

(6) Power line intermodulation or hum should be less than 0.5 db of total composite video modulation.

Solve amplifier and distribution line problems by observing established specifications and sophisticated measuring procedures

## Standards and Test Procedures

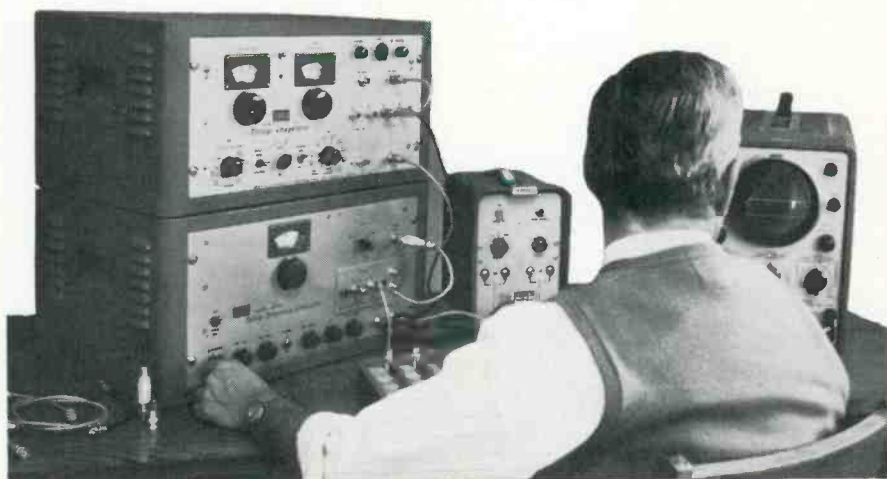

Set-up for checking master antenna systems' frequency response, line reflections, hum, sync compression and radiation levels.

## for Master Antenna Systems

by Vic Nicholson

Jerrold Electronics Corp.

(7) Sync compression should be less than 0.5 db.

(8) Radiation must conform to FCC specifications of less than 20  $\mu\text{V}$  or  $-35$  dbm at 10 ft on the low VHF band and 50  $\mu\text{V}$  or  $-26$  dbm at 10 ft on the high VHF band.

These are the standards. Now a method of measuring them is required. The primary requisite is a good field strength meter. This instrument measures signal strength in db and in addition (when used with an oscilloscope) permits observation of an individual signal.

Another indispensable instrument is a dc oscilloscope with phasing facilities. The scope should have good vertical response to permit critical composite signal observation.

The aforementioned instrument can be considered essential. Incidentally, a good TV receiver and VOM are in the same category, but they are needed for troubleshooting rather than measuring system standards. Other instruments (which are only slightly less essential) include a VHF sweep generator, a marker

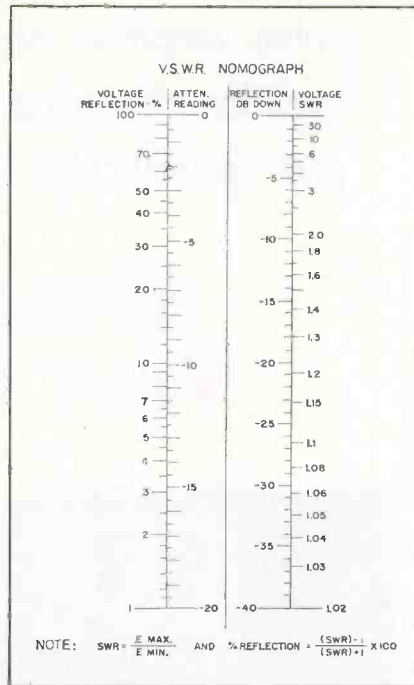
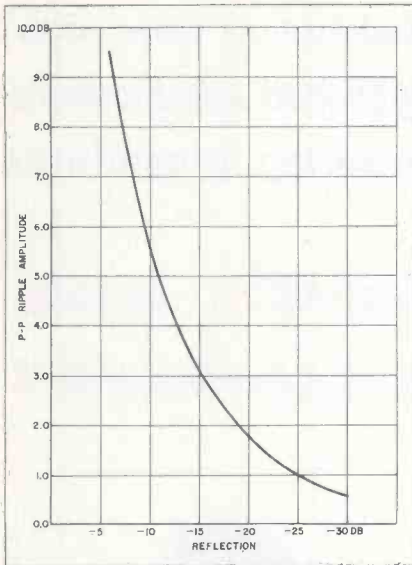

generator for locating frequencies, an attenuator to measure gain or VSWR, and a detector to observe system response.

Finally, equipment to provide faster, more sophisticated testing is highly desirable. An RF electronic switch (flip-flop) and a scope preamplifier are especially valuable. Comparison measurement techniques—comparing desired information from the unit to be measured with a known reference—can then be employed. This technique allows refined accuracy by virtually eliminating test “set-up” errors.

Test procedures must be sufficiently sensitive to measure up to required standards and sufficiently simple to permit frequent periodic system checks without consuming excessive time. A certain amount of time is involved in periodic preventive maintenance checks, but the alternative frequently results in considerable time lost attempting unsuccessfully to solve system problems.

## System Testing

The first system test determining signal levels, calls for a reliable field strength meter. This meter permits video and audio carrier relationship settings, selecting proper

taps to the home or schoolroom amplifiers, level adjustments, and measuring equipment gain or loss by merely feeding a signal through the meter with or without the equipment in the circuit.

The second test (determining signal-to-noise ratio in any part of the system) is also done with a field strength meter. First, a CW carrier is injected at the system’s head end. Next, this carrier as well as the noise at 3 Mc above it, are measured at system extremity. The difference in db between these two is the system’s relative ratio. To convert this to absolute S/N, it is necessary to consider the meter’s selectivity, its bandwidth, and the effect of the peak detector. Adding 5 db to the noise reading will provide the approximate correction factor.

For broadband low channel systems, the CW carrier could well be in the 72-76 Mc guard band. It should be kept 10 db lower than the video carriers so as not to affect the system amplifiers overload capabilities.

Measuring crossmodulation, the third test, is done with a field strength meter plus an additional trap. Crossmodulation is a third-order effect. An example of this would be the sum of two carriers minus a third. It is difficult to meas-

ure this third-order beat because it must be at least 50 db lower than the desired carriers and a frequency that passes through the various system amplifiers. For accurate measurement, use only the video carriers and keep all approximately at the same level.

To measure low band crossmodulation, for example: Channel 3 plus Channel 4 video carriers equal 128.5 Mc—subtracting Channel 2 leaves 73.25. The relative ratio of Channel 4 video vs 73.25 Mc (with Channel 4 audio trapped before the meter) will give the crossmodulation in db.

The fourth test, measuring amplitude variations or the system’s frequency response, should be made while all stations are off the air. This test will interfere with users’ TV reception otherwise. For this test, a sweep generator is installed at the head end. It is adjusted to cover the desired frequency range with output equivalent to a normal TV signal. An oscilloscope, detector, and marker generator are connected to the amplifier output or tap-off device at a system extremity. Response should be flat within 2 db on any channel. If this test shows corrective alignment is needed, amplifiers should be tuned for an over-all flat response.

While making this summation sweep, line reflection (“ghosting”) information can be noted. These reflections show up as sharp ripples or spikes on the over-all response. Spike determines reflection amplitude. A ripple of 2 db P-P represents about 20 db down. Chart I may be used to obtain other signals’ correlations. A VSWR nomograph is shown in Chart II. The outgoing trunk line’s condition can also be determined as this time. Response variations more than 2 db within any channel indicates the outgoing line contains one or more serious discontinuities within the first 10 db of cable.



# and Test Procedures *Continued*

Referring to Chart I, the method of calculating P-P response is as follows:

$$\text{ratio} = \frac{\text{Main Wave} + \text{reflection}}{\text{Main Wave} - \text{reflection}}$$

The voltage is expressed as a decimal number—for example, -20 db reflection equals 0.1.

$$\text{Max. total voltage} = \text{Main} + \text{reflected} = 1 + 0.1 = 1.1$$

$$\text{Min. total voltage} = \text{Main} - \text{reflected} = 1 - 0.1 = 0.9$$

$$\text{db P-P} = 20 \text{ Log}_{10} \frac{1.1}{0.9} = 20$$

$$\text{Log}_{10} 1.22 = 1.74 \text{ db.}$$

## Reflections, Hum and Radiation

The fifth, and a very important measurement, helps determine the amplitude and location of reflections. It is important to determine the amplitude first. Time must first be applied to chasing "first class" reflections. When the large reflections are corralled the smaller ones can be tracked in a leisurely manner.

A "big" reflection, by a somewhat arbitrary definition, is less than 20 db below the main signal—a small reflection, by the same definition, is more than 20 db below the main signal. (See chart II).

When an objectionable reflection is observed in a portion of the system, a VSWR measurement is made on that portion, using the standard sweep-frequency method of introducing the sweeping oscillator signal into the trunk line, through a "feed thru" type of detector. The test set-up is shown in Fig. 1. Ripple pattern amplitude is noted and then compared to a ripple pattern provided by a calibrated reflection source. The calibrated reflection is obtained from a relatively short piece of unterminated coaxial cable (35 ft). This provides a reflection approximately zero db down or about 100 percent reflection condition. A calibrated RF attenuator

is inserted between the "feed through" detector and the short piece of reference cable. The attenuator is adjusted until the ripple pattern is identical in amplitude to the ripple pattern noted from the trunk line—measurement is obtained by doubling the amount of attenuation inserted, since the reflected energy made a round trip through the attenuator.

Having measured the reflection's amplitude, let us assume that the reflection is found to be in the large category (less than 20 db down). All that is needed to calculate its source is to measure the frequency separation of the half wave voltage peaks and use the formula

$$L = \frac{325}{\Delta f}$$

with a propagation velocity of 650

$$\text{ft}/\mu\text{sec} \text{ or } L = \frac{405}{\Delta f}$$

dielectric cable with a velocity of 830 ft/ $\mu\text{sec}$ . "L" is the distance to the point of reflection in feet.  $\Delta f$  is the frequency in megacycles between two peaks which is a half-wave length for a single cycle. Best accuracy is achieved by measuring  $\Delta f$  over 3 or more cycles and averaging the results.

Hum and sync compression levels (tests six and seven) are both measured in the same manner. The field strength meter is used to select, amplify, and detect any desired signal. This detached output is fed to the vertical input of a dc coupled scope. Checks can be made whenever and wherever signal levels are measured. The meter function switch is placed in the "percent modulation" position. This bypasses the meter peak detector and prevents waveform distortion.

A dummy plug placed in the phone jack will prevent meter "pegging;" the range switch should be placed in the "percent modulation" position and the variable con-

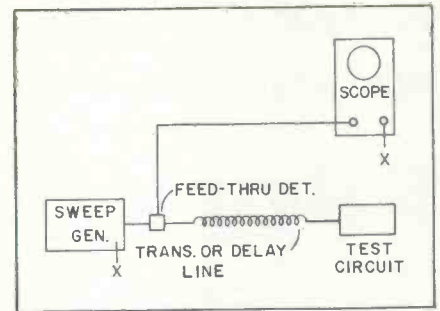

Fig. 1—Block diagram of test set-up used to check VSWR on master antenna systems.

trol or tuner compensator used as a gain adjustment.

The scope's horizontal sweep frequency is adjusted to 30 cps. This permits observation of two frames—readily disclosing hum modulation on the carrier. Both 60 cps hum (usually caused by tube cathode-heater leakage) and 120 cps hum (usually caused by defective filtering in the power supply) can be detected. To observe and measure the percentage of hum or sync, it is necessary to have a reference base line to represent zero. Assuming the scope has 20 divisions, each division is roughly 5 percent or 0.5 db. The hum's P-P should be within one division and the total amount of sync 5 divisions of the 20.

While observing the scope for these factors, it can be noted whether other degradation factors exist: co-channel interference, sync pulse distortion, linearity of modulation and snow in the picture.

The eighth test, for determining radiation levels, is important since radiation may cause interference on TV receivers external to the system. Radiation is measured by a tuned dipole, mounted on a pole. The signal received can be read on a field strength meter at 10 ft from the amplifier or lines.

These are field measurement techniques for signals of "no visible degradation," using the minimum amount of equipment. Additional pieces of test equipment—RF electronic switch and scope preamplifier offer even more sensitive test procedures. ■

Cut troubleshooting time with bold application of logic, experience and knowledge of basic theory

# Solving 'Tough-Dog' Oscillation

by George P. Oberto

■ TV-radio "tough dog" oscillation and regeneration problems are major headaches for technicians—especially if the trouble is intermittent. And considerable time is generally wasted before defects are finally pinpointed. But if technicians use logic, theory, experience, and observe symptoms carefully, most of these tough-dog problems can be solved quickly.

Although a book could easily be written to cover all oscillation and

regeneration faults and troubleshooting techniques for localizing malfunctions, considerable knowledge can be gained by evaluating a few typical cases and by noting how they were resolved—including test procedures and methods used for quick and effective repair.

## TV RF Oscillations

A Philco model 53-T2183 TV chassis was recently brought in. A herringbone pattern appeared on the screen at times. The picture lacked fine detail on stronger channels. Reception on weaker channels was wiped out when the intermittent condition occurred. And the set would often operate normally for weeks in the owner's home before trouble developed.

Subsequent checks showed that the trouble was originating in the channel selector's RF section. Further checks revealed the 1M cascode RF circuit resistor from the 6BZ7's pin 2 to ground (Fig. 1) had increased in value. Replacement of the resistor and 6BZ7 tube

appeared to eliminate the trouble. A few weeks later, however, a call from the customer indicated the trouble had returned. The set was brought back to the shop.

A recheck of the tuner showed nothing wrong. When the trouble finally returned, a .02  $\mu\text{f}$  capacitor was bridged across the 6BZ7's pin 2 and ground (Fig. 1). No change was noted. Then a .01  $\mu\text{f}$  capacitor was bridged across the PC unit containing a .01  $\mu\text{f}$  capacitor and 470K resistor. This PC unit is connected to the tuner AGC line and to a 22K resistor from pin 7 of the 6BZ7. The oscillation disappeared. When the capacitor was removed the trouble returned. A .01  $\mu\text{f}$  capacitor and 470K resistor was substituted for the PC unit and no further trouble occurred.

A somewhat similar problem was encountered with a G-E portable having a 3BC5 amplifier tube. The complaint was similar in nature and the 1000 pf screen bypass capacitor had changed to a much lower value (Fig. 2).

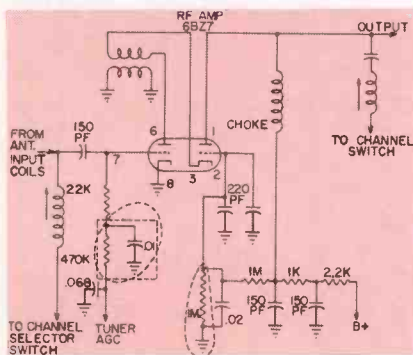

Fig. 1—Simplified schematic from Philco's Model 53-T2183 TV chassis. Oscillations were caused by a defective PC unit in the 6BZ7's AGC circuit. The 1M resistor in the pin-2 circuit had increased in value also.

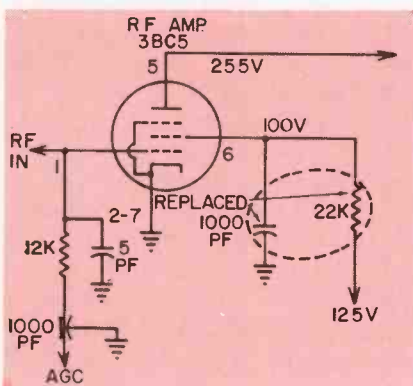

Fig. 2—RF amplifier circuit of G-E's portable where oscillations were caused by a defective 1000 pf screen bypass capacitor. The 22K screen resistor had drifted out of tolerance too.

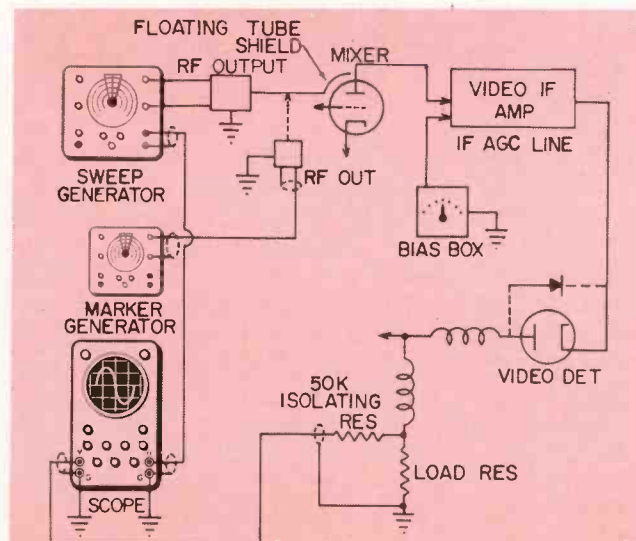

Fig. 3—Hook-up for checking regeneration and oscillations in TV mixer and video IF circuits.

# and Regeneration Problems

Since the trouble in the G-E set appeared only after it had operated for several hours or more, the 1000 pf capacitor's intermittent condition was determined shortly after the set was switched on in the shop by placing the tip of a hot soldering iron close to the component. When the capacitor was allowed to cool, the trouble disappeared. Replacement of the capacitor and resistor eliminated the trouble permanently.

## TV Mixer Regeneration

Trouble in the channel selector's mixer circuit can also cause regeneration or oscillation problems. The mixer can react as a tuned-plate tuned-grid oscillator or regeneration circuit. To locate trouble, a sweep generator, oscilloscope, AGC override bias box and a 50K isolating resistor can be used.

Begin by disabling the local oscillator (remove tube in parallel heater sets or use a special tube with either the grid or plate pin removed in series string sets). Connect the sweep generator output to a floating tube shield over the mixer tube (Fig. 3). Voltage from the bias box is then connected to the IF AGC line. Finally, connect the scope across the video detector load resistor through a 50K isolating resistor (Fig. 3).

Adjust the generator's sweep to 10 Mc and display the set's IF response curve on the scope screen.

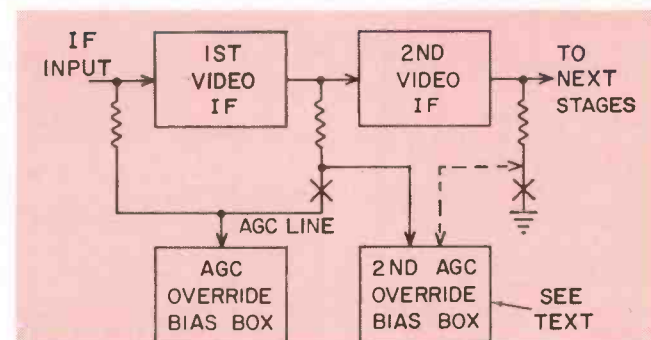
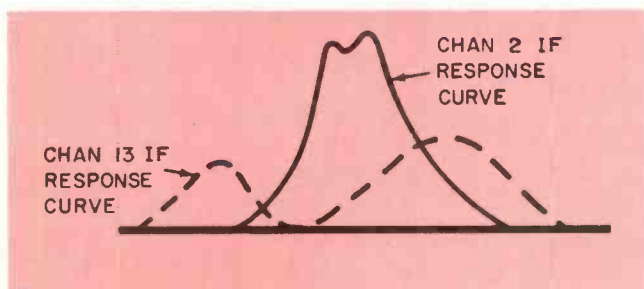

Fig. 6 — Block diagram showing separate bias box used to locate a regenerating or oscillating video IF stage.

Fig. 5 (A)—Normal over-all video IF response curve with marker pips as seen on scope. (B)—Curve indicating regeneration.

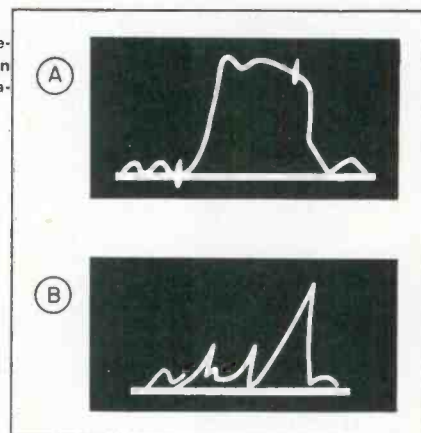

Fig. 4—Normal IF response curve on channel two. Channel 13 response curve (dotted) indicates regeneration or oscillation in the mixer stage.

Rotate the channel selector through channels 2 to 13. If regeneration or oscillation is taking place, wide changes will occur in the set's IF response curve as seen on the scope (See Fig. 4). If regeneration or oscillations are not taking place the response curve will remain essentially constant in shape.

## Checking Video IF

A video IF strip can be checked for regeneration or oscillation by using the same set-up shown in Fig. 3. The over-all response curve is displayed on the scope in the usual manner. But the bias is reduced to about 0.5 v. If the curve becomes distorted or is displayed as a marker or simple base line, the IF is going into oscillation or regeneration.

The IF is operating normal if the response curve remains reasonably stable at the low bias. Typical scope waveforms are shown in Fig. 5.

To signal trace an IF amplifier for a regenerative feedback loop, connect the sweep generator output through as large a resistor as will permit a reasonable signal into the last video IF input and allow observation of the response curve of this stage. Next, shunt a 0.01  $\mu$ f disc-ceramic capacitor across each IF grid and chassis ground. Start with the first IF and work up the line—noting any change in curve shape. If a change takes place in the response curve shape at a point when the bypass capacitor is shunted across a grid, this indicates the point of entry for the feedback

loop. If no change occurs when the bypass capacitor is shunted across a grid and chassis, this indicates that we have moved out of the feedback loop.

Now knowing where the feedback loop begins we proceed to check capacitors, resistors and other components until the trouble is isolated. By bringing capacitors across suspected plate, screen and AGC circuit capacitors we can frequently locate the trouble quickly.

Another method for tracking down a regenerating or oscillating stage is to increase grid bias on each stage at a time by connecting a separate override bias box (Fig. 6). When a stage is located where an increase in bias reduces regeneration or oscillation as seen on the scope's IF response curve, check for faulty components in this stage.

### Oscillations In TV Sound IFs

An olympic 17 in. portable (17-TU94) showed intermittent oscillations in both picture and sound. The trouble wouldn't show up for days, frequently disappearing a few min-

utes after beginning. We had to work fast to pinpoint this one.

Since picture and sound were both affected, the trouble could be in the tuner, video IF or sound IF. To localize the oscillating section, pin 7 (control grid) of the 6AU8 video amplifier was shorted to chassis with an insulated-handle screwdriver. This prevented entry of signals from the tuner and video IF area. But the oscillating sound could still be heard in the speaker. The scope was connected to the 3DT6 audio detector grid and the oscillation pattern was visible.

Next, the 4.5 Mc sound take-off coil was shorted and all oscillations disappeared—in both picture and sound. The same condition occurred when pin 2 of the 6AU8 (grid of the triode section serving as sound IF) and likewise when the 4.5 Mc sound IF coil in the 3DT6 grid circuit was shorted out. The trouble was thus pinpointed to the 6AU8 sound IF amplifier. The 6.8 pf NPO capacitor (See Fig. 7) was replaced, completely eliminating the trouble.

### Radio Oscillations

A customer entered the shop carrying an old prewar Philco 645 all-wave receiver he wanted completely overhauled. After tubes and needed components were replaced to put the set in tip-top condition, it was noted that the set tended to go into squeals and birdies—especially on the 6 Mc end of the 3 to 6 Mc band. All parts checked out okay.

After prolonged 6A7 oscillator circuit checking, the 15K resistor feeding the oscillator coil secondary, connected to B-plus and pin 4 of the 6A7, was increased to 25K. (See Fig. 8). The trouble disappeared. A 25K 1 watt resistor was installed permanently—completely eliminating the trouble. Variations in circuit components over the years frequently make a simple circuit change easier than rebuilding the entire radio.

A rather unusual oscillation problem was encountered with a simple 5 tube ac/dc radio. The owner complained of intermittent squeals, howls and birdies—completely ruining reception of most local stations. A VTVM was connected to the AVC line feeding the converter and IF control grids (Fig. 9). The receiver was switched on and tuned to a vacant spot on the dial. When the set finally burst into oscillation the AVC reading looked normal until the AVC was shorted out at the opposite end of the 3.3M resistor, connected to the high side of the set's volume control. The VTVM showed a slight positive reading—indicating a positive bias on the 12BE6 and 12BA6 control grids. When the first IF transformer secondary was disconnected from the circuit the VTVM read a slight positive voltage showing leakage across the first IF transformer. Replacing the faulty IF transformer eliminated the trouble.

### Some Precautions

When replacing parts in a TV tuner use exact replacement components when possible. Be sure to mount the parts with the same lead lengths and in the exact spot of the original. Check lead dress of grid and plate wires, check shielding, in-

*Continued on page 89*

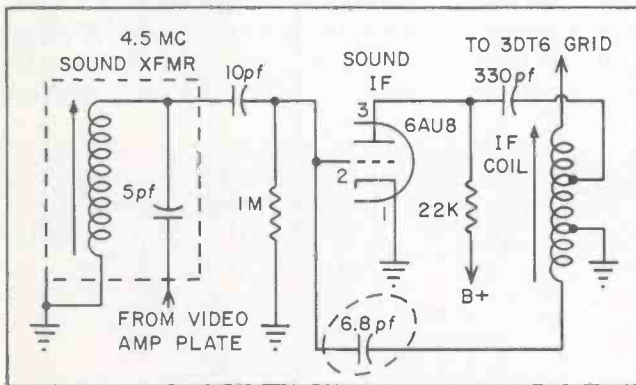

Fig. 7—Intermittent oscillations in Olympic's portable 17TU94 TV caused interference in both picture and sound. Interference disappeared when the defective 6.8 pf capacitor was replaced.

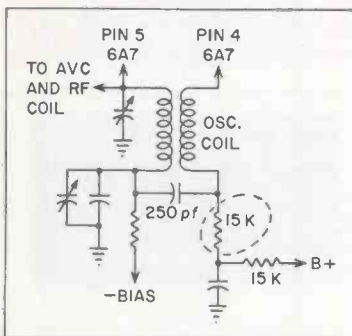

Fig. 8—Squeals and "birdies" in an old radio were eliminated by raising the resistor value in the radio's oscillator coil secondary.

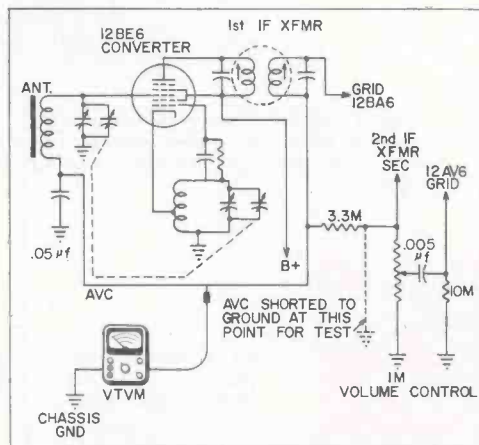
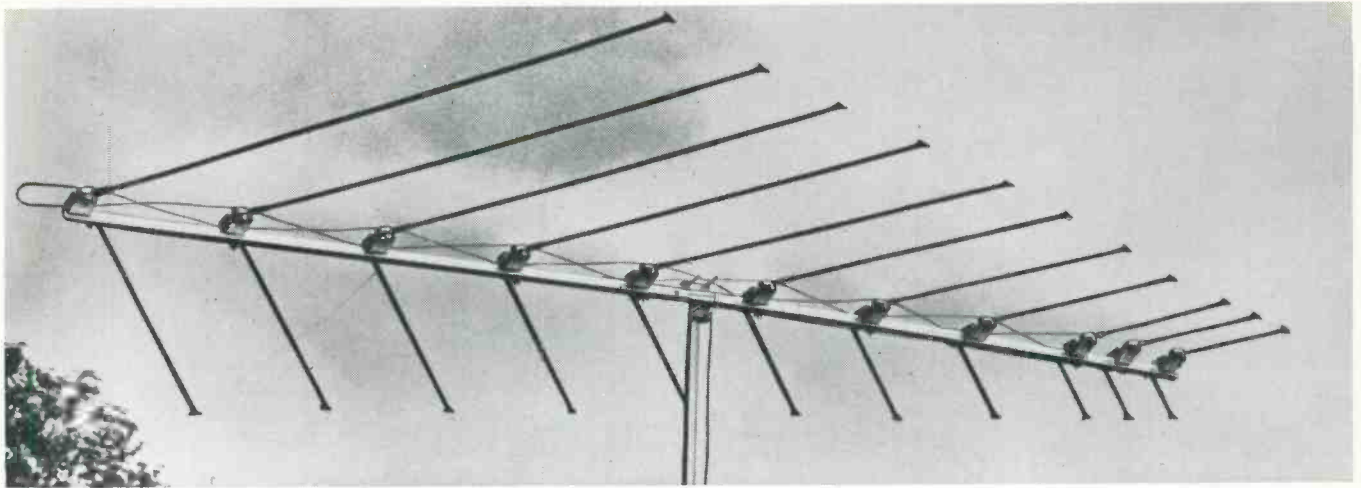

Fig. 9—Intermittent leakage across the 1st IF transformer was detected with VTVM by grounding AVC as shown.



# The LPV Antenna

■ Most antennas for fringe areas reception are based on the yagi design. However, while the yagi offers high gain and high front-to-back ratio, it cannot cover the entire VHF TV band from 54 to 215 mc. A simple yagi is most effective for a single channel, a spread of only six Mc. Modified yagis, which contain dipoles cut for the center of the low and high bands and an array of various size parasitic elements for broadening the bandwidth, generally yield good gain at the high end of each band and degenerate at the low ends. The LPV (log periodic "V") antenna, on the other hand, is relatively independent of frequency.

Since the spiral is based on a logarithmic shape and is relatively frequency independent, it was thought that a planar antenna, whose element lengths were related to each other in the same manner, might also exhibit the same independence of frequency and uniform impedance offered by the conical spiral. With this in mind, the JFD research department developed the LPV.

Essentially, the LPV antenna incorporates two separate design concepts: (1) the log-periodic factor, which determines the size and spacing of the elements and, (2) the forward V shape of the elements, which permits multi-mode operation.

The basic planar log-periodic an-

tenna is an array of dipoles in which the length of each element bears a fixed ratio to the length of the preceding element. This ratio is called the scale factor and is designated by the Greek symbol " $t$ " (tau). The spacing between adjacent dipoles may also be similarly fixed by a ratio,  $\phi$  (sigma). These relationships are shown in Fig. 1, where  $h$  denotes element length and  $d$  represents the spacing between dipoles. Each dipole is equal to an adjusted half-wavelength at a different frequency, making the dipole resonant to that frequency. The scaling factors  $t$  and  $\phi$  are chosen so the desired frequency range is covered with elements of overlapping resonances. In this way, as the frequency changes, the function of the resonant dipole will be transferred

smoothly from one to the next.

Typical values of tau and sigma are 0.9 and 0.985, respectively. These, in fact, are the actual values that were used in one of the many experimental models developed in the laboratory.

Of particular importance relative to gain, is the characteristic impedance of the antenna, and the closely allied factor, voltage standing wave ratio (VSWR). If the impedance of the antenna varies appreciably from that of the transmission line at any point in the bandwidth of the antenna, a mismatch will exist between the antenna and the lead-in. Such a mismatch decreases signal power and introduces standing waves along the line leading to further signal reduction and ghosts.

*Continued on page 89*

Fig. 1 — Simplified diagram of a seven-cell log-periodic V antenna showing how the elements are scaled. Each cell consists of a dipole and the associated transposed phasing harness.

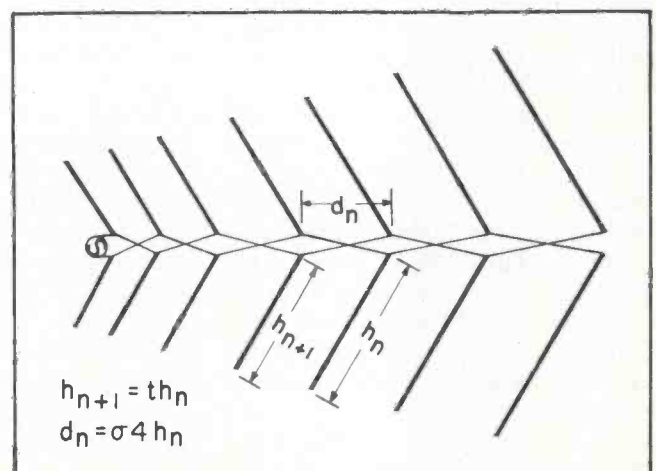

Multiply profits quickly and serve your customers better with in-home sales techniques

# Increase Your Income on TV Service Calls

by *Lon Cantor*

Blonder-Tongue Laboratories, Inc.



■ Every time you enter a customer's home to repair his TV you're working against a \$\$\$ handicap.

It costs \$2, \$3 and more, depending upon your overhead expenses, to get this far. Most TV repair charges aren't high enough to overcome this operating expense and leave net profits that truly reflect professional services. Even in the face of limited service fees, however, you can greatly increase in-the-home earnings with only modest additional efforts. You can make customers aware of a host of services and products you provide beside repairing TVs.

The minute you step across a customer's threshold on a service call, many extra sales opportunities suddenly present themselves. Items that will improve TV reception, increase operating convenience, add to listening enjoyment, are some you can sell with little effort.

You needn't adopt tactics of high-pressure door-to-door salesmen to make a sale. You don't have to. You've already been invited into the customer's home (something many companies spend fortunes to achieve). This invitation is an indication of the confidence your customer has in your integrity and technical capability. Thus any recommendation you make on a technical product will be accepted with this in mind. Remember, too, in

many cases the product you suggest is one your customer is not aware of and can't obtain readily from a local source. The result: you've got a natural sales platform without extra costs and requires little effort to add to your profits. It's good business sense to take advantage of it.

## In-the-home Sales Techniques

Perhaps the most difficult aspect of selling is the opening, the "approach" that starts a sale toward a successful conclusion. This is the area where TV-radio technicians lack confidence. Usually there are two reasons: (1) he's an inexperienced salesman, and (2) he's afraid to neglect his primary job — repairing the customer's TV set. How does he start a sales spiel?

Most technicians who have built up a successful sales business overcome these problems by carrying a prepared sheet of extra services and products offered. Some use a single typed sheet of items protected by a plastic covering. Others build sales with a more elaborate loose-leaf binder containing numerous sheets that include products such as transistor radios, phonographs, etc. Ask your distributor for manufacturers catalog sheets as giveaway stuffers. Others utilize inexpensive mimeographed flyers that customers may retain.

A simple sentence like, "You may be interested in some of the items shown here," can set the stage for handing the sheet to customers. They'll take it from there while you're repairing their TV set. Sometimes a provocative title like, "We Can Increase Your TV/Hi Fi Listening Pleasure," printed boldly on a cover sheet, is used to encourage customers. Whatever the message or method employed, it should induce customers to ask questions.

One manufacturer provides TV technicians with a plan to arouse customers' curiosity without uttering a single word. The plan is part of a caddy demonstration kit that enables technicians to set up a quick home demonstration of TV antenna boosters that few customers can resist. The kit contains two indoor TV signal boosters — a transistor unit and a tubed unit — in a unique package that bears the bold, imprinted message: "WANT A SHARPER TV PICTURE? ASK ME!" The compact kit fits snugly into all tube caddies for quick availability on house calls.

The successful sales technique devised and tested by the manufacturer can be used on any service call: Technicians are advised to place the item on top of the TV set with the message facing the customer, and then proceed to repair

the set. In most instances, the customer asks about the message, wondering how his TV picture can be improved. This is the technician's cue to reply that he'll give him a full demonstration after the set is placed in working order.

When the TV set has been restored to proper operating condition, the demonstration begins. First, the TV technician disconnects the antenna lead from the set. Next he attaches the lead to the selected booster's input terminals, and the booster's output to the set's antenna terminals. Technicians using this sales-demo device generally attach a short length of antenna wire to the output terminals for quick demonstration purposes. The customer sees the difference in before-and-after performance. The sharper picture resulting from increased signal strength fed to the receiver tells a dramatic sales story that sells signal boosters.

The booster demonstration, of course, can't be given in every case. In the event that signal strength is satisfactory, as indicated by a crisp, snow-free picture on all channels, it would be senseless to demonstrate the booster. Today, many TV boosters have integrated multi-set couplers. He can stress that the coupler and the amplifying power of the booster can improve reception of several TV sets and FM tuners and operate them from one antenna.

If a technician spots a situation where a customer is operating second or third sets from indoor antennas while the original set is operating from an outdoor antenna, the suggestion of a booster/coupler usually results in a sale.

It may be pointed out here that technicians should use their own judgment in selecting which booster to use — the transistor unit or the tubed unit. Most customers will prefer the transistor unit because it is more compact, draws minimum current and has an exotic space-age appeal. However, in areas with very strong local stations, it may overload and cause some interference effects. Accordingly, a tubed booster should be used in such cases. Stripless terminals permit antenna lead transfers to be accomplished in seconds without splicing or cutting.

TV Technicians in weak signal areas who make it a point to mention and demonstrate boosters have sold from 3 to 5 extra boosters a week — a sweet profit of about \$50.

#### Other Products Customers Need

There's virtually no end to the type of products and services that customers are interested in. Aside from signal boosters, passive couplers are fast-sellers in areas where TV signals are strong enough to drive multiple sets. There's a pressing need for couplers in strong-signal metropolitan areas but where only one set is operated from one antenna. Here's where a set now operating on rabbit ears in the children's room can benefit by increased signal strength from an existing roof antenna. At the same time it does away with the unsightly rabbit ears antenna. Also, an FM tuner's antenna, often formed into a half-wave dipole with a few feet of antenna wire, can be replaced by a 2 or 4-set coupler that will bring in more stations, make existing station reception clearer. With an FM multiplex tuner, in fact, it's often imperative to use a roof antenna to reproduce stereo signals satisfactorily because it's about 20 percent weaker than mono FM signals.

Since many TV set owners move

their receivers to different areas: bedroom to living room, living room to porch, etc., perhaps you can include wiring a home or apartment with TV jacks on your sales sheet. This will enable your customers to get better reception on their roaming TV receivers wherever they're moved. And TV jacks, in this case, will relieve owners from the irritating task of disconnecting the roof antenna every time they move the set from its original position.

Converting VHF TV sets for UHF reception is another promising sales area that TV technician's shouldn't neglect. With non-commercial UHF stations springing up all over the country, most consumers in areas with newly inaugurated UHF channels are strong prospects for conversions. Last year the Better Business Bureau of New York said it received innumerable complaints from consumers saying they couldn't locate anyone to convert their TV sets to receive New York's UHF channel 31. This proves that TV technicians must promote their own services, or they won't get their share of extra profit business.

If UHF programs have recently started in your area, conversions can be your hottest sales item. Your sales sheet can note the availability of a greater choice of pro-

*Continued on page 90*



Sign on TV antenna booster demonstration kit arouses TV owner's curiosity and helps sell boosters.

Select a lead-in to fit the particular antenna installation if you are aiming for 'fail-safe' results

## A Closer Look at

by *Roland Miracle*

Belden Manufacturing Co.

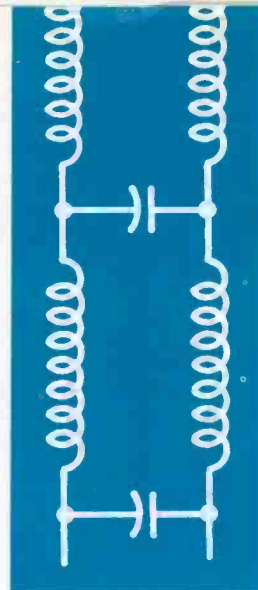

■ TV and FM radio antenna lead-in accounts for only a fraction of a receiving system's cost but its physical and electrical characteristics can make the difference between good and bad TV or FM reception. Selecting the optimum feed-line for a given installation is just as important as installing a suitable antenna. Additionally, consistent results over a long time period requires a high quality product.

### Lead-In Characteristics

The sole requirement for a dc or 60 cps power transmission line is low dc resistance. At RF frequencies, however, the effects of capacitance between the conductors and the inductance of the conductors must be considered.

Since each unit length of RF line has the same physical dimensions, each length will have identical inductance (L) and capacitance (C). When the transmission line is terminated in an impedance equal to  $\sqrt{L/C}$  (characteristic impedance) energy will travel along the line to the termination where it will be absorbed. When the line is terminated in an impedance other than  $\sqrt{L/C}$ , some of the energy is reflected back from the termination, causing a power loss (mismatch loss). TV and FM receivers generally have a characteristic input impedance of approximately 300Ω. Correct lead-in impedance is maintained by careful control of conductor size and spacing.

Lead-in is subject to three kinds

of signal losses (other than mismatch loss), and these losses increase with signal frequency.

**Conductor Loss.** Signal current flowing through the lead-in conductors dissipates energy in the form of heat. At VHF and UHF frequencies this loss rises rapidly with frequency increases because the current flows increasingly nearer the conductors' surface (skin effect), reducing the conductors' effective cross sectional area.

Since the incoming signal occupies only the thin outer layer of copper on the lead-in conductors, steel cores can be used in the center portion of the conductors. Iron-core type lead-in has about 150 percent greater breaking strength and about 250 percent greater flex life than lead-in made of similar size all-copper conductors. High frequency conductivity is approximately the same in either case.

**Dielectric Loss.** Dielectric losses are caused by insulation material heating when a voltage difference exists between the lead-in conductors. Air, cellular polyethylene, solid polyethylene and some other dielectric materials have relatively low losses. A dry air dielectric has the lowest loss.

**Radiation and Induction Losses.** These losses result from fields surrounding the conductors. When the field around the conductors is disturbed by a metallic object, a metal stand-off insulator for example, current is induced in the metal, resulting in power loss. Ad-

ditional loss occurs because some of the energy radiates into space.

### Feed-Line Types

Transmission lines for TV and FM receivers include flat lead, open wire line, tubular lines (cellular core and hollow), cellular polyethylene, shielded and co-axial lines.

Open line has two parallel conductors kept uniformly apart by insulating spacers. These open lines have a very low dielectric constant but losses increase with the amount of moisture in the air. The unwieldy physical structure and packaging of open lines discourage their use except in installations requiring minimum line losses especially when the antenna must be located a considerable distance from the receiver.

The most popular feed-line has been flat twin-lead. It has two parallel conductors molded in polyethylene insulation. This transmission line has become the work-horse of technicians installing antennas for VHF TV and FM radio reception. It is made with solid copper or copperweld conductors. The steel core conductor twin-lead (See Fig. 1) offers superior resistance to pulling and wind stresses, whipping and twisting and guarantees a longer lasting installation.

Losses in all transmission lines increase in wet weather. Moisture forms a conducting path across the dielectric between the conductors. (See Fig. 2.) Tubular twin-lead is designed to reduce wet weather



# TV/FM Transmission Lines

and normal dielectric losses by lengthening this conducting path between conductors and by providing air as part of the dielectric. Hollow tubular lines, however, accumulate considerable moisture through condensation caused by temperature changes.

Some tubular twin-lead is made with a core of cellular polyethylene between the conductors. This provides a lower dielectric constant (1.5 for cellular polyethylene) and results in a more rigid line too. This semi-rigidity reduces line flutter in heavy wind and when a rotor is used in the antenna installation, the lead-in holds a firm position around the rotor. The cellular core eliminates the need for end-sealing the lead-in after installation, and reduces moisture condensation to a very low level.

Electrical characteristics of cellular core twin-lead provide an excellent feed-line for UHF, VHF TV and FM antenna installations. Where optimum reliability is required — in color TV and FM stereo reception, for example — the cable offers significant advantages.

## Encapsulated Line

Signal losses caused by salt spray accumulating on the lead-in is a problem in some installations along coastal areas. The conducting material (wet salt) interrupts the electromagnetic field around the conductors and causes losses. The major portion of the electromagnetic field around the con-

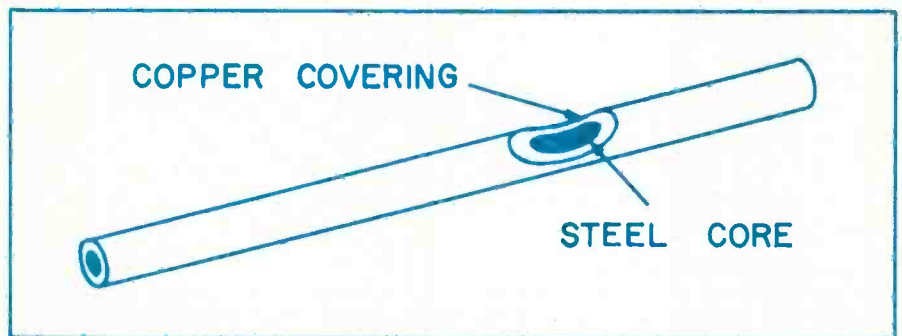

Fig. 1—Cut-away section of Copperweld twin-lead conductor.

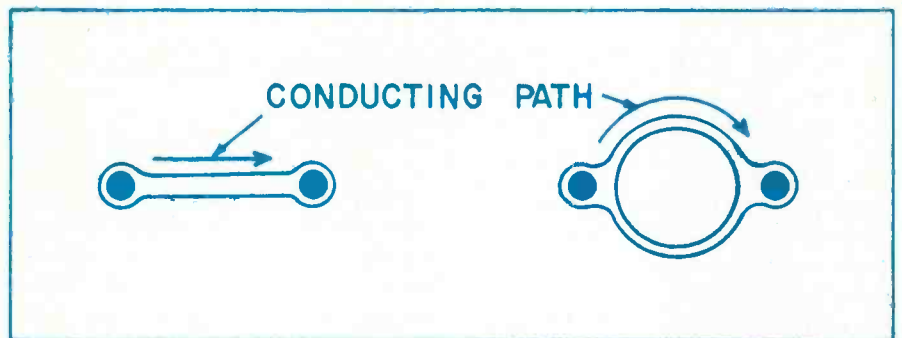

Fig. 2—Wet weather losses are greater across shorter moisture conducting path of flat twin-lead than across longer tubular twin-lead conducting path.

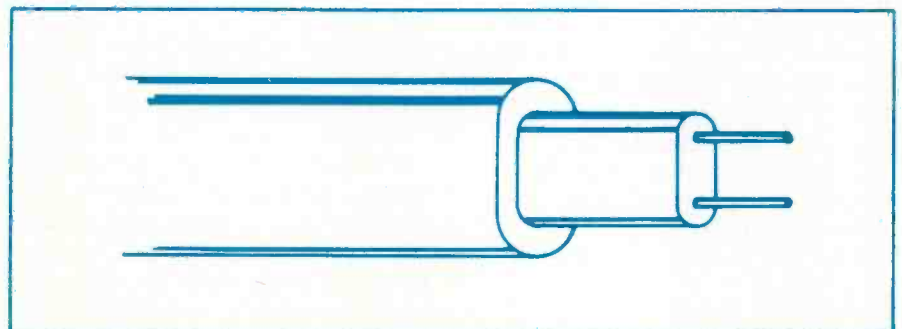

Fig. 3—Encapsulated twin-lead is designed to reduce salt-spray, smog, industrial contamination and snow deposit losses.

## A Closer Look

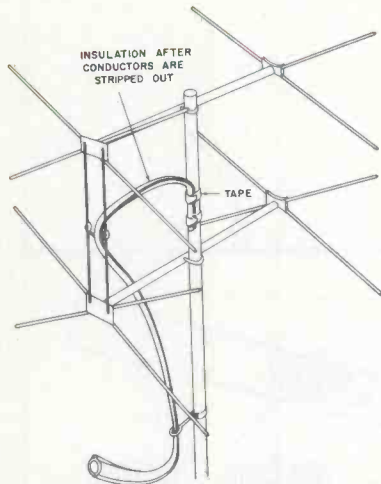

Fig. 5—Center of feed-line is taped to mast after conductors are connected to antenna terminals. This ship-shape job prevents strain on terminal connections. Terminals should be "doped" and taped over after conductors are connected.

## at TV /FM Transmission Lines

### Continued

ductors extends outward from the conductors only about one-half the spacing distance between conductors. By filling this area with cellular polyethylene salt accumulation is kept out of the field. Losses caused by smog, industrial contamination and snow deposits are also reduced.

The outer layer of cellular polyethylene encapsulated twin lead (See Fig. 3) is bonded to the inner web of solid polyethylene to prevent entry of outside moisture. This line is also recommended for installations within building walls where conducting objects may be present or moisture condensation takes place.

#### Other Lead-In Types

Shielded twin-lead has a braided

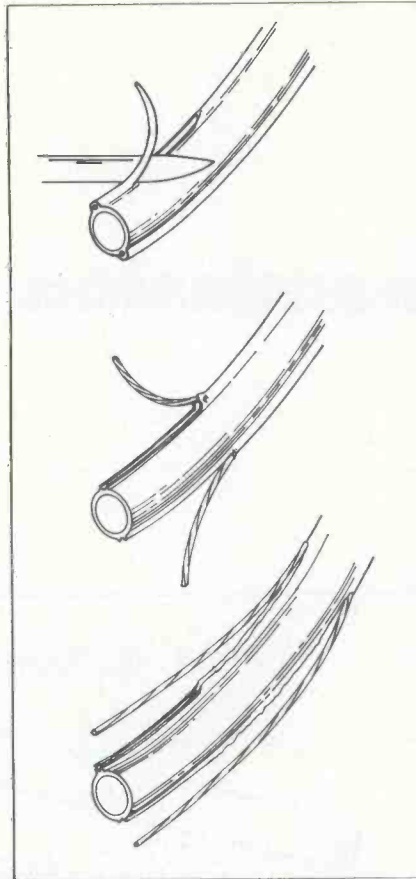

Fig. 4—Slice off polyethylene covering from both conductors, and pull back wires to prepare feed-line end for connection to antenna terminals.

copper shield outside both conductors. It has advantages and disadvantages. It eliminates the effects of conductive objects which would interfere with the field around the conductors. But losses may result at certain frequencies if the shield is in the outer edge of the electromagnetic field surrounding the conductors. In addition, since most shielded lines have a characteristic impedance of  $200\Omega$ , some mismatch losses will occur.

Coaxial Cable has concentric conductors separated by solid or cellular polyethylene insulation. It is used for special applications. Since coaxial transmission lines are unbalanced and have a  $75\Omega$  impedance, suitable matching transformers must be used to match TV/FM receiver inputs.

RG-11/U and RG-59/U coaxial cable types, with line amplifiers, are recommended for hotel, motel, hospital, apartment house and similar master antenna system installations, or in situations where high ambient noise levels exist.

#### Helpful Tips

Regular flat and tubular lead-ins should be routed away from gutters, conduit, water pipes, metal baseboards and similar obstructions. Insulated stand-offs should be used approximately every 4 to 6 ft. Special standoffs are required for UHF. Lead-in (except coaxial) should be twisted (conductors transposed) about once every 18 in. to minimize external object effects and electrical fields.

When the installation requires more than one lead-in (FM, UHF or VHF, individual lines should be spaced a minimum of 6-in.

Use a knife to prepare the twin-lead ends for termination (See Fig. 4). Cut the insulation along the outside of the conductors and spread the conductors to the side. This leaves the center intact for attachment to the mast (see Fig. 5), providing physical support for the lead-in at the antenna terminals.

Cellular core and encapsulated lead-in are heavier than flat twin-lead. Because of the added weight it is desirable to use No. 6 lugs to fasten the line to the antenna terminals. Coating the terminals with coil dope, acrylic spray or similar material after the connections have been made, will postpone corrosion damage. Insulated staples should be used to secure lead-in indoors. Metal nails, tacks and other metal fasteners interfere with signals.

Lead-in for antenna-mounted boosters where dc or ac power and RF signals from the booster must be supplied over the same line, should have 18 AWG size conductors.

Transmission line dielectric research in recent times has produced information indicating that a particular type of polyethylene insulation pigment is an important factor in preventing transmission line deterioration caused by certain rays in the solar spectrum. ■

# FM Stereo Antennas

■ The boom in FM stereo sales should lead technicians to extra antenna sales and installations. Here's why you need a good antenna for proper stereo reproduction.

The FM antenna found in console phonograph units is a dipole antenna usually constructed from 300  $\Omega$  transmission line. The antenna is permanently attached to the rear of the cabinet. Sometimes this antenna arrangement provides an adequate signal for satisfactory FM and FM stereo reception, but a large majority of sets will need a better installation for satisfactory FM stereo reception. In fact, to realize the best performance from FM stereo reception considerable thought and care should be given to the antenna system.

As in television service experience, a good antenna system is one of the most important items to consider to assure satisfactory reception. The stringent antenna requirements necessary for color television reception compared to monochrome television reception may be used as a guiding analogy to understand the requirements for FM stereo reception as compared to monaural FM reception.

The principal requirements of a good antenna system are: (1) to provide an adequate signal input to the tuner; (2) to prevent distortion-producing reflected signals from being picked up; (3) and to avoid reflected signals in the system itself which would result in losses and distortion.

The effective fringe area of FM stereo is much nearer to the station than the monaural FM fringe line. Because of the FM stereo composite signal and inherent noise characteristics, it is not uncommon in outlying areas, to experience background noise when receiving an FM stereo transmission and then to observe a quiet background noise level when switching to monaural FM while tuned to the same station.

The signal input requirements to the tuner for noise limiting is ten times (or 20db) for FM stereo transmission as compared to FM monaural transmission. As an example: if an FM tuner requires a

10  $\mu$  v signal for limiting on FM transmission, then this tuner would require a 100  $\mu$  v signal for limiting on FM stereo transmission. This condition explains the necessity for a better antenna system for good reproduction in areas which may be considered fringe areas for FM stereo, but adequate service areas for monaural FM.

A poor TV antenna can cause "ghosts" in the picture; the same condition can deteriorate FM stereo reception. The modulating

frequencies of monaural FM (or L+R) signals fall off at or below 15 kc. The FM stereo signal (L-R) ranges in frequencies up to 53 kc, and the same station may have a storecast channel where its signal frequencies are the area of 60 to 75 kc. Signal reflections (multipath) may affect the FM signal sub-carrier side bands (those frequencies that make up the stereo signal) and result in distortion. These distortions will not be apparent in the monaural (L+R) FM reception. Therefore, too often a

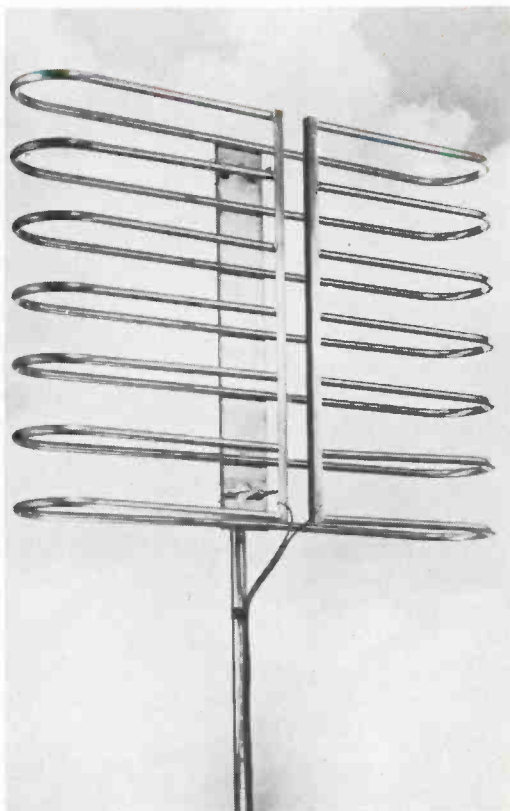

B&K/ Mark model ST7B FM antenna unit is omni-directional and is said to provide increased gain over crossed dipoles. Small size (30 x 22 x 5½ in.) makes the unit suitable for indoor or outdoor installation.

*by Paul Faler*

General Electric Co.  
Audio Products Dept.

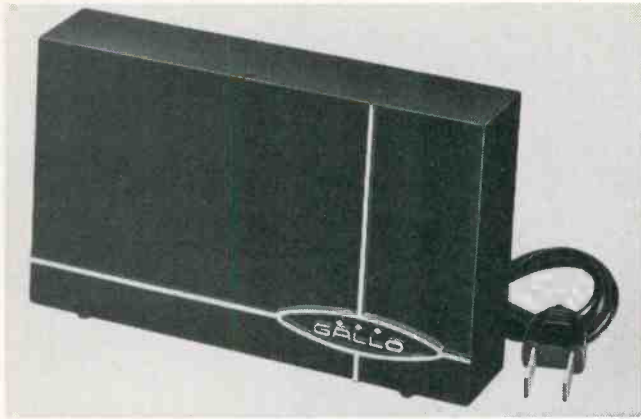

Small package built by Gallo contains FM antenna and pre-amplifier. The system is omnidirectional.

signal input or antenna problem is diagnosed as a set problem by the technician. This frequently occurs in a metropolitan area where strong signals are present from many local stations.

The built-in FM antenna orientation is limited by the location of the phonograph cabinet in the customer's home. The position of the phonograph is dictated by the interior decorations and space limitations. The technician therefore does not have the flexibility to orient the built-in FM antenna. An excellent tool for the technician to use is a low cost TV "rabbit ears" antenna. By connecting this antenna he may orient and probe the area and thereby diagnose an antenna problem from a set problem by listening for minimum or no dis-

tortion. Usually orientation and probing will reveal a distortionless and noiseless signal at a particular antenna position. That is, if we are working in a service area rather than a fringe area.

On the TV screen the technician will see the ghosts, but in audio work he must train his ear to detect the distortions. Examples of what he may hear with FM stereo reception with an improperly oriented antenna are excessive background noise, hiss, actual sound distortion of various degrees, beats, tweets and birdies. In fact, by careful mis-orientations, in some areas, a second program may be tuned in nearly undistorted which will over-power the desired station.

Where a TV station is located adjacent to the FM station it is

possible to obtain a fair evaluation of the FM station signal reflection content by monitoring the TV station signal. Tune in the TV station on the customer's TV set; if ghosts are noted it is quite probable that similar reflections are contained in the FM signal.

The foregoing discussion illustrates that in many cases a good outdoor FM antenna installation will be necessary for satisfactory FM stereo reception. One specific type of FM antenna cannot be recommended for use in all cases since the choice of antenna is dictated by an analysis of all the signal conditions of the particular location. FM antennas are available in types ranging from a simple folded dipole to a superb multi-element hi gain broad banded yagi. Occasionally the use of an existing TV antenna installation will provide satisfactory FM signal; in some cases however, a typical outdoor TV antenna may provide no more FM signal to the tuner than a good indoor antenna. Therefore, the technician must study the signal conditions of his service area and determine the best over-all antenna to use in order to overcome area signal problems. The past experience gained from TV antenna installations will provide a helpful background for FM outdoor antenna installations. ■

## Guide to Master TV Antenna Systems

Manual features list of 12 'packaged systems.'

■ A 30-page comprehensive guide to MATV systems outlines a variety of types with examples, gives installation tips, and serves as a guide to selection of proper equipment. The booklet is issued by Blonder-Tongue Laboratories.

Master antenna TV system-installers, service-dealers and technicians are being called upon by architects and engineers to aid in designing MATV systems for motels, apartment houses, hospitals, schools and other establishments across the country. TV-radio technicians in a number of localities have been keeping busy during

normally-slack summer months by installing these systems. Considerable demand for MATV systems has also been noted from owners of already completed older apartment houses and other buildings. Owners have found that MATV systems improve external appearance of their buildings and also prevent damage to roofs and side walls.

A special feature of the B-T manual is a list of 12 "packaged systems." With slight modifications these systems are said to cover up to 80 percent of all possible installations. Systems for two-story

*Continued on page 89*



Know ultra-high characteristics and solve antenna, tuner and converter problems

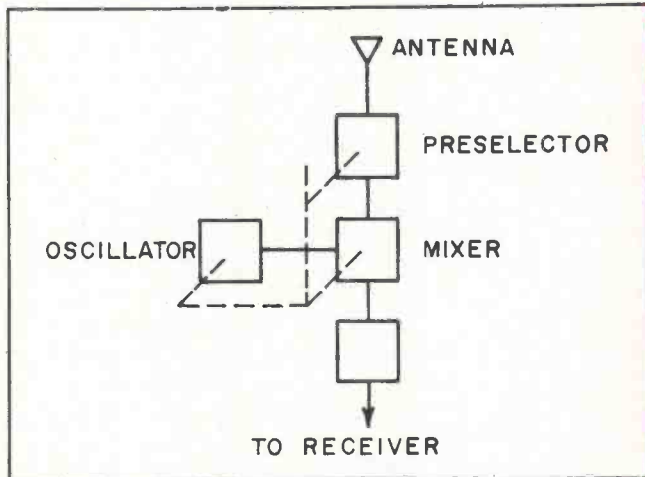

# What UHF means to the Technician

Fig. 1—Block diagram of set-top UHF converter. Lower block represents IF output (optional) at two adjacent TV channels. It may or may not be amplified.

by Jack Beaver

Jerrold Electronics Corp.

■ UHF TV telecasting appears to be following the pattern of FM broadcasting—an initial surge of interest, a period of rapid growth, followed by a phase of diminishing interest, then a new resurgence. The rapidly growing interest in UHF TV may be sparked by three things: Success of the Midwest Program for Airborne Television Instruction (MPATI) UHF telecasts; the channel 31 FCC tests in New York City; and the recent law requiring TV sets in interstate shipment to be equipped to tune UHF as well as VHF.

Effects of these three events will probably be felt over a much wider area than now seems possible, and the results may follow the pattern exhibited in FM broadcasting.

### Impetus For Growth

MPATI telecasts have given a boost to educational TV (ETV)—most outlets being on UHF channels in VHF served areas. This is not a mere quickening of interest because of spectacular transmission from an aircraft at 20,000 ft., but because part of this program's activity is the development of educa-

tional material suitable for telecasting.

The Federal law requiring UHF tuners in TV sets will eventually remove a major stumbling block which hindered earlier UHF telecasters: cost of converting VHF sets to UHF. It was difficult to get a set owner already able to receive two or more VHF channels to invest \$25 to \$50 merely to receive a third station on UHF.

The New York City tests have removed the fear of telecasters that UHF would not measure up to VHF in large city areas. Apparently, the only place where UHF coverage is significantly different is in the fringe areas, where VHF is superior because of greater diffraction beyond the horizon. Of course, higher and better transmitting and receiving antennas, boosters and CATV equipment, can be used to extend UHF ranges.

We can examine these small differences in detail. Experience indicates that transmitter antenna heights about 1000 ft over a fairly smooth terrain, a low VHF channel at 100 kw ERP (effective radiated power), a high VHF channel

at 316 kw ERP and a UHF channel at 1000 kw ERP can be expected to produce results shown in Table I. (The ERPs listed produce equal strengths.)

Other pressures will eventually drive the broadcasters toward UHF. VHF stations are in constant difficulty in their fringe areas with co-channel interference, especially in the low VHF band. These signals between 54 and 88 Mc have a much greater tendency to skip than was thought possible at the time TV allocations were made. The result is that midwestern viewers often find themselves looking at pictures disturbed by other transmitters as much as 1000 miles away. Cases have been reported of European TV broadcasts being picked up in the continental U.S.A.

There is also a great and pressing need for expansion of civilian, and possibly military communications bands. These services could be placed in the VHF-TV band. One VHF-TV channel can accommodate up to 300 voice channels at present development standards.

The service industry will soon be faced with the need to understand

how to properly install and service the UHF receivers which will come into increasing use—and alert technicians will arm themselves now with the necessary knowledge.

Application differences between UHF and VHF stem from the great difference in wavelengths. For example, the full wavelength of channel 2 is about 17 ft, channel 7 is about 5½ ft, channel 14 (UHF) is about 2.08 ft and channel 83 about 1.08 ft. These differences, as previously mentioned, make smaller size antennas possible. And they also produce higher transmission line losses. UHF also requires different tuners, where inductances are represented by either fractions of conductor turns or by resonant cavities. The great number of channels (14 through 83) require continuous tuning, usually with some kind of vernier arrangement.

#### Equipment Functions

Two general schemes of receiving UHF are in common use. One method is to add an auxiliary piece to an existing VHF-TV set, the "set-top converter," and the other calls for a built-in UHF tuner, plus a VHF tuner in the TV receiver. The two applications differ somewhat. A set-top converter block diagram is shown in Fig. 1.

The converter is obviously an incomplete superheterodyne receiver. It is completed by the addition of a TV receiver, which is a superheterodyne receiver, making the combination a double conversion superhet. The IF output is usually broad-band — two TV channels wide—and generally set for channels 5 and 6, but sometimes for channels 7 and 8.

A preselector is shown in Fig. 1. This is essential and is required by law, for the simple reason that an oscillator frequency which produces channel 5 must be either above or below the UHF frequency of channel 5—76 to 82 mc. Such a difference between the oscillator frequency and the UHF station leaves the oscillator frequency at some other UHF-TV frequency in most cases. Without a preselector, these oscillator signals would radiate from the receiving antenna and pos-

sibly cause interference in other UHF receivers for considerable distances.

Built-in UHF converters sometimes differ from the set-top type—producing an intermediate frequency at the same IF as the TV set. This output then bypasses the VHF tuner directly into the set's IF stages. The method has two advantages: the number of signal-path components is reduced and the UHF circuitry is allowed to operate in certain kinds of VHF failures, for example, an oscillator or mixer tube malfunction.

The preselector circuit is passive; it does not have a tube or amplification in most cases—except in specialized type converters.

The typical converter covering the UHF range uses a 6AF4 oscillator tube, a diode detector and, in higher priced models, an RF pentode as an IF amplifier. The major cause of failure in converters is the 6AF4 tube — a notoriously short-lived component. Tube manufacturers are developing better tubes and this situation can be expected to improve.

Assuming sufficient gain in a converter to keep the set's IF amp-

lifier out of the thermal noise levels, the critical operating factor is the converter's own noise level. In the typical converter this is determined by the crystal diode mixer and will produce noise figures from 14 to 20 db. Crystals vary in this respect, so that two converters of the same make may differ widely in a fringe application. A diode with a 14 db noise figure requires only half as much signal as a 20 db figure for a snow free picture.

Tubes are more practical than diodes in respect to noise figures, but they complicate the circuitry. Transistors are showing promise at UHF frequencies, but transistorized UHF converters will probably not become available for some time.

#### Problems in UHF

UHF converters are generally easier to repair than VHF tuners, but one precaution must be observed—wires carrying UHF should not be bent out of place. If this becomes necessary during repair, leads should be replaced in their original positions. At these frequencies, lead dress tunes the circuit. As an example, a strip of flat, silvered copper ⅛ x 0.001 x ¾ in.

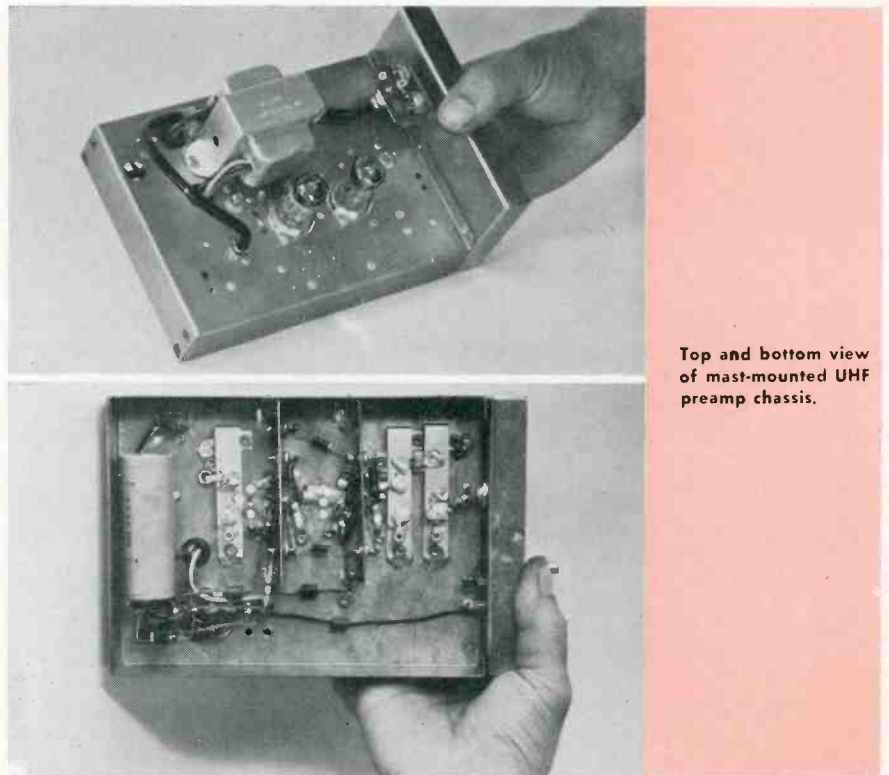

Top and bottom view of mast-mounted UHF preamp chassis.

with two "crinkles," is used as a plate tuning coil in one UHF amplifier. In another case, the UHF oscillator coil is a flat, triangular strip, about 2 in. long, tapped at the middle. The RF circuitry of these devices rarely gives trouble. Malfunction is usually confined to tube, diode, or power supply circuit failures.

Small antenna size at UHF allows the design of indoor antennas having higher gains than "rabbit ears." A common type is the twin bow-tie on a screen. These smaller antennas pose one difficulty for the installer—the set owner must be taught to adjust them. This can be done easily by comparing a channel 2 rabbit ear adjustment with a channel 38 twin bow-tie adjustment to get a good picture. The rabbit ear antenna, for example, may require a 1½ ft orientation

while channel 83, in the same situation, would require a 1⅞ in. movement of the UHF indoor antenna for the same result. TV owners who have become used to "batting" a rabbit ear around, find it a little difficult at first to become accustomed to slowly moving the UHF indoor antenna to a more precise setting.

The same situation occurs in rooftop installations: antenna orientation—in azimuth, up, down and sideways—is more critical and must be done more carefully. Compensating for this trouble is smaller antenna size and ease in handling.

More care must be used in handling UHF antenna feed lines. Losses at VHF frequencies are from two to three times greater. Flat lead isn't adequate since rain increases the line loss enormously—up to six times dry losses. Tubu-

lar twin leads are used, mostly with polyethylene foam filler, to prevent accumulation of water inside the tube. Stand-off insulators that place metal around the lead should not be used since this increases losses.

Line loss, which is a problem at VHF, is much more severe at UHF. In fringe installations where the antenna must be placed high in the air, a point is quickly reached where additional line losses overcome signal gain by elevation, and increased height gives reduced signals at the receiver.

The best solution to this problem is a preamplifier, mounted on or close to the antenna. This method provides enough gain to maintain the signal-to-thermal-noise ratio and overcome the down-lead losses.

Service technicians should be prepared to cope with this expanding field. ■

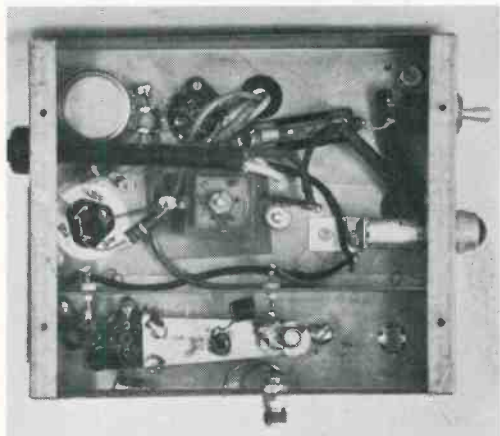

Inside view of UHF oscillator. Strip at bottom is tapped tank coil.

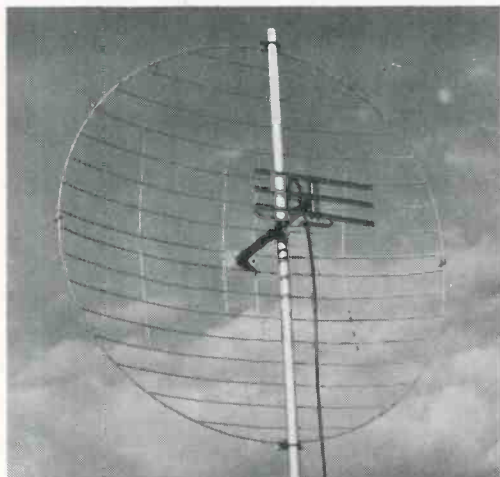

Parabolic UHF antenna by TACO.

Table I

Condition	Low VHF	High VHF	UHF
Signal strength, up to	Usable, with good		
40 miles	grades	Same	Same
40 to 50 miles (1)	Usable	Not as good	Worst
50 to 70 miles (1)	Poor, usable	Worse	Very difficult
70 to 90 miles (1)	Very Poor	Worse	Worst
Ghosting (2)	Depends on locale	Same	Same
Man-made interference	Common	Less common	Least common

Notes:

(1) By using translators, small unattended repeater transmitters which are now licensed, coverage may be extended to greater ranges than VHF.

(2) High gain, hence highly directional antennas are much smaller at UHF, making ghosting problems easier to resolve. For example, a 6 ft. parabola, easily mounted by one man and costing no more than a high gain VHF broadband, will deliver 17 db gain — equal to about eight 5-element yagis at VHF. A similar VHF array at channel 2 would occupy a space approximately 16 x 30 ft.



## Difficult Service Jobs Described by Readers

### Horizontal Tube causes Vertical Failure

A Sylvania Chassis 1-542-3 was brought into the shop a short time ago with vertical drift and shrinkage after warm up complaint. We plugged the set in and sure enough, within a short time the picture started rolling and shrinking on top. Grabbing a can of coolant, I sprayed a few components in the vertical circuit, but to no avail. All voltages seemed to be in tolerance except for a slight discrepancy in bias on the grid of the vertical output tube. Substitution of components and parts had no bearing on the situation.

After looking over the schematic, I noticed the grid resistor from the output stage leading to pin 3 of the 12DQ6 horizontal output. A lead wire went from this point to the vertical linearity control. I clipped pin 3 from the tube socket. The problems immediately disappeared. The 12DQ6 checked good in the tester, and showed no signs of giv-

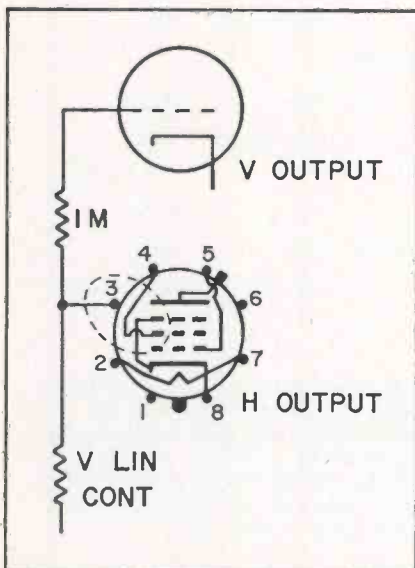

Leakage in the horizontal output tube caused shrinkage in the vertical circuit of Sylvania set.

ing any horizontal problems, but leakage developed between the unused pin 3 of the 12DQ6 and an element of the tube.

A new 12DQ6 was substituted and the vertical problems were solved. — *Darrell W. Lingbeck, Hammong, Minn.*

### Wrong Winding

Recently I was confronted with a set which burned out 3DG4 rectifier tubes. It was a late Zenith portable Model 16F27U.

After replacing the tube the set was restored to normal. Some time later the same tube had to be replaced. This time it was noted that the tube lit up too brightly.

It is sometimes hard to understand why a comparatively new receiver should have the wrong transformer winding in it, but contrary to the manufacturers print, this set had a five volt filament winding instead of a three volt winding. It is possible that someone replaced the transformer after the set left the factory. I rewired the rectifier socket for a conventional five volt tube and installed a 5U4 in place of the 3DG4; this corrected the burnout trouble.—*Audry A. Pizanie, Lake Charles, La.*

### Capacitor Causes Set Overload

When answering a call to service an Admiral 21A3Z for no picture or sound, I found a completely blocked out (overload) picture and no sound. Tuning to an unused channel or removing the 6J6 Oscillator I could get light on the screen. Also, I could get a snowy picture with antenna disconnected.

I changed the keyed AGC tube,

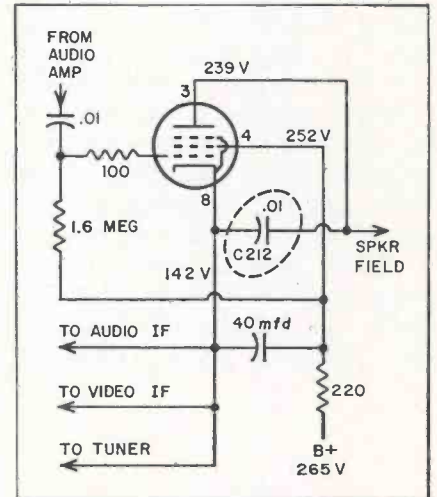

Shorted capacitor in audio stage caused overload on normal signals.

plifier with no results, so the set was brought to the shop. On the bench, I rigged up my AGC bias box and obtained a good picture. A scope check showed the AGC keying spike from the HOT was normal. Then it dawned on me I still had no sound. I then made voltage tests around the 6W6 Audio output tube. Plate: 239 v, screen: 252 v, cathode: 239 v the same as the plate. C212 was shorted, putting 239 v on the cathode. The 239 v was being applied to all IFs, the tuner, sync separator and noise gate tube. This caused the overload. Replacing C212 cured all troubles.—*R. E. Vogan, Birmingham, Ala.*

### TOUGH DOGS WANTED

\$10.00 paid for acceptable items. Use drawings to illustrate whenever necessary. A rough sketch will do. Photographs are desirable. Unacceptable items will be returned if accompanied by a stamped envelope. Send your entries to "Tough Dog" Editor, ELECTRONIC TECHNICIAN, 1 East First St., Duluth 2, Minnesota.





## ITT batteries...and ITT tubes...give you first-line quality ...and extra profit margin

ITT batteries—penlites, C, D, and 9-volt miniatures—now offer the same “extra value” and acceptance already experienced with fast-moving ITT Receiving Tubes.

ITT can provide this “extra value” of finest quality at higher profit margins in each of its lines because ITT products are on call from 154 factories and laboratories in 24 countries. If you are selling ITT tubes and batteries, you can compete with anyone in the world

... on quality, on price, and on acceptance. Brands without these worldwide resources are finding it tougher than ever.

Make sure *you* have this *value* leadership in *your* service market. Stock ITT tubes and batteries—the only worldwide lines with such a world-famous name.

ITT Distributor Products Division, International Telephone and Telegraph Corporation, Box 99, Lodi, New Jersey.

... for more details circle 29 on post card



For Partnership in Prestige and Progress

# SHOP HINTS

TIPS FOR HOME AND BENCH SERVICE

## Safety First

Before plugging a television set or almost any electrical equipment to be serviced, into a 110 v power line, use a "fused-plug" with your cheater cord. — approximately 3 amp — so that a possible solid "ground" or dead short will not cause high-current burning of components in the equipment or blow the house fuse. This is especially valuable on the customer's premises to avoid odors of overheating components in the house.

If the fuse in the fused-plug blows, you know a short or ground exists which will have to be cleared before proceeding with further tests.

Please note, however, that major electrical appliances often utilize motors having a rating of 14½ amp "starting current" and about 4½ amp "running current." For those appliances, you would need a different size fuse for safety first. This information can most often be found on motor name-plates. — *Frank J. Kish, Cleveland, Ohio.*

## Phillips Screw Holder

Service technicians who try to mount parts with a Phillips screw driver using a magnetic tip or with wax to hold the screw, know how aggravating it is to have the screw fall off the tool. Here is a simple solution to the problem. I take a small spring that fits tight on the shank of my Phillips and place it near the end. I spread out one turn at the end. This one turn is placed in back of the head of the screw and pulling back on the spring will make the screw tight against the driver.

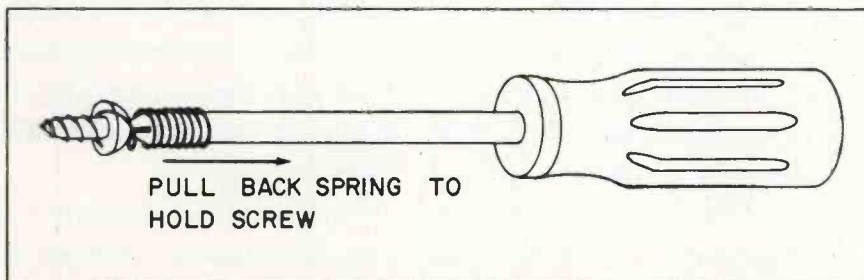

Loop on tight fitting spring holds Phillips-head screws for starting in hard-to-get-to locations.

Once the screw is started pull back on the screw driver and the one turn will be free, allowing the screw to be tightened. — *Leonard Blechman, Coatesville, Pa.*

## Cheater-Cord Holder

Salvage your next "dog eared" pocket-saver or use a new one, for your cheater cord. Double your cheater cord over and wind on hand,

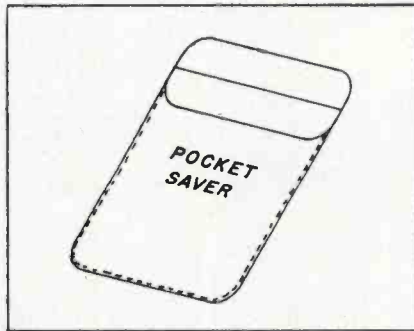

Old pocket-saver makes excellent holder for caddy cheater cord.

tuck into pocket saver. It makes a neat package in tube caddy. — *John Blazek, Portland, Ore.*

## Efficiency Coil Indicator

The new Admiral color chassis 25G6, (RCA chassis) has a Horizontal Efficiency coil (L710) that is very difficult to adjust accurately simply by watching the raster. The following gadget was devised which can be easily carried in the technician's caddy or pocket. It is a #44 lamp with a 6DQ5 cap and socket that is inserted between the 6DQ5 and the flyback and adjusted for minimum brightness. — *James Weldon, Central Islip, N. Y.*

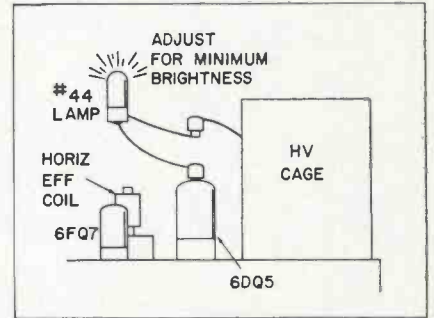

Efficiency coil of Admiral color chassis is easily adjusted with #44 lamp rig equipped with 6DQ5 cap and socket.

## Bypassing

For folks living in rural areas where the signal is extremely weak, I've found the following procedure exceptionally useful in reducing snow.

A capacitor is added from the CRT cathode pin 11 to the grid pin

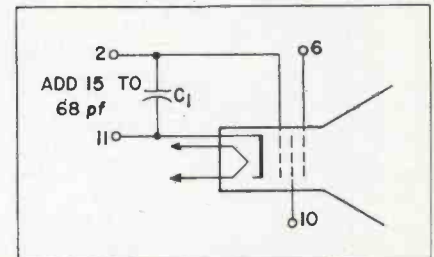

Bypass capacitor across CRT grid and cathode frequently reduces snow in weak-signal areas.

2 thereby bypassing some of the noise voltage. We use a capacitor from 15 to 68 pf. The capacitor's value must be selected experimentally, however. The picture may be slightly smeared, although it usually makes the picture more acceptable. — *Nobel C. Travis, Sheridan, Ky.*

## SHOP HINTS WANTED!

\$3 to \$10 for acceptable items. Use drawings to illustrate whenever necessary. A rough sketch will do. Photos are desirable. Unacceptable items will be returned if accompanied by a stamped envelope. Send your entries to Shop Hints Editor, ELECTRONIC TECHNICIAN, 1 East First St., Duluth 2, Minnesota.

# NOW EVERYONE CAN QUICKLY Set up and Service Color TV

**1 PATTERN DISPLAY STANDARD**  
Shows correct pattern in window viewer for visual guide

**2 PATTERN SELECTOR**  
Produces each pattern individually for quick, easy convergence

**3 AUTOMATIC DECONVERGENCE**  
Simplifies static and dynamic convergence. No digging into set



**4 COLOR SELECTOR**  
Produces each color one at a time for accurate color set-up

**5 COLOR GUN KILLER**  
Automatically enables the technician to actuate any combination of the 3 guns

**6 DEMODULATOR ALIGNMENT**  
Makes alignment extremely simple, without going into the color set

## New! **B&K** Model 850 **COLOR GENERATOR**

*Most Complete, Most Versatile, Portable Instrument for Use in the Home and in the Shop  
Makes Color TV Set-up and Service Easier, Faster than ever!*

Now every service technician can be ready to set-up and service color TV with amazing new ease and speed! New advanced design simplifies the entire operation, saves time and work in every installation. Eliminates difficult steps in digging into the color TV set. Gives you new confidence in handling color.

**Produces Patterns, Burst, and Colors Individually**  
—Provides dot pattern, crosshatch, vertical lines, horizontal lines, burst signal, and individual colors—one at a time—on the TV color set—for fastest, easiest check. Unique window-viewer on front of the instrument panel shows you each pattern as it should be—gives you exclusive display standard to use as a sure guide for quick, visual comparison.

**Provides Accurate, Individual Color Display**—Produces Green, Cyan, Blue, B-Y, Q, Magenta, R-Y, Red, I, Yellow, and Burst—one at a time. All colors are crystal-controlled and are produced by a precision delay-line for maximum accuracy. Each color is individually switch-selected—no chance of error.

**Provides Accurate NTSC-Type Signal**—Color phase angles are maintained in accordance with NTSC specifications.

**Makes Convergence and Linearity Adjustments Easy**—Highly stable crystal-controlled system with

vertical and horizontal sync pulses, assures the ultimate in line and dot stability.

**Simplifies Demodulator Alignment**—The type of color display produced by this instrument provides the ultimate in simplicity for precise demodulator alignment.

**Provides Automatic Deconvergence**—Eliminates the necessity for continual static convergence adjustments. The instrument automatically deconverges a white into a color dot trio without digging into the color set to mis-adjust the convergence magnets. It also deconverges a white horizontal or vertical line into red, green and blue parallel lines. This greatly simplifies dynamic convergence adjustments.

**Provides Exclusive Color Gun Killer**—Front-panel switch control makes it easy to disable any combination of the three color guns. Eliminates continuous adjustment of the background or screen controls, or connection of a shorting clip inside the receiver. The switch also selects the individual grids of the color tube and connects to a front-panel jack to simplify demodulator alignment.

**Provides Switch-Selected R.F. Signals**—Factory-tuned, for channels 3, 4, and 5—for open channel use in your area.

Model 850 also includes other features that make it invaluable for home and shop use. Net, \$199.95

See Your B&K Distributor  
or Write for Catalog AP20-T

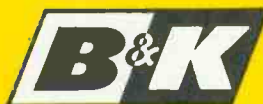

**B & K MANUFACTURING CO.**

Division of DYNASCAN CORPORATION

1801 W. BELLE PLAINE AVE. • CHICAGO 13, ILL.

Canada: Atlas Radio Corp., 50 Wingold, Toronto 19, Ont.

Export: Empire Exporters, 253 Broadway, New York 7, U.S.A.

— for more details circle 15 on post card

# NEW PRODUCTS

FOR MORE INFORMATION CIRCLE PRODUCT NUMBERS ON POST CARD

## TAPE RECORDER 200

The Stereo TransFlyweight, Series 314, is designed to fill the need for a compact, rugged, light-

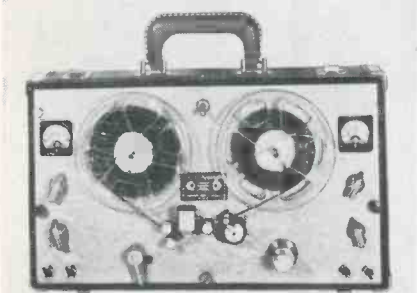

weight, professional stereophonic recorder for unrestricted field use. It provides independent gain adjustment for each channel. Recordings may be fed into any dual-channel amplifier for stereophonic loudspeaker playback. The motor operates from small replaceable or rechargeable batteries. Fully transistorized (22 transistors and 2 diodes); two isolated inputs are provided. Two separate VU meters are used for measuring each channel record, playback level, and battery voltage. Single and multi-speed models are available with tape speeds from 15/16 ips to 15 ips; 7½ and 15 ips models meet NARTB standards. Prices range from \$624 to \$684 net. Amplifier Corp. of America.

## MULTIPLEX RECEIVER 201

Called the S-8000 II, this high fidelity FM multiplex stereo receiver includes essentially the same circuitry used in the firm's S-2100 FM multiplex stereo tuner. The power circuitry in turn is similar to the 5550 II stereo amplifier. Additional S-8000 II specifications include: FM sensitivity of 1.8µV for -30 db noise and distortion

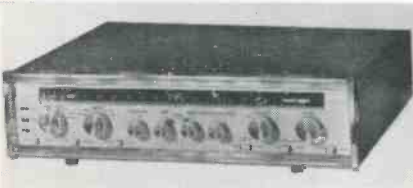

(IHFM); FM selectivity of 200 kc. at -3 db.; FM detector, 1.00 Mc P-P; FM distortion 1/3% at 100% modulation; Power output — each channel 32 w music power or 30 w continuous at 1½% IM distortion. Sherwood Electronic Labs, Inc.

## RECTIFIER ASSORTMENTS 202

Replacement rectifier assortments in caddy kits and bench cabinets, put a semiconductor replacement for every conceivable radio and TV audio servicing job right at the fingertips of the serviceman, and at a considerable saving in cost. The two basic assortments contain selenium stacks, plug-in type silicon rectifiers and axial lead type rectifiers. The caddy kit contains an assortment of 16 rectifiers



of the 10 most-used types, and is priced at \$14.95; a saving of \$3.22 over the total regular dealer net. A useful plastic divider box valued at \$1.50 is included. The bench cabinet for in-shop use contains an assortment of 31 rectifiers and diodes in the 16 most-used types. A permanent four-drawer storage cabinet is included free of charge. Dealer savings on the rectifiers, which regularly net \$28.10, amount to \$3.15. International Rectifier Corp.

## PORTABLE RADIO 203

The Model 6531, is a 6-transistor sub-miniature radio measuring 4½ x 2½ x 1½ in. It plays on a single 9 v battery, and comes in black or red, with a molded grille



in ivory. It lists for only \$14.95. The Model 6527 is the 6531 with accessories included. List price is \$17.95. Also available is the economy priced 6-transistor set. The list price of \$19.95 includes such accessories as a cowhide carrying case with leather strap, and a private earphone with leather case. Channel Master Corp.

## SPEAKERS 204

This line of three speaker systems — specifically ADC-14, ADC-16 and ADC-18 employs driver units that consist of a rectangular woofer of expanded plastic. The treble unit employs a very light 1½ in. "Mylar" diaphragm. The woofer employs a 9 lb ceramic magnet that provides a high flux density. The expanded plastic cone acts as a perfect piston throughout its range. Cone break-up and doppler distortion are virtually non-existent. The rectangular shape of the woofer used in the ADC-16 and ADC-18 has a

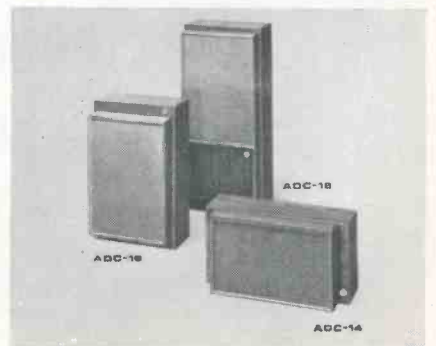

# NEW PRODUCTS

radiating area twice that of a conventional 12 in. paper cone, thereby resulting in very effective coupling to the air, requiring only small cone excursions for a large output even at very low frequencies. Price; for the ADC-14 is \$175, for the ADC-16, \$220 and for the ADC-18, \$250. Audio Dynamics Corp.

## CB-AM ANTENNA

205

This antenna works on both citizens and AM broadcast bands. The M-103 is carefully peaked for maximum C-B performance, but operates as well for AM broadcast reception. By merely turning on the CB rig, or the car radio, the antenna is automatically and simultaneously switched over. The M-103 is a center-loaded, cowl mount and fits in the  $\frac{7}{8}$  in.-1  $\frac{3}{16}$  in. hole normally provided for the average car radio. It is only 46 in. high in the operating position and telescopes to 31 in. Antenna Specialists Co.

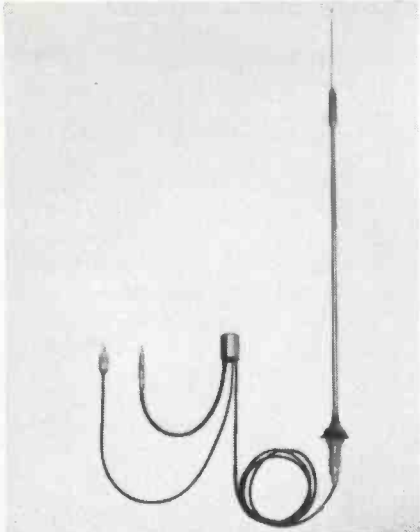

## TRANSMITTER TESTER

206

The Model 510B transmitter tester reads positive and negative modulation peaks on a meter scaled from 0% to 120%. Primarily for low power transmitters up to 160 Mc, the Model 510B reads RF output to a fraction of a watt. For this purpose the meter has a scale calibrated for 0-5 w RF output and 0-400 ma RF output. In addition to its primary uses of metering modulation and reading RF output, the Model 510B will serve as a field strength or remote RF indicator. It will also detect the presence of AM and hum modulation on FM transmitters. It has a high impedance input for Handy Talkies and a jack for use in headphone



## KIT OR WIRED

**NOW YOU CAN ENJOY FAMOUS HEATHKIT TEST INSTRUMENT QUALITY & ECONOMY EITHER WAY!**

Now, whether you choose to "do-it-yourself" or want your equipment factory assembled and tested, you save more, receive more for your money, with Heathkit. We now offer a selected group of Heathkit test and lab. instruments in factory assembled form, ready for you to put to work in your business . . . VTVM's, Power Supplies, 'Scopes, Probes, Generators, Testers, and Decades all at traditionally low Heathkit prices. Write for information.

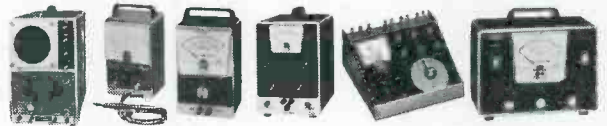

Heathkit Test Instruments Save Money, Make Money, For You!

## NEW HEATHKIT SERVICE-BENCH VTVM



The most versatile vacuum tube voltmeter ever designed! Mount it under a shelf, on a shelf, on the bench; tilt it for best vision with its "gimbal" bracket. Has 6" 200 ua meter, single-probe system, 7 voltage-ohm ranges. Kit IM-13, only \$32.95

## FREE HEATHKIT CATALOG

World's biggest kit catalog, over 250 kits for every interest at savings up to 50%. Send for your free copy.



**HEATHKIT**

a subsidiary of Daystrom

**HEATH COMPANY**  
Benton Harbor 24, Michigan

Please send my FREE Heathkit Catalog

Name

Address

City  Zone  State

... for more details circle 27 on post card



Be  
a hero  
at home

**GET G-E APPLIANCES WITH THE PURCHASE OF G-E RECEIVING TUBES**

Your G-E Receiving Tube Distributor is giving away goodies for the home with the purchase of G-E tubes. You can get General Electric Appliances . . . Automatic Toasters, Can Openers, Coffeemakers, Toothbrushes . . . designed to make you a hero with the whole family.



**GE AUTOMATIC TOOTHBRUSH**  
Most effective toothbrush ever designed, and even children will like to use it. Kit includes cordless handle, four personal snap-in brushes and automatic recharging holder. When you buy G-E tubes, ask for ETR-3536.



**GE AUTOMATIC CAN OPENER**  
Opens cans in a jiffy without cranking and twisting. Safe and easy to use . . . no sharp edges. Magnet automatically removes the cutout lid. Mounts on wall in seconds. Yours with the purchase of G-E tubes. Ask for ETR-3537.



**GE AUTOMATIC COFFEEMAKER**  
Makes 3 to 9 delicious cups of coffee. No watching or timing necessary. Just put in the coffee and water, set the control for strength and the coffeemaker does the rest. Take it home with your G-E tubes. Ask for ETR-3538.



**GE AUTOMATIC REFLECTOR TOASTER**  
Toasts both sides at once by reflected heat. Any kind of bread will fit . . . so will frozen waffles, pancakes, cheese sandwiches. Shuts itself off automatically. You can get it with the purchase of G-E tubes. Ask for ETR-3539.

Another accent on value from G-E **ELECTRONICS** Distributors

or  
 be your own  
 [sneaky] hero  
 down at the  
 shop

**GET A GENERAL ELECTRIC PLASTIC  
 TOOL CASE**

Your G-E Distributor will (quietly) slip you one of these handy tool cases made of high-impact polystyrene that resists oil, grease, battery acid . . . won't warp, rust or rot. Lids overlap the base to shed water. Equipped with 2 and 3-tier cantilever trays. Red-orange and grey in three sizes.

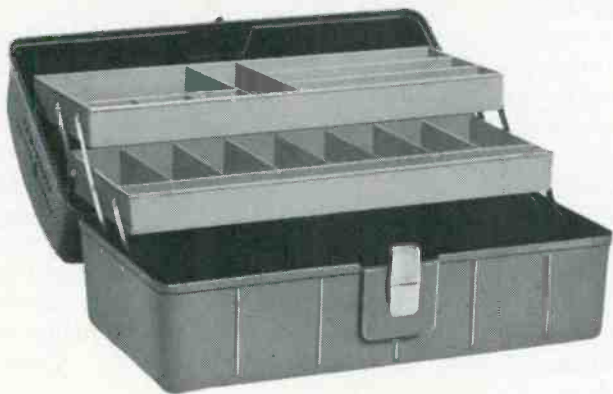

**ETR-3517** . . . Size 18 1/4" x 9 1/2" x 9 1/2". Yours with the purchase of G-E tubes



**ETR-3280** . . .  
 Size 15 3/4" x 8" x 8 1/4"  
 Get it with G-E tubes



**ETR-3516** . . .  
 Size 14" x 6" x 5 1/2"  
 Buy G-E tubes and it's yours

*Progress Is Our Most Important Product*

**GENERAL  ELECTRIC**

MARCH 1963



This program is available at the option of your local distributor.

--- for more details circle 26 on post card

# ADD NEW PROFIT TO YOUR HI-FI COMPONENTS BUSINESS THE EASY WAY!

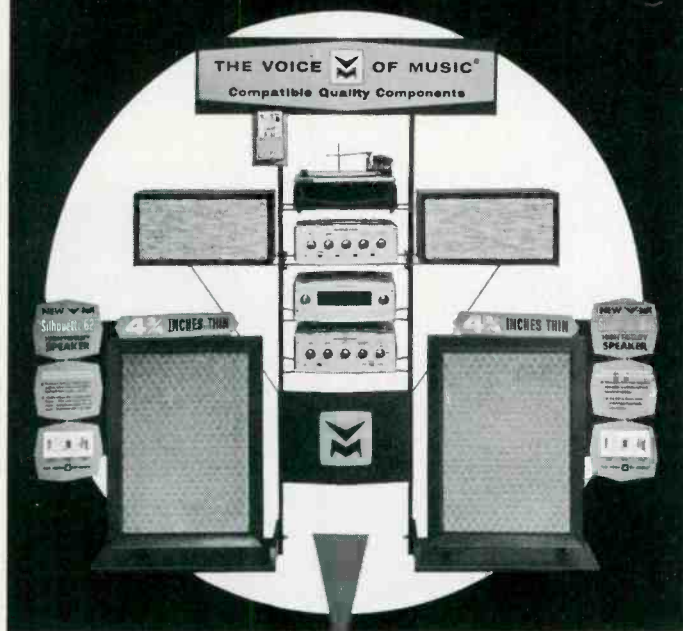

- Priced to attract *new* customers, this complete line of quality components is effectively displayed and demonstrated in only 5 square feet.
- Convenient one-source buying . . . backed by V·M's national network of Service Centers.



The store display fixture is complete with literature dispenser and the "Silhouette 62" speaker feature posters. It actually displays nine V·M component products!



High-Fidelity FM Stereo, FM, AM Component Radio Tuner Model 1465.



'Stere-O-Matic'® 4-Speed Automatic Record Changer Model 1571 11" turntable.

Automatic Manual-Play, Extra-long, dynamically balanced, non-resonant Tone Arm. Diamond Needle. Shadowlite stylus pressure.



Precision-Built AC Stereo Amplifier Model 1448. 40 watts (peak); 20 watts per channel. Frequency response, 40-25,000 cps.

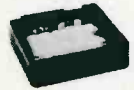

Changer Base Model 1438. For 'Stere-O-Matic'® Changers. Pre-wired receptacles.



"Silhouette 62" High-Fidelity Component Speaker System. Three speakers: 10" woofer, 6" mid-range, 3.5" tweeter. Frequency response, 30-16,000 cps.



Stereophonic High-Fidelity Component Amplifier Model 1428. 60 watts (peak); 30 watts per channel. Frequency response, 20-30,000 cps.



High-Fidelity Component Speaker Model 32. Three speakers: Two 6" and one 3". Frequency response 60-12,000 cps.

YOUR V-M DISTRIBUTOR IS READY NOW TO GIVE YOU ALL THE DETAILS AND POINT OUT THE MANY ADVANTAGES OF THIS NEW V·M COMPONENTS LINE. CALL HIM TODAY!

**THE VOICE  OF MUSIC®**

V-M CORPORATION • BENTON HARBOR, MICHIGAN  
KNOWN FOR THE FINEST IN RECORD CHANGERS, PHONOGRAPHS AND TAPE RECORDERS  
--- for more details circle 49 on post card

## NEW PRODUCTS

or scope monitoring. The unit comes complete with adapter and accessory kit for \$48.95 net. Seco Electronics, Inc.

### TV BOOSTER

207

An antenna-mounted TV/FM booster — the TELSTAR, model 0023 — features built-in lightning resistant circuit. Because the manufacturer found that induced lightning was responsible for a great number of booster failures,

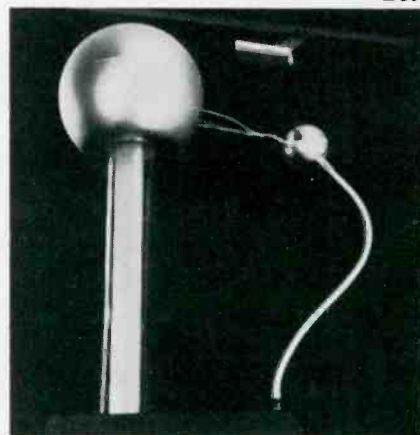

by causing transistors to burn out, the company developed a new lightning-resistant circuit for the Telstar. Utilizing the lightning rod principle, this circuit practically eliminates transistor burnout by harmlessly grounding the lightning. The protection offered by this built-in safety component has been laboratory proved through continuous exposure to 250,000 v bolts of lightning created by the Van De Graff Generator. Because of a low-noise transistor, the Model 0023 offers maximum gain and low noise figure on both high and low bands. It will feed up to four TV and FM sets—without isolation loss, and with excellent impedance match and isolation on all sets. List price is \$39.95. Channel Master Corp.

### CONTROL KIT

208

This kit is designed to enable the serviceman to assemble all of the single and dual concentric controls required for replacement applications. Designated as the FRK - 100, the



kit contains 36 controls, 8 switches, and 40 assorted shafts which enable the serviceman to assemble an almost infinite number of single and dual concentric controls. All of the controls are part of the firm's Fastatch II control system. These controls can be assembled in seconds. They plug-in and snap together by an exclusive method which provides a permanently locked control indistinguishable from a factory unit.



# THREE REASONS WHY TUNG-SOL ET TRANSISTORS ARE YOUR BEST REPLACEMENT LINE

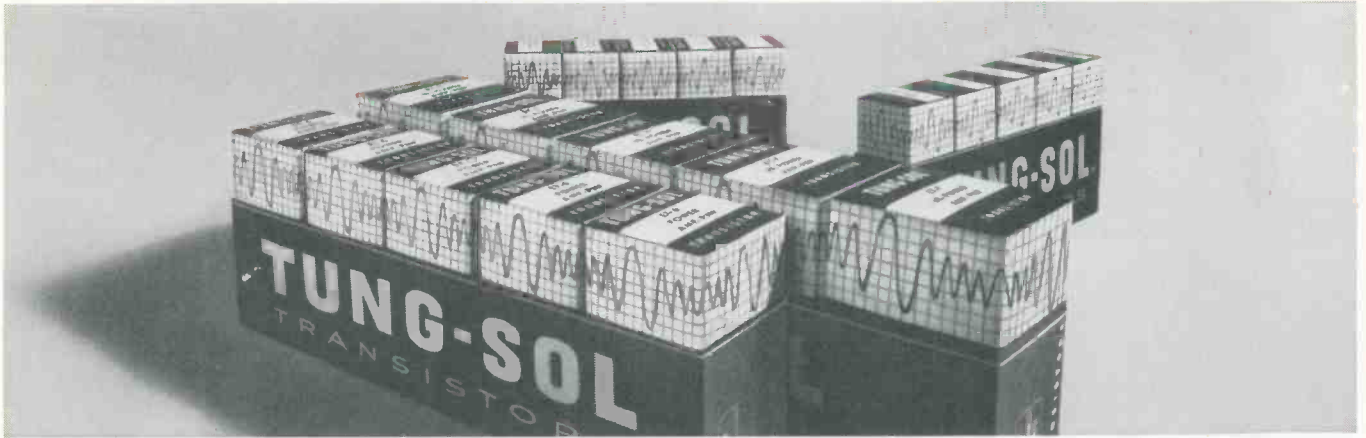

## 1. COMPLETE SERVICE NEEDS

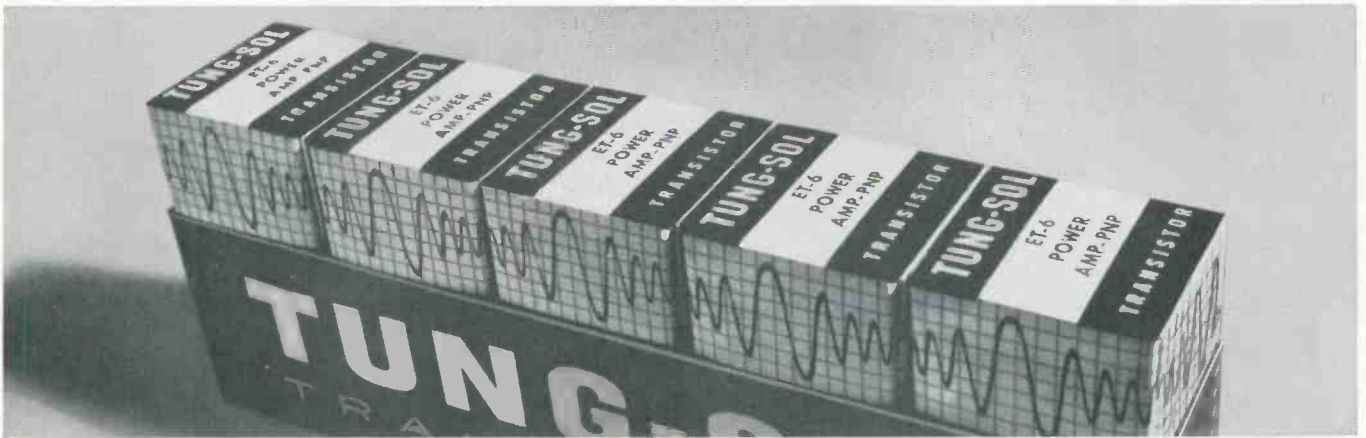

## 2. EASY PRODUCT SELECTION



## 3. TUNG-SOL RELIABILITY

You can make almost all radio transistor replacements from these twelve Tung-Sol types. In addition to part number, packages are marked with type of service. All units are the equivalent of the original part and are products of American plants. The ET transistor line reflects the same quality standards that have made Tung-Sol the leading independent tube manufacturer. Tung-Sol Electric Inc., Newark 4, N. J.

TELL YOUR SUPPLIER YOU'D RATHER HAVE  
CENTER LINE **TUNG-SOL**<sup>®</sup>  
  
QUALITY

carries a whisper  
... yet cuts out  
background noise

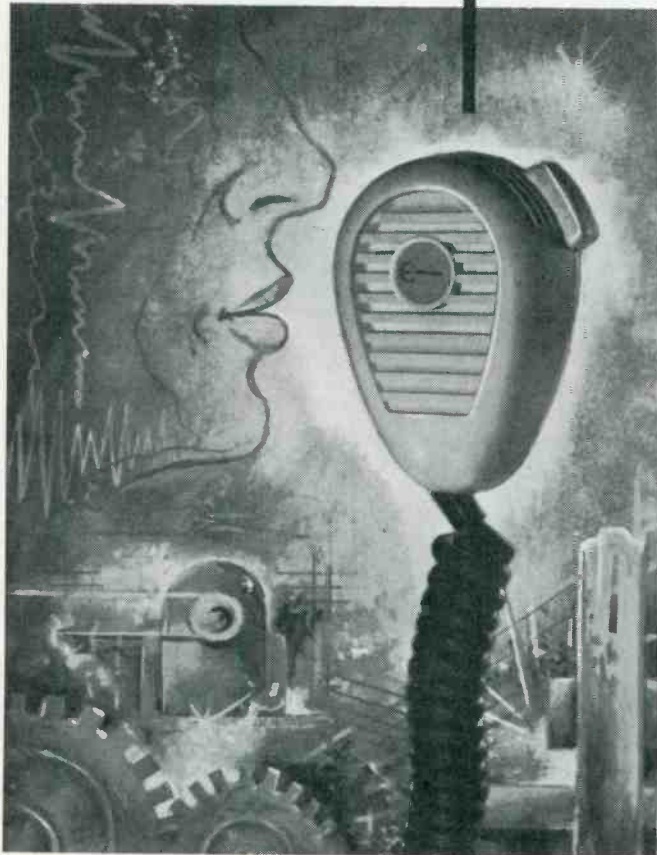

the exciting new  
**Hot Head**

The new Hot Head is the highest output ceramic microphone available. Transmits voice sharply and clearly in the noisiest areas where other microphones fail. Average level: -48 DB, twice the output of conventional ceramic mikes. Response: 300-4000 cps. Polar Pattern, differential to 600 cps; cardioid, 600-4000 cps. Covers a host of applications: CB, Ham, Radio, Marine and Commercial. Heavy duty, DBDT push-to-talk switch can be re-wired for special applications. Has Cicolac, hi-impact, take-apart case. With nickel-plated brass hardware, 3-conductor neoprene coil cord and spring hang-up clip.  
**Model C47D Hot Head** List Price \$16.00

**EUPHONICS C47 MICROPHONE**

A new general-purpose ceramic mike, same as the C47D except for noise-cancelling feature. Polar Pattern, essentially non-directional. Provides high level response curve for maximum intelligibility in all voice communication.

**Model C47 Hot Head** List Price \$14.00

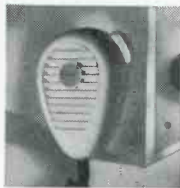

Manufacturers of  
Quality Microphones  
and Phono Cartridges

For complete details see your distributor or write Dept. ET-3  
**Euphonics**  
CORPORATION  
ALL PRODUCTS AMERICAN MADE  
GUAYNABO, PUERTO RICO, U.S.A.

for more details circle 24 on post card

**NEW PRODUCTS**

no twisting or complicated alignment of the controls is required for their assembly and the shafts provided are pre-cut to the exact lengths necessary for installation. Centralab.

**SCRATCH REMOVER**

209

Help for the television repair men confronted with fine scratches and abrasions on the outer protective plastic shield covering the television picture tube is offered by this product. Surefire Scratch Removing Compound contains a highly refined



abrasive and a protective wax. Further development of scratches is retarded by a microscopically-thin film that is left behind by the wax. The film will not dull the television picture in any way. The compound is non-flammable, will not scratch and is harmless to all plastic surfaces, hands and skin. Wilco Co.

**RECORD CLEANER**

210

A record cleaner which is being merchandized under the trade name of FOAM COAT is compounded of polyurethane. The round shaped sponge is chemically treated with "Lubri-Stat." The package is not only styled for consumer appeal, but also scientifically designed to retain the cleaning power of FOAM COAT even after many applications. To meet the space needs of the retail accessory department, 12 packages and mounted on an easel-type display board which can either be hung on a wall or set on a counter for quick and easy point-of-purchase sales. Fidelitone, Inc.



scientifically designed to retain the cleaning power of FOAM COAT even after many applications. To meet the space needs of the retail accessory department, 12 packages and mounted on an easel-type display board which can either be hung on a wall or set on a counter for quick and easy point-of-purchase sales. Fidelitone, Inc.

*Every RCA Victor New Vista® TV uses  
Space Age Sealed Circuitry... extra  
dependable easy-to-service circuits that are...*

# more precise

*than old-fashioned all hand-wired circuitry!*



Old-fashioned all hand-wired Circuitry

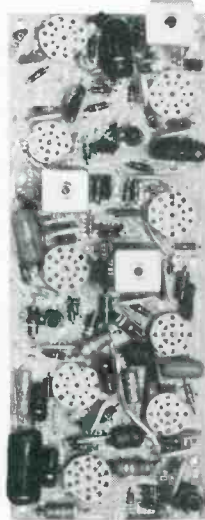

Precision Crafted RCA  
Space Age Sealed Circuitry

Let your own TV  
service records  
prove the   
dependability  
of RCA Victor  
New Vista® TV

SEE WALT DISNEY'S "WONDERFUL WORLD OF COLOR" SUNDAYS, NBC-TV NETWORK



The Most Trusted Name in Electronics

TMK (s)®

SERVICE  
NEWS from EPL

now...

# Electro dc power supplies everyone can afford!

FROM \$19.95

Output and filtering for every need

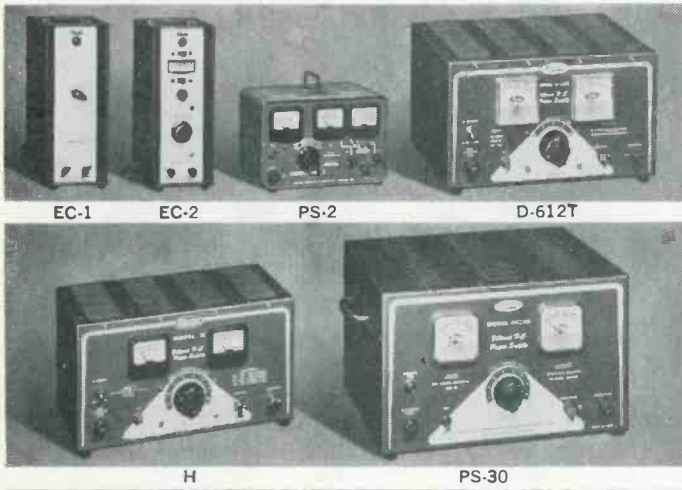

Voltage Outputs.....6 to 24 volts  
Amperage Outputs.....75 milliamperes to 30 amperes  
Ripple.....0.15% to 5%  
Regulation......15 to 1.8 volts/ampere

"Best value for the money" . . . say service technicians. Compare performance, quality and price.  
Guaranteed 1 full year . . . your best proof of superior quality.

Price (net)	Model	Voltage Output	Amperage Output	Regulation (V/A)	Maximum Ripple (%)	Meters
\$19.95	EC-3	0-20 (0-24)	150MA (100 MA)	---	1.5	0-24 V/100 MA
29.95	EC-1	12*	0-5	1.4 (0-5A)	0.5	---
39.95	EC-2	0-16	0-5	1.8 (0-5A)	0.5	0-20/10A
56.00	PS-2	0-20 0-16	0-75MA 0-5A	1.6 (0-5A)	0.15 0.5	0-20V, 0-10A & 0-75 MA
59.95	D-612T	0-16 0-8	0-10 0-10	.44 (3-10A) .3 (3-10A)	0.5 @ 5A, 2 @ 10A	0-20V, 0-10A
86.00	H	12* 6*	0-10 0-20	.23 (3-10A) .15 (3-20A)	5	0-20V, 0-30A
195.00	PS-30	12*	0-30	0.27 (0-30A)	1	0-20, 0-50

\*adjustable (selector switch)

Stocked at Your Electronic Distributor

Complete Line Bulletin PS-562 gives all details



**ELECTRO PRODUCTS  
LABORATORIES**

6125-V Howard, Chicago 48 (Niles), Ill.  
Phone: 647-6125

2170 A

Canada: Atlas Radio Ltd., Toronto

Since 1936...Pioneers in Low Voltage DC Power Supplies

--- for more details circle 23 on post card

## NEW PRODUCTS

### CONE SPEAKER

This 8-in. dual cone, extended range loudspeaker features a super-shallow profile having a depth of only 2-13/16 in. The Type C-835 two element loudspeaker is designed for applications where good music quality and speech intelligibility are demanded but with more modest loudspeaker cost. Power 10 w, response range 35-18,000 cps. Jensen Mfg. Co.

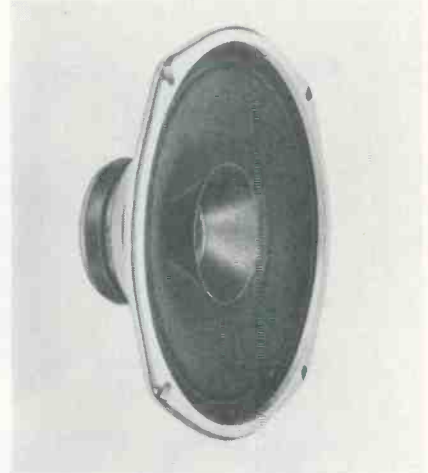

211

### VOLTAGE ADJUSTERS

The Planet voltage adjuster, #50-203 handles electrical equipment up to 300 w and the Polaris, #50-204 has a capacity to 500 w. Both change abnormally high or low ac voltage to normal. These Adjusters are said to be especially useful for television, in low voltage areas to restore the full height and width of the picture. Terado Corp.



212

### HI FI KITS

This line of stereo Hi Fi kits features new type of packaging principle for the consumer market. This packaging, called skin-pak, makes it almost impossible for the builder to make a mistake or lose any parts. PACO Electronics Co., Inc.



213

DISTRIBUTOR DIVISION / 1963

service  
components



resistors  
potentiometers  
switches

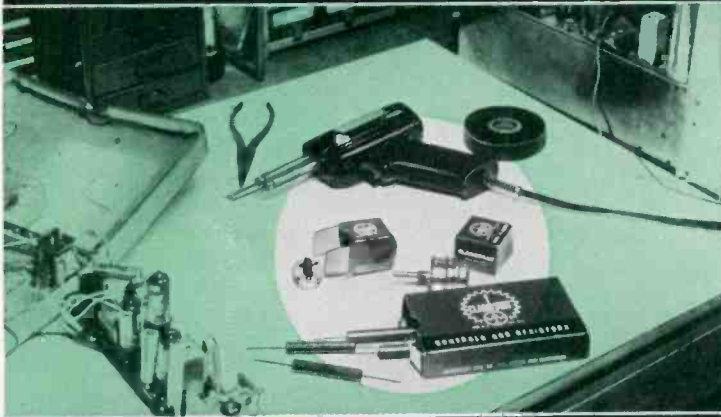

CLAROSTAT

PHONE, (AREA CODE 603) 742-1120 • TWX, 603-742-2038

# GUIDE TO PROFITS

Quality components are the first, and basic step, in profitable servicing. For resistors, potentiometers and switches always refer to the brand-new 1963 Clarostat Service Components Catalog now available from your Clarostat distributor, or write . . .

# CLAROSTAT

MFG. CO. INC., DOVER, NEW HAMPSHIRE



— for more details circle 20 on post card

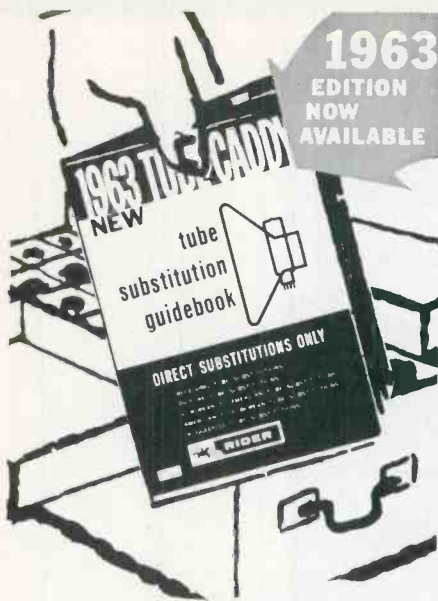

**1963**  
EDITION  
NOW  
AVAILABLE

## PAYS FOR ITSELF ON THE FIRST SERVICE CALL

**TUBE CADDY-TUBE SUBSTITUTION GUIDEBOOK**  
(Direct Receiving Tube Substitutions only—  
Direct CRT substitutions)

The Rider Tube Caddy-Tube Substitution Guidebook has become standard equipment in every TV technician's tube caddy. More than a quarter of a million copies have saved time and money for TV technicians. The new '63 edition is completely up-to-date—completely accurate—like its predecessors it contains only direct receiving tube substitutions which can be made without modification of the wiring! The new edition contains substitutions for receiving tubes, ruggedized tubes, European-to-American tubes, American-to-European tubes, and cathode-ray picture tubes. This guidebook will save you time by providing the information you need when you're in a customer's home; eliminate carrying needless tube types; enable you to select the best substitution and minimize sales losses because you don't have the right tube. #299 still only 90 cents.

### NEW . . . SERVICE 'TOOL'

**MASTER '45' SPINDLES, MOTORS & TURNTABLES GUIDEBOOK**  
by Jack Strong

Lists direct replacements for all current 45 rpm spindles. #321, \$2.00

### OTHER TIMESAVING RIDER SUBSTITUTION GUIDES

**MASTER RECEIVING — PICTURE TUBE SUBSTITUTION GUIDEBOOK**  
by H. A. Middleton

The answer to all tube substitution problems #244, \$7.45

**INTERNATIONAL TRANSISTOR SUBSTITUTION GUIDEBOOK (Direct Substitutions Only)**  
by Keats A. Pullen, Jr., Eng. D

It provides 4500 direct substitution both electrical and physical. #277, \$1.50

**MASTER CARTRIDGE SUBSTITUTION GUIDEBOOK**  
by Jack Strong

Saves time in locating the right replacement — saves money by cutting down the number of cartridges you need to stock. #288, \$2.00  
Get these guides at your distributor, or write

### Order today—10-DAY GUARANTEE

JOHN F. RIDER PUBLISHER, INC. DEPT. ET-3  
A Division of Hayden Publishing Co.  
116 W. 14th Street, New York 11, N. Y.

Please send:

Tube Caddy-Tube Substitution Guidebook (1963), 90c  Master '45' Spindles, Motors & Turntable Guidebook, \$2.00  Master Receiving-Picture Tube Substitution Guidebook, \$7.45  International Transistor Substitution Guidebook, \$1.50  Master Cartridge Substitution Guidebook, \$2.00

Payment enclosed — Rider pays postage.  
Send C.O.D. plus postage.

NAME \_\_\_\_\_

ADDRESS \_\_\_\_\_

CITY \_\_\_\_\_ ZONE \_\_\_\_\_ STATE \_\_\_\_\_

--- for more details circle 37 on post card

## NEW PRODUCTS

### CRT CHECKER

214

A cathode ray tube tester and rejuvenator, the Model CR125, uses dc on all checks to correlate



directly with tube manual data. Checks provided are inter-element shorts test, cathode emission test, dynamic control grid check, life test, cathode and control grid rejuvenation, shorts removal and cathode welding. Tube rejuvenation and short removal is accomplished through the use of a special RC timing which is designed to prevent over-rejuvenation regardless of the length of time that the rejuvenate button is held down. The timing circuit automatically applies rejuvenation voltage a longer period of time to cathode ray tubes with lower emission and a short duration of time to tubes that need little rejuvenation. Price is \$69.95 and the CR125 is available at parts distributors. Sencore, Inc.

### PICTURE TUBE

215

Pilot production of a 23-in KIM-CODE television picture tube has been started. The company says that 19 and 16-in. tubes will become available in the near future. The tubes employ fiberglass cloth to hold and retain the glass. The fiberglass is cemented around the



# NEW

## antenna specialists brand

# Black Beauty

## Fiberglas CB antennas

now you can whip two problems most common to fiberglass antenna performances!

First: through the "black magic" of exclusive Thermofit PVC process, brittleness and cracking are eliminated. Much more resistant to constant abrasions.

Second: The durable, black finish is inconspicuous yet gives an impressive, clean, classic look to your car. Looks good even after long, hard use. Center loaded and only 48" high. Choice of mounts. Available right now at your CB supplier or, for further information, write to

"Stripes of Quality"



the  
antenna  
specialists  
co.

12435 Euclid Avenue  
Cleveland 6, Ohio

Export Div., 15 Moore St.,  
New York 4, N. Y.

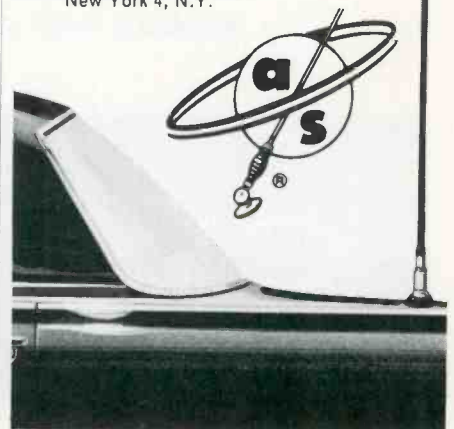

--- for more details circle 12 on post card

ELECTRONIC TECHNICIAN

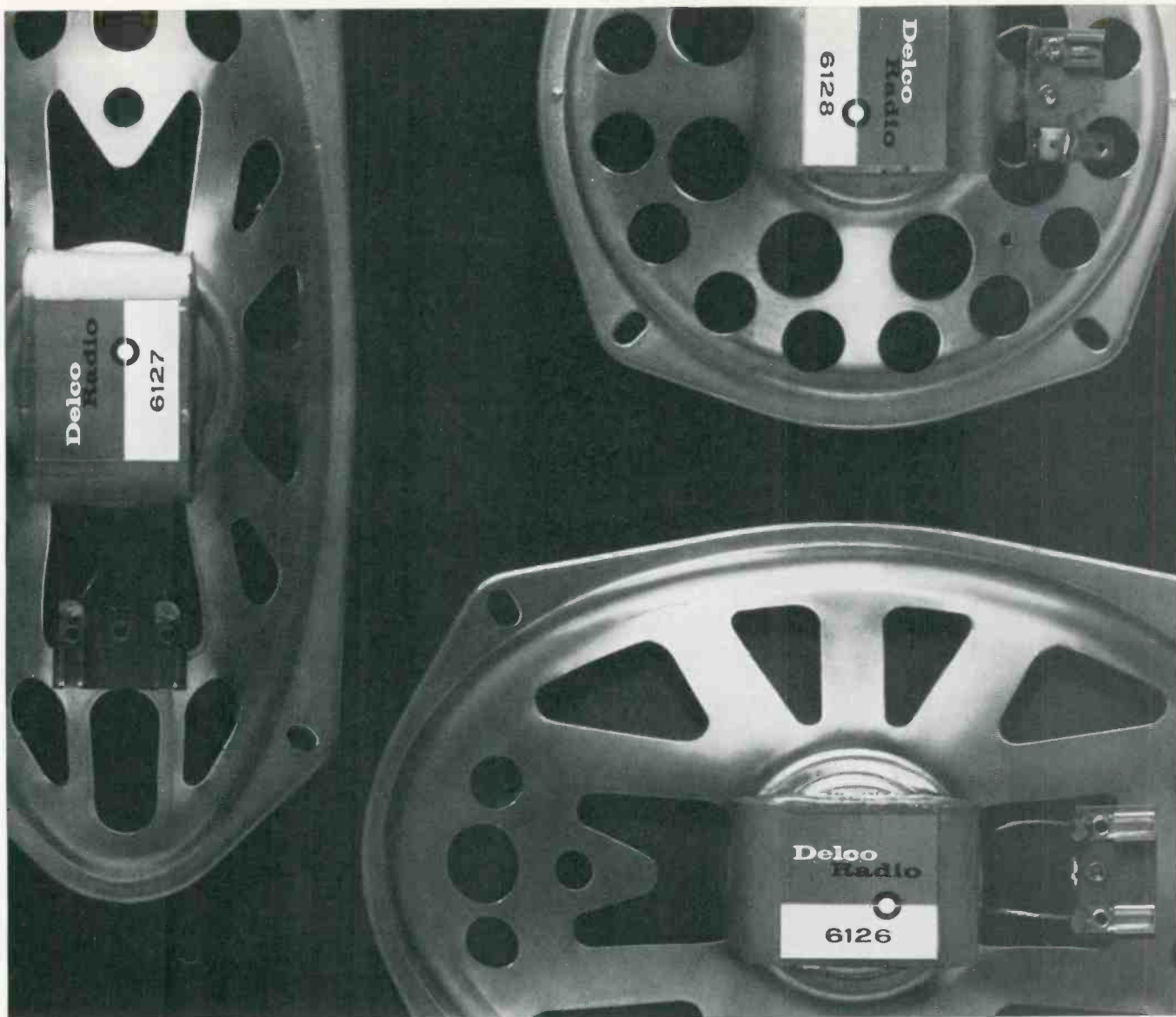

**3 SPEAKERS CAN NOW REPLACE 16**

# simply say **Delco**

These three new Delco Radio 8-10-ohm replacement speakers permit you to cut 16 numbers from your inventory. They can replace all units in current General Motors cars and many competitive makes. They

install easily and quickly, take a "tip jack," "blade," or solder connection. Excellent for home hi-fi and TV sets, too! Speak up for the latest in replacement speakers. Call your United Delco supplier today.

**THREE NEW SPEAKERS, ALL WITH SLOTTED MOUNTING HOLES**

Number	Size	Magnet Wt.	Mounting
6126	6 x 9"	1.6 oz.	front/rear
6127	4 x 10"	1.6 oz.	front/rear
6128	6" round	2.5 oz.	rear-seat

**SPECIAL**

**UNIVERSAL 8-10-OHM  
6 x 9" REAR SPEAKER PACKAGE**  
Contains all materials necessary for rear-seat speaker installation: Speaker, Grill, Wiring, Switch. Part No. 6122.

**Delco Radio** Automotive Radio Service Parts and Electro-Mechanical Devices are distributed nationally through **United Delco**

DELCO RADIO, Division of General Motors, Kokomo, Indiana



--- for more details circle 21 on post card

# NEW PRODUCTS

funnel with epoxy resin and a metal band of 0.018 in. thick annealed steel is formed to the contour of the face panel and extends into the viewing area about 1/16 of an in. The rim band is fastened with a 1 1/4 in. steel strapping band tightened under 2000 lb. tension and locked by a metal seal. Sylvania Electric Products, Inc.

## TUNER AND AMPLIFIER KITS 216

Leaders in this line of 1963 HiFi kits are the ST-55MX FM stereo multiplex tuner and the SA-50 integrated stereo preamplifier kits. The ST-55MX tuner features dual limiters, a Foster-Seeley discriminator and a grounded-grid RF stage to provide performance free from noise and interference. It offers 30 db of stereophonic separation with minimum distortion. The SA-50 is a 50 w preamp-amplifier designed to provide top performance and



maximum flexibility in any stereophonic or monophonic system. The SA-50 front panel includes 14 controls and switches. Price for the ST55MX in kit form is \$99.95 less enclosure. A semi-kit version with tuner front end and multiplex circuitry factory-wired and prealigned is priced at \$119.95 less enclosures. The SA-50 in kit form is \$79.95 less enclosure. Factory wired it is \$149.95, including enclosure. Paco Electronics Co. Inc.

## CB RADIO

217

A five channel two-way radio designed for commercial and professional Citizens Radio applications, the Model 515 is completely

transistorized and meets latest FCC and DOT regulations. Modular construction of the transmitter, receiver, audio section and power supply permits compact packaging and extremely low current drain. Built-in speech limiting, squelch, automatic gain control, and noise limiting provide excellent range and clarity. Included are ac and dc power cords, a mounting bracket, and a special dynamic microphone. Weight is 6 lb and dimensions are



11 1/2 x 3 1/4 x 5 1/2 in. The Model 515 features five crystal controlled channels for base or mobile communications. A matching rechargeable battery pack called the 500-1 converts the 515 to a lightweight portable. The pack, which includes a telescoping antenna, costs \$29.95 and 6 v nickel cadmium batteries are \$10.95 each. The 515 is priced at \$187.50. Cadre Industries Corp. Commercial Products Div.

## CB TRANSCEIVER

218

A compact but powerful "walkie-talkie" set, will carry two-way conversation at distances up to four miles. The Medallion Citizen Band Transceiver (Model 42R99), has many useful applications on the farm, in plants, for Civil Defense work, and anywhere else that optimum battery powered short distance communications is desired. The 42R99 has a frequency range of 26.97 to 27.27 Mc. The pocket size nine-transistor set measures only 6 1/2 in. high, 1-9/16 in. deep and 2 3/4 in. wide. It comes complete with two matching transceivers, genuine leather carrying cases, leather shoulder straps and



# NEW! FROM CHEMTRONICS

## 16 oz. ECONOMY SIZE

# TUN O LUBE

TUNER CLEANER

**for a limited time ONLY...**

16 oz. TUN O LUBE	2.98
3 oz. TROL AID	.98
<b>REGULAR PRICE</b>	<del>3.96</del>

**NOW**

# \$2.98

DEALER NET

**CHEMTRONICS INC.**  
NEW! NON-FLAMMABLE TUNER CLEANER

# TUN O LUBE

**special offer**  
only \$2.98

**FREE!**

## 98c CADDY SIZE CAN

# TROL AID

Control and contact cleaner  
FORMULATED TO CLEAN AND LUBRICATE CONTROLS AND SWITCHES

**SPECIALY FORMULATED TO CLEAN AND LUBRICATE ALL TYPES OF TUNERS.**

**FREE FLEXIBLE STAINLESS STEEL NEEDLE, FOR PIN-POINT APPLICATION**

**CHEMTRONICS INC. 870 East 52nd Street • Brooklyn 3, N. Y.**  
MANUFACTURERS OF CHEMICAL PRODUCTS FOR THE ELECTRONIC INDUSTRY... EXCLUSIVELY

--- for more details circle 19 on post card



# Greatest 1-2 Signal Punch in the Industry—from Winegard

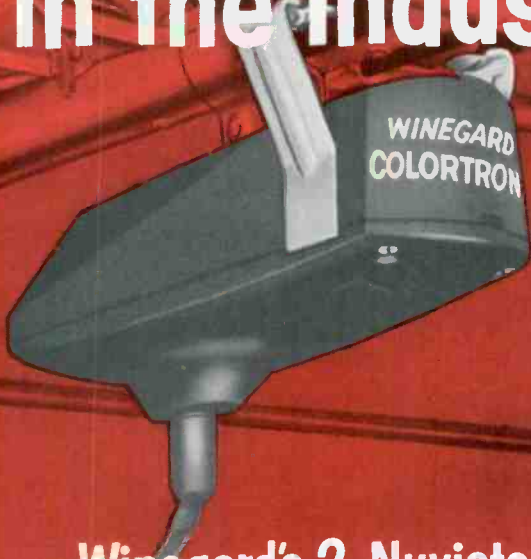

**Winegard's 2-Nuvistor  
Colortron Antenna Amplifiers**



**Single Transistor  
Red Head Antenna Amplifier**

Take your choice of Winegard's 2-nuvisor Colortron or single-transistor Red Head antenna amplifiers — both great — both trouble-free! Both work with any TV or FM antenna. Here's the story!

**COLORTRON ANTENNA AMPLIFIER . . . ONLY \$39.95 • EXCELLENT FOR COLOR • WON'T OVERLOAD • TAKES UP TO 400,000 MICROVOLTS OF SIGNAL**

**FINEST ANTENNA AMPLIFIER MADE . . .** Because the COLORTRON amplifier takes up to 400,000 microvolts of signal input, strong local signals won't overload and cause interference on distant fringe stations. It takes 20 times more signal input than any transistor antenna amplifier and without compromising its ultra low noise ability to pull weak signals out of the snow.

A special "lifesaver" circuit gives the 2 nuvisitors an expected life of 5 to 8 years. It's the only amplifier that's completely weather-proof — nothing exposed, even terminals are protected. Install it and forget it! Fits any TV or FM antenna.

Colortron Amplifiers are Available in 2 Models for TV

**FOR TV—Model AP-200N—twin nuvisor, takes up to 400,000 microvolts, input 300 ohm, output 300 ohm, \$39.95 list.**

**FOR TV—Model AP-275, twin nuvisor, takes up to 400,000 microvolts, input 300 ohm, output 75 ohm, \$44.95 list.**

**RED HEAD TRANSISTOR MODEL . . . ONLY \$29.95 • FOR COLOR AND BLACK & WHITE • MOST RELIABLE TRANSISTOR ANTENNA AMPLIFIER EVER MADE.**

With the Red Head, you won't have transistor "pop-out" because of its special advanced circuit that protects against lightning flashes, precipitation static and power line surges. Has high pass interference filter, 2-set coupler, fully AC—no polarity problems. Tremendously effective in remote areas where all signals are less than 20,000 microvolts. Uses latest low noise MADT transistor. Bright red amplifier housing gives lasting product identification. The Red Head supersedes Winegard's famous MA-300 amplifier.

**For TV or FM—Model No. RD-300, single transistor, takes up to 20,000 microvolts, 300 ohm input and output, \$29.95 list.**

Stereotron Amplifiers are Available in 2 Models for FM

**FOR FM—Model AP-320, twin nuvisor, takes up to 200,000 microvolts, input 300 ohm, output 300 ohm, \$39.95 list.**

**FOR FM—Model AP-375, twin nuvisor, takes up to 200,000 microvolts, input 300 ohm, output 75 ohm, \$44.95 list.**

Write for technical data or ask your Winegard distributor.

**There's a Winegard Quality Antenna  
for Every Reception Need**

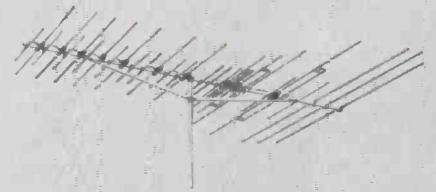

**COLORTRON ANTENNA  
Model C-44 • Gold Anodized • \$64.95**

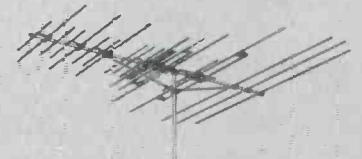

**COLORTRON ANTENNA  
Model C-43 • Gold Anodized • \$51.90**

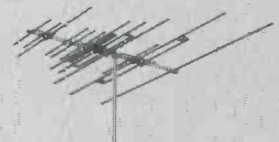

**COLORTRON ANTENNA  
Model C-42 • Gold Anodized • \$34.95**

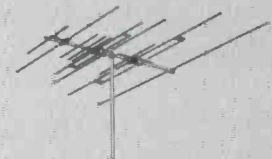

**COLORTRON ANTENNA  
Model C-41 • Gold Anodized • \$24.95**



YOU GET AN EXTRA BONUS OF QUALITY AND VALUE FROM WINEGARD

**Winegard** ANTENNA SYSTEMS

WINEGARD COMPANY • 3019-3 KIRKWOOD BLVD. • BURLINGTON, IOWA  
for more details circle 50 on post card

# TV TIPS FROM TRIAD

NO. 20 IN A SERIES

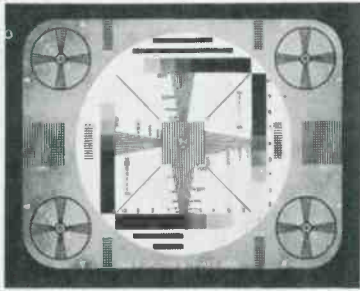

Joe scowled at the burned power transformer facing him on the bench. "Haven't we seen this chassis before, Bill?" he asked the Senior PTM. "Right. We replaced the original power with another original a few months ago."

"The problem," Bill elaborated, "arises from the fact that the components are aging—capacitors act like resistors, resistors change value, line voltages are higher, and new rectifiers are more efficient. All of these things add up to increased current demands on the power transformer."

"What say we install one of those neat new Triad Triple X powers that Hank, our parts pusher, told us about the other day? He was sure sold on that 30% reserve resulting from the use of high-efficiency, grain-oriented steel laminations," said Joe. "So, you were paying attention," commented Bill with a hint of a smile. "What else did he say?"

Joe continued as if he hadn't heard, "Grain-oriented steel, along with new engineering design, permits much greater flux density without saturation. Furthermore, it provides that extra reserve without the use of cumbersome radiating fins or other special ventilation."

Joe paused a moment, but quickly added with obvious enthusiasm: "By the way, did you notice the schematics in the Triad technical replacement handbook? It shows the rectifier winding tapped at 3.8 volts, so you can use the new 3-volt rectifiers, such as the 3DG4, as well as the 5-volt types."

"I'm overwhelmed," said Bill. "Get on that phone and rush order that R-91HA."

**MORAL:** Ask to see the new Triple X series of compact powers in 26 different voltage and current ratings at your favorite Triad Distributor. He's the one who has those good-looking red and white boxes on his shelves. Packed in each box is an instruction sheet containing a bonanza of schematic, technical, and installation data. These small (but mighty) Triple X powers will make your life more pleasant when you need a replacement for those tightly packed portable TV sets. They're equally fine for the larger roomier sets, too. Write Triad Distributor Division, 305 No. Briant St., Huntington, Indiana.

A DIVISION OF LITTON INDUSTRIES 

... for more details circle 47 on post card

## NEW PRODUCTS

a supply of 12 batteries, all packed in an attractive gift box. The suggested retail price is \$99. Arvin Industries, Inc.

### PA AMPLIFIER

219

A 30 w mobile public address amplifier weighs only 11 lb and features an all-transistor design. Its

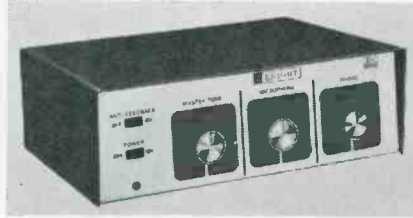

transistor circuit has extremely low battery drain, and idling current of only ¼ amp. which is less than that used by a car's parking lights. At full rated power, the KN-3230M uses only 4.5 amp. The KN-3230M is styled with a black cabinet and aluminum-finish panel. It measures a compact 3½ in. by 10¾ in. by 6 in. Price is \$69.95. Allied Electronics Corp.

### CONTROL TRANSMITTERS

220

Six push-button operated industrial multi-signal transmitters have been added to a line of radio control system components. The units can be used in the remote control of commercial and industrial doors, signal annunciators, lighting equipment and machinery. They are fixed frequency, single-tone modulated units for transmitting any one

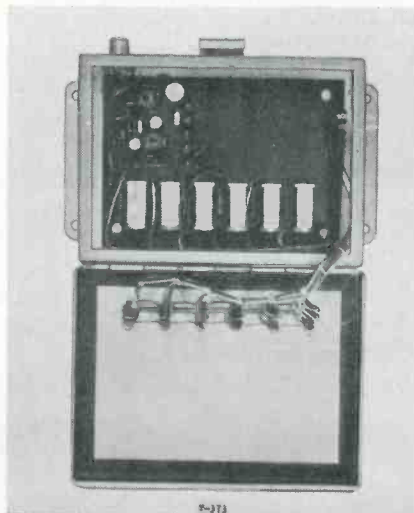

of up to 36 coded signals. All are certified for use without license under FCC Low Power Rules, and are suitable for fixed or mobile use. Distances of up to 1½ miles may be obtained using these transmitters with Citizens Band antennas. They operate on any of six Class C Citizens Band frequencies, and have a carrier power output to 45 mw, AM with crystal oscillator frequency control. Perma-Power Co.

### SLIMLINE TWO-WAY

221

A 35 w, VHF-FM two-way mobile radio set, the 6N35/SLT, SLIMLINE '35, is designed for "up-front" mounting in any vehicle. If desired it may be mounted in the truck or other convenient location and operated by a compact Remote Control Unit (optional) mounted under the dash. A selector switch mounted on the brushed silver ano-



dized panel provides for instant selection of up to four channels. The unit is supplied with one channel as standard equipment with three others available at extra cost. Weighing less than 9 lb, and measuring 4¾ by 11 by 8½ in., the SLIMLINE '35 is the most compact 35 w VHF-FM set on the market today. Net fleet price for the single-channel SLIMLINE '35 is \$395. AEROTHON.

### "Y" ADAPTER

222

The flexible "Y" adapter, Part No. 330H, allows an owner of a foreign manufactured tape recorder to use American made accessories, such as microphones, telephone pickups, mixers and extension speakers. The adapter is actually a 3-pin Hirschmann type plug connected to two Switchcraft type phono jacks. The phono jacks are color coded. The plug of the

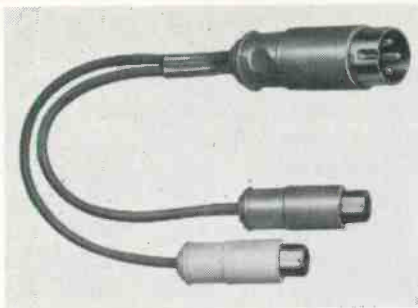

adapter can be inserted in the input or output sockets of the Norelco, Grundig, Uher, or Korting tape recorders. American made recorder accessories can then be plugged in the phono jacks. No soldering, wiring or tools are needed. List Price for the 330H Adapter is \$3. Switchcraft, Inc.

### SPEAKER SYSTEM 223

The CH-2 CHALLENGER is super-slim in size, measuring only 18 in. wide, 12 in. high and 3 1/2

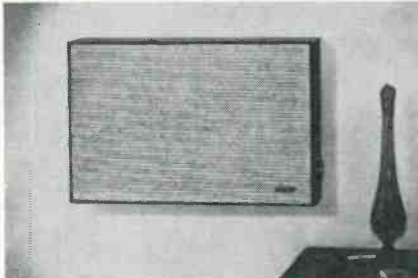

in. thick. It features three advanced design speakers specifically engineered for slim enclosures. Two high efficiency 6 x 9 in. speakers and a 4 in. closed-back tweeter with an electrical crossover are used. Peak power is 15 w. A volume control is incorporated for remote regulation of sound. The CHALLENGER is as easy to hang as a picture . . . special mounting clips are included for flush wall mounting. Suggested user net is \$29.75. Mercury Electronic Corp.

### AMPLIFIER 224

A new firm has entered the high fidelity components field with the introduction of the model VC-50 stereo amplifier and preamplifier. Featured is an electron eye balance

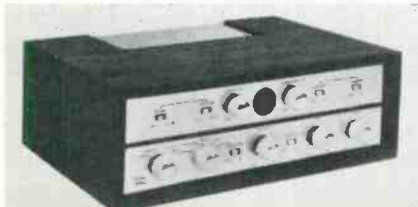

# SARKES TARZIAN Silicon Rectifiers

*are first choice among service technicians (according to nation-wide polls) for good and simple reasons:*

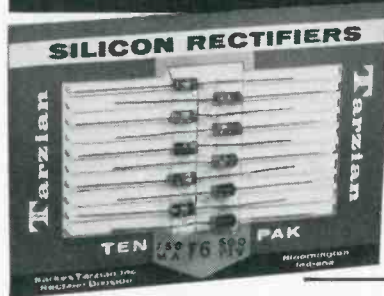

Tarzian 400V and 600V "F" Series units in handy Ten-Paks, Doubler Replacement Kits, and in bulk



Tarzian 400V and 600V "H" Series units in handy Ten-Paks, Doubler Replacement Kits, and in bulk



- ★ They are immediately available from distributors throughout the nation
- ★ They are "handy-packed" in the quantities and sizes you need most
- ★ Their proven quality and dependability eliminates callbacks that waste your time and profits

A free Tarzian "Replacement Line" catalog is yours for the asking. It's your guide to replacement rectifiers with competitive prices, unsurpassed performance.

Write or call your nearest Tarzian distributor, or:



Tarzian's nine standard tube replacement rectifiers replace over 95% of all vacuum tube rectifiers



Tarzian M-500 and M-150 units in Conversion Kits and in bulk

Tarzian's four "condensed stack" selenium rectifiers fit small-size, high-efficiency applications



## SARKES TARZIAN, Inc.

World's Leading Manufacturers of TV and FM Tuners • Closed Circuit TV Systems • Broadcast Equipment • Air Trimmers • FM Radios • Magnetic Recording Tape • Semiconductor Devices  
SEMICONDUCTOR DIVISION • BLOOMINGTON, INDIANA  
Canadian Licensee: Marsland Engineering Limited • 350 Weber Street North, Waterloo, Ontario

--- for more details circle 38 on post card

# COLOR CODED NUTDRIVER SETS

no fumbling...  
you reach for  
the right one  
every time!



No. 17  
HANDY  
BENCH STAND

- 7 Most-used sizes —  $\frac{3}{16}$ " thru  $\frac{3}{8}$ "
- High carbon steel, polished and plated
- Precision fit case-hardened sockets
- Shockproof plastic handles (UL)
- Large, readable size indexes



No. 127  
SPACE-SAVING  
WALL RACK (Lockable)

OTHER SETS, TOO: hollow-shaft or mixed  
PLUS A FULL RANGE OF SEPARATE NUTDRIVERS:  
3/32" thru 3/4" — Regular, Stubby, Extra-long,  
Midget (Pocket clip)  
available through leading electronic distributors

XCELITE, INC.

14 Bank St. Orchard Park, N. Y.  
Canada: Charles W. Pointon, Ltd., Toronto, Ont.

## XCELITE

### HAND TOOLS

Quality screwdrivers, nutdrivers, pliers,  
wrenches, service kits, and special purpose tools.

for more details circle 51 on post card

## NEW PRODUCTS

indicator for accurately balancing both left and right channels and a genuine oil finished walnut cabinet. Specifications include: power output, 50 w (25 w each channel), peak power; 80 w; Frequency response,  $\pm 1$ DB, 30 to 30,000 cps at rated output and  $\pm 1$ DB 30 to 50 kc at 2 w. Vidair Electronics Mfg. Co.

### KIT-PAK CONTAINER 225

The prize-winning Kit-Pak container has been restyled to make it even more useful to the kit build-

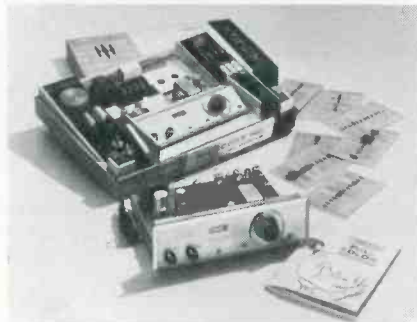

er. The orange and black package now has a completely removable cover. The box opens to become a self-contained work table for use during construction. It prevents loss of parts and protects the table used during construction of the kit. When the kit builder wants to stop work he simply replaces the top and puts the uncompleted kit out of the way for safe storage. H. H. Scott, Inc.

### TAPE RECORDER DISPLAY 226

A compact, pilfer-proof, operational, point-of-purchase display has been made available to dealers for use with the Hitachi TRQ370 7-transistor tape recorder. The simple, but attractive Econo-Lok-



Display can be set up in a few minutes on a counter top or attached to a wall. Simple instructions next to the microphone ask passers-by to "Try it yourself — remove mike from holder — turn switch to 'on' — turn knob to 'play'." The recorder operates on 2 speeds — 1 $\frac{7}{8}$  ips and 3 $\frac{3}{4}$  ips. It weighs less than 5 lb and operates either on 4 "C" batteries, or 110 vac with the adapter. The display is offered free to dealers with order of 4 TRQ370 Hitachi tape recorders. The Sampson Co.

### PLUG AND SOCKETS 227

Series 8-8145 Preh plugs and sockets are designed to assure positive connections and freedom from noise, leaks or shorts. Most noteworthy features of the new connectors are their quick-action changeability in circuit opening and closing, and their exceptional quality at low cost. The 9/16 by 9/16 in. plug incorporates a snap action assembled, plastic housed two-pin configuration with metal strain relief. Sockets are of molded phenolic with easy-to-solder terminals standard on all models. Firm chassis



mount is assured by metal mounting brackets (9 different configurations) providing screw holes and/or rivet flanges. Prices range from 10c to 50c. Telephone Dynamics Corp.

### CITIZENS BAND 228

Double Side Band Reduced Carrier, BSBRC, permitting a range breakthrough in CB is incorporated in the RANGE GAIN transceiver. DSBRC provides up to four times the coverage of previous CB units. New features include: 23 crystal controlled channels for transmitting and receiving; 4-way illuminated meter with two scales, meter glows red on transmit; illuminated channel selector for all 23 channels; antenna matching adjustment for resistive antenna loads of 30 to 75 ohms and four simple function switch settings,

# Belden

## TV lead-in cables

(and cartoons, too!)

Instead of running an ad about how good Belden lead-in cables are, we thought you might enjoy re-reading some of the recent cartoons we have published. Besides, you already know that Belden Weldohm\* is strong and flexible... Permohm and Celluline give better color TV pictures... and Permohm gives better signals in spite of industrial contamination and salt spray... don't you?

\*Belden Trademark—Reg. U.S. Pat. Off.  
 ✓Belden Trademarks and Patents—U.S. Patent No. 2782251 and 2814666



power supply cords • cord sets and portable cordage • electrical household cords • magnet wire • lead wire



8-13-2



# TRANSCCEPTOR



## THE ONLY INDUCTIVE SET COUPLER

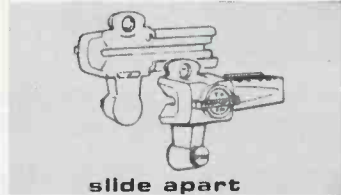

slide apart

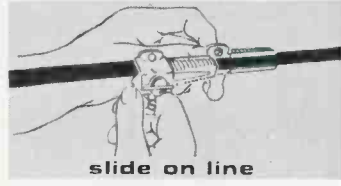

slide on line

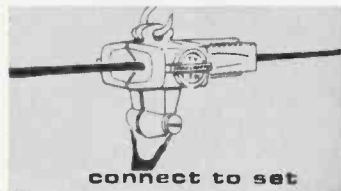

connect to set

## ANYONE CAN INSTALL IN SECONDS

Any number and combination of TV and FM sets can be run off one antenna with foolproof, simple, rugged TRANSCCEPTOR. Because it uses electromagnetic pickup, TRANSCCEPTOR simply snaps on main antenna line without tools, stripping, splicing or soldering. Line is not cut, signal loss is minimized, set-to-set isolation is improved (12 db).

Impedance is matched automatically. Uses standard 300-ohm flat line. Operates up to 20 sets without amplification in normal signal areas. Easy to sell, easy for customer to use, TRANSCCEPTOR is guaranteed for life of the set.

As an inexpensive impulse purchase, accessory sales builder, or give-away on larger purchases — you'll build sales and profits with TRANSCCEPTOR.

**AEROGAP CORPORATION**  
1680 VINE STREET HO 6-7385  
LOS ANGELES 28, CALIFORNIA

**\$2<sup>98</sup>**  
RETAIL

for more details circle 10 on post card

## NEW PRODUCTS

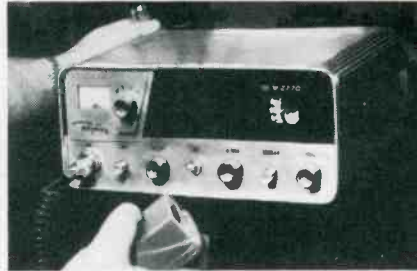

R,T,V,C, for the 4-way meter. Weight of the transceiver is 13 lb and it is 11 in. wide by 4½ in. high by 8¾ in. deep. Price is \$250 complete. Regency Electronics Inc.

## HI FI HEADSET 229

Each earcup of the KN-845 is actually a precision, 3½ in. cone-type dynamic transducer with full



response range of 25 to 16,000 cps, housed in a perfectly balanced acoustic chamber. The KN-845 can be used for private stereo listening in the same room with other activities such as television or children playing, and many stereo owners prefer headsets to general speaker listening. The set weighs only 2½ lb and has soft, sponge rubber padded earcups and headband. Headband and ear pieces feature a medium blue leatherette covering. The set is offered for \$19.95. Allied Radio Corp.

## CB TRANSCEIVER 230

The Drake M-506 is 8 in. wide,



3 in. high and 9 in. deep and is one of the smallest transceivers of its type on the market. It can be mounted in any car, boat or other vehicle in a matter of minutes. Receiver sensitivity is 0.4  $\mu$ v for 10 db signal to noise ratio and selectivity is 5 kc at 6 db with adjacent channel 50 db down. Browning Laboratories, Inc.

## TUBE TESTER 231

The model 88 tube tester is unconditionally guaranteed to be up-to-date and adaptor kits or set-up



data will be furnished without cost for any tube types that appear within one year of purchase. The meter reads grid emission and all common leakage and short faults in one step. Filament continuity and open ele-

**5 CORES**  
**WETS FASTER**  
**MELTS FASTER**  
**Solders Better**  
**5-CORE SOLDER**  
**WORLD'S FINEST**

ERSIN  
*Multicore*  
BIC ENDORSED QUALITY  
Multicore Sales Corp. Port Washington, N.Y.

For information, write Department MC553  
for more details circle 33 on post card

ments are also indicated as well as cathode emission in a special low impedance circuit. Grid circuit and tube merit test scales show all tube faults quickly and accurately on a single, burnout-proof meter. The Grid Circuit Test is patented. Seco Electronics.

**PA SYSTEM 232**

The "Ampli-Vox Roving Rostrum" is now adaptable for audience participation. The self-contained

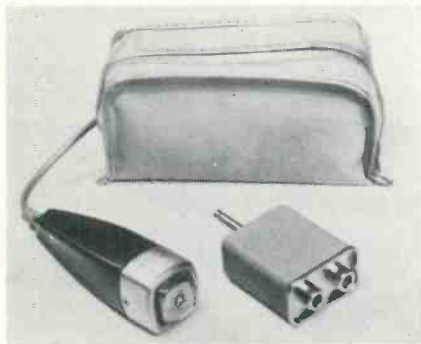

battery-operated public address system can be provided with a microphone extension kit, permitting the simultaneous use of 2 microphones, even in separate rooms. The microphone extension kit includes a

microphone with 10 ft cord, a mixer and a 25 ft extension cord, ready to plug in to the Rostrum. The kit sells for \$29.95. Perma-Power Co.

**PRE WIRED BAFFLES 233**

The Decorator line wall and ceiling baffles are available with factory-installed speaker, m a t c h i n g

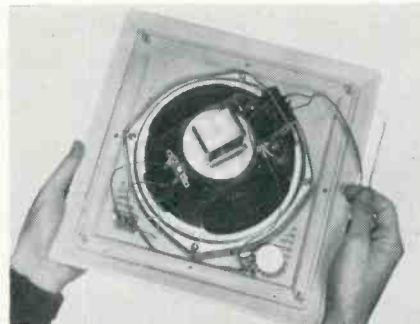

transformer, L-pad, on-off switch and volume control, pre-wired and ready for installation. An extensive selection of Jensen and Oaktron speakers are available, and the sound installer may choose speaker quality, size and components to suit the particular installation. According to the manufacturer, not only does the packaged unit cost less than if components were pur-

chased separately, but the factory-wired units are faster and more economical to install. Wald, Inc.

**STYLUS GAUGE 234**

An easy-to-use stylus gauge measures the tracking force of any stylus and cartridge assembly from 8 to 1/2 g. The Model SG-2 which lists at \$1.45, is calibrated in 1/2 g increments and works on a balance principle with counter-balance weights permanently in place. To determine tracking force, the user places his stylus on the gauge and moves it until the platform is level with the base of the gauge. He can then make the necessary adjustments to reduce or increase the tracking force. The plate on which the stylus rests is made of soft brass. Robins Industries Corp.

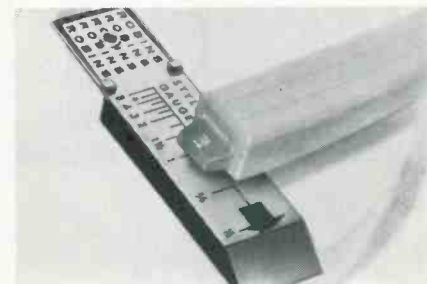

**SELF-SERVICE TUBE TESTERS**  
are **BIG INCOME PRODUCERS**

**NEW** MODERN EYE-STOPPING TESTERS... TOPS  
in PERFORMANCE... QUALITY... and VALUE

Here is everything you want in self-service tube testers at down-to-earth prices. **MORE VERSATILITY**—Tests emission, shorts and gas of over 1200 tube types including the very latest NUVISTORS, NOVARS, COMPACTRONS, etc... Also tests fuses, pilot lights, 6 and 12 volt auto radio vibrators, all type batteries under load. **SMARTER LOOKING**—Modern cabinet design finished in a rich green and white color combination with gold trim... Eye-stoppers in any location—will attract do-it-yourself customers as never before and sell tubes in a big way. **MORE QUALITY FEATURES**—Completely self-service... Only two easy-to-use controls are required to test any tube... Easy-to-read quick flip tube charts list over 1200 tube types... Engineered to accommodate new tube types as they are introduced... Etched aluminum panel always retains its handsome appearance... 63 phosphor-bronze beryllium tube sockets assure positive contacts and long life.

Replace old self-service tube testers with Mercury testers and spark-up your present locations... place them in new locations and be assured of the greatest profit results.

*Slightly higher in the West*



**Model 202-LB**  
(Lo-Boy Floor Model) **\$184.50**  
Dealer Net

**Model 202-C**  
(Counter Model) **\$129.95**  
Dealer Net



**Model 203-LB**  
(Deluxe Lo-Boy Floor Model) **\$254.50**  
Dealer Net

**Model 203-C**  
(Deluxe Counter Model) **\$166.95**  
Dealer Net

**MERCURY ELECTRONICS CORPORATION, 111 ROOSEVELT AVENUE, MINEOLA, NEW YORK**

... for more details circle 32 on post card

IT PAYS TO USE AEROVOX!

Let's face it...this radio-TV-electronics servicing business is a highly demanding business. Your customers demand good service at a fair price. Your work at the bench or on service calls requires skill and efficiency. The rapid pace of new circuits and equipment demands time to keep up with the industry. And how well you know that time means money! That's why you can't afford costly callbacks or customer complaints due to premature component failures. When it comes to capacitors, you know you can depend on Aerovox. You see, at Aerovox there's absolutely no compromise with quality. Since the early days of radio, Aerovox engineers have pioneered capacitor improvements. Take electrolytics, for example. Your Aerovox distributor stocks the most dependable and complete line of exact replacement types in every rating you need...a few of the most popular types are shown here. Get all the facts...ask him for a free copy of the new Aerovox TV Electrolytic Capacitor Replacement Guide AFG-462. ▶



**If you demand the best—use AEROVOX ELECTROLYTIC EXACT REPLACEMENT CAPACITORS**

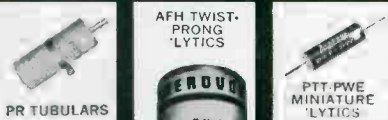

**AEROVOX CORPORATION**  
DISTRIBUTOR DIVISION, NEW BEDFORD, MASS.  
Technical Leadership—Manufacturing Excellence

## NEW BOOKS

**BASIC OSCILLATORS.** By Irving M. Gottlieb. Published by John F. Rider Publisher, Inc. 202 pages, soft cover. \$4.50.

It is a fact, as the author of this book indicates in a very brief preface, that most technical literature on oscillators is either oversimplified or "explained" in a circular manner in the direction of infinite abstract complexity. Both approach methods, of course, never develop enough Gs to get off the ground—so far as practical technicians and engineers are concerned. This book not only hits in between, it is oriented in a direction to minimize confusion and enhance clarity. All this is reasonably well done in five modest chapters covering Oscillator Definitions and Parameters, Components and Oscillator Characteristics, Oscillation Producing Devices, Theory of Oscillation and Practical Oscillators. Despite the fact that the writing "style" leans in the direction of "formal overwordiness," the author has succeeded well in his stated objective of revealing clearly the relationship between oscillator theory and practical application. The text lists components and characteristics of oscillators and appropriate mathematical equations. Text material is adequately illustrated with drawings, schematics and necessary charts. This is a valuable reference for the technical minded, whether engineer, technician scientist or experimenter.

**IT'S EASY TO USE ELECTRONIC TEST EQUIPMENT.** By Larry Klein and Ken Gilmore. Published by John F. Rider Publishers, Inc. 186 pages, soft cover. \$4.00.

There is nothing technically new in this book. But you can bet your "bottom dollar" that it is *not* another re-hash of previously published literature on the subject. Moreover, the technical material is presented in a fresh, almost new style, reflecting practical technical writing experiences of the authors. But that is not all—wide practical experience with the equipment makes it possible for the authors

to describe and tell how to use it in simple easy terms. This is no "remote-control" ivory-tower job and the volume is aimed directly at the TV-radio and Hi Fi technician. Its 19 brief chapters are chock-full of practical information on VOMs, VTVMs, scopes, voltage calibrators, flip-flops, probes, tube testers, transistor testers, bridges, RF signal generators and how to use them; sweep generators, audio and square-wave generators. The ac VTVM—with dc and audio power measurements — is detailed. Harmonic and intermodulation distortion analyzers are discussed. The text is very well illustrated with schematics, drawings and photos.

**REPAIRING HOME AUDIO SYSTEMS.** By E. Eugene Ecklund. Published by McGraw-Hill Book Company, Inc. 320 pages, hard cover. \$6.95.

Technicians who have shied away from home audio system repairs as well as those who have been in the business for years, will find this volume helpful in many ways. Introductory chapters outline

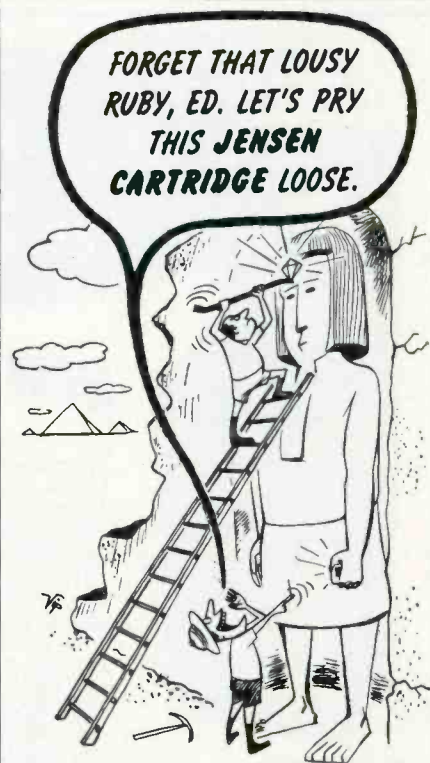

The Customer Reminder Plan is yours—

**FREE!** Write

**Jensen<sup>®</sup> INDUSTRIES, INC.**

301 Interstate Rd., Addison, Ill.

... for more details circle 30 on post card

ELECTRONIC TECHNICIAN



the profit opportunities in this field and specify basic shop facilities and tools required for successful operations. Each of the remaining 14 chapters deals with "how it works" and the practical aspects of troubleshooting and repairing home audio systems. Preamps, amplifiers and tuners are thoroughly detailed. Phonograph records, pickups and needles are discussed. Record changers, their motors and drives; tripping, record-dropping and shutoff mechanisms are thoroughly covered. Tape recorders and complete music system troubleshooting is elaborated in three chapters. The book's substance is unusually well organized and the text has a minimum of useless redundancy. Schematics, drawings and photos are adequate. This is a basic volume that fills a necessary niche in every TV-radio technician's library.

## NEWS OF THE INDUSTRY

### Radio, TV Sales Climb

Brisk December business at the distributor level closed out a record year for sales of radios and the best 12-month period since 1956 for turnover of television sets, ac-

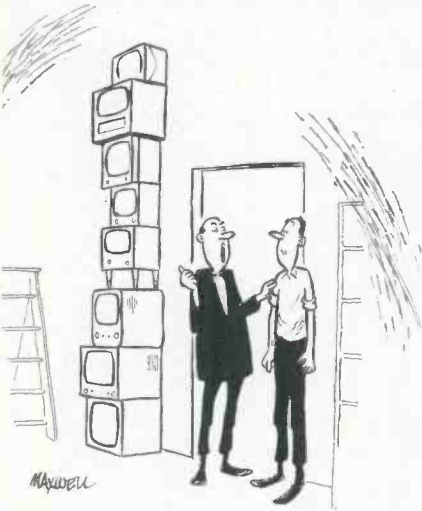

"I like neatness too, McZeal. . . . But that's ridiculous."

Photos of the loudspeaker installations seen on ET's popular February issue cover were furnished through the courtesy of University Loudspeakers, Inc., White Plains, N. Y.

ording to year-end tabulations released by the Electronic Industries Association. Radio production last year fell just short of a record peak set 15 years ago, and output of TV sets hits the highest point since 1956. Total auto radio production outstripped that of 1961 by better than 1.5 million sets to reach an all-time high. Manufacturers turned out 19,161,906 new radios last year, a total exceeded only by the 20 million produced in 1947. Output of automobile radios paced the 1962 rise with a record total of 7,249,-

857. The year before the cumulative total was 5,568,345. FM radio sales climbed to 1,227,081 last year compared with a total of 915,297 the year before. Television production stood at 6,471,160 at the end of 1962, the highest annual total since 7,387,029 produced in 1956, and 293,363 sets above total output in 1961. Production of all-channel receivers — those capable of receiving ultra-high-frequency as well as very-high-frequency transmissions rose from 370,977 in 1961 to 598,446 in 1962.

# BOOST YOUR BRITENER SALES

with these

## SIX MAGIC WORDS

from *Perma-Power*

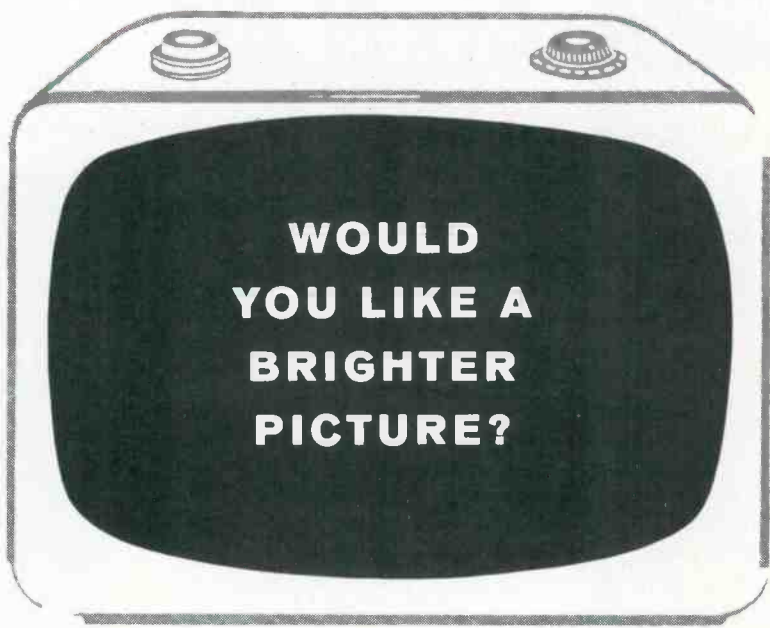

That's a question with only one possible answer—YES. Every customer wants a better, brighter picture . . . but doesn't realize how easy it is to get one.

When you say you'll brighten the picture—When you quote the low cost—you've sold the customer.

### Don't sell Briteners—sell Brighter Pictures!

On every service call, remember to use Perma-Power's 6 Magic Words—Would You Like A Brighter Picture? You'll sell a 12-pack of Briteners almost as fast as you can say Perma-Power!

*Perma-Power* COMPANY—3104 N. Elston Ave.—Chicago 18

for more details circle 34 on post card

## BUSS Sub-Miniature PIGTAIL TRON FUSES

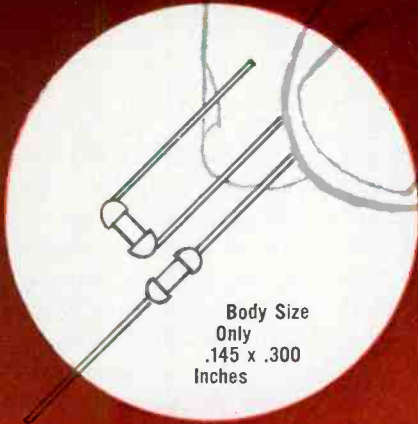

Body Size  
Only  
.145 x .300  
Inches

Tron fuses are so small they can be used as an integral part of circuit—to protect miniaturized devices—or gigantic multi-circuit electronic devices, without sacrifice of space.

They are hermetically sealed for potting without danger of sealing material affecting operation and have high resistance to shock or vibration. Operate without exterior venting. May be teamed with other components in replaceable unit.

# BUSS

Write for BUSS  
Bulletin SFB.

BUSSMANN MFG. DIVISION, McGraw-Edison Co., St. Louis 7, Mo.

... for more details circle 16 on post card

Audio Equipment for Home Use.” (Such a rating, under the standard, would require the delivery of 5w with not more than 5 percent distortion.)

2. The over-all phonograph system should have a minimum acoustical (or sound pressure level) output of 77 db at 100 cps, 80 db at 1000 cycles per second, and 74 db at 8000 cps.

### Opposes Warranties

The Empire State Federation of Electronic Technician Associations, Inc. (ESFETA) meeting in executive session in Syracuse, N.Y., Jan. 20, passed the following motion, “ESFETA goes on record as opposing manufacturers extended warranties,” Max Leibowitz, who was appointed liaison chairman, welcomes correspondence from all local, state, and national electronic technicians associations so that the activities of ESFETA can be coordinated with those of other interested groups, Mr. Leibowitz can be contacted at 24-09 41st St., Astoria 3, N.Y.

### Philco Color

Philco Corporation's Consumer Products div. will begin the manufacture of color television receivers in its own plants beginning late this spring. The 1964 model Philco color sets will be assembled at Plant 10 on Tioga Street in Philadelphia. “We are taking this step and making the necessary investments in new facilities and tools because we are convinced of the sound growth potential of the color business and be-

**BUSS : the complete line of fuses .**

## NEWS OF THE INDUSTRY

### FTC Gets Hi Fi Report

The Electronic Industries Association (EIA) recently submitted to the Federal Trade Commission a report on a survey conducted in response to an FTC staff request for information useful in developing a minimum definition of high fidelity sound reproduction. Incorporated in the report was a draft definition, applicable only to factory-assembled packaged phonograph systems, prepared by an ad hoc committee representing the Association's Consumer Products Division and the EIA Engineering Committee on Packaged Audio Equipment. But the document emphasized that, because of a wide divergence of views disclosed by EIA's survey of the industry. “It is quite apparent that there exists no industry-wide recognition of a dominant view of what constitutes ‘high fidelity’ with reference to sound producing equipment.”

The definition of high fidelity for packaged phonographs was drafted in terms of the following minimum capabilities:

1. The amplifier should have a music power output rating of five watts minimum as defined by the EIA standard, “Power Output Ratings of Packaged

## Let BUSS Fuses Help Protect Your PROFITS

To make sure BUSS fuses will operate as intended under all service conditions, each and every BUSS fuse is individually tested in a sensitive electronic device.

This is your assurance that when you sell or install BUSS fuses, you are safeguarded against complaints, call-backs and adjustments that might result from faulty fuses and eat away your profit.

It is just good business  
to sell fuses the BUSS way.

# BUSS

Write for BUSS  
Bulletin SFB.

BUSSMANN MFG. DIVISION, McGraw-Edison Co., St. Louis 7, Mo.

... for more details circle 16 on post card

ELECTRONIC TECHNICIAN

# BUSS Sub-Miniature FUSE-HOLDER COMBINATION

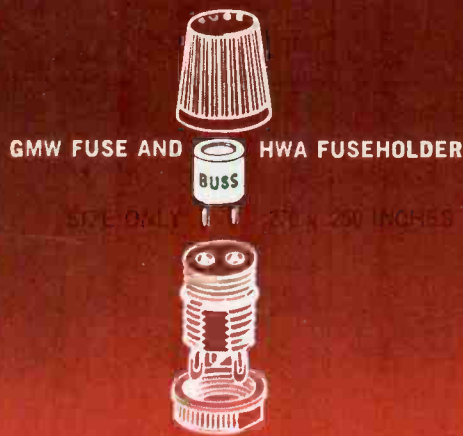

A light weight, protective device for space-tight applications in multiple circuit apparatus. Fuse has transparent window for visual inspection of element. Fuse may be mounted alone or used in holder on printed circuit boards.

HWA holder can also be panel mounted with or without use of knob. Knob makes holder water proof for front of panel.

## BUSS

For full details  
write for BUSS  
bulletin SFB

BUSSMANN MFG. DIVISION, McGraw-Edison Co., St. Louis 7, Mo.

... for more details circle 16 on post card

## of unquestioned high quality

cause we are determined to secure an increasing share of this important segment of the market."

Philco is forecasting domestic industry color sales of 500,000 to 550,000 units in calendar 1963. Philco's 1964 color line will reach the market in early summer. It will be a full line, ranging from table models to consoles. The tube will be the 70-degree, 21-in. type which is the current industry standard.

### Motorola Wins Design Award

Motorola, Inc. received its fourth successive Best-of-Class award in as many Annual Mahogany Awards Competitions, taking top honors in Class V1 (radio, Hi-Fi, stereo and television cabinets) with its "Designer and Decorator Collection" of furniture-styled home entertainment equipment. Edward R. Taylor, president of Motorola Consumer Products, Inc., accepted the trophy at the Mahogany Association's fourth annual Evening of Awards banquet in the Sheraton-Chicago hotel recently.

### Licensing of Techs

The Indiana Electronic Service Association (IESA) is again sponsoring a bill in the Indiana General Assembly for licensing all television technicians. IESA is soliciting funds from members to finance a campaign backing the legislation. The organization is seeking "lobby support" by having members personally contact local legislators to secure passage of the bill.

### New Olympic Models

Olympic Radio & Television Div. of Lear Siegler, Inc., Long Island City, N. Y., has introduced three new 19-in. portable television models, now in production at its Long Island City plant. All three models carry an open list price. Morris Sobin, Olympic president, said that the new portables are part of Olympic's announced program of expanding its portion of the portable market. The new models feature three IF stages, 114 deg aluminumized picture tube, hand wired chassis, automatic focus and circuit overload protection. They are also available in 82 channel UHF/VHF in line with the new industry requirements for all channel capabilities.

### Record Phono Sales

Total sales of phonographs at both factory and distributor outlets moved close to the \$5-million mark in 1962, the EIA reports. Factory sales stood at a record 4,954,434 units, nearly a million above the 1961 total of 3,988,680. Sales by distributors advanced by 860,159 sets, from 3,981,651 in 1961 to 4,841,810 last year. The Department's breakdown according to types of phonos shows both stereophonic and monaural sales in 1962 comfortably above totals for the previous year. At the distributor level, monaural sales totaled 1,351,589 last year, against 1,061,148 the year before. Distributors sold 3,490,221 stereo sets in 1962, compared with 3,920,503 in 1961. The figures point up the return of a few consumers to monaural sets at the expense of stereo.

## BUSS MINIATURE FUSES Made To Foreign Standards



5MM x 20 MM  
(.197 x .769 INCHES,  
GLASS TUBE)

Designed for protection of miniaturized circuits or equipment. Commonly used in equipment of foreign make.

## BUSS

Write for BUSS  
Bulletin SFB.

BUSSMANN MFG. DIVISION, McGraw-Edison Co., St. Louis 7, Mo.

... for more details circle 16 on post card

### New Tubes from RCA

Three new novar type beam power tubes for use in high-efficiency horizontal-deflection-amplifier circuits of both VHF and UHF television receivers have been introduced by the RCA Electron Tube div. The tubes, designated RCA-6JB6, 12JB6, and 17JB6, are alike except for differences in heater ratings. They utilize a T12 bulb and a large-button novar 9-pin base. The novar construction, according to RCA engineers, assures exceptionally strong mount support and relatively cool operation. All three new types have a separate base-pin connection to grid No. 3. Positive voltage can be applied to this grid to minimize interference from "snivets" ("tearing" of a TV picture). To assure long life and dependable performance, the RCA-developed "Dark Heater" is featured in the design of the new novar tubes. The heaters of the RCA-

tube types 12JB6 and 17JB6 have controlled warm-up time for use in series-heater-string arrangements.

### UHF Report Available

The Electronic Industries Association's Consumer Products div. has prepared copies of the transcript of a seminar on UHF television conducted recently for TV dealers and servicemen in the Washington area. The seminar, featuring a panel of experts on all aspects of UHF, was conducted to provide information to assist dealers and servicemen with the transition from very high frequency to all-channel TV receiver distribution and installation. The event, planned as a model for similar UHF clinics in other parts of the country, was sponsored by the Electric Institute of Washington in cooperation with the FCC and EIA. Copies of the complete proceedings are available at 50 cents each from L. M. Sandwick, Staff director, Consumer Products Div., Electronic Industries Association, 1721 DeSales Street, N. W., Washington 6, D. C.

### Mar. 25-28:

IEEE International Convention, Coliseum & Waldorf Astoria Hotel, New York City.

### Apr. 1-3:

Third Alabama Electrical and Electronics Exposition, Birmingham City Auditorium, Birmingham, Ala.

### Apr. 17-19:

SWIRECO (Southwestern IRE Conference & Electronic Show) Dallas Memorial Auditorium, Dallas, Tex.

### Apr. 23-25:

Eleventh National Conference on Electromagnetic Relays, Student Union Building, Oklahoma State University, Stillwater, Okla.

### May 20-22:

Electronics Parts Distributors Show, Conrad Hilton Hotel, Chicago, Ill.

## INCREASE AUDIO

# 100%

**GLOBE  
POWER  
TALK  
VOICE  
BOOSTER**

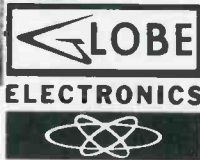
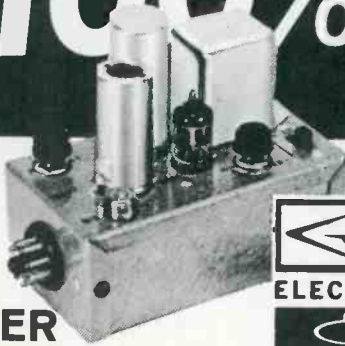

Peak limiting audio preamplifier that clips and filters speech frequencies and levels exceeding preset amplitude. Increases modulation intensity for most efficient audio. Includes audio harmonic suppression. Adaptable to any Transceiver or transmitter.

Model 65-419 Voice Booster..... CB Net 24.95

Completely assembled at your distributors now.

FREE CATALOG of the entire Globe CB line. Send to GLOBE dept. 27, 400 So. Wyman St., Rockford, Ill. USA

Name \_\_\_\_\_

Address \_\_\_\_\_

City \_\_\_\_\_ State \_\_\_\_\_



**GC ELECTRONICS CO.**

Division of Textron Electronics, Inc.  
400 SOUTH WYMAN STREET • ROCKFORD, ILLINOIS • USA

--- for more details circle 25 on post card

# IEEE

## HEAR

DISTINGUISHED  
SPEAKERS &  
PANELISTS

at

## I-TRIPLE-E's

International Convention  
and Exhibition in New York

### MARCH 25, 26, 27, 28

The COLISEUM at Columbus Circle  
& The WALDORF ASTORIA HOTEL

admission: MEMBERS \$1.00; NON-MEMBERS \$3.00  
MINIMUM AGE: 18

# SHOW

(formerly the IRE Show)

## 'TOUGH-DOG' OSCILLATION

*Continued from page 48*  
intermittent connections on PC boards, etc.

Sometimes when one of the less-expensive radios are aligned in the conventional manner, whistles appear when the set is tuned through the BC band. Or tuning may be too sharp because of slight regeneration in the IF section. Instead of wasting time fiddling with the IFs in a haphazard manner, use a sweep generator and align the IFs. Adjust the generator to a 30 kc sweep. If the receiver's IFs are on the verge of oscillation, the scope pattern will show a small amount of modulation on the response curve. To eliminate this, the IFs are aligned to obtain a normal symmetrical response curve—indicating a somewhat wider bandpass. ■

## ... LPV ANTENNA

*Continued from page 49*

The LPV antenna is unique in that it maintains essentially constant impedance across the full bandwidth of the antenna. As important as high gain and constant impedance are in fringe area reception, the antenna would be worthless without good directional sensitivity. Even in the heart of cities, good directional response is necessary to reject the ghost-causing interference signals that bounce from building to building. In fringe areas, interfering signals from adjacent channels and other sources, picked up by the antenna from the rear and sides, cause venetian blind effects, herringbones, fading, and other picture distortions.



"The chassis is okay but I'll have to pull the cabinet!"

Yagi antennas obtain good directivity and high front-to-back ratios by the use of parasitic elements—directors and reflectors—for a sharp forward pattern. The LPV antenna obtains its sharp forward response pattern from the V-ing of the elements and the phase-reversed feeders. ■

## ... ANTENNA GUIDE

*Continued from page 56*

buildings — smaller schools and hospitals with under 100 outlets —

to large 20-story apartment structures with up to 400 outlets are included. Packaged systems are also tailored to a variety of locations, varying from 15 miles to 40 and 100 miles from telecasting stations.

Because the MATV area offers broad opportunities to all service-dealers and technicians, this manual will no doubt serve as a useful sales tool.

The booklet, *Planning Master TV Systems*, is available without charge from Blonder-Tongue Labs, Inc., 9 Alling Street, Newark 2, N.J. ■

"good enough"

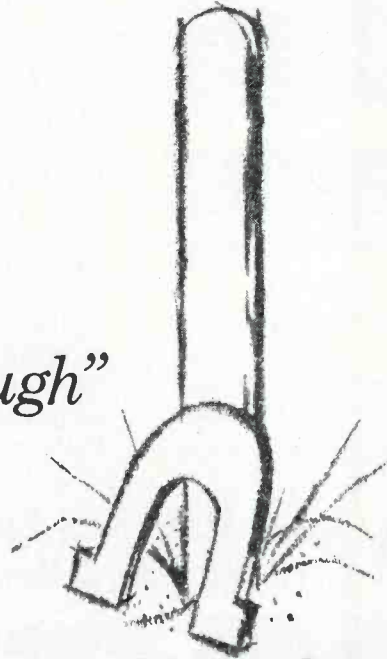

**is not enough at Stancor**



We will never be content to rest on our laurels. Even though proof of customer satisfaction is expressed for Stancor products by our position of leadership in the marketplace—our Product Development Program is working every day to make our product not merely the best available . . . but the best possible.

Check our brand-new Admiral, Philco and Silvertone replacements. You'll find:  
• Complete, detailed, self-sufficient instruction sheets • Slotted mounting brackets for easier installation • Longer leads for greater versatility and convenience • Improved insulation to minimize corona.

These features are all part of Stancor's program to give you replacement transformers that are better than Original parts with servicing simplicity built right in . . . because good enough is *not* enough for Stancor's customers.

**STANCOR**  
ELECTRONICS, INC.  
3501 W. ADDISON • CHICAGO 18, ILL.

from Scott...

# FREE STEREO KIT CATALOG

Have fun . . . save money . . . build the best! Now world-famous Scott stereo components come in easy-to-build kit form. You can build an FM Multiplex tuner, your choice of an 80 watt or 48 watt stereo amplifier, a preamp, power amplifier, and a speaker. Write for complete details.

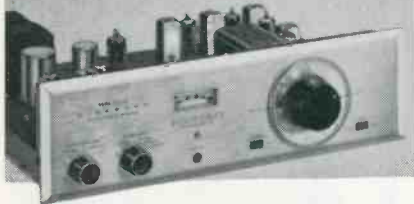

**SCOTT** DEPT 140-3

H. H. Scott, Inc. 111 Powdermill Road, Maynard, Mass.

Rush me your new Kit Guide and your Free 20 page "Guide to FM Stereo."

Name \_\_\_\_\_  
Address \_\_\_\_\_  
City \_\_\_\_\_ State \_\_\_\_\_

Export: Morhan Exporting Corp., 458 Broadway, N. Y. 6.  
Canada: Atlas Radio Corp., 50 Wingold Ave., Toronto

--- for more details circle 39 on post card

## INCREASE YOUR INCOME

*Continued from page 51*

grams. If possible, include a typical week's programming schedule on your sales sheet. Most UHF stations will be pleased to cooperate with TV technicians. They'll generally provide free program literature for promotional purposes.

UHF channel strips for specific TV chassis are available in many instances to convert an unused VHF channel to receive a UHF program. UHF top-of-set converters are also available for single or full UHF channel coverage. Considering the labor involved to substitute a channel strip in a tuner, it's often less expensive to attach a top-of-set converter. Its hookup is simple, as shown in Fig. 1.

Earphones, too, represent a leading sales item on service technicians' lists. They're easy to sell; practically sell themselves when featured on a sales list. What customer wouldn't like to avoid annoying a spouse during late night while listening to TV or Hi Fi stereo? Inexpensive mono head-sets are available as well as more expensive Hi Fi stereo units. Both sell especially well, and they

can be installed in minutes, as indicated in Fig. 2.

The same installation ease is exhibited by extension speakers. Anyone with a Hi Fi set is a likely sales candidate for a remote speaker for the bedroom, den or porch. Outdoor speakers impervious to weather are desirable accessories for many customers; especially in warmer climates that allow them to be used year 'round.

Still another fast-moving item is the clock-timer that automatically shuts off sets at a predetermined time, awakens people to Hi Fi music and to coffee already "perked." Here's a 1-2-3 plug-it-in sale that adds profits on so many TV service calls with hardly any selling time involved.

Replacing broken TV knobs, phono needles, phono cartridges,

### IF YOU CHANGE YOUR ADDRESS

Notify us at 1 East First Street, Duluth 2, Minn. Please include the address label from a recent issue and allow 6 weeks for the change.

## SAVE! Arrow Staple Gun Tackers Save You Time & Money!

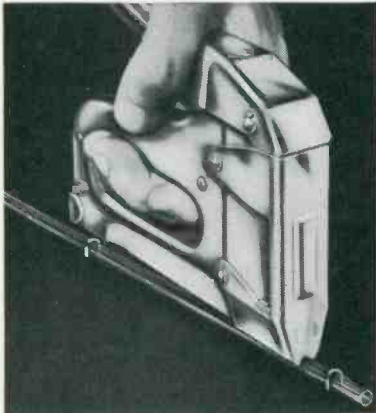

Tapered striking edge gets into tight corners!

MODEL T-18 — For wires 3/16" and less in diameter. Loads (85) T-18 staples with 3/16" crown, divergent-pointed, of .050 wire in 3/8" leg length.

MODEL T-25 — For wires up to 1/4" in diameter. Loads (85) T-25 staples with 1/4" crown, wedge or divergent-pointed, of .050 wire in 9/32", 3/8", 7/16" and 9/16" leg lengths.

Write for catalog and information.

**ARROW FASTENER CO., INC.**  
ONE JUNIUS STREET, BROOKLYN 12, N. Y.

--- for more details circle 14 on post card

### SAFE!

Can't damage wire because staples automatically stop at right height! Won't even break 1/4" hollow glass tubing.

### FAST!

Proved by test 10 times faster than old hammer method. Saves you 70% in fatigue and efficiency . . . saves many dollars a year.

### HOLDS!

New staples get tremendous holding power from tack points that spread to lock themselves into wood!

- All-steel construction with lasting chrome finish.
- Jam-proof patented mechanism for continuous, trouble-free operation.

# I E E E

## SEE

THE NEW  
ELECTRONIC  
WIZARDRY

at

## I-TRIPLE-E's

International Convention  
and Exhibition in New York

### MARCH 25, 26, 27, 28

The COLISEUM at Columbus Circle  
& The WALDORF ASTORIA HOTEL

admission: MEMBERS \$1.00; NON-MEMBERS \$3.00  
MINIMUM AGE: 18

# SHOW

(formerly the IRE Show)

worn tape heads all can spell extra profits. The way to reap these rewards is by suggestion selling.

### Service Sales Force

Sales profits from service calls can easily outdistance service profits. If you're a shop owner with outside technicians or a sales-service dealer who maintains a service department to stimulate sales, you can make in-the-home sales rise quickly by offering sales incentives to housecall technicians. This may take the form of straight commissions, bonuses above a specified gross, special prizes for top sales of the month, or any other type of incentive that prompts servicemen to promote sales. In fact, make it foolish for them not to induce sales.

Add other products in the natural province of your home electronics business as your sales business grows: intercoms for electronic baby sitting or kitchen-to-back porch communications, electronic educational kits for children, citizens band radios, etc. And watch profits grow as word gets around. ■

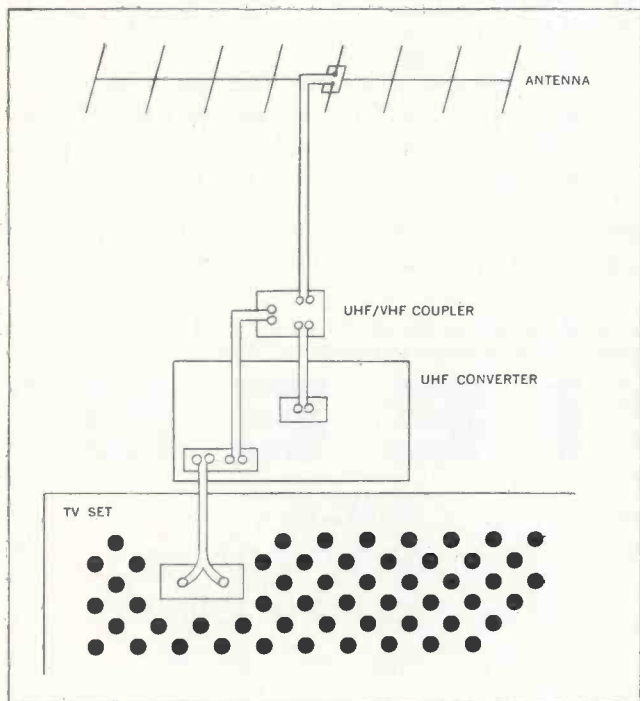

Fig. 1—Block diagram showing UHF/VHF coupler and UHF converter atop TV set.

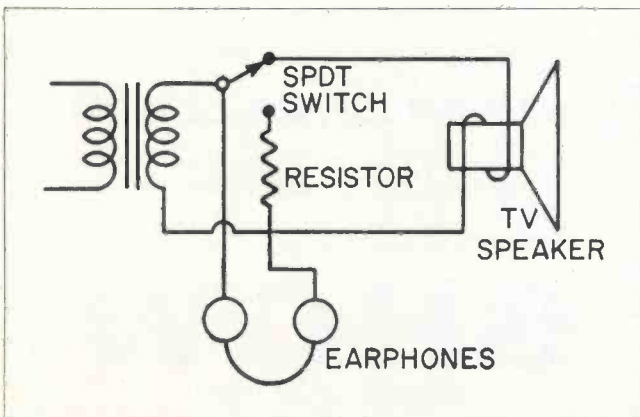
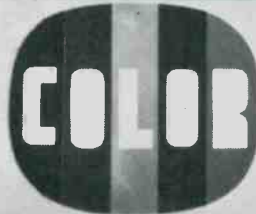

Fig. 2—Hookup for adding phones to TV sound output for late-night listening.

# 4 ways to increase your income

RCA Institutes, Inc. offers these four comprehensive home study courses especially designed to help build your income immediately!



**COLOR TV** Add Color TV Servicing to your skills with this up-to-the-minute home training course and take advantage of the growing profit potential in this area! Train under the direction of RCA...experts in Color TV.

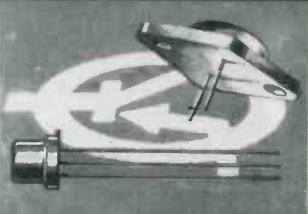

**TRANSISTORS** You get the necessary background for semiconductor technology including characteristics of tunnel diodes, rectifiers and other solid state devices. Transistor trainer also available.

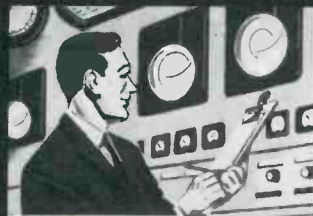

**AUTOMATION ELECTRONICS** Trains you for the many applications of automation electronics in industry and government including Photoelectronics, Digital Computer Techniques, Synchros and Servomechanisms, Automatic Control Systems, and many more!

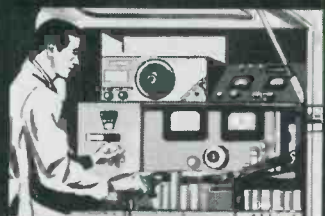

**MOBILE COMMUNICATIONS** Trains you to service and maintain 2-way radio communications on land, sea, and air! Gives you the technical foundation for space communications!

Take advantage of RCA's Liberal Tuition Plan. You only pay for lessons you order; and have no long-term obligations. Licensed by New York State Education Department. Approved for Veterans.

## RCA INSTITUTES, INC.

A Service of Radio Corporation of America  
350 West Fourth Street, New York 14, N. Y.



The Most Trusted Name in Electronics

■ ■ ■ SEND THIS COUPON NOW FOR COMPLETE FREE INFORMATION ■ ■ ■

RCA INSTITUTES, INC. Home Study School, Dept. ET-33  
350 West Fourth Street, N. Y. 14, N. Y.

Without obligation, rush me free information on the following RCA Home Training Course: COLOR TV \_\_\_\_\_ TRANSISTORS \_\_\_\_\_ MOBILE COMMUNICATIONS \_\_\_\_\_ AUTOMATION ELECTRONICS \_\_\_\_\_

Name \_\_\_\_\_ Age \_\_\_\_\_

Address \_\_\_\_\_

City \_\_\_\_\_ Zone \_\_\_\_\_ State \_\_\_\_\_

CANADIANS—Take advantage of these same RCA courses at no additional cost. No postage. No customs. No delay. Send coupon to: RCA Victor Company, Ltd., 5581 Royalmount Ave., Montreal 9, Quebec.

**General Catalog 300**

This 40-page "General Master Catalog #623" contains the complete listing of the firm's lines, including all new additions to date. It features a new departure in pricing, showing NET (suggested resale) prices throughout. Included are: electronic kits, Hi Fi Equipment Accessories and Industrial Electronic Components. Philmore Mfg. Co., Inc.

**CC-TV 301**

Closed circuit TV has emerged from the developmental stage and now ranks as a major contributor to industrial efficiency and dollar savings, according to this booklet. The report offers illustrations of CC-TV installations now operating in steel and chemical plants, schools and even churches. It is designed to stimulate thinking on how closed circuit TV can save money or perform difficult jobs in a variety of industrial operations. A non-technical

description of CC-TV, a list of basic equipment and a glossary of terms are provided. Blonder-Tongue Laboratories, Inc.

**Receiving Tubes 302**

Receiving tubes designed to reduce space requirements and entertainment equipment costs are described in a 19-page loose-leaf folder. The 38 new tubes described are multiple function, 9-pin (novar) and 12-pin (compactron) types including T-9 and T-12 standard envelopes and T-5½ and T-6½ miniatures. Tubes described include integral, all-glass button bases for use as high-voltage rectifiers, full-wave rectifiers, remote and sharp cut-off IF pentodes, VHF single and double triodes; video, audio and twin pentodes; and separate and combined horizontal amplifiers and damper diodes. Raytheon Co.

**Speakers 303**

This Catalog describes speakers, including response and distortion curves of AR-2, AR-2a and AR-3 speaker systems. Also a brief description and order form for two books on high fidelity published by

the firm with excerpts from current reviews. Acoustic Research, Inc.

**UHF Translators 304**

An eight page report, "UHF Translators for Expanding Television Coverage" is a reprint of a paper, which was presented at the 1962 Radio Fall Meeting of the Electronic Industries Association. It describes the technical and economic advantages of using UHF translators to extend the coverage of VHF and UHF originating stations. Adler Electronics, Inc.

**Window Poster 305**

The latest addition to the window poster series that has earned high favor among service dealers as in the past, the theme is the importance of professional service. Sprague Products Co.

**Stereo 306**

This brochure illustrates and describes the company's line of stereophonic amplifiers multiplex stereo tuners and stereo receivers. Amplifiers are available in audio power capacities of from 24 to 70 w. Power capacities of from 30 to 70 w

**ANOTHER SERVICE-PROVED  
PRECISION INSTRUMENT  
NEW MODEL CR-60  
PICTURE TUBE TESTER  
AND REJUVENATOR.  
HEATER VOLTAGE  
CONTINUOUSLY  
VARIABLE  
FROM 1.5 TO 12V  
INDEPENDENT OF  
LINE VOLTAGE  
VARIATIONS**



At last a picture-tube tester that can't become obsolete! Operating on the proven true "Beam-Current" circuit method, the CR-60 is a time and labor saver that pays for itself many times over. Tests and rejuvenates all picture tubes — black & white (110°, 114°, low G2) and color (each gun separately). Renews tube life, checks and repairs shorts, leakage, opens and low emission. Determines need for booster and predicts probable tube life. Portable, leatherette-covered case. See your PRECISION distributor or write. Net only \$64.95. This and all other PRECISION PRODUCTS are guaranteed for one full year

**PRECISION APPARATUS CO., INC.**

SUBSIDIARY OF PACOTRONICS, INC. 70-31 84th ST., GLENDALE, NEW YORK

for more details circle 35 on post card

**IEEE**

**MEET**

THE BEST BRAINS,  
THE BEST PRODUCTS  
IN THE INDUSTRY

at

**I-TRIPLE-E's**

International Convention  
and Exhibition in New York

**MARCH 25, 26, 27, 28**

The COLISEUM at Columbus Circle  
& The WALDORF ASTORIA HOTEL

admission: MEMBERS \$1.00; NON-MEMBERS \$3.00  
MINIMUM AGE: 18

**SHOW**

(formerly the IRE Show)



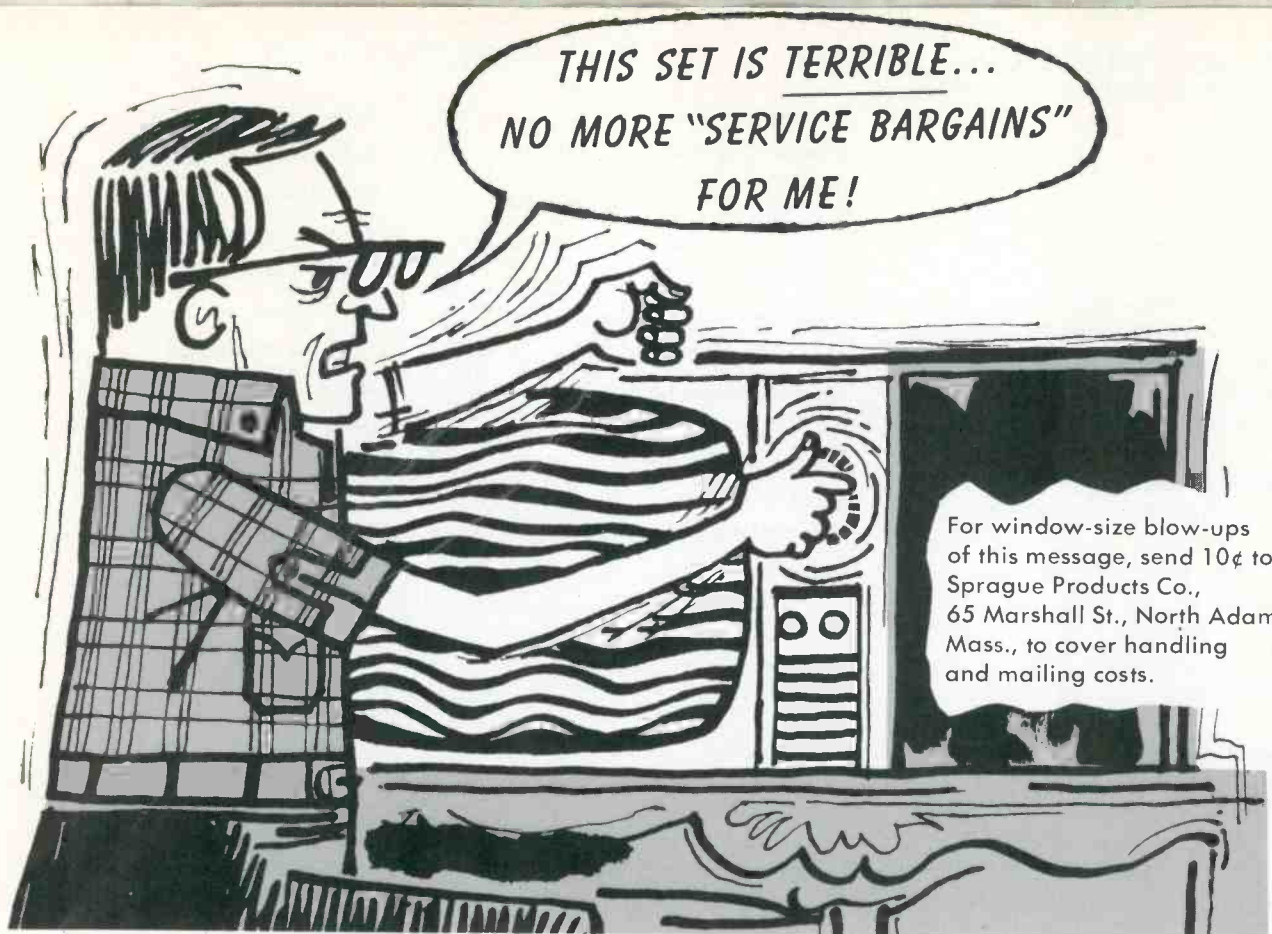

## HOW TO BE SURE OF GOOD TV SERVICE...

**1. Beware the Service "Bargain."** If you shop around for cut-rate prices or extra-liberal service contracts, you're *asking* for trouble. A "something-for-nothing" offer usually means cut-rate parts and sub-standard service methods. The *reputable service dealer* spends years in study and training—thousands of dollars on test equipment, tools, and service manuals—countless hours in keeping up-to-date on new developments and service techniques. Because of this heavy investment, he can't *afford* to offer "bargains."

**2. Rely on a Fully Qualified Independent Service Dealer.** Well known and highly regarded by your friends and neighbors, his professional training and experience have made him a real technical expert. He takes pride in his work. He wants to stay in business. And he stakes his reputation and his future on satisfying *you*. So he'll use only component parts of the highest quality and latest design—plus his thorough knowledge and keen skills—to do the job right. Depend on him; he can't *afford* to let you down!

Your TV set provides you with a wealth of entertainment. Keep it in the best repair . . . at lowest cost . . . by calling your local TV-RADIO Service Dealer at the first sign of trouble!

THIS MESSAGE WAS PREPARED BY SPRAGUE PRODUCTS COMPANY,  
DISTRIBUTORS' SUPPLY SUBSIDIARY OF SPRAGUE ELECTRIC COMPANY, NORTH ADAMS, MASSACHUSETTS FOR . . .

**YOUR INDEPENDENT TV-RADIO SERVICE DEALER**

QS-342

are offered in stereo receivers. Other models described in the brochure include the 510FM and 511 FM-AM tuner-amplifiers. Also shown is the Model M1 multiplex-stereo adapter, and Model LJ8 monaural amplifier. Grommes Div., Precision Electronics, Inc.

**Assembly Tools 307**

A complete 24-page brochure lists precision electronic pliers, super-fine tweezers and other items essential to the aerospace needs. Over a hundred stock items are listed for immediate delivery. Techni-Tool, Inc.

**Sales Aids 308**

A catalog of advertising, sales promotion and service aids for radio and television service dealers tabbed for quick reference. Lists more than 300 items to help service dealers increase profits. General Electric Co.

Aerogap Corporation .....	82	Mercury Electronics Corp. ....	83
Aerovox Corporation .....	84	Multicore Sales Corp. ....	82
Antenna Specialists Company .....	74	Perma-Power Company .....	85
Arco Electronics, Inc. ....	24	Precision Apparatus Co., Inc. ....	92, 94
Arrow Fastener Co., Inc. ....	90	RCA Electron Tube Division .....	4th Cover
B & K Manufacturing Company .....	63	RCA Institutes, Inc. ....	91
Belden Manufacturing Company .....	81	RCA Sales Corporation .....	71
Bussmann Mfg. Division .....	86-87	John F. Rider Publisher .....	74
Centralab, Electronics Div. of Globe- Union, Inc. ....	28	Sarkes Tarzian Semiconductor Div. ....	79
Channel Master Corporation .....	33	Sarkes Tarzian Tuner Service Div. ....	20
Chemtronics, Inc. ....	76	H. H. Scott, Inc. ....	90
Clarostat Manufacturing Company .....	73	Seco Electronics, Inc. ....	31
Colorgrams, Inc. ....	35, 36, 37, 38	Sencore Service Instruments Corp. ....	19
Delco Radio Division .....	75	Sonotone Corporation .....	26
EICO Electronic Instrument Co., Inc. ....	22	Sony Corp. of America .....	27
Electro Products Laboratories .....	72	Sprague Products Company .....	23
Euphonics Corporation .....	70	Sprague Products Company .....	93
GC Electronics, Inc. ....	88	Stancor Electronics, Inc. ....	89
General Electric Company .....	66-67	Standard Kollsman Industries, Inc. ....	3rd Cover
Heath Company .....	65	Triad Distributor Division .....	78
IEEE .....	88, 90, 92, 94	Tung-Sol Electric Inc. ....	69
International Resistance Company...2nd Cover		V-M Corporation .....	68
ITT Distributor Products Div. ....	61	Winegard Company .....	77
Jensen Industries .....	84	Xcelite, Inc. ....	80
P. R. Mallory & Co., Inc. ....	25		

**ANOTHER SERVICE-PROVED**

**PRECISION  
INSTRUMENT  
MODEL 650  
GRID CIRCUIT  
ANALYZER  
TUBE TESTER  
AND  
MEGOHMMETER**



Tests most tubes including 10-pin miniatures, 12-pin Compactrons, 5- and 7-pin Nuvistors, Novars, octals, picture tubes (with optional adapter AD-65) and a wide variety of foreign and industrial types. Indicates gas currents as low as 1 ua. Checks for intermittent shorts, gas content, grid emission, leakages (sensitivity over 100 megohms). Special megohmmeter circuitry for measurement of condenser leakage, continuity and leakage of printed circuitry. Complete in leatherette-covered case. See your PRECISION distributor or write today for a complete catalog. Net only \$69.95. AD-65 Adapter: Net only \$5.95. This and all other PRECISION PRODUCTS are guaranteed for one full year

**PRECISION APPARATUS CO., INC.**

SUBSIDIARY OF PACOTRONICS, INC. 70-3184th ST., GLENDALE, NEW YORK

--- for more details circle 36 on post card

**IEEE**

**SPEAK**

TO OUTSTANDING  
ELECTRONICS ENGINEERS,  
SCIENTISTS, PHYSICISTS  
at

**I-TRIPLE-E's**

International Convention  
and Exhibition in New York

**MARCH 25, 26, 27, 28**

The COLISEUM at Columbus Circle  
& The WALDORF ASTORIA HOTEL

admission: MEMBERS \$1.00; NON-MEMBERS \$3.00  
MINIMUM AGE: 18

**SHOW**

(formerly the IRE Show)



## STANDARD KOLLSMAN BRINGS

# Beauty TO UHF CONVERTERS

The Model "A", the only UHF converter you can show and sell with pride. Designer styled in beige and tan to blend with today's decor . . . to harmonize with modern TV cabinet design. Standard waited . . . and tested, analyzed, and re-tested until they could bring you the quality instrument you and your customers have a right to expect from the leading manufacturer of tuners. As a result, you now have a converter which is beautiful, profitable, and dependable.

Contact your Standard representative . . . or write

**standard kollsman** INDUSTRIES, INC.

Formerly Standard Coil Products Co., Inc., Melrose Park, Illinois / WORLD'S LARGEST MANUFACTURER OF TELEVISION TUNERS

## PERFORMANCE YOU CAN SEE

New low-noise, shielded tuner permits fine tuning for all 83 UHF channels. Functions perfectly with color or black and white sets. Two simple controls: one for VHF, UHF, and "off" . . . the other for channel selection and fine tuning. The "SK" installs in about a minute with just a screw-driver.

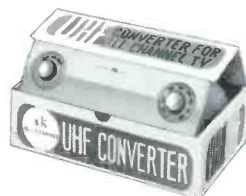

Feature this exciting counter-top display carton

## POWER IN PROMOTIONAL

**SUPPORT** With a first order of 12 units or more, Standard supplies 3 newspaper ad mats . . . 3 radio spot scripts . . . materials for a powerful TV spot . . . 2-color catalog sheets . . . a giant (3' x 6') 2-color window banner . . . a counter card . . . as many pre-printed jumbo post cards as you can use PLUS hard hitting ads in TV Guide.

- - - for more details circle 46 on post card

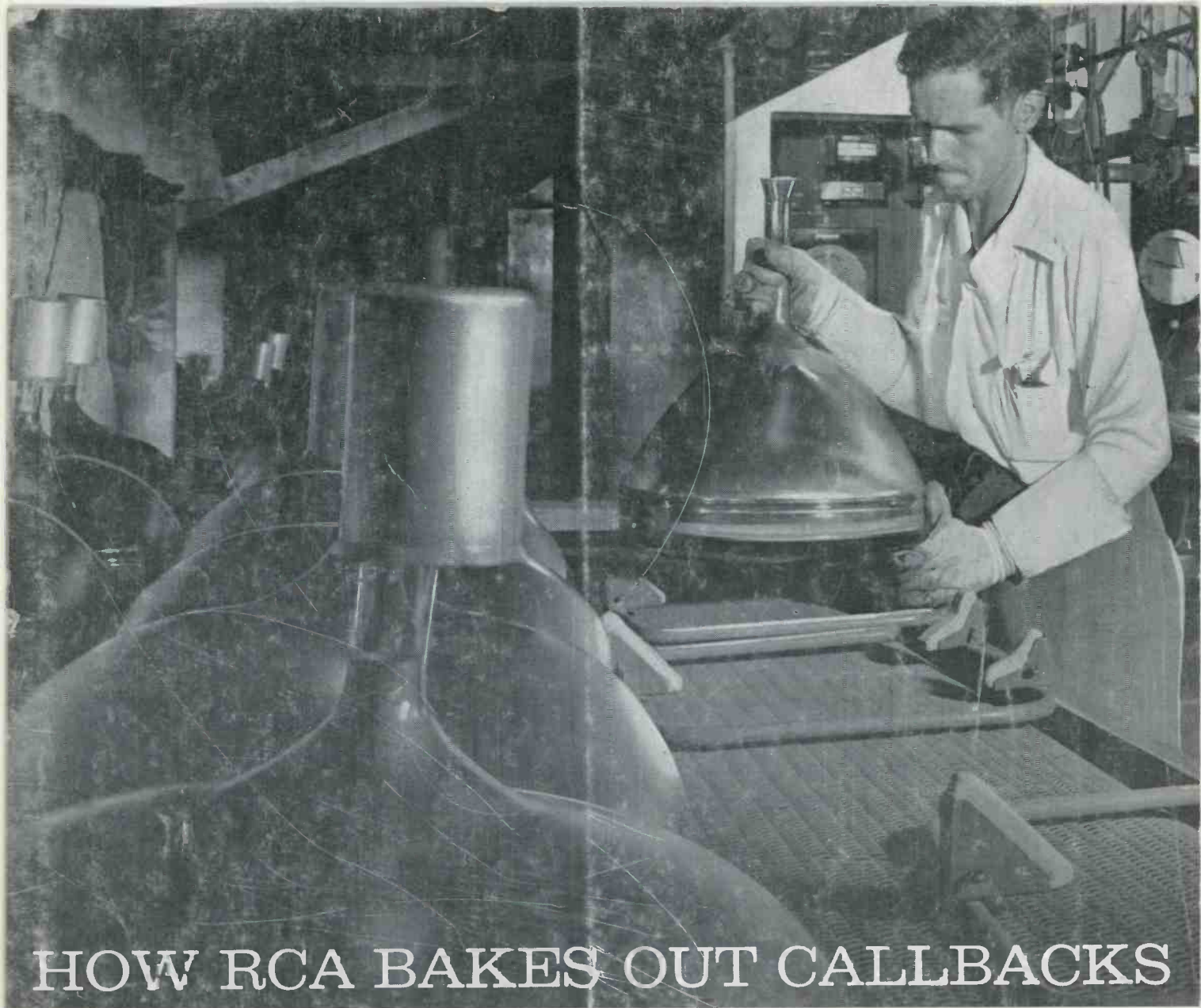

# HOW RCA BAKES OUT CALLBACKS

## Oven-drying Silverama® bulbs improves performance, prolongs life

You are looking from-inside-out of a Lehr oven—a high-temperature “picture tube kiln” designed to bake potential troubles out of Silverama picture tube bulbs.

This oven—in our Marion, Indiana picture-tube plant—bakes aluminized picture-tube bulbs for 2½ hours; peak temperature during bake out: 460°C. Objective? Bake out all moisture and decompose all organic material that might short-

en the life of the tube or otherwise affect its performance.

This long bake-out also produces favorable stresses in the glass itself to increase strength and long life. It is but one of many stringent manufacturing steps taken to assure the high quality standards of RCA Silverama. Result: substantial reductions in callbacks and in-warranty picture tube failures when you install RCA Silverama.

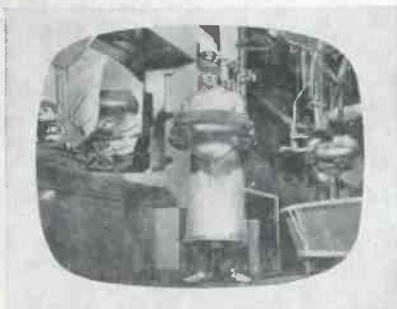

**Envelope Inspection.** After a series of acid baths the re-used envelope is thoroughly inspected to make sure it meets the standards of an original new envelope.



**Screen Quality Inspection.** After rescreening, each bulb undergoes rigorous inspection for screen quality. A strong reflected light behind the bulb reveals even the smallest flaws in the screen; even the smallest is cause for rejection of the bulb.

RCA ELECTRON TUBE DIVISION, HARRISON, N. J.



The Most Trusted Name in Television