

TECHNICIAN & Circuit Digests

PROFILE OF THE
TECHNICIAN

How many hours does he work each week?
What is his weekly salary?
How many TV technicians are self-employed?
How does he compare with other electronic techs?

See "Radio-Electronic-TV Technician: A Profile"

How much will his business expand in 1955?
How big is his potential in high-fidelity audio?

See Editorial

What does he think of
governmental licensing?

What does he think of
fee regulation by unions?

What does he think of
industry certification?

See "Licensing & Accreditation—
Pro & Con—What the
Associations are Doing"



January • 1955

In Two Sections • Section One

Caldwell-Clements, Inc.

NEW



Here are wire wound power resistors designed for today's servicing requirements. New, rectangular design is more compact. Famous IRC element is sealed in ceramic case for complete insulation and protection. Axial leads are easily soldered and speed replacement. Clear, permanent markings give full identification.

- 2 SIZES—PW-7 seven watts; PW-10 ten watts.
- COST LESS—new, low price for IRC Power Resistors.
- FULL POWER—Conservative ratings permit continuous operation at full power.
- NEW VALUES—in keeping with today's needs.

WIRE WOUND POWER RESISTORS

in handy Resist-O-Card Assortments



IRC Resist-O-Cards are easier to buy, stock and use. Values are printed on each card—you always know what you have, and you always have what you need. Assortments are based on popular usage.

- ASSORTMENT # 19—Twenty 7 watt resistors. Dealer Price \$6.20
- ASSORTMENT # 20—Twenty 10 watt resistors. Dealer Price \$6.60
- ORDER NOW—From your IRC Distributor

NEW



INTERNATIONAL RESISTANCE COMPANY

401 N. BROAD STREET, PHILADELPHIA 8, PA.

Wherever the Circuit Says

TECHNICIAN & Circuit Digests

TELEVISION • ELECTRONIC • RADIO • AUDIO • SERVICE

M. CLEMENTS O. H. CALDWELL
Publisher *Editorial Consultant*

SIDNEY C. SILVER, *Managing Editor*
 CREIGHTON M. MARCOTT, *Assistant Editor*
 ANN O'ROURKE, *Assistant Editor*
 ALBERT J. FORMAN, *Consulting Editor*
 J. L. STOUTENBURGH, *Consulting Editor*
 DR. A. F. MURRAY, *Contributing Editor*
 CHARLES F. DREYER, *Art Director*
 ELMER KETTERER, *Circuit-Digest Production*
 GEORGE PUGLICI, *Circuit Diagrams*

BUSINESS DEPARTMENT

M. H. NEWTON, *Business Manager*
 H. A. REED, *General Sales Manager*
 LEE GRAVES, *Eastern Sales Manager*
 CHARLES S. ROEVER, *District Manager*
 P. J. CARNESE, *Sales Promotion Manager*
 N. McALLISTER, *Asst. Business Manager*
 CAROL YOUNG, *Production Manager*
 KATHLEEN CAFARO, *Reader Service*
 JOHN J. BORGHI, *Controller*
 W. W. SWIGERT, *Credit Manager*
 ELMER DALTON, *Circulation Manager*
 480 Lexington Ave., New York 17, N. Y.
 Telephone PLaza 9-7880

S. M. GASKINS, *Western Manager*
 JOHN D. LUPTON, *District Manager*
 R. E. SCHULTZ, *District Manager*
 201 N. Wells St., Chicago 6, Ill.
 Telephone RAndolph 6-9225

CHRIS DUNKLE & ASSOCIATES
California Representative
 3257 W. 6th Street, Los Angeles 5, Calif.
 Telephone DUmkirk 7-6149
 1651 Market Street, San Francisco 3
 Telephone Underhill 3-5282



TECHNICIAN & CIRCUIT DIGESTS* January 1955, Vol. 61, No. 2. \$50 a copy. Published monthly by Caldwell-Clements Inc., Publication Office, Emmett St., Bristol, Conn. Editorial, Advertising and Executive Offices, 480 Lexington Ave., New York 17, N. Y. Entered as second class matter at the Post Office at Bristol, Conn. June 10, 1954. M. Clements, President; M. H. Newton, Assistant to President; John J. Borghi, Vice President and Secretary; M. B. Clements, Treasurer. Subscription rates: United States and Canada, \$4.00 for one year; \$6.00 for two years; \$8.00 for three years. Pan-American and foreign countries; \$7.00 for one year; \$10.00 for two years; \$14.00 for three years. Printed in U.S.A.

Copyright by
 Caldwell-Clements, Inc., 1955

JANUARY, 1955

FRONT COVER: The focus for the editorial spotlight this month, as well as for the cover, is you. The prospects this year for radio-TV-electronic technicians, their attitudes, their earning capacities, and other factors that may influence professional service people are given extensive attention.

<i>The Crystal Ball</i>	13
<i>"Tuning in the Picture"</i>	14
<i>Convergence & H-V Circuits For Large Color Tubes</i> ... Peter Orne	16
<i>Your Stand ... Licensing & Accreditation</i>	18
<i>Industry Groups Split as N. Y. Licensing Vote Nears</i>	19
<i>Antenna Installation Notes</i>	20
<i>Service That Picture Tube!</i>	21
..... Jack Gutstein	
<i>Electronic Photo Timers</i>	23
..... M. G. Goldberg	
<i>Shop Hints</i>	25
<i>Radio-TV Electronic Technician: A Profile</i>	26
<i>New Color TV Projection System</i>	27
<i>"Tough Dog" Corner</i>	28
<i>New Test Equipment</i>	32
<i>Bench & Installation Aids</i>	34
<i>New TV Antennas</i>	36
<i>Parts for Sales & Service</i>	38
<i>New Parts & Components</i>	40
<i>Is Your VTVM Reliable?</i>	42
..... H. P. Manly	
<i>Circuit Digests</i>	57

Admiral: Chassis 17XP3
 Hoffman: Chassis 306-21
 308-21

DuMont: Chassis RA-321, 322

Olympic: Chassis 14"-AD, 17"-AE
 Philharmonic: Model 54CM21, etc.
 RCA: Chassis KCS87C, KCS87D

DEPARTMENTS

Letters to the Editors	6	Catalogs & Bulletins	48
Calendar of Coming Events	15	New Books	49
New Products	30	Service Association Reports	50
New Product Briefs	39	News of the Industry	51

CALDWELL-CLEMENTS, INC.

Publication Office, Bristol, Conn.

Editorial/Business Offices 480 Lexington Ave., New York 17, N. Y., Tel. Plaza 9-7880
 Publishers also of MART and TELE-TECH & ELECTRONIC INDUSTRIES

*Reg. U. S. Patent Office

SPECIAL REPORT

Introducing the WALSCO Star...*

FIRST INDOOR ANTENNA TO BE COMPARED WITH OUTDOOR INSTALLATIONS

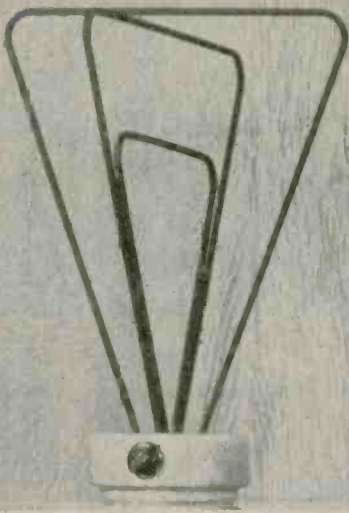

Attractive, compact in design...the new Walsco Star doesn't stick out like a sore thumb. Smart styling and distinctive colors (char-treuse, sand, green) are being recommended by interior decorators. No ugly rods to manipulate. Proven comparable in performance to a good *outdoor* antenna in most metropolitan and suburban areas.

Electronic tuner selects right combination of elements automatically for crystal-clear picture reception. Receives VHF and UHF stations in opposite directions or on widely separated channels. The Walsco Star is the most advanced indoor antenna ever built.

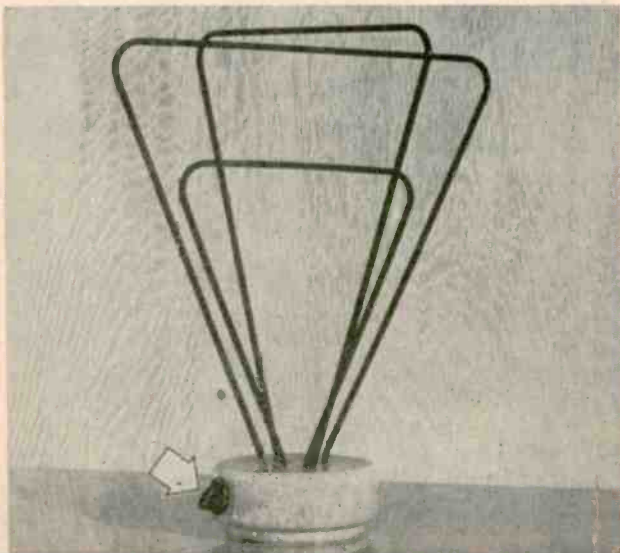

Los Angeles...A new standard in the design and performance of indoor antennas can be found in two new models recently introduced by Walsco. This is the first indoor antenna with a built-in, electronic rotating and tuning control that changes its directivity. Without moving, twisting or pulling, the new Walsco Star can be positioned perfectly by a simple turn of the control. Ghosts and interference are reduced or eliminated completely...and the correct combination of elements provides perfect reception on each channel.

The sharp, clear performance of the Walsco Star has made it the only indoor antenna that can, in most cases, be compared with a good *outdoor* installation. It was designed specifically for outstanding VHF and UHF reception in metropolitan and suburban areas. List price is \$12.95. The Walsco Starlet (without tuning control), for use in strong signal areas, lists for \$10.95. Available at jobbers everywhere in 3 smart, decorator colors.

Walsco Electronics Corporation, 3602 Crenshaw Blvd.,
Los Angeles 16, California.

*Patent Applied For

RAYTHEON



Makes Long Lasting
Aluminized Picture Tubes

With **RAYTHEON LUMILAC**

Exclusive Aluminizing Lacquer

Now you can get all the benefits of aluminized picture tubes — sharper picture, superior contrast, high light output — and *excellent picture tube life!*

Raytheon aluminized picture tubes are processed with the purest aluminum *plus* LUMILAC — a lacquer especially blended and used exclusively by Raytheon.

This lacquer produces an extra smooth unbroken surface for the aluminized coating, yet leaves no gas-

producing residues which could impair cathode emission and hence shorten tube life.

Next time you replace a picture tube try a Raytheon LUMILAC Aluminized Picture Tube. You'll be delighted with its performance in any set — amazed at how it will improve the picture of a low cost, low voltage range TV receiver. And so will your customer. Ask your Raytheon Tube Distributor for Raytheon Aluminized Picture Tubes with LUMILAC. Like all Raytheon Picture Tubes they are Right for Sight, Right for You and Always New.



RAYTHEON MANUFACTURING COMPANY

Receiving and Cathode Ray Tube Operations
Newton, Mass., Chicago, Ill., Atlanta, Ga., Los Angeles, Calif.

Excellence in Electronics

RAYTHEON MAKES ALL THESE: RECEIVING AND PICTURE TUBES • RELIABLE SUBMINIATURE AND MINIATURE TUBES • SEMICONDUCTOR DIODES AND TRANSISTORS • NUCLEONIC TUBES • MICROWAVE TUBES

1930
THE FIRST 4...



RADIO SERVICE CEMENT



VARNISH CAMBRIC



RADIO SERVICE SOLVENT



STEEL SPEAKER SHIMS

How 4 Radio Service Products

Celebrating the first 25 years of



Radio—
Television

SERVICE AIDS

Just 25 years ago this month, General Cement was little more than a hopeful gleam in its two founders' eyes. Yet such was their determination to bring quality, imagination and utility to the then infant radio service industry that today G-C is one of the best known names in radio—

television—electronics. For this great acceptance, we of G-C are truly grateful and promise to maintain our reputation for manufacturing economically priced, top quality service aids . . . chemicals . . . tools . . . hardware . . . whether it's one item or several thousand!

1930 Production Facilities 850 sq. ft.



1955 Five plants, 150,000 sq. ft.

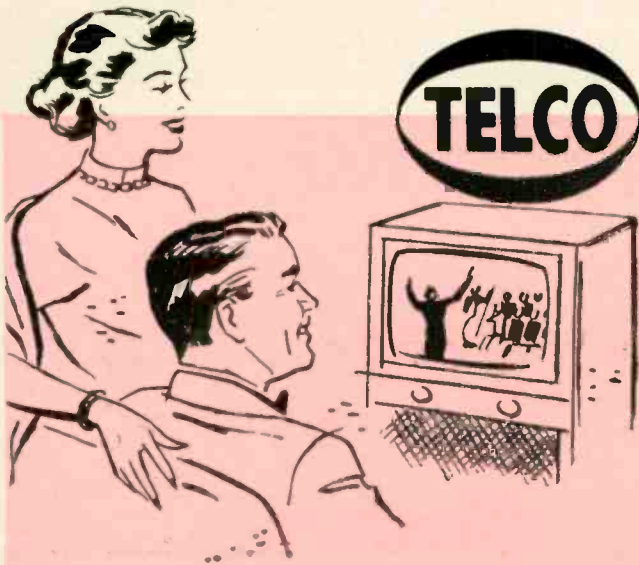

FOR BETTER TV SERVICE!

Remember the TELCO name for all your television service needs—antennas, antenna mounts, accessories and hardware. Television Hardware Mfg. Co., is a separate G-C division to make sure you get *what you want when you want it!*

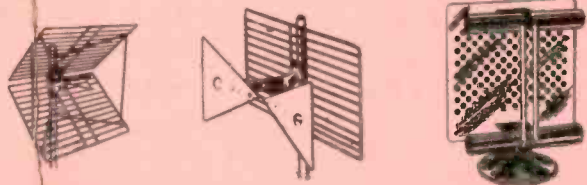



FOUNDERS . . . S. B. Valiulis, President, and R. G. Ellis, Secretary, Treasurer and General Sales Manager, founded G-C (General Cement Mfg. Co.) on January 6, 1930.

Became 4000!



1955
OVER 4,000
G-C SERVICE AIDS



General Cement Mfg. Co.

902 TAYLOR AVENUE • ROCKFORD, ILLINOIS

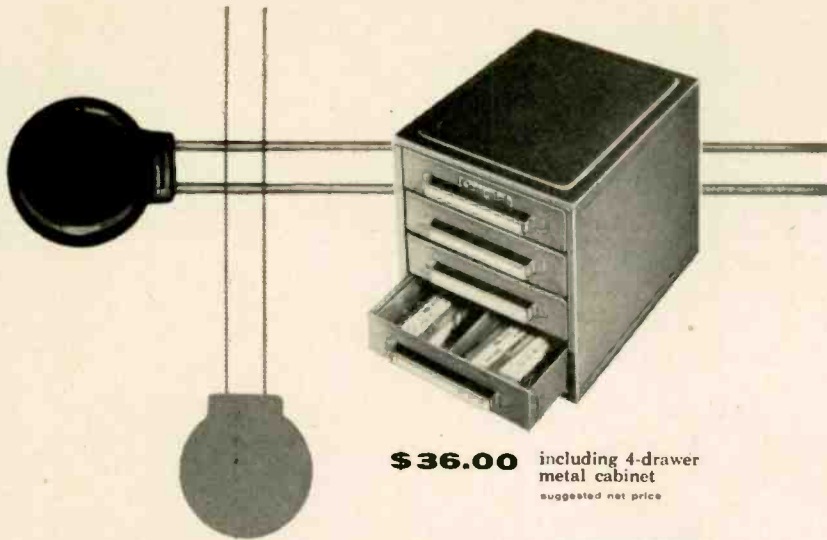

\$36.00 including 4-drawer metal cabinet
suggested net price

Time-saving workbench kit

of 200 new Centralab Molded Disc Capacitors

Centralab Metal Kit MDK-200

provides comprehensive assortment of 31 most generally used values

You don't have to delay a job until you get the right ceramic disc capacitor — because you always have the right one handy in this MDK-200 selection of 31 popular types.

It's easy to find just what you're looking for. All capacitors are packed five to a polyethylene envelope — with values, part numbers, and ratings clearly shown.

This gives you another good reason to use Centralab Molded Discs on all bypass, coupling, and general applications. You save time and money — your customer gets premium performance.

Call your Centralab distributor and have him deliver a Centralab MDK-200 Kit today. And send coupon for Centralab Catalog No. 29.

Only Centralab Type MD Molded Discs provide all these and other advantages

Lead strength greater than the breaking strength of the wire itself.	The only truly insulated ceramic capacitor — 2500 V.D.C. breakdown to ground.	Electrical properties constant to 3,000 megacycles.
Insulation resistance of molding, 300,000 megohms.	Fungus-proof. Unaffected by ozone, salt water, or solvent at room temperature. Will not become brittle at -55° C.	Moisture absorption, .005% or less.

Centralab

A DIVISION OF GLOBE-UNION Inc.
943A E. Keefe Ave., Milwaukee 1, Wisconsin

Send me Centralab Catalog No. 29.

Name _____
Company _____
Address _____
City _____ Zone _____ State _____

D-555

Letters to the Editors

Professional Pride

EDITORS, TECHNICIAN:

Not long ago I was approached in my service lab by a salesman who wanted me to purchase work uniforms with my business name on the back. It was stated that many TV shops use them for technicians on house calls. I've known this from way back—seven years ago—when I was employed by another.

This is one sure way of degrading our profession and I'm against it. Our work takes us into living rooms. A uniform is all right for a baker, milkman, etc., but, to a professional man who has pride in his work, it's no credit. Take the doctor. On a house call he wears a suit, and so should we. After all, on a house call he gives pills or penicillin (as we give tubes) and, if the trouble is really bad, he sends the patient (as we do the chassis) to the hospital (or lab) to be repaired.

JOHN L. MANCINI

Winthrop, Mass.

● As usual, there are two sides . . . We agree on the matter of professional standing. We also agree that a business suit makes the right impression—but how many house calls can you make while all dressed up? Does a uniform make a better impression than any old work clothing? Let's hear from other readers on this point.—Ed.

Helpful Hints

EDITORS, TECHNICIAN:

If the manufacturers would only get together and standardize their drawings and appearance of circuit diagrams to make them easy to read . . . I am also interested in trying to prevent consumer publications from publishing net prices on our merchandise. Some of our trade magazines are guilty of this also.

HARVEY LITCHFIELD, JR.

Anderson, Ind.

ARTICLES WANTED

TECHNICIAN is in the market for short articles from expert servicemen on the following subjects:

- Hi-Fi (Theory and Servicing)
- TV and Radio Interference
- Industrial Electronics (Theory and Servicing)
- TV Antennas (Installation and Servicing)
- Test Equipment
- UHF

Preferred length is three typewritten pages, double-spaced. Two or three drawings should accompany the articles.

If you'd like to do a piece for us, query first, telling us something about your background, and briefly summarizing what you propose to write about.

Payment is excellent.

Write to S. C. Silver, Managing Editor, TECHNICIAN, Caldwell-Clements, Inc., 480 Lexington Ave., N. Y. 17, N. Y.



... for **you**
or
for leading
television receiver
manufacturers

At Du Mont there is only one

Standard of Quality...



All Du Mont picture tubes are built to the highest standards of quality — whether for leading TV receiver manufacturers as initial equipment, or for the individual serviceman. The same careful assembly, processing and inspection is done on *every* picture tube bearing the Du Mont name.

Do as leading TV receiver manufacturers do — choose Du Mont initial quality picture tubes for new set performance.

CATHODE-RAY TUBE DIVISION
ALLEN B. DU MONT LABORATORIES, INC.
CLIFTON, N. J.

*Trade Mark.

**this great all-channel antenna discovery
is smashing sales and performance records
in every TV area!**

Single bay
SUPER RAINBOW
model no. 331

the
CHAMPION

RAINBOW*

brilliant black-and-white performance —
and really ready for COLOR!

these 3 revolutionary, power-packed
design features — found in no
other antenna today!

- 1. New spacing formula:** Radical new spacing arrangements between the directors and reflectors has, for the first time, extended the full efficiency and high gain of the basic narrow band Yagi over the *full width of an entire VHF band.*
- 2. New "triple power" High Band directors and reflectors:** Three-section directors and reflectors, with insulated segments, provide combined power of three High Band Yagis, operating side by side, in phase.
- 3. New "inter-mix" design:** Combines — into one single antenna — two separate, *independent* sets of directors and reflectors, one for High Band, one for Low Band. Each parasitic system operates *only* on its own band. *Fullest efficiency — no compromise design.*

PLUS Channel Master's patented, super-gain TRI-POLE . . . the unique triple-power dipole that made the Champion America's most wanted antenna.

Write for complete technical literature

Stacked
RAINBOW
model no. 330-2

CHANNEL MASTER creative engineering

Here's how the RAINBOW out-performs the famous Champions:

		CHANNEL	7	8	9	10	11	12	13	14	15	16	17	18	19	20
Gain Over 1-Bay Champion	1-Bay RAINBOW	0	0	0	+1	+2	+3	+2.5	+1	+5	+5	+1.5	+2.5	+2.5	+2.5	+2.5
	1-Bay SUPER RAINBOW	+1	+1	+1.5	+2.5	+2.5	+3.5	+3	+2	+1.5	+2	+3.5	+4.5	+4.5	+4.5	+4.5
Gain Over Stacked Champion	Stacked RAINBOW	+1.5	+2	+1.5	+1.5	+2	+5	+5	+0	+0	+0	+1	+1.5	+1.5	+1.5	+1.5
	Stacked SUPER RAINBOW	+2	+2.5	+3	+3	+4	+5	+1	+1	+2	+2	+2.5	+3.5	+3.5	+3.5	+3.5

horizontal
polar pattern
(relative
voltage)

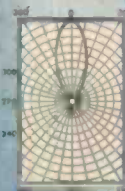

for fringe and super-fringe areas:

Super Rainbow, model no. 331

\$37⁵⁰ list

stacked Super Rainbow,

model no. 331-2

\$75⁷⁰ list

for suburban and near-fringe areas:

Rainbow, model no. 330

\$23⁰⁰ list

stacked Rainbow, model no. 330-2

\$48⁰⁰ list

something new in indoor antennas

for UHF and improved High Band VHF reception



for VHF reception

- features 3 telescoping sections.
- tilt-proof polystyrene base — cannot tip over.
- handsomely packaged for display.

the ALL-VU*

*all VHF . . . all UHF

the only indoor antenna with this "2-Way" feature.

model no. 381 \$6⁹⁵ list

the PRE-VU

for all-channel VHF reception only.

model no. 380

\$5⁹⁵ list

brings you today's **5** newest installation ideas

for . . . more effective installations
 . . . greater customer satisfaction
 . . . higher profits for you!

ALUMast

Aluminum Masting.
 The new idea in antenna masting—

can never rust!

- in telescoping sections
- in swaged 5, 10, and 14 foot sections

Lightweight ALUMast is $\frac{1}{3}$ the weight of steel, making it so easy to install — it swings right up! Stronger than steel, ALUMast is easier to stock and actually more economical.



SELECTENNA COUPLING SYSTEM

permits unlimited antenna combinations with only one transmission line!

- for the first time, you can tie together an unlimited combination of antennas, including separate antennas operating on the same band.
- ideal for areas currently using rotators, manually-operated selector switches, and "omni-directional" antennas.

list price:

\$542

each including hardware and wire for joining couplers.

This interlocked stack consists of 4 antenna couplers and 1 Hi-Lo coupler; joins 4 antennas.

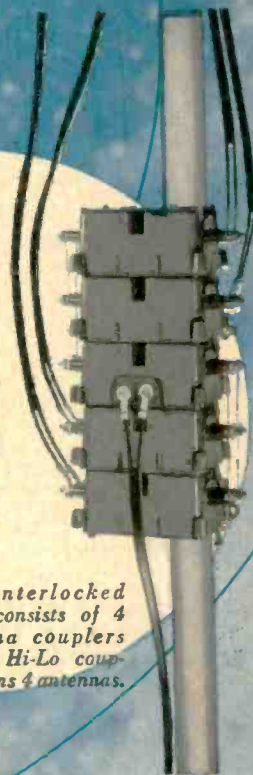

TV ROTATOR

with features found in no other rotator today:

- flexible worm gear, built-in thrust bearing.
- removable motor, electrical and mechanical stops.
- weatherproof, lightweight, strong.
- straight-thru mast mounting built-in chimney mount.
- extremely high torque.



model no. 9521, \$49⁹⁵ list

model no. 9520, without directional indicator, \$44⁹⁵ list



Beautifully-styled cabinet has great consumer appeal — is smallest on market (2 $\frac{3}{4}$ " x 4"). Finger-tip control bar.



CHANNEL MASTER CORP. ELLENVILLE, N. Y.

WORLD'S LARGEST MANUFACTURER OF TELEVISION ANTENNAS



Superior's new
Model 670-A

SUPER METER

A COMBINATION VOLT-OHM MILLIAMMETER PLUS
CAPACITY REACTANCE INDUCTANCE AND DECIBEL MEASUREMENTS

SPECIFICATIONS:

D.C. VOLTS: 0 to 7.5/15/75/150/750/1,500/7,500 Volts
A.C. VOLTS: 0 to 15/30/150/300/1,500/3,000 Volts
OUTPUT VOLTS: 0 to 15/30/150/300/1,500/3,000 Volts
D.C. CURRENT: 0 to 1.5/15/150 Ma. 0 to 1.5/15 Amperes
RESISTANCE: 0 to 1,000/100,000 Ohms 0 to 10 Megohms
CAPACITY: .001 to 1 Mid. 1 to 50 Mid. (Good-Bad scale for checking quality of electrolytic condensers.)
REACTANCE: 50 to 2,500 Ohms 2,500 Ohms to 2.5 Megohms
INDUCTANCE: .15 to 7 Henries 7 to 7,000 Henries
DECIBELS: -6 to +18 +14 to +38 +34 to +58

ADDED FEATURE:

Built-in ISOLATION TRANSFORMER reduces possibility of burning out meter through misuse.

The Model 670-A comes housed, in a rugged crackle-finished steel cabinet complete with test leads and operating instructions.

\$28⁴⁰
NET



Superior's new
Model TV-11 **TUBE TESTER**

- ★ Tests all tubes, including 4, 5, 6, 7, Octal, Lock-in, Peanut, Bantam, Hearing Aid, Thyatron Miniatures, Sub-miniatures, Novals, Sub-minors, Proximity fuse types, etc.
- ★ Uses the new self-cleaning Lever Action Switches for individual element testing. Because all elements are numbered according to pin-number in the RMA base numbering system, the user can instantly identify which element is under test. Tubes having topped filaments and tubes with filaments terminating in more than one pin are truly tested with the Model TV-11 as any of the pins may be placed in the neutral position when necessary.
- ★ The Model TV-11 does not use any combination type sockets. Instead individual sockets are used for each type of tube. Thus it is impossible to damage a tube by inserting it in the wrong socket.

- ★ Free-moving built-in roll chart provides complete data for all tubes.
- ★ Newly designed Line Voltage Control compensates for variation of any Line Voltage between 105 Volts and 130 Volts.
- ★ NOISE TEST: Phono-jack on front panel for plugging in either phones or external amplifier will detect microphonic tubes or noise due to faulty elements and loose internal connections.

The model TV-11 operates on 105-130 Volt 60 Cycles A.C. Comes housed in a beautiful hand-rubbed oak cabinet complete with portable cover

\$47⁵⁰
NET

EXTRA SERVICE—The Model TV-11 may be used as an extremely sensitive Condenser Leakage Checker. A relaxation

type oscillator incorporated in this model will detect leakages even when the frequency is one per minute.

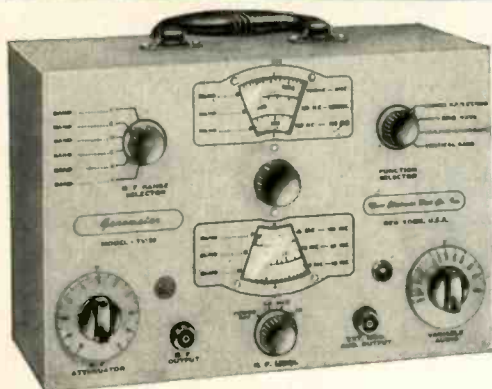

THE NEW
MODEL
TV-50

GENOMETER

A versatile all-inclusive GENERATOR which provides ALL the outputs for servicing:
A.M. Radio • F.M. Radio • Amplifiers • Black and White TV • Color TV

7 Signal Generators in One!

- ✓ Bar Generator
- ✓ R. F. Signal Generator for A.M.
- ✓ R. F. Signal Generator for F.M.
- ✓ Audio Frequency Generator
- ✓ Cross Hatch Generator
- ✓ Color Dot Pattern Generator
- ✓ Marker Generator

R. F. SIGNAL GENERATOR: The Model TV-50 Genometer provides complete coverage for A.M. and F.M. alignment. Generates Radio Frequencies from 100 Kilocycles to 60 Megacycles on fundamentals and from 60 Megacycles to 180 Megacycles on powerful harmonics.

VARIABLE AUDIO FREQUENCY GENERATOR: In addition to a fixed 400 cycle sine-wave audio, the Model TV-50 Genometer provides a variable 300 cycle to 20,000 cycle peaked wave audio signal.

BAR GENERATOR: The Model TV-50 projects an actual Bar Pattern on any TV Receiver Screen. Pattern will consist of 4 to 16 horizontal bars or 7 to 20 vertical bars.

CROSS HATCH GENERATOR: The Model TV-50 Genometer will project a cross-hatch pattern on any TV picture tube. The pattern will consist of non-shifting, horizontal and vertical lines interlaced to provide a stable cross-hatch effect.

DOT PATTERN GENERATOR (FOR COLOR TV) Although you will be able to use most of your regular standard equipment for servicing Color TV, the one addition which is a "must" is a Dot Pattern Generator. The Dot Pattern projected on any color TV Receiver tube by the Model TV-50 will enable you to adjust for proper color convergence.

MARKER GENERATOR: The Model TV-50 includes all the most frequently needed marker points. The following markers are provided: 189 Kc., 262.5 Kc., 458 Kc., 600 Kc., 1000 Kc., 1400 Kc., 1600 Kc., 2000 Kc., 2500 Kc., 3579 Kc., 4.5 Mc., 5 Mc., 10.7 Mc., (3579 Kc. is the color burst frequency.)

THE MODEL TV-50 comes absolutely complete with shielded leads and operating instructions. Only ...

\$47⁵⁰
NET

SHIPPED ON APPROVAL NO MONEY WITH ORDER — NO C.O.D.

Try any of the above instruments for 10 days before you buy. If completely satisfied then send down payment and pay balance as indicated on coupon. No Interest or Finance Charges Added! If not completely satisfied return unit to us, no explanation necessary.

MOSS ELECTRONIC DISTRIBUTING CO., INC.

Dept. D-93, 3849 Tenth Ave., New York 34, N.Y.

Please send me the units checked. I agree to pay down payment within 10 days and to pay the monthly balance as shown. It is understood there will be no finance, interest or any other charges, provided I send my monthly payments when due. It is further understood that should I fail to make payment when due, the full unpaid balance shall become immediately due and payable.

Model 670-A Total Price \$28.40
\$7.40 within 10 days. Balance \$3.50
monthly for 6 months.

Model TV-11 Total Price \$47.50
\$11.50 within 10 days. Balance \$6.00
monthly for 6 months.

Model TV-50 Total Price \$47.50
\$11.50 within 10 days. Balance \$6.00
monthly for 6 months.

Name
Address
City Zone State

Your Parts Jobber has

A FREE SHIRT FOR YOU !

to Introduce CERTIFIED RECEIVING TUBES



VAN HEUSEN CENTURY #100
REGULAR COLLAR

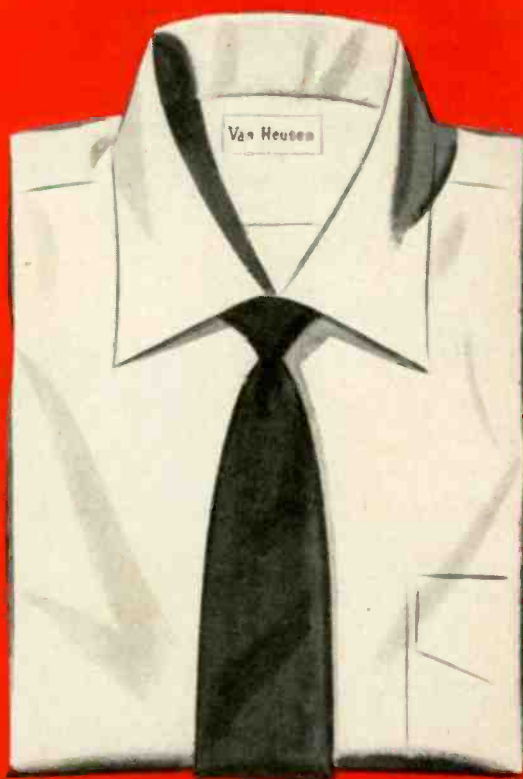

VAN HEUSEN CENTURY #200
WIDE SPREAD COLLAR

VAN HEUSEN CENTURY SHIRT

The shirt with the soft, one-piece collar that won't wrinkle . . . ever!

BE SURE TO ASK YOUR JOBBER FOR YOUR SHIRT

FREE with your purchase of **ONLY 25 CERTIFIED RECEIVING TUBES**

If Your Parts Jobber Cannot Supply You, Write

CERTIFIED TUBE COMPANY 16th and Luzerne Sts., Philadelphia 40, Pa.

the most complete line...

a model for every application

C·D·R ROTORS

C·D·R Rotors have

AXS 679*

** The highest grade premium die cast aluminum... so rugged and durable that it is used for aircraft landing gear.*

**MOST
POWERFUL**

**MOST
DEPENDABLE**

**SHARPEST
TUNING**

PRE-SOLD

for you to **MILLIONS**
through spot announce-
ments on television.

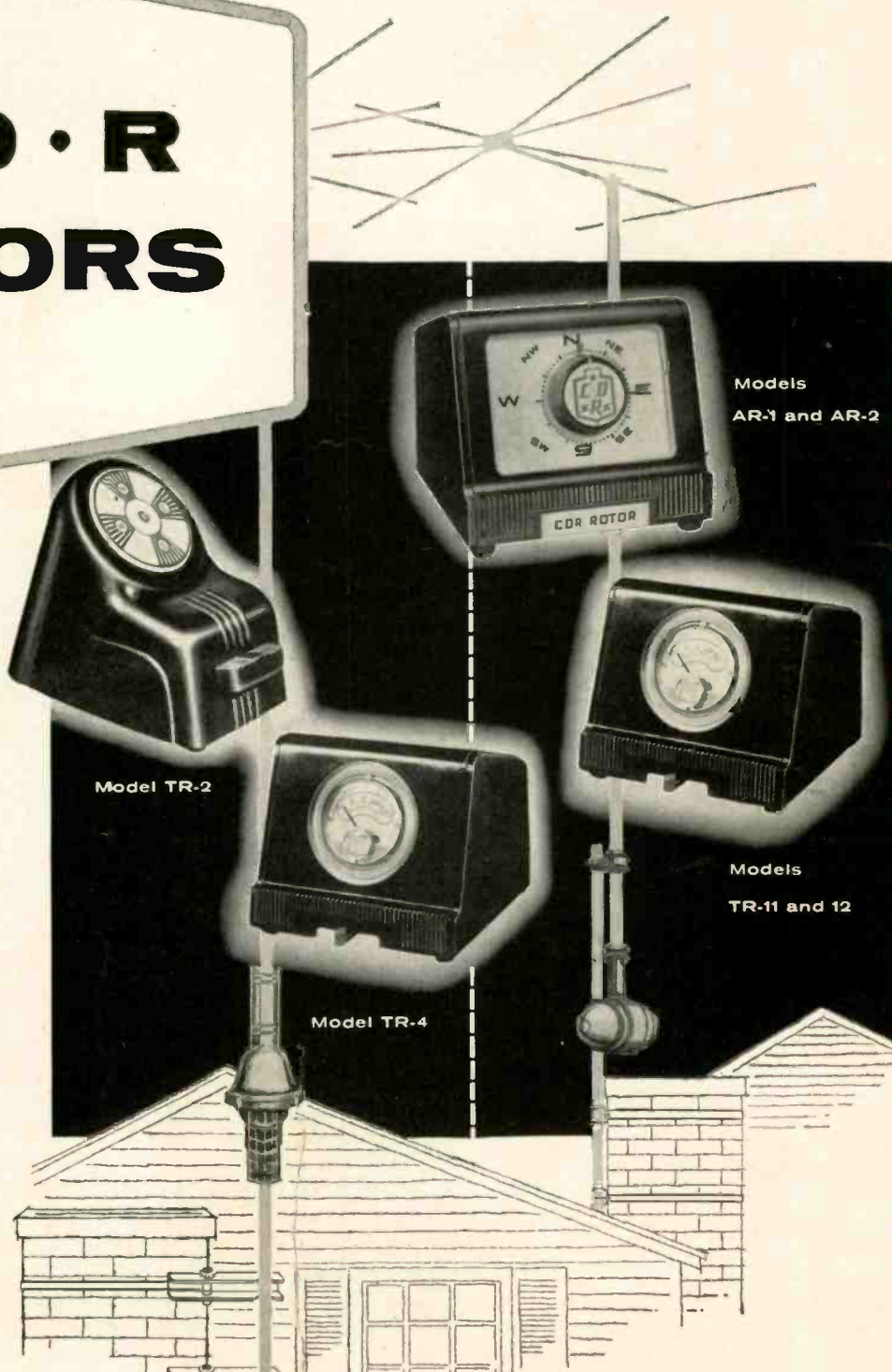

Models
AR-1 and AR-2

Model TR-2

Models
TR-11 and 12

Model TR-4



CORNELL-DUBILIER
SOUTH PLAINFIELD, N. J.



THE RADIART CORP.
CLEVELAND 13, OHIO

TECHNICIAN & Circuit Digests

CALDWELL-CLEMENTS, INC., 480 LEXINGTON AVENUE, NEW YORK 17, N. Y.

The Crystal Ball

At the end of this year, you will definitely *not* be in much the same position that you are now, at the outset. One way or another, your position will be affected by this fact: there will be more change in our field in 1955 than there has been in any year since the television revolution began. You will ride along with the changes, and move ahead—or you will eat the dust of the front runners. Adjusting to new factors will be the keynote.

The rosier part of the picture is this: service revenue is heading upward on all fronts. **TECHNICIAN** editors predict that 1955 will be the biggest year for the sale of replacement pix tubes, for example. We also foresee increases in all categories of service as follows: radio service revenue will be up 15%; revenue from TV service will rise 16%; PA work is headed for an 11% increase. The biggest rises in service revenue, however, will be in work on phono players (18%), recorders (24%) and Hi-Fi service and installations (33%). We believe that audio is on its way—as is color.

By itself, the fact that things are getting better in general does *not* mean that they will get better for you in particular if you just sit back and wait. That could be a fatal mistake. For instance, you may be in for a stiff battle from big outfits that are not primarily in the servicing business, but which maintain their own service departments. You could be hurt by the discount houses this year. These organizations have been stung by the charge that they are able to keep prices cut because they eliminate or drastically reduce associated services to customers. The attack is being answered by a new trend: the bigger discount houses are establishing or expanding their service departments.

More Pitfalls

Other competition will come from department stores. Many of these which formerly turned over service work to outside firms are setting up their own units. Others, with service departments already set up, are pushing for new business. Aware of the fact that service can be profitable, department stores are beginning to attract accounts with offers you will have difficulty duplicating. They can put repair bills on the charge account. Many of them are doing that right now. This makes it tough for the independent who must work on a C.O.D. basis.

Another factor that could turn into a stumbling block—or a blessing—is the re-awakened interest in licens-

ing. Much talk and little action, which has been the pattern until now in this area, will not be the case in 1955. The year will see laws enacted throughout the country to regulate the service profession.

Plan Ahead

To pick your way through the pitfalls, you will need a program—a clear-cut idea of where you want to be heading. Here are some planks you might consider:

- To meet competition from new sources, you must rely on more than technical skill. The good will on which your business is based, the personal relationship between you and your customer, was never more important. The appearance of yourself and your shop, and the patience with which you handle people, are part of this pattern.
- Customers must know that they can depend on you for *all* types of service. If you can't or won't handle the 5-tube radio, the record changer, the tape recorder and the FM tuner, they'll seek out *one* man who can take care of all of these items in addition to the television set.
- To give people the service to which they are entitled, you cannot shrug off the need for picking up know-how in audio work, color television, transistor radio or printed wiring. In 1955, you will be asked to perform service in these relatively new fields. Will you have to send your customers to your competitors?
- If licensing comes to your community, how will it affect you? Can you do anything to prevent its arrival? Do you *want* to forestall it or should you welcome it? Would supervision from within the industry itself be better or worse? The answers to these questions are complicated. You will see the angles better if you talk things over with your fellow technicians—in your associations. As a member, you will also have a stronger voice in formulating and administering licensing regulations, in those areas where the law is unquestionably on its way. As a member, you can act together to develop credit programs, responsibility funds and other features that will put you in a better competitive position.

The big year ahead will see much growth in the service industry, particularly in those shops alert to new technical developments and business trends. Make sure you're one of those forging ahead—taking advantage of 1955's new opportunities.

Tuning In the

DUE TO EVER-INCREASING costs of doing business, dealers are going to think twice before they spend money on "gimmick" advertising this year. Prominent Eastern retailer who maintains one of the largest independent service departments in the country, has this advice to offer: "Stick to newspapers, classified phone directories and direct mail. Keep your name in the papers even if you use small-space or classified ads; on direct-mail pieces, be sure to make specific offers. So far as local programs—such as those issued by schools, churches and the like—are concerned, you may incur ill-will by not going along with an ad. But make sure the programs are locally-sponsored and are not money-making schemes by outside promoters."

HIGH VOLUME FOR HI-FI SEEN FOR '55. **TECHNICIAN** editors estimate that "fine music" equipment—merchandise which would be acceptable to most consumers as "high fidelity" instruments and components—will ring up a total sales volume of about \$300,000,000 retail value this year. The figure includes recorders, phonos, miscellaneous combinations, cabinets (custom), Hi-Fi records, Hi-Fi needles, magnetic tape, speakers, tuners, amplifiers, and other components.

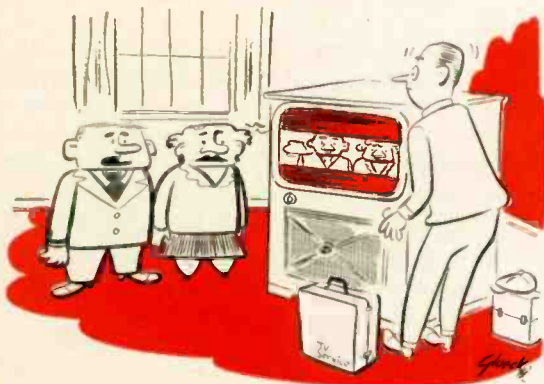

"No, frankly, we never noticed the picture was distorted."

ELECTRICAL ENGINEERS took the honors in a handwriting poll conducted by the Norma Pencil Co. The survey, which asked secretaries to rate the handwriting of their bosses on the basis of legibility, gave electrical engineers an easy-to-read rating of 71 percent, which was tops. Overall average was 59 percent. Booby prizes went to ad men, aviators and architects, who scored down in the 25-percent-legible class.

QUOTE WITHOUT COMMENT: "Some manufacturers are beginning to re-evaluate their position and price set-up in order to restore quality and consumers' lost confidence . . . Prices must also provide for a reasonable profit margin for the dealer . . . The average consumer will not knowingly accept sub-standard quality for the sake of a few dollars' savings."—F. A. D. Andrea, prexy of Andrea Radio Corp.

TAPE (NOT RED) TANGLES LAWBREAKERS in Baltimore, Md. When the cop on the beat makes his hourly phone report to headquarters, he gets his latest info on robberies, stolen cars, fugitive descriptions, etc., from a continuous-loop tape recorder. Two Magnecorders are alternated, with one being played for an hour while the next one is being prepared with fresh material. New items may be added at any time. The system had enabled Baltimore police to cut their switchboard staff in half, is estimated to have saved \$50,000 already.

HI-FI MARKETING ITEM punctuates the growing trend toward encouraging growth in this field by setting up sane distribution and sales practices. Tape Recorders, Inc., of Chicago announces the following strict policy: (1) No distributor can be authorized who sells at retail, (2) No distributor or wholesaler can be authorized whose catalogs are permitted to reach consumers and (3) no dealer who advertises at less than the established list prices will be permitted to handle the new line of recorders.

MAGNETIC CAKE RECORDING—that's right; don't blame the printer—is now with us. In a recent demonstration of automation, a tape recorder-playback unit was used to combine and mix ingredients in the proper amounts and sequence. Tape-recorded signal, when played back, operated a series of relays. With a single tape and accessory equipment such a unit, conceived by Magnecord, Inc., could simultaneously produce dozens or even hundreds of cakes . . . Anyhow, this is no half-baked idea—it was set up to dramatize the possibilities of automation in industrial and scientific applications.

TRANSISTORIZED FLIGHT. Pilotless airplane operation from the ground with automatic equipment has been achieved with a completely transistorized automatic pilot. Though the first such flight took place last May, security requirements kept the development under wraps. Engineers of the Bendix Aviation Corp. designed and installed the autopilot, which was first used in a B-25.

Anticipated increases in various fields of electronic service, 1955

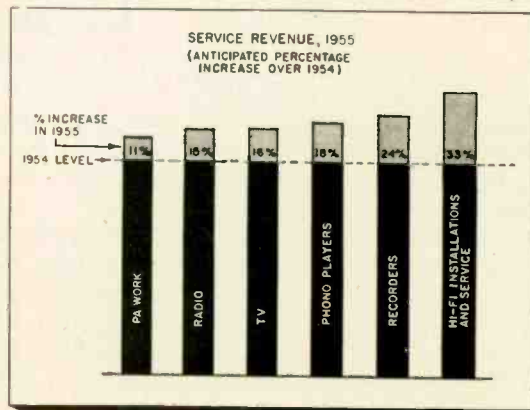

Picture



THAT TECHNICIAN'S DUMB GIRL FRIEND is still alive in '55, and is starting the new year wrong. Right off the bat she says that, if tool manufacturers would strive to make trouble-free products, there wouldn't be the need for so many screwdriver mechanics . . . And she'll bet that the sync output will be up this year because all those new homes being built need modern kitchens . . . To cap the climax, she and her boy friend were watching a goat eat an old radio chassis in a vacant lot. When the BF asked her if she thought the mess of wires, tubes, etc. would hurt the animal, she is said to have replied, "Not if the Circuit Digests!"

OPERATOR OF A LARGE SERVICE DEPARTMENT estimates that, in 90% of all cases, husband and wife discuss whom to call and when to call for service. He also estimates that 70% of all daytime calls for service, either on phone or in person, are made by women, and that 78% of all calls for service evenings, Saturdays and holidays are made by men.

TECHNICIAN RHYME: Joe Doakes was known as Santa Claus, and the reason simply was because he extended credit like a dope, and tried to live in the fond hope that folk who said, "Just charge it, Joe," would really pay this hard-earned dough. And while he slaved just like a Turk turning out a raft of work, many failed to pay their debts for long-since-serviced TV sets. Now Joe is servicing no more. A "For-Rent" sign is on his door. Poor Joe works now but once a year—in a big store to bring good cheer—to small fry, where his long white beard proclaims him Santa Claus indeed.

SOMETHING NEW UNDER THE SUN? Transistorized transmitter, about the size of a pack of cigarettes, operates from solar energy instead of from batteries. As developed by GE engineers in Syracuse, the transmitter gets electrical energy from self-contained selenium solar-energy converters, which are activated by the sun's rays.

VERTICAL-CHASSIS DESIGN, well established in TV, is spilling over into radio. Recently announced GE table radio uses an upright printed-wiring board to support components. Electrically, the set is of conventional design, using 4 tubes and a rectifier.

SPEAKING OF PRINTED WIRING, alert folk in the service biz will pick up the simple new techniques required for this type of construction in a hurry. Some technicians refuse to recognize that these chassis exist. Might as well refuse to recognize the imminence of color TV. You won't stop progress—so you may as well ride ahead with it.

WHAT HAPPENS AT THE SHOP END of the telephone can spell either good or bad public relationships with customers. An efficient, courteous method for handling calls is a must—but too many shop operators fail to realize it. In some departments, busy technicians let phones ring a long time, and often treat customers impatiently, brusquely; in still others some person, often a girl who doesn't know enough about the business, chases the trade away. And just about the worst thing that does take place in a few establishments is when the place is closed for varying lengths of time, with no answer at all for those who want service. The alert department manager "sells" himself and his service over the phone, and doesn't scoff at playing the role of the voice with the smile.

FM BROADCASTING may be getting a boost from new table-model receivers now reaching the market. Incorporating 6-in. speakers, the new FM receivers are intended to provide performance far beyond that possible with their AM counterparts—and they are selling at no higher a price than one pays for a fair AM table radio.

A FIVE-MAN SHOP WE KNOW OF averages 6 TV sets per day per man, repaired on the bench. The owner is not satisfied with the present rate, and wonders how his "output" stacks up with that in similar departments. We'll appreciate hearing from readers and learning of their "averages" per man per day.

CALENDAR OF COMING EVENTS

- Jan. 23: First Annual Industrial Amateur Electronics Show, Grand Ballroom, Park Sheraton Hotel, New York, N. Y. Sponsored by Arrow Electronics, New York, N. Y.
- Feb. 11-13: Audio Fair—Los Angeles, Alexandria Hotel, Los Angeles, Calif. Sponsored by Los Angeles Section of Audio Engineering Society.
- Mar. 21-24: 1955 Institute of Radio Engineers National Convention, Kingsbridge Armory, New York, N. Y.
- May 16-19: The 1955 Electronic Parts Show, Conrad Hilton Hotel, Chicago, Ill. Sponsored by Assoc. of Electronic Parts & Equip. Mfrs., Radio-Electronic-Television Mfrs. Assoc., West Coast Electronic Mfrs. Assoc., National Electronic Distributors Assoc., Sales Managers Club (Eastern Group).

Convergence & H-V Circuits

Adjustment of Magnetic Rather Than Electrostatic

BY PETER ORNE

• The advent of larger three-gun shadow-mask tubes has had considerable impact on design of the associated receivers. This impact has not so much been felt in the signal and color circuits as in the high-voltage and convergence sections.

One important difference is the requirement of increased high-voltage. While the 15-in. 3-gun tube used between 18 and 20 kv, the new tubes require between 24,000 and 26,000 volts of ultor (2nd-anode) output. This means that—for the present, at

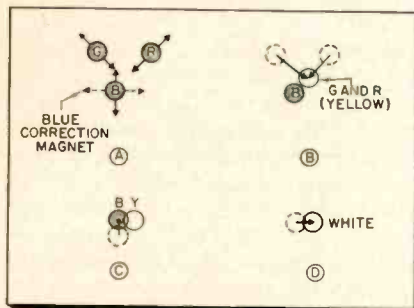

Fig. 1A—Position of 3 color dots in one triangle before convergence. B—First green and red dots are converged. C—Blue dot is brought up into line. D—Blue correction magnet is used to achieve single fully converged dot.

least—the flyback cannot supply a pulse from which the desired voltage can be developed directly. Voltage doublers are therefore used, as was also the case with the earlier sets built around the 15-in. tube and, during a still earlier period, as was the case with monochrome projection tubes.

Confusing at first glance is the fact that *three* high-voltage rectifier tubes appear in the schematics for most color sets. The circuit, however, is not a tripler. It is a doubler, with only two of the tubes being used for rectifier action. The third tube is used to couple the pulse to the second rectifier. This tube takes over the function of the coupling resistor used in black-and-white receiver high-voltage doublers, thus eliminating a circuit component that was often the cause of much difficulty. (For typical doubler circuits used in large-screen color high-voltage sections, see *TECHNICIAN* for October 1954, Section II, and the Circuit Di-

gest Section for December 1954.)

Since the new crt's use a wider deflection angle along with the increased high voltage, ordinary horizontal output tubes are not adequate to provide sufficient sweep. Experimental types now in development are close to production. In the meantime, entirely satisfactory operation is being achieved by using two conventional types, such as the 6BQ6 or the 6CU6, in parallel. The shunt regulator tube, used to stabilize the high-voltage output, was the 6BD4 in the 15-in. sets. Since this is usable only to 20 kv, the 6BD4A has been developed, along with others not yet designated.*

Major differences in the large-screen sets occur in the convergence arrangements, as compared to the earlier designs. As the reader may remember (*Servicing Convergence Problems*, *TECHNICIAN*, June 1954), the smaller pix tube used *electrostatic* convergence lenses. This approach to the problem involved certain difficulties. For example, a potentiometer was needed to permit variation of the convergence voltage. This component had to be built and insulated to withstand the 14 kv to which it was subjected. Also, high-voltage condensers were required to couple the dynamic convergence voltages to their associated electrode within the crt. Furthermore—and this was the most obvious drawback to the eye—misconvergence that resulted from production errors in the tube could only partially be compensated for by the magnets placed near each of the three guns. Dynamic convergence, applied to an electrode common to all guns, had to rely on uniformity of construction in the tube. As a result, there tended to be some residual misconvergence that was not eliminated.

Magnetic Convergence

For the new larger tubes, *magnetic* convergence is being used. With pole pieces now built into the neck of the tube, the field required for convergence is reduced. This field is supplied by a *convergence yoke*, which consists of three cores, one for each gun. Around each core there are two

windings, one for the vertical convergence circuit and one for the horizontal. In addition, mounted between the two sections of the core is a permanent magnet. The latter is pivoted so that the field strength applied to the gun can be varied and the direction of the field can be reversed. This magnet—one for each gun—is used to adjust for convergence at the center of the screen. In addition to these three, there is one more permanent magnet mounted separately near the blue gun.

What the new arrangement boils down to is this, in terms of service adjustments: For center-screen (or dc) convergence alone, four magnets are used. The directions of travel for a group of three dots near the center of the screen as these magnets are varied is shown in Fig. 1A. First the magnets near the red and green guns are adjusted to superimpose or converge the red and

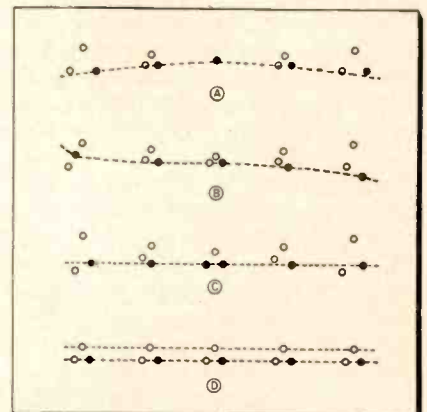

Fig. 2A—Dynamic convergence not yet applied; green (darkened) dots form an arc. B—Addition of parabola straightens center. C—Adjustment of tilt results in proper horizontal convergence for green. D—All guns are adjusted.

green dots. This movement takes place as shown in Fig. 1B, with a yellow dot resulting. The blue dot is then brought up to the proper height with its appropriate yoke magnet, as shown at 1C; that is to say, it is lined up with the yellow dot, although not necessarily converged with it. Finally, by adjustment of the separate correction magnet for the blue gun, convergence is completed as shown at 1D, and a single white dot results.

Correction is now achieved at the

in Large-Screen Color Sets

Convergence Is More Complicated. New Circuits; New Tubes

center of the screen, but the following controls must also be manipulated to produce overall convergence for each gun: horizontal convergence amplitude, horizontal convergence tilt, vertical convergence amplitude, and vertical tilt. Since there are four for each gun, there are a total of 12 controls for dynamic convergence. Add to these the four used for dc convergence—and we have a total of 16 convergence controls! We now have twice as many of these adjustments as in the earlier small-picture color receivers—but the possibility of getting uniform convergence is now greatly enhanced.

Dynamic Correction

The procedure for adjusting dynamic convergence is somewhat painstaking and cannot be performed rapidly. Nevertheless, if the action of the various controls is understood, the operation is simple to perform. As the reader may remember, the need for dynamic convergence arises because the electron beam has to travel a greater distance to reach the screen when it is deflected to the sides of the tube than when it strikes the screen's center. This is true because the screen is relatively flat, rather than curved to match the arc through which the electron beam swings. The convergence *amplitude* controls adjust the *amount* of correction voltage applied; the convergence *tilt* or phase controls adjust the *shape* or symmetry of the parabolic correction voltage.

The first adjustment in the overall procedure to obtain dynamic convergence would be that of the amplitude control. For example, assume that horizontal dynamic convergence is going to be corrected first and that the procedure will commence with the green gun. We start by observing the center horizontal row of dots on the face of the tube. If we look at the green dots only (the dark row of dots) we observe that they form a curve rather than a straight horizontal line, as in Fig. 2A. As we turn up the green horizontal convergence control, the dots begin to approach a straight line. If this action is uneven—that is, if the dots on one side of the line tend to

straighten out before the dots on the other side, as in Fig. 2B—we then use the horizontal tilt adjustment for the green gun to achieve the desired symmetry. This enables us to line up the entire row of green dots, as shown in Fig. 2C.

The procedure just described is then performed again for the red gun while observing the horizontal row of red dots at the center of the screen. Finally, the same series of adjustments is made for the blue gun. The last adjustment should produce a horizontal line of equally spaced triangles, as shown in Fig. 2D. It is important that all of the triangles be of the same size. If any unevenness in size is evident, the dynamic controls should be readjusted to correct this condition.

The procedures described for each of the three guns is now performed in similar fashion for the *vertical* dynamic convergence and tilt controls, while observing the center vertical row of dots. When this is successfully completed, all triangles over the face of the tube should be uniform in shape and equal in size. After this condition is reached, the *dc convergence* magnets are then manipulated to bring each triangle of separate dots together; that is, to superimpose or converge them. The result will be, in the place of each triangle, a single white dot.

Some other hints will be helpful in adjusting for convergence. For example, although dynamic convergence is adjusted first and the triangles are superimposed into white

dots by means of the dc convergence magnets at the very end, there will be justification for using these dc adjusting magnets ahead of time. Since it is more convenient to work with triangles that are as small as possible, the dc magnets may be used at any time during dynamic adjustment to reduce the size of the triangles, short of bringing them into final convergence. Another suggestion: while a dot generator is recommended for this procedure, a transmitted, steady test pattern or a bar-generator signal can be used in a pinch. Adjustment while a picture is in motion on the screen is a hopeless task.

Circuits used to develop signals for dynamic convergence vary considerably. The 28-tube RCA design uses networks, but no tubes. A pulse is taken from the flyback transformer, and tuned circuits are used to develop a sine wave from it. This sine wave is phased so that positive peaks occur during retrace time; the portion remaining during the trace period then resembles a parabola, which is the shape desired for proper correction of horizontal convergence.

Vertical Parabola

To obtain the vertical parabola, a signal is taken from the cathode of the vertical output tube and fed through an RC network, by means of which tilting and amplitude variation is accomplished. This arrangement results in marked interaction

(Continued on page 47)

Fig. 3—Simplified schematic of convergence circuit for 1 gun in CBS-Columbia receiver. The convergence output tube and set of 4 controls for one gun only is shown. There are 3 such sets.

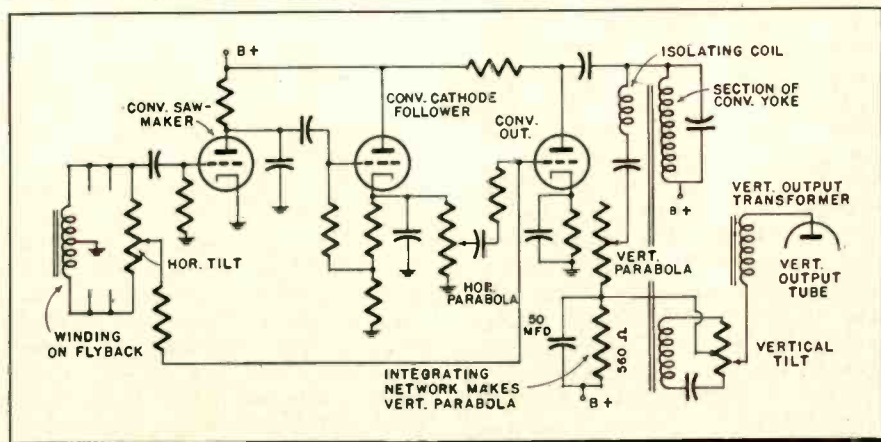

Your Stand ... Licensing

Should the Service Industry Be Regulated? How?

Industry Report

• Once a favorite theme for stirring up a little excitement among technicians, the subject of licensing has appeared to slip into the background of late. Never dead, it keeps on smoldering, always ready to break into full blaze when fanned by a favorable—or unfavorable—wind. **TECHNICIAN** editors believe the bonfire may, after years of talk without action, be on its way.

The wind that may start the embers glowing again is the current flurry of interest, on the part of the City Council of New York City, in legislation to license and regulate radio-TV technicians. While a bill now before the council only sets up the machinery out of which a licensing program would develop, its passage (which appears probable) would establish the principle of government regulation. The larger metropolitan centers, like New York, have traditionally set the pattern for the rest of the country in the matter of local laws covering problems that exist in communities throughout the nation. Acceptance of the principle in New York, then, might set off a wave of similar laws throughout the country.

Your Views

We of **TECHNICIAN**, of course, have our own opinions concerning the desirability or undesirability of government licensing. However, we decided to avoid the frequent editorial pitfall of putting the cart before the horse. Instead of telling you what you ought to think, we asked you to tell us. All of the answers were interesting; some upset assumptions we had been making. Five key questions were put to service

associations representing thousands of technicians throughout the country. Here are the questions:

1. Are you in favor of government licensing?
2. Are you in favor of fee regulation by municipal or state authorities?
3. Are you in favor of fee regulation by unions?
4. Are you in favor of self-regulation of fees by the servicing industry?
5. Are you in favor of certifying competent technicians by the servicing industry?

On the matter of licensing by the government, respondents tended to be against the principle, but not strongly. About 45 percent of those who offered answers to the first question favored government control, 55 per cent were against. Possibly of greater significance, was the fact that many of those who answered "Yes" qualified their replies. Policing by the authorities would be acceptable, that is, if certain strings were attached. These strings will be discussed later.

For Certification

To the 5th question, closely related to the 1st, there was a much more clearcut pattern of response. In favor of certification or accreditation by the industry itself were 77 percent of those who gave their opinions, with only 23 percent giving a flat "No." This pattern may not appear to correspond with the trend shown in the answer to Question 1, but it merely indicated a particular approach to the problem—one which the editors had not taken into account. It seems that a large segment of the service industry does not attach great importance to the type of agency responsible for supervision. In other words, respondents had definite opinions, in general, on whether there should or should not be some form of control. However, once that was decided, not all technicians could see much difference between putting the responsibility for regulation in the hands of the industry or of the government. This is shown by the fact

that about 40 percent of those replying answered either "Yes" or "No" to Questions 1 and 5 both, often giving the same reasons for answers to both questions.

Fee Regulation

On all three questions pertaining to fee regulation (2, 3 and 4), technicians seemed to be concerned about maintaining a competitive situation. If there had to be some form of fee regulation, the general feeling was that it should come from within the industry. Even if in the hands of the industry, only 1 out of 3 favored control. Most emphatic response came to Question 3, concerning fee regulation by unions. Although the reasons varied, respondents were almost unanimously in the negative. Some accompanied their replies with attacks against unions; others took pains to say that they were either for unions or, at least, not opposed to them, but did not consider fee regulation to be the primary concern of these organizations.

Responses to Questions 2, 3 and 4 should not be considered as definitive because, judging from reasons accompanying the answers, there were various interpretations as to the intent of the questions. In Question 2, for example, the editors had wished to sound out feeling on the matter of fee control by government agencies on any level. Many people answered by stating that they preferred either state or municipal regulation. Also complicating answers to these questions was the varying interpretation placed upon the word "fee." Some took it to mean the salary or amount per call paid to the employed technician; others understood it to be the amount charged the consumer for repair. In most cases, however, respondents did not see a distinction. This appeared to underscore the widespread character of the small-shop self-employed operator; that is, the man to whom the amount paid for a repair by the customer and the amount he gets are one and the same.

As for existing licensing legislation, laws of this nature were found not to have taken hold to any sig-

and Accreditation

By Whom? New Angles to an Old Problem

nificant extent on a nation-wide basis. Significantly, however, there were many cases reported where such bills were pending or being proposed. It is also significant that associations were active in promoting some of these bills. In such cases, the technician-supporters of the legislation often envisioned some sort of combination arrangement that united government regulation with industry accreditation. In one such plan—the “Minnesota Plan” developed by MINTSE (Minnesota Television Service Engineers), an affiliate of NATESA (National Alliance of Television & Electronic Service Associations)—the service association defines the qualifications for rating as technician, serviceman, apprentice, student, technical assistant, specialist, etc. State laws are being sought to issue licenses and to provide police action in accordance with these standards.

The clarifications and explanations accompanying the straight “yes” and “no” answers were often more enlightening as to the real thinking of technicians than were the stands taken, by themselves. We present some of these reactions, on the various points covered, now; and hope to devote more space to them in forthcoming issues.

Government and Industry

“Government licensing, like penicillin, cannot be prescribed universally. The needs of each area must be weighed individually. Obviously, though, in the absence of any desire on the part of the industry as a whole to cooperate with democratic service associations . . . this (government licensing) may, in many areas, be the only answer.”—NATESA, Chicago, Ill.

* * * * *

“The industry (if you will be realistic) is not able to successfully provide the unity, funds or policing authority, at this time, to produce the desired results.”—Television Installation Service Assn., Chicago, Ill.

* * * * *

“We are not in favor of governmental licensing because such regulations may increase the cost of service and add just one more tax burden . . . (On industry regulation) No, because this may lead to discrimination and, again, it might be anti-free-enterprise.”—Electric League of L.A., Calif.

* * * * *

“We feel that no man should be permitted to engage professionally in the electronics business just because he has read a book on the subject.

(Favoring both industry and government supervision.)”—Waterbury TV Technicians Assn., Conn.

* * * * *

“A certification or accreditation program based on the Advanced Television Techniques Program as recommended by the Radio-Electronics-Television Manufacturers Association would provide a uniform standard . . . In addition, a well organized association of industry certified technicians could institute a program of up-grading . . . An association would also have the advantage of being in the best position to promulgate a standard . . . so as to exercise internal regulation and discipline.”—Certified Electronic Technicians Assn., N. Y., N. Y.

* * * * *

“Haven’t seen a proposed licensing law that could be considered as a workable item . . . we are groping in the dark for a Utopia and individual.” (Continued on page 45)

Industry Groups Split as N.Y. Licensing Vote Nears

As we go to press, hottest industry news is the licensing bill now before the New York City Council. Since it may have considerable impact on similar legislation over the country, the bill is being watched closely. Pigeon-holed over the holidays, the bill is due for a final vote after the first of the new year. Hugh Quinn, chairman of the Council’s General Welfare Committee, plans a session for a final vote somewhere about January 6 or 7.

At a public hearing held November 29, representatives of manufacturers, local service technicians’ organizations and citizens’ committees differed sharply on the need for licensing.

Glen McDaniel, president of

Radio-Electronic-TV Manufacturers Association, opposed the bill. The number of calls per set, he pointed out, had dwindled markedly over the past few years, and will continue to do so. He also pointed to the RETMA educational program, already in effect, planned to bring about a steady improvement in the technical competence of service technicians.

In favor of the bill, District Attorney Edward Silver of Brooklyn described a TV service racket his office had recently exposed. The long process of bringing this ring to justice, he said, would have been unnecessary had the present bill already been in force. The organization’s license would simply have

been revoked.

Other support for the legislation came from local service technicians’ organizations. National Electronic Technicians and Service Dealers Assoc., Associated Radio and TV Servicemen of N. Y. and representatives of service shops spoke in favor. Opposed was the Certified Electronics Technicians Assn., a group campaigning for accreditation and certification from within the industry itself.

In its present form, the legislation does not define levels of competence or set up specific supervisory machinery. It is merely an enabling bill that provides for the establishment of an 8-man board to govern the industry.

Antenna Installation Notes

One-Man Orientation Device; Shortcuts to Save Time & Money

Inexpensive Home-Made Mast

There have been occasions on which it was necessary to erect 30- to 40-ft. masts for TV antennas, with the necessity (imposed by the customer's financial limitations) of keeping the price down. Such a job, of course, requires a minimum expenditure of labor and material. I

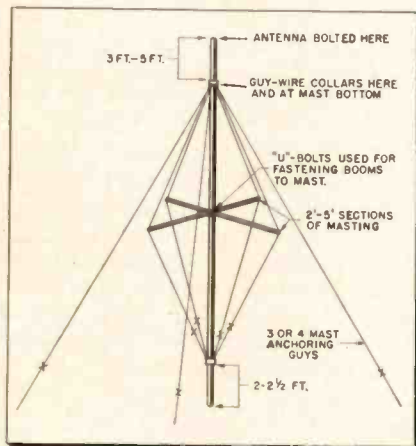

have devised a good, simple, cheap yet effective means of doing the kind of job just referred to. The accompanying diagram shows the construction needed. It is known as a "ship-boom" or "mast-boom" construction. The set-up requires less guy wires for holding it erect and withstanding wind, thus reducing the incidence of broken guys and the frequent repeat calls needed to replace such guys.

The "boom" guys cause the mast itself to become extremely rigid, therefore making it simple to assemble masts, antenna, wire, hardware, etc., in one operation, then to erect the entire structure, and finally to fasten the guys securely.

Turnbuckles should be installed at points marked "x" in the diagram, to take up any slack and even off the tension on the guys.

Only the heaviest guys should be used. Lighter-weight guys should be doubled up, for additional strength.—*Phil Smith, New York, N. Y.*

TV Mast Service Note

Replacing a mast on a TV antenna is an expensive job, especially with a stacked array, or where it is on a hard-to-get-at roof. To cut corrosion on the *inside* to a minimum, I

cut a short length (2-5 inches) of broom or mop handle, and drive it into the mast at the top. I then smear it with rubber cement, to seal it against water. Then I spray the whole mast with Krylon or some other similar sealer. A longer length may be used (up to 8 or 10 inches) to give the antenna cross-arm clamp more "bite" without the possibility of caving in the tubing wall. This can be done at the bottom also if the mast has a base clamp; but, in this case, be sure to drill a small hole close to the bottom in order to allow any water which may come in thru screw holes to run out.—*M. G. Goldberg, St. Paul, Minn.*

Coupling-Transformer Caution

In putting up antennas with coupling transformers, it's well worth your while to test the transformer with an ohmmeter before installing the antenna. Considerable time and expense may be saved in doing so. I recently installed a 50-ft. antenna mast with hi & low-band yagi on it to find that the unit did not work. When I had taken it down and tested it, I found that the transformer between the 300 ohm line and the antenna circuit was open.—*M. T. Brittingham, West Chester, Penna.*

Wireless Antenna Orienter

The device described here will satisfactorily aid the orientation of a TV antenna in medium to strong signal areas. It does not require wires to the roof, nor two men using a telephone system. While the tuned circuit, as shown, permits adjustment only up to Channel 6, a change in the constants would make it useful for the higher frequency channels.

The circuit is a tuned autotransformer with a crystal rectifier feeding a high impedance headset shunted by a 15K (to 20K if desired) $\frac{1}{4}$ watt resistor. The crystal may have its polarity reversed. No capacitor is added across the phones since the phone cord itself supplies enough capacitance for VHF signals. The coil comprises six turns of plastic-covered wire, wound on a $\frac{1}{4}$ -in. dowel, and spaced about $\frac{1}{16}$ -in. apart from each other. Tuning is provided by the 50 mmfd (max.) variable con-

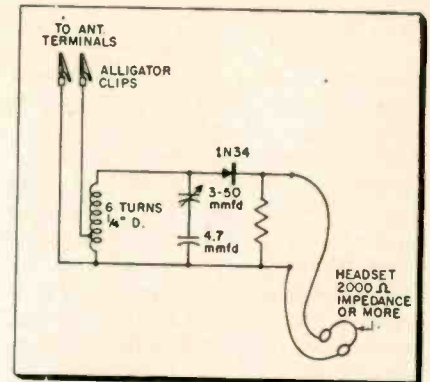

denser in series with a 4.7 mmfd fixed ceramic condenser.

Two alligator clips attach to the antenna terminals or to ordinary household pins piercing the transmission line. A 300 ohm ribbon extends from the clips to the coil. One lead in the ribbon attaches to the end of the coil as shown, while the other goes to a tap at about one and a half turns. This provides an approximate match to a 300 ohm line. In a rather weak signal area, removal of the regular transmission line from the antenna will give a stronger signal. Otherwise, the line from antenna to set may be left in place.

In use, the 60 pulses per second of the vertical pulse group (heard as a single pulse) are tuned in by varying the tuning condenser. The antenna is then turned on its mast for maximum intensity of the buzz. The antenna mast is then locked into position.—*James A. McRoberts, Brooklyn, N. Y.*

Ounce of Prevention

In our fringe area, antenna towers poke many feet into the air and hunting an open circuit in the lead-in means a good climb. We eliminate many of these contingencies by hooking up a 100,000-ohm resistor permanently across the terminals of the simple dipole antennas when we make the original installation. Thus we have a return path for a continuity check at the receiver without doing any climbing.—*Stanley Clark, E. Bradenton, Fla.*

• While this set-up isn't needed with folded dipoles or other antennas that have continuity, it isn't limited to simple dipoles. Other types, such as conicals, can take the resistor.—*Ed.*

Service That Picture Tube!

Verdicts on the CRT Should Follow Systematic, Thorough Checks

BY JACK GUTSTEIN

• The reliable method of checking a TV receiver's cathode-ray tube, when defectiveness is suspected, by temporarily substituting another tube, cannot always be applied. There are many cases where a good substitute may not be available, as when a defective crt is suspected while the set is being checked in the customer's home. The complex inter-relationship between various circuits in TV sets results in confusing symptoms that present a challenge. A gassy picture tube, for example, could first show up as a loss of sync. This can happen where sync take-off is in the grid circuit of the picture tube. Suppose, in addition, that the set uses keyed agc. The keying pulses will not be timed to occur properly when there is an out-of-sync condition. In addition, therefore, the gassy

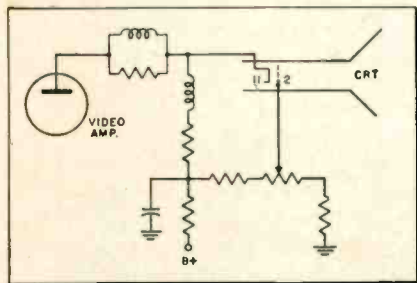

Fig. 1—Circuit showing direct coupling to crt.

picture tube in this receiver might produce confusing side symptoms affecting contrast and sound.

In the absence of a known good picture tube as a temporary substitute, a system of checks can be made without removing the crt from its mounting. First, of course, is the check for correct positioning of the ion trap and for the trap's effectiveness. It may be that this magnet itself requires replacement. Other tests may be made quickly with a vtvm or 20,000-ohms-per-volt meter.

1. Test the applied voltages. This is performed by removing the picture tube socket from the base of the tube and inserting test prods in the pin sockets to check the associated circuit independently of the tube. Measure in the following order:

(a) First anode voltage, measured between pin no. 10 and ground, should read at least 200 volts.

(b) Filament voltage, checked be-

tween pins no. 1 and no. 12, should of course read 6.3 volts ac.

(c) Second-anode voltage may be measured directly from the second-anode connector to ground with a high-voltage probe. The reading will depend on the size of the picture tube. Typical values for pix tubes between 10 and 14 in. in size are 9 to 12 kv; for 16-17 in. tubes, 12 to 14 kv; for 19-21 in. tubes, 14 to 16 kv. 24 and 27 in. tubes generally use respectively 18 and 20 kv. Checking high-voltage by bringing the 2nd-anode lead near the chassis should produce a hot spark no less than 1/4-in. long. Arcing should be done quickly, since prolonged sparking may produce damage to components.

Failure to discover suspicious readings during the procedure just described does not prove the existence of a defective picture tube.

2. Test the bias voltage. This reading should not be checked with respect to ground. The most significant indication is obtained between grid and cathode. The first check is made at the crt socket with the tube still disconnected:

(a) Set the meter to its 100-volt dc range. The positive probe goes to pin no. 11 (cathode) and negative prod to pin no. 2 (grid).

(b) Tune in a station and set the contrast control at about its center point. Turn the brightness control to minimum.

(c) The reading should be 40 volts or more, with the meter prods connected as described. Actually, this means that the grid will be *minus* 40 volts or lower (greater in magnitude) with respect to the cathode.

(d) Turn the brightness control to its maximum position and observe the meter. The reading should be only 10 volts or less; that is, minus 10 volts.

Should marked variations from the suggested readings occur, a defective brightness control or inadequate range of brightness control is indicated. In some sets where the video amplifier is directly coupled to the cathode of the picture tube, as in Fig. 1, a faulty tube or other com-

ponent in the output of the video amplifier may be causing the trouble, rather than the picture tube. In chassis with a low-voltage negative supply, like the 630 type (see Fig. 2), a defect involving this supply may be producing symptoms that throw suspicion on the picture tube. Also in circuits like this one, a faulty dc restorer stage may be at the bottom of the trouble.

3. Test bias voltage again. This time, the procedure is performed *with the picture tube in its socket:* Allow the picture tube to warm up,

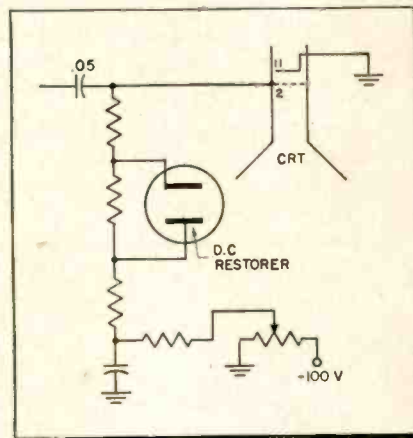

Fig. 2—Picture-tube circuit in 630-type set.

then repeat steps 2(a) through 2(d). Marked variations in the meter readings with the picture tube in its socket as compared to readings taken on the unconnected socket indicate a faulty tube.

Subsequent procedures are for determining the *nature* of the fault in the cathode-ray tube, since something can be done to correct the fault in many cases. Procedure 4, for example, can be used to pinpoint "hot" shorts; that is, shorts that exist only during actual operation. Usually a short between grid and cathode shows up as a loss of control over brightness. Excessive brightness cannot be reduced and retrace lines are likely to be present. Sync may be adversely affected. A *marked* variation in grid bias when the picture tube is re-inserted, as described in procedure 3, would confirm such a short. A less marked variation in bias would indicate a gassy tube, as discussed later.

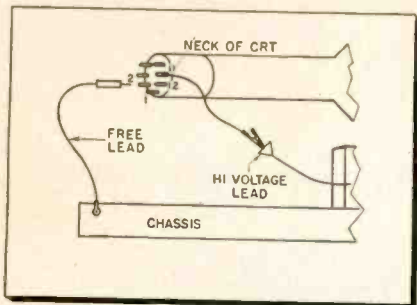

Fig. 3—Set-up for restoring low emission and sparking out certain interelectrode shorts.

4. Test for "hot" shorts:

(a) Let the picture tube warm up for five minutes and set up the meter to read high resistance, as an ohmmeter.

(b) Quickly remove the socket of the picture tube and apply the ohmmeter between the element pins of the picture tube, especially between grid and cathode (2 and 11) and cathode and filament (11 and 12).

(c) The resultant short reading may be sparked or arced out as described later, but this is not always a permanent cure.

5. Test to determine whether a suspected tube is gassy:

(a) Allow the picture tube to warm up for one minute.

(b) Set the meter on dc volts.

(c) Quickly remove the socket from the picture tube and connect test prods to pins 2 and 11 of the picture tube.

If pin 2 (grid) reads *negative* with respect to pin 11 (cathode), this is due to electron accumulation on the grid, and the tube is not gassy. However, if pin 2 (grid) yields a *positive* reading with respect to pin 11 (cathode), there is an *ion* accumulation

on the grid, and the tube is gassy.

Should the voltages applied to the picture tube be normal and the picture tube not gassy or shorted, but still fail to produce a raster, there are two possibilities left: the cathode emission is "dead," or there is an open circuit in the picture tube.

Open circuits often occur at picture-tube base pins. It is always advisable to resolder the pins carefully. Beyond this, nothing can be done for an open connection.

6. Should the picture be dim due to low emission, rejuvenation may be attempted in the customer's home by the following method:

(a) Remove the socket from the picture tube and the high voltage lead from the second anode.

(b) Attach a piece of high voltage cable to the end of the existing high voltage lead, and securely attach the free end to pin 11 (cathode) of the picture tube, as shown in Fig. 3.

(c) Attach another piece of high voltage lead securely to ground.

(d) Turn the set "on." Allow to warm up.

(e) Keep tapping the free end of the second piece of high voltage lead on pin 2 rapidly for about 60 seconds. Arcing should appear in the picture tube neck. If arcing appears between the pins of the tube base, the voltage is too high. The horizontal drive must be reduced to drop the high voltage. If no arcing occurs, the high voltage is too low and the horizontal drive should be increased. (This procedure will also "burn out" inter-element shorts.)

(f) The socket and the high voltage lead should be reconnected to the picture tube and the picture tube should be tried out again.

(g) The focusing coil and ion trap will require slight readjustment, if the tube has been successfully rejuvenated, because of increased beam current.

If the picture tube had undergone the rejuvenation procedure for low emission unsuccessfully, a "booster" can be attached to the filament of the picture tube as a last resort. The limitations of this latter method should be carefully explained to the set owner.

The outlined procedures eliminate guesswork and haphazard checking, also remove the doubt or lack of confidence in discerning customers. The necessity of removing the picture tube from the TV set has, in many cases, also been eliminated.

New Custom Printed Circuit TV Receiver

The new Model PC-9 remote-controlled, 25-tube printed circuit receiver being introduced by Walsco Electronics Corp. consists of 9 individual printed circuit sub-chassis plug-in mounted on a vertical chassis. Each panel deals with a single function—audio i-f, video i-f, horizontal sweep, etc.—so that servicing is greatly simplified. The number of soldered connections has been reduced, through printed circuitry, from approximately 2900 to 56.

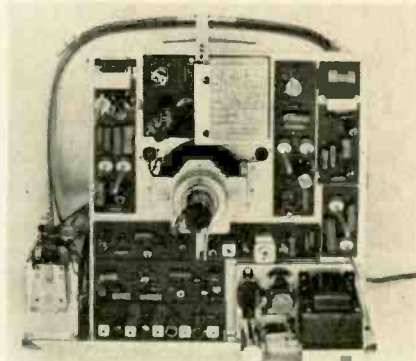

Emphasis is on quality video and audio reproduction. Four video i-f stages are employed, and 2 stages of video amplification. The intercarrier-type sound system has 2 audio i-f stages. The front end is a Standard Coil cascade tuner which is remote-controlled through a 20-ft. cable. Other features are the use of keyed agc, automatic brightness and contrast, vertical retrace elimination and sensitivity is said to be 10 microvolts or better. The chassis is designed for operation with 21, 24 or 27 in. tubes employing 90-degree deflection.

For more detailed coverage on printed-circuit sectionalized TV receivers, see March 1954 TECHNICIAN.

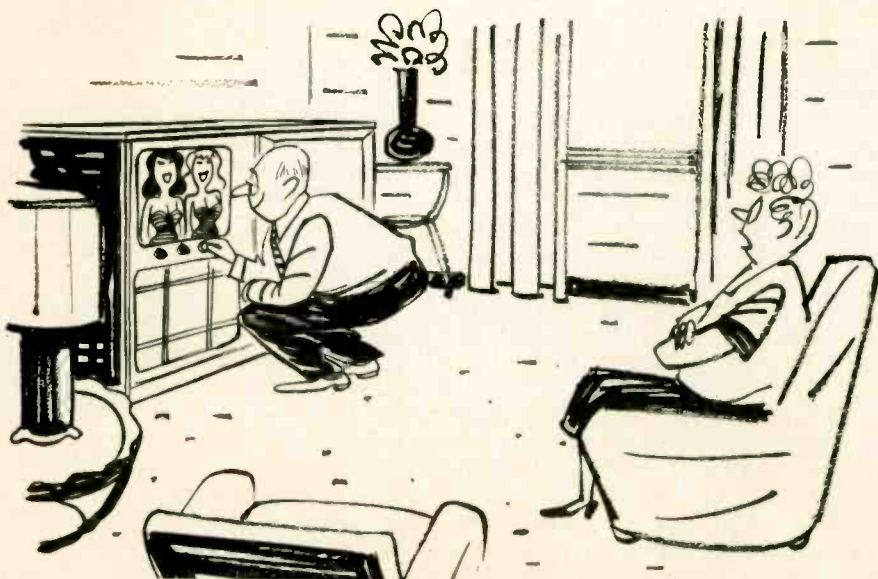

"I notice it only needs adjusting when the girls are on."

Electronic Photo Timers

Servicing Sideline: Practical Circuits of Common Models

By M. G. GOLDBERG

Part 2

• With the basic principles of operation behind us (Part I of this article, November 1954), we can go on to discuss practical examples of electronic timers.

Fig. 1A shows the schematic of the Lektra timer. This unit has been manufactured in several models, all of which have the same basic circuit. Two multi-point switches are used. The left half of the right-hand switch in Fig. 1B selects time intervals of from .2 to 1.0 second in five steps. The right half of same switch selects values from 10 to 50 seconds in steps of 10 seconds each. The left-hand switch permits the user to choose values from 1 to 10 seconds in steps of 1 second each. Each switch has an OFF position to which it can be set while the other is used. The values are cumulative, insofar as timing is concerned. That is, if the left-hand switch is set to 5, the right one to 20, the total time will be 25 seconds, as the selected resistors from both sides are in series across the timing capacitor. This capacitor, incidentally, usually has a value of 2 mfd. In some models the capacitor may consist of 1 mfd and two 0.5 mfd units in parallel.

Some timers use a single 117L7, while others employ a 35W4-GT and 50B5 (or 50C5), with a line cord in series with the heaters. The toggle switch marked TIME-FOCUS is in series with the timing-tube cathode and relay coil (refer to Fig. 1A).

When set on FOCUS, the switch is open, releasing the relay armature and causing the (normally-closed) relay to close (see Fig. 1A). The printing lamp circuit is now completed, permitting the user to adjust his lens(es) for correct focus. The exposure time is selected and the switch set back to TIME, shutting off the lamp. Under subdued light, the negative is placed in the holder and when the exposure is to be started, the center switch (Fig. 1B) is moved from RESET to START. This connects the charged capacitor across the timing resistors previously se-

lected (refer to Fig. 1B). In this position, the full (negative) voltage of the capacitor is applied between grid and cathode of the timing tube, blocking all plate current and causing the (normally-closed) relay to be de-energized and close. Since the lamp is connected to the rear relay contact, it stays on as long as 117L7 grid bias is excessively negative. The value of the resistance selected determines how soon this high negative charge will leak off and permit the relay to be energized.

Most timer users are not so much concerned with exactness of timing—although this is important—as they are about the *constancy* of timing. If, for instance, the 10-second setting provides a 9.4-second exposure, the

user can utilize the .6 setting in conjunction with it to obtain a full 10 second exposure.

If the unit, however, starts out with a 10 second timing which gradually decreases the longer the unit is operated, the timer becomes more of a liability than an asset, particularly when dozens or hundreds of prints are to be made, as in microfilm copying. Such a drop-off can be caused by gas leakage in the timing tube, such leakage acting as a shunt across the timing resistors, and causing the 2 mfd timing capacitor (Fig. 1A) to discharge faster than normal.

If the customer complains that the timing is off, and gets worse with long use, try a new timing tube

Fig. 1A—Schematic of the Lektra TM-5 Electronic Timer. The left-hand section of the 117L7 is the timing or relay-energizing tube; the right-hand section is the half-wave rectifier. B—Front view of the same timer, showing the switches and controls present.

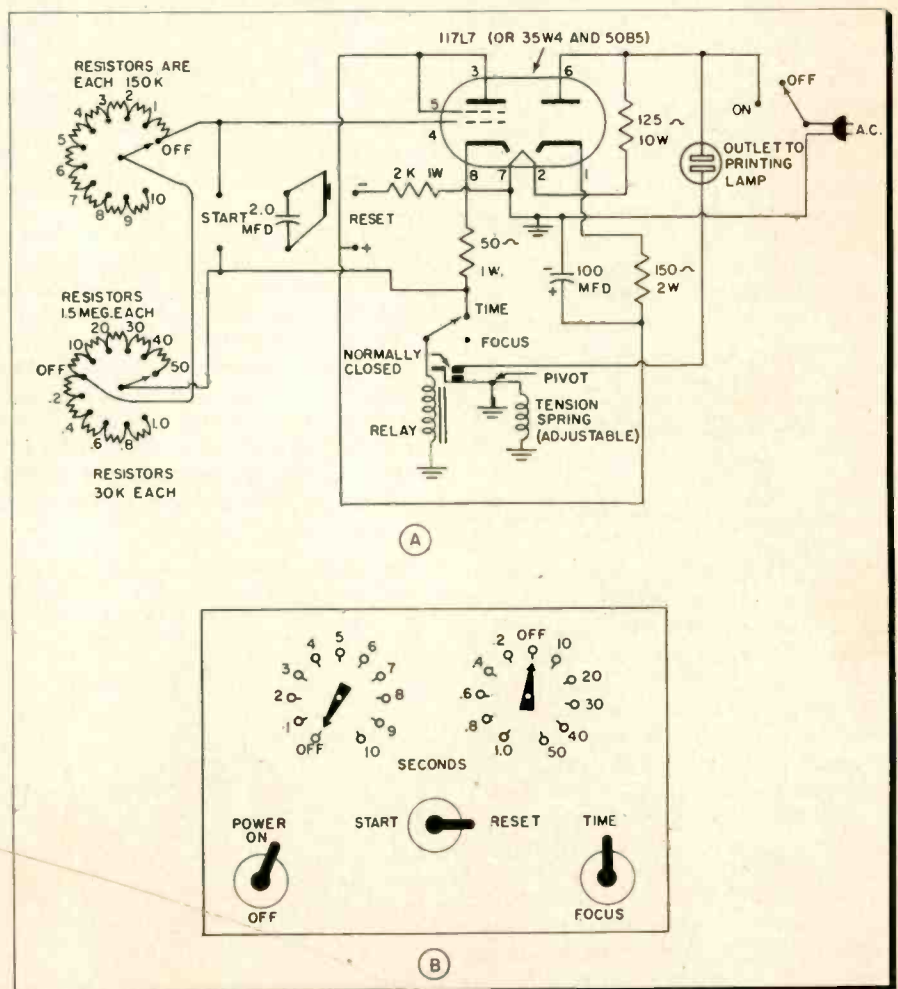

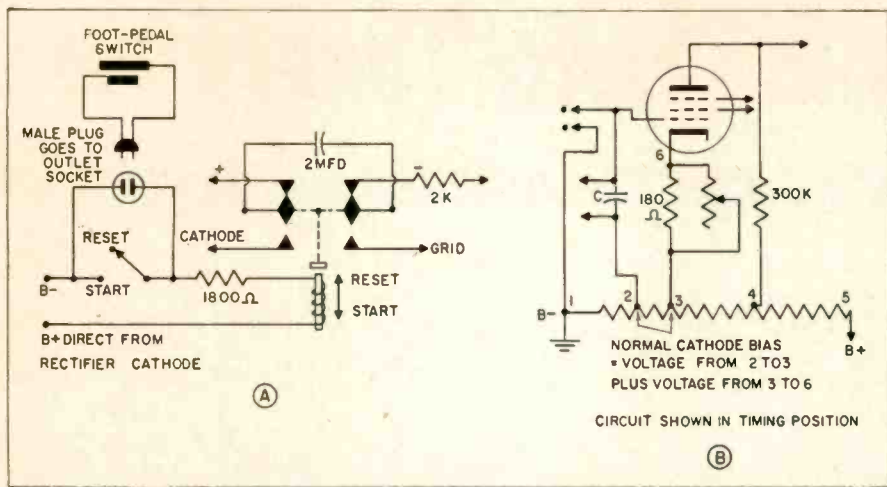

Fig. 2—Sketch showing how double-pole double-throw relay replaces toggle switch for remote-control operation (of Lektra model TM5-R). When foot pedal is to be used, the single-pole switch is left on reset position (open) permitting the foot-pedal switch to take over. Line input is not shown. The 2 mfd condenser charges on "reset," and discharges on "start."

(50B5, 50C5, etc.). Since the resistors used for short timing periods are relatively low in value, a gassy tube will not, unless it is extremely bad, have much effect at such settings. The higher the time selected, however, the more effect the bad tube will have on timer accuracy. For instance, a 10-meg leak in the capacitor or tube will affect the timing at low settings from about .3% to 2%. On 1 to 10 second positions, the timing will be off 2 to 7%, while on the 10 to 50 second positions, a 10-meg leak will make a difference of 13 to 43%, depending on the setting of the selector knob.

If the 100 mfd filter capacitor is dried out, the timing will be off in the low direction, as the lowered voltage now blocking the grid will cut the tube off for a shorter length of time. A low-emission tube will have the same effect. Metal scrapings between relay contacts sometimes cause erratic operation; if present, they should be washed out thoroughly with cleaning fluid.

Defective Switches

When in doubt as to erratic operation of any toggle switch, replace it, as the labor cost of looking for the trouble will be more than the cost of the switch. Use bat-handle types for replacement switches, since the switches are used dozens, sometimes hundreds of times a day, and a short handle can be hard on the fingers.

One timer uses a single-pole toggle switch to close a dpdt relay circuit, in place of a dpdt toggle used as START-RESET switch. This is for remote-control operation, and permits operation by means of a foot pedal, allowing the photographer to

use both hands for his work (see Fig. 2). The relay coil is supplied with direct current from the output of the rectifier through an 1800-ohm 2-watt limiting resistor. Contacts corresponding to points on the manually-operated timer shown in Fig. 1A are similarly marked.

Lektra TM-8

Lektra model TM-8 uses a somewhat different circuit variation to accomplish the same result (Fig. 3). Heavy-duty contacts are used to carry the larger currents needed for the higher-wattage printers. Direct coupling is employed between the two tubes. The action of the circuit is as follows:

In the FOCUS position, a 2k resistor is shunted from grid to ground. This causes a cutoff voltage to be applied between grid and cathode (by returning the grid to ground). The plate current of the 14C7 becomes zero in consequence. The voltage drop across the 300k plate resistor also becomes zero. This resistor is also the bias resistor for the 35A5 tube. The absence of a voltage

drop across it means that the bias of the 35A5 drops to zero, causing the 35A5's plate current to rise, and producing closing of relay coil B. The downward movement of the moveable contact on relay B produces closing of the ac coil circuit of relay C, thus causing the printing light circuit to be completed.

The same action occurs with the FOCUS-TIMING switch on TIMING, except that as soon as the high negative charge present on the timing capacitor has leaked off through the timing resistors, current once more flows in the 14C7 plate circuit, and the voltage across the 300k resistor rises. This voltage (negative-going so far as the grid of the 35A5 is concerned) cuts off the 35A5's plate current, causing relay B to open, de-energizing relay C and turning off the printing light. The movable relay contact now closes the red safety light circuit.

A novel feature of this circuit is the adjustable cathode resistor in the 14C7, used to compensate for differences in line voltage. If the timer is calibrated for 115 v operation, and then placed in service on 120 v, the voltage applied to the timing resistor-capacitor circuit will rise, and a longer time will elapse before the voltage drops to a specified level. By lowering the cathode resistance (bias), the effective increase in net bias is reduced to its former level. The action is similar, but reversed, when the timer is used on a lower line voltage. The same effect is produced by varying the spring tension adjustment in the timers previously discussed.

Quite a number of other types of timers are on the market, but they are mostly mechanical, being either of the spring-loaded or motor-driven types. The principles of operation of these units are readily understood from even a casual inspection of the mechanism, so no service instructions are necessary. ●

Fig. 3—Simplified direct-coupled timer circuit for Lektra model TM-8. Timing resistor circuit is similar to the one illustrated in Fig. 1A. Note that the "cut-off bias" indicated above is not effective when the switch is set to Timing, since this bias is not applied to the grid at this setting.

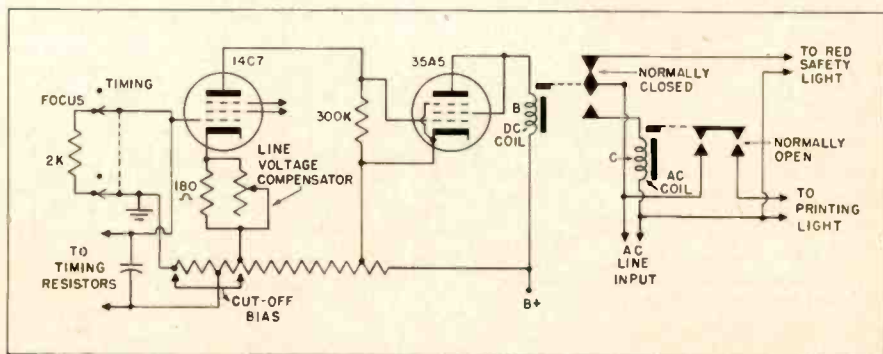

Shop Hints to Speed Servicing

Tips for Home and Bench Service Contributed by Readers

Repeat Tube Failure

This unusual case of a receiver operating reasonably well with an incorrect wiring connection may be useful, when similar trouble occurs, to other readers servicing the same model clock-radio. The radio was the GE model 535. The sketch shows the heater wiring of this radio in simplified form, and also the power supply. Resistor *PL* represents the

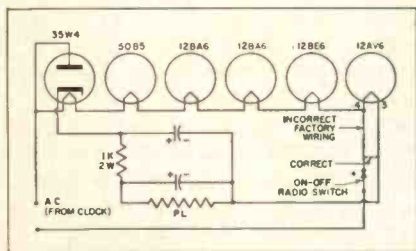

total load imposed on the dc supply by all tubes other than the 35W4. The receiver was brought in with the complaint that, while it appeared to be playing well, the 12AV6 tubes didn't last in it very long. They needed frequent replacement.

A thorough check of wiring revealed the reason for the complaint. Note that the wire from the switch, instead of going to filament pin 3, originally went to pin 4. Under ordinary conditions, this would bypass the 12AV6 tube filament completely, and there would be no sound output. However, note that the negative leads from the filter capacitors and the plate currents for all the tubes are returned to pin 3 of the 12AV6 socket. This would be normal except that, to complete the circuit, these currents must pass through the switch to the other side of the ac line. In order to do this, they pass from pin 3 to pin 4 through the filament. The voltage drop (dc instead of ac) measured across the 12AV6 filament as a result of this action was found to be 4 volts. This was

SHOP HINTS WANTED

TECHNICIAN will pay \$5 for acceptable shop hints. We are particularly interested in hints on the following subjects: HI-Fi servicing, TV and radio interference, industrial electronics, TV antennas, test equipment and UHF. Unacceptable items will be returned. Send your hints to "Shop Hints" Editor, TECHNICIAN, Caldwell-Clements, Inc., 480 Lexington Ave., N. Y. 17, N. Y.

just enough to allow the tube to operate reasonably well if the volume was not turned up too high. The only change required to wire this set correctly is to disconnect the lead that goes to the switch from pin 4 and to reconnect it to pin 3.

The question may be asked, "Why did the tube burn out prematurely with only 4 volts on the heater?" The answer lies in the fact that, whenever the set was turned off and then on again soon after, a heavy surge of current occurred to charge up the capacitors. Each time the set was turned off and on again, the effect of this surge could be seen. The heater of the 12AV6 would make a sharp twist in each case, contributing to a combination mechanical-electrical failure.—M. G. Goldberg, St. Paul, Minn.

Line-Cord Anchor

Many receivers come into the shop without the protective knot on the line cord, inside the set. To unsolder the cord connections and knot the wire, then resolder the connections, takes a lot of time and work. Wrapping the cord with many turns of tape, while the cord is still in place, is also tedious if a sufficient number of turns to do the job properly are wound on.

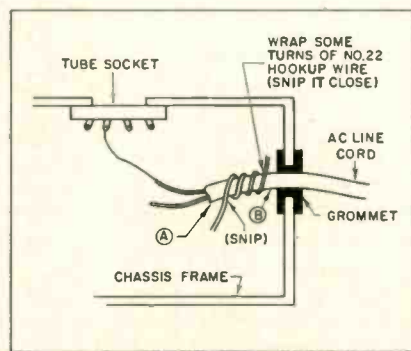

A quick, easy method is the technique illustrated in the accompanying figure. First, wrap a few turns of insulated hook-up wire around the ac cord. Snip the ends close, as shown. Then start winding some tape around the line cord at point A. Wind in the direction from point A to point B. This anchors the hook-up wire which, in turn, protects the line cord connections, and keeps them

from pulling loose just as effectively as though a knot were tied on the end of the line cord. The whole job can be done in just a few minutes.

Instead of using ordinary friction tape for this job, I use the newer type of plastic insulating tape that may be stretched. It is easier to handle, is thin, is strong, and does not dry out, slide or unwind after exposure to heat, as does friction tape.—Joseph Amorose, Richmond, Va.

Buzz Correction

Leakage in an electrolytic condenser is a common component failure. When leakage occurs in an electrolytic condenser used in the ratio detector circuit of a TV receiver (condenser C in the figure), buzz results.

Before starting a time-consuming search for other sources of buzz, an ultra-fast check of this capacitor can be performed without even remov-

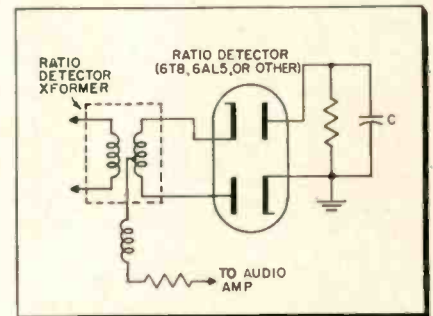

ing the back of the receiver. Rotate the fine tuning control back and forth rapidly. This will vary the average voltage across C. If the condenser is leaking, the rise and fall of volume will be erratic, and may be accompanied by a clicking sound, whereas if the condenser is good, the rise and fall of volume will be smooth.—F. S. Mattioli, Racine, Wisc.

Obscure Hum, Arvin TV

If the customary checks for hum fail to produce results on an Arvin D382 receiver, try a new agc tube (V10, 6AU6). The source of the difficulty may be interelectrode shorts in this tube of such high resistance that they do not show up on a check with a tube tester. Nevertheless, sufficient leakage is present to produce the hum symptom.—James A. McRoberts

Radio-TV Electronic

Part 2

The electronic technician has a decided edge over his fellow skilled workers in educational achievements. This is due, first, to the benefits received under the GI bill, and, second, to the fact that electronic techs, as a group, are considerably younger. Steady increases have been made in the educational attainments of each succeeding generation over the past few decades.

Table 1 gives us a picture of the levels of education found in our radio-TV repair group, and of how we compare, education-wise, with all the electronic techs, taken together. Though no extreme contrasts are apparent (they are unlikely when 50% of those interviewed are TV repair technicians) it is worth noting that the average for our group is generally lower than that for the industry as a whole.

Table 1

Regular School	All Establishments		Radio-TV Repair	
	No.	Percent	No.	Percent
Total	1,926	100.0	1,017	100.0
0 - Below 8th grade	32	1.7	26	2.6
1 - 8th to 11th grade	421	21.9	272	26.7
2 - Graduated high school	962	49.8	511	50.3
3 - Some college	401	20.8	167	16.4
4 - Graduated from college	90	4.7	37	3.6
5 - Graduate work	19	1.0	4	.4
J - Not reported	1	.1		

Table 1: The level of education is high

Worker or Boss?

Three features attract men to TV servicing. First, and most important, is the opportunity for the tech to own his own business; second, the comparative freedom enjoyed by both the technician and technician-owner—the lack of direct supervision, and production schedules, etc.; and finally, the high level of interest which surrounds the trade, and the “professional” status of its members.

The tendency toward shop ownership is reflected in the figures of Table 2. As we see, approximately 2 in 5 of all TV technicians own their own business. Actually, had this survey been nation-wide, covering the towns as well as the cities, the percentage would no doubt have been higher—possibly approaching 50%.

It is worth noting too, that not a single technician in the other classifications of electronic tech reported being self-employed.

Shop owner, or not, the TV technician enjoys a degree of freedom unequalled elsewhere in the industry. Over 54% of the servicemen polled reported that they worked independently. The only comparable figures came from the radio-TV manufacturing technicians who reported better than 49%, but these figures can be discounted, since they are still under direct supervision, a considerably different arrangement from the technician making service calls on a house-to-house basis.

Table 2

Type of Earnings	All Establishments		Radio-TV Repair	
	Number	Percent	Number	Percent
Total, all types	1,916	100.0	1,017	100.0
0 - Income from own business	333	20.4	393	38.6
1 - Salary	800	41.5	433	42.6
2 - Hourly rate	702	36.4	162	15.9
3 - Other	30	1.6	28	2.8
J - Not reported	1	.1	1	.1

Table 2: Self-employment is a key feature

Wages-and-Hours

The seamier side of the TV servicing picture is seen graphically in Tables 3 and 4. During the past few years, the complaints have been increasing from all corners of the servicing industry that the tendency toward decreased wages and longer hours has to be stopped; that the quality of work, and the calibre of men attracted to the business would inevitably be affected. No figures are available on the latter counts, but an analysis of information provided by these two tables might allow us to draw some conclusions of our own.

Interpreting these figures in their relation to each other, using their most optimistic values, we come up with a calculated average wage for the radio-TV technician—of \$1.50 per hr. Since the per hr. wage figure is a standard measurement in industry, this figure is important for comparison. To find a comparable wage at this time we would have to turn to the lowest level of skilled worker, the most menial jobs that industry has to offer.

Remember, too, that this figure of \$1.50 is based on a survey conducted

in urban areas. In the rural districts, where money is less plentiful, the figure will be even lower.

The average work week for the TV

Table 3

Average Weekly Hours	All Establishments		Radio-TV Repair	
	Number	Percent	Number	Percent
Total, all respondents	1,926	100.0	1,017	100.0
Less than 35	40	2.1	34	3.5
35 - 39	40	2.1	23	2.3
40	697	36.2	194	19.1
41 - 47	310	16.1	128	12.6
48	320	16.6	232	22.8
49 - 54	177	9.2	108	10.6
55 - 59	68	3.5	36	3.5
60	126	6.5	116	11.4
61 - 69	29	1.5	26	2.5
70 and over	119	6.2	119	11.7

Table 3: Hours are long for TV technicians

technician is calculated, from these figures, to be 51.4 hrs. This average is weighted heavily by the approximately 25% who report working 60 hrs. or more each week. Most of these, we can assume, are shop owners.

The fact that only 25% of the technicians reported work weeks of 40 hrs. or less indicates that the 6-day week is standard.

Nearly 12% of the TV technicians polled reported work weeks in excess

Table 4

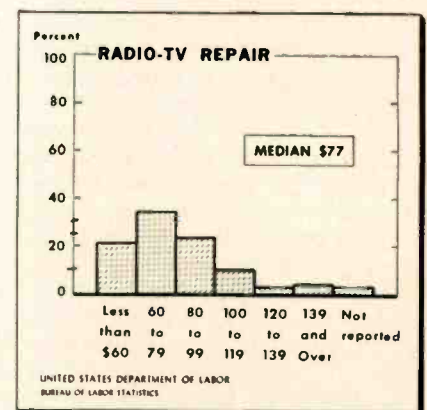
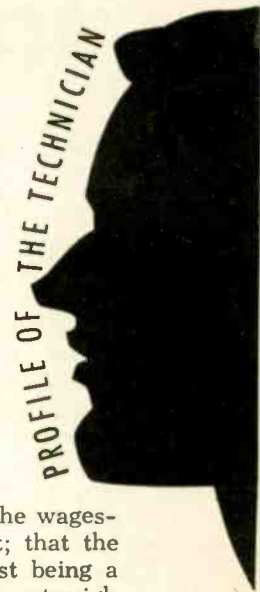

Table 4: Range of earnings is very wide

of 70 hrs.; a figure which should be diluted somewhat. If we can assume that those reporting these hours were shop owners, then much of this time can be considered as tending the store, lunch hour, and other activities not directly concerned with repairing radio or TV receivers.

The other five classifications of electronic technician showed very

Technician: A Profile



wide variations in their median weekly salaries. Highest is the broadcasting industry, with \$107;

Table 5

Tenure in job held at time of survey	All Establishments		Radio-TV Repair	
	Number	Percent	Number	Percent
Total.....	1,926	100.0	1,017	100.0
1 - 6 months.....	285	14.8	137	13.5
7 - 12 months.....	220	11.4	106	10.4
13 - 18 months.....	181	9.4	73	7.2
19 - 24 months.....	146	7.6	74	7.3
25 - 36 months.....	217	11.3	150	14.8
37 - 60 months.....	327	17.0	173	17.0
61 - 96 months.....	278	14.4	181	17.7
Over 96 months.....	272	14.1	123	12.1

Table 5: TV-repair techs hold jobs longer

next is aircraft electronics, at \$95; then, in order, manufacturing of electronic equipment, \$84, research, \$82 and radio-TV manufacturing, \$73. Radio-TV technicians are sec-

ond from the lowest in average weekly earnings. Though no other group has as much as 1% of its technicians in the below-\$50 category, 10% of the TV techs are in this group.

Job Tenure

In the course of the study, the tendency of radio-TV repair technicians to change jobs also came in for consideration. The survey turned up the fact that more than 60% of the TV techs had held their present job for more than 2 years. More than 12% had been in their present job more than 8 years—the former radio repairmen of pre-television days.

Interestingly enough, the radio-TV repair tech was second only to the broadcast technician in average length of job tenure; an indication, perhaps, that the TV servicing pic-

ture is not so gloomy as the wages-and-hours figures suggest; that the pleasure derived from just being a part of this business may outweigh the dollar-and-sense considerations.

The study referred to in this article was conducted by the Bureau of Labor Statistics of the U. S. Dept. of Labor during the months of April and May, 1952. The information was obtained through a personal interview survey of 1,926 electronic technicians employed in Atlanta, Baltimore, Boston, Chicago, Detroit, Los Angeles, New York and Philadelphia. Of those interviewed, 1,017 were radio-TV repair technicians.

New Color TV Projection System

A developmental projection-type color TV receiver has been unveiled by Hazeltine Corp. By using a folded light path, a 240 sq. in. picture is produced in a cabinet only 24½ in. deep. With some redesign the picture area can be increased to 280 sq. in. without change in cabinet depth.

Color TV projection receiver showing backs of three monochrome crt's below picture screen

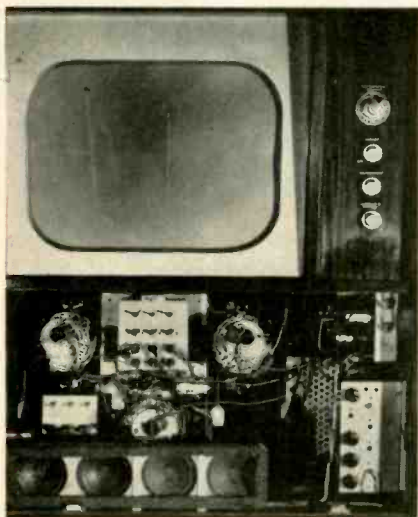

The unit employs three 2½ in. crt projection tubes with color phosphors, one green, one blue and one yellow with a red optical filter (red phosphors evidently do not have sufficient output). The tubes require 25 kv, and draw about 200 µa in the red tube, less in the others. Through an elaborate lens and mirror arrangement, the images on the three tubes are enlarged and fused on the flat screen.

Credit for the optical work goes to American Optical Co. Libby-Owens-Ford made the mirrors. Interim quantities of the tube may be obtained from North American Philips. Large scale production, should demand warrant it, will be undertaken by Tung-Sol. Pre-production models can be supplied in four months, and mass production can start six months later. Hazeltine will not do any mass producing.

Based on a yearly production of 100,000 units, the projection system would sell for approximately \$250, excluding the basic receiver chassis. This would be equivalent to a direct view color tube with deflection components.

According to Hazeltine's Vice President in Charge of Research, A. V.

Loughren, projection is "no longer out of the picture." In competition with the direct view picture tube, projection offers certain advantages and drawbacks at the present state of the art. Among the factors in projection's favor are low cost crt tube replacement (about \$12 each), no problem with color purity, and simple control of color characteristics in manufacturing.

Among the disadvantages pertaining to color projection are lower contrast, light directivity necessary to achieve sufficient light output, resulting in brightness loss outside the normal viewing area, and possible dust collection on critical internal surfaces. Initially, registration stability (equivalent to direct view convergence stability) is achieved by using a regulating circuit to control focus current as high voltage changes occur.

Broad public acceptance of projection color TV appears to depend on further engineering refinements to improve performance and lower cost. It is believed that projection and direct view can exist side by side only until competitive factors decide which one will be most favored by viewers.

"Tough Dog" Corner

Difficult Service Jobs Described by Readers

Sync or Swim—Ho Hum!

A set that came into the shop for intermittent vertical sync operated all right on a local (San Diego) channel for a few days. I hopefully continued the air check, but this time on an out-of-town channel (Los Angeles, 130 miles). Lo and behold, the picture was found to lose vertical sync and roll about ten frames every five minutes or so. Weak signal alone could not be the cause, since other sets operated well from the same antenna.

Inspection of the vertical sync pulse with an oscilloscope showed 60-cycle hum also present on all operating channels. The sync pulse remained on a "peak" of the hum for all local channels (see part A of the illustration), but was noticed to

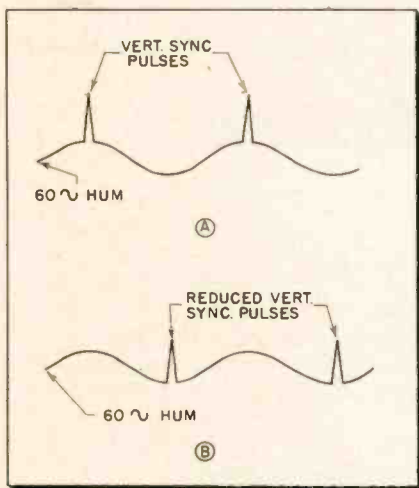

move in relation to the hum on out-of-town channels. When the pulse occupied a null (as in part B), the pulse was reduced in amplitude to a point that caused the picture to roll.

Out-of-town channels operate from a source of electrical power different from the one used by the local transmitter. Stations lock their sync to the local line frequency. When the sync pulse and the hum were additive (part A), as was always the case with local stations, which were using the same source of ac power as was being used by the receiver, the picture locked in well. When the sync pulse and the hum were subtractive (part B), the picture would roll. This was intermittently the case with out-of-town channels when the phase happened to shift between the

two power-line frequencies.

Once this was determined, the cause was traced to a 6BQ7 r-f amplifier in which there was slight cathode-to-filament leakage. Although the hum must obviously have been present in the i-f signal, it was not strong enough to produce the usual tell-tale hum bars in the picture.—G. T. Davis, Lemon Grove, Calif.

AM Interference from TV

I recently had occasion to replace a 19DP4 picture tube. Since this type was not available, I used a metal-shell equivalent. Everything appeared to work out fine until a week later when the customer, an ardent radio listener, called to complain about a loud click from his radio, which he said was being caused by the television set.

At his house, the clicking sound could be heard on the radio when the TV set was on; but there was no click when the TV receiver was turned off. I checked for a high-voltage arc, believing this was the cause of the trouble. Arcing could be heard, but it could not be seen anywhere. Spraying the high-voltage circuit with an insulating plastic proved to be no help. Moving wires, re-positioning the pix tube, grounding the yoke housing and grounding the focus coil housing also failed to cure the trouble. I sat down to watch the TV set in operation. It performed perfectly. The picture was good, the sound quality was excellent, and none of the usual signs of arcing appeared on the screen. I was at a loss. In desperation, I finally grounded the speaker housing. To my amazement, the clicking stopped and another Tough Dog was cured.—Julius Turken, Brooklyn, N.Y.

Crack Kills Video

Video and sound were lost on all channels on this 12½-in. set, but the raster was normal. After replacement of all suspected tubes without any change for the better, voltages were measured in the following circuits: video i-f amplifiers, tuner, and agc. All were found normal. There wasn't any snow on the screen either. An injected r-f signal did not get through. Still in a dead end after

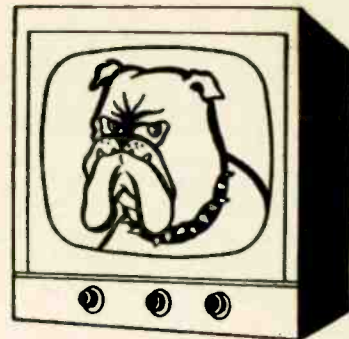

all normal troubleshooting procedures, I decided to make use of my three senses, look, smell and listen.

Looking did not help, but I did hear a very faint hissing sound on close examination. Along with it was the smell of corona. This condition, of course, had to be corrected first even though it seemed to have no

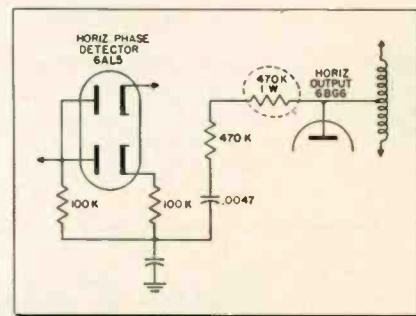

bearing on the symptom. It was found that the 470k feedback resistor between the plate of the horizontal output tube (encircled in the accompanying sketch) and the horizontal phase detector was slightly cracked in the middle. It was replaced. Immediately after this repair, the sound and video came back in.

Hard to explain? Well, I figured the small crack wasn't bad enough to affect operation of the high-voltage and horizontal circuits, but it did radiate enough energy back to the tuner to kill the r-f local oscillator, thus eliminating video and sound.—John L. Mancini, Winthrop, Mass.

● Effect on the local oscillator would not be likely to occur uniformly on all channels, as oscillator frequency would vary. Radiation from the cracked resistor may have been heterodyning signal at some later fixed-frequency stage, such as one of the i-f stages.—Ed.

\$ For Your "Tough Dog Story"

Have you tangled with a difficult or obscure service problem recently? Write it up, telling us how you licked it, and send it to "Tough Dog" Editor, TECHNICIAN, Caldwell-Clements, Inc., 480 Lexington Ave., New York 17, N.Y. \$10 will be paid for usable material. Unacceptable items will be returned to the contributor.

P. R. MALLORY & CO. INC.
MALLORY
APPROVED PRECISION PRODUCTS

P. R. MALLORY & CO. INC.
MALLORY
APPROVED PRECISION PRODUCTS

P. R. MALLORY & CO. INC.
MALLORY
APPROVED PRECISION PRODUCTS

You've made them the leader FOR 25 YEARS

Ever since Mallory introduced the first commercial vibrators 25 years ago, they have consistently led the field. They have led . . . and are still leading . . . not only in quality but also in acceptance by service men and manufacturers alike.

Service men prefer them. Surveys show that 5 out of 6 service men use Mallory vibrators for replacement work.

Set manufacturers prefer them. More Mallory vibrators are used as original equipment than all other makes combined.

Now better than ever. New standards of quiet operation are set by the latest Mallory vibrator. A floating mounting for the internal mechanism cushions out hum . . . makes these the quietest vibrators ever.

See your distributor today. Ask him about the special Mallory Vibrator Deal—6 vibrators that cover 75% of your replacement jobs. And get a copy of the latest Mallory Vibrator Guide.



ON AUTO RADIO JOBS BE SURE TO USE . . .



MALLORY MIDGETROLS®—Simplified design cuts replacement time to minutes. Accurate tapers, noise-free operation, and excellent stability. Versatile line of single and dual types.



MALLORY CAPACITORS—FP electrolytics . . . the only fabricated plate capacitors for replacement work . . . have long life even at 85° C. Plascaps®, tubular plastic type, have permanent, moisture-proof terminal seals.

P. R. MALLORY & CO. INC.
MALLORY

CAPACITORS • CONTROLS • VIBRATORS • SWITCHES • RESISTORS
RECTIFIERS • POWER SUPPLIES • FILTERS • MERCURY BATTERIES
APPROVED PRECISION PRODUCTS

P. R. MALLORY & CO. Inc., INDIANAPOLIS 6, INDIANA

P. R. MALLORY & CO. INC.
MALLORY
APPROVED PRECISION PRODUCTS

P. R. MALLORY & CO. INC.
MALLORY
APPROVED PRECISION PRODUCTS

P. R. MALLORY & CO. INC.
MALLORY
APPROVED PRECISION PRODUCTS

New Audio Equipment

Amplifiers, Speakers, Turntables; Hi-Fi Cartridge and Changers

Dactron STEREO ADAPTER

Binaural stereophonic reproduction is made possible for home tape recorders by the new "Microadapter." The unit contains four Dynamu miniature magnetronic record and playback tape pickups, two record-playback and two companion erase, with micro-azimuth factory sealed alignment for standard 1 $\frac{1}{8}$ -in. binaural spacing. Frequency response is 20 to 15,000 cps at 7 $\frac{1}{2}$ ips. Price, for model used with Webcor recorders, is \$49.00; varies slightly for other makes. Dactron Distributing Co., 104 Spruce Pl., Minneapolis.—TECHNICIAN (Ask for No. 1-50)

Sonotone CARTRIDGE

Single-needle, high-fidelity ceramic cartridge, Model 1P, features high compliance and an extended frequency response. Does not require a preamplifier and is unaffected by moisture or tem-

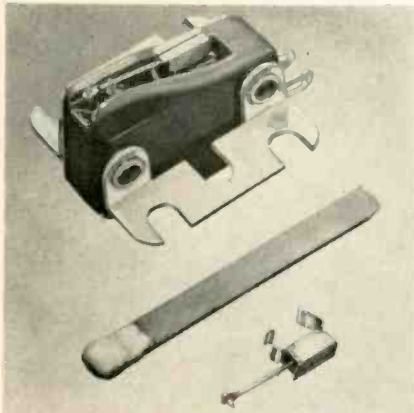

perature. In two models, one for 33 and 45 rpm; the other for 78 rpm. Small size makes it adaptable to wide variety of tone arms. Available with either diamond or sapphire tip. Sonotone Corp., Elmsford, N. Y.—TECHNICIAN (Ask for No. 1-16)

Newcomb AMPLIFIER

'Compact 12' is 12-watt amplifier, preamplifier and control unit in single housing. Distortion is below 1% at 12 watts and response is ± 1 db from 20 to 20,000 cps. Seven inputs include radio, microphone, high-output magnetic pickup, low-output magnetic pickup, crystal pickup, tape input and auxiliary or TV. New tape output jack allows recording while listening. Hum balance control assures lowest hum. Output impedances are 8 and 16 ohms. \$99.50. Newcomb Audio Products Co., Hollywood, Calif.—TECHNICIAN (Ask for No. 1-51)

W-Z SPEAKER

Hard-of-hearing TV viewers will be customers for this new Model 320 dynamic "Personalized Speaker." Thirty-foot cord which is clipped across the voice coil terminals of the radio or TV

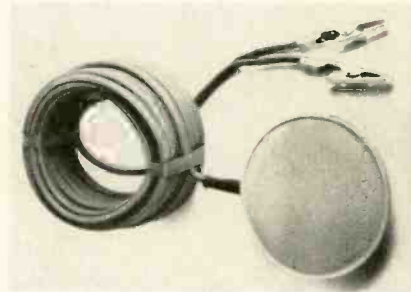

speaker permits its use anywhere within normal viewing distance of the receiver. Measures 3 in. in diameter, and $\frac{7}{8}$ -in. thick. List price—\$12.95. Wright-Zimmerman Inc., 330-5th Ave., New Brighton, Minn.—TECHNICIAN (Ask for No. 1-39)

E-V AUDIO AMPLIFIER

Model A20C 20-watt amplifier includes a damping factor control which permits perfect match of the amplifier output impedance to the critical damping resistance of the loudspeaker, as well as to the type of enclosure. Operates optimally into the variable impedance of a speaker load rather than a purely resistive load. Frequency response is ± 1 db from 20-20,000 cps, at full 20 watts. \$110.00. Electro-Voice Inc., Buchanan, Mich.—TECHNICIAN (Ask for No. 1-52)

Gramercy RECORD CHANGER

Feature of the new Model R-66 "Ristaucrat" 45 rpm changer is the automatic re-stacking mechanism which can be set to any number of plays, to play continuously or shut off automatically. Spring brush mounted on the chassis cleans the needle after every play. Complete with cartridge and sapphire needle ready to plug into amplifier. Gramercy Sound Assoc., 175 Fifth Ave., N. Y. 10, N. Y.—TECHNICIAN (Write for No. 1-80)

MORE TECHNICAL INFORMATION

describing the new products presented here may be obtained by writing on company letterhead to New Products Editor, TECHNICIAN, 480 Lexington Ave., New York 17, N.Y., listing numbers given at end of each item of interest. Please mention title of position held. Use coupon on page 40.

Fisher HI-FI EQUIPMENT

Professional type FM tuner Model FM-80 uses the Armstrong system with two i-f stages, dual limiters and a cascade r-f stage. Sensitivity is 1.5 μ v for 20 db of quieting on the 72-ohm input; 3 μ v for 20 db of quieting on the 300-ohm antenna input. Two bridged outputs of the low-impedance cathode-follower type, permitting output cables up to 200 ft. in length. New Mixer-Fader Model 50-M mixes two signal sources of equal, or varying amplitudes into a recorder. Three independent level controls and a master volume control to regulate the level of both channels simultaneously. Model FM-80—\$139.50; Model 50-M—\$19.95. Fisher Radio Corp., 21-21 44th Dr., Long Island City 1, N. Y.—TECHNICIAN (Ask for No. 1-81)

Regency AMPLIFIER

Model HF-80 is a moderate output level hi-fi 10-watt amplifier, with preamplifier and power supply unit. Chas-

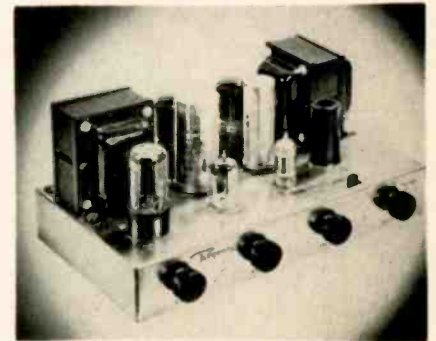

sis is brass-plated steel and total weight is 10 $\frac{1}{2}$ lbs. \$69.95. Regency Div. I.D.E.A. Inc., 7900 Pendleton Pike, Indianapolis.—TECHNICIAN (Ask for No. 1-82)

Rek-O-Kut TURNTABLES

Two new 3-speed, 12-in. precision turntables, the Rondine, Model B-12, and Rondine Deluxe, Model B-12H, have rumble and noise content 40 to 50 db below average recording level. Flutter and wow are virtually non-existent. Single selector knob sets the desired speed, with 'off' positions between settings. Model B-12 has 4-pole induction motor; Model B-12H has hysteresis synchronous, self-lubricating motor. Price, for Model B-12—\$69.95; for B-12H, \$119.95. Rek-O-Kut Co., 38-01 Queens Blvd., Long Island City, N.Y.—TECHNICIAN (Ask for No. 1-53)

**MORE NEW PRODUCTS
ON PAGE 32**

NEW

SYLVANIA

TUBE *and* TOOL TENDER

... ends
"tool hunting"
for good!



Here's the newest idea in TV service cases. It's the Tube and Tool Tender's "PEG PLATE" panels and adjustable metal holders. With this combination, set up your tools in the arrangement that suits you best. Then enjoy the time- and temper-saving convenience of having the tools you want, right where you want them, whenever you need them.

And of course the Sylvania Tube and Tool Tender also gives you generous tube and equipment storage.

Your Sylvania Distributor has your Tube and Tool Tender now. It's another Sylvania exclusive, designed for your easier TV servicing, offered only by your Sylvania Distributor.

It's spacious — carries tubes, tools, meter, mirror, parts... everything you need on your calls.

See it at your Sylvania Distributor

FREE
with the purchase of
Sylvania Tubes
\$15.95 VALUE
... for only
32 Sylvania Tokens

Remember, you get one Sylvania Token each time you buy 25 Sylvania Receiving Tubes.

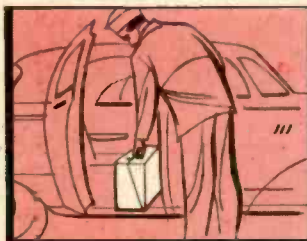

It's light and attractive, it's aluminum... weighs only 20 pounds fully loaded.



It's durable and sturdy — will stand up in constant field use.



It's convenient — for shop as well as field use. Complete with "shelf-service."

SYLVANIA

Sylvania Electric Products Inc.
1740 Broadway, New York 19, N. Y.
In Canada: Sylvania Electric (Canada) Ltd.,
University Tower Bldg., St. Catherine St.
Montreal, P. Q.

LIGHTING • RADIO • ELECTRONICS • TELEVISION • ATOMIC ENERGY

New Test Equipment

Audio Analyzer, Scope, VTVM and Other Test Gear

Heath AUDIO ANALYZER

The Model AA-1 combines the functions of three separate instruments; an ac VTVM, a wattmeter, and a complete intermodulation distortion analyzer. Prime applications are seen to



audio system analysis and hi-fi performance testing. Construction features include built-in load resistors of 4, 8, 16 and 600 ohms, and low and high-frequency oscillators. One set of input and output connectors serves for all functions of the instrument. Heath Co., Benton Harbor, Mich.—TECHNICIAN (Ask for No. 1-1)

Kirby SCOPE PRE-AMP

The voltage gain of the average oscilloscope can be increased 100 times using the Model SA-103 pre-amplifier. Gain is variable from 0 to 100 and calibrated so that fixed amounts of gain can be pre-selected. Frequency response is 60 cps to 100 KC. Maximum input—3 v.; maximum output—30 v. Input impedance—.2 megohm. Contains a voltage regulated power supply and adjustable hum balancing circuit and low frequency compensating circuit. Kirby Products Corp., 20 E. Herman St., Phila. 44, Pa.—TECHNICIAN (Ask for No. 1-8)

Winslow FREQUENCY METER

Model 360 is designed to check ac in the 400 cps range, particularly on 400-cycle generators. The meter operates on the principle of a series of progressively tuned reeds, with the ac frequency indicated by vibration of the corresponding reed or reeds falling within a sharply peaked resonance response curve. Insulated test probes are provided for shunting a portion of the voltage in the test line across the 10 K internal resistance of the meter. Winslow Co., 9 Liberty St., Newark, N. J.—TECHNICIAN (Ask for No. 1-7)

**MORE NEW PRODUCTS
ON PAGE 34**

GE FILAMENT CHECKER

Finding the open heater in a string of series-connected tubes is simplified by this new pocket-size battery operated checker. Sockets are provided for 8-pin octal, 7- and 9-pin miniature



and picture tubes. Since the unit is battery operated, indication of the good filament—a flashing light—is instantaneous. Complete unit weighs less than 8 oz. Tube Dept., General Electric Co., Electronics Park, Syracuse, N. Y.—TECHNICIAN (Ask for No. 1-18)

Approved FIELD STRENGTH METER

Quick indication of the TV picture signal present in fringe or other reception areas is provided by the Model A465 VHF-UHF direct reading TV field strength meter. Signal indicator is a 0-500 μ a meter, calibrated in μ v on 2 scales—5 to 100, and 25 to 30,000—full scale. Contains 12-channel front end, 2 i-f stages, crystal detector and



1 video amp stage. Output provided for scope or phone. Self-contained power supply. 300 or 72 ohm inputs. UHF strips available on order. \$59.50. Approved Electronic Instr. Corp. 928 Broadway, N. Y. C. 10—TECHNICIAN (Ask for No. 1-30).

Hickok OSCILLOSCOPE

Designed for rack-mounting, the new Model 670R scope provides excellent square wave response—down to dc—through the use of direct-coupled amplifiers. Additional features include:

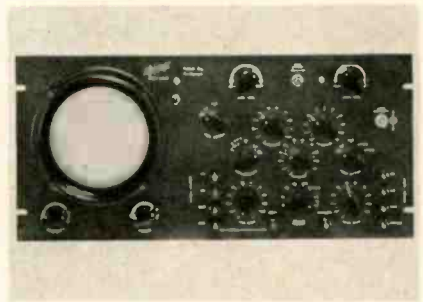

sensitivity of 15 mv/in.; demodulation circuit for viewing modulation on r-f signals; recurrent linear sweep—3 cps to 50 kc; wide band vertical amplifier, useful beyond 2 mc; push-pull amplifiers for both vertical and horizontal deflection; and provision for Z-axis modulation. Hickok Electrical Instr. Co., 10523 Dupont Ave., Cleveland 8, O.—TECHNICIAN (Ask for No. 1-40)

Superior CRT TESTER

Model TV-40 CRT checker can measure the emission of any magnetically deflected tube—in or out of the set. It also indicates open elements and inter-element shorts and leakages of up to 5 megohms. Completely self-contained, including a built-in power supply. Round cornered, molded bakelite case. \$15.85. Superior Instruments Co., 2435 White Plains Rd., N. Y. 67.—TECHNICIAN (Ask for No. 1-5)

Franklin VTVM

Features of the new Model FV-1 vtvm kit include a large 4½-in. meter, a recessed carrying handle and an etched, rub-proof panel. Seven volts ranges—from 1.5 v. to 1500 v. 1½ volt low scale provides more than 2½-in. scale length/volt. Comes in kit form, which includes tubes, assembly material, test leads and detailed assembly manual. \$24.50. Franklin Electronics, King St., Franklin Park, Ill.—TECHNICIAN (Ask for No. 1-3)

MORE TECHNICAL INFORMATION

describing the new products presented here may be obtained by writing on company letterhead to New Products Editor, *TECHNICIAN*, 480 Lexington Ave., New York 17, N.Y., listing numbers given at end of each item of interest. Please mention title of position held. Use coupon on page 40.

HICKOK

MODEL 605A



Complete TUBE TESTER AND SET ANALYZER

Large
5"
Meter

TECHNICAL DESCRIPTION

Enthusiastically accepted everywhere, this fine instrument is specifically designed to meet the technician's need for a smaller size, lower cost portable tube and set tester. The 605A is built with HICKOK Dynamic Mutual Conductance circuits with a 3-range micromho scale of 0-3000, 6000, 15,000. Tests all tubes normally encountered in all phases of communications and electronics. Provides the HICKOK Tube Gas Test. New bias fuse prevents accidental damage to bias potentiometer. Operating voltages, including DC grid bias, are applied to the control grid and large 5" meter shows AC component in plate current. This HICKOK test is the same test used by tube manufacturers in their own laboratories.

See your nearest parts jobber and ask for a demonstration of this lighter, smaller, handier Tube & Set Tester. (Also available as Model 600A without multimeter.)

THE HICKOK ELECTRICAL INSTRUMENT CO.

10514 DUPONT AVENUE • CLEVELAND 8, OHIO

INCLUDES: High Sensitivity MULTIMETER

The Model 605A, in addition to being a complete and highly accurate tube tester, also contains a handy 20,000 ohm per volt DC multimeter to measure . . .

Volts: AC-DC; 0-10, 100, 500, 1000

Sensitivity: 20,000 ohms per volt DC; 1,000 ohms per volt AC

Resistance: 0.1 ohm to 100 megohms, (center scale 25, 2500, 500,000 ohms)

Inductance: to 70 henries through use of conversion chart furnished

Capacitance: Microfarads; 50, 5, as low as .0001

Current: DC; 10, 100, 500 M.A.

Built with minimum number of jacks. Ranges are selected with a rotary master switch.

Write for the latest HICKOK Test Equipment Brochure Today

Bench and Installation Aids

Voltage Regulating Units, Test Sockets; Antenna Couplers, Line Tap

Sico VOLTAGE BOOSTER

Switch-operated step-up transformer device is designed to increase line voltage by 10 v., reduce it 10 v., or restore it to normal when turned off. NE51 neon indicating lamp warns when volt-



age has risen to 128 v., stops glowing when voltage falls below 126 v. Service Instruments Co., 422 S. Dearborn, Chicago, Ill.—TECHNICIAN (Ask for No. 1-54)

Terwilliger MASTS

Light-weight telescoping TM-53 masts are claimed to be rust-resistant both inside and out, through the protection offered by specially developed paint. Crank assembly for telescoping operation is available at extra charge, in Model TM-54. A side arm feature, also at extra charge, simplifies guying the mast. Terwilliger TV Mast Co., 531 Lincoln Ave., Pontiac, Ill.—TECHNICIAN (Ask for No. 1-20)

JFD ARRESTOR

Low-loss characteristic of the AT130 UHF-VHF lightning arrestor makes it particularly suitable for UHF installations. Case is of UL approved plastic

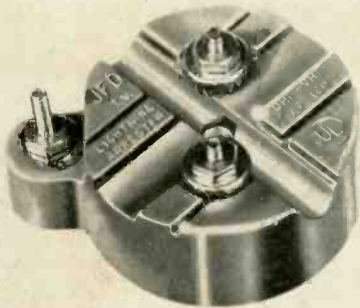

and is weather-proof. Comes with rust- and corrosion-proof brass hardware, and can be used with 300 ohm VHF or UHF flat or tubular transmission line, or open wire. 70¢. JFD Mfg. Co., Inc., 6101-16th Ave., Brooklyn, N. Y.—TECHNICIAN (Ask for No. 1-11)

Pomona TEST SOCKETS

Wear and tear on the sockets in tube testers and other heavily used electronic equipment can be sharply reduced by using the newly-designed Socket Savers. They are available in 7-pin

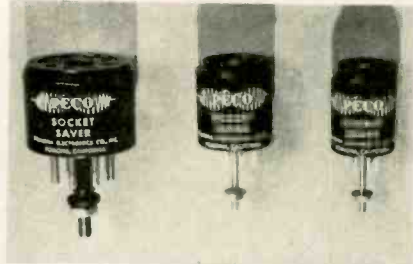

miniature, 9-pin miniature and 8-pin octal sizes. All have silver plated contacts and pins. Pomona Electronics Co., Inc., 524 West Fifth, Pomona, Calif.—TECHNICIAN (Ask for No. 1-2)

Leader CONTROL UNIT

"Twin Light" control unit for Leader's Superrotor antenna rotator features a novel tuning method. Two arrows on the dial face, pointing to left and right, light up automatically when the antenna is being rotated. The relative brilliance of the arrows indicates the direction in which the antenna is being rotated. Leader Electronics Corp., 2925 E. 55th St., Cleveland, O.—TECHNICIAN (Ask for No. 1-15)

Superex ANTENNA COUPLER

Two functions are served by the "Filta-Coupler," which combines a high pass interference eliminator with a 2-set TV coupler in single housing. It is claimed to eliminate both outside interference and interset interference. \$2.49. Superex Electronics Corp., 23 Atherton St., Yonkers, N. Y.—TECHNICIAN (Ask for No. 1-55)

Javex COUPLER

"Mini-Coupler," for connecting two sets to single antenna, features printed circuitry and molded polystyrene construction. Measures 1 x 2 x 1/4 in. Solderless construction. Complete with mounting screws. Javex, P.O. Box 646, Redlands, Calif.—TECHNICIAN (Ask for No. 1-56)

MORE TECHNICAL INFORMATION

describing the new products presented here may be obtained by writing on company letterhead to New Products Editor, TECHNICIAN, 480 Lexington Ave., New York 17, N.Y., listing numbers given at end of each item of interest. Please mention title of position held. Use coupon on page 40.

Authorized POWER SUPPLY

Variable dc voltages from -135 v. through 0 to +135, and ac voltages from 0 to +135 v. are provided by the Model 301 Multivoltmeter. It also provides 1 a. of 6.3 filament volts at separate



terminals. The unit weighs 2 lbs. and will fit in a tool box or tube caddy. A neon indicator provides indication of current output. Authorized Manufacturers Service Co., Inc., 919 Wyckoff Ave., Brooklyn 27, N.Y.—TECHNICIAN (Ask for No. 1-4)

Taco LINE TAP

The need for cutting and trimming the coaxial cable at each individual outlet in a master antenna system is eliminated by the Tacoplex Automatic Line Tap. A half-round notch is first filed in the cable, until the center conductor shows. Then the tap is placed over the cable and clamped in

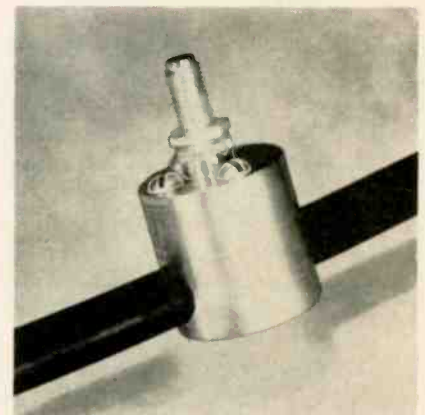

place by two machine screws. A screw makes the ground connection with the coax shield. Connection to tap line is provided by a standard coaxial fitting with built-in resistance. Technical Appliance Corp., Sherburne, N. Y.—TECHNICIAN (Ask for No. 1-17)

**MORE NEW PRODUCTS
ON PAGE 36**

RCA Speakers Provide Performance You Can Be Proud Of!

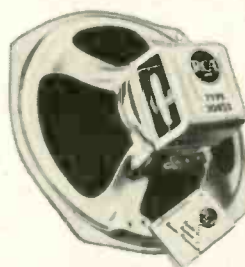
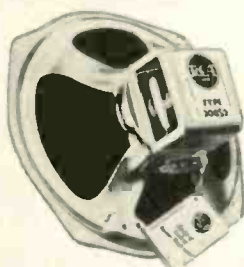
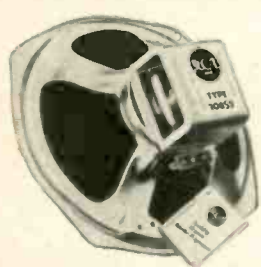

✓ ALNICO V MAGNETS ✓ ELECTROPLATED POTS ✓ ELECTROPLATED FRAMES ✓ MOISTURE-RESISTANT CONES

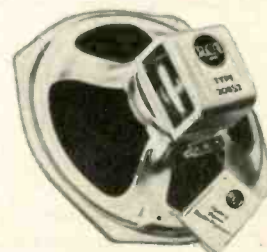
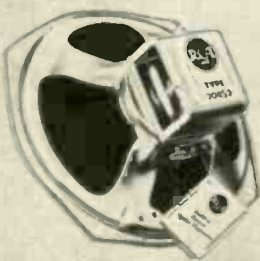
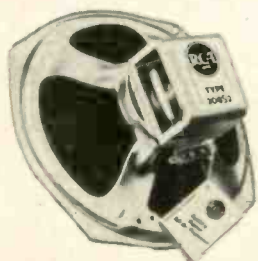

✓ HIGH SENSITIVITY ✓ DUST-SEALED, RUGGED CONSTRUCTION ✓ RETMA STANDARD MOUNTINGS

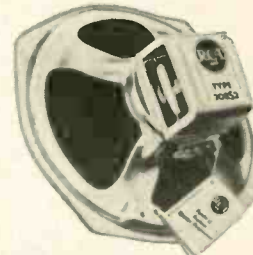
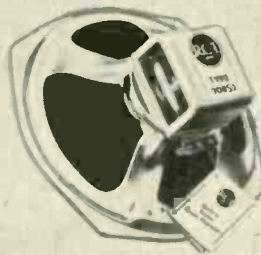
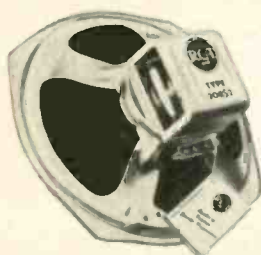

✓ MOUNTING BRACKETS PACKAGED WITH POPULAR SIZES

(Ask your local RCA
Distributor for catalog 3F687)

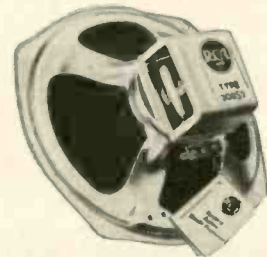
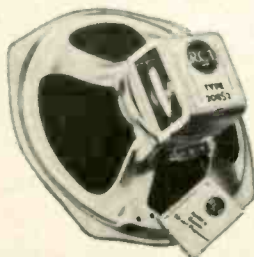
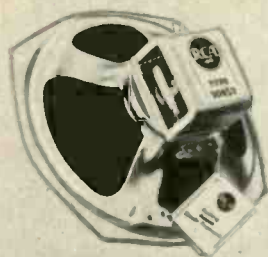

RADIO CORPORATION of AMERICA
ELECTRONIC COMPONENTS

HARRISON, N. J.

New Television Antennas

Latest Designs in UHF-VHF Indoor and Outdoor Antennas

Telco ANTENNAS

All-channel "Mity-V" antenna, shown, is for close-in reception areas. It is of all-aluminum construction, with a molded plastic insulator. The twin elements are adjustable from 60° to 90°.

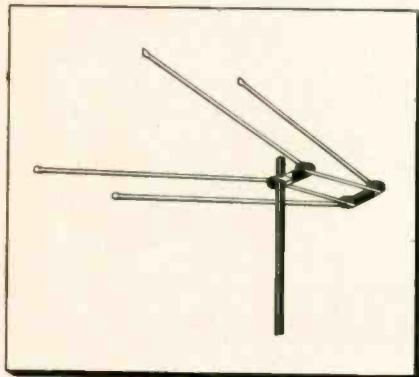

An economy model, the "Bonnie-V," consisting only of 2 dipoles, without reflectors, also finds application in local areas. Price: "Mity-V"—\$3.75; "Bonnie-V"—\$1.75. Television Hardware Mfg. Co., 919 Taylor Ave., Rockford, Ill.—TECHNICIAN (Ask for No. 1-10)

Tennalab COLOR ANTENNA

3-stacked collinear array "Colorbeam" antenna features a particularly wide-band characteristic, suitable for both b & w and color reception. Gain is 15 db on channels 7-13, slightly lower on channels 2-6. Uses single 300-ohm line. \$42.50. Tennalab, Quincy, Ill.—TECHNICIAN (Ask for No. 1-57)

Snyder INDOOR ANTENNA

Working elements on the "5D Directional 8-Position Push Button Indoor Antenna" consist of two 3-section staffs and an adjustable dual-phasing bar in

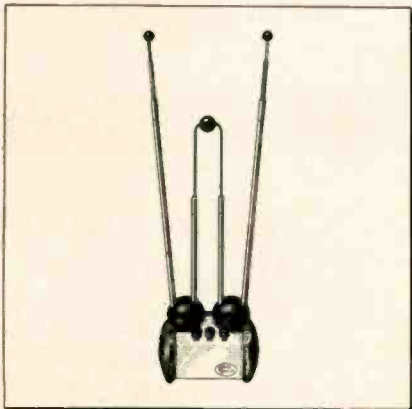

the center. Orientation is accomplished electronically by push-buttons mounted in the base; 8 combinations are possible. Antenna, collapsed, stands 17-in. high, extends to 41 in. \$12.95. Snyder Mfg. Co., 22nd & Ontario Sts., Phila. 40, Pa.—TECHNICIAN (Ask for No. 1-13)

Welco VHF ANTENNA

The "Sabre Senior" is claimed to provide exceptionally high gain on all VHF channels through a unique inter-element coupling arrangement which permits the low band dipoles to func-

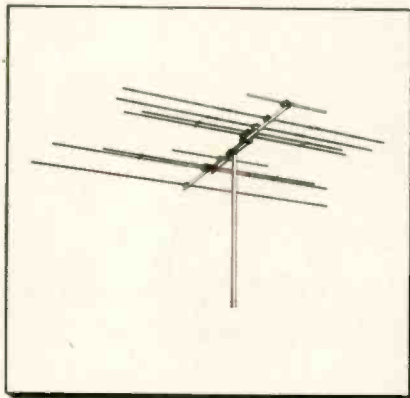

tion with proper gain and pattern response in the high band. This "Miracle Phase" feature is also claimed to provide high rejection to noise and co-channel interference. It is particularly recommended by the mfr. for fringe area installations. Welco Mfg. Co., Burlington, Ia.—TECHNICIAN (Ask for No. 1-12)

K-G INDOOR ANTENNA

A 6-position impedance switch and telescoping dipoles makes the Golden Beauty Model 6A adjustable to all TV channels, 2 through 83. Finished in

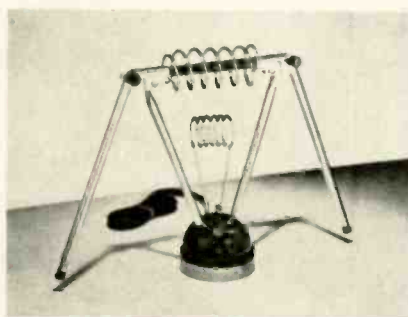

gold with black and gray non-marring base. \$9.95. K-G Electronics Corp., 2738 N. Sheffield, Chicago 14, Ill.—TECHNICIAN (Ask for No. 1-9)

MORE TECHNICAL INFORMATION describing the new products presented here may be obtained by writing on company letterhead to New Products Editor, *TECHNICIAN*, 480 Lexington Ave., New York 17, N.Y., listing numbers given at end of each item of interest. Please mention title of position held. Use coupon on page 40.

ASP TV ANTENNA

Ideally suited for installation on pleasure boats, this new all channel antenna is of all-aluminum construction and consists of two 15-in. open mesh, triangular screens forming a pyramid.



For boat installations it is mounted on a 2-ft. length of mast on the foredeck. A glass door knob on the lower end of the mast, inside the cabin, permits rotating the antenna to aim at the TV stations. American Screen Products Co., 807 Northwest 20th St., Miami 37, Fla.—TECHNICIAN (Ask for No. 1-58)

Wizard INDOOR ANTENNA

Designed for both UHF and VHF, the "Decorator" antenna provides a forward gain of approximately 10 db. on UHF due to reflector action of rear decorative screen. Patented compound curves in the bow tie dipoles are claimed to

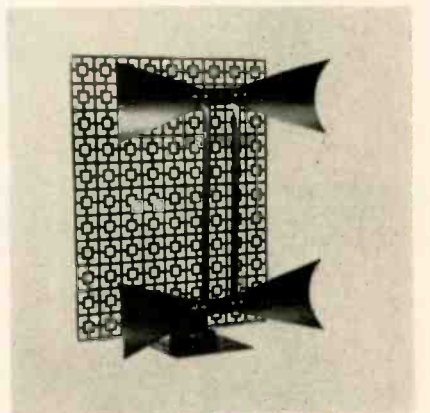

make it suitable for color reception. Available in velvet, black or sage green. \$9.95. Wizard Electronics, 705 Heman Ave., St. Louis 5, Mo.—TECHNICIAN (Ask for No. 1-59)

**MORE NEW PRODUCTS
ON PAGE 38**

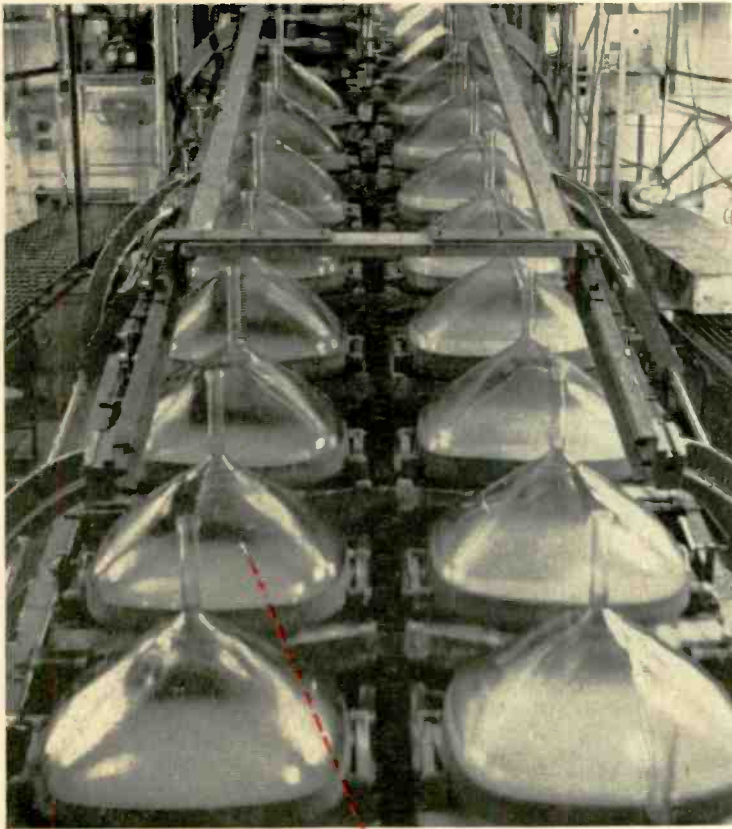

From ZERO to CAPACITY PRODUCTION IN THREE MONTHS!

The same "advanced-engineering" that produced the CBS-Colortron and the Mirror-Back picture tube also engineered and built this modern CBS-Hytron plant at Kalamazoo, Michigan. The same drive typical of CBS-Hytron activity brought this complex industrial operation up to capacity production just three short months after first shipments began. For the ability to keep pace with your demands . . . for premium quality in TV picture tubes, look to the fastest-growing, most modern and forward-thinking company in the industry — CBS-Hytron.



CBS-HYTRON

Main Office: Danvers, Massachusetts

A Division of Columbia Broadcasting System, Inc.

A member of the CBS family: CBS Radio • CBS Television • Columbia Records • CBS Laboratories • CBS-Columbia • CBS International • and CBS-Hytron

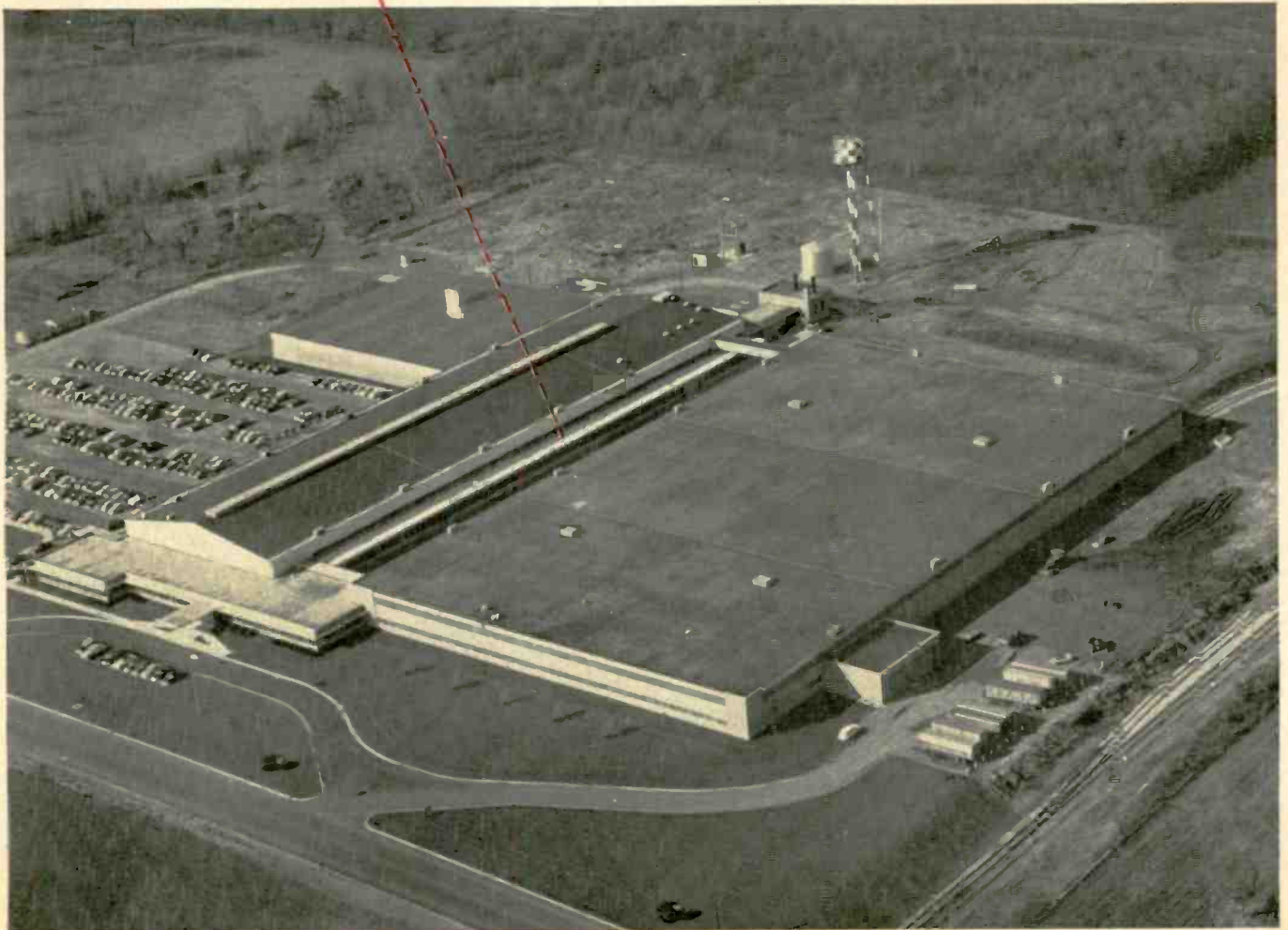

Parts For Sales & Service

Audio Equipment, Speakers, Changers; Test Instruments

Shasta VTVM

The Model 201 covers the dc voltages in 7 full scale ranges of 1.5 to 1500 v. at an impedance of 11 megohms. AC ranges are calibrated both in rms values of sine waves and peak-to-peak



values of 4 to 4,000 v. Separate scales are provided for the 0-4 peak-to-peak and the 0-1.5 v. rms ranges for greater accuracy. Seven resistance ranges, from 1 K to 1,000 megs. Provision is made for operating the Shasta Model 952 Illuma-Probe, a miniature lamp built into the plastic end of the probe for illuminating dark corners of the chassis. \$68.00 Shasta Div., Beckman Instruments, Inc., 1432 Nevin Ave., Richmond, Calif.—TECHNICIAN (Ask for No. 1-6)

Sightmaster SPEAKER SYSTEM

New Model X-100 system consists of a 15-in. woofer, special horn-type tweeter and a crossover network. Woofer has a 5-lb. magnet and a voice coil of 2.1 in. for bass reproduction down to 25 cps without boom or hang-over. Special tweeter unit combines both direct-radiator and compression type action. Throat diameter of the horn corresponds to the piston diameter of the diaphragm. Acoustic stiffness is obtained by allowing the rear wave to operate in a sealed cavity of less than 1 cc. volume. \$99.50. Sightmaster Corp., 111 Cedar St., New Rochelle, N. Y.—TECHNICIAN (Ask for No. 1-70)

Lowell GRILLES

New type expanded decorative aluminum grille material is rigid, light weight and vibration-proof. Finds application in hi-fi cabinets, speaker enclosures and similar housings. Available in $\frac{3}{16}$ -in., $\frac{3}{4}$ -in. and 1-in. mesh sizes. Standard finish is bronze but material is available unfinished or painted any color on request. Lowell Mfg. Co., 3030 Laclede Sta. Rd., St. Louis 17.—TECHNICIAN (Ask for No. 1-71)

Turner CARTRIDGE

Ninety-five percent of all 78 rpm pickups will take the new Model AU phono cartridge, according to the mfr. Performance is claimed to be exceptionally free of needle hum or hiss. Model AU has an externally mounted condenser for low-voltage (2.0 v. or lower) applications. Also available without the condenser, as Model A. Price: Model AU—\$4.95; Model A—\$4.45. Turner Co., 903 17th St., N.E., Cedar Rapids, Ia.—TECHNICIAN (Ask for No. 1-19)

GPC PILLOW SPEAKER

New miniature speaker, particularly applicable as pillow speaker, is housed in a hermetically sealed steel case weighing less than 1 oz. It uses the magnetic flux principle—opposed alnico magnets mounted on a fibre tone platform with a flat coil on the reverse side. There are no moving parts. Very low impedance input, to match any radio or TV. Trade-named "Silent-Sound." General Phones Corp., 5711 Howe St., Pittsburgh 32, Pa.—TECHNICIAN (Ask for No. 1-21)

Deltron R-C BRIDGE

Self-contained, portable resistance-capacitance bridge measures capacitors from 10 μ f to 50 μ f, and resistors from 10 ohms to 50 megohms; also useful for continuity checks on circuits, coils and transformers. Direct reading scale has six overlapping ranges with selector switch for various R and C measurements. Power factor of electrolytics is indicated by eye detector tube. Deltron Inc., 2905 N. Leithgown St., Phila., Pa.—TECHNICIAN (Ask for No. 1-72)

Ampex SOUND SYSTEM

Twenty-five-lb. portable amplifier-loudspeaker unit incorporates a specially-designed loudspeaker with a complementary 10 watt audio amplifier in an acoustically correct enclosure. Response is essentially flat from 60 to 10,000 cps. Encased in Samsonite luggage for portability. Main applications—portable P.A. system, sound demonstration unit, broadcast monitoring. Designated Model 620. Price—\$149.50. Ampex Corp., 934 Charter St., Redwood City, Calif.—TECHNICIAN (Ask for No. 1-73)

MORE TECHNICAL INFORMATION

describing the new products presented here may be obtained by writing on company letterhead to New Products Editor, TECHNICIAN, 480 Lexington Ave., New York 17, N.Y., listing numbers given at end of each item of interest. Please mention title of position held. Please use coupon on page 40.

Dubbings TEST TAPES

Reel of prerecorded tape enables user to test his tape recorder and also enjoy choice musical selections. The 3-in. reel, designated Dubbings D-210 and called the "Plus-50 Music and Test Sampler," offers 50% more playing time by using a tape with a thinner base, allowing more tape to be wound on a reel. The timing tests are 2 timing beeps accurately spaced 7 mins. apart to measure tape speed, and a 15-sec. 5,000 cps tone for aligning the play head. The $7\frac{1}{2}$ -in./sec. recording is full track. The musical selections are from Bizet's Carmen and Rimsky-Korsakov's Song of India. May be used on either full-track or half-track machines. Price—\$1.00. The Dubbings Co., 41-10 45th St., Long Island City, N.Y.—TECHNICIAN (Ask for No. 1-75)

Skila TAPE SPLICER

Professional $\frac{1}{4}$ -in. magnetic tape splicer Model K1 automatically ejects, applies, cuts off and presses into place the correct amount of splicing tape; hands never touch tape. Cutting blade is easily removed and turned and has eight usable cutting edges. Both bar and blade are easily resharpened and are nonmagnetic. Price, with roll of splicing tape, \$69.75. Available from F. Reiter Co., 3340 Bonnie Hill Dr., Hollywood 28, Calif.—TECHNICIAN (Ask for No. 1-74)

ARF TWEETER

Electrostatic high-frequency unit is designed to extend the range of existing installations. Response is flat from 7,000 to 20,000 cps. Package consists of one or two electrostatic units, with a

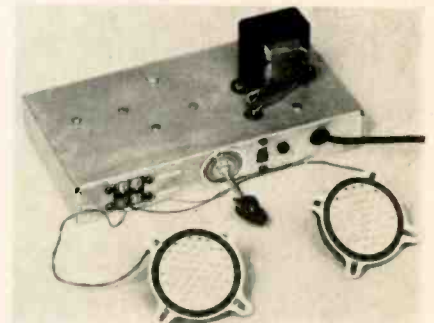

matching transformer and network components, for installation in an existing cabinet, or, as a cabinet model which is placed on top of the bass-reproducer enclosure. Price—for single unit, matching transformer and network components—\$17.95. A.R.F. Products, Inc., 7627 Lake St., River Forest, Ill.—TECHNICIAN (Ask for No. 1-83)

New Product Briefs

HV TRANSFORMERS: New flybacks, models HVO-28, 29, and 30, for replacement on a number of Motorola, Crosley, Hallcrafters, and Hoffman receivers, have a built in 1B3 tube socket; also, a horizontal centering pot, and variable gap width control. Merit Coil & Transformer Corp., 4427 N. Clark St., Chicago 40, Ill.—TECHNICIAN (Ask for No. 1-31)

RESISTORS: Hermetically sealed deposited carbon resistors feature a treated ceramic shell for moisture-proofing and temperature compensation. In 5 sizes. Exceed specs of MIL-R-10509A. Radell Div., I.D.E.A., Inc., 7900 Pendleton Pike, Indianapolis, Ind.—TECHNICIAN (Ask for No. 1-32)

RESISTORS: In the Series 850 metal film type resistors, the metal resistive element is deposited on the inner surface of a glass tube. Connections are silver bands fused to the element and glass. Glass-to-metal end seals withstand over 60 psi. Daven Electronic Sales, The Daven Co., 191 Central Ave., Newark, N.J.—TECHNICIAN (Ask for No. 1-33)

CHILDRENS HOBBY KIT: Parts and instructions with which to conduct a series of basic experiments in electricity and electronics. Includes parts for a 2-tube AM receiver and a transmitter, electromagnet, batteries, galvanometer. By RCA, the Encyclopedia Britannica and Museum of Science & Industry. Available from Central Scientific Co., 1700 Irving Park, Chicago—TECHNICIAN (Ask for No. 1-34)

CHANGER: Collaro Model RC-54 intermixes all size records of any 1 speed. Features include: 4-pole motor, automatic switch-off, automatic muting switch and instant reject. \$48.75. Rock-

"He's the most thoughtful guy on television—he always tunes in the fights for the men folk who don't care for his stuff."



bar Corp., 215 E. 37th St., N.Y. 16—TECHNICIAN (Ask for No. 1-35)

ANTENNA AMPLIFIER: "Masterline" Model MLA broadband TV amplifier, with auxiliary AGC, employs cascode circuits. Delivers more than 37 db gain on all VHF channels, with less than .75 db variation over any 6 mc range. 75-ohm input and output co-ax fittings, separate high and low band gain controls. \$119.50. Blonder-Tongue Labs., Inc., 526 North Ave., Westfield, N.J.—TECHNICIAN (Ask for No. 1-36)

HI-FI AMPLIFIER: Table-top unit combines amplifier and preamp-equalizer. Includes 6 positions of record equalization,

four inputs, plus cathode follower output for tape recording. Built-in filters eliminate record noise, rumble and spurious high and low frequencies. 4 x 11½ x 14½. \$113.50. The Radio Craftsmen Inc., 4401 N. Ravenswood Ave., Chicago 40, Ill.—TECHNICIAN (Ask for No. 1-37)

INSULATING TUBING: Poly-vinyl chloride electrical cable tubing, "Protektinsul," protects wires against chafing, moisture-vapor and corrosive elements. High dielectric strength. Furnished in several standard colors and clear. Miracle Adhesives Corp., 214 E. 53rd St., N.Y. 22—TECHNICIAN (Ask for No. 1-38)

New PORTABLE DOUBLE-DUTY Money-Maker



Size only 11"x7½"x5"

Spots the Trouble and Quickly Corrects it—without removing tube from set!

Now it's easy to save thousands of weak and inoperative TV picture tubes. As much as 80% of the troubles which arise in picture tubes may easily be repaired with the CRT. This amazing portable instrument creates new profitable picture tube repair business. Saves servicing time, speeds work. Assures more satisfied customers. Eliminates tube transportation. Saves money on trade-in reconditioning. And at such low cost, the CRT quickly pays for itself—and continues to make big profits for TV service-dealers.

Write or Wire for Full Facts

TESTS and REPAIRS TV PICTURE TUBES

Amazing **\$54⁹⁵**
Low Price **NET**
No extra accessories necessary



CATHODE REJUVENATOR TESTER

DOES ALL THIS

TESTS FOR Emission, Inter-Element Shorts, Leakage, Open Circuits, Grid Cut-Off, Gas Content, Probable Useful Life

RESTORES Emission and Brightness

REMOVES Shorts

REPAIRS Open Circuits

Less than one foot long.
Weighs only five pounds.

B&K MFG. CO. 3731 N. Southport · Chicago 13, Illinois

New Parts and Components

Transmission Line; Resistors, Condensers; Remote Door Opener

Radix TWIN LEAD

Low-loss, quick-sealing tubular line, "Strip-Ease," is notable for its ease of handling. Conductors, when stripped from line, remain enclosed in polyethylene. Center tubular section remains

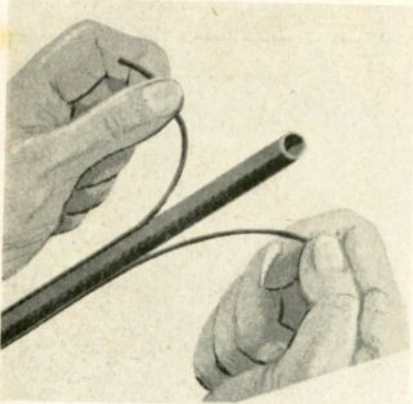

intact since wall covering is never cut. Moisture-proofing is accomplished by heating end of tubular section and crimping with pliers. Radix Wire Co., 26260 Lakeland Blvd., Cleveland, O.—TECHNICIAN (Ask for No. 1-14)

Ram FLYBACKS

Six new horizontal output transformers just released are exact replacements on 91 chassis and 436 models. They are designed to operate in 66 to 70° deflection systems, delivering 11 to 18 kv. Designations are X107, X108, X109, X110, X111, X112. All contain compounded windings, permitting additional applications with no physical changes necessary. Ram Electronic Sales Co., Irvington-on-Hudson, N. Y.—TECHNICIAN (Ask for No. 1-60)

Westinghouse TRANSISTORS

Types 2N54, 2N55 and 2N56 transistors are now available for low-power, low-frequency amplifier applications. Each is capable of dissipating 200 mw at 25°C. Average cutoff at the 6-mw power level is 500 kc. The average current gain of the transistors are 2N54—0.97; 2N55—0.95; 2N56—0.92. Westinghouse Electronic Tube Div., Dept. T-291, Box 284, Elmira, N.Y.—TECHNICIAN (Ask for No. 1-61)

Aerovox CAPACITORS

Closer temperature-coefficient tolerances than normally available are provided in the Type CNP ceramic capacitors. Units are supplied in a non-insulated tubular style with radial leads and a clear non-hygroscopic plastic coating. Hi-Q Div., Aerovox Corp., Olean, N.Y.—TECHNICIAN (Ask for No. 1-62)

Clarostat CONTROLS

An improved wiper arm which contacts the edge rather than the side of the resistance winding permits higher resolution, more intricate tapers and closer tolerances in overall resistance

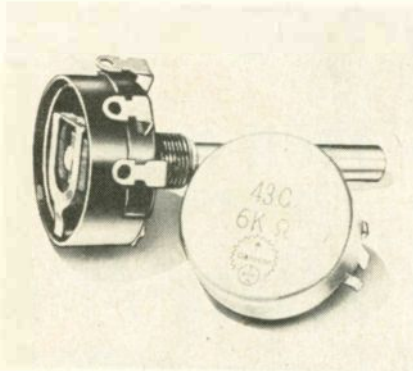

on the new Series 43c line of wire-wound controls. End termination is also improved in that terminals are directly fastened to the winding, insuring low contact resistance. Series 43c is available in standard ohmages from 1 to 50 K. Rated at 2 watts. Various taps and tapers are available. Clarostat Mfg. Co., Inc., Dover, N.H.—TECHNICIAN (Ask for No. 1-63)

C-D DECADE RESISTORS

Series of 3 decade boxes makes possible a range of resistance values from 1 ohm to 1 megohm—in steps of 1 ohm. Each unit has 2 direct reading panel switch scales in series, permitting 110 different resistance values. Models are: the RDA, with range of 1 to 110 ohms, in steps of 1 ohm; the RDB, 100 to 11,000 ohms in steps of 100 ohms and the RDC, 10,000 to 1,010,000 ohms in 10,000 ohm steps. Cornell-Dubilier Electric Corp., 333 Hamilton St., S. Plainfield, N. J.—TECHNICIAN (Ask for No. 1-64)

Tru-Ohm RESISTORS

New 5- and 10-watt "Econohm" replacement resistors are claimed to hold their rated value over long periods of time due to use of ceramic cores. Tinned copper leads are attached in a manner

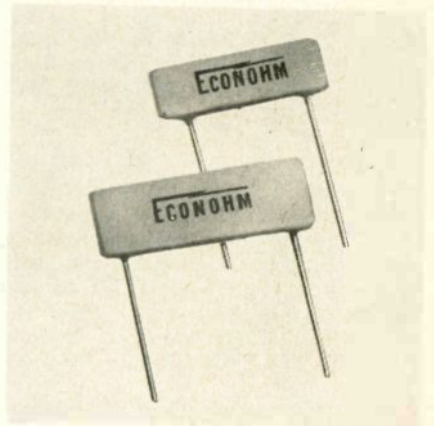

eliminating the possibility of stresses being transmitted to the winding. Joints of resistance wire to terminals are securely soldered. Resistors are impervious to moisture. Tru-Ohm Products, 2800 Milwaukee Ave., Chicago 18, Ill.—TECHNICIAN (Ask for No. 1-65)

Perma-Power DOOR OPENER

Radio-controlled garage door opener is operated from owner's car. Unit consists of a motor mechanism, which comes completely assembled, and a transmitter for the car and a receiver for the garage. Carrier power output of 200 milliwatts makes system functional over distances up to 300 ft. Adaptable to overhead-type garage doors up to 18 ft. wide by 8 ft. high, one piece or sectional. Complete system—\$179.85. Individual units can also be purchased separately. Perma-Power Inc., 4727 N. Damen St., Chicago, Ill.—TECHNICIAN (Ask for No. 1-66)

FOR MORE TECHNICAL INFORMATION ON NEW PRODUCTS OR BULLETINS

use this convenient coupon. Enter below the reference numbers for all items desired. (Other New Products appear on pages 30, 32, 34, 36 and 38. Catalogs and bulletins on pages 48 and 49.)

New Products Editor
TECHNICIAN & Circuit Digests
480 Lexington Ave.
New York 17, N. Y.

Please send me more information on the following items:

.....
My company letterhead or business card is enclosed.

Name

Address

City State

Firm My position

Business address (if different from above)

AMERICA'S MOST DEPENDABLE ROTATOR

ONLY ROTATOR AVAILABLE
IN FOUR GLORIOUS COLORS:

BROEGE MARBLE
MAHOGANY
GOLDEN WHEAT
DECORATOR'S GRAY

THE TRIO
"ARISTOCRAT"

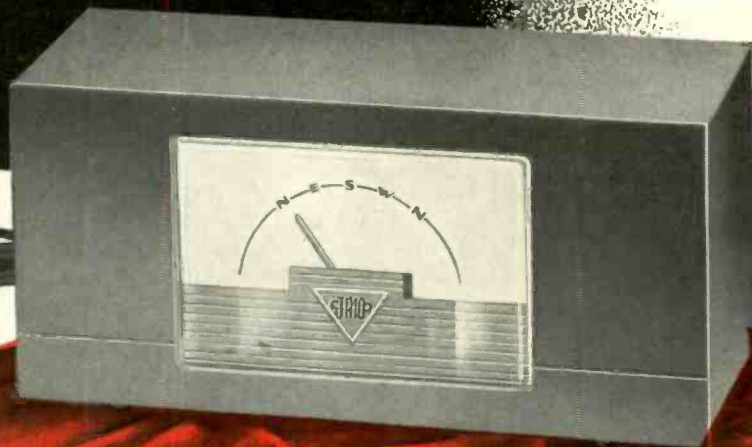

NOW ...

*America's
most
beautiful!*

The sleek, modern, low silhouette of the new TRIO rotator control case marks a new high in styling.

Beauty, here, is more than skin deep since its low center of gravity makes it tip-proof! Note, too, that there are NO unsightly control knobs or switches to spoil its beauty. These are located at top rear of case — where your hand naturally rests in operation of rotator!

There is no obscuring the easily-read lighted dial.

Available in four glorious colors — to blend perfectly with any decor.

TRIO has a new plan which makes it convenient for the dealer and distributor to carry a complete selection of colors

with no major increase in rotator investment. With this plan the home-maker has a choice of colors — even at the time of installation.

Switch and directional controls are located at top rear of case for most convenient manual operation. Lighted dial permits operation in darkened room and also indicates when rotator is on. When on, pointer always shows exact position of antenna.



✓ Only Rotator With Factory Attached Cable.



✓ Only Rotator With Two-Year Guarantee.

THE TRIO
"ARISTOCRAT"
... CULMINATION OF
SIX YEARS RESEARCH
AND PRODUCTION

Copyright 1954 by
Trio Manufacturing Co.



TRIO

Manufacturing Co.

GRIGGSVILLE, ILLINOIS

Is Your VTVM Reliable for

Frequency, Waveshape or the Circuit Under Test Can Be

By H. P. MANLY

• A pocket flashlight takes more power than 250 vacuum-tube voltmeters measuring dc volts on that many amplifier plates, all at the same time. A vtvm measuring dc volts loads circuits so lightly that its connection to the grid of a high-frequency oscillator won't stop oscillation, and voltages measured across one-megohm resistors drop less than ten per cent below normal operating values.

But, when measuring alternating voltages, we run into the effects of capacitance in meter circuits, and become involved with impedances rather than mere ohmic resistances.

Rating the ac input of a vtvm only in megohms of resistance is meaningless. Specifying input impedance is impossible, because impedance varies with frequency of measured voltages. Consequently, we find listings such as "ac input, 8 megohms and 60 mmfd," or something of this general nature.

Ac input of 8 megohms and 60 mmfd means that, between low-side and high-side terminals of the instrument, we have these values of resistance and capacitance effectively in parallel, and they will be shunted across any circuit whose ac voltage is measured.

Power drawn from the measured

circuit will be *inversely* proportional to impedance at the operating frequency. To illustrate; with our assumed 8 megohms and 60 mmfd at the ac input of a vtvm, rising frequency *drops* impedance along curve A of Fig. 1. Were input resistance decreased to one megohm, still with 60 mmfd shunt capacitance, the impedance curve would change to B. Quite plainly, resistance is responsible for most of whatever loading

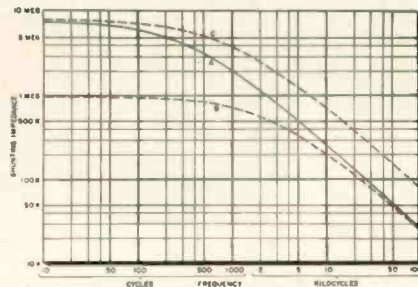

Fig. 1—Shunt impedance (input resistance and capacitance) varies from one vtvm to another.

exists at lowest frequencies, while shunt capacitance is responsible for nearly all the loading at high frequencies.

Input impedance at high frequencies might be raised by lessening the internal capacitance of the vtvm. Were it possible to reduce this capacitance to 20 mmfd, while keeping 8 megohms resistance, impedance

would vary along curve C of Fig. 1. But stray capacitance and tube capacitance so small as 20 mmfd is difficult to attain, even with one tube and the few circuit components in a single stage of a broadband video amplifier. With all the switches, resistors, and connections in a multi-range multi-function vtvm, such small capacitance is impossible without exceeding convenient size and permissible cost for a service instrument.

It might seem logical to raise the vtvm impedance and lessen the loading of measured circuits by using either a high-ohms resistor or a small capacitor in series with one of the ac leads while measuring high-frequency voltages. The trouble is, enough series resistance or capacitive reactance to materially reduce high-frequency loading completely upsets the meter calibration. Voltage errors are not directly or inversely proportional to either series resistance, series capacitance, or frequency. There is no simple method of interpreting the readings.

High-frequency loading often is increased needlessly by using an ac input cable with grounded shield. A good quality coaxial cable will add something like 50 to 80 mmfd of shunt capacitance. This cuts high-frequency impedance to about half the value which usually exists when

Fig. 2—Maximum impedances across which error-free readings can be made at various frequencies, on one specific vacuum-tube voltmeter.

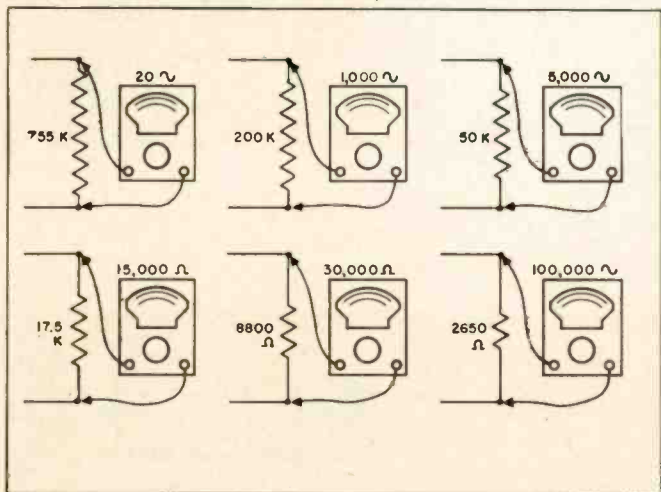
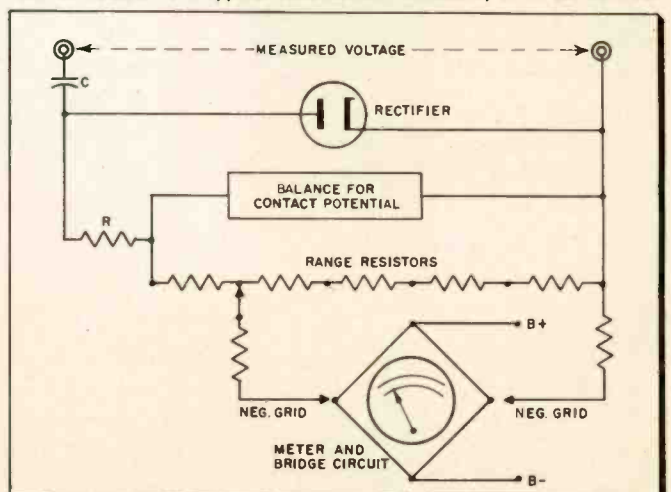

Fig. 3—The principal elements of a peak rectifier system, as used in the ac section of a typical vacuum-tube voltmeter, or in an ac vtvm.



AC Measurements?

Responsible for Inaccurate Readings.

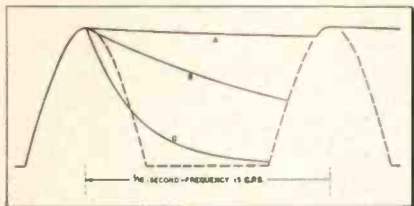

Fig. 4—Time constants affect ac readings.

using an unshielded insulated cable, and, of course, doubles the loading effect.

To avoid serious errors, many technicians follow the rule that resistance or impedance of any voltmeter should be at least ten times the resistance or impedance of the measured circuit. Applying this rule to the vtvm having 8 megohms and 60 mmfd at its ac input, relations between frequencies and maximum impedance of measured circuits would be as in Fig. 2. Except across circuits of low impedance, measurements at frequencies much in excess of 30 kc should be made with a high-impedance detector probe feeding into the dc input of the vtvm.

Meter Response

We have talked about high frequencies as they affect loading of measured circuits. Now let's examine the high-frequency response of the vtvm itself. To put it another way, if we get rid of impedance loading effects by maintaining constant ac voltage across the measured circuit, regardless of operating frequency, how will changes of frequency affect meter readings?

The answer is the same as for oscilloscopes, or for radio and TV amplifiers. If tubes are of types designed to work well at high frequencies, if other circuit components are of small physical size and properly dressed, and if connections are not unduly long, response should be good at frequencies far beyond the highest audio range.

As an example, a fairly typical vtvm was found to have frequency response almost flat to 15 kc, and down only one db at 100 kc. At one megacycle the response was down nearly 7½ db, but at this frequency the

measured circuit would be so heavily loaded by meter impedance that the best of frequency responses wouldn't help. Furthermore, even 20 or 30 mmfd of shunt capacitance would put a tuned high-frequency circuit out of action so far as normal performance is concerned.

Having considered some of the things which happen at high frequencies, we shall go to the other extreme—where the high-fidelity worker makes measurements at 15 to 20 cycles per second. At such low frequencies there are relatively long time periods between successive peaks of rectified voltage, and the result may be serious errors.

Rectifier Constants

The rectifier circuit for ac voltage measurements in some vtvm's is similar in principle to a rectifier circuit in TV receivers, or to the avc rectifier system in many radios. We find a peak rectifier. Fig. 3 shows the major parts of such a vtvm circuit. The rectifier tube is fed through a series capacitor, C. This capacitor is charged during peaks of measured voltage, and can discharge only through resistor R and other high resistances from R to the low-side terminal. The longer the time constant of this capacitance-resistance combination, the more nearly the average rectified dc voltage approaches the peak value of measured voltage.

Effects of rectifier time constants are illustrated in Fig. 4. Here we have two rectified half-cycles of a sine-wave alternating voltage whose frequency is assumed to be 15 cycles per second. Accordingly, the time between peaks is ⅓ second. After a few cycles, a series input capacitor in a vtvm will be charged to peak voltage every ⅓ second.

Curve A shows the rate at which a series capacitance of 0.1 mfd discharges through a total resistance of 10 megohms. Even at this very low frequency, average capacitor voltage and resulting reading of the vtvm remain close to the peaks of measured voltage. Curve B shows the discharge rate of 0.05 mfd through 1.5

(Continued on next page)

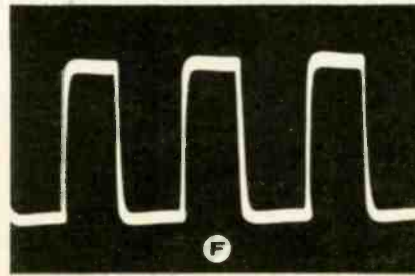
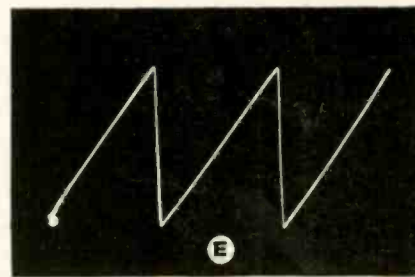
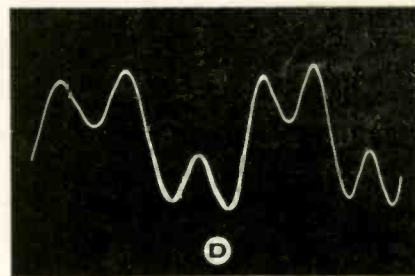
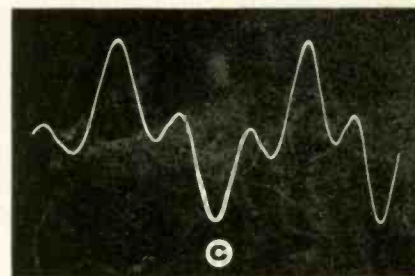
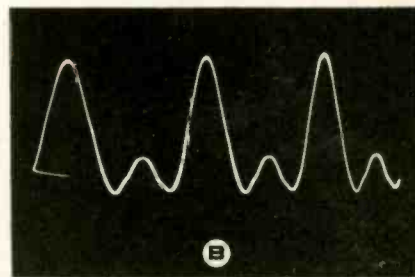
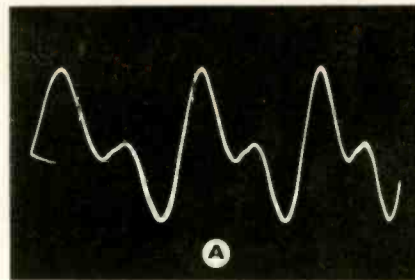

Fig. 5. Complex waveforms may upset accuracy.

Outstanding

FROM EVERY ANGLE

CROWN[®]
Tenn-a-Liner

in consumer's
acceptance

in dependable
performance

in dealer
profits

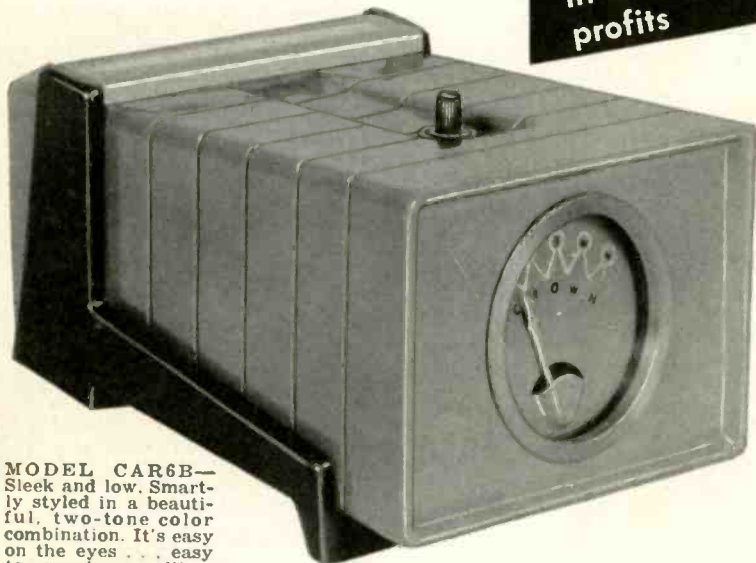

MODEL CAR6B—Sleek and low. Smartly styled in a beautiful, two-tone color combination. It's easy on the eyes . . . easy to operate . . . literally sells itself.



MODEL CAR6A—Has all the famous proved and exclusive features synonymous of Crown engineering. Attractively styled in rich mahogany bakelite.

See both outstanding models of the new Crown Tenn-a-Liner . . . Get the complete story about Crown's outstanding consumer acceptance . . . dependable performance . . . and outstanding profit plan. Then look at the Crown Tenn-a-Liner from every angle. You will be amazed at the bigger profits you will make by selling the exclusive, sales appealing features of the new Crown Tenn-a-Liner. You, too, will agree it's the best buy in antenna rotators on the market. Contact your Crown distributor or write us direct. Get the complete story on Crown, today!

SELL *with confidence*
sell **CROWN**[®]

CROWN[®] CONTROLS Co., Inc. NEW BREMEN, OHIO

Canadian Subsidiary Crown Controls Mfg. Ltd. Export Division, 15 Moore St., New York, N. Y., Cable—"Minthorne"

megohms. Average capacitor voltage drops to about 63 per cent of the peaks. Curve C shows discharge of 0.01 mfd through 1 megohm. Average capacitor voltage is very low in relation to peaks.

A vtvm designed to rectify on voltage peaks usually will have a dial scale graduated in peak volts. There will be additional scales for rms or effective ac voltages. Graduations on these rms scales are at 0.707 times the peak values. If the meter is not designed to hold rectified voltage very close to peak values, and is calibrated only for rms or effective voltages, its ac volts scales will be graduated accordingly. Multiplying readings on the rms scales by 1.414 then will give peak voltages of sine waves, but *not* of other waveforms.

Audio Waveforms

Actual audio voltages, other than from a signal generator, seldom are sine waves. Instead they consist of fundamentals and various harmonics. Peaks may be either sharper or broader than those of sine waves. When measured voltages are not sine waves we encounter one variety of waveform error.

A second harmonic combined with phase shift may sharpen the peaks in both polarities, as at A of Fig. 5, or may sharpen one peak while making the opposite one effectively broader, as at B. A third harmonic may sharpen the peaks as at C, or make them effectively broad, as at D.

When peaks of measured voltage are narrow, a short time constant in the vtvm rectifier circuit will allow indicated voltage to drop. On the other hand, a very long time constant will hold the charge of the series capacitor at practically the peak value of applied voltage, whatever the audio waveform, and readings are little affected.

Without a very long time constant, indicated voltage will be decidedly low when measuring a TV sawtooth voltage like that at E of Fig. 5. At the end of each rise, the sawtooth plunges sharply through zero. Then charge of the series capacitor and indicated voltage are maintained only by the time-constant discharge rate in the vtvm rectifier circuit. Anything approaching a square wave voltage, such as used in audio amplifier testing (trace F), shortens the discharge intervals and tends to make indicated voltage somewhat too high.

The usual method of checking any ac voltmeter for waveform error is to take a reading, then reverse the leads to the meter and take a second

reading. Any material difference between readings indicates waveform error. When measuring a sawtooth the two readings may differ in a ratio of three or four to one, unless the meter rectifier circuit has a long time constant. Yet on sine wave voltages the two readings will be almost identical.

If the two readings are decidedly different in spite of a long time constant in the vtvm, measured voltage is of different amplitudes in opposite polarities. Theoretically, both readings are correct; one is presumed to indicate positive amplitude and the other to indicate negative amplitude. This does not work out in practice. Even though the vtvm is designed to read peak voltages of symmetrical waves, neither adding nor averaging the two readings will give true peak-to-peak voltage of a non-symmetrical wave. •

Licensing & Accreditation

(Continued from page 19)

ual licensing is not the answer."—*Radio TV Serv. Assn., Buffalo, N. Y.*

"We are opposed to (licensing) because it exceeds the province of government to invade small business down to the individual . . . a welter of regulatory red tape and confusion . . . (On certification:) Men who are recognized and certified by manufacturers, and associations in concert with manufacturers, will do a tremendous amount of good."—*Assoc. Radio & TV Serv. Men, Chicago, Ill.*

"By accreditation you could bring up the technician to a certain undisputed level. This could best be accomplished by the RETMA plan."—*Long Island Electronic Technicians Assn., N. Y.*

"Although the original plans (for licensing) are always fair sounding, politics must rear its ugly head and destroy the equity."—*Indianhead Radio-TV Servicemen's Assn., Eau Claire, Wisconsin.*

"Realizing that the least governed are often the best governed and that a licensing act would not be a cure for all ills, we believe it would be the lesser of two evils . . . if it could be written by those engaged in the legitimate service business."—*Macom Electronics Assn., Mt. Clemens, Mich.*

(Continued on page 46)

WHOA, Mr. Serviceman!

DON'T JUST REPLACE—

MODERNIZE

with wide-range, high-compliance

SONOTONE

TITONE
CERAMIC CARTRIDGES



Always install a Sonotone, the original ceramic cartridge—your customers will love you for it. It will start them on the road to high-fidelity—and additional new business for you!

Write for free Sonotone manual today!

New Sonotone Phonograph Modernization Manual includes an up-to-date cross reference and phonograph model index, fully explains how to use Sonotone Ceramic Cartridges. Send coupon below for your free copy, now!



ELECTRONIC APPLICATIONS DIVISION

SONOTONE CORPORATION

Elmsford, New York

SONOTONE CORPORATION, Dept. T
Elmsford, N.Y.

Please send me a free copy of the Sonotone Phonograph Modernization Manual

Name _____

Address _____

City _____ State _____

AMPHENOL

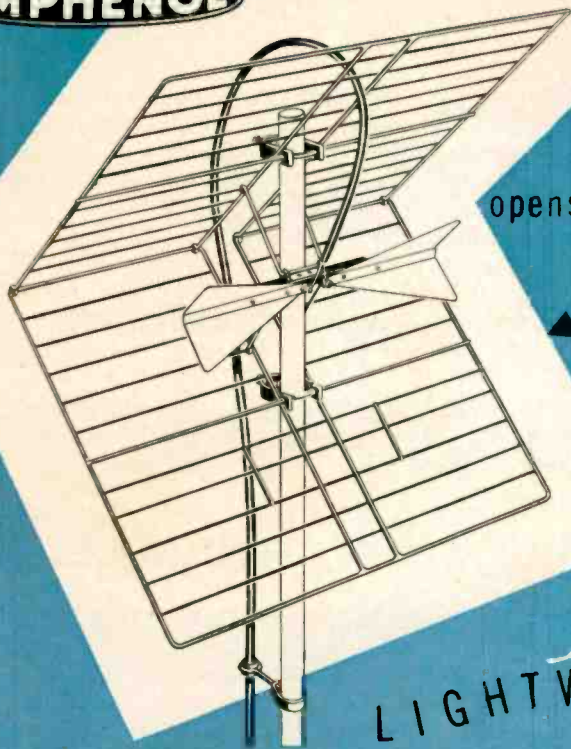

opens like a book!

model 114-093

LIGHTWEIGHT

UHF CORNER REFLECTOR

- easy installation!
- high gain!
- fine directivity!

Fast and easy installation, high db gain, exceptionally fine directivity—these aren't new features, by themselves, but when combined in a single fine antenna, that's news! They have made the AMPHENOL Lightweight Corner Reflector popular alike with dealers, servicemen and set owners. Installers are particularly happy with the Lightweight. When the reflector screens are opened (like a book) the element snaps out and the antenna is easily attached to the mast That's all there is!

Gain rises from 8 db at 470 mc to 12½ db at 890 mc for the single bay model. When two Lightweights are stacked these figures are 11 db to 15 db. Directivity patterns reveal a single strong forward lobe on each channel, single and stacked.

Reflector screens are made of sturdy electro-galvanized steel with a positive rust-resistant chromate conversion seal. The element is heavy gauge aluminum. The Lightweight is a rugged antenna which will give many years of fine service!

All these PLUS features at only \$9.85 list each.

AMERICAN PHENOLIC CORPORATION
Chicago 50, Illinois

In Canada: AMPHENOL CANADA LTD.,
Toronto

AMPHENOL

"Industries should control their own problems in the public interest . . . If they don't, laws are inevitable, and when a political entity has control over business, the gate is opened for all types of skullduggery."—Wichita Appliance Dealers Assn., Kansas.

Fee Regulation

"No, but we would like to have guides for pricing."—Southern Penna. Radio & TV Assn., York, Penna.

* * * * *

"The price a technician charges should be set by him alone. He is the best judge of his costs, rate of profit and operating procedures."—Waterbury TV Technicians Assn., Conn.

* * * * *

"Anti-social and contrary to free enterprise."—Electric League of L. A., Calif.

* * * * *

"We feel this would be dictatorship."—Radio & TV Assn., Springfield, O.

* * * * *

"Economic stability can be maintained (by regulation)."—TV Technicians & Electronics Assn., Joplin, Mo.

* * * * *

"No fee regulation should ever be left in the hands of governmental authorities any more than there should be price or wage controls regulating other business . . . The members of the service industry are businessmen as well as technicians and are entitled to their full rights."—Radio & TV Servicemen, Provo, Utah.

Fees and Unions

"Although we believe employed service people should choose whatever bargaining agent they prefer, TV operations other than self-employed would find their employees would exercise improper control over the management of business."—NATESA.

* * * * *

"The union's objective is to benefit labor . . . as such is not a true representation for an industry."—TV Installation Service Assn., Chicago, Ill.

* * * * *

"Don't believe labor should have complete control. It should be represented by union, management and labor equally."—Long Beach Radio Technicians Assn., Calif.

* * * * *

"We want professional recognition. Most unions are labor and wage conscious."—TV Technicians & Electronics Assn., Joplin, Mo.

Convergence & H-V Circuits

(Continued from page 17)

between the controls for the three guns. For example, varying the green tilt control will also change blue and red tilt somewhat. For best correction in such circuits, back-and-forth adjustment of the controls is necessary.

In the CBS large-screen receiver, five triode sections, each one-half of a 6BL7, are used to achieve horizontal dynamic convergence. A pulse from the flyback transformer is used to trigger a sawtooth generator. Sawtooth output is coupled, as shown in Fig. 3, to three convergence output stages (one for each gun) through a common cathode follower stage. For simplification, only one of the output stages is illustrated in Fig. 3; the others are similar. Sawtooth amplitude for each of the three output amplifiers can be varied through the potentiometer at its grid, which is connected like a volume control. Tilting is achieved through another potentiometer (also three, one for each color). Each pot is connected across a center-tapped winding on the flyback. When the pot's moving arm is centered, no voltage is taken off. On either side of the center position, the arm may tap off a pulse whose amplitude and polarity (degree and direction of tilt) will depend on the position of adjustment. This pulse is combined with the sawtooth pulse at the grid of the convergence output tube to produce the overall shape needed for correction. The convergence output then produces the desired parabolic current waveshape in the inductive load represented by the associated section of the convergence coil.

For vertical dynamic convergence, the sawtooth pulse used is taken from the vertical output tube. Amplitude and tilt are adjusted through center-tapped pots (one of the three vertical tilt controls is shown). This current is then fed through an integrating network, whose output is a parabolic waveshape. A pot for each color (the vertical parabola control) then is used to feed the desired amount of parabola to each of three coils in the convergence yoke. Note that the horizontal and vertical parabolas for any given color are fed to the same winding of the convergence yoke. Isolating inductors are used to prevent interaction, which would deteriorate interlace.

Changes in other adjustments involving the picture tube concern

color purity. In many circuits, the purity coil has been replaced by a permanent magnet, which encircles the neck of the picture tube and looks very much like the centering magnet used on some monochrome receivers. This ring-like device has two tabs, which are kept stationary with respect to each other as the entire magnet is rotated around the neck of the tube to obtain best color purity. If it is desired to increase the strength of the purity magnet, then the two tabs are moved apart.

The field neutralizing coil has also been replaced in some sets. Doing its

work is a ring of eight permanent magnets so mounted that each of them can be varied in strength and direction. (This assembly also eliminates the need for a mu-metal shield.) These magnets are used, after adjustment of the purity magnet, if some areas on the picture tube screen near the edges continue to show some impurity. •

* Between completion of the article and press time, the following new types were announced: 6CB5 horizontal output; 6BL4 damper; 6BK4 voltage regulator. Type number assigned to the RCA 21-in color crt is 21AXP22.

Your Ideal **SECOND** Soldering Tool

NEW
Weller
Junior

for your service truck . . .
service kit . . .
extra bench tool

MODEL
8100
ONLY
\$795
LIST
over 100 watts

This newest Weller Soldering Gun fills your need for an *extra* soldering tool. Its new, compact design includes *all* regular Weller Gun features, at a rating of over 100 watts. Its new, low price makes it as convenient to buy as it is to own!

SEE THE WELLER **Junior** AT YOUR DISTRIBUTOR NOW

Weller **Junior** SOLDERING GUN
805 Packer Street, Easton, Pa.

MFRS' Catalogs & Bulletins

ANTENNA ROTATORS: The need for the antenna rotator and the important features of its performance are the subjects of a new 8-page brochure available from JFD Mfg. Co., 6101-16th Ave., Brooklyn, 4, N.Y. (Ask for No. B 1-3)

INDOOR ANTENNAS: 8-page multi-colored catalog describing a line of indoor antennas is available from RMS, 2016 Bronxdale Ave., N.Y. 62. (Ask for No. B 1-4)

AUDIO RECORDING: Line of audio test products, test records, test tapes and test level indicators, and services available to all audio engineers and enthusiasts are described in a 12-pager (Bulletin C) from The Dubbings Co., 40-10 45th St., L.I.C. 4, N.Y. (Ask for No. B 1-9)

RECTIFIERS; DIODES: Comprehensive 8-pager from International Resistance Co., 401 N. Broad St., Phila. 8, provides data on construction, applications, types, ratings, reference curves on a line of selenium rectifiers and selenium diodes. Catalog SR-1A. (Ask for No. B 1-5)

TEST EQUIPMENT: 38 kits and 42 factory-wired instruments are described in the 14-page 1955 catalog now available from

Electronic Instrument Co., Inc., 84 Withers St., Brooklyn 11, N.Y. (Ask for No. B 1-6)

MAGNETIC TAPE: The characteristics and applications of "Scotch" brand No. 190 "Extra Play" tape are discussed in "Sound Talk" bulletin No. 30 available from Minnesota Mining and Mfg. Co., 900 Fauquier St., St. Paul 6, Minn. (Ask for No. B 1-7)

HI-FI EQUIPMENT: 34 illustrated pages describe a full line of hi-fidelity gear; includes a 5-page discussion of the meaning of hi-fi and tips for selecting units for home installations. Free. Harvey Radio Co., 103 W. 43rd St., N.Y. 36. (Ask for No. B 1-8)

BUSINESS AIDS: "Business Builders Catalogs," 12 pp., features more than 50 items of promotional material, technical literature, and service tools for the radio-TV serviceman. Free. Available as No. PA-37 from CBS-Hytron distributors, or directly from CBS-Hytron, Danvers, Mass. (Ask for No. B 1-1)

TOWERS: Illustrated 8-pager from Tower Structures, Inc., Gregg St., Lodi, N.J. offers important design and fabrication information for technicians interested in antenna tower construction. Write for "Guyed and Self-Supporting Towers" on company letterhead. (Ask for No. B 1-2)

SERVICING DATA: 4-page bulletin released with the "Most-Often-Needed 1955 TV Servicing Information" manual describes this volume and similar annual publications covering TV receivers back to 1947, radios to 1926. Write to Supreme Publications, 1760 Balsam Rd., Highland Park, Ill. (Ask for No. B 1-13)

TRANSFORMERS: More than 100 TV mfrs. and 5800 models are cross-referenced with the correct replacement transformers in Catalog TV-55 just released by Triad Transformer Corp., 4055 Redwood Ave., Venice, Calif. (Ask for No. B 1-10)

POTENTIOMETERS: Definitions of the four different types of potentiometer linearities are found in Bull. No. 753813, "Linearities Defined and Compared," available from Clarostat Mfg. Co., Inc., Dover, N.H. (Ask for No. B 1-11)

MASTER ANTENNAS: RCA's new MI 5185 broadband amplifier, for smaller distribution systems, is described in a new folder, "For the Best in Multiple TV Distribution," Form 3R2468. Write Engineering Products Div., Building 15-1, R.C.A., Camden, N.J. (Ask for No. B 1-12)

INADEQUATE WIRING A MAJOR PROBLEM AFFECTING TV PERFORMANCE

One of the greatest problems of the electrical industry is that of inadequate distribution and insufficient wiring. Systems that are planned to standards that existed years ago when the average residential load was only 25% or less of today's demand are inadequate to main-

tain the capacity and maintain the voltage necessary for the proper performance of all the *usual* appliances and equipment available in the average American home. The extreme sensitivity of a TV receiver is instantly effected in performance by a low voltage condition. This problem

CAN BE SOLVED WITH THE ACME ELECTRIC T-8394M VOLTAGE ADJUSTOR

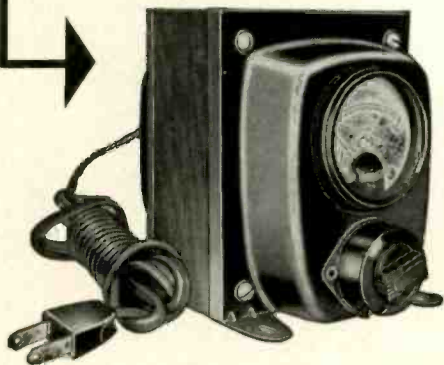

The T-8394M Voltage Adjustor can be used by the service man to reproduce the operating condition about which the customer complains by turning tap switch to the voltage which simulates such condition. For example, customer complains that evening program pictures flicker and shrink. When service man calls next day all operation appears normal — voltage tests out properly. But, by adjusting voltage to 97 volts the condition about which the complaint was made is reproduced. This indicates low voltage condition during evening that can be corrected with a T-8394M Voltage Adjustor.

ORDER FROM YOUR JOBBER

ACME ELECTRIC CORPORATION
MAIN PLANT: 889 Water Street • Cuba, N. Y.
West Coast Engineering Laboratories: 1375 W. Jefferson Blvd. • Los Angeles, Calif.
In Canada: ACME ELECTRIC CORP. LTD. • 50 Northline Road • Toronto, Ont.

Acme  **Electric**
TRANSFORMERS

OBTAIN THE BULLETINS described here by writing on company letterhead to Bulletins Editor, **TECHNICIAN**, 480 Lexington Ave., New York 17, N.Y., listing numbers given at end of each item of interest. Please mention title of position held. Please use coupon on page 40.

New Books

AUDELS HOME APPLIANCE SERVICE GUIDE. By Edwin P. Anderson. Published by Theo. Audel & Co., Publishers, 49 W. 23rd St., N. Y., N. Y. 824 pp. Hard cover. \$4.00.

As a source of extra income, the home appliance repair field has long held a strong appeal for the TV technician interested in drumming up business. The chief drawbacks have been the lack of familiarity with these appliances and the lack of time for studying the principles of operation. In the latter respect, this book can prove invaluable. It not only covers the whole field of major appliances, it also explains in detail the servicing procedures to be followed and the rules for preventive maintenance. Among the appliances covered are: toasters, irons, broilers, electric ranges, refrigerators, washing machines, vacuum cleaners, fans and oil burners. Also included is a particularly thorough treatment of home wiring principles and repairs.

ELEMENTS OF MATHEMATICS FOR RADIO, TELEVISION AND ELECTRONICS. By Bernhard Fischer and Herbert Jacobs. Published by the Macmillan Co., 60 Fifth Ave., N.Y. 11, N.Y.

The authors have divided this book into two sections; part one is non-algebraic, and deals with the fundamentals of arithmetic and their application to electronics; part two goes into negative numbers, literal equations, logarithms and sine and square wave analysis. By discussing all these operations in the light of their application to specific radio-electronic design, the authors have avoided the seeming aimlessness characteristic of books dealing with the mechanics of mathematics. The radio-electronic subjects covered include: inductive and capacitive reactances, meters, the TV test patterns, sound amplifiers, grid bias, Kirchoff's law, oscilloscope deflection sensitivity, and tube characteristics.

EXPERIMENTAL ELECTRICITY FOR THE BEGINNER. By Leonard R. Crow. Published by the Scientific Book Publishing Co., 1102 Shelby St., Vincennes, Ind. 284 pp. Paper cover. \$2.50.

This book has a dual function. It serves, first, as a guidebook for the Crow Beginner's Experimental Kit in Magnetism and Electricity, and second, in its own right, as an excellent introductory volume for those interested in re-examining the fundamentals of electronics. While it is more desirable to use the book in conjunction with the kit, the diagrammatic presentations are so clear that the mechanics and conclusions of the experiments are self-evident. The methods of presentation are refreshingly simple.

The experiments dealing with color make-up, sound, relays, ac and dc motors, and transformers will be found particularly interesting.

NATIONAL ELECTRICAL CODE HANDBOOK. By Arthur L. Abbott and revised by Charles L. Smith. 8th Edition. Published by McGraw-Hill Book Co., Inc., 330 W. 42nd St., N.Y. 36, N.Y. 642 pp. Hard cover. \$7.50.

This valuable reference work which was prepared under the supervision of the National Fire Protection Assoc., deals with the restrictions imposed on all electrical installations by the National Electrical Code. The format of the Code has been retained and exactly the same numbering system is used. A comprehensive index is provided so that the relevant rule for specific wiring or equipment can be quickly located.

Of particular interest to the TV-electronic technician are the sections dealing with the installation of sound equipment and television receivers.

tronic technician are the sections dealing with the installation of sound equipment and television receivers.

FUNDAMENTALS OF COLOR TV FOR SERVICE TECHNICIANS. Prepared by Radio-Electronic-Television Manufacturers Association. Published by John F. Rider Publisher, Inc., 480 Canal St., New York 13, N.Y. 44 pages, paperboard. (Available only through RETMA member companies.)

This compact volume clearly presents the basic principles of the color TV system presently in use. It is divided into five parts: 1) color fundamentals; 2) basic color systems; 3) compatible color TV signal; 4) tricolor picture tubes; and 5) color TV receiver.

HOTTEST IN THE FRINGES..NATION-WIDE! CLEAR BEAM'S BIG

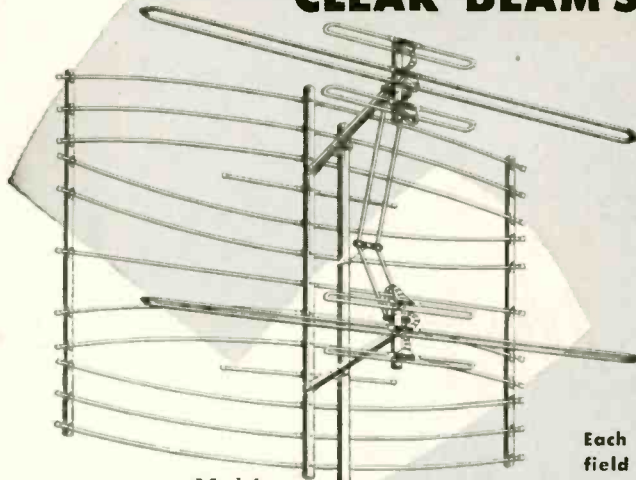

Model
TK1500

TRI-KING

3 ALL-BAND FRINGE ANTENNAS

Each a peak performer in its field . . . a triple threat to any fringe problem . . . with more dollar-for-dollar construction value!

The Tri-King TK1500 offers super fringe performance through better design features. Half wave electrical spacing between dipoles for higher gain on every channel. Positive "back up action" through the use of a full radar screen . . . acclaimed industry-wide as the finest reflector ever designed for ghost rejection and elimination of co-channel interference!

Fully wind tunnel tested. Available in single bay (Model TK1000) and Super, wide spaced array (Model TK1800).

Clear Beam
BIG CHIEF
2 Bay Model BC 12-2

An advanced conical-Yagi with element diameters varied for precision tuning, matched sensitivity and peak performance on high and low band!

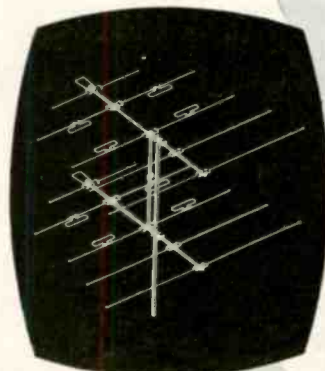

Clear Beam
HUNTER

2 Bay Model MYH 50-2

New wave trap principle gives extremely high gain, sharp directivity, in-phase tuning on all channels. New, flat design for low wind resistance!

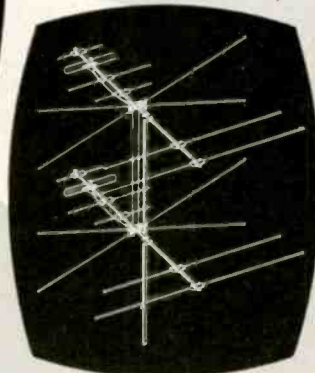

B CLEAR ANTENNA CORP.
BEAM

Canoga Park, Calif. • Chicago, Ill.
affiliated with TEMPO TV products

Warehouses in Seattle, Portland, San Francisco, Honolulu, Dallas, Kansas City, Chicago, Detroit, Baltimore

SERVICE ASS'N REPORTS

Public Relations Drive TSDAP, Philadelphia, Pa.

The Television Service Dealers Assoc. of Phila., 6017 Ogontz Ave., has enlisted the aid of the District Attorney's office and the Better Business Bureau to assist them in a drive on the bait advertising which is now plaguing that city. Funds have been set aside to purchase radio and TV time to solicit recognition for its membership.

Gets BBB Backing OTRSA, Oklahoma City

The local Better Business Bureau went to bat for the Oklahoma Television and Radio Service Assoc., 111 N.W. Ninth, in a 2-page booklet describing the operation of the average TV service shop. A graphic breakdown was provided of the problems and expenses incurred by the TV technician, and suggestions were included to help the customer in selecting the honest serviceman.

At the same time, Harrol Eales, president of OTRSA, was given 2 pages in "Televviewer" magazine to outline the problems which the average technician faces. Two addi-

tional pages were devoted to a question-and-answer discussion of servicing from the consumer's standpoint, and a history of OTRSA, and its role in the community.

Moch Reelected TISA, Illinois

Frank J. Moch of Aide Service Corp., Chicago was unanimously reelected president of Television Installation Service Assoc., 5908 S. Troy St., Chicago, Illinois for 1955. Elected to serve with him were Walt Krzak, 1st vice-pres.; Russ Havill, 2nd vice-pres.; Larry Corlew, secretary; Geo. Hingson, treas.; and Mel Brown, sgt.-at-arms.

Grass Roots Approach NLCESA, Ephrata, Pa.

The Northern Lancaster County Electronic Service Assoc., P.O. Box 264, one of the newest groups in the Federated Radio Servicemen's Assoc. of Pennsylvania, hired a display booth at the local fair in Ephrata, Pa., to bring attention to their cause. Their feature attraction was an RCA TV Eye closed circuit

TV camera, which they had connected to several sets around the fair. In addition, there were chassis, tubes, parts and equipment, and a drawing for 10 prizes donated by the group. Over 20,000 tickets, all from visitors to the booth, were involved in the drawing.

Services Offered To Educational TV Station-RTSA, Pittsburgh, Pa.

The Radio and TV Servicemen's Assoc. of Pittsburgh, P.O. Box 6844, has offered technical assistance to the local educational TV outlet, WQED, Ch. 13, to help in clearing up their reception difficulties. The station's poor coverage is believed due to the fact that most of the receivers in the area have not been adjusted to receive their signal. In "Tuning Adjustment Project," the members of RTSA, working with the engineering dept. of WQED, will adjust 25 carefully chosen sets distributed over the local area. They will then file reports on each receiver with WQED so that the station will have a clear picture of the field pattern being radiated.

**NEW STOCK OF FIRST QUALITY
TELTRON TUBES**
GUARANTEED LOWEST PRICE EVER!
All tubes individually boxed
and unconditionally guaranteed

FREE BONUS OFFER!
Model 625K
• Illum. gear-driven "Speed Rotachart"
• New lever-action switches for individual testing of every element
• Tests all conventional and TV tubes
This Eico Tube Tester is yours FREE when you buy \$199 worth of tubes or more within 90 days at Teltron.
May be bought outright from Teltron for \$34.95.

TYPE	PRICE	TYPE	PRICE	TYPE	PRICE	TYPE	PRICE
1A7GT	.53	6AL5	.43	6CU6	.95	12AV7	.73
1N5GT	.51	6AQ5	.48	6F6	.42	12AX4GT	.60
1L4	.51	6AR5	.48	6F5GT	.44	12AX7	.61
1L6	.51	6AU5GT	.60	6H6	.50	12A27	.65
1L6C	.49	6AU6	.43	6J5GT	.49	12B4	.72
1N5GT	.51	6AV5GT	.60	6K6GT	.39	12BA6	.46
1T4	.51	6AV6	.37	6L6	.78	12BA7	.58
1U5	.43	6AX4GT	.60	6S4	.41	12BE6	.46
1X2	.65	6AX5GT	.60	6S8GT	.65	12BY7	.65
2A3	.35	6BA6	.56	6SA7GT	.45	12B27	.63
2A7	.35	6BA7	.58	6SK7GT	.45	12SL7GT	.60
304	.53	6BE6	.46	6SL7GT	.60	19T8	.71
305GT	.51	6BF5	.48	6SQ7GT	.38	25L6GT	.41
3S4	.48	6BF6	.48	6T8	.71	25Z5	.55
3V4	.48	6BG6G	1.18	6U8	.76	25Z6GT	.36
5U4G	.43	6BH6	.51	6V3	.80	35B5	.48
5V4G	.49	6BJ6	.51	6V6GT	.48	35C5	.48
5Y3GT	.30	6BK5	.75	6W6GT	.53	35W4	.33
5Y4G	.40	6BK7	.78	6X4	.37	35Y4	.42
6A8	.40	6BN6	.90	6X5GT	.38	35Z5GT	.33
6K7	.40	6BQ7	.85	6X8	.80	50A5	.49
6Q7	.40	6BL7GT	.78	7F8	.49	50B5	.48
6AF4	1.02	6BQ6GT	.83	7N7	.49	50C5	.48
6AC5	.52	6BY5G	.60	12AL5	.43	TYPE 80	.40
6AH4GT	.65	6BZ7	.95	12AT6	.37	117Z3	.33
6A15	.96	6C4	.41	12AU6	.43	117Z6GT	.65
6AK5	.96	6CB6	.51	12AU7	.58		

GIFT OFFER! One 6BG6G Tube will be shipped FREE with any order accompanying this ad.



CAP-CHECK!

the only precision instrument that checks condensers WHILE IN THE CIRCUIT!

- Checks condensers in the circuit and eliminates the time consuming need of unsoldering and resoldering.
- The only direct reading microfarad meter.
- Convenient jacks for using CAP-CHECK with frequencies from audio generator or RF generator.
- Large easy-to-read dial. A flip of the switch instantly gives the condition of the capacitor without removing it from the circuit.
- Eliminates the need for carrying multiple units. Has built in voltmeter, an ohmmeter, plus the capacity meter — All using one master function selector switch.
- Uses a 4 1/2" precision microammeter.
- Engineered and precision made to give dependable and accurate service.
- Each instrument backed by written registered warranty and conforms to standard RTMA guarantee.

AC only **\$44.95**

CAP-CHECK gives High Performance at Low Low Cost!!
See your local jobber or write for full information.

IS Instruments for Service Inc.
96 SOUTH GRAND AVENUE, BALDWIN, LONG ISLAND, N. Y.

SPECIALS!
Till February 1st.

1B3GT	.56	6W4GT	.37
1R5	.42	12A7	.55
1U4	.42	12SA7	.42
6AC7	.59	12SK7	.40
6CD6G	.99	12SQ7	.36
616	.49	25BQ6GT	.73
6SN7GT	.49	50L6GT	.42

SAME DAY SERVICE
48 Hour Postal Delivery To West Coast

TERMS: Save all freight and postage charges. All orders accompanied by full remittance will be shipped POSTAGE PAID anywhere in the continental U.S.A. 25% deposit required on C.O.D.'s. Minimum order \$10.00. Open accounts to rated firms only.

TELTRON ELECTRIC COMPANY
DEPT T-1 428 Harrison Ave., Harrison, N. J. Humboldt 4-9848

News of Industry

Bill Miller, mgr. of the community operations division of Jerrold Electronics, was one of the survivors of that Northeast Airlines crash in New Hampshire. He was on his way to open the community TV system at Berlin, N.H., when the plane went down. He escaped with minor head injuries. Nice afterthought: Milt Shapp, Jerrold president, sent \$1,000 checks to the families of the co-pilot and flight supervisor who perished in the crash.

Birthdays and Anniversaries: Setchell-Carlson Inc., St. Paul, Minn., TV mfr. recently celebrated its 20th anni-



A. P. Chermak, B. Setchell, C. D. Carlson

versary. Cake-cutting was done by the founders, Bart Setchell, pres., C. Donald Carlson, secretary-treas., and Alice P. Chermak, vice-pres. . . Plans afoot for a big celebration at JFD Mfg., Brooklyn, N.Y., next month on the occasion of their 25th birthday. . . The 50-millionth U.S.-built General Motors car brought a citation to Technical Appliance Corp. of Sherburne, N.Y., for their role as a supplier of antenna equipment.

It was moving day — at Precision Apparatus Co., Inc. With their meter mfg. subsidiary, Pace Electr. Instr. Co., they relocated to brand new quarters at 70-31 84th St., Glendale 27, L.I., N.Y. . . The opening of Insuline Corp.'s new plant in Manchester, N.H., brought out more than 150 city, state and federal officials, and customers of the company. Extensive radio and TV coverage was provided for the ceremonies, which were highlighted by the presentation of a plaque to Samuel J. Spector, Insuline pres.

CBC Electronics Co., Inc. has completed the move to their new location at 2601 N. Howard St., Phila. . . Fryling Electric Products Inc., a subsidiary of Erie Resistor Corp., has opened its new plant in Holly Springs, Marshall County, Miss. . . Motorola's Communications and Electronics Div. recently completed its new research and development lab in Riverside, Calif. . . Work has begun on Raytheon's new 1½-million dollar engineering and research lab at Wayland, Mass. . . Shure Bros. Inc. are planning to construct a modern, 1-story plant in Evanston, Ill. to serve as the new home for the entire Shure organization. . . Henry L. Crowley & Co., West Orange, N.J. has been purchased by Aerovox.



The ASD TELEVISION Tube Tester

NET \$124.50

MODEL TV-20

- NO ROLL CHART
- PRACTICALLY NO SET-UP
- HIGH GAS SENSITIVITY
- 20 CONNECTED SOCKETS
- Now includes all of the latest 600 mil, color TV, and most of the popular radio tubes.

The tube tester designed especially for the television servicemen. With this tester you can test an entire set of TV tubes in a few minutes. This means less time spent per job, more profit, more tube sales and fewer call-backs.

Write for Details or See Your Distributor.

Developed and Manufactured by

AMERICAN SCIENTIFIC DEVELOPEMENT CO.

334-336 S. Main St., Ft. Atkinson, Wisc.

KESTER



Absolutely non-corrosive and non-conductive, KESTER "RESIN-FIVE" CORE SOLDER contains an activated type of resin that gives you that fast, positive action on all your jobs . . . including the most difficult.



KESTER SOLDER COMPANY
4264 Wrightwood Avenue • Chicago 39, Illinois
Newark 5, New Jersey • Brantford, Canada

SOLDER

CLEAR TV PICTURE PERMANENT INSTALLATION—

WITH A

WINPOWER TV TOWER

Permanent, one-man tower erection—fewer guy wires—no special tools. Offer better reception at lowest cost—eliminate mounting troubles and service calls.

Adapter locks most or serves as rotor bracket.

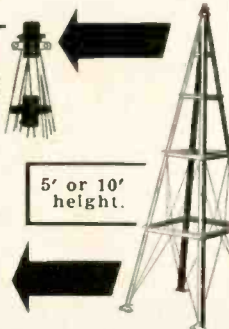

"All-Angle" feet fit any roof.

5' or 10' height.

WRITE FOR FREE FOLDER TODAY!

WINPOWER
NEWTON, IOWA

CASH IN ON COLOR!

Exclusive Details on RCA 21" Color Set Revealed For First Time In

ELEMENTS of TV SERVICING

By Abraham Marcus, (co-author of famous "Elements of Radio" which has sold over 1,000,000 copies!) and Samuel E. Gendler.

Gives New Money-Making Tips, Time-Saving Methods of TV Repair & Servicing. Covers in Detail all Phases of Black-&-White and Color Installations!

In 544 pages—packed with diagrams, tables, charts, circuitry—this clearly-written book wraps up the whole subject of TV servicing so that anyone can make money in it! You see how to rig an antenna quickly . . . how to cure picture troubles fast . . . valuable service hints . . . how to trouble-shoot . . . how to get and keep customers . . . tips for profitable bench servicing . . . and many more. **COLOR CHAPTERS ALONE ARE WORTH MANY TIMES PRICE OF BOOK!** Color TV theory . . . color transmission . . . components of color receiver explained . . . comparison of color & B & W systems . . . blueprint of color picture tubes.

USE 10 DAYS FREE! Coupon below brings you "Elements of TV Servicing" on FREE trial for 10 days, without obligation. But you must mail now! Offer Limited!

Prentice-Hall, Inc., Dept. M-T-155
Englewood Cliffs, N. J.

Send me for 10 DAYS' FREE TRIAL "Elements of TV Servicing." I will return it in 10 days and pay nothing—or keep it and send \$7.35 (plus small postage).

Name
Address
City Zone State

SAVE! Send \$7.35 with coupon, we'll pay postage & handling! Same return privilege.

News of Industry (Cont'd)

Names in the News: Robert G. Marchisio to v.p. at CBS-Hytron, in charge of all phases of operation. . . Irving P. Wolfe, new eastern sales mgr. for Walsco Electronics. . . Harold J. Schulman, John F. Rider and TECHNICIAN'S Al Forman, as new chairman, vice-chairman, and member, respectively, of RETMA's Service Committee. . . Robert E. Kessler, with DuMont since '36, to mgr. of their Communications Prod's Div. . . E. Gordon Burlingham to sales service mgr. at CBS-Hytron, with offices at the Danvers, Mass., plant. . . Donald R. Fleming, as mgr. of Trav-Ler's new factory distributing branch in San Francisco. . . E. Alvin Rich, to industrial sales rep for the New England area for Permoflux Corp., Chicago.

South of the Border — far south — antenna towers are big business. Here's a 150-footer going up at Valencia, Venezuela. This one is of aluminum con-

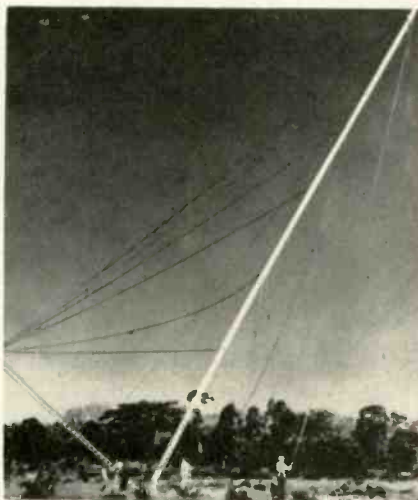

struction, manufactured by Alprodeco Inc., Mineral Wells, Tex., who point out that tower weighs only 1½ lbs. per foot, can be installed in half-a-day by a 5-man crew.

New Names: Tape Recorders Inc., 1501 W. Congress St., Chicago, manufacturing a line of magnetic tape recorders marketed as the "Tri Fy" line. President of the new company is Hugh Daly. . . First aluminized picture tubes manufactured by a West Coast mfr. are being turned out by Calvideo Tube Corp., Los Angeles, according to Steve Tidik, Calvideo's v.p.

RETMA's role, in TV technician training, was presented in detail at the 48th annual convention of the American Vocational Association held Dec. 3-7th in San Francisco. Panel discussion, under A. Coumont, RETMA service coordinator, outlined instructional material developed by RETMA for use by vocational instructors throughout the country.

FLY-BACK INTERVAL & INDUCTANCE CHECKER

AT A GLANCE!



NO DISCONNECTING NECESSARY

EXCLUSIVE

SECO FLY-BACK INTERVAL CHECKER

MAKE THIS 3 WAY CHECK:

1. Fly-back interval (Exclusive Feature!)
2. Checks flyback transformers individually.
3. Checks yokes individually.

See your Jobber or write for literature and prices.

SECO MFG. CO. 3015 PENN. AVE. S. MINNEAPOLIS, MINN.

The Secret Is In The Lips

JFD "LITTLE GIANT" LIGHTNING ARRESTER

Look for the exclusive strain-relief patented retaining lips that protect your lead-in—VHF or UHF.



U. S. Pat. Nos. 2,654,857 D-159,330 D-4664

You see positive contact made.

No. **AT105** (for wall or window sill mounting) **\$1.25** list

No. **AT105S** (with stainless steel strap for universal mounting) **\$1.50** list

Look to JFD for Engineering Leadership

JFD MFG. CO., Inc., Brooklyn 4, N. Y.
INTERNATIONAL DIVISION
15 MOORE ST. N. Y. C.

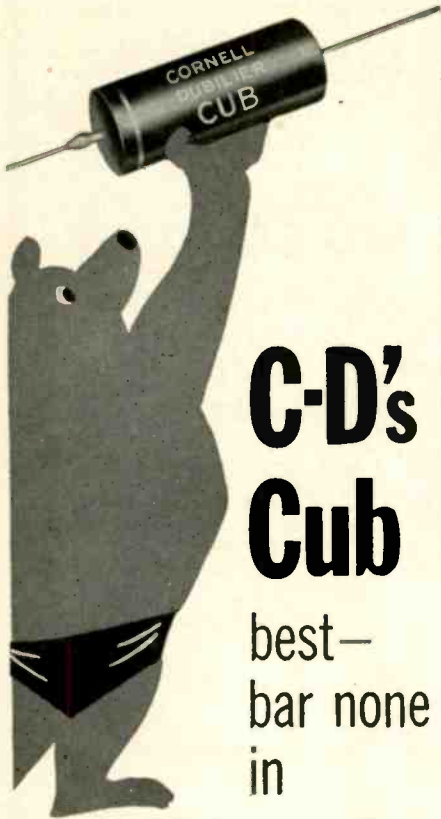

**C-D's
Cub**

best—
bar none
in

**molded tubular
capacitors**

The C-D "Cub" capacitor has proven itself the best on the market today—by out-lasting, out-performing, out-selling any other replacement capacitor for radio or TV. For consistent high quality—always rely on C-D, the only tubulars with the built-in extras required in servicing sets today. That's why distributors *who know*, carry the complete C-D line.

Special! "Cub-Kit" with bonus plastic service dispenser. IT'S FREE!

Ask your C-D Distributor. He's listed in your local Classified Telephone Directory.

CONSISTENTLY
**CORNELL-
DUBILIER**
DEPENDABLE



THERE ARE MORE C-D
CAPACITORS IN USE TODAY
THAN ANY OTHER MAKE.

PLANTS IN SO. PLAINFIELD, N. J.; NEW BEDFORD, WORCESTER AND
CAMBRIDGE, MASS.; PROVIDENCE AND HOPE VALLEY, R. I.; INDIANAPOLIS,
IND.; SANFORD AND PUGUAY SPRINGS, N. C.; SUBSIDIARY, RADIART
CORP., CLEVELAND, OHIO.

News of Industry (Cont'd)

Packaging News: Jensen Industries has cooked up an attractive deal for the retailer. With an order of 10 Jensen diamond needles he receives, without charge, a gray metal strong box. . . **General Electric** is now packing their 1N72 and 1N64 replacement germanium diodes in plastic envelopes mounted on yellow and blue cards. One hundred diodes are mounted on each card: 16 in packs of 5, and 20 in individual packs.

Electronics Measurements Corp., 280 Lafayette St., N. Y. 12, has extended "Display Packaging" to their line of test equipment. Each EMC instrument is pictured actual size on the box lid, and its main operating features are given, together with the model number and type. New counter display introduced by Cornish Wire Co., 50 Church St., N. Y., contains 5 coils—each 100 ft.—of their No. 520 tubular TV twin lead.

"The largest parts distributor location in N.Y. state," is the title claimed for Rochester Radio Supply's new home in downtown Rochester. The building con-



tains more than 35,000 sq. ft. and has parking area for 120 cars. It was formerly occupied by one of the country's largest automobile dealers.

New RCA Color TV Parts

Announcement that RCA was in commercial production on its 21-in. 3-gun color tube was shortly followed by publication of data on new tubes and other circuit components for use in the receiver designed to handle the larger pix tube.

The cathode-ray tube, which has a viewing area of 250 sq. in., is now being delivered to set manufacturers at the same price that was originally charged for the 15-in. color tube. Using a 70-degree deflection angle, the tube is slightly shorter than its 15-in. predecessor. It uses a light-weight metal shell.

Associated circuit components include: Deflection Yoke 230D1, Converging Magnet Assembly 231D1, Dynamic-Convergence Inductor Packs 223R1 and 224R1, Flyback Transformer 246T1 and Vertical-Output Transformer 247T1. New tubes include horiz. output 6CB5, shunt voltage regulator 6BK4 and damper diode 6BL4.

**They're new...
and go in fast!**

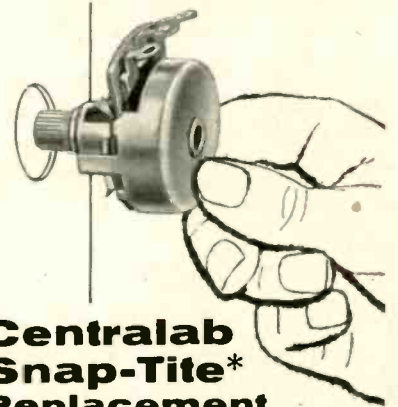

**Centralab
Snap-Tite*
Replacement
Controls**

75¢ at your distributor
suggested list price

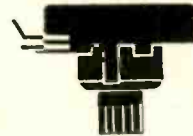

**Speed servicing of "hidden"
or rear-end TV volume controls**



Two fingers are all you need to install a Snap-Tite. Just push it into the chassis mounting hole — it snaps into place.

You need no tools — no nuts, lock-washers, or other hardware.



Six spring clips grip panel for positive, non-twisting mounting.

Shaft is molded, high strength polystyrene, fingertip knurled and slotted for screw-driver adjustment. Extends 1/2" from face of mounting surface.



Snap-Tite replaces any "short-shaft" standard control — and, at 45¢ suggested net, costs you about 35¢ less! You have less stock to carry — ten values replace 75% of current rear-end TV controls.

Order a supply of Centralab Snap-Tite Replacement Controls today from your Centralab distributor.

Send coupon for new Centralab Catalog No. 29 describing this and other new Centralab developments.

*Trademark
Centralab

--- TEAR OUT COUPON AND MAIL TODAY! ---

CENTRALAB, A Division of Globe-Union Inc.
943-A E. Keefe Avenue, Milwaukee 1, Wis.

Send me new
Centralab Catalog No. 29

Name.....

Company.....

Address.....

City..... Zone..... State.....

8-3454-A

News of the Reps

Chicagoland chapter of "The Reps" sponsored a 2nd report on Color TV recently which was attended by over 200 reps. **Kenneth Prince**, exec.-secy. of EP&EM, was the moderator, of the four-sided discussion which featured talks by **Jim Brown** of CBS-Hytron, **Harry Alter** of the Harry Alter Co., **Ed Lethane**, mgr. of sales development of CBS, and **Motorola's J. B. "Kip" Anger**.

The Mid-Lantic chapter of "The Reps" reports that **Stanley A. Harris** has moved to larger offices at 317 Chestnut St., Needham 92, Mass., and **Robert L. Wilkinson** has settled into new offices at 707 Stevenson La., Towson, Md.

The number of new senior and associate members recently added to the Buckeye chapter of "The Reps," brings the total membership to 22 senior and 41 associate members.

David Kubrick Co., 200 W. 34th St., N.Y., has been named to represent Tunkl Industries' line of Vidonair indoor TV antenna in the N.Y. metropolitan area and northern N.J. **Sidney H. Gatty**, Margate, N.J., will be the Vidonair rep in Phila., Balt. and Washington, D.C. . . **Sheldon Electric Co.**, Irvington, N.J., mfr. of TV picture tubes has appointed 2 new reps: **Geo. J. Rodgers**, 198 Old Farm Rd., Springfield, Mass., for the state of N.Y. and **John Mustico** of Foster Rd., Phila., for Pa., Del. and Southern N.J.

Technical Appliance Corp., Sherburne, N.Y., has named the **Bob Cox Sales Co.**, 1411 East Bates Ave., Parkway, Englewood, Col., to represent the Taco line in Col., Utah, Wyo., and N.M. . . **Tri-Onie Sales, Inc.**, Detroit, is the new Michigan industrial sales rep for the **Electronics Div.**, **Erie Resistor Corp.** for the state of Mich. . . The appointments of **Allen S. Nace**, 7601 Parkview Rd., Brecksville, as industrial rep, and **James and Frank A. (Doc) Daugherty**, 1120 Croyden Rd., Cleveland, as distributor rep, for the state of Ohio excepting Dayton and Cincinnati, have been announced by **Cehtralab Div.** of **Globe-Union Inc.**

Jack Brown Assoc., 25 Beaumont Circle, Tuckahoe, N.Y., was recently named rep for metropolitan N.Y. and northern N.J. by **Supreme Publications**, 1760 Balsam Rd., Highland Park, Ill. Supreme appointments also went to **David Ellis Co.**, Altadena, Calif., **Eugene L. Park, Jr.**, Feasterville, Pa., and **Douglas Sales Co.**, West Richfield, O.

Bob Miller Sales Co., 805 Eldorado, Clearwater Beach, is now handling sales of **General Instrument Co.'s GI converter** to wholesalers in Fla. **Bittan-Boenecke Co.**, of 210 North Sixth St., Camden, N.J., was appointed GI rep for the Eastern Pa. territory, Wash., D.C., and Md.



"Watch that old dame.
She uses
a JENSEN NEEDLE."

AUDELS TV-RADIO SERVICE LIBRARY

HERE IS LATE INFORMATION IN A HANDY FORM FOR RADIO AND TELEVISION REPAIRMEN, SERVICEMEN AND STUDENTS

2 VOLS. \$6 COMPLETE \$1 A MONTH PAY ONLY

AUDELS T.V.-RADIO SERVICE LIBRARY—Highly Endorsed—1001 Facts—Over 1552 Pages—625 Illustrations, Diagrams of Parts. Presents Important Subjects of Modern Radio, Television, Industrial Electronics, F.M., Public Address Systems, Auto, Marine & Aircraft Radio, Phonograph Pick-Ups, etc.

IT PAYS TO KNOW!

The Basic Principles—Construction—Installation—Operation—Repairs—Trouble Shooting. Shows How to get Sharp, Clear T.V. Pictures. Install Aerials—How to Test, Explains Color Systems, Methods of Conversion, Terms, etc. Includes Ultra High Frequency (U.H.F.)—Valuable for Quick Ready Reference & Home Study. Tells How to Solve T.V. & Radio Troubles—Answers Your Questions.

Get this Information for Yourself.
7 DAY TEST—ASK TO SEE IT!

MAIL ORDER

AUDEL, Publishers, 49 W. 23 St., N.Y. 10, N.Y. Mail AUDELS T.V. RADIO SERVICE LIBRARY 2 Vols. \$6 on 7 days free trial. If O. K. I will remit \$4 in 7 days and \$1 monthly until \$6 is paid. Otherwise I will return them.

Name _____
Address _____
Occupation _____
Employed by _____ TC

COMPLETELY SERVICE... COLOR TV with only two NEW instruments!



\$4995
NET

RAINBOW GENERATOR Model 150 Patent Pending

NEW CIRCUITS incorporated in this instrument greatly simplify the TEST and ALIGNMENT of color TV circuits. NEW LINEAR PHASE SWEEP produces the COMPLETE PHASE RESPONSE CURVE, assuring greater accuracy with faster alignment and elimination of color bar drift problems.

APPLICATIONS

- MASTER PHASE CONTROL test and alignment
- CHROMA DEMODULATOR test and alignment (either I/Q or R-Y/B-Y)
- QUADRATURE TRANSFORMER test and alignment
- MATRIX CIRCUIT test and alignment
- BURST AMPLIFIER test and alignment
- PHASE DETECTOR CIRCUIT alignment for reference oscillator
- REACTANCE CONTROL and REFERENCE OSCILLATOR adjustment
- 3.58 MC TRAP alignment
- TROUBLESHOOTING and PHASE ALIGNMENT in the home by picture patterns.



\$7995
NET

WHITE DOT GENERATOR Model 160

THE WHITE DOT GENERATOR ENABLES COMPLETE ALIGNMENT OF ALL COLOR CONVERGENCE CIRCUITS PLUS SWEEP CIRCUIT LINEARITY AND SIZE, AS WELL AS GENERAL TROUBLESHOOTING BY SIGNAL TRACING.

APPLICATIONS

- DYNAMIC CONVERGENCE—vertical and horizontal test and adjustment
- DC CONVERGENCE—test and adjustment
- DEFLECTION COIL—positioning for best convergence
- BEAM MAGNETS—alignment for best convergence
- DYNAMIC PHASE ADJUSTMENT—vertical and horizontal
- FOCUS—test and adjustment of DC and dynamic focus
- TROUBLESHOOTING of all circuits affecting convergence
- LINEARITY—test and adjustment of horizontal and vertical sweep linearity

FREE LITERATURE ON REQUEST

WIN-TRONIX

WINSTON ELECTRONICS, INC.

Dept. 105 4312 Main Street
Philadelphia 27, Pa.

COMING JAN. 15!

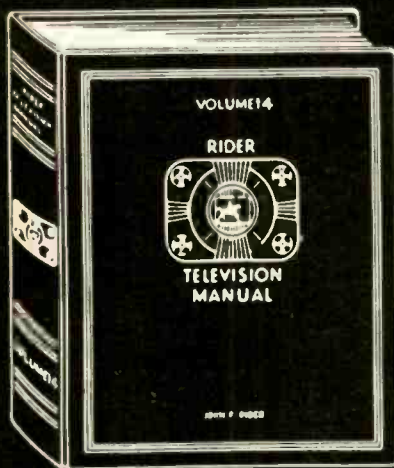

RIDER'S TV 14

LIMITED PRINTING.

*tell your jobber to
reserve your copy now!*

only \$24.

ADVERTISERS INDEX JANUARY, 1955

Acme Electric Corp. 48
Allied Radio Corp. 55
American Phenolic Corp. 46
American Scientific Development Co. 51
Audel, Publishers 54

B & K Manufacturing Co. 39

CBS-Hytron Div., Columbia
Broadcasting System, Inc. 37
Centralab Div., Globe-Union Inc. 6, 53
Certified Tube Co. 11
Channel Master Corp. 8, 9
Clear Beam Antenna Corp. 49
Cornell-Dubiller Electric Corp. 12, 53
Crown Controls Co., Inc. 44

Du Mont Laboratories, Inc., Allen B. 7

General Cement Manufacturing Co. 4, 5

Hickok Electrical Instrument Co. 33

Instruments for Service, Inc. 50
International Resistance Co. Cover 2

Jensen Industries, Inc. 54
JFD Manufacturing Co., Inc. 52

Kenwood Engineering Co., Inc. 55
Kester Solder Co. 51

Mallory & Co., Inc., P. R. 29
Moss Electronic Distributing Co., Inc. 10

Prentice-Hall, Inc. 52
Pyramid Electric Co. 56

Radiart Corp. 12
Radio Corporation of America 35, Cover 4
Raytheon Manufacturing Co. 3
Rider Publisher, Inc., John F. 55

Seco Manufacturing Co. 52
Sonotone Corp. 45
Sprague Electric Co. Cover 3
Sylvania Electric Products, Inc. 31

Teltron Electric Co. 50
Trio Manufacturing Co. 41

University Loudspeakers Inc.
Section 2, pp. 1 & 4

Walsco Electronics Corp. 2
Weller Electric Corp. 47
Winpower Manufacturing Co. 52
Winston Electronics, Inc. 54

While every precaution is taken to insure accuracy, we cannot guarantee against the possibility of an occasional change or omission in the preparation of this index.

KENCO KATE SAYS

**"NO
INSTALLATION
PROBLEMS
when you use
KENCO
MOUNTS"**

Patented Kenco Eave Mounts

Easily mounted on hanging rafters or trim boards of eave. Eliminates need for drilling into brick or masonry walls. Ideal for buildings with extended roofs. Hot dip galvanized.

Available in 3 sizes:
Model # 122 . . . 22" Eave Mount
Model # 128 . . . 28" Eave Mount
Model # 148 . . . 48" Eave Mount

OTHER KENCO PRODUCTS: All-Position Mounts; Parapet Mounts; Sky Struts; "Snap-In" Wall Brackets; "Snap-In" Chimney Mounts; Z-Type Chimney Mounts; Lag Screws and Hardware.

KENWOOD ENGINEERING CO., INC.
Kenilworth, New Jersey

FREE

**1955
308-PAGE
ALLIED
ELECTRONIC
SUPPLY
CATALOG**

Send for It

*Everything in Electronics
For Service Technicians and Engineers*

Get the complete, up-to-date 1955 ALLIED Catalog. It's packed with the world's largest selection of TV and radio parts and accessories, test instruments, Hi-Fi systems and components, P. A. systems, tubes, tools—everything for service work and industrial electronic application. Depend on ALLIED for fast shipment from the world's largest stocks—save time and money. Send today for your FREE 308-page ALLIED Catalog.

ALLIED RADIO CORP., Dept. 25-A-5
100 N. Western Ave., Chicago 80, Ill.

Send FREE 1955 ALLIED Catalog

Name _____
Address _____
City _____ Zone _____ State _____

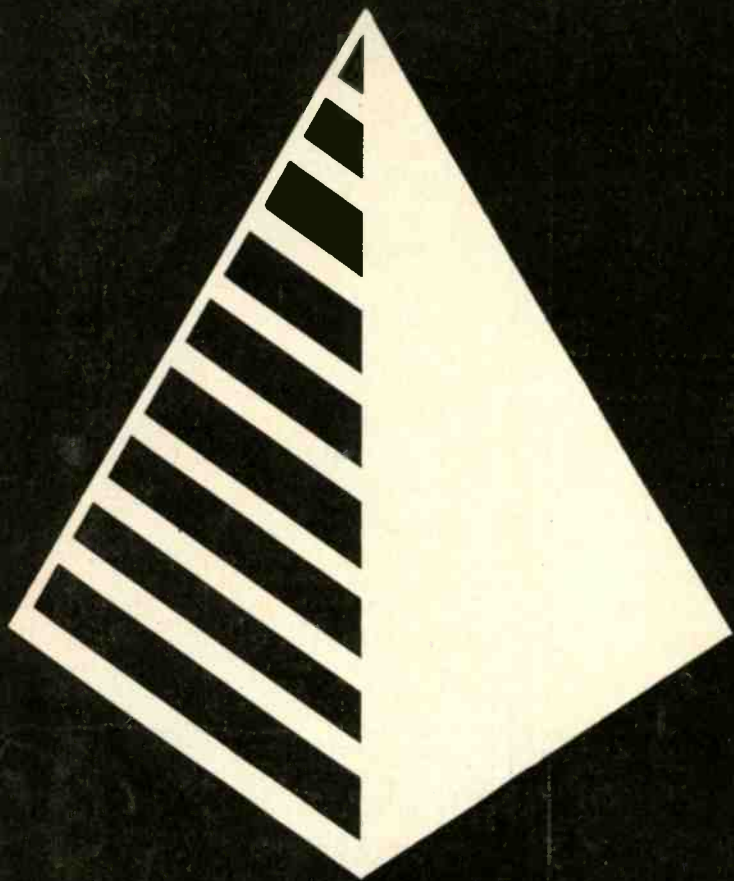

Better for you

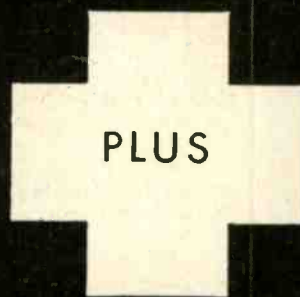

*Pyramid will now
be listed in
Photofact folders.*

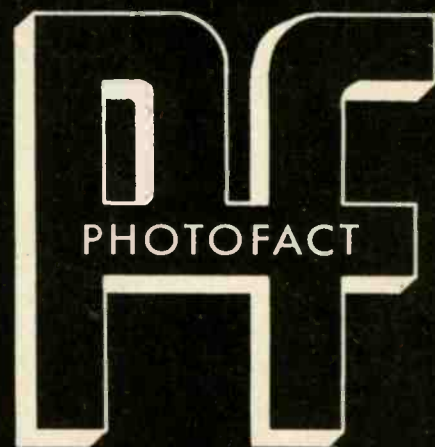

Pyramid has joined the select group of manufacturers who participate in this most valuable of all service aids to make available to you an immediate cross reference between the set manufacturer's part and the part number of the exact Pyramid equivalent.

You will find Pyramid capacitors as original components in sets bearing such famous brand names as

RCA • GE • CBS • Arvin • DuMont • Zenith • Raytheon • Emerson
Motorola • Sylvania • Packard-Bell • Hallicrafters • Westinghouse • Hoffman
and at leading parts distributors everywhere.

 PYRAMID ELECTRIC CO., 1445 Hudson Boulevard, North Bergen, N. J.

capacitor replacements

FOR SETS OF THE MONTH

ADMIRAL CHASSIS 17XP3

Symbol No.	Rating μF @ WVDC	Admiral Part No.	Sprague Replacement
C206	4 @ 50	67B27-3	TVA-1303
C214	40 @ 200	67A4-21	TVA-1511
C410	10 @ 475	67A4-22	TVA-1802
C502	200 @ 150	67D15-118	TVL-1431
C503	100 @ 300/60 @ 200/ 10 @ 150/20 @ 50	67D15-117	TVL-3562 TVA-1406
C504	100 @ 300	67D15-119	TVL-1578

HOFFMAN CHASSIS 306-21, 308-21

Symbol No.	Rating μF @ WVDC	Hoffman Part No.	Sprague Replacement
C103	5 @ 50	4209	TVA-1303
C801	200 + 100 + 40 μF	4204A	TVL-4561
C802			
C803			

DUMONT CHASSIS RA-321, -322

Symbol No.	Rating μF @ WVDC	DuMont Part No.	Sprague Replacement
C286	80 + 40 + 10 + 4 @ 350	03151425	TVL-3792 TVA-1601
C287	80 + 10 @ 350	03151427	TVL-2672
C288	5 @ 100	03138362	TVA-1402
C633	100 @ 50	03138770	TVA-1310
C634	25 @ 50	03138760	TVA-1306
C635	10 @ 350 (SP)	03250421	R-1468
C637	80 + 80 @ 400	03151423	TVL-1675 TVL-1675
N201	Integrator Plate	88000631	V-1

OLYMPIC CHASSIS 14"-AD, 17"-AE

Symbol No.	Rating μF @ WVDC	Olympic Part No.	Sprague Replacement
C1	10 + 10 @ 350/150 + 150 @ 150		R-1650
C2	150 @ 150		TVA-1422
C3	150 @ 150/100 @ 50/ 80 @ 25		R-1651

Sprague makes more capacitors . . . in more types . . . in more ratings . . . than any other capacitor manufacturer. Send 10¢ for the 65-page giant seventh edition TV Replacement Manual to Sprague Products Co., 65 Marshall St., North Adams, Mass., or get it FREE from your Sprague distributor.

PHILHARMONIC MODEL 54CM21 etc.

Symbol No.	Rating μM @ WVDC	Philharmonic Part No.	Sprague Replacement
C19	4 @ 450		TVA-1303
C42	80 + 40 + 20 @ 350		TVL-3645
C43	40 @ 350/100 @ 200/ 100 @ 50/25 @ 25		TVL-4637 TVA-1205

RCA CHASSIS KCS87C, KCS87D

Symbol No.	Rating μF @ WVDC	RCA Part No.	Sprague Replacement
C114	100 @ 250	79314	TVL-1535
C132	80 @ 400/80 @ 200	79147	*TVL-3764
C134	100 @ 400	79700	TVL-1760

* Parallel 40 μF sections.

SPRAGUE "T-C" RULE



Use this handy pocket-size Sprague Temperature Coefficient Rule to find quickly the values of stock N750 and NPO type ceramic capacitors to connect in parallel to equal a capacitor of desired intermediate temperature coefficient of the required capacitance.

COLOR CODE CHARTS

Complete charts for color codes on all types of ceramic capacitors are on the back face of this rule.

Get your Sprague "T-C" Rules now from your Sprague distributor, or directly from Sprague Products Company, 65 Marshall Street, North Adams, Massachusetts. Only 15¢ each.

DON'T BE VAGUE...INSIST ON

SPRAGUE

(Distributors' Div. of the Sprague Electric Co.)

GET BETTER PERFORMANCE From TV-Deflection and High-Voltage Circuits . . .

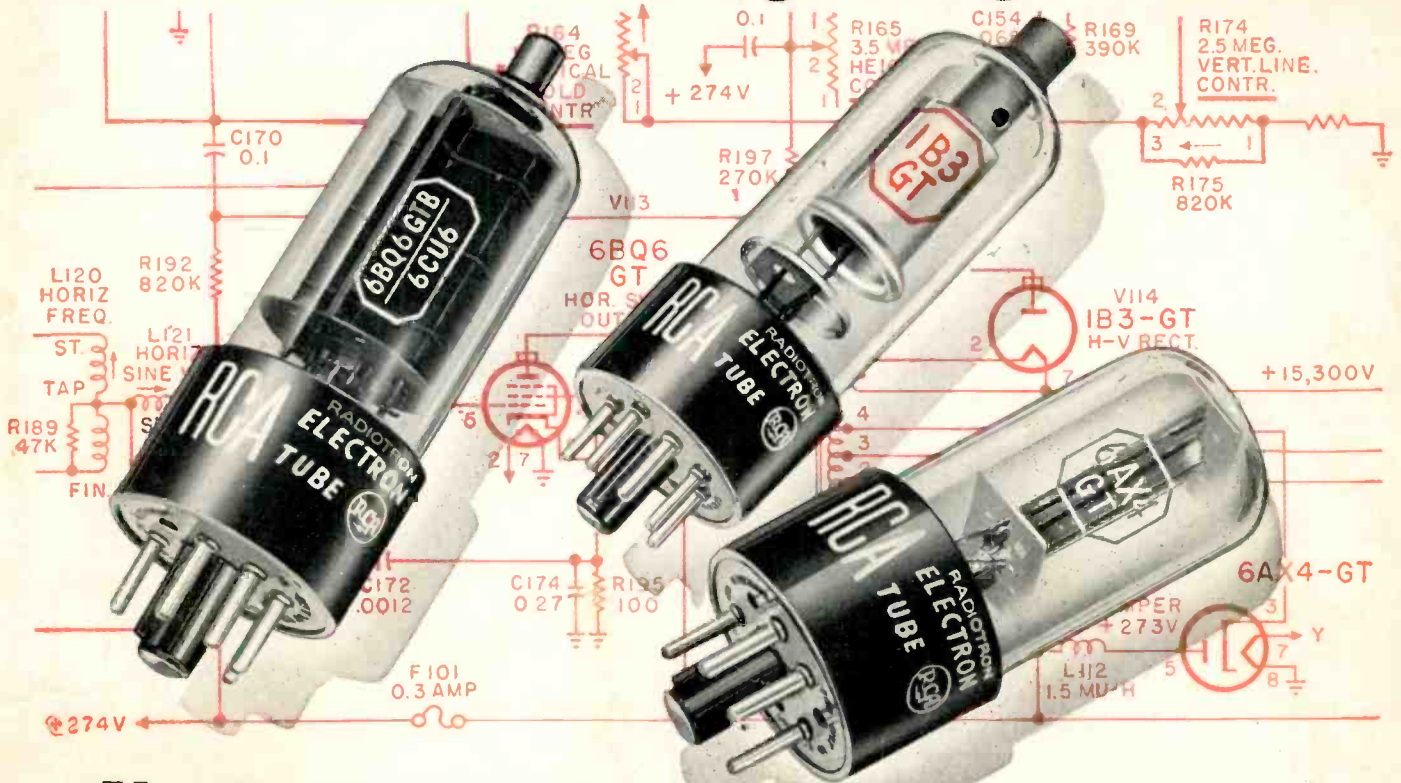

Use **RCA TUBES**...with built-in quality!

Better performance and longer life are *built into* each RCA Tube. In TV Deflection and High-Voltage Circuits, RCA Tubes operate with high efficiency. That's because rigid structural specifications help them to deliver the required currents or to withstand the high voltages. For instance, on the new RCA 6BQ6GTB/6CU6 striking structural changes have produced a decidedly uniform temperature radiation and new cathode material assures greater reliability. You get greater deflection and higher efficiency. RCA's severe dynamic life tests simulate actual operating conditions and help assure you better-performing, long-life tubes.



When you replace with RCA Tubes, your customers are sure of dependable performance. Insist on genuine RCA Tubes for all your service work!



RADIO CORPORATION of AMERICA
ELECTRON TUBES
HARRISON, N.J.

First Choice for TV circuits . . . dependable RCA Tubes!