

TELEVISION RETAILING

A Caldwell-Clements Publication

In 3 Sections
Section 1

Thank You...

To the tens of thousands of subscribers to TELEVISION RETAILING ...

... who voted TELEVISION RETAILING "tops" every time the question "Which publication in the radio-television field do you prefer?" was asked ...

... who voted for it consistently for 32 years -- first as Electrical Retailing ... then as Radio Retailing ... and finally as TELEVISION RETAILING ...

... to all you retailers and servicemen -- our sincere thanks.

We want you to know that you'll find TELEVISION RETAILING's same high quality in the two new full-sized magazines that will succeed TELEVISION RETAILING in September -- MART, for selling ... and TECHNICIAN, for servicing.

They'll be under the direction of M. Clements and O. H. Caldwell, the same men who for 32 years (first with McGraw-Hill, then with Caldwell-Clements) made TELEVISION RETAILING the magazine preferred in all the reader-survey polls.

Remember, retailers -- the new MART which you'll receive is an expansion of TELEVISION RETAILING -- including the pre-tested Price Mart, the greatest merchandising help ever.

Remember, servicemen -- the new TECHNICIAN that you'll receive is an outgrowth of the Technician section of TELEVISION RETAILING -- featuring the famous Circuit Digests, the most valuable contribution ever made to you by any publication.

Thanks again for those votes of confidence in the past. We're making MART and TECHNICIAN of such high calibre as to continue to deserve your enthusiastic votes in the future.

Very truly yours,

M. Clements
O.H. Caldwell

and Now

Coming in September, 1953

MART
TELEVISION • APPLIANCES • RADIO

— Largest TV-appliance retailer circulation; features list prices, specifications.

TECHNICIAN
TELEVISION • ELECTRONICS • RADIO • AUDIO • SERVICE

— Largest audited circulation among TV-electronic servicemen; features circuit digests, schematics.



NEW TYPE "SUMMER SLUMP"

There was a time when a "summer slump" meant no business. But the new "summer slump" . . . the TV slump . . . has changed all that.

Today, thanks to top-flight all-year television shows like "Toast of the Town," "Studio One," "Strike It Rich," "Lux Video Theatre," "Man Against Crime," and the "Arthur Godfrey Shows," TV viewing remains at high levels throughout the summer months — and sets are sold — lots of sets.

How? With the *right merchandise* . . . the merchandise CBS-Columbia dealers have.

Low Leader Priced Models — with a 17" table model at \$179.95 and a 21" console at \$249.95 — are the answer to slack-season merchandising. And they're promotional models with legitimate profit margins!

In addition, CBS-Columbia gives you the greatest *demonstrable sell* of all, Full Fidelity TV . . . plus authentic styling and trouble-free performance . . . trade-up models for longer profit margins . . . the valuable Profit Package Plan . . . and the prestige of the greatest name in television, CBS.

Don't you think it would be wise to look further into the most profitable franchise in the industry? Contact your CBS-Columbia distributor for full details, now!

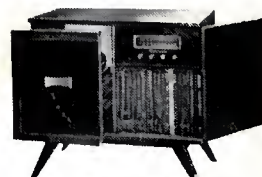

360 RADIO-PHONOGRAPH. "Switch it on and the whole room plays!" CBS 360 sound system uses two speakers and two sound outlets to create the effect of sound that radiates around you.



THE SPOTLIGHT—21-inch big-screen console at a table-model price. Television's value leader to stimulate TV volume now. Rich mahogany-veneer cabinet.



CBS-COLUMBIA INC.

"Putting Vision in Television"

A Subsidiary of the Columbia Broadcasting System

TELEVISION RETAILING

A Caldwell-Clements Publication

AUGUST 1953

★ **AM, FM Television**

Cover—Business Comes Back to Main Street
 TV and Appliance Price MART, See Section 2
 Selling "Service-Free" Products Overcomes Customer Fears 31
 What's Ahead—in Radio, Appliances, Records and Television 32, 33
 Next Month—Business Comes Back to Main Street 34, 35
 Product Knowledge Clicks With Customers 36, 37
 Gear Salesmanship to Customer Wants 38, 39
 Wholesalers & Retailers CAN Work Together 40, 41
 Money for HOUSE OF MUSIC in Hi-Fi, Records, Instruments 46, 47
 Latest Television, Radio Sets on the Market 48, 49
 State of the Market 92

Records, Phonographs, Accessories

List Prices of Phono Records, See the MART, Section 2
 That's Gold in Them Thar Platters! 42, 43
 Record-Go-'Round 44
 Phono Market News and Trends 32, 33

★ **Electrical Appliances**

List Prices of Electrical Appliances, See the MART, Section 2
 Here's the Way to Sell More Clothes Dryers 50, 51
 Don't Let Your Customers Think the Food Freezer's a Luxury Item 52, 53
 Latest Electrical Appliances 54
 Activities in the Electrical Appliance Industry 32, 33

★ **TV-Electronic Technician**

Color-TV Is Coming 57
 What the Technician Should Know About Color-TV 58, 59
 Aligning Radio Receivers 61
 Speed Servicing Through Shop Shortcuts 62
 New Products for Servicers 64, 66
 Circuit Digest—For 16 Pages of Latest Schematics, See Section 3

Latest Product Specifications, Directories, etc.
 that have appeared in TELEVISION RETAILING:

Specifications:	Washing Machines This Issue, the MART
Television Receivers This Issue, the MART	Directories:
Radios, Clock This Issue, the MART	Mfrs. of Radio, TV, Records
Phono Records This Issue, the MART	Components May, '52, p. 101
Clothes Dryers This Issue, the MART	Distributors Jan., '53, p. 99
Dishwashers This Issue, the MART	Electric Housewares This Issue, the MART
Electric Ranges This Issue, the MART	Roster of Representatives ... Oct., '52, p. 103
Food Freezers This Issue, the MART	Mfrs. of Hi-Fi Equipment,
Ironers This Issue, the MART	Instruments July, '53, p. 46
Refrigerators This Issue, the MART	Reference Charts:
Room Air Conditioners .. This Issue, the MART	Four-Field Statistics Jan., '53, p. 36
Vacuum Cleaners This Issue, the MART	TV Sets in Use Nov., '52, p. 30

Future Events of Interest to Readers, page 33, This Issue

TELEVISION RETAILING, August 1953, Vol. 58, No. 2. 35 cents a copy. Published monthly by Caldwell-Clements, Inc. Publication Office, Emmett St., Bristol, Conn. Editorial, Advertising and Executive Offices, 480 Lexington Ave., New York 17, N. Y. Entered as second class matter at the post office at Bristol, Conn., July 17, 1952, under the Act of March 3, 1879. M. Clements, President; Orestes H. Caldwell, Treasurer. Subscription rates United States and U. S. Possessions \$4.00 for three years. Canada \$5.00 for three years. Pan American Countries \$10.00 for three years. All other countries \$10.00 for three years. Printed in U.S.A.

CALDWELL-CLEMENTS, Inc.
 Publication Office, Bristol, Conn.
 Editorial/Business Offices 480 Lexington Ave., New York 17, N. Y., Tel. Plaza 9-7880
 Publishers also of TELE-TECH & ELECTRONIC INDUSTRIES

TELEVISION RETAILING'S CIRCULATION, 32,000

Because of increases in circulation which obviously cannot be shown in current audited statements, advertisers should disregard any comparison based on a previous period or any that fails to show TELEVISION RETAILING'S guaranteed circulation of 32,000.

Westinghouse '54

THE LINE WITH THE

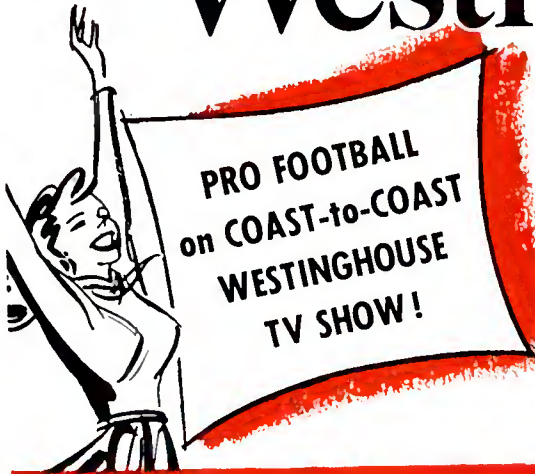

Now, Westinghouse kicks off a record-breaking fall merchandising program that tops 'em all . . . for dealer traffic-building . . . for dealer sales-getting . . . for dealer sales profits. Yes, Westinghouse is backing its dealers all through the fall selling season with Westinghouse Pro Football TV Show plus \$100,000 in prizes. And there's a hook

that pulls 'em into your store. They must register at your store for a chance at those wonderful Westinghouse prizes. Make your store headquarters for prizes with new 1954 Automatic Westinghouse Television—hottest TV line of all! Packed with "demo" features and pre-sold by bigger-than-ever advertising. So get set—CASH IN—now!



The Burton, Model 765T17 \$179.95



The Winston, Model 766T17 \$219.95



The Harmon, Model 810T17 \$239.95



The Woodmere, Model 793K21 \$299.95



The Elmont, Model 769T21 \$229.95



The Wharton, Model 776T21 \$249.95



The Denfield, Model 770T21 \$279.95
In blond, The Beekman, Model 771T21 \$289.95



The Tremont, Model 780T21 \$349.95



The Allerton, Model 786K21 \$379.95
In blond, The Barlow, Model 787K21 \$399.95

Cash in with the Pros!

Cash in with Westinghouse!

TV AND RADIO

MOST ON THE BALL!

**\$100,000 IN PRIZES!
THE PAYOFF'S
ON YOUR FLOOR!**

**BACKED BY BIGGEST
TRAFFIC-BUILDING
PROMOTION in the INDUSTRY!**



The Stockton, Model 774K21 \$399.95
In blond, The Fernwick,
Model 775K21 \$429.95



The Granville, Model 791K21 \$499.95
In blond, The Sulgrave,
Model 792K21 \$499.95

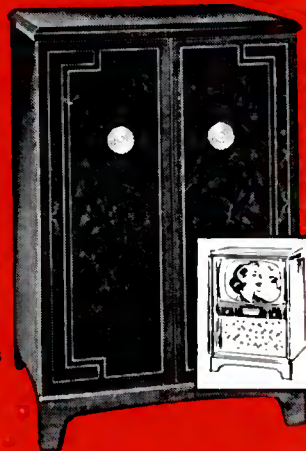

The Middleton, Model 784K21 \$479.95
In blond, The Lansdale,
Model 785K21 \$499.95



The Shelby, Model 772K21 \$339.95
In blond, The Easton,
Model 773K21 \$359.95



The Westford, Model 788C21 \$549.95

**"POWERPAK" RADIO
SCORES HIGH ON IMPULSE BUY**

Compact, trouble-free complete
radio line, styled to sell on sight.
Advertised and merchandised to
SELL FAST, MOVE FAST!

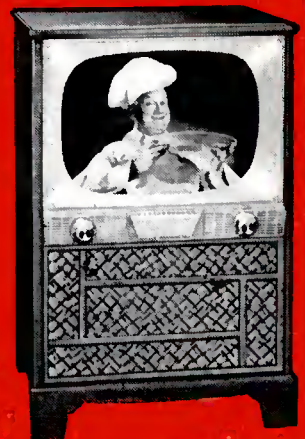

The Maybridge, Model 782K21 \$399.95
In blond, The Bradleigh,
Model 783K21 \$419.95



**Tune in our two big TV shows:
Westinghouse Studio One and Pro Football**

WESTINGHOUSE ELECTRIC CORPORATION,
TELEVISION-RADIO DIVISION, METUCHEN, N. J.

Prices slightly higher in the south and west.

YOU CAN BE SURE...IF IT'S

Westinghouse



Regency

makers of VHF Boosters, FM Boosters, UHF Converters,

Professional High Fidelity Equipment

RECIPE...

for profitable selling

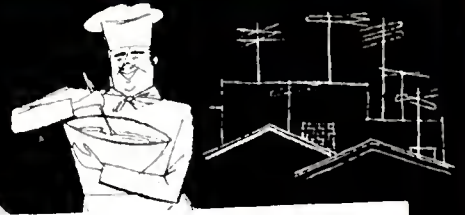

FIRST...

Sentinel's Unsurpassed TV Performance!

backed by a quarter-century reputation

PLUS... THESE NEW EXTRA-PROFIT INGREDIENTS

① **23 New Fast-Selling Models**

A full line of up-to-the-minute consoles and table models...screen sizes from 17" to 27". Sound styling and sound pricing make every one a sure, swift seller.

② **Complete All-Channel Coverage**

Every Sentinel set offers full coverage of all vhf and uhf channels...a "must" in today's television selling. Strip tuning on low-cost economy sets and complete coverage on all others.

③ **Ideal Pricing**

A pricing policy that means more and better sales...higher profits and greater customer satisfaction.

④ **Big National Advertising**

Every month...Fall, Winter, Spring...high-impact advertisements will reach into every community in America through the powerful pages of *The Saturday Evening Post*, *Better Homes and Gardens*, *American Home*, *Time* and *Newsweek* and other media.

⑤ **Full Range Local Advertising**

A complete program of co-op advertising to roll up sales in *your* community. Hard-hitting promotions make full use of all local media. Newspapers, radio, outdoor posters, calendars and direct mail pieces are all hard-working traffic-builders for you.

⑥ **Point of Sale Material**

A program of display material for use inside, outside, in store windows...everything that will help you sell!

⑦ **Fast Delivery**

Production accurately keyed to consumer demand. Prompt deliveries and no unbalanced dealer inventories.

IT'S A SUPER-POWERFUL PROGRAM
backed by the finest TV sets
on the market!

Call your distributor or write
Sentinel Radio Corporation • Evanston Illinois

Watch your
profits rise!

Sentinel TV



**BRAND
NEW**

23 G-E

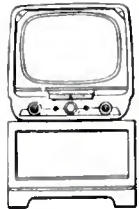

Model 21T10 \$239.95*
Black plastic, 21-inch.
Base extra.



Model 21T15 \$289.95*
Comb grain blond oak,
21-inch. Stand extra.

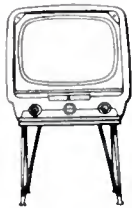

Model 21T12 \$289.95*
Mahogany plastic, 21-inch.
Stand extra.



Model 17T15 \$179.95*
Mahogany plastic, 17-inch. Stand extra.

*Includes Federal Excise Tax, one-year
Factory Warranty on picture tube and
90 days on parts. Prices subject to
change without notice. UHF at additional
charge.

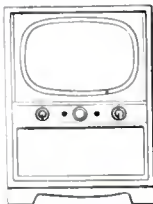

Model 21C117 \$365.00*
Blond comb grain oak,
21-inch.

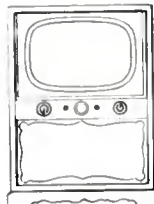

Model 21C119 \$375.00*
Genuine mahogany veneers,
21-inch.

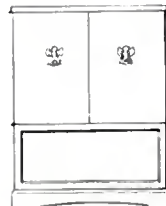

Model 21C121 \$419.95*
Blond white oak, 21-inch.

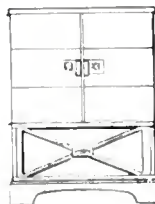

Model 21C120 \$399.95*
Genuine mahogany veneers,
21-inch.

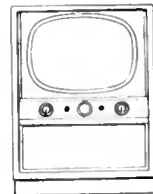

Model 21C115 \$299.95*
Genuine mahogany veneers,
21-inch.

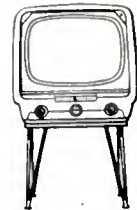

Model 21T11 \$259.95*
Mahogany plastic, 21-inch.
Stand extra.

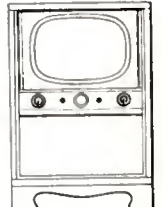

Model 17C127 \$269.95*
Genuine mahogany veneers,
17-inch.

GE BLACK-DAYLITE TV

• Priced competitively from \$179.95!† Every one under \$300.† Yet these 6 G-E models offer many selling advantages of sets priced near \$500—noise canceller circuit... exceptionally sensitive chassis... excellent fringe reception... retrace line eliminator... new functional mask.

Available with All-Channel UHF-VHF Tuner



Model 21C116 \$349.95*
Genuine mahogany veneers, 21-inch.

GE BLACK-DAYLITE TV DE LUXE

• 6 G-E Black-Daylite models with real step-up sales features! Features that give a finer picture... features you can demonstrate. 21-inch Aluminized Picture Tube... tilted, deep-tint safety glass... features found in the most expensive G-E sets.

HEADLINERS

COVERING every taste and price range, G-E presents 23 headline models styled and engineered to lead the profit parade for the next 12 months. Here is furniture in the world's choicest woods...mahogany, cherry, comb grain limed oak...modern and traditional...to delight every buyer's taste. Two all-new

G-E chassis for the finest *all-channel* VHF and UHF reception ever achieved in any price range. All this in one line a year, for simpler, cleaner inventories—for profits right down the line, right through the year. No wonder top television dealers are saying, "The one 'must' line for '53 is now G-E!"

General Electric Company, Radio and TV Department, Electronics Park, Syracuse, N. Y.



BLACK-DAYLITE Ultra-Vision

580% more picture contrast than average of 9 other sets**
Available with ALL-Channel UHF-VHF Tuner

• In nationwide side-by-side comparisons, Ultra-Vision is voted Best Picture by 7 to 1. Famous G-E Aluminized Tube, greatest G-E chassis, increased band width of 50 megacycles for TV's sharpest picture. 40° wider viewing angle. "Compare!"

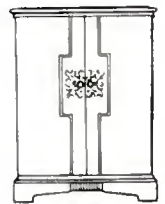

Model 21C233 \$489.95*
Classic modern—genuine
limed oak. 21-inch.



Model 21C232 \$489.95*
Genuine cherry, American
Provincial. 21-inch.

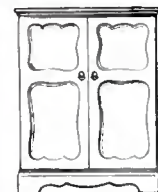

Model 21C231 \$489.95*
Genuine mahogany veneers.
21-inch.

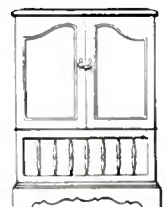

Model 21C230 \$469.95*
American Provincial—cherry
veneers. 21-inch.

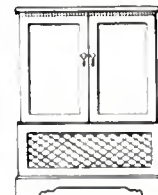

Model 21C229 \$459.95*
Genuine mahogany veneers.
21-inch.



Model 21C225 \$399.95*
Genuine mahogany veneers. 21-inch.

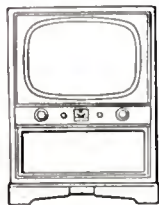

Model 21C228 \$419.95*
Comb grain white oak.
21-inch.

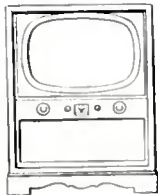

Model 21C226 \$419.95*
Provincial cabinet—cherry
veneers. 21-inch.

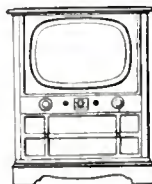

Model 21C227 \$419.95*
Genuine mahogany veneers.
21-inch.

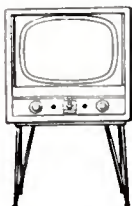

Model 21T21 \$349.95*
Comb grain white oak.
21-inch. Stand extra.

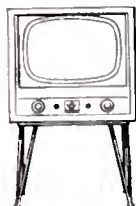

Model 21T20 \$329.95*
Genuine mahogany veneers.
21-inch. Stand extra.

*Includes Federal Excise Tax, one-year Factory Warranty on picture tube and 90 days on parts. Prices subject to change without notice, slightly higher West and South. UHF at additional charge.

**U. S. Testing Co. Report # E-6187-1/26/53

You can put your confidence in—

GENERAL  ELECTRIC



Helping you get new customers is his business

The job of the Classified Telephone Directory representative is to show you exactly how the 'yellow pages' can be helpful in expanding your business.

He knows a lot about people's shopping and buying habits in your town. He's also familiar with sound business-building ideas and can offer many valuable suggestions for directing more customers to you.

His experience in helping others to promote their business can be profitable for you. A few minutes of your time will prove it. Call him today at the local telephone business office.



TELEVISION RETAILING

Including **MART** and **TECHNICIAN**

O. H. CALDWELL M. CLEMENTS
Editorial Director Publisher

JOHN L. STOUTENBURGH
Executive Editor

SOLOMON HELLER B. V. SPINETTA
Technical Editor Price-Mart Editor

STANLEY KEMPNER A. P. MASSON
Associate Editor Assistant Editor

DOLORES A. ALLEN S. BRESLAU
Assistant Editor Assistant Editor

CHARLES F. DREYER, *Art Director*

E. KETTERER *Circuit Digest Production*

BUSINESS DEPARTMENT

M. H. NEWTON, *Business Manager*

H. A. REED, *General Sales Manager*

HAROLD PRINCE, *Sales Promotion Mgr.*

DIXON SCOTT, *District Manager*

LEE GRAVES, *District Manager*

CHARLES S. ROEVER, *District Manager*

N. McALLISTER, *Asst. Business Manager*

A. O'ROURKE, *Production Manager*

MARTHA USDIN, *Asst. Production Mgr.*

BARBARA PARK, *Reader Service Dept.*
480 Lexington Ave., New York 17, N. Y.

Telephone Plaza 9-7880

S. M. GASKINS, *Western Manager*

JOHN D. LUPTON, *District Manager*

201 N. Wells St., Chicago 6, Ill.

Telephone RAndolph 6-9225

CHRIS DUNKLE & ASSOCIATES

California Representative

3257 W. 6th Street, Los Angeles 5, Calif.

Telephone DUmkirk 7-6149

1355 Market Street, San Francisco 8, Calif.

Telephone KLondike 2-2311, Ext. 579

WARREN S. BROWN, *Circulation Manager*

M. GROENING, *Asst. Circulation Manager*

JOHN J. BORCHI, *Controller*

W. W. SWIGERT, *Credit Manager*

CIRCULATION, 32,000

Because of increases in circulation which obviously cannot be shown in current audited statements, advertisers should disregard any comparison based on a previous period or any that fails to show TELEVISION RETAILING'S guaranteed circulation of 32,000.

TELEVISION RETAILING is the only publication rendering an editorial service of great intrinsic value in meeting the complete needs of retailers in the sale and maintenance of TV, appliances and radio. Each monthly issue has two supplements—separate sections containing much-needed data for guidance in sales, management and servicing, as follows: MART—giving latest list prices on TV, clock radios, records and appliances.

TECHNICIAN—Containing technical digests and schematics of a large group of models currently reaching retailers.

TELEVISION RETAILING

Trade-Mark Reg. U. S. Pat. Off.
Copyright 1953 by Caldwell-Clements, Inc.

Why You Can't Buy a MAGNAVOX at a Discount

TELEVISION is one of the great scientific miracles of our miracle age. It is of inestimable value in relation to the great joy, entertainment and education it has brought into the American home.

Yet, many people who believe they are shopping for a TV are primarily shopping for a discount—that's because most brands can be purchased at a cut price. Thrift is commendable, bargaining a universal trait. We all seek the maximum value for our money and no one wants to suffer the embarrassment of paying more than the lowest price. But a discount doesn't necessarily enhance the value of a purchase. In television it often misleads the buyer, and gives him only short-lived satisfaction.

* * *

Owners of Magnavox television and radio-phonographs know this.

They know there is only one price—the lowest price—to everyone and here's why: Magnavox management recognized that it could not achieve its objective of building superior, custom-quality instruments within reach of the average family if burdened with the usual high distribution costs. So we have no wholesalers or jobbers.

Magnavox instruments go *directly* from our factory to our dealers. Magnavox dealers were painstakingly chosen on the basis of their standing in the community and their ability to serve you because the long-term satisfaction of a television receiver is largely dependent on the ability and integrity of the dealer.

* * *

Magnavox is sold through relatively few of the ninety-thousand dealers selling television. We do less business that way than some of our competitors, but our ambition is not to make the *most* but the *best* . . . and the *best*, in this case, is the greatest dollar value.

Your Magnavox dealer is the respected merchant who has been in business for many years. He has had "staying power" because he has rendered good service to his community and has done so at a modest profit to himself. He is generally the fine department store; the old, dependable music store; the quality furniture

store and the friendly and successful television and appliance dealer who has already won your confidence through his fair dealings and good service.

If he were to give away any portion of his small profit margin he could not maintain his establishment, properly display the merchandise to give you selectivity or give you satisfactory service in every respect.

In order to retain his Magnavox franchise—he is prevented from cutting prices by virtue of the Magnavox "One Price" policy. Magnavox instruments are sold under the legal agreements provided by the Miller-Tydings Act which prohibit him from engaging in unfair trade practices.

* * *

But, you may logically ask . . . "How does this 'One Price' policy help me get a bargain?" A Magnavox is your greatest bargain because it is the best value for every dollar you spend regardless of discounts you can obtain on other brands. And you are assured of satisfaction through the integrity and ability of your dealer. These together with the integrity of the product will give you an enduring pride of ownership. And by by-passing the jobbers and the extra margin of selling cost to which such wholesalers are entitled, we are able to offer you a substantially greater value—reflecting savings up to 20%.

* * *

We are as proud of our efficient distribution as we are of our efficient engineering and manufacturing.

Marketing surveys show that people consider Magnavox either the best, or one of the best, television receivers made. But they also think of it as high priced, because fine quality is usually synonymous with high price.

A direct comparison with other brands will prove to you that this is not the case. You will find that Magnavox, model for model, is actually lower in price than other recognized quality brands . . . prove this to your own satisfaction. Go to your Magnavox dealer. See these fine quality instruments at your nearest Magnavox dealer listed in the classified telephone directory.

President

THE MAGNAVOX COMPANY • FORT WAYNE 4, INDIANA

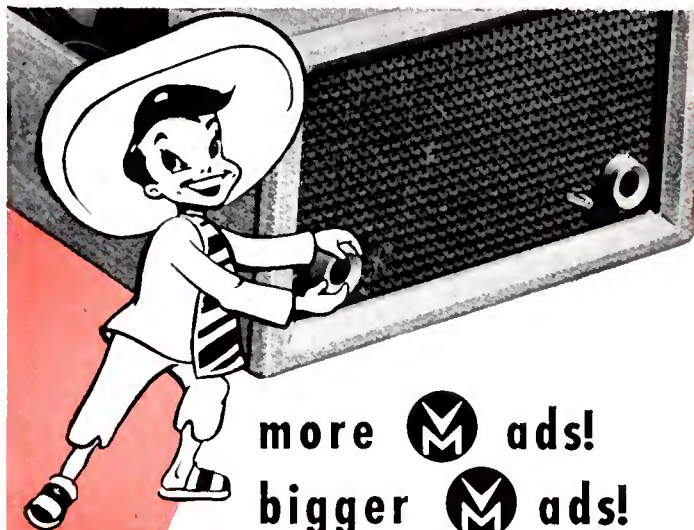

M TURNS

more **M** ads!
 bigger **M** ads!
 ALL in **COLOR!**



to help you turn up
 the volume of your
 Sales and Profits!

plus Merchandising Aids!

triomatic®

trisppeed®

PHONOGRAPHS AND RECORD CHANGERS

Tie-in to Cash-in on V-M's Biggest, Most Powerful Promotion to Date!

Hundreds of *your* prospects will see V-M's color ads in September issues of one or more of these influential publications. V-M ads will create desire to see V-M models. Turn their desire into decision

... to buy from YOU. Display and demonstrate V-M merchandise! Use the colorful literature, eye-catching displays, spot radio announcements and newspaper advertising mats available from V-M.

See Your V-M Man for Merchandise.....for Sales Aids.....for Profit!

Here Is Your "Tie-In to Cash-In" Calendar! Tie your promotion to these On Sale dates.

DATE	PUBLICATION	AD
August 7	Esquire	2-color, 1/2-page
August 20	Household	2-color, 2/3-page
	Living for Young Homemakers	2-color, 1/2-page
August 21	Coronet	2-color, full page
August 25	Sunset	2-color, 2/3-page
September 1	Seventeen	2-color, 1/2-page

DATE	PUBLICATION	AD
September 13	American Weekly	Full color, 1/2-page
	Parade	Full color, 1/2-page
	Atlanta Constitution	Full color, 1/2-page
	Denver Post	Full color, 1/2-page
	Des Moines Register	2-color, 1/2-page



THE
 RECORDED
 VOICE OF
 MUSIC

V-M CORPORATION
 BENTON HARBOR, MICHIGAN

WORLD'S LARGEST
 MANUFACTURER OF
 PHONOGRAPHS AND
 RECORD CHANGERS
 EXCLUSIVELY

UP THE VOLUME

<p>American Weekly Full color, 1/2-page! 9,283,326 CIRCULATION</p>	<p>Parade Full color, 1/2-page! 5,238,896 CIRCULATION</p>	<p>Coronet 2-color, full page! 2,693,744 CIRCULATION</p>
<p>Esquire 2-color, 1/2-page! 771,087 CIRCULATION</p>	<p>Seventeen 2-color, 1/2-page! 1,045,795 CIRCULATION</p>	<p>Sunset 2-color, 2/3-page! 533,228 CIRCULATION</p>
<p>Living 2-color, 1/2 page! 437,299 CIRCULATION</p>	<p>Household 2-color, 2/3-page! 2,285,209 CIRCULATION</p>	<p>Denver Post Full color, 1/2-page! 352,285 CIRCULATION</p>
<p>Des Moines Register Full color, 1/2-page! 533,204 CIRCULATION</p>	<p>Atlanta Constitution Full color, 1/2-page! 474,555 CIRCULATION</p>	<p>DOUBLE THE IMPACT OF YOUR ADS! TIE IN WITH THIS CAMPAIGN</p>



V-M tri-o-matic 990 Portable Automatic Phonograph. Large speaker in lid! 2 sapphire needles in "flip-under" cartridge. Plays all size, speed, records automatically. \$69.95*.

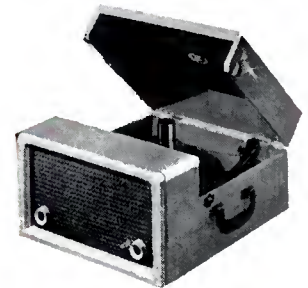

V-M tri-o-matic 986 Portable Automatic Phonograph. 5" x 7" speaker outperforms many costlier models. Choice of Rose and Gray or Rich Brown case. Includes adjustable tone chamber and automatic V-M 45 spindle. \$86.50*.



V-M tri-o-speed 121 Portable Manual Phonograph. World's smallest, lightest phono playing all size, all speed records. Choice of Satin Red or Green case. \$29.95*.

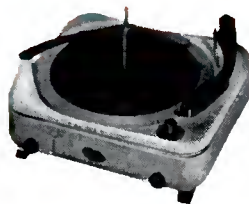

V-M tri-o-matic 972 Table Model Automatic Phonograph. A nationwide favorite with superb speaker system! Siesta Switch, 2-needle tone arm, New Clem-Rose styling. \$59.95*.



V-M tri-o-matic 920 Automatic Record Changer Attachment. Has Siesta Switch. Plays records of all three sizes, speeds, through any standard TV or radio. \$39.95*.

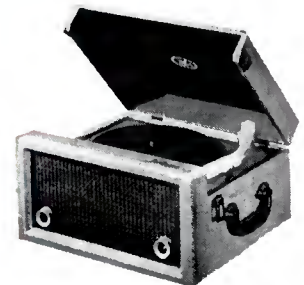

V-M tri-o-speed 151 Portable Manual Phono. Console quality speaker. Plays all size, speed, records. Rose and Gray or Rich Brown styling. \$49.95*.



THE
RECORDED
VOICE OF
MUSIC

V-M CORPORATION
BENTON HARBOR, MICHIGAN

*Slightly higher in the West.

WORLD'S LARGEST
MANUFACTURER OF
PHONOGRAPHS AND
RECORD CHANGERS
EXCLUSIVELY

PRE-SOLD
for you-



the C-D-R Rotor

by an extensive consumer campaign in TELEVISION and NEWSPAPER... in KEY ROTOR MARKET AREAS*

**coming to your city too!*

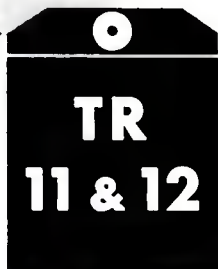

The TR-12 is a special combination value consisting of complete rotor including thrust bearing... handsome modern design plastic cabinet with meter control dial—

The TR-11 is the same unit without the thrust bearing.

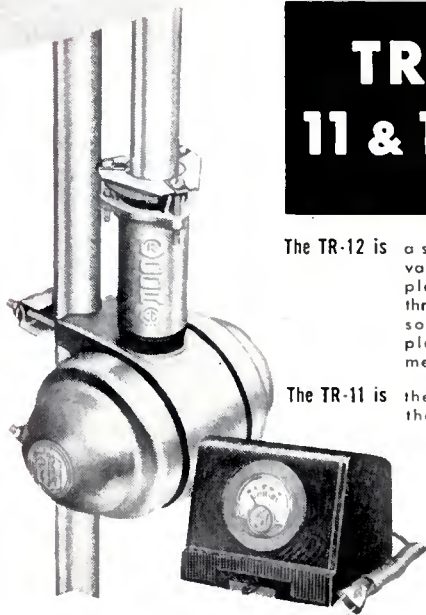

The TR-2 is the HEAVY DUTY rotor especially suited for special TV antenna installations. Complete rotor with "Compass Control" cabinet having illuminated "perfect pattern" dial.

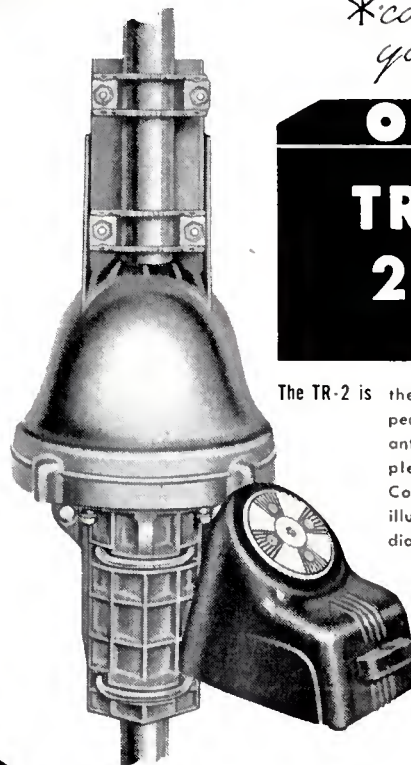

THE RADIART CORPORATION
CLEVELAND 13, OHIO

CORNELL-DUBILIER ELEC. CORP.
SOUTH PLAINFIELD, NEW JERSEY

FADA
Television

27 inch

UHF-VHF ALL CHANNEL

Built-in **"Silverdyne"**

Cascode Tuner

TABLE MODEL



Every FADA TV receiver is outstanding for superior performance and eye appeal. But this 27 inch table model is the GIANT SIZE picture screen that gives you reception beyond your fondest expectations. Illuminated UHF and VHF channel dials. Built-in separate "Fada-Scope" Antennas. All models available in mahogany or limed oak.

All models available in mahogany or limed oak.

with
**"ALUMINIZED
KINESCOPE
SCREEN"**
for superior
contrast
and brightness
Available in either
VHF or UHF-VHF
**PRESIDENT or IMPERIAL
Series**

FADA RADIO & ELECTRIC CO. INC. Belleville . . . New Jersey



G-E MAKES THE

● General Electric gives you a complete new line to outsell, outgross and outnet them all. Prices range from \$17.95—the lowest G-E radio price in 10 years—to \$69.95...for a 7-tube (plus rectifier) AM-FM radio. Now you can offer a G-E Radio to fit every purse—and there's no extra charge for choice of colors! See your G-E Radio Distributor today.

General Electric Company, Radio and Television Department, Electronics Park, Syracuse, New York

Prices subject to change without notice.

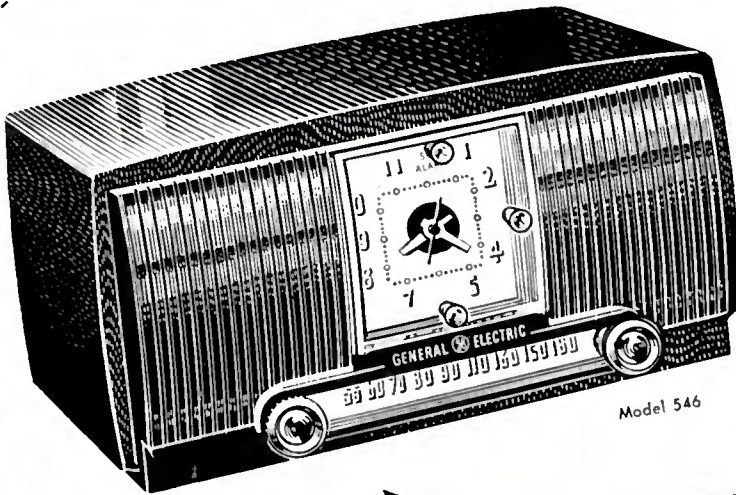

New! Again GE gives more than any other Clock-Radio \$39.95*

New! At no added cost—phono-jack and Audio-Magic Switch—one-knob volume control for radio and records.

Choice of 4 colors, same low price!

Plus! All the other famous G-E Clock-Radio features. Lulls you to sleep, wakes you to music or news, turns appliances on or off automatically.

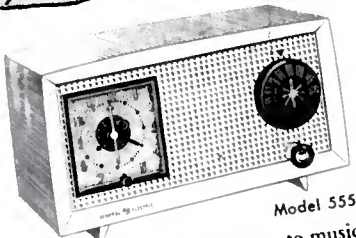

Model 555

New Low Price! Wakes you to music—turns on your favorite programs. Only \$26.95

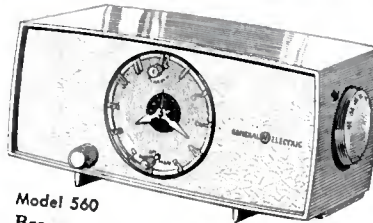

Model 560

Brown or ivory—same low price. Wake-up feature—buzzer alarm. \$32.95*



Model 564

New! Lulls you to sleep—wakes you to music. Green, red or ivory. \$36.95*

You can put your confidence in—

BIGGEST NEWS IN RADIO!

New! \$17.95 Radio for mass sales!

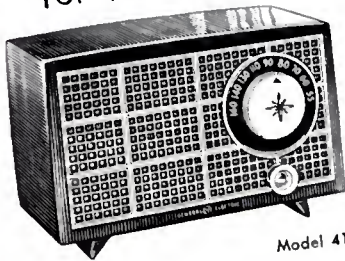

Model 419

• Lowest G-E price in 10 years! Famous G-E features—G-E Dynapower Speaker, G-E Beamscope antenna. Attractive compact cabinet.

New! Easy-tune dial Mahogany or Ivory—Same low price!

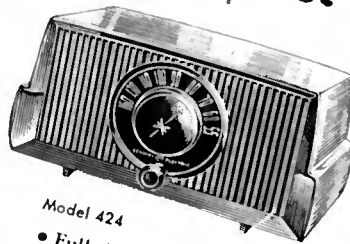

Model 424

• Full-size G-E Dynapower speaker for fine tone. Powerful G-E Beamscope antenna. Large station numbers for fast tuning. **\$21.95***

New! Dial-Beam Model with radio's brightest selling feature!

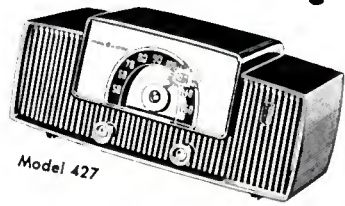

Model 427

• Now with phono-jack and G-E Audio-Magic Switch—one-knob volume control for radio, records. Three colors—same low price. **\$26.95***

New! 2-in-1 All-Year Radio!

A powerful portable and a smart table model too!

• AC-DC or batteries. Plays upright or on its side. New finger-tip controls—more accurate tuning. **\$49.95***

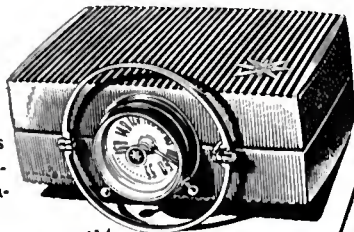

Model 614

New! Double Feature Radios!



Model 436

• Standard and Short-Wave. Full 6-18-megacycle short-wave band. Finely engineered tuning. **\$39.95***

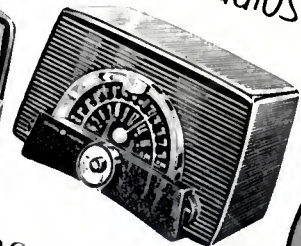

Model 440

• G-E FM-AM Radio. 7 tubes plus rectifier—phono-jack with Audio-Magic Switch. Tone Control. **\$69.95**

**Slightly higher West and South*

GENERAL



ELECTRIC

NEW

Arvin

**4 Screen Sizes
21 Cabinet Styles**

**40 MODELS TO
CHOOSE FROM**



with ALL the important improvements your customers will want ... by the pioneers of built-in one-knob all-channel tuning

Arvin commands the market—with all screen sizes—all the years-ahead features your customers will demand—all cabinet styles—and all prices from \$199.95 to \$699.95! Sell Arvin and you'll sell complete satisfaction!



27"

Model 7276CB-UHF—for your customer who wants the absolute finest, regardless! Superbly crafted full-door white oak cabinet houses a 27-inch aluminized spherical picture tube, powered by the famous Arvin Super Custom Chassis, with built-in one-knob all-channel tuning to receive all 82 UHF and VHF channels. **\$699.95.**



Model 7279CM-UHF—27 inch screen; Super Custom Chassis; full-door console of imported mahogany. One-knob all-channel tuning **\$699.95.**



Model 9240CB—24 inch white oak console; Super Custom Chassis. An unbeatable value! All-channel tuning, **\$519.95.** Straight VHF, **\$469.95.**



Model 9212MEA—21-inch Early American console in solid rock maple with Super Custom Chassis. All-channel, **\$529.95.** Straight VHF, **\$479.95.**



Model 9212CFP—21-inch full-door French Provincial model in fine cherry. Super Custom Chassis. All-channel, **\$529.95.** Straight VHF, **\$479.95.**



Model 9216CB—21-inch screen in superb full-door console of white oak. Super Custom Chassis. All-channel, **\$519.95.** Straight VHF, **\$469.95.**

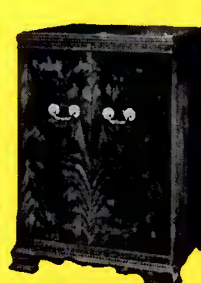

Model 9219CM—21-inch full-door console of hand-rubbed imported mahogany. Super Custom Chassis. All-channel, **\$499.95.** Straight VHF, **\$449.95.**



Model 8215CM—21-inch screen; beautiful African mahogany panels. Dual Power Jet Chassis. All-channel tuning, **\$349.95.** Straight VHF, **\$299.95.**



Model 8211TB—21-inch table model in lined oak. Table to match, extra. Dual Power Jet Chassis. All-channel, **\$339.95.** Straight VHF, **\$289.95.**



Model 8211TM—21-inch table model, mahogany veneer. Table, extra. Dual Power Jet Chassis. All-channel, **\$329.95.** Straight VHF, **\$279.95.**



Model 8213TM—21-inch table model, mahogany finish Marlite. Table extra. Dual Power Jet Chassis. All-channel, **\$299.95.** Straight VHF, **\$249.95.**



Model 8171TM—17-inch table model in mahogany finish. Base extra. Dual Power Jet Chassis. All-channel, **\$279.95.** Straight VHF, **\$229.95.**

Nationally Advertised

Millions of readers will read about Arvin Years-Ahead TV in the Saturday Evening Post, Life, Better Homes & Gardens, Sunset, Country Gentleman, and Progressive Farmer. Make your local selling tie in with these dynamic ads!

Years-ahead

TV

**ALL-CHANNEL
AND VHF**



24"

Model 9240CM—another supreme Arvin achievement for the top-quality trade, with 24-inch aluminized spherical picture tube and a world of surplus power in its Arvin Super Custom Chassis. The cabinet is rich with the beauty of genuine mahogany. With built-in one-knob all-channel tuning, \$499.95. Straight VHF, \$449.95.



21"

Model 9210CM—Stunningly beautiful in hand-rubbed mahogany finish with two-thirds doors. 21-inch cylindrical aluminized picture tube with plenty of power provided by the Arvin Super Custom Chassis. This is today's top value in a closed-face console. With all-channel tuning, \$449.95. Straight VHF, \$399.95.



17"

Model 8179TM—This is a natural traffic-builder, an amazing value! 17-inch glare-proof cylindrical picture tube; the sensational Arvin Dual Power Jet Chassis; a truly beautiful cabinet in mahogany finish Marlite. Table or console base to match at low extra cost. With all-channel tuning, \$249.95. Straight VHF, \$199.95.



Model 9210CB—21-inch screen in lined oak console with two-thirds doors. Super Custom Chassis. All-channel, \$469.95. VHF, \$419.95.



Model 9216CB—21-inch screen in all the beauty of modern lined oak. Super Custom Chassis. All-channel, \$439.95. Straight VHF, \$389.95.



Model 9218CM—21-inch screen in smoothly rich mahogany console. Super Custom Chassis. All-channel tuning, \$419.95. Straight VHF, \$369.95.



Model 8218CB—21-inch screen in lined oak with dual power Jet Chassis. An outstanding value. All-channel, \$409.95. Straight VHF, \$359.95.



Model 8218CM—21-inch screen in hand-rubbed mahogany finish. Dual Power Jet Chassis. All-channel tuning, \$389.95. Straight VHF, \$339.95.



Model 8215CB—21-inch screen in lined oak finish of lustrous beauty. Dual Power Jet Chassis. All-channel tuning, \$369.95. Straight VHF, \$319.95.

All prices are suggested retail for Zone 1 and include federal tax and warranty

Sell not one, not two, not three—but ALL these advantages!

Most makes of television will feature some of the newest improvements. Most well-informed prospects will want them ALL! With Arvin TV you can meet that demand with ALL FIVE most-wanted advancements:

1 Built-in one-knob all-channel tuning . . . Arvin pioneered it, now vastly improves it for finest reception of all 82 VHF and UHF channels! UHF and VHF antennas built in.

2 Automatic stabilization to prevent picture flop-over . . . Arvin's Electronic Stabilizer checks all types of interference—assures a rock-steady picture that "stays put."

3 Automatic contrast control . . . Arvin's Robot Compensator adjusts automatically for strong or weak station signals, maintains contrast as your customers want it.

4 Maximum picture power . . . Arvin's 18,000 volts, with aluminized picture tube in most models, give a sharper, more brilliant picture—never a gray, fuzzy image.

5 Finest picture detail, noise-free sound . . . Arvin's new High Fidelity Interlace assures "front row" realism.

Radio and Television Division, ARVIN INDUSTRIES, Inc., Columbus, Ind.

ONLY TELCO UHF ANTENNAS HAVE THE "WISHBONE"

TELCO

UHF

"WISHBONE" HIGH DI-ELECTRIC INSULATOR

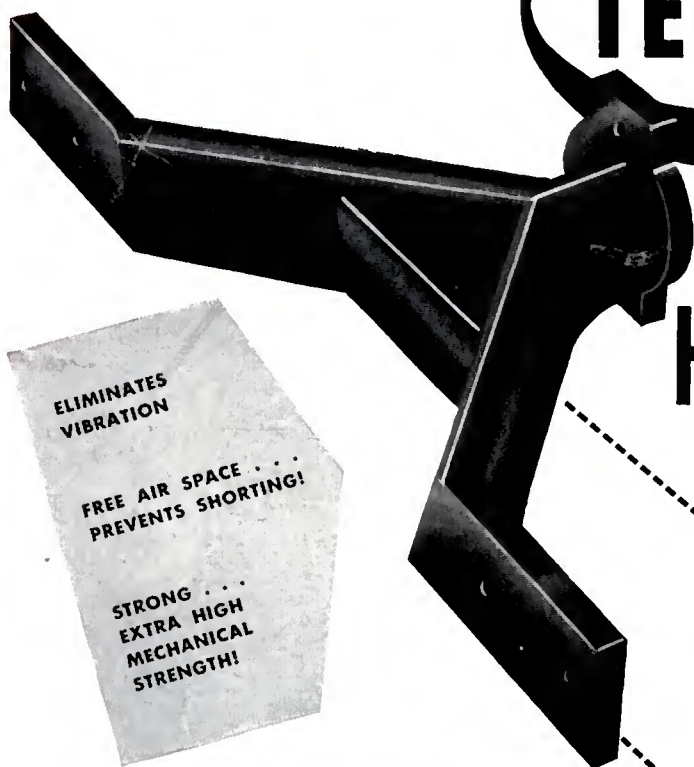

ELIMINATES
VIBRATION

FREE AIR SPACE . . .
PREVENTS SHORTING!

STRONG . . .
EXTRA HIGH
MECHANICAL
STRENGTH!

- EASY TO INSTALL
- ELIMINATES GHOSTS
- VERY HIGH GAIN

THAT'S RIGHT . . . Only TELCO'S got this remarkable new free air insulator . . . the "Wishbone" . . . that absolutely prevents shorting out under any conditions. Sturdy vibration-proof reflector and rugged aircraft aluminum elements are fastened to the "Wishbone" to prevent vibration and shaky pictures. Antenna performance is proved by actual UHF field testing . . . assures high gain on all channels. Better buy TELCO . . . your all-ways best UHF Antennas!

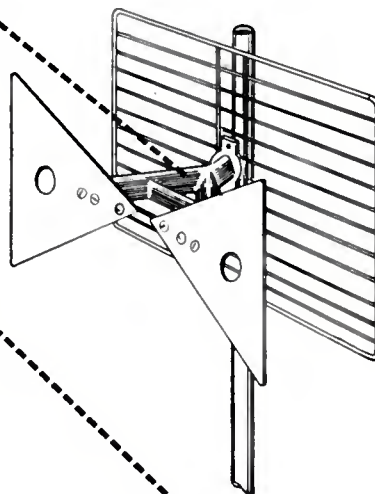

No. 8965—Butterfly
Wishbone Antenna,
complete with
stacking bar.
List \$7.50

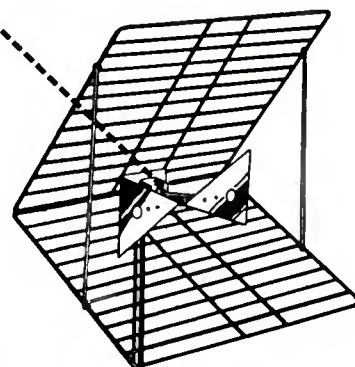

No. 8984 Wishbone
Corner Reflector.
List \$14.50



FREE! WRITE TODAY for all-new 32-page
TELCO Catalog. Send Postcard.

TELEVISION HARDWARE MFG. CO.
DIVISION OF GENERAL CEMENT MFG. CO.
902 TAYLOR AVENUE • ROCKFORD, ILLINOIS



Watches may look alike in shape and size
The big difference in time-keeping performance depends on the "works" inside the watch.

It's what's
inside that
counts...

—in Radio Batteries too



It's what's inside a radio battery that makes the big difference in long-lasting performance, too. Take RCA's new Alkaline "B" Battery (VS216) for instance.

The Alkaline principle of operation makes possible more efficient utilization of the cell's active materials. Result: it is practical to reduce the size of both cell and battery.

The "crown-type" cell of RCA's new Radio "B" Battery is a compact, self-contained unit which delivers more useful energy per unit of volume than do

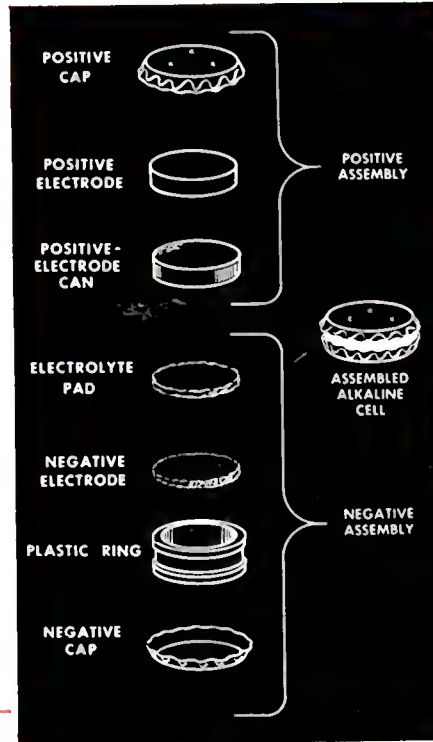

The cells in RCA's new Alkaline "B" Battery, VS216, resemble two shallow soda bottle caps. Sandwiched between the two "bottle caps" are the elements shown in the sketch above. One cap serves as the positive terminal; the other, the negative.

conventional types of cells. Result: the RCA VS216 is 22 per cent smaller than conventional "B" Batteries formerly used in personal portables—YET it plays a new-design personal portable TWICE AS LONG as conventional 67½-volt types.

It's smart to sell RCA Radio Batteries—they're *radio engineered* for extra listening hours. RCA Radio Batteries are sold principally through Radio Dealers and Service Men.

Call your RCA Radio Battery Distributor and cash in on the big radio battery replacement market.



RADIO CORPORATION of AMERICA

RADIO BATTERIES

HARRISON, N. J.

New 1954 Zenith TV with Spectacular

plus 5 fabulous
"firsts" to demonstrate
and sell!



New Zenith Spotlight Dial—big channel number lights up the second you turn on a new 1954 Zenith TV. You can see which channel you're tuned to clear across a room! Channel number changes automatically when you switch stations. A dramatic demonstration feature!



New Zenith Band Shell Speaker—pops up. Beams the sound at you like the consoles do. This plus Zenith super-sensitive FM circuits means table TV with big set tone. An easy-to-demonstrate showroom showpiece that makes trading up as easy as listening.

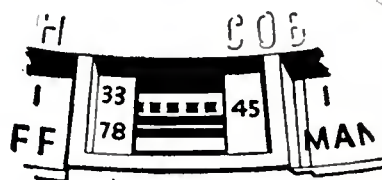

New High Fidelity Cobra-Matic® with Stroboscope in new Zenith combinations exclusively. Amazing dot of light shows when records play at exact recorded speed. Plays 33 $\frac{1}{3}$, 78, 45, and new 16 $\frac{3}{4}$ RPM records. New high-fidelity Cobra® Tone Arm. 5 beautiful models included in line with Zenith's brilliant new High-Fidelity tone system!

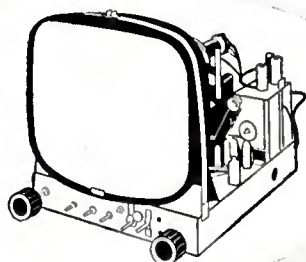

New Zenith Super-Power Super-K Chassis—brings in clear, sharp pictures and full, rich tone in fringe areas and tough trouble spots. "Bull's Eye" Turret Tuner locks in station, sound and picture perfectly—UHF and VHF! New, optional All-Channel Continuous Tuner covers 70 UHF channels without modification.

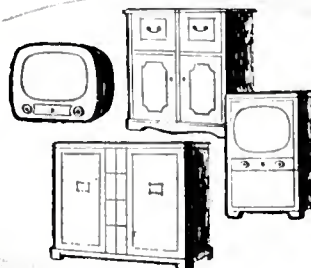

New Zenith's 52 Beautifully Crafted Showpiece Styles! Smartest collection of fine furniture TV ever! Exquisite Contemporary designs... luxurious Traditionals... popular Provincials. Wonderful choice of woods and finishes—ebony, cherry, walnut, mahogany, blond oak and afara. The leadership look that leads to sales!

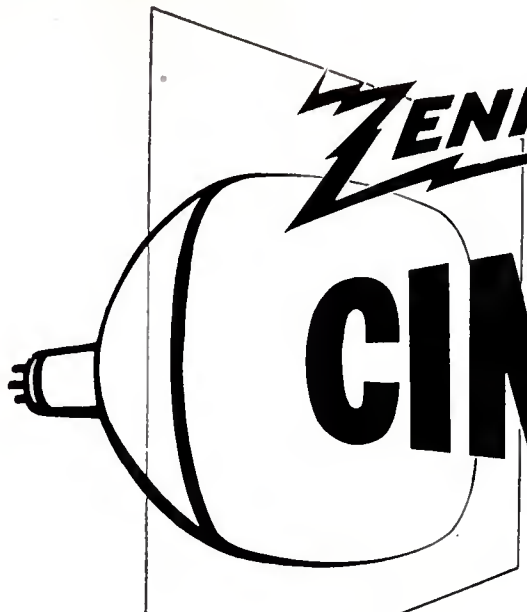

ZENITH[®] CINÉBEAM[®]

Picture Tube

Brings you pictures that sell on sight!

CINÉBEAM—with twice the Picture Power!
Double the brightness, because you see all the light there is. None leaks back into the tube.

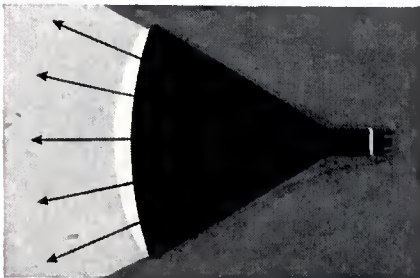

CINÉBEAM—Pictures just like the Movies!

Because inside face of tube is coated with silver-activated phosphors, sealed in for life by millions of tiny, non-tarnishable particles which act as mirrors. These mirrors reflect *all* the light to give you movie-like pictures from a silver screen. Demonstrate this million-mirrored Silver Screen. Set Zenith's Cinébeam picture alongside *any* other—it'll sell on sight!



CINÉBEAM—for Longer Tube Life! Even though Zenith's new Cinébeam gives twice the picture power, it actually uses 20% *less* beam current. The tube lasts longer, stays brighter! And yellow spots on the picture screen are banished forever with Cinébeam. That means years of cinema-perfect pictures and more *really satisfied* customers for you.

CINÉBEAM—In 21, 24, and 27-Inch Screens.

In a brilliant selection of consoles that only Zenith can show you. Here are the styles and the woods your customers want. You'll sell them on sight!

Just three of 52 beautiful styles—yours exclusively from Zenith!

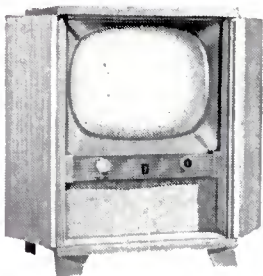

The Fulton—Model L2573E
Distinctively modern blond comb-grained Oak veneers and solids. High fidelity 10-inch speaker for exquisite sound reproduction. Full doors. 24-inch Cinébeam picture tube.

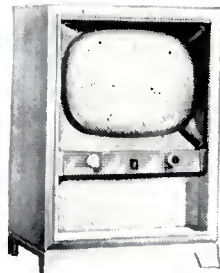

The Todd—Model L2573E
Superbly designed combed grain Oak veneers in the most modern mood. Giant, 24-inch Cinébeam picture tube gives double the picture power. Super-sensitive FM sound reproduction.

The Carrol—Model L2878R

A masterpiece in impressive Traditional styling, this full-doored aristocrat has a 27-inch Cinébeam picture tube and Zenith high-fidelity 10-inch speaker, built-in VHF-UHF antenna.

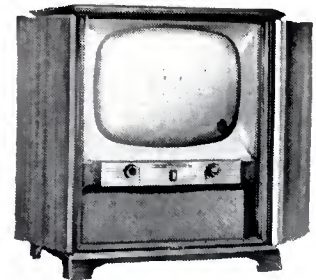

ZENITH



The royalty of radio and **TELEVISION[®]**

ZENITH RADIO CORPORATION, Chicago 39, Illinois
Backed by 35 years of "Know-How" in Radionics Exclusively.
Also makers of Fine Hearing Aids.

One high standard of quality at every price

COPYR. 1953

Depend on Mallory
for
Approved Precision Quality



The
MALLORY UHF Converter
can mean
EXTRA PROFITS
when UHF television comes
to your area

Where UHF television has already gone on the air, the Mallory Converter has proven to be one of the fastest moving items in the new UHF market. And for good reason too.

- The Mallory Converter will equip any TV set to receive *all* channels—old and new.
- Picture definition is excellent... tuning is easy.

Another outstanding feature of the Mallory Converter is that it tunes in *all* channels in *any* area. The customer who has one has nothing more to buy, no adjustments to make... even if he moves to another broadcast area.

YOUR MALLORY DISTRIBUTOR will be glad to show you the Mallory Converter... tell you how successful it has been for dealers in other areas. Get complete information today, so you can make the most of the new UHF market tomorrow.

Installation is
FAST and EASY

... and it can be done right in your customers' homes in a matter of minutes. Simply connect the antenna leads and power lines from the Converter to the set. That's all there is to it.

P. R. MALLORY & CO. Inc.
MALLORY

CAPACITORS • CONTROLS • VIBRATORS • SWITCHES • RESISTORS
RECTIFIERS • POWER SUPPLIES • FILTERS • MERCURY BATTERIES
APPROVED PRECISION PRODUCTS

P. R. MALLORY & CO., Inc., INDIANAPOLIS 6, INDIANA

Tele King introduces

24" TV

the **BIG** set...set for
bigger than ever profits!

Here Are Only A Few Of TELE KING's
Sure-Sell Features!

- **Bigger, Clearer Picture!**
Rectangular screen.
- **Continuous, BUILT-IN UHF
All Channel Tuning!***
No Strips...no additions needed.
- **Super Cascade Tuner!**
- **Directional Sound!**
Auditorium tone quality.
- **Handsomely Styled Cabinets!**

**all this and more...
plus the biggest
mark-up in television!**

TELE KING offers 17", 21",
24" and 27" TV with all of these
sales-attracting features.

** Available at a small added cost!*



KC 42

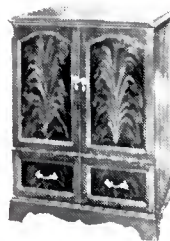

KD 43



KC 43B

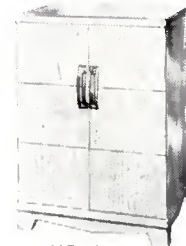

KD 42B

Tele King

CORPORATION

601 West 26th Street, New York 1, N. Y.

Win a 7-day all-expense paid trip-for-two to BERMUDA and NASSAU!

Enter the big RCA Victor Bermuda "45" CONTEST NOW! You could be one of the RCA Victor dealers who will be aboard the RCA Victor-chartered "Ocean Monarch" when she sails on the gala mid-winter cruise

HERE'S WHAT THE WINNERS GET!

- Air or Rail Transportation from Home to New York City and Return.
- Double Occupancy outside stateroom (For Two Persons) Aboard the magnificent "Ocean Monarch" (which is exclusively RCA Victor's for the duration of this cruise).
- Superb meals, drinks and all gratuities paid.
- Full use of lavish recreational facilities aboard the "Ocean Monarch."
- Use of the "Ocean Monarch" as a floating luxury hotel in Bermuda and Nassau.
- Thrilling entertainment and recreation in Bermuda and Nassau.
- Return voyage to New York City aboard the "Ocean Monarch."

- There will be at least one dealer winner in each distributor area.
- Dealer prize awards will be based on dealer purchases of models 45J2, 45EY2, 45EY3 and 45EY4 from distributors. Their quotas will be set by the distributor and final determination of dealer winners is in distributor's hands.
- Dealer winners will be determined by percentage attained against quota for the last six months of 1953 (dealer purchase quotas are set by the distributor).
- Each dealer winner will be provided with one double occupancy cabin (for two persons). All cabins on the "Ocean Monarch" are outside cabins and will be assigned by lot.
- There will be no cash refund in lieu of the cruise or of transportation to and from New York City. Stop-over accommodations before or after the trip will not be paid for.

Contest Began July 1, 1953 and ends December 31, 1953.
Contest Winners Will Be Announced Early in January, 1954 in Time to make ready to board the "Ocean Monarch" in New York, February 6, 1954.

HERE'S HOW YOU WIN!

Complete Rules for the RCA Victor Bermuda "45" Dealer Instrument Sales Contest:

- All RCA Victor Dealers handling "Victrola" 45 instruments are eligible (contest open to dealers within continental limits of U. S. A. only).

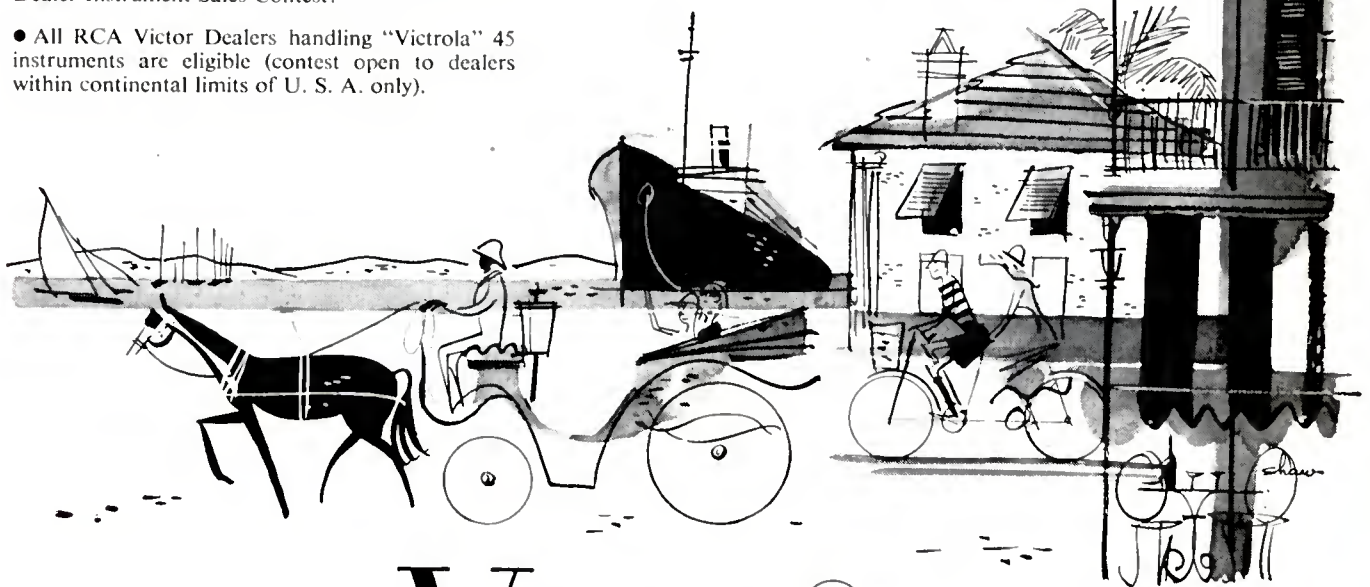

Tmks. ®

RCA VICTOR

Division of Radio Corporation of America



Satisfying Your Demand

Here is the one truly revolutionary Television Table for any TV set regardless of size or weight. A rotating table extending on custom-made slides like the finest dining-room table—with extension leaves furnished. In mahogany, limed oak or blonde. COMPETITIVELY PRICED FOR FULL PROFITS. We invite your inquiries.



with shelf,
rotated
Model XS550



Closed view
Model XT500

-also

new wrought iron extension television table

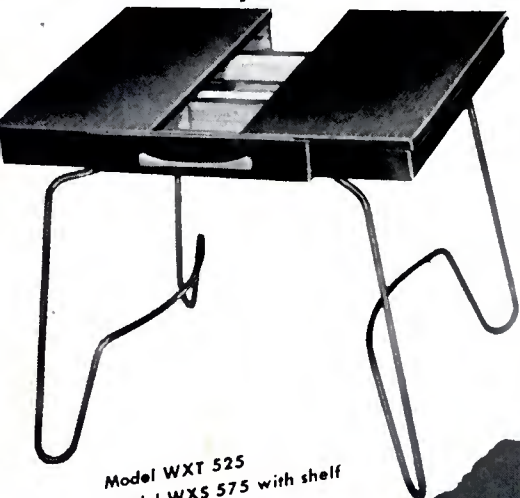

Model WXT 525
Model WXS 575 with shelf



Sold through recognized distributors only.



**Universal
WOODCRAFTERS inc.**

of LA PORTE, Indiana

The Nation's Leading Furniture Specialists to the

Radio and Television Industry

Motorola Stands Alone

against

Shorter Discounts

and

Longer Lines!

Motorola refuses to join the trend toward Longer Lines and Shorter Discounts AT THE DEALERS' EXPENSE!

Motorola and its major competitors have now announced their new lines and discount policies for the fall season. Among all the leaders in the television industry, *Motorola alone* has taken a forthright stand against the two serious blocks to retail profits today . . . *shorter discounts and longer lines*. These are the growing tendencies of the industry, which we oppose. Each of our competitors has now announced:

- *Longer lines for retailers to carry . . . up to 55 different models, with infinite numbers of cabinet variations and chassis combinations.*
- *Lower list prices on certain "strategic" models, at the expense of proper margins for the distributor and dealer.*
- *Shorter trade discounts on many models, particularly in the brackets that provide most of the volume, thereby causing the greatest loss of profit to the dealer.*

Motorola believes these shortsighted policies are bad for the retailer and for the distributor . . . and therefore bad for the whole industry. We do not feel that the industry can afford to ignore a situation which undermines the interests of those upon whom the industry depends.

Longer lines mean heavier inventories, slower turnover, greater financial requirements, confusion confounded. *Narrower margins* on biggest-volume sellers mean tremendous slashes in net

profit right where they hurt the most— at the very time when retailers' profits are being squeezed most severely.

Motorola's line is short and sharp. It covers all the bases, but allows inventories that are within the bounds of reason. It is a broad line, a complete line, a beautiful line from every viewpoint. List prices range from \$179.95 to \$695.00. The entire line is priced competitively, but with full attention to the problems of inadequate discounts.

This is Motorola's Program:

- 1. We are limiting the number of models in our fall line.**
- 2. We are holding to competitive list prices.**
- 3. We are lengthening the discount on the majority of the models in the line.**
- 4. We are lengthening the discount on every model priced under \$300.**

Simply stated, our program is this: **The Shortest Line—with the Longest Discounts!**

We feel that we are right in taking this stand, which is directly opposite to that of the rest of the industry. It is Motorola's conviction that our franchise should provide a fair and equitable profit to our distributors and dealers.

We take our stand with full assurance that our friends in the trade will support us wholeheartedly, and that Motorola's position, as well as theirs, will be stronger as a result.

Better See Motorola TV



"The Shortest Line...with the Longest Discounts"



WHY STOCK 12 WHEN 2 WILL DO THE JOB?

PANORAMA-TENNA

**2 PANORAMA-TENNAS
DO THE JOB OF
12 DIFFERENT
YAGIS!**

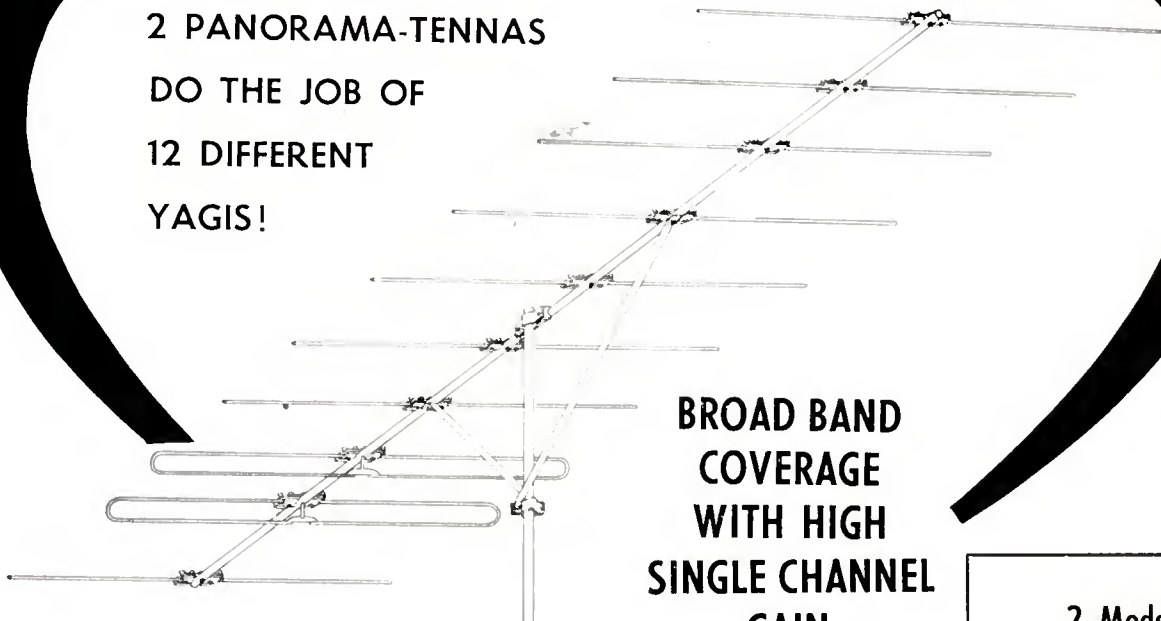

**BROAD BAND
COVERAGE
WITH HIGH
SINGLE CHANNEL
GAIN**

**YOUR PROFITS GO UP . . . BUT YOUR INVENTORY GOES DOWN!
SENSATIONAL PHOENIX PANORAMA-TENNAS
ARE 3 WAYS BETTER FOR BUSINESS!**

1. THE PANORAMA-TENNA WILL NOT BECOME OBSOLETE WHEN CHANNELS CHANGE!

When VHF stations on the same band change, single channel Yagis become immediately obsolete. The Panorama-Tenna gives more brilliant reception than Yagis on TODAY'S channels and will provide equally brilliant reception when shifts are made.

2. THE PANORAMA-TENNA WILL PULL IN ADDITIONAL CHANNELS!

A Panorama-Tenna installed NOW will bring in new stations! Eliminates having to put up additional single channel Yagis—costly switching arrangements—cluttered rooftops. The Panorama-Tenna does the work of two and more Yagis with spectacular results at lower expense!

3. IN AREAS WITH 2 PRESENT STATIONS, THE PANORAMA-TENNA COVERS BOTH FAR BETTER THAN OTHER TYPES OF ANTENNAS!

The Panorama-Tenna combines tremendously high gain with easy, quick low-cost installation; it's a true broad-band antenna with single channel Yagi features!

**2 Models
Solve Every
Reception Problem!**

Model PD
Multi-Channel Covers
Channels 2 thru 6

Model PA
Multi-Channel Covers
Channels 7 thru 13

**WRITE TODAY
FOR COMPLETE
DETAILS**

PHOENIX ELECTRONICS, Inc. • Lawrence, Mass.

DuMont Television

The Direct Line to Profits
with New

"COMPLETE COMPARISON" Selling Features!

- **A Great Sales Story!** Du Mont invites comparison with every other make, at every point in every set at every price!
- **New Powerful National Advertising!**—pre-selling Du Mont's complete quality performance! In top magazines...newspapers!
- **Right Prices for Every Customer!** And better value in every set, with Du Mont quality control from end-to-end of the line!

Now, with Du Mont advertising urging buyers to make the "Complete Comparison" check... with the great new sales features in the Du Mont line... with more attractive dealer discounts... you can see why featuring Du Mont means easier, more profitable sales!

**Optional Du Mont 82-Channel Tuning
— Most Sensitive in Television —
Ideal for UHF-VHF Areas**



DuMont de Luxe
WARWICK

American Contemporary table model. Mahogany or limed oak finish. Matching base at slight extra cost. Glare-free picture from 21-inch Du Mont Selfocus* tube. Phono jack. Built-in UHF-VHF antenna. 82-channel tuning optional.

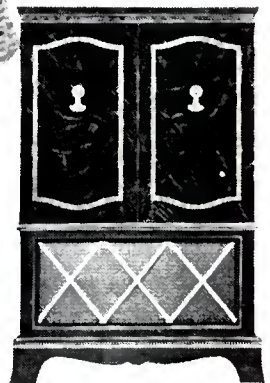

DuMont de Luxe
WINDSOR

21-inch Du Mont Selfocus* tube. Removable safety glass. Fine 18th Century cabinet on casters, hand-rubbed mahogany finish. Phono jack. 82-channel tuning optional. Built-in UHF-VHF antenna.

THE SELECTIVE DU MONT DEALER FRANCHISE IS MORE VALUABLE THAN EVER TODAY!

Write, wire or phone your Du Mont Distributor for full details, or write to: Allen B. Du Mont Laboratories, Inc., Television Receiver Division, East Paterson, New Jersey.
Canadian Affiliate: Canadian Aviation Electronics Ltd., Du Mont Television Division, Montreal, Canada.

All your customers can afford **DU MONT** QUALITY TELEVISION... from \$199.95**

(for 17" table model, not illustrated)

**Prices include full-year picture tube Warranty, Federal Excise Tax. Prices slightly higher in the South and West and subject to change. *Trade Mark.

Now!
**24 INCH
 TV**

*with an
 unmatched
 extra*

exclusive
PANORAMIC VISION*
by
STROMBERG-CARLSON

From the pioneer in 24-inch TV now comes the greatest viewing thrill of all—24-inch PANORAMIC VISION, with the widest viewing angle, the greatest picture visibility in television!

Outstanding performance on UHF or VHF—proved even in the tough fringe areas—and distinguished new cabinet styling give you other unmatched extras to sell in this great 1954 line of 24-inch receivers.

All 1954 models available with either VHF-UHF strip-type tuner or, at additional cost, all-channel VHF-UHF continuous tuner.



THE WENTWORTH—24-inch Panoramic Vision picture. Concert-type speaker for finest tone. Tone control. Phono jack. Built-in antenna. Cabinet of rich mahogany veneers—with a true decorator touch in the interesting recessed speaker grill.

*Patent applied for



THE EMPIRE—24-inch Panoramic Vision picture. Concert-type permanent magnet speaker. Tone control. Phono jack. Built-in antenna. Decorator styled cabinet of blond oak veneers with disappearing tambour doors. Also in hand-rubbed mahogany veneers.



*For prospects who want everything
 and the best of everything—*

THE IMPERIAL—24-inch Panoramic Vision picture. Custom 400 high fidelity audio system. AM-FM radio. De luxe automatic 3-speed record player. The period cabinet in Georgian style is built of selected Honduras mahogany veneers, and provides liberal album space.

"There is nothing finer than a
STROMBERG-CARLSON®

Stromberg-Carlson Company, Rochester 3, N. Y.

TELEVISION RETAILING

Also "RADIO & TELEVISION"
"RADIO & TELEVISION TODAY,"
"TV TECHNICIAN" and
"APPLIANCE RETAILING"

Including **MART** and **TECHNICIAN**

O. H. CALDWELL, Editorial Director



M. CLEMENTS, Publisher

Selling "Service-Free" Products Overcomes Customer Fears

The TV-Appliance customer does not *want* to buy service! Instead, he *tries* to buy a *service-free* product.

Naturally, the customer's fear of a service problem will influence his buying actions on certain products. This is especially noticeable with products such as television, room air conditioners and automatic washers.

Yet, even with a product which may be a "service problem" (in the customer's eyes), the customer doesn't *want* too much service or too much of the dealer's servicing facilities. Nothing can be more annoying to the home owner than the frequent visits of the serviceman—the television going haywire in an 0-0 ball game, or the room air conditioner conking out on a 98-in-the-shade day. The customer has probably experienced some similarly exasperating problem—and he tries desperately to avoid another. At the same time, he expects prompt and efficient service if he needs it.

Have We Got The Right Sales Slant?

Salesmen in discount-houses give a fast brush-off to most questions about service. They say there's no such problem with good merchandise. They say there's nothing to installation, either.

Psychologically, these operators are on the right track in minimizing any fear of service that lurks in the customer's mind. Their most vulnerable weakness, perhaps, lies in their efforts to make installation seem unimportant.

In some cases, the honest legitimate dealer has used the "service" angle too freely in trying to make a sale against the cut-price artists. Such overboard stressing of service builds the customer's fear—rather than allays it.

But the merchant can sell the need for proper installation for top performance of the product. He can sell his know-how, his skill, his reliability. He can sell the necessity of any fine product getting the proper adjustment, or "tune-up," when initially installed—and he can sell proper maintenance afterward, when needed.

To fight the gyps you've got to remember the customer's point-of-view, too. Don't sell 'em service in a frightening manner—sell 'em a "service-free" product, guaranteed by you, when properly installed.

Good reputation can be built by speedy, efficient service whenever the customer requires it. Satisfied users will come back and recommend the firm to others because of such satisfactory service. But with today's vastly improved products, it isn't necessary to jeopardize any sale by over-emphasis on an angle which may well scare off the prospective purchaser.

What's Ahead!—In Radio

UTILITIES TO STEP UP MERCHANDISING on the low-saturation and high-load appliances . . . at least the power company boys are thinking that way, according to conversations during the recent EEI shindig in Atlantic City . . . Efforts will be directed largely to better (and more) aid for dealers, but there are some threats to resume selling. Big gripe is "price" selling instead of "better living" through electrical service . . . P.S.: Will the utilities tolerate the discount houses? Should be interesting. Hmmm!

MANY DEALERS DON'T KNOW their true overhead according to numerous successful TV-appliance retailers. If close scrutiny were made on the returns for the capital investment in the business, cost of doing business, and net returns to the operators, the retailers would stop giving away merchandise and strive for greater profits on their investments of money and time, claim these critics.

DECENTRALIZATION OF THE POPULATION to suburban and country areas throughout America is a trend every dealer should examine thoroughly. If, by now, you haven't yet investigated the fantastic sales potentialities of your built-up suburbs and country areas, take out the family car this week-end and start touring your city's and town's borders. You'll come back brimming with enthusiasm and a feeling of "rarin' to go" . . . and start expanding or moving your entire operation into the more fertile and lucrative markets.

DON'T THINK that the specialty manufacturers are sleeping easy these nights as they dream of the inroads contemplated by full-line and diversified producers. Several of the independents, particularly in TV, are wishfully thinking of increasing their basic lines. But they'll probably settle reluctantly by adding Hi-Fi equipment and angling their ad copy along "we specialize-and-therefore-have-the-know-how" or some similar theme.

MORE THAN ONE DISTRIBUTOR has begun to realize that the small dealer is his bread-and-butter mainstay. The failures of several get-rich-quick chains within the past year resulting in losses of thousands of dollars have had sobering effects. Thinking today is that it might be better to have scores of small dealers, each owing lesser sums, than to be in the hook for big amounts with fast-moving promoters who seem to be getting the skids under them more and more.

SOMETHING NEW IN COOKING SCHOOLS will appear in a big way this Fall. The electric housewares boys will boost the "casual living room cookery" idea by means of preparing full meals with electric housewares, using regular living room furnishings to stage their acts. Rotisseries, broilers, deep fryers, etc., will be in the stage setting right in the middle of tea carts and cocktail tables. Nobody can say just how consumers will respond to such cooking schools, but optimism is high!

MANY DISTRIBUTORS are pleasantly surprised at the continued loyalty of their dealers. Seems many of the established retailers still remember the kind deeds of yesteryear when they were given extra time to pay their bills, co-op ties, and the courtesy of special models as needed. Distributors are now being repaid by the fact that numerous dealers are being coy to the blandishments of competing wholesalers and manufacturers and insist on retaining their present lines and affiliations.

PHONO RECORDS, long the forgotten child of many dealers, are in for a new reappraisal by across-the-board retailers. Taking a hint from the present day trend of manufacturers to full-lines and diversification, smart dealers are expanding into records, phonos, and high fidelity equipment.

THE AVERAGE VERY SMALL DEALER earns from \$5000 to \$6000 annually on his business, one distributor pointed out. He could earn the same amount working for someone else without the present-day headaches of operating a marginal outlet and spending most of his hours worrying how to make ends meet. But this analyst had to admit that most dealers are rugged individualists who would rather be in business for themselves than work at a job for someone else.

MANY RETAILERS EXPRESS the need of monthly merchandise showings rather than annual or semi-annual get-togethers at distributors' or manufacturers' showrooms. Smaller gatherings would enable dealers to absorb features of merchandise much easier, learn the producer's promotional and ad plans, and permit the retailers to feel more relaxed, it was pointed out. Serving of refreshments would aid to bring about a mood of congeniality, several dealers suggest.

WATCH FOR ONE INFANT TV manufacturer's all-out attempt to crack open the consumer market. Irked by its initial failure to achieve immediate national consumer-acceptance on its own timetable, the firm has brought in a new whip-snapper. Tons of greenbacks will go into publicizing the name brand and there is no doubt this producer will raise itself by its own dollarstraps to be among the top leaders in our field. (So say astute competitors!)

THE DAYS OF PM'S for appliance salesmen are back. No longer do the floor men rush to show the best-seller or the loss-leaders merely to exhibit sales figures at the end of the day. Trend is back to giving the inside men incentive premiums and bonuses for sales at list, on discontinued models or on overstocked numbers.

OVERLOADING OF DEALERS by zealous distributors is causing retailer grumbling. One small retailer pointed out that he has been compelled to purchase in one-half carloads in order to obtain any appliances from his wholesalers.

Appliances, Records and Television

MART and TECHNICIAN—these are the names of the two new magazines which will succeed TELEVISION RETAILING in September. They are going to be great magazines—and we're proud of them. Retailers—learn all about your new magazine, MART, by turning to page 86. Servicemen—the complete details on the magazine written especially for you, TECHNICIAN, is on page 90.

THE PRICE-CUTTING TV-APPLIANCE DEALER stands accused of being in the forefront among the leaders who are teaching the American public the facts of retail discounts. The accusers are the retailers themselves. There is practically no more selling in the TV-appliance stores, in the New York area, a survey reveals. When a customer enters the store and asks casually "How much?" the immediate answer is: "We'll sell it to you cheaper." No attempt is made to explain the features or switch the customer in most instances. (These statements were made by the dealers themselves during the course of many interviews).

HI-DE-HO . . . and HI-FI! Reports say the boppers are real gone, but cool, on Hi-Fi systems—even though hop is on the wane.

ALTHOUGH THE NUMBER OF TV-appliance dealers rose in 1952 over the preceding year, the gloomy prophets are again writing obituaries for the industry. They say the next six to eight months will see a shake-up of the medium and small operators, many of whom are supposed to be getting out of the field while the going is good. Seems we've heard this one before . . . several times. But new blood keeps coming into our fold. It is estimated that forty per cent of all present-day dealers have entered the field since the end of World War II. There is no danger that our industry, therefore, will shrivel away to oblivion.

REMEMBER 'WAY BACK WHEN radio repairmen were making \$35 a week; when white goods were green, and the late Booth Tarkington said, in 1936, that after radio's inroads, television would about finish novel reading as a pastime in American homes? . . . And do you recall these old appliance names: Arnold hairdryers, Federal washers, "Sunny Day" electric clothes dryers, Bock clothes dryers, Woodrow washing machine; Farrell washer-dryer, Dover electric irons? . . . And it seems like only yesterday that metal tubes came into popularity with many being sold as replacements.

SECOND SET TREND. A survey just completed by Emerson Television and Radio indicates that Junior is coming into his television own. The results indicate a strong trend towards a second video receiver in the home and, surprisingly enough, it does not go into the family den or study. The conflict on who will watch what program at a given time is resolved, reports the Emerson survey, by 83% of the second sets being installed in Junior's room. Only 6% go into the family den and 11% are in the parents' bedroom.

SALES TRAINING HAS STEPPED UP IN '53, but manufacturers will blast with both barrels in 1954. Extremely strong programs are being formulated now to reach deeply into the retail selling picture. Watch for very earnest, realistic sales training efforts next year on an unprecedented scale.

CORRUPTION OF STORE SALESMEN by several distributors has many retailers up in arms. "A disguised form of bribery to sell specific brands of appliances," is the way many dealers are describing the activities of a few wholesalers. Inducements include suits of clothing, shirts, or tickets to the ball games. Retailers point out that if discounts equivalent to the cost of the bribe were made on each appliance, the merchandise might move faster and the store owner might make a slightly better profit.



"EVERYONE'S GOT TO FEND FOR HIMSELF" was the answer of Eastern dealers received when they complained to a large distributor that he was selling everyone who came to his showroom. What rankled the retailers was that this same wholesaler allegedly sold retail at 30 per cent off list to anyone who approached him. "On one hand, the distributors dine and wine us," one spokesman said bitterly. "With the other hand, they slap our faces."

COMMUNITY ANTENNA SYSTEMS which pipe TV reception via coaxial cable into mountain and valley areas and other inaccessible dead spots, will enable more than 350,000 families to buy home receivers within another year. So says Milton J. Shapp, president of the Jerrold Electronics Corp., Philadelphia, a major supplier of community antenna systems in America.

Future Events of Interest to Readers

- Aug. 2-5: Western Gift, China, Glass, Toy and Housewares Show, Western Merchandise Mart, San Francisco, Calif.
- Aug. 19-21: 1953 Western Electronic Show & Convention, Civic Auditorium, San Francisco, Calif.
- Sept. 1-3: International Sight and Sound Exposition, Palmer House, Chicago.
- Sept. 14-17: National Electronic Distributors Assoc. Fourth Annual Convention and Mfrs. Conference, Chase Hotel, St. Louis, Mo.
- Oct. 9-11: National Alliance of Television and Electronic Service Assns., Morrison Hotel, Chicago.
- Oct. 14-17: Audio Fair, Hotel New Yorker, New York.
- Nov. 9-12: 8th All-Industry Refrigeration and Air Conditioning Exposition, Cleveland, Ohio.

Next Month—Business

While the Customer's Away, the Dealer Will "Play"—With Big Ideas That Will Result in Good Profits During the Approaching Autumn Season.

• Many a consumer still lolls away the last days of his vacation. But the enterprising dealer is sweltering in the midst of plans for a big Fall selling season.

The vacationer will soon return—and the TV-appliance dealer is making ready.

The big TV shows will be coming back—better than ever this year. The women will be thinking of household improvements they can make for the long winter ahead. It's "get-the-house-in-order" time for millions of homemakers.

Now, just what plans can the dealer make to get a better share

ties, such as removing slip covers from furniture, painting the storm sashes, new school clothes for the children, and so on. Then there will be the items of specific interest to the dealer. Adjust burners or replace elements for the range, clean the condenser on the refrigerator, clean the automatic washer drain, repair the iron, check the TV.

It's a worthy idea. It reminds the customer of the numerous tasks that usually come up in the Fall. Naturally, it offers the dealer's service facilities for the TV-appliance check-ups.

Many dealers have realized the Fall bonanza for years, and they have geared their efforts accordingly. A number of TV-appliance retailers will spend better than 70% of their advertising budget during these last four months of the year. It's the time for the dealer to tell the customer about himself in a big way—with heavy consistent advertising and well-planned promotions.

TIME TO SPRUCE UP: These tail-end-of-Summer days are the

time for remodeling or "touching up" the store. If the interior displays are to be rearranged it's wise to get it over before the Fall season hits. If there's lighting, heating, painting, carpentry, etc., to be done the dealer can get it out of the way now—then get his mind back to selling enough merchandise to make all this refurbishing worth while.

FILL OUT THE LINES: It takes merchandise—and plenty of it—to do a top job in selling. Most dealers will be studying the inventory situation now—from the selling standpoint, that is. They'll want merchandise on hand for step-up selling and for fast delivery. They'll want to offer the widest possible selection, perhaps.

New fill-in models in white goods may have been announced—and the full new TV-radio lines have been shown. The dealer has had time to figure out his needs. These last days of Summer let the dealer sit down and make decisions on buying. He'll be in good order when the Fall perk-up comes along.



of the "home-again" dollars to be spent this Fall?

TELL 'EM ABOUT YOURSELF: Most dealers who employ direct-mail advertising agree that special attention should be given to mailings which reach the customers directly after Labor Day. The same holds true for newspaper advertising and radio and/or television spots.

Recently a dealer revealed a plan for an interesting Fall campaign. He expects to provide a "check chart" for the housewife. It will list usual Fall household activi-



Comes Back to Main Street!

TRAIN THE SALES STAFF: Many dealers devote a great deal of time to sales training during these late Summer days. Business is seldom as brisk as during the Fall season—so the staff is more “available” for training. Since very few new pieces of merchandise will be introduced and sold at retail during the last four months of the year, the dealer can feel assured that his final “brush-up” training in late Summer will carry through into the next year.

Also, in late Summer the factory man and the distributor's salesman probably can give more time to sales training. They'll be more readily available for aiding dealers in staff meetings. The new TV-

the merchandise they already know.

Like a well-oiled machine, the TV-appliance retailer can hit September in finely-tuned condition—but it isn't just by luck or wishful thinking that he does so. He toils and plans during these August days so that he can hit September with his best foot forward.

The TV shows are expected to hit a new peak of quality and mass appeal this Fall. Already there's talk of the new professional football telecasts. The movies are expected

few dollars more than the list on the new job. He had acquired and reconditioned enough used sets so that he could fill most demands for two-set ownership by combining them with higher priced new receivers. Most parents seem to want



radio lines are out, and franchising has advanced far enough so sales training is the next order of business for the distributor's man.

TRAIN THE SERVICE MANAGER, TOO: With the rush back to home in September, there will be tremendous increases in service calls. The service department will need every spare moment for actual service work in just a few weeks now. Again, the late Summer is the ideal time for the service department to be schooled on new models and improved service methods on

to be vastly improved both through new technical aids in transmitting and in the quality of shows.

Consumers will learn of these improvements in TV shows—but the dealer always should implement the education of the consumer with promotions which point up these advances in TV programs.

The 1954 television receivers are designed, mostly, to capture those consumers who have been waiting for the combined VHF-UHF tuning. Dealers who have listed TV prospects who are holding back for this reason will have a solid sales approach now with the new receivers. Other improvements, too, in the new 1954 lines will aid dealers with both new sales and with replacements.

This Summer a Connecticut dealer sustained his off-season TV business very successfully by offering two sets for a price of but a

an extra set for the kids—and this two-set market is expected to grow very rapidly with the coming Fall season.

Retailers have been reporting an increasing tendency of the public to early Christmas shopping. Here is a factor that some TV-appliance dealers are expected to capitalize on this Fall. Some dealers are even planning direct-mail pieces along the Christmas theme for release in September. There may be special lay-away Christmas plans that will get prominence in Fall merchandising. Apparently the consumer doesn't object to these early reminders to do Christmas shopping. In fact, most consumers seem to appreciate them.

So late Summer is a busy time! It's time for the spade-work—time for the Fall planning. The dealer with the carefully planned Fall program will get his rightful share of those consumer dollars that'll be coming out of hiding with the first brisk autumn days. Most good sales results are the product of sound planning—and now's the time to do it!

Product Knowledge Clicks With Customers

• The "big brass" in many TV-appliance manufacturing organizations has good solid retail experience. Not enough of 'em, maybe. But some of these fellows have been through the mill at dealer level. Usually they're the best—best, anyhow, for knowing just what the TV-appliance dealer problems are.

When you meet a big exec at one of the hand-shaking sessions you can usually tell pretty quickly whether he "belongs" or not—whether or not he's got a retail-level record or a lot of book learning. If he's the real McCoy he's usually happy to talk plenty with the dealer, for it's a language he knows. He has confidence in himself—and he knows he can *always* learn!

How about your own sales force? Do they reflect confidence? Not only in their personal appearance; not only in manner and speech. But are they confident that they know the products which they are selling?

Sure, the big idea is selling a service or a better way of living. But it's the product that does the job. If the salesman knows the product he certainly reflects this knowl-

edge in his sales efforts, thus inspiring confidence of his customer.

Personnel problems have plagued almost every dealer in recent years. A doubtful quality of trainees; high turnover. Most of all, there has been a flat unwillingness to learn. Human nature being what it is, well, there's no such thing as a formula for handling salespeople.

If the salesman, however, can be wheedled, coerced or threatened into really knowing the products—that's a Number One step.

Manufacturers are placing more emphasis now on sales training than at any previous time in the TV-appliance field. Quite a number of manufacturers have tremendous organizations geared up solely for this training job. Some of these programs are effective—some are not. But, in any event, product knowledge is never a one-shot sales meeting job. It requires follow-through by the dealer.

Many dealers hold the early morning sessions at which a distributor or factory man tosses out a combined sales story and product study. Usually, the retail salesmen

get a great deal out of these sessions. Most dealers agree there should be more of these product meetings.

Follow-Up Is a Must!

But what happens *after* the product meeting? Here's where dealer follow-through plays a vital role. Many merchants have learned that they can follow-up by spending time individually with each salesman after such a meeting. Or, sometimes, they can get the wholesaler to follow up. This means getting Joe (a pretty fair salesman) out in front of the product and going over the features again—and again! Maybe Joe got a good number of the basic points in the meeting—but he couldn't hang onto everything that was said or demonstrated. And, for sure, he couldn't think through all the comparisons with competitive merchandise.

Human nature again. The human mind just can't take in everything that fast—at least, not so firmly that it gives real confidence to a man.

Has he used the product? Does he know what it will *not* do, as well as its varied uses?

More dealers are taking full advantage of home economist demonstrations that are offered by utilities, distributors and manufacturers. They want their salesmen to know the homemaker's problems, techniques and manner of thinking. *Dealers can get their salesmen to attend!* It's tough, perhaps—but even the hard-bitten veteran salesman can learn a lot. If the dealer hires salesmen instead of headquartering for a bunch of free-lance hot-shots, he can control his men so that he can truly help them. But the dealer himself must have good sense of organization to give proper direction in product training.

One dealer recently started an "up-grading" program in product training by setting up three mornings each week to on-the-floor meetings. They were scheduled for each Monday, Tuesday and Thursday. The salesmen had to get in thirty



Salesmen Need Frequent Briefing to Keep Them on the Ball. Dealers Urged to Have Their Men Use Manufacturer - Distributor Training Material, Facilities

minutes ahead of the usual time—but there wasn't a single complaint. In fact, the men worked throughout in closest cooperation with the dealer. The salesmen themselves were so completely sold on product training that each man felt that it was a voluntary plan which he helped to organize.

When the program was laid out, the dealer contacted all of his TV-appliance suppliers and advised them of the program. Immediately, he was booked up for eight weeks of the Monday and Tuesday sessions. The dealer and his salesmen held the Thursday sessions for themselves. On Thursdays they reviewed the previous product sessions and tried to iron out any confusing points. Most of the attention was given to repetition of sales features, product facts and comparisons with competitors. These were the real "sweat-box" sessions. If there were no customer interruptions these meetings frequently carried over as long as an hour after store opening hours.

"The men love it," the dealer reported after the first few meetings. "They feel they're learning something. It makes them better salesmen in every way—especially, it gives them self-confidence."

In Chicago, For Instance

The area around Chicago can boast of many fine manufacturing plants which turn out television receivers and appliance products. So, normally, you would expect the people who depend upon TV-appliance sales in that area to know something about what goes on in those factories. But a recent "sampling" of twenty-eight TV-appliance salesmen and dealers in the Chicago area showed that only one man had ever made the "production tour" of a manufacturer's plant. Yet there is no better way to learn the methods, craftsmanship, materials, testing devices and a generally convincing quality story than an actual plant tour.

A few dealers are beginning to appreciate the value of plant tours—and, even where manufacturers



may not welcome such an idea, they are insisting that their salesmen be taken on such tours. They learn the "why" and "why not" of product design from the manufacturing viewpoint. They learn "nuts and bolts"—although they may seldom sell by such methods. Yet it equips them for the unusual questions of some customers—and, above all, it gives them confidence—a feeling that here's a product which they really know from the ground up.

Most men want to learn. But very few will proceed to learn at the same rate. That's why many dealers are realizing that product training requires a great deal of personal attention.

Product training is based on factual data. There are definite features, sizes and measurements, materials, and so on. But product

knowledge goes far beyond these tangible facts. The salesman must know how to apply these facts to the consumer's needs. In the TV-appliance field there's no room for a so-called "spec-sheet salesman." He needs his facts—and he must know how to use them. He needs the confidence which only thorough product knowledge can give him. Then sales training is linked with product training. But many an able salesman can fail because of insufficient knowledge of the product itself.

The able salesman may be either overly impatient or improperly guided. If so the dealer performs a real service both to himself and the salesman by setting up sales clinics, demonstrations for his staff, factory tours—and most of all, giving the salesman the best possible individual attention in product training.

Gear Salesmanship to

By Observing the Basic Human Reactions, the Man Who Sells Will Make His Job



• Let's face it. Selling itself is intangible—whether the item or idea is a TV set, a washing machine or a life insurance policy.

This means—among other things—that a salesman is constantly dealing with that thing known as a human reaction. The prospect who has been called on many times before may prove just as unpredictable, too, with each call that the salesman makes. Most salesmen have experienced this. Here's a prospect that has been belligerent, unmovable, negative. Then just one more call—and the prospect has completely reversed himself. He's pleasant, manageable, and moves readily to the dotted line.

Human reaction is changeable! That is why the salesman must be constantly alert with each word his prospect utters—and highly conscious of the effect of his every response to the prospect!

Let's consider inside and outside selling for the television-appliance dealer. While the "fine points" of human reactions will vary violently, the broad concepts of human behavior are fairly well known. Let's approach it from the "wants" of the prospect, and consider points such as these:

ONE: The prospect wants, as a human being, pleasantness (not necessarily friendliness) in a business approach.

TWO: The prospect places a high value on genuine sincerity (not the wide-eyed "all for you" stuff that makes a salesman look like a ham actor).

THREE: Sincerity, consistency and knowledge of product are the factors that build confidence—and the prospect must have confidence in the salesman.

FOUR: The prospect wants consideration—the sympathy to his ideas, thoughts, feelings; he wants courtesy and respect.

FIVE: Likewise, the prospect usually wants to have high regard for the salesman—so the salesman's conduct should be such that he fulfills this want.

SIX: The prospect prefers to discuss his own problems, his own needs—so the salesman must, through his alertness, seek the opportunity to let the prospect "open up" on his needs as they are related to the salesman's products.

SEVEN: The prospect wants help—practical ideas for easier living, honest evaluations of products with which the salesman may be familiar.

EIGHT: The prospect seeks a good value—needs the assurance that his money will be spent properly and to best advantage.

NINE: The prospect wants financial guidance in purchasing (although few will openly admit it)—they want to know terms, if any, and should be so advised voluntarily by the salesman.

TEN: The prospect wants service—assurance of prompt delivery, proper installation and the other attendant services which may be required.

These "wants" of a prospect follow a pattern which is quite well known by most trained salesmen, but frequently forgotten in the pressure to build quick sales volume. If we tried to compress these wants of the prospect into one all-encompassing need probably the best description would be: *The prospect wants to have confidence!*

In outside selling you are going more than half-way to get the prospect's business. The prospect knows this. This prospect is not in the same frame of mind as the prospect who walks onto your sales floor. So, in outside selling, it is more difficult to gain the prospect's confidence and it's more important that you do so.

When a salesman is on cold canvass, the housewife probably experiences one of these emotions when she sees a strange man at her door; curiosity, anger, fear, indifference or disdain. Perhaps she's giving the baby a bath, or she has been awakened, or interrupted on a telephone gab-fest. The chances are pretty great that the salesman certainly won't be welcomed.

Here's One Technique

One salesman who specializes in cold calls has a technique of immediately saying, "Oh, I'm sorry, Mrs. Smith. Didn't realize you'd be busy now. I'll come back some other time." Naturally, this man figures, the woman's curiosity will jump sky-high. This will give him that precious first moment to begin winning her confidence. This seems a risky procedure, however. Another well-known technique, of course, is giving the woman something for nothing before she has time to voice her resistance. Yet another stunt is

Customer "Wants"

Easier and More Profitable. 10 Things the Prospect Looks for Are Outlined Here

determining by the city registry (if available) something about her family, such as number and names of children or the husband's occupation. Then the salesman opens up immediately with a remark such as, "I was wondering if your daughter, Margaret, has shown much interest yet, Mrs. Smith, in learning to cook." The salesman shows a knowledge of something personal about her life and her family.

A woman can make a quick decision—as most of us know. Perhaps she will call it intuition. But, in a moment's time, she will make up her mind whether she wants to hear any more. And the job is by no means finished in that first moment. In rapid-fire manner, she will study the salesman's clothes and grooming—perhaps to determine whether she thinks he's reliable; she will measure his first few words and his facial expression for pleasantness and sincerity. She will note that he stands well-removed from the door, not using that mis-used "foot-in-the-door" method; he is courteous and considerate. Then, perhaps, she decides that, at least, she respects this stranger who stands before her—and on that basis—well, she might want to ask him how much a freezer like Mrs. Jones' cost, or something about these clothes dryers she's been reading about, or why her vacuum cleaner doesn't seem to pick up the dog's hair any more.

One salesman's belief is "get her talking—about almost anything." Perhaps he has a point there—but some of these gals can really cut loose with what they think of door-to-door salesmen, too.

But this is *business*—and the housewife usually thinks so, too. There is no excuse for the salesman to try to be amusing or flip or to digress from his subject. She will retain her respect for the salesman only if he conducts himself in a business-like manner and genuinely contributes ideas that aid her in achieving better living.

Every salesman, almost, prefers to work by appointment. In his first telephone call the woman's reactions are likely to be just about the same, and the salesman strives to give her confidence just by his conversation.

Here's a suggestion on telephone calls. If the man or woman seems definitely open for a house call, of course the salesman makes a firm appointment. If the prospect attempts to get all information he can get by telephone, however, it may be advisable to just vaguely say you'll drop by some day soon and just leave a catalog. It's often best not to press for a definite appointment when the prospect is unduly reluctant. Then, too, there's the approach in which the salesman says he's coming out in that neighborhood right away, anyhow, so he'll just take a minute to stop by.

Phone Approach Often Clicks

Canvassing by telephone is very effective! Don't sell it short. However, plan your telephone approach just as carefully as possible. Again, the job is to gain the prospect's confidence. To prevent a quick hang-up, you may have to get

the answerer's curiosity aroused quickly, or hit upon a sure-fire interest of the prospect.

When the salesman feels he has reasonably good interest from a housewife, it's usually a good idea to gently feel out her inclination to buy without her husband's approval. If the husband's approval appears to be necessary, some salesmen will not even attempt a close—but will promptly suggest that they'll be out that way on another call after dinner, and will drop in for a moment then.

Remember, you are dealing with human reactions, however. *Always* be alert to that crucial moment when enthusiasm for your product is at "buy-now" peak. Follow the rules for the broad pattern. But the *fine points* of human reactions are almost never the same. Yet the salesman must win confidence, and these fine points are the real test of his ingenuity.

Most "big-ticket" items are purchased by both husband and wife. If this applies to your customer, a return call when both are at home may help close your sale.



Wholesaler and Retailer

Come On, Fellows, Let's Deal From the Top of the Deck!

Wrong With Distributor-Dealer Relations

• TV-appliance dealers and wholesalers have so much in common that it's almost inconceivable that there could be any rift in relations between the two groups. Yet, unfortunately for both dealers and distributors, you do hear of feudin' and fightin' between them.

But, like most misunderstandings, any dealer-distributor "beef" is usually the up-shot of not having

clearly-defined and firm policies that have been carefully set forth.

Here are common-place distributor gripes about dealers: carries too many lines; no loyalty; doesn't give enough volume; runs embarrassing or unauthorized advertising; won't cooperate on special promotions; always wanting to return merchandise; doesn't handle service properly; slow pay; won't take sales and service training; shifts lines too often; always chiseling; bookkeeping headache; gets an exclusive but doesn't

produce; and that all-inclusive gripe that the dealer is just plain "dead" as a dodo.

Now, here's what dealers usually cry about in talking of their distributors: franchising too many dealers; no loyalty; high pressure boys; their lines are no good; want you to carry everything they have; impossible discounts; always trying to load a dealer; inadequate service help; bad delivery practices; should make no builder sales; no guarantees against price reductions; not enough promotional aid; sells undesirable competitors; poor bookkeeping and billing practices; charges for all small services and promotional materials; and the general gripe that the distributor is "high-handed" as all get-out.

These are just a few of the problems. Yes, and most of these accusations are based on actual experience—on both sides of the fence. Some distributors have been guilty—and so have some dealers.

On the other hand, there have been both distributors and dealers who have followed strictly ethical business practices for years, and have made good money as well as attaining good business stature for themselves. The ethical distributor tries to capture as much of his market as possible—but with consideration, also, for his dealer's ability to get fair profits, too. The reputable dealer strives for retailing profits—but he is considerate, too, of the distributor's operations and policies.

Both dealers and distributors are supposed to be merchandisers. They ride in the same boat. If they row together smoothly—well, they usually get where they're going.

Probably the most helpful infor-

**REPEAT BUSINESS COMES WITH
CONFIDENCE, COOPERATION**



The Griping Distributor Says:

Dealers . . .

"Have no loyalty"

"Carry too many lines"

"Are interested in discount only"

"Want exclusives, but won't sell"

"Are dead as dodos"

CAN Work Together!

We're In a Great Business—and There's Nothing That a Little "Straight Talk" Won't Cure.

mation to the dealer-distributor relationship is a clear picture of the market. For instance, one town with a 25,000 trading area may be absorbing 500 refrigerators per year. Another market of the same size may be buying just half as many during the same period. Many factors can influence this big difference in refrigerator purchases—economy or personal income; shifting of population; and so on.

Obviously, unless both distributor and dealer understand these details in a particular market it's possible that there may be a bit of name-calling.

The number of dealers in a given market will govern, to some extent, the share of business to be obtained. Also, if certain chain operations are strong merchandisers in an area, it may throw the "averages" out of kilter. The distributor usually knows just about what share of a market he can expect in his overall territory. Sometimes, however, he fails to balance out each individual market on a sort of handicapping system. Dealers, also, frequently fail in this regard; they, too, can think they're doing better than they really are.

If the distributor puts on another dealer or if the dealer takes on a competing line—well, in either case, the action and the reasons for it should be clearly thrashed out in advance. Talking it over may build mutual confidence—and it may prevent business up-sets that may be costly in several ways.

All business is based on confidence—that's a well-worn creed, but it's quite true. Neither the dealer nor the distributor is a street-corner pitchman. The distributor lives on

re-orders; the dealer lives on satisfied customers. Thus, it pays dealer and distributor to make every reasonable effort to really know and understand each other.

The distributor salesman plays a key role in dealer-distributor relations, of course. He catches the dealer's complaints—then the policy and pressure from his own boss. This distributor salesman needs a "tape recorder" mind to transfer thoughts

back and forth from dealer to boss, from boss to dealer—and, of course, the ability to adjust and compromise. Briefly, his "selling" talent reaches its peak when he's welding the dealer-distributor relationship into a solid, trustworthy business operation.

If the distributor salesman has any ethics at all—or just plain common sense—he's not going to pres-

(Continued on page 74)

"SALESMAN, STAY AWAY FROM MY DOUGH,"

says the dealer

who's been sold an

unprofitable deal.

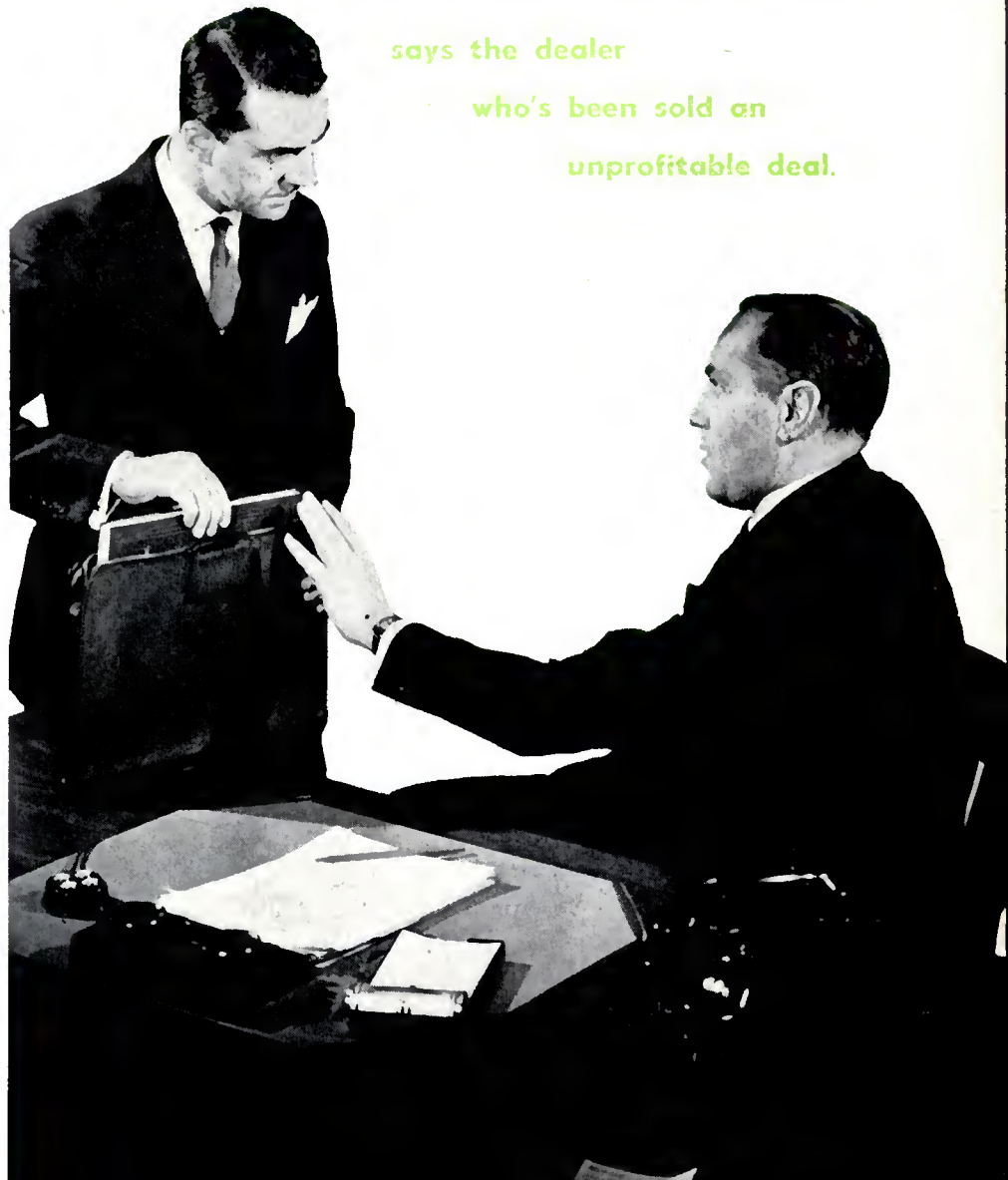

The Griping Dealer Says:

Distributors . . .

"Have no loyalty"

"Franchise too many dealers"

"Will sell anybody"

"Don't give enough discount"

"Are high-handed as all get-out"

Thar's Gold in

A TV-Appliance Dealer Added Phono Record Volume Sky-High. Here's How



• Does it pay for an established, successful television-appliance store to put in a phonograph record department? Can such a department be immediately successful? Can this be done without detracting from the operating efficiency of the rest of the store?

The answer to all these questions is a definite "yes," if you ask anybody at Dee's Radio and Television stores in Philadelphia.

Dee's, owned by Louis Dion, has three stores in different sections of America's third ranking metropolitan market. One has a well-established record department. The other two added record departments in October and November of 1952.

How're they doing? Just fine. Leading phono record distributors in Philadelphia, when asked to identify a television-appliance store doing a good platter merchandising job, often point to Dee's. And Mrs. Marna Yohannan, record buyer at the main store who set up both new departments last fall, says: "We've showed regular increases in business and there are signs this improvement will continue. Results to date definitely have been more than satisfying."

How do the Dee's stores do it? Mrs. Yohannan, who buys only for the Broad and Erie store at 3646 N. Broad, has no foolproof formulas for record department success. But

planned, systematic, controlled operation is the foundation of this department's success. It is seen in inventory records, buying, display, advertising, selling. In the words of Mrs. Yohannan, "Nothing is left to chance."

Here are some of the fundamentals of the Dee's record department:

DISPLAY—The department occupies an 11-by-27-foot room a few steps down from the main floor of Dee's appliance showroom. Above the entrance is an attractive "RECORD DEPARTMENT" sign. The department is long, slightly narrow, and comparatively secluded from the rest of the store.

Displays are intended to encourage self-selection. Twenty-two feet of receding racks display the full faces of a total of 416 albums (45 rpm) along the left wall. Although there are no physical divisions, albums are grouped as closely as possible according to subject. Ad-

Photo at left shows the 11x27 foot step-down room (previously used for storage) which was converted to the Record Department of Dee's Broad and Erie store. Over on the right, Mrs. Yohannan posts the album sales. Entries are made daily to show what has sold and when it sold. This makes reordering simple.



Them Thar Platters!

Departments to His Three Stores and Zoomed His the Philadelphia Merchant Did It.

ditional albums are stored below, just above floor level.

Running about 14 feet along the opposite wall is a similar display of long-playing album faces. The remainder of the wall space is taken by three "merchandisers" which are rotating shelves mounted on a stand. Each "merchandiser" holds up to 250 platters and a good variety of recordings. Each of its shelves has a metal holder for a strip of paper which can be inserted easily to identify the recording. Two of the "merchandisers" are used for 45 rpm recordings and the other holds 78's. The display units were obtained from a distributor.

Self-Selection Encouraged

"Although we're not a self-service department, we do encourage self-selection—and that helps when it gets busy," says Mrs. Yohannan. "I'd say our fixtures do about 50 percent of our selling in this store."

The only counter in the department is at the far end, away from the entrance. The player used for listening is beside the counter. The department, in general, appears neat, compact, simple. Most popular and semi-classical as well as special interest recordings not available in the merchandisers are carried in standard wall bins to one side of the counter. They're categorized according to artists, types, and similar routine subdivisions.

PERSONNEL—Mrs. Yohannan, who has a knowledge of music as well as experience in her own business, is buyer and manager of this progressive, live-wire record department where buying discs is made easy.

Mrs. Yohannan has freedom in selecting and recommending her assistants, and has some definite ideas on the subject.

"Look first for a person who has a knowledge of classical music; that

is essential. He can learn the rest," she says. "Personality also is a big factor. He must like people, and not be prejudiced against any type of music. Sales ability is preferred but it can be developed. But a classical knowledge is important for several reasons. First, when a customer mentions a particular number, that's a sign of the customer's taste, and he can immediately suggest other music of the type requested. Second, it helps him find a specific recording, mentioned by the customer by name, which actually is part of a larger opera or grouping and which is not listed under the specific name given by the customer."

Store hours are 9:30 to 9:30. Mrs. Yohannan and her assistant alternate early and late shifts weekly, one working 9:30 to 5:30 and the other 12:30 to 9:30. This enables them to handle detail work in mid-day. The buyer believes it especially

(Continued on page 72)

At left, two customers select popular platters from the "merchandiser," a rotating bin of shelves mounted on a stand. This display idea encourages self-selection. At right, a customer drops a card in the box in hopes of winning the record player offered by Dee's. Contest resulted in a fine prospect list.

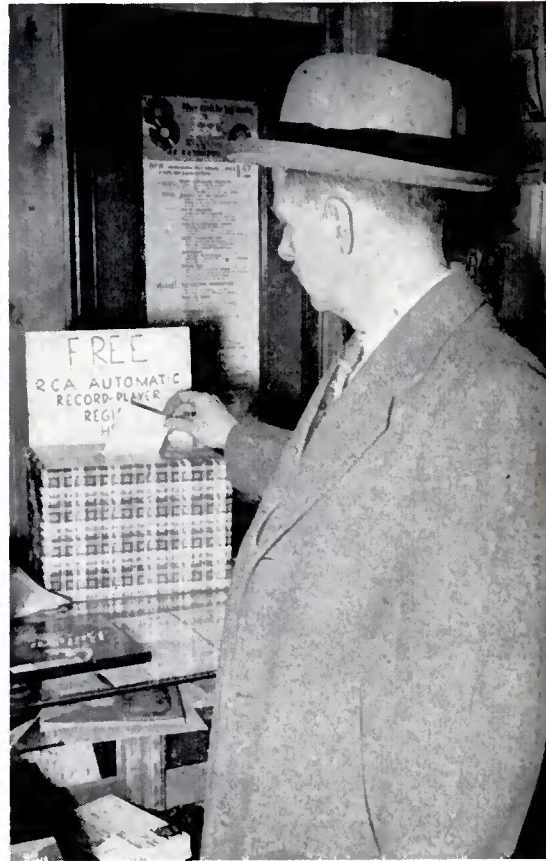
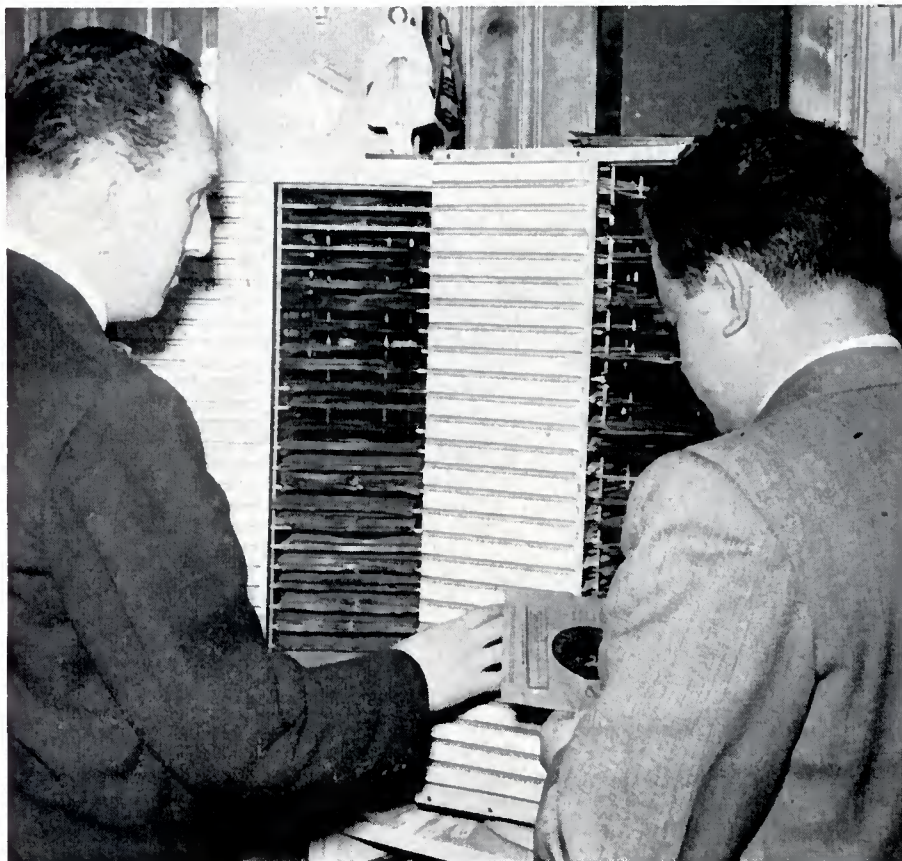

Record-Go-'Round



MGM...

The very talented young American pianist Joseph Battista adds to his repertoire of MGM recordings a long-playing recording of Villa-



Lobos' *Cirandas*. This work consists of 16 piano pieces based upon Brazilian folk tunes. The score was prepared for this first recording under the composer's own supervision. The music covers a wide range of moods and is excellently portrayed by Battista.

Decca...

That wonderful orchestra led by that wonderful Gordon Jenkins (shown) provides some wonderful



backing for Dick Haymes' vocal rendition of *Your Home Is In My Arms*. Melody is from the classic *Swedish Rhapsody* (not the currently popular one) and Dick turns in a fine performance. Backing is the ever-loved *Gone With the Wind*. Two smashers from the Jenkins-Haymes team here!

Columbia...

James Michener's novel "Return to Paradise" has inspired Dimitri Tiomkin (who wrote academy-award-winning *High Noon*) to compose a lovely melody to serve as background music to the forthcoming film of the same name. In turn, Columbia's Percy Faith has waxed two sides of *Return to Paradise* and come up with another possible *Moulin Rouge*. The talented Maestro



(shown) leads his lush string orchestra on a 7-minute musical safari to the South Pacific. All things combined, this is a sure-fire seller!

Keep your ear on Rosie Clooney's terrific waxing of *Cheegah Choonem*, another in the Armenian vein of her smash success, *Come On-A-My House*. Mighty good! Flip is *Stick*

Watch These...

"My Love, My Love"
Joni James (MGM)

"Cheegah Chonem"
Rosemary Clooney
(Columbia)

"If Love Is Good To Me"
Nat Cole (Capitol)

"The Glad Song"
D. Cornell and T. Brewer
(Coral)

With Me. Judy Garland's lovely voice soars on Columbia to the tune of *Heartbroken* and *Go Home Joe*. Judy just keeps sounding better and better. Nelson Eddy and Jo Stafford make a surprisingly good combination when they team up for *With These Hands* and *Till We Meet Again*. This is Jo's first teaming with an opera concert star, and the results are fabulous!

RIAA Selects Slogan!

Development of a slogan suitable for use by all segments of the industry was one of the first tasks assigned to the Promotion Committee of the R.I.A.A. At a recent meeting, this committee selected "Make Friends With Records" as the official motto for the whole record industry. It was originated by Wendell Buck, of New York City.

RCA Victor...

Again from the pens of Rodgers and Hammerstein we have a couple of hits! Ever-so-popular Perry Como sings the very beautiful ballad *No Other Love* from the musical production "Me and Juliet." As



usual the Como pipes sound terrific on this one. Flopside is another good one, a bouncy thing entitled *Keep It Gay*. This one's also from "Juliet."

WESTMINSTER...

From Westminster Recording Co. comes the Barylli Quartet playing *Beethoven's String Quartet in B Flat Major Op. 18, No. 6*. The Quartet features Wilhelm Huebner on the violin in *Quintet in D Major Op. 29*.

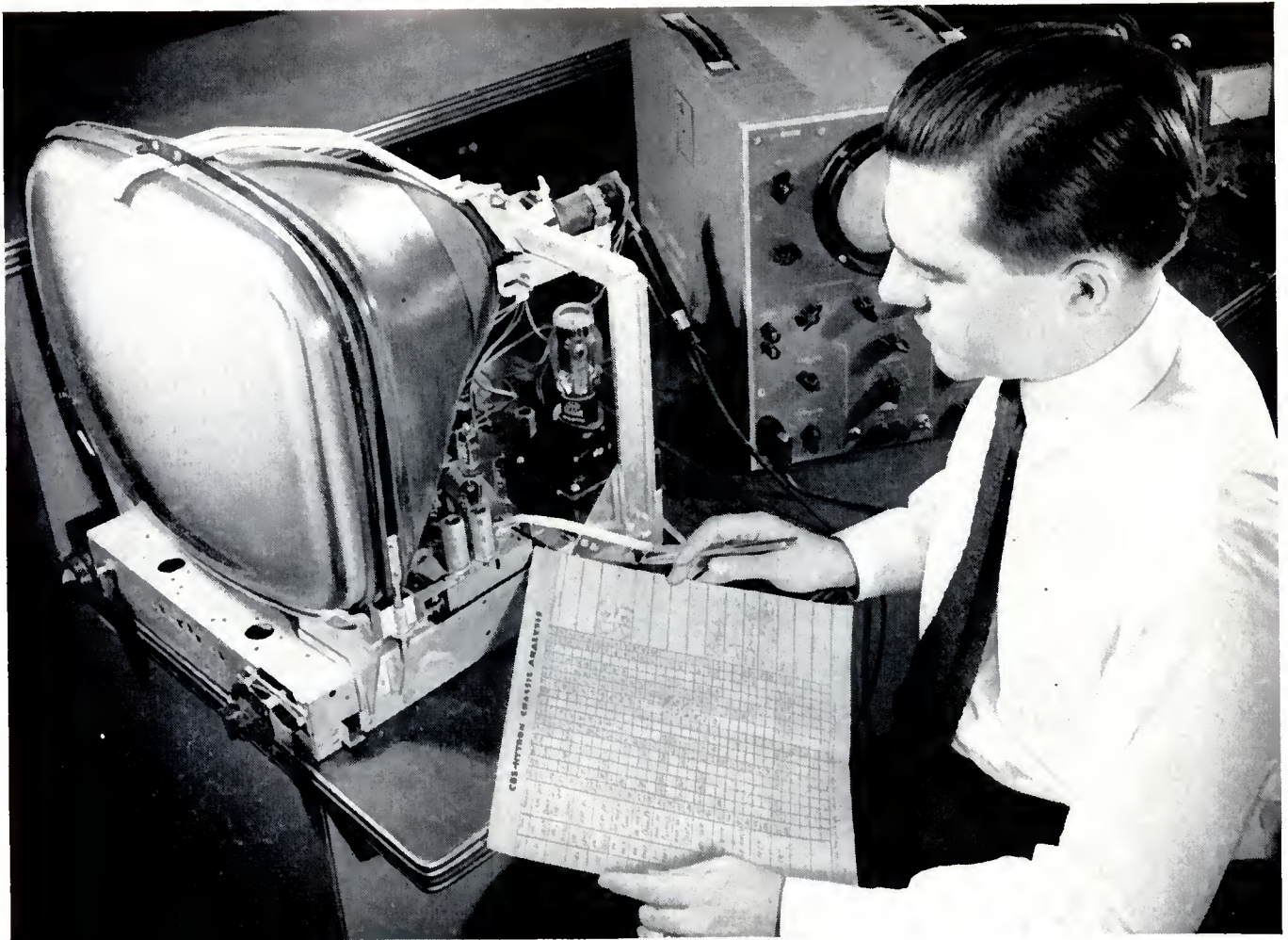

Bring back that New-Set Sparkle with **Performance-Tested Tubes**

Meet John Cunningham, a CBS-Hytron Commercial Engineer. John is beginning at the beginning for you. Socket by socket, he is analyzing the tube requirements of a brand-new TV set design.

John knows the superior performance demanded. He concentrates his know-how on insuring top tube operation within standard specification limits. He tests sample tubes . . . checks analysis data. Working hand-in-glove with the set designer . . . and with CBS-Hytron engineers . . . he assures control of the characteristics of all tubes for this new chassis. Finally he achieves . . . from rectifiers to picture tube . . . the perfect performance all of this engineering team (and you) seek.

Constantly CBS-Hytron carries on teamwork like this. Socket by socket analysis. Day in, day out — with 9 out of 10

leading TV set makers. Both tube and set engineers pool their specialized skills. Scores of the nation's foremost TV set engineers help make endless CBS-Hytron improvements. Help assure you of unsurpassed performance in virtually *all* leading TV sets.

Small wonder that your CBS-Hytron replacement tubes recapture that new-set sparkle. Please *your* customers. Cut *your* call-backs. Profit more. Take advantage of CBS-Hytron engineering. Demand CBS-Hytron . . . your logical replacement tube, because it is performance-tested all the way . . . from original to replacement.



Now
**CBS-
HYTRON**
MIRROR-BACK

ALUMINIZED PICTURE TUBES
27EP4 and 24TP4 . . . both
mirror-backed, spherical, elec-
tromagnetic types.

Leading TV set makers demanded maximum brightness from their large-screen sets. Without strain on component parts. For them, CBS-Hytron introduced its *Mirror-Back* picture tubes. Mirror-like effect of their aluminumized backing steps up light output. Adds sparkling brilliance to the picture. Gives greater contrast and freedom from screen discoloration. You, too, will want CBS-Hytron *Mirror-Back* tubes for replacement. Because your customers can *see* them recapture that bright, new-set sparkle. Order the performance-tested 27EP4 and 24TP4 from your CBS-Hytron distributor.



Manufacturers of
Receiving Tubes Since 1921



CBS-HYTRON Main Office: Danvers, Mass.

A Division of Columbia Broadcasting System, Inc.

RECEIVING . . . TRANSMITTING . . . SPECIAL-PURPOSE AND TV PICTURE TUBES • GERMANIUM DIODES AND TRANSISTORS

TELEVISION RETAILING • August, 1953

Money for HOUSE OF MUSIC in *Hi-Fi, Records &*



Clay McDaniel, manager, and one of the founders of the firm, stands beside record rack.

Crowds attended the opening of the new House of Music Store.

Location Selected to Improve Traffic, Provide Space for Better Display of Discs, Fine Instruments, Sheet Music

• Started six years ago by five World War II veterans, the House of Music in Southampton, Long Island, New York, has made steady progress to a point where 1952 sales were almost 13 times the original investment in the store. Now the firm has entered a third phase of its operations, and one which they expect will not only provide at least a 15% increase in volume ('53 over '52) but an even greater increase in profit.

In phase one, H of M started out as a record store. In phase two, TV was taken on. After considerable costly pioneering in fringe installations, the firm (now two stores) succeeded in building a sizeable sales volume in TV.

In 1952, sales volume for the House of Music stores was 43% from the sale of TV sets, 23% from the sale of records and 34% from service and miscellaneous (pianos, Hi-Fi, sheet music, etc.). In other words, TV was (and is) bringing in the lion's share of the volume, and especially when TV service is added in. But phono records, with a much higher realized mark-up (almost double, in fact) were returning a considerably larger proportion of

the "take-home" profit in dollars than their share of the sales would indicate. And high-fidelity custom work continues also to contribute to the firm's profit picture.

Naturally, a continued growth in sales is expected and is aimed at; but a much quicker road to larger profits was foreseen in increased record sales. This was one of the motives behind the Southampton store's move to larger quarters in May of this year.

The new store is located in an area calculated to increase store traffic. In addition to providing 50% more floor space (almost 3000 square feet), the new location permits more space to be devoted to the display of records; "and records must be displayed to be sold," says Southampton manager (and one of the founders) Clay McDaniel. Also new at the new store is a very attractively furnished Hi-Fi demonstration room. H of M had been doing a fairly good volume in custom installations at the old store, and expects to do close to \$20,000 in that line this year.

The service department, which accounts for seven of the fourteen H of M employees, has been pro-



Instruments

vided with a separate building in the rear of the store. These quarters will not only provide them with more working space, better working conditions, and more storage space, but also provides for a "private" parking area for the service trucks. At the old Main Street location, as much as two hours in a day were lost during busy seasons, trying to find a place to park returning service trucks.

An unusual situation prevails which will enable the service building to perform double duty. The new H of M store is right next to an A & P Super Market. Because the village has provided a new public parking lot behind the A & P, the grocery store has put in a rear entrance, facing the parking area. The House of Music service building is directly adjacent to this back door, so a show window has been built into the building, designed to catch the traffic going into the A & P. An alley leads from there to the back door of the House of Music store. The alertness and vision of the H of M in capitalizing on this fortunate circumstance, typical of the way they have built their business, puts them in the way of increased store traffic at both the front and rear of the food store.

Store Is Attractively Divided

The forward half of the store interior is devoted to TV sets, small radios, phonographs, recorders and pianos, with the TV sets most prominent in the "full-vision" store front. The rear half of the interior is devoted to records, with one wall for 33's, one for 45's, and islands in the middle for 78 pop singles, kiddie records and popular albums.

The 45's are mostly EP's, which McDaniel states have caused 45 sales to double. One of the factors in this increase, McDaniel feels, is that EP's have re-filled a position which was for some time vacant—namely, the sale which used to exist for higher priced classical and semi-classical singles. The EP's are displayed in a manner somewhat similar to that used for greeting cards, on a table-height counter. A perpetual inventory card system is incorporated into the racks to simplify stock replacement.

(Continued on page 72)

At right is a glimpse of the attractive HI-FI demonstration room. H of M looks forward to a \$20,000 volume in this line during 1953. Below we see the House of Music's new storefront. The new location provides 50% more floor space and is situated right near an A & P Super Market, which pulls much traffic for the music outlet.



Latest TV, Radios, Phonos

Emerson "POCKET RADIO"

The "pocket radio," model 747 (shown), weighs less than a pound and measures six inches by 1 1/4 inches. Unit has built-in sub-miniature parts from the antenna to a full-volume speaker. It is powered by self-contained batteries. Other features of the "pocket radio" are a full-vision dial, automatic volume control and easy battery re-

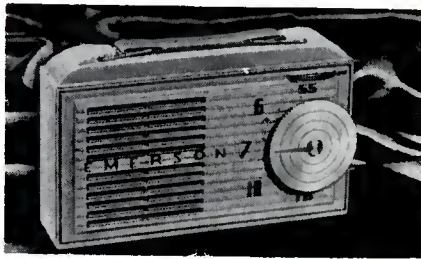

placement. Also included in the Emerson line are table models 708 and 756. Emerson Radio & Phonograph Corp., 111 Eighth Ave., New York 11.—TELEVISION RETAILING.

GE RADIO-TV LINE

Ten clock-radios ranging in price from \$26.95 to \$49.95 and eight table models ranging from \$17.95 to \$69.95 make up the new GE radio line. Units are available in a wide choice of color and design. Three series of TV models, black Daylite, black Daylite deluxe and black Daylite with ultra-vision, range in price from \$179.95 to \$489.95. Ultra-vision units feature the aluminized picture tube. For further details see Mart, section 2. General Electric Co., Syracuse, N. Y.—TELEVISION RETAILING.

CBS-Columbia FALL LINE

Highlights of the line are a Hi-Fi TV sound system, a 21-inch mahogany console the "Spotlight" (shown) and a 17-inch table model, the "Ambassa-

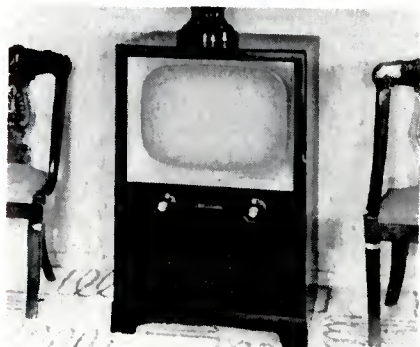

dor" in an ebony metal cabinet. The "Spotlight" lists for \$249.95, while the "Ambassador" has a list price of \$179.95. (See Mart, section 2.) CBS-Columbia, Inc., 3400-47th Ave., Long Island City 1, N. Y.—TELEVISION RETAILING.

V-M 1953 PHONO LINE

Model 990 features a folded horn speaker in the lid. This model plays records of all speeds and sizes auto-

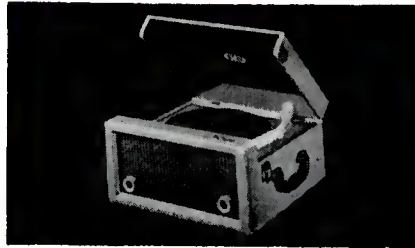

matically. According to the manufacturer, model 121 is the world's smallest, lightest three-speed amplified phono. Unit plays all speeds and sizes and has a 4-inch speaker and a one tube amplifier, plus electronic rectifier. Available in satin red and glowing green. Model 986 has an adjustable tone chamber to suit the music to the size of the room in which it is played. This automatic three-speed portable is available in a two-tone gray and rose tweed or a brown leatherette and has a two tube amplifier plus electronic rectifier plus a 5- by 7-inch PM speaker. Model 151 (shown) is a three-speed manual portable phono, has a 4- by 6-inch alnico V PM speaker and two tube amplifier plus electronic rectifier. V-M Corp., Benton Harbor, Mich.—TELEVISION RETAILING.

Shura-tone PHONO

A new Howdy Doody phonograph, model PLA, weighs three and one-half pounds. Size is 12 1/2 by 9 1/2 by 6-inches.



An acoustic phono in a plastic table model cabinet, unit features Howdy Doody Phono-Doodle name. Shura-tone Products, Inc., Brooklyn, N. Y.—TELEVISION RETAILING.

Alliance UHF CONVERTER

Trade-named the Convaire, this new converter is designed for use in conjunction with conventional VHF receivers to provide reception of UHF stations within signal range. It is made to operate on all standard voltages at 60 cycles. Tuning is done with a single knob. Other advantages claimed are high-gain combined with a low-noise factor. Alliance Mfg. Co., Alliance, Ohio.—TELEVISION RETAILING.

Rauland-Borg ENSEMBLE

Model 1826 "ultra-fidelity" ensemble features "libretto" remote control. Ensemble consists of 1805 master amplifier and 1801 libretto remote control-preamp. All input equipment plugs directly into the master amplifier. Six-position crossover and roll-off controls provide automatic compensation. Rauland-Borg Corp., 3515 W. Addison, Chicago 18.—TELEVISION RETAILING.

Phonola's "MAGIC CENTER"

A built-in feature on phonographs made by Waters Conley is the "Magic Center" which eliminates the disc or plug when 45 rpm records are played. The retractable center plus a new con-



tour turntable are the latest developments of the line. The firm makes Phonola and Melodier phonographs. Illustrated is a three-speed unit. Waters Conley Co., Rochester, Minn.—TELEVISION RETAILING.

National Teletable TV WAGON

A dual-purpose unit, the TV Wagon can serve both as a base for a receiver and also as a serving cart. Model 305 (shown) will hold any TV set up to and including the 21-in. size. Wagon measures 20 in. high; 22 in. deep; 25 in. wide. Comes in a choice of mahog-

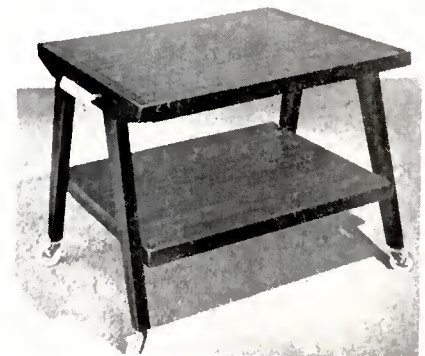

any and limed oak. National Teletable Corp., 488 Seventh Ave., New York 18.—TELEVISION RETAILING.

HIGH Profits in LOW Saturation Appliances

Freezers, Clothes Dryers, Ironers, Room Air Conditioners and Other Products Can Make Money for Merchants Who Sell Hard, Promote Actively

• A highly-successful appliance distributor was bending our ear during the last Chicago market. He had some very solid remarks about making money in the appliance business. One comment was especially worthy of passing along.

"The dealer who is willing to sell just a little harder can specialize in appliances that are between 3 and 20% saturation and show a substantially higher over-all profit, percentage-wise. And his business on high-saturation appliances will improve, also, in almost direct ratio to his efforts on low-saturation items."

Briefly, this means that a dealer's efforts on low-saturation appliances will build both replacement and new sales on refrigerators, ranges, washers, vacuum cleaners, and other products, while the dealer is gaining a good spot for himself on the newer "specialty" items.

So-called specialty selling, when performed properly, affords the salesman his best opportunity to gain a prospect's confidence. And confidence, of course, is the prime requisite in selling a product about which the prospect has limited knowledge. Along this line, let's con-

sider the customer's point-of-view.

Hundreds of articles—good and bad—have appeared in women's magazines on how to use a range. Some of these articles have covered various cooking feats; some have covered care of the appliance.

Nearly every woman in the country has her own ideas on cooking. Most women, however, (so the experts say) know less about cooking than they think they know. Nonetheless, if a woman thinks she knows all about using a range—well, from the salesman's viewpoint she *does* know! You can't walk into her kitchen and arouse her wrath by suggesting that her cooking technique is all wet. Nor can you infer immediately that her range is a piece of junk. She may love it.

Capitalize on Woman's Curiosity

On the other hand, almost any woman has enough curiosity about a freezer, a clothes dryer or a dishwasher to *want* to know the latest things these appliances will do for her. The well-informed and experienced dealer brings her the answers to many questions.

He approaches her as an expert in the art of better living—not as a guy trying to make her dissatisfied with equipment she already has. She doesn't want anybody telling her how to stack milk bottles in a refrigerator—she's been doing that for years. But she hasn't had first-hand experience in using a clothes dryer. She's read and heard about them. But here's the man who's an expert—or should be. Perhaps she'll lead off with a question or two to test the dealer's knowledge. Remember, she isn't entirely uninformed. There have been articles on clothes dryers, too—and she may have a friend or two who have purchased them. If the dealer knows his business he can quickly become *the* man who knows, in that woman's eyes. He must justify that confidence continually, of course.

There is only one way to gain and
(Continued on page 88)

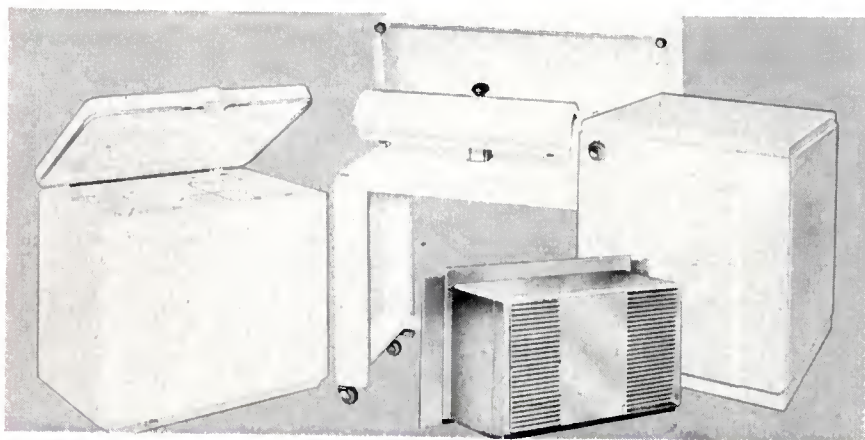

Here are your low-saturation appliances. Choose a major NOW and learn all you can about it! Get stock for a representative display. Put at least one operating display on your floor. Servicemen must study this product in detail.

Major Appliances (Low-Sat.)

Air Conditioners (room)
Dishwashers
Dryers
Disposal Units
Ironers

Electric Housewares (Low-Sat.)

Blenders
Deep Fryers
Roasters
Rotisseries
Steam Irons

NOTE: Study the growth-rate of the particular appliance you select. Some items which have been on the market for many years have not enjoyed the growth-rate shown by more recently introduced appliances.

Here's the Way to Sell More Clothes Dryers

• The complete home laundry has really "arrived" now—thanks to the clothes dryer. This appliance holds promise of bringing about, on a mass scale, that great dream of the home laundry equipment industry—the complete laundry, a distinct service unit in itself in the American home. The dryer, probably, will account for more sales of washers, ironers, cabinets and other home laundry items than the industry will ever realize.

Not only does the dryer get sales itself, but it makes the homemaker visualize a complete service that she never could have dreamed of possessing without a clothes dryer. The "complete laundry" before the dryer, was only a partial reality.

The dealer has a genuine bonanza in his hands here! Certainly, he has a real selling job cut out for himself. In fact, the dryer is an item that will bring back some of those solid specialty selling techniques that too often have been forgotten

in recent years. Again, the dealer is called upon to sell a new way of life—a higher standard of living. He gets a chance to specialize, and profit accordingly.

Where should the dealer begin?

Well, oddly enough, he should begin right in his own store, with a good working display. That sounds familiar, of course, but it is important. If space permits, a complete laundry is highly desirable—complete with an automatic washer, an ironer, cabinets and all the "dress-up" you can put into it. It's a complete laundry that most women want—everybody seems in agreement on this. The dryer gives it this "completeness"—but the other appliances give the woman the full picture.

Based on experience thus far, dealers agree mostly that the best immediate sales prospects are their own customers who have previously purchased automatic washers. These homemakers have discovered al-

ready the advantages of modern home laundry equipment, and now they have only one step further to go. The dryer means only the completion of a modernized laundry installation which they have already started.

Good Prospects

Women who have stuck by old type washers make up the next batch of good prospects. These homemakers have not yet traded in their old machines for many various reasons—but one reason, as always with an improved product, is that they *haven't been sold the compelling need* for a modern washer.

Here's a stunt that a dealer is using now on dryers. Along with other things in his sales pitch, he points to a basket of wet clothes which he keeps on his floor—not sopping clothes, but well saturated. He tells the woman that the basket contains only a normal load—seven or eight pounds, dry. He picks up the basket and, if the woman permits, gets her to hold it. It's plenty heavy, of course. To prove his point he even drags out a bathroom scale and shows her the weight. He says it really works—but good!

Free Trial Angle

Some of the dryer manufacturers say that there's nothing like a free home trial. This free trial angle, however, almost boils down to individual cases. Certainly, it's wonderful if you feel certain the unit is about 99% sold already, and you know the customer to be serious. Free home trials will undoubtedly be a widely practiced selling technique as the unit reaches a greater saturation point.

There are plenty of top-notch sales points on dryers (see panel in this article), but there's one small point that's *certain* to make a hit with a great many homemakers. This is *fast night drying!* Most of the working wives have one objective: to add to the family income. Therefore, this group, largely, are economy-minded and particularly efficient in their homemaking methods. The fact that they can do their laundry completely—even the *dry-*



There's No New Appliance Which Has Captured the Housewife's Imagination More Than the Dryer—But She Still Needs to Be Told More About What It Will Do

ing and finishing—in one evening is a tremendously important relief in their lives.

Another thought: If a woman with a small child figures she can save \$25 each year in buying of washable clothing, well, in twelve years of such buying economy (to avoid out-growth) she can pay for the initial cost of the dryer. Remember, however, that most mothers don't buy for one year's wear. They get junior some over-sized dungarees and shirts—over-sized the first year—and he wears them until they split the seams, maybe three seasons later. Certainly, this "pays-for-itself" approach is doubtful—yet there are some genuine savings. The basic approach is still the service that the dryer renders.

The dryer can inspire another type of sales effort which has only been partially touched upon in the laundry equipment field. This is the "Laundry School" plan. Heretofore, there have been only partial demonstrations—that is demonstration of the washer by itself, or of the

ironer by itself. Even when the two were combined there was a noticeable "gap" in the completeness of

Here Are 10 Facts About Dryers That You Should Explain To Every Woman:

A Clothes Dryer Will:

1. Permit Drying In Any Weather—Rain, Clouds, Fog, NIGHT
2. Make Drying So Very Easy—No Hanging, No Steps and Doors, No Heavy Baskets
3. Eliminate Sun Fading
4. Make Fewer Clothes Necessary—Especially For Growing Children
5. Speed Up The Laundry Job—Get it Over Faster
6. Reduce Disorder About the House
7. Eliminate Outdoor Hazards to Clothes (Soot, Birds, Wind)
8. Provide Better Moisture Control
9. Improve Home Tinting Methods
10. Give More Fluffiness to Bath Towels, Mats, Rugs, Etc.

the service. Women were aware of this gap, too. But now the Laundry School can be approached almost

like the cooking school. The one big difference is this: cooking is creative, and appeals to the artistic cravings; laundry is a chore, and should be demonstrated as simply as possible. Remember this one difference in setting up any Laundry School promotion.

Yet the Laundry School is complete now—thanks to the dryer. It can be put on simply, thoroughly and completely within a very short time—quickly enough to really hold the interest of a group of women who sincerely want to improve their own wash-day efficiency.

The laundry-room has been the vision of architects, home planners and laundry equipment manufacturers for years. Yet most "laundry-rooms" remain a dark corner of the basement or a sloppy service porch. The clothes dryer could very possibly be just the thing to bring the real laundry room into full bloom. It could make the laundry room a true, finely-planned service room such as the modern kitchen as we know it today.

Latest in Electrical Appliances

Kelvinator CHEST FREEZER

Model FR-7D (shown) is the latest addition to this company's line. It provides seven cu. ft. of storage space in a cabinet of essentially the same exterior dimensions as former six-ft. models.



Other features include a lock-type latch with key; interior trim of colonial blue; easy-lifting lid; and a special high-speed freezing section which is separated from the frozen food storage compartment by a metal grid. This model has a food capacity of 245 pounds, stands only 36 in. high, is 39 in. wide. Kelvinator Div., Nash-Kelvinator Corp., Detroit.—TELEVISION RETAILING.

Markel COOLING FAN-HEATER

Production of a newly-designed and engineered combination cooling fan and radiant heater, the Kool-N-Heetaire, is announced by this company. Unit comes in two models, model 25 (1320 watts); model 26 (1650 watts). Utilizing both infra-red and fan-forced heated air, the device features a four-blade, 8 in. fan. Features: 3-position switch; baked enamel finish; induction-type motor; lightweight. Operates on AC. Unit measures 12 in. wide; 13½ in. high; 6½ in. deep. Packed one to a carton. Markel Electric Products, Inc., 147 Seneca St., Buffalo, N. Y.—TELEVISION RETAILING.

Telechron CLOCK-RADIO TIMER

The result of a manufacturing project aimed at reducing to a minimum the number of parts required to turn on a radio automatically at a pre-selected time, the Telechron timer, C-88, is priced well below that of any previous model made by this company. The timer's single front knob controls automatic radio turn-on and manual on and off. A single shaft in the rear sets

time of day and radio turn-on time. Its switch is totally enclosed in a plastic housing. Telechron Department, General Electric Co., Ashland, Mass.—TELEVISION RETAILING.

STEAM 'N DRY IRON

Lightweight, this iron is designed for efficient dry ironing or steam pressing. It works with ordinary tap water (except in hardwater areas) and changes from one operation to the other instantly with fingertip switch on handle. A fabric control dial indicates proper temperatures for all materials. Tank capacity is about 8 ounces, providing almost 45 minutes of ironing time. Has



chrome plated finish, operates on AC. Comes with 8-ft. cord. Weight is 3½ pounds, empty. Price is \$18.95. Landers, Frary & Clark, New Britain, Conn.—TELEVISION RETAILING.

More Appliance Products
On Page 54

Don't Let Your Customers Think **The Home Freezer's**

**Specialty Selling Gets The Acid Test In These Appliances—
Who Proves They're A NECESSITY**

• Home freezers, unfortunately, are today regarded as a luxury by many householders. This appears to be the greatest sales obstacle which the TV-appliance dealer has to overcome.

Many users, however, have learned to depend upon freezers—so much so that the freezer has become a necessity.

dered just why they bought the freezer in the first place. And, of course, such owners say it's a luxury—and a very expensive luxury.

These "non-enlightened" owners certainly do not help in the sale of home freezers.

Many dealers today are actually re-tracing their steps and trying to do a real education job among

foods, a new way of living. Certainly a good sales story can be tied into any of these points.

Recent studies show that a goodly percentage of housewives accept these stressed values of the home freezer. They admit it's very highly desirable.

So—why don't they buy? Basically, they feel the home freezer is a luxury. They feel they can get along without it, as they've always done. They feel that the cost is too great. They feel they can wait—that there's nothing that compels them to buy *now*.

To Up Volume in Freezers



**Get the product IN USE in the customer's home
Use the free home-trial plan with "good" customers
Show them the wisdom (and savings) in buying a unit now**

On-the-level food plans have accomplished one great feat—that of providing the home freezer owner with a means of immediately getting genuine service out of the appliance. A few new home freezer owners found themselves merely owning a frosty pit which perhaps held only a couple of packs of green peas for many months. Naturally, such owners became discouraged, and won-

dered just why they bought the freezer in the first place. And they follow up closely on current sales, making every reasonable effort to get that freezer stocked up and in use.

The experts have batted about the "how-to-sell-'em" problem on home freezers for the past several years. You hear pros and cons on savings in food costs, convenience, better

What Can Dealers Do?

This is the situation that confronts the home freezer dealer at this time. So, what can the dealer do about it?

Many dealers are tossing out some of the elaborate "educational" selling efforts. They are concentrating on how to make the freezer a *necessity* in a housewife's life. They're not stressing how to use a freezer—but how to get it into her home. Then they'll follow up later to make sure she gets best use out of it. Dealers, mostly, are accepting the fact that women want home freezers. They're concentrating on the big gap between desire to own and actual ownership.

Old Technique Returns

This trend in selling brings back a basic technique which has been employed in specialty selling for years. Get the product *in use* in the prospect's home!

As one dealer says: "We've been putting the cart before the horse. We've been giving a lot of fancy talk on using the freezer—even before the customer had a freezer to use."

Apparently a lot of dealers are thinking the same way. Some dealers point out, too, that "how-to-use" information has been much too complicated—even frightening to the housewife who has had no experience with a home freezer.

So many methods have been tried in setting up free home trials that

a Luxury Item

**And Pays Off In Big Profits For The Dealer
In The Housewife's Life**

they hardly need any review. Most dealers have their own special techniques. Most dealers have found, too, that it's not too easy to get a responsible housewife to accept a product on a trial basis. This is why, for one reason, some dealers prefer to place a product on a nominal rental basis for a limited time. Some women just don't want to feel obligated—thus they'll rent when they won't accept a free trial.

One Dealer's Experience

Recently a dealer reported good results from a special "personalized" direct-mail campaign. His mailing piece started off approximately like this:

"You have been selected as a (name of town) homemaker who may wish to assist us in a study of food storage and meal preparation in the home. To pursue this study, we have been authorized to install twenty (20) home freezers in (name of town) homes. Temporarily, we have assigned home freezer No. — to you, pending a discussion of this food study with you."

Then the mailing piece went on to explain that the dealer's representative would call to talk over details.

Takes a Survey

The follow-through consisted of an actual survey—especially to learn if a freezer could be installed easily on a temporary basis. Also, the home call allowed the salesman to size up his chances for a sale after a trial period. This plan, according to the dealer, was devised to make the housewife feel definitely that she must do something, too, to get the freezer even temporarily. She was given an inventory sheet which she was required to keep. It showed purchase dates on items she would store in the freezer. Then she was supposed to check out removal dates. The form was simple—not too demanding. Yet it gave her a feeling of "earning" the use of her freezer—and some assurance to the dealer that she would use it.

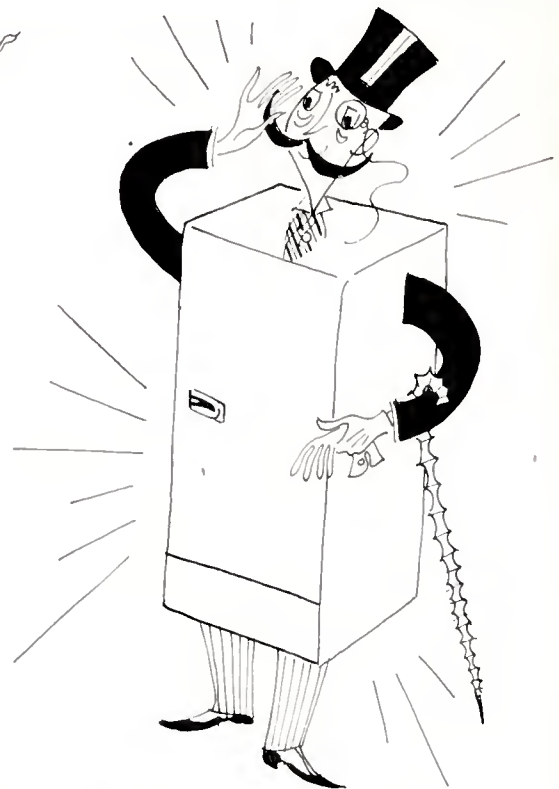

This plan was reported as quite successful—both in getting freezers out on trial and getting them used.

The dealer who has a good list of loyal customers usually can persuade a number to accept a freezer on a trial basis. The housewife who regards him as *her* dealer may be willing to accept a free trial offer as a result of her friendly feeling toward the store owner.

But the follow-up to get the freezer *in actual use* has another important angle. The freezer should be put into use *fast*. After all, the dealer has plenty of money tied up. Certainly he can't afford many trial units out at one time. He must try pretty quickly for closing a sale—and a freezer takes time to prove itself. The dealer can't afford to let a trial-user take his own sweet time

to get the freezer habit. He's got to press the householder into using it at once.

By and large, most TV-appliance dealers seem to get a tremendous satisfaction out of making a home freezer sale. It's a sizeable sales ticket, with good profit. Furthermore it's a product which most dealers sincerely believe in. The home freezer both whets and satisfies the appetite of the real specialty salesman.

What is a luxury to one person is merely a necessity to another. In this home freezer business the gap can be closed—making a necessity out of a luxury—by getting more units in use through specialty selling methods. It's a challenge to the dealer—but fascinating and highly profitable, too.

**Why Do Many Prospective Customers Balk at
Buying a Home Freezer? It's NOT the Price That
Worries Them, Nor Is It the Lack of Desire to
Own One! What, Then? The Answer to This
Dealer Dilemma Can Be Found on These Pages**

New Appliance Products

GE AUTOMATIC BLANKET

A custom-contoured automatic blanket with the bottom corners contoured in the mattress-fitting style, is now being marketed by GE. The new design is said to make bed-making easier and yet not bind the feet of the user. Blanket is finished in acetate satin binding, and the cordset in an ivory color. Blanket is available in six colors. Retail prices: \$47.95 for twin-bed, one-control model; \$49.95 for double-bed, one-control model; \$59.95 for double-bed, two-control model. General Electric Co., 1285 Boston Ave., Bridgeport, Conn.—TELEVISION RETAILING.

I-H UPRIGHT FOOD FREEZERS

Two new freezers have been added to the line produced by this company, one of which, model L-14-V, is illustrated. This freezer is a 14 cu. ft. type which holds 490 pounds of food yet is said to occupy less floor space than an ordinary 8 cu. ft. refrigerator. Among its features are a green interior color, three shelves with fast-freezing coils



and one adjustable shelf, quiet operation, pre-set temperature control, outside warning light, an inside light, three frozen fruit juice dispensers and three roll-out drawers that hold 20 pounds each. International Harvester Co., 180 N. Michigan Ave., Chicago 1.—TELEVISION RETAILING.

Pennwood Numechron CLOCK

The "Gotham," self-starting electric numeral clock, comes in four finishes—walnut, mahogany, Swedish blond, ebony—all in wood cases. Height, 4¼ in.; width, 7½ in.; depth, 3¾ in.; and the weight is 2¼ lbs. Units are packed individually, six to a master carton. U-L approved motor and cord. Model No. 851; list price \$24.50. Pennwood Numechron Co., 7249 Frankstown Ave., Pittsburgh 8, Penna.—TELEVISION RETAILING.

ELECTRIC COFFEE-MAKER

With this Golden Jubilee Coffeematic unit, model 4410, coffee is automatically brewed and kept at correct serving temperature. Complete in one unit, there are no bowls to remove or add.



Has a capacity of 10 five-ounce cups. Features: flavor selector; automatically signals when coffee is ready; non-drip spout; cold water pump providing instant starting; distributes hot water steadily and evenly over coffee grounds. Operates on AC and is furnished with a detachable, six ft. rubber cord. Finish: scroll pattern. Chrome on nickel over copper body. Black plastic base, two-tone gray control panel. Priced at \$29.95. Landers, Frary & Clark, New Britain, Conn.—TELEVISION RETAILING.

Bendix REFRIGERATOR

A new 10.5 cu. ft. (NEMA) refrigerator featuring a full-length freeze chest and shelves in the door, has been added to the Bendix line. Carrying a suggested list price of \$349.95, the new model features adjustable shelving; a



Cool-Tone color styling; butter compartment; two crispers and a frozen storage tray. The unit is defrosted manually. Bendix Home Appliances, Division of Avco Manufacturing Corp., South Bend, Ind.—TELEVISION RETAILING.

Easy WASHER AND DRYER

Recently introduced by this company, the automatic washer and dryer feature complete flexibility. Main feature of the washer is the Spiralator agitator. (The automatic washer is illustrated). This unit travels the clothes in a constant one-way spiral path to provide an equally thorough washing action in all parts of the tub. A new addition is the "Master-Mind" dial which is located on the back panel of the top-loading machine. This dial controls two separate, automatic washing cycles from fill to stop. One pre-setting of it allows "walk-away" operation. The dryer operates on the company's



"Regulaire" drying principle and features an ultra-violet lamp, cycle-end bell, automatic shut-off switch among others. Suggested retail price for the washer is \$289.95; electric dryer \$239.95. Easy Washing Machine Corp., Solar and Spencer Sts., Syracuse, N. Y.—TELEVISION RETAILING.

Electromode PORTABLE HEATER

The small room electric portable heater made by this firm now comes with a built-in thermostat for automatic

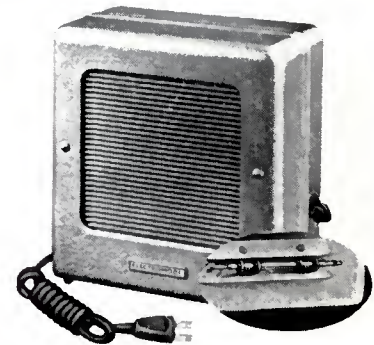

temperature control. Finished in silver gray hammer-tone, the unit has a handle for portability. It is also equipped with a six-ft. cord and rubber feet. Also a feature is its cast-aluminum heating element which has no exposed hot wires or glowing coils. The new model is designated No. PJA-13. Electromode Corp., 45 Crouch St., Rochester 3, N. Y.—TELEVISION RETAILING.

NEDA Exhibitor List Grows

The exhibitor list for the fourth annual convention of the National Electronic Distributors Assn., September 14-16 in St. Louis, continues to grow, NEDA officials report. At this writing, the following firms have selected space: Aerovox Corp.; All Channel Antenna Corp.; Alliance Mfg. Co.; American Phenolic Corp.; Astatic Corp.; Belden Mfg. Co.; Bell Sound Systems; David Bogen Co.; Burgess Battery Co.; Bussman Mfg. Co.; CBS-Hytron; Channel Master Corp.; Columbia Wire & Supply Co.; Cornell-Dubilier Electric Corp.; Davis Electronics; Electronic Publishing Co.; Finney Co.; General Cement Mfg. Co.; General Electric Co.; General Fuse Co.; Industrial Development Engineering Assoc.; Insuline Corp. of America; International Resistance Co.; JFD Mfg. Co.; Jensen Industries; Jones & Laughlin Steel Corp.; Lowell Mfg. Co.; Merit Coil & Transformer Corp.; Moore Tower & Equipment Co.; Mosley Electronics.

Also National Carbon Co.; National Electric Products Corp.; National Union Radio Corp.; Ohmite Mfg. Co.; Pentron Corp.; Permo, Inc.; Precision Apparatus Co.; Quam-Nichols Co.; Radiart Corp.; Radio City Products Co.; Radio Corp. of America; Raytheon Mfg. Co.; Howard W. Sams & Co.; Walter T. Schott Co.; Shure Bros.; South River Metal Products Co.; Standard Transformer Corp.; Sylvania Electric Products; Triplett Electrical Instrument Co.; Tung-Sol Electric; United Catalog Publishers; United Transformer Co.; Westinghouse Electric Corp.

Emerson Franchise Changes

The Emerson Radio and Phonograph Corp. franchise it has held for 18 years was recently relinquished by Electrical Products, Inc., Baltimore, Md. The firm decided to concentrate on other major appliances. The new distributor for Emerson in Delaware, Maryland and part of West Virginia is Allied Appliance Distributors, Inc., also of Baltimore.

Farm Market Ripe for TV

The nation's farm market, with an annual gross of over forty billion dollars, can become a major factor in the sale of TV receivers, said Irving Rosenberg, of Allen B. Du Mont Laboratories, Inc., at a recent industry group meeting. With the freeze on new station construction lifted, he said, "almost one-third of this country's five million farms are within reception range of a TV station."

ATR

Makes it easy to
DEMONSTRATE and TEST
D. C. apparatus from A. C. lines
with **"A" BATTERY**
ELIMINATORS



for
Demonstrating
and Testing
Auto
Radios

6 VOLT
OR 12 VOLT!
6 or 12 volt D.C. combination output available by means of simple toggle switching arrangement, properly safeguarded to prevent accidental switching.

See your jobber
or write factory

New Models . . . Designed for testing D.C. Electrical Apparatus on Regular A.C. Line Equipped with Full-Wave Dry Disc Type Rectifier, Assuring Noise-less, Interference-Free Operation and Extreme Long Life and Reliability.

✓ NEW MODELS ✓ NEW DESIGNS ✓ NEW LITERATURE
 "A" Battery Eliminators, DC-AC Inverters, Auto Radio Vibrators

ATR

AMERICAN TELEVISION & RADIO Co.

Quality Products Since 1931
 SAINT PAUL 1, MINNESOTA—U. S. A.

TV-Electronic TECHNICIAN

Section of **TELEVISION RETAILING**
Including Radio Service and Sound

*Trademark

Color-TV Is Coming

What the Serviceman Should Know about Current Developments. Outline of System Employed. Receiver Requirements.—By Dr. W. R. G. Baker, Chairman NTSC

In 1950, the FCC approved a field sequential system of color television. The principal objection to this system lay in the fact that it was not compatible to the system under which black and white television was operating, which meant that the 8,000,000 black and white receivers then in American homes could not receive color broadcasts either in color or black and white, without extensive alterations and expense to the owner.

The importance of that major shortcoming is evidenced and magnified by the fact that, today, the public has invested over \$7-billion in some 25-million black and white receivers, that would not be able to receive such color broadcasts in black and white without such expensive alterations.

Obviously, the solution of the problem lay in the possibility of developing an all electronic system that would be "compatible"—that is, a system that would make it possible for any and every black and white receiver in the home to receive future color broadcasts in black and white, without any alteration or expense.

National Television System Committee

The development of this system was the task undertaken by the National Television System Committee, formed under the auspices of the Radio-Television Mfrs. Association.

It should be appreciated that in the development of the standards for a compatible color system the NTSC had the full and complete cooperation of the companies comprising our industry. The source of an idea was completely disregarded. The only question was—Is this the best way to do the job?

Ninety-one companies in the industry contributed the skill and services of over 200 of its leading scientists and engineers toward the color assignment. One of the first actions of the NTSC was the naming of a five-man Ad Hoc Committee to determine whether a compatible Color television system could be evolved within the standard 6 m.c. band. While RCA in 1950 proposed and demonstrated a compatible system which would operate within the standard band, it was thought desirable to initiate a comprehensive analysis of the entire field to review existing material and thoroughly explore new approaches to the problem.

Monochrome TV

The standard black and white television transmitter sends out two signals, one carrying the picture, the other the sound. The picture signal is produced in the television camera which views the scene in full color and transforms it into a representation in shades of gray. In so doing, the camera removes the "color" aspect of the image. In the monochrome television image, it is not possible, for example, to tell whether an object is red or green, nor to tell whether the colors are deep and intense or are displayed in pastel shades. The monochrome system thus omits any reference

The accompanying excerpts from Dr. W. R. G. Baker's recent address to the 45th Annual Convention of the National Association of Electrical Distributors summarize the past, present and future of compatible color-television. Dr. Baker is vice-president of the General Electric Co. and Chairman of both the National Television System Committee and the RTMA Television Committee.

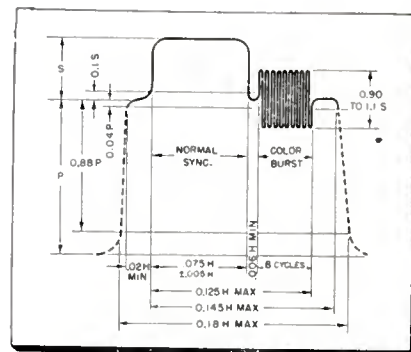

Diagram of NTSC compatible color-TV horizontal sync signal showing amplitude-time relationship. P is pedestal, S is sync and H is time for one horizontal line. Note location of color burst

to the spectral quality of the color itself (known to artists as "hue") or its visual depth of color (known as "saturation").

In transmitting a full-color image, then, it is necessary to take into account the missing elements of hue and saturation. In the NTSC system, these are transmitted by a third signal, known as the color carrier, which is fitted into the channel between the picture signal and the sound signal.

How NTSC Color-TV Works

The NTSC color system is thus founded on the principle that a color image may be reproduced from two signals, one of which carries a monochrome version of the image in shades of gray, while the second superimposes on the monochrome image the missing hues and saturations. This principle is well suited to compatible operation of monochrome receivers. It is merely necessary so to arrange the transmissions that monochrome receivers respond only to the monochrome

(Continued on page 58)

What the Technician Should

A Report on the NTSC and RCA

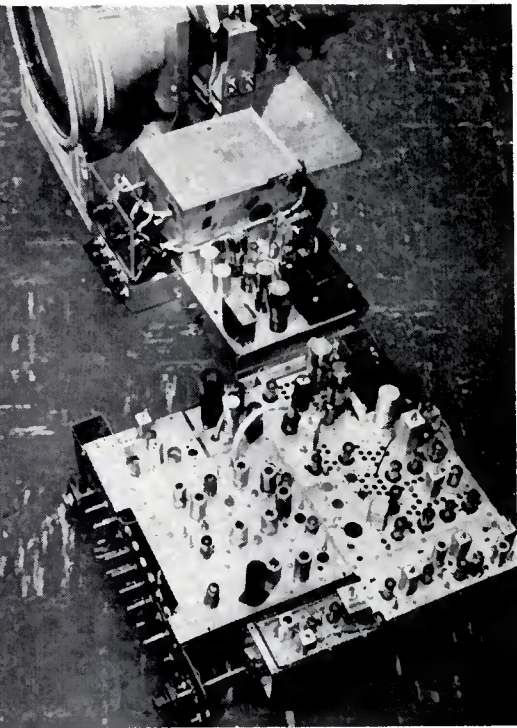

Close-up showing present day experimental General Electric NTSC color-TV receiver.

(Continued from page 57)

signal, ignoring the color signal. Color receivers, on the other hand, are designed to accept and make use of both signals.

Simple as this principle appears, it was a major task to develop a system based on it. The principal problems were two:

- 1) How to fit all the information of both monochrome values and hue and saturation values into the standard television channel without overcrowding, and

- 2) How to assure that monochrome receivers would ignore the color information for which they have no use.

The first problem was solved by the NTSC with the discovery that the monochrome aspect carries the essential pictorial detail of a full-color image. Once the monochrome portion is available in full detail, the hues and saturation can be superimposed in a relatively coarse manner, "painted with a broad brush," so to speak. Hence, the color carrier need not occupy as much channel space as the picture carrier, and

overcrowding of the channel is avoided.

The second problem was solved by the NTSC when the color signal carrier frequency was assigned a precise numerical value relative to the picture signal carrier frequency. When this exact frequency relationship is maintained, the monochrome receiver retains its full sensitivity for the picture signal, but finds itself virtually blind to the color signal. Mutual interference between the signals is thereby avoided.

In summary, the NTSC system achieves compatible color transmissions by building on the existing monochrome system. No basic changes are required in the existing FCC regulations governing black and white broadcasting beyond tightening of tolerances which has the effect of improving the performance of receivers now in the hands of the public and making a minor addition to the synchronizing pulse. To these regulations must be added a group of supplementary standards, which set up the color signal, specify its frequency, and outline the techniques by which the hue and saturation values are transmitted.

On April 14, 1953, this NTSC system was formally demonstrated by RCA to the Wolverson Committee and to the Industry on April 16, 1953. It was acclaimed as highly successful. It is now undergoing final and extensive field tests, preparatory to formal submission to FCC for consideration [in late July.—*Editors*].

A television transmitter broadcasting a monochrome signal will accommodate the color signal without change. Precautions necessary to insure satisfactory monochrome transmission are, in general, the only precautions necessary to insure proper color transmission, although misadjustment will be more objectionable in the picture when transmitting color.

Transmitters which will take color signals from the network will probably be required to utilize an additional piece of equipment known as a "synchlock" to insure the adequacy of the received synchronizing pulse. This, fortunately, is a rather simple and inexpensive piece of equipment and could be supplied quickly to any

station then on the air with black and white.

The Networks

Signals have been satisfactorily transmitted over the telephone company's networks. The telephone company's engineers have taken a very active part in the affairs of the NTSC, and are thoroughly familiar with the NTSC proposal. The development of the telephone company's facilities has kept pace with the development of the system generally.

These two factors mean that a color program originated at a network key station and put on the network, could, for a minor capital investment and at practically no extra operating expense, be taken off the network and rebroadcast by any local station.

Thus, color programs on a national basis could be available a few months after the system is approved.

Studio Equipment

It is in the color television studio that the most extensive changes will be required. A three-tube camera initially will be used, although development now intensively underway, may result in a single camera tube which, if successful, will materially reduce the bulk and complexity of the color camera.

The signal from the camera is directed to a system of rack mounted

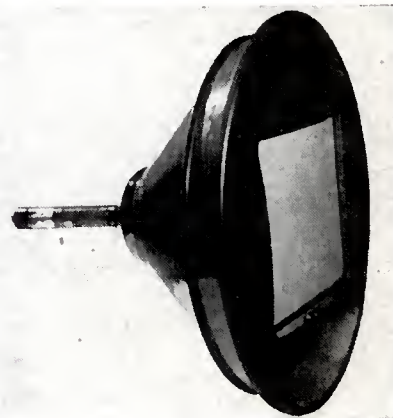

Chromatic's Lawrence tube, now in pilot production, is 22 in. in diameter, 21.5 in. long, and has rectangular color screen 11 by 15 in.

R_x for UHF's fringe areas!

CHANNEL MASTER'S all-UHF TWIN CORNER REFLECTOR

the most sensitive fringe area antenna ever developed for UHF!

- Two dipoles—actually two antennas in one.
- Provides twice the gain of any standard-type UHF Corner Reflector.
- Instantly installed in just three steps.
- Furnishes far better picture quality — at far greater distances.
- Eliminates UHF's TWIN TERRORS. Features vibration-proof construction; and "free-space" terminals.

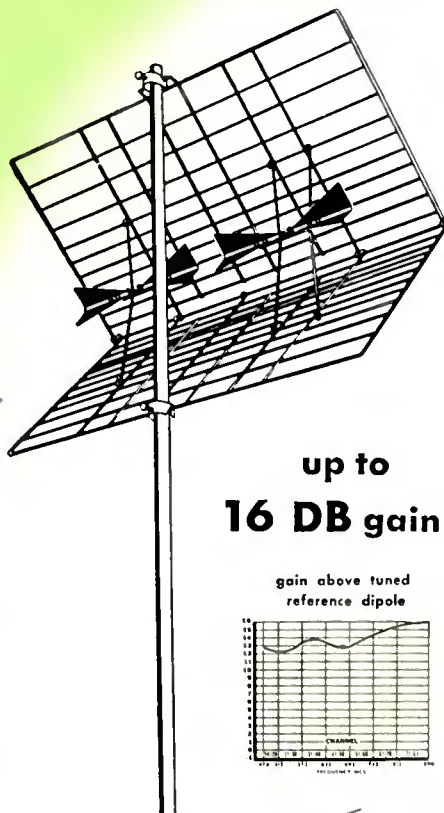

model no. 406

up to
16 DB gain!

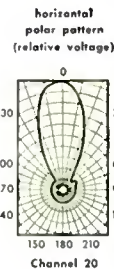
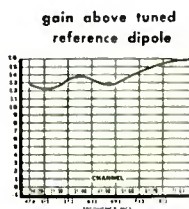

practically
no
assembly
necessary

CHANNEL MASTER'S 10-ELEMENT DELTA-WELD YAGI

custom-designed for your specific area!

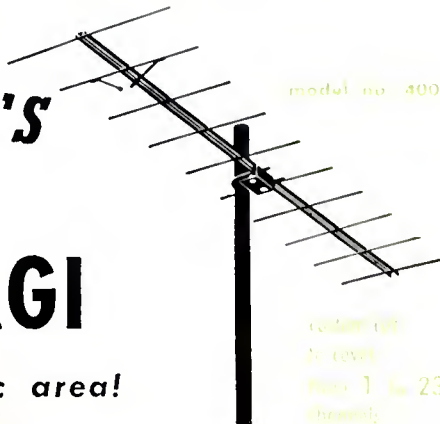

model no. 400

covers
all UHF
from 1 to 23
channels

**CHANNEL MASTER
engineering
pays off on UHF!**

- Elements permanently WELDED IN POSITION on crossarm.
- Custom construction — designed for almost any UHF area.
- Delta-matched dipole for excellent impedance match.
- Brilliant performance. Average gain: over 11 DB, single bay; over 14 DB, stacked. Even higher on some models.
- Eliminates UHF's TWIN TERRORS.



CHANNEL MASTER CORP.

RICHMOND, N. Y.

Write for complete technical literature.

Know About Color-TV

Proposals Now Before FCC

equipment, where the signal is dissected and each of the signal components is then optimized and dealt with individually. At this point, also, the special synchronizing pulse is generated. From this equipment then, there is delivered a complete signal which is ready to modulate a standard transmitter or to be fed to the networks.

Providing the necessary studio equipment for hundreds of stations across the country is a very substantial technical and production job. But, this need not necessarily preclude the possibility of originating a national color television signal quickly, as above. Enough studio gear, much of it now only in prototype stages, is available to equip at least several key network stations. This equipment, however, could be used for a small percentage of color programs through the networks in parallel with the standard black and white programs.



Tricolor kinescope tubes in pilot production are checked at RCA plant in Lancaster, Penna.

One of the three important elements of the NTSC color television signal is that it employs the same monochrome signal as used for present day black and white television. This, of course, is the feature of the system which makes it fully compatible. This feature in the NTSC

system does simplify to some degree the design of color television receivers. The fact remains, however, that to incorporate in one chassis and in one picture tube, the ability to receive either color programs or black and white, at the turn of a switch, is a complex problem in engineering and costly in production.

The first sets must be "good" if color is to be given its proper chance to prove its desirability and win the approval of the public. Nothing could retard color quicker than the advent of "compromise" color receivers that would offer less than the maximum performance. Cost reduction can come later as a logical development, but the first units must be "tops" and that means that they will be expensive in comparison to present black and white receivers: Industry estimates indicate they will be at least double the price and may

(Continued on page 60)

Simplified block diagram illustrating equipment interconnections within typical color-TV studio.

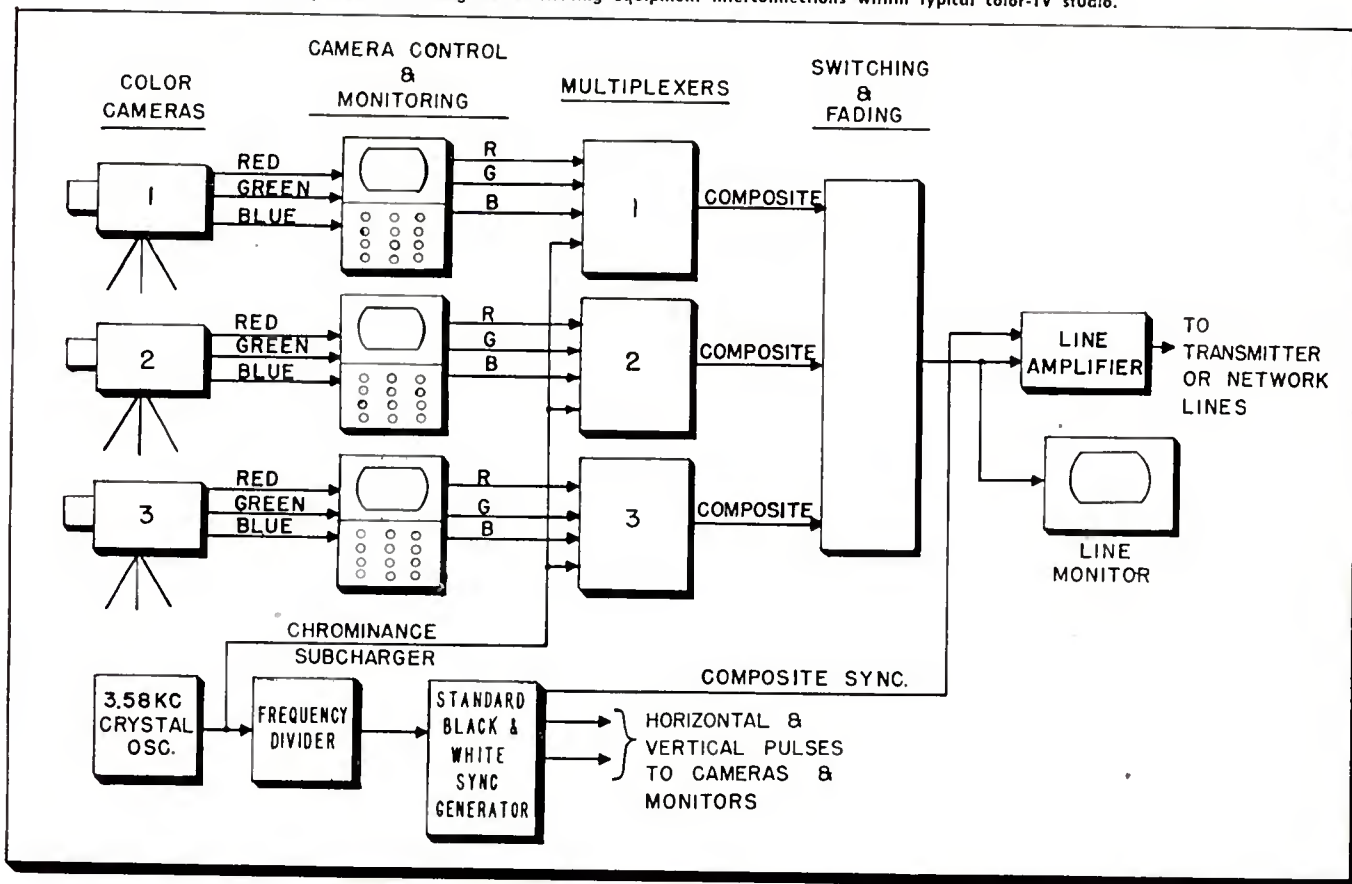

COLOR TELEVISION (Continued)

run three times the cost of comparable picture-size monochrome sets.

It has been estimated that somewhere in the neighborhood of 100 color receivers have been built to date. These have been kept "up to date" with the latest NTSC developments and, by and large, have been successful after the expected "prototype" bugs have been eliminated.

Receiver Availability

Actual commercial designs, however, cannot be completely frozen until final specifications have been determined and the system receives final approval by FCC. Much design work, however, can be anticipated, which will materially reduce the time cycle required for final designing, tooling and getting color receivers into production. In spite of this, it may well develop that the receivers will be the bottleneck and that color programs will be on the air months before any reasonable supply of receivers is available.

The major remaining problem in color television lies in the picture tube. One industry leader has made the statement "We do not have a picture tube." This is not actually true, but the severity of this problem should not be minimized.

Color Tubes for TV Receivers

All tri-color tubes have in common the requirements that the phosphor surface utilize not a homogeneous deposit, as is the case in monochrome, but three separate phosphors for red, green and blue, deposited as hundreds of thousands of dots, or, as fine vertical or horizontal stripes. Here the similarity ends and development is progressing in two general directions:

1) Using a single electron beam with a change in beam direction at the front of the tube to provide color selection. Such approaches are exemplified by the Lawrence tube of Chromatic Laboratories, and by the Lafferty tube of General Electric. Such tubes, in general, are simpler and cheaper than the ones next to be described, but depend upon complicated chassis and require greater circuit precision in order to insure color fidelity. Furthermore, the beam bending operation requires an appreciable amount of power at high frequency, which raises the problem of interference radiation.

Three-Gun Picture Tubes for Color Reception

2) The second general category of tubes comprises those utilizing three separate electron beams whose possible paths are restricted physically so that the green gun, for instance, can only reproduce green, etc. These tubes are exemplified most familiarly by the one introduced by RCA. The use of these tubes permits a reduction in chassis and circuit precision and complication, but the tube complexity and cost is increased. The radiation problem, of course, does not exist. Several laboratories are known to be working in this direction.

In summary, then, as regards the picture tube, the Industry seems to have two choices:

a) Build the precision in the tube, thus permitting simpler chassis circuits with the assurance that when a given color is called for, only that color can be reproduced. The radiation problem does not exist.

b) Build the precision into the chassis. This alternative possibly will result in lower cost tubes. It involves the hazard of radiation and probably puts more of the responsibility for reliable operation into the hands of the customer.

Color Receiver Costs

The picture tube holds, not only the key as to how the chassis is to be designed, but also in a great measure, the cost of the finished end product—the complete color television receiver.

If the three-gun type, such as this RCA tube is used, and if current price estimates of \$150 to \$200 pre-

vail, it is obvious that the picture tube component alone in the receiver might add \$325 to \$350 to the list price. Just adding this difference in picture tube price to the price of an average good quality 21" console would bring the total cost to \$750 or more. Further, a color receiver will probably use 45 to 50 receiving tubes, more than twice that of a black and white set. Add the cost of these tubes and necessary circuitry and it becomes evident that a color receiver will have to be priced at \$800 or more. There is no doubt that they will be expensive.

Color-Picture Sizes

I am presuming in this projection that the color picture size will be equivalent to the 21" black and white picture. Most demonstrations to date have shown smaller size pictures. This problem still lies ahead of the tube industry, but must be resolved if color is to compete successfully with black and white.

Looking forward to picture sizes for color television, it is obvious that sizes must be equal to black and white, probably starting with a 21-in. picture and later including 24 and 27-in. pictures.

Conclusions

I mentioned previously that I was convinced that this would be a good thing for the industry. This is an important point of my talk, so let me set forth my reasoning and conclusions in orderly fashion:

1) I believe that color television will come as an evolution and not a revolution.

2) Color will prove to be a supplementary service and will not quickly, or perhaps ever, completely replace the monochrome service.

3) I am confident that the standard black and white receiver will continue to be the back-bone of television sales for at least five years into the future.

4) But, there will be a very critical period in sales while the public appraises the value of color against black and white—becomes educated to the true facts of the actual advantages of color television—the programs that will be available—just how much color adds to the programs and what they would have to pay over and above the cost of a good black and white receiver.

The quicker we can give the public the opportunity to make this side by side comparison and appraisal, the shorter will be the period of indecision and hesitancy to buy a black and white receiver.

Tri-Color Camera Tube

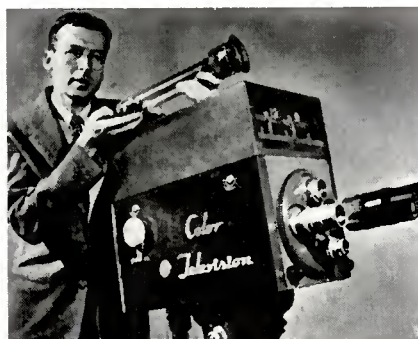

Dr. Paul K. Weimer of RCA's David Sarnoff Research Center, Princeton, N. J., holds the new tri-color TV camera tube which will replace three tubes now needed in color TV cameras. Many TV stations are expected to be equipped for color broadcasts during '53 and '54.

Aligning Radio Receivers

Pointers on Tuning Adjustments in AC-DC Sets

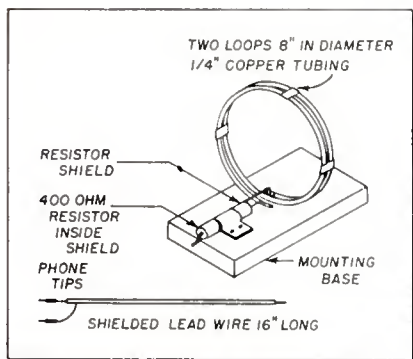

Fig. 1—Dummy antenna. The generator connects to the phone tips. The "hot" wire coming from the "hot" phone tip is connected to the 400-ohm resistor. Two loops are 1/4" copper tubing 8" in diameter spaced 1/4" apart with 500 ohms resistor in series. Connecting cable and resistor must be shielded. The loop should be spaced twice the diameter of the loop from the receiver being aligned to prevent an over-modulated signal and poor alignment of the receiver.

• A reader recently wrote to us concerning an alignment difficulty, as follows:

"In my town, the chief stations we hear in the daytime are on 1070, 960, 900, 690 and 610 kilocycles. These stations usually come in far better if the oscillator and antenna trimmers are adjusted for loudest reception at 900 KC, rather than the 1400 KC usually recommended by the set manufacturer. Why then do the manufacturers advise that oscillator and antenna trimmers be peaked at 1400 KC? Another point: I have noticed that many new sets are aligned extremely well. So much so, that when I try touching up the alignment of one of these sets (after I have put in a new tube) I can never get the set to working quite as well as it was before I attempted to realign it. Will you please let me know how factories align their new sets? If you know of any tips on the alignment of the AC-DC sets with which I largely work, I will thank you for them."

Our reply is as follows: In many, possibly most lower-priced radios, particularly AC-DC midget sets, the oscillator tuning is adjusted by means of a trimmer (condenser in parallel with the oscillator tuning condenser). This trimmer's effect is greatest at the high-frequency end of the dial—that is, at the fully-unmeshed setting of the tuning condenser. The effect of any RF trimmers present is similarly greatest at the high-frequency end of the tuning dial. It is for this reason that set manufacturers suggest alignment at a 1400 KC setting on the dial. If you have ever tried to align an RF

trimmer at the low-frequency end of the band (around 550 KC) you probably remember how much you had to rotate the trimmer before it affected the amplitude of the signal coming through.

If the receiver oscillator circuit contains a low-frequency padder (variable condenser in series with the oscillator coil) the receiver is aligned at both the high and low frequency ends of the band, the alignment of the padder being made at the low-frequency end of the band, where its adjustment has the greatest effect.

If you find that reception around 900 KC is better when the receiver's RF section has been aligned at 900 KC than it is when its tuning has been adjusted at 14 KC, the explanation may be that the tracking of the receiver is not perfect. Injection of a 900 KC signal, with the receiver dial set at 900 KC (after alignment at 14 KC) should be made in such a case, to see whether maximum output occurs at exactly this point, or some dial setting just before or after. If maximum output is obtained at a receiver dial setting other than the one to which the signal generator is set, improper tracking in the re-

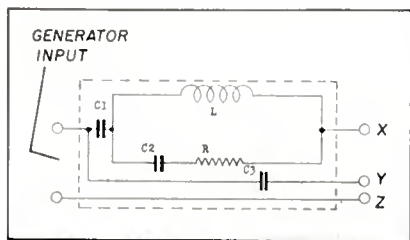

Fig. 2—Second type of dummy antenna. The antenna terminals of the receiver are connected between points X and Z for RF alignment. A connection between the receiver converter grid and point Y is made for the IF alignment. Point Z is connected to chassis in either case. When using this dummy antenna the generator output impedance should be 10 ohms or lower. C1-200 MMF, 400 V; C2-400 MMF, 400 V; C3-.02 MMF, 400 V; R-100 Ohms, 1/4 W; L—choke coil;—case shield; choke coil specification: tubing-3/8" diameter, Bakelite; wire-No. 38 enameled; turns-59, closely wound (impregnated).

ceiver is probably present. (Correct alignment of the receiver, generator accuracy, and correct pointer setting on the receiver dial are all assumed). There is nothing wrong with aligning the receiver at a setting in the vicinity of desired station frequencies, to minimize the effects of the mis-tracking.

Using an accurate signal generator is extremely important for correct alignment. Perhaps the largest single reason why servicemen cannot duplicate a factory alignment lies in the inaccuracy of their generators. This is

probably the chief reason why an alignment without instruments is sometimes more successful, in the case of AC-DC receivers, than one with instruments. (To test the accuracy of your signal generator, the procedure described in our October '52 Shop Hints section may be employed.)

The following additional pointers may prove helpful:

1—Let the receiver and signal generator warm up for 10 minutes before

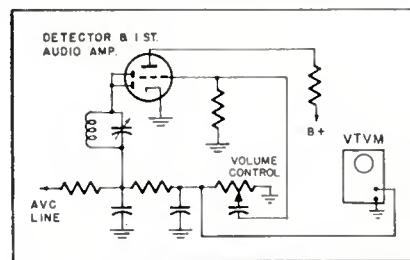

Fig. 3—Connection of VTVM during IF alignment.

proceeding with the alignment. 2—Always use the smallest possible signal generator input, to prevent receiver stages from overloading and producing incorrect alignment. Set the receiver volume control at maximum to make the small input produce the largest possible output. 3—Use an output meter across the voice coil, if you don't trust the accuracy of your ear to detect slight changes in volume. For even more accurate results, place a VTVM across the volume control (see fig. 1), and align for maximum negative voltage reading. 4—Couple the signal generator loosely to the receiver, to prevent it from loading down the receiver's tuned circuits and producing incorrect alignment. Two methods used by factories to obtain loose coupling rate are shown in fig. 1. Simpler means of loose coupling may be effected as follows:

Make up a three-turn loop out of some wire; connect one end of the loop to the signal generator, and bring its other end near the receiver antenna. This coupling can be used for aligning both RF and IF sections of the set. In cases where insufficient or no signal is heard when IF stages are being aligned, couple the "hot" lead of the signal generator through a .05 condenser to the grid of the converter (at the stator of the RF section of the tuning condenser). The negative lead of the generator goes to chassis or B-.

A final point: IF tuning adjustments may have to be touched up, using the ear as judge, to get rid of sideband clipping due to too sharp an IF alignment. Adjust the IF trimmers or slugs for best fidelity compatible with minimum volume loss.

Shop Shortcuts Speed Servicing

Tips for Home and Bench Service Contributed by Readers

Connecting Headphones to Radio

One of the simplest, fastest and least expensive ways of connecting a set of headphones to a radio is illustrated in the sketch below. The jack used is of the normally-closed type. When the phone plug is inserted into the jack, the voice coil is disconnected from the output transformer secondary, while the headphones are connected into the circuit. Although the headphones return to ground through the output transformer secondary, no

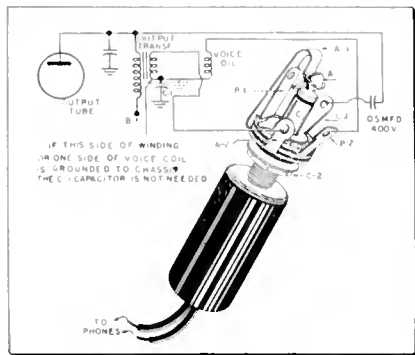
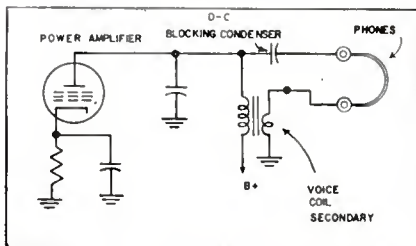

A and C are on phone plug; A-1, A-2, B-1, B-2 and C-1 are on phone jack. A-1 contacts A-2 at all times; C contacts C-1 and C-2, and A contacts A-1, only when plug is in jack. B-1 contacts A-1 only when plug is out of jack. B-1 contacts A-1 only when plug is out of jack. If a capacitor is present between chassis ground and B—, or if the jack is mounted on a metal chassis, use insulating grommets on jack, to prevent signal at the plate of the output tube from being short-circuited to ground.

detrimental effect results, since the impedance of this winding is very low compared with the 3,000 ohm or better impedance of the headphones we have in mind. If the receiver is an AC-DC type whose chassis connects to one side of the line, insulating grommets should be installed between the jack and chassis. *M. G. Goldberg, 130 E. 4th Street, St. Paul, Minn.*

Condenser Failure in 'Static Sets

Twice, recently, electrostatic sets in which I have replaced a shorted coupling condenser from a vertical amplifier to a vertical CRT deflecting plate have bounced back—not because the replacement was bad, but because of the failure of a condenser in a circuit

SHOP HINTS WANTED

Payment of \$5.00 will be made for any service hint or shop kink accepted by the editors as usable on this page. Unacceptable items will be returned to the contributor. Send your ideas to "Technical Editor, TELEVISION RETAILING, 480 Lexington Ave., New York 17, New York."

associated with the vertical amplifier. When I run into similar cases now, if any appreciable leakage has existed in the HV coupling condenser, I replace any low-voltage condensers present in the associated circuit (as well as the HV coupler, of course). Using a 60-cycle bridge, I have found excessive power factor in the low voltage condensers referred to. The dielectric apparently becomes strained in these units (just as a wire that is repeatedly bent becomes brittle before it breaks) and the safe thing to do is to replace the condensers without regard to their condition, as revealed by tests. The time required to disconnect, test and reconnect the condensers does not make such a practice economical, anyway. It is cheaper, if time is valuable to the technician, to replace some forty to fifty-cent condensers, than to spend time on a callback, even if the latter occurs only once in a while. *James A. McRoberts, 746 Carroll Street, Brooklyn 15, N. Y.*

Battery Saving

I use a pen-type flashlight a good deal in my bench work. The life span of the batteries present in these units is short when they are used in a fairly steady fashion. By attaching two leads to the appropriate points in the unit, and connecting them to a suitable source of voltage (I use a tube-tester socket for my source) the bother as well as the cost of replacing batteries frequently is dispensed with. *S. Sandler, 29 Niagara Street, Providence, R. I.*

Tips on Meters

Here's a shop hint that saves us a lot of grief. On all our meters, especially our voltmeters and continuity checkers, we replace any pin-type jacks present with threaded coax connectors that can't pull out, but must be unscrewed. Good sweep and signal generators generally have such connectors on them; vacuum-tube volt-

meters generally have these connectors on their DC probe terminals. The coax connectors eliminate the annoyance (common with the pin-jack terminal set-up) of having the test lead pull out during the course of tests. False voltage readings that occur when the common lead falls out of its receptacle are a familiar nuisance to servicemen. Another thing: a wire that pulls out of a pin-type jack may drape itself over a hot connection in the chassis under test. If the technician touches the test prod at that time—as has happened in our shop—he can get an unpleasant jolt. The coax connectors prevent such undesired episodes. *Harry J. Miller, 708 West 48th Street, Sarasota, Fla.*

Alignment Test Device

Many servicemen would probably like to be able to turn the slugs in TV IF transformers while noting the effects on the picture tube of the set. I have till now been reluctant to manipulate the adjustments, feeling that I might not be able to return them to their original settings, if this was required, and thus possibly necessitating a large-scale realignment. I now put an alligator clip on the shank of an insulated screwdriver (see sketch) and

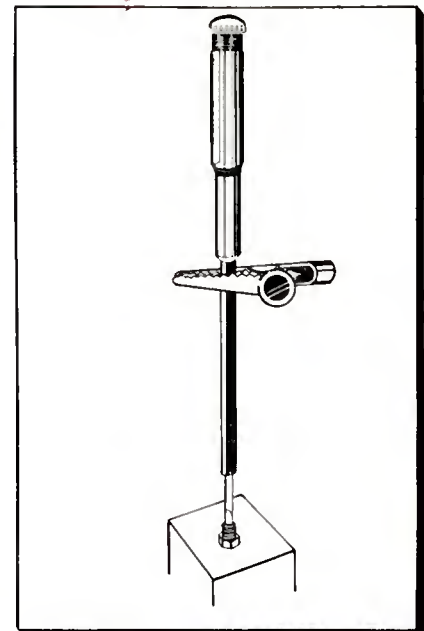

line up the direction of the clip points with some definite nearby object on the TV chassis. The screwdriver blade is, of course, first inserted into the slot on the adjusting slug. It is now a simple matter to return the adjustment to its original position, if manipulating it shows that this position was correct. *Walter Hohlfeld, Hohlfeld Electric Co., Greenleaf, Kansas.*



while others plunged
WE WAITED

while others promoted
WE TESTED

while others gambled
WE ENGINEERED

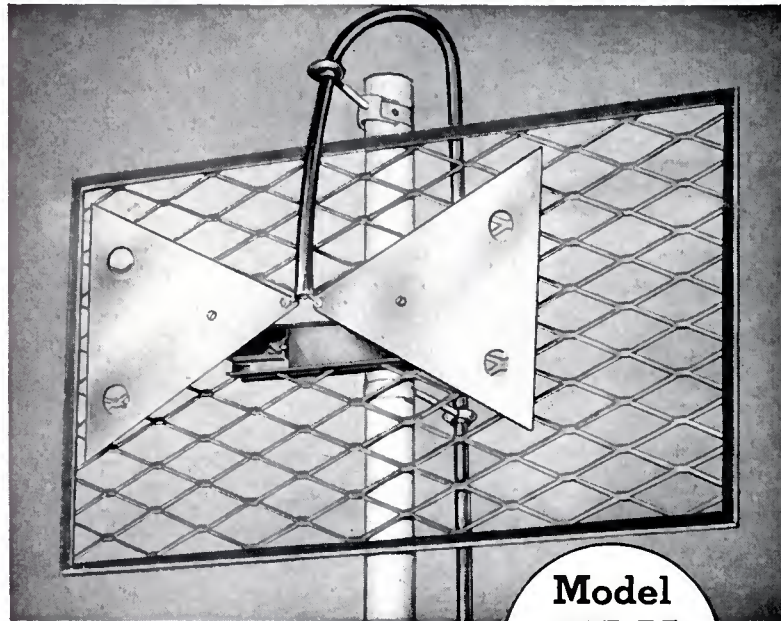

**Model
BT-U**



The Aristocrat of Bow Ties

Compare!

- Precision-built
- Easiest to install
- Brilliant performer
- 8 db gain across the entire UHF band
- 50% additional gain on stacked arrays
- Engineered for super sharp picture reception from 470 to 890 mcs.
- Assembled in less than a minute
- Weather-resistant finish
- Compact packaging — only 12" by 20" by 1½" deep
- No insulators required

LaPointe ELECTRONICS INC.
ROCKVILLE, CONNECTICUT

NOW VEE-D-X GUARANTEES YOU THE finest BOW TIE OF THEM ALL

BASED ON A COMPLETELY New Antenna Formula

- Eliminates insulators
- Permits all-metal construction
- Higher gain
- Flatter response over the

ENTIRE **UHF** BAND

EXCLUSIVE VEE-D-X FLEX-CLAMP

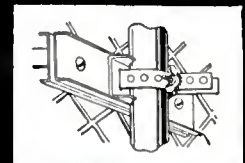
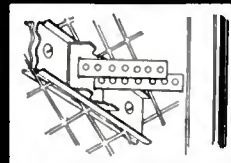

This exclusive VEE-D-X feature makes mounting of the BT-U amazingly fast and easy, especially when adding to existing installations at rooftop. No more fussing or fumbling with U-Bolts — just one screw to tighten and FLEX-CLAMP holds the antenna with a vise-like grip. FLEX-CLAMP completely facilitates probing — just loosen the screw and the antenna can be moved up or down the mast with ease. Will accommodate up to 1½" mast.

VEE-D-X STACKED BOW TIE For fringe area reception

This stacked array provides 50% additional gain on all UHF channels. A special phasing harness, VEE-D-X screen clips, plus exclusive FLEX-CLAMP, permit fast, easy installation of this unit. Order stacking harness Model BTH-U.

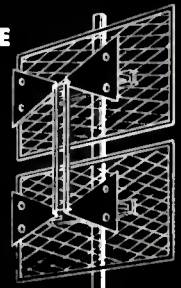

Technical New Products

JFD LIGHTNING ARRESTER

Lightning arrester models AT110 and AT110S may be used in UHF and VHF installations, with flat ribbon, tubular,

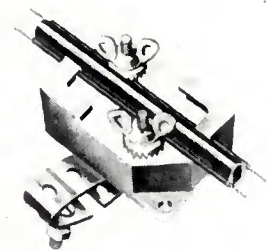

oval tube, double-barrel or open-wire twin lead transmission lines. The AT110 lists at \$1.50 and the AT110S at \$1.75. JFD is also manufacturing an antenna designed for use in UHF fringe locations—Model UHF633. This unit provides a 12 DB average gain and a 20-1 front-to-back ratio, according to the manufacturer. Manufacturer provides a one-year guarantee against corrosion and rust. List price is \$7.50. JFD Manufacturing Co. Inc., 6101 16th Ave., Brooklyn 4, N. Y.—TELEVISION RETAILING.

Webster FX CARTRIDGE

The first two-needle, dual-output cartridge developed for replacement use, the FX is adaptable to either high- or low-output applications by means of a shunting capacitor. Without the capacitor, this cartridge develops 4.4 volts at 78 RPM and 2.6 volts at 33½ and 45 RPM. With the capacitor, it develops 1.2 volts at 78 RPM and 0.6 volts at 33½ and 45 RPM. The lightweight FX cartridge has a tracking pressure of 8 grams and a cut-off frequency of 3500 CPS. Webster Electric Co., 1900 Clark St., Racine, Wis.—TELEVISION RETAILING.

Merit FILAMENT TRANSFORMERS

Ten new filament transformers for use with selenium rectifier applications cover the complete range of present requirements for rectifiers used in industrial, laboratory, TV and power applications, the manufacturer says. Merit Transformer Corp., 4427 N. Clark, Chicago 40.—TELEVISION RETAILING.

Stackpole FIXED CAPACITORS

Series of tiny capacitors measuring only 0.160-in. in diameter and 0.150 to 0.400-in. in length. Values from 0.10 MMF to 10.0 MMF. These units have been developed to meet the growing need for inexpensive, low-value fixed composition capacitors for UHF TV and other applications. Working voltage is 500 V DC. Electronic Components Division, Stackpole Carbon Co., St. Marys, Pa.—TELEVISION RETAILING.

Channel Master YAGI

Model 525 is a twin-tuned Yagi antenna peaked for channels 2 and 5. The antenna features a transformer-type dipole. It has a gain of 6½ DB on Channel 2, and almost 8 DB on Channel 5, for a single bay. Stacking provides substantially higher gain. Directivity and rear rejection are excellent, according to the manufacturer. The 2-channel antenna operates with a single transmis-



sion line; no switching is necessary. Other twin-tuned Yagis include Model 536 and Model 545, covering channels 3 & 6, and 4 & 5, respectively. Channel Master Corp., Ellenville, N. Y.—TELEVISION RETAILING.

Crest CRT REJUVINATOR

Designed to replace six different types of isolation and booster transformers, the Crestbrite Multi-Use Tube Brightener and Rejuvenator has a switching device which permits it to operate with either series or parallel-connected cathode-ray tube filaments. It can be used to isolate the tube filament, to increase the tube filament voltage, or both. Crest Transformer Corp., 1834 West North Ave., Chicago 22.—TELEVISION RETAILING.

Astatic CONVERTER-BOOSTER

Combination UHF TV converter and VHF TV booster, model CB-1, provides continuous tuning for UHF channels 14 through 83. UHF signals are converted to the frequencies of either channel 5 or 6. VHF amplification is secured with the booster section of the unit. Necessary



switching and tuning units are incorporated so that the VHF amplifier circuits may be used as a booster only on all VHF channels. List price is \$59.50. Astatic Corp., Conneaut, O.—TELEVISION RETAILING.

C-D NEW CAPACITORS

The Cornell-Dubilier Electric Corporation has extended their Demicon Capacitor line to include the new TWM series of high-temperature, metal-cased miniaturized tubular capacitors. Insulation resistance is extremely good at any operating temperature, according to the manufacturer, and the variation of capacitance with thermal change is small. Hermetic sealing of the capacitor within the metal housing is accomplished with glass-to-metal sealed terminals. These capacitors are available in six variations, providing a selection of mounting brackets and threaded studs for different application problems. Cornell-Dubilier Electric Corp., So. Plainfield, N. J.—TELEVISION RETAILING.

Heppner CRT MAGNET

The Heppner Model BCC603 centering magnet is designed for use with all sizes of electrostatically-focused picture tubes. Manufacturer says unit will

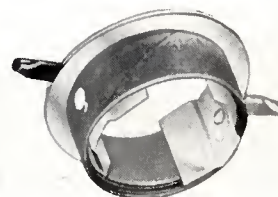

not cause de-focusing; distortion-free beam is assured by the uniformity of field. Beam centering is achieved by rotating individual magnets housed in a tenite plastic frame. Heppner Manufacturing Co., Round Lake, Ill.—TELEVISION RETAILING.

Workman VOLTAGE BOOSTER

A Model 5TV4 B plus booster is intended to replace the 5U4G in TV receivers, to provide more picture height



and width, and greater overall gain. Workman TV, Inc., Teaneck, N. J.—TELEVISION RETAILING.

To help you boost your sales
and make more money



makes these
SALES AND SHOP AIDS
available to you

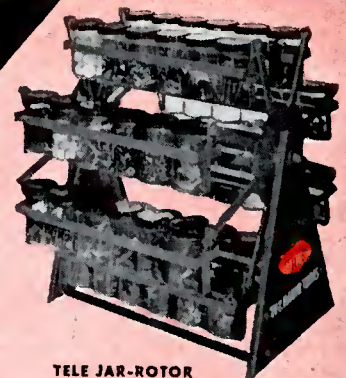

TELE JAR-ROTOR
A perfect small parts storage unit. Only 17" x 15" x 13".
Has 48 transparent plastic jars.



ILLUMINATED OUTDOOR SIGN
Double sided, formed plastic sign. 36" x 24" UL approved.



We use RAYTHEON TELEVISION and RADIO TUBES

RIGHT for Sound and Sight...

THREE DIMENSIONAL PLASTIC ILLUMINATED SIGN
A colorful "3-D" flasher illuminated formed plastic beauty.



DISPLAYS
Six color displays that sell your service.



REFLECTORIZED OUTDOOR METAL SIGN

Two sided metal sign to catch the eye of passers-by.



TUBE AND TOOL CARRYING CASE
Holds 137 tubes — plus all regular tools.



TRANSPARENT PLASTIC WINDOW STREAMER



PLASTIC "WILL RETURN" DIAL SIGN



SHOP JACKETS AND COATS
Full length or jacket style.



ILLUMINATED TEST PATTERN CLOCK
A Telechron Motored beauty.

Write
for
FREE BOOKLET!



Pictured are only a few of the many useful shop aids and sales promotion items that Raytheon has made available to you. There are many others — job tags and record cards, imprinted stationery, post cards, ad mats, shipping labels, decals, paper bags, giant outdoor thermometers, etc. — all designed with your needs in mind. Many items are free, the rest available at very low cost. Ask your Raytheon Tube Distributor about them or write for free Booklet. Address your request to Department C, Raytheon Manufacturing Company, Receiving Tube Division, 55 Chapel Street, Newton 58, Mass.



Excellence in Electronics

RAYTHEON MANUFACTURING COMPANY

Receiving Tube Division
Newton, Mass., Chicago, Ill., Atlanta, Ga., Los Angeles, Calif.

RAYTHEON MAKES ALL THESE:

RECEIVING AND PICTURE TUBES - RELIABLE SUBMINIATURE AND MINIATURE TUBES - GERMANIUM DIODES AND TRANSISTORS - NUCLEONIC TUBES - MICROWAVE TUBES

Service Technician

Brach UHF INDOOR ANTENNA

The Brach UHF Indoor Bow-Tie Antenna, Model 483, uses the same design that is employed on outdoor UHF bow-tie antennas to insure the highest pos-

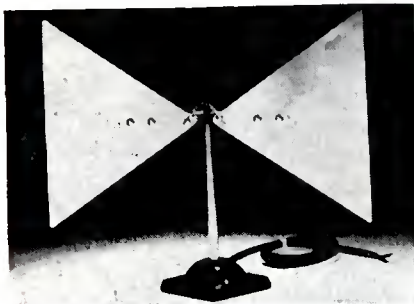

sible gain. The bow-tie elements are mounted on an attractive black porcelain base that gives the entire unit a modernistic finish. The antenna is supplied with 5 feet of lead-in wire. Brach Manufacturing Corp., Division of General Bronze Corp., 200 Central Ave., Newark 4, N. J.—TELEVISION RETAILING.

Tennalab VHF ARRAY

The Omnitenna is a stacked colinear array for all-channel VHF reception. The array comes complete with mast and requires only one 300-ohm lead-in line. Maximum gain is 15 DB, according to the manufacturer. Tennalab, Quincy, Ill.—TELEVISION RETAILING.

Haldorson TRANSFORMER

The FB410 is a new multi-purpose fly-back transformer possessing electrical and mechanical characteristics that make it a suitable replacement in a wide variety of TV chassis, according to the manufacturer. Unit accommodates horizontal yoke windings of from 8 to 25 MH and width coils ranging between 0.1

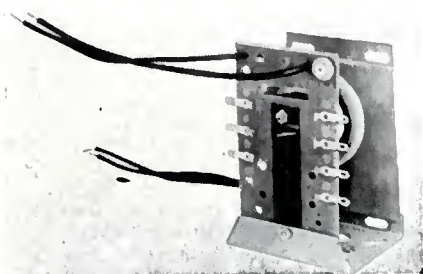

and 30 MH. Flexible construction permits conformation with popular inductively coupled and autotransformer-type horizontal output circuits. A separate winding for AGC and/or horizontal phase detection is provided. No additional dual-winding width controls are needed. The Haldorson Transformer Company, 4500 Ravenswood, Chicago 40.—TELEVISION RETAILING.

South River MOUNTING BRACKET

The UM-1 is a one-piece TV antenna mounting bracket with hot-dip galvanized finish and banding of stainless steel to prevent corrosion. Chimney corner

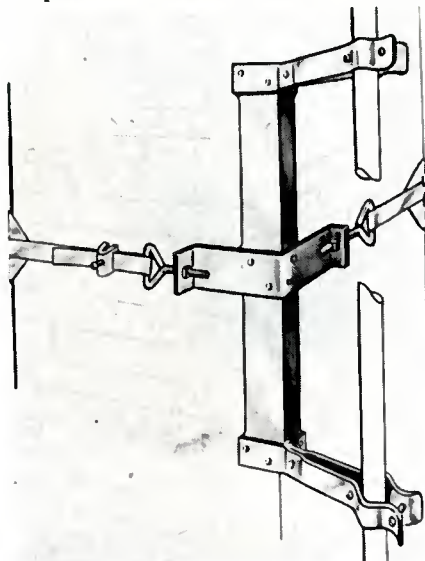

guards are included to protect banding and chimney. South River Metal Products Co., Inc., 377-379 Turnpike, South River, N. J.—TELEVISION RETAILING.

RMS SWIVEL BOW-TIE

Window sill bow-tie antenna for UHF. Extreme flexibility in positioning for maximum signal is afforded by the incorporation of a rotating head and a swivel-action extension arm. Installation to window sill is easily accomplished by expanding the mounting section until it fits securely between the extremes of the window. The WB-10 Swivel-Bow accommodates windows from 32-in. to 42-in. wide. Extension mounts are also available. Radio Merchandise Sales, Inc., 2016 Bronxdale Ave., New York 60.—TELEVISION RETAILING.

Reynolds COLLOIDAL GRAPHITE

Collo-Graph Tube Coat S-110 is a colloidal graphite solution used to repair the coating on the outside of glass cathode-ray tubes. Also employed to spray a graphite shield on vacuum tubes. Reynolds Industries, Inc., 4500 Euclid Ave., Cleveland 3.—TELEVISION RETAILING.

U. S. Wire TWIN LEAD

"Hol-O-Kor" is a low-loss 300-ohm line designed for UHF reception. Changes in weather and atmospheric conditions do not affect either impedance or electrical efficiency of this cable. U. S. Wire & Cable Corp., Progress & Monroe Streets, Union, N. J.—TELEVISION RETAILING.

Crest BAR GENERATOR

A pocket-size portable TV bar generator, model MA4, requires only a plug-in installation to the base of the CR tube in a TV receiver. A switch on the

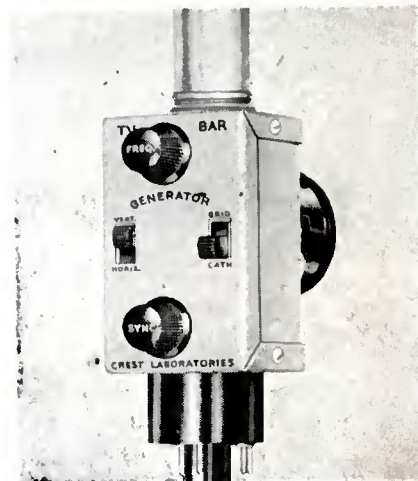

unit permits either vertical or horizontal linearity marker signals to be produced. Net price is \$10.95. Crest Laboratories, 84-11 Rockaway Beach Blvd., Rockaway Beach 93, N. Y.—TELEVISION RETAILING.

Aviation Service PRECISION TOOL

Precision-made nut and screw starter to aid technicians and repairmen in starting small nuts as well as screws in difficult, hard-to-reach places. Has a special lever-mechanism in the handle which controls the movable blades and adjusts them for gripping all standard sizes of small nuts and screws. Blades of specially tempered drill-rod steel in six different sizes are designed to accommodate all standard sizes of small nuts and screws from a No. 6 to a ¼-in.



nut, and from a No. 4 to a No. 10 screw. Prices range from \$1.45 for the 5-in. model to \$2.15 for the 8-in. heavy-duty unit. Aviation Service Supply Co., Denver, Colo.—TELEVISION RETAILING.

the leading name...
 the Top Performer
 in fringe areas

the NEW
 double CO-Lateral

FINCO

400-A

All Channel TV Antenna
 -32 Driven Elements

Perfect Pictures
 120-150 Miles
 FROM STATIONS

- Perfect Reception 120 miles to 150 miles from Station — We Can Prove This!
- Double CO-Lateral — 32 Driven Elements
- One antenna. One transmission line.
- Rugged all aluminum construction. Completely pre-assembled. Light weight — total weight only 8 lbs.

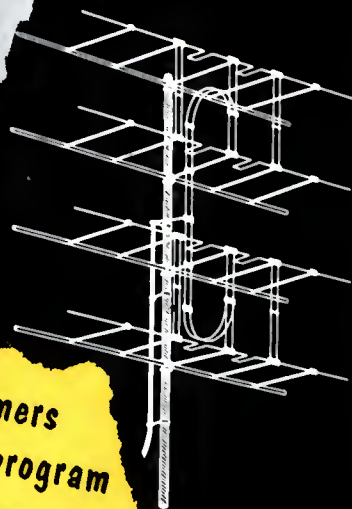

FINCO—a name Your Customers
 KNOW because of this powerful program

- LOCAL NEWSPAPERS
- LIFE
- TELEVISION
- FARM MAGAZINES
- RADIO

**YOU CAN CAPITALIZE ON OUR
 National Advertising**

Ask your jobber for the free
 LIFE DISPLAY CARDS AND WIN-
 DOW STREAMERS — and "AD-
 VERTISED IN LIFE" AD MATS.
 Ask about the Co-op News-
 paper ads that enable you to
 tie-in with LIFE ADVERTISING.

YOU CAN WRITE US DIRECT

THE FINNEY COMPANY
 Dept. TR-28
 4612 St. Clair Ave.
 Cleveland 3, Ohio

RUSH

- information on the new 400-A
- LIFE merchandising material
- Co-op newspaper ad mat brochure.

Name.....

Company Name.....

City.....Zone.....State.....

Your Jobber

**THE
 FINNEY COMPANY**
 4612 ST. CLAIR AVENUE • CLEVELAND 3, OHIO

finco

Specifically DESIGNED FOR

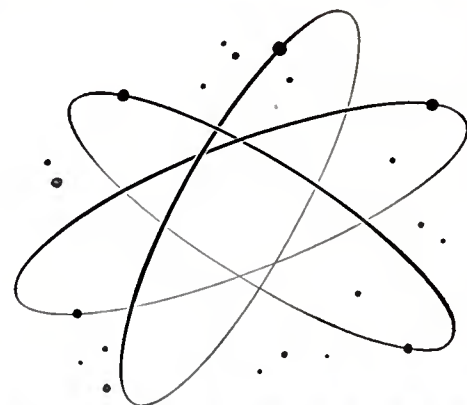

UHF Auto-Level Sweep Generator

Model G-8002. The newest, most modern, most inexpensive UHF sweep generator on the market. Checks sweep alignment with *any* test oscilloscope. Its output is controllable... makes possible overall trouble shooting and testing of low level units such as UHF tuners, boosters, converters, etc.

PHILCO Test Equipment



Field Strength Meter

Model M-8104. More features than any other unit at this popular price. Reads signal strength directly from the dial from 10 to 100,000 microvolts. A serviceman's time saver to measure actual TV picture signal strength.

**NOW YOURS
ON NEW
EASY PAYMENT
PLAN**

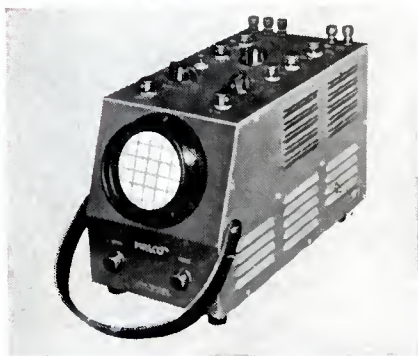

3-inch TV Oscilloscope

Model S-8200. The most practical portable unit available for bench or field servicing. Preset horizontal and vertical sweep rates take the guesswork out of trouble shooting. Ideal for television because of its high sensitivity and wide response.

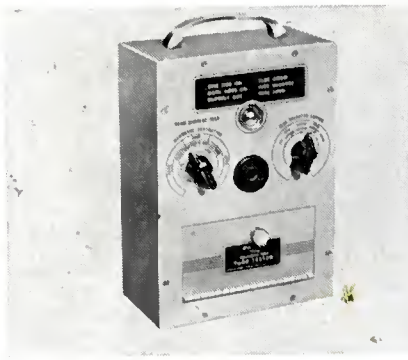

Cathode Ray Tube Checker

Model 7053. Tests *all* picture tubes used in home TV receivers. Special cathode-ray tubes are easily checked by using plug-in adapters. Eliminates trouble shooting guesswork. Neon lamp indicates shorts and open elements in the electrodes of the gun.



Dynamic Signal Tracer

Model 7031. An extremely versatile instrument... this unit is designed for fast diagnosis of radio trouble by audibly monitoring RF and AF circuits. Can be used to accurately check P.A. systems, microphones and phonograph pick-up circuits.

THE SERVICEMAN

The Philco test equipment line is new! New circuits, new styling, new ruggedness, new versatility, new accuracy! Each piece of equipment is precision-built and now brings new features specifically designed *with your needs and your problems in mind!* Look over the individual instruments shown on these pages, and then mail the coupon below or get in touch with your Philco distributor to find out how easy it is to own a complete Philco Test Equipment Service Laboratory.

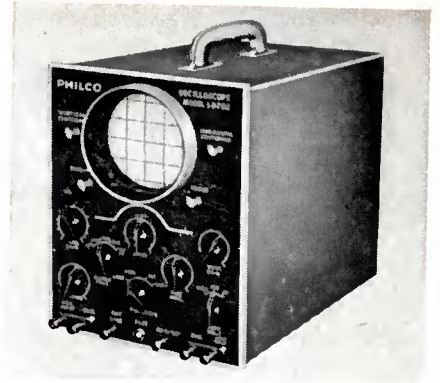

5-inch High Gain Oscilloscope

Model 5-8202. This outstanding scope is built to the highest standards of test instruments... It features the highest gain 10 millivolts/inch, and widest frequency range at its popular price. Wide sweep ranges allow flexibility in sweep circuit trouble shooting.



Mutual Conductance Tube Checker

Model 7052. Tests more different type tubes than any unit on the market, from subminiature to acorn low power transmitting tubes... Forecasts tube life... employs roll chart instead of cards... for use as a portable or counter top unit.



Model M-8100



Model M-8102

Model M-8100. The rugged PHILCO CIRCUIT MASTER is one of the finest vacuum tube voltmeters ever designed. With its companion unit the famous...

Model M-8102. PHILCO CIRCUIT TESTER you have a combination engineered to meet the most rigid specifications for reliability, durability and accuracy of design.

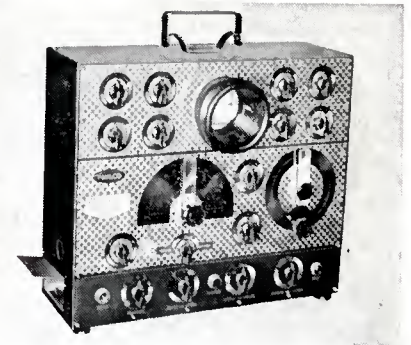

Visual Alignment Generator

Model 7008. Combines in *one* economical instrument functions that can be approached only in a cumbersome collection of costly devices. No special scope connections are required for the most accurate visual alignment that is possible to achieve.

For new FREE BOOKLET fill out and mail this coupon
OR SEE YOUR PHILCO DISTRIBUTOR

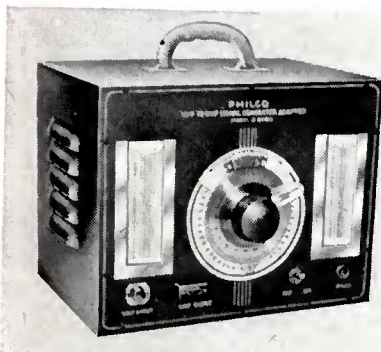

VHF to UHF Signal Generator Adapter

Model G-8000. The most economical system yet designed to produce UHF signals for TV receiver tests. Through a conversion process this unit produces from an input VHF signal, UHF signals having the same characteristics as the VHF signal.

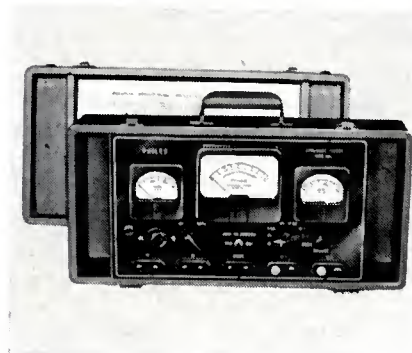

Appliance Tester

Model 5007. The ultimate in versatility. A one package, all purpose, portable appliance service unit. Permits over-all analysis of refrigerators, ranges, air conditioners and household appliances. With "pick-up" elements to determine temperature.

PHILCO CORPORATION
Accessory Division
Allegheny Ave. & "A" St.
Philadelphia 34, Pa.

I am interested in the Philco Test Equipment shown here. Please send me details of your SPECIAL PURCHASE PLAN for obtaining these units.

Please send FREE copy of your new booklet on Philco Test Equipment.

NAME

ADDRESS

CITY..... STATE.....



New GE Food-Waste Disposer

A new food-waste disposer, model FA-45, is sized to fit 90% of existing sinks without alteration of drain connections, General Electric's sink and cabinet department announces. Two inches shorter than other models in the line, the new unit employs the same shredder mechanism and motor. Suggested retail price is \$124.95.

Manages Gibson Freezer Sales

W. J. Browne has been appointed manager of food freezer sales, the Gibson Refrigerator Co., Greenville, Mich., announces. He had formerly managed the company's electric range sales, the announcement made known.

Freezer Packaging Plan

A frozen food packaging program designed to help build freezer sales and increase dealers' store traffic through return business is announced by Servel, Inc. The program consists of two sales aids—the Servel Freezopak and frozen food packaging rack. Freezopak is an assembly of packaging materials in a carry-all carton, all designed to aid in packaging fruits and vegetables. Also included is a bundle of "twist-ems"—wire tapes to close the bags. The all-metal packaging rack holds all the items in the Freezopak.

Moppets Get a Look-See



The Thor "Wash 'N Dry" children meet and approve the new automatic washer and dryer recently introduced by the Thor Corp. With an eye to kitchen planning, the company is now making a line of look-alike appliances.

Deepfreeze Offers Clock-Sign

A versatile electric clock-sign is available to dealers from distributors of the Deepfreeze Appliance Division, Motor Products Corp. Measuring 19 by 29 in., the unit can be hung, suspended or, by reversing the clock and sign, placed on a counter. Sign has a plastic face embossed in three colors and is illuminated by fluorescent bulbs. Clock has an 8-in. face with sweep hand. Dealer cost: \$11.95.

Range Manufacturer Appoints

A. J. Lindemann & Hoverson Co., Milwaukee, producers of Lectro-Host electric ranges and other products, has appointed Anthony Celio as sales promotion manager.

Activities in the Appliance Field

NARDA Hears GE's Warren

The objective of the major appliance industry is to develop a five-billion-dollar-plus business within the next ten years, according to Herbert A. Warren, manager of distribution for General Electric's Major Appliance Division. Speaking on "The Value of a Franchise" at a recent meeting of National Appliance and Radio-TV Dealers Assn. in Chicago, Warren said such a figure might even be low "in light of the fact that our industry this year will probably sell at retail more than three billion dollars worth of major appliances."

Pennwood Clocks Gift Packed

To take advantage of their gift possibilities, the Pennwood Numechron Co. announces that all of its electric clocks are now gift packaged in red and black glossy boxes.

Appointments at RCA Estate

Thomas F. Bartley has been appointed RCA Estate division manager for the east central region, taking over the division formerly handled by John Holzman, who has been named vice-president in charge of sales of the RCA Victor Distributing Corp., headquartered in Chicago. Walter A. Summers has been appointed RCA Estate division manager for the eastern region.

Telechon Augments Line

Six new models and the addition of the "new look" to six standard types have been announced by the Telechon Department, General Electric Co., as it launches its largest clock advertising campaign of the Fall. Designs range from ultra modern to conventional, with prices from \$6.95.

Ky. Firm Gets Bendix Line

Electric Appliance Distributors, Louisville, Ky., has been appointed distributor for Bendix home appliances in that state and in several Indiana counties.

Frozen Food Plan Is Told

A new merchandising program for selling Deepfreeze home freezers with frozen food was unveiled recently by the Deepfreeze Appliance Division of Motor Products Corp. Called the "National Co-Operative Freezer Food Service," it is described as a program designed especially for appliance dealers, locker operators and retail food outlets.

LF&C Appoints Andrews

John A. Andrews has been named sales development manager of the Electric Housewares Division of Landers, Frary & Clark, New Britain, Conn. Andrews, who has been with the company for 14 years, succeeds Robert A. Beyers, who has retired to engage in his own business.

GE Ups Retail Prices on Five Refrigerator Models

Increases of \$10 and \$20 in the recommended national retail prices of five refrigerators have been announced by General Electric Co., because of material and labor cost increases. Models affected are LH-11; LM-95; LD-87; LB-92 and LA-92.

NATESA Convention Dates Set

The annual Fall convention of the National Alliance of Television and Electronic Service Assns. will be held at the Morrison Hotel, Chicago, October 9-11, with TISA-Illinois as host. A large attendance is expected.

Kelvinator Promotion A Hit

The first phase of Kelvinator's "Homemaker's Holiday" reaped excellent results according to Raymond Rosen & Co., Kelvinator's Philadelphia distributors. The promotion required every salesman giving a demonstration of Kelvinator appliances to fill out a slip which was placed in a freezer unit for drawing. Winners received a trip to New York City and other prizes. The second part of the promotion will award even bigger prizes.

Crosley Names Johnston Co.

The George L. Johnston Co., 1420 Holden Ave., Detroit, has been appointed exclusive distributor of the full line of appliances and electronics for Crosley Division of Avco Mfg. Corp.

Dehumidifier Dolly Shown

A dolly to make its electric dehumidifier completely portable, is to be marketed by the Fresh'nd-Aire Division of the Cory Corp. Made of steel, the unit is equipped with swivel casters and fits on the dehumidifier's "feet." The dolly is also said to be useful for moving laundry baskets and boxes. It will retail at \$5.

To Handle Amana Freezers

Graybar Electric Co., Nashville, Tenn., will distribute Amana Refrigeration Co.'s home freezers in central Tennessee and several counties in Kentucky and Virginia.

TRIO

AMERICA'S MOST DEPENDABLE TV ROTATOR

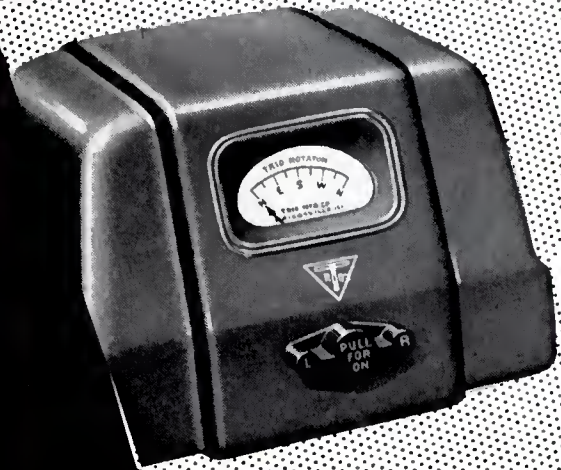

TRIO *Manufacturing Co.*

GRIGGSVILLE, ILLINOIS

FACTORY TESTED to equivalent of three months normal use before shipment.

TEMPERATURE PROOF. Operates perfectly at -50° , even under heavy icing conditions.

FOOLPROOF. Stops itself at ends of rotation. NO burned out motors: NO broken feedlines.

IMPROVED BRAKE. NO coasting; NO drifting.

TWO MOTORS. Separate motor for each direction of rotation.

SMART—EASY TO USE Control unit. Indicates direction without turning rotator.

TWO YEAR GUARANTEE instead of the usual one.

**Write for literature.*

House of Music

(Continued from page 47)

Long-playing records are displayed vertically on "swinging-door" racks which fill an entire wall. This display permits the customer to see a vast quantity of 33 $\frac{1}{3}$ albums, facilitating browsing and self-service. Albums are grouped according to composer, so that the different recordings of a particular work are all visible in one place.

Sales volume for the store comes mainly from local, year-round residents, largely rural, with somewhat of an increase during the warm weather from city people who spend the Summer in this resort town. It has been found that more long-plays are sold during the Summer, while 78 pop singles have the edge in the Winter, which may be related to the change in character of the clientele. A year-round average of disc sales, however, gives the over-all edge to 33's, with 43.8% of dollar sales; 78 pop singles and kid records account for 37.5%, while 45's accounted for 18.7% in 1952. As noted above, the latter have shown a tremendous increase since EP, and the '53 breakdown may vary. 78's have been slowly but continuously slipping, and the only classical albums and singles in the store at this speed now are those in a small inventory of old stock.

The new store has double the record booth space of the old one, showing that H of M still considers this feature important in disc sales. Placed across the rear of the store, the booths have large glass windows which provide excellent visibility from the center of the store, where the sales counter is located. This makes it possible for the salespeople to keep an eye on the occupants.

The listening rooms are quite narrow, but a large glass window between each two booths tends to give a feeling of spaciousness, felt necessary because some customers suffer from claustrophobia in a booth. Booth ceilings are covered with acoustic material (as is the entire store ceiling), and a quiet exhaust fan is provided for ventilation. Ceiling treatment used is a new Celotex product called "Random Pattern," which is not only considerably more attractive than previously available Acousticalcelotex blocks, but is considerably more sound-absorbent. Installation in the entire store was found necessary,

due to the pronounced echo condition which originally existed.

Typical of the aggressive promotional attitude of the store's operators was the opening at the new location, which was extensively advertised, and which was highlighted by "live" entertainment consisting of local talent plus "in-person" appearances of recording stars Percy Faith, Tony Arden and Sunny Gale. Store was jammed all day long, with real business being done, including as many TV set sales as are normally made in a week.

Advertising in local newspapers is continuous all year round. In addition, considerable direct-mail work is done, making use, whenever possible, of brochures and mailing pieces provided by manufacturers. A new feature since last Christmas is a regular program of recorded music sponsored by H of M on an FM station blanketing the whole county. H of M claims to have the largest record volume, as well as the widest selection of discs, of any record store in the county, as well as a sizeable proportion of the TV business done in their (Eastern) end of the area. Volume is expected to reach \$260,000 this year.

At a special five-year anniversary event last year, the firm sold 45 TV sets in one day, an outstanding achievement in a fringe location where the entire trading area is less than 30,000 total population (about five towns) and a fairly high degree of saturation exists. "Gimmick" for the sale was free installation of a one-station antenna with each set purchased. Event was so successful that they plan to repeat it again this year.

List Prices and Service

While within three hours traveling distance of an active price-cutting area, H of M has built a steadily increasing business based on list prices by means of service (both from the merchandising and from the technical sense) and a neighborly attitude. While disc sales depend on store traffic and displays, TV, and Hi-Fi sales are almost entirely the result of home calls, satisfied-customer referrals and the good reputation of the service department for fine installations plus prompt and efficient service.

Trade-ins are accepted on all types of merchandise (the writer witnessed a trade-in on the sale of a \$34.95 phonograph) and the store makes money or at least breaks even on the resale of traded-in items. "There is always a sale for a

used radio or phonograph," McDaniel stated, adding that a traded-in TV set must be moved very quickly, however, before the receiver becomes too obsolescent.

Special orders on records or sheet music are accepted without question and are promptly filled, this being one of the many services which are emphasized in order to build customer friendships, loyalty and repeat business. The customer who bought the \$34.95 phonograph, or who ordered one record not in stock may (and usually does) wind up eventually buying a TV set or a custom Hi-Fi installation.

The tastefully decorated Hi-Fi demonstration room is separate from the main part of the store (somewhat reminiscent of the TV demonstration rooms of a few years ago) and, as mentioned before, represents a new departure. Formerly, Hi-Fi sales were handled solely in the home after leads had been developed on the sales floor (usually in the disc department). The new room features not only custom components for special installations, but also a few pieces of "complete package" units already in attractively designed cabinets. This latter merchandise is just recently beginning to be available to dealers with a good retail markup price schedule.

It is expected that the new Hi-Fi room (unusual yet for TV-music retailers) will boost Hi-Fi sales. A display in the front of the store will call attention to the availability of this type of merchandise and services, and the existence of the demonstration room.

Growth of the House of Music firm in six years is not high-lighted by any revolutionary sales tactics, but rather by the continual and consistent application of time tested retail sales fundamentals, and proves that these fundamentals pay off in healthy gradual growth, steady profits and a solid position in the community.

Gold in Platters

(Continued from page 43)

important that everybody in the department be fully aware of all functions of operation of the department, in order to prevent confusion in the buyer's absence, and also to train people for openings which may develop for buyers at any of the three Dee stores. At present there are three separate buyers because of

(Continued on page 74)

You wanted it... *here it is*—

THE RCA

"SERVI-CHEST"

the truly portable "workshop"
you'll be proud to take into the home

YOURS FOR JUST 30



RCA SILVER TOKENS!

Look at these features!

- 1** GIANT SERVICE MIRROR—Top-quality glass. 11" x 16" working surface. Removable hinges for flexibility of use. Wedges provided for adjustment of mirror angle.
- 2** SOLDERING GUN COMPARTMENT—Will accommodate all popular makes of soldering guns or irons.
- 3** UTILITY DRAWER—Roomy enough for tools, flashlight, large capacitors, high-voltage probes, etc.
- 4** RESISTOR DRAWER—Will hold large assortment of popular resistor sizes.
- 5** CAPACITOR DRAWER—Plenty of space for working supply of radio and TV types.
- 6** SPARE PARTS DRAWER—Suitable for small components and tools.
- 7** VOLTMETER COMPARTMENT—Designed to accommodate the popular RCA "Volt-Ohmyst"®. Instrument can be operated without removal from compartment.
- 8** UTILITY COMPARTMENT—Suitable for socket wrench kit, drop cloth, carrying strap, etc.



DELUXE CONSTRUCTION
Measures 13 1/4" high,
9" deep, 18 1/4" wide.



How to get your RCA "SERVI-CHEST"

IT TOOK SIX MONTHS TESTING in the field to develop just the right kind of carry-all case for you . . . the RCA "SERVI-CHEST." It's the "little black bag" that identifies you as a "professional" Radio and Television Service Technician. The "SERVI-CHEST" is just what you asked for . . . and you can get yours *without cost*.

During the next three months, you will receive one RCA Silver Token from your *RCA Tube Distributor* for each RCA Kinescope or for each 25 RCA Receiving Tubes you purchase. When you have collected 30 Silver Tokens, present them to your *RCA Tube Distributor* and receive, *without cost*, the complete RCA "SERVI-CHEST." Start earning yours today.

PLUS THIS BIG BONUS

With every RCA "SERVI-CHEST" you earn, you get these seven RCA Technical Publications.

1. "Service Parts Directory for RCA Victor Radios."
2. "This Business of Radio and TV Servicing."
3. "RCA Receiving Tubes" booklet.
4. "RCA TV Replacement Guide."
5. "TV Servicing Supplement."
6. "RCA Kinescopes" booklet.
7. "TV Servicing."



Now you can earn an RCA Drop Cloth and Carrying Strap
For only 3 Silver Tokens each, you can earn these two valuable servicing aids. See your RCA Tube Distributor.



Now available from your RCA Tube Distributor . . . The famous RCA "TREASURE CHEST" a perfect companion piece to the RCA "SERVI-CHEST"

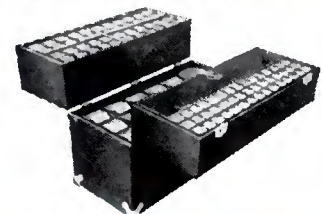

See your RCA Tube Distributor today for full details



RADIO CORPORATION of AMERICA
ELECTRON TUBES
HARRISON, N. J.

Gold in Platters

(Continued from page 72)

divergent interests among the clientele of the individual stores.

PROMOTION AND ADVERTISING

—One of the most interesting promotions was staged several months after the opening of the record department at the Broad and Erie store. A newspaper ad, supported by a window sign, urged record enthusiasts to "come in and register" for a give-away of a record player normally retailing at \$34.95. To register, the prospect had to fill out a numbered card, keep a stub, and drop into a box the card listing his name, address, 'phone number, type of record player currently owned, and various musical preferences. Registration was heavy and Mrs. Yohannan pointed out that she had obtained the basis for an excellent list which could be contacted, by 'phone or mail, during a slow day or season, with news about the latest single and album releases.

Another promotion Mrs. Yohannan favors is a twice-a-year clearance selling slow moving platters at cost. This is timed to precede the suppliers' five per cent return authorizations which come every six months. The sale runs about two weeks, and is intended to bring in new customers, give old customers a price break, and clean up dead stock, says the buyer.

Dee's record department is mentioned in the store's larger newspaper ads, but also gets its own space regularly in Thursday morning and afternoon papers. Most frequently Mrs. Yohannan will insert some holiday or seasonal message in a standard mat in a co-op ad, but occasionally she'll borrow an old appliance promotion method and run her own 'price leader' ad, then 'trade up.'

INVENTORY CONTROL—Careful stock control, or the lack of it, can make or break your record department, declares Dee's buyer.

Mrs. Yohannan keeps a perpetual inventory of the department's entire album stock. She has several books. One is 45 rpm's of her top selling label segregated into series as numbered by the manufacturer. There is an LP book, another book for 45's, and a book for the new 'extended play' albums. Additions are made when an invoice is received, and deductions are made in the morning from the previous day's sales records. Entries are made by the person working the early shift.

"It's good to have all personnel know how this works, especially if there is more than one store. Careful control means we eliminate guesswork on orders and on what to drop. We know what's been selling, and on what dates it has sold."

Dee's re-orders once every week or two weeks from distributor's salesmen, who call personally.

On single recordings, the department uses the fairly standard method of a green envelope to which is attached a sales record sticker. When the last platter is sold, or when stock is low on a popular tune, the green envelope is "pulled" immediately for quick reordering.

The Broad and Erie record department sells about 30 percent classical and 70 percent popular recordings, with heavy neighborhood demand for Irish numbers, polkas, and string bands. The 19th & Scheltenham store breakdown is 60 percent for classical and 40 percent popular, with Jewish recordings a favorite. At the 1633 Ridge Avenue store, in a predominantly Negro district, race, blues, and jazz numbers go best. Each store attempts to build special departments to conform with localized interest, as well as basic stocks.

Working Together

(Continued from page 41)

sure a dealer into any situation that will bring the dealer to grief. He may try to "load"—but within reason. If he does so, he'll make a real effort to aid the dealer in moving his inventory. But, remember, no wholesale man can grasp all of the dealer's problems and cope with them. The dealer can listen, and try to cooperate—but he still has to run his own business himself.

Some dealers complain of "tie-in" deals or "packages." But the need

Raytheon Lauds NARDA Stand

Raytheon Mfg. Co.'s Television and Radio Division, via a recent telegram to Wallace Johnston, president of the National Appliance and Radio-TV Dealers Assn., endorsed that organization's dealer platform, "the first manufacturer to take a firm stand on a matter termed 'controversial' by industry spokesmen." Citing appliance dealers for their roles in building billions of dollars in sales, Raytheon Vice-President William L. Dunn said they "deserve the manufacturers' closest support and deepest understanding, both in formulating policies and in carrying them out."

for such deals may be brought about, too, by the dealer's inclination to move only the high-demand merchandise. Here again, the distributor salesman should be the man to decide just what dealers to pressure into line. And, if the distributor has a real inventory problem (and, if it's an honest problem that doesn't occur with suspicious frequency), the dealer should cooperate with a loyal supplier.

Most dealers and distributors are sensitive—and rightly so—on one point. Each wants recognition from the other, and cooperation, on special efforts they make that can have mutual benefits. For instance, when the dealer holds an open house or a cooking school, he usually wants distributor men in attendance. And when the distributor holds a line showing or sales training session he wants the dealer there.

The larger retailers have defined their policies rather clearly. Salesmen call only on certain days; deliveries are made at certain times; freight shipments are handled in fixed routines; invoices must be in triplicate or what-have-you.

The average dealer, however, doesn't even attempt such fixed "rules" for doing business. He isn't an "organization" in the same sense as the department store or distributor. Yet there are certain practices which make it easier for him to conduct his business. Whenever possible, the distributor should accede to these wishes; if impossible, then there should be a mutually-satisfactory compromise.

Clear understanding, most dealers and distributors agree, is the greatest need to cement good relations. Linked with loyalty and honesty-of-intent, the "cards-on-the-table" approach usually solves almost any of the complex problems that arise in this business which has one common aim—the aim of moving more merchandise profitably to the ultimate consumer.

CBS-Columbia Credit Plan

Available nationally is a summer credit program designed to help dealers display and sell more CBS-Columbia TV sets over summer months and pay for them in the heavier selling season. Dealers make a down payment of 10% on purchases of at least four sets. The remaining 90% will be financed for a period of 90 days, at no cost to the dealer. The finance charges are borne jointly by CBS-Columbia Inc., (manufacturing subsidiary of the Columbia Broadcasting System) and the distributor. The plan was arranged with Commercial Credit Corp. and will run through Aug. 31.

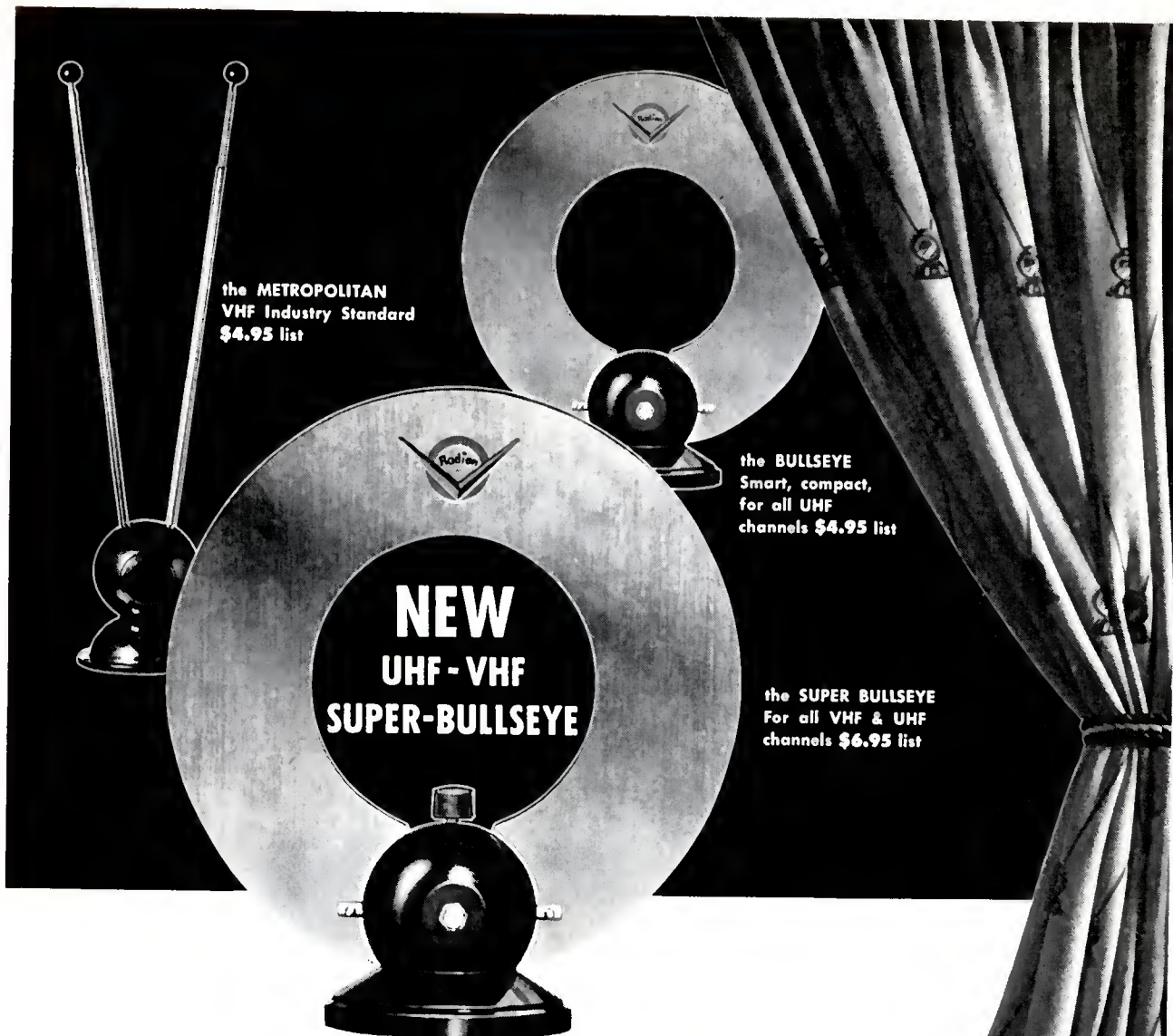

the METROPOLITAN
VHF Industry Standard
\$4.95 list

the BULLSEYE
Smart, compact,
for all UHF
channels \$4.95 list

NEW
UHF - VHF
SUPER-BULLSEYE

the SUPER BULLSEYE
For all VHF & UHF
channels \$6.95 list

SELL MORE TV SETS IN EVERY MARKET

If yours is a straight VHF city you know how the Radion indoor antenna has sold TV sets for you. One out of every six sets sold is installed with a Radion Metropolitan! Now, if your city has UHF or is adding UHF service to existing VHF there's a Radion to help you sell...to give you the advantages of low installation costs and manpower saved. Radion is THE quality name in the field...most popular, for appearance and performance. Stronger signals and more sensitive sets make Radion indoor antennas more practical than ever for a majority of your installations.

Sell Radion and you sell the *best*...and the *best* way to sell TV in volume—in every market—is with Radion!

GET THE DETAILS ON ALL RADION ANTENNAS... SEND TODAY

Radion

THE RADION CORP.
1130 W. Wisconsin, Chicago 14, Illinois

TVR-8

Please send information on the Metropolitan _____ the Bullseye _____ the Super Bullseye _____ to:

Name _____

Firm _____

Address _____

City _____ Zone _____ State _____

Export Sales Div. Scheel International, Inc., 4237 N. Lincoln Ave., Chicago 18
In Canada: A. T. R. Armstrong Co., 50 St. Clair Ave., West, Toronto

an Amphenol antenna on the roof
means a satisfied customer
for you!

What is the reason that AMPHENOL antennas are not only maintaining but increasing their front position as the finest antennas ever offered? The answer, of course, is that the name AMPHENOL has become synonymous with quality—to more and more dealers and servicemen. They know, first, that *antenna quality is measured in performance* and that the performance of AMPHENOL antennas is outstanding. Dealers in cities where there have been severe ice storms or high winds feel proud that the AMPHENOL antennas they have installed are still standing when other antennas have collapsed. They like, also, to hear the satisfied comments of customers about the fine picture quality they are getting on their TV sets—and dealers know how much that picture depends on the AMPHENOL antenna.

Important to dealers, and further proof of performance, are published antenna measurements. Making all such measurements in accordance with current RTMA standards, AMPHENOL provides accurate information that can be relied on. Dealers realize they can read the db gain of an AMPHENOL antenna and believe it.

AMPHENOL

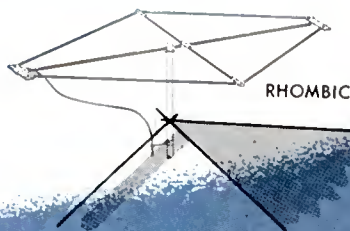

RHOMBIC

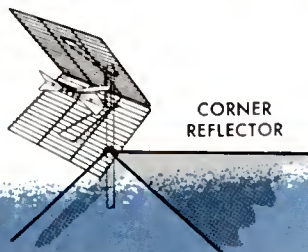

CORNER REFLECTOR

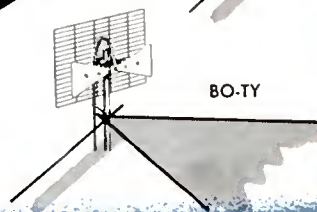

BO-TY

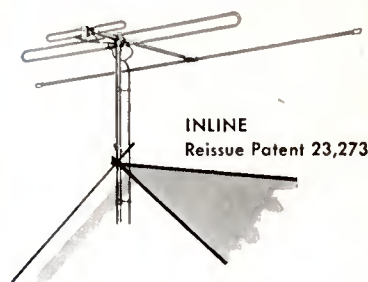

INLINE
Reissue Patent 23,273

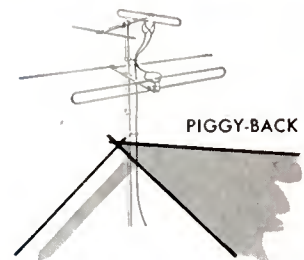

PIGGY-BACK

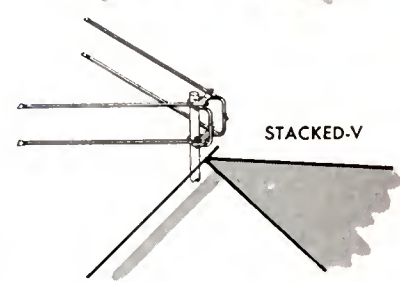

STACKED-V

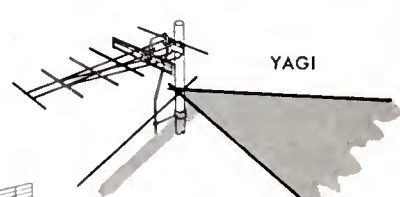

YAGI

IT PAYS TO BUY QUALITY

See the new
UHF-VHF Antenna
Film



AMPHENOL has prepared an attractive new folder with Kodachrome illustrations from the new AMPHENOL film "The UHF-VHF Television Antenna Story". Besides giving a short version of the important facts in the film, it also encloses AMPHENOL antenna and accessories catalog sheets—and is designed to hold new sheets as they are issued. Write AMPHENOL today for your copy of "The TV Antenna Folio".



See this complete antenna folder

The new AMPHENOL film "The UHF-VHF Television Antenna Story" is now available for you to see by just contacting your distributor. Done in slide-film and full color, it gives helpful information on UHF and VHF television. It discusses, fully and frankly, antenna characteristics for the different frequencies—shows gain charts and radiation patterns. Be sure and see "The UHF-VHF Television Antenna Story".

see your **AMPHENOL** dealer...

King Sets N.Y. Distributor

Colen-Gruhn, Inc., has been named exclusive Metropolitan New York distributor for King freezers, manufactured by King Refrigerator Corp., Glendale, N.Y. King's current line includes three chest-type models of 4, 9 and 12 cu. ft. capacities and an upright unit of 11.4 cu. ft.

Harriss Firm to Rep for RMS

L. H. Harriss Sales Co., San Francisco, will represent Radio Merchandise Sales, Inc. in northern California and Nevada. RMS has also appointed the Frank A. Emmet Co., Los Angeles, to handle its line of antennas and accessories in southern California, southern Nevada and Arizona.

Webster Electric Adds Unit

The addition of the SS-464 portable sound system to its line is announced by the Sound Division of the Webster Electric Co., Racine, Wis. Net weight of the unit is 22 pounds.

GE Promotion for Coullard

John B. Coullard has been appointed sales engineer for General Electric Co.'s Electric Components Department at Syracuse, N.Y. He has been with GE for 11 years.

Radell Sets Southern Rep

Cartwright & Bean, manufacturers' reps of Memphis, Tenn., has been named southeastern rep for the Radell Corp., resistor manufacturers.

CBS-Columbia Franchises

Igoe Bros., Inc., Newark, N.J., has been appointed distributor in that city as well as in northern New Jersey for CBS-Columbia's line of TV and radio receivers.

Tesco Gets Underway With Advertising Campaign



This striking display was used at a recent trade show as a springboard to introduce an advertising campaign by TV Products Co., Springfield Gardens, N. Y., producers of Tesco antennas. Shown are Elliot March and David Fox, Tesco owners, discussing future plans with Ed Conti, of Conti Advertising. Campaign theme evolves around the slogan "It's the cat's whiskers and just as sensitive." Several promotions are planned, using the decorative Jean Nevin and Doris Africk, who are also shown.

GE's Dr. Baker Accepts RTMA's 1953 Medal of Honor

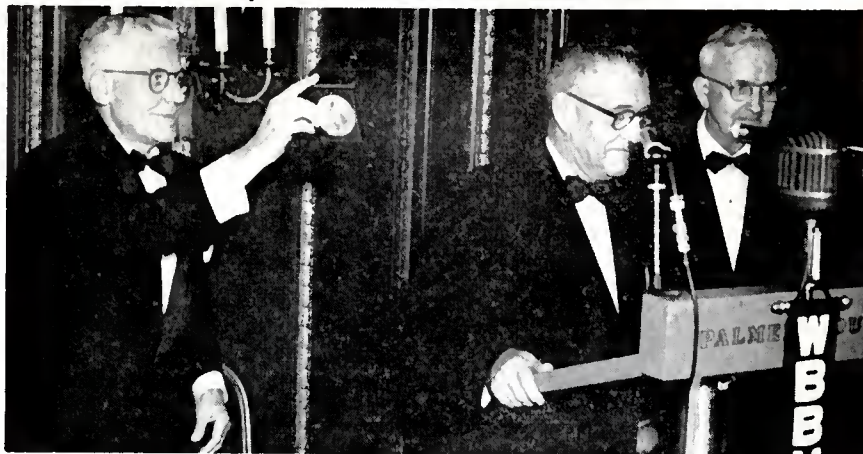

For his "outstanding contributions to the radio-television industry," Dr. W. R. G. Baker, vice-president of General Electric Co. (above, center) receives the 1953 Medal of Honor. Presentation was made at the association's recent banquet in Chicago. Pictured with Dr. Baker are A. D. Plamondon, Jr., former RTMA president and chairman of its board (left); and Max F. Baicom, of Sylvania Electric Products.

Joseph to Rep Electri-Cord

Ben Joseph has been appointed to represent Electri-Cord Mfg. Co. in the Metropolitan New York jobber trade. The Manhattan manufacturer of cord sets will soon move to larger quarters in Brooklyn.

Turner Co. Has New Converter

A new UHF-TV converter for low signal area installations is now available from the Turner Co., Cedar Rapids, Iowa. Firm reports excellent performance in fringe and shadow areas with signal strength of 500 down to only 100 MV.

Flip Chart Ups Norge Sales

Distributor salesmen are using a 52-page flip chart in selling the new Time-Line clothes dryer, Norge Division of Borg-Warner Corp. reveals. Chart emphasizes all features of the unit including "lowest operating temperatures, greatest volume of air and economical, 'selective drying.'"

New Office for Audio Devices

Audio Devices, Inc. announces the opening of a sales office in Chicago for distribution in Indiana and Illinois of the company's magnetic recording tape and recording discs.

To Distribute for Du Mont

Morley Brothers, of Saginaw, Grand Rapids and East Lansing, Mich., has been appointed to distribute Allen B. Du Mont Labs., Inc. television receivers. Also handling the line in Michigan is Specialties Distributing Co., Detroit.

Westinghouse Franchises

Television Accessory House, Providence, has been awarded a Westinghouse Reliatron tube distributorship for Rhode Island, eastern Connecticut, southern Massachusetts. Firm will handle all types of tubes.

Altorfer Bros. Elect

Henry W. Altorfer has been elected president and general manager of Altorfer Bros. Co., Peoria, Ill. manufacturers of home laundry equipment. He succeeds his brother, A. W. Altorfer, who has retired.

To Rep Merit Coil in East

A manufacturers' representative firm, Technical Representation, of Glenside, Pa., will handle the Merit Coil & Transformer Corp. line in Eastern Pennsylvania, Delaware and southern New Jersey.

Distributor Names Fissell

Robert E. Fissell has been elected a vice-president of Walker-Jimieson, Inc., Chicago distributors.

Capehart Awards Franchise

Swanson-Nunn Sales Co., Evansville, Ind., will distribute Capehart-Farnsworth TV and radio receivers in southwest Indiana, western Kentucky and southeast Illinois, it is announced.

New TV—Radio Lines

Zenith TV MODELS

Forty-eight new TV models with top-mounted bandshell speaker for table TV, "Spotlite" dial and built-in pre-tuned VHF-UHF antenna are available in blond afa, limed oak, walnut, brown-toned and ebony-finished cherry, coppertone and mahogany. Suggested retail prices range from



\$199.95 to \$1250. The Stratosphere model L2894HU, (shown) is a 27-inch TV console with an AM-FM radio and a high-fidelity Cobra-Matic record player. This unit carries the \$1250 suggested retail price. For further details of Zenith line, see Mart, section 2. Zenith Radio Corp., 6001 W. Dickens Ave., Chicago 39.—TELEVISION RETAILING.

Admiral TV AND RADIOS

Eighteen TV models and six radios, including a 15-tube Hi-Fi AM-FM radio-phono have been announced by Admiral. Two 27-inch and three 24-inch consoles, one 17-inch table model and four 21-inch table models, five 21-inch consoles and three 21-inch combina-



tions comprise the latest Admiral units. Model T2232, a 21-inch table model with optional wrought iron stand is shown. Two table radios, two clock-radios, a table radio-phono and the Hi-Fi combination are included in the radio line. (See Mart, section 2) Admiral Corp., 3800 Cortland St., Chicago 47.—TELEVISION RETAILING.

RCA Victor "ROTOMATIC" TV LINE

The "Rotomatic" TV line exploits the advantages of fully automatic tuning, according to the manufacturer. The

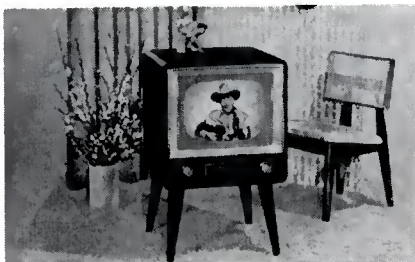

automatic tuner, the KRK-12 "clicks" a station into position and has extreme sensitivity and picture clarity in strong signal and fringe areas. Tube sizes in this line are 17-, 21- and 27-inch. Cabinets are of modern, contemporary and period design. Suggested retail prices range from \$199.95 to \$750. The Bristol, model 17S-351 (shown) is available in mahogany at suggested list price of \$229.95 or blond at \$239.95. (See Mart Section for further details). RCA Victor Div., Radio Corp. of America, Camden, N. J.—TELEVISION RETAILING.

River Edge HI-FI CABINETS

River Edge has a complete new line of "care-constructed" cabinets engineered for high fidelity acoustical per-

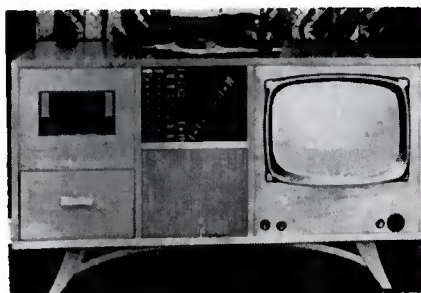

formance, according to the manufacturer. River Edge Industries, 5 River Edge Rd., River Edge, N. J.—TELEVISION RETAILING.

Magnavox NEW SETS

A new line of 24-inch and 27-inch television consoles include at least ten watts of power and two large speakers mounted coaxially in the cabinet. The 24-inch models are priced at \$475 and \$495. Full door 27-inch lists at \$695 and open face 27-inch console at \$595. Also new are a radio-phono combination, a console phono and a table model phono. Prices range from \$99.50 for table model phono to \$495 for deluxe radio-phono. Magnavox Co., Ft. Wayne 4, Ind.—TELEVISION RETAILING.

Stewart-Warner TV SETS

Half of the thirty-four new TV models feature a new automatic, all-wave, single knob tuner, capable of receiving all of the 70 UHF channels and 12 VHF channels now authorized by the FCC. Sets range in price from \$229.95 to \$565 and in screen size from 21 to 27



inches. (See Mart, section 2.) Stewart-Warner Corp., 1826 Diversey Parkway, Chicago 14, Illinois.—TELEVISION RETAILING.

Crosley 1954 TV LINE

Twelve custom and eight deluxe sets, ranging from table models to TV-radio-phono combinations are offered in the 17 and 21-inch screen sizes. Sets are designed in modern or traditional styling in mahogany or limed oak finish with VHF or UHF coverage. Prices range from \$189.95 to \$595. The six 24-inch receivers include two TV-radio-phono combinations, two full-door consoles and two open-face consoles. Prices range from \$575 to \$725.



Also included in the Crosley line are four 27-inch sets. Two of these models are open-face consoles and the other two are three-way combinations. Prices range from \$595 to around \$1000. (See Mart, section 2) Crosley Div., Avco Mfg. Corp., 1329 Arlington, Cincinnati 25.—TELEVISION RETAILING.

Distributor Sales Manager



Maury R. Jungman (above) succeeds Jerome Berger as distributor sales manager for the Brach Division of General Bronze Corp. Jungman will have charge of an expanded jobber program. Berger has transferred to national accounts television sales manager.

JFD Offers Flasher Display

JFD Mfg. Co., Brooklyn, N.Y., is making available to dealers a flash-a-light display designed to help sell Tele-Plex set couplers as well as second, third and fourth TV sets. Pamphlets and a stock of couplers are supplied with the display unit.

Gross Corp. Forms Subsidiary

Gross Distributing Corp., East Orange, N.J., announces the formation of a subsidiary firm, Gross Service, Inc., to function as a unit in its enlarging scope of activities in engineering, installation, service and parts merchandising. Officers of the new firm, which is located at 57 N. Clinton St., East Orange, are A. P. Hummers, president; Benjamin Gross, vice-president; and Robert A. Gross, secretary-treasurer.

NSEC Hears Motorola Exec

The recent National Sales Executives Convention, held in Atlantic City, N.J., had as one of its main speakers Edward E. Taylor, vice-president of Motorola, Inc. In his topic, "New Techniques in Holding Sales Meetings," Taylor urged more serious, informal and economical types of meetings as opposed to the overdone "razzle-dazzle" kind which have "gone about as far as good judgment allows."

Channel Master TV Spots

Channel Master Corp., Ellenville, N.Y., has prepared six 90-second-long TV spot commercials for use by its dealers and distributors. Each film provides "space" for the local advertiser to insert his own name and message. The company's advertising material also includes displays, decals and streamers, all of which have been combined in special kits.

RCA Victor Hikes Two Execs

Election of W. Walter Watts as vice-president in charge of technical products, and of Theodore A. Smith as vice-president in charge of the Engineering Products Department, were made known recently by the RCA Victor Division, Radio Corp. of America.

Don Good Names Sales Reps

Don Good, Inc., South Pasadena, Calif. manufacturer of TV leadlines, has appointed these factory sales reps: Kenneth L. Brown, for the New England states, and W. J. Doyle Co., Chicago, for Illinois, Wisconsin.

Gets Crosley Radio Post

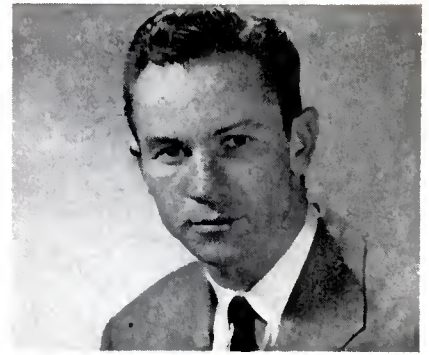

C. F. McGraw (above) has been appointed product sales manager for radio of the Crosley Division, Avco Manufacturing Corp., it is announced.

27" Custom Built Television at Volume Prices!



The illustrated 27" open-face console is an example of our quality merchandise.

Stratford TELEVISION

You can have a 27" custom-built television set at a price which will really make profits.

Included are these features:

- Consoles in 27" and 24" with rectangular tubes
- Finished in mahogany or limed oak
- Table models and consoles in 17", 20", 21"
- Standard RTMA requirements
- All the exclusive features you find in most expensive sets
- Adaptable to UHF
- From factory to you . . . write for your deal today

Large merchandisers are invited to write for particulars on private label sets.

Illustrated literature is available upon request.



A few choice territories are available for experienced representatives with dealer following.

2555 West 21st Street
Chicago 8, Illinois
CUSTOM BUILT TELEVISION

Sylvania Introduces 42 New TV Models

The Radio and TV Division of Sylvania Electric Products, Inc. has introduced 42 new 1954 TV models. Prices of these models range from \$189.95 for a 17-inch table model to \$899.95 for a 27-inch console with doors, (shown). Chairside control in the 27-inch set houses a three-speed phonograph and an AM-FM radio. Distributors were shown, for the first time, Sylvania's pilot color television console. John K. McDonough, general manager of Sylvania's Radio and TV Division, stated that, although the approval of compatible color by the FCC is expected, the strong possibility exists that small-screen color receivers will cost up to three times as much as today's 21-inch black and white picture sets. He asserted that when color television is ready, Sylvania will certainly have it. All of Sylvania's cabinets are of contemporary styling. New Photo Power chassis is "engineered to provide the finest UHF or VHF reception in any location." Built-in one-knob all-channel UHF-VHF tuner is optional on all new 1954 Sylvania models. A radio-clock, the "Nightlighter," has a dial face made of an electric light compressed almost to paper thinness between two thin sheets of glass. (See MART, Section 2, for complete listing.)

Canadian TV Boom Seen

Sales of TV receivers in Canada will be at least twice as great in 1953 as they were last year, Dr. Courtney Pitt, vice-president for finance, Philco Corp., predicted at the recent ground-breaking ceremony for a new Philco manufacturing plant in Toronto. The 80,000 sq. ft. plant will be occupied early next year, Pitt believed. He pointed out that 137,000 sets were sold in Canada during 1952, and this year, manufacturers plan to produce and sell 350,000 receivers.

Berti Joins Stewart-Warner

The recent appointment of Henry A. Berti as resident field engineer covering the Midwest, has been announced by the radio, TV and electronics products division of Stewart-Warner Corp.

RCA Victor Offers Service Kits

A compact carrying case designed to accommodate parts, tools and test equipment required by TV technicians on house calls has been produced for the tube department of RCA Victor. The "Servi-chest" kit is offered to dealers with the purchase of 750 RCA receiving tubes or 30 TV picture tubes.

GE Managership to Weathers

Edward B. Weathers has been named manager of the Chicago district of the General Electric Co.'s Major Appliance Division, succeeding Joseph S. Strecker, who was named manager of the recently established central region.



Above is the Hampshire, new 27" TV set which is part of Sylvania's '54 line. Nicknamed the "Chairside Theatre," the set is controlled completely from an end table located at the side of a sofa or chair across the room from the television set. Matching end table also houses 3-speed record changer plus AM-FM radio. The Hampshire is available in either mahogany or blonde korina.

Arvin to Wholesale Supply

Arvin Industries, Inc., according to Paul W. Tanner, general sales manager, has named Wholesale Supply, Inc., Little Rock, Ark., as Arvin distributors for that area, handling the radio and television products of the company.

Raytheon Names Union Supply

William J. Helt, general sales manager of Raytheon Television and Radio Corp., Chicago, has announced the appointment of Union Supply Company, Inc., Davenport, Iowa, as distributors serving Eastern Iowa and Western Illinois.

Emerson Signs St. Louis Firm

Latest distributor appointment by Emerson Radio & Phonograph Corp. is that of the Wm. M. Wider Distributing Co., Inc., St. Louis. The firm's area includes that city's metropolitan section, eastern Missouri and southern Illinois.

To Handle Du Mont in Maine

Rice and Miller Co., Bangor, Me., has been appointed distributor for Du Mont TV receivers, according to Allen B. Du Mont Laboratories, Inc. The franchise will cover both the central and eastern Maine areas. James White is president of the Bangor company.

Polio Victim Operates TV Set by "Breathing" Device

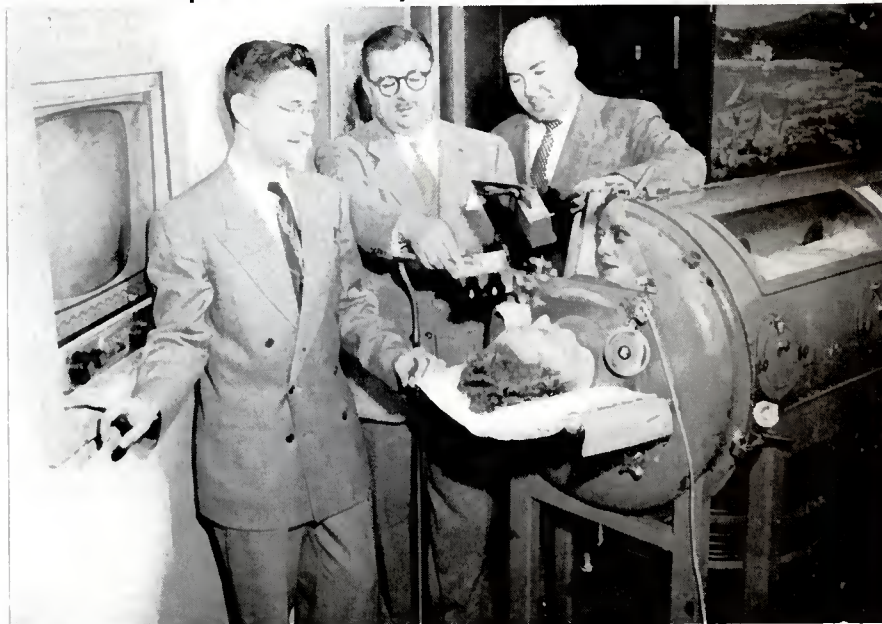

By puffing lightly into the mouthpiece of a "breath-controlled" device, Mrs. Mary Kitsmiller, polio victim confined to an iron lung, is able to change stations and turn the sound off and on in her Lion Mfg. Corp. remote control TV set. Shown with Mrs. Kitsmiller in her Park Ridge, Ill. home are three Lion Co. members, Wilbur Hample, Paul H. Eckstein, and Charles Troeller. They developed the device, the only one of its kind in the country. The mouthpiece is used to funnel the stream of air into the unit and against a delicately balanced vane. When the vane moves, it actuates a cam-operated switch. When the switch contacts close, a relay is energized. The relay, in turn, activates the station-changing mechanism on the Lion TV set. The one mouthpiece enables Mrs. Kitsmiller to change stations, while the other turns the speaker on and off. The entire unit is approximately 2 by 2 by 4 inches in size.

\$24⁹⁵
VALUE
 for only \$5.00
 and 30 Sylvania
 Premium Tokens . . .

*You get
 both chest
 and parts tray*

Between Aug. 1st and Nov. 15th

Servicemen! Here's Your Sylvania

T-N-T CHEST

(TUBE AND TOOL)

The Most Valuable Service Aid You've Ever Seen!

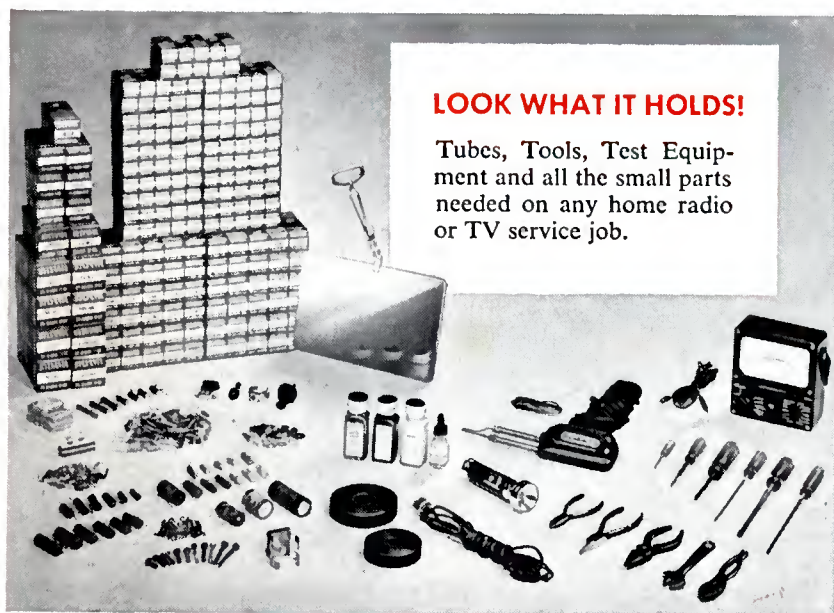

LOOK WHAT IT HOLDS!

Tubes, Tools, Test Equipment and all the small parts needed on any home radio or TV service job.

Talk about a useful servicing aid . . . this Sylvania T-N-T (Tube and Tool) Chest is really it! Carries more tubes, tools and parts than any chest on the market!

LOOK AT THESE FEATURES:

- Bass and fir plywood case
- Waterproof Du Pont Fabrikoid cover
- Holds 187 receiving tubes
- Lightweight folding aluminum tool and parts tray
- Unbreakable plastic handle
- Brass-plated hardware
- Room for mirror and ohmmeter
- It's a complete, portable service shop!

ACT NOW . . . Offer Limited!

This chest is now yours for only \$5.00 and 30 Sylvania Premium Tokens. Offer good only between August 1st and November 15th. See your Sylvania Distributor who has these kits now.

SYLVANIA

Sylvania Electric Products Inc., 1740 Broadway, New York 19, N. Y.

LIGHTING • RADIO • ELECTRONICS • TELEVISION

In Canada: Sylvania Electric (Canada) Ltd.
 University Tower Building, St. Catherine St., Montreal, P. Q.

Remember, you get 1 Sylvania Premium Token with every 25 receiving tubes or with every picture tube you buy.

Zenith Honors Distributors for Their Long Service



Seven Zenith Radio Corp. distributors were honored at the company's recent sales convention for their length of service. Sam Kaplan, vice-president and treasurer (far right in photo) made presentations. Recipients are (l to r): J. L. Pleasants, J. D. Cohon, Thad Gordon (15-year-men); R. J. Mallhouse, D. M. Giltinan, S. A. Crysler, and A. H. Rodefild (20-year-men). The men received plaques and lapel pins for personal wear.

THE HIT LINE OF THE CHICAGO MUSIC SHOW!

Selling Features Galore for '54!



PORTABLE RECORD PLAYERS AND RADIO-PHONO COMBINATIONS

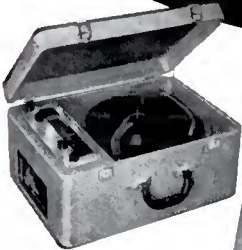

- SINGLE SPEED MODELS
- 3-SPEED MODELS
- 3-SPEED AUTOMATIC MODELS
- 3-SPEED AUTOMATIC RADIO-PHONO COMBINATIONS
- TRANSCRIPTION-DEMONSTRATORS

DISTRIBUTORS! Limited number of profitable territories available to established distributors. Your territory may be open!

DEALERS! Write, Wire or Phone direct to factory for full particulars!

Distributors, Buyers and Dealers Acclaim the First Showing of the New 1954 Symphonic Line!

They had a front row seat! They compared Symphonic with every other line displayed at the Music Show! Everyone agreed that Symphonic for '54 offered the greatest opportunity to increase sales and profits. You too will agree when you see Symphonic's exciting new styling, thrilling new performance and sensational new values, that it will increase your sales and profits. Symphonic's new 1954 full colored line broadside is just off the press . . . see your distributor or write direct to factory for your copy and complete dealer information.

SYMPHONIC RADIO & ELECTRONIC CORP.

Main Plant: 160 North Washington Street, Boston 14, Mass.

N. Y. Sales Offices: 250 West 57th St., New York 19, N.Y.

Dr. Lazier Joins Sprague

Sprague Electric Co., North Adams, Mass., has announced the appointment of Dr. Wilbur A. Lazier as vice-president and technical director in charge of the company's research and engineering. It was also made known that Neal W. Welch becomes vice-president for sales, and Paul J. Crittenden and Hollis R. Wagstaff are to be assistant treasurers. Preston Robinson, former head of research and engineering, and a board member, will continue to serve as a consulting engineer.

New York "Reps" Play Golf

Among those attending the recent golf outing held by the New York Chapter of "The Representatives" at the White Beeches Golf & Country Club in Haworth, N.J. were Bob Breuer, Jules Bressler, Barrett Border, Bill Hicks, Wally Shulan, Mike Woolf, Bill Gold, John Kopple, Frank Brennan, F. Boeck, B. Forrest, S. Diamond and P. Leighton.

"Fargo TV Towers" Marketed

Fargo Mfg. Co., Fargo, N.D., recently announced that its "Fargo TV Tower" is in production for national distribution. Unit incorporates five sizes in one unit.

TV Servicemen Fare Well In Survey Made for RCA

A recent survey made for RCA Victor Division of Radio Corp. of America by Elmo Roper, noted researcher, revealed an even higher public regard for TV technicians than was shown in a similar survey taken by Roper last year. The great majority of the five million families interviewed found servicemen competent, courteous, prompt and fair and reasonable in charges, said RCA.

Webcor Book for Distributors

A giant 11- by 14-in., 280-page book, *Marketing Webcor Products*, has been collated and published especially for its distributors and their salesmen, the Webster-Chicago Corp. announces. The handsomely-printed volume contains more than 300 articles which have been culled from leading trade and professional magazines as well as from lectures and meetings. Each article, replete with marginal notes, has been analyzed in terms of what it means specifically when related to Webcor products. Copies are \$10 each.

iE Co. Expands Facilities

An extensive expansion and modernization program is underway at the iE Mfg. Co., Chicago, one which, when completed next year, will increase the plant area to nearly 100,000 sq. ft., or double the present space. The firm produces TV mounts, hardware and accessories, all of which are described in a new catalog, number 16, just released.

Mitchell Franchises Five

Among those recently awarded franchises to handle Mitchell Mfg. Co.'s 1953 line of window-type room air conditioners are Cranshaw-Blaine, Inc., Memphis; Schiffer Distributing Co., Atlanta; Catlett-Johnson Corp., Richmond, Va.; Emerson-Long Island, Inc., Mineola, N. Y.; and Emerson-Mid State, Inc., Newburgh, N. Y.

L F & C Appoints Three

Three new appointments to the home cleaning equipment division of Landers, Frary & Clark, New Britain, Conn., have been announced by Lee Moss, division sales manager. They are Morris J. Stone, district manager for Kansas, Missouri and Nebraska; Roland J. Amelotte, assistant district manager, New England; and James O'Kane, Jr., Chicago sales representative.

Whirlpool Adds Distributors

According to John M. Crouse, sales manager, the Whirlpool Corp. has appointed five new distributors. They are Pearce & Johnson Co., Jacksonville, Fla.; Roskin Distributors, Inc., East Hartford, Conn.; Roskin Bros., Inc., Albany, N. Y.; Burden-Bryant Co., Springfield, Mass.; and Onthank Davidson Co., Davenport, Iowa.

Joins CBS-Columbia Branch



Harry Schechter (above) is newly appointed as general manager of CBS-Columbia Distributors, Inc., New York factory branch. He has a background of 23 years in the radio industry, the last nine of which were spent with Motorola, New York.

C-D Plant Nears Completion

Cornell-Dubilier Electric Corp.'s new capacitor manufacturing plant, being built at Sanford, N.C., is nearing completion. After months of intensive personnel training, production has already begun on paper tubular and electrolytic type capacitors at the new site.

New Hammarlund Rep

E. B. Schwerin has been appointed representative for the Kansas City area for the Hammarlund Mfg. Co., Inc., New York.

Snow in Florida for Du Mont!

M. D. Snow has been named general manager of Allen B. Du Mont Laboratories, Inc., receiver division Florida factory distributing branch.

GE Names Reik

Donald G. Reik has been appointed a district sales manager for General Electric replacement sales, Tube Department. Reik's headquarters will be in Washington, D.C., and his territory will include the Baltimore, Norfolk, Richmond, Roanoke and Washington wholesale trading areas.

20,000 to See Audio Fair

Over 20,000 people are expected to attend the 1953 Audio Fair at Manhattan's New Yorker Hotel, October 14-17, according to Harry Reizes, Fair manager. To date, more than 100 major manufacturers of hi-fi equipment have engaged display space.

Raytheon Coast Franchise

The Television and Radio Division of Raytheon Mfg. Co. has announced the appointment of Graybar Electric Co., Inc., San Diego, Calif., as its distributor of TV sets there.

NOW...

a three-speed phonomotor designed for

HIGH-FIDELITY REPRODUCTION...

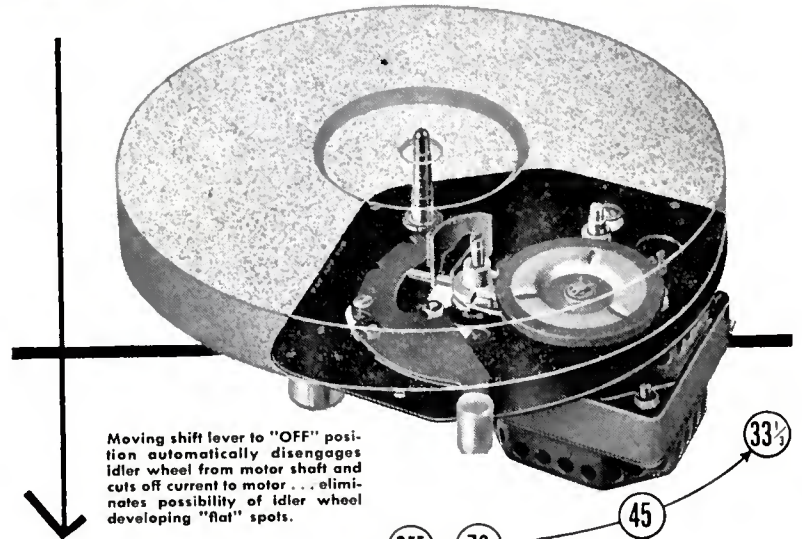

General Industries

MODEL DSS (4-pole) PHONOMOTOR

Here's a three-speed phonomotor that was designed expressly to meet the requirements of high-fidelity reproduction. From its dependable, heavy-duty 4-pole motor to its unique step-shaft speed change mechanism, this new GI Model DSS Phonomotor represents the ultimate in phonomotor engineering, design and construction.

Specifications, quantity price quotations on this or its companion, the new Model SS, with 2-pole motor, will be furnished promptly upon request.



THE GENERAL INDUSTRIES CO.
DEPARTMENT MD • ELYRIA, OHIO

NATESA Convention Dates Set

The annual Fall convention of the National Alliance of Television and Electronic Service Assns. will be held at the Morrison Hotel, Chicago, October 9-11, with TISA-Illinois as host. A large attendance is expected.

"The Reps" Now 612 Strong

With the addition of 16 new senior members and 28 associate members in recent months, the membership of "The Representatives" national organization now stands at an all-time high of 612, according to George Pettitt, newly elected treasurer.

Assn. Reps to Attend Meeting

Some thirty representatives of the five trade associations which co-sponsor the annual Electronic Parts Show are expected to attend the annual board meeting of the Radio Parts & Electronic Equipment Shows, to be held at Dixville Notch, N. H., August 10-12.

Sylvania Advances Bowser

Aaron F. Bowser has been promoted to district sales manager by Sylvania Electric Corp. With the company for over six years, Bowser's new territory will include cities in New York State and Pennsylvania.

New Pix Tube for Zenith Line

A Cinebeam picture tube with a reflector that acts like built-in mirrors to produce fine-grained pictures is now featured in 20 TV receivers in the 1954 line of Zenith Radio Corp. The tube is produced by Rauland Corp., a Zenith wholly-owned subsidiary.

Arvin's Pre-Christmas Bonus



Timed to stimulate autumn gift-buying, Arvin Industries is offering this convertible Tray-Table with the purchase of either an Automatic Coffee Perk or Letric Cook. Slight pressure on the handles converts unit from a tray to a smart 16-in.-high table. With the appliance, the tray costs customer \$1.50, or \$31.45 complete.

Duotone Offers Needle Kit

An inspection kit which allows a dealer to examine needles without removing them from the cartridge has been prepared by the Duotone Co., Inc., Keyport, N. J. Kit includes a high-powered microscope, electro-wipe cloth, a needle-replacing tool and a plastic container for these items. Kit is offered free with a \$12.50 needle purchase.

S-C Names Ulrich as Rep

The radio-television division of Stromberg-Carlson Co. has appointed Ludwig J. Ulrich, Jr. as sales representative in northwestern Pennsylvania and nearby New York counties.

Martin Bettan Heads AMA



Recently elected as president of the Antenna Manufacturers Assn. is Martin Bettan (above), director of sales and engineering for Radio Merchandise Sales, Inc., and noted lecturer. Other new officials are Ben Snyder, Snyder Mfg. Co., vice-president; and Edward Finkel, JFD Mfg. Co., who will serve as secretary-treasurer.

New Exciting

ENGINEERING ACHIEVEMENT

DYNAVOX

3-D in Sound 3-SPEED AUTOMATIC PORTABLE PHONOGRAPHS

With the new DYNAVOX diatonic amplifier—*sound qualities never before achieved in a portable phonograph.*

Model 504 (open & closed)

Here's the greatest value in a hi-fi quality 3-speed portable automatic ever developed by modern engineering—*third dimension in sound!* Unusual depth—dulcet tones—fine timbre, it's the finest sounding portable you've ever sold.

Plays all size records of every make in all three speeds, with lid closed. Deluxe VM changer with automatic stop, floating light-weight pickup arm, turnover cartridge with two osmium point styli.

additional features:

Powerfully engineered DYNAVOX diatonic 4-tube, push-pull, high-gain amplifier with hi-fi quality. Heavy-duty 8" PM Alnico V speaker with 3.16 oz. magnet.

Luxurious cabinet—with split-lid styling—is made of solid wood with locked corners, covered in two-tone duPont leatherette pyroxilin coated to repel water, trimmed in contrasting plastic beading, matching handle and brass plated teardrop hinges and catches.

PORTABLE AUTOMATIC RADIO-PHONO COMBINATION

Model 402C An elaborate radio-phonograph combination—VM changer plays all size records in all three speeds with lid closed. Reversible cartridge with two permanent needles. RADIO is a 5-tube superhet. with two IF transformers, built-in loop antenna, large slide-rule dial. Magnificently covered with duPont leatherette.

3-SPEED PORTABLE

Model 306 Features a 5" PM speaker in front, outside grille backed with acoustic baffle for extra tonal quality. Luxurious, compact carrying case has locked corners, covered in duPont leatherette pyroxilin coated to repel water, trimmed with complementary beading. Plays all size records in all three speeds, hi-fi twist crystal pick-up, hi-gain amplifier with variable volume and tone controls.

DYNAVOX has 24 new models for 1953-54.

Write for
NEW
CATALOG!

DYNAVOX CORPORATION

40-05 21st Street, Long Island City 1, N. Y.

LARGEST MANUFACTURERS OF QUALITY PHONOGRAPHS AND RADIO-PHONO COMBINATIONS SINCE 1936

GE Gears Big Fall Plans

The General Electric Company radio and television department is slanting its fall production, advertising and promotion plans to what it expects to be one of the most satisfactory years in radio-TV history. Twenty-nine TV receiver models were put on display at the Midwestern Furniture Market in Chicago. Emphasis for '54 will be geared to a completely new styled line at competitive prices. Numerous dealer aids and interesting promotions are planned. Twenty-four radio models have also been unveiled. The GE radio line, according to E. F. Peterson, marketing manager for the radio-TV department, is the most complete in company history. He pointed out that a radio designed for every room in the house is the basis for GE's 1954 line.

In Crosley Radio-TV Post

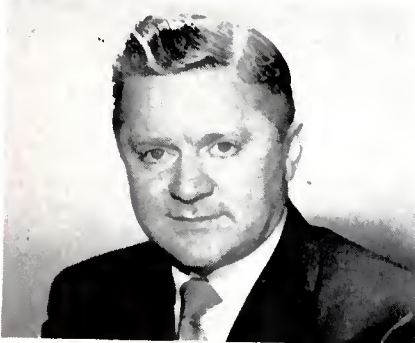

Harry E. McCullough (above) has been made general sales manager for TV and radio, the Crosley Division, Avco Mfg. Corp. announces. He succeeds E. W. Gaughan, who joins Division Sales.

Graybar Opens New Branch

The 111th branch office of Graybar Electric Co., Inc., has been opened in Green Bay, Wis.

Kaye-Halbert Sets Franchises

Kaye-Halbert Corp., California TV manufacturer, put its Gold Seal franchise program into effect in San Diego, Sacramento, Fresno and Los Angeles. The plan includes a Fair Trade price agreement to which each selected dealer must subscribe. As soon as applications from other areas can be processed, more franchises will be awarded, the company says.

Radio-TV Service Records

To aid the serviceman in keeping an accurate account of the work he performs on a radio or TV set, Service Records Co., Mattituck, N.Y., has devised a simplified card form, part of which also serves as the customer's claim check. The parts cards are priced at \$3.95 per thousand, together with 1,000 time cards and full instructions for their use.

Main Joins Viking Division

Robert V. Main has joined the Blower Division of Viking Air Conditioning Corp., Cleveland, as sales manager, according to Frank Gibbons, general sales manager.

RCA Victor Promotes Dittman

George E. Dittman, pioneer field sales rep, has been appointed manager of the east central renewal sales district of the Tube Department, RCA Victor Division. He succeeds J. J. Kearney, who is now product sales manager for RCA batteries.

Motorola Opens Parts Depot

Motorola Communications and Electronics Inc. has established a regional parts depot in Dallas, Tex., one which is an integral part of the southwestern regional sales office.

For Ease in Stock Moving

A combination steel hand truck and step ladder, the Step-Truk, has been designed by the Fairbanks Co., New York, to aid dealers and wholesalers in moving and storing stock. The device can also be used for maintenance work in stores and warehouses.

New, Improved

DAVIS SUPER-VISION ALL-CHANNEL TELEVISION ANTENNA

**WIND-TESTED
and WEATHERIZED**

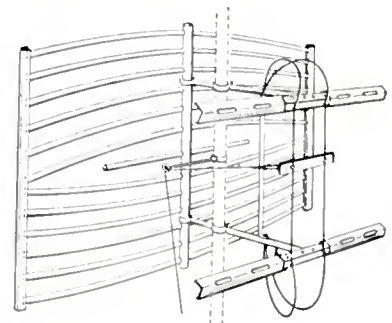

UNBEATABLE FOR FRINGE AREA OR DX

1. EXCELLENT FOR FRINGE AREA and DX RECEIVING—and broad band receiving with high gain on all channels—2 through 13.
2. CLEARER PICTURES UP TO 125 MILES OR MORE—from the station.
3. GHOST PROBLEMS REDUCED or eliminated due to excellent pattern.
4. PROVIDES 10 DB OR MORE GAIN ON HIGH CHANNELS where gain is needed most.
5. EXCELLENT FRONT TO BACK RATIO on all channels. No co-channel interference.
6. MINIMIZES INTERFERENCE: Airplane Flutter — Diathermy and Ignition — F. M. — Neon Signs — X-Ray — industrial — Etc.
7. ELIMINATES DOUBLE STACKED ARRAYS, and out-performs 2 bay yagis on low band and 4 bay yagis on high channels.
8. ONLY ONE TRANSMISSION LINE NECESSARY.
9. NO WORRY OVER POSSIBLE CHANNEL CHANGES on either high or low channels.
10. CAN BE TIPPED WITHOUT TILTING MAST to take advantage of horizontal wave lengths.
11. Can be used with ANTENNA ROTOR

\$34.95

"THE ORIGINAL ANTENNA SOLD WITH
A MONEY-BACK GUARANTEE"

**Brings in the Signals
STRONG and CLEAR
up to 125 Miles and More
Away from the Station**

WRITE FOR NEW BULLETIN—SV-7—
& TECHNICAL DATA SHEETS

ASK YOUR JOBBER —
"The Backbone Of Your Industry"
FOR COMPLETE INFORMATION

DAVIS ELECTRONICS
AMERICA'S FASTEST GROWING
ANTENNA MANUFACTURER
BOX 1247 BURBANK, CALIFORNIA

DAVIS ELECTRONICS	TR-3
BOX 1247, Burbank, California	
SIRS: RUSH INFORMATION TO ME AS CHECKED:	
<input type="checkbox"/>	Send Complete Information and Technical Data on New SUPER-VISION ANTENNA.
<input type="checkbox"/>	Send Name and Address of NEAREST JOBBER.
Name _____	
Street _____	
City _____ State _____	

the market:

TELEVISION, AUDIO, ELECTRONIC SERVICEMEN

the potential:

\$1,546,000,000 . . . 1,889,655,000 SOCKETS*
—and growing rapidly

the new magazine:

TECHNICIAN

Coming in September! — Pretested for 12 months as the Technician Circuit Digest Section of TELEVISION RETAILING! — Acclaimed by TV Electronic Servicemen!

WHY A NEW MAGAZINE FOR THE TV ELECTRONIC SERVICEMAN?

Today, the serviceman is part of a 1½-billion dollar industry, servicing 25-million television sets, 120-million radios, 1,889,655,000 sockets . . . to say nothing of the tremendous industrial electronic maintenance market. His investment in instruments, equipment, replacement parts, and special automobile trucks, ranks him dollar-wise with the top businessmen in his community. The serviceman's status grew rapidly with

television . . . will soon receive another fabulous boost from color TV.

But—color, Hi-Fi, UHF, all require technical servicing that would tax an engineering graduate. To keep abreast of developments, the serviceman *must* rely on a competent, up-to-the-minute technical publication. That's why TECHNICIAN will step into the picture in September.

HOW DOES TECHNICIAN SATISFY THE TV-ELECTRONIC SERVICEMAN'S NEEDS?

With the largest, experienced editorial staff, TECHNICIAN will enable the serviceman to keep step with new developments *as they occur*. It will supply him with a complete monthly package of technical, business, and equipment information—covering such important subjects as TV, home radio, auto radio, Hi-Fi, recorders, record changers, public

address, industrial electronic equipment, etc. In addition, the serviceman will receive the *exclusive* Circuit Digest—which give him schematics and explanatory facts about radio and television sets currently reaching the market. Demanded by TV-electronic servicemen, there's no other magazine like TECHNICIAN in the field.

And... TECHNICIAN IS YOUR BEST BET DOLLAR-WISE

TECHNICIAN boasts the lowest rate per thousand service outlets of any paper in the field. What's more, the publishers plan 50,000 service organizations to be reached by TECHNICIAN as of January 1, 1954. That's the largest audited service circulation of its kind that can be bought.

* "TECHNICIAN'S" REPLACEMENT MARKET AND INDEX, INCLUDING ESTIMATED SALES OF TUBES FOR 1953 AND 1954 . . .

	Active Tube-Sockets (Tubes in Use): Receiving Tubes. Units **	Sales of Receiving tubes, initial equipment and renewal		Sales of Picture Tubes, initial equipment and renewal		Receiving Tube and Picture Tube \$ volume retail
		Units	\$ volume retail	Units	\$ volume retail	
1952	1,216,617,000	368,500,000	\$ 775,000,000*	7,800,000	\$312,000,000	\$1,082,000,000
1953	1,458,622,000*	447,660,000*	895,000,000*	11,000,000*	440,000,000*	1,335,000,000*
1954	1,889,655,000*	513,169,000*	1,026,000,000*	13,000,000*	520,000,000*	1,546,000,000*

* Estimated.

** Number of sockets represents market factors for capacitors, coils, and hundreds of other parts and components.

The Greatest Service Feature Ever Published Anywhere—TECHNICIAN'S CIRCUIT DIGEST

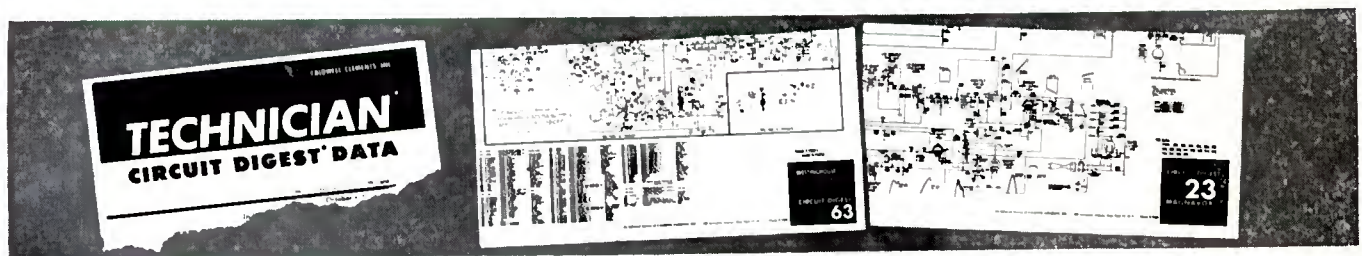

So . . . START YOUR SALES-BOOSTING CAMPAIGN IN THE FIRST ISSUE OF THIS GREAT NEW PUBLICATION. RESERVE SPACE TODAY!

CALDWELL-CLEMENTS, INC.
480 LEXINGTON AVENUE
NEW YORK 17, NEW YORK PLaza 9-7880

CHICAGO 6—201 N. Wells Street. RANDolph 6-9225
LOS ANGELES 5—Chris Dunkle & Associates, 3257 W. 6th St. DUnkirk 7-6149
SAN FRANCISCO 8—Chris Dunkle & Associates, 1355 Market St. KLondike 2-2311 ext. 579

Channel Master Display

A "silent salesman" in the form of a four-color counter display for its inter-action filters, has been made available by the Channel Master Corp., Ellenville, N.Y. Actual merchandise is mounted on the card. Unit measures 13- $\frac{3}{4}$ by 21- $\frac{1}{2}$ in.

Joins Crockett Rep Firm

Bruce E. Crockett has joined his brother, William, in the sales management of the Wisconsin district for the Mitchell Mfg. Co. The Crocketts handle Mitchell's air conditioning, radio-TV and commercial and industrial lighting accounts.

Sight-Sound Exposition Set

The International Sight and Sound Exposition, scheduled for Chicago's Palmer House, September 1-3, will occasion the first public showing of both audio and video products in the Midwest, ISSE officials said.

GE Surveys Radio-TV Dealers

In an effort to determine the business characteristics of the so-called average dealer, and thereby give the individual a "bench mark" by which he can better evaluate his own operation, General Electric Co.'s Tube Department has mailed 40,000 questionnaires to every major TV area in the country. Survey is the third such effort made by GE.

Threldkeld Joins Duckett

Julian Threldkeld will handle the state of Alabama for the Grady L. Duckett Sales Co., an organization which covers the electronic distributor markets in Southeastern states.

Du Mont Sets Maine Firm

Emery Waterhouse Co., Inc., Portland, Me., will distribute TV sets made by Allen B. Du Mont Laboratories. Franchise covers four Maine counties and all of New Hampshire.

Videon UHF Converter

Videon Electronic Corp. announces a new all-channel UHF converter featuring single-knob tuning over the UHF band, and covering channels 14 through 83. Self powered, it is factory-adjusted to operate on channel 5 or 6. Pressed steel cabinet is coated with maroon enamel and the gray plastic tuning knobs are centered with gold color metal inserts. Lists at \$39.50.

To Handle CBS TV and Radio

Pugh Furniture Co., Charleston, West Virginia, has been selected to distribute CBS-Columbia TV and radio receivers.



sell this one
for **PROFIT**
and
CUSTOMER
SATISFACTION

the precision engineered

PRESTO 15-G

turntable

designed and manufactured by
the world's largest producer
of professional tape and disc
recording equipment.

- Heavy, cast aluminum 12" table
- Precision, constant speed motor
- Instant 3-speed selection
- Quiet, rumble-free performance

Retails at \$53.50 (chassis only)

Write for
dealer arrangements
and attractive
counter display

PRESTO
RECORDING CORPORATION
PARAMUS, NEW JERSEY

First Choice

OF TV MANUFACTURERS, DEALERS, BUYERS

Better Built, Smarter Styled, Greater Value

RIDGEWAY TV BASES

The Chicago Music Show was the Acid Test. Every TV Table and Base Line was Displayed and Judged Accordingly. As in Years Before, Ridgeway's Smarter New Styling, Quality Construction and Opportunity for Greater Profits Were the Reasons why Manufacturers, Distributors, Dealers and Buyers Selected Ridgeway TV Bases as the Line to Feature.

Manufacturers! Distributors! Dealers! Write for information about America's finest styled TV furniture!

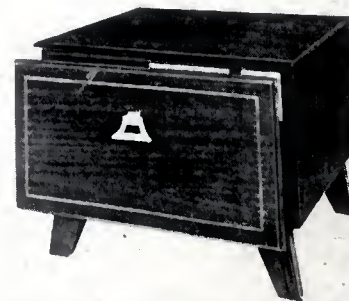

New York Sales Offices, TV Furniture

LOUIS R. GOLDMAN & CO.

251 West 42nd St., New York 36, N. Y.

Low-Saturation

(Continued from page 49)

hold that trust—the dealer *must know his product!* This means the services it will and will not perform. It means the physical aspects of the product and the care of the appliance. He must know how it performs its intended service and be able to teach the proper use of the product.

Actually, this product knowledge isn't too much of a problem. The dealer has manufacturer-supplied manuals and use literature, the services of his factory field man, the wholesale salesman, the factory or distributor, home economist dept., the utility home service facilities and the factory or distributor service department. Most important, the dealer can gain tremendous know-how by setting up actual installations in his own store and using them also as selling and demonstration displays.

Especially on low-saturation appliances, it is imperative that a call-back be made shortly after each installation—even if no service call has come in. The dealer can (1) learn good points about his own product and its installation; (2) learn any flaws and correct them promptly (thus he may avoid similar problems again); (3) instruct the customer on proper usage; (4) build his own reputation for genuine service to his customers; and (5) broaden his own avenue to further sales to the customer or to her friends.

The profit is sufficient on most low-saturation appliances to devote the time necessary for such an operation. Most of these items enjoy healthy discounts, little competition and practically no trade-in problems.

If a dealer wants to make a quick check on his profit-per-unit experience to date he can get a good comparison between clothes dryers and ranges. The average retail prices are nearly the same—unless the individual dealer leans heavily to either high-end or low-end merchandise in his particular operation. Assuming the dealer is average, however, he can quickly figure his cost-per-unit on both dryers and ranges which he has sold during a given period.

To arrive at a net selling price, the dealer can deduct any trade-in allowances. Also, he should deduct any estimated charge-free installation costs. When these figures are averaged, the dealer should get a good rough idea of his profit-per-unit, aside from sales and service costs. If the dealer expects any net recovery on units taken in trade he must esti-

mate these amounts, too, and credit to the proper sales. Some dealers have experienced pleasant surprises by applying such a simple yardstick against their low-saturation appliance sales. This is no pattern for dollar volume, of course—but only for a profit-per-unit pattern.

But the best part of the whole deal—as our distributor friend pointed out—is that the dealer's business on high-saturation appliances improves almost in direct ratio to his efforts on low-saturation items.

Air Conditioner Distributors

The following firms will distribute Quiet-Kool room air conditioners in the metropolitan areas of New York, New Jersey and Pennsylvania: General Electric Supply Co. of N. Y.; General Electric Supply Co. of N. J.; General Electric Supply Co. of Philadelphia; and Melchor Armstrong & Desauer, Ridgefield, N. J. The units are made by the Quiet-Heet Mfg. Corp.

Dickinson to Sylvania Post

Charles A. Dickinson has been named to the position of district sales manager for the Sylvania Electric Corp.'s Radio and Television Div. He will cover Washington, Montana, Oregon and Alaska.

Ampro Sets Division Post

William L. Haas has been appointed central division manager for Ampro Corp., tape recorder manufacturers. Haas will cover Ohio, Indiana, Michigan, Pittsburgh, Pa., western Pennsylvania, northern Kentucky.

Western Distrib for Emerson

Keefe Auto Supply Co., Billings, Mont., has been named distributor for Emerson Radio and Phonograph Corp.'s TV and radio lines. Firm will cover Montana and the northern Wyoming territory.

McGranaghan in GE Post

John C. McGranaghan has been appointed a district sales manager for General Electric replacement tube sales with headquarters in St. Louis. His newly-formed territory includes parts of Missouri, Illinois, Indiana, Kentucky, Tennessee, Mississippi and Arkansas.

RCA Victor Promotes Duncan

A. Cameron Duncan, a veteran of 17 years with the company, has recently been made manager of merchandise operations for the Home Instrument Department, RCA Victor Division, Radio Corp. of America. Joseph J. Kearney succeeds to the post vacated by Duncan.

Mass. Firm Reprs Rauland

W. B. Pray Sales Co., Wellesley Hills, Mass., has been named New England representative for the Rauland Corp., producers of TV tubes.

Kaplan Joins CBS Branch

Ben Z. Kaplan has resigned a similar position at I. T. & T. Distributing Corp. to accept the post of advertising and promotion manager of CBS-Columbia Distributors, Inc., New York factory branch of CBS-Columbia, Inc.

Wedel Co. Reprs Halldorson

The Frank Wedel Co., Seattle, will represent Halldorson Transformer Co., Chicago, in Washington, Oregon, western Idaho and western Montana.

Joins Emerson Sales Staff

Bodie L. Stahlschmidt has joined the field sales staff of Emerson Radio and Phonograph Corp. The regional salesman's territory includes Indiana, Kentucky and Kansas.

New Recording Reel Shown

A seven-inch plastic reel for use in magnetic recording, with diagonal "V" slots for faster threading and a larger hub for more constant tape speed, has been introduced by Minnesota Mining & Mfg. Co. It is said to be the first large-hub reel to accept all standard recording tapes, regardless of thickness.

New Videon Reprs

The following have been named to represent Videon Electronic Corp., manufacturers of boosters and UHF converters: H. G. Maerlander, Ohio; Earl Schenck, Kentucky; O. M. Williamson, Tennessee and Mississippi; Wm. G. Kelly, Missouri, Kansas, Iowa and Nebraska.

Home Is a Cool, Cool Place

The Clearwater, Fla. home of Dr. and Mrs. Franklin L. Hazelton is probably the coolest one in that state, opines Mitchell Mfg. Co., because it is equipped with four of the company's 1 H. P. window-type air conditioners. The units are placed in the kitchen, master bedroom and at each end of the living room.

Du Mont's 'Limed Oak' Story

Designed to serve as a string tag with its blond Telesets, a promotion piece titled "The Story of Limed Oak" is now being distributed by the receiver division of Allen B. Du Mont Laboratories, Inc. Printed in two colors, the pamphlet traces the development of limed oak as a modern furniture finish.

Presenting . . . at most moderate cost . . .

ESPEY

**25th Anniversary "Trophy" Models
AM-FM CHASSIS • TUNERS • AMPLIFIERS**



In commemoration of twenty-five years' experience in the manufacture and development of high-fidelity audio equipment, Espey is proud to present its distinguished "Trophy" models. Renowned for beauty of styling and excellence of performance, the new Espey models are so reasonably priced that for the first time magnificent listening pleasure is within the means of all lovers of fine audio reproduction.

Descriptive literature on the new Espey AM-FM chassis, tuners and amplifiers is now available . . . your inquiry is invited.

SYLVAN A. WOLIN & ASSOCIATES SALES CORP., 409 GRAND AVENUE, ENGLEWOOD, N. J.

Here's something new to SELL TV!

**No More
Blind Tuning!**

The first sensible, functional approach to a major TV problem

See what we mean at your distributor's early August showing of the Hallicrafters anniversary line for '54! It's the first visible, external design change to come to TV. You'll see it at a glance—know at a glance it's sales dynamite! Finally, here is a real reason for your customers to trade in their old sets. They'll see it—and THEY'LL BUY IT!

See the new Hallicrafters—SEE the DIFFERENCE!

hallicrafters 20th Anniversary

4401 West Fifth Avenue, Chicago 24, Illinois
Hallicrafters Ltd., 51 Camden Street, Toronto, Canada

TELEVISION RETAILING • August, 1953

Delight Customers with deliveries like this!



WEBB
WRAPABOUTS
FOR RADIO • TV PROTECTION

Deliver your TV and radio sets with the modern protection of Webb Wrapabouts . . . protective packages of strong, water-repellent canvas thickly padded to prevent scratching and to absorb damaging shocks and jars. Easy to slip on and off. Can be used repeatedly to cut your costs.

FOUR WRAPABOUT MODELS
fit all sizes of every make.

Write for details and prices

WEBB MANUFACTURING COMPANY
2920 N. 4th St., Philadelphia 33, Pa.

the
new
magazine for
TELEVISION-APPLIANCE RETAILERS

MART

a
new
way
to
a
\$8,756,000,000
market . . .

AN ESTIMATE OF THE MART MARKET AHEAD—

PRODUCT	Total Units in use 1/1/54	Percent Saturation 1/1/54	Estimated Units to be sold in 1954	1954 Sales— Estimated Retail \$ Value of Units
Television Receivers	28,000,000	63.6	7,000,000	\$1,960,000,000
Refrigerators	40,200,000	91.3	4,200,000	1,176,000,000
Washing Machines	34,000,000	77.3	4,000,000	720,000,000
Freezers	6,500,000	14.8	1,800,000	684,000,000
Radios	120,500,000	*98.0	11,900,000	570,000,000
Ranges, Electric	11,900,000	27.0	1,800,000	360,000,000
Room Air Conditioners	1,582,000	3.6	1,000,000	340,000,000
Vacuum Cleaners	28,700,000	65.2	3,200,000	256,000,000
Clothes Dryers	1,900,000	4.3	1,000,000	250,000,000
Water Heaters, Electric	6,400,000	14.5	1,000,000	128,000,000
Sewing Machines, Electric	18,000,000	41.0	1,600,000	176,000,000
Dishwashers	2,000,000	4.6	400,000	92,000,000
Ironers	4,600,000	10.4	320,000	54,000,000
Disposal Units	1,500,000	3.4	200,000	30,000,000
Housewares, Electric	—	—	—	960,000,000
Misc. (Supplies, bulbs, etc.)	—	—	—	1,000,000,000
TOTAL				\$8,756,000,000

*Two percent of electric customers without radio; but multiple-unit owners among 98.0% account for 120,500,000 units.

The above figures are simply estimates based on interviews with manufacturers and industry leaders.

And . . . MART is your best bet dollar-wise!

That's because: MART reaches more TV-appliance retailers than any other magazine in the field. MART reaches them at the lowest cost per thousand of any magazine in the field.

And MART is bound to be the preferred magazine of the TV-appliance dealer. The Price Mart feature (list prices, specifications of national lines) alone makes MART indispensable.

So . . . for the greatest retailer coverage, at the greatest economy, with a publication that's a retailer must—it's MART.

COMPARE!

	Cost per thousand retailers.*	Retailer Circulation
MART	\$20.97	31,000
Publication "B"	\$21.49	29,082
Publication "C"	\$25.65	26,896
Publication "D"	\$35.68	16,709

*based on the 12-time page rate

**EXCLUSIVE
FEATURE**



PRICE MART

Specs and list-prices
of national lines of
TV-sets and appliances

Caldwell-Clements, Inc. • 480 Lexington Avenue, New York 17, New York

TUNG-SOL statistical quality control methods produce the industry's most reliable tubes for all uses.

Tung-Sol makes: All-Glass Sealed Beam Lamps, Miniature Lamps, Signal Flashers, Picture Tubes, Radio, TV and Special Purpose Electron Tubes.

TUNG-SOL ELECTRIC INC.
Newark 4, N. J.

Sales Offices: Atlanta, Chicago, Culver City (Los Angeles), Dallas, Denver, Detroit, Newark

TUNG-SOL®
RADIO, TV TUBES, DIAL LAMPS

Gross Firm Names Burstein

Clarence Burstein has been named general manager of Gross Service, Inc., East Orange, N.J., the servicing unit of Gross Distributing Corp. He had been service manager for the latter organization.

Distrib Puts Shop on Wheels

The most recent concept of "bringing the merchandise to the retailer" is the "Sales-Mobile" adopted by Horn & Cox, Inc., southern California distributor. The firm has leased a 35-ft. semi-trailer and truck which is fitted as a mobile showroom. Major appliances, TV and electrical housewares are all stocked in the "store on wheels." The merchant, just by walking a few feet from his store, can view and order complete lines.

Rohn Adds 3 Sales Reps

Recently appointed as sales representatives for the Rohn Mfg. Co.'s TV towers and accessories are A. Sidney Hardy Assoc., Atlanta, for Georgia, Florida, Alabama, the Carolinas and Mississippi; Logan Sales Co., San Francisco, for northern California and Nevada; Edward Diamant, Cleveland, for Ohio, Pennsylvania, Maryland and West Virginia.

Gravely TV Furniture Shown

The initial showing of its 1954 line of TV furniture was held at the recent NAMM Music show, the Ridgeway, Va. Division of Gravely Novelty Furniture Co. reports. Line features solid top tables and bases; revolving tops and others.

14,000 to See Coast Show

An attendance of 14,000 is expected as the ninth annual Western Electronic Show and Convention gets underway August 19 at the Civic Auditorium, San Francisco. The products of 327 manufacturers will be on display.

Big Ad Support for RCA Victor's New TV Line

RCA Victor's new Rotomatic (rotary-plus-automatic) tuner TV line will be backed up with the largest, most comprehensive advertising and promotion campaign in the company's history, the Home Instrument Department says. In addition to radio and TV network programs, almost 200 newspapers and 16 magazines will be used to tell the story of the line. Cooperative programs are available to dealers and distributors.

Emerson Ups S. L. Abrams

Stanley L. Abrams, director of purchases for Emerson Radio and Phonograph Corp., has been promoted to director of the material division. In his newly created post, Abrams will supervise overall logistics.

Here's the new SHURE SLIM-X All-Purpose Crystal MICROPHONE



MODEL 777
List Price \$18.95
MODEL 777s
(with switch)
List Price \$20.95

(Price includes cradle for mounting on stand)

Its Versatility and "Hand-a-Bility" make it an ideal low-cost all-purpose microphone



LIGHT! The new "777" Slim-X Microphones are rugged little microphones weighing only 6 ounces! They are designed for good-quality voice and music reproduction. Their versatility and "hand-a-bility" make them ideal for use by lecturers, announcers, instructors, and Hams; for audience participation shows; carnivals; panel and quiz shows; and use with home-recorders. When mounted on either cradle or swivel, the "777" can be removed in a flash (no tools necessary)—simply by lifting it out of the holder. This makes it an ideal "walk-around" hand-held microphone.

TECHNICAL INFORMATION: Smooth frequency response—60 to 10,000 c.p.s.; special-sealed crystal element—for long operating life; high impedance; 7' single-conductor cable, disconnect type. Dimensions: (Microphone only) Length, 4½"; Diameter 1". *Finish:* Rich satin chrome overall.

NOTE: Lavalier cord for suspension of Microphone around neck is available. (optional).

ACCESSORIES FOR "777"

MODEL 538 STAND is a heavy die-cast base. Includes metal screw machine stud for connecting microphone adaptor to stand base.

List Price: \$3.00

MODEL A25 SWIVEL ADAPTOR features a long-life, high-quality swivel connector. Is lined with a long-life nylon sleeve—for noise-free and scratch-free insertion and removal of microphone.

List Price: \$5.00



SHURE BROTHERS, Inc.
MICROPHONES and ACOUSTIC DEVICES
225 W. Huron St., Chicago 10, Ill., Cable: SHUREMICRO

Telephoned Reports from All Sections Reveal

STATE of the MARKET

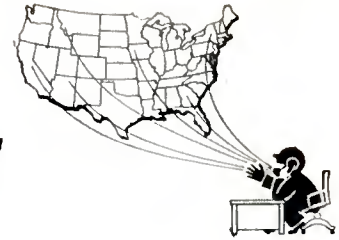

BOSTON

TV QUIET HERE with distributors claiming sales on a par with last year; some dealers reporting it's 2-3 per cent below a year ago. . . . TV dealers are optimistic; looking for a good Autumn season. . . . Room air conditioners, washers and refrigerators selling at a good rate. . . . Radio and record sales improved. . . . Tight credit situation here as distributors clamp down on dealers, and dealers clamp down on customers.

BUFFALO, N. Y.

AIR CONDITIONERS, FREEZERS AND REFRIGERATORS performing well. . . . Washers and dryers steady. . . . TV very slow, and as one dealer puts it, "TV's hit the bottom. Now it can only go one way - up". . . . Clocks, irons and toasters in good demand. . . . Electric ranges move steadily. . . . Clock-radios active, but phono records are slow. . . . Electric fan sales brisk.

CINCINNATI

PRICE-CUTTING RAMPANT, AND MOST PRODUCTS SLOW. . . . Television sales behind last year, with many dealers blaming talk on Color-TV. . . . Refrigerators up and down, but merchants and distributors expect to end up year with a total of 35,000 units sold. Trade-ins go with about 40 per cent of all boxes sold. . . . Air conditioners are active but lists are being slashed. . . . Fans have been moving well. . . . Steady sales in automatic washers, dryers and ranges. . . . Phono records doing very well, with volume about doubled over last year.

ATLANTA

TV SALES FAIR, AND AHEAD OF LAST YEAR, with consoles going well in city, and de-

**Merchandising
Appliances
Radios, records
Television**

mand for tables strong in outlying towns. . . . White goods fair to good, selling in order of refrigerators, washers and ranges.

CHICAGO

ROOM AIR CONDITIONERS, FANS going like wildfire here, with stocks very short and a real famine expected. . . . Refrigerators fairly lively but have not reached the looked-for peak. . . . Great interest in Hi-Fi at Music Show with fair sales in TV, radio to dealers who attended event. . . . Phono records fair. . . . Laundry equipment fair.

NEW YORK

TV SALES LAGGING IN NEW YORK, but room air conditioners are really on the go, though being price-cut right and left. . . . Laundry equipment pretty good, and refrigerators moving well in some spots in the metropolitan area. . . . Portables quite active, and small radios continue to move off shelves. . . . Electric fans being sold in large volume, and small table appliance sales are slow but steady. . . . Electric ranges not moving too well. . . . Phono record biz is fair in most localities; phonos going along well.

MINNEAPOLIS-ST. PAUL

SIGNS OF TV PICKING UP here, with prices holding up satisfactorily. . . . Major appliances moving at fair rate of speed, with washers, gas ranges and refrigerators neck-and-neck. . . . Air conditioners and dehumidifiers active. . . . Phono record sales good.

SAN FRANCISCO

TV SALES SLOW, LAUNDRY EQUIPMENT GOOD, gas ranges and refrigerators fairly active and picking up. . . . Portables selling well, and Hi-Fi perking up. . . . Radios and phonos not too active. . . . Record sales are ahead of last year. . . . Plenty of price-cutting.

DALLAS

AIR CONDITIONERS, FANS AND WATER COOLERS have broken all sales records here, spurred on by 100-degree-plus heat. . . . Ranges, refrigerators and dishwashers moving well, too, but laundry equipment sales have been off. . . . Records and phonographs have been better than average. . . . TV sales have risen slightly but are still disappointing.

REVOLUTIONARY NEW "UNIVERSAL-UHF-VHF" INSERT

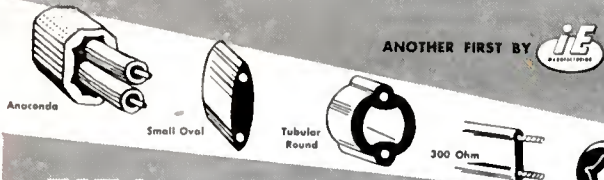

FITS 'EM ALL!

CUTS INVENTORY... SIMPLIFIES HANDLING!



Now, a new "4-in-1" polyethylene standoff insert that outperforms anything on the market! It's the versatile "UNIVERSAL-UHF-VHF" insert... product of iE "look ahead" planning and precision engineering. Functionally designed to carry the tubular cable, small oval, large oval and 300 ohm line. Available on all iE standoffs... will cut down your inventory and reduce your shipping problems!

OTHER OUTSTANDING iE STANDOFF INSERTS



UNIVERSAL

Designed for all VHF installations and the new open line.



LARGE CO-AX

Made specifically to carry the large round lead-in.



325 NORTH HOYNE AVE., CHICAGO 12, ILL.

ANTENNAS • MOUNTS • ACCESSORIES

The New, Improved P-238

14 element, Yagi-type all wave ANTENNA

Pat. App. For

- Two-stacked
- Fringe Area
- Pre-assembled
- Separate matching network for different stacks
- Now furnished with Impedance matcher to improve gain on high band.

Model P-38
Single Unit

Model P-238
Two-stack with stacking bars and impedance matcher

Model P-438
Four-stack with stacking bars, impedance matcher and stacking harness

ORDER TODAY!

SOLD THROUGH JOBBERS ONLY!



Write for new technical literature.

Tricraft Products Co.

1535 N. Ashland Avenue, Chicago 22, Ill.
Manufacturers of complete line of Television, FM and AM antennas and accessories

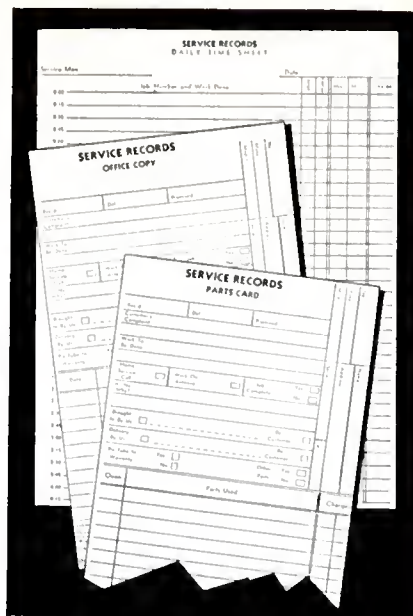

SAVE MONEY

with
NEW TV SERVICE RECORDS

Here is a new copyrighted 3-piece system that gives you everything you need in a business-like record of service rendered

1. Better job records
2. Simplified time sheet
3. Accurate pricing
4. Check on parts used
5. No forgotten items
6. Prevents errors
7. Makes help careful
8. Customer confidence

All necessary forms

For samples and prices, write

SERVICE RECORDS CO.

Mattituck

New York

SAVES TIME-MONEY ON EACH CALL

N.U. VIDEOTRON

PICTURE TUBE CHECKER

- PORTABLE
- RUGGED
- ACCURATE

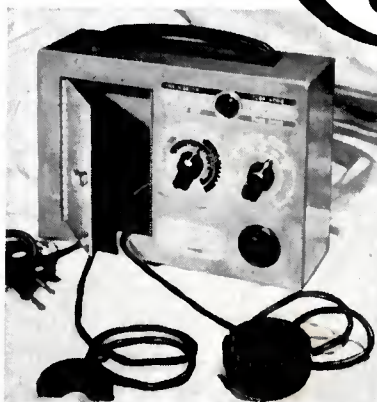

28⁷⁵

Net to Dealer

- Checks all magnetically and electrostatically deflected tubes.
- Uses beam current principle of test.
- Checks electron gun for continuity and shorts.
- Checks tubes in carton or set without removal.

AVAILABLE AT LEADING DISTRIBUTORS OR WRITE FOR CATALOG

NATIONAL UNION RADIO CORP. HATBORO, PENNSYLVANIA

4 for 53 NEW Trav-Electric CONVERTERS

CHANGE 6 OR 12 VOLT D.C. TO
110 VOLT A.C. 60 CYCLE
Just plug into Cigar Lighter on Dash.



**Trav-Electric
Super**
Model 6-71160
60 cycle
60-75 Watts
\$37⁹⁵
LIST

Size
4"x5"x6" Operates

- Wire Recorders
- Amplifiers
- Soldering Iron
- Dictating Machines
- Turntables
- Small Electric Drill



**Trav-Electric
Master**
Model 6-51160
60 cycle
40-50 Watts
\$24⁹⁵
LIST

Size
4"x5"x6" Operates

- Curling Irons
- Radios
- Turntables
- Small Dictating Machines
- Test Equipment, etc.
- Portable Phonographs

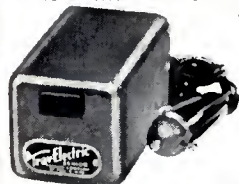

**Trav-Electric
Senior**
Model 6-1160
60 cycle
35-40 Watts
\$15⁹⁵
LIST

Size 2 1/2"x2 1/2"x4 1/2" Operates

- Test Equipment
- Turntables
- Lights
- Short, Long Wave Radios
- Portable Phonographs
- Electric Shavers, etc.



**Trav-Electric
Midget**
Model 6-11160
50 cycle
10-15 Watts
\$11⁹⁵
LIST

Size 2"x2"x3 1/2"

Operates Test Equipment, All Electric Shavers

Fully Guaranteed

Attractive Jobber Discounts

TERADO COMPANY

MFRS. OF PRECISION EQUIPMENT

1068 RAYMOND AVE. • ST. PAUL 14, MINN.

In Canada write: Atlas Radio Corp., Ltd.
560 King St. West, Toronto 28, Ont.

Export Sales Division: Scheel International, Inc.,
4237 N. Lincoln Ave., Chicago 18, Ill., U. S. A.
Cable Address—Harscheel

Ad Manager for GE Division

Paul A. Wassmansdorf has been appointed advertising manager of General Electric Co. Major Appliance Division, succeeding John G. Porter, who has been named manager of the company's Home Bureau. Both men joined GE in 1934 and have had extensive experience in advertising and sales promotion work.

Samson United Corp. Sold

Jay Broiler Co., Long Island City, N. Y. manufacturer of rotisseries and broilers, has purchased Samson United Corp., Rochester, N. Y., and will market the Samson lines of fans, toasters, irons and hot plates. Several of the Samson products will be re-designed and re-engineered by Jay.

In Raytheon District Posts

Recently appointed as district sales managers in the midwest area for the Television and Radio Division, Raytheon Mfg. Co., are James L. Thompson and Ralph Bloom. Both men had been merchandising representatives for the company.

Kaye-Halbert Moves to Mart

Kaye-Halbert Corp. has moved its San Francisco headquarters to the Western Merchandise Mart in that city, where it will maintain offices and showrooms in the space formerly occupied by Raytheon Mfg. Co.

Zenith Adds to '54 Line

The addition of a 17-in. table model to its 1954 TV line, one to retail at a suggested price of \$179.95, has been announced by Zenith Radio Corp. The mahogany-colored set is identified as model L1800R.

Hoover Advances Quandt

Robert R. Quandt has been promoted to midwestern regional manager for the special products division of the Hoover Company, with headquarters in Chicago. His area of operations will include all territory east of the Rockies and west of the Mississippi, including Illinois and Wisconsin.

Remington Corp. Appoints

W. G. Adair as sales rep and Christian M. Ebersole as field service rep, both for the south central states, have been appointed by the Air Conditioning Division of the Remington Corp.

Stinson Reps Publisher

John T. Stinson Co., Havertown, Pa., sales organization, will represent John F. Rider Publisher, Inc., in eastern Pennsylvania, Delaware and in several New Jersey cities.

Perma-Power
merchandise

sells!



Our Newest
Catalog is
Now Available

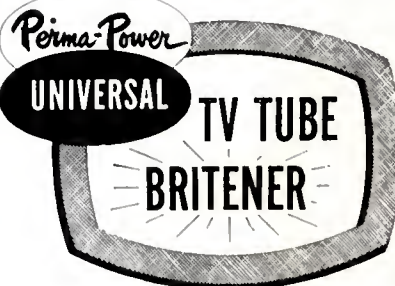

Here is Engineering
at its Peak!

IT'S PARALLEL!
IT'S SERIES!
IT'S ISOLATION!
IT'S ELECTROSTATIC!
IT'S UNIVERSAL!

List Price
\$4⁴⁵

Sold Through Better Jobbers





"Mr. Elkins, this floors me ...
a genuine JENSEN
DIAMOND NEEDLE!"

Closing Dates for MART

25th of second preceding month for all ads requiring proofs, composition, foundry work, key changes, etc.

5th of preceding month for complete plates only—no setting.

1st of month—Publication Date.

TECHNICIAN

1st of preceding month for all ads requiring proofs, composition, foundry work, key changes, etc.

10th of preceding month for complete plates only—no setting.

10th of month—Publication Date.

CALDWELL-CLEMENTS, INC.

480 LEXINGTON AVENUE
NEW YORK 17

INDEX TO ADVERTISERS— AUGUST, 1953

American Phenolic Corp.	76
American Telephone & Telegraph Co.	8
American Television & Radio Co. ...	55
Arvin Industries, Inc.	16, 17
CBS-Columbia Inc.	Cover 2
CBS-Hytron Div. of Columbia Broad- casting System, Inc.	45
Caldwell-Clements, Inc.	86, 90
Channel Master Corp.	56
Commercial Credit Corp. MART, Page 22	
Crosley Div., Avco Manufacturing Corp.	MART, Pages 5, 6
Davis Electronics	85
DuMont Laboratories, Inc., Allen B.	29
Dynavox Corporation	84
Emerson Radio & Phonograph Co. ...	MART, Pages 2, 3
Espey Manufacturing Co., Inc.	89
Fada Radio & Electric Co. Inc.	13
Finney Co.	67
General Electric Co.	6, 7, 14, 15
General Industries Co.	83
Hallicrafters Co.	89
Hobbs, Inc., Guy	MART, Page 21
IE Manufacturing	93
JFD Manufacturing Co., Inc.	95
Jensen Industries, Inc.	95
LaPointe Electronics Inc.	63
Magnavox Co.	9
Mallory & Co., Inc.	22
Motorola, Inc.	26, 27
National Union Radio Corp.	93
Perma-Power Co.	94
Philco Corp.	68, 69
Phoenix Electronics, Inc.	28
Presto Recording Corp.	87
Radiart Corp.	12
Radio Corp. of America ...	19, 24, 73, Cover 4, MART, Page 19
Radion Corp.	75
Raytheon Manufacturing Co.	65
Regency Division, IDEA	4
Ridgeway Div., Gravely Novelty Furniture Co., Inc.	87
Sentinel Radio Corp.	5
Service Records Co.	93
Shure Brothers, Inc.	91
South River Metal Prods. Co., Inc. ...	95
Sprague Products Co.	96
Standard Coil Products Co. Inc. Cover 3	
Stratford Television Co.	79
Stromberg-Carlson Co.	30
Sylvania Electric Products Inc.	81, MART, Pages 9-16
Symphonic Radio & Electronic Corp.	82
Tele King Corp.	23
Television Hardware Mfg. Co., Div. General Cement Mfg. Co.	18
Terado Co.	94
Tricraft Products Co.	93
Trio Manufacturing Co.	71
Tung-Sol Electric Inc.	91
Universal Woodcrafters Inc.	25
V-M Corp.	10, 11
Webb Manufacturing Co.	89
Westinghouse Electric Corp.	2, 3
Zenith Radio Corp.	20, 21

While every precaution is taken to insure accuracy, we cannot guarantee against the possibility of an occasional change or omission in the preparation of this Index.

WHO SAYS

"It Always Takes
Two?"

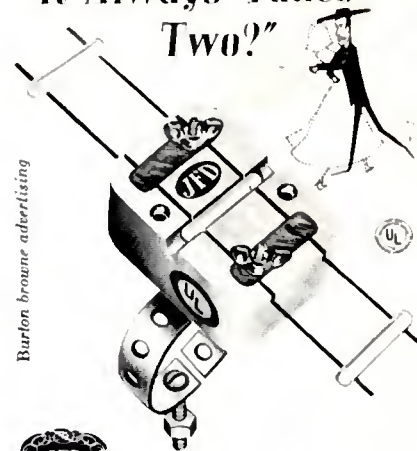

Barlton brochure advertising

JFD "OPEN WIRE" LIGHTNING ARRESTER

It may take two to tango—but one JFD "Open Wire" arrester protects both UHF and VHF signals. That's the model AT107—the perfect arrester for special safeguarding of open wire installations against lightning and static. Complete with aluminum ground wire and stainless steel strap. Write for bulletin No. 139.

No. AT107 \$3.50 list

JFD MANUFACTURING CO., INC.
Brooklyn 4, New York
World's largest manufacturer
of TV antennas and accessories

South River ★ ★ NEWS ★ ★

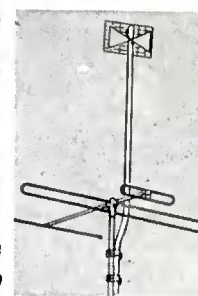

**ULTRA-HIGH
FREQUENCY
ANTENNA
MOUNTING
ADAPTERS
MODEL
UHM-1**

Minimizes attenuation of signal due to coupling effect between antennas and ghost effect due to close proximity of antennas.

Mounts UHF antenna without disturbing present installation. Of magnesium; extends 5' above present antenna.

Also available in Model UHM-2 which fastens below present antenna, 30" away from mast.

Write for our new 1953 catalog.
In Canada—A. T. R. Armstrong Co.,
Toronto

**SOUTH RIVER METAL
PRODUCTS CO., INC.**
SOUTH RIVER, N. J.

PIONEER AND OUTSTANDING PRODUCER
OF FINEST LINE OF ANTENNA MOUNTS

SPRAGUE

TV REPLACEMENT CAPACITOR GUIDE

SETS of the MONTH

CBS COLUMBIA MODELS 27C11, 27C21 (Chassis 1027)

Symbol No.	Rating MF@ WVDC	CBS Part No.	Sprague Replacement
C107	4 @ 50	A20149	TVA-1402
C114	10 @ 250	A20145	TVA-1504
C118	10 @ 250	A20145	TVA-1504
C119	1 @ 50	A20138	TVA-1300
C303	120 @ 250/80 @ 200	A20173	R-1396
C304	20+20+20+10 @ 450	A20172	R-1397
C305	80 @ 450/100 @ 50	A20169	R-1345
C322	4 @ 50	A20149	TVA-1402
C323	10 @ 250	A20145	TVA-1504
C417	4 @ 50	A20149	TVA-1402

WESTINGHOUSE MODELS H-746K21, H-747K21

Symbol No.	Rating MF@ WVDC	Westinghouse Part No.	Sprague Replacement			
C211 } C413 } C414 } C440 } C220 } C441 }	30+10 @ 450/150+20 @ 50	V-11535-1	} TVL-3753 } TVA-1306			
C501 } C502 } C310 }				40+40 @ 450/30+30 @ 350	V-9891	TVL-4720
				10 @ 450	V-10293-1	TVA-1705

ZENITH MODEL L507 (Chassis 5L42)

Symbol No.	Rating MF@ WVDC	Zenith Part No.	Sprague Replacement
C31	60+40+20 @ 150/200 @ 10	22-2410	R-1079
C35	12 @ 150	22-2056	TVA-1407

SHERATON SERIES 250 X L

Symbol No.	Rating MF@ WVDC	Sheraton Part No.	Sprague Replacement			
C7	4 @ 50	ECE-2001	TVA-1402			
C14 } C16 } C47 } C73 }	100+40 @ 300/125+50 @ 50	ECE-1006	R-1391			
C61				4 @ 50	ECE-2001	TVA-1402
C72 } C74 }				110+40 @ 300	ECE-1005	TVL-2589
C75						

TOP QUALITY ALL YEAR for ALL SETS

● PAPER TUBULAR REPLACEMENTS

"Black Beauty Telecap" molded tubular capacitors.

● CERAMIC CAPACITOR REPLACEMENTS

"Ceramide" Discs and "Bulplate" rectangulars have every needed rating!

● TWIST-LOK★ 'LYTIC REPLACEMENTS

Type TVL—world's most complete line of electrolytic capacitors.

● TUBULAR 'LYTIC REPLACEMENTS

Type TVA "Atoms" are small enough to fit anywhere, work anywhere.
★ TRADEMARK

Don't Be Vague-Insist on SPRAGUE!

THE WORLD'S LARGEST



CAPACITOR MANUFACTURER

For Dependable Call-back Free Replacement Capacitors, use only the proven products of the most complete capacitor line! Sprague has the ratings you need every time! Send 10¢ for 44 page TV Replacement Capacitor Manual to Sprague Products Co., 65 Marshall St., North Adams, Mass., or get it FREE from your Sprague Distributor.

260 UHF Stations
on the air or going on soon!

*Meet the
Big Demand
for Conversion*

with

STANDARD UHF Strips

- Economy wins fast acceptance. The customer makes no large investment—additional UHF strips may be substituted as stations go on the air.
- Ease and simplicity of installation saves valuable time.
- Absolute, positive detent tuning—no fishing for channel. Tune UHF as easily, as perfectly as VHF.
- Adjust fine tuning smoothly, without effort.
- No outside cabinet to take up space—no adjustments, wires or extra parts of any sort.

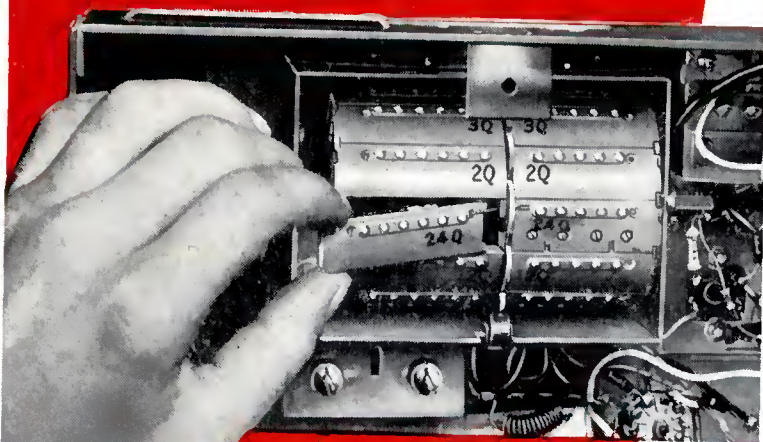

Over
9,000,000
Standard Tuners
in operation—Each
a prospect now
or later for
UHF Strips!

**Here's what an independent survey
found out about Standard UHF strips:**

"Satisfactory results were obtained in every case. After making the necessary oscillator slug adjustment, no further adjustments were required. The units were very stable and any retuning which was required during warm-up was hardly noticeable."

IN TV IT'S STANDARD

Standard
COIL PRODUCTS CO. INC.
CHICAGO • LOS ANGELES • BANGOR, MICH.

Send for this
brochure today—**FREE!**

Get facts on how to order
UHF strips, how to install.
Write Standard Coil
Products Co., Inc.,
2085 N. Hawthorne Ave.,
Melrose Park, Ill.



am
men
sche

See p

The "big moment"

...but whose big moment is it?

YOU FLICK THE SWITCH. This is the moment ... the final check.

And this is the big moment your customer has been waiting for.

But, it's a big moment for you, too ... because your reputation rests on the job the new tubes do from this moment on.

Still, you have no worries ... for your own experience has proven—time and again—that the superior quality of RCA Receiving Tubes is your best measure of protection against premature tube failures.

So, when your call is completed, you can be confident that you've won *another* steady customer.

Helping you to safeguard your reputation is a vital, everyday service of RCA Tubes. And that protection is yours at no extra cost.

"Sign up" for Success

Identify yourself with RCA! Ask your RCA Tube Distributor today how you can qualify for a Dealer Identification Plaque displaying your name. He'll give you all the exciting details on the dynamic new RCA promotion plan to help you build your business.

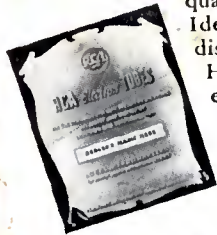

RADIO CORPORATION of AMERICA
ELECTRON TUBES

HARRISON, N. J.



1953