

# RADIO & TELEVISION RETAILING

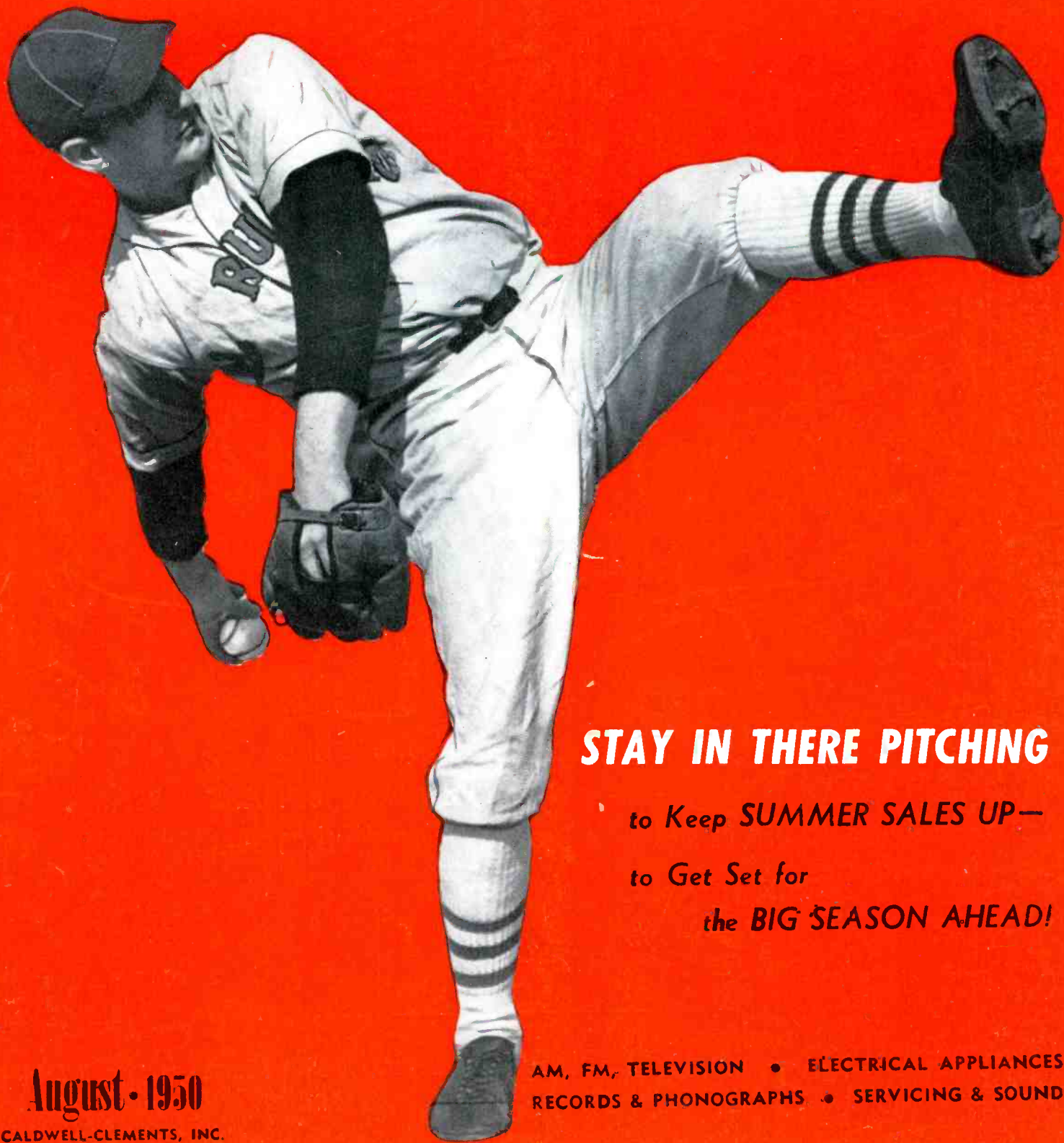

**STAY IN THERE PITCHING**

*to Keep SUMMER SALES UP—*

*to Get Set for*

*the BIG SEASON AHEAD!*

**August • 1950**

CALDWELL-CLEMENTS, INC.

AM, FM, TELEVISION • ELECTRICAL APPLIANCES  
RECORDS & PHONOGRAPHS • SERVICING & SOUND



# Arvin TV



## VISIBLE VALUE

### You can see the difference!



**ARVIN MODEL 4080T**— Gives you the inside track on small apartment, trailer, and "second set" business. Smartest modern design, easily portable, weighs only 40 lbs. What's more, it comes in three colors—Mahogany, Lined Oak, or Willow Green—to please all tastes. 8½" black tube for easy daylight viewing; straight AC operation; easy-as-radio tuning. **\$119<sup>95</sup>**



**ARVIN MODEL 2123 TM**— Here is sales dynamite! No imitation wood grain painted on metal, but beautifully styled hardwood with mahogany veneer! 12½" black tube! Phono-jack; built-in antenna; a marvelous value that puts you out in front! **\$149<sup>95</sup>**

(Table to match at extra cost.)

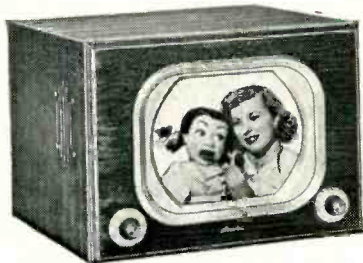

**ARVIN MODEL 2121 TM**— Unequaled value in a deluxe quality 12½" table model TV, with high-styled hardwood cabinet in rich mahogany finish. Sharp, steady pictures of highest quality, like a fine photograph! Black tube; AC operation; simplest two-knob tuning; highest immunity from interference. Velvet Voice FM tone; phono-jack and built-in antenna. **\$169<sup>95</sup>**



**ARVIN MODEL 2126 CM**— They'll look! They'll listen! They'll wonder if you've made a mistake! Because this beautiful 12½" mahogany console is so far ahead of anything your customers have seen at this price! Black tube for sunlight-sharp pictures; easy-as-radio tuning; AC operation for longest tube life; phono-jack and built-in antenna. Priced at only **\$179<sup>95</sup>**



**ARVIN MODEL 2120CM**— This is the finest 12½" mahogany console in the whole Arvin TV line, with all the luxury trimmings your deluxe-class customers could want! Cabinet styling of exquisite beauty, set off by sparkling lucite control knobs and Finish-O-Gold trim. Inside, a wealth of famous Arvin features insure top performance. Phono-jack and built-in antenna. **\$199<sup>95</sup>**

In less than a year Arvin TV has earned an outstanding reputation in every important respect . . . clarity of picture . . . faithfulness of tone . . . beauty of cabinet . . . and, highly important to dealers . . . service-free performance.

Those early months were full of promise for the future. And now that promise has been amply fulfilled with introduction of Arvin's great new TV line for 1951.

Here is a *complete* line, built around eleven basic models, every one designed and engineered to a quality standard, not to a price. Yet, Arvin prices are highly competitive throughout the line.

Backing up the new Arvin line is the most intensive advertising and merchandising program in Arvin history with dominant space in these leading national magazines: Life, Post, Newsweek, Better Homes & Gardens, Look and Time.

Is it any wonder that Arvin is the fastest growing name in television? And isn't it just sound business for you to get full details on this great new line from your distributor? Phone, write or wire for his name, today! Arvin Industries, Inc., Columbus, Indiana. (Formerly Noblitt-Sparks Industries, Inc.)



# Fulfills a Promise!



**ARVIN MODEL 2161 TM**—Not a metal cabinet, but solid selected hardwoods with mahogany veneer! Crystal lucite control knobs. 16-inch rectangular black tube; phono-jack; built-in antenna. Matching table at extra cost. **\$219<sup>95</sup>**



**ARVIN MODEL 2160 CM**—High-styled, beautifully finished mahogany console for your customers who know fine furniture. 16-inch rectangular black tube; lucite and finish-o'-gold appointments. Phono-jack and built-in antenna. Super-powered for sharp pictures everywhere! **\$249<sup>95</sup>**  
(2160 CB, Limed Oak finish \$259.95)



**ARVIN MODEL 2124 CCM**—They'll shop all over town without finding another such TV-radio-phono combination value! 12½" black tube; AM-FM radio, 8 tubes including rectifier. Plays 33, 45, 78 rpm records, intermixes 10 and 12-inch, shuts itself off. Selected imported mahogany finish. **\$279<sup>95</sup>**

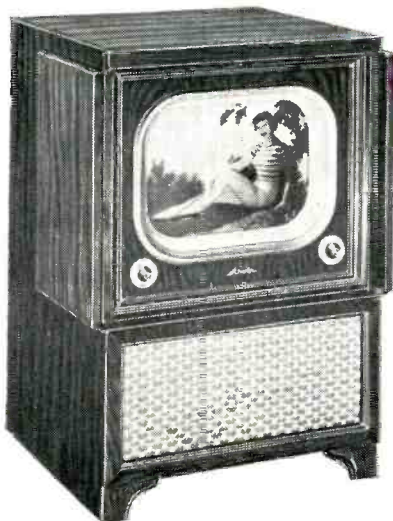

**ARVIN MODEL 2164 CM**—Where else have you seen a super-powered sixteen-inch TV so beautifully styled, so perfect in performance, at such a price? Rectangular black tube; sharp, steady daylight pictures even in fringe areas; imported mahogany veneers; two-thirds doors; phono-jack; built-in antenna! **\$279<sup>95</sup>**  
(2164 CB, Limed Oak finish \$289.95)



**ARVIN MODEL 4162 CM**—This is for your "carriage trade"—the man who wants the finest TV built, regardless of price! This is it!—America's most beautiful mahogany console and most powerful 16-inch TV set—at any price! Two-thirds doors; lucite controls; phono-jack; built-in antenna. **\$329<sup>95</sup>**  
(4162 CB, Limed Oak finish \$339.95)



**ARVIN MODEL 2162 CCM**—No ifs or ands about it, this is America's outstanding value in 16" TV-radio-phono combination! Rectangular black tube for sunlight-sharp pictures; finest interference controls; AM radio, 6 tubes including rectifier. 3-speed record changer plays 33, 45, 78 rpm, intermixes, shuts itself off. **\$349<sup>95</sup>**

# MASTER KEY to Profit Control... Simplified Systems

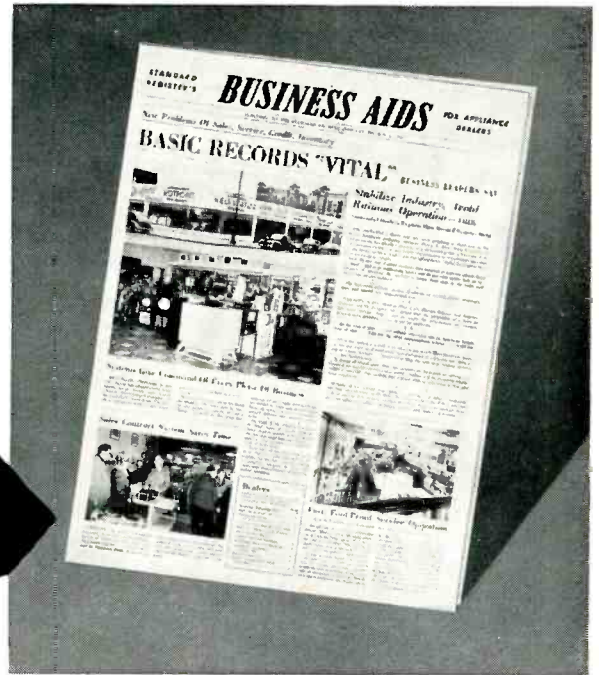

Get this **FREE HELP** in applying simple forms to **YOUR** business

Here is the system "know how" of your business. In the fact-filled pages of **BUSINESS AIDS**, outstanding dealers tell in their own words how they secure **PROTECTION** against profit-leaks, losses, mistakes, delays and disputes through complete, accurate and efficient records of every transaction.

A leading Brooklyn television dealer, for instance, tells how **ONE COMBINED FORM** provides exact duplicate

copies for accounting, delivery, shipping, C. O. D., service, customer and audit. A Detroit dealer explains a four-copy Sales Contract, **CONSECUTIVELY NUMBERED**, giving complete bookkeeping, customer, delivery and audit information, and a **NEW Service Form** that prevents errors and losses.

## GET THIS HELP . . . NOW

**BUSINESS AIDS** is packed with the practical system experience of leaders in your line of business. Let us send your copy **FREE**. Standard's nearby Representative, skilled in Paperwork Simplification, can help design and apply the most efficient forms and method of writing to suit your exact needs: A **FORM FLOW REGISTER . . . UNIT ZIPSET . . .** or **KANT-SLIP Continuous Forms (typewriter) System**.

*The Standard Electric Form Flow Register. Fully automatic! Write, touch a button, that's all! Hundreds of other models—desk, counter and portable, for every record need in business.*

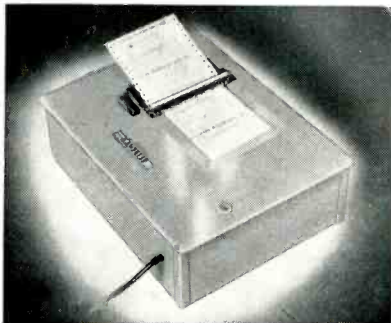

## Standard Register

Originator of Pin-Wheel Feed  
and Marginally Punched Continuous Forms

THE STANDARD REGISTER COMPANY, 1308 CAMPBELL STREET, DAYTON 1, OHIO  
PACIFIC COAST: Sunset McKee-Standard Register Sales Company, Oakland 6, California.  
CANADA: R. L. Grain Limited, Ottawa. GREAT BRITAIN: W. H. Smith & Son, Ltd., London.

**MAIL THIS TODAY!**

The Standard Register Company  
1308 Campbell Street, Dayton 1, Ohio

Please send me, without obligation, **BUSINESS AIDS**, containing practical-experience articles on systems and forms as used in our business.

Name \_\_\_\_\_

Type of Business \_\_\_\_\_

Street Address \_\_\_\_\_

City \_\_\_\_\_ Zone \_\_\_\_\_ State \_\_\_\_\_



# PHILCO

## FIRST in QUALITY

## FIRST in PERFORMANCE

## FIRST in VALUE

Yes, Philco for 1951 continues its Quality Crusade! It's the first consideration in every step of the planning, engineering, design and production of Philco television receivers. Here you see some of the processes that keep Philco "First in Quality"!

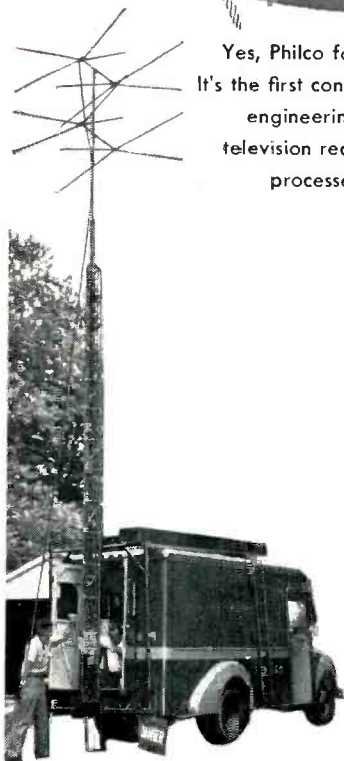

**Laboratories On Wheels.** A fleet of travelling laboratories cover practically every television area to test performance and gather engineering data which helps to establish Philco's high standards of quality.



**From Each Day's Production,** forty completed television sets, packed exactly as a dealer receives them, are selected at random and given a rigorous 40 hour continuous test to assure that every standard of Philco quality is achieved in production.



**Life Tests.** All components of Philco receivers are rigorously life-tested to assure that they meet Philco standards of dependability with an ample safety margin. Here the Philco electronic built-in aerials and television tuners are being tested.



**Comparative Field Tests** are being made constantly in all TV areas. Through these tests, Philco maintains the standards of performance through which Philco television receivers outperform all others.



**Sound Proof Laboratory.** Special sound proof booths have been built to test Philco television combinations for sound quality on video, phonograph and radio.

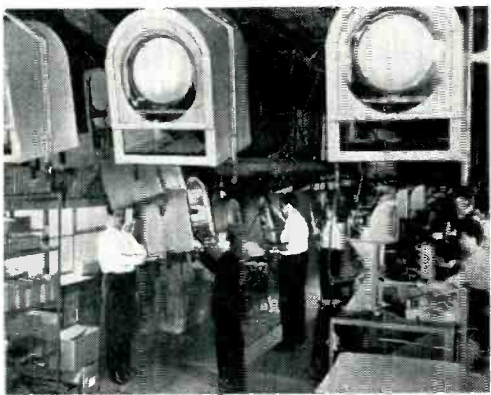

**Unique Performance Test.** Every completed chassis is operated for several hours on this specially designed conveyor and tested at several points for picture and sound quality.



## PHILCO Television for 1951

FULFILLS THE PROMISE OF  
20 YEARS OF LEADERSHIP



It's a "natural" for promoting  
**FREE** Home Demonstrations!

Brand New  
1951 Model!

**Admiral**

Now!  
Pictures Clear  
as the Movies

Clear close up  
because of NEW  
"Filteray" Tube

Complete with  
Built-in Directional  
Roto-Scope Antenna



ON TV—"STOP THE MUSIC," ABC, Thurs., 8 PM, EDT

Now! Big picture television from Admiral that's a "natural" for promoting sales through free home demonstrations. Has everything! Good looks! Outstanding performance! Sensational low price! Easy as a 12½ to carry. Measures only 18" square . . . most compact 16" TV built. Complete with built-in directional Roto-Scope antenna. Quantities limited . . . see your Admiral distributor!

(Prices subject to change without notice)

**\$199.95**  
TAX EXTRA  
16R12  
MAHOGANY

RADIO & TELEVISION RETAILING • August, 1950



# "MEET MY ACE SALESMAN!"



**T**HE G-E monogram on the tubes I stock and install—that's Reason No. 1 why I'm doing more business than ever before!" Plenty of radio-TV servicemen are saying this. It pays to handle a winner; public preference for General Electric puts real money in servicemen's pockets, will profit *you* and accent your reputation for first-class repair-work and quality tubes and parts. . . . Reason No. 2 why you'll do more business, is General Electric tube promotion aids! Help to you from G-E headquarters never stops. Stunning new signs and displays; advertising items that crackle and spark; a host of useful serviceman's aids; a continuous flow of up-to-date TV repair tips in *Techni-Talk Magazine*—these become dollars-and-cents sales figures. Ask your distributor *today* for the full G-E-tube success story!  
*Electronics Dept., General Electric Company, Schenectady 5, N.Y.*

## ONE SOURCE FOR ALL YOUR TUBE REQUIREMENTS

—metal and glass tubes; miniatures; TV picture tubes in a wide range of sizes and types; also germanium diodes and selenium rectifiers. General Electric's line is complete! G.E.'s list of types includes *newest* tube designs for new radio-TV receivers! . . . Stock G-E 100-per cent, to simplify ordering—benefit from unit deliveries—profit from General Electric tube quality and popularity!

*You can put your confidence in—*

**GENERAL  ELECTRIC**

181-JAG



# TV-RADIO SERVICEMEN

**Here are 2 Big Ways Federal Helps  
You Make More Profits . . . and Keep Them!**

## 1 Lead-in installations and replacements that save "FREE" Service Calls

—IN HIGH AND LOW NOISE LEVEL AREAS

Federal's K-1046 and K-111—300-ohm lead-in cables—are your answers to the problem of keeping service calls down and TV installation profits UP. K-1046, for low noise level conditions, is insulated with amazingly durable "silver" polyethylene . . . providing 30% more service life . . . plus numerous inherent features. K-111 is tops in noisy areas . . . minimizing noise, snow and ghosts due to transmission line pick-up. Pictures are clearer, brighter, steadier . . . *all the time!*

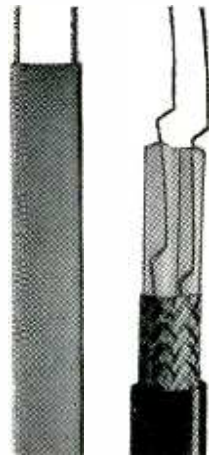

K-1046

K-111

Federal is America's leading manufacturer of solid dielectric coaxial cables!

## 2 FEDERAL SELENIUM RECTIFIERS★ for Replacement in TV and Radio sets

OVER 10,000,000 FEDERAL SELENIUM RECTIFIERS NOW IN SETS OF LEADING MAKERS

For servicemen everywhere this means a new and important replacement market . . . a steadily growing source of extra income!

Be ready for this new profit opportunity by being ready to replace selenium rectifiers with Federal . . . the *original* miniature selenium rectifier. Federal has the industry's *most complete line!*



FTR-1023

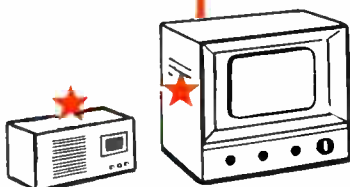

Every year, more and more millions of Federal selenium rectifiers are being installed in AC-DC, portable, table and console radios and TV receivers!

**Check your stock now—and call your distributor for Federal TV lead-in cables and Federal miniature selenium rectifiers. It pays to install the best!**



*Federal Telephone and Radio Corporation*



SELENIUM and INTELIN DIVISION, 100 Kingsland Road, Clifton, New Jersey  
In Canada: Federal Electric Manufacturing Company, Ltd., Montreal, P. Q.  
Export Distributors: International Standard Electric Corp., 67 Broad St., N. Y.

**profit by the extra  
advantages of a**

**SCOTT**

**"distinguished dealer"  
franchise!**

Scott Dealers are distinguished dealers. They have the distinction of selling the world's finest radio-phonograph combinations and television receivers. Scott Dealers attract customers who want only perfect quality. They enjoy the profitable *pre-sold* patronage of customers who readily pay for products bearing the Scott name.

The Scott Distinguished Dealer franchise is protected through restriction of distribution, making your store *Scott Headquarters* in your entire trading area. You are protected by a retail mark-up that always gives a good margin of profit.

Although the number of Scott dealerships must of necessity be limited, there are a few franchises available. Write for details about the Scott franchise today.



**The Scott KENILWORTH at \$398.50 Retail. Triple speed automatic phonograph—AM-FM radio. Hand-rubbed dark mahogany cabinet, two full-length doors.**

**Scott Radio Laboratories, Incorporated  
4541 N. Ravenswood Avenue,  
Chicago 40, Illinois**



# Dealers' orders

# BREAK



**Big as Life—Real as Life!**

Customers will be happier longer with G.E.'s life-size, lifelike pictures!



**Model 16C116**, above. 16" rectangular black tube. Finely figured doors. Stunning mahogany veneers. Swivel casters. **\$299.95\***



**Model 16C113**. Exquisite, genuine mahogany veneers. 16" rectangular black tube. **\$279.95\***



**Model 16T3**. Beautiful mahogany veneered cabinet. 16" rectangular black tube. **\$239.95\***

In blond, **\$259.95\***

# ALL RECORDS

for newest, big-screen rectangular



## BLACK-DAYLITE TELEVISION

Sparked by overwhelming public demand, dealer orders for the new G-E Black-Daylite Television line topple all previous records for any two months period in G-E history. What a profit picture! New big-as-life, true-to-life pictures, lastingly beautiful furniture, spell quality that sells on sight . . . backed by a name you and your customers can depend on. Terrific G-E promotion . . . hot G-E prices . . . advanced G-E rectangular black tubes . . . G-E automatic sound . . . and the powerful G-E Built-in-Antenna . . . mean sales faster than you've ever sold before. It's a Profit-Parade you can't afford to miss. Call your G-E TV distributor today, or write *General Electric Company, Receiver Division, Syracuse, New York.*

*\*Plus tax. Installation and picture tube protection plan extra. Prices slightly higher West and South.*



**Model 14T2.** 14" rectangular black tube. Genuine mahogany veneers. **\$199.95\***  
In blond, **\$219.95\***



**Model 14C103.** Handsome blond veneered console. 14" rectangular black tube. **\$259.95\***  
In mahogany, **\$239.95\***

*You can put your confidence in—*

**GENERAL**  **ELECTRIC**





**YOU NEED ONLY ONE LINE TO MAKE A CATCH!**

**YOU NEED ONLY ONE BRAND TO CATCH**

## **BIG BATTERY BUSINESS!**



- "Eveready" radio batteries land big battery business because they're the batteries your customers want! They're the most widely advertised brand in the world. Your customers *know* that famous "Eveready" batteries give long, satisfactory playing life in *any* portable. It makes sense to use this one complete line to streamline inventories, to cut overhead costs, to bring in big profits for *your* store!

The terms "Eveready", "Nine Lives"  
and the Cat Symbol are trade-marks of

**NATIONAL CARBON DIVISION**  
**UNION CARBIDE AND CARBON CORPORATION**  
30 East 42nd Street, New York 17, N. Y.

District Sales Offices: Atlanta, Chicago, Dallas, Kansas City,  
New York, Pittsburgh, San Francisco

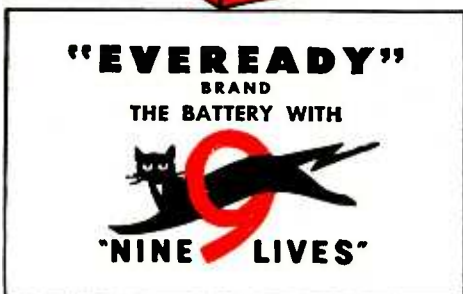

**"BATTERY-ENGINEERED BY BATTERY MANUFACTURERS  
FOR BEST BATTERY PERFORMANCE!"**

**America's millions on the move mean BIG MONEY for you with...**

# ZENITH PORTABLE RADIOS!



## AMERICA'S FINEST PORTABLE

A summer-long parade to resorts, picnics, beaches, sports events, camps—to countless places from coast-to-coast—will boost Zenith Portable Radio sales to all time highs! Anyone who goes anywhere wants to take their entertainment with them—so make the most of Americans on the move. Sell Zenith Portables!

The

### TRANS-OCEANIC is Always a Best Seller

Outperforms any portable, anywhere. The one set to sell when customers want long-range reception. Gets standard, plus International Short Wave on 5 separate bands. Humidity-Proofed against loss of sensitivity. For AC/DC or battery. **\$9995†**  
*less batteries*

### The New UNIVERSAL\* Sets New Sales Records!

Grand, new super-powered long distance Zenith portable, with newer, finer features. Plays on AC/DC or battery, has sturdy, buffalo-grained case in Black, Brown. **\$4995†**  
*less batteries*

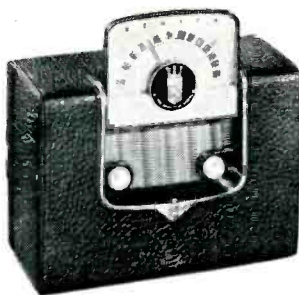

### Tops for Turnover TIP-TOP HOLIDAY\*

Giant "Tip-Top" Dial with built-in Wavemagnet swings up above the set for tuning ease, doubles the sensitivity of reception. For AC/DC or battery. Cabinet of Ebony or two-tone Blue-Grey plastic. **\$3995†**  
*less batteries*

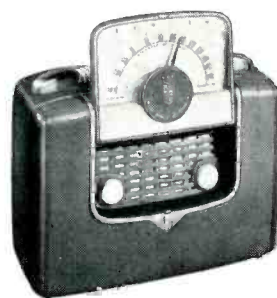

### Powerful and Popular ZENITH ZENETTE\*

Hardly bigger than your hand, yet plays with big-set volume and tone! Open lid, set's on—close lid, set's off. Weighs but 5½ lbs. Battery or AC/DC operation. In Burgundy, Ebony or White plastic. **\$3995†**  
*less batteries*

†Suggested retail price. West Coast and far South prices slightly higher. Prices subject to change without notice.

\*Reg. U. S. Pat. Off.



**ZENITH RADIO CORPORATION**  
6001 DICKENS AVENUE • CHICAGO 39, ILLINOIS



# 5 SENSATIONAL

Already the fastest growing line in radio, G. E. now doubles production on 5 sensational new models headed straight for the top in today's 5 hottest price ranges. Setting the pace in style and performance and backed by the biggest promotion in G-E history, this new merchandise means a golden tide of profits for smart dealers everywhere. For the first time ever you can now offer choice of colors all at same low price . . . Sensational Dial Beam that lights up each station number as you dial (No other radio at any price has this feature—what a hook in a \$19.95\*

model!) . . . Full-size radios priced little more than midgets . . . World's finest FM-AM table radio at its price . . . Amazing sunburst dial . . . Genuine mahogany veneered table sets. Radios for every room, purse and market! All offering a great big sales-PLUS—a name customers can depend on! The feast's on, the values hot—come and get 'em! Call your G-E radio distributor or write *General Electric Co., Receiver Division, Syracuse, New York.*

**DELUXE!** Actually outperforms many consoles—how's that for sales bait! Extra sensitivity, extra power, extended tonal range, 5 tubes plus rectifier. Congo brown (Model 404 below) or alabaster ivory. Same low price. **\$29.95\***



MODEL 404

**FULL-SIZE!** Not a midget radio with midget performance but a full-size G-E for only pennies a week more! Big beautiful mahogany plastic cabinet—over 13" wide, over 8" high! "Big set" features: built-in antenna, dial light, slide-rule dial. Model 402. **\$24.95\***

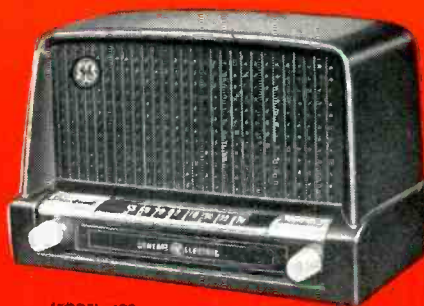

MODEL 402

**FINEST FM-AM EVER!** Never before such quality at the price! Here's G.E.'s finest ever, with *unusual, eye-catching, sales-catching sunburst dial* . . . 7 tubes plus rectifier . . . genuine Armstrong FM circuit . . . 2 built-in antennas . . . G-E Dyna-power speaker . . . lovely mahogany plastic cabinet. Model 408. **\$49.95\***



MODEL 408

**GENUINE MAHOGANY!** You've never sold a lovelier table model! Stunning wood cabinet is veneered in CHOICE, HAND-RUBBED, GENUINE MAHOGANY. Sure-fire with the "cream" market. With its 5 tube plus rectifier chassis, 3-gang tuned RF stage, Model 410 outperforms many consoles! **\$39.95\***

\*Prices slightly higher West and South.



MODEL 410

*You can put your confidence in—*

# MODELS-50 HOT

*-we've doubled  
our production!*

Choice of \$19<sup>95</sup>\*  
COLORS

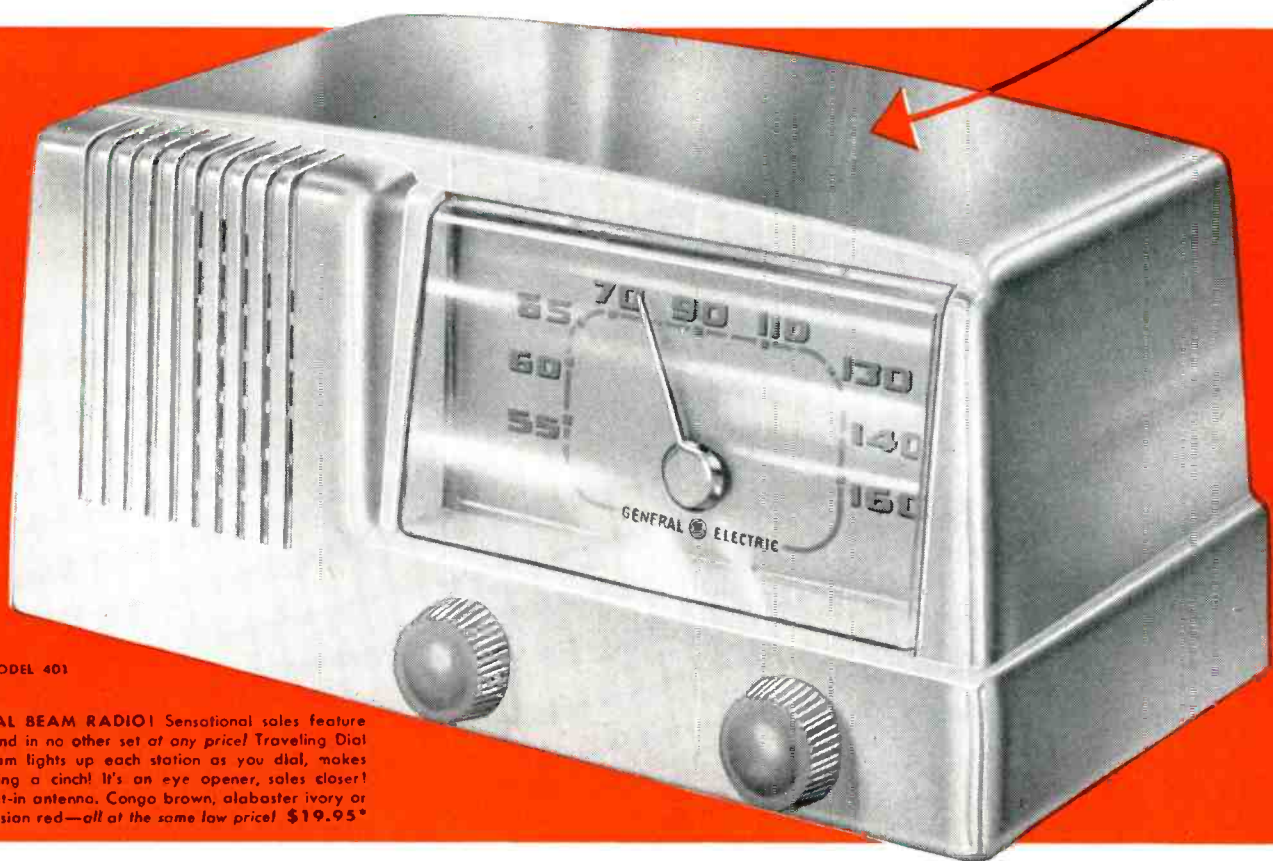

MODEL 401

**DIAL BEAM RADIO!** Sensational sales feature found in no other set at any price! Traveling Dial Beam lights up each station as you dial, makes tuning a cinch! It's an eye opener, sales closer! Built-in antenna. Congo brown, alabaster ivory or Persian red—all at the same low price! \$19.95\*

# GENERAL



# ELECTRIC



THE BEST **LP** NEWS SINCE **LP** ITSELF!

THE NEW COLUMBIA

# **LP** Automatic Changer Attachment is here!



A \$32.95 Value  
That Sells for Only

**\$16<sup>95</sup>**

Just What You've  
Waited For! Just What  
Your Customers Want! **MODEL 104**

Makes a modern, up-to-the-minute instrument of any radio, radio-phonograph or TV set!

Plays 7-inch 33 $\frac{1}{3}$  LP Records automatically—twelve hits high!

Plays twelve 10-inch 33 $\frac{1}{3}$  LP Records automatically.

Plays ten 12-inch 33 $\frac{1}{3}$  LP Records automatically.

Plays a mixed selection of ten 10- and 12-inch 33 $\frac{1}{3}$  LP Records automatically.

Up to 4 hours of music at a single loading!

The Model 104 LP Changer Attachment is readily connected to any radio, radio-phonograph or TV set. Neat, compact, sturdy—designed in collaboration with Columbia engineers—it puts the perfect clincher on the "one speed is all you need" idea!

**DEMONSTRATE IT—DISPLAY IT—SELL IT!**

**HERE'S  
HELP**

Store and Window Displays  
Merchandising Features  
Radio and TV Promotion

National Magazine Ads  
Publicity Campaign  
Complete Co-op Program

**It's An Unbeatable Combination For Sure,  
Steady Profits—**

**The Changer That Fits The Records—  
The Records That Fit The Music!**

**COLUMBIA **LP** RECORDS**

Originator of LP Records—One Speed . . . One System — One Record For Everything from a 3-minute Pop Hit To a 50-Minute Symphony

"Columbia," "Masterworks," **LP** and **LP** Trade Marks Reg. U. S. Pat. Off. Marcas Registradas



on the next pages  
you will see the  
most beautiful  
Radio and Television  
sets ever built...

new 1951  
**Motorola**  
Television  
Radio

awarded

*Fashion Academy Medal*

for authentic and distinctive

*Furniture Styling*







MODEL 20F1 . . . 20 inch Rectangular tube. FM/AM radio . . . 3-speed phono. Limed Oak or Mahogany.



MODEL 19K2 . . . 19 inch picture tube. Mahogany or Limed Oak.



MODEL 19K3 . . . 19 inch Rectangular tube. Mahogany cabinet only.



MODEL 19K4 . . . 19 inch picture tube. Mahogany or Limed Oak.



MODEL 17K2 . . . 17 inch picture tube. Mahogany or Limed Oak.



MODEL 17F4 . . . 17 inch Rectangular tube. FM/AM radio . . . 3-speed phono. Rich Mahogany cabinet.



MODEL 17K1 . . . 17 inch picture tube. Mahogany or Limed Oak.



MODEL 17F5 . . . 17 inch Rectangular tube. FM/AM radio . . . 3-speed phono. Mahogany or Limed Oak.



MODEL 17K4 . . . 17 inch picture tube. Mahogany cabinet only.



MODEL 14K1 . . . 14 inch Rectangular tube. Limed Oak or Mahogany.



MODEL 14T3 . . . 14 inch Rectangular tube. Plastic case. Value Price.



MODEL 17T3 . . . 17 inch Rectangular tube. Plastic case. Value Price.

## HERE IS YOUR TOP LINE FOR '51

In TV MOTOROLA is the outstanding line by any comparison you choose to make! Beautiful and distinctive styling . . . unequalled variety of models and screen sizes . . . BEST SELLING FEATURES and the most competitive dollar for dollar pricing in the industry for performance-tested merchandise. For the TV showing of the year see them at your MOTOROLA distributor's preview. Motorola is BEST LOOKING . . . BEST ADVERTISED . . . BEST BUY FOR '51!!!

the most beautiful sets ever built . . .

# Motorola RADIOS



MODEL 5C1 . . . "Radio-larm" Clock Radio. Plastic case in Forest Green, Ivory or Brown.



MODEL 5X21 . . . Short-wave radio band, AM radio. Walnut, Ivory, Black.



MODEL 5X11 . . . AM radio in smart Black, Ivory or Walnut plastic.





MODEL 17F1 . . . 17 inch Rectangular tube. FM/AM radio . . . 3-speed phono. Mahogany or Limed Oak.



MODEL 17F2 . . . 17 inch Rectangular tube. FM/AM radio . . . 3-speed phono. Walnut cabinet.



MODEL 17F3B . . . 17 inch Rectangular tube. FM/AM radio . . . 3-speed phono. Smart limed oak cabinet.



MODEL 17K3 . . . 17 inch Rectangular tube. Limed Oak or Mahogany.

# Motorola

## TELEVISION



MODEL 17T1 . . . 17 inch Rectangular tube. Limed Oak or Mahogany.



MODEL 17T2 . . . 17 inch Rectangular tube. Mahogany or Limed Oak.

and packed with fast selling features

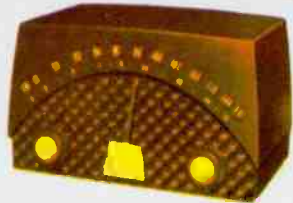

MODEL 7XM21 . . . FM/AM table radio. Brown, Emerald Green Bakelite case.



MODEL 6X11 . . . AM table radio. Moulded Bakelite case in Walnut or Ivory.



MODEL 8FM21 . . . FM/AM radio. 3-speed record changer. Limed Oak or Mahogany.



MODEL 9FM21 . . . FM/AM radio. 3-speed record changer. Limed Oak or Mahogany combination.



MODEL 5R11 . . . AM radio in Walnut, Ivory, Gray, Maroon, Green, Yellow.



MODEL 5H11 . . . AM radio in Ivory, Green, Walnut Bakelite case.





here is the lead-off ad

in **MOTOROLA'S BIGGEST CAMPAIGN!**



here is one of twenty-nine new "beautiful buys"

1951

# Motorola TV

**NEW** "18th Century" off-the-floor cabinet . . . in select grain, hand-rubbed mahogany . . . so very beautiful in your home. **NEW** 17 inch rectangular pictures . . . brighter, steadier than ever before. **NEW** "controlled quality" chassis for extra long trouble-free service. **EASY** 2-control tuning . . . turn it on, select station, that's all. **EXCLUSIVE** Bilt-in-Antenna . . . just plug in and play! **NEW** fool-proof 3-speed phonograph, plus Golden Voice FM/AM radio. *And above all, NEW value at a new low price!*



**all so new**  
that a demonstration  
will convince you  
that your new set  
**MUST** be one of  
the twenty-nine  
new Motorola  
TV models.

MODEL 17F4 in Mahogany

There's a style to fit your home—at a price to fit your budget. See your Motorola dealer soon.



# Jensen presents... **G-610 TRIAXIAL**

a NEW loudspeaker which for the first time spans the full frequency range of the ear!

A new, skillfully integrated combination of three independently-driven units . . . two compression driver and horn combinations, plus heavy-duty direct radiator . . . with 3-channel electrical crossover and control network . . . achieving the widest frequency range and finest reproduction ever attained!

*Write for Data Sheets 160 and 152 which describe the G-610 and other Genuine Jensen Wide Range Speakers.*

**JENSEN MANUFACTURING COMPANY** Division of the Muter Company  
 6625 So. Laramie Ave., Chicago 38, Portsmouth 7-7600 In Canada: Copper Wire Products, Ltd., 351 Carlaw, Toronto.





HERE COME THE NEW  
**DU MONT'S**

*The biggest line, the biggest pictures,  
 the lowest prices in Du Mont history!*

New cabinets, new features, big new pictures, here are the most exciting new telesets on the market. Sixteen stunning new models—a style for every taste—make this the biggest Du Mont line ever. And famous Du Mont manufacturing superiority—improved by exclusive new Du Mont quality control methods—makes this the finest line of telesets ever built!

Every set has a giant 17- or 19-inch picture. Here is natural

Rectangular television, generous Life-Size television. Here are the tube sizes everyone wants. Here are the tube sizes the markets of today and tomorrow will demand. But stand by for the most exciting news of all: *These are the lowest priced telesets Du Mont has ever built!*

Yes, Du Mont electronic genius has raised the quality, increased the picture size and still reduced the final list price. Never before has the best in television been so easy to own.



↳ the **HANOVER**  
 by **DU MONT**  
 19-inch direct-view  
 Lifetone\* picture.  
 Phono-jack  
 for record player.  
 Built-in  
 static-free FM radio.

↳ the **SHERBROOKE**  
 by **DU MONT**  
 19-inch direct-view  
 Lifetone\* picture.  
 Built-in  
 FM and AM radio  
 with dual tone controls.  
 Fully automatic  
 three-way record player.



16 MAGNIFICENT PERFORMERS  
 including these models not illustrated:  
 17-inch Rectangular Picture Telesets  
 • the SUMTER • the STRATHMORE  
 • the CARLTON • the ANDOVER  
 • the BURLINGAME  
 19-inch Life-Size Picture Telesets  
 • the WESTERLY • the WINSLOW



**the MT. VERNON by DU MONT**  
 19-inch direct-view Lifetone\* picture.  
 Phono-jack for record player.  
 Built-in static-free FM radio.



**the ARDMORE by DU MONT**  
 19-inch direct-view Lifetone\* picture.  
 Phono-jack for record player.  
 Built-in static-free FM radio.



**the TARRYTOWN by DU MONT**  
 17-inch direct-view Lifetone\* picture.  
 Built-in FM and AM radio with dual tone controls.  
 Fully automatic three-way record player.

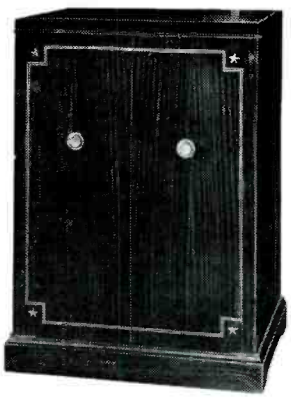

**the REVERE by DU MONT**  
 17-inch direct-view Lifetone\* picture.  
 Phono-jack for record player.  
 Built-in static-free FM radio.



**the BROOKVILLE by DU MONT**  
 17-inch direct-view Lifetone\* picture.  
 Phono-jack for record player.  
 Built-in static-free FM radio.

Never before have Authorized Du Mont Dealers faced such a tremendous profit opportunity. Now all America can afford Du Mont big picture television.

To move these new Du Monts to their fast-growing market Du Mont will stage its biggest promotions, run its most lavish advertising and selling campaigns. The biggest and best magazines and newspapers in America will carry the story of the magnificent value of these new Du Monts. And Du Mont

Dealers will do their biggest Du Mont year!

Now, today, call your Du Mont Distributor. See these new telesets at the earliest possible moment. Get your order in. Get your sales promotion material. Get excited because you have the most exciting merchandise in the market—the new Du Monts—television's finest, at Du Mont's lowest prices!

**SOLD THROUGH AUTHORIZED DU MONT DEALERS**

\*Trade Mark



**the PARK LANE by DU MONT**  
 17-inch direct-view Lifetone\* picture.  
 Phono-jack for record player.

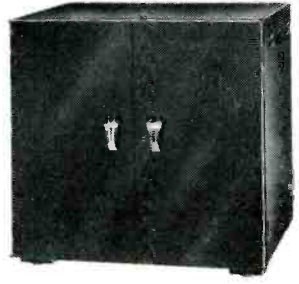

**the VENTURA by DU MONT**  
 17-inch direct-view Lifetone\* picture.  
 Phono-jack for record player.  
 (Table Model)

the  
 big show  
 in  
 television

**DU MONT**

*First with the finest in Television*



Copyright 1950, Allen B. Du Mont Laboratories Inc., Television Receiver Division, East Paterson, N. J. and the Du Mont Television Network, 515 Madison Avenue, New York 22, N. Y.



Why there's big profits ahead for Webster-Chicago dealers!

**12 million<sup>†</sup>**  
**RECORD CHANGERS**  
**need replacement**

**AMERICA'S FINEST!**  
**SENSATIONAL NEW**  
**Webster-Chicago**  
**Diskchanger\***



Balanced Tone Arm  
 Gives perfect record  
 touch on all size and  
 all speed records.



Velocity Trip  
 New mechanism gives  
 all records increased  
 quality playing life.



Cushion-Drop  
 New spindle  
 gently lowers records;  
 heavy flock turntable  
 cushions drop.



**Easiest to sell because it has  
 every wanted feature!**

Webster-Chicago dealers are cashing in on this huge conversion market because they sell Webster-Chicago Diskchangers—the only replacement changer with *all* these features:

- Automatically plays 12-inch, 10-inch or 7-inch records at 33 $\frac{1}{3}$ , 45 or 78 rpm without any special adjustments.
- Pick-up arm comes to rest position after last record is played.
- Idler wheel retracts when control speed is off; eliminates flat spot which causes "wow."
- Fewer working parts for longer life of carefree operation.
- New automatic manual position plays home recordings or "inside-out" records without special adjustment.

Webster-Chicago dealers know fast sellers like this Diskchanger mean bigger profits... that's why they're stocking up now for the big fall-winter selling season!

† Radio and Television Retailing—May

\*T. M. Reg.

Another  Product

**WEBSTER-CHICAGO**  
 Chicago 39, Illinois

# RAYTHEON

# means business!

## Raytheon Television Gives You All This Proof of Dependability!

Look at These Electronic Devices Made by  
RAYTHEON . . . unexcelled in electronics for 25 years!



**Tubes**—Raytheon pioneered in cathode ray, subminiature and other electronic tubes.



**Radar**—Raytheon revolutionized the making of radar.



**2-Way Radiophone**—Raytheon is a leading manufacturer of this electronic device.



**Radio**—Raytheon engineers made possible the first house current radios.

**Broadcasting Equipment**—Raytheon is a leader in TV and radio equipment.



## PLUS

### THIS EXTRA PROOF OF DEPENDABILITY



**PROOF!**  
Backed by famous Good Housekeeping Guaranty Seal.



**PROOF!**  
Backed by the most liberal one-year Warranty.



**PROOF!**  
Backed by Underwriters' Laboratories Seal.

with This Exciting NEW 1951 Line That Is  
**DEPENDABLY Built**  
for **DEPENDABLE**  
**Performance!**

A NEW LINE  
CONSUMERS WILL LIKE!



The new 1951 Raytheon television line can mean big profits for you! New models have extra sales appeal that means fast turnover—and they're priced to sell! Line includes table, console and combination models. Raytheon's generous discount on them means *big profits for you*.

**Backed by Aggressive Promotion** National advertising—plus hard-hitting merchandising—plus local advertising will all make your job of selling Raytheon easier.

**Don't Miss Out!** Discover the profits in store for you with this new 1951 Raytheon line. For complete information, contact your Raytheon distributor or write us today.

**BELMONT RADIO CORPORATION**

5921 W. DICKENS AVE., CHICAGO 39, ILLINOIS

Subsidiary of

RAYTHEON MANUFACTURING CO.

IT ALL ADDS UP TO  
BIGGER PROFITS  
FOR YOU!



A Dramatic New Line  
*Introducing Exclusive*  
 "Hidden Values"  
*by*  
**STROMBERG-CARLSON--**  
*Specialists in*  
**BIG-PICTURE TELEVISION**

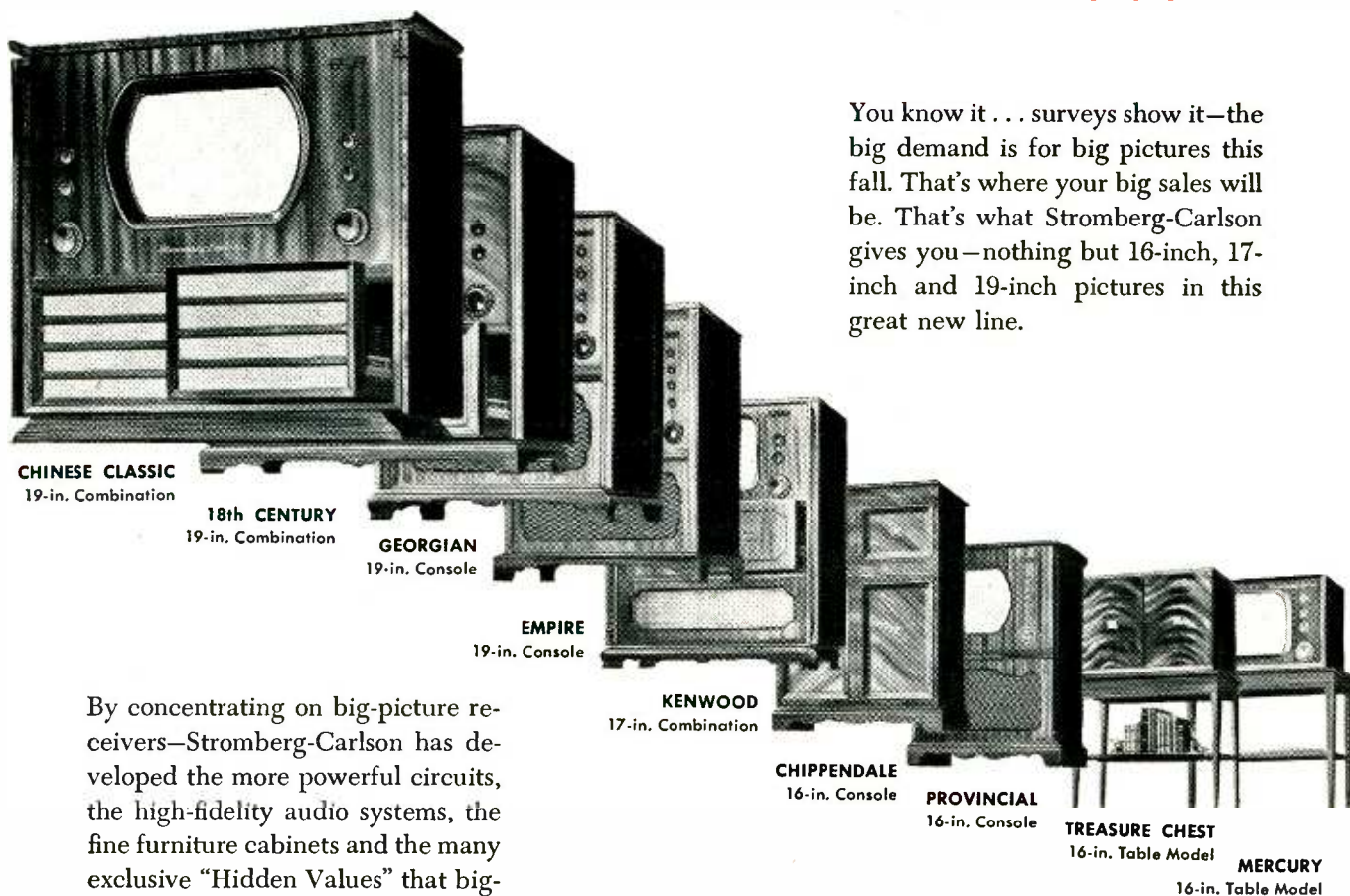

You know it . . . surveys show it—the big demand is for big pictures this fall. That's where your big sales will be. That's what Stromberg-Carlson gives you—nothing but 16-inch, 17-inch and 19-inch pictures in this great new line.

By concentrating on big-picture receivers—Stromberg-Carlson has developed the more powerful circuits, the high-fidelity audio systems, the fine furniture cabinets and the many exclusive "Hidden Values" that big-picture television demands.

*There is Nothing Finer Than a*  
**STROMBERG-CARLSON**

Stromberg-Carlson Company, Rochester 3, N. Y.—In Canada, Stromberg-Carlson Co., Ltd., Toronto

# RADIO & TELEVISION RETAILING

Including "RADIO & TELEVISION,"  
"RADIO & TELEVISION TODAY,"  
and "ELECTRICAL RETAILING"

O. H. CALDWELL, Editorial Director



M. CLEMENTS, Publisher

## *You and Radio-TV in America's Present Crisis*

The American military operation in Korea, coupled with worldwide unrest in a number of other hot spots, presents many serious problems for radio-TV here at home.

Rearmament on even a minor scale, with its tremendous demands for radio apparatus, is bound to involve acute civilian shortages in raw materials, parts, components, tubes and equipment.

Outright conversion of the radio-TV industry back to full war production is not yet up for consideration. But Washington officials are already studying plans by which radio factories will be called upon to assign, by priority, 20% to 25% of their facilities to military output of short lines.

The remaining 75% to 80% could then be continued in civilian and commercial manufacture of TV and radio, with all its benefits to our national economy and public morale.

### **Maintain High-Spirited Morale**

The manufacturers will thus be doing their part. Distributors and dealers can help by promptly absorbing available production, taking on normal inventories, and facilitating movement of sets and supplies to the public. For in this way, through the great agency of TV-radio (itself measured in billions), a vigorous national economy can be promoted and high-spirited national morale can be maintained.

At the retail level, the dealer's position is vitally

important in this crisis. In buying early and adequately he can help forestall shortages, thus performing a real service to his customers and to himself.

### **Preparedness for the Dealer**

The present situation should provide food for calm thought for far-sighted merchants. A concrete plan entitled, "What I would do if —" is very much in order. For instance, what merchandise are you selling today which is likely to dry up *immediately* if a "hot" war develops? What merchandise is likely to fade out slowly, and what is likely to be available all along? What will you do to replace the revenue from the short-supply items? What plant-and-equipment items do you have which are already in need of replacement or repair, and which are likely to become scarce, "if"? What plans can you make to fill gaps in personnel which might be caused by the draft? Remember how important Service was during the scarcity—can you expand your present facilities, "if"? These are but a few of the questions that merchants can ask themselves now in order to formulate a good working plan for the future.

\* \* \*

Sincerely, we hope the present crisis will not go beyond its present dimensions. But if it does, and radio-TV is eventually called upon to convert to all-out war production, radio-TV men will be found ready to tackle any job required of them.



# What's Ahead!—in Radio,

**SOME PANIC BUYING OF ELECTRICAL APPLIANCES** reported by dealers. As we went to press, one very large Eastern dealer was completely sold out of refrigerators and washers. Others say that flocks of "waiters" have suddenly made up their minds to replace old refrigerators and other equipment. "We're operating 15 hours a day to keep up with the demand," says one retailer.

*THE SITUATION IN THE TV-RADIO FIELD shapes up like this: Brisk buying by dealers is under way, but this is not due to the Korean situation, since before the trouble abroad started, the industry anticipated a heavy demand; expected to sell all it could produce this year. Many believe, however, that a greatly accelerated consumer demand is near at hand, and that it is likely to gobble up TV-radio inventories, thus shortening the duration of the peak selling season.*

**TELEVISION SETS IN USE** number 6,950,000 as of August 1. Number of TV stations on the air is still 106, with the following stations expected on the air before the end of this year (but none this summer): WSM-TV, Nashville, Tenn.; WJAX-TV, Jacksonville, Fla.; and WCON-TV, Atlanta, Ga.

*"THE UPTREND IN BUSINESS IN RECENT months has brought the economy as a whole back to within a stone's throw of the 1948 peaks."—Ewan Clague, commissioner of labor statistics, U.S. Department of Labor.*

**BETTER BUSINESS BUREAUS CRACKING DOWN** on "bait" advertising copy frequently used in offering rebuilt vacuum cleaners and sewing machines.

*BIG BUSINESS IN PA. REPORTED* by some dealers, with those in certain resort areas experiencing a real boom.

**WHAT MAKES A TV CITY?** Analysis of growth of TV shows four important factors: 1) Population, 2) Number of stations, 3) Whether stations originate programs, get them via network, or via kinescope, and 4) A difficult factor to define, which we might call "sales effort." Number of months with TV, with coax, and with more than one station are qualifying factors of the above. The following list of cities selected at random show the effects of these factors.

City	Years with TV	No. of Stations	Sets per 1000 families	Pop. Rank	Network
New York	11	7	403	1	Yes
Los Angeles	3	7	403	3	Yes
Boston	2.1	2	354	5	Yes
Minneapolis	2.3	2	306	16	Yes
New Haven	2.1	1	154	13	Yes
Seattle	1.7	1	102	19	Yes
Cincinnati	2.5	3	364	15	No
San Francisco	1.8	3	78	8	No
Providence	1.1	1	67	6	No
Milwaukee	2.7	1	357	17	No

**VICTIM OF THE PRICE-CUTTER** "is the competing retailer whose customers desert him because they have been led to believe that he overcharged on popular brands. Forced into an unequal price war against 'superior dollar power' of the price cutter, the small merchant may eventually be driven out of business, although honest and efficient."—Maurice Mermey, director of the Bureau of Education on Fair Trade.

*SIXTH ANNUAL PACIFIC ELECTRONIC EXHIBIT* opens in the Long Beach, California, municipal auditorium September 13, for a three-day run. The West Coast IRE convention will be held at the same time. L. W. Howard is chairman of the WCEMA exhibit committee; Heckert Parker is the exhibit manager. Displays will be housed in 136 booths.

**13-MEMBER SPECIAL SENATE COMMITTEE** will study problems of small business. Following will serve: John J. Sparkman, Alabama, chairman; Ernest W. McFarland, Arizona; Herbert R. O'Connor, Maryland; Russell B. Long, Louisiana; Guy M. Gillette, Iowa; Hubert H. Humphrey, Minnesota; Charles W. Tobey, New Hampshire; Leverett Saltonstall, Massachusetts; Edward J. Thye, Minnesota; R. C. Hendrickson, New Jersey; A. F. Schoepel, Kansas; Lester C. Hunt, Wyoming, and William Benton, Connecticut. U.S. Dept. of Commerce considers the small businessman to be a retailer whose annual sales are less than \$100,000 a year.

*SELLING IS MORE THAN PERSUASION. It is communication. It is skill in determining the other person's needs and problems. It is skill in helping people visualize the results and benefits of products and services. It is skill in seeing that products are used properly. This means that selling calls for more than the capacity to influence people and bowl them over.—From Electric Institute of Washington (D.C.) bulletin.*

**INCREASED LABOR COSTS FOR RADIOS** are analyzed in a recent report by the U.S. Bureau of Labor Statistics. Report shows that factory man-hours expended per unit increased 16% between 1939 and 1947. Broken down by types, the report shows that man-hours per unit for table radios rose 24%; console radios and combinations rose 27%; portable radios decreased 8% and auto radios decreased 5%. Actual (average) man hours expended per unit in 1947 ranged from 1.8 for table radios to 8.9 for console radio-phonograph combinations.

*WHETHER THEIR SALESMEN SHOULD "SPECIALIZE" in one product, such as TV, for instance, or whether men making calls on dealers should sell all products, is a big question confronting leading distributors who sell radio, appliances, etc. Many different plans now being used; others being considered by set and appliance wholesalers.*

# Appliances, Records and Television

**TIP TO DISTRIBUTOR SALES MANAGERS.** Comments made by a couple of retailers who recently returned questionnaires to this magazine: "I buy the most from the jobber salesman who visits me most frequently." . . . "In this area we seldom see the wholesale salesman because he has too many accounts to look after. We order by phone and by mail, but would buy more if someone came in once in a while and tried to sell us."

*THE TV BUSINESS WILL BE "JUST SIMPLY TERRIFIC" for the next 3 years, Ross D. Siragusa, Admiral president said at a Chicago meeting. He expressed the opinion that it would be two and one-half to three years before we'll have color television.*

**THE APPLIANCE BUSINESS IS GROWING!** According to H. L. Andrews, the vice-president in charge of the Appliance & Merchandise Department of GE, the new appliances introduced since the war produced a sales volume last year equal to the entire volume of all appliances in 1939. The entire electrical appliance industry, he said, has expanded more than 25 times since the end of World War I.

*SUGGESTIONS TO IMPROVE MERCHANDISING conditions as made by some distributors at recent Atlantic City convention included: "Instead of dropping prices on existing models to meet competition, the manufacturer should bring out a promotional model" . . . "To improve sales of electric housewares, the manufacturers should divide the country into 12 zones in order to get intensified promotion" . . . "To help dealers sell the newer products, such as dryers, disposers, air conditioning units, and dishwashers, the utilities could perform a great service if they'd introduce and promote such appliances for the retailer" . . . "You've got to love a product to do a good job with it" . . . "Dealers can often increase freezer sales by tying in promotion with perishable foods currently in good supply."*

**RECTANGULAR TV PICTURE TUBES** are expected by the end of this year to dominate most lines of new receiver models. The rectangulars, of course save space and reduce dimensions of cabinets (which cabinets account for 20% of the cost of average sets). In order to establish a basis for comparison with round tubes (which are measured by their diameter), rectangular

tubes are measured in terms of the diagonal. Efforts to bring about a future practice of rating sets in terms of picture width, are meeting with objections from sales managers who do not relish back tracking in the case of, say, pictures now known as "16-inch," to the more conservative 14 inches (or less) which is the real width of such a picture, as the home viewer sees it.

*"INSTALLMENT BUYING HAS BEEN A MAJOR FACTOR in giving the American people their highest standard of living. It is part and parcel of our economy and restrictions on its use can only slow up business and employment."—T. J. Newcomb, sales manager, Westinghouse Appliance Division.*

**BAD WEATHER FOR AM RADIO,** and the need for lightning protection, on all installations is shown on the accompanying chart, which reveals the average number of thunderstorm days in the U.S. for one summer month. Contours show which parts of the country get the most storms, and therefore the most

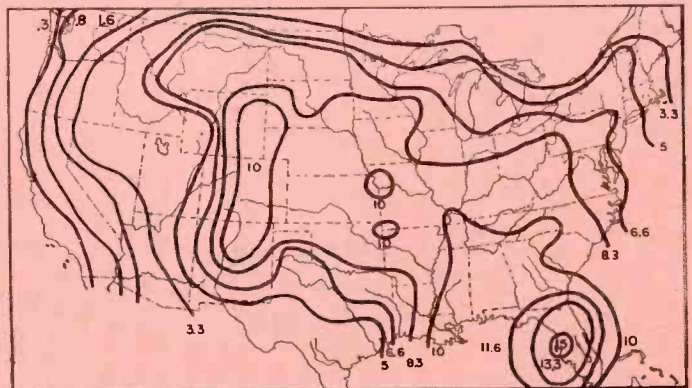

static. Noise intensity as received on radios follows the same contours, and is three to four times worse all over the country in the summer than in winter. It is during this "noisy weather" and especially in the "noisiest" areas on the map that the static-free qualities of FM radio are most appreciated.

*A NEW TRICOLORED XMAS TREE bulb with an enamel coating that can stand at least five Christmas seasons outdoors without fading has been developed by Westinghouse Lamp Division. It will sell at 13 cents, plus tax.*

## FUTURE EVENTS OF INTEREST TO READERS

**AUG. 7-19:** U. S. International Trade Fair, Chicago Coliseum, International Amphitheater and Navy Pier, Chicago.

**AUG. 27-30:** Western Housewares Show, Biltmore Hotel, Los Angeles, Cal.

**AUG. 27-SEPT. 1:** Radio Parts Distributors' Convention (NEDA), Cleveland Auditorium, Cleveland, O.

**SEPT. 13-15:** Pacific Electronic Exhibit, Municipal Auditorium, Long Beach, Cal.

**SEPT. 23-30:** First Consumer National Television and Electronics Exposition, 69th Armory, New York, N. Y.

**SEPT. 25-27:** 2nd Annual Radio and Television Service Convention and Exhibition, Broadwood Hotel, Phila., Pa.

**SEPT. 25-27:** National Electronics Conference Exhibition, Edgewater Beach Hotel, Chicago.

**SEPT. 30-OCT. 8:** Third Annual National Television & Electrical Living Show, Chicago Coliseum, Chicago.

**OCT. 11-Oct. 14:** 15th Annual Conference of the North Central Electrical Industries, Copley Plaza Hotel, Boston.



*It's a sell-out sensation!*

# RCA VICTOR MILLION PROOF *television*

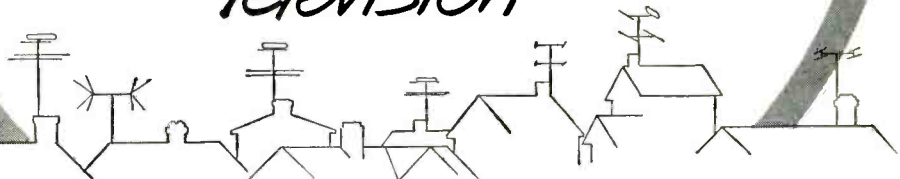

**PROVEN IN OVER A MILLION HOMES**



**The Fairfield.** Magnificent 16-inch console adds distinction to any home-setting. You'll name it the finest television, the finest furniture... and it's priced for you.

**The Provincial.** Authentic French Provincial-style cabinet—Million Proof 16-inch television. There's no finer—anywhere. 6T76.

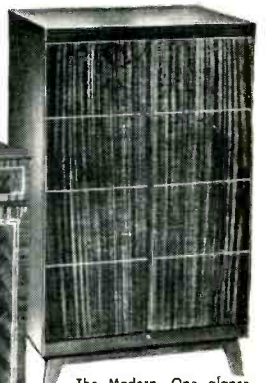

**The Kingsbury.** A blend of dignity and modern furniture design. Big 16" pictures are all modern—the clearest, swiftest Eye Witness view ever achieved. 6T64.

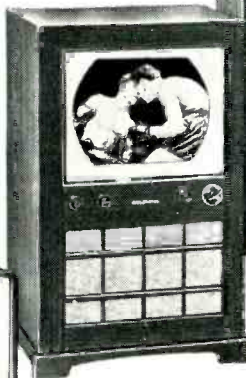

**The Highland.** Finely styled, and its big 16-inch screen shows you the finest view in television—Million Proof Eye Witness pictures. 6T65.

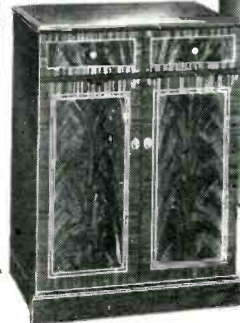

**The Regency.** Open these beautiful doors and you'll say, "The clearest, most modern television in the world!" 16-inch pictures are steady—locked in place. 6T74.

**The Modern.** One glance, and you'll know nothing could be more new-fashioned. Swivel cabinet can be turned to give you the best view of television's most popular 16-inch pictures. 6T75.



**The Kent.** Something different, something finer in 16-inch television—a conveniently complete furniture-ensemble. TV's favorite pictures in a high-style setting, at a new, low price. 6T54.

## **16-inch picture**

*Favorite size in America's favorite television*



**The Newport.** Tops in table-top television! 16 inches of clear, steady Million Proof pictures! A value only RCA Victor can offer. 6T53.

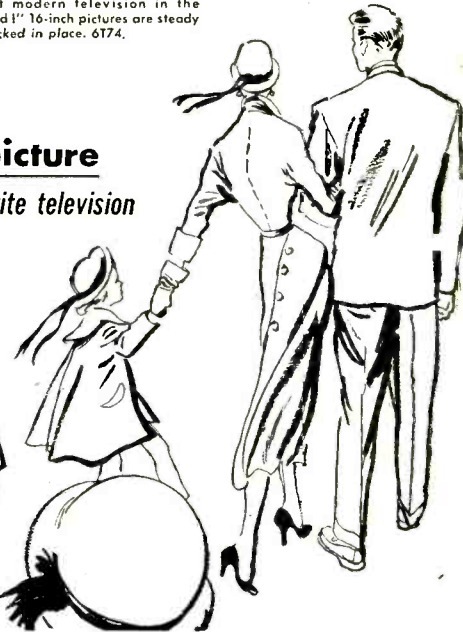



**TV's top  
12½-inch  
values**

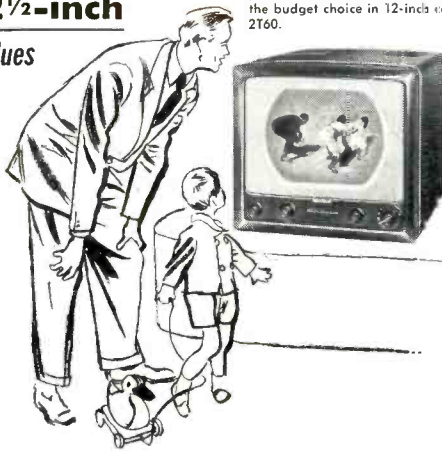

The Cumberland. Happy choice for period or contemporary rooms. The perfect choice for viewing pleasure, the budget choice in 12-inch consoles. 2T60.

The Shelby. Compact, maroon-plastic cabinet that's one-fourth smaller than previous 12½-inch sets. Matching Console-ette Base at slight extra cost. 2T51.

**19-inch pictures  
—almost as big as these 2 pages**

The York. RCA Victor television's biggest view... 19-inch screen. Exclusive Million Proof features. Matching Console-ette Base is optional, extra. 9T57.

The Hilldale. 19-inch Eye Witness pictures, thrillingly lifelike, in a cabinet of 18th Century elegance. Its performance is equally fine—Million Proof television—Styled to match. 9T77.

The Northampton. Superb—from the pictures on its huge, 19-inch screen to the last detail of its exquisite English Regency cabinet. 9T79.

It's almost unbelievable! Even with our factories smashing record after record, even with the greatest output in our entire history rushed to the field—the cry for more swells louder than ever. RCA Victor Million Proof Television is a sell-out success. Proven in over a million homes. More wanted than ever before. That's why the 18 brand-new TV models, RCA Victor's newest and finest speak for themselves as television's most complete, most profitable line. Million Proof RCA Victor is today's living proof of bigger-than-ever profits for you.

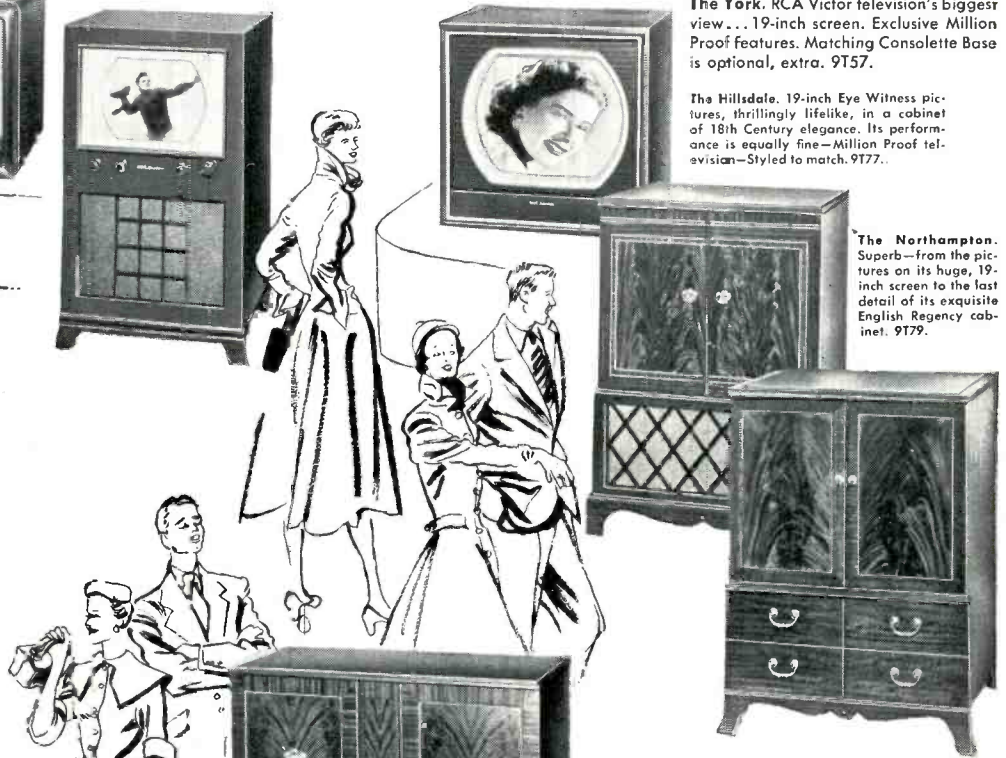

**TV-Radio-Phonograph  
Combinations**

The Fairfax. Superb 16-inch Eye Witness television plus AM radio, automatic changers for all-speed records—all in one distinguished cabinet. One of RCA Victor's newest combinations. 6T84.

The Hartford. 16-inch television, luxurious AM-FM radio, RCA Victor "45" and a second changer for 78 and 33½ rpm records. Extended tone range, too, for more lifelike music. 6T87.

The Sedgwick. 19-inch Eye Witness television, AM-FM radio, 2 automatic record changers. Extended tone range makes music more alive, more realistic. 9T89.

The Rutland. Traditional setting for up-to-the-minute entertainment! 16-inch television, AM-FM radio, and changers for all-speed records. Extended tone range adds depth and brilliance to music. 6T86.



The Somervell. An invitation to pleasure—at an invitingly low price. Beautifully grained doors conceal 12½-inch Million Proof television, AM radio, automatic record changers for all speeds. 2T81.

# RCA VICTOR

DIVISION OF RADIO CORPORATION OF AMERICA



**WORLD LEADER IN RADIO . . . FIRST IN RECORDED MUSIC . . . FIRST IN TELEVISION**





# Dealers Active at Their

## Personalized Service Is Aim of Remodeled Store

County Hardware Corp., selling TV, radio, records, appliances, housewares and hardware has opened its expanded and remodeled store, one of the largest in Westchester County, at 161 Gramatan Avenue, Mt. Vernon, N. Y.

Dimensions of the enlarged quarters and its capacity reach impressive figures. The sidewalk frontage of the store covers 190 feet. The square footage of the interior totals 18,000, and the fluorescent lighting tubes which interlace the ceiling approximate 1,200 running feet. An estimated 10,000 separate and different items are on display.

Wire for fixtures on display, for house current, and for aerials for television sets runs into thousands of feet.

The new "County" is twice as large in size as it previously was.

Although thoroughly departmentalized, a clear view of the entire store is possible from all sections.

### Modern Merchandising

A totally new and ultra-modern method of merchandising has been achieved throughout the premises. Straight lines have been eliminated, giving way to angulation which proves not only attractive but restful to the eye.

Rounded, cloud effects have been adopted in many of the departments, giving contrast to the angulation in other sections.

Show windows, as such, have been completely eliminated. The show windows now use the entire store as a picture, with emphasis on the entire content rather than on set pieces.

The decor uses clashing colors which have been subdued to their softest tones, thus giving a nicely blended effect.

Hy Cohn, vice president of the corporation, speaking for the firm emphasized that only the finest of nationally known brands are being handled, declaring, "It costs no more to own the best, and the customer deserves and gets the best."

Mr. Cohn emphasized that although the new premises now constitute "big store capacity," that the prime policy of the firm will be "personalized service."

"Everything that we do, from sales, delivery, and service, is contained within our store. The department manager

will always be available to our customers, and our service men will be only as far away from our customers as the nearest telephone," Mr. Cohn said.

The firm that now is operating County Hardware took over the store two-and-a-half years ago, and the expansion which now makes the store twice its original size is the climax of a program which has been developing since the beginning.

Officers of the firm include Jack Cohn,

president; Hy Cohn, vice president, and Sidney Sieger, secretary-treasurer. The firm has 70 employees on its staff.

Brands carried include Dumont, Magnavox, Caphart, RCA Victor, Admiral, Shaw, Freed-Eisemann, General Electric, Frigidaire, Westinghouse, Magic Chef, Tappan, Anderson, Welbilt, Hamilton, Estate, Easy, Bendix, Thor, Apex, Iron-Rite, Crosley, Hoover, Regina, Youngstown, Hygrade, Custom Kitchens, Toastmaster, Mixmaster, etc., and in phono records, Columbia, Decca, RCA Victor and London.

## Huge Sign Attracts Gothamites



One of the largest and most dramatic neon and incandescent signs ever built tops the new Dynamic Stores' Broadway and 65th Street operation in New York. It has 14 different animations. The interior of the store has been designed to create the effect of three stages, all open and visible from the sidewalk. The front of the store presents an expanse of 75 feet of glass and stainless steel.

**TUCSON, ARIZONA, DEALER** uses small newspaper space effectively. Don Means, 738 E. B'way, runs copy like the following: "Don Means Sells Westinghouse," and another, "Need Appliances? See Don Means." Address and phone number appears in foregoing ads—nothing else. Ads are single column, about 1½ inches deep.

**BRIDGEPORT, CONN., DEALERS HAVE** been using newspaper ads offering to convert small TV sets to larger screen units. Two of those stressing such service are Television & Appliance Headquarters and Barney's.

**REED ELECTRIC, LANSING, MICH.,** advertising that it replaces "slow, inefficient" electric heating units in ranges with T-K Monotubes.

"**TELEVISION HEADQUARTERS IN LANSING**" is the heading over attractive newspaper copy run by Barker-Fowler Electric Co., in the Michigan state capital. Ads plug GE, Admiral, Motorola, Zenith. Vandervoort, in the same city, features the "Arvin Television Show" in its advertisements. Others running attractive copy include East Lansing Electric Co., Campus Music Shop, Willis Radio Co., Central Stores, and Arbaugh's.

**FREE HOME OR OFFICE TRIAL PLAN** on Philco air conditioners being offered by Zemel Bros., Bridgeport, Conn., via newspaper ads. The firm has also been advertising Webster-Chicago record changers and wire recorders.



# Point-of-Sale Posts

## 50 Thousand Saw Exhibit



Ideas for a display at fairs, home shows, etc., can be obtained from a study of the photograph of this novel set-up of Universal major appliances shown at a recent home exhibit in Springfield, Mass., by the Pieroway Electric Company.

## Display of Old and New



This window exhibit showing the "then and now" of television proved to be a traffic stopper for the Center Music Store, 63 West 49th St., New York City. At the left is a 1928 Pilot TV set with a mechanical scanning disc, which in its day provided a "picture" about 2 inches square, while at the right are the latest model Pilot sets.

**LUXURY LINKED WITH LEISURE** proved good selling for Electric Service, Inc., Holyoke, Mass. The firm borrowed a mannequin from a nearby dress shop for use in its window display of GE dishwashers. It sold more dishwashers and the dress shop sold more dresses! Dress shop proprietor wanted this double-barreled display continued for another week.

**A TELEVISION TONIC** is offered in ads by the Television Engineers, Inc., 1539 W. Harrison, Chicago, Ill. The firm is plugging a periodic checkup including a written report on the condition and performance of TV set and antenna. The "tonic" includes: check antenna performance, examine chassis, readjust kinescope alignment, readjust kinescope coils, readjust electronic controls, readjust horizontal synchronization control, calibrate tuning, test over-all performance, clean and polish safety glass and tube face, and furnish complete analysis report.

## He Takes the Products to the Customer!

Home appliance sales have been increased greatly by the Hough Home Equipment Co., 144 King St., St. Augustine, Fla., through use of a house-to-house demonstrator truck which carries the products of seven nationally known manufacturers.

Actual washing of clothes and ironing are demonstrated in the unique truck which is driven into the driveway of a prospective customer. There water and electrical connections are made quickly, and dramatic demonstrations are given to the housewife and any neighbors she may invite.

G. S. Hough, enterprising owner of the home appliance retail sales concern, decided to put the mobile demonstration unit in operation when he noticed a small decline in buyers in his store. He now takes his goods to the buyers.



Salesman J. K. Getchell demonstrates one of the two washers installed in the house-to-house Dodge Route-Van truck operated by Hough Home Equipment Co. of St. Augustine, Fla. Housewives always are glad to supply the soiled clothes necessary for making a home demonstration.

He chose a 12½-foot Dodge Route-Van truck with 462 cubic feet of display space to serve as the home appliance "store-on-wheels." This newly developed vehicle provides six-foot, four-inches of headroom for the display of kitchen cabinets above sinks, washers and ironers. Six feet of width also provide ample aisle space between the two rows of merchandise on display.

The "store-on-wheels" carries Norge appliances, two Bendix automatic home laundries and clothes dryers, six wall cabinets and sinks made by Youngstown Kitchens, a New Home sewing machine, Kresky oil burners, an Iron-Rite ironer, and Zenith radio sets. Mr. Hough also plans to carry smaller items such as hand irons, electric fans, por-

table electric heaters, toasters, and hair dryers.

Salesmen for the company no longer wait for prospects to visit the downtown



All the home appliances needed to do a family wash are demonstrated in the house-to-house truck by Hough Home Equipment Co. of St. Augustine, Fla. Wet clothes from the washer are first dried in the gas dryer. Then the housewife is shown how easy it is to iron the clothes on the electric ironer. Many sign an order on the spot.

home appliance store. Instead, they drive the truck to the home of prospects both in the city and in surrounding areas and conduct actual demonstrations.

The Dodge truck has been equipped with a built-in water system, a heater which uses bottled gas, and a built-in electric system wired for 110-volt current. Water is supplied to the copper pipes within the truck by connecting an



Hough Home Equipment Co. reports increased sales of home appliances from this house-to-house Dodge truck.

ordinary garden hose to the faucet which is available at the side of most homes. Likewise, the electric current is obtained through a long extension cord carried within the truck.

(Continued on page 102)



# Go After Those Summer Sales

**Effects of Seasonal Drop in Store Traffic Can Be Offset by**

**Making More Calls at the Homes in Your Territory**

• When store traffic falls off in the summer, the smart salesman increases his activity in the outside field, making calls on regular customers, recently-contacted prospects, those who've made recent purchases, or on just plain "suspects."

Since it is an established and well-known fact that most couples go into huddles over the purchase of any big-ticket product in our field, the ideal way to get more sales is to see the husband and wife together. The salesman who makes evening and Saturday calls is bound to obtain satisfactory results. He can often close a pending deal. He can often close a new transaction, and he is bound to develop a lot of new prospects.

Those early evening and Saturday calls often provide the opportunity to meet the family on the porch, on the lawn, or out in the garden. In such cases, the salesman doesn't even have to ring a doorbell. He meets the husband and wife in the relaxed atmosphere of their own home. His call is done in a casual manner. He can discuss the flowers, the householder's lawn,

The field is ripe for door-to-door selling which is not overworked at this time.



## Put These on Your CALLING LIST

Your regular customers  
Recently contacted prospects  
"Strangers" (through cold canvassing)  
Those who've made recent purchases

and a hundred and one other subjects that suggest themselves.

In making such calls, eager-beaverism tactics are definitely out. This doesn't mean that the salesman should fail to make known the reason for his call, nor should he continue to talk about other subjects to the exclusion of trying to sell something. On the other hand, salesmen making home calls must realize that they are meeting prospective customers under totally different conditions than those prevailing in the store. Store visitors are usually, and we might say inherently, on their guard. They may *want* to buy something, but they also *want to be sold*. At the same time they want to retain the right to say "no."

The salesman who drops in on a couple, working, say in a garden, usually finds such folks to be a lot more on the friendly side than they are in the more or less stilted atmosphere of even the friendliest store. They are at

## "Preparing" the Territory

A day or so ahead of making cold canvass calls, have circulars or business cards distributed in area to be worked. Good idea to use the "Our-John - Smith - will - call-on-you-soon" message on printed material.

ease, and they are in the midst of everything that's dear and personal to them. They are proud of what they have, and they like to share this pride with others—even salesmen, provided the latter act like *human beings* when making home calls.

To act like a human being, the salesman needs to be much more than a man who merely hopes to sell some-

thing, and get out. The good salesman is *genuinely interested* in people, and in many other things as well. He is willing to spend some of his time talking the householder's "shop", and in return, can expect to be given time to sell his own products.

In making outside calls, the successful salesman needs to possess a "versatile" education, not necessarily acquired in any school. The ability to talk on many subjects is just as necessary as is the ability to present products in a manner designed to create desire to own on the part of the customer. The salesman who likes to meet and talk with people feels right at



The good salesman enjoys outside selling. (Photo courtesy Landers, Frary & Clark, New Britain, Conn. They have again made available the vac cleaner sales manual, "Joe Goes to Town.")

home in the outside field.

Various situations require different approaches in making calls. The man on a cold canvass trip should immediately introduce himself and make known the purpose of his call. Greeted with a "not interested" response, many a good salesman has gotten an immediate sale or a well qualified prospect by accepting such statement graciously, and changing the subject, temporarily, at least.

When calling on regular customers whom the salesman knows well, a cordial greeting is in order. This may be



# in the Outside Field!

followed by some small talk which, before long, should be developed by the salesman into a direct inquiry as to possible needs, or the suggestion of some particular product.

## Good Leads

Calls on those customers who've recently bought something from the store are good-will visits. The salesman should offer to explain or demonstrate any features not thoroughly understood. Importantly, too, he should make an endeavor to get leads. Many important leads can be had from such recent customers. Statements such as "I was showing my neighbor how my new washing machine works," should instantly suggest to the alert salesman that there is a neighbor in the vicinity who has shown interest in a washing machine and may very well be a prospect for another sale.

Follow-up calls on recently-contacted prospects should be made on a direct-action basis. In other words, the salesman should make a forthright statement concerning the purpose of his visit, suggesting that the customer give him the order at that time. By "recently-contacted" prospects we mean those who have visited the store, expressing interest in some product as well as those the salesman has previously called upon in the home.

In making those "yard" and "porch" calls, it's a good idea to carry a few products in the car. A hot evening, for instance, is a good time to say, "I have

## Evening and Saturday Visits Are the Best Bets, Because—

You'll usually find the husband and wife at home. Remember that 90% of all sales decisions on purchases of TV, expensive radios, and large appliances are made jointly by married couples.

a new type electric fan in my car. Would you like to try it?" or, the salesman can suggest the demonstration of a portable radio, or a three-speed phono changer to replace the one in that combination he sold in this home some years ago.

Other "equipment" the salesman needs to carry includes manufacturers' literature on TV and radio receivers, laundry and kitchen equipment, etc., as well as a list of satisfied users in the particular vicinity he's working.

"Prepared" territory is always easier



In viewing the importance of outside selling it is well to realize that almost all big-ticket sales are actually decided upon in the home.

to operate in. In addition to the use of newspaper, direct-mail, radio time and other mediums, it's an excellent idea to circularize a certain area a few days before the calls are made. (The follow-

## Take Products with You

The outside man should carry some items in his car. For instance, a vacuum cleaner, a portable radio, a couple of fans, a 3-speed phono replacement unit, and circulars on TV, combinations, major appliances, etc.

ing day is the best.) Printed matter should carry some such message as, "Our John Smith will call on you shortly. We will appreciate your courtesy in giving him some of your time." Such messages should never term the salesman "mister", nor should he call himself by this or any other title.

The outside field is wide open now. It's not overworked as it was before the war, and any good salesman who is willing to work hard can make a lot of sales.

Outside selling on Saturdays and early evenings has been emphasized because such times usually produce the greatest number of actual sales, but no firm should overlook the value of outside work at any time. Calls made during weekdays often result in outright sales, and are a prime method of obtaining leads and preparing the way for callbacks.

Also, in this article considerable space has been devoted to the "psychological"

"Backyard" selling is profitable for the salesman who makes calls in a friendly, human manner. The couple shown working in the garden need to take a breather just about the time Salesman Jones drops in. Under relaxed conditions, Mr. and Mrs. Householder can talk about their needs, free from the restraint many consumers place themselves under while in stores.

side of "yard, porch and garden" selling, because here, the salesman who loves his work and likes people is going to shine—the knock-'em-dead type who hasn't time to smile at the kids, is going to get the cold-shoulder.

The salesman who is invited to sit down and sip a cold drink by the couple who feel like taking a little breather, a little rest from that chore of weeding the garden, is in. If he doesn't make a sale then and there, the latchstring will be out for him when he calls again.

Work, out in the field is fun—especially in the summer. It's not only fun, but it's profitable. And it's just what the doctor ordered to make up for that seasonal drop in store sales.

One salesman we know signed up an order for a new refrigerator while sitting as a guest in the cool backyard of a customer who'd invited him to enjoy a barbecue supper. "For this I get paid," he thought to himself. And, brother, he was right!





# Distributors Ready for Cleveland Convention

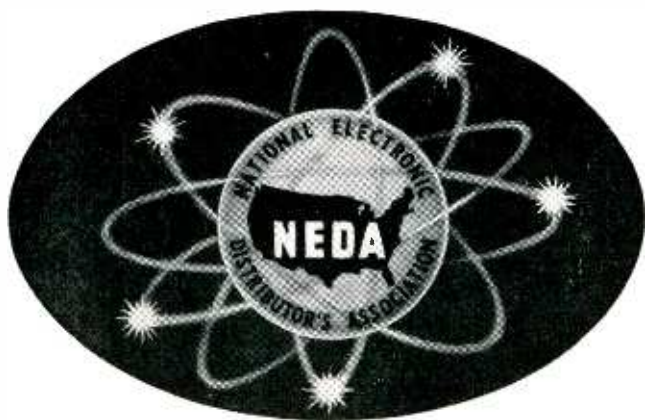

• Cleveland is ready to act as host to parts distributors from all over the country when the National Electronic Distributors Association holds its convention and show, August 27 to 31. Prior to the official opening, NEDA committee meetings will be held in the Hollenden Hotel. Exhibits in the Cleveland Auditorium will open on August 29, and will close August 31, at 6 P.M. A busy and worthwhile program has been arranged. There will be lectures and open discussions on store arrangement, sales techniques, cost of doing business, taxes, inventory, etc. All recognized parts distributors are invited to attend, and members of NEDA registering at the convention and attending lectures will receive a total of approximately \$50.00 per member firm. The national office stated that it hopes that in succeeding years it may be able to share to an even greater extent, the expenses of its membership.

## Program of Events

On Monday, at 9 A.M., Harold H. Bredell, treasurer of the American Bar Association, will deliver an address, "A Business Is Born." At 11 A.M., Donald J. Erickson, member of a firm of international accountants will use as his subject, "A Business in Operation." At 2 P.M., Don G. Mitchell, president of Sylvania Electric Products, Inc., will speak on "Building for the Future." Members and non-members of NEDA are invited to the annual general meeting at 8 P.M.

On Tuesday, the fourth technical session will be addressed by H. F. Bersche, manager of renewal sales, RCA Tube Department. At 9 A.M., Wednesday, Joseph T. Bellew, analyst-consultant, will speak on "The Distributor's Place in the Community." A special women's program has been arranged.

A number of leading manufacturers will have interesting displays in the Auditorium.

Exhibits will feature a wide range of radio-TV components and accessories, test instruments, public address systems and phono equipment. Member and non-member distributors from various sections of the country will attend.

## List of Exhibitors

Aerovox Corp., 740 Belleville Ave., New Bedford, Mass.  
Aircraft-Marine Products, Inc., 1523 N. Fourth Ave., Harrisburg, Pa.  
All Channel Antenna Corp., 70-07 Queens Blvd., Woodside, N. Y.  
Alliance Mfg. Co., Lake Park Blvd., Alliance, Ohio  
Alprodc, Inc., Mineral Wells, Texas  
American Phenolic Corp., 1830 S. 54th St., Chicago, Ill.  
The Astatic Corp., Harbor & Jackson Sts., Conneaut, Ohio  
Automatic Radio Mfg. Co., Inc., 122 Brookline Ave., Boston 15, Mass.  
Baker Mfg. Co., Evansville, Wis.  
Bell Sound Systems, Inc., 555 N. Marions Rd., Columbus 7, Ohio  
L. S. Brach Mfg., 200 Central Ave., Newark, N. J.  
Bud Radio, 2118 E. 55th St., Cleveland, Ohio  
Burgess Battery Co., Freeport, Ill.  
Centralab, Div. of Globe-Union, Inc., 900 E. Keefe Ave., Milwaukee, Wis.  
Channel Master Corp., Napanoch Rd., Ellenville, N. Y.  
Chicago Transformer Division, 3501 W. Addison St., Chicago 18, Ill.  
Cleveland Electronics, Inc., 6611 Euclid Ave., Cleveland 3, Ohio  
Copperweld Steel Co., Glassport, Pa.  
Cornell-Dubilier Electric Corp., 1006 Hamilton Blvd., So. Plainfield, N. J.  
DuMont Laboratories, Inc., 1000 Main Ave., Clinton, N. J.  
Eicor, Inc., 1501 W. Congress St., Chicago 7, Ill.  
Electro-Voice, Inc., Cecil & Carroll Sts., Buchanan, Mich.  
Electrovox Co., Inc., 60 Franklin St., East Orange, N. J.  
Erie Resistor Corp., Erie, Pa.  
Fidelitons, Inc., 6415 Ravenswood Ave., Chicago 26, Ill.  
General Cement Mfg. Co., 919 Taylor Ave., Rockford, Ill.  
General Electric Co., 1 River Rd., Schenectady 5, N. Y.  
Greenlee Tool Co., Rockford, Ill.  
Hallcrafters Co., 4401 W. Fifth Ave., Chicago, Ill.  
Hickok Electrical Instrument Co., 10514 Dupont Ave., Cleveland, Ohio  
Hytron Radio & Electronics Corp., 76 Lafayette St., Salem, Mass.  
International Resistance Co., 401 N. Broad St., Phila. 8, Pa.

**Large Attendance Expected - -  
Business Forums to be Held - -  
Many Exhibits**

Jensen Industries, Inc., 329 S. Wood St., Chicago, Ill.  
Jersey Specialties Co., Little Falls, N. J.  
JFD Manufacturing Co., Inc., 6101 Sixteenth Ave., Brooklyn 4, N. Y.  
The LaPointe Plascomold Corp., Unionville, Conn.  
Littelfuse, Inc., 4757 Ravenswood Ave., Chicago, Ill.  
P. R. Mallory & Co., Inc., East Washington St., Indianapolis, Ind.  
Meissner Mfg. Div., Mt. Carmel, Ill.  
Merit Coil & Transformer Corp., 4427 N. Clark St., Chicago 40, Ill.  
Minnesota Mining & Mfg. Co., 900 Fauquier St., St. Paul, Minn.  
Modern-Aire Mfg. Corp., 4436 W. Roosevelt Rd., Chicago, Ill.  
National Carbon Division, Union Carbide & Carbon Corp., 30 E. 42nd St., New York 17, N. Y.  
National Co., Inc., 61 Sherman St., Malden 48, Mass.  
National Union Radio Corp., 350 Scotland Rd., Orange, N. J.  
Oak Ridge Products, 239 E. 127th St., New York, N. Y.  
Ohmite Mfg. Co., 4835 Flournoy St., Chicago 44, Ill.  
Penn Boiler & Burner Mfg. Co., Lancaster, Pa.  
Penn Television Products Co., 131 N. Seventh St., Phila. 6, Pa.  
C. M. Penney Co., 3471 W. 140th St., Cleveland 11, Ohio  
Pentron Corp., 611 W. Division St., Chicago 10, Ill.  
Permoflux Corp., 4909 W. Grand Ave., Chicago, Ill.  
Phoenix Electronics, Inc., Lawrence & Canal Sts., Lawrence, Mass.  
Precision Apparatus Co., Inc., 92-27 Horace Harding Blvd., Elmhurst, L. I., N. Y.  
Radelco Mfg. Co., 7580 Garfield Blvd., Cleveland 25, Ohio  
Radiart Corp., 3571 W. 62nd St., Cleveland 2, Ohio  
Radio Corporation of America, RCA Victor Division, Camden 2, N. J.  
The Radio Craftsmen, Inc., 1617 S. Michigan Ave., Chicago 16, Ill.  
Radio Merchandise Sales, Inc., 1165 Southern Blvd., New York, N. Y.  
The Rauland Corp., 4245 N. Knox Ave., Chicago 41, Ill.  
Raytheon Mfg. Co., 55 Chapel St., Newton, Mass.  
John F. Rider Publisher, Inc., 480 Canal St., New York 13, N. Y.  
Howard W. Sams & Co., Inc., 2201 E. 46th St., Indianapolis 5, Ind.  
Sangamo Electric Co., Springfield, Ill.  
Sheldon Electric Co., 68-69 Colt St., Irvington 11, N. J.  
Shurite Meters, 61 Hamilton St., New Haven 8, Conn.  
Simpson Electric Co., 5208 W. Kinzie St., Chicago, Ill.  
Snyder Mfg. Co., 22nd & Ontario Sts., Philadelphia 40, Pa.  
South River Metal Products Co., Inc., 17-19 Obert St., South River, N. J.  
Sprague Electric Co., North Adams, Mass.  
Stevens Walden, Inc., 475 Shrewsbury St., Worcester, Mass.  
Sylvania Electric Products, Inc., 1740 Broadway, New York 19, N. Y.  
Technical Appliance Co., Sherburne, N. Y.  
Telematic Industries, Inc., 1 Joralemon St., Brooklyn 2, N. Y.  
Television Equipment Corp., 238 William St., New York 7, N. Y.  
Telrex, Inc., Asbury Park, N. J.  
The Triplett Electrical Instrument Co., Harmon, Rd., Bluffton, Ohio  
Trio Mfg. Co., Griggsville, Ill.  
Tung-Sol Lamp Works, Inc., 95 8th Ave., Newark, N. J.  
T-V Products Co., 152 Sandford St., Brooklyn, N. Y.  
U. S. Devices Corp., So. Plainfield, N. J.  
University Loudspeakers, Inc., 80 S. Kenisco Ave., White Plains, N. Y.  
Utah Speakers, Huntington, Ind.  
Vaco Products Co., 317 E. Ontario St., Chicago 11, Ill.  
Victoria Mfg. & Sales Co., 619 N. Michigan Ave., Chicago 11, Ill.  
V-M Corporation, Fourth & Park Sts., Benton Harbor, Mich.  
Ward Products Corp., 1523 E. 45th St., Cleveland, Ohio  
Webster-Chicago Corp., 5610 Bloomingdale Ave., Chicago 39, Ill.  
The Workshop Associates, Inc., 66 Needham St., Newton Highlands 61, Mass.  
Worner Electronic Devices Co., Rankin, Ill.  
Wright, Inc., 223 University Ave., St. Paul 4, Minn.  
X-Tra Signal Co., 60 E. 42nd St., New York 17, N. Y.

# Successful Selling in Fringe Areas

**Dealer Making Money on Long-Distance TV Finds Sales and  
Service Go Hand-in-Hand in Building Profits**

• If you ask Clay McDaniel and his partners how their "House of Music" has achieved success selling TV in a fringe area, you will probably get the answer, "Well, it's a long story . . ." It isn't such a long story from the standpoint of time, as these up and coming dealers in Riverhead, N. Y., have only been in business three years. But the story of how they became one of the leaders in TV in their area takes a little telling—and points several interesting lessons for other dealers in this type of business, or about to embark on it.

## **One Year Ago**

A little over a year ago, television didn't mean much to the House of Music, or to any of the other dealers in their area. Some TV sets had been and were being sold, but at a very slow rate—perhaps 2 or 3 sets a month for H. of M.

This was mainly due to very poor pictures received, so poor and unpredictable that TV was more or less of a novelty. In addition, installations were expensive (as well as experimental) to get such results as could be obtained. Added to the cost of the set, this brought the sale to a figure which made the prospective customer think twice about the value of the pictures and the programs which he was offered.

The owners of House of Music (representing sales) sat down with the service department and had a council of war to decide what to do: to drop TV, or to find some new way to make it acceptable both to the customers and to the P & L statement.

## **Best Picture in Town**

The situation as analyzed was as follows: House of Music was new in the area, and in order to get this business it would have to do better than any of the older established dealers. The parties to the pow-wow decided that this meant the best picture in town.

The physical situation was like this: the area covered by this Long Island, N. Y., firm is from 80 to 125 miles from the seven stations in New York City, and from 40 to 70 miles from the one



Ed Geyer, service manager of Southampton store, House of Music.

station in New Haven Conn. (Channel 6). Despite the relative closeness of the latter station, results obtained on it had not been too good, reception being more difficult than the conditions would indicate.

## **Concentrate on Good Picture**

House of Music decided to concentrate on getting a good picture from Channel 6 because it was closer and more likely to be dependable, even though (from the standpoint of number of stations) it offered only one-seventh as much entertainment as an antenna pointed toward the west.

It was also felt that it was necessary to bring down the cost of the initial installation, and that the closer station offered more possibilities in this quarter.

The service managers of House of Music's two stores had heard considerable about Yagi antennas, and felt that there was much to be hoped for in this type. At that time, however, there were no Channel 6 Yagis available. Deciding to give this a try, they persuaded an antenna manufacturer to make a few especially for them.

"That antenna put us in business," McDaniel and his group unanimously agree. The first pictures with a Yagi were so superior to anything hitherto

obtained in that area, they stated, that the House of Music was immediately placed on the television map. According to the enthusiastic proprietors and employes, they found older and more experienced dealers following the lead of what they described as their "little record shop."

They did not "junk" the seven New York stations. They merely used their nearly-perfect Channel 6 picture as an opening wedge to make their reputation and make sales. They also provided an antenna for the other stations, either at the time of installation (if the customer requested it) or later on (sooner or later the customer always asked for the other stations). But now, with improved techniques due to their experience, with improved materials which had become available, and particularly with the better antennas that had come on the market, the firm is really in the fringe selling business.

## **Importance of Servicemen**

Recognizing the importance of the servicemen in this set-up, House of Music of course maintains its own service department, and chooses employes best suited to the operation. The men must have know-how in TV, must be  
(Continued on next page)



**RECEPTION poor..**

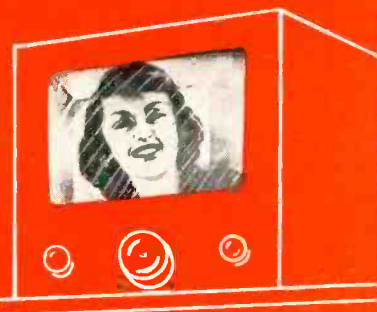

# **ANCHOR BOOSTERS**

**See your TV  
reception become  
gloriously life-like**

means the difference between good reception  
and bad.

If you live in a suburban or fringe area or in an  
area with strong electrical interferences, or if your  
TV set has a built-in antenna, you probably need a  
booster. If you do, let us show you how an ANCHOR  
BOOSTER makes every picture clear and distinct.



**Anchor is the nation's leading booster, and the odds-on favorite of TV engineers everywhere. For real "front row" performance, insist on an Anchor. Superbly styled, compact, efficient, it will give you years of top notch reception.**

... is your TV REC

*then ask us about*

# ANCHOR BOOSTERS

*The Finest  
TV  
Pre-Amplifiers  
Ever Made!*

Take a front row seat for your favorite TV program. Thousands of apartment dwellers, suburban and fringe area residents the nation over are getting that "front row" view, that clear, sharp, snow-free reception, by simply adding an ANCHOR BOOSTER. Inexpensive, easy to install, the ANCHOR BOOSTER eliminates that fuzziness and haziness which

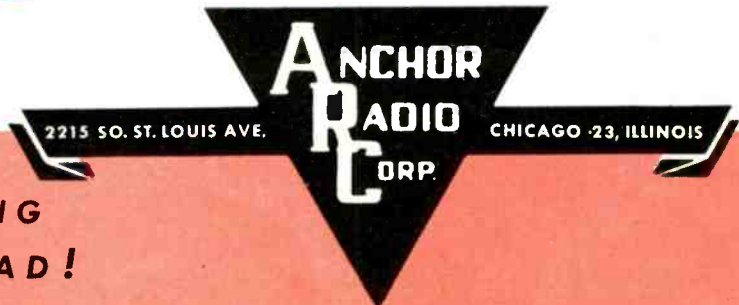

ANCHOR ENGINEERING  
ALWAYS A YEAR AHEAD!



## Successful Selling in Fringe Areas

(Continued from preceding page)

personable and able to meet the customer in his home on even ground, and in addition must have native abilities as a carpenter and mechanic. These latter abilities were underlined, since a fringe installation is practically a major construction job.

House of Music was born on a beach in the Pacific during the war, the idea being conceived by Clay McDaniel and the concert piano team of Whittemore and Lowe, who were all GI's together, and who decided that they jointly wanted to open a record store after the war. The execution of the idea had to wait until they could find a suitable location and raise the necessary capital. The opportunity came in Southampton, N. Y. in 1947, and for capital they brought in two additional partners, Dibble, and Bill Judd, a member of the concert booking agency which handles Whittemore and Lowe. McDaniel and Dibble do most of the managing of the firm, with the other partners more or less "silent."

When TV came along, they natu-

rally went along with it, with the experiences before described. This merchandise is rapidly assuming major importance in their operation, which includes radios, TV, records, radio-TV service, sheet music, pianos, and musical instruments. Started with a capital of \$18,000 three years ago, the firm expects to do \$150,000 business this year.

TV installation and service accounts for the bulk of the activity of the service department, and this department is designed to show a profit—and it is showing a profit, though a small one. This is due to a careful estimation of costs, buying only the best materials (so as to cut down maintenance costs), and efficient methods.

"You can't save money on a fringe installation by using lower-priced equipment and materials," Ed Kukla, service manager of the Riverhead store pointed out. "This is especially true where the installation is subject to high winds and salt water corrosion."

### Fringe "Facts-of-Life"

Some of the facts-of-life of fringe installations as outlined by Kukla and by Ed Geyer, Southampton House of Music service manager, are: Salt spray in the air will cause low-priced twin-lead to corrode *inside the polyethylene sheath* within a matter of two or three weeks, causing severe attenuation of the signal. In a fringe area, where the signal is weak to start with, these may mean complete loss of picture. Lead-in wires laying on the roof, or very close to it will result in very severe loss of signal when the roof is damp. House of Music uses 7-inch standoffs to keep the lines away from the roof and the sides of the building. When separate lead-ins from two antennas are brought into the house through the same hole, interaction and attenuation result which makes the installation of two antennas virtually useless. In extreme fringe locations (as in this area, 75 to 125 miles) the signal does not come to the antenna directly through the air, since the line of sight path would be several thousand feet up. Actually, due to refraction from the ionosphere, the signal is bent down to the earth, and may be available relatively close to the ground. House of Music installers found that, in most of their locations, height above 20 or 30 feet was of no particular value in getting the New York stations. For Channel 6, however, reception is line of sight, and a height of 75 feet above sea-level was found necessary on the south shore of Long Island to get this Connecticut station. Therefore, oddly enough, House of Music puts the higher antenna up for the closer station. There is not complete agreement on this fact in that area, some installers putting the New York antenna on top of the mast, but House of Music points to its superior results for proof of their contention. They find that a very good grounding of the mast is essential, not only for lightning protection, but also for the elimination (or at least the reduction) of ignition interference. They sink a good ground rod several feet into



Ed Kukla, service manager, Riverhead branch.

the ground, and use a guy-wire for a ground wire. Kukla and Geyer agreed that it is necessary to keep lead-in wires (which they twist for noise-reduction) "as tight as a violin string." This is because any swaying in the breeze will cause "breathing" of the picture at those distances. House of Music always sells a booster for reception of the distant (N. Y.) stations, and have standardized on one particular make which they feel gives the best results. Receivers, where results are particularly critical, are slightly realigned to bring the sound and picture carriers closer together when the customer tunes his set for the brightest picture (which actually puts the picture higher on the curve than was intended).

### Combos, Records Sell Well

Started as a record store, House of Music still finds records important. "Our biggest gross profit (dollars) is in TV, but our biggest take-home profit is in records." House of Music claims to have one of the largest and most successful record departments within a 50-mile area. Two of the key sales features which make this possible are: 1) That the sales personnel know their stock well, and have a good knowledge of artists and repertoire on classical and semi-classical music, which accounts for a substantial portion of the trade; and 2) Very careful attention is given to handling orders for records which are not in stock. These items are ordered, the orders are followed up, and the customer is promptly notified as to disposition of the order, or the receipt of the record. This program has had signal success in building record trade in an area which doesn't warrant handling as large a stock as the metropolitan stores. In the Riverhead store, a loud-speaker on the sidewalk is in use most of the time, and can be connected to radio, TV or phonograph turntable. This serves to draw attention to the "Music" in "House of Music." This is not done in Southampton due to an ordinance against it. Console radio-phonographs and portable radios play an important part in the overall sales picture, with FM considered important in obtaining interference and static free reception not available on AM: "Reception on AM is too good here—you can get hundreds of stations, but it is difficult to get only one at a time."

An actual tower installation by the House of Music.

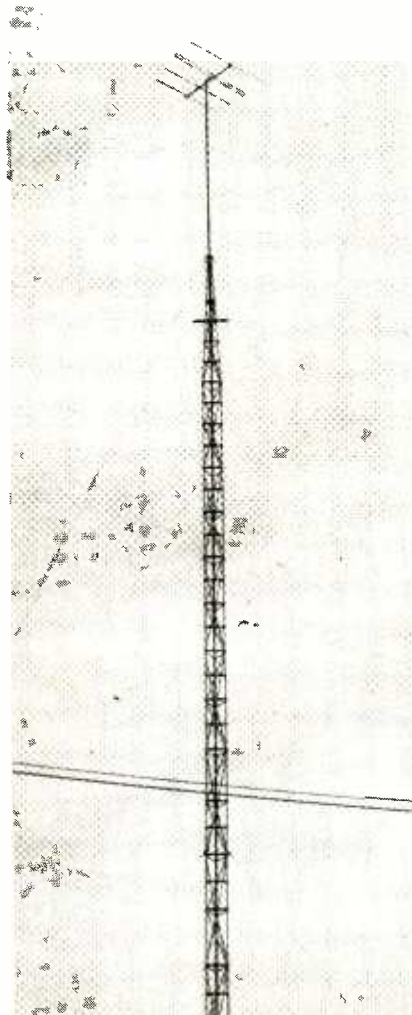

# DIRECTORY (continued)

## Antenna Mounting Equipment & Hardware (cont.)

Koenig Engineering Co., H. G., 735 Southwest Blvd., Kansas City 3, Kansas  
 LaPointe-Plascomold Corp., Unionville, Conn.  
 Lucerne Products, Inc., Chardon, Ohio  
 Marvin Radio-Television, 8906 Buckeye Rd., Cleveland 4, Ohio  
 Master Mobile Mounts, Inc., 5200 Wilshire Blvd., Los Angeles, Calif.  
 Mastercraft Products, 60 South St., Boston 11, Mass.  
 Metalance Corp., 2101 Grand Concourse, New York 53, N. Y.  
 Miller Co., J. W., 5917 S. Main St., Los Angeles 3, Calif.  
 Modern-Aire Mfg. Corp., 4436 W. Roosevelt Rd., Chicago 24, Ill.  
 Modern Insulation Co., 535 E. Price St., Philadelphia 44, Pa.  
 Mosley Electronic Specialties, Overland, Mo.  
 Mueller Electric Co., 1583 E. 31st St., Cleveland 14, Ohio  
 National Co., 61 Sherman St., Malden, Mass.  
 Network Mfg. Corp., 19 Cottage St., Bayonne 7, N. J.  
 Nicholas Equipment Co., Bellevue, Ohio  
 Oakridge Products, Inc., 239 E. 127th St., New York, N. Y.  
 Odagard Mfg. Co., 5116 Eighth Ave., Brooklyn 20, N. Y.  
 Paragon Plastic Corp., 513 W. 29th St., New York 1, N. Y.  
 Park Metalware Co., Orchard Park, N. J.  
 Peek, Inc., Walter E., 2842 W. 30th St., Indianapolis 22, Ind.  
 Peerless Mfg. Co., 2165 Morris Ave., Union, N. J.  
 Penn Television Products Co., 131 N. 7th St., Philadelphia 6, Pa.  
 Phalo Plastics Corp., Commercial St., Worcester, Mass.  
 Philco Corp., C & Tioga Sts., Philadelphia, Pa.  
 Philson Mfg. Co., 60 Sackett St., Brooklyn, N. Y.  
 Phoenix Electronics, Inc., Lawrence, Mass.  
 Pittsburgh Coil Co., Carnegie, Pa.  
 Plasteck, Inc., 18 Beach St., E. Portchester, Conn.  
 Plymouth Electronics Corp., 68 High St., Worcester, Mass.  
 Porcelain Products, Inc., P. O. Box 300, Findlay, Ohio  
 Precision Products Co., 325 N. Hoyne Ave., Chicago 12, Ill.  
 Premax Products Div., Chisholm-Ryder Co., Niagara Falls, N. Y.  
 Products Engineering Co., 4753 N. Broadway, Chicago, Ill.  
 Progress Mfg. Co., 2165 Morris Ave., Union, N. J.  
 Radiart Corp., 3571 W. 62nd St., Cleveland 2, Ohio  
 Radio Corp. of America, Harrison, N. J.  
 Radio Merchandise Sales, Inc., 550 Westchester Ave., New York 55, N. Y.  
 Radio Tube Merchandising Co., 508 Clifford St., Flint, Mich.  
 Raytron, 443 Summit St., Toledo, Ohio  
 Safe Flight Instrument Co., 21 Russell St., White Plains, N. Y.  
 Schott Co., Walter L., 9306 Santa Monica Blvd., Beverly Hills, Calif.  
 S/O Laboratories, Inc., 37 George St., Newark 5, N. J.  
 Shore Engineering, Inc., P. O. Box 325, Long Branch, N. J.  
 Shure-Antenna Mount, Inc., 266 Sea Cliff Ave., Sea Cliff, N. Y.  
 Smith Electric Mfg. Co., Ashland, Ohio  
 Smith, Inc., Herman H., 436 18th St., Brooklyn 15, N. Y.  
 Snyder Mfg. Co., 22nd & Ontario Sts., Philadelphia 40, Pa.  
 South River Metal Products Co., South River, N. J.  
 Star Expansion Products Co., 147 Cedar St., New York 6, N. Y.  
 Super Tool Co., 21650 Hoover Rd., Detroit 13, Mich.  
 Taylor Mfg. Co., Lima, Ohio  
 Technical Appliance Corp., Sherburne, N. Y.  
 Telcite Television Corp., Carleton Ave., E. Islip, N. Y.  
 Television Equipment Corp., 238 William St., New York 7, N. Y.  
 Television Laboratories, 1408 Wilmington Ave., New Castle, Pa.  
 Telrex, Inc., Rutherford Ave. & Route 35, Asbury Park, N. J.  
 Towers Corp., 3332 E. 55th St., Cleveland 4, Ohio  
 Transvision, Inc., 460 North Ave., New Rochelle, N. Y.  
 Trio Mfg. Co., Griggsville, Ill.  
 TV Products Co., 152 Sanford St., Brooklyn 5, N. Y.  
 Veri-Best Television Products, Inc., 233 Spring St., New York 13, N. Y.  
 Walco Products, Inc., 60 Franklin St., E. Orange, N. J.  
 Ward Mfg. Co., 3754 N. Southport Ave., Chicago, Ill.  
 Ward Products Corp., 1523 E. 45th St., Cleveland 3, Ohio  
 Warren Mfg. Co., 461 Main St., E. Haven, Conn.  
 Western Coil & Electrical Co., 215 State St., Racine, Wis.  
 Wincharger Corp., E. 7th & Division Sts., Sioux City, Iowa  
 Wind Turbine Co., E. Market St. & Penna. RR., West Chester, Pa.  
 Workshop Associates, 66 Needham St., Newton Highlands 61, Mass.

## Television Towers

Air-Up Tower Corp., 350 E. Broadway, Muskegon Heights, Mich.  
 Alpar Mfg. Co., 466 St. Francis St., Redwood City, Calif.  
 Aluproco, Inc., Kenipont, Ind.  
 Aluminum Co. of America, 1959 Gulf Bldg., Pittsburgh 19, Pa.  
 Baker Mfg. Co., 133 Enterprise St., Evansville, Wis.  
 Berger Communications, 109-01 72nd Rd., Forest Hills, L. I., N. Y.  
 Camburn, Inc., 32-40 57th St., Woodside, N. Y.  
 Camburn Sales & Mfg. Corp., 392 W. Michigan Ave., Battle Creek, Mich.  
 Easy-Up Tower Co., 3800 Kinzie Ave., Racine, Wis.  
 Energy Farm Equipment Co., Monticello, Iowa

Etraco Mfg. Co., Inc., Woods Church Rd., Flemington, N. J.  
 General Cement Mfg. Co., 919 Taylor Ave., Rockford, Ill.  
 Grem Engineering Co., 206 8th Ave., Brooklyn 15, N. Y.  
 LaPointe-Plascomold Corp., Unionville, Conn.  
 Lingo & Son, John, E. 28th & Buren Ave., Camden, N. J.  
 Marvin Radio-Television, 8906 Buckeye Rd., Cleveland 4, Ohio  
 Milner Mfg. Co., Jackson, Mich.  
 Oak Mfg. Co., 1260 Clybourn Ave., Chicago, Ill.  
 Olson Co., 201 S. Kendall St., Battle Creek, Mich.  
 Parris-Dunn, Clarinda, Iowa  
 Peters, A. A., 231 N. 7th St., Allentown, Pa.  
 Penn Boiler & Burner Mfg. Corp., Lancaster, Pa.  
 Ramsey Tower Co., P. O. Box 45, Ramsey, Ill.  
 Rostan Corp., 202 E. 44th St., New York 17, N. Y.  
 Sewell, Inc., Norman M., Lansdale, Pa.  
 Shore Engineering, Inc., P. O. Box 325, Long Branch, N. J.  
 Tabet Mfg. Co., 254 W. Tazewell St., Norfolk 10, Va.  
 Telco Mfg. Co., New Castle, Pa.  
 Tele-Steel Towers, P. O. Box 21, Normandy 21, Mo.  
 Thompson & Ruby, Inc., Brownstown, Ind.  
 Towers Corp., 3332 E. 55th St., Cleveland 4, Ohio  
 Universal Products Co., 4100 Taylor Ave., Racine, Wis.  
 Veri-Best Television Products, 233 Spring St., New York 13, N. Y.  
 Walco Products, Inc., 60 Franklin St., E. Orange, N. J.  
 Western Coil & Electrical Co., 215 State St., Racine, Wis.  
 Wincharger Corp., E. 7th & Division Sts., Sioux City, Iowa  
 Wind Turbine Co., E. Market St. & Penna. RR., West Chester, Pa.  
 Workshop Mfg. Co., Newton, Iowa

## Television Masts

Alpar Mfg. Co., 466 St. Francis St., Redwood City, Calif.  
 Aluminum Co. of America, 1959 Gulf Bldg., Pittsburgh 19, Pa.  
 American Phenolic Corp., 1830 S. 54th St., Chicago 24, Ill.  
 American Tube Products, Inc., Riverdale Bldg., Natick, R. I.  
 Best Vue Products, 247 Centre St., New York 13, N. Y.  
 Berger Communications, 109-01 72nd Rd., Forest Hills, L. I., N. Y.  
 Camburn, Inc., 32-40 57th St., Woodside, N. Y.  
 Cass Machine Co., 691 Antoinette St., Detroit 2, Mich.  
 Channel Master Co., 15 Chapel St., Ellenville, N. Y.  
 Cole-Worner Corp., 345 Albert Ave., Mansfield, Ohio  
 Delson Mfg. Co., 126 11th Ave., New York, N. Y.  
 Electronic Indicator Corp., 53 Wyckoff St., Brooklyn 2, N. Y.  
 Energy Farm Equipment Co., Monticello, Iowa  
 Etraco Mfg. Co., Inc., Woods Church Rd., Flemington, N. J.  
 General Cement Mfg. Co., 919 Taylor Ave., Rockford, Ill.  
 Grem Engineering Co., 206 8th Ave., Brooklyn 15, N. Y.  
 Hy-Lite Antennae, Inc., 1060 Washington Ave., Bronx 56, N. Y.  
 Insuline Corp. of America, 3602 35th Ave., Long Island City 1, N. Y.  
 JFD Mfg. Co., Inc., 6101 16th Ave., Brooklyn 25, N. Y.  
 LaPointe-Plascomold Corp., Unionville, Conn.  
 Metalance Corp., 2101 Grand Concourse, New York 53, N. Y.  
 Milner Mfg. Co., P. O. Box 993, Jackson, Miss.  
 Modern-Aire Mfg. Corp., 4436 W. Roosevelt Rd., Chicago 24, Ill.  
 Peters, A. A., 231 N. 7th St., Allentown, Pa.  
 Philco Corp., C & Tioga Sts., Philadelphia, Pa.  
 Plasteck, Inc., 18 Beach St., E. Port Chester, Conn.  
 Plymold Corp., Lawrence, Mass.  
 Premax Products Div., Chisholm-Ryder Co., Inc., Niagara Falls, N. Y.  
 Public Operating Corp., 100 W. 42nd St., New York 18, N. Y.  
 Radiart Corp., 3571 W. 62nd St., Cleveland 2, Ohio  
 Radio Corp. of America, Harrison, N. J.  
 Radio Merchandise Sales, Inc., 550 Westchester Ave., New York 55, N. Y.  
 Radio Tube Merchandising Co., 508 Clifford St., Flint, Mich.  
 Raytron, 443 Summit, Toledo, Ohio  
 Safe Flight Instrument Co., Techni-Vision Div., 21 Russell St., White Plains, N. Y.  
 S/O Laboratories, Inc., 37 George St., Newark 5, N. J.  
 Schott Co., Walter L., 9306 Santa Monica Blvd., Beverly Hills, Calif.  
 Shore Engineering, Inc., P. O. Box 325, Long Branch, N. J.  
 Snyder Mfg. Co., 22nd & Ontario Sts., Philadelphia 40, Pa.  
 South River Metal Products Co., South River, N. J.  
 Special Purpose Products Co., 144 Perry St., New York 14, N. Y.  
 Technical Appliance Corp., Sherburne, N. Y.  
 Tele-Beam Industries, 420 Soscol Ave., Napa, Calif.  
 Telrex, Inc., Rutherford Ave. & Route 35, Asbury Park, N. J.  
 Towers Corp., 3332 E. 55th St., Cleveland 4, Ohio  
 Transvision, Inc., 460 North Ave., New Rochelle, N. Y.  
 Trio Mfg. Co., Griggsville, Ill.  
 TV Products Co., 152 Sanford St., Brooklyn 5, N. Y.  
 Universal Products Co., 4100 Taylor Ave., Racine, Wis.  
 Veri-Best Television Products, Inc., 233 Spring St., New York 13, N. Y.  
 Walco Products, Inc., 60 Franklin St., E. Orange, N. J.  
 Ward Products Corp., 1523 E. 45th St., Cleveland 3, Ohio  
 Western Coil & Electrical Co., 215 State St., Racine, Wis.  
 Wincharger Corp., E. 7th & Division Sts., Sioux City, Iowa  
 Wind Turbine Co., E. Market St. & Penna. RR., West Chester, Pa.  
 Workshop Associates, 66 Needham St., Newton Highlands 61, Mass.

## Antenna Rotators

Aircraft Products Co., 113 St. Clair Ave., N. E., Cleveland, Ohio  
 Alliance Mfg. Co., Lake Park Blvd., Alliance, Ohio  
 Anchor Radio Corp., 2115 S. St. Louis Ave., Chicago 23, Ill.  
 Berger Communications, 109-01 72nd Rd., Forest Hills, L. I., N. Y.  
 C & G Tool Mfg. Co., 39 Main St., E. Orange, N. J.  
 Cleveland Aircraft Products Co., 113 E. St. Clair Ave., Cleveland 14, Ohio  
 Cornell-Dubilier Electric Corp., S. Plainfield, N. J.  
 Crown Controls Co., 124 S. Washington St., New Bremen, Ohio  
 Jaco Products, 6408 Euclid Ave., Cleveland 3, Ohio  
 Johnson Co., E. F., 206 Second Ave., S.W., Wasco, Minn.  
 Koenig Engineering Co., H. G., 735 Southwest Blvd., Kansas City 3, Kans.  
 Lyte Parts Co., 11 Washington Ave., Plainfield, N. J.  
 Penny, C. M. Co., 3471 W. 140th St., Cleveland, Ohio  
 Radiart Corp., 3571 W. 62nd St., Cleveland 2, Ohio  
 Shaw Co., Joseph 6225 Benore Rd., Toledo 12, Ohio  
 U. S. Devices Corp., Hillside Ave., S. Plainfield, N. J.  
 Walco Products, Inc., 60 Franklin St., E. Orange, N. J.

## Transmission Line (Lead-in Wire)

Aerolite Electronic Hardware Corp., 24 Cliff St., Jersey City 6, N. J.  
 Alden Products Co., 117 N. Main St., Brockton, Mass.  
 Alpha Wire Corp., 50 Howard St., New York, N. Y.  
 American Phenolic Corp., 1830 S. 54th St., Chicago 24, Ill.  
 Anaconda Wire & Cable Co., 25 Broadway, New York 4, N. Y.  
 Andrew Corp., 363 E. 75th St., Chicago 18, Ill.  
 Atlantic Wire & Cable Corp., 251 Huron St., Brooklyn 22, N. Y.  
 Belden Mfg. Co., 4617 W. Van Buren St., Chicago 44, Ill.  
 Birnbach Radio Co., 145 Hudson St., New York 13, N. Y.  
 Chester Cable Corp., Chester, N. Y.  
 Columbia Wire & Supply Co., 2850 Irving Park Rd., Chicago 18, Ill.  
 Consolidated Wire & Associated Cos., 1635 N. Clinton St., Chicago 16, Ill.  
 Cornish Wire Co., Inc., 15 Park Row, New York, N. Y.  
 Crescent Insulated Wire & Cable Co., Trenton, N. J.  
 Electronic Indicator Corp., 53 Wyckoff St., Brooklyn 2, N. Y.  
 Etraco Mfg. Co., Inc., Woods Church Rd., Flemington, N. J.  
 Federal Telephone & Radio Corp., Nutley, N. J.  
 Flexo Wire Co., Oswego, N. Y.  
 General Cable Corp., 420 Lexington Ave., New York 17, N. Y.  
 General Cement Mfg. Co., 919 Taylor Ave., Rockford, Ill.  
 General Electric Co., Electronics Park, Syracuse, N. Y.  
 General Insulated Wire Corp., 69 Gordon Ave., Providence, R. I.  
 Gonsset Co., 72 E. Tujunga Ave., Burbank, Calif.  
 Good, Don, Inc., So. Pasadena, Calif.  
 Insuline Corp. of America, 3602 35th Ave., Long Island City 1, N. Y.  
 Kellogg Switchboard & Supply Co., 6650 S. Cicero Ave., Chicago 38, Ill.  
 Lenz Electric Mfg. Co., 1751 N. Western Ave., Chicago 47, Ill.  
 Nicholas Equipment Co., Bellevue, Ohio  
 Phalo Plastics Corp., Commercial St., Worcester, Mass.  
 Philco Corp., C & Tioga Sts., Philadelphia, Pa.  
 Plastoid Corp., Hamburg, N. J.  
 Plymouth Electronics Corp., 68 High St., Worcester, Mass.  
 Radio Corp. of America, Harrison, N. J.  
 Schott, Walter L. Co., 9306 Santa Monica Blvd., Beverly Hills, Calif.  
 Technical Appliance Corp., Sherburne, N. Y.  
 Transvision, Inc., 460 North Ave., New Rochelle, N. Y.  
 TV Products Co., 152 Sanford St., Brooklyn 5, N. Y.  
 U. S. Wire & Cable Co., 27 Haynes Ave., Newark, N. J.  
 Walco Products, Inc., 60 Franklin St., E. Orange, N. J.  
 Ward Products Corp., 1523 E. 45th St., Cleveland, Ohio  
 Workshop Associates, 66 Needham St., Newton Highlands 61, Mass.

## Lenses, Magnifiers, Filters

Aero Needle Co., 619 N. Michigan Ave., Chicago 11, Ill.  
 Aim Industries, 11 Union Square, New York 3, N. Y.  
 Atlas Sound Corp., 1449 39th St., Brooklyn 18, N. Y.  
 Celomat Corp., 521 W. 23rd St., New York, N. Y.  
 Courmand & Co., E. L., 3835 Ninth Ave., New York 34, N. Y.  
 Celutone Co., 23 E. 26th St., New York 10, N. Y.  
 Clarkstan Corp., 11927 W. Pico Blvd., Los Angeles 34, Calif.  
 Crosdale & de Angelis, Inc., Lenni Mills, Pa.  
 Crystal X Corp., W. Lenni Rd., Lenni Mills, Pa.  
 Deitz Miracle Lens Co., 141 President St., Passaic, N. J.  
 Drake Co., R. L., 11 Longworth St., Dayton 2, Ohio  
 Duotone Co., Inc., Locust St., Keyport, N. J.  
 Durable Formed Products, 6 Greene St., New York 13, N. Y.  
 Durst Mfg. Co., 11100 Compton St., N. Hollywood, Calif.  
 Eby Sales Co., 130 Lafayette St., New York 13, N. Y.  
 Electro-Steel Products, Inc., 112 N. Seventh St., Philadelphia 6, Pa.

(Continued on page 82)



...due to distance or local interference

THE SINGLE-STAGE ANCHOR BOOSTER  
INCREASES ORIGINAL TV SIGNAL STRENGTH

more than **3 TIMES** and  
assures  
consistently  
good reception  
up to 75 miles



**Single-Stage**

ARC-101-75

only \$**33.00**

- Adds unsurpassed brilliance
- Makes pictures glorious
- Produces sparkling clarity
- Puts you right in the picture

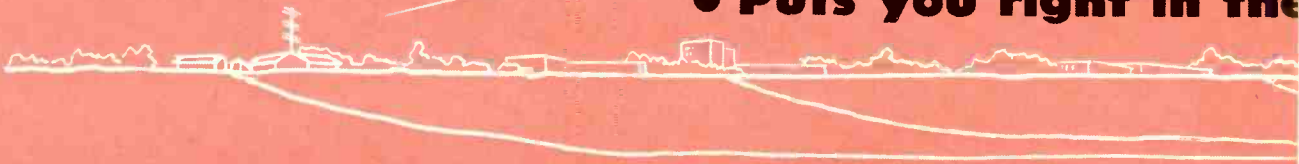

**ANCHOR RAD**

2215 SOUTH ST. LOUIS AVENUE

ference?

THE TWO-STAGE ANCHOR BOOSTER  
INCREASES ORIGINAL TV SIGNAL STRENGTH

more than **5 TIMES** and  
assures  
consistently  
good reception  
up to 100 miles



**Two-Stage**

ARC-101-100

only **\$44.95**

ance and clarity  
usly life-like  
ear detail  
e midst of the action

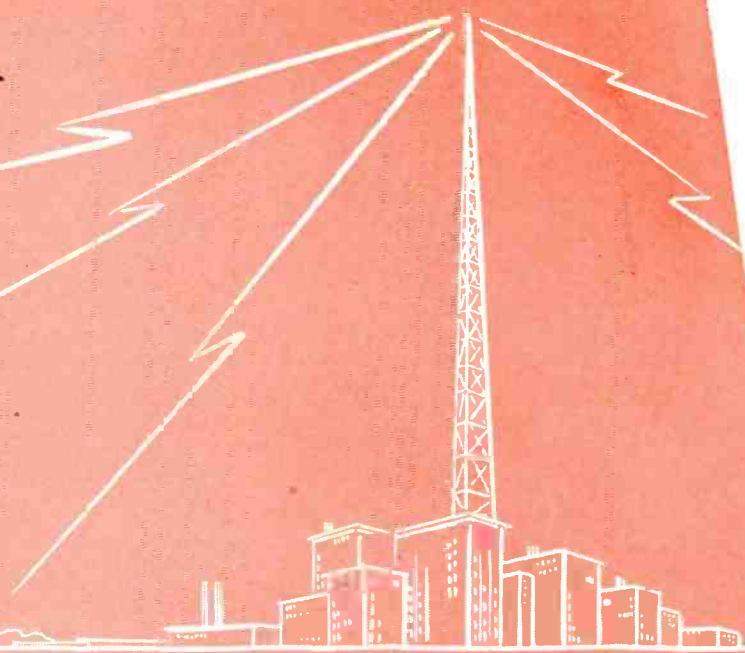

**IO CORP.**  
CHICAGO 23, ILLINOIS





## Manufacturers of TV-FM Antennas & Accessories

### Antenna Distribution System

Brach Mfg. Corp., L. S., 200 Central Ave., Newark 4, N. J.  
 Electro Engineering & Mfg. Co., 627 W. Alexandrine, Detroit, Mich.  
 Industrial Television, Inc., 359 Lexington Ave., Clifton, N. J.  
 Intra Video Corp. of America, 238 William St., New York, N. Y.  
 Jerrold Electronics Corp., 121 N. Broad St., Philadelphia 7, Pa.  
 Lynmar Engineers, 1721 Delancey St., Philadelphia 3, Pa.  
 Reeves Soundcraft Corp., 35-54 36th Ave., Long Island City, N. Y.  
 Radio Corp. of America, Harrison, N. J.  
 Workshop Associates, 66 Needham St., Newton Highlands 61, Mass.

### TV-FM Antennas

Admiral Corp., 3800 Cortlandt St., Chicago, Ill.  
 Aerolite Electronic Hardware Corp., 24 Cliff St., Jersey City 6, N. J.  
 Aero Needle Co., 619 N. Michigan Ave., Chicago 11, Ill.  
 Aeronics, Inc., 195 William St., New York 7, N. Y.  
 Airdesign, Inc., 10 E. 52nd St., New York 22, N. Y.  
 Airflyte Electronics Co., 22 Evergreen St., Bayonne, N. J.  
 All Channel Antenna Corp., 70-07 Queens Blvd., Elmhurst, N. Y.  
 Aluminum Co. of America, 1959 Gulf Bldg., Pittsburgh 19, Pa.  
 American Phenolic Corp., 1830 S. 54th St., Chicago 24, Ill.  
 American Radio Hardware Co., 152 McQueston Parkway, Mt. Vernon, N. Y.  
 American Tube Products, Riverdale Bldg., Natick, R. I.  
 Ampower Co., 109 W. Hubbard St., Chicago 26, Ill.  
 Anchor Radio Corp., 2215 S. St. Louis Ave., Chicago 23, Ill.  
 Andrew Corp., 363 E. 75th St., Chicago 18, Ill.  
 Antenna Products, 1809 N. Ashland Ave., Chicago 22, Ill.  
 Antenna Research Lab., Inc., 797 Thomas Lane, Columbus 22, Ohio  
 Autoflex Corp., 101 Park Ave., New York 17, N. Y.  
 Barb City Industries, Inc., 1150 S. Fourth St., Dekalb, Ill.  
 Belden Mfg. Co., 4647 W. Van Buren St., Chicago 44, Ill.  
 Belnord & Co., 474 Sterling Pl., Brooklyn, N. Y.  
 Berger Communications, 109-01 72nd Rd., Forest Hills, L. I., N. Y.  
 Best Vue Products, 247 Centre St., New York 13, N. Y.  
 Birnbach Radio Co., 145 Hudson St., New York 13, N. Y.  
 Bowers Battery & Spark Plug Co., Box 1262, Reading, Pa.  
 L. S. Brach Mfg. Corp., 200 Central Ave., Newark 4, N. J.  
 Brooklyn Television Co., 1630 St. John's Pl., Brooklyn 33, N. Y.  
 B. B. Butler Mfg. Co., 3432 N. Avondale Ave., Chicago 18, Ill.  
 Camburn, Inc., 32-40 57th St., Woodside, N. Y.  
 Cameron Tool & Supply Co., Cameron, W. Va.  
 Central Industries Corp., 4865 San Fernando Rd., W. Los Angeles, Calif.  
 Channel Chief Co., 37 Mali Dr., N. Plainfield, N. J.  
 Channel Master Co., 15 Chapel St., Ellenville, N. Y.  
 Circle "X" Antenna Corp., 500 Market St., Perth Amboy, N. J.  
 Clear Beam Television Antennas, 618 N. LaBrea St., Los Angeles 36, Calif.  
 Cole-Worner Corp., 345 Albert Ave., Mansfield, Ohio  
 Collins Antenna Co., 158 Albany Post Rd., Buchanan, N. Y.  
 Communication Coil Co., 2839 N. Narragansett Ave., Chicago 34, Ill.  
 Communication Measurements Lab., 120 Greenwich St., New York 6, N. Y.  
 Consolidated Wire & Assoc. Cos., 1635 S. Clinton St., Chicago 16, Ill.  
 Cornell-Dubilier Electric Corp., S. Plainfield, N. J.  
 Delson Mfg. Co., 126 11th Ave., New York, N. Y.  
 Electronic Indicator Corp., 53 Wyckoff St., Brooklyn 2, N. Y.  
 Electro-Steel Products, Inc., 112 N. 7th St., Philadelphia 6, Pa.  
 Electro-Vision Industries, Rochelle, Ill.  
 Etraco Mfg. Co., Inc., Woods Church Rd., Flemington, N. J.  
 Ferris Television Laboratories, 1057 W. Wellington Ave., Chicago, Ill.  
 Fleron & Son, M. M., 113 N. Broad St., Trenton 8, N. J.  
 Flippen Mfg. Co., P. O. Drawer 29, Santa Ana, Calif.  
 Frazier Engineering Co., 1965 Peck St., Muskegon, Mich.  
 Gadgets, Inc., 3629 N. Dixie Dr., Dayton 5, Ohio  
 Gee-Lar Products Co., 4739 W. Montrose Ave., Chicago 41, Ill.  
 Geist Associates, Henry J., 60 E. 42nd St., New York, N. Y.  
 General Cement Mfg. Co., 919 Taylor Ave., Rockford, Ill.  
 General Electric Co., Electronics Park, Syracuse, N. Y.  
 Gosnet Co., 72 E. Tujunga Ave., Burbank, Calif.  
 Grem Engineering Co., 206 8th Ave., Brooklyn 15, N. Y.  
 Hedco Mfg. Co., 1282 Burke Ave., Bronx 67, N. Y.  
 Hi-Lo TV Antenna Co., 2810 W. Melrose St., Chicago 18, Ill.

Hi-Par Products Co., 347 Lumenberg St., Fitchburg, Mass.  
 Hy-Lite Antennae, Inc., 242 East 137th St., New York, 51, N. Y.  
 Insuline Corp. of America, 3602 35th Ave., Long Island City 1, N. Y.  
 Interstate Mfg. Co., 138 Sussex St., Newark, N. J.  
 Islip Radio Mfg. Corp., Beech St., Islip, N. Y.  
 Jerrold Electronics Corp., 121 N. Broad St., Philadelphia 7, Pa.  
 JFD Mfg. Co., Inc., 6101 16th Ave., Brooklyn 25, N. Y.  
 Johnson Co., E. F., 206 Second Ave. S. W. Waseca, Minn.  
 Laco Mfg. Co., 3747 W. Division St., Chicago, Ill.  
 LaMagna Mfg. Co., 51 Clinton Pl., E. Rutherford, N. J.  
 LaPointe-Plascomold Corp., Unionville, Conn.  
 Louis Bros., 3543 E. 25th St., Los Angeles, Calif.  
 Lyman Electronic Corp., 12 Cass St., Springfield 4, Mass.  
 Lyte Parts Co., 11 Washington Ave., Plainfield, N. J.  
 Master Mobile Mounts, Inc., 5200 Wilshire Blvd., Los Angeles, Calif.  
 Masta TV Antenna Corp. of N. Y., 1133 Broadway, New York 10, N. Y.  
 Muter Co., The, 1255 S. Michigan Ave., Chicago 5, Ill.  
 Network Mfg. Co., 19 Cottage St., Bayonne 7, N. J.  
 Nicholas Equipment Co., Bellevue, Ohio  
 NST Corp., 2642 S. Fifth St., Philadelphia, Pa.  
 Oakridge Products, Inc., 239 E. 127th St., New York, N. Y.  
 Ohio Aerial Co., 4553 Lewis Ave., Toledo 12, Ohio  
 Omega Laboratories, Inc., 23 Maple Ave., Pine Brook, N. J.  
 Olson Co., 201 S. Kendall St., Battle Creek, Mich.  
 Orthon Corp., 196 Albion Ave., Paterson 2, N. J.  
 Otis Radio & Electric Corp., 918 Central Ave., Hawarden, Iowa  
 Peek, Inc., Walter E., 2842 W. 30th St., Indianapolis 22, Ind.  
 Peerless Products Industries, 812 N. Pulaski Rd., Chicago 51, Ill.  
 Philco Corp., C & Tioga Sts., Philadelphia, Pa.  
 Philson Mfg. Co., 60 Sackett St., Brooklyn, N. Y.  
 Phoenix Electronics, Inc., Lawrence, Mass.  
 Pittsburgh Coil Co., Carnegie, Pa.  
 Plastec, Inc., 18 Beach St., E. Portchester, Conn.  
 Precision Plastic Products, Inc., 628 W. Lake St., Chicago 6, Ill.  
 Premax Products Div., Chisholm-Ryder, Inc., Niagara Falls, N. Y.  
 Printup Antenna Co., 8543 Glenoe Circle, Milwaukee, Wis.  
 Public Fabricating Corp., 429 E. 164th St., New York 56, N. Y.  
 Public Operating Corp., 100 W. 42nd St., New York 18, N. Y.  
 Quam Nichols Co., 33rd Pl. & Cottage Ave., Chicago 16, Ill.  
 Rad-El-Co. Mfg. Co., 7580 Garfield Blvd., Cleveland 25, Ohio  
 Radiart Corp., 3571 W. 62nd St., Cleveland 20, Ohio  
 Radio Corp. of America, Harrison, N. J.  
 Radio Craftsmen, Inc., 1617 S. Michigan Ave., Chicago 16, Ill.  
 Radio Merchandise Sales, Inc., 550 Westchester Ave., New York 55, N. Y.  
 Radion Corp., 1137 Milwaukee Ave., Chicago 22, Ill.  
 Radio Tube Merchandising Co., 508 Clifford St., Flint, Mich.  
 Rauland Corp., 4245 Knox Ave., Chicago 18, Ill.  
 Raytron, 443 Summit, Toledo, Ohio  
 Rowland-Kendall Co., 715 E. Mansion St., Marshall, Mich.  
 Safe-Flight Instrument Co., 21 Russell St., White Plains, N. Y.  
 Schott Co., Walter L., 9306 Santa Monica Blvd., Beverly Hills, Calif.  
 S/C Laboratories, Inc., 37 George St., Newark 5, N. J.  
 Shore Engineering, Inc., P. O. Box 325, Long Branch, N. J.  
 Shure-Antenna Mount, Inc., 266 Sea Cliff Ave., Sea Cliff, N. Y.  
 Snyder Mfg. Co., 22nd & Ontario Sts., Philadelphia 40, Pa.  
 Special Products Co., Silver Spring, Md.  
 Spiraling Products Co., 62 Grand St., New York 13, N. Y.  
 Square Root Mfg. Co., 901 Nepperhan Ave., Youkers 3, N. Y.  
 Stanwyck Winding Co., 104 S. Lander St., Newburgh, N. Y.  
 Symphony Radio & Television Corp., 825 W. Pico Blvd., Los Angeles 15, Calif.  
 Technical Appliance Corp., Sherburne, N. Y.  
 Tel-a-Ray Enterprises, Inc., P. O. Box 332, Henderson, Ky.  
 Telcite Television Corp., Carleton Ave., E. Islip, N. Y.  
 Telcraft Corp., 2 W. 15th St., New York 11, N. Y.  
 Telematic Industries, Inc., 32 Wyckoff St., Brooklyn 2, N. Y.  
 Television Laboratories, Inc., 1408 Wilmington Ave. New Castle, Pa.  
 Television-Radio Electronics, Vaughn Ave., Merced, Calif.  
 Telrex, Inc., Rutherford Ave. & Route 35, Asbury Park, N. J.  
 TELVISION Products, Inc., 542 Parkside Ave., Chicago 44, Ill.  
 Transvision, Inc., 460 North Ave., New Rochelle, N. Y.  
 Tricraft Products Co., 1535 N. Ashland Ave., Chicago, Ill.  
 Trio Mfg. Co., Griggsville, Ill.  
 Trio Products, Franklin, Mich.  
 TV Products, 152 Sanford St., Brooklyn 5, N. Y.  
 Twin-Vex Mfg. Co., E. Hunting Park Rd., Philadelphia, Pa.  
 UHF Resonator Co., 224 Seventh St., Racine, Wisc.

Veri-Best Television Products, Inc., 233 Spring St., New York 13, N. Y.  
 Vertrod Corp., 17 William Ave., Brooklyn, N. Y.  
 Wabash Mfg. Co., 2318 S. Western Ave., Chicago 8, Ill.  
 Walco Products, Inc., 60 Franklin St., E. Orange, N. J.  
 Ward Products Corp., 1523 E. 45th St., Cleveland 3, Ohio  
 Warren Mfg. Co., 461 Main St., E. Haven, Conn.  
 Westinghouse Electric Co., Sunbury, Pa.  
 Woodland Mfg. Co., 416 Woodland Ave., Toledo 2, Ohio  
 Workshop Associates, 66 Needham St., Newton Highlands 61, Mass.  
 X-TRA Signal Co., 60 E. 42nd St., New York 17, N. Y.  
 Zenith Radio Corp., 6001 W. Dickens Ave., Chicago, Ill.

### Antenna Mounting Equipment & Hardware

Aerolite Electronic Hardware Corp., 24 Cliff St., Jersey City 6, N. J.  
 Aetna Radio Service, 2846 Milwaukee Ave., Chicago 47, Ill.  
 Aircraft-Marine Products, Inc., 1523 N. Fourth St., Harrisburg, Pa.  
 Airdesign, Inc., 10 E. 52nd St., New York 22, N. Y.  
 Aiden Products Co., 117 N. Main St., Brockton, Mass.  
 Alliance Mfg. Co., Lake Park Blvd., Alliance, Ohio  
 Alpar Mfg. Co., 466 St. Francis St., Redwood City, Calif.  
 American Phenolic Corp., 1830 S. 54th St., Chicago 24, Ill.  
 American Tube Products, Inc., Riverdale Bldg., Natick, R. I.  
 Andrew Corp., 363 E. 75th St., Chicago 18, Ill.  
 Antenna Products, 1809 N. Ashland Ave., Chicago 22, Ill.  
 Antenna Research Lab., Inc., 797 Thomas Lane, Columbus 22, Ohio  
 Baker Mfg. Co., 133 Enterprise St., Evansville, Wis.  
 Band-It Co., 2550 Walnut St., Denver 5, Colo.  
 Belden Mfg. Co., 4647 W. Van Buren St., Chicago 44, Ill.  
 Berger Communications, 109-01 72nd Rd., Forest Hills, L. I., N. Y.  
 Best Vue Products, 247 Centre St., New York 13, N. Y.  
 Birnbach Radio Co., Inc., 145 Hudson St., New York 13, N. Y.  
 Blaco Mfg. Co., 6541 Euclid Ave., Cleveland 3, Ohio  
 Brach Mfg. Corp., L. S., 200 Central Ave., Newark 4, N. J.  
 Bud Radio, Inc., 2118 E. 55th St., Cleveland 3, Ohio  
 Camburn, Inc., 32-40 57th St., Woodside, N. Y.  
 Cass Machine Co., 691 Antoinette St., Detroit 2, Mich.  
 C & G Tool Mfg. Co., 39 Main St., E. Orange, N. J.  
 Chester Cable Corp., Chester, N. Y.  
 Cole-Worner Corp., 345 Albert Ave., Mansfield, Ohio  
 Columbia Wire & Supply Co., 2850 Irving Park Rd., Chicago 18, Ill.  
 Commercial Plastics, Merchandise Mart, Chicago 54, Ill.  
 Communication Measurements Lab., Inc., 120 Greenwich St., New York 6, N. Y.  
 Cornell-Dubilier Electric Corp., S. Plainfield, N. J.  
 Cornish Wire Co., 15 Park Row, New York, N. Y.  
 Crown Controls Co., 124 S. Washington St., New Bremen, Ohio  
 Crum's, Inc., 128 S. Market St., Wooster, Ohio  
 Decimeter, Inc., 1430 Market St., Denver 2, Colo.  
 Delson Mfg. Co., 126 11th Ave., New York, N. Y.  
 Easy-Up Tower Co., 3800 Kinzie Ave., Racine, Wisc.  
 Eby Sales Co., 130 Lafayette St., New York 13, N. Y.  
 Electro Engineering & Mfg. Co., 627 W. Alexandrine, Detroit, Mich.  
 Electronic Indicator Corp., 53 Wyckoff St., Brooklyn 2, N. Y.  
 Electronic Measurements Corp., 423 Broome St., New York 13, N. Y.  
 Electro-Steel Products, Inc., 112 N. 7th St., Philadelphia 6, Pa.  
 Federal Engineering Co., 37 Murray St., New York 7, N. Y.  
 Fleron & Son, M. M., 113 N. Broad St., Trenton 8, N. J.  
 Frazier Engineering Co., 1965 Peck St., Muskegon, Mich.  
 General Cement Mfg. Co., 919 Taylor Ave., Rockford, Ill.  
 Gosnet Co., 72 E. Tujunga Ave., Burbank, Calif.  
 Grayhill, 4534 Madison St., Chicago 24, Ill.  
 Grem Engineering Co., 206 8th Ave., Brooklyn 15, N. Y.  
 Hamilton Electronics, 2726 Pratt Ave., Chicago 45, Ill.  
 Hawthorne Mfr. Co., O. V., 710 Hauselman Bldg., Kalamazoo 1, Mich.  
 Hayden Products Corp., 1801 Eighth Ave., Brooklyn, N. Y.  
 Hi-Par Products Co., 347 Lumenberg St., Fitchburg, Mass.  
 Holub Industries, Inc., Sycamore, Ill.  
 Hot Nails, Inc., 40 W. Fourth St., New York, N. Y.  
 Industrial Precision Products Co., 325 N. Hoyle Ave., Chicago, Ill.  
 Industrial Products Co., 325 N. Hoyle Ave., Chicago 12, Ill.  
 Insuline Corp. of America, 3602 35th Ave., Long Island City 1, N. Y.  
 Jaco Products, 6408 Euclid Ave., Cleveland 3, Ohio  
 JFD Mfg. Co., 6101 16th Ave., Brooklyn 25, N. Y.  
 Johnson Co., E. F., 206 Second Ave. S. W. Waseca, Minn.  
 Kenwood Engineering Co., Inc., 265 Colfax Ave., Kenilworth, N. J.

*the magnificent*  
**Magnavox**  
*radio - phonograph - television*



**R FOR EXTRA PROFITS**

**... Factory-To-Dealer Distribution!**

**D**EALERS profit two ways from the Magnavox policy of direct, factory-to-dealer distribution. First, by performing some of the functions of distributors, they enjoy higher markups than would otherwise be possible. And second, they realize many extra sales, for streamlined selling concentrates the business among the relatively few selected dealers. Furthermore, Magnavox markups do not shrink, for this is the company known for enforcing its fair trade prices wherever they are recognized by law.

**The Magnavox Company  
Fort Wayne 4, Indiana**



# Three Steps to Making

**An Orderly, Planned Method Can Reap Plus Profits—**

• Because of the high saturation reached by many products, replacement sales are on the increase, and this means that a considerable number of deals will involve the taking of trade-ins, or more accurately, the “buying” of used merchandise, because that’s actually what the merchant is doing when he accepts a trade-in. The more he’s aware of the fact that he’s *buying* old products the more likely he is to do such trading cautiously, and to have a plan for rapid disposal of the units he accepts.

By and large, in our field, as in the automobile industry, dealers are divided into two schools of thought. One group heartily dislikes the practice of trading-in, which, nonetheless, is forced upon them. The second group actually solicits business with the acceptance of trade-ins as one of its chief merchandising hooks. It is interesting to note that

**In this article, read how to  
NEGOTIATE competitively  
RECONDITION used items  
RESELL traded-in units**

“educated” to expect no allowances for used products.

Of course the ideal sale is the clean deal that has no trade-in, and any merchant should get as many of these as he can possibly corral, but the dealer who has an inventory of new products which he must move, cannot let too many vacuum cleaner, refrigerator or washer sales go to the competitor who has a more effective trade-in plan. Since, as before stated, so much business today

is replacement business, it just isn’t good sense to hide one’s head in the sand when confronted with the trade-in situation. The thing to do is to face the issue squarely, and to meet it with a plan.

## **A Three-Way Activity**

The three phases of profitable trade-in activities which follow are based upon the actual operations of a number of successful merchants in our industry, and it will be seen that such techniques, interestingly enough, almost parallel those employed in the retailing of automobiles. Car dealers do one of two things with the used merchandise they take in. Either they “wholesale” the trade-ins, or they fix them up and sell them at retail. A few merchants in our field “wholesale” the trade-ins, but most of them either let the used products kick around without rhyme or reason (or profit), or they use vigorous methods to turn the products into cash. (Most of our dealers who “wholesale” trade-ins are located in communities where there are very few customers who are willing to buy used products.)

The action plan is divided into three parts: 1. Negotiating. 2. Reconditioning. 3. Selling.

Under “negotiating,” we find such activities as appraising the value of the product, and making an offer based entirely upon what the dealer feels the traffic will bear so far as his profit structure is concerned. In other words, he takes the trade-in, but doesn’t take a shellacking, because he has a pretty good idea in advance on two angles:

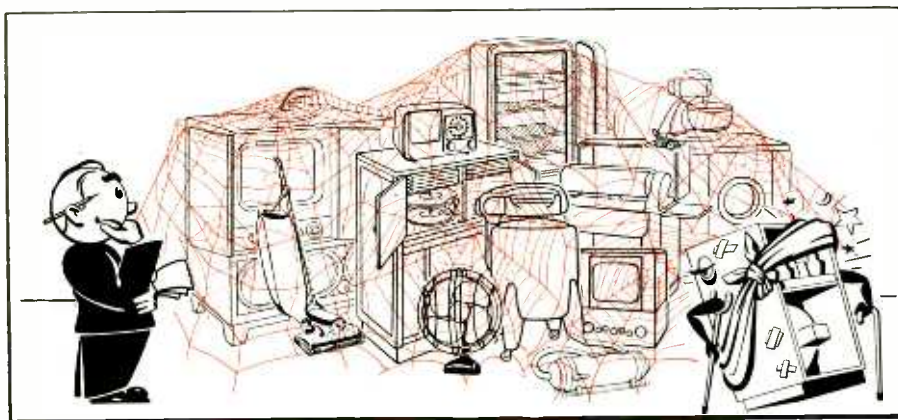

**IS YOUR MONEY Tied Up in Dust-Gathering Trade-ins**

**OR**

**ARE YOU GETTING IT BACK, and Making Plus Profits as Well?**

most of the merchants who hate trade-ins worse than poison are doing poor jobs in (1) negotiating, (2) reconditioning, and (3) selling the used units. On the other hand, most of those who go all-out on trading-in activities, have effective negotiating methods, efficient reconditioning set-ups, and a good, and usually profitable, turnover of the used products.

A small minority of retailers who refuse to accept any trade-ins whatsoever are able to do big-volume business, and make money, too, but in order to operate in this fashion they are either located in areas where competition is lukewarm, or they have built up large followings of customers whom they’ve

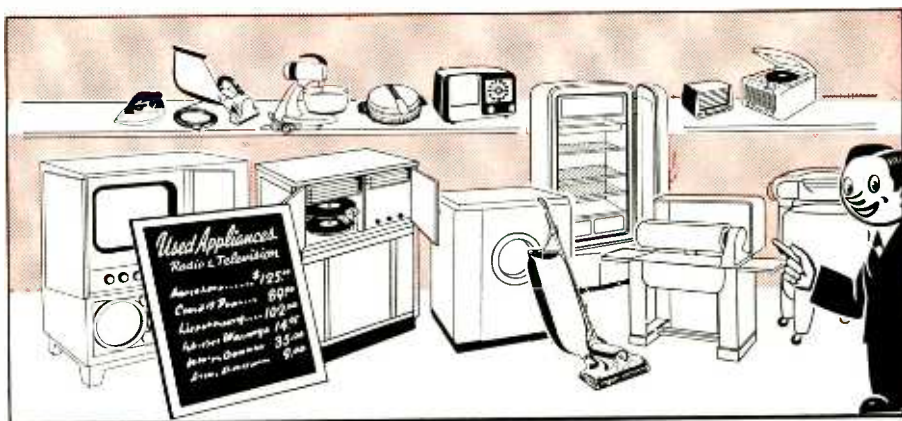

# MONEY with TRADE-INS

## Haphazard Handling Is a Risky Business with Frequent Losses

(a) The resale value of the product, and (b) its marketability. In cases where he feels the product has *no resale value*, he either refuses it or makes an allowance on a basis of what he can get through junking the parts.

In negotiating, the dealer must weigh various factors in arriving at his price, but he should always view the trade-in as something he is *buying* with his own money. In this connection, it is necessary to realize that *age* of the product, while serving as a useful yardstick, is not as important as the *condition* and *appearance* of the product plus its prospective saleability. In most instances, however, the customer will be willing to realize that the dealer is justified in using age as a general yardstick.

### Trade-in "Don'ts"

Trade-in negotiating embraces salesmanship, and the following "don'ts" are designed to create not only sales, but customer good-will as well:

A. *Don't "beat down" the customer's old product. This is an antagonistic attitude, and may cost you the sale.*

B. *Don't say the used merchandise has no value; then make an allowance for it. The customer will think your profit margin is out of line, and, that therefore you can afford to give away money.*

C. *Don't always believe statements to the effect that a competitive dealer offered a high allowance. The customer may be making an innocent mistake, or may be deliberately misrepresenting the facts.*

D. *Don't make an allowance on a product and suggest that the owner give or throw it away.*

E. *Don't accept a trade-in, then fail to pick it up. Such practice is annoying to the customer.*

F. *Don't let customers, whom you have reason to believe are "replacement" shoppers, leave your store without making an offer to accept a trade-in.*

### Reconditioning Practices

Just as clothes make the man, *appearance* makes the piece of used merchandise take on sales appeal. The reliable dealer not only puts the used product in good mechanical condition so that he can stand back of it, but he also makes the appliance look as nearly "new" as is possible. These two operations *go together* to make friends of customers and money for the merchant. Some dealers do a first-class overhaul job but fail to enhance

### Read

**"PROFITABLE TV TRADE-INS" in the March, 1950 issue of this magazine. It will help you to get TV replacement business (selling bigger screen sets) in your community.**

the appearance, with the result that the unit looks old and battered. Customers buying such product get a much better deal than they do from the gyp who spends all of his effort on appearance, and sells an appliance he knows to be in poor operating condition. The happy medium is the thorough repair job plus the skillful application of polish and paint.

Those merchants who use systematic methods in rebuilding trade-ins never permit the used products to pile up awaiting a slack period. They put the trade-ins right into the "production" lines along with the repair jobs being handled for customers on a service basis. This is because they have their own hard-earned money tied up in the products they've taken in. For instance, it's just as important to do a rush job of reconditioning a refrigerator on which \$35 has been allowed out of the dealer's profit, as it is to turn out any other piece of service work. The quicker he reconditions and sells the trade-in, the sooner the dealer gets back his money, and, usually, some additional profit as well.

### Selling Used Products

Great care needs to be used in "estimating" just how much each reconditioning job will cost to complete, and to weigh such cost against the resale price. In some instances, where expensive parts are needed, the trade-in's repair will run up to more than the dealer can afford to spend. In such cases, the product should be junked, and the good parts salvaged.

Of course, the dealer who rebuilds his trade-ins successfully has a well equipped shop. In the radio department he has all of the necessary meters and tools, and also the facilities for refinishing cabinets. In the appliance repair department he has lathes, grinders, buffers, paint sprayers, testing equipment, receptacles for "dunking" washer gear-cases, etc.

Many successful selling methods are being practiced by dealers who get

their money back, plus additional profit on trade-ins. Some merchants operate separate stores for the sale of used merchandise. Others use basements, separate floors and sections. Almost all dealers agree that the used products offered for sale must be kept separate from the new ones.

In order to speed up sales, many merchants use lettered or typewritten tags to describe the products. The information on the tags lists such things as original list price, new parts used, and other data on reconditioning; also guarantee terms and the price. Rebuilt products cannot be sold successfully unless some sort of guarantee protecting the purchaser is offered and lived up to.



You don't have to turn thumbs down on all trade-ins. There's money to be made in many of them. Figure them into your regular plans for some extra cash.

There are many ways to increase sales of used products in most communities. Classified advertising listing specific items and prices appears to be one of the best bets. Use of in-store and in-show-window bulletin boards helps pull business, too, just as those listings of used cars, with their prices, stop traffic in front of the automobile dealer's show-window, or outside his used car lot.

Many a smart customer will be willing to pay *more* for a rebuilt, used appliance than he will pay for a brand-new one in cases where the original list price of the used product is considerably higher than that of the new unit. And, in many instances, where good rebuilding is practiced, the retailer can make *more money* on resale of the trade-in than he can on the sale of the new product figuring in the trade-in deal.

Trade-in deals are on the increase, and the merchant who has a plan that's slanted profit-wise can keep his business on a competitive basis without losing his shirt.



# How to Sell More

## Capitalize on Sales Features of These Discs for Larger Volume

• Before we discuss *how* to sell micro-groove records, we might answer the question, *why* sell them. This is an easy question to answer, for these records have two important sales angles which can lead to larger dollar transactions on every record customer. First of all, microgroove records have *sales features* which make possible record *salesmen* instead of record *clerks*.

These features include: more recorded time per inch of surface, and consequent saving in record storage space; improved recording techniques and consequent higher fidelity records; and these records are pressed on vinyl plastic for longer wear and less surface noise (while *some* 78 RPM records are on plastic, *all* the microgrooves have this feature).

The second sales angle to these records is that they give an opportunity to sell record-playing equipment. If the customer can't play them at all, he may be sold a player or a changer. If he already has a player or changer, it may be that he does not have equipment which will play all three speeds. Find out what the customer has and/or needs after you sell him the records. And it is a good idea to demonstrate the records on a type of equipment which you are selling (as opposed to a special demonstrator).

### Know Who Makes Them

It is perhaps already a hackneyed sales hint to say that the record salesman must know his stock, but this has special application now that we have the new types of records. The sales person should know what companies press 45's and 33's. . . . whether they duplicate *all* 78's on either 45 or 33 or both . . . . and which of these lines are actually carried in stock in the store. This is not as complicated a task as it seems at first glance. For the convenience of our readers, we have listed on these pages the names of the companies marketing microgroove records. Only five companies are making all three speeds (Victor, Capitol, Mercury, Decca and London) and of the others making one or the other (45 or 33) it is unlikely that the store will stock so many brands that it will be difficult to remember.

Knowing the key artists associated with each record firm, and keeping abreast of the current "best seller" situation are two habits which help sell any type of records, but which have special application in selling the slow speeds. If, for instance, the customer

## Who Makes 'Em

45

RCA Victor  
Decca  
Capitol  
MGM  
Mercury  
London  
Caravan  
Dana  
Rainbow  
Signature  
Tempo  
Mayfair  
Standard Phono  
Crystalette  
Discovery  
Horace Heidt  
Life  
Modern  
Parade  
Regent  
Savoy  
Allentown  
Evangelical  
Singspiration  
High Point  
Synthetic Plastics  
Rondo

33

Columbia  
RCA Victor  
Capital  
Decca  
London  
Mercury  
National  
Discovery  
Vox  
Allegro  
Cetrasoria  
Atlantic  
Modern  
Westminster  
Summit  
Key  
Oceanic  
Seeco  
Concert Hall Society  
Lone Star  
Polydor  
Oxford  
Bibletone  
American Elite  
Varsity  
Remington

asks for Vaughan Monroe or King Cole, we know they are available on 45 as well as 78; on the other hand, Harry James and Frank Sinatra are not available on 45's.

All these facts are essential to a smooth sales presentation, and one which will give the customer confidence in the dealer and in the stability of the record-making situation. If, on the other hand, the sales person has to fumble around with catalogs and release sheets to find out what is available, and does so with a confused air, as to say, "Who can keep track of these things when they have changes every day!"—then the customer is led to believe that the situation is confused, and won't buy any of the new types of records until things "settle down."

Demonstrating records, or having facilities available for their demonstration, is hardly avoidable. Demonstration equipment should preferably be, as stated above, units from stock, and it would be well to have a price tag affixed to them. This equipment should

be kept in tip-top working order, and the needle should be inspected at regular intervals. It is important that no technical flaw should mar the customer's impression of the record he plans to buy. It is a good idea, also, to have printed operating instructions attached to each demonstration unit.

It may be that it is not the dealer's policy to allow the customer to play records himself. As a matter of fact, there has been a trend away from record booths since the advent of the microgroove records (especially the more expensive LP's) due to the possibility of the records being damaged. Even if this is the case (namely, that the customer cannot take records off by himself), the same facts hold true. That is, demonstration facilities should be provided, and they should be in good working condition. It will be necessary to provide an attendant in this case, and the greatest effort should be made not to keep the customer waiting who wishes to hear a record . . . . and he should be able

# Microgroove Records

to hear this record without the confusion of a lot of other music dinning in his ears. Headphones provide one of the best solutions to "private" listening without booths. Many dealers, on the other hand, have found it very practical and successful to install "open booths" or stalls which are lined with sound absorbent material. In such a stall, the customer listens to a loud-speaker operating at a low volume level, with his selection being fed in from a centrally located turntable.

In order to prevent damage to or pilferage of microgroove records, some stores display the jackets only. In this way, the customer can "browse" as is his habit, and select the record(s) he wishes to hear and/or buy.

## Tell Your Customers

Displays of records in the window and in the store should point up the fact that certain records are available on two or three speeds. In the case of albums, where the price differential with respect to 78's may be considerable, it is important to point this out. It is usually not sufficient just to display a "doughnut" record or a 33 alongside of a 78, since many customers still don't recognize these types; or don't



Microgroove records have features which make possible record salesmen instead of record clerks. The new features provide new sales ammunition.

know that the same records that they wish to buy on 78 are available on the other speeds; or don't know the advantages of these new speeds; or don't know that reasonably priced equipment is readily available to play them. In other words, every time these records are displayed or presented, do a complete selling job for them.

Not only is the record dealer likely to up sales as a result of consistent pro-

motion of microgroove records, but also he will hasten the day when the so-called "confusion" will be straightened out, by getting more and more of these records into the hands of the public. This will help the public to decide which speed or speeds, and which sizes and types they prefer. This decision can only help the record dealer in the end, by ultimately simplifying the selection which it is necessary to carry.

## News of the Record Industry

"One best speed is 33- $\frac{1}{3}$  RPM," Columbia Records president Edward Wallerstein says in a statement entitled "One Best Speed," copies of which are being distributed to the public through record dealers. More than a million copies of the pamphlet have been produced. Mr. Wallerstein points out that anything from a three-minute pop hit tune to a 50 minute symphony can be obtained on a single record with one speed, 33- $\frac{1}{3}$  RPM, and one size spindle hole.

Decca Records and its subsidiaries, Coral and Brunswick will add 45 RPM unbreakable vinylite recordings to their present line of 33- $\frac{1}{3}$  Long Play and 78 RPM records this month. The initial Decca 45 RPM release to dealers, consisting of a minimum of 50 famous albums and numerous standard single records will be made on August 15. "All new Decca records will now be recorded in both 45 and 78 RPM speeds," Decca president Milton Rackmil stated.

RCA Victor announced a promotion campaign designed to accelerate sales of the 45-J record player attachment and encourage periodic visits by record buyers to dealer stores. The purchaser of a 45-J attachment will receive at the time of purchase, a record bonus book containing six coupons. Each coupon, redeemable at any RCA Victor record shop, entitles the holder to one 45 RPM record of his choice each month for six consecutive months. Included in the coupon book is a registration form which, when filled out and mailed by the purchaser automatically places him on the subscription mailing list for the monthly "Picture Record Review." "While essentially an instrument promotion, which should add substantially to well over a million 45 RPM turntables already in use, the bonus plan will also greatly benefit the 45 RPM record dealer," said H. G. Baker, vice-president and general manager of the RCA Victor Home Instrument Department.

Maas Organ Co. has announced the release of a series of recordings of sacred music, made with the new Maas 50-bell Symphonic Carillon. The series includes the most popular hymns and carols, such as Rock of Ages, Onward Christian Soldiers, Adeste Fideles, Hark the Herald Angels Sing, and many others. The record releases are 10-inch, 78 RPM vinyl records and can be played on any standard phonograph or record player. Retail price is \$1.85. Full details and list of releases are available from Maas Organ Co., 3015 Casitas Ave., Los Angeles 39, Calif.

MGM Records announced that beginning with the 85th release, selected platters will be released in both 78 RPM and 45 RPM speeds at the same time. Heretofore, the production of 45's had been confined to the choicest of standard tunes—usually numbers that had been on the market a year or more and had established themselves as catalog favorites.



# New Television Sets

## RAYTHEON

The new line includes the following: N. Y.—RADIO & TELEVISION RETAILING. circular screen sets: table models M-1106 and M-1105, both 12½" sets, listing at \$179.95 and \$199.95, respectively; and consoles C-1104 and C-1602, 12½" and 16" sets at \$219.95 and \$279.95, respectively.

All other models have rectangular picture tubes. They are: table models, M-1408 and M-1402 both 16" sets at \$229.95 and \$249.95, respectively. Consoles include the 16" models C-1401, \$269.95; C-1615, \$279.95; and C-1616, \$299.95; the 17" models C-1715, \$289.95, and C-1716, \$309.95; the 19" models RC-1901, \$379.95, and RC-1902, \$399.95; and the 20" models C-2001, \$399.95, and RC-2002, \$419.95.

TV-AM-3-speed phono combos include: two 16" models, RC-1618, \$399.95, and RC-1619, \$429.95; and two 17" models, RC-1718, \$409.95, and RC-1719, \$439.95. Two other models include TV-FM-AM-3-speed phono. They are: RC-2005, 20" set, \$595, and RC-1905, 19" set, \$575. Raytheon Mfg. Co., 55 Chapel St., Newton, Mass.—RADIO AND TELEVISION RETAILING.

## ARVIN

A new 12½-inch table model TV set, the model 2122 TM, has been added to the line.



Available in mahogany cabinet only, the 2122 retails for \$189.50.

Two new 8-tube table radios have been announced. They are: model 480TFM, listing at \$54.95, and model 481TFM, listing at \$49.95. Both are AM-FM models. Arvin Industries, Inc., Columbus, Ind.—RADIO & TELEVISION RETAILING.

## STROMBERG-CARLSON

The new TV line includes: four 16-inch models, The Mercury, model 116TM, table model, at \$259.95; The Treasure Chest, model 116TD, table model, at \$279.95 in mahogany, \$289.95 in avodire; The Provincial, model 116C, console, \$329.95 in mahogany, \$339.95 in maple or avodire; and the Chippendale, model 116CD2, console, \$389.95. One 17-inch model, the Kenwood, model 17RPM, includes FM-AM radio and 3-speed record changer, lists for \$575. Four 19-inch models are the Empire, model 119CM, shown here, at \$419.95; the Georgian, model 119CDM, \$495; the 18th Century, model 119RPM,



with FM-AM radio and 3-speed changer, \$675; and the Chinese Classic, similar to the 18th Century, \$750 in mahogany, \$775 in avodire, \$865 in red, green, ivory and ebony hand decorated, and \$875 in avodire hand decorated. Stromberg-Carlson Co., Rochester 3, N. Y.—RADIO & TELEVISION RETAILING.

## MERCURY

New addition to the line is the model 0800; radio, phono and 16-inch black rectangular tube TV. It features full length doors and lists at \$369.95 in walnut. It will also be available in mahogany, blonde and maple. Mercury Television & Radio Corp., 861 N. Spring St., Los Angeles 12, Calif.—RADIO & TELEVISION RETAILING.

## DU MONT

Ten new 17" sets have been announced. They are: "Tarrytown", console with doors and FM-AM-3-speed changer, \$575; "Burlingame", console with doors and FM-phono jack, \$399.95; "Revere", console with doors, FM, phono-jack, \$399.95; "Brookville", console with FM and phono-jack, \$359.95; "Andover", console \$349.95; "Park Lane", console with doors, \$339.95; "Strathmore", console, \$299.95; "Carlton", metal cabinet table model, \$279.95; "Ventura", metal cabinet table model, \$279.95; and the "Sumter", metal cabinet table model, \$249.95.

Seven 19" sets complete the new line. They are: "Mount Vernon", console with doors, \$479.95; "Westerly", console with doors, \$459.95; "Ardmore", console \$399.95; "Sherbrooke", console with doors, \$695; "Hanover", console with doors, \$565; "Winslow", console, \$495; and the "Westminster", with FM-AM, 3-speed changer and automatic tape recorder, \$1500. Allen B. Du Mont Labs., Inc., 515 Madison Ave., New York 22,—RADIO & TELEVISION RETAILING.

## TELE-KING

Nine new models made up the line: 312, 12½" table model, \$139.95; 114, 14" table model, \$169.95; 162, 16" table model, \$199.95; 117C, 16" rectangular, open faced console, \$229.95; 117CA, 16" rectangular, FM-AM-3-speed combo, \$299.95; 916C, 16" console with doors, \$289.95; 201, 20" table model, \$279.95; 202C, 20" open faced console, \$299.95; and 919C, 19" console with doors, \$369.95. Tele-King Corp., 601 W. 26 St., New York 1, N. Y.—RADIO & TELEVISION RETAILING.

## BRUNSWICK

Two new models, both 16-inch black rectangular tube sets, have been announced. Model 616, "The Marlowe," is a table model in mahogany veneer cabinet. Model 6161, "The Glasgow," is a console in mahogany veneer cabinet. They list for \$189.95 and \$219.95, respectively. Brunswick Radio & Television, Div. of Radio & Tel., Inc., 244 Madison Ave., N. Y. 16, N. Y.—RADIO & TELEVISION RETAILING.

## Stay in There Pitching to Keep Summer Sales Up— to Get Set for the Big Season Ahead!

We can make this business of ours a 12-inning thriller for 1950 if we continue to play ball during the present hot-weather period. All indications point toward a much bigger and better business in the coming Fall and Winter than we experienced last year when a terrific consumer demand was dumped like a ton of bricks on an inventory-starved industry. Let's sell now, and buy adequately so that we'll be ready to take care of all that extra volume right around the corner. If we stay in there pitching we'll be in a position to cop the profit-pennant for 1950, and in making wanted products available to our customers, we'll help keep up public morale in these troubled times.





Here it is...

*The New Leader Line!*

# Westinghouse TELEVISION



- \* Leader for Features
- \* Leader for Style
- \* Leader for Price

**NEW MODELS IN ALL  
POPULAR BRACKETS**

Try this headliner in your store  
Model 624T16, THE SUTTON,  
16-inch rectangular  
black tube television

*Only \$199<sup>95</sup>*  
PLUS TAX

Complete with ALL Features . . . Built-In  
Antenna, Single Dial Control, Advanced Wide  
Band IF, 1/3 less power consumption plus *all*  
of the features marking larger sets in the line.

SEE COMPLETE NEW TELEVISION  
AND RADIO LINES AT YOUR  
WESTINGHOUSE DISTRIBUTOR'S,  
OR WRITE

Sales Manager, Westinghouse Electric Corp.  
Television-Radio Division • Sunbury, Pa.

YOU CAN BE SURE...IF IT'S

# Westinghouse

\*Suggested List Prices slightly higher in West and parts of South.



# New Television Models

Compiled by Our Editors as a News Service to Our Readers

## WESTINGHOUSE

A table model TV set in mahogany colored plastic cabinet, the model 624T16, with 16-inch rectangular tube, listing at \$199.95, highlights the new TV line of 12 TV sets. Others in the line are: model 625T12, 12½" walnut table model, \$159.95; model 630T14, 14" rectangular mahogany table model, \$199.95; model 63T14, rectangular 14" mahogany colored plastic set, \$189.95; model 624TB16, same as model 624T16 with mahogany console base, \$229.95; model 626T16, rectangular 16" mahogany table model, \$239.95; and model 626TB16, same as model 626T16 with mahogany console base, \$259.95.

Consoles include: model 622K16, rectangular 16" mahogany set, \$269.95; model 627K16, round 16" mahogany set, \$299.95; model 628K16, round 16" mahogany set, \$279.95, in limed oak, \$299.95; model 631K19, rectangular 19" mahogany set, \$399.95; model 633C17, AM-FM, 3-speed combination with 17" tube in mahogany cabinet, \$49.95, in blond mahogany (model 634C17), \$469.95.

New radios announced include two radio-phono consoles in three cabinets, three table models available in seven different cabinets, and two portables in five cabinets. Prices range from \$17.95 to \$249.95. Westinghouse Electric Corp., 1354 Susquehanna Ave., Sunbury, Pa.—RADIO & TELEVISION RETAILING.

## BENDIX

The new Bendix line includes the following TV sets: model 2051, the Harford, 14" rectangular tube table model, \$169.95; model 3051, the Somerset, a 14" rectangular tube console, \$199.50; model 2060, the Baltimore, 16" rectangular tube table model,



\$219.95; model 6003, 16" rectangular tube console, \$259.95; model 6001, 16" rectangular tube console with doors, \$279.95; and the Dorchester, shown here, model 6100, 16" rectangular tube console combination, \$399.95. Bendix Radio, Div. of Bendix Aviation Corp., Baltimore 4, Md.—RADIO & TELEVISION RETAILING.

## SYLVANIA

Included among 21 new TV models announced are: 14-inch models 4120 (table model) at \$189.95 and 4130 (console) at \$229.95 in walnut, \$239.95 in mahogany, and \$249.95 in blond; 16-inch table models 6110, at \$229.95 and 6120, at \$249.95 in walnut, \$259.95 in mahogany and \$269.95 in blond; 16-inch consoles 6140, \$339.95 in walnut and \$349.95 in mahogany, and 6130, \$299.95 in walnut, \$309.95 in mahogany and \$319.95 in blond. Also combination models 6150, \$449.95, and 6160, \$479.95.

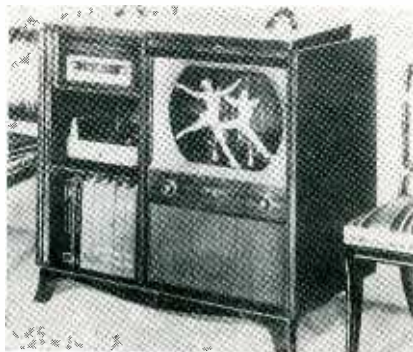

19-inch models include: console models 5130, \$399.95 in walnut, \$419.95 in mahogany and \$449.95 in blond, and model 5140, \$539.95 in mahogany and \$559.95 in blond; and combination 5150, shown, \$645. Sylvania Television, 1280 Main St., Buffalo, N. Y.—RADIO & TELEVISION RETAILING.

## STEWART-WARNER

New line includes two 16-inch rectangular tube TV consoles. Model 9108-A, with FM-AM radio, lists for \$349.95. Model 9108-B, shown here, has a 3-speed changer



as well as FM-AM radio. It lists for \$399.95. Other models in the line are the 9200-A, 14" rectangular table model; 9120-A, 16" rectangular table model; 9120-C, 16" rectangular console with doors; 9120-B (mahogany) and 9120-F (blond), 16" rectangular console without doors; 9120-E (mahogany) and 9120-D (blond), 16" rectangular console with half-doors; 9121-A, 16"-FM-AM-3-speed combination; and 9122, 19" console with doors and AM-FM radio. Stewart-Warner Corp., 1826 Diversey Pkwy., Chicago 14, Ill.—RADIO & TELEVISION RETAILING.

## ADMIRAL

The 18 models in the new line include a 16-inch rectangular tube table model priced at \$199.95. Another 16-inch rectangular tube set, a console, lists for \$229.95. In the combination line, a full-sized combination, containing 14-inch rectangular tube television, 3-speed phonograph, and AM radio, has been announced. It lists for \$299.95. A 16-inch round tube console announced in the new line lists for \$269.95. This is \$80 less than previously announced similar models. The single console in the 19-inch line is priced at \$399.50. This is \$95.50 less than similar previous model. Another 19-inch round tube model is a combination, which features a 3-speed phonograph and AM radio. It is priced at \$499.50, which is \$200 less than previous similar model. Admiral Corp., 3800 Courtland, Chicago, Ill.—RADIO & TELEVISION RETAILING.

## MOTOROLA

Four advance models of the 1951 line have been announced. They are: two 16-inch rectangular tube table models, the model 17T1-A, in limed oak, for \$249.95, and the model 17T2-A, in mahogany, for \$239.95; a 16-inch console, model 17K1-A, \$269.95 in mahogany and \$279.95 in limed oak; and a 14-inch rectangular tube, console, \$239.95 in mahogany and \$249.95 in limed oak. Motorola, Inc., 4545 Augusta Blvd., Chicago 51, Ill.—RADIO & TELEVISION RETAILING.

## EMERSON

15 television models have been introduced ranging in price from \$149.95 for a 12½-inch model to \$339.50 for a 19-inch console. The line includes 12½-inch, 14-inch, 16-inch and 19-inch sets using both rectangular and round tubes. Shown here



is the 16-inch combination model 666. Also announced is a line of radio sets including AC/DC compacts, AM/FM radios, portables and phono-radios. These range in price from \$14.95 to \$149.95. Emerson Radio and Phonograph Corp., 111 8th Ave., New York 11, N. Y.—RADIO & TELEVISION RETAILING.

# Alive

with **NEW** features  
**NEW** sales punch!

Features sell sets. **NEW** Sentinels sure have those lively features that keep them moving off your floor. **TRULY** automatic tuning—practically “Tunes Itself.” Superpowered Intercarrier System for greater simplicity, clearness, superiority of sight and sound—Built-in Tuneable Antenna—“Concertorium” Sound System, even table models have speaker in front for rich, full tone, **NOT** muffled off at top or sides.

It costs us far more to build a Sentinel—so it costs you far less to sell and service them! That’s why every dollar on your Sentinel sales means **BIGGER NET PROFIT**, more customer-satisfaction, for you! Phone, wire or write your Sentinel Distributor **TODAY!**

## Sentinel

*Television*

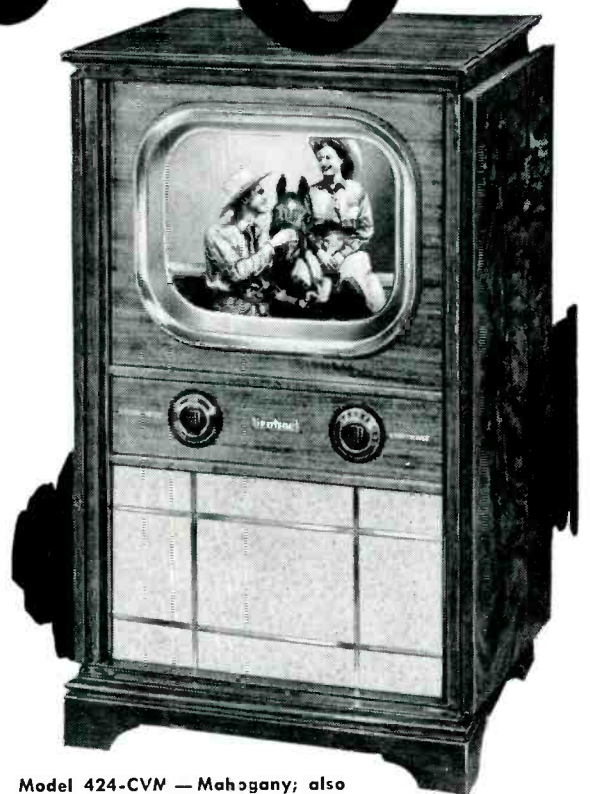

Model 424-CVM — Mahogany; also available in Blonde (Model 424-CVB)



Sentinel Sets  
**Snub**  
Service  
Calls!

**SENTINEL RADIO CORPORATION, EVANSTON, ILLINOIS**



# Latest Television Lines

Compiled by Our Editors as a News Service to Our Readers

## RCA VICTOR

Leading the 18 models in the new TV line is the "Fairfield," 16-inch console with doors, listing at \$299.95 in walnut or mahogany. The three new 12½-inch models are: the Shelby (2T51), plastic table model, listing at \$159.95; the Cumberland (2T60), open-faced console, at \$189.95 in walnut or mahogany, \$199.95 in limed oak; and the Somervell (2T81), TV-AM-phono combo at \$299.95 in walnut or mahogany, \$309.95 in limed oak.

The two smallest 16-inch models are the Newport (6T53), metal table model priced at \$199.95, and the Kent (6T54), metal ensemble model at \$239.50.



Five other 16-inch TV-only consoles are: the Kingsbury (6T64), open-faced unit at \$259.50 in walnut or mahogany, \$269.50 in limed oak; the Highland (6T65), also open-faced, at \$279.50 in walnut or mahogany, \$299.50 in limed oak; the Regency (6T74), with two full-length doors, at \$329.50; the Modern (6T75) shown here, swivel-mounted on a specially designed base, listing at \$349.50; and the Provincial (6T76), with full-length, paneled doors, maple, walnut or mahogany, \$359.50.

Three 16-inch combos are: the Fairfield (6T84), TV-AM-phono, \$439.50 in walnut or mahogany, \$459.50 in limed oak; the Rutland (6T86), TV-FM-AM-phono, \$495; and the Hartford (6T87), with four doors, replaces the S-1000, \$550 in walnut or mahogany, \$570 in limed oak.

Four 19-inch models are: the York (9T57), table model at \$329.50 in walnut or mahogany, \$339.50 in limed oak; the Hillsdale (9T77), half-doors console, \$389.50 in walnut or mahogany, \$409.50 in limed oak; the Northampton (9T79), with four doors, \$425; and the Sedgwick (9T89), TV-FM-AM-phono combo, \$695. Radio Corp. of Amer., RCA Victor Div., Front & Cooper Sts., Camden, N. J.—RADIO & TELEVISION RETAILING.

## SPARTON

The Sparton TV line includes four 12½-inch table models from \$189.95 to \$214.95, five 16-inch table models from \$239.95 to \$264.95, three 12½-inch consoles from \$229.95 to \$329.95, six 16-inch consoles from \$279.95 to \$309.95, two 19-inch consoles at \$399.95 and \$409.95, and four 16-inch combinations from \$399.95 to \$449.95. Sparton Radio-Television, Div. of The Sparks-Withington Co., Jackson, Mich.—RADIO & TELEVISION RETAILING.

## ZENITH

New TV models announced include the following:

12½-inch models, 3 table models: H2227R, in mahogany Pyroxylin, \$179.95, same model in blond Pyroxylin, \$189.95, and the H2226R, mahogany, \$199.95; 2 consoles: H2250R, open-faced, \$239.95, and in blond (H2255E), \$259.95.

16-inch circular models: 5 consoles: H2438R and the H2449E, both open-face, list for \$279.95 and \$299.95, respectively; the H2437, with doors, in mahogany for \$359.95, in blond for \$379.95; the H2439R, also with doors, for \$349.95; 4 console-combos: H3469E, in blond, for \$549.95; the H3475R, in mahogany, for \$499.95; and the H3267, at \$429.95 in walnut, \$449.95 in mahogany.

19-inch models: two consoles: H2447R and the H2445R, at \$399.95 and \$449.95, respectively. The console combinations are the H3477R, at \$650, and the H3478E, at \$695.

16-inch rectangular models: 3 table models: H2328E, in Ireme'wood, at \$259.95, in mahogany (H2328R), at \$249.95, and the H2329R, in mahogany Pyroxylin, at \$229.95. Two consoles: the H2352R, in striped mahogany, at \$289.95; and the H2353E, in blond Ireme', at \$309.95. Zenith Radio Corp., 6001 W. Dickens Ave., Chicago 39, Ill.—RADIO & TELEVISION RETAILING.

## MECK

Six new TV sets are included in the new line. They are a 10-inch table model in mahogany cabinet for \$99.90; a 12½-inch table model in mahogany for \$149.90; a 16-inch mahogany table model for \$199.90; a 12½-inch mahogany console



for \$189.90; a 16-inch mahogany console for \$229.90; and the 19-inch console, shown here, in mahogany cabinet, priced at \$349.90. John Meck Industries, Inc., Liberty St., Plymouth, Ind.—RADIO & TELEVISION RETAILING.

## MERCURY

Included in the TV line are: model 0800, 16-inch black rectangular set; model TV111, 16-inch console in mahogany; model TV114, 16-inch console in blond or mahogany; model 9101, 19-inch round tube console; and model 6193, 16-inch rectangular set available in three different cabinets. Mercury Record Corp., 839 S. Wabash Ave., Chicago 5, Ill.—RADIO & TELEVISION RETAILING.

## PHILCO

The new models in the Philco line include the following 12½" round tube sets: 1207, plastic table model, shown here, \$149.95; 1208, wood table model, \$169.95; 1234, wood console, \$199.95; 1282, console with phono, \$269.95.

14" rectangular sets: 1443B, wood table



model, \$199.95; 1443M, wood table model, \$219.95; 1443, blond table model, \$239.95; 1443X, mahogany console, \$259.95; 1443XL, blond console, \$279.95; 1443PW, walnut combo, \$339.95; 1443PM, mahogany combo, \$359.95; 1443PL, blond combo, \$379.95.

16" round sets: 1601, metal model, \$199.95, with table and built-in aerial, \$229.95; 1602, wood table model, \$239.95; 1604M, mahogany table model, \$249.95; 1604L, blond table model, \$269.95; 1606, mahogany table model, \$269.95; 1634M, console, \$299.95.

17" rectangular sets: 1835, mahogany console, \$299.95; 1836M, mahogany console, \$349.95; 1836L, blond console, \$369.95; 1838, mahogany console, \$429.95 (with remote controls); 1870, combo, \$359.95; 1872, combo, \$399.95; 1874M, mahogany combo, \$449.95; 1874L, blond combo, \$479.95; 1875, mahogany combo, \$499.95; 1876, mahogany combo, \$575, with remote controls.

20" rectangular sets: 2134, mahogany console, \$399.95; 2136, mahogany console with remote controls, \$525; 2175, combo, \$650; and 2176, combo with remote controls, \$695. Philco Corp., C & Tioga Sts., Phila. 34, Pa.—RADIO & TELEVISION RETAILING.

## PILOT

A new addition to the line is the model TV-128. It is a TV-FM-3-speed phono combination using a 12½-inch picture tube. Cabinet is mahogany veneer. List price is \$269.50. Pilot Radio Corp., 37-06 36th St., L. I. C. 1, N. Y.—RADIO & TELEVISION RETAILING.

## MAGNAVOX

Two new 14-inch rectangular tube TV sets have been added to the line. Identical electronically, they are the Hampshire table model, listing at \$198.50, and the Plaza console, listing at \$239.50. Also announced is the Contemporary, 16-inch rectangular tube combo with FM-AM radio and 3-speed record changer. It lists for \$479.50 in blond oak and \$459.50 in mahogany. Also available without TV (to be added later) for \$269.50 in blond and \$249.50 in mahogany. Magnavox Co., 2131 Beuter Rd., Fort Wayne 4, Ind.—RADIO & TELEVISION RETAILING.

# Mr. Dealer:

*You've asked for them! Now they're ready!*

# Two new low-priced radio-phonographs

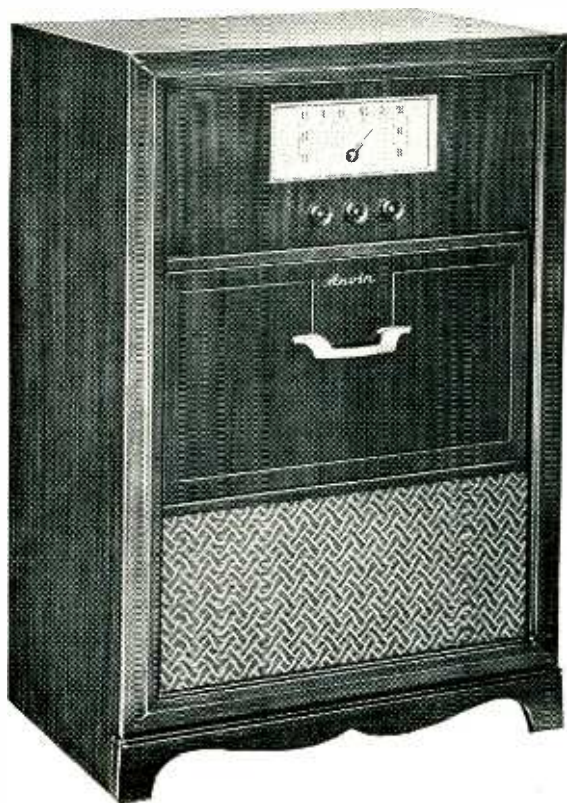

**ARVIN MODEL 462 CM — Mahogany**

Six tubes including rectifier for standard AM band. 462 CB, Blond finish, \$139.95.

**\$129<sup>95</sup>**

**ARVIN MODEL 482 CM — Mahogany**

Eight tubes including rectifier for straight A.C. FM and AM reception. 482 CFB, Blond finish, \$159.95.

**\$149<sup>95</sup>**



Mahogany cabinets! Blond cabinets! AM radio! FM/AM radio! These beautifully styled, expertly engineered Arvin Combinations have everything your customers want—at much less than they expected to pay! Finest automatic record changer built—takes 33, 45, 78 rpm records, intermixes 10-inch and 12-inch, automatically shuts off after last record! Player unit in drawer. These stunning Arvin Combinations fill a real need in today's market. Be ready for the demand! *Mail coupon today for name of your Arvin distributor!* Arvin Industries, Inc., Columbus, Indiana. (Formerly Noblitt-Sparks Industries, Inc.)



ARVIN radio advertising will appear this fall in Life, Saturday Evening Post, Better Homes & Gardens, Country Gentleman, Successful Farming, Progressive Farmer, Pathfinder.

RR-8

Rush name and address of my Arvin distributor

Name .....

Street .....

City ..... Zone ..... State .....



# Latest Phonographs

Compiled by Our Editors as a News Service to Our Readers

## STEELMAN

A new line has been announced, which will include four portable radio-phonos, one radio-phono table model, nine portable phonos, and four children's phonos. The portable radio-phonos list for \$79.95, \$39.95, \$49.95, and the model 515, shown here, for \$44.95. The table model lists



for \$89.95. The portable phonos range in price from \$19.95 to \$79.95; children's line range from \$9.95 to \$19.95. Steelman Phonograph & Radio Co., Inc., 742 E. Tremont Ave., Bronx 57, N. Y.—RADIO & TELEVISION RETAILING.

## TONE

Latest addition to the line is the model 153, shown here, a 3-speed portable phono burgundy or brown leatherette case.



Crystal pickup with 3-speed needle. Tone Products Corp., 225 W. 17th St., N. Y. C.—RADIO & TELEVISION RETAILING.

## BEAM

A new phonograph player attachment for playing all 3 speeds through any radio or TV set has been announced. Called the model BW3, it comes in a leatherette covered case. Uses a single needle for all speeds. List price is \$12.95. Beam Radionics, 224 N. Des Plaines, Chicago 6, Ill.—RADIO & TELEVISION RETAILING.

## HUDSON

The complete line of phonos recently announced includes three "Collectors Series" models, L-51, L-52, and L-53, at \$29.95, \$34.95 and \$39.95, respectively. All are 3-speed, covered in leather. Also announced is a table model radio-phono in mahogany cabinet, with a V-M 3-speed changer.

The children's line includes a console at \$29.95, a table model at \$19.95, and a promotional unit at \$14.95. Twenty-five models in the regular line include: 320, 3-speed manual, \$19.95; 20, 78 RPM at \$14.95; 332, 3-speed, at \$24.95; 347 and 360, 3-speed players; 350, 3-speed, at \$69.95; and 400, radio-phono combination, at \$79.95. Hudson Electronics Corp., 110 E. Third St., Mt. Vernon, N. Y.—RADIO & TELEVISION RETAILING.

## WEBSTER-CHICAGO

Recent additions to the line include the amplifier and portable record changer shown here. The amplifier is model 166, featuring an 8-watt output and 10-inch speaker. It lists for \$68.75. The record changer, model 100-641, is a 3-speed, 3-size unit. It lists for \$63.25. Also an-



nounced is a portable wire recorder with 28 new features. Called the model 288, it replaces the model 180. List price is \$149.50. Webster-Chicago Corp., 5610 Bloomingdale Ave., Chicago 39, Ill.—RADIO & TELEVISION RETAILING.

## SHURACK

Latest addition to the line is the model 3-PJ, a three-speed adaptor, with permanent single needle for all speeds. Designed for use with television or radio sets not having a phonograph, the unit lists for \$14.95. Irving B. Shurack, Inc., 1133 Broadway, N. Y. C., N. Y.—RADIO & TELEVISION RETAILING.

## NEWCOMB

A new portable phono, added to the line, is the model R-12. It features a 3-speed player and will play records up to 12". Amplifier has 5 watt output. Weight: 20 pounds. Newcomb Audio Products Co., 6824 Lexington Ave., Hollywood 38, Calif.—RADIO & TELEVISION RETAILING.

## PHONOLA

Shown here is the new addition to the line, the model TK-146 3-speed auto-



matic changer. It features a 5" speaker and variable tone and volume controls. Waters Conley Co., Rochester, Minn.—RADIO & TELEVISION RETAILING.

## DUOSONIC

A new portable 3-speed phono, shown here, has been announced. Designated the model 104, it is in a simulated leatherette case, stripped with plastic piping. Uses 2 amplifier tubes plus rectifier. Separate tone and volume controls. Also available are two companion models, model 105, 3-



speed phono with dual needles, and model 205. Sonic Industries, Inc., 221 W. 17th St., N. Y. C.—RADIO & TELEVISION RETAILING.

## ANSLEY

A new table model phonograph has been announced. Called the model LP-6, it features a 3-speed automatic changer and mahogany cabinet. List price is \$119.50. Same instrument with manual 3-speed record player, called model LP-6S, lists for \$99.50. Arthur Ansley Mfg. Co., Doylestown, Pa.—RADIO & TELEVISION RETAILING.



## ***Picture of a prospect deciding where to buy***



**AMERICA'S BUYING GUIDE  
FOR OVER 60 YEARS**

She uses the 'yellow pages' or the telephone directory like 9 out of 10 shoppers in your community... to find the products and services she needs... to save needless shopping trips... to save time.

You can turn more prospects in your direction by using the familiar 'yellow pages' to advertise your radio and television store. Your

messages about the branded sets you sell and services you offer, go right into the homes in the community. They are within reach of prospective customers *just when they're ready to buy.*

The 'yellow pages' of the telephone directory make *good looking* for your prospects and *good selling* for your products.

**For further information, call your local telephone business office.**





# HERE'S YOUR REPLACEMENT

*No Other Control Gives You All These*

**59 IRC CONTROLS WITH AMAZING ADAPTABILITY MEET ALL YOUR NEEDS WITH LESS STOCK**

Compare the amazing adaptability of your IRC Q Control with any other. You'll agree no other control so closely meets all your servicing needs . . . no other gives you so much for your money! Feel its cushioned turn, examine its lustrous finish, study its practical design—ask your Distributor for IRC Q Controls, and you know you're buying the very best.

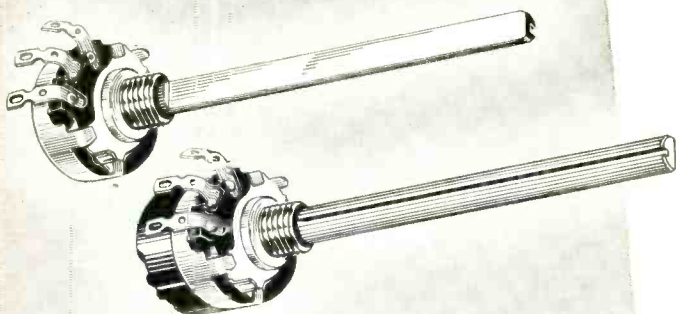

**KNOB MASTER FIXED SHAFT**  
 Standard fixed shaft fits most knobs without alteration or inserts. Flatted, knurled and grooved. 3" length meets TV requirements. Ample cross-section prevents bending.

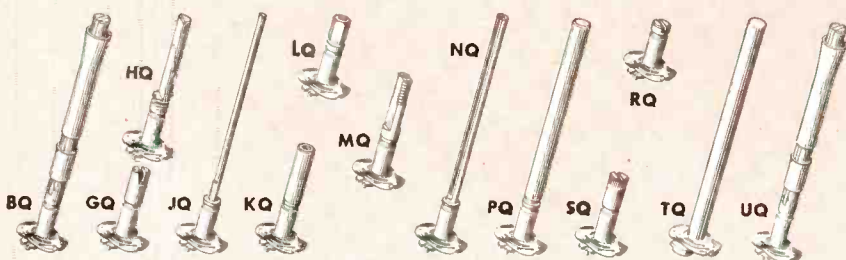

**INTERCHANGEABLE FIXED SHAFTS**  
 Easy replacement of standard shaft with any of 13 special fixed shafts is made possible by exclusive IRC Resilient Retainer Ring. This revolutionary feature provides widest replacement control coverage.

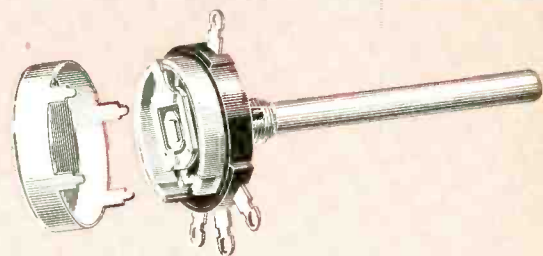

**WIRE WOUND CONTROLS**  
 Dependable 2 watt controls available with center tap for TV centering. Specific TV values now available with Knob Master Shaft to accommodate both knurled and flatted knobs.

# No. 1 CONTROL

*Modern Servicing Features!*

- ★ Fits both flatted and knurled knobs
- ★ Separate switches
- ★ Modern small size
- ★ Fixed shaft convenience with complete shaft interchangeability
- ★ 23 tapped types
- ★ Shorter bushing
- ★ Sparkling appearance
- ★ 1/2 watt rating



## INTERNATIONAL RESISTANCE COMPANY

401 N. BROAD STREET, PHILADELPHIA 8, PA.

*Wherever the Circuit Says*

In Canada: International Resistance Co., Ltd., Toronto, Licensee

*Concentrikit*



This original IRC feature provides a ready solution to your special control requirements. With this kit of parts you assemble practically any concentric dual control quickly and easily. In a matter of minutes you can prove the advantages of this practical IRC feature.

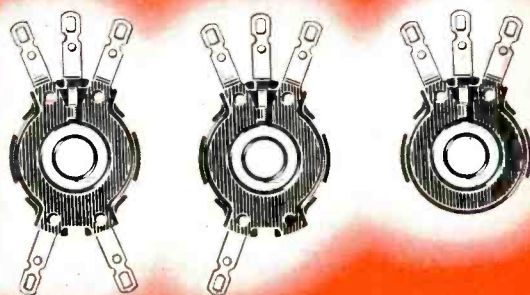

### INTERCHANGEABLE BASE-ELEMENTS

Principally intended for use with Concentrikit, this IRC innovation gives you limitless opportunities for adapting controls to specific requirements. Each unit includes molded base, element, terminals and collector ring—no loose parts. Available in 33 resistance values and a variety of taps.

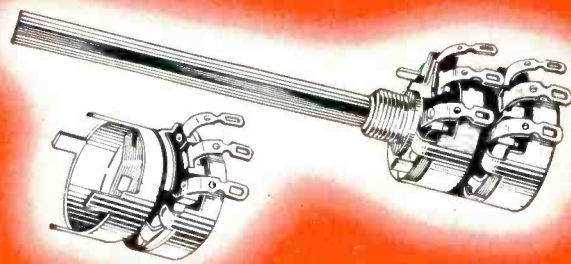

*Multisections*

For standard duals, IRC Multisections are added to Q Controls like switches. 17 values provide over 11,000,000 variations of dual, triple and quadruple controls; accommodate switches, too!

### INTERNATIONAL RESISTANCE COMPANY

425 N. Broad Street, Phila. 8, Pa.

Please send me additional IRC Q Control information checked below:

- Free Catalog Bulletin DC1A
- Enclosed find 25c in stamps or coin for comprehensive Concentric Dual Replacement Manual

Name \_\_\_\_\_

Company \_\_\_\_\_

Address \_\_\_\_\_



# Emerson

**NEW!** Sensational EMERSON FULL-SCREEN FOCUS!... Pictures CLEAR to the edges

**NEW!** EMERSON BLACK-MAGIC CONTRAST! Pictures actually CLEAR in bright daylight

**PLUS!** All Emerson advanced engineering features—Simplimatic One-Knob Tuning — Built-in Antenna — Miracle Picture Lock — Super-Powered Long-Distance Circuit — the basic reasons why EMERSON PERFORMS WHERE OTHERS FAIL!

*Number 1 in Volume!*

*Number 1 in Performance! Number 1 in Value!*

*Number 1 in Profits!*



**12½-inch Table Television, \$169.95**  
Fine Mahogany Cabinet. Model 673  
*Slightly higher in South and West*



**19-inch Picture De Luxe Mahogany Console. Model 669**  
**\$399.95**  
*Slightly higher in South and West*



**16-inch Picture DeLuxe Hand-Rubbed Mahogany Cabinet. Model 661**  
**\$239.95**  
*Slightly higher in South and West*

**16-inch TV-FM and AM Radio — 3-Speed Automatic Phonograph — Selected Mahogany Cabinet. Model 666**  
**\$399.95**  
*Slightly higher in South and West*

**IN EVERY SCREEN SIZE, EVERY STYLE, EMERSON IS AMERICA'S NUMBER ONE BUY!**

**TABLE MODELS**

- 12½-inch, Mahogany\* Cabinet, Model 673.....**\$169.95**
- 12½-inch, De Luxe Mahogany, Model 660.....**\$179.95**
- 14-inch, Rectangular Tube Figured Walnut Bakelite Cabinet, Model 662.....**\$189.95**
- 16-inch, Rectangular Tube Compact Mahogany Cabinet, Model 663.....**\$229.95**

- 16-inch, De Luxe Mahogany, Model 661.....**\$239.95**

**CONSOLES**

- 12½-inch, Mahogany\* Console Cabinet, Model 664.....**\$199.95**
- 16-inch, Mahogany\* Console Cabinet, Model 668.....**\$259.95**
- 16-inch, De Luxe Mahogany\* Console, with doors, Model 667.....**\$299.95**

**COMBINATIONS**

- 19-inch, De Luxe Mahogany\* Console, full-length doors, Model 669.....**\$399.95**
- 12½-inch TV, AM Radio, 3-Speed Automatic Phonograph, Mahogany Console Model 665.....**\$299.95**
- 16-inch TV, FM-AM Radio, 3-Speed Automatic Phonograph, Mahogany Console, Model 666.....**\$399.95**

\*AVAILABLE IN BLONDE AT SMALL ADDED COST Note: All prices slightly higher in South and West.



# Number ONE for 1951!

**Emerson has what it takes! Multi-Million-Dollar Advertising!**

Millions of dollars budgeted for hard-hitting television, national magazine, radio, newspaper, car card, and outdoor advertising. Plus the smartest point-of-sale displays you ever saw!



**New! World's Top FM-AM Radio Value.** Model 659. Eight tubes and rectifier. High-style modern walnut plastic cabinet, with slide-rule tuning. **\$49.95**

*Slightly higher in South and West*

Emerson Radio & Phonograph Corporation  
111 Eighth Avenue, New York 11, N. Y.

**3-Speed Automatic Phonoradio Mahogany Console.** Model 670. Plays and changes all speeds and sizes of records from 7 to 12 inches. Super-powered radio. Decorator-designed console that's a best seller at this low Emerson price. **\$149.95**

*Slightly higher in South and West*

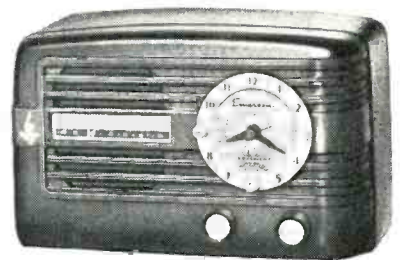

**New! Automatic Clock Radio.** Model 671. Nothing like it anywhere near this low price! Quality clock can be set to turn radio on and off, or operate alarm. Walnut\* plastic case. **\$29.95**

*Slightly higher in South and West*

**2½ Times more  
plant capacity!**

Remember, it takes more than pictures and promises to build your profits. It takes *merchandise* that you can *sell and deliver*. And, with plant capacity multiplied 2½ times, **EMERSON HAS WHAT IT TAKES!**



## EMERSON'S 1951 RADIO VALUES FOR EVERY PURSE AND EVERY PURPOSE!

### PORTABLES

- Self-Powered Portable, Model 645 less batteries..... **\$18.95**
- Three-Way Portable, Model 646 less batteries..... **\$24.95**
- Super-Powered 3-Way Portable, Model 656 less batteries **\$39.95**
- Super-Powered 3-Way De Luxe Portable, Model 657 less batteries..... **\$44.95**
- Pocket-Personal, Self-Powered, Model 640..... **\$24.95** complete
- Pocket-Personal, 3-Way, Model 584..... **\$39.95** complete

### TABLE COMPACTS

- Compact AC-DC Radio (Ebony\*) Model 587..... **\$14.95**
- New AC-DC Bakelite Compact (Ebony\*) Model 652... **\$16.95**
- Super-Powered AC-DC Compact (Maroon\*) Model 636... **\$19.95**
- De Luxe Table Compact (Walnut\*) Model 653..... **\$22.95**
- New Super-Sensitive Compact (Walnut) Model 641... **\$29.95**
- Moderne, Ebony-Gold Compact Model 561..... **\$29.95**
- New FM-AM Table Compact (Walnut) Model 659... **\$49.95**

- Automatic Clock Radio (Walnut\*), Dependable alarm and timer, Model 671..... **\$29.95**

### PHONORADIOS

- 45-RPM Automatic Phonograph Model 590..... **\$29.95**
- 45-RPM Automatic Phonoradio Model 635..... **\$49.95**
- 3-Speed Automatic Phonoradio Mahogany Cabinet... Model 634..... **\$89.95**
- 3-Speed Automatic Phonoradio Mahogany Console De Luxe Model 670..... **\$149.95**

\*AVAILABLE IN IVORY AT SMALL ADDED COST Note: Prices slightly higher in South and West



# Television & Appliance Retailing

## Westinghouse ELECTRIC RANGE

The new 1950 Commander model electric range is shown here. A double-oven model, it has a suggested list price of \$369.95. Features include Color-Glance controls that indicate heat positions by color. The single-oven model Commander will retail at suggested list price of



\$329.95. Westinghouse Electric Corp., Electric Appliance Div., Mansfield, O.—RADIO & TELEVISION RETAILING.

## Cory MATIC-MAID

A new, portable dishwasher weighing 25 lbs. has been announced. Designed to operate on either a right or left hand drain-board sink, it will wash a full dinner service for four in ten minutes. Uses a hydraulic centrifugal pump. List price is \$89.95. Cory Corp., Chicago 1, Ill.—RADIO & TELEVISION RETAILING.

## Astral REFRIGERATOR

A type of refrigerator new to the American market has been introduced. This new unit, shown here, operates on the heat absorption principle using a 95-watt electrical heating device. Operates on 110-115 volts AC or 32 or 12 volts DC.

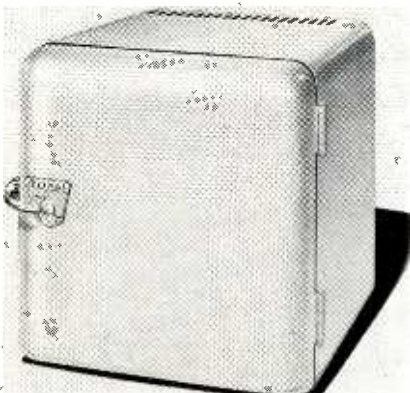

The unit measures less than 2 x 2 x 2 feet and weighs about sixty pounds. List price is \$129.95. Astral Industries, Inc., Rockleigh, N. J.—RADIO & TELEVISION RETAILING.

## Philtain DEFROSTER

An automatic refrigerator defroster has been announced. Called the De-Frost Master Defroster, the unit is housed in a white plastic case. List price is \$9.95. Philtain Electric Corp., 2131 S. Fairfield Ave., Fort Wayne 6, Ind.—RADIO & TELEVISION RETAILING.

## Hotpoint DISHWASHER

A new automatic electric dishwasher sink has been announced. Called model MC16, it features a built-in electric dryer. Also available as the model MCP16, a pre-plumbed unit, and with the model MD5 Disposall. As the model MC15 and MC14, the washer is available separately, for installation among or under existing cabinets. Hotpoint, Inc., 5600 W. Taylor Street, Chicago 44, Ill.—RADIO & TELEVISION RETAILING.

## Prevore INFRA-RED BROILER

A new infra-red oven broiler, priced at \$24.95, is offered. Unit is 14½" long, 10" high and 12" wide. Has a cast-aluminum broiling pan and bakelite handle. Operates on AC or DC. Prevore Electric Mfg. Corp., Fulton St. at Clinton Ave., Bklyn. 16, N. Y.—RADIO & TELEVISION RETAILING.

## Industrial ELECTRIC CROCK

A simmer crock is offered, consisting of two crocks sealed one inside the other with an electric heating element sealed in between them. Temperature is pre-set at the factory; capacity is 2 quarts. Does not boil over. Made of glazed chinaware. Industrial Radiant Heat Corp., Gladstone, N. J.—RADIO & TELEVISION RETAILING.

## GE NEW RADIOS

New radios announced include table models 400, 401, and 411, at \$19.95; model 410 in wood cabinet for \$39.95; models



404 and 405 at \$29.95; and model 402 at \$24.95.

An AM-FM table model is model 408, shown here, listing at \$49.95.

Eight clock radios range in price from \$29.95 to \$39.95. Four console-combinations include: model 740 at \$169.95; model 755 at \$279.95; model 752 at \$229.95; and model 753 at \$239.95. General Electric Co., Receiver Div., Electronics Park, Syracuse, N. Y.—RADIO & TELEVISION RETAILING.

## Hoover HAND VACUUM

A hand-type electric vacuum cleaner, the Norca Dustette, shown here, has been added to the line. Designed to retail for \$24.95, it includes a wire storage hanger for storing on wall or closet. Also announced is a new floor polisher. Equipped with two sets of buffing pads, one of felt,



one of lambs wool, the polisher lists for \$69.95. Hoover Co., North Canton, Ohio.—RADIO & TELEVISION RETAILING.

## Motorola RADIO-LARM

A new radio-clock combination has been announced, the model 5C1. Clock operates independently of the radio. Will turn radio on at any set time and off within one hour. Available in green or ivory with brass trim. List price is \$32.95. Motorola, Inc., 4545 Augusta Blvd., Chicago 51, Ill.—RADIO & TELEVISION RETAILING.

## Air King 16" TV SET

Latest addition to the line is a 16" table model in metal cabinet. Called model 16M1, it lists for \$189.95. Baked enamel finish is mahogany grained. Air King Products Co., Inc., 170 53rd St., Bklyn. 32, N. Y.—RADIO & TELEVISION RETAILING.

## RCA NEW RADIOS

New additions to the radio line include: model 45-W-9, an AM-FM-45 RPM console combo at \$179.95; model A-82, 3-speed console combo, \$199.95; model A-91, FM-AM-3-speed combo, \$239.95; model A-108, AM-FM-3-speed combo, \$269.50; X551 series, plastic table radios at \$24.95 and \$27.95; and model X-711, AM-FM plastic table radio, at \$49.95. Radio Corp. of Amer., RCA Victor Div., Front & Cooper Sts., Camden, N. J.—RADIO & TELEVISION RETAILING.

## Scott TV SETS

Leading the new Scott line is the "Cressy," a 16" TV-FM-AM, 3-speed combo. List price is \$695. Also available without TV, which can be added later, at \$465. Heading the radio-phono combos is the "Chippendale," at \$995, available with remote control at \$100 extra. Other radio-phonos are the "Kenilworth," \$398.50; the "Sheffield," \$425; the "Britanny," \$465; the "Wilmette," \$295.50; and the "Highlander," \$335.50. Scott Radio Labs., 4541 Ravenswood, Chicago 40, Ill.—RADIO & TELEVISION RETAILING.

# 12

## months a year... Profitable Turnover

# with Hotpoint



Hotpoint's dynamic year 'round sales program is a working fact—not just a theory! Profit-wise merchandisers, everywhere, are feeling the impact of the Hotpoint plan in their profit statements month after month.

The Hotpoint Full-Line Franchise provides every major unit for the complete electric kitchen and home laundry, plus a fully developed merchandising program for every month of the year. *There is never a dull month with Hotpoint.*

Talk to your Hotpoint distributor and get all the facts concerning the complete line of Hotpoint products and the Hotpoint Full-Line Franchise. Get on the right track now to constant, profitable turnover . . . every month.

**THE HOTPOINT FOOD FREEZER**  
As a sales leader for August we proudly present the Hotpoint Food Freezer . . . with a size for every family need. THRIFTMASTER unit . . . automatic temperature control . . . freezer alarm signal . . . rust-proof interior and all steel cabinet are but a few of the many sales appeal features engineered into this amazingly popular product.

- ★ **No more "letdowns" following hot selling seasons**
- ★ **No more "doldrums" that eat away profits**
- ★ **No more "Valleys" that reduce profit peaks**

**...but a full line of products that insures a full year of profits**

# Switch to Hotpoint!

**for YEAR 'ROUND Profits!**

Ranges • Refrigerators • Dishwashers • Disposalls® • Water Heaters • Food Freezers • Automatic Washers • Clothes Dryers • Rotary Ironers • Cabinets

## Hotpoint Inc.

(A General Electric Affiliate)  
5600 West Taylor Street • Chicago 44, Illinois



# New Electrical Appliances

Compiled by Our Editors as a News Service to Our Readers

## GE "REPEATER" CLOCK

Nine new electric clocks have been added to the line. Featured is the repeater alarm which automatically resets itself. List price is \$7.95. Other clocks announced include the Gourmet, kitchen clock, at \$5.95; the New Herald, Nudger, and Lumalarm are new alarm clocks listing for \$4.95, \$5.95 and \$6.95, respectively. The Tune-A-Larm, which turns on the radio and sounds seven minutes later, lists for \$8.95. Two other alarms, the Gay Hour and the Candlewick list for \$7.95 and \$13.95, respectively. The Designer, occasional clock in mahogany case, lists for \$8.95. General Electric Co., Appliance Dept., Bridgeport 2, Conn.—RADIO & TELEVISION RETAILING.

## Freez-In PORTABLE REFRIGERATOR

A portable electric refrigerator, shown here, has been announced. A 1½ cubic



foot model with 1/10 H.P. freezing unit, it carries a 5-year warranty. Has three ice cube trays, with space for three more. Operates on 110 volts AC. Freez-In Mfg. Corp., 2144 Mack Ave., Detroit 7, Mich.—RADIO & TELEVISION RETAILING.

## Fresh'nd-Aire "FANETTES"

Two new ivory and gold "Fanettes" have been added to the line. The new models, aimed at the gift market, are model 80DX and model 100DX. The 80DX

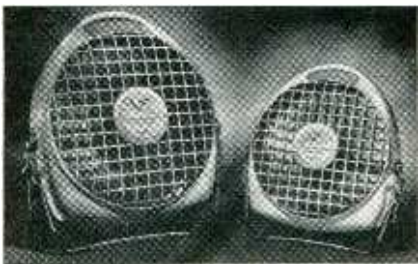

in 8-inch size lists for \$12.95; model 100DX, a 10-inch size, lists for \$17.95. Fresh'nd-Aire Co., 221 N. LaSalle St., Chicago 1, Ill.—RADIO & TELEVISION RETAILING.

## Horton WASHER

A new automatic washer, the model 500, shown here, has been announced. With a capacity of 10 pounds, the washer

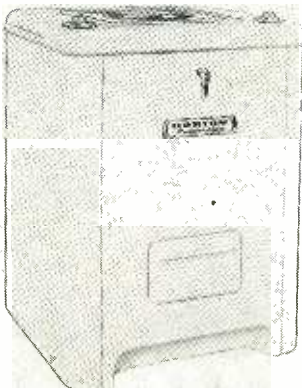

features safety automatic shut-off when the lid is lifted. Spins clothes dripless dry. Also offered is the model E49 electric dryer. Dials allow setting for degree of dryness desired. Also completely automatic. Horton Mfg. Co., Fort Wayne, Ind.—RADIO & TELEVISION RETAILING.

## Westinghouse NEW APPLIANCES

The electric blanket shown here is available with single control (EB-501) for \$39.95, or with dual controls (EB-502) for \$47.45. It is among the latest additions to the electric housewares line which include: an electric comforter (EC-61) at \$49.85;



an electric sheet (ES-71) at \$24.95; a 1,150 watt square waffle baker (WB-501) at \$22.50; a pop-up toaster (TO-501) at \$20.95; an automatic sandwich grill (SG-501) at \$17.95, and a non-automatic model (SG-502) at \$14.95; a new electric iron (ID-723) at \$12.95; a twin waffle baker (WB-503) at \$16.95; and two warming pads, the model WP-502, with standard 3-position control, at \$6.45, and the model WP-501, with Brailway control which can be read in the dark, at \$7.95. Westinghouse Corp., Mansfield, Ohio.—RADIO & TELEVISION RETAILING.

## Youngstown DISHWASHER

The 27" automatic electric dishwasher shown here has been added to the line. It is operated by a front panel switch, dishes are air dried. Features center spray action, sound deadened tub. Also announced is an electric sink incorporating

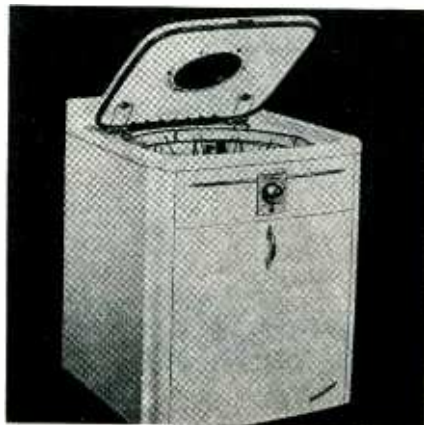

a similar washer with a sink in one unit. Mullins Mfg. Corp., Warren, Ohio.—RADIO & TELEVISION RETAILING.

## NuTone VENTILATOR

Model NF-10 kitchen ventilator, shown here, is one of a series of eight NuTone



wall and ceiling fans. Its features include an eight ounce removable grille, designed for easy cleaning; "separate unit packaging"; and "screwdriver installation." Carries a five year guarantee on motor, one year guarantee on rest of fan. List price is \$29.95. NuTone, Inc., Madison and Red Bank Rds., Cincinnati 27, O.—RADIO & TELEVISION RETAILING.

## Coolerator FREEZER (Correction)

The new 10.3 cubic feet freezer, model FB-102, announced in the June issue, is priced at \$299.95, not as previously listed at \$211.95. The freezer features a counter-balanced lid, built in lock and temperature adjustments from 0° F. to -10° F. It will hold up to 360 pounds of frozen foods. The Coolerator Co., Duluth, Minn.—RADIO & TELEVISION RETAILING.

**TIME SALES**  
build profitable  
**VOLUME**

**COMMERCIAL**  
**CREDIT**  
financing protects your  
**PROFIT**

*Helps Dealers Make*  
More **SALES** • More **PROFITS**  
More **SATISFIED CUSTOMERS**



**COMMERCIAL CREDIT CORPORATION**

*A Subsidiary of*

*Commercial Credit Company Baltimore • Capital and Surplus Over \$100,000,000*

MORE THAN 300 OFFICES IN PRINCIPAL CITIES OF THE UNITED STATES AND CANADA

RADIO & TELEVISION RETAILING • August, 1950

Every appliance dealer knows that his volume sales must still come from the time payment buyers. Though there has been a considerable improvement in family incomes since 1941, 80% are still in the under \$5,000 class.

You see how important it is to be as choosy as all-get-out in picking your financing connections.

Because the most of your merchandise profits come from time payment sales, you want to be sure that your time payment plan gives you every advantage to promote those sales and protect those profits.

Commercial Credit service assures you of liberal and complete wholesale financing, wide but wise latitude in granting retail credits, and a profit-protection feature that irons the wrinkles out of your brow.

Check with any of the leading appliance distributors. They know.



NO WONDER *Regency*  
**TV IS THE LARGEST SELLING  
 SIGNAL BOOSTER!**

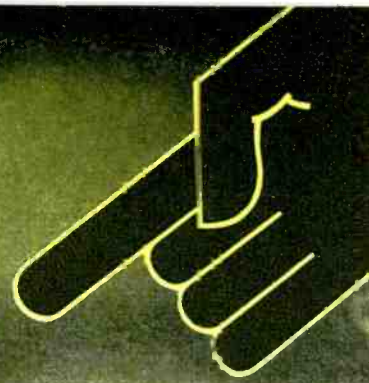

... it wins all  
 performance tests!  
 ... is also  
 lowest priced!

THE DB 400  
**\$29.95**  
 LIST



**REGENCY FEATURES:**

- Single-knob tuning control.
- Off-on switch controls the TV set.
- Easy installation. TV set plugs into the booster—booster plugs into wall outlet!
- The use of Contra-Wound Bifilar Coils with push-pull triode design gives a balanced circuit.
- Electrical symmetry makes possible balanced-bridge neutralization which insures stability and eliminates self-oscillations.
- No external impedance matching devices required.



**REGENCY FEATURES:**

- A handsome plastic case net design in mahogany or blonde; created to please the most discriminating interior decorator.
- Wide bandwidth assures equal enjoyment of both video and audio on all 12 channels.
- Underwriters'  Approved.

  
*Regency*  
 Division, I.D.E.A., INC.

52 N. New Jersey St., Indianapolis 4, Indiana



# SERVICE & SOUND

Section of **RADIO & TELEVISION RETAILING**

## Getting the Most Out of Fringe TV

• In the article on this subject in our June issue, we discussed some of the theoretical and some of the practical considerations involved in getting the best possible results in the fringe. These considerations were divided into five headings: Antenna height, Antenna type, Transmission Line, Accessories, and Alignment.

We shall start off this month by discussing that factor which was most lightly treated last time, namely the receiver itself.

In the first article on Fringe TV, we pointed out that the most important section of the TV receiving system for fringe operation is that which lies ahead of the 1st RF plate. Actually, a very small portion of the amplification takes place in this section. The reason for its importance is that this is the only place where the all-important signal to noise ratio can be improved.

The first thing that should be attended to, however—and before expensive antenna-and-tower installations are made—is the set itself. First, make sure that it is operating properly according to its specifications, and second, alter it where possible (and desirable) to get even better results when coupled with the best type of installation. The following suggestions may prove helpful in this connection.\*

### Removing the AGC

Where a booster is used regularly (as it is in most fringe areas), the set will be working against itself if there is any AGC on the 1st RF, for the booster will cause an AGC voltage to be developed which will cut down the gain of the stage and to a certain extent nullify the effects of the booster. Therefore it is advisable to remove

\* For many of these suggestions we are indebted to Caywood Cooley, Philco TV Field Engineer, who incorporated them in a speech at the recent Philco Service Managers Convention

### Practical Reception-Improving Techniques on Installation and Alignment for Weak-Signal Areas



Height increases the range of this antenna.

the AGC from this stage. In "medium" fringe areas, even where a booster is not used, the S/N ratio will be somewhat improved by allowing this stage to operate wide open.

The sync clipper or sync limiter operates to remove noise and therefore prevent it from triggering the sync circuits falsely, throwing the set out of sync. This action is designed to operate with a normal ratio of signal-to-noise. If however, the signal is very weak, the clipper will only clip the peaks off the noise pulses, leaving the signal still way down in the noise. It is possible to change the clipping level for fringe operation by lowering the plate voltage on this stage, thereby causing the tube to cut off sooner. This will result in better noise immunity and more stable sync.

In receivers with keyed or gated AGC, however (for more information

on this subject, refer to article in November 1949 issue of Radio & Television Retailing) the receiver is immune to noise (as far as sync is concerned) most of time, when the "gate" is "closed."

Alignment of the IF's can be utilized to get more gain out of the set at the expense of bandwidth and definition. These latter two factors are not too important, however, when the main object is to get a picture. In the first place, the picture carrier can be moved higher up on the response curve (to about the 75% point). This is, in effect, what happens when the fine tuning control is operated. The picture gets brighter, but the sound gets distorted because we are in effect moving the response curve away from it. If we wish to take permanent advantage of the brighter picture obtained with the pix carrier higher on the curve, we must also move the sound in to insure intelligibility and clarity.

### Lower IF Bias

In connection with alignment, it is well to consider what bias is being used. Most receiver alignment instructions specify that the technician set the bias on the IF bias bus at -3 volts, which is supposed to approximate normal operating conditions. In a fringe area, however, the bias may not even approach this figure. Alignment in weak-signal areas should be performed with the bias set at the point approximating actual operating conditions, so that response with a real signal will be the same as test-bench conditions.

(Continued on page 66)



# Getting the Most Out of



TV receivers are supposed to operate with a 4 MC video bandpass. A usable picture will be obtained (for fringe operation) with as little as 2 MC, however. As a matter of fact, coax cable transmissions on the networks cut off at about 2.7 MC for normal operation. Peak alignment for narrower bandpass will result in considerably more gain at the expense of definition. The chief pitfall to avoid is that the various stages of stagger-tuned IF's are not tuned to the same frequency so that regeneration occurs. Precautions for avoiding this condition are included in the alignment instructions for most receivers.

More gain can also be achieved in the video amplifier (again at the cost

of definition) by increasing the value of the video load resistors from the video detector to the output stage.

If the technician does not wish to, or does not feel it necessary to alter the receiver operating conditions in any of the ways described above, it may still be possible to find ways to improve gain by a careful sensitivity check of the receiver. The gain of a receiver from antenna to kinescope is so large (probably in the neighborhood of 100 DB), that many values and alignment points are not critical for normal operation. Better results may be obtained, however, by bringing every circuit "up to snuff."

Even line voltages may be important to getting the most out of a TV receiver in a fringe area. Since best reception in these areas is usually experienced at night, and since power

companies carry their heaviest loads at night, it has been found in some localities results obtained on a test bench in the daytime did not correlate with operating conditions at night. In particular, this has been found to affect picture width and brightness. Some servicers have found it advantageous to use voltage regulators or voltage regulating transformers in order to maintain consistent levels of operation and to avoid rapid fluctuations in brightness and focus, as well as dropping out of sync. One technician writes that he ties in a filament transformer in the power supply to get an extra few volts to compensate for low line voltage.

## Actual Cases

Getting back to the "appendages" ahead of the receiver (antenna, transmission, line, booster, etc.), we have collected together a number of field experiences sent in by readers, and reproduce them herewith with the idea that they may be practical hints for use by other readers, or at least, in some cases, food for thought.

We find mixed reactions from installers consulted concerning lightning protection. Many dealers are omitting arresters because of troubles experienced with intermittent or noisy contacts, high resistance losses, line reflections, etc. We would highly recommend the use of arresters on every installation, these reports notwithstanding. It may be necessary to shop more carefully for a more trouble free type than you were using, and it may also be necessary to make periodic checks to see that the arrester is in good shape—but the trouble is worth it. Lightning doesn't strike very often, but once is enough. In addition, although direct

Above and below are typical fringe area antenna installations.



# Fringe TV

strokes are rare, indirect strokes can cause a good deal of trouble. The astronomically high voltages present in the vicinity for a split second have often burned out or opened up antenna input transformers, and have sometimes caused trouble farther along in the receiver.

## Grounding the Antenna

Almost all dealers agree that grounding the mast (for lightning protection) is a must. Many, however, do not go to great lengths to accomplish; some even feel that it is sufficient that the mast or tower is resting on the ground. It may be of merit to consider, if you really want to do a good job of grounding, that the mast may provide a path of relatively high resistance (depending on the material of which it is constructed). Some servicers run a good heavy copper conductor to a stake in the ground to overcome this. A few dealers stated that they rely on the guy wires to act as ground wires, and choose these cables accordingly for good conductivity and high current carrying capacity.

On the subject of transmission lines, there is a good deal of difference of opinion concerning the use of shielded and unshielded lines. The regular (unshielded) twin-lead is said to have lower attenuation, and besides is easier to work with and cheaper than coax and shielded twin-lead. On the other hand, one dealer writes, "We have considerably lessened interference and at the same time have not had any loss by using RG-11-U cable; that is to say, any more than 300-ohm ribbon. Although the cable is more in price by about 10¢, in a noisy area it is well worth its cost by providing a better signal to noise ratio at the set, providing a proper match is made at the set." It is obviously important that if shielded line is to be used, proper, water-tight, constant impedance connections be made. An increasing number of our readers seem to be falling into agreement with the one quoted above, however, and especially where installations have to be made (in a fringe town) in a store on the main street,

where ignition noises, cash registers, air conditioning machines, etc., raise hob with the picture. The most popular type, though, is still open twin-lead.

## Antenna Types

There is virtually no generalization which can be made concerning the most popular antenna types. Some swear by conicals, some by inlines, some by 4-stack straight dipole-reflector combinations, some by Yagis, etc. This is, of course, as one might expect, since conditions vary in each locality. Fringe areas are often right between two broadcasting areas, with stations on the same channel coming in from different directions. Here a sharp front-to-back ratio is desirable. In other places, high channels may be in one direction, low channels in another. And in many localities, only one channel is received. Yagi antennas are most often preferred where reception is desired on only one channel; and those dealers who like Yagis and get several channels have one for each station. Economy often dictates the favorite antenna, on the other hand, and this

will be that which provides for best all-round reception on all the channels which can be received, with sometimes a rotator to pick them up from different directions.

As for antenna heights, 50 feet seems to be a popular figure, regardless of location and distance from the station. This may be due to the availability and cost of various towers and masts; or it may be because, as one reader put it, "We have tried heights up to 85 feet and compared results with 50 foot antennas, and found not enough difference in picture quality to warrant the additional expense and hazards of a taller tower."

These are a few of the comments and abstracts of comments which we have received from our readers on the subject of fringe TV. The editors of Radio & Television Retailing will be pleased to continue these comments, which help to appraise dealers in different parts of the country of what their colleagues elsewhere are doing to get results. Please address your letters to the Technical Editor, Radio & Television Retailing, 480 Lexington Ave., New York 17, N. Y.

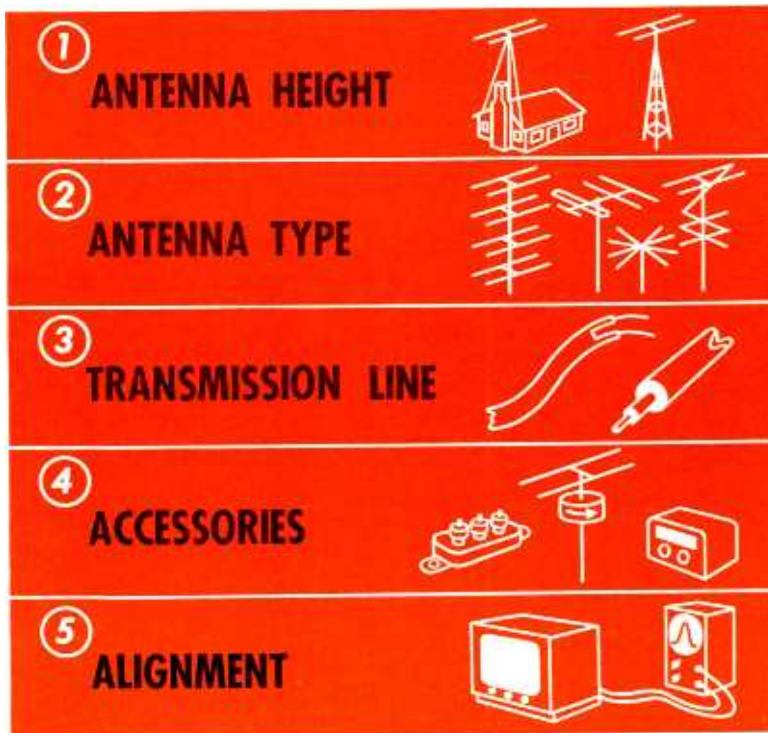

All these things must be considered when working in a fringe area.

Left: Sync limiter operating at normal S/N ratio; center, normal sync level with lower signal, more noise is passed; right, sync cut-off lowered for improved fringe area operation.

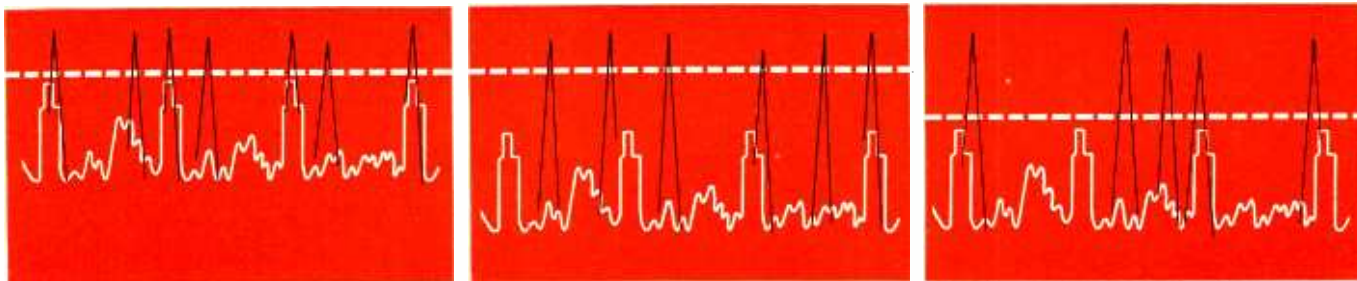



# How to Locate Set Troubles

Tested Procedures and Practical Methods for

By Solomon Heller

• Tube shorts may be divided into 3 categories: 1—Shorts that readily show up in the tube tester. 2—Shorts that are revealed by a tube-tester check only when an experienced hand is at the throttle, so to speak. 3—Shorts that are not brought to light by a tube-tester check.

Defects in category 1 are too simple to warrant discussion. Those in categories 2 and 3, however, are worth considering.

What is to be done when a tube that is suspected of being shorted, reads normal in the tube tester? First, leave the tube in the tester for several minutes, allowing it to get thoroughly warmed up. Then try testing it for shorts. When the above check is negative, but suspicion remains centered on a particular tube, let the latter heat up in the receiver, under its normal load; then remove it quickly and test it while still hot. Still another check is to let the tube heat up in one of the 2 ways just described, then test it for shorts between elements while tapping or finger-flicking it from various angles.

If the above tests do not reveal the trouble, other procedures will have to be used. A number of clues will often point to the defective tube. Overheating is one of these clues. A shorted tube will (when the defect is of such a nature as to cause an excessive flow of plate current) become abnormally hot.

The experienced serviceman will often have a good idea of how much some tube in a certain section of the receiver should heat up. He can then, by his sense of touch, determine when a tube is suspect.

The wise serviceman will not, of course, touch a 35 or 50-volt tube and then write scathing letters to the editor with a blistered hand. He will, however, quickly touch a 6-volt oscillator, r-f, i-f or detector tube which he knows becomes quite warm normally, but not extremely hot. If he finds the tube is too hot, it may be shorted.

In one receiver, 2 6C5s were present in similar stages. One of these tubes was becoming much hotter than the other. The question naturally arose: Was the overheating tube defective, or was the circuit to blame? The quickest check in this case was to interchange the 6C5s. The same tube that overheated in one 6C5 socket overheated in the other, readily indicating the defect (a bad 6C5). If both tubes had overheated when placed in one of the 6C5 sockets, the circuit associated with the

socket would, of course, have been to blame.

If a shorted tube has a glass envelope, it may be seen to light up excessively or arc internally, depending upon the nature of the short. An alert serviceman will readily spot such symptoms.

A shorted tube may cause the cathode resistor in its circuit to smoke, due to the excessive current flowing through it. This is still another clue to such a defect.

Voltage tests may be used to locate many types of shorted tubes. When a "hot" short between the control grid and some positive element in a tube is taking place, the presence of a positive voltage between the grid and ground will indicate the trouble. The cathode voltage may also be excessive in such a case, due to the large plate current flow produced by the positive bias.

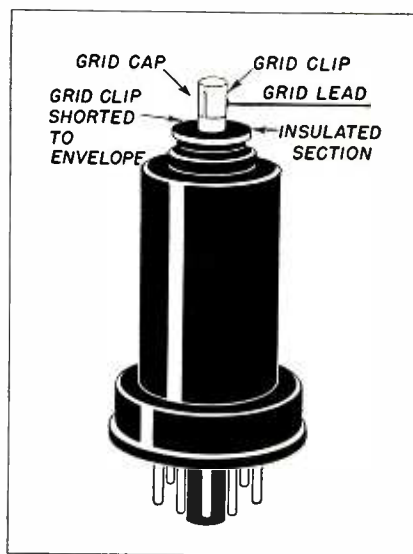

Fig. 1—Grid clips on metal tubes may short very unobtrusively against the envelope of the tube.

If the "hot" short appears between a positive tube element, like a plate or screen, and a considerably less positive or negative element, like a cathode, suppressor grid or control grid, the plate and/or screen voltage will be considerably reduced. When the resistance from plate and screen socket connections to ground reads normal, this type of trouble is indicated.

The defective tube will frequently reveal its secret if resistance checks are made between the various elements of the tube while the latter is still warm.

To cite an example: The control grid of a 25L6 in one receiver shorted to cathode when the tube heated up. A resistance check made immediately after the set was turned off showed that 5000 ohms was present between the cathode and grid of the 25L6. When the tube had cooled off, however, the resistance between these elements (with the 25L6 out of its socket) was infinite. The defect in the tube thus became readily apparent.

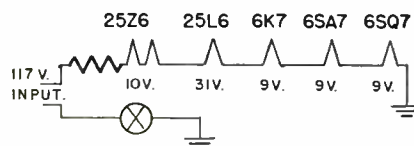

Fig. 2—How a peculiar defect in a 25Z6 eventually burned out a 6K7. When the set was first turned on, a voltage distribution similar to that indicated above occurred, due to the below-normal resistance of the 25Z6 filament.

A trouble that sometimes catches the unwary serviceman off guard is an intermittently shorting grid clip. We refer to metal tubes whose grid clips make contact with grounded tube envelope (see fig. 1). The presence of an excessive amount of solder at the point where the grid wire meets the grid clip is frequently the cause of this trouble. When the shorting contact is intermittent, a good deal of troubleshooting may take place before the defect is located, unless the serviceman is on the alert for this kind of short.

Some types of tube troubles (intermittent shorts or other defects) give the serviceman's brain a greater workout than his instruments. The author recalls a set on which a 6K7 filament was burnt out. The customer bought a new tube. Within a week, the new 6K7 had bit the dust.

Another 6K7 was substituted, and the power turned on. It was noted that the 25L6 and 6K7 filaments flashed up much more brightly than normal, while the 25Z6 filament's brightness was less than normal. After this momentary flashing, the tube filaments steadied down to their normal illumination, and the radio played satisfactorily. It was further noted that the abnormal flashing process occurred only when the set was turned on after it had been off for a while. If the set was turned off and then on again while the tubes were still warm, the abnormal flashing did not occur.





## Antenna & Accessories

### Anchor ANTENNA-BOOSTER

A fringe-area "package" is available consisting of a remote tuned high-gain 2-stage booster (mounted on antenna); a 4-stack Yagi array, tuned antennas for any of four different channels selected by remote control; an antenna rotating mechanism allowing a 10-degree correction movement of the antenna array; all the above mounted in a weatherproof cabinet suitable for mast or tower mounting. The remote control unit consists of a cabinet containing power transformer, tuning indicator, and all switches. Anchor Radio Corp., 2215 S. St. Louis Ave., Chicago 23, Ill.—RADIO & TELEVISION RETAILING.

### Ward ATTIC TV ANTENNA

Model TVH-52, called a "high gain, high-low antenna," can be installed suspended from the attic ceiling and is said to give the same reception as outdoor types. It is designed for areas where signal from high and low band station transmitters originate from the same general direction. Bracket C-14 is available to suspend the antenna upside down. Ward Products Corp., 1523 E. 45th St., Cleveland 3, Ohio.—RADIO & TELEVISION RETAILING.

### Regency TV BOOSTER

The new model DB400 booster amplifier for the 12 TV channels features single knob tuning control (plus on-off switch and hi-lo band selector); on-off switch controls the TV set; no external impedance match-

ing devices required; plastic cabinet in mahogany or blond, and wide bandwidth amplification. List is \$29.95. Regency Div., I.D.E.A., Inc., 55 N. New Jersey St., Indianapolis 4, Ind.—RADIO & TELEVISION RETAILING.

### X-Tra TV ANTENNA

The "Four-Squared" antenna designed for fringe operation utilizes three 1/4-wave radiators operating in phase, the center radiator being broken in the middle to provide a feed-point. Result is a single high-gain lobe in the forward direction. Since all ends are mechanically joined together, there is greater strength in less vibration. For information, write X-Tra Signal Co., 60 E. 42 St., New York 17, N. Y.—RADIO & TELEVISION RETAILING.

### Workshop TV ANTENNA

The "Dubl-Vee" is an all-channel antenna utilizing the end-fire principle, and consisting of two "V's" in the same plane and driven in phase. The single bay is model VV, and the double stack is model 2VV. High gain and low standing wave ratio is claimed for this antenna. Half-power beam width is 82 degrees on channel 2, 26 degrees on channel 13. For more information, write Sales Dept., the Workshop Associates, Inc., 135 Crescent Road, Needham Heights 94, Mass.—RADIO & TELEVISION RETAILING.

### Shaw TV ROTATOR

"Tele-Tuner" is a mechanically rotated, non-electric rotator designed for low-cost installation and maintenance combined with ease of operation and trouble-free service. Complete with directional indicator, inside manual control and all necessary hardware, the unit sells for \$14.95. Joseph Shaw Co., 6225 Benore Rd., Toledo 12, O.—RADIO & TELEVISION RETAILING.

### JFD TV ANTENNAS

A lightning arrester is molded into the dipole bakelite insulator of the "D-Xer" conical antennas Nos. TA160, TA161, and TA162. No additional labor in assembling is involved. Normal installation plus grounding of mast is all that is required. Any type of lead-in is accommodated. Also announced is a new "Vee-Beam" series of antennas employing the "end-fire" principle. Feature of these antennas is that they give higher gain and directivity on the high band. The unit is available in single and double stack, models C800, SR800, C801 and SR801. JFD Mfg. Co., Inc., 6101 Sixteenth Ave., Brooklyn 4, N. Y.—RADIO & TELEVISION RETAILING.

### Gonset TV LEAD-IN

"Gonset Line" is a low-loss open wire line consisting of two #18 conductors spaced one inch by polystyrene spacers. Firm claims it is the lowest loss lead-in made (.5 DB per 100 ft. at 200 MC). Impedance is 450 ohms, which it is said can be substituted for 300 ohm line. Designed to be especially effective for fringe, beach, and long-line-run installations. Gonset Co., Burbank, Calif.—RADIO & TELEVISION RETAILING.

### G-C ANTENNA SWITCH

The "Magna-Switch" is designed to provide a means for dealers to demonstrate several sets from one antenna. One unit is said to handle 5 sets or more. Unit operates with a solenoid that automatically connects and disconnects the antenna to any set that is turned on. All the signal goes to one set at a time. General Cement Mfg. Co., Rockford, Ill.—RADIO & TELEVISION RETAILING.

## How to Sell More

# JENSEN NEEDLES

Put me on Your  
**COUNTER**  
I'll sell Needles

a new  
needle will restore  
original brilliance...

**BUY A Jensen  
NEEDLE**

FREE: This attractive display, measuring eight inches in width and eleven inches in height, is available through your distributor or by writing to Jensen Industries, Inc.

**Jensen NEEDLES**

... Preferred by  
leading phonograph manufacturers.  
A complete price selection  
from 50¢ to \$2.50

**Jensen INDUSTRIES, INC.**  
332 South Wood Street, Chicago 12, Ill.

# PULL MINIATURES PAINLESSLY!

**WHY STRAIN,** fry, and slice your fingers? Why break tubes? Pull or insert 7-pin miniatures the e-a-s-y way. With economical Hytron Tube Puller. Result of two years' research. Positive grip pulls first time from meanest sockets. Special Neoprene rubber resists heat. Does not harm tube. Adjusts automatically to varying tube diameters. Tube Puller works by suction and friction on top of tube. Removes even tiny 6AK5 and 6AL5 from shielded sockets. Reaches into tightest spots — to pull or insert.

Only 75¢! You cannot afford to be without this temper-time-and-money saver. Get your Hytron Tube Pullers from your Hytron jobber today.

**It's Easy!** **TO PULL:** Push Tube Puller onto top of 7-pin miniature. Just enough for firm grip, and without depressing release button at top. Pull straight up and out; no need to bend pins by violent rocking. Hold tube securely in one hand. With other, push release button quickly. Compressed air pops out tube. Or, holding down release button, remove Tube Puller by rocking it. **To insert:** Align arrow on skirt of Tube Puller with keyway of tube. Push tube into Tube Puller. Using arrow as guide, insert tube. Push button quickly to release. Maintain pulling action at peak. Wipe inside of Puller occasionally with clean cloth to remove dirt and grease.

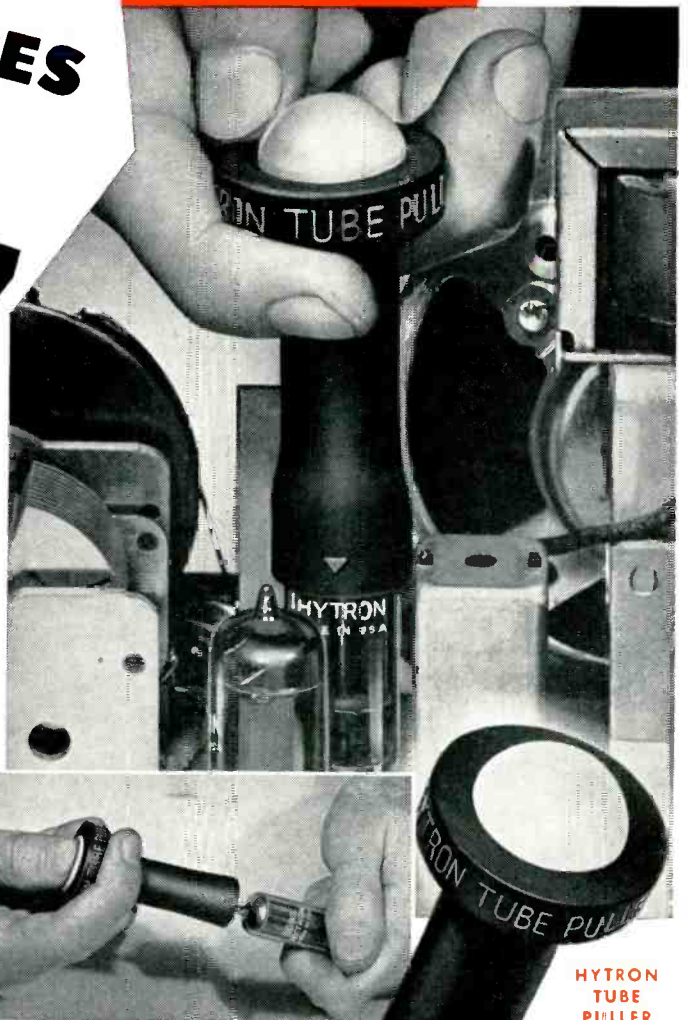

**HYTRON  
TUBE  
PULLER  
75¢ net**

## THEY COST PENNIES, BUT SAVE DOLLARS!

**OVER 50,000 SERVICEMEN** know! These Hytron tools pay for themselves again and again. Save time . . . temper . . . dollars — daily. Read what they'll do for you. Write for complete Tool Catalogue. Better still — get these tools from your Hytron jobber today!



**PIN STRAIGHTENERS, 7-Pin and 9-Pin — 55¢ net ea.** You merely press tube gently into Hytron Straightener until button base seats squarely. Presto, pins are straight! Fast . . . safe. Avoiding one broken tube pays for Straightener twice over. Precise, stainless-steel insertion die. Comfortable knurled aluminum holder. For hand, bench, or tube tester use.



**AUTO RADIO TOOL — 24¢ net.** Substitutes for control cables of universal auto radio. Quickly, precisely turns set on/off, tunes, adjusts volume and tone, re-aligns dial. Square also fits splines. Vee fits spade and other key fittings. Minimum backlash. Compact. Bright-zinc plated. Non-rolling large handle for fine adjustments.



**SOLDERING AID — 49¢ net.** Fork tip effortlessly, quickly unwraps "mechanically solid" joints. Straddles wire, grips, unwraps, pulls it free. Guides new wire, holds it firm while soldering. Spade tip reams solder from lug hole, pushes other wires aside. Tips are hardened, twist-proof, insulated, hard-chromed to shed solder. Tool handles like pencil. Reaches tight spots. Has dozens of other uses.



**TUBE LIFTER — 15¢ net.** Lift 'em all the e-a-s-y prybar way. Tubes (GT, G, standard, lock-in, metal). Vibrators and plugs (Jones, Amphenol) — and knobs. A natural for compact auto radios, etc. Slotted end lifts lock-ins, snap-in trimounts . . . easily, safely. Of stainless steel with comfortable rolled edges.



**TUBE TAPPER — 5¢ net.** Handy combination pencil, eraser and tube tapper. Discovers microphonism, shorts, and opens in tubes, etc. Compact, non-metallic, rugged. Doubles in brass for writing orders, etc.

OLDEST MANUFACTURER OF RECEIVING TUBES  
**HYTRON**  
RADIO AND ELECTRONICS CORP.

MAIN OFFICE: SALEM, MASSACHUSETTS





## Magnavox Ups Combo Production

The Magnavox Company is preparing a bid for volume radio-phonograph business in the fall and winter markets, it was revealed by Stewart Roberts, director of merchandising and assistant sales manager.

Despite the competition of television—including its own line of 15 models—Magnavox has been stepping up radio-phonograph production monthly since last fall and expects to reach peak volume this summer with a complete line of 11 instruments ranging in price from \$199.50 to \$795.

## Radiart Expansion

Milton S. Roth, jobber sales manager of the Radiart Corp. of Cleveland, Ohio, announces the further expansion of their sales organization with the addition of two sales representatives. Charles N. Hoemig, 1730 Clover Lane, Fort Wayne 7, Ind., has been appointed to cover Indiana and western Kentucky. Northern California will be covered by Hardie & Osborne, Inc., 1127 Wilshire Blvd., Los Angeles 17, Calif., who returns to the Radiart family after an absence of about a year.

In Cleveland, Radiart now has five plants devoted to the television and automotive aerial field.

## Sylvania Names Sommers

George R. Sommers has been appointed general sales manager of the Sylvania Radio Tube and Television Picture Tube Division, it was announced by H. Ward Zimmer, executive vice president, of Sylvania Electric Products, Inc. Sommers succeeds C. W. Shaw who has been made assistant to the vice president in charge of sales.

## Discounts Increased

An increase in dealer profit margins on Magnavox TV sets and some TV-radio-phonograph combinations has been announced by Frank Freimann, executive vice-president of The Magnavox Company.

Based on quantity orders and including cash discounts, Magnavox television discounts now range from approximately 32 per cent on the lowest price models to just under 40 per cent on several instruments in the \$400-\$500 price bracket. Magnavox radio-phonographs range from 38 to 45 per cent.

## Industry to Show New Lines at "Fair"

Television will hold an industry-wide show in N. Y. at the 69th Armory, Sept. 23-30 for 5,000,000 buyers who are expected to become TV owners in the next year. Irving Fromer, director of the National Television and Electronics Exposition, said the accent will be on progress for the eight days of the exposition.

## DuMont Distributor

The Cathode-ray Tube Div., Allen B. DuMont Labs., Inc., 750 Bloomfield Ave., Clifton, N. J. has announced the addition of Rucker Radio Wholesale Co. to its Teletron distributor organization. With headquarters at 1312 14th St., N. W., Wash., D. C., and branch stores in Rosslyn, Va., and Silver Springs, Md., they will provide the D. C. area with across-the-counter television picture tube replacement service.

## Combo Purchase



Irving Sarnoff, executive vice president of Bruno-New York, Inc., signs an order for RCA Victor combos. It is claimed to be the largest distributor order for consumer products ever received by the Radio Corp. of America. Shown above are (l. to r.): Jack Marden, RCA Victor representative; David Wagman, Bruno-New York sales official; Gerald O. Kaye (standing), Bruno-New York vice president in charge of sales, and Irving Sarnoff, executive vice president of Bruno-New York, Inc.

KIND *to record*  
KIND *to ear*  
KIND *to purse*

*the Magic Touch*

# Fidelitone

LONG LIFE PHONOGRAPH NEEDLES

FROM 50c to \$5.00

**PERMO, Incorporated**  
CHICAGO 26,

# UNMATCHED

# Excellence

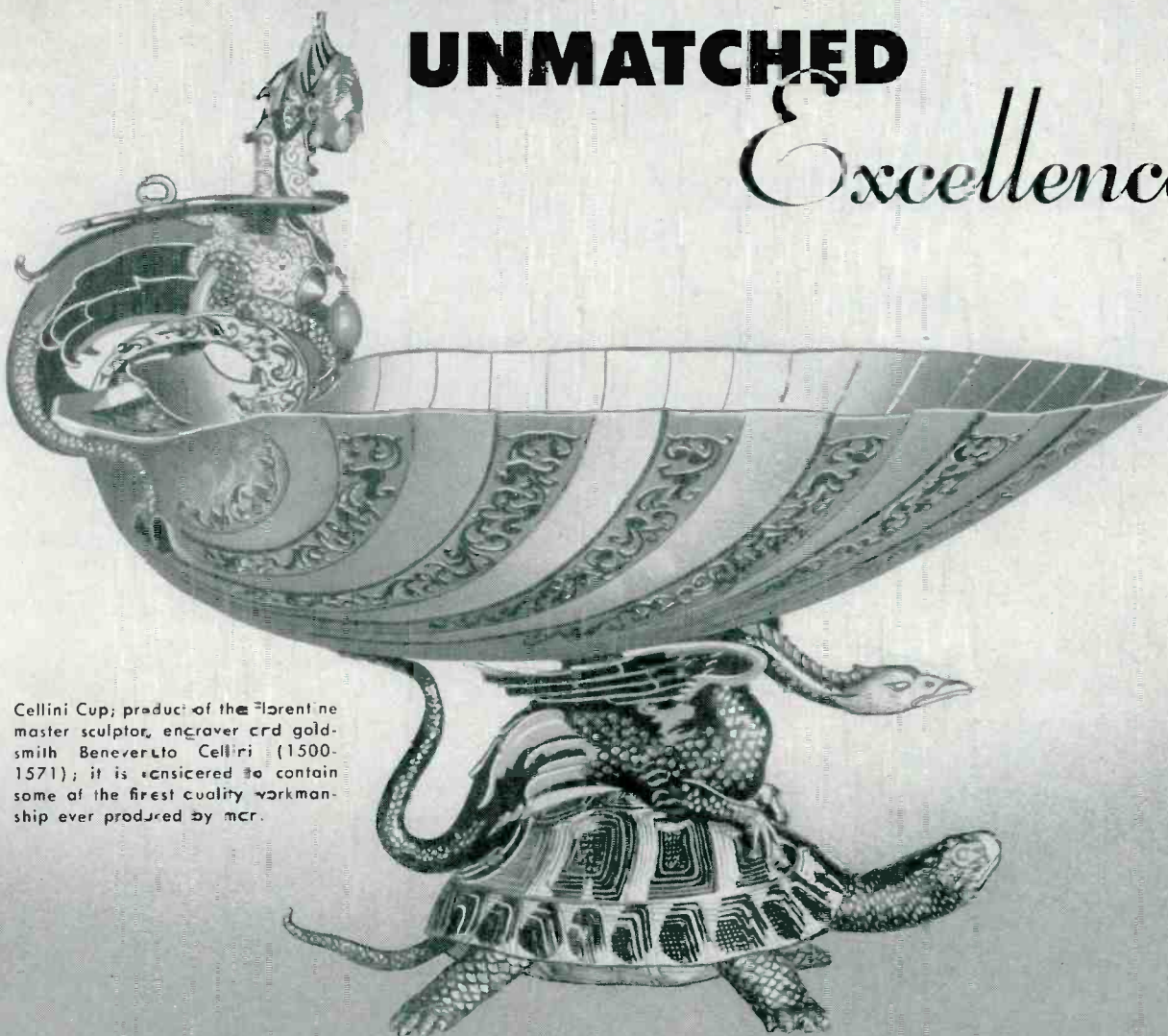

Cellini Cup; product of the Florentine master sculptor, engraver and goldsmith Benvenuto Cellini (1500-1571); it is considered to contain some of the finest quality workmanship ever produced by man.

In electronics as in the delicate art of the goldsmith, superb quality workmanship distinguishes its producer as the master of all those who practice his art. In electronics, that distinction is proudly borne by Tel-O-Tube—producers of extra-fine quality cathode ray tubes.

Yes, of the many fine quality television picture tubes on the market today, there is nothing which can compare with the matchless excellence of Tel-O-Tube.... truly the work of master craftsmen.

"THE GREATEST Names in Television  
PROTECT Their Names with Tel-O-Tube"

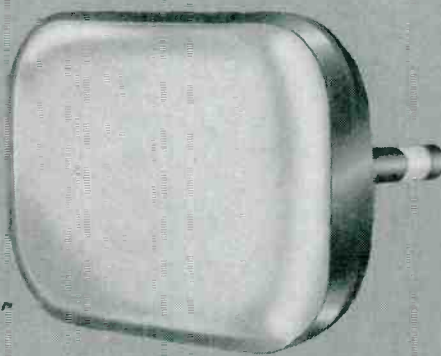

## TEL-O-TUBE Sales Corporation

580 Fifth Avenue

New York 19, New York

Judson 2-2967-8-9

Plant: TEL-O-TUBE Corporation of America 180 Van Riper Ave., E. Paterson, N. J.

Cellini Cup courtesy of the Metropolitan Museum of Art



# New VIDEO RECTANGULAR 16 RP4

PHYSICAL DIMENSIONS—16" Rectangular—  
1 1/8" Dia.—18 1/4" Long—14.738" Wide—11.5" High



**WEIGHT and SPACE  
SAVING ...for  
COMPACT DESIGN**

**Over an acre of our space is being devoted  
to the exclusive production of the 16 RP4**

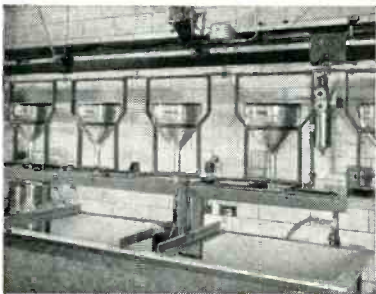
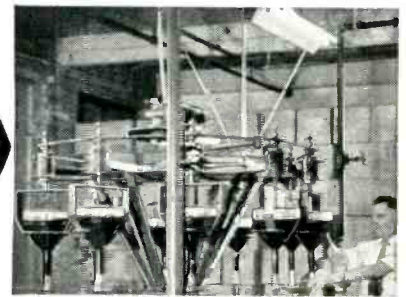
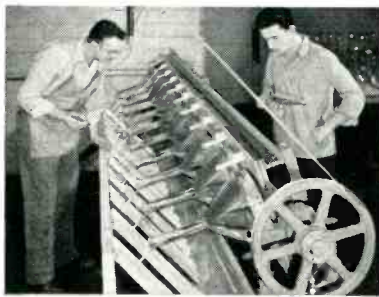
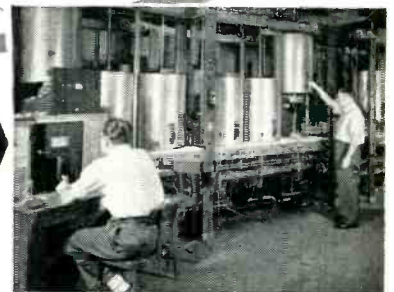

The new Video 16 RP4 sets a new standard in the all-glass rectangular television tubes. Combining all the precision engineering features and years of development, Video's new tube is the foremost in its line. It permits smaller cabinets, larger viewing screens, lighter weight units, smaller dimensions, and gets all the picture which is transmitted.

With this new style magnetic focus tube, manufacturing problems are simplified.

Engineering and specification details giving complete data will be supplied. Write for Video's illustrated brochure today!



## **NATIONAL VIDEO CORPORATION**

3019 WEST 47th STREET • CHICAGO 32, ILLINOIS

YOU ASKED FOR IT...

*here it is!*

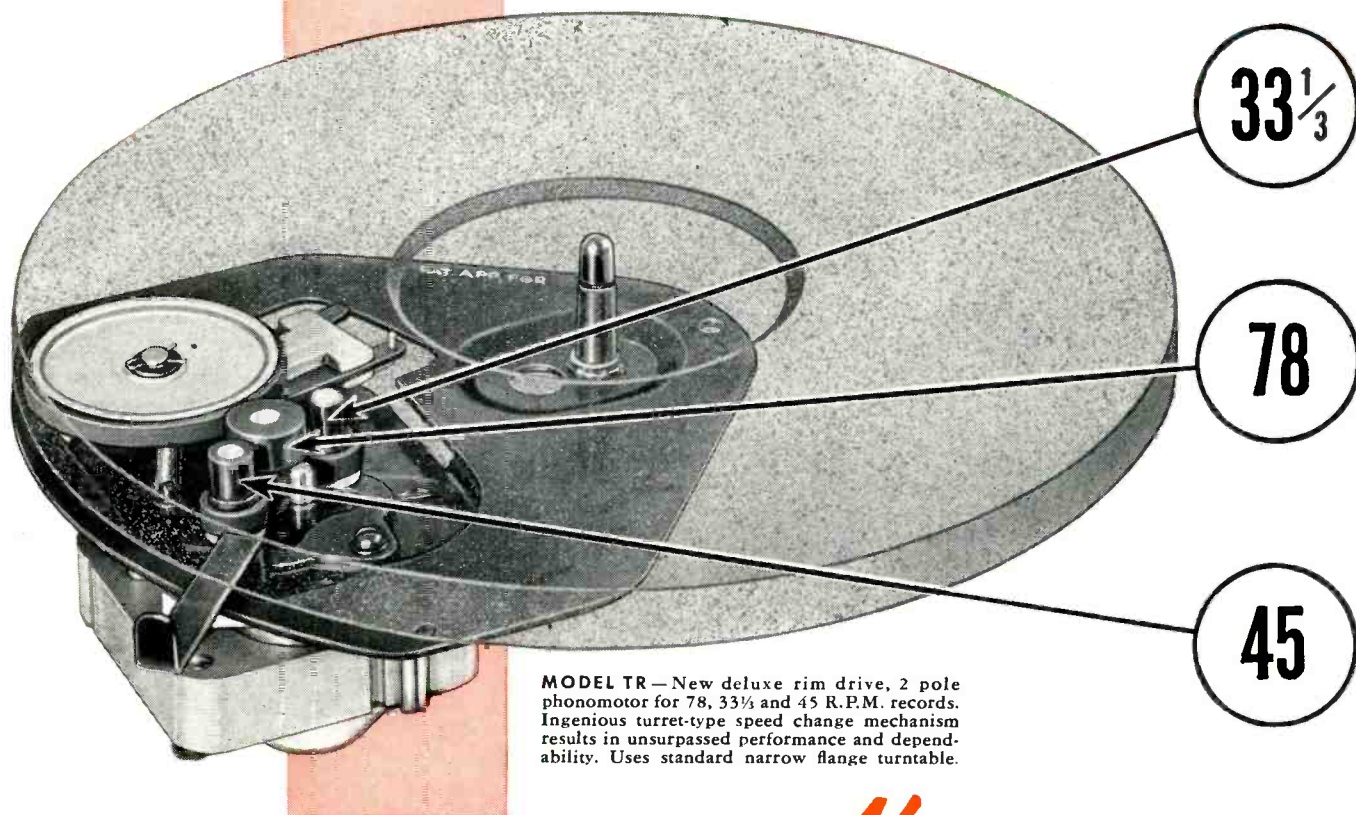

MODEL TR—New deluxe rim drive, 2 pole phonomotor for 78, 33 $\frac{1}{3}$  and 45 R.P.M. records. Ingenious turret-type speed change mechanism results in unsurpassed performance and dependability. Uses standard narrow flange turntable.

## General Industries' *New* Deluxe 3-SPEED PHONOMOTOR

Now . . . in answer to the tremendous demand for a manual version of the popular GI turret model 3-speed record changer motor, General Industries presents the *new* Model TR. Truly the last word in compact 3-speed phonomotors, the Model TR is designed for use in the finest phonographs and radio-combinations.

In addition to the Model TR, General Industries will continue to offer the ever-popular Model TS, 3-speed neoprene belt-driven model for both manual and record-changer use.

Today, as always, General Industries leads the field with the *only* complete line of phonomotors for every record-playing requirement. Write, wire or phone for the latest General Industries catalog containing specifications and description of the full GI *Smooth Power* lineup.



The GENERAL INDUSTRIES Co.

DEPARTMENT I • ELYRIA, OHIO



## In Capehart Sales Post

Chester A. Bejma is the newly-appointed manager of the Capehart-Farnsworth Corp.'s Chicago region, E. Patrick Toal, general sales manager has announced. Bejma has been district representative of the receiver division of the General Electric Co., in the Chicago district, for the past four years.

## Tele King Sales Rep

Harvey L. Pokrass, president of Tele King Television Corp., has announced the appointment of Theodore Sharaf as sales representative for the states of Alabama, Tennessee, North Carolina and South Carolina.

## Rauland Sales Manager

The appointment of Ben Farmer to the position of sales manager of the Rauland Corp., Chicago, Ill., was announced by W. E. Phillips, vice-president and general manager. The company manufactures TV picture tubes.

## Rider Appoints Farber

Maury Farber, 157 Hartwell Road, Buffalo 16, N. Y., has assumed the position of sales representative for John F. Rider Publisher, Inc., 480 Canal St., New York 13, N. Y., announced John F. Rider, president of the organization.

## New Products

### Hytron TUBE PULLER

Neoprene rubber tube puller is designed for use with miniature tubes. Suction grip makes it possible to pull tubes straight up, without bending pins. Arrow on tube puller makes it possible to line keyway up with the socket. Price is 75¢, available from Hytron tube jobbers. Hytron Radio & Electronics Corp., Salem, Mass.—RADIO & TELEVISION RETAILING.

### Monitoradio MOBILE FM SET

Model M-101 is a complete mobile FM receiver designed to operate in the 152-162 MC communications band. In addition to other emergency band services, the M-101 also brings in taxicab calls. The set has five tubes plus rectifier and voltage regulator, and operates from 6 or 12 volts (internal vibrator power supply). Provided in a metal cabinet, it is suitable for mounting in cars, trucks, etc. Radio Apparatus Corp., 310 Fountain Square, Indianapolis 3, Indiana.—RADIO & TELEVISION RETAILING.

### TV BLACK TUBE FILTER

A neutral filter for "black tube" TV sets is said to increase contrast and picture quality and at the same time reduce glare, by eliminating the tendency of reflected room light to "wash out" the picture, and by cutting out ultraviolet radiations which are said to tire the eye. 12½ inch size sells for \$2.95, 16-inch at \$4.95. TV Development Corp., 2505 Surf Ave., Brooklyn 24, N. Y.—RADIO & TELEVISION RETAILING.

### RCA TUBES

The 6CB6 is a sharp-cutoff pentode of the 7-pin miniature type designed especially for video IF-amplifier service at frequencies in the order of 40 megacycles per second. It is also well suited for use as an rf amplifier in vhf television tuners. Featured in the 6CB6 is very high transconductance combined with low interelectrode capacitances, and separate basepin terminals for grid No. 3 and cathode. The separate terminals permit the use of an unbypassed cathode resistor to minimize the effects of regeneration. Tube Dept., Radio Corp. of America, Harrison, N. J.—RADIO & TELEVISION RETAILING.

### E-V SPEAKERS, BOOSTER

This firm, which has been known as a manufacturer of microphones and phonograph cartridges, has introduced a line of high fidelity loudspeakers ranging from an 8-inch coaxial to a 4-unit system with an 18-inch woofer. A variety of cones, horns, cross-over networks and specially designed cabinets make possible a number of high quality systems. For complete information and catalog, write direct to the firm. A TV booster has also been announced which requires no tuning or attention of any kind, and which may be consequently installed in a concealed position. An automatic power switch turns the booster on and off with the TV receiver. Electro-Voice, Inc., Buchanan, Mich.—RADIO & TELEVISION RETAILING.

# Telrex

## CONICAL-V-BEAMS\*

*memo* **These 3 basic facts prove TELREX SUPERIORITY!**

- 1** Since the advent of Telrex "Conical-V-Beams" into the field of TV reception, no antenna to date has been able to outperform them except on paper.
- 2** 90% of all Television Antennas being produced today are genuine Telrex "Conical-V-Beams" or imitations thereof.
- 3** Performance counts! It takes more than extravagant claims to produce results. That's why Telrex delivers the goods when others fail.

**THERE'S NO PRACTICAL SUBSTITUTE FOR SOUND DESIGN, THOROUGH ENGINEERING, QUALITY MATERIALS!**

Once for ounce, dollar for dollar, Telrex laboratories have designed and produced more worthwhile, service-tested antennas designed for application and long service life. There's no substitute for Telrex. Install one on your next TV installation. You'll see and hear the difference!

**OUTSTANDING  
... FOR DESIGN  
WORKMANSHIP  
PERFORMANCE  
QUALITY...**

**TRULY AMERICA'S  
STANDARD OF  
COMPARISON!**

Call or Write for  
Complete Catalog

\* REGISTERED  
TRADE MARK

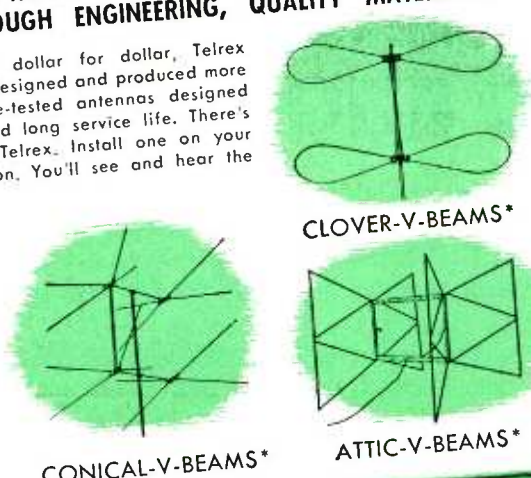

CONICAL-V-BEAMS\*

CLOVER-V-BEAMS\*

ATTIC-V-BEAMS\*

SEE THEM ALL AT THE SHOW!

Don't fail to see us at the Radio Parts Distributors Convention  
(NEDA SHOW) BOOTH 126, Cleveland Auditorium, Cleveland, Ohio.

Copyright 1950      Patents Pending

Be sure it's a "CONICAL-V-BEAM"  
—Look for the TELREX\* Trademark

AMERICA'S  
STANDARD OF  
COMPARISON

**THE SKILL  
TO DESIGN  
THE FACILITIES  
TO PRODUCE  
THE ABILITY  
TO DELIVER**

# Telrex INC.

CONICAL-V-BEAMS\* ASBURY PARK 2, N. J.





# New Aids for Servicemen

## Anchor TV BOOSTER

The new model ARC-101-100 TV pre-amplifier features high signal gain combined with noise reduction and 6 MC bandpass. Two 6AK5's are permeability-tuned in both their grid and plate circuits. Feature of the unit is the switching arrangement, which moves the tube sockets and circuit components to the coils, instead of vice versa. A pre-cut, shielded 225-ohm lead is provided for connection to the receiver. Gain of the unit is said to be at least 14 DB on every channel. Anchor Radio Corp., 2215 S. St. Louis Ave., Chicago 23, Ill.—RADIO & TELEVISION RETAILING.

## Channel Master TV ANTENNA

The "Hideaway" indoor TV antenna provides two 4-section telescopic dipoles to form a Vee antenna. Feature of the unit is that it clamps on the rear of the TV cabinet and can be folded down behind the



cabinet, out of sight, when not in use. Wood finishes available to match mahogany, walnut or blond sets. List price is \$9.25. Channel Master Corp., Napanoch Road, Ellenville, N. Y.—RADIO & TELEVISION RETAILING.

## Approved TV BOOSTER

Model A-TVB is a TV preamp for two adjacent channels only (12 and 13) and is said to have a bandwidth of 15 MC. Utilizing two 6J6's and a selenium rec-



tifier, the A-TVB is fixed tuned, and has only an on-off switch. Models available for other pairs of channels on order. Price is \$19.75 for the A-TVB. Approved Electronic Instrument Corp., 142 Liberty St., New York 6, N. Y.—RADIO & TELEVISION RETAILING

## Alprodco TV TOWER

These aluminum towers feature light weight (one pound per foot) combined with great strength due to triangular cross-brace construction, which features are

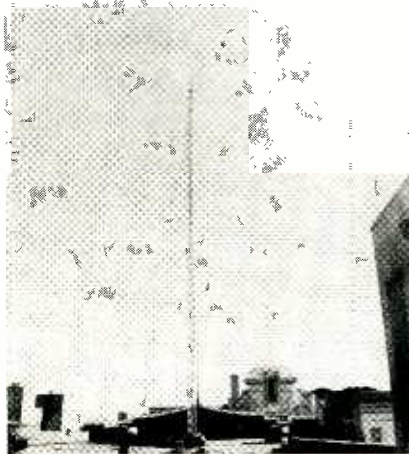

said to make them easy to erect yet durable and capable of supporting heavy loads. Available in knock down or built-up six-foot sections, the towers will stand self supported to 24-feet, guyed to 120 feet. Alprodco Inc., Box 56-F, Mineral Wells, Texas.—RADIO & TELEVISION RETAILING.

## Krylon ALUMINUM SPRAY

Krylon aluminum plastic spray is a new aerosol type "bomb", similar to the original Krylon plastic spray, which offers a decorative and protective surface resistant to both discoloration and oxidation. It is water repellant and easy to clean.



The flexibility of the plastic coating prevents cracks and breaks due to climatic changes. Krylon aluminum plastic spray dries to touch in 10 minutes and is hard in 2 hours. Retail price of a 12 oz. can is \$1.95. Foster & Kester Co., Inc., 2601 N. Broad St., Philadelphia 32, Penna.—RADIO & TELEVISION RETAILING.

## U.S.Devices ROTATOR

This UL approved rotator for TV antenna masts features "in-line" construction between antenna and mast and is said to be capable of supporting as much as 1000 pounds. Rotator unit is completely enclosed and designed for low wind resistance. Model 501 rotator and control box with end of rotation light is priced at \$39.95; 502 rotator with control box with directional indicator is \$49.95. U. S. Devices Corp., Hillside Ave., South Plainfield, N. J.—RADIO & TELEVISION RETAILING.

## Super Sonic BOOSTER

The Super Sonic TV-FM booster model IT5 is a new model featuring a minimum of controls: one continuous tuning control



and an on-off-switch, with no vernier or Hi-Lo Switching. Adequate bandwidth is said to be combined with good selectivity. 72 or 300 ohm input is provided for, and an isolation transformer is included. UL approved, the model lists for \$32.50. Sonic Industries, Inc., 221 West 17th St., New York, N. Y.—RADIO & TELEVISION RETAILING.

## Penn ROOF MOUNT

PRA-148 is a cast aluminum universal peak roof mount, designed to adjust and



lock at any angle and to any pitch of roof, and to support TV masts of from 3/4 to 2" O.D. Penn Television Products Co., 131 North 7th St., Philadelphia, Penna.—RADIO & TELEVISION RETAILING.

# THE BIG 3 IN TV



By  
**RADIART**

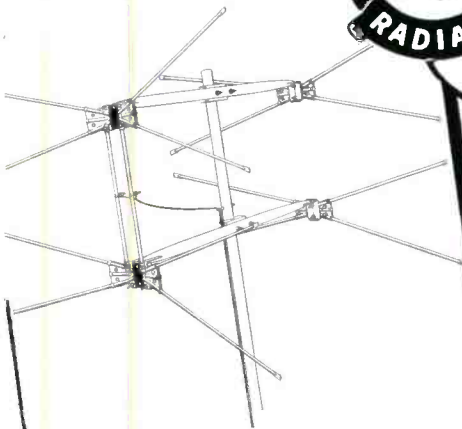

THE "LAZY-X" . . . RADIART engineered for peak performance, making them the most popular everywhere! An all-channel array . . . with the new UNIVERSAL bracket that permits any desired arrangement of the elements.

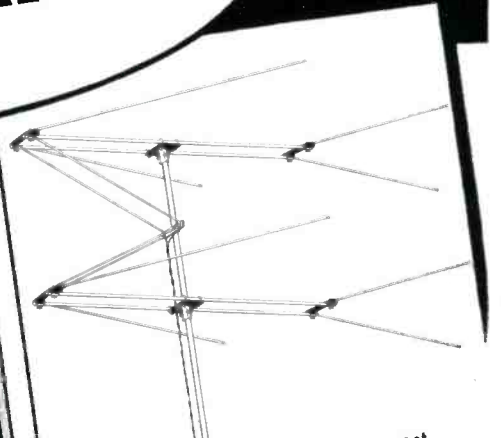

THE "SUPER-VEE" . . . the newest development in TV antennas. Extra high gain . . . sharp directivity . . . and all channel reception. Available in single and double stacked arrays. Completely PRE-ASSEMBLED with FAST fold-out design for speedy installations.

## THE RADIART **TELE-ROTOR**

Just a few months old in the field . . . but gaining in popularity — zooming to the top in sales! Feature for feature it can't be beat! Most powerful . . . unusually rugged . . . and built to last and perform in a trouble-free manner. Available with the "Perfect Pattern" dial control cabinet with illuminated dial that gives instant indication of antenna position.



- Available in the following models:**
- **TR-1** . . . rotator and Control Unit with end of rotation light (uses 4 wire Cable) **\$37.45**
  - **TR-2** . . . Compass Control Rotator with illuminated "Perfect Pattern" dial (uses 8 wire Cable) **\$44.95**

YOU CAN'T BEAT A RADIART ANTENNA ON A TELE-ROTOR . . . IT'S TOPS!



IT'S RIGHT WHEN IT'S RADIART

THE **RADIART** CORPORATION  
CLEVELAND 2, OHIO



- VIBRATORS
- AUTO AERIALS
- ROTATORS
- TV ANTENNAS
- POWER SUPPLIES





“My responsibility for the picture quality of the television set you have purchased prompts me to suggest that you insist upon an Amphenol INLINE\* Antenna when the installation is made.

Your service man will be glad to comply because although he pays a little more—he’ll save installation and call back time and he, too, likes to be sure that you receive the best picture quality that the set can produce.”

**AMPHENOL**

\*U. S. PAT. NO. 2,474,480

**AMERICAN PHENOLIC CORPORATION**  
1830 SO. 54TH AVENUE • CHICAGO 50, ILLINOIS

**MERIT**  
SINCE 1924—FINE RADIO PARTS  
*News*

**FREE!**  
**MERIT TV**  
**“REPL” GUIDE**

**MAY 1950 ISSUE**

**63 MANUFACTURERS—**  
**575 MODELS — MOST**  
**COMPLETE, UP-TO-DATE**  
**LISTING**

Get this easy-to-use, time-saving guide to correct replacements for all popular television receivers. Simplifies servicing, cuts repair-bench time. Write us today for your free copy.

**USE MERIT TV!**  
ONE SOURCE FOR  
TV Tape-Marked Components:  
Powers, Blocking Oscillators,  
Vertical Outputs, Focus Coils,  
Deflection Yokes, Flybacks.

WATCH FOR Merit's future issues of the TV "Repl" Guide.

See us at the NEDA National Convention, Booth 417

**TAPE-MARKED TO HELP YOU!**  
Handy tape marking on every Merit Transformer shows permanent hookup data for quick reference. Originated by Merit

**MERIT**  
TRANSFORMER CORP.

**MERIT**  
SINCE 1924  
FINE RADIO PARTS

4415 NORTH CLARK ST., CHICAGO 40, ILL.



**YOU CAN HAVE  
THE FINEST T-V CABINET  
IN THE WORLD . . . BUT**

***YOU AIN'T GOT NOTHIN'!***

**YOU CAN HAVE  
THE FINEST T-V CHASSIS  
IN THE WORLD . . .**

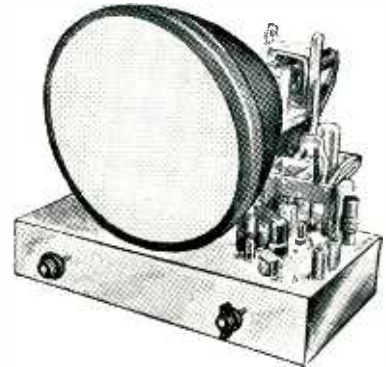

***YOU STILL AIN'T GOT NOTHIN'!***

**BUT WHEN YOU ADD A**

**Sheldon  
PICTURE TUBE,**

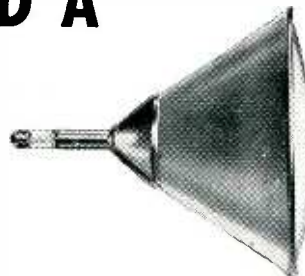

**THE FINEST IN THE WORLD . . .**

***YOU REALLY HAVE SUMPTHIN'!***



**SHELDON ELECTRIC CO.**

*Division of Allied Electric Products Inc.*

68-98 Coit Street, Irvington 11, N. J.

Branch Offices & Warehouses:

CHICAGO 7, ILL., 426 S. Clinton St.

LOS ANGELES 26, CAL., 1755 Glendale Blvd.

SHELDON TELEVISION PICTURE TUBES • SHELDON CATHODE RAY TUBES • SPRING ACTION PLUGS  
TAPMASTER EXTENSION CORD SETS & CUBE TAPS • SHELDON REFLECTOR AND INFRA-RED LAMPS  
PHOTOFLOOD & PHOTOSPOT LAMPS • FLUORESCENT STARTERS & LAMP HOLDERS • RECTIFIER BULBS



## 3 NEW books

... containing more factual information, more practical data ... more clearly presented than anywhere else. You can't afford to be without them! Order NOW!

### TV AND OTHER RECEIVING ANTENNAS

(Theory and Practice)

by **Arnold B. Bailey**

An outstanding book that explains and teaches. Clear and thorough. It can be used as a daily work reference. Complete coverage. All the latest type receiving antennas. Present VHF and proposed UHF frequencies. Learn how to select the proper antenna. Avoid costly mistakes. Learn what an antenna can and cannot do. 12 chapters, bibliography and index. Approx. 500 pages .... **\$4.50**

### TV INSTALLATION TECHNIQUES

by **Samuel L. Marshall**

A completely practical "how to do it" book, giving the answers to just about every TV antenna installation problem. Transmission lines, receiver adjustments and mechanical requirements whether for short chimney-attached mast or 80-ft. tower, including foundation. This book means more profitable installations—fewer return calls—faster installations—dollars in your pocket. Approx. 300 pages. 262 illustrations. 8 3/4" x 5 1/2". Cloth bound **\$3.60**

### ENCYCLOPEDIA ON CATHODE-RAY OSCILLOSCOPES AND THEIR USES

by **RIDER and USLAN**

This is undoubtedly the greatest and most complete reference book ever written on the cathode-ray tube. It is a practical encyclopedia which teaches how to use an oscilloscope, and how to get the most out of the device you now own. It assures your money's worth from your scope. It helps you select the proper equipment. The book begins with basic theory of cathode-ray tube operation, and proceeds through application in scopes and TV receivers ... with full and clear explanations for uses in every field and research activity which employs a cathode-ray oscillograph. All scopes produced and sold during the last 10 years, more than 70 different models, are described completely—with schematic wiring diagrams. Almost 500,000 words and about 3000 illustrations are incorporated in more than 960 pages. Invaluable for engineers, servicemen, teachers, students, Armed Forces, radio amateurs, research laboratories, etc. 22 chapters. 8 1/2 x 11 inches ..... **\$9.00**

**JOHN F. RIDER PUBLISHER, INC.**

480 Canal Street, New York 13, N. Y.

**MAIL THIS COUPON! FAST DELIVERY!**

We pay postage if you remit with order. Slight postage charge on C.O.D.'s.

**JOHN F. RIDER PUBLISHER, INC.**

480 Canal Street, New York 13, N. Y.

Please send me the following RIDER books:

TV and Other Receiving Antennas (Sept.) **\$3.60**

TV Installation Techniques (August) .... **4.50**

Encyclopedia On Cathode-Ray Oscilloscopes (August) ..... **9.00**

Total ..... \$

Name .....

Address .....

City ..... Zone ..... State .....

Check Enclosed  Money-Order Enclosed

Send C.O.D.

# DIRECTORY

Manufacturers of TV-FM  
Antennas & Accessories

(Continued from page 44)

Flexon Products Corp., 249 W. 34th St., New York, N. Y.  
General Cement Mfg. Co., 919 Taylor St., Rockford, Ill.  
Gordon Laboratories, J. M., 437 10th Ave., New York 1, N. Y.  
House of Television, 40 W. 4th St., New York, N. Y.  
Industrial Products Suppliers, 434 Broadway, New York 13, N. Y.  
Insuline Corp. of America, 3602 35th Ave., Long Island City 1, N. Y.  
JFD Mfg. Co., Inc., 6101 16th Ave., Brooklyn 25, N. Y.  
Liquid Lens Co., 77-17 Parsons Blvd., Flushing, N. Y.  
MacMonagle Products, 1820 E. Waterloo Rd., Akron 6, Ohio  
Marvel Lens Industries, Malvern, Pa.  
Molded Insulation Co., 335 E. Price St., Philadelphia 44, Pa.  
Optigem, Inc., 322 E. 39th St., New York 16, N. Y.  
Paragon Plastic Corp., 515 W. 29th St., New York 1, N. Y.  
Pioneer Scientific Corp., 295 Lafayette St., New York 12, N. Y.  
Plasteck, Inc., 18 Beech St., E. Portchester, Conn.  
Plits Television Filter Co., 1154 Stratford Ave., New York 59, N. Y.  
Precision Plastic Products, 628 W. Lake St., Chicago 6, Ill.  
Radio Corp. of America, Harrison, N. J.  
Radio Merchandise Sales, 550 Westchester Ave., New York 55, N. Y.  
Tea Vee Lens Co., 2800 Limekiln Pike, North Hills, Pa.  
Television Accessories & Products, 6145 W. Century Blvd., Los Angeles, Calif.  
Television Filter Co., 225 W. 34th St., New York 1, N. Y.  
TELVision Laboratories, Inc., 542 N. Parkdale Ave., Chicago 44, Ill.  
Thall Plastic Eng'g Co., 155 Chambers St., New York 7 N. Y.  
Transmira Products Corp., 1650 Broadway, New York 19, N. Y.  
Transvision, Inc., 460 North Ave., New Rochelle, N. Y.  
TV Development Corp., 2505 Surf Ave., Brooklyn, N. Y.  
Walco Products, Inc., 60 Franklin St., E. Orange, N. J.  
Warren Mfg. Co., 461 Main St., E. Haven, Conn.  
Wilson Magazine Camera Co., 6022 Media St., Philadelphia 31, Pa.

#### Traps, Interference

Custom-Craft Mfg. Co., 256 E. 98th St., Brooklyn 12, N. Y.  
Decimeter, Inc., 1430 Market St., Denver 2, Colo.  
Drake, R. L. Co., 11 Longworth St., Dayton 2, Ohio  
Meissner Mfg. Div., Maguire Ind., Inc., 7th & Belmont Sts., Mt. Carmel, Ill.  
Precision Electronics, Inc., 641 Milwaukee Ave., Chicago 22, Ill.

#### Mobile Antenna Equipment

Artisan Products, Inc., 3490 W. 140th St., Cleveland 11, Ohio  
Price Tenna-Trailer Co., 115 N. 4th St., Watseka, Ill.  
Stamford Coasting Co., 816 Atlantic St., Stamford, Conn.  
Van Der Voort Hardware Co., P. O. Box 89, Lansing, Mich.

#### Lightning Arrestors

Alpha Wire Corp., 50 Howard St., New York, N. Y.  
American Phenolic Corp., 1830 S. 54th St., Chicago 24, Ill.  
Belden Mfg. Co., 4647 W. Van Buren St., Chicago 44, Ill.

L. S. Brach Mfg. Corp., 200 Central Ave., Newark 4, N. J.  
Camburn, Inc., 32-40 57th St., Woodside, N. Y.  
Cleveland Electronics Co., 6625 Euclid Ave., Cleveland, Ohio  
JFD Mfg. Co., 6101 16th Ave., Brooklyn 25, N. Y.  
LaPointe-Plascomold Corp., Unionville, Conn.  
Lennox Industries, 6007 Euclid Ave., Cleveland, Ohio  
Philco Corp., C & Tioga Sts., Phila., Pa.  
Pittsburgh Coil Co., Carnegie, Pa.  
Radio Corp. of America, Harrison, N. J.  
Radio Merchandise Sales, Inc., 550 Westchester Ave., New York 55, N. Y.  
Technical Appliance Corp., Sherburne, N. Y.  
Ward Products Corp., 1523 E. 45th St., Cleveland 3, Ohio

#### Booster Manufacturers

Anchor Radio Corp., 2215 S. St. Louis Ave., Chicago 23, Ill.  
Approved Electronic Instrument Co., 142 Liberty St., New York, N. Y.  
Astatic Corp., Harbor & Jackson Sts., Conneaut, Ohio  
B. T. Laboratories, 20 Gunther Ave., Yonkers, N. Y.  
Bogen Co., Inc., David, 663 Broadway, New York 12, N. Y.  
Bowers Battery & Spark Plug Co., Box 1262, Reading, Pa.  
Bud Radio, Inc., 2118 E. 55th St., Cleveland 3, Ohio  
Clarion Products Mfg. Corp., 559 McDonald Ave., Brooklyn, N. Y.  
Coastwise Electronics Co., 130 N. Beaudry St., Los Angeles 12, Calif.  
Decimeter, Inc., 1430 Market St., Denver 2, Colo.  
Federal Television Corp., 137 Duane St., New York 13, N. Y.  
Electro-Voice, Inc., Buchanan, Mich.  
Feiler Engineering Co., 945 W. George St., Chicago 14, Ill.  
Jerrod Electronics Corp., 121 N. Broad St., Philadelphia 7, Pa.  
JFD Mfg. Co., 6101 16th Ave., Brooklyn 25, N. Y.  
Lennox Industries, 6007 Euclid Ave., Cleveland, Ohio  
Lyman Electronic Corp., 12 Cass St., Springfield 4, Mass.  
National Co., 61 Sherman St., Malden, Mass.  
Orthon Corp., 196 Albion Ave., Paterson 2, N. J.  
Peek, Inc., Walter E., 2842 W. 30th St., Indianapolis 22, Ind.  
Philco Corp., C & Tioga Sts., Philadelphia, Pa.  
Precision Electronics, Inc., 641 Milwaukee Ave., Chicago 22, Ill.  
Precision Plastic Products, Inc., 628 W. Lake St., Chicago 6, Ill.  
Radio Merchandise Sales, Inc., 550 Westchester Ave., New York 55, N. Y.  
Regency Division, I.D.E.A., Inc., 55 N. Jersey St., Indianapolis 1, Ind.  
Silver Co., McMurdo, 1249 Main St., Hartford, Conn.  
Simpson Mfg. Co., Mark, 32-28 49th St., Long Island City 3, N. Y.  
Sonar Radio Corp., 59 Myrtle Ave., Brooklyn, N. Y.  
Sonic Industries, Inc., 221 W. 17th St., New York 11, N. Y.  
Standard Coil Products Co., 2329 N. Pulaski Rd., Chicago 39, Ill.  
Tech-Master Products Co., 443 Broadway, New York 13, N. Y.  
Telcite Television Corp., Carleton Ave., E. Islip, N. Y.  
Television Equipment Corp., 238 William St., New York 7, N. Y.  
The Turner Co., 909 17th St. N.E., Cedar Rapids, Iowa  
Walco Products, Inc., 60 Franklin St., E. Orange, N. J.  
Warren Mfg. Co., 461 Main St., E. Haven, Conn.

## Rural Market Sales Aid Brings TV to the Home



Dealers who want to accelerate the rural marketing of TV by making a sales pitch right at the customer's door are taking unusual interest in the roving TV display room and testing unit developed by Edward VanDervoort, president of VanDervoort Hardware Co., distributors for Arvin in Lansing and other central Michigan towns. Fully equipped trailers are available to distributors and dealers at reasonable cost.

# New Products

## Dickson SOLDERING IRON

The "Vari Hot" is a new type soldering iron which heats in 30 seconds and will idle at 500 degrees F. whenever plugged in. A booster button on the pistol type handle offers extra heat, which can be varied as desired. The iron has dual heating elements which are located in

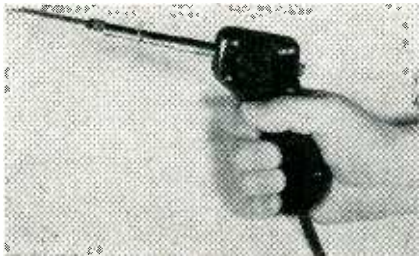

the tip. Only 25 watts is required to maintain tip temperature, and 100 watts is provided when the booster button is pressed. The unit has no xformer, weighs 9 oz. complete and retails for \$6.95. Dickson Engineering & Sales Co., 4701 Townes Rd., Minneapolis 10, Minn.—RADIO & TELEVISION RETAILING.

## Cornish APPLIANCE CORD

"Coroprex" fixture wire for high-current appliances such as toasters is a 2-conductor cord (either 18 or 16 gauge available) insulated only with neoprene (no conventional outer braid). Features are smaller size, neat appearance, easy installation, chemically resistant surface and long life. Cord with 18-gauge conductors measures .175 by .315 inches overall. Cornish Wire Co., Inc., 15 Park Row, New York 7, N. Y.—RADIO & TELEVISION RETAILING.

## Philson CHIMNEY BRACKETS

Set of chimney mounting brackets (TCMS) for mounting TV masts to chimneys with adjustable eye bolts on each side of both brackets. Comes complete with all hardware, including 3/4" galvanized straps. Philson Mfg. Co., Inc., 60 Sackett St., Brooklyn 31, N. Y.

## Philmore CRYSTAL SETS

Crystal receiving sets component parts, and kits for youngsters learning radio are available for resale in a variety of styles and types. Catalog available on request. This firm also manufactures TV chassis and receivers. Philmore Mfg. Co., Inc., 113 University Place, New York 3, N. Y.—RADIO & TELEVISION RETAILING.

## Phoenix TV ANTENNA

"Par-5" is a Yagi-type antenna consisting of a low and a high-band folded dipole in the same plane, with two directors and a reflector. Unit features "quick-rig" construction and is said to match 300-ohm line. Phoenix Electronics, Inc., Lawrence, Mass.—RADIO & TELEVISION RETAILING.

RADIO & TELEVISION RETAILING • August, 1950

# RIDER MANUALS mean SUCCESSFUL SERVICING

"The results of a recent survey of our branches in the Bronx, Brooklyn, Roosevelt and Baltimore, to determine the technical reference requirements, developed conclusive evidence that the relative use of your manuals, as compared to all our other reference data, is the most outstanding because of its overall reliability and concise, useful detail per set.

... our commendations to you for your television manuals ... fast proving a most worthy contribution to the potentials of success in the servicing aspect of the television industry."

—CONLAN ELECTRIC CORPORATION  
Television Division

For your own success in servicing ... make sure that you have ALL of the RIDER MANUALS. Order missing volumes ... TODAY ... NOW!

## COMING SOON!



In Answer To Requests From The TV Servicing Industry!

## RIDER TV FIELD MANUALS

A New Type of RIDER Manual Designed Specifically For Light TV Servicing in the Home

Here, at last, are the "on the job" servicing Manuals that you asked for ... companion volumes to the regular RIDER TV MANUALS which are intended for shop use. The RIDER TV FIELD MANUALS are accurate, authoritative ... with information DIRECT from the manufacturers themselves. The coverage includes all production runs ... not just pilot models.

Everything you need for light TV servicing in the home will be found in the RIDER TV FIELD MANUALS, covering views and functions of tubes, pre-set controls, key-voltage points, crt socket designations, i-f trimmer locations ... and all the other data needed by the TV man in the field.

TV receiver coverage will be complete. AND PRICE WILL BE RIGHT. Don't be misled into buying substitutes. Place your order now with your jobber for the RIDER TV FIELD MANUALS.

### RIDER AM-FM MANUALS

Volume XX	\$18.00
Volume XIX	\$19.80
Volume XVIII	\$19.80
Volume XVII	\$16.50
Volume XVI	\$ 8.40
Volume XV	\$19.80
Volume XIV to VII (each vol.)	\$16.50
Volume VI	\$12.50
Abridged Manuals I to V (one volume)	\$19.80
Master Index, Covering Manuals, Vols. I to XV	\$ 1.50
PA Equipment Manual, Vol. 1	\$18.00

JOHN F. RIDER PUBLISHER, Inc., 480 Canal Street, New York 13, N. Y.

Export Agent: Rocke International Corp., 13 East 40th St., N. Y. C., Cable, ARLAB



## RIDER TV MANUAL VOLUME 4

Complete coverage from October, 1949 through February, 1950. 494 models. 235 chassis ... the greatest collection ever assembled in one handy volume. Authentic, Accurate, Factory-Authorized. New, Larger page size, 12" x 15" and all pages filed in place. Giant pages have only one fold for extra convenience and greater durability. Equivalent of 2296 pages (8 1/2 x 11) PLUS Cumulative Index Volumes 1, 2, 3, 4 ... and "HOW IT WORKS" BOOK. ALL for only ... \$21.00

**RIDER TV MANUAL Vol. 3** ... 74 manufacturers, 441 models, 243 chassis. Page size, 12" x 15". Equivalent of 2032 pages (8 1/2 x 11) PLUS Cumulative Index Volumes 1, 2, and 3 ... and "HOW IT WORKS" Book ... \$21.00

**RIDER TV MANUAL Vol. 2** ... Complete coverage to January, 1949, 67 manufacturers. Page size, 12" x 15". Contains all data formerly in 8 1/2 x 11 size, plus Cumulative Index Volumes 1 and 2 ... and "HOW IT WORKS" Book ... \$21.00

**RIDER TV MANUAL Vol. 1** ... Coverage up to early 1948. 34 manufacturers. Equivalent of 2000 pages (8 1/2 x 11) Plus Index and "HOW IT WORKS" Book ... \$18.00

**NOTE:** Are you receiving your copy of "Successful Servicing"? A publication of interest to every Serviceman. Write for it.

**NOTE:** The Mallory TV Service Encyclopedia, 1st TV Edition, makes reference to only one source of TV receiver schematics—Rider TV Manuals.

**NOTE:** The Mallory Radio Service Encyclopedia, 6th Edition, makes reference to only one source of radio receiver schematics—Rider Manuals.

**NOTE:** The C-D Capacitor Manual for Radio Servicing, 1948 Edition No. 4, makes reference to only one source of receiver schematics—Rider Manuals.



## Presenting the **NEW** Astatic TV and FM Boosters Models BT-1 and BT-2

Astatic raised tremendously the level of improved TV reception through pre-amplification of signal, when it developed its famous deluxe model AT-1 Booster with exclusive variable gain control and dual tuning. Now Astatic brings another great advancement to the progress of TV enjoyment—with two low-cost boosters that equal, to all practical purposes, the primary function of the highest priced units. Never before has so much quality been incorporated in a booster to sell at so low a price. Why not get the complete details? Write today.

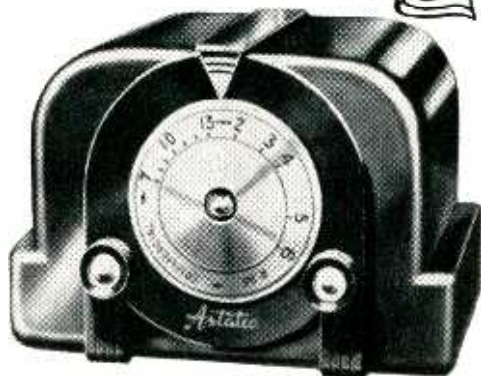

**Booster Model BT-2**  
List Price \$32.50



**Booster Model BT-1**  
List Price \$29.95

**Only ASTATIC offers  
as complete a choice of  
BOOSTER MODELS**



**Booster  
Model AT-1**  
List Price  
\$49.50

Increasing numbers of TV set owners will still want the finest Booster that money can buy—and that means Astatic's deluxe Models AT-1 and AT-1B, with rich furniture finish mahogany or blond wood cabinet, exclusive and variable gain control, dual tuning and powerful four-tube operation.

### LOOK AT THE AMAZING QUALITY FEATURES IN THESE LOW-PRICED BOOSTERS

- 1 Employ Mallory Inductuner for continuous variable tuning.
- 2 High gain, very uniform on both high and low channels.
- 3 Simplified controls—single tuning knob with continuous tuning through both TV and FM bands.
- 4 Band width adequate over entire range.
- 5 Low noise design and construction.
- 6 No shock hazard to user.
- 7 Off-on switch for easily cutting in and out of circuit.
- 8 Selenium rectifier.
- 9 Use single 6AK5 Tube.
- 10 Provide for either 72 ohm or 300 ohm impedance input and output.
- 11 Model BT-2 has handsome, dark brown plastic cabinet.
- 12 Model BT-1 has metal cabinet in rich mahogany woodgrain finish.
- 13 Large dial face is easy to see in tuning.
- 14 Model BT-2 has recessed pilot light to show when booster is on.



### Zenith Expansion

It has been announced by E. F. McDonald, Jr., president of Zenith Radio Corp., that Zenith has purchased property located at 1500 N. Kostner Ave., Chicago. This building will be used for the manufacture of radio and TV components. The purchase also includes almost 300,000 square feet of vacant property which will allow ample space for future expansion.

### Predicts for the Industry

The television industry will pass the automotive industry in sales volume within the next three years, Nathan Chirelstein, president of Allied Electric Products Inc., said recently at the company's annual meeting at Irvington, N. J. Television will hold this lead, once it has been gained, he predicted, for about two years and then settle down to a position ranking from third to sixth in the nation's economy.

### Graybar Appointments

W. E. Henges, Cleveland district manager for the Graybar Electric Co. will become assistant to the president, A. H. Nicoll, president, has announced. He also disclosed that C. E. Kirkpatrick, manager of the company's Memphis branch will succeed Henges as Cleveland district manager. J. W. Horne will succeed Kirkpatrick as manager of the Memphis branch. Also announced was the appointment of Wm. McNulty as manager of the Syracuse branch of the company.

### HALLICRAFTERS TV

Sixteen-inch rectangular tube sets in the new line are: four mahogany table models, 809, \$199.95, 810 at \$229.95, 815 at \$249.95, and the 811, with radio, \$269.95; one combo, the 853, at \$399.95; a mahogany console, the 805, at \$279.95, and a blond console, the 806, at \$295. Three round tube sets complete the 16-inch line: the 832, mahogany console, at \$259.95, the 822, mahogany console, at \$299.95, and the 818, mahogany console with radio, at \$329.95.

Seventeen inch rectangular tube sets include: 870, mahogany console, \$299.95; 871, blond console, \$319.95; 820, mahogany console with radio, \$349.50; 821, blond console with radio, \$379.95; 860, mahogany combo, \$449.50; and the 861, blond combo, \$489.50. The only 19-inch set in the line is the 880, round mahogany console, \$379.95. Completing the line are three 20-inch rectangular combos: 890, Provincial, \$595; 894, Sheraton, \$595; and the 898, Modern, \$595. Hallicrafters Co., 4401 W. 5th Ave., Chicago 24, Ill.—RADIO & TELEVISION RETAILING.

### TRAV-LER TV SETS

New TV sets announced include: 62R50, 16" rectangular tube table model, at \$149.95; 63R50, 16" rectangular tube table model, \$179.95; 64R50, 16" rectangular tube console, \$199.95; 65G50, 16" rectangular tube console, \$229.95; and 16R60, 16" rectangular tube console, \$269.95. Also announced is a line of radios priced from \$11.95 to \$79.95. Trav-ler Radio Corp., 571 W. Jackson Blvd., Chicago 6, Ill.—RADIO & TELEVISION RETAILING.

Take a Radion with you ... make that T-V set sale

# Stay Put!

**Over 1,000,000 sold!**  
**The METROPOLITAN—TA-49**  
 The industry standard, Model TA-49 indoor TV Antenna, Mahogany bakelite. 10 feet of 300 ohm line. 3-section telescoping tubular steel dipoles. Fully assembled. Individually packaged. Shipped six to a master carton. Shipping weight, 11 pounds. LIST PRICE, \$6.95.

**Cinches "borderline" sales!**  
**The SUBURBAN—TA-51**  
 Model TA-51 Conical Outdoor Antenna. For wall, window or attic mounting. Weatherized ebony bakelite head. 15 feet of 300 ohm line. Four telescoping tubular steel dipoles, triple chrome plated. 4-foot telescoping mast. Steel base mount, black copper-oxide, rustproof. All channel coverage without adjustment. Fully assembled. Individually packaged. Packed 6 to a master carton. Shipping weight, 30 pounds. LIST PRICE, \$9.95.

**Newest in outdoor antennas,**  
**The TOWN&COUNTRY—TA-53**  
 Model TA-53 fully assembled Hi-Lo conical, complete with 10-foot mast, 50 feet of lead-in, universal mounting bracket for all roofs or side walls, equipped with UHF stubs. Aluminum dipoles, steel mast. Individually packaged. LIST PRICE, \$14.95.

**Fast sales! Fast installation!**  
**LINKED LEAD-IN—TL-10**  
 The new TL-10 ... ten foot lead-in stripped, split ... terminals already on ... packaged complete with combination standoff and insulator ... 12 to a box ... 144 to a shipping carton. Shipping weight, 25 pounds. For 20 feet, snap 2 lengths together. A natural for counter sales ... a time-and-money-saver for service departments! LIST PRICE, 69c.

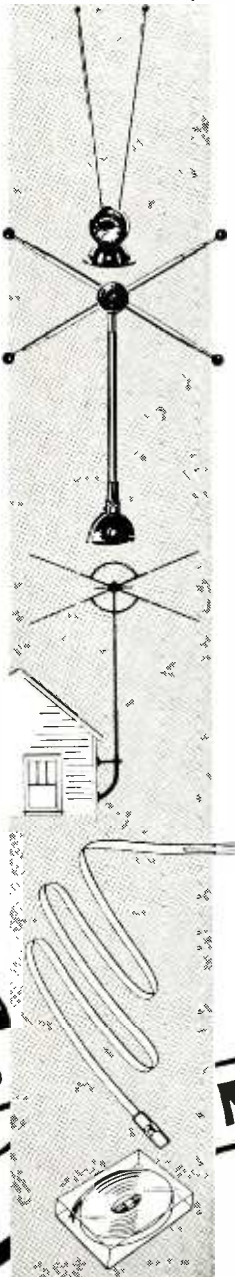

## NEW TA-53 GIVES YOU THAT FINAL SALES-WALLOP!

Do you want that T-V set really to "do its stuff" when you take it out to demonstrate? Want to leave it—have the sale *stay put*? Then include a RADION with your demonstrator—TA-49 for close-in, TA-51 for the next step and, NOW, the *new* TA-53 for the farther reaches where outdoor installation is a "must."

Wherever your T-V prospect may be, today there is a RADION to make your sale stick—neat and attractive in appearance, quick and easy to install, tried and proved in performance. Besides, all by itself RADION is a sales building traffic item bought by *hundreds of thousands* of individual set-owners.

Add the unit sales of your complete RADION line to the PLUS-sales of T-V sets—sales closed for you by RADION—and you'll find that RADION really helps that bank balance!

# Radion

THE RADION CORPORATION  
 1137 Milwaukee Ave., Chicago 22, Illinois

GET MONEY-MAKING FACTS *Quick!*

THE RADION CORPORATION R-8  
 1137 Milwaukee Ave., Chicago 22, Illinois  
 For Money-Making Data on Radion Products check here:  
 Metropolitan No. TA-49  Town & Country No. TA-53  
 Suburban No. TA-51  Lead-in Package No. TL-10

Name.....  
 Company.....  
 Address.....  
 City.....Zone....State.....





".. one of many  
'firsts' at Rauland..."

says **Harold T. Cookson,**  
manager, Hatry & Young, Lawrence, Mass.



"My experience with Rauland picture tubes has shown that you have an outstanding product. Rauland research has developed feature after feature that result in easier servicing and better viewing. Your new Indicator Gun, for accurate ion trap magnet adjustment without

mirrors or guesswork, is one more of the many 'firsts' at Rauland that are contributing to television progress. And the variety of types offered, supplementing our regular tube line, enables us to give the complete picture tube service our customers expect."

From Rauland Research in the past year...

The **FIRST** Luxide Screen ("Black" Tube)

The **FIRST** Indicator Gun

The **FIRST** 12" Metal Tube

The **FIRST** Reflection-Proof Screen

**THE RAULAND CORPORATION**



*Perfection Through Research*

4245 N. KNOX AVENUE • CHICAGO 41, ILLINOIS



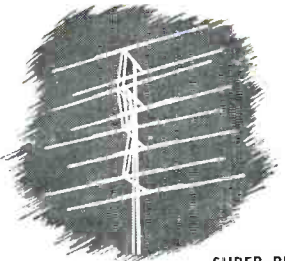
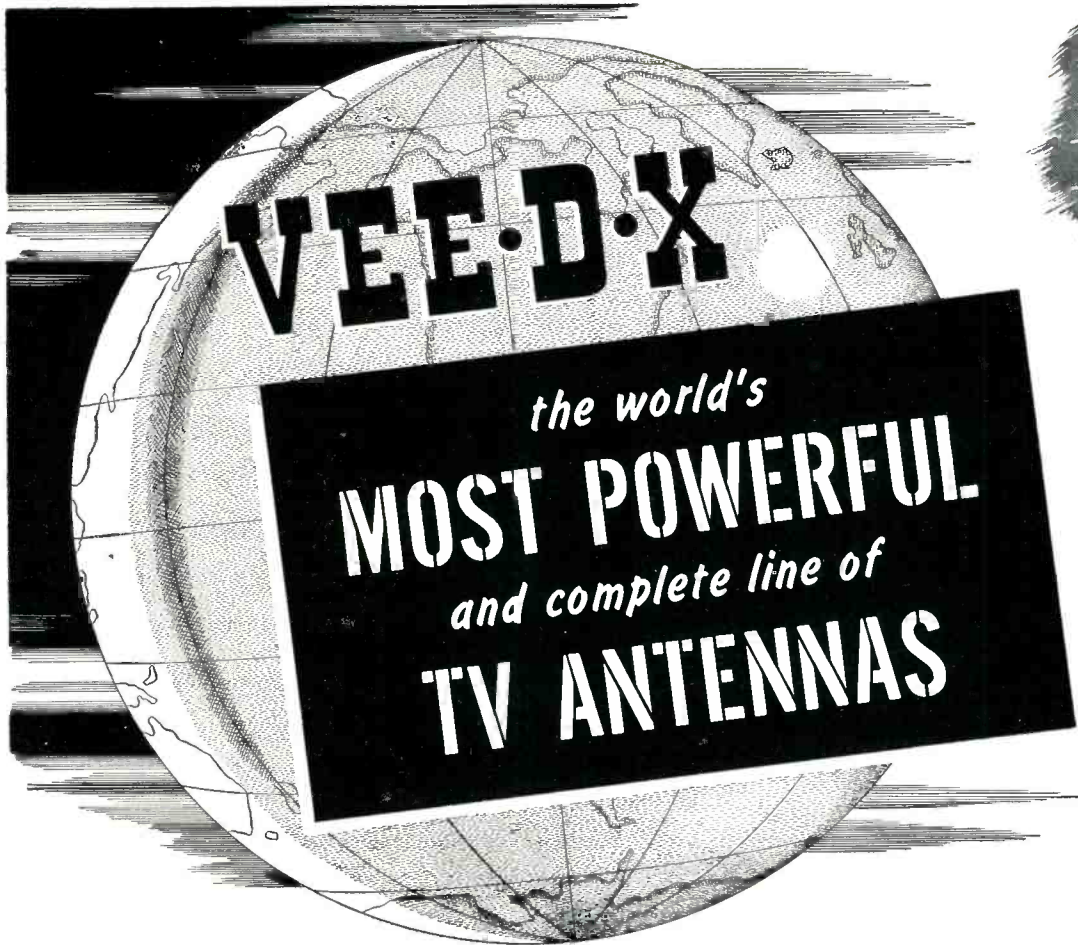

**SUPER RD-13A**  
 Holds every long distance  
 reception record. Eight antennas  
 in one. \$129.50 list.

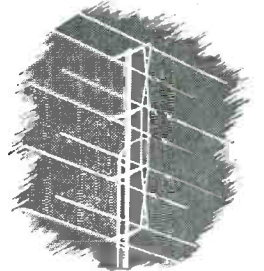

**CHALLENGER HL SERIES**  
 For fringe or near fringe areas  
 . . . high and low channel  
 reception. \$38.95 list.

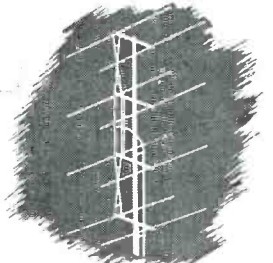

**CA 213 COLINEAR ARRAY**  
 The great new pre-assembled all  
 channel 4 bay antenna. Vee-D-X  
 exclusive. Only \$23.75 list  
 (less mast).

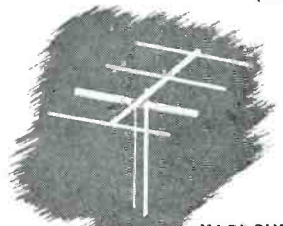

**YAGI RLY SERIES**  
 For sensational results on a  
 single channel. Yagis may be  
 stacked for additional gain.  
 \$35.85 list (low channel)  
 \$14.95 list (high channel)

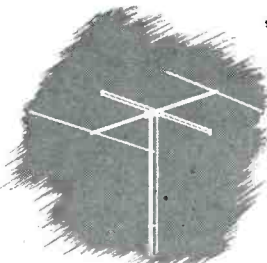

**ECONOMY EC SERIES**  
 Economical 3 element  
 beam affords more DB  
 gain per dollar than any  
 other antenna.  
 \$19.75 list (low channel)  
 \$ 8.50 list (high channel)

# for brilliant performance

Yes, true to its name, VEE-D-X means video distance. It's an established fact that the VEE-D-X Super holds every long distance record . . . and it's also fact, proven through extensive tests and letters received from enthusiastic owners, that our low priced arrays are producing powerful, long distance reception never thought possible. You can always count on VEE-D-X for the finest in powerful antennas.

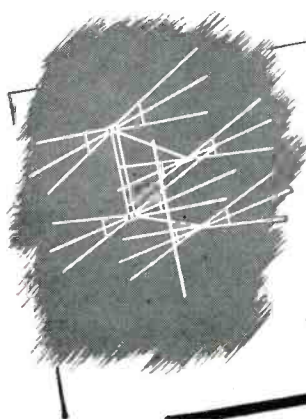

**NEWEST  
 LOW PRICED  
 CONICAL**  
 Broad-band  
 conical antenna.  
 Excellent performer  
 on all channels.  
 Available in  
 1, 2 or 4 bays. Phenolic  
 vibration straps prevent  
 "whistling" in high wind.  
 As low as \$6.95 list.

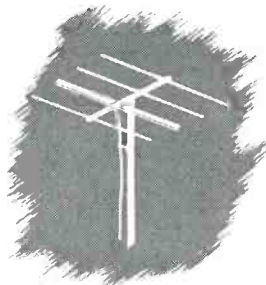

**LOW PRICED PRE-ASSEMBLED  
 YAGI J SERIES**  
 Sensational in performance —  
 low in price. Pre-assembled  
 for fast, easy installation.  
 Available in 4 and 5 element,  
 and double stack 3 element.  
 As low as \$7.95 list.

LaPOINTE-PLASCOMOLD CORP. 5  
 Unionville, Conn.  
 Send me information on the entire line of VEE-D-X  
 antennas and accessories.

Name \_\_\_\_\_  
 Company \_\_\_\_\_  
 Street \_\_\_\_\_  
 City \_\_\_\_\_ Zone \_\_\_\_\_  
 County \_\_\_\_\_ State \_\_\_\_\_



# Simple as 1 - 2 - 3

✓ One Cartridge ✓ Two Voltages ✓ Three Terminals

*"Featheride"*  
*Replace-All Cartridge*  
 MODEL W. S.



**Replaces more than 50 current models of crystal cartridges**

**FEATURES**

- The one cartridge develops either 1½ volts or 4 volts at ¼ ounce tracking pressure.
- Crystal is coated to protect it against moisture and humidity.
- Rest button and terminal clips furnished.
- Needle and cartridge are wedged at the factory. The needle you receive is the one approved by factory test. Replacement needles are also available.
- Packed individually in attractive Dri-Pack Containers.

It's New! Here's the cartridge that simplifies your stocking problem. It may be installed in any tone arm having ½ inch standard R. M. A. mounting. See your jobber or write us for Bulletin 156A Replacement Chart.

**WEBSTER ELECTRIC**



Webster Electric Company, Racine, Wisconsin • Established 1909

**"Where Quality is a Responsibility and Fair Dealing an Obligation"**

**BBB Code on in New York**

The sweeping provisions of the Better Business Bureau voluntary fair practices code, recently adopted by leading manufacturers, distributors, dealers and service companies in the New York metropolitan area to protect the public against deception in advertising, selling and servicing of radio and TV sets and appliances, is now in effect. The code was drawn up by the Bureau in cooperation with all segments of the industry as part of a campaign to cut down the increased consumer complaints in the field.

The Bureau has alerted advertising media and individual advertisers regarding certain current practices which will be in violation of the new code. These include misleading or incomplete statements pertaining to such matters as free trials, home demonstrations, "exaggerated" savings, trade-in allowances, performance claims, guarantees and the number of tubes.

**Operadio Sells Plant**

The Quincy, Illinois loudspeaker division of the Operadio Mfg. Co., St. Charles, Ill. has been sold to a group of Quincy businessmen. The manager of the Quincy plant, Stuart Bell, has been elected president of the Quincy Speaker Mfg. Corp. Operadio will continue to manufacture tape recording equipment, sound field projectors and intercoms.

**Olin Flashlights**

Four new Bond streamlined flashlights, with removable end caps have been introduced, it was announced by J. C. Calhoun, assistant sales manager of the electrical division of Olin Industries, Inc. It is claimed that the new styling of these flashlights not only gives them a sleek, modern appearance, but also makes them easier to hold, handle and stay in pockets or belt sockets.

**Tel-O-Tube Reps**

Plans for the completion of an integrated system of manufacturer's representatives for the Tel-O-Tube Sales Corp., sales outlet of the Tel-O-Tube Corp. of America, were announced by Nat Malamuth, head of the sales organization. Included among new Tel-O-Tube representatives are: Albert Leben, Phila.; R. M. Karet, Associates, Chicago; Carl A. Stone, Los Angeles; Albert Levine, Pitt.; the Texport Co., Dallas; Arnold A. Sinai, San Francisco; D. D. Dale, Des Moines; Theo. B. Lowell, Missouri and Southern Illinois.

**Stewart-Warner Jobbers**

H. G. Bogart Co., Toledo, Ohio, distributor of major appliances and radios since 1926, has been appointed distributor of Stewart-Warner television and radio products. The firm will cover nineteen Ohio counties.

# FREE!

LOW RESISTORS  
BEAM RESISTOR  
BEAM BENDER  
SOUND REPLACEMENT RESISTORS

## CLAROSTAT TV REPLACEMENT CONTROLS

Model & Chassis No.	FUNCTION	VOLUME PICTURE SWITCH	VERTICAL HOLD	BRIGHTNESS	VERTICAL CENTERING	HORIZONTAL CENTERING	HORIZONTAL DRIVE	VERTICAL LINEARITY	HEIGHT	FOCUS	VIDEO BIAS	TRAP	TONS VOLUME SWITCH	BRIGHTNESS PICTURE	PICTURE	VOLUME & SWITCH	A.C.C.	HORIZONTAL LINEARITY	
Model: 9224E Chassis: KCS-30-1 RC-16N (16" tub)	Description		1 meg. & 10,000 ohms Carb.	5000 ohms Carbon				1000 ohms Carbon	2.5 meg. Carbon	240 W W 10-2250					10,000 ohms Carbon	1.5 meg. Carbon	100,000 ohms Carbon		
	Circuit #		R-158 R-173	R-131				R-162	R-155	R-191					R-122	R-14 5-7	R-138		
	Stock #		72734	73156				71841	71840	72735					97011-1	73663	73662	73579	
	Part #		97011-24	97011-29				97011-4	97011-5	97011-25					RTV-13				
	List Price		3.10	1.25				1.25	1.25	1.85					1.85				
Model: 9224E Chassis: KCS-30 (10" tub)	Description		1 meg. & 10,000 ohms Carb.	5000 ohms Carbon				1000 ohms Carbon	2.5 meg. Carbon	100 W W 45-K 1300					10000 ohms & 10,000 ohms Carb.	1 meg. Carb.			
	Circuit #		R-158 R-173					R-162	R-155	R-191					R-122 R-131				
	Stock #		72734					71841	71840	74397					97011-11				
	Part #		97011-24					97011-4	97011-5	97011-19					RTV-12				
	List Price		3.10					1.25	1.25	2.75					1.18				
Model: 648PTK Chassis: KCS-24-1 KCS-20-1 KCS-21-1 KCS-1-1 RK-121A RS-121A (projection tub)	Description		1 meg. & 10,000 ohms Carb.	5000 ohms Carbon	30 Center 10-41-30	10 ohm W W 41-10	1000 ohms Carbon	1000 ohms Carbon	2.5 meg. Carbon										
	Circuit #		R-141 R-156		R-180	R-141	R-140	R-175	R-149										
	Stock #		72738		72181	72181	71841	71841	71840							74971			
	Part #		97011-8		97011-22	97011-12	97011-4	97011-5							RTV-17				
	List Price		3.10		1.85	1.25	1.25	1.25	1.25						3.10				

# GET YOUR DATA SHEETS NOW

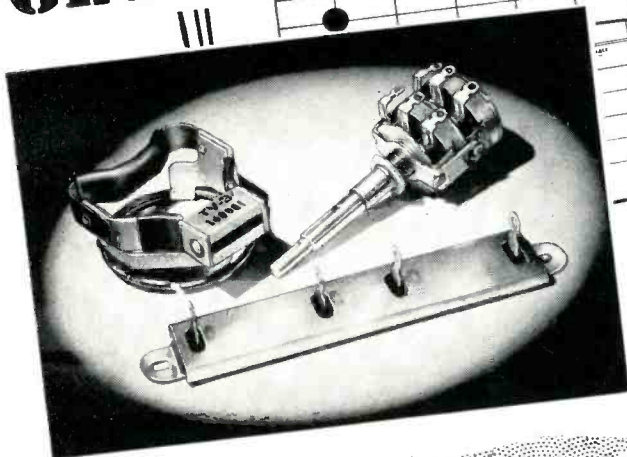

There's money to be made out of those several million TV sets in daily use. But if you want to get your share, you've got to service those TV sets accurately, promptly, satisfactorily.

That's where Clarostat's TV Replacement Data can help you. At a glance you know the correct control, power resistor and beam bender for those popular TV chassis and models. So don't guess: KNOW! Do the job right the first time and eliminate costly call-backs that rob you of your profits.

Ask your Clarostat jobber for the Clarostat TV Replacement Data Sheets. Also order those TV replacement items from him. He stocks them for your convenience.



CLAROSTAT MFG. CO., INC. • DOVER, NEW HAMPSHIRE • In Canada: CANADIAN MARCONI CO., LTD. Montreal, P. Q., and branches



### Meck Distributor

Hood Electric Co., of Youngstown, Ohio, has been appointed distributor for Meck Industries, Inc., in Youngstown area and in Lawrence County, Penna., immediately adjoining Youngstown. Hood Electric Co. is headed by Jim Adams and located at 128 W. Rayen St.

### Audak Appoints Carduner

Eugene Carduner, of Carduner Sales Corp., 164 Duane St., New York 13, N. Y., has announced that they have been appointed representatives for the Audak Co., 500 Fifth Ave., N. Y. C. Carduner Sales Corp., will cover the New York metropolitan area.

### Westinghouse Names Lee

G. H. Melinger, manager of the household refrigeration department of the Westinghouse Electric Appliance Div., has announced the appointment of Jack D. Lee to the refrigeration sales department. Lee will be responsible for increasing the scope of promotional activities for the Westinghouse line of refrigerators and home freezers.

### New "Federated" Store

Federated Purchaser Inc., distributors of electronic products, has announced the opening of a new store in Newark, N. J., at 114 Hudson St., at Central Ave. The store will be managed by Phil Barr.

### New Allied Quarters

Allied Electrical Products Inc. and its subsidiary, Sheldon Electric Co., of Irvington, N. J. announces that it has moved its Los Angeles branch office and warehouse to enlarged quarters at 1755 Glendale Blvd. According to Harry Martin, branch manager, this move was necessitated by the greatly increased demand for products.

### Snyder Field Rep

Appointment of Charles Schlagel as eastern field representative for Snyder Mfg. Co. has been announced by Dick Morris, sales manager of the Philadelphia television and automotive accessory firm.

### Admiral Ups Discount

Admiral Corp. has increased discounts by up to 2%. The action was announced to Admiral's distributors throughout the country in a bulletin signed by Wallace C. Johnson, vice-president in charge of sales.

### GE Regional Manager

G. L. Roark has been appointed regional manager of GE tube divisions with headquarters in Chicago. Roark was formerly GE electronics district manager in New York City.

### Jerrold Ad Director

Sydney J. Mass has been appointed to the post of advertising and sales promotion director of the Jerrold Electronics Corp., Phila., Pa., it was announced by Milton J. Shapp, president. He was formerly advertising director of the National Pressure Cooker Co. and its subsidiaries.

### Symphonic Moves Plant

Moving of its entire plant and facilities into new and more spacious quarters at 160 Washington St., No., Boston 8, Mass., has been announced by Symphonic Radio & Electronic Corp. formerly of Cambridge, Mass., through its president, M. H. Cogan.

### Sylvania Distributor

Appointment of Ramco, Inc., of Chicago, Ill., as distributors of Sylvania radio and television sets for the Chicago area has been announced by J. K. McDonough, general sales manager of the Radio & Television Div. of Sylvania Electric Products, Inc., Buffalo, N. Y.

### TV Conversion Service

The formation of a conversion department which will convert any type of television set to any required large screen size has been announced by Sightmaster Corp., New York. Service will be rendered to retail store dealers, service agencies and department stores. Conversions will range in price from \$49.00 up, according to the size screen and cabinet selected.

# WARD

PUTS THE ACCENT ON

# Star Performance



The true measure of antenna performance is in the reception it provides. Ward leadership in engineering and design is your assurance of good TV reception.

### NEW WARD FLYING ARROW:

An all-band antenna that hits the bulls eye with exceptionally high gain throughout the entire high band. Sharp directivity, maximum energy transfer, fast assembly. Completely preassembled. Stacking kits available for assembling 2 bay arrays. **\$7.95** LIST

### NEW WARD CONICAL:

High in quality—low in cost. Unique element spacing and angular adjustments eliminated pattern breakup with no falling off of high band response. New molded universal insulator permits any desired element arrangement to suit local conditions and preferences. Stacking kits for 2 single bays and 4 bay arrays.

### NEW WARD YAGI:

Outstanding in performance for fringe and super-fringe areas. Built-in impedance transformer steps up impedance. Pin point directivity. Very high front to back ratio. No co-channel interference. Minimum standing wave ratio guarantees maximum energy transfer. Plus Ward rugged construction and complete factory preassembly. A model for each channel 2 to 13. Stacking kits for high and low bands.

Write for free catalog pages or call your jobber or distributor now.

**THE WARD PRODUCTS CORP.**

1523 EAST 45th STREET • CLEVELAND 3, OHIO

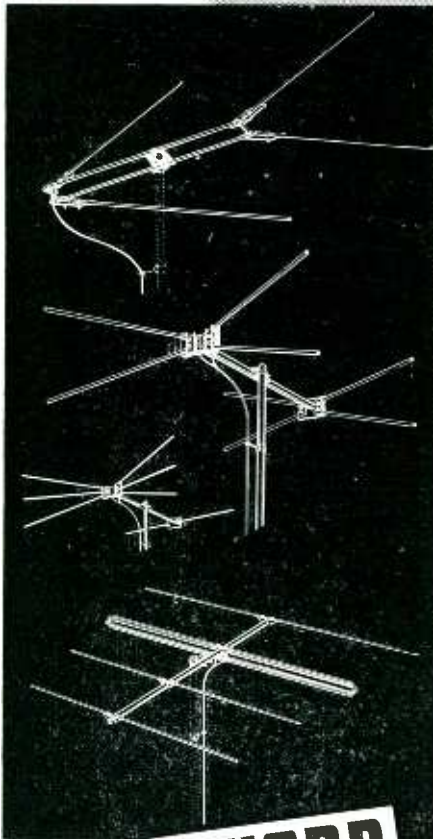

only **WARD**  
OFFERS  
TV-FM-AUTOMOTIVE  
HOUSE MAST-SPP  
ANTENNAS

Here's Our Investment In Your Future...



THIS IS TO CERTIFY THAT  
FRANKS RADIO & TELEVISION SERVICE  
has met the requirements of  
**RAYTHEON**  
FOR  
**BONDED ELECTRONIC TECHNICIANS**

A Surety Bond Has Been Issued by the AMERICAN MUTUAL LIABILITY INSURANCE COMPANY  
Expiring the 31st day of December, 1950, covering this firm respecting its Agreement with Raytheon Manufacturing Company to

1. GUARANTEE FOR NINETY (90) DAYS FROM DATE OF REPAIR AND REPLACEMENT PARTS FOR NINETY (90) DAYS FROM DATE INSTALLED.
2. Use only parts of recognized quality in such repair work.
3. Not charge more than fair price for parts installed in such repair work.
4. Treat customers' tubes as accurately and reliably as possible.
5. Keep charges for labor in such repair work as a fair and reasonable level.
6. Perform only such repair work as is necessary and authorized.

7. Maintain and use service equipment essential to good repair work and replace when obsolete.
8. Maintain in such repair work the high quality service indicated by the experience required of all bonded Electronic Technicians.

Signed  
AMERICAN MUTUAL LIABILITY INSURANCE COMPANY  
By *John A. ...*



The amount of coverage with respect to the above Dealer under this Surety Bond is limited to the sum of Four Hundred and no/100 (\$400.00) Dollars in the aggregate and no/100 (\$250.00) Dollars for any claim involving any single customer.

Now it covers Television, too!

### THE RAYTHEON BONDED ELECTRONIC TECHNICIAN PROGRAM

Raytheon considers the tremendous amount of money invested in the Raytheon Bonded Electronic Technician Program exceedingly well spent *because it is an investment in your future.* And your success is tightly tied up with ours.

RAYTHEON Bonded Electronic Technicians can offer their customers a *cash protected* guarantee on all radio and television repair work and parts for 90 days. Think what this guarantee, backed by almost \$100,000,000.00 resources of American Mutual Liability Insurance Company, can do to create customer confidence and good will and to stimulate sales. And yet this big business builder costs you *not one cent.*

Even before it covered *Television*, the Raytheon Bond lifted hundreds of Service Dealers head and shoulders above the crowd. Now that it covers *Television*, too, it's the most coveted key to better business in the industry.

You'll be building a firmer foundation for your business when you ask your *Raytheon Tube Distributor* to help you become a Raytheon Bonded Electronic Technician.

**RIGHT... For Sound and Sight**  
**RAYTHEON RADIO and TELEVISION TUBES**



**RAYTHEON MANUFACTURING COMPANY**

Receiving Tube Division

*Excellence in Electronics* Newton, Mass., Chicago, Ill., Atlanta, Ga., Los Angeles, Calif.

RADIO AND TELEVISION RECEIVING TUBES, CATHODE RAY TUBES, SPECIAL PURPOSE TUBES, SUBMINIATURE TUBES, MICROWAVE TUBES



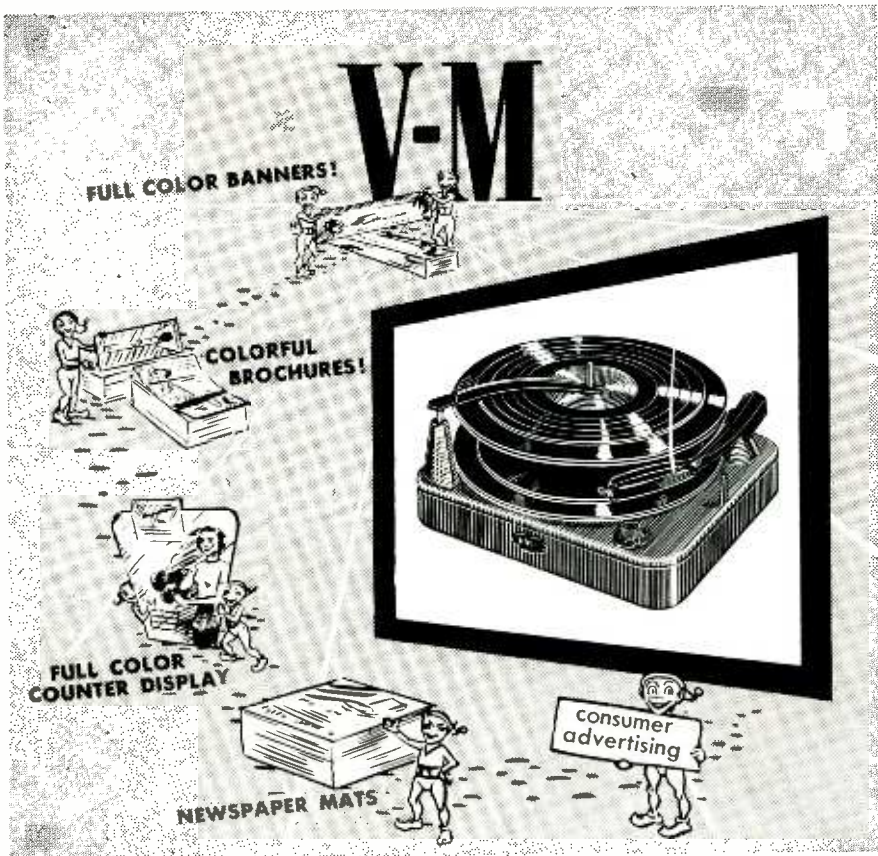

## Now! A Complete Promotion Package to Help You Sell V-M tri-o-matics!

Colorful counter displays — full color banners — newspaper mats — attractive brochures — national advertising in consumer magazines — plus a brand new cooperative advertising plan that can't be beat! The complete new line of V-M tri-o-matic record changers plus this complete promotion package, adds up to fast, big profits for you! Get full details today from your Jobber or Representative.

**V-M CORPORATION**  
Benton Harbor, Michigan

**Taylor's** TELEVISION ANTENNA BASES

See Your Jobber Now . . . .  
or Write Direct for Details!

**TAYLOR MANUFACTURING CO. • LIMA, OHIO**

## New Printed Circuit



William J. Halligan, president, the Hallicrafters Co., points out the printed circuit in the new Dynamic Tuner. The unit held by "Daisy Mae" is the tuner and IF strip featured in the '51 Hallicrafter line. Photo taken at the firm's TV "County Fair", Knickerbocker Hotel, Chicago.

## In New GE Posts

Louis H. Miller has been appointed manager of marketing of the General Electric Company's Appliance & Merchandise Department, it has been announced by H. L. Andrews, vice-pres.

At the same time, Mr. Andrews announced that Charles K. Rieger has been appointed manager of the household refrigerator division, succeeding Mr. Miller.

## To Headquarter's Post

The appointment of William B. Creech, of Atlanta, Ga., as assistant sales manager of the Westinghouse Appliance Div. has been announced by T. J. Newcomb, sales manager.

## N.A.E.D. President



W. G. Peirce, Jr., at right, newly elected president of the National Assoc. of Electrical Distributors and president of Peirce-Phelps, Inc., Phila., receives the congratulations of his predecessor, D. M. Salsbury, president of Westinghouse Electric Supply Co., N. Y.

## Radion TV ANTENNA

Model TA55 "Foto-Tenna" is an indoor TV antenna designed to provide good reception in metropolitan locations and at the same time blend into the interior decoration scheme. The antenna is concealed in a brown leatherette photo easel, and comes complete with 10 feet of 300-ohm lead-in. List price is \$7.50. Radion Corp., 1137 Milwaukee Ave., Chicago 22, Ill.—RADIO & TELEVISION RETAILING.

# How You Can Multiply Your TV Sales Volume with the BRACH Antenna and Accessories Line

## 1 With MUL-TEL—The Fastest Selling Non-Amplified TV Distributing System

Thousands of alert dealers and servicemen are making money with MUL-TEL—demonstrating more sets at one time—and selling more TV sets because MUL-TEL paves the way for the sale of extra sets in any home, extra sets in any tavern, extra sets in garden apartments, extra sets anywhere. Up to 16 sets operate from one Antenna—cost consumer as low as \$2.50 per set for brilliant, clear pictures.



## 2 With Antenna Features That Assure Better Reception

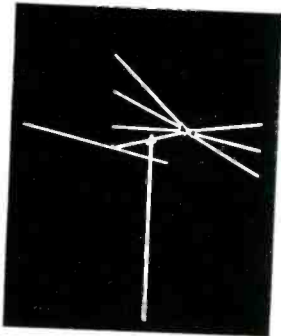

The Brach 6-Bar

Brach's 44 years of quality electrical production shows up in precision-engineered antennas. Only the best antennas do justice to any TV set. A Brach Antenna is more ruggedly constructed, is better insulated and provides higher gain.

**The Brach 6-Bar.** Preferred for match with balanced transmission line. Highest gain multi-element V-construction.

**The Brach T-Bar.** The only in-line type antenna designed for coaxial cable. Free of side-lobe pick-up.

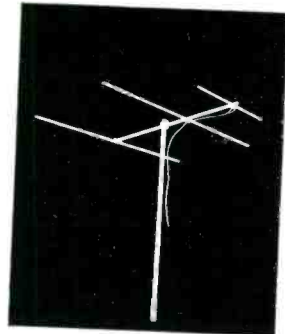

The Brach T-Bar

## 3 With An Accessories Line That Has Everything

Carry the Brach complete antenna line for greater profits and greater customer satisfaction. Base-mounts, chimney brackets, U-L approved Arresters, stand-offs form only part of this "one-stop-service" accessories line.

## 4 With A Unique Merchandising Plan

—that tells you how to convert prospects into buyers. Send for "The Mul-Tel Story" today.

PLEASE PRINT

DEALER'S NAME.....

ADDRESS.....

CITY..... STATE.....

YOUR JOBBER'S NAME.....

ADDRESS.....

RTR-8

**BRACH**

MFG. CORP. • Div. of General Bronze Corp. • 200 Central Ave., • Newark 4, N. J.

See Us At the NEDA Show Booth No. 127



# ALPRODCO ALUMINUM TOWERS

The  
HEIGHT  
of  
Perfection!

LIGHT!  
STRONG  
EASILY  
ERECTED  
ATTRACTIVE!

ONLY

**\$1 15**  
PER FOOT  
K.D.

- Weight of one pound per foot assures safe, easy installations.
- Attractive "life-time" beauty with no maintenance worries.
- Heights up to 120 feet may be safely used.
- Aircraft Aluminum is used exclusively in AlprodcO Towers.
- Available in knocked down or assembled six foot sections.

Commercial and Economy towers also available.

"Write for literature".

## ALPRODCO, INC.

MINERAL WELLS, TEXAS  
KEMPTON, INDIANA

If your jobber can't supply,  
write direct to either factory.

## Hotpoint Trailer



All-electric kitchen and home laundry on wheels takes to road for southern tour on first leg of nation-wide trip. Developed by Hotpoint, Inc., mobile kitchen is housed in trailer. Sides open, allowing visitors to inspect appliances. The trailer will visit more than 50 cities in Alabama, Kentucky, Mississippi and Tennessee.

## Spirling Distributors

Milton Spirt, president of Spirling Products, 62 Grand St., N. Y. C., announced the following additional reps: L. Quackenbush, Illinois; Theo. B. Lowell Associates, Normandy, Mo.; Midwest Sales Co., Cleveland, O.; Ralph Cantall, Buffalo, N. Y.; Wm. Goldman, Boston, Mass.; Central Sales Co., Ft. Wayne, Ind. They are carrying the Spirling line which includes the Super Phantom Tenna, the Phantom-Tenna, the Tenna-Master and the Masterette line of indoor antennas and the new E-Z Bee outdoor antenna.

## Admiral Service Manual

Seeking to eliminate installation and service difficulties which occasionally crop up due to individual servicemen's unfamiliarity with various makes of sets, Admiral has prepared an eight page installation and service manual for its own use. According to Max Schinke, Admiral service manager, the booklet is issued with each set and is fastened to the inside wall of the cabinet near the TV chassis so that it can be consulted, if needed, during installation.

## Proctor Names Davis

F. J. "Bud" Davis is the new Seattle district manager for the Proctor Electric Co., C. P. Culbert, western regional sales manager, has revealed. His territory will cover the states of Washington, Oregon and Montana.

## Hytron Sales Manager



John Q. Adams, vice president in charge of sales of Hytron Radio & Electronics Corp., has announced the appointment of Richard A. Malmberg, above, as Hytron's renewal sales manager.

# Duosonic LONG PLATING PHONOGRAPHS



THE most popular name in phonographs today is DUOSONIC, which stands for the ultimate in phonograph perfection . . . exceptionally rich in tone, dependable in construction, richly styled for unusual beauty . . . they are the choice of progressive dealers everywhere . . . available in models and colors to suit every taste and budget.

Franchises are still open. Write about the availability of this top line for your territory.

Address all inquiries to Dept. TRD6

**SONIC**  
INDUSTRIES INC.  
221 West 17th St.  
New York 11, N. Y.  
Manufacturers of Super Sonic TV+FM Amplifiers

# TELE-TURNER... AMAZINGLY LOW PRICED ... BRINGS QUICK SALES

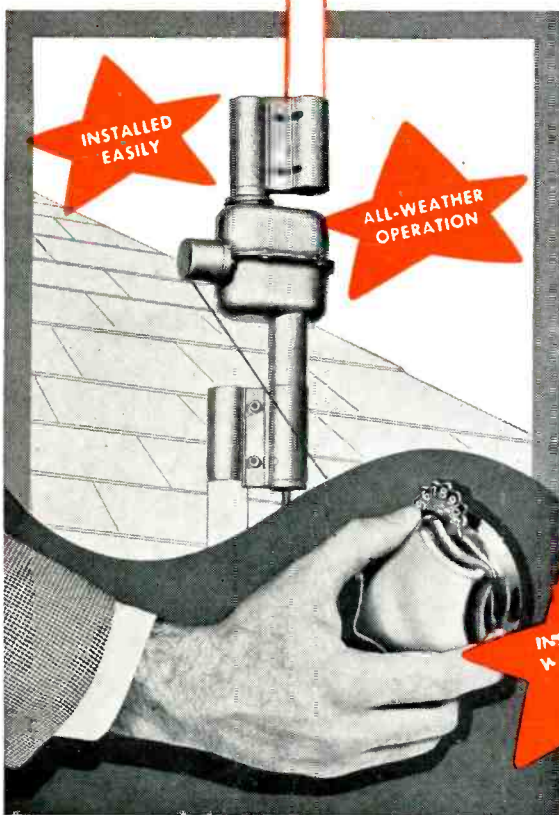

Manufactured by  
JOSEPH SHAW CO., Toledo, Ohio

**New TELE-TURNER T.V. Rotor  
is priced to sell . . .**

Tele-Turner sells for \$16.45 complete with directional indicator, inside manual control and all necessary hardware. Cash in on the profit-making Tele-Turner.

- GUARANTEED TO OUTPERFORM MOTOR ROTORS
- FOOLPROOF MECHANICAL OPERATION
- PIN POINT RECEPTION—WITHIN 1 DEGREE
- ONE YEAR GUARANTEE

**\$16<sup>45</sup>** RETAIL PRICE  
(Plus Cable)

**IMMEDIATE DELIVERY**

**... learn more about profit-making TELE-TURNER ... mail coupon today!**

Please send me full information on how I may cash in on the profit making Tele-Turner.

Name \_\_\_\_\_  
Company \_\_\_\_\_  
Street \_\_\_\_\_  
City \_\_\_\_\_ State \_\_\_\_\_



**C. M. PENNEY CO.**

3471 West 140th St. • Cleveland, Ohio



Since the earliest days of Radio...



have been preferred for their absolute uniformity, superior qualities and ultimate economy. Foremost set manufacturers specify CORNISH, because our engineers keep abreast of electronic developments. Let us serve YOU.

Write for catalog #57

"MADE BY ENGINEERS FOR ENGINEERS"

**CORNISH WIRE COMPANY, INC.**  
15 Park Row New York 7, N. Y.



## NEW TV CHASSIS AVAILABLE!

New chassis now available includes TV's latest developments. Custom television manufacturers can obtain a 19 tube humless intercarrier chassis on a 630 frame with Standard Coil front end; keyed A.G.C.; and the General Ceramic Hot 107 Fly-Back. All these features are available at the lowest price in the industry.

Call Dan Deaner



**International TELEVISION CORP.**

238 WILLIAM ST., Dept. RR N. Y. 7, N. Y. CO 7-5160

## LOWEST PRICED PIPE MOUNT ON THE MARKET

Another Superior South River Product

Made of rust proof, sturdy aluminum extrusion. Write for samples and liberal jobber discounts. Fits any size pipe up to 6".

Write for complete catalog of famous South River line.

List \$2.50

South River Metal Products Co., Inc.  
Dept. RR. 17 Obert St., South River, N. J.

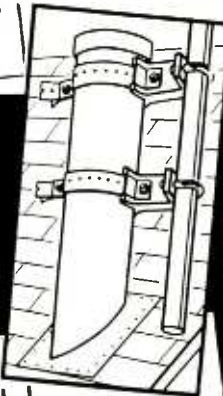

## "SNOW-FREE" PICTURES WILL INCREASE YOUR BUSINESS



ELIMINATES 80% OF FEEDLINE LOSSES



The new GOODLINE AIRLEAD eliminates excessive losses found in ordinary feedlines used in T-V and amateur installations. . . . Losses through leakage of the signal in the dielectric web between wires of ordinary feedline can be so excessive that proper clear, sharp "snow-free" pictures are impossible to obtain.

With the new GOODLINE AIRLEAD 80% of the loss producing dielectric web is removed permitting the maximum practical transfer of the signal from the television antenna to the television receiver. Also, standard close spacing of wires and standard nominal 300 Ohm impedance eliminates losses through re-radiation due to poor balance to ground so prevalent in wide-spaced lines. . . . Loss of signal during rainy weather has been a constant source of serious trouble to both amateur and T-V set users. GOODLINE AIRLEAD effectively eliminates wet weather losses.

INSTALLATION IS SIMPLE AND QUICK. Just install GOODLINE AIRLEAD in the usual manner. Standard insulators can be used—no special insulators required. Wire can be pulled taut without bringing wires close together—thus no loss of effectiveness for which it is designed. . . . No special transformers or "experimenting" required. . . . Lower in cost than other leadlines purported to accomplish the same results.

SPECIFICATIONS: Weather resistant polyethylene with nominal dimensions of .375" x .083". Use 2 only 7 x 28 conductors. . . . PACKAGED FOR EASY HANDLING AND INSTALLATION: On practical reels in standard lengths: 55' - 100' - 250' - 500' - 1,000'.

\* PATENT PENDING

\* TRADE MARK

Write for Samples—Literature—Prices—and Name of Your Jobber

*Don Good, INC.*

Exclusive Licensee and Sole Manufacturer

1014 Fair Oaks Ave. Phone: SYcamore 9-1194 South Pasadena, Calif.  
DON GOOD, INC. also manufactures TELETRAPS (F.M. and Diathermy and Amateur Interference Traps) and TELEPASS (High Pass Interference Filters).

## Lowest Prices in the Industry

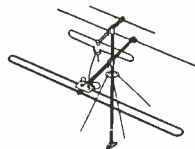

DUO-BEAM hi-gain stacked array for high and low TV bands. Independently oriented. Isolation network prevents pick-up by the low frequency dipole on the upper T.V. channels. Heavy, seamless aluminum tubing. Designed for fast erection.

## FACTORY TO YOU!

Save money, get better quality, thru

our plan of DIRECT SELLING

We also manufacture conical antennas and hi-gain Yagi arrays.

Our products have withstood three years of severe conditions.

Write today for complete price list.

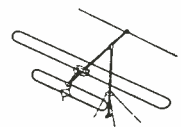

DI-BAND hi-gain array for high and low band TV. Low band dipole acts as double reflector for high band. Isolation network prevents pick-up by the low frequency dipole on the upper T.V. channels. Heavy, seamless elements. Easy, high-speed erection.

ANTENNA PRODUCTS, 1809 N. Ashland Ave. CHICAGO 22, ILL.

## HAVE YOU A JOB FOR A TRAINED TECHNICIAN?

We have a number of alert young men who have completed intensive training in Radio and Television Repairing. They learned their trades thoroughly by working on actual equipment under personal expert supervision. If you need a trained man, we invite you to write for an outline of our course, and for a prospectus of the graduates. No fees, of course. Address:

Placement Manager, Dept. P110-8

**COMMERCIAL TRADES INSTITUTE**  
1400 Greenleaf Chicago 26

# REVOLUTIONARY NEW AMPRO-TAPE RECORDER OPENS RICH \$50,000,000<sup>00</sup> MARKET!

## 1001 USES

for homes, offices, factories,  
schools, churches, institutions

### RECORDS BABY'S VOICE

Babies' voices can be preserved on tape forever; older children can be helped with language and music lessons through recording on the amazing Ampro.



### MAKES DICTATION EASY



Businessmen find the Ampro-Tape Recorder invaluable for dictation at home or office; for recording important conferences; for special recordings to use at sales meetings, etc.

## 9 BIG FEATURES!

- Records 2 Full Hours on 7" Tape
- Cannot Erase Accidentally
- Motor Rewind and Fast Forward
- Tone Control
- Instant Stop Switch (Foot pedal attachment available)
- Portable—Weights only 17 Pounds
- Large 5" x 7" Speaker
- High Fidelity—Wide Frequency Range
- External Speaker Outlet



*I Haven't Seen  
Anything Catch On So  
Fast Since Television  
First Came In!*

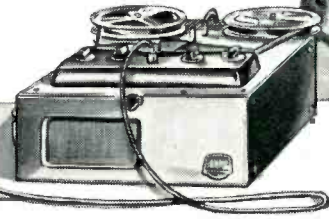

Anyone Can Operate It! Anyone Can Afford It!

## \$1000<sup>00</sup> WORTH OF FEATURES FOR

Sells Itself in One Demonstration to  
Parents, Businessmen, Students, Musicians,  
Teachers, Ministers, Many Others!

## \$109<sup>50</sup>

Your prospects for this completely new Ampro-Tape Recorder are limited only by the number of families and businesses in your town! One customer brings in ten more; every machine you sell becomes a "demonstrator" that brings in more sales!

The Ampro records at a slow speed on a dual

track, recording twice as much material as conventional recorders. On each reel upkeep is negligible. The same tape can be used over and over again. The Ampro is easily portable—weights only 17 pounds.

And remember, the Ampro-Tape Recorder is a quality machine, made by a company which has been a leader in the field of precision manufacturing for over 20 years!

Write today for full details on this astonishing new profit-builder!



AMPRO CORPORATION • CHICAGO



\*Trade Mark Reg.  
U. S. Pat. Off.

A General Precision Products Corporation Subsidiary

### Don't Delay...Write Today!

AMPRO CORPORATION  
2835 N. Western Ave., Chicago 18, Illinois

KTR-8-50

I am interested in complete information on a franchise for the new AMPRO-TAPE RECORDER. I am a  Dealer  Distributor.

Name.....  
Firm Name.....  
Address.....  
City..... Zone..... State.....





the most  
Beautiful,  
Easiest to Install,  
Lowest-Cost

Mast  
for TV is the  
ALL-ALUMINUM

# MILNER MAST

patent applied for

## Check These Points Before You Buy a Mast

- 50 ft. Mast complete weighs less than 50 lbs.
- Minimum wind resistance. No painting, no rusting, no corrosion
- Threaded section of Mast tubing stronger than the tubing itself
- No climbing—entire assembly is done from the bottom even on 100 ft. heights
- Can be erected from horizontal position up to 40 ft.
- Rotatable from the bottom
- Less space to stock
- All shipments prepaid

Get full details, write  
**MILNER MANUFACTURING CO.**  
Jackson, Mississippi



All-aluminum fittings. Universal top adapts to any size antenna.



Can be placed anywhere. Bases designed for any type installation.



Tubing in 10-ft. sections is joined by special rolled thread design (patent applied for).

## GE Appointees



Arthur A. Brandt, above, left, has been appointed as general sales manager in the General Electric Receiver Div. to direct expanding commercial operations. W. H. Sehloff, division manager, has announced. Also announced was the appointment of Harrison Van Aken, above, center, as assistant manager of the division, and W. M. Skillman, above, right, as manager of marketing services.

## RTMA Appointments

President and chairman of the board, Robert C. Sprague has appointed Dr. W. R. G. Baker chairman of the television committee of the Radio-Television Manufacturers Association. President Sprague also announced the appointment of past RMA president R. C. Cosgrove to the television committee.

The complete membership of the RTMA Television Committee, together with their company affiliations, follows: Dr. W. R. G. Baker, chairman General Electric Co.; Benjamin Abrams, Emerson Radio & Phonograph Corp.; Max F. Balcom, Sylvania Electric Products Inc.; W. J. Barkley, Collins Radio Co.; H. C. Bonfig, Zenith Radio Corp.; R. C. Cosgrove, past president of RMA; John W. Craig, Crosley Division, Avco Mfg. Corp.; Allen B. DuMont, Allen B. DuMont Laboratories, Inc.; J. B. Elliott, RCA Victor Division; Paul V. Galvin, Motorola Inc.; G. M. Gardner, Wells-Gardner & Co.; W. J. Halligan, The Hallicrafters Co.; L. F. Hardy, Philco Corp.

Sprague also appointed a reorganization committee to carry out the mandate of the membership of the association to formulate and present to the RTMA board of directors a reorganization plan for the association. The membership of the committee follows: Max F. Balcom, chairman, Sylvania Electric Products Inc.; J. J. Kahn, vice-chairman, Standard Transformer Corp.; Benjamin Abrams, Emerson Radio & Phonograph Corp.; W. R. G. Baker, General Electric Co.; William Balderston, Philco Corp.; Alternate, L. F. Hardy; W. J. Barkley, Collins Radio Co.; Frank M. Folsom, Radio Corp. of America, Alternate, J. B. Elliott; Paul V. Galvin, Motorola Inc.; Arie Liberman, Talk-A-Phone Co.; W. A. MacDonald, Hazeltine Electronics Corp.; E. F. McDonald, Jr., Zenith Radio Corp., Alternate, H. C. Bonfig; Leslie F. Muter, The Muter Co.; A. D. Plamondon, Jr., The Indiana Steel Products Co.; Robert C. Tait, Stromberg-Carlson Co.

## Proctor Sales Executive

The appointment of Robert H. Dewalt as sales manager of the western region of the Proctor Electric Co. has been announced by Joseph Tiers, general sales manager in charge of distributor sales.

## WHEN THE PICTURE TUBE GOES BAD . . .

That's when servicemen need



—at low cost, plus full  
year guarantee.

CATHOTRON is a fast replacement channel for servicemen—preventing legwork, loss of time and loss of profit—putting TV sets back in service in a hurry.

CATHOTRON eliminates delays due to shortages and shipping, or awaiting warranty red tape.

Because speed is vital—to both serviceman and customer—the Cathotron Exchange-Sale Plan requires distributors to make pickup and delivery. They pick up a worn-out or damaged picture tube (if free of scratches on the face) and, at low cost, deliver a brand new tube of equivalent size, identical to those we supply to TV set manufacturers for original equipment. Available sizes, round or rectangular, are:

10" - 12" - 12½" - 14" - 15" - 16"

Remember—CATHOTRON is the tube with "the vacuum baked screen"—a product of General Electronics, Inc.; supplier to Set Manufacturers, Broadcasters, the Armed Forces and Industry.

**SERVICEMEN**—Write for exchange prices and name of nearest distributor.

**DISTRIBUTORS**—Write for details of franchise. Some choice territories open.

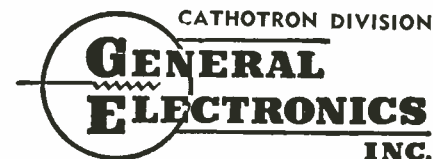

101 Hazel St., Paterson, N. J. MULberry 4-5271

so **E-A-S-Y** yet so **FAST** and so **GOOD!**



# "PLUG-IN" TV ANTENNAS

## ALL-ALUMINUM CROSSARMS and ELEMENTS

- NO RUSTING • NO CORROSION
- ELIMINATES COSTLY CALL-BACKS

Simply "PLUG-IN" Elements and Tighten Wing Nuts . . . Mechanically  
Sturdier and Electrically Superior!

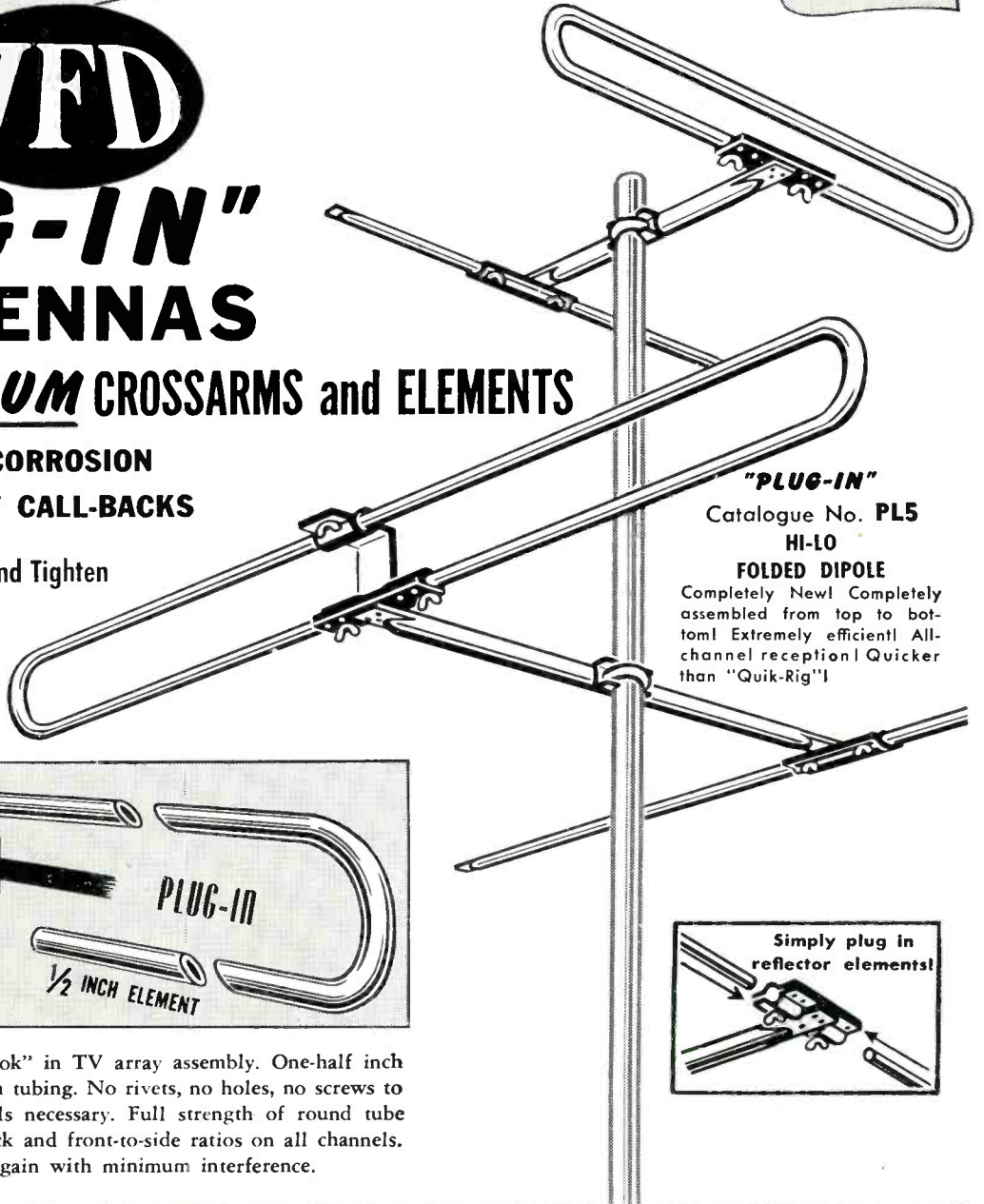

"PLUG-IN"

Catalogue No. PL5  
HI-LO

FOLDED DIPOLE

Completely New! Completely assembled from top to bottom! Extremely efficient! All-channel reception! Quicker than "Quik-Rig"!

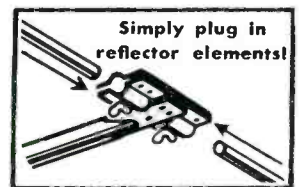
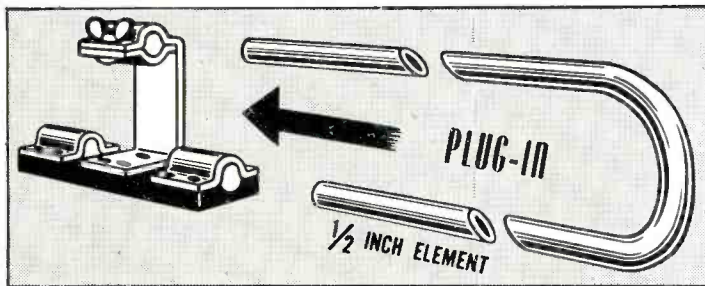

JFD presents the "new look" in TV array assembly. One-half inch seamless aircraft aluminum tubing. No rivets, no holes, no screws to weaken elements. No tools necessary. Full strength of round tube retained. High front-to-back and front-to-side ratios on all channels. Engineered for maximum gain with minimum interference.

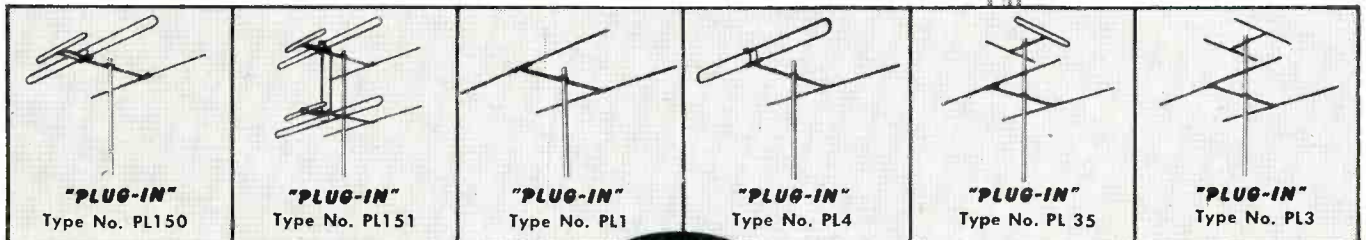

Write for FREE descriptive literature on this new line of JFD "PLUG-IN" antennas. For the most complete line of television antennas and accessories, ask for the latest catalog No. 58.



**Manufacturing Co., Inc.**

6103 16th AVENUE, BROOKLYN 4, N. Y.

"The 'Exclusiveness' of JFD is the Quality of its Product"



# Help end INTERFERENCE

★

## AUTO-LITE Resistor SPARK PLUGS

THE NEW Auto-Lite Resistor Spark Plugs reduce spark plug interference with radio and television reception and in addition offer car owners smoother idling, better engine performance on leaner gas mixtures and longer electrode life. Gain friends by recommending them to your customers with TV sets, car radios and radio telephone installations.

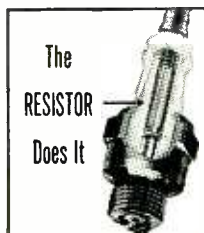

### FREE PROMOTION MATERIAL

- ✓ Helpful instructive folder, "TV brings change in car ignition behavior."
- ✓ Big, colorful reprint of Auto-Lite's Saturday Evening Post television ad for your window.
- ✓ A highly informative folder showing construction features of Auto-Lite Resistor Spark Plugs.
- ✓ An attractive counter card featuring "Suspense" on radio and TV. Creates interest in television and set purchases.

The Electric Auto-Lite Company, Toledo 1, Ohio  
Please send me FREE promotion material on suppression of spark plug interference with radio and TV through use of Auto-Lite Resistor Spark Plugs.

Name \_\_\_\_\_  
Address \_\_\_\_\_  
City & State \_\_\_\_\_

## Across the U. S. A.

(Continued from page 33)

Although salesmen offer to pay for the small amount of electric current and water which they use in demonstrations, most housewives are so fascinated by the demonstrator unit that they refuse payment.

Salesmen find it is much easier to gain an audience with housewives by driving the attractive "store-on-wheels" up to their homes than it is to knock at the front door and attempt to gain entrance with only literature to show. The truck is painted light cream and is kept washed and immaculate to present an appearance similar to the dream kitchen every housewife longs for. The fact that it attracts attention is proved by the large number of telephone calls received from those housewives who have read the invitation (Phone 1834 for Demonstrator) painted on the side of the truck.

### Workshop Representatives

Gardiner G. Greene, president of Workshop Associates, Inc., has announced the appointment of three new sales representatives: The Henry W. Burwell Co., 1133 Ponce de Leon Ave., Atlanta, Ga.; Gerald Wilson, a member of "The Representatives," 403 Second St., Jackson, Mich. and a branch office at 11816 McCracken Rd., Cleveland, O.; and S. W. Simberkoff, also a member of "The Representatives," 347 Fifth Ave., New York 16, N. W. and a branch office on Donnybrook Lane in Silver Springs, Md.

### Counter Display Kit

A recording-wire merchandising kit for counter display is being offered by Webster-Chicago Corp. The kit holds five spools: two 15-minute, two 30-minute and one full-hour spool. The spools are packed in a counter display box in such a way that all the information the customer needs to select his own spools is immediately visible. The kit has a retail value of \$13.70.

### Starrett President



R. D. Burnet, above, has been elected president of the Starrett Television Corp., 601 W. 26th St., N. Y. He was formerly secretary-controller and assistant treasurer of the Zenith Radio Corp.

Get MORE stations...

CLEARER pictures...

make COSTLY TV TUBES LAST LONGER with a

**TRYLON  
TV  
MAST**



As almost every dealer knows by now, built-in television antennas are really satisfactory in only a small percentage of installations. Even indoor antennas often leave a lot to be desired. But that's only part of it!

### AVOID TUBE STRAIN!

Indoor antennas of any kind usually mean that sets must be operated at high volume. This means a big reduction in tube life—including the costly picture tubes!

An outdoor antenna mounted on a Trylon Mast assures clear pictures, reduces interference, brings in more stations. Also, it enables the set to operate at lower power with a minimum of tube strain. A leading dealer states: "I'm convinced that a Trylon Mast actually pays for itself in what it saves the TV set owner on tube replacements!"

★

Trylon TV Masts are easy to install—safe and easy to climb. Supplied in 10-foot sections for heights to 60 feet. Weight is about 2 lbs. per foot at a dealer cost of only about \$1.00 per foot. They're hot dip galvanized against the weather—designed for real dependability under all conditions. Write for Catalog R.



**WIND TURBINE CO.**

Mast and tower specialists  
for over 17 years  
WEST CHESTER, PENNA.

# THE FACTS

## about hallicrafters

### dynamic tuner

with the PRECISION PRINTED CIRCUIT

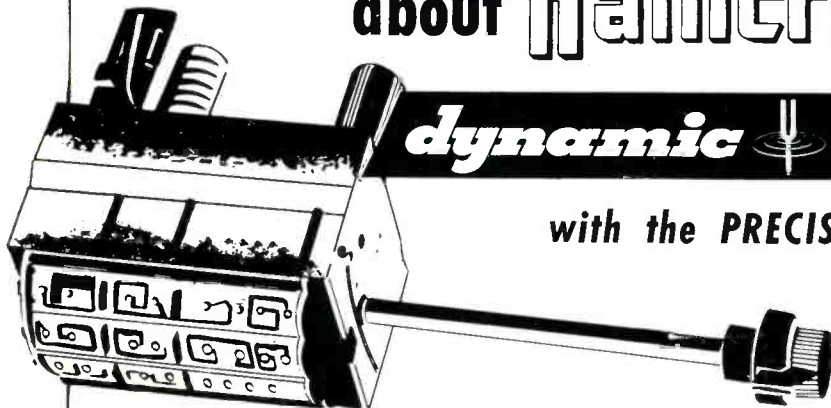

#### 1 TELEVISION'S CLEAREST PICTURE!

Located at the beginning of TV chassis where signals are the weakest, the dynamic tuner uses the photographic accuracy of the precision printed circuit: TO AMPLIFY WEAK SIGNALS MORE EFFECTIVELY; TO REJECT STATIC OR OTHER INTERFERING SIGNALS.

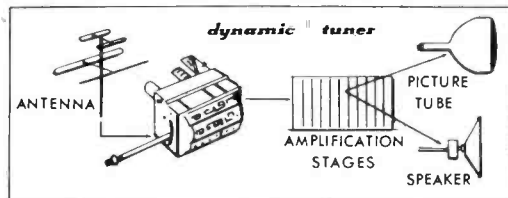

#### 2 ACTUAL PROOF OF SUPERIORITY!

HALLICRAFTERS . . . BEST of five leading sets tested! Two to four times *greater sensitivity* than the best of the other leading TV chassis tested, and on *all 12 TV channels!*

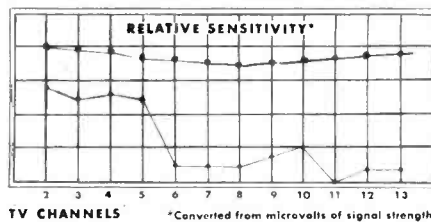

#### 3 "FRINGE AREAS" MOVE TO TOWN!

Hallicrafters longer-distance reception means that you, the dealer, have a greater sales territory! It's yours to capture, now! You can guarantee "city-clear" reception in many former "fringe area" locations.

#### 4 SUPER-SENSITIVE CHASSIS

Every chassis coming off the line is "hot" in sensitivity; variations in tuning alignment are practically eliminated! Neither climatic changes nor motion in shipment alter the precision-fixed position of the flat, photo-etched coils.

#### 5 EXCLUSIVE: "SILVER VORTEX ANTENNA"

Hallicrafters' second major development in antennas, the Silver Vortex Antenna is a triumph of Precision engineering. It is "omnidirectional," actually *draws in* signals like a magnet through a precision-printed, circular pattern of metallic silver ribbons.

WORLD'S LEADING MANUFACTURER OF PRECISION RADIO & TELEVISION  
CHICAGO 24, ILLINOIS





# LOSING MONEY

## on your TV Installations?

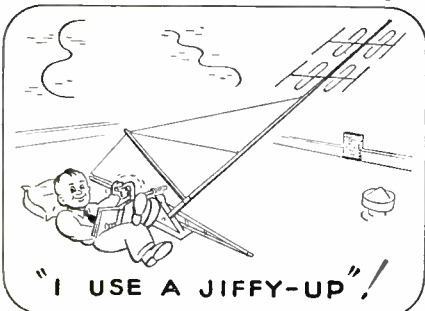
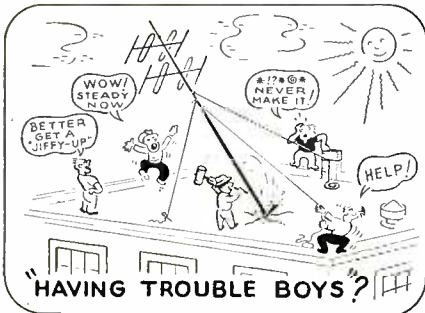

## DEALERS—

- Jiffy-Up Mast Hoist speeds TV antenna installations
- Erects or lowers masts up to 50 ft. high
- 2 men do the job of 6 in far less time
- Works on flat or gable roof
- Special designed heavy steel roof mount
- Hoist connected to roof mount in less than 5 min.
- Permanent guy wires used for hoisting—no ropes or cables required
- Accommodates large masts up to 3" in diameter
- One hoist pays for itself in a few installations
- Hoist will raise or lower most towers

Jiffy-Up TV Mast Hoist . . . .net \$49.50  
 Jiffy-Up Roof Mount . . . . .net 6.00

## ORDER TODAY

IF JOBBER IS UNABLE TO SUPPLY  
 —WRITE DIRECT TO:

**HAUGEN MFG. CO.**  
 412 S. FRONT ST.  
 MANKATO, MINN.

## Auto-Lite Ad Manager

Appointment of Donald B. Seem as advertising manager of The Electric Auto-Lite Co. has been announced recently by Royce G. Martin, president and board chairman of the company. Seem has been associated with Auto-Lite since 1947 when he became assistant advertising manager.

## Lewyt Convention

A national sales convention will be held August 9, 10 and 11 at the Barbizon-Plaza Hotel in New York City. Plans include showing of latest Lewyt product improvements and promotions, and two days of clinic sessions for selling information.

## GE Appoints Six

Six new appointments to sales positions in the General Electric Receiver Div. have been announced by Arthur A. Brandt, general sales manager of the division.

R. W. Ferrell has been made assistant general sales manager; David Davis, sales manager of television receivers; D. S. Beldon, Jr., sales manager of radio receivers; E. J. Hendrickson and D. E. Weston, Jr., assistant sales managers of TV receivers; and G. O. Crossland, assistant sales manager of radio receivers.

## Cashman New Director

The Association of Electronic Parts & Equipment Manufacturers, has elected John H. Cashman, president of Radio Craftsman, Inc., of Chicago, as director of the Radio Parts & Electronic Equipment Shows, the non-profit corporation which conducts the all-industry sponsored show held in Chicago each May.

Cashman succeeds Les A. Thayer, of Belden Mfg. Co., Chicago, whose term as director representing EP&EM expires. The other EP&EM member of the show board of directors is Charles A. Hansen, of Jensen Mfg. Co., Chicago.

## Offer 45 RPM Kit to Convert Jukeboxes

The RCA Victor Division of the Radio Corporation of America and the Rudolph Wurlitzer Company, manufacturer of automatic coin-operated phonographs, have joined forces in a program to introduce the 45 RPM record-playing system in automatic coin-operated phonographs. Effective immediately, the Wurlitzer organization will make available to the owners and future purchasers of its latest model, the "Twelve Fifty," a special kit of replacement parts to convert it from 78 RPM to 45 RPM operation. At the same time, RCA Victor will furnish to those coin-machine phonograph operators desiring to convert to 45 RPM an initial library of twenty-four 45 RPM popular records of the operator's choice. The conversion kit, valued at \$8.75, and the record library, worth \$16.56, will be offered without charge through local Wurlitzer and RCA Victor distributors.



## THE FASTEST SELLING Ground Rods

For TV AND OTHER INSTALLATIONS

With a new quick-acting, time-saving clamp that insures positive contact on #4 to #14 gauge conductor. 3/8-inch solid steel rods, copper plated and pointed for easy driving. Available in 4 and 6-foot lengths. Also 1/2-inch rods in 5, 6 and 8-foot lengths.



At your Jobber

**PREMAX PRODUCTS**  
 DIVISION CHISHOLM-RYDER CO., INC.

5005 Highland Ave., Niagara Falls, N. Y.

New Low Dealer and Jobber Prices

on

## CHAMPION STEEL TELEVISION TOWERS

THE TRIED AND PROVEN LINE.

Write for literature

**NORMAN M. SEWELL, INC.**  
 BOX 752, LANSDALE, PENNA.



## Heads RTMA Group



At the annual meeting of the amplifier and sound equipment division of the RTMA, Ernest Keller, above, was appointed chairman of the TV booster committee. Keller, vice-president and sales manager of Anchor Radio Corp., is very much interested in the publicity and sales promotion of all good boosters. He believes that TV accessories such as a booster, aside from being a profitable item in itself, will play a vital part in extending TV sales to untapped markets.

### Spiraling TV ANTENNAS

The Phantom-Tenna indoor TV and FM antenna is a V-type dipole antenna on a bakelite base with the following features: fixed length dipoles, 17½ inches long, no need for telescoping; built-in matching stub to provide proper match for TV set; and "adjusta-knob" control provides tuning equivalent to former adjustment of dipoles. List price of the TV-501 is \$5.95. Spiraling Products Co., Inc., 62 Grand St., New York 13, N. Y.

### Goodline TV FEEDLINE

Manufacturer claims that through the use of this new product, "by the removal of 80% of the loss-producing dielectric web between the wires, the Goodline Airlead permits the maximum practical transfer of the signal from the TV antenna to the receiver so that proper, clear and sharp 'snow-free' pictures can now be obtained." A series of rectangular slots have been cut out of the web between the conductors. Prices: 55'—\$3; 100'—\$5; 250'—\$12.50; 500'—\$25.00; 1,000'—\$41.25. Don Good, Inc., 1014 Fair Oaks Ave., So. Pasadena, Calif.

### Alprodco TV TOWER

The new "Tower-Pack" is a 36-foot aluminum tower package which is pre-assembled and includes all necessary parts (with the exception of guy wires) for making an installation. This new Economy Tower is designed to provide improved reception with a minimum of expense. Alprodco, Inc., Box 607, West Lafayette, Indiana.

### JFD ARRESTER

The "safeTVguard" TV twin-lead lightning arrester described in a previous issue is now available in 3 models: AT102 for regular twin-lead, AT103 for oval jumbo and tubular twin-lead, and AT105 for any type of twin-lead. A 4' length of aluminum of ground wire is supplied for use when mounting the arrester on walls. The glazed porcelain arrester is UL approved for indoor or outdoor use. JFD Mfg. Co., Inc., 6101 Sixteenth Ave., Brooklyn 4, N. Y.

### James VIBRATOR

The new vibrator features right angle ("Angle Drive") reed arm construction, low voltage starting, high contact pressure and optimum transformer-buffer relationship. James Vibrapower Co., 3224 West Armitage Ave., Chicago 47, Ill.



The antenna that winds don't break; the antenna that the birds don't bend; the antenna that STANDS UP against stress and strain — that's the soundly engineered PHOENIX Line! It takes just as much gas and almost as much time to service a broken antenna as it does to service a set — and you probably have to replace it, too! Save mileage and labor time by installing a PHOENIX Antenna the *first* time. Properly mounted, it's there for good. Your customers will love the rugged PHOENIX rig — and so will you!

#### FIVE PHOENIX FEATURES

1. Super Gain
2. 1 Call Installation
3. 30 Second Assembly
4. The Rig That's Rugged.
5. The Quality Line That's PRICED RIGHT.

write  
FOR FOLDER C  
containing complete line of television accessories.

All types — all sizes, complete with all hardware — less mast.

**PHOENIX**  
ELECTRONICS, INC.

AT LEADING  
JOBBER'S

LAWRENCE, MASS.

**TEC**

**UNTUNED  
TELEBOOSTER**

MODEL  
**S-505**



A  
NEW  
MODEL  
WITH AN  
**ADDED  
GAIN CONTROL**

The NEW S-505 untuned telebooster now features a gain control for reducing the gain on channels where the S-505 provides too much gain for proper operation. This feature makes the S-505 an ideal booster in all areas. Immediate delivery.

ONLY  
**\$37<sup>50</sup>**  
LIST

WRITE FOR CATALOGS

- NEW!**
- No tuning required—all channel reception.
  - Amplification of the order of 20 db over entire UHF TV range, achieved by the use of two stages of amplification.
  - Input and output 300 ohms.
  - Handsome appearance—professional styling.
  - Uses 2-6AK5 VHF pentodes and 1-12AT7 VHF duo triode for maximum performance.
  - Exceptionally long life; uses selenium rectifier; all components conservatively rated.
  - Pilot light added for your convenience.
  - Wideband, flat response ideal for intercarrier sets for equal amplification of both video & sound signals.

**TEC**

TELEVISION EQUIPMENT CORP.  
238 WILLIAM ST., NEW YORK 7, N. Y.  
IN CANADA THE AHEARN & SOPER CO. LTD. OTTAWA



**Top Value**  
in **TV**  
**Towers**

# Easy-Up

## MODEL 300 "ROTA-TOWER"

- ★ Strong steel tube construction, all-electrically welded
- ★ Multiple cross-braces—90 in each 10 foot section
- ★ Saves many man-hours. Shipped pre-assembled—only 5 minutes to complete
- ★ Entire assembly hot-dip galvanized
- ★ Rotatable 360° to orient antenna after installation
- ★ Built-in ladder—safe to climb
- ★ Light—less than 1½ lbs. per foot of height
- ★ Quiet in the wind—all rounded surfaces
- ★ Hinged base—fits peaked or flat roof—tip up from any of four directions
- ★ Neat, trim, unobtrusive
- ★ Wide choice of heights
- ★ Minimum guy support needed

ONLY \$64<sup>50</sup> LIST for basic 30-ft. model complete

Actual photo of Easy-Up "Rota-Tower" with two extensions, elevating stacked Amphenol antenna and Alliance rotator 50 ft. above 30 ft. rooftop.

Also, extra-heavy-duty square and triangular towers for heights to 100 feet.

Easy-Up Tower is a quality product through and through... Built to make your installation job just as simple as possible... Your most economical way to elevate TV antennas for clearest reception.

See your jabber, or write

## Easy-Up Tower Co.

3800 KINZIE AVENUE  
RACINE • WISCONSIN

### Circle "X" Antenna Reps

A. deLaski, sales manager for Circle "X" Antenna Corp., div. of Continental Copper & Steel Industries, Inc. has announced that Norman Herman, 55 Lawrence Ave., Roxbury, Mass., and Herman Lewis, 1622 68 Ave., Phila., Pa., have been appointed as manufacturer's representatives.

### In Tele King Sales Post

Edward Berliant, vice-president of the Tele King Corp. of N. J., has announced the appointment of Walter Ferry as sales manager for the company.

### Jewel Names Shurack

A. R. Lieberman, general manager of the Jewel Radio Corp., Long Island City, N. Y., has announced that Irving B. Shurack, Inc., 1133 Broadway, N. Y. C., has been appointed as exclusive factory representative for the metropolitan New York area.

### Jobber Sales Manager

Robert A. Elliot has been appointed to fill the newly created post of jobber sales manager by Standard Coil Products Co., Inc., Chicago, and Bangor, Mich. Elliot will have complete charge of jobber sales, advertising and merchandising for both the domestic and foreign markets.

### News of the "Reps"

Jerome J. Golten, owner of Jerry Golten Co., 2750 W. North Ave., Chicago 47, has been elected to senior membership in the Chicagoland Chapter for 1950.

James D. McDonough, who is a partner with Ed Metzger in the Memac Sales Co., 9 South Clinton St., Chicago 6, has also been elected to senior membership.

Dudley Alfred Hansen, a partner in the Lund-Hansen Co., 1900 West Montrose, Chicago 13, was elected to associate membership in the Chicagoland Chapter.

### Eureka Representative

The Eureka Television & Tube Corp., Hawthorne, N. J., announces through Tom Stave, general sales manager, the appointment of J. R. Dannemiller Associates as sales representatives for the state of Ohio. J. R. Dannemiller Associates is located at 4334 Groveland Road, Cleveland 18, Ohio.

### New Book on Fringe

"Better TV Reception in Fringe and Low-Signal Areas" is the title of a new book published by Editors and Engineers, Ltd., 1300 Kenwood Rd., Santa Barbara, Calif. The book was written by W. W. Smith, author of the "Antenna Manual," and R. L. Dawley, editor of the "Radio Handbook." The 141-page, soft-cover volume is illustrated with photos, sketches and schematics. Lists for \$2.50 (\$2.60 by mail from Calif.). Discounts available on quality orders.

"HAVE YOU HEARD THE SOUND OF QUALITY?"



### NEWCOMB SOUND IS BETTER

- Manufacturers of public address, mobile, phonograph, musical instrument and wired music amplifiers • Portable systems • Portable phonographs and radios • Transcription players • Rack and panel equipment.
- Write today! Circle items of interest and indicate whether you are a Dealer, Parts Jobber or Sound Specialist.

NEWCOMB AUDIO PRODUCTS CO.  
DEPT. A, 6824 LEXINGTON AVE.  
HOLLYWOOD 38, CALIFORNIA

**Portable TRI-TUBE Antenna MASTS**

**TELEVISION FM • AMATEUR COMMERCIAL**

LOW COST  
•  
LIGHT  
•  
QUICK  
•  
EASY

Mast section is triangular in construction using 1" ID steel tubing with proper bracing, all electric welding. Lower unit is 20 ft. long hinged on frame with locking device. Levelling device compensates for position of vehicle on any test location. Upper unit is a smaller triangle and telescopes into lower unit on rollers, which allow smoother operation. Cable and drum provided with pin assembly for safety and locking into any height. Antenna mast can be set up by two men in a few moments... NO GUYS - NO WRENCHES - NO BOLTS All bolts have 'T' handles. Demountable by removing two bolts in four minutes. Aluminum painted ready to mount.

- #250 Basic Unit Complete 50 ft., 10 ft. pole
- #251 Same as 250-Orientation at Any Height
- #252 Same as 251, with Antenna Height 70 feet  
Dealer & Distributor Inquiries Invited

A. A. PETERS  
**TRI-TUBE MASTS**  
231 N. 7th Allentown Pa.

SHIPPED F. O. B.  
ALLENTOWN, PA.

\$295  
and up



# ADVERTISERS

## August, 1950

Admiral Corp. ....	6	Milner Mfg. Co. ....	100
Air King Products Co., Inc. ....	Cover 2	Motorola, Inc. ....	17-20
Alproco, Inc. ....	96	National Carbon Div., Union Carbide & Carbon Corp. ....	12
American Phenolic Corp. ....	80	National Video Corp. ....	74
American Telephone & Telegraph Co. ....	57	Newcomb Audio Products Co. ....	106
American Television & Radio Co. ....	107	Noblitt Sparks Industries, Inc. (Now Arvin Industries) ....	2, 3, 55
Ampro Corp. ....	99	Permo, Inc. ....	72
Anchor Radio Corp. ....	37-44, Cover 3	Penney Co., C. M. ....	97
Antenna Products ....	98	Peters, A. A. ....	106
Arvin Industries, Inc. ....	2, 3, 55	Philco Corp. ....	5
Astatic Corp. ....	86	Phoenix Electronics, Inc. ....	105
Belmont Radio Corp. ....	25	Radiart Corp. ....	79
Brach Mfg. Corp. ....	95	Radia Corp. of America ....	30,,31, Cover 4
Chisholm-Ryder Co., Inc. ....	104	Radion Corp. ....	87
Clarostat Mfg. Co., Inc. ....	91	Rauland Corp. ....	88
Columbia Records ....	16	Raytheon Mfg. Co. ....	93
Commercial Credit Corp. ....	63	Regency Div., I.D.E.A., Inc. ....	64
Commercial Trades Institute ....	98	Rider Publisher, John F. ....	82, 83
Cornish Wire Co., Inc. ....	98	Scott Radio Labs., Inc. ....	9
DuMont Labs., Inc., Allen B. ....	22, 23	Sentinel Radio Corp. ....	53
Easy-Up Tower Co. ....	106	Sewell, Inc., Norman M. ....	104
Electric Auto-Lite Co. ....	102	Sheldon Electric Co. ....	81
Federal Telephone & Radio Corp. ....	8	Sonic Industries, Inc. ....	96
General Electric Co. ....	7, 10, 11, 14, 15	South River Metal Products Co., Inc. ....	98
General Electronics, Inc. ....	100	Standard Register Co. ....	4
General Industries Co. ....	75	Stromberg-Carlson Co. ....	26
Good, Inc., Don ....	98	Sylvania Electric Products, Inc. ....	77
Hallicrafters ....	103	Taylor Mfg. Co. ....	94
Haugen Mfg. Co. ....	104	Technical Appliance Corp. ....	108
Hotpoint, Inc. ....	61	Television Equipment Corp. ....	105
Hytron Radio & Electronics Corp. ....	71	Tel-O-Tube Sales Corp. ....	73
International Resistance Co. ....	58, 59	Telrex, Inc. ....	76
International Television Corp. ....	98	U. S. Devices Corp. ....	85
Jensen Industries, Inc. ....	70	V-M Corp. ....	94
Jensen Mfg. Co. ....	21	Ward Products Corp. ....	92
JFD Mfg. Co., Inc. ....	101	Webster Chicago ....	24
LaPointe-Plascomold Corp. ....	89	Webster Electric Co. ....	90
Magnavox Co. ....	45	Westinghouse Electric Corp. ....	51
Merit Transformer Corp. ....	80	Wind Turbine Co. ....	102
		Workshop Associates, Inc. ....	84
		Zenith Radio Corp. ....	13

While every precaution is taken to insure accuracy, we cannot guarantee against the possibility of an occasional change or omission in the preparation of this index.

*For AC CURRENT ANYWHERE . . . .*  
**NO MAGIC just use** **ATR** **INVERTERS**



**ATR**  
**STANDARD AND HEAVY DUTY INVERTERS**



**For Inverting D. C. to A. C.**  
 Specially Designed for operating A. C. Radios, Television Sets, Amplifiers, Address Systems, and Radio Test Equipment from D. C. Voltages in Vehicles, Ships, Trains, Planes and in D. C. Districts.

**NEW MODELS** **NEW DESIGNS**  
**NEW LITERATURE**  
 "A" Battery Eliminator, DC-AC Inverters  
 Auto Radio Vibrators  
*See your jobber or write factory*

**ATR**  
**AMERICAN TELEVISION & RADIO CO.**  
*Quality Products Since 1931*  
 SAINT PAUL 1, MINNESOTA-U. S. A.



# SIMPLE!!!

takes 1 second  
to set up!

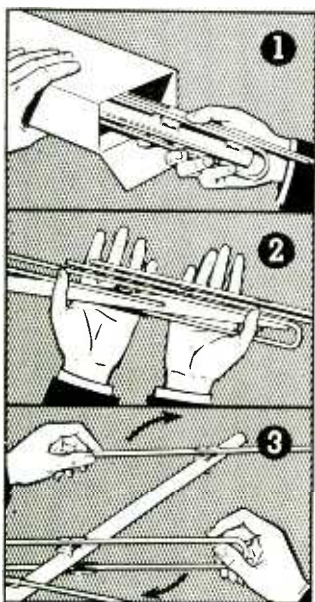

# CLICK-RIG

**NOTHING TO TIGHTEN...  
NOTHING TO LOOSEN!**

*featuring the  
spring-loaded  
action*

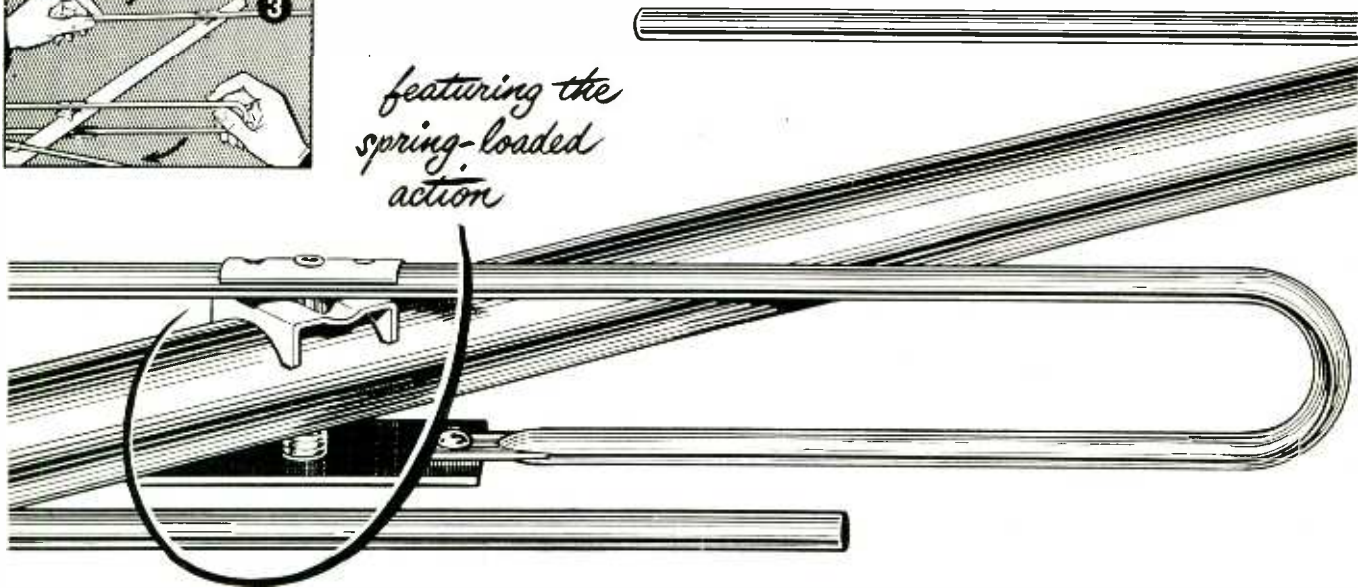

## ANTENNA ASSEMBLES IN 1 SECOND!

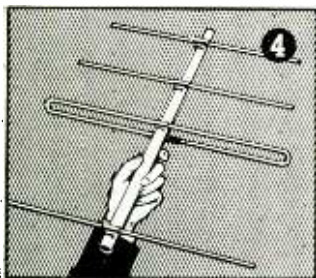

- Costs dollars less than any other antenna to install.
- Can be carried to mast in folded-up condition and opened with one hand in 1 second.
- Guaranteed permanence when installed — no screws or nuts to lose or loosen.
- The combination of Click-Rig construction and the TACO name means electrical and mechanical perfection as it has for the past 17 years.
- **ASK YOUR JOBBER FOR THE BRAND-NEW 1950 TACO CATALOGS**

TV-FM-AM  
ANTENNA SYSTEMS  
TECHNICAL APPLIANCE CORPORATION,  
SHERBURNE, N. Y.

# TACO

IN CANADA:  
STROMBERG-CARLSON  
CO. LTD.  
TORONTO 4, ONT.

***Sure There Are Other Boosters on the Market!***

**BUT... Your fringe area customers will more**

**than THANK**

**YOU**

**for**

**selling**

# ANCHOR

THE  
FINEST TWO-STAGE  
**TV**  
Pre-Amplifier  
EVER MANUFACTURED

List Price

**\$4495**



Only ANCHOR can provide your customers with ALL of the most Ultra-Modern advantages for consistent, top-notch, long-range TV reception. Here's why!

- ANCHOR has the highest gain of any TWO-STAGE BOOSTER.
- ANCHOR has the highest Signal to Noise Ratio.
- ANCHOR is the only non-regenerative unit available. The unit that is not returned.
- ANCHOR'S Single Knob Construction is so convenient, for Booster is turned on and can be switched and tuned all on the same knob.
- ANCHOR'S New and Revolutionary method of construction of the RF Stage (Pat. Pend.) is the only real engineering advance in Boosters in recent years.
- ANCHOR'S TWO-STAGE BOOSTER is modernly styled with streamlined plastic escutcheon, soft mahogany leatherette finish.
- IMPORTANT! ANCHOR'S TWO-STAGE BOOSTER is often the answer to installation difficulties well within the normal TV areas where their New Single Stage Model fails to give complete satisfaction.



ANCHOR'S TWO-STAGE BOOSTERS NOW ROLLING OFF PRODUCTION LINE

Yes, the finest TWO-STAGE Pre-Amplifier is no longer a promise but a reality... and what a reality! When you receive your first order be sure to study the instruction book which accompanies each ANCHOR TWO-STAGE Model ARC-101-100. You Retail Dealers will soon enjoy a tremendous promotional campaign backing all ANCHOR BOOSTERS so be sure YOU know all the answers. We'll send you the customers.

## ANCHOR TIPS



ANCHOR employs a totally new method of construction of the RF Stages in maximum gain with best possible Signal to Noise Ratio. When the noise factor was measured in DB it actually showed up better than the best TV tuner tested at the Hazeltine Laboratories.



Your customers will thank you if you don't make an antenna installation that is too hazardous and costly when you can give them a more satisfactory installation at a profit to yourself with an ANCHOR BOOSTER.

OVER  
**100 MILES**  
CONSISTENT  
TV RECEPTION

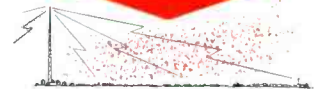

Field tests made by independent service engineers have proven the Anchor Booster can give consistent top-notch TV reception over 100 miles. This is not a possibility but a FACT! This, of course, will extend TV sales to many untapped markets.



ANCHOR ENGINEERING ALWAYS A YEAR AHEAD!

**ANCHOR RADIO CORP.**

2215 SOUTH ST. LOUIS AVENUE

CHICAGO 23, ILLINOIS



**NOW... see how you score on the**

**RCA BATTERY**

**"Get the Facts"  
Quiz**



*The battery for the Radio Trade!*

Try yourself out on these leading questions about RCA Radio Batteries. You'll profit by the answers whether you get a

high score or not...because these are the facts about RCA Radio Batteries every dealer and serviceman should know.

**Official Questions and Answers from the \$10,000 RCA Battery "Get the Facts" Contest (Ended July 10, 1950)**

**1. Of all the radio battery brands sold—which brand is recognized as "The Battery for the Radio Trade"?**

(Answer) RCA.

**2. Why is RCA recognized as "The Battery for the Radio Trade"?**

(Answer) Because RCA sells its batteries to Radio Dealers and Servicemen through Radio-Electronics Distributors.

**3. What sales advantage does RCA's Battery distribution give retailers?**

(Answer) Virtually no RCA Battery competition from non-radio outlets.

**4. How complete is RCA's line of Radio Batteries in terms of consumer needs?**

(Answer) RCA's line covers 99% of today's radio battery demand.



**5. What is the most outstanding Battery in RCA's line?**

(Answer) The RCA-VS036—flashlight-size "A" battery.

**6. Why is the RCA-VS036 an outstanding battery?**

(Answer) Because it contains a Special Radio Mix—is completely Sealed-in-Steel—top, bottom, and sides.

**7. What important advantages does the RCA-VS036 offer retailers?**

(Answer) Sealed-in-Steel construction eliminates shelf-life problems—the battery stays fresh until used.

**8. Why will customers prefer the RCA-VS036?**

(Answer) It's virtually leakproof and, in radio operation, gives more operating hours than competitive flashlight-type batteries.

**9. Is the RCA-VS036 good for Flashlight use?**

(Answer) Yes. It exceeds the U. S. Bureau of Standards Household Flashlight Cell Capacity requirements by nearly 50%.



**10. What RCA "Exclusive" helps you sell the RCA-VS036?**

(Answer) The "Carry Kit" merchandiser—a "carry-away" container that sells batteries like soda pop—eight at a time!

**11. What is your assurance of top quality in RCA Batteries?**

(Answer) Only the finest materials and skilled workmanship go into RCA Batteries. Every cell is aged and individually tested.

**12. How has it been proved that RCA Batteries give extra listening hours?**

(Answer) Exacting laboratory performance tests show that RCA Batteries exceed the average of competitive brands.

**13. What steps are taken to safeguard the quality standard of RCA Batteries?**

(Answer) Constant research, product development, and the continued application of latest production techniques.

**14. Are radio set manufacturers recommending RCA Batteries for their Portables?**

(Answer) Yes—in ever-increasing numbers!

**15. What specialized knowledge does RCA bring to Radio Battery retailers?**

(Answer) RCA—World Leader in Radio—is closer to radio-battery market requirements than any other battery supplier. Such knowledge assures dealers availability of the right types—at the right time—backed by proved radio trade sales programs.

**16. What selling aids does RCA provide?**

(Answer) All types of displays and merchandisers, together with technical literature—the most complete line in the industry—all geared for radio trade use.

**17. What are some RCA "Firsts" in battery sales promotion?**

(Answer) The RCA "Carry Kit," Toy Shipping Container, Basic Sales Aid Kit, and, Radio-gear Sales Aids!

**18. What is your guarantee of high consumer acceptance of RCA Batteries?**

(Answer) Today, as always, the RCA Trade Mark is your assurance of immediate customer acceptance. Consumers everywhere recognize RCA as "the Greatest Name in Radio."

**19. What can radio dealers and servicemen do to prove to themselves that they can sell more RCA Batteries than any other brand?**

(Answer) Starting now—sell RCA Batteries. Watch your business grow!

**See your RCA Battery Distributor for fast, reliable service.**



**RADIO CORPORATION of AMERICA**

**RADIO BATTERIES**

**HARRISON, N. J.**