

MAR 50

RADIO & TELEVISION RETAILING

IN TWO PARTS • PART ONE

MAR 50

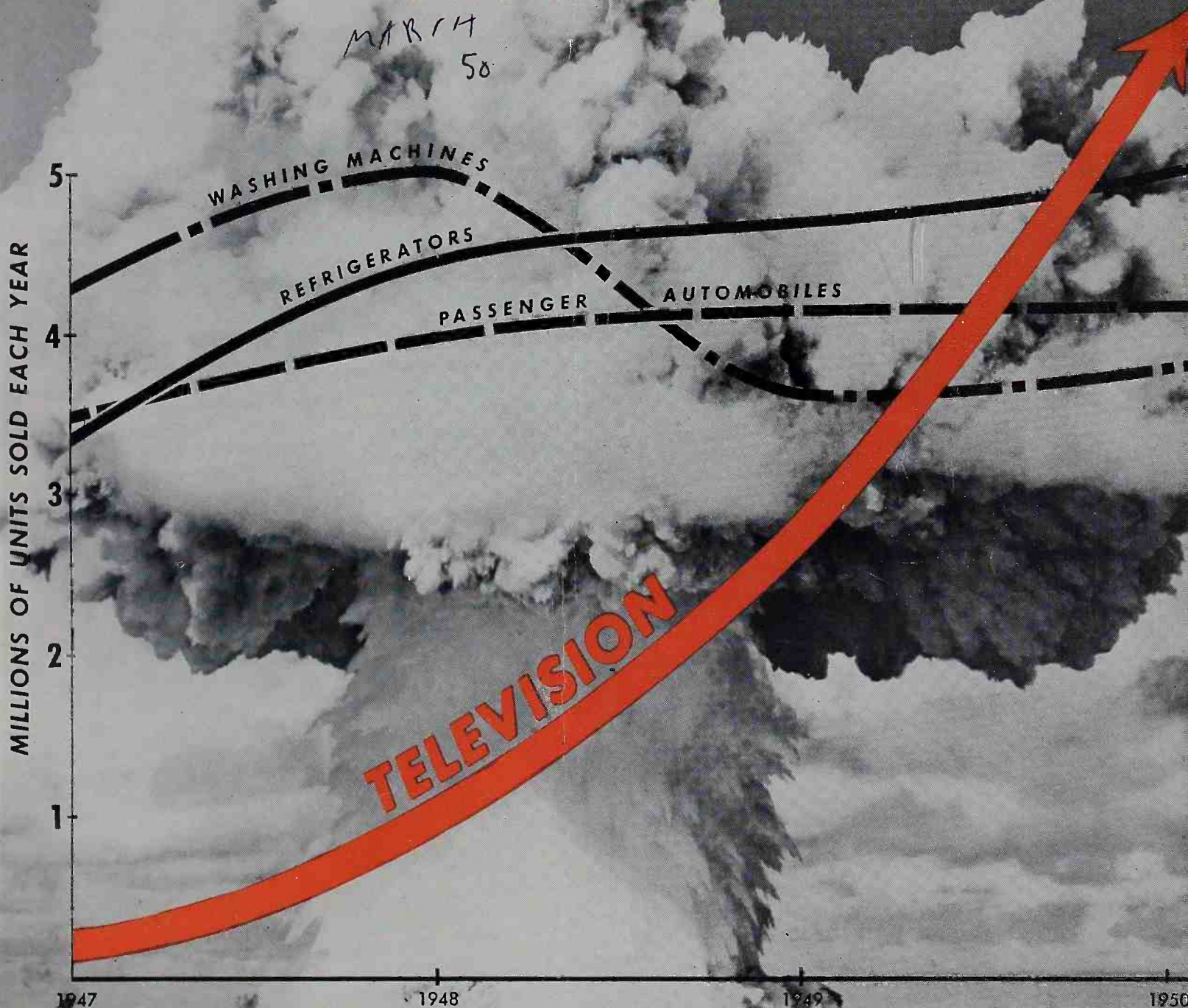

TV—ATOMIC BOMB of 1950 SELLING!

With unparalleled power of expansion, TV sets sold this year will exceed refrigerators, washers, and even automobiles!

March • 1950

CALDWELL-CLEMENTS, INC.

SO EASY



Model 16 C1

TUNE WITH ONE KNOB

Sell a sharper picture,
exactly as telecast, with
the new Soft-lite Full-view

- ★ **16" Rectangular Tube**
- ★ beautiful compact cabinets
- ★ new super-power chassis
(a cinch to service)

\$299⁹⁵

Price slightly higher
West of the Rockies



AIR KING PRODUCTS CO., INC. • 170 - 53rd Street, Brooklyn 32, N. Y.
NATIONAL DISPLAY • 1454 Merchandise Mart, Chicago 54

has everything!

RADIO & TELEVISION RETAILING

IN TWO PARTS—PART TWO, MARCH, 1950 • CALDWELL-CLEMENTS, INC.

March 1950

TELEVISION RECEIVER SPECIFICATIONS

(See bottom of this chart for explanation of symbols)

MAKER'S NAME AND MODEL NUMBER	TUBE SIZE (Inches)	LIST PRICE (Not inc. tax)	TYPE	AM-FM CHANGER	MAKER'S NAME AND MODEL NUMBER	TUBE SIZE (Inches)	LIST PRICE (Not inc. tax)	TYPE	AM-FM CHANGER
Admiral Corp., 3800 Cortlandt St., Chicago 47, Ill. See Advt. PP. 74-75, Part 1.					5018-C	16-0	299.95	C-W	AM
12x12	12 1/2-0	\$179.95	T-P		5060-A	16-0	359.95	C-W	AM
22x12	12 1/2-0	199.95	C-P		5018-C	16-0	459.95	C-W	AM
22x25	12 1/2-0	249.95	C-W		Baco Television Corp., Green & Leuning Sts., S. Hackensack, N. J.				
22x26	12 1/2-0	259.95	C-W		160 TM	16-0	318.00	T-W	
22x27	12 1/2-0	269.95	C-W		160 C	16-0	365.00	C-W	
26x45	16-R	299.95	C-W		18 RCH	16-0	495.00	C-W	
26x46	16-R	309.95	C-W		16 RCC	16-0	590.50	C-W	
26x35	16-0	349.95	C-W		190 C	19-0	485.00	C-W	
26x36	16-0	369.95	C-W		19 RCH	19-0	599.50	C-W	
26x37	16-0	389.95	C-W		19 RCC	19-0	695.00	C-W	
29x15	19-0	495.00	C-W		Bell Television, Inc., 552 W. 53rd St., New York 19, N. Y.				
29x16	19-0	515.00	C-W		19" Remote	19-0	1095.00	T-M	
29x17	19-0	535.00	C-W		18" Remote	18-0	895.00	T-M	
32x15	12 1/2-0	299.95	C-W	AM-RC	19" Club	19-0	695.00	T-W	
32x16	12 1/2-0	319.95	C-W	AM-RC	16" Club	16-0	695.00	T-W	
32x35	12 1/2-0	379.95	C-W	AM-FM-RC	T-16	16-0	399.95	T-W	
32x36	12 1/2-0	399.95	C-W	AM-FM-RC	T-19	19-0	499.95	T-W	
32x26	12 1/2-0	399.95	C-W	AM-FM-RC	DD-16	16-0	449.95	C-W	
32x27	12 1/2-0	419.95	C-W	AM-FM-RC	DD-19	19-0	549.95	C-W	
36x35	16-0	499.95	C-W	AM-FM-RC	TD-16	16-0	499.95	C-W	
36x36	16-0	519.95	C-W	AM-FM-RC	TD-19	19-0	599.95	C-W	
36x37	16-0	539.95	C-W	AM-FM-RC					
39x16	19-0	695.00	C-W	AM-FM-RC	Belmont Radio Corp. (Raytheon), 5921 W. Dickens Ave., Chicago, Ill. See Advt. P. 45, Part 1.				
39x17	19-0	775.00	C-W	AM-FM-RC	M-1101	12 1/2-0	219.95	T-W	
Air King Prods. Co., Inc., 170 53rd St., Brooklyn 32, N. Y. See Advt. Inside Front Cover, Part 1.					M-1106	12 1/2-0	199.95	T-P	
A-711	12 1/2-0	179.95	T-W		M-1107	12 1/2-0	209.95	T-P	
A-712	12 1/2-0	199.95	T-W		C-1102	12 1/2-0	249.95	C-W	
A-2016 R	16-R	299.95	C-W		C-1401	16-R	299.95	C-W	
A-2017-R	16-R	279.95	T-W		C-1802	16-0	329.95	C-W	
A-718-R	16-R	369.95	C-W		Bendix Radio Div. of Bendix Aviation Corp., Baltimore 4, Md.				
A-2014	12 1/2-R	249.95	C-W		2025	12 1/2-0	199.95	T-W	
Andrea Radio Corp., 27-01 Bridge Plaza No., Long Island City 1, N. Y. See Advt. P. 4, Part 1.					3033	12 1/2-0	239.95	C-W	
SARATOGA	12 1/2-0	\$349.95	T-W	AM-FM	6002	16-0	299.95	C-W	
SHARRON	12 1/2-0	349.95	T-W	AM-FM	Berger Communications, 109-01 72nd Rd., Forest Hills, L. I., N. Y. PHY1000	3-0			AM-FM-RC
GRAMERCY	12 1/2-0	399.50	C-W	AM-FM		3"x4"-X			
CARONIA	15-0	795.00	C-W	AM-FM-RC	Brunswick Div., Radio & Television, Inc., 244 Madison Ave., New York 16, N. Y.				
NORMANDY	19-0	649.50	C-W	AM-FM	512	12 1/2-0	179.95	T-W	
Ansley Radio & Television, Inc., 41 St. Joe's Ave., Trenton 9, N. J.					513	12 1/2-0	189.95	T-W	
CROYDEN	16-0	445.00	C-W		5125	12 1/2-0	219.95	C-W	
HAMPSHIRE	16-0	495.00	C-W		6165	16-0	289.95	C-W	
HAMPSHIRE	19-0	565.00	C-W		Capehart-Farnsworth Corp., 3700 Pontiac St., Fort Wayne 1, Ind. See Advt. P. 28, Part 1.				
CAMBRIDGE	16-0	795.00	C-W	AM-FM-RC	3001-M	12 1/2	269.50	T-W	
GAINSBOROUGH	19-0	1195.00	C-W	AM-FM-RC	3001-B	12 1/2	279.50	T-W	
Atwater Television Co., 360 Furman St., Brooklyn, N. Y.					3002-M	12 1/2	299.50	C-W	
351	12 1/2	199.95	T-W	FM	3002-B	12 1/2	309.50	C-W	
513	16	349.95	C-W	FM	3004-M	12 1/2	489.50	C-W	AM-FM
135	19	469.95	C-W	FM	3006-M	18	589.50	C-W	AM-FM
153	16	299.95	C-W	FM	3007-M	16	399.50	C-W	
Automatic Radio Mfg. Co., Inc., 122 Brookline Ave., Boston 15, Mass. See Advt. P. 29, Part 1.					3007-B	16	409.50	C-W	
709	7-0	119.95	T-W	AM	4001-M	12 1/2	639.50	C-W	AM-FM-RC
707	7-0	129.95	T-W	AM	504P18	16	795.00	C-W	AM-FM-RC
711	7-0	129.95	T-W	AM	Cascade Television Co., 179-181 South St., Newark, N. J.				
710	7-0	149.95	C-W	AM	LD118	18-0	399.00	C-W	
712	7-0	159.95	C-W	AM	LD145	18-0	359.00	T-W	
P490	7-0	139.95	T-L	AM	LD119	19-0	745.00	CO	
5000-X	12 1/2-0	179.95	T-W	AM	F38-4x3	6-X	1695.00	CO	
5002-T	12 1/2-0	199.95	T-W	AM	Certified Radio Labs., 5507 13th Ave., Brooklyn 19, N. Y.				
5012-C	12 1/2-0	239.95	T-W	AM	508	8 1/2	59.50	K**	
5006-T	16-0	269.95	C-W	AM					

(Continued on following page)

AM—AM
C—Console
CH—Chassis

CO—Commercial
FM—FM
K—Kit

K**—Kit, less tubes
L—Leathorette
M—Metal

O—Round
P—Plastic
R—Rectangular

RC—Changer
T—Table
W—Wood

X—Projection
* Available in blonde finish at slightly higher price.

Note: Basic list prices are shown. In some instances, prices are slightly higher in certain localities.

Note: Prices shown are those received up to February 20, 1950

MAKER'S NAME AND MODEL NUMBER	TUBE SIZE (Inches)	LIST PRICE (Not inc. tax)	TYPE	AM-FM CHANGER	MAKER'S NAME AND MODEL NUMBER	TUBE SIZE (Inches)	LIST PRICE (Not inc. tax)	TYPE	AM-FM CHANGER
(Continued from preceding page)									
2050	10, 12 1/2				731	12 1/2	259.95	C-W	
2050-10	16, 19	84.50	K**		740	12 1/2	279.95	C-W	
2050-12	10	129.50	K		741	12 1/2	289.95	C-W	
2050-16	12 1/2	137.50	K		745	16	279.95	T-W	
2050-19	16	167.50	K		750	16	329.95	C-W	
2050-10C	19	197.50	K		751	16	339.95	C-W	
2050-12C	10	149.50	CH		760	16	359.95	C-W	
2050-16C	12	157.50	CH		761	16	369.95	C-W	
2050-19C	16	177.50	CH		770	16	399.95	C-W	
Conrac, Inc., Glendora, Calif.					Hoffman Radio Corp., 3761 S. Hill St., Los Angeles 7, Calif.				
536	16-0	365.00	C-W		620	12 1/2	239.95	T-W	
520	12-0	290.00	C-W		621	12 1/2	229.95	T-W	
Crosley Div., Avco Mfg. Corp., 1329 Arlington St., Cincinnati 25, Ohio					622	12 1/2	299.95	T-W	AM-FM
10-401	10	169.95	T		623	12 1/2	289.95	T-W	AM-FM
10-404MU	12 1/2	239.95	T		841	12 1/2	309.50	C-W	
10-412MU	12 1/2	329.95	C		842	12 1/2	299.50	C-W	
10-414MU	16	499.95	C		843	12 1/2	309.50	C-W	
10-416MU	16	379.95	C		847	16	379.50	C-W	
10-418MU	12 1/2	289.95	C		848	16	369.50	C-W	
DeWald Radio Mfg. Corp., 35-15 37 Ave., Long Island City, N. Y.					849	16	379.50	C-W	
See Advt. P. 111, Part 1.					850	16	450.00	C-W	
DT-1020	10-0	199.95	T-W		851	16	450.00	C-W	
DT-1030	10-0	209.95	T-W		852	16	450.00	C-W	
DT-122	12 1/2-0	239.95	T-W		856	19	550.00	C-W	
DT-162	16-0	299.95	T-W		857	19	550.00	C-W	
DT-163	16-0	339.00	C-W		858	19	550.00	C-W	
DT-190	19-0	399.95	C-W		930	12 1/2	459.50	C-W	AM-FM-RC
Allen B. Du Mont Labs., Inc., 35 Market St., East Paterson, N. J.					931	12 1/2	459.50	C-W	AM-FM-RC
See Advt. P. 49, Part 1.					932	12 1/2	459.50	C-W	AM-FM-RC
BRADFORD	19-0	725.00*	C-W	FM-RC	936	16	550.00	C-W	AM-FM-RC
MANSFIELD	19-0	645.00*	C-W	FM	937	16	550.00	C-W	AM-FM-RC
WELLINGTON	15-0	645.00*	C-W	AM-FM-RC	938	16	550.00	C-W	AM-FM-RC
WESTWOOD	19-0	545.00*	C-W	FM	International Television Corp., 238 William St., New York 7, N. Y.				
FAIRFIELD	19-0	495.00*	C-W	FM	D-16	16-0	289.95	C-W	
HASTINGS	15-0	425.00*	T-W	FM	T-16-019S	16-0	249.95	T-W	
CANTERBURY	12 1/2-0	379.50*	C-W	FM	D16-019S	16-0	279.95	C-W	
RUMSON	12 1/2-0	329.50*	T-W	FM	D19-HD	19-0	499.95	C-W	
Emerson Radio & Phonograph Corp., 111 8th Ave., New York 11, N. Y.					D19-FD	19-0	499.95	C-W	
See Advt. P. 72, Part 1.					REX-019FDB	16-0	299.95	C-W	
648	10-R	179.95	T-P		REX-019FDM	16-0	299.95	C-W	
650	12 1/2-R	229.50	T-W		D-16HD	16-0	359.95	C-W	
654	12 1/2-R	249.50	C-W		D-16FD	16-0	359.95	C-W	
651	16-R	289.50	T-W		Jackson Industries, Inc., 58 E. Cullerton St., Chicago 16, Ill.				
629	16-R	329.50	C-W		See Advt. P. 106, Part 1.				
649	235-X	329.50	C-W		10T	10-0	139.95	T-W	
Espy Mfg. Co., 528 E. 72nd St., New York 21, N. Y.					12T	12-0	159.95	T-W	
TV3K	3-0	69.50	K-T		16T	16-R	199.95	T-W	
Fada Radio & Electric Co., Inc., 525 Main St., Belleville, New Jersey					12C	12-0	199.95	C-W	
See Advt. PP. 26-27, Part 1.					16C	16-R	249.95	C-W	
R-1045	12 1/2-0	269.95	T-W		312	12-0	299.95	C-W	AM-RC
R-1025	16-0	364.95	C-W		316	16-R	349.95	C-W	AM-RC
S-1015	12 1/2-0	199.95	T-W		412	12-0	349.95	C-W	AM-FM-RC
S-1020	12 1/2-0	239.95	C-W		416	16-R	399.95	C-W	AM-FM-RC
R-1050	16-0	329.95	T-W		22T	12-0	219.95	T-W	
S-1030	12 1/2-0	209.95	T-W		26T	16-R	269.95	T-W	
Federal Television Corp., 139 Duane St., New York 13, N. Y.					22C	12-0	249.95	C-W	
MOHAWK	16-0	\$359.50	T-W		26C	16-R	299.95	C-W	
PACEMAKER	16-0	399.50	C-W		29C	19-0	399.95	C-W	
COMMODORE	16-0	499.50	C-W	AM-FM-	512	12-0	449.95	C-W	AM-FM-RC
1632	16-0	499.50	C-W		516	16-R	499.95	C-W	AM-FM-RC
1932	19-0	599.50	C-W		Jamaica Television Mfg. Co., 95-26 Sutphin Blvd., Jamaica, L. I., N. Y.				
FLEETWOOD	16-0	795.00	C-W	AM-FM-RC	TELCO	12 1/2-0	169.50	T	
WALDORF	16-0	695.00	C-W	AM-FM-RC	TELCO	16-0	199.50	T	
MAYFAIR	16-0	649.00	C-W	AM-FM-RC	MERLIN (a)	16-R	189.50	T	
MANHATTAN	16-0	379.00	T-W	FM	MERLIN (b)	16-0	269.50	C	
NEW YORKER	12 1/2-0	299.00	T-W	FM	MERLIN (100)	19-0	389.50	C	
BARCLAY	12 1/2-0	695.00	C-W	AM-FM-RC	Magnavox Co., The, 2131 Bueter Rd., Fort Wayne, Ind.				
Freed Radio Corp., 200 Hudson St., New York 13, N. Y.					See Advt. P. 17, Part 1.				
65	16-0	429.50	C		MV 11A	12 1/2-0	249.50	T	
66	16-0	449.50	C-W		MV 27C	16-0	315.00	T	
64	16-0	449.50	C-W		MV 22C	16-0	495.00	C	
68	16-0	479.50	C-W		MV 19C	16-0	495.00	C	
Garod Electronics Corp., 70 Washington St., Brooklyn 1, N. Y.					MV 62C	16-0	995.00	C	AM-FM-RC
1671	16	279.95	T-W		MV 72A	12 1/2-0	469.50	C	AM-FM-RC
1672	16	339.95	C-W		MV 75C	16-0	595.00	C	AM-FM-RC
1673	16	369.95	C-W		MV 26C	16-0	339.50	C	
1674	16	379.95	C-W		MV 23A	12 1/2-0	299.50	C	
1675	16	410.00	C-W		MV 64C	16-0	795.00	C	AM-FM-RC
1974	19	489.95	C-W		MV 67C	16-0	795.00	C	AM-FM-RC
1975	19	520.00	C-W		MV 74	12 1/2-0	439.50	C	AM-FM-RC
General Electric Co., Electronics Park, Syracuse, N. Y.					Majestic Radio & Television Corp., 70 Washington St., Brooklyn 1, N. Y.				
See Advt. P. 11, Part 1.					12T2	12 1/2	199.95	T-W	
10T6	10-0	179.95	T-P		12C4	12 1/2	249.95	C-W	
12T3	12 1/2-0	229.95	T-W		16T2	16	269.95	T-W	
12T4	12 1/2-0	239.95	T-W		16T3	16	289.95	T-W	
12C107	12 1/2-0	279.95	C-W		16C4	16	299.95	C-W	
12C108	12 1/2-0	289.95	C-W		16C5	16	325.00	C-W	
12C109	12 1/2-0	299.95	C-W		19C6	19	449.95	C-W	
16T1	16-R	269.95	T-W		19C7	19	479.95	C-W	
16T2	16-R	279.95	T-W		Marathon Sales Co., 466 W. 42nd St., New York 18, N. Y.				
16C110	16-R	299.95	C-W		NEW YORKER	16-0	349.50	C-W	
16C111	16-R	309.95	C-W		HOLLYWOOD	16-0	395.00	C-W	
16C115	16-R	329.95	C-W		NASSAU	19-0	445.00	C-W	
19C101	19-0	550.00	C-W		CAMBRIDGE	19-0	495.00	C-W	
12T7	12 1/2-0	199.95	T-W		BRIGHTON	16-0	495.00	C-W	
Grem Engineering Co., 208 8th Ave., Brooklyn 15, N. Y.					CLARIDGE	19-0	565.00	C-W	
256-L	16-0		C	AM	Mars Television, Inc., 112-33 Colonial Ave., Corona, N. Y.				
The Hallicrafters Co., 4401 W. 5th Ave., Chicago 24, Ill.					ACADEMY	16-0	399.00	C-W	
See Advt. P. 64, Part 1.					LA SALLE	16-0	495.00	C-W	
715	12	\$179.95	T-P		DARTMOUTH	16-0	1095.00	C-W	AM-FM-RC
730	12 1/2	249.95	C-W		X100	19-0	495.00	C-W	
					X101	19-0	545.00	C-W	
					X102	19-0	545.00	C-W	
					Mattison Television & Radio Corp., 893 Broadway, New York 3, N. Y.				
					CHALLENGER	16-0	299.95	C	

SPECIFICATIONS

**RADIO-TELEVISION
RETAILING**

(Notation of symbols)

MAKER'S NAME AND MODEL NUMBER	TUBE SIZE (Inches)	LIST PRICE (Not inc. tax)	TYPE	AM-FM CHANGER	MAKER'S NAME AND MODEL NUMBER	TUBE SIZE (Inches)	LIST PRICE (Not inc. tax)	TYPE	AM-FM CHANGER
HALLENGER	19-0	449.95	C		Peerless Television & Radio Co., 6508 Euclid Ave., Cleveland, Ohio				
ONTINENTAL	16-0	349.95	C		612	12 1/2	275.00	C-W	
ONTINENTAL	19-0	495.00	C		616	16	325.00	C-W	
EAUMONT	16-0	399.95	C		Philco Corp., Tioga and C Sts., Philadelphia 34, Pa.				
UADRILLE	19-0	595.00	C		1403	12 1/2-0	199.95	T-W	
AROLYN	16-0	479.00	C	RC	1404	12 1/2-0	229.95	T-W	
IKING	12 1/2-0	199.50	T-W		1406	12 1/2-0	249.95	T-W	
IPLOMAT	16-R	289.50	T-W		1404C	12 1/2-0	259.95	C-W	
Industries, John, Inc., Plymouth, Indt. P. 24, Part 1.					1406C	12 1/2-0	279.95	C-W	
N	10-0	139.90	T-W		1432C	12 1/2-0	299.95	C-W	
NA	10-0	149.90	T-W		1476W	12 1/2-0	399.95	C-W	AM-FM-RC
O	12 1/2-0	179.90	T-W		1476M	12 1/2-0	429.95	C-W	AM-FM-RC
OA	12 1/2-0	189.90	T-W		1484	12 1/2-0	479.95	C-W	AM-FM-RC
QA	12 1/2-0	219.90	T-W		1600	16-0	299.95	T-W	
QR	12 1/2-0	239.90	T-W	AM	1632	16-0	349.95	C-W	
TA	16-0	249.90	T-W		1633	16-0	379.95	C-W	
TR	16-0	269.90	T-W	AM	1443	12-0	369.95	C-W	
RA	12 1/2-0	259.90	C-W		Pilot Radio Corp., 3706 36th St., Long Island City, N. Y.				
RPS	12 1/2-0	299.90	C-W	AM-RC	123	12 1/2-0	269.95	T-W	FM
RPT	12 1/2-0	319.90	C-W	AM-RC	124	12 1/2-0	279.95	T-W	FM
SA	16-0	299.90	C-W		125	12 1/2-0	239.50	T-W	FM
SPS	16-0	339.90	C-W	AM-RC	161	16-0	319.50	T-W	FM
SPT	16-0	359.90	C-W	AM-RC	126		249.50	T-W	FM
ola, Inc., 4545 Augusta Blvd., Chicago 51, Ill.					RCA Victor Division, Radio Corporation of America, Camden, N. J.				
dv. PP. 18-19, Part 1.					See Advt. P. 36, 37, Part 1.				
L1	8 1/2-0	149.95	T-L		T100	10-0	169.95	T-M	
T1	8 1/2-0	139.95	T-P		T120	12 1/2-0	229.95	T-M	
OT2	10-0	169.95	T-W		TC124	12 1/2-0	279.95*	C-W	
2T2	12 1/2-0	189.95	T-W		TC125	12 1/2-0	279.95*	C-W	
2T1	12 1/2-0	219.95	T-W		TC127	12 1/2-0	299.95*	C-W	
2T1B	12 1/2-0	229.95	T-W		TA128	12 1/2-0	439.50*	C-W	AM-FM-RC
6T1	16-R	269.95	T-W		TA129	12 1/2-0	495.00*	C-W	AM-FM-RC
6T1B	16-R	279.95	T-W		T164	16-0	299.95*	T-W	
2K1	12 1/2-0	249.95	C-W		TC165	16-0	349.50*	C-W	
2K1B	12 1/2-0	259.95	C-W		TC166	16-0	369.50*	C-W	
2K2	12 1/2-0	269.95	C-W		TC167	16-0	399.50*	C-W	
2K2B	12 1/2-0	279.95	C-W		TC168	16-0	435.00*	C-W	
6K2	16-0	299.95	C-W		TA169	16-0	650.00*	C-W	AM-FM-RC
6K2B	16-0	309.95	C-W		S1000	16-0	795.00	C-W	AM-FM-RC
9K1	19-0	525.00	C-W		Reeves Soundcraft Corp., 35-54 36th St., Long Island City, N. Y.				
6F1	16-R	399.95	C-W	AM-FM-RC	AR-100	3x4-6x8X	1995.00	CO	
6F1B	16-R	419.95	C-W	AM-FM-RC	AR-200	3x4-6x8X	1195.00	CO	
9F1	19-0	825.00	C-W	AM-FM-RC	Regal Electronics, 603 W. 130th St., New York, N. Y.				
9F1B	19-0	850.00	C-W	AM-FM-RC	See Advt. P. 13, Part 1.				
ple Television Mfg. Co., 987 German Ave., Brooklyn 8, N. Y.					1207	12 1/2-0	197.50	T-W	
FM1600	16-0	349.50	T-W		1208	12 1/2-0	229.50	C	
600-C	16-0	369.50	C-W		1607	16-0	249.50	T	
660-C	16-0	395.00	C-W		1230	12 1/2-0	290.50	T	
900-C	19-0	445.00	C-W		16T31	16-0	329.50	T	
990-C	19-0	495.00	C-W		16T36	16-0	376.50	T	AM-FM
600-R	16-0	495.00	CO		CD31	16-0	360.50	C	
900-R	19-0	545.00	CO		CD36	16-0	415.50	C	AM-FM
nal Company, Inc., 61 Sherman Maiden 48, Mass.					Remington Radio Corp., 80 Main St., White Plains, N. Y. (Rembrandt)				
M	7-0	89.95	T-M		1606	12 1/2-0	339.00	C-W	FM
W	7-0	99.95	T-W		1606-15	16-0	429.00	C-W	FM
OW	10-0	189.95	T-W		1950	12 1/2-0	289.00	T-W	FM
201	12 1/2-0	229.95	T-W		721	16-0	329.00	T-W	FM
226	12 1/2-0	269.95	C-W		130	16-0	429.00	C-W	FM
601	16-R	289.95	T-W		80	12 1/2-0	339.00	C-W	FM
625	16-R	339.95	C-W		NIGHTWATCH	19-0	495.00	C-W	FM
nal-Simplex-Bludworth, Inc., 92 d St., New York 7, N. Y.					Scott Radio Laboratories, Inc., 4541 Ravenswood Ave., Chicago, Ill.				
-10	5-0	1850.00	CO		400	2 1/2-0	495.00	T-W	
en Television Corp., Norwalk, In.					Sentinel Radio Corp., Evanston, Ill.				
620E	16-R	395.00	C		See Advt. P. 6, Part 1.				
620T	16-R	295.00	T-W		414TVM	12 1/2-0	199.95	T-W	
220T	12 1/2-0	239.00	T-W		413TVM	12 1/2-0	229.95	T-W	
ti-Sparks Industries, Inc., Arvin Radio & Television Div., Columbus, Indt. P. 20, Part 1.					415CVM	12 1/2-0	259.95	C-W	
080T	8 1/2-0	129.50	T-M		416CVM	16-0	349.95	C-W	
100TM	10-0	199.50	T-W		420TVM	16-R	289.95	T-W	
100TB	10-0	209.50	T-W		419CVM	19-R	445.00	C-W	
120CM	12 1/2-0	279.50	C-W		Shevers, Inc., Harold, 33 West 46th St., New York, N. Y.				
120CB	12 1/2-0	299.50	C-W		BRYANT	19-0	359.00*	C-W	
121TM	12 1/2-0	229.50	T-W		BRYANT	16-0	299.00*	C-W	
160CM	16-0	349.50	C-W		CLASSIC	19-0	465.00*	C-W	
pic Radio & Television, Inc., 3401 h Ave., Long Island City 1, N. Y.					CLASSIC	16-0	399.00*	C-W	
dv. P. 62, Part 1.					REGENCY	19-0	465.00*	C-W	
KL-210	12 1/2-0	179.95	T-W		REGENCY	16-0	399.00*	C-W	
KL-211	12 1/2-0	229.95	C-W		TRADITIONAL	19-0	465.00*	C-W	
KL-612	16-0	249.95	T-W		TRADITIONAL	16-0	399.00*	C-W	
KL-613	16-0	279.95	C-W		Sightmaster Corp., 385 North Ave., New Rochelle, N. Y.				
DX-214	12 1/2-0	209.95*	T-W		WESTCHESTER	19-0	465.00	C-W	FM
DX-215	12 1/2-0	289.95*	C-W		ROCHELLE	16-0	339.00	C-W	FM
DX-950	16-0	269.95*	T-W		EMPIRE	16-R	299.00	T-W	
DX-619	16-0	369.95*	C-W		MANHATTAN	12 1/2-0	249.50	T-W	
DX-620	16-0	329.95*	C-W		REMOTE	16-0	350.00	CO	
DX-931	19-0	479.95*	C-W		REMOTE	19-0	550.00	CO	
DX-621	16-0	499.50*	C-W	AM-FM-RC	Snaider Television Corp., 540 Bushwick Ave., Brooklyn, N. Y.				
ard-Bell Co., 12333 W. Olympic d., Los Angeles 64, Calif.					CRUSADER	12 1/2-0	199.50	C	
001	12 1/2-0	199.95	T-W		KNIGHT	16-0-R	279.50	C	
002	12 1/2-0	239.95	C-W		AUDITORIUM	26x20X	995.00	CO	
297	12 1/2-0	299.95	C-W		Sonora Radio & TV Corp., 325 N. Hoyne Ave., Chicago 12, Ill.				
298	12 1/2-0	249.95	T-W		302	12 1/2-0	199.50	T-W	
601	16-0	359.95	C-W		303	12 1/2-0	249.50	C-W	
801	16-R	459.95	C-W	AM-FM-RC	305	16-R	299.50	C-W	

AM—AM
C—Console
CH—Chassis

CO—Commercial
FM—FM
K—Kit

K**—Kit, less tubes
L—Latherette
M—Metal

O—Round
P—Plastic
R—Rectangular

RC—Changer
T—Table
W—Wood

X—Projection
* Available in blonde finish at slightly higher price.

Note: Basic list prices are shown. In some instances, prices are slightly higher in certain localities.

Note: Prices shown are those received up to February 20, 1950

March 1959 TELEVISION RECEIVER SPECIFICATIONS

RADIO-TELEVISION
RETAILING

	MAKER'S NAME AND MODEL NUMBER	TUBE SIZE (Inches)	LIST PRICE (Not inc. tax)	TYPE	AM-FM CHANGER	MAKER'S NAME AND MODEL NUMBER	TUBE SIZE (Inches)	LIST PRICE (Not inc. tax)	TYPE	AM-FM CHANGER
	Sovereign Television Co., 5508 N. Utrecht Ave., Brooklyn 19, N. Y.					301.....	10-0	169.95	T-P	
	5020.....		84.50	K**		305W.....	12 1/2-0	189.95	T-W	
	5020-10.....	10-0	149.50	CH		305M.....	12 1/2-0	189.95	T-W	
	5020-12.....	12-0	157.50	CH		306.....	16-R	249.95	T-W	
	5020-16.....	16-0	177.50	CH		307W.....	16-0	279.95	C-W	
	5020-19.....	19-0	219.50	CH		307M.....	16-0	299.95	C-W	
	Sparton Radio-Television, Jackson, Mich.					Televisa Corp., 1201 44th Ave., Long Island City, N. Y.				
	See Advt. P. 68, Part 1.					EMPRESS.....	16-0	\$299.95*	C-W	
Conr	5002.....	10-0	\$199.95	T-W		ARISTA.....	16-0	279.95*	C-W	
	5003.....	10	204.95	T-W		DUCHESS.....	16-R	229.95*	T-W	
	5006.....	12 1/2	229.95	T-W		Trad Television Corp., Asbury Park, N. J.				
	5007.....	12 1/2	234.95	T-W		P14.....	3x2 1/4X	\$1495.00	CO	FM
Cross	5052.....	12 1/2	299.95	C-W		P13.....	4x3X	1695.00	CO	FM
Ar	5053.....	12 1/2	304.95	C-W		D190.....	19	495.00	CO	FM
	5064.....	16	399.95	C-W		Trans-Vue Corp., 1139 S. Wabash Ave., Chicago 5, Ill.				
	5065.....	16	404.95	C-W		400.....	12 1/2-0	\$269.95	C	
	5068.....	12 1/2	329.95	C-W		601.....	16-0	339.95	C	
	5010.....	10	169.95	T-W		90.....	12 1/2-0	219.95	C	
	5011.....	10	174.95	T-W		610.....	16-0		C	
DeW	5014.....	12 1/2	189.95	T-W		160L.....	16-0	399.95	CO	
Lo	5015.....	12 1/2	194.95	T-W		Trav-Ler Radio Corp., 571 W. Jackson Blvd., Chicago, Ill.				
See	5056.....	12 1/2	249.95	C-W		12L50A.....	12 1/2-0	\$199.95	C-W	
	5057.....	12 1/2	254.95	C-W		16R50A.....	16-R	249.95	C-W	
	Starrett Television Corp., 601 W. 26th St., New York City, N. Y.					16G60A.....	16-R	299.95	C-W	
	See Advt. P. 8, Part 1.					19A60.....	19-0	399.95	C-W	
	NATHAN HALE.....	12 1/2	\$199.95	T-W		12L70A.....	12 1/2-0	299.95	C-W	AM-RC
	SAM HOUSTON.....	12 1/2	279.95	T-W		16G70A.....	16-R	349.95	C-W	AM-RC
	JEFFERSON DAVIS.....	12 1/2	299.95	C-W		TRU-VUE Television Co., 99 Featherbed Lane, Bronx 52, N. Y.				
	HENRY PARKS.....	16	369.95	C-W		16R31.....	16-0	\$319.00	T-W	
	ROBERT E. LEE.....	16	399.95	C-W		16T31.....	16-R	319.00	T-W	
	HENRY HUDSON.....	16	299.95	T-W		16C31.....	16-0	369.00	C-W	
	JAMES MONROE.....	16	479.95	C-W	AM-FM-RC	18D31.....	16-0	399.00	C-W	
	ALEXANDER HAMILTON.....	19	479.95	C-W		19T31.....	19-0	469.00	T-W	
	JOHN HANCOCK.....	16	795.00	C-W	AM-FM-RC	19C31.....	19-0	495.00	C-W	
	CHINESE HANCOCK.....	16	895.00	C-W	AM-FM-RC	16C20.....	16-0	299.00	C-W	
	CLEVELAND.....	16	895.00	C-W	AM-FM-RC	PT38.....	5-0			
	GOTHAM.....	16	1095.00	C-W	AM-FM-RC		8x10X	1295.00	CO	
	LINGOLN.....	16	1095.00	C-W	AM-FM-RC	U. S. Television Mfg. Corp., 3 W. 61st St., New York, N. Y.				
	COSMOPOLITAN.....	16	1295.00	C-W	AM-FM-RC	T10823.....	10-0	\$219.95	T	
	WASHINGTON.....	16	1295.00	C-W	AM-FM-RC	T12925.....	12-0	269.95	T	
	Stewart-Warner Electric Co., 1826 Diverser Parkway, Chicago 14, Ill.					TFM 12925.....	12-0	279.95	T	FM
	See Advt. PP. 22-23, Part 1.					T15925.....	15-0	369.95	T	
	9104-C.....	12 1/2-0	\$299.95	C-W	AM-FM	CFM15925.....	15-0	449.95	C	FM
	9103-C.....	12 1/2-0	269.95	C-W		KRV15932.....	15-0	799.95	C	AM-FM-RC
	9105-A.....	230-X	795.00	C-W	AM-FM-RC	T16030.....	16-0	399.95	T	
	9104-B.....	12 1/2-0	349.95	C-W	AM-FM-RC	T19031.....	19-0	499.95	T	
	9109-B.....	14-R		T-W		CFM16031.....	16-0	469.95	C	FM
	9106-A.....	16-R	279.95	T-W		KFM19032.....	19-0	599.95	C	FM
Espr	9108-A.....	16-R	349.95	C-W	AM-FM	K-30936.....	80x22 1/2-X	1795.00	CO	
Yr	9109-A.....	14-R		C-W		K-25936.....	25x19-X	1595.00	CO	
	9110-A.....	14-R		C-W	AM-FM-RC	KFM30936.....	80x22 1/2-X	1795.00	CO	FM
						KFM25836.....	25x19-X	1695.00	CO	FM
Fadi	Stromberg-Carlson Co., 100 Carlson Road, Rochester, N. Y.					Vidcraft Television Co., 780 E. 137th St., New York 54, N. Y.				
M	See Advt. P. 32, Part 1.									
Sc	TC 19 M5M.....	19-0	\$965.00	C-W	AM-FM-RC					
	TC 19 LM3.....	19-0	645.00	C-W						
	TC 19 LM2.....	19-0	539.50	C-W						
	16 C.....	16-0		C-W						
	16 T.....	16-R		T-W						
	TC 19 LA2.....	19-0	549.50	C-W						
Fedi	TC 125 LSM2.....	12 1/2-0	349.95	C-W						
Sl	TC 125 LA4.....	12 1/2-0	319.95	C-W						
	TC 125 LM3.....	12 1/2-0	299.95	C-W						
	Sylvania Television, Colonial Radio Corp., 1280 Main St., Buffalo 9, N. Y.					Video Corp. of America, 229 W. 28th St., New York, N. Y.				
	See Advt. PP. 30-31, Part 1.					VS-690.....	16-0	\$249.50	T-W	
	177.....	10-0	\$169.95	T-W		VS-690.....	16-0	259.50	T-W	
	125.....	12 1/2-0	199.95	T-W		VS-695.....	16-0	279.50	C-W	
	210.....	12 1/2-0	209.95	T-W		VS-695.....	16-0	299.50	C-W	
	246.....	12 1/2-0	229.95	T-W		VS-696.....	16-0	299.50	C-W	
	114.....	12 1/2-0	249.95	C-W		VS-1625.....	16-0	319.50	C-W	
	245.....	12 1/2-0	269.95	C-W		VS-1625.....	16-0	439.50	C-W	AM-FM-RC
	197.....	12 1/2-0	299.95	C-W		VS-991.....	19-0	465.50	C-W	AM-FM-RC
	247.....	16-0	349.95	C-W		VS-991.....	19-0	399.00	C-W	
Fren	090.....	16-0	379.95	C-W		Westinghouse Electric Corp., Home Radio Division, Sunbury, Pa.				
N	128.....	12 1/2-0	399.95	C-W	AM-FM-RC	See Advt. PP. 14-15, Part 1.				
	Taybarn Equipment Co., 120 Greenwich St., New York, N. Y.					H-617T12.....	12-0	\$229.95	T-W	
						H-610T12.....	12-0	249.95	T-W	
Gar		16-0		C		H-614T12.....	12-0	259.95	T-W	
S		19-0		C		H-618T16.....	16-R	279.95	T-W	
		16-0		C	AM-FM-RC	H-613K16.....	16-0	375.00	C-W	
		19-0		C	AM-FM-RC	H-611C12.....	12-0	419.95	C-W	AM-FM-RC
	Tele King Corp., 601 W. 26th St., New York, N. Y.					H-615C12.....	12-0	429.95	C-W	AM-FM-RC
	See Advt. P. 70, Part 1.					Wilcox-Gay Corp., Charlotte, Mich.				
	T 510.....	10-0	\$159.95	T		O-459B.....	19-0	\$725.00	C-W	AM-FM-RC
	T 812W.....	12 1/2-0	179.95	T		O-459M.....	19-0	695.00	C-W	AM-FM-RC
	T 812M.....	12 1/2-0	189.95	T		O-439M.....	19-0	545.00	C-W	FM
	C 612.....	12 1/2-0	239.95	C		O-446B.....	16-0	509.50	C-W	AM-FM-RC
	T 516.....	16-R	259.95	T		O-446M.....	16-0	499.50	C-W	AM-FM-RC
	C 716X.....	16-0	329.95	C		O-426B.....	16-0	339.50	C-W	
	C 919X.....	19-0	459.95	C		O-426M.....	16-0	329.50	C-W	
	C 416C.....	16-0	499.95	C	AM-FM-RC	O-402B.....	12-0	249.50	C-W	
	Telequip Radio Co., 1901 S. Washtenaw Ave., Chicago 8, Ill.					O-402M.....	12-0	239.50	C-W	
	TS-12.....	12 1/2-0	\$179.95	T-W		O-302M.....	12-0	219.50	T-W	
	TD-112.....	12 1/2-0	199.95	T-W		Zenith Radio Corp., 6001 W. Dickens Ave., Chicago 39, Ill.				
	CD-212.....	12 1/2-0	229.95	C-W		See Advt. PP. 2-3, Part 1.				
	CS-312.....	12 1/2-0	199.95	C-W		G2327.....	12-0	\$219.95	T-L	
	CS-16.....	16-0	269.95	C-W		G2350.....	12-0	269.95	C-W	
	TD-116.....	16-0	259.95	T-W		G2355E.....	12-0	289.95	C-W	
	CD-216.....	16-0	299.95	C-W		G2356R.....	12-0	309.95	C-W	
	TS-316.....	16-0	239.95	T-W		G2438.....	16-0	359.95	C-W	
	TD-416.....	16-R	259.95	T-W		G2439R.....	16-0	399.95	C-W	
	CD-516.....	16-R	299.95	C-W		G2437R.....	16-0	429.95	C-W	
Gr	Tele-Tone Radio Corp., 540 W. 58th St., New York 19, N. Y.					G2437E.....	16-0	439.95	C-W	
B						G3173.....	12-0	449.95	C-W	AM-FM-RC
						G3174R.....	12-0	489.95	C-W	AM-FM-RC
Wh	300.....	10-0	\$129.95	T-P		G3276.....	16-0	599.95	C-W	AM-FM-RC
O						G3275R.....	16-0	625.00	C-W	AM-FM-RC
See										

For Explanation of Symbols, See Front Page and Preceding Page

RADIO & TELEVISION RETAILING

IN THIS ISSUE

MARCH, 1950

PART ONE

★ *AM, FM, Television*

COVER—TV—Atomic Bomb of 1950 Selling!

WHAT'S AHEAD—In Radio, Appliances, Records and Television . . .	33, 34, 35
MERCHANTS UTILIZE MODERN PROMOTION METHODS	38, 39
PRICE-CUTTING LEADS IN SURVEY OF BASIC TRADE EVILS	40, 41
LATEST TELEVISION MODELS	42
NEW TV AND RADIO SETS	44
PROFITABLE TV TRADE-INS	48
REVAMP YOUR SERVICE DEPARTMENT	60, 61
NEW RECORDERS, INTER-COMS, TV AND RADIO PRODUCTS	77

★ *Records, Phonographs, Accessories*

NEW DISC HITS BOOST DEALER PROFITS	50, 51
RECORD INDUSTRY NEWS	76

★ *Electrical Appliances*

WHERE TO GET THOSE REFRIGERATOR PROSPECTS	46
NEW ELECTRICAL APPLIANCES	53, 57

★ *Servicing and Sound*

UNIVERSAL TV SWEEP TRANSFORMER	91
HIGH PASS FILTERS FOR MINIMIZING TV INTERFERENCE	92, 93
TELEVISION TECHNICIAN	96
NEW AIDS TO SERVICERS	98
NEWS OF THE INDUSTRY	Begins on p. 78

Photo Credits

<i>Ewing-Galloway</i>	Cover
<i>Frederic Lewis</i>	54

PART TWO—MARCH 1950 TELEVISION RECEIVER SPECIFICATIONS



CALDWELL-CLEMENTS, INC.
480 LEXINGTON AVE., NEW YORK, N. Y.

Including "Radio & Television" and
"Radio & Television Today"

Established in 1922
as ELECTRICAL RETAILING

•
ORESTES H. CALDWELL
Editorial Director

•
M. CLEMENTS
Publisher

•
JOHN L. STOUTENBURGH
Executive Editor

RUTH MORRIS
Records Editor

EDWARD A. CAMPBELL
Technical Director

CHARLES F. DREYER
Art Director

•
BUSINESS DEPARTMENT

M. H. NEWTON
Sales Manager

HOWARD A. REED
Asst. Sales Mgr.

EDWIN WEISL, JR.
District Manager

A. O'ROURKE
Production Supervisor

N. McALLISTER
Director, Reader Service

•
BRANCH OFFICE
CHICAGO 6

S. M. GASKINS, Western Manager

JOHN ROMANCHAK, District Manager
201 N. Wells St. Randolph 6-9225

•
CIRCULATION DEPARTMENT

B. V. SPINETTA
Circulation Director

•
W. W. SWIGERT
Credit Manager

•
RADIO & TELEVISION RETAILING*

March, 1950, Vol. 51 No. 3. 35 cents a copy. Published monthly by Caldwell-Clements, Inc. Publication Office, 1309 Noble St., Philadelphia 23, Pa. Editorial Advertising and Executive Offices, 480 Lexington Ave., New York 17, N. Y. M. Clements, President; Orestes H. Caldwell, Treasurer. Subscription rates United States and U. S. Possessions, \$2.00 for one year, \$3.00 for two years, \$4.00 for three years. Canada \$3.00 for one year, \$4.00 for two years, \$5.00 for three years. Pan American Countries \$4.00 for one year, \$5.00 for two years, \$6.00 for three years. All other countries \$5.00 for one year, \$7.50 for two years, \$10.00 for three years. Printed in U.S.A. Entered as second class matter February 21, 1949 at the Post Office at Philadelphia Pa., under the act of March 3, 1879.

*Trade-Mark Reg. U. S. Pat. Off.

Copyright 1950 by

CALDWELL-CLEMENTS, Inc.
Publishers also of TELE-TECH

NOW! Another Sensational



only Zenith has
**New "Super-Range"
 Turret Tuning**

Clearer, steadier pictures—with a fraction of the signal strength formerly required! The sturdiest, most expensive tuner in any TV receiver.

Zenith's Amazing New Television

Values **GUARANTEE** You Maximum Television Volume in 1950

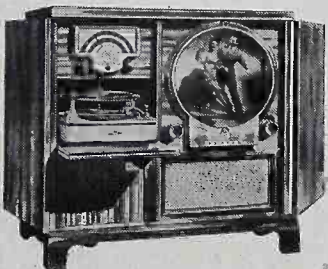

The Washington. Model G3275R. Superb radio-phonograph-television, with 165 sq. inches of picture area. In genuine Mahogany veneers.

\$625.00*



The Jefferson. Model G3276. De Luxe television-radio-phonograph. "Giant C" Giant Circle Screen with "Black" Tube picture. In genuine Walnut veneers.

\$599.95*

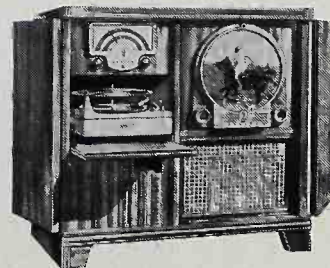

The Madison. Model G3173R. Handsome new combination television-radio-phonograph with "Big B" Giant Circle Screen. Cabinet of genuine Mahogany or Walnut.

\$449.95*

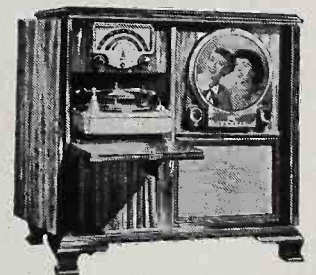

The Van Buren. Model G3174R. New, improved Zenith combination, with "Super-Range" chassis and "Big B" Giant Circle Screen. In genuine Mahogany veneers.

\$489.95*

ZENITH

REG. U.S. PAT. OFF.

FIRST!

to Keep You FIRST in TV Sales!

ZENITH'S NEW 1950 "PRESIDENTIAL" LINE OF *Black Magic Television*

With the Great, New "Super-Range" Chassis!

The most terrific selling story in TV history—that's Zenith's new 1950 line! With both Black Magic Television and the years-ahead, super-powered "Super-Range" chassis, Zenith brings clearer, sharper television to areas where many other sets can't even hold an acceptable picture.

Now you can back up your claims of Zenith superiority with stronger-than-ever, customer-convincing *proof*—proof that stamps Zenith as the far-and-away greatest buy ever offered by any dealer, anywhere. This year, it's Zenith for popular prices . . . better performance . . . bigger profits!

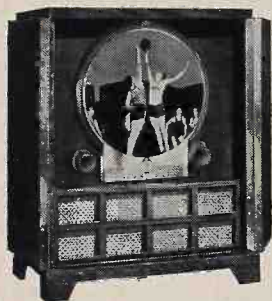

The Jackson. Model G2437R. Beautiful new console in genuine Mahogany veneers. "Giant C" Giant Circle Screen plus all Zenith's great chassis features. **\$429.95***



The Fillmore. Model G2437E. Stunning new style in lustrous blonde-finished cabinet. "Giant C" Giant Circle Screen—165 sq. inches of picture area. **\$439.95***



The Monroe. Model G2439R. New Zenith Console with Glare-Ban "Black" Picture Tube—165 sq. inches of picture area. Gorgeous cabinet of genuine Mahogany veneers. **\$399.95***



The Lincoln. Model G2438R. Zenith's new "Super-Range" chassis with Glare-Ban "Black" Picture Tube in handsome new cabinet of genuine Mahogany or Walnut veneers. 165 sq. inches of picture area. **\$359.95***



The Harrison. Model G2356R. New console brings the utmost in picture quality in a "Big B" Giant Circle Screen. 18th Century cabinet of genuine Mahogany veneers. **\$309.95***



The Tyler. Model G2355E. Greater distance, greater clarity in this striking console with 105 sq. inches of picture area. In handsome blonde finish. **\$289.95***



The Adams. Model G2350R. Choice of genuine Walnut or Mahogany veneers in new Zenith Console. "Big B" Giant Circle Screen. With Blaxide "Black" Picture Tube. **\$269.95***



The Garfield. Model G2327. Popular Table Model in smart, long-wearing Walnut Brown Pyroxylin. "Big B" Giant Circle Screen plus new "Super-Range" chassis. **\$219.95***

*Plus Federal Excise Tax. Prices subject to change without notice. West Coast and Far South prices slightly higher.

Look to Zenith to be FIRST with the Finest in Television!





"It is fitting that on this, my 30th Anniversary in radio and television, the ANDREA engineering organization should present such new picture perfection utilizing the 19-inch "Filtered-Light" tube."

Frank A. D. Andrea

PIONEER FRANK ANDREA PROUDLY PRESENTS

the first of his *30th Anniversary* models ...with the "TRUE-LIFE-SIZE" Picture

ONCE AGAIN ANDREA leads the way with the custom-built *Normandy*, incorporating all the very latest advances in television . . .

206 sq. in. sharp-focus picture, as only ANDREA can bring it out . . . *Picture Lock*, *Touchlight Tuning*, a complete 30-tube chassis and the ANDREA Built-In Antenna . . . FM radio and AM radio, both . . . with a handy record player plug-in.

Everything about the new ANDREA *Normandy* is "sell" . . . from its classic mahogany cabinet to its competitive price tag.



Closed view of the Normandy, showing graceful crotch-center doors of matched mahogany veneers

HAVE YOU SEEN THE ANDREA "PROFIT PLAN"?

It's simple. It's sensible. You'd think a dealer or distributor, himself, wrote it. It's based on the four things you must have to make television profits, steady profits.

1. OUTSTANDINGLY FINE MERCHANDISE
2. EXTRA LIBERAL DISCOUNT
3. ABSOLUTE PRICE PROTECTION
4. POSITIVE FREEDOM FROM EXCESSIVE SERVICE HEADACHES

More and more alert dealers and distributors are finding out it's good to do business with ANDREA . . . and ANDREA stands for good business . . . The ANDREA distributor franchise is available in a few selected territories. Wire or write for full details.

ANDREA

SHARP · FOCUS TELEVISION

The Finest Franchise in Television

ANDREA RADIO CORPORATION • 27-01 BRIDGE PLAZA NORTH • LONG ISLAND CITY 1, N.Y.

from
PHILCO
 for '50



**Greatest Combination
 Refrigerator-Freezer
 Value on the Market**

**With Giant 2 cu. ft. Freezer
 at up to \$100 less than other
 designs in the Industry!**

Here it is . . . the new 1950 Philco 1104 . . . the value sensation of the industry in a big capacity, refrigerator-freezer combination. Not a "10" but a full "11", with a huge 2 cu. ft. built-in freezer that delivers *true zero-zone temperatures* . . . yes, *every* scientifically approved service for long-time storage of up to 70 lbs. of frozen foods. And besides, a big general storage compartment that *solves the problem of excess moisture!*

All this behind ONE CONVENIENT DOOR . . . at a saving of as much as \$100 over other refrigerator-freezer designs!

It's the industry's biggest value . . . your greatest opportunity for volume sales in the higher unit, bigger profit brackets. Get the full story from your Philco distributor.

In addition, Philco Advanced Design for 1950 gives you:

★ **THE QUICK CHILLER** . . . a brand new service that offers the extra sales appeal of *twin horizontal features* in the Deep Cold Zone.

★ **COLD FROM TOP TO BOTTOM** . . . a true full-length refrigerator with extra room for *all kinds of foods* . . . now bigger capacity than ever before in this size cabinet.

★ **FULLY ADJUSTABLE SHELVES** . . . from top to bottom . . . the exclusive Philco feature that creates the most flexible refrigerator ever designed, truly sensational in its appeal to the public.

PHILCO FOR '50 . . . QUALITY FIRST

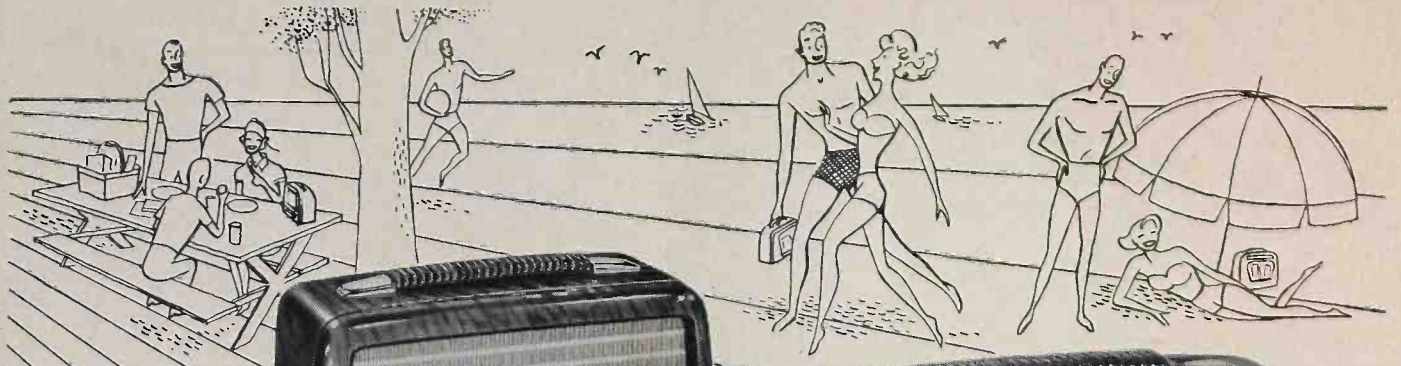

All-around smash hit. Plug-in plus battery. Price that does! Model 335. Four sales compelling colors.

REACH! Here's D-X and clarity that are brand-new in a portable... plus LOOKS, plus PRICE! Three gang-R. F. in two beautiful colors. Model 312.

This is **it** in Portables for '50!

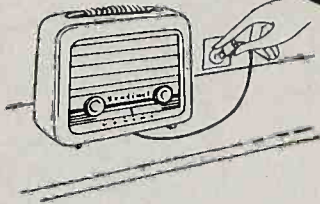

There's a BIG season ahead in portables. And NOW is the time to get ready—to get off to a flying start—with these two new Sentinel honeys. Outstanding in appearance, price *and* performance.

And these two beauties are far ahead of those famous Sentinel sales Sensations of the past.

Get in touch now with your Sentinel Distributor! He has all the story for you on the Sentinel full line of Table Models and Television, too.

look to Sentinel for up-to-the minute fast selling TELEVISION, too

Sentinel

RADIO AND TELEVISION

Evanston, Illinois



"MY BIG SALES ASSET!"

"**W**HAT helps me sell tubes, and the radio-TV service that goes with them, is buyers' preference for the G-E brand." You hear this from pleased servicemen . . . everywhere . . . who are cashing in on the strong trend to General Electric. Good tubes and popular—available in all the types you need, including latest designs—backed by advertising and promotion aids that really pull business *your way* . . . these form a bright sales picture when you feature the G-E line. Build a fast-growing income on your public's faith in the General Electric monogram! Your G-E tube distributor will be glad to help. Phone or write him today! *Electronics Department, General Electric Co., Schenectady 5, N. Y.*

You can put your confidence in—

GENERAL  ELECTRIC

81-JA3

**ONE SOURCE FOR
ALL YOUR TUBE
REQUIREMENTS!**

TV PICTURE TUBES

METAL TUBES

GLASS TYPES

MINIATURES

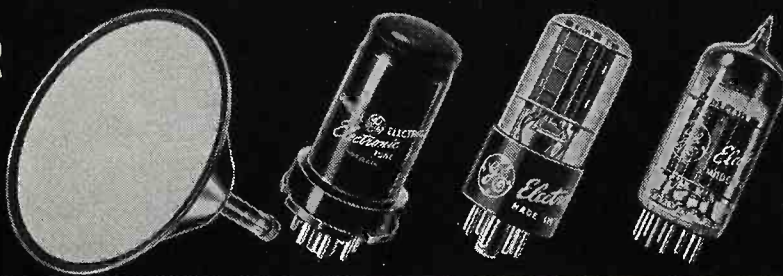

—also GERMANIUM DIODES and SELENIUM RECTIFIERS. Stock G-E 100-percent, to save time and routine in ordering—to have the benefit of bulk deliveries from your distributor—to profit from General Electric tube quality and product popularity.

STARRETT "DOUBLE-FEATURE" PROFIT DEAL!

Starrett



TELEVISION

with scientifically **FILM-FREED*** picture tube and built-in antenna.

QUALITY FEATURES AT EVERY PRICE, AND A PRICE FOR EVERY PURSE—\$199.95 to \$1295.00



THE NATHAN HALE . . .
12 1/2" tube Walnut Table Model.
\$199.95

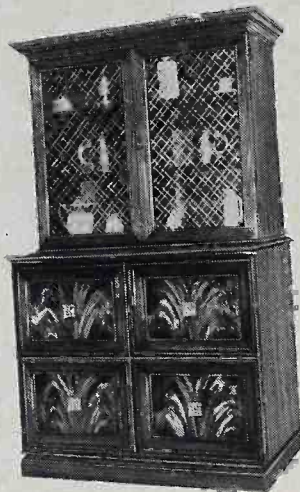

THE COSMOPOLITAN . . .
16" Tube Complete Combination
Breakfront, made of world's finest
woods. \$1295.00

- America's finest receiver housed in the world's finest cabinets.
- Warranted by the only maker to user personal warranty in television.
- Sold only on a direct to selected franchise dealer basis.

DISCOUNTS UP TO 40%

plus special **DEALER BONUS PLAN**, big cooperative advertising allowances, and other profit extras!

*pat. pending

Slightly higher in west

And now... *Starrett* gives you
SUMMER PROFITS
STARRETT FILLS AMERICA'S GREATEST
HOME-APPLIANCE NEED... with the
Revolutionary New **LOWEST PRICED**

Starrett

COOLATRON*

ROOM AIR-CONDITIONERS



Window and Console Models \$239 retail
priced from as low as . . .

COOLS • FILTERS • CIRCULATES
DE-HUMIDIFIES • VENTILATES • DE-ODORIZES

- WITH EXCLUSIVE FEATURES NO OTHER AIR-CONDITIONER HAS EVER ACHIEVED!
- BUILT-IN DE-FUMIDOR!
- COOL EFFICIENT ANGLE GIVES 54% MORE COOLING AREA!
- EXCLUSIVE "VISIBLE FILTER"!
- TAKES LESS ROOM SPACE THAN ANY OTHER UNIT!

*Pat. Pend.

Slightly higher in west

*T.M.

STARRETT TELEVISION CORP.

601 WEST 26th STREET, NEW YORK 1, N. Y.

"Recorders will SELL in 1950"

— SAY NATIONAL AUTHORITIES

Yes, the clipping on the right (from *Radio & Television Retailing*, January, 1950) tells the story. Read it—and get ready to cash in!

RECORDERS

Watch this new business! **RADIO & TELEVISION RETAILING** predicts that 400,000 recorders of all types, disc, wire and tape, will be sold in 1950. Principal markets now are: (1) Commercial, including broadcasting. (2) Home use by musicians, singers, music lovers, public speakers, authors and hobbyists.

...and here is a new set designed and priced to meet the demand!



\$59⁹⁵

(East of the Rockies)



This new luggage case in modern design, beautifully complemented with a rich maroon and gold escutcheon, is without parallel in the portable recorder field. Crystal microphone included.

weighs less than 20 pounds

WILCOX-GAY RECORDETTÉ SR.

the Sensational new
recording radio-phonograph

● Get your share of profitable home recording sales—with the most amazing instrument in home recording history. It's the handsome new WILCOX-GAY Recordette, Sr. Easy to operate, easy to demonstrate—and so easy to SELL!

No bothersome needle changes! You make a record from microphone or radio by raising the tone-arm. To play the record back, just lower the tone-arm—and the play-back needle is automatically in place.

But that isn't all. For only \$59.95, WILCOX-GAY also includes a powerful superheterodyne radio. And a phonograph that plays all 78-rpm records up to 12 inches!

So get into the home recording business—FAST! Ask your distributor to show you the WILCOX-GAY Recordette, Sr.,... or write directly to

WILCOX-GAY CORPORATION ● CHARLOTTE, MICHIGAN

ANOTHER **HYTRON FIRST** YOU'LL BE BUYING SOON



new HYTRON 12BH7

does more for less

- Ideal Sweep Amplifier
- Higher-Perveance Twin Triode
- Designed for TV
- Permits Lower-Cost TV Sets
- Another Hytron TV First

Here's another Hytron original you'll be buying soon. New 12BH7 twin triode is enthusiastically hailed as tops for sweep circuits by leading makers of TV sets. One half 12BH7 sweeps wide-angle 16-inch picture tube at 14 kilovolts. One section alone matches performance of: Paralleled 6SN7GT. Or equivalent single triode. Or triode-connected beam pentode. Other half of 12BH7 is free for other uses—such as blocking oscillator.

How does Hytron do it? Higher perveance (lower tube loss)? Yes. Also the Hytron 12BH7 is: designed for TV. Rated for TV. Tested for TV. Again a Hytron TV first. Again a Hytron contribution to lower-cost TV for the mass market. Watch for the 12BH7. Write for Bulletin E-149.

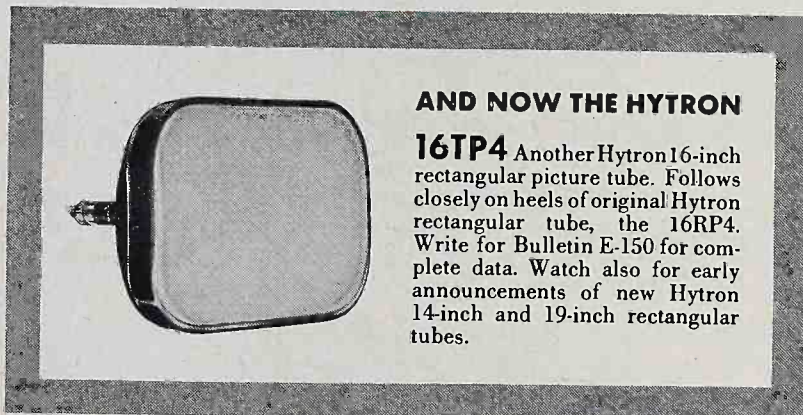

AND NOW THE HYTRON

16TP4 Another Hytron 16-inch rectangular picture tube. Follows closely on heels of original Hytron rectangular tube, the 16RP4. Write for Bulletin E-150 for complete data. Watch also for early announcements of new Hytron 14-inch and 19-inch rectangular tubes.

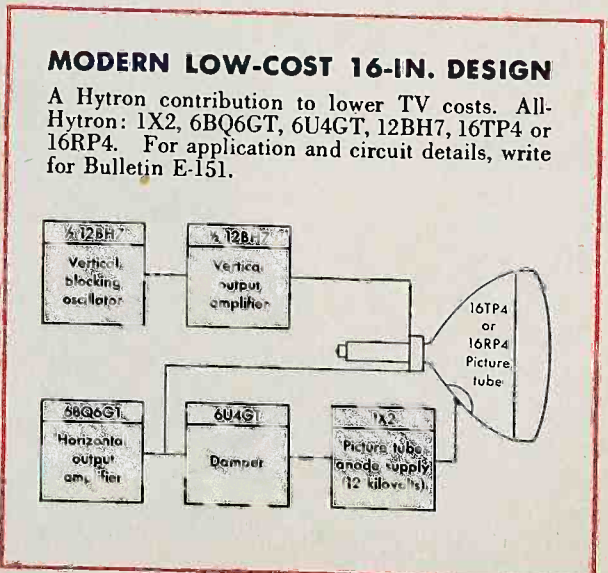

OLDEST MANUFACTURER OF RECEIVING TUBES
HYTRON
RADIO AND ELECTRONICS CO. INC.



MAIN OFFICE: SALEM, MASSACHUSETTS

ACCLAIMED!

Finest TV

TO SEE!

TO SELL!



**BLACK-DAYLIGHT
TELEVISION**

ORDINARY TV—
Limited range
of picture tones



G-E TV—
Widest range of picture tones

Model 12C109—12½" tube. Built-in antenna. Automatic Sound—just tune picture, sound is right every time. Genuine mahogany veneered console. Smartly styled doors, swivel casters—easy to turn. Approved by Underwriters' Laboratories. **\$299.95***

Overnight—

THE INDUSTRY SALES SENSATION!

DEALERS everywhere report sizzling sales of sensational new G-E Black-Daylight TV. In store after store dramatic side-by-side comparisons are *proving* that these G-E Black-Daylight TV models offer the finest picture to sell because it's finest to see! Blacker blacks, whiter whites, sharper contrast, more detail . . . all made possible by 140% greater range of picture tones than ordinary TV—proved in every test on these models. All this plus freedom from annoying glare and reflection adds up to the greatest eye comfort ever achieved in TV. Ask your General Electric TV distributor for the whole wonderful story or write General Electric Company, Syracuse, New York.



Model 12T3—12½" table model of genuine, matched mahogany veneers with genuine inlaid trim found only in much more expensive cabinets! Built-in antenna, Automatic Sound. Underwriters' Laboratories approved. **\$229.95***



Model 12C107—12½" tube. Built-in antenna. Automatic Sound. Stunning, full height console, veneered in genuine mahogany. Swivel casters. Approved by Underwriters' Laboratories. **\$279.95***

*In East. Subject to change without notice. Plus tax, installation and picture tube protection plan.

You can put your confidence in—

GENERAL  **ELECTRIC**

WEBSTER-CHICAGO DOES IT AGAIN!

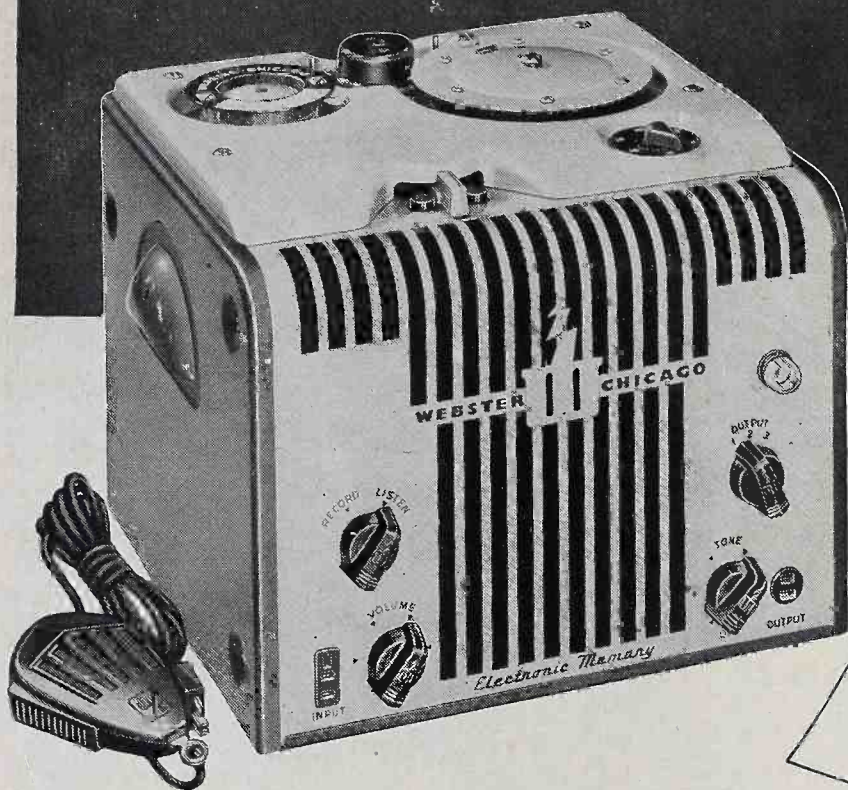

\$98.50

A new, low price on one of the most popular wire recorders on the market, the famous Studio Model — used in thousands of studios, classrooms, and homes. Available immediately at this unbelievable low price!

• \$99.75 west of the Rockies

● Be first with Webster-Chicago. Here's a chance to sell more and more Studio Model 181 wire recorders. There's wonderful *increased* profit in each sale and you have one of the most fertile markets for this favorite model *right now*.

Because of tremendous volume, Webster-Chicago engineers have effected production economies to bring the price way down on this fast seller. Check your leads today—and tell them the Webster-Chicago "Electronic Memory" Story. They will be amazed—and they will BUY!

- Can be carried from room to room.
- Amazing high fidelity.
- Instant playback.
- Magic eye recording indicator.
- Record-O-Magic controls.
- 15-minute spool of pre-tested wire.
- Automatic stops.
- Elapsed time indicator.

"ELECTRONIC MEMORY"



... the ultimate in magnetic recording

Another



Product

WEBSTER-CHICAGO CORPORATION • CHICAGO 39, ILLINOIS

NEW 1950 REGAL TELEVISION

It is with pride that we present the new 1950 line of Regal television receivers. They have the styling, performance and value you can offer your most discriminating customers because

**Regal Builds the Best
... Not the Most!**

With Performance Proven

KEYED AUTOMATIC GAIN CONTROL

For Better Reception Everywhere



MODEL 19C36—Giant 19-inch console with AM-FM radio, Mahogany veneer cabinet, 36-tube chassis, Voltage Doubler. 527.50

Available in Straight TV, 497.50



MODEL 1207—The value and performance leader in 12 1/2-in. television. Mahogany veneer cabinet. 197.50

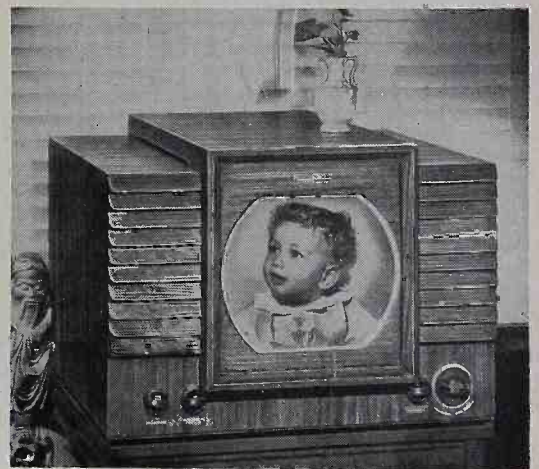

MODEL 1230—De Luxe 12 1/2-in. television. 30-tube chassis. Mahogany veneer cabinet. 290.50

THE REGAL FRANCHISE OFFERS GREATER PROFIT PROTECTION



MODEL CD36—Giant 16-in. television with complete AM-FM radio, 36-tube chassis, Voltage Doubler. 415.50



MODEL CD31—Giant 16-in. console, 31-tube chassis, Voltage Doubler. 360.50



MODEL 1208—Big 12 1/2-in. console, 12-in. speaker, Mahogany veneer cabinet. 229.50

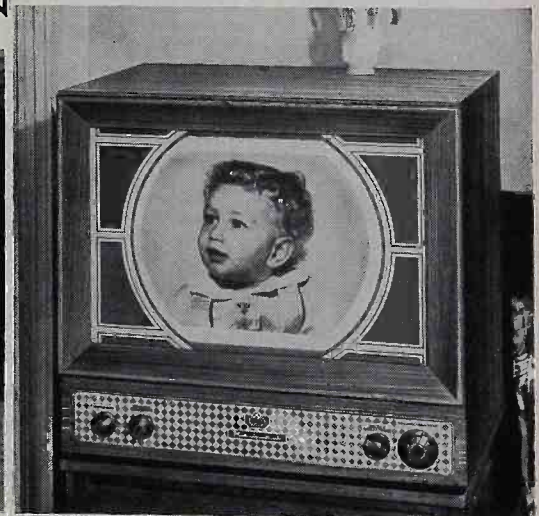

MODEL 16T31—De Luxe 16-in. television, 31-tube chassis, Voltage Doubler. Mahogany veneer cabinet. 329.50

Regal Has the Feature Values and Performance for Bigger Profits. Get in Touch with Your Regal Distributor or Write Direct to Factory.

REGAL ELECTRONICS CORPORATION

603 WEST 130th STREET, NEW YORK 27, N. Y.



MORE PROOF

means

The first honest-to-goodness
PRICE-PROTECTION POLICY
offered to the trade



THE **BIG SHOW** IS ON Westinghouse **TELEVISION** with these top-performance features:

★ Exclusive
ELECTRONIC MAGNIFIER
for big picture at small picture cost

★ **SYNCHRO-TUNING**
for perfect picture and sound with single dial setting

★ **BUILT-IN ANTENNA**
electronically tuned for improved reception

★ **NEW BLACK TUBE**
for maximum non-glare contrast
Adaptable to UHF (Ultra High Frequency)

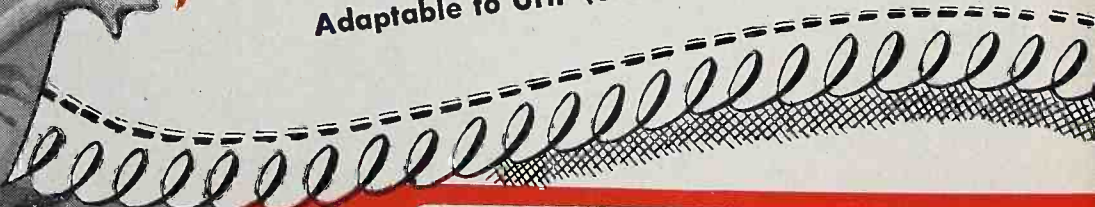

See your Westinghouse Distributor
WESTINGHOUSE ELECTRIC CORP. •

YOU CAN BE SURE...

that Westinghouse business in TELEVISION

Now, brand new Westinghouse models that give you more television per dollar . . . more features per set!



◀ Westinghouse 610T12—12½" BLACK TUBE table set of unusual beauty and simplicity . . . Exclusive ELECTRONIC MAGNIFIER with choice of *full vision* or GIANT CLOSE-UP . . . AGC. Built-In Antenna.

Westinghouse 619T12—12½" BLACK TUBE . . . Synchro-Tuning . . . Built-In Antenna . . . powerful EM speaker . . . Fast-keyed AGC . . . modern mahogany cabinet.



▶ Westinghouse 613K16—The ultimate in picture performance . . . 16" BLACK TUBE has extra large 160 sq. in. screen, with clarity and definition . . . Synchro-Tuning . . . Built-In Antenna . . . 12" P.M. Alnico V speaker . . . mahogany cabinet with doors.

◀ Westinghouse 611C12—Complete home entertainment unit with every deluxe feature, yet so compact it takes ¼ less floor space . . . AM-FM . . . 3-speed automatic record player . . . 12½" BLACK GLASS tube . . . Electronic Magnifier, Built-In Antenna.



▶ Westinghouse 618T16—New 16" RECTANGULAR Black Glass tube offers extra-large picture in a much smaller cabinet . . . new tube gives complete picture transmitted without waste . . . Synchro-Tuning . . . Built-In Antenna.

Get on the BANDWAGON!

Feature for feature Westinghouse wins . . . even the name Westinghouse tips the scale in many a sale, because 2 out of 3 families in your area are satisfied users of Westinghouse products.

Besides, you get the backing of advertising in the same newspapers you use . . . plus a full arsenal of point-of-sale and promotional aids.

HOME RADIO DIVISION • SUNBURY, PA.

IF IT'S **Westinghouse**

Sylvania's NEW

Tube Testers

are one jump
ahead of
tomorrow!



MODEL 220

Once again Sylvania has anticipated radio and television developments. Sylvania's new tube testers, both counter and portable models, are not only capable of testing every modern receiving tube . . . they are calibrated to Sylvania's latest tube production standards.

Experts in tube-testing have built this new instrument . . . but you don't have to be an expert to operate it. Counter clerks, uninitiated in radio technicalities, can use it after a few minutes'

MODEL 219

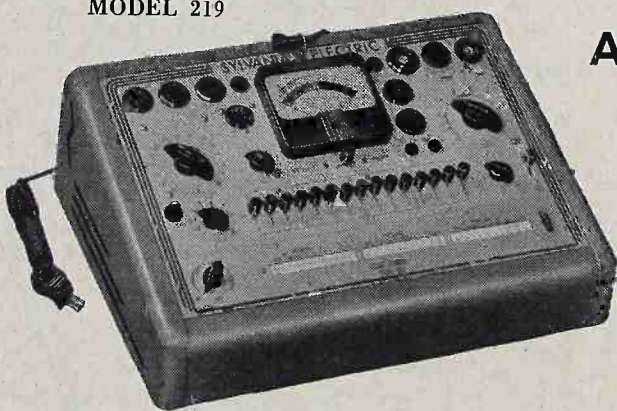

instruction. For the benefit of the customer, the illuminated meter reads "GOOD" or "REPLACE" for all tubes, including diodes. Gas tests can be made easily. It is the first tester with both circular and linear subminiature sockets. The new fast, smooth-running roll-chart is easily removable from the front panel.

Modern styling of both models tells even the layman that your up-to-the-minute service is one jump ahead of tomorrow!

A few more facts on what's NEW

In Tube Testers 219 (Counter) and 220 (Portable)

- Novel voltage controls prevent tube damage
- Switch-numbers correspond to tube pin-numbers
- Switching arranged for easiest operation
- Exclusive ohmmeter-type indicator for shorts and leakage
- Shorted tube reads "REPLACE"—no neon lamp
- Double-size power transformer

NOTE ON "KNOW-HOW"

A comprehensive explanation of tube characteristics and tube tester applications comes free in each Operating Manual.

SYLVANIA ELECTRIC

RADIO TUBES; CATHODE RAY TUBES; ELECTRONIC DEVICES; FLUORESCENT LAMPS, FIXTURES, SIGN TUBING, WIRING DEVICES; LIGHT BULBS; PHOTOLAMPS

the magnificent
Magnavox
radio-phonograph - television

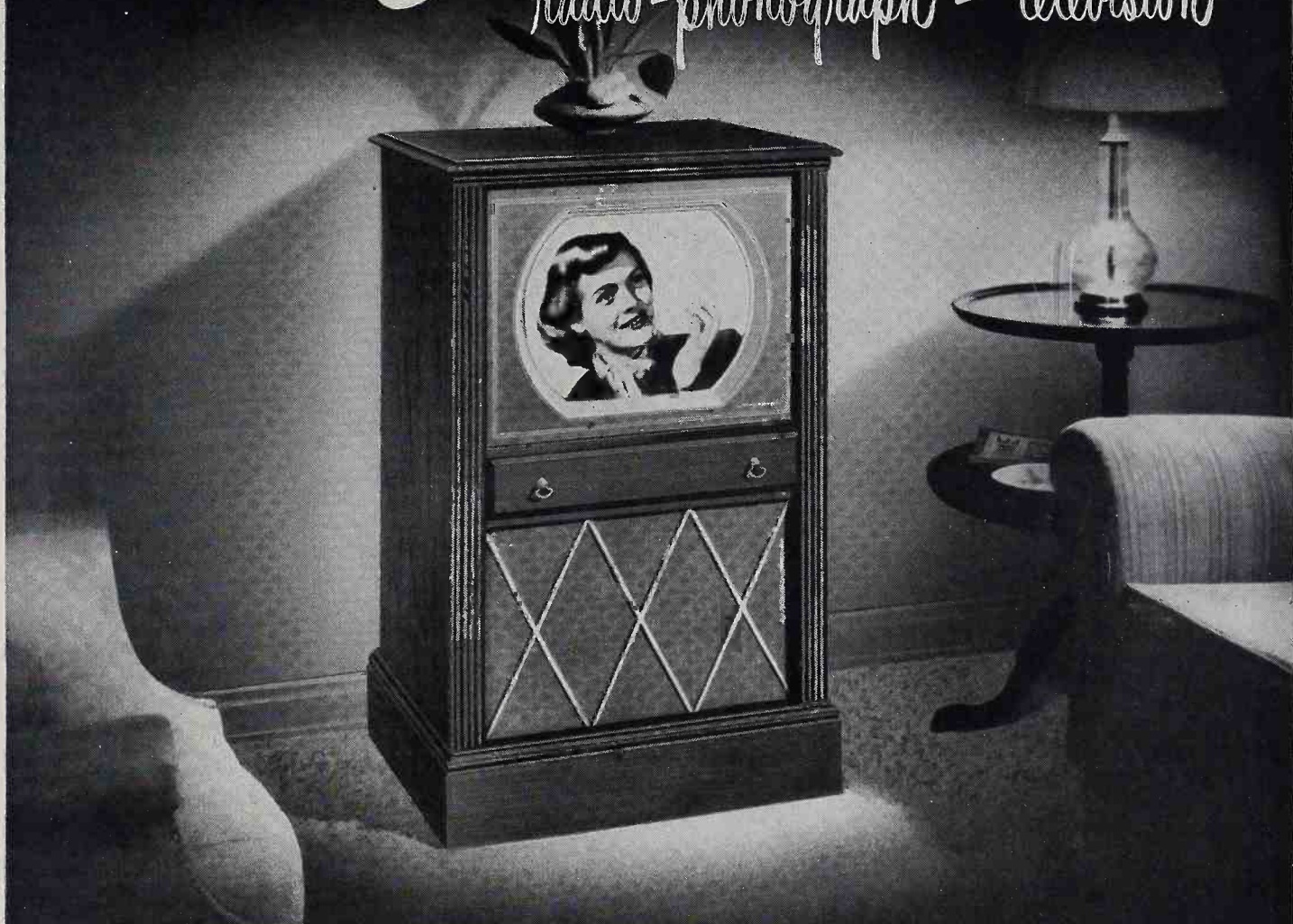

Magnavox Positive Price Protection
Safeguards Against Unfair Profit Cutting

DEALERS enjoy television's brightest profit picture with Magnavox. For rigid enforcement of Magnavox prices, fair traded where permitted by law, assures rightful markups. Magnavox selects only a few dealers in each market, and they sell Magnavox television-radio-phonographs on a direct-from-factory basis.

The Magnavox Company
Fort Wayne 4, Indiana

the AUTO RADIO MARKET

the demand for



5½ million cars sold in '49!

Out of this overwhelming figure a gigantic market is yours for the taking! One big-three manufacturer reports that 75% of their lower priced cars are shipped *WITHOUT* RADIOS. By an average of the four post-war years for all models of cars made by this manufacturer, the number of cars shipped without radios totals 85%! This added to other production figures from the auto industry represents a terrific market for America's favorite auto radio—Motorola, of course!

Again this year Motorola development, design and production of auto radios lives up to the Motorola tradition of high quality. Again, tireless product research combined with mature engineering techniques pay off for you—pay off for your customers! Unfailing power, 3-dimensional Golden Voice tone, and precision construction that minimizes servicing are the qualities your customers seek in auto radios. Feature Motorola and you feature these profit-producing qualities!

40 million families read about Motorola every month!

And they're *buying* families every one! They're the people who read such powerful national magazines as LIFE, THE SATURDAY EVENING POST, COLLIER'S, TIME, NEWSWEEK, LOOK, NEW YORKER, NATIONAL GEOGRAPHIC, SUNSET, COUNTRY GENTLEMAN, FARM JOURNAL, SUCCESSFUL FARMING and others—*believed in* by folks in all walks of life. Tie-up with Motorola—a product that's *believed in*—backed by big-name national publications!

for more sales, contact your Motorola distributor today!



the BEST is now BETTER than ever before

is BIGGER THAN EVER!

Motorola is tremendous!

*new 1950 models
are the best ever*

... WITH SELLING FEATURES GALORE!
Motorola—with more "FIRSTS"
than any other, now presents a
brand new line for '50! Always
the standard for the industry, the
new Motorola auto radios give
your customers an even greater
measure of value for their radio
dollars . . . and promise you a
year 'round source of easy sales
and trouble-free profits! Ac-
tion now will ring your
register later!

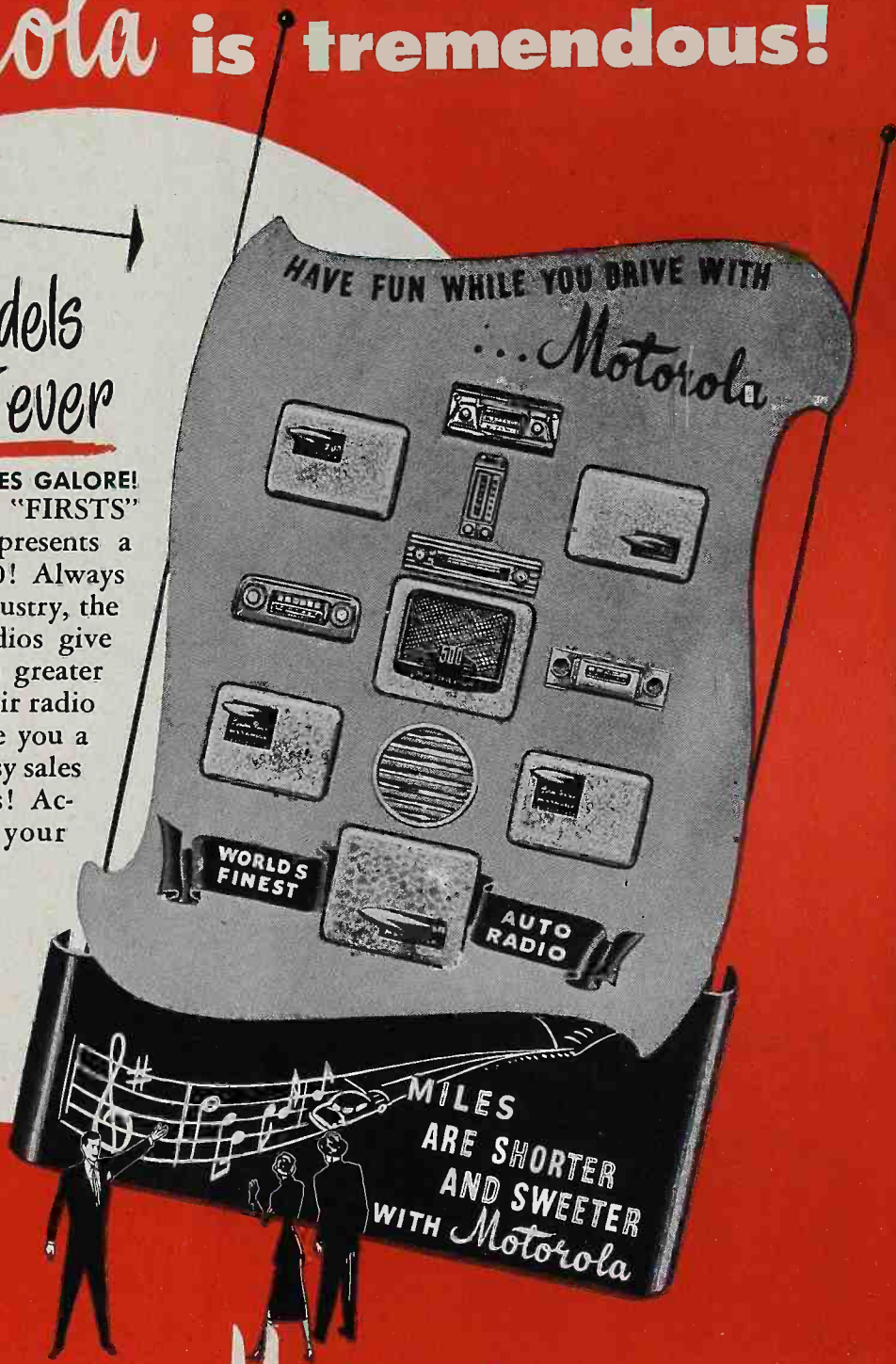

use this
display-demonstration
board and you'll sell

everybody knows and prefers

Motorola

RADIOS • AUTO RADIOS
TELEVISION

MOTOROLA INC. • 4545 AUGUSTA BLVD. • CHICAGO 51, ILLINOIS

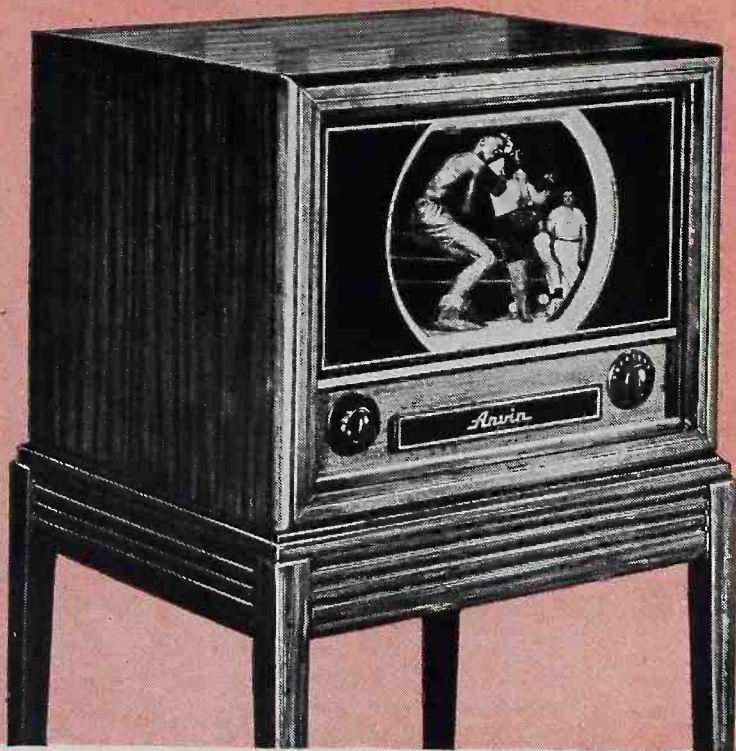

12½" Screen Table Model

\$229.50*
Plus Federal Tax \$1.47

with Built-in Versi-Tenna
and phonograph jack

Arvin DeLuxe Model 3121TM—Full 92 sq. in. of undistorted picture, securely locked in by the exclusive Arvin MAGIC MODERATOR. Only two visible groups of controls mean simplified tuning—easy as tuning a radio. Super-powered for sharp reception, even in fringe areas. Beautifully styled hardwood cabinet finished in selected mahogany. Loaded with fast-selling features!

Arvin DeLuxe Model 3120CM—Same fine chassis in beautiful eye-level mahogany console, **\$279.50***
Plus Federal Tax \$1.69

If you measure TV in terms of **VALUE**

ARVIN IS YOUR LINE!

ARVIN
Visible Value
TELEVISION

*you can SEE
the difference!*

Arvin is not the lowest priced TV line. Arvin is not the highest priced TV line. But, set for set and dollar for dollar, Arvin TV offers your customers more for their money than any other TV line. **ARVIN IS THE BIGGEST VALUE TV LINE!** Arvin Visible Value Television is packed with quality features. It is built to deliver dependable, service-free performance. Even in fringe

areas, owners report amazingly clear, steady reception. Arvin's refusal to compromise with quality protects your profits, pays off in customer satisfaction!

Sell ARVIN and you're selling sheer value and long-time satisfaction—the purchase-pleasure that makes one customer send in more customers. Start selling ARVIN now!

Arvin Radio & Television Division

NOBLITT-SPARKS INDUSTRIES, INC., Columbus, Indiana

**Slightly higher in Zone 2*

Arvin Value Sensation! New 8½" Screen Table Model



The Low Cost TV
with **BIG SET** features!

\$129.50*
Plus Federal Tax \$1.26

NEW NO-GLARE "BLACK" TUBE

Arvin Model 4080T—No-glare Black Tube • Simplified tuning • Service-free electromagnetic circuit • Straight AC operation for longer tube life • Horizontal automatic frequency control • Delayed automatic gain control • Graceful modern cabinet in lacquer mahogany finish, weighs only 35 lbs. *Ideal as a "Second set."*

For Lower Costs and Greater Profits

IN INSTALLING TV & FM ANTENNAS . . .

Compare



ANTENNA MOUNTING ACCESSORIES

Whether you keep your full profit or waste most of it on the roof, depends upon the convenience, speed and adaptability of the mountings you use.

With C & G mounting equipment, you can speed up all chimney-mounted installations and all wall-mounted installations, and, at the same time, give your customer a better job.

No fumbling. No call-backs. Make it a quick, one-man job nine times out of ten.

All accessories complete with hardware.

Our superior facilities and mass production methods enable us to offer high grade accessories at lower prices.

C&G-2 CHIMNEY MOUNT

Offset bracket mounting

Easy to install. Bracket is made of non-corrosive steel, 1½ in. wide. Two 12-ft. galvanized straps with eye-bolts attached to each strap. Note the method of clamping and locking strap.

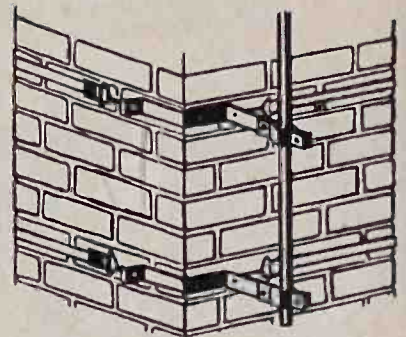

Detail of C&G-2 mounting—



C&G-3 DELUXE Y-TYPE CHIMNEY MOUNT

Made of heavy gauge steel and weatherproof plating. Two 12-ft. galvanized straps with eye-bolts attached to each strap.

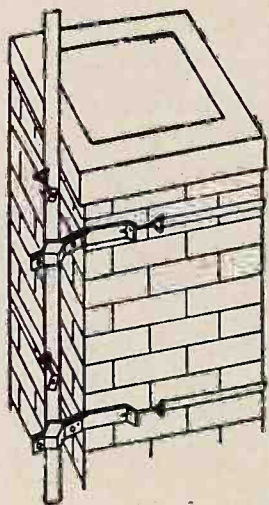

Detail of C&G-3 Y-TYPE MOUNT

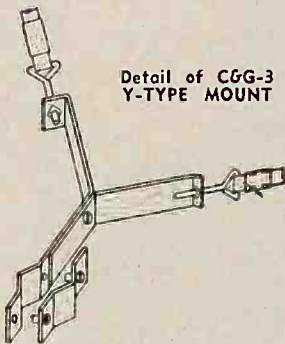

C&G-5 WALL MAST BRACKET

Stands off 15 inches from wall. For mounting TV mast on side of building. Made of 11-gauge steel, 1½ inches wide, with Cadmium plating.

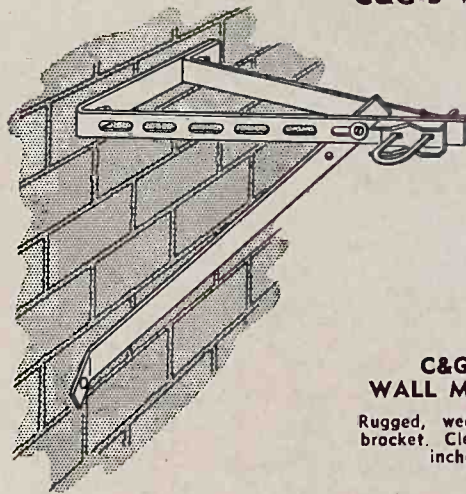

C&G-4 WALL MOUNT

Rugged, weatherproof bracket. Clearance 4 inches.

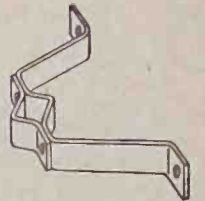

C&G-1 DELUXE WALL MOUNT

For wood or masonry. Clearance, 7½ inches.

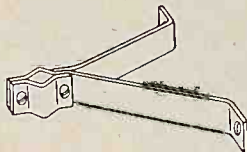

C&G 4" U-BOLT & JAW PLATE

Fits most diameters up to 1⅝ inches.

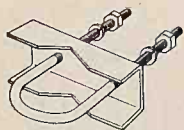

C&G GROUND ROD

4 ft., copper plated, ⅜" round rod.



C&G GUY RING

Made in 3 sizes of mastholes — 1¼, 1⅜ & 1½. Outside dia. 2½ in.



DEALERS—Contact your nearest distributor.

DISTRIBUTORS—Write for prices and COMPARE.

THE **C&G** TOOL MANUFACTURERS, INC. 39 Main St., East Orange, N. J.

Fabricators for leading TV set manufacturers

Builders of Magne-Rotor antenna rotator.

A Complete New RECTANGULAR

STEWART WARNER

A complete *NEW* line featuring the **RECTANGULAR "BLACK" TUBE...16" Table, 16" Console FM-AM Radio, 14" Table, 14" Console with FM-AM Radio, 14" Console TV only, 14" Console with FM-AM and new 3 Speed Record Changer!**



PLUS
THESE STEWART-
WARNER
EXCLUSIVES...

Line 14" and 16" - "BLACK" TUBE TV

Here's the *hottest* line in the television business! New models, new designs, revolutionary new features—all paced by the amazing new Rectangular "Black" Tube in giant 14" and 16" picture sizes! And all priced to assure you **MAXIMUM TURNOVER AND PROFIT IN THE MOST COMPETITIVE MARKET!** Your Stewart-Warner distributor has the facts! See him today!

STEWART-WARNER ELECTRIC

Division of Stewart-Warner Corporation
1826 Diversey Parkway • Chicago 14, Ill.



BUILT-IN AERIAL

No costly installation. Compactly located inside cabinet. Cannot be seen from exterior.

UNI-PANEL CONTROL

All controls centered on one easy-to-use panel! Quick, automatic, accurate!

MIRACLE TURRET TUNER

Industry's finest tuner! Quick adjustment, provides reception of proposed U.H.F. channels.

DYNA-POWER CHASSIS

Supersensitive assures greater distance reception from built-in aerial.

See Your
STEWART-WARNER
DISTRIBUTOR - *Today!*

Meck *Exclusive*

TELEVISION plus RADIO Combinations

BIG PROFITS FOR DEALERS



Here's the "sell-up" opportunity that really has some "sell" to it. Your customers want this sensible combination of big screen television and AM radio. This Meck "exclusive" can make you some really big money...for it carries the famous Meck big discount for dealers.

If you are getting that "tired feeling" trading dollars on low discount merchandise...give your profits a lift... get on the Meck Profit Line...now, today. Call, write or wire for your confidential price sheet and complete information.

**AM RADIO
Television
12½" Tube
\$239⁹⁰**

If you know your merchandising you know this is it... big screen television with that extra sensitivity for clear reception in fringe areas and difficult locations AND AM radio. Beautiful mahogany cabinet...built-in antenna...low price. Model XQR



For those who want giant screen television in a tabletop model... here it is including that big merchandising bonus...AM radio. Features huge 145 sq. inch screen, 16" tube, built-in antenna and rich hand-rubbed mahogany cabinet.

Model XTR
Retail price only..... **\$269⁹⁰**

TV-AM and PHONO COMBINATIONS, too

Lowest retail prices on proven television... tops for dealer discounts, these full-size mahogany consoles offer 12½" or 16" television, AM radio in combination with automatic phonograph. Includes built-in antenna. Model XRPS, 12½" TV Combination, retail \$299.90.

Model XSPS
16" TV Combination, retail **\$339⁹⁰**

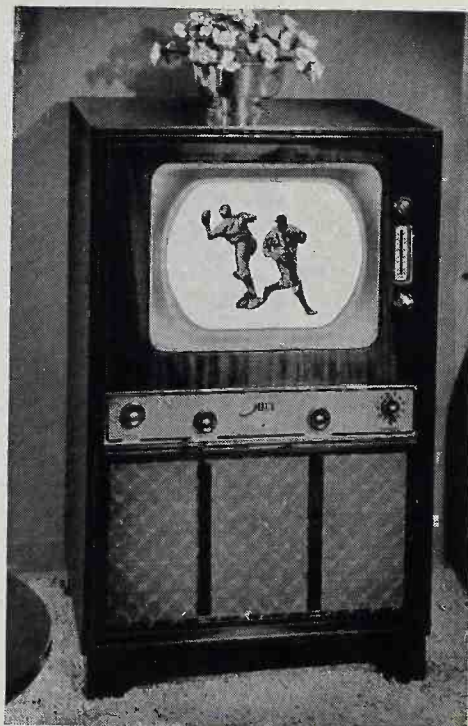

Meck

ISO-RAMIC TELEVISION

JOHN MECK INDUSTRIES, INC.
Plymouth, Indiana

4 Ways to Top Profits in T.V.!

Radion

Radion cuts that installation cost . . . makes spot sales a cinch . . . gives you that final punch to close the set sale . . . and that's where your profit lies. Radion products are packaged . . . anyone can install them . . . that's why Radion is the nationally recognized leader. Spark your TV sales today. Get Radion profit packages.



NEW! LINKED LEAD-IN

The TL-10, 69c List

Not once, not twice, but a hundred times you've had it happen. Your customer needs more lead-in . . . you've got seconds when you need hours to make an installation. The Linked-lead-in is your answer. A ten foot package of lead-in stripped, split, with terminals already on, complete with a combination standoff and insulator. If you need twenty-feet, snap two lengths together. A natural for counter sales . . . a time and money saver for service departments.

Coming!

THE TOWN AND COUNTRY . . . a packaged fringe-area outdoor antenna . . . loaded with never seen-before features. Watch for it . . . it will boost your TV sales even higher.

THE SUBURBAN . . . Radion's new TA-51 . . . a packaged conical . . . the only one with complete channel coverage and full orientation. Completely weatherized . . . fully assembled . . . packaged . . . ready to use. List, \$9.95.

THE METROPOLITAN . . . Radion's famed TA-49 . . . recognized tops for all indoor installations . . . nearly a million in use. Packaged complete . . . List, \$6.95.

THE RADION CORPORATION RTR3
1137 Milwaukee Ave., Chicago 22, Illinois

FOR DATA ON RADION PRODUCTS AND YOUR NEAREST DISTRIBUTOR CHECK HERE:

Metropolitan No. TA-49. Suburban No. TA-51.
 Town & Country No. TA-53 Outdoor Mount. TL-10 Lead-in Package.

Name

Company

Address

City State

It's Fada

Here are the new,
revolutionary TV sets that

Fada gives more for your customer's dollar because of:

Fada has gone all out in presenting the most sensational TV line in Television history. Table and console models featuring revolutionary engineering trends that provide TV reception beyond compare. Every new 1950 model has the new **glare-proof glass** screen kinescope tube. Every new 1950 Model has the built-in "Fada-scope" antenna requiring no outside aerial except in some difficult locations. Fada features simplified tuning—picture and sound comes in automatically . . . no fussing with fine tuning.

Matching
tables for Models
S-1015 and S-1030
available

Models S-1020,
S-1015 and S-1030
have 91 square
inch Screens

*You really haven't seen
'NEW DAY' television until
you've seen the new revo-*



Model S-1020 - 12½ in. Console - List \$239.95



Model S-1015
12½ in. Table
Model
List \$199.95

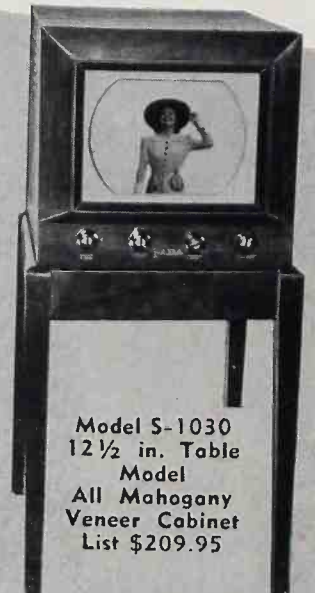

Model S-1030
12½ in. Table
Model
All Mahogany
Veneer Cabinet
List \$209.95

FADA RADIO & ELECTRIC CO., INC.

for '50!

will make volume selling history in 1950

- Superior revolutionary performance
- Beauty and quality custom-built cabinetry
- Low prices that will sell these sets on sight

Fada's revolutionary AGC (amplified automatic gain control) makes for amazingly smooth contrast control without distortion or pulling of pictures.

Advanced design Vertical and Horizontal, hold circuits, bring smooth, brilliant stable pictures . . . yes, many more revolutionary ideas that make for the finest television reception ever. Here are sets that the service-man will bless for the real ease in which they can be serviced. Entire chassis is removable from cabinet with kinescope tube as a unit. Don't wait another day before getting details of the TV line that will make TV selling history in 1950.

Matching
tables for
Models
R-1045 and
R-1050 available

**lutionary Fada TV line for
1950. Contact your Fada
Jobber for details NOW!**

Model R-1045 has
91 sq. inch Screen.
Models R-1050 and
R-1025 have 145
sq. inch Screen

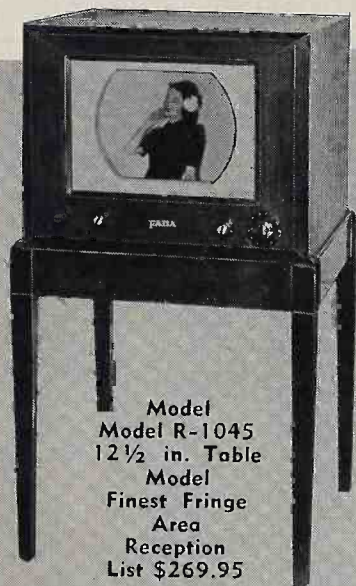

Model
Model R-1045
12 1/2 in. Table
Model
Finest Fringe
Area
Reception
List \$269.95



Model R-1050
16 in. Table Model
Ace Fringe Area Performance
List \$329.95



Model R-1025 - 16 in. Console
The greatest of Fringe Area Receivers
List \$364.95

BELLEVILLE, NEW JERSEY

Not One—but Two Great

RESEARCH ORGANIZATIONS

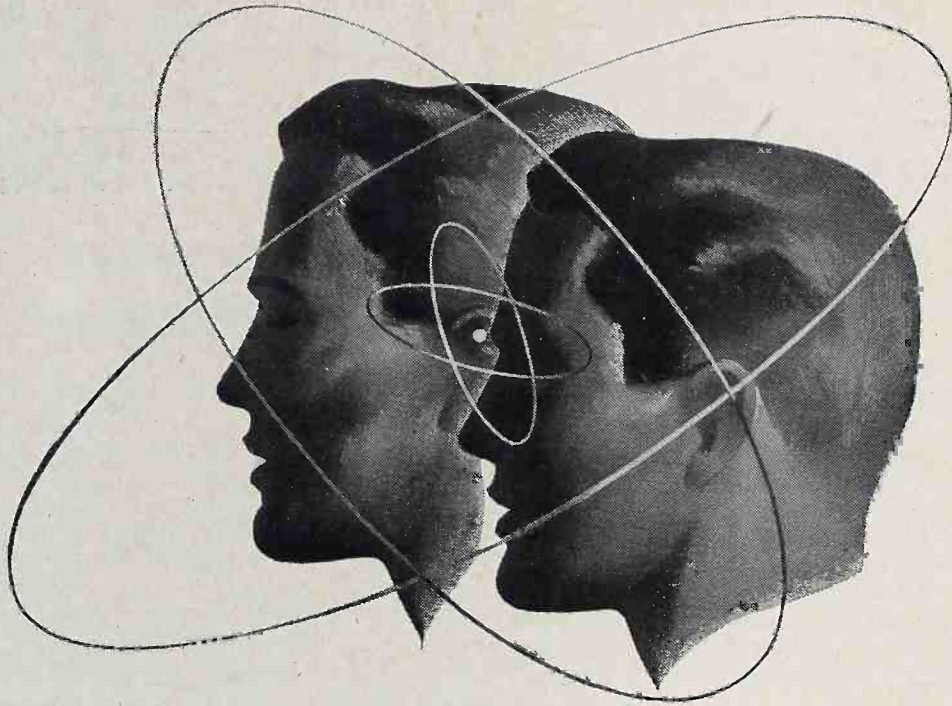

...bring *Capehart* dealers the most in TELEVISION!



The CAPEHART Nocturne—Big 16-inch, needle-sharp television picture. Master-crafted cabinet in mahogany finish. With Polatenna, Capehart's built-in aerial.

CAPEHART-FARNSWORTH and International Telephone and Telegraph Corporation—two great research, man-

ufacturing, and sales organizations—combine to provide the most advanced television receivers available today.

They bring dealers these outstanding sales exclusives

1. Exclusive Capehart Tone in Sound . . . the Tone that Brings Television to Life!
2. Exclusive Capehart Tone in Pictures . . . the Polatron* direct-view television tube that makes pictures clearer and sharper.
3. Polatenna, Capehart's famous built-in aerial.
4. Capehart's new modest price range starting at \$269.50!**

These solid selling points are not only helping Capehart dealers produce profitable floor sales—but, advertised

in national magazines, these exclusive features are also bringing Capehart customers directly to dealer showrooms!

*T. M. Reg. Available at slight additional cost

**Western prices slightly higher

**CAPEHART - FARNSWORTH
CORPORATION**
Fort Wayne, Indiana



CREATED A SENSATION

at the New York Show!

★ **Enthusiasm**
and **BUYING** response
WAS TERRIFIC!



1949 and 1950 FORD AUTO RADIOS

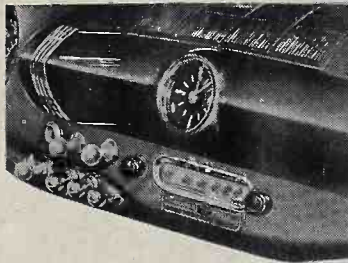

Six-tube superheterodyne. Six volt storage battery operation. Two dual purpose tubes. Eight tube performance. Specifically designed to fit all 1949 and 1950 Ford cars. Features two unit construction. No hole drilling required for mounting. Installation in a few minutes. Three-gang tuning condenser and tuned R. F. stage for extreme sensitivity. Permanent magnet dynamic speaker with powerful Alnico #5 magnet. Low battery drain. Weight 10 lbs.

UNIVERSAL MOUNT AUTO RADIOS



Model X-50
LIST PRICE \$29.95



Model M-90
LIST PRICE \$36.95



Model M-92C
with battery charger
LIST PRICE \$45.95

1949 and 1950 PLYMOUTH and DODGE AUTO RADIOS

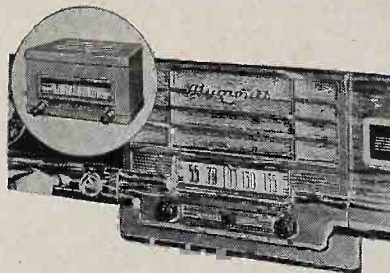

Six-tube superheterodyne. Six volt storage battery operation. Two dual purpose tubes. Eight tube performance. Specifically designed to fit 1949 and 1950 Plymouth and Dodge cars. Single unit construction. Very simple installation. Three-gang tuning condenser and tuned R. F. stage for extreme sensitivity. Permanent magnet dynamic speaker with powerful Alnico #5 magnet. Low battery drain. Weight 10 lbs.

1949 and 1950 CHEVROLET AUTO RADIOS

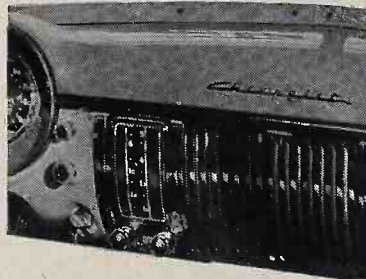

Six-tube superheterodyne. Six volt storage battery operation. Two dual purpose tubes. Eight tube performance. Specifically designed to fit 1949 and 1950 Chevrolet cars. Features two unit construction. No hole drilling required for mounting. Installation in a few minutes. Three-gang tuning condenser and tuned R. F. stage for extreme sensitivity. Permanent magnet dynamic speaker with powerful Alnico #5 magnet. Low battery drain. Weight 10 lbs.

"AUTOMATIC" MEANS TOP PERFORMANCE

AUTOMATIC RADIO MFG. CO., INC.

*Automatic
Radio*

**122 Brookline Ave.,
BOSTON 16, MASS.**

SYLVANIA 16" MAHOGANY CONSOLE #247. Big picture television at its finest! 147 sq. in. of motion-picture clarity. All 12-channel reception, "one-hand" tuning, built-in antenna!



SYLVANIA 12 1/2" MAHOGANY CONSOLE #245. 90 sq. in. of Movie-Clear TV All 12-channel reception, long-distance chassis, built-in antenna!

With These 4 Magnificent Your Television Console Line is Complete!

● Satisfying your every console need, the finest TV line on the market is now complete! Sylvania Movie-Clear Television brings you 3 new consoles—in addition to fast-selling, popular 090 model to provide full coverage for every price and taste!

Yes! The word is going around — in price and performance, Sylvania offers

Movie-Clear Television that's years in advance of any other make. Dollar for dollar, model for model, Sylvania Movie-Clear Television gives your customers the finest TV performance available today!

Phone your Sylvania distributor! Complete the one television line that satisfies all your customers' needs!

SYLVANIA **MOVIE CLEAR** **TELEVISION**

*TRADEMARK

SYLVANIA 16" MAHOGANY CONSOLE #090, 147 sq. in. of Movie-Clear TV with all 12-channel reception, long-distance chassis, built-in antenna!



SYLVANIA 12 1/2" MAHOGANY CONSOLE #197, 90 sq. in. direct view Movie-Clear TV with all 12-channel reception, long-distance chassis, built-in antenna!

1950 Sylvania Models



SYLVANIA TELEVISION

SYLVANIA ELECTRIC PRODUCTS INC.

Colonial Radio and Television Division • 1280 Main Street, Buffalo 9, New York

You Have No Competition
WHEN YOU SHOW A PROSPECT
 the Chinese Classic De Luxe
19-INCH TELEVISION-RADIO-PHONOGRAPH



CHECK THESE FEATURES!

- **EXCLUSIVE STROMBERG-CARLSON TUNER**
—super-sensitive—for maximum picture clarity and stability, even in “fringe” areas.
- **TOP TUNING FOR TV**
—controls concealed at top of cabinet, no bending or crouching to tune.
- **AUTOMATIC GAIN CONTROL**
minimizes picture adjustments.
- **AUTOMATIC FREQUENCY LOCK**
keeps picture steady.
- **ROCKET TUNING**
for radio and *Chromatic Tone Control* for radio and phonograph.
- **BUILT-IN ANTENNA**
for TV, FM and AM.
- **TRUE-TO-LIFE TONE**
on all services, with balanced audio system and 12-inch speaker.

There is just no match for this superb instrument. It offers the finest of *everything* in a complete home entertainment unit—

- **BIGGEST DIRECT-VIEW PICTURE**—on a 19-inch tube—wonderful to view in any size room, close up or at a distance.
- **HIGH FIDELITY FM-AM RADIO**—with the most sensitive chassis ever built by Stromberg-Carlson.
- **TRI-O-MATIC RECORD CHANGER** for any type of record on the market—33½ rpm, 45 rpm, 78 rpm. Record storage compartment.
- **DECORATOR-DESIGNED CABINET** of classic beauty, in ribbon-stripped mahogany veneers, hand-rubbed to a satin finish. Also hand-decorated cabinets available in red, green, ivory or ebony.

For a prospect who wants nothing but the finest, the Chinese Classic De Luxe is the logical choice—the *only* choice! When you demonstrate it to such a prospect—*you sell it!*

® **THERE IS NOTHING FINER THAN A**

STROMBERG-CARLSON

Stromberg-Carlson Company, Rochester, 3 N. Y.

In Canada, Stromberg-Carlson Co., Ltd., Toronto

RADIO & TELEVISION RETAILING

Including "Radio & Television"
and "Radio & Television Today"

Established in 1922
as ELECTRICAL RETAILING

O. H. CALDWELL, Editorial Director



M. CLEMENTS, Publisher

TV HOGGING THE LIMELIGHT, and breaking records too! In 1950, television, unit-wise, will sell ahead of refrigerators, washing machines, and passenger automobiles. Many revised production estimates on TV have come in from leaders in the industry, all of such figures revised upward.

THE BIG 1950 PARTS DISTRIBUTORS SHOW is all set for Chicago's Hotel Stevens, May 22-25. The event is sponsored by the Radio Manufacturers Assn., the National Electronic Distributors Assn., the Association of Electronic Parts and Equipment Manufacturers, the Sales Managers, Eastern group, and the West Coast Electronic Manufacturers Association, and is operated by the Radio Parts and Electronic Equipment Conference and Shows, Inc.

MANY OF THE BIG STORES BEING SMART in helping customers to readily identify floor salespeople, thus helping to speed sales and eliminate confusion. Such salesmen and women are provided with a variety of "tags," such as large buttons, flowers, special jackets, etc.

TREND TOWARD STORE "INTERIOR DECORATING" noted. Numbers of dealers have cooked up ideas that have resulted in store and show window improvement without drastic rebuilding. Some are covering walls with various permanent materials in order to enhance appearance, while still others have beautified stairways that were once unsightly, and have used various methods to improve and utilize pillars.

CARRIER CORP. BRINGS OUT THREE NEW room air conditioners, having six models in all in its present line. For the first time, the units will be available in a wide range of colors. Windowsill types come in 1/2, 3/4 and 1 HP; consoles, 1/3, 1 and 1 1/2 HP.

A LOT OF PEOPLE ARE CORRECT IN saying that TV has brought back vaudeville with its jugglers, tumblers, trained animals, and so forth, but video has also brought to the American public a number of shows employing totally new and different techniques and formats which will have a most significant effect upon the millions of viewers. Such shows differ from any ever seen either in movies or on the legitimate stage.

ON BEHALF OF ITS MEMBERSHIP of nearly 1,000 distributors, the National Association of Electric Distributors is advocating prompt repeal of existing excise taxes on electrical products.

"SIX TYPES OF RETAIL MUSIC CUSTOMERS and How to Sell Each Type," is title of an interesting and informative booklet issued by the National Association of Music Merchants. Available from the organization's offices, 28 E. Jackson Blvd., Chicago 4; costs 30 cents.

A FIVE-YEAR SERVICE WARRANTY guaranteeing both the Arvin model 2300 and 2200 iron now in effect, announces Gordon T. Ritter, director of sales, electrical housewares division of Noblitt-Sparks Industries, Inc., Columbus, Ind.

ANOTHER HEALTHY BUSINESS SIGN seen in fact that dealer credit at this time is on a sound footing in the over-all picture, according to wholesalers, banks and financing companies.

A PERSONALIZED SELLING AID for TV has been developed by Sylvania. The new merchandising idea consists of a large map which gives the prospective set owner all the information he wants on TV in his area. Map shows exactly where each prospective set owner lives in relation to available transmission.

APPEARANCE ON TV OF SOME famous recording stars responsible for skyrocketing sales of current discs they made in all areas covered by video. Watch for TV to continue to be that something new that platters need.

Status of TV

The following stations are expected to go on the air this month: WHBF-TV, Rock Island, Ill.; WTAR-TV, Norfolk, Va.; and WCON-TV, Atlanta, Ga. Sets in use as of March 1: 4,660,000.

What's Ahead!—in Radio,

MORE STRAIGHT-COMMISSION SALESMEN now working for dealers, with TV the chief reason for the increase in the ranks. Smart salesmen know that TV is the greatest seller ever to have hit the American market, and they realize that in working on a straight-commission basis, they can make more money.

MANUFACTURERS PLANNING BIGGEST DRIVES EVER to up sales of dishwashers, disposal units, clothes dryers and food freezers during 1950.

LOOK FOR NEW TYPE ELECTRIC fans to obtain a large share of the air-circulating business this year, with some manufacturers having no conventional models at all in their lines.

AS IN PAST ISSUES, THE 1950 "World Almanac" credits RADIO & TELEVISION RETAILING and TELE-TECH, published by Caldwell-Clements, Inc., as sources for information on the TV, radio and electronic industry appearing in this widely-circulated book of facts which has been published for 65 years.

"THE PRIME QUESTION FOR DEALERS and distributors is not how many television and radio receivers will be sold by the industry in 1950, but the share of that volume each distributor and dealer will be able to obtain for himself."—John W. Craig, vice-president Avco Mfg. Corp., and general manager of its Crosley Division.

78.2 OF THE COUNTRY'S FARMS ARE now electrified. Today there are 3,044,000 rural electricity consumers under REA, and over 934,000 miles of line.

AMANA REFRIGERATION, INC., HAS TAKEN OVER the Refrigeration Division of Amana Society. The new owners will continue to manufacture Amana refrigerators and food freezers. Howard Hall, prominent Cedar Rapids, Iowa, industrialist, heads the new organization.

DEALERS PLANNING ACTIVE participation in the 1950 Mother's Day observance, May 14. The national committee urges retailers to handle their promotions with "dignity and restraint." This year, the official poster features a young mother.

IMPACT OF TV ON "OUTSIDE" entertainment field dramatically emphasized by those advertisements reading, "Wrestling—Not Televised."

REPERCUSSIONS OF THE COAL STRIKE will be felt this Spring by radio-TV-appliance retailers. Slow-downs, and in some cases cessation of production by manufacturers was necessitated by shortages of fuel and steel. The way the picture shapes up at the present time, it seems likely that many wanted models will be in short supply. A halt in the downward trend in list prices is also a possibility as a result of the situation.

TANK TYPE VACUUM CLEANER SALES continuing to run ahead of the uprights, the tanks selling like hot-cakes to apartment and multi-dwelling residents. Sales of cleaners in '50 should be ahead of '49 totals.

BUSINESS IS GOOD SIGN. Reports by veteran dealers indicate that their open-account customer collections continue to be satisfactory; much better, in fact, than any pre-war period.

TODAY, MORE THAN HALF OF THE DOLLAR volume in clock sales in the United States is produced by electric clocks, according to Telechron, Inc., which recently produced its fifty-millionth electric timing unit.

PROBLEM OF TRYING TO ARRIVE AT THE RIGHT list price said to be holding back the market debut of a couple of new automatic washers.

RADIO SERVICE VOLUME continuing at high rate in almost all sections of the country, and really pouring into those dealerships located in TV areas.

WHAT IS A CUSTOMER?

- A CUSTOMER** is the most important person ever in this store . . . in person or by mail.
- A CUSTOMER** is not dependent on us . . . we are dependent on him.
- A CUSTOMER** is not an interruption of our work . . . he is the purpose of it. We are not doing him a favor by serving him . . . he is doing us a favor by giving us the opportunity to do so.
- A CUSTOMER** is not an outsider to our business . . . he is a part of it.
- A CUSTOMER** is not a cold statistic . . . he is a flesh-and-blood human being with feelings and emotions like your own, and with biases and prejudices.
- A CUSTOMER** is not someone to argue or match wits with. Nobody ever won an argument with a customer.
- A CUSTOMER** is a person who brings us his wants. It is our job to handle them profitably to him and to ourselves.

Author Unknown

Appliances, Records and Television

SALES PEAKS OF MANY PRODUCTS in our field will continue to level off due to the demands of modern American living, and as this trend continues it should have a very good effect on the market, tending to reduce the number of depression periods, and, hence, curtail dumping and price-cutting. Today, there are very few "highly seasonal" products. The average consumer will buy almost any item any time of the year.



PHONOGRAPH RECORD BUYING PUBLIC now familiar with the 3-speed situation. At least, the great majority of them are, dealers report, though they still have to educate those customers who don't own players but want to. Dealers feel that '50 will be a good year for platter and player sales, and, of course, for TV combos.

STORES GEARED TO NEIGHBORHOODS doing good jobs odd ways. In one small Midwestern city the boss sports suspenders and shirt sleeves; serves sandwiches to his customers. A college town dealer did a land-office business in platters by installing a free-play jukebox, and passing out Cokes. Many stores adopt and play up local historical themes, etc. Oddest report of all comes from a large Latin-American city where the radio-appliance stores have *no doors*. Seems residents won't open them for fear they'll be obligated to buy. (At night, large metal folding barricades are dropped down.)

SOME OF THE DEPARTMENT STORES using a number of "expeditors" (male) in effort to speed up sales. Similar to floorwalkers, these "expeditors" approach browsers asking qualifying questions. If the shopper says he's "just looking," he's left alone. If, however, the customer expresses the desire to see something specific, a salesperson is summoned.

IN THE APRIL ISSUE OF RADIO & TELEVISION RETAILING look for a great line-up of worthwhile features, among them specifications of all types of recorders, with current list prices; detailed specifications, prices, etc., of all portable radios. Look, too, for the article in May telling the dealer how to run a "Tune-Up, Tube-Up, Check-Up" campaign in his territory, to increase his service revenue.

VEST-POCKET PRICE LIST, itemizing products it distributes, issued by The Harry Alter Co., Chicago jobbers, well received by retail dealers and dealer salesmen.

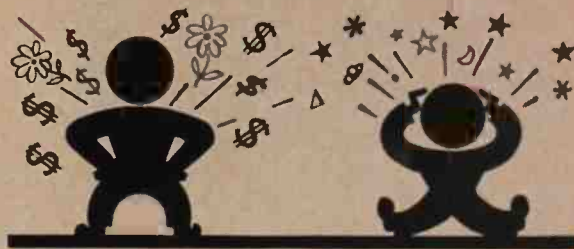

TRADE-INS REALLY ON THE INCREASE, particularly in the appliance field. TV trade-ins (small-screen jobs for bigger ones) showing up in considerable numbers. Funny thing how dealers view trade-ins. There's a definite pattern. Those who have a well-defined fix-'em-up-for-resale plan just love to take in the old stuff—those who don't know what to do with traded-in products hate 'em like poison.

FUTURE EVENTS OF INTEREST TO READERS

MAR. 6-9: IRE Show, Grand Central Palace, N. Y.

APR. 14-22: National Electric Housewares Week.

MAY 7-14: National Music Week

MAY 22-26: Parts Distributors' Conference & Show, Hotel Stevens and Exhibition Hall, Chicago.

JUNE 12-16: National Association

Electrical Distributors, Convention Hall, Atlantic City, N. J.

JULY 16-19: National Assn. of Music Merchants (NAMM), Music Industry Trade Show & Convention, Palmer House, Chicago.

AUG. 7-19: U. S. International Trade Fair Chicago Coliseum, International Amphitheater and Navy Pier, Chicago.

AUG. 27-SEPT. 1: Radio Parts Distributors' Convention (NEDA), Cleveland Auditorium, Cleveland, O.

SEPT. 29-OCT. 8: Third Annual National Television & Electrical Living Show, Chicago Coliseum, Chicago.

OCT. 11-OCT. 14: 15th Annual Conference of the North Central Electrical Industries, Copley Plaza Hotel, Boston.

RCA VICTOR'S
new
TEL-ENSEMBLE
 (model T120)

*"The newest 12½ inch
 Deluxe Television!"*

Customers everywhere are saying about this sensational new RCA Victor Eye Witness Television value: "What a set!"

Merchandise the "Tel-Ensemble" at your store and you'll cash in on its tremendous sales-appeal to all the folks who want 12½-inch RCA Victor television. What's more—you'll find it a money-making "sell-up" set that helps you move easily to higher priced sets when your prospect seems ready for a jump.

Remember—like all RCA Victor instruments, the "Tel-Ensemble" offers your customers the performance guarantee of RCA Victor's exclusive Factory-Service Contract. And that's further help in assuring you of faster turnover . . . bigger profits.

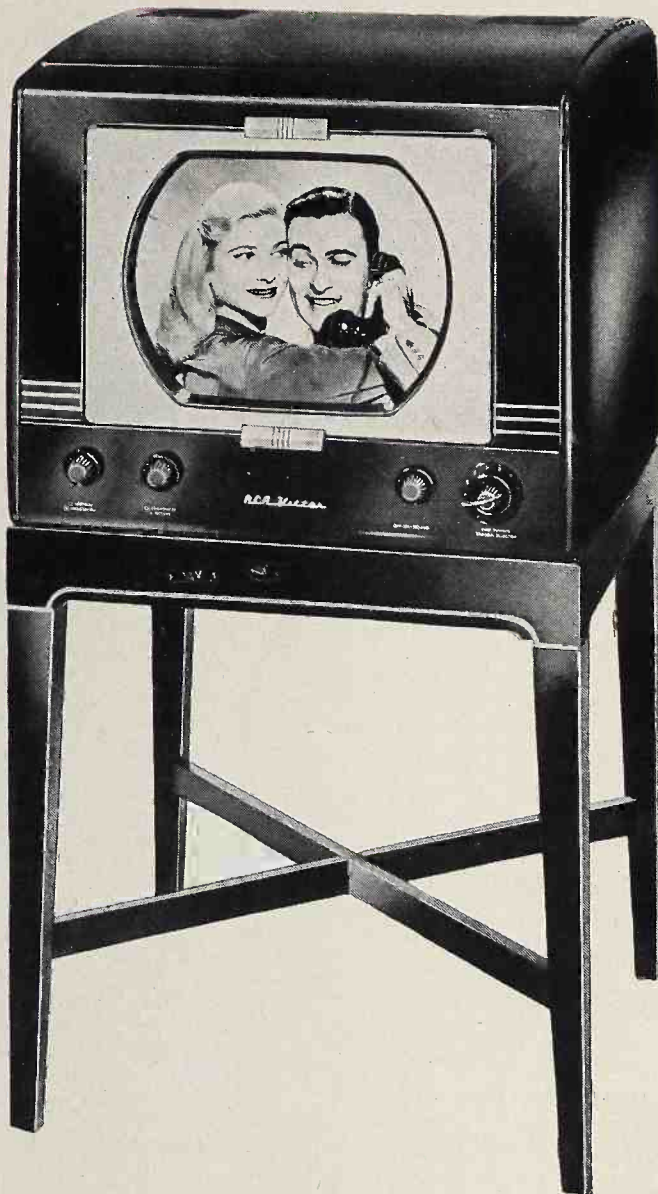

ONLY RCA VICTOR
 HAS THE
 "GOLDEN THROAT"

ONLY RCA VICTOR
 MAKES THE VICTROLA

RCA VICTOR



"Victrola"—T. M. Reg. U.S. Pat. Off. DIVISION OF RADIO CORPORATION OF AMERICA

Here's why your profits are greater with this RCA VICTOR

*Higher quality and outstanding selling points of
ALL RCA VICTOR instruments keep turnover high!*

Look at these features of the value-packed Tel-Ensemble!

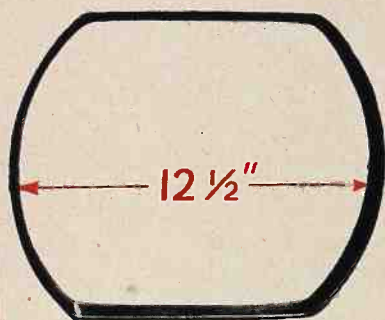

*Big Deluxe
12 1/2 inch
Television!*

Yes—12 1/2-inch Eye Witness Television. It's the size most people want. It's the furniture most people want. It's the television most people want—RCA Victor.



*Comes as
Complete
Furniture!*

The "Tel-Ensemble" is complete furniture. The lovely matching support places the screen at the exact height for best viewing. Has built-in antenna.



*Steady, Clear
Eye-Witness
Pictures!*

Explain to your prospects how RCA Victor's new, improved Eye Witness Picture Synchronizer "locks pictures in tune" on the new "Tel-Ensemble."

*And for only \$12.95 more, your
customer can have a
Television-Phonograph
combination with
RCA VICTOR'S 45 J*



Show your "Tel-Ensemble" prospects the phono-jack for RCA Victor's "45" record changer. Let them hear "45's" amazing "live talent" performance! Make a double-close! P. S.—Other television sets—radios, too—have phono-jacks for the 45J.

RCA VICTOR—World Leader in Radio... First in Recorded Music... First in Television

Modern Selling Methods

Stresses "WOMAN'S ANGLE" to Push Freezers

THAT A COMMON SENSE APPROACH to the merchandising problem, combined with a little dramatization, will sell home freezers rapidly has been thoroughly demonstrated by Mrs. Nat Berman, head of Franklin Radio & Appliance Company, in Walnut Park, Missouri.

Despite the fact that her store is a typical small neighborhood dealership, Mrs. Berman is doing a good job in selling food freezers. The store is completely modern, and is located in a residential district, composed almost entirely of moderate-income working people. Nevertheless, through simply



Mrs. Berman keeps demonstration freezers stocked with food for better sales approach.

making a study of the neighborhood, and capitalizing upon the few natural advantages, Mrs. Berman has been able to sell more home freezers than some of the large dealerships in the downtown district.

The whole secret, according to the woman appliance retailer, lies in "selling what the home freezer can do for the average family." Mrs. Berman started out on a moderate basis, some time ago, when she began keeping large quantities of sharp-frozen foods on hand in one of the displayed freezers. This created so much interest that she amplified the idea by stocking more and more quantities of food, until at present two home freezers are

completely filled. Ready for instant display and demonstration to customers are frozen chicken, rolls, corn, a complete side of beef, soup, ice cream, vegetables, fruits, and dozens of prepared items. Actually, there are several hundred pounds of foods always kept on display in the freezers, ready to be cooked up in the store's model kitchen and served to dubious prospects if necessary.

"One of the most important sales helps, we have found, is demonstrating to economy-minded housewives that it is possible to make large quantities of soups, gravies, chicken-ala-king, stew, etc., and to freeze what is left over for later service. This point goes a long way with women who dislike planning and cooking a complete meal when unexpected guests drop in, for late-evening snacks, etc. Demonstrating to them that there need be nothing thrown away, and that sharp-freezing will keep such food items indefinitely, always scores heavily."

Since her own home kitchen is located next door, with a handsome dinette, breakfast nook, etc., it isn't unusual for Mrs. Berman to take some food item out of the home freezers and "cook up a quick snack" to prove her

point. As a result, a lot of neighborhood home owners are sold on the idea that the freezer will not only pay for itself in food savings, but that it will also add a lot of pleasure to family life, through providing "out of season foods."

Mrs. Berman sets up credit payment plans to suit the incomes of her customers, and to date has sold every home freezer at full list price, with no markdowns whatsoever.

Thus far there has been no outside solicitation program in this St. Louis store. Instead, Mrs. Berman keeps a television set going every evening in the window of the store. This invariably brings a crowd of adults and youngsters to the store front from the residential area surrounding—who are naturally "exposed" to displays of home freezers, refrigerators, ranges, washing machines, etc. "It takes a lot of talking to sell a freezer," says Mrs. Berman. "But when the sales talks are backed up with the tremendous amount of food we keep constantly on display, and the customer is shown figures which she can readily understand, we feel we get results. Eventually, we believe, any prospect who goes far enough to actually eat foods which have been sharp-frozen in the freezer, and cooked in our kitchen, will become a customer."

To Save TIME Is to Save MONEY

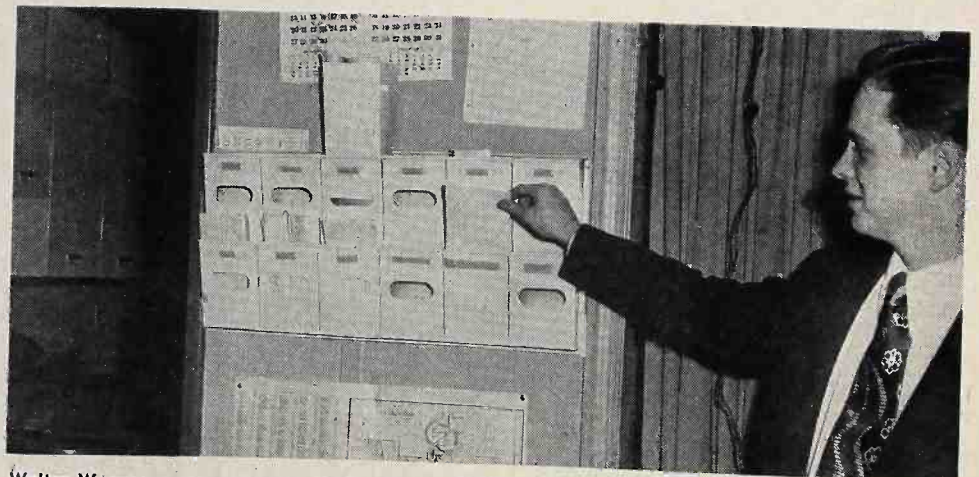

Walter Warmee, owner-manager, Elyria Electric, Elyria, O., expedites his daily management problems by utilizing mail-boxes for communications and messages for employees. Each box carries a label (or name) and contains pertinent information and directions for individuals designated. In the photo, salesman Jack Bishop checks his box, receives a note about a customer that will call later. Included are boxes for salesmen, the local cartage firm, store deliverymen, television installers, completed service calls, calls for other than TV, and secretarial work.



for Bigger Profits

Selling TV DOOR-TO-DOOR Proves Profitable for Retailer

OUTSIDE SELLING SELLS TV. Kem International, Inc., TV-appliance dealer, located at 2454 East 75th St., Chicago, reports TV sales of over four figures a day!

How "Les" Bautsch, vice-president, and Lionel Ives, president of the firm, built this dealership up through sound merchandising policies, is an example.

Bautsch and Ives do not claim anything spectacular about their success. As a matter of fact, they are rather reluctant to talk about the business, saying it is just another case of hard work paying off. Perhaps they are right, but Kem International is a "living monument" to hard work aimed aggressively in the right direction.

Surrounding Markets

Kem International's sales force is the real secret of the store's success. The company's officials early in the game realized that the street on which it is located would bring in very little traffic. Nevertheless, they knew they were in the midst of a good area.

East 75th Street cuts right through the heart of the populous and prosperous South Shore Section on Chicago's south side. To the north are the homes of the wealthy, abutting on beautiful Jackson Park. To the south are the sprawling installations of huge steel mills, the financial lifeblood of the south side. And in between are houses and apartments sheltering a highly concentrated middle class with plenty of money to spend and good living as its primary mission in life.

To tackle this lush market, Kem International started to assemble a sales force. Their task was to go from house to house, selling television just like the Fuller Brush man. "Doorbell pushers," they are, and proud of it.

There are now 25 Kem salesmen on the outside. They drive their own cars, carrying television sets right with them. Usually they work in pairs. They operate strictly on a commission basis, without benefit of an expense account.

"We want our salesmen to build up a route, too," says Bautsch. "That way, they can keep in touch with customers and prospects, selling them lots of things besides television sets."

The salesmen cover a large territory. Fully half of them work in Indiana, going all the way into Gary on their calls. Working in the other direction, they reach into Evanston and beyond on the north, and into Joliet on the west.

Today Kem has about three times the space it started with, and there's still not enough room. Of the slightly more than two thousand square feet of selling space, roughly about one-fifth is presently devoted to television. Meck, Motorola, Crosley, Stromberg-Carlson, Philco, and General Electric are some of the TV lines carried.

The store is open every evening except Sunday, throughout the year. Company officials have found that being open at night gets the husband into the store, the lady of the house and the young ones being won over during the daytime.

"Make no mistake about it, the kids are selling television for us," Bautsch says. "Once you get a set into the home, the children will see that it stays!"

The younger group, incidentally, is responsible for the store's increasing business in selling a family its second

television set. For how else are you going to be able to see a rip-snorting western when the kids want "Howdy Doody?" "Pretty soon we'll be pushing 'TV in every room,'" quips Bautsch.

Kem maintains a fully equipped service department, staffed with four experienced servicemen who have to hustle to keep up with the installation business provided by the sales force.

What does Kem look for in a potential television salesman? "Previous TV or appliance experience is not necessary," says Les Bautsch. "We think it is more important that a man has some background in door-to-door selling, preferably with an established territory."

This store gives its salesmen all the help they need. The company has an extensive advertising program, running ads regularly in all the regional newspapers. Thousands of mailbox stuffers are printed each week for distribution by the sales force. Noteworthy is the fact that the leaflets and other materials carried by each salesman give his own name, address and telephone number. Good psychology there, as it makes for a more personal service between the customer and salesman.

Kem International finds that evening demonstrations bring big returns.



Price-Cutting Leads in

Dealers in Small Towns and Large Cities Alike Score

This "Evil" Above All Others Encountered in Current Selling

• "What are the basic trade evils you are encountering today?" was one of the questions Caldwell-Clements, Inc., publishers of RADIO & TELEVISION RETAILING, asked its dealer-readers in the radio-TV-appliance field. 61.8% of those answering named price-cutting in some form, far and away the most overwhelming vote "for" any evil.

Complaints about "short discounts" came second with 10%, while all other answers ran less than 10%.

The results show a marked change from a similar survey made by this magazine approximately one year ago,



"Back-Door" selling is an evil.

in which price cutting registered 47% and short discounts 22%.

The numbers of ways in which today's customer can obtain merchandise at less than list price are legion, according to those responding to the recent survey. Some dealers advertise specific price cuts (in the newspapers or in their windows), while others advertise a general cut-price policy. Still others publish nothing but will "haggle" with each individual customer. High trade-ins conceal price-cuts, as do give-away record players, TV filters, indoor antennas, etc. In the "free" category also are such items as free installation of TV. More subtle reductions often include absorption of the Federal excise tax.

The foregoing are mentioned as dealer methods of price-cutting. Referred to frequently in those categories are retail outlets whose primary business interest is other than radio, TV or appliances, and who run this type of merchandise as "loss leaders."

Before coming to the non-retail type of competition, we pass over the middle ground of dealers who sell "wholesale" to employes of utility companies, large factories in the vicinity, veterans' organizations, school teacher groups, employes of broadcasting companies,

etc. These so-called "discount clubs" are accused of siphoning off the cream of the retail trade in a community by catering to what may be the largest group or groups of wage-earners in that community.

Certain non-retail type outlets are considered part and parcel of the price-cutting scene by those answering this survey. This includes distributors who sell at the established dealer net price to a list of consumers who would ordinarily be retail customers, and in many cases, indiscriminately to all consumers. "Discount Houses," operating as they often do with the blessing of the distributors, are an offshoot of this type of merchandising.

All these forms of price-cutting (and many others not mentioned often enough to classify) were cited by the respondents, apparently, because regardless of who cuts the price or how he does it, he puts the squeeze on the retailer trying to do a "legitimate" list price business.

Actually, the "squeeze" comes from more than this one "evil," as a recitation of the other evils cited shows. Lower discounts (trade discounts) than pre-war combined with an absence of cash discounts, as well as very short terms on such cash discounts as are offered (many cite 2% 10 days from delivery instead 10 days after the first of the next month) are three instances where the squeeze is put on the other end—on the gross profit, even before the price cut.

On top of that, many dealers cited too much free service as an additional cost, which they attributed to poor quality control in the factories.

"Too many model changes" was mentioned by many of those writing in as an additional squeeze on already con-



Price-cutting starts "Price Fights"

stricted profits, since a mark-down had to be taken without benefit of adjustment from distributor or manufacturer.

The actual "hit parade" of price-cutting evils, according to the exact wording of the response on questionnaires was: "Price Cutting"—33%, "Dis-

count Selling" and "Back-Door Selling"—16.6%, and "High Trade-Ins"—7.9%, with the other 4.3% (of the 61.8% mentioned in the first paragraph) distributed among many differently worded complaints.

Territorial distribution of the "price-cutting" answers was in every state of the union, in all types and sizes of towns and cities. In businesses, all types were included: stores handling TV, stores handling only radio and appliances, etc. Over a third of the respondents also handle records. Price-cutting in service was scored as well as in sales.

Dealers had several suggestions as to why price-cutting is so prevalent. Most recurrent of these was "too many dealers." Distributors are blamed for franchising indiscriminately and selling indiscriminately. Dealers find themselves competing with what they feel is an excessive number of radio-TV-appliance dealers, plus jewelry, auto accessory, furniture, utility, and many other types of retail outlets, plus



Discount Clubs siphon off the cream.

discount houses, and certain distributors themselves (via backdoor selling), and finally with mail order houses.

Most of the dealers feel that the distributors (and indirectly the manufacturers, through their policies in connection with distributors) could police the price-cutting situation, as well as limiting the extent of their distribution, but that in many cases no effort is made to stop it. As a matter of fact, many of those dealers responding to the questionnaire feel that distributors and manufacturers give this practice a pat on the back by selling to price-cutters, by giving preferential discounts to price-cutters, and by letting a large segment of the public "get it wholesale."

Since the practice is so widespread, it might occur to some to say, "Is this

Survey of Basic Trade Evils

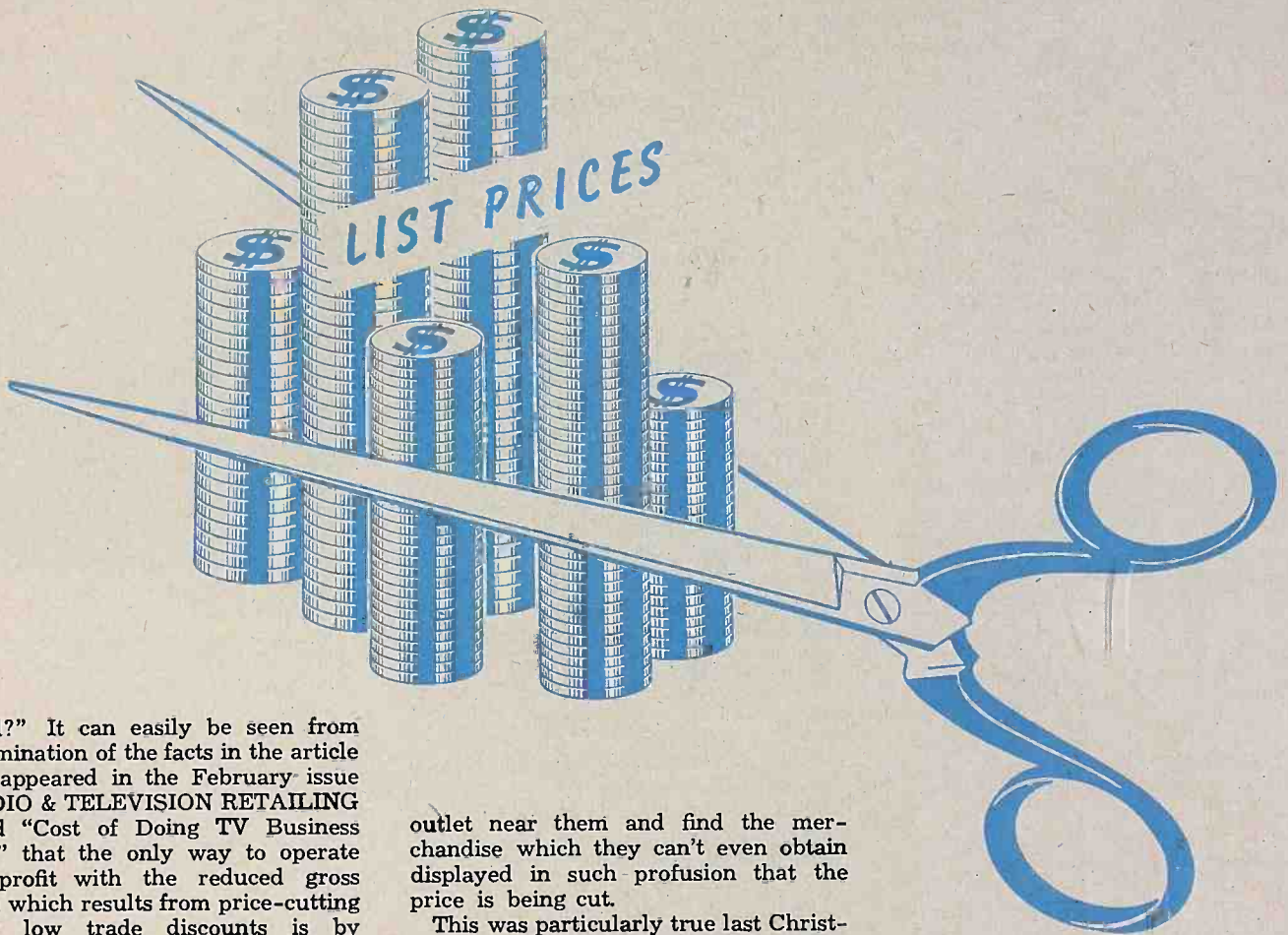

an evil?" It can easily be seen from an examination of the facts in the article which appeared in the February issue of **RADIO & TELEVISION RETAILING** entitled "Cost of Doing TV Business—1950," that the only way to operate at a profit with the reduced gross margin which results from price-cutting and/or low trade discounts is by increased volume and turnover. Increased volume does not result from price-cutting alone, since when one store cuts prices, others follow suit, and no one has an advantage.

Large volume is generally associated with larger markets and high traffic locations. The logical inference is that, by countenancing price-cutting, the distributor is furthering the interests of the big outlet in the big market and furthering the decline of the small store.

As a matter of fact, many of the smaller stores complained that they have difficulty getting franchises, that they have difficulty getting prompt delivery, difficulty getting sufficient quantities, and difficulty getting wanted merchandise. They are particularly irked when they "shop" a big urban

outlet near them and find the merchandise which they can't even obtain displayed in such profusion that the price is being cut.

This was particularly true last Christmas with radios, especially consoles. Non-urban (and especially non-TV) retailers were almost unanimous in crying for more good radio consoles, whereas in some large (especially TV) cities, this merchandise was being offered at a great reduction in order to get rid of it. (This allegation is made by readers who answered the survey.)

With several large stores around the country giving up television and radio departments because they feel it is not profitable to carry this type of merchandise in face of the situations outlined above, it is not improbable that manufacturers and their distributors will give thought to a different approach to the problem of radio-TV-appliance distribution. It seems obvious at this moment that a sudden re-

turn to discounts of over 40%, as were not uncommon before the war, would serve rather to aggravate the present situation than to solve it, since it would give price-cutters a larger margin to "play with."

Although leading in mentions in the survey of trade evils, price-cutting was not the only subject. Among the others, which will only be briefly touched on, are: "terms too easy . . . no down payment"; "misleading advertising" and fraudulent claims, on the part of manufacturers, distributors, dealers; "poor service" and lack of cooperation on the part of distributors in handling damaged or defective merchandise and replacement parts; "too many record speeds"; "tie-in sales"; "dumping"; "need more manufacturer promotions"; "need more manufacturer coop ad money"; "high handling cost of records."

Although the percentage of returns on these questions did not run as high as on price-cutting, the numbers of returns are considerable enough to mention. Already mentioned in the discussion on price-cutting, and therefore not included in the above list of "other trade evils" are such things as "too many dealers," "too much free service," "too many model changes," "no price protection," and "preferential discounts."

How Dealers Across the Country Ranked TRADE EVILS

1. Price Cutting
2. Back-door Selling
3. Short Discounts
4. High Trade-Ins
5. Too Many Dealers
6. Terms Too Easy
7. Too Much Free Service
8. Misleading Advertising
9. Too Many Model Changes
10. Poor Mfr., Distr. Service

Latest Television Models

Emerson PROJECTION SET

Model 649 is a projection receiver with a 235 square inch picture, equivalent to a



20-inch direct-view tube picture. The price is set at \$329.50, about half the price of a similar type projection receiver released last year with a 192-square inch picture. The 649 has 24 tubes plus 4 rectifiers. Emerson Radio and Phonograph Corp., 11 Eighth Ave., New York 11, N. Y.—RADIO & TELEVISION RETAILING.

Philco TV LINE

Five models complete the 1950 line. Model 1633, one of two 16-inch consoles, has 20 tubes and 5 rectifiers in a Sheraton-style cabinet. Model 1632, console and model 1600, table model, are also 16-inch sets. Two combinations with FM-AM radio and 3-speed changers are No. 1476-M, a Hepplewhite mahogany cabinet and No. 1476-W, a modern walnut cabinet. Philco Corp., C and Tioga Sts., Phila. 34, Pa.—RADIO & TELEVISION RETAILING.

Arvin TV LINE

Model 4080, shown, priced at \$129.50, is the lowest priced Arvin set yet produced. The set has 16 tubes and two rectifiers and is housed in a metal cabinet. Other new models are: No. 3100TM, 10-inch ma-

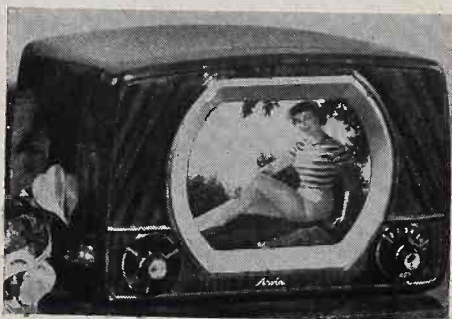

hogany table model at \$199.50; No. 3100TB, blonde table model at \$209.50; No. 3120CM, 12½-inch mahogany console, at \$279.50; No. 3121TM, 12½-inch mahogany console, at \$229.50; and No. 3160CM, 16-inch mahogany console, at \$359.50. Noblitt-Sparks Industries, Inc., Columbus, Ind.—RADIO & TELEVISION RETAILING.

Magnavox TV LINE

Four console combinations and three TV-only sets have been added to the line. The "American Traditional," shown here, has 16-inch TV, FM-AM radio and 3-speed changer. With TV the price is \$595; without, \$325. The "French Provincial" and "American Modern" are also combinations and list for \$795 with TV and \$375



without. The other combination, "Embassy," also has 16-inch TV and lists for \$995. The three TV-only sets are the "Shoreham 200," a 19-inch set in mahogany or maple at \$495 and the "Normandy" and "Contemporary" at \$495. Magnavox Co., 2131 Beuter Rd., Fort Wayne 4, Ind.—RADIO & TELEVISION RETAILING.

Crosley TV SETS

Two additions to the "Family Theater Series" are the model 10-412, 12½-inch



screen set with full length doors for \$329.95 and the model 10-418 (shown), a 12½-inch open front set for \$289.95. Crosley Div., Avco Mfg. Corp., Cincinnati, Ohio.—RADIO & TELEVISION RETAILING.

Brunswick TELEVISION

Model 512, a 12½-inch model, has been announced. It has mahogany top and sides and silk screen glass front with brass rails. List price is \$179.95. Brunswick Radio & Television, Div. of Radio & Television, Inc., 244 Madison Ave., New York 16, N. Y.—RADIO & TELEVISION RETAILING.

Hoffman SPRING MODELS

Includes three 19-inch TV consoles, nine 16-inch TV consoles, three of which are



FM-AM, 3-speed phono combinations, six 12½-inch consoles, also including three combinations, and two 12½-inch TV table models. Shown is model 847, 16-inch rectangular screen model in blond oak. Also introduced were two table and three console FM-AM receivers, the first Hoffman radio sets in over a year. Hoffman Radio Corp., 3761 So. Hill St., Los Angeles, Calif.—RADIO & TELEVISION RETAILING.

Pilot TV LINE

A new 12½-inch set has been announced, model TV-125. It includes FM radio and phono-jack. List price is \$239.50. It is available in mahogany or limed oak. Pilot Radio Corp., 37-06 36th St., Long Island City 1, N. Y.—RADIO & TELEVISION RETAILING.

Bendix TV LINE

One table model and two consoles have been introduced. All sets use a 14-tube plus two rectifier circuit. Model 2025, shown here, is a 12½-inch table model



listing at \$199.95. Model 3033 is a 12½-inch console listing at \$239.95. Model 6002 is a 16-inch console. It lists for \$299.95. All sets are finished in mahogany veneer. Bendix Radio Div., Bendix Aviation Corp., Baltimore 4, Md.—RADIO & TELEVISION RETAILING.

ANCHOR

Ahead Again



**New 2-Stage Pre-Amplifier
Increases Original TV Signal
Strength 5 TIMES**

LIST PRICE

\$44.95

You'll be Ahead Too . . . With Greater Profits Than Ever!

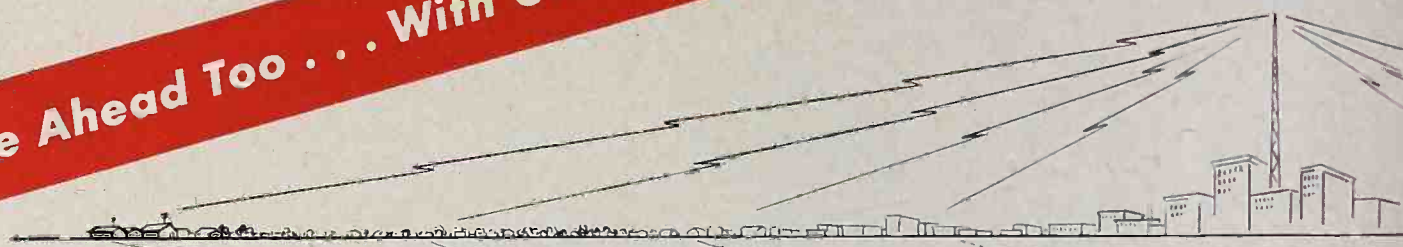

ANCHOR'S NEW 2-STAGE BOOSTER NOW Enlarges Your TV Market for Sales to Thousands of New Suburban and Fringe Area Residents

In 1949 the ANCHOR Single Stage BOOSTER improved television reception for 1 out of every 4 TV Set Owners. Thousands of apartment dwellers, suburban and fringe area residents the nation over demonstrated their preference by making ANCHOR the Number One BOOSTER in sets sold. ANCHOR developed this recognition only through its own top-notch performance by being able to deliver sharp snow-free pictures in most difficult conditions. Now ANCHOR has added the new Two Stage BOOSTER to their line to bring television, and the finest television reception, to everyone. The New ANCHOR Pre-Amplifier Will Out-perform Any Two Stage BOOSTER on the market.

ANCHOR'S
performance
curves have
never been
challenged.
Undisputed
laboratory
tests prove that
the ANCHOR
Two Stage
BOOSTER
increases the
original TV
signal strength
5 TIMES.

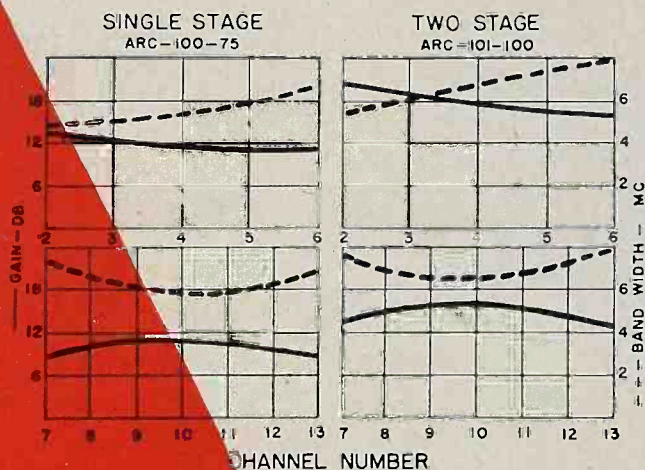

- Single Knob Construction allows switching and tuning with a flick of the wrist.
- Radically new switching of tube and circuit components.
- Modernly styled with streamlined plastic es-cutcheon. Soft mahogany leatherette finish.
- Most stable non-regenerative unit available. The unit that is not returned.

**ANCHOR
ENGINEERING
ALWAYS A
YEAR AHEAD!**

ANCHOR RADIO CORP.

2215 SOUTH ST. LOUIS AVENUE

CHICAGO 23, ILLINOIS



New TV and Radio Sets

RCA RADIO-PHONOGRAPHS

Two new consoles, Traditional (Model A-78) and 18th Century (Model A-106), feature two record changers: one for 45 RPM discs and a dual-speed for 33½ and 78. The A-78 is priced at \$199.95 in mahogany

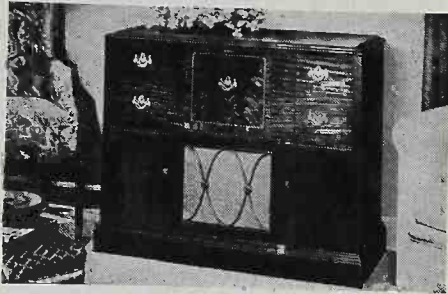

or walnut; \$209.95 in limed oak. The A-106, shown, is \$269.50 in mahogany or walnut; \$285 in blond finish. A new self-contained 45 RPM phono (model 45-EY) at \$29.95, and a player-attachment for 45 RPM (model 45-J) at \$12.95, have also been added to the line. RCA Victor Division, Camden, N. J.—RADIO & TELEVISION RETAILING.

Hallicrafters TV MODELS

Model 745, shown, is a 16-inch mahogany table model priced at \$279.95. It is available with consolette base for \$299.95. Seven other models include a 12-inch plastic table model (No. 715) at \$179.95, two 12½-inch consoles, two 16-inch consoles, a 19-inch console and a 16-inch radio-phonograph combination priced at \$399.95 in ma-

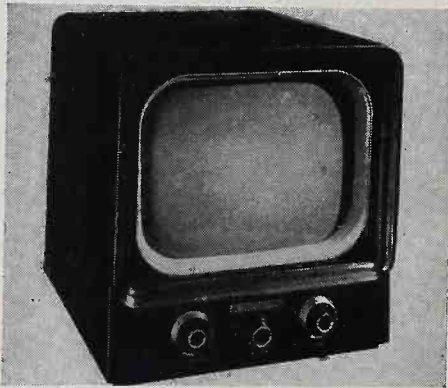

hogany (No. 770) and \$409.95 in limed oak (No. 771). The Hallicrafters Co., 4401 W. 5th Ave., Chicago, Ill.—RADIO & TELEVISION RETAILING.

Sonora TABLE RADIOS

One radio-phonograph and five table radios are offered. One table radio is FM-AM. The radio-phonograph has a 3-speed automatic changer. Also offered are two 3-way portables, and a 12½-inch table model TV set. Sonora Radio & Television Corp., 325 N. Hoyne Ave., Chicago 12, Ill.—RADIO & TELEVISION RETAILING.

Capehart "CONCERT GRAND"

Model 4002, "Concert Grand," is a 29-tube, 16-inch TV console combination with



FM-AM radio and 3-speed changer. The 18th Century styled cabinet is mahogany and contains a 12-inch speaker, built-in antenna and single tone arm. It replaces model 504P16, "The Symphony." List price is \$795. Capehart-Farnsworth Corp., Fort Wayne 1, Indiana.—RADIO & TELEVISION RETAILING.

Lear "DYNATROPE"

A radio-phonograph combination with FM-AM radio, single record disc turntable and arm, and wire recorder, has been announced. Lear, Inc., 110 Ionia St., N. W., Grand Rapids 2, Mich.—RADIO & TELEVISION RETAILING.

DeWald "KING SIZE"

The 19-inch TV console, Model DT-190, sells for \$399.95. It has a 23-tube chassis and 10-inch speaker. Cabinet is mahogany veneer. DeWald Radio Mfg. Corp., 35-15 37th Ave., Long Island City 1, N. Y.—RADIO & TELEVISION RETAILING.

Vidcraft TELEVISION

New line features the 16-inch, 24-tube set shown. Available in blond or ma-



hogany with FM for \$259.95; TV only for \$249.95. A 19-inch consolette with FM radio is priced at \$279.95 and a 12½-inch table model at \$189.95. These sets have a jack for phono attachment. A 16-inch console combination with FM-AM radio and 3-speed record changer lists for \$385.95. Vidcraft Television Corp., 780 E. 137th St., New York 54, N. Y.—RADIO & TELEVISION RETAILING.

Philco RADIO-PHONOGRAPHS

Two new AM radio and 3-speed changer combinations have been introduced. Model 1424, mahogany veneer table model shown, sells for \$109.95. Model 1718, ma-



hogany finished console, sells for \$149.95. Philco Corp., C and Tioga Sts., Phila. 34, Pa.—RADIO & TELEVISION RETAILING.

Motorola AUTO RADIOS

Five miniature tube sets comprise the new line. Two are dual-unit sets: model 800, 7 tubes plus rectifier, at \$79.95 and model 700, 5 tubes plus rectifier, at \$69.95. The three single unit sets are: model 400 for \$39.95, model 500 for \$49.95 and model 600 for \$59.95. Motorola, Inc., 4545 Augusta Blvd., Chicago 51, Ill.—RADIO & TELEVISION RETAILING.

Raytheon TV LINE

Prices on the eight new models range from \$199.95 for "The Rover," model M-1106 shown here, to \$329.95 for the model

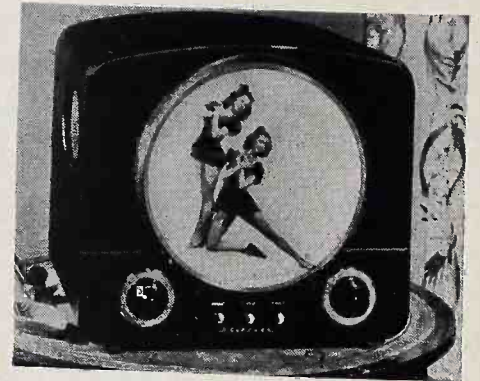

C-1602, 16-inch console. "The Rover" is one of five new 12½-inch models, four of them table models, one console. The other three models are 16-inch consoles. Raytheon Manufacturing Co., 60 E. 42nd St., New York 17, N. Y.—RADIO & TELEVISION RETAILING.

Mercury TV LINE

Model 9101, a 19-inch consolette with full-length doors and circular screen has been added to the line. It is available in walnut, mahogany and blonde and lists for \$399.95. Mercury Television & Radio Corp., 861 N. Spring St., Los Angeles 12, Calif.—RADIO & TELEVISION RETAILING.

Brightest Sales Star in
Your TV Profit Picture!



SILVER
ANNIVERSARY
MODEL
\$299.95
New 16-inch Rectangular Tube

A Price and Picture to Please Everyone!

The Criterion. 16 inch Super Circle Screen. 176 sq. in. Picture.

The Suburban. 12½ inch Super Circle Screen. Big 110 square inch Picture.

The Console. 12½ in. Super Circle Screen. Big 110 sq. in. Picture.

The Rover. 12½ inch Super Circle Screen. Big 110 sq. in. Picture.

SELL



TELEVISION

PRODUCT OF 25 YEARS OF LEADERSHIP IN ELECTRONIC ENGINEERING

Brightest sales star in the ever brightening television sales horizon is RAYTHEON. Raytheon TV is built on one of the strongest and broadest foundations in the entire radio and electronics industry—with 25 years of invaluable experience in radar and high frequency communications. Watch Raytheon—the bright TV sales star—the company best qualified to bring you the consistent high quality and lowered costs that will add up to more sales and profits for you.

SELL RAYTHEON... ALL THESE NEW 1950 MODELS HAVE ALL THE SURE-SELLING, CUSTOMER WINNING FEATURES YOU WANT

- **GLARELESS GRAY TUBE**
Holds eye-straining glare *inside* the tube. Increases clarity and contrast by 60%.
- **SYNCHROMATIC STABILIZER**
Assures constant brilliance, minimizes fade, flutter, interference from outside sources.
- **PRE-FIXED FOCUS**
Permanent magnet focalizer holds image in exact center and in sharpest focus always.
- **LONG-RANGE SENSITIVITY**
Raytheon's electronic excellence develops circuits that bring in wonderfully clear and steady pictures in outer TV signal areas.
- **ADJUSTABLE "RAY-TENNA"**
Raytheon's exclusively designed, built-in aerial eliminates expensive outside installations, most locations.

FOR FRANCHISE DETAILS WRITE, WIRE OR PHONE.

BELMONT RADIO CORPORATION

Subsidiary of Raytheon Manufacturing Company

5927 Dickens Ave., Chicago 39, Illinois

DESIRABLE DISTRIBUTION TERRITORY STILL AVAILABLE



THE CRITERION
\$329.95



THE CONSOLE
\$249.95



THE SUBURBAN
\$219.95



THE ROVER
\$199.95

Prices slightly higher in West and South

Where to Get Those REFRIGERATOR PROSPECTS



• To do a big job in selling refrigerators, the merchant should have a well balanced program. First, he needs to maintain an adequate number of live prospects in his files, and second, he must sell a satisfactorily high percentage of such prospects by (a) stocking makes that are popular in his community, and (b) by employing effective sales techniques.

Since it is comparatively easy for any good dealer to stock acceptable brands of refrigerators, and because he must employ efficient sales methods to stay in business, the problem of getting enough live leads remains as one of paramount importance.

Your Own Back Yard

Too many dealers who complain about not having enough leads to more refrigerator sales go along year after year ignoring the opportunity existing in their own service departments, or in the files of customers serviced by their factory set-ups. Certainly, a homeowner who spends good money maintaining an old refrigerator is a prime prospect for a replacement unit. Many a dealer has had the sad experience of keeping an old box operating through sheer ingenuity for a long time, only to find out one day to his sorrow that some other merchant has sold the customer a new refrigerator.

The salesforce in every store should use refrigerator service calls as leads, and should be provided with data concerning age and condition of the equipment serviced. Armed with such information, the salesman can make a personal or phone call in an endeavor to get a replacement sale. Some customers are so used to paying out good

money to keep some old "dog" operating that they never give a thought to buying a new refrigerator until some clever salesman suggests it to them. As a matter of fact, some consumers may take it for granted that even new refrigerators require frequent service, basing such premise on the experience they've had with some aged and failing box.

In many instances, one major repair job will cost a user *as much as a third* of what it would cost to buy a new refrigerator! In addition to the many advantages, such as faster freezing, better storage arrangement and appearance, modern refrigerators cost less to operate, smart salesmen are quick to point out after stressing the money saving on repairs.

A good rule to follow is to make it a point to offer to trade in any out-of-guarantee refrigerator you're called on to repair.

Get Leads From—

- Service department
- Store visitors (follow them up!)
- Just-sold customers
- New residents
- Free-lance salespeople
- Advertising and canvassing

Another angle to getting replacement business is the size proposition. Many refrigerators, even though in good working condition, are too small for present-day use, and many can be replaced on this basis alone. Many of such too-small refrigerators were purchased because they fitted into some particular space. Today's trend toward

more interior storage space in a box of smaller outside dimensions opens the way to a great many sales for the dealer who knows how to put such features across to the prospective purchaser.

Prospect Sources

In addition to leads from the service department there are numerous other sources at the disposal of every dealer.

First, there are the "drop-ins"—the strangers who come in to look at the dealer's products. Today, many salesmen wait on drop-in visitors in a routine fashion, permitting such folk to leave the store *nameless and addressless*. The important thing to remember is that most of the people who come in to look around are first-class prospects, since they have done just what every merchant wants them to do—*visit his store!* No salesman, however astute, can determine in a casual fashion whether the "lookers" are prospects or "suspects" until he has made a follow-up call on them, or until they come in again.

Another prime lead source is in the home of the "just-sold" customer. The salesman who calls soon after the sale to ask for the names of some likely prospects who are friends of the purchaser, will seldom leave without a few hot leads.

"Newly-come" residents usually need numbers of new things, and refrigerators rank high among their wants. Many do not move old refrigerators with them, and those who do bring the old box to the new location often find that the size is not right, or that from an appearance standpoint, a replacement is something to be desired. Names of newcomers can often be obtained from local utilities, real estate agents, etc.

The multiple dwelling offers opportunities for new and replacement refrigerator business either from purchase by the landlord or by the individual tenant. Though many dealers cannot get their hands on landlord business in some of the very large apartment houses, they can very often sell the owner of a smaller multiple dwelling, where, for instance, the landlord fur-

(Continued on page 105)

ARVIN
Performance
Tested
RADIOS

Sweet, Hot, and Profitable!



3-Way Portable that Really performs EVERYWHERE

Only \$**34**⁹⁵
Less Batteries

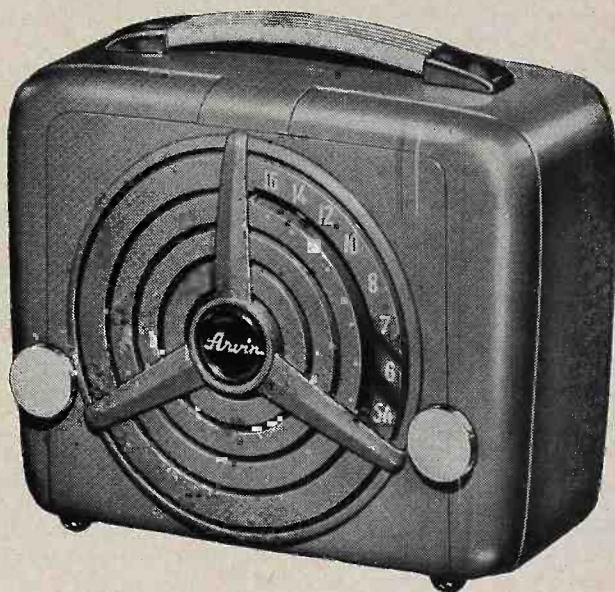

Arvin SUPER-POWERED Portable

MODEL 350-P—in appealing Jade Green, favorite Kingfisher Blue, Sandalwood or rich Burgundy. Appeals to your customers through its greater beauty, richness of tone and attractive price. It's smart to look at, sweet to listen to, and the greatest value on the market. Super-powered for super-results—but compact in size and light in weight. Whether on batteries, AC or DC, it performs rings around most portables. Build your portable display round this great Arvin NOW!

Other ARVIN Portables, \$16.95 and up

BRAND NEW AM-FM Arvin with straight AC chassis!

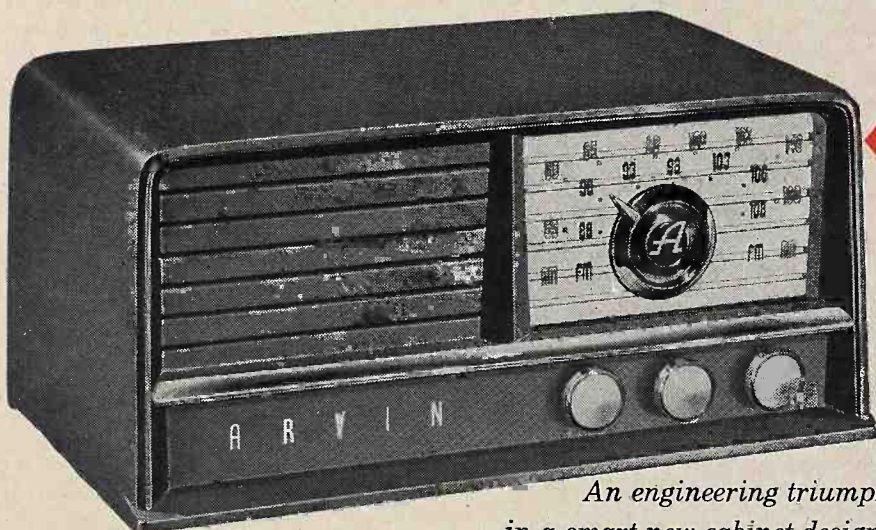

*An engineering triumph
in a smart new cabinet design!*

\$**49**⁹⁵*

MODEL 480FM—straight AC chassis for greater power, sensitivity, distance—in an all-new plastic cabinet that's a triumph of sleek, modern styling! Choice of walnut or ivory with satin finish gold color metal. Big, beautiful, easier-tuning dial. Genuine Alnico V speaker; long-range built-in antenna.

*Slightly higher in Zone 2

Arvin Radio & Television Division

NOBLITT-SPARKS INDUSTRIES, INC. • COLUMBUS, INDIANA

Profitable TV Trade-Ins

Flexible Formula Allows for Variables, Permits Tailor-Made Policy to Fit Any Situation

• As saturation increases in established TV market areas, the necessity for accepting trade-ins on larger-screen or improved models is fast growing. Unlike many used small appliances which are relatively worthless from a resale point of view, and on which trade-in allowances are given as a form of discount, a used TV set at the right price may find a ready sale to a "new" TV family with limited funds, or to others as a "second set." It is often possible for such purchasers to get a better or even bigger used set than the new one which carries the same or similar price.

A few dealers have already discovered that the resale of TV trade-ins can be carried on at a profit. At the same time, a realistic trade-in offer from such a dealer (who can afford to make such an offer because he sincerely intends to resell the receiver), attracts many new sales from users who are ready for a larger screen set . . . or one with more features, such as a combination console.

The formula for figuring trade-in allowances which is outlined below is based on the premise that the trade-in set will be resold. It bears no particular relation to the price of the new set being bought at the time of the trade-in, with this exception: that it is assumed the new set will be at least comparable in value with the old one. We do not mean by this that it will be as expensive as the old one, since the prices have gone down. But comparable value might be stated this way: the same size or larger screen if the old set was a straight TV set; and if the old set was a combination, then the new one should be a combination with the same size or larger screen, or a straight TV set with at least the next size larger screen.

Establish Selling Price

The first step in determining the trade-in allowance on a used TV set is to establish a "suggested retail price" at which the set can be resold. The following table has proved successful in several areas. If, however, after testing these percentages on paper with several known models, the dealer feels that the resultant prices are too high or too low for his area, he may scale the whole list up or down a few per cent to arrive at a more suitable figure.

The following table for obtaining the resale price shows the age of the trade-in, followed by a percentage. To obtain

the sale price, take that percentage of the most recent price of a comparable receiver:

Age	Percentage
90 days to 1 year	65%
1 to 2 years	50%
2 to 3 years	30%
3 to 4 years	20%
4 to 5 years	10%
Over 5 years	5%

Let us cite an imaginary case to show how this table works. As an example, we shall take a 10-inch table model TV-only receiver made by manufacturer "X". This receiver originally cost \$375. The set is between 2 and 3 years old, so the percentage is 30%. The current price for a 10-inch table model of the same manufacturer is \$169.50. The resale price on the old set is therefore 30% of \$169.50, or approximately \$50. This is not the trade-in allowance, but the resale price. To take another example, we have for trade a 2-year-old 12-inch table model which cost \$475. The most recent price on a 12 (now 12½) inch table set of the same manufacturer was \$329.50. The resale price of the old set is therefore 30% of \$329.50, or \$98.85 (which we might round off to \$100.).

Reconditioning Costs

It can be seen that basing the resale value on the current or most recent price of a receiver comparable to the old one and made by the same manufacturer protects the dealer on lines which have been greatly reduced. In the two examples just cited, the 12-inch receiver is now valued at 21% of its original cost, whereas the 10-inch receiver is only 13% of its original price. This might not have been true had different hypothetical cases been cited as examples, but serves to show how the formula adjusts itself to take into account these variables.

Now that we have established the retail price for resale, we can determine the trade-in allowance. The trade-in allowance is equal to the resale price less a percentage to cover the dealer's profit, and a percentage to cover reconditioning for resale.

Reconditioning the receiver must be predicated on the original cost of the set, since a "comparable" new one most likely has fewer tubes and parts. In several instances checked, 5% of the original cost of the set was found sufficient to cover reconditioning where this does not include replacing the picture tube. This percentage may be adjusted by the dealer if his experience or judgment

prompts him, but we shall use it for the sake of example. In the case of the \$375. set, the allowance for reconditioning (at 5%) would, therefore, be \$18.75, and for the \$475. set, \$23.75. If the dealer chooses to replace the picture tube automatically in reconditioned sets, 5% would not cover it. Although prices on tubes are changing, and also vary according to which brand the dealer buys and what quantity he buys, we might generalize by saying that a 10-inch tube costs him about \$25., and a 12-inch about \$35. To cover this sum, the percentage for reconditioning would have to be raised to about 12% of the original cost of the receiver. In the case of the 2-year-old 10-inch set cited above as an example, it would not be possible to give any trade-in allowance at all on this basis. We believe that with trade-in prices being closely paced by the lowered cost of new sets, the dealer will be forced to reject the picture tube replacement idea, and in addition, would give full trade-in allowance only on sets that work.

The final item in determining the trade-in allowance is profit. This is strictly at the discretion of the merchant and may vary from 0 (one dealer we know of does not attempt to make a profit on trade-ins, but only breaks even) to 100%. In order to cite an example, we will choose 10% profit as an average figure for this type of sale (the dealer will also make a profit on the new item sold in place of the trade-in). Ten per cent, then, of the resale value of the receiver is profit. On our 10-inch, 2-year-old set, therefore, we find the following:

(A) Original Cost	\$375.
(B) Resale Value	50.
(C) Reconditioning cost.	18.75
(D) Profit (10% of \$50.)	5.00
	<hr/>
(E) Trade-In Allowance	26.25

On the 12-inch, 2-year-old set:

(A) Original cost	\$475.
(B) Resale Value	100.
(C) Reconditioning cost.	23.75
(D) Profit	10.00
	<hr/>
(E) Trade-In Allowance	66.25

To review these procedures, we first arrive at the resale value (B) by using the percentage in table 1 (based on the age of the set) and multiplying this

(Continued on page 105)

DU MONT LEADS THE INDUSTRY...IN

Electronic research

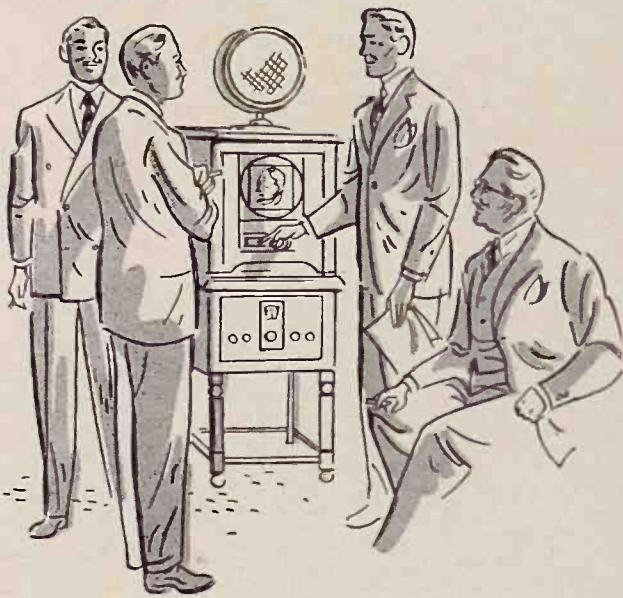

Du Mont's staff of 250 engineers is headed by two of the world's leading electronic authorities—Dr. Allen B. Du Mont, President, and Dr. Thomas T. Goldsmith, Jr., Director of Research.

Much of the development in the field of television since 1931 has come out of the Du Mont Laboratories. And this is only natural. For it was Du Mont's development of the cathode ray tube from a laboratory curiosity that made electronic television commercially practical; and Du Mont has pioneered every phase of television—broadcasting, and transmitter as well as receiver manufacture.

Today, every Du Mont receiver is the direct result of this vast background of technical experience. That's why we say: "What no other receiver can give you, costs you nothing in a Du Mont."

DU MONT

First with the finest in Television

Invite your prospects to see the Morey Amsterdam show over the Du Mont television network. Morey is a great salesman.

Copyright 1950, Allen B. Du Mont Laboratories, Inc.

Allen B. Du Mont Laboratories, Inc., Television Receiver Div., East Paterson, N. J. and the Du Mont Television Network, 515 Madison Ave., N. Y. 22, N. Y.

First in Precision Electronics. Du Mont Laboratories are the world's foremost makers of scientific instruments employing the cathode ray tube.

First in Radar. In 1933, Dr. Du Mont filed a patent application which the Army asked him to withdraw and develop the invention in deepest secrecy. That was radar.

First in Broadcasting. Du Mont operates the first television network, and now has affiliated stations in almost every television city.

First in Station Equipment. Many of the television broadcasting stations now on the air were planned by Du Mont engineers and built with Du Mont broadcasting equipment.

First in Fine Receivers. Du Mont built the first commercial home television receivers (1939) and was first on the market with a full line of postwar receivers (1946).





Cartoon extreme left depicts crooner Frank Sinatra in role of featured conductor. "Frank Sinatra Conducts Music of Alec Wilder" is title of Sinatra's new Columbia release. Another Columbia album of especial interest is Oscar Levant's forthcoming Khachaturian "Concerto for Piano and Orchestra." Mr. Levant is pictured at left.

Best-Selling Disc Hits

Decca's ANTA "Album of Stars" offers outstanding stage artists in memorable scenes from Broadway productions in which they have appeared. The tremendous appeal of this collection to theatre-goers, students, local groups, and collectors in general should afford dealers a wide range of promotional possibilities.

Cab Calloway, right, has signed with London records. Look for his first releases to do well. Richard Hayes, lower right, has come up with another successful discing for Mercury, "The Flying Dutchman."



At right: RCA Victor songbirds Fran Warren and Lisa Kirk collaborate on a unique pair of sides, "Dearie" and "Just A Girl That Men Forget." Below: Conductor Arthur Fiedler, left, and composer Leroy Anderson work together on the Red Seal recordings of the composer's "The Irish Suite," a timely March release. The album comes in a bright Kelly green.

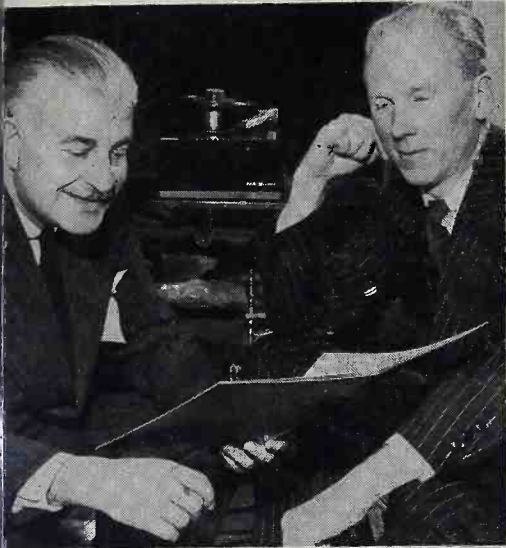

Boost Dealer Profits

Capital Records' singing star, Jo Stafford, is featured on a new album entitled "Autumn in New York." Package contains title song, as well as a selection of collectors' item tunes, rendered in the popular Stafford style.



Ames Bros. indulge in a bit of zaniness in the wake of their "Rag Mop" success for Coral.



MGM has issued six of "Mr. B's" best songs, providing dealers with a sure-selling collection.

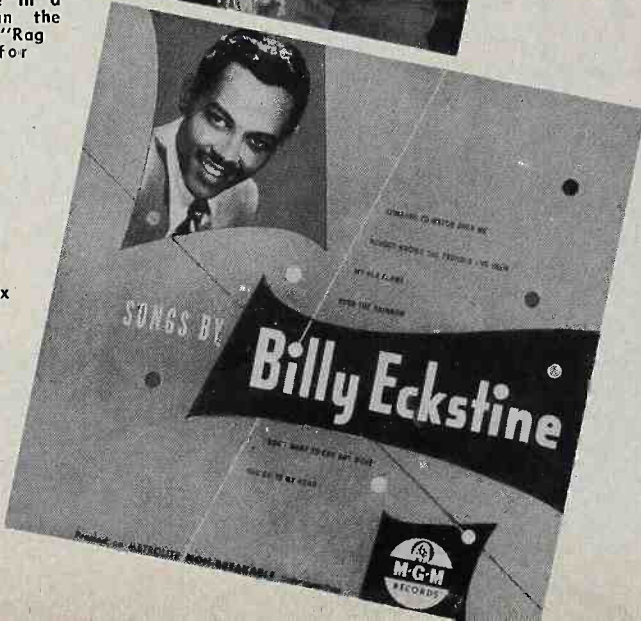

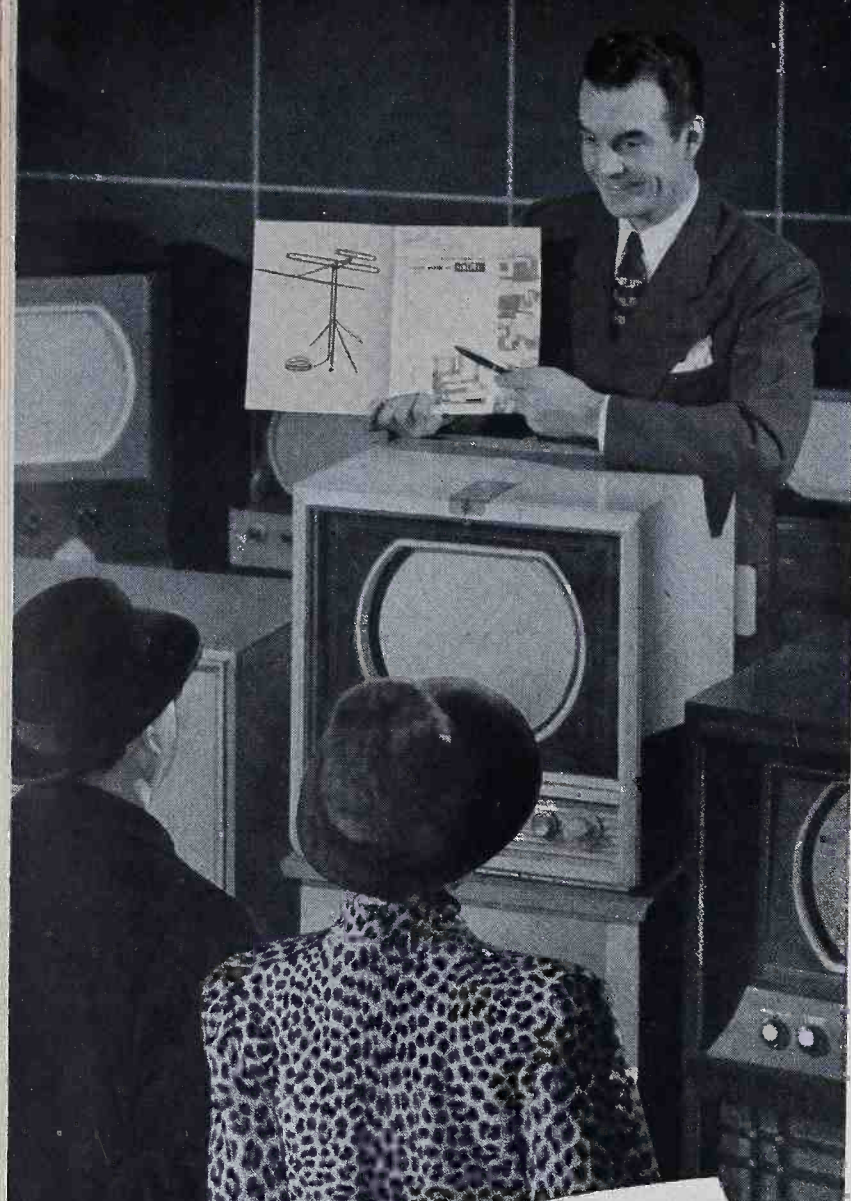

"You can't get any more out of a TV set than you put into it. And that means signal strength supplied by the antenna. That's why we always recommend the antenna accepted as standard by the whole TV industry — the Amphenol INLINE* Antenna."

*U. S. PATENT NO. 2,474,480

The booklet he is showing gives the whole TV story. Write for your copy — a postcard will do it.
AMERICAN PHENOLIC CORPORATION
 1830 SO. 54TH AVENUE • CHICAGO 50, ILLINOIS



COMMAND PERFORMANCE



RECORD PLAYERS

Performing miracles in quality . . . price . . . construction . . . design . . . and fidelity.

- **VOLUME SALES** 
- **SOLID PROFITS**  
- **RMA**
RCA Licensed Manufacturers

18 Models in full price range. All speeds in manuals and automatics

Distributors — write for brochure.

SYMPHONIC RADIO & ELECTRONIC CORP.
 292 MAIN STREET • CAMBRIDGE, MASS.

TV TUBES ...



We can ship your order IMMEDIATELY!

Our new East Paterson Plant does more than simply get the tubes off the line...a lot more! Higher vacuum, screen and component standards make for top tubes ...less inspection and reject headaches on your part! Ask top set manufacturers...they'll tell you.

Write for full information on the new black 19" and 16" round and rectangles.

TEL-O-TUBE CORPORATION OF AMERICA



180 VAN RIPER AVE. EAST PATERSON, N. J.

New Electrical Appliances

Frigidaire APPLIANCE LINES

Introduced by the company are refrigerators of three types, four series and 10 sizes, plus new 30-inch electric ranges featuring extra-large full-width ovens, new large capacity food freezers, and an improved electric dehumidifier for use in homes and business.

Food storage flexibility and new cabinet styling keynote the new refrigerator line. Frozen food storage capacities from over 70 lbs. in larger models to 15 lbs. in the smaller ones. Two deluxe refrigerators have full-length doors; model DM-107 has 10.7 cu. ft. storage space, model DM-90 has 9 cu. ft. Three new Master series refrigerators are cooled by extra-large Super-Freezers located in the upper right side. Two new Standard series models in the low price bracket include models SM-76 and SM-60 with frozen food storage capacities of 19 and 15 pounds. A full 6 cu. ft. model is available at a price of \$189.75. Imperial models of 8 and 10 cu. ft. storage capacities are two-door combination models with separate Locker-Top freezers which hold 50 and 70 lbs. of frozen food.

Two new electric ranges, models RM-30 and RM-35, porcelain finished, feature the new "giant" oven. 40-inch electric deluxe ranges include one model featuring two ovens (RM-75) and the other (RM-65), equipped with a single oven and warming drawer. Also there are two 40-inch economy models (RM-27 and RM-17) plus two 24-inch ranges.

Food freezers available in three sizes with food storage capacities of 8.8, 11.7 and 17 cu. ft. Frigidaire Div., General Motors, Dayton, O.—RADIO & TELEVISION RETAILING.

Fresh'nd-Aire CIRCULATOR

Three-speed electric circulator, model F-12, designed to resemble a coffee or cocktail table, is styled in two toned green-grey and yellow plastic. Features: 3 operating



speeds controlled by a recessed speed switch; noiseless, draftless circulation; good guard construction. Dimensions: 14 inches high, 17 inches in diameter. Unit retails for \$47.50. Fresh'nd-Aire Co., 221 No. La Salle St., Chicago 1, Ill.—RADIO & TELEVISION RETAILING.

Universal SELECT-A-RANGE

Flexible electric range design, illustrated, one of many combinations possible. Range designs feature greater convenience with everything at the right cooking level. "Convenience-Level" oven can be set where homemaker desires to have it. Functional, easy to install, it does away with rigid dimensions and limited planning. The



Select-A-Range is comprised of three basic interchangeable self-contained units, consisting of an oven, surface cooking unit, and a roomy storage cabinet. More than 25 different arrangements can be created from these basic units. Oven has a one piece enamel-lined interior, thermostat control and preheat push button, automatic timer, Minute Minder, Signalites, smokeless slotted broiler grid and no-warp broiler pan. Surface units have controls with adjustable seven-heat control switches. Landers, Frary & Clark, New Britain, Conn.—RADIO & TELEVISION RETAILING.

GE LAUNDRY EQUIPMENT

Introduced in the company's line were: an automatic washer which permits the homemaker to reduce water consumption when washing a small load of clothes; washer is rectangular, features top-loading, has capacity of 9 lbs. dry clothes; retails for \$369.95. Top model in the wringer washer line is the deluxe AW-452, priced at \$169.95. Other new wringer washers are the AW-352, priced at \$139.95, and the AW-152, priced at \$124.95. Seven new ironer models are in the 1950 line. Two of the rotary ironers are automatic, thermostatically controlled cabinet models with 26-inch ironing rolls. The AR-70, which operates at two speeds and has a pressing position, is priced at \$169.95. The AR-60, a one-speed machine, is a manually operated machine with a 22-inch roll and a press control, priced at \$49.95. General Electric Co., Home Laundry Division, Bridgeport, Conn.—RADIO & TELEVISION RETAILING.

Westinghouse FLOOR FAN

10-inch hassock type floor fan, "The Debonaire," can circulate 1700 cu. ft. of air a minute without creating a draft. Fan is finished in maroon and chrome. Operates quietly; stands 13 inches high; weighs 15 lbs. It will sell at a suggested retail price of \$29.95. Westinghouse Electric Corp., Box 2099, Pittsburgh, Pa.—RADIO & TELEVISION RETAILING.

Kelvinator REFRIGERATOR

"Moist-Master" refrigerator, shown, refrigerated from top-to-bottom provides 14



cu. ft. of food storage space in a cabinet that occupies no more kitchen floor area than pre-war 6 ft. models. Features include an across-the-top freezer, glass shelves, Cold-Mist freshener area with self-closing clear polystyrene doors and 40 qt. super-crisper. Kelvinator Div., Nash-Kelvinator Corp., Detroit 32, Mich.—RADIO & TELEVISION RETAILING.

Proctor IRONING BOARD COVER

Ironing table pad with cover in color; cover cannot fade or shrink, slip or slide; easily removed for cleaning; available in sturdy sail-cloth. Custom-fit pad and cover package priced at \$3.95; includes set of 7 smooth wooden dowel-sticks and three spring-stretchers. Available in blue, yellow, beige and "sun-bleached" white. Proctor Electric Co., Philadelphia, Pa.—RADIO & TELEVISION RETAILING.

Starrett AIR CONDITIONER

Model 50, shown, has a suggested retail price of \$299.95. Dimensions: 15 3/4 inches high, 27 inches wide, 25 3/4 inches deep. Features: 1/2 H.P.; built-in De-Odifier; air di-

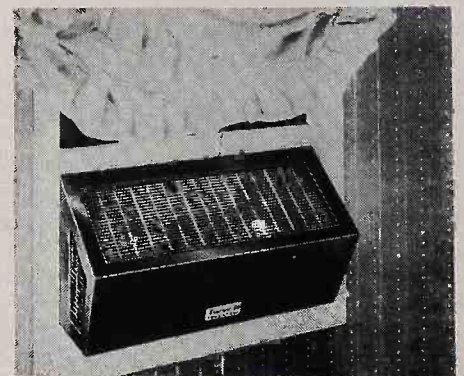

rected towards ceiling to assure draft free ventilation; "Dry-Namic" moisture remover; variable capacity regulator for regulating air flow. Starrett Television Corp., 601 W. 26th St., New York, N. Y.—RADIO & TELEVISION RETAILING.

8224

8223

8222

8205

8209

8204

8216

8225

8235

TRANSMISSION LINE CABLES

Every Type for Every Service

Sold Exclusively Through Recognized Wholesale Distributors

8210

8226

8227

8229

8228

Belden

Radio WIRE

New Electrical Appliances

Gibson FREEZER

Freezer model HF 1890 has a total capacity of 18 cu. ft., 2 compartments with 2 doors, incorporating a 2.5 cu. ft. fast freeze compartment. Both compartments may be used for storage. Retail price is

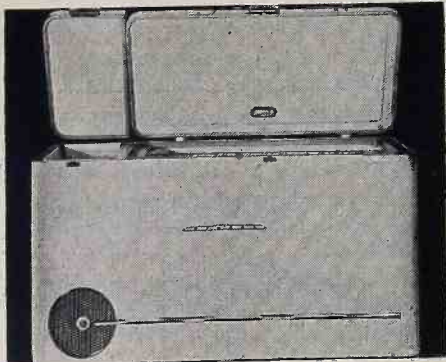

\$489.95. Total outside dimensions are: 30 $\frac{3}{4}$ inches wide, 71 $\frac{1}{4}$ inches long; 40 $\frac{3}{32}$ inches high. Gibson Refrigerator Co., Greenville, Mich.—RADIO & TELEVISION RETAILING.

Thor CLOTHES DRYER

Automatic electric clothes dryer designed to retail for \$239.50. Capacity of 8 lbs. clothes (dry weight) or 16 lbs. (wet weight). Cabinet is 30 inches wide, 24 $\frac{3}{4}$ inches deep and 36 inches high. Finished in white baked enamel; unit's outer panels are designed to be removed easily to facilitate servicing any portion of the dryer chassis. Dryer employs a positive vacuum (or suction) drying system. Thor Corp., Chicago 50, Ill.—RADIO & TELEVISION RETAILING.

Freez-Pak REFRIGERATOR

Unit proportioned and designed in cheerful colors to blend with home and office decor. Provides for keeping food with ideal temperature and moisture conditions; plus freezing compartment with abundant space for frozen food storage and ice cube capacity. Overall dimensions: 31 inches wide, 19 inches deep, 25 inches high. Storage

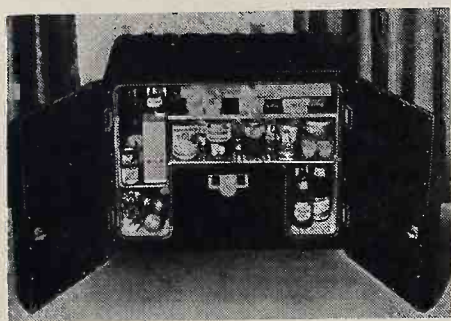

capacity of 2.66 cu. ft. All steel cabinet; bonderized and finished with durable baked-on enamel. Powered by precision built and hermetically sealed unit; Stand of tubular steel with chrome plate available. Freez-Pak sells for \$159.95; stand for \$14.95. Freez-Pak Corp., 122 E. 42 St., New York City.—RADIO & TELEVISION RETAILING.

Leonard ELECTRIC RANGES

1950 range line includes four models built to standard width of 39 inches, and two small-kitchen ranges 21 inches wide. Leader is model LER-502, shown, with three



7-heat tilt-up surface units, 6 quart deep well cooker, 22-element oven with automatic preheat cut-off. Range is priced at \$195.95 (with lamp, clock and oven control accessory); \$189.95 (with lamp and minute timer accessory); \$179.95 (standard equipment). Other models are priced from \$309.95 to \$154.95. Leonard Div., Nash-Kelvinator Corp., Detroit 32, Mich.—RADIO & TELEVISION RETAILING.

Hotpoint IRONER

Low-priced rotary ironer, LR-4, is fully automatic. Features: thermostatically con-



trolled; cabinet enclosed model; automatic knee control; manual shoe release; 26-inch roll; white Calgloss enamel finish. Hotpoint, Inc., 5600 W. Taylor St., Chicago, Ill.—RADIO & TELEVISION RETAILING.

Lonergan FANS

Two new three-purpose fans in the line. The 20-inch model lists at \$59.95; the 24-inch model lists at \$69.95. Fans have two speed operation, and reversible feature as an exhaust or intake fan; no special attachments needed for use as a floor model. Included with each unit is a device which holds the fan in the window without screws or hooks. Ivory cabinet enclosed on all sides, built-in handles. Lonergan Mfg. Co., Albion, Mich.—RADIO & TELEVISION RETAILING.

Blackstone WASHERS, IRONER and DRYER

Full family-size washing machine, shown, model 136, retails in Zone 1 at \$89.95. Incorporates precision-built mechanism, fully-enclosed wringer head, wringer post cover, cord hooks, and many addi-



tional features. Washer is equipped with a Lovell target release type wringer and has a plastic high vane agitator. Capacity is eight pounds.

Model #130A has been reduced to \$119.95 and \$129.95 (pump model) in Zone 1; eye-appeal strengthened by addition of polished chrome hand rests and a chrome decorative trim between tub and base ring. Top model in the line is model #330, which features new wringer die-cast in one piece of aluminum which forms the end frames and drain boards; finished in white Suprenamel, making for extra strength and elimination of rust. Retails in Zone 1 for \$149.95 and \$159.95 with "Hydrospout," a unique built-in drain system for pump models.

Model #180 portable ironer features: stainless steel shoe, knee and finger-tip control, heat control. Retails in Zone 1 for \$89.95. Also available as a cabinet ironer for \$150.00.

Gas dryer, model #290 is fully automatic; identical in appearance and dimensions to the electric dryer, model #190. Blackstone Corp., Jamestown, N.Y.—RADIO & TELEVISION RETAILING.

York AIR CONDITIONERS

Six new models of hermetically sealed room air conditioners introduced. Models 150 and 200, two larger models, can be equipped with duct work attachments for conditioning multiple areas; models 12 and 23, $\frac{1}{2}$ and $\frac{3}{4}$ H.P. units, are window-sill models, finished to harmonize with interiors; models 33 and 100, $\frac{3}{4}$ and one H.P. console units, styled in furniture-like cabinets; models 150 and 200, $1\frac{1}{2}$ and 2 H.P. units are self-contained console type air conditioners, designed for commercial and home use. York Corp., York, Pa.—RADIO & TELEVISION RETAILING.

We have what it Takes for



UNIVERSAL *Gives You*

The most saleable line of home laundry equipment ever offered. Accepted the country over for its "way-ahead" features, quality of manufacture and trouble-free performance. You'll find more to talk about—more features to sell . . . when you handle UNIVERSAL, the line that can't be topped.

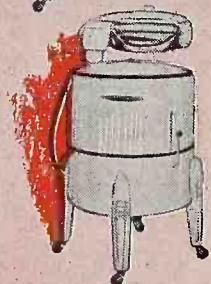
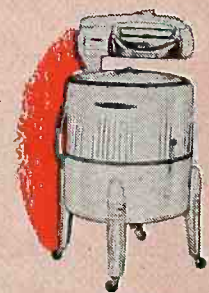
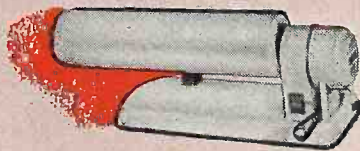
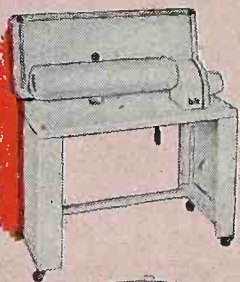
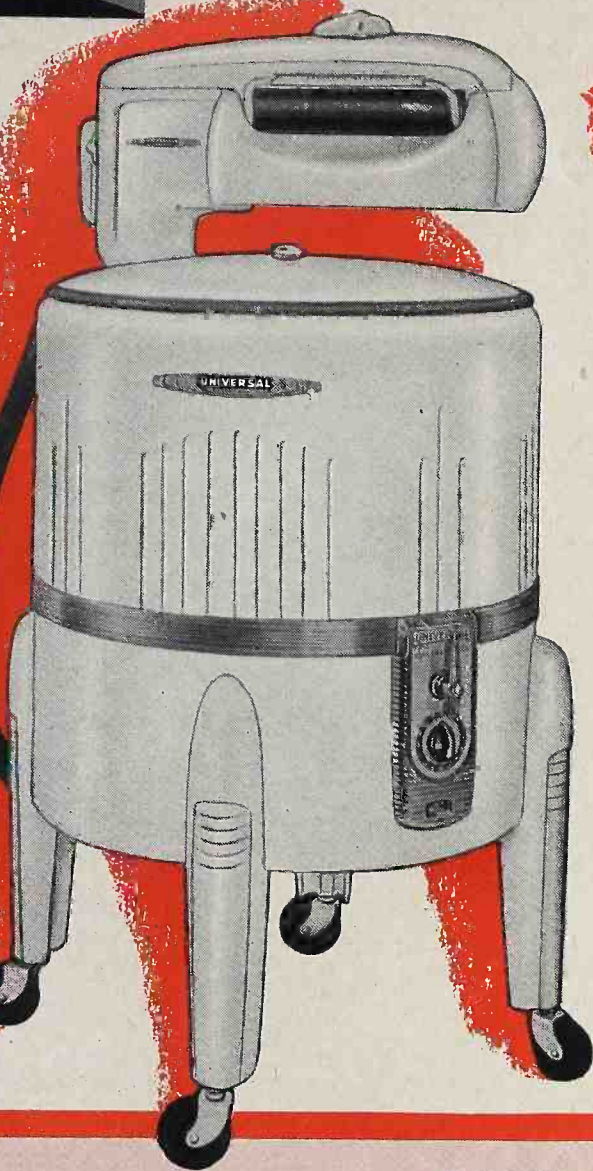
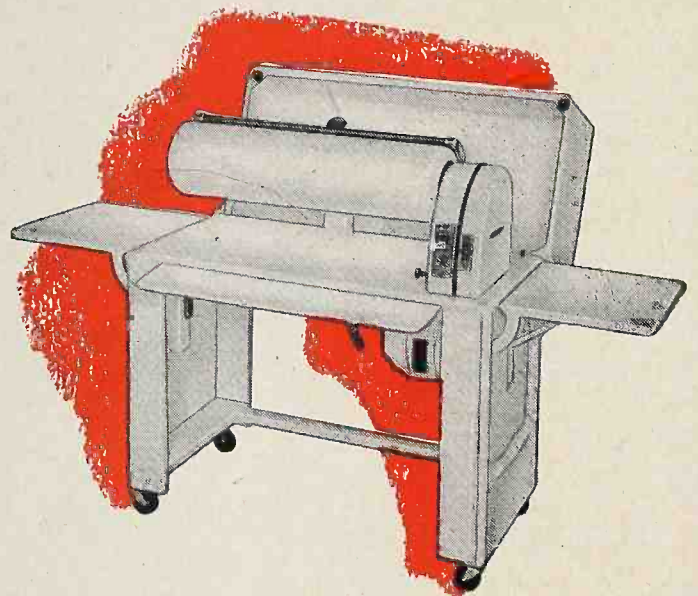

A Complete line of Home Laundry equipment for every purpose, to fit any budget. Four famous electric washers led by Universal's exclusive, 2-speed model with its Super-Safe Control-O-Roll Wringer, Time-A-Matic Timer and safety-switch. Two Cabinet type Automatic Ironers and a portable table-top model gives any purchaser a choice for any laundry requirement. They're UNIVERSAL—the Best in Home Laundry Equipment!

Laundry Equipment Sales!

**For Success in Competitive Spring Selling
be sure you have the right tools...**

You need

- 1 A fast-selling, complete line with National acceptance.
- 2 A compelling consumer offer to attract prospects.*
- 3 A power-packed promotion to focus consumer attention.

2 UNIVERSAL Gives You

The most sensational premium offer of the industry—and at a full-profit margin! More sales—easier sales with this extra-plus sales getter... a 53 piece silverware setting complete with Tuckaway case to every purchaser of one of the Universal top three model washers or the deluxe 2-speed ironer! And this premium at no extra cost to the retailer!



3 UNIVERSAL Gives You



A hard hitting nation-wide promotion designed to make prospects of every woman in your sales area. Hard hitting, local newspaper campaigns... colorful displays, window streamers and direct mail material... all sure-fire to move Universal laundry appliances off the dealer's sales-floor and into customer homes!

See your UNIVERSAL DISTRIBUTOR NOW!

*This special offer will be for a limited time only—don't miss out on Spring profits.

UNIVERSAL

LANDERS, FRARY & CLARK, NEW BRITAIN, CONN.

QUALITY AND VALUE SINCE 1842 *Centennial Anniversary Presentation*

Revamp Your Service Department

**And Make Sure to Sell Your Know-How
and Facilities to Your Customer**

• The importance of adequate, competent, and efficient service to television has been emphasized so often that it is almost an axiom—and it has usually been given a quick brush-off by dealers who don't handle TV service in their stores.

There are several merchandising aspects to this subject, however, which a dealer can ill afford to ignore, regardless of his present position in the TV picture.

While we, of course, do not subscribe to the idea that "television isn't perfected yet," we must face the fact that TV sets require special service. This is due to factors such as the complexity and size of the receivers, the unfamiliarity of the customer with the art, the complexities of antennas and reception at Very High Frequencies, etc.

With over 4 million homes equipped with TV, the consumer has come to accept the necessity of TV service,

and has come to realize the importance of good service: prompt, skilled and efficient. Many people have come to understand (and even more will if alert dealers promote the fact) that television enjoyment must include not only the purchase of a good set but also of good service. A cut-price TV set is a poor bargain if it is not accompanied by top-notch installation and service. The logical inference of this statement is that it is worthwhile to pay a little more (or in other words, to pay list) to get the assurance of continued enjoyment throughout the life of the set.

But how can the dealer sell the idea to the customer that he is able to pro-

vide the best of service? It will be helpful to *tell* the customer about the numbers of his trucks and servicemen, the up-to-date facilities of his shop, the know-how of his men, etc. But many dealers are finding that it is more effective to *show* the customer some of these facts. The customer will not understand, but will be impressed nevertheless by the complex appearance of oscilloscopes, signal generators,

Service Out Front!

Customer's eye-view at Star Radio & Television Company, Allston, Mass., reveals an out-front service department that's been successful for a number of years. Close-up view on opposite page.



for Better TV Merchandising

chassis exposed on the bench, etc. And he will be impressed by a large, neat, busy service department, shiny panel trucks with ladders on top, etc.

This suggests not only an expanded, revamped service department, new test equipment, and the like. It also suggests an entrance from the front of the store, or a window, or even a counter, where the customer can see the "genius at work."

These are merchandising aspects of

bers of organizations who "bit off more than they could chew," and were unable to get sufficient skilled help to handle all the contracts they accepted. There have been others who quoted too low a price on the contract and found themselves unable to do a really thorough job without going broke. And, of course, there have been a few who were just downright incompetent.

Regardless of competence, however,

really a "concealed asset" in the purchase of a TV set from your store.

"Merchandising" the service facilities can be done, as mentioned before, by word of mouth and by demonstration, and also through advertising and direct mail.

This may include "service" not only in the mechanical sense, but also the more general services of a store such as delivery, charge accounts, etc.

The actual physical layout of the "revamped" service department will require the consultation of technical personnel, but certain generalities may be observed. The television chassis is on the average considerably larger than the radio and consequently requires more working space on the bench, both as to depth and width. It is becoming conventional to provide a shelf above the bench for test equipment so that these items will be at eye level, and also out of the way of the rather bulky chassis. The larger average number of tubes in a TV set means a larger stock on hand for these items, as well as other components, and adequate bins and shelves for their storage must be provided which will also afford convenient access. Cathode ray tubes in boxes are exceptionally large and will require special shelves. It is usually advisable, where space permits, to provide a special storage place for antennas and antenna accessories, since this material bulks rather large and would probably crowd out the service department.

Shop Layout Hints

If it is planned to have an entrance, window or counter from the service department into the front of the store, it is recommended that sound absorbent material such as Celotex be used on the walls and ceiling of the service department. This is due to the fact that the test tones broadcast with TV test patterns combined with the output of signal generators makes quite a din of shrill sounds which apparently no one but veteran servicers can abide.

Panels of test equipment on the test-bench, rather than groups of individual units, present a more neat and attractive appearance and are suggested, especially where customers will be permitted to look into the shop. And in conclusion, it is suggested that customers be permitted to look in, for a pride in your own service facilities can easily be conveyed to them in this manner, and will be an important factor on the sales floor.



the service department which have actually helped make sales in many instances where they are employed. There are other reasons why an efficient and impressive service department is helpful on the sales floor. Many dealers who had merely a token service department for handling radios within guarantee, and who did not wish to go to the expense of building and staffing a TV service unit, farmed out this work.

"Farmed-Out" Service

The result of this farming out has often been the loss of customers due either to the tardy or inefficient handling of the work. We do not mean to imply that no independent service organization is capable of handling contract work. But there have been mem-

bers of organizations who "bit off more than they could chew," and were unable to get sufficient skilled help to handle all the contracts they accepted. There have been others who quoted too low a price on the contract and found themselves unable to do a really thorough job without going broke. And, of course, there have been a few who were just downright incompetent.

Regardless of competence, however, the contract servicer cannot be expected to treat your customer as you would yourself. You look upon your customer as a potential source of additional business in the future, as well as a word-of-mouth advertiser to bring in new customers. Your contract servicer cannot be counted on to preserve this relationship, since he has nothing to gain or lose from the customer. This is an additional reason why, for merchandising purposes, you should have a good service department of your own for television.



The Senator—DX 950—16 inch table-top cabinet with improved Super-DX chassis. Built-In Gyro-Tenna, Anti-Interference traps.



The President—DX 931—19 inch tube in a deluxe period console cabinet with matched figured doors. Super-DX chassis.



The Reveller—XL 211—12 1/2 inch budget-priced Excell console. Straight A.C. circuit, Turret-type tuner, genuine Mahogany cabinet.

QUALITY
IS THE
LINE
OF
LEAST
RESISTANCE

Olympic
Star☆brite
TELEVISION



The Varsity—XL 210—12 1/2 inch budget-priced Excell table-top cabinet in genuine Mahogany. Powerful straight A.C. chassis, Gyro-Tenna.

11 WONDERFUL MODELS

12 1/2 INCH TO 19 INCH
FROM

\$17995



The Whitehall—DX 619—16 inch tube in a decorator-styled period console. Super-DX chassis, with all the latest electronic features.

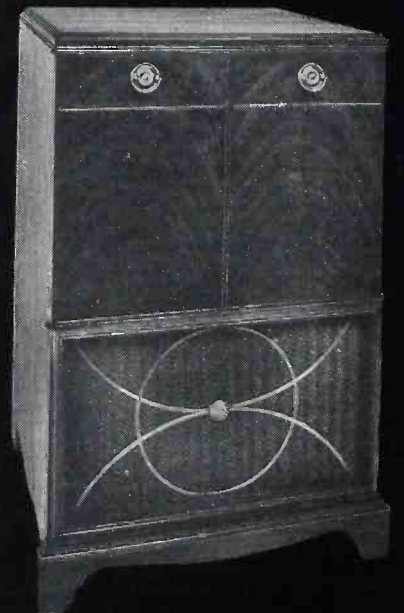

The Vanderbilt—DX 215—Period console with matched doors. Genuine mahogany. 12 1/2 inch tube, complete Super-DX chassis.

Write for illustrated literature.

OLYMPIC
RADIO AND TELEVISION, INC.
LONG ISLAND CITY 1, N. Y.

New Low Cost Tape Recorder OPENS VAST MASS MARKETS



AMPRO *Magnetic* TAPE RECORDER and PLAYBACK UNIT

\$94⁵⁰

• Complete with Microphone and Cable • Radio Speaker Attachment Cord • Plastic Take-Up Reel • Manual Rewind Crank • Attractive Carrying Case

Ampro introduces a revolutionary new Magnetic Tape Recorder and Playback with basic advantages that appeal to millions

Vast new markets for tape recorders are smashed wide open with this new Ampro unit. Utilizing a basically new electronic design this is the first complete tape recorder ever offered for less than \$100—a simplified, easy-to-operate recorder that is truly portable because it weighs only 15 lbs.—a recorder that takes up to *two full hours* of recording on one standard 7" reel! Can't you picture how your customers in homes, schools, churches, clubs, organizations, offices and industry will go for this sensational value? And, best of all, you can sell this recorder with complete confidence because it is built and guaranteed by AMPRO—a name famous for dependable, high quality precision engineering.

Write for Dealership Information

For full details about this remarkable new Ampro Magnetic Tape Recorder and Playback—and information on obtaining a dealer franchise—fill out and mail the coupon below—today!

*Trade Mark
Reg. U. S. Pat. Off.



1 Lowest first cost

Fair Traded to retail at only \$94.50, complete . . . this new unit compares favorably with recorders selling for up to 50% more money!

2 Lowest operating cost— Two full hours of recording from one standard 7" reel!

Almost twice as much recorded material on each reel of tape, as compared with conventional recorders.

3 Lightest weight—most compact

The basically new design of this recorder makes possible tremendous savings in weight. It actually weighs less than any other tape recorder on the market today . . . a mere 15 pounds!

4 Simplest to operate

A young child can operate this new tape recorder . . . it is that easy! Operation has been reduced to its simplest terms, uncluttered by costly, complicated "gadgets" that merely confuse the operator.

5 Built and guaranteed by Ampro

. . . a name famous for fine craftsmanship in the design and manufacture of precision cine' equipment.

A General Precision Equipment Corporation Subsidiary

AMPRO*
8mm. Silent • 16mm. Silent
16mm. Sound-on-film • Slide Projectors
16mm. Arc Projectors

AMPRO CORPORATION RT350

2835 N. Western Ave., Chicago 18, Ill.

Please send me descriptive literature on the new Ampro Tape Recorder and complete information on obtaining a dealer franchise.

Name _____

Store Name _____

Address _____

City _____ State _____

New VIDEO RECTANGULAR 16 TP4

PHYSICAL DIMENSIONS—16" Rectangular—
16 1/8" Dia.—18 1/4" Long—14.738" Wide—11.5" High



WEIGHT and SPACE
SAVING... for
COMPACT DESIGN

OVER AN ACRE DEVOTED TO PRODUCTION

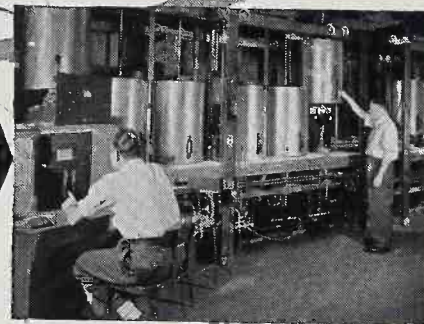

The new Video 16 TP4 sets a new standard in the all-glass rectangular television tubes. Combining all the precision engineering features and years of development, Video's new tube is the foremost in its line. It permits smaller cabinets, larger viewing screens, lighter weight units, and smaller dimensions.

With this new style magnetic focus tube, manufacturing problems are simplified.

Engineering and specification details giving complete data will be supplied. Write for Video's illustrated brochure today!

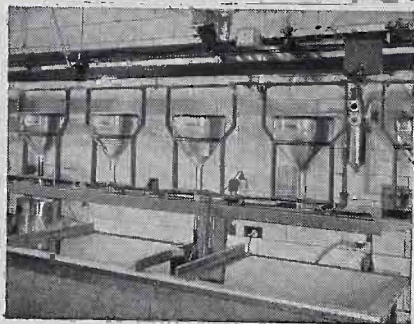
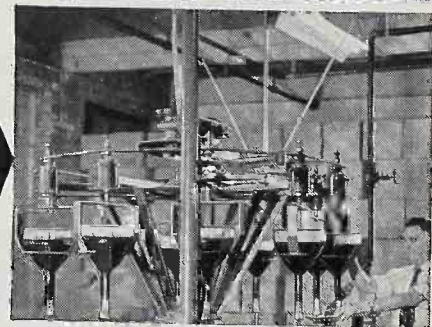
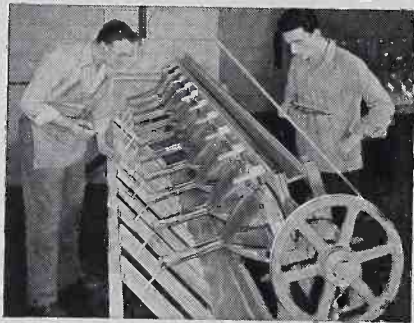

NATIONAL VIDEO CORPORATION

3019 WEST 47th STREET • CHICAGO 32, ILLINOIS

An **EXTRA**
SALES-FORCE
for **YOU**

From your own business experience you know that the big months for selling many of the major electrical appliances are just ahead.

Statistics confirm this, especially as to refrigerators, ranges, vacuum cleaners and water heaters.

To make the most of this seasonal angle, remember that the biggest sales potential lies in the greater volume of time payment sales. Right around the corner, or at the other end of a telephone wire, there is a Commercial Credit representative ready to hop to your assistance.

He is an expert on credit and financing — a specialist who knows how to make your time payment service convert more prospects into buyers . . . turn more merchandise into profits. He, and his counterparts in more than 300 Commercial Credit offices all over the country are doing it every day, for thousands of other appliance dealers.

It would be good business to call him in and have a talk with him.



More **SALES** • *More* **PROFITS**
More **SATISFIED CUSTOMERS**

COMMERCIAL CREDIT CORPORATION

A Subsidiary of

Commercial Credit Company Baltimore, ■ Capital and Surplus Over \$100,000,000

MORE THAN 300 OFFICES IN PRINCIPAL CITIES OF THE UNITED STATES AND CANADA

Sparton

TOWN and COUNTRY TELEVISION



MODEL 5014. Sparton Town Series table television, especially designed for city locations. Console-size 12½" picture tube. Sparton Sound-Lock, continuous tuning, built-in antenna. Adaptable to UHF. Mahogany veneer cabinet.

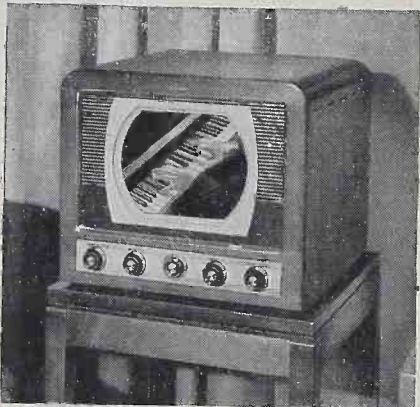

MODEL 5010. Sparton Town Series table television . . . city TV at its finest at such a price. 10" picture tube, automatic gain control, continuous tuning, Sparton Insta-Set knob control. Model adaptable to UHF. Cabinet of mahogany veneer.



MODEL 5006. Sparton Country Series table television—big, good, low-priced. 12½" screen. Internal cord antenna. Automatic gain control. Adaptable to UHF. Mahogany veneer cabinet.

- with Sparton pay-for-what-you-need design
- new discounts, sales plans
- guaranteed prices through April 30, 1950

CAST YOUR EYES on these sleek, new 1950 Sparton sales-makers . . . Sparton's Golden Jubilee Town & Country Television line.

Then check these *big* Sparton plus features for you. First, Sparton pay-for-what-you-need design—TV specifically designed for city or suburb, and priced for your customers' needs. Second, Sparton's new discounts and sales plans. Third, Sparton's *guaranteed* prices.

Is the TV future looking rosy for Sparton dealers? And how! Better write today for full details on the new Sparton direct-to-dealer selling plans for '50. Chances are *you* can share the Sparton profits waiting in your community.

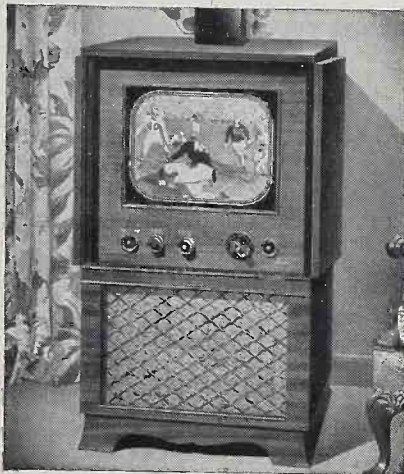

MODEL 5056. Sparton Town Series television console. Striking television performance and beauty at the lowest possible cost.

12½" picture tube, drift-free sound system, automatic gain control. Built-in power antenna. Adaptable to UHF. Mahogany veneer cabinet, burnished-brass trim, gold rayon grill cloth.

MODEL 5064. Sparton Country Series console. Superb styling, matchless engineering, 16" kinescope. Insta-Set knob control, Sound-Lock, automatic gain control, volume control. Model adaptable to UHF. Mahogany veneers.

Sparton

Radio-Television's Richest Franchise
SPARTON RADIO-TELEVISION
Division of

THE SPARKS-WITHINGTON COMPANY, JACKSON, MICHIGAN

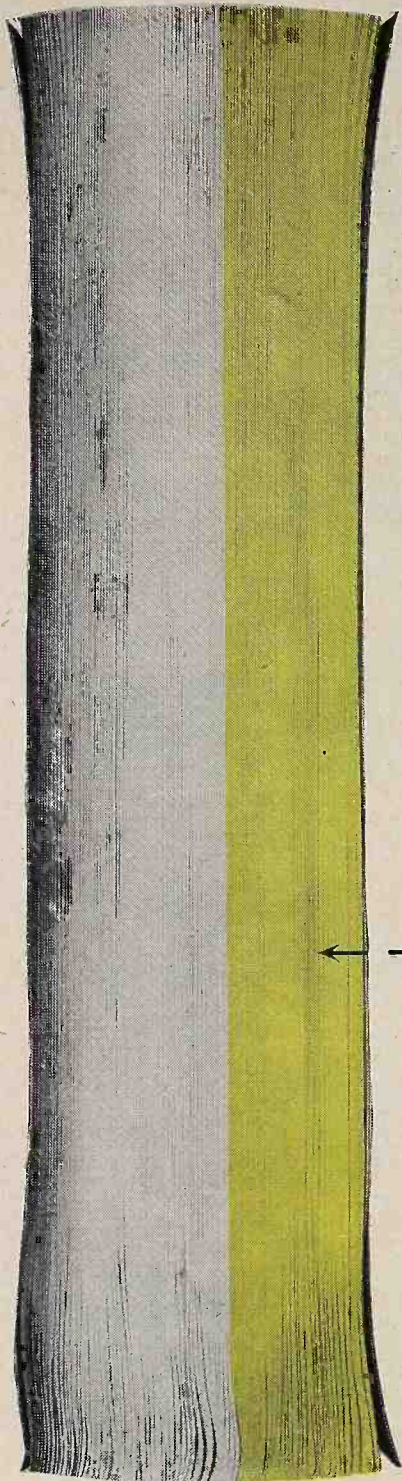

What's so important about YELLOW?

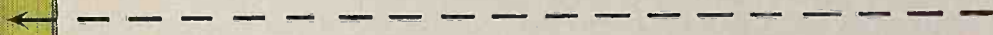

Yellow, when it's the 'yellow pages' in the Classified section of the telephone directory, means just one thing to the people in your community . . . "Here's where I can find who sells it."

The 'yellow pages' are at the elbow of practically everyone in town, *all day . . . and every day*. Surveys show that 9 out of 10 shoppers reach for them when they're ready to buy. With your business and your sales message appearing under all important classifications, the 'yellow pages' can be an important builder of new business.

*BUYERS REACH FOR
THE 'YELLOW PAGES'*



**FOR FURTHER INFORMATION, CALL YOUR
LOCAL TELEPHONE BUSINESS OFFICE.**



TELE KING...PERFECTED TELEVISION PIONEERS •

TELEVISION PIONEERS •

TELE KING...PERFECTED

Tele King

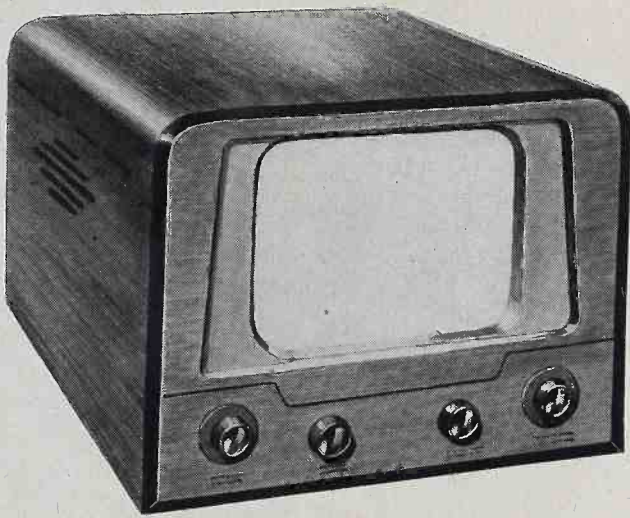

FIRST

with the

Revolutionary

14"

Now...

- 100% of the transmitted picture
- 100% of the viewing surface
- Neater...less bulky cabinets
- Low...low price
- Volume sales

Rectangular

GLARE FREE

"BLACK"

TUBE!

Tele King CORP.

601 WEST 26th STREET • NEW YORK, N. Y.



YOUR CHOICE

for every

INSTALLATION PROBLEM

Snyder

PHILADELPHIA

TV AERIALS

TV AERIAL
MAST SECTIONS

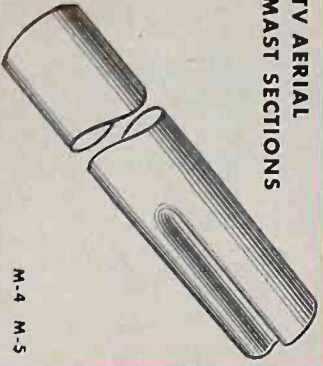

M-4 M-5

PORTABLES



P-1X

TV-13
HI-10



TV-17
LO-HI

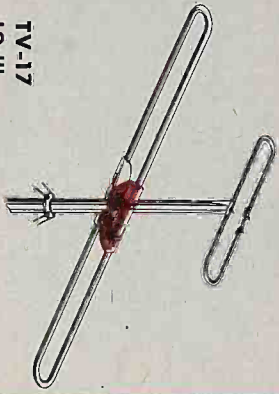

TV-16
IN-LINE



TX-30
REDI-X

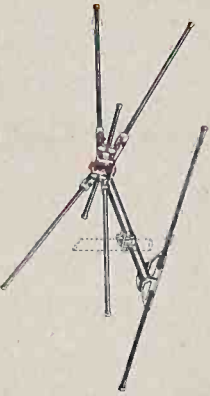

TX-2
LAZY XX

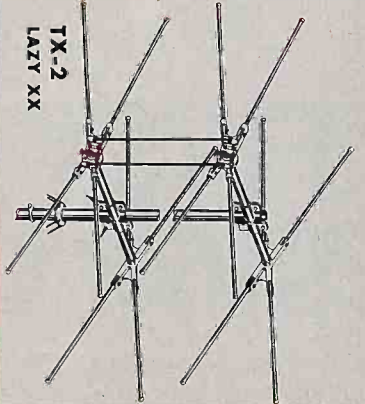

TV-21
SUPER-CHIEF



TV AERIAL BRACKETS

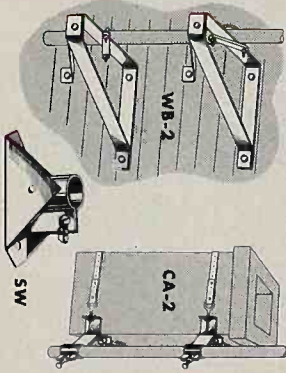

TV-14
STRAIGHT-AWAY

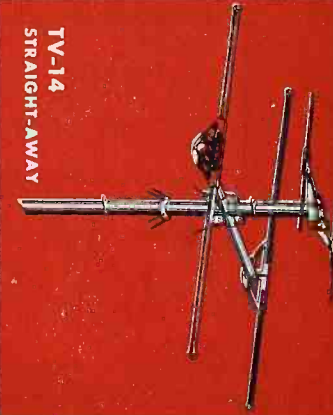

TX-A
SERVICEMEN'S ARRAY

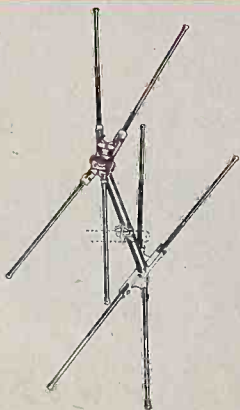

TV-22
CHIEF



SNYDER MFG. CO.

ANTENN - GINERS

PHILADELPHIA 40, P.A., U.S.A.

Distributed By the Best—Everywhere

In New York City, M. L. Doherty, Inc.
In Philadelphia, H. S. Alma Radio Co.
Export: Robson Agencies, Inc., N.Y.



Model 649

Emerson First AGAIN!

**BIGGER THAN LIFE-SIZE 235
SQUARE INCH PROTELGRAM
TELEVISION. CREATED BY
EMERSON FOR VALUE, FOR**

**VOLUME, FOR
GREATER
DEALER
PROFITS!**

Built-in Antenna.
Long-Distance Cir-
cuit. Fine Mahogany
Decorator Console.

**PERFORMS WHERE
OTHERS FAIL!**

**FIRST AT THIS
LOW-PRICE**

\$329⁵⁰

FIRST on the Best Seller List!

Giant Direct-View
Tube. Bigger picture,
smaller cabinet. Built-in Antenna. Super-Powered Long-
Distance Circuit. One-knob tuning. Comparison proves
—EMERSON PERFORMS WHERE OTHERS FAIL!

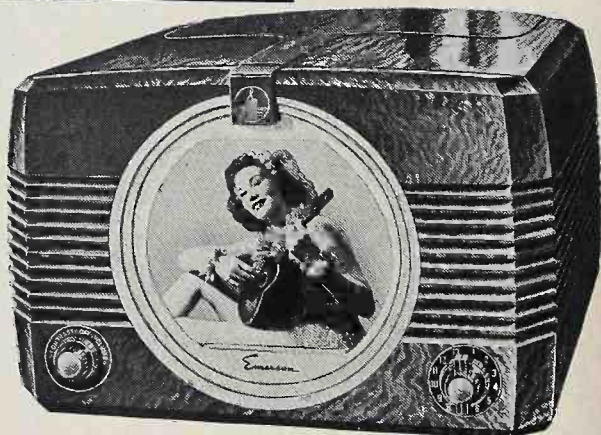

**Model
614**

\$159.95

EMERSON RADIO AND
PHONOGRAPH CORP
NEW YORK 11, N. Y.



Prices Slightly Higher in the
South and West

Emerson

First for Value, First for PROFITS!

"THIRSTY WATER"

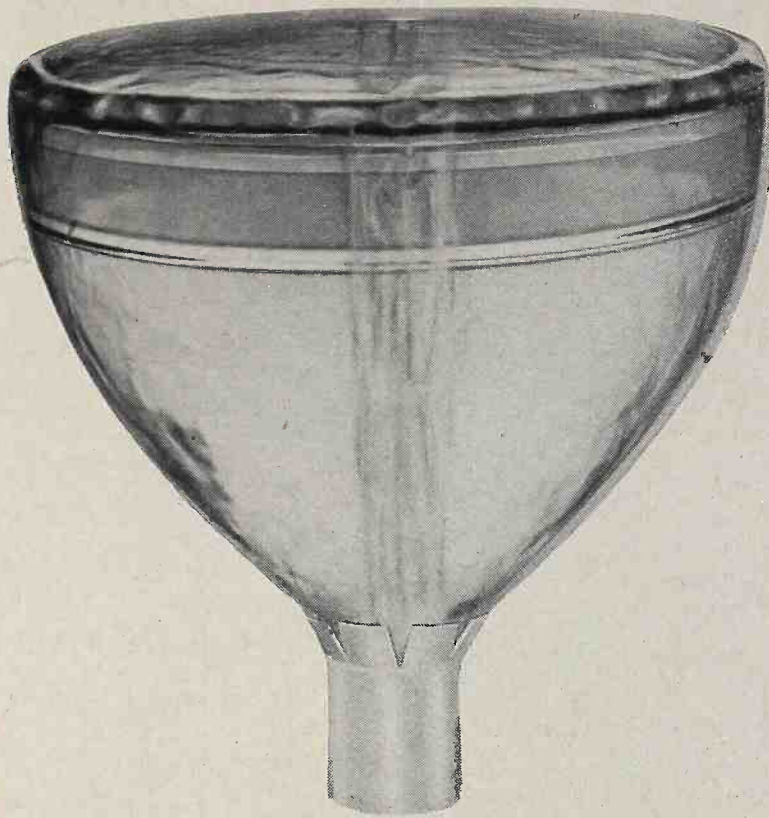

Makes PERFECT Sheldon Picture Tube Screens!

First, the inside face of the glass blank gets an acid wash; then it is rinsed with water. Next, the inside face is given a caustic wash and rinsed with water. *As the final step*, the inside face is given a rinse with a high pressure stream of "thirsty water" for several minutes.

"Thirsty water" is water from which all MINERALS and FOREIGN SUBSTANCES have been removed by special equipment and techniques in our plant. It is so pure that it becomes "hungry" or "thirsty" to re-absorb these foreign substances. The use of "thirsty water" leaves the inside surface of the glass blank bacteriolog-

ically clean and medically sterile. The inside surface is now PRIMED to receive the phosphor-coating.

This clean, sterile surface when coated with the phosphor coating, produces a uniformly perfect screen without blemishes.

During the coating process, every known precaution is taken against contamination. The rooms in which the tubes are coated are temperature-controlled, air-conditioned and kept dust-free . . . this assures the consistently perfect screens of Sheldon "Telegenic" Picture Tubes.

WRITE for Descriptive Literature on these NEW All-Glass Tubes:
 10", 12½" and 16" Velour Black . . . 16" 52° Deflection Angle, interchangeable with glass-metal 16AP4 . . . 16" Rectangular • 16YP4 70° Deflection Angle, interchangeable with glass-metal 16GP4 • Short 16" 70° Deflection Angle, 17½" overall . . . 19" 70° Deflection Angle • NEW Rectangular 14BP4 . . . NEW 19AP4 and 19AP4A Glass-Metal •

Sheldon
 NATURAL IMAGE

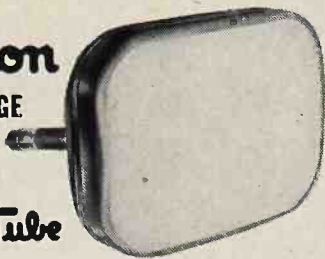

SOFT GLOW
 Picture Tube

SHELDON ELECTRIC CO.

Division of Allied Electric Products Inc.

68-98 Coit Street, Irvington 11, N. J.

Branch Offices & Warehouses: CHICAGO 7, ILL., 426 S. Clinton St. LOS ANGELES 6, CAL., 2559 W. Pico Blvd.

SHELDON TELEVISION PICTURE TUBES • CATHODE RAY TUBES • FLUORESCENT STARTERS AND LAMP HOLDERS • SHELDON REFLECTOR & INFRA-RED LAMPS
 PHOTOFLOOD & PHOTOSPOT LAMPS • SPRING-ACTION PLUGS • TAPMASTER EXTENSION CORD SETS & CUBE TAPS • RECTIFIER BULBS

→ VISIT THE SHELDON BOOTH NO. 201, PARTS DISTRIBUTOR SHOW, MAY 22-25, STEVENS HOTEL, CHICAGO ←

New 1950 Models



Admiral

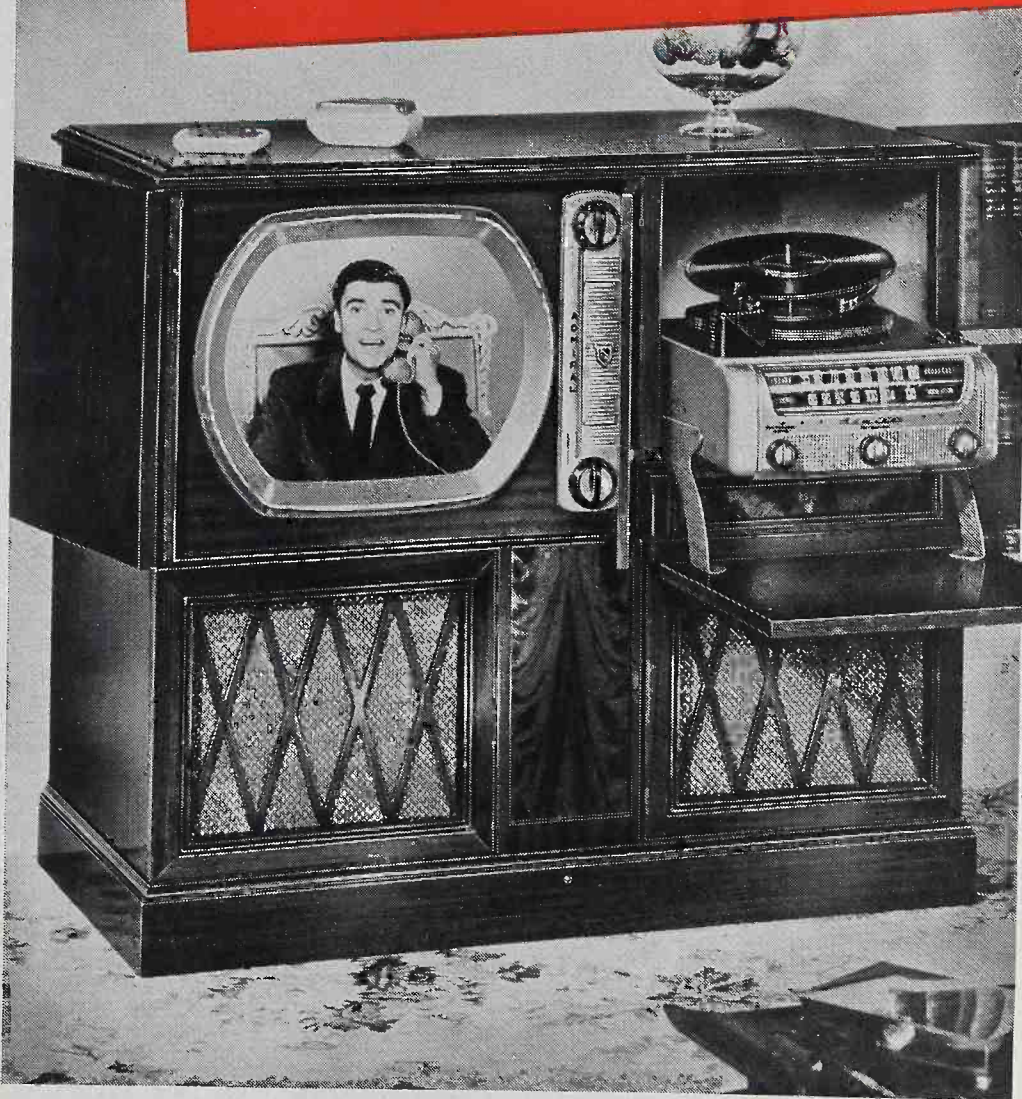

First
in performance

First
in value

First
in features

36X36—(16" Tube). Custom-quality 18th Century TV console combination. Superpowered chassis. Dynamagic FM/AM Radio. "Triple Play" Phonograph. Hand-rubbed walnut, mahogany or blonde cabinet. In walnut,

\$499.95

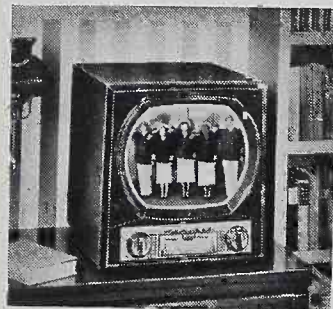

12X12—(12½" Tube). New low price table television sensation. In smart mahogany color cabinet, **\$179.95**

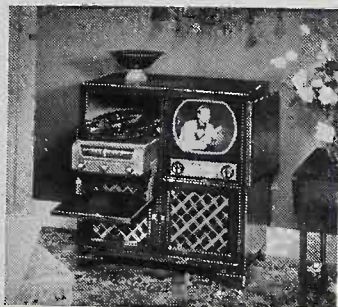

32X15—(12½" Tube). Thrilling new television combination. Walnut or mahogany. In walnut only **\$299.95**



32X27—(12½" Tube). New television combination sensation in mahogany or blonde cabinet. Mahogany, **\$399.95**



32X36—(12½" Tube). Admiral 3-way TV combination in traditional walnut or mahogany. Walnut, **\$379.95**

1st in television

WITH THE clearest picture of them all!

- Sensational superpowered chassis... brings in pictures as clear as the movies even in outlying "fringe" areas.
- 12½", 16" and 19" full-vision tubes... new rectangular 4 x 3 "aspect ratio" tubes. Wide choice of cabinet styles.
- Built-in directional Roto-Scope antenna... one-knob automatic tuning... automatic gain control... balanced contrast circuit... improved sharp focus.
- "Triple Play" Automatic Phonograph... one spindle... one tone arm... one needle for all RPM speeds, all record sizes.
- Dynamagic FM/AM Radio... most compact... powerful.



22X12—(12½" Tube). TV Console at a sensational price. Pictures clear as the movies. Built-in Directional Roto-Scope antenna. Sturdy modern cabinet. Mahogany color,

\$199.95



26X46—(16" Tube). Admiral TV combination. Rectangular tube. Walnut or mahogany. In walnut, **\$299.95**

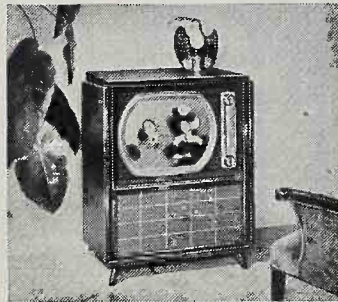

29X16—(19" Tube). Ultra modern mahogany- or blonde television console. In walnut, a sensation at **\$495.00**



39X17—(19" Tube). Superb new TV combination in modern mahogany or blonde. Mahogany, **\$695.00**

Admiral
Presents Two Great Shows
Every Week on Television

●
"Stop the Music," ABC-TV
NETWORK, THURSDAYS, 8 PM, EST

●
"Lights Out," NBC-TV STATIONS,
MONDAYS, 9 PM, EST

Prices slightly higher south and west... subject to change without notice. Tax extra.
Admiral Corporation, Chicago 47

Record News Notes

Columbia Records, Inc., has named Mitchell Miller as director of the Popular Records Division. Mr. Miller will have charge of selecting and recording all material released on Columbia's popular label. He reports directly to Goddard Lieberson, executive vice-president of the company. Mr. Miller was formerly director of popular music at Mercury Record Corp.

Ken McAllister, director of advertising and promotion for Columbia, has announced plans for one of the most complete and comprehensive merchandising campaigns in the company's history. The keystone of the campaign is "The Columbia LP Record Parade," broadcast over the CBS

network on Sunday afternoons. The program features Columbia LP records of all types, including 7-inch, 10-inch and 12-inch popular and masterworks selections. Each program features specific LP recordings, with national advertising promoting the feature record.

R. H. Coffin, advertising director, RCA Victor Division, Radio Corporation of America, has announced the publication of "The RCA Victor Good News," designed to keep record and instrument dealers informed on all phases of "45 rpm" activities. Sales promotion ideas, national advertising and promotion campaigns, and suggestions for local tie-ins are included in the newspaper. Pages are profusely illustrated.

Arturo Toscanini and the NBC

RCA Victor Artist, Execs



Standing are Bob Macrae, merchandise manager, and Dave Finn, advertising manager for the RCA Victor Record Department, beaming approval as wax artist Phil Harris, right, transcribes interview with disc jockey Jack Lacey during Manhattan visit.

KIND to record
KIND to ear
KIND to purse

the Magic Touch

Fidelitone

LONG LIFE PHONOGRAPH NEEDLES

FROM 50c to \$5.00

PERMO, Incorporated
CHICAGO 26,

Symphony Orchestra will hold the opening concert of its coast-to-coast tour on April 14 at Carnegie Hall, New York. The tour is under the auspices of the RCA Victor Division, and according to Frank M. Folsom, president of RCA, has been planned in observance of the musical achievements made in America during the past 50 years. The 6-weeks tour will average three concerts a week. Maestro Toscanini and the orchestra will play in the following cities: Baltimore, Richmond, Atlanta, New Orleans, Houston, Austin, Dallas, Pasadena, San Francisco, Portland, Seattle, Denver, St. Louis, Chicago, Detroit, Cleveland, Pittsburgh, Washington and Philadelphia.

Mr. Folsom also announced the signing of Margaret Truman to an exclusive long-term RCA Victor Red Seal recording contract, and the appointment of Emanuel Sacks as director of artists relations at RCA Victor and at NBC.

"Needle Tips" issued by Jensen Industries, Inc., Chicago, is featuring the new packaging of the Jensen Royal Jewel Needle in novel plastic containers on a wood display, suitable for use on counter or wall. The containers are letter openers, and the blunt end contains a magnifying glass where the needle is attached. Glass may be used for inspecting needle, etc.

Permo, Inc., Chicago, has announced that they will again supply Fidelitone bags for records to dealers as part of a long range sales helps program. The bags are a combination of yellow and black, are durable, and designed especially for record carrying. Prices are: \$8.50 per 1,000 in lots of 1,000 to 4,999; \$8.25 per 1,000 in lots up to 24,999; \$8.00 per 1,000 in lots of 25,000 or more.

Regional meetings of the National Association of Music Merchants scheduled for this month include: Central States Regional Conference, to be held at the Hotel Statler, Cleveland, March 13-14; East Central States Regional Conference, Hotel Statler, Washington, D. C., March 27-28.

Recorders & Inter-Coms

New Products

Dealer Profit-Makers Announced

Universal TAPE RECORDER

The Reelest is a two-track tape recorder with one hour capacity on a standard seven inch reel of tape. Universal Moulded Products Corp., Bristol, Virginia.—RADIO & TELEVISION RETAILING.

Knight TAPE RECORDER

Records both halves of a 1200-ft. reel of tape in an hour. 5-watt amplifier output and single tape control. List price is \$99.50. Allied Radio Corp., 833 W. Jackson Blvd., Chicago 7, Ill.—RADIO & TELEVISION RETAILING.

Miles "WALKIE-RECORDALL"

Records and reproduces by self-contained battery power. Weighs 8 pounds and measures 4 by 8 by 10 inches. Uses endless plastic tape. Up to 3½ hours of continuous recording. Miles Reproducer Co., Inc., 812 Broadway, New York 3, N. Y.—RADIO & TELEVISION RETAILING.

DuKane TAPE RECORDER

A two channel tape recorder in carrying case. Weighs 26 lbs. 4-tube amplifier with 7-watt output. List price: \$189.50. Operadio Mfg. Co., St. Charles, Ill.—RADIO & TELEVISION RETAILING.

Sonar TAPE RECORDER

Model T-10 uses 10 tubes and has an amplifier output of 10 watts. G.E. 1201D speaker is supplied in separate baffle. Complete outfit lists for \$395. Sonar Radio Corp., 59 Myrtle Ave., Brooklyn, N. Y.—RADIO & TELEVISION RETAILING.

Wilcox-Gay RECORDERS

Three new models are now offered. Model OA10 "Recordio" records and plays discs at 33½ or 78 RPM. Includes crystal mike, separate crystal cutting head and extension speaker jack. It is priced at \$139.50. The "Recordette, Sr.," No. OJ10, combines a radio and 78 RPM phono and recorder in one carrying case. Lists for \$59.95. Model 9C10 is a tape-disc recorder. Records from one to the other or from mike or external radio. List price is \$187.50. Wilcox-Gay Corp., 604 W. Seminary St., Charlotte, Mich.—RADIO & TELEVISION RETAILING.

Vocatron INTER-COM

A wire-less inter-communicator has been announced which operates over a range of 1 mile. List price is \$69.50 per pair. Vocaline Company of America, Inc., Old Saybrook, Conn.—RADIO & TELEVISION RETAILING.

Magic Voice INTER-COM

A two-way AC-DC inter-com has been announced at \$29.95. Magic Voice Mfg. Co., Inc., 608 S. Dearborn St., Chicago 5, Ill.—RADIO & TELEVISION RETAILING.

Cambridge PRESTOCALL

An AC-DC two-way inter-com with 3-tube amplifier and drawn steel case. List price is \$29.95. Cambridge Co., 2561 N. Clark St., Chicago 14, Ill.—RADIO & TELEVISION RETAILING.

Wilcox-Gay TV CONSOLES

One 16-inch and two 19-inch TV receivers have been added to the line. Model 0-446, a 26-tube, 16-inch model, has FM-AM radio and 3-speed phono. Model 0-439, 19-inch model at \$449.50, has FM radio. Model 0-459, shown here, features a 19-inch metal tube, FM-AM radio, a



V-M 3-speed changer and automatic gain control. It is priced at \$695. All models have 12-inch speakers, automatic frequency and volume controls, built-in TV-FM antennas and mahogany veneer cabinets with doors. Wilcox-Gay Corp., 604 W. Seminary St., Charlotte, Mich.—RADIO & TELEVISION RETAILING.

Supreme PHONOGRAPHS

Single speed (78 RPM) phono is available in two vanity type cases, No. 704-UL, standard model, at \$26.95, and No. 705UL, deluxe model, at \$29.25. 3-speed phonos also available in two cases, No. 748LPM-UL, standard, at \$35.95, and No. 755LPM-UL, deluxe, at \$39.95. AIM Industries, 41 Union Square, New York 3, N. Y.—RADIO & TELEVISION RETAILING.

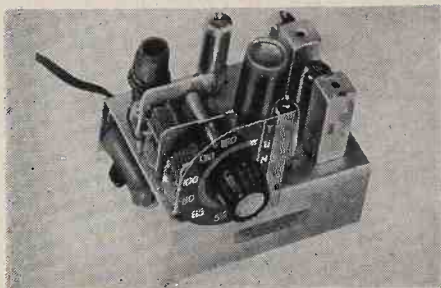

Approved AM TUNER

Model A-600 is a broadcast superhet tuner for use in PA systems, with record players, wire recorders, motion picture sound projectors, etc. Using 3 tubes plus rectifier, the unit has self-contained AC-DC power supply. Approved Electronic Instrument Corp., 142 Liberty St., New York 6, N. Y.—RADIO & TELEVISION RETAILING.

Starrett TELEVISION

Nine new "Metropolitan Series" models are offered. Two 12½-inch table models, two 12½-inch consolettes, two 16-inch consolettes, one 16-inch table model, one 16-inch console and one 19-inch consolette range in price from \$199.95 for the Nathan Hale 12½-inch table model in walnut to \$479.95 for the Alexander Hamilton 19-inch consolette. One model, the James Monroe 16-inch console, is a radio-phono combination priced at \$479.95. Starrett Television Corp., 601 W. 26th St., New York 1, N. Y.—RADIO & TELEVISION RETAILING.

Air King TELEVISION

Model A-2017R, shown, is a 16-inch rectangular tube table model priced at \$279.95. Also announced were three 12½-inch sets, two of them table models (A-711 at \$179.95 and A-712 at \$199.95) and one console (A-2014 at \$249.95), a 16-inch console (A-2016R at \$299.95) and a 16-inch console in mahogany cabinet with full



length doors (A-718R at \$369.95). Air King Products Co. Inc., 170 53rd St., Bklyn. 32, N. Y.—RADIO & TELEVISION RETAILING.

Electrovox PHONO NEEDLE

A new shaped phonograph needle tip is said to permit playing both microgroove and standard records without needle change. The truncated design of the needle, the maker states, enables the tip to track in both types of record grooves. Both sapphire and osmium tips are available. Electrovox Co., Inc., 60 Franklin St., East Orange, N. J.—RADIO & TELEVISION RETAILING.

Covinco PHONOGRAPH

Model 305 is a 3-tube, 3-speed record changer priced at \$64.50. It is mounted in a luggage-type carrying case covered in simulated alligator. Covrall Industries, Inc., 55 Ferris St., Bklyn. 31, N. Y.—RADIO & TELEVISION RETAILING.

New V-M Representative

V-M Corporation, Benton Harbor, Mich., announces the appointment of S. K. MacDonald and Associates as representatives of V-M in the states of Pennsylvania, Maryland, Delaware, southern New Jersey (from Trenton south), Virginia and West Virginia.

Telrex Names Bressler

Telrex, Inc., manufacturers of the Conical "V" beam antenna, announces the appointment of Jules Bressler, as its sales representative for New York City and lower Hudson Valley.

Crosley Appointment

The appointment of Clarence G. Felix as assistant to the general manager has been announced by the Crosley Division, Avco Mfg. Corp. John W. Craig is general manager of the Crosley Division and a vice-president of Avco.

New Starrett Ad Manager

Adele Godnick has been appointed advertising manager of the Starrett Television Corp., N. Y. Miss Godnick formerly handled sales promotion for DeJur Amsco Corp.

GE Plan Will Boost Dealer Service Volume

Further indications that the Tube Divisions of the General Electric Co. intend to offer an even closer business-building support for radio and television service dealers during 1950 were revealed by John T. Thompson, receiving tube replacement sales manager. According to Thompson, a campaign especially designed for local use and based on the theme "Profits Plus for 1950," has been created for the exclusive use of service dealers everywhere. It is available through GE and Ken Rad tube distributors.

"Repeated customer-contacts offer the sure, the known way, to increase service business," Thompson said, "and our new Four-way Plan does just that. It gives the service dealer an easy way to increase his customer contacts—to make 1950 his year for profits plus."

A customer-prospect mailing campaign, a business solicitation plan, a low-cost newspaper and radio advertising schedule, and a store tie-in which re-emphasizes and combines all the efforts, make up the basic kit. Fully imprinted material for six months is contained in the three-pound package, Thompson added, but the only charge made to service dealers is the postage cost for the direct mail feature.

NEW!

DIRECTION INDICATOR



TV ANTENNA ROTATOR

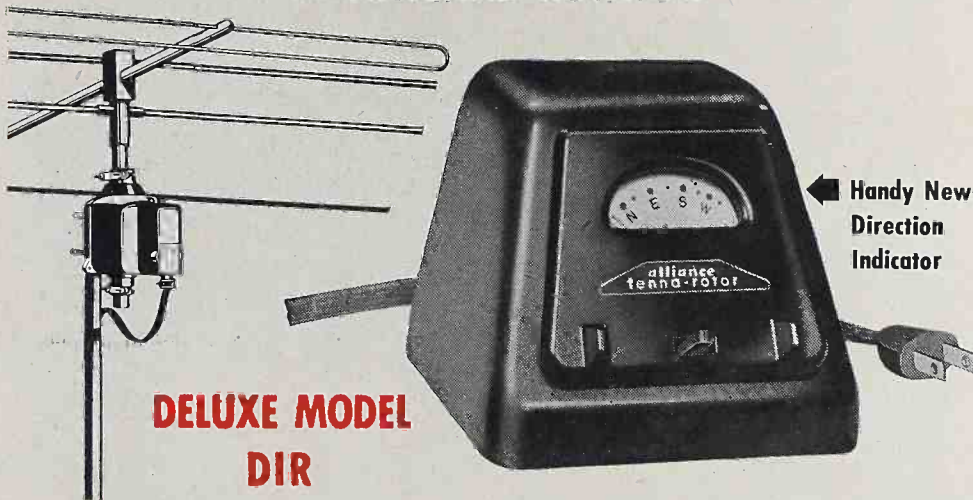

**DELUXE MODEL
DIR**

Handy New
Direction
Indicator

● This deluxe model Alliance Tenna-Rotor is in use and on sale in every TV market! Priced only slightly higher than the standard ATR, it provides a direction indicator which quickly shows where the antenna is pointed!

Here's why it pays to sell Tenna-Rotor!

- The only rotator proved by thousands of users in major TV markets from coast to coast!
- Tenna-Rotor is **demonstrated** in over 2 million TV homes each week! Millions see the Alliance films now scheduled on 52 TV stations!
- Tenna-Rotor has **Underwriters' Laboratories' approval!**
- Tests conducted by **Electrical Testing Laboratories Inc.** prove Tenna-Rotor works in **sub-zero—rainy, snowy and icy weather!**

The only rotator featuring the Alliance 4-conductor cable with "Zip" feature which makes for faster, easier installations!

Guaranteed for one year!

Write for your copy of "Fastest profit maker in Television today."

Alliance Manufacturing Company • Alliance, Ohio

Export Department: 401 Broadway, New York, N. Y., U. S. A.

Distributing Du Mont

The Allegheny Home Appliance Co., of 1801 Adams Ave., Huntington, West Virginia, has been appointed DuMont distributor for the Huntington and Charleston, W. Va., areas, it is announced by Ernest A. Marx, general manager of the receiver division of Allen B. DuMont Laboratories, Inc.

Tele-tone Salesmen



Out-of-town salesmen for Tele-tone Radio Corp. gather at the firm's convention in New York. They are (l. to r.): Norman Goldman, Washington, D. C.; Bob Shellow, Chicago; George Rosen, Baltimore; Jack Shafran, Newark; Morton M. Schwartz, general sales manager, and Henry Fine, Miami.

STAMINA!



T.E.I. television tubes, like all true champions, deliver an outstanding performance every time . . . and they keep on delivering!

Years of continual use* find the performance rating of these tubes practically unaffected—the tubes still capable of delivering thousands of additional hours of steady, clear, velvet-smooth pictures. For with every component, every operation, every inspection, stamina has been built in, has become an integral part of every Thomas tube.

Expect better performance, and more of it, from Thomas Electronics television tubes. They'll deliver every time!

*Life-test equivalents

See us at **BOOTH 295 I.R.E. SHOW**
Grand Central Palace March 6-9

THOMAS ELECTRONICS, Inc.

118 Ninth Street

Passaic, New Jersey



For *"Better-than-New"* Performance

..sell **RAULAND** replacements!

Here are the two greatest improvements in picture tubes since the war—both available from Rauland for your replacement business. Leading jobbers and dealers prefer and rec-

ommend them because they actually give customers better pictures than when their sets were new—assuring customer satisfaction that pays off in extra profits.

Rauland Luxide Screen Tubes

The public is clamoring for new Television sets featuring this new Rauland-developed tube. Now the Luxide Screen is available for replacement use in two tube types—metal-coned 16AP4-A, and all-glass 12LP4-A. The face of this new "black" tube contains a metallic oxide which gives the glass desirable light-absorbing characteristics. Both the reflection of ambient light and halation within the tube face are materially reduced. The result is a sharp, clear picture with such greatly increased contrast and clarity that it can be viewed in lighted rooms without "washing out" and without annoying glare.

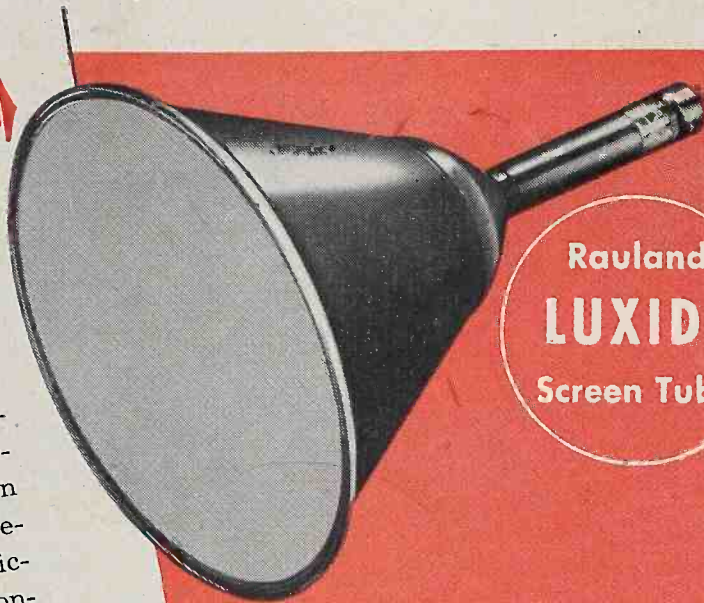

Rauland
LUXIDE
Screen Tube

Rauland
Aluminized
Luxide Screen
Tube



Rauland Aluminized Luxide Screen Tube

This Rauland-developed replacement tube has brought thousands of owners clearer, brighter pictures than they enjoyed before. The Rauland aluminized screen gives pictures up to 80% brighter than conventional tubes—with better contrast and sharper definition. The Rauland aluminized tube does not require any ion trap magnet—the adjustment of which, on ordinary tubes, will result in damaging the tube. The Luxide Screen feature is now available in the aluminized tube as type 12KP4-A.

THE RAULAND CORPORATION



Perfection Through Research

4245 N. KNOX AVENUE • CHICAGO 41, ILLINOIS



NOW...in all G-E Variable Reluctance Cartridges...at no extra cost!



"BATON" STYLUS



An Exciting New Discovery in High Fidelity Reproduction!

THERE'S terrific sales appeal—as well as listening pleasure—in this revolutionary General Electric Stylus! Like a baton in the hands of a skilled symphony conductor, it brings out the full tonal quality of recorded music as you've never heard it before!

Its feather-light tip, on the end of a dual-twist cantilever arm, follows every curve and dip of the record groove with a compliance so delicate it picks up frequencies through 10,000 cycles per second! The blasting, buzz, and hum so annoying in most record reproduction are virtually wiped out. Above all—the tone fidelity of the Baton Stylus is unsurpassed by any other commercially available unit! Equipped with diamond or sapphire tip, it fits any G-E replaceable stylus cartridge.

HOW COMPLIANT CAN A NEEDLE BE?

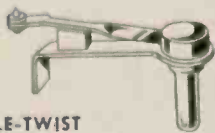

SINGLE-TWIST STYLUS

Until the development of the Baton Stylus, this model afforded unsurpassed fidelity. The single-twist arm and single damping block were designed for a tracking pressure of 21 grams. It was recognized, however, that lighter pressure would lengthen both record life and stylus life.

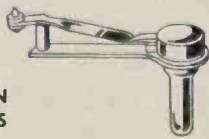

BATON STYLUS

Bending and twisting to every undulation of the record groove, this stylus reproduces each tone value with amazing clarity. Tracks at 6 grams—thus providing the maximum degree of compliance that may be used successfully with commercially available tone arms. Double damping blocks filter out superfluous vibrations.

Dealers and Servicemen!

There's a big market for the Baton Stylus among present users of General Electric cartridges. Hi-fi fans and record enthusiasts everywhere will want this sensational new model in their phonograph tone arms. Be sure you get your share of this business... the coupon below can open the door to new customers, new sales, new profits.

FREE Baton Stylus Folder!

General Electric Company, Section 2630
Electronics Park, Syracuse, New York

Send me FREE folder on the new Baton Stylus.

NAME _____
ADDRESS _____
CITY _____ STATE _____



You can put your confidence in—

GENERAL  ELECTRIC

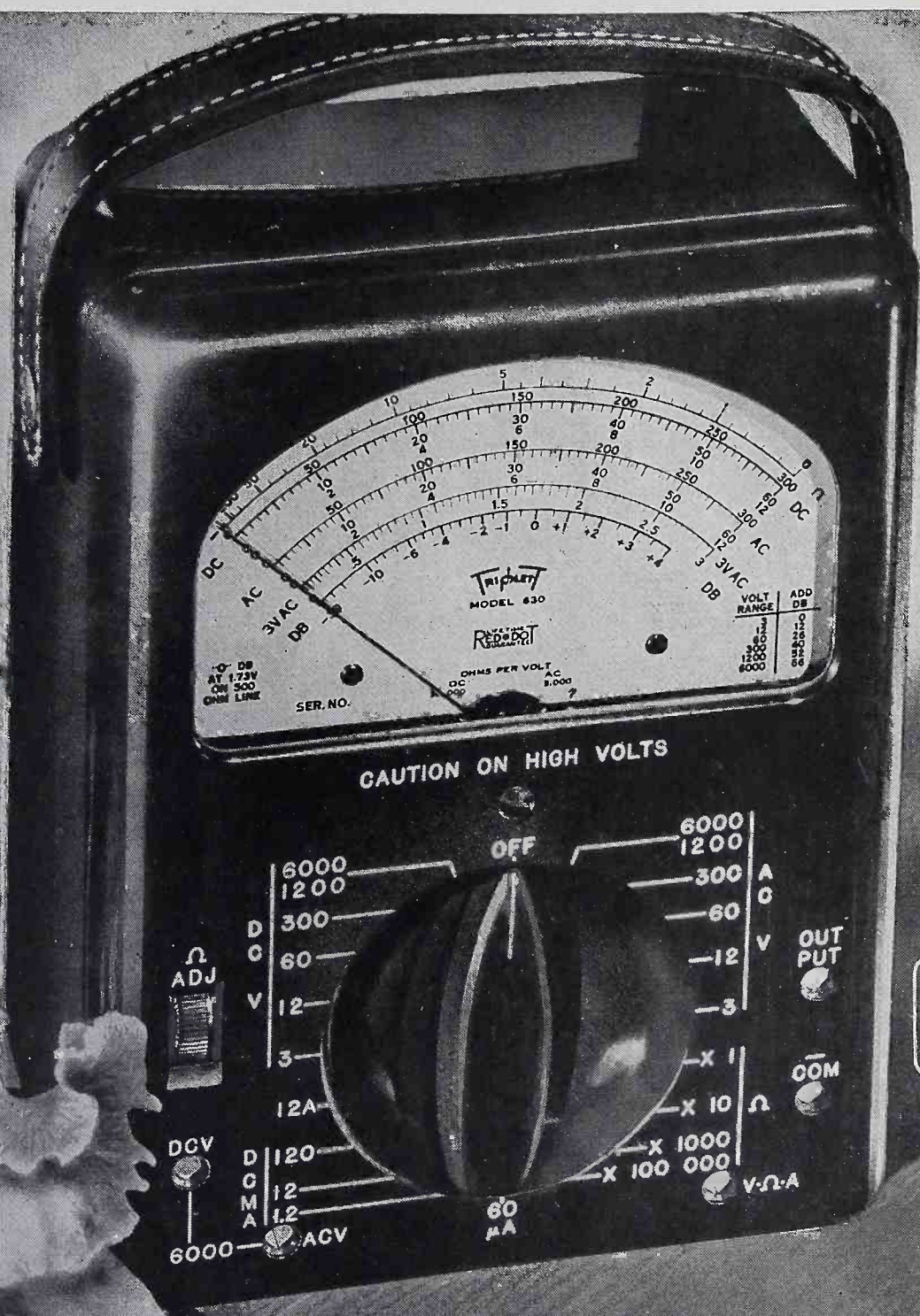

Model
630

*There is no more useful
and dependable instrument made*

FOR THE MAN WHO TAKES PRIDE IN HIS WORK

Triplet

TRIPLET ELECTRICAL INSTRUMENT COMPANY • BLUFFTON, OHIO, U.S.A.

ONLY \$37.50 AT YOUR DISTRIBUTOR

SERVICE & SOUND

Section of RADIO & TELEVISION RETAILING

Universal TV Sweep Transformer

New Unit Adaptable for 8 to 19 In. Tubes—

Develops 14 KV Without High Voltage Doubler

• A recently introduced horizontal sweep output and high voltage transformer, the GE 77J1 incorporating a ceramic core, has proven adaptable in application to directly viewed picture tubes from 8AP4 to 19AP4 designed to operate at supply levels from 125 to 325 volts with power tubes such as the 19BG6-G, 6AU5-GT, 6BQ6-GT, 6CD6-G or 6BG6-G, and with damper tubes such as the 6AS7-G, 5V4-G or 6W4-GT within all rating limits to produce adequate sweep and high voltage power with a single 1B3-GT at 8KV for the 8AP4 (54° sweep) and at 14KV for the 19AP4 (67° sweep).

Operation of the transformer for tubes operating at 10KV or less may be considered as exactly comparable to flyback high voltage power supplies to which we have become accustomed since the introduction of the RCA 630 in 1946. The sawtooth voltage generated by the horizontal oscillator and amplified by the output tube (the 6BG6-G may be considered as a modification for TV of the transmitting beam power amplifier type 807 so familiar to hams) is induced into the secondary of the sweep transformer. When the tube cuts off for the flyback

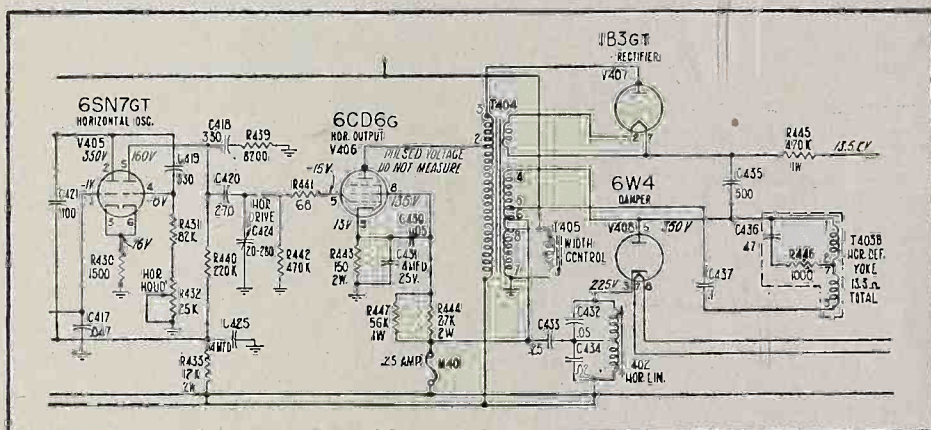

Sweep section of Admiral chassis using one 1B3 to provide 13.5KV wide angle deflection for 16GP4. Chassis numbers 24D1, 24E1 and 24F1 are used in models 26X45, 26X46, 26X35, 26X37, 36X35, 36X36 and 36X37.—Courtesy Admiral Corp.

between one horizontal line and the next, this field collapses, inducing a high voltage in the primary (the 6BG6 side) of the transformer, of the order of 6000 volts. This voltage is stepped up to the neighborhood of 9500 volts by means of the additional turns on the primary (between terminals 2 and 3 on the above schematic), which is really an autotransformer. This high voltage is applied to the high voltage rectifier (1B3/8016) and from there to the picture tube 2nd anode contact.

The output transformer may therefore be considered as two transformers. The primary between points 1 and 2, and the secondary between points 4 and 7 constitute a step-down matching transformer to apply a high sawtooth current to the deflection yoke. On the flyback, this much of the transformer steps up the voltage induced by the collapse of the magnetic field in the yoke. The autotransformer in the primary further steps up the voltage induced between points 1 and 2 during flyback to a higher voltage between points 1 and 3.

The amount of voltage resulting from this cycle is partly dependent on

the amount of plate current delivered by the horizontal output tube (which could be varied somewhat by altering its plate and screen voltages) but was limited by the efficiency of the old output transformers, as well as their high voltage insulation.

The new transformer achieves higher efficiency and better high voltage insulation due to closer coupling between primary and secondary and due to the use of a ceramic iron core material (a porcelain like material). For these reasons, by using different output tubes capable of passing different amounts of plate current, or by using the same tube with different plate and screen voltages (within its ratings) and therefore obtaining different outputs, it is possible with the new transformer to obtain appropriate deflection power and high voltage for the wide range of picture tube sizes mentioned above.

Using the 25BQ6-GT with this transformer permits full horizontal sweep of the 54° 8AP4 picture tube and produces an 8KV picture with only 125 volts of filtered power supply, all within the ratings of the tube.

(Continued on page 105)

Physical appearance of the ceramic iron core sweep transformer.—Courtesy General Electric Co.

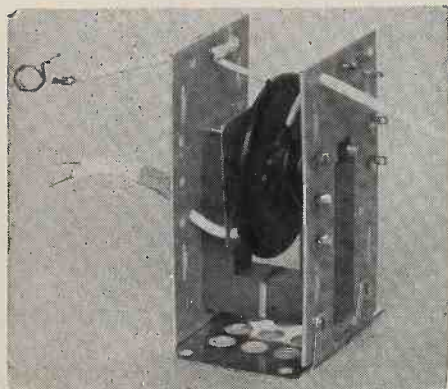

High Pass Filters for

RF Below 40 Megacycles May Be Attenuated by

• Present television facilities are largely confined to urban areas for economical reasons. Unfortunately, built-up areas where audiences large enough to be profitable exist, are generally saturated with interference—particularly the harmonic radiations from radio services operating at lower carrier frequencies. The net total of all such sources is generally referred to by the public as either “diathermy” or else “amateur” interferences (to the disgust of those operating in these particular fields). The amateurs particularly, whose reputations having been tarred with such adverse publicity, right or wrong, have been concerned with many developments aimed at reducing or eliminating causes for such complaints as are justified.

Receiver Improvements

More attention has been given to RF interference in the late model receivers, with the addition of a tuned circuit, of shielding, and more traps included in the original equipment. These methods have not been, in every case, completely successful. In addition, a great many of the older models are in use which do not incorporate these features.

For the serviceman attempting to solve these problems in the field there

have been several approaches: band-pass elimination filters, traps, stubs, shielding, and boosters (which furnish additional tuning for unwanted-signal rejection). Many of these methods were outlined in the article, “Clearer TV Pictures,” in an earlier issue of RADIO & TELEVISION RETAILING.

Particular value has been found for a high-pass filter attached to the television receiver that effectively cuts out all signals having frequencies below the TV band; and therefore diathermy, RF heating, and most amateur and commercial communications. A low-pass equivalent for amateurs and others is available to connect in the transmitter output circuits to eliminate frequencies (that is, harmonics) which would fall in the TV band.

Marked improvement in picture quality has been noted with these filters, with the advantage that they do not need to be tuned to eliminate some particular frequency.

High-pass units are available which are simple, cheap and easy to install, and in addition may be constructed by the TV technician, as outlined in this article. Low-pass units must be constructed to more precise standards, and must be capable of handling the power involved (in transmitters).

Direct application of well-known filter formulas is made, using two

or more “m” and “k” type sections. The components are simple, air spaced coils of a few turns; some small capacitors and the necessary shielded can and terminals. Two general forms take care of most of the high-pass receiver designs: for a 300 ohm twinex lead, and for a 75 ohm coaxial. Factors known are the terminal impedance, cut-off frequency, and, from standard practice, simple circuit configurations that produce a good low frequency attenuation. It is also convenient to be able to use standard values of fixed capacitors—those readily obtainable. The high pass application is based on a two section m-derived filter, having two T type half end sections and a T type intermediate section with a cut-off at 40 MC.

High Pass

Fig. 1 shows the resulting configurations for (a) a high-pass filter for receivers with balanced input, and (b) a 75 ohm coaxial line input. The commercial versions of the filters (a) and (b) are shown in Figs. 4 and 5. The coils shown can be air wound coils, self supported to reduce their capacitances, and hung by their leads, or can be spaced wound on forms. No. 20 enameled wire has been found to be satisfactory for coils wound on insulated tubes and #16 bus wire is for self supported coils. The capacitance of all components with respect to the shield should be minimized and equalized.

Excessive coupling between the coils should be avoided. Some technicians may prefer to mount the coils with their axes at the well known “magic angle”

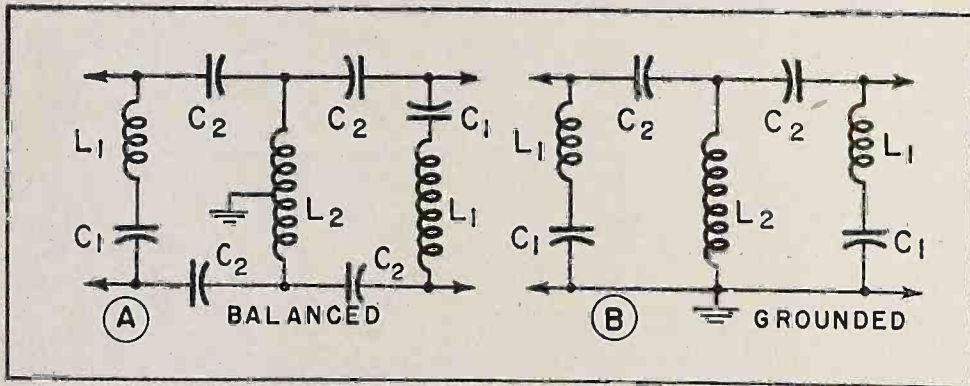
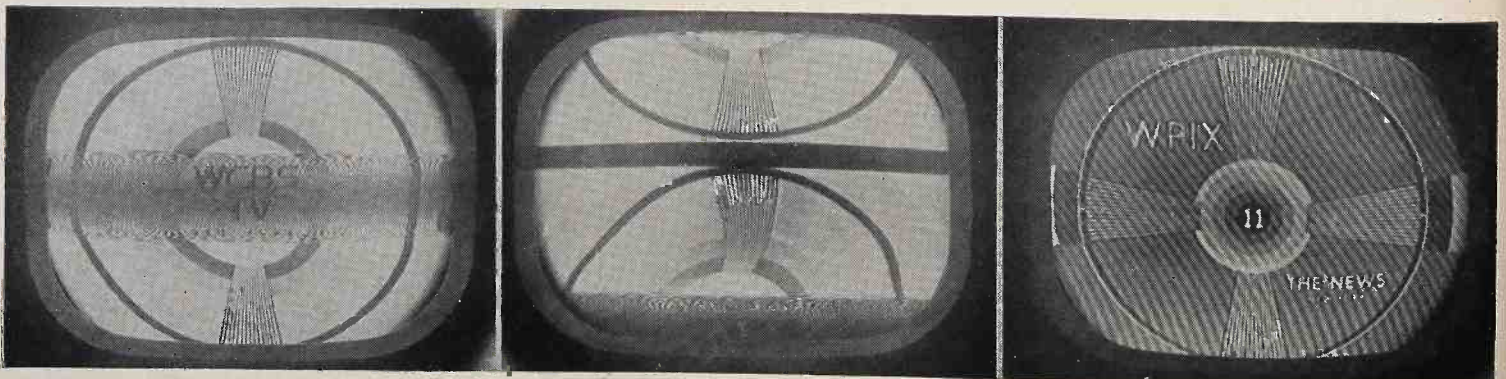

Fig. 1: Basic diagram of balanced line (left) and unbalanced cable filters (right).

Fig. 2: Typical forms of television interference due to signals of low carriers are reduced by high pass filters of type described. (Photos by Sylvania Electric Products.)



Minimizing TV Interference

Low-Cost Attachment for Existing Television Receivers

so common on TRF receivers produced in the "20's." Here an angle of about 50° is maintained between the axes of the coils (which are parallel) and an imaginary line connecting their centers. (The exact angle is one having a tangent equal to $\sqrt{2}$.)

In mounting, such a filter is connected in the antenna lead as close as possible to the TV set input jacks. The case (shield) is usually grounded to chassis, although with some receivers it may well be left floating. The filter causes little insertion loss in the TV bands and in some cases is installed as a general principle on the chassis by the service man before delivery to a customer. Table 1 gives the equations by which the filter arrangements shown can be computed. Here R

ponents to handle the transmitted power. Several arrangements have been considered. The commercial form of one effective circuit is shown in Fig. 6. It consists of two-half sections, one at each end ($m=0.6$) with their attenuation factor peaked at 40 MC,

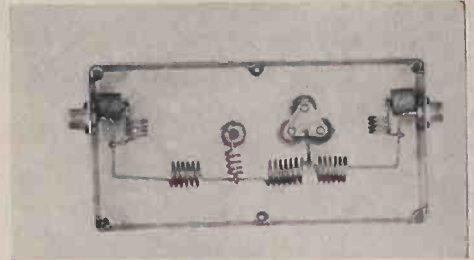

Fig. 6: Commercial heavy duty form of low pass filter illustrated in Fig. 3.

use with line impedances of 52 to 72 ohms.

The constants selected may be altered according to the values in the table by selecting other values of cut-off frequencies should it be necessary to attenuate some unusually strong harmonic present.

The several arrangements which are pictured and described are the work of Russell Valentine, engineer for New York's high fidelity station WQXR and amateur station W2GX at the instigation of the Electronic Distributing Co., 43-31 Douglaston Parkway, Douglaston, N. Y., who are producing these filters shown here, as complete units or in kit form.

Figures 4, 5, 6, Courtesy of Eldico. High pass filters similar to those described above are also manufactured by the R. L. Drake Co., 11 Longworth St., Dayton 2, Ohio.

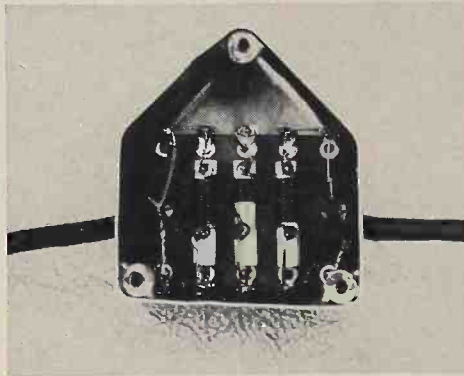

Fig. 5: High pass filter for 75 ohm coaxial cables.

with two intermediate low-pass sections in the center, giving an effective attenuation of over 80 db. Fig. 3b shows practical values for a filter for

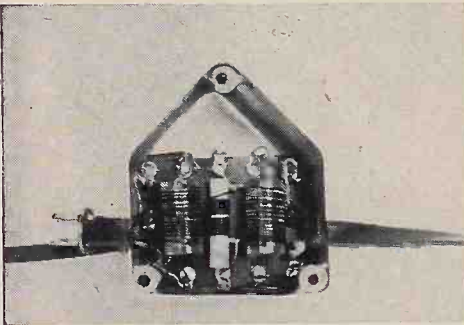

Fig. 4: Commercial version of TV receiver filter for use with 300-ohm line.

equals the line impedance, each way, and F is the cut off frequency in megacycles. The values derived are in microhenries and microfarads. In practice capacitors having $\pm 10\%$ of these values and coils based on either Q-meter or inductance formula values will operate satisfactorily.

Other designs can be made up for filtering the interferences from TV bands 7 to 13 should a separate dipole connection be available on the receiver. Here a cutoff of 167 MC can be assumed.

Low Pass

The second part of the job consists of a low-pass filter design suitable for use on amateur transmitters operating at 10 meters or higher, where antenna radiation at the fundamental and its harmonics are prone to cause TV interference. Installed between the set and the antenna, or the antenna tuning circuit, it effectively cuts off all radiation above 40 MC. This filter differs from the preceding designs in two ways: it uses a low-pass circuit conformation and it must have heavy enough com-

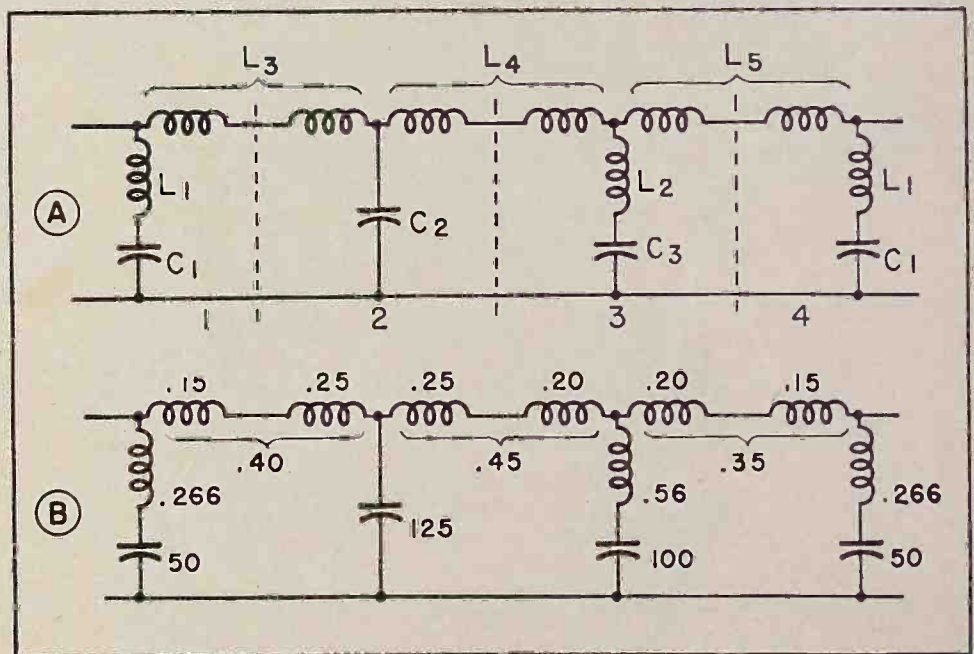

Fig. 3: Practical version of low pass filter suitable for use with transmitters operating at lower than television frequencies is shown in diagram above. Circuit constants depending upon line impedance and cut-off frequency (F) are given in the table below.

	L_1	L_2	L_3	L_4	L_5	C_1	C_2	C_3
FIG 1A	$0.28 R/F$	$0.08 R/F$	—	—	—	$0.15/R F$	$0.2/R F$	—
FIG 1B	$0.26 R/F$	$0.08 R/F$	—	—	—	$0.15/R F$	$0.1/R F$	—
FIG 3A	$0.17 R/F$	$0.036 R/F$	$0.255 R/F$	$0.286 R/F$	$0.298 R/F$	$0.095/R F$	$0.318/R F$	$0.255/R F$

R = OHMS LINE IMPEDANCE F = FREQUENCY IN MEGACYCLES

New Cory Sales Aid

Cory Corp., Chicago, has announced the availability of a new 12-pack display carton for use as a counter sales dispenser featuring the Cory glass filter rod. The display measures only 6½ by 8¼ inches and stands 10 inches high.

Designed as a box into which 12 of the Cory glass filter rod 50¢ retail items fit the unit is made so that the top folds back into a two color Cory glass coffee brewer illustration with the Cory glass filter rod fitting into die cuts showing it in its actual working position.

Coolerator Distributors

The Arnold Wholesale Corp. of Cleveland, Ohio, has been appointed Coolerator distributor for the northeastern Ohio territory, it was announced by William C. Conley, Jr., Coolerator sales manager.

A pioneer distributor in the Cleveland area since the turn of the century, Arnold Wholesale Corp., is a subsidiary of the Tracy Wells Co., hardware wholesalers in Columbus, Ohio. However, the Arnold operation is completely independent of the parent firm, company officials point out.

**LITTELFUSE First
IN TELEVISION FUSES**

8 out of 10 TV receivers are built with Littelfuse TV pigtail fuses, as original components. Pigtail and other TV fuses are a "must" for stock today.

Use only original equipment quality. Buy Littelfuse. Buy all Littelfuse!

LITTELFUSE INC.
4789 N. RAVENSWOOD AVENUE
CHICAGO, ILLINOIS

*Top Value
in TV
Towers*

Easy-Up

MODEL 300 "ROTA-TOWER"

- ★ Strong steel tube construction, all-electrically welded
- ★ Multiple cross-braces—90 in each 10 foot section
- ★ Saves many man-hours. Shipped pre-assembled—only 5 minutes to complete
- ★ Entire assembly hot-dip galvanized
- ★ Rotatable 360° to orient antenna after installation
- ★ Built-in ladder—safe to climb
- ★ Light—less than 1½ lbs. per foot of height
- ★ Quiet in the wind—all rounded surfaces
- ★ Hinged base—fits peaked or flat roof—tip up from any of four directions
- ★ Neat, trim, unobtrusive
- ★ Wide choice of heights
- ★ Minimum guy support needed

ONLY \$64⁵⁰ LIST for basic 30-ft. model complete

Actual photo of Easy-Up "Rota-Tower" with two extensions, elevating stacked Amphenol antenna and Alliance rotator 50 ft. above 30 ft. rooftop.

Also, extra-heavy-duty square and triangular towers for heights to 100 feet.

Easy-Up Tower is a quality product through and through... Built to make your installation job just as simple as possible... Your most economical way to elevate TV antennas for clearest reception.

See your jobber, or write

Easy-Up Tower Co.

3800 KINZIE AVENUE
RACINE • WISCONSIN

It's Rotor-ific!

The RADIART

TELE-ROTOR



Makes the MOST of Television Reception
By Making Possible CLEAR, SHARP PICTURES
and PERFECT, TROUBLE-FREE PERFORMANCE

To Rotate TV Antennas Under Even
The Most Adverse Conditions!

POWER

- Streamlined WEATHER-PROOF Housing! Keeps Out Water, Snow and Ice.
- Powerful Heavy-Duty Motor that Reverses Instantly! Handles 150-Pound Loads Easily.
- Heavy-Duty Precision STEEL Gears for Years and Years of Wear.
- Twelve Heavy-Duty Ball Bearings in Two 6½" diameter Races for Smooth, Easy Rotation.

THE RADIART
TELE-ROTOR
CONTROL

... With the "PERFECT PATTERN" Dial... Fingertip Control with Instant Indication of Antenna Position shown on the Illuminated Two-Tone Face.

Available in These Models:

- TR-1... Rotator and control unit with end of rotation light (uses 4 wire cable) \$39.95
- TR-2... Compass Control Rotator with illuminated "Perfect Pattern" dial (uses 8 wire cable) \$44.95

IT'S RIGHT WHEN IT'S RADIART

THE **RADIART** CORPORATION
CLEVELAND 2, OHIO



- VIBRATORS • AUTO AERIALS
- ROTATORS • TV ANTENNAS • POWER SUPPLIES

* You Can't Beat a RADIART ANTENNA on a TELE-ROTOR.... It's TOPS!

Television Technician

Section of RADIO & TELEVISION RETAILING

TEC TELEBOOSTER

Model S-504 "Telebooster" is a booster for fringe TV reception over the entire TV band which requires no tuning—only a switch for high and low bands. High



gain as well as uniform response over the 12 channels is claimed, with input and output impedance of 300 ohms. Utilizes 2-6AK5's and 1-12AT7. Television Equipment Corp., 238 William St., New York 7, N. Y.—RADIO & TELEVISION RETAILING.

Insuline SERVICING KIT

Nine specially designed TV servicing tools are included in the "Handi-Kit." Made to fit the adjusting screws of all types of RF and IF transformers, padders, trimmers, etc., the tools are furnished in a pocket-size leatherette case at the list price of \$6.95. Insuline Corp. of America, 3602—35th Ave., Long Island City 1, N. Y.—RADIO & TELEVISION RETAILING.

Radion TV ANTENNA

TA-51 is a packaged conical window-mount TV antenna. It comes fully assembled complete with 15-foot lead. It has 4 chrome-plated telescoping dipoles,

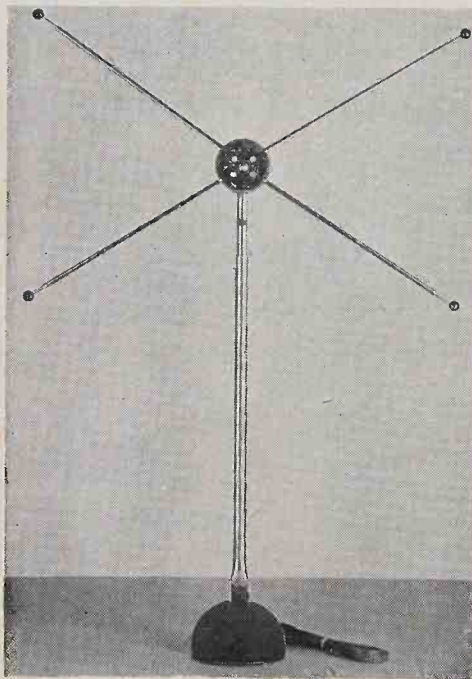

360-degree rotation, chrome-plated mast, bakelite head, black oxide swivel base. Completely weatherized, it lists at \$9.95. Radion Corp., 1137 N. Milwaukee, Chicago, Ill.—RADIO & TELEVISION RETAILING.

Odegaard TV NAILS

The "Original Nail Polyethylene Stand-off" for securing TV antenna lead-in consists of a cadmium-plated steel flat nail and a small piece of punched poly-



ethylene to hold the lead-in cable. Easily hammered in, the nail eliminates drilling holes and screwing in standoffs. Write for free sample and details to Odegaard Mfg. Co., 5416 Eighth Ave., Brooklyn 20, N. Y.—RADIO & TELEVISION RETAILING.

Drake TVI FILTERS

The filters are designed to aid in the reduction of interference in TV sets, and are installed in the lead-in near the antenna terminals of the set. Being high-pass filters, they require no tuning, and

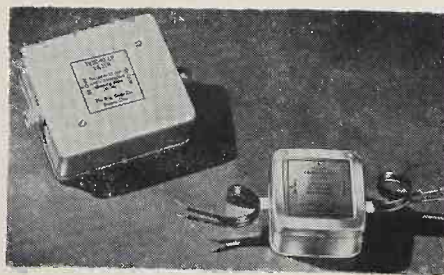

attenuate all RF below 50 MC, which includes short wave, diathermy, X-ray, industrial heating, etc. The company is also offering a series of low-pass transmitting filters to radio amateurs for harmonic reduction purposes. R. L. Drake Co., 11 Longworth St., Dayton 2, Ohio.—RADIO & TELEVISION RETAILING.

TACO TV ANTENNA

The "Twin-Driven" Yagi is designed to overcome the usually reduced impedance of Yagi arrays. The antenna is made up of two folded dipoles and two parasitic elements on one horizontal crossarm. The first director (a folded dipole) is fed with a transmission line from the main driven element. Gain may be increased with a stacked array of this antenna, for which a special matching network is provided producing a 300-ohm impedance at its output. Technical Appliance Co., Sherburne, N. Y.—RADIO & TELEVISION RETAILING.

Alliance ANTENNA ROTOR

Tenna-Rotor permits 360-degree rotation of TV, FM or other directional antenna by means of an electric motor on the mast. Rotation is controlled at the receiver by



a remote control box (shown), with indicator showing in which direction antenna is pointed. Special 4-conductor cable available to facilitate installation. Alliance Mfg. Co., Alliance, Ohio.—RADIO & TELEVISION RETAILING.

Vee-D-X TV ANTENNA

The "Economy Line" of low-priced 3-element beam antennas is designed to match 300-ohm line. Although cut especially for each particular channel, the Model EC is broader than the four-element type and can be used to cover several

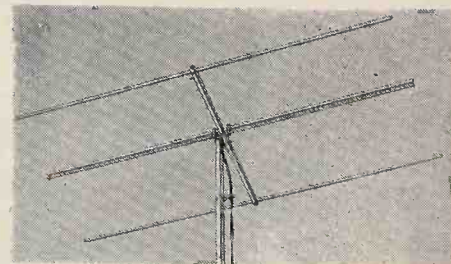

channels. The antenna consists of a director, a stepped-up driven element, and a reflector. List price is \$19.75 for the low channels and \$8.50 for the high channels. LaPointe Plascomold Corp., Unionville, Conn.—RADIO & TELEVISION RETAILING.

Tricraft TV ANTENNA

"Vidiette," indoor TV antenna model 700 requires no adjustment of rods, but simply moving selector knob of "tuner"



to proper channel. Covers all 12 channels. Tricraft Products Co., 1535 N. Ashland Ave., Chicago 22, Ill.—RADIO & TELEVISION RETAILING.

MANUFACTURERS TELL US...

"You are rendering an excellent service to the industry... and TV Manual, Volume 3, should evoke praise from television technicians"

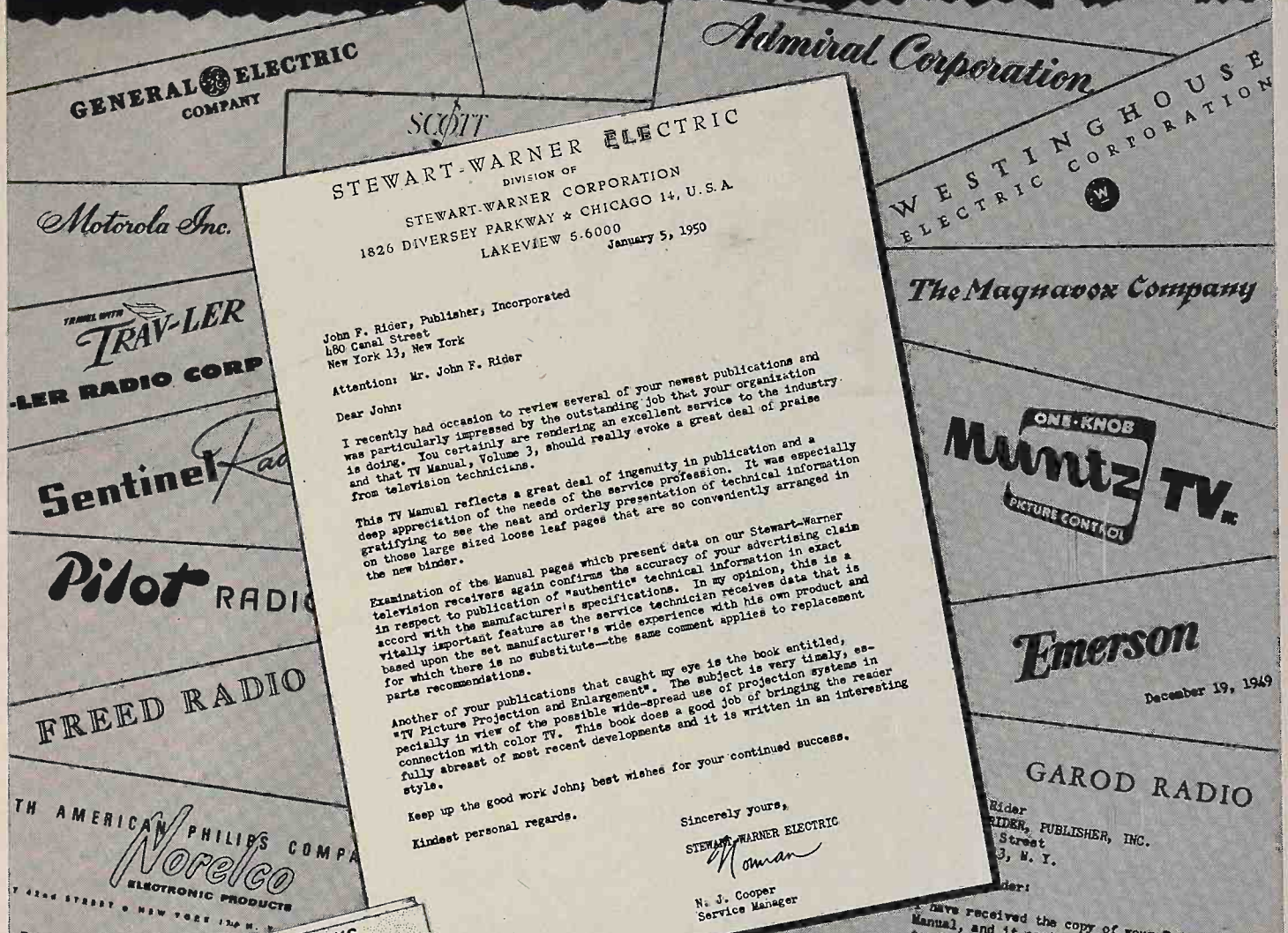

STEWART-WARNER ELECTRIC
DIVISION OF
STEWART-WARNER CORPORATION
1826 DIVERSEY PARKWAY & CHICAGO 14, U.S.A.
LAKEVIEW 5-6000
January 5, 1950

John F. Rider, Publisher, Incorporated
480 Canal Street
New York 13, New York
Attention: Mr. John F. Rider
Dear John:

I recently had occasion to review several of your newest publications and was particularly impressed by the outstanding job that your organization is doing. You certainly are rendering an excellent service to the industry and that TV Manual, Volume 3, should really evoke a great deal of praise from television technicians.

This TV Manual reflects a great deal of ingenuity in publication and a deep appreciation of the needs of the service profession. It was especially gratifying to see the neat and orderly presentation of technical information on those large sized loose leaf pages that are so conveniently arranged in the new binder.

Examination of the Manual pages which present data on our Stewart-Warner television receivers again confirms the accuracy of your advertising claim in respect to publication of "authentic" technical information in exact accord with the manufacturer's specifications. In my opinion, this is a vitally important feature as the service technician receives data that is based upon the set manufacturer's wide experience with his own product and for which there is no substitute—the same comment applies to replacement parts recommendations.

Another of your publications that caught my eye is the book entitled, "TV Picture Projection and Enlargement". The subject is very timely, especially in view of the possible wide-spread use of projection systems in connection with color TV. This book does a good job of bringing the reader fully abreast of most recent developments and it is written in an interesting style.

Keep up the good work John; best wishes for your continued success.
Kindest personal regards.

Sincerely yours,
STEWART-WARNER ELECTRIC
Moman
N. J. Cooper
Service Manager

Rider
RIDER, PUBLISHER, INC.
480 Canal Street
New York 13, N. Y.

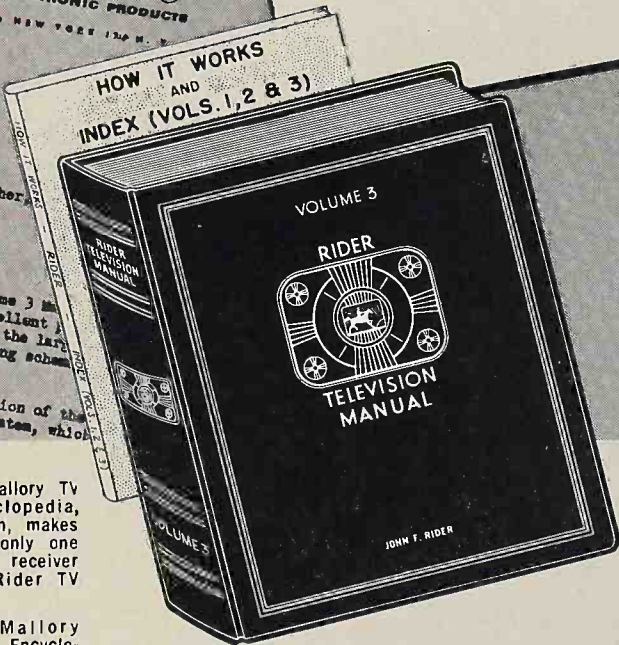

RIDER TV MANUAL VOLUME 3

Latest, Complete, Accurate, Authentic Factory-Authorized Servicing Data from 74 television manufacturers. 441 models. 243 chassis. Larger page size, 12" x 15". All pages filed in their proper place. Giant pages are retained, but now have only one fold for greater convenience and durability.

Equivalent of 2032 Pages (8 1/2" x 11") Plus Cumulative Index Volumes 1, 2 and 3, plus the famous RIDER "HOW IT WORKS" Book.....\$21.00

RIDER TV MANUAL VOLUME 2

Complete factory authorized coverage up to January 1949. 67 manufacturers. Equivalent of 2300 pages, (8 1/2" x 11") PLUS the RIDER "HOW IT WORKS" Book, and Cumulative Index Volumes 1 and 2.....\$18.00

RIDER TV MANUAL VOLUME 1

Complete factory authorized coverage up to early 1948. 34 manufacturers. Equivalent of 2000 pages, (8 1/2" x 11") PLUS Index and the RIDER "HOW IT WORKS" Book.....\$18.00

All Rider Manuals Mean Successful Servicing

JOHN F. RIDER PUBLISHER, INC., 480 Canal Street, New York 13, N.Y.
Export Agents: Rocke International Corp., 13 E. 40th Street, N.Y.C. • Cable ARLAB.

NOTE: The Mallory TV Service Encyclopedia, 1st TV Edition, makes reference to only one source of TV receiver schematics—Rider TV Manuals.

NOTE: The Mallory Radio Service Encyclopedia, 6th Edition, makes reference to only one source of radio receiver schematics—Rider Manuals.

NOTE: The C-D Capacitor Manual for Radio Servicing, 1948 Edition No. 4, makes reference to only one source of receiver schematics—Rider Manuals.

New Aids To Servicicers

Stamford TRUCK RACK

This rack was designed for carrying ladders and other bulky equipment on panel trucks, and is suited for TV serv-

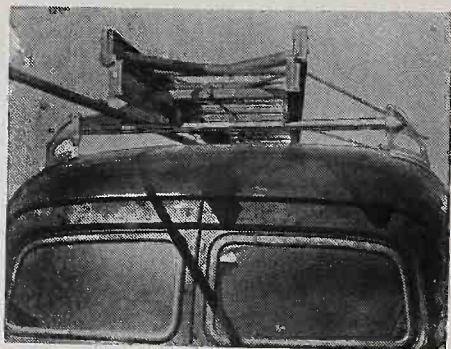

icers. Load carrying capacity is over 350 pounds, rack itself weighs less than 10 lbs. Priced so rack installed can be sold for about \$35.00. Stamford Casting Co., 816 Atlantic St., Stamford, Conn.—RADIO & TELEVISION RETAILING.

Kedman SCREW HOLDER

A specialized screwdriver called "Quick-Wedge" has a double spring steel blade that holds, starts and drives the screw. Designed to avoid dropping screws in inaccessible places, and starting screws in hard-to-reach spots. Kedman Co., 233 S. 5th West, Salt Lake City 1, Utah.—RADIO & TELEVISION RETAILING.

Grayhill TEST CLIP

For speed and convenience in tests and experiments, the test clips may be permanently or temporarily mounted on the panel of any test equipment or chassis,

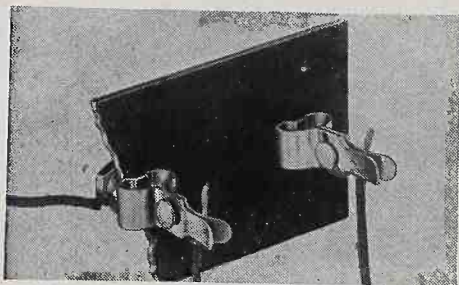

providing a firm physical and electrical contact for leads. Leads are slipped in or out of the clamp-type jaws. Tension of the spring action in the jaws may be adjusted. Hex nuts are included with each clip for mounting and wire attachment. Grayhill, 4524 W. Madison St., Chicago 24, Ill.—RADIO & TELEVISION RETAILING.

Blackburn GROUND CLAMP

An adjustable ground clamp is available in two sizes: one to fit 3/8- to 1 1/4-in. pipe, and the other 3/8- to 3-inch pipe. A tightening screw chafes the pipe, draws up the slack, cuts through rust and dirt, and at the same time contracts band around pipe surface. Solder or solderless lugs available take up to #4 AWG. Blackburn Specialty Co., 6541 Euclid Ave., Cleveland 3, Ohio.—RADIO & TELEVISION RETAILING.

Wassco SOLDERING TOOL

The Wassco "Glo-Melt" features a 24-heat selector to handle lightest up to heaviest work. With capacity equal to a 450-watt iron, soldering is done with a handpiece weighing only 5 ounces. The



carbon pencil glows when put in contact with the work, permitting solder to flow, and cools immediately on removal. Advantages claimed are faster, more accurate work with quick-heat, light-weight handpiece. Wasserlein Mfg. Co., Inc., 7400 3rd Ave., N., St. Petersburg 6, Fla.—RADIO & TELEVISION RETAILING.

Ohmite CALCULATOR

The new pocket-size Ohm's law calculator features separate slide rule and parallel resistance scales for quickly solving any Ohm's law problem—reading directly in ohms, volts, amperes and

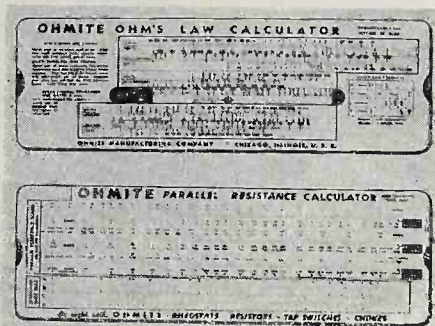

watts. The slide rule will multiply, divide, and find squares and square roots. Made of heavily varnished cardboard, the calculator is priced at 25¢ and may be obtained from the Ohmite Mfg. Co., 4937 Flournoy St., Chicago, Ill.—RADIO & TELEVISION RETAILING.

Technical TOOL CASE

Tool case designed for radio and electrical technicians is made of vulcanized fiber and measures 16" long by 12 wide and 5 1/2 deep. Sewn tool pockets in lid and on special hinged partition. Two pockets provided with zipper covers for small tools. Bottom of case is partitioned to accommodate test equipment and larger tools. Price for case \$24.00. Technical Tool Case Co., Box 6111, Charlotte, N. C.—RADIO & TELEVISION RETAILING.

Feiler APPLIANCE TESTER

The "Electroscope" is designed to test all appliances as well as electrical accessories and circuits, while in operation. Simply plug in appliance, push switch, and a system of light-indicators tells

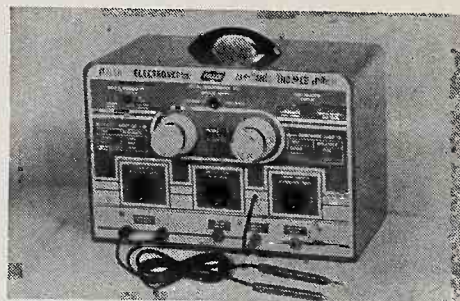

whether circuit is shorted, open, or has correct resistance. Operating on 95-125 VDC, and 25, 50 and 60 cycle AC, the tester sells for \$18.95. Feiler Engineering Co., 1601 S. Federal St., Chicago 16, Ill.—RADIO & TELEVISION RETAILING.

Superior POWERSTAT

New "Powerstat" variable transformers incorporate many features to make the units more rugged physically and more adaptable electrically. Type 116 operates from 115 VAC source to deliver 0-135 volts,



7.5 amperes; Type 216 operates from 230 VAC single phase to deliver 0-270 volts, 3.0 amperes. For more information on the redesigned Powerstat types 116 and 216, write the Superior Electric Co., Hannon Ave., Bristol, Conn.—RADIO & TELEVISION RETAILING.

Precision TEST INSTRUMENTS

Complete testing facilities for AM, FM and TV are provided by this set of 5 matched instruments. According to this firm, a complete set-up for all efficient service needs can be obtained for \$498, consisting of: Marker-signal generator, Sweep-signal generator, Cathode-ray oscillograph, VTVM-Megohmmeter and a Tube Tester. Different models and styles of equipment are available to suit individual applications. For catalog of specifications and prices, write Precision Apparatus Co., Inc., 92-27 Horace Harding Blvd., Elmhurst, L. I., N. Y.—RADIO & TELEVISION RETAILING.

New Products

Lynmar TV TRANSFORMER

Impedance matching transformer is made to match a 70-95 ohm coaxial line to the 300-ohm input of a TV receiver, or a 300-ohm antenna lead to a receiver made for



use with coax. Reduction of noise pickup and of ghosts due to line reflections is claimed. Lynmar Engineers, 1721 Delancey St., Philadelphia 3, Penna.—RADIO & TELEVISION RETAILING.

Cletron TV ARRESTER

The new FM-TV lightning arrester is of combined bleeder and gap design, built with a universal base to accommodate flat or round 300-ohm and twin-x. Weather-proof and U/L approved, the light-weight unit is easily installed by hanging on the lead-in cable. Cleveland Electronics Inc., 6625 Euclid Ave., Cleveland, Ohio.—RADIO & TELEVISION RETAILING.

Superior APPLIANCE TESTER

Pocket size utility tester is capable of measuring current consumption of any appliance either AC or DC, while the unit is in operation. The appliance is plugged into the front panel receptacle.



Insulated clip leads are supplied for motors. Resistance range covers resistances commonly used in appliances and motors, and can indicate opens, shorts and grounds. Superior Instruments Co., 227 Fulton St., New York, N. Y.—RADIO & TELEVISION RETAILING.

The Skill to Design...

the Facilities to Produce...

the Ability to Deliver...

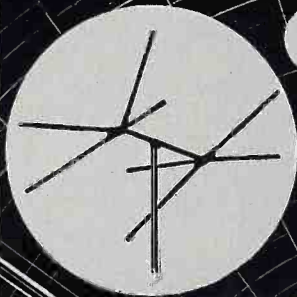

2X-TV

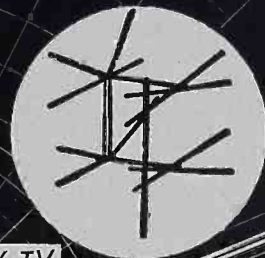

4X-TV

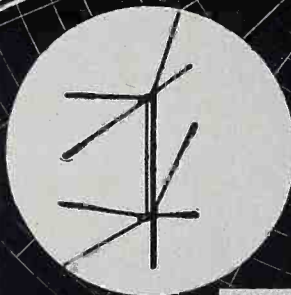

2X-BD

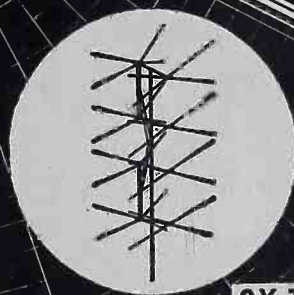

8X-TV

YOU CAN GET OPTIMUM RECEPTION!

Telrex manufactures 15 models for better TV and Ultra, High Frequency Reception. For literature and advice on your particular problem write — Dept. B, Telrex, Inc., Asbury Park, N. J.

Available through Authorized TELREX Distributors

TELREX Engineers have designed and will continue to develop America's foremost TV and FM antennas. CONICAL "V" BEAMS are manufactured to exacting specifications in a modern plant.

The name TELREX, on any product, is your guarantee of quality and value.

To Be Sure it's a CONICAL "V" BEAM Look for the TELREX Registered Trademark*

Telrex INC.

CONICAL "V" BEAMS*

ASBURY PARK 2, N. J.

AMERICA'S STANDARD OF COMPARISON

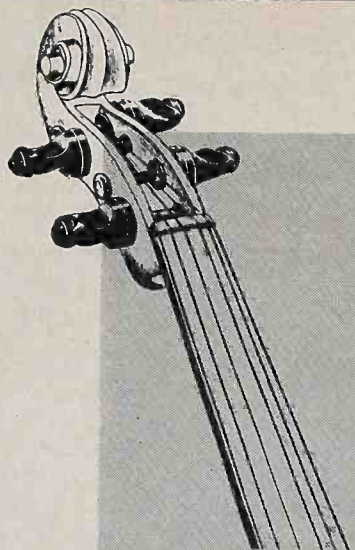

Duosonic

LONG PLAYING
PHONOGRAPHS

"the tone of the master"



THE most popular name in phonographs today is DUOSONIC, which stands for the ultimate in phonograph perfection exceptionally rich in tone, dependable in construction, richly styled for unusual beauty they are the choice of progressive dealers everywhere available in models and colors to suit every taste and budget.

Franchises are still open. Write about the availability of this top line for your territory.



Address all inquiries to Dept. TRP1

SONIC INDUSTRIES, INC.

Manufacturers of Super Sonic TV + FM Amplifiers

221 WEST 17th STREET • NEW YORK 11, N. Y.

Test Equipment

Transvision VTVM

This new test instrument provides 6 DC voltage ranges with 11 megohm input resistance; a 0-30KV range with 1100



megohm input resistance; 6 AC voltage ranges at 1000 ohms/volt; 6 resistance ranges; and 4 RF ranges to 100 MC with RF probe. Transvision, Inc., New Rochelle, N. Y.—RADIO & TELEVISION RETAILING.

Kay TV MARKER

The "Dual Mega-Marker, Sr." for alignment of TV receivers provides crystal controlled markers for sound and picture carriers (both simultaneously available) on each of the 12 channels. Tone modulation may be switched on or off the sound marker, and the sound marker may be switched off, leaving only the picture marker. Output level is 100,000 microvolts, and attenuators are provided. Price is \$350. F.O.B. factory. Kay Electric Co., Pine Brook, N. J.—RADIO & TELEVISION RETAILING.

Simpson VTVM

Model 303 vacuum tube voltmeter provides DC, AC, AF and RF voltage ranges as well as five ranges of ohms and of decibels. Input resistance for DC voltage is 10 megohms. High frequency probe for



RF is available as well as high voltage probe to extend range to 30,000 volts. Dealer's net is \$58.75. Accessory probe is \$7.50, high voltage probe is \$14.85. Simpson Electric Co., 5200 W. Kinzie St., Chicago 44, Ill.—RADIO & TELEVISION RETAILING.

Tricraft TV ANTENNA

No. 950 "Duo-Band" is designed to be assembled in a matter of seconds, and is constructed entirely of aluminum. Matching connection harness is designed to correctly match high band elements with low band elements. High and low folded dipoles with reflectors are provided in this antenna. For further information on the new #950, as well as a copy of their latest catalog, write Tricraft Products Co., 1535 N. Ashland Ave., Chicago 22, Ill.—RADIO & TELEVISION RETAILING.

JFD TV ANTENNAS

The TA-#60 "D-Xer" conical series are made of all-aluminum tubing reinforced at all points of strain, designed to endure in adverse weather conditions. Single bay conical is \$13.95 list, ¼ wave stacked conical is \$29.25 list, ½-wave stacked is \$30.90, and double stacked 4-bay conical is \$61.80. JFD Mfg. Co., Inc., 6101 Sixteenth Ave., Brooklyn 4, N. Y.—RADIO & TELEVISION RETAILING.

T-V CHIMNEY MOUNT

Model CM-200 chimney mount for TV antenna masts consists of two brackets held in place by perforated metal strapping with ring bolts. A U-bolt holds the mast. Each bracket is a one-piece stamping of heavily plated steel, with simplicity and ease of assembly stressed in the whole unit. The CM-200 comes with all necessary hardware, including 24 feet of strapping. T-V Products Co., 152 Sanford St., Brooklyn, N.Y.—RADIO & TELEVISION RETAILING.

Milner TV MAST

This mast for TV antennas comes in 10-foot sections, can be used in heights up to 100 feet. The tubing is joined by a special rolled thread. With a variety of bases offered, it will serve all types of installations. Its universal cap is said to adapt to any size antenna. All fittings, as well as the mast, are made of rust-proof, non-corrosive aluminum alloy. Milner Mfg. Co., P.O. Box 993, Jackson, Miss.—RADIO & TELEVISION RETAILING.

Mueller CLIPS

Type 50-C is a solid bronze crocodile type needle clip for making electric contact by piercing insulated wires. Spring and needle are cadmium plated. The entire clip except jaw may be insulated with standard Mueller No. 49 flexible vinylite insulators. Mueller Electric Co., 1583 E. 31 St., Cleveland 14, Ohio.—RADIO & TELEVISION RETAILING.

C-D AUTO AERIALS

Two models of auto aerials, designed for quick installation on any contour at any angle, are included in the new Skyhawk line of antennas. Skyhawk 4-B is priced at \$3.33, while model 8-B will sell at \$5.95. The latter is chrome-plated and waterproof in construction. It is in 3 sections; will extend to 60 inches, with a 36-inch polyethylene lead-in. Complete details may be had by writing Cornell-Dubilier Electric Corp., South Plainfield, N. J.—RADIO & TELEVISION RETAILING.

Strong, light...won't stain houses...

THAT'S WHY YOU WANT ALCOA ALUMINUM



Elements made of Alcoa Aluminum by leading manufacturers are widely preferred for their excellent performance and ease of installation. Strong and light, they are easy to handle on ladder and roof. They resist weather and won't cause ugly streaks on customer's homes. If you make elements, contact the nearest distributor listed below for quick service on the Alcoa Aluminum Tubing you need.

Masts of Alcoa Aluminum can be purchased from Alcoa Distributors in standard lengths. You save shipping costs, get a lighter mast that's easier to install. Homeowners like masts of Alcoa Aluminum because they resist weathering and leave no unsightly streaks. For best results, fasten aluminum elements to aluminum masts with Alcoa Aluminum Fasteners, available from your Alcoa Distributor.

YOU CAN BUY

ALCOA ALUMINUM LOCALLY

Atlanta, Georgia
• J. M. Tull Metal & Supply Co., Inc.

Baltimore, Maryland
• Whitehead Metal Products Co., Inc.

Boston (Cambridge), Massachusetts
• Whitehead Metal Products Co., Inc.

Buffalo, New York
• Brace-Mueller-Huntley, Inc.
• Whitehead Metal Products Co., Inc.

Charlotte, North Carolina
• Edgcomb Steel Company

Chicago, Illinois
• Central Steel & Wire Company
• Steel Sales Corporation

Cincinnati, Ohio
• Williams & Company, Inc.

Cleveland, Ohio
• Williams & Company, Inc.

Columbus, Ohio
• Williams & Company, Inc.

Dallas, Texas
• Metal Goods Corporation

Detroit, Michigan
• Steel Sales Corporation

Houston, Texas
• Metal Goods Corporation

Kansas City, North, Missouri
• Metal Goods Corporation

Los Angeles, California
• Ducommun Metals and Supply Co.
• Pacific Metals Company, Ltd.

Milford, Conn.
• Edgcomb Steel of New England, Inc.

Newark, New Jersey
• Whitehead Metal Products Co., Inc.

New Orleans, Louisiana
• Metal Goods Corporation

New York, New York
• Whitehead Metal Products Co., Inc.

Philadelphia, Pennsylvania
• Edgcomb Steel Company
• Whitehead Metal Products Co., Inc.

Pittsburgh, Pennsylvania
• Williams & Company, Inc.

Portland, Oregon
• Pacific Metal Company

Rochester, New York
• Brace-Mueller-Huntley, Inc.

San Francisco, California
• Pacific Metals Company, Ltd.

Seattle, Washington
• Pacific Metal Company

St. Louis, Missouri
• Metal Goods Corporation

Syracuse, New York
• Brace-Mueller-Huntley, Inc.
• Whitehead Metal Products Co., Inc.

Toledo, Ohio
• Williams & Company, Inc.

Tulsa, Oklahoma
• Metal Goods Corporation

ALUMINUM COMPANY OF AMERICA

1959C Gulf Building • Pittsburgh 19, Penna.

INGOT • SHEET & PLATE • SHAPES, ROLLED & EXTRUDED • WIRE • ROD • BAR • TUBING • PIPE • SAND
DIE & PERMANENT-MOLD CASTINGS • FORGINGS • IMPACT EXTRUSIONS • ELECTRICAL CONDUCTORS • SCREW
MACHINE PRODUCTS • FABRICATED PRODUCTS • FASTENERS • FOIL • ALUMINUM PIGMENTS • MAGNESIUM PRODUCTS

ALCOA ALUMINUM TUBING



TYPE T-WA

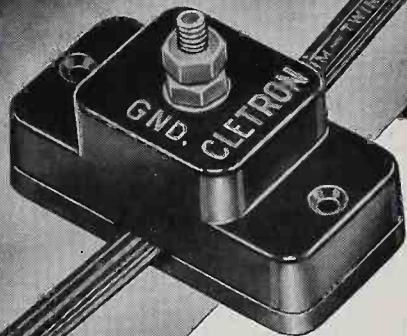

NEW Cletron

safe UL approved TV-FM LIGHTNING ARRESTER

Outstanding Features

- Quickly — easily installed without cutting line.
- Universal Base—Accommodates all types of lead-in cable.
- Absolutely does not affect signal strength on any channel.
- Prevents static build-up in antenna.
- Maintains constant antenna potential relative to ground.
- Acts like a switch in bypassing high, harmful voltages.
- Thoroughly insulated—Underwriters Lab. approved.
- Weatherproof—Built to last.
List Price \$2.25

Combined Bleeder and Gap Design

For Flat or Round 300 Ohm
and Twin-x Cables

- The first arrester to successfully combine bleeder and gap principles for FM-TV.

Electrically balanced to ground—The balanced bleeder resistors prevent any static build-up in the antenna.

Keeps the antenna and all surrounding conductors, reflectors, directors and masts at a constant potential relative to ground. Momentary, high and harmful voltages break the gap and are by-passed harmlessly to ground.

A lightweight unit, easily mounted or installed by hanging on the lead-in cable.

With a Cletron Arrester, any antenna installation is safe.

Order out a stock today—Build more satisfied customers.

* CLEVELAND ELECTRONICS, INC. *

6613 EUCLID AVENUE, CLEVELAND 3, OHIO

MORHAN EXPORTING CORP.
458 Broadway, New York

Make Extra Profits . . . selling and installing

Installation is easy. We furnish Plug Adaptors to fit most cars at no extra cost. Illustrated below.

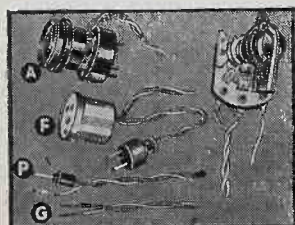

MAGNA-TONE uses the QUAM Adjust-a-Cone speaker, made expressly for rear seat application. Has unusual power handling capacity needed in auto speakers. Large diameter 1-inch voice coil. Distinctive chromium grill enhances car interior. Quality throughout. Established manufacturer.

Only \$12.95 list
with full trade margins

**AERO-TONE
MFG. CO., INC.**

4836 Joy Road, Detroit 4, Mich.

MAGNA-TONE Auxiliary AUTO SPEAKERS



Approved MARKER GENERATOR

Model A-450 generator provides a marker, modulated or unmodulated, for indicating frequencies on a TV response curve



when used with a sweep generator and an oscilloscope. Range is 19.5 to 40 MC. An external crystal may be utilized. Approved Electronic Instrument Corp., 142 Liberty St., New York, N. Y.—RADIO & TELEVISION RETAILING.

Heath VTVM

Model V-4 VTVM kit features a new balance control in the AC voltmeter circuit, said to eliminate contact potential and remove meter shift on various ranges. 200

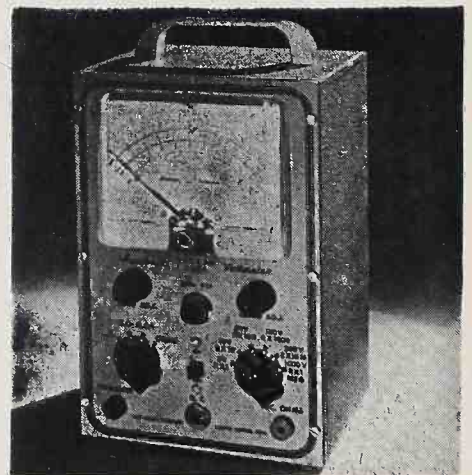

microampere meter and 1% ceramic divider resistors are incorporated. 24 ranges are included, and meter may be offset for zero-center alignment. Heath Co., Benton Harbor, Michigan.—RADIO & TELEVISION RETAILING.

Astron CAPACITORS

New midget self-healing metallized paper capacitors are available in both hermetically sealed and cardboard tubular designs, and are said to be about 1/3 to

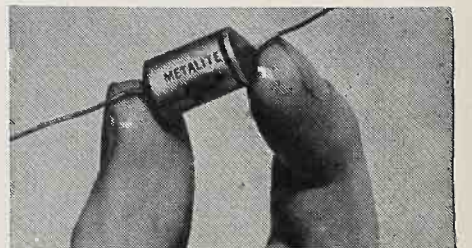

1/4 the size and weight of conventional designs. They are available in voltage ratings up to 600 volts, from .01 to 6.0 mfd. Astron Corp., 900 Passaic Ave., East Newark, N. J.—RADIO & TELEVISION RETAILING.

New TV Service Stations

Abington Television Service, Inc., of Garden City, N. Y., has opened two new affiliated organizations. The Queens-Abington Corp., at 8948 Metropolitan Ave., Forest Hills, N. Y., will serve the Queens and Brooklyn areas of New York City, under the directorship of Don T. Oliva. The Barriete Television and Radio Service Co., Inc., at 2500 Ninth St., N. E., Washington, D. C., will serve that city under the direction of M. H. Rider, previously general manager of the parent station in Garden City. Both these new affiliated organizations are devoted exclusively to installation and service of General Electric TV receivers. The officers of the founding organization, as well as its affiliates, are Samuel L. Barriete, president, and Charles Wigutow, vice-president.

Oak Ridge TESTERS

Model 103 miniature TV-FM signal generator incorporates three separate tuning bands and modulation output and attenuator. It is designed to provide modulated or unmodulated RF signals for testing and aligning all sections of TV and

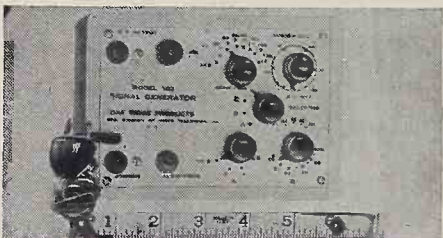

FM receivers from antenna to CRT or speaker. A feature of the unit is its small size. Model 102 miniature high voltage tester has 3 scales: 0-500, 0-15KV and 0-30KV, and comes complete with high voltage test lead. Oak Ridge Products, 239 E. 127th St., New York 35, N. Y.—RADIO & TELEVISION RETAILING.

Racon PA LOUDSPEAKER

Model MN-15B is designed to cover a wide-range of paging requirements and so make it unnecessary to carry so many types in stock. It combines good speech penetration, all-weather performance, and

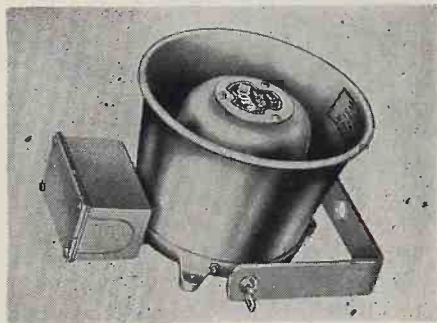

economical cost. Built-in watertight transformer housing is provided. Brackets furnished facilitate horizontal, vertical or flush rear mounting. Rated at 20 watts continuous, frequency range 450-6000 cycles, available in 8, 15 or 45 ohms. List price \$34.00. Racon Electric Co., Inc., 52 E. 19th St., New York 3, N. Y.—RADIO & TELEVISION RETAILING.

CLIMB ABOARD!

for **EXTRA PROFITS**

and

GREATER SALES

with the

Super Sonic

MODEL IT4 **TV + FM AMPLIFIER**

(2 INSTRUMENTS IN 1)

Impartial and exhaustive tests prove that the new SUPER SONIC-MODEL IT4 TV+FM AMPLIFIER delivers a higher usable gain with full bandwidth and higher signal to noise ratio than other leading brands at ANY PRICE!

\$32.50

List

- Improves TV reception in weak signal areas, with indoor or outdoor antenna.
- Continuous tuning of all 12 TV channels, also FM with ONE knob control.
- Reduces electrical, diathermy interferences and minimizes "ghosts and snow" effects.
- Frequency range: 50 mc to 220 mc, continuously tuned.
- Bandwidth: Adequate at all channels.
- Insertion gain: Minimum of 18 db at any frequency with 300 input and output impedances.
- Highest signal to noise ratio.
- Input and Output Impedances: 300 ohm balanced to ground and 72 ohms unbalanced.
- Inductances wound with PURE SILVER wire.
- All moving contacts heavily silver plated.
- Isolation transformer

CHOICE TERRITORIES STILL AVAILABLE

Write for Free Brochure to Dept. RR2

SONIC INDUSTRIES INC.

"MANUFACTURERS OF DUOSONIC PHONOGRAPHS"

221 WEST 17th STREET, NEW YORK 11, N. Y.

Will Sell Through Dealers

Arthur Ansley Mfg. Co., Doylestown, Pa., has announced a new policy in the distribution of its line of Audio-Aid school phonographs and sound equipment. Previously sold only direct to schools, the line will now be handled through exclusive dealerships in each area. The use of audio and visual aids in teaching is expanding rapidly, and Arthur Ansley, head of the company manufacturing the Audio-Aid, feels that many radio and music dealers are in a logical position to serve the needs of their local schools and at the same time build up a profitable business for themselves in this specialized field.

Now Bittan-Boenecke Co.

The Philadelphia division of the D. R. Bittan Co. is now known as Bittan-Boenecke Co., Inc., located at the same address as heretofore, 1505 Race St., phone Rittenhouse 6-8690. New York will continue to operate as the D. R. Bittan Co.

All lines and territory formerly covered by the D. R. Bittan Co. in the Philadelphia area will be handled by the new corporation. Officers of the new corporation are Dan R. Bittan, president; Charles A. Boenecke, vice-president and secretary. Also associated with the company are Roy Sunday and Del Roswick.

Raytheon Names Trojan

The Trojan Radio Co., of Troy, N. Y., has been appointed as a distributor for Raytheon receiving, television and special purpose tubes, it has been announced by F. E. Anderson, distributor sales manager of Raytheon's Radio Receiving Tube Division.

Established in 1945, the Trojan Radio Co. has recently moved to larger quarters located at 420 River St., Troy, N. Y., to better serve their customers in northwestern New York state and western Vermont.

Anchor MOUNTING RING

A new plastic mounting and insulating ring is available for the Dumont 19-inch metal tube which makes it possible to utilize the full width of the tube face for "wide screen" masking while

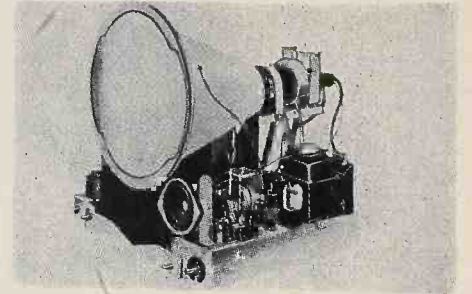

providing secure mounting and adequate insulation. Also announced is an improved mounting for the 16-inch metal tube which incorporates a full 2-inch creepage path. The firm also makes plastic sleeves for the metal cone of these tubes. Anchor Plastics Co., Inc., 533 Canal St., New York, N. Y.—RADIO & TELEVISION RETAILING.



Play the
PROFIT TUNE

WITH THE

Wonderful New CARBONNEAU PLAYSALL

45 & L.P. (RECORD CONVERTER)

Meet the PLAYSALL the new 45 and L.P. record converter that features PRECISION AT A PRICE. The brilliant new Playsall plays records of all sizes and speeds, fits your customer's present set and better yet the "Speedy Connector" hook-up makes it possible to install Playsall in a jiffy.

Take a look at Playsall's stunning, compact design, see its premium features and now take a good long look at the retail price. Mister, it's going to be your biggest '50 profit maker and your customers favorite "buy" at only **\$795**



Dealers: Full 40% off list on 6 or more units

The Playsall during recent months has successfully passed its "sales appeal" tests with flying colors, in several of America's toughest retail testing areas. It's a cinch to be surefire in your local market, so profit with a proven seller. Send your order today.

CARBONNEAU INDUSTRIES, INC.

21 Ionia N.W. Grand Rapids, Michigan

Please send me Playsall converters. Check enclosed.
 Bill my Account.

NAME _____

ADDRESS _____

CITY _____ STATE _____

TVCA

Television Cabinets

CUSTOM QUALITY at PRODUCTION PRICES



AVAILABLE FOR 16" and 19" ROUND OR RECTANGULAR TUBES

● HEIGHT 42" WIDTH 30" DEPTH 25"

● SUNBURST GRILLES OPTIONAL

CONSOLE MODELS WITH FULL-LENGTH DOORS, featuring

Piano Finish . . . Master Craftsmanship
Finest Mahoganies . . . Leather Doors
Modern Cabinets in Bleached or Cordovan Mahogany.

TELEVISION CABINET CO. OF AMERICA

2436 Grand Concourse, Bronx 57, New York
Telephone LUdlow 4-2502

Figuring Profitable TV Trade-Ins

(Continued from page 48)

percentage with the most recent price for a comparable model of the same manufacturer (comparable with the original, or trade-in set).

Having found the resale value, we next determine the reconditioning cost (C) by taking a fixed percentage (we have used 5%) of the original cost of the set (A).

Next we determine the profit (D), which is a fixed percentage of the resale value of the set (B). We have used 10% for our example.

Finally, we add together the deductions from the resale price to determine the trade-in allowance (E). In other words, we add the profit and the reconditioning cost together, and subtract from the resale price. The result is the sum we can allow the customer on a new set provided he buys one at least comparable in value to the old one, as explained in the beginning of this article.

We shall conclude with one final example: The original set is between 1 and 2 years old, is a 10-inch console-combination which cost \$399.95. Most recent price on a comparable model is \$299.95, establishing the resale value (using 50% from table 1) as 50% of \$299.95, or \$150. Profit will (at 10%) be \$15., reconditioning cost (5% of \$399.95) \$20, total deductions \$35., trade-in allowance \$150. less \$35., or \$115. And one final word: the percentages are not mandatory, but may be adjusted to suit your store.

Refrigerator Prospects

(Continued from page 46)

nishes the electric current, and where his repair bills for existing refrigeration units have been high.

Many dealers have found the employment of "bird-dogs," both male and female, to be a profitable and satisfactory undertaking. Offering commissions to people in all walks of life on sales closed as a result of leads such folk bring in, has definitely increased the sales volume for two large dealerships, one in the North and one in the South. These merchants have set up regular, well-organized "bird-dog" groups.

The more obvious methods for obtaining refrigerator leads such as canvassing and advertising have not been stressed in this article. Canvassing, of course, is always considered to be a top method, along with advertising.

In the final analysis, the more live leads the dealer has in his card file, the more sales he can expect to make, provided he works the leads consistently and effectively.

In an article in the January issue of RADIO & TELEVISION RETAILING it was pointed out that the sales peaks in refrigeration selling are leveling off.

This means that the "seasonal" aspect is diminishing in importance, and that the alert merchandiser can assure his salesmen that they can sell refrigerators all the year 'round. But to sell 'em in quantity, they must have leads for every day in the year.

TV Sweep

(Continued from page 91)

The 6BG6-G sweeps a 54° 12 or 16 inch tube at 12KV operation with a 250 volt B supply, and with a 325 volt B supply will adequately sweep a 14KV cathode ray beam in a 19AP4

picture tube with a 67° sweep angle. Use of a special short yoke is required for the wider deflection angles.

The accompanying photo shows the physical appearance of the GE Type 77J1 transformer (in GE sets stock number RTO-071). Notches in the phenolic terminal boards are provided to allow for addition of mounting plates to hold a wafer socket for the high voltage rectifier. The schematic shows the sweep section of Admiral chassis providing deflection and 13.5KV for the 16GP4 (wide angle, "short" 16" tube) using the new RCA 6CD6-G beam power horizontal deflection amplifier.

25¢ a day or an hour



SELLS

TELEVISION!

Break down all sales resistance and watch your TV sales rise with the—

A. B. T. COIN PAY METER

The only low cost, completely automatic Coin Pay Meter on the market!

Join the hundreds of other alert dealers who are promoting and cashing-in with real TELEVISION SALES VOLUME with the A.B.T. COIN PAY METER PLAN. Can be timed for any intervals desired, holds \$25.00 in quarters, small and compact, completely automatic.

Use the television set as the collection medium, just plug TV set into the meter and meter into wall. It's simple... the ideal way to increase sales and profits.

order your coin pay meter sample today

\$6.95

(in small lots)
F.O.B.
Chicago

Distributors' inquiries invited. Illustrated literature and merchandising help is available upon request.

A. B. T. MANUFACTURING CORP.

General Offices and Factory: 715-723 N. Kedzie Ave., Chicago 12, Ill.

FOR OVER 31 YEARS—

The World's Largest Manufacturers of All Types of Coin Control Equipment

Webster Names Clancy

Webster Electric Co., Racine, Wisc., announces the appointment of J. J. Clancy, 3611 Webster St., Fort Wayne, Ind., as sales representative of their sound division in northeastern Indiana and southern Michigan.

Centralab Sales Manager

Wickham Harter has been appointed as sales manager of the distributor division of Centralab, division of Globe-Union, Inc., Milwaukee. He was formerly vice-president and sales manager of Solar Manufacturing Corp.

Absorbs Colonial Radio

Sylvania Electric Products Inc. has absorbed its wholly-owned subsidiary, Colonial Radio Corporation, manufacturers of radio and television sets, it has been announced by Don G. Mitchell, Sylvania president.

Onthank Sales Head

The appointment of Don P. Frank as sales manager of the G. W. Onthank Company, Omaha, Nebr., DuMont television distributor in that area, has been announced by G. W. Onthank, president.

Scher in New Sales Post

Appointment of Martin L. Scher as general sales manager has been announced by Nathan Cooper, president of Motorola-New York Inc., local distributor for the Chicago television and radio manufacturing firm. Prior to joining Motorola, Mr. Scher was for four years general sales manager for Admiral Corporation's New York distributing division and for the Dale Distributing Co., predecessor to the Admiral division.

Sylvania Distributors

Electrical Wholesalers Inc., Atlanta, Ga., has been appointed Sylvania television distributor for the Georgia territory, according to C. K. (Larry) Bagg, sales manager, Colonial Radio Corp., Buffalo, wholly-owned subsidiary of Sylvania Electric Products, Inc., which manufactures Sylvania TV receivers. F. H. Dendy, Sr. is president of Electrical Wholesalers and J. Q. Forrester is sales manager of the Georgia distributor.

Astatic Uses TV Time

Plans of The Astatic Corp., Conneaut, Ohio, to use television on a national scale for advertising its TV booster were revealed when the first one-minute commercial appeared over WNBK, Cleveland, February 13, during the Bob Reed Show, which runs from 6:30 to 6:52 PM.

Six one-minute motion picture films, with sound and using live talent, have been produced to show the Astatic television booster in use and point up its exclusive features, according to William J. Doyle, Astatic general sales manager. The films will be alternated in appearances two or three times weekly from each station added to the company's TV advertising schedule, Doyle stated. New films will replace the original six before the latter have lost their interest through too much repetition, he declared.

Business and Pleasure



Relaxing in the Florida sun are (at left) B. Abrams, president, Emerson Radio and Phonograph Corp., New York; (at right) Manuel Eskind, president, Capitol Radio and Television Company, Emerson distributor in the Nashville, Tennessee area, and son Robert Eskind (center).

Jackson For 1950



Dimensions: 28 1/4" W; 16 1/4" D; 36" H

4 RADIO PHONO
COMBINATIONS WILL
BUILD TREMENDOUS
Dealer Profits
IN 1950!

- ★ Full-tone 10" Speaker
- ★ Slide-rule Easy-to-read dial
- ★ Wide range audio response
- ★ All models available in blonde

MODEL 150 AM RADIO, 1 SPEED PHONOGRAPH

Continuous tone control • Built-in loop antenna • Push-pull audio system • 7 tubes, including rectifier • Plays standard 10 and 12 inch records automatically.
In Gleaming Mahogany—
List.....

\$119⁵⁰

MODEL 250 AM-FM RADIO, 1 SPEED PHONOGRAPH

8 tubes, including rectifier • Straight AC chassis • Triode Mixer • 3 position tone control • Built-in dipole antenna with provision for external antenna • Plays standard 10 and 12 inch records automatically.
In Mahogany—List.....

\$159⁵⁰

HERE'S A REAL SALES LEADER

Kiddy Phono

- Symphonic sound box for rich true tone
- Built-in tone chamber
- Plays any record up to 12" symphony
- Streamlined one-piece plastic base
- Approved by Underwriters' Laboratories
- Absolutely guaranteed

LIST \$995

MODEL 153 S AM RADIO, 3 SPEED PHONOGRAPH

Continuous tone control • Built-in loop antenna • Push-pull audio system • 7 tubes, including rectifier • Plays standard 10 and 12 inch records (intermixes sizes) • Plays 33 1/3, 45 RPM, and 78 RPM Records.
In Gleaming Mahogany
List.....

\$149⁵⁰

MODEL 350 AM-FM RADIO, 3 SPEED PHONOGRAPH

Shuts off automatically after playing last record • Intermixes 10 and 12 inch records • Plays 33 1/3 LP, 45 RPM, and 78 RPM records • 8 tubes, including rectifier • Straight AC chassis • Triode Mixer • 3 position tone control • Built-in dipole antenna with provision for external antenna.
In Mahogany—List.....

\$199⁵⁰



FULL TV LINE
12 1/2" to 19"
TABLE MODELS
CONSOLES

JACKSON INDUSTRIES

1112 South Michigan Ave., Chicago Ill.

HA7-5084

New Officers Named By Radio Pioneers

Frank E. Mullen, chairman of the board of Jerry Fairbanks, Inc., film producers, formerly NBC executive vice-president, has been nominated president of the Radio Pioneers, to succeed William S. Hedges, NBC, whose term expires April 4.

O. H. Caldwell, editorial director of RADIO & TELEVISION RETAILING, who served during the past year as vice-president and treasurer, has been nominated first vice-president. Others nominated: Arthur Church, KMBC, Kansas City, Mo., 2nd vice-president; Paul W. Morency, WTIC, Hartford, vice-president and secretary; Carl Haverlin, president of BMI, vice-president and treasurer; J. R. Poppele, WOR, New York, vice-president, and Martin Campbell, WFAA, Dallas, Texas, vice-president.

Radio men who have been 20 years in the industry are invited to join. Radio Pioneers headquarters are at 30 Rockefeller Plaza, New York, N. Y.

In Westinghouse Post

The appointment of A. George Rogers as assistant manager of the Westinghouse Home Radio Division with responsibility for television and radio receivers, both engineering and manufacturing, was announced recently by F. M. Sloan, division manager. He succeeds Harold W. Schaefer who resigned.

Utah Representatives

Marshall E. Neil, general sales manager for Utah, Inc., Huntington, Ind., announces the appointment of J. R. Dannemiller Associates, 4334 Groveland Rd., Cleveland 13, Ohio, as jobber representation in Ohio, western Pennsylvania, West Virginia, and western Kentucky.

Admiral Distributor



J. Gower Chapman, vice-pres. and general manager of Major Appliance Co., Lansing, Mich., signs as distributor for Admiral Corp. products in central and northern Michigan. With Chapman are Admiral officers Walter C. Johnson (left), vice-pres. in charge of sales and Walter M. Davis (right), district manager.

Clarostat Appointment

The appointment of Bruce Cumming & Associates of 228 No. LaSalle St., Chicago 1, Ill., as industrial and jobber reps, is announced by Clarostat Mfg. Co. Inc., Dover, N. H. The Cumming firm will handle the Clarostat line of resistors, controls and resistance devices for the jobbing trade in all of Illinois with the exception of Benton and Harrisburg counties, and Wisconsin with the exception of Marinette, Eau Clair, LaCrosse and Wassau. They will handle the industrial accounts for Illinois with the exception of metropolitan Chicago, and Wisconsin with the exception of Milwaukee.

Distributing Peerless

Radio specialties Co., Detroit, has been appointed sole distributor for the Greater Detroit area, of Peerless transformers, according to an announcement by H. S. Morris, eastern sales manager of Peerless Electrical Products Division of Altec Lansing Corp.

New Regal Models

Received too late for inclusion in Part II (March 1950 Television Receiver Specifications), were two new Regal TV Models: 19C31 and 19C36. Both are 19-inch console models in wood cabinets. 19C31 lists for \$497.50, 19C36 lists for \$527.50.

"KNOW-HOW"
YOUR
TUNG-SOL
DISTRIBUTOR
HAS IT!



"Know-How" in wholesaling is a lot of things collectively which are of great importance to a retailer. It is up-to-date knowledge of product improvements and new developments... it is thorough knowledge of technical engineering in radio and television sets and components... it is training in relative qualities of competitive products... it is knowing how to carry a balanced stock to serve dealers... it is knowing the importance of service to dealers and giving that service promptly.

There is a distributor in your vicinity who has a TUNG-SOL franchise because

he possesses all of this "know-how" in full measure. You'll find him a friend as well as a supplier, reflecting the friendly helpfulness of TUNG-SOL's business policy. This distributor carries a full line of TUNG-SOL "vibration-tested" Radio and Television Tubes, which are made to the high standards you want represented in your own service work. Order from your TUNG-SOL distributor.

TUNG-SOL LAMP WORKS INC.

Newark 4, N. J.

Sales Offices: Atlanta • Chicago • Dallas
Denver • Detroit • Los Angeles • Newark

TUNG-SOL

TELEVISION TUBES
RADIO TUBES
DIAL LAMPS

ALSO AUTO LAMPS, ALL-GLASS SEALED BEAM LAMPS & FLASHERS

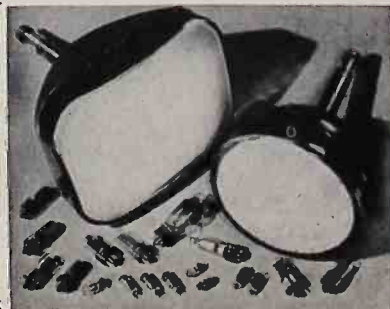

JACKSON

Announces a Sensational, New 5 Inch Oscilloscope



Band Width to 4.5 megacycles! High Sensitivity of .018 volts-per-in.

Now, for the first time—thanks to an amazing electronic discovery—Jackson has combined in one oscilloscope both wide band width and High deflection sensitivity. By merely flipping a switch you can choose from one of three sensitivity ranges, or one of three other band width ranges. Here is a fine instrument, perfectly suitable for laboratory analysis, yet well within the price range of the average radio serviceman.

The new Jackson Model CRO-1 is in production right now! It is priced at only \$195.00 net. A special high-frequency signal tracing demodulation probe is also available at \$9.95. Get your order in today!

Just look at these Features

Wide Band Amplifier: Easily usable to a full 5 megacycles. Flat within plus or minus 1.5 db. from 20 cycles to 4 megacycles.

Deflection Sensitivity: Vertical amplifier, .018 RMS volts-per-inch on narrow band. Horizontal amplifier .55 RMS volts-per-inch.

Input Impedance: Direct balanced, 6 megohms shunted by 11 uufd; unbalanced 3 megohms shunted by 22 uufd. Horizontal amplifier 1.5 megohms.

Sweep Frequencies: Saw tooth wave, 20

cycles to 50 kilocycles in 5 steps.

Special Features: All controls on front panel. Provision for 60 cycles or external sweep. Also has provision for grid modulation at 60 cycles or with external voltage. Full 5-inch CRT. Same height as new Jackson TVG-1 TV Sweep Generator. Rear terminal strips for direct connection, through capacitors, for A.C. voltages to CRT deflection plates. Light weight, easy to carry. Provided with leather carrying handle. Attractive all steel cabinet with gray Ham-R-Tex finish.

JACKSON

Service-Engineered
Test Equipment

remember—this Jackson oscilloscope supplies wide band width considered essential for TV sync. circuit testing.

Write for bulletin D-12 today.

Jackson Electrical Instrument Company • Dayton 1, Ohio



YOU NEED Mastercraft Deluxe PLASTIC PRICING SETS That "Tell" and "Sell"

Placed upon a radio or television set, furniture or household appliance, Mastercraft is your "BEST SILENT SALESMAN." Descriptive slogans on Pennants and Bases make a selling combination that adds sales appeal to your products.

EXTRA SELLING FEATURES

Bases cannot tip over. Numerals always upright. Easy as A-B-C to slide numerals into patented pressure groove base. Numbers cannot fall out. Bases, Pennants and Numerals sold separately. Orders filled to your specifications from selection of slogans.

• Send for illustrated circulars and order form today •

To do more business in '50 use

MASTERCRAFT PRODUCTS
223 TYLER ST. Dept. R TRENTON 9, N.J.

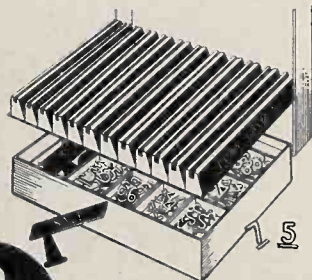

180 Numerals—1" high, Red or White
12 Pennants
12 Black bases—6" long
204 pieces

Mastercraft
PLASTIC PRICING SETS

News of the "Reps"

Arthur J. Nelson, a member of "The Representatives" with offices in Denver, Colo., has been appointed sales representative in the Rocky Mountain States for the John F. Rider Publications, Inc., 480 Canal St., New York 13, N. Y.

Ray T. Schottenberg, recently elected to membership in the Mid-Lantic Chapter, has been appointed the LaPointe Plascamold representative for southern New Jersey, eastern Pennsylvania, Maryland, Delaware, and the District of Columbia for their Vee-D-X antenna line.

Boonton Radio Corp. of Boonton, N. J., has appointed the Neely Enterprises of Hollywood to represent its lines in California, Nevada, New Mexico, and Arizona.

Ernest Roberts, a member of the Los Angeles Chapter, spent recent weeks introducing Charles Crede, chief engineer of the Barry Corp., Cambridge, Mass., to the trade in southern California. Roberts represents Barry in four western states.

A member of the Chicagoland Chapter, J. K. Rose, has been named as sales representative in his territory for the Circle "X" Antenna Corp., Perth Amboy, N. J.

Jack Yount, member of the Southwestern Chapter, has been named as sales representative for the Rauland-Borg Corp., 4245 N. Knox Ave., Chicago, manufacturers of television picture tubes and other electronic equipment. Mr. Yount will cover Texas, Oklahoma, and Arkansas.

Don Hagen has been added to the staff of E. V. Roberts & Associates, 5014 Venice Blvd., Los Angeles 35. Hagen holds a B.S. degree in physics from Lewis and Clark College, Portland; Oregon. He saw service in the Pacific as a seabee for two years and was with the Naval Laboratory at San Diego before joining the Roberts firm.

Snyder Sales Manager



Dick Morris (center), sales manager of Snyder Mfg. Co., 2218 W. Ontario St., Philadelphia, Pa., talks things over with Bert Count of the S & M Supply Co. of Minneapolis, Minn.

Since the earliest days of Radio...



have been preferred for their absolute uniformity, superior qualities and ultimate economy. Foremost set manufacturers specify CORNISH, because our engineers keep abreast of electronic developments. Let us serve YOU.

Write for catalog #57

"MADE BY ENGINEERS FOR ENGINEERS"

CORNISH WIRE COMPANY, INC.
15 Park Row New York 7, N. Y.



KEEPING PACE with SERVICE-DEALER NEEDS

Expanded manufacturing and technical facilities enable us to serve you better . . . faster. A modern equipped plant and laboratory; latest production methods and trained technicians producing dependable electronic products help you save time and increase your operating profits. Our staff engineers are constantly developing new products to offer you the latest and best in equipment.

NEW Model "B" Supplies 1 to 20 Amps 6 Volts DC, Continuous Duty — 3 to 9 Volts at Other Ratings



Potent Pending

Test or operate auto radios, relays, telephone circuits, instruments and other low voltage devices

New conduction cooling method increases rectifier power rating 1½ times, providing lower cost per ampere output over any other type. The Electro "B" gives you highest efficiency, offering ample power

to operate two auto radios simultaneously. Peak instantaneous current rating of 35 amperes (from 50 to 60 cycle 115 volt power source).

Write today for literature



Pioneer Manufacturers of Battery Eliminators

ELECTRO PRODUCTS LABORATORIES, Inc.

4499 NORTH RAVENSWOOD AVENUE, CHICAGO 40, ILLINOIS

only WALSCO

gives so much for so little...



crystal-clear TV reception.

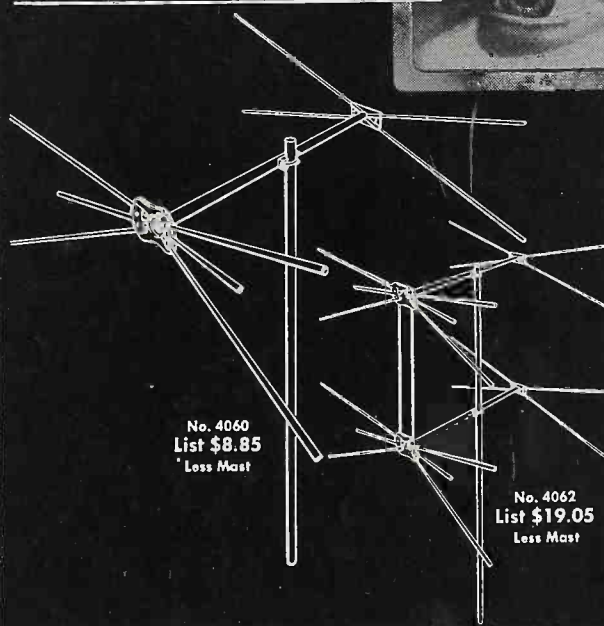

No. 4060
List \$8.85
Less Mast

No. 4062
List \$19.05
Less Mast

amazing antenna out-sells all others!



WALSCO features a *silicone-treated styron molded insulator* to assure crystal-clear TV reception.

WALSCO uses *marine type high tensile dural* for elements . . . with a "yield point" 94% higher than ordinary aluminum.

WALSCO uses a *butt-seamed tubing* for elements to assure the *highest elasticity*.

WRITE FOR FREE ILLUSTRATED CATALOG 49-T

WALSCO New TV Alignment Tools are used everywhere. Available at your local jobber.

WALTER L. SCHOTT CO.

Beverly Hills, California
Chicago 5, Illinois

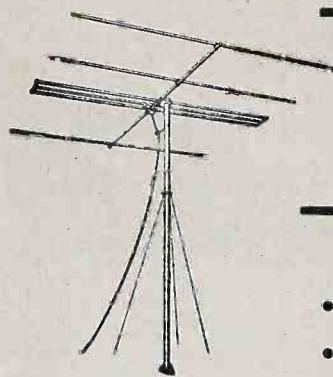

GREATEST ADVANCE IN YAGIS!

The TRIO Double Folded Dipole

- Outperforms Conventional Large Arrays
- Sturdy Construction, light in Weight
- Exact Impedance Matching
- Gain Flat Over Entire Channel

Here's the antenna that's sweeping the field in fringe areas—the TRIO Double Folded Dipole. It's designed by G. N. Carmichael, one of the nation's foremost antenna engineers. Available for each of the 12 TV channels. Considerable gain achieved on adjacent channels. The double folded dipole accurately matches antenna to conventional 300 ohm line. Only 5 lbs. weight for channel 5, 2¼ lbs. for channel 9. Unusually sturdy. More than one bay may be mounted on mast with independent orientation of each. Available with or without mast. Specify channel when ordering.

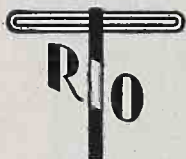

AVAILABLE THROUGH YOUR JOBBER

Trio

MANUFACTURING COMPANY
GRIGGSVILLE, ILLINOIS

for 1950

Approved PRODUCTS

MODEL A-460



TV Field Strength Meter
\$7950

Field Strength Meter; television 12 channel

tuner; video if channel; large 6" directly calibrated meter; hammer-tone finished panel; ideal for locating antenna systems; testing transmission lines; testing efficiency of indoor antennas; checking booster efficiency, etc.

The Model A-460 Television Field Strength Meter is housed in a heavy gauge steel cabinet, battleship gray finish with 6 tubes (standard brands) 1N34 Crystal operating instructions, circuit diagram and guarantee. Shpg. weight 25 lbs. Size: D—8" x H—10" x W—12".

JOBBERS

WRITE FOR OUR NEW
1950 EDITION 12 PAGE
CATALOGUE AND JOB-
BER NET PRICES

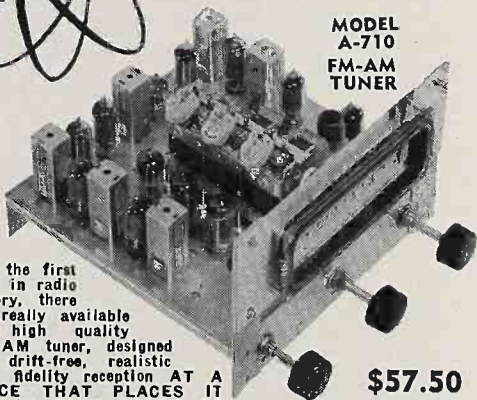

MODEL
A-710
FM-AM
TUNER

\$57.50

For the first time in radio history, there is really available

a high quality

FM-AM tuner, designed

for drift-free, realistic

high fidelity reception AT A

PRICE THAT PLACES IT

WITHIN EASY REACH OF

THE CUSTOM BUILDER,

SERVICEMAN, MANUFACTURER, EXPERIMENTER, ETC.

TUBES USED ON FM: 1—6AG5 RF Amplifier; 1—6BE6

Mixer-Detector; 1—6J6 Oscillator; 2—6AU6 IF Amplifier; 1—

6AU6 Limiter. 1—6AU6 Limiter; 1—6AL5 Discriminator.

TUBES USED ON AM: 1—6BA6 RF Amplifier; 1—6BE6 Con-

verter; 1—6BA6 IF Amplifier; 1—6AT6 Diode (audio am-

plifier common to AM-FM).

Chassis dimensions: 8½" x 5½" high, 8" deep. Net

weight: 5½ lbs.

Power requirements: 170 V DC 20 MILS and/or 140

V DC. 37 MIL. 6.3 V 4 AMP.

APPROVED ELECTRONIC INSTRUMENT CORP.

142 Liberty St., Dept. F New York 6, N. Y.

New Books, Pamphlets, Catalogs, Sales Aids

Merit Transformer Corp., 4425 N. Clark St., Chicago 40, Ill.—1950 TV Replacement Guide lists approximately 400 popular TV sets of 60 manufacturers, showing correct replacement parts. Free copies of the "Repl" guide as well as information on new Merit "Flybacks," focus coils, yokes and 12 new TV transformers (including power, audio, vertical output and chokes) available by writing the manufacturer direct.

Best-View Products, 247 Center St., New York, N. Y.—An illustrated brochure of the "Phenix," "Onyx," and other antennas in the new 1950 line of TV antennas may be had on request.

International Rectifier Corp., 6809 So. Victoria Ave., Los Angeles 43, Calif.—Literature is available covering a new hermetically sealed selenium photoelectric cell of the self-generating type, requiring no external source of power.

Oxford Electric Corp., 3911 S. Michigan Ave., Chicago, Ill.—A new catalog in color gives complete listings of Oxford loudspeakers with all pertinent data, including illustrations. Speakers cover every TV, FM, AM, PA and auto application.

Peerless Electric Products Div., Altec Lansing Corp., 161 Sixth Ave., New York 13, N.Y.—A new transformer catalog contains a complete line of transformers for broadcasting and other professional applications, as well as for amplifier constructors, audio enthusiasts, the replacement field, and hams. The line includes output, input, interstage, plate and filament, power smoothing and swinging chokes, and replacement types. Copies may be had by writing the manufacturer.

Seletron Div., Radio Receptor Co., Inc., 251 West 19th St., New York 11, N.Y.—A new 4-page pamphlet has been prepared on the design, application and service of selenium rectifiers. Includes a complete description and tabulation of test and repair procedures and troubleshooting methods. Copies of the pamphlet are available without charge on request.

Westinghouse Electric Corp., 306 Fourth Ave., Pittsburgh 30, Penna. A 4-page "Small Motor Selector" covers why there are different types of fractional horsepower motors, the factors to be considered in selecting the right motor for the application, and a large chart showing the various types with complete data concerning horsepower range, speed characteristics, torque, reversibility, bearings, mountings, and applications. For a copy of this booklet (B-3075-C) write the Westinghouse Electric Corp., Box 2099, Pittsburgh 30, Penna.

Permo Inc., 6415 Ravenswood Ave., Chicago 26, Ill.—"The Permo Reporter" bulletins are a series of semi-technical and informative data regarding phonograph needles and their relation to recording and reproduction. Bulletin #2 includes a chart of ratings of needle point materials in hardness, life expectancy, effect on record life, etc.

(Continued on page 111)

(Continued from page 110)

John F. Rider, Publisher, Inc., 480 Canal St., New York 13, N.Y.—"Radio Operator's Q&A Manual" by Milton S. Kaufman is a 608-page book of questions and answers to past FCC exams, constitutes a reference volume, study guide, a quick review of essential theory and a refresher for advancement in the field of radio operation. Book includes 193 illustrations and is priced at \$6.00.

Pitman Publishing Corp., 2 West 45th St., New York, N.Y.—"Radio Technology," Ernest J. Vogt is designed to furnish a single volume radio reference library that features a complete technical course in radio with higher mathematics eliminated, for use by radio technicians, hams and operators. The text covers the general field of radio communications, and is considered applicable for study for any FCC ticket. Price is \$6.00.

Aim Industries, 41 Union Square, New York 3, N.Y.—A new catalog is available covering the complete line manufactured by this firm, including price lists, covering all types of phonographs, record accessories, recording blanks, and television tables. Free on request written on your business letterhead.

Technical Appliance Co., Sherburne, N.Y.—Explanation and detailed drawings of the proper procedure in stacking high-band antennas is given in Engineering Bulletin No. 58. Dimensions and proper phasing of antennas are given for both the 2-stacker and 4-stacker array.

Sylvania Television, 1280 Main St., Buffalo, N.Y.—A selling aid for TV sets is being recommended to all Sylvania TV dealers and distributors. The idea consists of a large map which gives the prospective TV owner all the information he wants on TV in his area: where he lives with relation to the transmitters, and to major landmarks, especially high structures that might alter reception. The map will explain in non-technical terms how expert installation will provide the best possible reception.

Jensen Industries, Inc., 329 S. Wood St., Chicago 12, Ill.—"Replacement needles by Jensen" is a 12x13 inch chart showing catalog number, actual size illustration, list price, point material and point size for all the Jensen needles, showing also the make and model phono cartridge and instrument in which the needles are used.

Easy-Up Tower Co., 3800 Kinzie Ave., Racine, Wis.—A bulletin is available showing accessories for TV antenna masts, including guy-wire "thimbles," guy clamps, guy rings (fixed and rotating), mast foot mounts, and antenna mast couplings. Bulletin includes illustrations and list prices and is available on request.

Standard Transformer Corp., Elston, Kedzie and Addison Sts., Chicago 18, Ill.—A 20-page booklet, "Stancor Television Components Replacement Guide," lists Stancor replacement transformers for 215 receivers and chassis made by 43 manufacturers. Stancor replacement part numbers are listed together with manufacturers' part numbers. Free copies are available direct or from Stancor distributors.

Get Set for LAND OFFICE BUSINESS on the *Astatic* TELEVISION BOOSTER Soon to be Advertised Nationally on TELEVISION

OWNERS OF TV RECEIVERS, and their friends, the nation over, will soon see the Astatic Television Booster in operation . . . and hear its exclusive advantages explained . . . from their favorite TV stations. It doesn't take a crystal ball to forecast the impact of TV advertising on sales of Astatic Boosters. When set owners in your area actually see weak, washed-out pictures on a TV screen changed to bright, clear action by the Astatic Booster, the skyrocketing of sales will be automatic. They'll be asking—by the thousands—for the "four-tube booster" with "variable gain control," "dual-tuning," "handsome furniture-finish mahogany cabinet," and other exclusive features they've seen and heard about ON TELEVISION. They'll ask by name for the Astatic Booster.

If there is anything you don't know about the Astatic Booster, write for specifications and complete details. Get behind this surefire program to help you sell. Check your stock. Order TODAY for your needs.

Astatic Crystal Devices manufactured under Brush Development Co. patents

THE *Astatic* CORPORATION
ASTATIC CONNEAUT, OHIO
IN CANADA: CANADIAN ASTATIC LTD. TORONTO ONTARIO



Bigger and Better Than Ever!

DEWALD's New 1950
19" King-Size TV with
BUILT-IN ANTENNA \$399.95
Retails for only

From the new King-Size 19" model, thru the 16", 12½" and 10" table and console models — all with Built-In Antennas — this new line offers the finest in TV enjoyment. Clearer, brighter, steadier pictures plus extra-dependable performance.

And, this great new TV line plus an outstanding group of Superformance Radios are available

NOW at NEW LOW PRICES

JOBBERS-REPRESENTATIVES: Some choice territories now available. Write for full information.



19" King-Size Model DT-190

Proven Quality for Over a Quarter Century

in
RADIO
and
TELEVISION

for
SOMETHING
BETTER,
it's

DEWALD

DEWALD RADIO MFG. Corp. 35-15 37th Ave. Long Island City 1, N. Y.

Help end INTERFERENCE

AUTO-LITE Resistor SPARK PLUGS

THE NEW Auto-Lite Resistor Spark Plugs reduce spark plug interference with radio and television reception and in addition offer car owners smoother idling, better engine performance on leaner gas mixtures and longer electrode life. Gain friends by recommending them to your customers with TV sets, car radios and radio telephone installations.

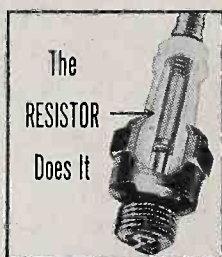

FREE PROMOTION MATERIAL

Helpful instructive folder, "TV brings change in car ignition behavior."



Big, colorful reprint of Auto-Lite's Saturday Evening Post television ad for your window.



A highly informative folder showing construction features of Auto-Lite Resistor Spark Plugs.



An attractive counter card featuring "Suspense" on radio and TV. Creates interest in television and set purchases.

The Electric Auto-Lite Company, Toledo 1, Ohio
Please send me FREE promotion material on suppression of spark plug interference with radio and TV through use of Auto-Lite Resistor Spark Plugs.

Name _____
Address _____
City & State _____

Tune In "Suspense"... CBS Radio Thursdays... CBS Television Tuesdays

New Books, Pamphlets, Catalogs, Sales Aids

Electromode Corp., 45 Crouch St., Rochester 3, N. Y.—Industrial Catalog (EC-62) and Domestic Catalog (EC-63) contain descriptions, complete specifications, and illustrations of Electromode electric unit heaters, including typical installations, and helpful information concerning heating by electricity. List prices are included.

Sprague Products Co., 65 Marshall St., North Adams, Mass.—A new capacitor code indicator makes it easy to decipher molded paper tubular capacitor color codings. The indicator consists of a pocket-size plastic device with rotating color-marked dials. Available for 15¢ from the manufacturer or from Sprague distributors.

John Wiley & Sons, Inc. (publishers), 440 Fourth Ave., New York 16, N. Y.—"Photoelectricity and Its Applications," by V. K. Zworykin and E. G. Ramberg, covers TV illumination control, picture transmission, automatic inspection, hot-body detection, traffic control and many other applications of photoelectricity. 494 pages, 393 illustrations, \$7.50.

Waldom Electronics, Inc., 911 N. Larrabee St., Chicago, Ill.—A new 24-page catalog contains a complete listing of replacement speaker cone assemblies, both pre-war and postwar for all makes of sets. Information includes part number, set model and number, O.D. of cone and all pertinent dimensions of speaker, voice coil, spider, etc. Copies available by writing the firm.

Starrett Television Corp., 601 W. 26th St., New York 1, N. Y.—"21 Terrific Television Parties" is a booklet of games being offered to consumers through Starrett dealers. Dealers are provided with mat ads offering the booklet free to consumers.

Tung-Sol Lamp Works, Inc., 95 Eighth Ave., Newark 4, N. J.—"Electron Tube Base Connections" is a 3 x 3-inch plastic bound book containing 301 base diagrams of nearly 800 different electron tubes. The book is available through all Tung-Sol wholesalers.

Baker Mfg. Co., Evansville, Wis.—Bulletin 501 describes the Monitor line of towers for TV, including model numbers, specifications, weight and retail price. Accessories for tower mounting are also described.

"Modern Oscilloscopes and Their Uses," published by Murray Hill Books, Inc., of New York, written by Jacob H. Ruiter, Jr., 326 pages, 370 illustrations. After explaining the theory and construction of oscilloscopes, the author explains how the instrument is used in receiver testing (AM, FM, TV, etc.), and how to interpret wave forms. Typical applications in other branches of the electronic industry are also covered.

NO MATTER HOW YOU LOOK AT IT

PHOENIX
Speed-Mounts and Speed-Tennas
DO A BETTER JOB!

Strong—light in weight—fast, easy installation. Engineered to give highest quality electrical performance . . . and designed to withstand the toughest weather conditions. Pre-assembled—no loose hardware.

ANTENNA MAST STAND-OFF INSULATORS
Famous PAM-11—faster, stronger, easier to install—genuine Polyethylene inserts—attaches to any mast in just 10 seconds.

AT LEADING JOBBERS

PHOENIX ELECTRONICS, Inc.
Lawrence, Mass.

WRITE FOR NEW CATALOG

"Freeze" Limits Audience

Only about two-thirds of the people of the United States who should be able to receive television programs this year will actually enjoy this service, because of the prolonged "freeze" of applications for new television stations, it was stated at the joint meeting of the Franklin Institute and the Institute of Radio Engineers, Philadelphia, by David B. Smith, vice-president, Philco Corp.

Smith pointed out that, by the most conservative estimates, television broadcast service is within reach of 47,000,000 people, and the actual coverage of the 98 television stations now on the air is more probably 65,000,000 people. "But this figure represents only about two-thirds of all the people who should have television service within reach," he said.

More Space for Starrett

Mitchell Fein, vice-president of Starrett Television Corp., announces that his firm has taken sufficient additional space in the Starrett-Lehigh Bldg., 601 W. 26th St., New York, to facilitate its going into a television set production schedule three times that of 1949. This stepping-up of production by 300% is already under way.

Heads Vidcraft Corp.

Vidcraft Television Corp., manufacturers of television receivers, announced, at a recent meeting of the board of directors, the promotion of Michael J. Kingsley from executive vice-president to president. Mr. Kingsley has also been general manager of the corporation since its organization in August, 1948.

G.E. Prices Drop

General Electric has reduced prices on three of its latest television receivers from ten to twenty dollars. The table model (12T-3) was reduced from \$239.95 to \$229.95 in mahogany cabinet; in blond korina cabinet (12T-4) it now lists for \$239.95, formerly \$259.95. A console has been reduced ten dollars from \$289.95 to \$279.95 in mahogany cabinet (12C-107); in blond cabinet (12C-108) it now lists for \$289.95, formerly \$309.95. The third receiver, a console, with mahogany cabinet (12C0109), was cut twenty dollars from \$319.95 to \$299.95.

New Rectangular Tubes

Corning Glass Works has announced a new 14-inch rectangular all-glass bulb for TV picture tubes. The new rectangular bulb has a picture area of 97 square inches, comparable to the 12½-inch diameter circular tube. Utilizing wide angle deflection, the tube will be shorter than the 12½-inch tube, however, and also weighs less. Feature of the tube is that it takes up considerably less space in a TV set than previous round tubes.

CIRCLE X ANTENNA

ENGINEERED TO PROVIDE
**CLEAR SHARP
PICTURES ON
ALL CHANNELS**

COMPARE CIRCLE-X
TO ANY OTHER TV ANTENNA

No other antenna combines all the mechanical and electrical features engineered into the Circle-X.

The high gain of the Circle-X is equal to stacked arrays. It is made of light weight corrosion resistant aluminum alloys that stand up in all atmospheric conditions.

When you use Circle-X you stock only one type of antenna for all jobs. It has one wire lead-in and weighs only 2½ lbs.

We urge you to compare Circle-X TV Antennas to any other TV antenna on the market.

Use Circle-X on your next tough TV installation. It may save you a lot of "no profit" call backs.

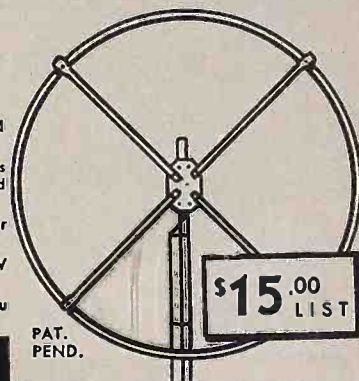

PAT.
PEND.

DEALERS: Air Express or Parcel Post Special Delivery direct from factory to you through your jobber, if he cannot supply you with the Circle-X from his stock.

CIRCLE-X ANTENNA CORP.
502 MARKET ST., PERTH AMBOY, N. J.

CIRCLE X

ANTENNA CORPORATION

SHOOTS TROUBLE

FASTER! Makes more money for you
on job or at service bench!



PRICE
\$9.95

at distributor
or postpaid,
direct. No
COD's please
Ohioans add
3% State
Sales Tax.

Signalette

MULTI-FREQUENCY GENERATOR

In radio service work, time means money. Locate trouble faster, handle a much greater volume of work with the SIGNALLETTE. As a trouble shooting tool, SIGNALLETTE has no equal. Merely plug in any 110V. AC-DC line, start at speaker end of circuit and trace back, stage by stage, listening in set's speaker. Generates RF, IF and AUDIO Frequencies, 2500 cycles to 20 Megacycles. Also used for checks on Sensitivity, Gain, Peaking, Shielding, Tube testing. Wt. 13 oz. Fits pocket or tool kit. Satisfaction, or money back! See at your dist. or order direct.

Clippard Instrument
Laboratory,
Inc.

Dept. G, 1125 Bank St., Cincinnati 14
Qualified Jobbers write, wire for details.

New Fringe Areas Open
With Each New TV Station

CHAMPION STEEL TOWERS

Will Solve Your Problem

FOR THAT
FRINGE AREA

STURDY
EASILY ERECTED
PRICED RIGHT
GUYED TOWERS

45 Feet
65 Feet
85 Feet

(Extra 20' Sections Available for
Greater Heights)

SELF-SUPPORTING
TOWERS

40 Feet
53 Feet
67 Feet
80 Feet

DEALERS and JOBBERS
WRITE FOR LITERATURE

NORMAN M. SEWELL, Inc.
LANSDALE PA. TITUSVILLE FLORIDA

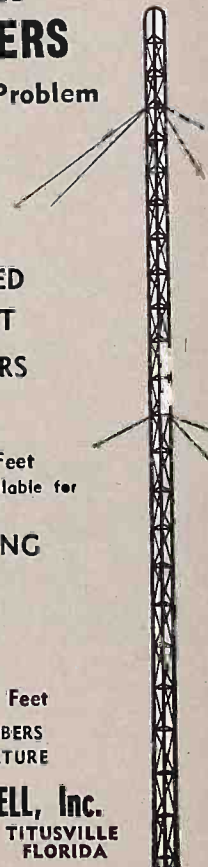

Ridiculous

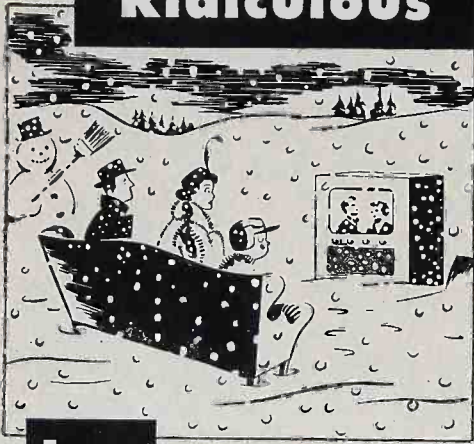

but

NO WORSE THAN



**SNOW INSIDE
on your TV Screen**

WITH a properly engineered antenna, you can generally eliminate the effect of snow in your television picture. It strengthens the signal without amplifying the noise factor. Snow, after all, is just visual noise . . . the result of electrical disturbances which overpower the strength of the signal. Even though your set is located in an area where there is a high incidence of random noises, much of this visual noise can be eliminated with a high gain VEE-D-X antenna.

send for FREE BULLETIN

If your television forecast is snow, send coupon below for latest bulletin on Snow Removal issued by the VEE-D-X Television Laboratory. VEE-D-X antennas are nationally famous for fine performance and long distance reception. When you have a VEE-D-X . . . you have the finest.

VEE-D-X

VEE-D-X means video distance

LA POINTE PLASCOMOLD CORP., 5 Unionville, Conn.

Send me the VEE-D-X free bulletin, "Eliminating Snow in TV Reception."

Name _____

Company _____

Street _____

City _____ Zone _____ State _____

Electric Housewares Week

Retailers everywhere are urged to tie in with National Electric Housewares Week, April 14 to 22. It will be launched with 4-color national advertising. Complete material is being prepared for retail use—including window and in-the-store displays, streamers and suggestions for local advertising and "stunts." This material will be available to dealers about March 1, through their electric housewares distributors.

Arvin Personnel Changes

Reassignment of sales, merchandising and promotion personnel of the Arvin division of Noblitt-Sparks industries, Inc., is announced by Glenn W. Thompson, president. Paul W. Tanner, who has been appliance sales manager, and Glenn Mills, formerly of the advertising department, will now devote their efforts to the Arvin radio and television division where they will work with Harlan B. Foulke, vice-president, and Raymond P. Spellman, sales manager. Mr. Tanner's new duties will identify him as merchandising manager for radio and TV activities, while Mr. Mills will act as sales promotion manager of that division.

Leo Burns and Walden Johansen have been appointed assistant sales managers of the Arvin electric housewares division where they will be associated with Gordon T. Ritter, director of sales. Mr. Burns was until a short time ago a buyer of appliances for Sears, Roebuck & Co., Chicago, and Mr. Johansen was formerly with Chatfield Paper Corp., Cincinnati. John Anderson, former advertising manager of Manning-Bowman Co., Meriden, Conn., and for many years vice-president and art director of the Powers House advertising agency, Cleveland, has joined the Arvin advertising department. He will be associated in that department with James M. Jewell, advertising manager.

Promoted by Proctor



Mrs. Mary Reynolds Riedel has been appointed as director of women's activities for the Proctor Electric Co., Philadelphia. She will also continue her former duties as director of the publicity and public relations department.

**MODERN DISPLAYS
NEED LIGHTED MOTION!**

Model "712"
KASSON
Roto-Sho
ELECTRIC TURNTABLES

**The ACTION Display-Way
To Boost Your Sales!**

MODEL "712" ROTO-SHO's two-way built-in electric outlet permits novel, self-contained lighting effects as well as operation of electrical devices while the turntable revolves three times a minute! (Lights turn with table.)

There's nothing like "712" to revolutionize your window trim, because motion plus correct lighting is the key to successful displays. Sturdy construction, guaranteed, carries up to 200 lbs. Table 18" in diameter. A.C. only.

Write for our complete ROTO-PRODUCTS catalog!



GENERAL DIE AND STAMPING CO.
Dept. TV, 262 Mott St., New York 12, N. Y.

**TELEVISION
CLARIFIER**

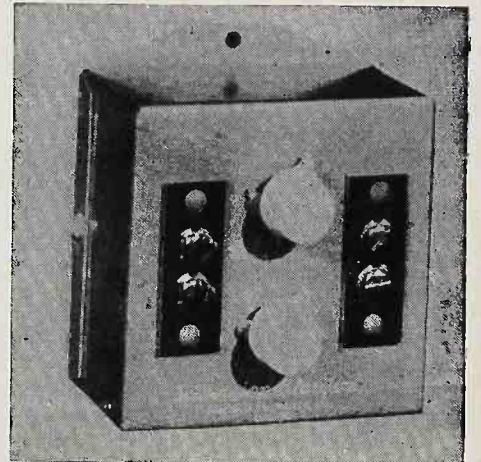

Effectively reduces FM, Amateurs, Diathermy, Adjacent channels, Ignition, Shortwave and Appliances. Attenuates Lines, Tears, Snow, Waves and Herringbones. Simple to adjust and install in either antenna lead or AC Line.

Write for literature and name of your nearest jobber.

PRECISION ELECTRONICS, Inc.
641-643 MILWAUKEE AVENUE
CHICAGO 22, ILLINOIS



TACO ANTENNAS

Suit every
Purse & Purpose

FEATURING

Jiffy-Rig

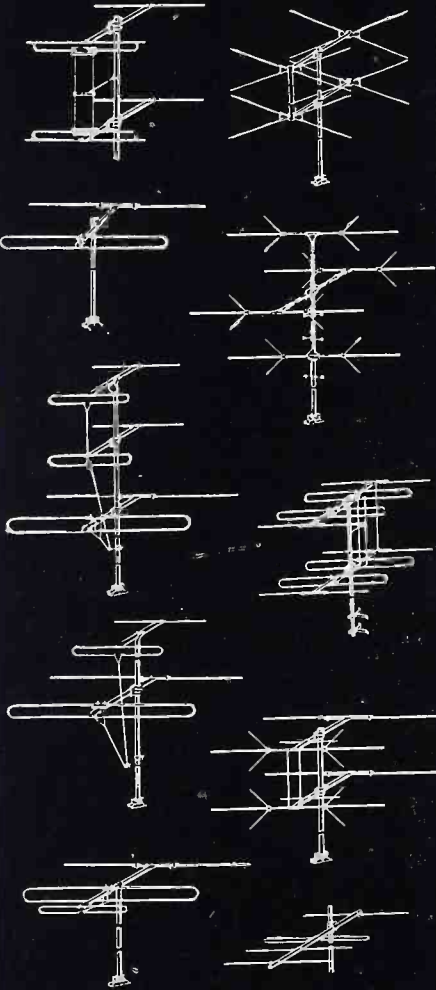

● Antenna designs for all locations, conditions, and price ranges. For 16 years Taco has been giving you the antennas you want—antennas that assure customer satisfaction and help close that TV sale for you. For 16 years Taco Antennas have proved their sturdiness under ice loads, hurricanes, and other adverse weather conditions. Taco stands for dependability coupled with performance beyond comparison.

TV - FM - AM ANTENNA SYSTEMS

TACO
TECHNICAL APPLIANCE CORP.
SHERBURNE, N. Y.

Universal Plans Campaign

Landers, Frary & Clark plans an "Electric Housewares" campaign to begin with National Electric Housewares Week in April. The campaign, styled to blend with the present day home decorating trend of carefree, gracious living, is scheduled to run through spring and summer with new promotions injected periodically to tie in with seasonal sales events. Emphasis will be placed on the Universal Coffee-matic, Cook-a-matic, toaster, waffle iron, sandwich grill, Twosome percolator, food mixer and Mixablend, which the company features in multiple combinations in national advertising, displays, broadsides, etc. The campaign is designed to strike a new note in electrical housewares merchandising.

Heads Thor Sales

The appointment of M. Robert Wilson, widely known sales consultant, as general sales manager of Thor Corporation, producer of home laundry appliances, has been announced by John R. Hurley, president of the appliance firm.

Simultaneously, Mr. Wilson announced his resignation as president of Mason-Wilson, Inc., sales consulting firm of Chicago and New York City. Among the firm's clients have been Cory Corp., Federal Enameling and Stamping Corp., Leetex Rubber Co., and Swing-A-Way Products Co. Mr. Hurley said Mr. Wilson's appointment climaxes a series of postwar steps to strengthen and expand Thor's sales program.

New Hotpoint Factory

Hotpoint will erect a new refrigerator factory on a 21-acre site facing 1,000 feet on 54th Ave., at 16th St., Chicago. James J. Nance, president, who made the announcement, also said that tooling and machine installations to complete the conversion of the company's former range plant for the manufacture of home laundry equipment would be completed during the year. The machine was placed on the market a year ago, but complete conversion of specialized tooling for laundry manufacture was held back until the present. These moves, which represent the final phase of the company's expansion program launched in 1947, will be accompanied by moving the manufacture of the Disposall into the company's plant at Milwaukee where it will be made along with automatic dishwashers and sink units as a companion piece. The Disposall has been manufactured in an eastern plant.

Appliance Mfg. Managers

The Appliance Manufacturing Co., Alliance, Ohio, announces the appointment of the following district sales managers: H. J. Zehner, Albany, N. Y., for western New York State, and C. O. Nelson, Oshkosh, Wisconsin. The announcement was made by F. W. McGrath, vice-president in charge of sales for Appliance Mfg. Co.

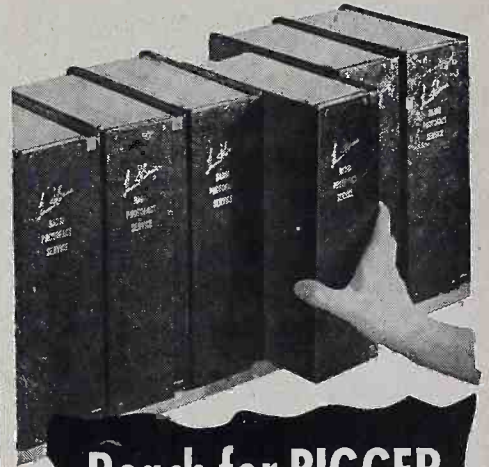

Reach for **BIGGER PROFITS** in your Service Dept.!

PHOTOFACT lays dollars right smack in your hand

SAVE TIME
BOOST OUTPUT
SIMPLIFY WORK
CUT PARTS STOCK

Proved in
Hundreds of
Service
Shops!

Your service department will show bigger profits with PHOTOFACT on the job! It's the only Service Data based on actual laboratory analysis of all postwar AM, FM and TV receivers. Uniform, accurate, complete—it helps your men turn out more jobs in less time! It standardizes proper servicing procedures, cuts errors and waste, minimizes your parts stock inventory. PHOTOFACT pays for itself because it saves time and labor, because it guarantees bigger radio repair profits. Put PHOTOFACT to work on your service bench now—you'll earn the thanks of your men—and you'll earn more!

FREE! Photofact Folder of your choice!

Learn for yourself—at our expense—how PHOTOFACT earns bigger radio repair profits for you! Ask for a FREE Folder covering any postwar AM, FM or TV receiver of your choice. Examine it. Put it to work at your service bench—then judge for yourself.

WRITE FOR FREE FOLDER TODAY!

HOWARD W. SAMS & CO., INC.

HOWARD W. SAMS & CO., INC.
2205 EAST 46TH ST., INDIANAPOLIS 5, IND.

- Send FREE PHOTOFACT Folder covering following receiver
- Send full details on the PHOTOFACT Service Data Library.

Name

Address

City Zone State

Attn

NARDA New Officers

The National Appliance & Radio Dealers Association has elected the following officers for 1950: James Lee Pryor, Wilmington, Del., re-elected president; Phil S. Urner, Bakerfield, Calif., vice-president; M. E. Brunderman, Chicago, Ill., re-elected secretary and to 3-year term on board of directors; Ken J. Stucky, Fort Wayne, Ind., re-elected treasurer. The board of directors is made up of: Mort Farr, Upper Darby, Pa.; Francis L. Monette, Lowell, Mass.; Wallace Johnston, Memphis, Tenn.; Herb Names, Denver, Colo.; Julius Kovach, Racine, Wisc.; Harry B. Price, Jr., Norfolk, Va.; E. O. Kuehn, Belleville, Ill.; Vergal Bourland, Fort Worth, Texas, and R. B. Garlock, Lansing, Mich.

RCA Anniversary Book

On the occasion of its 30th Anniversary, RCA has published a booklet called "30 Years of Pioneering and Progress." The 80-page booklet traces the achievements of RCA and the course of radio from Marconi's first signal in 1895 and TV from RCA's first tests in the Empire State building in 1931. The account covers both wars, a string of presidents and many notables of by-gone days in so far as they influenced or were influenced by radio and television. It is well illustrated with many scenes of yester-year.

De Wald Color TV

The DeWald Radio Manufacturing Corporation of 35-15 37th Ave., Long Island City, N. Y., has announced that the vice-president in charge of engineering, Mark Glaser, has developed a color TV system for which patent application is being made. The system is said to be fully electronic, fully compatible, and adaptable for present receivers at a cost of less than \$100, operating with present picture tubes. Although this new TV color system shows great promise, the firm stated, it will take several years to fully commercialize the new method of color transmission and reception.

Television Tables

Television tables with antennas built into the tops are being made by Guy Hobbs, Inc., Dallastown, Penna. They are designed to fit many present day models and are fitted with casters for easy manipulation of the receiver. Retail prices range from \$9.95 to \$29.95.

Rejoins Hallcrafters

Paul H. Eckstein, formerly sales manager of the home radio division of Hallcrafters Co., has rejoined the company as TV sales manager. Mr. Eckstein will head activities of 32 distributors for the company.

C&G Names Distributors

Louis Simpson, sales manager of C&G Tool Mfrs., E. Orange, N. J., announced the appointment of Bruno, New York; Krich-Radisco, Newark, N. J.; Aaron Lippman, Newark, N. J., and Raymond Rosen, Philadelphia, Pa., as distributors of the CG-5 15-inch wall mast bracket. The bracket is used for mounting TV antenna mast on the side of a building. It stands off 15 inches; is made of 1½-inch wide cadmium plated 11 gauge steel.

Meinken Appointed

Kenneth C. Meinken, Jr., has been appointed to the post of Midwestern sales manager of tube sales to initial equipment manufacturers, according to an announcement by Kenneth C. Meinken, Sr., president of National Union Radio Corp., Orange, N. J.

Rep for R.M.S. Line

Hy Bloom, sales manager of Radio Merchandise Sales, Inc., New York City, manufacturers of antennas and other television accessories, announces the appointment of Joe Clancy of Fort Wayne, Indiana, as representative of the R.M.S. line for the state of Michigan. In addition to the new territory, Mr. Clancy continues to represent R.M.S. in the states of Ohio, Indiana, and Kentucky.

The Perfect Magnetic Tape Eraser



MAGNERASER

*Trade Mark Registered

Here's the low-priced efficient tape eraser that's becoming the most popular tape recorder accessory. It's invaluable for professional and amateur use, for quick, convenient erasure of a complete reel of tape—within seconds — without rewinding. To operate, simply place the MAGNERASER on top of, and move it around the reel of tape.

Erases all brands of tape — even when severely overloaded and actually brings the noise level lower than unused tape! Also demagnetizes record and erase heads. The MAGNERASER is easy to handle, easy to demonstrate, and sells itself. Write today for full description and special jobber discount and sample offer.

ACCESSORIES DIVISION

LIST PRICE
\$24.00

Jobber discount
40 and 10%

SPECIFICATIONS

Operating current: 100/130 volts, 25/60 cycles
 Size: 4½" diameter, 2" high
 Construction: Linen Bakelite housing
 Weight: 2½ lbs.
 Furnished with 6 ft. line cord, molded rubber plug, and operating instructions.

AMPLIFIER CORP. OF AMERICA

396-7 Broadway • New York 13, N. Y.

PHILSON

TELEVISION ANTENNAS

— superior PERFORMANCE —

proves them BEST!

PROVE IT TO YOURSELF!

— test any **PHILSON WOOD** or **METAL CROSSBAR** Antenna, under any condition —

With Our Money-Back Guarantee!



We can make this amazing offer because more and more jobbers are selling retailers these superior antennas that are **PROVED BEST BY TEST!** *Performance*—not words—sells PHILSON Antennas, keeps customers satisfied, minimizes call-backs. Make the test, and prove it to yourself, PHILSON'S are BEST! Try one, under any condition. Your money back if it's not the BEST!

More SPACE . . . increased PRODUCTION assure you Faster & Better Deliveries!

Don't lose sales because of undelivered antennas—tie-up with PHILSON! We have doubled our space and stepped-up our production to assure you dependable deliveries.

Write for catalog R of complete line
 Pioneer and Leading Manufacturer of Automobile and Television Antennas since 1929

PHILSON

MANUFACTURING CO., INC.

60-66 SACKETT STREET • BROOKLYN 31, N. Y.



Portable TRI-TUBE



Antenna MASTS

TELEVISION
FM • AMATEUR
COMMERCIAL

LOW
COST
•
LIGHT
•
QUICK
•
EASY

Mast section is triangular in construction using 1" ID steel tubing with proper bracing, all electric welding. Lower unit is 20 ft. long hinged on frame with locking device. Levelling device compensates for position of vehicle on any test location. Upper unit is a smaller triangle and telescopes into lower unit on rollers, which allow smoother operation. Cable and drum provided with pin assembly for safety and locking into any height. Antenna mast can be set up by two men in a few moments. ... NO GUYS - NO WRENCHES - NO BOLTS All bolts have 'T' handles. Demountable by removing two bolts in four minutes. Aluminum painted ready to mount.

- #250 Basic Unit Complete 50 ft., 10 ft. pole
 - #251 Same as 250-Orientation at Any Height
 - #252 Same as 251, with Antenna Height 70 feet
- Dealer & Distributor Inquiries Invited

A. A. PETERS

TRI-TUBE MASTS

231 N. 7th Allentown Pa.

SHIPPED F. O. B.
ALLENTOWN, PA.

\$295

and up



Today's Biggest Value
in 3-speed Portables!

V-M

Model
8025-A



FEATURES:

- FULLY AUTOMATIC OPERATION for all records—33-1/3, 45, & 78 rpm.; 7", 10" and 12".
- AUTOMATIC SHUTOFF after last record.
- AUTOMATIC INTERMIX, 10" and 12" records of same speed.
- TONE AND VOLUME CONTROLS.
- 5" ALNICO SPEAKER.
- BEAUTIFUL LEATHERETTE CASE.
- Utilizes well-known V-M Tri-O-Matic Record Changer, preferred by most manufacturers of Radio-Phono-TV combinations.

LIST PRICE \$69.95

Get full details today from your local jobber.

V-M CORPORATION
Benton Harbor, Michigan

Outlined Sales Program



Alex Lewyt, president of the Lewyt Corp., Brooklyn, N. Y., was the featured speaker at a recent meeting of the Sales Executives Club in New York. He described the firm's selling campaign, and explained how "putting a little excitement into an otherwise conservative industry" helped sell so many Lewyt vacuum Cleaners.

In Magnavox Sales Post

V. J. Sanborn, general division manager of The Magnavox Co., announces the appointment of Franklyn B. Snyder of Cleveland Heights, Ohio, as Magnavox district sales manager with headquarters in Pittsburgh. Mr. Snyder replaces G. L. McGowen who has been appointed district sales manager of the Cleveland district.

Knight Co. Appointed

Jack W. Jones, president of the two new companies, The House of Television, Inc. and Hot Nails, Inc., both at 40 W. 4th St., New York City, announced the appointment of the W. Bert Knight Co. to be their manufacturers' representatives. Working out of Los Angeles, Knight, Wes Alderman and the company's other 3 men will cover southern California and Arizona for the video accessories manufacturing firms.

Making Recording Tape

A. C. Travis, Jr., vice-president of sales of Reeves Soundcraft Corp., well known manufacturers of transcription recording blanks and sapphire needles, announces that the company is entering into the manufacture and sale of magnetic recording tape.

A change of location of the sales office formerly at 10 E. 52nd St., New York, to a three-story building at 35-54 36th St., Long Island City, provides space for the new tape producing facilities as well as for another affiliate, Reevesound Co., Inc., manufacturers of photosound and magnetic film recorders. Soundcraft recording discs will continue to be manufactured in the Allentown, Pa., plant. The new building also houses the New York sales office for two Soundcraft subsidiaries: Tele-Video Corp. (projection TV) and Airdesign, Inc. (transformers).

WHAT IS YOUR PROBLEM?

You will
find the
answer
in

*Radio & Television
Mathematics*

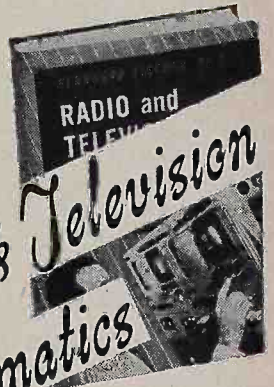

A Handbook of 721 problems AND SOLUTIONS

Save time and trouble. Arranged under radio and electronic headings and completely indexed for quick reference, these problems give you step-by-step solutions to every problem commonly arising in work on receivers, power supplies, antennas, amplifiers, tubes, transmitters, etc. If you are ever "stuck" on a calculation; if you need a check on your figuring; or if you want to refresh your memory on the formulas to use for a certain problem—you will find your answer quickly and easily in this book.

Good practice for your FCC exams. This book shows you how to solve every problem requiring mathematics in the FCC STUDY GUIDE for licenses of all classes. You will find no better handbook for practice in solving problems with ease, speed and accuracy. \$6.00

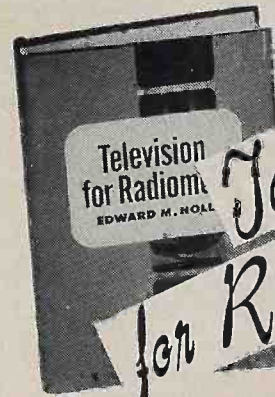

Just
Published

*Television
for Radiomen*

The how's

AND WHY'S in the practical terms of operation & servicing

This book explains the theory as well as the techniques of television construction, operation, and servicing in the clearest, most practical terms. It gives the radioman all the basic information he needs to meet the increasing demand for skilled television technicians. It shows how and why all modern equipment operates; includes all the essential mathematics and especially good material on antennas. \$7.00

SEE THEM FREE

The Macmillan Co., 60 Fifth Ave., New York 11

Please send me a copy of the books checked below. I agree to remit in full or return the books within ten days without further obligation.

- Radio & Television Mathematics, \$6.00
- Television for Radiomen, \$7.00

Signed.....

Address.....

Reduces
STRAIN
on the
ROOF!

TRYLON TV MAST

Not only is the Trylon TV mast outstandingly easy to erect, easy to climb and built to last for a lifetime of clear, troublefree television reception! . . .

Equally important in many installations is the fact that it puts far less downward strain on a roof than even a 2" pipe of the same height. That's because the Trylon TV mast has no flat surfaces or riveted members to catch the wind or to hold large quantities of sleet or ice. Actually, the weight of a mast has far less to do with its "download" strain on a roof than its wind resistance. Compared with ordinary flat surface masts—even masts that weigh less—the Trylon mast causes from 50% to 75% LESS roof strain!

Trylon offers:

Heights up to 60 feet in 10 foot sections.

Weight only 2 lbs. per lineal foot.

Low cost—easy to install. Double welding for real safety.

Hot dip galvanizing after fabrication.

You'll improve TV reception in 9 cases out of 10 with a Trylon mast—you'll please TV customers—and you'll make installation jobs far easier for yourself!

Write today for
Circular "R"

WIND TURBINE CO.



Tower and mast specialists
for 17 years

West Chester Penna.

Stewart-Warner Jobbers

Southwest Distributing Co., headed by Albert F. Harris, has been appointed distributor of Stewart-Warner radio and television products in the Kansas City territory. This was announced by E. L. Taylor, sales manager of Stewart-Warner Electric, the radio and television division of Stewart-Warner Corp.

RCA Victor Wholesalers

Sea Coast Appliance Distributors, Inc., 36 N. E. 21st St., Miami, has been appointed distributor for RCA victor home instruments in the Miami region and for RCA Victor records throughout the state of Florida, Robert A. Seidel, vice-president in charge of RCA Victor distribution, has announced.

Meck Ups Radio Output

The unprecedented demand for table model AM radios continues apace with the television set boom . . . or so it would seem to John Meck Industries, Inc., Plymouth, Ind., according to officials of the firm. The fast-growing TV company has just completed the moving of its radio assembly lines and other facilities to a modern two-story building located in Argos, Ind., eight miles south of Plymouth.

Du Mont Appointment

The appointment of Harry T. Goerger as executive assistant to Rowland Guildford, sales manager for the New York regional sales office, Allen B. DuMont Laboratories, Inc., has been announced by Mr. Guildford. Mr. Goerger's appointment is another in a series of DuMont personnel expansion necessitated by the tremendous growth of sales, both in this area and all over the country.

Raytheon Distributors

Lay and Nord, 112 South Second St., Yakima, Washington, was recently appointed as a distributor of Raytheon receiving, television, transmitting and special purpose tubes, F. E. Anderson, distributor sales manager of Raytheon's Radio Receiving Tube Division, announced.

G.E. Talking Clock

General Electric has announced a clock which delivers a recorded message, an electronic version of the cuckoo. The clock will deliver the same message over and over or it may be changed each day. Commercials may be of various lengths, so long as their total is two minutes or less.

Sylvania Sales Managers at Chicago Conference



J. K. McDonough (far left), director of sales for Sylvania Television, talks with district sales managers at a recent Chicago conference. The district managers are, left to right: V. W. Wittman, J. D. Cathcart, James O'Connor, Ben Holsinger, advertising manager; C. K. Bagg, general manager; M. C. Olson, J. W. Safford, A. A. Currie, A. G. Kemp, Walter Lefebre, Leo Kolosko.

"New Techniques" Cooking Class in Wisconsin

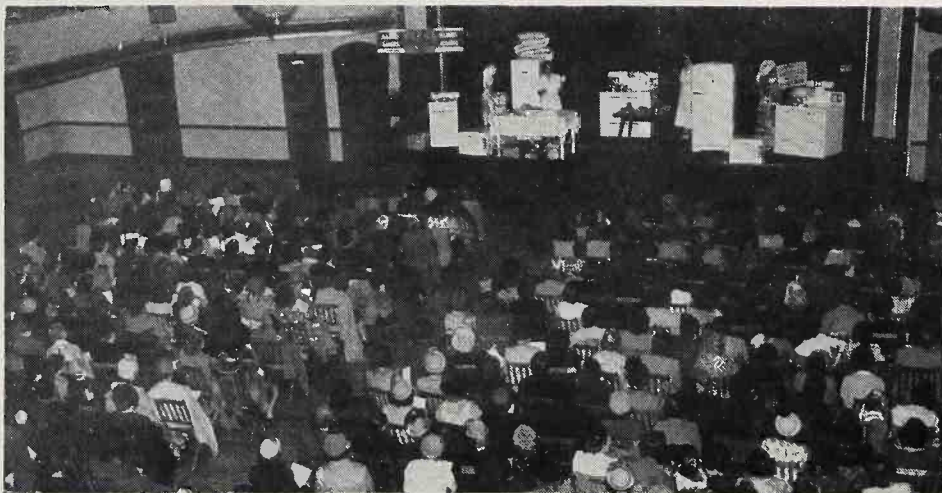

Marion McKeivitt, home economist of Landers, Frary & Clark, conducting a cooking school in cooperation with K & M Radio Electric Co. in Sheboygan, Wisconsin. Over a thousand women attended to learn new techniques in cooking.

ADVERTISERS

March, 1950

A.B.T. Manufacturing Corp.	105	Meck Industries, Inc., John	24
Admiral Corp.	74, 75	Motorola, Inc.	18, 19
Aero-Tone Mfg. Co., Inc.	102	National Video Corp.	66
Air King Products Co., Inc.	Cover 2	Noblitt-Sparks Industries, Inc.	20, 47
Alliance Mfg. Co.	78	Olympic Radio & Television, Inc.	62
Aluminum Co. of America	101	Perma, Inc.	76
American Phenolic Corp.	52	Peters, A. A.	117
American Telephone & Telegraph Co.	69	Philco Corp.	5
Amplifier Corp. of America	116	Philson Mfg. Co., Inc.	116
Ampro Corp.	63	Phoenix Electronics, Inc.	112
Anchor Radio Corp.	43, Part 2	Precision Electronics, Inc.	114
Andrea Radio Corp.	4	Radiart Corp.	95
Approved Electronic Instrument Co.	110	Radio Corp. of America	36, 37, Cover 4
Astatic Corp.	111	Radion Mfg. Co.	25
Automatic Radio Mfg. Co., Inc.	29	Rauland Corp.	80
Belden Mfg. Co.	56	Regal Electronics Corp.	13
Belmont Radio Corp.	45	Rider Publishers, Inc., John F.	97
Bond Equipment Co.	120	Sams & Co., Inc. Howard W.	115
C & G Tool Manufacturers, Inc.	21	Schott Co., Walter L.	109
Caldwell-Clements, Inc.	120	Sentinel Radio & Television	6
Capehart-Farnsworth Corp.	28	Sewell, Inc., Norman M.	113
Carbonneau Industries, Inc.	104	Sheldon Electric Co.	73
Circle-X Antenna Corp.	113	Snyder Mfg. Co.	71
Cleveland Electronics, Inc.	102	Sonic Industries, Inc.	100, 103
Clippard Instrument, Inc.	113	South River Metal Products Co., Inc.	120
Commercial Credit Corp.	67	Sparks-Withington Co.	68
Commercial Trades Institute	120	Standard Coil Products Co., Inc.	65
Cornish Wire Co., Inc.	109	Starrett Television Corp.	8
Covrall Industries, Inc.	Cover 3	Stewart-Warner Corp.	22-23
DeWald Radio Mfg. Corp.	111	Stromberg-Carlson Co.	32
DuMont Laboratories, Inc., Allen B.	49	Sylvania Electronic Products, Inc.	16, 30, 31
Easy-Up Tower Co.	94	Symphonic Radio & Electronic Corp.	52
Electric Auto-Lite Co.	112	Technical Appliance Corp.	115
Electro Products Laboratories, Inc.	109	Tele King Corp.	70
Emerson Radio & Phonograph Corp.	72	Television Cabinet Co. of America	104
Fada Radio & Electric Co., Inc.	26, 27	Tel-O-Tube Corp. of America	52
General Die & Stamping Co.	114	Telrex, Inc.	99
General Electric Co.	7, 11, 89	Thomas Electronics, Inc.	79
Hallicrafters Co.	64	Trio Mfg. Co.	110
Hytron Radio & Electronics Corp.	10	Tricraft Products Co.	120
Jackson Electrical Instrument Co.	108	Triplett Electrical Instrument Co.	90
Jackson Industries, Inc.	106	Tung-Sol Lamp Works, Inc.	107
Landers, Fray & Clark	58, 59	V-M Corp.	117
La Pointe-Plascomold Corp.	114, 119	Webster-Chicago Corp.	12
Littelfuse, Inc.	94	Westinghouse Electric Corp.	14, 15
Macmillan Co.	117	Wilcox-Gay Corp.	9
Magnavox Co.	17	Wind Turbine Co.	118
Mastercraft Products	108	Zenith Radio Corp.	2 and 3

While every precaution is taken to insure accuracy, we cannot guarantee against the possibility of an occasional change or omission in the preparation of this index.

VISIT US AT BOOTH NO. 316
I.R.E. SHOW

**POSITIVE
PROTECTION**



Approved by Underwriters
Laboratories Inc.

VEE-D-X TWIN LEAD LIGHTNING ARRESTOR

1. For outdoor or indoor use
2. High frequency — low loss
3. Easy to install
4. Unnecessary to cut transmission line for installation
5. Unnecessary to change spacing of transmission line
6. Does not vary impedance
7. High dielectric — low loss plastic material. Will not absorb moisture.

\$2.00 list

*The Pioneer Lightning Arrestor
for Television and FM*

VEE-D-X

VEE-D-X means video distance

LA-POINTE-PLASCOMOLD CORP., 5
Unionville, Conn.

Please send me further information about
your TV antennas and accessories.

Name

Address

City Zone State

New Regal TV Line

Walter Spiegel, president of Regal Electronics Corp., New York, has announced the 1950 line of Regal TV sets. There are seven models, starting at \$197.50 for a 12½" table model in a mahogany veneer cabinet. The Regal receivers feature keyed automatic gain control, and this manufacturer was among the first in the field to include this feature. Specifications of the new Regal television sets appear elsewhere in this issue.

Bendix Merchandisers

The new firm of H. J. Sommer Company, recently organized to supplant the R. W. Fordyce Company with headquarters in Ardmore, Pa., will serve as district merchandiser for Bendix television and radio, it was announced by R. W. Fordyce, Bendix Radio general sales manager.

Capehart Wholesalers

The appointment of Harger & Blish Co., Des Moines, Ia., as distributors for the Capehart line of television receivers and phonograph-radios in central Iowa.

is announced by C. R. Ward, sales manager of the Capehart-Farnsworth Corp., Fort Wayne, Ind., a subsidiary of the International Telephone & Telegraph Corp.

New Motorola Phono

Motorola has announced a new phonograph which features a special spindle to be inserted for playing 45 RPM records and a tone arm which can be moved at any time during its cycle without injury to it. It is a 3-speed changer which plays all sizes and has a single needle for all speeds.

**A
Better
Model
at an even
Better
PRICE**

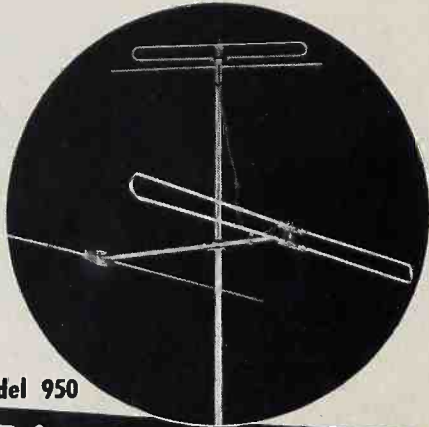

Model 950

The New "Tricraft Duo-Band"

HIGH AND LOW BAND arrays orient individually . . . can be assembled in matter of seconds . . . here is the new outdoor antenna that is unexcelled for quality, construction and price value . . . matching connecting harness is designed to correctly match high band elements with low band elements. Factory assembled with sturdy weatherproof construction for fast installation.

ALWAYS QUALITY— NOW LOW PRICE!

Tricraft Antennas are accepted for their unsurpassed quality. We have increased our production facilities in order to offer our complete line at greatly reduced prices . . . but our quality will still "lead the field."

"TRICRAFT ANTENNAS" are sold through jobbers • Jobbers: send for our new low price list!



Tricraft Products Co.

1535 North Ashland Ave., Chicago 22, Ill.

Manufacturers of complete line of Television, FM and AM antennas and accessories

PRINT YOUR OWN POST CARDS

**COMPLETE OUTFIT
only \$7.50**

Amazing results in sales, inquiries and contacts . . . save time and money . . . very easy to use. GEM STENCIL DUPLICATOR is ideal for Advertising, Announcements, Notices, Labels, Forms, Price Lists—hundreds of



uses for every type of business and organization. Comes complete with all supplies, instructions and 60-page Book of Ideas. **FREE TRIAL OFFER:** Try it before you buy it! Write and a GEM OUTFIT will be sent you postpaid. After 10 days, send only \$7.50 or return the GEM, no questions asked. The GEM must sell itself; you be the judge.

BOND EQUIPMENT CO. DEPT. 125 — 6633 Enright St. Louis 5, Mo.

SEND NO MONEY • FREE TRIAL OFFER

C.T.I. TRAINED MEN ARE AVAILABLE!

Each month C.T.I. graduates ambitious young men who have completed an intensive course in Radio and Television maintenance and repairing. *Their training has been practical.* They've learned by working on modern equipment under personal, expert supervision. *If you need a trained technician,* we invite you to write for an outline of our course, and for a prospectus of the graduate. (No fees, of course.) Address:

Placement Manager, Dept. P110-3

COMMERCIAL TRADES INSTITUTE

1400 Greenleaf

Chicago 26

1 Out of Every 2 Outdoor TV Installations Is made with SOUTH RIVER PRODUCTS

Write for catalog describing Chimney Mounts, Wall Brackets, Pipe Mounts, etc.

WARNING . . . South River Chimney Mounts are patent protected. Imitations and infringements are being prosecuted. See U. S. Patent No. 2482575.

South River Metal Products Co., Inc.

Dept. RR, 17 Obert Street,

South River, N. J.

CLOSING DATES FOR

RADIO-TELEVISION RETAILING

5th of preceding month for all ads requiring proofs, composition, foundry work, key changes, etc.

10th of preceding month for complete plates only—no setting.

1st of month—Publication Date.

Cancellations not accepted after 5th of preceding month.

CALDWELL-CLEMENTS, INC.

480 LEXINGTON AVENUE, NEW YORK 17

These Birds Know Where to Roost!

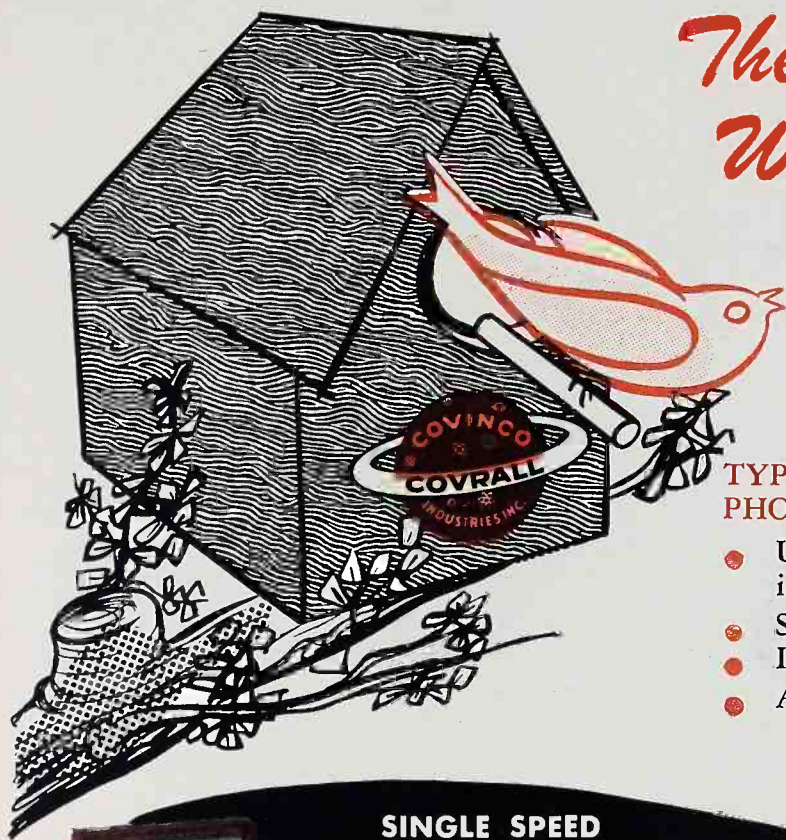

You're right — in the COVRALL nest they live happily . . . wisely . . . *profitably!* Hear them sing about the gleam that lights customers' eyes when they mention the low prices. So join these trade leaders NOW while the nest still has room. Fly in early — Stock COVRALL for '50.

TYPICAL FEATURES THAT SELL COVRALL PHONOGRAPHS ON SIGHT

- Ultra-new tropical two-tone alligator covering in Red, Blue or Tan.
- Special high gain electronic amplifiers
- Individually packed in air-cushioned cartons
- All COVRALL units have:
High fidelity tone control
Volume control

SINGLE SPEED RECORD PLAYERS

(78 RPM)



No. 101

Suggested list price — \$19.95
Special padded stitch top.



No. 109

Suggested list price — \$24.95. Plays all size records up to 12" with cover closed.



No. 108

Suggested list price — \$25.95
Miracle retractable arm feature
Will not break or crack records no matter how abused.

3 SPEED RECORD PLAYERS

(33 1/3 — 45 — 78 RPM)



No. 301

Suggested list price — \$34.95
Plays all records with cover closed. Same feature as No. 300



No. 305

Suggested list price — \$64.50
3 speed automatic record changer.



No. 300

Suggested list price — \$29.95. Lowest priced 3 speed phonograph with reversible type cartridge for quick change over. Special motor mechanism to facilitate change from speed to speed.

We also carry a complete line of Juvenile Phonographs.

Write today for your copy of Covrall for '50, your FREE invitation to profits.

DISTRIBUTORS:

Rollan Sales
Chicago, Ill.

Mercury Dstr.
Boston, Mass.

Carnegie Radio Co.
Cleveland, Ohio

J. G. Storminger
San Francisco, Cal.

George Rosen Co.
Baltimore, Md.

Covrall INDUSTRIES, INC.
"Famous for Fine Phonographs"

55 FERRIS STREET, BROOKLYN 31, N.Y.

THE QUALITY OF RCA TUBES IS UNQUESTIONED



Higher Quality Standards

for TV, FM and AM

THE *QUALITY LEVEL* of RCA miniatures has been continually advanced in step with circuit progress. Improved design . . . more rigid control over manufacture and inspection . . . and more exacting tests, including rigid re-test before shipment, are the reasons why RCA miniatures have unusually uniform characteristics, so important to tubes for television receivers in particular, and also for FM and AM receivers. Their dependability in criti-

cal circuits cuts down costly service call-backs.

And now . . . this *extra* quality of RCA miniatures is "packed in so it can't be shaken out." A new type "snug-fit" carton protects tubes against damage by holding them securely in place during transit.

RCA's engineering leadership adds *value beyond price* to the RCA tubes you sell. Your customers know about this advantage too.

Always keep in touch with your RCA Tube Distributor



RADIO CORPORATION of AMERICA

ELECTRON TUBES

HARRISON, N. J.