

ELECTRONIC TECHNICIAN

Including 16 pages of
Circuit Digests

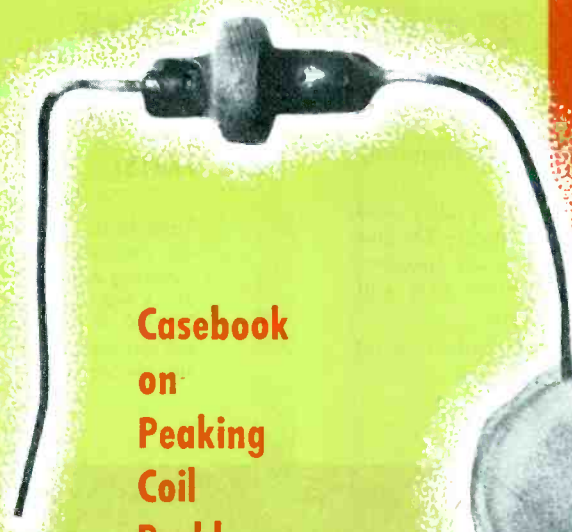
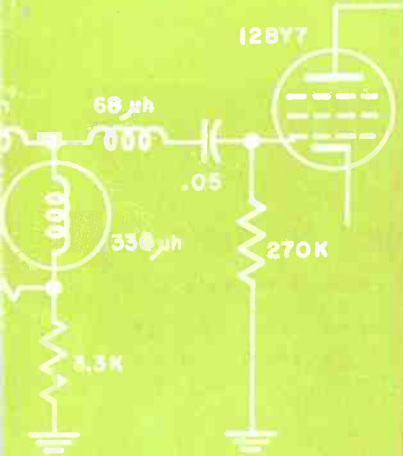
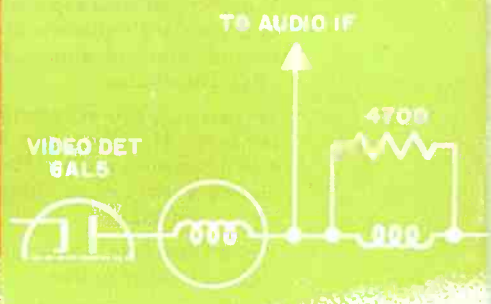
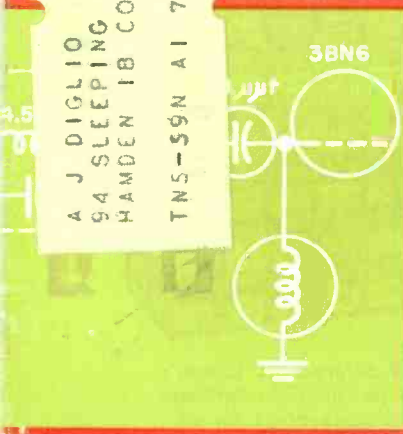
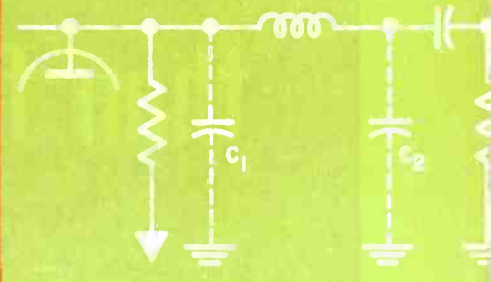
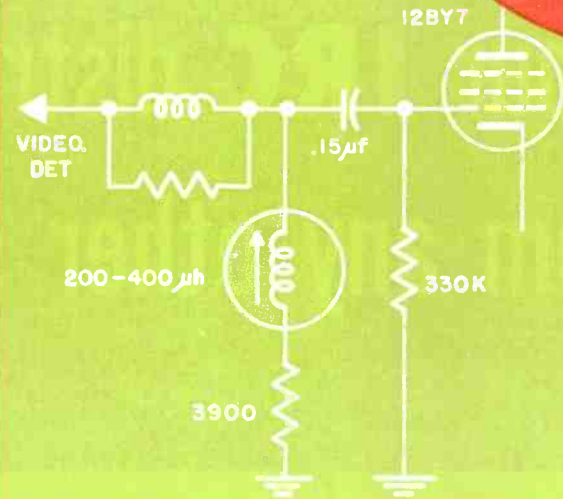
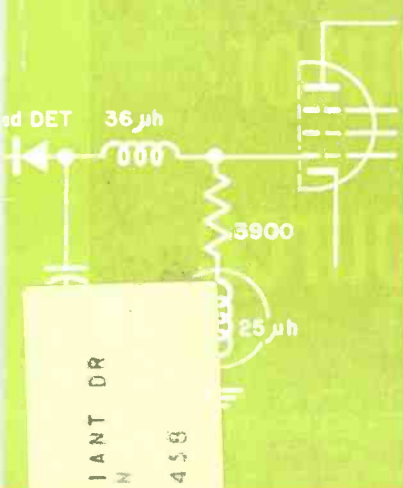

Casebook
on
Peaking
Coil
Problems

50¢

You are more apt to get the volume control you need from **your IRC distributor** than from any other source

Whether you need a special exact duplicate control or a standard replacement carbon or wire-wound control, you are almost sure to find it at your IRC Distributor.

He carries the most versatile line of controls in the industry. He offers you better, more complete replacement coverage. He can supply an almost endless variety of combinations of resistance elements and shafts.

He can take care of your needs far more frequently than any other source.

And you can depend upon IRC quality and dependable performance. Exact duplicate TV and Auto Set controls (over 850 of them) are specified to manufacturers' procurement prints—they will fit and operate without modification.

Make your IRC Distributor Your Volume Control Headquarters.

FINGERTIP COVERAGE OF 3704 MANUFACTURERS' PARTS!

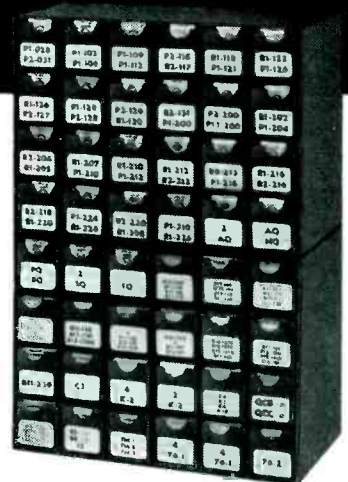

From basic parts, you can now assemble any of 809 different IRC Controls covering 3704 Manufacturers' parts. IRC Dealer Parts Stock No. 22 offers this amazing coverage for only \$93.00. If you already own Parts Stock No. 21, you can get the same coverage simply by adding IRC Conversion Stock No. 21S. Only \$50.00.

Wherever the Circuit Says



INTERNATIONAL RESISTANCE CO.

Dept. 574, 401 N. Broad St., Phila. 8, Pa.

In Canada: International Resistance Co., Ltd.
Toronto, Licensee

ELECTRONIC TECHNICIAN

Including
Circuit Digests

TELEVISION • ELECTRONIC • RADIO • INDUSTRIAL AUDIO

ALBERT J. FORMAN *Editor*
M. CLEMENTS *Publisher*
O. H. CALDWELL *Editorial Consultant*
ROBERT CORNELL *Technical Editor*
A. O'ROURKE *Assistant Editor*
CHARLES F. DREYER *Art Director*
PAT DRUMM *Editorial Assistant*

Address all mail to
480 Lexington Ave., New York 17, N. Y.
Telephone Plaza 9-7880

BUSINESS DEPARTMENT

H. A. REED *General Sales Manager*
WM. P. KENNEDY *Regional Manager*
N. McALLISTER *Production Manager*
M. N. WINQUIST *Accounting Manager*
M. RAMSAY *Accounting Supervisor*
W. W. SWIGERT *Credit Manager*
M. RUBIN *Circulation Manager*
S. LA MACCHIA *Asst. Circulation Mgr.*

P. H. DEMPERS *Regional Manager*
5010 Howard St., Skokie, Ill.
Telephone ORchard 5-1355

CHRIS DUNKLE & ASSOCIATES
California Representative
740 S. Western Ave., Los Angeles 5, Calif.
Telephone DUmkirk 7-6149

BERNIE EDSTROM *Regional Manager*
2169 Eldred Ave., Cleveland 7, Ohio
Telephone LAkewood 1-7900



ELECTRONIC TECHNICIAN & Circuit Digests, July 1957, Vol. 66, No. 1. \$5.00 a copy. Published monthly by Electronic Technician, Inc., an affiliate of Caldwell-Clements Co. Publication office, Emmett St., Bristol, Conn. Editorial, advertising and executive offices, 480 Lexington Avenue, New York 17. Telephone PLaza 9-7880.

Entered as second class matter at the Post Office at Bristol, Conn., June 10, 1954. Subscription rates: United States and Canada, \$4.00 for one year; \$6.00 for two years; \$8.00 for three years. Pan-American and foreign countries: \$7.00 for one year; \$10.00 for two years; \$14.00 for three years. Copyright 1957 by Electronic Technician, Inc., New York. M. Clements, Chairman of the Board; H. Reed, President; A. Forman, Executive Vice-President. Title registered in U. S. Patent Office. Reproduction or reprinting prohibited except by written authorization of publisher. Printed in U.S.A. by Hildreth Press, Bristol, Conn.

July, 1957

FRONT COVER This month we focus attention on an electronic component — the peaking coil — and the typical circuits in which it performs. The story of how this important unit causes troubles, and how these difficulties may be tracked down and remedied, is presented starting on page 24.

FEATURES and ARTICLES

| | |
|--|--------------------|
| <i>People's Capitalism and You (Editorial)</i> | 21 |
| <i>"Tuning in the Picture"</i> | 22 |
| <i>Casebook on Peaking Coil Problems</i> | A. Margolis 24 |
| <i>Solving Loudspeaker Replacement Problems</i> | H. F. Breit 26 |
| <i>Use of Printed Circuits in Modern Electronics</i> | A. Lytel 28 |
| <i>Why Special Tubes For Series String Operation?</i> | V. H. Ritter 30 |
| <i>"Tough Dog" Corner</i> | 32 |
| <i>You and the Law</i> | F. Wilkins Jr. 33 |
| <i>TV Radiation Scare</i> | 36 |
| <i>Right or Wrong in Labor Relations</i> | 36 |
| <i>Bench-Testing Mockups for Two-Way Radios Speeds Servicing</i> | J. Darr 37 |
| <i>Shop Hints</i> | 40 |
| <i>Antenna Wall Reflectors</i> | J. A. McRoberts 41 |
| <i>New Audio Products</i> | 43 |
| <i>New Electronic Products</i> | 44 |
| <i>New Electronic Components</i> | 45 |
| <i>Latest Test Instruments and Aids</i> | 46 |

DEPARTMENTS

| | | | |
|-----------------------------|----|---------------------------------|----|
| Editor's Memo | 2 | Calendar of Coming Events | 23 |
| Letters to the Editor | 6 | Audio Newsletter | 35 |
| News of the Industry | 14 | New Products | 42 |
| Employment | 18 | Catalogs & Bulletins | 48 |
| Representatives | 19 | New Books | 49 |
| Association News | 51 | | |

CIRCUIT DIGESTS

57

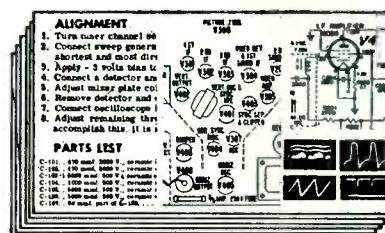

**NO
MATTER
WHAT
THE
WEATHER...**

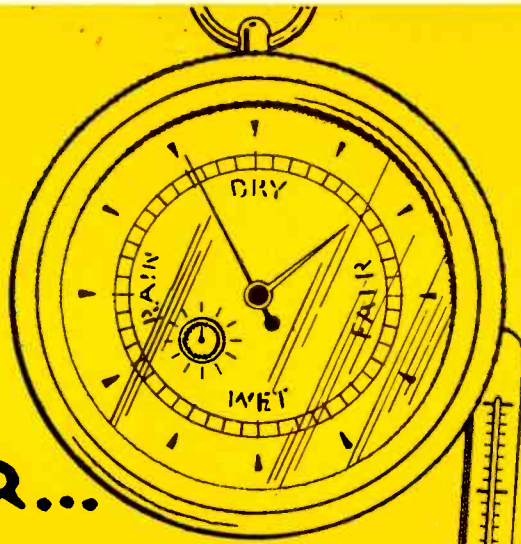

Hot-and-humid or cold-and-damp... Aerovox "DURAMIC" Capacitors give you "trouble-free" operation even under the most adverse weather conditions. You avoid costly call-backs when you specify-and-buy "DURAMIC" capacitors because the severe-service characteristics are built into each capacitor.

AEROVOX "DURAMICS"

...utilize a dense steatite case to provide exceptional protection against humidity. All terminal lead wires are firmly imbedded into the end seals so that they will not pull out or work loose even under the most severe operating conditions.

AEROVOX "DURAMICS"

...have that exclusive Aerovox end-fill which will not soften or flow nor separate from the case at any rated temperature.

AEROVOX "DURAMICS"

...have excellent power-factor, insulation resistance and temperature characteristics. Operating temperatures from -55°C. to $+85^{\circ}\text{C.}$ Available in 10 standard voltage ratings from 200 to 15,000 VDC.

...back of
capacitance values and
a copy of the latest
Aerovox components.

CORPORATION

**SALES DIVISION,
DORFORD, MASS.**

CANADA LTD., Hamilton, Ont.
New York, N. Y., Cable: Aurilema, N. Y.

Editor's Memo

What's in a name? That which we call a rose by any other name would smell as sweet.

So said the Bard of Avon, William Shakespeare, in his play *Romeo and Juliet*.

As with any eternal truth, this gem of wisdom is still applicable. Nevertheless, we still apply "good" names to objects we like. Sure, you might name your son Joghead Jones; he could still become president. But think of the years of difficulty that would lay ahead of him. No, we are all inclined to select the names which are descriptive, fitting and proper.

This brings to mind a study published in a recent issue of the Long Island, N.Y., *Guild News*. In it, the writer found that out of 97 associations on the Guild's mailing list with individual representation indicated in the name, 52 said "Technicians." The runner-up was "Servicemen," with 27 names.

Although a man may operate an electronic service business, he generally prefers to be called a technician, judging from the mail received of late. My guess is that prestige is only a small part of the reason for this name preference. More important, from a descriptive viewpoint, the word technician conveys the idea of a skilled specialist; the electronic technician is such a specialist in one of the most complex segments of technology.

Serviceman, on the other hand, brings back memories of olive drab, GI scrub parties and a tired saluting arm. In another connection, serviceman is related to automobile repairs and lubrications. In neither of these two occupations is there any shortcoming, but serviceman is not the name that conveys the idea of an electronic specialist.

Among manufacturers, we note periodic name changes to keep up with the times. A name such as Zilch Radio Company becomes Zilch Electronics, Inc.

Even the word electronics is too narrow for some firms, particularly giant manufacturers. The name General Dynamics was evolved to describe the broad scope of one company's activities.

Of course, once a name is established, you hate to change it. Name acceptance is an equity. But you've got to keep up with the times.

There's a real old joke about names. In the laundered version of the story, a fellow named John Jackass petitions the court to have his name changed.

"I understand your problem," sympathizes the judge. "What do you want for a new name?"

"The name I really want," replies the man, "is James Jackass!"

Al Forman

"Sensational I calls it"

A **2** SPEED
 $\frac{3}{8}$ " POWER DRILL
 by **WEN**

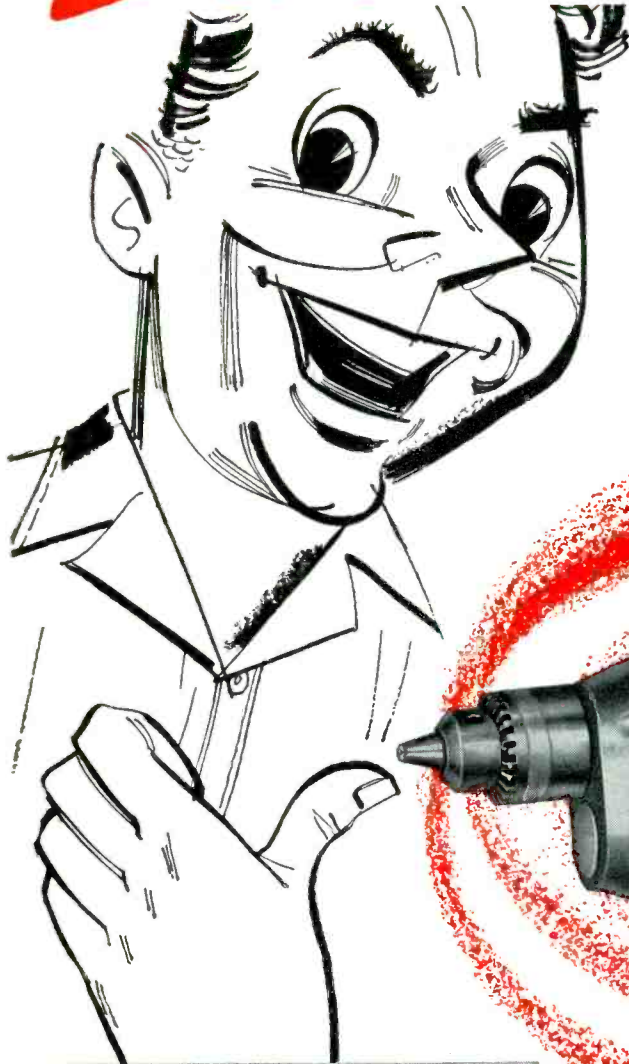

Lets you change from 1,000 to 3,000 RPM and back again as desired, to get just the right speed for different jobs. Speed change is easy, quick, positive. Auxiliary grip handle can be inserted in either end for proper grip at either speed. Ingenious motor defluers maximum torque under load. $\frac{3}{8}$ " geared chuck. Handy, kooky, streamlined design. Fully guaranteed.

MODEL #808



only
\$29.95
 LIST



Rounds Out the **WEN** Line

of high grade, low cost, electric power tools ideal for home and shop.



3 "Quick-Hot" Electronic Soldering Guns and Kits—\$7.95 to \$12.95 List.



3 Electric Sanders, Polishers and Kits, with assorted abrasives and polishers — \$13.95 to \$19.95 list.

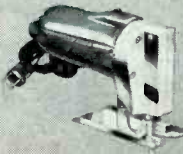

8 Power Saws in 1. Cuts practically anything, any shape. Complete with 3 blades — \$29.95 List.

AND SAW TABLE \$12.95

A TRUE ALL PURPOSE DRILL

Here in 1 tool is everything needed in an electric drill. The $\frac{3}{8}$ " size is just right for most work — and the 2-Speed feature gives you just the right speed. Hi Speed (3000 RPM) for drilling through Steel to $\frac{5}{32}$ " — Wood to $\frac{3}{8}$ " — Aluminum, Brass, Copper to $\frac{1}{4}$ ". Best also for Rotary Sanding, Sawing, Grinding, Buffing. The Lo Speed (1000 RPM) is best for heavier materials and Masonry, Concrete to $\frac{1}{2}$ ". Also for Polishing, Waxing, Screw Driving, Paint Mixing, etc. Naturally, there's big demand for such a multi-useful tool. Deliveries are already a problem.

Orders pouring in. Don't delay.

WEN PRODUCTS, INC.

5808 NORTHWEST HIGHWAY • CHICAGO 31, ILL.
 (Export sales, Scheel International, Inc., Chicago)

for Servicing in "Quick Time"...

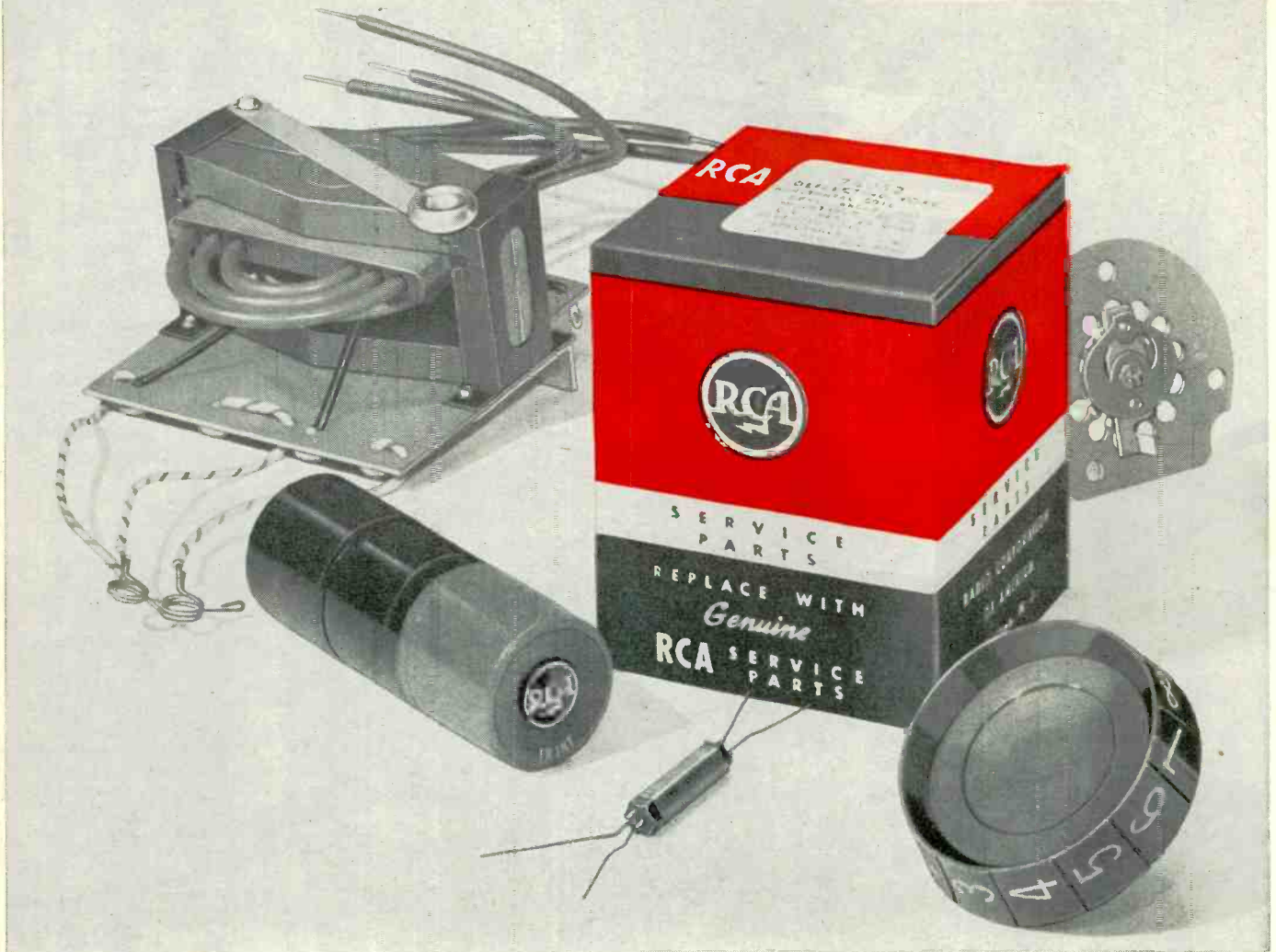

ALWAYS USE **RCA** SERVICE PARTS

Fact is, it's not only *quicker*, but *more profitable* when you use RCA Service Parts for servicing RCA Victor TV, Radios and Phonographs!

Makes sense, too, when you realize that every one of the thousands of RCA Service Parts have been designed and produced for one purpose . . . to replace original parts used in RCA Victor instruments. Each is an identical mechanical and electrical duplicate, factory-tailored to fit without time-consuming filing, drilling, or sawing. Out with the old, in with the new . . . it's as simple as that!

On your next trip to your local distributor, stock up on fit-right, install-fast RCA Service Parts—and keep your servicing on the go—profitably!



RADIO CORPORATION of AMERICA

COMPONENTS DIVISION

CAMDEN, N. J.

RCA PRODUCTS AND RCA SERVICE PARTS — made for each other!

UNIVERSITY ANNOUNCES THE VERSATILE

MODEL

CLH WIDE-ANGLE PROJECTOR

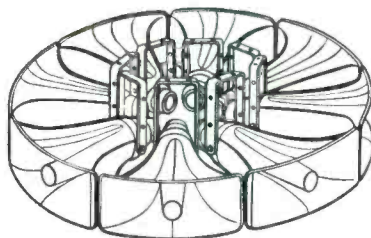

PATENTS
PENDING

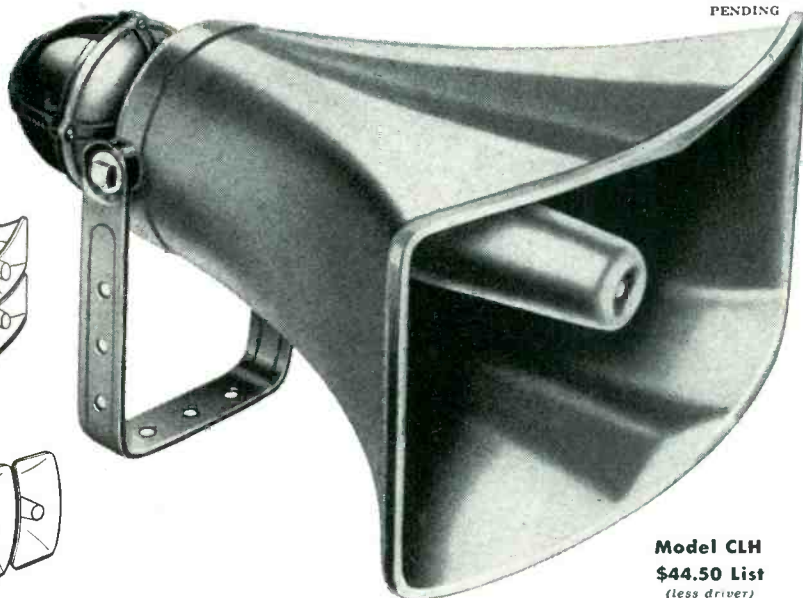

Model CLH
\$44.50 List
(less driver)

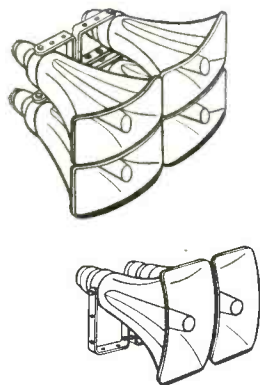

EXCLUSIVE OMNI-DIRECTIONAL MOUNTING

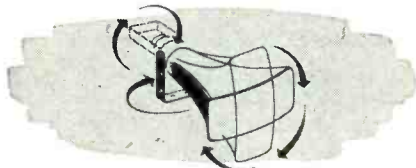

Horn bell rotates full 360° on its axis, while the 'U' mtg. bracket provides better than 180° vertical and 360° horizontal adjustment of projector positioning. Thus, sound can be distributed in any direction regardless of projector location.

USE SINGLY OR STACKED

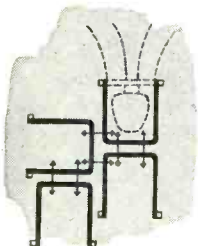

The 'U' mounting bracket of the Model CLH is specially designed to link two or more projectors into any configuration, achieving exactly the sound distribution pattern required. Even diagonal or alternating projections are just as easy to achieve as "standard" patterns.

"TUNE OUT" ECHO & REVERBERATION

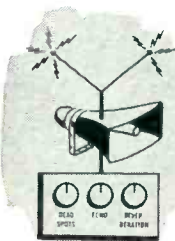

The unique pin-point adjustment possible with the CLH at last provides the long-awaited answer to coverage of "dead spots" and control over troublesome echo and reverberation—regardless of structural or physical placement limitations!

VERSATILITY & ADAPTABILITY UNLIMITED



Meets every soundcasting requirement. Use the CLH wide-angle projector with any University driver to get exactly the frequency response, efficiency and power handling capacity you need. Here is dependable performance and real economy—for actual dollar savings you can count on year after year.

THE MOST COMPLETE SELECTION
OF DRIVERS IN THE INDUSTRY NOW
AVAILABLE FOR USE WITH THE CLH



Model PA-50. Features extended high and low frequency range, highest continuous duty power capacity, greatest conversion efficiency, husky built-in multi-match transformer with terminals conveniently located at base of unit. The answer to the toughest sound problem. Nothing finer!
Response: 70 to 10,000 cps. Power Capacity: Full Range 50 watts; Adjusted Range* 100 watts; List Price: \$57.50.



Model PA-HF. For applications requiring the greatest power handling capacity, maximum sensitivity, widest range frequency response, plus rugged lifetime construction. Completely die-cast aluminum housing. Increased sound output cuts amplifier requirements in half!
Response: 70 to 10,000 cps. Power Capacity: Full Range 50 watts; Adjusted Range* 100 watts; List Price: \$47.50.



Model SA-30. "Battleship" construction for maximum durability against abuse or in hazardous environments. Completely die-cast aluminum housing and built-in matching transformer for connection to high impedance lines or "constant voltage" systems.
Response: 80 to 10,000 cps; Power Capacity: Full Range 30 watts; Adjusted Range* 60 watts; List Price: \$47.50.



Model SA-HF. Will deliver that extra punch needed to cut through heavy noise. Use for speech or high quality music.
Response: 80 to 10,000 cps.; Power Capacity: Full Range 30 watts; Adjusted Range* 60 watts; List Price: \$36.00.



Model MA-25. Low in cost, high in quality, featuring high efficiency magnet, tropicalized 2" voice coil, "rim-centered" breakdown-proof bakelite diaphragm.
Response: 85 to 6500 cps.; Power Capacity: Full Range 25 watts; Adjusted Range* 50 watts; List Price: \$27.50.
*Program response adjusted to horn cut-off.

ACCESSORIES



2YC Connector enables two driver units to be used with one CLH trumpet for up to 200 watts output. Now you can get the Super-Power you want...when you want it, using standard stock drivers.

PMA Adapter fits standard 1/2" dia. threaded pipe to the CLH 'U' mounting bracket. Takes the headache out of mounting on pipe!

LISTEN

University sounds better



UNIVERSITY LOUDSPEAKERS, INC., 80 SOUTH KENSICO AVENUE, WHITE PLAINS, N. Y.

**It's a sure thing
...the odds are 4 to 1
in your favor!**



**Put your
money on
Wirewounds ...
out of
Centralab**

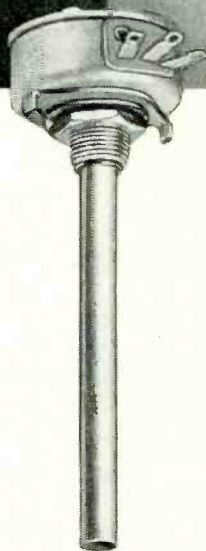

Stable mates in Centralab's long line of champions—Model WW and WN Wirewounds pack a 5-watt control into a 2-watt size, in short- or long-shaft styles. Now, one size takes care of 2-, 3-, 4-, and 5-watt replacements in TV, hi-fi, home and auto radio sets.

Every Centralab Wirewound is a real thoroughbred — and gives you a winning ticket that cuts inventory, helps save time, helps you make more money.

Here's another sure thing — Centralab Wirewounds are favorites in the rich industrial handicap.

Ask your Centralab distributor about these versatile controls. Complete information on these and other top-quality Centralab components can be found in Centralab's new catalog 30.

Centralab
8-1558

A DIVISION OF GLOBE-UNION INC.
902G EAST KEEFE AVENUE • MILWAUKEE 1, WISCONSIN

LETTERS

To the Editor

Taxpayer Support

Editor, **ELECTRONIC TECHNICIAN**:

It is because of the multitude of people, such as the letter writer in your May issue ("Part-Timer View"), who hold down government positions or defense jobs in and around the District of Columbia, being supported by the tax payers, that the TV service business pie is cut so thin that no decent firm can reach a sufficient volume whereby they can compete with government subsidized private industry in offering equal pay and security privileges. His claim about gimmick operators, which ethical service companies have been trying to curb for years, is no justification for his views in defense of part timing.

NORMAN R. SELINGER

Video Engineering Co.
Washington, D.C.

Reason for Renewal

Editor, **ELECTRONIC TECHNICIAN**:

I am renewing my subscription because your publication has improved and added features and articles which more truly reflect its name. There must be countless numbers of electronic technicians who are bored with magazines that feature only TV and hi-fi. It seems to me your publication is presenting a better balance with the inclusion of industrial electronics. I hope this trend continues.

JOHN A. GARLICK

Hialeah, Fla.

More Self-Service Testers

Editor, **ELECTRONIC TECHNICIAN**:

While gathering the weekly groceries in my neighborhood grocery store, I ran into a big new self-service tube tester on a cabinet chuck full of Reliable tubes. I was immediately reminded of your cartoon of the technician inviting the corner druggist to visit the new prescription department just installed in his TV shop. I thought these do-it-yourself tube sales were for the large cities and gave them no more thought. Yesterday I found another in the local news and book store. This may not be a threat to tube sales by independent technicians, but it must be at least a small leak. I would like to see an article on the subject in a future issue of my favorite magazine.

THEODORE E. BRAND

Brand Radio & TV Service
Chambersburg, Pa.

• We studied the self-service tester market when it first became a significant factor, and published our findings in the Nov. 1955 issue.—Ed.

(Continued on page 10)



BURTON BROWNE ADVERTISING

Everyone Looks First to LITTELFUSE

Whenever there is
a new fuse need
for service...

It's always Littelfuse that gives you the complete package for your requirements.

Now—the LC fuse caddy for your tube caddy—an assortment of 15 LC fuse types to cover over 94% of all service requirements for this new fuse which is rapidly becoming *the* TV fuse

Part No. 094041



NEW LC FUSE CADDY



Sylvania

TV Tuner

Tubes



“R-X metered” at

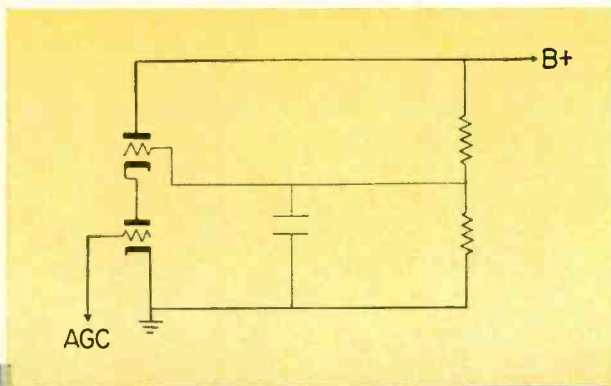

Simplified schematic is a typical cascade circuit in which double-triode amplifiers are tested for transconductance and plate current under actual operating conditions. In this way, Sylvania offers you maximum assurance of proper circuit performance when you repair TV tuners. Regardless of make or model TV, Sylvania tuner tubes mean dependability backed by industry's most exhaustive dynamic testing program.

Type by type, Sylvania's own JEMC (Joint Engineering and Manufacturing Committee) establishes test conditions which represent the most realistic measure of a tube's ability to stand up in the sets you service. Their working knowledge of the needs of TV tuner manufacturers eventually means greater service profits through less call-backs for you.





200 mc for controlled, dependable performance

Measuring input resistance and capacitance of all TV tuner tubes at 200 mc, places important controls over gain and tuning characteristics. This and many other tuner tube tests have been developed by Sylvania to provide you with maximum assurance of dependable performance regardless of make, model, or age of the TV sets you service.

All tuner tubes are fixed-bias tested under conditions which simulate actual

applications in TV sets. Cascode types are subjected to series Gm and series Ib tests in typical circuits. In addition, all types are checked both before and during life tests for serviceability at high and low line voltages.

Protect yourself against costly and unnecessary callbacks. Specify Sylvania TV Tuner Tubes in the new yellow and black carton.



SYLVANIA

SYLVANIA ELECTRIC PRODUCTS INC.
1740 Broadway, New York 19, N. Y.
In Canada: Sylvania Electric (Canada) Ltd.
University Tower Bldg., Montreal

LIGHTING • RADIO • ELECTRONICS • TELEVISION • ATOMIC ENERGY

ELECTRONIC TECHNICIAN • July, 1957

Whatever you want in a V.T.V.M.—**PRECISION** has it!

for High Performance at Low Cost—

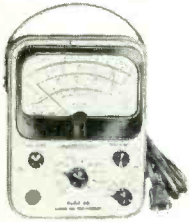

the Model 68 Modestly Priced, Metal-Cased VTVM

- 5 Peak-to-Peak Voltage Ranges: 0-8-32-160-800-3200 volts
- 5 (+) Plus and 5 (-) Minus DC Voltage Ranges: 0-3-12-60-300-1200 volts, 1 1/3 Meg. input
- 5 Hi-Impedance RMS AC Ranges: 0-3-12-60-300-1200 volts
- 5 Resistance Ranges Up to 1000 Megohms
- 5 Zero-Center Reference Ranges
- Extra-Large, 5 1/4" Wide-Angle PACE Meter

Model 68: blue-grey ripple-finished steel cabinet, 5 7/8" x 7 3/4" x 3 1/2". Complete with tubes, ohmmeter battery and manual. Net Price: \$54.50

for Battery-Powered Portability—



the Model 78 Battery-Operated, Metal-Cased VTVM

- A MUST Where Power Line is Unavailable
- A MUST Where Power Line Connection is Undesirable
- 6 Zero-center DC Voltage Ranges: 0 = 1.5, = 6, = 30, = 150, = 600, = 1500 volts; 1 1/3 Meg. input
- 5 Ohmmeter Ranges to 1000 Megohms
- 5 Hi-Impedance RMS AC Ranges: 0-3-12-60-300-1200 volts
- Extra-Large, 5 1/4" Wide-Angle PACE Meter

Model 78: blue-grey ripple-finished steel cabinet 5 7/8" x 7 3/4" x 3 1/2". Complete with tubes, batteries and instruction manual. Net Price: \$62.50

for Wide-Range Laboratory Quality—



the Model 88 Compact, Lab-Type VTVM

- More Functions—More Ranges—More Sensitivity: 7 functions . . . 40 ranges . . . 26 2/3 megs input
- 6 Peak-to-Peak Voltage Ranges: to 3200 volts specially engineered for accuracy on pulsed and TV wave forms
- 6 Zero Center DC Voltage Ranges: to 1200 volts . . . also, 6 (-) minus and 6 (+) plus DC voltage ranges
- 5 Electronic Ohmmeter Ranges: to 1000 Megohms
- Extra-Large, 5 1/4" Wide-Angle PACE Meter

Model 88: Molded phenolic case, 5 3/8" x 7" x 3 1/8". Complete with AC line cord, ohmmeter battery, 3-way probe and manual. Net Price: \$74.50

for The Ultimate in Performance and Operating Ease—

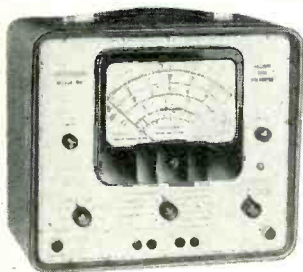

the Model 98 Laboratory VTVM with 7" Meter

- PRECISION's Finest VTVM: More Ranges—More Functions—High Sensitivity
- 6 P-to-P Voltage Ranges to 3200 volts: specially engineered for maximum accuracy on pulsed wave forms
- 6 True-Zero-Center DC Voltage Ranges: 26 2/3 Megohms input to = 1200 volts
- 6 Electronic Ohmmeter Ranges to 1000 Megohms
- 6 Minus and 6 Plus DC Voltage Ranges: to 1200 volts 1 1/3 Megs input
- 6 Hi-Impedance RMS AC Ranges to 1200 volts
- 8 DC Current Ranges: from 0-300 microamps to 12 Amps
- 6 Decibel-Output-Meter Ranges: -20 to + 63 DB

Model 98-MCP: in blue-grey, ripple-finished cabinet and two-color brushed aluminum panel, 11 1/2" x 13" x 6 5/8". Complete with 3-way VTVM probe and manual. Net Price: \$119.50

PRECISION VTVM ACCESSORIES AVAILABLE

| | |
|---|-------------------|
| Model RF-10A.....High-Frequency Vacuum-Tube Probe (for Models 88 and 98)..... | Net Price \$14.40 |
| Model RF-12.....High-Frequency Crystal Probe (for Models 68 and 78)..... | Net Price \$10.95 |
| Model TV-4.....Super-High-Voltage Safety Test Probe (for Models 68 and 78)..... | Net Price \$14.75 |
| Model TV-8.....Super-High-Voltage Safety Test Probe (for Models 88 and 98)..... | Net Price \$14.75 |
| Model LC-1.....Leather Carrying Case (custom-designed for Model 88)..... | Net Price \$9.50 |
| Part No. ST-1.....Retractable Snap-On-Tilt Stand for Model 88..... | Net Price \$1.00 |



PRECISION Apparatus Company, Inc.

70-31 84th Street, Glendale 27, L. I., N. Y.

Export: 458 Broadway, New York 13, N.Y., U.S.A. • Cables: MORHANEX
Canada: Atlas Radio Corp. Ltd. • 50 Wingold Ave. • Toronto 10, Ont.

Available and on display at leading electronic parts distributors.

Index Misunderstanding

Editor, ELECTRONIC TECHNICIAN:

I was at first pleased to see the index for all Circuit Digest to date in the May issue. However, after finding an error for one schematic, I checked the rest of the index, and I am afraid there is a complete inaccuracy up as far as #200. Apart from the above gripe, I am quite pleased with your publication.

D. W. GENTRY

SERVICE MANAGER

Norburn Electric Ltd.

N. Burnaby, B.C., Canada

• Perhaps Reader Gentry is confusing the individual Circuit Digest number listed in the index with the group number appearing in a white circle in the upper right-hand of the front of the Digest section. This circled group number is only intended as a chronological filing aid, not as an index reference; the Circuit Digest number is on the schematic itself. A close check of the index did turn up these few errors (we're sorry): Bogen #317 should be #319; Pilot #319 becomes #317; Circuit Digest #5 for Philco Chassis 91 was omitted; schematics for Radio Craftsmen are listed under that name or Craftsmen. All other Circuit Digest numbers in the index are correct.—Ed.

Loaded Request

Editor, ELECTRONIC TECHNICIAN:

Please send me any information you have on electronics. Thank you.

RICHARD ELLIOT

Newport Beach, Calif.

• Our information files and library would fill a good-sized trailer truck. Please, Dear Readers, be specific.—Ed.

Former Shop Owner

Editor, ELECTRONIC TECHNICIAN:

I was very much interested in your May editorial. At one time I operated a full time shop, but today I work for the government servicing Nike guided missiles. I predict that in not very many years to come, most of the good honest technicians will be working for big industrial electronic concerns. Like many other technicians I have spoken to, I sincerely enjoy servicing and will continue to do so on a part time basis. I can see a brighter picture for technicians IF the correction of inequities are begun where they should be begun, with the manufacturers. Until the time arrives when a man cannot walk off the street and buy tubes and parts at the same price, or even less, than a technician, the present chaos will grow. Sometimes I even think there is something to the rumors that the 12 plagues of the TV servicing industry are a product of manufacturers who would like to take over servicing.

RALPH CHALON

Shelton, Conn.

Reputation Builder #3: it pays to be neat



- Treat a set-owner's home like a dog house and you're likely soon to be living in one

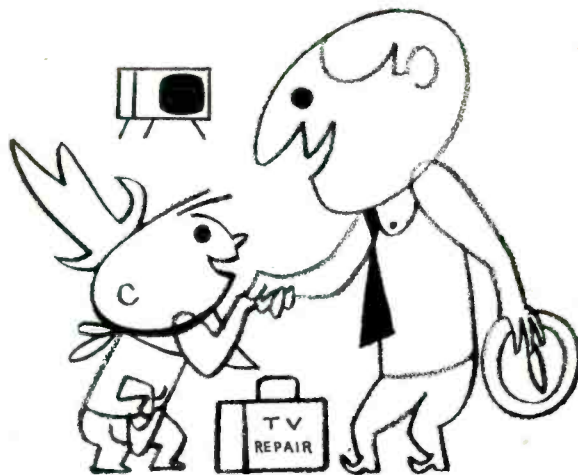

- BUT ... treat his possessions as you would your own, and you'll always be an honored guest

it pays to replace with Sprague Atom[®] Miniature 'Lytics



don't be vague...insist on

- Another way to build and hold a reputation is to insist on top quality replacement parts. Callbacks due to replacement failures not only cost you *money* ... they also cost you customers! Replace with less than the best and you place your reputation at stake. In capacitors, the best is *Sprague*.

- Take Atom Tubular Electrolytics, for example. The smallest TV 'lytics made, they're the only small ones for 85°C (185°F) up to 450 VDC. Guaranteed for low leakage and long shelf life, they withstand high temperatures, high ripple currents, high surge voltages. From crowded TV chassis to jam-packed portables, Sprague Atoms fit them all.

- Get your copy of Sprague's latest radio and TV service catalog, C-455. Write Sprague Products Co., Distributors' Division of Sprague Electric Company, 65 Marshall Street, North Adams, Mass.

SPRAGUE[®]

world's largest capacitor manufacturer

SPRAGUE RESEARCH IS CONSTANTLY PRODUCING NEW AND BETTER CAPACITORS FOR YOU

give them

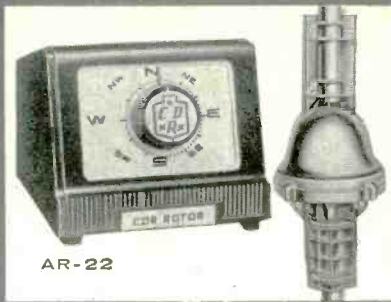

AR-22

what they want...

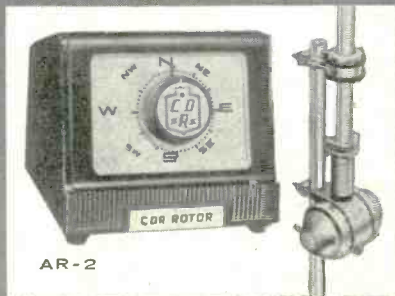

AR-2

give them—

CDR

ROTORS

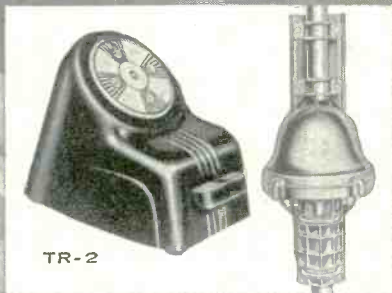

TR-2

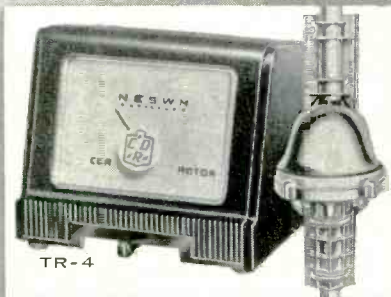

TR-4

It's easy for you to give your customers EXACTLY what they want...and at the same time EXACTLY what is BEST for them...because CDR ROTORS are the single answer! The complete line with a model for every need...proven performance and dependability through years of experience. This combination has made CDR ROTORS the favorites everywhere...that is why your customers should have CDR ROTORS!

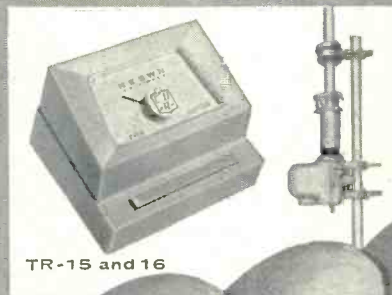

TR-15 and 16

Especially important for color TV reception. Critical tuning requirements call for CDR Rotors.



CORNELL-DUBILIER
SOUTH PLAINFIELD, N. J.



THE RADIART CORP.
CLEVELAND 13, OHIO



... by and for the technician, \$1.50 net

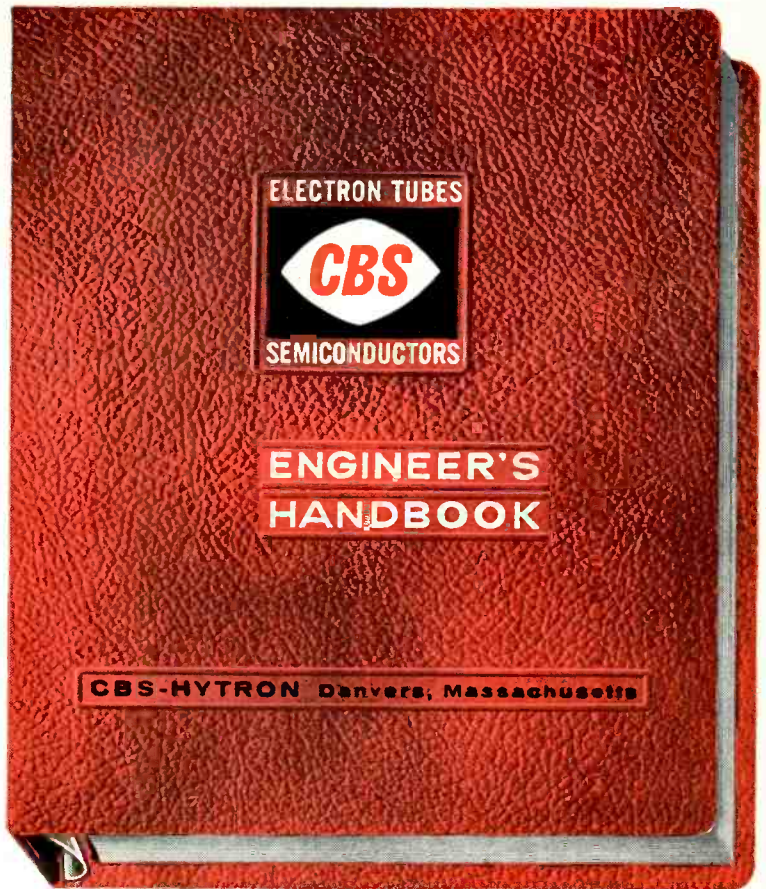

... by and for the engineer, \$7.50 net

Two new CBS handbooks

The new CBS Technician's Handbook and Engineer's Handbook are complete. They contain data for receiving, special and picture tubes as well as crystal diodes and transistors. Designed for on-the-job use, they are single, compact, handy volumes that lie flat. They feature modern styling for quick, easy reference. Supplementary services are available. Ask to see these Handbooks at your CBS Tube distributor's. You will want them both.

CHECK THESE FEATURES

Technician's Handbook

- Comprehensive data for all popular types
- Reference data for seldom-used types, grouped by application
- All popular special-purpose tubes and semiconductors
- 450 pages
- Handy 5¼ by 9 inches
- Rugged plastic binder
- Appendix especially prepared for service technicians

Engineer's Handbook

- Complete RETMA engineering design data
- Seldom-used types tabulated for quick reference
- 300 two-color design curves
- 650 pages, two colors
- Handy 8¼ by 9½ inches
- 16-ring metal binder
- Appendix includes description of terms, symbols, characteristics ratings, etc.

Reliable products
through Advanced-Engineering



tubes • semiconductors

CBS-HYTRON, Danvers, Massachusetts
A Division of Columbia Broadcasting System, Inc.

News of the Industry

Simpson...the most Complete Line of VOM's

Select the one that fits your needs!

MODEL

260

world's most popular!

Over half a million Model 260's have been sold to date! 20,000 Ohms per volt. You'll find it wherever quick, accurate, electrical checks are needed. It's so handy, so dependable, so sensibly priced! Ask your jobber. Price, including Adjust-A-Vue Handle, only ... **\$43.95**

Carrying Cases from **\$7.75**

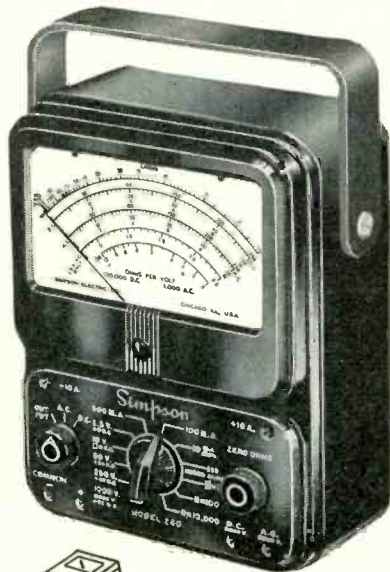

MODEL **262**

Deluxe!



the new VOM with a 7" meter

20,000 Ohms per volt DC and 5,000 Ohms per volt AC sensitivity ... 33 ranges ... compact 7" case with Adjust-A-Vue Handle ... **\$59.50**

Carrying Case ... **\$ 9.95**

MODEL **269**

100,000 Ohms per volt!

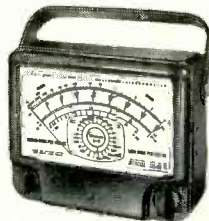

Most sensitive VOM

available! A Volt-Ohm-Microometer with a big 7" meter in a compact 7" case ... 33 ranges ... Adjust-A-Vue Handle ... **\$88.00**

price complete ... **\$ 9.95**

NEW!

➔ **MIDGETESTER** Model 355—New shirt-pocket size Volt-Chmmeter **\$34.95**
MODEL 240—Small VOM; 14 ranges; up to 3000 volts AC or DC **\$28.95**
MODEL 230—Small VOM; 12 ranges; up to 1000 volts AC or DC **\$27.95**
ROTO RANGER Model 221—25 Separate meters at turn of a switch **\$75.00**
LABORATORY STANDARD—For instrument calibration. Price on application.

Simpson ELECTRIC COMPANY

World's Largest Manufacturer of Electronic Test Equipment

5200 W. Kinzie St., Chicago 44, Ill. • ESTebrook 9-1121
 In Canada: Bach-Simpson, Ltd., London, Ontario

ALLEN B. DUMONT LABS. announces the elections by the Board of Directors of **STANLEY J. KOCH** and **MAJOR GEN. RAYMOND C. MAUDE** as Vice Presidents.

PHILCO CORP. names **ALFRED H. CHATTEN**, formerly regional manager of North Atlantic Div., as General Mgr. of the new Elizabeth, N. J. distribution center.

BRACH MFG. CORP. has appointed **JERRY BERGER** to the position of Director of Sales.

SEL-SON reports that approximately 40,000 sq. feet of manufacturing and warehouse space have been added to the plant in Darby, Penna.

SNYDER MFG. CO. has opened its ninth regional warehouse in Dallas, Texas.

RAM ELECTRONICS has moved to new and larger quarters at 600 Industrial Ave., Paramus, N. J. The new plant is 22,000 sq. feet in size.

CLAROSTAT MFG. CO. announces the construction of a new wing to be added on the present five-story building.

RCA promotion plan to distributors suggests an offer to the service dealer of an RCA Color TV Pict-O-Guide free with the purchase of 300 tubes.

FORMATION OF A \$75 MILLION company through the merger of **UNI-TRONICS CORP.** and the **HUFFORD CORP.** into the **SIEGLER CORP.** has been announced.

JERROLD ELECTRONICS CORP. has purchased the community antenna systems in Walla Walla, Wenatchee and Richland, Washington, bringing their total to nine owned and operated systems.

(Continued on page 19)

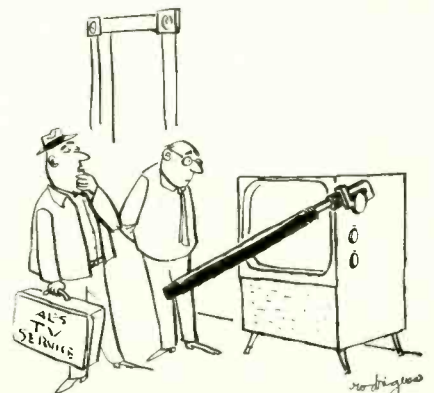

"Looks like you've got tuner trouble, sir."

**You Profit More When
You Sell the Finest!**

Electro-Voice®

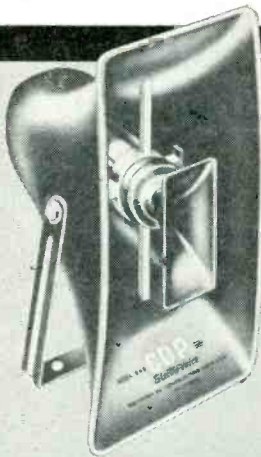

Model 848 CDP for the biggest jobs. 25 watts, 16 ohms. Response: 175-10,000 cps, crossover at 1000 cps. Sensitivity rating, 52 db. Size, 10½" x 20½" x 20". Wt., 12 lbs. List.....\$75.



Model 847 CDP. 12 watts, 16 ohms. Response, 250-10,000 cps, crossover at 1500 cps. Sensitivity rating, 51 db. Size, 11¾" x 7¾" x 10½". Wt., 6½ lbs. List.....\$46.33.



E-V Model 664

**CDP—the Speakers With a Difference:
Greater Intelligibility, More Coverage**

CDP SPEAKERS—Compound Diffraction Projectors—reach more people more clearly. Because they do a better job, they help build your reputation for dependability.

CDP units consist of two coaxially-mounted diffraction horns working from opposite sides of a single diaphragm over a 120° polar pattern. They deliver 2½ more octaves of sound reproduction—essential for highest intelligibility—than conventional P. A. Horns.

**Step Up Your Sales With the World's Finest P.A.
Microphone E-V 664 High-Fidelity Cardioid Dynamic**

UNIQUE E-V "VARIABLE D"® gives you amazing versatility, highly directional sound selectivity, smooth, peak-free response at all frequencies from 40 to 15,000 cps, no boominess. GUARANTEED to outperform any other P. A. cardioid or YOUR MONEY BACK! List price, \$85.00.



Model 636 slim dynamic omnidirectional microphone. 60-15,000 cps response range. List.....\$72.50.



Model 623 dynamic omnidirectional microphone. 60-12,000 cps response range. List.....\$57.00.



Model 927 crystal omnidirectional microphone. 60-8000 cps response range. List.....\$22.50.

Electro-Voice

ELECTRO-VOICE, INC. • BUCHANAN, MICHIGAN
Export: 13 East 40th Street, New York 16, U.S.A. Cables: ARLAD

Ask a Broadcast or Recording Engineer about E-V Microphones. Write TODAY for A B C's of Microphones, Dept. ET-77.

You Have More TO SELL WITH A Winegard

The more sound selling facts you can put before a customer, the more chance you have of closing a sale! And the Winegard Color-Ceptor gives you selling points no other antenna can offer . . . exclusive buying appeals that clinch 9 out of 10 sales!

They See the Gold and They're Sold

The gold-anodized finish of the Color-Ceptor gives it a rich, quality appearance not found in any other antenna. When you show the Color-Ceptor alongside competitive models, the Color-Ceptor is so distinctive, so finished-looking that it is invariably selected by your customers. Gold-anodizing has a practical sales advantage, too. It provides immunity to corrosion—prevents deterioration in performance.

If the Winegard Color-Ceptor won't bring in a station you want to see . . . nothing will! Proof of performance was dramatically illustrated when Robert Seybold of Dunkirk, New York—using a Winegard Antenna—broke all long-distance reception records in 1956 (see Radio-Electronics Magazine Jan. '57). Equipped with optional signal-boosting Power-Pack and patented "Electro-Lens" focusing, the Color-Ceptor is second to none for long-distance reception and clear watchable pictures in both black-and-white and color!



The Sign of Better Business

The Winegard Authorized-Dealer decal (pictured above) is proving a real business-builder for every dealer who displays it. Heavily promoted in Winegard's national advertising, the decal tells the world that "here's the place to buy the gold-anodized Color-Ceptor."

Want More Details?

Mail coupon below for all the facts on Color-Ceptor's spectacular success story! Winegard gives you everything you need to make antenna sales boom—the product, free display, national advertising, proven sales techniques. Join the swing to Winegard—it's the best move you can make!

WINEGARD COMPANY
Dept. C-7, 3000 Scotten Blvd., Burlington, Iowa

Name

Please rush me free 4-color descriptive literature on your gold-anodized Color-Ceptor and information on display material.

I'm interested in the complete line of new 1957 Winegard antennas.

Company

Address

City State

Winegard Color-Ceptor TV Antenna

Gold Anodized

all 12 VHF Channel
Reception For Both
Black-and-White
and Color

Color so bright they sell on sight!

Note:

Each gold Color-Ceptor you install helps sell another. Once folks see these bright gold antennas sprouting up in their neighborhood, they won't be satisfied until they own the gold antenna, too!

Horizontal Directivity

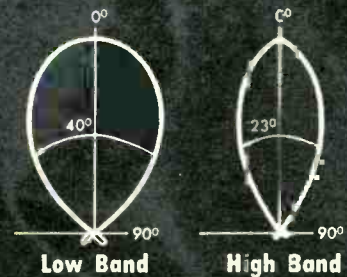

Gain Chart
CL-4X with Power-Pack

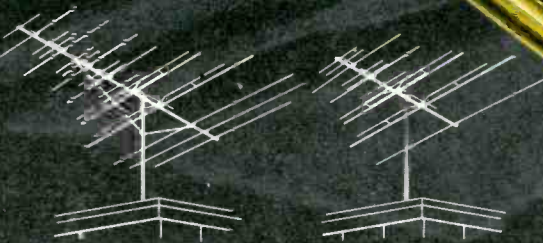

Color-Ceptor Model CL-4X — \$44.90 **Color-Ceptor Model CL-4 — \$29.95**

If Color-Ceptor won't bring in a station you want to see . . . nothing will!

Exclusive Color-Ceptor features

- Completely non-corrosive gold-anodized finish.
- Power-Pack—up to 47.1% more sensitivity.
- Pat. "Electro-Lens"—clearer pictures at greater distance.

Winegard Color-Ceptors are consistently advertised in leading national magazines your customers read!



Winegard Co.

3000 Scotten Blvd., Burlington, Iowa
Cable Address: Western Union JRWCO

*Pat. No. 2,700,105 Copyright USA, 1957

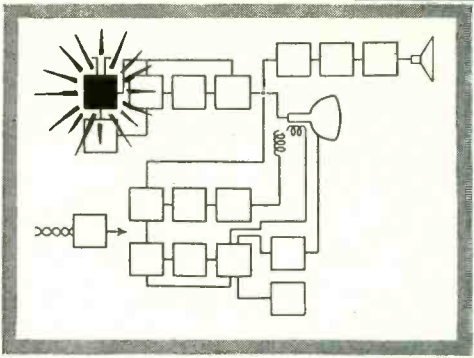

Using a special v-h-f tuner, a General Electric applications engineer double-checks a G-E r-f-amplifier tube for low noise level . . . meaning sharp, virtually snow-free TV pictures, even in weak signal areas. ▶

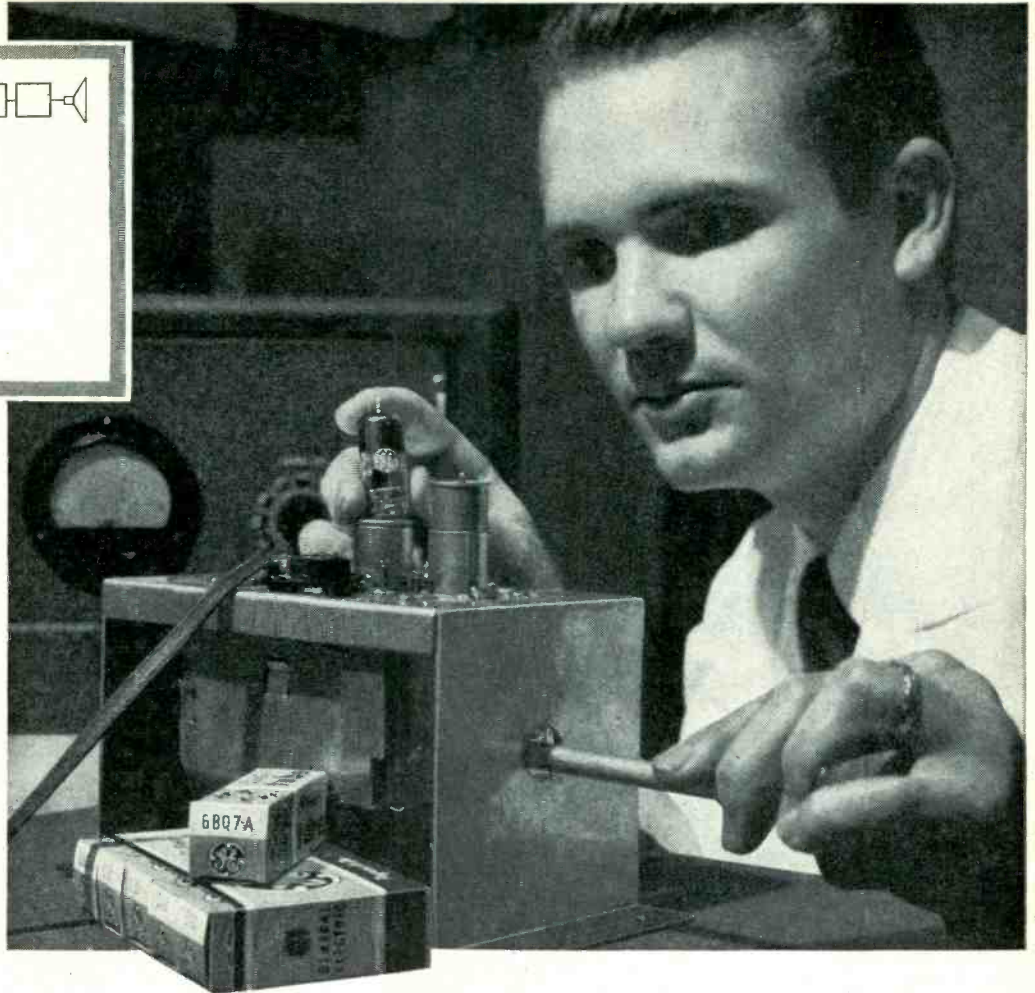

Extremely low noise level accents quality performance of General Electric r-f-amplifier tubes!

ALL G-E r-f-amplifier tubes have a low noise figure—well below normal—bringing better TV to your service customers. Even in fringe areas where the signal is weak, General Electric tubes pull in clean, sharp pictures, with seldom any trace of snow.

Improved design . . . advanced processing techniques . . . extensive tests . . . all contribute to maintaining low noise level. Also, sturdy General Electric tube construction plus precision manufacture keep down microphonics, with tests under severe operating conditions added to make sure that performance holds to the highest possible standards.

Customer satisfaction is further increased by long

r-f-amplifier tube life. To this end, tests of 6BN4's, 6BQ7-A's, 6BS8's, and other G-E types are performed at max plate dissipation in circuits most conducive to grid emission, in order to establish that grid emission and gas current are negligible. Also, heater-cathode shorts have been sharply reduced throughout the r-f-amplifier group, further prolonging tube life.

For pleased service customers, and the greater business this can bring, always install General Electric high-quality tubes! Your G-E tube distributor can fill every need, gives prompt delivery. Phone him today! *Distributor Sales, Electronic Components Division, General Electric Company, Schenectady 5, New York.*

Progress Is Our Most Important Product

GENERAL  **ELECTRIC**

161-1A7

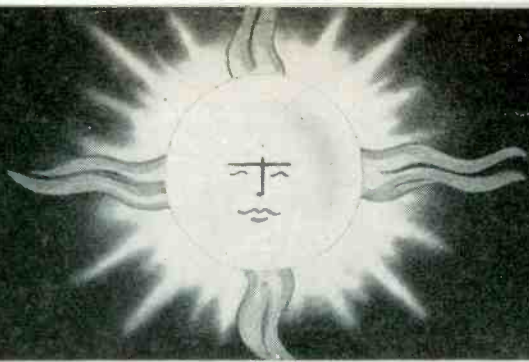

**YOU SAVE
TIME**

when you use

STANCOR

CONSERVATIVELY RATED

EXACT REPLACEMENTS

No re-wiring, no circuits to change, because almost all STANCOR transformers are exact replacements, built for quality from original manufacturers' physical and electrical specifications. At better distributors everywhere. Write for your free catalog.

**CHICAGO STANDARD
TRANSFORMER CORPORATION**

3513 ADDISON STREET • CHICAGO 18, ILLINOIS

Export Sales: Roburn Agencies, Inc., 431 Greenwich St., New York 13, N.Y.



Important Notice to Subscribers

Changes of address require four weeks' notice. Notify your Postmaster and ELECTRONIC TECHNICIAN Circulation Department, 480 Lexington Ave., New York 17, N. Y., at the earliest possible moment.

When ordering change, please INCLUDE IMPRINTED STRIP showing exactly how magazine is now addressed. This will enable us to put the change into effect with a minimum of delay.

EMPLOYMENT OPPORTUNITIES

For further information about employment openings, write directly to address noted in advertisement, or list companies of interest and mail to:

Personnel Dept.
ELECTRONIC TECHNICIAN
480 Lexington Avenue
New York 17, N.Y.

Positions Wanted

ELECTRONIC TECHNICIAN has 10 years experience in radio, TV and public address systems. Would like to work for several dealers on part time basis in and around Wilkes Barre area. Peter Wnukowski, 334 Ridge Ave., Kingston, Penna.

ELECTRONIC TECHNICIAN will consider any U. S. location. FCC radiotelephone 2nd class commercial license, "ham" radio operator since 1951. Some amateur radio construction, some practice with test instruments. Single, salary open. R. D. Sterling, Box 162, Binger, Okla.

BROADCAST STATION position desired. Graduate of Grantham School of Electronics. Have first class FCC radiotelephone license and some experience in radio & TV servicing. Salary open. Clarence Broecker, 412 N. Park, Brenham, Texas.

TV-REPAIRMAN, recent graduate, some experience. F. P. Crasco, 136 Pleasant St., Boston 25, Mass.

TECHNICIAN, graduate of Air Force Electronics Fundamentals School, G. C. A. Radar School, has some experience with military equipment. Location open, prefer overseas. Louis F. Isley Jr., 1212 S. National, Springfield, Mo.

TECHNICIAN attended Marine Radar Operator School, Navy Radar Maintenance School, Indiana Technical Coll. Employed as TV trouble-shooter. Been doing proto-type construction of electronic units. Would like work in NY state area, would go elsewhere. Salary, \$4,200, age 32. Frank A. Carrameckoe, 1629 Lexington Ave., New York 29, N. Y.

TECHNICIAN, aircraft & ground radar & radio transmitter & receiver experience. Flight radio operator, 10 yrs.; radio-TV technician, 10 yrs.; FCC licenses; 1st-class phone, 2nd-class telegraph, radar & aircraft indorsement, advanced amateur W2MRY. CAA licenses: commercial pilots, flight radio operators. Salary open, any location incl. foreign. 34. married, C. J. Gillen, POB 1351, Mastic Beach, Long Island, N. Y.

Business For Sale

FLORIDA TV SERVICE BUSINESS, excellent reputation for reliable work. Best location in Sarasota on Tamiami Trail, Motel and Apartment accounts. Box BS701.

"Business for Sale" and "Help Wanted" listings are available in this section to aid shop management and owners in obtaining qualified personnel or selling their business. This section is not open to manufacturers.

(Continued from page 14)

INSULINE CORP. OF AMERICA reports two new officers—**JAMES L. LEWIS** as President and **PAUL C. EBERHARDT** as Vice President.

INTERNATIONAL RECTIFIER CORP. announces the opening of a New England area branch office located at 17 Dunster St., Cambridge, Mass. **HENRY DiMOND** has been named District Mgr. of the new sales office . . . other appointments are **JOHN VICK-EREY** to Industrial Sales Mgr. and **HERMAN BLOOM** to Distributor Sales Mgr. at main office.

Reps & Distributors

BERNARD L. CAHN CO. is a new sales rep organization covering industrials and distributors in Northern California and Northern Nevada.

BENJAY ASSOC. has been appointed rep in metropolitan New York and Northern New Jersey for **ELECTRONIC PUBLISHING CO.**

PRODUCTION SALES has been appointed the rep for **ACTIONCRAFT PRODUCTS** of Port Washington, N. Y.

MERIT COIL & TRANSFORMER has changed its representation in the metropolitan New York City market. **ART CERF & CO.** will service all distributors in the territory.

WELWYN INTERNATIONAL INC. announces the appointment of **FORSHAY SALES CORP.** as its distributor in metropolitan New York, Northern New Jersey and Long Island.

PRECISION RADIO, LTD. has been appointed Hawaiian outlet for **WYCO METAL PRODS.**

VICTOR ELECTRIC WIRE & CABLE has appointed **HOOD CO.** as sales rep for New York state.

S. A. SHAW CO. has been appointed as metropolitan New York rep for the semi-conductor products division of **U. S. DYNAMICS CORP.**



look what **\$24⁵⁰** buys
in test equipment!



**HEATHKITS
GIVE YOU
TWICE AS MUCH
equipment for
every dollar
invested**

The famous model V-7A Vacuum-Tube-Voltmeter is a perfect example of the high-quality instruments available from Heath at $\frac{1}{2}$ the price you would expect to pay! Complete, only **\$24⁵⁰**

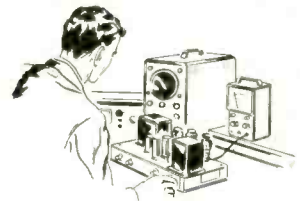

Get the most out of your test equipment budget by utilizing HEATHKIT instruments in your laboratory or on your production line. Get high quality equipment, without paying the usual premium price, by dealing directly with the manufacturer, and by letting engineers or technicians assemble Heathkits between rush periods. Comprehensive instructions insure minimum construction time. You'll get more equipment for the same investment, and be able to fill your needs by choosing from the more than 100 different electronic kits by Heath. These are the most popular "do-it-yourself" kits in the world, so why not investigate their possibilities in your particular area of activity! Write for the free Heathkit catalog now!



Contains detailed descriptions of Heathkit models available, including VTVM's, scopes, generators, testers, bridges, power supplies, etc.



Also describes Heathkit ham gear and hi-fi equipment in kit form. 100 interesting and profitable "do-it-yourself" projects!

FREE catalog

Mail coupon below for
your copy—Now!

HEATH COMPANY
A SUBSIDIARY OF DAYSTROM, INC.,
BENTON HARBOR 24, MICHIGAN

Name _____

Address _____

City & Zone _____

State _____

Mr. Independent Service Dealer...

IF YOU'RE FEELING THE SQUEEZE of
Rising Costs • National Service Company Competition • Lack of Manpower

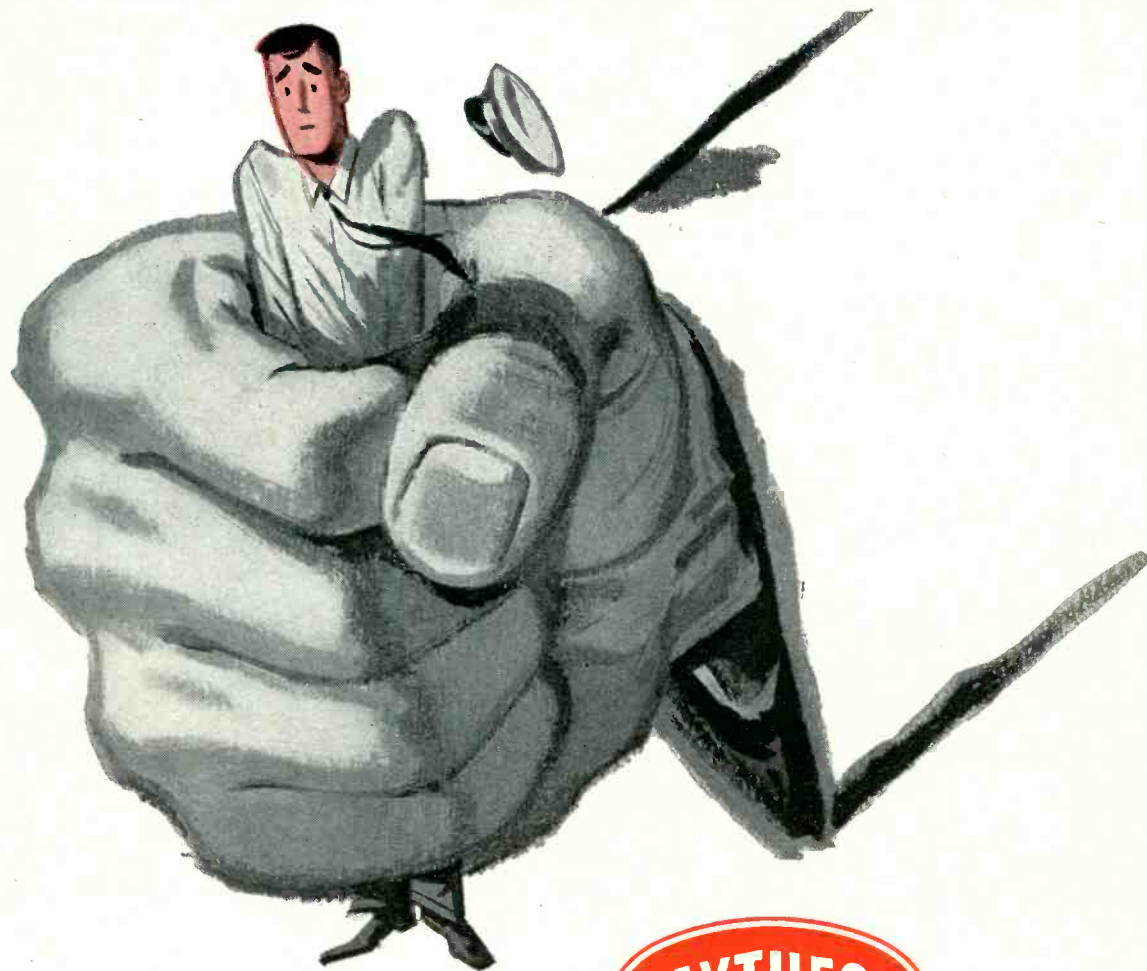

Better look into the



BONDED ELECTRONIC TECHNICIAN PROGRAM

Today, more than ever before, qualifying as a Raytheon Bonded Electronic Technician will help you in many ways:

First, your service work is backed by a Bond issued through one of America's largest insurance companies. This bond means you can charge and get a proper price for your work because the bond creates customer confidence in your shop.

Second, you get the services of Western Union "Operator 25," who, in answer to requests, is sending customers to Raytheon Bonded Dealers from coast to coast.

Third, you get the backing of national advertising which sells your *bonded* service as the customers' best buy:

Fourth, you become a member of a national group of service dealers who can feature the national sym-

bol of superior TV-radio service . . . the Raytheon Bonded Decal. *Yet you retain your own independence.*

Fifth, you'll find technicians prefer to work for Raytheon Bonded Dealer organizations because these companies have earned the respect of their customers.

Your Raytheon Sponsoring Bonded Tube Distributor will be glad to explain the program to you.

TV-Radio service is your business . . . serving you is ours



RAYTHEON MANUFACTURING COMPANY

Receiving and Cathode Ray Tube Operations

Newton, Mass. • Chicago, Ill. • Atlanta, Ga. • Los Angeles, Calif.

Raytheon makes all these { Receiving and Picture Tubes, Reliable Subminiature and Miniature Tubes, Semiconductor Diodes and Transistors, Nucleonic Tubes, Microwave Tubes.



Excellence in Electronics

ELECTRONIC TECHNICIAN

Including
Circuit Digests

People's Capitalism and You

Recently 12 leading Americans met at Yale University to seek a solution to a major problem facing our country today: What can be done to correct the often dangerous misconceptions about the American economic system that exist around the world?

Out of this meeting grew the concept and name to describe our free enterprise system: People's Capitalism. It is a concept of wide consumer choice in a free market, of economic enterprise conducted with regard for the public good, of broad participation in business ownership, of equal opportunity in a classless society. This is what we must make clear to many people throughout the world. Our survival may some day depend on such understanding.

Few segments of our economy so vividly demonstrate the role of People's Capitalism as our own electronic service industry. The 62,000 major service outlets which maintain this nation's more than 200 million radios, TV sets, audio and industrial electronic units were set up by electronic technicians responding to the call of economic opportunity, not government decree. Each technician is free to buy the brand of product he chooses. Each consumer is free to patronize the technician of his choice. There is nothing remote about electronic service business ownership; each technician-owner lives it every day. This is People's Capitalism at its best.

Flies in the Ointment

Of course, all is not sweetness and light in this People's Capitalism. The very fact that everyone is allowed free choice almost assures some unwise or selfish selections . . . a modest price for freedom. Over the years we have severely criticized those technicians—fortunately a small minority—whose lack of integrity, competence and initiative have kept them from functioning efficiently with regard to the public good. Their actions or inactions have been contrary to the spirit of People's Capitalism.

So too has manufacturer institution of captive service made a mockery of the grass roots spirit of People's Capitalism.

From both moral and economic viewpoints, it is the obligation of every technician and manufacturer to act in a manner which reflects the virtues of our way of life. The eyes of the world are on America's People's Capitalism.

Myopic Newspapers

It's amazing how near-sighted some newspapers can be. A case in point is a Long Island, N. Y., newspaper, but the facts apply to many newspapers across the country.

At periodic intervals this newspaper comes out with a screaming headline "exposing" the gyp tactics of TV technicians. If anyone takes the trouble to read through their articles, they will finally come across the fine print which says that most technicians are not gyps after all. Thanks for nothing.

This journalistic double-talk might irritate us only a little (some days a city editor can't find a headline H-bomb, war brink or sex murder to save himself) were it not for one additional element. In the same issue which decries gyp technicians, you find paid bait ads which offer TV house calls for \$1, or even for parts alone, labor free. We need not explain how these sucker traps make a living; every professional technician knows too well. The newspaper shares guilt for accepting these ads.

What to do? Contact the editor and publisher and acquaint them with the facts. Place your own ads only in papers which do not permit the come-on variety. If the facts warrant, don't hesitate to call on the Better Business Bureau and even the District Attorney.

In any case, buy that editor a pair of glasses so he can see that the gyms he talks about are in his own paper.

Tuning In the

1958 TV SET TRENDS point to an accent on the "Slim Look," cabinets for 21-in. sets being slimmed down to about 15 in. deep. These newly designed compact receivers are made possible by the 110° deflection picture tubes which shorten overall length. Admiral, General Electric, Hotpoint, RCA and Sylvania are among the set makers using 110's in practically all new models. DuMont, Emerson, Motorola, Philco and Westinghouse will probably carry both 110° and 90° tubes. Magnavox and Zenith will stick with the 90°. Some new 90° tubes feature short guns which cut tube length about 1 in. All RCA sets have eliminated "doghouse" on set backs. Prices should generally remain firm, with a few adjustments, mostly upwards on the order of \$10 per set. Major accent will be on 21-in. sets (including 50 to 60 lb. "portables") and 17's; 24-in. sets should show more activity, while 9 and 10 in. models may decline. Increase in color sales is in the cards, but question of large-scale sales breakthrough is debated pro and con—depending on company attitudes. Industry shakeout of some manufacturers has largely minimized fears of any future cut-price dumping. Industry will probably produce very close to 7,000,000 sets in 1957.

MAGNETIC TAPE layer-to-layer print-through, which can sometimes mar a tape in a week, is no problem for Master Audiotape. The manufacturer, Audio Devices, claims it will take more than 100 years for this tape to reach an annoying print-through level.

TOUGHER-THAN-TOUGH MATERIAL

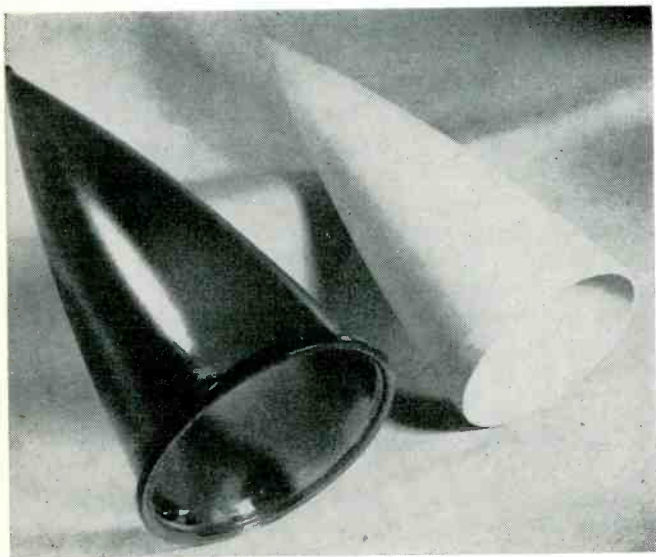

Pyroceram, a new family of materials made by Corning from basic glass substances, is heat resistant to 2460°F, harder than steel, lighter than aluminum, and has extremely low loss factor at high frequencies. Units shown are radomes—radar nose cones for guided missiles. Material opens up possibilities for new electronic and mechanical parts.

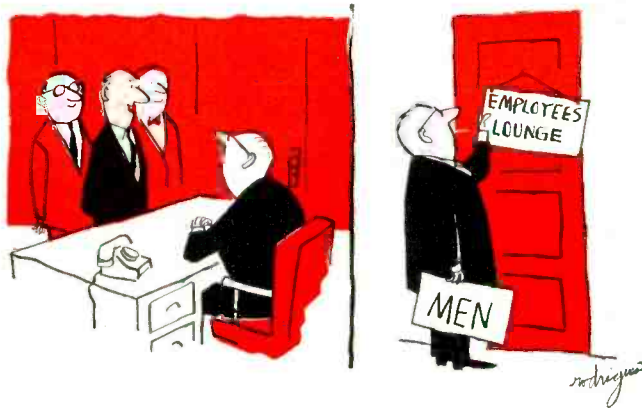

"The boys and I thought it would be nice if we had sort of an employees lounge."

FOSDIC II (no relation to the Fearless namesake of comic strip fame) is a high speed Film Optical Scanning Device for Input to Computers, developed by the National Bureau of Standards. This electronic device reads filmed images of punched cards, and searches for information in card files at a rate of over 4,000 cards per minute for a ten-column field.

AIR CONDITIONER progress in standardization is being made. Instead of one manufacturer comparing its "ton" rating with another's horsepower or square-foot coverage, 25 air conditioner producers, representing 90% of all units made, have agreed to rate their coolers in BTU (British Thermal Units; one BTU raises 1 lb. of water 1°F). One firm, Fedders-Quigan, has come up with a 9,000 BTU air conditioner (one ton, that is) which can operate on 7½ amps at 115 volts, instead of the more usual 12 amps, which often requires special wiring.

NEW SOLAR RADIO priced at only \$12.95 is being offered by Hess Brothers, Allentown, Pa., department store. Created by the Acopian Technical Co., Phillipsburg, N.J., the radio contains a lifetime solar battery which converts sunlight or artificial light to electrical energy. It also has a transistor and germanium diode. Size is only ¾" x 2" x 3".

TRUST BUSTERS in the Justice Department are asking the Federal Communications Commission to alter its restrictions which severely limit the use of microwave communication frequencies by industrial operators. Present FCC rules support common carrier use; that is, AT&T and Western Union rent their microwave services to industrials. This, say the trust busters, encourages monopoly.

Picture

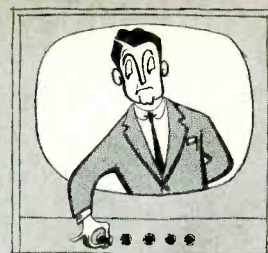

HI-FI SALES increases reported by S. I. Neiman's Hi-Fi Show News during the past 12 months are: Buffalo, 105%; Minneapolis, 90%; New Orleans, 77%; Detroit, 65%; St. Louis, 45%; Atlanta, 45%; Cincinnati, 39%; Baltimore, 29%; Los Angeles, 26%; Chicago, 23%; Dallas, 20%; New York, 18%; Pittsburgh, 17%; Salt Lake City, 11%; Denver, 7%; San Francisco, 6%; Omaha, 5%; and Kansas City, 2%. We've found more and more electronic technicians getting into hi-fi sales . . . and finding it quite profitable.

BATTERY-OPERATED TV is made possible, claims Multi-Tron Lab, by a new cathode-ray tube which operates directly from diode or transistor output, thus eliminating the video amplifier in home receivers. We may see such a set produced in 1958 if all goes well.

FERROELECTRICS, those interesting crystals used in switching circuits and memory devices, have had a new type added to their species by Bell Labs. It's called triglycine sulphate, and one of its more interesting properties is that of a rectangular voltage hysteresis loop. If you recall the usual magnetic hysteresis loop for iron, it's "S" shaped.

HEAVY COLOR TV PROMOTION by RCA in Milwaukee has reportedly boosted color set sales in that city from an average of 12 per week to 106 weekly during the campaign. Interestingly enough, some 70% of the sets sold were expensive models, not \$495 price leaders. As a byproduct of this Carnival of Color, black-and-white sales jumped 50% during the promotion.

CALENDAR OF COMING EVENTS

- Aug. 2-4: Texas Electronic Association Clinic and Fair, Hotel Texas, Fort Worth, Texas.
- Aug. 16-18: National TV-Radio-Electronic Service Industry Convention, sponsored by NATESA, Sheraton Hotel, Chicago, Ill.
- Aug. 20-23: Western Electronic Show & Convention (WESCON), Cow Palace, San Francisco, Cal.
- Sept. 24-25: Sixth Annual Industrial Electronics Symposium, Morrison Hotel, Chicago, Ill.
- Oct. 7-9: 1957 National Electronics Conference, Hotel Sherman, Chicago, Ill.
- Oct. 9-11: Fall Assembly Meeting, Radio Technical Commission for Marine Services, Ambassador Hotel, Los Angeles, Calif.
- Oct. 16-18: Institute of Radio Engineers' Canadian Convention, Automotive Bldg., Exhibition Park, Toronto, Ontario.
- Nov. 11-13: Radio Fall Meeting, King Edward Hotel, Toronto, Canada.
- Jan. 6-8: Fourth National Symposium on Reliability & Quality Control, Hotel Statler, Washington, D. C.
- Jan. 17-19: Long Island Guild Electronics Fair, Hempstead Armory, Hempstead, New York.

INFRARED DETECTION equipment, which identifies or photographs objects by virtue of the difference in temperatures between the object and its surroundings, is used in aerial reconnaissance and as jam-proof radar. Now Servo Corp. has come up with another application; it detects glacial crevasses covered by snow in the Arctic.

RETMA, the Radio-Electronic-Television Manufacturers Association has changed its name to EIA, the Electronic Industries Association.

RANDOM NOISE

TOM HIGGINS JR.

ELECTRONIC IMPORTS OF \$8,491,510 FOR RADIOS AND PARTS IN '56 WAS \$5,000,000 OVER '55
MAJOR COUNTRIES WERE:

| | |
|----------------------------|-------------------------|
| W. GERMANY...\$3,124,355 | NETHERLANDS...\$801,285 |
| JAPAN.....\$2,482,424 | CANADA.....\$788,868 |
| UNITED KINGDOM \$1,013,716 | FRANCE.....\$163,201 |

MAGNETIC PILLS SWALLOWED BY PATIENTS HELP U. OF CALIF. DOCTORS STUDY EMOTIONAL DISTURBANCES-A MAGNETOMETER TRACES PILL MOVEMENT, WHICH IS CORRELATED WITH EMOTIONAL UPS AND DOWNS

"OPERATION HEARTBEAT"

FOR STUDYING HEART AND PULSE ACTION OF WHALES EMPLOYS ELECTRONIC PICK-UPS IN HARPOONS. SIGNALS ARE RELAYED TO SHORE VIA FLOATING TRANSMITTERS

65% OF ALL CANADIAN FAMILIES NOW OWN TV SETS-FIRST STATIONS WENT ON AIR IN '52

Casebook on Peaking

In the Presence of Weak and Smearly Pictures, or Absence of

ART MARGOLIS

• A young fellow is serving an apprenticeship on our bench. After cleaning up a 21" RCA he called me over and said, "Look at this wild picture." The video was weak, jagged and smearly. An announcer's face was smeared from left to right, like running wet ink. It was a classic case of high frequency video response loss.

Since the symptoms clearly indicated peaking coil troubles I began measuring them with my ohmmeter. The third one I hit measured open instead of its usual less than ten ohms. See Fig. 1. I took a magnifying glass and examined it carefully. On one end of the unit, where the coil windings were supposed to be soldered to the resistor it is wound on, the winding was loose. I took a low wattage iron and dropped a bead of solder there. That healed the break. When I turned on the set the picture was back to normal. My helper snorted, "I thought peaking coils were supposed to be hard to service."

Unfortunately for all of us, this case history does not exemplify peaking coil problems. More often than not, by the time a TV technician zeroes in on a defective peaking coil, he has lost much time and experienced much frustration. This is due partly to the fact that peaking coils do not fail that often and the backlog of experience on them is not too great. Also these troubles

Fig. 1—Smearly picture caused by open coil.

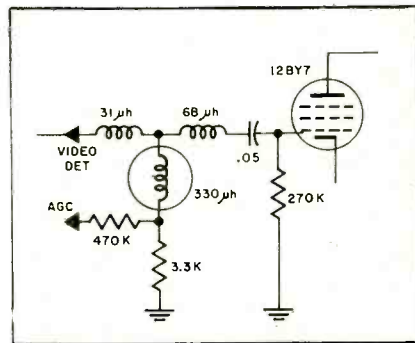
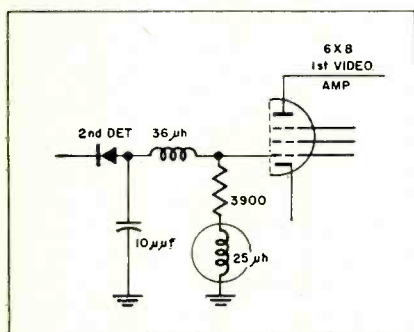

Fig. 2—A combination of agc trouble and picture smear was due to an open peaking coil.

are often intermittent, do not always show up as classic symptoms, and voltage and resistance checks do not reveal much information.

Shunt Peaking Troubles

While defective shunt peaking coils can give the classic smearly picture, unfortunately they usually show other perplexing symptoms. I had a 21" GE on the bench whose symptoms were quite confusing. When the receiver was first turned on the picture was perfect. Then as the set warmed up the picture gradually became contrasty and started to weave. After a little more time, the sync became very unstable. In addition to these primary symptoms there was one subtle secondary symptom; a slightly smeared picture. Then suddenly it would snap out of its doldrums, into perfection.

Video frequencies range from zero to 4.5 mc. In order to get a good picture all these frequencies should be passed linearly into and through the video amplifiers. However, a deterrent to the linear passage is unavoidably built into every TV set. This deterrent is distributed capacitance. It is the few micromicrofarads that exist in every tube and its input and output circuits. It is the tiny bit of capacitance that comes about when any wire is placed near a chassis. It is the invisible capacitor that is created by any capacitor's or resistor's proximity to each other and the chassis.

In most circuits these parasitic capacities are no problem. In the

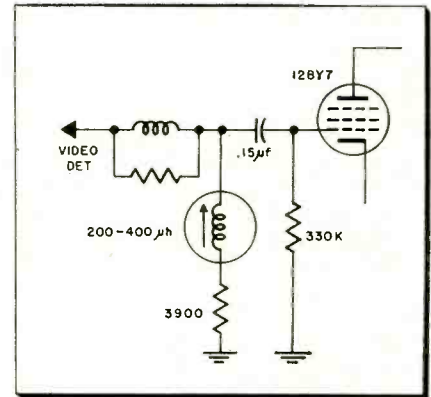

Fig. 3—Intermittent variable shunt peaker caused negative picture and phase distortion.

video circuits though, where a wide band of frequencies need to be passed they cause considerable depreciation of signal quality. Shunt peaking coils are placed in the video circuits to offset some of this difficulty. Here's how. The distributed capacity shunts the plate-load resistor. At low frequencies, this capacitive reactance, in comparison to the load resistor, is so high as not to have any effect. But as the frequencies rise toward 4.5 mc the distributed capacitive reactance decreases. As the frequency increases the reactance gradually approaches the load resistance and then becomes less. At the higher frequencies the reactance shunts to ground more of the video signal than the load resistor develops. To partially offset this effect, video plate load resistance is made lower in value. This sacrifices some gain but helps equalize frequency response. In order to keep the load resistor at a high enough value, shunt-peaking coils are inserted in the circuit to lend a helping hand. The peaking coil is designed to be of such value so that when it combines with the distributed capacity, it forms a broad resonant tank at the high frequency end. In that way, as the frequency increases the shunt reactance remains high and a minimum amount of video energy goes down the shunt drain.

In this particular GE set Model 21C104, Fig. 2, I used the tedious

Coil Problems

Audio and Video, Look to the Peaking Coil

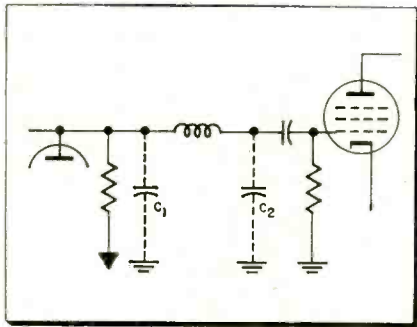
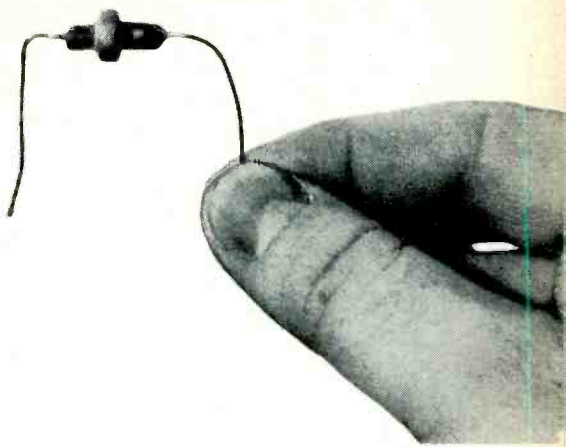

Fig. 4—Peaking coil isolates stray capacitances and forms a low-pass filter network.

substitute and wait procedure until I gradually eliminated everything except a shunt peaking coil that was intermittently opening up. Since this peaking coil was located in the age leg, it was causing age trouble as well as picture smear.

Another mixed up peaking coil symptom showed up on a 24" Philco, Model TU354. It too was intermittent. Every half hour or so the picture would go halfway negative. That is, some of the blacks would turn white, and whites would turn black, but not all of them. Also as the picture tried to go inside out sync became very unstable. To add to the troubles, after waiting for the set to act up, if I tried to make a voltage or scope reading, turn the set off or even play with the aerial, the picture would snap back to healthy performance. My only course of action was to analyze the symptoms as carefully as possible while they were occurring, then try to reproduce these antics with shorts, opens and leaks. I pitched my tent and began operations between the video detector and video amplifier.

Diode detectors inherently develop their strongest output at the middle range of video frequencies. Here again, high frequency degeneration is due to the effects of distributed capacitance. In addition to degeneration some side effects may creep into the picture also. One of these is phase distortion. For example, low frequencies may reach the grid of the CRT sooner or later than the high frequencies with a result-

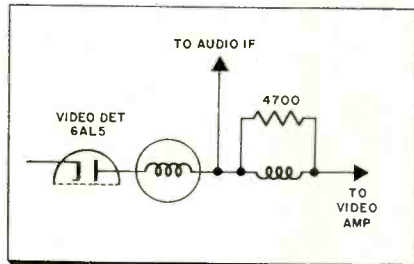

Fig. 5—Admiral Model 19L2. Both audio and video were lost as a result of a coil break.

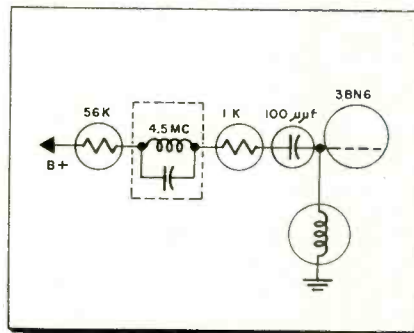

Fig. 6—Shorted 100 μ f capacitor permitted B+ to flow; which caused both resistors to burn open and the peaking coil to become shorted.

ing blurriness and negativeness in the picture. The Philco seemed to be suffering from this condition. To spread the response out linearly, lower values of detector load resistors are used as in the video amplifier circuit. Also shunt peaking coils are employed to further nullify the effects of the distributed capacitance.

As I went from part to part, opening, shorting, etc., I came to the variable shunt peaking coil shown in Fig. 3. When I opened it, the exact same symptoms showed up on the screen. A new coil eliminated this distortion.

Series Peaking

Series peaking coil symptoms are not as subtle as the shunt troubles, but they can lead you astray. They usually show up as straight-forward symptoms. For some reason or other the peaking coil always turns out to be the last component checked. The symptoms on a 21" Admiral were clear cut, no audio, no video but

good raster. I hooked up the scope with a demodulator probe and began signal tracing at the tuner output. Some video appeared on the scope. Gradually I worked my way through the if's to the input of the video detector. I changed the detector probe for a low capacitance job and continued. Across a series peaking coil between the detector and first video amplifier the video disappeared.

A peaking coil is placed in series with the detector for two reasons: One, the high inductive reactance of the coil effectively isolates the distributed capacitance on the detector output side from the distributed capacitance in the input circuit of the next stage. The lower capacitance reactance permits the use of a larger load resistor in the detector stage. Two, the series peaking coil is located between the two distributed capacitances. In Fig. 4, we can see how this arrangement resembles a low pass filter. It passes all video frequencies up to 4.5 megacycles but restricts any rf or if frequencies that may manage to get past the detector.

In the Admiral, Fig. 5, the series peaking coil had opened up, cutting off all communication between the two stages. As a check I shorted the coil momentarily. The sound and picture came through although both were deteriorated. The reason I came to the peaking coil last was the fact that both sound and picture were gone which indicated tuner or if trouble. I suppose I could have started the signal tracing procedure at the output of the second detector, thereby determining, with just one test whether or not the trouble was before or after the detector. It really doesn't matter what system is used, so long as the procedure is systematic. From more than one experience I have discovered that the

(Continued on page 50)

Solving Loudspeaker

Determine Speaker Size, Shape, Method of Mounting, Voice Coil

HERBERT F. BREIT
QUAM-NICHOLS Co.

• The most confusing problem which confronts the technician when replacing a loud speaker in a small radio set is the variety of speaker mounting methods employed by the radio set manufacturer. Some of these methods are: the old standard of attaching the speaker to the set chassis using machine screws through two of the holes in the rim or mounting flange of the speaker, or some variation thereof as shown in Fig. 1; fastening the speaker to the chassis using the two tapped holes located in one end of the magnet structure is shown in Fig. 2; and a variety of brackets may be used to hold the speaker in some particular position as in Figs. 3A and 3B.

Speakers which have been mounted by the rim or flange holes present no problem for replacement. All that is required is to consult the replacement speaker manufacturer's catalog to be certain to obtain a speaker of the proper physical size to meet the space limitations. Replacing a speaker which is attached by screws passing through the magnet structure as in Fig. 2 is a somewhat more difficult problem, which cannot be solved by using any speaker and drilling and tapping holes in the proper location. It must be remembered that although speakers are considered dustproofed, they contain a magnet which will attract the steel chips produced by drilling and tapping. These chips will somehow find their way through the dustproofing

Fig. 1—Speaker rim used as a flange mount.

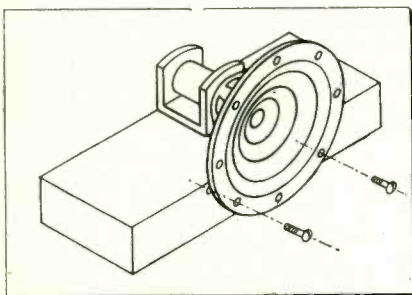

into the voice coil gap and eventually damage the speaker. Fortunately, some manufacturers of replacement speakers provide their speakers with magnet structures containing tapped holes for mounting purposes. To install this type of unit, all that is necessary is to drill new holes in the chassis to match the hole centers in the replacement speaker magnet structure.

Bracket Mounts

Probably the most difficult replacement is that which involves replacing a bracket mounted speaker. These brackets are usually welded to the magnet housing of the original speaker and cannot be used on the replacement unit. There are however, some replacement speakers which are provided with a universal mounting bracket. This is usually a flat steel strip with several slotted holes arranged so that when bent in the proper manner it will provide a method of attachment to the speaker magnet housing and to the set chassis. Fig. 4 illustrates this type of bracket, and shows some of the ways in which it can be used.

Occasionally a set manufacturer finds it necessary to use a speaker which has a segment of the mounting rim or a corner sheared off in order to squeeze a larger sized speaker into his set. This situation can present a replacement problem inasmuch as replacement speaker manu-

Fig. 2—Magnet structure fastened to chassis.

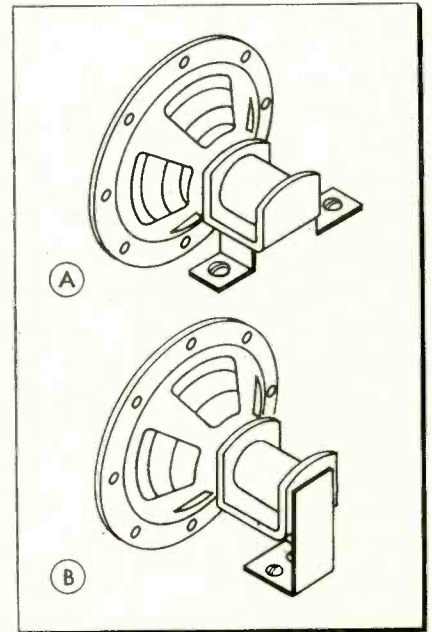
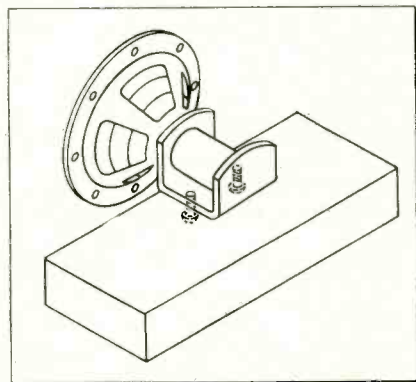

Fig. 3—Different types of bracket mounts.

facturers do not catalog such items and a standard speaker may be easily damaged if the shearing is attempted by the technician. There are however, some ways to get around this problem. One way is to use the "pincushion" version of the speaker size being replaced. Fig. 5 shows the standard speaker shapes now used. Some years ago all speakers were either square or round, therefore, a 5-inch speaker was 5-inches in diameter, a 6½-inch speaker was 6½-inches in diameter and an 8-inch speaker was 8-inches in diameter. More recently the "pincushion" type of basket has come into use. Although this type uses a standard cone, its diameter is smaller. For instance a 5-inch "pincushion" speaker is only 4⅝-inches in diameter; a 6½-inch unit is 6⅞-inches; and an 8-inch job is only 7½-inches. It can therefore be seen that in many instances a "pincushion" speaker will have small enough dimensions to be used in place of a sheared round speaker. In the case of a square speaker the flat corners may be sheared if reasonable care is taken.

If none of the above suggestions

Replacement Problems

Impedance, Size of Magnet and Phasing When Making a Change.

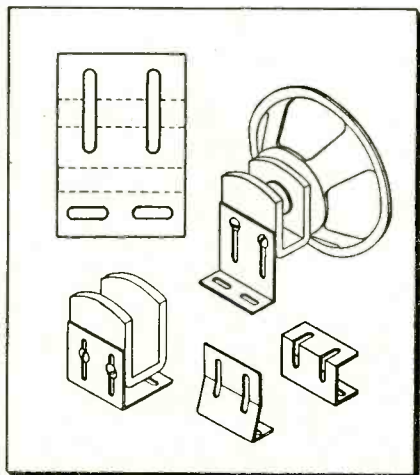

Fig. 4—Universal type of bracket can be bent to shape to fit most installations.

solve the problem, try using a slightly smaller speaker than the original. If this technique is used, be sure to compensate for the loss in performance by choosing a speaker with a larger magnet. Magnet weight is the easiest standard to use as a means of comparing speaker efficiency. Table I gives the RETMA standard magnet sizes. By measuring the magnet diameter, a technician can easily determine what weight magnet is required in the replacement speaker. The magnet diameters and lengths are usually figured in decimals but have been converted to fractions in this table, for easier use. It is always advisable, space permitting, to replace a speaker with one having a magnet as large or larger than the original speaker. Thus you will insure performance as good or better than the original.

Speaker Resonance

Some set manufacturers have used speakers with magnets smaller than the RETMA series and still obtain satisfactory results. This is made possible by using a resonance and obtaining a cone response which is closely matched to the cabinet and circuit design. When replacing such a speaker always use one with a larger magnet than the original. This will insure good results even though

the cone and speaker resonance are not the same as the original.

There are many small sets on the market today using multiple speakers which may be connected in a series or parallel arrangement and may have voice coil impedances of 3.2 ohms, 6.4 ohms, 8 ohms or some other value. It is imperative that such speakers be replaced with ones having the same or similar voice coil impedance, otherwise mis-matching will occur. Since the use of multiple speakers in small radio sets and record players is relatively new, many replacement speaker manufacturers do not catalog small speakers in any impedance other than 3.2 ohms. It is usually possible however, to obtain these special speakers directly from the speaker manufacturer, through the distributor. It is extremely simple to measure the voice coil impedance in order to provide the proper replacement. The

EIA Standard Magnet Table

| Magnet No. | Weight Ounces | Center Pole Diam. | Length |
|------------|---------------|-------------------|--------|
| 1 | .68 | 9/16 | 7/16 |
| 2 | 1.0 | 9/16 | 17/32 |
| 3 | 1.47 | 9/16 | 5/8 |
| 4 | 1.47 | 3/4 | 17/32 |
| 5 | 2.15 | 3/4 | 21/32 |
| 6 | 3.16 | 3/4 | 49/64 |
| 7 | 3.16 | 1" | 5/8 |
| 8 | 4.64 | 1" | 3/4 |
| 9A | 6.8 | 1" | 31/32 |

Table I—Measure magnet diameter to determine weight of magnet. Magnet weight may be used for comparing speaker efficiency.

voice coil impedance is only slightly greater than the d-c resistance.

If a replacement for a speaker with an unusual voice-coil impedance is not available, and if the audio output is sufficient to overcome some loss, several solutions are possible. A new output transformer could be obtained to provide proper match, but this is a little costly. Another method is to use

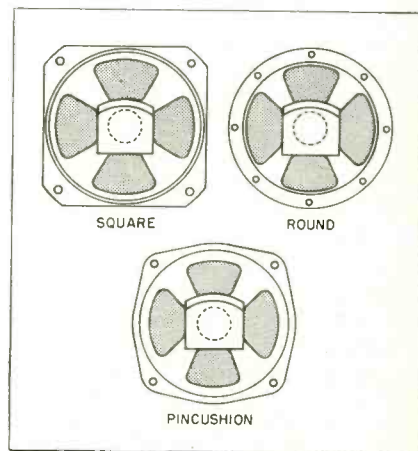

Fig. 5—The pincushion type of basket uses a standard cone and has a smaller diameter.

make-up resistors connected in series or parallel as the situation may require. Still another method consists of actually trying the closest match you can obtain and listening for ill effects such as distortion, loss of highs or lows and loss of volume. In some cases a mismatch up to 50% can be tolerated.

When connected in multiple all speakers must be properly phased. They must be connected so that all the cones will move out at the same time, or in at the same time. It is important to check this because not all manufacturers of speakers magnetize their units in the same direction. To make this check, connect a 1½ volt battery across the voice-coil terminals of each speaker. The positive battery terminal connected to the same speaker terminal in each case. If the cones all move in the same direction when the circuit is momentarily closed, they have the same phasing. If the replacement speaker cone moves in the opposite direction when so tested, simply reverse the leads to the speaker terminals and in this way correct the phasing.

Large speakers of the type that are used in consoles should offer no replacement difficulty. It is advisable however, to check voice coil impedance, magnet weight and voice coil diameter before ordering a replacement. •

Use of Printed Circuits

New Wiring and Construction Techniques Make Possible Mass Pro-

ALLAN LYTEL
ELECTRONICS LAB.
GENERAL ELECTRIC CO.

• Printed circuits are here to stay. They are being used in all types of electronic equipment including TV and radio receivers, tape recorders, audio amplifiers, test equipment, digital computers, guided missiles, etc.

Manufacturing and design techniques can be held to closer tolerances as a result of the printed circuit. Many a fine circuit has been kept from the production line in the past because production tolerances exceeded the engineers' specifications. As quick as a bug can be removed from a new gadget, that is how fast a new and better design is attempted. Stray capacitance, heretofore a relatively unpredictable

characteristic which could vary widely from set to set, is now within controllable and predictable limits. Electronic circuits are being called upon to operate in all kinds of environments. Many military and industrial demands are being met only because of progress made in this type of wiring technique. As equipment is amortized and new techniques developed, the consumer will benefit from lower selling prices and more dependable equipment.

Some of the latest developments include circuits which will operate above 1000° F. Many technicians may be surprised to learn that with proper tools and techniques it requires less time to change even a major component on a printed circuit board than it does in a conventional wired chassis. The term printed circuit is very loosely and broadly

Fig. 1—Several stages in the assembly of an AC/DC radio using conventional tubes and parts.

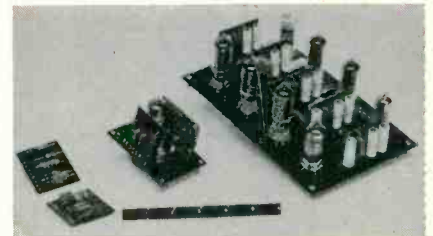
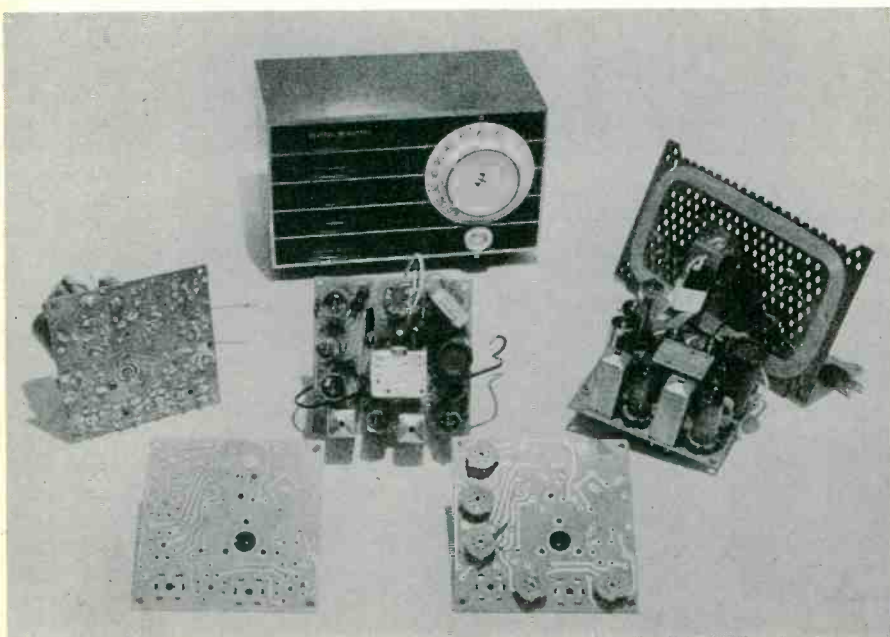

Fig. 2—Modular type construction uses regular components mounted on a printed board.

applied to include all circuits wherein conventional wiring and components are substituted for by other processes variously known as etched, plated, ceramic based, stamped, embossed, metal sprayed, and many other molded types.

The use of transistors in printed circuits is a natural combination and is a major factor in miniaturization. Fig. 1 illustrates several stages of construction of a small table radio. A single board serves as the chassis. All the parts of the receiver, except the speaker and loop antenna, are mounted directly on the board. Both sides of this particular board contain printed wiring. Some boards are wired on one side only. Note the mounting of the tuning capacitor and the volume control. The printed circuit has far from reached the end of its possibilities.

Modular Construction

A different type of construction is shown in Fig. 2. There are 3 different sizes of boards. The smallest units, on the left, each hold a group of components. The one in the center is larger and contains a tube socket and 2 smaller component boards, which in turn can be mounted on a still larger board. The board on the right has 8 tubes and 5 smaller component boards. The smallest component board may be considered as

in Modern Electronics

duction, Quality Control and Mechanization of Electronic Industry.

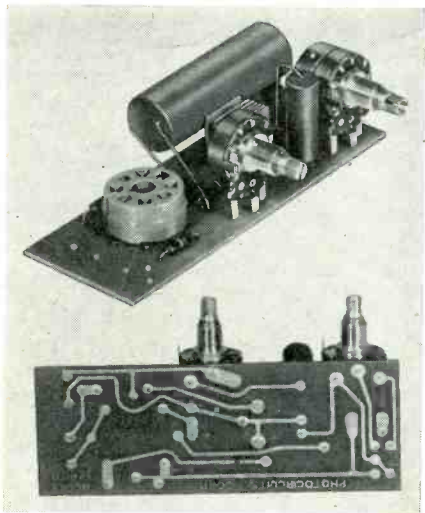

Fig. 3—Simple 1-tube audio amplifier complete with tone and volume controls; uses a 1-sided wiring board and conventional components.

one unit or module. A defect traced to a particular board requires the repair or replacement of the unit. Where the components are conventional, the defective coil, capacitor or resistor itself may be replaced. However many modules, including printed circuits or encapsulated to resist atmospheric conditions. If this should be the case, then the entire unit is replaced in the event of a defect.

Several additional examples of printed circuit applications follow. Fig. 3 is a one-tube audio amplifier. Note the extreme simplicity of the board. A portable transistor radio is shown in Fig. 4. A more complex circuit for a tape-recorder is shown in Fig. 5. Because this is a single sided board, jumper wires are used to accomplish some connections. Fig. 6 shows a portable radio using a combination of conventional components and a module. Each layer within the module contains printed components, and a tube enjoys a penthouse view.

High Temperature Printed Circuits

Many types of military electronic equipment are required to operate in situations where the temperature



Fig. 4—Personal portable radio using printed wiring enables small size and lightweight.

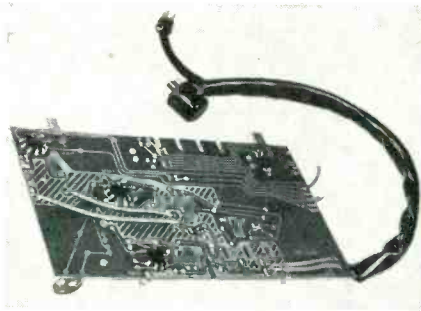

Fig. 5—Printed board used in tape recorders. Single sided wiring requires jumper wire.

is well over 1000° F; guided missiles, for example, experience high friction heat as they enter the earth's atmosphere. Ordinary components require a great deal of cooling apparatus to prevent breakdown and in some cases melting. Electronic equipment which could operate at these elevated temperatures would eliminate the need for cooling and

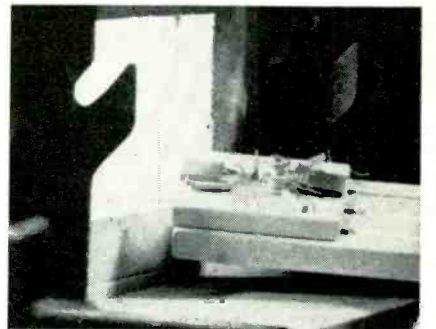

Fig. 7—Top: red-hot receiver still plays, Bottom: Printed circuit about to enter furnace.

would be valuable in reducing the weight and increasing the payload, especially in airborne equipment.

Laboratory demonstrations of high-temperature circuits have been made recently. Fig. 7 shows a radio receiver operating while "red hot." Three blowtorches are being played on the Pyrex glass jar which con-

(Continued on page 47)

Fig. 6—Portable radio employs a printed circuit board, conventional components and a module.

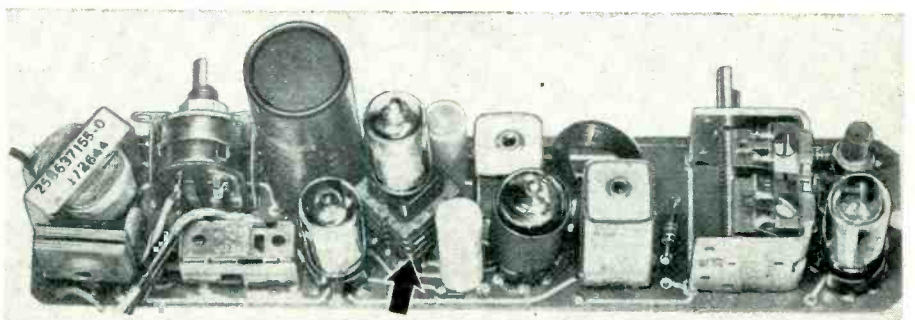

Why Special Tubes For

Controlled Warm-up Time and Reduced Surges Causes Fewer Burn-

VERNON H. RITTER

• Quite a while back (at least ten years ago) series strings were tried in a few TV receivers. "What was wrong with them then? What's so different about these new series string tubes? And what is the meaning of heater warm-up time and heater current?" These are just a few of the questions that have been asked since the introduction of series string tubes in TV receivers.

The vacuum tube heater is not a tremendously difficult thing to understand. To supply enough heat for the cathode, it must be able to develop a temperature of 1125° C or more. At present the three conducting materials which can be drawn into wire, able to withstand the high temperature continuously, and be cycled on and off are tungsten, molybdenum, and tungsten-molybdenum alloy. Of these, tungsten is by far the best and is the one most used, especially in picture tubes. Tungsten-molybdenum alloy is used in some receiving tubes. Molybdenum is very seldom used because of its tendency to become brittle and break. After the wire is drawn to proper thickness, it is either coiled or folded and then in-

Fig. 1—Folded tungsten heater mounted sleeve has positive temperature coefficient.

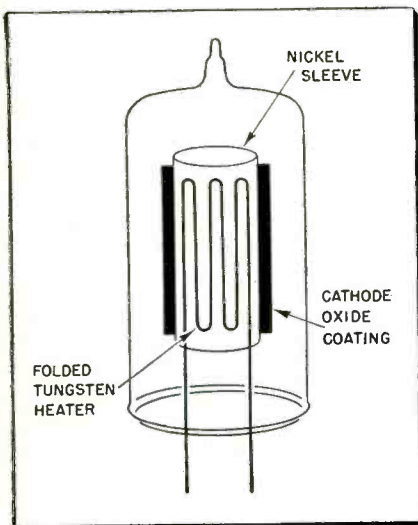

Table 1

| Heater Voltage Rating Volts | Resistance in Ohms | | |
|-----------------------------|--------------------|------------|------------|
| | Usual Cold Range | 600 MA Hot | 450 MA HOT |
| 25. | 4. to 12 | 41.7 | 55.5 |
| 17. | 3. to 10 | 28.4 | 37.8 |
| 12.6 | 2. to 8 | 21.0 | 28.0 |
| 8.4 | 1.5 to 6 | 14.0 | 18.7 |
| 6.3 | 1. to 4 | 10.5 | 14.5 |
| 4.7 | 1. to 3 | 7.84 | 10.4 |
| 4.2 | .5 to 2.5 | 7.00 | 9.33 |
| 3.15 | .4 to 2 | 5.25 | 7.00 |
| 2.35 | .3 to 1 | 3.92 | 5.22 |

sulated by coating it with a mixture of aluminum oxide and a bonding material. The characteristics and thickness of the aluminum oxide determine the heater-cathode breakdown potential. Fig. 1 shows a folded heater inside the cathode cylinder of a typical receiving tube.

Hot and Cold Resistance

The type of wire used in making heaters gives them a characteristic common to all—the cold resistance is much lower than the hot resistance. And, as will be explained later, this characteristic led to one of the great difficulties of the series string. Table 1 indicates the usual range of cold resistance for various heaters along with the hot resistance for 600 ma and 450 ma heaters.

A typical early television string is shown in Fig. 2. In practice this type of string was found to give a high number of heater burnouts for two main reasons: excessive warm-up surge voltage on certain heaters, and, or, excessive steady state voltage. The warm-up surges resulted because of the wide variation in the rate of heater warm-up from tube to tube. In other words, if a heater reached its final hot resistance much faster than the others in the string it then absorbed more than its share of the string voltage until the other heaters could warm up and begin taking their share of the voltage. Surges as large as four times the rated voltage have been measured on an especially fast heating tube in a string of this type. The wide variation in heater hot resistance origi-

nally used in tube manufacture caused the excessive steady state voltages. Steady state voltages of nearly double have been measured on a tube with excessively high hot resistance.

On April 24th, 1954, Frank Roberts presented a paper before the Institute of Radio Engineers in Cincinnati, which showed that in order to reduce the voltage surges in such a string it was necessary to manufacture both receiving tubes and picture tubes with nearly identical heater warm-up times. He recommended a circuit for measuring the warm-up time and specified the test conditions for several different types of heaters. The test circuit is shown in Fig. 3. The warm-up time of a tube is defined as the time necessary for the heater to reach 80% (V_1) of its final value in the test circuit from a cold start. E is the applied voltage and is specified as approximately four times the rated voltage of the heater. R is the total series resistance and is specified as approximately three times the rated hot resistance of the heater. Mr. Roberts also indicated that warm-up times ranging from 9 to 14 seconds would be desirable. Using these definitions and keeping in mind that E_r is rated heater voltage and I_r is rated heater current,

Fig. 2—Typical early type series string.

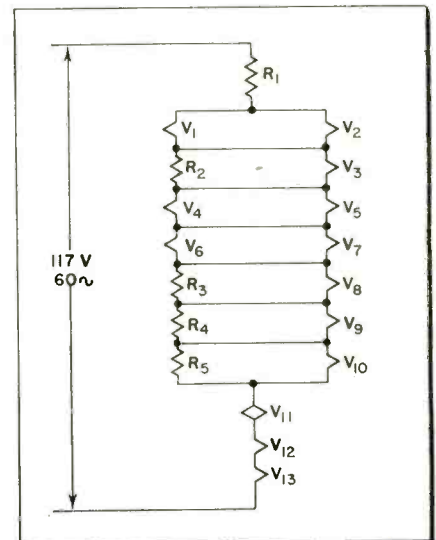

Series String Operation?

outs. Standard Circuit and Methods Used To Make Heater Tests.

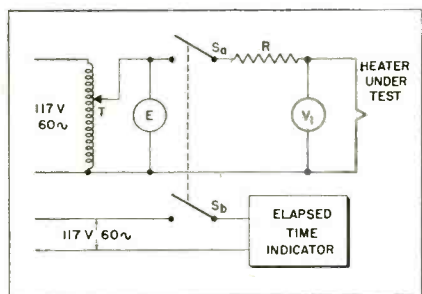

Fig. 3—Circuit used to find warm-up time.

the specifications shown in Table 2 were set up.

Since that time the test circuit and the specified values have been adopted as the standard for the industry. However, the center value for heater warm-up time has been set at 11 seconds and the first group of tubes manufactured were 600 ma type. Recently a group of 450 ma

Table 2

| E_p Volts | I_r MA | E Volts | R Ohms | V_1 Volts |
|----------------|-------------|------------|-----------|----------------|
| 6.3 | 300 | 25 | 63 | 5 |
| 12.6 | 300 | 50 | 126 | 10 |
| 25. | 300 | 100 | 252 | 20 |
| 6.3 | 600 | 25 | 31.5 | 5 |
| 12.6 | 600 | 50 | 63 | 10 |

tubes have also been developed. This heater warm-up time is not the time required for one of these tubes to heat up in a series string but, as defined, the time for the heater to reach 80% of its rated voltage in the test circuit. It is a measured property of the heater in the same way that heater current is a measured property. It should be noted that the heater current, and therefore the hot resistance, is being held within much tighter limits—about $\pm 5\%$ —to insure an even steady state voltage distribution in the series string.

Using all controlled heaters it is now possible to construct a series string in which the warm-up surge on any one heater is kept within the tolerable limit of 1.5 times rated voltage, the steady state voltage is kept within the desired limit of $\pm 10\%$, and no heater is shunted by

another heater or resistor. Thus, fewer heater burnouts result, giving longer trouble-free service in series string TV receivers. Fig. 4 shows a typical series string using 600 ma tubes and Fig. 5 shows a typical string using 450 ma tubes.

Voltage Ratings

It is interesting to note how the voltage ratings for these heaters came about. It was necessary to have approximately the same power in the heater of the series string tube as in its prototype so (using a 600 ma example) the current rating of each heater was placed at 600 ma and the voltage changed to give the proper power (heater power=heater current x heater voltage). For instance: the ratings of the 6CB6 are 300 ma at 6.3 volts (1.89 watts). These were changed to 600 ma at 3.15 volts (1.89 watts) for the 3C6B.

Much data has been obtained from cycled life tests of these tubes. Many strings have been operated on a cycle of two minutes on, and 18 minutes off for over 4,000 cycles. This is roughly equivalent to 8,000 hours of operation in so far as the off-on operation is concerned. Since 2,000 hours per year is considered normal

Fig. 4—Series string using 600 ma tubes.

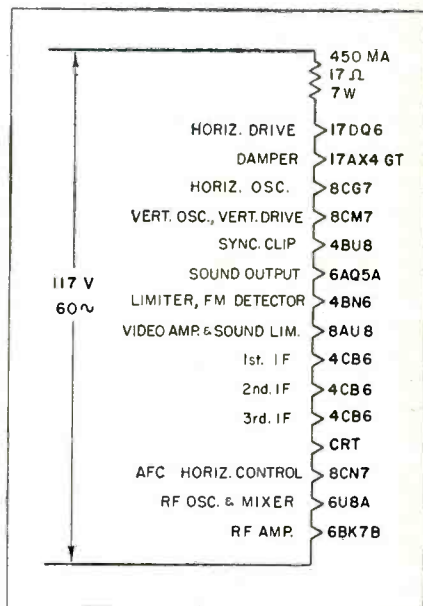
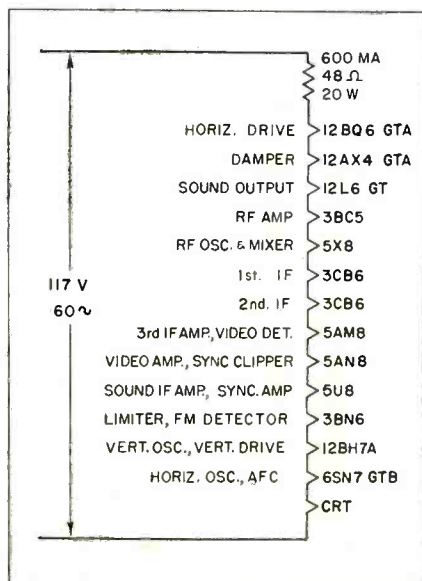
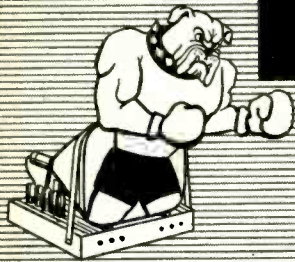

Fig. 5—Series string using 450 ma tubes.

operation for a receiver in an average home, these tests indicate little trouble from present series string designs. •

Series string using 600 ma tubes

The chances of burnout have been greatly reduced. However, the problem of determining which tube heater is out in a series string still exists. All sorts of devices have been tried. The tube checked and tube substitution techniques may be employed but these are time consuming. The best consistent labor saving method is to use the ohmmeter. Most set makers now show the heater circuit on the tube layout label in the back of the receiver. Refer to this diagram, remove the tube in the center of the string (usually the video amplifier), take a reading to ground. The side showing open or unusually high resistance is the one to track down. Thus in one test, half the tubes in the set have been eliminated. The next test point would be to pull the tube in the middle of the defective half of the string. In an 18-tube string the maximum number of checks before a defective tube is isolated is 5, and it is possible to find it in only 4 moves. •



Tough Dog



Corner

Difficult Service Jobs Described by Readers

Loud Pop and Thin White Line

A modified large screen 630 chassis was pulled into the shop for an extensive overhauling. With the repair complete the set was given a thorough air check and delivered. Everything went along satisfactorily for three days. When the customer called to say that, while watching the set, he heard a large popping noise and the picture shrank into a thin horizontal line.

The repair looked easy. The 6SN7 vertical oscillator tube had an open filament and a new one quickly restored the picture. We sat down and watched the set perform a while until we were convinced everything was normal. Again everything went along fine for a few days and again the customer was on the phone with the exact same complaint—loud pop and thin white line.

In exasperation the set was hauled back to the shop and looked over again. Another new 6SN7 was needed. This time we studied the circuit very carefully, to try to figure

out what was causing these sudden failures. Evidently what was happening was that on occasion the tube cathode was firing across to the filament accounting for the pop and the burned out filament. Since the set worked fine once the tube was replaced all the voltages checked normal. The only one that was a bit off and that might have been a cause of the trouble, we thought, was B- which read -115 volts instead of the usual -100. A check with the tube manual showed that the maximum allowable voltage difference between cathode and filament of a 6SN7 is 100-v dc when the filament is positive in respect to the cathode. Since the cathode of the vertical oscillator tube was tied directly to B- and the filament was at practically ground potential was it possible, we wondered, that the extra 15 volts was causing the breakdown.

Working out the tube current drain we placed a resistor and bypass condenser in series with the cathode lifting it off B- and in

effect putting the cathode at a -90 volt potential. This, we thought, would eliminate the tendency for the cathode to bridge the gap to the filament. The set tested fine for five days so again it was delivered, quietly complimenting ourselves on a job well done.

More trouble

Our feeling of pride was short lived, however, because two days later another call was in. That old familiar pop was heard and this time there was nothing at all on the screen not even the thin white line.

This time, at least we got a little variety—the 6SN7 horizontal discharge tube had an open filament. In spite of the monotony we took the set into the shop again. Once we studied the horizontal circuit we noted a fact that was overlooked before. The discharge tube cathode was also tied direct to B- and so was subject to the same type of failure as was being experienced with the vertical oscillator. In view of this we abandoned our former theory as to the cause of trouble and searched for another.

Could it be possible, we asked ourselves, that one of the B- bleeder resistors developed an intermittent open? And if so wouldn't an excess voltage pile up on the B- bus in that instant? And then wouldn't that horde of electrons look for an escape and force itself through any convenient gate?

The answers to all three questions was yes. Doctoring the vertical oscillator circuit did not eliminate the trouble but merely shifted the site of tube breakdown to the horizontal section. We replaced the complete B- bleeder network and haven't had trouble since. *Frank A. Salerno, Long Island City, N.Y.*

Modified large screen 630 chassis had an intermittent bleeder network.

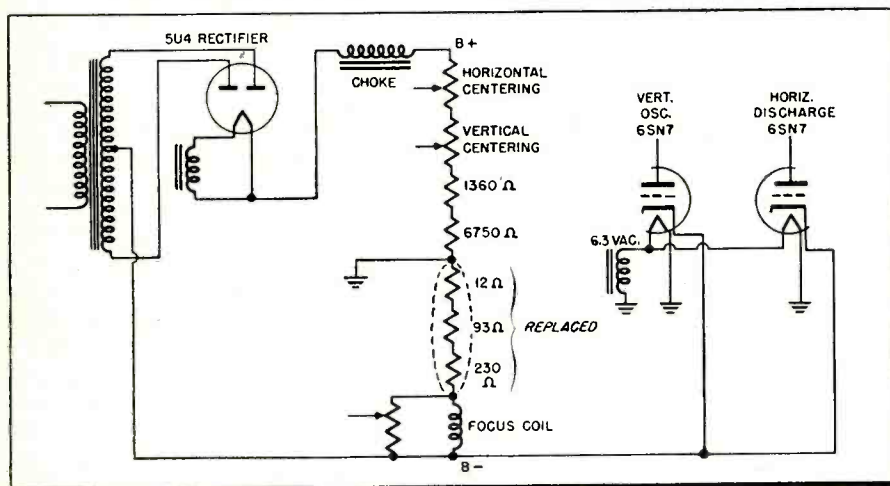

You and the Law

Employer's Responsibility For Employee's Acts

FLOYD WILKINS JR.
Member, New York Bar

• This article might be called "When is an employee an employee." The problem is how to meet the all too frequent situation where an employer is charged by a third person with responsibility for harm to that person or his property due to an accident occurring while the employee is engaged in business or pleasure at least partly for himself. Such a situation arises in a number of ways; many could occur in the technician's business, particularly in view of the great need to use an automobile or truck. This problem is illustrated by cases where the employer has been held liable for injuries caused by his employee while on a "detour" or otherwise serving his own purposes as well as those of his employer.

An Illinois driver having delivered some equipment, was returning to the store to leave the truck for the night. A fellow employee persuaded him to leave him at a nearby tavern. The driver went home but returned to the tavern, picked up the employee and drove him to a second tavern. Several hours later while returning to the store the truck collided with a car causing injuries for which the employer had to pay.

No Riders

In New Jersey a driver stopped his employer's truck for a child who had been injured. He took the child, intending to leave him at the hospital on his way, but the truck collided injuring the child further. The driver was held to be acting within the scope of his employment. Even the sign on the truck saying "No Riders" did not change the result.

An employer's rule forbidding employees from carrying passengers was not enough to avoid liability for the death of an employee's passenger. The effectiveness of this rule was overcome by frequent violations known to the employer, who did nothing about them. But for the passenger the trip would not have been made until the next day. How-

ever, the court applied the general rule that an employee's act may be within the scope of employment even though he did it to serve his own purpose or that of another.

Finally there is the employee, while proceeding on his employer's business, who stopped to chat with a young lady. Upon learning that she was going in the same general direction, he offered her a ride. She being in no hurry, he first took care of his employer's business. The accident occurred shortly thereafter. The court held that he was still engaged in the employer's business at the time of the accident.

Scope of Employment

Other cases indicate that if the employee had driven in the opposite direction to deliver the young lady to her destination, had no business for his employer in the vicinity and intended not to transact any, he would have been outside the scope of his employment at the time of the accident. But just as an employee may leave the scope of his employment for a personal errand, he may return after completing it. That is the lesson of the case of the Illinois truck driver.

As one must have gathered from reading this far, the employer is liable to third persons for injuries caused by the wrongful acts or omissions of his employee occurring within the scope of employment. There is a qualification to this general rule, namely, the employee must be known as a servant. This does not mean that he is a butler or gardener; it means that the employer has the right to control the employee's physical conduct in performing services for the employer. It is assumed that the reader is concerned only with employees in this class. Once one finds that the employee is a servant, the next question is, Was he within his scope of employment, that is, was he acting as an employee at the time he caused the injury? Except in the clearer cases, this is a question of fact for the jury to decide. However, we do have some guiding principles.

One principle is that the employee's conduct must be of the same



general nature as the work authorized by the employer. For instance, a technician whose sole duty is to inspect and repair sets in the home is not authorized to drive to the same home to sell a set. However, if he intends to sell a new part or attachment to make the set work better or to correct a condition he found during his inspection, he probably will be within the scope of his employment. This would be so even though he had been forbidden to sell anything, because there is a second principle to the effect that although an act is forbidden it may be within the scope of employment.

Liability Insulation

A number of factors are to be considered in deciding whether an employee acted within the scope of employment. Knowing these factors, one can adjust his method of operations and the duties of his employees so as to reduce the scope of employment of each which in turn reduces his chances of incurring liability. It is recognized, however, that this suggestion attempts what is ideal only from the legal point of view. The businessman cannot insulate himself from all liability, certainly not from all attempts to hold him responsible for his employees. Therefore, these factors are discussed with the realization that they will be tempered by the needs of each reader's business.

First, is the act one commonly done by this type of employee? For example, is it the practice for a technician who does nothing but analyze and repair sets in the shop to drive to answer emergency calls? If he does, there is strong evidence that the employee is within the scope of his employment when something happens while answering such a call.

Second, when did the act take place? During working hours? On the way to or from work? After an

(Continued on page 34)

MALLORY Clippings

P. R. MALLORY & CO. INC.

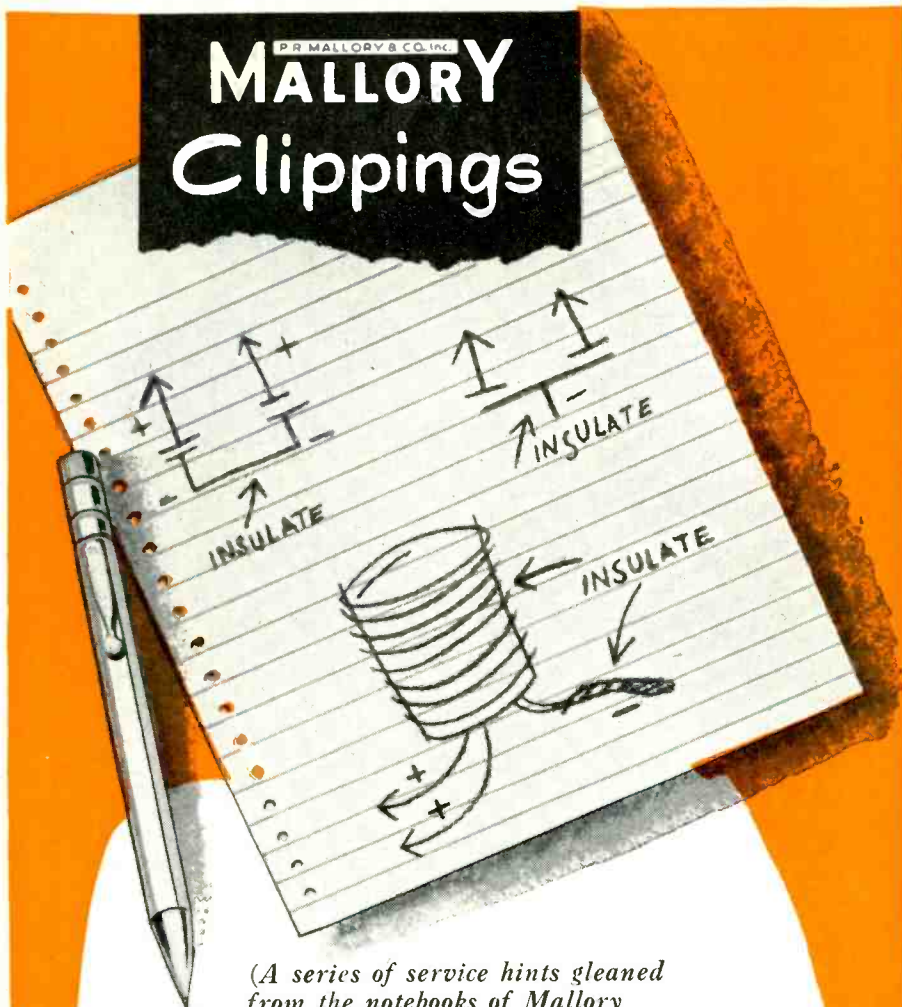

(A series of service hints gleaned from the notebooks of Mallory design and application engineers)

Once in a while, on some special service job, you're apt to need a *non-polarized* capacitor. Here's a way to make temporary repairs until you can get down to your distributor's for a Mallory replacement.

Use a common negative dual capacitor, each section having the *same* voltage rating and *twice* the capacity rating as the unit being replaced. Use the two positive leads *only*—don't connect the negative lead (or the can) to anything, just insulate them well!

Assuming sufficient physical space, the same thing can be done with two single capacitors—by connecting the negative leads together and insulating them, and the cans, carefully. Use the two positive leads.

Of course, for an exact replacement or temporary repairs such as above, you ought to use Mallory FP Capacitors. They're tougher, longer lived, and plenty dependable—but, you probably know that from experience. See your Mallory Distributor today—lay in a working replacement stock.

P. R. MALLORY & CO. INC.
MALLORY

P. R. MALLORY & CO. Inc., INDIANAPOLIS 6, INDIANA

Capacitors • Controls • Vibrators • Resistors • Switches • Rectifiers
Power Supplies • Filters • Mercury and Zinc-Carbon Batteries

You & the Law

(Continued from page 33)

evening party? While on vacation? The first clearly is the strongest evidence that the act was within the scope of employment. But time alone is not decisive; in fact, no one factor is decisive.

Third, where did the act take place? Upon leaving or entering the employer's place of business? En route to or from one or more repair or installation jobs? While driving a friend to his home?

Fourth, what was the employee's purpose at the time of the act? Was it to further the employer's business or the employee's convenience? Here the answers are clear, but what about where the purposes are mixed? The answer then depends on other factors. In any case the employer cannot create a state of mind for the employee, except as the latter's actions tend to be trained by the employer's rules.

Fifth, was the act related to the employer's business, regardless of what the employee intended? Nothing can be done to vary this fact; it varies with the business. But the employer can make clear what aspects of the business are not to be handled by any employee.

Sixth, could the employer foresee that the act would be done? Most important here is whether the same or any other employee has gone on similar excursions even though no harm resulted. Some deviation in routes can be expected. Personal use of the employer's vehicle also seems likely. In this area the employer can do little more than restrict the use of the vehicle. However, if for convenience or employee relations a car is available to the employee, the scope of his employment tends to be extended, although not to the point where a purely personal trip is within the scope of employment.

Seventh, whose car is used? Standing alone the fact that the car or truck is furnished by the employer is not conclusive. Of course, where an employee uses his own car for the employer's work and is reimbursed, the result is the same as if the employer furnished the car.

Eighth, was the employee's act a crime or a serious wrong? The employer must expect some lawbreaking but not serious infractions. For

(Continued on page 53)



Audio NEWS LETTER

UNIVERSITY LOUDSPEAKERS reports good response to its new discount, Promotion and Profit Participation Plan. Among features are maximum discounts for items normally ordered in small quantities, and "dividends" for promotional activities.

HIGH FIDELITY SHOWS scheduled by RIGO ENTERPRISES this fall are Cincinnati, Sept. 6-8; Miami, Oct. 18-20; Portland, Ore., Nov. 1-3; Seattle, Nov. 8-10; St. Louis (exhibit rooms already sold out), Nov. 22-24.

UNITRONICS (Bogen, Presto, Olympic) has merged with SIEGLER CORP. and HUFFORD CORP. The new firm expects \$75 million annual sales, and will retain the Siegler name.

MINNESOTA MINING has issued a 12-page glossary of 99 hi-fi and tape recording terms. Available free from 3M at Dept. M7-177, 900 Bush St., St. Paul, Minn.

DEWALD has entered the hi-fi components field.

H. H. SCOTT has appointed Mike Roth Sales as hi-fi component rep in Ohio, Western Penna. and W. Va. territory.

STROMBERG-CARLSON division of General Dynamics has come up with a sound system especially designed for motels and hotels. Latest installation at the 44-room Trenholm Motor Lodge, Rochester, N. Y., incorporates radio, records and paging. It is offered on a lease plan whereby the system, including installation and service, is procured with no down payment.

SHURE BROTHERS has appointed Raymond E. Ward distributor sales manager.

Tops in performance and value for today's growing market...



Mallory Mercury Batteries...

To get your share of the growing, profitable battery market—sell the batteries that helped make the new transistor radios possible. Amazing Mercury Batteries, pioneered by Mallory, lead all others in small size, long life, fade-free performance. No wonder they're the leading choice of set manufacturers and distributors!

Mallory Mercury Batteries stay at full strength for months on the shelf. They last far longer and cost far less per hour of use. They deliver the unequalled performance that builds repeat sales. And they're backed by consistent Mallory promotion and strong Mallory advertising in the Saturday Evening Post, Time, Newsweek and Business Week.

Get full facts today from your Mallory distributor, on the TWIN-LINE of Mallory Mercury and Zinc-Carbon Batteries... leaders in profit and performance for both transistor and vacuum-tube portable radios.

For vacuum tube radios—Mallory Zinc-Carbon Batteries.

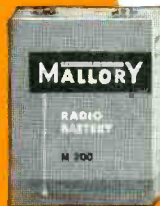

- Capacitors
- Vibrators
- Resistors
- Power Supplies
- Mercury and Zinc-Carbon Batteries
- Controls
- Switches
- Rectifiers
- Filters

P. R. MALLORY & CO. Inc.
MALLORY

P. R. MALLORY & CO. Inc. INDIANAPOLIS 6, INDIANA

TV Radiation Scare

• A good example of what happens when electronic laymen attempt to interpret technical matters came up last month. In an address before the Radiological Safety Conference, Dr. James B. Kelley, industrial consultant for the New York State Commerce Department, warned that the use of boosters to pep up aging TV picture tubes might be harmful to home owners. These boosters, said Dr. Kelley, increased typical high voltage from 15 kv to 30 or 40 kv, causing more penetrating rays. Medical X-rays start at 50 kv.

Unfortunately, newspapers picked up this bit of misinformation, probably causing some consternation among viewers who have boosters on their sets. What Dr. Kelley failed to understand is that there are two types of boosters, neither of which function under high voltage. The signal strengthening type of booster for fringe areas is basically an r-f stage. The picture brightening type of booster is a simple transformer arrangement which raises CRT filament voltage from say 6.3 volts to perhaps 7.5 or 8 volts, thereby increasing electron emission from the cathode to its original level. High voltage does not enter into it. Those rarities where a completely new 30 kv high-voltage system has been substituted for the 15 kv section are too few to consider.

Subsequent to the newspaper pub-

lication of the misleading information, at least one paper came out with the correct explanation. Any improbable "mild X-rays" generated by TV sets would be absorbed by the face of the tube and the safety glass plate, but boosters have nothing to do with this. The whole confusing booster situation, no doubt frightening to many TV owners, particularly those parents whose children sit close to the screen, could have been avoided. All Dr. Kelley or the newspapermen who reported his talk would have had to do was check the facts with the nearest TV expert at hand . . . the local electronic service technician.

Worthwhile Investigation

Perhaps the above "case of the deadly booster" has not been in vain. There is a serious question which deserves scientific scrutiny, and if the publicity encourages someone to investigate TV radiation, a public service will have been performed.

Scientists have found that the effects of nuclear radiation are cumulative. That is, two hours of exposure to 0.1 roentgen is about the same as one hour of exposure to 0.2 roentgen.

Now we know that picture tubes at 15 kv give off some small radiation. This warning is even affixed to some tubes. It is generally believed that a completely negligible amount

of radiation is received when the safety glass is in place, and the viewer is six or more feet away, watching one set only a few hours a day.

However, consider the TV technician who may work right next to several operating sets for 40 or more hours per week, almost every week in the year, without benefit of safety glass. The radiation starts to add up. According to several picture tube authorities, the total radiation is still negligible, and 10 years of experience tends to bear them out. Nevertheless, none would deny that it is conceivable for long range effects to occur (e.g., possibly shortening life span a year or two) which are beyond our present scope of understanding.

As color TV gains momentum, any possible problem existing today may be multiplied since color sets employ higher voltages, and higher voltages in the 15 to 30 kv range certainly mean stronger radiation.

To the best of our knowledge, no injuries directly traceable to TV radiation have been uncovered, so TV technicians should be able to work with continued peace of mind. Neither have we seen any exhaustive research study of TV radiation, excluding electromagnetic radiation.

The electronic industry—indeed, a nation of TV owners—would welcome such a study. •

Right Or Wrong In Labor Relations

A roundup of day-to-day employee problems and how they were handled. Each incident is taken from a true-life grievance which went to arbitration. Names of some principals involved have been changed. Readers who want the source of any of these case histories may write to ELECTRONIC TECHNICIAN.

WHEN CAN'T YOU FIRE AN EMPLOYEE FOR REPORTING TO WORK DRUNK?

What Happened:

When Jim Benson turned up for work Christmas Eve morning, the boss thought he'd "had a few." There was alcohol on his breath, his eyes were bloodshot, his speech was slurred and he weaved when he

walked. All in all, the boss didn't think Jim was fit for work that day. He didn't make a big production of it—just told Jim to go home. Jim went. When he returned to work on schedule three days later, he was told that he had been fired as of Christmas Eve for reporting to work drunk. Jim insisted his firing was unjustified:

1. I hadn't been drinking. I'd taken some medicine for a cold, that's all. And my eyes are always bloodshot because of an accident I had a few years ago.
2. The boss should have told me right then that he thought I was drunk and that he was going to hand out a penalty. Not three days later, when I don't remember who I met on the way out who could be a witness that

I was cold sober.

3. I'm 55, and I've been with the company for 12 years. At my age, getting 'canned' is pretty darned serious, and it shouldn't be done to me without more proof.

Usually, if they think a man is drunk, they let other people see if he is drunk.

The boss didn't see it that way at all:

1. The counterman thought Benson was drunk, too. Neither of us was born yesterday. We've had plenty of experience, and we know when a man is drunk and when he isn't.
 2. Benson had been warned for drinking before. He'd also had a five-day layoff for reporting out sick when all the time he
- (Continued on page 54)

Mockups For Two-Way Radios

Mockups Enable The Technician To Remove Only The Unit To Be Bench Tested. Cables and Other Accessories Are Left Intact.



Fig. 1—Mockup harness in use on an RCA CMC-3E1, enables bench check.



Fig. 2—Assorted mockups for troubleshooting different 2-way radios.

JACK DARR

• The technician working with two-way radio will usually find that most troubles can be cleared up without removing the sets from the vehicle. However, there will inevitably be times when the receiver or transmitter must go to the bench, for more detailed tests or measurements. Therefore, some means of actually operating the set, both the transmitter and receiver, must be provided for on the work-bench.

Almost all of these sets are remotely controlled. The sets themselves may be located in the trunk, under the seat, behind the seat, etc. The control box is usually mounted on the dash within easy reach of the driver. In order to operate the set, either the entire cable network and control box must be removed from the vehicle, an obvious laborious and expensive procedure, or a suitable substitute set of controls may be used on the bench. Those who worked on Air Force radios during the War will remember the "mockups"; a complete set of equipment for each type radio, complete with all plugs and harness, and power supply, mounted on each test bench. This type of operation, while handy, is somewhat beyond the financial

reach of most service shops, so we must look for a more economical method.

There are 4 basic functions which must be duplicated in a mockup: for receivers, a power supply and switch, volume control, squelch control, and a speaker connection;

for transmitters, a power supply, modulation, keying, and a dummy antenna will be enough. Quite often the transmitter will have a microphone socket on its chassis thus eliminating the need for this in the mockup. Some sets have only a keying switch. When designing a mock-

Fig. 3—Proper test equipment is a prerequisite. Speed, accuracy, profit and pleasure are the rewards.

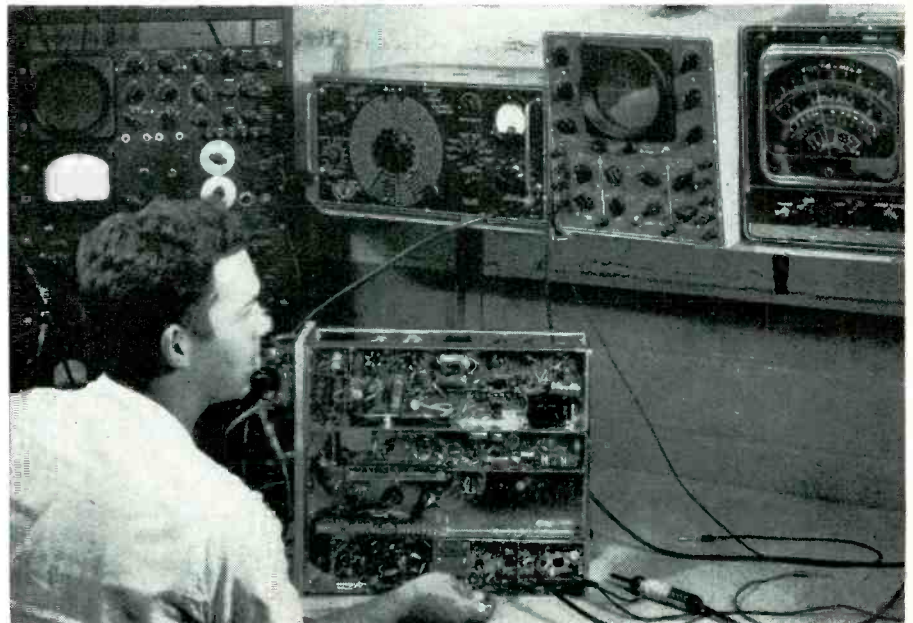

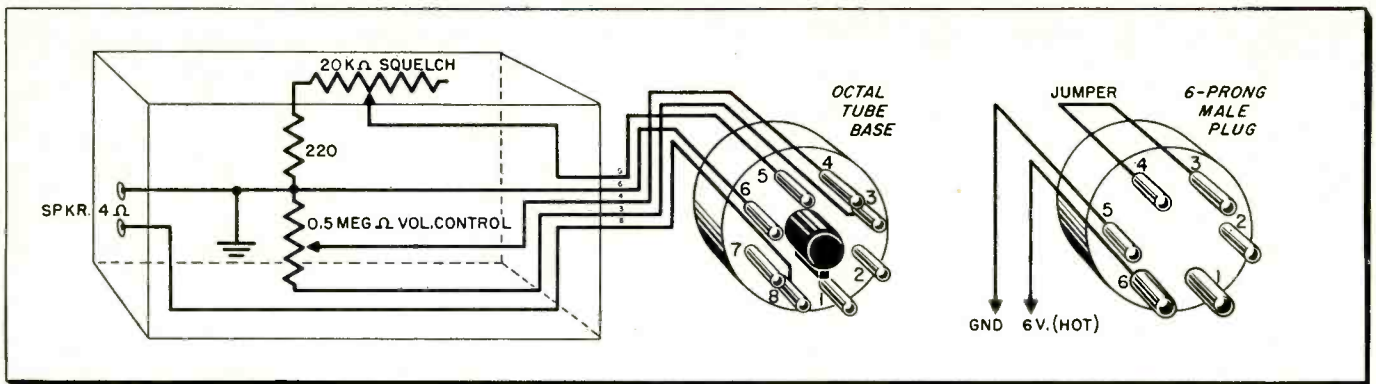

Fig. 4—Used for the Motorola P-8328-A,-B receiver mockup, octal base or Amphenol 86-PM8 may be used.

up make it as simple as possible, for both economy and utility.

The control mockup has another utility, aside from bench testing. If trouble is suspected in the control box or cabling, the mockup may be taken to the vehicle and connected in place of the regular system. Both the transmitter and receiver hookup may be tested in this manner.

There are only 3 things, outside of the mockup, which must be provided for on the bench, for checking set operation. These are a power supply, which should be able to furnish 6 or 12-volts, dc, at a high enough current rating to take care of the largest transmitters that the shop may be called upon to service; a test speaker having a 4-ohm voice coil, and a dummy antenna, for use when testing transmitters. The best and cheapest for this is a 2-foot piece of RG-11/U cable, with plug equipped on one end, and a standard weather-proof socket on the other end. Into this socket, insert an incandescent lamp of appropriate size for the transmitter being tested; a 60-watt lamp for 60-watt transmitters, 40-watt (nearest standard size) for 30-watt, etc. If this load lamp can be brought to full brilliance by tuning the transmitter, the set can be installed in the vehicle. For small hand-held

transmitter, solder a #222 penlite bulb directly to a plug; this makes a good dummy for these low-output sets.

For the actual power supply, we would recommend the use of two medium-sized storage batteries, plus a small 12-volt charger to keep them up. These are preferred over low-wattage power a-c or battery-eliminator supplies, because of the large currents drawn by some of the transmitters; as high as 40 amperes, under load. The cost of an a-c powered unit for a 40-ampere drain could be high, but the convenience of little maintenance could make it attractive. The service life of the batteries is very good, ours averaging five to six years. They should be kept full of water at all times, and checked regularly.

The batteries may be located under or behind the service bench, in an accessible location, and connected to a bench panel through heavy cables. Heavy-duty binding posts should be used. A 30-ampere ammeter is invaluable for detecting troubles in power supplies, final amplifiers, etc. For the larger sets, a meter with a 40-ampere scale would be better. All connections should be

either soldered or tightly-bolted together. The heavy current drawn through them has burned binding posts completely out of our masonite panel, in the past, due to a dirty joint. Use heavy-duty spade lugs, on the ends of connecting cables, for the mockups themselves. The wiring from the batteries to the panel should be heavy enough to carry the load without too much voltage drop.

The actual construction of a receiver mockup, requires two controls, a switch, and speaker connections plus a means of connecting it to the set under test. Most sets use special plugs for making the connections from control and power circuits to the chassis themselves. As a rule, the quickest way to get these is to order them directly from the radio manufacturer, or his nearest service parts depot. From past experience, I can testify that there are no commercial equivalents.

For convenience, the best way to

Fig. 5—Plug no. 28A81161 for the Motorola PA-8332A,-B,-C transmitter.

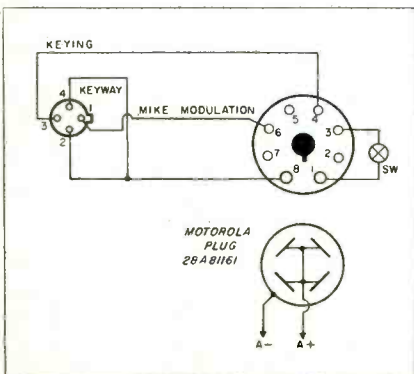

Fig. 6—Amphenol male 86PM8 for the GE receiver 4ER6B4, 5 and 6.

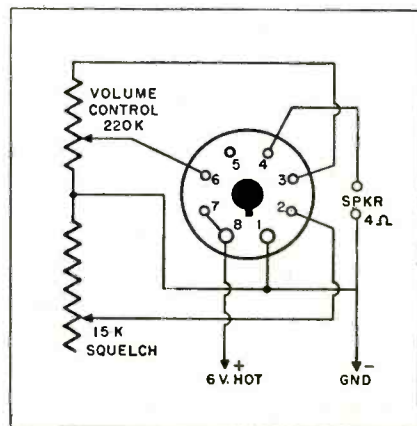
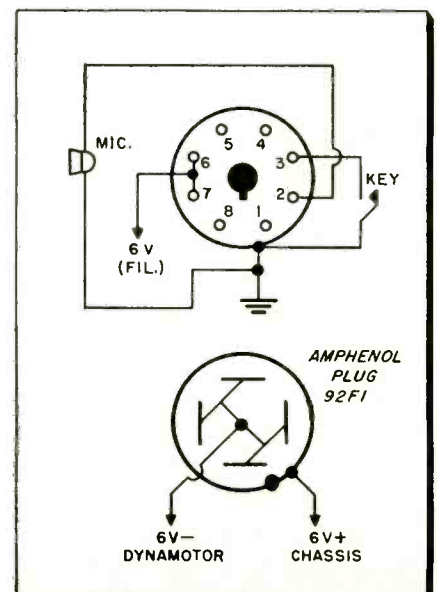

Fig. 7—Amphenol type 92F1 for the GE transmitter, companion to Fig. 4.



make up one of these units is to use a small aluminum box.

The controls are mounted on one side of the box and speaker jacks may be placed on the other side. If desired, the speaker leads may be brought out of the control box itself, and attached directly to the speaker. The first step in building one of these is to look up the schematic of the receiver or transmitter and see what parts will be needed.

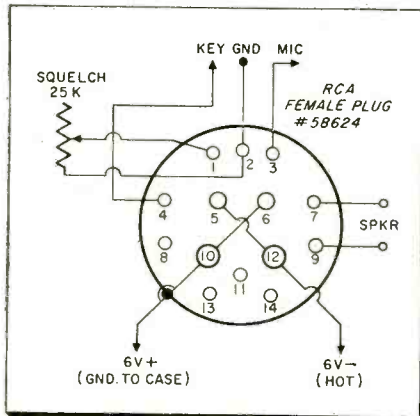

Fig. 8—Female connector, RCA part no. 58624, for RCA CMV-3E1 cable mockup.

For instance, many sets have a separate volume control on the chassis; thus, the control-box gain control could be omitted entirely. The only thing to remember here is to be sure and reset this control to maximum before reinstallation. Volume controls are of two types; the standard audio-grid circuit, which uses a 0.5 megohm control in most sets, some running as low as 220,000 ohms. Shielded wire should be used in the hookup of these

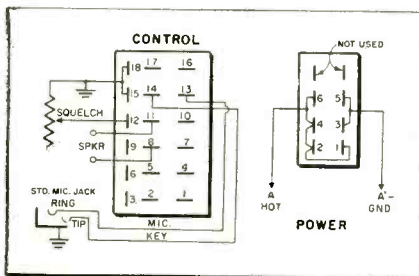

Fig. 9—Control plug no. 28A890788, power 9A890787, Motorola Research sets.

controls. The second type is a simple low-resistance pad across the speaker voice coil. Any resistance pad may be used as a gain control, from 100 ohms down to 20 ohms, with satisfactory results.

Squelch controls, on the other hand, are much more critical, and the exact value specified in the schematic must be used. Voltages in
(Continued on page 52)

HICKOK Model 295X

all-band microvolt GENERATOR

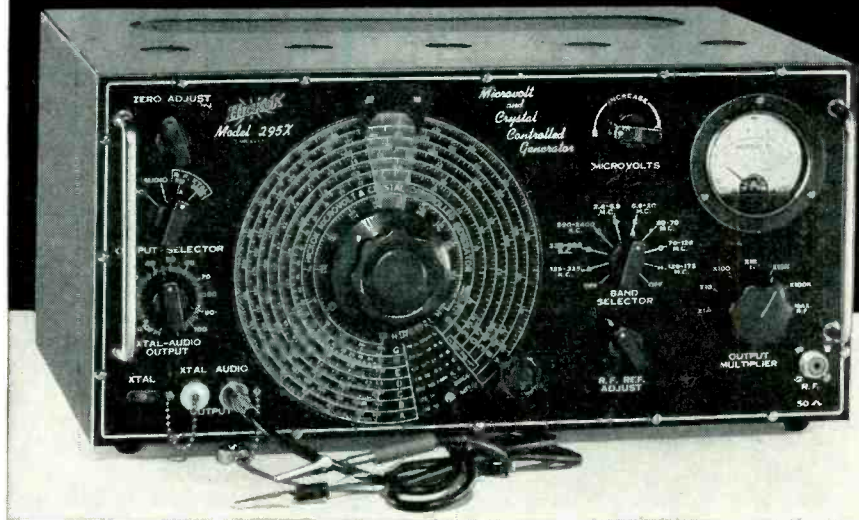

- 125 KC to 175 MC continuous on fundamentals
- Attenuation down to 0.1 microvolt
- Output of 0.1 to 100,000 microvolts on all ranges
- No external pad required

Model 295X Microvolt and Crystal Controlled Generator meets military requirements and is designed primarily to service receivers in the mobile and aircraft field. Sensitivity, selectivity and frequency of a receiver can be readily determined with extreme accuracy, and without use of correction factors or reference tables. Features an unusually wide range of frequencies both variable and crystal controlled, wide range of output voltage accurately metered, exceptional stability of frequency and amplitude adjustment and calibrated RF output level as low as 0.1 microvolt. This equipment combines features generally available only in two separate generators:

MICROVOLT GENERATOR—An accurate, known microvolt source covering frequencies from 125 KC to 175 MC continuous on fundamentals. Metered output from 0.1 microvolt to 100,000 microvolt on all ranges. No external attenuator pad required. Extremely low leakage is the result

of proper shielding (silver plated over copper). Direct reading of the output level results from precision attenuation and monitoring.

CRYSTAL CONTROLLED OSCILLATOR—Separate crystal controlled RF oscillator... 400 KC to 20 MC... on fundamentals and controlled harmonics up to 250 MC provides crystal accuracy for frequency checks. Crystals with .01 and .005% accuracy are available as optional equipment.

APPLICATION FEATURES INCLUDE: Measurement of threshold sensitivity of squelch circuits... Checking noise quieting performance of FM, mobile and aircraft receivers... Measurement of gain per stage and overall gain of RF and IF sections... Alignment and adjustment of RF and IF stages of communication equipment, to 175 MC... Measurement of sensitivity and selectivity of radio receivers... Tuning and alignment of discriminator... Adjustment of AGC circuits.

TECHNICAL FEATURES

Variable RF Oscillator:
Ranges:

- | | |
|------------------|-----------------|
| A—125 to 325 KC | E—6.9 to 20 MC |
| B—325 to 890 KC | F—20 to 70 MC |
| C—890 to 2400 KC | G—70 to 120 MC |
| D—2.4 to 6.9 MC | H—120 to 175 MC |

Frequency accuracy: 1%

RF Output Level: Metered in microvolts adjusted by a precision decade multiplier and vernier control.

- | | |
|----------------------|-------------------------------|
| X1 Step, 0.1 to 1 | X1K Step, 100 to 1,000 |
| X10 Step, 1 to 10 | X10K Step, 1,000 to 10,000 |
| X100 Step, 10 to 100 | X100K Step, 10,000 to 100,000 |

Output Impedance: 50 ohms

Modulation: 400 cycles, 30%

Crystal Controlled RF Oscillator:

The 295X is by far the finest alignment equipment for Mobile Radio receiver servicing. Write for 4-page technical bulletin today!

Fundamental frequency range: 400 KC to 20 MC

Crystal harmonic frequency range: 20 MC up to 200 MC

RF Output Level: Variable from a maximum of approximately 2 volts

Modulation: 400 cycles, 30%

Audio Oscillator:

Frequency: 400 cycles

Output Level: Variable to a maximum of approximately 1 volt

Outputs:

Unmodulated RF

Modulated RF (400 cycles, 30%)

Crystal-modulated or unmodulated

Audio—400 cycles

THE HICKOK ELECTRICAL INSTRUMENT CO.

10523 Dupont Avenue • Cleveland 8, Ohio
In Canada: Stark Electronic Sales Co., P.O. Box 240, Ajax, Ontario

SHOP HINTS



Tips for Home and Bench Service by Readers

Transformer First Aid

What may appear to be a transformer replacement job in a fairly new set may in fact turn out to be only a minor repair to a major component. In many cases a winding which reads open or very high resistance may be due to a defective or broken solder joint inside the transformer, where the heavy leads are attached to the comparatively very thin winding ends. Power, audio output, i-f transformers, chokes and other coils may suffer

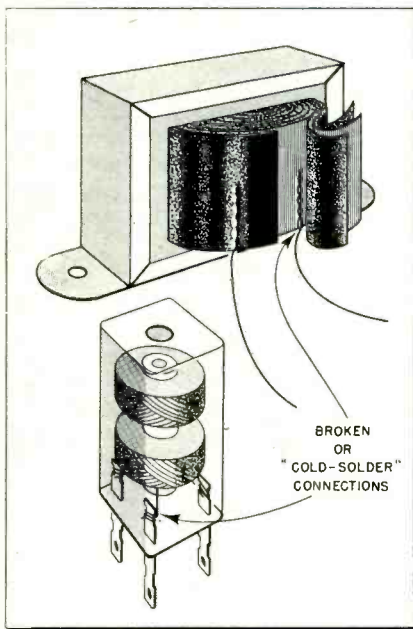

Breaks usually occur at these points.

from this difficulty. All that is needed is to clean and re-solder the joint to restore the transformer to operating condition. It is more likely that this condition will be found in new equipment. Breakdown in older transformers usually occurs within the windings. In some cases it is possible to dig the coil, find the trouble and correct it. The chances for breakdown are ever present in the latter procedure and is therefore not usually recommended. With a sharp knife, cut one layer or insulation at a time and fold back. Cut only as many layers as needed to

expose the coil winding ends. Precaution against cutting too deep should be exercised to avoid damaging the transformer coil windings.

Extreme care should be exercised in preparing the short coil ends for connection, a break too close to the coil proper may terminate any further first aid procedure. Use fine emery cloth to remove the enamel coating. It is a good idea to provide strain relief on these leads. Fold the insulation back into place and tape. *K. Bramham, Vancouver, B.C.*

Hum & Shrunk Picture

This tough dog was a GE 21C120. It all started with the customer complaint of hum in the audio and at the same time the picture would shrink then would clear up. The chassis was pulled and brought into the shop. Upon examination of the 680-ohm 2-watt resistor, used as an audio output filter in conjunction with the 30 μ f capacitor, it was obvious that the resistor had been heavily overloaded and burned. I checked the 30 μ f filter capacitor, 6V6 tube, .008 capacitor and the output transformer. Everything checked ok and no clue as to the cause of the overheating could be found. A new resistor was installed and the set operated satisfactorily. After the customer used the set for two weeks alas the same complaint. This time the resistor had definitely burned and was open. Same procedure was used to locate the apparent short

AC voltages in DC circuits may be tricky.

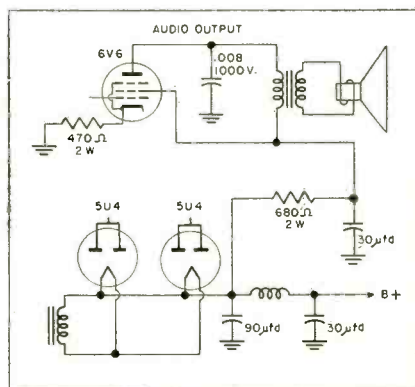

circuit that must have existed to burn the resistor, no luck. A new resistor was installed; it also overheated. The voltage drop across it should give us a clue. Lo and behold! no voltage drop, an ammeter was inserted in series and no current! It finally dawned on me that something other than dc was concerned. A scope on the high side of the resistor showed a high amplitude pulsating dc waveform. This pulsating dc was causing the resistor to overheat. The 30 μ f capacitor offered a low impedance path to ground. The culprit in this case was the 90 μ f input filter capacitor to ground at the output of the 5U4. It had opened up and was not doing its filtering job. A check showed various readings from 4 μ f to 60 μ f at different times. *E. C. Bruning Jr., Milwaukee 6, Wis.*

Salvaged Detector

An excellent crystal detector probe for signal tracing and observing waveforms in the i-f strip of a TV set can be made from a scrapped chassis. Any set having a crystal detector will do, GE Model 10T1, Motorola TS 4, etc. Remove the detector circuit complete with can, coils, resistor, capacitor and crystal diode. Use a good quality coaxial lead from the can to the scope. The leads from

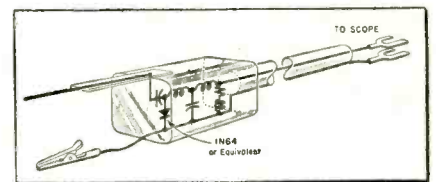

Crystal detector probe from salvaged set.

the probe head to the set should be as short as possible to avoid stray pickup. Use proper terminals to fit your scope. An alligator clip should be used on the ground lead and for convenience may also be used on the probe end. The can and probe tip can be mounted on a small board and handled as a unit. You may be able to construct an insulated probe tip right on the can itself. *John B. Vedo, Gary, Indiana.*

Antenna Wall Reflectors

Building walls used as a shield and reflector to eliminate ghosts in metropolitan areas.

JAMES A. MC ROBERTS

• Metropolitan and even suburban TV antenna installations are often plagued by ghosts that may be eliminated by using the building wall as a shield or a properly phased reflector, in much the same manner as some deluxe antennas have incorporated in its design and makeup. Actually no two installations are the same and the degree of success achieved will depend on the ingenuity and knowledge the technician can harness. Most antennas used in metropolitan and primary areas will pick up almost as much signal from the back as it will from the front. To convince yourself, try orienting the antenna 180° from its recommended position. One possible solution is to select a more highly directional antenna. From experience, serviceman's preference and how much the customer is paying for the job, the antenna is selected and installed. Still we have ghosts galore. Some attempt to solve the problem by orientation, antenna brand or type changing, and trying to convince the set owner that these are neighborhood conditions which are beyond

your control only leads to dissatisfaction and frustration. However, some changes in the ghosts were noted, during all these manipulations, such as on some channels reception was cleaned up almost completely while other channels, which were clean before, were now plagued by these multiple images. In some locales all the TV-stations signals come from one general direction and in spite of this, we have ghosts on some channels and not on others. This is easily explained by the fact that the angle of reflection is different for different frequencies. The problem is further complicated by the reception of more than one reflection.

Radar techniques may be employed to pin point the probable cause and location of the building responsible for the ghosts. Since it isn't practical to chop down the guilty structure, the technician is forced to use other means. The solution is fairly simple if all of the extraneous signal paths are attacking from the rear.

As an illustration, let us consider a typical antenna installation at point "A" on the top of an apartment-house building. A folded dipole

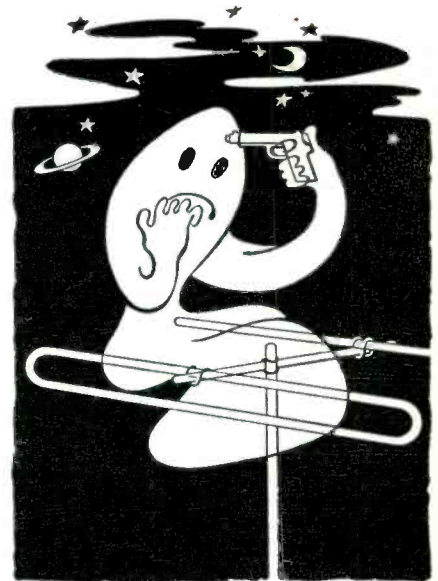

and parasitic reflector is mounted on a 10-foot mast over the roof parapet facing the TV station. Behind the antenna is a penthouse over the stairs leading to the roof. The reflections from the structure were responsible for the ghost on the TV screen.

In another very similar instance, the ghost was caused by reflections from an adjacent building wall behind the antenna. In both situations the solution to the problem was made possible by using the wall as a shield or reflector. Three alternate positions are shown in Fig. 1, at points B, C, and D.

The installation at B required a bracket to hold the antenna about two-feet away from the wall. The

(Continued on page 53)

A typical city rooftop showing different methods of mounting positions so as to take advantage of the building walls to help eliminate ghosts.

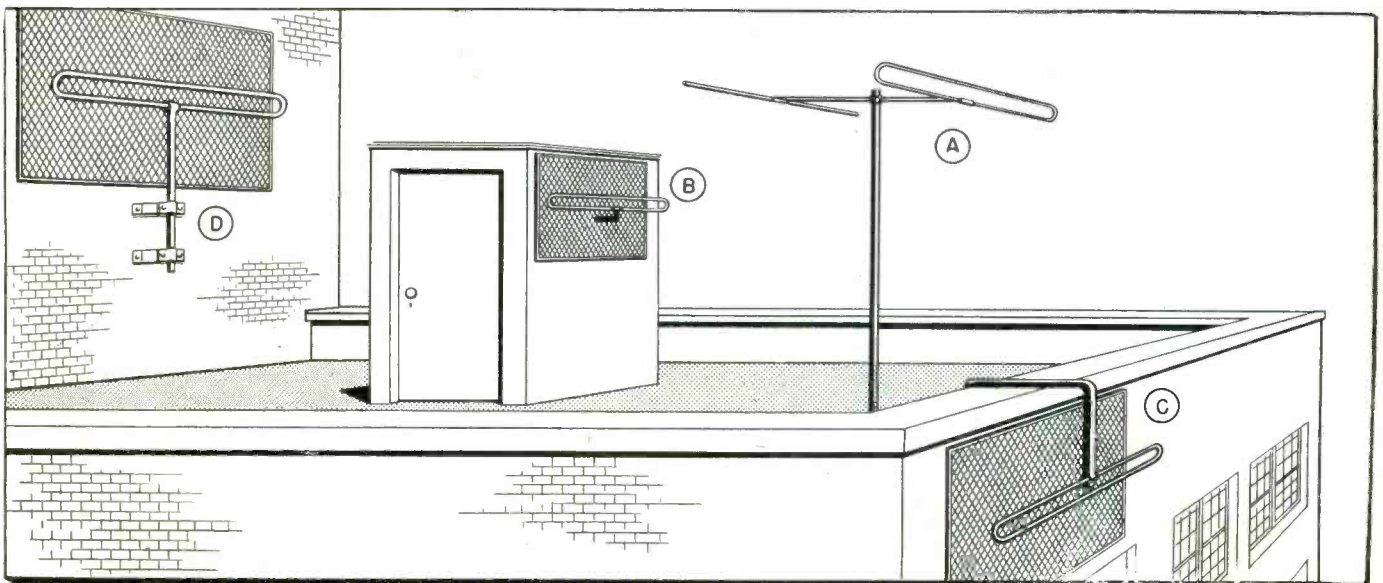

New Products for Technicians

Trio ANTENNA →

The indoor TV antenna, the Silver V, incorporates many new features heretofore found only in larger outdoor equipment. Spring tension aluminum tubing maintains constant tension on the center element and therefore avoids eventual loosening of the elements; a common cause of inferior reception. Spring-loaded ball sockets move easily, yet give a positive hold on position. It has been designed to achieve maximum life and bright sharp reception. Trio Mfg. Co., Griggsville, Ill. (ELECTRONIC TECHNICIAN 7-10)

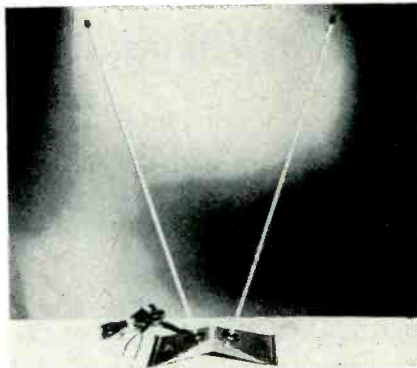

ATR SHAV-PAK →

Shav-Paks are miniature dc-to-ac inverters designed especially for the operation of standard a-c electric shavers from 6 or 12-volt storage batteries in automobiles, buses, trucks, boats, etc. The unit plugs into the cigarette lighter receptacle. The d-c battery power is changed to 110-volt ac, and is suitable for the operation of electric shavers and other a-c devices having a wattage requirement of not more than 15 watts. American Television & Radio Co., St. Paul 1, Minn. (ELECTRONIC TECHNICIAN 7-9)



Belden SQUARE SPOOLS →

After testing many packaging ideas, a highly efficient new way of packaging wire and cable was developed. This method of packaging retains the tried and true advantages of the round spool and adds some new features. The square spool won't roll off the shelf or work table. It has a much neater appearance when displayed on a rack. Additional protection for the wire is provided by a clear vinyl covering which allows easy identification. Belden Mfg. Co., Chicago 80, Ill. (ELECTRONIC TECHNICIAN 7-8)



Delco ANTENNA DISPLAY

A new colorful counter stand features a mount to display an auto antenna and a pocket for descriptive folders. It is made from heavy durable cardboard and is easy to assemble. United Motors Service, Detroit 2, Mich. (ELECTRONIC TECHNICIAN 7-14)

Snyder ANTENNA

The new antenna, "Indoor Torque TV Tenna," is small and compact. It can be attached, via an easy twin-screw attachment, directly to a portable TV set in a matter of minutes. The staffs can rotate in complete circles for best reception and can be concealed behind the receiver. The Model PT-B is \$5.95 and Model PT-C is \$4.95. Snyder Mfg. Co., 22nd & Ontario Sts., Philadelphia, Pa. (ELECTRONIC TECHNICIAN 7-13)

James POWER CONVERTERS

These units generate 117 volts at 60 cps plus or minus 1 cps from d-c sources. Models are available for 6, 12 and 27.5-volt operation. They contain a new precision frequency power vibrator which operates over a wide d-c input voltage range with accurate frequency maintenance. The new converters are primarily designed for operating in a portable or mobile location instrumentation which requires accurate 60 cps input frequency. The output can be both resistive and inductive to include recorder motors and control circuits. James Vibrapowr Co., 4050 N. Rockwell St., Chicago 18, Ill. (ELECTRONIC TECHNICIAN 7-11)

Scala ANTENNA

A new line of five and ten-element heavy duty yagis cut for TV channels, are designed especially for community, TV antenna companies and apartment house applications and are available in 72 or 300-ohm impedances. All elements are made of 3/4" O.D. aluminum tubing and held in place on the boom with high strength precision machined castings. The "T" match is welded to the dipole. The boom is also made of heavy aluminum pipe. Other features include stainless-steel terminals and splice-free elements. Scala Radio Co., 2814 19th St., San Francisco, Calif. (ELECTRONIC TECHNICIAN 7-75)

FOR MORE TECHNICAL INFORMATION ON NEW PRODUCTS OR BULLETINS

use this convenient coupon. Enter below the reference numbers for all items desired.

NEW PRODUCTS EDITOR
ELECTRONIC TECHNICIAN
480 Lexington Ave.
New York 17, N. Y.

Please send me more information on the following items:

My company letterhead or business card is enclosed.

Name
Address
Firm My position
City State
Business address (if different from above)

More New Products on page 51

New Audio Products

EV MICROPHONE →

The Model 951 is a crystal type cardioid microphone. The cardioid pattern is obtained through the use of two sound entrances located in the microphone case at different distances in back of the diaphragm. This microphone is especially useful in locations where ambient noise and severe reverberation exist. High crystal capacitance makes possible the use of moderately long microphone cables. L.P. \$49.50. Electro-Voice Inc., Buchanan, Mich. (ELECTRONIC TECHNICIAN 7-1)

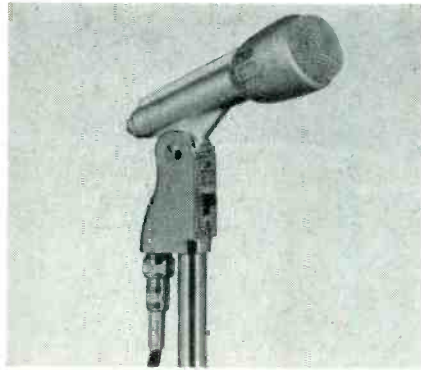

Fairchild TURNTABLE

A new high fidelity 4-speed turntable uses a hysteresis synchronous motor to provide variable speed. Variable speed from a hysteresis motor is possible through the use of an extremely accurate variable frequency electronic power source. The desired frequency can be selected by a single control. Moving parts have been reduced to an absolute minimum. The unit will function normally on 50 or 60-cycle current. Turntable performance more than meets NARTB specifications for rumble, flutter and wow, and exceeds requirements for professional playback tables. Price of the turntable is \$79.95 in a 1-speed version and \$159.95 as a 4-speed turntable. The electronic drive is also available separately at \$84.00. Fairchild Recording Equipment Co., 10-40 45th Ave., Long Island City 1, N.Y. (ELECTRONIC TECHNICIAN 7-4)

Shure MICROPHONE →

A professional quality, super-cardioid, uni-directional microphone, the Model 330 "Unitron" is designed for fine tape recording applications and public address systems. The microphone reduces pickup of random noise energy, and is equipped with an anti-"pff," anti-blast filter screen. A sturdy self-adjusting "lifetime" swivel is built in to the unit. Professionals as well as hobbyists alike can afford to satisfy their high standards. Shure Brothers Inc., 222 Hartrey Ave., Evanston, Ill. (ELECTRONIC TECHNICIAN 7-60)

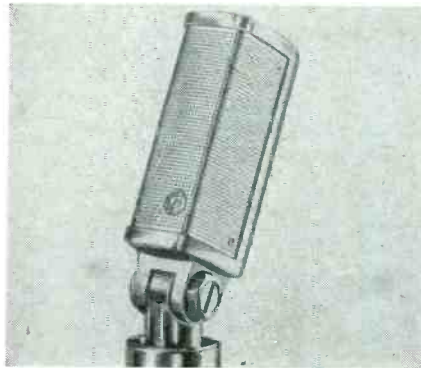

Pilot AMPLIFIER →

The new Model AA-908 is a 40-watt heavy duty basic amplifier having only 1/2% harmonic distortion and excellent transient response. Features are: a 5-step compensation control which counteracts dropping bass response by feeding progressively greater power at lower frequencies; an adjustable damping factor; and a 4-step compensated attenuator permits convenient volume control settings without a change in frequency response. Pilot Radio Corp., Long Island City 1, N.Y. (ELECTRONIC TECHNICIAN 7-3)

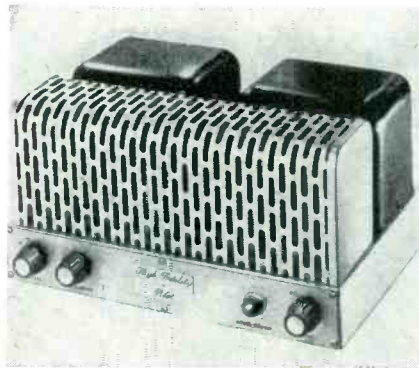

Audiotape C-SLOT REEL

The new C-Slot Reel features a curved groove in the hub for threading. The tape is simply slipped into this groove in the opposite direction of reel rotation and the recorder is ready for operation. No kinks or twists are made in the tape and no tape ends are left sticking up. Since the C-Slot is self-locking, there is no need to turn the reel by hand. All sharp edges have been eliminated, including those on the inner surface. Audio Devices Inc., 444 Madison Ave., New York 22, N.Y. (ELECTRONIC TECHNICIAN 7-7)

Atlas SPEAKER →

The Model CJ-44 "King Cobra-Jector" features the integral construction of the projector with an "Acousti-Matched" built-in driver. Matched design assures maximum conversion efficiency in an all-purpose all-weather wide-angle PA speaker. Its controlled response, carefully confined within frequency limits most useful in PA, and high level music reproduction, provides smooth reproduction free from peaks that so often create and sustain acoustic feedback. Atlas Sound Corp., 1451 39th St., Brooklyn 18, N.Y. (ELECTRONIC TECHNICIAN 7-2)



Vidaire SPEAKER SWITCH

Any combination of 6 speakers may be switched into a circuit and a constant impedance maintained at the amplifier output transformer with the Model MS-6 speaker switch. The 6 individual switches are mounted on a panel which enables centralized control of all speakers. Any size or impedance of speakers may be used with this unit. It is ideally suited for PA installations having a combination of speakers. Simplified installation instruction are furnished. Vidaire Electronics Mfg. Corp., 576-80 W. Merrick Rd., Lynbrook, N.Y. (ELECTRONIC TECHNICIAN 7-5)

New Electronic Products

Regency PREAMPLIFIER →

The new, all transistor, high-fidelity pre-amplifier equalizer is only 7½" x 2½" x 3⅞". With equalizer controls in a "flat" position and selector switch on "magnetic phono," response follows the RIAA curve. Control adjustments to conform to other recording curves are covered in the instruction manual. The Model HFT-1 will be available either in kit form, or wired and tested. The self-contained battery will last 1 year in normal operation. Regency Div., I.D.E.A., Inc., Indianapolis 26, Ind. (ELECTRONIC TECHNICIAN 7-15)

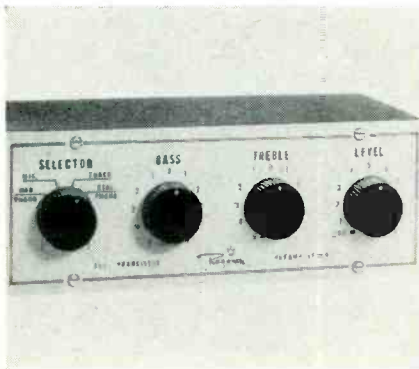

Anchor VOLTAGE ADJUSTER →

The LA 350 line adjuster boosts or reduces voltage to assure the best TV or other appliance operation at approximately 115 volts. It is for use with units rated up to 300 watts. It increases voltages approximately 10% to restore picture tube size and brightness, or it reduces voltages approximately 10% to protect against damage, if the line voltage is too high. Features a 4-position switch. It measures 3" x 3" x 4" and is of heavy duty construction. Anchor Prod. Co., 2712 W. Montrose Ave., Chicago 18, Ill. (ELECTRONIC TECHNICIAN 7-18)



Raypar BRIGHTENER →

Three picture tube brighteners to cover all applications encountered by the technician. Model BT-1 is an auto-former brightener for parallel-filament TV sets. The BT-2 is an autoformer type for parallel and series circuits. Model BT-3 is a universal unit that brightens pictures, and relieves cathode-filament shorts in any parallel or series circuits. A novel printed-circuit selector sets up any of the BT-3 functions in seconds. Raypar Inc., 7800 W. Addison St., Chicago 34, Ill. (ELECTRONIC TECHNICIAN 7-16)

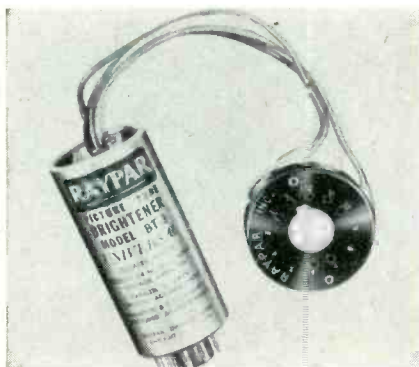

Walsco SCREWDRIVER →

The "Mini-hold" is a precision tool having a wedge-action which securely grips extremely tiny screws, (#1 to #4) to end fumbling and losing them. Designed primarily to speed replacing phono cartridges, the new screwdriver measures 2⅞" overall. This special short length enables technicians to work easily in tight spots and makes it invaluable in repairing miniature electronic equipment. Catalogue #2568. Dealer net \$1.98. Walsco Electronics Mfg. Co., 100 W. Green St., Rockford, Ill. (ELECTRONIC TECHNICIAN 7-17)

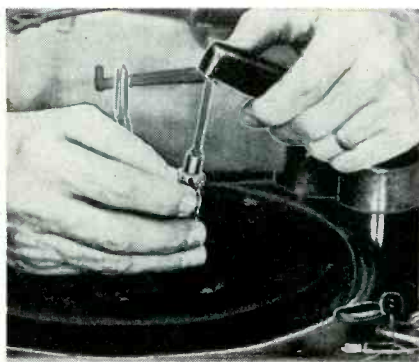

Dage RF CABLE CONNECTORS

A new sub-miniature series of RF coaxial cable connectors includes 12 different groups of jacks, receptacles and adapters. They are only half the size of BNC's, yet can withstand a cable pull of better than 50 lbs. Assembly requires no crimping tools. The cable is clamped with a threaded nut. Dage Electric Co., Inc., 67 N. Second St., Beech Grove, Ind. (ELECTRONIC TECHNICIAN 7-20)

Automatic TRICKLE CHARGER

The new, low-cost battery trickle charger has a continuous adjustment range from 50 to 200 ma and includes a meter to indicate charging current. The output is fused to protect charger components. Output voltages are 12 and 24-volts dc with input voltages of 110 to 120-volts 60-cycles ac. A full wave selenium rectifier circuit is provided. Automatic Switch Co., Florham Park, N.J. (ELECTRONIC TECHNICIAN 7-19)

Powerstat TRANSFORMER

The variable transformer type LW 136 is a double wound assembly with an isolated secondary on a single core. The absence of an electrical linkage between the windings permits connections for its use as either a source of adjustable low voltage output, a limited range line corrector or a limited range "buck-boost" variable transformer. The primary consists of two windings arranged for either parallel or series connection. It is offered in numerous models for manual or motor-driven service. The Superior Electric Co., Dept. LW, 83 Laurel St., Bristol, Conn. (ELECTRONIC TECHNICIAN 7-21)

Jackson DEPTH SCANNER

A new, low cost depth scanner, employing the sonar principle, incorporates 3 units: a transducer, which is installed in the bottom of the boat; an electronic unit, which can be installed wherever most convenient; and an indicator with adjustable mounting. A 200-kc signal is emitted from the transducer, and the time required to travel from transducer to water bottom and back is interpreted in feet of depth on the indicator. The unit is said to be accurate within 1 foot from 2 to 120 feet. The indicator includes a 1200-rpm motor providing 20 indications per second. The entire unit is available for 6 or 12-volt supply. Regular price is \$99.95. Jackson Electrical Instrument Co., Dayton 2, Ohio. (ELECTRONIC TECHNICIAN 7-22)

New Electronic Components

Int'l SILICON RECTIFIER →

The new silicon TV rectifier is a direct and universal replacement unit for all existing selenium stacks up to 500 ma. The "Unistac TV500," employs a silicon diode mounted on a finned heat exchanger, and is especially suited to the elevated operating temperatures inherent in most TV sets. One unit in a half-wave circuit will deliver 500 ma at 130-v dc. Two units in a half-wave voltage-doubler circuit will deliver 500 ma at 240-v dc. International Rectifier Corp., 1521 E. Grand Ave., El Segundo, Calif. (ELECTRONIC TECHNICIAN 7-66)

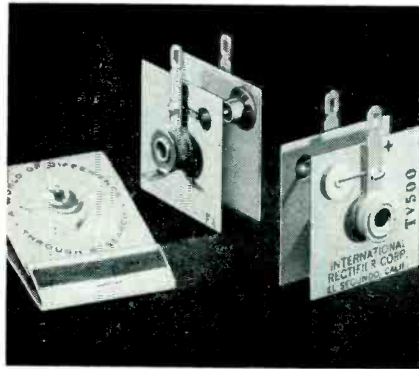

Clarostat POTENTIOMETERS →

Further refinement of the Series 49M miniaturized wire-wound potentiometers, by way of still higher dielectric strength, has been incorporated. A new molding material, green in color, is now used. This feature, together with design improvements results in exceptionally low electrical leakage in operation. Tests indicate complete compliance with the high performance standards. They are 3/4" in diameter x 1/2" deep; 1.5 watts; and 4 to 20,000 ohms resistance. Clarostat Mfg. Co. Inc., Dover, N.H., (ELECTRONIC TECHNICIAN 7-65)

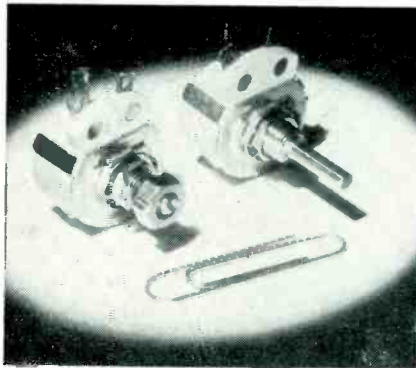

GE SILICON TRANSISTORS →

The new high frequency, high temperature silicon transistors are designed for use in military and industrial equipment. The new transistors are made by a diffused-meltback process which offers a higher degree of uniformity and process control. Silicon transistors are capable of operation at temperatures ranging from -65°C. to 150°C. For maximum reliability and stability, these transistors are aged at high temperatures for a minimum of 150 hours before shipment. GE Semiconductor Prod., Syracuse, N.Y. (ELECTRONIC TECHNICIAN 7-68)

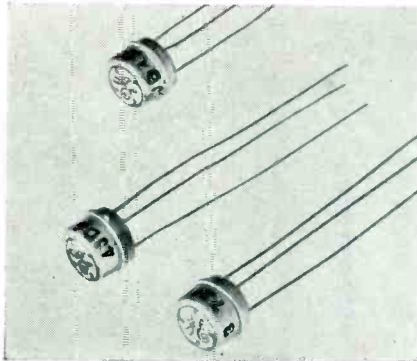

Federal RECTIFIER →

A new 65-mil selenium rectifier which is ideal for use in phonographs, small radios, TV boosters and other small electronic chassis is designated as Type 1263-A for standard mounting, and 1263-B for bracket mounting. The new rectifier has the following characteristics for single phase capacitive load: max. RMS input, 130 volts; max. peak inverse, 380 volts; rectifier drop 7 volts; min. series resistance, 22 ohms; and max. plate operating temp is 85°C. Federal Telephone and Radio Co., 100 Kingsland Rd., Clifton, N.J. (ELECTRONIC TECHNICIAN 7-67)

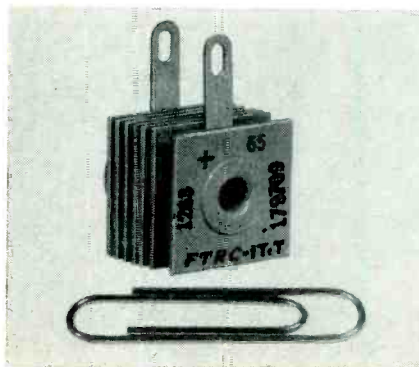

Pyramid CAPACITOR

Designed for applications with high reliability electronic equipment, telephone networks and industrial control systems, the new electrolytic capacitor, type TQ, is manufactured under quality controlled processes with special attention to vibration, container seal and life test. Pyramid Electric Co., 1445 Hudson Blvd., North Bergen, N.J. (ELECTRONIC TECHNICIAN 7-72)

Crest TRANSFORMERS

Taking the list of foreign transistor transformers and then adding several new items, the most complete USA-manufactured line of transistor transformers is available from stock. The units are all cored with 48% nickel-silicon steel, wound on nylon bobbins, made with formvar wire, produced in 2 core sizes and boxed in translucent plastic housings. The transformers fall into categories which will find almost universal applications. These units sell for less than the foreign counterpart, which is unusual. Crest Transformer Corp., 1834 W. North Ave., Chicago, Ill. (ELECTRONIC TECHNICIAN 7-69)

United TRANSFORMERS

Seven new types of ultraminiature transistor transformers have been added. These units weigh only 0.1 ounce and are fully hermetically sealed. Included in this new group of additional types are a number of 500-milliwatt units designed for pushpull transistor hookup to a 600-ohm line, a chopper input transformer, transistor interstage transformer, and a line-to-line matching transformer. United Transformer Corp., 150 Varick St., New York 13, N.Y. (ELECTRONIC TECHNICIAN 7-70)

Switchcraft SWITCH KIT

This handy kit contains varying quantities of contact spring blades in various thicknesses; silver contact points, phenolic spacers; insulating tubing; brackets; screws and assembly pins. Everything needed to assemble a stack switch to requirements plus complete instructions is included. Switchcraft, Inc., 1328 N. Halsted St., Chicago 22, Ill. (ELECTRONIC TECHNICIAN 7-71)

SE DIODE

A new temperature limited diode type 1236C is designed for service as an RMS detector for differential voltmeters; as an RMS detector for a-c voltage and current stabilizers; or as a detector for d-c voltage and current stabilizers and other similar applications. The Superior Electric Co., Dept. DO, 83 Laurel St., Bristol, Conn. (ELECTRONIC TECHNICIAN 7-64)

Latest Test Instruments & Aids

Precise OSCILLOSCOPE →

The oscilloscope, Model 3151, in kit or wired form, goes up beyond 9 mc and is designed for color-TV testing. Features are: highly sensitive push-pull vertical and horizontal amplifiers; a 5CP1 CRT with post acceleration; vertical and horizontal frequency compensated step attenuators; focus, intensity and astigmatism controls; and an output voltage for calibration. The vertical amplifiers are flat through 5 mc and ± 8 db through 9 mc. Sensitivity is 10 mv/cm. Precise Development Corp., 2 Neil Court, Oceanside, N.Y. (ELECTRONIC TECHNICIAN 7-43)

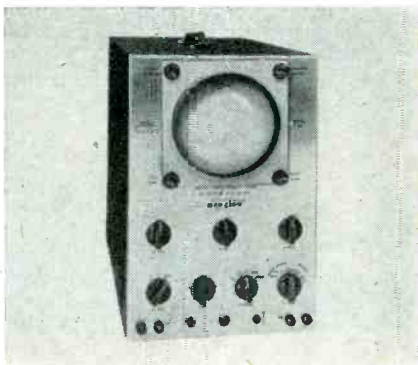

Jerrold COAXIAL SWITCH →

An electronically-operated coaxial switch transforms an ordinary oscilloscope into an instrument that takes accurate quantitative measurements. It can save up to 80% of inspection time on the alignment of i-f and r-f amplifiers, filters, etc. The switching unit has a maximum current rating of 5 amperes at 500 volts. It can be used to display diode or transistor characteristics, and as a square-wave generator. Jerrold Electronics Corp., 23rd and Chestnut Sts., Philadelphia 3, Pa. (ELECTRONIC TECHNICIAN 7-40)



Kay TRANSIPLY →

A new all transistorized regulated power supply provides all the characteristics of an infinite life battery. Special features include a stable metered and continuously variable output, low impedance, no ripple, high current, small size, light weight, and no hum. The unit may be used as a power supply for transistor circuitry, and as a source for filament and bias voltages from 0.5 to 7.0-volts dc. Maximum output current is 300 ma. Kay Electric Co., 14 Maple Ave., Pine Brook, N.J. (ELECTRONIC TECHNICIAN 7-41)

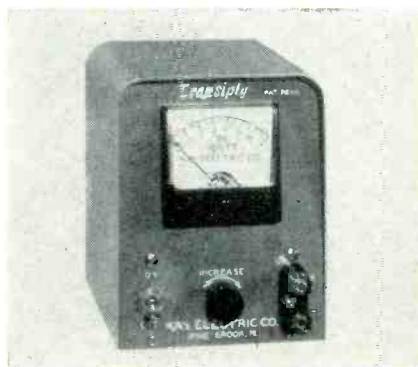

Shell TUBE TESTER →

The "Test-O-Matic" is a new self-service electron tube tester. It has 117 separate tube sockets and a large meter which indicates whether or not tubes should be replaced. New tubes are vended directly from a compartment in the machine. Predictions are that within 2 years 10,000 service dealers will be operating tube tester routes, says the manufacturer. The color of the cabinet is green and yellow. Shell Electronic Mfg. Co., 1688 Utica Ave., Brooklyn, N.Y. (ELECTRONIC TECHNICIAN 7-42)



EMC FILTER

You can now use your battery eliminator for transistor radio checking with the additional filtering provided by the Model BEA, battery eliminator adapter. No internal connection or changes need be made. Wired and tested, \$9.70. Electronic Measurements Corp., 625 Broadway, New York, N.Y. (ELECTRONIC TECHNICIAN 7-44)

Wassco SOLDERING TOOL

High efficiency cooling fins in combination with a molded high-impact plastic handle and cork grip allow the use of this new miniature resistance soldering tool on relatively high heat, continuous duty applications. It is a single tip type and is available in 2 carbon tip sizes, $\frac{1}{8}$ " and $\frac{3}{16}$ ". Nicely balanced and weighs 2 oz. It is designed for use with a Model 105-B2, 500-watt power unit. Wassco Electric Prod. Corp., 204 S. Larkin Ave., Joliet, Ill. (ELECTRONIC TECHNICIAN 7-45)

Standard GRIPROBE

The Griprobe is a new test probe made of durable plastic, precision engineered to grip-hold terminals, lugs, wires, etc., thus freeing the hands of the operator to handle other tools or test equipment. By a simple press of the thumb, the hook-shaped metal probe opens; by removing the thumb, it closes in a self-lock grip. It is designed to speed up trouble-shooting procedures. Standard Electronics Inc., 5523 Satsuma Ave., Burbank, Calif. (ELECTRONIC TECHNICIAN 7-46)

Eby TRANS-TESTER

The Trans-Tester is designed to work in conjunction with any VTVM, VOM or any basic movement capable of reading current up to 10 ma or lower. It provides tests on all types of PNP & NPN transistors. Net \$4.95. Eby Sales Co., 130 Lafayette St., New York 13, N.Y. (ELECTRONIC TECHNICIAN 7-12)

Phaotron PROBES

A Hi-voltage and RF probe for the Phaotron model 777 VTVM, which extends the voltage range to 50 KC and frequency response to 400 MC respectively. \$15.00 ea. Phaotron Instrument & Electronic Co., 151 S. Pasadena Ave., S. Pasadena, Calif. (ELECTRONIC TECHNICIAN 7-76)

More data on these new products available to you free, unless noted otherwise. Fill in code number on coupon page and mail to Reader Service Dept., ELECTRONIC TECHNICIAN, 480 Lexington Ave., New York 17, N. Y.

Printed Circuits

(Continued from page 29)

tains the radio circuit. The purpose of the jar is to distribute the heat evenly and not to shield the circuit from the flames. These parts are capable of operating at very high temperatures and are also resistant to nuclear radiation damage. While these components are somewhat similar to ordinary parts in appearance, they use new and different materials. Fig. 8 shows a printed circuit using some of these materials, just about to enter a furnace.



Fig. 8A—High-temperature tube operates in direct flame. No heater voltage is required.

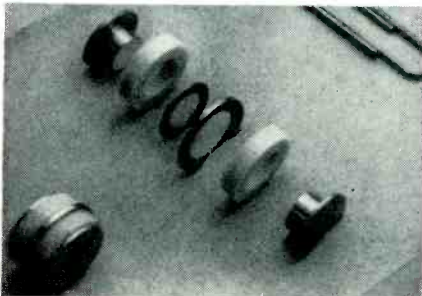

Fig. 8B—Construction of a high-heat tube.

Resistors, capacitors, tubes and other components have been specially designed to operate at these very high temperatures. Figs. 9A and B show a tube in operation while in the presence of a direct flame and an exploded view respectively. These tubes do not have heaters—at temperatures as high as 1500° F, cathode emission is sufficient and does not require additional heating.

As a tube is operated at higher temperatures, less heater power is required for cathode emission. Plate, grid and other elements operating at the same high temperature might also act as emitters. Special ceramics and titanium metal is used in the construction of these tubes.

Resistors are made from hollow ceramic tubes coated on the inside with a resistive coating. The tubes are sealed after being evacuated, and titanium caps are used to make electrical connections to the rest of the circuit. Capacitors have been made using pure single-crystal alumina (sapphire) as a dielectric; normally mica cannot be used at high temperatures because it crumbles. Special heat-treating methods have been developed so that certain micas

can now be used at high temperatures.

Copper wire alone cannot be used, but ceramic-coated wires protecting the metal from oxidation have been made into inductors and coils for r-f circuits. These printed circuits and components are the first to operate at temperatures as hot as the interior of a furnace. •

ILLUSTRATION CREDITS
Harmon Kardon, GE, RCA, Photocircuits Corp., Regency, Motorola.

LIFE'S "LITTLE" PROBLEMS

ARE EASILY
SOLVED
WITH

LITTLE SPACE

QUAM has a full line of shallow speakers, covering all popular applications.

LITTLE TIME

QUAM speakers mount quickly and easily in the most difficult installations because of QUAM's unusual mounting bracket.

LITTLE MONEY

QUAM speakers cost no more—and frequently cost less—than other speakers of the same size and magnet weight.

QUAM

Adjust-a-Cone

SPEAKERS

ask for QUAM, the quality line for all your speaker needs

Quam speakers are listed in Photofact Folders, Counterfacts, File-O-Matic, and Radio's Master.

A FREE copy of the latest QUAM catalog, listing over 100 replacement speakers, is available from your distributor, or from the Quam-Nichols Company.

QUAM-NICHOLS COMPANY

234 East Marquette Road Chicago 37, Illinois

FOR A
brighter

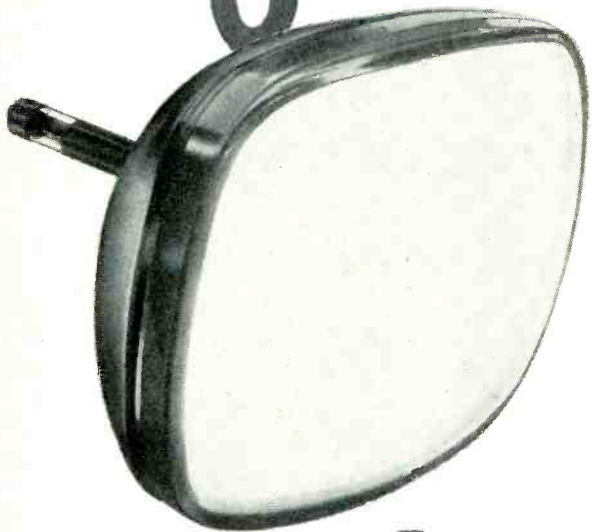

TV
picture

Rely on the tube that has always been specified by leading independent set makers.

Blue Chip Quality

TUNG-SOL[®]

Magic Mirror Aluminized

PICTURE TUBES

TUNG-SOL ELECTRIC INC., Newark 4, N. J. Sales Offices: Atlanta, Ga.; Columbus, Ohio; Culver City, Calif.; Dallas, Tex.; Denver, Colo.; Detroit, Mich.; Irvington, N. J.; Melrose Park, Ill.; Newark, N. J.; Seattle, Wash.

Catalogs & Bulletins

WIRE WOUND RESISTORS: A 12-page catalog on tubular and flat power wire wound resistors. Comprehensive data on construction, characteristics, coating, winding, insulation identification, mechanical strength, terminals and brackets. Bulletin C-1b available from International Resistance Co., 401 N. Broad St., Philadelphia 8, Penna. (ELECTRONIC TECHNICIAN No. B7-1)

TEST EQUIPMENT: A new 8-page composite test equipment catalog lists 25 pieces of new test gear, 2 new color generators and the new Cardmatic "automatic" tube testing machine. Form SM-30 available from Hickok Electrical Instrument Co., 10523 Dupont Ave., Cleveland 8, Ohio. (ELECTRONIC TECHNICIAN No. B7-2)

KITS: A flyer introducing the new line of kits for radio & TV service, hi-fi custom building and service, hobbyists and amateur radio, science education and technical schools and industrial testing and quality control. Available from Paco Electronics Co., Inc., Div. Precision Apparatus Co., 70-31 8th St., Glendale 27, L. I., N. Y. (ELECTRONIC TECHNICIAN No. B7-3)

SELENIUM DIODES: A bulletin on sub-miniature selenium diodes showing characteristic curves and other data. Manufacturers' price list also included. Available from International Rectifier Corp., 1521 E. Grand Ave., El Segundo, Calif. (ELECTRONIC TECHNICIAN No. B7-4)

ALLIED CATALOG: The 72-page Spring Supplement No. 165 illustrates and describes a great number of high fidelity components, test equipment, tubes, parts and electronics devices. Allied Radio, 100 N. Western Ave., Chicago 80, Ill. (ELECTRONIC TECHNICIAN No. B7-5)

MICROPHONES: 24-page colorful catalog, No. 57, introducing three new low cost microphones—the "Comando" series. This series can be used indoors and outdoors and provides practical versatility of operation. Available from Shure Brothers, Inc. 222 Hartrey Ave., Evanston, Ill. (ELECTRONIC TECHNICIAN No. B7-6)

AUTO RADIO POWER SUPPLY: A four page folder, explaining the construction and operating principles of a specially filtered DC power supply. Electro Products Laboratories, 4500 N. Ravenswood Ave., Chicago 40, Ill. (ELECTRONIC TECHNICIAN No. B7-7)

WIRE & CABLE: Catalog No. 857 is a new electronic wire and cable catalog, containing new audio cables, mike cables, new hook-up wire and others. For quick easy reference, wires and cables are grouped according to use and applications. Belden Manufacturing Co., 4647 W. Van Buren St., Chicago, Ill. (ELECTRONIC TECHNICIAN No. B7-8)

MICROVOLT GENERATOR: 4-page technical bulletin illustrating and describing new microvolt generator for mobile radio communication receiver servicing. The Hickok Electrical Instrument Co., 10523 Dupont Ave., Cleveland 8, Ohio. (ELECTRONIC TECHNICIAN No. B7-9)

CAPACITORS: A reference chart giving data on capacitors in quickly available form. The plastic card is 7 $\frac{7}{8}$ " x 4 $\frac{1}{8}$ ". It shows dielectric qualities and temperature coefficients of tubular and disc-ceramics, as well as maximum available nominal capacities in MMF. Erie Resistor Corp., Electronics Div., Erie, Penna. (ELECTRONIC TECHNICIAN No. B7-10)

New Books

ANTENNAS. By Alexander Schure. Published by John F. Rider Publisher, Inc., 116 W. 14 St., New York 11, N.Y. 88 pages. Paper cover. \$1.50.

Here is a handy book with a balanced coverage of theory and practical application. Only a minor portion is directly applicable to TV, but all of the text is informative for technicians and amateurs interested in getting into communications. Subjects include transmission lines, antenna impedance, polarization, and radiation resistance, to name a few. Antenna types discussed range from the simple dipole to parasitic arrays, long wires, V's, and rhombics.

MOST-OFTEN-NEEDED 1957 RADIO DIAGRAMS AND SERVICING INFORMATION. Compiled by M. N. Beitman. Published by Supreme Publications, 1760 Balsam Rd., Highland Park, Ill. 192 pages. Paper cover. \$2.50.

This volume contains schematics, alignment data, replacement parts lists, voltage values and information on stage gain, location of trimmers and dial stringing. Also includes material on portables, clock radios, transistor radios, record changers, FM and auto sets. The material is based on the set manufacturer's servicing data.

TRANSMISSION CIRCUITS. By Everard M. Williams, Ph.D. and James B. Woodford, Jr., D.Sc. Published by The Macmillan Co., 60 Fifth Ave., New York 11, N.Y. 156 pages. Hard cover. \$4.25.

This text comprises material used for some years in a one-semester course for senior students majoring in electrical engineering at Carnegie Institute of Technology. This work is assembled primarily for use in teaching rather than as a reference work. A selection of typical problems is included for student solution, some of which frequently necessitate unusual analytical ingenuity.

TV PICTURE TUBE—CHASSIS GUIDE. By The Rider Laboratory Staff. Published by John F. Rider Publisher, Inc., 116 W. 14th St., New York 11, N. Y. 63 pages. Paper cover, \$1.35.

Lists CRT's used in all TV receivers made since 1946. Up-to-date listings include sets listed in Rider's TV Volume 20 just released. It is an everyday aid to the technician in determining picture tube types without the necessity of checking through schematics or removing components.

MAGNETIC-AMPLIFIER CIRCUITS. By William A. Geyger. Published by McGraw-Hill Book Co., 330 W. 42nd St., New York 36, N. Y. 394 pages. Hard cover. \$7.00.

In this second edition the treatment of magnetic-amplifier circuits has been considerably revised and enlarged to embrace new developments and applications in this rapidly-advancing field. Basically the book is a practical exposition of the fundamental principles, characteristics, and applications of magnetic-amplifier circuits. It develops logically the various kinds of basic and more complex circuit arrangements, with as much emphasis as feasible on experimentally observed phenomena. Extended mathematical considerations and cumbersome proofs are avoided. Mostly, descriptive and graphical methods are used to give a qualitative and quantitative interpretation of the essential facts.

RADIO OPERATOR'S LICENSE Q & A MANUAL. 6TH ED. By Milton Kaufman. Published by John F. Rider Publisher, Inc., 116 W. 14th St., New York 11, N. Y. 720 pages. Hard cover. \$6.60.

The new edition is in complete accordance with the FCC Study Guide now being used as a basis for radio license examinations. The text has been brought up-to-the minute, particularly with regard to new operating procedures and new frequencies. Questions which have become obsolete since the last edition have been deleted. Questions have been renumbered to make them conform to the latest Study Guide. Discussions to many questions have been amplified so that the reader may achieve maximum background information.

FOR A brighter



profit picture

Rely on the tube that has always been a favorite with leading independent service dealers.

Blue Chip Quality
TUNG-SOL[®]
RECEIVING TUBES

TUNG-SOL makes All-Glass Sealed Beam Lamps, Miniature Lamps, Signal Flashers, Picture Tubes, Radio, TV and Special Purpose Electron Tubes and Semiconductor Products.

Peaking Coils

(Continued from page 25)

culprit I am looking for will be the last item on the list of things to be checked.

Uses Other Than Video

Peaking coils are normally associated with video and wide band circuits. However, they do appear in other circuits. When they do and

they break down they can really be perplexing.

The tag on a 21" CBS chassis read, "resistors burning." I located the two charred resistors quickly and changed them. Then before turning on the set, I checked the resistance to ground. There was a low-ohm short. Since this was a B+ line and no low-ohm shorts should exist at that point, I pulled out the schematic. The two resistors were in series with a 100 μ f capacitor and a peaking coil to ground, as shown in Fig. 6. The little capacitor was supposed to block the B+, but it was shorted. This allowed B+

to go through the resistors, through the capacitor, through the peaking coil and finally to ground.

So I changed the capacitor. Then with much confidence, I turned on the set. The tubes lit, the picture came in, but no audio. I turned the volume control up to maximum. Some sound came out of the speaker, but it was low and distorted. I checked the audio circuit. After a lot of futile voltage readings and touch-up alignment, I decided to review the theory behind this audio circuit. There was no audio i-f amplifier circuit. The audio i-f signal was transferred directly from the 4.5 mc trap, through the two resistors that had been burning, and the condenser I had installed.

This was a clever circuit. The peaking coil in the grid of the gated beam tube instead of a conventional grid leak resistor works in this manner. The gate tube's grid input distributed capacitance and the peaking coil forms a parallel resonant circuit which is broadly tuned to the 4.5 mc sound i-f frequency. Only this desired frequency is fully developed across the tank and passed into the gate tube.

I checked the resistance of the coil. It measured about two ohms. I checked the resistance of a new coil of the same value. It measured about eight ohms. With fingers crossed and a little less confidence I changed the coil. The audio blasted loud and clear. All the current pushed through the coil had shorted it internally. The 4.5 mc tuned circuit had been destroyed. The audio signal had not been able to get through to the 3BN6. The longer I remain in this business the more stories I shall be able to add to this casebook •

This Month Only!

NEW

G-C

TV AND FURNITURE BEAUTY KIT

G-C SHOP and HOME SPECIAL

SPECIALY PRICED FOR YOU —AND YOUR CUSTOMERS!

CONTAINS • CREME-O-WAX POLISH

• 3 GENERAL SKRATCH STIKS • FREE: G-C KLEER LENS

SELL A KIT ON EVERY SERVICE CALL! Here's a G-C "special" you can't afford to pass up . . . the new TV & FURNITURE KIT. Contains everything you need to make TV and fine furniture finishes sparkle like new. Buy a kit for your shop . . . sell one on every service call. Hurry . . . while this special offer lasts!

| | |
|---------------------------|-------------------------|
| REGULAR LIST | List |
| THIS MONTH ONLY | \$3⁸⁰ |
| | \$2⁵⁵ |

SEE YOUR G-C JOBBER NOW!

GENERAL CEMENT MFG. CO.

Division of Textron Inc. 400 South Wyman Street, Rockford, Illinois

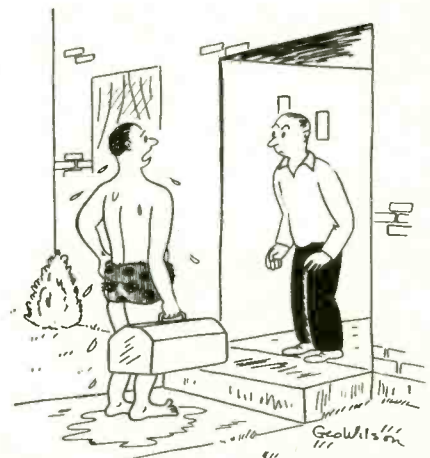

"You the guy with the rush job?"

Rayovox INTERCOM

An all-master 9-room package intercom system uses only one amplifier. Any station may turn on the amplifier by remote control and originate a call with one or all other stations. The system requires only one electrical outlet. A door-answering remote unit plus a door-latch release may be added to serve as an electronic butler. Retail price is \$300. Rayovox Mfg. Co., 902 Albemarle Rd., Brooklyn 18, N.Y. (ELECTRONIC TECHNICIAN 7-6)

RCA CRT'S

The new 14ATP4 is a low-voltage electrostatic-focus, magnetic 90° deflection type having a 450-ma, 8.4-v controlled warm-up time heater. Weighing only 8½ pounds, this rectangular glass picture tube has a 14-inch envelope diagonal and an overall length of 13¾ inches. A new straight type electron gun minimizes deflection distortion and permits a shortened neck. No ion-trap magnet is required. It has a spherical filterglass faceplate and an aluminized screen.

The 21CYP22 is a new round, all-glass shadow-mask type color CRT. It is capable of generating full-color and b&w pictures measuring 19¼ inches by 15½ inches. The all-glass envelope reduces the high-voltage insulation requirements of the color receiver. Radio Corp. of America, Harrison, N.J. (ELECTRONIC TECHNICIAN 7-61)

Association News

TEA Annual Fair

The Texas Electronics Association's Fifth Annual Clinic and Fair will be held in Fort Worth, Texas at the Texas Hotel and Hall of Exhibits on August 2, 3, and 4, 1957. A minimum attendance of an excess of 1,000 service men and service dealers from the five state area, Texas, Arkansas, Oklahoma, Louisiana, and New Mexico is expected.

The 3-day program is crammed full of: management seminars; technical lectures and demonstrations; and entertainment. Hon. Thomas A. McCann, the Mayor and Hon. Robert S. Calvert, Comptroller of the state of Texas are scheduled to speak. Manufacturers, distributors and factory representatives have been invited to participate in this clinic and fair.

NATESA Convention

The annual Radio-TV Electronic Service Industry Convention and Institutes will take place at the Chicago Sheraton Hotel, 505 N. Michigan Ave., August 16th, 17th, and 18th, 1957. This affair has been sponsored over the last seven years by the National Alliance of Television & Electronic Service Associa-

tions. This year, three separate local affiliates, Will County Television & Radio Service Association of Joliet, Milwaukee Association of Radio & Television Services (MARTS) of Milwaukee, and Television Electronic Service Association (TESA) Chicagoland will be co-hosts.

New ESFETA Officers

The 1957-58 officers of Empire State Federation of Electronic Technicians Assoc. are: Pres. Gordon Vrooman; VP Robert Larsen; Secy. George Carlson; Treas. P. P. Pratt;

Sgt. at Arms Thomas Salisbury. ESFETA comprises local associations in N. Y. State.

TESA-MISSOURI Elects

At a meeting held in the Missouri Hotel, the following officers were elected: Wayne Lemons, Pres.; Ed Engel, Secy.; James M. Callison, Treas.; Dennison Houghton, Howard Friener, M. C. Crane, and Arent Patterson, V.P.; Howard Seigen, Mac Metoyer, and Jack Mulford, Board of Directors.

Our
Guarantee
is printed
on our
product



On every packaged PLANET electrolytic capacitor sold through distributors you will find this statement:

GUARANTEED FOR ONE YEAR

Because PLANET CAPACITORS ARE "ENGINEERED FOR QUALITY", because they are carefully controlled through all stages of production and because the finished product is given a 100% electrical and mechanical check—our one-year guarantee is not only made possible, but is conservative.

Actually, thousands and thousands of Planet capacitors five, six and even seven years old are performing excellently, every day, in TV and radio sets all around the world. When you solder a Planet capacitor into a circuit your guarantee of satisfactory performance is right there in front of you—and will be in the circuit for a long, long time. So when you order capacitors—order PLANET.

PLANET SALES CORPORATION

228 BELLEVILLE AVE.

BLOOMFIELD, NEW JERSEY

New

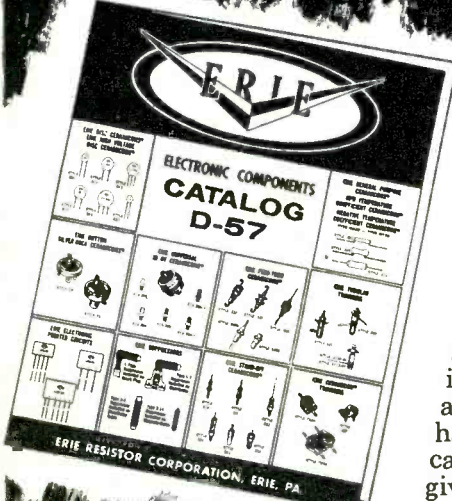

D-57 CATALOG at your Authorized ERIE DISTRIBUTOR

The new ERIE D-57 Catalog, including the complete and enlarged line of ERIE Electronic Components and Corning Glass Works items, is ready. Your authorized ERIE Distributor has a copy for you. If he can't supply you, write us, giving his name.



Make the ERIE Catalog
Your Catalog

ERIE Electronics Distributor
DIVISION
ERIE RESISTOR CORPORATION
ERIE, PA.

MORE

ACTIVE! EFFECTIVE!



KESTER "RESIN-FIVE" CORE SOLDER

THE BEST FOR TV-RADIO WORK . . .
EVERYTHING ELECTRICAL—Kester "Resin-Five" Core Solder is better and faster than any solder ever developed. It has an activated flux-core that does a perfect job on all metals including zinc and nickel-plate. The flux residue is absolutely non-corrosive and non-conductive.

Available in all practical Tin-Lead Alloys; 40/60, 50/50 and 60/40 in diameters of 3/32", 1/16", 3/64", 1/32" and others.

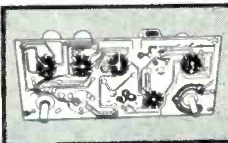

Printed Circuit Soldering
On Copper-etched boards use 60% Tin-40% Lead Alloy . . . for those that are Silver-surfaced use 3% Silver-61 1/2% Tin-35 1/2% Lead

KESTER SOLDER COMPANY

4264 Wrightwood Avenue, Chicago 39, Illinois • Newark 5, New Jersey, Brantford, Canada

Mockups

(Continued from page 39)

the squelch circuit are always very particular, and it would be impossible to get a reliable check on squelch action without the correct resistance in the circuit. This circuit gives perhaps as much trouble as several others combined. Practically everything that happens in a receiver affects squelch action; so it will pay to duplicate original parts as closely as possible. Resistance found in this circuit range from 10,000 to 25,000 ohms and are usually wirewound types.

The multi-conductor cable may be brought into the box through a hole or slot, and anchored inside by a loop-type clamp, to keep the strain off the connections. If the plug has some kind of strain-relief, it is a good idea to use it. Troubles from open wires in a mockup are misleading.

These are usually simpler than the receiver mockups. In general, all that the transmitter requires is its power supply, the microphone connection, and the dummy antenna.

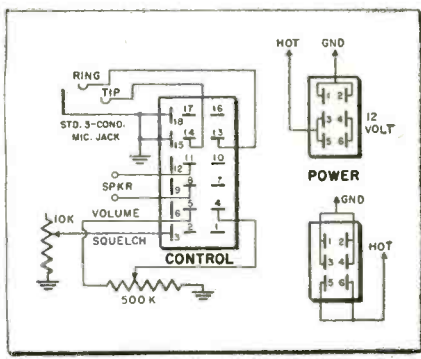

Fig. 10—Control male plug no. 28B890846, female power 9C930034, Motorola T51GGV.

In practically all of the later models, both the transmitter and receiver are mounted in the same box. Sometimes there is an interconnecting-chassis, having plugs and sockets, which interconnect the two units and the power supply. Often in this type of set the receiver's high-voltage supply is used as part of the transmitter's supply, powering the early stages. The final amplifier will then have its own supply. These use one or two large plugs. In the first case, the power supply and control will be combined (RCA) while others (GE and Motorola) may use separate power supply and control plugs. In the latter case, both transmitter and receiver controls are connected through the same large plug.

It is just as easy to combine all functions in a single control mock-up. In addition to the volume and squelch controls, and speaker jacks, a microphone socket is installed on the control box. In some of the mockups, a standard 3-conductor mike-jack is used, and an old reliable T-17B carbon microphone is used. In the early Motorola, the same carbon microphone is used, but with a 4-conductor microphone plug, having a special pin arrangement. (These are the standard Motorola mikes. The pin arrangement is the same as that of the regular Amphenol 4-pin plug, but the #1 pin is exactly in line with the locator notch in the shell. If the Motorola plugs are available, a standard plug may be used.

Remove the set-screw in the shell and allow the insert to float. The pins will then be able to enter the holes in the socket. RCA's mobiles also use the same mike on many models. Some RCA's and GE use a mike-cord terminated in four spade lugs fastened to a 4-contact terminal strip in the control head.

You & the Law

(Continued from page 34)

instance, speeding, driving on the wrong side and going through a stop sign usually are acts within the scope of employment, but deliberately ramming another car probably is not. Certainly shooting another driver is not.

Unfortunately this subject is in one of those areas of the law where answers depend primarily on the facts of each case. However, having the above factors in mind, the technician will be able to reduce his potential liabilities due to acts of his employees. Although use of the automobile has been common to the examples given, the same factors are to be weighed for other acts of the employee. •

Antenna Reflectors

(Continued from page 41)

TV set and reported the effect of the adjustments on all channels. A pair of sound-powered phones was used for intercommunication.

The spacing between the reflector

and the driven element is theoretically $\frac{1}{4}$ wavelength. Inasmuch as more than one channel is involved and other small variations exist, even if the technician was inclined to get out the paper, pencil and formula book, the computations would hold true for only one condition. It is more practical to use the try, look and try again method. The building wall itself may serve as a original antenna reflector was removed and in its place a metal screen was fastened to the wall and used as a reflector for the folded dipole. A ground wire was soldered to the

screen and run to a nearby water pipe riser. The distance of the dipole from the wall was checked by trial adjustments. One man watched the reflector, however, considerable variation in efficiency and effectiveness will occur because of changes in the moisture content on the wall. Some form of metal reflector is more desirable as a permanent installation.

Window screening, a metal plate, or a panel of metal mesh as used for burglary protection on store doors, may be used for the reflector. The type that has all the separate wires

(Continued on page 54)



Sell More Antenna Replacements with the new **CHANNEL MASTER[®]** **TV Antenna Check-Up Kit**

Who says antenna sales must slow down during the Spring and Summer months? Channel Master offers you a **brand new concept in antenna merchandising** that's sure to perk up your antenna business. It's the nationally advertised "TV Antenna Check-Up Kit" — designed to **build store traffic** for you by making present TV owners aware of their faulty antenna installations.

CALL YOUR CHANNEL MASTER DISTRIBUTOR NOW! He also has Posters, Streamers, and Newspaper Mats to help you merchandise the "TV Antenna Check-Up Kit."

This 3-piece consumer literature kit includes:

- 16-page illustrated booklet "Better Pictures On Your TV Set"
 - 10-point check-up folder "Spotting Antenna Trouble"
 - Literature about the TW Antenna
- Use these kits as free giveaways or mailing pieces to build store traffic.



Tie-In with Channel Master's High-Powered National Advertising in America's Leading Magazines

CHANNEL MASTER CORP. ELLENVILLE, NEW YORK

Copyright 1957 Channel Master Corp. Reg. U.S. Pat. Office and Canada

FOR HOUSE CALLS

—it's

HEXA-CON

FEATHERWEIGHT

INSTANT SOLDER GUN

FITS TUBE CADDY—Takes Half the Space of Transformer Guns

SMALLEST SOLDER GUN

WEIGHS ONLY 8 OUNCES

— but

POWER-PACKED AT 150 WATTS and

SOLDERS IN SECONDS

No heavy bulky transformer — sturdy lifetime tip—never wears or bends—effective spotlight

Model G14 with 1/4" tip — \$7.95
Order from your distributor today

HEXA-CON ELECTRIC COMPANY

180 W. CLAY AVE., ROSELLE PARK, N. J.

SERVING INDUSTRY AND CRAFTSMEN FOR A QUARTER OF A CENTURY



SELL-SWAP-BUY

Turn your unneeded equipment into dollars. CORNELL-DUBILIER'S pocket-size monthly magazine gives you space for a Sell-Swap & Buy ad. The ad is FREE—the magazine is FREE. Mailed to your home every month for the asking—use coupon.

CORNELL-DUBILIER ELECTRIC CORP.
DEPT. RT-77, SOUTH PLAINFIELD, N. J.

OK! Send me "The Capacitor"—Free

Name _____ Please Print!

Address _____

City _____ Zone _____ State _____

My occupation or job title is _____

(Continued from page 53)

welded is preferable to avoid static from the reflector due to intermittent or bad contacts.

For ghosts due to frontal or side pickup, the best solution is to take advantage of a high quality antenna, its directional qualities, and its ability to accept the desired signal only. Rotators and multi-element arrays may have to be resorted to under severe circumstances.

It is not always possible to take advantage of the ideal spot. Inaccessibility, congestion, restrictions and unsuitable antenna supporting construction often dictates the use of secondary locations. However, the basic problem remains the same. In any event, leadin should be twisted to avoid stray pickup, and kept as short as possible. Every inch of wire is an inch of loss. Standoff insulators should keep the wire away from all objects including the mast, the edge of roof and the building wall. Impedance matching should be observed both at the antenna and at the set. Installation at points B and D are not only safer, but ignition noise from the streets below may be considerably reduced by the shielding effects of the building itself. •

Labor Relations

(Continued from page 36)

was lapping it up in a tavern. There wasn't any need to spell it out for him this time.

Was The Boss:

RIGHT WRONG

What Arbitrator Carl Warns ruled: "Mr. Benson should have been told at the time he was sent home that he was indefinitely suspended because of intoxication, or that he was discharged. Other supervisory personnel should have been notified in order that the degree of proof customarily obtained be available to support the serious charge. Of course, in those cases where an employee is obviously drunk, inarticulate and abusive, a full hearing prior to leaving the premises is not expected. The evidence does not reveal that the grievant was in that condition. Under the necessity for substantiation of the serious charge, Mr. Benson's prior layoff, although worthy of consideration, is not sufficient to justify his termination of employment. He shall be reinstated without back pay." •



**MERIT DOES NOT
carry water
on both shoulders
MERIT SELLS**

its entire Production to
*Independent Electronic Parts
Distributors for re-sale to
Independent Service Dealers!*

MERIT

MERIT COIL & TRANSFORMER CORP.

4427 N. CLARK ST., CHICAGO 40, ILLINOIS



"... and ... and
JENSEN NEEDLES, too?"



Pat. No. 2757316

RESTORES PICTURE TO DEFECTIVE PICTURE TUBE OF ANY TV SET —

Model K-101

\$550

List Price



LOCATES AND CORRECTS FOR

- Control Grid-Cathode Short
- Heater-Cathode Short
- Open Control Grid
- Open Cathode
- Low Emission
- Combinations of above

Perma-Power COMPANY

3100 N. ELSTON AVE. • CHICAGO 18, ILLINOIS
There's Always Something NEW Being Developed by Perma-Power

ask the
"Man-on-the-Roof"
why he prefers

South River

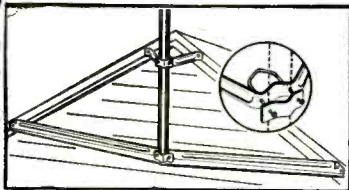

EAVE MOUNT Model EM-48

One piece construction of heavy gauge, embossed steel, Hot-Dip galvanized to prevent corrosion. Unique design of lower bracket gives extra strength and rigidity. Extended lip supports mast during installation. 48" spread permits generous spacing between brackets for excellent mechanical mast support. Both 3" embossed steel upper bracket and lower bracket have new "reversed" U bolt and clamp feature for Spintlite fastening.

Also available with 60" spreads: EM-60.

Write for 1957 Catalog

SOUTH RIVER
METAL PRODUCTS CO., INC.
South River, New Jersey

pioneer & outstanding producer of finest line of antenna mounts

INDEX TO ADVERTISERS

July, 1957

| | |
|---------------------------------------|-------------|
| Aerovox Corp. | 2 |
| American Television & Radio Co. | 55 |
| CBS-Hytron | 13 |
| Centralab Div., Globe-Union, Inc. ... | 6 |
| Channel Master Corp. | 53 |
| Chicago Standard Transformer Corp. 18 | |
| Cornell-Dubilier Electric Corp. ... | 12, 54 |
| Deutschmann Corp., Tobe | Cover III |
| Electronic Technician | 18 |
| Electro-Voice, Inc. | 15 |
| Erie Resistor Corp. | 52 |
| General Cement Manufacturing Co. 50 | |
| General Electric Co. | 17 |
| Heath Co. | 19 |
| Hexacon Electric Co. | 54 |
| Hickok Electrical Instrument Co. | 39 |
| International Resistance Co. ... | Cover II |
| Jensen Industries, Inc. | 54 |
| Kester Solder Co. | 52 |
| Littelfuse, Inc. | 7 |
| Mallory & Co. Inc., P. R. | 34, 35 |
| Merit Coil & Transformer Corp. | 54 |
| Motorola, Inc. | 56 |
| Perma-Power Co. | 55 |
| Planet Sales Corp. | 51 |
| Precision Apparatus Co. Inc. | 10 |
| Quam-Nichols Co. | 47 |
| Radiart Corp. | 12, 54 |
| Radio Corp. of America ... | 4, Cover IV |
| Raytheon Manufacturing Co. | 20 |
| Simpson Electric Co. | 14 |
| South River Metal Products Co. | 55 |
| Sprague Products Co. | 11 |
| Sylvania Electric Products, Inc. ... | 8, 9 |
| Tung-Sol Electric, Inc. | 48, 49 |
| University Loudspeakers, Inc. | 5 |
| Wen Products, Inc. | 3 |
| Winegard Co. | 16 |

While every precaution is taken to insure accuracy, we cannot guarantee against the possibility of an occasional change or omission in the preparation of this index.

EXPAND YOUR PORTABLE TV SALES

WITH



INVERTERS

for changing your storage battery current to A. C. HOUSEHOLD ELECTRICITY

Anywhere ... in your own car!

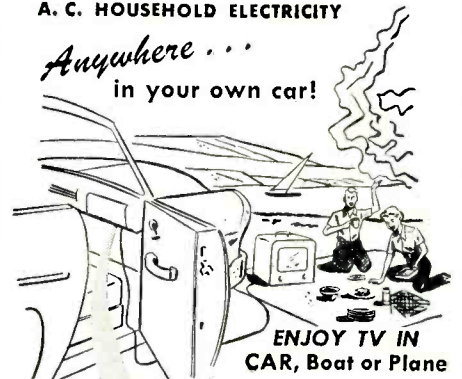

ENJOY TV IN CAR, Boat or Plane

mounted out of sight under dash or in trunk compartment!



EASY TO INSTALL
EASY TO OPERATE

ATR INVERTERS

especially designed for operating standard 110 volt A.C. portable TV sets

- also
- TAPE RECORDERS
 - WIRE RECORDERS
 - DICTATING MACHINES
 - ELECTRIC RAZORS

for

- EXECUTIVES
- SALESMEN
- PUBLIC OFFICIALS
- POLICEMEN
- FIREMEN
- OUTDOOR MEN
- REPORTERS
- FIELD INSPECTORS
- DOCTORS
- LAWYERS, ETC.

See your jobber or write factory

✓ NEW MODELS ✓ NEW DESIGNS ✓ NEW LITERATURE
"A" Battery Eliminators, DC-AC Inverters, Auto Radio Vibrators



AMERICAN TELEVISION & RADIO CO.

Quality Products Since 1931

SAINT PAUL 1, MINNESOTA, U. S. A.

How to add \$1,040 to your profit this year

One simple fact will put at least \$1,040 extra profit into the pockets of many men in your business this year. That fact is: *Every fourth car on the road needs a car radio.*

This means one out of every four of your customers is a good car radio prospect. And you can close most car radio sales in less than five minutes—just by telling prospects these two things:

They can own a Motorola® Car Radio for as little as \$39.95.

There's a Motorola Car Radio custom-designed to fit like it came with their car.

And even if you sell only one Motorola Car Radio a week, your yearly profit will amount to at least \$1,040!

Sales higher than ever. Car radio sales increased by 25% last year. And this year—with the most revolutionary improvement in 27 years—Motorola Car Radios are selling faster than ever.

Transistor-powered '57 Motorola Car Radios give you selling advantages like these: Transistors (1) have extra long life, (2) replace 16 parts that cause 75% of the trouble in other car radios, (3) cut battery drain by 50% or more, and (4) end all mechanical noise and vibration.

Priced to move fast. Motorola Car Radios retail at prices your customers are ready to pay—as low as \$39.95, with a big profit margin for you.

No installation problems. You can do it yourself for extra profit or your Motorola installation depot will do it for you.

Why miss out on this easy, plus-profit opportunity any longer? Just mail this coupon today for all the facts. No obligation, of course.

Motorola, Inc., Dept. T-7
4545 W. Augusta Blvd.
Chicago 51, Illinois

Attn: Car Radio Department

Please give me all facts about the plus-profit Motorola Car Radio business. Thank you.

Name _____

Address _____

City _____ Zone _____ State _____

 **MOTOROLA**
World's Largest Exclusive Electronics Manufacturer

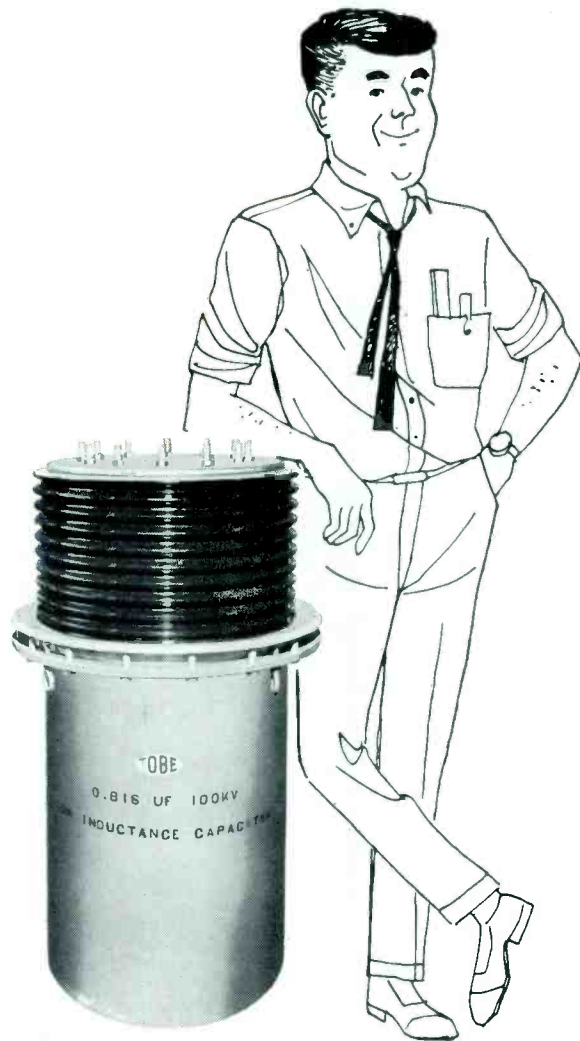

20,000 megawatts

What's this "big feller" doing in a service ad?
The story behind it is important to you.

The "big feller" is known as a "low-inductance energy-storage capacitor." It's made by Tobe, and used in nuclear research. And get this . . . it has a rating of 100,000 volts. What's more, it is capable of delivering a peak power of 20,000 megawatts.

This is just one example of the many types of capacitors Tobe has been building for 35 years. This fact is important to you because the new quality line of Tobe service capacitors is built to the same high standards. The line includes all the popular types required to meet 90% of all replacement needs.

You'll be pleased when you switch to Tobe. So will your customers. See your Tobe jobber today for full details, or write Tobe Deutschmann Corp., Service Div., 2900 Columbia Ave., Indianapolis, Ind.

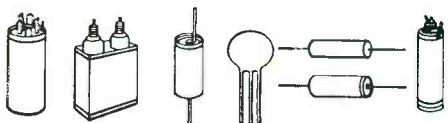

Specify

TOBE

Capacitors • Pioneers Since 1922

Temperatures are rising

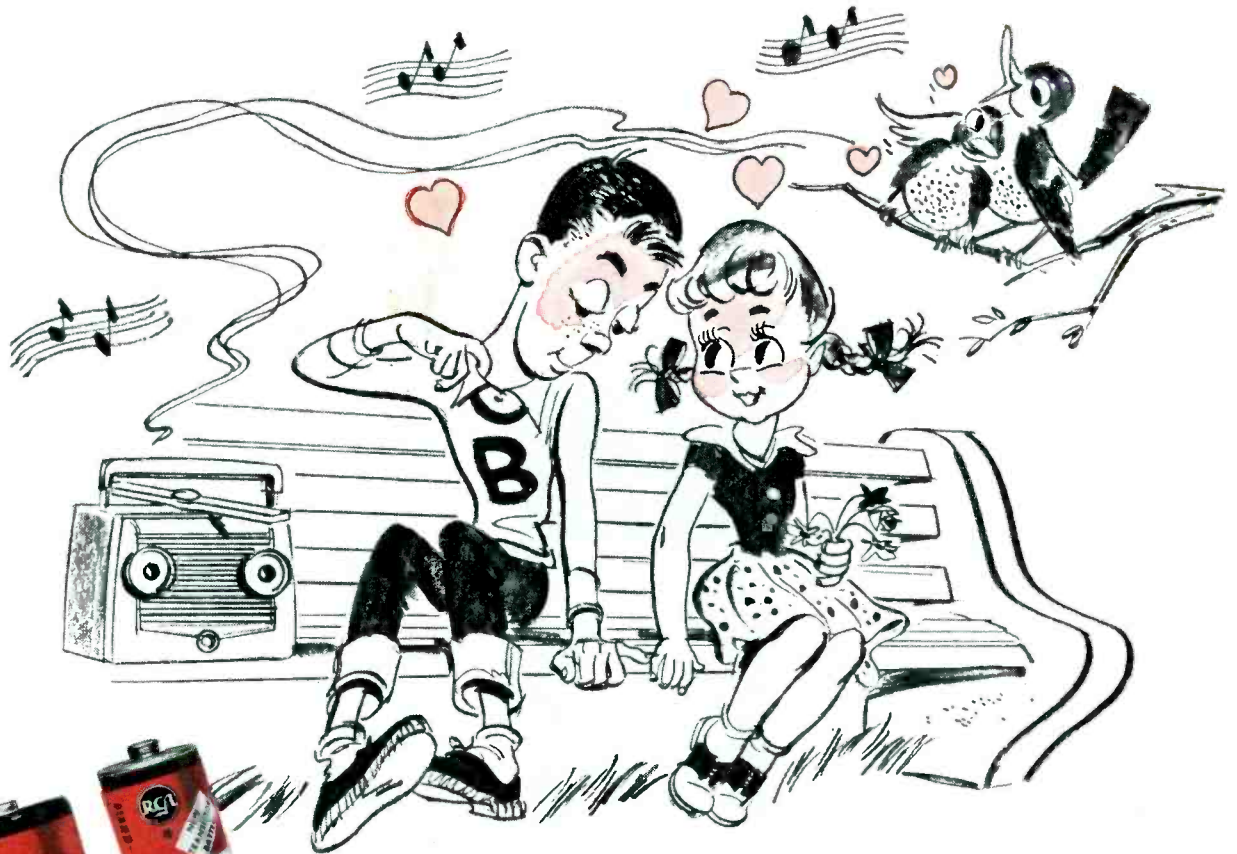

...and so are profits with

RCA Batteries!

There's a mighty big market for RCA Battery sales with all America, young and old, heading for the great outdoors with millions of portable radios in tow!

This is far and away your best battery selling season. NOW is the time to cash in on high turnover, easy-to-take profits with RCA Batteries. Stock 'em, display 'em, sell 'em! Available from your local distributor—so do it now!



RADIO CORPORATION of AMERICA

COMPONENTS DIVISION

CAMDEN, N. J.

RCA BATTERIES...THE BRAND THAT COMMANDS PUBLIC DEMAND!