

1947 MARCH

RADIO RETAILING
& Television

CALDWELL-CLEMENTS, INC.

TELEVISION •

RADIO



ELECTRICAL

APPLIANCES

PHONOGRAPHS &

RECORDS

SOUND &

SERVICE

● Look for this symbol of
PREMIUM QUALITY

**APPROVED
 PRECISION
 PRODUCTS**



Your guarantee of **PERFORMANCE** *at no extra cost*

The words "Approved Precision Products" on a Mallory box mean something more than an advertising slogan. They're your guarantee of *premium quality*—a guarantee backed by fifteen years of performance.

They're reminders that more Mallory-made vibrators are in use today than all other makes combined... that Mallory capacitors are universally preferred because they're backed by the most rigid purity-control standards

in the industry... that Mallory resistors, fixed and variable, are justifiably famous for closer tolerances, extra dependability.

"Approved Precision Products," too, mean a *complete line* of parts—parts that are sold through carefully-selected, conveniently-located distributors with the *capacity* and *desire* to serve you well. Look for the words "Approved Precision Products." They're not a symbol of higher cost—just that

YOU EXPECT MORE AND GET MORE FROM MALLORY

P. R. MALLORY & CO. Inc.
MALLORY
 VIBRATORS . . . VIBRAPACKS* . . . CAPACITORS . . . VOLUME CONTROLS . . . SWITCHES . . . RESISTORS . . . FILTERS . . . RECTIFIERS . . . POWER SUPPLIES.
 *Reg. U. S. Pat. Off.
APPROVED PRECISION PRODUCTS

P. R. MALLORY & CO., Inc., INDIANAPOLIS 6, INDIANA

RADIO & Television RETAILING

Including RADIO & Television TODAY

ORESTES H. CALDWELL
Editor

M. CLEMENTS
Publisher

JOHN L. STOUTENBURGH
Executive Editor

DARRELL BARTEE
Managing Editor

HAROLD R. ELLIS
Technical Editor

RUTH MORRIS
Records Editor

CHARLES F. DREYER
Art Director

LUCILLE M. JONES
Assistant Editor

READER SERVICE
JANE NORMAN

BUSINESS DEPARTMENT

LEE ROBINSON
Sales Manager

M. H. NEWTON
Business Manager

EDWIN WEISL, JR.

R. A. WHITE

BEN MORRIS
Promotion Manager

BETTY HALL
Production

CIRCULATION DEPARTMENT

B. V. SPINETTA
Circulation Manager

W. W. SWIGERT
Credit Manager

BRANCH OFFICES

CHICAGO 6

R. Y. FITZPATRICK, Manager
S. GASKINS THOMAS FAHEY
201 N. Wells St. RAN. 9225

CLEVELAND 14

DAVID J. O'ROURKE, Manager
Citizens Bldg., 850 Euclid Ave.
MAin 8270

LOS ANGELES 5

THE ROBERT W. WALKER CO.
684 S. Lafayette Park Pl.
Drexel 4388

SAN FRANCISCO 4

68 Post St. SUtter 5568

RADIO & Television RETAILING,
March, 1947, Vol. 45, No. 3, 25
cents a copy. Published monthly by
Caldwell-Clements, Inc., 480 Lexing-
ton Ave., New York 17, N. Y. M.
Clements, president; Orestes H. Cald-
well, treasurer. Subscription rates
United States and Latin American
countries, \$1.00 for one year, \$2.00
for three years. Canada \$1.50 for one
year, \$3.00 for three years. All
other countries \$2.00 for one year,
\$4.00 for three years. Printed in
U. S. A. Re-entered as second class
matter April 21, 1944, at the Post
Office at New York, N. Y., under
the act of March 3, 1879. Member
of Audit Bureau of Circulation.
Copyright by Caldwell-Clements,
Inc., 1947. *Trade-Mark Reg. U. S.
Pat. Off.

IN THIS ISSUE

MARCH, 1947

★ **Radio, FM, Television**

EDITORIAL—Multi-Selling Will Keep Us Prosperous!	33
RADIO, APPLIANCES, RECORDS & TELEVISION TODAY	34
FOUR-WAY FLOW OF PROFITS	38
BETTER PROFITS FROM BETTER SERVICE	40
DESIGNED FOR SELLING	42
NEW SETS TO HIKE PROFITS	44
STORE ROUNDS UP SALES	46
LIST OF HOME RADIO MANUFACTURERS	48
FM—WHAT IT IS—HOW IT WORKS	52
FM GO-AHEAD TO THE DEALER	54
EXTRA PROFITS IN SELLING FM SETS	58
FM SALES WILL CLIMB!	60
FM SETS TO SELL	64 and 70
224 FM STATIONS ON AIR	72
FM—CONDITIONAL GRANTS & CONSTRUCTION PERMITS	76
FM DIPOLES "UP" PROFITS	79
HOW FM WAS DEVELOPED BY E. H. ARMSTRONG	85

★ **Records, Phonographs, Accessories**

COVER—Record News Flashes	87
MAKE EVERY KICK A BOOST!	89
RECORD \$\$ PAVE ROAD TO PROFITS	90
MODERN RECORD CENTER	94
TOP-SELLING TUNES	98
NEW PHONO LINES	100
USE DISCS TO SELL PHONOS	102

★ **Electrical Appliances**

COVER—You Know, But Does the Customer?	119
MAKE CLEANER SALES CLIMB!	121
MAKE-TO-ORDER FINANCING FOR THE DEALER	122
NEW CONTACTS WITH FARM BUYERS	124
NEW ELECTRICAL HOME APPLIANCES	126 to 130
APPLIANCE SERVICE TIPS	132
LATEST LIGHTING ITEMS	134
NO "PAY" FOR SERVICERS	136
LIST OF HOME ELECTRICAL APPLIANCE MANUFACTURERS	138

★ **Service and Sound**

COVER—FM Service—The Profits at Stake	143
HOW TO INSTALL FM	145
FILE YOUR CLAIM IN FM SERVICING	146
TRACING OUT FM RADIOS	148
USE THESE IDEAS IN FM WORK	154
MORE WAYS TO SAVE TIME	156
NOVEL PA JOBS	158
NEW AIDS FOR FM SERVICE	160
NEW EQUIPMENT FOR SOUND INSTALLERS	162

SALES TIPS AND PROFIT POINTERS	166
TELEVISION NEWS	168
MONEY-MAKING MERCHANDISER	170
NEWS OF THE INDUSTRY	Starts on page 172

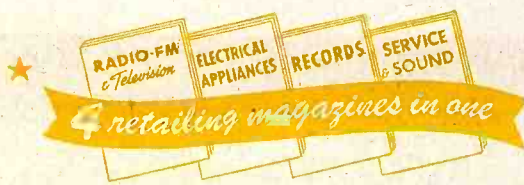

**29,000 COPIES
THIS ISSUE**

member of
**AUDIT BUREAU
OF CIRCULATION**

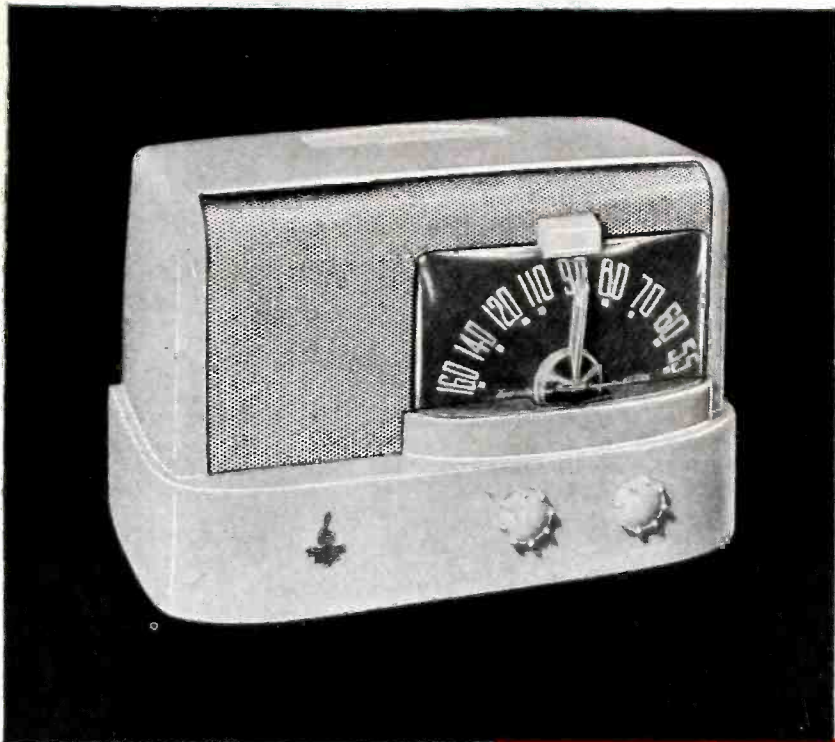

*IN THE
Moderne
Manner*

Emerson Radio Model 511. In ivory and gold (also Model 517 in ebony and maroon) AC-DC superheterodyne. Modern design which creates a sensation wherever shown. Feature it as a style and **\$29⁹⁵** reception LEADER

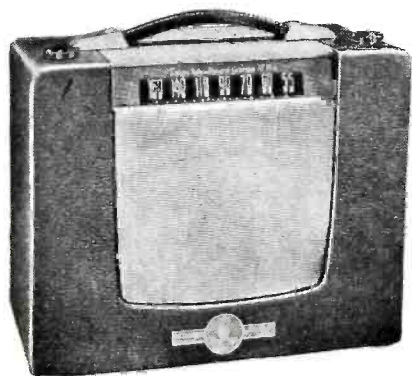

Emerson Radio 3-Way Portable Model 536. Most highly powered set. Handsome cabinet, sturdily constructed. All advance features. *Less batteries.* . . . **\$39⁹⁵**

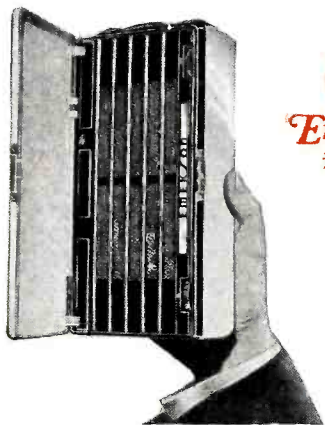

Emerson Radio Model 508. Tremendous selling pocket receiver in unbreakable tenite case. Unbelievable power and tone. *Complete* . . . **\$37⁵⁰**



*Lead with the
Leader
in '47*

Radio's Greatest Promotion Campaign

Backing greatly increased production and dealer shipments of new 1947 Emerson Radio models in all territories —

A new series of BIG Factory-Distributor ads in more than 300 cities . . .

Local tie-up ads by hundreds of Franchised Emerson Radio Dealers . . . Participating dealer ads in more than 1,000 towns.

Big space — continuously — by major outlets. Dramatic point-of-sale promotion.

EMERSON RADIO AND PHONOGRAPH CORPORATION • NEW YORK 11, N. Y.

World's Smallest AC-DC SUPERHETERODYNE

Emerson Radio Model 540. A handful of SUPER POWER and TONE. All new quality set features. Tubes: 1 type 12BE6, 1 type 12BA6, 1 type 12AT6, 1 type 50B5, 1 rectifier 35W4. In colors—Walnut Finish, Ivory, Green, Red. **\$19⁹⁵**
(in Walnut Finish)

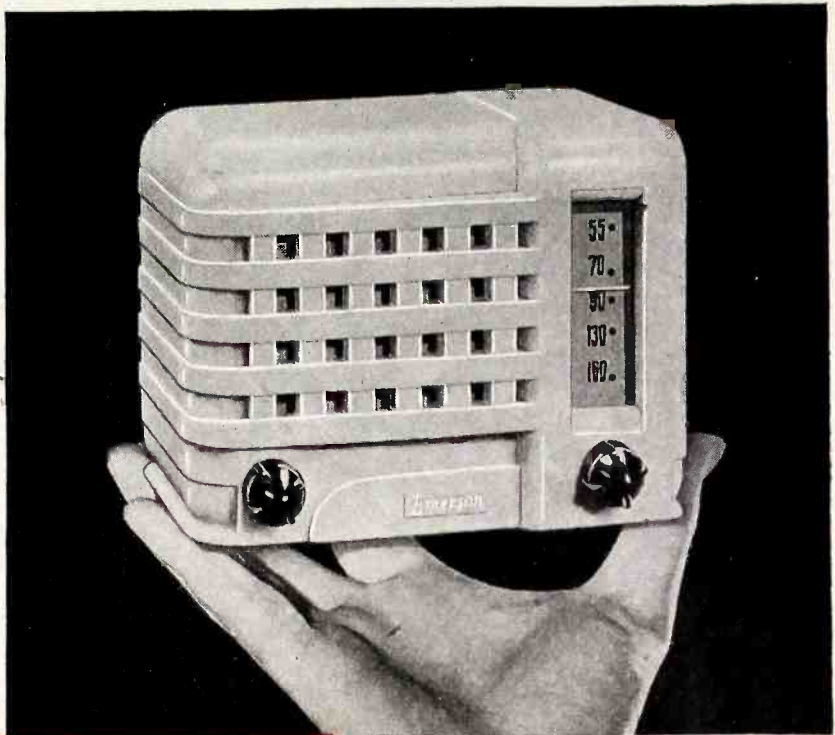

THE NEW 1947 Emerson Radio

In Behalf of ALL Dealers Alike

Emerson Radio headquarters and all Emerson Radio distributors are united in this promotion for ALL DEALERS ALIKE.

All advertising in this campaign carries the urge to "SEE YOUR EMERSON RADIO DEALER."

In addition to the overall promotion, all dealers are given opportunity to tie in with their own newspaper copy. Newspapers everywhere are cooperating in this joint effort.

This is the COMPLETE promotion service which enables YOU to "Lead with the Leader in '47!"

Call Your Emerson Radio Distributor



Emerson Phonoradio Model 525. Completely automatic. It has "everything" in advanced features and outstanding performance. Walnut cabinet. **\$99⁹⁵**



Emerson Electric Record Player Model 542. Plays 10-inch and 12-inch records. Easy portability. Full, rich tone. Beautiful, sturdy, cabinet **\$39⁹⁵**

EMERSON RADIO AND PHONOGRAPH CORPORATION • NEW YORK 11, N. Y.



Everything in production facilities plus engineering resourcefulness means the utmost in transformer performance and dependability today. Merit Quality is the answer to your problems.

EXPORT DEPARTMENT:
1791 Howard St., Chicago 26, U. S. A.

Cable Address: MERIT



MERIT COIL & TRANSFORMER CORP.

TELEPHONE
4427 North Clark St. Long Beach 6311 CHICAGO 40, ILL.

Spring-time—

As Any-time—

Is "Big Four" Time

March is Spring-Cleaning time. That's when you check your merchandise and plans, as warm weather products replace winter stocks. This is also a good time to review your "Big Four" activity of offering your community a full line: Radio, Appliances, Records, Service. This year, with the exception of a few appliances and some large consoles, much merchandise is available. Manufacturers and distributors plan their production and deliveries well ahead, so get your orders in now.

Your biggest bet is in the portable and personal RADIO. With new models coming on the market, you can sell "music wherever they go"—to beach parties, for weekends in the country, or for personal use in the city. Don't forget to order batteries, too, for replacement sales.

Promotion of warm-weather APPLIANCES starts now. Do you know that refrigerators and laundry equipment, to say nothing of fans (and now, food freezers) sell best during the next few months? Make the most of that.

PHONOGRAPHS and radio-phonograph combinations are in better supply to meet increasing demand. Portable sales pick up as the "outdoors" open up. Sell these together with RECORDS. And don't overlook needles and accessories.

Remember our national "Tune-up, Tube-up, Check-up" program last Fall? End of Winter gives you an opportunity to check reception of sets, to repair antennas, to install or overhaul auto radios. Check November's SERVICE Section for a refresher.

The publishing job of RADIO & Television RETAILING is to serve dealers and distributors with selling and servicing information on all their chief activities. The trade handles these together; we publish within the covers of a single monthly magazine, all the information you need. Success of this Big Four publishing policy: thousands of dealers across the U.S. are now in Big Four retailing to stay—for more business, for business throughout the entire year, for larger profits. Nothing succeeds like success.

The Publishers

Opinions on radios may differ- but facts* *Never!*



MODEL 131. Automatic phono-radio in portable-style cabinet. Has newly developed Selenium rectifier, giving twice the power of comparable sets. AC only.



MODEL 132. AC-DC. Amazing console quality tone, power, performance: 7 tubes (incl. rectifiers); 3 watts undistorted output. Greatest value in table radios.



MODEL 201. With new war-developed miniature tubes... greater power, sensitivity, selectivity. Ideal "extra" radio. AC-DC.

***ECA** Radio Warranty Tag gives the facts... builds customer confidence . . . clinches sales!

Precision engineering, magnificent tonal quality, superb cabinetry, outstanding dollar-for-dollar value . . . all these are yours with ECA Radios. But added to these, is an exclusive sales *plus*—the ECA Radio Warranty Tag—the first "informative label" on radios . . . hailed—and used—by dealers as a powerful sales-making feature.

- **ECA RADIO DIRECT-TO-DEALER SALES POLICY**—Means greater value for your customer.
- **DEALERS ARE SELECTED—AND LIMITED.** That means protected territories and higher sales potential for *your* store.
- **RETAIL PRICES MAINTAINED:** Freedom from price-cutting, competition, and *protected profits* for you.
- **NATIONAL ADVERTISING**—Reaching millions of prospects and pre-selling them for you.
- **COOPERATIVE NEWSPAPER ADVERTISING**—To help you bring 'em into *your* store.

The ECA Radio Dealer Franchise offers an outstanding money-making opportunity. Your territory may still be open . . . write for information, **TODAY!**



ELECTRONIC CORP. OF AMERICA

170 53rd STREET, BROOKLYN 32, N. Y.

RADIOS • RADIO PHONOGRAPHS • PORTABLES • FM • TELEVISION • RECORD PLAYERS

ELECTRONIC CORP. OF AMERICA
170 53rd St., Brooklyn 32, N. Y.

R-3

I am interested in the ECA Radio Dealer Franchise. Please send details.

Name Please Print

Store Name

Address

City Zone State
Attach to your letterhead

A totally new radio experience!

Stewart-Warner's thrilling new



Strobo-Sonic Tone



Against a background of velvet silence, you hear music in the richness of its full dimensions. You hear, at last, the beautiful harmonic overtones and the real-life-quality of every instrument and voice.

With FM, static and interference vanish. Fading disappears. Your favorite type of music is revealed in a thrilling new brilliance, as true and natural as a personal performance.

Stewart-Warner FM reception is unbelievably distinct and clear—a totally new kind of listening pleasure.

Listen to Stewart-Warner *FM* Strobo-Sonic Tone for the wonderful difference!

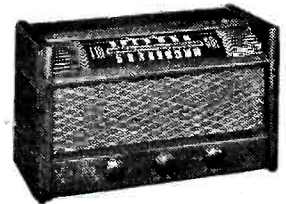
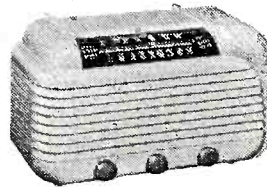

FM-AM TABLE RADIOS

Selenium rectifier and 7 tubes, AC-DC, built-in antennae, 5-in. PM dynamic speaker, inverse feed-back. Smart wood cabinets in desert tan, walnut; plastic in ivory, walnut.

FM-AM CONSOLE RADIO-PHONOGRAPH

AM push-button tuning, rectifier and 8 tubes, tone control, permeability tuning, inverse feed-back, RF stage both bands, built-in antennae. AC-operated. Intermix changer. Two album compartments. Mahogany cabinet, no-lift top.

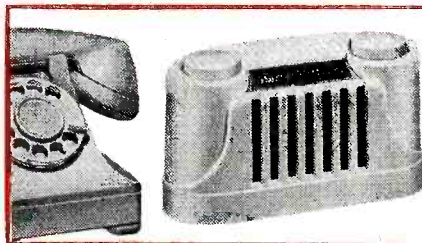

THE AIR PAL *A Console in a Jewel Case!*
Powerful AM performance anywhere you plug in AC-DC—ship, train, hotel, office, home. Small as a phone, yet has slide-rule dial, planetary tuner, built-in aerial. UL-approved. Weighs 3¼ lb. Ebony, walnut, ivory plastic. It's terrific!

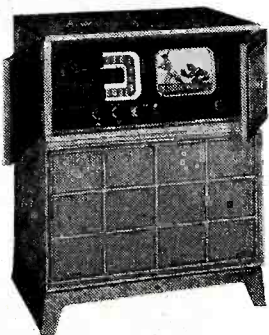

DIRECT-VIEW TELEVISION All 13 telecast bands with FM sound, plus the finest AM radio. Bright, clear pictures under living-room lights. A whole theater for the home, tavern, or hotel! Big 10-in. picture tube. Custom-built cabinets.

A MODEL FOR EVERY PURPOSE—A RADIO FOR EVERY ROOM

Stewart-Warner

AM Radios FM

Radio-phonographs • Television

CHICAGO 14, ILLINOIS





RADIO TUBES

EVERY SERVICE-MAN DISCOVERS

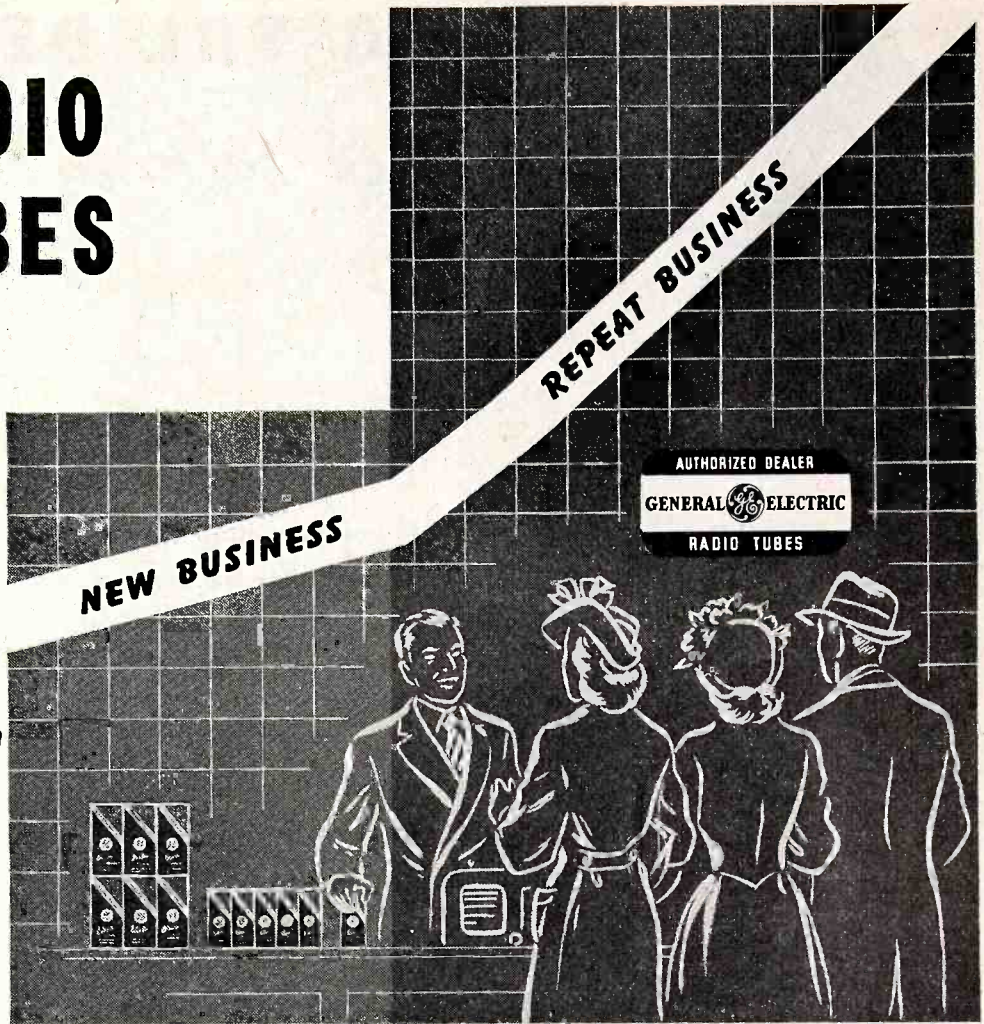

...WHEN HE CHARTS HIS SALES, THAT GROWTH AND RISING PROFITS COME FROM SATISFIED CUSTOMERS WHO BUY AGAIN!

VITAL to your shop's expanding success are the clients you've served well—who therefore will come back... as well as recommend you to *other* radio owners needing service.

Tubes which you install, determine to a great extent how well—and how long—repaired sets will perform. So give *your* clients the BEST! Always replace faulty radio tubes with General Electrics. They're tops in quality... long-lived... carry a famous

name in which the public has learned to place complete confidence.

Thus you'll make loyal friends of owners whose radios you service, to a point where brand-new customers will become "frosting on the cake" instead of your principal source of revenue. From today on... build for *more repeat business*, increased profits, by installing and selling G-E precision-made radio tubes! *Electronics Department, General Electric Company, Schenectady 5, New York.*

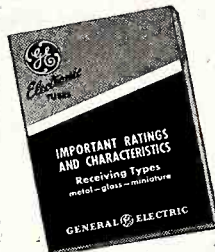

● G. E.'s fact-filled Tube Characteristics Book ETR-15 will help you in your radio service work. Send for your copy. It's free!

GENERAL ELECTRIC

FIRST AND GREATEST NAME IN ELECTRONICS

176-F3-8850



The new 6B16
AMPLIFIER
PENTODE
Actual Size

TUNG-SOL DEALERS

can't help talking about it!



"Now, take that fish line, Joe. If it breaks now you'll be plenty sore. It doesn't make any difference if the fellow who made it made a thousand or ten thousand perfect lines before this one. It's the one you're using that counts.

"It's the same with a line of radio tubes. The one you're using is the important one. You know we dealers have learned that it pays to look for quality in the lines we carry. Quality does two things for

us. It builds customer good-will and assures that the work we do stands up . . . don't have to do it over on a no-charge call-back.

"That's why I recommend the Tung-Sol line. Those Tung-Sol people know quality. They should! They've been maintaining high standards on precision

jobs in mass production since 1907. Their tubes and dial lights are tops.

"The line's complete so you can take care of everything that comes in, Joe, if you can, deal with a Tung-Sol jobber. He's not only interested in selling you but he will give you some idea on how to move merchandise and get more service business. Get your fish in, Joe. Don't let my talking bother you."

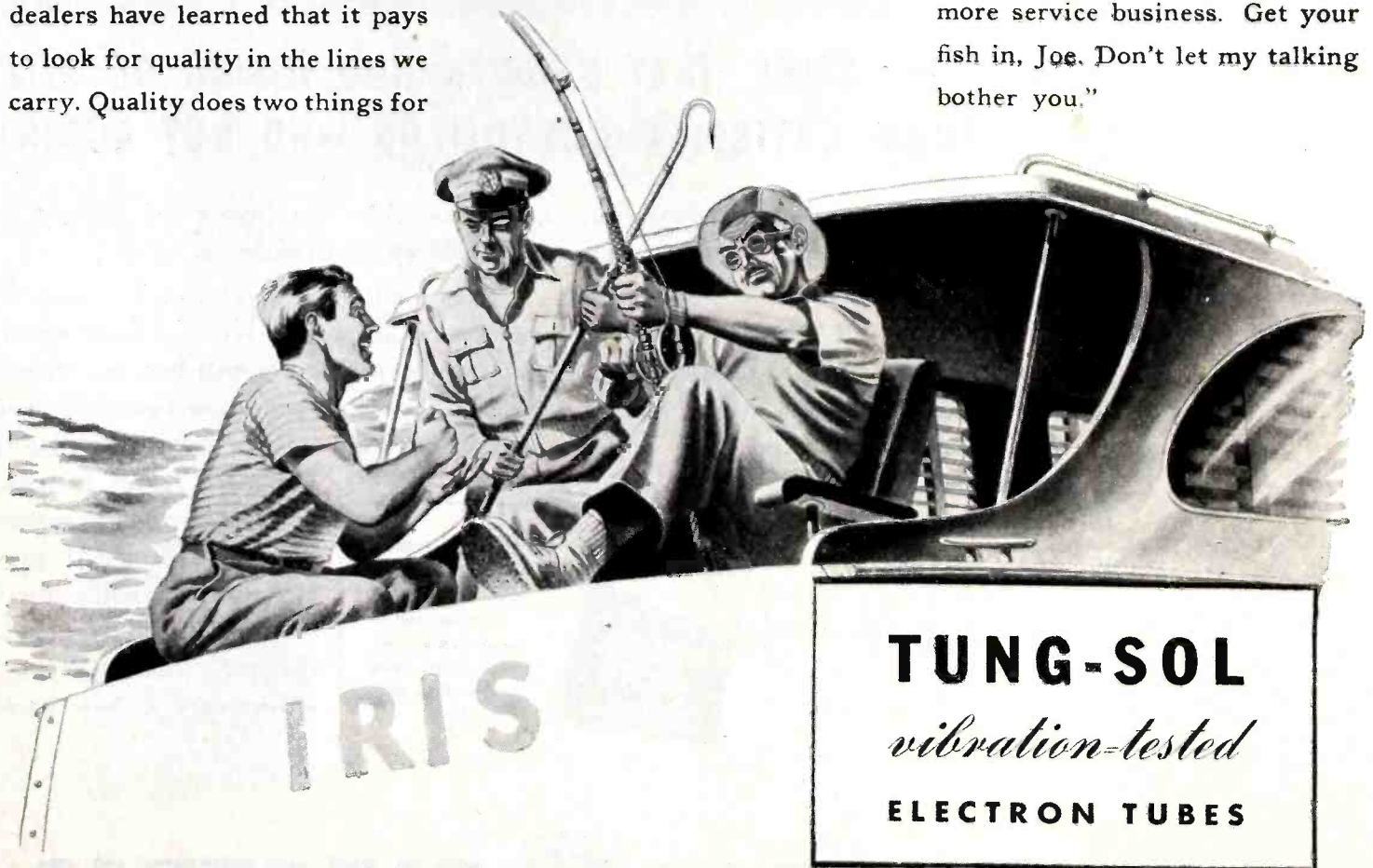

TUNG-SOL LAMP WORKS, INC., NEWARK 4, NEW JERSEY
Sales Offices: Atlanta • Chicago • Dallas • Denver • Detroit • Los Angeles • New York
Also Manufacturers of Miniature Incandescent Lamps, All-Glass Sealed Beam Headlight Lamps and Current Intermittors

SALES MULTIPLY WHEREVER THEY GO...

WITH THE

Portable Recordio

T. M. REG. U. S. PAT. OFF.

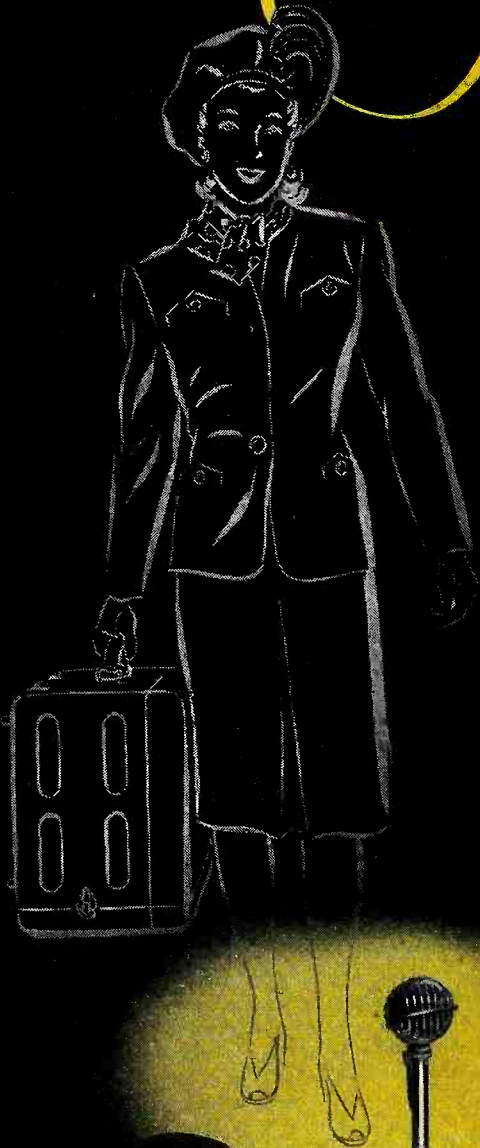

● Each RECORDIO sale starts a series of allied repeat sales of RECORDIO DISCS and RECORDIOPPOINT NEEDLES. This is especially true of the DUO-CORDER... a dual-speed, portable RECORDIO—Recorder-Phonograph. The Duo-Corder offers professional-type recording excellence and its dual speed recording feature more than doubles the recording time on standard size recording discs. Begin your cycle of repeat profits now... the Duo-Corder is available for *immediate delivery!*

RECORDIO *by* WILCOX-GAY CORPORATION • CHARLOTTE, MICHIGAN

110M

Collier's

is Beamed
to the Age
of Acquirement



Facts Prove Collier's

The Best Buy of the "BIG 3" Weeklies

Collier's spotlights America's richest market . . . the Age of Acquirement . . . the 25 to 45 year age group. And to the advertiser who thinks ahead this is important . . . for these are the people who buy. These are the men and women who are carving out a future for themselves . . . establishing homes, starting families, acquiring possessions . . . in other words, making their dreams come true. Recently, The Psychological Corporation . . . in a survey of eight thousand homes in 125 representative towns and cities . . . proved that Collier's families rate well above the average buyer in their "plans to buy." To tap this profitable market costs less through Collier's than through either of the other "Big 3" weeklies.

FOR FEWER DOLLARS

That Collier's rates have not increased in five years is no accident. The low rates are the result of a determined effort to keep the circulation constant in order to continue to deliver the same quality market at low cost. The cost per thousand circulation of Collier's is the lowest of the "Big 3" weeklies.

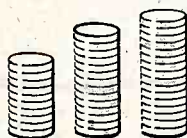

THE "BIG 3" WEEKLIES	PAGE RATE	COST PER M CIRCULATION
COLLIER'S WEEKLY (B)	\$ 7,000	\$2.49 *
WEEKLY (C)	14,500	2.79 †
	10,000	2.70 †

*A.B.C. †Publisher's Guarantee

MORE SALES MESSAGES

Collier's low unit rate brings continuity within reach of the limited budget . . . enables the advertiser to buy *more* insertions, *more* impressions, *more* weeks of national coverage . . . makes deeper penetration of the market possible.

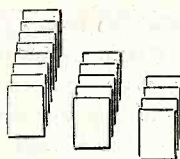

THE "BIG 3" WEEKLIES	\$50,000 WILL BUY	SALES MESSAGES
COLLIER'S WEEKLY (B)	7.14 pages	20,058,695
WEEKLY (C)	3.45 pages	17,940,000
	5.00 pages	18,500,000

MORE BUYERS

Collier's is particularly appealing to the "Age of Acquirement" . . . the 25 to 45 year age group . . . the men and women who buy. Of the "Big 3" weeklies, Collier's has the greatest percentage of men and women in this bracket.

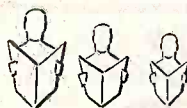

THE "BIG 3" WEEKLIES	% OF MEN AND WOMEN IN AGE OF ACQUIREMENT
COLLIER'S WEEKLY (B)	42.6%
WEEKLY (C)	38.1%
	38.7%

Collier's for Action...

ON THE BEAM

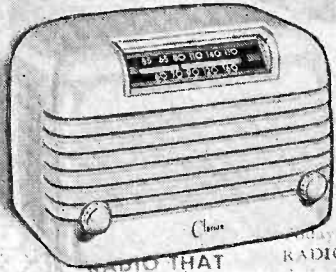

The **MANHATTAN**—Table model. Beautifully styled, competitively priced.



3-WAY PORTABLE—AC, DC, battery. Many exclusive features.



The **SYMPHONETTE**—Table combination. 275% more power.

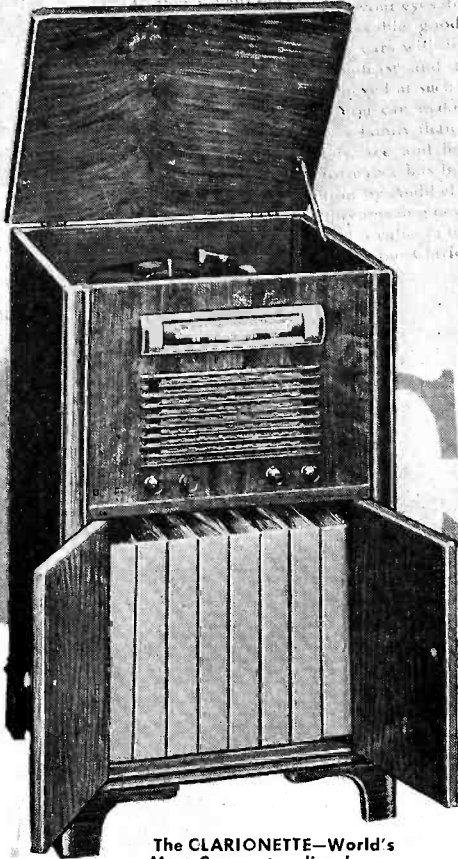

The **CLARIONETTE**—World's Most Compact radio-phonograph console combination.



Four models of a distinguished line . . . leaders in their price class . . . backed by consistent national advertising . . . entrenching Clarion Dealers against the coming buyers' market. The sensational success of the **CLARIONETTE** is being duplicated by the Symphonette table combination, the 3-Way portable and the Manhattan table model, a strictly competitive value. Each is "beamed" to reach today's most active consumer market. Write for booklet "Sound Selling Steps."

WARWICK MANUFACTURING CORPORATION
4640 West Harrison, Chicago 44, Illinois

Calls the World to your Door

Clarion

RADIO

AMERICA'S FIRST
AUDIBEL RATED

MAKING TUBES IS EASY..

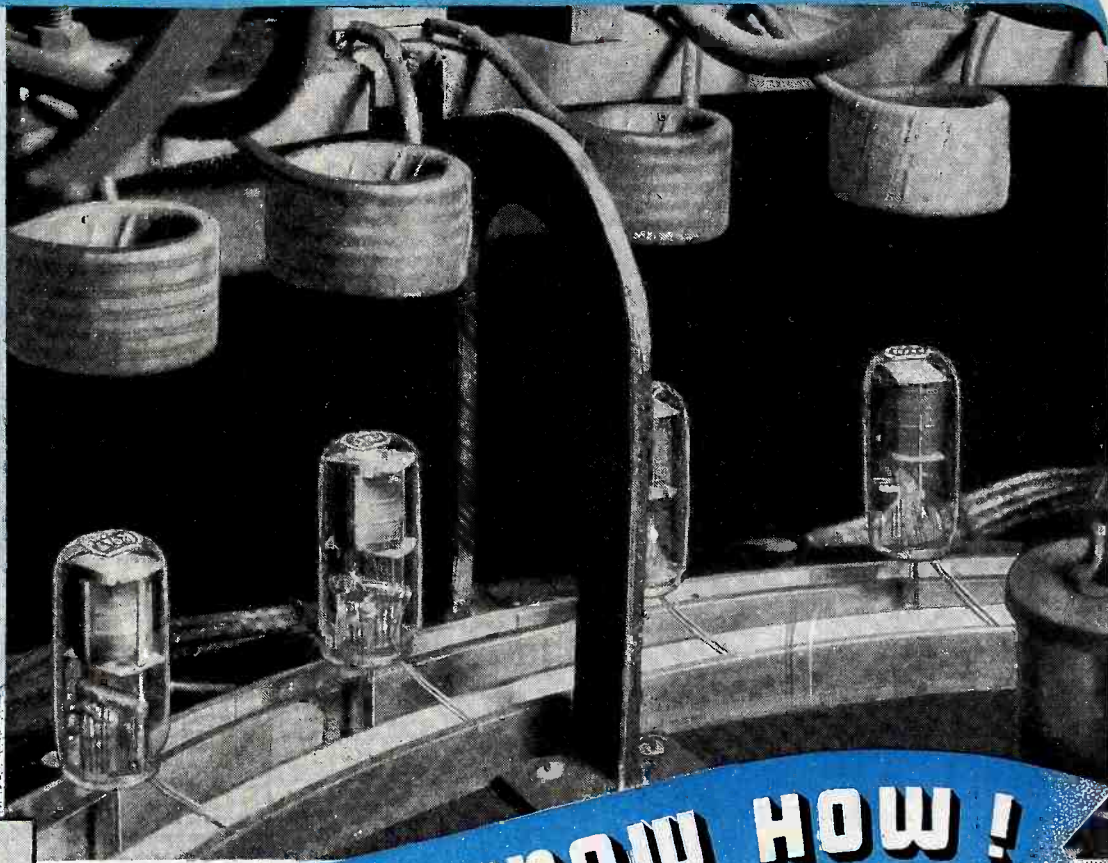
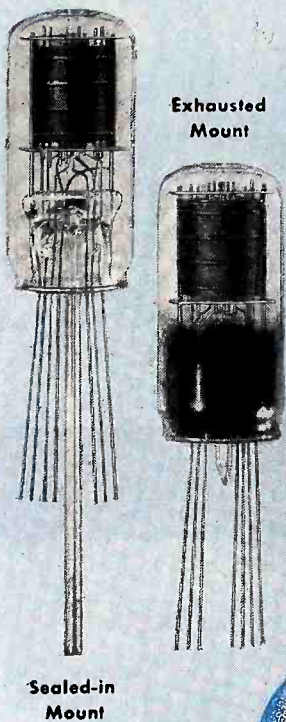

IF YOU KNOW HOW!

BIG TUBES MAKE LITTLE ONES

That's right. Big power tubes help build little receiving tubes. Secret of the electronic tube is its ability to pass a controlled stream of electrons through a vacuum. During the intricate exhaust process, electronic induction heating assists in creating that vacuum.

The induction heater (small illustration) is a 750-kilocycle, 6-tube, 10-kilowatt power oscillator whose tank coil is coupled to the exhaust coils. Four of these coils poised over Hytron 12SA7GT sealed-in mounts are caught by the camera a split second before the exhaust machine automatically positions them around the mounts.

High frequency current in the coils quickly heats red hot by induction the internal metal parts of the mounts. Gas driven off is sucked through the exhaust tube of each mount by the vacuum pumps. Heater leads riding in the two circular tracks supply filament power to activate each cathode. Also by induction heating, "getters" are flashed to absorb residual gasses. Fingers of gas flame finally melt and seal off the exhaust tubes.

An intricate machine—assisted by electronics itself—performs the ticklish exhaust job easily, speedily. Again know-how supplants the element of human error with the infallibility of the machine. Machine-paced, a sequence of finely-controlled precision operations gives you Hytron tubes of typically uniform quality.

SPECIALISTS IN RADIO RECEIVING TUBES SINCE 1921



HYTRON

RADIO AND ELECTRONICS CORP.

Have you received your copy of the new, comprehensive Hytron Miniature Tube Reference Guide? If not, write for it today.

MAIN OFFICE: SALEM, MASSACHUSETTS

THIS coöperative advertising plan helps you and your dealers!



EACH DEALER GETS:

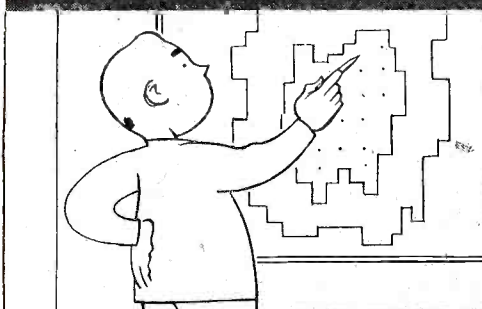

1 Selective coverage of his local market

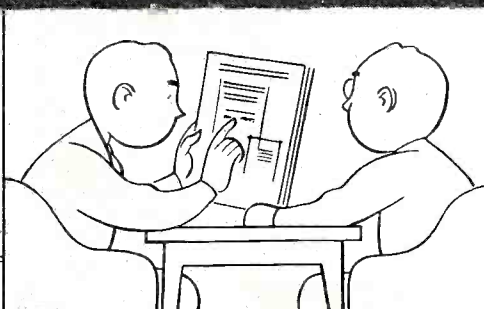

2 Prominent display of his name and location



3 The low rate of 2-1/6¢ a line!

YOU GET:



1 Better identification of your local outlets

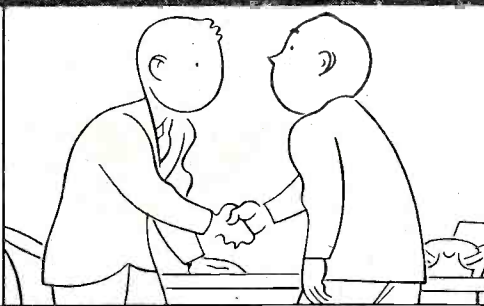

2 Enthusiastic dealer support

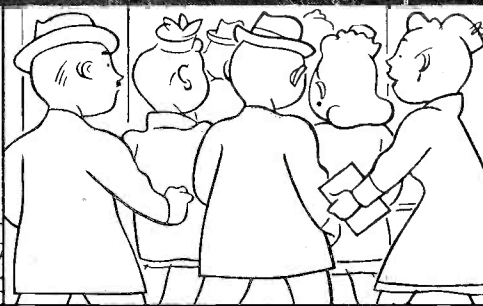

3 Advertising that pays off right away!

RESULT: More sales for your products in the Great Chicago Market!

Now! Coöperative advertising can pay off better for you and your dealers. The Chicago Tribune's new Plan gives each of your dealers the kind of a campaign he likes . . . aimed directly at the market he serves. And he pays just 2-1/6¢ a line!

Under this Plan, you can get the jump on competition . . . and corral more of the Great Chicago Market . . . a market whose size is revealed in the Tribune's Durable Goods Study among Consumers and Dealers.

To find out more about the Plan and the Durable Goods Study, contact your nearest Tribune representative.



For quick, effective coverage of the Great Chicago Market, there is no medium quite like the Chicago Tribune. 63.4% of the \$414,757,552 volume for home appliance purchases during the first year they are available will be spent by Tribune-reading families. Rates per line per 100,000 circulation are among the lowest in America.

Chicago Tribune

The World's Greatest Newspaper

January average net paid total circulation:
Daily, over 1,040,000; Sunday, over 1,500,000

H. N. King, Chicago Tribune
810 Tribune Tower, Chicago 11

E. P. Siruhsacker, Chicago Tribune
220 E. 42nd St., New York City 17

Fitzpatrick and Chamberlin
155 Montgomery St., San Francisco 4

W. E. Bates, Chicago Tribune
Penobscot Building, Detroit 26

MEMBER: AMERICAN NEWSPAPER ADVERTISING NETWORK, INC., FIRST 3 MARKETS GROUP, AND METROPOLITAN SUNDAY NEWSPAPERS, INC.

ANOTHER ALL-STAR BENDIX RADIO...



A Gorgeous Chairside Table

All the eye appeal of a period chairside table—handsome and practical.

A Full-Toned Radio with the Famous "Phantom Dial"

Turn a drawer pull and the "Phantom Dial" glows through the mahogany grained panel as if by magic.



..PACKED WITH SALES APPEAL!

A Fully Automatic Phonograph

Slide back the "table top" for easy access to the automatic record player.



THERE'S PROFIT

IN THE STARS FOR YOU!

With this all-star Bendix Radio-Phonograph in your showroom you just can't miss extra sales—extra profit! There's more eye appeal—more demonstration magic—more practicality—more performance—more value in this sensational Bendix than in any other chairside radio-phonograph. Here's another example of the far-sighted, extra effort of Bendix Radio to give you all that's best of all that's newest. Another reason why there's added profit for you in Bendix Radio—the stars of 1947!



THE BEST IN RADIO IS ALWAYS BETTER WITH *Bendix Radio*

DIVISION OF BENDIX AVIATION CORPORATION

BALTIMORE 4, MARYLAND



HERE'S THE

"speed way"
TO SALES

28 feet of front-row food

new ~~CROSLEY~~
retail promotion



*REG. U. S. PAT. OFF.

featuring the biggest story in refrigeration

Any refrigerator does *all* its business through its door! This simple, basic fact makes the new Crosley campaign the high-voltage refrigerator promotion for right NOW.

This smashing program will tell the women in your community that the exclusive Crosley Shelvador* is the *only* refrigerator that gives extra *help* every time she opens the door; that "28 feet of front-row food" is her "Speed Way For Meals," and that *only* her Crosley dealer can deliver her big Shelvador*.

It's ready. A buttoned-up program to give every Crosley dealer a stand-out advantage in his community.

speed way for meals

~~CROSLEY~~

Shelvador*



Faster, easier breakfasts • Faster, easier lunches • Faster, easier dinners

with everything you need



NATIONAL ADVERTISING

98,568,587 hard-hitting messages in 60 days! Full-color, full-page ads in American Weekly, This Week, Parade, Saturday Evening Post, Collier's, American, Good Housekeeping, Ladies' Home Journal, McCall's, Better Homes and Gardens, Parents', Woman's Day and Household.

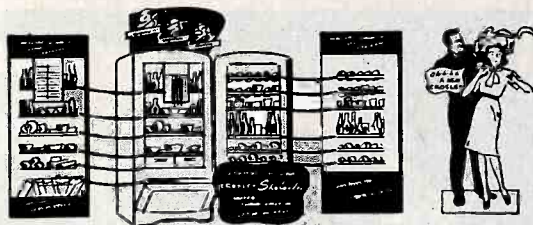

STORE DISPLAYS Striking displays carry the theme of this story right into your store windows . . . onto your sales floor . . . attract store traffic . . . capitalize to the fullest on the national advertising.

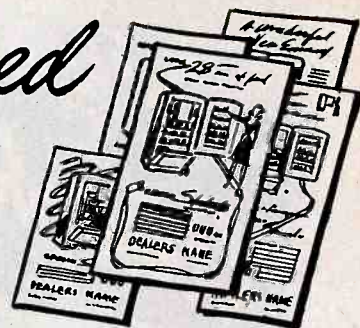

NEWSPAPER ADS

Hard-hitting ads are ready to run in local newspapers over Crosley dealers' signatures; they tie-in with the national advertising, and the displays.

RADIO SCRIPTS

A new national recorded radio program is ready—the 30-minute hit "SHOWTIME" . . . and available through Crosley distributors for dealer promotions. Spot radio announcements for local use are available now . . . to hit the "Speed Way For Meals" theme day-in-and-day-out.



HELPFUL BOOKLET

Every woman who walks into a Crosley Dealer's store will get her copy of an authoritative guide on food arrangement . . . telling her what shelf arrangements will save her food and time, and why . . . explains the many advantages of orderly food organization and why the Crosley Shelvador* is the only refrigerator feature that helps solve that universal household problem.



*REG. U.S. PAT. OFF.

all wrapped-up in a guide to dealer activity
on the way to you now

The retail guide to this activity is on its way to Crosley dealers now. It outlines the entire activity . . . gives a time-table that makes it easy to fit this program to your own sales activities.

Be on the alert for this "Speed Way To Sales".

- Refrigerators—Home Freezers
- Kitchen Sinks and Cabinets
- Ranges—Laundry Equipment
- Radios—Radio-Phonographs
- FM—Television—Short Wave
- Radar—Home of WLW, "The Nation's Station"

CROSLEY

DIVISION—The Aviation Corporation,
 Cincinnati 25, Ohio.



**Over 100,000 Sales
Last Year!**



You just push the button to talk . . .
lift the finger to listen!



No need to raise voice . . . no need to
lean toward speaker to be heard.

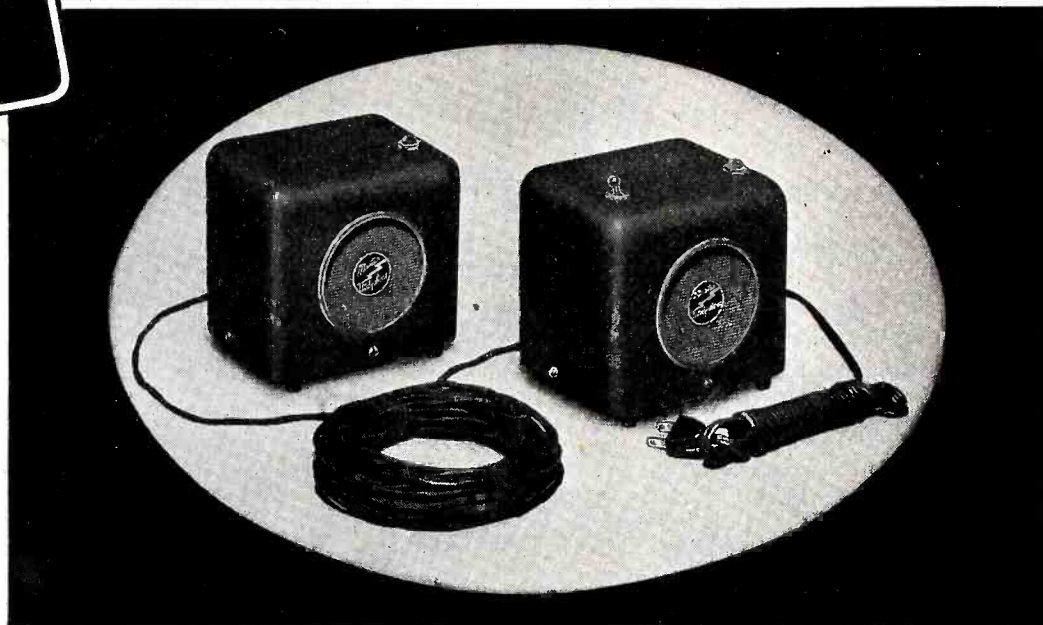

**THE FIRST *Top-Quality* INTERCOM
IN THE POPULAR PRICE RANGE!**

● You'll find the Utiliphone an entirely new and bigger value in a two-station intercom set. Handsome in contour and styling, the Utiliphone, with its metallic, grey-bronze finish and chromium trim, graces any surroundings. Its up-to-the-minute electronic designing, plus the use of the finest components exclusively, make it as outstanding in operation as it is in appearance. In addition, the Utiliphone offers a number of important features that make it not only the finest intercommunication equipment available anywhere for the money, but the most convenient and easiest to operate in every way.

The Utiliphone is the efficient, economical answer to intercommunication in smaller offices, stores, homes, on farms and estates! Business men, doctors, dentists, lawyers, car dealers, garages, radio shops, farmers, housewives, all find it useful wherever there is need for

people in two different places to talk back and forth. The sub-station may be placed anywhere, as far as 500 feet from the master. With its high utility . . . wide range of application . . . fine quality . . . and reasonable cost, the Utiliphone opens a wide and profitable market for distributors and dealers! Order your stock of Utiliphones now.

**Good Looking . . . Expertly Designed . . .
Has These and Other Important Features**

- **Individual Station Control**—Simple, instantaneous operation, push-button control.
- **High Amplification**—Highly sensitive, 3-tube amplifier has plenty of power. You speak in normal tones.
- **Easy to Install**—You merely connect the master and the sub-station with the wire, plug the master into an electrical outlet, and turn it on.
- **Sturdily Built**—Housed in unbreakable steel case, attached to sturdy steel chassis.
- **Operates on AC or DC**

Limited Number of Distributorships Still Available

Wire or Phone Sales Division, Indianapolis, Riley 1551

LIST PRICE

\$29⁹⁵

Complete with
Interconnecting Wire

PRICES SLIGHTLY HIGHER, DENVER AND WEST

ELECTRONIC LABORATORIES, INC.
INDIANAPOLIS, INDIANA

The Time Is Always Right for **FADA** Sales



MODEL 602
New Superheterodyne AC Table Model Radio Phonograph Combination with Automatic Record Changer in a Cabinet of Beautiful Mahogany Veneers.



MODEL 1000
AC-DC Superheterodyne in beautiful gem-like "Fada-lucent" cabinets. Five Tubes plus Rectifier Tube.

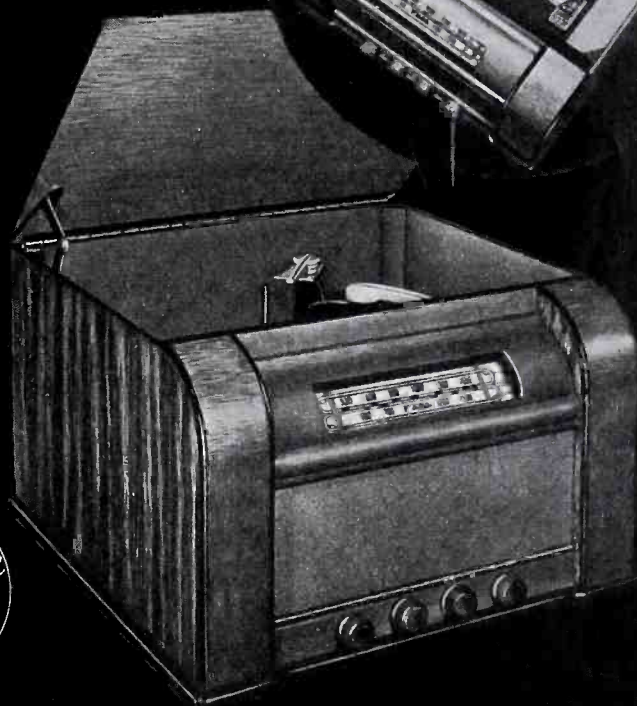

FADA 5-tubes—plus-rectifier-tube models are equipped with the new FADA "Sensitive-Tone" ... assuring greater sensitivity and clearer reception.



MODEL P82

Tri-power portable Superheterodyne with Hi-Gain tuned RF stage in rich two-tone simulated leather covered wood cabinet. 5 tubes plus rectifier tube.

YOU CAN ALWAYS DEPEND ON

FADA
Radio

Famous Since Broadcasting Began!

FADA RADIO AND ELECTRIC COMPANY, INC., LONG ISLAND CITY, N. Y.

America's Smart Set!

Admiral

3 WAY PORTABLE RADIO

Full rich voice speaks
with the power and clarity
of a console radio!
Weighs only 13 pounds



The ideal traveling companion!
Plays on AC-DC current
or self-contained batteries
Outstanding reception everywhere!



Stunning leatherette case
of simulated alligator!
A delightful eyeful, earful!
Hear it! See it, today!



As advertised in
**THE SATURDAY EVENING
POST** March 8, 1947

Available now at your dealer!

Get the most out of Television with Du Mont Prestige

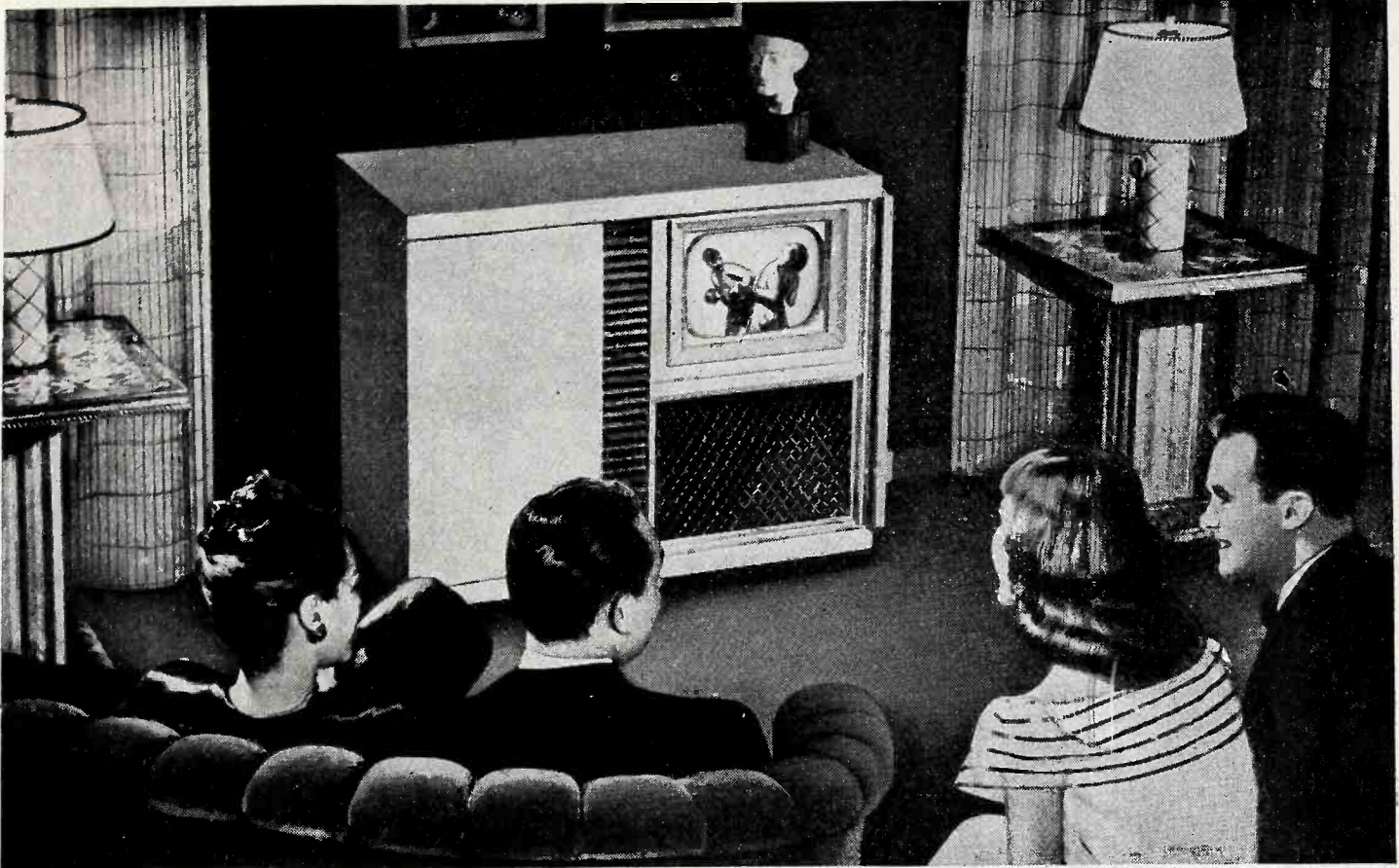

The Du Mont DEVONSHIRE combines superb large-screen television, standard radio, FM, shortwave, and automatic record player in a distinguished cabinet designed by Herbert Rosengren. Six other models.

DU MONT PRESTIGE IS GUARANTEED

Du Mont prestige is built on technical superiority, superb cabinet artistry, made known to the public through dominating advertising. Du Mont Telesets* undergo 150 scientific tests to assure perfect performance. And to assure service satisfaction, your technicians will be Du Mont-trained to install and service the complete line of Du Mont Telesets, under the Du Mont Certified Service Plan.

DU MONT

First with the Finest in TELEVISION

FEATURES OF THE DU MONT *Dealer Franchise*

1. Limited to community leaders.
2. Liberal discount.
3. Strong 1-year picture tube warranty.
4. Training program for dealer salesmen and servicemen.
5. Extensive magazine and newspaper advertising.
6. Effective dealer helps.
7. A prestige-building product ... the world's finest television receivers.

ALLEN B. DU MONT LABORATORIES, INC. • GENERAL TELEVISION SALES OFFICES AND STATION WABD, 515 MADISON AVE., NEW YORK 22, N. Y.
DU MONT'S TELEVISION STUDIOS, WANAMAKER PLACE, NEW YORK 3, N. Y. • HOME OFFICES AND PLANTS, PASSAIC, NEW JERSEY

Copyright 1947, Allen B. Du Mont Laboratories, Inc.

*Trade-mark

LISTEN

LISTEN

LISTEN

IT'S A

Jensen



SPEAKERS

priced from
\$5 to \$1500

CONSTANTLY INCREASING PRODUCTION

LISTEN



Designers and Manufacturers of Fine Acoustic Equipment

JENSEN MANUFACTURING COMPANY 6625 S. LARAMIE AVE., CHICAGO 38, U.S.A.
In Canada: Copper Wire Products Ltd., 11 King St. W., Toronto, Ont.

GROUP 'EM ALL TOGETHER

... make more money!

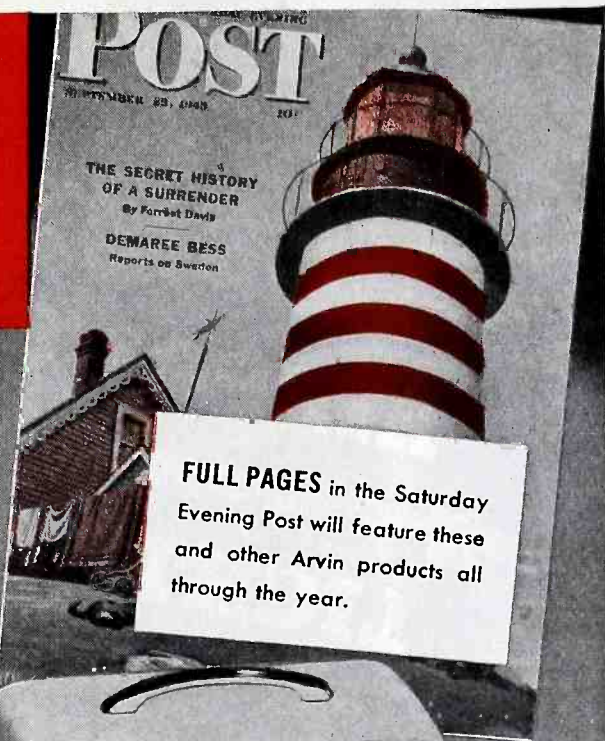

FULL PAGES in the Saturday Evening Post will feature these and other Arvin products all through the year.



FAN-POWERED HEATER

ELECTRIC COOK

RADIO 664-A

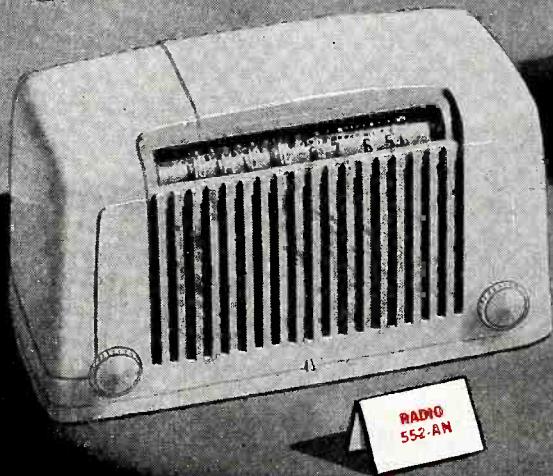

RADIO 552-AM

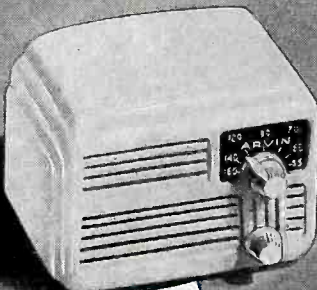

RADIO 444-A

AUTOMATIC IRON



ARVIN
Family Products
WELL-KNOWN IN
MILLIONS OF HOMES

● Here's a money-making idea for you: When you get your stock of these Arvin family products from your distributor, display 'em as a group—all together—in your window and in your store. Then, many customers will take two or more—and you'll make more money from multiple sales.



... is the name on profit-building products from
NOBLITT-SPARKS INDUSTRIES, INC., COLUMBUS, INDIANA

**AIRPORT
★ LIGHTING
★ EQUIPMENT**

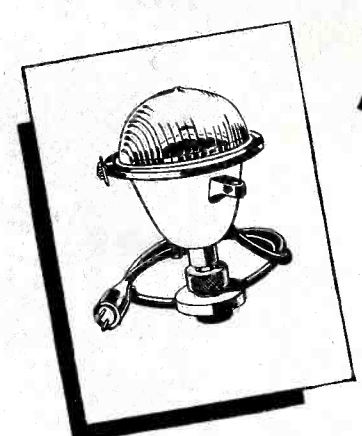
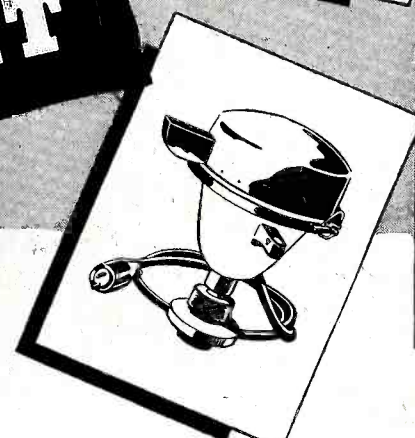
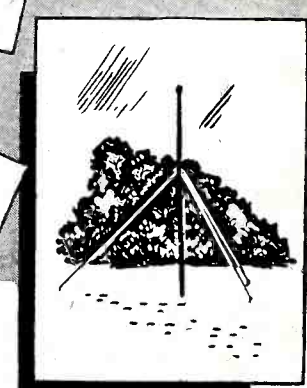
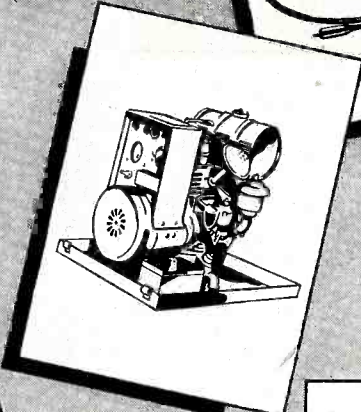

Many types of Airport and Airway lighting equipment including runway marker lights, cone assemblies, globes, portable field lighting sets and associated equipment, are now available.

Much of this equipment can be adapted to many uses calling for outdoor portable lighting fixtures.

Most of this inventory is offered on a sealed bid basis. You may bid on entire sets complete or on such parts as are specified in sealed bid offering lists. Some items are sold at fixed prices only.

Write to the Birmingham Regional Office requesting that your name be placed on their mailing lists when offerings are made of this type of equipment.

**Adaptable to a
Variety of uses**

OFFICE OF GENERAL DISPOSAL

★ WAR ASSETS ADMINISTRATION

Offices located at: Atlanta • Birmingham • Boston • Charlotte • Chicago • Cincinnati • Cleveland • Dallas • Denver • Detroit • Fort Worth • Helena • Houston • Jacksonville • Kansas City, Mo. • Little Rock • Los Angeles • Louisville • Minneapolis • Nashville • New Orleans • New York • Omaha • Philadelphia • Portland, Ore. • Richmond • St. Louis • Salt Lake City • San Antonio • San Francisco • Seattle • Spokane • Tulsa



1031

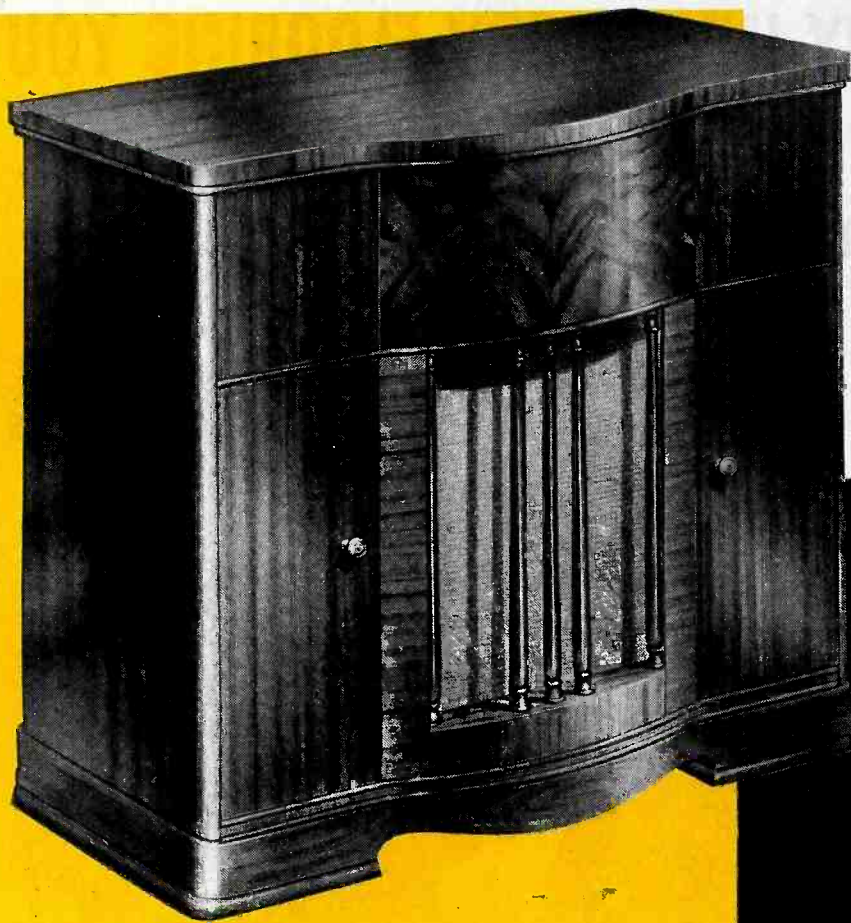

● RMR-219... Beautifully styled cabinet of finest selected and matched ribbon-striped mahogany. Gives "Clear As A Bell" reception for complete shortwave and standard band broadcasting. Variable tone control gives every possible tonal variation with a simple twist of the wrist. Fast action record changer plays twelve 10" or ten 12" records.

Leaders in beauty—champions of tone . . . the new SONORA radio phonograph combinations have a buy-compelling eye appeal topped only by the famous "Clear As A Bell" Tone that has made SONORA a leader in perfect tone reproduction for over 30 years. Watch for the dramatic national ads in eleven of America's major magazines that tell your customers of the tone brilliance of new SONORA models. And watch the increased consumer preference for SONORA in '47.



The choice
in '47 is
Sonora 
Clear as a Bell
with
"Clear as a Bell"
Tone

● RKR-215... Table model phono-radio with automatic Record Changer. Plays ten 12" or twelve 10" records. New low-pressure crystal pickup and long-life needle. Big dynamic speaker, no aerial or ground required. Cabinet of choicest walnut veneer, glamorously styled with handsome curved lid that adds a note of distinction.

Sonora 
Clear as a Bell

HOME ENTERTAINMENT AT ITS BEST

SONORA RADIO & TELEVISION CORP
325 North Hoyne Avenue • Chicago 12, Illinois

RADIOS • FM COMBINATIONS • TELEVISION SETS • RECORDS • PHONOGRAPHS • RECORDERS

SNARLED BATTERY INVENTORY FLOORING YOU?

Simplify your stock with one complete line -

"Eveready" Radio Batteries



IF YOU'RE tired of stocking all kinds of "Johnny-come-lately" radio batteries, just think of this:

"Eveready" radio batteries fit virtually *all* makes of sets! You carry less inventory, tie up less capital, and insure *more* customer satisfaction . . . because you are giving your customers

the recognized *battery* brand! You don't have to buy anything else to get "Eveready" radio batteries—and they are *never* marketed under any other brand name, or private label!

Get out from under that complicated battery inventory. Standardize on famous "Eveready" radio batteries now!



The registered trade-marks "Eveready" and "Mini-Max" distinguish products of
NATIONAL CARBON COMPANY, INC.
 30 East 42nd Street, New York 17, N. Y.
 Unit of Union Carbide and Carbon Corporation



Go to a Radio Manufacturer for Radios — a Battery Manufacturer for Batteries!



MODEL A-403



AIR KING "Court Jester"

THE OUTSTANDING COMBINATION FOR QUALITY AND FAST SALES!

The smart new, versatile "Court Jester" is the latest addition to the brilliant Air King line. Here is the popular priced radio-phonograph combination your customers can afford to buy. Masterfully engineered for tone; superbly styled for beauty.

The huge demand for just such a high-quality, low-priced combination means that here is a unit that will sell itself—built for quick turn-over and increased profit. Too, the all purpose "Court Jester" is a natural in every home because it goes in any room.

Air King "Court Jester" Features

Compact, modern design in glistening, hand rubbed walnut finish. Superheterodyne radio receiver with

precision die-cut antenna rendering superb sensitivity and maximum signal. *All* controls conveniently located. Alnico V PM speaker. Stepped-up power stage for increased volume. Plays 10- or 12-inch records. Equipped with Fidelatone lifetime needle.

List Price \$39.95

The Royalty of Radio Since 1920

AIR KING RADIO

Division of HYTRON RADIO & ELECTRONICS CORPORATION

The Royal Family of Radio

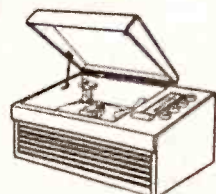
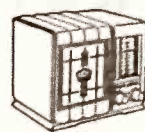
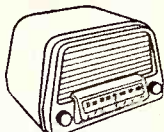
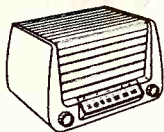
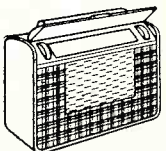

★ WE HAVE A LIMITED NUMBER OF DISTRIBUTOR AND DEALER TERRITORIES OPEN ★

Write: Air King Products Co., Inc., 1523-29 63rd St., Brooklyn, N. Y. Export Address: Air King International, 75 West Street, New York 6, N. Y.



Keeping Tone Conscious Customers Well Satisfied

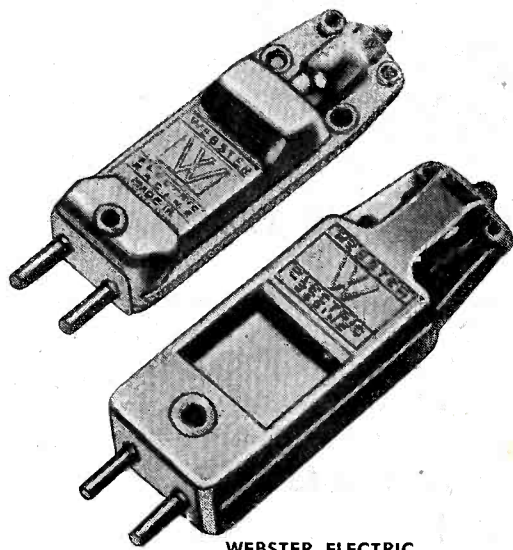
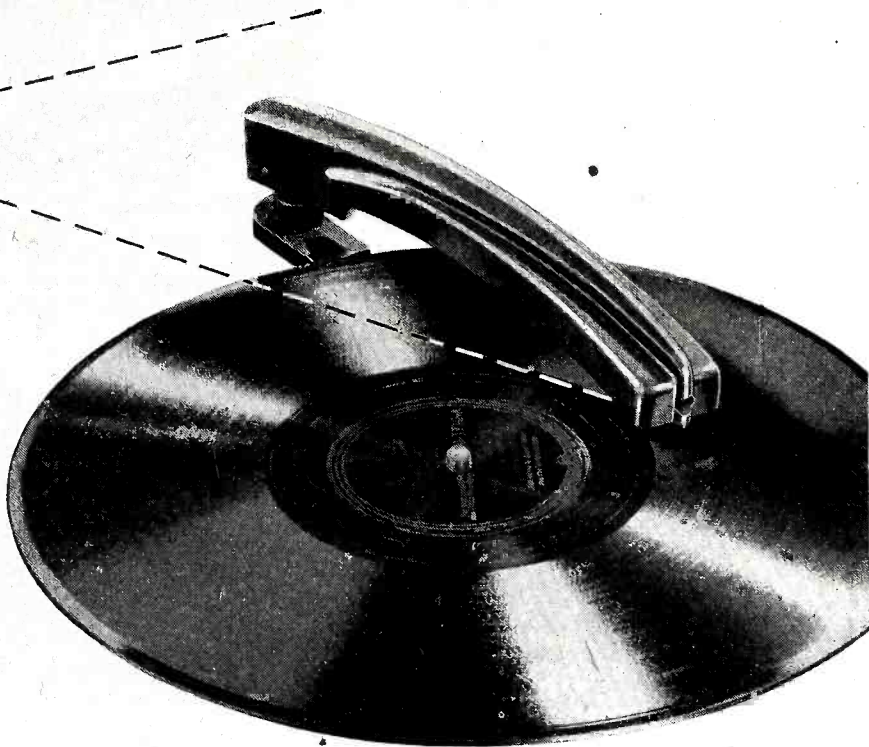

WEBSTER ELECTRIC
CARTRIDGES

Every Business Man Keeps His Eye on Satisfying the Customer

—that's why Webster Electric Tone Arms and Cartridges are widely sold for use on radio-combinations and record changers.

The Webster Electric crystal cartridges are uniform producers of true tone quality. In addition to faithful reproduction, they are dependable and have long life. Their past record of performance insures their future dependable service.

The Webster Electric cartridge has balanced construction that produces maximum output at designated tracking pressures—with minimum distortion and minimum mechanical reproduction. There are models designed for sharp cut-off at higher frequencies, while others provide response over an exceptionally wide frequency range through use of an extremely lightweight moving mass—a Webster Electric development. Sharp resonance peaks are avoided and efficient performance obtained.

Write Webster Electric Company, Racine, Wisconsin, for full information and complete listing of tone arms and cartridges that are now available.

(Licensed under patents of the Brush Development Company)

WEBSTER

RACINE



ELECTRIC

WISCONSIN

Established 1909

Export Dept. 13 E. 40th Street, New York (16), N. Y. Cable Address "ARLAB" New York City

"Where Quality is a Responsibility and Fair Dealing an Obligation"



Smooth sailing from here in ?

WE CERTAINLY hope there is smooth sailing ahead for radio retailers.

Production headaches have been soothed. There is still a big unsatisfied demand for nationally known and accepted radios, but . . .

How much would it take to turn that sweet zephyr you're sailing with into a hurricane of old distribution miseries? Remember those camouflaged discounts, circus promotions, the dumping, and the regular whirlwinds of price cutting.

Sparton dealers aren't worried about what's over the horizon. S. C. M. P.* is full protection against any storms brought on by a return to the practices that once made radio retailing second-cousin to election day in a Banana Republic.

First, they are backed by full-scale production in Sparton's factories. They have

beautifully styled and skillfully built models to offer. They have the gorgeous full tone of "Radio's richest voice since 1926!"

Second, Sparton dealers have S. C. M. P.* —the exclusive merchandising plan with one, and *only one*, Sparton dealer for each area. Distribution costs are slashed by direct factory-to-dealer shipments. All of which means *profitable* selling prices that are *amazingly low*—competitive with mail order house brackets.

A final point, Sparton's appealing and eye-catching national advertising works 100% for the *one* Sparton dealer in any area. *Every* copy of *every* ad coming into the territory goes to *his* prospects. It's easy to see why S. C. M. P.* is here to stay.

It *pays* to be a Sparton dealer!

THE SPARKS-WITHINGTON CO., JACKSON, MICH.
Radio and Appliance Division—Plant 5

ONE
Sparton
DEALER
in each community

Check These Profit-Increasing Features

- One exclusive dealer in each area
- Direct factory-to-dealer shipment
- Low consumer prices
- National advertising
- Factory prepared and distributed promotion helps
- Seasonal promotions
- Uniform retail prices
- Products styled by outstanding designers

Sparton

Radio's Richest Voice Since 1926

*S·C·M·P·

SPARTON CO-OPERATIVE MERCHANDISING PLAN. A proven exclusive method of profitably retailing radios and home appliances that has been and is being advertised regularly to consumers in leading magazines.

it's better to **get the whole** picture

If you want to know about Frequency Modulation, there's no sense getting part of the picture one place, another part somewhere else.

Not when you can have it all—presented concisely, accurately, intelligently—in FREQUENCY MODULATION BUSINESS, the *only* magazine that is 100% for and about FM.

Through its pages you can follow the expanding pattern of this new broadcasting service. You can learn the latest facts about FM development. You can read the opinions, predictions, case histories and interpretations of leading FM authorities. You can learn about FM trends before they become realities, follow the technical advancements of FM, gain important information about every phase of this new, booming industry.

All this—presented in a crisp editorial package, easy to read, in understandable language—is yours with FREQUENCY MODULATION BUSINESS.

Nowhere, no matter how many publications you read, can you find so much information about FM—information that is up-to-the-hour, pertinent, profitable. Three dollars brings you FREQUENCY MODULATION BUSINESS for one year. Three hundred dollars can't get you as many facts about FM anywhere else. It's so much for so little.

100% for and about FM

Subscribe Today

FREQUENCY MODULATION
BUSINESS

FREQUENCY MODULATION BUSINESS
Murray Hill Hotel
Park Avenue at 40th Street
New York 17, New York

YES, we want to receive FREQUENCY MODULATION BUSINESS regularly.
Please enter our subscription to start with the current issue as checked below:

2 years \$5. 1 year \$3.

Add 50c yearly for Canada

Name Position

Firm

Address

City Zone No. State

Bill firm

Bill Me

Check enclosed

Your all-star radio sales force for 1947
is
Olympic's Supreme Court
of Radio Listening



The wives and families of your customers' favorite radio stars are the Supreme Court of Radio Listening. When these famous people tell the big news about the new 1947 Olympic 'tru-base' radios, everyone pays attention!

Every month during 1947 this Supreme Court of Radio Listening will be doing just that! Telling customers about the thrills of 'tru-base,' Olympic's exclusive, electronic development that enables table radios for the first time to reproduce the full, audible tonal range, from the richness of deepest bass notes to the wispy delicacy of reediest trebles. And that's just one of many electronic advances Olympic is featuring for 1947.

The new Olympic cabinets are big 1947 news, too. 1947 cabinets are fashioned of precious hardwoods and lustrous plastics by master designers. They're cabinets that add richness to any living room. So beautiful that these new 1947 models are meeting with an enthusiasm exceeding even that which greeted the 1946 models.

Smashing color ads in national magazines tell the powerful story. This big 1947 Olympic news breaks in two of America's most potent customer-convincing magazines —The Saturday Evening Post and Collier's. With full page ads in full color. Every month of the year!

Add 'em up—all these strong points of the new 1947 Olympic Radios—and get a brand new idea of how to make bigger and better radio profits. Just think! 'Tru-base' plus other electronic advances plus greater cabinet beauty plus the convincing Supreme Court of Radio Listening. With all these, the coming year should be your biggest Olympic year... your biggest radio year, ever!

Olympic Radio
REG. U.S. PAT. OFF.
 The only radio with 'Tru-Base'

OLYMPIC RADIO & TELEVISION, INC., LONG ISLAND CITY 1, NEW YORK

What you should know about **sex** to sell Refrigerators

According to a fly-by-night research organization, most of our feathered friends are notoriously fickle in their friendships.

Pigeons, though, are different. In a way, they're more like *people*—male and female generally sign a long-term contract. But note that a pair of pigeons have *simple* needs—they ask only for each other and bread crumbs. While *people*, when they pair off, must augment amour with everything from roast beef to refrigerators.

Now a new refrigerator takes a big bite out of the family budget. So male and female must *agree* on the *make* before they make with the moola. Not so with, say, *phonograph records*. If *he* yearns for Bach while *she* burns for boogie-woogie, each can buy the platters *he* or *she* wants.

So whether you're pushing refrigerators or phonograph records, washing machines or radios, you've got to sell *two sexes*—*males* and *females*. Either *together* or *separately*.

And who can woo *males* and *females* like The American Magazine!

Dollar for dollar, page for page, *no other* magazine can match the multi-million circulation delivered by . . .

*The American
Magazine*



THE CROWELL-COLLIER PUBLISHING CO., 250 PARK AVE., NEW YORK 17, N. Y., PUBLISHERS OF THE AMERICAN MAGAZINE, COLLIER'S, AND WOMAN'S HOME COMPANION

RADIO *& Television* **RETAILING**

Including Radio and Television Today

O. H. CALDWELL, Editor ★ M. CLEMENTS, Publisher ★ 480 LEXINGTON AVENUE, NEW YORK 17, N. Y.

Multi-Selling Will

Keep Us Prosperous!

The "radio-in-every-room" campaign touched off by the Radio Manufacturers Association symbolizes a large section of the rampart being erected by a far-sighted American industry against a possible depression.

In order to keep prosperity we must sell an output of goods virtually as high as the colossal amount we produced during the war.

Maintenance of such huge-scale manufacture is a pushover for our factories. The real feat is to sell this merchandise fast and at fair prices. We must sell more and more to each home. To do this we must view yesterday's "saturation" goals as being pitifully inadequate today. Multi-selling is the formula which not only promises more profits but a continued prosperity, and a better living standard for Americans.

Just as we used lethal weapons to win the war we can use manufacturing and sales weapons to win a continued era of peace and plenty. Inspired by RMA's campaign to sell a radio for every room we can apply this multi-sales theme to the other products we sell.

For instance, fans in every room, a food freezer along with the refrigerator; clocks in every room, electric blankets on every bed—electric table appliances in the basement rumpus room; vacuum cleaners for each floor; space heaters and room coolers throughout the home.

There are many new and exciting things to sell too. There is radio with new features such as FM and television; electric ranges for an almost-virgin market, new automatic washers, more and more new "health" lamps and scores of other things. Added to all these, the great new interest in discs and record players will continue to bring new dollars to the field.

We have the selling weapons, so let's train our sales sights in order to calibrate them with continued high-production. Manufacturers, jobbers, dealers and consumers must make more, sell more and buy more goods. In this way we can prevent a depression from creeping up on us.

RADIO, Electrical Appliances,

FCC CHAIRMAN DENNY PREDICTS 700 FM stations by the end of 1947. Sees public demand for FM home receivers growing rapidly from here on. FM broadcasters continue to plan active tie-ins with retailers in order to promote sales of sets.

RETAILING TRENDS IN RADIO/APPLIANCE field. Dealers planning to resume wide-scale outdoor selling. . . . Few trade-ins thus far, but dealers figure they're on the way in great numbers soon. . . . Priority-buying about done with. When customers can't get what they want they "shop" for it. . . . Flood of "please deliver" requests costing merchants real dough. . . . Dealers rushing to get in line to sell fans and room coolers for what looks like biggest season ever. . . . Easy terms being advertised again. . . . Possible changes in discount structure present topic of great interest.

RADIO/APPLIANCE MANUFACTURING TRENDS. Small number of "straight" consoles turned out in '46 bears out predictions made a couple of years ago. . . . Concentration of more facilities in factories aimed at less dependence on suppliers. . . . Exciting news on airborne TV transmitters being readied. . . . Some manufacturers working on appliances to "make" concentrated coffee in the home. . . . With exception of those having totally different vacuum cleaner models, practically every manufacturer now has tank models; most have hand vacs, too. Few have straight suction uprights. . . . Improved insulation techniques make possible placing of ranges right up against metal and non-metal walls. . . . Manufacturers getting lots of good publicity via announced price reductions.

JOBBER, ALONG WITH MANUFACTURERS and retail merchants, find that their costs of operating have climbed sky-high. Some of the upped-expenses have been pointed out by L. B. Calemaris, executive secretary of the National Electronic Distributors Association, as follows: counter-men, who before the war were paid \$20 to \$25 a week now receive \$50 and \$60 and sometimes \$70; jobbers who formerly traveled a couple of salesmen at \$30 to \$35 a week, now employ five or more at an average weekly salary of \$75.

"TELEVISION HAS HAD MORE STARTS and stops than a horse-drawn milk wagon" quipped Ray C. Cosgrove, president RMA, before American Marketing Association. He looks for production of 300,000 TV sets during 1947, most of which will go into NY area. (In '46, TV output totalled 5070 table models, 1385 consoles and 10 projection sets.)

"DON'T-YOU-KNOW-THE-WAR'S-OVER?" gripes from consumers to dealers becoming more frequent along the service-estimating front. Such beefs put the merchant on a spot because his costs have skyrocketed, and are still climbing, particularly, his labor expenses. It's often difficult to justify repair charges to consumers who see many commodity prices dropping, but who fail to realize that the merchant must still pay top salaries.

WHOLESALE TRENDS IN THIS INDUSTRY. More men being put on road to call on dealers. . . . Smart distributors frowning on compulsory "assortment" deals. . . . Many a jobber considering further diversification of his lines. . . . Wholesale store improvement programs being aimed at encouraging visits by retailers. . . . Great new interest in dealer-financing problems as money tightens up. . . . Discount structures being analyzed and discussed. . . . Jobber visits to factories increasing.

SOME SIGNS MARKING RETURN OF COMPETITIVE selling: "Personal" lending companies doing big volume of business, "One-Day Watch Repairing Service" signs in windows; some electrical appliances being offered at 50% off to retail customers, cut-priced cigarettes, smiling head-waiters; installment business increasing; taxi drivers soliciting customers; used car "for sale" advertising space away up, and "thank-you's" being given in return for smaller-than-ever-tips in restaurants, barber shops, etc. Up to \$100 trade-in allowance on old radios offered by one New York chain.

THERE IS NO EVIDENCE OF A TREND on the part of refrigeration manufacturers to set up additional jobbers and dealers for their food freezers. Most announce they will continue to use established outlets. Newcomers will have to do battle with the famous-name brand makers who'll go after the market, hammer and tongs. Some predictions for freezer sales for 1947 run as high as 750,000 units. There are about 450,000 in use today.

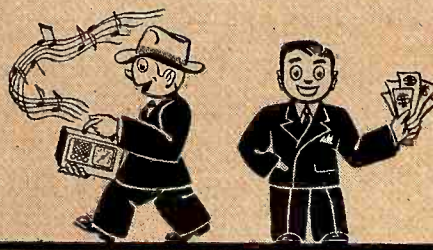

"YOU CAN TAKE IT WITH YOU" is the statement alert radio/appliance merchandisers will be making to many a customer interested in buying a portable radio during the coming vacation season—a season not so far off that the dealer has any too much time to plan his purchases, promotion and sales of the carry-about sets, which last year were scarce as hen's teeth.

BENDIX PRODUCED 300,000 home laundry units in 1946. Firm estimates that it will turn out 700,000 automatic washers, 150,000 automatic dryers and 100,000 automatic ironers in 1947.

THERE'S A MOVE ON FOOT AMONG manufacturers in the radio field to standardize diagram representation of tube sockets, switches and similar elements, for the benefit of the retail servicer.

Records, and Television, **TODAY**

THE SPECIAL EMPHASIS ON FM IN RMA'S DRIVE to promote "A Radio for Every Room—A Radio for Every Purpose," has been pointed out by Edward R. Taylor, chairman of the RMA sub-committee in charge of the campaign. "FM broadcasting opens an entire new field of radio entertainment," says Mr. Taylor, "and offers a compelling reason for every family to increase the number of radios in its home." The increased number of radio stations which FM is bringing to the air makes it more imperative for the consumer to have additional radio receivers, he declared.

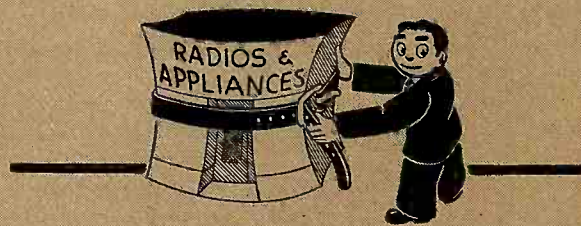

DEALERS ARE TIGHTENING UP ON "OPEN CREDIT" now that money is getting tighter, and many "transient" householders are considering the possibility of going back from whence they came. Due to this trend, look for a sharp increase in business being done by the nation's lending institutions.

MAKE MORE MONEY, MAKE MORE FRIENDS by selling more of this-and-that in every home. Here's a theme for radio/appliance retailers to adopt for 1947. In order to keep prosperity, full-employment and to prevent another depression, we must sell more goods. Along with active participation in RMA's radio in every room campaign, dealers should try to sell certain appliances for every room, too. Multi-sales will increase dealer's profit, and will help raise American living standards.

BACKLOG OF DEMAND FOR STANDARD discs in manufacturers' catalogs which have been built up, now shows promise of being filled. Production of records has been going ahead at such a steady pace that manufacturers are planning to re-issue recordings of established contact artists for which demand has been great.

"UNFAIR AND DETRIMENTAL TO THE TRADE" is the "Common" practice of requiring dealers to make "tie-in" purchases, etc., in order to secure special franchises or desired merchandise, asserts the Westchester Gas & Electrical Appliance Dealers Assn., Mount Vernon, N. Y., in a resolution. Copies will be sent to manufacturers, jobbers and sales representatives with whom the members do business.

PROMINENT RADIO MANUFACTURER will shortly appoint service centers in dealer establishments for installation and warranty repairs of his television receivers. A full year guarantee will be offered, but the consumer will pay for it under an "insurance policy" plan.

REVISED RMA PRODUCTION FIGURES estimate 1946 total receiver output at fifteen million. Of the sets reported by RMA members, 10,219,191 were table models, including 1,215,924 radio-phonos; 925,171 were consoles, of which 820,979 were also combinations. 1,153,458 auto radios were produced and the total number of portables was 1,022,689.

"WE ARE HEADED FOR A BUYERS' MARKET just as sure as shooting! The days of soft selling are numbered. In some instances those days are gone—definitely. Smart dealers are getting set to sell. They are recruiting able sales staffs and training them to do a selling job."—H. L. Clary, Norge general sales manager.

NEW "UNIVERSAL" PRODUCTS ANNOUNCED by Landers, Frary & Clark include a two-speed washer, a bantam electric range which plugs in regular outlet, and a vacuum cleaner having an automatic light, warning user when bag needs emptying. The firm's large and complete line of major and small appliances is currently being shown in a number of cities. Details of a new automatic washer will be announced soon by the company.

HYTRON WILL SHORTLY ANNOUNCE a new ultraviolet ray lamp which will be marketed at a popular price.

THE PEAK OF THE LABOR CRISIS HAS BEEN REACHED New York advertising executive, B. M. Reiss, believes. He predicts that there will be fewer strikes in '47 than in '46; fewer workers involved in strikes this year than last, and that strikes in 1947, will last for a shorter average period than in 1946.



SELLING REFRIGERATORS TO ESKIMOS, that mythical super-salesmanship qualification, may one day be put to test now that we're commencing to inhabit the Arctic regions, punned an appliance manufacturing executive. One way around obvious arguments against purchasing on the part of the Eskimo, we suggest, would be to offer him the appliance as a device in which he could keep food warm.

AN EXPEDITION TO AFRICA'S fabulous Mountains of the Moon, to explore the mysterious Lost Lakes of the Ruwenzori, and to conduct scientific research and short-wave radio experiments has been announced by the Gatti-Hallicrafters Expedition. The group which will leave the United States in August, expects to keep in constant touch with Hams throughout the world.

Here's why your customers want



The demand is terrific . . . and no wonder! The exclusive "Golden Throat," and other RCA Victor features, join to produce the finest instruments in RCA Victor history! Dynamic full-page advertising in leading magazines creates an advertising campaign unequalled in dominance!

And, 148 NBC stations, from coast to coast, bring the latest news on RCA Victor instruments to over 6 million people . . . with the popular RCA Victor program, "Music America Loves Best."

Turn to the striking full page of color that tells your customers about the 65U Victrola radio-phonograph in:

Life—March 10
Saturday Evening Post—March 8
Collier's—March 15

Try the 65U yourself . . . listen to any radio program . . . play any record, jazz or symphony . . . compare it with *any other* radio-phonograph in or near its price class and you'll understand why your customers want . . . and will wait for this Victrola.



Here are a few of the outstanding features the 65U offers:

"GOLDEN THROAT" acoustical system brings out the singing, golden tone of records and radio programs.

"SILENT SAPPHIRE" permanent jewel-point pick-up eliminates "hiss" and needle chatter . . . prolongs record life . . .

produces new high-fidelity reproduction. UP TO TWELVE RECORDS (10-inch) may be played without change to insure up to 40 minutes of recorded music. Ten 12-inch records may be played for up to 50 minutes of enjoyment.



The 65U . . . richly finished in walnut and other carefully selected woods.

 ONLY RCA VICTOR MAKES THE VICTROLA

"Victrola"—T.M. Reg. U. S. Pat. Off.

RCA VICTOR instruments!

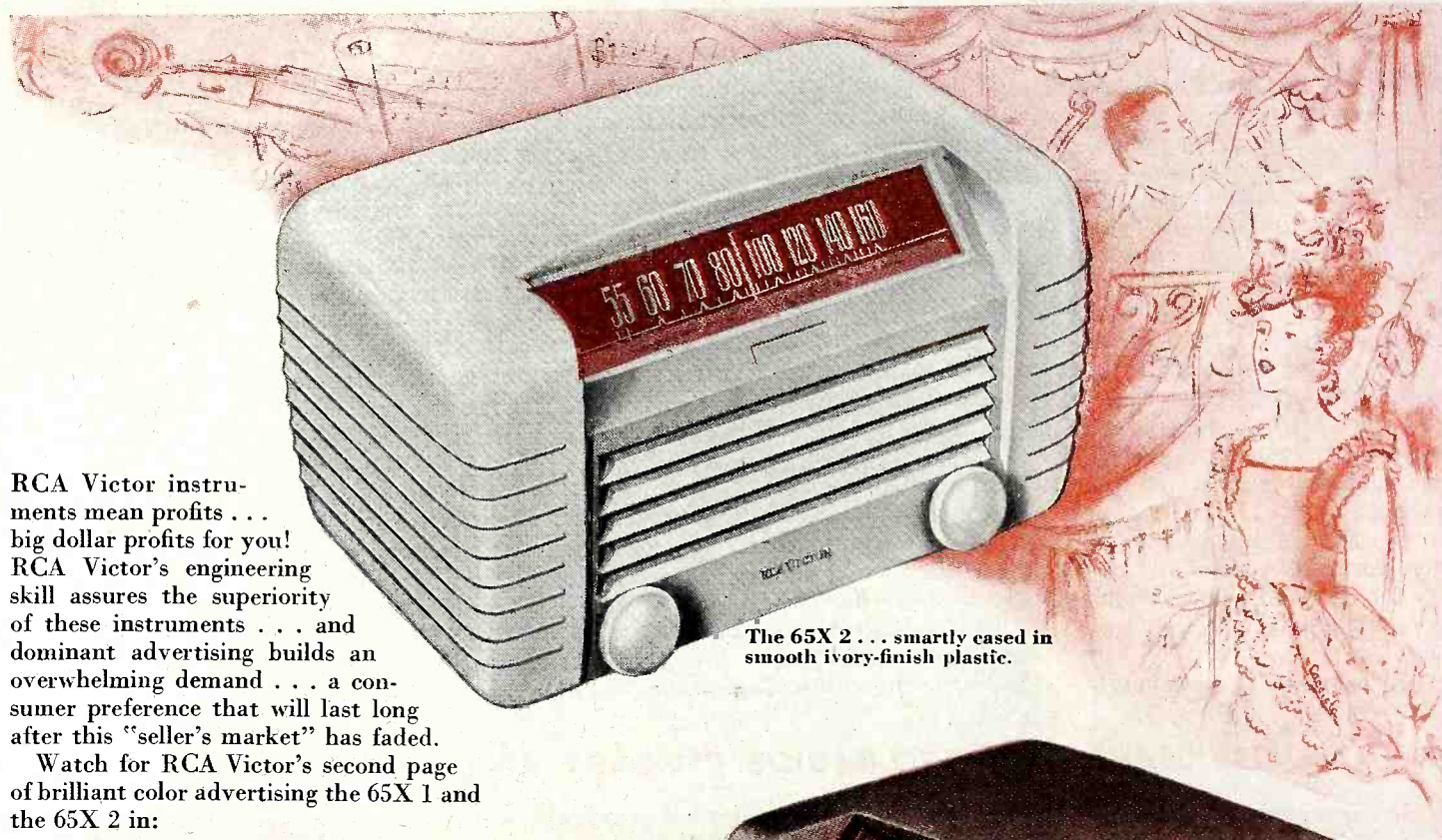

The 65X 2 . . . smartly cased in smooth ivory-finish plastic.

RCA Victor instruments mean profits . . . big dollar profits for you! RCA Victor's engineering skill assures the superiority of these instruments . . . and dominant advertising builds an overwhelming demand . . . a consumer preference that will last long after this "seller's market" has faded.

Watch for RCA Victor's second page of brilliant color advertising the 65X 1 and the 65X 2 in:

Life—March 24 Collier's—March 29
Saturday Evening Post—March 22

Then compare these two compact table model sets for beauty of appearance *and* performance with any other radio in the same price class. See for yourself how they give better value to your customers . . . faster profits for you!



The 65X 1 . . . rich in its walnut-plastic cabinet,



"Golden Throat"

The finest tone system in RCA Victor history! Richer, higher fidelity is produced by the "Golden Throat" . . . the exact balance of cabinet, loudspeaker and electronic amplification.

Listen to the "Golden Throat" in action, and you'll know why your customers will come to you—to see, hear, *and buy* RCA Victor radios and Victrola radio-phonographs.

RCA VICTOR



DIVISION OF RADIO CORPORATION OF AMERICA

Four-Way Flow of

• "Big-Four" store layout designed to "draw" buyers through every department, plus exclusive representation of many famous makes and top-flight merchandising methods is one New Jersey merchant's formula for increasing sales volume and profits.

Opening on Election Day 1945, the Harmony Shop in Millburn, N. J., had by the following year been voted Number One Big-4 Dealer in the area, according to the local utility company's survey.

The phenomenal record of this fast-growing outfit is easily explained by store manager Donald W. Collins, formerly record and radio buyer for the well-known Sarnberger department store in Newark, N. J.

Housed in a beautiful new build-

ing constructed not on high-rental Main Street or Millburn Avenue, but around the corner on Essex Street, the store faces on the municipal free parking lot adjoining the railroad station. This location is also at the base of the roads entering town from the Short Hills community, one of the richest in the East, the residents of which find the store's location a great convenience.

Consoles Act as Magnet

The layout was designed with great attention paid to traffic movement, with the result that visitors entering the front door are inevitably attracted through the appliance and record salesrooms down to the radio displays in the

back of the store.

Although the eye can see directly through the entire store, to reach the back rooms requires twisting through many attention-getting displays, each punching out its own sales message.

One more room is being added to the store, extending still further the succession of displays. The archway to this last unit space will be broken through the rear wall of the console radio showroom. To be used in radio demonstrations, the ceiling will be dome-shaped for acoustic reasons, while the floor will be supported on pillars flanking an inclined auto drive ramp. The new room will thereby act as shelter for auto-radio servicing work.

Seen behind one of the delivery

4-WAY STORE LEADS BUYERS TO RADIOS, RECORDS, APPLIANCES, SERVICE

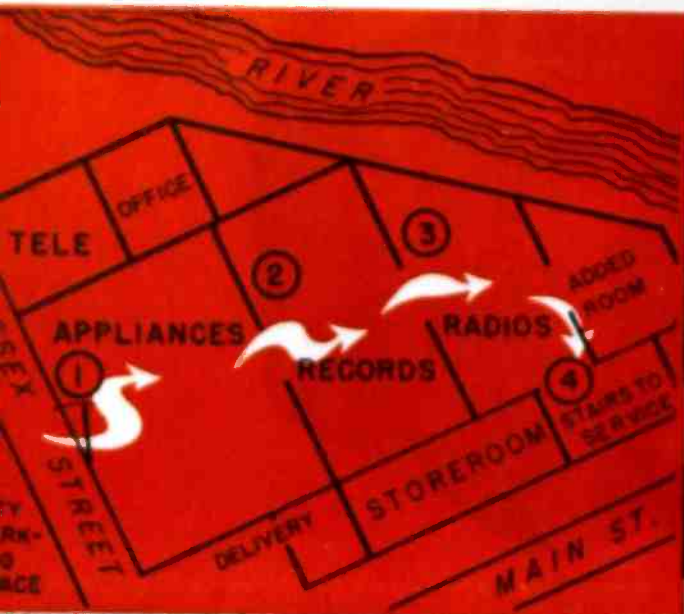

1 Appliance department, above, carries one of the largest collections of heavy and small appliances in the country. Featured items include washers, irons, cleaners and freezers.

Looking through low, well-lighted window display at left, shoppers see past multiple arches to inner store. Floor plan, above left, illustrates four-way division of space.

Profits

Store Planned to Draw Customers Set-by-Step Through Big Sections of Varied Merchandise



3 Manager Don Collins demonstrates a deluxe console in the comfortable, sound-treated big-radio sales room.

4 The service department entrance adjoins the sales room above, leading downstairs to two clean modern shops.



2 Four walls of the record department carry part of this store's large stock. Behind the small-radio display a long island offers every type of portable and table model record player.

trucks is a room now used as an office, which is to contain the television displays, although ultimate plans call for a separate shop along the lines of a "television center".

Layouts of the various rooms were selected partly from plans submitted by leading distributors based on their experience.

Stresses Leading Makes

Every attempt has been made to secure exclusive representation in the town on many of the leading makes of radios and appliances, while the store carries a record stock claimed to be the largest in Essex County. Besides the record display room shown, a large stockroom is jam-packed with replacements.

Activities of the Harmony Shop extend to the sound field, including the installation, and rental of PA and the sale of intercoms. This work, like the radio and appliance service department, is under the charge of Jules Seiler, a 20-year specialist in service.

Fifty per cent of the shop's service activity is "outside" console work, in which the two trucks are used, while a well-organized service bench and stockroom permit quick action on repairs, doing the kind of job that has rapidly earned the store a fine reputation for reliability and service.

Appliance sales represent a large proportion of the Harmony Shop's trade, and the first room at the store's entrance is filled with white stock, as well as light appliances.

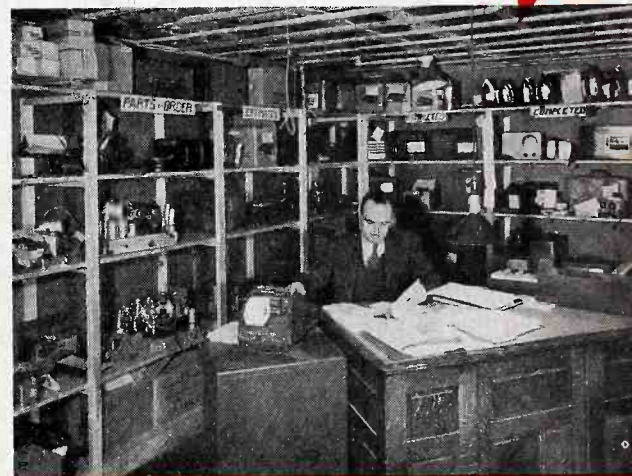

Better Profits from



This Texas dealer had been a specialist in auto radio sales and service, but postwar times brought expansion into home products.

• Vigorous support of the theory that reliable radio servicing is the key to profitable radio sales is furnished in the spectacular growth of the Deason Radio Company, San Antonio, Texas.

When a manufacturer of a leading line of radios recently revealed that C. G. Deason's concern had merchandised 54.4 per cent of the car radios of that line sold in the San Antonio territory, he confirmed the idea that Deason's is headquarters for many car radio owners.

Specialty servicing and specialty selling has been a company strong point since its beginning. The work is done on modern equipment amidst stimulating surroundings.

In a 25' x 25' shop, with steel incased, frosted-glass windows, which provide a natural light, the technicians turn out from twenty-five to forty service jobs daily.

"We're the biggest auto radio repair outfit in town," claims Mr. Deason. "Although we ballyhoo

our virtues less than any radio dealer in San Antonio, we closed the 1946 books with a yearly business that totaled over \$100,000.00. Personal attention to each service problem, that results in regular, satisfied customers; money-back guarantee on repair work, that really sticks; up-to-the-minute service facilities; and the finest advertising in the world—a well-lighted showroom—was the combination that produced the 1946 record-crashing service and sales volume."

Appliances Are Demanded

Four years ago, in a building on one of the city's main arteries of traffic, after moving from a location four years previously which he shared with a gas service station, C. G. Deason resolved that, with the exception of service equipment, future alterations would be limited and inexpensive.

He failed to reckon with his service customers' postwar demand for

the complete galaxy of electrical appliances. His intuition didn't tell him that the friends his service department had been accumulating since 1938 would be beating a steady path to his door, not merely to buy home and auto radios, but to purchase the complete gamut of appliances from electric clocks to refrigerators.

Deason remodeled again. Counters and other fixtures were finished in blond oak. A green vitrolite finish was applied on counter tops. Walls were painted a gleaming white. But of all the modernization features, Deason fancies the eight big, 4-tube fluorescent fixtures, which he keeps burning all night.

Four years ago the San Antonio dealer maintained that he would never again remodel his quarters. He had just finished a sparkling modernization that transformed the building into something pretty advanced in the way of design, lighting and decoration. A spacious

Better Service

**San Antonio Retailer
Serenades the Auto
Radio Fans — and
Others—to the Tune
of \$100,000 a Year**



C. G. Deason says that this modern building is practically "the house that service built."

drive-in arrangement with provisions for fifteen automobiles had been completed. A shelter arrangement for minor auto radio servicing had been installed—in bad weather, the shelter is a boon for motorists whose ailing sets require only cursory attention.

Deason calculates that the interest kindled by the window displays has figured plenty in the development of his enterprise into "the most profitable little business in this man's town".

He has ideas by the boatload about window display arrangement, but his chief principle is to change

window exhibits freely and move merchandise about in the building, because "if you place a large display of merchandise in the windows and allow it to remain indefinitely, it creates the impression that no one is buying."

Merchandise Circulated

"Shifting merchandise around is a key tactic of effective visual selling," asserts Mr. Deason. "We remove half of our merchandise one day, install a new line-up, and replace the other half the next day. The window shoppers assume that

the replaced products have sold, conclude that the merchandise has customer approval, investigate for themselves. We shift merchandise constantly, make daily changes of the spotlighted products featured under the big fluorescent lighting equipment, and leave the lights on all night."

Among the facilities of the Texas radio company is a complete parts department, an essential section in operating a successful service shop, according to this dealer.

"Not only does it conserve time to have every part at your finger-

(Continued on page 176)

Radio technicians at the store turn out from 25 to 40 jobs daily. The department has spacious drive-in facilities, complete parts stock.



Better Profits from



This Texas dealer had been a specialist in auto radio sales and service, but postwar times brought expansion into home products.

• Vigorous support of the theory that reliable radio servicing is the key to profitable radio sales is furnished in the spectacular growth of the Deason Radio Company, San Antonio, Texas.

When a manufacturer of a leading line of radios recently revealed that C. G. Deason's concern had merchandised 54.4 per cent of the car radios of that line sold in the San Antonio territory, he confirmed the idea that Deason's is headquarters for many car radio owners.

Specialty servicing and specialty selling has been a company strong point since its beginning. The work is done on modern equipment amidst stimulating surroundings.

In a 25' x 25' shop, with steel incased, frosted-glass windows, which provide a natural light, the technicians turn out from twenty-five to forty service jobs daily.

"We're the biggest auto radio repair outfit in town," claims Mr. Deason. "Although we ballyhoo

our virtues less than any radio dealer in San Antonio, we closed the 1946 books with a yearly business that totaled over \$100,000.00. Personal attention to each service problem, that results in regular, satisfied customers; money-back guarantee on repair work, that really sticks; up-to-the-minute service facilities; and the finest advertising in the world—a well-lighted showroom—was the combination that produced the 1946 record-crashing service and sales volume."

Appliances Are Demanded

Four years ago, in a building on one of the city's main arteries of traffic, after moving from a location four years previously which he shared with a gas service station, C. G. Deason resolved that, with the exception of service equipment, future alterations would be limited and inexpensive.

He failed to reckon with his service customers' postwar demand for

the complete galaxy of electrical appliances. His intuition didn't tell him that the friends his service department had been accumulating since 1938 would be beating a steady path to his door, not merely to buy home and auto radios, but to purchase the complete gamut of appliances from electric clocks to refrigerators.

Deason remodeled again. Counters and other fixtures were finished in blond oak. A green vitrolite finish was applied on counter tops. Walls were painted a gleaming white. But of all the modernization features, Deason fancies the eight big, 4-tube fluorescent fixtures, which he keeps burning all night.

Four years ago the San Antonio dealer maintained that he would never again remodel his quarters. He had just finished a sparkling modernization that transformed the building into something pretty advanced in the way of design, lighting and decoration. A spacious

Better Service

**San Antonio Retailer
Serenades the Auto
Radio Fans — and
Others—to the Tune
of \$100,000 a Year**



C. G. Deason says that this modern building is practically "the house that service built."

drive-in arrangement with provisions for fifteen automobiles had been completed. A shelter arrangement for minor auto radio servicing had been installed—in bad weather, the shelter is a boon for motorists whose ailing sets require only cursory attention.

Deason calculates that the interest kindled by the window displays has figured plenty in the development of his enterprise into "the most profitable little business in this man's town".

He has ideas by the boatload about window display arrangement, but his chief principle is to change

window exhibits freely and move merchandise about in the building, because "if you place a large display of merchandise in the windows and allow it to remain indefinitely, it creates the impression that no one is buying."

Merchandise Circulated

"Shifting merchandise around is a key tactic of effective visual selling," asserts Mr. Deason. "We remove half of our merchandise one day, install a new line-up, and replace the other half the next day. The window shoppers assume that

the replaced products have sold, conclude that the merchandise has customer approval, investigate for themselves. We shift merchandise constantly, make daily changes of the spotlighted products featured under the big fluorescent lighting equipment, and leave the lights on all night."

Among the facilities of the Texas radio company is a complete parts department, an essential section in operating a successful service shop, according to this dealer.

"Not only does it conserve time to have every part at your finger-

(Continued on page 176)

Radio technicians at the store turn out from 25 to 40 jobs daily. The department has spacious drive-in facilities, complete parts stock.





**California Style in
Store Lay-out Is a
Magnet to Customers**

This window display of the San Diego dealer is very simple, but looks effective through wide glass. All display areas are kept polished.

Designed for Selling

• After thirty years of doing business at 630 C Street in San Diego, Calif., the Southern California Music Company has remodeled its store and combined functional beauty with profit-making.

The plans were changed seven times before the present store layout was chosen. Alfred D. La Motte, the landlord, and Eugene R. Jaeger, the executive vice-president and manager, were determined to have a store that (1) would be easy to operate, (2) would handle a large number of customers, and (3) would have an atmosphere appropriate to the firm's reputation.

Mr. Jaeger says that "there is a definite reason for the location of every section of the store. From the customer's viewpoint, a visit to the Southern California Music Company of San Diego is a pleasant experience; from the employe's viewpoint, the establishment is both a beautiful and a convenient place in which to work.

With a frontage of only 50 feet, the store is 200 feet from front to rear with a full basement and mezzanine—a total of 23,000 square feet of usable floor space. The front third of the main floor is occupied by a large radio and piano display area (left) and a record sales department (right). A wide corridor along the center extends from the middle of the store to the rear. Opening off this corridor is the manager's office, cashier's office, general office, accessory sales department, a band instrument sales room, and several rooms for radio and piano sales.

Prospects Are Stopped

Pedestrians on the sidewalk can look through the full length windows into the store's glittering interior. Entering through the solid glass doors, the customer finds to his left a display of the leading models of the company's lines, in-

cluding Magnavox, Zenith, RCA-Victor, Philco, General Electric, and Stromberg-Carlson. Corner shelves are effectively used for the exhibition of table model sets.

Here they have an opportunity to make a casual inspection of merchandise and to ask questions. This area also serves as a sort of "separation center" where the salesman has an opportunity to become acquainted with the customer, discover his likes, and determine what models most specifically interest him. When a prospective customer has been separated from the ranks of the "suspects," he is then escorted to one of the radio sales rooms opening off the corridor.

In the radio sales room the customer has an opportunity to see and hear and compare the various makes and models in a quiet atmosphere. Here, too, the salesman has an opportunity to do a thorough selling job without the inter-

At the left, the "salon" type sales room for quiet demonstration and sales of more expensive console models. At right, basement repair shop.

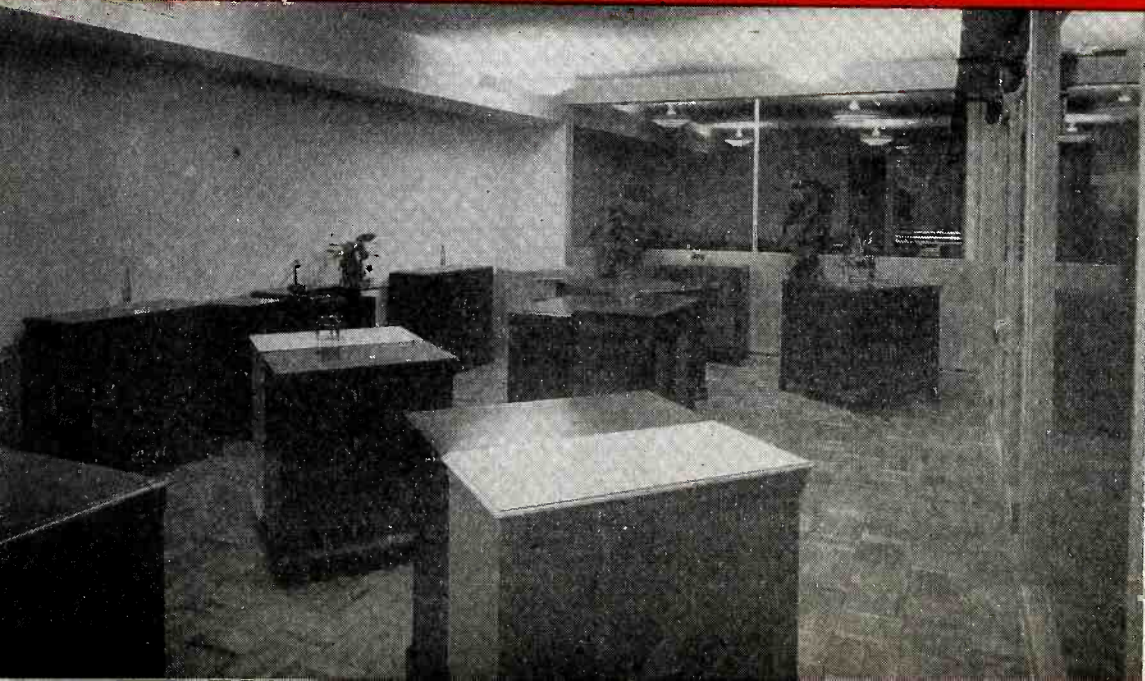

ference and noise of store traffic and without interruptions from other customers. Two cardinal rules laid down by manager Jaeger are (1) customers must be greeted within a minute or two after they enter the store, and (2) under no circumstances may a salesman be disturbed when he is with a customer in any one of these sales rooms.

The record sales department occupies the large area to the right of the entrance and just opposite the radio display floor. Working on the theory that customers will be prompted to make additional purchases if they are allowed to browse through the titles, the store has albums displayed on open shelves and single records banked up on special counters. There are six modern, comfortable listening booths equipped with Magnavox players, in addition to the five listening posts next to the single record counters.

Floor Strategy

Adjoining the record department is a separate department for the sale of needles, record brushes, and accessories. Directly across the corridor from the accessory department is the cashier's office and general business office. A glass-enclosed manager's office adjoins the cashier's office and is next to the radio display floor. From this vantage point the manager can keep an eye on all activity in the store. He is able to go to the aid of salesmen when help is needed, answer the questions of customers, and is available for decisions needed by the general office.

The mezzanine forms a balcony which rings the entire corridor. It is reached by two stairways in the center of the store and contains seven soundproof studios, in addition to

(Continued on page 176)



Above, the radio display floor shows all table units on neat shelves. Only smaller sets are sold here. Below, the record dept. is "engineered for browsing"—with an electric lift concealed behind curved wall section. At bottom is the final floor plan that seven revisions produced.

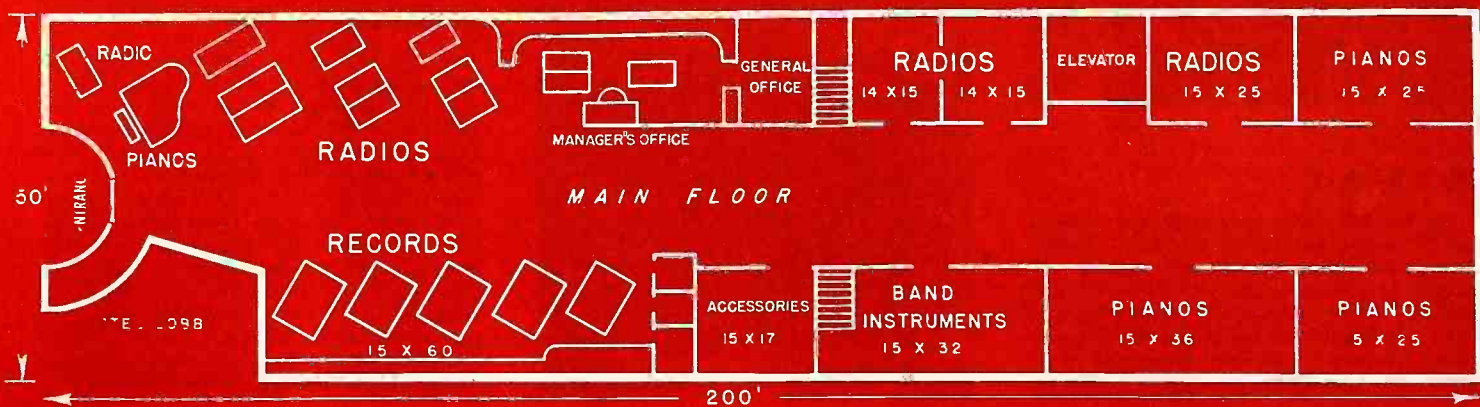
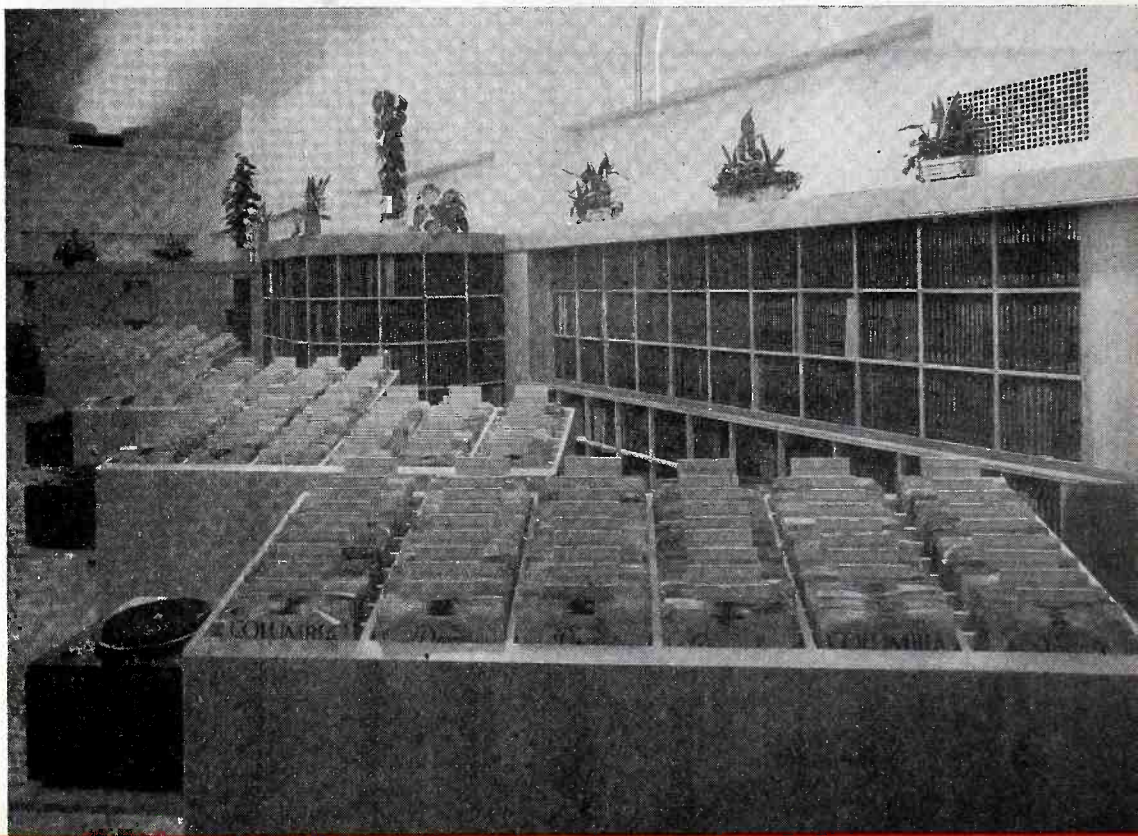

Crosley COMBO

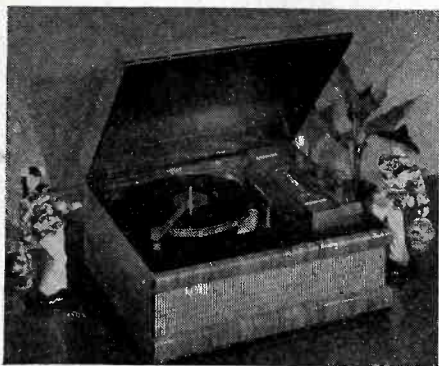

Model 56-TZ table style automatic radio-phonograph. PM-type oval speaker, beam power output tube, Signal Web antenna. Two-position tone control for both phono and radio, automatic sensitivity control, 4 radio tubes plus rectifier. Plays ten 12" and 10" intermixed records, or ten 12" or twelve 10" discs. Automatic shut-off, Floating Jewel tone system. Walnut veneer cabinet has woven plastic grille cloth framed with Macassar ebony (Model 57-TQ is lime walnut with New Guinea wood trim). Measures 9 $\frac{5}{8}$ " high by 19 $\frac{3}{4}$ " wide by 17 $\frac{5}{8}$ " deep. Crosley Division, Aviation Corp., 1329 Arlington St., Cincinnati, Ohio.—RADIO & Television RETAILING

Hoffman COMBO

Model B-400 end-table size automatic radio-phonograph engineered for small apartments and crowded rooms. Illuminated slide rule dial, ac-dc, built-in loop antenna, automatic volume control. Alnico PM dynamic speaker. Low pressure tone arm, plays ten 12" or twelve

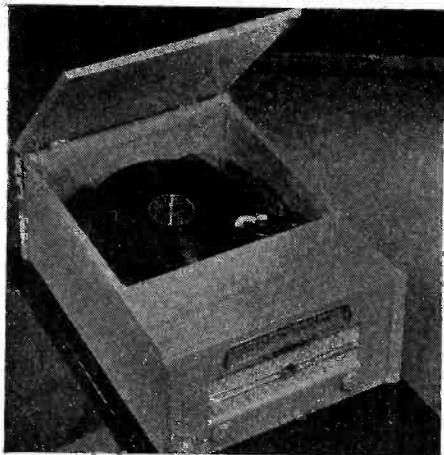

10" discs. Modern design cabinet "Styled in California." Measures 8 $\frac{3}{4}$ " high by 15" wide by 21" deep. Will list under \$100. Hoffman Radio Corp., 3430 S. Hill St., Los Angeles, Calif.—RADIO & Television RETAILING

ECA RADIO

Model 204 three-way portable receiver, 7 tubes including rectifier. Three-gang variable condenser, tuned RF stage, one watt undistorted power output on ac-dc. Separate power output tube on batteries—for economical operation. Alnico 5 speaker. Recessed controls on slenderized design cabinet.



New Sets to

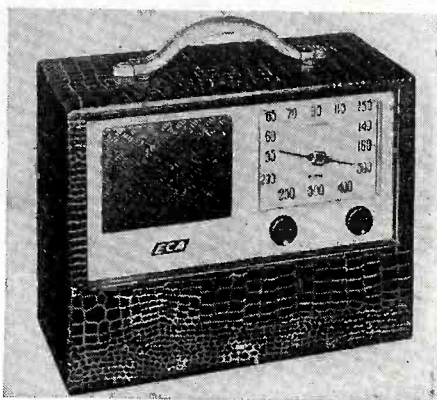

Sturdy case covered with leatherette. Electronic Corp. of America, 170-53 St., Brooklyn, N. Y.—RADIO & Television RETAILING

Communophone INTERCOMMUNICATORS

New Deluxe line of intercommunication units consisting of LA, LC and LS series, from which all types of systems can be designed. LA units are for systems using one master and a number of remotes. LC series includes all master systems providing a number of private simultaneous 2-way conversations—this series has the "Discrete Busy Signal" indicator system. LS series provides a number of masters operating with a number of remotes. Master units in each series come with either 10 or 20 selective pushbuttons. Handsets available for LC and LS series. Operate on 110 v AC. David Bogen Co., Inc., 663 Broadway, New York 12, N. Y.—RADIO & Television RETAILING

Tele-tone RADIO

Model 145 three-way superhet portable receiver, self-contained loop antenna, Alnico 5 PM speaker. Operates

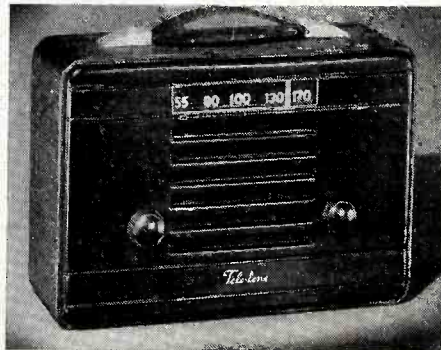

on ac-dc or self-contained batteries—uses 5 flashlight size D cells as A supply plus single Eveready No. 467 67 $\frac{1}{2}$ -volt battery or equivalent for B supply. Four tubes plus selenium rectifier—no waiting for heat-up. Slide rule dial, automatic volume control. Simulated leather cabinet with plastic front measures 9 $\frac{3}{4}$ " by 3 $\frac{1}{2}$ " by 7". Weighs 5 $\frac{1}{2}$ lbs. with batteries. \$29.95 retail. Tele-tone Radio Corp., 609 W. 51st St., New York, N. Y.—RADIO & Television RETAILING

Emerson RADIO

Model 511—the "Moderne" table unit with three-dimensional dial, five tubes. Plastic cabinet molded in one piece of Resinox; plate and dial are Lustron. Recess streamlined into top of cabinet to provide carrying handle. Grille is fabricated from pierced metal in color contrast to cabinet. Curved transpar-

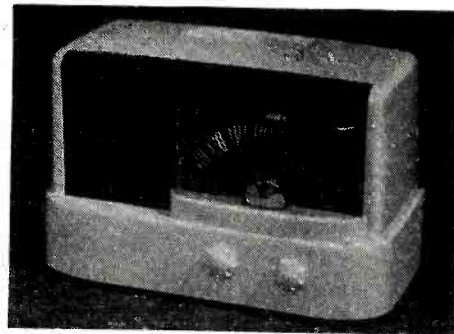

ent plate for feature dial. Comes in selection of black, ivory and gold combinations. Emerson Radio & Phonograph Corp., 111 Eighth Ave., New York 11, N. Y., \$29.95.—RADIO & Television RETAILING

Setchell Carlson PORTABLE RADIO

Model "55" battery-or-ac portable receiver with two bands. Tunes 540 to 1820 kc plus 6.3 to 2.3 mc. Uses two small 45-v "B" batteries and four regular flashlight cells, all self-contained. Five tubes, directional adjustable loop antenna. Automatic cut-off switch disconnects batteries when used on ac. Dynamic speaker, slide rule dial. Sturdy weather-proof case, modern aero-luggage style. Measures 7 $\frac{3}{4}$ " high by 12 $\frac{1}{4}$ " long by 6 $\frac{3}{4}$ " deep. Weight, less batteries, 13 lbs. Setchell Carlson, Inc., 2233 University Ave., St. Paul, Minn.—RADIO & Television RETAILING

Hike Profits

Faraday REFRIGERADIO

Model C-259 kitchen receiver, table unit, designed to simulate tiny refrigerator. Superhet with 6 tubes, including rectifier; ac-dc, Alnico 5 speaker. Built-

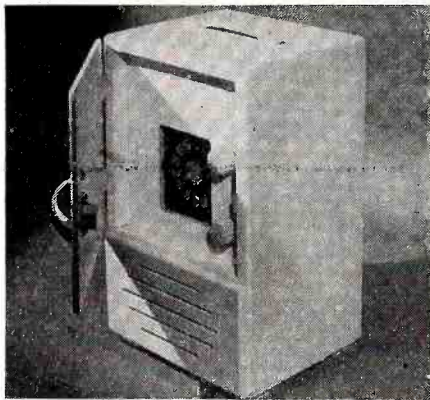

in Franklin directional antenna, two-gang condenser, white-on-black dial letters to contrast with white cabinet. Machine lock-cornered cabinet of solid wood; door made of special plywood to retard warping. Washable finish. Measures 12 $\frac{1}{4}$ " high by 7 $\frac{1}{2}$ " wide by 7" deep. Faraday Radio Mfg. Co., 259 Church St. Annex, New York 8, N. Y.—RADIO & Television RETAILING

Farnsworth FM-AM COMBO

Model EK-141 console ac superhet combination, with AM, shortwave, FM and automatic record changer. Push-button tuning for AM or FM, phono compensated circuit, continuously variable base & treble tone controls. Shielded rotatable Bilt-In-Tenna for AM; built-in dipole for FM. Band spread tuning, 3-gang tuning condenser with tuned RF amplifier. Beam power output,



push-pull amplification, 12" PM Alnico speaker. Slide rule Travelite dial AVC, automatic stop. Tune 540 to 1600 kc; FM from 88 to 108 mc; shortwave from 9.4 to 15.4 mc. Cadmium plated steel chassis. Farnsworth deluxe 3-point suspension automatic disc changer plays twelve 10" or ten 12" records. Feather weight tone arm, sealed crystal pickup, precious-metal stylus. Automatically illuminated changer compartment. Cabinet measures 35 $\frac{1}{4}$ " high by 42 $\frac{1}{2}$ " wide by 18" deep. Farnsworth Television & Radio Corp., Ft. Wayne 1, Ind.—RADIO & Television RETAILING

Jewel RADIO-CLOCK

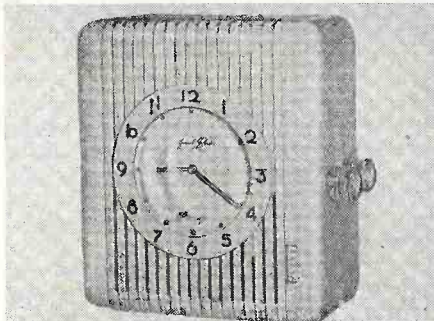

Model 505 "Pin-Up" superhet receiver-and-electric-clock, for use on the kitchen or bedroom wall or any shelf or table. Circuit uses selenium "Miracle Rectifier" plus 4 tubes. "Magic Voltage Control" to handle voltage surges—helping to increase tube life. Plastic case comes in variety of colors. \$39.95. Jewel Radio Corp., 583 Ave. of the Americas, New York, N. Y.—RADIO & Television RETAILING

Cyart RADIO

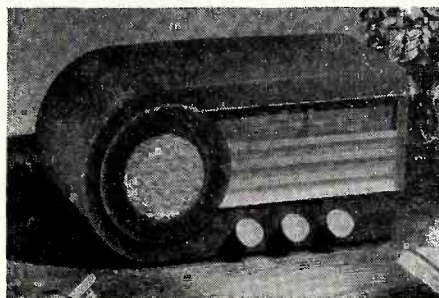

Model B two-band table receiver with 6 tubes. Five-inch Alnico 5 speaker. All visible parts made of plastic. Features use of grille made of Plexon (Product of Plexon, Inc.) which can be wiped clean with damp cloth. Plexon yarns come in 120 different colors, providing

many color combinations. Grilles of red-and-white or red-and-yellow used on this set to compliment lucite cabinets of yellow, red, butterscotch or blue. \$65.95. Cyart Plastics, Inc., 2292 Harlem River Terrace, Bronx, N. Y.—RADIO & Television RETAILING

Bendix COMBO



Model 697-A step-table automatic radio-phonograph with Phantom Dial. Superhet tunes 540 to 1620 kc, 6 all-radio tubes plus selenium wafer-type rectifier. Push-pull beam power output, 8" Alnico speaker, "Super-Signal" built-in antenna. Automatic changer (under sliding top) plays up to twelve 10" discs, featherweight tone arm, semi-precious alloy permanent-type needle. Mahogany step-table styles, designed to make radio-phono functions invisible, serves occasional, end table or chairside use, measures 28 $\frac{5}{8}$ " high by 16 $\frac{7}{8}$ " wide by 28 $\frac{1}{4}$ " deep. Bendix Radio Division of Bendix Aviation Corp., Baltimore 4, Md.—RADIO & Television RETAILING

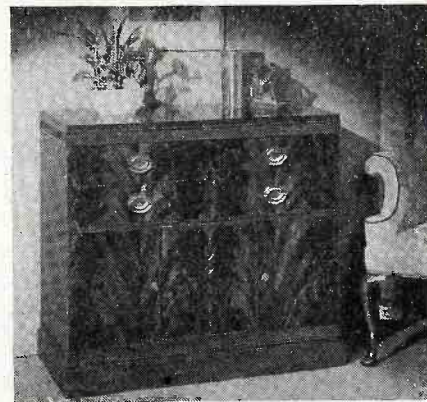

Brunswick AM-FM COMBO

Model T-1711 "The Buckingham" automatic AM-FM-radio-phonograph combination, with 10 tubes, 12" PM speaker. Covers new FM band, push-pull output, 8 w undistorted output. Deluxe disc changer with automatic stop plays ten 12" or twelve 10" records, permanent needle. Cabinet in early 18th Century English Georgian style; hand-rubbed African crotch mahogany throughout the front; classic design mouldings and drawer pulls. \$375 in East including tax. Radio & Television, Inc., 244 Madison Ave., New York 16, N. Y.—RADIO & Television RETAILING

(New Phonographs on page 100)

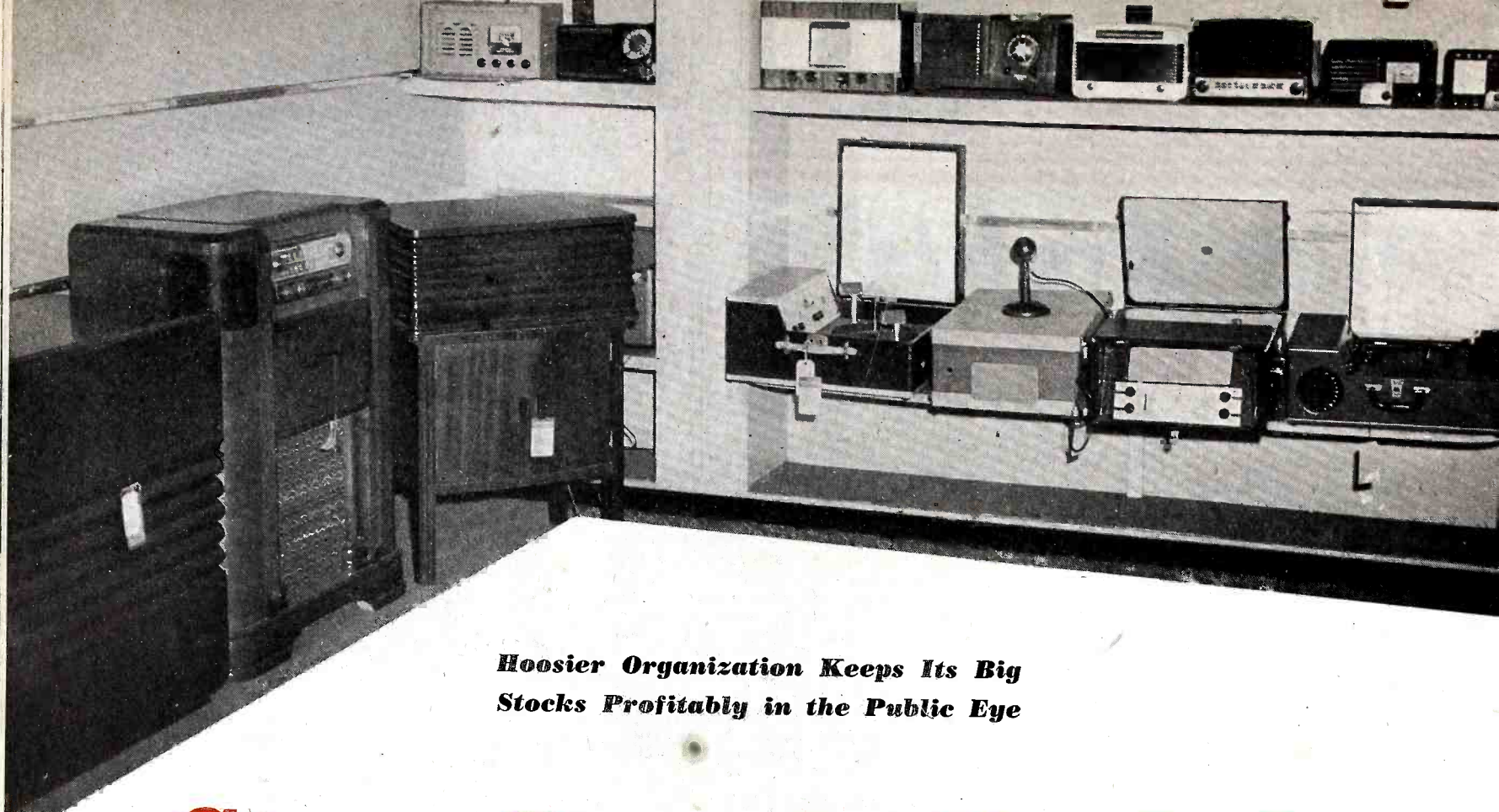

Hoosier Organization Keeps Its Big Stocks Profitably in the Public Eye

Store Rounds Up Sales

• Sales of radios, records and appliances are piling up at the Wm. H. Block Company, Indianapolis, Ind., and the managers report that it's all due to a steady and consistent emphasis on extensive advertising, unusual window displays and strictly modern methods in the store showrooms.

The firm advertises in three local newspapers, and broadcasts over four radio stations. The store sponsors news broadcasts and sporting events as well as amateur musical

In this corner—an array of appliances at Block's neatly shown with suppliers' displays.

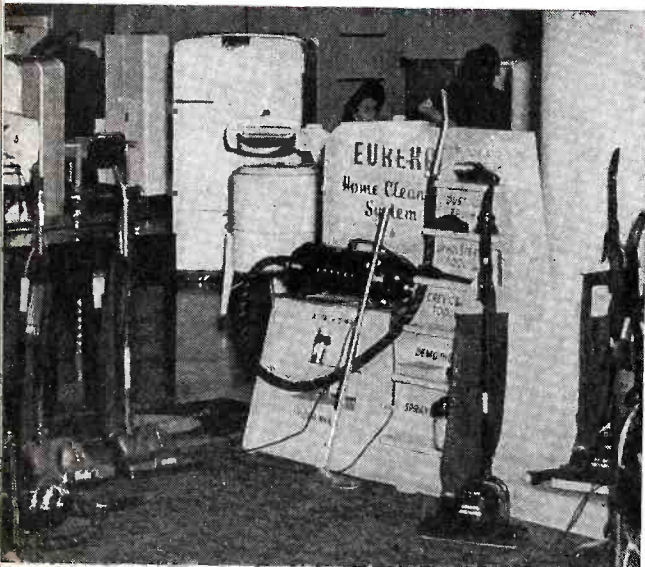

programs and recorded shows. Block also goes in for direct mail—using elaborate pamphlets mailed to a restricted list, as well as a regular “shopping news.”

The company is one of Indiana's largest and most modern stores and it now operates three neighborhood outlets. Some of the points stressed in Block's big-scale advertising are: (1) A complete assortment of all types and models, (2) Merchandise in all price ranges, (3) The policy of stating openly that stocks are limited if such be the case in some lines, (4) Use of the store's prestige and buying power to offer values, and (5) Centrally located stocks in pleasant surroundings.

“Take It Easy” Note

The store has a spacious record department, which has been arranged to look specially restful and pleasing. There are a total of 15 listening booths, and room has been provided for those who want to relax in the midst of their buying.

The appliance section has been made as complete as it is possible to do, with shortages still existing in some major lines. Salespeople are trained not only to sell the merchandise, but to instruct the customers carefully on the proper

uses of the units in the home. Automatic washers and ironers, for instance, are demonstrated in the home by trained experts, after the appliances have been delivered. The officials at Block's have found that this pays off, in eliminating complaints that might result from confusion as to how the units can best do their job.

Service Gets a Play

The service department plays a big part in keeping the customers all satisfied. This section is the one which inspects all outgoing merchandise, and is charged with the job of seeing that all the merchandise is properly installed for best service and results. “Block's Dependable Service” is stressed as a merchandising idea. Guarantees are given detailed and careful attention.

There is no elaborate sales training program but there is a marked effort to make full use of all the “sales helps” which the manufacturers have to offer. This often involves a great deal of detail because Block's handles a complete assortment in several lines and the firm is an exclusive dealer for a number of suppliers. But regardless of the number of these point-of-sale materials that are pressed



On the theory that customers buy more if given a chance to relax, Block's supplies plenty of comfort in the record dept. At the semi-circular counter is disc buyer J. Gasaway. On the left hand page, a sample of how the Indianapolis store shows a variety of radios against light-colored walls and shelves.

into use, the store is careful to keep the showrooms and display areas looking neat and trim at all times.

The Block advertising and promotion experts have a tendency to list complete technical data on the advertised sets. More than at the average store, ad writers at Block's feel that the reader is entitled to know the fundamental characteristics of the circuits. However, great care is taken in the ad layouts to keep the display from looking dull. Sets are most often shown in large sizes, and the combinations with the roll-out features are shown as they look in use, as well as in their more handsome "closed" position. Block's likes to present the new models in photos or drawings of home settings, as a rule.

Lively Advertising

Although the store prefers to include a wealth of circuit information in its new paper ads, the language of the set description waxes enthusiastic in the headlines. For instance the store said recently, in presenting a new combination, that "You've been waiting a long time for just such a radio as this new radio-phonograph . . . when you hear it you'll find fresh enjoyment in your favorite radio programs and

records, and discover new programs for your delight . . . it's built by furniture craftsmen of beautifully matched veneers with a smooth satin finish."

The store makes little effort to keep the radio-appliance window displays within the conventional rules and has attracted wide attention with its novel effects. The newest ideas get a brisk try-out at Block's, in lighting, seasonal ideas, and color trims.

With all this emphasis on display, advertising and the "front" aspects of the business, Block's remains a store that will continue to accent its service department. The pace of future promotions will undoubtedly increase as the industry moves deeper into the buyers' market, but it can be seen that the company's ads will never get too big or too fancy to feature a sound policy of standing behind its rule of "Block's Dependable Service."

On decorative flooring material appropriate to kitchen merchandise, the Indiana firm has grouped enough ranges to make the selection look like the last word. On duty is buyer C. Sheets.

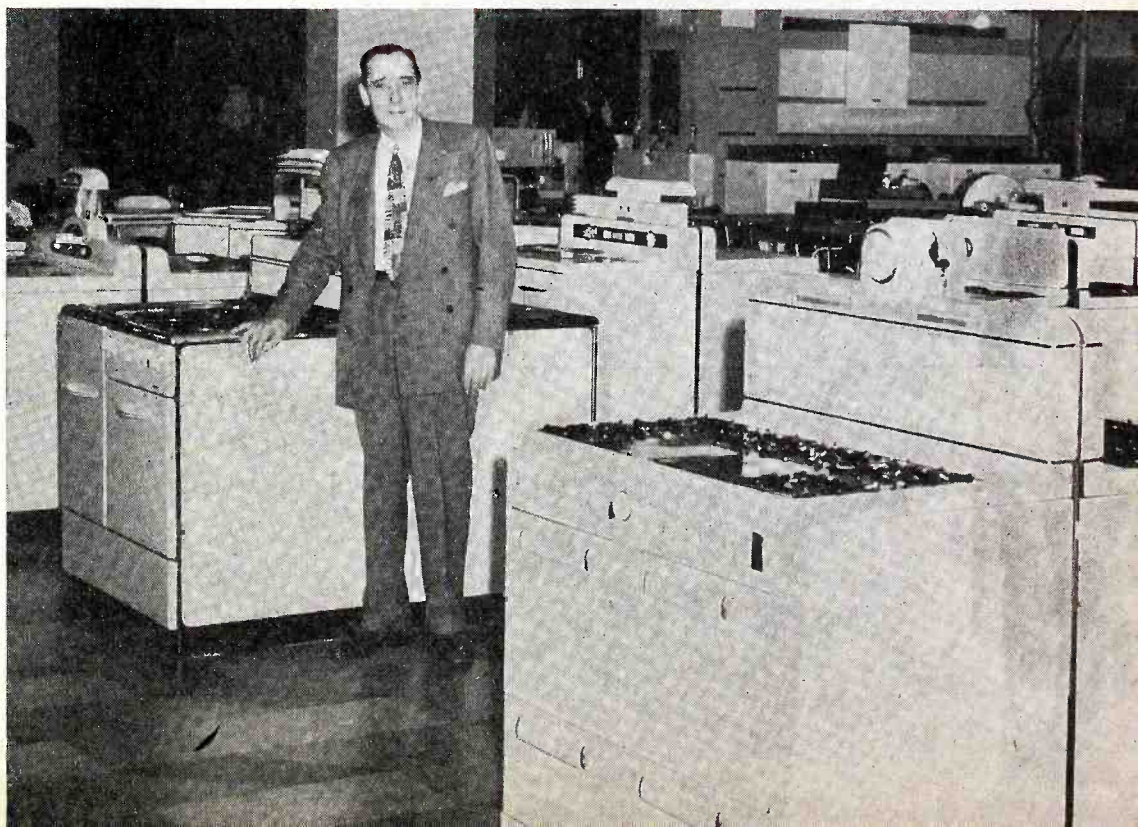

PRODUCTS OF RADIO AND TELEVISION MANUFACTURERS

Listing the companies whose lines cover one or more of the six groups of greatest importance to retailers and distributors

Compiled by RADIO & Television RETAILING, 480 Lexington Ave., New York 17, N. Y.

The following manufacturers of radio receivers have returned our editorial questionnaire giving the information needed for these listings	Home AM-FM	Combinations	Television	Auto Radio	Amateur	Commercial*	Manufacturers not listed may furnish data for the next issue. No advertising obligation. Additions or revisions will be made monthly.	Home AM-FM	Combinations	Television	Auto Radio	Amateur	Commercial*
Abbott Instrument, Inc., 8 W. 18th St., New York, N. Y.							Fred M. Link, 125 W. 17th St., New York, N. Y.						
Admiral Corp., 3800 W. Cortland St., Chicago, Ill.							Magnavox Co., 2131 Bueter Rd., Ft. Wayne 4, Ind.						
Aero Communications Co., 231 Main St., Hempstead, L. I.							Maguire Industries, Inc., 936 No. Michigan Ave., Chicago, Ill.						
Air Associates, Inc., 5827 W. Centry Blvd., Los Angeles 45, Calif.							Majestic Radio & Television Corp., St. Charles, Ill.						
Air Communications Co., 2233 Grand Ave., Kansas City, Mo.							Marco Industries, 245-A So. Beverly Dr., Beverly Hills, Calif.						
Air King Prod. Co., Inc., 1523 63rd St., Brooklyn, N. Y.							Mason Radio Products Co., Kingston, N. Y.						
Airplane & Marine Instruments, Clearfield, Pa.							McGrade Mfg. Co., 406 W. 34th St., Kansas City, Mo.						
Allied Radio Corp., 833 W. Jackson Blvd., Chicago 7, Ill.							McCrad Div., Black Industries, 1400 E. 222nd, Cleveland 17, O.						
American Communications Co., 306 Broadway, New York, N. Y.							Medco Mfg. Co., 5 W. 45th St., New York, N. Y.						
Andrea Radio Corp., 43-20 34th St., Long Island City, N. Y.							Mesgard Corp., 1601 S. Burlington Ave., Los Angeles, Calif.						
Ansley Radio Corp., 41 St. Joes Ave., Trenton, N. J.							Meissner Mfg. Co., 936 N. Michigan Ave., Chicago, Ill.						
Apex Industries, 192 Lexington Ave., New York 16, N. Y.							Midwest Radio Corp., 909 Broadway, Cincinnati, Ohio.						
Atlantic Mfg. Co., Hamburg, Pa.							James Millen Mfg. Co., 150 Exchange St., Malden, Mass.						
Atomic Heater & Radio Corp., 104 Park Row, New York, N. Y.							Mineva Corp. of America, 238 William St., New York, N. Y.						
Autoerat Radio Co., 3855 N. Hamilton Ave., Chicago							Molded Insulation Co., 335 E. Price St., Philadelphia 44, Pa.						
Automatic Radio Mfg. Co., Inc., 122 Brookline Ave., Boston							Monitor Equipment Co., 640 W. 249th St., Riverdale, N. Y.						
Aviola Radio Corp., Phoenix, Ariz.							Musitron Co., The 223 W. Erie St., Chicago, Ill.						
Baronette Radio & Tube Corp., 220 Fifth Ave., New York, N. Y.							National Co., Inc., 61 Sherman St., Malden, Mass.						
Rex Bassett, Inc., 311 N. W. 1st Ave., Ft. Lauderdale, Fla.							National Design Service, 96 Liberty St., New York, N. Y.						
Bell Radio Co., 125 E. 46th St., New York, N. Y.							National Union Radio Corp., 57 State St., Newark 2, N. J.						
Belmont Radio Corp., 5921 W. Dickens Ave., Chicago, Ill.							Noblitt-Sparks Industries, Inc., Columbus, Ind.						
Bendix Radio, Div. of Bendix Aviation Corp., Baltimore, Md.							Northeastern Engineering, Inc., Canal St., Manchester, N. H.						
Biltmore Radio Corp., 15 Ave. "A", New York 3, N. Y.							Northern Radio Co., 2208 4th Ave., Seattle, Wash.						
Cavaleade Industries, 39 S. La Salle St., Chicago, Ill.							Olympic Radio & Tele., Inc., 510 Sixth Ave., New York, N. Y.						
Collins Radio Co., 2920 First Ave., Cedar Rapids, Iowa							Packard-Bell Co., 3443 Wilshire Blvd., Los Angeles, Calif.						
Colonial Radio Corp., 254 Rano St., Buffalo, N. Y.							Panoramic Radio Corp., 242 W. 55th St., New York 19, N. Y.						
Columbia Electronic, Inc., 185 E. 122nd St., New York, N. Y.							Pileo Corp., Tioga & C Sts., Philadelphia, Pa.						
Communications Co., Inc., 300 Greco Ave., Coral Gables, Fla.							Pilot Radio Corp., 37-06 36th St., Long Island City, N. Y.						
Communications Equip. Corp., 134 W. Colo. St., Pasadena, 1, Cal.							Port-O-Matic Corp., 985 Madison Ave., New York, N. Y.						
Concord Radio Corp., 901 W. Jackson Blvd., Chicago							Precision Specialties, 210 N. Western Ave., Los Angeles, Calif.						
Continental Electronics Ltd., 252 Norman Ave., Brooklyn, N. Y.							Press Wireless, Inc., 1475 Broadway, New York 18, N. Y.						
Crosley Corp., 1329 Arlington St., Cincinnati, Ohio							Quality Industries, 25 E. Jackson Blvd., Chicago 4, Ill.						
Crystal Products Co., 1519 McGee Trafficway, Kansas City, Mo.							Radio Craftmen, Inc., 1341 S. Michigan Ave., Chicago						
Deleo Radio, Div. of General Motors Corp., Kokomo, Ind.							Radio Engineering Laboratories, Inc., 36th St., L. I. City, N. Y.						
DeWald Radio Mfg. Corp., 35-15 39th Ave., Long Is. City, N. Y.							Radio Laboratories, 2701 California Ave., Seattle 6, Wash.						
Allen B. DuMont Laboratories, 515 Madison Ave., New York							Radio Mfg. Engineers, Inc., Peoria 6, Ill.						
Dynavox Corp., 40-35 21st St., Long Island City, N. Y.							Radio Navigational Inst. Corp., 305 E. 63rd St., New York 21						
Eastern Electronics Corp., 41 Chestnut St., New Haven, Conn.							Radio Press Co., 7618 Melrose Ave., Los Angeles, Calif.						
Echophone Radio Co., 2611 So. Indiana Ave., Chicago, Ill.							Radio & Television, Inc., 244 Madison Ave., New York, N. Y.						
Eckenroth Co., 32 Ross Street, Brooklyn, N. Y.							Radio Wire Television Inc., 100 Ave. of the Americas, New York						
Eckstein Radio & Television Co., 1400 Harmon Pl., Minneapolis							RCA Victor Div., Radio Corp. of America, Camden, N. J.						
Electronic Mfg. Co., 88 University Pl., New York, N. Y.							Regal Electronics Corp., 20 W. 20th St., New York, N. Y.						
Electronic Corp. of America, 170 53rd St., Brooklyn, N. Y.							Remler Co., Ltd., 2101 Bryant St., San Francisco, Calif.						
Electronic Devices Co., 601 W. 26th St., New York, N. Y.							E. M. Sargent Co., 219 9th St., Oakland, Calif.						
Electronic Laboratories, Inc., 24 W. 24th St., Indianapolis, Ind.							Scophony Corp. of America, 527 5th Ave., New York, N. Y.						
Emerson Radio & Phono Corp., 111 8th Ave., New York, N. Y.							Scott Radio Labs., Inc., 4450 Ravenswood Ave., Chicago, Ill.						
Emor Radio, Ltd., 400 East 118th St., New York, N. Y.							Searle Aero Industries, Inc., P. O. Box 111, Orange, Calif.						
Espey Mfg. Co., Inc., 528 E. 72nd St., New York, N. Y.							Selectograph Mfg. Co., 502 W. Colo. Ave., Colorado Spgs., Colo.						
Fada Radio & Electric Co., Inc., Long Island City, N. Y.							Sentinel Radio Corp., 2020 Ridge Ave., Evanston, Ill.						
Farnsworth Television & Radio Corp., Fort Wayne, Ind.							Setchell-Carlson, Inc., 2233 University Ave., St. Paul, Minn.						
Federal Telephone & Radio Corp., 591 Broad St., Newark, N. J.							Sheridan Electronics Corp., 2350 S. Michigan Ave., Chicago						
Fisher Radio Co., 41 E. 47th St., New York, N. Y.							Signal Electronics, Inc., 114 E. 16th St., New York, N. Y.						
Fisher Research Lab., 1961 University Ave., Palo Alto, Calif.							Silver Co., McMurdo, 1240 Main St., Hartford 3, Conn.						
Flush Wall Radio Co., 15 Washington St., Newark, N. J.							Sonora Radio & Television Corp., 325 N. Hoyne Ave., Chicago						
F. M. Radio Mfg. Co., Inc., 10314 Superior, Cleveland, Ohio							Sparks-Withington Co., Jackson, Mich.						
Freed Radio Corp., 200 Hudson St., New York, N. Y.							Stewart-Warner Corp., 1326 Diversey Pkwy., Chicago, Ill.						
Galvin Mfg. Corp., 4545 Augusta Blvd., Chicago, Ill.							Stromberg-Carlson Co., 100 Carlson Rd., Rochester, N. Y.						
Garod Radio Corp., 70 Washington St., Brooklyn, N. Y.							Symphonic Radio & Electronic Corp., Main St., Cambridge, Mass.						
General Electric Co., Bridgeport, Conn.							Taibern Equipment Co., 120 Greenwich St., New York, N. Y.						
Gilfillan Bros., 1815 Venice Blvd., Los Angeles, Calif.							Teletop Radio Co., 609 W. 51st St., New York, N. Y.						
Globe Electronics, Inc., 225 W. 17th St., New York, N. Y.							Telex, Inc., 451 S. 5th Ave., Mt. Vernon, N. Y.						
Hallierafters Co., 2611 S. Indiana Ave., Chicago, Ill.							Telcom Corp., 851 Madison Ave., New York, N. Y.						
Hammarlund Mfg. Co., 460 W. 34th St., New York, N. Y.							Templestone Radio Mfg. Corp., New London, Conn.						
Harris Mfg. Co., 2422 W. 7th St., Los Angeles							Trav-Ler Radio & Tel. Corp., 571 W. Jackson, Chicago						
Harvey Machine Co., Inc., 6200 Avalon Blvd., Los Angeles							Trebner Radio Co., Box 497, Pasadena, Calif.						
Harvey Radio Labs., Inc., 447 Concord St., Cambridge, Mass.							Union Electronics Corp., 38-01 Queens Blvd., Long Island City						
Harvey-Wells Electronics, Inc., Southbridge, Mass.							United States Television Mfg. Co., 3 W. 61st St., New York, N. Y.						
Herbach & Rademann Co., 522 Market St., Philadelphia, Pa.							Vibracoe Mfg. Co., 325 Miguel St., San Francisco, Calif.						
Hoffman Radio Corp., 3430 So. Hill St., Los Angeles, Calif.							Viewtone Co., 81 Willoughby St., Brooklyn, N. Y.						
Howard Radio Co., 1735 Belmont Ave., Chicago, Ill.							V.lectrical Engineering Co., 828 N. Highland Ave., Los Angeles						
Hudson-American Corp., 25 W. 43rd St., New York 18, N. Y.							Walker, Inc., 684 S. La Fayette Park Pl., Los Angeles, Calif.						
Industrial Electronic Corp., 505 Court St., Brooklyn 31, N. Y.							Warwick Mfg. Corp., 4640 W. Harrison St., Chicago, Ill.						
Industrial Tool & Die Works, Inc., Minneapolis, Minn.							Waterson Radio Mfg. Co., 2700 Swiss Ave., Dallas, Texas						
International Detrola Corp., Beard Ave., Detroit, Mich.							Wells-Gardner & Co., 2701 N. Kildare Ave., Chicago, Ill.						
Ray Jefferson, Inc., 40 E. Merrick Rd., Freeport, L. I., N. Y.							Western Electric Co., 120 Broadway, New York						
Jewel Radio Corp., 583 Sixth Ave., New York 11, N. Y.							West'n Sound & Elec. Labs., Inc., 2512 W. St. Paul Av., Milwaukee						
Kaar Engineering Co., 619 Emerson St., Palo Alto, Calif.							Westinghouse Electric Corp., Receiver Div., Sunbury, Pa.						
Kingston Radio Co., Inc., Kokomo, Ind.							Wileox Electric Co., Inc., 1400 Chestnut St., Kansas City, Mo.						
Kluge Electronics, Inc., 1031 N. Alvarado St., Los Angeles 36, Cal.							Wileox-Gay Corp., 604 Seminary St., Charlotte, Mich.						
La Magna Mfg. Co., 51 Clinton Pl., E. Rutherford, N. J.							Zenith Radio Corp., 6001 Dickens Ave., Chicago, Ill.						
Laurehk Radio Mfg. Co., 3931 Monroe Ave., Wayne, Mich.													
Lear, Inc., 110 Ionia Ave., N. W., Grand Rapids 2, Mich.													
Lostradio Corp., 4 St. Francis St., Newark, N. J.													
Lincoln Electronics Corp., 653 11th Ave., New York, N. Y.													

Republication prohibited. See copyright notice, page 1. For "Where to Buy Electrical Appliances", see page 138.

FM

... a challenge to the radio industry

Frequency Modulation radio is out of the theory and experimental stage. FM is now a commercial reality, ready to provide the public with radio communication far superior to anything known in the past. *In fact, FM has obsoleted old-fashioned AM radio.*

This simple fact presents the radio industry—including the manufacturers, the dealers and the broadcasters—with the biggest single challenge in radio history—and with the biggest single opportunity.

The opportunity lies in the greater service made possible by FM's superior quality of radio transmission, and its vastly improved coverage through greater numbers of non-interfering stations. The opportunity is equally apparent in the enormous new markets which such advance opens for the radio industry.

The challenge lies in the *manner* in which these opportunities are acted upon. They can be *developed* to the great and mutual advantage of the public and the radio industry. Or they can be *exploited* for the short run gain of a few and permanent harm for the many.

The opportunity will best be realized and the challenge squarely met:

—If manufacturers see to it that the true advantages and quality of genuine Frequency Modulation are built into every piece of FM broadcasting and receiving equipment.

—If dealers are careful to demonstrate the true performance and educate the public on the selection, use and enjoyment of bonafide FM receivers.

—If broadcasters are quick to bring new FM stations to high power levels of efficient signal transmission and coverage.

—In short, if all the components of the radio industry will work together to give the public the full advantage of Frequency Modulation *from the outset.*

FM has been pioneered, proven and is now in mass production. We have entered the FM era of radio. The public is entitled to the best from FM from the beginning.

Edwin H. Armstrong

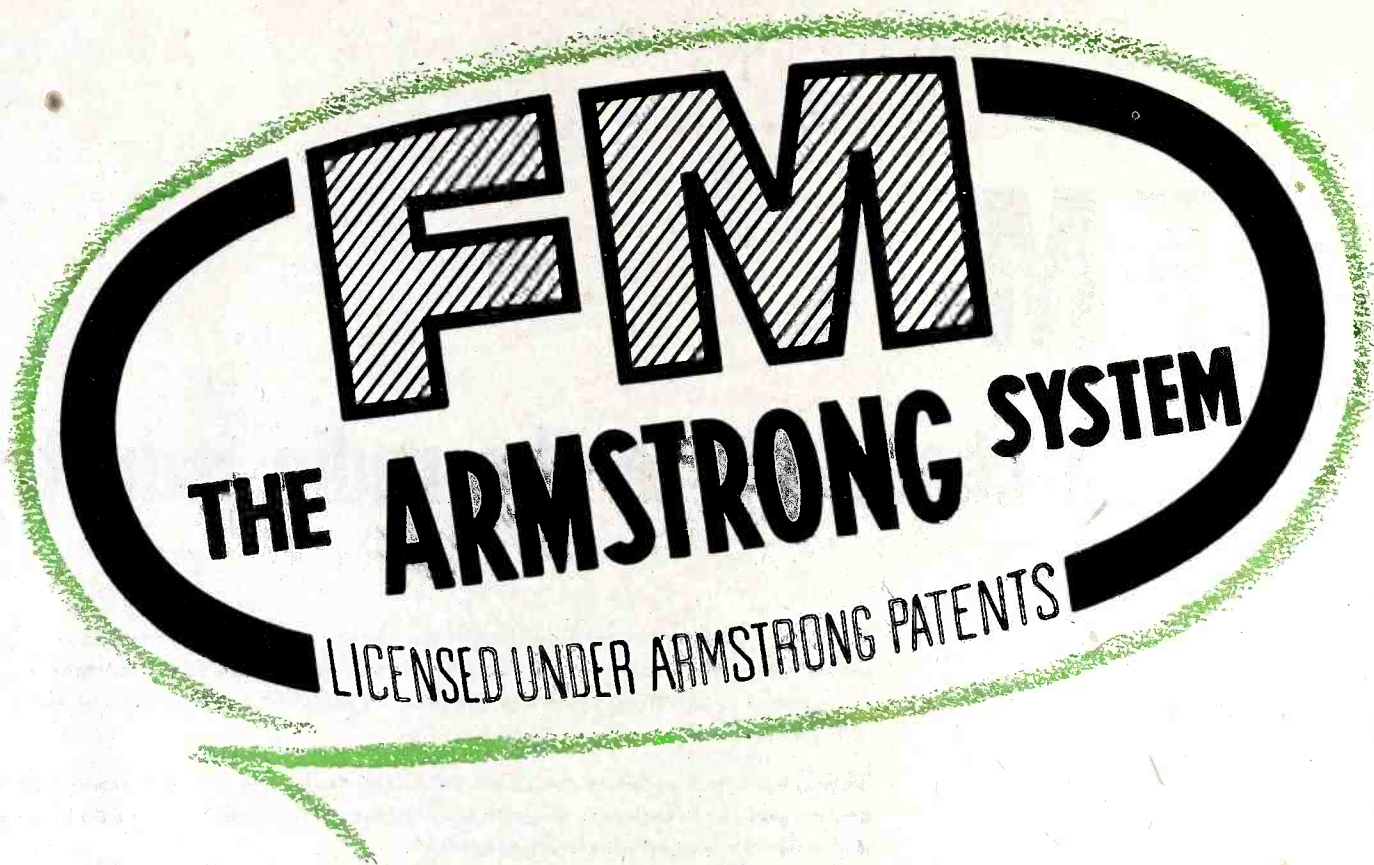

FM stands for Frequency Modulation, the revolutionary static-free system of radio broadcasting and receiving perfected and patented in 1933, after 20 years of research, by Dr. Edwin H. Armstrong, who also invented the regenerative circuit, the super regenerative circuit and the superheterodyne radio circuit.

FM represents the highest state of the art of radio communication. It is now available to serve the public with high-fidelity, natural, staticless broadcasting and receiving of the finest music and clear, faithful reproduction of all radio signals.

The public has heard *about* FM, and daily increasing numbers are actually hearing *FM itself*. Having once heard what radio can be like, they are no longer satisfied with old-fashioned AM radio.

If FM progress had not been delayed by the war and other barriers, more than a billion dollars worth of FM sets would already be in use. Now that the barriers are finally down, production of FM sets is proceeding at a rate of well over 100 million dollars per year, and increasing every month.

The buyers of the thousands of new FM sets which will be built this year are entitled to, and should insist on obtaining, the full advantages of genuine frequency modulation.

Accordingly, for the public's protection, all manufacturers licensed to use the Armstrong System of Frequency Modulation are authorized to identify their sets with the symbol reproduced above. A complete list of these licensed companies is printed on the next page.

These are the companies which are authorized and licensed to build radio receiving sets and other apparatus utilizing the genuine Armstrong system of Frequency Modulation:

- Airadio, Inc.
- Ansley Radio Corporation
- Browning Laboratories, Inc.
- Canadian Marconi Co.
- Cover Dual Signal Systems, Inc.
- Doolittle Radio, Inc.
- Electric and Musical Industries, Ltd.
- Espey Manufacturing Company, Inc.
- Fada Radio and Electric Company, Inc.
- Finch Telecommunications, Inc.
- Freed Radio Corporation
- Garod Radio Corporation
- General Electric Company
- Hallicrafters Company
- Howard Radio Company
- Fred M. Link
- Magnavox Company, Inc.
- Maguire Industries, Inc.
- Minerva Corporation of America
- Pilot Radio Corporation
- Scott Radio Laboratories, Inc.
- Radio Engineering Laboratories, Inc.
- Stewart-Warner Corporation
- Stromberg-Carlson Company
- Templetone Radio Manufacturing Corp.
- Western Electric Company, Inc.
- Westinghouse Electric Corporation
- Zenith Radio Corporation



The following pages include a series of statements and advertisements by authorized manufacturers of genuine Armstrong FM equipment.

FM Go-Ahead

Up to the Dealer

This is the time when the retailer can drop a few measured words into a sweet new industry and make a very tasty financial dish for himself.

Thousands of Americans will shortly be saying yes or no to the specific suggestion that they buy FM receivers. A vast number of transmitters are being set up. The sets are expected to move in fabulous carloads into U. S. homes, and all eyes are now turned to the man who finally gets the answer from the buying public.

Thus the fellow who has the most to say at this climax in the FM market is the retailer himself. When this man receives the set, the critical instant has arrived. It's up to him to give the right signal — the Go-Ahead kind.



In coming months, masses of buyers will get their most important impression of what FM can do. And these folks will probably act as self-appointed missionaries to the rest of the population, so that their opinions are truly trade-shaking.

Now the development of FM has been no simple trick. When the heart-warming tones first tumbled from the speaker and the music lovers went to their knees, everybody agreed that FM's costly and complicated pioneering process had been worth while.

FM, stopped in its tracks by the advent of the war, has come back to add a great new impetus to the radio market.

The Signal for Sales

It is a dramatic fact that FM is here with a reception quality which fits the ear of the U. S. It is up to the retailer — the man at the strategic point of sale position, to give FM the sort of sales promotion it needs — plus the right kind of installation and maintenance know-how.

The situation is one which calls for an alerted status on the part of all merchants. The FM manufacturer and supplier should remind themselves that they must now place the FM products totally in the hands of the retailer. And the dealer should tell himself again that if he is to be the well-paid hero of the piece, he should make his performance a first-rate one.

As the retailer occupies the key spot in a new industry, he should make dead certain that he has the information and the optimism required for the position. When an aggressive and well-equipped merchandiser says "Go!" to a proposition like FM, that's about all the industry needs.

GENERAL  ELECTRIC
COMPANY
SYRACUSE, NEW YORK

W. R. G. BAKER
VICE PRESIDENT

AN OPEN LETTER TO RADIO DEALERS

1947 is proving itself the year when FM comes of age. We who have pioneered in FM since its original development by Major Armstrong are happy that at last this new kind of broadcasting is taking its rightful place in the sun.

Today there are 136 FM stations in actual operation. The FCC has granted approximately 400 additional construction permits and has made 199 conditional grants. It still has 118 FM applications pending.

So far the potential market for FM radio receivers has been little more than sampled by the 350,000 to 400,000 sets built up to the beginning of 1947. The demand for sets equipped to bring in FM programs is so great that taking the year as a whole, we believe that 15 to 20% of the 1947 sets will contain FM bands. By the fourth quarter of this year, we believe the actual rate of production of FM sets will have arisen to around 30% of the total.

Chairman Denny of the Federal Communications Commission has predicted that more than 700 stations will be operating by the end of this year. We at General Electric are bending every effort to supply the potential audience of these stations with the FM receivers they want—receivers that not only will bring in FM programs, but which will recreate them with the full realism and fidelity of tone that is FM's birthright.

Very truly yours,

W. R. G. Baker

GENERAL  ELECTRIC

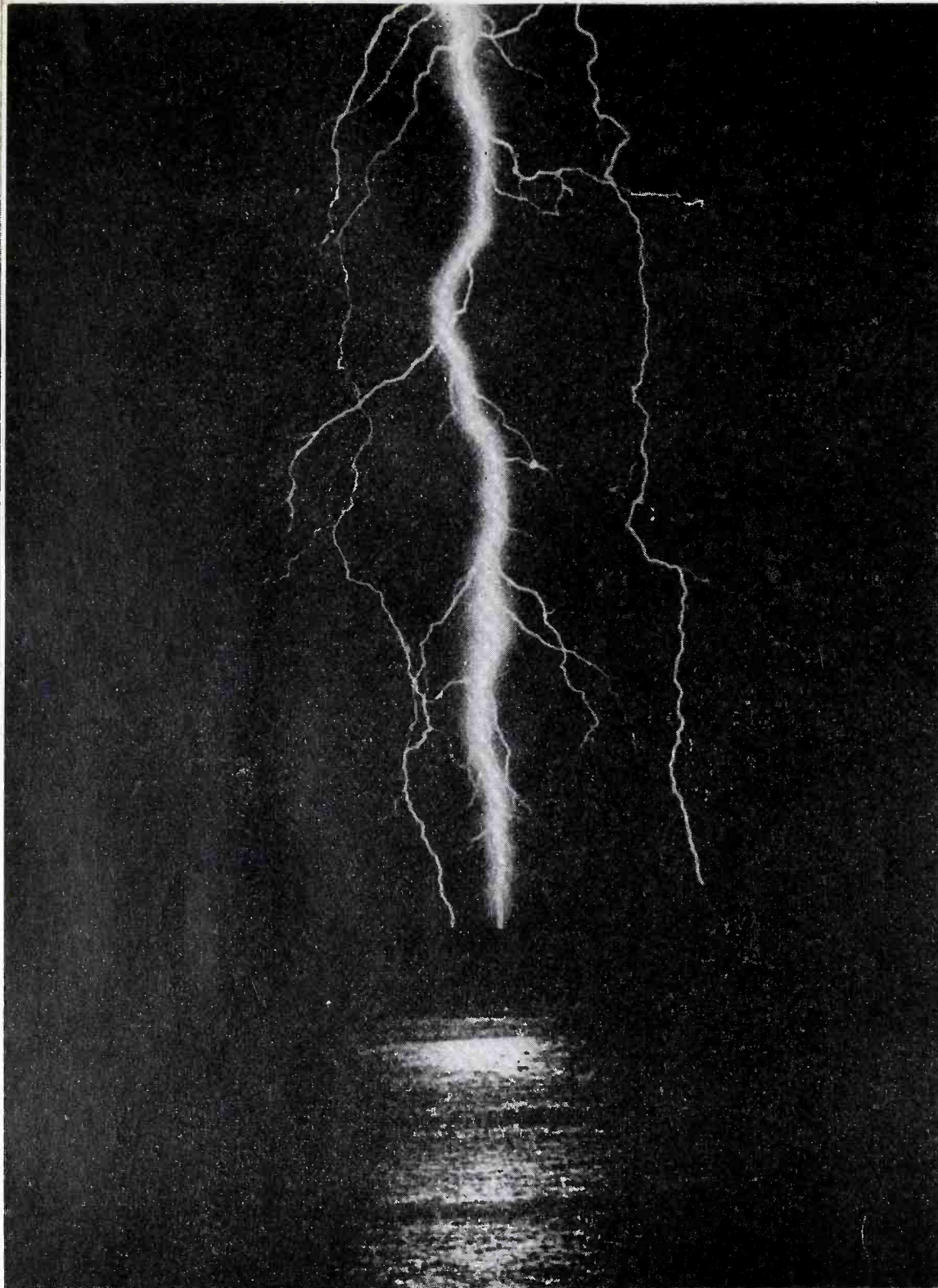

FM

*On Nights
Like This....
Listen to FM*

• FM gives the listener just what he has always wanted in radio—static-free reception, high fidelity and absence of “background” noise.

FM provides such remarkably different and better reception that its first-time hearers are profoundly impressed; its regular listeners become ardent FM fans who will never be satisfied to do without this great modern-day radio.

The matchless performance of a good FM receiver is due to the inclusion of an FM circuit engineered and built into the chassis at the factory. To receive satisfactory FM reception a precision-built instrument must be used.

For the same reason that a “regular” AM radio receiver must be built with first-class components and must have a speaker capable of producing rich, full tones, in order to operate at peak, so must an FM set be a first-class product. It must be engineered, manufactured and installed in a technically correct manner.

FM’s many features have been forcefully demonstrated by the nation’s retail merchants who have been a big factor in educating the consumer—convincing him that FM is truly different.

A leading dealer in Massachusetts gave shelter to a man and his wife who were caught in a severe thun-

derstorm. While in the store the visitors were treated to a demonstration of an FM console. In spite of the fact that the electrical storm was right on “top” of the town, the set poured out its superb music without any static. Flashes of lightning which made the customers flinch, even inside the store, found the set operating with a background of dead silence.

That’s one of the ways sales are made. One of the methods employed by retailers in selling FM. The Massachusetts dealer sold an FM radio to the couple who’d come in out of the storm.

Moreover, later the man and wife enthusiastically “demonstrated” the

What It Is—How It Works

Brings Static-Free Reception, High-Fidelity to the American Home

set in their home, too, described the episode of the store demonstration to visitors and sent numbers of "recommended" sales to the dealer.

FM has been a boon to dealers and users who live in areas where "interference" exists to a high degree. Dealers have made vivid demonstrations in noisy sections, particularly in large cities, by playing AM and FM sets alternately.

If FM had but the single feature of providing static-free operation it would still be worth the extra cost over an AM set, but the fact that it provides its listeners with a wider range of tones, greater clarity and improved fidelity makes an FM radio a value-plus instrument.

Because there is no noise within the hearing range in the background when a station is properly tuned in, FM reception, even *without* its high-fidelity feature would be considered a phenomenal instrument on this point alone. Background noises which are always present to some degree in AM reception materially affect the quality of any program.

Buying Factors

In buying an FM receiver, the purchaser should consider three things as being essential to satisfactory operation. First, he should make sure that he gets a real FM receiver, capable of all the merits of FM reception as listed at the right. Second, he should insist upon a first-class installation, having suitable antenna. Third, he should realize that an FM set is very critical of tuning, and he should make sure that he, and others who will operate the set, know exactly how to tune in for peak performance.

One of the false impressions one might get about FM is that it is strictly for the "long-hairs"—those lovers of fine—and often ponderous—music. This supposition is far removed from actual fact. FM reception enhances the quality of *any* radio program. It makes the newscaster's voice more pleasing to the ear and increases the intelligibility of his speech. FM brings in the high, liquid notes of the flute, the true bass of the 'cello. There is true reception of the various tones

and sounds actually present at the transmitter to be heard over the good, properly-installed, correctly-operated FM set.

The following explanation of FM, written in non-technical terms by O. H. Caldwell, editor of RADIO & Television RETAILING, can be used by dealers in talks on FM with customers, and by all others who want to understand what this great new contribution to radio is—and how it works:

Everyone has heard of FM, the two letters which stand in the radio world for Frequency Modulation. But many people do not understand what Frequency Modulation means in general, and may mean to them as radio listeners in particular. FM is a new and improved system of broadcasting which radio engineers accept to be superior to the usual standard broadcasting known as AM or Amplitude Modulation.

FM cuts all static out of radio. In FM broadcasting there is not even any background noise. FM is noted also for its high fidelity.

There can be no static on FM because (1) the wave lengths (or radio frequencies) on which FM operates carry very little natural static, and (2) any residual static is completely eradicated by special arrangements of radio circuits (notably those of Dr. E. H. Armstrong). The radio frequencies now authorized for use by FM range from 92 to 106 megacycles or millions of cycles a second.

High fidelity, which is such an

important feature of FM broadcasting, simply means that the high notes or frequencies, as in music, are fully reproduced and brought into the tone picture which the ear hears. In the AM type of broadcasting, because of its limited band (5,000 cycles), these finer shades of sound cannot be reproduced. Therefore, in regular broadcasting as we have known it, a certain "cut-off" or distortion of sound takes place. FM is able to reproduce the higher notes because of the wider frequency bands assigned to it by the Federal Communications Commission (which supervises all arrangements of radio frequency and channeling of the air waves).

In FM the sound waves are reproduced in quite a different way than in AM. Momentary changes (or modulations) of the frequency of the radio waves account for the fidelity of the sounds heard on FM. In AM it is the amplitude or volume of the radio wave which is being constantly changed, and not the frequency. Hence we might compare broadcasting in general to the sending of messages by a light-blinker system. In this blinker system let us suppose that dots and dashes are used to convey the messages. We could say, carrying on the comparison, that AM broadcasting would be like switching the light on and off to give the desired long and short light signals. In FM broadcasting the brightness of the light would always remain the same, but the light would change in color, or frequency.

FM—Magic Initials Which Mean—

Superb Reception Without Static

Elimination of Electrical Interference

Wider Range of Tones for Music and Speech

Increased Fidelity With No Distortion

Absence of "Background" Noise

FM Go-Ahead

Up to the Dealer

This is the time when the retailer can drop a few measured words into a sweet new industry and make a very tasty financial dish for himself.

Thousands of Americans will shortly be saying yes or no to the specific suggestion that they buy FM receivers. A vast number of transmitters are being set up. The sets are expected to move in fabulous carloads into U. S. homes, and all eyes are now turned to the man who finally gets the answer from the buying public.

Thus the fellow who has the most to say at this climax in the FM market is the retailer himself. When this man receives the set, the critical instant has arrived. It's up to him to give the right signal — the Go-Ahead kind.



In coming months, masses of buyers will get their most important impression of what FM can do. And these folks will probably act as self-appointed missionaries to the rest of the population, so that their opinions are truly trade-shaking.

Now the development of FM has been no simple trick. When the heart-warming tones first tumbled from the speaker and the music lovers went to their knees, everybody agreed that FM's costly and complicated pioneering process had been worth while.

FM, stopped in its tracks by the advent of the war, has come back to add a great new impetus to the radio market.

The Signal for Sales

It is a dramatic fact that FM is here with a reception quality which fits the ear of the U. S. It is up to the retailer — the man at the strategic point of sale position, to give FM the sort of sales promotion it needs — plus the right kind of installation and maintenance know-how.

The situation is one which calls for an alerted status on the part of all merchants. The FM manufacturer and supplier should remind themselves that they must now place the FM products totally in the hands of the retailer. And the dealer should tell himself again that if he is to be the well-paid hero of the piece, he should make his performance a first-rate one.

As the retailer occupies the key spot in a new industry, he should make dead certain that he has the information and the optimism required for the position. When an aggressive and well-equipped merchandiser says "Go!" to a proposition like FM, that's about all the industry needs.

GENERAL  ELECTRIC
COMPANY
SYRACUSE, NEW YORK

W. R. G. BAKER
VICE PRESIDENT

AN OPEN LETTER TO RADIO DEALERS

1947 is proving itself the year when FM comes of age. We who have pioneered in FM since its original development by Major Armstrong are happy that at last this new kind of broadcasting is taking its rightful place in the sun.

Today there are 136 FM stations in actual operation. The FCC has granted approximately 400 additional construction permits and has made 199 conditional grants. It still has 118 FM applications pending.

So far the potential market for FM radio receivers has been little more than sampled by the 350,000 to 400,000 sets built up to the beginning of 1947. The demand for sets equipped to bring in FM programs is so great that taking the year as a whole, we believe that 15 to 20% of the 1947 sets will contain FM bands. By the fourth quarter of this year, we believe the actual rate of production of FM sets will have arisen to around 30% of the total.

Chairman Denny of the Federal Communications Commission has predicted that more than 700 stations will be operating by the end of this year. We at General Electric are bending every effort to supply the potential audience of these stations with the FM receivers they want—receivers that not only will bring in FM programs, but which will recreate them with the full realism and fidelity of tone that is FM's birthright.

Very truly yours,

W. R. G. Baker

GENERAL  ELECTRIC

From the very beginning **GENERAL ELECTRIC**

1938
1939
1940
1941

1942

1943

1944

1945

1946

1947 ▾



This exciting new film in kodachrome is a real sales builder. Now General Electric helps you build business with this graphic, simple explanation of the advantages of FM. Ask your G-E distributor's salesman about getting the "Naturally—It's FM" film, so that you can arrange showings in your town.

and today **General Electric** backs its **FM line** with promotions more powerful than ever!

SINCE 1938 General Electric has been a leader in FM radio receiver production, transmitter production and in FM promotion. This leadership began when G. E. built for Major Armstrong the first receivers, other than laboratory sets, used in this new kind of broadcasting.

General Electric FM is featured in striking four-color ads month after month in Life, Saturday Evening Post, Look, and Collier's. G.E. also has prepared powerful FM promotional aids for you.

Ask your General Electric Radio Distributor's salesman about the 1947 complete G-E plan for building FM business. Use the promotion material General Electric has prepared to help you ring up more and bigger sales. Or write Electronics Department, Receiver Division, General Electric Company, Bridgeport, Conn.

PORTABLES • TABLE MODELS • CONSOLES • FARM SETS • AUTOMATIC PHONOGRAPH COMBINATIONS • TELEVISION

HAS PIONEERED

FM

GENERAL ELECTRIC
FM *It's wonderful* **A.M.**

You'll hear the full glory of natural color tone in this great new radio-phonograph

GENERAL ELECTRIC
RADIOS

LEADER IN RADIO, TELEVISION AND ELECTRONICS

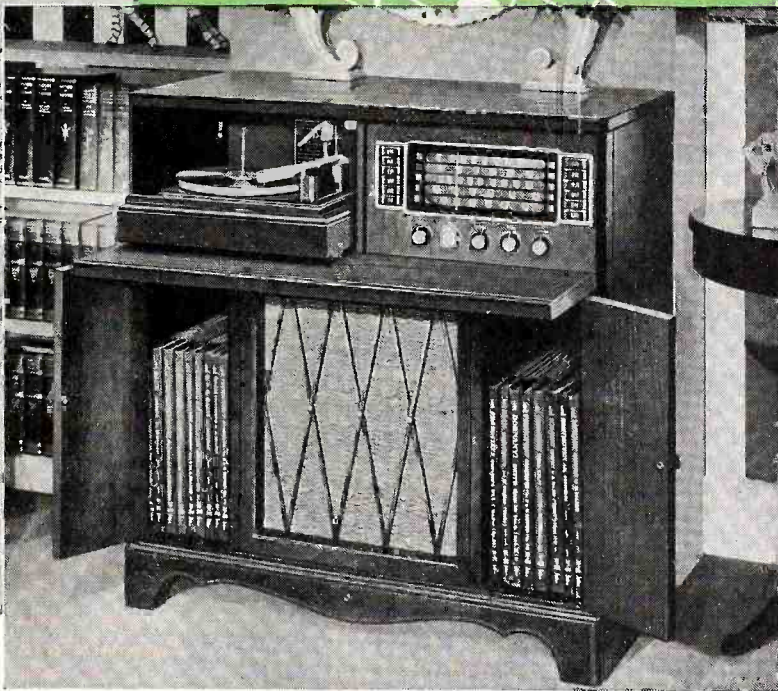

SUPERB GENERAL ELECTRIC FM-AM RADIO-PHONOGRAPH—MODEL 417. Leader of the G-E FM line. Both old and new FM bands and finer reception of standard and short-wave. Precision tuning with the G-E Guillotine Tuner. Sensational G-E Electronic Reproducer. Handsome 18th Century-inspired mahogany cabinet. Stores approximately 120 records. 9 tubes plus rectifier.

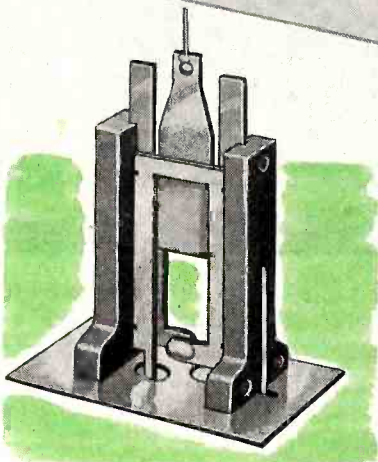

NEW G-E GUILLOTINE TUNER. This General Electric development now makes tuning of high frequency bands as accurate and convenient as tuning of standard broadcasts.



SENSATIONAL G-E ELECTRONIC REPRODUCER—for the finest record reproduction you ever heard! Recreates every note. No needles to change. Self-protecting sapphire jewelled stylus normally is unharmed by accidental dropping or sliding on record.

THE FIRST AND GREATEST NAME IN ELECTRONICS

GENERAL ELECTRIC

175-F3B

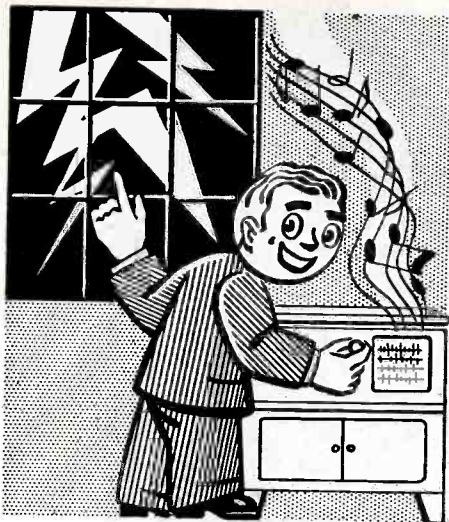

Sell the static-free reception.

• The more good FM receivers the dealer sells the more money he makes for himself; the more friends he makes of his customers and the more sales prospects he makes of the customers' friends.

All in all, this FM merchandising picture is certainly something for the book!—the book that carries an account of the merchant's profits.

Successful Selling

But selling FM isn't just a push-over proposition. FM isn't something that will sell itself. FM needs special sales treatment by the retail merchant who wants to do a real job. FM merchandise needs glamorous surroundings, sparkling demonstration, attractive display and the best there is in installation and maintenance.

In order to impress the customer with the fact that the extra he pays for good FM in a radio set is a sound investment, the salesman must first make certain that the

FM sales are plus-sales.

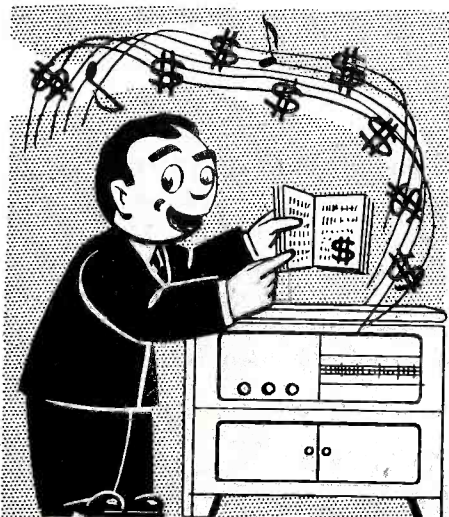

customer knows *what* FM is; how its superb reception sounds, how it will operate during a severe electrical storm without any static, and how its absence of background noises enhances the quality of music, whether it is played by musical instruments or comes to the listener via the human voice.

In featuring FM, the salesman must not take it for granted that the customer will know what he is talking about if he merely says, "this set has FM" While it is true that nearly everyone has heard of FM, it is also true that comparatively few people have ever *heard it* at this time. Moreover, it is true

wider range. This is called high-fidelity. It permits you to hear for the first time over radio certain 'highs' and 'lows' as they are actually being played in the studio. Second, the reception is static-free, even during a severe thunderstorm. Then too, there are no background noises in FM."

Of course the salesman doesn't have to use a "canned" speech for his introductory remarks, but it is important that he get across to the customer the chief features of FM as quickly as he can.

In demonstrations, FM is certainly a "natural." The dealer can compare the set by actually play-

FM

that while nearly everyone has heard of FM, most of your prospective customers do not really know what makes it "tick."

FM radio operation should be explained simply and briefly to the prospective purchaser, the salesman should make sure that the customer knows the true features. The next step is to demonstrate the set to the customer.

Here's a sample introductory statement for the salesperson to use:

"Frequency Modulation—or FM—as it is usually called, is a great new improvement in radio. First, there is remarkably true tone in a

ing an FM and AM receiver alternately. Some dealers have provided interference-makers which they turn on while an AM set is playing. They then switch over to FM—and, presto, the noise has vanished!

One of the most important things for the FM dealer to set up is a reasonably quiet spot in the store in which to demonstrate the receivers. Prospective customers should be provided with comfortable chairs under surroundings which will permit them to see and hear FM in an advantageous setting. Some dealers have constructed sound-proof rooms for the

display of FM and de luxe receivers of all types.

FM show window displays must be interest-intriguing and should be changed frequently. In each display, the dealer should make certain that the passerby understands that the sets being shown are FM.

He can put across such message in many ways. By cutting "lightning" streaks out of pieces of red cardboard and fastening them together to make one continuous jagged "bolt", the window dresser can bring this piece down from the ceiling to the set, thus stressing the static-free operation which is fur-

sign reading, for example: "FM—Radio's NEWEST MAGIC is in this receiver. . . . You CAN'T SEE it, but you CAN HEAR IT by stepping inside for a demonstration."

Another idea is the "living room" in the show window. Using rugs on the floor, and some living room furniture and floor lamps together with suitable backgrounds, the merchant can quite easily arrange a traffic-stopping display. Some "dummies" of adults and children could be borrowed from a local non-competitive store by the dealer who agrees to place a small card crediting such store in a conspicuous place. Backgrounds for the



Sound-proof demonstration room pays.

...is a new profit-maker--a great sales "natural" for TODAY

...makes friends of the buyers--prospects of buyers' friends

...must be sold and serviced in a specialized sort of way

...should be dramatically displayed in show windows and in store

ther explained on a card beside or on top of the set. "Perfect Reception Even During Electrical Storms," or similar phrase can be used.

Instruments such as flutes, violins, clarinets, etc., can be placed on easels in the show window displaying the FM's. Cards on each musical instrument can be worded, "LIKE TO HEAR THE FLUTE?—You'll marvel at the true fidelity, bell-like clarity in your own home over FM." Other themes could include stressing the fact that FM is *not* really expensive, proving this point via price cards on some of the models. Other ideas include exhibiting an FM chassis, with a

"living room" may be made of wall-board, painted or covered with wall paper. A whole "dummy" window, glass, frame and all, set off with curtains and placed on the background setup, will create further the desired illusion.

Manufacturers' advertising display pieces should be used in all displays in the store and in the show windows. Large FM letters can be sawed out of various materials, then painted and used to get over the FM message to the prospective customers.

The dealer should use newspaper copy on FM which urges the reader to hear the newest thing in radio—

FM. He can suggest a visit to the store, or, if he specializes in home demonstrations, he should feature this service in his ad copy. Merchants who buy radio time can make good use of the FM theme in their advertising messages too. Direct mailing of manufacturer-provided stuffers or printed to order pieces will bring results also. The dealer who is known as an FM expert will get more sales.

Careful Installation

Because FM usually requires special installation handling in many cases, and certainly depends upon skillful service for top performance, the merchant should sell *all of the necessary* "extras" at the time the set is sold. Such procedure will result in satisfied customers, and will prevent after-sale arguments.

The day of money-making in FM is at hand and the dealer who sets himself up to sell and service it the *right* way will make real money.

Compare FM to make more sales.

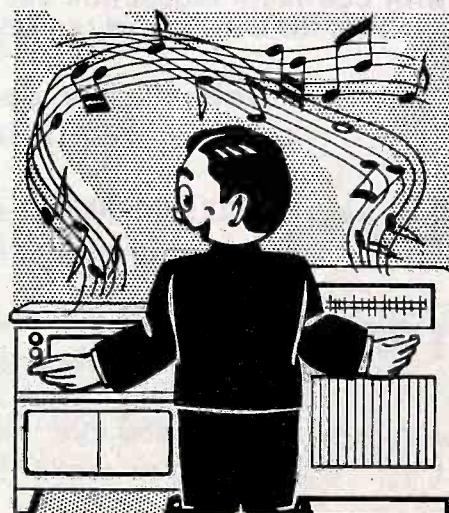

FM Sales Will Climb!

Big Money-Maker Will Bring Profits, Prestige to the Industry

• FM is that great *new* something in radio!

Manufacturers, wholesalers and dealers in this field are on the threshold of a new and exciting sales era in FM merchandising because FM is spreading like a prairie fire across the nation's sales terrain.

Interest grows by leaps and bounds in the many communities where stations have opened up and in those sections—and they are widespread—where FM stations are on the way (see lists of cities and towns on following pages).

The prospects for great new profits through the sale of FM receivers are rosy indeed. The term "FM" is an every buyer's tongue. The money to buy FM is in the consumer's hands and the buying desire is in his heart.

It may be that the estimates appearing on this page are over-optimistic. On the other hand, they may be too low. What's important, though, is that FM is here! The "missionary" work in acquainting the public with this great new radio art has been completed. Now we're ready to sell it!

The history of radio development is highlighted with examples where new things have sparked new profits, new interest and new life into the sales picture. It will be remem-

WHAT FM MAY DO

Since industry leaders figure that somewhere between fifteen and eighteen million sets of all kinds will be produced in 1947, and that 20 per cent of them will be FM, continued growth in the same ratio can be expected in the years 1948 and 1949, as follows:

1947 -	3,200,000	\$320,125,000
	<i>F-M SETS</i>	
1948 -	6,200,000	\$496,326,000
	<i>F-M SETS</i>	
1949 -	12,140,000	\$728,400,000
	<i>F-M SETS</i>	

bered that the radio field took on a Klondike appearance when "all-electric" sets commenced replacing of battery models. Inclusion of short-wave bands came along too, hopping up buying-desire, as did "combinations", push-button equipped types and the all-wave portable.

Today's "new" is FM! There's real money in it, and there's real promotion behind it. FM is being "sold" by the manufacturer, the broadcast interests, the wholesaler, the retailer and the FM user.

FM is here!

Get Three Sales in One with FM!

Average Midget	+	Average Table Model
\$22.50		\$49.50

Average Table Combo
\$99.50

SELL ALL 3 — GET

\$171.50

Sell One FM-COMBO SET

\$ 355⁰⁰

\$80.00 More with FM!

AM Combo-Console
\$275.00

AM Combo-Console

Plus FM
\$355.00

F-Money! F-Money! F-Money!

WITH CONTINUED PRODUCTION AND SALES OF FM FOR THE YEARS 1947, 1948 AND 1949, THE NATION'S KEY DEALERS WILL GET—

The Nation's key dealers will get following **EXTRA** money out of FM

1947 -	\$225,000,000 Extra Gross business from FM alone or more than \$7,000 per dealer.
1948 -	\$347,428,000 Extra Gross business from FM alone or more than \$11,000 per dealer.
1949 -	\$509,880,000 Extra Gross business from FM alone or more than \$17,000 per dealer.

STROMBERG-CARLSON COMPANY

Established 1794
ROCHESTER 3, NEW YORK

"There is Nothing New Under the Sun"

To Radio Dealers:

OUR FM MARKET IS HERE! Most reliable industry authorities estimate that 1947 sales of FM receivers will total between 3,000,000 and 4,500,000 units.

By year end, according to Chairman G. R. Denny of FCC, there will be more than 700 FM stations supplying an ever widening choice of programs for these millions of new FM receivers.

It is important that we in the industry - manufacturers, distributors and retailers - not lag behind the public in our promotion of FM. The great market for FM, for which we have hoped, is here. Let us all determine to further this great improvement in radio broadcasting and reception with all the promotional tools at our command.

If we do so now, we can make 1947 and the next few years the most profitable and most satisfactory in the history of our industry.

Our faith in the future of FM is so strong that our 1947 plans include the introduction of popular priced FM-AM table models and FM models in all Stromberg-Carlson floor models.

Ray H. Hanson

RAY H. HANSON
President
Stromberg-Carlson Company

CHICAGO

DENVER CITY

LOS ANGELES

SAN FRANCISCO

THE GEORGIAN—Model 1135-PF—The finest Stromberg-Carlson automatic radio-phonograph ever made. In an exquisitely-rich cabinet of matched African swirl mahogany. Twelve push-buttons control both AM and FM programs. Automatic push button AM-FM switching. Exclusive "Acoustical Labyrinth" and matchless Carpinchoe speaker. Plays 10 and 12-inch records intermixed. With complete FM and engineered for wire recording.



FIRST in production. Stromberg-Carlson produced more FM receivers with the Armstrong System than any other manufacturer in the prewar period. Stromberg-Carlson's FM receiver production in the postwar period, up to January 1st of this year, was 16.7% of that of the whole radio manufacturing industry. Stromberg-Carlson's production of FM-AM phonograph consoles in the same postwar period was 20.6% of that of the industry.

FIRST manufacturer to produce a complete line of Armstrong licensed FM receivers, including phonograph combinations, starting in 1939.

FIRST manufacturer of FM receivers to own and continuously operate on a full-time basis an FM station using a commercial type of standardized FM transmitter.

THE 18TH CENTURY—Model 1121-PF—Superb automatic radio-phonograph in cabinet of fine traditional design. Hand-rubbed matched walnut or mahogany veneers. Push buttons for eight stations. Exquisite tone is due to the exclusive, full-floating 12-inch electro-dynamic speaker with cone suspended in live rubber and the precision-engineered audio system. Plays ten 12-inch or twelve 10-inch records in sequence. With complete FM and engineered for wire recording.

and now... a complete line



THE FUTURA—Model 1121-MI—Splendid automatic radio-phonograph combination. In a beautiful modern cabinet of pin-striped oak or walnut. Push buttons for eight stations. Exclusive full-floating 12-inch electro-dynamic speaker suspended in live rubber. Plays ten 12-inch or twelve 10-inch records in sequence. With complete FM and engineered for wire recording.

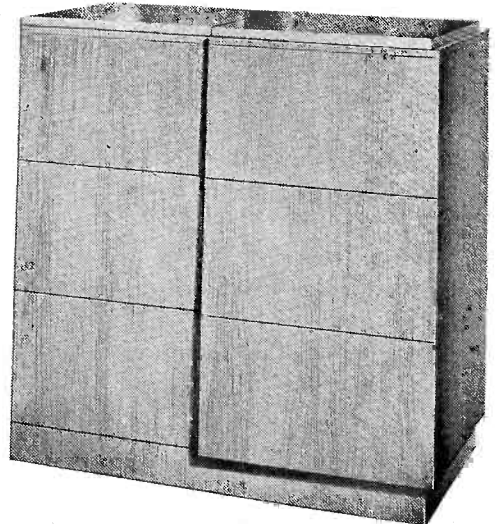

THE EMPIRE—Model 1121-PL—Automatic radio-phonograph in a graceful bow-front cabinet. Available in mahogany or walnut veneers carefully selected, matched, and hand-rubbed to a fine satin finish. Push-button control of both AM-FM. Exclusive full-floating 12-inch electro-dynamic speaker suspended in live rubber. Plays ten 12-inch or twelve 10-inch records in sequence. With complete FM and engineered for wire recording.



THE HEPPLEWHITE—Model 1121-PG—Beautifully appointed automatic radio-phonograph in a perfectly proportioned cabinet of classic design. In mahogany or walnut veneers. Tuning is automatic for standard broadcast and both FM bands with eight station push buttons. Exclusive full-floating 12-inch electro-dynamic speaker suspended in live rubber. Plays ten 12-inch or twelve 10-inch records in sequence. With complete FM and engineered for wire recording.



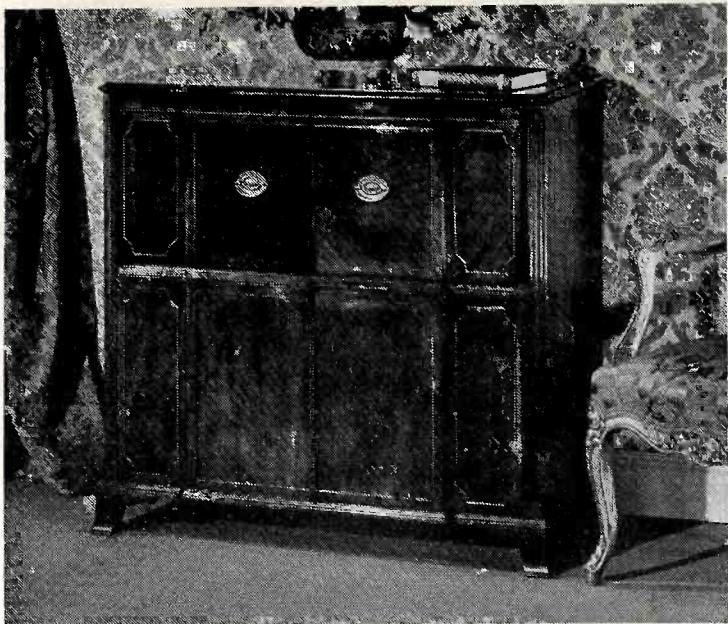

THE AUTOGRAPH—Model 1135-PL—A distinguished automatic radio-phonograph in a classic 18th century cabinet. In either mahogany or walnut veneers, carefully matched and rubbed to emphasize the natural beauty of the rare woods. Push-button control of both AM and FM programs. Automatic push button AM-FM switching. Exclusive "Acoustical Labyrinth" and matchless Carpinchoe speaker. Plays 10 and 12-inch records intermixed. With complete FM and engineered for wire recording.

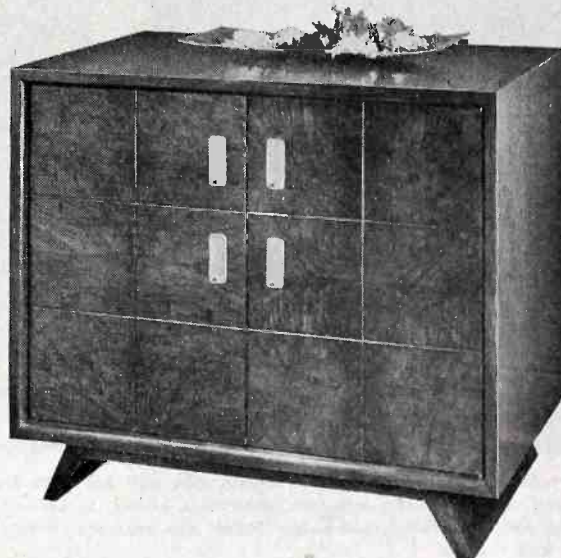

THE NEW WORLD—Model 1121-M2—Automatic radio-phonograph combination in a completely functional cabinet designed for tomorrow's living. Choice of mahogany or walnut. Exclusive full-floating 12-inch electro-dynamic speaker with cone suspended in live rubber. Plays ten 12-inch or twelve 10-inch records in sequence. Fitted with nine handsome record albums. With complete FM and engineered for wire recording.

with COMPLETE FM

- 1** Really cuts out static... Reception is quiet — virtually static and interference free — with Stromberg-Carlson's true-wide-band design, FM detectors and limiters in FM circuits.
- 2** Gives complete naturalness... With proper speakers, correct acoustical and electrical design, all Stromberg-Carlson FM receivers take advantage of FM's wider audio range and provide life-like fidelity.
- 3** Brings in all FM programs... With two FM bands — 42 to 50 mc and 88 to 108 mc — Stromberg-Carlson FM receivers give you *all* programs in every FM station service area.



THE SALEM CHEST—Model 1121-PF—Automatic radio-phonograph in a beautifully proportioned antique mahogany cabinet of colonial design. Edge-lighted slide rule dial. Push buttons for eight stations. Exclusive full-floating 12-inch electro-dynamic speaker suspended in live rubber. Plays ten 12-inch or twelve 10-inch records in sequence. With complete FM and engineered for wire recording.



THE IMPERIAL—Model 1121-LW—Superb console radio. Beautifully designed cabinet of fine furniture construction in selected walnut veneers. Push buttons for eight stations. Exclusive full-floating 12-inch electro-dynamic speaker suspended in live rubber. With complete FM and engineered for wire recording.



THE INTERNATIONAL—Model 1121-HW—A table radio with complete FM! In shining walnut highlighted by gleaming white metal grille. Push buttons for eight stations. Standard broadcast and spread-band short wave. Electro-dynamic speaker. Edge-lighted dial. Built-in antennas. Engineered for wire recording.



There is nothing finer than a

STROMBERG-CARLSON

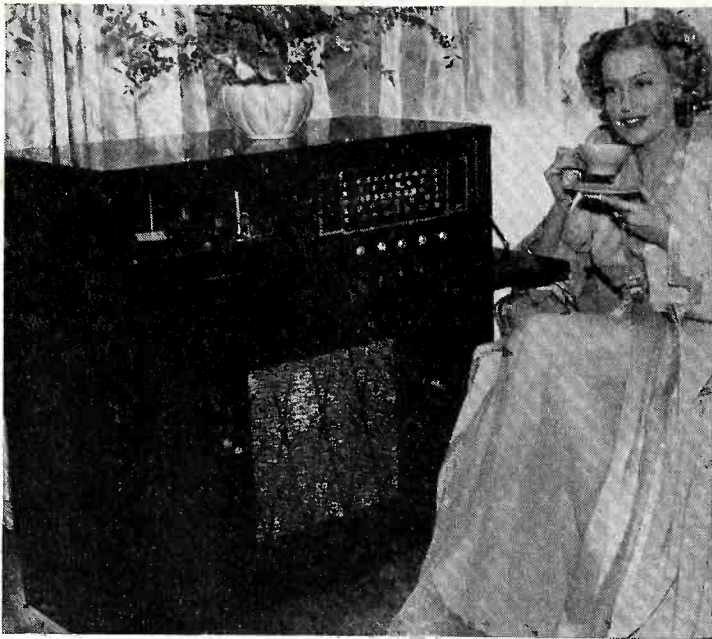

General Electric's new Model 417 combination unit has both high and low band FM, standard and two shortwave bands, automatic record changer with electronic reproducer. MGM star Jeanette MacDonald is shown with the set.



Magnavox has introduced this new Hepplewhite model with optional FM. Automatic disc changer is in left hand drawer—radio controls at right. The shelves will hold 175 records, or decorative items as illustrated above.

FM Sets to Sell

Variety of Frequency Modulation Units Available to Retailers

Receivers to fit every kind of demand are now forthcoming from the FM suppliers. The new units range from the compact and popular-priced table models to the big deluxe jobs which the manufacturers offer as "the ultimate in radio—designed without regard for expense."

In this array of new FM sets the

emphasis is on the higher-priced floor models in traditional cabinets, due to the general "upper-bracket" tone of the whole FM picture. These units are solidly identified with the "quality" market, and in many cases the suppliers have really shot the works.

In a survey of what's available, the dealer will find a wide assort-

ment of FM sets combined with other features such as automatic radio phonographs, wire recorders, short wave facilities and television.

Among the features of the new combination receivers are push buttons that operate both AM and FM, robot dials, new type automatic record changers, oversize speakers

(Continued on page 70)

Scott combination in a Chippendale cabinet is a 24-tube combination with full broadcast band plus shortwave (19, 25, 31 and 49 meter bands) in addition to FM. Hand-rubbed mahogany cabinet has fluted-column corners.



Freed-Eisemann offers this New World Hepplewhite Model 32 with standard AM, two shortwave bands, plus FM. Dual Concentric Pan-phonetic speaker, a Garrard automatic record changer which plays 10" and 12" intermixed discs.

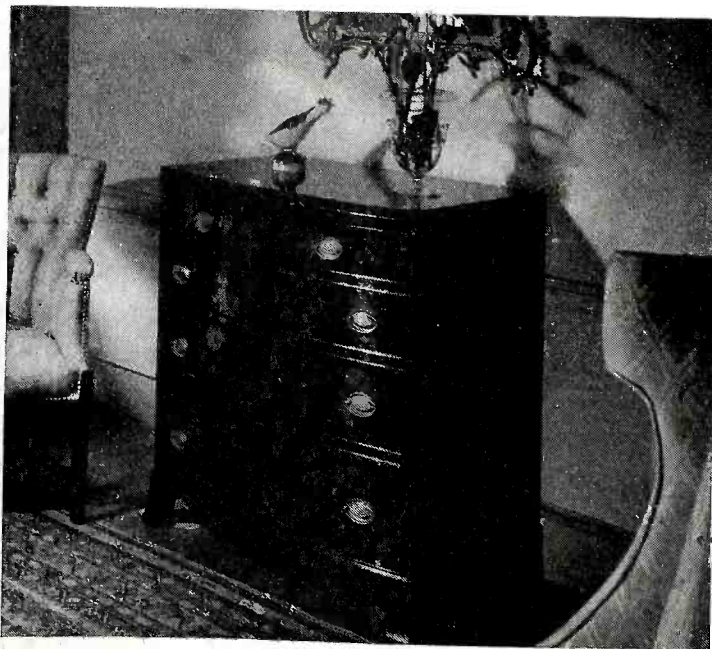

ZENITH

FM RADIOS

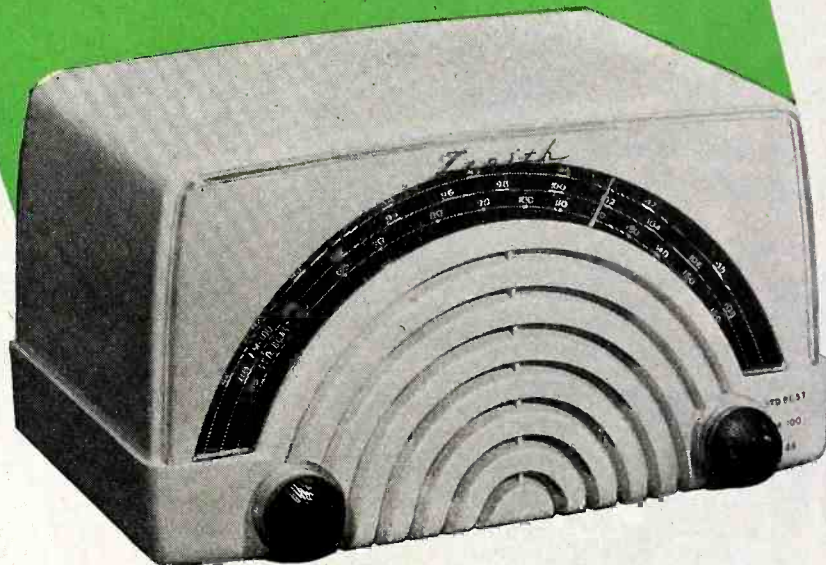

...featuring the
Genuine Armstrong
Circuit in Both the
 50 and 100
 Megacycle Bands

\$ 59⁹⁵
 And Up!

The Public Is Demanding FM ... And Zenith Has The Answer

It will shortly be very difficult to sell any radio (except in the lower price brackets or portables) which does not incorporate FM. Zenith has long recognized the universal appeal of this new kind of static-free, true fidelity broadcasting as developed by Major Edwin H. Armstrong. To meet it, Zenith engineers have perfected two-band Armstrong FM in table model sets designed to appeal to the mass, volume market, as well as in the finest console combinations . . . all with Zenith's patented built-in light-line antenna. That is why Zenith is recognized by broadcasters, dealers and the public as the outstanding manufacturer of FM receivers.

Zenith Is Building A Mass FM Audience:

70.10% of all the FM equipped table model sets produced during the period from January 14, 1946 to January 4, 1947 were Zeniths. These latest available figures (February 5, 1947) are from Haskins & Sells, the official reporting agency of the Radio Manufacturers Association.

ONLY ZENITH HAS THIS!

- ★ Genuine Armstrong FM On Both Tuning Bands
- ★ Super 6-Purpose Tube
- ★ Built-in FM Antenna, Even for Table Models
- ★ Big, Easy-Tuning Dial
- ★ Permeability Tuning
- ★ Compact Chassis
- ★ Built-in Wavemagnet
- ★ Sensitive, Selective Circuit



ZENITH RADIO CORPORATION

CHICAGO 39, ILLINOIS



RADIO'S FIRST

FM

AND PLENTI-POWER

THE PERFECT PERFORMANCE COMBINATION

FOUND ONLY IN *Westinghouse Radios*

Westinghouse FM incorporates the most advanced engineering. With Westinghouse FM you get all the tones and overtones that blend to make great music or a great speaking voice against a background of perfect silence.

Westinghouse Plenti-Power is an exclusive development that provides Westinghouse radios with TWICE the undistorted power output of comparable prewar sets. Plenti-Power gives you all of the dynamic range of sound exactly as it is broadcast.

Just as FM greatly increases the *frequency* range, PLENTI-POWER greatly increases the *dynamic* range. Together, they reproduce the program exactly as broadcast—with brilliant, true-to-life realism never before achieved.

Westinghouse will have ready shortly a complete new line of FM sets in various tube complements and in each of the low, medium and deluxe value levels. Every Westinghouse console radio-

phonograph and console radio will have FM. Every deluxe table model radio also will include FM. Westinghouse radio retailers will have a broad selection of models to meet the public's requirements.

Westinghouse Radio is prepared for the expanding FM market.

Westinghouse Radio will continue to produce a complete line of top performance AM receivers with outstanding competitive sales advantages, for while FM indicates a tremendous market potential in the next few years, AM is and will remain, a major factor in the receiver business for some time to come.

You can depend on Westinghouse Radio originality and engineering to give you both AM and FM receivers that are built right, designed right, and priced right.

Home Radio Division, Westinghouse Electric Corporation, Sunbury, Pa.

NAME IS *Westinghouse*
RADIO TELEVISION

Magnavox

the symbol of quality in radio since 1915

FROM the fine contemporary styling of the Modern Symphony to the authentic Chippendale of the Belvedere, every Magnavox is a masterpiece of music, style and beauty. Each of ten distinctive models combines the best in furniture craftsmanship and musical reproduction with the wonders of radio science, FM, and automatic record changing. Yet Magnavox is not high-priced — console models start at \$187.



The Regency Symphony. A fine traditional furniture piece in mahogany, walnut or prima vera (blond). Static-free Armstrong FM, twin 12-inch Magnavox Duosonic speakers, and 20 watts undistorted superpower.

F M

MAGNAVOX

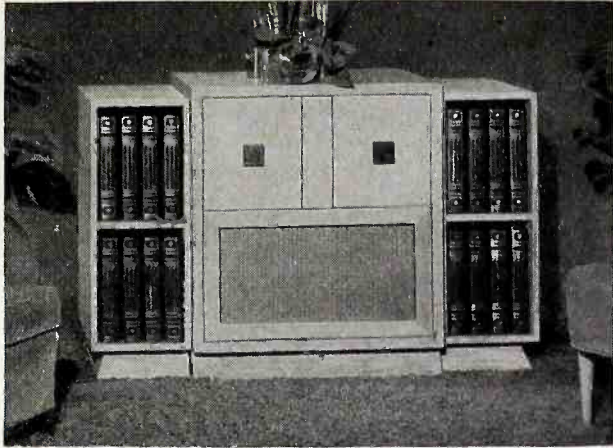

The Modern Symphony. The best in contemporary styling . . . in mahogany or white oak. Static-free Armstrong FM, twin 12-inch Magnavox Duosonic speakers, and 18 watts undistorted superpower.

MAGNAVOX and FM are natural companions. The best in wide-range FM reception is limited to the excellence of the audio system . . . and in this, Magnavox has been the leader for many years.

The Magnavox Duosonic speaker system was designed expressly to provide for the expanded tonal range of FM reception. The two 12-inch speakers cover not only the extended audio range, but give heretofore unattained smoothness of tone over the entire range.

So . . . to hear FM at its very best, listen to the new Magnavox radio-phonograph. Discover for yourself why Magnavox is the choice of discriminating buyers everywhere.

You can trust a great name

KKNOWN to three generations for quality speakers and component parts, it was only natural that Magnavox should also produce a great new radio-phonograph. Through the years Magnavox has been known for both product and policy innovations that have revolutionized the radio industry. The non-competitive, profit-protecting Magnavox franchise, first of its kind, created sound and profitable merchandising . . . ample markets and rapid turnover in an industry once noted for distribution abuses. Further attesting Magnavox quality and leadership are the thousands of magnificent new models already delighting owners in their homes.

The Magnavox Company, FM Division, Fort Wayne 4, Indiana



The Hepplewhite. Truly a "decorator's" piece . . . in mahogany. Shelf will hold 175 records. Static-free Armstrong FM, 18 watts undistorted superpower, and twin 12-inch Magnavox Duosonic speakers.



The Belvedere. Distinctive Chippendale Commode available in mahogany, walnut or white oak. Static-free Armstrong FM, 20 watts undistorted superpower, and twin 12-inch Magnavox Duosonic speakers.

M

THE MAGNIFICENT

Magnavox

RADIO-PHONOGRAPH



Westinghouse combination Symphonic 14 model is a deluxe FM radio-phonograph with single-button record-changer control and greatly increased record storage space. Plenti-Power circuit, modified Chippendale cabinet design.



Stromberg-Carlson's Model 1121-PS is the "Salem Chest" unit with two FM bands in addition to standard and shortwave. It has eight station push-buttons, automatic record changer, electro-dynamic Full-Floating speaker.

More FM Sets to Sell

(Continued from page 64)

or multiple ones, extra space for record storage, choice of FM bands, extra tone controls, built-in antennas, and improved reproducers.

With such a variety of features involved in the design of FM receivers, dealers can see again that this market has that more-profit-per-unit - sale advantage to a marked degree. As FM appeals to a quality trade, and dealers are in

position to offer so many quality features in combination with FM, it is distinct advantage in profits.

The fact is, there are enough sets already "in the swim" for a dealer to set up a complete FM department in his store. With modern cabinets, traditionals, chairsides, communication type, and table units available, there is plenty of chance for an FM "store within a store" where customers can be given

a fine choice of the static-free sets.

By the time the retailer gets the necessary demonstration fixtures and techniques set up in this one spot in the store, the "FM department" will be big and impressive. Deluxe shelves for the table models, extra floor space for the bigger jobs, plus room for the noise-making demonstration units, are the main elements of the FM section.

Zenith's deluxe model 20H097E has two FM bands plus standard and virtual full coverage of shortwave. FM "Silentuner," robot dial, Cobra tone arm, six push buttons, coaxial PM speaker, intermix automatic record changer.

Meissner offers this "18th Century" model automatic radio-phonograph with three i-f stages on FM, two on AM. It has three built-in antennas, four controls each for base and treble—one of six different cabinet designs.



HOWARD...in FM

**Since the
Beginning!**

Before the war, Howard was a volume producer of FM-AM radio-phonograph combinations. Being an early licensee of the Armstrong System, Howard has gained a world of experience in building FM receivers at their very best.



The quality reputation and consumer acceptance of the Howard name is your assurance of a favorable selling position that spells profits and permanence.

HOWARD RADIO COMPANY

CHICAGO 13, ILLINOIS

America's Oldest Radio Manufacturer

224 FM Stations on Air!

The following FM stations are now in operation, or will be shortly. According to FCC reports nearly all FM stations are employing interim equipment pending full construction. Some are operating equipment in the old FM band on a temporary basis. This list has been compiled from FCC reports in conjunction with results of a survey made by RADIO & Television RETAILING. Engineering personnel responding to our survey indicated that stations reported here were well on the way if not in actual operation as we go to press.

ALABAMA

Birmingham
WAFM

CALIFORNIA

Fresno
KRFM

Los Angeles
KHJ-FM

Ontario
KOCs-FM

Richmond
KRCC

Riverside
KPOR

Sacramento
KANY

San Bernardino
KFXM-FM

San Diego
KFMB-FM

San Francisco
KJBS-FM
KRON

Santa Maria
KPJM

Stockton
KGDM-FM

CONNECTICUT

Hartford
WDRG-FM
WTIC-FM

New Britain
WKNB-FM

New London
WNLC-FM

DISTRICT OF COLUMBIA

Washington
WASH
WINX-FM
WWDC-FM

FLORIDA

Jacksonville
WMBR

Miami
WIOD-FM
WQAM-FM

Miami Beach
WKAT-FM

Palm Beach
WWPG-FM

Pensacola
WCOA-FM

GEORGIA

Columbus
WRBL-FM
WGBA

Macon
WBML-FM
WMAZ-FM

Rome
WRGA-FM

Savannah
WSAV-FM
WTOC-FM

Toccoa
WRLC-FM

IDAHO

Boise
KIDO-FM

Twin Falls
KTFI

Pocatello
KSEI-FM

ILLINOIS

Bloomington
WJBC-FM

Chicago
WBBM-FM
WGNB
WEFM

Cicero
WEHS

Decatur
WSOY-FM

Evanston
WEAW

Freeport
WFJS

Herrin
WJPF

Mt. Vernon
WMIX

Rock Island
WHBF-FM

INDIANA

Elkhart
WTRC

Evansville
WMLL

Fort Wayne
WOWO-FM

Indianapolis
WABW

Muncie
WLBC-FM

South Bend
WSBF

IOWA

Burlington
KBUR-FM

Cedar Rapids
KCRG-FM

Des Moines
KSO-FM
WHO-FM

KANSAS

Topeka
KTJS
WIBW-FM

Wichita
KFH

KENTUCKY

Lexington
WLAP-FM

Louisville
WBOX
WCJT

Paducah

WKYC
WPAD-FM

LOUISIANA

Alexandria
KPDR-FM

Baton Rouge
WJBO
WBRL

New Orleans
WRCM
WSMB-FM
WTPS-FM
WWLH

MAINE

Portland
WARY
WGAN-FM

MARYLAND

Baltimore
WASA
WITH-FM

Frederick
WFMD-FM

Hagerstown
WJEJ

MASS.

Boston
WBZ-FM
WGTR
WMNE

New Bedford
WFMR

Springfield
WBZA-FM

Worcester
WTAG-FM

MICHIGAN

Ann Arbor
WGUN

Battle Creek
WELL-FM

Bay City
WBCM-FM

Detroit
WENA
WJR-FM
WLOU

Mt. Clemens
WMLN

MINNESOTA

Mankato
KYSM-FM

Minneapolis
WTCN-FM

Rochester
KROC-FM

St. Paul
KSTP-FM

MISSOURI

Joplin
WMBH-FM

Kansas City
KCFM
KMBC-FM
KOZY
WDAF

St. Louis
KWGD
KWK-FM
WIL-FM

NEBRASKA

Omaha
KOAD

N. HAMPSHIRE

Claremont
WLOB

Mt. Washington
WMNE

NEW JERSEY

Alpine
W2XEA [WFMN]
W2XMN [WFMN]

Bridgeton
WSNJ-FM

NEW YORK

Binghamton
WBNF-FM

Buffalo
WBEN-FM
WBNY
WEBR-FM

Hornell
WWHG

Ithaca
WHCU-FM

New York
WABF
WCBS-FM
WGHF
WGYN
WMGM
WNBC-FM
WNYC-FM
WQXQ

Niagara Falls
WHLD-FM

Poughkeepsie
WHVA

Rochester
WHEF
WHFM
WRNY-FM

Rome
WRUN

Schenectady
WBCA
WGFM

Syracuse
WSYR-FM

Troy
WTRI

Utica
WIBX-FM

NORTH CAROLINA

Asheville
WISE
WLOS

Burlington
WBBB-FM

Goldsboro
WGBR-FM

High Point
WMFR-FM

Raleigh
WRAL-FM

Wilson
WGTM-FM

Winston-Salem
WAIR
WSJS-FM
WMIT

OHIO

Canton
WCMW-FM
WHBC-FM

Cincinnati
WLWA
WSAI-FM

Columbus
WCOL-FM
WELD
WHKB

Fostoria

WFOB

Fremont
WFRO

Steubenville
WSTV-FM

Toledo
WTOD-FM

Warren
WRRN-FM

Youngstown
WFMJ

OKLAHOMA

Muskogee
KMUS

Oklahoma City
KOCY-FM
KTOK-FM
WKY-FM

OREGON

Albany
KWIL-FM

Portland
KALE
KGW-FM
KPFM
KPRA

PENNSYLVANIA

Allentown
WSAN

Harrisburg
WABX
WHP-FM

Johnstown
WJAC

Lancaster
WEAX
WGAL

McKeesport
WMCK

New Castle

WKST-FM

Philadelphia
KYW-FM
WCAU-FM
WFIL-FM
WIP-FM
WPEN-FM

Pittsburgh
KDKA-FM
KQV-FM
WCAE
WMOT

Reading
WEEU

Scranton
WARM-FM

Wilkes-Barre
WBRE-FM
WIZZ

SOUTH CAROLINA

Greenville
WFBC-FM
WMRC-FM

Spartanburg
WSPA-FM

TENNESSEE

Bristol
WOPI

Chattanooga
WAPO-FM

Jackson
WTJS-FM

Knoxville
WKPB
WROL-FM

TEXAS

Dallas
KERA
KRLD-FM

Houston
KOPY
KPRC-FM

San Antonio
KISS
KYFM
WOAI-FM

Texarkana
KCMC-FM

Wichita Falls
KTRN

UTAH

KSL-FM

VIRGINIA

Danville
WBTM

Harrisonburg
WSVA-FM

Lynchburg
WLDC-FM

Portsmouth
WSAP-FM

Richmond
WCOB

Winchester
WINC-FM

WASHINGTON

Seattle
KEVR
KRSC-FM

WEST VIRGINIA

Beckley
WCFC

WJLS-FM

Huntington
WLPH

WISCONSIN

LaCrosse
WKBH-FM

Madison
WIBA

Milwaukee
WMAW
WTMJ-FM

Superior
WDUL

WYOMING

KFBA

For List of Conditional Grants and Construction Permits, see page 76

“Where
FM
also
means
Finest
Made”

Orchids to Major
Armstrong for his out-
standing achievement—
and a bouquet to our
own engineers and crafts-
men for making the most
of it! Watch Temple for
FM at its finest!

**TEMPLETONE
RADIO MFG. CORP.**

New London, Conn.

Executive Offices:

220 E. 42nd St., New York, N. Y.





Model S-36A

The Model S-36A is probably the most versatile VHF receiver ever designed. Covering a frequency range of 27.8 to 143 Mc it performs equally well on AM, FM or as a communications receiver for CW telegraphy. Equipment like this was introduced by Hallicrafters more than 5 years ago, clearly anticipating the present trend toward improved service on the higher frequencies.

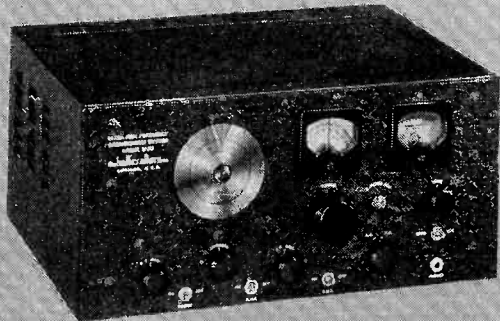

Model S-37

Model S-37 FM-AM receiver is an outstanding example of Hallicrafters pioneering work in the upper regions of the spectrum. Covering the frequencies between 130 and 210 Mc, the S-37 provides superior VHF performance. An indispensable instrument for all engaged in FM experimentation.

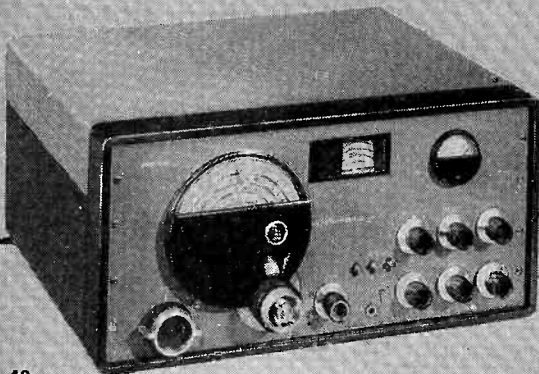

Model SX-42

With the introduction of the new Model SX-42 Hallicrafters further strengthens its foremost position in FM. The SX-42 offers the greatest continuous frequency coverage of any communications receiver . . . from 540 kc to 110 Mc. Tremendous frequency range made possible by new "split-stator" tuning system and the use of dual intermediate frequency transformers.

FIRST...

**FOREMOST
IN FM RECEIVERS**

By experience and accomplishment Hallicrafters is a factor to be reckoned with in FM. This brief summary shows how models like the S-36A and the S-37 were developed more than 5 years ago — five years in advance of other commercially developed receivers. The new

Model SX-42 and other FM receivers now in development will continue to maintain Hallicrafters foremost position in the highly specialized FM field. Hallicrafters will have high quality FM equipment available in every price bracket.

COPYRIGHT 1946 THE HALLICRAFTERS CO.

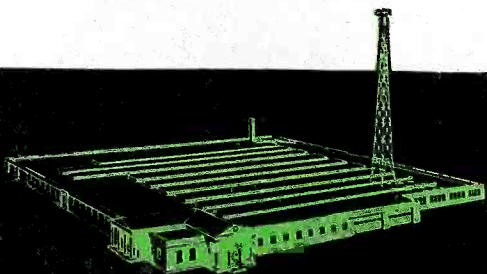

hallicrafters RADIO

THE HALLICRAFTERS CO., MANUFACTURERS OF RADIO AND ELECTRONIC EQUIPMENT, CHICAGO 16, U. S. A.

in 1947...

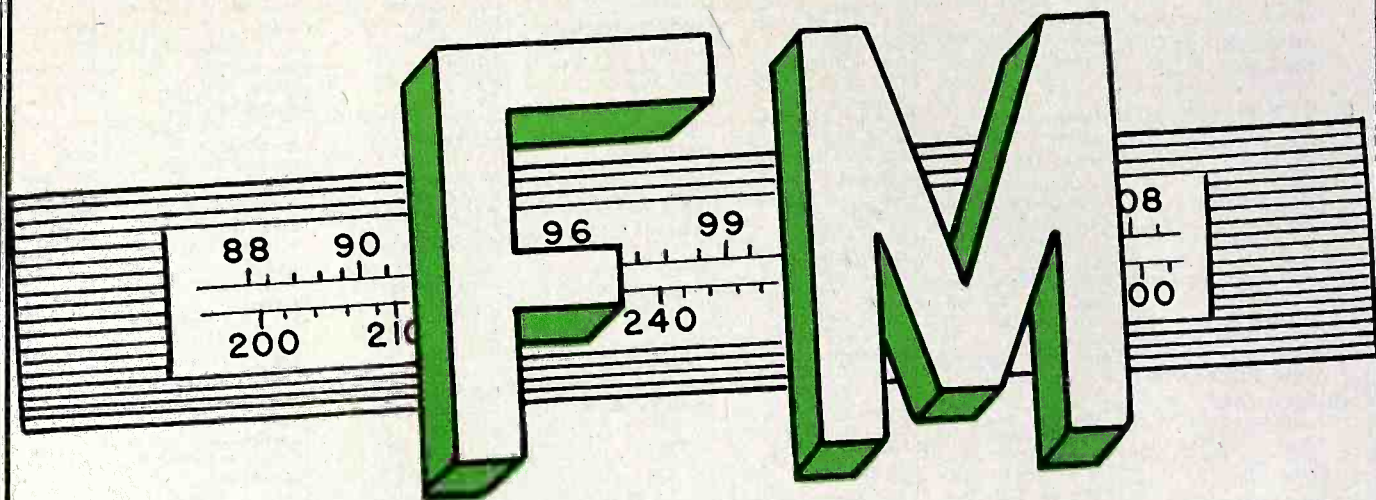

with **PILOT RADIO**

WORLD-FAMOUS PILOT RADIO—and a name in *FM fame* since the advent of Major Armstrong's revolutionary method of radio transmission—continues to bring you FM at its *finest* in 1947. FM pioneers in 1939, Pilot Radio's superb engineering skill in frequency modulation was developed during the past decade—and now forges ahead toward new horizons of radio achievement. Today—and in the months to come—look to Pilot Radio for high-fidelity FM reproduction in all its realism...in exquisite table model and radio-phonograph console sets.

PILOT Companion—High-Fidelity PILOTONE VINYLITE RECORDS

WHAT FM IS TO RADIO—that's what Pilotone's brilliant VINYLITE recordings are to the record industry! Crystal-clear, life-like reproduction of beloved music and favorite tunes—all "collectors' items"—recorded on the miracle non-breakable VINYLITE for a new thrill in listening pleasure. (What finer testimonial than the accepted preference by FM stations for high-fidelity VINYLITE on recorded musical programs.) Twenty-five Pilotone albums of four 10-inch records have been released to date—with frequent releases planned for 1947.

PILOT



RADIO

Long Island City 1, N. Y.

PILOT A M—F M RADIOS

PILOT PORTABLE RADIOS

PILOT RADIO-PHONOGRAPH COMBINATIONS

PILOT RADIO TELEVISION RECEIVERS

FM — Conditional Grants and Construction Permits

- ALABAMA**
Anniston
 Harry M. Ayers
Birmingham
 Thomas N. Beach
 Birmingham Bdstng. Co.
 Birmingham News Co.
 Johnston Bdstng. Co.
Gadsden
 Gadsden Bdstng. Co.
Huntsville
 Huntsville Times Co.
Lanett
 Valley Bdstng. Co.
Mobile
 Giddens & Rester
 Mobile Daily Newspr.
 Nunn Bdstng. Co.
 Pape Bdstng. Co.
Montgomery
 G. W. Corington, Jr.
 Dixie Bdstng. Co.
 Montgomery Bdstng. Co.
- ARIZONA**
Phoenix
 Sun County Bdstng. Co.
ARKANSAS
Fort Smith
 Okla-Ark Bdstng. Co.
 Record & Times
 Southwestern Hotel Co.
Siloam Springs
 John Brown Univ.
- CALIFORNIA**
Alameda
 Times Star Publ. Co.
Bakersfield
 McClatchy Bdstng. Co.
Berkeley
 Central Calif. Bdsters.
Beverly Hills
 Beverly Hills Bdstng. Co.
Chico
 Golden Emp. Bdst. Co.
Eureka
 Redwood Bdstng. Co.
Fresno
 KARM
 (George Harm Station)
Los Angeles
 KMPC-FM
 (Stat. of the Stars, Inc.)
 Los Angeles Bdstg. Co.
 Metro-Goldwyn-Mayer
 Studios
 Radio Bdsters., Inc.
 Standard Bdstng. Co.
 Unity B Corp. of Calif.
Marysville
 Marysvll-Utah City Bdctr
 Sacramento Val. Bdsters.
Merced
 Golden Emp. Bdstg. Co.
 Merced Bdstng. Co.
Modesto
 KTRB Bdstng. Co.
Monterey
 Monterey Pen. Bdstng. Co.
Oakland
 Oakland Tribune
 Warner Bros.
Palo Alto
 Peninsula Newspr., Inc.
Pasadena
 Rose Bowl Bdsters., Ltd.
 South Calif. Bdst. Co.
Redding
 Golden Emp. Bdstng. Co.
Riverside
 FM Radio & Telev. Corp.
Sacramento
 Central Val. Bdstng. Co.
 Haimco, Inc.
 KXOA-FM
 (Lincoln Dellar)
Salinas
 Luther E. Gibson
San Bernardino
 Sun & Telegram
San Bruno
 Radio Diable, Inc.
San Diego
 Airfan Radio Corp.
 Studebaker Bdstng. Co.
San Francisco
 Associated Bdsters.
 National Bdstng. Co.
 Pacific Bdstng. Co.
San Jose
 Pacific Agri. Foundation
 Santa Clara Bdstng. Co.
 Valley Bdstng. Co.
San Luis Obispo
 Valley Electric Co.
San Mateo
 Amphlett Printing Co.
Santa Ana
 Voice of the Orange Emp.
- Santa Barbara**
 News-Press Publ. Co.
Yreka
 Siskiyou Bdstng. Co.
- CONNECTICUT**
Danbury
 Berkshire Bdstng. Corp.
Hartford
 Hartford Times, Inc.
 State Bdstng. Corp.
Meriden
 Silver City Crystal Co.
New Britain
 New Britain Bdstng. Co.
New Haven
 Colony Bdstng. Corp.
 Conn. Radio Foundation
 Elm City Bdstng.
Stamford
 Western Conn. Bdst. Co.
Waterbury
 Amer. Republican, Inc.
- DELAWARE**
Wilmington
 Delaware Bdstng. Co.
 Port Frere Bdstng. Co.
 WDEL, Inc.
- FLORIDA**
Coral Gables
 Southern Media Corp.
Daytona Beach
 News-Journal Corp.
Fort Lauderdale
 Gore Publ. Co.
Jacksonville
 City of Jacksonville
 The Metropolis Co.
Miami
 Paul Brake
 Everglades Bdstng. Co.
 Fort Industry Co.
 Southern Media Corp.
Orlando
 Hazlewood, Inc.
 Orlando Dall. News., Inc.
St. Petersburg
 Pinellas Bdstng. Co.
Tallahassee
 Capital City Bdstng. Co.
Tampa
 Tampa Times Co.
 The Tribune Co.
- GEORGIA**
Ailey
 Carter C. Peterson
Athens
 J. K. Patrick & Co.
Atlanta
 Constitution Publ. Co.
Augusta
 Augusta Bdstng. Co.
 Augusta Chronicle Co.
 Voice of Augusta
Cedartown
 Northwes. Ga. Bdst. Co.
Columbus
 Radio Columbus, Inc.
Dublin
 Dublin Bdstng. Co.
Macon
 Macon Teleg. Publ. Co.
Moultrie
 J. F. Pidcock, Sr.
Savannah
 Atlantic Bdstng. Co.
Valdosta
 E. D. Rivers
- IDAHO**
Nampa
 F. E. Hurt & Son
- ILLINOIS**
Aurora
 Aurora Beacon News
Brookfield
 George M. Ives (WRGK)
Carbondale
 Southern Ill. Bdstng.
Champaign
 Champaign News-Gaz.
Elgin
 Copley Press, Inc.
Elmwood Park
 Elmwood Pk. Bdst Corp.
Evanson
 North Shore Bdstng. Co.
 Sentinel Radio Corp.
Harrisburg
 Harrisburg Bdstng. Co.
Kankakee
 Kankakee Daily Jour. Co.
Mt. Vernon
 Midwest Bdstng. Co.
Peoria
 Central Ill. Radio Corp.
 Ill. Valley Bdstng. Co.
 Mid State Bdstng. Co.
 Peoria Bdstng. Co.
- INDIANA**
Columbus
 Syndicate Theatres, Inc.
Connersville
 News-Examiner Co.
Evansville
 Tri-State Bdstng. Corp.
Elkhart
 Truth Publ. Co.
Fort Wayne
 Rarnsw'th Tel & Rad Corp
 Northeast Ind Bdstg Co
 Fort Wayne Bdstng. Co.
Franklin
 Syndicate Theatres, Inc.
Hammond
 South. Shore Bdst. Co.
Kokomo
 Kokomo Bdstng. Corp.
Lafayette
 WFAM, Inc.
New Castle
 Courier-Times, Inc.
Shelbyville
 Shelbyville Radio, Inc.
Terre Haute
 Banks of the Wabash Inc.
 Wabash Val. Bdst. Corp.
- IOWA**
Cedar Rapids
 The Gazette Co.
Davenport
 Central Bdstng. Co.
 Tri-City Bdstng. Co.
Des Moines
 Cowles Bdstng. Co.
 Independent Bdstng. Co.
Dubuque
 Dubuque Bdstng. Co.
 Telegraph-Herald
Mason City
 Lee Radio, Inc.
Sioux City
 Perkins Bros. Co.
Waterloo
 Josh Higgins Bdstng. Co.
- KANSAS**
Hutchinson
 Hutchinson Publ. Co.
 Nation's Cent. Bdst. Co.
Kansas City
 Sunflower Bdstg. System
Lawrence
 The World Co.
Wichita
 Farmers & Bank. Bdctg Co
 Wichita Beacon Bdctg Co
- KENTUCKY**
Ashland
 Ashland Bdstng. Co.
Bowling Green
 Bowl. Green Bdstng. Co.
Henderson
 Henderson Bdstng. Co.
Hopkinsville
 Hopkinsville Bdstng. Co.
Louisville
 Wave, Inc.
Owensboro
 Owensbo. on the Air, Inc.
 Owensbo. Bdst. Co., Inc.
Winchester
 Winchester Sun Co.
- LOUISIANA**
Alexandria
 Alexandria Bdstng. Co.
New Orleans
 Stephens Bdstng. Co.
- MAINE**
Lewiston
 Twin City Bdstng. Co.
- MARYLAND**
Annapolis
 Capital Bdstng. Co.
Baltimore
 Baltimore Bdstng. Co.
 Balti. Radio Show, Inc.
 Belvedere Bdstng. Corp.
 Monumental Radio Co.
Cumberland
 Tri-State Bdstng. Co.
Salisbury
 Peninsula Bdstng. Co.
Takoma Park
 Tri-Suburban Bdst. Co.
- MASSACHUSETTS**
Brockton
 Cur-Nan Co.
- Quincy**
 Lee Bdstng. Co.
 Quincy Newspr., Inc.
Rockford
 Rockford Bdstng. Co.
Springfield
 WCBS, Inc.
 WTAX, Inc.
Waukegan
 Keystone Print. Service
- Fall River**
 Fall River Bdstng. Co.
- Fitchburg**
 Meyers & Aronheim
Greenfield
 John W. Haigis
 Recorder Publ. Corp.
Haverhill
 Haverhill Gazette Co.
Holyoke
 Hampden-Hamp. Corp.
Lawrence
 Hildreth & Rogers Co.
Lowell
 Merrimac Bdstng. Co.
New Bedford
 Bay State Bdstng. Co.
 Southeast Mass Bdctg Co
North Adams
 James A. Hardman
Pittsfield
 West. Mass. Bdstng. Co.
 M. B. England
Salem
 North Shore Bdstng. Co.
 WMAS, Inc.
- MICHIGAN**
Ann Arbor
 University of Michigan
Benton Harbor
 Palladium Publ. Co.
Detroit
 Board of Education
 James F. Hopkins, Inc.
 King Trendle Bdstng. Co.
 Knight Radio Corp.
 Herman Radner
 UAW-CIO Bdstng. Corp.
Escanaba
 J. P. Norton
Flint
 Advertisers Press, Inc.
 Flint Bdstng. Co.
Grand Rapids
 Fetzer Bdstng. Co.
 Grand Rap. Bdstng. Co.
 Lear, Inc.
 Leonard A. Versluis
Jackson
 WIBM, Inc.
Lansing
 WJLM, Inc.
Muskegon
 Ashbacker Radio Corp.
Owosso
 The Argus-Press Co.
Pontiac
 Pontiac Bdstng. Co.
Port Huron
 Times-Herald Co.
Royal Oak
 Royal Oak Bdstng. Co.
Saginaw
 Saginaw Bdstng. Co.
- MINNESOTA**
Minneapolis
 Ind. Merch. Bdstng. Co.
St. Cloud
 Times Publ. Co.
St. Paul
 Minnesota Bdstng. Co.
 WMIN Bdstng. Co.
Winona
 Winona Radio Service
- MISSISSIPPI**
Columbus
 Birney Imes, Sr.
Jackson
 Lamar Life Insur. Co.
- MISSOURI**
Cape Girardeau
 Oscar C. Hirsch
Clayton
 Evans Lutheran Synod
E. St. Louis
 Miss. Val. Bdstng. Co.
Jefferson
 Capital Bdstng. Co.
Kansas City
 Sch. Dist. of Kansas City
 WHB Bdstng. Co.
St. Joseph
 KFQ-FM
St. Louis
 Columbia Bdstng. System
 Pulitzer Publ. Co.
 Star-Times Publ. Co.
 St. Louis Univ.
 Unity Bdstng. Corp.
- NEBRASKA**
Lincoln
 KFAB Bdstng. Co.
 Cornbelt Bdstng. Co.
Omaha
 Inland Bdstng. Co.
- NEVADA**
Las Vegas
 Nevada Bdstng. Co.
- Reno**
 Reno Newspr., Inc.
 Saviers Elec. Prdts. Corp.
- NEW HAMPSHIRE**
Manchester
 Harry M. Bitner
 Radio Voice of N. H., Inc
Portsmouth
 WHEB, Inc.
- NEW JERSEY**
Asbury Park
 Asbury Park Press, Inc.
 Radio Indus. Bdst. Co.
Atlantic City
 Neptune Bdstng. Corp.
 Press Union Publ. Co.
Carteret
 Bamberger Bdstg. Serv.
Elizabeth
 Radio Elizabeth, Inc.
Jersey City
 Fidelity Media Bdtg Corp
New Brunswick
 Home News Publ. Co.
Passaic
 Passaic Daily News
Trenton
 Mercer Bdstng. Co.
- NEW YORK**
Albany
 Hudson Val. Bdstng. Co.
Brooklyn
 Elias F. Godofsky
Coram
 Suffolk Bdstng. Corp.
Corning
 The Evening Leader
Dobbs Ferry
 Radio Elizabeth, Inc.
Dunkirk
 Dunkirk Printing Co.
Elmira
 Elmira Star Gazette, Inc.
Jamestown
 Jamestown Bdstng. Co.
Massena
 The Brockway Co.
Mount Vernon
 Hudson Bdst. Sys., Inc.
New Rochelle
 Brooklyn Bdtg Serv, Inc
New York
 Amer. Bdstg. Co., Inc.
 30 Rockefeller Plaza
 New York 20, N. Y.
 The Engineer—Dr. F. G. Gear
 Hearst Radio, Inc.
 Hudson B. System, Inc.
 Radio Projects, Inc.
Ogdensburg
 St Lawrence Bdtng Corp
Oneonta
 Oneonta Star, Inc.
Oswego
 Palladium-Times, Inc.
Rochester
 Amalgamated Bdstng.
 System, Inc.
Rome
 Copper City Bdst. Corp.
Syracuse
 Onondaga Rad Bdtg Corp
 Radio Projects, Inc.
 Syracuse Bdstng. Corp.
 WAGE, Inc.
 WOLF-FM
Troy
 Troy Record Co.
Watertown
 The Brockway Co.
White Plains
 White Plains Reporter-
 Dispatch
- NORTH CAROLINA**
Ahoskie
 Parker Bros., Inc.
Ashville
 Radio Ashville, Inc.
Burlington
 B'Y'g'n-Graham Bdtg Co
Charlotte
 Southeastern Bdstg. Co.
Durham
 Durham Radio Corp.
Fayetteville
 Cape Fear Bdstng. Co.
Gastonia
 F. C. Todd
Greensboro
 Greensboro News
 N. C. Bdstng. Co.
Greenville
 Greenville Bdstng. Co.
Hickory
 Catawba Val. Bdstg. Co.
High Point
 High Point Ent'prise, Inc
Morganton
 Beatrice Corp.
Raleigh
 News & Observer Publ Co
 WPTF Radio Co.
- Roanoke Rapids**
 WCBT, Inc.
Rocky Mount
 Josh Horne
 W. A. Wynne
Salisbury
 Piedmont Bdstng. Corp.
Statesville
 Statesville Bdstng. Co.
Washington
 Tar Heel Bdst. Sys., Inc.
Wilmington
 R. A. Dunlea
 Wilmington Star & News
- NORTH DAKOTA**
Fargo
 KVOX Bdstng. Co.
OHIO
Akron
 Nield & Stevens
 Knight Radio Corp.
Alliance
 Review Publ. Co.
Ashland
 Beer & Koehl
Ashtabula
 WICA, Inc.
Wilmington
 Messenger Publ. Co.
Bellaire
 Tri-City Bdstng. Co.
Canton
 P. C. Wilson
Cincinnati
 Cincinnati Times-Star
 Scripps Howard Rad, Inc
 L. B. Wilson, Inc.
Cleveland
 United Garage & Ser. Corp
Columbus
 Sky Way Bdstng. Corp.
Dayton
 Skyland Bdstng. Corp.
Dover
 Tuscora Bdstng. Corp.
Findlay
 Findlay Radio Co.
Fostoria
 L. E. Kinn
Hamilton
 Ft. Hamilton Bdst. Co.
Lima
 N'thw'tern Ohio Bdtg Cor
Marion
 Marion Bdstng. Co.
Newark
 Advocate Printing Co.
Portsmouth
 Scioto Bdstng. Co.
Tiffin
 J. R. David
Toledo
 Fort Industry Co.
 Ohio Michigan Bdstg Co
Wooster
 Wooster Repub. Ptg. Co.
Youngstown
 WKBN Bdstng. Corp.
- OKLAHOMA**
Ardmore
 J. F. Easley
Durant
 Democrat Printing Co.
Lawton
 Okla. Qual. Bdstng. Co.
Norman
 State Univ. of Okla.
Oklahoma City
 KOMA, Inc.
 Sooner Bdstng. Co.
Shawnee
 KGFF Bdstng. Co.
Stillwater
 Okla. Agri. & Mech Col
 Stillwater Publ. Co.
Tulsa
 Fred Jones Bdstng. Co.
 Pacific Radio Corp.
 Tulsa Bdstng. Co.
- OREGON**
Ashland
 Rogue Val. Bdstng. Co.
 Siskiyou Bdstng. Co.
Eugene
 Eugene Bdst. Station
 Valley Bdstng. Co.
Grants Pass
 South. Ore. Bdstng. Co.
Medford
 Medford Printing Co.
Portland
 Bdsters. Oregon, Ltd.
 KLX Bdsters.
 KOIN, Inc.
- PENNSYLVANIA**
Allentown
 Penn-Allen Bdstng. Co.
Altoona
 Gable Bdstng. Co.
Beaver Falls
 Tribune Printing Co.
Bethlehem
 Bethlehem Globe Publ Co
Bradford
 Bradford Publctns., Inc.
Butler
 Butler Bdstng. Co.
Clearfield
 A'plane & Marine Inst Co
DuBois
 Tri-County Bdstng. Co.
Easton
 Associated Bdsters., Inc.
 Easton Publ. Co.
Erie
 Preque Isle Bdstng. Co.
Harrisburg
 The Patriot Co.
Lewistown
 Lewistown Bdstng. Co.
Meadville
 Dr. H. C. Winslow, M.D.
Pittsburgh
 Pittsb'gh Rad Sup House
 Kenneth Ed Rennkamp
Pottsville
 Miners Bdstng. Co.
 Pottsville Bdstng. Co.
Reading
 Hawley Bdstng. Co.
Scranton
 Scranton Bdsters., Inc.
 Scranton Times
Sharon
 Sharon Herald Bdstg Co
Sunbury
 Sunbury Bdstng. Corp.
Uniontown
 Fayette Bdstng. Corp.
 Uniontown Newspr., Inc.
Washington
 Observer Publ. Co.
Williamsport
 WRAC, Inc.
York
 Susquehanna Bdstng Co
 White Rose Bdstng. Co.
- SOUTH CAROLINA**
Anderson
 Wilton E. Hall
Charleston
 Atlantic Coast Bdstg Co
Columbia
 Surety Life Insur. Co.
Greenwood
 Greenco, Inc.
Lancaster
 Lancaster Bdstng. Co.
Rock Hill
 York County Bdstng. Co.
Wilmington
 Wilming'tn Star-News Co
- TENNESSEE**
Chattanooga
 Unity Bdstng. Corp.
 Mark K. Wilson
 WDD Bdstng. Corp.
Clarksville
 William Kleeman
 Leaf Chronicle Co.
Jackson
 Jackson Bdstng. Co.
Kingsport
 Kingsport Bdstng. Co.
Memphis
 Herbert Herff
 Memphis Publ. Co.
 WMPB, Inc.
 H. B. Wooten
Nashville
 WSIX Bdstng. Co.
- TEXAS**
Abilene
 The Reporter Bdstng Co
Amarillo
 Amarillo Bdstng. Co.
 Plains Radio Bdstng Co
Beaumont
 KRIC, Inc.
Belton
 Mary Hardin-Baylor Col.
Brownsville
 Brownsv'l Herald Pub Co
College Station
 Agric. & Mech. College
Dallas
 City of Dallas
 KRLD Radio Corp.
 Variety Bdstng. Co.
Denton
 Harwell V. Shepard
- Fort Worth**
 Carter Publ. Inc.
 Lone Star Bdstng. Co.
Galveston
 KLUF Bdstng. Co.
Harlington
 KGBS-FM
 (Harbenito Bdstng.)
Houston
 Harris Coun. Bdstng Co.
 KTRH Bdstng. Co.
 Lee Segal Bdstng. Co.
Lufkin
 Darrel E. Yates
Long View
 R. G. Le Tourneau
San Angelo
 KGKL, Inc.
San Antonio
 Southern Bdstng. Corp.
 Sunshine Bdstng. Co.
Temple
 Bell Bdstng. Co.
Tyler
 East Texas Bdstng. Co.
Vernon
 Northwestern Bdstng Co
Wichita Falls
 Wichita Bdsters
- UTAH**
Salt Lake City
 Intermountain Bdstg Co
- VERMONT**
Rutland
 Herald & Globe Ass'n
 Philip Weiss Music Co.
Scranton
 Scranton Bdsters., Inc.
 Scranton Times
Sharon
 Sharon Herald Bdstg Co
Sunbury
 Sunbury Bdstng. Corp.
Uniontown
 Fayette Bdstng. Corp.
 Uniontown Newspr., Inc.
Washington
 Observer Publ. Co.
Williamsport
 WRAC, Inc.
York
 Susquehanna Bdstng Co
 White Rose Bdstng. Co.
- SOUTH CAROLINA**
Anderson
 Wilton E. Hall
Charleston
 Atlantic Coast Bdstg Co
Columbia
 Surety Life Insur. Co.
Greenwood
 Greenco, Inc.
Lancaster
 Lancaster Bdstng. Co.
Rock Hill
 York County Bdstng. Co.
Wilmington
 Wilming'tn Star-News Co
- TENNESSEE**
Chattanooga
 Unity Bdstng. Corp.
 Mark K. Wilson
 WDD Bdstng. Corp.
Clarksville
 William Kleeman
 Leaf Chronicle Co.
Jackson
 Jackson Bdstng. Co.
Kingsport
 Kingsport Bdstng. Co.
Memphis
 Herbert Herff
 Memphis Publ. Co.
 WMPB, Inc.
 H. B. Wooten
Nashville
 WSIX Bdstng. Co.
- TEXAS**
Abilene
 The Reporter Bdstng Co
Amarillo
 Amarillo Bdstng. Co.
 Plains Radio Bdstng Co
Beaumont
 KRIC, Inc.
Belton
 Mary Hardin-Baylor Col.
Brownsville
 Brownsv'l Herald Pub Co
College Station
 Agric. & Mech. College
Dallas
 City of Dallas
 KRLD Radio Corp.
 Variety Bdstng. Co.
Denton
 Harwell V. Shepard

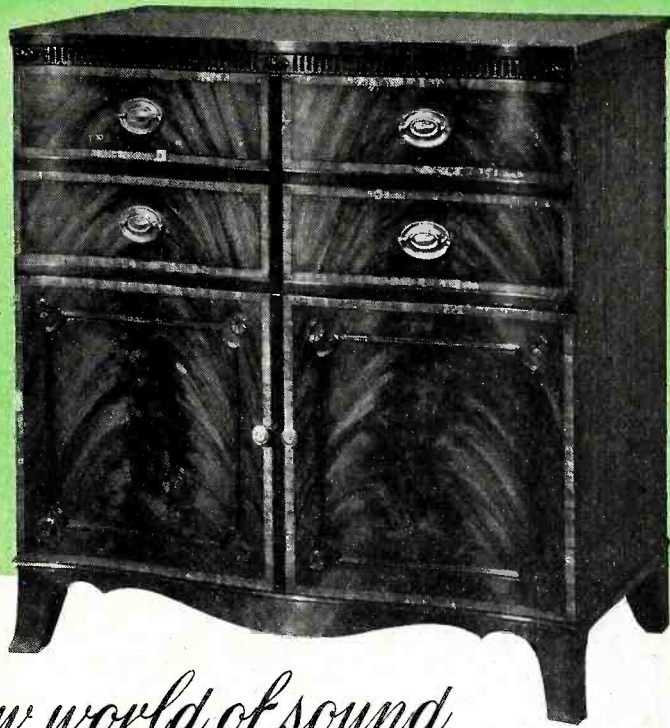

*a new world of sound
with MEISSNER... and FM*

Back in 1941 when Meissner engineers first turned their efforts toward designing the finest in quality radio phonographs, Meissner was already an Armstrong licensee . . . the second company in the entire nation to be awarded this coveted warrant.

Step by step, as these new Meissners grew from our planning boards, the latest developments in electronics were constantly being checked. Those few which represented tangible advances, and which measured up to the high standards of Meissner, were included in the design. One of those chosen was Frequency Modulation.

Today, with the new Meissner being acclaimed everywhere as the finest reproducing instrument ever offered, we are aware of the great part FM has played in making the matchless perfection of this new instrument possible. And as we believe in the future of the new Meissner so too do we have complete faith in the future of FM. Together they will open up a new era in radio . . . a new world of sound.



MEISSNER MANUFACTURING DIVISION OF MAGUIRE INDUSTRIES

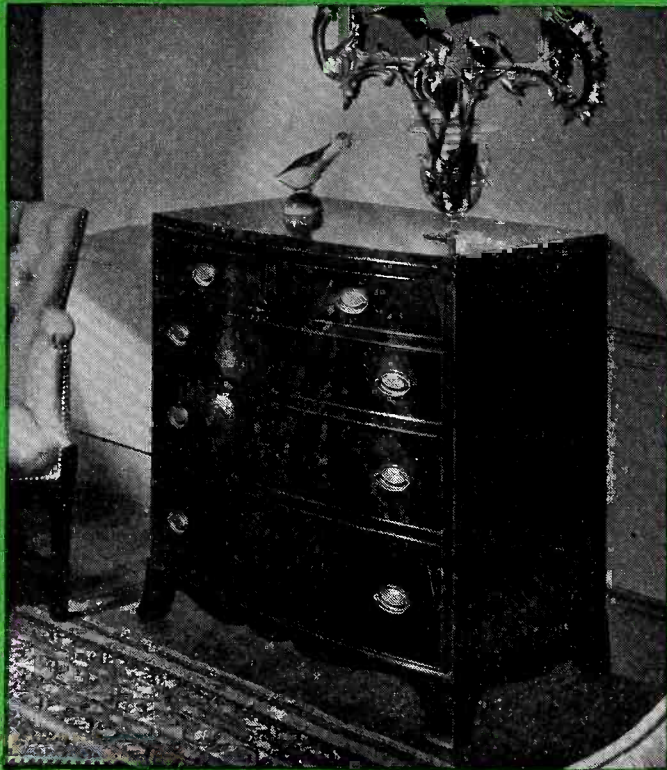

THE FREED-EISEMANN
NEW WORLD HEPPLEWHITE

Pioneers, Specialists and Leaders in quality production of console radio-phonographs with FM

The new Freed-Eisemann Radio-Phonograph is today's outstanding achievement in FM engineering and high-fidelity reception. This is no idle claim. It is the opinion of radio authorities, eminent musical artists and leading retailers. Acknowledgment has come even from the ranks of competing manufacturers.

It is easy to explain Freed-Eisemann superiority. From the beginning, the makers of Freed-Eisemann have been pioneers and specialists in FM. Every model produced since 1940 has contained an FM receiver. Production throughout the war was devoted to FM military equipment. All Freed-Eisemann models, now and in the future, will continue to be equipped with genuine Armstrong FM.

Quite naturally, phonograph performance, automatic record changers, standard broadcast and international shortwave also measure up to exacting Freed-Eisemann standards.

Equally outstanding are the handsome period cabinets which house the new Freed-Eisemann. Created by leading decorators and craftsmen for beautifully appointed homes, they excel in simple elegance of design, in choice of woods, and in finish and patine.

Freed-Eisemann Radio-Phonographs are sold on a direct basis to a limited number of dealers who serve a discriminating clientele. Priced from \$520.



Freed-Eisemann

ONE OF THE WORLD'S GREAT RADIO-PHONOGRAPHS

FREED RADIO CORPORATION • 200 HUDSON STREET • NEW YORK 13, N. Y.

FM Dipoles "Up" Profits

In Selling the New Type Radios, Don't Fumble This Extra Income Source

● The great increase in sensitivity of the sets built for several years before the war has for many years pretty well undercut the market for AM antennas. The development of the compact and often invisible loop antenna, the increased use of ground wires and line cord taps, the gradual elimination of the most bothersome sources of man-made static, and the increase in power of the broadcasting stations had accustomed both public and dealers to putting up \$10 aerials only in poor-reception areas.

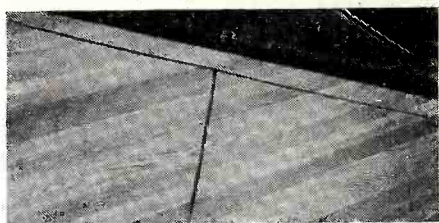

Simplest FM aerial is folded dipole made of 300 ohm line, recommended by Federal Tel. & Radio Co.

The loss of this trade has been gradual, and not too greatly bemoaned. Perhaps it should have been. For a good part of the dealer's profit per radio sale had been slipping away from him. But this year, things will change for the better.

The advent of FM has once more brought into the merchandising spotlight the importance of the radio antenna. FM, like television, operates on the very high radio frequencies (VHF). At these frequencies, it is essential to pick up every bit of signal available, with as little static as possible.

This is done by using a direc-

Kings dipole is adjustable, to suit locality.

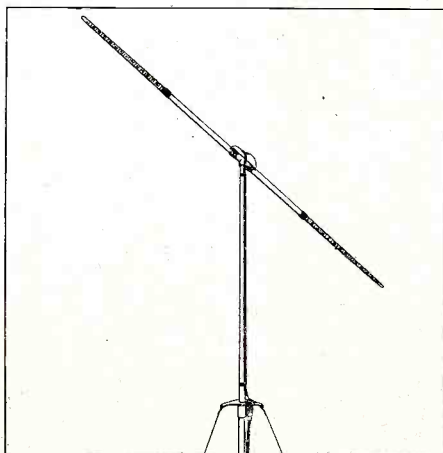

tional antenna, designed to have maximum pickup sensitivity in the direction of the FM transmitters, and least response toward the buildings below, from which arise the major part of the noise interference.

On these pages are illustrated some varieties of FM antennae. Perhaps the simplest to construct

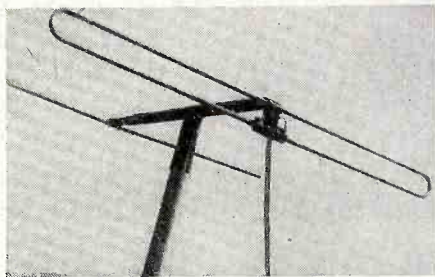

Taco 620 folded dipole with reflector for FM.

and install are those which use a half-wave section of parallel-conductor line as a folded dipole. This type of antenna can be tacked to the baseboard behind the radio, or slipped under a portion of the rug upon which people do not ordinarily walk, as illustrated.

While simple dipoles will work nicely in the vicinity of cities or towns having an FM transmitter, dipoles with reflectors are needed in outlying areas. The action of a reflector is to make the antenna more directive, so that it will pick up and reinforce signals which are

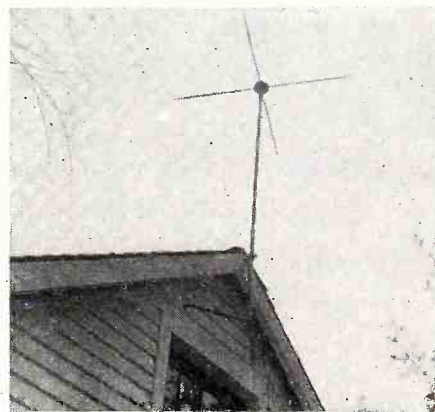

Workshop Associates Kit 1 is non-directional, becoming directional with added Kit 2 elements.

coming from a direction broadside to the "active" dipole and reject signals coming from the opposite direction, broadside to the "parasitic" element, or reflector.

No doubt the majority of instances will require the use of a more elaborate antenna, of which

several varieties are shown. Virtually all of these antennas take a 300-ohm line lead-in.

Two parallel spaced conductors are covered with special flexible, low-loss vhf insulation. These lead-ins will match most receiver input circuits, and should be run on stand-off insulators.

A special stand-off insulator is sold for the purpose, having a springy notched fork into which the 300-ohm line snaps tightly in place. Within the rooms, the lead-in may be simply tacked to the molding by a thumb-tack piercing the center section of the insulation.

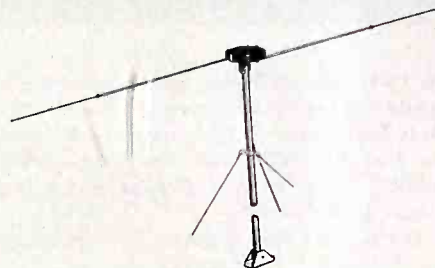

Vertrod "Continental" dipole is calibrated for and adjustable to any frequency in the American FM and television bands.

Above all other considerations, one final fact must stick in the mind of alert retailers. FM is a huge new field, in which the privilege of leadership is being won today in each neighborhood and town. While antenna installations may seem primarily a source of good quick income, remember that from a long range point of view the reputation which a good installation builds or a poor installation destroys will be worth a hundred times as much in new-set sales and old-set repairs. Treat FM carefully, for you're playing with the beginning of a business that may become far bigger than AM radio.

Oak Ridge aluminum-and-lucite single dipole.

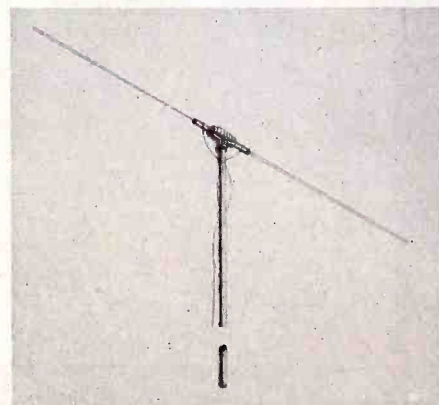



Western Electric and FM Go Together

1940 First Western Electric FM transmitter went on the air. This 1 kw station, W2XW1, later grew into today's 10 kw station WBAM, New York.

In 1940 when FM was in its infancy the first Western Electric-made FM transmitter went on the air. Since that time the team of Bell Telephone Laboratories and Western Electric has set the pace in designing and manufacturing FM transmitting equipment . . . has helped FM grow to its present importance in Radio Broadcasting.

During the war Western Electric applied FM to radio equip-

ment for tanks, Field Artillery communications and landing craft and produced more than 213,000 units of FM mobile equipment.

Today Western Electric is using all this experience to supply the finest fixed and mobile FM equipment for mobile radio-telephone service, and to furnish better listening to radio audiences by building outstanding transmitters for FM broadcasting.

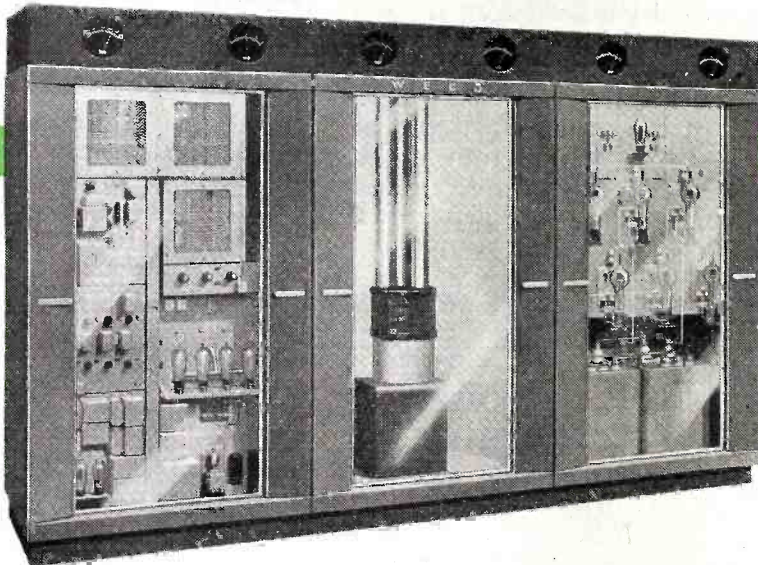

1947 This 10 kw Transview design FM transmitter is typical of Western Electric's new line, which also includes 250 watt, 1 kw, 3 kw, 25 kw and 50 kw units.

Western Electric FM Transmitters on the air

- KHJ-FM, Hollywood, Calif.
- KJBS-FM, San Francisco, Calif.
- KPFM, Portland, Ore.
- KUSC, Los Angeles, Calif.
- WABF, New York, N. Y.
- WAFM, Birmingham, Ala.
- WBAM, New York, N. Y.
- WBCM-FM, Bay City, Mich.
- WDLM, Chicago, Ill.
- WELL-FM, Battle Creek, Mich.
- WGHF, New York, N. Y.
- WIOD-FM, Miami, Fla.
- WIP-FM, Philadelphia, Pa.
- WITH-FM, Baltimore, Md.
- WMGM, New York, N. Y.
- WNYC-FM, New York, N. Y.
- WTPS, New Orleans, La.
- W4XAC, Atlanta, Ga.
- W8XMV, Dayton, Ohio
- W8XUB, Cleveland, Ohio
- W9XEK, Louisville, Ky.
- W9XLA, Denver, Colo.

Characteristics of Western Electric FM Transmitters

Audio Frequency Response	± 0.25 db from 30 to 15,000 cycles
Harmonic distortion—for ± 75 kc swing	Less than 0.5% from 30 to 15,000 cycles
—for ± 100 kc swing	Less than 0.75% from 30 to 15,000 cycles
Intermodulation —for ± 75 kc swing	Less than 0.5% for 80% 50 cycles and 20% 1000 cycles; less than 1.0% for 80% 50 cycles and 20% 7000 cycles
FM noise level	65 db below ± 75 kc swing
AM noise level	50 db below 100% amplitude modulation
Carrier Frequency stability	Less than 2000 cycles deviation (no crystal heater)

— QUALITY COUNTS —



WORLDWIDE FM

It is a pleasure to announce that Electrical & Musical Industries Limited is now a licensee under the Armstrong FM patents.

Since our operations are international in scope, the procurement of an Armstrong license and the utilization of our own extensive technical facilities will hasten the day when people throughout the world can enjoy genuine FM reception comparable to the finest in America.

As pioneers in television and manufacturers of all classes of radio transmission and receiving equipment, we invite correspondence with responsible firms interested in FM broadcasting or FM receiver marketing.

ELECTRICAL & MUSICAL INDUSTRIES LIMITED

Head Office . . . HAYES, MIDDLESEX, ENGLAND

Subsidiaries and Associated Companies in

Argentina
Australia
Brazil
Chile
China

Czechoslovakia
France
Greece

India
Italy
New Zealand
Spain
Turkey



ARMSTRONG'S LATEST CONTRIBUTION

to FM

A NEW PHASE-SHIFT MODULATOR

Used Exclusively in the New **REL** DL Line of FM Broadcast Transmitters

SIMPLER — MORE EFFICIENT



MAJOR E. H. ARMSTRONG — the inventor of FM — has recently developed a new phase-shift modulator circuit which REL has now incorporated in all of the new DL line of FM broadcast transmitters — now available for early delivery in five power ratings from 250 W. to 50 KW.

Remember — when you deal with REL — you deal with FM's Pioneer Manufacturer — with experience and knowledge gained from having built and put in operation — more FM broadcast transmitters than all other manufacturers combined.

The general overall characteristics of DL FM transmitters are:

★ **OPERATING FREQUENCY:** Available to operate on any predetermined frequency from 40 to 50 mc. The exact frequency must be specified when the order is placed.

★ **FREQUENCY STABILITY:** These transmitters are guaranteed to maintain the frequency within less than 200 cycles of the assigned frequency. The frequency is controlled by a single crystal, with use of complicated mechanical or devices.

★ **FIDELITY:** The overall response is in plus or minus 1 db from 30 to 15,000 cycles.

★ **DISTORTION:** The measured r.m.s. harmonic distortion is less than 1% for signal frequencies between 50 and 15,000 cycles at ± 75 kc. swing, (100% modulation) AND IS LESS THAN .2% FOR FREQUENCIES FROM 400 to 15,000 CYCLES.

★ **NOISE LEVEL:** The signal-to-noise ratio is better than 70 db, measured at the output of a monitor receiver. This is an unweighted measurement, with 150 kc. maximum swing, and includes hum.

★ **INPUT:** The audio input to the transmitters is zero level, 500 ohms, 6 milliwatts.

★ **ECONOMY:** New Type 558 Modulator employs only 28 small tubes from program input to operating frequency — affording lowest possible tube cost; for example, a complete set of tubes for the new catalog 518 DL 1000 W. transmitter including modulator is only \$238.

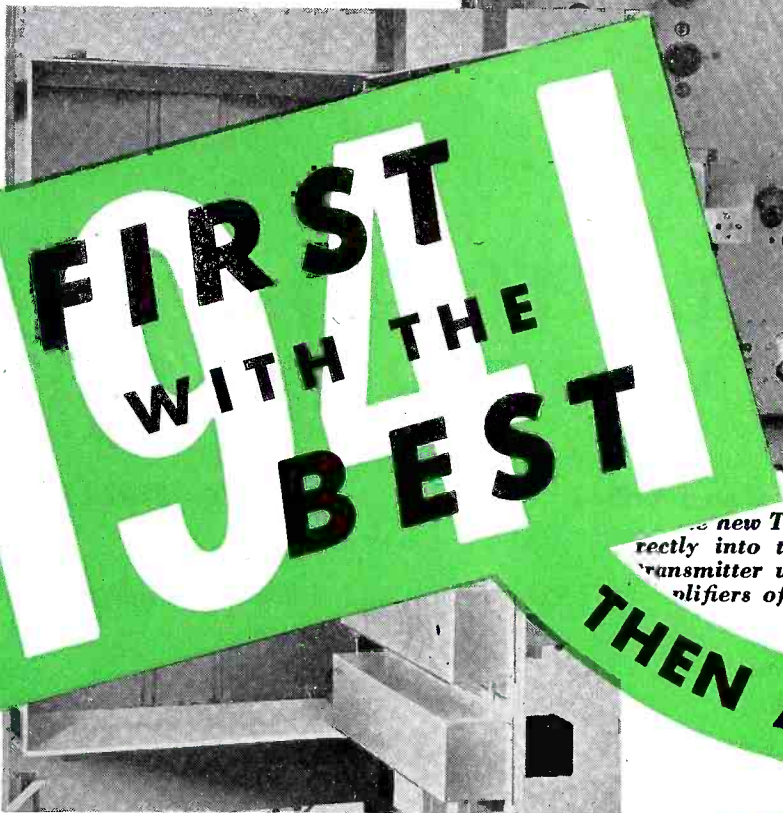
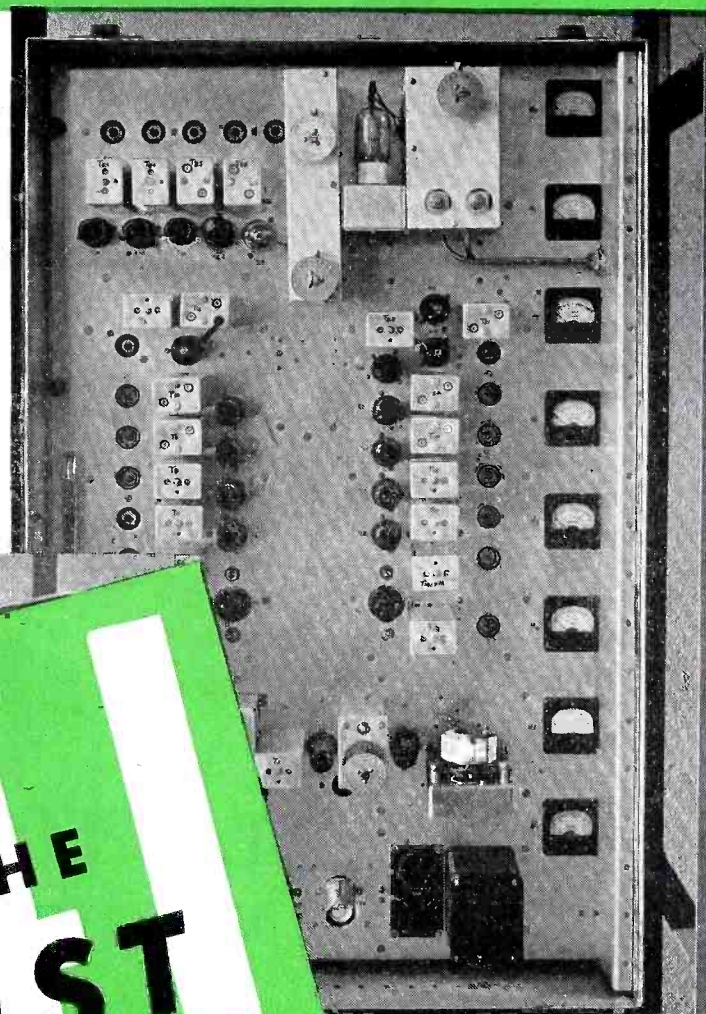

new Type 558 modulator — built directly into the 250 and 1000 watt basic transmitter units, which are used to drive amplifiers of all higher powers.

THEN AND NOW

Illustrating a new, exclusive REL feature: Type 558 modulator panel hinged to swing out of its cabinet — making all parts quickly and easily accessible for adjustment and maintenance.



Write for booklet describing this new DL line of FM transmitters.

RADIO ENGINEERING LABORATORIES, INC.

35-54 36th Street

Long Island City, New York

REL

1947

REL



REL HIGH-POWERED FM EQUIPMENT

THE BROADCASTERS FIRST CHOICE BECAUSE REL...

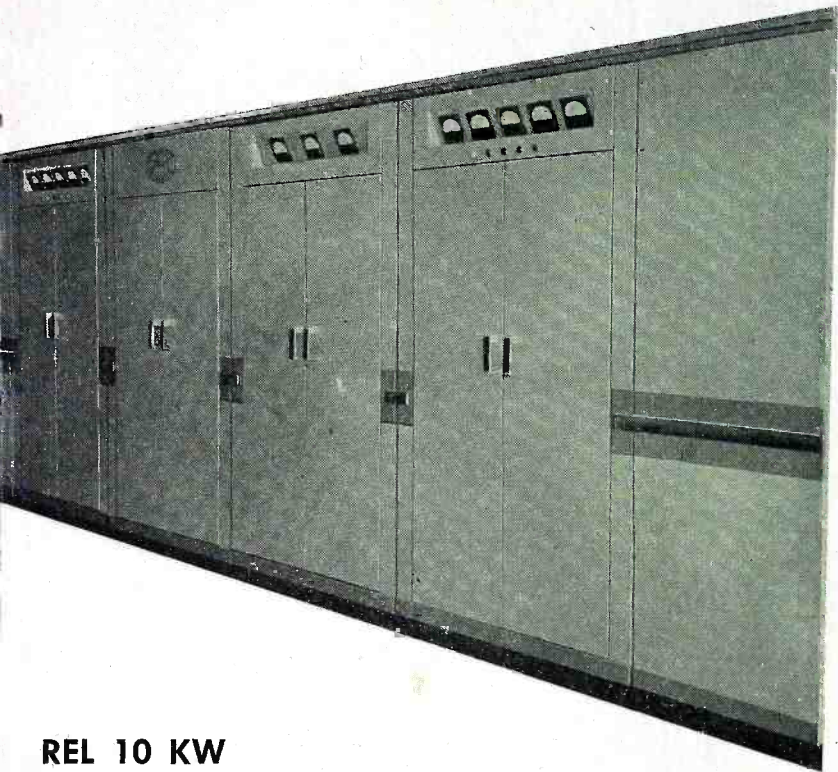

REL 10 KW

FM Broadcast transmitter—using the same basic modulator but in modern dress.

Six years of research find us still convinced of the overall superiority of the Armstrong Phase shift modulator over all other known types.

- Was the sole pre-war high power FM manufacturer
- Continues application of rigorous wartime component specifications
- Employs masterful mechanical design
- Builds all driver units around the reliable, non-critical Armstrong Phase shift modulator

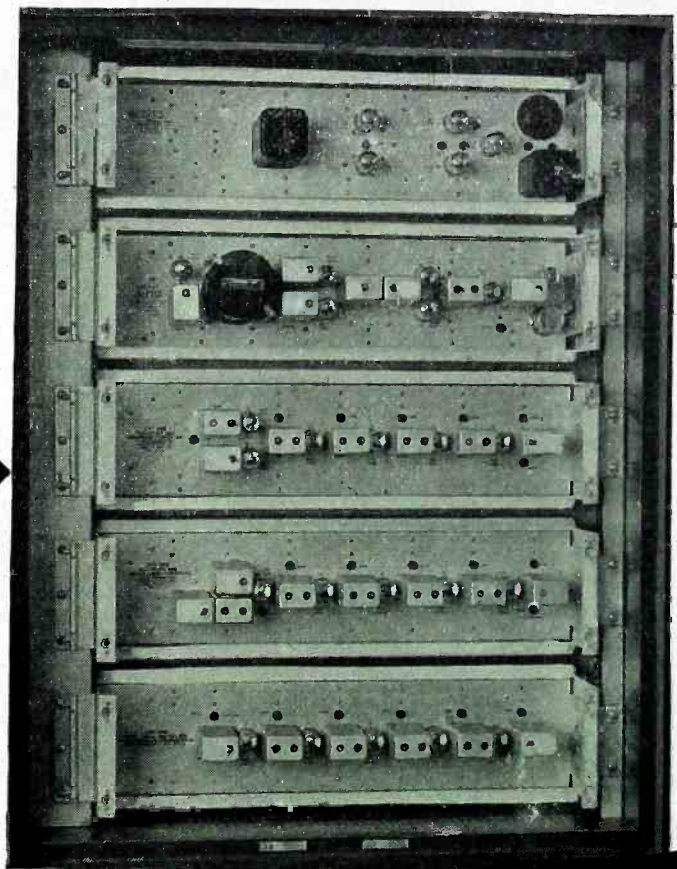

JOIN
F M A
NOW!

RADIO ENGINEERING LABORATORIES, INC.

35-54 36th Street

Long Island City, New York

The Westinghouse
STRATOVISION ANTENNA
 gives you the finest
 FM reception . . .

The new WESTINGHOUSE STRATOVISION ANTENNA is not only a highly efficient and practical FM antenna, specially designed and engineered for fine FM reception, but it is available at a highly competitive price.

Eight features make it an outstanding value for you to sell.

HIGH EFFICIENCY—Streamlined, seamless tubular elements achieve increased efficiency and reduce cost.

LOW LOSS COMPONENTS—All major electrical components are designed for minimum transmission loss.

FIXED ELEMENTS—Pre-tuned and permanently tuned antenna elements cannot get out of adjustment.

DURABLE-WEATHERPROOF—Streamlined, high strength aluminum construction and molded plastic insulation are weather-proof.

EASY-TO-INSTALL—Simple design, and tubular aluminum construction make installing the Westinghouse antenna a quick one man job.

SWIVEL MOUNTING BRACKET—Specially designed base for mounting on vertical, horizontal, or slanting surface.

SPECIAL GUY WIRE CLAMP—An easily adjustable guy wire clamp makes it possible to vary the guy wire span as needed.

OUTSTANDING VALUE—This complete Stratovision Antenna kit including antenna, guy wire supports, transmission wire, mounting bracket and stand-off insulator is highly competitive merchandise . . . only \$9.95.

Home Radio Division, Westinghouse Electric Corporation, Sunbury, Pennsylvania.

only \$9⁹⁵

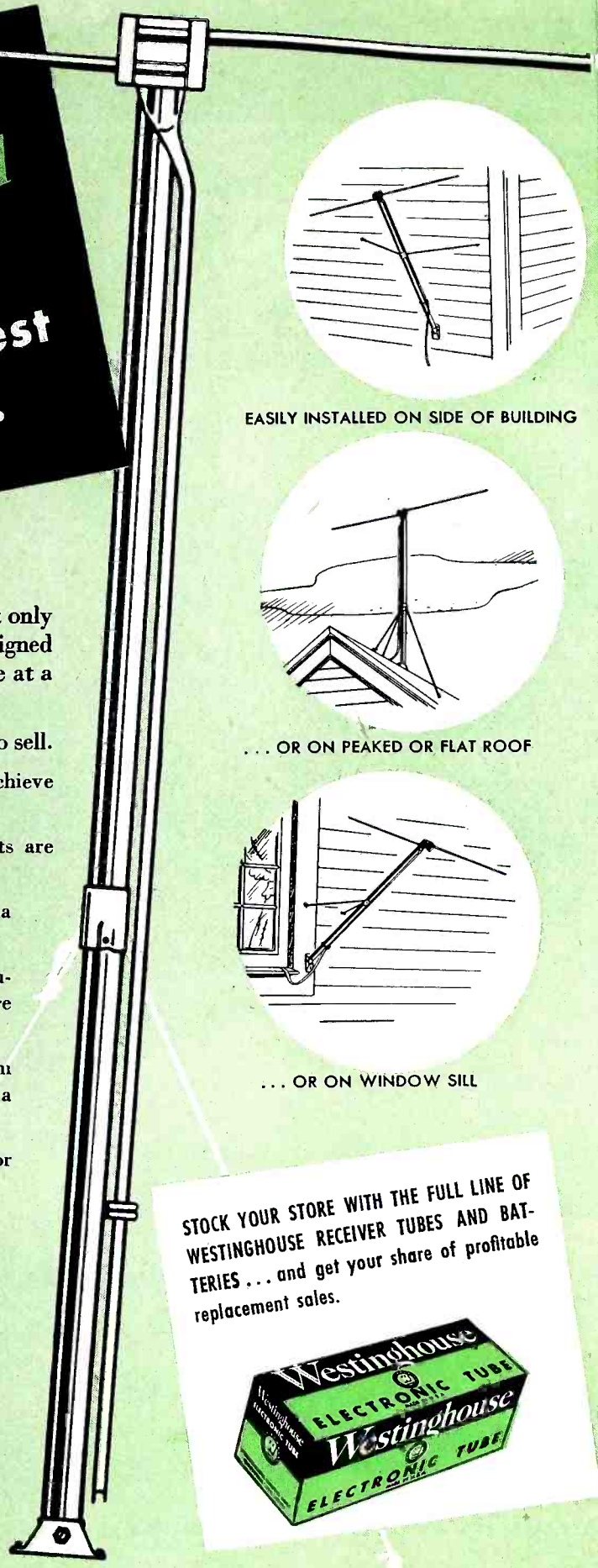

EASILY INSTALLED ON SIDE OF BUILDING

... OR ON PEAKED OR FLAT ROOF

... OR ON WINDOW SILL

STOCK YOUR STORE WITH THE FULL LINE OF WESTINGHOUSE RECEIVER TUBES AND BATTERIES . . . and get your share of profitable replacement sales.



RADIO'S FIRST NAME IS

Westinghouse
 RADIO TELEVISION

How FM Was Developed by E. H. Armstrong

Edwin H. Armstrong announced FM to the radio world in November, 1935.

FM was the product of more than ten years of research and inventive effort, directed toward a single goal—the development of a radio system in which the transmitter would impress on the carrier wave some characteristic not present in natural and man-made static, and in which the receiver would be “deaf” to all impulses except that particular characteristic.

“In the course of years of experiments,” says Major Armstrong, “I discovered that there was one wave characteristic not found in natural and man-made disturbances—the wide frequency swing. It was that which led me to the basic FM invention, the essentials of which are a transmitter that will produce this characteristic and a receiver that will respond to it and that will reject all minor frequency variations and all variations of amplitude.”

It goes without saying that the inventor knew that an instrument did not have to be an FM receiver in order to get FM programs. But he did know that only a real FM set would give the quality and freedom from noise that the public expects of FM reception. If a receiving set will not eliminate the effects of amplitude modulated disturbances it is not an FM set. On this premise he perfected the system which bears his name.

FM's great contribution to the world of amusement and enlightenment did not come about over night, nor was there clear-sailing and problem-free work associated with the launching of the inventor's development.

“My experience as the inventor of FM,” Dr. Armstrong says, “has paralleled that of others who have made basic inventions. It took ten years to master the unseen forces of nature and arrive at the solution of the technical problems, and several years more to translate that solution into apparatus that would give commercially acceptable performance.

“Then came five years of continuous effort to overcome those tangible forces which exist in every industry and which have their basis in the characteristic resistance of human nature to change.

“The fight was won in May, 1940, when the Federal Communications Commission cleared the way for FM to proceed on a commercial basis.

Great Opportunity

“FM broadcast installations are now going ahead as rapidly as present conditions permit and the demand for FM receivers is exceeding the most optimistic predictions.

“FM offers an opportunity such as seldom comes to an established industry. It is certain to expand at a rate reminiscent of the early days of broadcasting.”

For outstanding services to the United States during World War 2, Major Edwin H. Armstrong, right, receives the highest civilian decoration, the Medal for Merit, from Chief Signal Officer Major General Harry C. Ingles.



**"THE WORLD'S GREATEST ARTISTS RECORD
THE WORLD'S FINEST MUSIC FOR R.C.A. VICTOR"**

*These Precious Records Deserve
Best of Care and Shelter.*

**The Country's Leading
R.C.A. VICTOR DISTRIBUTORS**

Bring You the Famous

Regina

HASSOCK RECORD HOLDERS

Marie Carroll,
Popular Songstress,
Who Has Been Chosen
"Miss Regina Hassock"
of 1947

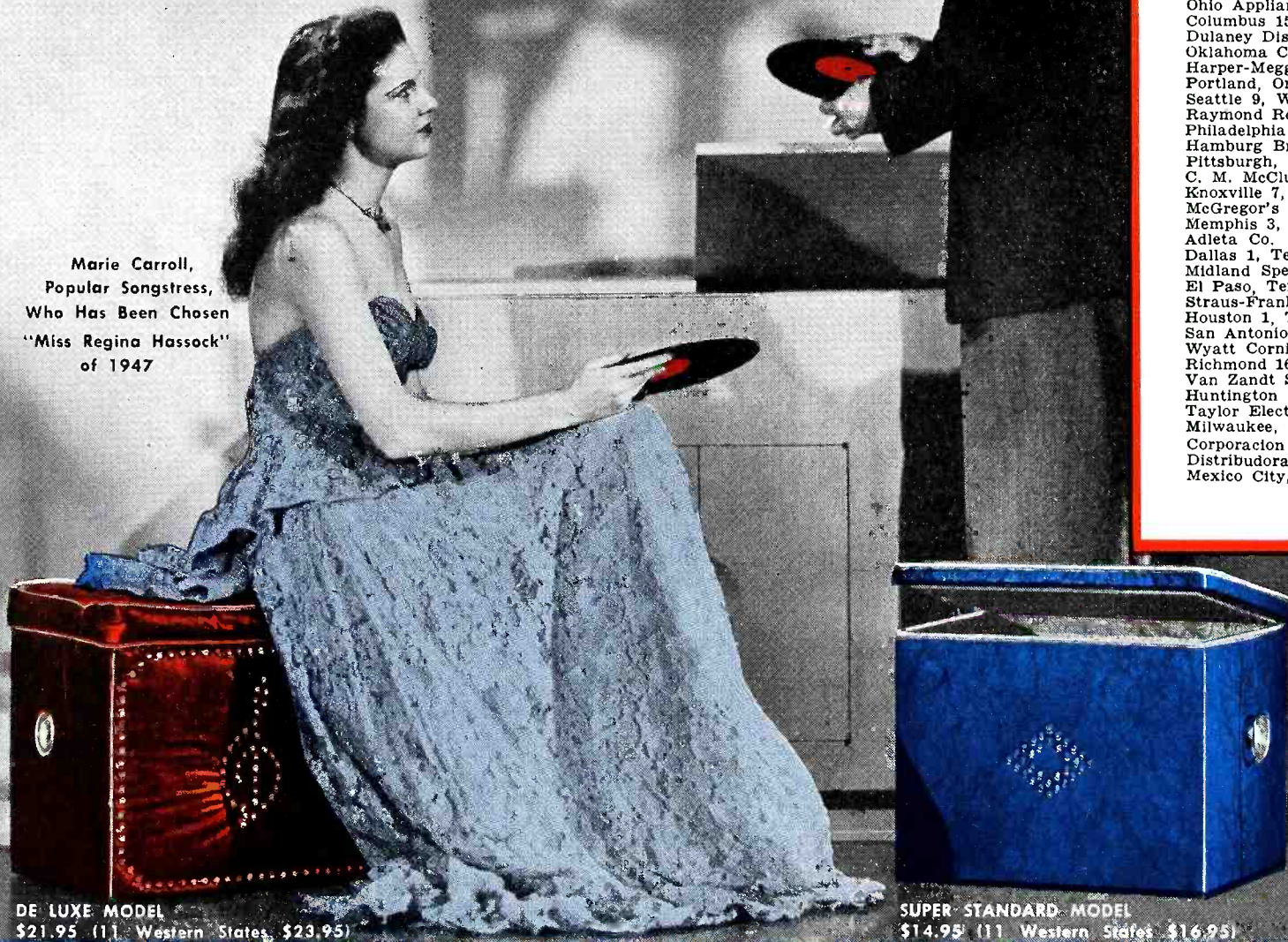

DE LUXE MODEL
\$21.95 (11 Western States \$23.95)

SUPER STANDARD MODEL
\$14.95 (11 Western States \$16.95)

HASSOCKS AVAILABLE
IN 5 COLORS
STANDARD MODEL
NOT ILLUSTRATED

DISTRIBUTORS

- R. P. McDavid Co., Inc.
Birmingham, Ala.
- Leo J. Meyberg Co.
Los Angeles 7, Calif.
- San Francisco, Calif.
- Radio & Appliance Dist. Inc.
East Hartford 8, Conn.
- Southern Wholesalers Inc.
Washington 5, D. C.
- Yancey Co., Inc.
Atlanta, Georgia
- RCA Victor Dist. Corp.
Chicago, Illinois
- Klaus Radio & Electric Co.
Peoria, Illinois
- Associated Distributors
Indianapolis 4, Ind.
- George W. Onthank Co.
Des Moines 8, Iowa
- Ewald Distributing Co.
Louisville 8, Ky.
- Electrical Supply Co.
New Orleans, La.
- Cressey & Allen
Portland, Me.
- D & H Distributing Co.
Baltimore, Md.
- Harrisburg, Pa.
- The Eastern Co.
Cambridge Mass.
- RCA Victor Dist. Corp.
Detroit 7, Mich.
- F. C. Hayer Co.
Minneapolis, Minn.
- Interstate Supply Co.
St. Louis, Mo.
- RCA Victor Dist. Corp.
Kansas City 6, Mo.
- Northwestern Auto Supply Co.
Billings, Montana
- Krich Radisco Inc.
Newark 8, N. J.
- RTA Distributing Co.
Albany 4, New York
- Morris Distributing Co., Inc.
Binghamton, N. Y.
- Syracuse, New York
- Bickford Brothers
Rochester, N. Y.
- Buffalo, N. Y.
- Bruno-New York, Inc.
New York 1, N. Y.
- Southern Radio Corp.
Charlotte, N. C.
- Cleveland Radioelectric Inc.
Cleveland 14, Ohio
- Ohio Appliances, Inc.
Columbus 15, Ohio
- Dulaney Distributing Co.
Oklahoma City 2, Okla.
- Harper-Meggee Inc.
Portland, Oregon
- Seattle 9, Wash.
- Raymond Rosen & Co.
Philadelphia 4, Pa.
- Hamburg Bros.
Pittsburgh, Pa.
- C. M. McClung & Co.
Knoxville 7, Tenn.
- McGregor's Inc.
Memphis 3, Tenn.
- Adleta Co.
Dallas 1, Texas
- Midland Specialty Co.
El Paso, Texas
- Straus-Frank Co.
Houston 1, Texas
- San Antonio, Texas
- Wyatt Cornick Inc.
Richmond 16, Va.
- Van Zandt Supply Co.
Huntington 1, W. Va.
- Taylor Electric Co.
Milwaukee, Wisc.
- Corporacion Nacional
Distribudora, S. A.
Mexico City, Mexico

DAVAL COMPANY 19 West 44th St., New York 18, N. Y.

Exclusive National Representative

Manufactured by Grand Novelty Co., Brooklyn, N. Y.

\$32.95 11 West States \$14

RECORDS

Section of RADIO & Television RETAILING

"FREE" ADVERTISING—One of the best means the dealer has for getting his store name known around town doesn't have to cost him a cent. By imprinting all literature that goes out of his store, the retailer is assured of an almost unlimited audience. Retailers can stamp pamphlets found in record albums, the inside flap of the album covers, and paper pockets in which the manufacturer wraps singles. In this way guests in the home, students at school, and dancers at socials see Dealer Brown's name, and connect it with the records he sells.

RECORD COLUMNS IN DAILY NEWSPAPERS are sweeping the country. Several New York dailies have added this type column for the first time in their history, indicating public demand for news about latest recordings. Dealers can clip these platter-chatter columns, and feature the records that have been reviewed and recommended—in the same way that the theaters utilize movie reviews.

RETAIL RECORD SALES in 1947 should surpass last year's record take, according to Wm. A. Mills, executive secretary of the National Association of Music Merchants. Mr. Mills is another one of many key figures in the industry who have made this prediction, based on increased production capacity and jump in sales of both players and platters.



CELEBRITIES TAKE OVER at the turntable—Woody Herman, Ted Husing, Bea Wain and Andre Baruch are just a few of the "big names" who are now engaged in spinning records over the air-waves. The disc jockey has long been regarded as the "best salesman" the dealer has, and the addition of these people to the salesforce gives the record dealer and his products a big boost.

NOTED IN WINDOWS is an increasing number of rotating displays showing record accessories. Because this merchandise is small and lightweight, it's ideally suited to this method of display—just the thing to add eye-grabbing action to record-radio windows.

BIGGEST SALES WEEKS ever experienced by the recording industry, it is interesting to note, occurred during the period covering the final quarter of last year.

DEMAND FOR ALBUMS INCREASING. The avid "record collector" has usually been the best album customer. Growing trend toward packaging of all types of pop material has been educating other record buyers to the value of purchasing their discs in sets. In addition, they have discovered that the cost is approximately the same—that the colorfully packaged set "looks nice" and eliminates the problem of storage. Also, the reading material such as pamphlets and fly leaf introductions are interesting and enjoyable.



ARTISTS HELP SELL THEIR DISCS—It is a known fact that customers will flock into a dealer's store to see, hear and obtain the autograph of a famous recording celebrity. Following this same pattern, distributors are sponsoring shindigs for local record retailers at which they may meet and speak with the band-leaders and vocalists whose platters they sell. These "get-together" sessions for dealers are an enjoyable, as well as a profitable, means of learning the selling features of individual artists, and their discs.

QUALITY RECORD DEPARTMENTS are in the same position as book stores in that both have to carry an ample variety of merchandise, in order to meet the demands of the "connoisseur" as well as the "mass" customer. Says one dealer, "If you have what the customer is looking for, when we want it, then you're wonderful! If you don't, it's likely to lose a customer you do have to some other dealer who can meet the particular request."

DISC GIFT BOXES—One enterprising dealer is garnering a lot of extra trade by offering white gift boxes for all records and albums. Engraved on the cover in gold letters are the words "to" and "from" which the purchaser fills in. He reports that many people are going out of their way to buy at his store, and take advantage of the packaging offered.

PRODUCTION OF RECORDS proceeding at a rapid pace, according to industry officials. Manufacturers' suppliers are having a hard time keeping up with increased pace, says one prominent executive. Pressing companies, therefore, are developing substitute materials, of thoroughly acceptable quality, which may be used shortly in manufacturing processes.

Your next month's RCA Victor promotions

1. "POP"...in "Life," "Look," fan and teen-age magazines



Wayne King

Your customers will soon be reading news of this smooth, new Wayne King album... Time your displays to hit their eye when the ads appear! "WAYNE KING'S WALTZES" Vol. 2: *Song of the Islands, In Apple Blossom Time; Mexicali Rose and Maria Elena; Carolina Moon, the Anniversary Waltz, Roses of Picardy and 'Til The Sands of the Desert Grow Cold.* Order RCA Victor Album P-171, \$3.15.

2. RED SEAL...in "Life" and "Time"



Horowitz:

Sonata in C-Sharp Minor Op. 27, No. 2 ("Moonlight")—Beethoven. RCA Victor Album M/DM-1115, \$2.85. To be featured in "LIFE" April 7.



Koussevitzky:

Symphony No. 5—Prokofieff. Boston Symphony Orchestra. RCA Victor Red Seal Album M/DM-1095, \$5.85. To be featured in "LIFE" April 7.



Rubinstein:

Forgotten Waltz—Liszt; *The Prophet Bird*—Schumann. RCA Victor Red Seal Record 10-1272, \$0.75. Gets a full page in "TIME" April 28.



Shaw:

Bach Cantata No. 4. Christ Lag in Todesbanden. RCA Victor Chorale and Orchestra. Album M/DM-1096, \$3.75. To be featured in "LIFE" April 7.

ALSO... your "LIFE" page will contain next month's entire Red Seal listing!... Prices are suggested list prices, exclusive of taxes.



Your RCA Victor Distributor



**Smart Treatment of Customer "Beefs"
Results in Upped Prestige, Profits**



Make Every Kick a Boost!

● There is a way to turn a complaint situation around so that instead of kicking back at the dealer's good-will structure it can be made to be an asset.

It doesn't take any more time or cost any more money to try to satisfy a complaining customer than it does to try to get the better of him. More often than not the merchant who *wins* an argument with an irate customer actually *loses*.

Customers who buy records, phono players, sheet music and disc accessories require especially careful handling. Large numbers of them are "arty" folk who are likely to blow up temperamentally or to be hyper-sensitive. Even the bobby-soxers who come in the store to listen to the latest in their line are quick to sense treatment smacking of discrimination against their youth or tastes when they have a squawk to register.

While it is certainly true that there are a lot of "crabs" among the ranks of customers, the vast majority of buyers of platters, players and accessories are a reasonable bunch of human beings who play fair in their buying and expect the dealer to do the same.

Barring the need for trying to serve the occasional chronic pain-in-the-neck customer who is *impossible* to please, and whose patronage he can well do without, the retailer and his clerks should bend every effort toward making each sale a successful one, and to send each "legitimate" complainer away *happy*.

A "legitimate" complainer is a person who has an obviously just kick about merchandise, service or sales treatment. A "legitimate" complainer is *also* a customer whose complaint *may not* be justified but who is sincere in believing that it is.

The dealer should weigh each complaint calmly. He should not permit himself or his clerks to get excited during discussions with customers.

When confronted by a customer who asks for either a refund or an exchange because of alleged defective or unsatisfactory merchandise, the merchant should be able to make a decision right then and there.

Profitable Courtesy

If he decides to return the dissatisfied customer's money, he should do it courteously and promptly in order to impress the customer favorably enough for the latter to continue to do business with the firm.

If he "throws" the refund at the buyer he'll lose his own prestige, his money and the customer.

In cases where the retailer *knows* that he is in the right, and that the demands made upon him are unjustifiable ones, he should seek to explain the situation to the *customer's* satisfaction, not merely to his own. If he fails to do this, and values the particular customer's patronage, he may want to lose a few cents, or even a few dollars, as good-will insurance, in complying

with the client's request.

This does not mean, however, that the merchant should pass out new records, for instance, to every person who comes in with one he claims is defective. Overboard operations of the "easy-mark" dealer will only lead to heavy losses when the year's business is counted up. "Exchanging" records for customers who ask to do this merely because they "want something else" is poor business; is unfair to other buyers and is palpably unfair on the part of any customer requesting it.

The whole point is that some merchandise *is* defective; some fails to perform as it should, and, in such instances, when he feels obliged to "make good" the dealer should feel obliged to make a *good* impression too, and capitalize on the transaction by making the customer see him in the light of being a fair and honest merchant.

The rules, then, for capitalizing on customer complaints are:

1. Weigh complaints calmly. Don't *argue* with customer. Explain instead.
2. If you're going to make a refund or exchange, do so quickly, freely, courteously.
3. Don't permit salespeople to get "customer-antagonism" complexes.
4. Don't go overboard in making adjustments; but be fair.
5. Don't let the dyed-in-the-wool chronic kicker, who's impossible to please, get in your hair. Let him go elsewhere.

Band leader Johnny Long is a new Signature acquisition.



Malcolm Sargent, (insert) conducts the Liverpool Philharmonic Orchestra in Columbia's 19-record album of Handel's "Messiah", as presented in a concert performance.

First release of MGM Records is an album of music from the film "Till The Clouds Roll By" taken directly from the sound track.

Record \$\$\$ Dave Road to Profits

Variety of Artists in New Albums and Singles Build Remunerative Sales

RECORDED DIRECTLY FROM THE SOUND TRACK OF THE M

"TILL THE CLOUDS ROLL BY"

Music by JEROME KERN

JUDY GARLAND
 JUNO ALLYSON
 KATHY GRAYSON
 LENA HORNE
 TONY MARTIN
 VIRGINIA O'BRIEN
 CALEB PETERSON
 M-G-M STUDIO ORCHESTRA and CHORUS Conducted by LENNIE HAYTON
 M-G-M RECORDS

Till The Clouds Roll by
 Make Believe
 Who Cares If My Boat Goes Upstream?
 Sleepaway
 Look For The Silver Lining
 Life Upon The Wicked Stage
 Can't Help Lovin' Dat Man
 Leave It To Love
 O' Man River
 What?

Many valuable additions to the dealer's "standard" catalogs have been made available this month. Manufacturers have also hustled, and come up with several versions of hit tunes from current Broadway shows and novelty ditties.

Classical Albums

Columbia Records has issued a complete recording of Handel's "The Messiah." The oratorio was recorded in England with the Huddersfield Choral Society and the Liverpool Philharmonic Orchestra, conducted by Malcolm Sargent, and with four soloists: Isobel Baillie, soprano; Gladys Ripley, contralto; James Johnston, tenor; and Norman Walker, basso. The two albums include 38 sides, and retail for \$22.50.

Other featured Masterworks albums are: Rudolf Serkin with the

Pittsburgh Symphony Orchestra, Brahms' "Concerto No. 1 in D Minor"; Eugene Ormandy conducting the Philadelphia Orchestra in Richard Strauss' "Death and Transfiguration"; Beethoven's "Pastorale" Symphony, recorded by Bruno Walter and the Philadelphia Orchestra; Stravinsky's "Firebird" Suite and "Fireworks" interpreted by Philharmonic-Symphony Orchestra of New York, Igor Stravinsky conducting; soprano Eileen Farrell in "Irish Songs."

More Releases

Masterworks singles include: Moussorgsky's "A Night On Bald Mountain", Pittsburgh Symphony Orchestra, Fritz Reiner conducting; Chopin's "Polonaise Brillante in C Major", with Pavlovsky at piano and Gregor Piatigorsky on the cello.

Columbia pop releases feature Kate Smith, in an album of "Songs of Erin." "Open The Door, Richard!" has been waxed by Columbia, with The Three Flames. "Will

(Continued on page 92)



In her initial album for RCA Victor, Susan Reed, ballad singer, presents a group of "Folk Songs and Ballads."



June Christy does the vocals with Stan Kenton's orch. on Capitol's recording of "His Feet Too Big For De Bed."



Decca's Dick Haymes sings "How Are Things In Glocca Morra?" on new disc.



Reading in the usual order are: Eddy Howard, Majestic Records star; Joan Brooks of Diamond; Apollo's Lee Richardson; Jack Lawrence, song-writer and vocalist, recording for Rainbow Records. The platter manufacturers are featuring these artists in a number of popular sides.

Record \$ Pave Road to Profits

(Continued from page 91)

Bradley And His Orchestra", featuring Ray McKinley, is another Columbia album. Dinah Shore's rendering of "The Egg and I", backed by "Who Cares What People Say", is a new Shore single.

Add pops are: Les Brown's "Triskaidekaphobia", backed by "Why Don't We Say We're Sorry"; Pearl Bailey in "Row, Row, Row" and "That's Good Enough For Me"; Xavier Cugat's version of "Drume Negrita" and "El Botellero"; The Charioteers, "You Can't See The Sun When You're Cryin'", flipover, "Lonesome—That's All."

Tenor James Melton is being featured by RCA Victor in an album of "Irish Songs." Also on Victor's special release list are: William Kapell, pianist, in Khatchaturian's "Concerto for Piano and Orchestra"; Marian Anderson's "Bach Arias"; St. Louis Symphony, Vladimir Golschmann conducting Mozart's "Symphony No. 38 in D Major"; Copland's "Lincoln Portrait" for speaker and orchestra, with Melvyn Douglas as speaker and the Boston Symphony Orchestra, Serge Koussevitzky conducting.

New Singles

Red Seal singles include two spirituals performed by Robert Shaw and Collegiate Chorale, "Set Down, Servant" and "Soon-A Will Be Done"; Franz Waxman's "Carmen Fantasie" played by Jascha Heifetz; Irish tenor Christopher Lynch in "Then You'll Remember Me", flipover, "I Hear You Calling Me"; Arturo Toscanini conducting Wagner's "Prelude to Die Meistersinger"; other waxings are by Robert Merrill, Boston "Pops" Orchestra, and Jussi Bjoerling.

Capitol Records' bandleader, Stan Kenton, goes Calypso with "His Feet Too Big For De Bed", flipover, "After You." June Christy and The Pastels do the vocals. Jo Stafford vocalizes "Give Me Something To Dream About" and the torchy "That's Where I Came In" on new Capitol disc. Other waxings are: "Forever Paganini" and "Forever Nicki", Dave Barbour's orchestra; The King Cole Trio, "I Want To Thank Your Folks", backed with "You Should Have Told Me"; Jack Smith's rendering of "I Tipped My Hat And Slowly Rode Away" and "If This Isn't Love"; Tex Ritter's "One Little Tear Drop Too Late", flipover, "Ninety-Nine Years Is A Long Time"; and Paul Weston's Orchestra in "Roses In The Rain," "Linda."

Pop Platters

Decca's own Bing Crosby has waxed "That's How Much I Love You" and "Rose of Santa Rosa" with Bob Crosby and the Bob Cats. Other pop tunes include: "Open The Door, Richard!" and "It's So Easy", done by Louis Jordan; Joe Mooney Quartet's version of "Tea For Two" and "Warm Kiss And Cold Heart"; Bob Eberly vocalizing "If I Had My Life To Live Over", flipover, "I Tipped My Hat." Dick Haymes' rendering of "How Are Things In Glocca Morra?" backed by "Twas Only An Irishman's Dream" is another noteworthy Decca disc.

Decca's imported English Parlophone records feature tenor Richard Tauber in a wide selection of romantic ballads, and operatic arias. "The Carl Sandburg" album of cowboy songs and negro spirituals introduces a new "Sing-Along-

Book" which contains the melodies of the songs, as well as the texts and explanatory materials.

New Signature discs by outstanding Signature artists feature: Johnny Long's Orchestra, Francey Lane on the vocals, "How Are Things In Glocca Morra?" and "Last Night On The Back Porch"; Bobby Doyle's singing on "That's The Beginning Of The End", flipover, "Love Is A Random Thing"; Ray Bloch's arrangement of "When I Grow Too Old To Dream" and "Lydia"; Monica Lewis' tune, "I'm Gonna Be A Bad Girl", sung by the songstress, flipover, "We Could Make Such Beautiful Music Together"; Johnny Bothwell's version of "I Won't Promise" and "I'll Close My Eyes."

Add Waxings

New Majestic album featuring Eddy Howard is titled "Romance." Georgia Gibbs waxed two new sides for Majestic, "How Are Things In Glocca Morra" and "Necessity." "Latin Harmonie" is Noro Morales' new album. "Sweetheart Music" by Alfred Newman is another Majestic album.

Merry-Go-Sound Records, made by Tone Products, have issued the following children's records made of unbreakable materials: "Story Of Tom Thumb"; "Aesop's Fables"; "Children's Opry House"; "Old MacDonald Had A Farm."

Ted Straeter, band leader, has been signed by Sonora for its 39c label. Other titles on this Sonora black label are: "You Can't See The Sun When You're Cryin'" flipover, "We Could Make Such Beautiful Music," George Towne; "Anniversary Song," "Sonata," George Town; "Charmaine" backed with "Steel Guitar Rag" with Roy Smeck; "Hinky Man" with "You

(Continued on page 118)

for your
 very special
 customers . . .
 a magnificent
 new
 recording of



FOR STORE AND WINDOW PROMOTION!

This five-color display piece—
 35 inches high, 44 inches wide.

the Messiah

by GEORGE FREDERICK HANDEL

Music students, concert goers, religious groups in your community will hail this superb achievement—a once-in-a-generation musical event—the long awaited new recording of Handel's Messiah! This important Columbia Masterworks release is the complete concert version of the great oratorio—an ideal feature for the Easter season.



HANDEL: THE MESSIAH

Isobel Baillie, soprano; Gladys Ripley, contralto; James Johnston, tenor; Norman Walker, basso; with the Liverpool Philharmonic Orchestra, conducted by Malcolm Sargent.

Columbia Masterworks Set M-MM-666

Retails for \$22.50 plus tax

Two volumes, boxed, with explanatory booklet and complete text

order now from your

Columbia Records 

distributor



Spacious store layout lends itself to integrated displays. Note various groupings of records, floor models and table radios.

Modern Record Center

Clarke's, Peoria, Ill., Is Taking Advantage of "New Ideas" and Materials in Record Merchandising

• The record department of Clarke's, Peoria, Ill., incorporates the newest ideas in modern fixtures, floor layout and fluorescent lighting. The department has been designed so that self-service functions with a minimum of effort.

Mrs. May Pfenit, department manager, is making a special drive to attract the teen-age crowd and the "special order" groups. The latter customers are mainly in the "connoisseur" category, and order symphonic, operatic, and chamber music albums not carried in all stores.

A continuous line of fluorescent tubes extending above display racks and listening booths lights the department.



Teensters are invited to meet friends at Clarke's and an extra attraction offered is a "coke" machine. The full importance of youngsters as record customers is realized by the store management.

The records are grouped according to classics, semi-classics, hill-billy, folk and swing music, and children's discs. Customers make their own disc choices and play them in one of the five available listening booths.

Fixtures especially adapted to customer convenience and the department's floor plan encourage self-selection. Scientifically planned and executed the display pieces consist principally of drop bins arranged in tiers. The set-up contains approximately 260 bins, each bin numbered and displaying a disc title. The same numbers and titles appear on the back of each fixture, above each bin.

Attractive Booths

The listening booths are located at either end of the department. Each booth is equipped with a high fidelity record player and is sound-proofed and carpeted. As the door closes, a vertical fluorescent light is automatically turned on.

The record department is adjacent to the radio section, and forms an alcove 20 feet by 60 feet to one side of it. In the immediate foreground, as one enters, is a desk and wrapping counter, and two record player display tables. The three listening booths located in the front are separated from the radio department by a false partition finished in the same blond oak as the other fixtures. Some of the display racks are in back of this partition, and behind the wrapping counter.

Fluorescent Lighting

Lighting the entire department is a continuous line of fluorescent tubes, which extends along the molding trim above the album racks and listening booths.

Clarke's believes in advertising. Weekly ads and tie-in window displays followed the original advertisements which announced the record department's opening. In addition, radio advertising and direct mail promotion are engaged in. Attention is given to mailing lists.

Clarke's is also contemplating a plan similar to the "book-of-the-month" club plan for regular record customers.



PHILCO PRESENTS
a new way to sell
Phonograph Needles

YES! A way to sell *more* De Luxe jewel and precious metal needles—at greater profit per sale! For now Philco not only brings you the *first complete sell-up line of needles ever offered* . . . not only prices these needles in easy steps from 75c to \$3.50 . . . but actually merchandises them side by side—so customers compare each price-class against the others. Result? Folks who come in for a 75c needle go out with one for \$1.50—or higher! *And you pocket extra money!* Ask your Philco distributor how you can put this merchandiser to work for you FREE.

**THE NEW
 PHILCO
 NEEDLE
 MERCHANDISER**

. . . a complete needle department in just a few inches of space on your counter.

Every Sale a Sell-Up

. . . because customers always "buy something better" when full price-range is shown. Eye-stopper counter case ups traffic, and sales. Factory-sealed, tamper-proof packages assure buyers of getting genuine Philco De Luxe Needles never played before!

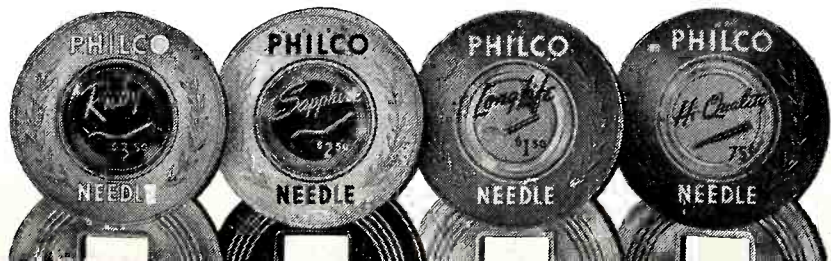

PHILCO

Famous for Quality the World Over



Look for this Label
— it's going places!

**we're up in the
 clouds with our
 FIRST GREAT**
Album

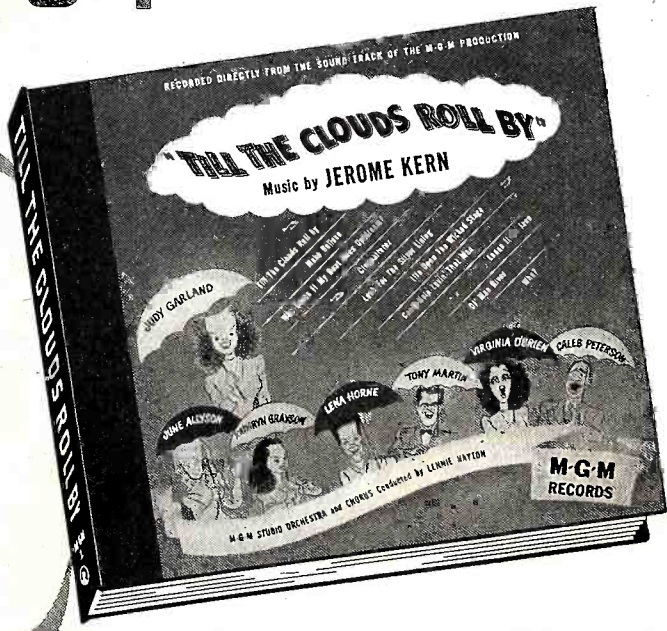

It contains ten of the greatest Jerome Kern songs recorded directly from the sound track of the picture and features June Allyson, Judy Garland, Kathryn Grayson, Lena Horne, Tony Martin, Virginia O'Brien, Caleb Peterson and the magnificent M-G-M studio orchestra and chorus directed by Lennie Hayton.

HERE ARE SOME OF M-G-M RECORDS'

Great Stars

LISTED
ALPHABETICALLY

★
Blue Barron

Lionel Barrymore

Jimmy Dorsey

Jimmy Durante

"Ziggy" Elman

Helen Forrest

"Slim" Gaillard

Kathryn Grayson

Harry Horlick

★
Van Johnson

Johnnie Johnston

Gene Kelly

King's Men

Korn Kobblers

Hal McIntyre

★
Lauritz Melchior

"Sy" Oliver

Carson Robison

David Rose

Allen Roth

Raymond Scott

Kate Smith

Mark Warnow

Keenan Wynn

"Buddy" Weed



Top-Selling Tunes

Surveys Indicate Hit Songs; Enable Retailers to Foresee Demand

• New songs appearing on the musical scene run the gamut from sublime sentimentality to catchy novelty ditties. There still is no "accounting for" what the public will take to, although most of the tunes listed in RADIO & Television RETAILING's survey for the first time are of the "sweet" variety.

"Gotta Get Me Somebody To Love" from the much publicized movie, "Duel In The Sun", hits the list in eighth place this month. The tune has been recorded by Tommy Dorsey, Claude Thornhill, Bing Crosby, Martha Tilton, Orrin Tucker, Chuck Foster and George Paxton.

Movies Popularize Tunes

"Anniversary Song" has received its new popularity boost largely as a result of the "Jolson Story" movie and Jolson's records, although it has been waxed by other artists as well.

Riding high on the air-waves is "Sonata", recorded by Claude Thornhill, Perry Como, Jo Stafford, Carmen Cavallaro, The Three Suns, Tony Martin and Hazel Scott. Also on RTR's survey for the first time are: "This Is The Night" available on wax by Andy Russell and Frank Sinatra; "You Broke The Only Heart That Ever Loved You" disced by Sammy Kaye; "Life Can Be Beautiful" from the film, "Smash-up", has been done by Harry James and Vaughn Monroe.

The motion picture "The Time, The Place, And The Girl" gives retailers another popular tune called "On a Rainy Night In Rio." Well worth promoting, this catchy song has been given platter play by Dinah Shore, Monica Lewis, Hazel Scott, and Sam Donahue. "Bless You", a tune that originated in England, has been recorded by Betty Rhodes, Dick Jurgens, Clark Dennis, the Ink Spots, Harry Cool and Eddy Howard.

"First" Listings

The Broadway musical "Finian's Rainbow" outstanding hit tune is "How Are Things In Glocca Morra?" Victor has a "Finian's Rainbow" album available; Buddy Clark, Martha Tilton, and Johnny Long have recorded the "Glocca Morra" tune.

THE NATION'S FIRST 50 TUNES ON THE AIR

Listed in Order of Their Popularity (RADIO & Television RETAILING'S Own Survey)

Current Ranking	Trend of Popularity
1	▲
2	▲
3	▲
4	▲
5	▲
6	▲
7	▲
8	▲
9	▲
10	▲
11	▲
12	▲
13	▲
14	▲
15	▲
16	▲
17	▲
18	▲
19	▲
20	▲
21	▲
22	▲
23	▲
24	▲
25	▲
26	▲
27	▲
28	▲
29	▲
30	▲
31	▲
32	▲
33	▲
34	▲
35	▲
36	▲
37	▲
38	▲
39	▲

"Too Many Times", also on the "first time" list, is featured on sides by Jack Smith, Frankie Carle, and Connie Boswell. "They Say It's Wonderful", another hit from the musical "Annie Get Your Gun", is available in the Decca show album, and in singles by Frank Sinatra, Andy Russell, Bing Crosby, Perry Como, Ray Bloch, and Al Goodman's orchestra.

"It Might Have Been A Different Story" has been waxed by Tex Beneke, and "If I'm Lucky" by Harry James, Perry Como, Skitch Henderson, Jimmy Dorsey, Eddy Howard, and Will Bradley.

Other songs that are still "coming up" and bear watching include: "Sooner or Later"; "Years And

Years Ago"; "Managua Nicaragua"; "And So To Bed"; "Sunset To Sunrise"; "This Time"; "You Are Everything To Me"; "Another Night Like This"; "Why, Oh Why, Did I Ever Leave Wyoming?"; "Love Nest"; and "Love Sends A Little Gift Of Roses."

MOTION PICTURES PROVIDE AMPLE DEALER TIE-INS

Films listed all feature outstanding hit tunes which have been recorded by a variety of artists. Watch for movies to hit local theatres—then cash in on added box-office appeal.

Blue Skies
Canyon Passage
Carnegie Hall
Carnival In Costa Rica
Dead Reckoning
Down To Earth
Duel In The Sun
Humoresque
If I'm Lucky
I'll Be Yours
I've Always Loved You
Jolson Story
Ladies Man
Lydia
My Heart Goes Crazy
Margie
New Orleans
Night And Day
Nora Prentiss
Smash-Up
Song of Scheherazade
Song of the South
Sweetheart of Sigma Chi
Till The Clouds Roll By
The Best Years Of Our Lives
The Egg And I
The Shocking Miss Pilgrim
The Fabulous Dorseys
The Night Is Young
The Time, The Place And The Girl
The Thrill of Brazil
Three Little Girls In Blue

10 Best Sellers on Coin-Machines

- 1 For Sentimental Reasons
- 2 Open The Door, Richard
- 3 Anniversary Song
- 4 Old Lamplighter
- 5 Huggin' And Chalkin'
- 6 Managua Nicaragua
- 7 Sonata
- 8 Oh, But I Do
- 9 Gal In Calico
- 10 Old Buttermilk Sky

—Reprinted from "Variety"

A NEW CAPITOL QUARTET

**to meet your
customers' moods!**

Starting right now, you can qualify for some really new business . . . from unexpected sources. Here are four new Capitol albums especially designed for large customer groups that sometimes get overlooked. Four more sales boosts in Capitol's campaign to make *every member of the family* a regular record buyer! Stock up on these through your nearest Capitol branch now . . . for a fresh appeal to a variety of ages and interests.

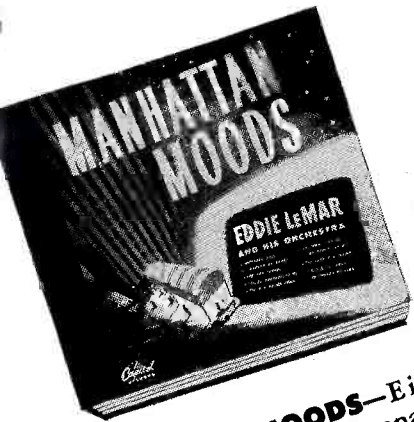

MANHATTAN MOODS—Eight sides of well-known listenable melodies, featuring Eddie Lemar, his sophisticated piano, and his orchestra. Intriguing arrangements with a real cosmopolitan air.
BD-43 \$3.15 plus tax.



GYPSY NIGHTS—A spirited lure to all who thrill to the gypsy's music. Jascha Datsko and his Gypsy Ensemble in folk songs of Greece, Russia, Spain, Hungary, and Rumania.
CD-42 \$3.75 plus tax.



SEASONAL HYMNS—California's famed St. Luke's Choristers present stimulating hymns, carols and chorals for all the major religious seasons. An ideal seller for Lent and Easter.
BD-45 \$3.15 plus tax.

SQUARE DANCES—Cliffie Stone's Band and eight delightful American folk numbers. With each album an illustrated instruction book on square dancing—all the terms, calls, and steps.
BD-44 \$3.15 plus tax.

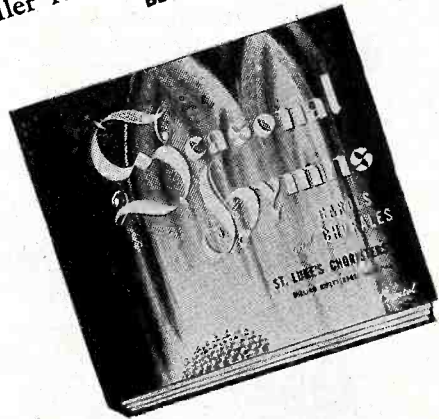
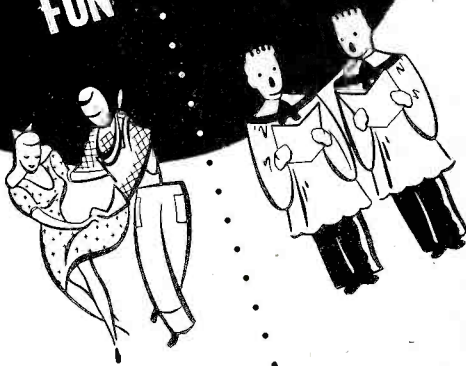
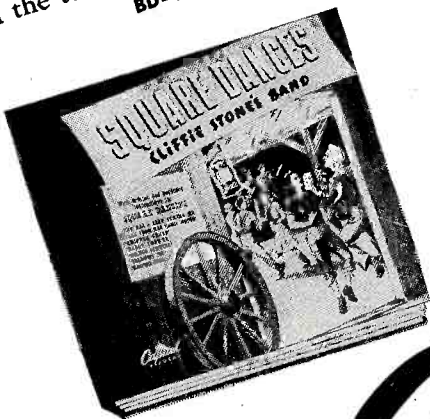

Capitol  **RECORDS**

Sunset and Vine

FIRST

WITH THE HITS FROM HOLLYWOOD

New Phono Lines

Latest Disc-Playing Equipment & Accessories

Portelec PHONOCONE

Model 16E electric record player of acoustic type. No tubes are used. Use of counterbalancing spring on special pickup reduces needle pressure to 2 oz. Small pointer indicates where to place pickup so that needles will catch

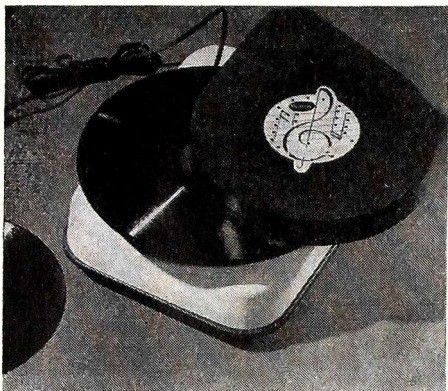

first groove of record. Plays 10" or 12" records. Measures 14" by 11" by 6". Shipping weight is 9 lbs. (Model 16S is hand-wound, same price) \$13.95. Pacific Sound Equipment Corp., 130 N. Beaudry Ave., Los Angeles 12, Calif.—RADIO & Television RETAILING

Biltmore RECORD PLAYER

Model D-100 electric portable phonograph, compactly designed with two miniature tubes. Air cooled Alliance motor, 5" Alnico speaker, Astatic crystal pickup with over 3½ v output. Variable tone and volume control, plays 10" and 12" discs. Operates on 110-120



v. 60 cycles ac. Covered with two-tone leatherette, measures 10½" by 12" by 5", weighs about 7 lbs. \$29.95. Biltmore Radio Corp., 15 Ave. A, New York, N. Y.—RADIO & Television RETAILING

Walco COIN-PHONO NEEDLE

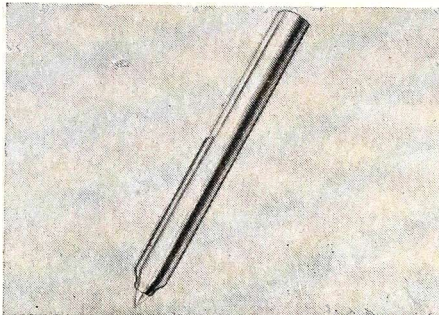

Model WS-900 jewel-tipped phonograph needle for coin machines, engineered for low-pressure tone arms on new coin-operated units. Rated at over 5,000 records per needle, as per recent tests. Dural shank, sapphire tip microscopically ground and polished; rounded playing point for "floating action." Electrovox Co., Inc., 31 Fulton St., Newark 2, N. J.—RADIO & Television RETAILING

St. George WIRE RECORDER

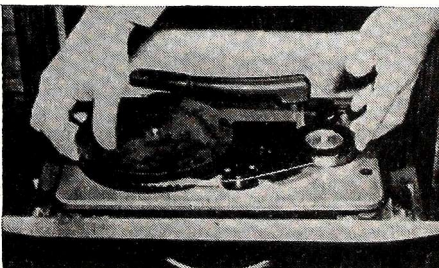

Recording unit on mounting plate. Records voice or music direct, or from radio or records. Wire can be cleared and used again unlimited times. Spools of wire play for full hour. Includes microphone and 3" spool of recording wire. Can be used as straight record player. \$97.50. St. George Recording Equipment Corp., 75 Varick St., New York, N. Y.—RADIO & Television RETAILING

Kary-Kase RECORD CARRIER

Model 1250 portable disc-carrying case with room for 50 twelve-inch records. Two record separators. Streamlined plastic handle. Available in two finishes—grey tweed or alligator leatherette. Measures 13" by 13" by 7". Retailers at \$7.95. Jackson Industries, 1708-16 S. State St., Chicago 16, Ill.—RADIO & Television RETAILING

National Acoustics WIRELESS RECORD PLAYER

Model WRA-1 wireless automatic phonograph playing fourteen 10" or twelve 12" records through any number of radios in the house. Lightweight design—for convenient transfer from room to room—turntable screwed into position. Three organ-type push button control keys. Aluminum lightweight tone arm with featherweight crystal cartridge. Fool-proof design—stays in gear though tone arm be handled while in cycle. Adjustable trimmer to eliminate station interference. Operates from any 110-120-volt 60 cycle



AC socket. Base covered with two-tone leatherette. Measures 13¾" by 12⅞" by 8¾"; net weight is 10 lbs. National Acoustics Products, 120 N. Green St., Chicago 7, Ill.—RADIO & Television RETAILING

Walton WIRELESS RECORD PLAYER

Model BL-100 wireless automatic phonograph, to play through any radio (up to 50 ft. away) without wire or connections; will play through more than one radio at a time. Designed for fool-proof, child-proof operation—tone arm may be lifted, even during change cycle, without damage. Plays ten 12" or twelve 10" records; two controls. Temperature compensated trimmer condenser to provide even operation and to



permit adjustment of frequency from 1000 kc to 1700 kc. Walnut finish base—simple streamlined designed throughout. Walton Mfg. Co., 612 S. Ohio Bank Bldg., Cincinnati 2, Ohio—RADIO & Television RETAILING

the needle with Spring in its heart

Fidelitone Supreme



A New Sales Leader Emerges

Yessir! Here's a needle with a sales wallop. "The finest needle at any price"—and the price is just \$2.50. (An excellent dealer profit is tucked into that figure.) Not only a money-maker for you — but a real good-will builder. Fidelitone SUPREME FLOATING POINT — the needle that pleases everybody.

PERMO, Incorporated CHICAGO 26

More Permo Needles sold than all other longlife needles combined



\$2.50

Beautifully packaged in a useful record brush

**Enlist Records as Sales
Force for Easy Profits**



A dollar record can
pull a \$100 sale.

Use Discs to Sell Phonos

● Selling is more than having a customer walk into a store, ask for Model A, pay for it, and walk out with the receipt tucked in his pocket. Selling is more often a method of persuasion, of indirect suggestion—in short, it is the origination of a sale rather than an order-taking procedure.

Sales Possibilities

In this respect a record that sells for one dollar can frequently be the determining factor which will land a sale of anywhere from \$10 to \$1,000. People need record players before they can play their discs. Some may want players that will give them better tone. Others may desire accessory players for upstairs, the downstairs rumpus room, or for picnics, the beach, etc. Records should be utilized to their fullest to realize all potential phonograph sales.

Dealers appeal to the "auditory" senses, as well as the visual in selling record players. A demonstration is given not only of the machine, but of the pleasure it will bring.

Customers can be "sized up" and an appropriate record selected to demonstrate the model. People who are interested in one of the larger console sets, in the higher price brackets, are likely to be interested in symphonic, semi-classical music. One of this type disc should be placed on the machine when demonstrating, and the quality of tone, volume, as well as other features, pointed out.

A salesclerk who is attempting to

sell a medium-priced set might do better with a musical comedy selection or something from a well-known operetta. On the other hand, if parents enter the store accompanied by a teen-age youngster in search of a portable phonograph there is no question but that they want to hear some of the pop tunes of the day, and the newer the song the better!

Common sense, capitalizing on personal tastes in music, and playing up the "pride of ownership" angle are the three things that do sell phonographs.

Selected Records

Salesclerks should make certain that they know how to operate each and every machine on the floor. A fumble at the critical instant can be fatal! Many a sale has been lost for want of the proper knowledge of how to handle the player. In addition, the players should be checked at frequent intervals to see that they are all operating properly.

A special stock-pile of records should be kept on hand for demonstration purposes only. These should not be left-overs that have been used in the record booths, or returns. Each disc should be in perfect condition, and examined minutely for scratches, surface abrasions, and rough edges. (The latter is extremely important when demonstrating automatic changers. Jamming frequently is the fault of an imperfect disc rather than a weakness in the changer.)

At the end of each day (these

"records for demonstrating purposes only" should be wiped with a clean piece of wet rayon to eliminate dust—another cause of "scratchy" surface noise.

Some dealers advise their sales people to carry permanent needles in their pockets. Since the needle is not in the machine, the player cannot be tampered with. In the event that a customer picks up a record, and wants to play it, "just to hear what the player sounds like," the salesman has a perfect opening wedge. Permanent needles also impart a better tone. This practice also prevents theft of needles which are left in the machine, an occurrence which many dealers found happening all too often.

One retailer goes through several models of each phonograph he receives in order to pick out the one with the quietest operation. He finds that there are variations in noises and he prefers to use the one that operates most efficiently for demonstrating purposes.

Listening Rooms

Where possible, demonstrator players should be kept in a room in which volume can be controlled, and distortion avoided. Rugs, curtains, sound-absorbing tile all serve to eliminate echo. Padded and upholstered furniture also help break up reflecting wall surfaces.

The use of a wisely chosen disc in conjunction with the proper demonstrating set-up is a must. Platters are an efficient and powerful means of obtaining phono sales.

WEBSTER

NYLON PHONOGRAPH NEEDLE

Nylon



**A New and Revolutionary Idea
in Needle Design, Construction and Performance**

... with the *Knee-Action* Nylon Cushioned Jewel Tip!

- ★ Nylon knee absorbs distracting needle scratch and surface noises.
- ★ "Knee-action" permits jewel tip to ride record groove in a gentle, floating motion.
- ★ Floating action of nylon knee improves needle tracking at both low and high frequencies.
- ★ Self-damping property of nylon knee reduces harmonic distortion.
- ★ Nylon knee creates vertical cam action of the tip which eliminates groove slapping.



Nylon knee absorbs vertical shocks caused by the pinch effect of the record grooves; it levels out horizontal shocks of needle "bounce." Nylon "knee-action" creates a gentle, floating needle ride—in effect like the smooth ride of the modern motor car.

- 1 A revolutionary nylon knee that produces a floating "knee-action" which absorbs and reduces needle scratch and surface noises and prolongs record life.
- 2 A top quality, hand-polished sapphire jewel tip, precision-machined to an extremely close tolerance to assure consistency of product and the complete satisfaction of discriminating music lovers.
- 3 A light-weight, great-strength aluminum shaft that fits securely in the pickup without danger of twisting or loosening.

Incomparable Results...

FOR MUSIC LOVERS... FOR INCREASED SALES

Protects valuable records from unnecessary wear... gives greater effectiveness to the superior playing qualities of the jewel tip... virtually eliminates breakage of sapphire tip by accidental dropping... greatly lengthens needle life... produces a pleasing, harmonious tonal balance... yields a minimum of needle talk... delivers a remarkably authentic record reproduction.

Nationally Advertised!

Watch for national advertising for the Webster Nylon Phonograph Needle. And ask your distributor for free advertising cooperation.

A DISTINCTIVE JEWEL CASE FOR THE INDIVIDUAL WEBSTER NEEDLE



You'll like this completely different, vest-pocket size jewel case, smartly styled of lustrous, clear plastic. A compact container for pocket or purse. And a handy, permanent case in which to keep an extra needle.



WEBSTER



CHICAGO

5610 Bloomingdale Avenue, Chicago 39

Now... as always... Webster means finer record reproduction

Capitol Signs Goodman



Benny Goodman signs a long-term exclusive recording contract with Capitol Records as Glenn Wallichs, vice-president and general manager, and Alan Livingston, assistant head of repertoire, look on.

Times-Columbia Party for Elliot Lawrence



Times-Columbia Distributors, Inc., New York City, conducted a get-together party for dealers and Columbia's youthful bandleader, Elliot Lawrence. Pictured are: Paul McNulty, sales manager; Julius Dubak, manager of foreign record department; Nick Barna, salesman; pretty band vocalist Rosalind Patton; Times-Columbia president, O. W. Ray; Lawrence; baritone Jack Hunter; and salesman Peter Wilchin. In the back row are salesman Jack Kelly, Milt Goldstein, Paul Linz and sales promotion manager Arthur Kenn. More than two hundred record sales and executive people attended the party.

MGM Records Label



MGM's "Leo" is prominently featured on the disc label of MGM records, a division of Loew's, Inc.

DISC-DOINGS in the Industry

News of Recording Execs, Artists and Dealers

Wins Aero Award



Burton Browne, left, president of Aero Needle Co., Chicago, presents a gold watch to J. P. Kay, Aeropoint needle representative in Mo., Iowa, Kansas and Nebraska, whose territory registered the largest percentage of increase in sales during 1946.

Kentucky Dealer Installs New Display Units





A. Bitter Construction Co., 721 E. 133 St., New York City, completed this new display installation at the Shackleton Piano Co., Louisville, Ky. The fixtures were built in New York, and shipped to Louisville in sectional units. The fixtures are of modern design, and employ selected straight grained Oak in a pickled antique finish. The set-up combines beauty with straight selling efficiency. Note ample storage space and compactness of design. Illusion of spaciousness is carried out, and self-selection encouraged by this floor layout.

SPECIAL RELEASE!

No. 5

New
APOLLO
RELEASES

Apollo presents
CALYPSO

by **King Houdini**
and his Calypso Parliament

 **Apollo's Lucky 7** 
SENSATIONAL ALBUMS

Apollo presents the stars of...
OKLAHOMA ROUND-UP!

THE BRAGGARD MY DARBY OVER MY HEART
WINK ME TO SLEEP IN MY SADDLE
TUCKER HOPPING LIKE A HOOP BALL-DUMMER WHEEPP
OHIONE BELLS
MY OLIVE RIDGE INDIAN TOWN HOME
ODDL WATER

Apollo presents
BOB MOSHLEY

Boog'e Woogie

Apollo presents
CARL BRISSON
... in songs of sophistication

GIRL AROUND THE CORNER
THE MAMMURST
LILLETTE
POODLE SONG
THE FRENCH MARQUISSE
THE PERFUME SONG

Special Request in recording
The Love of TWO CABBAGES
Compositions for Children

Presented by... **LESLIE DOUGLAS**
Music by... **HEATHER HIRSHBY - LARRY DRAKE - JACK BLISS**

Apollo presents
BOBBY GREGORY
In an album of...
HOBO SONGS

Adapted to the gentleness of the road!
HOBO POLKA • RAMBLIN' HOBO BLUES • CRYIN' HOBO
THE HUNGRY HOBO • YODELIN' HOBO • THE HOBO'S DREAM

Apollo presents
JOSE MORAND'S
Latin American
MUSIC

APOLLO RECORDS, INC.

NATIONAL DISTRIBUTORS FOR *Hub Records*

EXECUTIVE OFFICES: 342 MADISON AVE., NEW YORK CITY

NEW YORK • 615 10th Ave., New York 19, N. Y.
CHICAGO • 719 South State Street, Chicago, Illinois
DETROIT • 100-02 E. Atwater St., Detroit 26, Mich.

LOS ANGELES • 2705 W. Pico Blvd., L. A. 6, Cal.
ATLANTA • 367 Edgewood Ave., S.E., Atlanta, Ga.
BALTIMORE • 2015 Maryland Ave., Baltimore 18, Md.

NEW ORLEANS • 418 Gravier St., New Orleans, La.

WRITE FOR COMPLETE CATALOG

New Columbia Disc Jockey

Fred Robbins, dynamic young disc jockey, has assumed command as Master of Ceremonies of "The Record Shop," Columbia Records' weekly half-hour program of new releases by its famous recording stars. The recorded and transcribed platter parade is currently heard over 335 stations in the United States and Canada every Saturday, with new stations being added each week.

Sacred Records Series of Children's Discs

The Sacred Records Co. of Los

Angeles has completed the first of a series of children's records which offer a musical Sunday School lesson built around such popular fables as "The Three Little Pigs". The new records are aimed at youngsters five years of age or under, according to Earle E. Williams, president.

The records feature "Songs by Audrey". The music and lyrics are by Audrey Meir, who also renders the selections.

The first release features "The Three Little Pigs" and "The Whistle Song", a rendition designed to eliminate common juvenile faults.

Recoton Needle Display

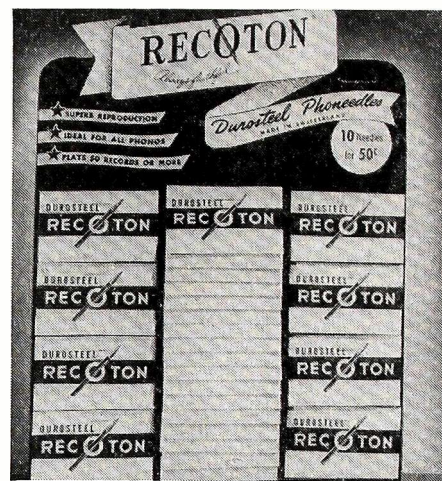

Durosteel display promoting Recoton's steel needles holds 25 packets individually stapled to the display. Designed in green and wine, and features a die-cut top for quick product-brand identification; easel-backed for convenient counter selling.

Feature Walco Needles

Walco Needles, product of Electrovox Co., Inc., 31 Fulton St., Newark, N. J., were featured in a large-size window display at Haynes-Griffin, New York City retailers of radio and records. All three needles of the "400" series—the Sapphire, Ruby and Precious Metal tips—received equal emphasis in the campaign.

Pan-American Plans

Under an extensive expansion policy for 1947, Pan-American Records of Hollywood plans to cover all phases of popular music with numerous additional artists to be signed to contracts during the next few months, president Alfred W. Birney announced.

Mr. Birney, who heads the Birwell Corp. of Hollywood, which acquired Pan-American Records a few months ago, including the firm's pressing plant, stated that an advertising department had been formed under the supervision of N. J. Hartford, formerly of Capitol Records. Pan-American's vice-president is William A. Otwell, while Robert A. Gray is sec'y.-treas.

Albums by Stinson

Stinson Trading Co., New York City, has announced the release of several albums of particular interest to individual tastes. They are: "Jungle Calypso," recordings of authentic Calypso; "Life For The Czar," Glinka, excerpts and arias performed by Russian operatic stars; "Strictly G.I.," featuring Sgt. Hy Zaret; and a forthcoming album, "Solid Stuff," with Kenneth Spencer.

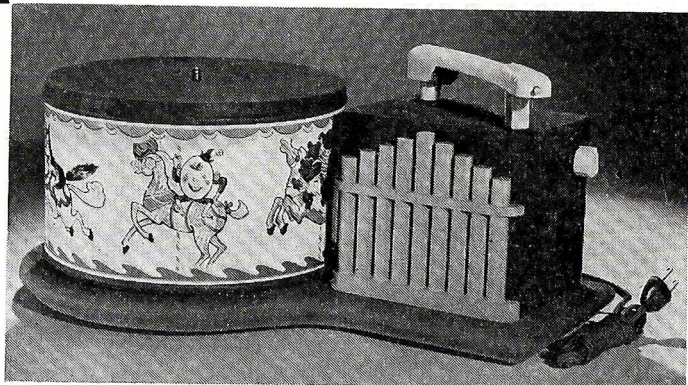

Merry-GO-Sound ELECTRIC PHONOGRAPHS for Children

The Merry-GO-Sound electronic child's phonograph is no toy—it's a high-fidelity electrically amplified record player, superior in tone quality to more expensive adult phonographs. It will play 7", 10" or 12" records—nursery rhymes, dance music or symphonies with concert hall clarity. The speaker is housed in the calliope. Designed with imagination, the turntable revolves in carousel fashion, giving animation to the fanciful storyland characters astride horses. The colorful "carousel" is scratch-proof and washable. Made of metal, plastics and wood, the unit will resist the rough usage of the most energetic child. It's constructed to last.

List Price \$24.98 (Including Excise Tax)



Merry-GO-Sound KIDDIE RECORDS of Unbreakable Vinylite

- ★ **RUMPELSTILTSKIN—TP-1**
A musical fantasy with song and sound effects—2 records
- ★ **SEVEN AT A BLOW—TP-2**
Set to music and enacted by the Merry-GO-Sound players—2 records
- ★ **MOTHER GOOSE PARTY—TP-3**
A "must" for all toddlers—starring Dick Brown—2 records
- ★ **OLD MACDONALD HAD A FARM—#107**
Animal imitations and sound effects in rhythm and music—1 record
- ★ **ADVENTURES OF TOM THUMB—TP-5**
Children love this story, set to music. Dramatically enacted—2 records
- ★ **AESOP'S FABLES—TP-6**
Stories with morals, set to music. Character-builders—2 records
- ★ **CHILDREN'S OPRY HOUSE—TP-7**
Imaginative portrayals in music. Educational—2 records
- ★ **WHO'S WHO AT THE ZOO—TP-8**
The animals sing. Merry-GO-Sound Orchestra. Dick Brown and big cast—2 records

★ ALSO AVAILABLE IN SHELLAC RECORDS

New York Representative: LAWRENCE R. SCHMIDT & CO., 200 Fifth Ave.
Territories Open for Distributors and Representatives

STONE PRODUCTS CORP. OF AMERICA
351 Fourth Avenue
New York 10, N. Y.

NOW! a new standard of performance in cutting heads

THE PRESTO 1-D

► The new Presto 1-D Cutting Head offers: *wide range, low distortion, high sensitivity and stability through a temperature range of 60°-95° F.* The Presto 1-D Cutting Head is a precision instrument made entirely of precisely machined parts, expertly assembled and carefully calibrated. These factors, plus its sound basic engineering design, produce a cutter unequalled in performance by any other mechanically damped magnetic device.

► Note from the light pattern below: The correct location of the cross-over point at 500 cycles, the 6 db per octave slope below this point, and flat response above 500 cycles, which is free from resonant peaks. The range of the cutter is 50-10,000 cycles. The Presto 1-D is damped with "Prestoflex" which is impervious to temperature changes between 60 and 95 degrees Fahrenheit.

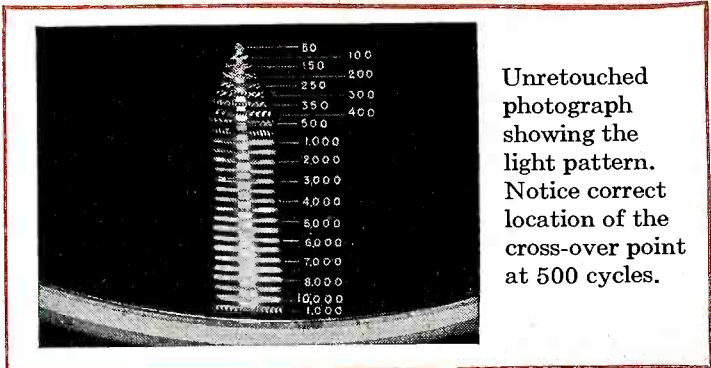
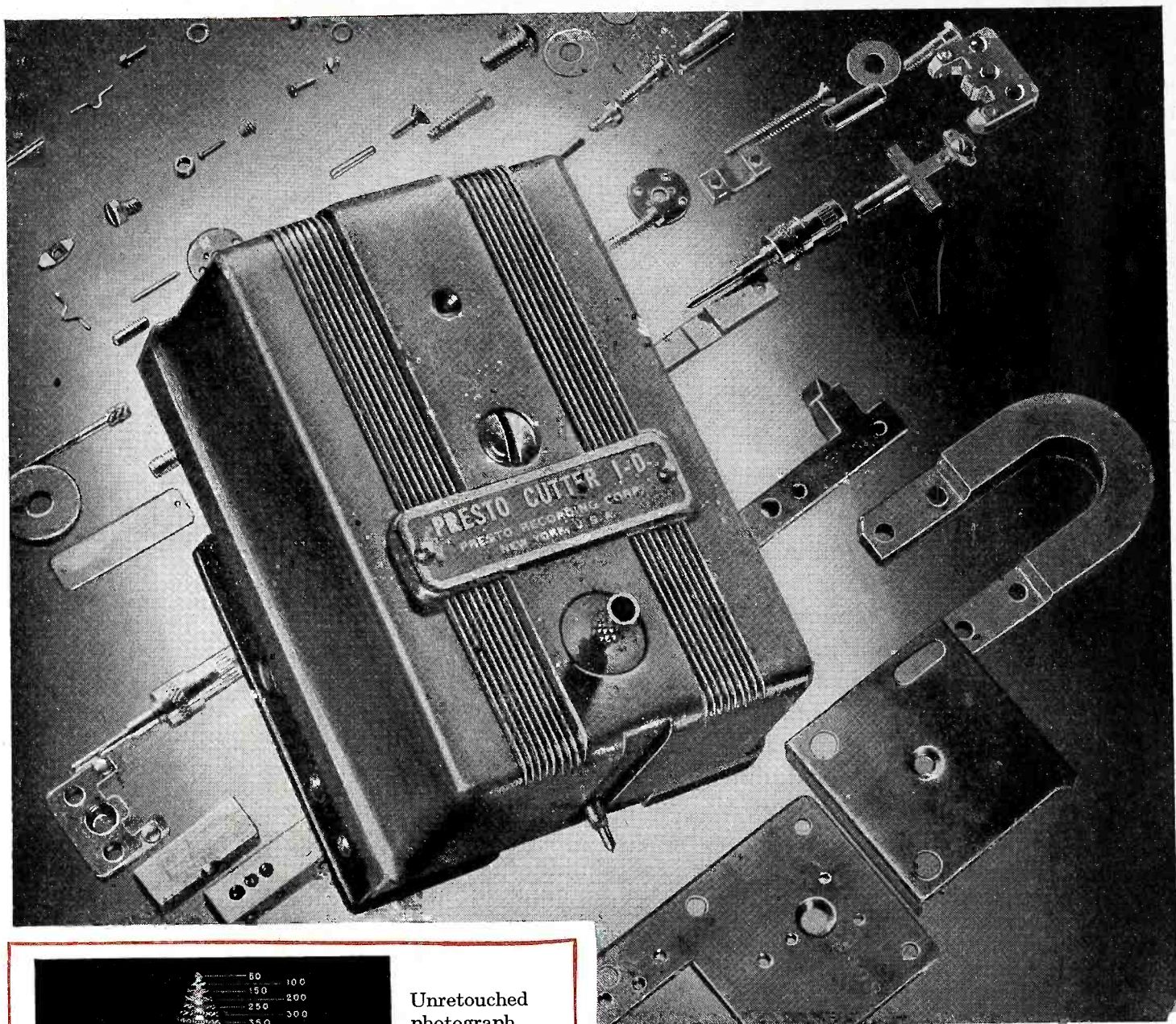

Unretouched photograph showing the light pattern. Notice correct location of the cross-over point at 500 cycles.

PRESTO

RECORDING CORPORATION
242 WEST 55TH STREET, NEW YORK 19, N. Y.
Walter P. Downs, Ltd., in Canada

WORLD'S LARGEST MANUFACTURER OF INSTANTANEOUS SOUND RECORDING EQUIPMENT & DISCS

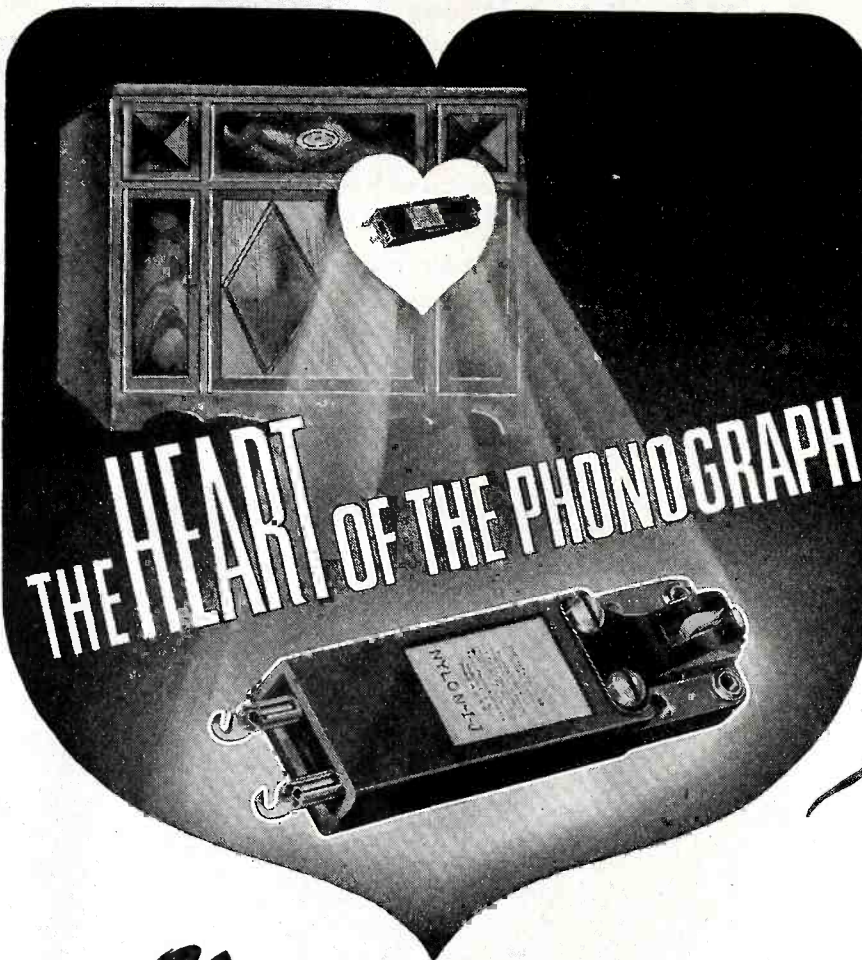

No other part of a modern phonograph is so important as the small crystal cartridge mounted in the pickup or reproducer arm. This cartridge is the pulsating heart of the instrument and upon the degree of efficiency of its operation depends the quality of reproduction.

It is not surprising, therefore, that many radio-phonograph manufacturers and engineers are expressing intense interest in Astatic's new Nylon 1-J Phonograph Pickup Cartridge. Designed with Nylon Chuck and MATCHED, sapphire-tipped, knee-action Nylon Needle, this cartridge improves performance with respect to needle life and frequency response, suppresses mechanical resonance, improves tracking at low needle pressure and reduces record wear. Other important advantages and details concerning Astatic's new Nylon Cartridge are given in special literature now available.



Visit your Radio Parts Jobber or Write for New Catalog.

New Columbia Supervisor

Arthur Tober has been named supervisor of Columbia Recording Corp.'s newly created department of transcription order service and production, it is announced by W. G. Wilkins, treasurer.

The new department, formerly combined with transportation, is being given separate status due to the press of the increasing volume of business in Columbia's transcription division.

Diamond Records Appoints Distributors

I. R. Gwartz, president of Diamond Records, 1650 Broadway, New York, announces the establishment of 37 distributors in the U. S., and plans are now being made to complete the organization with the establishment of 6 wholesalers on the West Coast, making a total of 43.

With the addition of several newly released albums, the company now presents an enlarged record catalog, plus a packaged vinylite recording of the late Franklin D. Roosevelt's War Address to Congress.

Riddle Joins Bibletone

George Riddle has joined Bibletone Records, Inc., as assistant to the president, Arthur L. Becker. Mr. Riddle will act as general supervisor and will assume charge of seeking new talent for Bibletone.

Bibletone Records has launched a nation-wide spot announcement campaign over 80 stations of the Keystone network.

Jamboree Obtains Plant

Jamboree Records, New York, announce that they have obtained their own pressing facilities and that they will now be able to lower the price of their retail waxings.

Symons Stock Albums

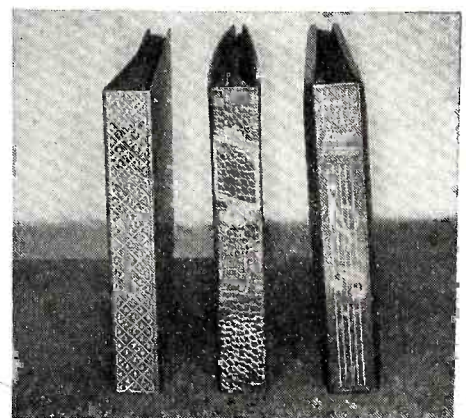

L. H. Symons & Associates, New York City, offer stock albums, with gold imprinted titles of: "hot jazz," "sophisticated strings," "folk songs." Albums come in a high varnish finish.

For phono-combinations that aren't being born in a hurry . . .

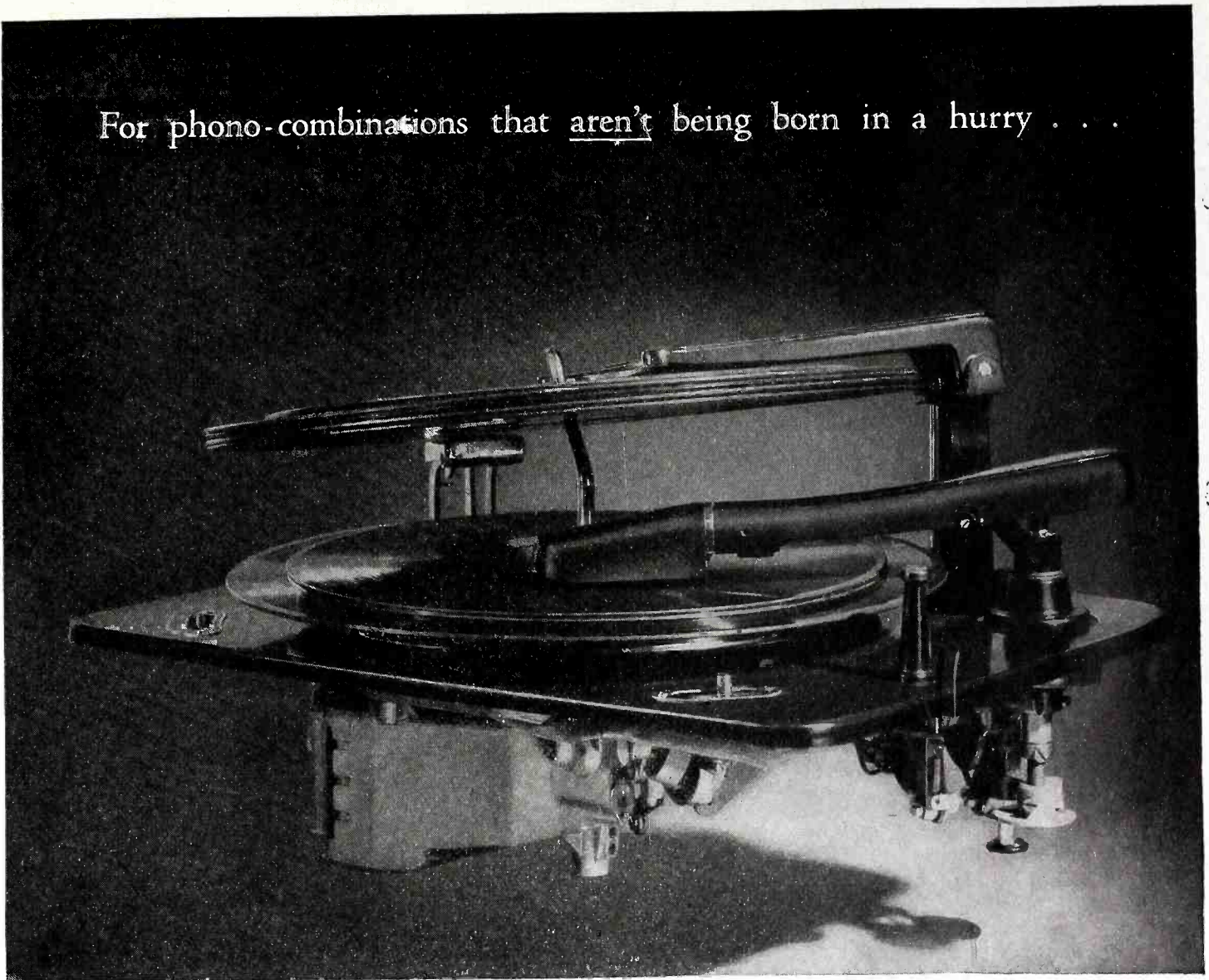

Soon you'll have, on your floor, the kind of combinations that take their precious time coming off the drawing board—and off the assembly line . . . combinations where you'll have to talk "quality" instead of "price." You should insist that they come equipped with the Garrard changer. You'll need the extra selling plus that Garrard gives you.

With a Garrard changer in the combination, you can feature the changer as you feature cabinetry and tone quality. You can point up the watch-like construction. You have exclusive features to talk about: a governor-controlled, speed-regulated motor; a non-slip spindle; the special light weight pickup arm . . . and more.

The Garrard definitely "belongs" in every one of your custom-built combinations where

you can hand-pick the components without a sidewise glance at costs.

Send for a sample changer. Garrard Sales Corporation, 315 Broadway, New York 7, N. Y.

PRECISE AS A WATCH

1. Exclusive speed-regulated, governor-controlled motor)
2. Completely automatic intermixing
3. True tangent, jewelled-pivot tone arm
4. Exclusive non-slip spindle
5. Automatic stop
6. Heavy fly-wheel action built into turntable
7. Only one operating control required
8. Full swivel tone arm for changing needles
9. Kind to fragile records; no knives or trick spindles

. . . they ask for it by name . . .

GARRARD

WORLD'S FINEST AUTOMATIC RECORD CHANGER

GARRARD ADS APPEAR CONTINUALLY IN EVERY IMPORTANT CONCERT PROGRAM AND IN LIFE • SATURDAY EVENING POST • NEW YORK TIMES MAGAZINE • HOUSE BEAUTIFUL • HOUSE AND GARDEN • RECORD REVIEW



Model RX Smooth Power Motor

Smooth Power

THAT PLEASURES YOUR CUSTOMERS

You'll make better friends of your customers when you equip your phonographs with General Industries *Smooth Power* Motors.

That's because of fine performance from the first instantaneous pick-up to the last note. Constant speed, quietness and vibration-free operation result in faithful, enjoyable reproduction.

These same high qualities characterize all *Smooth Power* mechanisms, including recording motors and assemblies and combination record-changer recorders. From our complete line, you can select fitting companions for your own fine products.

THE GENERAL INDUSTRIES CO.

DEPARTMENT MV • ELYRIA, OHIO

Regina Hassocks Get Sales Boost

Al Landes, head of the Daval Co., manufacturers of the Regina hassocks, announces two new promotional slants in the firm's 1947 advertising campaign. RCA Victor distributor factory branches in Chicago, Kansas City and Detroit will distribute the Regina hassock record holder. In addition, Marie Carroll, vocalist, has been chosen as



Marie Carroll, songstress, chosen as "Miss Regina Hassock," visits with Jack Winer, president of Dynamic Electronics in his New York City store, to see the Regina hassock record holder on display.

"Miss Regina Hassock" of 1947 and will be featured throughout the year in all Daval advertising. RCA Victor distributors that will handle the Regina line, the company says, will number in excess of fifty.

A new hassock utility unit will soon be announced by the firm.

Bibletone Sponsors Puppeteers Tour

Bibletone Records, Inc., has signed a contract with the Suib Marionette Co. for a nationwide tour. Sponsored by Bibletone, the puppeteers will give free performances of a specially-created 40-minute marionette show dramatizing material from the popular Bibletone children's album entitled "Adventures in Bibleland." All performances will be held in the stores of, or under the auspices of, local Bibletone dealers.

Joins Musicraft Jobber

Harry Sultan, owner of Harry Sultan's Record Shop, 26 East 23rd St., New York, has been named general manager of Musicraft Distributors Inc., according to an announcement by Oliver Sabin, vice-president in charge of sales. Mr. Sultan will be responsible for the exclusive distribution of Musicraft Records in the New York City area.

ANOTHER GENUINE DIAMOND

Richard Cannon

AN OVERNIGHT SENSATION

The Whole Country is Opening The Door For Richard—Richard Cannon—acclaimed as the most unusual singer to be discovered in many years. His style of singing has never been heard on records. Here is another terrific profit-maker brought to you on the same label that brought you Jan August—the Misirlou man.



HIS FIRST DIAMOND RECORD RELEASES

- | | | | |
|------------------------------|------------------|--------------------|-----------------------------------|
| 2057 | Maybe Heartaches | 2058 | It's a Sin to Tell a Lie Tomorrow |
| Your Cost.....48½c tax incl. | | List Price.....79c | |

THE FASTEST SELLING RECORDS IN THE COUNTRY

Jan August "Piano Magic"

- | | | | |
|------|------------------------|------|--|
| 2009 | Misirlou Babalu | 2010 | Tea for Two A Pretty Girl Is Like a Melody |
| 2029 | Besame Mucho Dark Eyes | 2030 | Make Believe My Melancholy Baby |
| 2032 | My Shawl Without You | 2031 | Ol' Man River Some of These Days |

Your Cost.....48½c tax incl. List Price.....79c

These 3 records sold in ALBUM D-5 List Price \$3.12



22 MONTHS ON N.B.C. NOW ON DIAMOND RECORDS

Danny Ryan



- | | | | |
|------|---|------|--|
| 2061 | Got A Soft Spot (In My Heart for You) Only Heaven Knows | 2062 | You Can Take My Word for It Baby Yes Yes Honey |
|------|---|------|--|

Your Cost.....48½c tax incl. List Price.....79c

Singing Star on Capitol N.B.C. "Danny Ryan Show." Exclusive Diamond Recording Artist.

All orders received shipped by the distributor in your territory

DIAMOND RECORD CORP.
1650 Broadway
New York 19, N. Y.

SEND CURRENT RELEASE SHEET

SHIP C.O.D.
 PAYMENT ENCLOSED
 OPEN ACCOUNT
(No shipments sent open account unless rated in Dun & Bradstreet)

Ship me at once the following:

- | | | | | |
|-----------|-----------|-----------|-----------|------------|
| 2057..... | 2010..... | 2031..... | 2061..... | JAN AUGUST |
| 2058..... | 2029..... | 2032..... | 2062..... | ALBUM D-5 |
| 2009..... | 2030..... | | | |

NAME.....
ADDRESS.....
CITY..... ZONE NO..... STATE.....

All shipments F.O.B. nearest distributor

Keynote YOUR SALES WITH WEBSTER



MODEL 60 *Automatic* PHONOGRAPH



This low price table model phonograph gets customer attention — builds sales for you.

Has fine tone — features full volume and tone controls. Automatic record changer plays a stack of ten 12-inch or twelve 10-inch records smoothly, gently — protects records. When your customers hear it — they'll buy. Comes complete with the New Webster Nylon needle.

*RETAIL
\$55.00



MODEL 55 *Plays through the radio*

*RETAIL
\$35.00

Adding a record changer to most radios is easy with Webster Model 55. Simply plug connection into the radio and the job is done. Your customers will enjoy the many features of Model 55 that contribute so much to listening pleasure; plays a stack of ten 12-inch or twelve 10-inch records; protects records; has "manual play" position, child-proof mechanism, and feather-touch pick-up. A proved best seller.

*Slightly higher
West of Rockies



The choice of Music Lovers

WEBSTER CHICAGO

5610 Bloomingdale Avenue Chicago 39, Illinois
33 Years of Continuous Successful Manufacturing

Show-go?

No-Show? . . .

RADIO & Television RETAILING

June MUSIC SHOW Issue

SELLS Your Products

At The Show and At Home

Whether or not you plan to attend the Music Show in Chicago (Hotel Stevens, June 1-5), your first medium for selling radios, phonographs, combinations, records, needles, albums, cabinets and accessories is the first choice of America's radio-music dealers: RADIO & Television RETAILING.

RADIO & Television RETAILING has always been the most helpful dealer magazine, because each monthly issue contains full information on dealers' chief retailing activities. In the RECORDS Section, for example, articles on merchandising, latest releases, seasonal selling tips, new products, news of the field, are concentrated for maximum dealer helpfulness.

If you have a Show exhibit, space in the June Show Number can direct the trade to it. If you do not, certainly you must attract buyers' attention. Space here reaches the most important buyers — for finished units as well as parts — as PAID subscribers. For all the merchandise sold in this trade, manufacturers have made RADIO & Television RETAILING their first choice since 1925. Deadline for June is May 5. See you at the Show!



Caldwell-Clements, Inc.

480 Lexington Avenue New York 17

Feature the needles that outrank them all

PRECISION-TURNED SHANK
for clear, faithful performance!

NEEDLE SCIENTIFICALLY
ANGLED to eliminate "needle
talk" (hiss and surface noise).

WHAT A POINT! It's a fine
sapphire jewel cut, ground,
polished and re-polished by
highly skilled craftsmen. Un-
conditionally guaranteed!

Primus \$2.50

Cash in on Recoton's national advertising campaign . . . on Recoton's selling aids . . . on Recoton's revolutionary new showcase display . . . (below) . . . on Recoton's free premium awards to your salespeople. Check into the powerful new Recoton point-of-sale campaign that has been so successful with dealers everywhere. Your wholesaler has all the particulars.

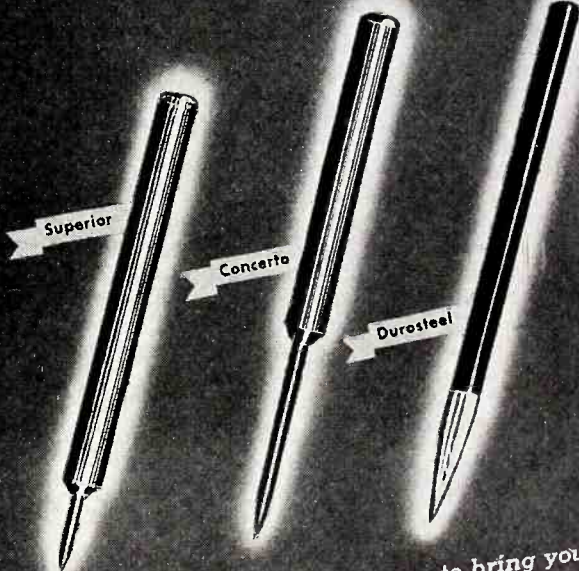

STEEL NEEDLES BY RECOTON. Trust Recoton to bring you the finest in steel needles! These precision-turned needles, made in Switzerland, maintain the same high standards of quality and performance that have made Recoton the standard among the world's finest phonedneedles.

*Reg. U. S. Pat. Off.

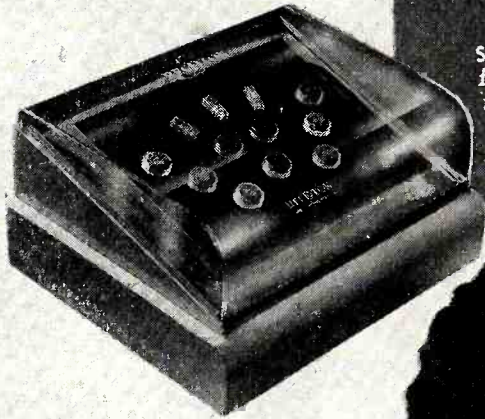

RECOTON*

Always faithful

... AND EVER PROFITABLE



**KEEPS DUOTONE UP FRONT EVERY MINUTE...
GET YOURS NOW AND WATCH SALES SKYROCKET!**

Here's a counter card, storage bin and silent salesman all in one! The brand new Duotone "Show Window" is a smartly-styled counter display case of wood and lucite that features the fast-selling line of Duotone Needles. Each package in the "Show Window" nestles in a handsome blue plush lining. An attractive glass top protects the contents. It's only 20" high, 12" long — takes up little room on your counter.

Your customers will stop, look and buy when they see this handsome display. You simply serve them from the built-in stock compartment. Here's an easy way of selling that gives you quick turnover . . . and rings up more profits.

Phone or wire your distributor today (or inquire direct) for our Special Introductory Offer on the new Duotone "Show Window".



Export Dept.: American Steel Export Company, Inc., 347 Madison Avenue, New York 17, N. Y.

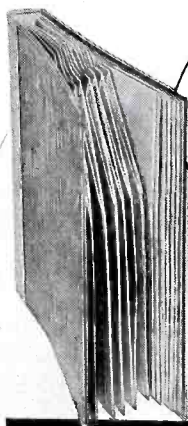

with
"TIP LOC"
THE SLIP PROOF, BREAK
PROOF SAFETY FEATURE

Exclusive with REC-ALBUM, Records won't fall out. Most advanced type DISK-ALBUM made. 10" & 12" storage, package type from 2, 4, 6, 10 or 12 heavy Kraft envelopes which lay flat with edges recessed. Merchandise your album space with NEW, FRESH & SMART REC-ALBUMS. The album they're all talking about. See your jobber or Write . . .

L. H. SYMONS ASSOC. 345 HUDSON STREET, NEW YORK 14, N. Y.

**MGM Records
Names Distributors**

Frank Walker, head of MGM Records, has announced the following distributors in the MGM setup:

Graybar Electric Co., Atlanta, Ga.; Northeastern Distributors, Inc., Boston, Mass.; Jos. Strauss Co., Inc., Buffalo, N. Y.; Allison-Erwin Co., Charlotte, N. C.; Zenith Radio Distributing Co., Chicago 11, Ill.; The Bimel Co., Cincinnati, O.; The Arnold Wholesale Corp., Cleveland, O.; Radio City Distributing Co., Dallas, Tex.; Savage & Son, Denver Colo.; A. A. Schneiderhahn Co., Des Moines, Iowa; Radio Distributing Co., Detroit, Mich.; Automatic Sales Co., Houston, Tex.; Rodefald Co., Indianapolis, Ind.; Graybar Electric Co., Jacksonville, Fla.; Sues-Young Co., Los Angeles, Calif.; Sutcliffe Co., Louisville, Ky.; Shobe, Inc., Memphis, Tenn.; Reinhard Bros. Co., Inc., Minneapolis, Minn.; The Plymouth Electric Co., New Haven, Conn.; Zenith Radionics Corp., Newark, N. J.; Radio Specialty Corp., New Orleans, La.; Zenith Radionics Corp. of N. Y., New York City; Radio Supply Co., Norfolk, Va.; Leo Maxwell Co., Oklahoma City, Okla.; Trilling and Montague, Philadelphia, Pa.; J. A. Williams Co., Pittsburgh, Pa.; Seattle Hardware Co., Seattle, Wash.; Sues-Young Co., San Francisco, Calif.; Hollander & Co., Inc., St. Louis, Mo.; Simon Distributing Corp., Washington, D. C.; S. A. Long, Inc., Wichita, Kans.

Tempo Foreign Jobber

Tempo Record Co. of America has announced the signing of a contract with the American International Trading Co. for the distribution of Tempo custom made records in China, the Philippines and the Netherland East Indies.

Cardinal Execs and Star



Orch leader Charlie Barnett, center, shown with Milton Barnett, left, sales director, and Harry W. Bank, president of Cardinal Records, New York City.



It's GOOD BUSINESS to Feature **ULTRATONE**

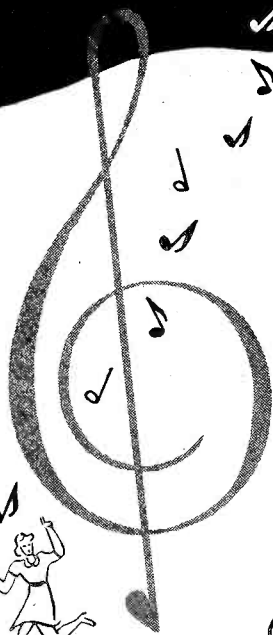

America's finest **PHONOGRAPHS**

Compare Ultratone phonographs with any competitive make. Compare it for appearance, tone, workmanship and price. Compare and you'll understand why we say "Today's market demands quality merchandise and Ultratone phonographs are built for today's market." But, don't take our word for it, ask your distributor to send you a sample.

JIVE & SYMPHONIC



Contact your **ULTRATONE** distributor

BIRMINGHAM 3, ALA.
Steel City Supply Co.

SAN FRANCISCO 7, CALIF.
Edward F. Hale Company

TAMPA 2, FLA.
Gulf App. Dists., Inc.

ATLANTA, GA.
Edwards-Harris Co.

CHICAGO 11, ILL.
General Utilities Dists., Inc.

INDIANAPOLIS 4, IND.
Appliance Dists., Inc.

SOUTH BEND 18, IND.
Colfax Company, Inc.

DES MOINES 9, IOWA
H. E. Sorenson Co.

NEW ORLEANS 19, LA.
Southern Radio Supply Co.

KANSAS CITY 8, MO.
Superior Distributing Co.

ST. LOUIS 8, MO.
St. Louis Music Supply Co.

BALTIMORE 2, MD.
Henry O. Berman Co.

BOSTON 15, MASS.
E. Stanley Freeman, Inc.

GRAND RAPIDS 2, MICH.
Radio Distributing Co.

ST. PAUL 4, MINN.
Motor Power Equip. Co.

OMAHA 8, NEB.
General Appliance Co.

ALBANY 4, N.Y.
Empire State Dists.

BUFFALO 5, N.Y.
H. D. Taylor Co.

NEW YORK 22, N.Y.
Gross Distributors, Inc.

ROCHESTER 4, N.Y.
Harmon Distributors, Inc.

CHARLOTTE 1, N. C.
Williams & Shelton Co., Inc.

CINCINNATI 2, OHIO
Rodney Young Company

CLEVELAND 15, OHIO
Grossman Music Company

HARRISBURG, PA.
Jules Alexandre, Inc.

PHILADELPHIA 30, PA.
H. & S. Distributing Co.

PITTSBURGH 3, PA.
I. & M. Sufrin

PROVIDENCE 3, RHODE IS.
Republic Distributing Co.

CHATTANOOGA 2, TENN.
Tri-State Supply Co.

MEMPHIS 2, TENN.
Stratton-Warren Hdw. Co.

DALLAS, TEXAS
Padgett Distributing Co.

HOUSTON 3, TEXAS
Crowe-Martin Dist. Co.

SAN ANTONIO 3, TEXAS
Crowe-Martin Dist. Co.

SALT LAKE CITY 4, UTAH
S. R. Ross, Inc.

NORFOLK 10, VA.
Bowers Wholesale Corp.

MILWAUKEE 4, WISC.
General Utilities Corp.

Audio INDUSTRIES

MANUFACTURERS OF **ULTRATONE** PHONOGRAPHS - MICHIGAN CITY, IND. U. S. A.

Book by Victor Exec

Jack L. Hallstrom, general merchandise manager, RCA Victor record department, has written a book entitled, "Relax and Listen." The book is being handled through record distributors for interested dealers.

Federal Euphonic Sapphire Phono Needle

Announced by the Federal Sapphire Products Co., P.O. Box 35, Elmhurst, N. Y., is a new Euphonic phonograph needle with a sapphire tip, introduced as the first of a complete line of needles. The

Euphonic is a diamond lapped, micro-polished needle of duraluminum, of the bent shank type, providing spring action and less record scratch. It is presented as a micro-inspected and shadowgraphed product, and retails at \$2.50.

Columbia Buys Building

The Columbia Recording Corp. has contracted to purchase, for its own use and occupancy, the seven story building on the southeast corner of Seventh Ave. and 52nd St., New York. The valuable property is in the heart of the music center of the nation.

Pfanstiehl Needle Contest Winners

Krich-Radisco, Inc., New Jersey major appliance, radio and television distributor, has announced the results of the Pfanstiehl Needle Jackpot Contest, held as a sales promotion feature for Pfanstiehl Needles in the New Jersey area.

Tied for first place were the National Music Shop of Montclair, Eclipse Music Shop of Paterson and Central Record Stores of Trenton. Following them in close order were K.B. Record of Newark, the Medical Tower Pharmacy of Newark, Farnsworth of Dover, Rivoli Music of New Brunswick, the Hurley-Tobin Record Department of Trenton, Tommy Tucker's of Asbury Park and Community Radio of Rutherford.

In addition to substantial cash prizes, the winners attended a victory dinner given in their honor by Mr. Cliff Williams, advertising manager of the Pfanstiehl Needle Co.

Modern Record Co. Purchases ARA Plant

The Modern Music Record Co., of Los Angeles, has completed the purchase of the ARA Record plant. Modern Records will consolidate their offices and operate a complete pressing plant whereby the two plants combined facilitates a pressing capacity of a million records per month.

Their national distribution is set up to be carried out on a new and extensive plan. Executive offices, advertising and sales promotion will also move into and occupy the new building which is located at 685 No. Robertson Boulevard, Hollywood, Calif.

for a **STEADY** resource
stick to **STEELMAN** PRODUCT



STEELMAN
Model No. 200

Compact, lightweight, attractive duo-tone overnight luggage type case. 3" Alnico V heavy slug speaker. 2 Watt output. ANDI improved tone quality attained through reflection of sound by lid placed at an acoustically designed angle (see sketch).

Acoustic-angled lid directs sound waves from speaker to listener.

Retails for **\$29.95**



Model No. 303

A phonograph with that PLUS value! 3 tube amplifier with **POWER TRANSFORMER!** 5" Alnico V heavy slug speaker and continuously variable tone control. 5 Watt output with wide, undistorted frequency response. Compact—yet plays 12" record with lid closed! Cased in beautiful duo-tone leatherette.

Retails for **\$39.95**



USE
this coupon
TODAY!

Made by America's oldest manufacturer—devoted exclusively to the creation of electric phonographs.

STEELMAN
RADIO CORPORATION

742 East Tremont Avenue, Bronx 57, N. Y.

STEELMAN RADIO CORPORATION RT-3

742 East Tremont Ave., Bronx 57, N. Y.

I am interested in the complete Steelman line; please send me descriptive literature.

Store.....
(please print)

Address.....

City.....Zone.....State.....

My regular jobber is.....

Amplitone Upright



Here's the new automatic record player made by Amplitone Inc., Philadelphia, Pa., designed as an "upright" to make use of large speaker and baffle in tilted vertical position—tone range is thus increased. Push-pull amplification; automatic disc changer on hinges at back.

Columbia Signs Pianist



Claudio Arrau, left, noted pianist, is shown with Goddard Lieberman, Columbia Records vice-president in charge of masterworks artists. Mr. Arrau signed an exclusive 3-year contract with the firm.

Capitol Appointments

Capitol Records, Hollywood announces that John Scalesi, formerly Eastern sales manager, has been named national sales director for chain stores. Floyd Bittaker is national sales manager. Robert Stabler takes over as Eastern regional manager, with Wm. R. Hill taking over Stabler's post as Midwest regional manager.

Majestic Appoints York

The appointment of Shelby York as record sales manager for Majestic Records, Inc., was announced by Parker H. Ericksen, vice-president of Majestic. Before joining Majestic, Mr. York was sales manager for one of the independent labels, and he brings to his new connection many years of retail, wholesale and manufacturing experience in the record industry.

Sonora Record Display



Unit features full-color reproductions of seven Sonora children's albums. Whimsical drawings appear on each panel of the merry-go-round. The juvenile record display is available in sizes suitable for counter, window and floor use.

New Victor Record Plant

A new phonograph record manufacturing plant which will greatly increase the capacity of the RCA Victor Record Department is to be established at Canonsburg, Pa., it was revealed with the announcement that the RCA Victor Division of the Radio Corporation of America has leased Building No. 40 of the War Assets Authority's multiple-tenancy project near Pittsburgh.

The building contains 115,000 square feet of manufacturing space, which will be devoted exclusively to record production, supplement-

ing existing facilities in the company's record manufacturing plants at Camden, Indianapolis, and Hollywood.

New Recording Firm, Rainbow Records, Formed

Rainbow Records, 234 W. 44 St., New York City, is a new recording firm headed by Harry Fromkes. Other officers are: Herb Hendler, vice-president in charge of recordings, and Eddie Heller, vice-president in charge of sales.

Rainbow will concentrate on the building of a standard catalog and the production of special albums.



NEW BUSINESS

WITHOUT

LIFTING A FINGER

THROUGH

The Record Album-of-the-Month Club's
"PACKAGED"
MAIL-ORDER PLAN

Profit in your own locality by RAM'S national operation and prestige.

- ✓ Get more immediate album business
- ✓ No detail work for your clerks...
- ✓ Direct mail promotion in your name
- ✓ Year-round volume from RAM members
- ✓ Deal with your own suppliers...
- ✓ "The Record Review"—Edited by David Hall—Mailed with your compliments.

* * *

IMPORTANT: Number of RAM dealers limited in each area.

Learn *ALL* about this proven way to profitable new business!

The Record Album-of-the-Month Associates, Inc.
116 Main Street
White Plains, N. Y.

Without obligation, please send details of your Associate Dealer Franchise.

NAME _____

TITLE _____

(Attach to letterhead and mail)

**Out to ^{sell} set a
New Record!**

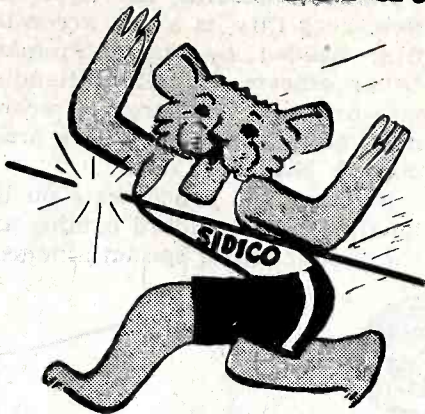

**of course, it's
SIDICO**

for M-G-M Records

*Exclusive Distribution in
Maryland — Northern Virginia and
District of Columbia*

Dealers Inquiries Invited

SIMON Distributing Corporation
615 PENNA. AVE., WASHINGTON 4, D. C.

**You Can Sell
Profitably in
ARGENTINA**

As active, well established, strongly financial importers and sales representatives, we can do a top job for you on products in the electrical field. Can arrange immediate distribution on household appliances and related items. We are interested in distributing your lines or in outright purchase. Best references. Write us about your lines.

Jack Firenstein & Cia.
Sarmiento 2192
Buenos Aires, Argentina

Record \$ Pave Road to Profits

(Continued from page 92)

And The Devil" done by Snub Mosley; and Jerry & Sky's versions of "Sparkling Brown Eyes," "Troubles In My Heart."

Other Sonora discings have been made by Bob Huston, "The Man Who Paints The Rainbow In The Sky" flipover "How Are Things In Glocca Morra" and D'Artega, Saxie Dowell, and Carolina Playboys.

Disc Co. of America is featuring a new Ethnic series; the first six albums contain on-location recordings from Haiti, Cuba, USSR, Micronesia, Ethiopia, and whoops from an Indian pow-wow in Michigan. A new album of "American Legends" is sung by the American Ballad Singers, accompanied by Elie Siegmeister.

Pop Discings

Mercury Record releases include: Dinah Washington "Embraceable You" and "That's Why A Woman Loves A Heel"; Harry Babbitt's "Far Away Island"; "To Me"; Two Ton Baker's waxing of "Managua Nicaragua" flipover "I Gotta Gal I Love," and "Uncle Remus Said" backed by "Everybody Has A Laughing Place."

Apollo Records is playing up Lee Richardson, and his recording of "Silent Love" and "All The Things You Are." Apollo albums include: "Boogie Woogie" piano solos by Bob Mosely; "Latin American Music" by Jose Morand.

Black & White Recording Co., introduces Nick De Lano, baritone on debut disc "Guilty" backed with "Honey." Other Black & White waxings are: "Five Guitars In Flight" and "Gangbusters" with Earle Spencer's orch; and two new albums: "Charlie Ventura & His Sextet" and "Little Girl Blue" with Lena Horne.

New Listings

National Records has recorded "Open The Door, Richard!" with Dusty Fletcher.

Sterling Records introduces some Westerns with: Hank Williams and the Country Boys "Calling You" and "Never Again Will I Knock At Your Door" and "I Can't Go On This Way" backed with "You Don't Have To Worry" waxed by the Oklahoma Wranglers.

John Laurenz, Pan-American artist has waxed, "If I Had You," "Blue Moon" and "Twilight On The Trail," backed up by "Silver On The Sage."

A new recording firm, Rainbow Records, announces its first two albums: Larry Clinton "Dipsy Doodle Dance Contest" album, and "How To Write A Song," featuring Jack Lawrence.

Stinson Records has released a "Jerry Jerome Trio" album, and an album by Max Perlman, singing "Yiddish Theatre Music."

Banner Record Co. Formed

Organization of a new recording company, Banner Records, Inc., with offices at 1674 Broadway, New York, is announced by Sam Selsman, president.

The new unit plans to cut 52 records and 24 albums in 1947, and will specialize in foreign recordings that utilize artists in this country and abroad. Peter Doraine, formerly with the professional departments of several music publishers, is treasurer of Banner, and Vincent Beck is secretary of the corporation. The list of jobbers in the U. S. and elsewhere is being augmented.

Sacred Records Jobbers

Burt Gildroy, sales manager for Sacred Records, Los Angeles, has signed the following firms to distribute Sacred records: Continental distributing division of C. G. Conn, New York City; Sni-Dor Radioelectric Co., Montreal; Frederick Lee Co., Kansas City, Mo. and Chicago; Record Sales Co., Birmingham, Ala.

Dealer Helps Orchestra

Casimir P. Holochwost, owner of the Holochwost Music Studio, Cicero, Ill., is one of the founders of the West Suburban Symphony Orchestra, consisting of a number of business men and civic leaders in the community. The orchestra unit is a non-profit organization, incorporated for the purpose "of promoting the intellectual and cultural welfare of its members and community..."

Leaves Stinson Trading

The withdrawal of Irving Proskey from partnership in the Stinson Trading Co., distributors of Stinson and Asch-Stinson records, 27 Union Square, New York, is announced by Herbert Harris, who has now become sole owner.

The firm plans to make available weekly promotional literature, consumer aids and exploitation programs as part of its new expansion plan for 1947.

ELECTRICAL APPLIANCES

Section of *RADIO Television* RETAILING

You Know, But Does the Customer?

Don't Gloss Over the Little Things Which Are Real Selling Features in Modern Electrical Home Appliances

• Knowledge on the part of the salesman is power when it comes to selling electrical appliances for the home. By the same token, knowledge is power to implement buying desire on the part of the prospective purchaser.

Too often appliance sales are lost or delayed because the salesman *takes it for granted* that the shopper *knows* just how the appliance works and what it will do for him in his own home.

The clever salesperson must be continually on his guard against the dangers of falling into the practice of glossing over certain salient points of a piece of equipment when describing it to a customer. Such points may seem so obvious and elementary to him that he may find it difficult to believe that the layman doesn't know all about them.

The customer who has never owned a washing machine may, for instance, not know that it is not necessary to soak clothes before washing, or that there are ways, even with the conventional type washer, of eliminating hand-rinsing.

The prospective purchaser of an electric range may not realize that

such device does away with the drudgery associated with scouring of cooking utensils because of the soot caused by flame fuels.

The economical operation and quiet efficiency of the modern refrigerator may be totally unknown to the present owner of a broken-down "dog" which had to do during the war and postwar days.

Would-be purchasers of electric circulating fans may never know that such appliances can be used to distribute heat and perform many other tasks—or that the exhaust fan in the kitchen helps to prevent grimy walls, ceilings, etc.

The "expert" in any line, be he college professor, engineer, farmer or mathematician often finds that those he seeks to instruct have failed to grasp the subject as a whole because they were not made to understand the simple factors which make up the entire unit.

The dealer should be careful to describe in clear language the features he considers *little* things because these small, and to him, obvious operational points may include one or more of the points of interest which will cause the prospective buyer to buy the appliance.

When you tell the present owner

of a "straight" suction type vacuum cleaner that the model you want to sell has a "motor-driven brush" be sure to explain just what you mean—that a revolving brush, having bristles, loosens the dirt, lint, etc., in the rug to facilitate suction of such material into the cleaner bag.

In selling a sun lamp, it isn't enough to merely state that it "tans the skin." Explain that it provides health-giving Vitamin D, etc. The infra-red lamp has other features besides its therapeutic "baking" qualities. For example, it can be used to dry hair, nail polish and so forth. These are just some of the facts that the customer should know about; and you should be the one to tell him.

Describe All Features

Automatic toasters don't *just toast bread*. They save current and eliminate the necessity for running back and forth to "tend" them. They save bread, too, and have controls which permit the customer to select the exact shade of "brown" desired.

One after another, our present-day labor-saving devices have many features which we, as appliance experts know all about, but about which many, if not most, of buyers, knew little or nothing.

Let's explain *all* of the features to each and every prospective buyer so that we can help them to make up their minds quickly, and, having once bought from us, will be satisfied customers who know all about how to operate their home appliances. Such customers will send much "recommended" business to our stores.



**ONLY NORGE GIVES
YOU THESE SIX MAJOR
HOUSEHOLD APPLIANCES—
EACH A LEADER IN ITS FIELD!**

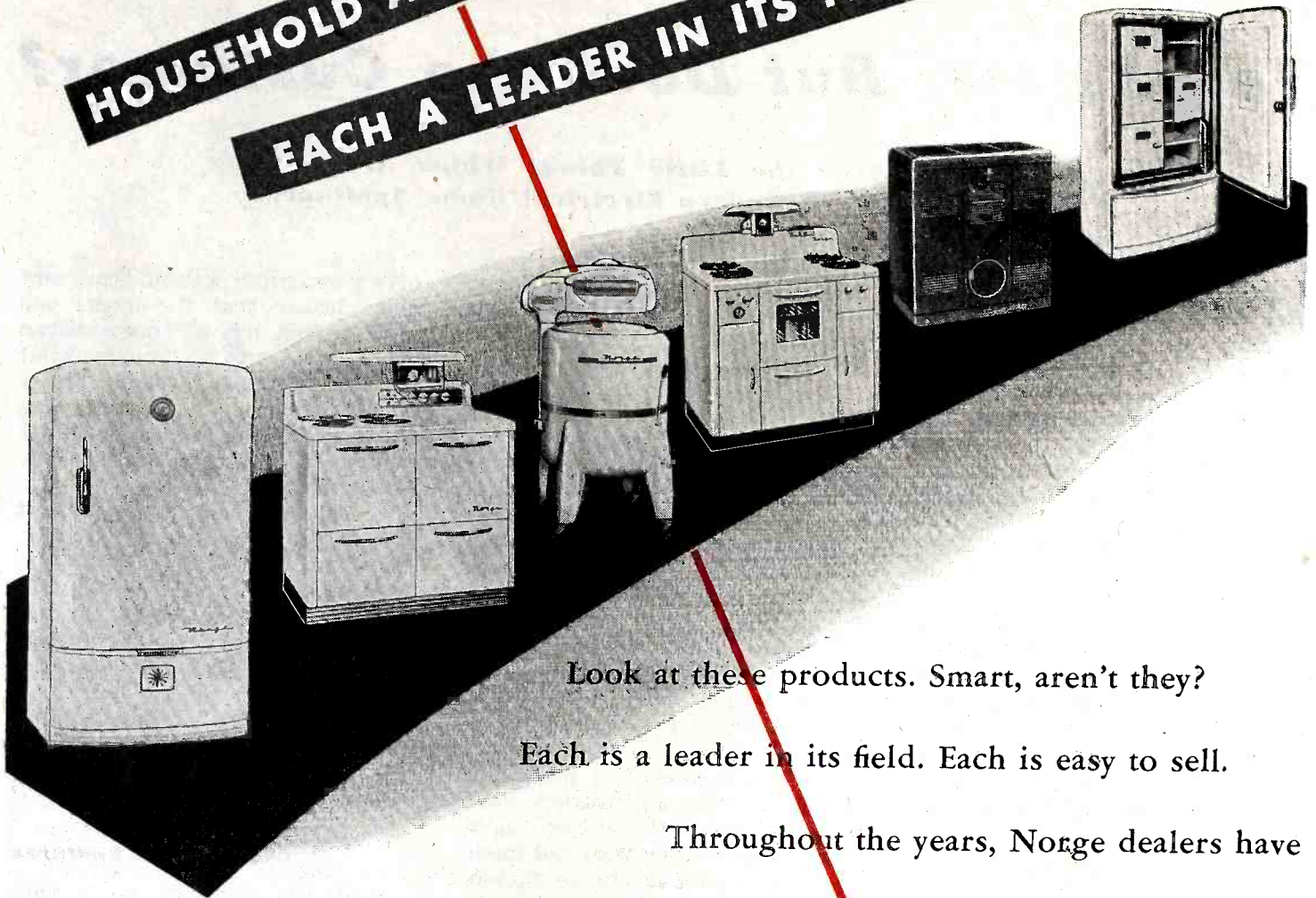

Look at these products. Smart, aren't they?

Each is a leader in its field. Each is easy to sell.

Throughout the years, Norge dealers have encountered no difficulty in securing a satisfactory volume of business . . . and they have been more than pleased at the ratio of profits to sales.

When you're in Norge, *you're in business!*

**THE BEST DEALER IN
TOWN SELLS NORGE!**

**SEE
NORGE
BEFORE YOU BUY**

A BORG-WARNER INDUSTRY—Norge is the trade-mark of Norge Division, Borg-Warner Corp., Detroit 26, Mich. In Canada: Addison Industries, Ltd., Toronto, Ont.

Make Cleaner Sales Climb!

Selling More Than One Vac in Each Home Is the Way to Do It!

"One-Cleaner Saturation" of homes is a thing of the past. Modern merchandisers will make more money, make living conditions better, selling two or more vacs to the householder.

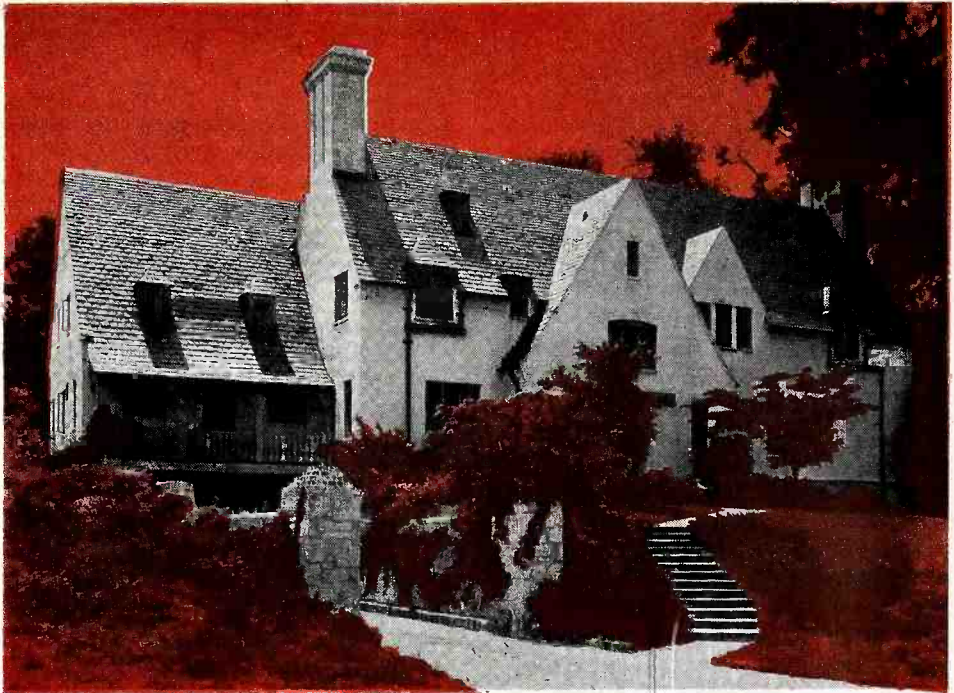

● Before the war a salesman who'd just sold a vacuum cleaner to a householder figured that such home was "saturated"—for the next year or so.

The purchase by a consumer of more than one cleaner in any one year was a rare event in the pre-war era, and such sale was seldom made except where the user was totally dissatisfied with the operation of the appliance, or in cases where the cleaner had failed mechanically or electrically and the owner had been unable to get service under the guarantee.

In these days and times the mer-

chandiser who's out to break sales records is going to do all he can to convince each prospective buyer that every home needs more than one vacuum cleaner.

This technique is the *something new* in the cleaner picture, and it will work, and pay off well for the retailer who knows all about the cleaning problems in the home; all about the products he sells.

A few years ago there was great rivalry between *types* of cleaners. Dealer X, for example, featured a line of straight-suction uprights. One of his competitors plugged a motor-driven brush model, exclusively. One dealer would push a line of cleaners having attachments while another would specialize in the sale of upright models along with hand cleaners. Outdoor salesmen, operating out of factory branches, sold tank cleaners door-to-door in direct competition with the local merchants.

Today, the whole thing has changed. Independent retailers now have a line of the various familiar types as well as some radically new ones. They have uprights, tanks and hand vacs, thus stocking not only all of the kinds the buyer knows about, but putting themselves as retailers into a better and stronger position to put across those more-than-one sales—sales which will bring them greater profits and, at the same time, provide greater satisfaction and convenience to the

user. Most modern householders will accept the more-than-one cleaner idea.

Even the very small home can keep a couple of vacuum cleaners busy. For example, a hand vac for upholstery, draperies, mothproofing and blowing purposes as well as to clean the interior of the family car, plus an upright for floors. The combination can be varied to suit particular preference of the buyer.

Large homes need cleaners on *each* floor. When the dealer explains the features of having more than one of these modern servants in the modern residence—how they save time by saving steps, and how they enhance the appearance; contribute to better sanitation—it's no feat to sell a couple of cleaners at a time.

In order to do a good job in vacuum cleaner multi-selling, the dealer needs to make his establishment known as "cleaning headquarters." He should carry a *complete line* of all the models he sells, and should set up an efficient and attractive demonstrating section in his store. The more he is able to instruct the customer in his own showroom, the less he will be called on to carry out costly in-home demonstrations.

Multi-selling of cleaners calls for expert knowledge of all the cleaning problems associated with house-keeping. It calls for a first-class cleaner service department too, be-

(Continued on page 140)

To Make More Money Retailing Cleaners . . .

Know all of the features of each model

- " **all the problems of home-cleaning**
- " **how to demonstrate and have a good in-store vacuum cleaner section**
- " **why the customer should buy more than one**
- " **how to operate attachments**
- " **how to repair cleaners in a first-class service department**

Made-to-Order

Distributing Expert Outlines Time-Payment Techniques.

• In a paper read at a meeting of the American Bankers Association, at St. Louis, John L. Busey, president of the National Electrical Wholesalers Association, presented ideas on what distributors think is required of the financing agency under a time payment plan.

After outlining the potential market, expected trends in time-payment purchasing and how multi-buying desires on the part of the consumer will require specialized financing plans, tailored to fit the situation, Mr. Busey outlined seven points, as follows:

1. We must first recognize that a time payment plan is a basic sales tool in the retail selling of major appliances, radios and television sets. As such it must be adapted to the overall sales activity and promotion program of the manufacturer, the distributor and the dealer.

A uniform plan for a given situation obviously operates most satisfactorily from the distributor's viewpoint. This can, and is, offered by the finance companies. May I

ask you gentlemen, can the banks develop a counterpart?

Second, as a sales tool, installment financing must be used in varying degrees under varying circumstances. When sales are brisk and volume is easily obtained, terms can be relatively short and down-payments relatively large. However, when sales volume falls off, and the consumers' income declines, terms must be extended as long as possible and down-payments reduced as low as possible within reasonable limits.

Such an approach by a bank would require quite a change in basic thinking since normally the tendency is to curtail terms and credit in difficult times and extend them in good times. As a depositor I find it difficult to criticize such a policy.

However, this kind of financing is necessary to carry the appliance business through a period when the consumers' income has been seriously reduced. Can the banks divorce their installment credit operations from their normal busi-

ness to the extent that would make this possible?

Third, we need financing agencies that will accept a reasonable number of borderline risks in order to serve our dealers adequately in all areas. In certain areas it might be good business for a finance agency to accept no conditional sales contracts. However, the dealer who serves such an area needs just that kind of assistance to obtain any volume from that market.

Collection methods must be adjusted to suit the territory involved and higher loss ratios must be expected in certain markets. To meet the commercial requirements of the distributor and dealer, the finance agency must accept these risks and look to its overall results for a satisfactory profit.

Character Counts

Fourth, the financing agency must be willing to judge a dealer not only on his net worth but to a large extent on his character and sales ability. An active dealer with relatively little net worth will have a large volume of conditional sales contracts to dispose of during certain seasons of the year.

Refusal to accept these contracts, because the total paper purchased during a short period appears excessive, will seriously handicap the dealer. Such a policy in less favorable times than the present would of course result in some losses since dealers are not always financially able to repurchase delinquent paper.

However, that's the nature of the business. If you want the discount rates enjoyed by the finance business you must accept the losses that go with them. Can the banks adopt such a commercial viewpoint?

Fifth, we have an interest in aiding the dealer in maintaining contacts with his customers. The individual appliance store does not have the natural store traffic enjoyed by the merchants of soft goods, food stuffs or similar products. Some of the progressive finance companies permit the dealer to accept installment collections

Seven Musts for the Dealer-Financing Agency

- 1. Realize that a time payment plan is a basic tool in retail selling.**
- 2. Financing plans must be elastic in order to change with the times.**
- 3. Acceptance of reasonable number of "borderline" risks should be made.**
- 4. Dealers should not be judged solely on their net worths. Character and sales ability should count.**
- 5. Agency should aid dealer in maintaining contacts with customers.**
- 6. Lending organization should train salesmen in time payment selling.**
- 7. Should provide inventory financing facilities.**

Financing for the Dealer

Stresses Specialized Needs in Radio/Appliance Field.

in his store. This draws the customer into the store at periodic intervals and exposes him to other appliances on display.

We think this is an important factor. Would the banks be willing to make similar arrangements? I do recognize that there is some hazard involved in this procedure since a dealer may not remit his collections promptly or intact. That has happened in the past and will undoubtedly happen again. What we must do is weigh the disadvantages from a strictly financial standpoint and the advantages from a commercial point of view. At the same time, I am not unaware of the importance to the bank of similar traffic on its banking floor, which might well be lost under such a setup.

Sixth, the financing agency must assume responsibility for training wholesale and retail salesmen in financing methods and routines and sell them on the merits of the plans offered. You must recognize that even today there is some fear of time payment plans and a considerable amount of misunderstanding or rather lack of understanding concerning them.

Must Know Plans

It is important to the dealer, the distributor, and the financing agency that the retail salesman who contacts the consumer has an adequate understanding of the finance plans in effect and an appreciation of whether they are sound, equitable to the customer, and justify their cost. The retail salesman can best obtain this understanding from representatives of the financing agency who are thoroughly versed on the subject.

The national finance companies work with the distributor organization in presenting this training, in conjunction with dealer sales meetings conducted by the distributor. Under this arrangement, the finance story can be fitted into the overall sales presentation and receive better acceptance. Can a bank work together with a distributor in this manner since usually the same territory would not be served by both the bank and the

electrical wholesaler? That is a problem that I assume you can overcome.

Seventh, our dealers must have inventory financing facilities—and flexible ones. This is a very essential part of the appliance distribution business and is generally handled under the so-called "Wholesale Floor Plan." This plan generally permits a dealer to carry a display and warehouse stock for 90 days with only a 10% investment, and a number of renewals if further payments are made. Because of the seasonal nature of the demand for some appliances, we as distributors must arrange for special floor plans from time to time during the year in order to move certain products out of our warehouses before the active retail selling season begins.

With a national finance company we can arrange one plan that will operate for all our dealers. How the banks could operate with us on such an easy basis I do not know as yet.

If a distributor's dealers all ob-

tain their floor plan financing through one agency the clerical work of the distributor is reduced to a minimum. Can the banks arrange similarly simple procedures?

I don't want you to conclude from some of my comments that I am trying to discourage the banks from entering or expanding their participation in the appliance installment finance business. My purpose has been to point out certain aspects of the business that from our standpoint are important.

Prewar you furnished the bulk of the money for installment purchasing through loans to the finance companies. But appliance installment financing is more than the furnishing of money—it is the furnishing of a service.

To the agency that furnishes the service best suited to the needs of the consumer and the industry should go the bulk of the business. If that describes the service your bank can offer, then to your bank should get an important share of the appliance time payment financing business in its community.

What the National Electrical Wholesalers Association Stands for

- 1. Maintenance of adequate stocks in marketing centers.**
- 2. Promotion of appliances by specialty selling.**
- 3. Training of retail sales personnel.**
- 4. Keeping manufacturers informed of market requirements.**
- 5. Performance of credit and collection functions.**
- 6. Assumption of investment and obsolescence risks.**
- 7. Assistance in product servicing and training of retail appliance repair personnel.**

New Contacts with Farm

• In the Spring of 1947, the go-getting radio-appliance retailer develops a new attitude toward his rural prospects.

The situation in postwar farming is one which changes at a fast clip. Modern agriculture is not an industry which quietly moves at the same old pace. Fact is, the business of farming has taken on streamlined qualities and modernized aspects fully as important and significant and the postwar changes in other industries.

Canvass Is Indicated

One of the best ways for the retailer to bring himself up to the minute in these changes is to schedule a call on every one of his farm prospects. A dealer can get, from such calls, down-to-earth information on buying trends which he would never get in any other way.

Many dealers in farm areas now make a practice of having a farm

Where dealer contacts with farmers are highly profitable—electrified farm pictured by REB.

specialist among their salesmen, and find that it pays. If this specialist will personally make a new check-up, as of springtime, 1947, he may find a lot of interesting and profitable trends among the RFD customers.

In making these new contacts with the farmers, the dealer should make a point of doing at least four things—(1) Get the last word on the farm electrification program in the community, (2) Make a thorough study of all the new radios and appliances for rural use, (3) Take a complete set of farm broadcast program material along on the calls, and (4) Circulate all the local examples of how farmers are using more than one radio, and multiple appliances per farm.

In farm electrification, which is moving at a lightning rate in some areas, the retailer will find that all the figures and predictions from "headquarters" will do him little good except in terms of local interest and reaction. Farmers in different areas react in markedly different ways to the coming of the power lines. Some of them buy everything in sight, including a new radio with a record player. Others will put lights in the house and barn, select an electric washer, and stop there. Others will ignore the power line even if it passes right over the mail box.

Personalized Selling

Most of them will allow their first decisions to be influenced by reasonable suggestions by the local retailer, particularly if he's an old acquaintance. However, a lot of them will resist the idea of being a part of a "bonanza" in which they represent a virgin market and are approached by droves of fast-talking strangers who knock at the door with the idea that it's a cinch to make a killing.

It is often very helpful to talk to farmers in groups, as to what they will do about the new power lines, as they are genuinely interested in the plans and ideas of their neighbors, whom they have known for years. In isolated areas, this "neighbor" bond between farmers is particularly important.

Second, in presenting to the farmer the latest information on farm radios and appliances, it is well to remember that the prospect is very likely a man who likes the salesman to relate the new equipment to his present equipment. It has been noted by farm sales experts that farmers, more so than other classes of buyers, like to be given some allowance for their old equipment, or to be shown some way in which the old units can continue to be used. It appeals to their (rather pronounced) sense of economy and they've grown used to it.

Farmers use the same outmoded receivers for years and years, and the salesman who is not prepared to suggest that it can be transferred to one of the other farm buildings, or that it is worth a trade-in allowance, may have a heck of a time selling a new unit.

Appropriate Literature

The agriculturist is also something of a mail-order "catalog" fan, and has developed the habit of studying the illustrated descriptions of merchandise. Thus it will be helpful if the dealer will provide him with booklets and leaflets which give the whole story on new electrical equipment. The farmer is a man who will examine these in detail.

Now for the third suggestion, which is to take along a supply of give-away broadcast schedules to leave with the farmers. Whether or not a dealer has ever sold programs before, he can really do it in the agricultural market, because the farmer has a strong and consistent interest in hearing broadcasts on market news, farm legislation, weather reports, news from agricultural experiment stations, livestock management problems, crop culture, etc.

As has been pointed out before, these broadcasts mean actual dollars to the farmer, especially now that he has become so generally receptive to new ideas and improvements in his business. Local stations often make a big point of staging his type of broadcast feature, and the more he can find out



Buyers

about what's on the air and what's coming, the better he likes it. It must be remembered that not all farmers are served by daily newspapers and timely broadcast information as furnished by the local radio/appliance man is very useful. The retailer whose name, address and phone number is on the radio program schedules kept around the radio in the farm home, is sure to benefit in the long run.

Sales to Be Made

The fourth and last suggestion, which has to do with the use of more than one radio on each farm, is signally important because the current number of farms with a single radio is enormous. The front-parlor location of an old battery set, the only one on the place, is practically a farm tradition. The number of second and third sets that can be sold in this field represents one of the richest markets to be found anywhere.

The barn, kitchen and machine shop are the best bets for the extra sets and of course many farmers still regard this idea as a frivolous novelty. One of the best ways to pry them loose from this belief, is to be prepared to give examples

A scene on a Kansas farm—one of the six million of the U.S.—where hard-working families welcome equipment that's new and efficient.

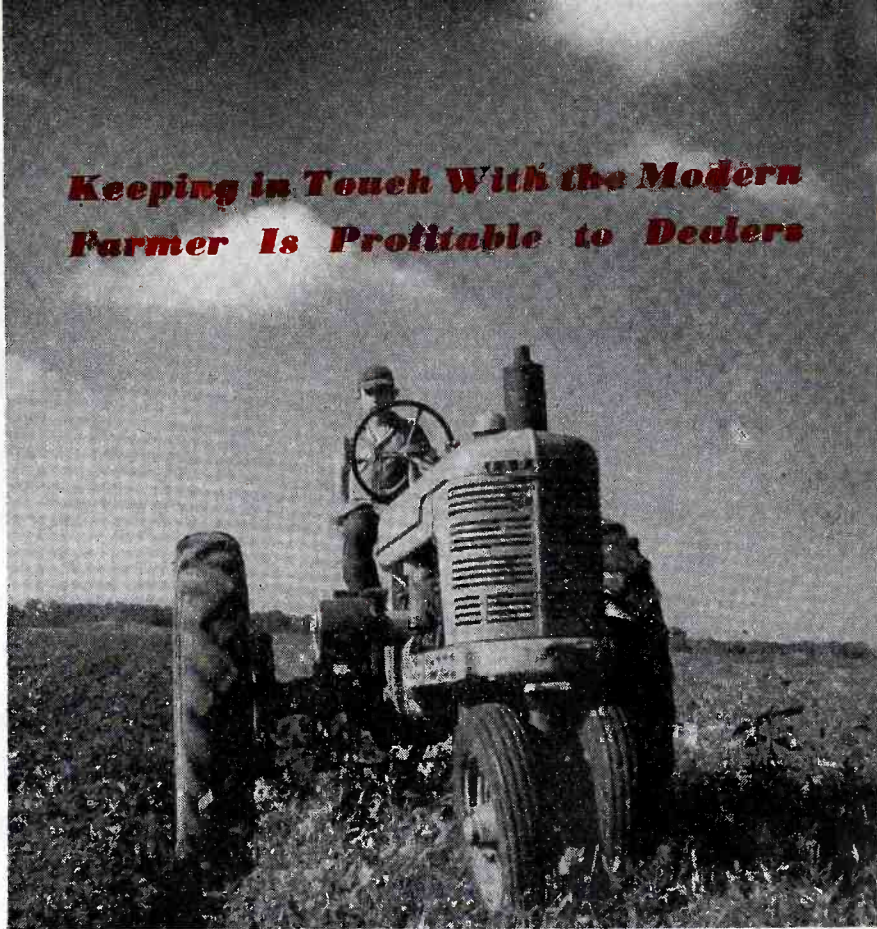

Keeping in Touch With the Modern Farmer Is Profitable to Dealers

of other farmers who own several radios and like the plan. This seems to be one of the most effective ways to convince the farmer that radios should be located at any point about the farm where any member of the family spends a lot of time.

The same applies to the great number of labor-saving electrical appliances that can be used if the farm is electrified. Local "testimonial" examples and demonstrations will help a great deal, although they require a lot of individual attention on the part of the

dealer.

For instance, a great many farmers have never heard a radio playing in the barn. If a radio man can manage to get a portable set actually playing full blast in the place, it's an excellent stunt. After all, a barn is a lonely place and farmers spend a lot of time there in work which does not engage their full attention. After a good radio has once been heard in the place, it's going to seem deadly dull and silent when it's turned off, and the effect may be remembered for some time.

The lights go on—signifying on many a farm that modernization, and electrical living have arrived. Photo by Rural Electrification Bureau.

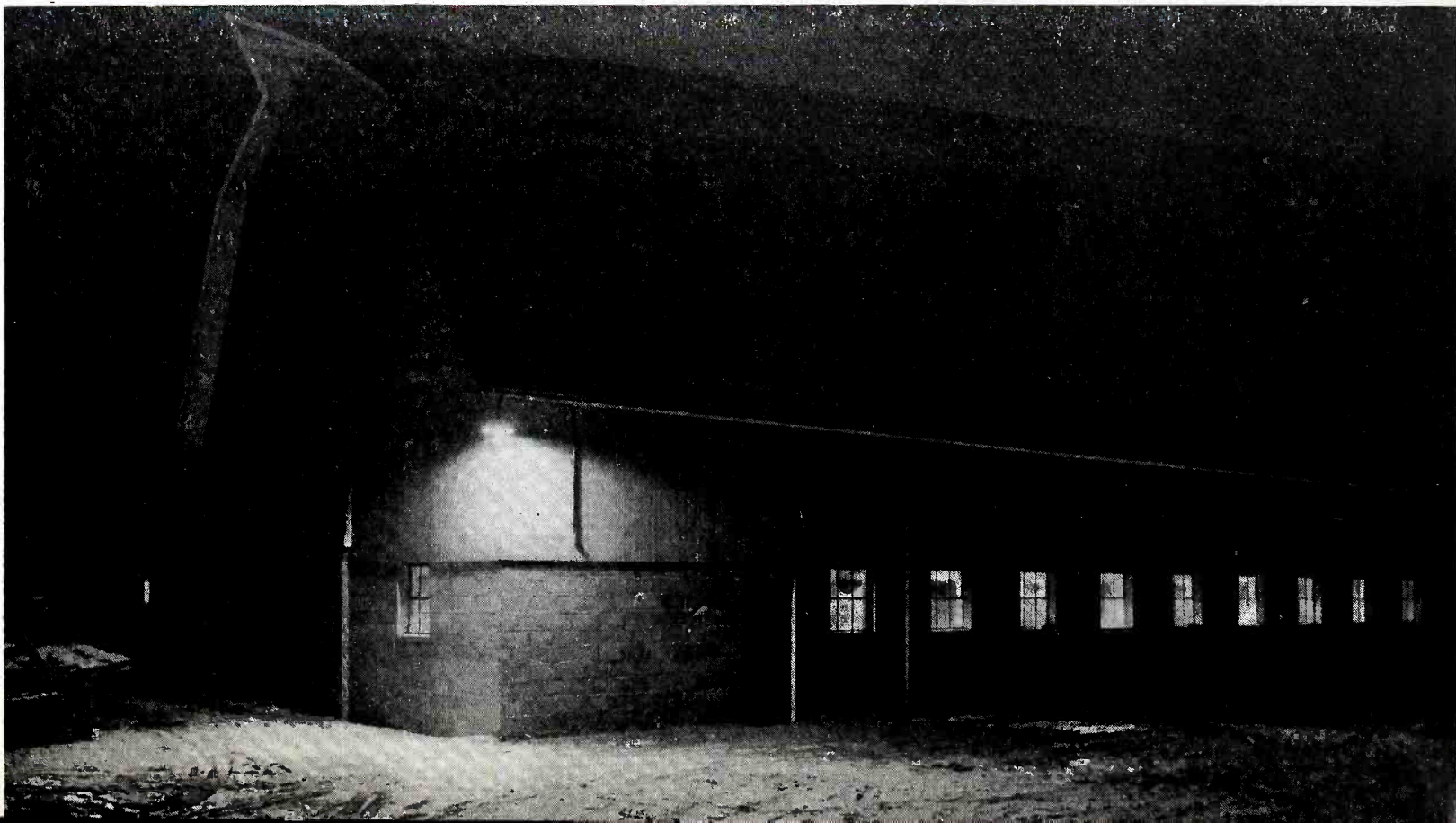

Refrigerators ★

★ Washers

★ Ironers

★ Ranges

★ Vacuum Cleaners

★ Food Freezers

New Electrical

Packard SHAVER

New Packard twin dual electric shaver, with four smooth round heads; famous for the "skin level shave." Features: openings provided for long and short hairs; four heads mounted as a single unit and locked into position;

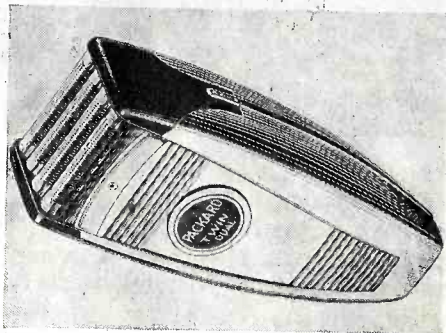

Vibra-Seal rubber cushion below head mounting; lightweight carrying case; lucite headguard; detachable hair pockets. Lektro Products, Inc., Milford, Conn.—RADIO & Television RETAILING.

Hotpoint FREEZER

Home freezer, model EK8-1; eight cu. ft. capacity. Storage space for 280 lbs. food; capable of "quick-freezing" 30 lbs. at a time. Four wire storage baskets near top surface; two refrigerated shelves for fast freezing. Top can be lifted to "stay" at angle desired; interior automatically lighted. Temperature con-

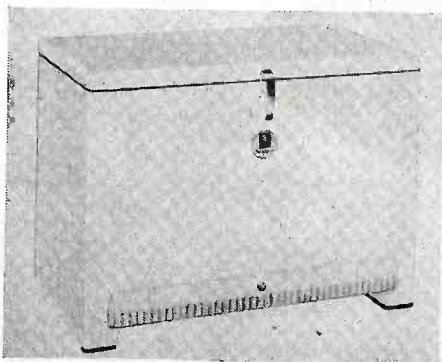

trols located at top of right rear wall. Thermometer placed on center basket. Four-inch Fiberglas insulation. Light alarm serves as warning in event of mechanical failure. Finished in Calgloss enamel, with chrome handle and trim; Dimensions: 36 inches high, 49 inches wide, 31 1/8 inches deep—RADIO & Television RETAILING

Norge WASHING MACHINE

Washing machine features "power leg" wringer mounting to prevent tip-

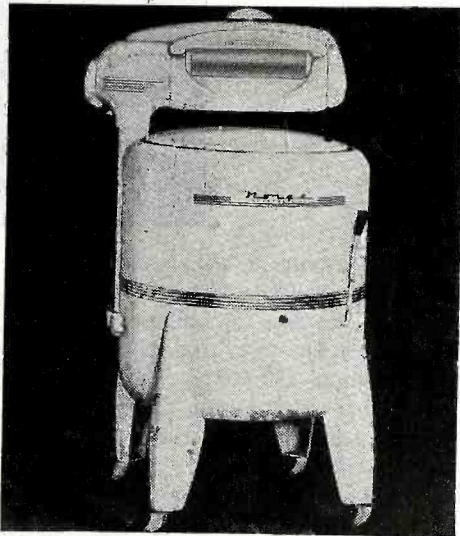

ping when wringer is swung out from machine. Also includes new anti-air lock pump assembly which assures positive emptying action. Norge Div., Borg-Warner Corp., 670 E. Woodbridge, Detroit, Mich.—RADIO & Television RETAILING

Gibson RANGE

Model ER-197-B. Dimensions: height, 42 inches; width, 40 inches; depth, 25 inches. Seven heat surface elements.

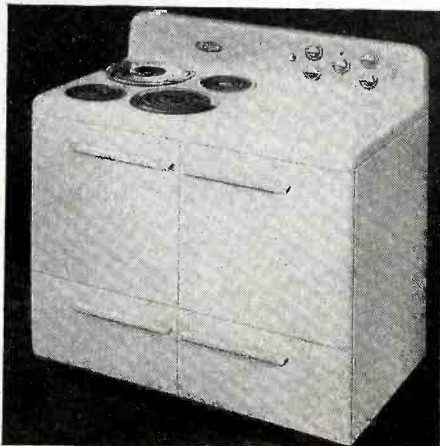

Six-quart, 7-heat kookall, with thick Fiberglas insulation. Large size oven, 16 inches x 16 inches x 20 inches. Gibson Refrigerator Co., Greenville, Mich.—RADIO & Television RETAILING

Westinghouse REFRIGERATOR

Seven cu. ft. two-temperature refrigerator; holds 56 lbs. frozen food. Freeze chest capact 1 1/4 cu. ft. Incorporates "temperature selector" for freeze chest temperature, and the second control regulates the temperature of the general



food storage area and adjusts automatically in relation to the outside temperature. Five ice trays available. Two large vegetable crisper containers are also included in the refrigerator. Plastic trim on door handle and interior. Westinghouse Electric Co., Mansfield, O.—RADIO & Television RETAILING

Pennsylvania Aircraft TOASTER

Pop-down automatic toaster, all-aluminum. Large openings to facilitate toasting of bread, muffins, etc. Toast drops into bottom receptacle where it is kept warm until used. Available in



a-c-d-c. Pennsylvania Aircraft Works, Inc., 611 No. 40 St., Philadelphia 4, Pa.—RADIO & Television RETAILING

Home Appliances

★ Toasters
★ Roasters
★ Hand Irons
★ Mixers
★ Clocks
★ Coffee Makers

Arvin "LECTRIC COOK"

Electric grill provides facilities for grilling, frying, toasting and baking. Provides 190 square inches of cooking

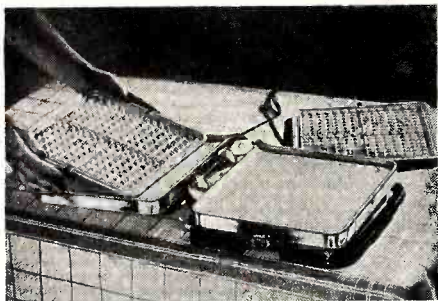

surface; designed so that waffle grid plates can be attached. Signal-light stays on until heat reaches the dialed temperature. Protected expansion hinge; built-in drip spout. When used as a waffle iron, grid plates clamp securely; bakes four waffles at a time. Automatic indicator for waffles. Noblitt-Sparks Industries, Inc., Columbus, Ind.—RADIO & Television RETAILING

Casco HEATING PAD

Electric fomentation heat pad for treatment of arthritis, rheumatism, sprains, strains, etc. Made with wet-proof vulcanized castex body for added protection, wet-dry pad equipped with nite-lite switch for selecting desired

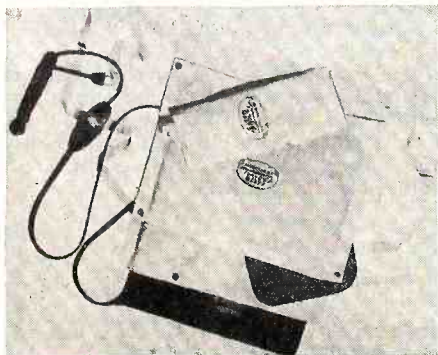

temperatures. Cascomatic reservoir placed between washable sheeting cover and flannel applicators holds moisture for 10 to 12 hours. Two tie-tapes for fastening pad to body. Casco Products Corp., Bridgeport 2, Conn.—RADIO & Television RETAILING

Premier CYLINDER CLEANER

All-purpose cylinder-type vacuum cleaner, "Aire-Matic" model 80. Streamlined, cleaner features a 1/2-H.P., rubber-mounted, ball-bearing 600-watt motor. Double-sized dust bag; exclusive rug nozzle with adjustable brush; swivel

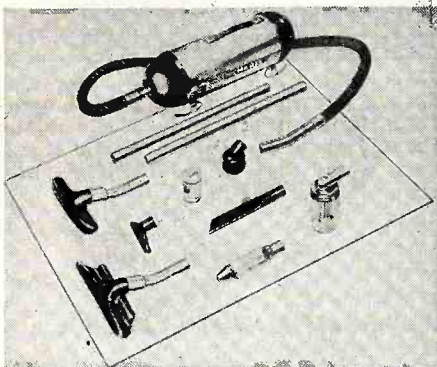

construction. Attachments include upholstery nozzle, round brush, swivel brush, crevice tool, lightweight extension tubes, deodorizer, liquid sprayer, 8 ft. reinforced hose. Premier Vacuum Cleaner Div., General Electric Co., 1734 Ivanhoe Rd., Cleveland, O.—RADIO & Television RETAILING

Handyhot PORTABLE WASHER

Stainless steel portable electric washer; rounded cover of white baked enamel. Streamlined cast aluminum handles finished in contrasting black



enamel. 3-blade aluminum agitator; oscillating agitator action employed. Capacity of seven gallons; washes up

to 3 lbs. of dry clothes. Cover can be removed at any time. Lightweight. Wringer which attaches to washer tub available at extra charge. Chicago Electric Mfg. Co., 6333 W. 65 St., Chicago 38, Ill.—RADIO & Television RETAILING

Knapp-Monarch WAFFLE BAKER

Automatic waffle baker. Signal light indicates when ready for batter. Cur-

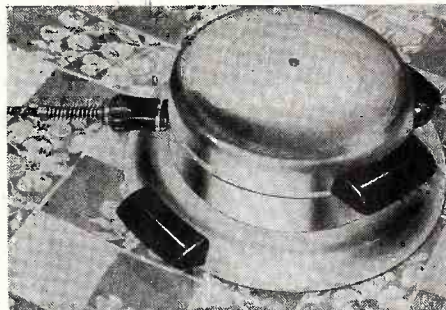

rent cuts off and light goes out when waffles are done. Automatic regulator selects shade desired. Chrome finish. Knapp-Monarch Co., 3501 Bart Ave., St. Louis, Mo.—RADIO & Television RETAILING

Manning-Bowman PERCOLATOR

Model 391; capacity 8 cups. Finished in mirror-like chromium. Natural grain, blonde maple handle. Chromium lined;



dripless spout. Spherical design; glass crystal top. Height 9 3/8 inches. Manning-Bowman & Co., Meriden, Conn.—RADIO & Television RETAILING

Appliances for Retailers

Dominion ELECTRIC IRON

Model No. 1004, deluxe "light-omatic" automatic flat iron; chromium plated. Fingertip heat control knob; indicator shows when proper heat has

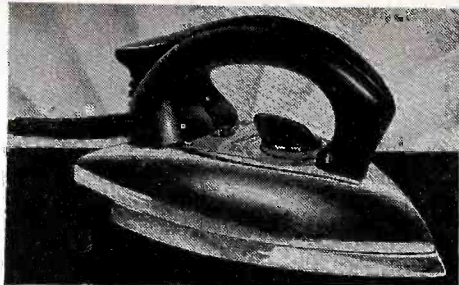

been reached. Iron weighs 4 lbs. Plastic handle, built-in thumb rest. Beveled base. Dominion Electrical Mfg., Inc., Mansfield, Ohio—RADIO & Television RETAILING

Surf SEASON-AIR

Room conditioning appliance with four-season utility. Detachable heater housing makes fan useful in hot

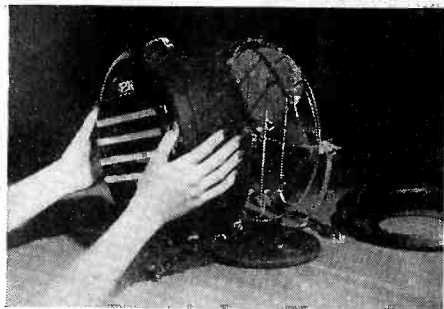

weather or cold. Sturdy all-metal construction with chromium trim; modern in design. Lightweight. G-M Laboratories Inc., Chicago, Ill.—RADIO & Television RETAILING

Ward Leonard LAMP RESISTOR

Fluorescent lamp resistor, plug-in type. Designed for use with single lamp portable fixtures for operation of fluorescent lamps on direct current, up to and

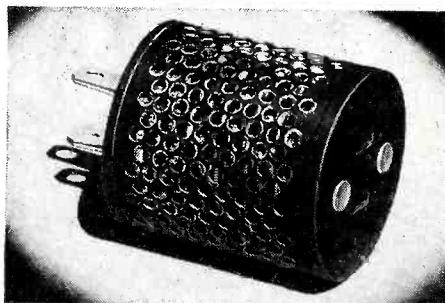

including a 20 watt, 24 inch size. Ward Leonard Electric Co., Mount Vernon, New York—RADIO & Television RETAILING

MatMatic FAUCET WATER HEATER

Faucet water heater attaches to faucet by a single screw, with outlet at faucet level. Automatic signal light



flashes on whenever unit is left operating. Retail priced at \$10.95. MatMatic Home Appliances, Div. of Matam Corp., Long Island City, N. Y.—RADIO & Television RETAILING

Universal "MINUTE-TIMER"

Timer is 2½ inches in diameter with black bakelite case. Gives ringing signal when cooking time is up. So designed that it can time from one to sixty minutes by turning dial to time desired. Landers, Frary & Clark, New Britain, Conn.—RADIO & Television RETAILING

York FROZEN FOOD CABINET

Capacity of 33 cu. ft. Designed for suburban and rural homes. Equipped with quick-freezing compartments to freeze fresh food. Front opening doors,

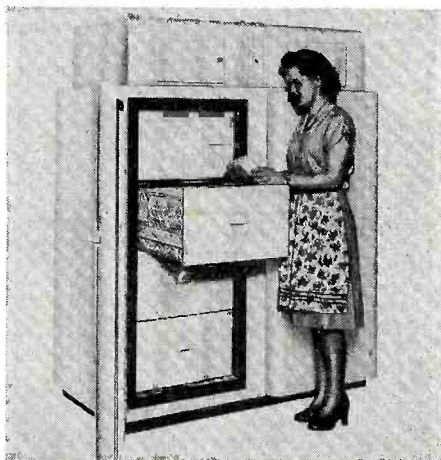

model has condensing unit and controls on top. Size: under 6 ft. high, approximately 5 ft. wide, and 34 in. deep. York Corp., York, Pa.—RADIO & Television RETAILING

Bersted TOASTER

Model No. 68N features: modern design; polished all-chrome finish; wide

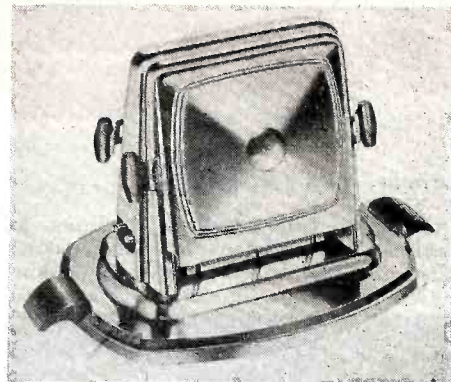

tray base; walnut handles on door and tray; turns toast when doors are opened; Dimensions: 12½ inches long, 8 inches wide, 7½ inches high. Bersted Mfg. Co., Fostoria, O.—RADIO & Television RETAILING

Sno-Breeze COOLER

Window type cooler, with metal fill-ins to fit any window adjustable from 24 inches to 34½ inches wide. Adjustable directional louvres, motor and

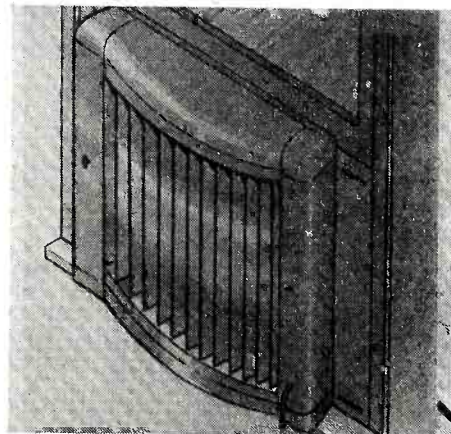

water switches placed on the front of the cooler for control of operation from within the room. Cabinet of rust-resistant steel. Quiet 16 inch fan. Palmer Mfg. Corp., Phoenix, Ariz.—RADIO & Television RETAILING

Selectron ELECTRIC CLOCK

Electric clock equipped with built-in time switch to turn radios on or off. Can also be used on appliances. Self-starting, automatic. Housed in maroon, plastic case. Retail at \$9.95. Arnold Clock Corp., 189 Sunrise Highway, Rockville Centre, L. I., New York—RADIO & Television RETAILING

PROOF
OF
1

LEADERSHIP THAT BUILDS YOUR DEALERSHIP!

No. 1 in the **UNIVERSAL
PRODUCT PARADE**

SENSATIONAL NEW WASHER



The first major improvement in a "Wringer" Washer in 20 years!

With two speeds for every washing need, Universal's new 2-Speed Washer is the *one* Washer for *all* the wash... rough stuff like heavy work clothes at regular speed and a slow gentle action for the fluff stuff like silks, rayons and woolens, all with the simple turn of the Speedselector. It features the new Super-Safe Wringer with Control-O-Roll for complete protection. It is a beauty for double duty.

PROOF in design...

PROOF in performance...

PROOF in value...



PROOF IN FEATURES!

1 Two-Speed Washing Action With the new exclusive Speed-selector gives you two-speeds for every washing need—for the rough stuff—for the fluff stuff.

2 Super-Safe Wringer with Patented Control-O-Roll Feature for easy feeding, no jamming, faster washing with safety.

3 Time-A-Matic Timer times any period from one to fourteen

minutes; shuts off current automatically.

4 Safe-T-Switch automatically shuts off motor instantly in case of overload or stalled Wringer.

5 Red Plastic Sterilator long, wide, triple vanes scientifically designed for thorough washing.

6 Heavy Duty Porcelain Tub... non-clog strainer, and friction drive kwik-pump.

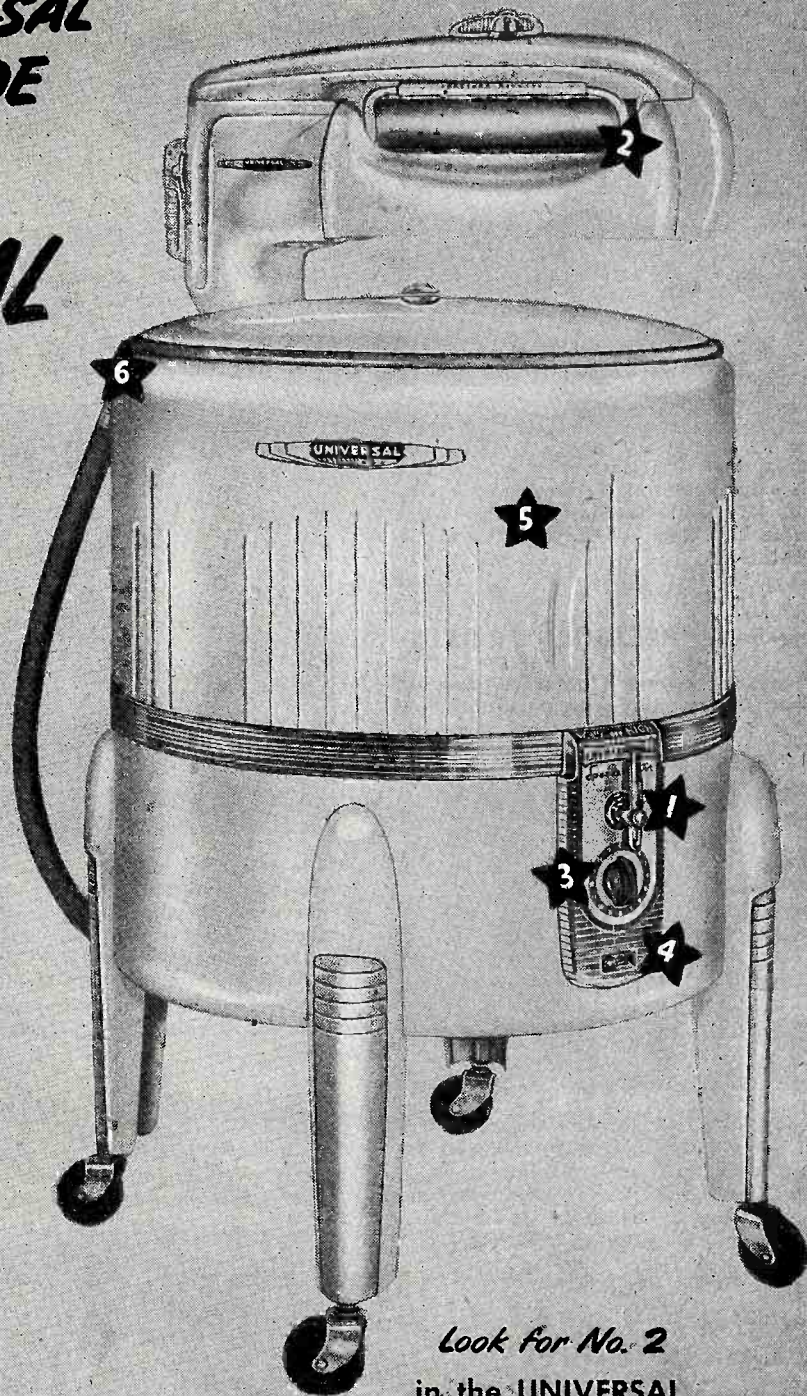

Look for No. 2
in the **UNIVERSAL
PRODUCT PARADE**
Next Month!

UNIVERSAL

LANDERS, FRARY & CLARK
New Britain, Conn.

Universal Electric Appliances Distributed in Canada Exclusively by
Northern Electric Company, Ltd.

See your nearest Universal distributor for full
details regarding this sensational new washer.

New Products for Profits

Babeeze FOOD WARMER

Baby food warmer constructed of spun aluminum and steel; clamps to automobile; operates on car battery.

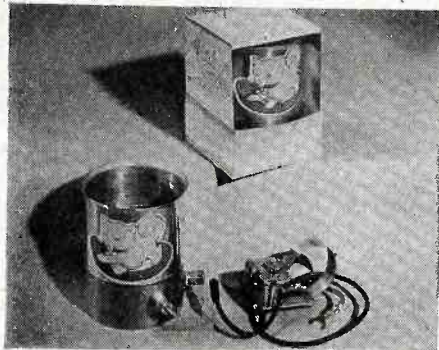

Dimensions: 3 $\frac{3}{8}$ inches deep and 3 inches in diameter. Newsome Bros. Co., Dept. RT, 3321 E. Slauson Blvd., Los Angeles 11, Calif.—RADIO & Television RETAILING

Time-Saver PRESSURE COOKER

Pressure cooker features: floating gasket; safety plug which cannot blow out at a given pressure and does not melt; pressure gauge scientifically cali-

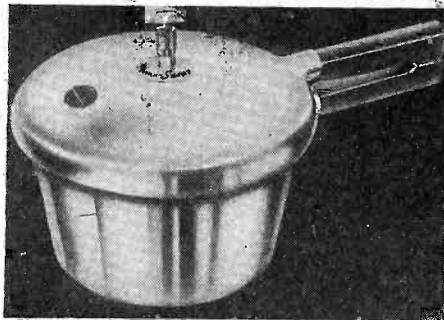

brated; additional steam vents to provide extra safety; pressure released by lifting up knob and placing it in a vertical position. Traubee Products, Inc., 924 Bergen St., Brooklyn 16, N. Y.—RADIO & Television RETAILING

Electricraft FLUORESCENT LIGHT

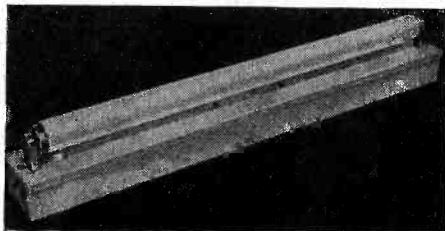

Fluorescent channel lights can be used individually in gang fashion or butted together for continuous strip lighting. Adapted for use in showrooms, stores, display windows and for trough lighting

where special effects are desired. Rust-proofed steel electrically welded throughout and finished with white enamel. Available in three models. Electricraft Corp., 42 Clifton St., Newark 5, N. J.—RADIO & Television RETAILING

Frostmaster FROZEN FOOD CABINET

Model HF-1346. Designed to fit in kitchen. Dimensions: 36 inches high, 26 $\frac{1}{2}$ inches deep, 29 $\frac{3}{4}$ inches wide. Capacity of 3.2 cu. ft. Easy-to-lift cover with one position safety latch, and

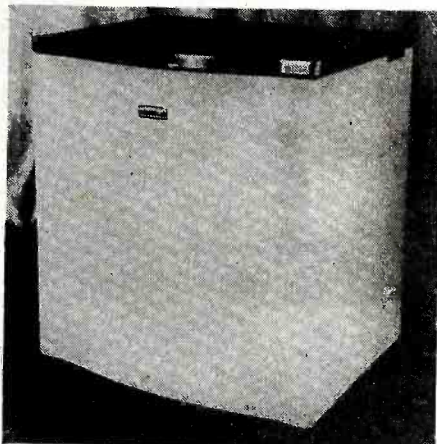
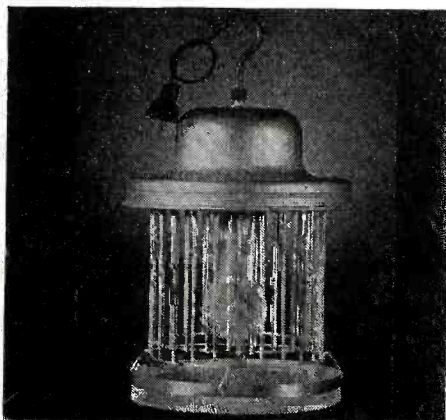

table top work surface of linoleum. Interior and exterior of white Dulux finish. Thermostatic control located beneath cabinet, factory adjusted. Powered by a hermetically sealed refrigeration mechanism. Frozen Food Products, Inc., 600 W. Genesee St., Syracuse 4, N. Y.—RADIO & Television RETAILING

Bugmaster INSECT KILLER

Kills insects by electrocution. Completely weather-proof, can be used with equal effectiveness indoors or out. Unit



will take up to and including a 200-watt lamp. Priced at \$17.50. Engineered Products Co., Cincinnati, Ohio—RADIO & Television RETAILING

Aeropel VENTILATOR

Built-in wall ventilator; gleaming white grill 12 inches x 12 inches. Designed to offer a minimum of resistance

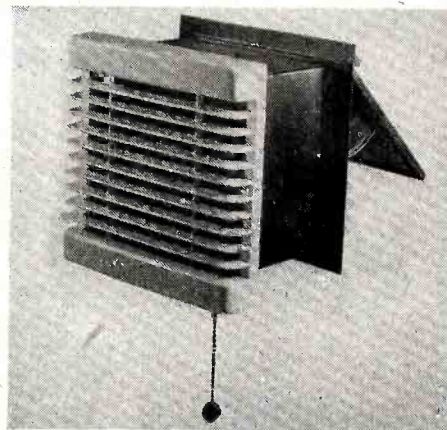

to air flow. 3-bladed propeller type fan driven by enclosed constant speed motor. American Blower Co., Detroit, Mich.—RADIO & Television RETAILING

Kitchen Maid SINK

Double sink unit features: resilient linoleum top, bread cutting board, lid rack, sliding towel rack, cutlery drawer, flour and sugar drawer, bread drawer,

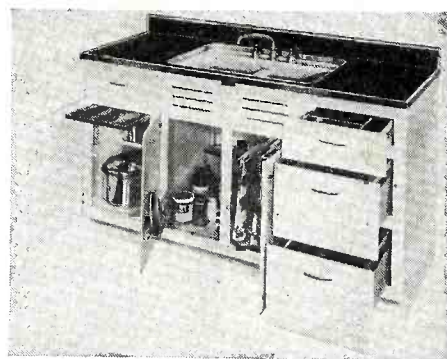

storage compartments for pots, pans, and cleaning supplies. Kitchen Maid Corp., Andrews, Ind.—RADIO & Television RETAILING

Baby Bear ELECTRIC WATER HEATER

Automatic electric water heater, available in three sizes—capacities 3, 5 and 7 gal. Ideal for point-of-use installation under cabinet sinks, in bath rooms, etc. Bodies and tubes of stainless steel; twin-band heat element insures fast reheating as water is drawn off; thermostat to insure automatic operation; asbestos covered electric cord. Vacuum Can Co., 25 South Hoyne Ave., Chicago 12, Ill.—RADIO & Television RETAILING

FOR LATEST RADIO MERCHANDISE, SEE PAGES 44 AND 45

Starting Place

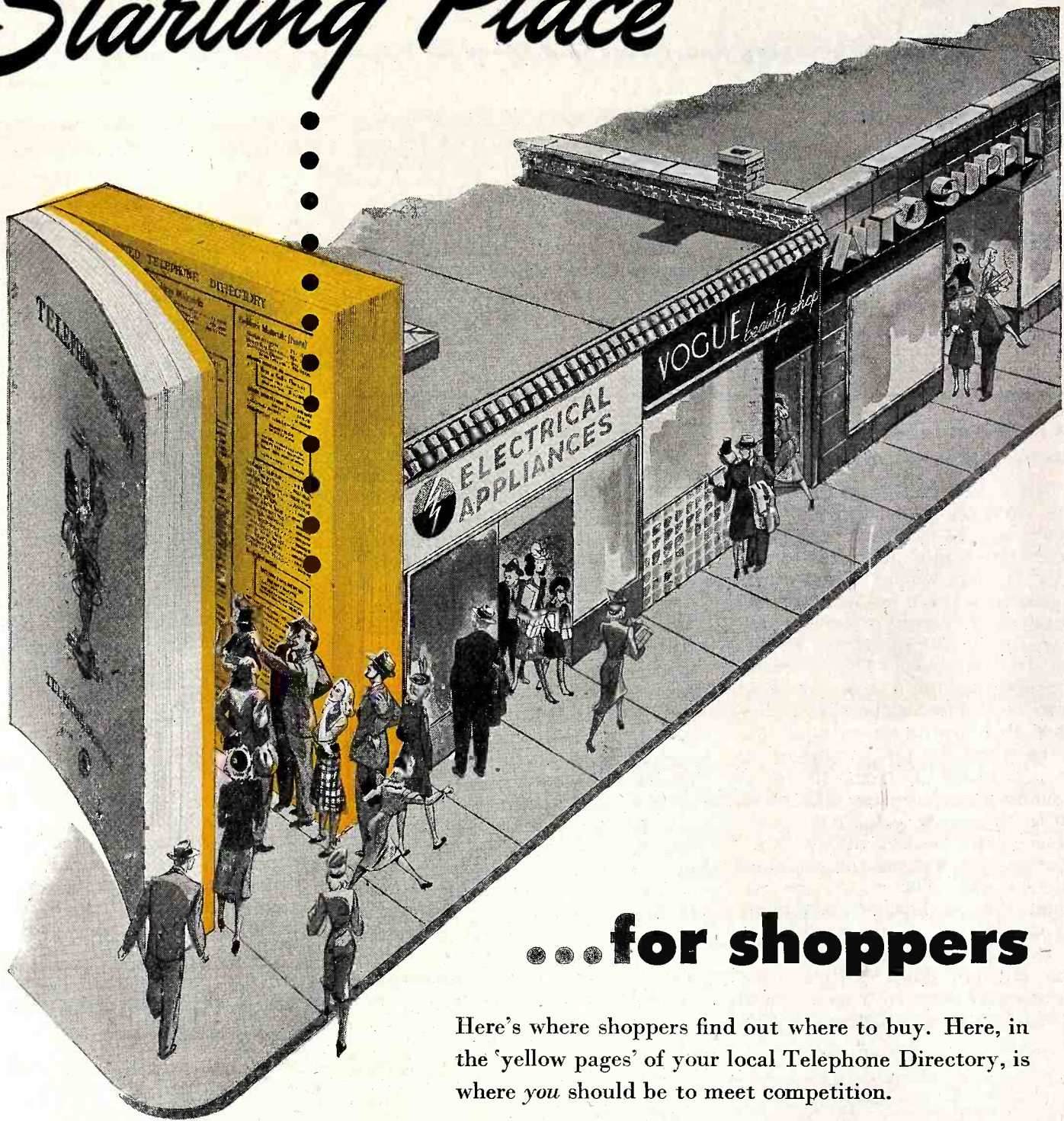

...for shoppers

Here's where shoppers find out where to buy. Here, in the 'yellow pages' of your local Telephone Directory, is where *you* should be to meet competition.

Because shoppers do go to the 'yellow pages' first for buying information, it's important that you be there to meet them . . . to catch their eye, to let them know what products or services you offer, and to direct them your way.

Years of publicizing the 'yellow pages' have helped make them the *starting place* for shoppers. Make sure prospects are started *your way*.



For further information, call your local telephone business office.

Appliance Service Tips

Money-Saving Short-Cuts and Ideas on Repairing and Testing

Timely Repair Hints

Shifting the position of a refrigerator will often eliminate excessive vibration and certain types of noise.

Try heated "penetrating" oil to unloosed "frozen" screw-type caps on top of washing machine agitators.

Brand-new glass coffee makers are frequently returned to the

store with the complaint that too long a time is consumed for the coffee to go "down" into the serving bowl. Save time and trouble by telling customer to remove entire maker from the electric stove as soon as all water has been drawn up into the top bowl. Point is, the heat retained in the element wires for some time after shutting off, prevents the return flow of the coffee.

Wittie Portable Steam Heater Operation Facts

When the unit is plugged into the ordinary socket carrying 110/120 volts AC current, energy is transmitted into the water to create steam, which steam upon reaching 4 to 5 rounds pressure through the pressure control, automatically introduces the electric fan into operation. This is accommodated within a space of from 7 to 10 minutes. The steam pressure then continues to build upward while the fan is running, to a maximum of from 10 to 12 pounds steam pressure. When such 10 to 12 pounds steam pressure is reached, the aforementioned pressure controls automatically shut off the electrical current to the element, the fan, however, continuing to operate.

The fan thus operating, draws the pressure down until a basic pressure of between 5 to 6 pounds is reached, at which time the elec-

tric current is again introduced into the element automatically. This cycle continues as long as the unit is in operation, and by this, clean, efficient, healthy steam heat is circulated into and throughout the room employing such heater.

It is estimated that with the approximate 4245 B.T.U. introduced by the 1250 watt element approximately 100% efficiency is accommodated in the dissipation of such heat. All in all, with the gentle flow, heat so dissipated by the enclosed electric fan, additional safety factors as to proximity with such heater is accommodated for children as well as grown ups.

It is well to remember that although each unit is tested as here-in described, the steam pressure created will at no time ever exceed 12 pounds of steam, and with the electrical safety controls and valves every point of safety has been adequately taken into consideration. Materials used are entirely steel and brass. (Below, Wittie heater.)

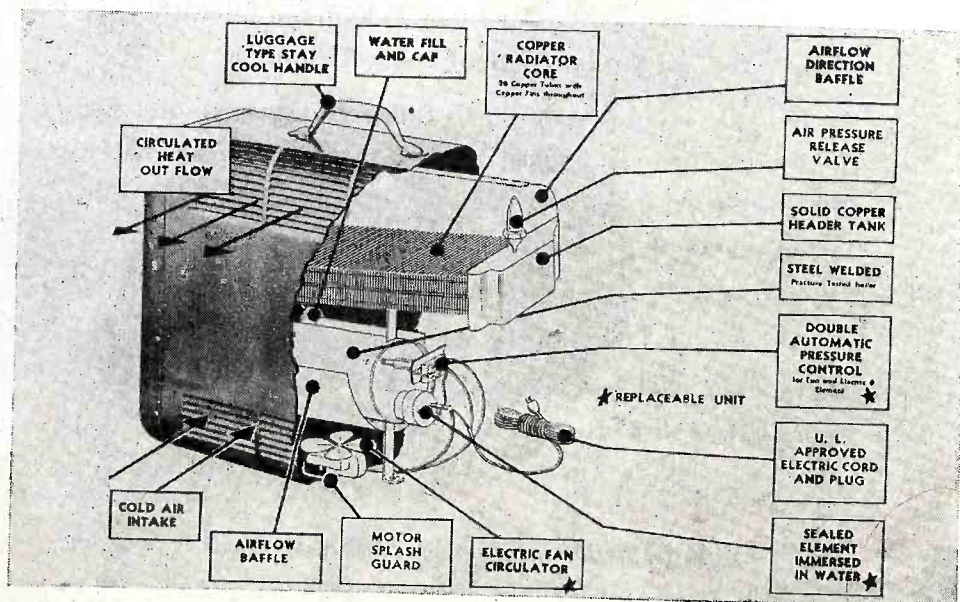

Checking "Poor Suction" on Motor-Brush Cleaners

If motor speed checks OK on a motor-driven brush type vacuum cleaner, and if fan is in good condition, go over the following points:

1. If brush-bristles are worn, re-

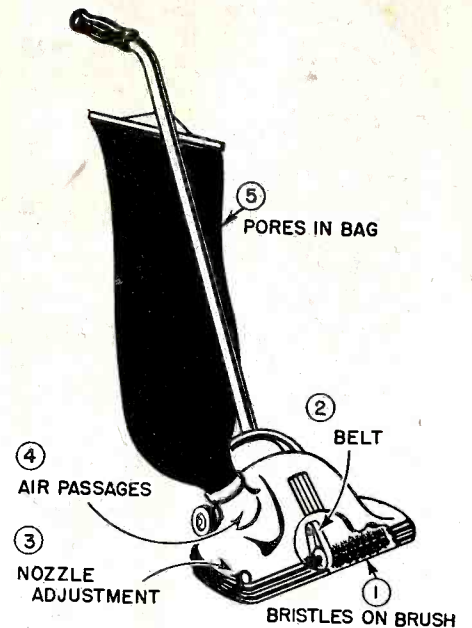

place brush or have re-bristled. 2. Check belt for slipping. 3. Find out if customer knows how to adjust nozzle to floor for proper suction sealing. 4. Check air-passages for clogging. 5. Check bag fabric for caked dirt which prevents passage of air through fabric.

How to Install New Hand Iron Elements

When an electric iron requires a new element, make certain that the terminal posts and plug clips are in good condition or replaced. Be sure to see that the cord is shortened sufficiently to remove all of the brittle wire and hardened insulation. *Always ask for the cord with every repair job*, because the cord might fail shortly after the other repairs have been made and lead to unwarranted complaint on the other repairs.

After the old element has been removed, *clean the sole plate and the pressure plate with a scratch brush*. Make certain that all rough particles that might puncture the mica are removed. Doing this also

(Continued on page 140)

Now! Get records that do these 9 vital jobs...easier, simpler, faster!



- ✓ DEPENDABLE TAX INFORMATION
- ✓ DETAILED SALES ANALYSIS
- ✓ PROTECTION OF MERCHANDISE
- ✓ INFORMATION ON PROFITABLE LINES
- ✓ CONTROL OF CASH
- ✓ ACCURATE INVENTORY CONTROL
- ✓ RECEIPTS FOR CUSTOMERS
- ✓ COMPLETE CUSTOMER LISTS
- ✓ ADEQUATE INFORMATION

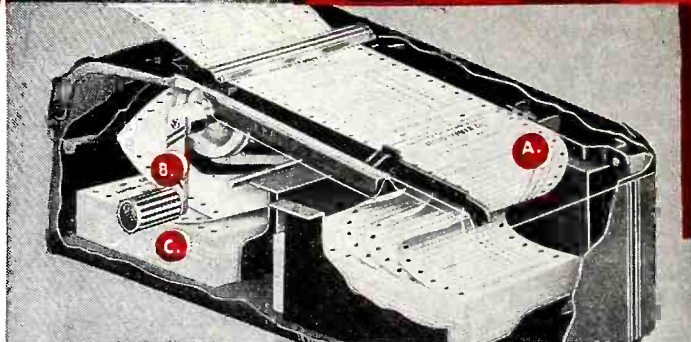

- A. Marginally punched Standard Register forms can't slip.
- B. Pin-wheel feed means extra speed, extra carbons, perfect alignment.
- C. Locked-in copies provide extra protection, positive control.

Radio and Appliance Dealers GET THESE SPECIAL BENEFITS

All records clear, legible, at one writing. Copies for customer, office, delivery and locked-in audit records. No copying errors. Foolproof check against lost records. Fixed responsibility, including delivery receipt. No confusion on terms of sale, payment, or delivery instructions. Complete legal contract and copies with *one* customer signature.

THE STANDARD REGISTER COMPANY

Manufacturers of Registers and Forms
for ALL Business and Industry

DAYTON 1, OHIO

Write for FREE folder! Discover how Standard's pre-tested Formcraft continuous forms and STANDARD'S FORM FLOW REGISTERS give you more complete records with less writing, less work

Many a record system that was "good enough" a few years ago is totally inadequate for the job it must do, today. That's why thousands of firms have adopted Standard Register's modern, exclusive, pre-tested systems and Form-Flow Registers. Standard Register systems help you get better, more useful records *faster*—records that conform to government regulations, income tax reports, and at the same time protect cash, merchandise and consumer good will. Get all the facts. Mail the coupon, today. There's no obligation.

The STANDARD REGISTER Company
Dept. 1300, Dayton 1, Ohio

Please send me Free Standard Register Business Digest which tells me how I can write better records in my business . . . easier . . . simpler . . . faster!

NAME _____

COMPANY _____

STREET _____

CITY _____ ZONE _____ STATE _____

Pacific Coast: Sunset McKee-Standard Register Sales Co., Oakland 6, Calif. Canada: R. L. Crain Ltd., Ottawa. London: W. H. Smith & Son, Ltd.

Latest Lighting Items

New Bulbs, Dealer Helps and Money-Making Plans

Good Light Is Cheap

The efficient bulb salesman should be able to tell his customers exactly how little its costs to obtain adequate lighting in the home. At a 3 cent rate, for instance, you can burn a 40-watt lamp for 8½ hours for 1 cent; a 60-watt lamp for 5 hours; a 75-watt lamp for 4½ hours; a 100-watt lamp for 3½ hours and a 150-watt type for 2 2/9 hours. And all for one cent!

New Lamp Tester at \$4.45

Westinghouse Electric Corp., Bloomfield, N. J., is offering an incandescent lamp tester to dealers. This device, finished in sprayed bronze, costs \$4.45, F.O.B. It is

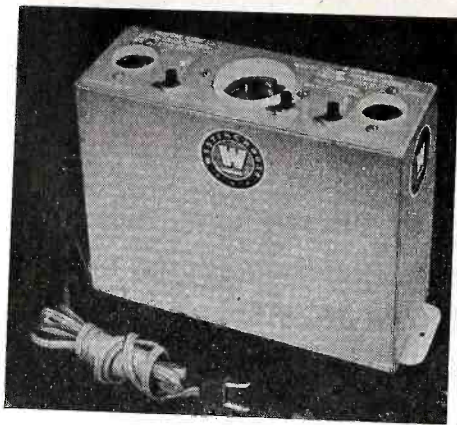

Tests "3-way" bulbs too.

equipped with push-button switches and unthreaded sockets. It will test regular, and medium base lamps as well as 3-light medium and mogul base lamps.

Tan-Lux Health Lamp

Retailing at \$39.95, the new Tan-Lux health lamp, manufactured by the Lux-Craft Corp., 28 So. Day St., Orange, N. J., has been placed on the market. (See page 91, February 1947 for illustration.) The lamp is used to provide sun tan as well as for germ-killing and deodorizing purposes.

New GE Sales Manual

General Electric has a new sales manual for its lamps. This is entitled "How to shine behind a GE bulb counter," and it is filled with valuable selling information, illustrated with cartoons. Among other things, the manual is designed to help sell the right size bulb; to increase the sale of extra lamps for spares; to help salespeople give customers helpful lighting advice and to increase the sales clerk's value to the dealer's store.

Penetray Reduces Price on Pyrex Heat Lamp

The Penetray Corp., of Toledo, Ohio, one of the nation's largest manufacturers of infra-red heat lamps for home and industry, has joined the Ford Motor Co., in its anti-inflationary fight. M. J. Grosse, vice-president in charge of sales has advised distributors by telegram of a major price reduction on the new Penetray heat lamp with Pyrex bulb. The new retail price of the lamp will be \$2.90, reduced from \$3.50.

The product was just introduced to the public last Fall after a large investment had been made by the company in its development and perfection. According to Grosse, this price reduction is being made despite a tremendous backlog of orders as Penetray's contribution towards checking the spiral of rising costs and higher prices.

Coincident with the price reduction, Grosse also announced the launching of an aggressive nationwide merchandising program to expand the markets for its products as a step towards increasing production to efficient and economical levels which provide greater job security and benefits for its employes.

New Small Infra-Red Lamp Hits Market at \$2.25

A new small infra-red heat lamp for localized application of soothing warmth to muscular aches and pains has been announced by D. C. Spooner, manager of the General Electric Company's automatic blanket and sunlamp division.

Weighing only seven ounces and small enough to be held comfortably in the hand, the heat applicator consists of an ellipsoidal ivory-enameled aluminum reflector de-

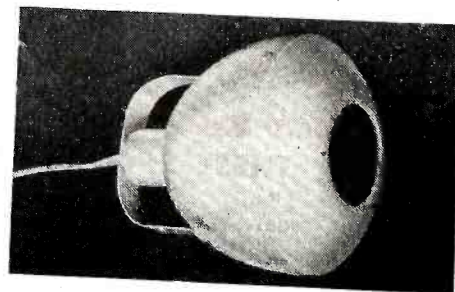

signed to concentrate the heat rays of the 15-watt, 1200-hour lamp through a two-inch circular opening. It is equipped with a six-foot cord.

The lamp operates on AC or DC at a cost of one cent for 20 hours' use. Retail price is \$2.25.

In addition to its use in carrying heat by radiation into the tissues, the new heat lamp is useful for quick-drying nail polish and other similar small jobs.

Modern Kitchen Lighting Job



Well distributed light, without glare, is produced in this model kitchen in Sylvania's new lighting center located in New York City.

Feature **GIBSON** UPS-A-DAISY

THE COOKING ADVANTAGE THAT GIVES YOU THE SALES ADVANTAGE!

Every dealer welcomes an exclusive feature that simplifies his selling job . . . like Ups-A-Daisy, the Gibson range innovation that spells fast sales action. Your customers get more with a Gibson Automatic Electric Kookall Range, for Ups-A-Daisy provides four surface units or three surface units and a Deepwell Kookall. Here's a feature you can promote and display with profit . . . a feature that interests every woman. Feature the Gibson Ups-A-Daisy and gain the sales edge.

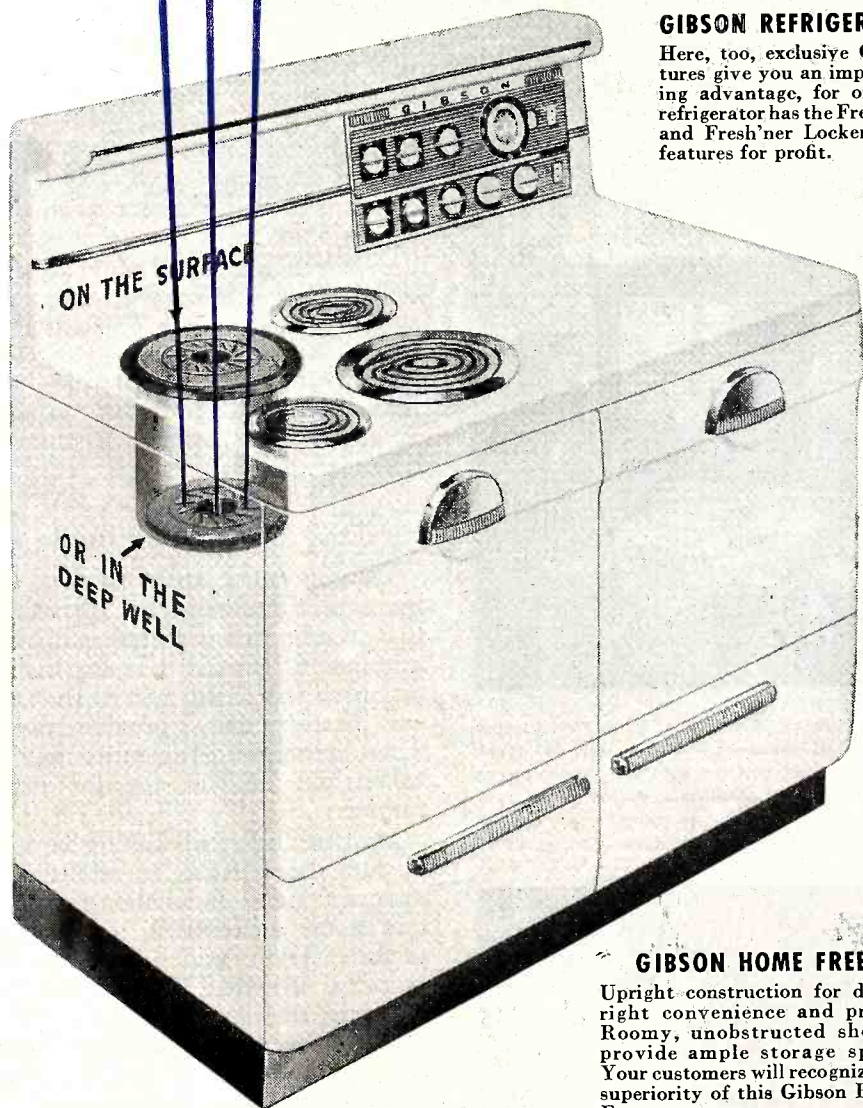

GIBSON REFRIGERATOR

Here, too, exclusive Gibson features give you an important selling advantage, for only Gibson refrigerator has the Freez'r Locker and Fresh'ner Locker . . . twin features for profit.



GIBSON HOME FREEZER

Upright construction for down-right convenience and profit. Roomy, unobstructed shelves provide ample storage space. Your customers will recognize the superiority of this Gibson Home Freezer.

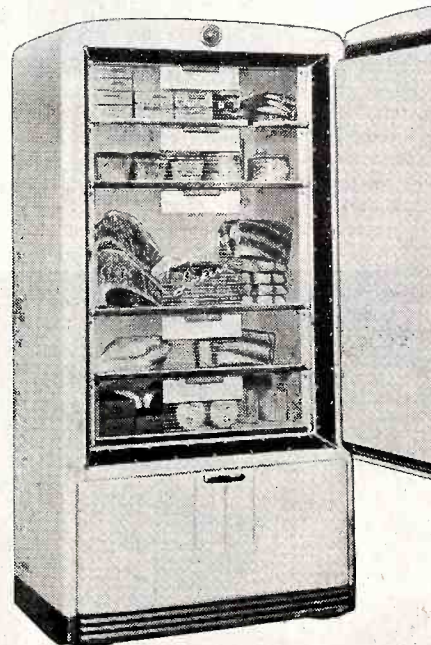

GIBSON REFRIGERATOR COMPANY
GREENVILLE, MICHIGAN

No "Pay" for Servicers

Time-Saving Methods, Incentive Plan, Boost Sales Volume

• The competent technicians who work for Leonard F. Ruhl, owner of Ruhl Appliance Shop, Columbus, Ohio, have developed service short-cuts that do work faster, cut down inventory, or sell customers on a better job.

An employe incentive plan in use by this merchant helps speed servicing and increases the efficiency of his technicians. "I might be called the Jack and Heintz of the radio retailing business," says Ruhl. "I don't have any labor troubles. I don't ever expect any. I never have to wonder whether one of my men is coming to work today or not, and if there is some job to be done that may require working far into the night, I know it will be handled properly. You see, I don't have any employes. Every man who works here is really a *partner!*"

Ruhl's idea is an adaptation of the famous Jack & Heintz profit-sharing plan. Ruhl has five men

working for him now, expects to have more as he expands further, and is planning on an outside sales-force of ten men as quickly as supplies make that possible.

How Costs Are Figured

No man gets any salary at all, nor keeps any record of his time worked. The cost is computed on every job, and half of the profit goes to the man who does the work. On a service job, material cost is deducted from the price and the balance split 50-50. When a customer drives in to have an auto radio installed, the net invoice cost plus an allowance for transportation cost is similarly subtracted from the selling price, and half the difference belongs to the man who handles the sale and installation.

On outside salesmen, Ruhl will work in exactly the same way—salesmen will get half the gross

profit, figured as shown. "I know that they are working and selling in the best way possible because their earnings depend directly upon the quantity and quality of work they do."

In servicing washing machines with new wringer rolls, employe W. M. Crabtree has developed a compact machine that makes it possible to cut down 12-inch rollers to other desired sizes in about five minutes—thus keeping only one size in stock instead of many. This device consists of a $\frac{1}{4}$ h.p. General Electric motor with direct drive $\frac{1}{2}$ -inch lead, converted through a metal adapter to the $\frac{5}{8}$ -inch diameter of the wringer-roll shafts. The other end of the roll is slipped into a chuck which slides (and bolts into position) on the angle iron base. Power is turned on, and an ordinary hacksaw cuts the rubber easily to proper size. Then the chuck is moved back for sawing off excess shaft.

Crabtree has also made a slip-over chuck with precut slits that simplify the accurate cutting of tongue ends on shafts needing this treatment. Total cost of these fixtures was only about \$11, he says, at a welding shop which followed his diagram.

Novel Auto Radio Tip

Another idea that is bringing much profitable business is the selling of standard portable radios for automobile use—with a jack installation on the dashboard so that the car battery may provide power when riding, and the radio may be taken out of the car for other service.

Most of the retail selling is done by Mrs. Doris Ruhl. In addition to an assortment of small appliances and home accessories, major lines include Arvin and Philco radios, Ironrite ironers, Eureka vacuum cleaners, Ilg ventilating fans, Presteline electric ranges, and Coolerator refrigerators.

Ruhl estimates annual sales at \$60,000—but his goal is a \$300,000 yearly business. "And I'll do it, too," he says, "just as soon as sufficient merchandise commences coming out of the factories!"

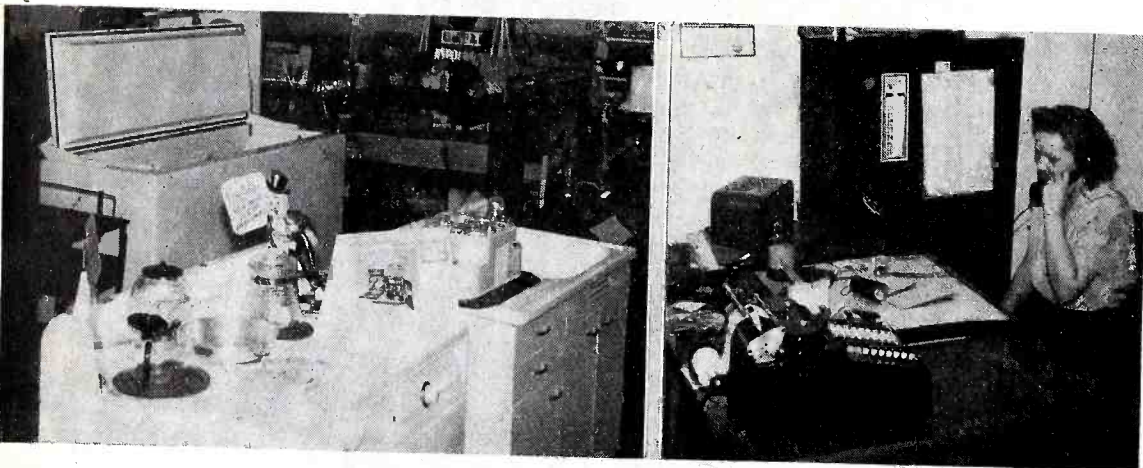

Above, left, this section of the store features electrical appliances. Right, Mrs. Doris Ruhl handles phone orders and inquiries in addition to sales of radios and appliances. Below, left, W. Wynn Rogers installs auto radio. Selling portable radios with jack installation for auto use (see story) is bringing the establishment much profitable business. Right, W. M. Crabtree, washer repair specialist, at work on a major service job. This technician has developed a machine which enables him to cut down 12-inch rollers to desired sizes in five minutes, thus keeping one size in stock.

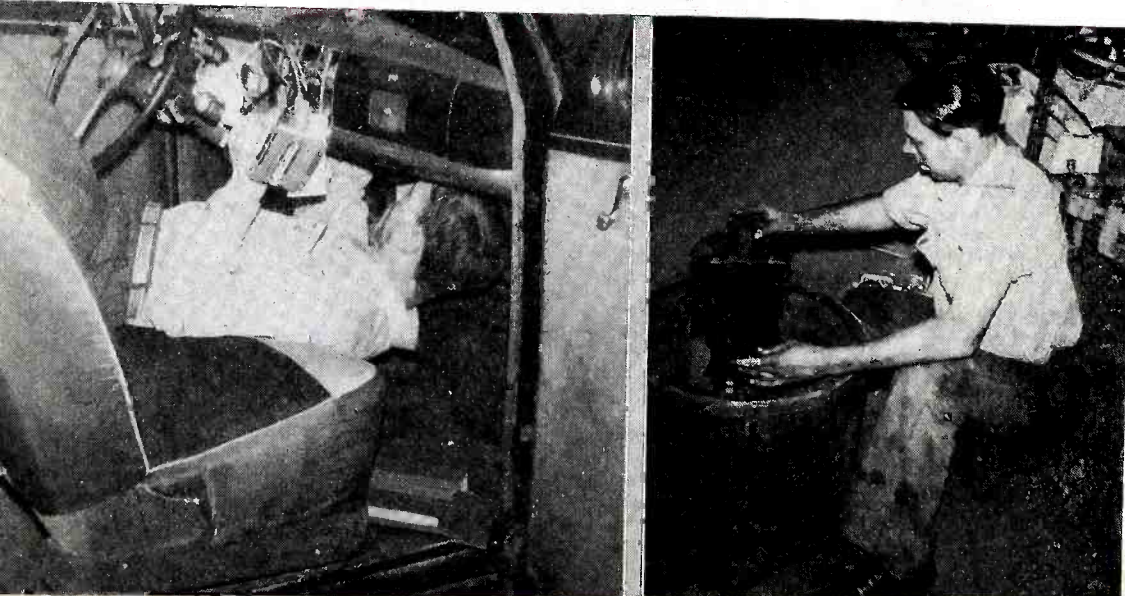

It takes keen perception

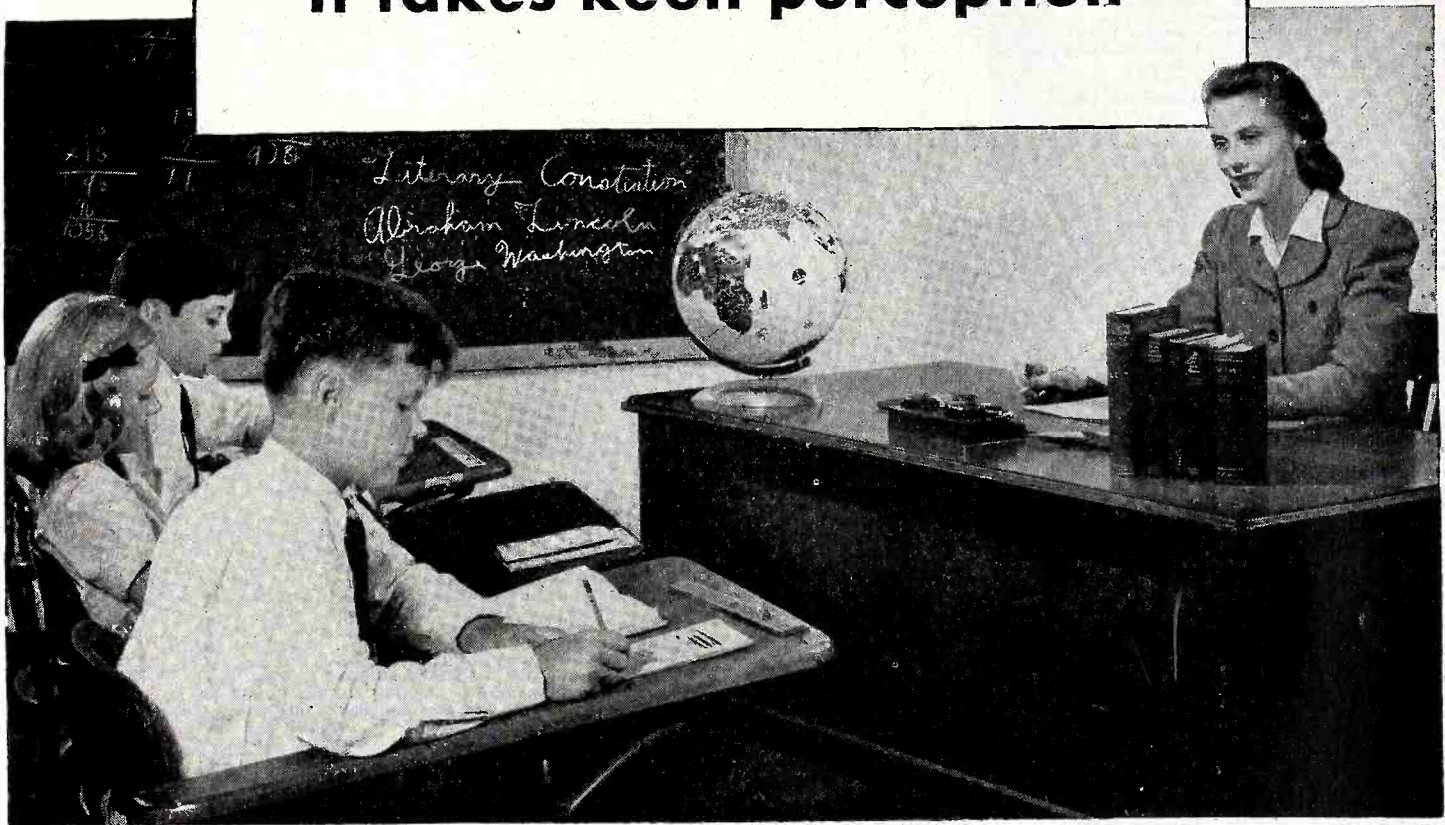

...to spot the "most likely to succeed"

... or to pick the appliance and radio lines that are "most likely to sell." That's true today especially — when there are so many new lines on the market, and when the long-established lines have so many new features.

And that's one reason why hundreds of dealers are glad they're associated with Graybar. They know that Graybar has the judgment and the freedom to select for distribution those lines which will net the highest profits for its dealers. This judgment has been gained — and proved — through many years' experience in distributing all types of electrical appliances and radio for the home. And "freedom of selection" is one of the principal ingredients in the

Graybar success formula. For Graybar — a solidly established, national distributor — has the confidence of leading manufacturers, yet has remained an independent, self-directing organization . . . one that can make unbiased recommendations to its dealers.

Other advantages Graybar dealers enjoy include the convenience of obtaining merchandise from local Graybar warehouses, and the profit-building guidance of Graybar merchandising men.

For information about a Graybar dealership, write *Merchandising Department, Graybar Electric Company, Graybar Building, New York 17, N. Y.*

4730



... an independent distributor with a talent for picking best-sellers

HOME RADIO • TRAFFIC APPLIANCES • MAJOR APPLIANCES

PRODUCTS OF ELECTRICAL APPLIANCE MANUFACTURERS

Listing the companies whose lines cover one or more of the seven groups of greatest importance to retailers and distributors.

The following manufacturers of electrical appliances returned our editorial questionnaire giving the information needed for these listings

Manufacturers not listed may furnish data for the next issue. No advertising obligation. Additions or revisions will be made monthly.

	Refrig.-Freezers	Laundry Equip.	Vac. Cleaners	Elec. Ranges	Gas Ranges	Space Heaters	Traffic Appl.		Refrig.-Freezers	Laundry Equip.	Vac. Cleaners	Elec. Ranges	Gas Ranges	Space Heaters	
Adel Precision Products Co., No. Hollywood, Calif.															
Admiral Corp., 3300 W. Cortland St., Chicago															
Altorfer Bros. Co. (ABC), East Peoria, Ill.															
Amana Society, Refrigeration Division, Amana, Iowa															
American Electrical Appl. Co., 5014 Ft. Hamilton Pkwy., Bklyn.															
American Ironing Machine Co., Detroit, Mich.															
American Stove Co., Algonquin, Ill.															
Apex Electric Mfg. Co., Cleveland, Ohio															
Appliance Indus. of Amer., 666 Lake Shore Dr., Chicago 11, Ill.															
Arista Mfg. Co. (Duchess), Alliance, Ohio															
Arista Associates, 446 Dean St., Brooklyn, N. Y.															
Armstrong Products Co., Huntington, W. Va.															
Atlantic Mfg. Co., Hamburg, Pa.															
Automatic Washer Co., Newton, Iowa															
Barlow & Seelig Mfg. Co. (Speed Queen), Ripon, Wis.															
Beam Corp., West Bend, Wis.															
Bell Appliance & Radio, 125 E. 46th St., New York, N. Y.															
Bendix Home Appliances, Inc., South Bend, Ind.															
Ben-Hur Mfg. Co., 634 E. Keefe Ave., Milwaukee, Wis.															
Berger Electric Co., 109-01 72nd, Forest Hills, N. Y.															
Bersted Mfg. Co., Fostoria, Ohio															
Birtman Electric Co., 4140 Fullerton Ave., Chicago, Ill.															
Blackstone Corp., Jamestown, New York															
Buffalo Forge Co., 205 Mortimer St., Buffalo, N. Y.															
Burkaw Electric Co., 105 E. 29th St., New York, N. Y.															
Calkins Appliance Corp., South Bend, Ind.															
Cameo Products, Inc., 57 William St., New York, N. Y.															
Camfield Mfg. Co., Grand Haven, Mich.															
Carrier Corp., Syracuse, N. Y.															
Casco Products Co., 512 Hancock Ave., Bridgeport, Conn.															
Central Rubber & Steel Corp., Findlay, Ohio															
Century Precision Works, Inc., 503 West 56th St., New York															
Chicago Dryer Co., 2210 No. Pulaski Road, Chicago, Ill.															
Chicago Electric Mfg. Co., 6333 W. 65th St., Chicago, Ill.															
Clements Mfg. Co. (Cadillac), Chicago, Ill.															
Rex Cole Inc., 21-05 51st Ave., Long Island City, N. Y.															
The Coleman Co., Inc. 248 N. St. Francis St., Wichita 1, Kan.															
Conlon Bros. Mfg. Co., 4512 W. Fillmore St. Chicago, Ill.															
Conlon Corporation, 1824 So. 52nd Ave., Chicago, Ill.															
Cooler Corp., Duluth, Mich.															
Copeland Refrigeration Corp., Sidney, Ohio															
Coroaire Heater Corp., Hanna Bldg., Cleveland, Ohio															
Cory Glass Coffee Brewer, 221 N. LaSalle St., Chicago															
Cribben & Sexton Co., 700 No. Sacramento Blvd., Chicago															
Cresley Corporation, Cincinnati, Ohio															
Dalbar Mfg. Co., 1314 Forest Ave., Dallas, Tex.															
Deepfreeze Division, Motor Products Corp., N. Chicago, Ill.															
Detroit Michigan Stove Co., 6900 E. Jefferson, Detroit															
Dexter Company, Fairfield, Iowa															
Dominion Electric Mfg. Co., Mansfield, Ohio															
F. A. Dormeyer Mfg. Co., 4316 N. Kilpatrick Ave., Chicago															
Duo-Therm, Div. of Motor Wheel Corp., Lansing 3, Mich.															
Easy Washing Machine Co., Syracuse, N. Y.															
Economaster Products Co., 9th Ave., Nashville, Tenn.															
Edison C. E. Appliance Co. (Hotpoint), Chicago, Ill.															
Edwards Company, Norwalk, Conn.															
Electric Steam Products Corp., Detroit, Mich.															
Electrical Industries, Inc., 42 Summer Ave., Newark, N. J.															
Electro-King Mfg. Co., 503 N. LaSalle St., Chicago, Ill.															
Electromaster, Inc., 1803 E. Atwater St., Detroit, Mich.															
Electromode Corp., 45 Crouch St., Rochester 3, N. Y.															
Electronic Enterprises, Inc., 1312 Forest Ave., Dallas, Tex.															
Emerson Electric Mfg. Co., 1824 Washington Ave., St. Louis, Mo.															
Empire Appliance Co., 480 Lexington Ave., New York															
Eureka Vacuum Cleaner Corp., 6060 Hamilton Ave., Detroit															
Evanair Division, Evans Products Co., 15310 Fullerton, Detroit															
Faraday Electric Co., 11 S. LaSalle St., Chicago, Ill.															
S. W. Farber, Inc., 141 S. 5th St., Brooklyn, N. Y.															
Featherline Corp., 299 Madison Ave., New York, N. Y.															
Finders Mfg. Co., 3669 S. Michigan Ave., Chicago															
Florence Stove Co., Gardner, Mass.															
L. K. Franklin Co., 1241 So. Hill St., Los Angeles 15, Calif.															
Fresh-nd Aire Co., 210 N. Clinton St., Chicago, Ill.															
Frigidaire Div., General Motors Corp., Dayton, Ohio															
Frostair Div., General Tire & Rubber Co., 332 S. Mich. Ave., Chicago															
P. A. Geier Co. (Royal), 540 E. 105th St., Cleveland, Ohio															
General Consumer Prods. Inc., 4610 N. Western Ave., Chicago															
General Die & Stamping Co., 262 Mott St., New York, N. Y.															
General Electric Co. Appl. & Merch. Dept., Bridgeport, Conn.															
General Mills, Inc., Chamber of Com. Bldg., Minneapolis, Minn.															
Getz Power Washer Co., 1025 Walnut St., Morton, Ill.															
Gibson Refrigerator Co., Greenville, Mich.															
A. C. Gilbert Co., 319 Peck St., New Haven, Conn.															
William L. Gilbert Clock Co., Winsted, Conn.															
Gillfillan Bros., Inc., 1815 Venice Blvd., Los Angeles															
Gill Electric Mfg. Co., Redlands, Calif.															
Glenwood Range Co., Taunton, Mass.															
Globe-American Corp., 101 E. Broadway, Kokomo, Ind.															
G-M Laboratories, Inc., 4326 N. Knox Ave., Chicago, Ill.															
Go Electric Corp., 200 William St., New York, N. Y.															
Grand Home Appliance Co., 2323 E. 67th St., Cleveland, Ohio															
Gray & Dudley Co., 222 3rd Ave., Nashville, Tenn.															
Haines Mfg. Corp., 4754 No. Clark St., Chicago, Ill.															
Hamilton Beach Co., Div. of Scovill Mfg. Co., Racine, Wis.															
Hamilton Mfg. Co., Two Rivers, Wis.															
Hammond Instrument Co., 2915 N. Western Ave., Chicago, Ill.															
Hanovia Chem. & Mfg. Co., Newark, N. J.															
Hardwick Stove Co., Cleveland, Tenn.															
Health-Mor, Inc., 203 N. Wabash Ave., Chicago															
Heinz & Munchauer, 20 Superior St., Buffalo, N. Y.															
Hill-Shaw Co. (Vaculator), 311 No. Desplaines St., Chicago															
Hobart Mfg. Co. (Kitchen Aid), Troy, Ohio															
Holland Rieger Corp., Sandusky, Ohio															
Hoover Co., North Canton, Ohio															
Horton Mfg. Co., 131 Osage St., Ft. Wayne, Ind.															
Hurley Mach. Div. (Thor), Elec. Household Util. Corp., Chicago															
Ilg Electric Ventilating Co., 2874 N. Crawford Ave., Chicago															
E. Ingraham Co., Bristol, Conn.															
International Appl. Corp., 1027 Metropolitan Ave., Brooklyn															
International Detroit Corp., 1501 Beard St., Detroit, Mich.															
International Harvester Co., 180 N. Michigan Ave., Chicago															
Ironrite Ironer Co., 332 Cass Ave., Mt. Clemens, Mich.															
Jackson Appliance Mfg. Co., 75 Front St., Brooklyn 1, N. Y.															
F. L. Jacobs Co. (Lauderall), 1043 Spruce St., Detroit															
Jewett Refrigerator Co., 10 Letchworth St., Buffalo, N. Y.															
Kalamazoo Stove & Furnace Co., Kalamazoo, Mich.															

Refrigerator, Washer in New Norge Line

The Norge division of Borg-Warner Corp. has introduced to the trade its 1947, "20th Anniversary" line of household appliances high-lighted by a brand new nine-cubic foot refrigerator with large frozen food storage space, and a completely re-engineered standard washing machine.

Announced by M. G. O'Harra, vice-president and director of sales, in connection with the showing of the products to distributors and retailers at Chicago, the new products are added to an already comprehensive line of major household appliances produced under the Norge name plate.

The new refrigerator has an "across-the-top" frozen food storage compartment which has a capacity of approximately 35 pounds of food. According to O'Harra, this, and another of the company's refrigerators which has a vertical frozen food storage arrangement, were designed to hold large quantities of frozen foods in response to housewife demand for this type of product. Glass shelves are another new feature of the nine-foot refrigerator.

Noma Reduces Prices on Two Food Freezers

An immediate reduction of \$51 on both Estate and Frigid-Freeze home freezers, models 746 and 1046, has been announced by John M. Bess, executive vice-president of Noma Electric Corp. appliance divisions: the Estate-Heatrola division and Refrigeration Corporation of America.

"That puts us one dollar up on Ford," remarked Mr. Bess as he explained that the reduction from \$450 to \$399 for the model 746 (12 cu. ft. capacity) and from \$650 to \$599 for the model 1046 (20 cu. ft. capacity) was established to conform with the price practice of some stores and to equalize the advantage for all. He indicated that the decision to lower prices was made months ago but awaited assurances from suppliers of materials and component parts.

Huge "Eveready" Plant Opens in New England

Another large industrial plant has been introduced to New England at St. Albans, Vt.—the plant of National Carbon Co., Inc., constructed for the large-scale production of "Eveready" flashlight cases at a cost of approximately \$2,000,000. Operations will begin immediately. When the plant swings into its full schedule, approximately 400 workers will be employed.

Many city officials and civic leaders of St. Albans and adjacent communities attended the plant's opening, which was marked by an informal public inspection.

Cotes Vice-President

Appointment of M. F. Cotes, Duo-Therm general manager, as executive vice-president of Motor Wheel Corp., has been announced by John E. Garlent, president of the latter firm.

What makes a man of parts?

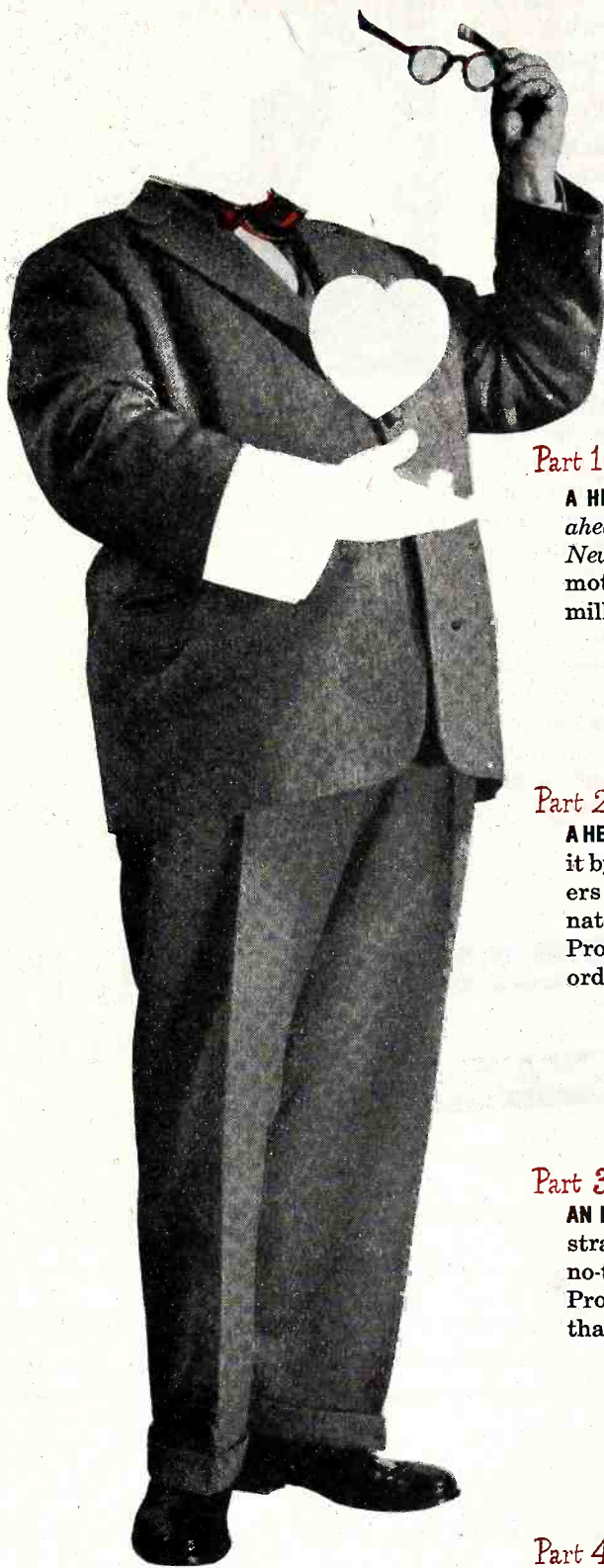

Part 1.

A HEAD FOR BUSINESS . . . he looks ahead, sells ahead . . . uses local *Never-Lift* advertising and promotion to tie in with Proctor's million dollar National program.



Part 2.

A HEART IN THE RIGHT PLACE . . . proves it by recommending his customers wait for the iron that eliminates tiresome lift-work, the Proctor *Never-Lift*, and takes orders for future delivery.



Part 3.

AN EXPERIENCED HAND . . . at demonstrating the amazing "no-lift, no-tilt, no-twist" action of the Proctor *Never-Lift* . . . the iron that lifts itself.



Part 4.

A PROCTOR NEVER-LIFT . . . on display at all times . . . in windows, on counters . . . the most distinctive, most distinguished iron made.

PROCTOR NEWSMAKER IN APPLIANCE MERCHANDISING

PROCTOR ELECTRIC COMPANY, PHILADELPHIA 40, PENNSYLVANIA

Cleaner Sales

(Continued from page 121)

cause the merchant will get many leads via those who bring in broken-down appliances for repair.

If the cleaner he sells has attachments, the salesperson should always try to sell the attachments with the cleaner. Most purchasers really want the attachments at the time they are buying the cleaner. This is proven by the fact that many come in to purchase them some time after they have purchased the appliance.

One of the main reasons that so many cleaners are sold without attachments is because the person who demonstrates them is unfamiliar with how they are attached and how they operate. Fumbling and stumbling through a demonstration is a sure way to knock out a sale of attachments.

Let's go after these multi-sales, thus injecting something new into the vacuum cleaner sales scene, and, at the same time, make more money, and more friends among our customers who will find that we have helped lighten the burdens of home-making.

Eastern Manager



R. H. Pizor, who was previously manager of laundry equipment sales, Norge division, Borg-Warner Corp., has been named sales manager for the firm's eastern region. He succeeds E. L. Frohlich, who resigned to become sales head for Warren-Connelly Co., Norge NY jobber.

Appliance Tips

(Continued from page 132)

assures even, tight pressure on all parts of the element and makes for long life.

Place the element in position so that all of the nickel-chromium ribbon is covered and will be under pressure when re-assembled. To

increase its mechanical strength, the WAAGE No. 1-E-6 element is made with holes in the center instead of a slot. If necessary join two of the holes together by clipping out the intervening mica to make room for the assembly bolts. This is only necessary in rare instances, as the holes are arranged to fit the bolts in the better known irons.

After tightening the pressure plate, test for ground, and connect the element tabs or terminal strips to the posts or terminals. In doing this, do not use asbestos sleeves, because such sleeves crumble away and while the iron may test "clear" on assembly may later on "short" or "ground." There are numerous holes in the element tabs, one of which will fit; fold the tabs if necessary, and trim off what is not needed. Test the posts for "grounds" and "shorts."

In assembling the complete iron, replace all washers under screw heads and handle brackets, because some of these may be spacers which are required to prevent too deep setting or bottoming of the screws on the element. Make a final test. (Suggestion from Waage Mfg. Co., 632 No. Albany Ave., Chicago.

SILTRONIC Temperature **SENTRY**
EASILY INSTALLED TO ANY MAKE, SIZE OR
SHAPE OF HOME FREEZER OR REFRIGERATOR
—for Frozen Food Safety!

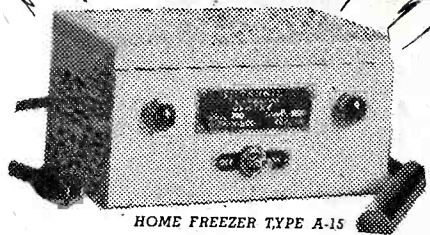

HOME FREEZER TYPE A-15

List Price \$21.50 complete

Automatically
Indicates

- Normal Operation
- Refrigeration Failure
- Power Failure

SPECIFICATIONS

CONTROL UNIT—Sturdy Steel Construction—Baked Enamel Finish—Heavy Duty Electrical Components—6 Ft. Approved Cord—Toggle Switch—Indicates Green Light (Normal Operation), Red Light and Alarm (Operation Failure).

THERMO-SWITCH—Hermetically Sealed Unit—1/10° Sensitivity—Silver Contacts—Instantaneous Operation—Laboratory Adjusted for Operation at 15°F. (Also available at any Temperature Adjustment From 100°-400°F.).

POWER SOURCE—110-115 Volts, 50-60 Cycles.

DIMENSIONS—Length 6", Height 3", Depth 3 3/4".

Other "Siltronic Sentries" for Industrial, Chemical and Laboratory Needs

THE SILTRONIC COMPANY, 320 Penn Ave., Pittsburgh, Pa.

(Inquiries Solicited from Sales Representatives and Distributors)

BIG PROFITS ON IN-DEMAND FAST SELLING ELECTRICAL APPLIANCES

Travel-Maid Traveling Electric Iron	\$4.15	General Mfg. Automatic Electric Iron	\$4.97
Improved Steam Electric Iron	8.48	Streamlined Electric Iron.....	2.37
Mercury Automatic Electric Iron	3.29	1-Burner Electric Stove.....	1.22
No. 1106 Dominion Push-Up Toaster	5.98	Neco Stainless Steel Flip-Flop Toaster	2.94
Faraday Electric Broilmaster	2.39	Novel-Aire 5 Tube Super Wood Case Radio.....	13.79

Write for Illustrated Catalog on Radios, Phonographs, Electrical Appliances, Lamps, etc. 25% With Order—Balance C.O.D.

SHEFFIELD RADIO & APPLIANCE CO. Wholesale Distributors

916 W. BELMONT AVE. Dept. RT3 CHICAGO 14, ILL.

WHO
SELLS
APPLIANCES

?

RADIO & Television RETAILING'S PAID dealer-subscribers—22,000 of them in our 27,000 ABC TOTAL. Many read it exclusively, because with its full merchandising and servicing information on their chief retailing activities, they need no other publication. Its unique helpfulness builds high reader-interest; manufacturers have found since 1925 that means sales.

Westinghouse Shows Line of New Products

Ten new products were shown in Chicago by the Westinghouse electric appliance division. In addition, a new line of redesigned kitchen cabinets, an improved line of electric ranges and the recently introduced electric comforter were being displayed.

T. J. Newcomb, sales manager of the division, reported the following new products on display: a two-temperature refrigerator; a new automatic toaster; a high powered electric food mixer; a streamlined, light-weight aluminum iron; a garbage disposer, the Waste-Away; new upright and tank type vacuum cleaners; a new 40-gallon water heater; a turn-over toaster and a streamlined, low cost fan.

However, the availability of these new products will, for the most part, be limited throughout 1947, according to J. H. Ashbaugh, vice-president of the division. He said that it is apparent the shortages of materials will delay marketing most of them nationally for several months. Some of these new products will be tested in two or three areas in 1947. No increase in the next six months production volume over the volume achieved in the final quarter of 1946 is anticipated on the appliances made last year, according to Mr. Ashbaugh. We may see a general volume increase of around 20 per cent in the last half of 1947, he said.

Toastmaster Adds to Its Sales Organization

Appointment of Edson Berry Thompson as domestic representative for the Cleveland-Pittsburgh territory and of William S. Maclear as the Kansas and Twin Cities territory representative was recently announced by W. E. O'Brien, general sales manager, Toastmaster products division, McGraw Electric Co., Elgin, Ill.

AWIMA President

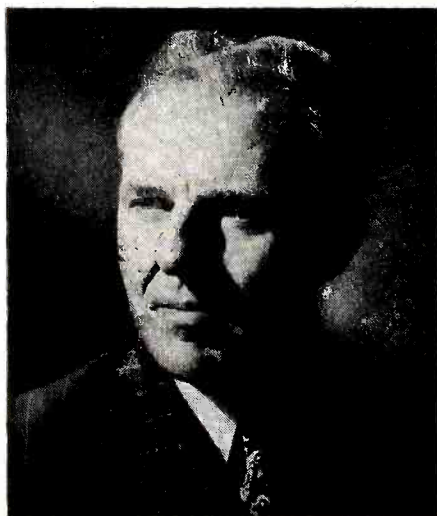

The new president of the American Washer & Ironer Manufacturers Association is Roy A. Bradt, vice-president in charge of sales, service & advertising for The Maytag Co., Newton, Iowa. He's been a member of the AWIMA executive committee for 6 years.

Philco Economist



Dr. Courtney Pitt, specialist in economics, has been named by Philco Corp. as head of its division of economic research. The move was a part of the firm's extensive expansion program.

Sales Changes in Telechron's Territory

David Blair, Jr., Telechron Inc.'s general sales manager, announces the following recent changes in Telechron territory personnel and the addition of a new district.

Harold D. Stanton, former district manager of the middle western district with headquarters in St. Louis, has been transferred to the central district which consists of the states of Ohio, Michigan and western Indiana with headquarters in Cleveland.

John F. Tigue, a former salesman in the Cleveland territory, has been promoted to district manager in charge of the large middle western district encompassing Missouri, Arkansas, Kansas, Nebraska, Iowa and parts of Wisconsin, Illinois and Indiana.

Mr. Blair's announcement also includes the establishment of a new Telechron district consisting of western New York, western Pennsylvania, West Virginia and Kentucky with headquarters in Pittsburgh, Pa. Richard D. Tyler, formerly a salesman working out of the Chicago office, has been appointed district manager of this new district.

With this new territory Telechron Inc. now has twelve district offices located in important marketing areas throughout the United States.

National Launches Large Sales Campaign

The National Stamping and Electric Works of Chicago, makers of "White Cross" electrical appliances, has appointed Geyer, Newell & Ganger, Inc., to direct its advertising.

Among products which National is now manufacturing are, a new automatic toaster, waffle irons, coffee vacs for home and commercial use, a lightweight automatic electric iron, and table electric stoves.

Initial promotion of the company's line was launched in an extensive list of trade papers.

The "White Cross" electrical appliance firm, which has been in business 55 years, recently became a subsidiary of the Eureka division of the Eureka Williams Corp. of Detroit, Mich., and Bloomington, Ill.

Four New Receivers Announced by Galvin

Four new short-wave and standard band Motorola receivers with spread-band tuning will be made available soon by the Galvin Mfg. Corp., Chicago. These models are designed for world-wide usage not only in temperate zones, but also in tropical latitudes having high temperature and humidity. The new Motorola models are humidity-proof throughout, with dustproof speakers and rust-proof chassis.

Because tropic areas produce more than one hundred thousand known types of fungi, these short-wave radios have been tropicalized and fungus-proofed. Radio engineers at Galvin drew upon three years' experience designing short-wave high frequency portable 2-way radios for overseas use by the U. S. Army Signal Corps to make the new shortwave radios efficient under severe climatic conditions. Only the best possible performance and utmost reliability has been built into this new line of Motorola receivers.

Increased Production in New Radio Era

"Production of Garod receivers in the first six months of '47 will be greater than all of 1946—and for the second six months the picture looks even brighter," declares Max W. Weintraub, president of Garod Radio Corp., in an annual statement. "Greater production will now be possible because of increasing availability of materials, general labor stability, and relaxation of government price controls." The year 1947 marks the silver anniversary of Garod.

Mr. Weintraub called upon retailers to keep pace with manufacturers' promotions. "A new dynamic brand of merchandising will be brought into play by the aggressive retailer—to do the first real selling job in years."

Soundmirror on the Market

Immediately preceding the initial marketing of the new "Soundmirror" magnetic tape recorder produced by the Brush Development Co., 3405 Perkins Ave., Cleveland 14, Ohio, a special showing was held at New York's Lotus Club. Notables of the stage and screen performed to demonstrate the wide capabilities of the instrument, following advertising and sales manager Blair Foulds' feature speech.

Mr. Foulds traced the development of the Brush organization from the days of its pioneering work on rochelle salt piezoelectric crystals up through its wire recording manufacturing activity during the war, to the final achievement of the new equipment which uses a 1/4 inch paper tape having an extremely thin coating of microscopic magnetic particles.



PAPER

CAPACITORS

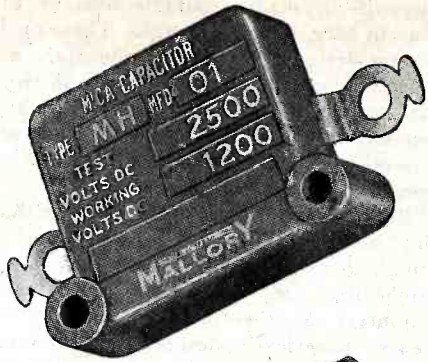

MICA



ELECTROLYTIC

MALLORY Precision Quality is Built in All Three

Service jobs that don't kick back are the ones that make a profit for you. When you use Mallory capacitors in your service work, you use capacitors *that don't kick back*. That's true whether the job calls for paper, mica or electrolytic capacitors.

Most servicemen know the big things behind Mallory capacitor quality. But there are many extra little things, too, that contribute to their life, uniformity and dependability.

Raw materials, for instance, that are held to an impurity level of less than one-half a part per million. Manufacturing techniques that prohibit human hands from even touching the capacitor cartridges. These are examples of the little things that make a world of difference in the final product. No wonder so many radio servicemen say:

You Expect More and Get More . . . from Mallory

P. R. MALLORY & CO. Inc.
MALLORY

VIBRATORS . . . VIBRAPACKS* . . . CAPACITORS . . . VOLUME
CONTROLS . . . SWITCHES . . . RESISTORS . . . FILTERS
. . . RECTIFIERS . . . POWER SUPPLIES.

*Reg. U. S. Pat. Off.

APPROVED PRECISION PRODUCTS

P. R. MALLORY & CO., Inc., INDIANAPOLIS 6, INDIANA

SERVICE & SOUND

Section of **RADIO & Television RETAILING**

FM Service — The Profits at Stake

• Mass scale FM has arrived. During 1947 a great many well-known makes of FM sets will be sold by the nation's radio retailers, to be followed by a gradual increase in the incoming flow of repairs.

Up until now, some retailers have avoided FM service jobs, and many, indeed, have even side-stepped thinking about the matter. But now is the time for decision, for while FM service properly handled can become a fine business-builder, improper handling can be a big black eye to any radioman.

The general public thinks of FM in somewhat the same light it observes atomic energy and MIT's mechanical brain. It is hungry for FM, but knows little about how it works. Only the salesman who can explain it intelligently, and guarantee reliable servicing, will have much prospect of doing a big merchandising job on these new sets.

Doing anything less than a satisfactory job will, to be sure, result in a quick loss of the reputation of the store, and a drop in traffic through other departments as well.

For these reasons, it will pay to make immediate plans for a complete FM service setup. For this, two requirements must be fulfilled: an expert FM servicer must be on the staff, and new, suitable test equipment must be purchased.

How much do you know about FM? Have you carefully studied the many excellent theoretical books which are advertised to servicers? Have you attended any of the spare-time or part-time schools for studying FM which many radio manufacturers, colleges and radiomen's clubs have set up? Do you ask questions of other servicers you know? Make it your business to prepare yourself technically im-

mediately, for you will need this knowledge sooner than you think.

Beginning with this issue, RADIO & Television RETAILING institutes a continuing series of articles that explain FM from the practical troubleshooter's point of view, with notes on current experiences of radiomen with all the new receivers. Study these explanations, and file them away for recurrent use.

The matter of suitable test equipment is not to be lightly decided. Certain basic instruments should long ago have been in the possession of efficient radio servicers, such as a vacuum-tube voltmeter, output meter, signal tracer and alignment generator.

Other essentials will probably have to be bought now, including a vhf signal generator of some sort,

and possibly a sensitive zero-center low-range voltmeter and a field strength meter. The first two are minimum needs for alignments.

While these basic units will permit servicing with a moderate investment in equipment, the forward-looking radioman who sees service as one of his four basic stocks in trade, will purchase an oscilloscope and FM-type signal generator which will allow FM alignments and troubleshooting to be done in a fraction of the time.

Finally, having decided to take steps to set up an adequate service department, the wise retailer will advertise that fact. Make a window streamer and tell the cautious passer-by that your store's service guarantee is backed by the most modern FM service shop in town.

The ideally-equipped service shop has nine basic instruments for FM servicing

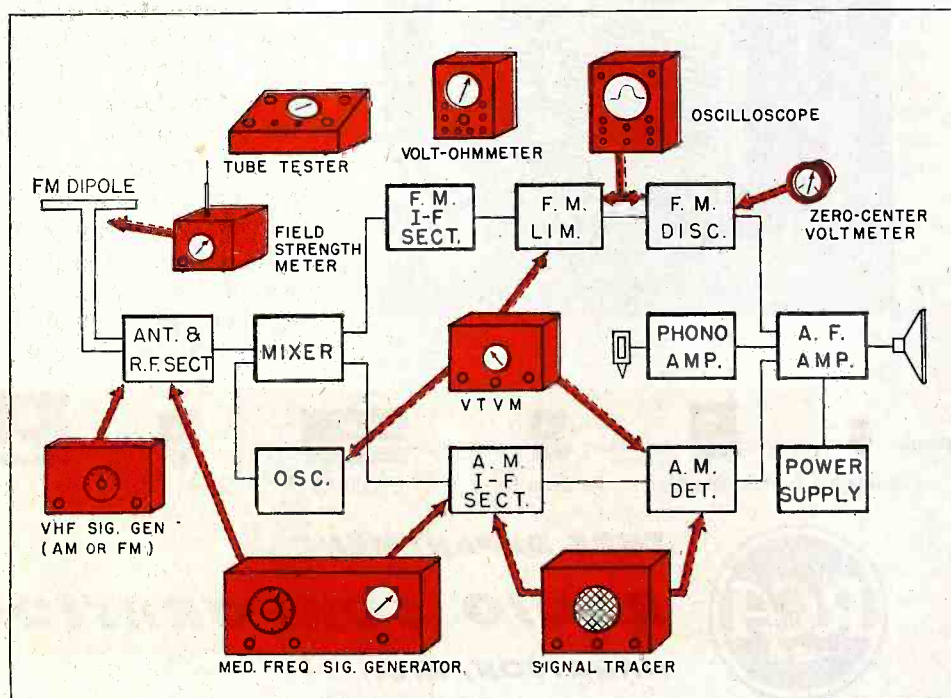



**Biggest
Year in
Portables**

**Get ready for record sales
with RCA long-life Batteries**

You're set to gain three ways by stocking RCA Preferred Type Radio Batteries for what looks like the biggest "portable" business in years.

- 1. Overwhelming Acceptance**—Customers prefer RCA types because they know RCA Batteries are designed and sold by radio specialists.
- 2. Extra Listening Hours**—RCA Batteries have longer life than prewar types—and they're engineered for radio.
- 3. Less Competition**—RCA Preferred Type Batteries are sold primarily in the *radio* retail field. This means a more extensive and profitable battery business for you.

RCA Batteries are smartly packaged and competitively priced. You can get your stock conveniently and quickly from the same RCA Distributor who supplies you with RCA tubes, parts, and test equipment.



TUBE DEPARTMENT

RADIO CORPORATION of AMERICA

HARRISON, N. J.

How to Install FM

Points to Watch in Setting Up Roof-Top Antennas

• Although there are well-known exceptions about which people like to spin yarns, the fact remains that FM signals, like television, are radiated along the "line of sight" of the transmitter. As a result, it can be said that if a person standing at the receiving antenna site could not see with a good telescope in clear weather the transmitter antenna site because of tall hills or mountains, large stone and metal buildings, the curvature of the earth, etc., good reception cannot be assured.

To install an FM radio in such a case may require exceptionally tall antenna masts, carrying aerials cut exactly to the wavelength of the desired stations, with reflectors and "directors" oriented carefully

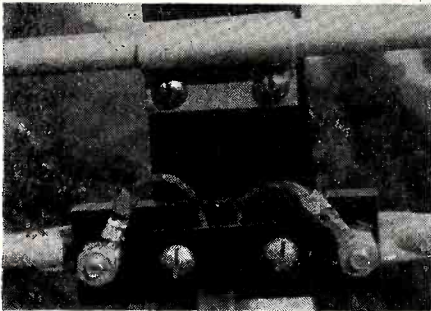

Taco folded dipole shows snugly-clamped lead.

to have great sensitivity in the direction of the transmitter.

Another factor is often overlooked by dealers selling FM sets in low-signal areas. FM is, and justly so, termed "static-free". This is true, however, only when a certain minimum value of signal is received from the station. Weak signals, although they may be heard perfectly well, do not have the power of causing the FM limiter to work perfectly.

If, therefore, after having exploited the possibilities in well-designed antenna arrays and tall masts enough signal is still not available, careful attention should be paid to the most obvious sources of static in the house and neighborhood. Past issues of *RADIO & Television RETAILING* (such as Nov. 1946, p. 119) have explained the causes and cures for most of the noise about the home, and these should be investigated.

In severe cases, where signals are to be picked up from more than

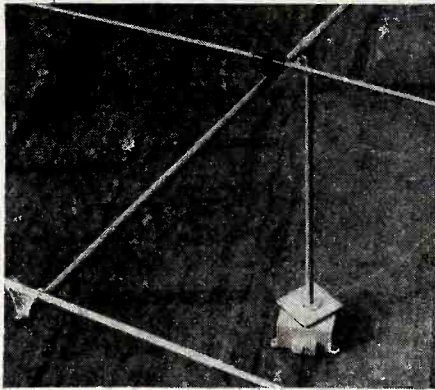

Workshop Associates sell this rotator, remotely controlled for optimum reception.

one general direction, a convenient method of increasing signal strength is to use a rotating antenna, which can be made to turn automatically to face the direction of each desired station as the set is tuned from one to another.

Having figured out a general line of attack for the installation of a given receiver in a given location, strong attention must be brought upon making the most of the case.

Many excellent antenna setups have been made worthless by poor mechanical and electrical connections. First of all, the proper mounting means must be used, which will guarantee the mast from working loose as a result of winds. Several companies make a specialty of manufacturing equipment just for the purpose, of which several types are shown. The installation man should be well trained along the lines of construction work, aside from an under-

Antenna supports are selected to fit individual conditions. Some typical types are shown.

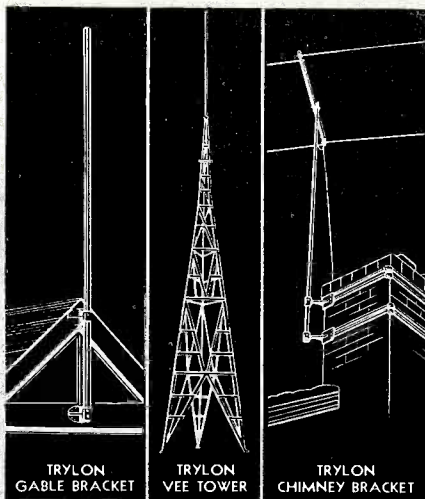

standing of fundamental antenna sensitivity patterns.

Unlike long broadcast antennas, dipoles often have connections made by means of nuts, screws and washers. Unless great care is taken in locking such joints tight, the ultimate loose contacts are going to make a noisy installation.

Be sure also to tape the lead-in down close to the connection points, to prevent breaks in the wire as a result of vibrating or swaying leads. The ends of hollow dipoles are another bad point, which tend to corrode and split, especially during freezing days.

The antenna arrays shown on this page are of the type which have greatest directionality in a horizontal plane, causing greatest pickup from certain points of the

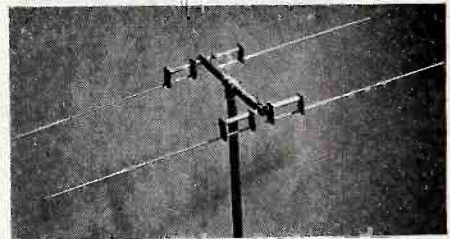

Shur "Interceptor" dipole with reflector.

compass, depending on their orientation. For most city installations, however, the vertical array, consisting of a dipole having the active element suspended parallel to and above the reflector element will be better. Its action is to discriminate against signals coming from the building and roof below it, which is a great source of static noise. Adding another parallel vertical stack $\frac{1}{2}$ -wave behind the first will produce a horizontal as well as vertical reception pattern.

In these instances, it can readily be seen that from the dealer's viewpoint, the sale of an antenna installation job may be at least equal in importance to the sale of the set itself. Of especial importance is the know-how of good antenna structure in neighborhoods in which a great deal of sloppy work by competing retailers have produced wide dissatisfaction with the results from FM purchases. Fast, smart technical work in such a situation will sew up a lucrative territory for many a dealer who knows how to merchandise service along with radios.

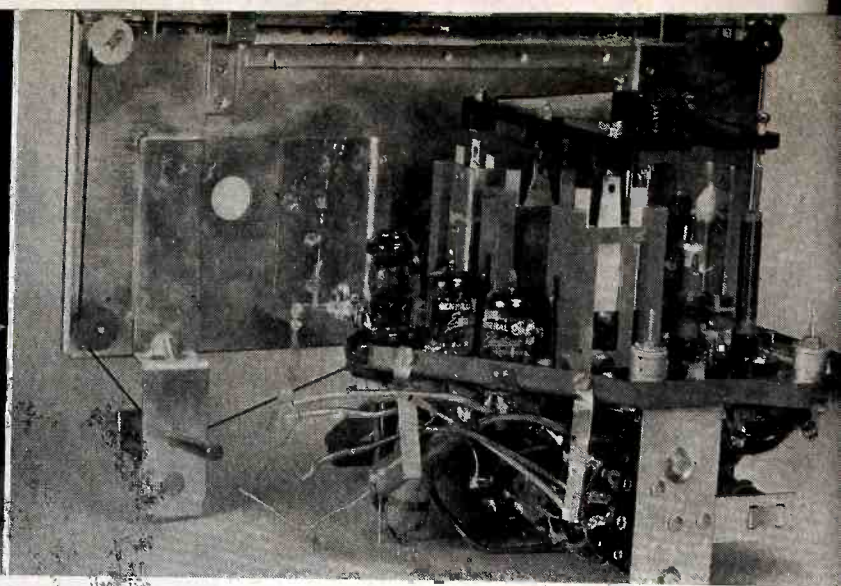
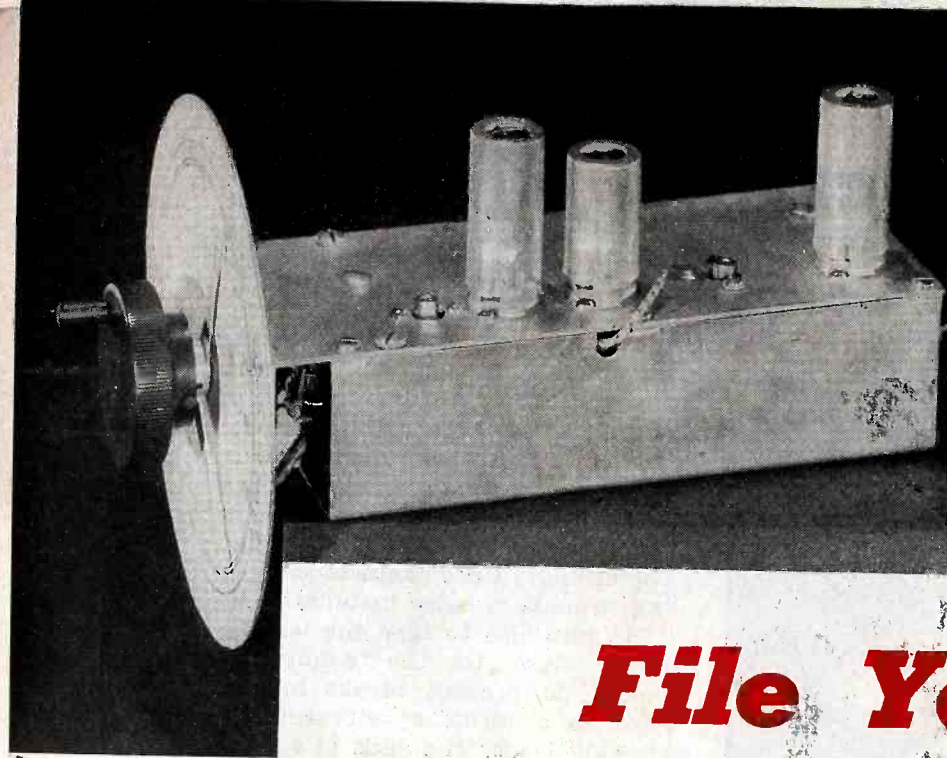

File Your Claim in

Begin Here to Learn the Basic Troubleshooting Methods.

• Except for the limiter-discriminator circuits, FM receivers have basically the same elements as the familiar AM superheterodyne receivers. Those circuits preceding the limiter and discriminator in an FM receiver differ only in their bandwidth and are generally operated at higher frequencies than those of the AM superheterodyne.

Therefore, troubleshooting an FM receiver presupposes a familiarity with generally-encountered troubles in superheterodynes such as undesired signals, weak signals, or a dead receiver. In addition to these there are noise and distortion to be considered.

FM Adds New Faults

However, unlike the AM receiver the presence of noise or distortion in an FM receiver can have causes unique for an FM receiver which will not apply to a similar condition in the AM receiver. Furthermore, it is quite common for certain faults to exist in an FM receiver which make no noticeable indication upon which the serviceman can put his finger, while the same condition in an AM set would cause noises, beat notes and other readily-identified symptoms.

We shall avoid in this discussion any reference to conditions in the audio systems due to the usual defects common to all radios, or to failures of the sets which are primarily due to component defects in the power supply or controls. Also, we will assume that normal voltages are present and that the tubes are all in good operating condition.

The tube checker and multimeter are the only tools necessary for this service.

For thoroughly testing the FM receiver an FM signal generator is a necessity. In addition, some means should be available to measure the limiter grid current, the center frequency, and to observe the discriminator cross-over characteristics. The last is best accomplished with the oscilloscope, although it is also possible with a high impedance d-c VTVM.

The center frequency deviation can be observed with a sensitive zero center meter having a range of 150-0-150 microamperes d-c. This is connected through a series current limiting resistance of about 1 megohm across the discriminator diode output, as illustrated. Shown as an alternate is a d-c VTVM.

Limiter grid current is measured by means of a d-c 0-1 milliammeter placed in the ground end of the limiter grid leak. Two types of limiter grid leak circuits are shown, with the meter correctly inserted.

Having provided a means for ob-

serving the limiter grid current, center frequency, and general discriminator action, the receiver should now be set up for alignment and overall response characteristics.

If an FM receiver is set up with the signal generator and oscilloscope as shown, any difficulty due to the failure of some portion of the RF system in the set can be immediately observed when a response check is attempted, and steps taken for its correction. A number of conditions that have been encountered in the author's experience are shown as patterns observed on the oscilloscope.

How to Make S-Curves

These patterns are made by applying the r-f output of FM signal generator (or sweep generator) to the radio's input, while feeding a portion of the generator's modulating voltage to the oscilloscope.

If the generator's modulating voltage is a saw-tooth wave, and provision is made for connecting

Alternative methods for connecting indicating meter for alignment of discriminator. Zero-center meter is preferable, but VTVM is also handy if it has a polarity-reversing switch.

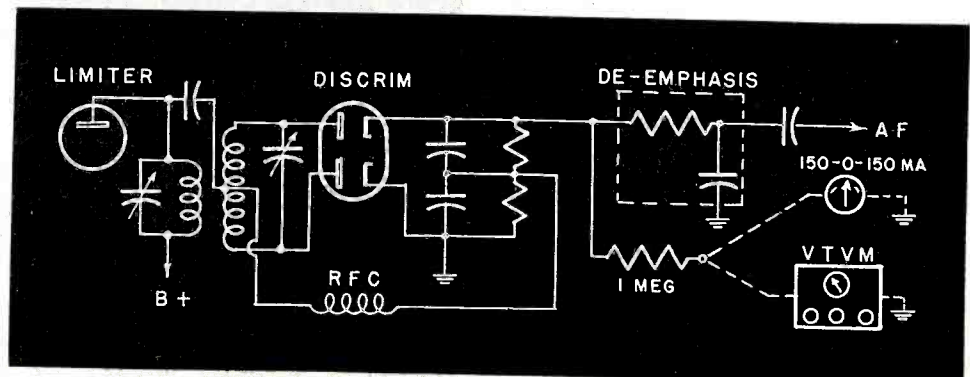

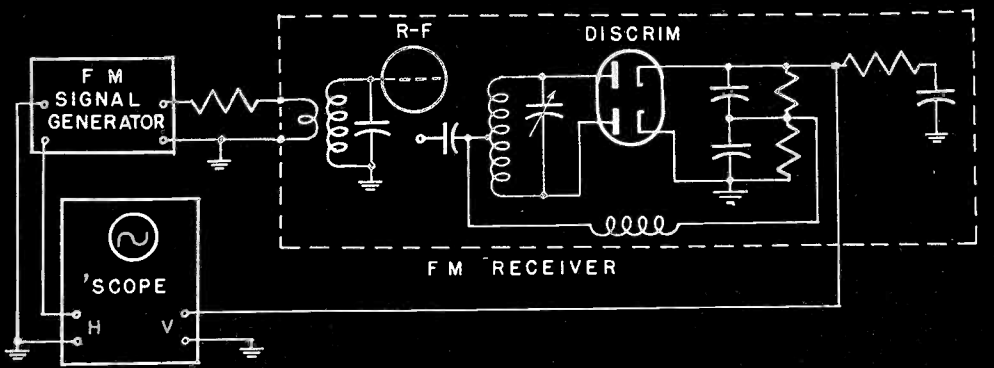

FM Servicing

Establish Your Reputation for Fast, Reliable Repairs.

a portion to some external apparatus, the modulation may be applied directly to the horizontal amplifier terminals of the oscilloscope as shown. If the sweep voltage is sine, however, better results may obtain by connecting to the external synchronization input, and using the internal saw-tooth of the oscilloscope.

What S-Curves Tell You

The vertical plates are connected to the output of the discriminator. As a result of the repetitive sweeping of an r-f signal through the FM receiver, the discriminator output voltage varies in value and polarity, producing the well-known discriminator S-curve as shown in the first, top illustration, when it is operating correctly.

In the illustration underneath, the pattern reveals an S-curve which is acceptable except for its narrowness, indicating a narrow overall bandwidth which would result in loss of high pitched tones.

The severe unbalance of the pattern, third from top, shows the result of a discriminator which is not tuned to the center frequency of the r-f circuits, while the next view downward demonstrates the case of a local oscillator which is not tuned to the center frequency of the i-f and discriminator circuits. It is presumed, of course, that a well-calibrated FM generator is used.

The fifth figure in the sample row shows the pattern observed when the FM generator sweeps through an i-f amplifier with a bad tendency to regeneration, while the bottom right-hand trace is caused

by a detuned or non-tracking r-f amplifier.

While the combination of FM generator and oscilloscope permits very rapid determination of the S-curve and overall response of the receiver, approximately the same information can be developed by other, more tedious means, namely, the r-f oscillator and VTVM.

In the latter case, a check of the output voltage's polarity and value should be taken every 10 kc across the full 200 kc bandwidth, and the results plotted on graph paper. After working with a set for a while, approximations can be made by eye without actually plotting the values. This will permit relatively rapid alignment and adjustments, provided a careful plot is again made at the end of alignment.

The next article in this series will discuss specific causes and remedies for the conditions revealed in the S-curves, as well as typical limiter troubles. However, there are other points in an FM set which differ from AM receivers, and from which trouble will be found to arise. FM is a new system of radio, and is developing rapidly. It is only to be expected, that along with its development new, unfamiliar faults will have to be repaired.

(Continued on page 177)

Top left to right: DuMont Inputuner manual drive covers 44-216 mc, including all FM. Uses moving taps on rotating inductors for ganged r-f circuits. GE Guillotine tuner drops shielding plate between turns of three coils to cover both FM bands. Described elsewhere in this issue. Schematic, above, shows connections for taking S-curve. Right, top to bottom: Correct S-curve; bandwidth too narrow; discriminator off center; osc. off center; regenerative i-f; r-f detuned.

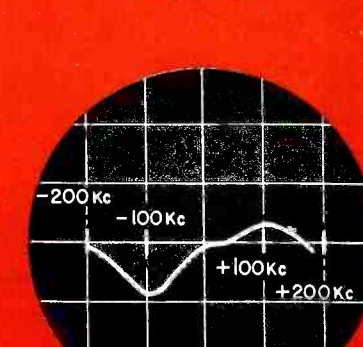
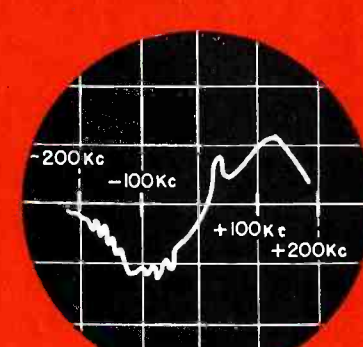
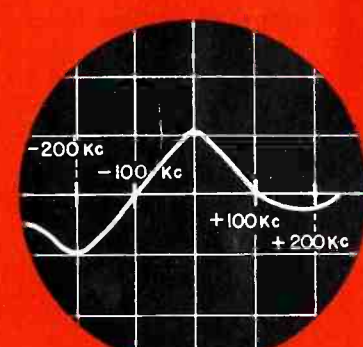
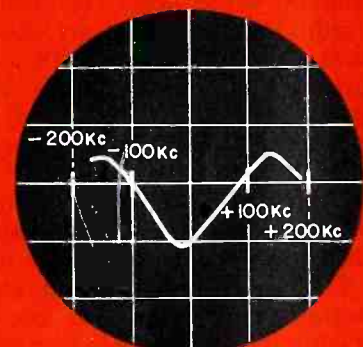
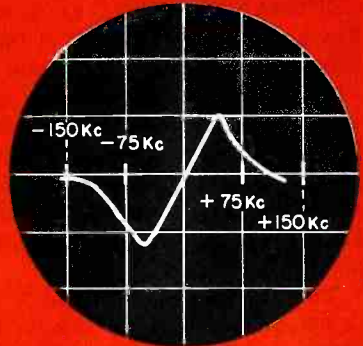
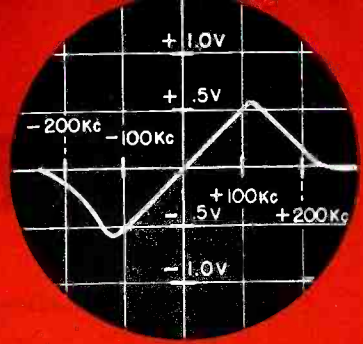

Tracing Out FM Radios

Newest Receivers Using Armstrong Circuits Show Important Innovations

GENERAL ELECTRIC 417 is an AM-FM combination covering both the lower (42-50 mc) and the upper (88-108 mc) FM bands as well as short wave bands 9.4-9.9 mc and 11.6-12.1 mc. Five pushbuttons are preset to broadcast frequencies (540-1600 kc), while the dial operates the G.E. "Guillotine Tuner" for all bands.

Tuning is accomplished by an "elevator" consisting of a horizontal plastic plate from which are suspended three powdered iron cores tuning the broadcast r-f, converter and oscillator coils T1, T6 and T3; and three "vanes" tuning low-inductance coils T2, T5 and T4 in both FM bands and both short wave bands.

As the set is tuned toward the higher frequencies, the vanes move downward into the fields of the coils, reducing the inductance by acting as a shorted turn, and by reducing the mutual coupling between the turns.

Bandspread tuning in the short

wave bands is obtained by inserting the guillotines in series with the higher inductances L7 in the converter stage and L1 in the oscillator. Trimmer capacitors C56 (converter, 9.6 mc) and C59 (oscillator, 9.6 mc) as well as C57 (converter, 11.8 mc) and C58 (oscillator, 11.8 mc) are shunted across the series-connected coils as trimmers for the short wave bands.

In the r-f amplifier stage, a section of the loop is used as the grid circuit. It is adjustable for resonance by shunt capacitors C54 (11.8 mc) and C55 (9.6 mc), but is not continuously tuned on the short wave bands.

In the AUTO(matic) pushbutton position of the band switch, the r-f stage is not used, and a separate antenna coil couples the antenna and loop directly into the converter, making the pushbutton circuits independent of the dial tuning mechanism. A comparable arrangement is used in the oscillator circuit.

The i-f amplifier transformers

are composite. With the band switch on FM, the 10.7 mc circuits deliver the i-f signal into a discriminator. At other positions, the amplifier operates at 455 kc, and screen voltage is removed from tube V6 which acted as an FM limiter, and this tube then acts as detector.

ZENITH MODELS 8HO23, 8HO34 cover broadcast, lower FM and higher FM frequencies, using two stages of i-f and one stage of r-f on all bands.

Although composite i-f transformers are used, tuning to 455 kc on AM and 8.3 mc on both FM bands, only the first primary coil is switched. This is done by shorting out the unused section of the primary by means of a set of contacts on the band switch.

Three i-f transformers are used on AM, and four on FM, although both feed into the same discriminator - detector - 1st audio tube. The audio output desired is selected by

(Continued on page 150)

General Electric Model 417, an a-c radio-phono combo uses a 2-stage amplifier with low-resistance variable-reluctance pickup.

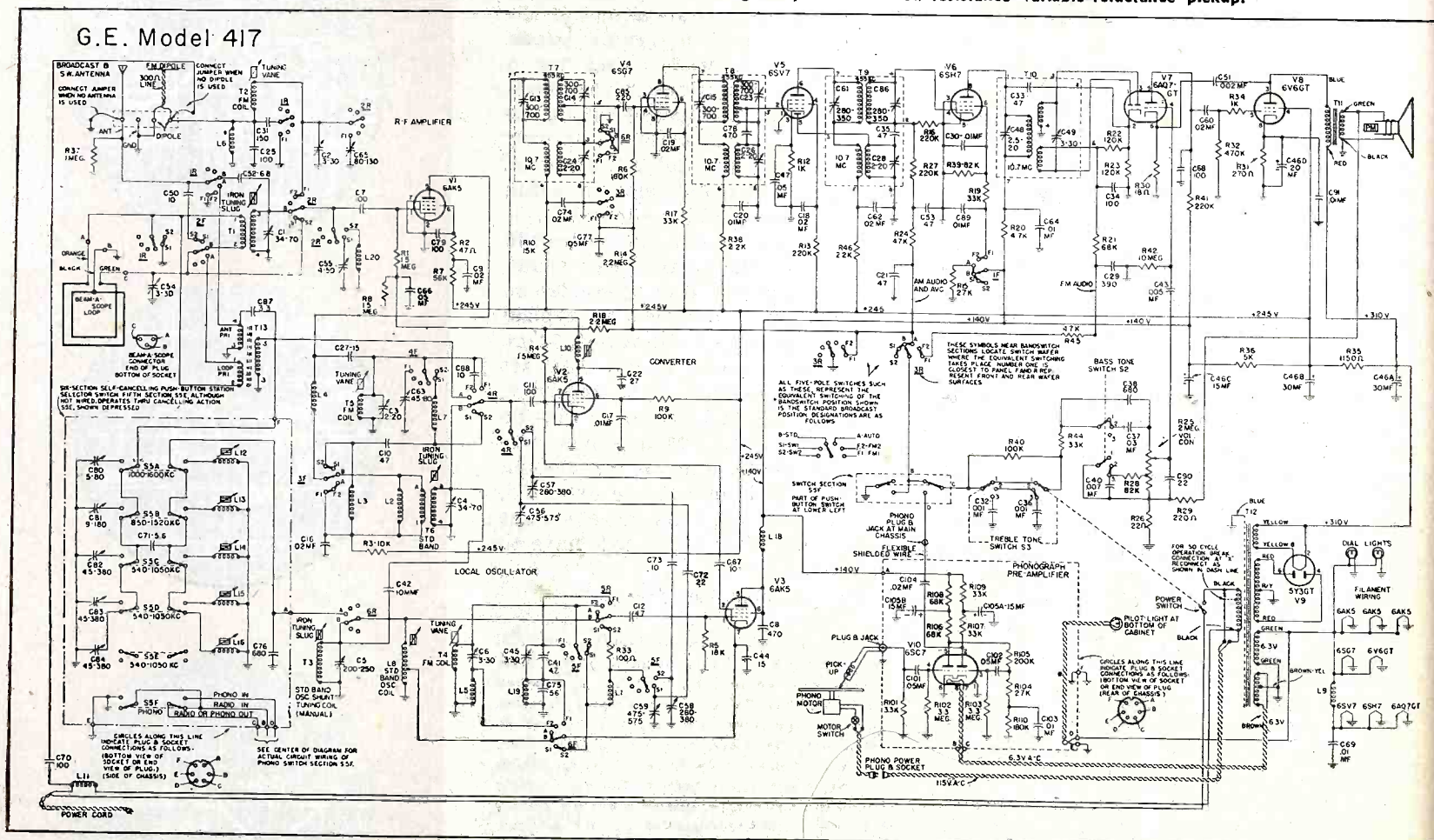

STROMBERG-CARLSON 1121 Series 10-11-12

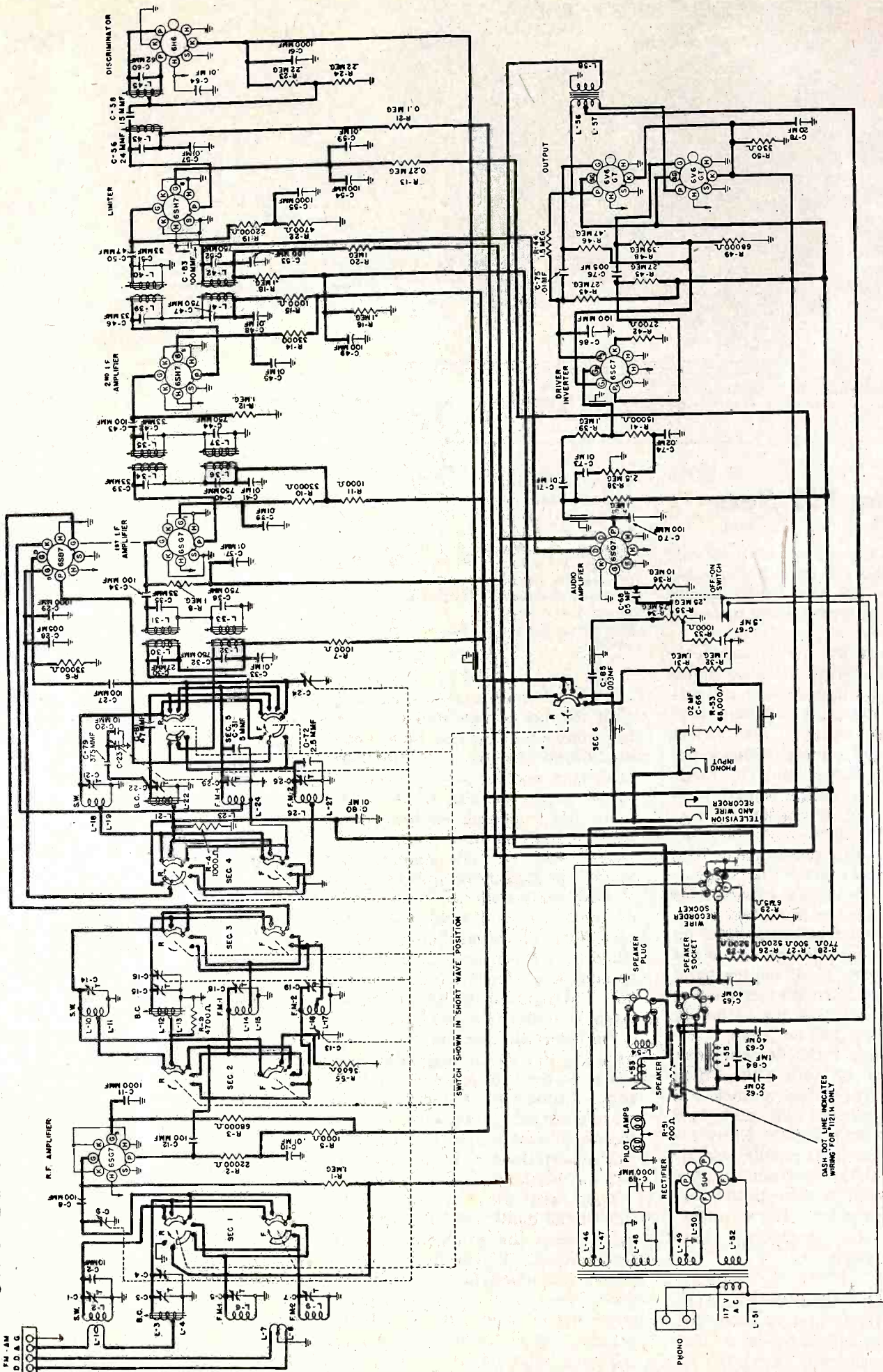

Stromberg-Carlson a-c receiver No. 1121, series 10, 11 and 12 use push-pull 6V6GT tubes to put 8 watts at less than 10% distortion into the dynamic speaker. In all, 11 tubes are used, and provision is made for connecting television sound input, magnetic wire recorders, and phonograph pickups where not already in the combination. A tone compensated volume control, inverse feedback and a phase-inverting driver stage are other features of the audio amplifier system. The folded dipole antenna is connected to a balanced 300-ohm input for both FM bands, while the broadcast and short-wave inputs use another antenna.

(Continued on page 150)

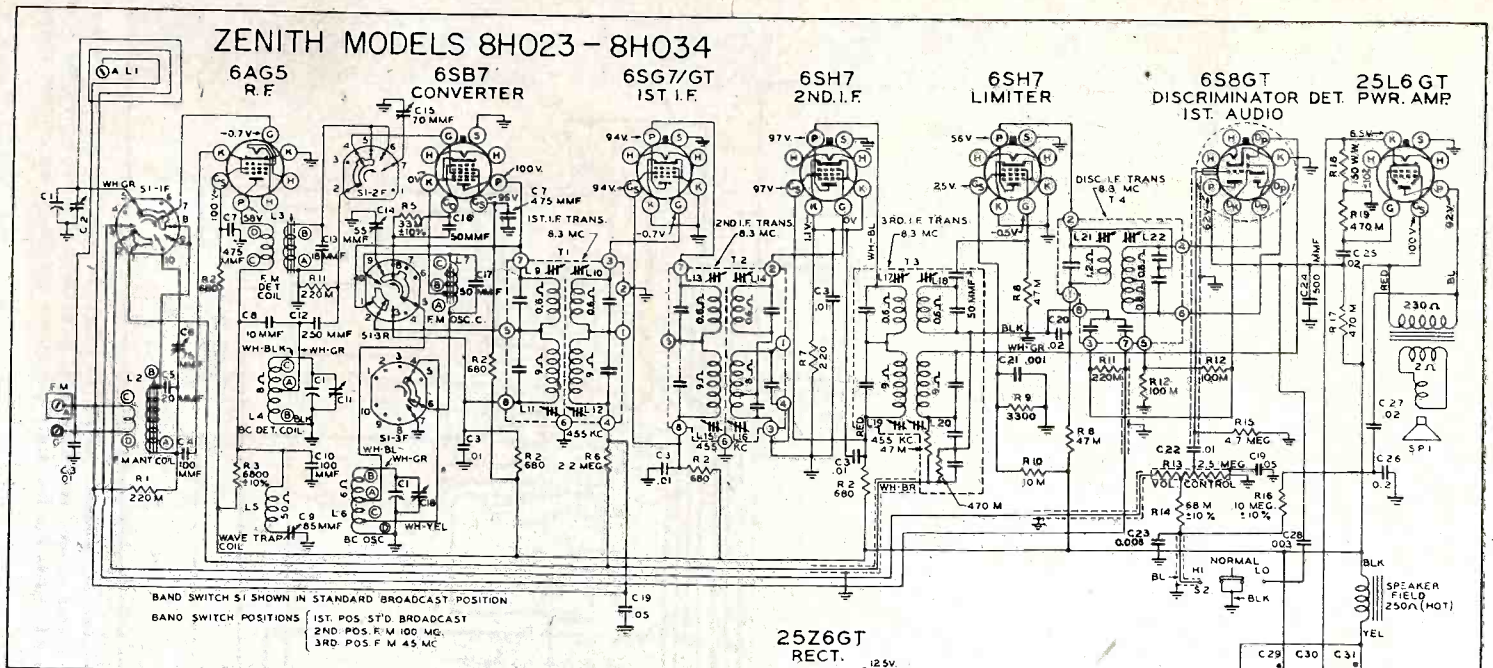

Tracing FM Sets

(Continued from page 148)

contacts on the same switch section which, in the r-f amplifier circuit, select either the loop tuned circuit on AM, or the separate FM antenna input coil.

The second 8.3 mc i-f stage is overcoupled, giving a wide band pass. When aligned with an unmodulated signal, a 300 ohm carbon loading resistor with short leads must be soldered across the secondary of the second i-f transformer, and a strong signal supplied from the generator. If insufficient signal is available, increase the loading resistance or feed the signal into a preceding stage.

While a three-gang capacitor is used for tuning the broadcast band, a coil slug arrangement is used on both the 100 mc and the 45 mc FM ranges. However, on 45 mc the band switch connects trimmer capacitors in parallel and padding wires in series with the 100 mc coils.

At the lower right of schematic can be seen L8 and C10, which comprise a vhf filter to pick FM signals off power line and feed them to the set's input. Early reports show excellent results at relatively good distances from stations. Because of phase cancellation effects, shifting power plug to different outlets may sometimes help improve reception.

STROMBERG-CARLSON No. 1121, Series Nos. 10, 11 and 12 cover the broadcast band from 540 kc to 1620 kc, short waves from 8.8 mc to 10.2 mc, and both the 42-50 mc and 88-108 mc FM bands. See circuit, p. 149.

Zenith 8H023 and 8H034 diagram shows innovation for ac-dc table models. Capacitor C10 and r-f choke L8 pick FM signals off power line, feed to antenna strip, eliminating dipole antenna.

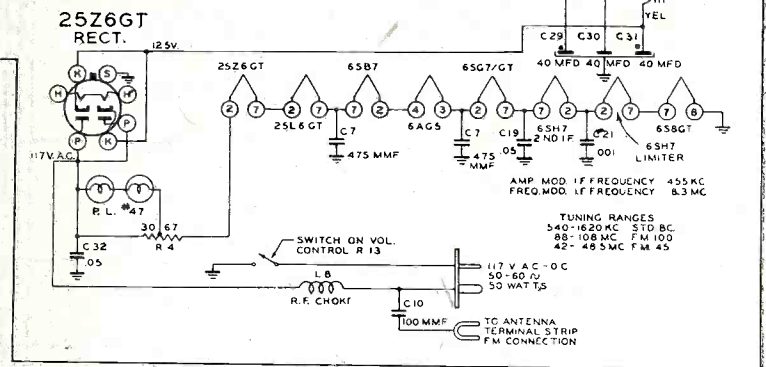

The AM i-f adjustments are made with the 455 kc modulated generator connected to the blue-dotted modulator grid pin 8 of the 6SB7 converter, and the r-f circuits tuned to 600 kc, by varying the i-f trimmers for maximum output on a weak signal.

The FM i-f adjustments are made for maximum indication on a vtvm connected to the junction of the 22,000 and 4,700 ohm resistors in the limiter grid circuit, identified by a green dot. The receiver should be set for channel 21 on the 2nd FM band, with the unmodulated generator on 10.7 mc.

For discriminator alignment, connect the 10.7 mc unmodulated generator to the grid pin 4 of the 6SH7 2nd i-f tube with the vtvm at the orange-dotted center junction of the diode load resistors, and adjust the discriminator input primary L43 for maximum vtvm reading.

Then, with the vtvm at the high side of the diode load resistors (red dot) adjust the secondary L45 for zero output. If varying the generator frequency 75 kc higher and lower does not produce equally large output voltages, repeat the primary and secondary settings.

Before aligning the r-f stages, check the dial pointer to see that it exactly splits the 2 in the number

201 of the 1st FM band, when the variable capacitor plates are fully meshed. Adjust the broadcast band first, with the loop connected, by coupling the modulated 1500 kc generator through a 200 mmf capacitor to the antenna terminal.

The bc alignment is standard, setting the capacitor trimmers at 1500 kc and the coil cores at 600 kc, with the modulated generator connected through a 200 mmf capacitor to the antenna terminal. By substituting a 400 ohm resistor for the 200 mmf, align the short wave band at 9.5 mc only.

The number 2 FM band is made first, with the dial at 61. With the outside dipole removed, connect the 46.1 mc generator to the D terminals through 39 ohm resistors in each of the ground and "hot" leads. Also connect the signal generator ground to the receiver chassis ground. The generator "hot" lead goes to the D terminal at the end of the input strip.

With the vtvm at the green-dotted junction mentioned before, vary the FM (2) oscillator, antenna, and r-f trimmers for maximum output. Finally, reversing the D terminal connections, align the 1st FM band in the same manner at 100.1 mc with the dial at channel 261.

**THIS PACKAGE
ON YOUR SHELF**

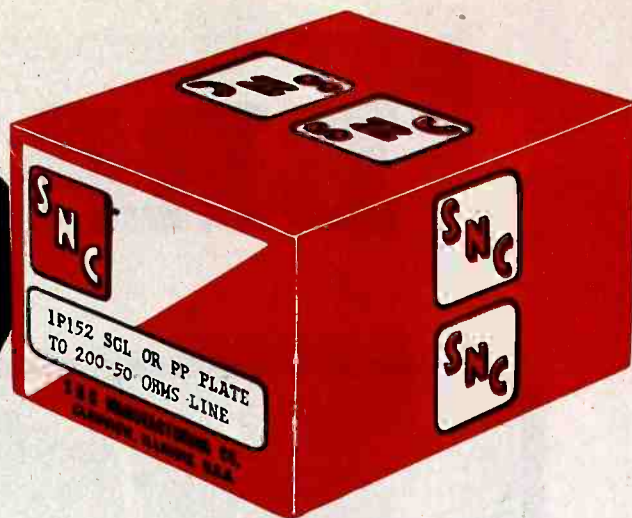

ends transformer troubles!

Mr. Service Dealer — Every SNC transformer is as distinguished for trouble-free performance as the package in which it comes is distinctive in design. A stock of SNC transformers on YOUR shelves means fewer come-backs, greater customer good will, and larger service department profits.

Hundreds of thousands of SNC transformers in use all over the world testify to the outstanding quality that has made SNC units popular with service men everywhere. And the rigid engineering specifications, expert workmanship and select materials built into every SNC transformer are your assurance of a perfect installation every time.

It will pay you to use SNC! For full information, write for the SNC catalog.

The partial list of audio transformers given below indicates the wide variety of SNC units now being made

S N C A U D I O T R A N S F O R M E R S

Type Number	APPLICATION	Wt.	Impedance		Pri. Ma.	Turns Ratio	Mtg.	Dimensions			
			Pri.	Sec.				A	B	C	D
1P121	V. C. to Grid	3/4	3-6	100,000	0	1:157	B	1 7/8	2 3/8	1 3/8	2
1P125	Low Z Mic. to Sgl. or P.P. Grids	3/4	50	100,000CT	0	1:50	B	1 7/8	2 3/8	1 3/8	2
1P128	Sgl. or D.B. Mic. to Sgl. or P.P. Grids	2 1/4	200-50	100,000CT	50	1:22	D	2 3/2	3 1/4	1 7/8	2 1/8
1P136	Line to Sgl. or P.P. Grids	2 1/4	500-125	100,000CT	0	1:12	D	2 3/2	3 1/4	1 7/8	2 1/8
1P145	Sgl. or P.P. Plates to Line	1 1/2	20,000CT	500-125	8	6.3:1	D	2 1/4	2 7/8	1 3/8	2 3/8
1P152	Sgl. or P.P. Plates to Line	1 1/2	20,000CT	200-50	8	10:1	D	2 1/4	2 7/8	1 3/8	2 3/8
1P161	Line to Line	1 1/2	500-125	500-125	0	1:1	D	2 1/4	2 7/8	1 3/8	2 3/8

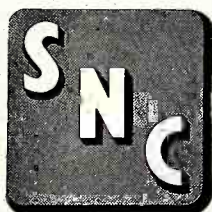

Remember! S N C gives MORE applications with SMALLER inventories for GREATER profit!

Manufacturing Company, Inc.
WEST LAKE AVE., AT LEHIGH GLENVIEW, ILLINOIS

BRAND NEW-

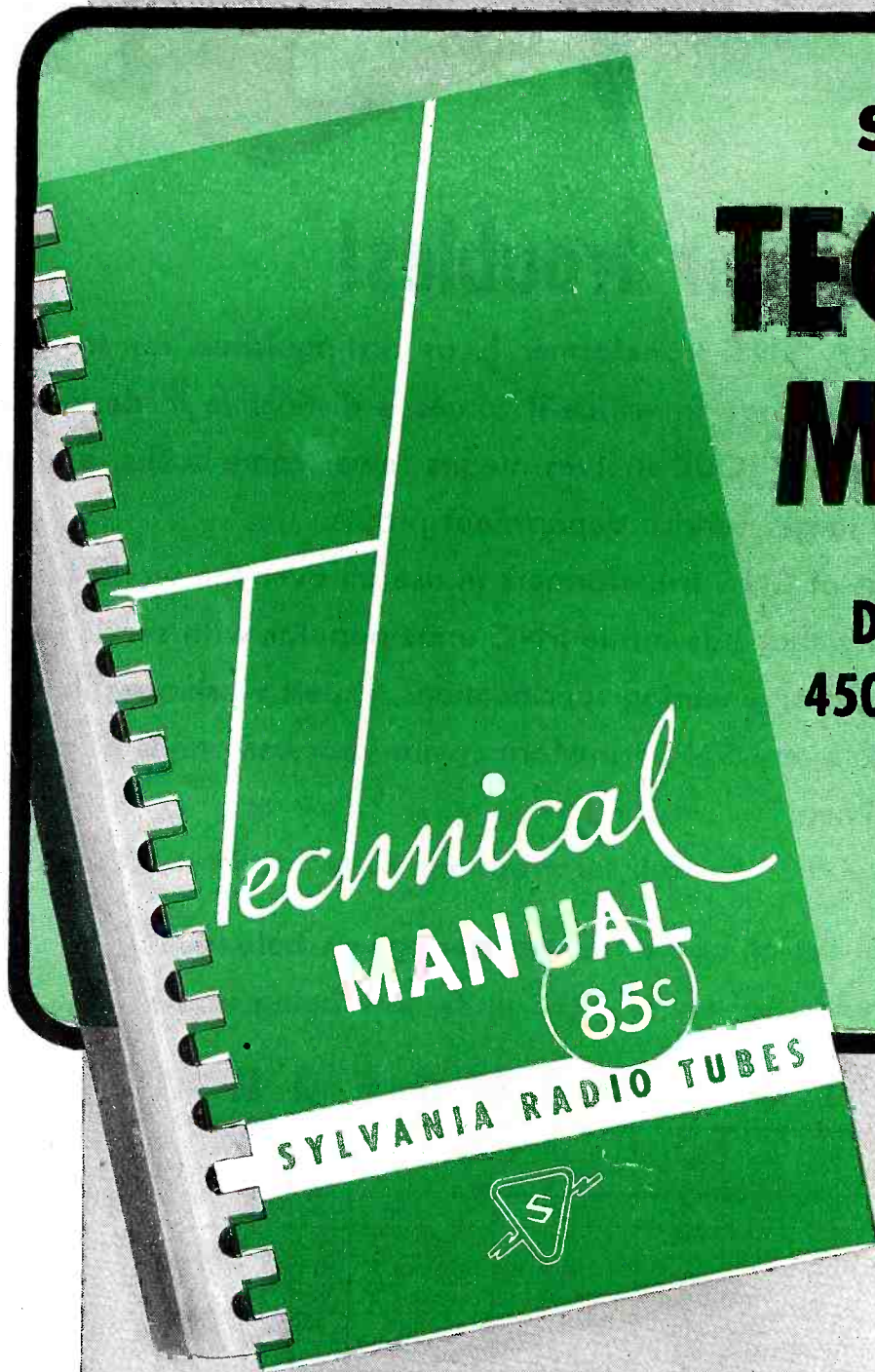

SYLVANIA'S TECHNICAL MANUAL

DESCRIBING OVER
450 RADIO RECEIVING
TUBES!

Here's the new, handy volume of valuable tube information radio retailer service departments have been waiting for. Bigger, better-than-ever, this latest Sylvania Technical Manual - listing over 450 tube types (old and new) - has been made available as a result of extensive and careful study of radio tube characteristics and applications.

Get yours today!



SYLVANIA

MAKERS OF RADIO TUBES; CATHODE RAY TUBES; ELECTRONIC DEVICES;

and ready for you!

HELPFUL VOLUME **MADE** for RADIO RETAILERS' SERVICE DEPARTMENTS

Radio servicemen will surely welcome this handy reference manual, with its important features, including: Fundamental Properties of Vacuum Tubes; Characteristic Curves; General Tube and Circuit Information; Resistance-Coupled Amplifier Data — and more.

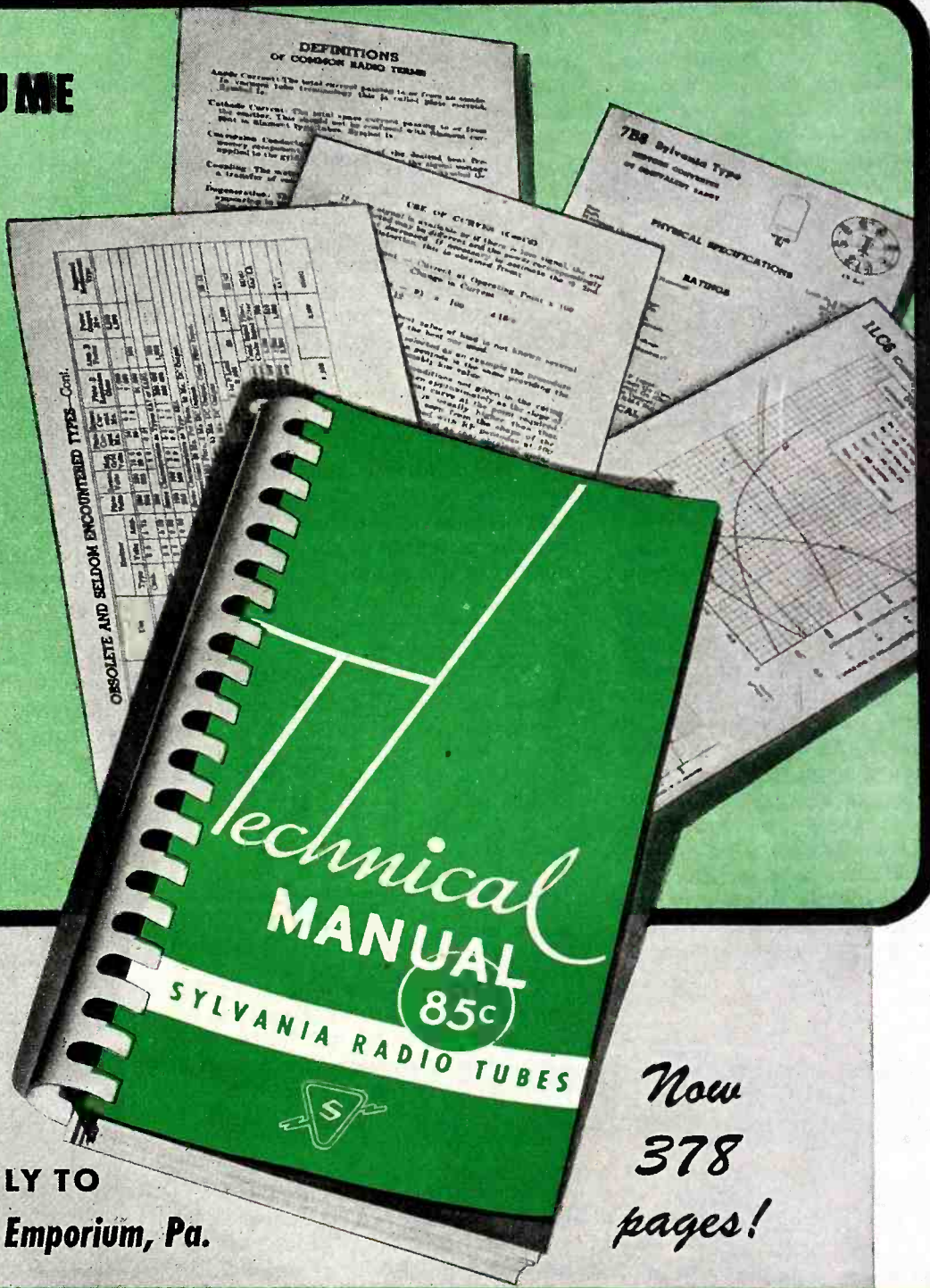

SEE YOUR
SYLVANIA
DISTRIBUTOR
OR WRITE DIRECTLY TO
Radio Tube Division, Emporium, Pa.

*Now
378
pages!*

ELECTRIC



FLUORESCENT LAMPS, FIXTURES, WIRING DEVICES; ELECTRIC LIGHT BULBS

Use These Ideas in FM Work

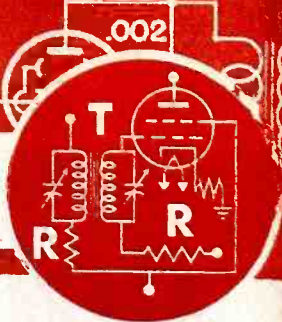

Install New Tuning Indicator for FM, AM

A new type of electron-ray tuning indicator tube has been produced by the Electronics Dept. of General Electric, Schenectady, N. Y., for use in FM and AM receivers. This new Type 6AL7-GT "builds blocks" on its target screen by using three separate deflection electrodes, as shown in the picture.

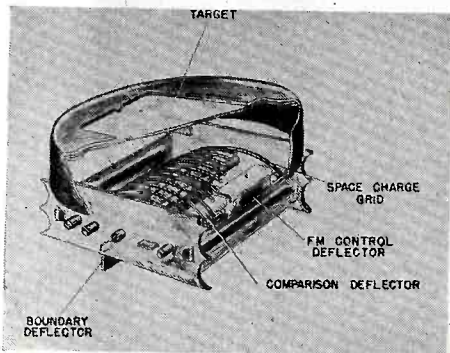

General Electric's new "block building" tuning eye indicator tube uses three deflector elements.

The circuit values for a typical installation given in the schematic diagram produce a deflection sensitivity of approximately 1.0 millimeter per volt. The filament is rated at 6.3 V, .15 A, while the base is a standard octal type.

The presence of three deflection electrodes permits the indication of either the discriminator voltage alone, as shown here, or the discriminator plus the limiter or the squelch circuit operation. In AM sets, AVC action may be shown.

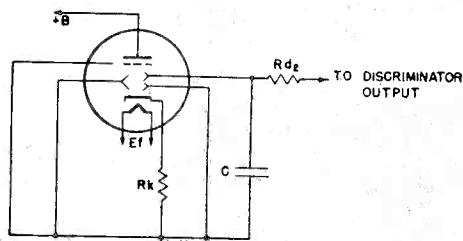

FIGURE 1
 Ef - 6.3 VOLTS
 Ef - 250 VOLTS d-c APPROXIMATE
 Rk - 3300 OHMS
 Rde - 10 MEGOHM
 C - 0.05 MICROFARAD

Circuit diagram with constants for attaching indicator to FM receiver, using discriminator.

Five circuits by which these aims may be accomplished are given in the GE specification sheet. In all of these circuits, the result on the target screen is a double column or shorter to follow the circuit emf's.

Make FM Folded Dipole from 300 Ohm Line

In servicing FM receivers, don't be surprised at some of the unusual FM antennas to be found on city rooftops. Several FM station engineers advise their friends to make an antenna from a half wave-length piece of 300-ohm parallel lead-in as illustrated. This makes a folded dipole antenna, which yields a fairly broad field pattern.

The half wave-length section is tacked to a horizontal board, shorted at each end, and broken in the middle of one conductor to attach a transmission line of the same 300 ohm lead-in. The board should be oriented broadside to the direction of the FM stations to be received.

If the available stations in the area are on a small band of frequencies, as is generally the case, cut the antenna to the center frequency of the group.

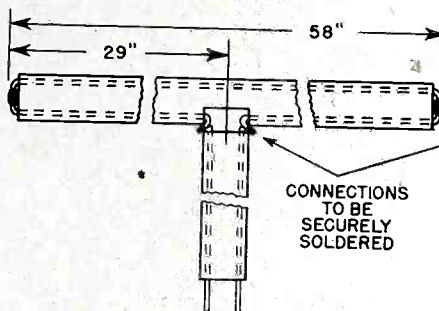

Typical lengths for folded dipole as given by Federal Telephone & Radio to users of their K-1046 300-ohm transmission line.

A convenient formula for the length of the half-wave section, in the band from 88 mc to 108 mc, where f is frequency in mc, and L is length in inches, is:

$$L = \frac{5650}{f}$$

The lead-in line must be accurately centered on the horizontal antenna, with the break in the latter being just wide enough to exactly match the width of the lead-in. After soldering, lacquer all joints.

Since the impedance of this antenna is almost exactly 300 ohms, using a 300-ohm transmission line to couple to a 300-ohm receiver input will result in practically perfect impedance matching.

This feature makes it valuable in television work, where very often the signal strength of the station is quite high. Using a folded dipole of this type within the house may clear up television ghost images caused by reflections or mismatching from a rooftop antenna, and overloading by excessive signal from the same source.

New Band FM Converter Uses Sylvania Crystal

An ultra-simple converter for adapting old-band FM receiving sets to the new frequency allocations is being used by radio station WWSW of Pittsburgh. Developed by Henry R. Kaiser and Frank R. Smith, the tube-less converter uses a Sylvania type 1N34 crystal diode.

The converter operates on the principle of double conversion—that is, the local oscillator of the low-band FM receiver beats with the incoming high-band FM signal to produce a heterodyned signal which will be found to fall within the band of the unconverted receiver.

Although this converter depends on stray pickup of the local oscillator's signal, prewar low-band FM sets generally had a significant amount of such signal in the antenna circuit. The input circuit C1-L2 is tuned to the center frequency of the local high-band FM station, while the output circuit C2-L3 is tuned to the frequency of the heterodyne signal. The converter will work only with sets using an i-f frequency of about 4.3 mc.

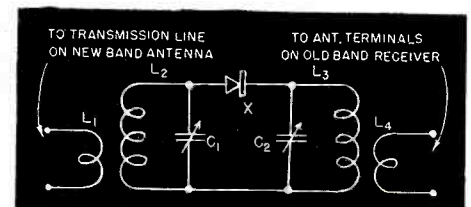

Parts values for new-band FM converter, as made for 94.5 mc station:

- C1, C2 — 8 plate midjet air trimmers
- L1 — 2 turns #18 insulated, interwound with L2
- L2 — 4 turns #10 solid enameled, space wound and self-supported, 7/16" diameter
- L3 — 10 turns, same as L2
- L4 — 3 turns #18 insulated, interwound with L3
- X — Sylvania 1N34 crystal diode

Old-Timers say:
"Keep up
the good work!"

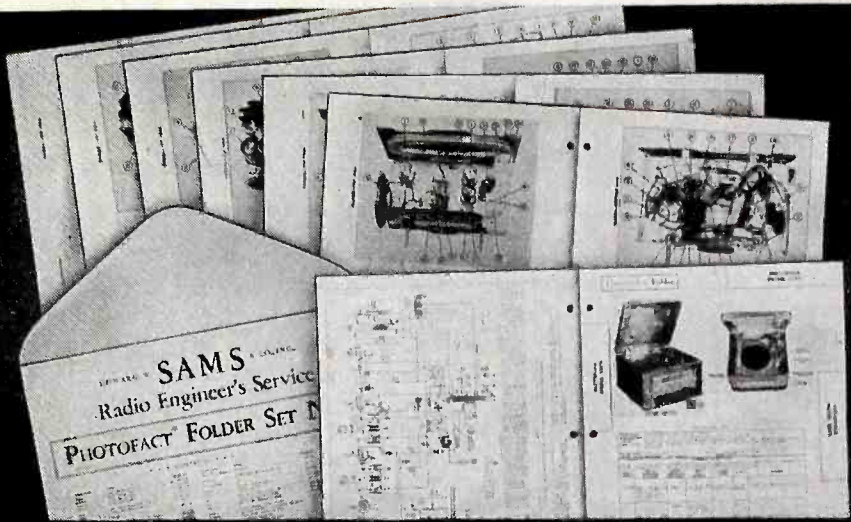

Seasoned Servicemen get
 Invaluable Help from
PHOTOFACT* FOLDERS

Exclusive
PHOTOFACT
 Features

"PHOTOFACT FOLDERS far exceed any service data I ever saw in my 15 years' experience in the radio field. Keep up the good work!"—Edmund H. Barnard, Gloucester, N. J.

"PHOTOFACT FOLDERS are all but human. They're the best I've ever seen—and I've seen everything since the early days of radio."—Ben Davis, Galena Park, Texas.

"Have never seen anything like it in 20 years of servicing. A gift from heaven."—Saunders Radio & Sound Co., Baltimore, Md.

"In 20 years of servicing radios, I've never seen diagrams so clear and easy to read, so complete in every detail. How can you put out so much for so little?"—Hollis L. Hicklin, Cristobal, Canal Zone.

COMPLETE

Everything you need in one handy, unified form—large schematics, pictorials keyed to parts lists and adjustment data, complete listings of parts values and replacements, alignment, stage gain, circuit voltage and resistance analysis, coil resistances, dial cord stringing, disassembly instructions, record changer analysis and repair.

ACCURATE

All sets are actually taken apart and analyzed by experts in the Sams laboratories. Every part is measured, tested and quadruple-checked for accuracy. All data is original. This means the data you get is right.

CURRENT

PHOTOFACT FOLDERS are issued twice monthly, as the new receivers come off production lines. You don't have to wait for information. As receiver changes are made, you get correction and addition sheets for your files. Your data is always up to the minute.

EASY TO USE

All diagrams are coded to numbered parts lists. Everything is positively identified for fast work. All folders are set up in uniform, easy-to-follow style: big type, big illustrations—no hunting, guessing or eye strain—no more loss of time and temper.

Hundreds who have been in radio servicing for ten years and more express complete satisfaction with PHOTOFACT FOLDERS. They say it's the best service they've ever found for saving time and money—and they ought to know.

Whether you're an old-timer or newly established, you'll find PHOTOFACT FOLDERS indispensable—equal to another man in your shop for less than 9c per day. They will save you hours of time and effort: place at your fingertips all the information you need to do a better job—information compiled from a personal analysis of each receiver.

PHOTOFACT FOLDERS are the result of actually examining and testing

*Trade Mark Reg.

sample sets that are brought to our laboratories. They cover all the latest radios, phonographs, record changers, recorders, communications systems and power amplifiers as they hit the market. And they come to you in sets of 30 to 50 at only \$1.50 per set. This low cost includes membership in the Howard W. Sams Institute, which entitles you to free service on special problems affecting your business.

PHOTOFACT FOLDERS actually cost you nothing because they pay for themselves over and over again in time saved. Spend less time, do better work at more profit. Order your PHOTOFACTS today. See your distributor, or use the convenient coupon.

Set No. 15 Due March 10—Set No. 16 Due March 25

MAIL THIS ORDER FORM TO YOUR DISTRIBUTOR TODAY. If you do not know his name and address, send it directly to Howard W. Sams & Co., Inc., 2924 East Washington Street, Indianapolis 6, Indiana, and we will see that your nearest distributor gets it. In Canada write to A. C. SIMMONDS & SONS, 301 King Street East, Toronto, Ontario. Canadian Price, \$1.75.

Send Set No. 15 Send Set No. 16 Send me Volume 1 (including Sets Nos. 1 to 10 inclusive) with De Luxe Binder, \$18.39.

(Circle one or more of following) Send Set No. 11, 12, 13, 14 (\$1.50 a set)

(Circle one or more of following) Send Set No. 1, 2, 3, 4, 5, 6, 7, 8, 9, 10 (\$1.50 a set)

My (check) (money order) (cash) for _____ is enclosed.

(If you send cash, be sure to use registered mail.)

PLEASE PRINT

Name _____

Address _____

City _____ Zone _____ State _____

HOWARD W. **SAMS** & CO., INC.
RADIO
PHOTOFACT SERVICE

In Canada—write to A. C. SIMMONDS & SONS,
 301 King Street East, Toronto, Ontario

More Ways to Save Time

**These Suggestions Show How to Get Increased Profits
and Cut Down Repair Shop Expenses. Second Part.**

• The various replacement parts companies offer many types of cabinets especially suitable to their kind of product, designed with an eye to orderliness and ease of inventory as well as convenience. Ask your distributor about these.

Preparation of a technical nature comes under two headings. First, the technician must know radio. It is a fact of nature that no person or thing stands dead still . . . if you're not going ahead, you're going back. For servicers, this means that unless you keep learning more than you know right now, you are going to be lost in the shuffle of competition.

Have You All the Dope?

The second fact in technical preparation is to have handy complete information on every set that might come your way. Few successful servicers are without the manuals and folders distributed by publishers of radio schematics and technical data, but many fail to read this material closely, to get from it all the value that is to be had. Without both circuit information and theoretical understanding, you can waste a huge amount of time in otherwise simple troubleshooting.

The lack of planning on the question of storage of radios in the service shop is really amazing . . . and the busier the shop the more amazing is the waste of time. Look at your shelves. Are the sections clearly labeled? Are the "incoming" radios apart from the "completed"? Where are the "awaiting parts" items?

Most important of all, is the available space being used to best advantage? For the busy shop, movable racks such as shown in the illustration are a great time saver. In the rear are kept sets and appliances awaiting parts or future delivery, while in front are items for current work.

A little independent canvassing as a "public opinion" researcher in an unfamiliar neighborhood would convince you that folks who have radios and appliances for repair are more conscious of the scratches and dirt marks that set "butchers" or sloppy servicers put into their

workmanship, than they are of many a more logical matter.

Learn to save not only customers and reputation, but also excessive repair time and cabinet-work-time by protecting the finish of wooden cabinets with covers while they are in your shop and while you are working in the home.

There is more than one way to waste time . . . there's the slow way and there's the quick way. Most of the time—consumers we've been talking about are more or less in the "slow" category.

The easiest and quickest waste of time, however, is that practiced by the "pure and simple servicer." This is the genius who is so wrapped up in the delights of troubleshooting, circuit analysis and electro-mechanical gadgets which he runs into on outside service calls, that he has no free brain cells for prosaic things such as selling the set-owner on a much-needed antenna, noise elimination job, extra radio for the kid's room, an FM receiver, or a good general overhaul of the present radio.

Some day ask the familiar brush

salesman who canvasses every door looking for an opportunity to get inside and sell a bill of goods, what he would say to any man who missed delivering a sales talk after being actually invited into the home as an expert adviser.

Or, for that matter, draw the obvious conclusion from the fact that chain dealers with large outside service crews often pay their troubleshooters on a percentage-of-the-profit basis, which, they find, works out very well.

Not New—But Still True

Time is a subject that is generally present in everyone's mind, and not the least in the mind of the radioman in a competitive industry. But if you need any convincing of its importance, please note that in the small-type index of the best-known volume of familiar quotations by the world's most renowned philosophers throughout the ages, the word "time" heads a list several pages long. As Benjamin Franklin said, in his *Advice to a Young Tradesman*, "Remember that time is money".

Simplified outline view shows how deep shelves can be cut apart and put on rollers to eliminate re-shuffling of radios, wasteful searching and effectively expand storage space.

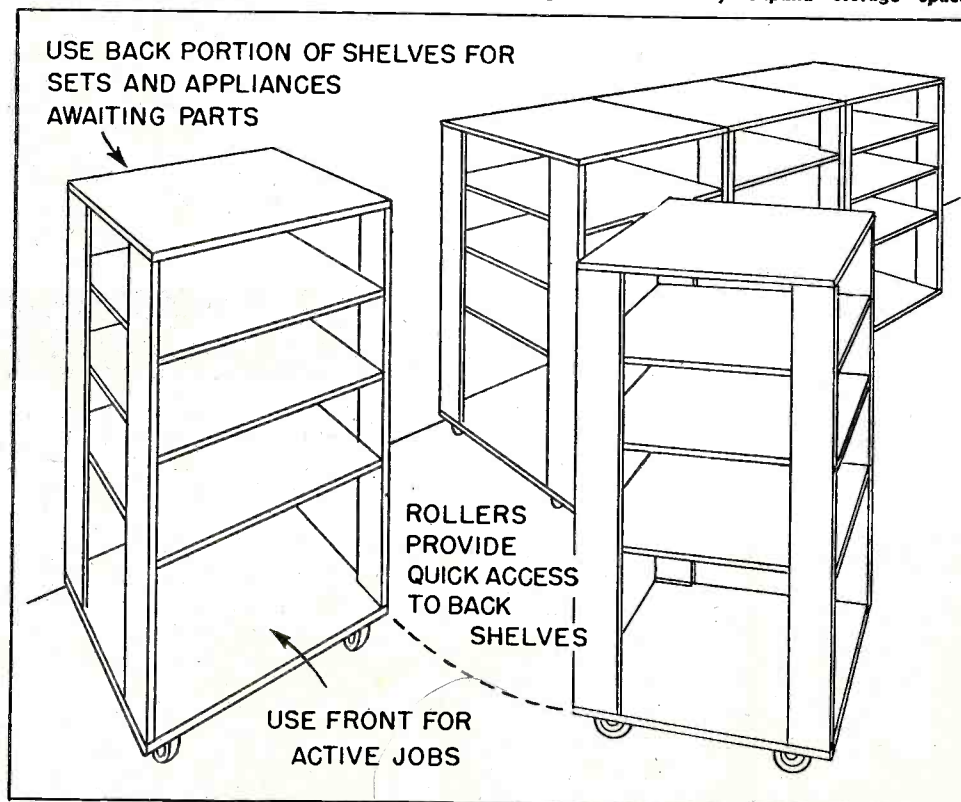

**A
Smash
Hit!**

**GENERAL ELECTRIC LINE
OF
UNIVERSAL PARTS**

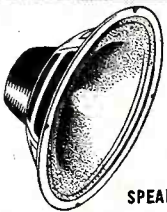

SPEAKERS

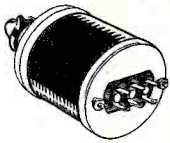

ATTENUATORS

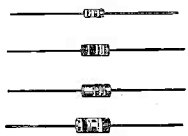

COMPOSITION RESISTORS

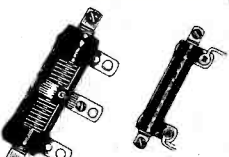

**FIXED AND ADJUSTABLE
WIRE-WOUND RESISTORS**



RHEOSTATS



**COMPOSITION
CONTROLS**



GENERAL ELECTRIC Line of Universal Parts—it's the name you'll see as the star in the parts picture—because it's a name known everywhere for Quality.

Every unit was screened and tested before it was accepted as a part of the line. Now, this top hit production of all-star parts is rolling across the country making new records wherever it has been shown.

It's the easy-to-sell line, the quality line—backed with plenty of promotion and push. Action now will bring you quicker profits.

*Write to: General Electric Company,
Electronics Department, Syracuse, N.Y.*

**THE FIRST AND GREATEST NAME
IN ELECTRONICS**

GENERAL  ELECTRIC

160-F2



**RESISTOR
TUBES**

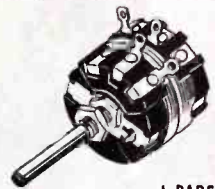

L-PADS

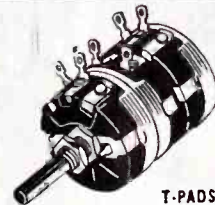

T-PADS



AUTO ANTENNAS

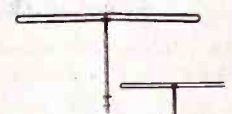

**FM AND TELEVISION
ANTENNAS**

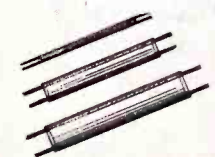

**FM AND TELEVISION
LEAD-IN CABLE**



**Alert Dealers Invent
Unusual Uses for Sound
to Rake in the Chips**

Novel PA Jobs

University B-3 150W speaker being mounted on Yultee AT-6, 300W 4A4 projector goes into Piper Cub. Bogen 150W amplifier used.



• Apace with the increasing use of sound in factories, churches, banks, stores and other familiar institutions, has come an equally rapid expansion in "PA with a new twist." Radiomen who keep their amplifier business in mind have wound up with some very profitable and interesting installations.

Oaks from Acorns

Indeed, the retailer who amuses himself with speculating on possible tie-ins of PA with whatever else happens to be engaging his attention has sometimes come up with novel sound uses that have finally developed very important markets.

Take for example the ballyhoo game . . . fairs, carnivals, amusement parks, pitch-stands. How many readers recall how novel was the use of speech reinforcement at fairs some years back. Today, of course, it is a dependable field for seasonal work.

Even here, by the way, unusual installations pop up, for novelty value has a high rating among showmen. A single element such as

the loudspeakers can become a strong attention-getting device in themselves, as illustrated below, at the right, where two huge reflex horns overshadow the barker.

The advent of more efficient equipment is also playing a part in opening new leads for PA men. Lighter loudspeakers and amplifiers, for example, now permit high-powered installations of sound in small, safe airplanes which are used for advertising, rescue work, clearing snarls on heavy-traffic roads and a multitude of other purposes which wide-awake installers dream up.

Apply Your Ideas

Seen above and at left are two such installations made under the advisory supervision of Saul White, chief engineer for University Loudspeakers.

What appears to be a section of the Maginot Line, below, at left, is in reality a combination radio-and-sound installation in a Brinks armored car rented by banks for carrying valuables. The Hallicraft-

(Continued on page 178)

Left: PA intercom with Hallicrafters SX-25 receiver helps make money truck "bandit proof." Driver and guards have instant communication. Right: Showmen are preparing sound equipment for this year's fairs. Spring your attention-getting ideas on them now. You'll find them immensely receptive.



NEW

Simpson Model 305RC Tube-Tester with

"No Backlash"* Roll Chart



With the addition of the new Simpson "No Backlash"* Roll Chart to the 1947 version of our Model 305, this famous instrument becomes beyond question the finest tube-tester on the market in its price range. Read the description of this new Roll Chart in the panel below.

Model 305RC provides for filament voltages from .5 volts to and including 120 volts. It tests local, single ended tubes, bantams, midgets, miniatures, ballast tubes, gaseous rectifiers, acorn tubes, Christmas tree bulbs, and all popular radio receiver tubes.

Like other Simpson tube-testers, the Model 305RC incorporates 3-way switching which makes it possible to test any tube regardless of its base connections or the internal connections of its elements. This method, the result of exhaustive research and expensive construction, protects the Model 305RC against obsolescence to a degree not enjoyed by competitive testers. No adapters or special sockets are required. In addition to having a complete set of sockets for every tube now on the market, this tester has a spare socket, to provide for future tube developments.

The Model 305RC has provision for testing pilot lamps of various voltages as well as Christmas tree bulbs. It tests gaseous rectifiers of the OZ4 type—also tests ballast tubes direct in socket for burnouts and opens. Has neon bulb of proper sensitivity for checking shorts. This tube-tester is fused, and has the latest improved circuit. It provides for line adjustment from 100 to 130 volts, with smooth vernier control.

Model 305RC is distinguished for its beautiful exterior. It has a two-tone metal panel in red and black on a satin-finished background. Sockets and controls are symmetrically arranged for quick operation. The large, modern, fan-shaped instrument has an exceptionally long scale. It has "good" and "bad" English markings, also a percentage scale for matching and comparing tubes. Cases, both portable† and counter style, are made of strongly built hardwood, durably and beautifully finished.

Size, 11"x11"x6". Wt. 10 lbs. Shipping wt., 15 lbs.
Dealer's net price, portable or counter model.....\$59.50
For 60 cycle 115 volt current only.

For 220 volt or 60 cycle, add..... 7.50
Standard Model 305, with book-type speed chart 49.50

Counter Model 305RC. Same instrument as portable model, but set in fine walnut finished hardwood case, with tilted, easy-to-use panel.

†Finished hardwood cases are standard on portable models. When these are not available, the instrument is housed in attractive simulated-leather covered case.

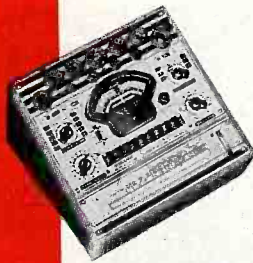

*6

**Exclusive Features Make
This the Finest Roll Chart Ever
Designed for Tube-Testers**

- "No Backlash" feature of this Roll Chart automatically takes up all slack in the paper chart and, by keeping it in constant tension, makes it impossible to turn the selector wheel without turning chart. Gives precision selection at all times. Also prevents chart from tearing or getting out of alignment.
- Gearing is such that only 6 turns of selector wheel will run the entire length of the 12½ ft. chart.
- Easy to read. The clear Lucite window is just wide enough to show 2 tube settings, or both settings on a multi-purpose tube.
- Entire unit removable by taking out four screws. Just lift from receptacle to make new entries or install new chart.
- Chart ingeniously fastened to rollers, affording easy replacement and constant alignment.
- Rigid, light-weight construction. Gear driving mechanism incorporates heavy-duty precision brass gears and parts.

Simpson

INSTRUMENTS THAT STAY ACCURATE

SIMPSON ELECTRIC COMPANY

5200-5218 W. Kinzie Street, Chicago 44, Illinois
In Canada, Bach-Simpson, Ltd., London, Ont.

New Aids for FM Service

Premier Electronic SIGNAL GENERATOR

Model 570 signal generator uses the Micromaster precision dial which contains spring-loaded split gears to eliminate backlash and provide split-cycle tuning. A fundamental frequency range

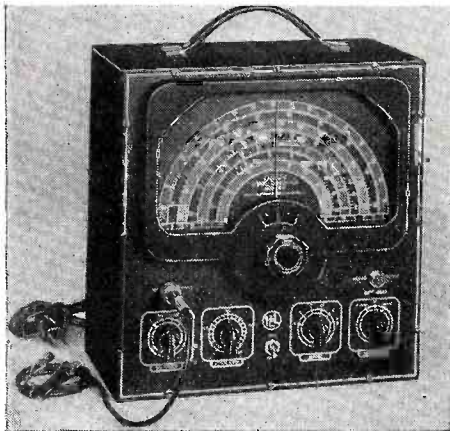

from 75 kc to 50 mc and strong harmonics to 150 mc at 1% tolerance of calibration makes the generator useful for FM and television alignment. Premier Electronic Labs., 382 Lafayette St., New York 3, N. Y.—RADIO & Television RETAILING

Barber HIGH FREQUENCY ELECTRONIC VOLTMETER

Model 32 is equipped with an r-f probe having the extremely low input capacity of $\frac{3}{4}$ mmf which extends the range of measurement to 500 mc, with a Q of about 200. Voltages are meas-



ured in five ranges, 0-3, 10, 30, 100, 300 volts r-f, from 500 kc to 500 mc. Alfred W. Barber Laboratories, 34-14 Francis Lewis Blvd., Flushing, N. Y.—RADIO & Television RETAILING

Simpson VTVM

Model 266 is a wide-range vacuum-tube-voltmeter. The r-f probe has an input capacitance of about 4 mmf., which, with a 6-megohm input resistance permits accurate work at 100 mc,



in the region of the new FM and television bands. Both full-scale and zero-center reading of d-c voltages to 5000 volts is provided, with an input resistance between 50 and 200 megohms. Seven ohms scales read to 1000 megohms, while current from 1 ma full scale to 10 amperes full scale can be measured. Simpson Electric Co., 5200-18 Kinzie St., Chicago 44, Ill.—RADIO & Television RETAILING

Triplett VACUUM TUBE VOLT-OHM-MILLIAMMETER

Model 2450 is an electronic volt-ohm-milliammeter for FM and television work. Two voltage regulator tubes provide stability for both positive and negative voltages, within a line varia-

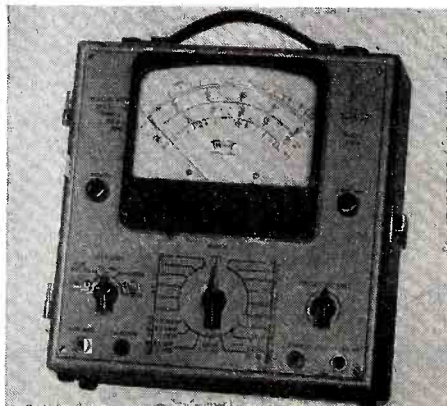

tion range of 90 to 130 volts. Six ranges cover d-c and a-c potentials to 1,000 volts and d-c current to 1,000 ma, while seven resistance ranges reach 1,000 megohms. Five capacity ranges check up to 500 mf on the long-scale 6" meter which has three-color markings for accurate readings. Triplett Electrical Instrument Co., Bluffton, Ohio.—RADIO & Television RETAILING

RCA ADVANCED VOLTOHMYST

Type WV-75A is an outgrowth of the familiar type 195A Volt ohmyst, designed for the servicing of FM and television on frequencies up to 250 mc. Employing a full wave diode rectifier probe,

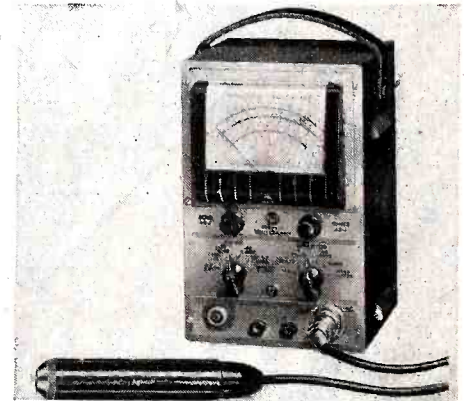

the meter can measure up to 1,000 volts d-c or peak-to-peak a-c, coupling directly to very-high-impedance circuits. Six resistance scales cover from 0-1,000 ohms to 0-1,000 megohms. RCA Victor Division, Camden, N. J.—RADIO & Television RETAILING

Federal FM-TELE TRANSMISSION LINE

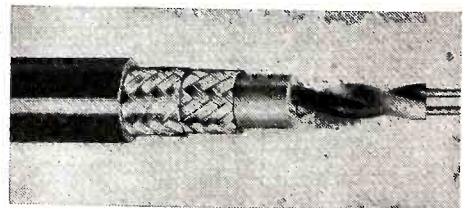

For use wherever a balanced transmission line is needed, the KT-51 cable is a twisted dual conductor high frequency cable designed to free FM and television receivers from locally induced static. Its characteristic impedance is 95 ohms. Federal Telephone & Radio Corp., Newark, N. J.—RADIO & Television RETAILING

Save **SPACE, TIME** and **MONEY!**

with the **PYRAMID "TYNEE-DRY"**

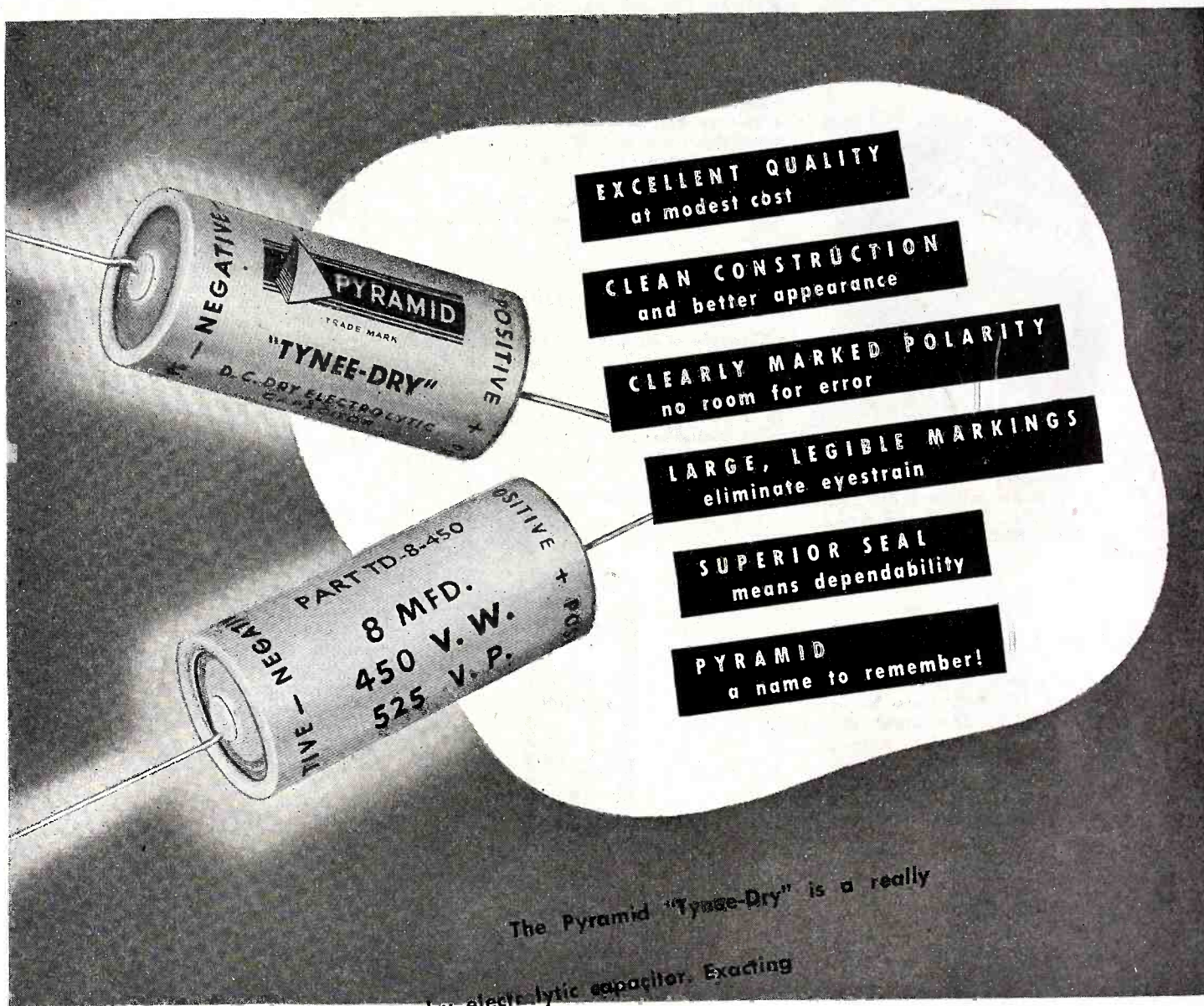

The Pyramid "Tynee-Dry" is a really tiny dry electrolytic capacitor. Exact

engineering and production controls provide maximum

quality within minimum space—and at

modest cost! Write for literature.

PYRAMID ELECTRIC COMPANY
JERSEY CITY 6, N. J.

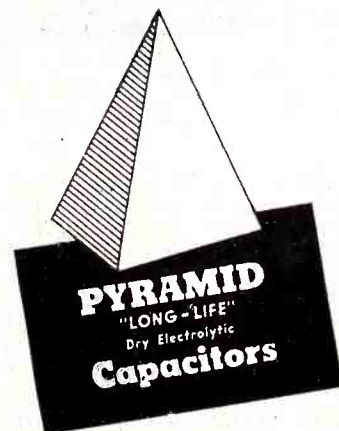

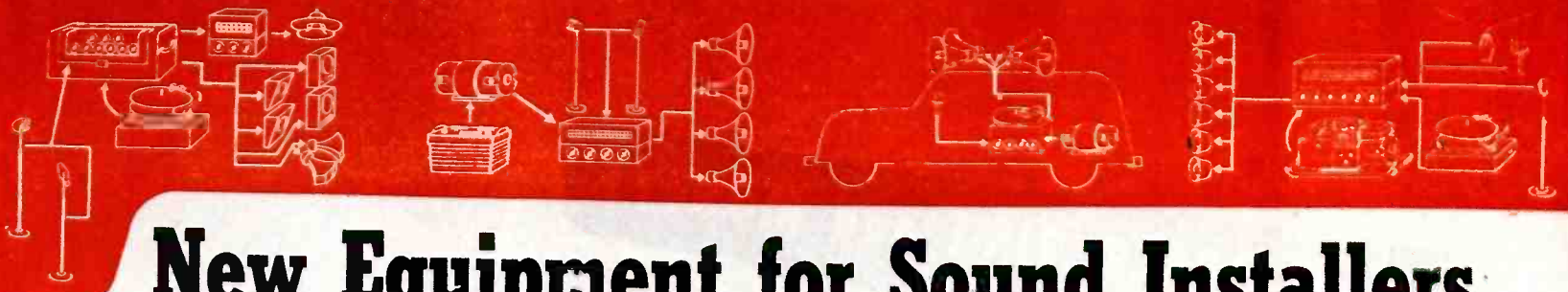

New Equipment for Sound Installers

Bell SOUNDMASTER

Model 3750 is a 50-watt amplifier with less than 5% distortion, and a peak output of 88 watts. Three 10-megohm microphone inputs are separately controlled, with a gain of 120 db. The 90-db phono channel's 1-megohm input is

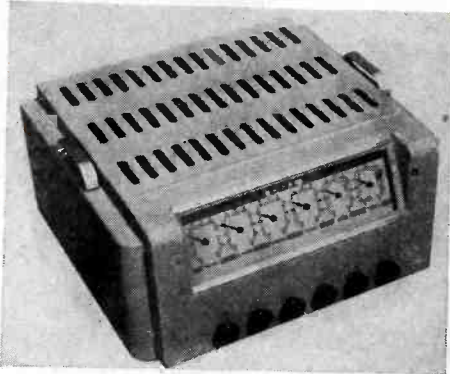

also individually controlled, while bass and treble equalizers are on the front panel. The frequency response of 30 to 15,000 cycles is flat within 1 db. Bell Sound Systems, Inc., 1183 Essex Ave., Columbus, Ohio—RADIO & Television RETAILING

ADC AMPLIFIER

Model 45B is a general purpose amplifier delivering 10 watts from 50 to 10,000 cycles ± 1 db. The input impedance is 100,000 ohms, while output taps are provided at 1, 4, 8, 16, 250 and 500 ohms. Audio Development Co., 2833 13th Ave. S., Minneapolis 7, Minn.—RADIO & Television RETAILING

Hallowell TOOL KIT

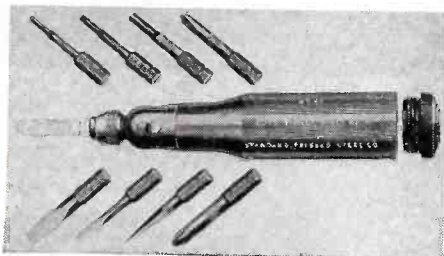

The Auto Key kit is typical of this new line of Hallowell Speed Tool Kits. With a hollow handle containing 8 different tools and a swivel bit-chuck that permits 5 driving or wrenching positions, the kit is a space saver for carrying in a small tool box. Standard Pressed Steel Co., Box 751, Jenkintown, Pa.—RADIO & Television RETAILING

Pan American REGULATED POWER SUPPLY

Model PAS-2000 is a new regulated power supply which delivers any voltage between 130 and 230 volts d-c. A 6L6 series regulator is controlled through a 6SJ7 regulator amplifier by a type NE-51 neon lamp which serves as a voltage standard and pilot light. Besides the d-c output of 50 ma., a 6.3 volt filament provides 3 amperes with ungrounded center tap. Pan American Electric Co., 132 Front St., New York 5, N.Y.—RADIO & Television RETAILING

Tel-O-Matic AMPLIFIER

Capable of supplying 2,000 subscriber locations, Type T-3-A Distribution Amplifier is a complete central unit for transmission of 3 independent programs on 2 telephone channels. The equipment includes an automatic timer and selector panel to turn the unit on or off

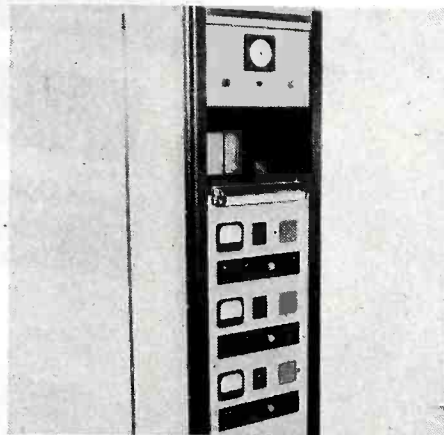

for any pre-set period, and to select any number or group of records at pre-determined intervals. Plays 10", 12" and 16" records manually. Many other features are described in a catalogue for this and other types of systems for wired music applications. Approved by telephone companies. Tel-O-Matic Products, Clifton, N. J.—RADIO & Television RETAILING

Amcon LITTLE CAPACITOR

The Amcon Little PL capacitor is a new small size plastic unit measuring only $2\frac{1}{8}$ " high by $1\frac{3}{8}$ " diameter, for top chassis mounting in places where space is limited. Self insulated because of its molded plastic case, the unit resists high temperatures. American Condenser Co., 4410 N. Ravenswood Ave., Chicago 40, Ill.—RADIO & Television RETAILING

Brook AMPLIFIER

Model 10C2 delivers 34 watts at less than 6% total distortion from 20 to 20,000 cycles flat within .5 db. A gain of 80 db with a hum level more than 70 db below full output is provided. An input impedance of .5 megohms is con-

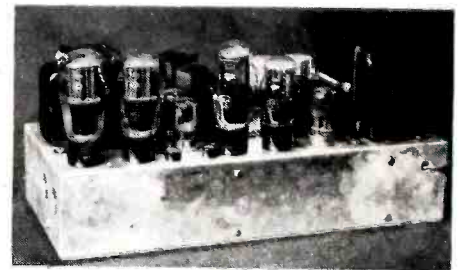

trolled by separate bass, treble and volume knobs, recommended especially for phonograph reproduction. Brook Electronics, Inc., 34 De Hart Place, Elizabeth, N. J.—RADIO & Television RETAILING

Altec AMPLIFIER

A correction should be made to the description of the Altec Lansing model A-319A amplifier mentioned on p.124 of the January 1947 issue. This unit, which was illustrated, comes in a wall cabinet. It employs inverse feedback taken from a tertiary winding on the output transformer, thus leaving the output ungrounded. Altec Lansing Corp., 1161 N. Vine St., Hollywood, Calif.—RADIO & Television RETAILING

Astatic MIKE

The new "Conneaut" is a crystal microphone with a chrome body and blond plastic grille. The overall frequency response covers up to 10,000 cycles. Model

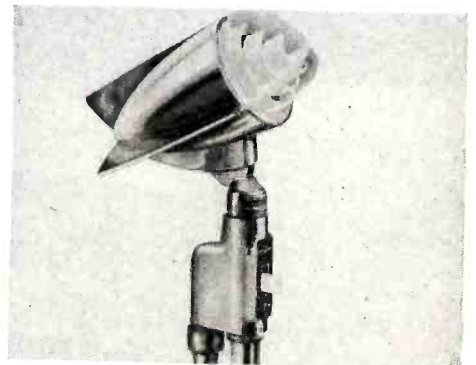

600-S, illustrated, is supplied with a type S on-off switch, swiveled head and screw-type microphone cord connector. Astatic Corp., Conneaut, Ohio.—RADIO & Television RETAILING

NEW ELECTRICAL APPLIANCES, PP. 126 TO 130

NEW RADIO SETS, PP. 44 AND 45.



★
MODEL 2470
The
TROUBLE-SHOOTER
FOR HOUSEHOLD
APPLIANCES

MODEL 666H



● **WATTMETER, AMMETER, AND VOLTMETER ELECTRICAL APPLIANCE TESTER CHECKS SINGLE PHASE 2-WIRE, SINGLE PHASE 3-WIRE, AND 3-PHASE 3-WIRE CIRCUITS**

Use this "trouble shooter" to measure wattage consumption, current and line voltage of all household appliances and small motors under actual operating conditions. Double-primary transformers and "Y" box resistors for accurate testing on lines with unbalanced currents or voltages. Just the tester for electric refrigerators, washers, radios, ironers, and other appliances. Power used by the smallest appliance is readily checked on the extremely low scale range of 0-20 watts (fused to prevent damage from accidental overload). All switches and leads are ample to carry full loads continuously.

- You need Model 666H Volt-Ohm-Milliammeter, shown at right—the handiest tester of all. Has A.C. and D.C. Volts at 1000 Ohms per Volt 0-10-50-250-1000-5000 (compensated copper-oxide rectifier provides for A.C. measurements); D.C. Milliamperes 0-10-100-500; Resistance 0-300 Ohms; 10 Ohms reading at center scale, 0-250,000 Ohms.

Precision first
...to last

Triplet

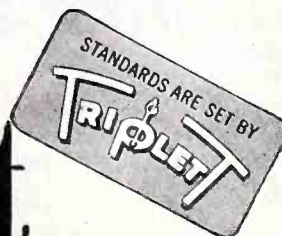

ELECTRICAL INSTRUMENT CO. BLUFFTON, OHIO

Announcing a new

THORDARSON

Transformer

Line!



Now... a completely new line, embodying the same dependable, quality-performance features which have been built into Thordarson Transformers since 1895. Designed to meet the same requirements and applications previously served by our older, more extensive lines, these modern units, while fewer in number, are broader in application and are engineered for every electronic need. Backed by 52 years of transformer manufacturing experience, they are your assurance of top-notch performance under all conditions.

Some of these new Thordarsons are already at your jobbers. Others are being turned out as fast as present-day manufacturing conditions permit. Ask your jobber for full information today or write for new free transformer catalog.

MEISSNER, THORDARSON,
RADIART PRODUCTS IN
PHOTO-FACT FOLDERS

EXPORT ADDRESS
SCHEEL INTERNATIONAL, Inc.
4237-39 N. LINCOLN AVENUE • CHICAGO 18, ILLINOIS
CABLE HARSHEEL

**ELECTRONIC
DISTRIBUTOR**

ADIART

VIBRATORS...

Effectively sealed against air and moisture seepage, thus preventing point oxidation. All-riveted assembly guarantees long-lived dependability.

AERIALS...

The finest aerial line ever offered. Patented Anti-Rattler feature eliminates grease packing . . . insures operation in all kinds of weather. For all cars.

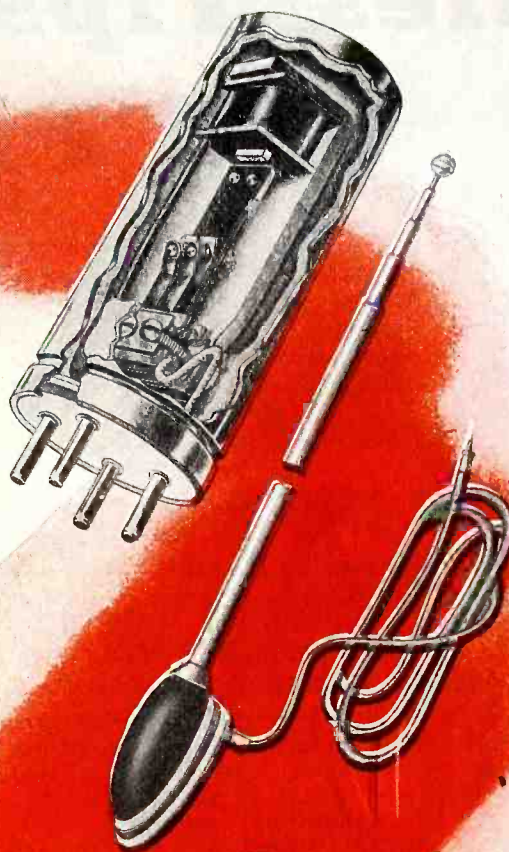

MEISSNER

ANALYST

THE MODERN SERVICE INSTRUMENT

Designed to handle the receivers of today, yesterday and tomorrow with equal facility. Tests by the signal tracing method . . . fastest and most reliable method to date. See it at your jobber's today.

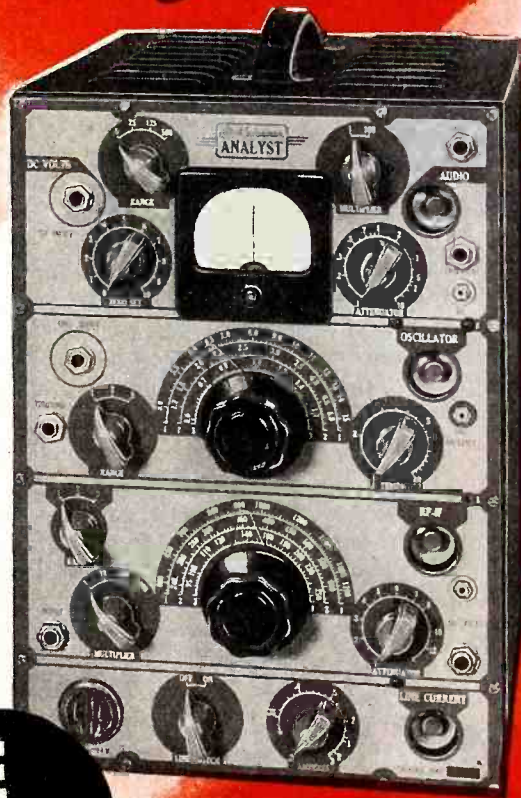

MAGUIRE
INDUSTRIES
INCORPORATED

AND INDUSTRIAL SALES DEPARTMENT
936 N. MICHIGAN AVE. • CHICAGO 11, ILLINOIS

Sales Tips and Profit Pointers

Your speech is your most powerful sales tool. In telephone selling, it operates alone. At other times, it supplements your appearance and actions. Improve your speech by reading manufacturers' product literature aloud.

The dealer who backs up his salesforce with smart merchandising principles puts himself in line for more profits and helps to build a loyal, permanent staff. Here's a five-way platform: 1. Treat customers fairly. 2. Advertise consistently. 3. Maintain bright store interiors and show windows. 4. Render prompt, efficient service. 5. Feature competitive prices and credit terms.



The dealer who wants to have a loyal, hard-hitting sales organization must make sure that each and every member of his staff understands his rules on split-sales, territories, floor-time sales, etc. Anticipate such problems in advance and prevent useless and discouraging arguments from arising.

A good sales personality helps you create an atmosphere that is conducive to a sale. You can influence customers favorably by your appearance, your manner of action and speech, and your knowledge of the proposition you are presenting.



Too many dealers who advertise "specials" are reluctant to show them to the customer who comes in specifically to look such specials over. Finagling around, and showing something "a little better" arouses suspicion and annoyance on the part of most prospective buyers. Show the special right off the bat and you'll be playing safe.

The Sales Experts of the Month Say—

Intensive, intelligent, consistent training on sales features of all products to be sold, gives needed assurance to retail salesmen.

Customers are quick to sense this assurance, which establishes confidence not only in the product but in the store as well.

We need new salesmen, who can be thoroughly indoctrinated in good selling methods and technique. We need old salesmen with their priceless experience to help train new sales organizations. But above all, we need the mental attitude that basic selling effort is *necessary*, not tomorrow but *today* if we are to realize our goal. — *L. H. D. Baker, vice-president appliance division, Admiral Corp., Chicago, Ill.*

Many hard goods are available today for immediate delivery — every day new items are added to this ever expanding list. The merchant who re-invests a portion of his easily gained profits of the day in a carefully chosen, well-trained, retail sales force, has wisely purchased an insurance policy against that inevitable day of competitive specialty selling. — *W. F. Linville, general sales manager, Bendix Home Appliances, Inc., South Bend, Ind.*

Our biggest reconversion job is not in retooling our factories for more and more production. That is only one of the physical aspects of readjustment. Our biggest job is our own mental reconversion. If we refuse to think in terms of more modern stores, fewer and better known lines, broader and better displayed inventories, planned advertising and promotions and sales training, then our reconversion is still to become an accomplished fact. — *Paul Southard, vice-president in charge of sales, Columbia Recording Corp., Bridgeport, Conn.*

The gradual but certain emergence of the long anticipated buyers' market is making the wise salesman increasingly product conscious. Whereas sales people generally have held availability foremost, during the immediate postwar period, greater production in industry now dictates serious product study by management and sales force.

The cardinal points of good constructive selling comprise thorough knowledge of the product, what the product will do for the buyer, and how it will in all respects satisfy the buyer's awakened needs. — *Charles O'N. Weisser, sales manager, Emerson Radio and Phonograph Corp., New York.*

SPRAGUE TRADING POST

SWAP—BUY—SELL

FOR SALE—Scarce tubes at up to 60% off: 1LA6; 43; 47; 50A5; 70L7; 6AS; 7A8; 1LN5; 2A6; 57; 58; 7B7; 7B8; 14R7; 32L7; 12A8; 6P5; 7C5; 71A; 35Z3; 25L6, new guaranteed, standard brands. Also many others. Write for list. Commercial Radio, 36 Brattle St., Boston 8, Mass.

FOR SALE OR TRADE—Webster 5-tube amplifier; 100 old and new tubes; 5-tube midget Majestic radio; 4-tube Philco, etc. Will trade for test eqpt., portable radio, communication receiver, or what have you? Harold Freeman, Box 3122, Q Station, Shreveport, La.

WANTED—0-1 milliammeter, 150 ohm resistance, any make or model. Also want tube tester transformer 1 to 117v auto type or separate primary. Have audio and power transformer cores and shells also Baldwin units for speakers or headphones. Hearns, 1227—37th Ave., San Francisco, Calif.

FOR SALE OR TRADE—Triumph #1-77B and #351 v.o.m.'s, a.c. volt-d.c. volt milliamp. and ampere meters, tubes, parts, tools, etc. Write for list. Want test eqpt., communication receivers, etc. Roby's, 1119 Milwaukee Ave., Chicago 22, Ill.

WILL SWAP Sprayberry Radio Course, complete, A-1 condition. Need Rider's manuals 6 to 14, also capacitance resistance bridge. Alex Heidt, R.R. #2, Scotts Bluff, Nebraska.

FOR SALE—Supreme 3" oscilloscope, \$50; Superior channel analyzer, \$20; Superior signal generator, \$18; R.C.P. multimeter, \$15; Triplett free-point tester, \$15; correspondence lessons in servicing and books on ditto. Write for list. Joseph Forster, 804 W. 180 St., Apt. 52, New York 33, N. Y.

FOR SALE—Rider's manuals vols. 1, 2, 3, 4 and 6. Price \$16. Good condition. Edw. J. Lynch, P. O. Box 165, Roulette, Pa.

WANTED—Any or all of the following European tubes; ECL-11; ECH-11; EBF-11. Also need schematic of European Radio model MS195W. Price no object. Floyd W. Wilton, Greenfield, Ill.

FOR SALE OR TRADE—Triplett Modulation Monitor #1696-A, have panel for rack mounting, instrument like new, \$30 or what have you? Leslie Redmond, 461 E. 143rd St., Cleveland 10, Ohio.

FOR SALE—New Superior #450 tube tester, \$39; used Superior #1230 signal generator, \$29; 35 new tubes and 10 slightly used tubes, \$20. Write for list. Robert Klinge, 7600 Penn St., Kansas City 5, Mo.

WANTED—Dynamotor complete in case for BC 312 receiver. David F. deLemos, Box 231, Bolinas, Martin County, Calif.

FOR SALE—Jackson 523 3" oscillograph; new Motorola 45B12 1000 hr. battery radios. John Repa, Jr., Richlandtown, Pa.

FOR SALE—Sprague Deluxe Tel-Ohmike, slightly used; Superior signal tracer CA-11 with headphones, slightly used; C-D interference filter IF-21 or IF-19 new. Plexico Hardware & Furniture Co., Edison, Ga.

WANTED TO BUY OR TRADE—Radio parts, test eqpt., recording and phono eqpt., P. A. supplies. Have for trade Ab-8 Astatic pickup, American #4100 V-O-M meter. Walter Bartell, 1107 N. Western Ave., Chicago 22, Ill.

FOR SALE—Radio parts; power output, input and choke transformers, resistors and magazines, books, etc. August Palermo, 223 So. Winebiddle Ave., Pittsburgh 24, Pa.

FOR SALE—General Radio amplifier 814A, \$20; Rubicon galvanometer, \$35; Dumont scope tube 5LP1, \$10. E. E. Harmon, Aero Radio Shop, 2440 Montrose Ave., Chicago 18, Ill.

FOR SALE—RCA 16mm sound projector; RCA Chanalyst; Hickok sig. generator #18; Triplett, 666-S v-o-m; ¼, ⅜ and ½ h.p. motors, etc. Joe's Radio Lab., 30 Wall St., Passaic, N. J.

FOR SALE—Hickok OS-10 oscillator with DB meter H. Pahl, Horicon, Wis.

FOR SALE—60-watt Airline amplifier; Electro-Voice mike (Cardak) and stand; 4 metal projectors with 2 Jensen and 2 RCA 12" speakers, cables and connectors; also Hallcrafters Sky Rider Jr. S-41W. All in excellent condition. William A. Riaski, Guthrie Center, Iowa.

FOR SALE—Philco tube tester #033 in A-1 condition, with circuit diagram, \$25. CW rig 6V6 xtal osc. Pr. 6L6's. All complete with tubes, power supply, two xtals for 40 and 80 meter band, \$35. Power output 40 watts. F. Bou, 3131 N. Percy St., Philadelphia 33, Pa.



Something new in

SPRAGUE ATOMS

The Handiest Dry Electrolytic Capacitor for Vertical Chassis Mounting

These unique Sprague Type LM Atoms with their universal mounting feature are just the thing for replacing inverted can, spade-lug or other types of vertically-mounted capacitors. They fit any chassis hole from 3/16" to 7/8" diameter. Special clamps fasten securely to the chassis in an instant. Separate positive and separate negative leads can be connected together to get common positive or negative sections. Ideal for replacing old common positive section capacitors because section-to-section electrolysis is eliminated. Available in popular capacities at leading jobbers. Ask for them by name—*Sprague Type LM's!*

WANTED—WORK IN RADIO FIELD—Experience: army radio operator, repairman for 3 years, service work in local shop, signal corps training, DeForest's. Veteran, married, age 28. V. E. Anderson, 512 W. 8th St., Fremont, Nebr.

FOR SALE—Clough-Brengle frequency modulator for use on a 'scope. Want an Accoustimator for a model 70 Motorola auto radio. Paul Capito, 637 W. 21 St., Erie, Pa.

WANTED—G.E. phonograph motor #5NC50GM2 115v 60 cy. State condition and price. Charles M. Conley, 806—24th St., Ogden, Utah.

WANTED—Hallcrafters SX-28A and speaker. Must be new or in perfect condition. Ronald Tew, 1288 Meadowbrook Ave., Los Angeles 35, Calif.

POSITION WANTED—Ex-radio technician wants position as Jr. E.E. or electronics technician B.E.E., industrial experience, age 33. Norman Vought, 7455 64th Lane, Glendale, L.I., N.Y.

FOR SALE—New tubes. 25% off on orders for 10, also discounts as high as 50% on some numbers. Also have many used tubes at bargain prices. What do you need? Ben's Radio, North Tonawanda, N.Y.

FOR SALE—Rider manuals 5, 6 and 7, excellent condition; also some hard-to-get tubes. Write for list. C. L. Dennis, Walton, N.Y.

FOR SALE—Superior 1946 model CA-10 signal tracer complete with instructions. Follows signal from antenna to speaker of any set. Almost new. \$12. Sal Radio Service, 1431 Park Ave., Cranston, R.I.

FOR SALE—Popular tube numbers, also other parts. Send list of what you need. C. H. Ferguson, 769 Columbia Rd., Westlake, O.

FOR SALE OR TRADE—Abbott radio receiver, navy type COA43027. Can be easily converted for 2 meters. Complete with 6v and 115v AC power supply. Will trade for ham receiver, or sell for \$55. Ned Klminson, 59 N. Bothwell St., Palatine, Ill.

FOR SALE—Philco 033 tube checker, excellent condition, checks all tubes up to 117v. Electrically & mechanically O.K. \$25. Also, amateur rig, 40 watts output, 6V6 osc. pair 6L6's final. Complete with 40 and 80 meter coils, crystals, tubes, power supply. \$40. Frank Rou, c/o Bot. Dept. U. of Penna., 38 Woodland Ave., Philadelphia 4, Pa.

FOR SALE—New Eclipse aviation type 1273A DC generator, fan regulator and cut-out supplying 30v 75a to type 800 motor generator ac output 115v. 10 amp. 800 cy., \$125. Harold Deck, Fallon, Nevada.

FOR SALE—Rider Chanalyst with tubes, test leads, clips, instruction book. A-1 condition. Will accept other test eqpt. In trade. H. W. Schendel, 518 W. Main St., Sparta, Wis.

WILL SWAP—50 assorted resistors, RMA color code, 1/3 to 2 watts for one variable tuning condenser, 365 mmfd. Irving Horowitz, 22B Packard Court, Niagara Falls, N.Y.

WANTED—Circuit diagram of Dayrad tube tester serial number 20-C-24016 by Radio Products Company. Frank Schillinger, Route #5, East St. Louis, Ill.

WANTED—Model "Little Pro" 12LP Federal recorder. Will pay cash or trade. Tiny's Radio Shop, 500 S. St., Sacramento 14, Calif.

WORK WANTED—Radio service. Industrious young man. Experienced. Write for details to James Glassel, St. Croix Falls, Wis.

YOUR OWN AD RUN HERE FREE

The Sprague Trading Post is a free advertising service for the benefit of our radio friends. Providing only that it fits in with the spirit of this service, we'll gladly run your own ad in the first available issue of one of the six radio magazines in which this feature appears. Write CAREFULLY or print. Hold it to 40 words or less.

Confine it to radio subjects. Make sure your meaning is clear. No commercial advertising or the offering of merchandise to the highest bidder is acceptable. Sprague, of course, assumes no responsibility in connection with merchandise bought or sold through these columns or for the resulting transactions.

Send your ad to Dept. RRT-37

SPRAGUE PRODUCTS COMPANY
North Adams, Mass.

(Jobbing distributing organization for products of the Sprague Electric Co.)

ASK FOR SPRAGUE CAPACITORS and *KOOLOHM RESISTORS by name!

*Trademark Reg. U.S. Pat. Off.

TELEVISION TODAY

Philadelphia Dealers In Big Matinee Series

"It's the opportunity you've been waiting for to demonstrate television during daytime business hours . . . it opens wide the door to a great new market, not only for television sets, but for other things which the housewife buys—things that you sell!"

Dealers in the Philadelphia area received this notice from the Electrical Association of Philadelphia as part of the announcements for the opening on Feb. 7th of the "Television Matinee" shows on local Station WPTZ. The matinee series, hailed as one of the most valuable stunts to occur thus far in the business, runs an hour each day from 2 to 3 p. m. on Monday, Wednesday and Friday.

The non-commercial shows are planned "for the ladies and the home" and include entertainment, fashions, beauty hints, cooking demonstrations. They are announced in big-scale ads in Philadelphia's four big daily newspapers, and EAP says that all electrical dealers who are prepared to demonstrate television in their stores can be listed in the advertisements.

The Electrical Association pointed out that "These programs are one of the first attempts in history to make this new medium (television) of real help and

value to the home. The entire electrical industry will benefit by them. To you (dealers) they represent the beginnings of a giant business which is right down your alley and in which you are going to play an active and profitable part. It makes it possible for you to have an active television demonstration in your store."

Offices of the Electrical Association are at 17th and Sansom Streets, in Philadelphia.

Display on Wheels



A television retailer in Brooklyn, N. Y., "makes a noise" when he delivers a video set. This trailer with its large lettering has attracted much notice for Consolidated Television.

Chicago Demonstration of New Console



Stewart-Warner has held the initial trade showings of its new tele sets (and 1947 FM sets) and here the company executives demonstrate a video console to a pair of S-W jobbers. L. to r., Frank A. Hiter, the senior S-W vice-president; Harry Ellis, Philadelphia Distributors, Philadelphia; Floyd Masters, S-W radio division manager, Chicago; and Wendell Kinney, Kinney Bros., Los Angeles.

Philco Projection TV Receiver

A long-awaited production model of the new Philco projection television receiver was shown in operation during the recent FCC hearing at Princeton, N. J.

This set, which has aroused wide curiosity throughout the trade, employs a modified Schmidt optical system (with

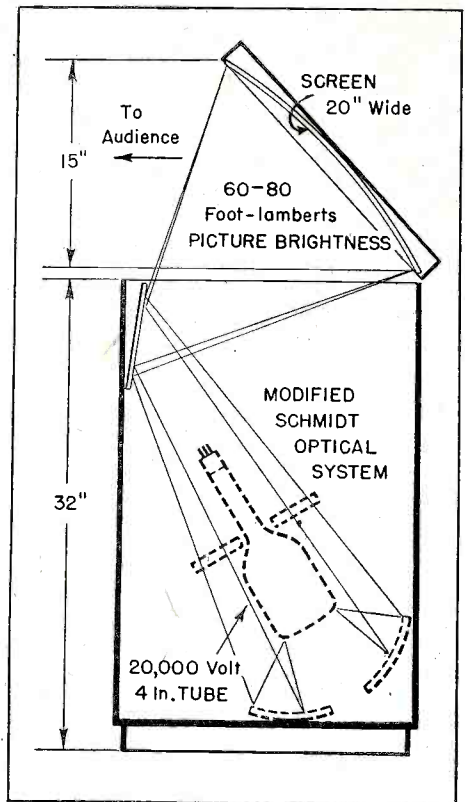

Light paths in new Philco projection TV set, as conjectured by observers at FCC hearing

special "askew" elements) and uses a 4-inch 20,000-volt projection tube. The picture beam from this unit is then reflected from the plane mirror inside the front of the cabinet, onto the inclined high-gain specular screen mounted inside the lifted lid.

Viewers seated or standing in front of the cabinet see a picture 15 by 20 inches in size, with a brightness of from 60 to 80 ft.-lamberts. Such a picture can be viewed comfortably in a well-lighted living room.

New Brightness Produced

The tipped screen with its specular surface results in velvety blacks far below the room illumination, so that pictures of great contrast and brilliancy are produced, even in brightly lighted interiors. The special screen structure itself is also held accountable for a four-fold amplification of picture brightness.

The projection tube used employs a new phosphor, estimated by Philco's vice-president in charge of engineering, David B. Smith, to produce a three-time increase of brightness. This phosphor brilliance is further increased by metallized backing giving a two-fold increase at the 20 kv voltage. The optical system produces a five to one gain over prewar designs.

New Crosley Unit Makes Trade Debut

The new combination television, FM and automatic radio-phonograph shown by Crosley Division, Aviation Corp., Cincinnati, Ohio, emphasizes a string of five features: swivel mounting of 10" picture

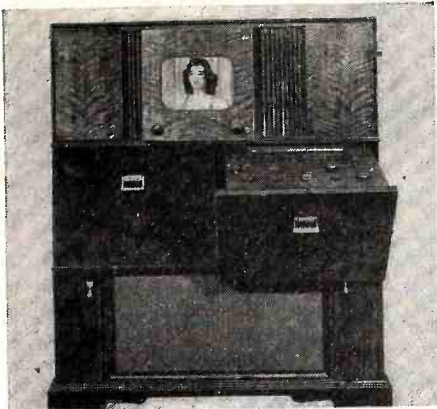

Crosley console with swivel-mounted tube.

tube through a 60-degree angle for better viewing, continuously rotatable hermetically sealed "Channel Selector" switch, an antenna system providing for use of combinations of separate antennas without auxiliary switching, an IF of 33 mc to eliminate interference, and special balanced input circuit. The four-position switch allows use of tele antenna for FM—turns off dial light when tele is on; turns off tele tubes on radio or phono; uses radio amplifiers for tele sound; turns off radio oscillators of tele or phono; and allows use of same tone and volume controls for tele, radio & phono. The unit has an aluminized tube, and Germanium crystal detector for video signal. It operates on standard AM band (540 to 1600 kc); band spread shortwave (9450 to 11,950 kc); FM band 88 to 108 mc; and any 8 of the 13 tele channels from 44 to 216 mc. The automatic changer handles ten 12" or twelve 10" discs. The cabinet measures 44 1/4" high by 37 1/2" wide by 18" deep.

Rembrandt Tele

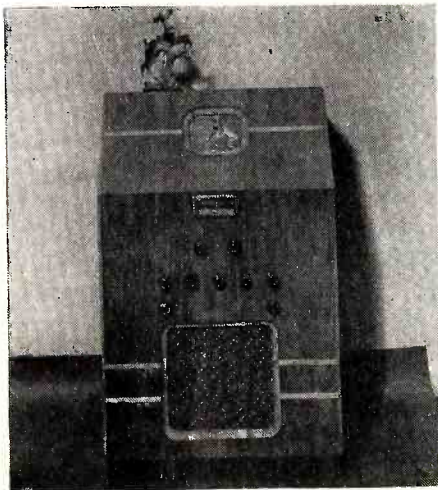

The first unit of the video line of the Remington Radio Corp., 175 Main St., White Plains, N. Y., is this console, with another console and a table job to follow. The firm is now planning a national distributor set-up, and will continue its line of Rembrandt record players.

Two Toppers of the LEAR Hit Parade



Lear radio-phonograph, table model, in hand-rubbed mahogany veneer, AC superheterodyne, 5 tubes plus rectifier tube. Automatic record-changer plays 10" and 12" records.



"Chairside" model radio-phonograph just 30" high. In hand-rubbed blond or mahogany veneer. World-wide bands. AC superheterodyne, 5 tubes plus rectifier tube. Automatic record-changer. Deluxe Alnico PM speaker in special "breathing" chamber.

It didn't take John Q. Public long to spot these two special honeys among the others of the Lear line. They caught his fancy—and it keeps us stepping to make them fast enough.

But that's true, too, of all our models. People see them, like them. They hear them and they're won.

Which proves to us it was worth while to make home radios with all that feeling for fineness which Lear has put in aircraft radios for more

than seventeen years. It was worth while to plan and fashion trim and efficient chassis and put them in particularly neat and well-designed cabinets.

It's all proving worth while to dealers, too—who are finding Lear sets sell easily and stay sold—and that the Lear Franchise really pays off.

This is a franchise you should know all about. Write for all the details.

COMING!

The Learecorder—
"The wire that remembers."



LEAR RADIO

LEAR, Incorporated, Home Radio Sales and Merchandising Division, 110 Ionia Avenue, N.W., Grand Rapids 2, Michigan.



Officials of the Massachusetts store, F. L. Monette, left, and Ernest Beaudry try "every known method for stimulating sales."

Money-Making Merchandiser

New England Retailer Gets Results from Hard-Hitting Sales Promotions

• The flourishing retail business at 199 Merrimack St., Lowell, Mass., is less than a year old but it's moving briskly toward the \$200,000 mark, and the owners are already planning an expansion into an adjoining store.

Beaudry-Monette, Inc., is a New England outfit which is not in the least "staid" about its promotional activity. The store makes the statement that it is using, or planning to use, every known method for stimulating sales. Lowell has a population around 120,000 and a big share of it has heard about Beaudry-Monette in spite of the fact that the establishment opened only last August.

The president of the firm is Er-

nest Beaudry, and Francis L. Monette, who has the benefit of some fourteen years experience in radio and appliance merchandising, is treasurer of the company. In addition to the two executives there are five outside salesmen, four salespeople in the record section, and four men in the repair department. The firm operates two pick-up trucks.

Besides the five salesmen who sell and demonstrate outside the store, the company has a heavy advertising schedule in local newspapers, a five-minute radio program, and a regular schedule of direct mail pieces.

With this barrage of promotion, Beaudry-Monette pulls 'em into the

store and holds its own with the department stores of the area. The store is situated on the main business street of Lowell. The owners expect to hike their appeal considerably when they take over the new space in the adjacent building and increase the sales floor space from 2,700 sq. ft. to 3,500 sq. ft.

The floor plan of the Beaudry-Monette salesroom calls for "straight line" merchandising. Four aisles lead from the main entrance to the back of the store, and each aisle features a different type of merchandise. The proprietors report that customers rarely leave the store via the same aisle they came in, and the value of getting them interested in several different lines is obvious.

The firm does its own financing and offers a full year guarantee on all repair jobs and tubes. Although the management puts a marked emphasis on its efforts to locate and to "sell" the customer, it by no means neglects its rightful servicing and follow-up responsibilities.

In a store like this one, where the merchandising is done so confidently and aggressively, it has of course turned out that Beaudry-Monette could sell more merchandise than they could get. Getting the merchandise has in fact been the chief problem. However, the firm has applied the same lively and reasonable policy used in its handling of customers, to its relations with its suppliers, so that when merchandise was allotted to retailers in the area, Beaudry-Monette didn't do badly at all!

Over-all view of the Lowell, Mass., lay-out shows merchandise compactly arranged in straight lines.



All roads lead to

1.) **1947 PARTS SHOW**
2.) **RADIO & Television RETAILING'S**
MAY Show Issue

These Products Will
Be Displayed at the
Show — Advertise
Them in May
**RADIO & Television
RETAILING**

tubes and tube parts
batteries
condensers
capacitors
resistors
volume controls
potentiometers
vibrators
transformers
coils
switches
relays
record changers
phonograph motors
microphones
loudspeakers
sound equipment
cabinets
racks and panels
inter-communicators
test equipment
power supplies
insulation and insulators
auto aeriols
dipole antennas
kits
transmission lines
hardware
connectors and
accessories
technical services, etc.

For five days in May (11-16, Stevens, Chicago), the attention of the entire radio-electronic parts industry will be centered on the 1947 Show. New products, new developments, will vie for buyers' attention. To sell the trade at the Show and at home, RADIO & Television RETAILING is indisputably first choice.

Nothing really comes close to the trade's dominant magazine for reaching dealers and distributors. Since 1925, it has always been first in paid ABC circulation, in balanced, helpful editorial service, and in the advertising of service parts and equipment. Over the years, and continuing in 1947, advertisers have spent far more money in this magazine than in any other radio trade publication.

The May Show Issue will be distributed from our booth at the Stevens to reach buyers there, but more important — it will cover the principal buying elements of the trade throughout the nation, including the thousands who cannot attend the Show. Deadline is April 5. See you at the Show!

**RADIO *Television*
RETAILING**

Caldwell-Clements, Inc., 480 Lexington Ave., New York 17, PLaza 3-1340

Publishers also of "ELECTRONIC INDUSTRIES & ELECTRONIC INSTRUMENTATION" and "TELE-TECH"

Chicago 6

Cleveland 14

Los Angeles 5

San Francisco 4

JOBBER IN ACTION

Distributors of 15 States Make Market News

SEATTLE, WASH.—A number of staff appointments have been announced by the *F. B. Connelly Co.*, 1015 Republican St. Heading the major appliance department is F. M. Williams, previously manager of the electrical department. Succeeding him in that post is Neal Wallberg. Harold Brandt succeeds Mr. Wallberg as service manager. Frank C. Porter, vice-president, called the appointments "additional moves to increase the departmentalization of our company to the point where more efficient service and sales promotional helps can be rendered to our dealers."

PHILADELPHIA, PA.—New headquarters at 418 Arch St., has been announced by David Shinberg and H. T. Freedoff of *Pennsylvania Wholesale Distributors*. The entire premises of this location will be occupied by their warehouse, show rooms and executive offices.

The firm says that "during 1946, our sales force covered the furniture, department store, home furnishings, hardware and electrical appliances trades with a staff of approximately thirty men throughout the country, placing the company in a position to merchandise direct factory lines in every state of the union."

LOUISVILLE, KY.—The annual banquet for employes of the *Foster Distributing Co.*, at 409 W. Main St., here was staged at the Kentucky Hotel, with R. M. Foster, president, announcing a bonus of 20% of yearly salary for each employe. Mr. Foster announced that sales for the firm had

Refrigerator Men at Merchandising Party



Shown at one of the dinners given for its distributors by the Gibson Refrigerator Co., at the Morrison Hotel, Chicago; during the Housewares Show are, l. to r., Walter D. Krauter, Gibson national service manager; John L. Stephens, Gibson sales promotion manager; E. D. Bozeman of Woodson & Bozeman, Inc., Memphis; E. S. Nobles, Gibson divisional sales manager; W. M. Riley, Otis Hidden Co., Louisville; Ralph Bacon and W. J. Bacon, Bacon's Hardware, Washington, Ind.

reached an all-time high. The company distributes Emerson radios, Automatic washers, Ironite ironers and other major appliances in the Kentucky and southern Indiana areas.

BROOKLYN, N. Y.—More than 400 distributors have applied for distributorships to market the new Multi-Purpose vacuum cleaner introduced by the Lewyt

Corp., 60 Broadway, here, according to officials of the firm. Alex M. Lewyt, company president, said that jobbers would be appointed on a progressive national basis; deliveries are scheduled for this month with a production goal of 12,000 units per month.

ATCHISON, KAN.—Announced by Garrod Radio Corp., as its new distributor here is the *Blish Mize & Silliman Hardware Co.*, 233 S. Fifth St. The firm will serve retailers in the western half of Missouri and in the entire state of Kansas except the counties of: Stafford, Reno, Harvey, Cutter, Pratt, Kingman, Sedgwick, Crowley, Barber, Harper and Sumner.

AKRON, OHIO—The new "Gift-of-the-Month Club" started by *Olson Radio Warehouse, Inc.*, 73 E. Mill St., of this city, now has over 12,000 radio servicemen members, according to an announcement by the firm. The Club sends a free gift each month to its participating members. The first gift was 100 cigarettes, and others are being announced periodically.

In the news bulletin printed in these columns last month concerning the Olson firm, the address was given as Dayton, Ohio; the correct location is Akron, as noted above.

SAN FRANCISCO, CALIF.—Word from V. N. Zachariah, president of *Zack Radio Supply Co.*, of this city is that the firm has purchased the entire stock and fixtures of the *Sah Jose Radio Supply Co.*, San Jose, Calif. Mr. Zachariah says that all materials from the San Jose site will

"A Sound Proposition" Shown by Distributor



Warren Radio Co., jobbers for Clarion in Ohio, held a special meeting for its branch managers and salesmen from their Toledo, Akron, Ft. Wayne and Lima areas, and showed the Clarion slide film, "A Sound Proposition" to the group. Owen Smith, Warren president, conducted the meeting and Dan McKinnon of Clarion showed the film as J. W. Hutchinson of the Lima and Ft. Wayne branches played host to the gathering at the Lima offices.

be moved to his San Francisco store; the former firm will be discontinued. This is the third purchase of this kind made by the Zack organization, the last one being in 1945 when he bought the entire stock of the Offenbach organization here.

AMARILLO, TEX.—Recently opened at 1003 Harrison St., here is the *Triple H Electric Co.*, wholesalers in electrical supplies including radios, traffic and major appliances, wiring materials, etc. David Hickman, M. M. Hickman and Ernest Haimes are the partners. The new firm is collecting information on new lines.

BOSTON, MASS.—Howard Jacobson, general manager of the appliance division of *Bigelow & Douse Co.*, distributor of Farnsworth products in New Hampshire and Eastern Massachusetts, has announced Oscar A. Chevretil as the new representative to cover the state of New Hampshire. Mr. Chevretil's experience in the merchandising of radios and appliances includes 20 years in wholesale and retail capacities in New Hampshire. He was in the European Theatre two years with the Army Corps of Engineers.

CHICAGO, ILL.—The prominent distributors, *Walker-Jimieson, Inc.*, 311 S. Western Ave., here, have been named as jobbers for the full line of Select-O-



Russ Jimieson of Walker-Jimieson Inc., jobbers who distribute Sonora radios, electronic supplies, etc., has been elected president of the Edgebrook, Ill., Kiwanis Club. Above, Howard Marquis, Kiwanis official, pins president's button on Mr. Jimieson.

Phone communication systems. The new "interior telephone" units are made by Kellogg Switchboard & Supply Co., 310 W. 6th St., Kansas City, Mo.

NORWALK, CONN.—Dilks, Inc., of this city, makers of "Vocal-Aire" sound systems, have named Hutchins Industries, Inc., 325 W. Huron St., Chicago, as national sales representatives for the product. Hutchins thereupon named six new jobbers for Vocal-Aire: *Pacific Wholesale Co.*, San Francisco, Calif.; *King & Irwin*, Huntington, W. Va.; *Buckeye Sound Systems*, Cleveland, Ohio; *All-State Distributing Co.*, Dallas 1, Tex.; *Lew Bonn Co.*, Minneapolis 4, Minn., and *N & N Radio Co.*, Muncie, Ind.

In addition, Dilks themselves have named three eastern distributors: *Krich-Radisco Co.*, Newark, N. J.; *Commercial Radio Sound Corp.*, New York 22, N. Y.; and *Radio & Appliance Distributors, Inc.*, Hartford, Conn.

TURNER MICROPHONES GIVE YOU ALL 3



Ingenuity and skill in applying sound engineering principles and combining them with modern streamlined styling have made Turner the top name in microphones. Whatever your need for accurate pickup and true life reproduction of voice or music there's a Microphone by Turner to do the job.

THE TURNER MODEL 211 BROADCAST QUALITY DYNAMIC

Engineered for the critical user who is satisfied only by finest reproduction, the Turner Model 211 Dynamic utilizes an improved magnet structure and acoustic network. The high frequency range is extended and the extreme lows raised 2 to 4 decibels. A specially designed precision diaphragm results in extremely low harmonic and phase distortion without sacrifice of high output level. Very sensitive to variations in tone and volume, its accurate pickup and smooth response is free from peaks or holes from 30 to 10,000 c.p.s. Ideal for both voice and music, the Turner 211 is recommended for quality recording, sound system, public address, and remote control broadcast work. It may be used with utmost confidence indoors or out, in any climate or temperature.

SPECIFICATIONS:

- **Output Level:** 54db below 1 volt/dyne/sq. cm. at high impedance.
- **Response:** Substantially flat within ± 5 db from 30 to 12,000 c.p.s.
- **Impedance:** 50 ohms, 200 ohms, 500 ohms, high impedance.
- **Directivity:** Semi-directional. Non-directional when tilted full 90°.
- **Case:** Salt-shaker type in rich satin chrome finish.
- **Cable:** 20 ft. shielded heavy duty 2-conductor removable cable set.
- **Stand Coupler:** Standard $\frac{5}{8}$ "-27 thread.

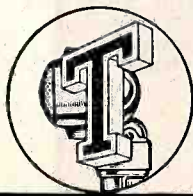

Ask your dealer for details or write

THE TURNER COMPANY

903 17th Street N. E., Cedar Rapids, Iowa

TURN TO TURNER FOR THE FINEST IN ELECTRONIC EQUIPMENT

LICENSED UNDER U. S. PATENTS OF THE AMERICAN TELEPHONE AND TELEGRAPH COMPANY AND WESTERN ELECTRIC COMPANY, INCORPORATED

is "Blanket Coverage" really warm?

LARGEST PUBLISHERS EXCLUSIVELY IN THE RADIO-ELECTRONIC FIELD covers your

TELE-COMMUNICATIONS

Developed for the designers, manufacturers and operators of tele-communications equipment for: radio, AM, FM, television, radar, microwave, police, aviation, railroads and government agencies. No other magazine publishes as much editorial information exclusively on the engineering and operation of tele-communications.

TELE-TECH

staffed by veterans in the fields of communications, broadcasting and ultra-high frequency engineering.

circulated to 17,000 engineers, executives and technical men concerned with designing, manufacturing and operating all types of tele-communications equipment. No "sidewalk superintendents" in TELE-TECH coverage; every issue directed at key men!



circulation: 17,000

FEATURING: New products! New methods! New procedures!—described and illustrated. Charts on circuits! Practical applications of communications equipment! Pictorial features on actual operations!



"BLANKET COVERAGE" ... now there's a term to snuggle up to. But wait—come closer. Find out what it really means ... and what it costs. Those who sell "blanket coverage" for your ads in radio-electronic papers would have you believe you are buying the "most" for the "least." But the gravest mistake you can make in trying to reach the vast radio-electronic audience is to pay for circulation figures instead of buyers.



SOME PUBLICATIONS OVERFLOW THEIR NECESSARY BOUNDARIES!

Beware of padded circulation—subscriptions that are high-pressured from groups outside the necessary boundaries of your market. Most industrial papers have 85-90% of their circulation among personnel actively engaged in their field. Many radio-electronic publications, confronted with "interested-but-not-buying" prospects, offer only 40% actual buying circulation. Careful selection of subscribers, based on their chief editorial interest, avoids dissipation of advertising dollars.



SOME ARE TOO LIMITED TO COVER THE FIELD!

In a field as lucrative as radio, there always have been comers and seekers of the hidden gold—publishers included. But the number of experienced editors who can interpret engineering technique is limited. The merchandising and technical specialists are few, and are concentrated on certain leading publications. And a magazine, being no better than the accumulated experience and talents of its staff, covers—or fails to cover—the field it surveys accordingly.



SOME "IRREGULARS" SHRINK FROM EXPOSURE!

Being a fertile field, radio has been the nesting ground for "cultivated" papers—as well as for fly-by-night "weed" publications. Examine some of these "irregulars" by advertising standards—ABC or CCA—and you'll find that circulation figures, if available at all, are reduced to their true proportions.

The distinguishing merit of Caldwell-Clements' publishing service is in its "selected circulation"; its competent editorial staff; and intelligently conceived, make-you-want-to-read formats.

CALDWELL-CLEMENTS

buying market where you need it...

FACTORY ELECTRONICS

Reaching the largest number of buyers of electronic equipment throughout all industry, as well as designers and manufacturers of electronic apparatus!



for manufacturers and industrial plants buying electronic products for induction heating, motor control, measuring, welding, sorting, industrial X-Rays, etc.

an easy-to-read format, convenient 11" x 16" tabloid size and generously loaded with photos and picture stories of actual factory electronic applications. Every ad rubs elbows with editorial material.



circulation:

25,000

FEATURING: How to push quality up... and costs down! A monthly industrial electronic digest of 150 magazines! New products and where to buy them! "Who's" doing "what" in the field! A giant two-page, technical color chart in every issue!



Caldwell-Clements serves every corner of the radio-electronic field with engineering handbooks, manuals, marketing data and directories! We will be glad to send manufacturers and agencies additional marketing information or a sample of this literature on written request.

MERCHANDISING and SERVICING

Here's your show window for radio sets, parts, phonographs, records, refrigerators, ranges, washers, vacuum cleaners, toasters, all electrical appliances and related items being sold through radio-appliance stores:



- first** in net paid and total circulation: 27,100 ABC
- first** in ABC circulation among independent radio-electrical retailers
- first** in advertising volume and number of advertisers
- first** in manufacturer-(and agency)-sponsored surveys
- first** in editorial service to "Big Four" dealers selling and servicing radios, electrical appliances, records and accessories.

circulation:

27,100



FEATURING: New products and where to buy them! How to make volume climb! Displays that help sell! How to meet the price-cutting trend! How to anticipate record sales! How to make credit selling work! How to make servicing pay off! In short: How to help the trade make more money!

Caldwell-Clements, Inc., 480 Lexington Ave., New York 17, N. Y., Plaza 3-1340

Cleveland 14 • Chicago 6 • Los Angeles 5 • San Francisco 4

Better Service

(Continued from page 41)

tips," explained Deason, "but it generates a feeling among patrons that we are capable of serving his every service need."

A model office containing an assortment of electrical equipment has attracted wide attention among San Antonio businessmen. The equipment includes an air conditioning unit, a refrigerator, a radio-combination, an automatic clock, an inter-com system, and a spe-

cially designed liquor cabinet.

"With a sports program on the radio, or their favorite record on the combination as a background, and either a sandwich from the refrigerator, or a spot of liquid refreshment, the sales resistance of the office caller is lessened, and I frequently take orders from home-owning businessmen for one or more of the products subtly displayed in the office. Outfitting my office into a 'model' for tired San Antonio businessmen was a profitable move," declared Deason.

Designed to Sell

(Continued from page 43)

tion to a sheet music room across the rear. Each department is labeled with a neon sign for the convenience of customers. An interesting feature of these signs is that the letters are removable, and thus special signs can be made up for special occasions such as sales, special offers, etc.

From this well-planned arrangement it can be seen that the bulk of store traffic is centered in the front. Curiosity seekers have easy access to the radio display floor. People wanting records or accessories do not have far to go. Customers making monthly payments can get in and out quickly. The same holds true for people calling at the general office or salesmen calling upon the manager. That means that higher-priced merchandise sales are conducted in the rear of the store where quiet prevails.

Assembly-Line Action

The basement has been arranged to receive and process merchandise shipments with a minimum amount of bother. As with the main floor, a wide corridor extends the entire length of the basement. Merchandise which is received from the sidewalk elevator is unpacked, tested, and prepared for display in an "assembly line" operation.

There are rooms for radio service, piano repair, band instrument repair, storage rooms, and a reserve record stock room. Merchandise received from the elevator landing is first unpacked. From here it goes to the repair rooms for testing, tuning, checking, etc. If any scratches, dents, or bruises are visible, or if the merchandise is to be refinished for any reason, it is then dropped off at the lacquer spray room. The last room is for dust removal, where the merchandise is given a final polish before being sent upstairs for display. Outgoing merchandise is handled the same way, in reverse.

Shipments of records are stored in a basement room. An electrically driven dumb waiter is used to transport the records upstairs. The basement is complete, even to an air conditioning plant which distributes filtered air to every part of the store and removes lacquer fumes in the basement.

Local truck drivers have been quick to discover that they could

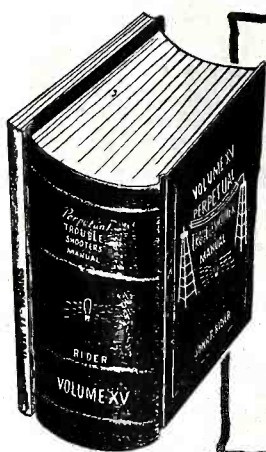

What are These Features of Rider Manual Vol. XV Worth to YOU?

What, in dollars-and-cents, is it worth to you, to have these exclusive features of Volume XV at your fingertips; this year, next year—for as long as the receivers produced during 1946 keep coming to you? (Volume I is still paying profits to those who bought it sixteen years ago!) Figure it out for yourself.

JUST OUT

RIDER MANUAL
VOLUME XV—2000 Pages
(Plus 150 page "How It Works")

Nowhere else will you find anything to equal Volume XV in completeness and helpfulness. Nowhere else will you find the wealth of vital servicing data—receiver schematics, voltage data, alignment data, resistance values, chassis layouts and wiring, and trimmer connections for receivers that were issued in 1946. Nowhere else will you find such authoritative data so complete and so systematically bound in one volume, ever ready, year after year for quick, easy reference.

RIDER MANUALS—IN 15 VOLUMES

Volume XV	\$18.00
Volumes XIV to VII each volume..	15.00
Volume VI	11.00
Abridged Manuals I to V (1 vol.)..	17.50
Record Changers and Recorders....	9.00

"clarified schematics"

★ "Clarified schematics" do a job which you have had to do on every multiband receiver and combination set coming into your shop. "Clarified schematics" break down the composite diagrams of hundreds of complicated multiband receivers, providing individual schematics of each circuit as it exists with each turn of the wave band or equipment switch. With a "clarified schematic" before you, you save the time heretofore spent tracing out an original schematic to find which components are in operation under different positions of the wave band switch. We have saved this time for your shop, by doing it for you in our laboratories.

WHAT'S IT WORTH TO YOU?

SEPARATE BOOK—"HOW IT WORKS"

★ Accompanying each copy of Volume XV is the 150 page book "How It works," a practical guide to the theories of operation of the new technical features of the latest receivers.

WHAT'S IT WORTH TO YOU?

OTHER IMPORTANT FEATURES

- ★ All popular "HAM" COMMUNICATION RECEIVERS are covered.
- ★ "Clarified schematics" on all SCOTT multiwave RECEIVERS.
- ★ MAGNAVOX Receiver Amplifier Combinations (from 1937 to '46).
- ★ Maximum coverage of postwar RECORD PLAYER COMBINATIONS.

WHAT'S IT WORTH TO YOU?

ORDER TODAY

JOHN F. RIDER Publisher, Inc. 404 Fourth Ave., New York 16, N.Y.

EXPORT DIVISION: ROCKE-INTERNATIONAL CORP • 13 E. 40th St., New York City • Cable: ARLAB

unload deliveries quickly and get away in record time. As a result many of them put the company's deliveries on the rear of the truck, and the store gets its merchandise first—and early!

The style and the efficiency of the store's new facilities have had an exceptional response from California buyers. Sales at the Southern California Music Co. over the past few months have exceeded all expectations!

FM Servicing

(Continued from page 147)

Such is particularly true of the r-f section of the receiver, which employs new tuning units such as the General Electric "Guillotine", the DuMont "Inputuner" embodying the Mallory-Ware "Inductuner" and various coaxial devices. Since most of these devices differ greatly from each other, the servicer must study them on an individual basis.

Microphonic howls are far more frequent in high frequency systems than in low frequency tuned circuits. Make a quick check to see if the howl is present when no signal is received. If it is, an audio or detector stage tube is the likeliest suspect.

When the howl rides in on the signal, use probe stick made of

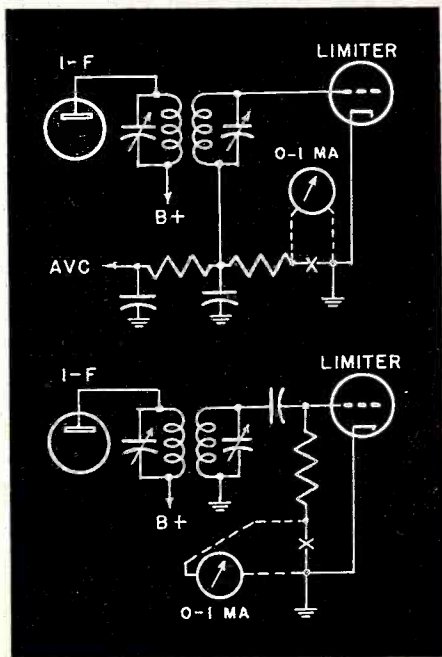

Method for connecting alignment meter to limiter depends on circuit used in receiver

some good insulation material to press against and steady elements in the r-f circuits which might vibrate due to the acoustic output of the speaker, such as variable capacitor plates, coils, etc.

Miniature tubes, and generally small sizes of components require

particular care in handling. Short leads are necessary to maintain satisfactory operation at high frequency and one should bear in mind that in changing a part, replacement should be made in exactly the same position as the original part with all leads trimmed to the same size and length.

It may seem surprising, but it is true that an inch or two of wire added in an r-f circuit component at 100 mc can cause a detuning of the affected circuit by as much as 20 mc due to the increased inductance resulting from its length.

PA Parade



Here's how the big display of amplifiers of Newcomb Audio Products Co., 6824 Lexington Ave., Hollywood 38, Calif., looked at the annual West Coast Electronic Manufacturers Association Show in Los Angeles.

What do You
Look for in a
Phono-Radio
Line?...



ELECTRO-TONE

#706
Portable
Automatic
Phono-Radio
Combination



#712
Portable
Phono-Radio
Manual
Record
Player



... offers a line that is taking a definite place among the nation's finest. For, here you have a line that is truly "The Right Combination" ... a line that has Style ... Tone ... Value. Dealers, coast-to-coast, are now featuring and selling "ELECTRO-TONE".

Our Exquisite #555: The new "Console-performance" table model phono-radio, 6-tube scientifically improved radio receiver plus the famous Seeburg dual-post automatic record changer.

On the way ... one of the most magnificently styled quality consoles to hit the market—destined for record breaking sales—wait 'til you see it!

Choice distributorships available ...
write, phone or wire

ELECTRO-TONE CORPORATION
221 HUDSON ST. • HOBOKEN, N. J.

Look to
WARD
the Leader!

The world's leading producer of auto aerials presents models unsurpassed in . . .

- DESIGN** { Each smart looking model is engineered and equipped to fit every car on the road.
- QUALITY** { Every model has been tested and approved by car and radio set manufacturers.
- DOLLAR VALUE** { Always "most for the money" Ward aerials are going down in price Feb. 1, 1947. List prices will be from \$2.95 up.

Write us for full information!

IN CANADA: Atlas Radio Corp., 560 King Street, West, Toronto, Ontario, Canada
EXPORT DEPARTMENT: C. O. Brandes, Mgr., 4900 Euclid Avenue, Cleveland 3, Ohio



WARD
Aerials

THE WARD PRODUCTS CORP.
1523 EAST 45th STREET
CLEVELAND 3, OHIO

Sales Specialist



Nate Hast, well known radio sales executive, has resigned his post as merchandising manager for Lear, Inc., home radio division, and has opened offices at 666 Lake Shore Drive, Chicago, as radio & appliances sales & merchandising specialist. In radio for 25 years, he will now act as direct factory representative-consultant for manufacturers, jobbers, etc., with 12 branch sales offices.

Novel PA Jobs

(Continued from page 158)

ers receiver is part of a setup incorporating an intercom and sound system by means of which this express money truck has been made "bandit-proof".

The selling days are here. Advertising, promotion, merchandising and salesmanship are again taking the stage, and in every line of business in the country, new ideas will be wanted. Look about you, size up the possibilities for applying sound wherever you may be.

When you have an idea in rough shape, see the right man and talk to him with enthusiasm. You'll find that there's a new interest in selling aids . . . and PA is one of the most versatile and profitable of them all.

Gold-Plated Radio

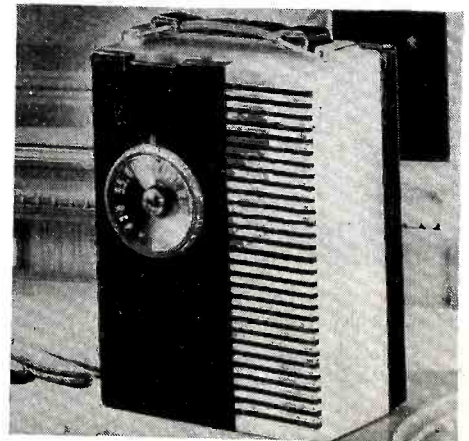

RCA Victor's new "Solitaire" pocket-size personal radio is a gold electro-plated and catalin job with strong appeal to the gift trade. The set features simplified battery replacement, elliptical speaker, built-in loop antenna.

NEWARK NOW AGENTS
OF WAA

HUGE STOCKS
OF TRANSMITTING AND
SPECIAL PURPOSE TUBES
at amazingly low prices

Make Newark your first stop for all the tubes you need. As agents of War Assets Administration, Newark has huge stocks of government surplus tubes, priced at a fraction of their original cost. WRITE NOW FOR NEWARK'S COMPLETE TUBE LISTING. YOU'LL SAVE TIME AND MONEY BY COMING TO NEWARK FIRST.

- Mail or Phone Orders Filled Promptly
- Write: 242-Y W. 55th St., New York City

NEW YORK Telephone
Offices & Warehouse Circle 6-4060
242 W. 55th St., N.Y. 19
NEWARK
ELECTRIC COMPANY, INC.

New York City Stores: 115-17 W. 45th St. & 212 Fulton St.
ACTING AS AGENTS FOR WAR ASSETS
ADMINISTRATION UNDER CONTRACT WAS(p) 7-167

TUBES: Perfect condition but not in sealed cartons. Guaranteed for 90 days. #26, 27 or 56 . . . 29¢; #24, 42, 75, 77, 78, 80, 89, 6K6 or 6K7 . . . 39¢; #50, 6A3, 6A8, 6F5, 6SA7, 6SK7, 12SA7 or 12SK7 59

- Phono Scratch Filter Transformer, (7/8" x 1 1/2" sq.) with hookup diagram 89
- Radioman's Hardware Treasure: Over 1000 screws, nuts, washers, lugs, etc. PLUS handy 36 compartment cardboard kit box 59
- 12" Speaker Grille. Round, heavy steel mesh 29
- Grille Cloth. Decorative gold or silver weave. Per square foot 20
- 100 ft. spool #21 insul. solid copper wire 39
- Filament Transformer; 6.3V at 3 amps 98

SERVICE MEN'S KITS

- #1—R.F., Antenna & Osc. coils; 10 asst. 98
- #2—Speaker Cones; 12 asst. 4" to 12" moulded & free-edge (magnetic incl.) less voice coll. 2.00
- #3—BAKELITE MICA CONDENSERS; 50 assorted .00001 to .2 mfd. 200-600VW clearly marked 2.95
- #4—Tubulaf By-Pass Condensers; 50 assorted .001 to .25 mfd. 200-600VW Standard brands 2.49
- #6—Dial Scales; 25 asstd. airplane & slide rule (acetate & glass included) 2.98
- #7—Escutcheon Plates; 25 asstd. airplane, slide-rule & full-vision types 2.95
- #8—Knobs; 25 asstd. wood & bakelite, including setscrew & push-on types 1.00
- #9—Wafer Sockets; 12 asstd. 4 to 7 prong 25
50 for 1.00
- #10—Voltage Dividers; 10 asstd. standard multi-tapped. High wattages included 1.98
- #11—Shield Cans; 15 asstd. for tubes, coils, transformers, etc. 1.00
- #12—Mica Padders & Trimmers; 15 asstd. incl. multiple & ceramic base types 69
- #14—Volume & Tone Controls; 10 asstd. wire-wound & carbon. Less switches 1.49
- #15—Wire-Wound Resistors; 15 asst. ohmages 5 to 20 watts 98
- #16—I F Coils; 6 asstd. including shielded & slug tuned. Peaks unmarked 1.95
- #17—Dial Windows; 12 asstd. sizes, incl. flat & moulded acetate and convex glass 1.29

PROMPT SERVICE ON ALL SPEAKER & PHONO PICK-UP REPAIRS

Min. Order \$2.00—20% Deposit Required on all Orders
Please Add Sufficient Postage WRITE DEPT. RT-3

LEOTONE RADIO
COMPANY
65-67 DEY STREET, NEW YORK 7, N. Y.

LET THESE WAA DISTRIBUTORS HELP YOU

Save with surplus

The War Assets Administration has appointed a representative group of competent well established distributors to help dispose of war-surplus electronic tubes and equipment. We suggest that you get in touch with the distributor nearest you. He will know the items available and how they can aid in solving your electronic problems.

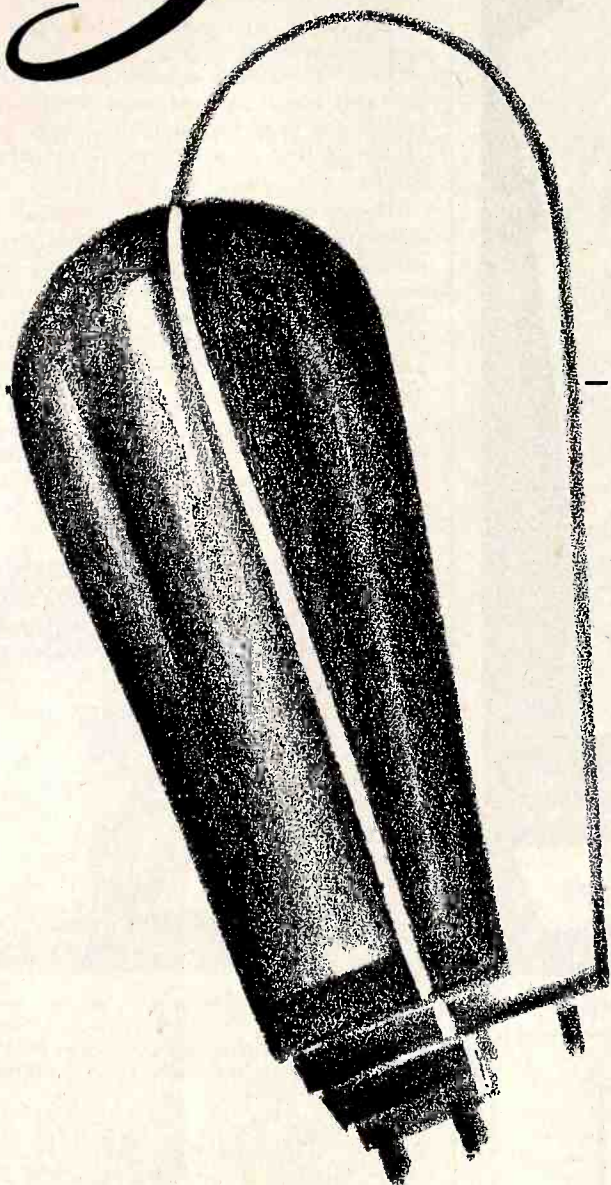

**Here is an up-to-date list of
WAA approved distributors.**

- | | |
|---------------------------------------|------------------------|
| BOSTON, MASS. | |
| Automatic Radio Mfg. Co., Inc. | 122 Brookline Ave. |
| Technical Apparatus Co. | 165 Washington St. |
| BUCHANAN, MICH. | |
| Electro-Voice, Inc. | Carroll & Cecil Sts. |
| CANTON, MASS. | |
| Tobe Deutschmann Corp. | 863 Washington St. |
| CHICAGO, ILL. | |
| American Condenser Co. | 4410 Ravenswood Ave. |
| Majestic Radio & Television Corp. | 125 W. Ohio St. |
| EMPORIUM, PENN. | |
| Sylvania Electric Products, Inc. | |
| FORT WAYNE, IND. | |
| Essex Wire Corp. | 1601 Wall St. |
| LOS ANGELES, CALIF. | |
| Cole Instrument Co. | 1320 S. Grand Ave. |
| Hoffman Radio Corp. | 3761 S. Hill St. |
| NEWARK, N. J. | |
| Standard Arcturus Corp. | 99 Sussex Ave. |
| Tung-Sol Lamp Works, Inc. | 95—8th Ave. |
| NEW YORK, N. Y. | |
| Communication Measurements Laboratory | 120 Greenwich St. |
| Electronic Corp. of America | 353 W. 48th St. |
| Emerson Radio & Phonograph Corp. | 76—9th Ave. |
| Hammarlund Mfg. Co., Inc. | 460 W. 34th St. |
| Newark Electric Co., Inc. | 242 W. 55th St. |
| Raytheon Mfg. Co. | 60 E. 42nd St. |
| Smith-Meeker Engineering Co. | 125 Barclay St. |
| SALEM, MASS. | |
| Hytron Radio & Electronics Corp. | 76 LaFayette St. |
| SCHENECTADY, N. Y. | |
| General Electric Co. | Bldg. 267, 1 River Rd. |
| WASECA, MINN. | |
| E. F. Johnson Co. | 206—2nd Ave., S. W. |

ELECTRONICS DIVISION
OFFICE OF AIRCRAFT DISPOSAL

WAR ASSETS ADMINISTRATION

425 Second St., N.W.

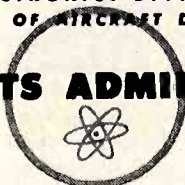

Washington 25, D. C.

945

By Popular Request
MASCO presents **A NEW STAR**

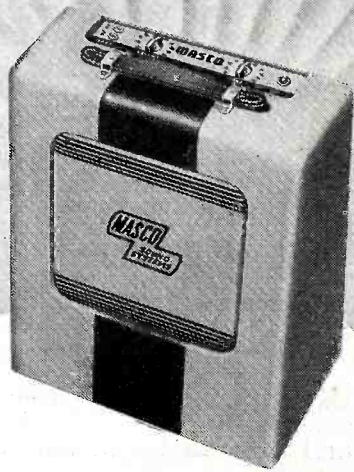

MASCO MODEL MAP-120
Musical Instrument Amplifying System

THESE FEATURES
 THAT YOU HAVE
 WANTED ARE
 INCLUDED:

- **TONE EXCELLENCE**
- **HIGH FIDELITY**
- **ACOUSTICALLY DESIGNED CABINET**
 For true reproduction of voice
 and string instruments.
- **FINGERTIP CONTROL**
 on top of case for ease of operation.

Two inputs . . . separate volume and Tone Control. On-off switch and safety fuse.
 Pilot light indicator. Extra heavy duty 10" P. M. speaker.

List price complete with kit of matched tubes \$75.00 (West of Rockies 5% additional)

Contact your local Masco distributor for
 immediate delivery. For descriptive literature
 or other information write direct to factory.

MASCO

MARK SIMPSON MANUFACTURING CO., Inc.
 32-28 49th Street, Long Island City 3, N.Y.

SOUND SYSTEMS and Accessories



RAvenswood 8-5810-1-2-3-4

WANTED

**SALES REPRESENTATIVES EXPERIENCED IN
 ELECTRONIC RADIO SERVICE EQUIPMENT**

Leading manufacturer of electronic and radio service equipment invites correspondence with fully experienced sales representatives who have a good technical knowledge of radio and electronic service instruments.

In writing, please give full details on experience and territory covered in contacting distributors and dealers. All replies confidential. Address box 301, Radio & Television Retailing, 480 Lexington Ave., New York 17, N. Y.

**Sams PhotoFact
 Service Expanded**

The need of servicers for a source of quick advice has caused the Howard W. Sams Institute of 2924 E. Washington St., Indianapolis 6, Ind., to make preparations for round-the-clock 24-hour-per-day operation, according to a letter from Howard Sams, president of the organization which publishes the PhotoFact Folders.

During the first 5 months' operation of the Institute, which is devoted to helping servicers with their educational and business problems, it received over 5,000 individual requests for aid.

Figured on an 8-hour day, this represents one request every 10 minutes. Considering the work necessary to solve the problems concerned and make individual replies, the need for multi-shift operation of the Institute has become increasingly obvious.

During this period, 1,557 photostats of schematic diagrams of prewar sets were provided without charge, while 1,564 letters containing information, recommendations, and advice covering receiver troubles, technical problems, replacement parts and the locating of parts or tubes were mailed.

Business advice was requested by 1,893 servicers aside from the many thousands who received free the helpful monographs completed during the same first five

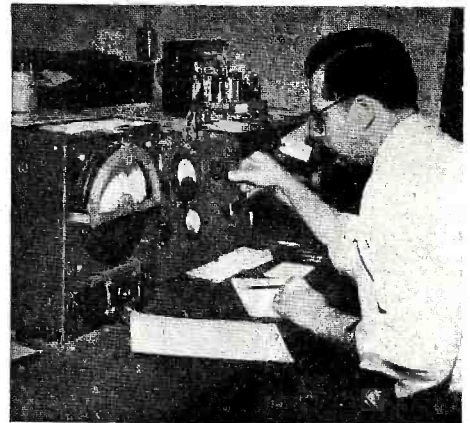

What are little coils made of? All day long this service engineer finds the answers to that question, for listing in the Sams radio PhotoFact Folders. All coils of all receivers are listed.

months. These monographs were: 1—"How Much Is Your Labor Worth?" by Don Shaw (4 parts); 2—"Accounting Procedures for Radio Service Engineers" (to run into 5 parts); 3—"How to Make Cabinet Repairs"; 4—"How to Increase Your Business".

In January, 1947, construction work was started on 3,000 square feet of floor space to house the new Radio Service Clinic Section of Howard W. Sams, Inc., at 2805 E. 10 St., Indianapolis, Ind. This will contain the most modern kind of service shop, operating on a clinical basis only, doing consulting work for over a score of retail service shops, dealers and jobbers.

Olympic Vice-Pres.



Director of sales for Olympic Radio & Television, Inc., J. F. Crossin has now been named a vice-president of the firm which makes "tru-base" radios and combos. He's been a well known figure in home appliances for 20 years—with Crosley and Nash-Kelvinator. Olympic now has 78 exclusive jobbers throughout the U. S.

Chicago "Reps" Elect

The Chicagoland chapter of "The Representatives" has elected new officers as follows: President, LeRoy Beier; vice-president, Gordon Gray; treasurer, Bill Ellinger, and secretary, R. Edward Stemm.

An executive committee composed of past presidents, Mr. Stemm, Russ Diethert, Ralph Brengle, was established, the members of which are able to contribute their wide experience to the planning of many chapter activities throughout the year.

The chapter is planning a series of meetings with allied associations. It is felt that through a free exchange of inter-association information, "The Representatives" can better serve their principals and customers.

New Record Player



The compact Model 200 portable phonograph just introduced by Steelman Radio Corp., 742 E. Tremont Ave., Bronx 57, N. Y., is an ac job with 5" Alnico speaker, duo-tone luggage type case. Lid is set at acoustically designed angle for improved tone quality. Lists at \$29.95.

Parts Show Dinner at Chicago, May 12

The Keynote Dinner of the 1947 Radio Parts and Electronic Equipment Conference and Show will be held in the Grand Ballroom of the Stevens Hotel, Chicago, on Monday, May 12, at 7 p. m. Bill Cunningham, the well known sports writer and commentator, will be the principal speaker at this industry-wide meeting of manufacturers and distributors.

According to information received from the show committee, space limitations will permit the acceptance of only the first 1500 requests. Accordingly reservations are now being accepted by the commit-

tee, at \$7.50 per plate or \$75 per table of ten. Checks should be mailed to the Radio Parts and Electronic Equipment Shows, Inc., Suite 1016, 33 North LaSalle St., Chicago 2, Ill.

Weston Appointments

Weston Electrical Instrument Corp., Newark, N. J., has appointed John H. Miller vice-president and chief engineer. He succeeds W. N. Goodwin, Jr., who although retired, has been retained as engineering consultant. The Weston firm also named C. H. Stout as sales "rep" for Arkansas, western Tennessee, northern Mississippi and northern Louisiana.



ACROSS THE COUNTRY!

WHILE one does not think of speakers spread out across the land, still if the OXFORD SPEAKERS already sold to over 77 leading radio receiver firms for their 1946-1947 line were laid end to end, they would reach almost from Philadelphia to Richmond! And at the end of this year, they should reach nearly three times that far.

THAT's a lot of loudspeakers, and attests to the excellence of their construction and their unquestioned popularity. The Jobber who knows this fact, can stock up on OXFORD SPEAKERS with the foregone conclusion that he can meet every requirement any customer can bring. And he can do it without a "special speaker." For the OXFORD SPEAKER line is designed to give the "Maximum Customer Coverage" with only the average Jobber stock pile.

THAT's why the better Jobbers heartily endorse the statement that OXFORD SPEAKERS are the ALL JOBBERS' CHOICE!

*OXFORD SPEAKERS/ALL JOBBERS' CHOICE

(Coming soon: The New Oxford Catalog. Write for your free copy!)



Copyright, OXFORD ELECTRIC CORPORATION, 1947.

OXFORD ELECTRIC CORPORATION

3911 SOUTH MICHIGAN AVE., CHICAGO

Distinctive

IT'S *Sky-Weight*



Model 82 Radio-Phonograph
Combination with exclusive
Miracle Eye Tuning

Really Portable

Sky-Weight — featured by better shops throughout the country

<p>MODEL 81</p> <ul style="list-style-type: none"> • 3-Tube Phonograph • Concealed Alnico V Speaker • Tone and Volume Controls • Plays 10"-12" Records • Size: 5½x11½x15½ Inches • Ten Pounds 	<p>MODEL 82</p> <ul style="list-style-type: none"> • 5-Tube Radio-Phonograph • Built-In Antenna • Radio-Phono Selector • Plays 10"-12" Records • Concealed Alnico V Speaker • Size: 5½x11½x15½ Inches • Eleven Pounds
--	---

Both in fine leather-bound luggage cases

CONTINENTAL ELECTRONICS LTD. • BROOKLYN 22, N. Y.

**Radio
PILLOW SPEAKER**



*"Here's the swellest
EXTRA-PROFIT item
you've ever seen!"*

- It's a "natural" for tie-in sales with small radios . . . ups your unit of sale.
- It's "just the ticket" for thousands of individuals who want to enjoy the news and other favorite programs by themselves *anytime without disturbing others*. The TELEX Radio PILLOW SPEAKER placed *under a pillow* permits one person — and one alone — to hear his radio.
- It "sells like hotcakes" as a *gift* for convalescents, hospitalized veterans, "shut-ins", and others. (The TELEX Magnetic Radio Pillow Speaker was originally designed for Army hospitals to replace uncomfortable head-phones, and is now being used as standard equipment.)

Don't pass up this "hot-selling" radio specialty. Write Dept. I or see your radio jobber. Complete merchandising helps to help you display and sell. *Immediate delivery.*

Complete with 10 foot plastic cord, plug, jack and mount, and instructions.

TELEX INC.
ELECTRO-ACOUSTIC DIVISION
Minneapolis, Minn.

Canadian Distributors:
ADDISON INDUSTRIES, LTD., Toronto

Masco Representatives



David Sonkin, left, and Ronald C. Nordstrom are two new sales representatives for Masco products, made by Mark Simpson Mfg. Co., Inc. Mr. Sonkin, with offices at 1775 Broadway, New York City, will cover that city, Long Island and parts of northern New Jersey. He's been national secretary of "The Reps" for past 12 years. Mr. Nordstrom has offices at 1102 Maccabees Bldg., Detroit 2, Mich.—he'll cover the state of Michigan as another part of Masco's expansion program

Three Are Appointed By Majestic Radio

Announcement of a series of key appointments has been made by E. A. Tracey, president, Majestic Radio & Television Corp., Elgin, Ill.

Louis A. Trojniar, with 25 years of traffic experience in the radio industry, has been named traffic manager. Fred J. Vogt has been appointed production manager of the radio division. Mr. Vogt, who has been with Majestic for the past five years, has been in radio production for two decades.

Another appointment was that of O. R. Owens, nationally known radio cabinet production authority, who has joined the company as production manager of the radio cabinet division.

Hoffman Expanding Radio Sales Areas

Hoffman Radio Corp., 3430 S. Hill St., Los Angeles, Calif., is now increasing its sales area into the states of Texas, Arkansas and Oklahoma, following a trip by R. J. McNeely, director of Hoffman sales, into that territory. Mr. McNeely said that increased production facilities of the firm now make it possible to expand from the original area of the 11 western states market.

W. D. Douglas, vice-president of the company, is now on a tour of Minneapolis, Chicago, New York and other Atlantic seaboard cities.

New Lines Ready

The Baronette Radio & Tube Co., 220 Fifth Ave., New York City, is now announcing a complete line of radios, phonographs and appliances, according to Charles Robbins, president of the company.

Heads Service Center

The appointment of L. C. Welsh as manager of the General Electric appliance service center in Cleveland, Ohio, has been announced by T. J. Killeen, manager of warehousing and distribution for the company's product service division.

Dalton Appointed Bendix Radio Sales Head

J. T. (Jack) Dalton has just been appointed general sales manager for radio and television at the Bendix radio division of Bendix Aviation Corp., Baltimore, Md. He succeeds L. C. Truesdell, who has resigned. The announcement was made by W. P. Hilliard, general manager of the division.

For the past three years, Mr. Dalton has headed up the Bendix radio distribution organization, which he created and which he gave many of its merchandising policies. He has been in radio for 25 years, and during that time has held a number of executive positions with leading manufacturers of radios and appliances.

Bendix has just introduced its new "step-table" chairside automatic radiophonograph, Model 697-A, with the "Phantom Dial" feature.

Globe-Shaped Design for New Receiver

Now creating wide interest in the trade is a new radio introduced by Michael Rabinowicz, head of Emor Radio, Ltd. Of unusual spectacular design, this five tube ac-dc all-wave superhet receiver is already known in many parts of the world. The factory is located at 400 E. 118 St., New York City, and is already in full production.

Exceptional features of the new Emor radio are its cabinet which is globe-shaped, chromium plated and also available in several pastel color finishes; its adjustable chromium tubular stand that has the tuning control, volume control and wave change fitted into it as sleeves and the loudspeaker grid which is placed at the top of the globe, allowing an even distribution of sound waves. At the recent presentation of the Willkie Award to Haile Selassie, an Emor radio was given to the Emperor.

Howard Ralbag is vice-president of the Emor firm. William R. Schoppe, who is chief engineer, was formerly associated with Philco, Fada, Federal Telephone, Hamilton and Hudson American.

FM-AM Table Model

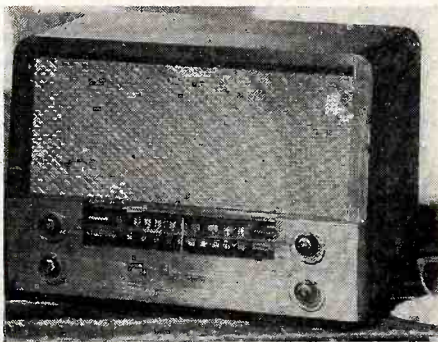

Pilot Radio Corp. has announced this table Model T-521 with FM—an ac-dc superhet with 7 tubes plus rectifier and germanium crystal. It has two antennas, 8" PM speaker, lucite dial, walnut cabinet, phono outlet with phono selector on band switch. Extra FM antenna where needed.

FOR
'47

Portable P.A. Profit-Package!

PD-835
35-WATT
PORTABLE
SYSTEM

**SELL THE COMPLETE
PORTABLE P.A. LINE!**

Rauland

RAULAND helps you fill the big demand for Portable Sound with three new perfect P.A. packages for '47: 14 Watts, 20 Watts, and 35 Watts (illustrated). Each is a smartly styled RAULAND-designed-and-built package, ready to plug in and operate. Perfectly-matched components assure top performance—full rated output, superb tonal fidelity, maximum flexibility, and trouble-free operation. Cash in on the reputation and acceptance of RAULAND Electronic Sound. Sell all your prospects for Portable P.A. with this complete, profitable line. Write today for full details.

PD-835 PORTABLE SYSTEM

The RAULAND 35-Watt PD-835 Portable System illustrated will cover approximately 20,000 people indoors, or 50,000 square feet outdoors. Two sturdy carrying cases house entire system: 35 Watt Amplifier, 2—12" PM Dynamic Speakers, Dynamic Microphone, mike floor stand, all necessary cables and plugs. Features: 4 Microphone Inputs; 2 Phono Inputs with Dual Fader; Separate Bass and Treble Tone Controls; illuminated amplifier panel. (Optional: remote mixing of 3 microphones.)

Electroneering is our business

RADIO • RADAR
SOUND

Rauland

COMMUNICATIONS
TELEVISION

THE RAULAND CORPORATION • CHICAGO 41, ILLINOIS

DEALERS AND JOBBERS... HERE IS YOUR IDEAL FM OR TELEVISION DEMONSTRATOR

**FINEST GRADE
ALUMINUM**

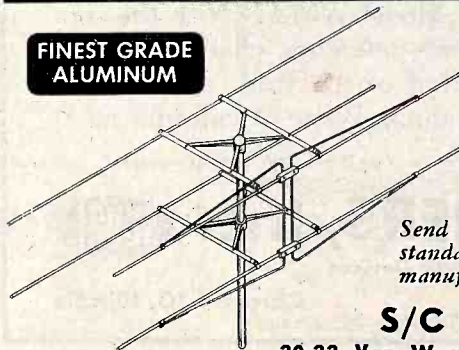

A truly broad-band high-gain antenna. Engineered to give the best results possible on any FM or Television receiver. Styled and calculated to offer the least amount of wind resistance and will withstand the severest weather conditions.

Send for circular on this antenna and our standard FM and television antennae. We also manufacture a complete line of amateur antennae.

S/C LABORATORIES, INC.

20-22 Van Wagenen Street

Newark 4, N. J.

BELL SOUND "MOTO-MASTER"



28-Watt Mobile Amplifier

ALWAYS "IN THE GROOVE"
even when **TILTED** to a 45° angle

In live-action tests, the amazing new phono pickup on this much-wanted Bell Mobile Unit shows uncanny ability to stay in the groove on recordings, despite jarring and tilting. Many other features, too, win wide sales appeal for this high gain 28-Watt Amplifier. Market research proves its capacity ample for most mobile phono-PA needs. Plays all records up to 12" on a 78-rpm turntable. Operates on 6-volt DC or 110-volt, 60-cycle AC. MOTO-MASTER also has a power economizer switch; inputs for two mikes and one phono; improved tone controls; beam power output tubes. Used with all standard mikes, trumpets, or horns.

From every angle, the MOTO-MASTER is a typical sales-gainer in the line of top-quality Bell Sound Systems that can create more profits for you. Ask your nearby Bell distributor for details.



MODEL
3728-M



BELL SOUND SYSTEMS, INC.
1197 ESSEX AVENUE COLUMBUS 3, OHIO
Export Office: 4900 Euclid Ave., Cleveland 3, Ohio

Frohlich Back to New York Sales

E. L. Frohlich has returned to New York to become vice-president in charge of sales of the Warren-Connolly Co., Inc., Norge distributors.

C. B. Warren, president of the Warren-



E. L. Frohlich

Connolly firm made the announcement and commented that "Mr. Frohlich is a friend of most of the Norge dealers because he was instrumental in forming the earliest Norge dealer organization . . . when, in 1935, the Warren-Norge Co. was formed to take over the business formerly carried on by the Norge Corp. of N. Y., he became sales manager of the dealer division. He carried out this work so ably that he was commandeered by the Norge factory to act as eastern sales manager."

In merchandising the full line of electrical appliances and kindred products distributed by Warren-Connolly, Mr. Frohlich will have an experienced staff. The dealer division will be headed by R. M. Caiani and the apartment house division by J. F. McGorty. Both have been with the firm for many years.

In New Chicago Home

The Hallicrafters Company has moved to its new plant at 4401 West Fifth Ave., Chicago. Invitations are out to the trade to visit the new factory and extensive laboratories.

Ivory Dyna-Mite

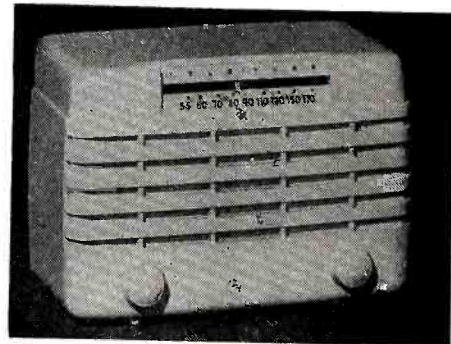

This new "Dyna-Mite" set for \$18.95 has an ivory plastic cabinet only 6" high, 8" long, 4" deep. The little ac-dc superhet has 5 tubes, avc, built-in loop aerial and is made by Tele-tone Radio Corp., 609 W. 51st St., NYC.

NEW SHURE CARTRIDGE "PACK" HANDLES REPLACEMENTS FOR 58 CARTRIDGES!



MODEL
W50

LIST PRICE
\$25.75

SERVICEMEN:

Solves your service problems with phonographs and record changers... builds new profits! 5 crystal cartridges have been "standardized" to replace 58 different popular types of all makes—a feature made possible by the new, post-war Shure Lever System. The "Pack" contains the 5 Shure Lever-Type Cartridges, including Model W57AN with the saphire-point needle.

Specific cross-reference chart for exact cartridge replacement is printed on carton. Your Shure Distributor has the "Packs" in stock. Write or call him now!

Manufactured under Shure Patents—Licensed under Patents of the Brush Development Company

SHURE BROTHERS, Inc. 

Microphones and Acoustic Devices

225 West Huron Street

Chicago 10, Illinois

NO-OX

WILL NOT GUM!

THE
MIRACLE
FLUID



NO-OX the "magic" ELECTRICAL CONTACT CLEANER. The answer to radio and electrical technician's need for an efficient cleaner to dissolve corrosion and prevent oxidation. No pre-cleaning required! Works instantaneously. Preserves surface up to one year! 1 oz. bottle 50c net; 2 oz. bottle 95c net. Satisfaction guaranteed or money back.

CLEANS
PRESERVES
RENEWS
DISSOLVES
LUBRICATES



AVAILABLE THROUGH
YOUR RADIO AND
ELECTRICAL PARTS
DISTRIBUTOR

Manufactured by
NO-OX LABORATORIES
1517 W. Pico Blvd.
Los Angeles 15, Calif.

DISSOLVES
CORROSION

PREVENTS
OXIDATION

Electro

ELECTRICAL AND RADIO EQUIPMENT



BATTERY ELIMINATORS

MODEL "P"

Sell Them Now for Winter Use With Portable Radios

A Complete Line for Every Requirement!

Models to convert dry battery radios to efficient AC receivers. Other models to convert dry battery radio for use only with 6 volt storage battery.

Cost but a few cents per hundred hours of operation. Completely filtered—hum free—silent and efficient. Sturdily constructed—no liquids or moving parts—operate in any position.

MODEL "Q"—Operates any 1.4 volt 4, 5 or 6 tube radio from 6 volt storage or dry battery, or Wincharger. Ideal for farms, camps, autos, boats, etc.

MODEL "R"—Operates 2 volt 4, 5, 6 or 7 tube radio from 6 volt storage or dry battery, or Wincharger. (0.5 Amp. filament max.)

MODEL "P"—Operates any 1.4 volt 4, 5 or 6 tube radio from 110 volt 60 cy. source. Cuts down current use and saves batteries for portable use.

MODEL "F"—Operates any 2 volt 4, 5, 6 or 7 tube radio from 110 volt, 60 cy. source. (0.5 Amp. filament max.)

Canadian representative, ATLAS RADIO CORP., Toronto, Canada

ELECTRO PRODUCTS LABORATORIES

Pioneer Manufacturers of Battery Eliminators

549 WEST RANDOLPH STREET CHICAGO 6, ILL.

Easily Sold

Easily Installed

RIG-FAST ANTENNAS

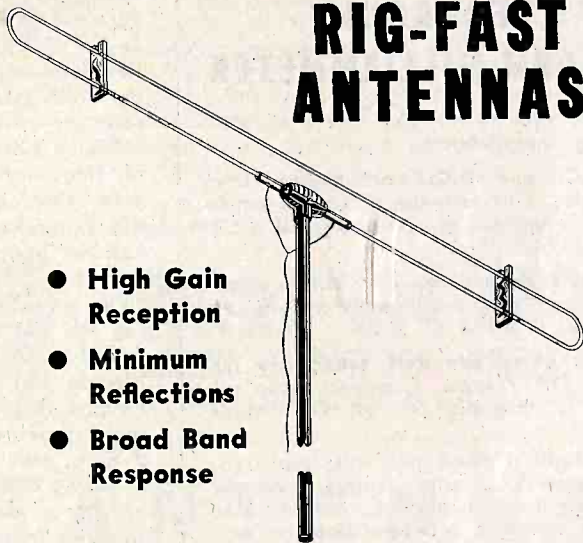

- High Gain Reception
- Minimum Reflections
- Broad Band Response

for

TELEVISION and FM

Built of aluminum and lucite, Rig-Fast Antennas are sturdy, lightweight and easily handled. Specially designed "Barrel T Clamp" cuts assembly time to less than five minutes. All parts are interchangeable and can be purchased and sold separately—an exclusive RIG-FAST Feature that enables you to service from stock.

RIG-FAST line consists of five models to meet every Television and FM requirement. Broad band response, minimum reflections and high gain reception assure customer satisfaction. Also available are the 300 ohm "Videowire" transmission line for television receivers, and a 72 ohm coaxial cable (R. G. 59U).

Immediate delivery can be made on this popular equipment so write to Oak Ridge Antenna Co., for literature about the entire line today.

"Installed in Minutes — Lasts for Years"

OAK RIDGE ANTENNA CO.

717 Second Avenue, New York, New York

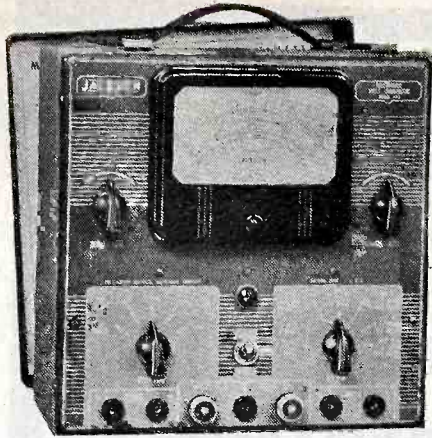

THE JACKSON Model 645 AC-DC ELECTRONIC VOLT-OHM-MILLIAMMETER

is the instrument for you. Here are the condensed specifications.

Both A.C. and D.C. volt ranges are Electronic. This provides maximum sensitivity and overload protection for all A.C., D.C., and ohms ranges.

Measures resistance up to 1 billion ohms (1 thousand megohms)—and as low as 2/10 ohm.

3 million ohms per volt sensitivity on 0-4 volt D.C. range. Constant input resistance 12 megohms on all D.C. volts ranges.

Over 4 million ohms per volt sensitivity on 0-1 volt A.C. range. Input resistance of 4.4 megohms on all A.C. ranges. Flat frequency response between 50 cycles and 200 kilocycles.

Meter cannot be damaged by accidental overload on any electronic range. Electronic overload protection on all A.C. and D.C. volts, and ohms ranges. Variations in line voltage do not affect accuracy within the range of 100 to 125 volts. Equipped with ballast control tube and self-compensating circuits.

Contains 3 tubes (6X5GT/6K6GT/7N7), neon regulator, 1-4 1/2 volt battery and ballast; self-contained, furnished with the instrument.

Meter ranges—

A.C. Volts: 0-1/4/10/40/100/400/1000
D.C. Volts: 0-4/10/40/100/400/1000
Ohms: 0-1000/10,000/100,000/1meg/10meg/100meg/1000meg
M.A.: 0-1/4/10/40/100/400/1000
Decibels: Minus 30 to minus 5/minus 10 to plus 15/10 to 35/30 to 55

Either positive or negative D.C. volt-meter indications instantly by means of reversal switch. Signal Tracing type test lead, isolation resistor in probe.

Dimensions — 8 1/2" x 8 1/2" x 6" — Unit welded steel case, grey morocco finish.

JACKSON

Fine Electrical
Testing Instruments

Jackson Electrical Instrument Co.
Dayton, Ohio

Hundred Million Dollar FM Business for 1947

Predictions that the FM set manufacturing business would amount to \$100 million a year and by the end of 1947 five million home receivers would be produced were made at the organization meeting of the FM Association in Washington which was attended by over 300 broadcasters and manufacturing company officials. Seven hundred FM broadcasting stations will be in operation by the end of this year, it was also forecast.

The FM Association unanimously elected Roy Hofheinz, KTHH-KOPY, Houston, Texas, as president; Everett L. Dillard of KOZY, Kansas City, and WASH, Washington, vice-president; Frank Gunther, vice-president of Radio Engineering Laboratories, as secretary; and Arthur Freed, vice-president and general manager of Freed Radio Corp., as treasurer. J. N. (Bill) Bailey, associate editor of Broadcasting Magazine, was elected as the FMA executive director and assistant secretary-treasurer.

Major Edwin A. Armstrong, inventor of frequency modulation, expressed the view that, based on December's consumer purchases of FM sets, the FM set business has a potential of \$100 million a year and "is going up." He declared "The evidence indicates manufacturers can sell FM sets as fast as they can be turned out." W. R. David, General Electric FM transmitter sales manager, forecast that the manufacturing industry could provide transmitters for the 700 stations which had been previously predicted by FCC Chairman Charles R. Denny, Jr., as the outlook for the stations in operation by the end of 1947. David also asserted that by the end of this year around 5 million FM receivers will have been produced.

The present year, 1947, was generally hailed by these speakers, together with executives of a half dozen other leading manufacturing companies, as "FM's Year." The other leading speakers were Dr. Ray H. Manson, President of the Stromberg-Carlson Co. who forecast that twenty to thirty per cent of the 1947 set output would be equipped for FM and that by December, 1947, the production would be about 400,000 FM sets monthly, compared with 40,000 in December last year; A. R. Hopkins of RCA Victor Division; Nor-

man Wunderlich of Federal Telephone & Radio Corp.; Fred Fisher of Westinghouse; Lester Whitten of Western Electric and Graybar; and Edward G. Taylor, Zenith Radio advertising and sales promotion manager, Chairman of the Radio Manufacturers Association committee in charge of the "Radio in Every Room" campaign.

Raytheon Active in FM

During its first year's operation, Raytheon Mfg. Company's broadcast equipment division, Chicago, has sold more than 120 complete AM and FM station installations and now has about 260 stations on its books. After having made a careful comparison of actual operation of all existing systems of FM modulators, Raytheon engineers developed the exclusive cascade system of phase shift modulation. This system, according to its developers, largely eliminates certain major disadvantages of other systems and introduces important improvements entirely new to FM transmission.

RCA Victor's Entry in De Luxe FM Combos

Now being shipped to jobbers and dealers are the first two FM consoles of RCA Victor's "Crestwood Series"—the first of the company's Victrola radio-phonographs to include frequency modulation. Enthusiastic reactions from the buying public are reported by Henry G. Baker, RCA Victor home instrument sales manager. The first models were No.'s 612V1 and 612V3 (see also "New Sets" sections of RADIO & Television RETAILING for Jan. and Feb. 1947).

In these sets, the turntable and controls for all three radio bands—standard broadcast, FM, and international short wave—are integrated into a single unit which rolls out on tracks for easier access when the drop-leaf door is tilted open. Once the records are placed on the automatic drop-type changer (up to 12), or the radio is tuned to the desired station, the roll-out unit can be rolled back and enclosed in the cabinet.

Each unit has a "Silent Sapphire" tone arm, Golden Throat tone system, generous record storage space, push-button tuning, 12" electrodynamic speaker, three built-in antennas and other features.

The first RCA Victor radio-phonograph combination with FM is this model 612V3 of the "Crestwood" series, now in production at the RCA Victor plant in Indianapolis. Decorative upper panel opens outward, forming a glide-out bed for radio-phonograph unit. After discs are placed on changer, or radio tuned, the unit may be closed.





Arthur Freed, vice-president and general manager of Freed Radio Corp., makers of Freed-Eisemann radio-phonographs with FM, was elected treasurer of the FMA.

RMA President Sees Two Million FM Sets

Production of FM receivers this year will number around 2,000,000, it has been estimated by R. C. Cosgrove, president of the Radio Manufacturers Association and head of the Crosley Division, Aviation Corp., Cincinnati. He predicted that prices of table models would run as low as \$50, and consoles down to \$175. Mr. Cosgrove put the number of FM sets now in use at about 580,000.

The RMA president's figure for production of television sets this year is 300,000. He said that black and white video had definitely "arrived"—that programs, sets and reception had all been developed to good quality. He did, however, cite the need for a good \$150 television receiver in order to develop the mass market.

NAMM Makes Mid-Year Meeting Plans

Plans for the 1947 convention and trade show of the National Association of Music Merchants were discussed at the two-day meeting of the NAMM Board of Directors held in Los Angeles. The big show is to be held at the Palmer House in Chicago, with some 225 exhibitors on hand.

Also the Board approved the appointment of a special committee to study the cost of operating a music store and to suggest a plan of uniform accounting.

E. R. McDuff, chairman of NAMM's Planning and Promotion Committee was elected NAMM's trustee on the Industry Planning and Promotion Board of Trustees. The By-Law and Executive Committees were instructed to develop a plan of financing the Association's participation in time for consideration at the annual convention.

It was decided to hold the 1948 convention in Chicago but the Board, in the motion fixing the place of the meeting, declared that this action was not to be interpreted that we had adopted a permanent policy of holding the convention in Chicago.

EASILY ADJUSTABLE FOR THE JOB

ADJUSTOHM RESISTORS

Seven Stock Sizes from 10 watts to 200 watts



You can often save time, work and money by using WARD LEONARD ADJUSTOHMS. Resistance can immediately be adjusted to the value you need . . . or tapped . . . on the job. Besides . . . you know these Resistors will give the finest service because they are WARD LEONARD quality. Available from Authorized Distributors Everywhere

WARD LEONARD ELECTRIC CO.

Radio and Electronic Distributor Division

53H W. Jackson Blvd., Chicago 4, Illinois

WARD LEONARD

RELAYS • RESISTORS • RHEOSTATS

Electric control devices since 1892

Send for Catalog D-2

Gives handy data and information on various types of Resistors and Rheostats available from stock.

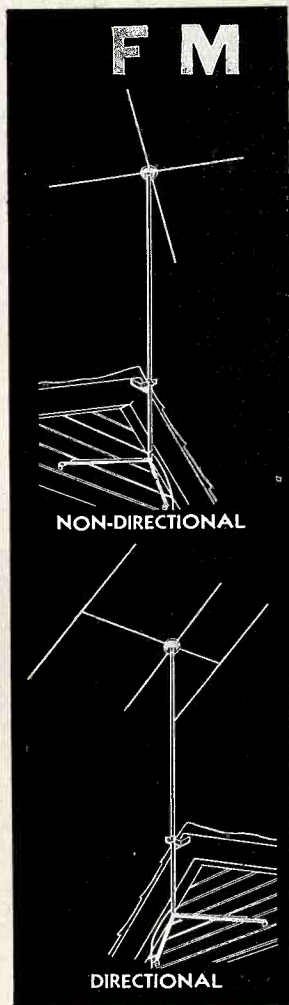

ANTENNAS

FISHER RADIO COMPANY
41 EAST 47TH STREET - NEW YORK

June 19, 1946

Mr. Gardiner G. Greene, President
The Workshop Associates
66 Needham Street
Newton Highlands 61, Mass.

Dear Mr. Greene:

We have just completed tests on your Non-Directional FM Receiving Antenna and have found the signal strength markedly improved over the dipole type that we have been using heretofore.

I want also to take this opportunity to compliment you on the rugged construction and unusual ease of assembly of the antenna kit. This equipment will be recommended without qualification to all of our dealers.

Sincerely yours,

Avery R. Fisher

Avery R. Fisher

The Workshop is proud of Avery Fisher's choice . . . the finest radio deserves the finest antenna.

Non-Directional — #FM-1 — A clean-cut assembly of four aluminum elements mounted on a rigid 7½' tubular steel mast.

Directional — #FM-2 — Additional aluminum elements which convert #FM-1 into a high-gain directional array.

The WORKSHOP ASSOCIATES, INC.

Specialists in High-Frequency Antennas
66 NEEDHAM STREET, NEWTON HIGHLAND 61, MASS.



**CAPACITORS
and
RESISTORS**
**JIFFY
CHECKED**
with the

**AEROVOX
MODEL 76 BRIDGE**



DEALER'S NET
\$44.75

● A twist of the knob . . . the positive wink of the indicator eye . . . a glance at the big, easy-to-read dial through the precision pointer . . . another glance at the multiplier switch—and you've got your capacitance or resistance reading. Power factor and leakage readings also available with equal simplicity. Checks for shorts and opens. It's all done in a jiffy—yet with real accuracy.

That's what you get in the Aerovox Model 76 Capacitance-Resistance Bridge just emerged from the Aerovox Engineering Laboratory in response to the demand for a simple, accurate, moderate-priced instrument for use in service shop, laboratory, or out in the field. You just can't afford to get along without it in this fast-moving postwar era!

Ask your Aerovox distributor or write us for the "Jiffy Checking" descriptive bulletin. Have your distributor show you this instrument and try it for yourself. You'll want to take one with you!



**FOR RADIO-ELECTRONIC AND
INDUSTRIAL APPLICATIONS**

AEROVOX CORP., NEW BEDFORD, MASS., U.S.A.
Export: 13 E. 40th St., New York 16, N.Y. • Cable: 'ARLAB'
In Canada: AEROVOX CANADA LTD., Hamilton, Ont.

Emerson Sales Manager



Charles O'Neil Weisser, formerly sales promotion manager for Emerson Radio & Phonograph Corp., has been appointed sales manager for the firm. A veteran sales executive, he was with Atwater Kent for 10 years and except for 2 years Army duty as 1st Lt. has been with Emerson since then.

**N. Y. "Reps" Hosts
to IRE Guests**

The New York Chapter of "The Representatives" will play host to the radio and electronic industry at the IRE Convention at the Grand Central Palace, New York City, March 3 to 6. A hospitality committee, with Dan R. Bittan as chairman, is in charge.

In the "Reps" booth (No. 79) visitors will find writing desks, stationery and envelopes, pen and ink, carbon paper, telegraph blanks, trade directories, listings of leading theaters, hotels, night clubs, restaurants, wrapping paper, mailing bags, typewriters, etc.

In short, "The Representatives" will do everything possible to make visitors feel that Booth 79 will be their office, meeting place, message center, etc.

Mr. Bittan's offices are at 53 Park Place, New York 7, N. Y.

**The "Court Jester"
Radio-Phonograph**

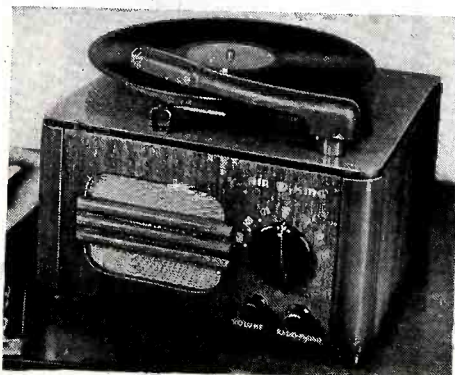

Newest addition to the line of Air King Products, Inc., 1523-29 63rd St., Brooklyn, N. Y., is the "Court Jester" Model A-403 radio-phonograph superhet with Alnico 5 speaker, Fidelity tone lifetime needle, playing 10" or 12" discs. Die-cut built-in antenna. Lists at \$39.95.

**BURGESS
Flashlight
BATTERIES**

Ready-packed
for ready
profit in
smart new
displays



**NEW ONE-DOZEN DISPLAY
OF SIZE 1 BATTERIES
No. 11V**

Here's a handy carton for rapid counter sales! To fit baby-size cases.

Dealer cost 78c Retail value \$1.20



**NEW ONE-DOZEN
DISPLAY OF SIZE 2 BATTERIES
No. 12V**

You'll get regular turnover with this counter salesman! Takes small space.

Dealer cost 78c Retail value \$1.20

**HANDY-PACK OF PENLIGHT CELLS
No. 12Z**

A little carton with big turnover for busy counters! For penlights and pocketlights.

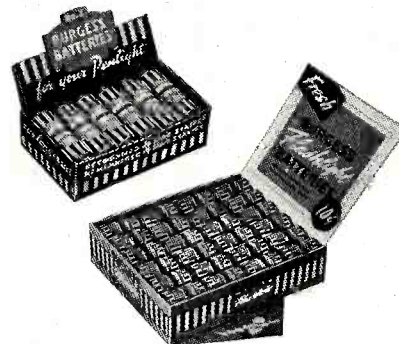

**EYE-CATCHING DISPLAY CARTON
SELLS FOUR-DOZEN SIZE 2 BATTERIES
No. 48V**

Colorful, sales-compelling carton gives you steady profits. Put it to work soon!
Dealer cost \$3.12 Retail value \$4.80

**ORDER FROM YOUR
DISTRIBUTOR
TODAY!**

**BURGESS
Flashlight
BATTERIES**

-----No. 11V -----No. 12V

-----No. 12Z -----No. 48V

BURGESS BATTERY COMPANY
Freeport, Illinois

Industry-Wide Promotions Outlined by RMA

New promotions for FM and television in 1947, and other industry projects including new services for RMA members, were the subjects of the 3-day conference of the Radio Manufacturers Association board of directors and other radio groups at the Stevens Hotel in Chicago, Feb. 17 to 19.

The RMA board of directors, with President R. C. Cosgrove, presiding, met Feb. 19, to pass on numerous industry promotion projects of various RMA divisions and committees. The Board session was preceded by a meeting Feb. 17, of the radio parts industry coordinating Committee with RMA director J. J. Kahn of Chicago, its chairman, presiding. On Feb. 18, the RMA parts division's executive committee and all section chairmen met also under the chairmanship of Mr. Kahn.

Complete plans for the "Radio-in-Every-Room" sales promotion program of the RMA advertising committee, in charge of Chairman John S. Garceau, of Fort Wayne, Ind., were taken up. Another project for 1947, "National Radio Week" observance, in cooperation with the National Association of Broadcasters, was planned. The final program for the Radio Parts Industry Trade Show, May 13-16, at the Stevens Hotel, Chicago, also were completed, and tentative plans made for the annual RMA convention and industry

Distributors See New Appliances



This group of jobbers, headed by George T. Bryant, general manager of the appliance division of Graybar Electric Co., is the Atlantic Coast delegation of Graybar—photographed at the distributors' convention held by Landers, Fray & Clark, makers of Universal appliances, at Hartford, Conn.

conference, also scheduled at the Stevens Hotel, June 10-13. Another 1947 project, for which industry participation is being arranged, is the International Marine Equipment Exhibition of the U. S. Coast Guard next April.

Among the new RMA membership services being completed is one to assist set manufacturers in disposal of surplus inventories. Weekly reports to RMA

headquarters, exchanging information on available surplus materials, are being arranged and will be circulated soon.

The RMA-NAB liaison committee, originally scheduled to meet on Jan. 30, held its meeting on Feb. 13 at the Mayflower Hotel in Washington, D. C. This initial meeting of the top executives of the two groups was headed by Mr. Cosgrove and president Justin Miller of NAB.

200 Pages

Establishing and Operating an...

Electrical Appliance and Radio Shop

FREE

Gift of the Month!

Olson Gives You a Big, Authoritative Book on How to Operate a Radio Shop Successfully

200 pages of practical advice and information, to help you make a go of your Radio and Appliance Shop. This book was recently prepared by recognized authorities in co-

operation with the Radio Manufacturers Association. If you are in business for yourself, or planning to open a shop or store, **YOU NEED THIS VALUABLE BOOK.**

HOW TO GET IT: We will send you a **FREE COPY** of this book with each order for \$10 or more, during the next 30 days. Your order must be written on one of our official order blanks, which is sent with our **FREE Confidential 48-Page Radio Repairman's Price Guide.** Just mail the coupon!

OLSON RADIO WAREHOUSE

73 E. MILL ST., DEPT. 74, AKRON, OHIO

Please send me Official Order Blank and Confidential Radio Repairman's Price Guide. No charge, of course.

NAME _____

ADDRESS _____

CITY _____ STATE _____

Clip this Coupon --

PASTE ON A PENNY POSTCARD AND MAIL TODAY

WHAT IS THE
FREQUENCY OF YOUR
DOLLAR\$?



**SUPREME Model 576
Oscillator.**

SUPREME Oscillators cannot measure the wave length of your dollars, but they can increase the frequency by which they find themselves stopping in your cash register.



**SUPREME Model 561 A.F.
and R. F. Oscillator.**

See these and other SUPREME Testers at your Authorized SUPREME Distributor.



OR, write for new catalogue No. 446 for complete details and descriptions.

SUPREME

**SUPREME INSTRUMENTS CORP.
GREENWOOD, MISS., U.S.A.**

EXPORT DEPT:
The American Steel Export Co., Inc.,
374 Madison Ave., New York 17, N. Y.

Salescrafter



Ray R. Hutmacher has announced opening of offices of The Salescrafters, Inc. at 510 N. Dearborn St., Chicago, a manufacturers representatives firm which he heads. The company will handle radio & electronic lines on national or territorial basis. Mr. Hutmacher, in radio for 21 years, recently resigned as assistant general sales manager of Maguire Industries radio & electronics division.

Complete Display Series from Proctor

Proctor Electric Co., Philadelphia, Pa., is offering retailers a complete set-up of display material to tie in with the firm's million-dollar advertising campaign just launched on its iron and toaster. The following merchandise is shipped directly to the dealer when ordered from the distributor, and sells for \$6.95 FOB the store:

1 life-size 60" full-color cutout display; 2 fourteen inch miniature, full-color cut-out displays; 3 months patented direct ad tie-in easel, one with a 30" reproduction of a color ad, the other a 14" counter miniature; 1 large 3-dimensional reflector back cut-out, 30 1/2" x 13"; 1 small, 3-dimensional, 15 1/2" x 6"; one 15 1/2" x 6" display sign; 1 shimmering 16" bulls eye and 2 window streamers, 24" x 4". Also included is a set of demonstration and sales training material, "sold" tags, consumer folders and a complete advertising guide, with mats and suggested radio scripts for use by dealers. Proctor announces that the total value of the dealer-aid package is \$13.52.



Typical material in Proctor's big promotion package—cards, stands, signs & streamers.

**—LAKE—
Amplifying Systems**

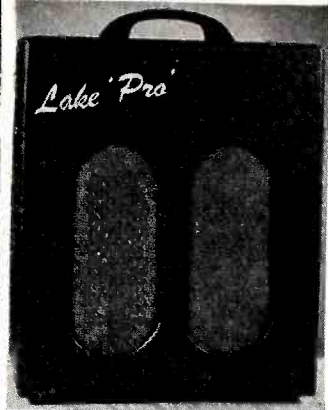

Excellent designed, compact amplifiers, ideal for students, professional entertainers, homes, factories, schools, etc. Perfect for voice, musical instruments, pickups and contact microphones; clear, rich tone; heavy plywood in luxurious leatherette covered, streamlined portable cabinets.

No.	Watts	Inputs	AS LISTED BELOW: List	Your Cost
A16	16	4	\$110.00	\$64.68
A15	15	3	97.50	52.86
A12	12	2	87.50	51.45
A8	8	3	87.50	51.45
A6	6	2	75.00	44.10
A5	5	2	60.00	35.28
ACDC Model	8	3	75.00	44.10

HAWAIIAN ELECTRIC GUITAR
Beautiful black plastic, trimmed with chrome
23" scale, 4 1/2 octaves of playing range
List—\$50.00—Your Cost.....\$29.40



**De Luxe
PHONO
CABINET**

Covered in luxurious genuine brown leatherette, has deluxe brass hardware throughout, made completely of plywood with brown plastic handle, has padded top and bottom. Motor board 14" x 14 1/2". Overall dimensions 16" L x 15" W x 8" H.
Your special net price **\$8.95**

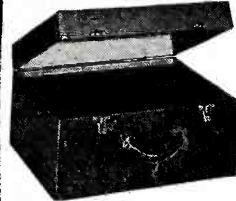

Portable Phonograph case, of sturdy durable plywood in handsome brown leatherette finish. Inside dimensions 16 1/2" long, 14" wide, 9 1/2" high. Has blank motor board. As illustrated specially priced at **\$6.95**

Also blank table cabinets of walnut veneer in the following sizes, with speaker opening on left front side: (*Note: #7 has center speaker grill)
#1 — 8 1/4" L x 5 1/2" H x 4" D \$1.95
#2 — 10 1/4" L x 6 1/2" H x 5" D \$2.75
#3 — 13 1/2" L x 7 3/8" H x 6 1/4" D \$3.25
#7* — 10 3/4" L x 7" H x 5 1/2" D \$2.50
*Speaker Opening in center of front side
All types of radio cabinets and parts are available at Lake's Lower prices. A large stock is listed in our catalog.
SERVICEMEN—RETAILERS
Write for our new, illustrated 16 page catalog NR-116. It's free. Get on our mailing list! Write for our special catalog on microphones, amplifiers and sound equipment.

**Order from Lake!
You'll make no mistake!**

Lake Radio Sales Co.
615 W. Randolph Street
Dept. B
Chicago 6, Ill.

"Twenty-Year Club" Pioneers Meet April 11

First meeting of the Twenty-Year Club of radio broadcasting pioneers will take place on the evening of April 11th. Occasion will be a banquet celebration at the New York Harvard Club which the National Broadcasting Company is organizing to mark the twenty-fifth anniversary of the first radio broadcast (April, 1922) by H. V. Kaltenborn, founder of the club.

In connection with the banquet, there will be a business meeting of the Twenty-Year Club to create a formal organization and elect officers and committees.

The "pioneer of pioneers" listed in the club's annual directory, is Dr. Orestes H. Caldwell, editorial director of RADIO & Television RETAILING, who back in 1904 in Indianapolis, Ind., with Richard H. Ranger (now Colonel, U. S. Signal Corps) using a Leyden-jar discharge as source transmitted a wireless signal which was picked up a block away by detector comprising a steel needle resting across two aluminum wires.

Special Train to Radio Parts Show in May

First announcement of the special radio train which will run from New York City to the Radio-Electronics Parts show at the Stevens Hotel in Chicago May 11-16 has been made by Perry Sattler, the well known manufacturers representa-

tive who is making the arrangements for the annual trek.

Mr. Sattler reveals that the train will leave New York either the 10th or 11th, depending on schedules to be announced later. His offices are at 53 Park Place, New York City, and the phone is REctor 2-5334.

Finn Appointed General Sales Mgr. of Victor Discs

D. J. (Dave) Finn has been named the general sales manager of the RCA Victor Record Department, according to an announcement by J. W. Murray, vice-president in charge of the department. Mr. Finn was formerly Renewal sales manager of RCA tubes. He has had wide experience in the retail field, during 17 years of advertising and sales activities in RCA, home instruments, tubes, sound and Photophone.

Admiral-Canada Director

Vincent Barreca, an officer of Admiral Corp., Chicago, for the last 12 years, has been appointed managing director of Canadian Admiral Corp., Ltd., according to Ross D. Siragusa, president of Admiral. Mr. Barreca will be in charge of producing and merchandising the company's radio and refrigerator line throughout Canada, where sales are expected to hit the \$3,000,000 mark this year, Mr. Siragusa announced.

Headquarters are at 8 Colborne St., Toronto, Ontario.

Ad Manager for Meck



New advertising manager for John Meck Industries, Plymouth, Ind., is Richard H. Schell-schmidt. He was previously personnel director for the firm, having joined the company last year.

Heads Sales for Clarostat

I. J. (Jim) Youngblood has been appointed vice-president in charge of sales for Clarostat Mfg. Co., Inc. He is well known as a veteran radio expert in the sales, engineering and operational fields, having had extensive experience with Atwater-Kent, Philco and Farnsworth since 1923. He joined Clarostat in 1940 as sales engineer.

a capacitor for every application

Confidence in Amcon Capacitors has been earned on the simple basis of performance. They do the job they were designed to do—efficiently and over long periods.



AMERICAN CAPACITORS



Look for this Amcon
Trademark.

*Amcon precision engineering
means unfailing dependability.*

WRITE FOR CATALOG

AMERICAN CONDENSER CO.
4410 N. Ravenswood Ave., Chicago 40, Illinois

JFD NEW "BIG 4" SERVICEMEN'S BASIC KIT!

**A Great New
TIMESAVER
For Radio Servicemen!**
FOUR Basic Radio Service
Kits in ONE Package

**SPECIAL!
SERVICEMEN'S COST**

\$18.00
LIST PRICE
~~\$33.35~~

These 4 Popular JFD Kits have everything needed for 25% of all radio service work!

1. B25A BELT KIT assortment of 25 Dial Belts in Metal Container
2. 5C25 DIAL CABLE & CORD RACK. Contains 5 metal spools of fast-moving dial cables and cords
3. 770 BALLAST KIT contains 5 JFD improved Air-cooled AD JUSTABLE Ballasts
4. BP-100-MC PLUG ASSORTMENT contains 100 radio battery plugs in 25 different popular types.

Above kits include much valuable radio service data.

*Write for
Literature*

J.F.D. MANUFACTURING CO.
4109-4123 FORT HAMILTON PARKWAY, BROOKLYN 19, N. Y.

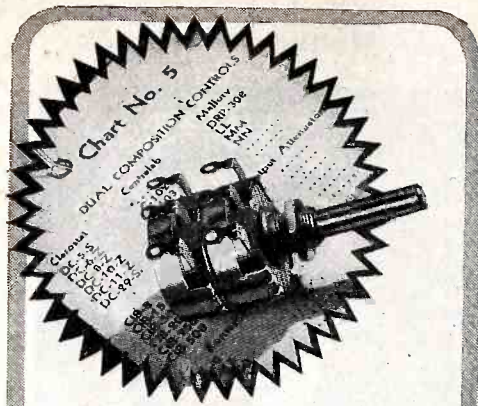

*Saves time...
and guessing...*

REPLACEMENT-CONTROL SELECTOR

★ It's now a cinch to pick the right Clarostat control for any other brand type.

Here's a handy cross-index listing of standard controls—wire-wound, composition-element, tapped, fixed-shaft and Ad-A-Shaft, dual-composition, power rheostats, and L- and T-pads. The Clarostat controls are arranged numerically according to types. Wherever other brands have corresponding types, same are indicated in parallel columns.

Printed on handy cards, strung together to hang on convenient nail or hook, this Replacement-Control Selector will save you untold time, trouble and guessing in picking the right control, every time.

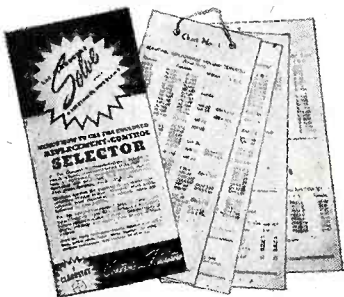

GET YOURS TODAY!

Ask your Clarostat distributor for the Replacement-Control Selector. He'll gladly give you one. Ask for latest Clarostat catalog. Or write us direct.



CLAROSTAT

Controls
and
Resistors

CLAROSTAT MFG. CO., Inc. • 285-7 N. 6th St., Brooklyn, N. Y.

20 Years Ago

From the March, 1927, Issue
of Radio Retailing

CHECK EVERY SET IN TOWN—Hundreds of extra sales and service jobs are to be found within walking distance of the store.

SERVICE CAR stocked with traveling supply of accessories builds good will for California dealer.

SYSTEMATIC COVERAGE of rural customers is required for dealers to develop steady volume of farm sales.

SEPARATE SPEAKERS are favored two-to-one by the trade in a survey made by RADIO RETAILING editors.

NEW RADIO LAW takes effect as Congress passes the Bill creating the Federal Radio Commission; President Coolidge appoints Dr. O. H. Caldwell as one of five commissioners:

PROFITS IN SMALL SETS—Chicago dealer finds that attention to cheaper radios leads to sales of better sets, too.

NEW PRODUCTS introduced by Sylvania, Crosley, F. A. D. Andrea, Standard Transformer, Centralab, Hammarlund, Amsco, De Jur, Sprague, etc.

Lear's Chairside Console Combination

Prices for the all-wave, three-band chairside console featured by the home radio sales & merchandising division of Lear, Inc., 110 Ionia Ave., N. W., Grand Rapids 2, Mich., are \$199.50 for mahogany and \$215 for the blonde finish. The prices were quoted incorrectly in a description of the unit appearing on page 54 of the February issue of RADIO & Television RETAILING.

This popular set has the radio and the automatic record changer in adjacent "drawers" in a Sheraton style cabinet. It stands 31" high.

New Trav-Ler Lines

Trav-Ler Corp. is now introducing its new 1947 line, Joe Friedman, president, has announced.

"Our new products have a much greater value with no price increase in some and a slight reduction in others. One example is the radio-phonograph combination which will retail at \$34.95, approaching the pre-war price level," he said.

The new line consists of table models, radio-phonograph combinations, portables and phonographs in a variety of colors, plastics and coverings.



Needle Packet Turntable Felt

Phono Turntable Stand—Spray Kit

G-C SERVICEMEN'S
PHONO NEEDLE PACKET

For every serviceman. Sell needle replacements with handy packet. Contains 10 needles, 2 ea. type; 2 record, stylus. No. 1432.....List \$8.50. (Retail value \$9.50)



G-C RECORD- TURNTABLE FELT

Replaces wornout felt; keeps record firmly in place, round pieces, center hole punched. No. 1292—7/8" dia. List 39c (Other sizes available)



G-C PHONO TURNTABLE SERVICE STAND

Steel stand on which to place any phono turntable; ideal for repairmen, easily adjusted, sturdy steel construction. No. 5205, List \$6.65



G-C FELT-KOAT FLOCK FINISH SPRAY KIT

For phono-turntables, cabinets, etc. Produces scratch-proof, velvet-like coat. Contains two colors, brown and ivory, easy to apply. No. 180—2-blower kit complete. List \$10.75



Available at leading distributors—Write for catalog.

RADIO DIVISION DEPT. G

GENERAL CEMENT Mfg. Co., Rockford, Ill., U. S. A.
Manufacturers of over 3,000 products
Sales offices in principal cities

JOBBER! QUANTITY BUYERS! SAVE MONEY

with MID-AMERICA'S
Sensational
Values!

**FREE MONTHLY
BULLETINS**

Here's proof of the BIG BARGAINS in radio parts and electronic equipment MID-AMERICA offers EVERY MONTH to qualified quantity buyers through special bulletins and flyers. Check the outstanding buys listed here against what you've been paying—then get MID-AMERICA'S FREE CATALOG and big MONTHLY BARGAIN BULLETINS!

RELAYS

CONDENSERS

TRANSFORMERS

METERS • SWITCHES

MID-AMERICA
Bargains

5" Dynamic Speaker, 450 ohm field, hum bucking coil, double shielded, 50L6 transformer (lots of 20) \$2.95 ea.
ELECTROLYTIC CONDENSERS with strap: 50/30 mfd—150 VDCW (lots of 100) 59c ea. 20 mfd—150 VDCW (lots of 100) 39c ea. 16 mfd—500 VDCW 1" Dia. Mallory FP (lots of 100) 79c ea.
ALUMINUM CONDENSER: 4 mfd—600 VDCW oil filled paper, 4 1/2" high x 1 1/2" dia., equiv. to 5 mfd—600 VDCW electrolytic; (lots of 100) 79c ea.
DPDT ROTARY RADIO-PHONO or BAND SWITCH, 1/2" shank 1 1/2" shaft (lots of 100) 36c ea.
ALLIANCE PHONO MOTOR, rim drive with 9" turntable (lots of 6) \$3.75 ea.
ASTATIC HIGH FIDELITY PHONO PICKUP with Astatic L-72-A xtal (lots of 25) \$1.95 ea.
50L6 GT TUBES, std. Brands (lots of 500) 70c ea.
For LOWER PRICES on LARGER QUANTITIES than those listed here write, wire

MID-AMERICA'S store address, Dept. RT-37

MID-AMERICA CO., Inc.

STORE 2412 S. MICHIGAN AVE. CHICAGO 16, ILL.
WAREHOUSE 2307 S. ARCHER AVE. CHICAGO 16, ILL.

Prizes for Best Radio Display Window

U. S. retailers now have a chance to compete for cash prizes in a national radio window display contest sponsored by Tele-tone National Corp., 609 W. 51st St., New York, N. Y.

John S. Mills, vice-president in charge of sales and advertising, reports that window displays have been sent out to all dealers who have entered the contest. Free rein has been allowed their ingenuity in expanding on the material sent to them.

The rules of the contest require the dealer to arrange his Tele-tone window to run from Mar. 1st to Mar. 15th, and to submit an 8" x 10" photograph of the display to Tele-tone who will turn it over to its advertising agency, where all entries will be judged. All photographs must be received by Tele-tone by Mar. 31.



W. J. Cashman, the Universal director of promotion and publicity, is congratulated by Al Bross, also of Universal, for his presentation of the firm's '47 promotion plans. In the other sales huddle are N. R. Thomas of Nelson Thomas, Los Angeles, and Ed Babbitt.

Universal Reveals Big-Scale Sales Plans

Three regional meetings of the national distributor organization of Landers, Fray & Clark have been held in San Francisco, Chicago, and Hartford, Conn., to introduce the firm's 1947 merchandising plans and its complete new lines of electrical appliances and housewares.

Speakers at the meetings included R. L. White, H. M. Parsons, E. J. Van Buskirk,

W. J. Russell, Lee Moss, E. L. Farquharson, H. B. Payor, A. S. Bross, W. J. Cashman and Stanley Fisher.

In outlining the company's program, B. C. Neece, vice-pres., general sales manager, stated that the company had kept its promise of giving distributors a completely new line of ranges, home laundry equipment, home cleaning equipment and small appliances and housewares, and disclosed that the company was prepared to make 1947 one of the biggest years in

its merchandising history, provided there were no upsets such as major strikes.

W. J. Cashman, director of promotion, publicity and advertising, outlined the Universal advertising and promotion program for '47 and stated that "dramatic full page color advertisements would appear regularly in leading national magazines, featuring sensational new Universal products in a dynamic campaign designed to bring dealers and consumers closer together than ever before."

**SHOCK-Proof
BREAK-Proof**

**VACO AMBERYL
SCREW DRIVERS**

fill every industrial,
radio, farm,
automotive,
home need.

173 Types

VACO 317 E. ONTARIO ST.
PRODUCTS CO. CHICAGO 11, ILL.
CANADIAN WAREHOUSE:
560 KING STREET WEST TORONTO 2, ONT.

WRITE FOR CATALOG

SCARCE RADIO TUBES

DISCOUNTS UP TO 60% OFF

- ALL POPULAR STANDARD BRANDS
- NEW, GUARANTEED
- SEALED CARTONS

OZ4, 1LA6, 1LN5, 1P5, 2A3, 5Z4, 6A8, 2A5, 2A6, 6E5, 6F5, 6J8, 6K5, 6K8, 6P5, 6Q7, 7A8, 7B4, 7B8, 7B5, 7B7, 7C5, 7F8, 7G7, 12A8, 12F5, 12J7, 12K7, 12Z3, 14Q7, 14R7, 25A7, 25L6, 25Y5, 25Z5, 25Z6, 30, 32L7, 33, 35, 35A5, 35Y4, 35Z3, 43, 45, 47, 50A5, 50Y6, 55, 57, 58, 59, 70L7, 71A, 84, 117L7, 117M7, 117N7, 117P7, 117Z3, 117Z6, XXL.

8 SPECIAL OFFERS 8

1. 25Y5 (Exact replacement for 25Z5). List price \$3.20. Your costea. \$.85
2. ACORN TUBES, Guaranteed 954, 955, 956, 957,ea. .49
3. 6AK5 Tubes, Guaranteedea. .75
4. HEARING AID TUBES—all types 501ax-509ax.....ea. .49
5. 6AH6 TUBESea. .49
6. 1T4, 1R5, 1S4, 3S4, TUBESea. .49
7. 6J5GT TUBESea. .49
8. 6SN7GT TUBESea. .49

CONDENSERS

BRAND NEW . . . INDIVIDUALLY BOXED . . . FULLY GUARANTEED FOR ONE YEAR. "The American Radio Repairman's 1st Choice in a Condenser" AT A PRICE YOU CAN'T BEAT.

20/20 MFD @ 150 voltsea.	\$.45
8 MFD @ 450 voltsea.	.32
16 MFD @ 450 voltsea.	.45
20 MFD @ 150 voltsea.	.32

SPECIAL DISCOUNTS ON ALL LARGE ORDERS

Wire or Write for Catalog—We Ship Anywhere

RICHmond 6951



COMMERCIAL RADIO
36 BRATTLE ST., BOSTON 8, MASS.

DATES AHEAD

Future Events of Interest to Readers.

- Mar. 3-6: The Institute of Radio Engineers, Annual Radio Engineering Show, Grand Central Palace, New York City
- Mar. 3-6: Tenth Annual Merchandise Fair, WGS Building, Philadelphia, Pa.
- Mar. 10-21: American Toy Fair, Hotel McAlpin, New York City
- Mar. 31-Apr. 1: 13th Annual Sales Conference, Edison Electric Institute, Edgewater Beach Hotel, Chicago
- Mar. 17-23: National Hobby Week
- Apr. 5-12: Electric Home Show, Municipal Auditorium, Birmingham, Ala.
- Apr. 12-19: Home and Building Show, Reading Fair Grounds, Reading, Pa.
- Apr. 14-15: Second Annual Television Institute, Hotel Commodore, New York City
- Apr. 19-26: Metropolitan Home Show, Grand Central Palace, New York City
- Apr. 22-24: Electrical Trades Show, Alcazar Hotel, Baltimore, Md.
- Apr. 27-May 3: National Housewares Show, Convention Hall, Philadelphia, Pa.
- May 4-11: National Music Week
- May 4-11: Houston National Home Show, Sam Houston Coliseum, Houston, Tex.
- May 5-9: National Electrical Wholesalers Association, Hotel Traymore, Atlantic City, N. J.
- May 5-11: National Plastics Exposition, Coliseum, Chicago
- May 11-16: Radio-Electronics Parts Show, Hotel Stevens, Chicago.
- June 1-5: National Association of Music Merchants, Trade Show, Palmer House, Chicago
- June 12-22: Second Annual Construction Industries Exposition & Home Show, Pacific Auditorium, Los Angeles

Clocks, Phono Needles in New Philco Line

Several new products, including a complete line of electric clocks, three new flashlight models, factory-sealed jeweled phonograph needles in a transparent plastic display, a new dynamic tester and a lightweight oscilloscope, were presented to about 700 Philco distributors and dis-

tributives at meetings in Chicago, Philadelphia and San Francisco arranged by James M. Skinner, Jr., general manager of the Philco accessory division.

Skinner pointed out that Philco volume in automobile radio receivers, aerials, tubes and other replacement parts, as well as "Easy-Out" ice trays, furniture polish, test equipment, dry cell batteries and similar products handled by the accessory di-

vision, reached record-breaking high levels during the past year.

During 1947 for the first time, the accessory division products—including such new items as electric clocks and flashlights—will share in intensive advertising and merchandising in which distributors and dealers will participate. James H. Carmine, vice-president in charge of merchandising for Philco, explained how national radio and magazine advertising, newspaper, trade and business magazine advertisements will be used to stimulate demand for the company's expanded line of accessories and parts.

Proctor Ad Campaign to Cost a Million Dollars

Proctor Electric Company, Philadelphia, Pa., has launched a huge advertising campaign in leading publications throughout the country. A million dollars will be spent in promoting two small appliances—Proctor's Never-Lift iron and the Color-Guard toaster. To tie in with the large promotion program, distributors will work closely with retailers, furnishing them with effective sales material, and aiding them in staging their own store promotion in order to take full advantage of company advertising. Proctor officials have urged retailers to take the following steps designed to increase sales: 1. Advertise. 2. Display Proctor merchandise. 3. Demonstrate appliances. 4. Sell "ahead"—taking orders for toasters and irons not immediately in stock.

SPECIALS for MARCH

2 CONDUCTOR TWISTED PAIR COMMUNICATION TYPE WIRE

22 Ga. solid wire with a plastic and glass insulation that is highly resistant to water, flame, oil and many other destructive factors. Special for this month only.

Per 1,000 ft. \$10.00

ANTENNA WIRE

19 Gauge 7/27 bare wire in 100 ft. coils.

Per 100 ft. coils, 28c ea.

REPLACEMENT CORD SET

6 ft. Rubber covered parallel cord set can be used as replacement on small appliances, lamps, fans, radios, etc. Has unbreakable rubber plug. Free end stripped and tinned ready for attaching. Underwriter Laboratories approved.

Per each, 20c

Many other types of cord, cable and wire are carried in stock, in gauges of from 24 to 0. Send for our latest catalog listing all available items.

See your local jobber or write direct

COLUMBIA WIRE & SUPPLY CO.
5740 ELSTON AVE., CHICAGO 30, ILLINOIS

For Originality

LOOK TO

XCELITE

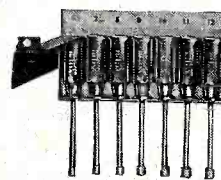

XCELITE "firsts" in tool craftsmanship mean fast, steady turnover for you! Mechanics know and appreciate the real convenience of the time-saving XCELITE De Lux Nut Driver Set at left, as well as the sturdy, quality construction of all XCELITE nut drivers and screwdrivers. Stock XCELITE and profit!

PARK METALWARE CO., INC.

Dept. M, Orchard Park, New York

Quality Tools

PREFERRED BY EXPERTS

SPECIAL DEALS FOR RADIO DEALERS AND SERVICEMEN

Kit No. 85 Heavy Duty Rim Drive Motor & Turntable.. List \$9.95	Kit No. 87—3 Tube Amplifier Kit complete with tubes and instructions—simple to build\$5.73
Crystal Pickup 6.50	Kit No. 88—Above Amplifier completely wired 8.70
Waterfall Walnut Open Case.. " 4.95	Kit No. 89—5 inch P. M. Speaker 1.95
1 Meg Vol. Control with switch. " 1.50	
1 six-foot AC Cord " .40	
Kit Total List \$23.30	
Your cost only 11.85	

Thousands of radio and sound equipment parts and supplies. Tubes, record changers, amplifiers, speakers, etc. Write for catalog No. TV-15.

Lifetime Sound Equipment Co.
911-913 Jefferson Ave., TOLEDO 2, OHIO

INDEX To Advertisers

MARCH, 1947

	Page		Page
Admiral Corp.	20	National Carbon Co., Inc.	26
Aerovox Corp.	188	Newark Electric Co., Inc.	178
Air King Radio Div., Hytron Radio & Electronics Corp.	27	Noblitt-Sparks Industries, Inc.	23
American Condenser Co.	191	No-Ox Laboratories	185
American Magazine	32	Norge Div., Borg-Warner Corp.	120
American Telephone & Telegraph Co.	131	Oak Ridge Antenna Co.	185
Apollo Records, Inc.	105	Olson Radio Warehouse	189
Armstrong Frequency Modulation System	49, 50, 51	Olympic Radio & Television, Inc.	31
Astatic Corp.	108	Oxford Electric Corp.	181
Audio Industries	115	Park Metalware Co., Inc.	194
Bell Sound Systems, Inc.	184	Permo, Inc.	101
Bendix Radio Div., Bendix Aviation Corp.	15	Philco Corp.	95
Burgess Battery Co.	188	Pilot Radio Corp.	75
Caldwell-Clements, Inc.	112, 171, 174, 175	Presto Recording Corp.	107
Capitol Records, Inc.	99	Proctor Electric Corp.	139
Chicago Tribune	14	Pyramid Electric Co.	161
Clarostat Mfg. Co., Inc.	192	Quam-Nichols Co.	195
Collier's	10, 11	Radio Corp of America:	
Columbia Recording Corp.	93	RCA Victor Division	36, 37
Columbia Wire & Supply Co.	194	RCA Victor Records	88
Commercial Radio	193	Tube Division	144, Cover 4
Continental Electronics Ltd.	182	Radio Engineering Laboratories, Inc.	82, 83
Crosley Div., The Aviation Corp.	16, 17	Rauland Corp.	183
Daval Co.	86	Record Album-of-the-Month Associates, Inc.	117
Diamond Record Corp.	111	Recoton Corp.	113
DuMont Laboratories, Inc., Allen B.	21	Rider Publisher, Inc., John F.	176
Duotone Co.	114	Sams & Co., Inc., Howard W.	155
Electrical & Musical Industries, Ltd.	81	S/C Laboratories, Inc.	183
Electro Products Laboratories	185	Seeburg Corp., J. P.	Cover 3
Electronic Corp. of America	5	Sheffield Radio & Appliance Co.	140
Electronic Laboratories, Inc.,	18	Shure Brothers, Inc.	184
Electro-Tone Corp.	177	Siltron Co.	140
Emerson Radio & Phonograph Corp.	2, 3	Simon Distributing Corp.	118
Fada Radio & Electric Co., Inc.	19	Simpson Electric Co.	159
Firestein & Cia., Jack	118	Simpson Mfg. Co., Inc., Mark	180
Freed Radio Corp.	78	SNC Mfg. Co., Inc.	151
Frequency Modulation Business	30	Sonora Radio & Television Corp.	25
Garrard Sales Corp.	109	Sparks-Withington Co.	29
General Cement Mfg. Co.	192	Sprague Products Co.	167
General Electric Co.	7, 55, 56, 57, 157, 196	Standard Register Co.	133
General Industries Co.	110	Steelman Radio Corp.	116
Gibson Refrigerator Co.	135	Stewart-Warner Corp.	6
Graybar Electric Co.	137	Stromberg-Carlson Co.	61, 62, 63
Hallicrafters Co.	74	Supreme Instruments Corp.	190
Howard Radio Co.	71	Sylvania Electric Products, Inc.	152, 153
Hytron Radio & Electronics Corp.	13	Symons Assoc., L. H.	114
Jackson Electrical Instrument Co.	186	Telex, Inc.	182
Jensen Mfg. Co.	22	Templetone Mfg. Corp.	73
J. F. D. Mfg. Co.	191	Tone Products Corp. of America	106
Lake Radio Sales Co.	190	Triplett Electrical Instrument Co.	163
Landers, Frary & Clark	129	Tung-Sol Lamp Works, Inc.	8
Lear, Inc.	169	Turner Co.	173
Leotone Radio Co.	178	Vaco Products Co.	193
Lifetime Sound Equipment Co.	194	War Assets Administration	24, 179
Magnavox Co.	68, 69	Ward Leonard Electric Co.	187
Maguire Industries, Inc.	164, 165	Ward Products Corp.	178
Mallory & Co., Inc., P. R.	142, Cover 2	Warwick Mfg. Corp.	12
Meissner Mfg. Div., Maguire Industries, Inc.	77	Webster Chicago Corp.	103, 112
Merit Coil & Transformer Corp.	4	Webster Electric Co.	28
M-G-M Records Div., Loew's Inc.	96, 97	Western Electric Co.	80
Mid-America Co., Inc.	192	Westinghouse Electric Corp.	66, 67, 84
		Wilcox-Gay Corp.	9
		Workshop Associates, Inc.	187
		Zenith Radio Corp.	65

While every precaution is taken to insure accuracy, we cannot guarantee against the possibility of an occasional change or omission in the preparation of this index.

LOOK
FOR THE
'U'-SHAPED
COIL POT
THE MARK OF
QUAM
QUALITY

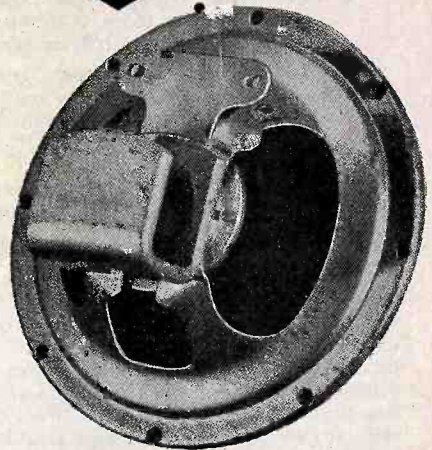

QUAM
Adjust-a-Cone
SPEAKERS

QUAM-NICHOLS
COMPANY

*Builders of Quality
Speakers Since 1923*
33rd PLACE AT COTTAGE GROVE
CHICAGO 16, ILL.

For Better Testing!

NEW GENERAL ELECTRIC SERVICE TEST EQUIPMENT FOR UP-AND-COMING SERVICE MEN

IT'S NEWS—and good news for service men who want to see work move into the shop fast—and out again. The new line of General Electric service test equipment has been designed to do just that. Quick, accurate, efficient service work means more dollars, more satisfied customers and more business.

First in this list of fine equipment is the Capacitance-Resistance Bridge, YCW-1. Check the jobs it can do to make your job easier.

- Measures capacitance from .000005 to 200 microfarads $\pm 1\%$ in three convenient ranges.
- Measures resistance 5 ohms to 20 megohms $\pm 2\%$ in two convenient ranges.
- Power factor is measured on the high capacitance range by a potentiometer in series with the standard which has a scale of 0 to 50 percent.
- Insulation resistance is indicated directly by a panel meter. A 0 to 2500 megohm range is covered with a dc voltage supply of 500 volts.
- Electrolytic leakage test is provided which will indicate whether the leakage is excessive.
- Polarizing voltage — a continuously variable dc voltage supply from 0 to 500 volts is available for polarizing the electrolytic condensers.
- Turn ratio of transformers is measured by switching one coil or section of a coil into the Wien bridge circuit and the other section of secondary coil is compared with it.

The YCW-1 is compact, portable and needs only to be plugged into any 115 volt 50 or 60 cycle line to operate.

GENERAL ELECTRIC ELECTRONIC VOLTOHMETER

The Type PM-17 permits measurement of actual operating voltages without excessive circuit loading or detuning. In addition to dc voltages, both audio and radio frequency voltages may be measured from 200 cycles to more than 100 megacycles. An ohmmeter circuit is included for convenience in measuring high and low ohmic values of resistance. Fluctuations in line voltage and changing of tubes have little or no effect on calibrations. Entirely portable, it can be carried anywhere and can be plugged into any 115 volt 60 cycle line. Supplied with the Electronic Volt ohm meter are two alligator clips, two pairs of leads, and an r-f probe.

GENERAL ELECTRIC OSCILLOSCOPE

The CRO-5A is really a laboratory quality unit for service work. Accurate and rapid, it was designed primarily for studying voltage and current wave-forms, but it also can be used to study any variable which may be translated into electrical potentials by means of associated apparatus.

All amplifier and sweep d-c potentials are electronically regulated to give a stable trace even under adverse power line variations. The unit is compact, portable, and sturdy in construction so that ordinary jars and vibration will not damage it. Completely self-contained, it will operate on any 115 volt, 60 cycle ac power source.

For complete information on these General Electric Service Test instruments, write to: *General Electric Company, Electronics Department, Syracuse 1, New York.*

GENERAL  ELECTRIC

164-F2

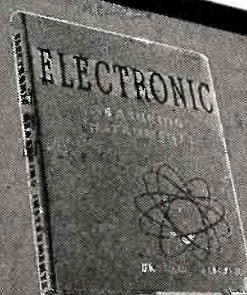
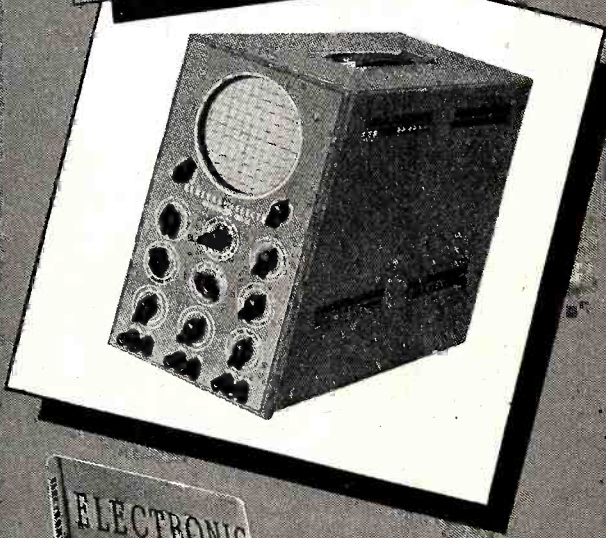
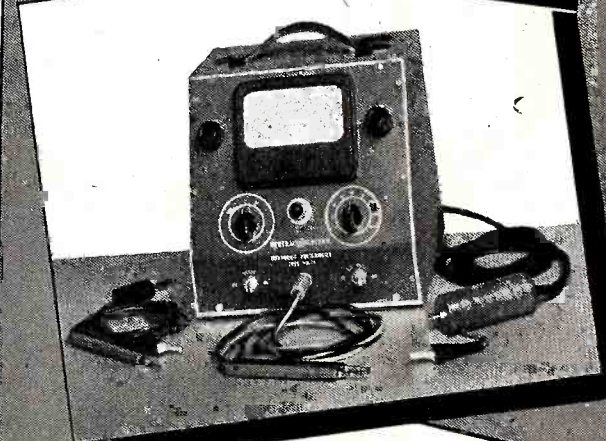
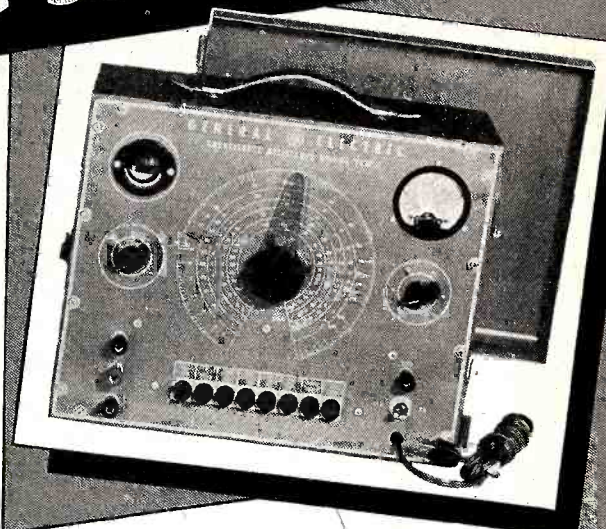

● Write for your copy of General Electric's Electronic Measuring Equipment Catalog. IT'S FREE!

Seeburg Changers for every radio-phonograph combination

• To help manufacturers provide the finest radio-phonograph combination, Seeburg offers three outstanding changers—the "M," the "L" and the "K."

While each is designed for use in radio-phonograph combinations of various price ranges, all are engineered to bring the

maximum in listening pleasure. Whatever Seeburg changers you build into your combinations, you may count on quiet, simple operation . . . constant, sustained speed . . . minimum time between changes . . . longer record life . . . the ultimate in reproduction fidelity.

the Seeburg "M"...

The new, deluxe changer that lends appeal to the most glamorous radio-phonograph combinations. Exclusive, three-post construction permits intermixed playing of 10 and 12-inch records . . . assures longer record life . . . increases record load. Capacity of fourteen 10-inch records, twelve 12-inch records or twelve 10-inch and 12-inch records intermixed. Size: 14¼ x 14¼ in.



...the Seeburg "L"

A finely engineered changer to enhance the listening pleasure of your beautiful table and console radio phonograph combinations. Two-post construction. Capacity: fourteen 10-inch or ten 12-inch recordings. Size: 14¼ x 14¼ in.

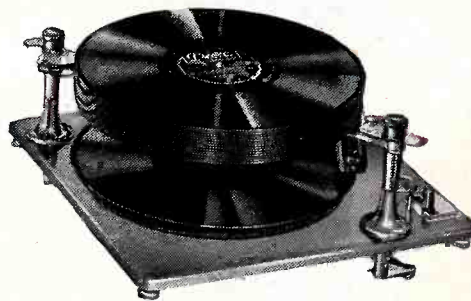

the Seeburg "K"

A simplified, compact mechanism to bring fine reproduction to competitively priced units. Two-post construction. Capacity of fourteen 10-inch or ten 12-inch recordings. Size: 12½ x 12½ in.

Seeburg
RECORD CHANGERS ★ MUSIC SYSTEMS
J. P. SEEBURG CORPORATION
700 N. PAVEN ST. CHICAGO, ILL.



You're in the lead with RCA ...*here's why*

RCA Laboratories, Princeton, N. J., where televising of outdoor scenes has been greatly advanced through the development of the ultra-sensitive Image Orthicon camera tube.



Engineering...

the fountainhead of modern tube development is RCA

Through the years, RCA has maintained engineering leadership in tube research and design. And as a result of this pioneering, many of the far-reaching advancements in radio, television and electronics can be attributed to the development of new and revolutionary types of tubes by RCA scientists and engineers.

These RCA tubes are the nucleus of your present and future business. They make possible new and improved products for you to sell, and open up ever-widening markets for you to reach. Thus it is that your business can expand as the vast engineering resources of RCA widen the horizons of radio and electronic applications through the development of new electron tubes.

Engineering Leadership is another reason why *you're in the lead with RCA*. So, push RCA tubes and watch your business grow!



TUBE DEPARTMENT
RADIO CORPORATION of AMERICA
 HARRISON, N. J.