

RADIO *& Television* RETAILING

CALDWELL - CLEMENTS, INC

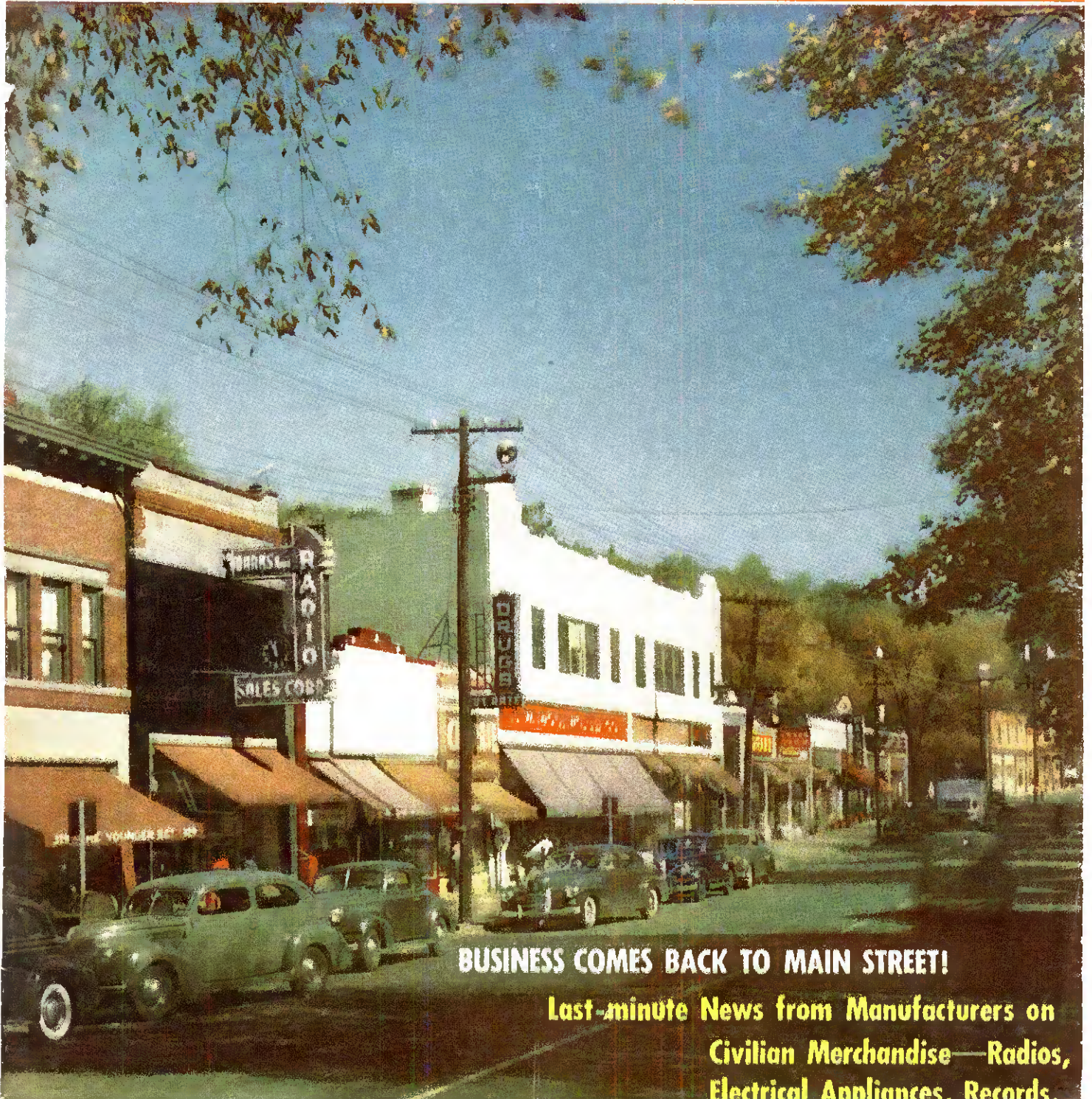

JUNE 1945



BUSINESS COMES BACK TO MAIN STREET!

**Last-minute News from Manufacturers on
Civilian Merchandise—Radios,
Electrical Appliances, Records.**

Ask Your MALLORY Distributor... He Knows

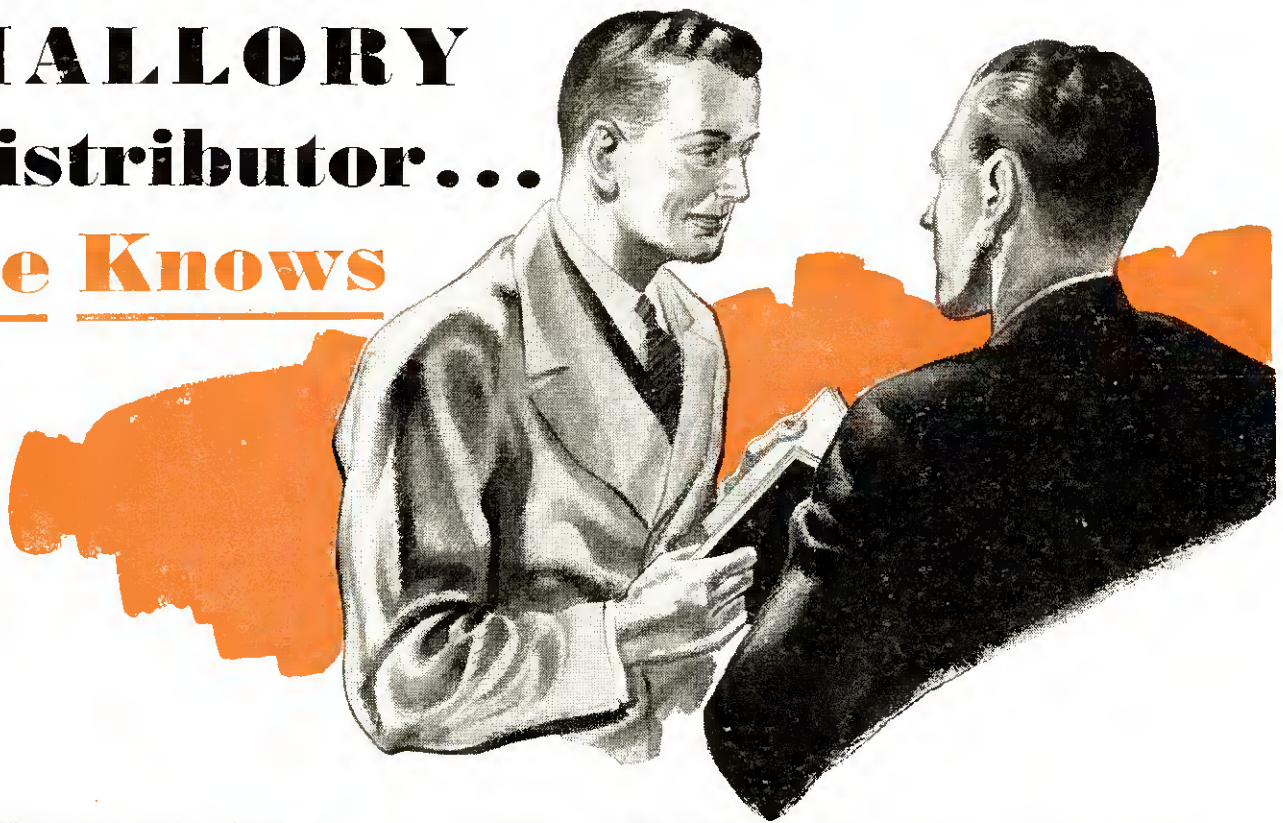

WHAT types of replacement parts are available today? How much do they cost? How soon can you get them? What information do you need to install them properly?

If a particular type of replacement part is no longer made, what other product will serve as well—maybe even better? The man to answer questions like these is your Mallory Precision Products Distributor.

His experience covers not only radio but the whole wide field of electronics. He's earned the Mallory franchise because of his alertness and "know how." He's prepared not merely to supply facts, but to give you service—to *do things for you*.

Your Mallory Distributor was selected for qualities of leadership and helpfulness. Feel free to ask his assistance *anytime*.

Here's What He'll Do For You:

1

Offer you a complete line of Mallory replacement parts... many of them first developed by Mallory research... ALL of them guaranteed against premature failure by years of service in the field.

2

Meet the maximum number of your application needs with the minimum number of parts. His program of Mallory Standardization will reduce your investment, simplify replacement, speed up delivery.

3

Give you detailed information on prices, parts, catalog numbers... work his head off to get you the items you need when you need them... give you prompt, efficient service *always*.

4

Provide you with bulletins, booklets, catalogs, letters, giving complete data on what to use and where to use it... offer you special publications and new developments and technical service fundamentals.

5

Offer his own personal experience in helping you solve unusual or difficult problems... help you train sales and service personnel... give you the extra help you need to meet emergencies.

6

Provide you, if asked, with sound methods of keeping your business on the beam... give you special promotion materials to help you sell your story to the public.

The Part Your Mallory Distributor Plays Is Important TODAY — to YOU!

P. R. MALLORY & CO., Inc., INDIANAPOLIS 6, INDIANA



More than ever—
ALWAYS
INSIST ON

P. R. MALLORY & CO. Inc.
MALLORY
APPROVED
PRECISION PRODUCTS

VIBRATORS • VIBRAPACKS* • CONDENSERS
VOLUME CONTROLS • SWITCHES • RESISTORS
FILTERS • RECTIFIERS • POWER SUPPLIES

ALSO MALLORY "TROPICAL"* DRY BATTERIES, ORIGINALLY DEVELOPED BY MALLORY FOR THE U. S. ARMY SIGNAL CORPS, NOT PRESENTLY AVAILABLE FOR CIVILIAN USE.

*Trademarks

It's a postwar Promise ... from

Admiral



Automatically CHANGES RECORDS
IN 5 SECONDS



TUNE IN Every Sunday—Admiral "World News Today," CBS, 2:30 P.M. EWT.

QUICK CHANGE ARTIST—that's what you'll call the post-war Admiral automatic record changer with its five-second record changing time. And what a selling feature it's going to be for you. No surface noises. Fool-proof, *trouble-free* operation. Only 3 moving parts. Beautiful cabinet designs and new high fidelity performance will make America's smart buy an Admiral Radio—America's Smart Set. There's a bright future ahead for alert dealers who Get Aboard With Admiral.



Admiral Electric Range

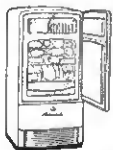

Admiral Dual-Temp Refrigerator



Admiral Home Freezer

Admiral Corporation CHICAGO 47, ILLINOIS



World's Largest Manufacturer of Radio-Phonographs with Automatic Record Changers.



more efficient
... in miniature



A half century ago, a call to a neighboring city was an adventure filled with uncertainty. Delays, inaudibility, and interrupted connections were accepted characteristics of the telephone. Today we use an instrument to talk across continents and oceans with the ease and assurance of face to face conversation. The development of more efficient equipment in miniature has indeed been remarkable.

So it has been with radio tubes. The new miniature tubes, much smaller than the older receiving tubes, are becoming increasingly important as their advantages are being realized in modern applications. The greater efficiency of TUNG-SOL Miniatures is particularly evident in high-frequency applications. Their lower capacity, their shorter leads with resulting lower inductance and their high mutual

conductance make them ideal for this use.

As soon as new radio sets and other electronic devices are available, you will find TUNG-SOL a dependable source of supply for miniature as well as the G-G's-metal and large glass tubes for servicing every type of equipment.

TUNG-SOL

vibration-tested

ELECTRONIC TUBES



TUNG-SOL LAMP WORKS INC., NEWARK 4, NEW JERSEY
Also Manufacturers of Miniature Incandescent Lamps, All-Glass Sealed Beam Headlight Lamps and Current Intermittors

RADIO & Television RETAILING • June, 1945



**LUCILLE
MANNERS**
plans on a
GAROD
postwar
console

LUCILLE MANNERS, soprano star of the Friday night Cities Service Concert program, has this to say about her choice of a postwar radio. *"I've enjoyed the performance of Garod instruments for years,"* says Miss Manners, *"and you may have my reservation now for one of your peacetime consoles."*

Will your peacetime business be a house of straws or will it be a solid, enduring, prosperous structure? That depends upon the kind of radios you sell *from the start*. Leaders in the trade, unwilling to risk even one dissatisfied customer, are signing up for the Garod line of postwar radios. In AM and FM, in all models and all prices, Garod radios will be built to give an extra measure of satisfaction to extra-critical purchasers. Their ear appeal and eye appeal, their superb construction and electronic refinements mean sets that "stay sold." Plan for the long haul . . . plan to carry quality from the start. Get in touch with your nearest Garod distributor, or write directly to us.

GAROD



RADIO

GAROD RADIO CORPORATION • 70 WASHINGTON STREET • BROOKLYN 1, N. Y.

You **WILL be
Interested
in the
TRANSFORMERS
We Are Designing**

MERIT COIL & TRANSFORMER CORP.

TELEPHONE
4427 North Clark St. Long Beach 6311 CHICAGO 40, ILL.

RADIO Television RETAILING

Including Radio and Television Today

MEMBER AUDIT BUREAU of CIRCULATIONS

June, 1945

COVER—Radio Sales Corp., Millburn, N. J.—one of the nation's many independent radio-appliance retailers who welcome business back to Main St. (see story on page 40).

- 33 Importance of Point of Sale
- 34 Radio and Appliances Today
- 36 Business Bound for Main St!
- 40 Appliance Selling
- 42 Open Display Increases Sales
- 44 Retailers Ready to Merchandise
- 46 Cash in Super-Service
- 48 Profit Picture
- 50 Variety on Summer Discs
- 52 Rapid-Fire Service
- 54 Look at the Record!
- 56 Hearing Aid Market
- 60 One-Day Repair Service
- 65 Retailers' Check-List
- 66 FM-Tele Allocations
- 76 Dual Repair Operation
- 78 Television Relay
- 80 Servicing Detectors
- 92 New Products Review
- 94 Television Today
- 98 Distributor Doings
- 102 to 123 Trade Talk

RADIO & TELEVISION RETAILING, June, 1945, Vol. 30, No. 6, 25 cents a copy. Published monthly by Caldwell-Clements, Inc., 480 Lexington Ave., New York 17, N. Y. M. Clements, president; Orestes H. Caldwell, treasurer. Subscription rates United States and Latin American countries, \$1.00 for one year, \$2.00 for three years, Canada \$1.50 for one year, \$3.00 for three years. All other countries \$2.00 for one year, \$4.00 for three years. Printed in U. S. A. Re-entered as second class matter April 21, 1944, at the Post Office at New York, N. Y., under the act of March 3, 1879. Member of Audit Bureau of Circulations. Copyright by Caldwell-Clements, Inc., 1945.

*Trade-Mark Reg. U. S. Pat. Off.

ORESTES H. CALDWELL

Editor

M. CLEMENTS

Publisher

H. L. M. Capron, Merchandising Editor
 William E. Moulic, Technical Editor
 John L. Stoutenburgh, Managing Editor
 Helen Thurman, Associate Editor
 Charles F. Dreyer, Art Director
 Assistant Editors
 Ruth Morris—Nathaniel J. Kern
 E. T. Bennett Hope Bedard
 M. H. Newton J. A. Samborn
 B. V. Spinetta O. H. Sutter
 I. Candy W. W. Swigert
 E. Duggan J. Cosin
 Lee Robinson, Sales Manager
 Ben Morris, Promotion Manager
 R. Y. Fitzpatrick, Western Manager
 Chicago, 201 N. Wells St.
 Telephone RANdolph 9225

Editorial and Executive Offices
 Telephone PLaza 3-1340
 480 Lexington Avenue
 New York 17, N. Y.

ONLY MECK HAS THE COURAGE TO KEEP TELLING
THIS STORY TO YOUR CUSTOMERS

"Buy Your New Radio
from Your Radio Dealer"

EVERY MECK NATIONAL ADVERTISING DOLLAR
SELLS THE PUBLIC
ON THE INDEPENDENT RADIO DEALER



Every month every John Meck Industries advertisement in national magazines tells one important story—"Buy your New Radio from your Radio Dealer."

Meck puts all its efforts behind the Dealer—to help the Dealer fight postwar competition. Tie in with the Meck Preferential Dealer plan. See your Meck distributor for full details on this worthwhile franchise.

John Meck



MECK RADIOS

JOHN MECK INDUSTRIES, Inc., PLYMOUTH, IND., U. S. A.

AM • FM • TELEVISION • CONSOLE COMBINATIONS • PHONOGRAPHS

travel with **Trav-Ler**

You'll fly high in sales with postwar Trav-Ler Radios! For their fidelity in capturing every shade of tone gives wings to a person's armchair.

Listening is like traveling

from home to studio. With brilliant performance in both AM and FM radios . . . striking cabinet design and price appeal . . . Trav-Ler Radios will poll a profitable postwar popularity. Future-minded dealers and jobbers are invited to write.

TRAV-LER KARENOLA RADIO & TELEVISION CORPORATION

New Address—General Offices: 571 W. Jackson Blvd., Chicago 6, Ill.
Factories in Orleans and Bedford, Indiana



Eugenie Baird, Kraft Music Hall, NBC



TRAV-LER

RADIOS

Karenola **RECORD PLAYERS**

KEN-RAD

METAL TUBES



Better Than Ever

In homes everywhere, Ken-Rad Metal Tubes serve by keeping alive radio's entertaining voice . . . These rugged, self-shielding tubes—now *better than ever* because of added great new facilities—tomorrow will help furnish greater enjoyment for listening millions . . . making the Ken-Rad franchise still more desirable and profitable.

Write for your copy of
"Essential Characteristics"
the most complete digest of tube
information available.

178-03-0950

KEN-RAD

OWENBORO, KENTUCKY

YOUR OPPORTUNITY
IS here

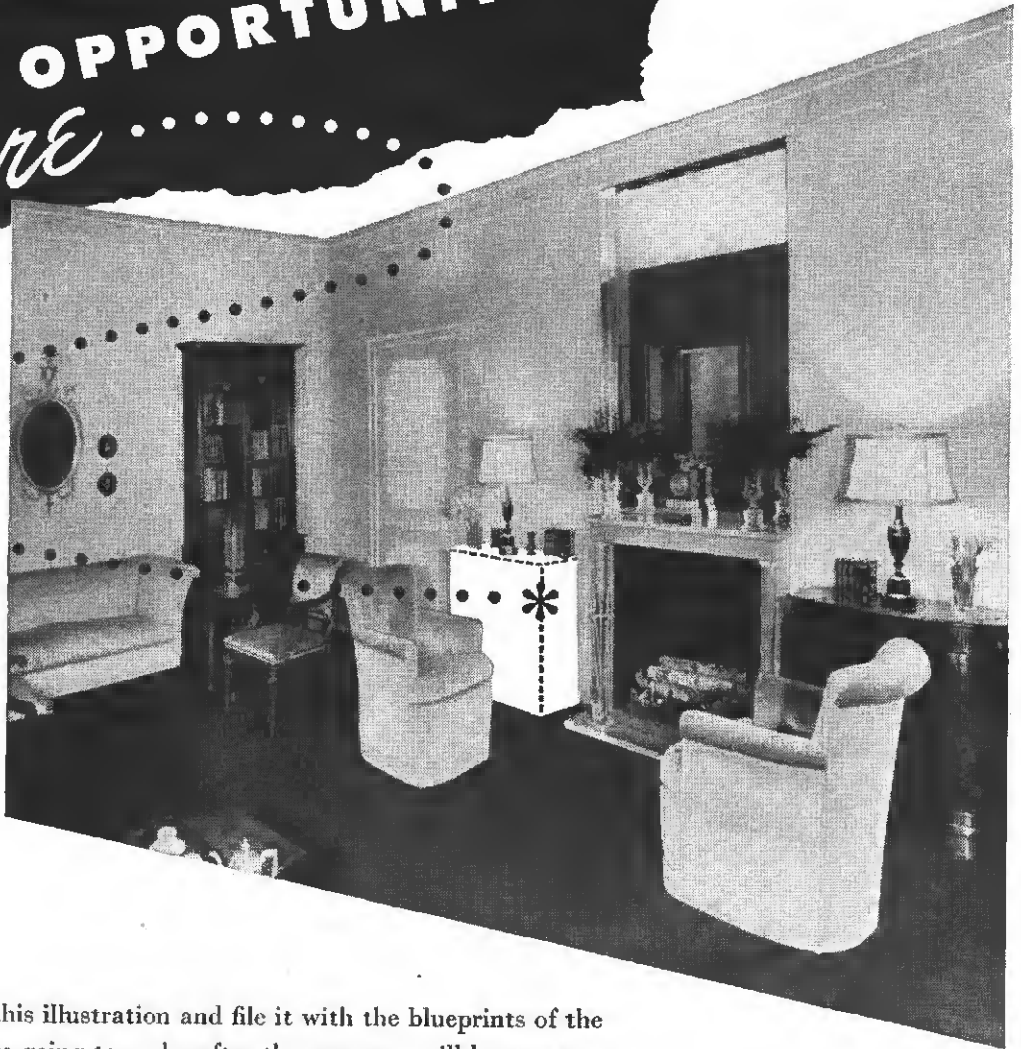

* If you clip this illustration and file it with the blueprints of the radio you are going to make after the war, you will have reason to congratulate yourself on your foresight. For this photograph can serve you as a memo covering one of the important specifications which must be filled if you are to cut the cost of marketing the model which will give you your longest profit margin.

That specification is something you can verify by checking over the furniture in this room and noting that all wood pieces have one thing in common! They are built of mahogany . . . the material which distinguishes the living rooms of most American families . . . outside those in the lower income groups.

Elementary, yes! So elementary and so universally true that to specify any wood but mahogany for any but your lowest priced instruments, will be to invite unnecessary sales resistance by violating one of the first principles of sound merchandising: the consulting of your customers' preferences.

Write for your copy of the informative 74-page "Mahogany Book."



MAHOGANY ASSOCIATION, Inc.

75 EAST WACKER DRIVE • CHICAGO 1, ILLINOIS

"After all . . . there is nothing like MAHOGANY"

P-I-N-G

\$

Promise
of
Post-War
Profits

Sentinel

RADIO

FOR STUDIO TONE IN YOUR HOME

■ If you could only be here at the Sentinel plants—see for yourself how Sentinel is planning for the coming days of peace—you'd know the promise of profits Sentinel holds for you!

New ideas, new methods, new skills and materials—many discovered and perfected in war production—will make the new Sentinel Radios tip-top values in the markets of Tomorrow—big business builders for Sentinel dealers everywhere!

Even now, while Sentinel is engaged 100 per cent in war production, Sentinel advertising continues to carry the story of Sentinel's *Studio Tone In Your Home* to millions of waiting buyers.



Sentinel RADIO CORPORATION

QUALITY RADIO SINCE 1920
2020 Ridge Ave., Evanston, Ill.



LOOMING LARGER EVERY DAY AS . . .

*... "THE FRANCHISE
WITH A FUTURE!"*



BUILD BEST WITH BENDIX . . . FOR



GREAT — IN EVERYTHING IT TAKES FOR YOUR SUCCESS

NAME . . .

For 27 years the fine products of Bendix Aviation Corporation have created a name known to millions of homes in America . . . the greatest name in aircraft radio . . . *famous among millions of civilians and servicemen.*

STAYING POWER

Bendix is big in resources—a vast organization of widely diversified interests . . . superbly equipped in every way to weather any economic changes the future may bring. *When you build with Bendix you build for keeps.*

MANUFACTURING
CAPACITY

As a leading producer of wartime radio, Bendix has the facilities, the experience and the *will* to build precision products on a volume basis. You can expect the best from Bendix at the right prices in the right quantities.

MERCHANDISING
"KNOW-HOW"

Bendix is now embarked on one of the largest advertising and promotion programs in the industry. The Bendix merchandising program is aggressive yet sound, providing a franchise that will be increasingly profitable and valuable.

AND PRODUCT

Bendix will build a complete line—outstanding in quality, appearance and performance. You'll do best with Bendix because Bendix is best with all that it takes to help you get your full share of the postwar market. *Write for full information on The Franchise With a Future.*

Bendix Radio Division • Baltimore 4, Maryland

PRODUCT OF

Bendix

AVIATION CORPORATION

PRESTIGE . . . PROFITS . . . PERMANENCE

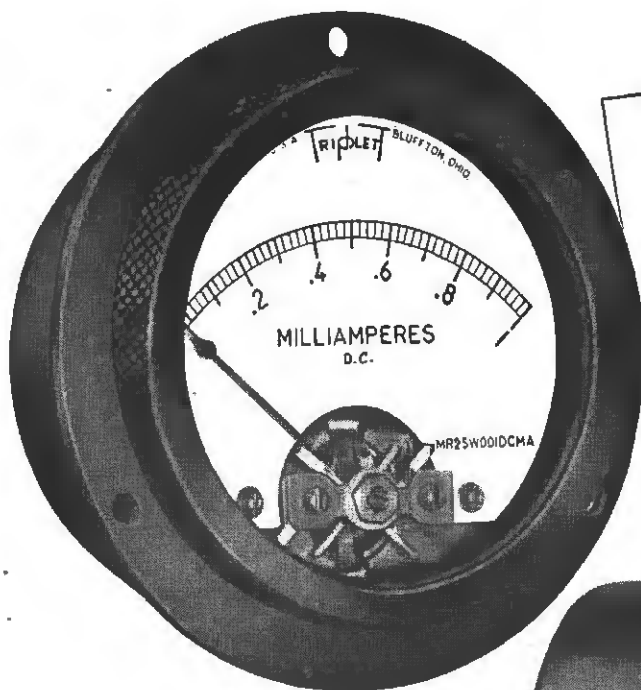

**INTRODUCING THE
NEW TRIPLETT LINE
OF
HERMETICALLY SEALED
INSTRUMENTS**

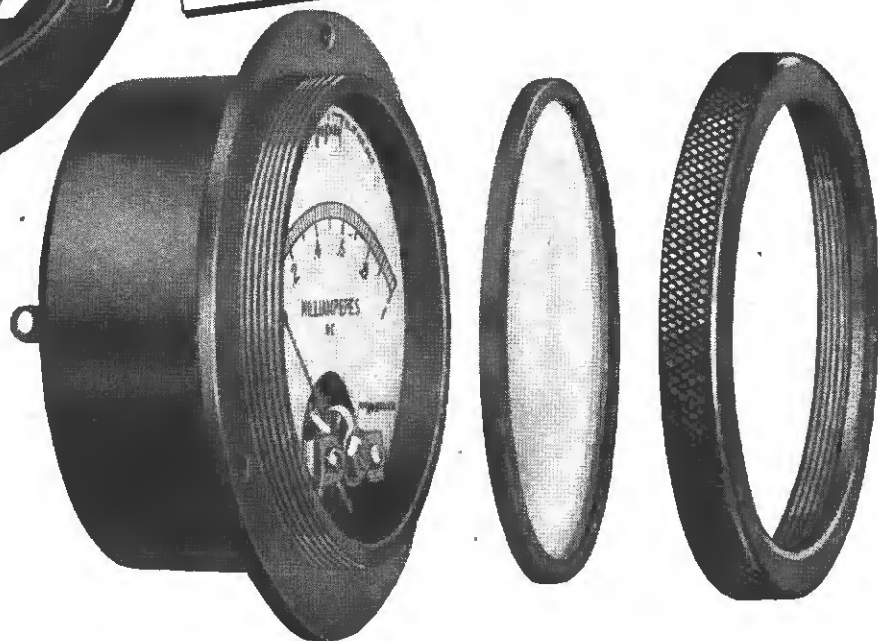
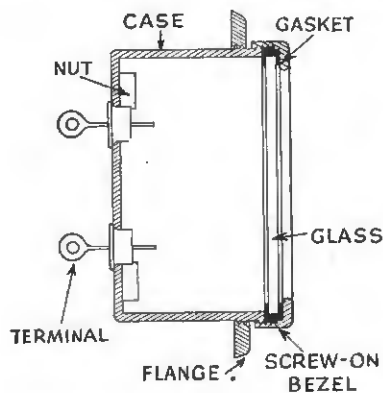

ALL THE FEATURES of STANDARD INSTRUMENTS RETAINED
Withstands submersion tests at 30 feet

A screw-on bezel provides uniform pressure for hermetically sealing the glass to the case. The gasket is pressed into every crevice around the edge of the glass and the top of the case, where the permanent seal is made.

Tempered glass window and ceramic sealed terminals are used.

The knurled screw type bezel permits servicing when necessary and resealing without replacing a single part or the use of special tools or equipment.

Complete dehydration of the interior is readily accomplished by recognized temperature difference

method (the bezel loosely attached for the escape of all moisture, after which the bezel is tightened to make the permanent seal). Interior is completely dry at slightly above atmospheric pressure.

These instruments comply with thermal shock, pressure and vibration tests. They also are resistant to corrosion. Instruments conform to S.C. No. 71-3159 and A.W.S. C-39.2-1944 specifications.

Furnished in 1½", 2½" and 3½" metal cases with 1/16" thick walls, in standard ranges. D.C. moving coil, A.C. moving iron and thermocouple types.

Write for circular

*Precision first
...to last*

Triplett

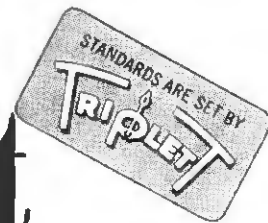

ELECTRICAL INSTRUMENT CO. BLUFFTON, OHIO



REG. U.S. PAT. OFF.



restores
the
"lost"
bass
tones

area of
acoustic loss

"Big Set" Tone in "Compact" Sets

In Olympic's "tru-base" system, new electronic principles replace, within the electrical circuit, the rich bass tones—heretofore "lost" in all but large, costly consoles.

By restoring true resonance to the bass register, "tru-base" releases "ear-balanced" realism throughout the entire tonal scale. "Tru-base" will be available in modestly-priced, brilliantly styled Olympic table sets and radio-phonograph combinations. Register your interest by writing to: Olympic Radio & Television, 510 Sixth Ave., New York 11, N. Y.

and only **Olympic** has tru-base



DIVISION OF HAMILTON RADIO CORPORATION



MAGAZINE AND
RADIO ADVERTISING

Here's your profit leader for tomorrow!

A big PRE-SOLD market awaits G-E receiving tubes

MONEY WILL BE MADE by radio dealers and service men who sell G-E electronic tubes, once these are available in volume. The market is ready and waiting. Every month 19 leading magazines with a total circulation of 30,000,000 tell readers about G-E tubes. Every week listeners in 7,000,000 radio homes hear a similar message over CBS.

The people who read and hear about G-E electronic tubes are favorably in-

fluenced by the fact that for years, they have known and used G-E Mazda lamps—have been familiar with G-E household appliances.

Here is your big chance, as a radio dealer or service man, to cash in on the popularity that goes with the biggest name in electronics. Here is your straight, sure road to volume sales of a product known to everybody—one that will be consistently profitable to handle: G-E electronic tubes.

Don't delay the steps to secure your share of this pre-sold tube market that's just ahead. Write for the name of your nearest G-E tube distributor. Address *Electronics Department, General Electric, Schenectady 5, N. Y.*

Hear the G-E radio programs: "The World Today" news, Monday through Friday, 6:45 p. m., EWT, CBS. "The G-E All-Girl Orchestra," Sunday 10 p. m., EWT, NBC. "The G-E House Party," Monday through Friday, 4 p. m., EWT, CBS.

GENERAL ELECTRIC

176-02-6820

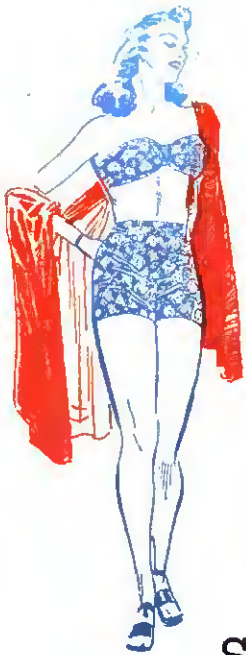

Good Looks!

Several famous designers are now giving special attention to the exterior appearance of Stewart-Warner radio cabinets. GOOD LOOKS as well as hidden qualities will be the very best obtainable when Stewart-Warner radio sets are again available.



**STEWART-
WARNER**
Radios
CHICAGO 14, ILLINOIS

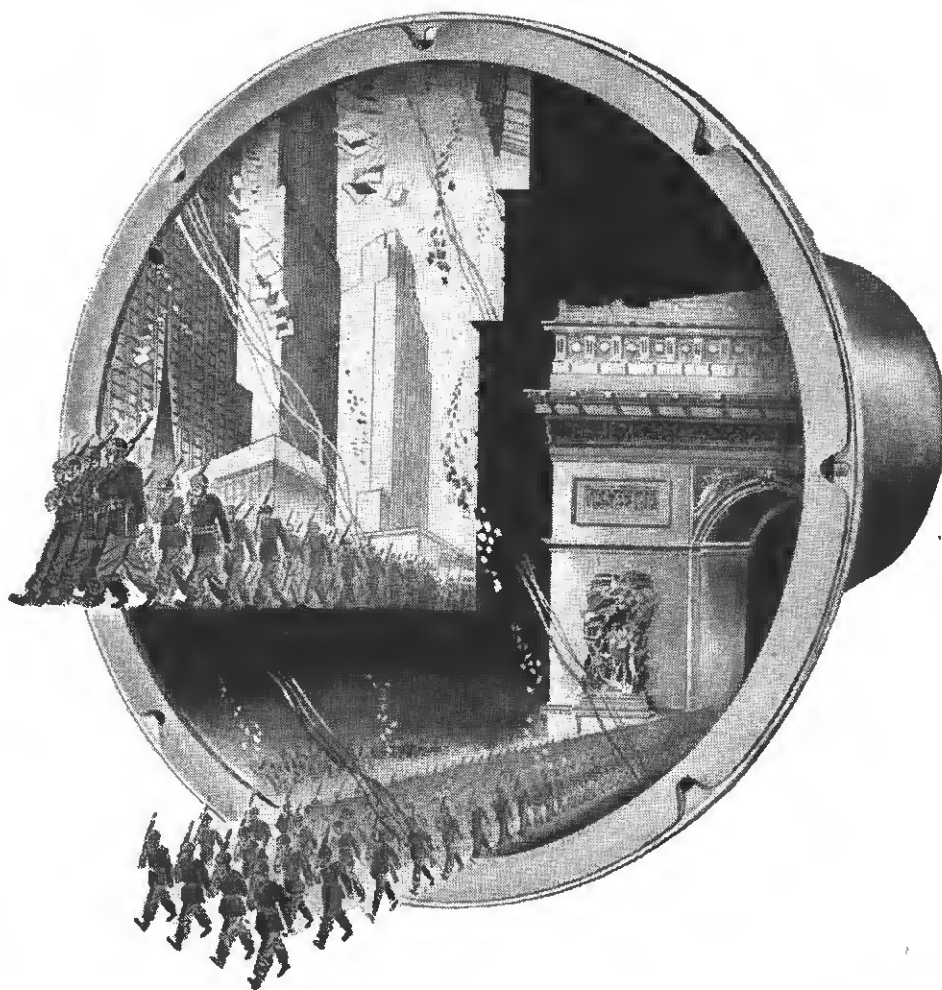

The Loudspeaker Everyone is Waiting for

NO, it isn't necessarily a Rola. The sound for which the Nation is so eagerly and confidently waiting is the news that Victory is ours . . . that men and women will come home . . . that the bright dawn of world peace is in sight.

In many homes it *will* be a Rola, for millions of radio sets have been Rola equipped, but regardless of who made it, the loudspeaker that brings this welcome news will be the

sweetest sounding speaker anyone ever listened to.

Afterward will come still finer Rola speakers, improved by discoveries and developments that can't be talked about now. Meanwhile, busy as it is in highly important war work, Rola can do no more than provide speaker models for authorized experimental work and consult with Manufacturers on their peacetime plans.

THE ROLA COMPANY, INC. • 2530 SUPERIOR AVENUE, CLEVELAND 14, OHIO

ROLA



MAKERS OF THE FINEST IN SOUND REPRODUCING AND ELECTRONIC EQUIPMENT

Depend on
ARVIN
for Customers

To bring customers to you for all the coming Arvin Products, family desires are being pre-sold now — through a series of full pages in leading national magazines. The page reproduced below is one of several different advertisements appearing in current issues of Better Homes & Gardens, Collier's Weekly, American Home, and The Saturday Evening Post . . .

The Family Speaks for Arvin!

MOTHER SAYS:



DAD SAYS:

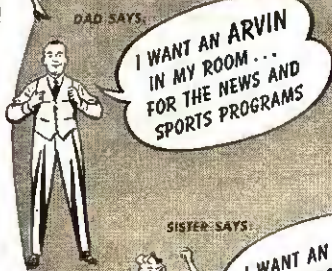

SISTER SAYS:



BROTHER SAYS:



ALL THROUGH THE HOUSE
... OUTDOORS, TOO

THEY ALL SAY:
WE WANT A BIG ARVIN RADIO PHONOGRAPH IN OUR LIVING ROOM . . . AN ARVIN PORTABLE FOR OUTDOORS, TOO!

ARVIN
Top Flight
RADIOS

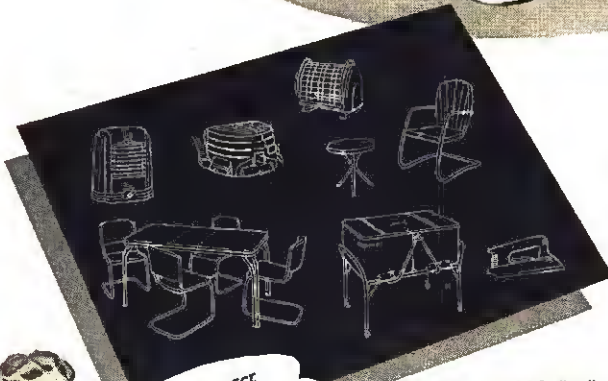

WE WANT THESE OTHER ARVIN PRODUCTS, TOO!

In addition to Top Flight Radios, the coming Arvin Products will include: Metal-Chrome Dinette Sets . . . Outdoor Metal Furniture . . . Roll-a-Round Laundry Tubs . . . Automatic Electric Irons . . . Portable Electric Heaters for bathrooms and other places . . . Hot Water Car Heaters and other things you need.

THE FAMILY HOME can be Arvin Radio-furnished completely and economically, when war demands on production facilities have passed.

Then, there'll be a complete new line of Arvin Top Flight Radios, including a wide choice of models for every one in the family — for every room and outdoors, too — little radios, big ones, middle-size ones, table and floor models, radio-phonograph combinations with automatic record changers and FM, portables and rural battery sets.

Top Flight designers and engineers have the new Arvin Radios ready for production. Veteran craftsmen will build into them their many years of war and peacetime radio experience. And you'll get really dependable values from ARVIN — in radios and other products the family enjoys. While you're waiting for them — buy more War Bonds.

NOBLITT-SPARKS INDUSTRIES, INC.
General Offices: Columbus, Indiana
Eleven plants in five Indiana cities — 25 years in manufacturing

AN A-1 FRANCHISE for A-1 RADIO MERCHANTS



The more you know about the radio business, the better you'll like the Lear franchise.

It's a clean-cut, down-to-earth, square-shooting deal that provides the dealer with sets to sell that aren't surpassed anywhere. It gives him merchandising advantage that definitely puts him in line for a profitable, fast-growing business.

They're the kind of radios that will create active consumer demand—with all the newest electronic developments—phonograph com-

binations and record changers, wire recording, television, FM, and improved world-wide tuning.

There are no jokers, no guesswork, no take-a-chance aspects in the Lear franchise. It has purposely been prepared to be one of the most advantageous opportunities in the industry.

If you are interested and feel you can meet the qualifications, address LEAR, Incorporated, Home Radio Division, 230 East Ohio Street, Chicago 11, Illinois.

LEAR RADIO





OWI uses RAYTHEON tubes
IN UNIQUE MOBILE RECORDER

● This "traveling recording studio" of the Office of War Information has everything for making recorded pickups for broadcasting on international short wave. Such important equipment must be the finest that science can provide, so Raytheon High-Fidelity Tubes are used to assure the highest quality reception.

Wherever they are employed, Raytheon Tubes live up to their reputation for fine performance. That is why they are first choice among electronic engineers planning post-war products . . . and first choice among radio service-dealers who are building soundly for the future.

There's a real promise of greater profits and greater customer-satisfaction for service-dealers who feature Raytheon Tubes. And there's a revolutionary Raytheon merchandising program planned, too . . . to help you be more successful than ever before.

Switch to Raytheon Tubes now!

Increased turnover and profits, plus easier stock control, are benefits which you may enjoy as a result of the Raytheon standardized tube type program, which is part of our continued planning for the future.

Raytheon Manufacturing Company
 RADIO RECEIVING TUBE DIVISION

Newton, Mass. • Los Angeles • New York • Chicago • Atlanta

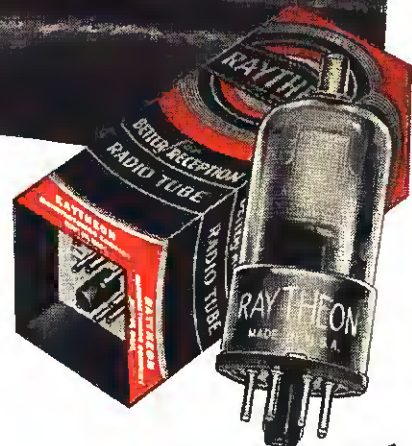

Listen to
"MEET YOUR NAVY"
 Every Saturday Night
AMERICAN BROADCASTING CO.
 Coast to Coast
 181 Stations



All Four Divisions Have Been Awarded
 Army-Navy "E" With Stars

RAYTHEON
High Fidelity
 ELECTRONIC AND RADIO TUBES



DEVOTED TO RESEARCH AND THE MANUFACTURE OF TUBES FOR THE NEW ERA OF ELECTRONICS

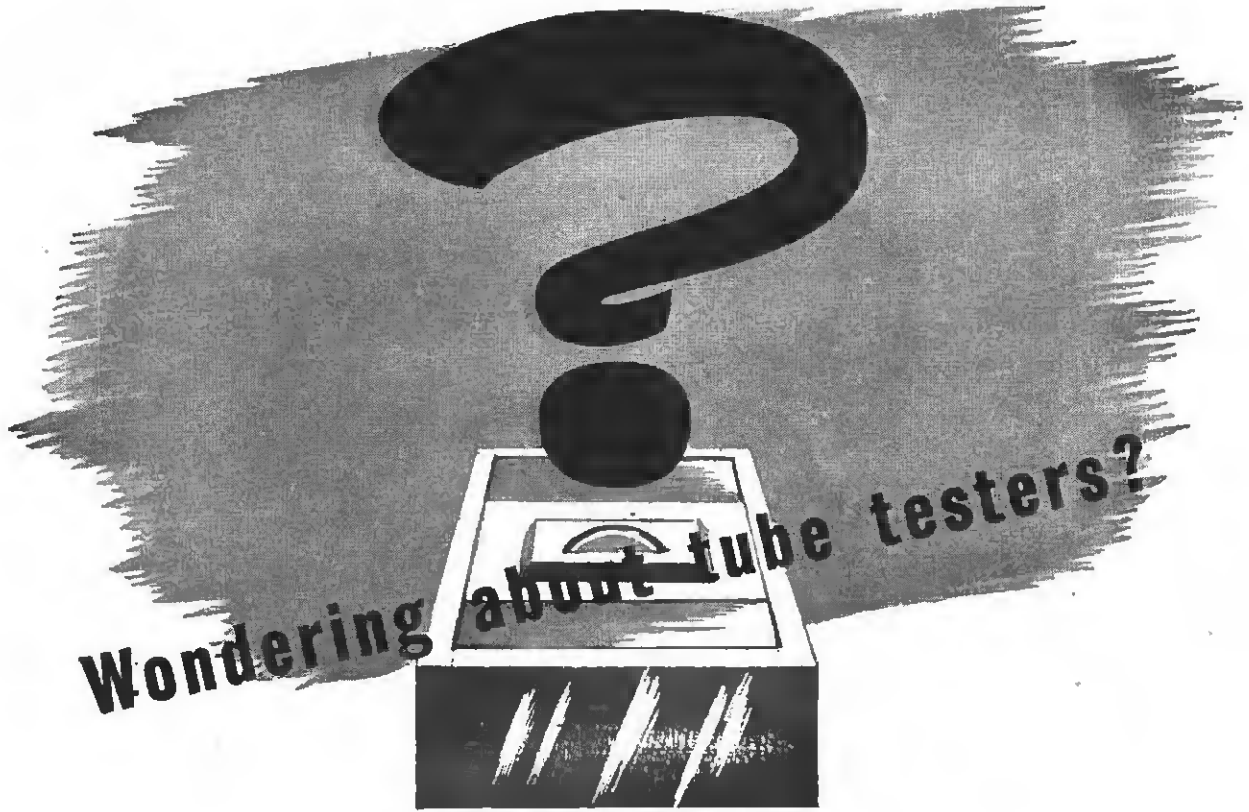

Wondering about tube testers?

*...Here's what Simpson has ready
and waiting for your postwar needs*

Sensational? Yes . . .

- 1.** This new Simpson Mutual Conductance Tube Tester tests tubes with greater accuracy than any commercial tube tester ever designed.
- 2.** Provides greater flexibility for future tubes than any other tester.
- 3.** Tests tubes with voltage applied automatically over the entire operating range.
- 4.** Simplifies as never before the interpretation of tube condition from mutual conductance readings.

Simpson
INSTRUMENTS THAT STAY ACCURATE

SIMPSON ELECTRIC COMPANY
5200-18 Kinzie Street, Chicago 44, Ill.

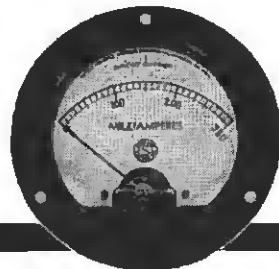

Greater Philco Service Is Here Today!

Greater Philco Service is not a dream of tomorrow . . . not a promise held out for those post-war days when everything is going to be streamlined, chromium-plated, and dished up on a silver platter. *Greater Philco Service is here today . . . in active operation . . . not experimentally . . . but on a nation-wide scale!*

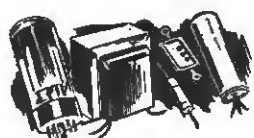

The Philco Service Division is already completely organized . . . organized in separate departments . . . *complete* departments for each Philco product . . . for radio and television, for auto radio, for refrigerators and for air conditioners.

Linking these all together, the Philco Service Division has organized a competent, carefully trained staff of Philco Field Service Engineers who will travel the country, give all the time your service manager asks to his specific problems, and help him train the men who will service ALL Philco products.

These Field Service Engineers have nothing to

sell. Their full time job is to help Philco distributors and dealers on all service problems . . . and to train dealers' servicemen by technical training methods tried, proved and approved by the Armed Forces of the United Nations. Fifteen thousand technicians were trained by these methods . . . in these courses . . . which will now be available through Philco Field Service Engineers for the Service Departments of every Philco Dealer.



Greater Philco Service is here . . . in active operation . . . at *your* command today! Write Philco, Philadelphia, Pa., for full details.

PHILCO



Radios • Phonographs • FM • Television • Refrigerators • Freezer Chests • Air Conditioners

"...Dawn's Early Light"



One hundred and thirty million Americans thrilled to the recent great news.

The Hun is finished. The evil powers of German militarism and Nazism have gone down for the count. May they never rise again.

So shall it be with the Japs. That war goes on . . . the end not yet in sight. But we have seen the dawn of peace and with redoubled effort we at home can help it rise in glory.

Meanwhile, we have another task to do . . . starting right now. Final victory in the field must not find us unprepared for economic victory at home.

No magic words will switch us overnight into the ordered channels of peace-time prosperity. To obtain it . . . to escape war's possible aftermath of silent factories, idle machines, dis-

content and bewilderment . . . we must plan carefully, wisely, promptly.

The responsibility falls upon all of us . . . employers and employes . . . in industry, agriculture or professional life . . . to map out a program of action.

Plan the ways in which you can further the cause of full and useful employment.

Plan so that you will have the means to carry out the program when the green light flashes on.

The first, and best way is to buy more bonds, and to hold on to all you buy.

Together, steadfast in purpose, we can work out a bright destiny.

NOW . . . ALL OUT FOR THE MIGHTY SEVENTH



COMMERCIAL CREDIT COMPANY

BALTIMORE 2, MARYLAND

Capital and Surplus more than \$65,000,000

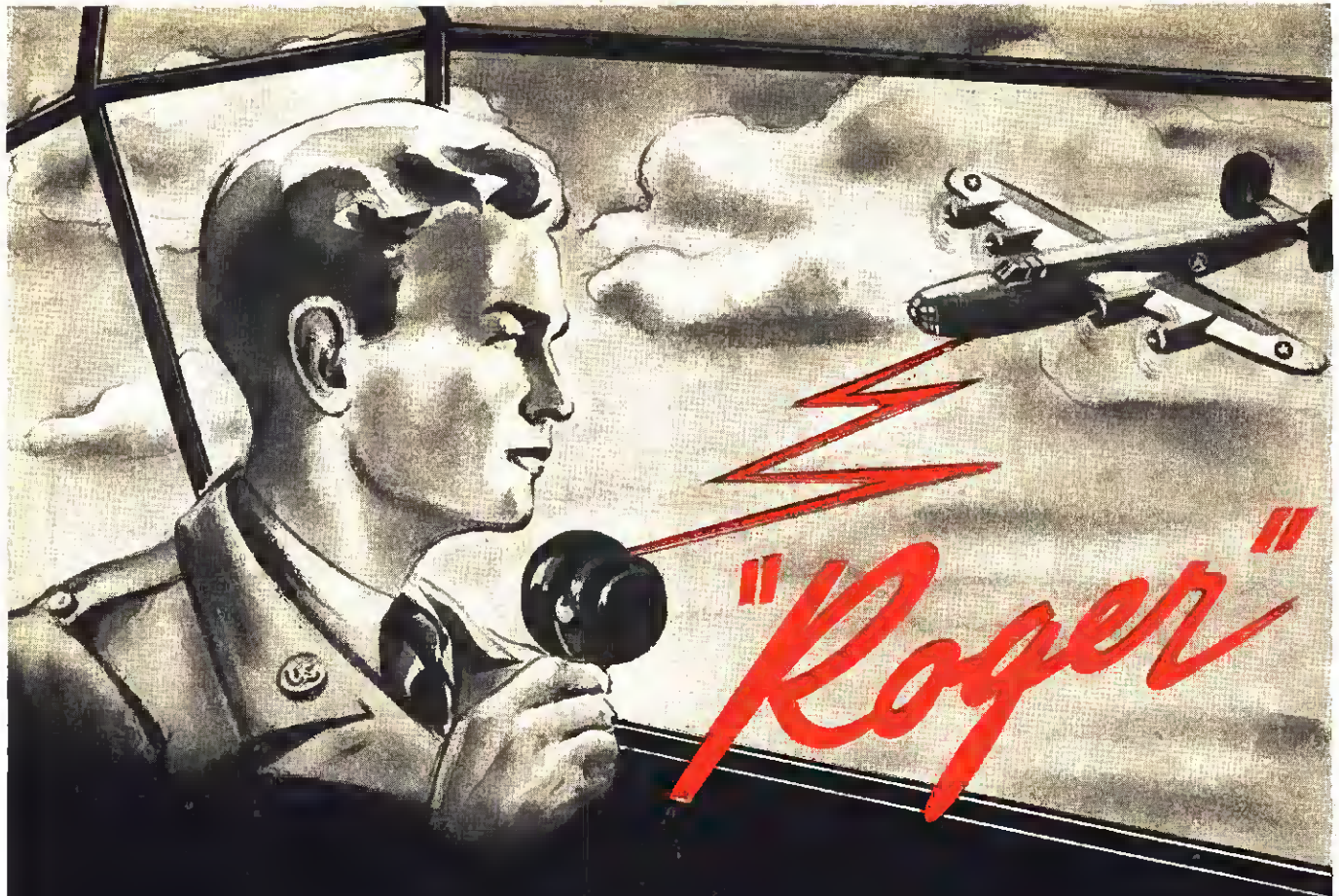

Nothing could be more welcome to the weary pilot as he prepares to land than that cheery "Roger" from the control tower assuring him that all is well and he may come in. One more mission completed . . . one more hazardous job well done!

That's the FADA contribution of today . . . making the dangerous business of war just a little safer for our courageous fighting men through electronic devices and radio equipment.

PLACE YOUR FAITH IN THE

FADA
Radio

OF THE FUTURE

Famous Since Broadcasting Began!

Tomorrow—the word "FADA" will be a cheery symbol of the finest in peacetime radio and electronic developments. Tomorrow, our dealers will be guided to new heights of profit by FADA achievements in the field of communications.

FADA RADIO AND ELECTRIC COMPANY, INC., LONG ISLAND CITY, N. Y.

**HERE'S WHY THE
MAJESTIC FRANCHISE IS**

*The hottest news in
the radio industry!*



HERE'S THE LINE that will meet the requirements of every profitable section of the radio and radio-phonograph market. A full complement of models, from portables to consoles. A complete range of prices, concentrating where maximum profits are assured but ranging all the way from the lowest prices at which satisfactory unit-profit is possible . . . up to the highest prices at which good turnover can still be secured.



HERE'S THE NAME—Majestic Radio—that's known to virtually 9 out of every 10 persons . . . proved by independent surveys to be familiar to 88.2% of the public. Think of all the extra sales in such familiarity with a name!



HERE'S THE NEWEST advantage of the Majestic franchise—Majestic Records—a great line of popular-priced and fast-selling recordings . . . soon to be expanded to include all types of recordings, in a full price-range. They'll help step up current sales volume! They'll help build still greater acceptance for the Majestic name when it appears on *Majestic Radios* and *Majestic Radio-Phonographs*!



HERE'S THE PLAN—Controlled Distribution—that enables every Majestic dealer to make a legitimate profit on every Majestic Radio or Radio-Phonograph.



HERE'S HOW to take the first step toward securing the finest franchise in the radio industry. Write us today for full information . . . for all the reasons why—

Majestic Means Business
... and lots of it!

MAJESTIC RADIO & TELEVISION CORPORATION, ST. CHARLES, ILL



MORE GOOD NEWS!

FRESH, DATED

"EVEREADY" BATTERIES ARE BACK!



SINCE PEARL HARBOR, virtually all "Eveready" Batteries have been going to the Armed Forces or essential war industries.

Now the War Production Board has authorized production for civilian use.

These "Eveready" Batteries are now available to you in reasonable quantities:

1. Flashlight Batteries
2. Farm Radio Batteries
3. "Eveready" "Mini-Max" "B" Batteries for Portable Radio
4. "A" Batteries for Portable Radio
5. No. 6 Dry Cells
6. "Eveready" "Hot Shot" Batteries

As in the past, the famous *date-line* assures *freshness* . . . the only way to be certain of dependability and long life.

Throughout the period of shortage, our advertising has reminded customers of the importance of this date-line on "Eveready" Batteries.

5TH ARMY-NAVY "E"! The Charlotte, N. C. plant of National Carbon Company, Inc. has recently been awarded the Army-Navy "E". . . the FIFTH National Carbon Company plant to be so honored.

EVEREADY
BATTERIES

NATIONAL CARBON COMPANY, INC.
Unit of Union Carbide and Carbon Corporation

UCC

General Offices: 30 East 42nd Street, New York 17, N. Y.

Division Sales Offices: Atlanta, Chicago, Dallas, Kansas City, New York, Pittsburgh, San Francisco

The registered trade-marks "Eveready," "Mini-Max" and "Hot Shot" distinguish products of National Carbon Company, Inc.

BACK AGAIN...
and popular as ever!



MALLORY VIBRATORS

MALLORY vibrators have always had an enviable record for dependable, trouble-free performance. That's why, before the war, most leading manufacturers of automobile radios selected them as standard equipment.

Small wonder that, when the Japs attacked, these famous vibrators were pressed into military service. Since then the roster of Mallory customers has included the U.S. Army and Signal Corps, the U. S. Navy and Coast Guard, the Marine Corps—not to mention the fighting forces of the United Nations.

Naturally military demands could not be met

without restricting civilian production. In spite of what this has meant to service engineers, we are glad to say that shortages have been understood and accepted.

But now Mallory vibrators are back again—and standards of quality are high as ever. Mallory, moreover, has further standardized its line so that selection and replacement are considerably easier. Ask your Mallory distributor about this line. Learn how 65 Mallory vibrators now replace 101 different types . . . how 90% of your replacement needs can be met with only 12 vibrators!

P. R. MALLORY & CO., Inc., INDIANAPOLIS 6, INDIANA



*More than ever—
**ALWAYS
 INSIST ON***

P. R. MALLORY & CO. Inc.
MALLORY
 APPROVED
 PRECISION PRODUCTS

**VIBRATORS • VIBRAPACKS* • CONDENSERS
 VOLUME CONTROLS • SWITCHES • RESISTORS
 FILTERS • RECTIFIERS • POWER SUPPLIES**
 ALSO MALLORY "TROPICAL"® DRY BATTERIES, ORIGINALLY DEVELOPED BY MALLORY FOR THE U. S. ARMY SIGNAL CORPS, NOT PRESENTLY AVAILABLE FOR CIVILIAN USE.
 *Trademarks



the period
of "easy selling" is
the time to

create satisfied customers

It will be easy to sell radios for a while after the war. But the dealer who looks ahead will make certain . . . even during the spending spree . . . that every radio he sells creates a SATISFIED CUSTOMER—a friend who will keep on buying at his store when he "needs the business".

ECA Radios have been designed to build for you an equity of customers who are satisfied and loyal. Advanced engineering . . . electronic and acoustic innovations . . . amazingly lifelike tone . . . craftsmanship cabinets . . . superb, trouble-free performance—these and

other features will give your customers greater value, yet cost them nothing extra. Satisfied customers are only one of MANY advantages which can be yours with the ECA Radio Dealer Franchise. Write for FULL details—TODAY.

every
ECA radio
you sell
will sell
another
for you

CHECK THESE ECA RADIO FRANCHISE FEATURES

- Complete line of radios and radio phonographs
- Advanced styling by top-flight designers
- Latest electronic features
- Exclusive ECA Radio DI-FUSA-TONE feature
- Priced to fit every purse
- Protected dealer profits
- Extensive Advertising
- "Pre-sold" consumers
- Sold direct, to limited number of select dealers
- Assured deliveries



"THE AMAZING ELECTRON" . . . Our program of pre-selling consumers is bringing in reservations for postwar ECA Radios every day. As another step in this plan, we are distributing to the public an interesting booklet, "The Amazing Electron". A copy is yours for the asking.



SEND THIS COUPON FOR DETAILS

ELECTRONIC CORP. OF AMERICA
45 West 18th St., New York 11, N. Y.

Gentlemen: Please send full details on the ECA Radio Franchise, without obligation.

Store Name _____

Address _____

City _____ State _____

ELECTRONIC CORP. OF AMERICA

45 WEST 18th STREET - NEW YORK 11, N. Y.



telling the world

whoever you are . . . whatever you do . . .
YOU NEED hallicrafters EQUIPMENT

HALLCRAFTERS herewith stakes out a claim to a special part of the radio market: high frequency communications receivers and transmitters that will find a new, wide acceptance in many fields.

BUY A WAR
BOND TODAY!

Hallicrafters advertising and promotional programs have proclaimed widely ". . . whoever you are . . . whatever you do . . . you need Hallicrafters equipment." In the field of radio distribution you will find an ever widening demand for Hallicrafters—known to millions as "the radio man's radio."



hallicrafters RADIO



COPYRIGHT 1945
THE HALLCRAFTERS CO.

THE HALLCRAFTERS CO., MANUFACTURERS OF RADIO AND ELECTRONIC EQUIPMENT • CHICAGO 16, U. S. A.

Remember?

HOW THE N. U. EQUIPMENT PLAN HELPED SERVICE DEALERS PROSPER!

Here's a typical example of how service dealers obtained the test equipment they needed through National Union deals. This N. U. plan was OK'd 60,000 times by radio service dealers — and helped make servicing more profitable for thousands!



NATIONAL UNION

RADIO AND ELECTRONIC TUBES

Transmitting, Cathode Ray, Receiving, Special Purpose Tubes • Condensers • Volume Controls • Photo Electric Cells • Panel Lamps • Flashlight Bulbs



We're Mighty Serious, too!



WAR is a grim business, even on the home front. And we here at Eastern are serious—mighty serious—about the job we are doing for Uncle Sam's fighting men. Eastern equipment flies the sub-stratosphere gales over Tokyo in American Superfortresses—Eastern equipment rides the surging waves of the Pacific in those valiant little PT boats.

Eastern performance means Eastern leadership in the field of sound and electronic equipment. For we at Eastern are not new hands—we've been in the business since 1921—and some of us even longer

than that. With the coming of peace, Eastern will go further and further into the field of electronics—contributing — *still seriously* — to the development and growth of this, tomorrow's industry.

Our engineers are available for consultation on any amplification problem. Eastern will continue to apply its resources to designing and manufacturing war equipment until the day of Victory. Meanwhile, on request, we will send you the next of a series of articles on peacetime sound and electronic equipment, prepared by our engineering staff. Ask for Brochure 6 A

Buy MORE War Bonds



EASTERN AMPLIFIER
CORPORATION

U. S. Reg'n. Applied For

794 EAST 140th STREET • NEW YORK 54, N. Y.

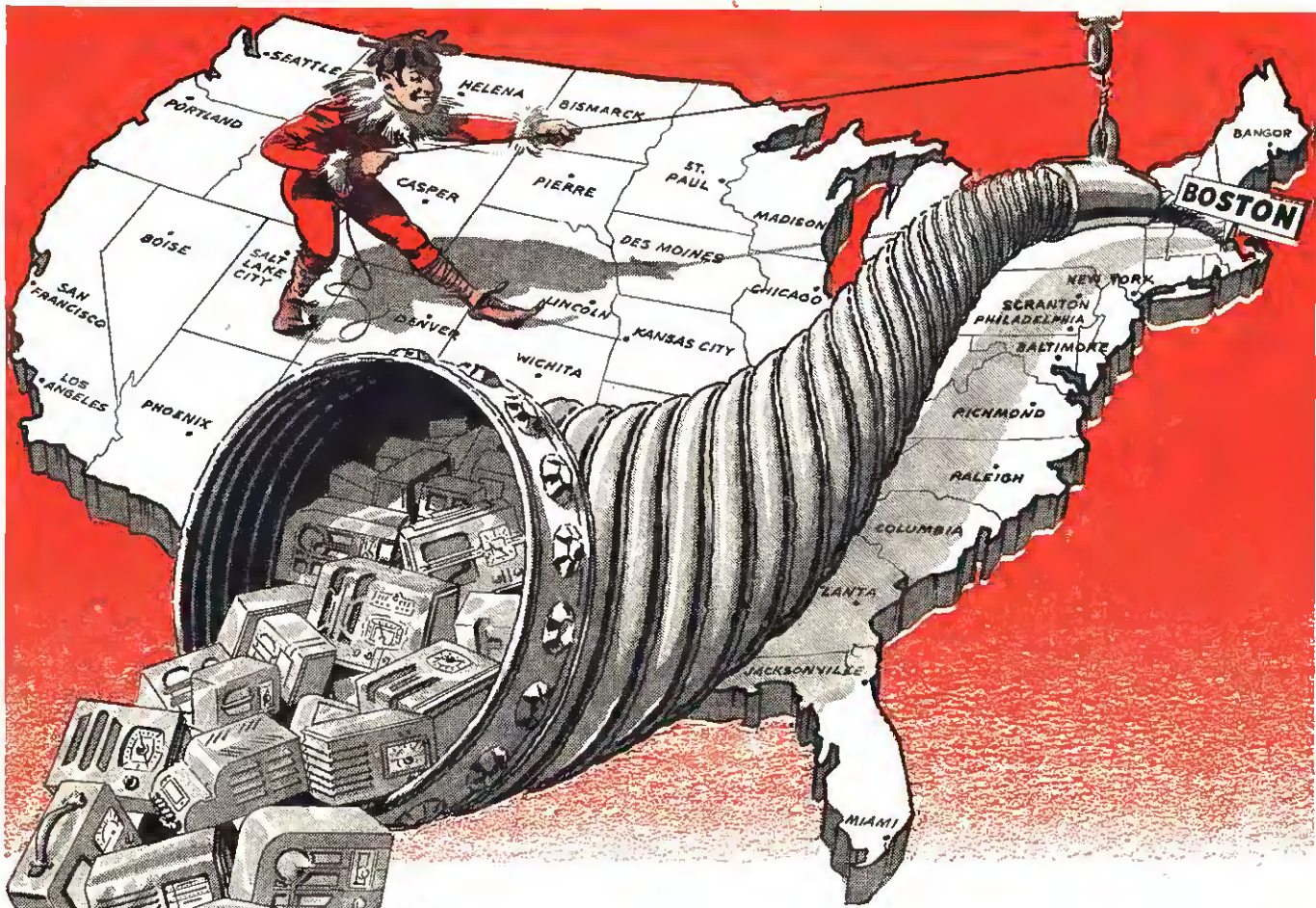

Automatic will be the **BUY**

There's still a war to be won. But we are now planning to meet the consumer demand for Automatic and Tom Thumb Radios when we get the green light.

Automatic will have a minimum of reconversion problems, and with expanded manufacturing facilities, is better equipped than ever before to meet your demand for quality sets. Sets that will be priced right, plus many new features, will assure their popularity and your profit.

Act now!!!

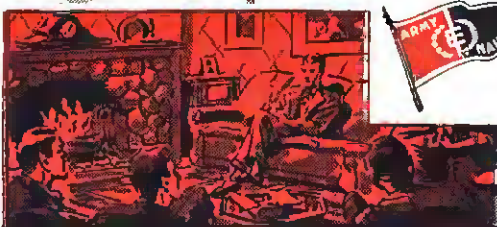

Automatic

RADIO MANUFACTURING CO., Inc.
122 Brookline Avenue, Boston, Mass.





Stromberg-Carlson dealer franchises are now ready!

Organize your postwar business around the popular Stromberg-Carlson line of radios, radio-phonographs and television receivers. For details regarding radio's most valued franchise, contact your Stromberg-Carlson distributor or write direct to the Stromberg-Carlson Company, Radio Division, 100 Carlson Road, Rochester 3, New York. Become an authorized dealer now—and build your future with the Stromberg-Carlson *Main Radio*—a consistent profit maker whether it be an outstanding table model, console or radio-phonograph combination.

With Stromberg-Carlson
the main radio in
your customer's mind...

Make Stromberg-Carlson
the main radio in
your showroom...

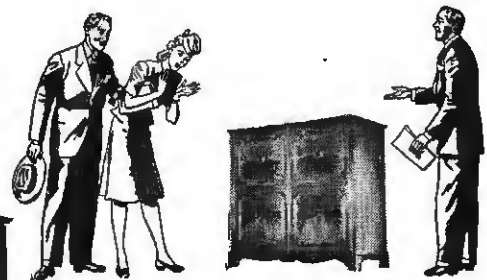
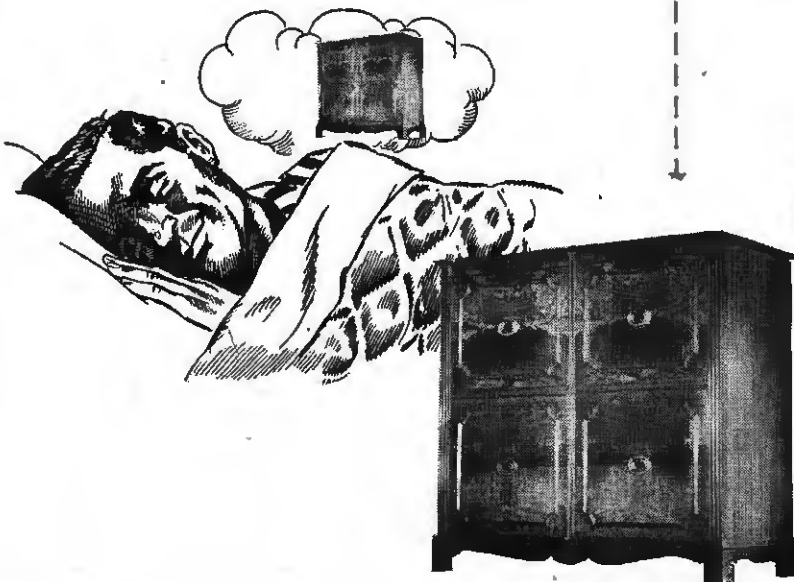

STROMBERG-CARLSON ROCHESTER 3, N. Y.

RADIOS, TELEVISION, TELEPHONES, AND
SOUND EQUIPMENT

RADIO & Television RETAILING

Including Radio and Television Today

O. H. CALDWELL, Editor ★ M. CLEMENTS, Publisher ★ 480 LEXINGTON AVE., NEW YORK 17, N.Y.

The "Point-of-Sale" is the Point of All Selling

The radio-appliance retailer is the *only* man in the vast merchandising field who actually *faces* the ultimate consumer.

The radio-appliance retailer stands guard at the *last* portal through which pour the manufacturers' products. Thus the retailer *controls* the flood-gates of consumer selling.

All the efforts of the raw-goods supplier, the designer, the engineer, the manufacturer and the wholesaler depend for their success upon the retailer's ability to make the customer say "yes."

The manufacturer realizes the importance of the retailer. The maker advertises his product for the purpose of securing customer acceptance, which will in turn help reduce sales resistance to the dealer's selling effort.

The distributor depends upon the retailer for his very existence. He knows that he must provide first-class merchandise and efficient selling aid to the merchant. The jobber cannot sell *more* of the *same* radios and appliances to the dealer *until* the dealer has sold his stocks to the consumer.

Dealers Are Indispensable

Manufacturers and jobbers are extremely conscious today of the dealer's indispensable position at the highly vulnerable point-of-sale. They are making plans to do more for the independent retailer than they have ever done before. They know that the dealer is happy, brand-loyal and *valuable* to them *only* when the prod-

uct is dependable, competitively-priced, publicly accepted, and truthfully and intelligently advertised.

Point-of-sale retailers want these things from the jobbers: No "wholesale-retailing," improved merchandising help; elimination of dealer "over-loading" practices, meticulous selection of products, and fair allocation of available merchandise.

The Retailer Deserves Recognition

The retailer wants these things from the manufacturer: Better merchandise, lower price to consumer to compete with private brands and "chains," and improved co-operative advertising plans.

That there is a definite trend today on the part of manufacturers and wholesalers to give the retailer the things he wants, is a healthy sign indeed. With prospects of *lowered discounts* postwar, the man at the point-of-sale position certainly merits every possible assistance to help him increase his sales volume.

Through his being stationed also at the *point-of-service* station during war-time, the independent dealer deserves the things he asks of the manufacturer and the jobber. The retailer has been sustaining brand-name good-will throughout these times by assuming the herculean task of keeping radios and appliances operating.

Never before has the consumer been so "brand-conscious"—so appreciative of the stability of various makes of equipment—and this feeling is due to the ingenuity and dependability of the dealer.

IT ALL LEADS UP TO THAT CRITICAL INSTANT AT POINT-OF-SALE

There's nothing to the race but the finish. And there's nothing to the whole chain of designing, manufacturing, packaging, advertising, selling and merchandising a product but that little instant when the customer hesitates and then lays a hand on your product, saying:

"I'll take it."

Everything the gatherers of raw materials, the processors, the manufacturers, the transporter, the salesman, the advertising agency and the retailer have done over a period of months or years, culminates in that little instant at point-of-sale!—Abbott Kimball



RADIO, Electrical Appliances,

SOME RADIOS BY SUMMER'S END? The reconversion picture has already started to change from the original WPB forecast with its two formulas of the transition for the radio-electronic industry to civilian production. Revaluation of the Signal Corps-Army Air Forces-Navy procurement programs is now in the works and may produce in the next 30 or 60 days some sharp cutbacks for the smaller companies.

SPECULATIONS BY WPB AND OPA LEADERS, together with hints from the military services, indicate that some home receivers may be produced for the civilian market by mid-summer. OPA officials have geared their price-determination machinery so as to catch sets on the market in 90 days. WPB sources felt that companies which have their military contracts greatly curtailed could get "spot authorizations" for civilian production with components not needed for the war.

SHORTAGES IN TUBES, TRANSFORMERS—Components, including tubes, are still very tight. The backlogs of unfilled orders still held by the component industry, notably tubes and transformers, are the largest since October.

VIDEO INDUSTRY IS PLEASED that present "low-frequency" tele will be available for a quick start of the new industry postwar, though regretting that exact receiver design and changeover of transmitters will be somewhat delayed, until FCC makes definite announcement later in 1945. However, industry leaders think this delay will not be serious for television.

TELEVISION'S GENERAL POSITION IS ASSURED in FCC's new allocations, but exact location of tele channels will depend on which of the three Commission proposals for FM is adopted, following engineering tests on FM to be carried on during the summer. (For three alternatives see chart, bottom of opposite page. More details on page 66.)

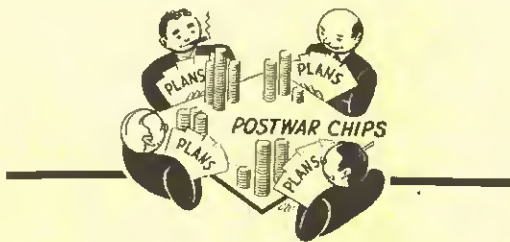

WON'T TIP THEIR HANDS—Most of the big manufacturers are keeping their plans for new things as aces in the hole for "full-production day." Two "giants," for instance, won't confirm that they're planning "midget" refrigerators for camps, trailer colonies, vacationers. Another "big-timer" has nothing to say about the chances of his producing a "second-line" refrigerator or a new type steam iron.

AN ELECTRIC CLOTHES DRYER has become a companion unit to the Westinghouse automatic washer—the Laundramat. The dryer, externally similar to the washer, contains a large metal tub in which the damp clothes are placed. The tub is rotated at slow speed while a fan circulates a current of air, warmed by electric heaters.

STRUGGLE FOR CLEANLINESS by the human race has a long and interesting history. Latest development appears in postwar home planning, in which the home laundry moves out of the basement to the first-floor. Smaller home plans make it a part of the kitchen unit! Mr. and Mrs. Home-Owner of the future will have a bigger and better rumpus room because of this—with plenty of space for that extra radio!

SIMMONS AUTOMATIC ELECTRIC BLANKET will be a new product of the famous manufacturer of Beautyrest Mattresses, and other aids to sleepers. It is understood Simmons has obtained the rights to produce this product from GE.

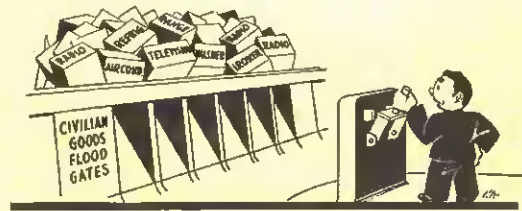

RADIOS—APPLIANCES—WHEN? See article next pages of this issue for exclusive, timely predictions by leading manufacturers.

HOTPOINT'S "YOUR NEXT KITCHEN" booklet, now being distributed to dealers for issuance to consumers, envisions a housewife's fondest dreams come true! The efficiency depicted in running a household should make Housekeeping a keen rival to Career among today's married women now lured by the World of Business!

INVENTORY TURNOVER RATES UP. In 1939, average manufacturer turnover rate was 4.1—4.9 in 1942 and 6.4 in June 1944, latest figures available reveal. Wholesaling turnover jumped from 13.2 in 1939 to 21.0 in 1944. Retailing went from 5.3 to 7.1 for the same period.

INCREASED USE OF ALUMINUM in the manufacture of electrical appliances is predicted for the future. The lightness of this metal and its ability to insulate, make it well suited for many household appliances requiring these qualities. Home freezers, the use of which is becoming increasingly popular, especially, is particularly adapted for the employment of aluminum in its construction.

Records, and Television, **TODAY**

INSTALLED PRICES ON RANGES?—Some of the **BIGGEST** manufacturers in the electric range field are beginning to think about plans for pricing ranges to include installation charge. This definitely would be a help for the dealer. It's been very hard in years past to sell a range for \$150 and then to have to tell the customer it's going to cost him anywhere from 30 to 85 dollars more—to put it in his house!

WAR'S TRIALS have brought invaluable knowledge to appliance manufacturers regarding the life span of their products during a period of minimum service, is the claim of Landers, Frary & Clark, manufacturers of many of these aids to better living.

GE's PEACETIME PLANS. According to a spokesman for General Electric Co., this manufacturer will go into the immediate postwar market not only with late pre-war models, but with certain new products, never previously sold, which the company had ready for the home when civilian production was curtailed.

NEW LINE OF DOOR CHIMES in engineering model form ready for production by The A. E. Rittenhouse Co., Inc., Honeoye Falls, N. Y., when necessary relaxation of materials and manpower permits.

MOVE ON FOOT on the part of several manufacturers of radio parts to make it possible for distributors to sell their industrial customers at same prices latter would pay buying directly from the manufacturer.

INSTALLMENT BUYING UP—Federal Reserve Board declares consumer credit stepped up 407 million dollars in 1944 against a drop of four and a half billions in 1942-43.

STEAM IRON, LIQUEFIER and other home electrical appliances will be made by the Winsted Hardware Mfg. Co., Winsted, Conn. The liquefier and the steam iron brand names are "Waring." These products will be distributed by the D. E. Sanford Co., 36 W. 47 St., New York.

NEW MANUFACTURER OF APPLIANCES will make home and commercial freezers as soon as restrictions are lifted. Known as the Quickfreeze Mfg. Co., Irvington, N. J., the firm will merchandise its products under the brand name of "Quickfreeze." Plans have already been completed for producing these freezers, which will be built in several models, ranging from those with a two cubic foot capacity to large-size appliances of thirty cubic foot capacity.

WASHERS RELEASED!—As we go to press, WPB proposes manufacture of 700,000 washers for last half of 1945—only a start on the estimated pent-up civilian demand for 5,865,000! Ironers and dryers also received WPB go-ahead, if manufacturers can get the men and material.

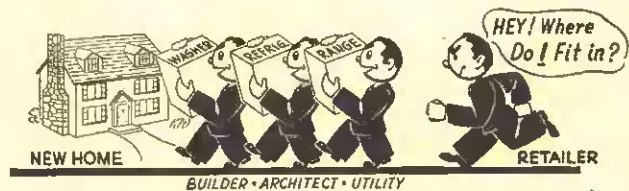

INDEPENDENT RETAILERS WORRIED about the "completed home" projects being formulated. One utility company's proposed program announces its interest in home dwellings "with all modern conveniences of living, the whole sold as a living unit . . . and to be financed by the lending institutions as one transaction. . . ." In all such plans, the independent radio-appliance dealer sees himself by-passed, with the selling of the electrical home equipment being handled by architects, builders, and possibly some utilities.

FM MAY BE LOSER ON 1945 HOME SETS as result of delay in fixing FM channels. If several million home radios are built during 1945, as now appears likely, these will undoubtedly be brought out as straight-AM receivers, instead of incorporating FM bands as most of the makers had previously intended. And if official FM tests run throughout summer, with analysis continuing into fall, actual FCC decision may not be reached until nearly first of the year, holding up design and production so that first FM-AM sets may not be available until fall of 1946.

Three Alternative Assignments for FM and Television Proposed by FCC

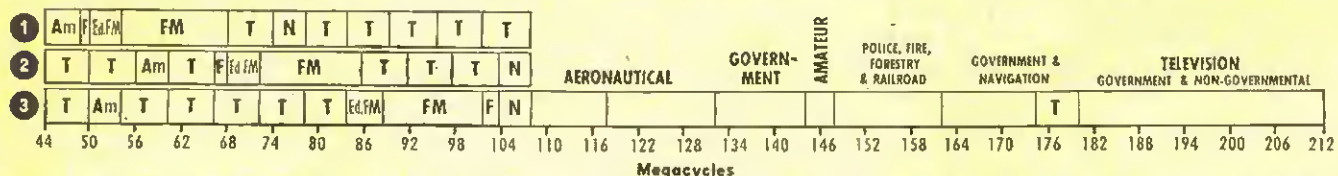

FM and television people are now figuratively tearing their hair and wondering which one of the above three arrangements will be finally adopted by Washington authorities after their engineers complete FM-reception tests this coming summer. In the chart above, abbreviation Am stands for Amateur; F for Facsimile; Ed. FM for Educational Frequency Modulation; T for Television, N for Non-governmental fixed and mobile services.

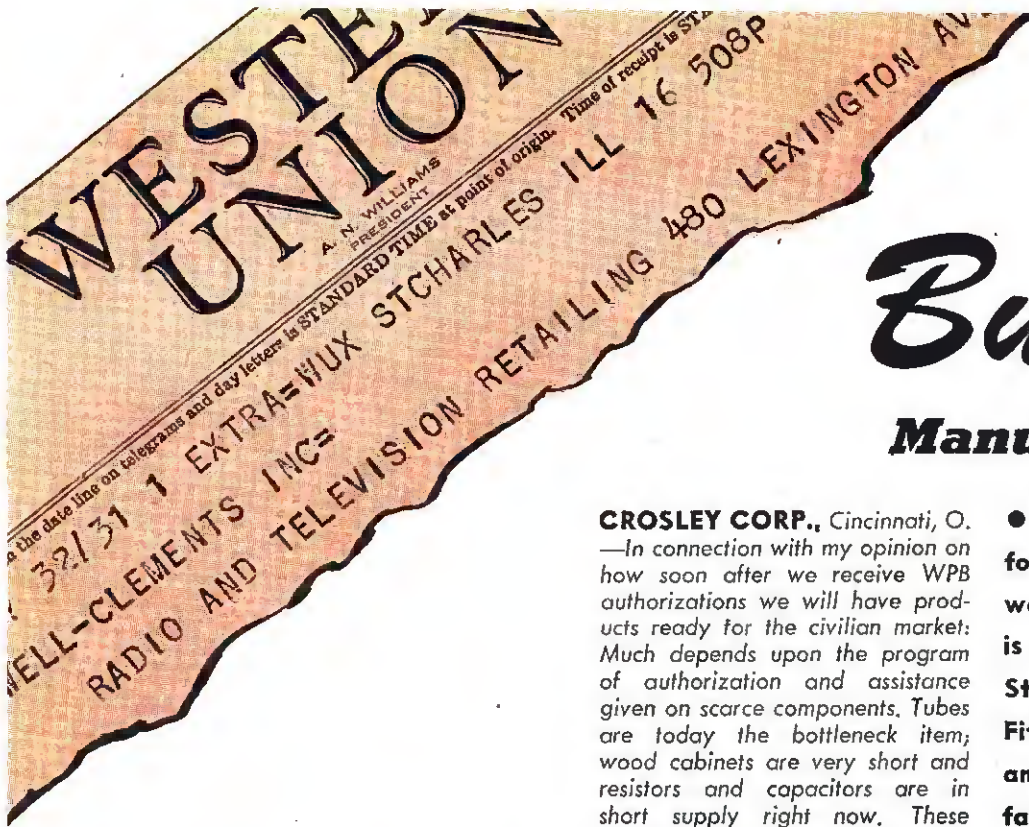

Business

Manufacturers Wire

● As a result of the splendid efforts of our fighting forces and our war plant manufacturers, business is on the way back to the Main Streets, the Market Streets, the Fifth Avenues, the Broad Streets and all the other retail thoroughfares throughout the nation. ● With the same lightning speed with which they converted to the pro-

CROSLY CORP., Cincinnati, O.—In connection with my opinion on how soon after we receive WPB authorizations we will have products ready for the civilian market: Much depends upon the program of authorization and assistance given on scarce components. Tubes are today the bottleneck item; wood cabinets are very short and resistors and capacitors are in short supply right now. These shortages are delaying the radio

radio sets within 60 to 90 days after WPB authorizes us to produce them, barring unforeseen restrictions.

JACK GEARTNER

EMERSON RADIO & PHONO. CORP., New York—Estimate that civilian radios can be produced by Emerson within 3 months after WPB authorization.

BENJAMIN ABRAMS

(Continued on page 38)

HOME RADIO RECEIVERS

ADMIRAL CORP., Chicago, Ill.—Radios with availability of material. Admiral will have civilian radios within 90 days after WPB gives permission for manufacture.
R. D. SIRAGUSA

ANDREA RADIO CORP., New York—Advise will be ready to deliver radio and television sets for civilian use immediately we get "green light" from WPB. Because of expanding our manufacturing facilities since 1942 by over 75% and nature of communication items produced, we face no problems of reconversion.

FRANK A. D. ANDREA

ANSLEY RADIO CORP., Long Island City, N. Y.—Estimate 4 months required after WPB authorization before start of our civilian radio delivery.

ARTHUR C. ANSLEY

AUTOMATIC RADIO MFG. CO., Boston, Mass.—Under present abnormal conditions, even with WPB authorization, radios would not come off production line for 4 months from "go ahead signal." However, with proper planning between WPB and parts manufacturers this period could be cut materially.

Receiver Situation

Some sharp cut-backs, particularly for the smaller companies in the radio-electronic field, may result in home receivers being in dealers' hands late this summer. The reconversion picture in this field had already changed considerably from its original pattern. Sets may be produced this year under the Spot Authorization plan as material not needed for military requirements becomes available.

division of WPB in taking action now similar to action taken by the automotive and refrigerator groups. If the radio program for domestic production now was authorized, production would be available only when these components were made available. If all components are available, our company can be in production of some models within 30 days. Sets with FM cannot be produced until the FCC decides on frequency allocation.

R. C. COSGROVE

ELECTRONIC CORP. OF AMERICA, New York—Circuits, models, sales and distribution plans lined up at present time. Our workers are fully trained; production lines have been laid out and advertising and promotion campaigns are ready to go. We estimate that we will be able to ship

Allocations Delay

Since many receiver makers had planned to bring out FM sets before FCC announced its allocation delay, industry leaders' opinions vary as to the probable effects of FCC's decision upon the civilian set market. Some authorities declare that comparatively high-priced sets, "combinations," etc., can be sold in considerable volume without the FM feature, and feel that the dollars-and-cents sales total in a war-time market would still be satisfactorily high. Others feel that the set unit sale, if and when war-time civilian receiver manufacture commences, will be low, and that most of the makers will bring out small sets at reasonable prices.

Bound for Main St.!

Us They Are Getting Ready!

duction of war materials, America's radio and appliance manufacturers are poised for rapid re-conversion. • Radio & Television Retailing has asked a number of leading radio and appliance manufacturers for estimated opinions on how soon after receiving authorization from WPB they will have products ready for the civilian market. The response is not only enlightening, but is most encouraging. Wires have poured in from all over the country, and excerpts from the messages are published in this article. The answers prove in a telling fashion just how close the nation's manufacturers are to the civilian goods situation.

ELECTRICAL HOME APPLIANCES

(Laundry Equipment, Refrigerators, Ranges, Cleaners, Traffic Appliances, etc.)

ADMIRAL CORP., Chicago, Ill.—Refrigerators and ranges—Admiral expects to have refrigerators and ranges within 120 days after WPB gives permission for manufacture.

R. D. SIRAGUSA

AUTOMATIC WASHER CO., Newton, Iowa—Resumption of civilian manufacturing limited only by our ability to secure raw materials. Heavy war contract cancellation eliminates any reconversion problems in our own plant.

W. NEAL GALLAGHER

BARTON CORP., West Bend, Wis.—We probably will be able to get into limited production within 60 days after we receive the WPB authorization. This, of course, will depend to a large extent on the position of our suppliers. Many items such as cartons and crates especially, may be on the critical list for sometime longer.

A. H. LABISKY

COOLERATOR CO., Duluth, Minn.—Will require approximately

90 days after WPB release to get into civilian production.

JOHN H. GANZER

COROAIRE HEATER CORP., Cleveland, Ohio—Sixty days.

A. W. CONLEY

CROSLEY CORP., Cincinnati, O.—See reply listed under Home Radio Receivers' section.

DUO-THERM DIV. MOTOR WHEEL CORP., Lansing, Mich.

—We have been in production for 9 months. Can materially expand production within 60 days after authorization.

K. EGELER

ELECTROMASTER, INC., Detroit, Mich.—Necessarily future plans depend on many variables. We have hopes of producing in limited way about 90 days after getting go-ahead. Within 6 months after start expect to be in reasonably full production. Again everything depends on such variables as manpower also securing of materials.

GERALD HULETT

ESTATE STOVE CO., Hamilton, O.—Expect to have products available for civilian market 60 days after WPB authorization.

S. C. BERNHARDT

EVANS PRODUCTS CO., Detroit, Mich.—Expect to start shipping space heaters and water heaters in July.

F. W. MUNRO

EUREKA VACUUM CLEANER CO., Detroit, Mich.—Due to shortage of critical materials no definite date can be determined at this time.

G. T. STEVENS

FRANKLIN - McALLISTER CORP., Chicago, Ill.—After we receive go ahead, it will be a question of how quickly our suppliers can furnish us necessary material, etc. Upon receipt of all supplies, we can get into production immediately. Notwithstanding this is new model, we use same principles that were so successful in our pre-war cleaner, and much of our tooling is already done.

H. J. McALLISTER

FRIGIDAIRE DIV., GEN. MOTORS, Dayton, O.—Our best guess is that some products will be available sometime this fall. Regarding electric ranges, we have been permitted to build a few thousand and expect to receive authorization to build another limited quantity. For several months we have been building a limited

Some Answers Too Late

A number of responses from manufacturers were received too late for publication with this article. We thank the senders, nevertheless, and regret that existing facilities did not permit us to include their contributions.

number of commercial refrigeration compressors and cooling units subject to sale on priority basis. Priority restrictions on this commercial refrigeration equipment are now removed, but our ability to fill un-rated orders depends entirely upon

(Continued on page 38)

HOME RADIO RECEIVERS (Continued)

ESPEY MFG. CO., INC., New York—It appears that time lag between the WPB authorization and radios on the retailers shelves is entirely dependent on component manufacturers, including cabinet sources. As our internal reconversion poses little problem, my best estimate is 60 days.

HAROLD SHEVERS

GAROD RADIO CORP., Brooklyn, N. Y.—Estimate that we will be ready to deliver civilian radios approximately 60 days after WPB authorization.

M. W. WEINTRAUB

GENERAL ELECTRIC CO., Bridgeport, Conn.—Your question cannot be answered directly since it depends upon performance of component parts manufacturers. Assuming no delay on this account, we could probably produce some models within 30 days after WPB release.

I. J. KARR

HOFFMAN RADIO CORP., Los Angeles, Cal.—The length of time it will take us to get products on the market after release by WPB is entirely predicated on the time it will take to get components and ability to deliver components is entirely contingent on the war load. If the release is made within the next 4 months it undoubtedly will take 3 months after the release before any sets are on the market.

H. L. HOFFMAN

MAJESTIC RADIO & TELEVISION CORP., St. Charles, Ill.—Presuming that the component parts manufacturers can make rather prompt initial deliveries, Majestic can begin to reach the civilian markets 60 to 90 days after WPB authorization.

E. A. TRACEY

JOHN MECK INDUSTRIES CO., Plymouth, Ind.—Will ship large volume on a restricted number of models within 60 days after release of restrictions by WPB. Could produce approximately 2,000 radios a day, within 60 days of the resumption of unlimited civilian production.

JOHN MECK

MEISSNER MFG. CO., Chicago, Ill.—We expect to have some products ready for civilian market within 30 days after WPB authorization. Other products will require from 30 to 90 days depending upon our ability to secure necessary raw materials.

O. F. JESTER

TIME BREAKDOWN

How soon after "green light" manufacturers estimate they will have products ready.

RADIOS

30 days	10%
6-9 weeks	5
30-90 days	5
60 days	24
60-90 days	14
90 days	27
120 days	15

APPLIANCES

30 days	18%
30-60 days	4
30-90 days	5
60 days	23
60-90 days	4
90 days	19
90-120 days	5
120 days	4
6 months	13
6-9 months	5

NOBLITT-SPARKS INDUSTRIES, Columbus, Ind.—We estimate some Arvin products will roll off the production line about 60 days after WPB authorization and materials are available.

G. W. THOMPSON

RCA VICTOR DIV. OF RCA, Camden, N. J.—Present indication is first sets will be coming off production lines approximately 90 days after we receive WPB authorization, provided component parts and skilled labor are not bottlenecks. We still have large army and navy commitments and RCA's long standing policy gives the war program first priority.

FRANK M. FOLSOM

REMLER CO., LTD., San Francisco, Cal.—We can be in production on civilian electronic end equipment within 4 months after receipt of WPB authorization.

E. G. DANIELSON

E. H. SCOTT RADIO LABS., INC., Chicago, Ill.—Within a minimum of 60 days we can have complete sets ready for some shipments to our selected dealers. A maximum time required would be 90 days.

WILLIAM S. HILTON

SONORA RADIO & TELEVISION CORP., Chicago, Ill.—After WPB authorization and availability of component parts for civilian production of radios, we can start production in from 6 to 9 weeks from such date.

JOSEPH GERL

TEMPLETONE RADIO MFG. CORP., Mystic, Conn.—Relative to production of civilian radios, we expect to make some shipments approximately 90 days after WPB authorization.

OSCAR DANE

WESTINGHOUSE ELEC. CORP., Sunbury, Pa.—Providing WPB authorization comes simultaneously with termination of war contracts, our facilities could be converted within 90 days.

GEORGES FAURIE

ZENITH RADIO CORP., Chicago, Ill.—We could have Zenith sets available for the civilian market within 60 days after WPB authorization.

H. C. BONFIG

ELECTRICAL HOME APPLIANCES

(Continued)

the availability of materials and labor to increase manufacturing schedules.

J. F. PEDDER

GENERAL ELECTRIC CO., Bridgeport, Conn.—See reply listed under Home Radio Receivers' section.

GENERAL MILLS, Minneapolis, Minn.—Our first appliances will be ready for the consumer market within 6 to 9 months after WPB authorization. According to present plans those items will be two models of Automatic Irons and one or two sizes of non-electric pressure saucepans. Other items will follow as rapidly as our development and reconversion programs permit. Our plant and other plants in this are still busy with war production.

JOHN A. SULLIVAN

ELECTRICAL HOME APPLIANCES

(Continued)

GRAND HOME APPLIANCE CO., Cleveland, O.—Plant completely converted to civilian production currently producing limited quantity Grand gas ranges. All we require for large scale production is sufficient raw materials and several hundred workers, plus authority from WPB to proceed full speed ahead.

W. L. MARSHALL

HAMILTON MFG. CO., Two Rivers, Wis.—Production of clothes dryers is still restricted, and it is rather difficult for us to tell you just how soon after present restrictions are released, we will have dryers ready for distribution. Quite a few of the parts required for the production of the dryer are considered critical, and it might be several months before we could get delivery on them. Therefore, our guess is that we might have dryers within 6 months to a year after present restrictions are released.

R. S. SCHEUER

HEALTH-MOR, INC., Chicago, Ill.—Our estimated opinion: we will be able to fully supply tremendous demand for Filter Queen sample units to the thousands of dealers now franchised by our distributors, within a 60 to 90 day period after we have WPB authorization to resume manufacturing.

A. E. KRAMER

HORTON MFG. CO., Fort Wayne, Ind.—Assuming that all raw materials will be available as and when the green light is given on the resumption of civilian production of washers and ironers, Horton should be in limited production from 30 to 60 days after the wheels start turning.

E. A. JORDAN

IRONRITE IRONER CO., Detroit, Mich.—We estimate we can produce ironers within 90 days after WPB approval providing material can be obtained.

W. R. DABNEY

MALLEABLE IRON RANGE CO., Beaver Dam, Wis.—How soon after WPB authorization will Monarch ranges be available for

civilian market is the \$64 question and I'd prefer to take the \$32. Monarch ranges and all makes of ranges require steel, porcelain products, oven temperature controls and other component parts, and production depends entirely on our ability to get the necessary materials. The war in the Pacific will control deliveries of the materials. We intend to continue furnishing goods for the Armed Forces, and all manufacturers will do likewise so as to save lives of our fighting men. Production of civilian goods can start in our plant in less than 30 days, subject to the above conditions.

M. J. MAIER

UP-TO-THE-MINUTE RADIO APPLIANCE PICTURE —SEE PAGE 119

MANNING-BOWMAN, Meriden, Conn.—Believe we can develop limited production within 90 days after release of material and labor. Will take from 9 to 12 months after all restrictions are removed for maximum production.

A. L. WILKINSON

MAYTAG CO., Newton, Iowa—Regret account uncertainties of reconversion and lack of information as to formula of return to civilian manufacturing, we are unable to make any statement.

ROY A. BRADT

NOBLITT - SPARKS INDUSTRIES, Columbus, Ind.—See reply listed under Home Radio Receivers' section.

NORGE DIV., BORG-WARNER CORP., Detroit, Mich.—In a news release, Howard E. Blood, president, says: "Given prompt priority assistance in material acquisition, Norge can begin building washing machines in a few months."

ONE MINUTE WASHER CO., Kellogg, Iowa—We do not contemplate a plant reconversion problem. Time required to produce one minute washers after WPB authorizes resumption of production will depend upon availability of material and labor.

C. BASSETT

PREMIER DIV., ELECTRIC VAC. CLEANER CO., Cleveland, O.—After WPB authorization, it would appear that we should be delivering Premier vacuum cleaners within 30 days after receiving the green light from the government agency.

E. R. BERKELEY

PROCTOR ELECTRIC CO., Philadelphia, Pa.—Limited quantity of Proctor irons is being produced at moment for civilian market and we hope to reflect additional releases in our production within 90 to 120 days after authorization is received.

H. S. PERKINS

ROBERTS & MANDER STOVE CO., Hatboro, Pa.—Due to early completion of certain war contracts portion of plant already reconverted and civilian production on quality gas and electric ranges now under way in appreciable quantities. Can continue remaining war work and fully reconvert to peacetime levels within 60 days after WPB authorization due to plant and equipment improvements.

R. S. AGEE

SEEGER - SUNBEAM CORP., St. Paul, Minn.—Relet: 6 months for household refrigerators; longer for other items.

R. M. REAY

SWARTZBAUGH MFG. CO., Toledo, O.—Subject to receipt of materials on order, and no restrictions by local manpower authorities, we can resume civilian manufacture within 30 days, but our guess is that it will require 90 days to reconvert and start shipments of any consequence.

J. B. SWARTZBAUGH

VIKING MFG. CORP., Dayton, O.—Anticipate shipment civilian orders 30 days after the WPB authorization, assuming WPB enables material and manpower.

P. B. PATTON

WESTINGHOUSE ELEC. CORP., Mansfield, O.—Electric Appliance Division has as yet received no releases to build consumer durable goods. Time and quantities to produce them will vary depending on production. Probably 6 months is good average.

DORA TALCOTT



This attractive, well-lighted store-front and eye-catching display are good attention-getters.

Future Volume Insured by Aggressive Merchandising Linked to Expert Service (See Front Cover for this Dealer's Store Location.)

sold the most Bendix washers in the state of New Jersey—and this list included “chain” store competition.

Marks attributes this splendid merchandising record to two factors: (1) Department stores divided their effort among several lines; (2) The Radio Sales Corp. placed the emphasis on rendering excellent service on the goods which it sold. The store's sales area covered a 15 mile radius, and that, coupled with good service, may explain why its appliance sales volume mounted. One-third of all the volume transacted at this establishment stems from satisfactory service on appliances.

When new appliances are once more available, some people may be reluctant to part with their old and obsolete refrigerators, washers, etc., this merchant feels. This may be particularly true, he believes, if a customer has spent a considerable sum on repairing worn equipment.

To illustrate precisely what he means, Marks saves the few small appliances, which he receives in infrequent shipments, until he has accumulated a number of these items.

Strategy in Appliance

• “The dealer who will get the business in the postwar competitive market,” declares Milton Marks, president of the Radio Sales Corp., 327 Millburn Ave., Millburn, N. J., (see illustration on front cover) “will be the one with the best sales argument and the best-equipped organization. ‘Catch-as-catch-can’ merchandising will be catastrophic for some dealers,” asserts this radio-appliance retailer.

Keeps Priority List

Basing his statements on his own long and practical experience, Marks is prepared to carry his own suggestions into actual operation. With the prospect of civilian merchandise approaching closer, now that victory in Europe has been achieved, this mer-

chant is getting set to throw his merchandising operation into high gear.

In order to distribute his first shipments of appliances fairly, Marks maintains a priority book, in which are listed those customers who will receive new merchandise as soon as it is available. The prospective purchasers listed are preferred customers, who were chosen with great care and discrimination. Only customers who really *intend to buy*, and who *genuinely need* new appliances, are recorded in the book. The names are listed in the order in which they were received.

Prior to Pearl Harbor, the firm did an outstanding volume of business in appliances—particularly, washing machines. This establishment was one of the five stores which

Upon offering the goods for sale, the public response is not what had been anticipated, as, even today, consumers are cautious and hesitant in buying.

Deplores Dishonesty

It is apparent that appliance merchandising will be of a highly competitive nature when goods are once again available in quantity. In the days to come, this merchant maintains, “second story dealers,” “surplus houses,” and “cut rate artists,” offering extravagant and unreasonable discounts or trade-in allowances on appliances, will represent a threat to established radio-appliance retailers.

In order to combat this menace effectively, Marks suggests that dealers, distributors, and manufac-

turers combine their efforts for their mutual benefit. In that way, the unethical merchant will be forced to abandon his practices.

In addition to doing a sizeable volume of business in well-known brands of radios, before the war, this organization did an excellent job in constructing and merchandising custom-built radio-phonograph combinations. When an order was received for a make-to-order set, this retailer, or his technicians, would visit the prospective purchaser's home to determine the acoustical nature of the room in which the combination was to be placed. Also, the set would be constructed to emit sound at a pre-determined pitch, in accordance with the purchaser's wishes.

These radio-phonograph combinations retailed from \$250 to \$450, and represented a very profitable phase of this firm's activities. The gross volume from selling custom-built receivers reached large proportions annually, before the war curtailed this operation. When conditions permit, this organization definitely plans to continue this part of its business.

Ads Attract Interest

Advertising occupies a prominent position in the firm's merchandising set-up. The store is advertised weekly in the community's newspaper, and also in the local high school's paper. Marks spends approximately \$750

Selling

yearly on newspaper ads, and about \$100 annually in scholastic advertising. The latter form of publicity, however, is primarily a builder of good-will.

One way to make a person read a newspaper advertisement, the Radio Sales Corp. has discovered, is to have something wrong in it! In error, the firm once ran an ad in which a typographical mistake had been made. The ad brought an immediate response, as many persons hurried to the store to inform the proprietor about the oversight.

In the next ad which the organization inserted, the error was repeated—this time intentionally. To draw attention to the advertisement, the firm offered an inducement to com-

(Continued on page 96)



▲ While concentrating on radio and appliance repairs, the firm is also doing a major selling job in records. The bulk of the disc business today is in populars, but Marks, shown above, sees profits in library builders in the days ahead.

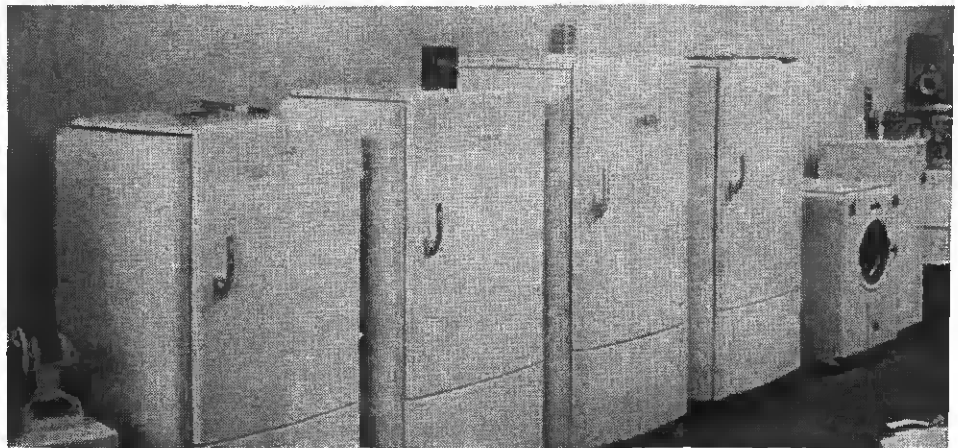

▲ The large volume of business done in major appliances pre-war is attributed to giving first-rate service. ▼ Sheet music and housewares build traffic and boost volume. Due to intensive selling, washer sales were particularly good at this establishment prior to the war.



Open Display

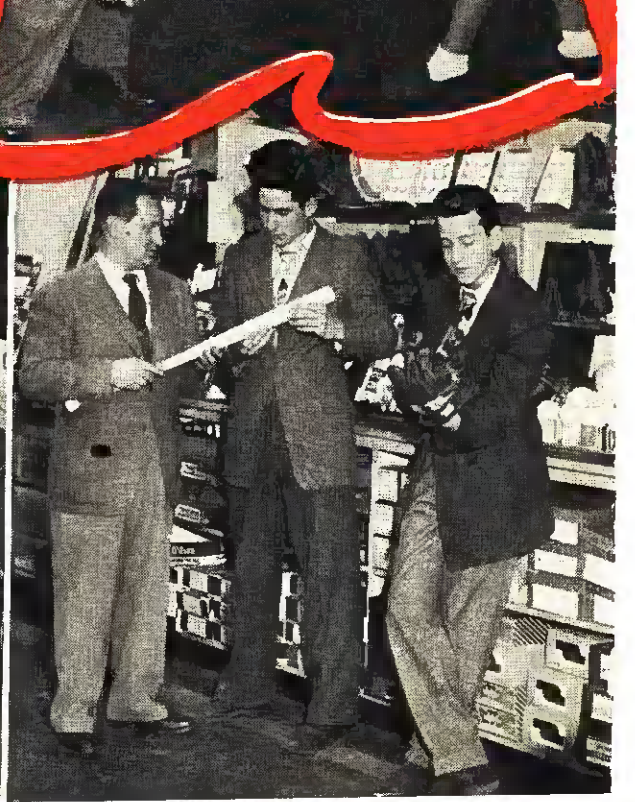

Increases Sales

Penn. Merchant Uses New Sales Methods. Finds People Buy What They Can See. Bright Interior Attracts Interest

• "The 'traffic item can make that extra sale for you" is Louis Pincus' opinion. And combining this belief with the best features of display, he is able to sell more merchandise in his store at 5520 Germantown Ave., Germantown, Penn.

People are more likely to buy if they can see the merchandise, he claims, and it is around this principle that he has built his new store interior, one of the first of its kind in his community.

Basing his theories on actual fact, Pincus has built his new store around the theme of open display, which backed by the right amount of salesmanship, moves merchandise and effects a good rate of turnover. And, in these days of shortages of merchandise, a competent and attractive dis-

Record department proves open display and inviting store interior are strong selling factors. Young people make it their record-buying headquarters. Photos at left also show other departments at Pincus' where open display is applied. Louis Pincus, upper left.

play of all products for sale is an eye-catcher to trade, of itself.

"It worked so well with records," continued Pincus, and that's what gave him his idea about display for all stock.

Every part of the new interior plays its role in creating more sales. Limed oak trim and light colored asphalt tile floor, plus cream painted wall surfaces, all combine to make the interior bright. Specially placed indirect lighting fixtures give plenty of "viewability" to all merchandise on the wall shelves. Island counters hold current traffic makers, such as darts, small games, novelties and various small items for the home, which the householder so often needs and frequently forgets when he is in the store, unless they are called to his attention.

With this same principle in mind, Pincus plans a new store front to complete his new set-up.

This new front (see diagram on page 96) will feature full-vision plate

glass windows and glass double-entrance doors. The rest of the front will be colored glass brick and will include a wide horizontal window on the second story for further display of large radios and appliances. Pincus likes the idea of this additional display space because the merchandise in this window can be seen by passers-by on the opposite side of the street.

Modern Materials

Aluminum sash and sills will be used and will match the aluminum letters of the store name on the building's front "Pincus—Radios, Records, Appliances, Sport Goods." The letters will be illuminated from behind by neon lights.

As to advertising, Pincus believes that actions speak stronger than words. He feels that a well arranged store with a thoroughly attractive exterior and interior gives a feeling of reliability to an establishment that the buying public will see and appreciate. If an individual is going to spend a sizeable sum for a reliable product he wants to purchase it from an established and successful merchant whose operation methods and place of business both indicate his reliability as a retailer in the community.

Seeks New Ideas

A tremendous amount of thought has been put behind all these developments at Pincus'. This dealer has put a lot of thought and purpose into all his preparations for the postwar market. He is tireless in his trips to any localities where merchandising may be seen at its finest. He observes the way other merchants handle their problems of location, store set-up, interior display, etc. He attends all the distributor and manufacturer meetings that he can find time for. He is always ready to investigate a new idea or a new way of doing business.

It is Pincus' aim to make his store the liveliest one in town, and he believes he is doing just that!

Before the war, Pincus specialized

(Continued on page 96)



A portion of dealer Pincus' radio and electrical home appliance grouping. He maintains his identity with this merchandise today through radio and appliance repair and by sales of available "related" lines.



▲ Luggage is a new line, and will be retained by this dealer after the war. ▼ Section reserved for traffic appliances. Heaters, coffee-makers, cocktail sets, lamps and bottle-warmers now fill this space.



Retailers Ready to

RADIO

APPLIANCES

RECORDS

MERCHANDISING

SERVICE

FM

PHOENIX, Ariz.—Norman Hendry, proprietor of the Dependable Radio and Electronics Co., 1635 West Jefferson St., has his future plans carefully mapped out. "Choosing our line, we shall stick to one or two leading name brands that have proven successful through the years, plus one or two newcomers that have the qualities of success indicated in their technical and management background. By balancing between new producers and old producers, we should get a winning combination," Hendry says.

Hendry found that in Phoenix, where industrial growth had brought so many newcomers, word of mouth recommendations by customers were a strong factor in business growth. In addition, Hendry is the first president of a newly organized radio dealers club of this city.

PHILADELPHIA, Pa.—The policy of Passon's Inc., radio appliance merchandisers at 507 Market St., (see picture below) is based on the solid foundation of giving the customer a square deal. Sam Passon, the treasurer of the organization, declared that the firm operates on a money back guarantee, with no questions asked, if a customer is dissatisfied with his purchase. This, according to Passon, is one reason why the firm has been doing such a successful business since 1917.

Prior to the outbreak of hostilities, the store sold a complete line of radios, and major and table appliances, in addition to its large line of sporting goods. At

the present time, radio servicing, sales of records, and sporting equipment are shouldering the burden of maintaining the establishment's volume at a satisfactory level.

For advertising and publicity, the firm frequently places ads in the city's newspapers, and also sponsors football, baseball, and other athletic teams. The latter form of promotion is primarily a builder of good-will.

EAST MOLINE, Ill.—When Frank De Gheselle, proprietor of the De Gheselle Radio & Refrigeration Store, 1102 15th Ave., went into the automotive parts business 25 years ago, he little dreamed that he would eventually go into the electrical appliance field. Twelve years ago, De Gheselle took on lines of radios and appliances, and has done well with them ever since.

This merchant did not drop the auto parts line completely, and even today he still retains some of this merchandise. Items such as spark plugs, auto polish, etc., are part of his regular lines. Prior to the war, he sold several well-known makes of receivers and appliances, including Philco, Motorola, Westinghouse, Speed Queen, etc.

An unusual article which this radio-appliance dealer merchandises is the outboard motor. De Gheselle has done very well with this item in the past, and definitely plans to sell it when it is once more available.

JAMAICA, N. Y.—William Still, owner of Jamaica Radio & Television, uses a 12" oscillograph to attract attention to his show windows. A sign invites the passerby to speak into a microphone, mounted on the frame of the window, and see his voice "oscillographed." This microphone is connected to a high-gain amplifier. Still's experimental television station W2XJT, is scheduled to go on the air 15 hours a week, commencing June 30.

BELLAIRE, Ohio—Earl J. Heil, proprietor of a radio and appliance store at 3281 Belmont St., is well known in this area. Prior to the war, this dealer carried on an active business in radios, refrigerators, washing machines, and other important items.

In 1941, when goods were still available, Heil saw the "handwriting on the wall" and took in many sidelines which help him weather this period of merchandise scarcity. Among the substitute lines which he took on were linoleum, floor waxes and polishes, bedding, coffee-makers, blankets, mirrors, all of which have aided in maintaining sales volume.

Due to the lack of skilled technicians today, servicing represents a minor phase of this retailer's business. The sidelines represent the current mainstay, and that is where Heil places most of his effort.

While this dealer will return to radio and appliance merchandising after Victory, he plans to retain most of his substitute lines. He has established a reputation as a houseware retailer, and has done so well with these goods that they will become a permanent part of his business.

INDIANAPOLIS, Ind.—In order to further their interests and to elevate their status, radio retailers and technicians in this area have banded together to form the Radio and Electronic Assn. of Indianapolis. The president, and organizer of the group, is William Jarretts, who is proprietor of Jarretts Electric Shop, 2758 Roosevelt Ave.

In the future, the association proposes to issue window stickers, which members can display in their stores in order to identify themselves with the organization.

There are 71 members in the group at the present time, but the association intends to expand by encouraging all those who are interested in improving the position of the dealer-serviceman to become active in this organization.



Sam Passon, front, waits on a record customer in his Philadelphia store. See story above.

Resume Merchandising

TELEVISION

REFRIGERATORS

WASHERS

REPAIRS

SIDELINES

POSTWAR PLANS

SAN DIEGO, Cal.—Orlando Carrillo, of Carrillo & Nelson's Radio Shop, 1543 Fifth Ave., believes in filling vacant display space in order to give his store a well-stocked appearance. Efforts at display also serve as a reminder to customers of his postwar merchandising plans. Keeping his business going with repairs, Carrillo polishes up the cabinets and table models, and then displays them effectively on the floor and in windows.

FRANKFORT, Mich.—Robert Mauseph, owner of the Mauseph Electric Co., built a display with popular appeal by placing pictures of community men in the service in his windows. At present, he has more than 150 pictures on display. Mauseph finds that he has received an increased flow of store traffic, and a resulting increase in sales and service calls since the inception of his novel display. Good-will has also been created.

WHEELING, W. Va.—Frank and Louis Marchlenski, co-proprietors of the Electric Appliance Service Co., 1009 Main St., did a good volume of business merchandising radios and appliances before the war. Among the brands handled were RCA, Stewart-Warner, Hotpoint, Thor, Gibson, Royal and other important makes. In pre-war days, merchandising of radios and refrigerators constituted the bulk of the sales, with the volume running about 50 per cent for receivers and approximately the same for appliances.

Servicing is the mainstay today for this firm, and more than enough work is on hand to keep the technicians busy. The sale of records and record accessories such as racks, needles, etc., also add to the volume of business transacted.

Most of the discs sold in this establishment are foreign records, with popular platters next in volume, and classical records also contributing its share of business. Victor and Bluebird records exclusively are handled by this firm. Before merchandising became scarce, an adjacent store was used in which records were sold. When radios and appliances vanished from the market, this establishment was closed and the stock was moved into the present location. However, future plans call for the use of both stores.

These co-owners advertise weekly in a local newspaper, and find that this publicity helps to maintain their volume of business. They are looking forward to "M Day," when they can resume radio and appliance merchandising.

DAVENPORT, Iowa—Radio repair work is going "great guns" at the Modern Radio Service, 532 Brady St. Bernard Phares, the proprietor of the store, states that he is "loaded" with servicing. Due to the shortage of radio technicians in this area, this establishment has repair work farmed-out to it from other retailers who are swamped with servicing. Phares' store features a pick-up and delivery service.

Some merchandise, such as phonograph needles, is sold by the firm. However, the emphasis is placed on service work.

ST. PAUL, Minn.—Radio Engineers Co., Sixth near Wabasha St., features in its windows an attractive display of materials used in the repair of radios. Since the shop concentrates on radio repairs, this tie-in display is valuable in bringing the attention of the passers-by to the store's service specialty.

MOLINE, Ill.—"Charge legitimate prices, give the customer a square deal, and, above all, keep him happy," advises L. P. Olson, owner of the Markee Appliance Store, 1512 6th Ave. In war or peace, this dealer's advice seems to be excellent.

With appliances virtually non-existent today, this firm derives its income from servicing refrigerators, washers, and coal stokers. Occasionally, Olson does get a shipment of these stokers, and is able to fill some of the orders—and there are many of them on hand—for this merchandise. This store has sold RCA radios, Bendix washers, Kelvinator refrigerators, Anchor coal stokers, and other well-known products in the past.

KALAMAZOO, Mich.—"Carry well-known brands of merchandise only, and render efficient and courteous service," is George Y. Miyagawa's formula for successful radio-appliance merchandising. This forward-looking dealer, who operates George's Radio and Appliance Shop, 494 W. Michigan, firmly believes that a satisfied service customer today means a radio-appliance purchaser tomorrow.

Prior to the war, Miyagawa carried a full line of leading and well-advertised brands of radios and appliances. Today, through his insistence on doing thoroughly good repair jobs, without neglecting any details, this retailer is doing a very profitable business in servicing. (Miyagawa's methods of operation were discussed in greater detail in the June, 1944, issue of this publication.)

ROCKY FORD, Colo.—Keeping the customer satisfied by giving prompt and polite service, is the policy of the radio service store operated by Amos & Co. As soon as top capacity for taking on additional repair jobs is reached, a sign is placed in the window stating that no more work will be taken in until a specified date. Honesty has definitely proven to be the best policy for this establishment, for customers are reassured, and don't mind waiting until Amos & Co. are ready for more radio repairs.

TERRE HAUTE, IND.—Harry R. Youngblood, proprietor of Harry's Radio Service, 2400 Washington Ave., is managing to get along fairly well, despite shortages, with the help of his son Owen Youngblood, and his grandson, Lyman Bedwell. "Although we have over 100 sets to be repaired, we hold up very few



Harry Youngblood, his son, and grandson at work in the repair shop.

waiting for spare parts," says Harry Youngblood, whose store has been in operation for 20 years.

Referring to the present radio situation, Youngblood explained that people allow too many amateurs to tinker with their sets. "We can tell when we get a set if it has been tinkered with," he added.

PRESTON, Idaho—Owens Baur and Clarence Kendrick are looking forward to the time when they can merchandise appliances in their newly reopened store, the Preston Electric Co. They purchased the building, and have added a line of furniture to the present stock.



Cash in Super-Service

J. H. Springer, left; J. T. Springer, right, demonstrating signal-tracing equipment built up from units. When intermittent radio

Duluth Dealers Show How They Speed Repairs — Operate Profitably Today

• The inconsistencies brought about by war are well exemplified in the sign on the front of the store of the Springer Bros., Radio Service and Sales Co., 28 Lake Ave., North, Duluth, Minn. It reads, "We are closed Monday, Tuesday, and Wednesday." But that doesn't mean that there is a lack of business. Rather, it indicates more business than the establishment can take care of in a satisfactory manner.

Customer-Confidence

The store had always maintained a service department, and through the years had acquired a reputation for turning out A-I work. Consequently, when radios went off the market, people from all parts of the

city began to bring in sets for repair, or phoned to inquire about service. "We had so many radios to repair that we were unable to turn them out within a reasonable time," said J. H. Springer, who with his brother J. T. Springer owns and is co-manager of the business.

"There were so many interruptions during our working hours that we despaired of ever catching up. Our two telephones, which formerly saved us time, now became a handicap with our lack of help. They were always ringing, taking us away from our work to answer them. Even with overtime we couldn't begin to do the work and still attend to the shop. So, we tried the experiment of shutting up shop for three days a week,

tying down our telephones and putting those three days into uninterrupted work. It was a good experiment. We are continuing the practice as long as necessary," the brothers explained.

Work Schedule

The first days of the week were chosen for closing because employees are at their best after a week-end of rest and recreation. Another reason was that Monday was only partly lost to trade, as most business houses in the downtown district do not open until noon on that day.

"A great amount of work can be done if there are no interruptions. Customers have been cooperative and understanding when we explained that the closed hours made it possible

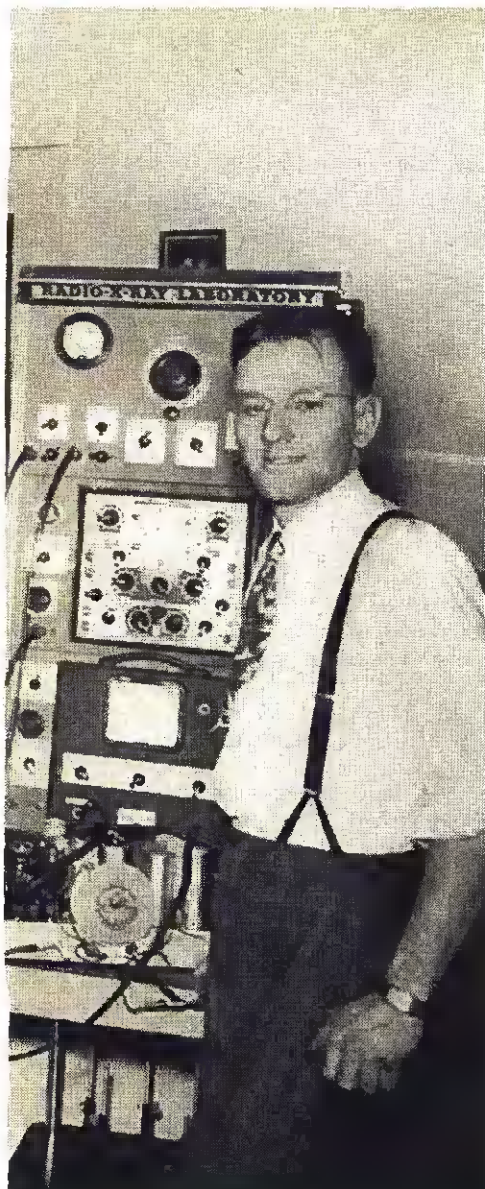

trouble appears, an audible signal is produced.

for the shop to give them better service," Mr. Springer states.

When pick-up and delivery service is desired, the Springers give it, but customers are urged to bring work in if they possibly can. A lower price on work that is not called for and delivered has been an important inducement.

Service Techniques

About two years ago, when tube scarcities developed, the store resorted to conversions, changing whole sets of tubes, but this soon put too heavy a drain on the tubes that could be procured. Now they change only one tube circuit instead of five or more. This not only cuts down labor, but leaves tubes for five other radio repairs. "We were really putting ourselves out of business by using up all our tubes," remarks Mr. Springer.

Prices for repairs are computed strictly on a time basis. The rate is the same as before the war.

Explain Charges

Conversion changes are expensive because of the time required, yet customers do not seem to mind, as long as they can have their radios put into working order. The store disarms resentment by thoroughly explaining the labor required, even telling the customer that it would rather not use this method of repair. If a customer insists, however, he has been forewarned, and thus has no cause to complain of the cost.

No radio is taken for repair unless it can be put into good working order. The number of radios piled about waiting for service attests to the confidence the public has in Springer service.

The store is in the downtown business district, where it is easy for men who work in that part of the city to bring in their sets, and to pick them up when they are ready. Now that so many hours can be devoted to uninterrupted work it is possible to estimate accurately when the job will be finished, and to give the exact day when a set can be picked up.

Store Layout

The store is interestingly laid out. The front part, formerly the show room, is reserved for radios to be repaired. At one side is a testing board and small bench for work. A railing running across the room shuts customers away from other benches, but still keeps the working part of the shop before their view. The office at the opposite side of this back section is compact and easy to work in.

Windows make up the front of the store. One is filled with radios to be repaired *today*; the other has advertising of future electric devices spread out on the floor, where the passerby may easily study "what's coming."

The Springer brothers have made no attempt to put in any other lines, as the repair work has been sufficient to keep them busy full time. Another reason is that the brothers believe the change-over to sales of new radios will be much simplified, and their immediate prospects greatly increased, if the store sticks exclusively to radio.

Solve Help Problem

So much time is required to train new help that the Springers have made no attempt to bring in inexperienced men—and they are all that are obtainable—to learn the trade. They feel that such help, during the learning period, would cause the store's standards of repair to be lowered, and result in the loss of goodwill.

Until conditions change, the short week for receiving customers will be continued, and the excellently done work will move out promptly, to the store's and customer's satisfaction.

Springer Brothers' store will be ready to sell new receivers as soon as production starts. Efficient war-time service to customers has provided them with a large prospect list.

SPRINGER SERVICE SPOT-LIGHTS

- Closes to public Monday, Tuesday, Wednesday.**
- Gets customer co-operation through fair treatment.**
- Works on time basis at pre-war price.**
- Makes most of manufacturer publicity material.**
- Repair department, out front, advertises business.**
- Customers' sets serve as window displays.**
- Set for changeover to sales.**
- Price reduction cuts delivery service.**
- Efficient store layout speeds work.**

**Dealer Takes Keen Interest in Local Affairs
Stocks Hard-to-Get Records; Recording Pays**

LOOK TO THE PROFIT

• Catering to the demand for radios, records, musical instruments and related merchandise are Paul and Ruth Hultquist, co-proprietors of Hultquist, 228 West 3rd St., Davenport, Iowa. This husband and wife team is doing a grand job in helping to fill the demands of its discriminating customers.

Give Advice on Music

Not only are the Hultquists in business to earn a profit, but they also enjoy being in the radio-music field. Mr. and Mrs. Hultquist are very much interested in music and take an active part in the community's musical activities. Both are competent musicians, and are well qualified to give advice to their customers on things pertaining to music. Purchasers of records, sheet music, and musical instruments are aided in their selection of merchandise by the Hultquists' musical training. Customers who buy classical records especially are at an advantage, as the store's

owners can "talk their language."

Mr. Hultquist has successfully organized bands for the high schools in the area. Mrs. Hultquist, in addition to instructing students in voice and the piano in the store's music studios, directs choral groups.

The record department, which is managed by Miss Dorothy Smith, is going full blast these days. Among the brands of discs which this establishment handles are Decca, Sonora, Victor, and Columbia. Classical and popular platters sell very well, but the recordings of more serious music have the edge over records of lighter music.

The firm has established a reputation as a headquarters for rare and hard-to-get discs. Recordings of viola solos and other platters of this type—which many stores do not stock—are available at this establishment.

Self-selection racks, where albums are attractively displayed, help to keep the sales of discs at a high level. Customers can browse among the

record racks and calmly deliberate before making any purchase.

For the convenience of platter purchasers, three record listening booths are provided where the benefits of recorded music can be best appreciated. Two of the listening stations are employed mostly for the playing of popular records. The third booth is located in a separate room, where serious music can be fully appreciated, away from noise or other distractions. Lovers of classical music find this store an excellent place to do their record purchasing.

Recording Studio

An important adjunct of the Hultquist establishment is its recording studio. Recordings are made in a separate room, located on one side of the main floor. Most of the people who record are vocal students, who use the discs to keep a constant check on their progress.

Added revenue in recording is obtained from cutting discs from other

Left, many music students make recordings at this store. Co-owner Mrs. Hultquist, at piano, plays the accompaniment, and is qualified to give advice on musical matters. Center, most of the "war goods" taken in by the firm may not be kept in the future. Music boxes, however, retailing up to \$13 do well. Right, record department manager, Miss Dorothy Smith, hatless, waiting on customers. Classical discs lead at this establishment.



PICTURE



View of store interior showing neatness of layout.

records for customers who want additional copies of platters they already have. This store charges 75 cents for making a recording on a six-inch disc, \$1.50 for cutting an eight inch platter, and \$3 for making a twelve inch record.

Among the items that have been consistently good sellers are music

boxes. These articles, retailing up to \$13, have done very well, and the firm will probably keep this line after the war. Many radio and music establishments, in addition to Hultquist, have been successful with music boxes, and dealers may find this merchandise a profitable postwar line.

Until recently, this store advertised frequently over the local broadcasting station, but due to difficulties which arose in presenting the radio advertisement, this form of promotion was discontinued.

The firm did engage in some forms of promotion in the past, but with the lack of merchandise and manpower, the Hultquists feel that there is no need for extensive advertising at the present time. However, after "V-J Day," when keen competition among radio merchandisers once again sets in, these dealers, like most others, may be forced to demonstrate their merchandising skill.

In addition to its advantageous location, attractive window displays, which are frequently changed, demand attention and succeed in drawing customers into the store.

The Hultquists have done a good business in radio and music in the past. Their proven business ability seems to indicate that even brighter days lie ahead for these merchants in the days following Victory.



Variety Keynotes

**Music for Every Mood Makes
Summer Sales for Alert Dealers**

• Languorous summer days fast approaching should be busy record-selling days for active retailers.

Public's approaching vacationtime will bring leisure for summer relaxation, the opportunity for enjoyment of popular and the lighter music.

Manufacturers have done a good roundup of variety discs for this coming season. Live dealers will have plenty of variety to offer their customers.

Decca has readied its "Louis Armstrong Jazz Classics" album, Brunswick-1016, in line with the current trend toward hot jazz. Included are many favorites, among them "Wild Man Blues," "Static Strut" and "Santa Claus Blues."

Next on the Decca list for good summer listening is album A-395, "Up In Central Park," the Sigmund Romberg music which is a current smash hit on New York's

Broadway. Dealer promotion pieces available on request include 30 x 31" easel-backed blowup in 2 colors for window display, 10 x 20" three-color streamer, counter card reproduction of album cover, and 1, 2, and 3 column mats for newspapers.

Singles include 23414—Carmen Miranda—"Tico-Tico;" Bing Crosby and Louis Jordan—"Yip Yip De Hootie," 23417; Guy Lombardo—"Bell Bottom Trousers," 18683.

Josh White, now appearing in a new Broadway show "Blue Holiday" is on Decca disc 23416, "Beloved Comrade," done in the real American folk song manner.

Jimmy Savo is loose on a new Decca platter with "One Meat Ball," 23415.

Something very different is Decca's new album DA-386, "The Snow Goose" featuring Herbert Marshall with supporting cast in a dramatization with sound effects of the famous story by Paul Gallico. Promotion available on request.

To complete Decca's introductory



Top, Louis Armstrong, popular recording artist, is featured in Decca's new Brunswick album, "Louis Armstrong Jazz Classics," and in one of Victor's "Hot Jazz" albums. Below, Columbia's Harry James has waxed some new hit tunes from the New York musical "Carousel"—"It I Loved You" backed by "Oh Brother."



Summer Records

summer variety offering is album A392, Johann Strauss Waltzes for Dancing.

Columbia's June offering is also on the vacation-days beam. Excellent range of choice is suggested by "Gotta Be This or That," Columbia 36813, Benny Goodman in a tune specially written for him. This is a two-sider.

Another lively Columbia disc is "If I Loved You" from the New York hit musical "Carousel," 36806, featuring Harry James. Flipover "Oh Brother!"

Kay Kyser and his orchestra have done a disc of "Bell Bottom Trousers" on Columbia platter 36801.

Frankie Carle has waxed Columbia 36805 "Counting the Days" and "Missouri Waltz."

"Stars and Stripes on Iwo Jima," Bob Wills and his Texas Playboys, Okeh 6742, should afford plenty of window display possibilities in connection with the Seventh War Loan drive.

June Masterworks include Rach-

maninoff's Symphony No. 2 in E Minor, Rodzinski conducting the Philharmonic-Symphony Orchestra; and Lalo's Symphonie Espagnole with Eugene Ormandy and the Philadelphia Orchestra.

Victor announces its first on the summer list: album "A Vladimir Horowitz Program" and Rubinstein's "Piano Music of Claude Debussy" album. The list also includes Toscanini's Wagnerian symphony recording of "Prelude" from "Lohengrin," showpiece album of Ravel's "Daphnis and Chloe," and a Boston "Pops" recording of Mendelssohn's "Fingal's Cave" overture.

Later in June Victor will have ready Jose Iturbi's performance of Chopin's "Polonaise." On the lighter side, Victor has
(Cont'd p. 119)



▲ Victor's new artist, Martha Stewart, signed for populars, was formerly with Glenn Miller, Claude Thornhill and Jerry Livingston, and on the radio program "All Time Hit Parade."

◀ Peggy Lee, talented North Dakotan who now makes her home in Hollywood, records for Capitol. Her latest: "What More Can a Woman Do" and "You Was Right Baby," No. 197.



Sun, sand and summer tunes on discs! Today's war-time travel restrictions will mean more vacations-at-home with occasional short trips. Music will enhance these summer pleasures.

Note for Record Sales!

With FM delay, radio-phono combinations loom as the chief high-priced sets between manufacturing authorization date and FCC's final decision!



There is no lost motion at Ostasiewski's store. Every moment counts with this dealer.

Rapid-Fire Servicing

• "Service with a capital S" is the slogan of Walter's Radio Service, 3219 Guernsey St., Bellaire, Ohio, under the direction of its competent proprietor, Walter Ostasiewski.

On an average, this dealer and his assistants repair between 200 and 220 sets per month, and very often 9 receivers a day are brought into the store.

In an effort to accelerate the time required for turning out a completely serviced set, Ostasiewski has adopted a mass production technique.

All radios which need the same type of repair work are grouped together. Receivers that come into the store are placed on the work bench twelve at one time. All resistors of one type in need of soldering are given this attention. When this operation is completed, resistors of another kind are given the soldering iron treatment down the line. Then other parts in all twelve sets which require work of a particular nature are attended to.

Operates Two Vehicles

This merchant maintains that his firm is the only radio store in his vicinity which will pick up and return receivers. For this purpose he employs a car and a truck. The car takes care of smaller sets while the larger vehicle calls for and delivers console models.

The Walter's Radio Service opens its door to the public every morning at 9. It remains open until 5 o'clock in the evening at which time the

WALTER'S METHOD OF OPERATION

He has an excellent store location in a heavy traffic area.

Picks up and delivers.

Uses production line methods.

Makes some hard-to-get parts.

Keeps long working hours.

Runs weekly ad in newspaper.

technicians go out for dinner. After meal hour, work is continued on radios until 11 P.M. However, from 5 P.M. until closing time, the store is closed to the public, permitting the servicemen to work undisturbed.

As a further aid to fast and efficient repairing, Ostasiewski occasionally makes his own parts, winds his own coils, and does similar jobs.

The shortage of tubes is causing the owner of this radio establishment a good deal of difficulty, as it is with almost all dealers throughout the country. Added to this problem is another—scarcity of batteries—which affects some parts of the nation. As many set owners in this area are rural dwellers and farmers who do not have electrification, there are a great

many battery-operated receivers in this locality.

A strong merchandising point which the firm has in its favor is its location. The store is situated directly opposite the post office, and is in constant view of the people who use that government building.

Window Display "Pulls"

To make the most of its excellent location, the owner of this radio firm keeps a constant display of console radios in his windows. These receivers, which were left at the store for repairs, succeed in advertising the establishment, and have a definite "pulling power" which draws customers into the store.

Ostasiewski does not depend solely on his window display to attract attention to the fact that he is servicing radios. Once every week, he inserts a 5-inch advertisement in one of the community's newspapers. This has consistently proven to be a worthwhile investment which has brought good results.

This dealer has seen service in the Army Signal Corps. The additional knowledge and experience gained from this time spent with the armed forces should prove of material value to him.

Many radio dealers feel that radio servicing will be more important than ever in the days to come. If this is true, then Walter's time-proven ability should be a great asset in bringing in additional profits in the future.

RECORDIO ...
... then RECORDIO DISCS
and *Recordioint* NEEDLES

"BALANCED COMBINATION"

Here is the "balanced combination", RECORDIO DISCS and *Recordioint* NEEDLES--so necessary for achieving those better results... those thrilling tones of pure naturalness in your recordings, faithfully reproduced for everyone to hear and compare.

WILCOX-GAY engineers who made a miracle come true when they designed the RECORDIO, first successful home recorder, have made available this "balanced combination" for everyone desirous of superb tone quality in their recordings.

As dealers in sound and sound equipment, why not take advantage of selling merchandise which stays sold... because its truly "sound engineered". All RECORDIO PRODUCTS are available to you through your distributor.

"SELL RECORDIO ACCESSORIES for MORE PROFIT IN YOUR POCKET"



RECORDIO

Recording instruments for home, commercial and professional use.

MANUFACTURED BY
WILCOX-GAY CORP.
CHARLOTTE MICHIGAN
U. S. A.

"Let's Look at the Record!"

Dealer in Discs Keeps Close Tab on Turnover. Sees Big Album Future.

• Today's young industrial workers and "bobby sockers" will be the home-builders of tomorrow is the contention of the Sherry brothers, owners of Sherry Radio, 1805 Park St., Hartford, Conn.

Located in the Parkville residential section of Connecticut's state capital, these merchants are already well represented in their community as radio receiver repairers and record sales headquarters for this rapidly growing home community.

They will add refrigerators, radio sets and table appliances to their sales efforts as soon as these units are obtainable.

Records to Stay!

Meanwhile, these retailers are doing a first-class job in record sales. Nor do they intend to drop this line when the war is won. They will definitely retain it, and expect to sell many more discs and albums, in particular, when record players and radio combinations come back to the sales floor.

A firm believer in the benefits of the self-service method of record selling, Harold Sherry has given very careful thought and attention to his record groupings.

His major classifications of the classical singles and albums are: symphonies, concertos, opera, rhapsodies, sonatas, suites, overtures, chamber music.

The singles and albums in the popular and lighter ballad divisions are set up alphabetically by artist, and under each artist's grouping the discs are arranged by song title. "This keeps Crosby and Sinatra at different ends of the tables," laughed Harold Sherry, "and gives them an even play!"

Perpetual inventory is kept by card record, and is a constant indicator of the public's ever-changing tastes and musical trends, and is a most helpful guide to selection when re-ordering or buying new stock.

The Sherry method is to arrange this card index by catalog numbers. Each card carries the number of the

disc, preceded by the initial of the company who makes it. Next is given the size of the record—12 inch or 10 inch, etc. Price, exclusive of tax, follows.

Next is recorded date album or single disc was received and date sold. Hence, every disc or album has this complete information on its own card.

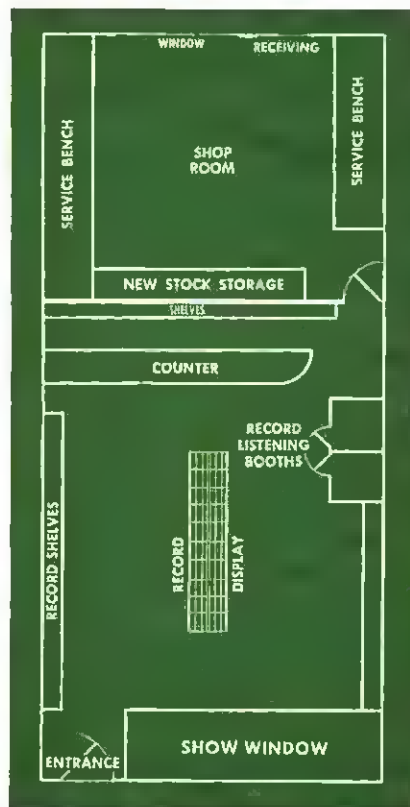

Simplicity is the keynote of this ample store layout. Through use of movable record fixtures, floor space is reserved for additional display of radios and refrigerators.

"Let's look at the record" is one of the best ways, Sherry claims, to find out whether a disc or album really went over with his buying customers.

Victor Red Seal, Columbia Masterworks, Decca, Okeh and Bluebird discs and albums are carried, and the Sherry brothers find that this variety of stock pretty well covers all requests.

Two record listening booths, which the Sherry brothers built themselves, are most attractive and provide excellent listening posts for their record trade.

Self-selection has doubled the sales of recorded music, declares Harold Sherry. People like to browse and discover new types of music for themselves, he claims. If let alone, amidst proper display, they will not only find what they came in to buy, but go out with much more record merchandise than they had set out to buy originally.

It's an effort to ask, he states, and an effort on the part of the clerk to locate the merchandise.

Remedy—have your stock so well arranged that the customers can find what they want themselves, and you'll find they'll buy more.

Israel Sherry is in charge of the radio department, and right now he and his two technicians, Seymour Ronner and Harold Olsen, have all they can do to keep the home sets playing.

Both Sherry brothers have had a good backlog of experience in the field of radio merchandising and repair, and have been doing a profitable business in Hartford for some years past.

Chains No Threat

Before that, their experience with a large radio-sporting goods chain in New York taught them much about that kind of retail operation. And this experience has better equipped them to cope with chain competition, since they have been on their own.

Israel Sherry and his technical staff are also kept busy with local aircraft radio maintenance and communications repair in and about the capital's hotels and legislative buildings.

Their greatest satisfaction, the Sherry brothers claim, is the good reputation they have built in and around Hartford in the past decade for reliable sales and service to their customers. Word-of-mouth advertising means a lot when you see it materialize into new customers.

SURE-FIRE!

on Broadway
on Decca Records!



WILBUR EVANS,
BETTY BRUCE
and other members
of the ORIGINAL CAST, with
CELESTE HOLM and
EILEEN FARRELL

WILBUR EVANS EILEEN FARRELL BETTY BRUCE
AND
CELESTE HOLM

UP IN CENTRAL PARK ORCHESTRA AND CHORUS UNDER THE DIRECTION OF MAX MERZ
THE BIG BACK YARD WHEN YOU WALK IN THE ROOM AFTER SNOW THE FIREMAN'S BRIDE
CURRIER AND IVES CAROUSEL IN THE PARK IT DOESN'T COST YOU ANYTHING TO DREAM CLOSE AS PAGES IN A BOOK
COMPLETE ON FOUR 10-INCH RECORDS
DECCA ALBUM NO. A-395 LIST PRICE \$3.50

ORDER NOW
from your regular
DECCA BRANCH



SELECTIONS INCLUDE:

THE BIG BACK YARD	CAROUSEL IN THE PARK
WHEN YOU WALK IN THE ROOM	APRIL SNOW
THE FIREMAN'S BRIDE	CLOSE AS PAGES IN A BOOK
CURRIER AND IVES	IT DOESN'T COST YOU ANYTHING TO DREAM

COMPLETE ON FOUR 10-INCH RECORDS
DECCA ALBUM NO. A-395 LIST PRICE \$3.50

(Price does not include Federal, state or local taxes)



DECCA DISTRIBUTING CORPORATION
Executive Offices: 50 West 57th Street, New York 19, N. Y.

Boon to Better Hearing

New Field for Technicians—Sound Systems for the Hard-of-Hearing

• Every community has its quota of persons with hearing deficiencies—men, women and children—who can be helped by some form of electronic sound amplification. In fact, at least one person in every ten is afflicted with such hard-of-hearing difficulties.

The magnitude of this special sound-apparatus market for the radio dealer and technician, will be apparent when it is recalled that even a town of one thousand population has a hundred or so hard-of-hearing persons; a city of 10,000 has a thousand partially-deaf individuals.

Humane Activity

The radio-sound technician can perform a humanitarian service by utilizing his knowledge of electronic devices to assist the hard-of-hearing, or those who are partially deaf, in improving their hearing capacities. At the same time, this activity can prove profitable for retailers or technicians who perform this work.

There are three distinct opportunities for the radio-sound technician in the sound system and hearing improvement field: (1) Installing and servicing sound systems, with individual microphones and earphones, for

use in schools and other institutions for teaching deaf children; (2) Wiring seats in theatres, lecture halls, churches, etc., for use with hearing aids or other amplifying devices; (3) Retailing of hearing aid equipment.

At Public School 47, in New York, deaf children, who have never heard sound and therefore cannot speak, are being taught speech. Approximately 500 pupils, ranging from two years

old up to junior high school age, are being given a thorough education at this unique institution. Through the intelligence and resourcefulness of the school's 56 instructors, these children who, unfortunately, were born without the ability to hear, or who developed deafness because of illness, are being molded into competent citizens.

What makes possible the teaching of deaf children is the use of elec-



Right, teacher with her pupils in wired classroom. Instruments on desks regulate sound. Below, child feels sound vibrations with hands.



tronic devices with which each classroom in the school is equipped. Every student in each class has his own individual microphone and head-set. As the teacher speaks into the microphone, addressing herself to the child, she is able to regulate the volume of sound going to the ear phones.

Volume Controls

Therefore, if the student's hearing impairment is very bad, the volume can be turned up higher. The intensity of the sound is kept in accordance with the degree of deafness with which the child is afflicted.

Many of the children who are taught at this institution, especially if they begin their instruction at two years of age, the time when most normal children learn to talk, grow up to become useful citizens, and to do constructive work. Some of the

(Continued on page 114)

ADMAN IN WONDER LAND

IT'S A WONDER TO ME!



SILENCE is a crime!

by Sidonie M. Gruenberg
Director, Child Study Association of America

...You worried parents cannot help your children combat the alarmingly increasing venereal diseases by shutting your eyes, by looking the other way, by hoping the storm was not meant for you. Speak to your children frankly, honestly—and now. It is the home that must furnish both the basic teachings and the guidance in conduct that will prevent the venereal diseases in the rising generation and so eliminate them from our civilization...

I NEVER FOUND OUT BEFORE!

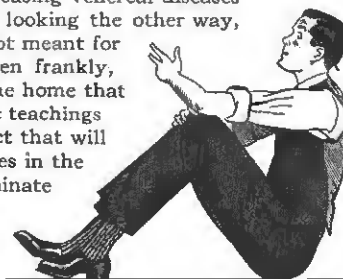

THE SIDEWALKS OF NEW YORK

I HADN'T REALIZED!



...“What’s the matter, Phoney?” she said. “Nothing!” I muttered. “You’d better get in and clean up a bit. It’s getting late.”
“But I thought you were going to kiss me?”
“So I was,” I blurted out. “But guys like me don’t kiss angels!”
She smiled. “That’s one of the nicest things you’ve said to me in all the time I’ve known you, Phoney O’Farrell. And I want you to kiss me... And now I want you to tell me your *real* first name.”
“Clarence,” I whispered back, “Clarence Aubrey O’Farrell. That was the label Mom pinned on me before I started getting tough...”

To Live Again!

By BETSEY BARTON
as told to Eleanor Early

...For ten years Betsey Barton lay helpless, her spine shattered, both legs paralyzed. But she has found the strength and courage to build a new, richer life. And now, in speaking deeply and honestly about herself and her experience, she is speaking for all whom the world calls *crippled*... “Families of wounded soldiers,” she said, “must be taught how to treat their boys—must be made to realize that the disabled are never so badly handicapped in their bodies as in their minds”...

THAT'S VERY INTERESTING!

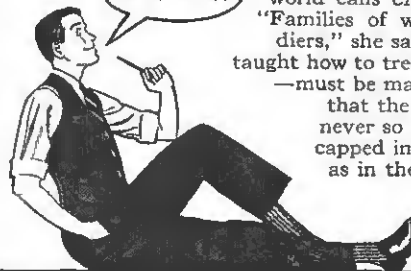

THE TRUTH ABOUT OUR SERVICE-WOMEN OVERSEAS

by Will Oursler, War Correspondent

WHY, CERTAINLY!



...I have just returned on temporary leave from the Philippines. For many months I traveled through battle areas of the Pacific... Since my return home I have been astonished by hearing such things as one gray-haired mother said: “We’ve heard of the conditions our girls run into overseas. We’ve heard the stories, too, even though they try to hush them up—about moral conditions and the men and all that!” The truth is that if any girl were to travel alone through the war zones she would probably be much safer than when traveling alone back home...

He Belongs To Me!

...“Diana and I know each other, Mitch,” I said. “She’s the girl who broke up my engagement to the man I told you about. She wanted him for herself. But she refused to see him after she knew he would probably be a cripple. She let him die alone!”
“She broke her engagement to you because she knew you had received a face wound, and she was afraid you might be scarred for life.” Mitch’s face was a mask. After a long moment he put his hand on Diana’s arm. “Come, Diana,” he said quietly. “We’d better go.” When they had gone I stood very still...

I'VE GOT A NEW SLANT NOW!



True Confessions is a surprising magazine. Perhaps you *think* you know it from hearsay...but you don’t really know True Confessions at all until you’ve seen for yourself the fine, big stories and articles that make every issue so honestly human. True Confessions—“Your Magazine for a Better Life”—sincerely tries to help people.

TRUE CONFESSIONS

Bought at newsstands by 2,000,000 women a month for the living service it gives.

"The following is electrically transcribed..."



on PRESTO discs!

How are great commercials born? Rinso's happy little wash-day song was born in the woods. An advertising man, trying to get away from it all, listened raptly to the song of a bob-white—the special three-note call Bob uses to sell himself to his mate. "Golly," said the ad man, "why couldn't we . . ." And the rest is soap history.

Rinso "spots" are cut on PRESTO discs. *Most*

important transcriptions are. For recording engineers know that PRESTO discs give finer results with less margin for error—*actually perform better than most of the recording equipment on which they are used.* That's why you'll find, in most large broadcasting stations, recording studios and research laboratories, the standard recording disc is a PRESTO.

WHY BROADCASTING STUDIOS USE MORE PRESTO DISCS THAN ANY OTHER BRAND

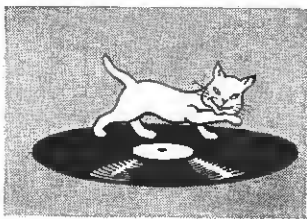

Less Surface Noise

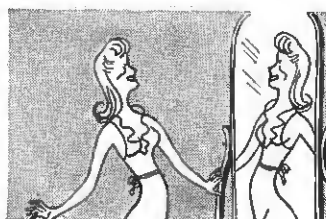

No Distortion

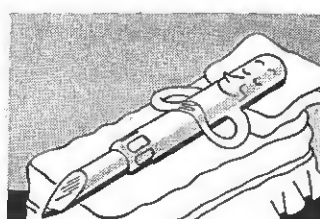

Easier on Cutting Needle



No Fussy Needle Adjustments

**WORLD'S LARGEST MANUFACTURER
OF INSTANTANEOUS SOUND
RECORDING EQUIPMENT
AND DISCS**

PRESTO

RECORDING CORPORATION

242 West 55th Street, New York 19, N. Y.

Walter P. Downs Ltd., in Canada

OFFERED TO ADVERTISERS



A NATIONAL SHOW for your product FOR \$37,200 A YEAR complete



One of the stars This is a great writer — Somerset Maugham. He wrote one of the world's classics, "Of Human Bondage." He also wrote "The Razor's Edge," his newest great novel . . . which appeared first in Redbook magazine.

And that is just one example of the kind of great writing which assembles for your product's advertising . . . Redbook's audience of 1,500,000 families who happen to like *fine* fiction. And 1,500,000 is better than a 5.0 rating.

THERE is no trick in that statement — a national show for \$37,200. For the show is Redbook magazine, with as cohesive, important an audience for its kind of entertainment — really good reading — as the audience of any daytime radio serial, for example.

Yet the cost of doing an important selling job on this worthwhile segment of America — with a full page in every one of Redbook's 12 issues — is only \$37,200 a year, *not* \$370,000!

Even though Redbook space is sold out, at the moment, it is not too soon to make plans for the day when space is available.

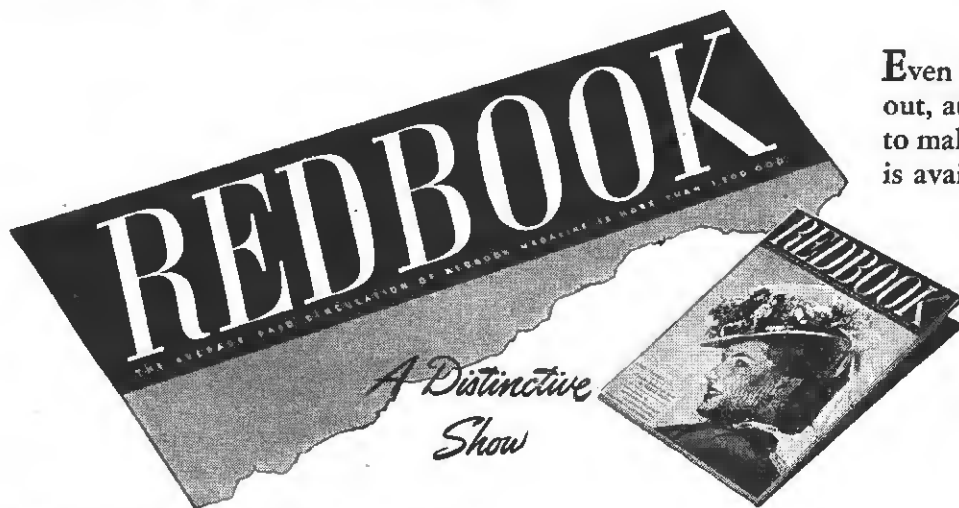

To Nearly 1/5 of America —
A Program of proven Sales Power Redbook, Cosmopolitan, and American, THE 6 MILLION GROUP, reach six million families with less than 15% duplication — approximately one out of every 5 in the United States. *And a full page in every issue of all 3 magazines costs only \$160,000 a year.*

One Day Repair Service

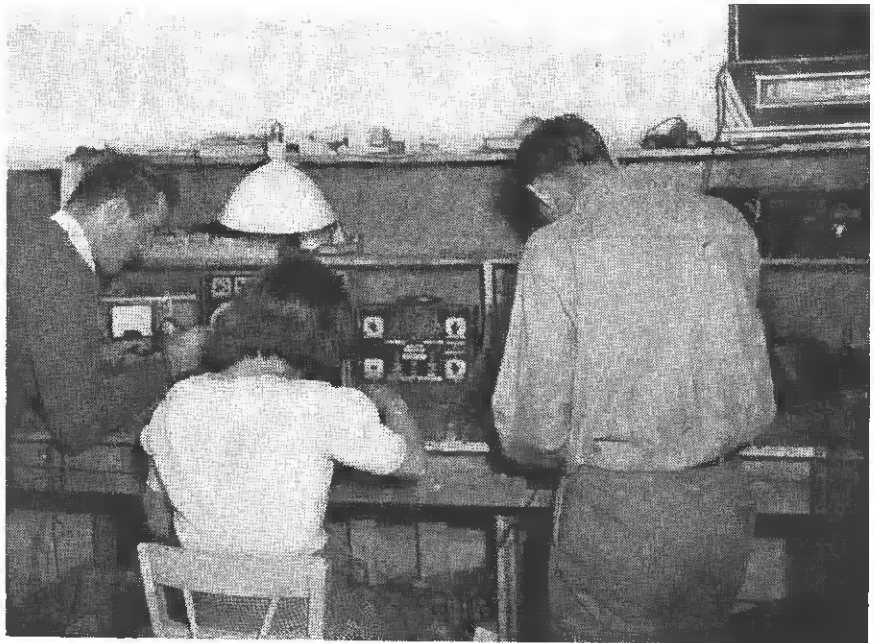

Shown is one of the firm's three work areas, all of which are fed from a central supply room.

Aggressive Policy Solves Parts, Manpower Problems

• Two years ago, shortages of trained radio repairmen and materials was a challenge to Moody Connell of Wichita, Kan. He opened a radio repair business and began an extensive advertising campaign.

Newspaper ads feature one-day service to out-of-town customers who bring their radios in; three day service to anybody.

Naturally such advertisements attract widespread attention. While anyone can get the business with such an approach, many would find it impossible to live up to the service promised. Connell makes good.

He seems to be able to produce any tube or part needed. He gets them by going after them with the same aggressiveness with which he goes after service work. When he started in business, he took a trip through the East, personally contacting distributors and arranging for certain minimum stocks. This was far from enough, so he subscribed to every trade magazine in the radio field. He combs these thoroughly, and every advertiser offering any radio supplies gets a query from Connell.

Employs War Veterans

Another source of repair parts was found in stores being closed by men who were inducted, or who found it difficult to carry on, due to shortages.

Even with adequate supplies, however, the manpower shortage remains a tough problem. Asked how he secured, and kept, trained employes,

Connell replied, "We pay top wages to well-qualified key men, then we build around these men by taking unskilled people and giving them training. Discharged war veterans are preferred. We have also been using disabled civilians with excellent results."

The Veterans Administration has placed two men in the Moody Radio Hospital as a part of its rehabilitation program. These men receive a monthly salary from Uncle Sam, augmented by an hourly wage from the radio shop. The hourly rate is steadily increased as the men improve. The state of Kansas has a similar program for rehabilitating disabled people, and has also placed men with Connell.

These men, working under the supervision of the key radio technicians, are able to turn out a considerable volume of work.

Work Is Guaranteed

Every job turned out has a specific guarantee on it, and whenever a set is brought back, it is fixed then and there, while the customer waits. "We show him what we did originally, and let him see what we do now, so that there is no misunderstanding. Then, we thank him for returning it to us for adjustment."

The type of advertising used by the Moody Radio Hospital has brought in one kind of work that is usually very rare, according to Connell. In many of his ads, he lists the various services and adjustments that a radio might need, and lists specific price for each service. He has found that many radio owners will bring in a set that still plays, but needs some minor adjustment, because they real-

ize that they can get the adjustment made for a reasonable, stated fee. "Usually," said Connell, "the owner will wait until a set stops playing entirely before bringing it in, because he is afraid of running into a high repair bill. When he sees what it will cost him, plus parts, of course, he decides to bring his radio in now."

Plans Expansion

"You'd be surprised how much work our one-day service feature to out-of-town customers brings us, too," added Connell. "The radio stores of dozens of small towns around Wichita have been closed, and now that the residents of these towns can leave their radios with us when they come into town, and take them home when they leave the same day, they are taking advantage of it."







Profits from this war-time repair service will be invested in the finest equipment available, he says, and in the best store fixtures. He plans to have his postwar organization built by the time the war ends.

"After the war I intend to send at least two men each year to school in radio factories, at my own expense," he said. "We'll get a group of young fellows together who really know the facts about AM and FM sets, and television."

Connell also intends to secure the distributorship for a line of radios and appliances, and build an aggressive selling organization. "I firmly believe that if you have good merchandise and will give young men the chance to learn to sell and service it, you can match any competition in the field," said Connell.

How to Build Reputation For Your Service Business After the War

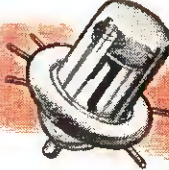
RCA TUBE ADVANCES THAT MADE RADIO HISTORY

 <p>A-C Tubes... took radio out of the storage-battery stage... made home radio practical for millions more people.</p>	 <p>Screen-Grid, Pentode, and Beam-Power Tubes... each helped make radios smaller, more powerful, more satisfying... thus increasing the market for radio sets.</p>
 <p>Kinescope and Iconoscope Tubes... made electronic television possible... helped bring the vast postwar television market years nearer.</p>	 <p>Miniature Tubes... opened up tremendous new markets for portable radios and farm radios... for civilian walkie-talkies after the war.</p>
 <p>Metal Tubes... improved performance, particularly in sets with high-gain circuits... eliminated need for tube shielding... made servicing easier, faster.</p>	 <p>Acorn Tubes... helped bring FM and television nearer... helped immeasurably in uhf developments prior to the war.</p>
 <p>Cathode-Ray Oscilloscope Tubes... made radio servicing more exact, faster, and more profitable, reducing the number of complaints received by servicemen.</p>	 <p>Electron-Ray Tubes... the "Magic Eye" tuning indicators... added sales appeal to larger radio receivers, and helped the service-dealer "sell up."</p>

Your reputation for servicing is built on two things... your ability to locate trouble and fix sets, and the prestige of the components you use.

Your ability comes first, of course... for your customer's first interest is in how well his set works. But don't forget how much the acceptance of the products you use... particularly the *tubes*... helps build your reputation for fine servicing.

Of all the replacement parts you use, tubes are the most familiar to your customer. If he looks at the set you've serviced, new tubes may be his only *visual* indication of the work you've done.

That's why it's important that the name on those tubes should inspire his confidence... should be immediately acceptable to him.

RCA tubes *are* accepted. Your customers know them, and rate them tops. Why? Because, year after year, the RCA name has been associated with leadership in tubes.

Since the early '20's, RCA has led the field in introducing major tube developments. Look at these examples... tube developments introduced and put across by hard-hitting RCA promotion and advertising... keys to major advances in the radio industry that have made your business become bigger and more profitable.

Developments like these brought prestige to RCA. And RCA, in turn, brings this prestige *to you* every time you display the RCA seal... every time you put an RCA tube in a customer's set. Give your servicing business every break you can after the war. Make the most of your chances with the *best-known name in tubes*.

The Fountainhead of Modern Tube Development is RCA



Listen to
"THE MUSIC AMERICA
LOVES BEST,"
Sundays, 4:30 P. M.
EWT, NBC Network



42-6636-93

RADIO CORPORATION OF AMERICA
RCA VICTOR DIVISION • CAMDEN, NEW JERSEY

LEADS THE WAY... In Radio... Television... Tubes
Phonographs... Records... Electronics

A PROGRESS REPORT

BY RCA

When can you expect

TELEVISION

Television is Ready Technically
Estimated First Sets Available About
After Civilian Manufacturing is A



PORTRAIT QUALITY PICTURES, ALMOST AS LARGE AS A NEWSPAPER PAGE, ASSURED
IN COMING TELEVISION RECEIVERS BY RCA REFLECTIVE OPTICAL SYSTEM

PICTURES AS BIG AS A NEWSPAPER PAGE and of bright portrait quality became a postwar reality when RCA scientists adapted a principle of astronomy (shown in simplified form here) to the projection of television images on large screens contained within the receiver itself. A. Receiving tube. B. Spherical reflector. C. Spherical correcting lens. D. Inclined mirror. E. Screen. F. Loudspeaker.

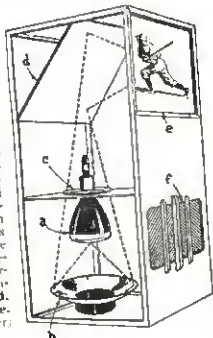

EXPERTS who have seen the laboratory model demonstration of RCA Large Screen Home Television acclaim the bright, life-like quality of the pictures . . . almost 5 times larger than pre-war

This is but one example of the remarkable technical progress that has been made in television largely as the outcome of RCA research before the war. Highlighting the many brilliant achievements of RCA scientists is Dr. V. K. Zworykin's development of the Iconoscope, which is the "eye" of the television camera; and the Kinescope, or "screen" tube from which the received picture is reflected to the screen. These revolutionary advances did away with mechanical scanning—and opened the way for the high-quality, all-electronic television system.

Thus far, more than a hundred application stations, located from coast to coast with the FCC.

If you live in or near New York, Philadelphia, Chicago or Los Angeles (where television stations operate now), you will be able to soon as receivers can be purchased . . . a year after Uncle Sam gives manufacturing for reconversion. Others throughout the broadcasting service as fast as new stations can be built. Then, television will begin scale its many golden promises . . . through a new public education service to provide jobs.

The television industry holds promise never before existed—for factory work, script writers, scenic artists, directors, men, building craftsmen and many others help for America's postwar economy, an even greater effect through the advertising by television. They forecast such facilities of public buying that thousands upon thousands of workers will be needed to keep America supplied.

RCA is uniquely equipped through its facilities to hasten the spread of television. For RCA leads in every phase of the manufacture of equipment for studios and home receivers . . . and television for your community, you'll enjoy it to bearing the mark of the pioneer . . .



RCA *Vu*

RADIO CORPORATION OF AMERICA - RCA VICTOR
In Canada, RCA VICTOR COMPANY LIMITED



RCA Victor

RADIO CORPORATION OF AMERICA • RCA VICTOR DIVISION • CAMDEN, N. J.

In Canada, RCA VICTOR COMPANY LIMITED, Montreal



TELEVISION?

ilily
it a Year
thorized

ons for new tele-
t, have been filed

phia, Schenectady.
broadcasting sta-
enjoy television as
dicted at about a
rs the green light
ountry will receive
ions and networks
unfolding on a wide
ling new entertain-
... a new industry

of creating jobs that
rs, engineers, actors,
take-up men, camera
rs. Beyond this direct
ading thinkers see an
ing of goods and serv-
r-reaching stimulation
hundreds of additional
s outlets and markets

ts wide experience and
evision after the war
vision . . . the manu-
stations . . . as well as
roadcasting through the
en television comes to
he fullest on a receiver
RCA Victor.

tor
VICOR • CAMDEN, N.J.
ACTED, Monmouth



TOMORROW . . . America looks to television, directly and indirectly, to provide brand new job opportunities and to stimulate employment with great benefit to men and women returning from the armed services.

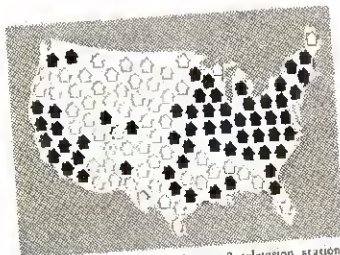

TOMORROW . . . Chart shows how 118 television stations now applied for with FCC might reach more than 50% of all wired homes. Black symbols very roughly show locations of wired homes where television might be available if all applications are granted.



TOMORROW Remarkable new television programs will take shape. Foremost leaders in political thought, education, religion and the great stars of the entertainment world, will be seen in radio's new "dimension"

THE RIGHT ANSWER means money in your pocket

TELEVISION . . . How soon? . . . How good? . . .
When will new broadcasting stations and home
receivers be ready?

America wants to know the answers.

RCA, as the pioneer and leader in every phase of television including broadcasting, research, the manufacture of studio and station equipment and home receivers, is best equipped to give the facts. America is getting the right answers on television from RCA—in a special series of advertisements in Time magazine.

Read these ads as they appear. They will help you plan your future merchandising strategy to get the most out of television . . . and radio, too. They will help you and your customers to understand how television will supplement and not replace radio. They will build your faith in the golden promises of television and renew your confidence in the rich and continuing market for radio.

All this means money in your pocket.



Why was Time chosen? Answer: Time goes to over 1,000,000 people who are leaders in political thought, business, education, religion and many other walks of life. They are the ones who will most quickly grasp—and act upon—television's many golden promises.

You can use the **NEW VOLTOHMYST** for checking **FM Discriminator Alignment**

(A ZERO-CENTER-INDICATOR IS INCORPORATED FOR THIS PURPOSE)

—and you can also use the 195-A Voltohmyst

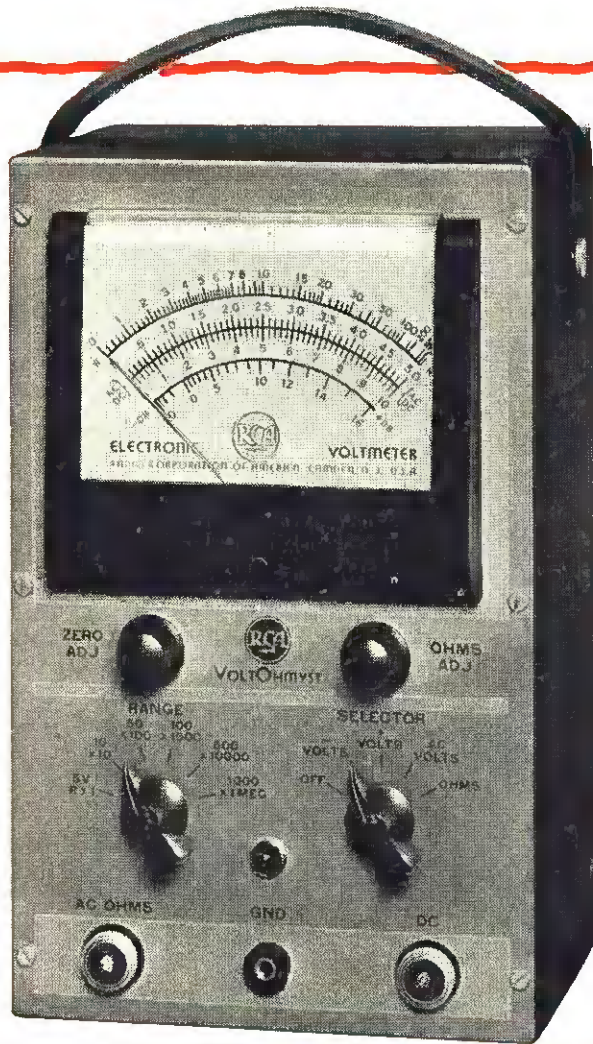

As an **ELECTRONIC D-C VOLTMETER**

Measures *d-c Voltage* to 1000 volts in six ranges—has high resistance input of 10 megohms constant on all ranges—plus isolation resistor in probe for dynamic socket voltage readings—polarity turnover switch eliminates confusion in reversing test leads—positive and negative indications are individually calibrated.

As an **ELECTRONIC OHMMETER**

Measures *Resistance* up to 1000 megohms with internal source of only 3 volts—six resistance ranges indicating from .1 ohm with shielded cable—zero resetting unnecessary with change of range—all ranges are indicated on "OHMS" scale.

As an **ELECTRONIC A-C VOLTMETER**

Measures *a-c Voltage* to 1000 volts r.m.s. in six ranges—with clear linear scale—Binding Jack with locking pin plug prevents accidental ground lead disconnection—meter protected against accidental burn-out.

As an **ELECTRONIC A-F VOLTMETER**

Measures *a-f and Supersonic Voltage* up to 100 volts with a range of 20 to 100,000 cycles—internal self-balancing diode—produces linear reading at any frequency.

As an **ELECTRONIC OUTPUTMETER**

Measures *Decibels* based on a-f voltage—calibrated in Volume Units for direct reading across 600 ohm audio circuits with standard zero level of 1 milliwatt.

The New Model Of The Famous RCA Junior Voltohmyst Incorporates Several New Features Including:

A diode for a-c measurements (flat 20 cycles to 100 kilocycles); linear a-c scale for all ranges; new plastic meter case

with one-piece crystal-clear transparent front (no glass to break or loosen); and a shielded a-c cable and probe.



Buy More
War Bonds

TEST AND MEASURING EQUIPMENT SECTION

Radio Corporation of America
Camden, N. J.

Name _____

Street Address _____

City & State _____

137AA

RADIO CORPORATION OF AMERICA

RCA VICTOR DIVISION • CAMDEN, N. J.

In Canada, RCA VICTOR COMPANY LIMITED, Montreal

Is Your Store Ready for Postwar Merchandising?

This CHECK LIST will enable you to determine how far your plans for active participation in the coming radio-appliance market have progressed.

	Yes	If not completed, when will you start? (Date)
1. STORE IMPROVEMENT		
(a) Store interior modernized?.....	(___)	_____
(b) Storefront improved?	(___)	_____
(c) New shelving, display tables, etc., ready?.....	(___)	_____
2. CREDIT ARRANGEMENTS		
(a) Plans for financing your purchases complete?.....	(___)	_____
(b) Customer-purchase finance methods readied?.....	(___)	_____
3. SALESFORCE REORGANIZATION		
(a) Personnel sources checked?.....	(___)	_____
(b) Number salespeople decided upon?.....	(___)	_____
(c) Compensation plans ready?.....	(___)	_____
(d) Sales training program complete?.....	(___)	_____
4. FRANCHISES-BRANDS		
(a) Franchises lined up?.....	(___)	_____
(b) Brands and lines selected?.....	(___)	_____
5. ALLOCATIONS AND DISCOUNTS		
(a) Arranged to receive early shipments of first merchandise?.....	(___)	_____
(b) Discount terms settled?.....	(___)	_____
6. "VISITING LINES"		
(a) Decided upon which "substitute" lines to retain?.....	(___)	_____
7. TRADE-IN POLICY		
(a) Tentative allowance scale made?.....	(___)	_____
(b) Plans for disposing of "trade-ins" completed?.....	(___)	_____
8. SERVICE DEPARTMENT		
(a) Has service section been re-located?.....	(___)	_____
(b) Have you decided whether service work will increase or decrease?	(___)	_____
9. ADVERTISING PLANS		
(a) Decided what media to use?.....	(___)	_____
(b) Amount to spend annually fixed?.....	(___)	_____
(c) Any cooperative ad plans made?.....	(___)	_____
10. POTENTIAL MARKET		
(a) Surveyed or otherwise tried to estimate your postwar market?..	(___)	_____
11. PROSPECT LIST		
(a) Have you re-vamped your list of prospective customers?.....	(___)	_____
12. OPERATING CONTROL		
(a) Is present record-keeping system adequate and effective?.....	(___)	_____
(b) Have "overhead" costs been examined for possible reduction?..	(___)	_____
13. SALES PLAN		
(a) Are sales soliciting plans completed?.....	(___)	_____
14. DELIVERY, SERVICE VEHICLES		
(a) Are your trucks, etc., repainted, overhauled, etc.? (Many dealer vehicles have been stored for duration).....	(___)	_____

Delay FM-Tele Positions

Three Alternatives Suggested. Final Allocations to Depend on Summer Tests—One More Television Channel

• FM is still up in the air—but not yet “upstairs.” Exact location of television channels, too, is still in doubt.

After more than six months’ deliberations, the FCC on May 17 made official, except for a few changes, the “proposed” radio allocations announced early in the year, with the exception of the television FM channels.

As shown on the chart on page 35, FM is to occupy one of three alternative spots in the spectrum, though which particular spot will not be known until after FCC engineers, in collaboration with industry engineers, conclude a series of tests designed to determine definitely the best of the three alternatives.

In the meantime television remains in its present general position, except that video service has been allotted one additional channel lying between 174 and 180 mc, bringing the total television channels up from 12 to 13. Two of the three alternative allocations suggested for the 44-108 region would make possible immediate use of all television channels.

No Definite Date

As to when service is to be started under the new allocations, nothing definite is stated. The wording of the report explains: “These allocations will probably be ordered into effect service by service, with the Commission taking into account such factors as the availability of manpower and materials, the results of the Inter-American conference at Rio, (slated for September 1—Editor)

Our New Radio Charts Held Up, Too

The big four-color charts of the 1945 FCC Radio Frequency Allocations which have been in course of preparation for RADIO & Television RETAILING’s subscribers will now be delayed as the result of the Commission’s postponement of definite announcement of the important FM and television channel locations.

As soon as authoritative channel assignments are available, the charts will be completed and made ready.—Editors

and the preparation of the Commission’s rules and standards.”

The reason for not making FM allocations at this time is ascribed to the desire of the Commission to complete tests which will set at rest all questions regarding the best position in the spectrum for the best FM service. Ever since the hearings that were held in Washington last October there has been concerted and practically continuous opposition to the proposal that FM be moved way “upstairs” to the proposed 84-102 band. Major Armstrong himself has been the Commission’s severest critic, and it is unquestionably as a result of his criticism and testimony, coupled with that of many others, that has resulted in the determination to make no further move without the result of conclusive tests to back it up.

Much disappointment is being expressed within the industry at the failure of the FCC to make definite FM and television assignments at this time, so that engineers and manufacturers may go ahead with the design of new home radios.

Till Fall of 1946?

Opinions indicated that the principal hardship would be felt in FM and that this growing service might be deprived of millions of 1945 receivers equipped for FM-AM reception. Nearly all home-set makers had previously announced plans to include FM in their postwar sets. But with the FM channels now indefinite, it is apparent that the first home sets authorized will have to be straight AM units. If the FCC engineering tests continue “throughout the summer” and then have to be analyzed during the Fall, it seems likely that FM allocations may not be forthcoming until nearly the end of 1945. In that event, designers will not be able to start until the opening of 1946, and the first FM-AM sets may not be ready before the Fall of 1946.

One other important change has been made from the “proposed” allocations. The band in the 27-mc region available for scientific, industrial and medical devices including diathermy machines, was enlarged in accordance with recommendations of manufacturers from a channel width of 30 kc to one of 270 kc. Other medical and industrial allocations were left unchanged.

“Radio Severely Handicapped by FCC Program”—President Cosgrove, RMA

“Of course it is impossible for us to plan for domestic radio-set production with FM reception, until FCC makes a firm allocation of frequencies. I understand ninety days before WPB authorizations for peacetime radio production are granted, FCC will freeze allocation. Believe this is unworkable because: First, time is needed for design of FM equipment after frequency allocations are made, and, secondly, believe WPB will grant production approval without being able to anticipate this time by ninety days: My personal position is that decision on frequency-modulation allocation should be made immediately; in fact, it is long overdue. The whole radio program for re-entry into civilian business will be severely handicapped by the announced program. If tubes, resistors, and capacitors become available, due to reduction in military requirements, the industry can make domestic radio sets in substantial quantities within thirty days.”

R. C. COSGROVE, VP & GM Crosley Corp., President RMA



Postwar project . . . personal

 "My old gang used to get away every year for two or three weeks in the woods. But something has come up every year since 1940 . . . I still have all my gear in the closet there. The guns need cleaning, and the boots a little neatsfoot—nothing a few hours some Sunday can't make shipshape . . . And when this war is out of our hair, you can believe me that the annual expedition is going to be resumed . . ."

 A lot of guns and tackle, trout streams and woods trails, travel folders and holiday schedules . . . have had to be shelved while there was a war to be won. In the interim we have had to be satisfied with retrospect and anticipation, remembering and reading . . . And TRUE has helped, too. TRUE is the young man's fancy



without leaving the fireside . . . the magazine for men who must take their adventure second-hand. TRUE watches the world and the war, the everlasting drama of man in conflict with nature, accident, circumstance; culls the color and chronicle of these off the beaten path, finds authentic fact more interesting than fiction.

 TRUE has found more than 600,000 eager buyers each month, virtually all-man, all newsstand at 25c per copy . . . earned exceptional readership and response that get exceptional action and returns for advertising . . . holds a market highly productive at present, and of tremendous profit potentials . . . has a story that ought to be heard now! . . . Inquire TRUE, a Fawcett publication, 295 Madison Avenue, New York 17, N. Y.



true

. . . the man's magazine

There's no let down in MT. CARMEL

Though the war news is good . . . and getting better every day . . . the men and women of Meissner's famed "precision-el" haven't let down. As you can see, in the photographs on this page, they devote the same concentration to their work now as they did when the going was tough. This stick-to-it-iveness is one more reason for Mt. Carmel's rapid rise to prominence as one of the centers of an exacting industry, electronics.



They Listen to a news broadcast during their lunch hour. Then it's back to work with a determination to equal military victories with new production records on the home front . . . without loss of Meissner quality.



"Precision-el" at Work. They're building Meissner quality into this vital electronic war material. After victory that same pride in a job well done will give new meaning to Meissner's slogan, "Precision-built by Precision-el."

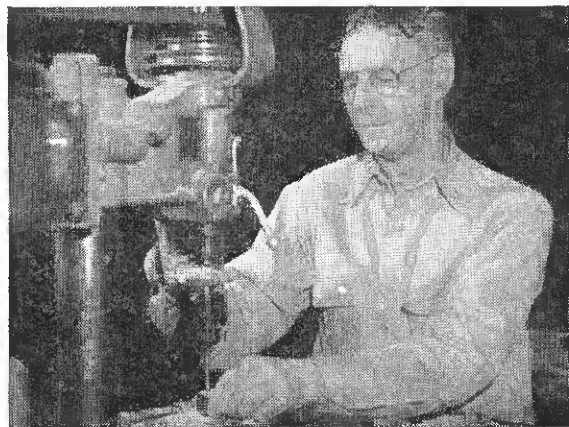

His Skilled Fingers have mastered many of the secrets of electronics. After victory, he and many of Meissner's "precision-el" like him will pass this knowledge and tradition of precision to a new generation.

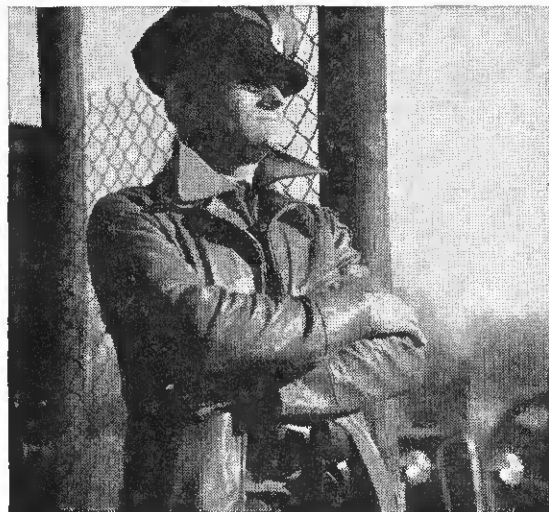

His Smile is a Reflection of the hundreds of smiles he sees each day as the men and women of Meissner pass through the gates he guards. If you ask him, he'll tell you it's the smile that helps put precision into "precision-el."

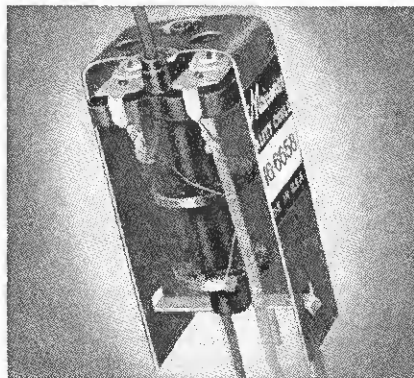

"Step Up" Old Receivers!

These Meissner Ferrocarril I. F. input and output transformers are getting top results in stepping up performance of old worn receivers. Special powdered iron core permits higher "Q" with a resultant increase in selectivity and gain, now available for frequency range 127-206. Ask for numbers 16-5728 input, 16-5730 output. List \$2.20 each.



MEISSNER

MANUFACTURING COMPANY • MT. CARMEL, ILL.

ADVANCED ELECTRONIC RESEARCH AND MANUFACTURE

Export Division: 25 Warren St., New York; Cable: Simontrice

RADIO & Television RETAILING • June, 1945

Radio Dealers Wanted Now!

Sell Internationally-Famous Radio Line on a Direct Factory-to-Dealer Basis. Big Volume and Profit Opportunity. Exclusive Franchise.

Do you want the exclusive franchise in your community for an internationally-famous radio line?

Do you want to receive shipments of fine radios and radio-phonographs direct from the factory?

Do you want to be in a position to meet national chain store competition—at a profit?

Do you want to avoid a lot of the headaches connected with radio retailing?

THEN READ THIS—

In 1938—Sparton realized there was something wrong with the radio retailing business.

Field surveys showed glaring faults.

Too many handling charges—too many jobber-distributor splits—too many price-cutting deals!

But — it all added up to this: *The cost of distribution was too high.*

Unfair to the dealer! Unfair to the consumer! So—Sparton decided to do something about it.

And that's how the S.C.M.P. (Sparton Cooperative Merchandising Plan) was created.

Has the plan been successful?

Look at the record!

Hundreds of America's leading department stores, radio and appliance dealers have endorsed and adopted the S.C.M.P.

Keep your eyes and ears on Sparton

SOON WE HOPE Sparton will offer a complete new line of radios and radio-phonographs — some with FM! — designed and styled for the bright new world to come. These new and finer Spartons will take full advantage of wartime developments in radar, radio and electronics.

Here's what the S.C.M.P. can do for you

- 1 If you qualify as a Sparton Radio dealer, you will be given an *exclusive* franchise for your community.
- 2 All radio shipments will be made to you *direct from the factory*, at dealer-delivered prices.
- 3 You will be sure of a dependable source of supply.
- 4 You will be able to offer customers a full line of fine radios—consoles, table models and combinations—some with FM (Frequency Modulation)—at lower-than-usual prices.
- 5 You will be relieved of the necessity of offering special discounts to make sales.
- 6 And last—but not least—your selling effort will be backed up with seasonal promotional helps and a powerful campaign of national advertising.

Think of what a relief it would be, if you wiped away the headaches!

Think what it would mean to you in *sales and profits*, if you were able to offer *top-quality nationally-accepted radios in direct competition with the biggest retail outlets!*

Are you interested in the S.C.M.P.?

Then — here's what to do about it!

Additional dealer appointments are now being made. *But — only a few territories are open.*

So — *act fast!*

Wire or 'phone collect! Ask if the Sparton franchise is still available in your community.

Address: Ed. Bonia, Sales Manager,
Radio and Appliance Division

The Sparks-Withington Co., Jackson, Mich.

Sparton

RADIO'S RICHEST VOICE SINCE 1926

Use this PLUS VALUE in your first year's selling!



• Build the volume sales you will need at once when you reconvert

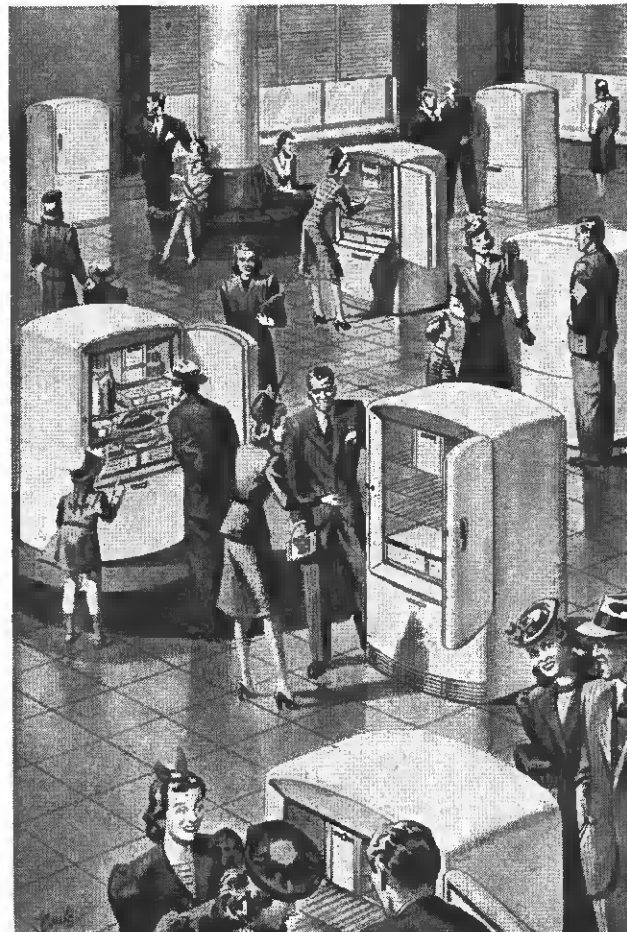

• Get set solidly with dealers and consumers when competition intensifies

Build volume quickly with your first year's factory production ... get set for a buyer's market

You can get double duty out of your first year's factory output in the \$4,496,734,000 Chicago market. Here is a tremendous pent-up demand for autos, washing machines, refrigerators, "big unit" products generally, in an easily accessible market famous for its record-breaking volume buying.

A powerhouse in selling

The Chicago market assures enough business to absorb all or the major part of the output of many individual manufacturers. Get the quick distribution and consumer buying you want. Do it at one low cost through a single advertising medium—the Chicago Tribune. Bought, read and bought from as is no other medium in the Chicago area, the Tribune is a powerhouse among dealers and consumers.

Practically every other family

One out of every three families in 756 cities and towns of 1,000 or more population in this market reads the Tribune daily—on Sundays, almost every other family. Only the Tribune gives you a choice of monochrome, color, comicolor, newsprint color, or black and white—at one of the lowest milline rates in the country.

No matter whether your production is large or small, big unit products or packaged goods, the rich Chicago market will reward your attention. It offers quick sales, continued dealer and consumer preference when the first easy selling conditions pass and the going gets tough.

For marketing facts and merchandising ideas, call a Tribune representative.

The Chicago Area: Located at the heart of America; big enough to absorb all that many a factory can make; famous for its wealth and huge buying activity. Available for your study and use is a specific sales program based on the findings of an auto and household appliance investigation among consumers and dealers. To get these pertinent facts, address C. S. Benham, Manager, National Advertising, Chicago Tribune, Tribune Tower, Chicago 11, Illinois.

Chicago Tribune

THE WORLD'S GREATEST NEWSPAPER
April average net paid total circulation: Daily
over 985,000; Sunday, over 1,300,000.

PERSONAL RADIO

TABLE RADIO

TABLE
COMBINATIONS

F. M. RADIO

CONSOLE
COMBINATIONS

AC - DC
PORTABLES

TELEVISION

COMMERCIAL
COMMUNICATION
EQUIPMENT

PUBLIC
ADDRESS
EQUIPMENT

AUTOMATIC
RECORD
CHANGERS

HERE'S WHAT IS BACK OF THE

MAGUIRE RADIO FRANCHISE

EVERYWHERE DEALERS AND DISTRIBUTORS ARE ASKING ABOUT MAGUIRE HOME RADIO. HERE ARE THE ANSWERS TO YOUR QUESTIONS:

THE MAGUIRE RECORD

Maguire came to prominence as a manufacturer of essential wartime equipment. Maguire won the Army and Navy "E" award with two stars. Maguire electronics business continues to increase yearly.

MAGUIRE FACILITIES

Maguire has grown from one small unit to six imposing plants, housing the most modern machinery; new electronically-controlled production lines plus especially designed laboratory and testing equipments.

MAGUIRE QUALITY

The finest in research, design, engineering and manufacturing talent; the use of only the best component parts; rigid inspection before, during and after manufacture . . . will assure continued high quality.

THE MAGUIRE FRANCHISE

The Maguire franchise assures a profitable operation for dealers and distributors. Maguire post-war radio will be backed by aggressive advertising, planned promotion, displays and masterful merchandising.

LOOK TO MAGUIRE

For post-war radio, designed for eye-appeal and priced to fit all pocketbooks . . . look to Maguire. For all details write Maguire Industries, Inc., Sales Department, Greenwich, Connecticut.

A NEW NOTE IN HOME RADIO



Maguire

INDUSTRIES INCORPORATED

ELECTRONICS DIVISION

PLANTS. BRIDGEPORT • STAMFORD • GREENWICH • CHICAGO • BROOKLYN • CLIFTON • NEW YORK

one step

Nearer...

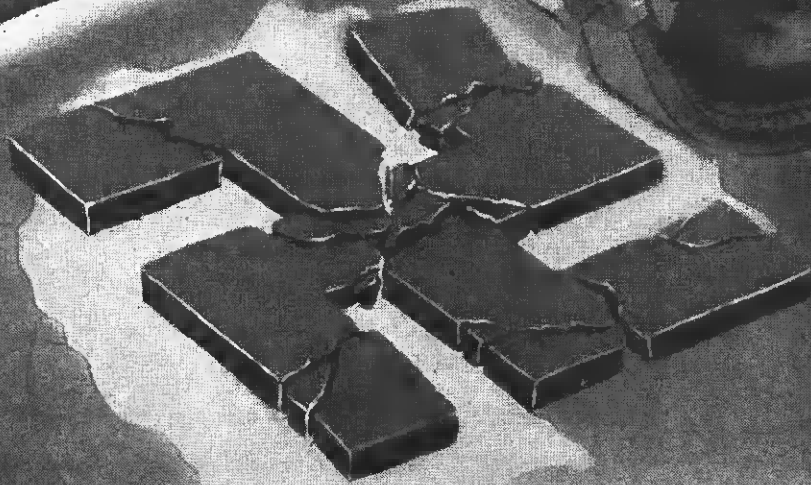

Smashing the Swastika does not mean total Victory. There is still the Rising Sun to be taken care of. . . . But, the victory in Europe is one step nearer to conversion to peacetime pursuits.

Here at JENSEN total conversion will be merely a matter of continuing to produce outstanding improved, high quality acoustic equipment. This is a continuing tradition at JENSEN. . . . One example of advancement will be JENSEN Loud Speakers with *ALNICO 5*.



Jensen
SPEAKERS WITH

ALNICO 5

Specialists in Design and Manufacture of Acoustic Equipment

JENSEN RADIO MANUFACTURING COMPANY, 6801 SOUTH LARAMIE AVENUE, CHICAGO 38, ILLINOIS

**SIMPLE—
ISN'T IT?**

*— yet, sealed
for all time!*



MARION

Glass-to-Metal Truly Hermetically Sealed 2½" and 3½" Electrical Indicating Instruments

A One-piece drawn steel cup-shaped case with high frequency induction soldered Kovar glass bead terminals. Black phosphate finished to meet 200 hour salt spray test.

B Marion Alnico magnet and moving system, with hardened beryllium copper instrument frame.

C Lithographed metal scale plate, individually printed.

D Double thickness glass window with Corning Glass Works metallized band on rim — high frequency induction soldered to steel case.

E Aluminum cover plate and flange, with anodic black satin finish.

"How is it done?" — this is the question on the tongues of hundreds of engineers from coast-to-coast. A simple basic design in conjunction with electronic production methods is the answer. And with it comes the final solution to the problem of completely tropicalizing electrical indicating instruments. There are no rubber gaskets and no cement seals. These instruments can be immersed in boiling brine or frozen in a cake of ice, for weeks, without deterioration of their seals or harm to their operating efficiency. And they are positively interchangeable: Type HM 2 with AWS Types MR 24 and 25 and Type HM 3 with AWS Types MR 34 and 35. Available in all DC ranges, for present or postwar applications. Write for additional information.

SPECIAL NOTE: *Marion Glass-to-Metal Truly Hermetically Sealed Instruments cost no more than standard unsealed instruments.*



MARION ELECTRICAL INSTRUMENT CO.
MANCHESTER, NEW HAMPSHIRE

In ratings from 1000 volts to 10,000 volts test . . .

Molded-in-Bakelite
MICA CAPACITORS

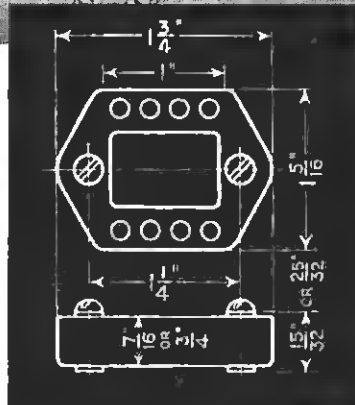

● The 1650 Series is the most rugged of the heavy-duty molded-in-bakelite mica capacitors of the extensive Aerovox line. These high-voltage units are intended for the most critical service of low-powered transmitting circuits, buffer stages, power amplifiers, laboratory equipment, etc. Also recommended for use in ultra-high-frequency circuits, and accordingly their r.f. current ratings are given in the Aerovox Capacitor Catalog.

The extra-generous use of high-grade dielectric material provides that greater factor of safety for longer service under severest operating conditions.

Standard units with tapped holes take 6/32 screws which serve for terminals. Also available with clearance holes through which screws or rods may be slipped, so that two or more units can be stack-mounted. Low-loss ceramic mounting insulators are available for mounting on metal surfaces. Standard units molded in brown bakelite. Also available in low-loss (yellow) XM bakelite.

In 1000, 2500, 5000, 7500 and 10,000 volts D.C. test. Capacitance ratings from .00005 mfd. to .06 mfd. in Type 1650 at 1000 v. D.C. test; .00005 mfd. to .001 mfd. in Type 1654L at 10,000 v. D.C. test.

● Literature on request . . .



Capacitors

INDIVIDUALLY TESTED

AEROVOX CORPORATION, NEW BEDFORD, MASS., U. S. A.

SALES OFFICES IN ALL PRINCIPAL CITIES

Export: 13 E. 40 ST., NEW YORK 16, N. Y. • Cable: 'ARLAB' • In Canada: AEROVOX CANADA LTD., HAMILTON, ONT.



DETROLA RADIO

DIVISION OF INTERNATIONAL DETROLA CORPORATION

DETROIT 9, MICHIGAN

RADIO & Television RETAILING • June, 1945

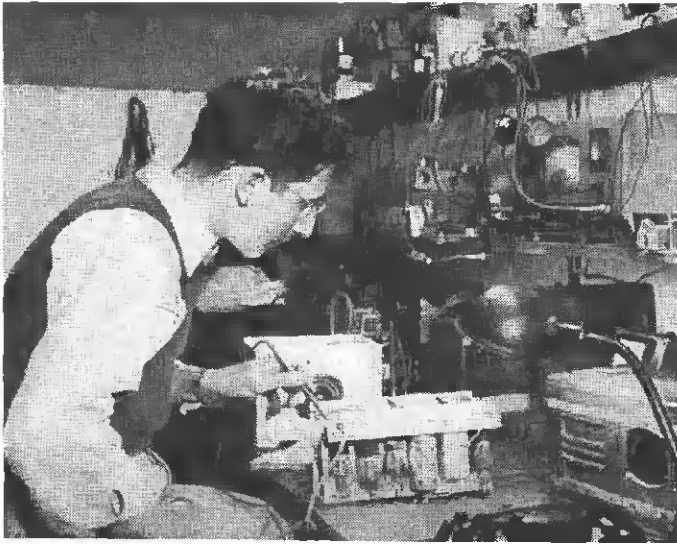

Ex-soldier Pat Mera in basement repair room.



Al Mera manages 1st floor service shop.

Dual Repair Operation

Two Service Departments in Store—Accelerate Work—Improve Efficiency

• The Broadway Radio and Electric Shop, Rockford, Ill., operated by Al, Carl, and Pat Mera, the latter a veteran of the Anzio beachhead, find that two service departments in the same building help speed service to customers during war-time.

Arrangement Saves Time

One of the service departments is located on the first floor, adjacent to the main sales room. The second is located in a roomy basement area. Al Mera works in the service department on the first floor and handles all incoming calls, while Carl and Pat Mera, as well as three part-time men, work in the basement department undisturbed by customers.

Several times a day the basement section gives Al Mera a list of radios repaired to date, so that he can tell customers who call by phone or in person that their radios are ready.

"We found out that there is no point in having two or three people waiting on the public during war-time," says Al Mera. "It wastes too much time, and takes the technicians away from their work. When our volume of work increased during war-time, we set up this basement department and retained the first floor department, too. This set-up has worked

out very well, enabling us to get much more work done and to operate our business very efficiently."

Al Mera reports that besides taking care of the incoming calls and customers, making out job tickets, listing the jobs, etc., he still has plenty of time during the day to handle numerous small radio repair jobs as well. In this way he makes the most of his time. He can route the work for the entire organization, dispense with the need for an office worker, and also do much bench work.

"As far as the downstairs service organization is concerned," declares Al Mera, "the men down there can go on working all day long without any interruption. By concentrating on their jobs, we have found that these men can turn out much more work each day."

Service Volume High

The basement service department at this store is quite large. The bench area is extensive enough to accommodate three part-time helpers who put in several hours now and then repairing radios. This, aided by the two service departments, helps this Rockford firm to turn out a large amount of profitable repair jobs during war-time.

Pat Mera, who works in the basement service department, returned to his private radio repair work in December, 1944, after a long period of service with the army. He is a veteran of the army's Italian campaign. A member of the 36th combat engineers, Pat and a detail went out one night on a special job. Germans spotted them and opened fire. Everyone in the detail, except Pat, was killed. Pat received nine wounds in this engagement with the enemy.

Army Training Valuable

He learned a lot in the army, he says, but he is glad he is back in private business.

In the days preceding the war, the store maintained a warehouse in the area, which was filled to the rafters with all kinds of products. With the disappearance of merchandise from the market, the picture has changed a great deal. The warehouse has been almost cleaned out, and the stock—what is left of it—has been placed in the company's sales room.

Radios that had been taken in trade have been hauled out, reconditioned, and sold. The same procedure has been carried out with refrigerators, washing machines, ironers and other equipment which the firm has sold.



***COMING!
A Sensational
Announcement
to All America!***

Hold everything until the big NEWS breaks!

**Through
EMERSON
Franchised
Dealers Only**

ONLY dealers who display the Emerson Franchise will share in the nationwide promotion campaign shortly to be announced.

If you have not already done so, ask your Emerson distributor how you can qualify for the Emerson Radio Dealer Franchise.

WHEN THE WORD "GO!" is given, the eyes of all America will be focussed on the NEW Emerson Radio line—superlative sets for every purpose and every purse—Television that creates a theatre in every home.

Engineered into the new chassis and imparted to the crisp outer designs will be entirely new concepts of Style, Tone, Performance and Value.

Emerson's leadership—the World's Largest Maker of Small Radio — will be reaffirmed, not only through sensational new products, but also in a campaign of advertising (cooperative and national) that will dwarf all previous promotion.

Before making ANY plans—before making ANY merchandise commitments—watch for the forthcoming announcement.



**Emerson Radio
and Television**



EMERSON RADIO AND PHONOGRAPH CORPORATION, NEW YORK 11, N. Y.

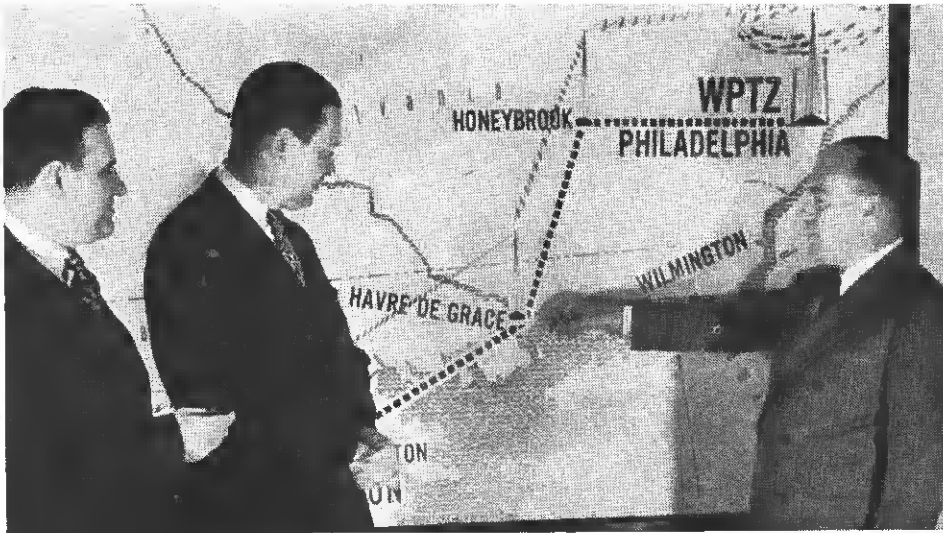

F. J. Bingley (left), chief television engineer Philco Corp., FCC chairman Paul A. Porter and Philco president, John Ballantyne, look over map of television relay network.

Television Relay Network

Multiple Video Repeater Stations Demonstrated

The antenna arrays mounted atop the towers are substantially identical. One tower is used to carry the receiving array, while the other mounts the transmitting array. The antenna system consists of 24 dipoles in a reflector-radiator combination, giving a gain of approximately 24. When used with the 40-watt transmitter, the overall reliability of the system is quite high.

The receiving equipment consists of a resonate line frequency controlled receiver with an if system at approximately 39 megacycles. The receiver is complete and independent

• Another outstanding development in the field of television relay operation recently has been demonstrated by Philco engineers. This network is considerably more elaborate than others previously demonstrated. It consists of four jumps of approximately forty miles each from Washington, D. C., to Philadelphia. A total of six transmitters handle the television program as it originates in Washington.

Five of these transmitters are rated at 40 watts each and operate in the frequency channels of 204-216 mc or 230-242 mc. That is, transmitters at alternate relay points operate on different channels so that received signals at any relay point are not obscured by the transmitted signals from the same relay station.

Transmitter Circuits

The 40-watt relay transmitters use a lighthouse type tube in a transmission line type of frequency controlled circuit. The transmitters are housed, along with other equipment, in automobile type trailers which are located at the base of the 100-foot towers supporting separate transmitting antenna arrays and separate receiving antenna arrays. The antenna towers are of structural steel with a triangular cross section. The towers and equipment at Arlington are shown.

Receiving and transmitting towers of Arlington relay (upper left). 40-watt transmitter (left), also receiving and monitoring equipment used at each relay point. This equipment is housed in portable trailers.

of the transmitter. The picked-up signal is amplified and demodulated down to video frequency. The video frequencies are then used to modulate the transmitter.

The results of the relay system, from an engineering standpoint, were considered to be quite satisfactory.

Recent Demonstration

This television relay has proven successful on its first public trial. On April 17th a program originating in Washington was relayed by the network to the television audience in the Philadelphia area. Appearing on this inaugural telecast from Washington, were the Honorable Paul A. Porter, Chairman of the Federal Communications Commission, Doctor Karl T. Compton, President of the Massachusetts Institute of Technology and Chairman of The Research Board for National Security and John Ballantyne, President of Philco Corporation. FCC Chairman Paul A. Porter speaking on this telecast said:

"The opening of this new multiple-relay is an example of the vigor with which the problems of television are being attacked. The creation of networks is the heart of the problem of how to expand television into a nationwide service.

"The Philco Corporation is to be congratulated on pioneering in this vital aspect of the television art. Its vision and enthusiasm thus give it a distinguished 'first.' This demonstration is a harbinger of exciting things to come."

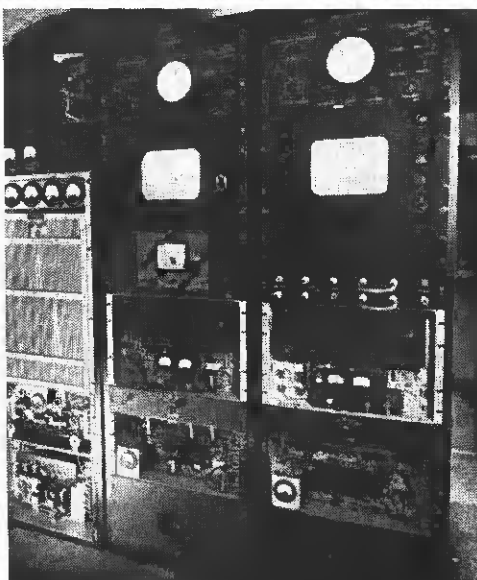
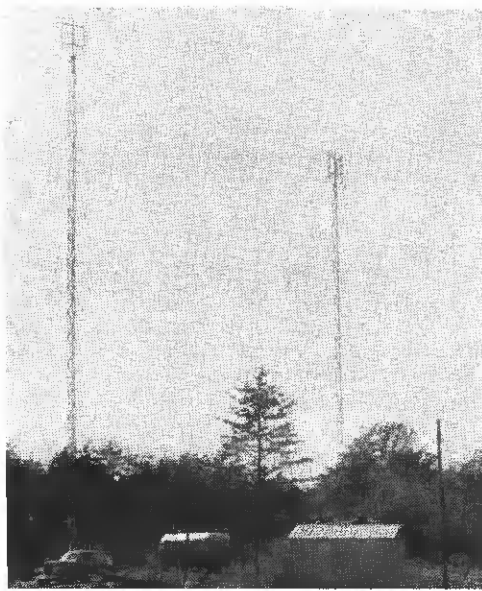

the **HOWARD** *Radio* franchise means

- ✓ **Outstanding Quality and Design**
- ✓ **Dependable Delivery Schedules**
- ✓ **Values that Generate Consumer Sales**

... these are the plus factors that have made our trade relationships so successful in the past decades.

With few exceptions, all components of Howard Radio receivers are designed and built right in our own plant—many of them under valuable patents which we control. From the most intricate mechanical and electrical parts to the rich character-styled cabinets, Howard Receivers are our own productions.

With this policy of Howard engineering and production personnel both working under one roof with the finest and most modern equipment, it is possible to maintain efficient manufacturing schedules and the highest degree of quality control—important factors that add up to greater consumer values and better business for Howard dealers.



GET THIS NEW HOWARD BROCHURE

an opportunity for progressive dealers and distributors . . .

Howard, as America's Oldest Radio Manufacturer, has proved its abilities to design and build radios that enjoy popularity, prestige and sales success. If you want a nationally advertised radio line with which you can build permanent post-war business get in touch with us now.

HOWARD RADIO COMPANY
1731-35 BELMONT AVE • CHICAGO 13, ILL.

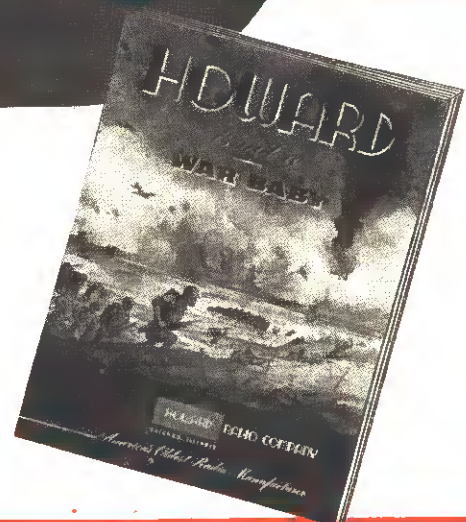

America's Oldest Radio Manufacturer

SERVICING DETECTORS

Plate and Diode Detection. Fading and Distortion. First of Two Articles.

• Radiomen generally find the detector stage more difficult to service than any other, except the oscillator or converter stage. This may be due to the two-fold or 3-fold action that often takes place in this stage: detection, amplification, and frequently, AVC. A brief review of the detection process may prove helpful in understanding and locating troubles that develop in detector circuits.

When a carbon microphone—the carbon mike is chosen for simplicity—changes speech sounds into elec-

trical impulses, a varying direct current results. Fig. 1A represents this current very simply. The audio wave shown here is not capable of traveling the great distances that radio signals must cover. It is therefore placed in a radio-frequency carrier, like a passenger in an airplane. Since these RF waves have far greater radiating ability than the audio frequencies, they provide ideal transportation for the broadcast audio signal.

When a carbon microphone—the carbon mike is chosen for simplicity—changes speech sounds into elec-

trical impulses, a varying direct current results. Fig. 1A represents this current very simply. The audio wave shown here is not capable of traveling the great distances that radio signals must cover. It is therefore placed in a radio-frequency carrier, like a passenger in an airplane. Since these RF waves have far greater radiating ability than the audio frequencies, they provide ideal transportation for the broadcast audio signal.

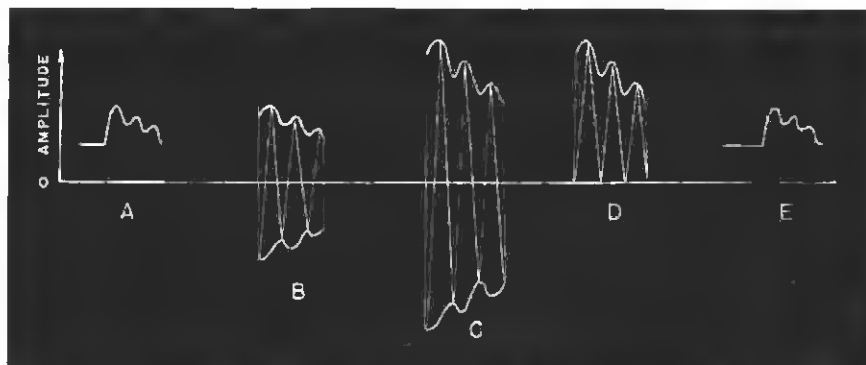

Fig. 1—Signal changes from carbon mike to detector. A—Original signal. B—Signal in modulated RF carrier. C—Amplified, signal-modulated IF wave. D—Rectified, signal-modulated IF carrier. E—Signal after detection.

trical impulses, a varying direct current results. Fig. 1A represents this current very simply. The audio wave shown here is not capable of traveling the great distances that radio signals must cover. It is therefore placed in a radio-frequency carrier, like a passenger in an airplane. Since these RF waves have far greater radiating ability than the audio frequencies, they provide ideal transportation for the broadcast audio signal.

Just as passengers get off their plane, or car, when they have reached the end of their journey, just so must the audio wave separate itself from its RF carrier. The right moment for this separation occurs after the audio-modulated RF wave has been received and amplified, the RF carrier changed to an IF wave for better selectivity, and the modulated IF wave has been amplified to the desired level.

The process is illustrated in Fig. 1. In A, we have the varying DC audio wave. In B, it has modulated the RF carrier. The audio-modulated RF wave is then received, amplified, and converted into an audio-modulated

input signal works along the linear part of the curve, and is accurately reproduced and amplified. The negative, unwanted part of the input signal works below the operating point B (see Fig. 2), along the non-linear portion of the curve. Very little amplification occurs in this section, because it is near cut-off. The result

is that the IF input signal is rectified. A small mica capacitor (C_1 in Fig. 3) by-passes the undesired IF variations from the plate circuit.

Diode detection is another very commonly used method of detection. The diode triode detector, in addition to performing the steps shown in Figs. 1D and 1E, supplied AVC to the tubes preceding it, and amplifies the audio signal as well. The operation of the entire stage may be described as follows:

The signal is impressed by transformer action across the diode coil and tuning capacitor L_1 and C_1 . (See Fig. 4.) These are tuned to resonance so that maximum signal voltage will be produced. When the AC signal is at the negative part of its cycle at the diode plate, no current flows between cathode and diode. When the positive portion of the cycle makes the diode plate positive toward cathode, electrons flow from cathode to diode, to A, to H, to E. The filter system C_3 , R_1 and C_5 shunts IF current to cathode, so only rectified, audio voltages appear between the control grid, G, and the cathode of the diode-triode detector.

Electrons, in addition to flowing from A to H to E, also flow, in parallel, to F and J, and the control grids of the tubes preceding. This electron flow varies with the signal strength. Greater signal strengths produce greater flows of electrons through the diode plate, and the circuits A to E, and A to J. The grids of the AVC-controlled tubes become more negative, resulting in the passage of

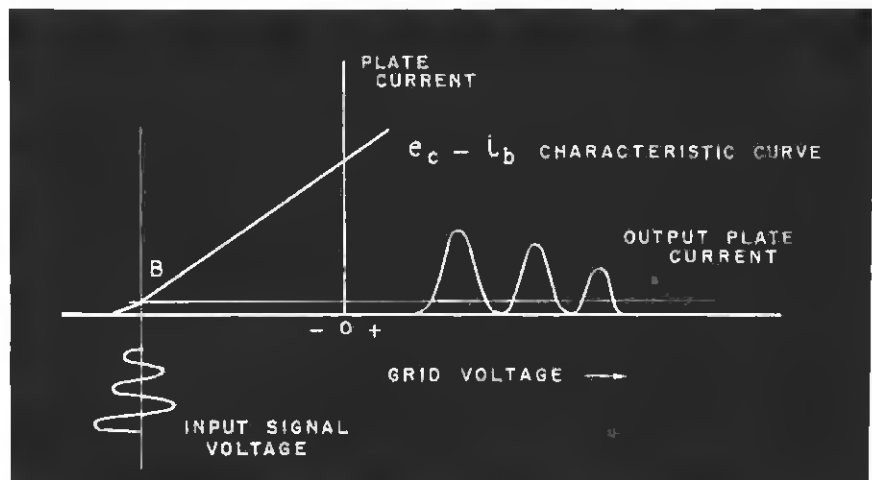

Fig. 2—Plate detection process. Biasing detector near cut-off rectifies the signal output.

less plate current, and less amplification occurs. Lesser incoming signal strengths produce lesser flows of electrons—control grids become less negative, and greater amplification results. The net effect is to keep amplification substantially constant, regardless of the great variations in signal input strength.

Blasting, uneven signal reception during tuning, and the passing over of weak desired stations, are thus prevented by this automatic volume control action. Capacitor C6, the AVC filter capacitor, by-passes audio variations in signal strength, because these are desired variations. If these variations were not by-passed, but were allowed to affect the grids of the AVC-controlled tubes, undesired flattening out of audio levels would occur. Fluctuations in RF carrier input alter the charge on the AVC capacitor, and thus change the bias on the controlled grids.

A trouble common to both plate and diode detector stages is fading. One of the most frequent causes of this fading is a faulty detector tube, like the 12SQ7, 6SQ7, 6Q7, 12Q7, 6C6, 75, 77, etc. Fading detector tubes

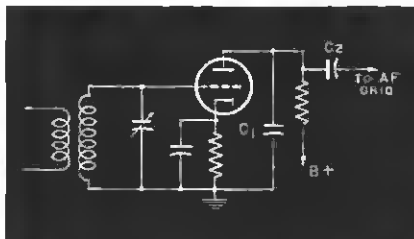

Fig. 3—Plate detector circuit. Bias resistor is large enough to operate tube near cut-off.

are generally noisy, and may be located often by this characteristic. When a detector tube produces a slight h-s-hing sound when tapped, it will very probably fade, and should be replaced.

Fading detector tubes have characteristics that differ from those of fading tubes in other circuits. Fading RF tubes generally cause most, if not all, stations to disappear. With fading detector tubes, however, most stations are still received, although distortion is generally present. This difference generally exists between fading detector and power tubes: distortion present when detector tubes fade is usually apparent at high or low volume, rarely on both. With fading power tubes, however, distortion is present at all volume control settings.

Very often, the fading detector tube produces rises and ebbs in vol-

Causes of Fading in Diode Detectors	
Trouble	Clue
1. Intermittent open in AVC filter capacitor.	Reception recurs gradually.
2. Fading detector tube.	Tube usually noisy when tapped.
3. Intermittent open in coupler (C2 in Fig. 4).	Reception after fading low but clear.
4. Intermittent open in blocking capacitor (C4 in Fig. 4).	Volume control has no effect after fading.
5. Intermittently shorted or dirty volume control.	Tapping control causes symptoms to appear.

ume, causing the set to play alternately loud and low. Tapping the tube will usually cause it to act up. Replacement, and retesting for fading, is the only sure test for a fading detector tube.

Another common cause of fading is an intermittent open in the coupling capacitor (C2 in Figs. 3, 4), located between the plate of the detector and the grid of the first audio tube. Fading produced by an open like this can generally be identified by this characteristic: reception will be very low, but not noticeably distorted. All stations appear, although not all can be heard.

Wiggling the capacitor about, or squeezing it gently with long-nose pliers, will usually cause it to become intermittent. When it has opened, but uncertainty is present whether this capacitor is actually to blame, try injecting antenna signal at plate and grid sides. If noise response is much greater at grid than at plate side, the capacitor is defective. Very often, a test of this sort is useless, because injection of antenna signal may heal the intermittent open. In such cases, signal tracing equipment may prove helpful. The presence of much weaker signal at grid than at plate is a sign that the coupler is open.

Fading not infrequently results from an intermittent open in C4, the volume control to detector grid coupler (see Fig. 4) in diode-triode systems. Reception is generally free from distortion when fading has occurred, and stations appear in their proper places. Symptoms produced will resemble those accompanying an open in C2, the detector plate to audio grid coupler. This difference,

however, generally exists: rotation of the volume control will affect the volume in the case of the C2 open, but not in the case of the open C4.

The effect in the latter case may be explained by considering the opening in C4 as equivalent to a high resistance in series with C4 (see Fig. 5). A voltage dividing system for the signal exists from A, to B, to G, to C. Whereas the signal formerly reached point G, the grid, with a strength reduced only by the volume control resistance, R1, and the small reactance of C4, it is now attenuated in greatest part by R2, which is so great compared to R1, that the controlling effect of R1 becomes negligible.

Shorting Capacitor

Intermittent shorts in C4 sometimes occur. Fading results. Reception may, or may not be noticeably distorted, depending on the degree of the short, and the tube and circuit present. When C4 short-circuits internally, it no longer blocks the DC voltage developed across R1 and R3 (see Fig. 4). The DC grid bias on the triode becomes more negative, and decreased amplification results. This type of trouble may be detected by checking voltage on either side of C4 to B-. Voltage to B- should be higher on the volume control side of the coupler than on the grid side. If the voltages are equal to B-, the coupler is probably shorted. To verify, disconnect it and test with an ohmmeter for short.

Dirty volume controls, or controls where poor contact exists between the rotating arm and the composition element, are very frequent causes of
(Continued on page 86)



Centralab

LEVER ACTION SWITCHES

particularly adapted to broadcasting, receiving, public address, test instruments and individual uses.

These Centralab switches are available in ten different combinations including positive and spring return action types with either shorting or non-shorting contacts used singly and in groups.

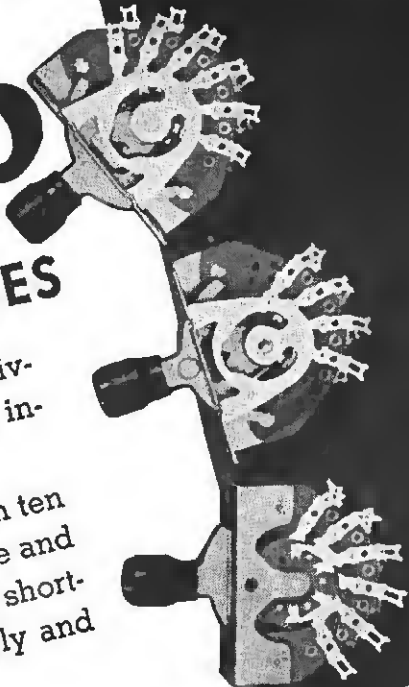

Centralab

SELECTOR SWITCHES

are available to servicemen and experimenters in kit form . . . or standard, completely assembled and individually cartoned.

Insulation . . . either steatite or bakelite. All switches have double-wipe contact terminals for long life and have a consistently low contact resistance of less than 2½ milliohms and are completely self-cleaning. Index is positive with 30° between each rotating position. Switches are also available for transmitter use.

Send for illustrated Catalog No. 24.



Producers of
Variable Resistors
— Selector Switches
— Ceramic Capacitors, Fixed and Variable
— Steatite Insulators
— and Button Type Silver Mica Capacitors.



Centralab

Division of GLOBE-UNION INC., Milwaukee

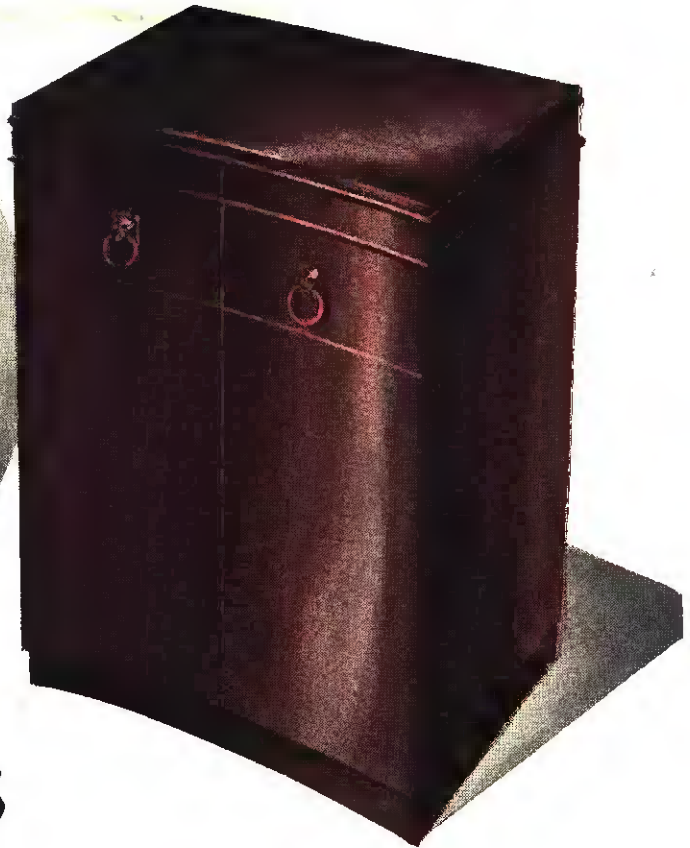
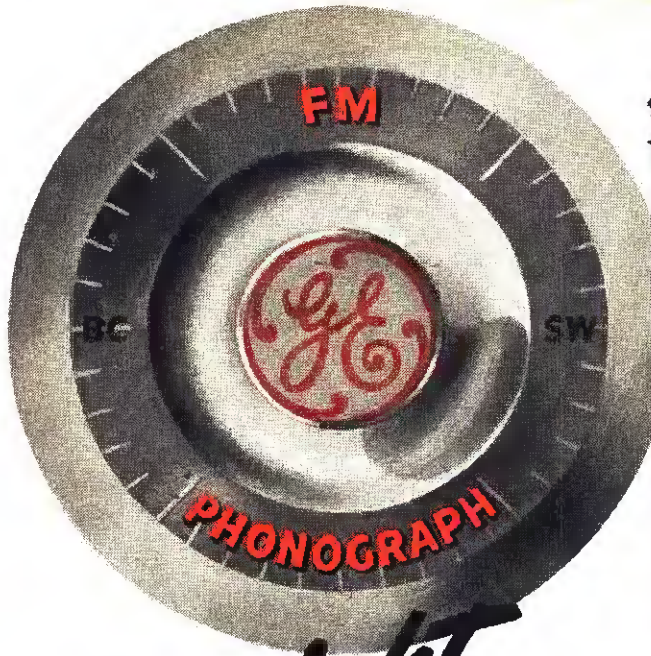

The right combination

...for post-war radio **SALES** and **PROFITS!**

THOUSANDS of your customers are eagerly waiting for the time when they can buy a G-E radio-phonograph or one of the other coming models. How do we know? *Because they've told us!*

This intense public interest in coming General Electric radios of all types, especially FM radio-phonograph combinations, is the result of these two important facts:

- 1 G-E radio will be of unprecedented quality, guaranteed by superior component parts, war production innovations and improvements, rigid inspection and testing methods;
- 2 The G-E tremendous pre-selling campaigns of the past three years—by far the greatest of any home radio manufacturer!

THE NEW G-E RADIO LINE WILL GIVE YOU THESE SALES-PRODUCING FEATURES:

FM (Frequency Modulation)—that virtually eliminates *static, interference and fading*; that brings *natural color music*, surpassing all previous standards of radio entertainment . . .

RADIO-PHONOGRAPH—that reveals music on records never heard before. G-E engineers have discovered a revolutionary way to bring to life

every tone of recorded music . . .

PLUS—brilliant improvements in all the regular features of radio.

Give your customers the best in post-war radio reception and radio-phonograph reproduction. Consult with your G-E radio distributor. Write to *Electronics Department, General Electric, Bridgeport, Conn.*

General Electric is building more military radio equipment than any other home radio manufacturer.

GENERAL ELECTRIC

175-02

PORTABLES • TABLE MODELS • CONSOLES • AUTOMATIC PHONOGRAPH COMBINATIONS
RADIO & Television RETAILING • June, 1945

Carmen Miranda's voice in natural color — a thrill only FM radio captures!

Her voice... her dancing... her "hot" personality... the thrill of her "natural color" in her radio talks. The G-E radio... the thrill of her "natural color" in her radio talks. The G-E radio... the thrill of her "natural color" in her radio talks.

GENERAL ELECTRIC
175-02
FM RADIO

One of the many full-color full-page G-E advertisements, carrying the story of FM radio to your customers.

PROTECTION

ALL THE WAY **UP**
AND **DOWN** WITH

THORDARSON

HERMETICALLY SEALED
UNITS

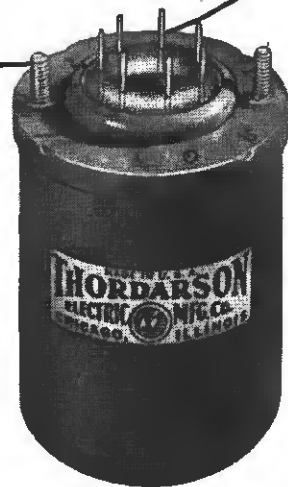
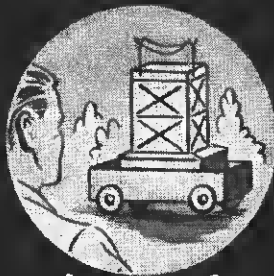
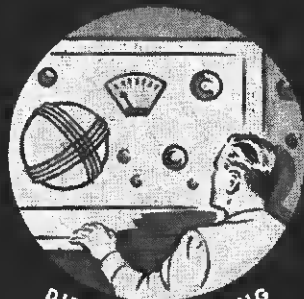
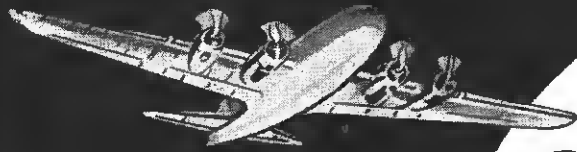

Thordarson pioneered with multi-terminal glass headers, thus insuring dependable service under all manner of conditions... in the tropics... high in the air... beneath the sea... *complete protection "from top to bottom"*! Your post-war transformers for communications and all types of electronic and industrial services will be available with Thordarson's hermetic seal.



THORDARSON

TRANSFORMER DIVISION
THORDARSON ELECTRIC MFG. CO.
500 WEST HURON STREET, CHICAGO, ILL.

Thordarson Special
50th ANNIVERSARY
SIGNALS OF TRUSTWORTHY SERVICE

Predictions in the News



Wear clothes that never
lose their press?
IT MAY BE SO



Will snow, bugs and dust
be deflected from wind-
shields of postwar autos?
IT MAY BE SO



I'll be late, honey
big conference

Will "Walkie-Talkie"
Replace Telephones?
IT MAY BE SO

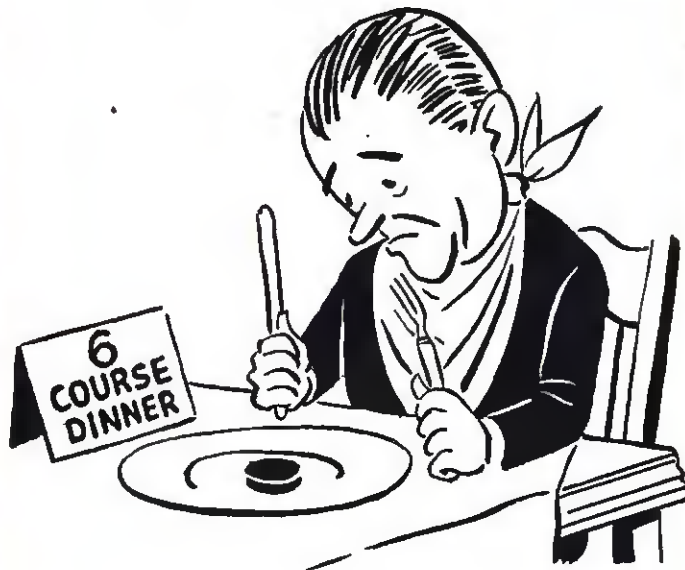

Super-Concentrated Foods?

IT MAY BE SO . . .



Future Clothes
Made of Glass?
IT MAY BE SO

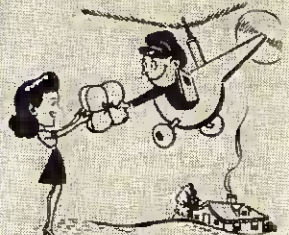

Department Store
Deliveries by Helicopter?
IT MAY BE SO

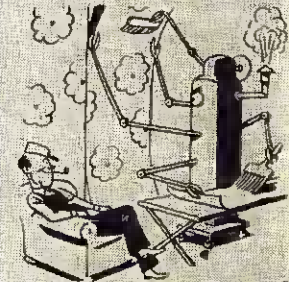

A Paper-Hanging Machine?
IT MAY BE SO

**IT MAY BE SO . . .
BUT THIS WE KNOW—**

YOU'LL HAVE A GREAT FUTURE WITH

NORGE

A BORG-WARNER INDUSTRY

SEE NORGE
BEFORE
YOU BUY

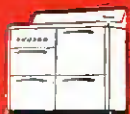

NORGE DIVISION
BORG-WARNER CORP.
DETROIT 26, MICH.
ADDISON INDUSTRIES, LTD.
TORONTO, ONTARIO

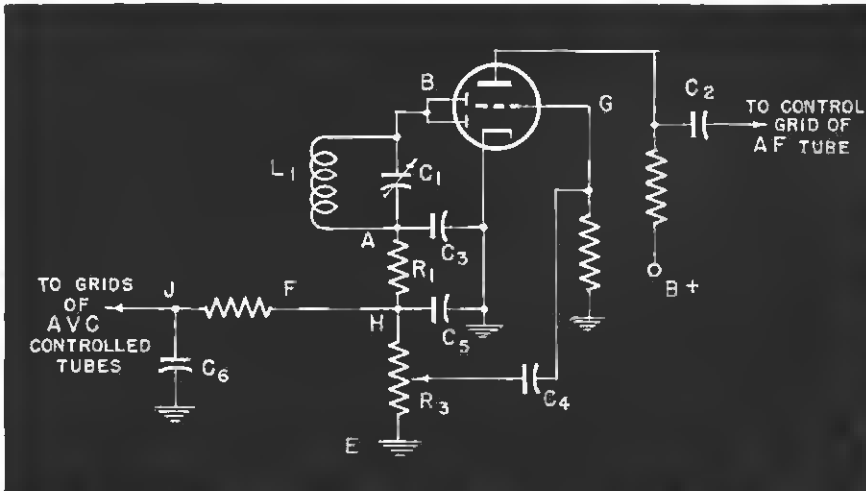

Fig. 4—Duo-diode triode detector circuit. Diode section of tube rectifies input signal and supplies AVC to preceding tubes. Triode section amplifies the rectified signal.

(Continued from page 81)

fading in duo-diode triode detector circuits. The high resistance opens that result from these poor contacts have the effect of very small capacitors placed in series with the resistance of the control. Signal is attenuated by these low-capacitance high reactance openings, and volume is therefore intermittently decreased.

Fading caused by intermittently shorted volume controls is sometimes difficult to track down. Tiny pieces of solder, or metal filings, may get between the blades of the control and its external, grounded envelope, producing transient shorts resulting in fading and distortion. If this type of trouble is suspected, disconnect the wires from the control, place one ohmmeter test lead on ground side, the other lead on each of the other terminals in turn. Tap the control from all angles, with varying degrees of force, rotating it during the process. If short readings occur momentarily between any two terminals, the control is defective.

Low volume is produced by shorts in the volume control because the diode load resistance becomes less, which causes "loading" of the diode coil, change in coupling, and lowered Q factor.

Intermittent AVC capacitor

The AVC filter capacitor, C6 in Fig. 4, may open intermittently, causing fading. Distorted, very low reception generally characterizes reception. Many stations are not received. Very low noise level is present at between station settings of the tuning capacitors.

If any uncertainty is present whether it is this capacitor or some other one that is opening and caus-

ing these symptoms, this characteristic may be looked for: when normal reception recurs in the case of an intermittent AVC filter capacitor, it will come up gradually, not all at once. This is so because a time constant is present; the capacitor must charge up fully before it affects the circuit.

Signal tracing equipment will readily detect an open in C6. Audio signal will be noticeably present at point J (see Fig. 4), the ungrounded side of the capacitor, whereas it is normally negligible there.

Intermittent opens in dry C cells used for detector grid bias may cause fading. Trouble of this sort can be readily detected by crossing the cell with the fingers, or voltmeter test prods. If volume of reception is brought up, the C cell is to blame.

Leaky Coupler

The most common cause of distortion in diode and plate detector circuits is a leaky or shorted coupling capacitor (C2 in Figs. 3, 4). When a full short occurs in C2, reception may be very low and distorted, or may not appear at all. This type of defect is easily located, since the grid of the power tube becomes positive toward its cathode in such a case, as a voltage test will show. Almost equal positive voltages toward B will exist from triode plate and first audio grid. Triode plate voltage will be low.

When a high resistance or leaky condition develops in this coupling capacitor, a positive voltage may not always be present from first audio grid to cathode. The voltage may be zero. Absence of negative voltage from audio grid to cathode should be sufficient grounds to test the

coupling capacitor. Even with zero bias, contact voltage effects should produce a deflection on the voltmeter when test leads are placed on control grid and cathode of first audio tube.

Sometimes very high resistance openings in coupling capacitors develop that do not swing the voltage from negative to positive, or to zero, from 1st AF grid to cathode. The negative voltage reading is merely decreased. Cases of seemingly obscure distortions, where all operating voltages appear to be correct, are often traceable to such high resistance leaks in coupling capacitors.

If a source of distortion is not readily apparent, it is a good practice to substitute another coupling capacitor and note effects. A rough test for a high resistance short in a coupler is to inject antenna signal into both sides of the capacitor in turn. If the capacitor is not leaky, it will practically short-circuit the antenna signal, so that noise response will be equal on either side. If it is leaky, noise response will be greater on the grid side than on the plate side, because the antenna signal will be attenuated by the leak resistance from plate to grid.

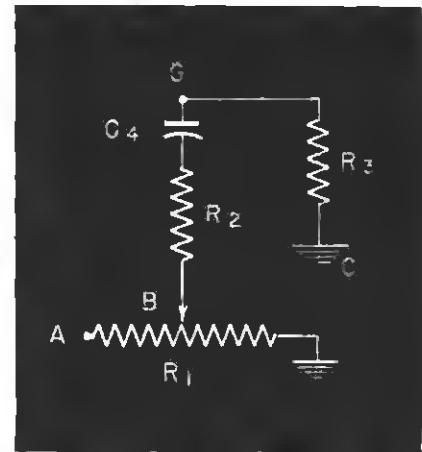

Fig. 5—An open in C4 is equivalent to a high resistance, R2, in series with C4.

Opens in volume controls in diode-triode detector circuits may cause distortion. If these opens are not revealed by resistance tests, watch for a deflection that seems a bit too sharp, when ohmmeter test prods are placed from either side of the control to center tap, and the arm rotated. Placing voltmeter prods from either side of control to center tap while set is playing, and listening for improvement, is often a good test.

Other defects in plate and duo-diode triode detector stages will be considered in the July issue of RADIO and Television RETAILING.

THESE ARE THE
Sonora
 DISTRIBUTORS
*and they're all set to help
 you sell—PLENTY!*

Akron: Graybar Electric Co.
 Albany: Rapid Sales Co.*
 Asheville: Graybar Electric Co.
 Atlanta: Charles S. Martin Distributing Co.
 Baltimore: Nelson & Co., Inc.
 Bangor: Maine Industries Co.
 Binghamton: Florence Electric Supply Co., Inc.
 Boise: Davis Supply Co.
 Boston: Milhender Distributors, Inc.
 Buffalo: Bison Electrical Co., Inc.
 Butte: George Steele & Co.
 Charleston, S. C.: C and D Distributing Co.
 Charleston, W. Va.: Chemcity Radio & Electric Co.
 Charlotte: Graybar Electric Co.
 Chicago: Walker-Jimieson, Inc.
 Cincinnati: Auto-Rad Supply Co.
 Clarksburg: Johnson Hardware Co.
 Cleveland: Graybar Electric Co.
 Columbus: Standard Paper Co.
 Dallas: Higginbotham-Pearlstone Hardware Co.
 Denver: Morey Mercantile Co.
 Des Moines: The Lagoe Co.
 Detroit: Graybar Electric Co.
 Durham: Graybar Electric Co.
 El Paso: Diehl and Lehman Appliance Co.
 Evansville: Boetticher & Kellogg Co.
 Fargo: Northwest Electric Supply.
 Flint: Graybar Electric Co.
 Harrisburg: Jno. E. Graybill & Co.
 Houston: Texas Farm Supply Co.
 Indianapolis: Electric Appliances, Inc.
 Jackson: Ryan Supply Co.
 Jacksonville: French Nestor Co.*
 Kansas City: Ryan Radio & Electric Co.*
 Knoxville: Valley Appliances, Inc.
 Lansing: Graybar Electric Co.
 Louisville: Sutcliffe Co.
 Marinette: G. M. Popkey Co.
 Memphis: W. B. Davis Electric Supply Co.
 Milwaukee: Clark Supply Co.
 Minneapolis: Leitz Carpet Corp.*
 Muskegon: Manufacturers' Sales Co.
 Nashville: Electra Distributing Co.
 Newark: Beller Electric Co.
 New Haven: The Electronic Sales Co.
 New Orleans: Monroe Hardware Co.
 New York City: Barth-Feinberg, Inc.
 Oklahoma City: M. L. Foster Co.
 Omaha: H. C. Noll Co.
 Peoria: S and S Distributors
 Philadelphia: Franklin Electric Co.
 Phoenix: Arizona Wholesale Supply Co.
 Pittsburgh: L. H. Smith, Inc.
 Pocatello: Billmeyer's
 Portland, Ore.: United Radio Supply, Inc.
 Providence: Milhender Distributors, Inc.
 Reading: The George D. Barbey Co.
 Richmond: Goldberg Co., Inc.
 Rochester: Masline Radio & Electronic Equip. Co.
 Rutland: Vermont Electric Supply Co.
 St. Louis: Appliance Distributor Co.
 San Antonio: Southern Music Co.
 Scranton: Charles B. Scott Co.
 Spokane: John W. Graham & Co.
 Springfield, Mass.: Springfield Radio Co.
 Toledo: Graybar Electric Co.
 Winston-Salem: Graybar Electric Co.
 Worcester: Radio Maintenance Supply Co.

* Includes branches



SONORA RADIO & TELEVISION CORPORATION
 325 North Hoyne Avenue • Chicago 12, Illinois

RADIOS • TELEVISION SETS • RECORDS • PHONOGRAPHS • RECORDERS
 • HOME ENTERTAINMENT AT ITS BEST •



HAVE YOU LEARNED
 ALL THE FACTS
 ABOUT THE SONORA
 FRANCHISE?

About SONORA's powerful national advertising campaign? About how SONORA advertising definitely builds checkable store traffic for SONORA dealers? About SONORA's powerful merchandising helps? About SONORA's complete line of 37 radios, built to sell in volume, to make bigger profits for SONORA dealers? Better not wait. Get in touch with the SONORA distributor in your territory now.

SPRAGUE TRADING POST

A FREE Buy-Exchange-Sell Service for Radio Men



371 of the 8037
Sprague Components ...

... produced in a
single year!

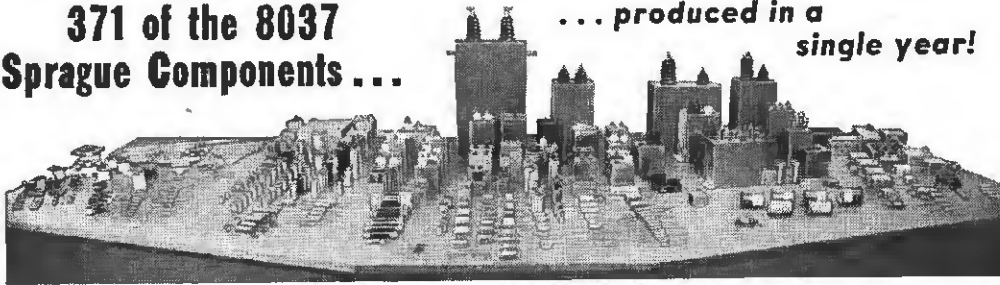

Some idea of the extent of Sprague's war effort may be gained by the fact that it took only 365 days to produce 8,037 types, sizes, and styles of Sprague Capacitors, Koolohm Resistors and other components such as those shown here. Many of

the types illustrated represent important engineering achievements which will mean still better, even more reliable capacitors and resistors for post war use. You can always count on Sprague for engineering leadership!

FOR SALE—New Hallcrafters SX-28 15-tube with 15" Jensen speaker in bass reflex cabinet. Want Howard 490, 14-tube receiver. C. Visser, 196 Moselle St., Buffalo, N. Y.

WILL TRADE—Stevens 12 gauge dbl hammerless shot gun for any make tube checker, late model tubes. Sgt. Wayne D. Copeland, Henderson Police Dept., 1251 Loeb, Henderson, Ky.

WANTED—A. C. sig. gen. for alignment work. Prefer late model Supreme, Hickok or Triplett. John G. Blake, 1009 Crenery Ave., Toledo 7, Ohio.

FOR SALE OR EXCHANGE—Superior sig. gen 1230; DayRad 331 tube tester, Philco Audio sig. gen.; Westinghouse type MX 0-250v d.c. meter and Westinghouse type NX 0-15v combined with 0-2 meg. both in same case. Waldo Senechal, Valua, N. Dak.

URGENTLY NEEDED—Code machine complete with tapes for instructional purposes. Cash. LAC. Stillin F. L., R-266982, Hqrs. N.W.A.C.-R.C.A.F. Edmonton, Alberta, Canada.

FOR SALE—Majestic radio tubes 6-6B7, 3-6B7, 3-6Z5, 3-2S, 2-89, 1-6C7, 2-59, 3-48, 1 Cardon 401. \$20. Bothyl Radio Shop, 1009 Sophia St., Muskegon 25, Mich.

WANTED—New or used phono pickup unit; phonomotor and parts; radio parts, kits, test equipment. What have you? Edward Howell, Route 2, Dillon, S. C.

FOR SALE OR EXCHANGE—New tubes in original cartons 18-35Z6G, 500-6JGT/G, 100-24A, 30-6SK7GT, 50-6F8G, 26, 35A, 37, 38, 39/44 Philco, exchange for 27, 58, 25Z5, 60L6, 45, 47, 6X5, 6A7, 6A5, etc. B. & M. Radio Company, 1110 Flushing Rd., Flint 4, Mich.

WANTED AT ONCE—Hallcrafters SX-25; SX-24 or S20R, for cash, Warren Chase, Vermont Sanitorium, Pittsford, Vt.

FOR SALE—Almost new ROP #666 electronic vacuum tube voltmeter, \$35.50; R.C.P. #419 master multimeter \$34.50. Bill Lifsey, 318 Page St., Flint 4, Mich.

FOR SALE—1-25L6, 1-80, 3-26, 1-71A, 3-X99 tubes, \$8. Also power supply (135v, 75v, 35v, 5v, 3a A-A. C.) uses 2-80, \$2; want double section 370-0mf variable with airplane dial assembly. Robert Annable, Chittanooga, Rt. 2, N. Y.

WANTED—Hickok 156 traceometer; 188X sig. gen; RFO-5 oscillograph; 210 voltmeter; Rider chanalyt, voltohmyst. Have camera equipment to trade. E. B. Stewart, Box 349, Forrest City, Ark.

WANTED—Automatic record changing unit. Will trade or sell G.I. dual speed basic recording unit and Thorderson driver transformer. #6578, 6F6 Triode to 1P 6F6 Triode. C. Schneider, 1624 Binney St., Omaha 10, Nebr.

FOR SALE—Superior sig. gen. #350 almost new, \$29.50. Harry W. Smith, East Setauket, Long Island, N. Y.

WILL TRADE—12K8, 12SA7, 25L6, 50L6, 35Z5 and other tubes for phono motors, pickups, auto. changers, recorders and table radios. J. B. Starnes, 1108 1/2 S. Alameda, Corpus Christi, Texas.

FOR SALE—BR-44 bridge, measures to 100 mfd. and 100 megohms; like new \$25. Charles B. Cerates, 2132 W. 78th St., Los Angeles 44, Calif.

WILL TRADE—Hard-to-get tubes and cash for Sprague Deluxe Telohmike, W. E. Myers, 4681 Mission St., San Francisco, Calif.

FOR SALE—Weston meters, 301 dc. and 476 ac. John J. Hanaski, 325 Bellevue Ave., Tonkers 3, N. Y.

WANTED—Phono motors and crystal pickups, tubes and radios. J. M. Stegert, 2018 Brownsville Rd., Pittsburgh 10, Pa.

WILL TRADE—Abbot DK2 uhf trans-receiver, mike, headset and power supply for Echophone EC-1 receiver. Morton Bardfield, 4 Brinsley St., Dorchester 21, Mass.

FOR SALE—H.R.O. receiver and Hallcrafters 8-16; also G.E. 12-tube chassis E-126, 550kc to 70mc. Willard Thiel, 96 Westbury Blvd., Hempstead, N. Y.

URGENTLY NEEDED—4523 tube, also want 1A7, 12SA7, 35L6, 35Z5, 60L6, 70L7, and 117Z6 tubes. State quantity and price. Otis H. Wyman, 217 Kingshighway, Murfreesboro, Tenn.

URGENTLY NEEDED—Complete set riders (or less) new or used. Boise Radio Service, 1604 Washington St., Boise, Idaho.

WILL TRADE—Slightly used 1H5G tube for 12SQ7 tube. Walford Thomas, Route 1, Headsick, Okla.

WANTED—Good amplifier 10-15 watt for phono pickup. T. Shapiro SAD 3/c R/S Navy Yard, Philadelphia 12, Pa.

WILL TRADE—Refrigerator tag temperature recorder 24 hr. factory rebuilt clock with 100 charts, for short wave receiver. Myron W. Hill, Rt. 2, Tiffin, Ohio.

WANTED—Sig. gen. tube tester or other test equipment. A. D. Casey 1203 Cherry St., Orange, Texas.

FOR SALE—Used RCA R-100 phono player attachment \$10; push-pull 4 1/2 watt ac-dc phono amplifier tone control with tubes \$30; home constructed 3 watt phono amplifier ac. with 5" pm speaker \$15. Herbert Jacobowitz, 1412 Franklin Ave., Bronx 56, N. Y.

WANTED—Heavy duty phono motor AC or AC-DC, 60 cycle, 78 r.p.m. Aaron Scheiner, 1323 Inwood Ave., Bronx 52, N. Y.

WILL TRADE—New RCA motor, turntable, crystal pickup and mounting plate for 35mm camera. Robert Hanson, 3007 Oakes St., Seattle 99, Wash.

FOR SALE—tubes 1 to 10 ea.: 6SN7; 6XFM; 7A5; 7A4; 7A6; 7A7; 7B8; 7C5; 7F7; 7Z4; 8Y6; 8U8; 6SK7; 57; 89; 1C7; 6N6; 12J5; 31; 39/44; 53; 19; 1B5/258; 1J6; 1E7; 1A4; 1C8; 40; 32; 1F4; 81; 10; 1A8; 46; 6C5; 6J5; 1L48; 1R5 with adapters for 1A7, 20% discount. Waters Radio Service, 19 Randall St., Greer, S. C.

URGENTLY NEEDED—Sig. gen. 25 cycle, all-wave; also late type tube checker. Cpl. Ralph E. Haines, Military Post Office, 107, Centuria, Ont., Canada.

FOR SALE—400 new tubes in cartons, incl. 12, 35 & 50v. types. No battery tubes. Will sell in one lot only. Also sell used Precision 912 tube checker; E-200 sig. gen.; Supreme 592 multimeter; Clough-Brengle 130 condenser tester; Rider chanalyt and Riders 1 to 13. John T. Duty, 140 Union St., Auburn, Maine.

FOR SALE—Superior ohmmeter and voltmeter 0 to 1000v d-c. 1500v a-c; 0-2 meg. Can be used as ohmmeter, milliammeter & output meter. \$26. Joseph Ruzicka, 924 - 17th Ave., S.E., Cedar Rapids, Iowa.

WANTED—Test equipment and tube tester not over 3 yrs. old. Sandy J. Jackson, R #1, Box #232-B, Blythe, Calif.

WANTED FOR CASH—RCA 165 Junior voltohmyst. Must be perfect. Vernon Kahane, Hudson House Branch, Vancouver, Wash.

SELL OR TRADE—Will build to your specifications sig. tracers, electronic VTVM reading AC-DC volts, ohms, megohms, and other test equipment, for cash or what have you? Nate Silverman, 435 Neptune Ave., Wilmington, Calif.

FOR SALE—Old short wave & transmitting tubes 01A; 71A; 112A; WD11, 228 —50c ea. 317—75c. Want 184 and 200. Radio Sales Co., 6202 Willard St., Shreveport, La.

WANTED—Hallcrafters SX-25 communications receiver or similar, any condition but estimate damage. D. E. Wilmoughby, 2208 Marion St., Columbia 1, S. C.

WANTED—Filter block #7269 for RCA B-11 power transformer—#44101 for Crosley 1117 speaker or Philco 20. F. A. Munson, Windham, N. Y.

FOR SALE OR TRADE—3A Shur 2-button mike like new. Want up-to-date tube tester or what have you? Walter A. Richards, 10 E. Badger St., Badger, Wis.

SEND US YOUR OWN AD TODAY!

For over three years now, the Sprague Trading Post has been helping radio men get the materials they need or dispose of radio materials they do not need. Send your own ad to us today. Write PLAINLY—hold it to 40 words or less—confine it to radio materials. If acceptable, we'll gladly run it FREE OF CHARGE in the first available issue of one of the five radio magazines wherein the Trading Post appears every month. HARRY KALKER, Sales Manager

Dept. RRT-65—SPRAGUE PRODUCTS CO., North Adams, Mass.

(Jobbing Sales Organization for Products of the Sprague Electric Company)



SPRAGUE CONDENSERS KOOLOHM RESISTORS

TM. REGISTERED U. S. PATENT OFFICE

Obviously, Sprague cannot assume any responsibility, or guarantee goods, services, etc., which might be exchanged through the above advertisements

1 I'M A LITTLE NEW at this game, see, and when this radio-phonograph prospect comes along, good old Joe flashes me the cue—

Quick
Watson,
the
needle!



2 THE NEEDLE of course! So before she can say a word I drop the Crosley Demonstration Record on the machine and let 'er roll. "Listen closely, Madam," I suggest. She smiles (very sweet). "You might try putting in a needle. I don't hear even a scratch."



3 "YOU'LL NEVER hear a scratch with the Crosley, Madam," I rejoin. "Strictly speaking this isn't a needle. It's the patented Crosley Floating Jewel* that says 'goodbye needle noise' forever". And I bring out the chart that shows the difference.



4 "NO MORE NEEDLES to buy, change, or hear—records last up to 10 times longer." She's all attention as the music comes in clear and true. "That is wonderful," she breathes. And then I show her how to work the Master Tone Control. Well—that's all brother . . .

HEARING is Believing

YOUR CROSLLEY floor models will sell themselves. Let your customers hear the Crosley Demonstration Record—the absence of needle noise and hiss—music as it has never been reproduced before. Then tell her this . . .

. . . Crosley offers every modern improvement in radio-electronic and phonograph engineering plus the finest cabinet work, plus unsurpassed mechanical skill, plus long-life construction. AND REMEMBER—every Crosley product brings your customers PLUS advantages they can see, feel or hear—features you can demonstrate—features that SELL!



Old fashioned sharp needles "Sora-a-itch! Hi-l-sss! Chatter!"

Crosley Floating Jewel* plays the untouched sides of record grooves!

CROSLLEY

THE CROSLLEY CORPORATION, CINCINNATI 25, OHIO

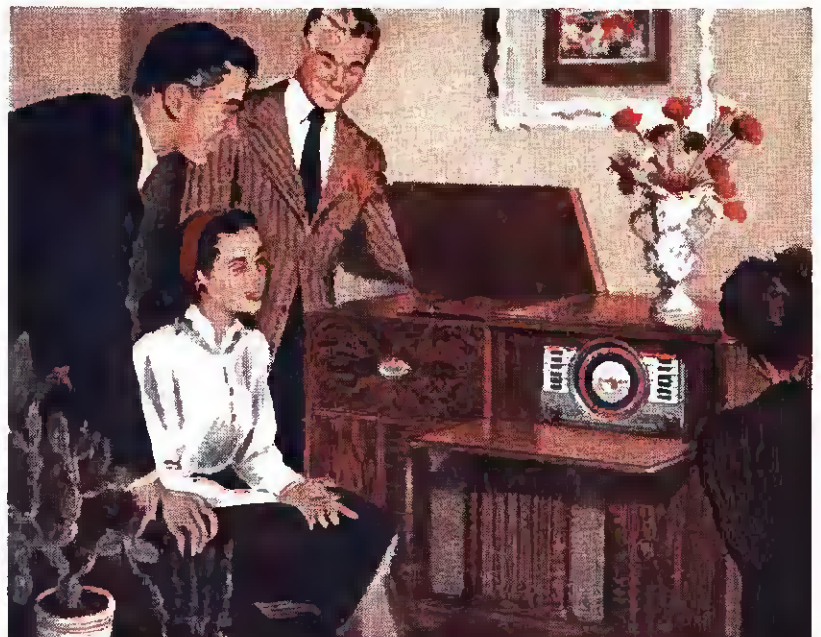

5 BUT NOT QUITE ALL. Because that customer has sent me in about a dozen prospects who have heard her Crosley and want one like it. That's what's good about qualities you can really see, or hear, or feel—when they can't argue with themselves you sell 'em every time.

*Patented

Radios ; Radio-Phonograph ; FM ; Television ; Short Wave ; Electronics ; Radar ; Refrigerators ; Home Freezers ; Household Appliances ; The Crosley Car Home of WLW, "The Nation's Station"



Helping to Broaden the postwar radio market!

IN further support of Sylvania's big advertising program designed to broaden the postwar radio market, the booklet shown below has been prepared and is being distributed to consumers everywhere.

In it there are answers to questions such as "How many people are planning to buy new radios after the war?"—"What type of postwar radio would they prefer to have?" (FM, television)—and many more—aimed to make it easier for radio manufacturers, distributors, retailers, to sell!

For copies write Sylvania Electric Products Inc., Advertising Department, Emporium, Penna.



SYLVANIA ELECTRIC

MAKERS OF RADIO TUBES; CATHODE RAY TUBES; ELECTRONIC DEVICES; FLUORESCENT LAMPS, FIXTURES, ACCESSORIES; ELECTRIC LIGHT BULBS



A FRIENDLY LETTER from One Business Man to Another

WARWICK MANUFACTURING CORPORATION

4640-50 W. HARRISON STREET



TELEPHONE ESTEBROOK 2727

CHICAGO 44, ILLINOIS

TO THE DEALER WHO IS BUILDING
HIS POSTWAR FENCES TODAY:

With a great number of radio manufacturers seeking to establish postwar dealer organizations, the problem confronting the retail merchant as to which lines he will handle, daily grows more complicated. Naturally, you want to know what CLARION offers that would make our dealer franchise a distinct advantage to the future of your business.

Here is the picture as I see it.

CLARION is aiming at the great middle market where volume sales mean volume profits. Our line will be built and priced to sell in volume against any competition.

CLARION is a name that has stood for quality for many years. Quality will continue to be our watchword.

CLARION believes in a sensibly short line. To avoid burdensome inventories, there will be no slow-moving luxury models, but there will be a model to meet every practical need.

CLARION believes in aggressive advertising and sales promotion. CLARION dealers will be backed to the limit.

CLARION believes in a limited distributor and dealer organization so that merchandise will be available in adequate quantities when it is needed.

So, if you should become a CLARION dealer, the CLARION factory will see, insofar as it is humanly possible, that you get your share of CLARION production when you need it.

That's about the biggest promise a manufacturer can make.

Cordially yours,
WARWICK MANUFACTURING CORPORATION

J. Holmes
President



YEARS OF PROVED PERFORMANCE

REVIEW OF

Jensen SPEAKER

Type NF-300 Reproducer is a special purpose speaker understandable through high ambient noise, useful where severe weather and trying operating conditions must be coped

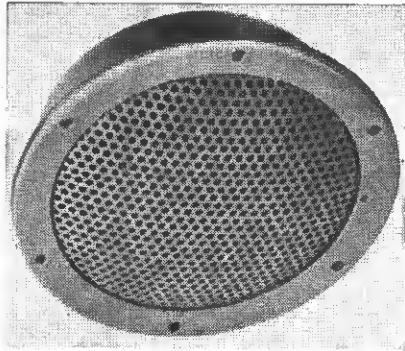

with. The design accentuates speech frequency, enabling the reproducer to override wind and background noise. Maximum power handling capacity for speech is 10 watts. Jensen Radio Mfg. Co., 6601 So. Laramie Ave., Chicago 38, Ill.—RTR

Apex MUSIC BOXES

Model 1-P1, piano cigarette music box, approximately 9 1/4" long, 5 5/8" wide, 4" high. Case made of genuine American walnut, top hinged with miniature piano hinges, and cigarette compartment holds two packages of

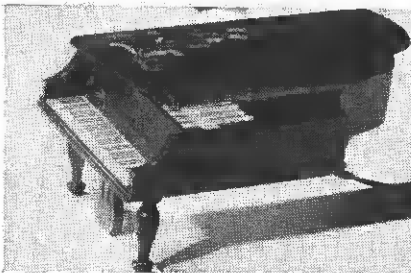

cigarettes. Imported Swiss movement. Suggested list price \$14.95.

Model 1-R1, child's radio-style music box, 7 3/4" long, 5 1/4" high, 3 1/2" deep. Available in pink and blue with colorful decalcomanias. Imported Swiss movement. Suggested list price \$9.95. Apex Industries, 192 Lexington Ave., New York 16, N. Y.—RTR

Langevin LOUDSPEAKER

The 24-A loudspeaker, a product of the Langevin Co., is designed primarily for outdoor applications. It is weatherproof and resists high corrosion conditions. The horn has a bell diameter of 25", over-all length 38", over-all width 26", and has a frequency response 110 to 6,500 C.P.S. Receiver attachments are available for coupling two or four driver units and making the horn capable of maximum inputs of 50 and 100 watts. The Langevin Co. Inc., 37 W. 65th St., New York, N. Y.—RTR

Casco ELECTRIC HEATING PADS

Can be used over wet dressings, and has illuminated dial that enables temperature to be fixed at any one of 30 desired heats.

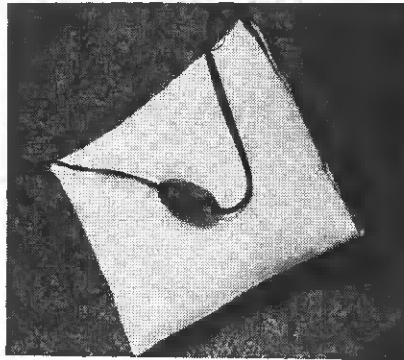

Company has started production of its quota, and will distribute them under a self-imposed rationing plan so that those who need pads most will receive them first. Casco Products Corp., Bridgeport, Conn.—RTR

In-Res-Co. RESISTORS

Hermetically-sealed resistors. Immune to moisture, corrosive fumes and fungus, with resultant freedom from circuit noise and premature breakdown due to leakage or electrolysis. Range to 1 megohm max. and 2 watts

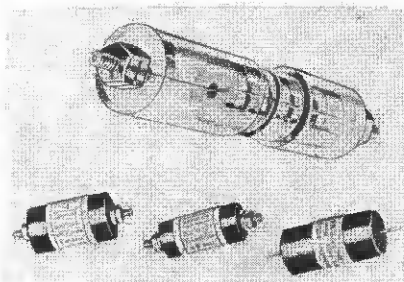

max. Standard tolerance 1%. Resistors are wound with manganin. Instrument Resistors Co., 25 Amity St., Little Falls, N. J.—RTR

GE ALARM CLOCK

Currently on the market are a limited number of GE electric alarm clocks. Available in plastic case, and except for minor non-operat-

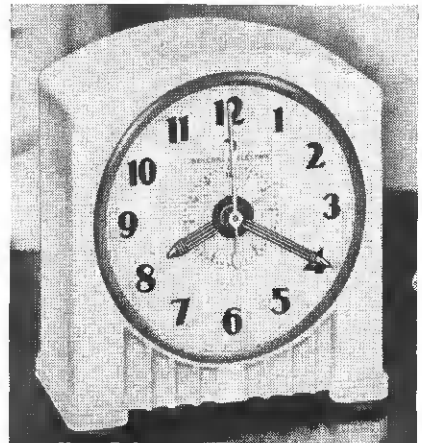

ing parts, the materials are the same as those in pre-war models. To retail at \$4.95. General Electric Co., 1285 Boston Ave., Bridgeport, Conn.—RTR

Tyler HARDERFREEZ

12 cu. ft. home and farm locker, illustrated. Hermetically sealed to eliminate infiltration of moisture; 5 in. certified insulation. Other up-



right models will be built in 15 cu. ft., and 21 cu. ft. capacities. (The 21 cu. ft. model can be used for both frozen foods and normal refrigerating purposes.) Tyler Fixture Corp., Niles, Mich.—RTR

Prestole MOUNTING CLIP

New universal capacitor mounting clip. Can be attached to the chassis instantaneously with one simple hand motion and without assembly tools of any kind. No nuts or bolts necessary. Pointed retaining tongues bite into the chassis firmly and prevent any loosening due to vibration. Sizes of clips available range from 5/8 in. up to 1 3/8 in. Prestole Division, Detroit Harvester Co., 4500 Detroit Ave., Toledo, Ohio.—RTR

NEW PRODUCTS

Shallcross MILLIOHMMETER

Medium range milliohmmeter. Has linear scales which eliminate crowding of the higher values of resistance at one end of the scale. Ranges: 0-0.5-1-5-10-50 and 100 ohms full scale. A single No. 6 built-in dry cell is used. Shallcross Mfg. Co., Collingdale, Pa.—RTR

GE ELECTRIC IRONS

Automatic electric iron, currently for sale, retails at \$8.55 including tax. Another model is available for retailing at \$5.70, including tax. Comparable to pre-war models. Available through GE's regular distributors, independent

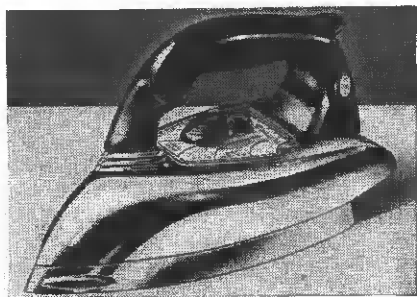

jobbers, and factory distribution branches. General Electric Co., 1285 Boston Ave., Bridgeport, Conn.—RTR

Masco PHONOGRAPH REPRODUCER

Model MPA-3 portable phonograph is designed for excellent tone, quality and durability. Features include: 3 tube amplifier, 2.5 watts power output, separate volume and tone controls, 5" heavy duty PM speaker, 115 volt

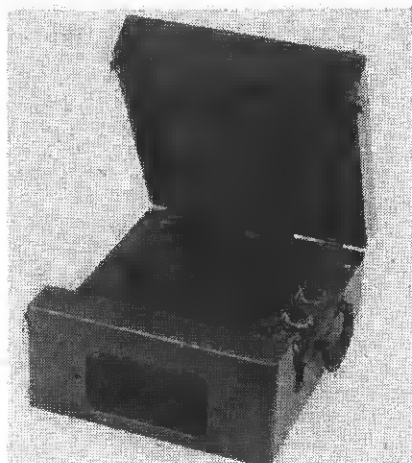

AC operation, plays 10" or 12" records with cover closed. Size 14 1/4" x 17 1/4" x 7", weighs 13 pounds net. List price \$48.50. Mark Simpson Manufacturing Co., 186-194 West Fourth St., New York, N. Y.—RTR

Telechron "SELECTOR"

The "Selector"—an electric alarm clock which will turn the radio on for selected programs, and automatically switch the set off. Can be used for starting a coffee percolator at a given time, switching household lights on and off, timing roasting operations and

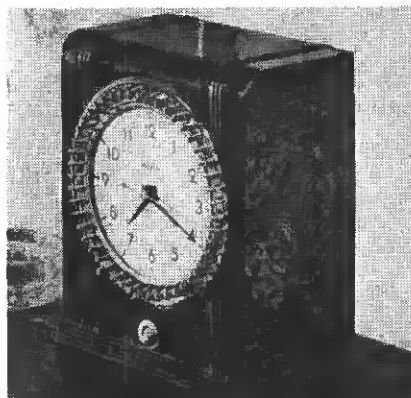

defrosting refrigerators. Due to its switch mechanism rated up to 1650 watts, it will time and control any household appliance which can be plugged into a conventional outlet.

The "Selector" will retail for approximately \$10, and will be available to the postwar buying public through regular distribution outlets. Warren Telechron Co., 75 Homer Ave., Ashland, Mass.—RTR

Kinner 5 HP ENGINE

The "Busy Bee," Kinner model AB-3, is an air-cooled, 4-cycle, L-head engine rated at 5 hp., at 2600 rpm., but develops 6 hp., at 3250 rpm. The single cylinder is horizontal and detachable, making maintenance easier. Unit occupies 2.4 cu. ft. of space. Kinner Motors, Inc., Glendale 4, Calif.—RTR

Magnus HARMONICA

Plastic harmonica, washable, hygienic, composed of but five parts as compared with 80 parts in old-type harmonica. Molded from

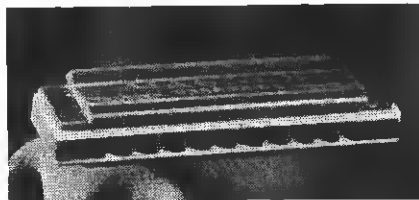

Bakelite polystyrene. Made in brilliant colors, is light-weight and non-fragile. Formerly made only for the armed forces, it will be available for general consumption shortly. Inquiries from jobbers and distributors invited. International Plastic Harmonica Corp., 49 Dickerson St., Newark 4, N. J.—RTR

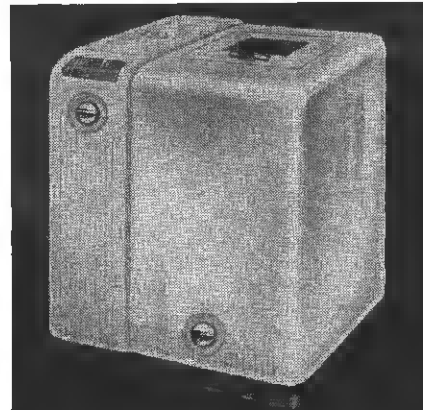

Jacobs LAUNDERALL

Completely automatic home laundry. Clothes inserted from the top; washer can be stopped to facilitate adding extra items. Dealer franchising program now in preparation. F. L. Jacobs Co., 1043 Spruce St., Detroit, Mich.—RTR

Seald-Ohm RESISTOR

Seald-Ohm resistors are hermetically sealed precision units, securely mounted in a drawn brass case. Connections are brought out through fused glass seals, soldered in the case. A special mounting bracket permits ver-

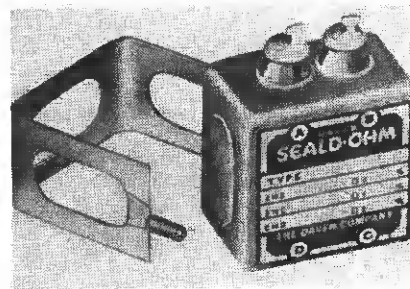

tical, inverted or horizontal mounting. Any desired resistance value available; maximum 1,600,000 ohms. Dimensions: 1-9/16 in. wide, 1 1/2 in. high, 3/8 in. deep. Add terminal height, 9/16 in. Daven Co., 191 Central Ave., Newark 4, N. J.—RTR

GE LAMPHOLDER

Fluorescent lampholder known as the Twin Turret, made for use with 40-watt lamps. Holds two Mazda F fluorescent lamps. Each Twin Turret has two discs with holes for the pins of the lamps. Lamps can be inserted by depressing either disc of the Twin Turret lampholder with one end of the lamp until the other end clears the disc in the opposite lampholder and slips into place. Lamps can be removed by simply depressing the face of either Turret with one end of the lamp until the pins on the other end clear the opposite lampholder and slide out of place. Retail price 80c each. Priority needed. General Electric Co., 1285 Boston Ave., Bridgeport, Conn.—RTR

TELEVISION TODAY

GE Sales Executive Looks to Video Expansion Soon

Television will be needed postwar to help maintain the one hundred forty billion dollar national annual income which will prevent unemployment, Paul L. Chamberlain, General Electric sales executive, told the advertising club of Boston.

"Boston will be one of the three cities having new television stations on the air by late summer," he said, "making a total of 12 in the nation." Other new stations will be in operation at Jamaica, Long Island, and Indianapolis. Three stations now operate in New York City, one in Philadelphia, another in Schenectady, N. Y., and two each in Chicago and Los Angeles. He predicted 500 television transmitters in operation in the United States within ten years after the war.

Relay Towers

Chamberlain exhibited a model of one of the towers in a proposed relay system which will handle two television programs, eight sound channels for present-day or frequency-modulation radio, two radio photo channels, and 120 business machine channels in one direction at one time. These towers will be located within sight of each other, spaced perhaps 30 miles in level country, perhaps 80 to 100 miles between mountain tops. The initial circuit will connect Schenectady, New York City, Philadelphia, Baltimore and Washington, he told the advertisers.

Mr. Chamberlain, who is manager of sales for General Electric's transmitter division, visualized two major applications for television after the war. Broadcast television will add a new dimension to home entertainment and will provide one of the most powerful mass advertising media ever developed. It will supplement other forms of advertising to maintain the national income needed to keep American workmen on the job, he said.

Sonora President Gerl on Video's Future Influence

Joseph Gerl, president of Sonora Radio & Television Corp., Chicago, Ill., addressed the University of Chicago's sociology club on "The Social Effects of Television." Gerl predicted that while television "will have a tremendous broadening effect on the intellectual horizons of the average family," it would also bring "a decrease in newspaper local display advertising, in national radio chain advertising and affect adversely the production of Class B and C movies."

He emphasized that television would be helpful to the housewife as far as instruction in housekeeping methods, cooking and sewing, is concerned. "As far as advertising is concerned," said Mr. Gerl, "television will be a powerful factor. It will dominate the advertising of manufacturers and retailers who depend on 'sight of product' for selling. Since television as we know it will be

a matter of local stations, it would seem like a natural medium for use by local merchants."

As far as national radio advertising is concerned, Mr. Gerl indicated that because of the "attractiveness" of television programs, it is very probable that in time far more people would prefer television broadcasts than ordinary radio broadcasts. "Under the circumstances," he said, "we may expect to see a shift of national radio advertising to sponsorship of whole series of local television advertising."

Middle-Distance Glasses Perfect for Tele Viewing

Designers and manufacturers of direct-viewing television sets seem largely to have overlooked the fact that for a considerable proportion of their customers and viewers, the best viewing distance for such a telepicture falls in the gap between reading glasses and good "distance" vision. This may account for the complaint sometimes heard that "watching television hurts my eyes."

Television sets involve a considerable outlay and hence will at the beginning be purchased by older persons. Most of these older people wear glasses designed for reading at 12 to 14 inches, but their unaided vision is usually still sharp at distances above 10 ft. For distances "in between," however, such persons are not equipped for comfortable vision. Hence when a television screen is to be viewed at 5 to 8 ft. ordinary reading glasses are of no service, while normal vision or distance glasses are not helpful either. As a result, such persons sitting 5 to 8 ft. away from the television image suffer unconscious strain, which manifests itself after an hour or two of television, as eye fatigue.

Good Solution

One solution will be to have oculists prescribe special glasses for viewing television screens at 5 to 8 ft., adapting the lenses to the particular eye conditions of the individual (in the same way other lenses are adapted for reading at 12 to 14 inches). One older television enthusiast found he could use his own earlier pair of reading glasses, for good television seeing at 5 to 8 ft. These outdated glasses were no longer suitable for reading close-held printed pages, as the changes in his eye-muscle control required stronger lenses. But these reading glasses of five years before, now are exactly right for viewing images 5 to 8 feet away, and so bring in the television images with new clarity and comfort. As a result, he has watched television shows hour after hour—including the V-Day all-day program—without any strain or fatigue whatever.

DuMont Uses Presto Turntables for Recordings



The Allen B. DuMont Laboratories television studio utilizes Presto turntables for sound transcription during video shows that originate on film, as well as for special effects during "live" tele shows. Sound recorded on discs is playing an increasingly important part in television.

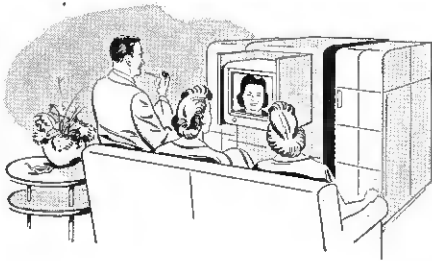

Kate Smith SAYS:

YOU'LL SEE AND LOVE AMERICA MORE-

WITH DUMONT TELEVISION

And your customers will echo her enthusiasm when viewing the screens of DuMont Telesets.

● For the DuMont product represents technical integrity of the highest order. It is a definite assurance of sharp, clear pictures, of rich tonal reception and of technical dependability...It is a promise of performance above comparison. ● You will gain both profit and pride from selling DuMont Telesets. From any angle DuMont Television is *Terrific*.

Copyright 1945, Allen B. DuMont Laboratories, Inc.

DUMONT



Precision Electronics and Television

ALLEN B. DUMONT LABORATORIES, INC., GENERAL OFFICES AND PLANT, 2 MAIN AVENUE, PASSAIC, N. J.
TELEVISION STUDIOS AND STATION WABD, 515 MADISON AVENUE, NEW YORK 22, NEW YORK

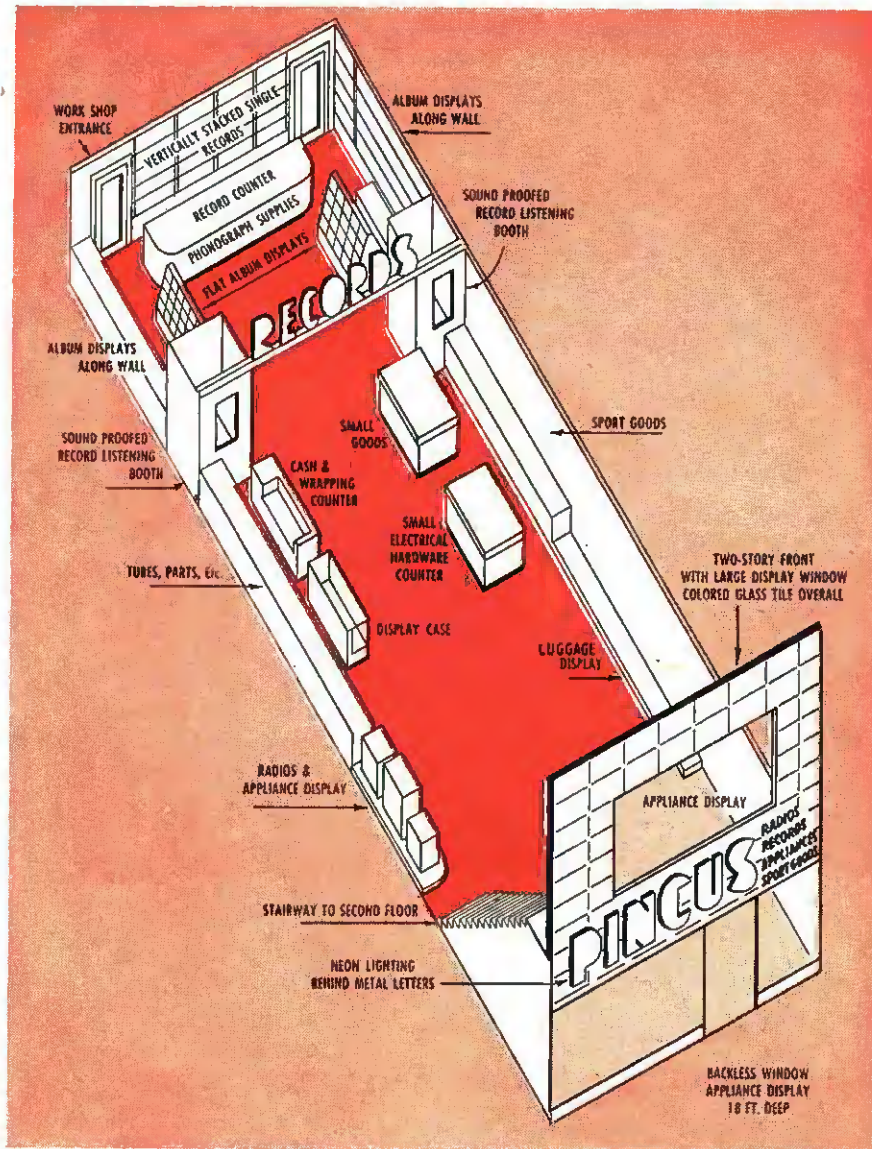

Floorplan and new front at Pincus'.

Open Display

(Continued from page 43)

in radio, home electrical appliances, and sporting goods sales, at a location a few doors from his present store.

During the shortages period he has done an excellent job of keeping the radios and home appliances in his community in working order. And to further retain his identity as a radio-appliance dealer, Pincus has carried whatever "related" lines he could get any amount of merchandise in, such as coffee-makers, heaters, lamps, lanterns, glassware sets, broilers and casseroles, bottle-warmers and hot-plates, etc. To augment his fast-vanishing sporting goods lines, he stocked games, and some small novelties, and retained whatever stock he could in

the way of athletic goods. GE lamps sold well, too.

In addition, he took on several new lines: 1) an extensive stock of modern, light-weight luggage, 2) phonograph records, and 3) paints.

After the war, Pincus plans to return his sales efforts to the merchandising of radio and television receivers, all major and minor appliances for the home, and sporting goods. In addition, he will retain the three new lines he annexed during war-time—luggage, records and paints. He expects to stick to standard brand names on everything, and will diversify his lines.

Although Pincus has been in business in the same community for some 13 years or more, he has never let his outlook on merchandising to these same people become static. He is ever

on the lookout for the changing trends in merchandising which he believes come with changing times.

The buying public, he believes, is ever interested in something new, or in a new method of presentation. The buying public is inquisitive and exceptionally curious about what it is going to purchase, Pincus has learned from his long association with his buying neighbors. It is his conviction that this consumer public has an imagination and likes to be intrigued into explorative purchases, rather than being high-pressured into sales.

There's a lot of showmanship in salesmanship, and a large part of this, Pincus summarizes, can be achieved by display!

Appliance Sales

(Continued from page 41)

pel people to look for the ad. The premium was a dust cloth, or a phonograph record valued at 37 cents. Requirement: the reader had to bring the newspaper into the store with him in order to collect the reward. Few actually came into the store with the paper, but hundreds heard about the advertisement!

At the present time, the store derives its revenue from radio and appliance servicing, in addition to merchandising records, record accessories, sheet music, etc. Also carried are such items as flashlights, batteries.

In the future, as in the past, radios and appliances will be prominently displayed in the store. In the days ahead, however, servicing will be relegated to the second floor of the building in which the establishment is located. This will permit more room for the showing of goods. In order to facilitate the handling of larger appliances, in moving them from one floor to the other, a rear freight elevator will be constructed.

When most of the demand for radios and appliances is satisfied, dealers will once again be confronted with the trade-in-problems. Marks believes that a shortened discount policy to the retailer should help to alleviate the headaches involved in handling trade-ins. This astute merchant maintains that he will accept the shorter discount providing that *all* radio-appliance dealers do the same. A shortened discount policy, he asserts, should curb the merchant from giving ruinous trade-in allowances, and at the same time give the consumer more for his money.

"SUPER-PROS"



ON THE LINE

Five thousand hours of continuous operation demand good engineering. The "Super-Pro" receivers in the CAA installation at La Guardia Airport have been on duty twenty-four hours a day for over four years.



HAMMARLUND

THE HAMMARLUND MFG. CO., INC., 460 W. 34TH ST., NEW YORK 1, N.Y.
MANUFACTURERS OF PRECISION COMMUNICATIONS EQUIPMENT

Distributor Doings

Ben Gross Announces Key Changes in Set-Up

Ben Gross, president of Gross Distributors, Inc., New York City, announced that his firm, with a record of representing the Stromberg-Carlson Company's radio line for 21 years, will in the future act as wholesaler throughout New York City and its environs, northern New Jersey, Connecticut and parts of western Massachusetts.

For the first time, the company will also distribute other products, each in certain portions of its area, including Premier vacuum cleaners, Schaefer Pak-A-Way food freezers for home, farm and commercial use, and Blackstone automatic washers and laundry equipment.

Gross Distributors, in representing Stromberg-Carlson since 1924, when the fifty-one year old Rochester firm entered the home radio field, has turned in a sales



Ben Gross

volume for the company's radios in that period in excess of \$65,000,000 at retail values.

Mr. Gross, announcing the new relationship, said that "heretofore our company has merchandised Stromberg-Carlson on a direct-factory-to-dealer basis. In future, the Stromberg-Carlson line, while continuing as our key line, will be represented in the same set-up as that which will govern our handling of the Blackstone, Schaefer and Premier lines, in which our firm will operate as exclusive wholesalers."

Mr. Gross noted that his firm's marketing policy includes a vital feature which provides that "each of the dealers our firm selects will have the privilege of choosing how many of the several distributor-dealer franchises he will take to best meet the demands of his own business. This tailor-made arrangement in the field of appliance selling is the

only workable answer to the dealer's needs to provide full freedom of action with leader lines. Our policy of intensive specialization for each product, in the way of individualized sales training, promotion and advertising, will be maintained toward the end that the business done by each dealer, as well as in the territory as a whole, will be on a maximum yield basis for each line handled," Gross stated.

Tower Co. to Take On Added Appliance Lines

The B. M. Tower Co., 366 Fairfield Ave., Bridgeport, Conn., jobbers serving greater Connecticut for the past twenty years, intends to add washing machines and home freezers to its pre-war table appliance lines. During war-time B. M. Tower, proprietor, and A. P. Tower, general manager, have concentrated their efforts on available appliance sales, especially priority sales, and replacement parts.

New Associated Group

The Associated Distributing Co., 308 Ivy St., N.E., Atlanta, Ga., a subsidiary of the American Associated Companies, has set up a new organization to handle a complete line of radios, refrigeration and household electrical appliances, for Atlanta and surrounding territories. Samuel M. Aiola will be general manager in charge of sales.

Joy Co. Establishes Bendix Division

The Edward Joy Co., Syracuse, N. Y., T. Frank Dolan, Jr., president, has established a new division to market the forthcoming Bendix radio line, and is building an experienced staff to handle the new division which will concentrate on electrical specialty lines in addition to the Bendix radio line. Announcement of the Syracuse firm as a Bendix distributor was made by Leonard C. Truesdell, general sales manager for home radio, Bendix radio division of Bendix Aviation Corp.

To Distribute New Lines

Radio Equipment Co., 1219 N. Meridian Ave., Indianapolis, Ind., Philco distributor, will also handle the following lines postwar in the 53 counties in Indiana which the firm covers: Estate ranges, Youngstown steel kitchen, Premier vacuum cleaners, Automatic washers, Knapp-Monarch small appliances, and Sun Rock water coolers.

Hayes Hollibaugh, vice-president of the organization, declared that most of the firm's dealers have already been signed up, and the company is anticipating a good postwar business.

Estate Stove Organizes Own Distributing Company

Plans for distribution of Estate Heatrola products in the greater Cincinnati area were completed with the formation of Estate Distributing Co. The new company, a subsidiary of The Estate Stove Co., Hamilton, Ohio, will have its headquarters at the parent company's home



S. C. Bernhardt (left) discusses opening of new distributing company with Ray C. Thomas.

office until release of civilian goods, when offices and show rooms will be opened in Cincinnati.

S. C. Bernhardt, Estate vice-president in charge of sales, who made the announcement, stated that because The Estate Stove Co. has changed its sales policy from direct dealer selling to sales through independent specialty distributors, they want to learn the distributors' problems at first hand.

Although definite merchandise policies of the new company are not yet fixed, Mr. Bernhardt revealed that the Estate Distributing Co. has recently signed a franchise with the Hurley Machine Co. for the distribution of Thor automatic washers, dishwashers and automatic Gladirons. There is a strong likelihood that they will seek the franchise of a selected few additional top major appliance lines. Mr. Bernhardt also disclosed that Ray C. Thomas has been appointed manager of the new company. Mr. Thomas joined The Estate Stove Co. in 1937 as sales correspondent and in 1939 was appointed district manager for the south central Ohio territory with headquarters at Hamilton.

Meck Franchises Complete

John Meck, president of the John Meck Industries, Inc., of Plymouth, Indiana, announced that his sales plan for the immediate postwar future is completed and that he would not grant franchises to any additional jobbers.

POPULAR REPLACEMENT CONTROLS...



TYPE UM (PLAIN)



TYPE TM (SINGLE TAP)

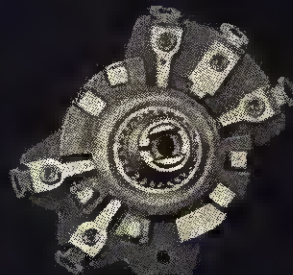

TYPE DTM (DOUBLE TAP)

...and KNURLED PLUG-IN SHAFTS

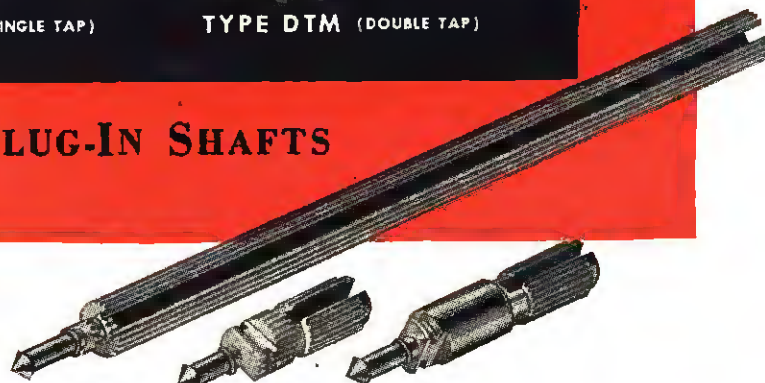

SS-25

SS-18

SS-22

WITH these three Mallory controls—and the three plug-in shafts—you can replace not merely three, or nine corresponding originals, but a very large number of volume controls.

Shafts SS-18 and SS-22, for instance, are made in lengths that are found very frequently in radio sets. The SS-25 shaft serves as a replace-

ment for any knurled shaft up to four inches in length. You simply cut the shaft to the right measurement and plug it in!

Then, too, Mallory provides 35 different resistance values and tapers in the Type UM control. There are 34 different resistance and taper values in the single tap TM type—and 8 in the double tap DTM type.

The fact is that with a surprisingly limited supply of Mallory controls and shafts, you can not only match but *duplicate exactly* almost any volume control in use today. Better still, only 16 controls are needed for approximately 85% of your replacement needs. See your Mallory distributor!



TYPE MK FIXED KNURLED SHAFT CONTROLS

Mallory offers the four most popular resistance values with fixed 4-inch shaft in this popular type MK knurled shaft control. Just select the proper resistance value, cut the shaft to required length, and install.

P. R. MALLORY & CO., Inc., INDIANAPOLIS 6, INDIANA



More than ever—
**ALWAYS
INSIST ON**

P. R. MALLORY & CO. Inc.
MALLORY
APPROVED
PRECISION PRODUCTS

VIBRATORS • VIBRAPACKS* • CONDENSERS
VOLUME CONTROLS • SWITCHES • RESISTORS
FILTERS • RECTIFIERS • POWER SUPPLIES

ALSO MALLORY "TROPICAL" DRY BATTERIES, ORIGINALLY DEVELOPED BY MALLORY FOR THE U. S. ARMY SIGNAL CORPS, NOT PRESENTLY AVAILABLE FOR CIVILIAN USE.

*Trademarks

24 HOURS A DAY

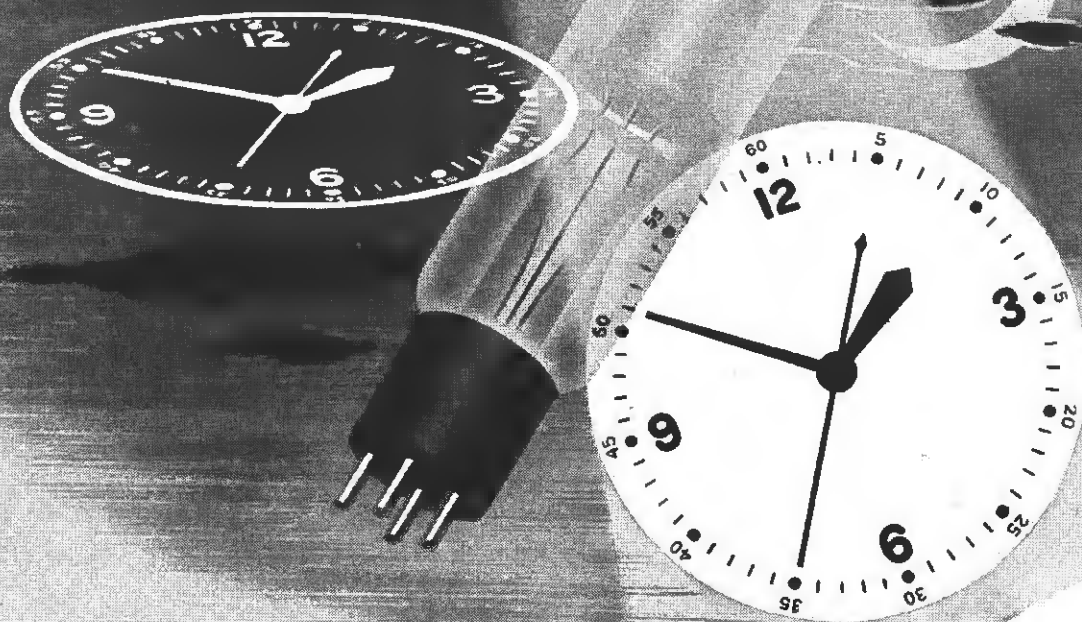

On every fighting front . . . on land, at sea, in the air . . . Delco Radio products aid in the coordination of military operations. Their assignments include communication, detecting and ranging, directional-finding and all the other varied phases of radio and radar activity. It's a full-time job, continuing and continuous, to which Delco Radio products bring an effective combination of engineering vision — manufacturing precision. Delco Radio Division, General Motors Corporation, Kokomo, Indiana.

Delco Radio
DIVISION OF
GENERAL MOTORS

*The Road to Tokyo is Tough —
Keep Buying War Bonds*

REPLACEMENT RAY-O-VAC BATTERY GUIDE

Make	MODEL NUMBER	Ray-O-Vac "A"	Ray-O-Vac "B"	Make	MODEL NUMBER	Ray-O-Vac "A"	Ray-O-Vac "B"
Admiral	32P5, 32P25, 32P30, 32P35, 32P40, 32P45, 32P50, 32P55, 32P60, 32P65, 32P70, 32P75, 32P80, 32P85, 32P90, 32P95, 32P100, 32P105, 32P110, 32P115, 32P120, 32P125, 32P130, 32P135, 32P140, 32P145, 32P150, 32P155, 32P160, 32P165, 32P170, 32P175, 32P180, 32P185, 32P190, 32P195, 32P200, 32P205, 32P210, 32P215, 32P220, 32P225, 32P230, 32P235, 32P240, 32P245, 32P250, 32P255, 32P260, 32P265, 32P270, 32P275, 32P280, 32P285, 32P290, 32P295, 32P300, 32P305, 32P310, 32P315, 32P320, 32P325, 32P330, 32P335, 32P340, 32P345, 32P350, 32P355, 32P360, 32P365, 32P370, 32P375, 32P380, 32P385, 32P390, 32P395, 32P400, 32P405, 32P410, 32P415, 32P420, 32P425, 32P430, 32P435, 32P440, 32P445, 32P450, 32P455, 32P460, 32P465, 32P470, 32P475, 32P480, 32P485, 32P490, 32P495, 32P500, 32P505, 32P510, 32P515, 32P520, 32P525, 32P530, 32P535, 32P540, 32P545, 32P550, 32P555, 32P560, 32P565, 32P570, 32P575, 32P580, 32P585, 32P590, 32P595, 32P600, 32P605, 32P610, 32P615, 32P620, 32P625, 32P630, 32P635, 32P640, 32P645, 32P650, 32P655, 32P660, 32P665, 32P670, 32P675, 32P680, 32P685, 32P690, 32P695, 32P700, 32P705, 32P710, 32P715, 32P720, 32P725, 32P730, 32P735, 32P740, 32P745, 32P750, 32P755, 32P760, 32P765, 32P770, 32P775, 32P780, 32P785, 32P790, 32P795, 32P800, 32P805, 32P810, 32P815, 32P820, 32P825, 32P830, 32P835, 32P840, 32P845, 32P850, 32P855, 32P860, 32P865, 32P870, 32P875, 32P880, 32P885, 32P890, 32P895, 32P900, 32P905, 32P910, 32P915, 32P920, 32P925, 32P930, 32P935, 32P940, 32P945, 32P950, 32P955, 32P960, 32P965, 32P970, 32P975, 32P980, 32P985, 32P990, 32P995, 32P1000	1-2P130 1-2P140 1-2P150 1-2P160 1-2P170 1-2P180 1-2P190 1-2P200 1-2P210 1-2P220 1-2P230 1-2P240 1-2P250 1-2P260 1-2P270 1-2P280 1-2P290 1-2P300 1-2P310 1-2P320 1-2P330 1-2P340 1-2P350 1-2P360 1-2P370 1-2P380 1-2P390 1-2P400 1-2P410 1-2P420 1-2P430 1-2P440 1-2P450 1-2P460 1-2P470 1-2P480 1-2P490 1-2P500 1-2P510 1-2P520 1-2P530 1-2P540 1-2P550 1-2P560 1-2P570 1-2P580 1-2P590 1-2P600 1-2P610 1-2P620 1-2P630 1-2P640 1-2P650 1-2P660 1-2P670 1-2P680 1-2P690 1-2P700 1-2P710 1-2P720 1-2P730 1-2P740 1-2P750 1-2P760 1-2P770 1-2P780 1-2P790 1-2P800 1-2P810 1-2P820 1-2P830 1-2P840 1-2P850 1-2P860 1-2P870 1-2P880 1-2P890 1-2P900 1-2P910 1-2P920 1-2P930 1-2P940 1-2P950 1-2P960 1-2P970 1-2P980 1-2P990 1-2P1000	1-2P130 1-2P140 1-2P150 1-2P160 1-2P170 1-2P180 1-2P190 1-2P200 1-2P210 1-2P220 1-2P230 1-2P240 1-2P250 1-2P260 1-2P270 1-2P280 1-2P290 1-2P300 1-2P310 1-2P320 1-2P330 1-2P340 1-2P350 1-2P360 1-2P370 1-2P380 1-2P390 1-2P400 1-2P410 1-2P420 1-2P430 1-2P440 1-2P450 1-2P460 1-2P470 1-2P480 1-2P490 1-2P500 1-2P510 1-2P520 1-2P530 1-2P540 1-2P550 1-2P560 1-2P570 1-2P580 1-2P590 1-2P600 1-2P610 1-2P620 1-2P630 1-2P640 1-2P650 1-2P660 1-2P670 1-2P680 1-2P690 1-2P700 1-2P710 1-2P720 1-2P730 1-2P740 1-2P750 1-2P760 1-2P770 1-2P780 1-2P790 1-2P800 1-2P810 1-2P820 1-2P830 1-2P840 1-2P850 1-2P860 1-2P870 1-2P880 1-2P890 1-2P900 1-2P910 1-2P920 1-2P930 1-2P940 1-2P950 1-2P960 1-2P970 1-2P980 1-2P990 1-2P1000	1-2P130 1-2P140 1-2P150 1-2P160 1-2P170 1-2P180 1-2P190 1-2P200 1-2P210 1-2P220 1-2P230 1-2P240 1-2P250 1-2P260 1-2P270 1-2P280 1-2P290 1-2P300 1-2P310 1-2P320 1-2P330 1-2P340 1-2P350 1-2P360 1-2P370 1-2P380 1-2P390 1-2P400 1-2P410 1-2P420 1-2P430 1-2P440 1-2P450 1-2P460 1-2P470 1-2P480 1-2P490 1-2P500 1-2P510 1-2P520 1-2P530 1-2P540 1-2P550 1-2P560 1-2P570 1-2P580 1-2P590 1-2P600 1-2P610 1-2P620 1-2P630 1-2P640 1-2P650 1-2P660 1-2P670 1-2P680 1-2P690 1-2P700 1-2P710 1-2P720 1-2P730 1-2P740 1-2P750 1-2P760 1-2P770 1-2P780 1-2P790 1-2P800 1-2P810 1-2P820 1-2P830 1-2P840 1-2P850 1-2P860 1-2P870 1-2P880 1-2P890 1-2P900 1-2P910 1-2P920 1-2P930 1-2P940 1-2P950 1-2P960 1-2P970 1-2P980 1-2P990 1-2P1000			

BE READY
for the return of
RAY-O-VAC
PORTABLE RADIO
BATTERIES

GET YOUR FREE COPY NOW
 If you haven't received a copy of the Replacement Guide, write RAY-O-VAC and we will gladly send you one.

RAY-O-VAC BATTERY REPLACEMENT GUIDE

The minute Ray-O-Vac portable radio batteries are available you will want to be ready to serve your customers. That's why we have developed this chart showing just which Ray-O-Vac batteries are required for almost every standard model of all makes of portable radios. It makes it amazingly easy for you to "prescribe" the proper Ray-O-Vac batteries. Be sure to have your copy ready. Write for a copy.

RAY-O-VAC
RADIO BATTERIES



RAY-O-VAC COMPANY, MADISON 4, WISCONSIN
 OTHER FACTORIES AT CLINTON, MASS. • LANCASTER, OHIO • SIOUX CITY, IOWA • FOND DU LAC, WIS. • MILWAUKEE, WIS. • KANSAS CITY, MO.

TRADE TALK

Lear Official Looks to Square Deal for Dealers

"One thing the postwar radio dealer will insist upon from his manufacturer is a square deal in merchandising the product; not just in the sale from manufacturer to distributor, but in the manufacturer's follow-up directly to the consumer, and in the manufacturer's stand on producing for a competitive market," according to Nate Hast, home radio merchandise manager of Lear, Inc., Chicago, Ill.

Mr. Hast, having just completed a tour of the western part of the country, where he has signed distributors for postwar commitments which reach more than seven figures, is particularly enthusiastic over the aggressive spirit on the part of the dealers.

Breech, Bendix President, Stresses Postwar Growth

Enormous war-time strides made by America's radio industry in broadening the efficiency of radio for all types of communications and transportation requirements have set the stage for a "real pioneering job" during the early postwar years, Ernest R. Breech, president of Bendix Aviation Corp., Baltimore, Md., declared. The industry has the increased skill, facilities and resources to undertake the pioneering job together with reconversion to meet estimated accumulated consumer demands for nearly 15,000,000 radios and radio-phonographs during the

Charles Robbins Resigns

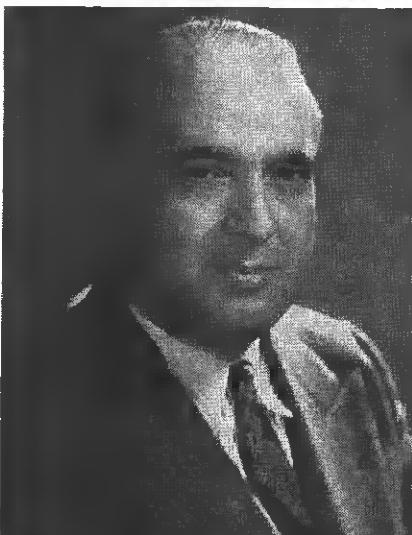

Charles W. Robbins, has announced his resignation as vice-president and general sales manager of Emerson Radio & Phonograph Corp. Mr. Robbins is in the process of organizing his own sales company, and will enter the manufacturers' representative field.

first full year of unrestricted civilian production, Breech told a meeting of mid-west Bendix radio distributors.

When the full "go ahead" signal is flashed, Breech predicted, the peacetime production accomplishments of the industry will prove to be as remarkable as its war-time rise to a peak annual volume of nearly four billion dollars, almost ten times the total of the nation's 1940 consumer expenditures for radios and allied products.

Galvin to Maintain Wage, Product Levels Postwar

Announcing that the Galvin Manufacturing Corp., Chicago, manufacturers of Motorola radio equipment, will maintain the current high levels of war-time wages on resuming civilian production, Paul V. Galvin, president, told the annual meeting of stock holders that the pattern of reconversion to peacetime production has been agreed upon by the industry and the radio-radar division of WPB and awaits formal approval.

"Public interest in television has brought it to the point that it will be ready to proceed with full speed at the end of the war and the future of television offers greater business possibilities than radio ever enjoyed before the war," Galvin said. "I think television is coming much faster than a lot of people concede . . . Motorola is ready to deliver television receivers as soon as television arrives on a commercial basis," he added.

Ray-O-Vac Batteries Back

After an absence of three years, Ray-O-Vac Leakproof flashlight batteries are again available for consumer use, the sales department of Ray-O-Vac Co., Madison, Wis., has announced. Ray-O-Vac portable radio batteries and a number of others are also back on the market.

Farnsworth Appointments

I. C. Hunter, sales manager of the Capehart division of the Farnsworth Television & Radio Corp., Ft. Wayne, Ind., announced the appointment of R. E. "Bob" Kane, pre-war district manager of Farnsworth's Chicago territory, as Capehart district manager in the Philadelphia area.

George S. Jeffers, southern sales representative, has been appointed district manager of the company's southwest territory with headquarters in Dallas, Texas, according to an announcement by E. H. McCarthy, Farnsworth sales manager. A pioneer in the field of sound transmission, Mr. Jeffers has been associated with several of the country's leading radio and phonograph development organizations.

Col. Rider Returns to Civilian Activities

With a number of commendations from the Chief Signal Officer, Lieut. Col. John F. Rider recently completed 3 years of service in the U. S. Army Signal Corps. For the past 17 months he had been stationed at Fort Monmouth, N. J., attached to the publications agency of which he was acting director.

As head of John F. Rider Publisher, Inc., he has already set in motion the plans for expanding the Rider Manual activities to embrace television, and when it becomes public, radar.

An activity to which John Rider is devoting much effort at the present time is that of the postwar problems of the servicing industry and of the individual and his adjustment to current and predictable conditions of the near future.

Stewart-Warner Jobbers

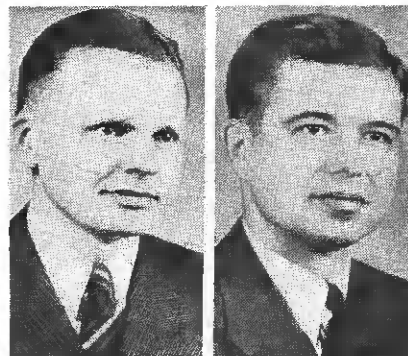

James Onstad (left), and Don Shirley, Minot, N. Dak. distributors, have been appointed as wholesalers for Stewart-Warner radios.

National Distributors Call on Zenith Officials

Distributors who have conferred with officials at the Zenith Radio Corp.'s Chicago offices include: "Red" Hodges, sales manager of Radio Supply Corp., Zenith distributor in Norfolk, Va.; Jake Blatt, of J. A. Williams Co., Pittsburgh, Pa.; B. R. Williamson of Persinger Supply Co., Williamson, W. Va.; Harry Warde of Columbian Electrical Co., Kansas City distributor. Bob Coblentz of the Barker Bros. store in Los Angeles, one of the firm's distributors in that city, also called on H. C. Bonfig, vice-president in charge of household radio and Edgar G. Herrmann at the Zenith factory.

Rola Production "E"

For outstanding achievement in producing materials essential to the war effort, The Rola Co., Cleveland, Ohio, pre-war manufacturers of radio loudspeakers, has received its fourth Army-Navy Production Award.



★ Every Utah speaker makes and breaks more than a billion contacts during its lifetime.

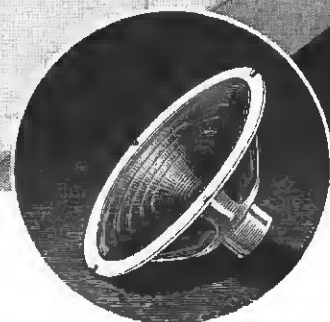

NO GUESSWORK HERE!

The manufacture of electronic devices and radio parts is an exacting job. It's a precision job and Utah does it to a plus degree. Take the loud speaker for instance: Utah's "precision-plus" methods go 'way back to the buying of raw materials that make the speaker. They go even further.

The tools used in the manufacture of the

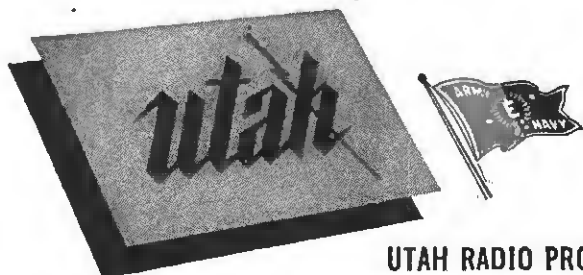

speaker are likewise made at Utah, to Utah's specifications. You see, every single phase in the manufacture of Utah is guess-proof . . . tool making, welding, punch press, electroplating, and all the other steps, to the shipping of the final finished product. *Check, re-check, test . . . supervise* are Utah words. Here Utah workers (with Utalins* back of 'em) know their value. Know they make for "precision-plus" performance—the proof of Utah quality.

*Utah's Helpers

UTAH RADIO PRODUCTS COMPANY, 820 ORLEANS ST., CHICAGO 10, ILL.

Utah Electronics (Canada) Ltd., 300 Chambly Road, Longueuil, Montreal (23) P.Q. • Ucoa Radio, S.A., Misiones 48, Buenos Aires



I found new beauty...

The Hush of Evening Reveals a New World of Sound to Helen Traubel

"Listen . . .

"There is a bird in flight . . . Even in this darkness I see it in the rhythmic beating of its wings . . . in the rustle of the leaves as it passes above me . . . in the sound of the swaying branch on which it comes to light . . . and in the crackle of the twig that has fallen beneath it . . .

"Each sound about me paints its picture . . . there is the wind . . . the faint splash of the stream . . . even of my own presence . . . for I must be in a new world of sound . . .

"How like this is the music of a symphony . . . each note clear and true . . . alive . . .

"How like this is the music of Beethoven as I heard it played by the Meissner . . . This is a new world of sound, yet I have been here before . . . and it is a

world I can visit again and again . . . with the magic carpet of my Meissner."

So vivid were Helen Traubel's impressions of the famous Meissner radio-phonograph that, even in this woodland world of *natural* sound, the memory of its rich voice was not dimmed. The world's greatest dramatic soprano had *recognized* in the Meissner the ability to reproduce recorded music with nature's own true tone.

☆ ☆ ☆

You, too, will marvel at the glorious, natural voice of the Meissner that graces your postwar home. You will appreciate the new convenience of the Meissner Automatic Record Changer that plays *both* sides of any record in sequence. You will take pride in the luxurious cabinets, designed by master craftsmen. And you will thrill to the Meissner's AM, FM, and Super Short-wave radio reception.

Now there is *only one* such Meissner in existence. In the music room of the high school in Mt. Carmel, Ill., it brings the inspiration of great music to the boys and girls of Meissner's home city.

After victory, when the men and women of Meissner who created this great, new instrument can turn their skills to production for peace, this beauty of tone that has won praise from many great artists will be yours.

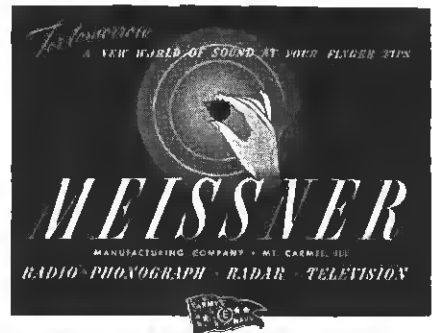



Your Community will point with pride to its Meissner Dealer

Why? Because the man who will be the Meissner dealer in your community has already established a reputation for quality and service with a clientele that appreciates the finest in any product. He has the facilities, the ability and the financial strength required to add an instrument such as the Meissner electronic radio-phonograph to his present line. He knows that the many people in his community who have responded to advertising like that shown here will naturally look to him for their postwar Meissner.

☆ ☆ ☆

You may be the Meissner dealer in your community. In many areas, Meissner exclusive dealer franchises are still available. The men who obtain these franchises will find new profits and prestige during the postwar period, and an immediate group of prospects who have been attracted to the Meissner by an extensive national advertising campaign.

If you meet the requirements outlined above, write to our Chicago office—936-B North Michigan Avenue, Chicago, Ill. today. An executive of our company will contact you at the earliest possible opportunity.

MEISSNER
MANUFACTURING COMPANY • MT. CARMEL, ILL.

Please address your inquiries
to Chicago Office:

936-B NORTH MICHIGAN AVENUE
CHICAGO, ILLINOIS

Stephen Hall Joins RTR As Consulting Editor

RADIO & Television RETAILING announces the addition to its staff of Stephen L. Hall as a consulting editor.

Mr. Hall is a merchandising expert. He comes to this organization from the War Production Board.

Mr. Hall was formerly director of retail-store research for Young & Rubicam and director of marketing for Benton & Bowles, two prominent advertising agencies. He handled the research work on the radio and appliance accounts of these firms. Previously he was a top salesman for Judson C. Burns, Philadelphia appliance distributor. Later he served as district manager for Gulf Oil, specializing in dealer merchandising methods.

Mr. Hall graduated from the Harvard School of Business Administration and from Brown University, cum laude. He is also a graduate of the Sales Analysis Institute and has helped develop and has taught several other sales training courses.

GE Personnel Changes

Three new personnel appointments have been made in the electronics department of the General Electric Co., Schenectady, N.Y. Paul L. Chamberlain has been appointed manager of sales for the receiver division by I. J. Kaar, division manager. He will make his headquarters at Bridgeport, Conn. Henry A. Crossland has been appointed assistant to the manager of the government division by V. M. Lucas, division manager. He will be located in the Washington, D.C. offices of the company. James D. McLean has been appointed manager of sales for the transmitter division by C. A. Priest, division manager, and will have headquarters at Schenectady.

Admiral Booklet Changes

The Admiral Corp., Chicago, Ill., has issued several changes in dimensions for some of the units originally shown in the Flex-O-Plan Store Modernization Booklet. Admiral believes these are an improvement over original plans. Pages are printed to facilitate easy clipping into Admiral booklet.

NOTICE on CLOSING DATES

Because RADIO & Television RETAILING must continue to be published on time, we must maintain our strict schedule of closing dates for all advertising. Ads requiring composition, proofs, key changes, etc., as well as those occupying preferred positions must be in our hands not later than the 15th of the preceding month. Complete ads, ready-to-run, with no proofs—not later than the 20th of preceding month. Publication date 1st of month.

For July issue: June 15th for incomplete, preferred position and color ads; June 20th for ready-to-run plates; July 1st publication date. Late advertising is self-rationed due to continuing paper shortage.

CALDWELL-CLEMENTS, INC.

480 Lexington Ave., New York 17, N. Y.

**IMMEDIATE
DELIVERY
FROM STOCK**

SPRAGUE - CORNELL DUBILIER AEROVOX CONDENSERS



10 mfd 450v Tubular	50¢
18 mfd 450v Tubular	65¢
20 mfd 450v Tubular	70¢
40 mfd 450v Tubular	99¢
20 mfd 150v Tubular	44¢
30 mfd 150v Tubular	47¢
40 mfd 150v Tubular	50¢
20-20 mfd 150v Tubular	76¢
40-20 mfd 150v Tubular	82¢
30-30 mfd 150v Tubular	79¢
50-30 mfd 150v Tubular	94¢
10 mfd 50v Tubular	32¢
25 mfd 25v Tubular	35¢

SPRAGUE Money-Saving Kits

6 ATOMS 8mfd 450v Tubular	\$2.56
15 TC-11 .01mfd 600v Tubular	1.59
15 TC-12 .02mfd 600v Tubular	1.59
15 TC-15 .05mfd 600v Tubular	2.12

TEST EQUIPMENT!!!

Volt-Ohm-Millimeters
GE UM-3 31.50
Superior PB-100 28.40
Service's Priority
AA-5 MRO CMP5A
Delivery—3 weeks



PM SPEAKERS



4" Square 2 os.	1.35
5" Round	1.25
6" Round 3.6 oz.	2.10
10" Round 20 oz.	7.20
12" Round 11 oz.	5.19
12" Round 31 oz.	10.14

TURNER MICROPHONES

Model	Type	Cord	List	Your Cost
BX	Crystal	7'	\$9.95	\$5.85
22X	Crystal	7'	18.50	10.88
33X	Crystal	20'	22.50	13.23
BD	Dynam. 7'		14.50	8.53
33D	Dynam. 20'		23.50	13.82



RADIART VIBRATORS

Type	Maturity	Equal	Base	Size	Used in	Each
S-1	4-1	4 Prong	1 1/2-3 1/2	Universal	\$1.35	
5300	294	4 Prong	1 1/2-3 1/2	Universal	2.09	
5326P	509P	4 Prong	1 1/2-2 1/2	Phileco	1.76	
5334	863	4 Prong	1 1/2-3 1/2	Delco	2.09	
5341M	901M	4 Prong	1 1/2-3 1/2	Motorola	1.76	
5400	248	6 Prong	1 1/2-3 1/2	Tru-tone	3.50	
5426	716	5 Prong	1 1/2-3 1/2	Buick	3.50	

ORDER OTHERS BY MAKE AND SET MODEL



TRIMM ACME DELUXE PHONES

2000 OHM	1.50
Cannon-Ball Dixie	1.56
Brush Crystal Phones	
Type "A"	7.95

ASTATIC CRYSTAL CARTRIDGES

L40..	2.35	LP6..	4.70	M22....	2.94
-------	------	-------	------	---------	------

PHILCO BEAM OF LIGHT

Selenium Cell only, no bolder 1.80

AC-DC RESISTANCE CORDS

135-160-180-220-250-290 OHM	
Each. 48¢	10 for 4.50
ICA Universal 22-330 ohm.....	73¢
560 ohm for 3-way Portable.....	73¢

BALLAST TUBES

K42B K55B L49C L55B	
100-79	
K49B K55C L49D 100-70	
100-77	
Each 45¢ 10 for 4.20	
ClaroStat Universal 23-55A	
(octal) each.....	59¢

20% deposit required on all C. O. D. orders. Orders of \$25.00 or more accompanied by payment in full, will be shipped prepaid. DON'T FORGET L-265 or AA-3 certificate.

RADIO SUPPLY & ENGINEERING CO., Inc.
128 SELDEN AVE. DETROIT 7, MICH.

RCA's President Sarnoff on Opportunities in Radio

Opportunities for returning servicemen in radio and electronics are outlined by Brigadier General David Sarnoff, president of Radio Corp. of America, in a booklet released by RCA as an aid to war veterans interested in applying their war-time training and experience to development of careers in civilian life. Listed among radio and electronic fields beckoning servicemen are those of broadcasting, television, radar, radio-facsimile, radio relays, radiothermics, electron microscopy, supersonics, aircraft and marine radio.

Gerl Speaks to Dealers

Sonora radio and record dealers of greater New York and Newark, N.J., met for dinner and merchandising conferences at which Joseph Gerl, president of Sonora Radio & Television Corp., and Sonora Record Co., was main speaker.

Barth-Feinberg, Inc., Sonora's radio and record distributor for greater New York held the first meeting, at which Gerl spoke on "The Future of Home Entertainment." The Beller Electric Co., Sonora's northern New Jersey distributor, held a second meeting in Newark at which Gerl discussed, "Radios, Today and Tomorrow."

Aero Needle New Location

Burton Browne, president of Aero Needle Co., Chicago, Ill., announces removal of its manufacturing plant to a district on the outskirts of the city. The sales offices will be moved to new quarters at 619 North Michigan Ave. Aero-point's expansion program includes plans for a number of new lines, one of which is a new sapphire needle retailing for \$2.50.

Detrola Radio "E" Award

The men and women of Detrola radio division, International Detrola Corp., Detroit, Mich., were notified by Robert P. Patterson, Under Secretary of War, that they will receive the Army-Navy Production Award, "as a symbol of your great contribution to victory in this war for human liberty." The division employs mostly women, including hundreds of mothers, sisters, wives, and daughters of servicemen, who make land mine detectors, radar, radio, and other electronic devices in Detroit's only radio-electronic plant.

Music War Council Looks for New Name

To encourage the creation of "living" musical memorials in memory of the nation's World War II heroes was announced as the immediate postwar objective of the Music War Council of America at a meeting of the officers in Chicago.

To carry out its postwar objectives, the Music War Council proposes changing its name because of obvious obsolescence. Members of the council and others interested are invited to suggest new names, keeping in mind that it is a non-profit organization dedicated to the non-commercial advancement of music for the sake of its benefits to people everywhere. Suggestions should be sent to executive secretary Howard C. Fischer, 20 East Jackson Blvd., Chicago 4, Ill.

Farnsworth Appointee



Frank H. Merritt, Avondale Estates, Ga., has been appointed Capchart southeastern territory district manager, for the Farnsworth Television & Radio Corp., Ft. Wayne, Ind.

ALL THE

Stability

THE NAME IMPLIES

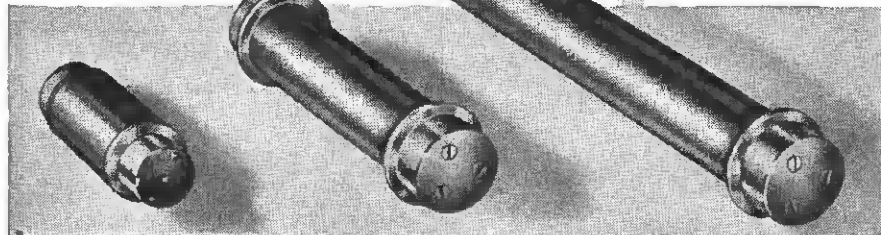

WESTON TUBULAR RESISTORS

WESTON tubular resistors . . . widely used since their introduction over a decade ago . . . furnish another outstanding example of sound engineering coupled with engineering foresight. For no new 'hurried' resistor design was needed in order to meet exacting military specifications that called for protection against tropical humidity, arctic and high working temperatures, and salt air. The WESTON tubular resistor met these new specifications . . . and in a rugged, non-fragile design tried and proved throughout the years. These resistors conform to and are approved under joint Army Navy Spec. JAN-R-29. Bulletin A-12 gives complete specifications. Send for your copy . . . Weston Electrical Instrument Corp., 581 Frelinghuysen Ave., Newark 5, N. J.

Weston
Instruments

Albany - Atlanta - Boston - Buffalo - Chicago - Cincinnati - Cleveland - Dallas - Denver - Detroit - Jacksonville - Knoxville - Los Angeles - Meriden
Minneapolis - Newark - New Orleans - New York - Philadelphia - Phoenix - Pittsburgh - Rochester - San Francisco - Seattle - St. Louis - Syracuse
In Canada, Northern Electric Co., Ltd., Powerline Devices, Ltd.



**DOWN
TO**

**BRASS
TACKS**



WE, at Templetone, are not going to make the most radios—nor the cheapest radios—nor the highest-priced radios. But we *are* going to produce radios so highly qualified in performance and appearance — and so invitingly priced—as to meet all or any competitive price ranges on all types of models: In brief, top values for your customers — top profits for you!

TEMPLETONE RADIO MANUFACTURING CORP.
New London, Conn.
FM...TELEVISION...RADIO-PHONO' COMBINATIONS

*"Where **FM** will also mean **Finest Made**"*





TURN *Your* BACK

On the Trade-building, Profit-making Possibilities of the Line of Inter-communication that "Has Everything"?

Investigate . . . and you will come face to face with these convincing facts: Talk-A-Phone is the world's most advanced and complete line of inter-communication. Talk-A-Phone provides a unit especially engineered to successfully meet every requirement. Talk-A-Phone is easily and quickly installed. Talk-A-Phone's reputation reduces sales resistance and greatly broadens your field of sales. Talk-A-Phone's rigid jobber policy gives your sales rights ironclad protection.

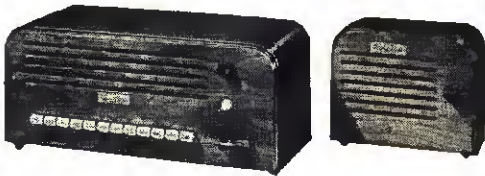

Write today for catalog and details . . . get the facts and get in on the ground floor of inter-communication business that will flourish for years to come. Good deliveries now. Address Dept. 3A.

Talk-A-Phone Mfg. Co.

1512 So. Pulaski Rd. Chicago 23, Ill.

WARD LEONARD ANNOUNCES



A NEW RELAY

This plug-in relay is a modification of a popular Ward Leonard type now used in small radio transmitters, aircraft control circuits and for similar applications. It is enclosed in a dust-proof cylindrical metal case (2 1/16" x 3 3/8") rigidly supported against shock and fitted with standard octal base. Operates on standard voltages up to 115 V., AC and DC. Double pole, double throw contacts. Write for price list and further particulars.

WARD LEONARD ELECTRIC CO.

Radio and Electronic Distributor Division
53 West Jackson Blvd., Chicago, Ill.



WARD LEONARD
ACCEPTED MEASURE OF QUALITY

RESISTORS
RHEOSTATS
RELAYS

BUY WAR BONDS!



TO THE AMERICAN PEOPLE:

Your sons, husbands and brothers who are standing today upon the battlefronts are fighting for more than victory in war. They are fighting for a new world of freedom and peace.

We, upon whom has been placed the responsibility of leading the American forces, appeal to you with all possible earnestness to invest in War Bonds to the fullest extent of your capacity.

Give us not only the needed implements of war, but the assurance and backing of a united people so necessary to hasten the victory and speed the return of your fighting men.

William B. Dealey
Joseph P. East
Dwight D. Eisenhower
W. M. C. M. M. M.

Halpin of RCA Sees Tele Billion Dollar Industry

"Before the people of Charlotte realize it, television may be in their own back yard," Dan D. Halpin, television receiver sales specialist of RCA Victor, told members of the Charlotte, N. C., Rotary Club. Mr. Halpin called attention to the fact that a coaxial cable for television is already being laid between Washington, D.C. and Charlotte.

"Television completely fulfills all the requirements of good sales promotion," Mr. Halpin declared. "It produces lifelike moving images, giving a fascinating new dimension to broadcasting. It will mean that the perfect, pre-tested sales message can accompany a demonstration of products presented in an informative, entertaining way to the family group interested in 'what's new'."

Mr. Halpin estimated that within five years after the commercialization of television it will develop into a billion dollar industry, and that by the end of another 5 years thereafter television service should be available to about 100,000,000 people in 23,700,000 wired homes, representing 82 per cent of the nation's buying power. Such a service, he pointed out, would provide the vendor of goods or services with the equivalent of 23,000,000 intimate "fireside" showrooms in which he could present simultaneous demonstrations under the most favorable conditions.

Motorola Jobber to Sell on Basis of 1941 Sales

When civilian merchandise is once again available, the Lofgren Distributing Co., 1202 4th Ave., Moline, Ill., Motorola jobber, will allocate goods to its retailer-customers on the basis of their 1941 purchases.

Expanding its distribution area, the company will also cover Ogle and Lee counties, both in Illinois, postwar, it was announced by Joseph Kehoe, proprietor of the firm.

Year-Round "Tree Light" Use Seen by Sadacca

Henri Sadacca, president of Noma Electric Corp., New York City, believes in the Christmas spirit and is preparing for the happy Christmases to come, by incorporating this spirit into the postwar plans of his company. It is Mr. Sadacca's thought that the festive spirit of Christmas with its colorful tree lights and decorations should be used for celebrating birthdays, national holidays and anniversaries. With this end in view, he has inaugurated a series of radio announcements pointing out how every party can easily be made into a really festive occasion.

Sparton Plans Include Ad Campaign Expansion

Fred T. Sterritt, advertising and sales promotion manager of the appliance division of the Sparks-Withington Co., Jackson, Mich., manufacturers of Sparton radios, announces that his firm has increased the trade paper list from one to eight publications covering all classifications of trade.

"The exclusive dealership policy under which we have been operating successfully—The Sparton Cooperative Merchandising Plan—has been given a great deal of deserved publicity, yet certainly there are thousands of men in the radio and appliance fields who are not familiar with its details," said Sterritt in explaining Sparton policy.

Move to New Location

Herman R. Rose, president of General Television & Radio Corp., Chicago, has announced the purchase of the building formerly occupied by Press Wireless, at 2701-17 Lehmann Court, Chicago. General plans on moving to its new location on or before June 10.

Joins Cinaudagraph



Cinaudagraph Speakers, Inc., Chicago, manufacturers of quality loud-speakers, announce the appointment of Norris "Kelly" Cohn to their sales staff. "Kelly" saw service as a paratrooper in Italian campaign.



is so

Exacting

AFTER the last enemy lays down his arms . . . then must follow the fabulous changeover whereby industry diverts production for War into production for Peace.

A critical and an exacting phase!

We at CORWICO are already planning for the transition. Soon millions of tons of basic materials formerly required by our armed forces can be diverted to peacetime uses . . . including, you may be sure, the fine CORWICO Wires that civilians have so patiently gone without for so long.

cornish

WIRE COMPANY, INC.

15 Park Row, New York City, New York



"Made by Engineers for Engineers"

The timing that makes work **SING...**



It will pay **YOU . . .** to sell
Webster Electric Sound Distribution Systems

Industrial efficiency is increased by the short, straight paths of movement, the better timing, the frictionless operation that music makes possible.

Webster Electric Sound Distribution Systems provide this music that makes work sing, the spirit that makes the wheels go round, in many shops and offices all over America.

Increased production for war has been made possible in hundreds of plants through the use of music in industry. It has pointed the way to the extent to which the use of good sound distribution systems . . . Webster Electric Systems . . . can promote the industrial efficiency of the sharp, competitive days ahead.

Alert radio dealers, seeking to broaden their base of operations for future business, see before them a tremendous market virtually untapped . . . one in which large sales can reasonably be anticipated in the next few years.

In the Webster Electric line of sound distribution equipment they will find a wide range of control cabinets, amplifiers, microphones, and speakers to meet the needs of both large and small establishments. These are manufactured by a company with many years of experience in the development of high fidelity sound systems, with a wide distribution of present installations to serve as valuable reference with prospects.

In every community there are department stores, factories, clinics, hospitals, schools and institutions . . . all need and will buy a modern sound distribution system. Now is the time to become thoroughly familiar with the superlative value, the profit-making possibilities of Webster Electric Sound Distribution Systems. Write us today.

(Licensed under patents of the Brush Development Company)

Let's All Back the Attack . . .



Buy Extra War Bonds

WEBSTER ELECTRIC

Madison, Wisconsin, U.S.A. - Established 1899 - Export Dept: 13 E. 40th Street, New York (16), N.Y. Cable Address "ARLAB" New York City

"Where Quality is a Responsibility and Fair Dealing an Obligation"

Astatic Officials



Two busy Astatic Corp. men relax momentarily for the cameraman—C. M. Chorpening, left, vice-president and director of engineering, and F. H. Woodworth, president and general manager.

Wilcox-Gay Speeds Work

The Wilcox-Gay Corp., Charlotte, Mich., is using assembly line tactics to build radio range equipment for the civil aeronautics administration for both Army and Navy use.

The complete unit is composed of two transmitters, one coupling unit, five antenna tuning units, one transmitting station control rack, one remote station control rack and a phantom antenna load. A single telephone dial operates the complete unit from a remote control rack over a two-wire telephone line which can be several miles long. This equipment is used to facilitate instrument flying along the airways all over the world.

Homer Robinson Feted

Salesmen of the National Union Radio Corp., Newark, N.J., gave a dinner for J. Homer Robinson, former sales manager, to mark his 15 years affiliation with the company. "Robby" is now vice-president and general sales manager of the American Radio-Hardware Co., Mount Vernon, N.Y.

DuMont Labs Plan Tele Station in Washington

Allen B. DuMont Laboratories, Inc., is conducting field tests in Washington, D.C., preliminary to the establishment of a television station, Dr. Allen B. DuMont, president of the company, announced. Dr. Thomas T. Goldsmith, Jr., director of research, and members of the research staff are conducting tests to determine field strength and propagation data in the territory in and around Washington.

The company has leased space on the tenth floor of the Hotel Harrington, and plans to erect a permanent antenna on the roof as soon as permission from WPB is granted. Call letters of the Washington station are W₃XWT. A tie-in between the station WABD in New York and the station in Washington is planned.

Ansley Appoints Reps

The Ansley Radio Corp., Long Island City, N. Y., has appointed the following representatives to handle its line of Ansley Dynaphone radio-phonographs and Ansley Dyna Tone electronic pianos:

R. A. Adams, 18288 Appoline Ave., Detroit, Mich. Frank H. Barstow, 1406-08 South Grand Ave., Los Angeles, Cal. C. A. Clinton, 941 Western Ave., Albany, N. Y. Reid H. Cox & Co., 276 Peachtree St., N.E., Atlanta, Ga. Hal Elthorn, 1325 W. Thorndale Ave., Chicago 40, Ill. W. G. Landes, 1355 Market St., San Francisco, Cal. Fillmore & Fillmore, Liberty Bank Bldg., Buffalo 2, N. Y. Earl Goetze, 2020 Walnut St., Kansas City, Mo. W. A. Leiser & Co., N.W. corner Race & Canmac St., Philadelphia, Pa. F. F. McMorrow, 459-B Hippodrome Annex, Cleveland, Ohio. J. O. Olsen, 1456 Waterbury Rd., Cleveland, Ohio. Harry D. Schoenwald, 209 South State St., Chicago, Ill. Fred A. Wiebe, 710 No. 12th St., St. Louis, Mo. Donald D. Wood, 3829 Greenbrier Drive, Dallas 5, Texas.

Major Appliance Jobber

The Basham Appliance Co., 218 North Main, is a new major appliance jobber in the Wichita, Kan., trade territory. Lee Basham, owner, has been appointed wholesale distributor of Arvin radios and other Arvin products for 66 Kansas counties, and will operate the jobbing division as a separate organization from his retail store, which he plans to continue after the war. During the war, Basham's retail store has kept open by servicing refrigerators, washers, etc., for dealers and customers.

Harold F. Foraker, Wichita, Kan., and Floyd Reece will work with Basham in his new outfit.

ECA Completes Plans for Released War Equipment

The Electronic Corp. of America, New York City, has completed detailed plans for the disposal of electronic and communications equipment and components released by the Armed Forces, according to an announcement by S. J. Novick, president. The company has acquired a six story building at 353 West 48th Street, New York City, to be used exclusively as a factory and warehouse in connection with the processing and distribution of electronic equipment as an agent of the Defense Supplies Corp.

A nation-wide staff of sales representatives has been recruited by Jack Geartner, sales manager of ECA, who will manage the defense supplies selling operations.

It is expected that a very wide range of items will be offered to buyers. Substantial amounts of the material have already been received by ECA and were found to be in excellent condition. Much of it can be sold without any need for factory reconditioning. Other equipment, including partially finished items, will be completed and put into salable condition by ECA or broken down into components.

The Standard of Quality for a Third of a Century



Instruments
that tell the truth . .



Volt-Ohm-Milliammeter

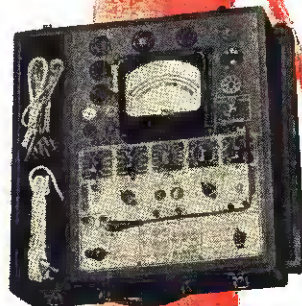

All-Purpose Tube and Set Tester



Signal Generators



Oscillograph

• In maintaining the highest standard of excellence the one and only HICKOK aim must always be the building of instruments that tell all the truth all the time. When quality is built up to a high standard instead of down to a price, the user has greater confidence in his work.

Whether you are selecting tube and set testers, signal generators, oscillographs, volt-ohm-milliammeters or any other service equipment, remember that the standard of quality for a third of a century has never been excelled. Having pioneered the major new developments and vindicated maximum accuracy and dependability, HICKOK equipment has been specified by the armed forces in both world wars. We are still bending every effort to speed the war program and trust it will not be long until we can again take care of your civilian needs with the service equipment that is held in highest esteem. Write for Radio Equipment catalogue.

THE HICKOK ELECTRICAL INSTRUMENT COMPANY
10523 Dupont Ave., Cleveland 8, Ohio

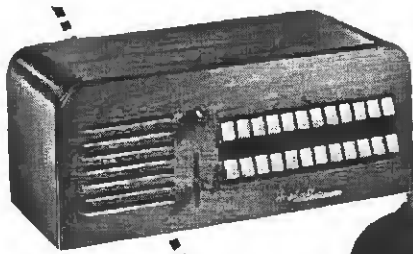

W200 Series AMPLICALL with facilities for up to 24 master stations and up to 12 possible conversations simultaneously.



AMPLICALL Sound Control Unit

AMPLICALL Weatherproof Speaker

AMPLICALL
gives a greater **GO** to business...

Distributors know the real job RAULAND AMPLICALL Paging and Two-Way Intercom Systems are doing today on the executive and production fronts of American Industry. They know that the reputation AMPLICALL is chalking up today is a sure sign of a steadier, more profitable business to come.

THE RAULAND CORPORATION • CHICAGO 41, ILLINOIS
Electroneering is our business

BUY MORE
WAR BONDS



HOLD THE BONDS
YOU HAVE!

RADIO • RADAR • SOUND • COMMUNICATIONS • TELEVISION

WOMAR

Manufacturers of
RADIO, ELECTRICAL AND
ELECTRONIC COMPONENTS

ELECTRONIC PRODUCTS MFG. CORP.
DEXTER, MICHIGAN

Schedule Templetone Ads

Templetone Radio Mfg. Corp., of New London, Conn., makers of Temple radios, announce a further expansion of advertising activities. Newspaper copy, stressing the Temple theme, "In Person" reception, is already scheduled for 20 major cities—both in rotogravure and black and white.

Snyder Morale Booster

The Snyder Mfg. Co., Philadelphia, Pa., with the help of Capt. Joseph Fineberg, a veteran recently returned from Italy, has devised a plan for lowering plant absenteeism and boosting G.I. morale. Each worker with a good attendance record is eligible to have a picture taken showing him at work. The pix is suitable for overseas mailing, and has room for a personal message at the bottom. The War Department vouches for the overseas morale value of these pictures, and civilians get a great deal of satisfaction out of knowing they are "doing their bit."

Meck Chicago Survey Shows Dealer Preference

In a statement released by John Meck, president of John Meck Industries, Inc., Plymouth, Indiana, the results of a consumer survey made in the Chicago area, were announced. Results of the Chicago survey show that 25 per cent of those asked the question, "Where will you buy your next radio?" said they would buy them from radio shops. Five per cent said department stores, 6 per cent from music and furniture stores and 64 per cent were uncertain. Mr. Meck, in a message to radio distributors, pointed out the need for good salesmanship and for personal contacts, which is one of the sales advantages of the radio service and sales shop, which has the opportunity to meet potential customers servicing radios in their homes and meeting customers as they come in the shop.

Cecil H. Boyd



Boyd Distributing Co. official whose Denver, Colo., firm has been appointed jobbers for Motorola radios.

design counts

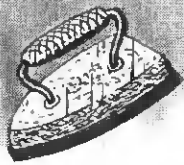

Remember the old flatiron? It did its job, of course; but just compare it with the modern electric iron which has been brought to its present high level of utility by careful application of design.

Here at THE WARD PRODUCTS CORPORATION, design is one of the most carefully considered factors in the manufacture of antennas. It is only through superior design that durability, styling and the benefits of superior production can be best brought to the user. For the finest antennas for all applications — for home and automobile use — look to WARD.

Back Again . . . Soon
WARD Aerials
"World's Finest for Car and Home"

WARD

Antennas

BUY WAR BONDS
THE WARD PRODUCTS CORPORATION
1523 EAST 45TH STREET • CLEVELAND 3, OHIO

GE Wire Recorder on Spot



Guthrie Janssen, front, NBC correspondent, uses a GE wire recorder to record his eyewitness account of a German U-Boat surrender off Cape May, N. J. The commentary was first played for the censor, and then broadcast.

Harold Cook of Tung-Sol Receives Promotion

Harold F. Cook, who for the past eight years has acted as assistant advertising manager under Walter B. Masland at Tung-Sol, Inc., Newark, N. J., has now been appointed advertising and sales promotional manager.

Mr. Cook has a keen interest in and knowledge of marketing, and has insisted on a well-rounded marketing program and sales promotion procedure.

Walt Masland recently resigned to operate the Indian River Marine Basin at Melbourne, Florida, which he purchased some time ago. The hailing port of his ocean racing yawl "Anchorite" has already been changed to Melbourne.

Automatic Radio on Air

The Automatic Radio Mfg. Co., of Boston, will sponsor a quarter-hour musical show, "G. I. Salute," every Thursday night from 7:45 to 8 p.m., over WNAC, Boston, WTHT, Hartford, Conn., and WICC, Bridgeport.

Paschkes Assumes Position as Head of Solar Board

Otto Paschkes relinquished the presidency of the Solar Mfg. Corp., New York City, at the organization meeting of directors following the annual stockholders' session to assume the newly created post of board chairman. Elected to succeed him as president was Paul Hetenyi, formerly executive vice-president.

In his new position, Mr. Paschkes will continue actively as chief administrative officer of the corporation which, at plants in Bayonne and West New York, N. J., and Chicago, Ill., manufactures radio and electronic devices, chiefly capacitors and filters. Both Mr. Paschkes and Mr. Hetenyi were instrumental in establishing the corporation in 1932.



The modern housewife knows that the quick, convenient way to squeeze fresh fruit juice is with JUICE KING. Throughout the war, national advertising in leading consumer magazines has kept the JUICE KING name...JUICE KING quality...vividly before her.

She'll be asking for JUICE KING, so plan now to merchandise this popular home juicer, *postwar*.

Watch for JUICE KING Advertising in Good Housekeeping, Ladies' Home Journal, Better Homes & Gardens.



Juice King

FINEST HOME JUICER

NATIONAL DIE CASTING CO.
Touhy Avenue at Lawndale, Chicago 45, Illinois

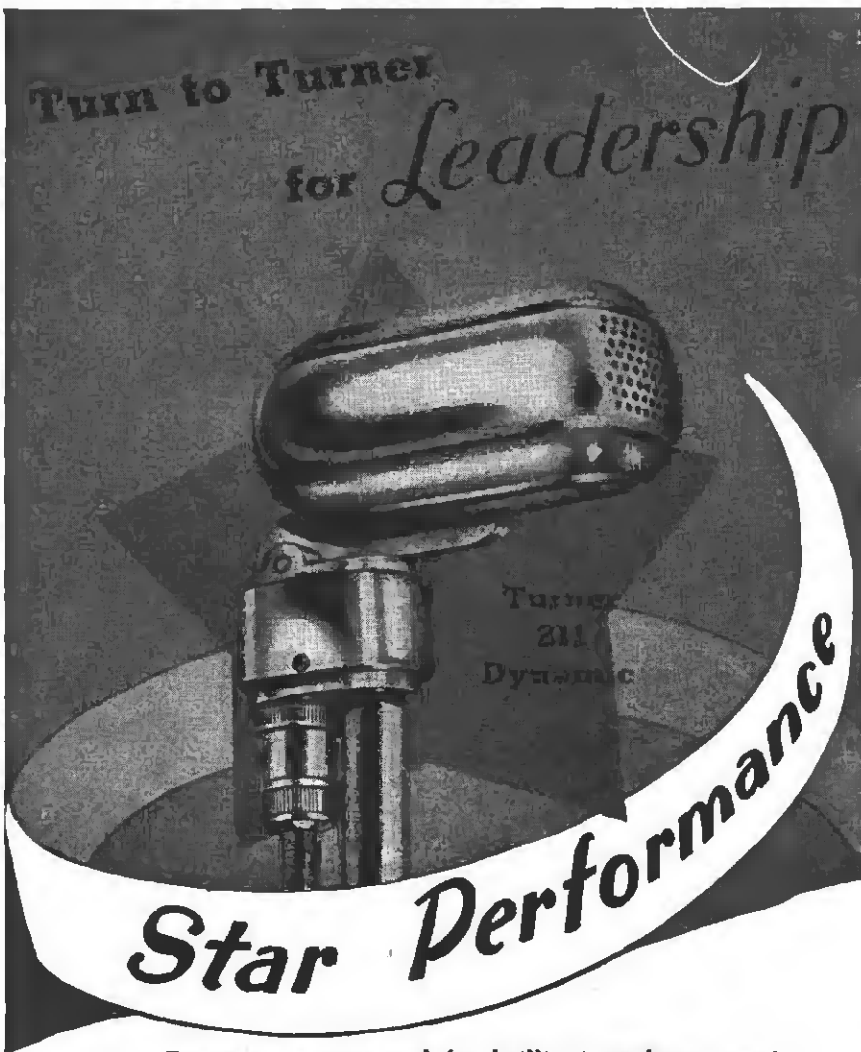

Precision engineered for brilliant performance indoors or out under the most difficult acoustic or climatic conditions, the New Turner 211 Dynamic combines rugged dependability with distinctive, modern styling. Utilizes a new type magnet structure and acoustic network. Unique diaphragm structure results in extremely low harmonic and phase distortion without sacrifice of high output level. Standard equipment with leading electronic communications manufacturers wherever faithful reproduction is paramount. Write for technical data and descriptive literature.



Turner Performance for Every Communications Need

There is a Turner Microphone for every electronic communications application. Get the full story of Turner performance. Write today for illustrated catalog giving descriptive data on all Turner Microphones for Recording, P.A., Call System, and Amateur and Commercial Broadcast work.

The TURNER COMPANY
903 17th St., N.E., Cedar Rapids, Iowa



TURNER -- PIONEERS IN THE COMMUNICATIONS FIELD

Turner
Microphones

Crystals licensed under patents of the Brush Development Co.

CRYSTAL

DYNAMIC

Better Hearing

(Continued from page 56)

school's graduates are doing excellent work for the war effort, while others are displaying initiative and ability while working in private industry.

The success which the school has had in teaching the deaf indicates that education of this kind will be expanded to many communities in the country. The radio-sound technician can play an important role in this commendable work by installing and maintaining the necessary sound equipment. Aside from the financial remuneration derived from performing service of this kind, the technician should obtain satisfaction and pleasure which cannot be measured in terms of money.

Another organization which has achieved an outstanding success in assisting the hard-of-hearing—not to be confused with those who are deaf—is the New York League of the Hard of Hearing. This group, located at 480 Lexington Ave., New York, is a non-profit, non-commercial enterprise whose purpose it is to help every man, woman and child in the Greater New York area who suffers from impairment of hearing.

Wired Seats for Public

According to Miss Estelle E. Samuelson, executive secretary of the New York League, there are at least 10,000,000 persons in this country who have hearing deficiencies, and who need aid in order to be fully dependent upon themselves.

Services offered by the league include hearing-aid consultation, lip reading instruction, vocational guidance, recreation, etc. One of the organization's objectives, and one in which it has already achieved success, is the wiring of seats for hearing aid devices in public gathering places.

Aids Hard-of-Hearing

At the present time, many places of entertainment and education, including the Metropolitan Opera House, Carnegie Hall, Hayden Planetarium, and numerous motion picture theatres, have seats especially wired in certain sections of their auditoriums. This innovation is a great step forward in enlarging the social life of folk who lack the ability to hear normally.

When a hard-of-hearing person presents himself at the box office of a theatre where hearing aids are available he receives a device which he plugs into the electrical outlet at

tached to the seat. The recipient of the hearing device leaves a deposit when he receives this equipment, which is refunded when the hearing aid is returned.

The New York League for the Hard of Hearing is endeavoring to expand the wiring of seats to legitimate theatres, hotel meeting rooms, lecture halls, and other public places, so that people with impaired hearing can enjoy a wide range of activity. This admirable organization envisions an increase in the number of wired-seat theatres in the future, and here is where radio technicians may find an opportunity to increase their sales volume.

Veterans Afflicted

When manpower and material are available in abundance, many theatres, meeting halls, etc., will be constructed which will include the wiring of seats in their plans. This is becoming more and more apparent due to the increase of people whose hearing has dropped below normal. Innumerable war workers and returning servicemen who have experienced an impairment in hearing during the war period will find an acute need for establishments with wired seats.

It is estimated that the cost of installing wired seats in a new theatre is between \$300 and \$500, which is a small amount compared to the outlay for erecting a theatre, and which should not deter builders from including this feature in their plans. In addition, many established public places will doubtlessly install wired-in sound amplifying equipment to accommodate the increasing demand. These facts are worthy of investigation by the aggressive dealer-technician who is interested in rendering an important service and earning a fair profit.

New Opportunities

During the war period, many radio dealers took on lines of hearing-aid equipment to compensate for the disappearance of receivers and appliances. Numerous merchants have successfully sold hearing devices, as various surveys have indicated. Merchandising hearing aids has aided retailers in maintaining a profitable sales level.

With the use of hearing devices becoming more widespread and increasingly important, the radio dealer may find a lucrative field in selling these items. In preparation for hearing-aid merchandising, the retailer should ascertain in advance the potential volume in his community, and the type of device preferred.

HOMER G. SNOOPSHAW says:

"Operator! Put this message through! These war battery ads are making Burgess dealers millions of friends in homes where folks are reading 45 favorite magazines and 1,629 weekly newspapers."



HE HAS YOUR BATTERY



Frontline command posts depend on battery-powered field telephones to link combat troops with regimental headquarters! Without full supplies of dry batteries this vital part of war communication would collapse—endangering the lives of fighting men. Thousands of dry batteries are used every day on every front to operate essential instruments and weapons. That's why we have to manage without them here on the homefront.



Save More Paper!—Send it to War!

BURGESS BATTERIES

IN THE NATION'S SERVICE

BURGESS BATTERY COMPANY, FREEPORT, ILLINOIS

BE SURE... Standardize on

STANCOR Transformers

Call your nearest Stancor Jobber...
or write us for his address

STANDARD TRANSFORMER CORPORATION

1500 N. HALSTED STREET · CHICAGO



*"You'll
HEAR MORE
from Astatic"*



BECAUSE of research and experiments now being made by Astatic engineers, in the application of advanced ideas in the pickup and reproduction of sound, you can be sure you'll hear more from the Astatic products of tomorrow. . . And for the same reason you will hear more of the name "Astatic," which, for so many years, has been synonymous with quality microphones, phonograph pickups, cartridges and recording heads. In design, performance and dependable service, Astatic products will continue to measure up to the very highest standards.

ASTATIC Crystal Devices
manufactured under Brush
Development Co. patents.

THE
Astatic
ASTATIC CORPORATION
CONNEAUT, OHIO
IN CANADA. CANADIAN ASTATIC LTD., TORONTO, ONTARIO



APPROVAL

Snyder products have the endorsement of jobber, retailer and consumer alike. There's a recognition of the superiority of Snyder products.

ANTENNAE
by

SNYDER
MANUFACTURING CO. • PHILADELPHIA

COMPLETE MANUFACTURERS
FROM START TO FINISH



Plug in
METAL TUBE RESISTORS

★ To facilitate the servicing of those AC-DC sets equipped with plug-in metal-tube resistors, Clarostat offers 10 Universal Types which replace upwards of 90% of the original numbers.

Clarostat Universal Types operate within voltage range specified on tube, regardless of what pilot current is drawn or of any pilot light combination. Operate regardless of burnt-out pilot lights and well within the .3 amp. range required for tube filaments. Also, these Universal Types operate efficiently regardless of line-voltage variations.



★ **Ask Our Jobber...**

Ask for these Universal Types of Plug-In Metal Tube Resistors. Ask for the Clarostat "Interim Line" catalog. Or write us direct.



CLAROSTAT MFG. CO., Inc. • 285-7 N. 6th St., Brooklyn, N. Y.

Start with any **1** Jackson Instrument
 to Build a Balanced Testing **TEAM!**

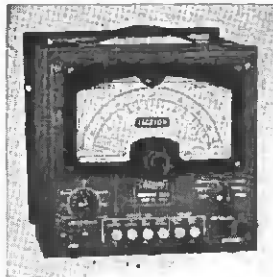

Condenser Tester
 Model 650A—Measures Capacity, Power Factor and Leakage

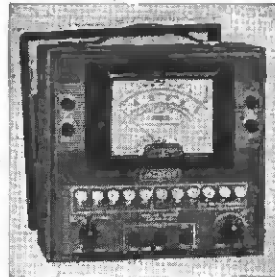

Sensitive Multimeter
 Model 642—20,000 ohms per volt—complete ranges



Electronic Multimeter
 Model 645—A new Jackson instrument of advanced design

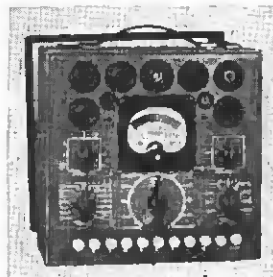

Tube Tester
 Model 634—Uses exclusive Jackson "Dynamic" Test Method



Multimeter
 Model 643—1000 ohms per volt. Push key range selection

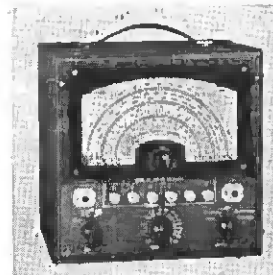

Test Oscillator
 Model 640—Accurate to 1/2%. covers full frequency range

IT'S A PLUS VALUE of the Jackson line. Each instrument is engineered and manufactured for long accurate life, as today's users know—but every one is carefully matched in appearance, dimensions and finish as well.

Start with whichever Jackson instrument you need first. Add to it as occasion demands. Your foresight will be repaid with a matched and balanced set of instruments built to give you testing results that you just can't get with hit-or-miss assemblies. Plan now to equip your shop with these Jackson instruments. See your distributor.

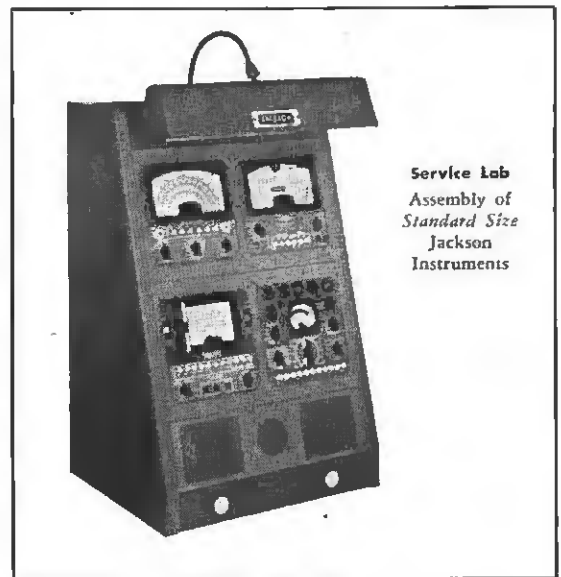

Service Lab
 Assembly of
 Standard Size
 Jackson
 Instruments

BUY WAR BONDS AND STAMPS TODAY

JACKSON

Fine Electrical Testing Instruments

JACKSON ELECTRICAL INSTRUMENT COMPANY, DAYTON, OHIO



WAR-TESTED

During the critical stress of battle, men and equipment prove themselves. Materiel that has performed dependably under highly abnormal War conditions has stamina to spare in normal peacetime operation. Performance under fire has given us invaluable information on how to make a fine pre-war loud speaker into a better post-war speaker. When conditions permit these better Atlas Sound Loud Speakers will be available for general use.

ATLAS SOUND

Complete Catalogue on Request

ATLAS SOUND CORPORATION

1445 39th Street Brooklyn, N. Y.

Westinghouse Official

F. D. Newbury, vice-president of the Westinghouse Electric Corp., Sunbury, Pa., announced the appointment of Frank W. Godsey, Jr., as manager of the new products division. Mr. Godsey replaces G. H. Woodard, who has been transferred to South Philadelphia as manager of the corporation's aviation gas turbine division.

Slagle Joins Colo. Firm

B. Walter Slagle has become an active partner and owner with O. F. Achtenhagen in the Radio and Appliance Distributing Co., Denver, Colo., long-established Philco distributor serving the Colorado area. For the past two and a half years, Mr. Slagle has been the civilian adviser to General Frank, Commanding General of the Air Force Command, Patterson Field, Dayton, Ohio.

"Trav-Ler" Moves Offices

Joe Friedman, president of Trav-Ler Karenola Radio & Television Corp., announces that the general offices, showrooms and research laboratory of Trav-Ler are now located at 571 W. Jackson Blvd., Chicago. The Trav-Ler firm occupies an entire four-story corner building which has been remodeled to meet requirements of current war work, and expanded postwar business plans.

Marshank New Location

David N. Marshank, founder of the Marshank Sales Co., and for eleven years factory representative for the Hallicrafters Co., Chicago, producers of high frequency radio equipment, announced the recent removal of his firm to more spacious quarters at 672 South Lafayette Park Place, Los Angeles, Cal.

Lear Prepares Booklet on Wire Recording

Lear, Inc., which recently made public its plans for Lear wire recording in connection with the Lear home radios as well as for commercial, industrial, and educational purposes, has prepared a booklet on wire recording. The many possible uses for this newest method for the recording of sound is treated. A brief complete explanation of Lear wire recording is given, with illustrations that explain the process very clearly.

Copies of the booklet may be obtained by writing to Lear, Inc., home radio sales division, 230 East Ohio St., Chicago 11, Ill.

Price Vice-President

Gwilym A. Price has been appointed executive vice-president of the Westinghouse Electric Corp., Pittsburgh, Pa., according to an announcement by George H. Bucher, president. Mr. Price was elected vice-president of the company in September, 1943, and was elected to the Westinghouse board of directors in January of this year.

The Soldering Iron That's HOT IN 90 SECONDS!

- COMPLETE U.S. APPROVAL
- COOL, SAFETY HANDLE
- LIGHT WEIGHT GOOD BALANCE
- THERMOSTATIC HEAT CONTROL
- QUICK HEATING ELEMENT
- THREAD TIP—GOOD CONTACT
- 6 INTER-CHANGEABLE TIPS



Only Kwikheat has a BUILT-IN THERMOSTAT

No more waiting for your soldering iron to heat up—the Kwikheat Iron is hot, ready to use only 90 seconds after plugging in! A built-in thermostat maintains proper temperature. Can't overheat—saves tips and retinning time. Powerful, 225 watts: yet exceptionally light, 14 oz. Cool, safety handle. Six interchangeable tip styles are available to adapt one iron to most any job . . . \$11.00

FROM TIP TO PLUG—IN A CLASS BY ITSELF

VANATTA **kwikheat**

THERMOSTATIC SOLDERING IRON

A Division of
Sound Equipment Corp. of California
3903 San Fernando Rd., Glendale 4, Calif.

RADIO TUBES

We have radio tubes combined with adaptors, sold as complete units, for the following critical numbers:

1A5	1N5	6K7
1C5	3Q5	1T5
1H5	6A7	1Q5
	6A8	

\$1.35 each

6Q7	6SC7	6X5
6SQ7	75	84-6Z4

\$1.20 each

Regular tubes—not substitutes

7H7	—\$1.10 each
7T7	— 1.10 each
6SN7	— .72 each
1T4	— .90 each
354	— .90 each
155	— .90 each
27	— .35 each

Signed supplier's certificates #L-265 must accompany all tube orders.

ADAPTORS

We manufacture a complete line of radio tube adaptors. Don't let your old tubes be idle, use our ADAPTORS.

50c each—doz. lots of any one type
60c each—smaller quantity

Send for our complete list of over 125 different types of adaptors.

Manor ELECTRIC & APPLIANCE CO.

3234 Southport Ave., Chicago 13, Ill.

UP-TO-THE-MINUTE RADIO APPLIANCE PICTURE

Substantial production of 4 critical appliances has been approved by WPB for last half of '45:

Electric hand irons 1,052,000
Washing machines 700,000
Electric and gas refrigerators 530,000
Electric ranges 70,000

These figures are only the allowed quotas approved as a program. Whether or not they become an actuality depends upon how fast military cut-backs make materials, manpower available.

Even if all are produced as scheduled, no one knows how many of these appliances will go to retailers. Most refrigerators will probably be stockpiled for purchase by essential buyers.

Some appliances reaching dealers will be reserved for essential civilian use. OPA may extend allotment plan to make sure critical appliances go first into homes needing them most.

Radios, vacuum cleaners, toasters and heating pads, will be produced this year as material becomes available from idle and excess inventory under Spot Authorization.

July 1, WPB will take step making production of consumer durable goods possible. After that date, manufacturers who get cut-backs and who have Controlled Materials in inventory may use or sell these materials. This means that many radio and appliance makers will be able to get materials they need for production of these products.

RECORDS

(Continued from page 51)

waxed "Kissing Bug," Duke Ellington, 20-1670, "June Comes Around Every Year," Tommy Dorsey 20-1669, and "There's No 'You,'" Martha Stewart, 20-1671.

Special Red Seal album DM-955 is recording of the hit highs in the New York stage success "On the Town," noted for its ballet music which was composed by Leonard Bernstein. He conducts this recording.

Other Red Seals are DeFalla's "Ritual Fire Dance," featuring Jose Iturbi at the piano; Morton Gould's "American Salute" and "Yankee Doodle Went to Town."

The Boston "Pops" recording of Mendelssohn's "Fingal's Cave" winds up the first phase of Victor's advertising program. Dealer advertising tie-ins are full color page in *Life* magazine on June 18th, dividender dispatcher in bright blue, black and white, "Music America Loves Best" radio program plug June 17, cooperative advertising through Regional Management.

TOUGH!



Cinaudagraph Speakers are made to take the tough raps. This is the built-in result of better manufacturing experience. Look at the record of achievement and you'll put Cinaudagraph Speakers at the top of your list.

Watch Cinaudagraph
Speakers After Victory!

Cinaudagraph Speakers, Inc.

3911 S. Michigan Ave., Chicago
Export Div., 13 E. 40th St., New York 16, N. Y.



"No Finer Speaker in all the World"

ALLIANCE "Even-Speed" Phono-motors



Good News!

ALLIANCE RESUMES PRODUCTION on One Standard Model

• We are now able to return to production of one standard variation of Alliance Model 80 Phono-motor, according to the following definite specifications and on the production plan explained below.

STANDARD SPECIFICATION No. 811—Turntable No. Y-278-S2; 110 Volt, 60 cycle, 9" Model 80

Production must be on the following practical basis under present conditions where there are no large volume priority orders—namely, by accumulating a sufficient quantity of small orders with necessary priority and making periodical single production runs at such time as the quantity of accumulated orders is enough to make this practical. Priority orders (currently only orders of AA-3 or higher, with GOVERNMENT CONTRACT NUMBER and MILITARY END USE, or where certified to be used in Sound Systems, Intercommunicating or Paging Systems, as exempted from order M-9-C) must allow delivery time required to obtain a minimum practical production run; to procure material for all orders in hand, and make one production run of the one type standard unit only, for shipment on the various accumulated orders. • Check the above against your requirements, and if you have proper priority, communicate with us.

REMEMBER ALLIANCE—Your Ally in War as in Peace!

AFTER THE WAR IS WON, WE WILL TELL YOU ABOUT SOME NEW AND STARTLING IDEAS IN PHONO-MOTORS

ALLIANCE MANUFACTURING COMPANY
ALLIANCE, OHIO

Jobber Appointments

SPARKS-WITHINGTON CO., Jackson, Mich., has named its district merchandisers to distribute the Sparton radio line. • J. B. Wheeler, Jr., Cataumet, Mass. • Victor H. Meyer, New York City. • Nypenno Sales Co., Warren, Pa. • Edmiston-Rimmer, Charlotte, N. C. • Lynn Dickerson Associates, Houston, Tex. • William C. Allen & Associates, Birmingham, Ala. • A. G. Everett, Lakewood, Ohio. • Gilbert B. Mueller, Milwaukee, Wis. • Campbell & Stenson, St. Paul, Minn. • Harry Moll, Inc., Denver, Colo. • L. A. Robinson, Seattle, Wash. • Myron H. Kent, Oklahoma City, Okla. • B. S. "Tommy" Tucker, Los Angeles,

Cal. • Whe-Gros Co., St. Louis, Mo.

NOBLITT-SPARKS INDUSTRIES, INC., Columbus, Ohio, announces additional distributors for the Arvin line of radios, radio-phonograph combinations, laundry tubs, electric heaters and other small appliances. • Stratton-Warren Sales Co., Memphis, Tenn. • Higgins Industries, the appliance division, Shreveport, La. • Allan Brown Co., Little Rock, Ark.

ESTATE STOVE CO., Hamilton, Ohio, announces the following appointments as Estate Heatrola distributors: • T. A.

O'Loughlin & Co., Newark, N.J., Consolidated Sales Co., Richmond, Va.

HOFFMAN RADIO CORP., Los Angeles, Cal., has named the Radio Parts of Phoenix, Arizona, as its distributor in the Arizona area.

JOHN MECK INDUSTRIES, INC., Plymouth, Ind., announces the following jobber appointments: James W. Clary Co., Birmingham, Ala. • Tucson Radio Supply, Tucson, Ariz. • Tanner Radio & Electric Co., Little Rock, Ark. • Wise Radio Supply, Fort Smith, Ark. • Radio Specialties Co., Los Angeles, Cal. • Wave Miller & Co., Oakland, Cal. • Pacific Wholesale Co., San Francisco, Cal. • Inter-State Radio & Supply Co., Denver, Colo. • R. G. Seeli & Co., Hartford, Conn. • Capitol Radio Wholesalers, Washington, D.C. • Railey-Milam, Inc., Miami, Fla. • Gulf Electric Supply Co., Pensacola, Fla. • Welch Radio Supply, St. Petersburg, Fla. • Electrical Wholesalers, Inc., Atlanta, Ga. • Butler Bros., Columbus, Georgia. • The Frank Corp., Savannah, Ga. • Lurtz Electric Co., Belleville, Ill. • Ashbach & Rubloff, Chicago, Ill. • Tri-City Radio Supply, Rock Island, Ill. • Harold Bruce, Springfield, Ill. • Wesco Radio Parts, Evansville, Ind. • Arlington Distributing Co., Indianapolis, Ind. • Archer & Evinger, Terre Haute, Ind. • Wholesale Radio Laboratories, Council Bluffs, Iowa. • Radio Equipment Co., Lexington, Ky. • The Ferguson Co., Paducah, Ky. • Shuler Supply Co., New Orleans, La. • Zimmerman Wholesalers, Hagerstown, Md.

AMERICAN STOVE CO., Cleveland, Ohio, has named Bickford Bros. Co., Rochester, N.Y., to distribute the Magic Chef range in this territory.

STEWART-WARNER RADIOS, Chicago, Ill., has appointed the Motter-Electric Co., York, Pa., as distributor for its postwar line of home radios.

STROMBERG-CARLSON CO., Rochester, N.Y., announced the following distributors for the company's radio, FM and television line. Byars-Forgy, Inc., Tampa, Fla. • Clark & Jones, Birmingham, Ala.

ZENITH RADIO CORP., Chicago, Ill., announced additional distributor appointments to include: • Radio Supply Co., Norfolk, Va. • Nash-Steel Motor Co., Raleigh, N.C.

Aeropoint's Plans Formed

At a gathering in Chicago's Bismark Hotel, Burton Browne, president, and Mrs. Dorothy Steven, vice-president of Aero Needle Co., entertained Earl Dietrich and R. L. Meyer of Cleveland; Don Burcham and Bill Earl of Portland, Ore.; Jim Hermans of San Francisco and Bob Campion of Texas.

At this meeting Aeropoint's new coin machine needle and the new Aeropoint sapphire needle were shown and plans for the new merchandising program were discussed.

Again! MASCO is back to the market first with

*This Pre-Pearl Harbor Item
at a Pre-Pearl Harbor Price*

RECORD CHANGER-TOP AMPLIFIER

IMPROVED and MODERNIZED

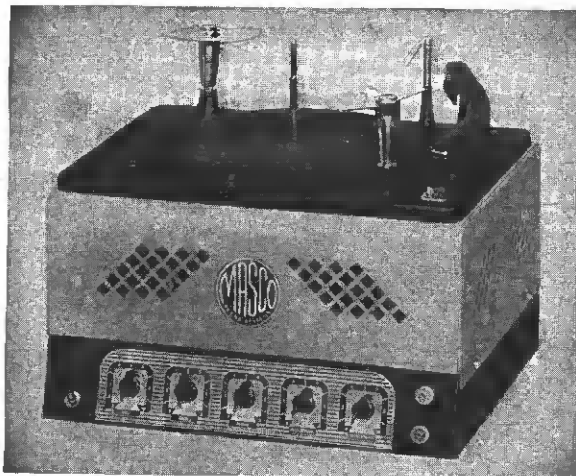

AMPLIFIER SPECIFICATIONS

- Power Output: 35 Watts.
- Gain: Microphone 125 DB, Phono, 78DB.
- Controls—Five: Two Microphones, Phono, Dual-Tone.
- Separate on-off Switch.
- Input—Three: Two Microphones, Phono.
- Tubes: 2-7C7, 1-7B4, 1-7F7, 1-6V6GT, 2-6L6GA, 1-5U4G.
- Output: Tapped—2, 4, 8, 15, 500 Ohms.
- Power Consumption: 130 Watts.
- Hum Level: Below zero level—20DB.
- Frequency Response: 50 to 10,000 cycles.
- Dimensions: 15" x 15" x 9".

MASCO Model MA-35RC
Amplifier with changer-top,
cover and mechanism. Plays
ten 12" records or twelve
10" records. Now improved
with Astatic LP-6 Low
Pressure Cartridge with Per-
manent Sapphire Stylus. **1350** list

MASCO kit of
matched tubes. **1350**

Available through your jobber on
priority of AA-3 or better with
proper end use. 60-day delivery.

Write for catalog 44D.

MARK SIMPSON MANUFACTURING CO.

MANUFACTURERS OF

Masco Sound Systems and Accessories

186-194 WEST FOURTH STREET :: NEW YORK 14, N. Y.

Telephone CHelsea 2-7112-3-4



"Columbia" is a reliable source

IMMEDIATE DELIVERY

**Largest Stock of
INSULATED ELECTRICAL
WIRE**

No. 22 Gauge to No. 12 Gauge

**CORD
SETS**

ready-to-
attach
assemblies

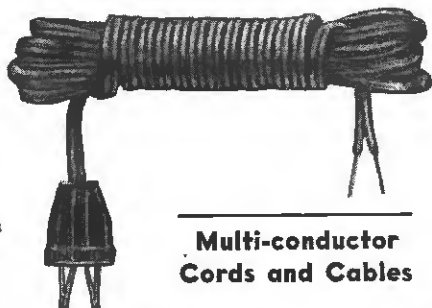

**Multi-conductor
Cords and Cables**

Write for Circular No. 5

COLUMBIA WIRE & SUPPLY CO.

4104 N. PULASKI RD., CHICAGO 41, ILLINOIS

Electro
ELECTRICAL AND RADIO EQUIPMENT

BATTERY ELIMINATORS

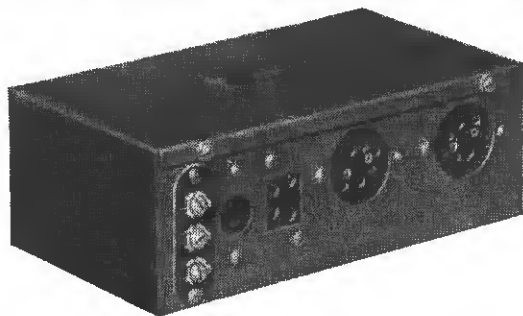

Announcing! Our New Models P and Q. They include every achievement of wartime ingenuity, and lift battery radio reception to new heights of satisfaction. Cost but a few cents per hundred hours of operation. Sturdily constructed—no liquids or moving parts—operate in any position. Completely filtered, hum free and silent in operation. Universal plugs and sockets to fit any radio.

MODEL P—For use in any place where normal AC is available. Operates any 1.4 volt—4, 5 or 6 tube battery radio from 115 v. 60 cy. source.

MODEL Q—For use wherever AC lines are not available—Farms, cottages, camps, or in car, motorboat, etc. Operating any 1.4 volt—4, 5 or 6 tube radio from 6 volt DC source.

NOTE: Due to War Production Board restrictions on Material our production is necessarily limited and deliveries at this time can be made only through established jobbers.

ELECTRO PRODUCTS LABORATORIES

Pioneer Manufacturers of Battery Eliminators
549 WEST RANDOLPH STREET CHICAGO 6, ILL.

General Industries Dual-speed
Home Recording and Phonograph
Assembly Model GI-R90

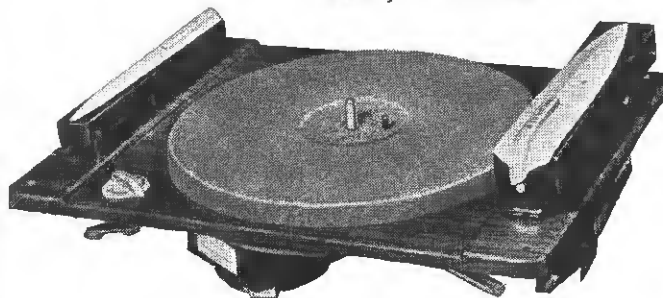

SURE THEY'LL BE BACK...

AS *Dependable*
AS *Ever*

Thinking about phonograph mechanisms for your future products? For turntable motors, recorder assemblies and combination record-changers-recorders, you can count on General Industries, as always.

They'll have those same smooth-running qualities, combined with complete dependability and long life, that for many years have distinguished General Industries products. They'll continue to please you and your customers, as always.

As soon as civilian production is authorized, we'll be glad to work with you to get you to the market quicker with your postwar products.

THE GENERAL INDUSTRIES COMPANY
DEPT. M ELYRIA, OHIO



The Mark of Maximum Value

Radiolite Master
FLOATING POINT PHONOGRAPH NEEDLE

Maximum value to your customers—maximum profit for you. An unsurpassed background of advertising and display material makes it easy to sell FM needles.

ATTRACTIVELY PACKAGED IN A USEFUL RECORD BRUSH
\$1.50

PERMO, Inc.
 6415 Ravenswood Ave. Chicago 36

Electricity

Models range from 350 to 25,000 watts; A. C. types from 115 to 660 volts, 50, 60, 180 cycles, single or three-phase and 400, 500 and 800 cycles, single phase. D. C. types from 6 to 4000 volts. Also available in dual voltage and special frequency types.

FOR RADIO AND ELECTRONIC APPLICATIONS

• **ONAN ELECTRIC GENERATING PLANTS** supply reliable, economical electrical service for electronics and television applications as well as for scores of general uses.

Driven by Onan-built, 4-cycle gasoline engines, these power units are of single-unit, compact design and sturdy construction. Suitable for mobile, stationary or emergency service.

Model shown is from W2C series; 2,000 to 3,500 watts; powered by Onan-built, two-cylinder, water-cooled engine.

D. W. ONAN & SONS
 2032 Royalston Avenue
 Minneapolis 5, Minn.

Write For Folder 690-A describing complete Onan Line

RADIART VIBRATORS

INDIVIDUALLY ENGINEERED for PROPER REPLACEMENT

RADIART VIBRATORS enjoy the confidence of Servicemen everywhere because they are always correct for the replacement for which they are specified.

Individual engineering for each replacement makes that certain. You may be sure that RADIART will continue to merit that confidence.

Consult the Radiart Vibrator Catalog for the proper RADIART VIBRATOR for every replacement need.

Radiart Corporation
 3571 W. 62nd St. CLEVELAND 2, OHIO

DEPENDABLE and COMPLETE SOLDERING IRON EQUIPMENT

Electric Soldering Irons, Spot Soldering Machines, Temperature Controls and Soldering Pots.

★ Reg. U.S. Pat. Off.

ELECTRIC SOLDERING IRON CO., Inc.
 2145 West Elm Street, Deep River, Conn.

NATION-WIDE MAIL ORDER DISTRIBUTORS SINCE 1928

RADIO AND ELECTRONIC DEVICES For Trade... Industry... Vocational... Communication... Public Utility and Experimental Applications

BURSTEIN-APPLEBEE CO.
 1012-14 McGee St. Kansas City 6, Missouri

Adaptol

ADAPTERS

Permit Use of AVAILABLE Tubes

Transform to scarce type tubes . . . convert for use of such tubes as you HAVE (what a blessing!) . . . eliminate wiring . . . and be SURE of quality, craftsmanship, PRECISION! Almost 200 types, many with BUILT-IN RESISTORS.

Laboratory men, servicers, jobbers, dealers . . . this is your meat! Now the tube shortage won't handicap you nearly so much.

WRITE FOR MORE DETAILS

ADAPTOL COMPANY

Department 27
260 UTICA AVE., BROOKLYN 13, N. Y.



Radio Man in Service



Technician 5th Grade, Angelo Benincaso, formerly employed as a radio repairman by the Myers Electric Co., Westwood, N. J., is now serving as a signal repairman in southwestern China.

American Central Plans

The American Central Mfg. Corp., Connersville, Ind., has already completed its postwar distribution set-up, and is looking forward to postwar reconversion. A Plan-A-Kit, by which a dealer can visualize in advance for the consumer what her finished kitchen will look like, reproduces the kitchen floor plan and window arrangement accurately on a miniature scale in American Central's sinks and cabinets.

20 Years Ago

From the June, 1925, Issue
of *Radio Retailing*

FRONT COVER—Young couple window-shopping; display advises "A Radio for every June Bride."

MILT GROSS, CARTOONIST, draws a series of sketches about "Tireless Tom," who knew how to get his customer. "They Didn't Come Into the Store to Buy—So 'Get Out and Sell 'Em!' was Tom's Battle-Cry."

"SLAM THE SUMMER SLUMP"—Practical ideas, aids and suggestions to make the summer months help the dealer sell more radio sets, parts and accessories.

"RADIO IS TO THE FARMER WHAT THE TICKER IS TO THE BROKER"—headline. Dealers sell radios to farmers as an information aid, from which he can plan his day's work.

OLSON Radio Warehouse
Super-Value!

192 inches,
VARNISHED

SPAGHETTI TUBING

Assorted colors and sizes! Will stand 5000 volts! Insulates and protects bare wires, leads, resistors, etc., from other parts. Various colors provide easy tracing of circuits. Neater and quicker than tape for connecting, splicing, insulating. Olson's Spaghetti Tubing is very flexible and guaranteed not to crack even after aging.

25¢
Postpaid

MAIL COUPON NOW

FREE MONTHLY CATALOGS of available parts—sent to you on request.

Olson Radio Warehouse

73-C Mill St., Akron, Ohio

I enclose 25c in coin. Please send me the 192" assortment of Spaghetti Tubing.

NAME

ADDRESS

DEPENDABLE MUTER PRODUCTS * DEPENDABLE MUTER PRODUCTS

DEPENDABLE **MUTER** PRODUCTS

Manufacturers of Component parts for the Radio, Electronic and Communications Industries

THE MUTER Co.
1235 South Michigan Avenue
Chicago, U. S. A.

MUTER PRODUCTS * DEPENDABLE

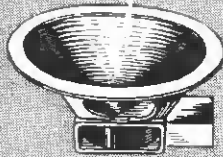

the excellence of your post-war radio engineering

will be faithfully interpreted for your customers by a **QUAM** Speaker

QUAM-NICHOLS CO. 33rd PLACE AT COTTAGE GROVE, CHICAGO

INDEX To Advertisers

	Page
Adaptol Co.	123
Admiral Corp.	1
Aerovox Corp.	74
Alliance Mfg. Co.	119
Astatic Corp.	116
Atlas Sound Corp.	118
Automatic Radio Mfg. Co., Inc.	31
Bendix Radio Div. of Bendix Aviation Corp.	10, 11
Burgess Battery Co.	115
Burstein-Applebee Co.	122
Centraiah	82
Chicago Tribune	70
Cineaudograph Speakers, Inc.	119
Glarostat Mfg. Co., Inc.	117
Columbia Wire & Supply Co.	121
Commercial Credit Co.	22
Cornish Wire Co., Inc.	109
Crosley Corp.	89
Decca Distributing Corp.	55
Delco Radio Div., General Motors	100
Detroit Radio Div., International Detroit Co.	75
DuMont Laboratories, Inc., Allen B.	95
Eastern Amplifier Corp.	30
Electric Soldering Iron Co., Inc.	122
Electronic Corp. of America	27
Electronic Products Mfg. Corp.	112
Electro Products Laboratories	121
Emerson Radio and Phonograph Corp.	77
Fada Radio and Electric Company, Inc.	23
Galvin Mfg. Corp.	Cover 4
Garod Radio Corp.	3
General Electric Co.	14, 83
General Industries Co.	121
Hallcrafters Co.	28
Hamilton Radio Corp.	13
Hammarlund Mfg. Co., Inc.	97
Hickok Electrical Instrument Co.	111
Howard Radio Co.	79
Jackson Electrical Instrument Co.	117
Jensen Radio Mfg. Co.	72
Ken-Rad	7
Lake Radio Sales Co.	124
Lear, Inc.	18
Maguire Industries, Inc., Electronics Div.	71
Mahogany Association, Inc.	8
Majestic Radio & Television Corp.	24
Mallory & Co., Inc., P. R.	Cover 2, 26, 99
Manor Electric & Appliance Co.	118
Marion Electrical Instrument Co.	73
Meck Industries, Inc., John	5
Meissner Mfg. Co.	68, 104, 105
Merit Coil & Transformer Corp.	4
Muter Co.	123
National Carbon Co., Inc.	25
National Die Casting Co.	113
National Union Radio Corp.	29
Noblitt-Sparks Industries, Inc.	17
Norge Div., Borg-Warner Corp.	85
Olson Radio Warehouse	123
Oran & Sons, D. W.	122
Permo, Inc.	122
Philo Corp.	21
Presto Recording Corp.	58
Quam-Nichols Co.	124
Radiart Corp.	122
Radio Corp. of America:	
RCA Victor Div.	61, 62, 63, 64
Radio Supply & Engineering Co., Inc.	105
Rauland Corp.	112
Ray-O-Vac Co.	101
Raytheon Mfg. Co.	19
Redbook	59
Roia Co., Inc.	16
Seeburg Corp., J. P.	Cover 3
Sentinel Radio Corp.	9
Simpson Electric Co.	20
Simpson Mfg. Co., Mark	120
Snyder Mfg. Co.	116
Sonora Radio & Television Corp.	87
Sound Equipment Corp.	118
Sparks-Withington Co.	69
Sprague Products Co.	88
Standard Transformer Corp.	115
Stewart-Warner Radios	15
Stromberg-Carlson Co.	32
Sylvania Electric Products, Inc.	90
Talk-A-Phone Mfg. Co.	108
Templestone Radio Mfg. Corp.	107
Thordarson Electric Mfg. Co.	84
Trav-Ler Karenola Radio & Television Corp.	6
Triplet Electrical Instrument Co.	12
True	67
True Confessions	57
Tung-Sol Lamp Works, Inc.	2
Turner Co.	114
Utah Radio Products Co.	103
Ward Leonard Electric Co.	108
Ward Products Corp.	113
Warwick Mfg. Corp.	91
Webster Electric Co.	110
Weston Electrical Instrument Corp.	106
Wilcox-Gay Corp.	53

While every precaution is taken to insure accuracy, we cannot guarantee against the possibility of an occasional change or omission in the preparation of this index.

LAKE Radio Cabinets and Parts

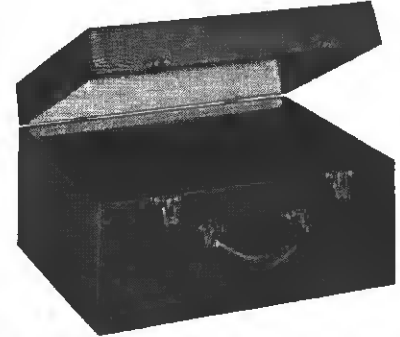

Portable Phonograph case, of sturdy durable plywood, in handsome brown leatherette finish. Inside dimensions 16 1/2" long, 14" wide, 9 1/2" high. Has blank motor board. As illustrated above, specially priced at..... **\$6.95**

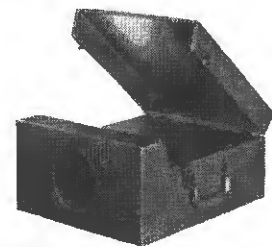

Portable Phonograph case in brown leatherette covering. Inside dimensions 17" long, 14" wide, 8 1/2" high. Has blank motor board and opening for speaker. As illustrated above, specially priced at..... **\$8.95**

Also blank table cabinets of walnut veneer in the following sizes, with speaker opening on left front side: (*Note: *7 has center speaker grill.)

#1	8 1/4"	L x 5 1/2"	H x 4"	D \$1.95
#2	10 1/4"	L x 6 3/8"	H x 5"	D \$2.75
#3	13 1/2"	L x 7 5/8"	H x 6 1/4"	D \$3.25
#7*	10 3/4"	L x 7"	H x 5 1/2"	D \$2.50
#8	17"	L x 9"	H x 9 3/4"	D \$4.50
#9	21"	L x 9 1/4"	H x 10 1/2"	D \$5.50

*Speaker Opening in center of front side. Cabinets available in ivory color and Swedish Modern. Write for prices.

POWER TRANSFORMERS

4, 5, or 6 Tube—6.3V at 2 amp.	\$2.45
50 Mill Power Transformer....	\$2.45
7, 8, or 9 Tube—6.3V at 3 amp.	\$2.65
70 Mill Power Transformer....	\$2.65

All types of radio parts available in today's market can be obtained at Lake's money-saving prices. Large stock listed in our catalog.

Write for Our Free,
New Illustrated Catalog!

Lake Radio Sales Co.

Dept. B

615 W. Randolph Street
Chicago 6, Ill.



**DEPENDABLE
TROUBLE-FREE
OPERATION**

**The new post-victory
line of**

**SEEBURG
RECORD CHANGERS**

will have

FEWER MOVING PARTS

BUY WAR BONDS →

Awarded to the J. P. Seeburg Corporation for outstanding production of war materials in each of its four plants



J. P. SEEBURG CORPORATION · CHICAGO

Seeburg

FINE MUSICAL INSTRUMENTS SINCE 1909



THE **LARGEST** OUTDOOR
SIGN PROGRAM IN THE
RADIO INDUSTRY!



Motorola
RADIO
FOR HOME & CAR
SALES AND SERVICE



Motorola
RADIO
For HOME and CAR

AUTOMATIC PHONOGRAPHS • TELEVISION

**ON STORE FRONTS
AND HIGHWAYS**
Coast to Coast!

ALL LINKED TO MOTOROLA'S ALL COVERAGE
NATIONAL MAGAZINE AND NEWSPAPER PROGRAM

Motorola Radio

GALVIN MANUFACTURING CORPORATION • CHICAGO 51, ILLINOIS

F-M & A-M HOME RADIO • AUTO RADIO • AUTOMATIC PHONOGRAPHS • TELEVISION • F-M POLICE RADIO • RADAR • MILITARY RADIO