

RADIO & Television RETAILING

Including Radio and Television Today

ALL THE MUSIC FROM
ONE TOUCH OF VENUS
RECORDED BY
THE ORIGINAL CAST
LIMITED QUANTITY
FOR IN STORE

KEEPS FOODS
Fresh!

In This Issue

★ Selling Radios, Home Appliances, Records,
Sound. ★ Jobber News, Service.

APRIL 1946

How to Use MALLORY Victory Electrolytic Capacitors In High Surge Applications

P. R. MALLORY & CO. INC.
MALLORY
Tips on
Radio Service
Short Cuts

Mallory Victory Electrolytics have the same surge voltage ratings as other Mallory units of the same working voltage.

When replacing electrolytic capacitors where a high surge voltage condition is suspected, the following information will be helpful:

1. The surge condition exists from the time the switch is closed until the tubes heat up establishing normal load.
2. While the electrolytics draw current during the warming-up period, this load is temporary and may be of no safety value after a period of continuous operation.
3. High line conditions should be considered.



The best way to determine actual surge possibilities:

- a. Disconnect all electrolytics (except cathode by-pass).
- b. Connect a 2 to 4 mfd. paper condenser (600 V.) across voltmeter terminals and read voltage at output of rectifier during warm-up period.
- c. Note line voltage and mathematically compute (by ratio) surge voltage at 130 volt line for safety.

Use following table in making replacement. Bear in mind that where series connection is necessary the capacity is one-half of one of the units (two 8 mfd. in series equal 4 mfd.). No equalizing resistors are necessary with electrolytics in series.

Working Volts of Unit	Maximum Surge Volts Allowable
150	200
250	300
450	525
two 250 V units in series	600
two 450 V units in series	1050

NOTE: Where heater type rectifiers are used, there is little likelihood of unusual surge conditions, and replacement may be made without this procedure.

The working voltage rating of capacitor should be equal to or higher than measured working voltage at high line, regardless of surge requirements.



Buy More War Bonds

Mallory Helps for the Service Engineer



MAYE TECHNICAL MANUAL
— 108 pages of complete data on capacitors, noise suppression, receiving tubes, loud speakers, vibrators, phono-radios, automatic tuning and other valuable information. Available from your Mallory distributor... Price, \$2.00.

4TH EDITION RADIO SERVICE ENCYCLOPEDIA . . . Complete information on repairing any make or model of receiver. Circuit references, original part numbers and recommended replacements. Available from your Mallory distributor . . . Price, 95 cents.

P. R. MALLORY & CO., Inc.
INDIANAPOLIS 6, INDIANA

P. R. MALLORY & CO., Inc.

MALLORY

Approved Precision Products

3, 4, 5, 6, 7, 8, 9, 10, 11, 12, 13, 14, 15, 16, 17, 18, 19, 20, 21, 22, 23, 24, 25, 26, 27, 28, 29, 30, 31, 32, 33, 34, 35, 36, 37, 38, 39, 40, 41, 42, 43, 44, 45, 46, 47, 48, 49, 50, 51, 52, 53, 54, 55, 56, 57, 58, 59, 60, 61, 62, 63, 64, 65, 66, 67, 68, 69, 70, 71, 72, 73, 74, 75, 76, 77, 78, 79, 80, 81, 82, 83, 84, 85, 86, 87, 88, 89, 90, 91, 92, 93, 94, 95, 96, 97, 98, 99, 100

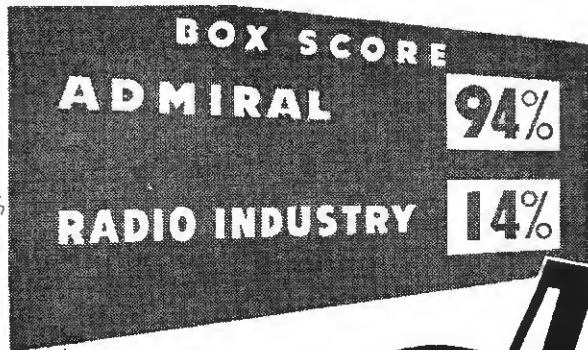

Admiral

growth outstrips industry



GET ABOARD WITH ADMIRAL

During the last eight years of peacetime production the radio industry expanded at an average rate of 14% per year. During this same period, Admiral's average annual increase in output was 94% . . . more than 6 times as fast as the entire industry!

There are no magicians at Admiral—they haven't "done it with mirrors"—but with hard work and the application of common-sense methods in engineering, production and merchandising.

Not content to rest upon past laurels, Admiral is going after more records in the post-war years. Plans include a new and better Admiral radio *plus* a line of major household appliances—refrigerators . . . home freezer lockers . . . electric ranges—that open new avenues of profits for distributors and dealers. Admiral will have the designs, the quality and the price. So, the tip of the year to live distributors and dealers is, *get aboard with*

Admiral Corporation

Tune In CBS, 2:30 P.M., EWT, Sundays for Admiral "World News Today."

Peacetime Makers of Admiral Radio • America's Smart Set
3800 CORTLAND STREET • CHICAGO 47, ILLINOIS



World's Largest Manufacturer of Radio-Phonographs With Automatic Record Changer

"MAJESTIC RADIO NEWS"

is winning the interest of millions

NOTHING that has happened in the radio business has caused so much comment, so quickly, as Majestic's new advertising and merchandising idea—the Majestic Radio News featuring "Standings of the Stars"—appearing 24 times a year.

Men and women in the street quote it... argue about the "Standings of the Stars". Dealers in their stores are encouraged by it. Distributors in their offices see a future for it, inquire about it. Literally millions... from Coast to Coast... who follow this advertising in major city newspapers of tremendous circulation, realize that, at a time when the radio industry and radio advertising are marking time, here is a progressive, aggressive idea—ready-to-use radio merchandising, preparing the way for post-war selling.

So New... that it is up-to-the-minute, never gets old or tiresome. The "Standings of the Stars" is one idea that gains momentum from week to week, pyra-

miding in interest from ad to ad, gaining new followers with each report.

Such a Natural... people kick themselves for not having thought of it first—and Majestic has the exclusive consumer use of the Hooper Reports, on which the "Standings of the Stars" are based.

So Powerful... Majestic has been swamped with letters of praise and questions wanting to know what we're up to, what comes next, what our future plans are. The Majestic Radio News is a natural to make any Majestic outlet the official headquarters for post-war radio sales.

All we can say is this: Majestic has plans that will make it easier for dealer and distributor alike to profit from the volume of radio sales Peace will bring. They are sound plans—as direct, as new, as practical as the Majestic Radio News itself. The Majestic Radio News is but the first indication that:

**Majestic means business . . .
and lots of it!**



MIGHTY MONARCH OF THE AIR

MAJESTIC RADIO & TELEVISION CORPORATION • CHICAGO 32, ILLINOIS

RADIO & Television RETAILING • April, 1944



It's an act of bravery to possess a radio receiver in any country occupied by the Nazi or the Jap today. It's an act of heroism to operate a transmitter.

What could prove more convincingly the total value of radio than the frantic haste with which it is silenced or controlled by the Totalitarian? Or its use by the Free Peoples in directing their offensives . . . and in keeping their will for victory living and single-purposed?

Some day, the experiences Jackson has been having in developing and supplying electrical testing equipment to our armed forces will be reflected in finer products for you.

In the meantime thousands of pre-war Jackson Instruments are still performing to keep 'em listening on the home front. The dependability this represents is but another benefit of the "hidden" plus of *all* Jackson Instruments . . . INTEGRITY OF DESIGN.

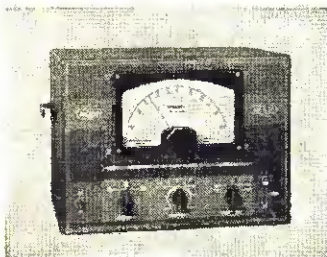

Model 652 Audio Oscillator

If your Jackson Instruments should need calibration, checking, or parts replacement, write to the factory. Maintaining products bearing the Jackson trade mark is a responsibility that we will fulfill as promptly as possible under wartime conditions.

Buy War Bonds and Stamps Today!

JACKSON

Fine Electrical Testing Instruments

JACKSON ELECTRICAL INSTRUMENT COMPANY, DAYTON, OHIO

RADIO & Television RETAILING

Including Radio and Television Today

APRIL, 1944

Page

21	EDITORIALS
22	MERCHANDISING PRINCIPLES
24	APPLIANCE REPAIR PLAN
26	SIXTY SETS A DAY
28	APPLIANCE SURVEY
30	REBUILT RADIOS
32	RADIO TODAY—ACROSS THE U.S.A.
34	\$'S IN RECORD MERCHANDISING
36	APPLIANCE RETAILERS
38	SOUND IN REHABILITATION
40	RECORD TIE-INS FOR DEALERS
42	VOLUME IN DISC SALES
44	RECORD BAR
46	DOVER SERVICERS
48	ELECTRONIC SERVICE
54	SWEEP CIRCUITS
61	SERVICE DELUXE
62	SERVICE NOTES
70	LETTERS TO THE EDITOR
74	JOBBER NEWS

RADIO & Television RETAILING, April, 1944, Vol. 29, No. 4, 25 cents a copy. Published monthly by Caldwell-Clements, Inc., 480 Lexington Ave., New York 17, N. Y. M. Clements, president; Orestes H. Caldwell, treasurer. Subscription rates United States and Latin American countries, \$1.00 for one year, \$1.50 for two years, \$2.00 for three years. Canada \$1.50 for one year, \$2.00 for two years, \$3.00 for three years. All other countries \$2.00 for one year, \$3.00 for two years, \$4.00 for three years. Printed in U.S.A. Re-entered as second class matter August 28, 1942, at the Post Office at New York, N. Y., under the act of March 3, 1879. Member of Audit Bureau of Circulations. Copyright by Caldwell-Clements, Inc., 1944.

ORESTES H. CALDWELL
Editor

M. CLEMENTS
Publisher

H. L. M. Capron, Merchandising Editor
William E. Moulic, Technical Editor
Helen Thurman, Associate Editor
John L. Stoutenburgh, Associate Editor
Charles F. Dreyer, Art Director
E. T. Bennett

M. H. Newton	J. A. Samborn
B. V. Spinetta	O. H. Sutter
N. McAllister	W. W. Swigert
J. E. Cochran	L. D. Chesson

Lee Robinson, Sales Manager

R. Y. Fitzpatrick, Western Manager
Chicago, 201 N. Wells St.
Telephone RANdolph 9225

Editorial and Executive Offices
Telephone PLaza 3-1540
480 Lexington Avenue
New York

"Bring me the order book, Miss Jones!"



"It's going to be a pleasure to make out this order. Although we are not getting all the tubes we'd like, Hytron surely is doing its utmost to help us by its allocations. We certainly can use these tubes."

Hytron is happy to be able to do at least something toward supplying your demands for civilian receiving tubes. WPB rulings guide our actions entirely; we must ration carefully the few tubes available.

Please bear in mind, too, that Hytron is still helping to fight this war. The WPB has our full cooperation in its conscientious effort to do everything possible to fill the insatiable demand for tubes—both on the home front and on the fighting front. Naturally, the boys in the Services come first.

HYTRON HIGHLIGHTS

The WPB has ruled that, insofar as possible, MR receiving tubes available for civilian use shall be allocated to established distributors on a pro rata basis of their 1941 purchases. Unfortunately, this means that Hytron cannot accept orders from new distributors. In addition, we ask our authorized distributors to refrain from sending in their orders until they have been informed by the factory or by their Hytron representative, that tubes have been allocated to them.



OLDEST EXCLUSIVE MANUFACTURER OF RADIO RECEIVING TUBES

HYTRON
CORPORATION ELECTRONIC AND RADIO TUBES
SALEM AND NEWBURYPORT, MASS.

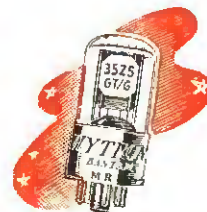

BUY ANOTHER WAR BOND

PRE-WAR... FASTEST

The new Crosley expansion program began in 1940. Just before Government restrictions, the sales gains of Crosley Refrigerators were twice the industry average.



Here is the most dramatic exclusive feature in refrigeration—

The **SHELVADOR**
TWICE-AS-MUCH
FOOD TO THE FRONT
... within easy reach

The patented shelves-in-the-door—the Shelvador—in Crosley Refrigerators make this line unique and outstanding on the dealer's floor.

POST-WAR... READY FOR

Pre-war progress, stepped up by the faster pace of war, enabled Crosley to pack into 4 short years the accomplishment of 10 normal years. The war program necessitated the complete modernization of every Crosley plant. The engineering department has grown from 40

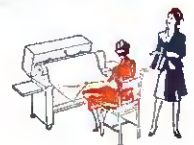

GROWING!

Crosley Radio sales were up 68% in the highly competitive season of 1941, and even that figure was surpassed before civilian production stopped in 1942.

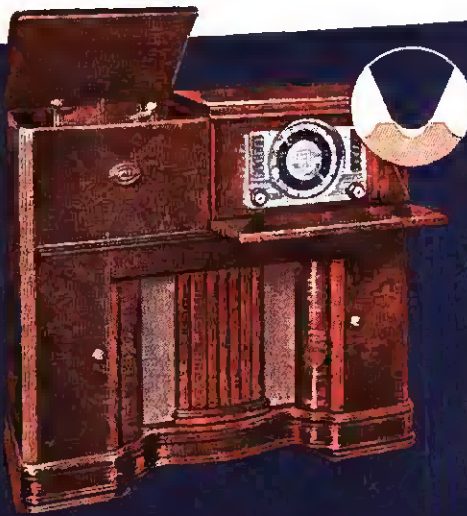

The virtual elimination of surface scratch, hissing and needle noise in Crosley Radio-Phonographs is made possible by the exclusive patented

FLOATING JEWEL

The up-sweep of Crosley Radio and Radio-Phonograph sales just before conversion was aided by this Crosley invention. Average prices of Crosley Radio registered tremendous gains. New sets will be even finer when civilian production is resumed.

NEW HIGHS!

to over 500. Ten times as many people are on inspection work to control quality. Total number of employees rose from a pre-war 1,800 to a 1943 peak of 8,600. A seasoned management group is ready for a greater-than-ever post-war business.



CROSLEY

THE CROSLEY CORPORATION • CINCINNATI, OHIO AND RICHMOND, IND.



the extra measure of **GAROD** magic

Though Garod craftsmen possess no supernatural powers, their accomplishments are almost magical. The tonal quality, the performance, the endurance of our radios are products of their competent design and adroit execution.

The extra measure of Garod magic will be characteristic of our future radios. It will be present in Garod sets ranging from table models to phonograph combinations in AM and FM to television. It will be present in right pricing, sales promotion and complete distributor protection. Information regarding postwar franchises is now available.

*Back the Future . . .
Buy More War Bonds
Today*

GAROD RADIO

FOR THE EXTRA MEASURE



GAROD RADIO CORPORATION, 70 Washington Street, Brooklyn 1, N.Y.



NON-CLOG TOP BURNERS . . . of exceptionally high efficiency and economy; porcelain finished. Flame adjustable to any size utensil.

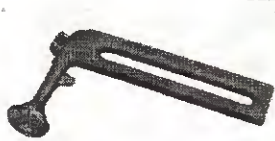

OVEN BURNER . . . operates on low heat and holds very low flame for slow cooking. Uniformity of heat results in perfect baking and roasting.

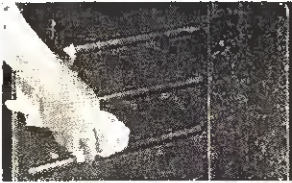

EASY-CLEAN OVEN . . . has smooth, one-piece interior of porcelain enamel. Rounded corners. Rack guides integral with oven lining.



ROCK WOOL INSULATION . . . on sides, back, doors and top. Results in efficient oven heat, keeps kitchen cool.

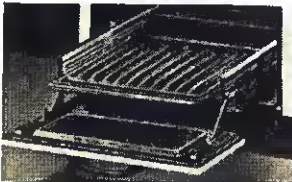

SLIDE-OUT, DROP-FRONT BROILER . . . makes it easy to watch and control broiler. Gravy well in drip pan.

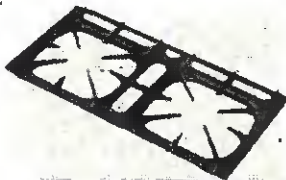

TOP GRATES . . . built in two sections for easy removal and cleaning. Finished in black porcelain enamel.



ONE-PIECE DRIP PAN . . . fits tight around burners, catching any spill-overs. Easy-to-clean black porcelain enamel finish.

RADIO & Television RETAILING

Ready Now for Norge Dealers!

New Norge gas range (model GW-024) is not a make-shift or tide-over "Victory" model—it is full-quality merchandise, built as it will be built after the war, and is now available to Norge dealers in limited quantities!

We repeat: Here is a full-quality gas range, built of highest-grade heavy materials and to Norge precision standards. It definitely is *not* a tide-over "Victory" model, but is a permanent postwar product.

Check These Features

Special white vitreous porcelain exterior; non-clog top burners; automatic top burner lighter; low-heat oven burner; one-piece porcelain enamel drip pan; one-piece tank-type oven and broiler lining, each porcelain enameled; safety oven lighter; slide-out, drop-front broiler; full rock wool insulation; black recessed base; black plastic hardware.

The Norge model GW-024 range is adaptable to the use of bottled gas as well as artificial and natural gases (ask about model BGW-024). Norge distributors have complete specifications and prices.

"SEE NORGE BEFORE YOU BUY"



NORGE

A BORG-WARNER INDUSTRY

NORGE DIVISION, BORG-WARNER CORPORATION, 670 EAST WOODBRIDGE ST., DETROIT 26, MICHIGAN

Only prewar producer of a complete line of ROLLATOR REFRIGERATORS * ELECTRIC RANGES * WASHERS * GAS RANGES * HOME HEATERS * COMMERCIAL REFRIGERATION

• April, 1944

Here

FM

will also

mean

Finest Made

*Buy
U. S. War Bonds*



There is always a better way to make anything!

Just as there is always a better market for things better made. It is for that market—the sound, permanent, quality market—that Temple FM radio receiv-

ers will be made, toward which Temple sales and merchandising policies will be aimed. As a forward-thinking dealer interested in good will, as well as good value, it will pay you to "team up with Temple".

TEMPLEONE RADIO COMPANY, MYSTIC, CONN.

FM...TELEVISION...RADIO-PHONO' COMBINATIONS

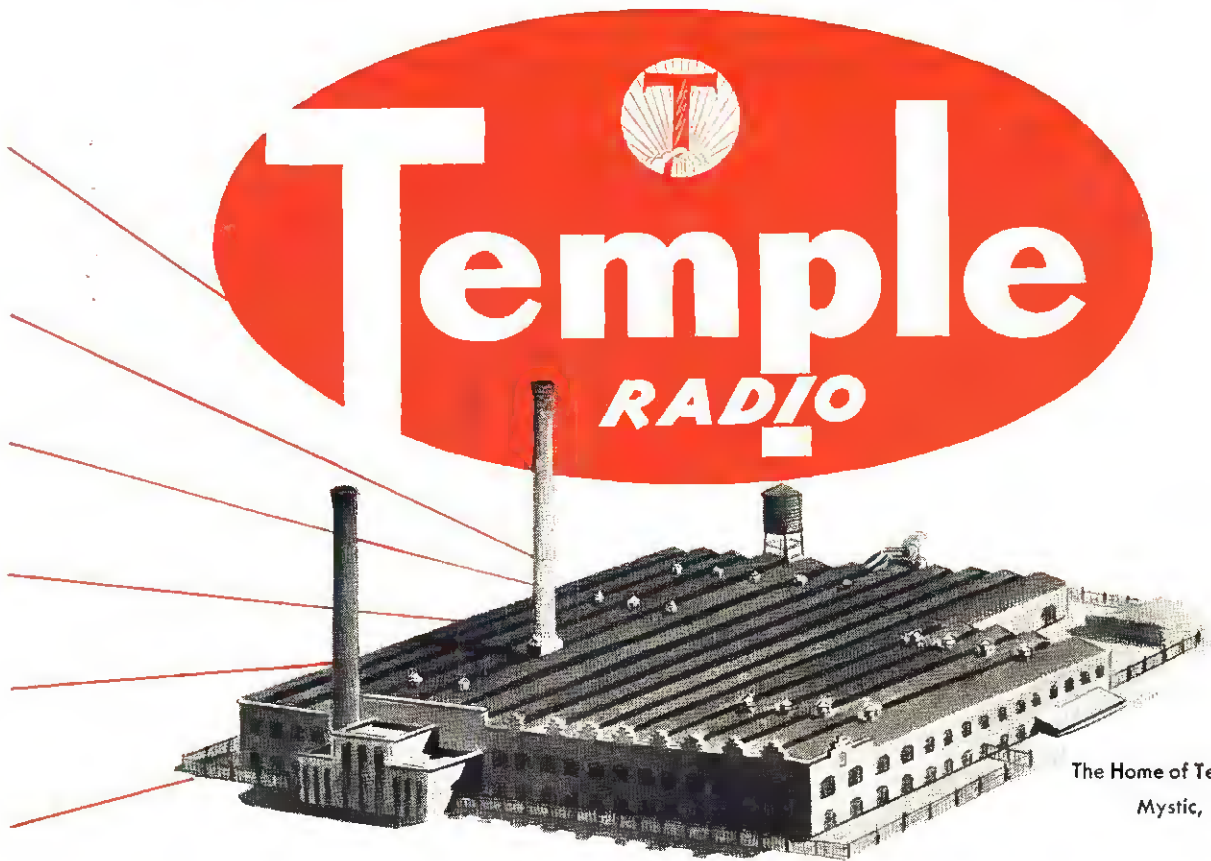

The Home of Temple Radio.
Mystic, Conn.

WITHIN the four walls of this vast plant, Temple engineers and craftsmen toil unceasingly to produce vital communications equipment for our armed forces — material calling for highest precision of design and

workmanship. Out of this war-gained experience have come untold advancements of tremendous importance — priceless knowledge from which will emerge the finest radio receivers ever to bear the Temple name.

Licensed under Armstrong and RCA patents

...It will pay you to "Team up with Temple!"

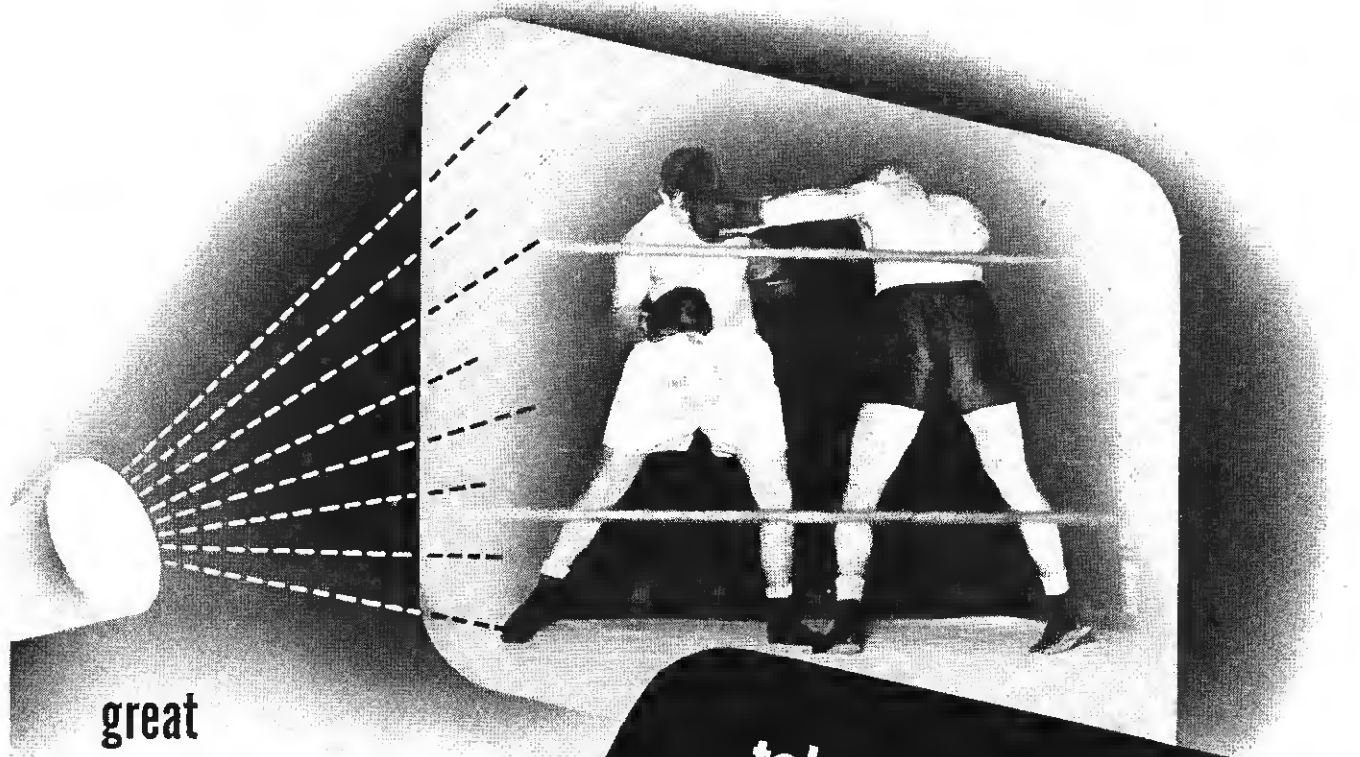

great
engineering
ideas
in small
packages



Out of Emerson Radio's war-occupied laboratories...out of a proving ground as wide as the world...there are coming engineering miracles...new light metals...new plastics...new concepts of design and style...new production techniques which will bring a new conception of small radio to America.

...and for the first time practical television at a price everyone can afford... Emerson Radio-built television.

Emerson Radio's vastly enlarged research facilities...its creative physicists and engineers...are now accomplishing miracles in the

creation of equipment for use on land, on sea and in the air. Emerson Radio of the future will be "an even greater new idea in a small package...compact...efficient...fine." In the promotion of these revolutionary new products there will be constructive policies which will add enormously to the value of your Emerson Radio franchise in the days to come.

Emerson Radio is creating tomorrow's business for you today, with powerful advertising in newspapers, national magazines...and on the air.

Tune in to "Green Valley, U.S.A." every Sunday afternoon at 5:00 PM., EWT over the coast-to-coast Mutual Network.

EMERSON RADIO & PHONOGRAPH CORPORATION, NEW YORK 11, N.Y.



TESTING TOMORROW'S RADIO TUBES

• Early in the war, Sylvania engineers stepped up experiment to perfect more rugged and more sensitive radio tubes for vital military communications.

Engineers added to a great array of precision checking instruments. They designed and built special new instruments to detect variations in radio tube characteristics never charted before.

This intensive research program has developed improved radio tubes. Many are now military secrets. But they promise to make postwar radio reception a revelation of clarity and fidelity.

After the war, as in the past, it will pay you to sell Sylvania.

Quality That Serves the War Shall Serve the Peace

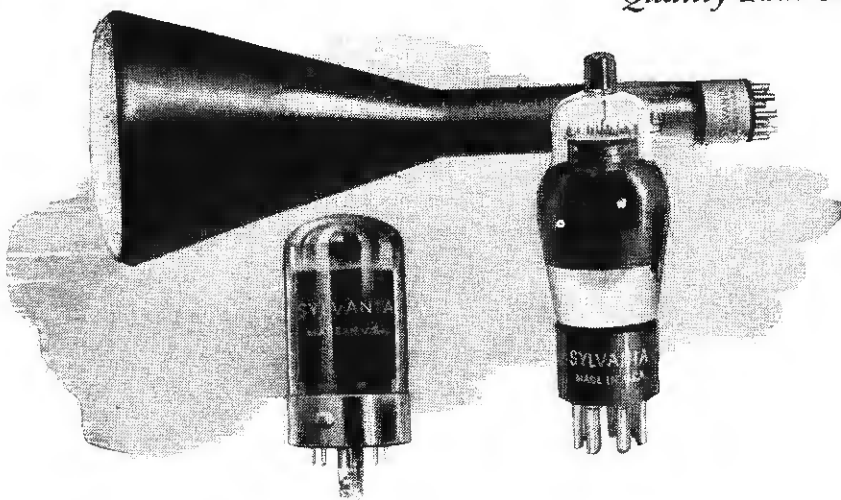

RADIO DIVISION EMPORIUM, PENNSYLVANIA

SYLVANIA
ELECTRIC PRODUCTS INC.

RADIO TUBES, CATHODE RAY TUBES, ELECTRONIC DEVICES, INCANDESCENT LAMPS, FLUORESCENT LAMPS, FIXTURES AND ACCESSORIES

Famous Signatures

Michelangelo Rembrandt

Morganstouff

Whistler

Leonardo da Vinci

Rubens

Vincent Van Gogh

A. VANDYCK

Raphael

P. Cezanne

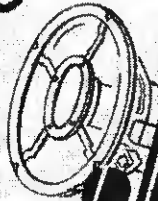

Jensen

Manufacturers and Designers of Fine Acoustic Equipment

America's

SECRET WEAPON

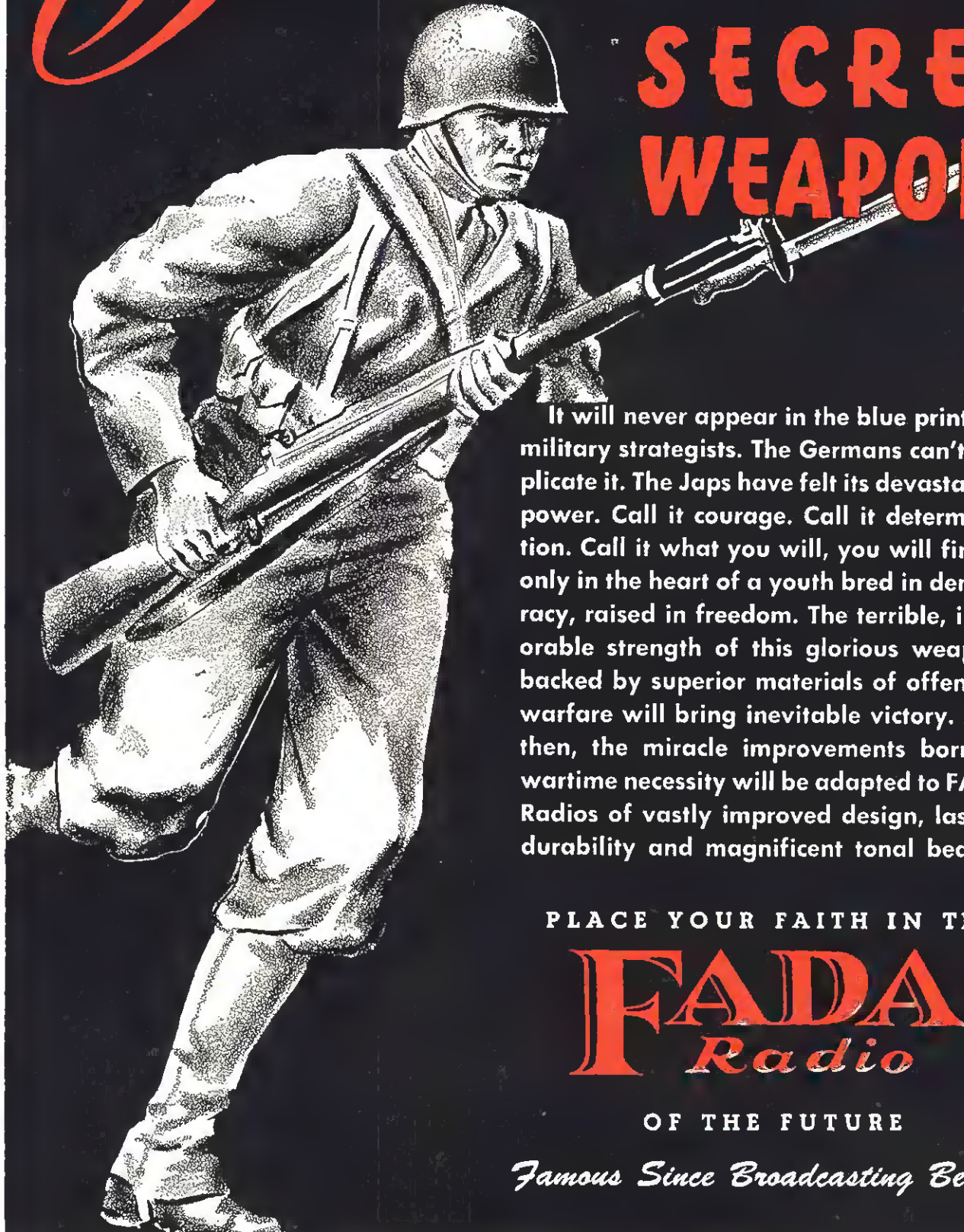

It will never appear in the blue prints of military strategists. The Germans can't duplicate it. The Japs have felt its devastating power. Call it courage. Call it determination. Call it what you will, you will find it only in the heart of a youth bred in democracy, raised in freedom. The terrible, inexorable strength of this glorious weapon, backed by superior materials of offensive warfare will bring inevitable victory. And then, the miracle improvements born of wartime necessity will be adapted to FADA Radios of vastly improved design, lasting durability and magnificent tonal beauty.

PLACE YOUR FAITH IN THE

FADA Radio

OF THE FUTURE

Famous Since Broadcasting Began!

FADA RADIO AND ELECTRIC COMPANY, INC., LONG ISLAND CITY, N. Y.



ON THE TOP OF THE WORLD

HOFFMAN EQUIPMENT FOLLOWS THE NAVY

THIS hut is a Navy listening post — dug into the frozen turf of Alaska.

Here in the lonely silence at the top of the world our Navy keeps vigil — making vital observations and relaying them to the center of Navy strategy.

Prominent in this picture is a Hoffman made Frequency Meter justly called the

heart of Navy communications. Its accuracy can be depended upon to one hundredth of one percent under any climatic condition.

The devotion of our engineering skill to the production of such battle-tested radio gear is certain to reflect itself in better radio and electronic equipment in the post-war market.

LOOK FOR THINGS TO HAPPEN AT HOFFMAN RADIO

Hoffman
RADIO CORP.

MANUFACTURERS OF MISSION BELL RADIOS
MITCHELL-HUGHES PHONO-COMBINATIONS
ELECTRONIC AND COMMUNICATION EQUIPMENT

3430 S. HILL STREET • LOS ANGELES 7, CALIF. • PR 3446

Thousands of Progressive Retailers are Making **BIG MONEY** Every Day with **NU-ENAMEL PAINTS**

It's Easy to Start Your Own "Paint-it-Yourself" Department

**LOW INVENTORY -- NO LABOR PROBLEMS
MERCHANDISE AVAILABLE N-O-W!**

An individualized "Paint-it-Yourself" Department in your store will help take care of lost sales on regular lines now — will build profitable repeat business for the postwar future. The nationally known Nu-Enamel Line is available now to responsible dealers in many locations. Write today for information about the successful, money-making Nu-Enamel Franchise and the "Planned" advertising-merchandising methods which provide a steady flow of "Ready-to-Buy" customers.

NU-ENAMEL CORPORATION
8 South Michigan Ave., Chicago 3, Illinois

MAIL This Opportunity Coupon NOW

NU-ENAMEL CORPORATION
8 South Michigan Ave., Dept. 10
Chicago 3, Illinois

We are interested in learning how Nu-Enamel could increase the sales and profits of our store.

NAME

ADDRESS

America's Finest FM Receivers Will Come From

HOWARD

AMERICA'S OLDEST RADIO MANUFACTURER

Before the war, Howard was one of the few radio manufacturers producing FM Receivers on a production basis. As a consequence, thousands of Howard FM Receivers are today providing superb FM enjoyment for their fortunate owners. When Howard to produce the finest FM Receivers—radios reflecting the experiences of over a quarter century in precision radio manufacturing. Howard's 100% war production program is helping bring Victory sooner—remember Howard in your plans for peace.



HOWARD RADIO COMPANY, 1731-35 BELMONT AVE., CHICAGO 13, ILLINOIS

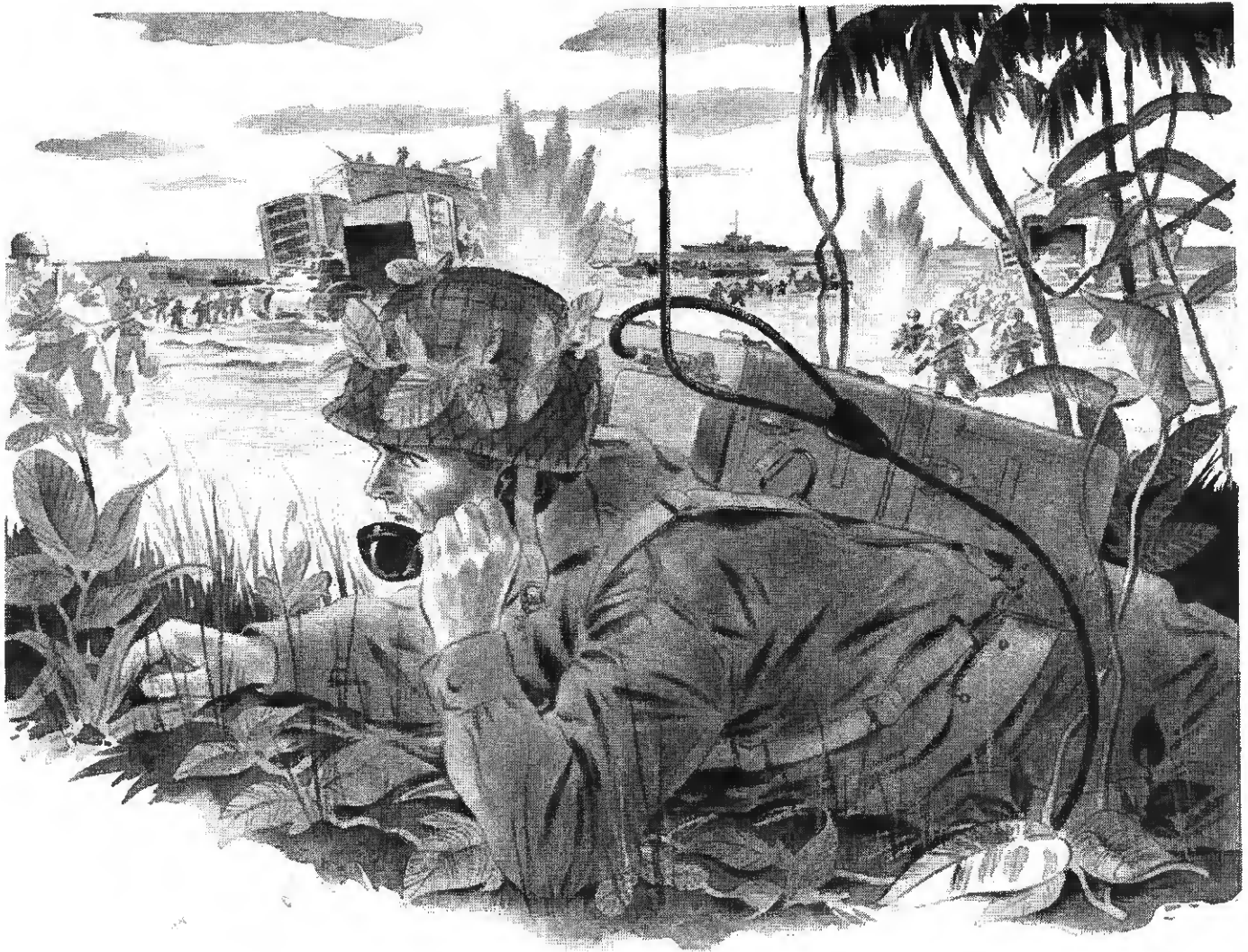

“Landing According to Plan”

IN the planning . . . and the execution . . . of landing operations Communications are playing a vital part. That's why in the forefront of every landing party there usually is to be seen the man with the Pack Set strapped to his back. Light and compact, yet powerful and sturdy, this adaptation of the walkie-talkie provides the *instant communication* by which our intricate military operations are planned . . . and carried out.

In the Pack Set, as in many other audio communication instruments, Transformers by Rola are living up to a reputation gained through 25 years of leadership in Sound Reproduction. That, no doubt, is the reason why so many of the largest producers of communication equipment are looking to Rola for Transformers, Headsets, Coils and other Electronic Parts . . . why others are saying, "Let's discuss our problem with Rola".

THE ROLA COMPANY, INC., 2530 SUPERIOR AVENUE, CLEVELAND 14, OHIO

ROLA

Let's do more



in forty-four!

MAKERS OF THE FINEST IN SOUND REPRODUCING AND ELECTRONIC EQUIPMENT
 RADIO & Television RETAILING • April, 1944



“NO MAN SHOULD ATTEMPT TO PLAY GOLF...”

This curious description of golf appeared in the American press fifty years ago: “No man should attempt to play golf who has not good legs to run with and good arms to throw with . . . his servant, who is called a ‘caddy,’ runs after him with all the other nine tools in his arms.” Golf, in those days, was one of many things people knew little about. “Wireless” was hardly more than a plaything. You had to shout into telephones. And sound equipment wasn’t even in use! As we mark our fiftieth anniversary year, we feel that there has scarcely been a single year in which we have not learned something of value to our customers. Because of this experience we are proud to say, “There is nothing finer than a Stromberg-Carlson!”

STROMBERG-CARLSON

ROCHESTER 3, NEW YORK

A HALF-CENTURY OF FINE CRAFTSMANSHIP



OUR PLEDGE FOR TOMORROW TO STROMBERG-CARLSON DEALERS

ONE: Soon after this war is won you will have a fine line of Stromberg-Carlson radios to sell . . . a line that will win customers and retain their good-will . . . a line that will offer value and fine performance in a range of prices.

TWO: The Stromberg-Carlson name in radio will be even more widely and more favorably known than ever before.

THREE: The Stromberg-Carlson policy of distribution will permit every authorized dealer to have a real opportunity for profit on the Stromberg-Carlson line.

O. H. CALDWELL, EDITOR
480 LEXINGTON AVE.,

RADIO & Television RETAILING

Including Radio and Television Today

M. CLEMENTS, PUBLISHER
NEW YORK 17, N. Y.

SELLING SOUND EQUIPMENT NOW — Radiomen having contacts with war-plant officials see a means of securing sales and installation of sound units at this time. Since the War Production Board has stated that "public address and sound equipment will be made available to a limited number of industrial plants," the procedure necessary to procure such equipment is of interest.

A scanning of the requirements contained in the WPB statement would indicate that the best methods to employ include the following steps: 1. Secure authority to survey the plant. 2. Recommend equipment (making sure it is available). 3. Submit purchase proposal to the plant. 4. Have the industrial plant officials sign form WPB-617. This form should include full details about the products the plant makes, its place in the war production program, and the uses to which it intends to put the sound devices. The request should come from the prospective user—the plant.

COVER—Dealing in electrical appliances, Temple of Music in Rockville Centre, N. Y., continues to keep its customers "sold," despite wartime shortages (see page 38).

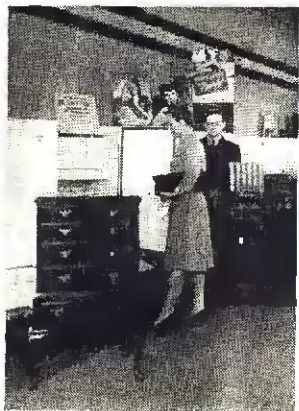

We Resume a Long-Familiar Name!

Beginning with the present issue you will note that the name of this magazine is being restored to RADIO and Television RETAILING.

This is a return to the original title which it bore in 1941 when Caldwell-Clements, Inc., bought from McGraw-Hill, the magazine and all of its lists, records, copyrights, statistical material and all other McGraw-Hill publishing equities in radio and television distribution.

The revival of the former name brings to mind the advantages gained by the industry and trade when the Caldwell-Clements magazine RADIO and Television TODAY and the McGraw-Hill magazine RADIO and Television RETAILING were merged by Caldwell-Clements, Inc., into one publication.

RADIO and Television RETAILING now stands preeminent in the field of radio and home equipment distribution, having won the top-ranking position in all radio reader-interest surveys made by manufacturers during the last 19 years. It now has, also, the *largest paid circulation* among:

Radio dealers and service dealers.

Piano, phonograph and radio-music dealers.

Radio and record buyers of department stores.

Big Plans Ahead—Based on 20 Years of Radio Publishing

Also it is of interest that the present magazine is continuing under the direction of O. H. Caldwell and M. Clements who launched it for McGraw-Hill in 1925, and who are thus rounding out their 20th year in this field, all spent with this magazine except for the five years when, beginning their present careers as independent publishers, they operated RADIO TODAY.

And now that big things are on the postwar horizon for home-radio, FM, television, phonograph combinations, records, electrical appliances and electronic maintenance, the publishers are keeping step with the industry and are now ready with enlarged plans which will project the postwar RADIO and Television RETAILING into its greatest usefulness in all its long history.

Retailer in Role of "Customer-Contact Man"

In the final analysis of any scrutiny into the problem of getting a certain make electrical appliance into the hands of the ultimate consumer, the independent retailer is seen as the *most* important factor. He is the manufacturer's "customer-contact man." He's the "purchasing agent" the manufacturer *must* sell, and he's the "buying agent" the customer *must* consult.

The importance of the dealer to the manufacturer is well stressed in the article in this issue which reports the results of a sample survey, conducted amongst 3000 readers of this publication.

This article shows that the retailer is the key-man between the maker and the taker of electrical appliances. And a breakdown of the answers received shows that *right now* these dealers are choosing lines, and are thinking seriously about tomorrow's selling techniques.

Merchandis

**Shrewd Buying, Smart
Should be Watchwords**



• Fundamental principles of sound merchandising remain as reliable now as they ever were—war or peace, good times or bad. Hunches and intuitions are not good guides. Stick to the principles that have been tried by wise merchants everywhere in all trades over the years and proved sound. They work for your profit. Remember, you are in business to make money. That's all you are in business for.

The essentials of sound merchandising are shrewd buying, clever selling and complete control of expenses. Of course, all three must be adapted to conditions, especially such abnormal conditions as we are in today. But that does not mean that these essentials should be given up for risky practices or unsound principles. These three should be working all the time to produce a net balance left over between what you pay out and what you take in.

Watch Expenses

That balance is your real profit, your net profit. Your gross profit is merely the margin between your cost and selling price, and does not include expenses. And expenses have frequently been known to eat up profits. Therefore, control expenses. A dollar saved, unless elsewhere wasted, is a dollar added to your profits. Watch every department of your business, every phase of every transaction, to see that it contributes to your profits.

Wise policies make fair profits.

Prudent merchants build their policies on sound principles and adapt their policies to the times. Notice that they "adapt" their policies, but do not change their principles. No better examples could be found than the successful radio retailers of today. Since the manufacture of radio sets for the public has been stopped because of war needs, they have turned to servicing and side lines. In doing so they have shown the most hopeful characteristic of the independent American merchant — adaptability. Many stories in RADIO & TELEVISION RETAILING afford good examples. In recent years radio dealers have gone into automatic heating equipment, furniture, refrigerators, electrical accessories and appliances, phonograph records, hardware, kitchenware and

You will want to ponder the merchandising philosophy of Marshall Field:

"To do the right thing at the right time, in the right way; to do some things better than they were ever done before; to eliminate errors; to know both sides of the question; to be courteous; to be an example; to work for the love of work; to anticipate requirements; to develop resources; to recognize no impediments; to master circumstances; to act from reason rather than rule; to be satisfied with nothing short of perfection."

other lines. The ability to alter business methods to changing conditions has been the life-saver of thousands of retail grocers, druggists, hardware dealers and others in large distributive trades older than radio retailing.

Many economic critics have told us in the last twenty years or more that large corporations would put

10 RULES

1. Remember you are in business to make money and for no other reason shall you continue in business.
2. Buy with an eye to the sale, but be not niggardly, lest you defraud yourself.
3. Sell that your customers may come back for more.
4. Control your expenses, lest they control you.
5. A dollar saved shall ring like a symphony in your cash-register.
6. By firm policies shall you excel; yet, behold, a shrewd merchant

the little fellows out of business. Such pessimists have continued their gloomy prophecies despite refutation by the census. But they forget the adaptability of the small merchant who has American ambition. The war has given radio retailers the opportunity to show their adaptability and they have taken advantage of it.

In older distributive trades independents have imitated chains and chains have imitated independents. over many years, so that expenses have been reduced and efficiency has been increased. In such trades "loss leaders" have prevailed for a long time as a merchandising practice. A "loss leader" is anything sold at a loss to attract customers and increase

ing Principles

Selling and Careful Control of Expenses for Alert Dealers in Making Money

volume. If the loss is held within the limits of legitimate advertising expense, the practice is sound. If it is carried beyond that limit, it may become destructive. And "loss leaders" must be changed often, because they lose their appeal quickly. They have not been in general use since price control has been in effect, but un-

Wanamaker said: "The capital of trade and commerce is much more than money. There must be visions, principles and profound devotion to well matured plans faithfully carried out, benefitting the public as well as the owners and investors. Such businesses cannot be extinguished."

FOR RETAILERS

setteth his sail to catch the wind.

7. Adapt your ways to the changing times, and in time shall you be rewarded.
8. Sell not at a loss, unless you can thereby make a gain.
9. Destroy not your competitor by unfair practices, lest they return upon you a hundredfold.
10. Profit, profit, profit—and again I say unto you profit, for volume at a loss profits you nothing, but a mite at a rapid turnover shall make you rich in due time.

will be a failure. "Loss leader" merchandising is clever, but it's tricky. Beware! Your competitors can play that game, too.

A while ago a group of retail sales people complained to their boss that a competitor was selling a lot of goods at cut prices, and asked what they should do. The sales manager made a correct merchandising diagnosis, when he answered, "Don't be selfish. Let him sell his full share of the unprofitable goods."

As cost-of-merchandise is the largest single item in the cost of selling radios at retail and as buying is the first step in merchandising, watch your buying. To buy the right thing at the right price in the right quantity at the right time is not enough.

Buying must be made to contribute to profit. Radio dealers who bought all the sets they could lay their hands on before the war, because they foresaw what was coming, were shrewd merchandisers and have reaped their reward. Of course extravagance is ruinous, but undue economy can be so, too. You can buy a thing so cheap that it is useless, and you can pay so little for an employee's services that you kill his enthusiasm.

Check Selling Costs

When a group of radio retailers, all doing business in the same neighborhood, report that since the war the cost of materials has increased from 10% to 100% and that labor has gone up from 20% to 300%, it is clear that they have demonstrated enough adaptability and ingenuity to survive such difficulties. But such figures also show the need for more accurate records of costs and expenses. Accurate records are the basis of sound merchandising.

A helmsman can not steer his ship to port by setting his course only as he sets out on his voyage. He must reckon his position from day to day, and all the time. You are entitled to know how your business is going, not once a year, that may be too late, but at most, once a month. You have noticed clearance sales by department stores after Christmas. There was no necessity for such sales during the holiday season, but left-over goods can not be allowed to sit on the shelves. Unsold goods eat profits. And that applies to the radio trade just as well as to any other.

(Continued on page 68)

doubtedly they will come back after the war.

"Loss Leader" Strategy

Something of the kind is likely to happen in radio retailing, as competition becomes keener in the postwar period. Phonograph records offer the opportunity. The stage is set. Many radio retailers have greatly increased their sales of records, as their supply of radios has been exhausted. They can display a popular record at a cut price, but unless it increases the sales of other records at fair profits, it will be a failure. If it is kept on display long enough to get stale and lose its drawing power, it

With profits just over the hill-top, don't waste effort running in circles fighting with your competitors.

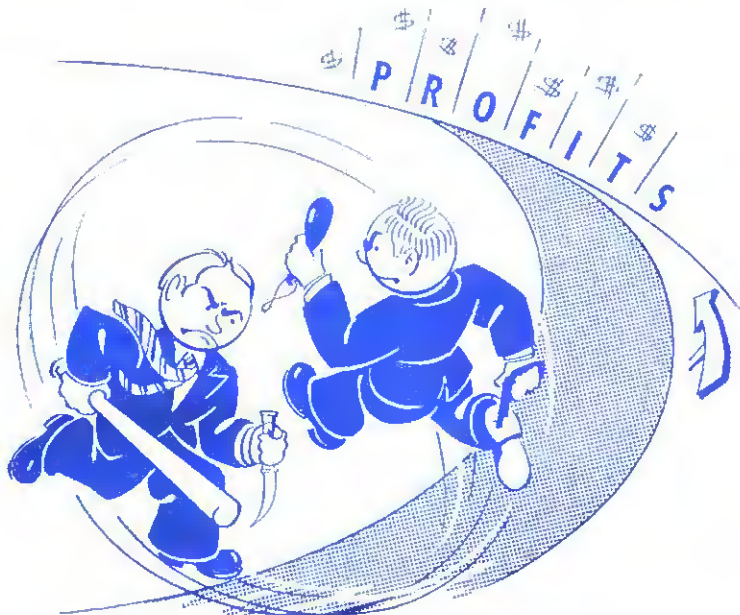

APPLIANCE

They Build Now for a Bright Sales Future in Major war Purchasers. Urgency Governs Service Priority.

• "Need rather than time determines the speed with which we can give customer service on the radios and other electrical appliances which we repair," says V. G. Gaines, veteran radioman at 3405 Milam St., Houston, Texas.

The Gaines Electric & Radio Co. finds that people are cleaning out their attics and having all fans, irons and appliances repaired, even though many of these models are obsolete and will not be used when new equipment is available. Here again, necessity determines the speed with which the repair is made.

Two Mechanics Deferred

This dealer is doing some refrigerator service, and because of the essential nature of this work, he has been able to get draft deferments for two good mechanics. He works two servicers full time, and three part time. These men work from 8 AM to 6 PM; and although Gaines stays on the job until 7 or 8 in the evening, he does not want his mechanics to work too long and lower efficiency, as a result.

Remember Business Slump

Mr. Gaines has been in business almost 30 years, and has seen war conditions before, good times and bad times. He says, "We try to get out every set that we can, but we have about 200 in the shop almost all the time. We don't turn down any repair job, for we can recall times in the past when we wouldn't have a single service call all day.

"But we do determine the urgency of the repair. If a man has only one radio, we can and do generally give him his set the following day. But if this man has several receivers, as most customers do, we tell him that we will get the job out just as soon

as we can, but sometimes it requires several weeks.

"If the customer does not like this

takes the time to courteously explain the situation."

Does Circuit Changing

With tubes especially hard to get, dealer Gaines finds it necessary to do a great deal of switching and substituting, often having to change sockets, re-wire, put in a resistor, or condenser, or make other adjustments, but he puts sets into operation. Many jobs that would require five minutes and \$1.50 if the parts were available, require two hours and \$6.00 to \$8.00 to the customer. Like most dealers,

Dealer Gaines Says—

• "We don't turn down any repair job, for we can recall times in the past when we wouldn't have a single service call all day."

* * *

• "Most customers are tolerant when the dealer takes time to courteously explain the situation."

* * *

• "These are days when we must be neighborly and try to save time, money, gasoline and trouble."

suggestion, we refer him to some other dealer, and explain that we are trying to take care of as many people as possible, so that everyone can have at least one radio, or other necessary electrical appliance in good working order.

Customers Cooperate

"In nearly all instances, the customer agrees with us, and we believe we make friends and regular customers, even of those who have had to wait long periods of time. Most customers are tolerant when the dealer



REPAIR PLAN

Electric Appliances. Current Repair Jobs Line Up Post-war. Owner Gaines Stresses Importance Retaining Good Will.

this service shop operator is mainly interested in keeping sets in service and being helpful to his clientele. He is using Victory condensers and finds them to be serviceable, and even then he frequently shops around to supplement the supply from his regular source.

Distributor Confidence

He believes that the distributors are doing the best possible job of dividing the limited stock of tubes and other critical parts. Mr. Gaines had

a large supply of tubes and parts on hand when these items first became scarce.

Time to Make Friends

"We do a lot of radio repair for servicemen in the military camps. We find out when these boys will be back in town, and make sure that their radios are ready on the next trip in, or if they bring in the sets early, we finish them on the day of receipt. We get a lot of business from small towns, too, and when these people bring in a set early enough, we finish

it in time to allow them to pick it up the same day. These are days when we must be neighborly and try to save everybody time, money, gasoline and trouble," says Mr. Gaines.

This dealer is doing everything in his power to sell his valuable service to as many customers as is humanly possible during these critical times—and he refuses to "play favorites." Mr. Gaines expects that this policy will bring him many new customers, and he knows that it pleases his regular ones.

Prepare *now* to handle postwar sales, is this dealer's motto.

V. G. Gaines, owner of V. G. Gaines Electric and Radio Co., left, discusses job with a prospect. At right, one of his two service men checks a radio.



Three-Man Shop in Chicago Makes Record. Lives Up to Name: "Emergency Radio":

• When J. F. Beranich opened his radio shop in Chicago, his capital amounted to \$25. His possessions consisted of an old radio tester and a junk car. Whenever a call came from a customer to service a radio Beranich would hop into the jalopy and arrive at the home in record time. His quick response to calls brought him this comment from a customer: "You really do give emergency service, don't you, Johnny?" Thus a name was born for his shop "Emergency Radio Service."

Today, Emergency Radio Service, 4439 Madison St., is doing a big job in records and has reached a new high in the number of radio sets repaired daily—60 being the average, according to the owner. And this with a three-man shop.

Assembly-line Tactics

"There was a time when we employed 10 service men," says Mr. Beranich. "Now there are only two beside myself, and you will be surprised when I say that we turn out more completed work with the small force than we did previously with 10.

"We work on an assembly line principle," he said. "The men are top technicians. With our modern testing equipment we are able to locate the trouble in short order, and then it is simply a matter of making a replacement, done by another man who is free to do this job, or it is done by the same man who locates the trouble. In this manner we are able to average 60 completed sets per day."

Fair Pricing

Beside rapid workmanship, the shop's policy is to do good work at reasonable cost. "We've always been honest with our customers," said Johnny. "Our basis of charge to a customer is governed by the amount of time and material that is required."

Prime concern of the owner is to

provide service which is definitely satisfactory to the customer, a fundamental upon which the shop has prospered. To this end, a card is sent to every customer who has had a radio serviced at Emergency. The card reads in large letters across the top:

"IT WAS A PLEASURE AND WE THANK YOU . . . It was a pleasure to have you select our Approved Laboratory a short time ago to service your radio . . . Our work and the parts we install are fully guaranteed. We want you to be satisfied and enthusiastic about the results of our efforts and the greatest compliment you could possibly pay us would be to recommend our services to your friends . . . Just have them phone Austin 2404 . . . Emergency Radio Service, John F. Beranich, 4437-39 W. Madison St., Chicago . . . Keep this card for reference."

SIXTY SETS



During the eight years that he has been in business, Mr. Beranich has consistently advertised for more business, and today has customers all over metropolitan Chicago.

Advertising Campaign

During these times, this shop plugs away for more business, using the following plans for advertising: Program on Station WAIT—local and metropolitan newspaper space—street car cards—space on Chicago Stadium event card—advertisements on match book covers, in church booklets and in the classified telephone directory. Beranich's firm also sponsors the "Emergency Radio Boys Baseball Team."

The extensive record department at the shop has been in operation for the past four years. Initial outlay amounted to \$500, which included racks from Columbia. Through careful planning, consistent promotion, and steady increase in clientele, the present stock amounts to \$12,000.

Records add to Emergency Radio's intake. Disc department is popular

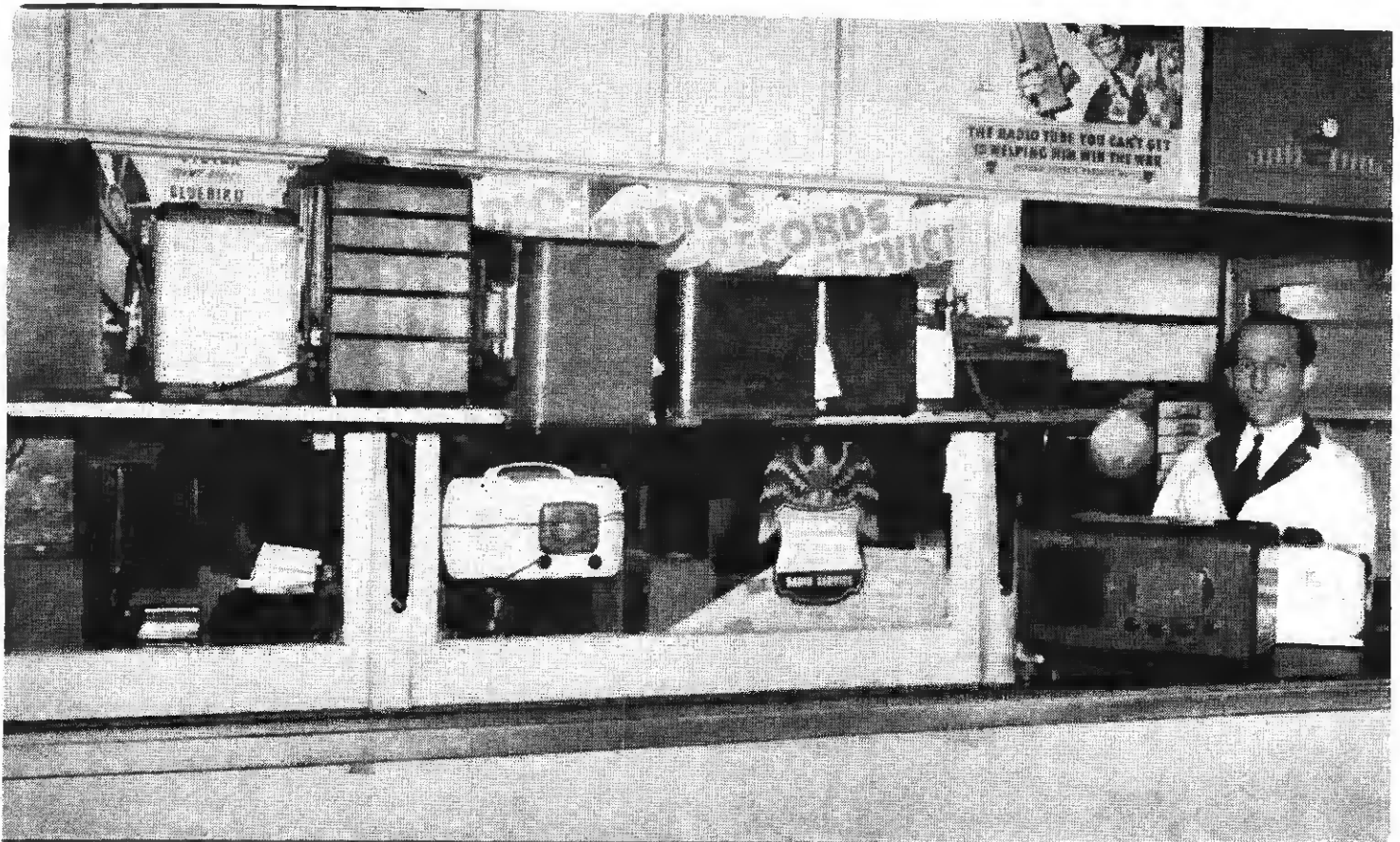

Just a few of the many sets on the repair production line at Beranich's

A DAY

There are five listening booths. A feature that is worthy of note is the auxiliary record player located atop the long counter to one side of the cash register. This may be dubbed a "quick-turn-over-transactor," since it proved to be exactly that.

A reporter for RADIO & TELEVISION RETAILING watched a customer come in and tell the young lady behind the counter that he wanted to hear a certain selection.

Time-saver in Sales

"Do you wish to take it in the booth or listen to it here?" she asked. The young man indicated the player on the counter, and the record clerk, Mr. Beranich's sister Ann, placed the disc on the turn-table. While the number was being played for this customer, the clerk attended to other buyers already lined up at the counter.

In the album department there is a good representation of works of the

Self-service cuts down on help difficulties. Note attractive and well-spaced display

masters. The Emergency Radio Service program on Station WAIT is at present featuring the playing of classical numbers which may be had at the shop, and as a result of this promotion, there has been a marked increase in the sale of classics.

The shop occupies the floor space of about two ordinary size stores. Consequently the window display area is large, and is used for the dis-

play of record promotional streamers as well as records. Another advantage in this extra large window space is that the pedestrian is able to see every section of the shop's interior.

Located in a heavy traffic section, much business is done with the "stray" record buyer who frequently becomes a steady customer.

After the war Johnny Beranich will continue to handle records as he has in the past, but on an even greater scale. One department will be devoted to records and the other to radios. Ask him how he feels about his record department and he'll tell you: "It's wonderful!"



DEALER

An Increasing Number of Dealers Now

SAMPLE SURVEY SHOWS

OUR DEALER-READERS
SOLD ELECTRIC APPLIANCES
BEFORE THE WAR

90%
SOLD

REFRIGERATORS

87%
SOLD

WASHERS

64%
SOLD

ELECTRIC RANGES

34%
SOLD
AIR
CONDITIONING

• In prewar days, when the epidemic of price-cutting, overboard trade-ins, loose credit terms and discount violations was widespread over the country, a bedeviled retailer asked a distributor's salesman what, if anything, could be done about the situation.

"Declare a 'merchandising holiday'—like the 'bank holiday,'" replied the salesman. "Halt all home-appliance manufacturing and selling. Then compel all manufacturers, wholesalers

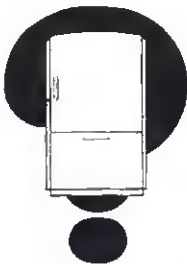

and retailers to clean up the whole mess, and start off with a clean slate.

"Of course," he added, "such a holiday could never be carried out. It's too fantastic. But it would be the only remedy."

Remarkably enough, a "merchandising holiday" is virtually here.

In this war-borne selling lull, merchants see an opportunity to stamp

out the familiar feverish selling practices, and they express themselves frankly in answer to a survey sample conducted by this magazine amongst 3000 radio-music and radio dealer readers, through mail and by personal contact.

Those answering do not expect to see a complete reformation take place, but they do hope for improvement. Results of the survey show that these dealers are extremely aware of the necessity for improved, profitable merchandising techniques.

The answers show that these retailers are going to take on more lines. That they are going to diversify, and that they are united in thought regarding future policies of manufacturers and distributors.

These dealers have very definite brand preferences, predicated upon various factors such as public acceptance, low service costs, fair-dealing experiences with manufacturer and jobber, advertising and warranty policies, discounts and franchises.

The following questions were asked:

Which of the following appliances did you sell before the war? Refrigerators, washers, electric ranges, air-conditioning.

Which brand or make of refrigerator was your best seller?

Which brand or make of washer was your best seller?

Which brand or brands of the following appliances, if any, do you expect to sell when merchandise is again available? (fill in names) Refrigerators— Washers—

Have you any comments on the merchandising of the above appliances which would be helpful in shaping our editorial policies?

90 per cent of those answering sold refrigerators before the war.

87 per cent sold washers in pre-war times.

64 per cent sold electric ranges and 34 per cent sold air-conditioning before the war.

What selling policies do the dealers



hope to see in the postwar period? A few typical answers follow:

Want New Selling Deal

"Keep merchandise out of the hands of the price-cutters. I never could understand why manufacturers set their price—the dealer's price, and then proceed to load the market. The point is this—the wholesale price is maintained—the dealer cannot always maintain his price in the face of competition."

"What about trade-ins after the war? How (if possible) will trade-in amounts allowed, be controlled? To me, this is a tremendously important item."

"I do think costs should be lowered allowing dealer more profit in order to buck chain-store competition."

"Cut out wholesale retailing (or price cutting)."

"We hope—refrigerator and washer gives the small dealer a chance—and not everything to the utility."

APPLIANCE QUIZ

**er of Radio-Music Dealers Will Sell Electrical Appliances When Merchandising Is Avail-
Determining Brands To Be Carried—Look for Clean-Up of Merchandising Practices**

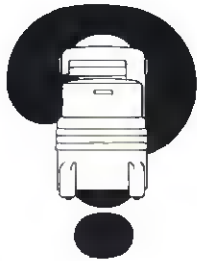

"Organize all electrical appliance merchants (independent) in order to boycott manufacturers of merchandise sold by chain stores and mail-order houses—cut discounts. . . ."

"Dealers would like to know the standard or first-line appliance manufacturers' plans toward the chain store as outlets for merchandise."

"Set prices on trade-ins according to year—make them low."

"Eliminate discounts by wholesalers and their employees to their friends, and over the counter."

"Advise jobbers and manufacturers to protect against price-cutters by selecting dealers carefully."

"There should be a law passed to cut out chiseling and price cutting."

Service Guarantee Problem

"We find this merchandise (naming refrigerator and washer) has public acceptance and requires very little service."

"We handled the same line for 10 years." (naming refrigerator and washer).

"Service of refrigerators should be via the retailer. Since the manufacturer took it over, via long-time warranty and direct service to the home, a big source of replacement sales has been affected."

"I believe that electric refrigerators should be guaranteed for one year only, from date of sale."

"Limit wholesale distribution to franchised dealers who took care of service during emergency."

"Pull for warranties of not more than one year."

"Get rid of sealed refrigerator units . . . have all serviceable."

Advertising Promotion

"Advertising. Keep it up. There is a great outlet for sales now."

"Past publicity in general will result in an over supply of appliances in one year. . . ."

"Genuine value, truthfully advertised, honestly sold and properly serviced is the only basis for long-term profitable appliance business."

"Would suggest the factory run local advertising and charge it to the dealer."

"Good display material and 50 per cent of costs of dealer advertising by manufacturer."

Dealer Postwar Plans

"I have six stores and just recently bought a large building, formerly occupied by a bank, for my display and sales room, and am considering the purchase of a large building of 28,000 ft. floor space for a warehouse."

"We did not sell appliances before the war, but expect to when they are again available."

"So far I have only repaired radios and small appliances. I am thinking of going into selling of all appliances."

"We expect to handle refrigeration, washers, electric ranges and small appliances."

"Kindly pass on my name to manufacturers of appliances as desiring now to shape up policies as a representative dealer."

"All I sell is radio, but may sell refrigerators and washers later on."

"We have never handled refrigerators, washers, or air-conditioning . . . we will probably stock them after the war, or when they are available . . . would like to read about appliance merchandising to help us be prepared."

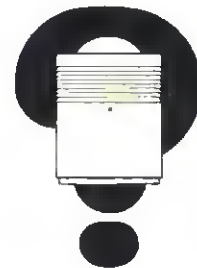

"We are wondering as to future outlets for appliances. Will drug stores sell 'em? Will gas stations sell 'em? Will 'borax' joints get the cream brands? Will purchasing departments of warplants have 'em for wholesale?"

"We feel that the old plan of long credit terms should not be used after the war."

"Will handle washers—don't know"

(Continued on page 68)

THE DEALERS WANT—

- Shorter warranty periods.
- Shorter customer-credit terms.
- Trade-in reforms.
- Maintenance of retail prices.
- Cooperative advertising.
- No more "wholesale retailing."
- Larger profits to combat "chains."
- Protective franchises.
- Utility competition eliminated.
- Control of service.
- Manufacturers postwar attitudes towards "chains."

Switch in Dealer-Preference in Washers

Position With Dealers in 1939		Same Dealers' Choice for Postwar
1st Place	A	4th place
2	B	5
3	C	2
4	D	1
5	E	8
6	F	6
7	G	3
8	H	9
9	I	7
10	J	0
11	K	10
12	L	0
13	M	11

Brands N, O, P, Q, R, S, T, U, V, W, X, Y and Z—accounting for approximately 10% of lines pushed by dealers in 1939, are not mentioned in 1944 sample survey of postwar brand choice.



Rebuilds Custome

Left, Charles Deason carefully supervises service to be certain customer gets a good job. Right, owner Deason is equally interested in sales.

Charles Deason of San Antonio Finds "Rebuilding" Radio Customers. Repairs Continued During the Day

• Charles Deason may not be able to furnish his customers new radios, but he will rebuild their old sets into first class made-to-order receivers in a week or so.

By building durable sets from salvaged parts, and by stepping up repair services to meet the increasing demands of a public facing a radioless duration, should their present receivers fail, the Deason Radio Co., San Antonio, Texas, had a business volume in 1943 that left the friendly face of its owner, Charles Deason, wreathed in smiles as he crystal-gazed into the new year.

30 to 40 Sets per Day

"We're all in this together," Mr. Deason told us as he stood watching a service department employee testing one of the 30 or 40 sets that sometimes pour into the establishment in one day for check-ups. "And as long as we can find the parts, we will fix the old radios or build serviceable ones for our customers."

Faced with a rapidly diminishing

stock of radios acquired in prewar days, Mr. Deason made a test run—building a set from parts on hand in the shop. The results were satisfactory, and the product didn't stay on the display racks, facing the wide, sunny street intersection long enough to collect even a thin coat of dust. So Mr. Deason set about building others.

A small advertisement in the San Antonio papers produced splendid results. In a few days useless and obsolete sets were pouring into the shop until the show room took on the appearance of a combination antique-junk shop. Purchase price of the offerings depended on the number of parts that could be salvaged. Cabinets were stacked in the store room.

Night Shift Rebuilds

All work is done on the rebuilt sets at night. Employees volunteer to stay after hours, and the jobs they turn out are indeed examples of Yankee ingenuity, plus industry born of wartime emergencies.

First the set is rebuilt. From the

base up, each part is carefully examined and tested for performance and probable life expectancy. The shop supply room is usually called on for new wiring, tubes and condensers.

So far, the supply of cabinets has been unlimited. If a second-hand box is selected, it is sandpapered and refinished, if of hardwood, or given a new coat of enamel, if composition. New dial rings and dial faces are applied, and the set placed in the cabinet.

Sets Built to Order

When a prospective customer enters the Deason Radio Co. store he is shown not only the sets on hand, but is also given a verbal picture of one that might be built for him. As a result, practically all productions are sold long before they are made. Mr. Deason maintains a waiting list, and sometimes is called upon to keep patrons informed of the progress being made on the construction of a radio.

When RADIO & TELEVISION RETAILING visited the shop, Mr.

mers' Sets

Deason pointed to a shining rebuilt model that he had placed in his window a short time before. It was a battery set, complete with a thousand-hour battery, of a portable type, and would do credit to a soldier on a picnic with his best girl, or to the living room of a prosperous Southwest Texas ranch.

"We sell lots of these battery sets," Mr. Deason said. "Country people

are buying more now than they have in a long time. We try to furnish them what they need in the way of radios, and by letting them know that we are personally trying to help them through these days of shortages. I think they will remember us after the war when new sets are back on the market."

But this emergency project is not allowed to interfere with the shop's

self-imposed primary purpose for the duration—keeping every radio in the customers' homes in tip-top working condition. All available servicers are kept busy during the day repairing and testing in the service shop. Army men and women make up a large part of the trade, and sometimes sets that are destined to "drink" plenty of salt spray, are placed on a high priority list on the work bench so some soldier or pilot can have his radio in the South Pacific or the European theater of operations. Otherwise, the sets are tagged as they come in and worked on in order.

Every effort is made to put the radio back into running order, but if that is impossible the usable accessories are purchased and put into rebuilt models.

Fair Treatment Stressed

"We may have a great advantage over the customer," Mr. Deason stated, "but no reputable radio man will capitalize on it. If a radio can't be fixed, we tell the customer so, without first letting him waste time and money on it. I think that after the peace is won, this practice will pay off in a big way. Soldiers and defense workers are going to remember who gave them a square deal. We take care of lots of new customers. What business man in an army or war plant center doesn't?"

"But we also service customers who have traded with us for years, many of them since we opened up here 17 years ago. And we treat them all just alike. I don't think that either our old customers or the new ones will forget that when radios are plentiful."

All sales and services are cash. Mr. Deason supervises the sales floor and the business office. Pasted in a conspicuous place near the door leading to his glass-enclosed office is a placard reading, "Quiet. Worry Period." He grinned when questioned concerning the significance of the sign.

"That's in case I run out of ideas," he said.

Mr. Deason holds no fear for the balance of 1944. In fact, he looks forward with enthusiasm. He has hope of regaining some of his employees who have been away on a trip. When asked if their journey was a special mission, he replied:

"Sort of. I loaned them to Uncle Sam to help operate his radios in bombers. They'll make good operators. I trained every man-jack of them myself."



Radio Today—

Ingenuity in Allied Lines—Radio Repairs

NEW YORK, N. Y.—Without having previously been in the radio business, but possessing an extensive engineering and business background, Charles Bond opened Bond's Radio Service, 152 E. 53rd St., a year and a half ago. He immediately attracted attention to his store by working on the only radio set he had in the place—in his show window. Catering to a high class trade, he used every means to make his showroom attractive.

Today, Charles Bond is doing a big business. He buys and sells radios, and is getting in between 50 and 75 sets a week for repair, and turning out as many completed jobs as he can in his one-man shop.

Bond bought a number of used receivers, and is now specializing in renting them to guests in high class hotels. He secured the contacts by calling on hotel managers. The demand for sets on the part of guests is due to the fact that they want to hear programs of their own choice, and at hours of their own selection.

When a representative of this publication called on Mr. Bond, he had 46 sets out on rental. Fees charged are \$7.50 a month, \$3.50 a week, and \$1 a day. The delivery and pick-up problem is simple, since bellboys from the hotels perform this duty. Bond is paid for the rentals by the managers of the hotels, who tack the fee on their customers' bills.

Bond does no circuit changing because he finds he is able to buy any desired tube by diligently searching for it in New York.

LOUISVILLE, Ga.—Where radios were formerly displayed, the Merchants Hardware Store is now displaying cement flower boxes painted in different colors. Along with these, instruction sheets on growing various types of pot flowers, and how to care for them, are available.

ST. PAUL, Minn.—The Schorn Radio shop, on Snelling near Minnehaha, St. Paul, has educated its customers to try to find their own tubes for replacement. So well has it succeeded that much searching time has been saved and consequently the shop can put more time on the actual work of repair with a larger number of radios put back into working order. So much work comes in (the shop

AUGUSTA, Ga.—John J. Kensey, owner of Delph Hardware, has established a new type of repair department in his radio shop. He repairs and remodels leather handbags. Due to the fact that leather is hard to get, he has made this a growing business, and keeps the store traffic up to par.

Glass and china ware have been added to take the place of former appliance volume.

For Civilian Protection and Morale

Keep Radios In Repair

Today with world history being made, with events taking place that affect you and the generations to come, your radio news broadcasts and bulletins assume an importance second to none. Are you getting a clear reception on your set? If not, we can guarantee that our expert repair services will make it as good as new.

LET US SOLVE YOUR RADIO TROUBLES

RADIO MAINTENANCE CO.

On 20th Street

Phone 244

Block East Hotel Collins

JASPER, Ala.—Forward-looking dealer S. E. Stevens, owner of Radio Maintenance Co. finds local newspaper advertising advantageous to his business needs in wartime. Also advertises for old radios to salvage parts.

has no deliveries or pick-ups) that now it is discouraging small repairs, preferring to work on machines which must have professional skill in order to put them back into working condition.

BALTIMORE, Md.—Linden Radio Service, 55 W. Oliver St., is registering a steady growth in servicing volume, according to Joseph M. Kippnes, general manager. A drive-in service station large enough to accommodate a dozen cars was built. Today, defense workers in this area keep this station busy. A charge is made for estimating cost of repairs to prevent "customers" from learning the set's trouble, then taking it elsewhere. Notice to this effect is posted

WOODSTOCK, Ill.—Ray Thompson, Thompson Appliance Co., is known as the farmers service man. While he does not do radio repairs, he handles almost all other appliance repairs. Farmers call him when trouble develops with washers, vacuum cleaners, milking machines, farm electric motors, oil burners and stokers. A woman helper takes care of store calls, so Thompson can spend most of his time out in the field doing service work. He finds this an excellent way to keep up his contacts with farmers. He believes that when the war is over, farmers hereabout will give him a large volume of new appliance business, and will continue asking for his service.

His "prospect" list grows.

from N.Y.C. to L.A.!

Increased—Electric Appliance Service Needed

HOUSTON, Tex.—"We have had to turn down repair work on only three sets within the last eight months," says W. B. Lambert, owner of the Lambert's Radio Service, 745 E. 11th St., who amplifies, "I am in this business on a permanent basis and probably I see it a little differently. There are times when I will take in a set to repair which I know will not pay me a profit, but I am thinking of tomorrow. Customers never consider the age of a radio, and if I send them away without repairing some old set, they get the idea that we can't, or we're not interested. So we simply make various conversions and substitutions and get along pretty well.

"For example, we have not had any OZ4 tubes for the past several months; but by putting a filament on

the socket—a hot lead on No. 2 and a ground on No. 7, we have a better tube than ever by using a 6X5 as a substitute for the OZ4.

"We don't repair many parts for we can get a fair supply, but we do rebuild coils by hand. We try to be patient with customers and explain the labor involved, so that they will understand why we have to charge \$8.00, possibly, for wiring a tube and checking a set completely. Such a job means two or three hours' work, and we try to operate on a policy of doing the job right, so there are very few comebacks. We take some of the bitter with the sweet, and feel that this is a time when we have to think first of keeping the customer's radio in service. Tubes are the most critical of our supplies, but we anticipate some relief in this field soon."

CHICAGO, Ill.—The Trybus Radio Shop, 5738 W. Fullerton Ave., operated by Fred Trybus, formerly W9WPZ, is swamped with repair work. When a RADIO & TELEVISION RETAILING representative stopped at his shop, he found all available floor space occupied with sets—some ready to go out; but most of them awaiting repairs.

LOS ANGELES, Cal.—J. H. Newman, of Hollywood-Beverly Radio Service, 7476 Melrose Ave., in addition to servicing radios, repairs small appliances and domestic refrigerators. Mr. Newman says, "The tube situation is still very bad. I have been able to get more tubes from (a mail order house) than at any of the local supply houses." The firm has

(Continued on page 56)

NORFOLK, Va.—Although sets awaiting repair are piled high in the former radio showroom of retailer R. L. Kidd, owner of Radio Sales & Service Co., 416 Monticello Ave. this dealer never turns a "customer" away without courteous attention to his queries.



\$'s in Record Merchandising

Radio-Music Dealer of Hackensack, N. J., Finds Complete Inventory Essential to Profits in Discs. Children's Records a Big Seller

• In 1942 Brunton's record inventory was a mere \$700. Today it is between the \$13,000 and \$14,000 mark!

Robert H. Brunton, owner of Brunton's Inc., 321 Main St., Hackensack, N. J. operates a business that came to him from his father. Andrew Brunton opened his music business in Jersey City, N. J., in 1898. With the advent of restrictions on new merchandise it became clear that one of the two stores would have to be closed for the duration. Following the premise that the independent retailer does best when in a growing suburban or "home" location, the Hackensack store was continued, and the Jersey City location closed.

Mr. Brunton has been in the music business with his father since 1918 when they operated several stores throughout the State of New Jersey, specializing in pianos until 1925. After that time musical instruments and radios were added, then recording machines and record players, and, of course records.

Retailer Brunton is a neighbor of Frank Sinatra and recalls selling Frank's mother her first recording machine in 1939—one of the early Wilcox-Gay models.

Despite shortages, Robert Brunton is bent on remaining in business to preserve his carefully developed customer lists and to keep valuable connections with distributors and jobbers that have been in existence in his and his father's time over the past forty odd years. These two factors he counts among his intangible but extremely valuable assets as an independent retailer.

The answer has been records and radio service. The store layout shows a few pianos, musical instruments,

and radio sets still for sale, but every available display space is given to discs, and the bright albums do much to add to color in the store and to fill in the gaps left by restricted merchandise. To accomplish this, wall and floor racks for self-service are used to good advantage. At the back of the store is the counter and record player.

An extensive stock of all discs and albums is kept, and particular attention is given to the merchandising of music on records for children. Dealer Brunton finds that there is much business to be done in supplying the surrounding schools with march music, for instance, and discs of music

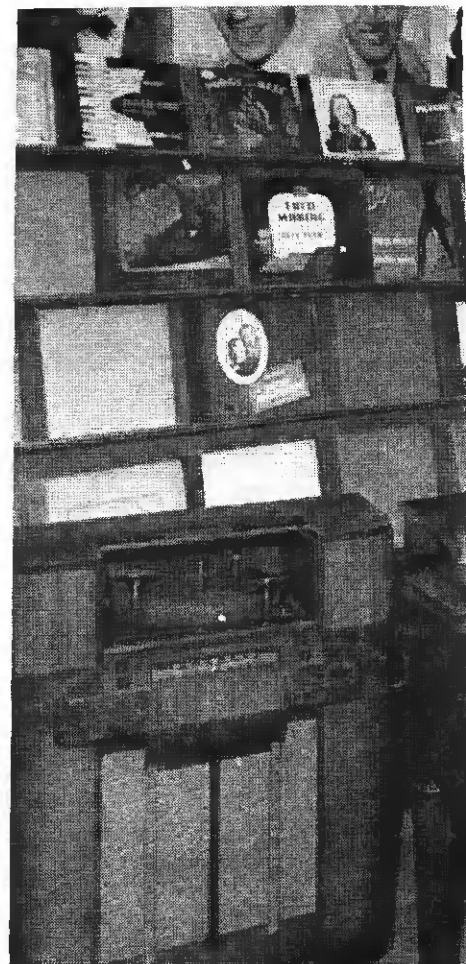

especially recorded for various gymnastic drills and dancing are also frequently requested. These are classed as rhythm records. Other discs for children include various kinds of recordings for all ages, from





Owner Brunton in action on sales floor.

inasmuch as he has lost all of his technicians to the armed services, with the exception of his brother, Frank Brunton, who can only give his time to this after hours. Formerly in charge of the servicing for Brunton's, Inc., Frank Brunton is currently engaged in shipbuilding.

Although in the radio business since 1922, Robert Brunton confesses that at the start of 1942 he hardly knew the difference between a condenser and a resistor. "When you are thrown on your own, though, it is surprising what you can learn in a short time!" he claims. Now with the help of his brother, Frank, several



Section of Brunton's display windows, and (above) well-stocked record department.



nursery rhymes up through stories and songs to Boy Scout talks, and right on to dramatic readings of condensations of famous literatures. This particular field is a large one, Mr. Brunton believes, and can be developed by the dealer, particularly in suburban communities and the smaller cities where home life and children's welfare is a paramount factor in the lives of customers.

Maintaining a radio service department has been somewhat more of a struggle for this retailer, however,

times a week after hours, he does a business in radio repair that is satisfying his customers *and* helping to pay the overhead.

A firm believer in "knowing your neighbor" as the first step to "knowing your customer," both Mr. and Mrs. Robert Brunton are active in local clubs and various war drives. With a son, Sergeant Frank Brunton, in the Army Air Corps, this couple are doing all they can to help win the war, and not the least of these is "staying in business"!

Home Appliance

Temple of Music Stores Never Relax Efforts in Keeping Showrooms Attractive. Sell Alternate Lines (See Front Cover)—Render Real Service

• Upon entering a Temple of Music store in Rockville Centre, Freeport or Hempstead, N. Y., more than a casual glance is needed to make the visitor realize that this isn't the pre-war period of plenty.

The impression one gets that the store is well filled with appliances, is due to the fact that an astute management makes every effort to create this welcome merchandising illusion—and is succeeding, despite the shortage of civilian goods.

Since the Rockville Centre store is illustrated on the cover of this issue, and also on these pages, a visit there provides the answers to the following two questions any alert retailer might ask:

1. "How does Temple of Music create and maintain such a favorable business-as-usual impression upon the customer?"

2. How does the organization make money?"

The answer to No. 1: Temple of Music's traditionally modern, clean and attractive interior and exterior appearance is religiously preserved. Available merchandise is *displayed*—not merely *shown*. Relations with the customer are tuned to a tempo of efficiency, courtesy and service.

The answer to No. 2: The organization's income is derived from sales of available merchandise, sales of records, and from its streamlined service department.

In the Rockville Centre store, a colorful display is made of a long row of non-mechanical iceboxes, extending from a position near the entrance, to the rear of the long showroom. These boxes fill space along an entire wall, and look a lot like the long-since vanished electrical ones. Brightly colored manufacturers' display pieces are placed on top of the iceboxes.

Temple of Music Stores does a good selling job on the wartime ice refrigerators—and obviously gets a

lot of display value out of them also.

The few remaining high-priced console radios are cleverly spaced on the large, carpeted showroom floor.

Always in the record business, when the war came, Temple of Music enlarged and improved the record department of each store, and maintains a large stock, attractively displayed. Local newspaper ads are used to promote sales of records, iceboxes and repair services.

In Rockville Centre, the entire wall, opposite the icebox display, is utilized by the record department. There is also a well-stocked sheet music section.

Service for all three stores is performed in the basement of the Rockville Centre establishment. This department, taking care of radios, rec-

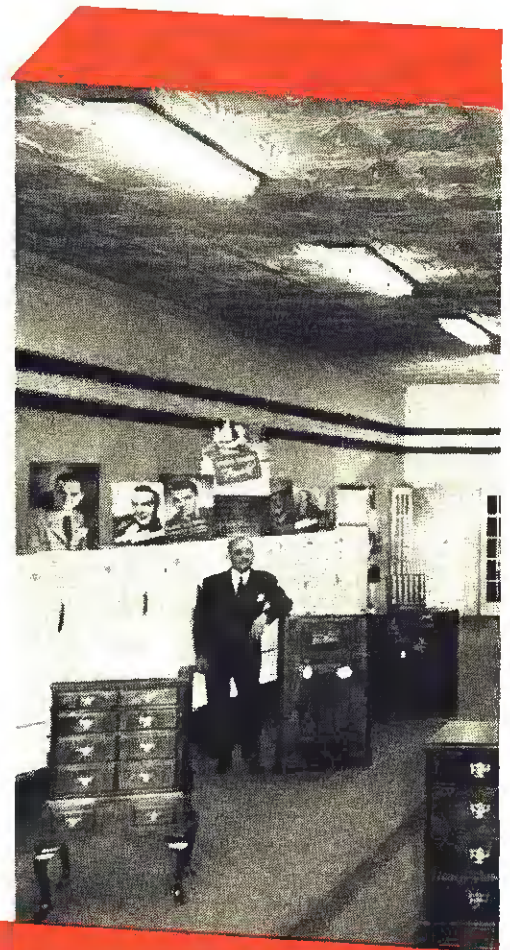

Rockville Centre shop. Well-lighted windows reveal handsomely displayed stock.

Merchants NOW

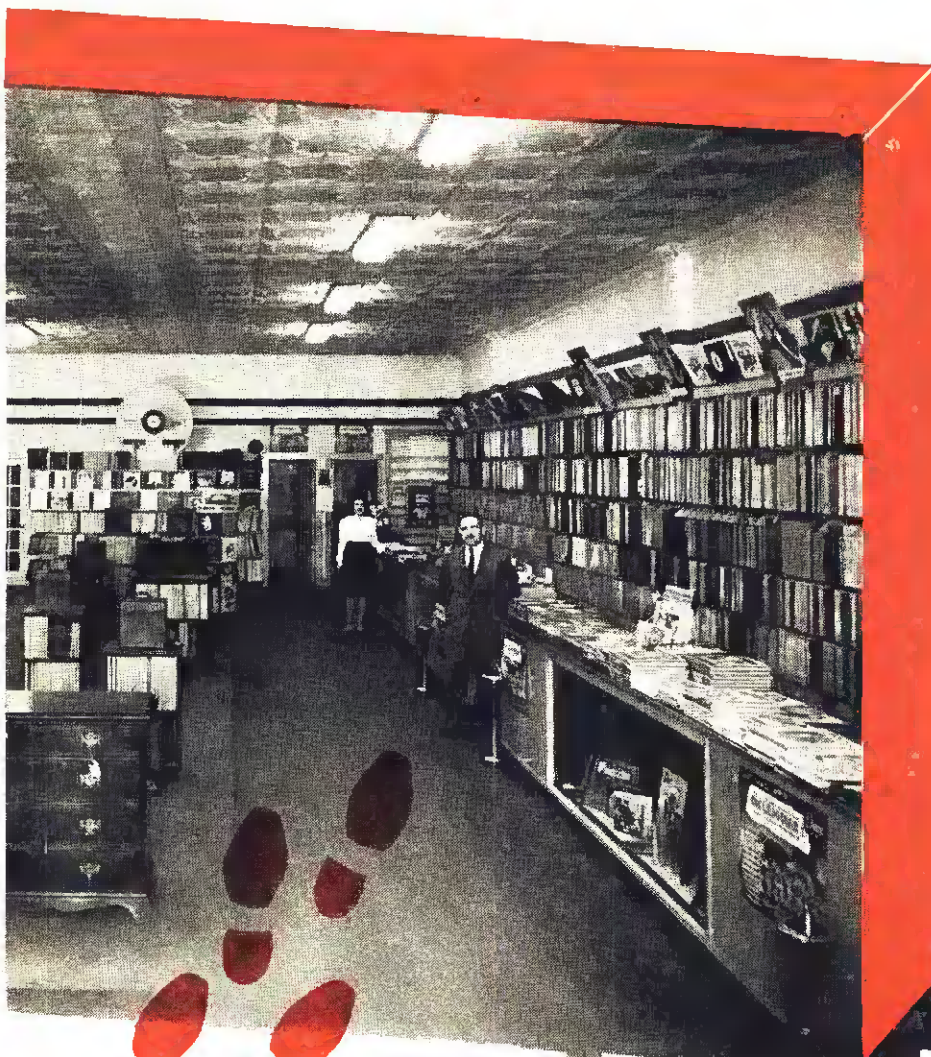

selling many well known make radios, refrigerators and a wide variety of minor and major household appliances.

This firm specializes in service to Bendix automatic washers. Before the war, the firm did an outstanding selling job with this make.

All repair work is rendered on a C.O.D. basis, and 75 per cent of the jobs are estimated in advance to the customer.

Production line methods are employed in the repair shop. Each servicer has his own number, and finds his work laid out for him on a shelf bearing this number. Each man has a simple bookkeeping routine to follow in completing his work, and each is required to polish the cabinet of the set as soon as it is finished. There is a separate department for polishing.

Since Temple of Music's basement is large, there is plenty of room to house the modern shop, and lots of shelf-room to store sets awaiting repairs, and the completed ones. Therefore there is no confusion—no bottleneck of sets. There is an office for

(Continued on page 50)

Ready to serve! Based on the premise that the public will buy what it can see, modern lighting and orderly display invite the customer to select.

ord changers, television, and Bendix washers, is one of the best equipped on Long Island, and is operated in a systematic fashion. There are four regular mechanics and two part-time men.

Being situated in wealthy Nassau County, near New York City, Temple of Music is called upon to service many television sets. Albert I. Sirota, vice president and general manager, estimates that there are about 300 television sets in his firm's territory. Temple of Music sold about 60 of these. They were also successful in



Service department of fourteen years' standing. Its manager, Earl Bernhardt, in foreground, is proud of the fine job this section of the Rockville Centre store is doing, despite help and material shortages.

SOUND IN

**St. Albans, N. Y. Naval Hospi
Day. Seen Playing Big Part in**



• Radio entertainment, which has helped sustain the morale of troops from the South Pacific to Iceland, is entering a new and important field of service in aiding in rehabilitation of our wounded fighters. Morale has always been a big part of radio's work. When the war came this industry provided music to lessen fatigue and aid production for a home army of factory employees working long hours at frequently monotonous if vital tasks.

Now it has been revealed that a great naval installation, St. Albans Naval Hospital, St. Albans, N. Y., Captain Lester L. Pratt, commanding, is using a sound system for approximately ten hours a day as part of the regular hospital program. Recorded music, radio programs, newscasts and ceremonies from the hospital auditorium are piped to the boys lying in the wards waiting for injuries received in battle to heal. When the great invasions of Europe and Asia are over, there will be thousands and thousands of boys like these and undoubtedly the radio industry will play a big part in their return to health.

Decentralized System

Funds for the St. Albans sound system and its installation were donated by the National Council of Jew-

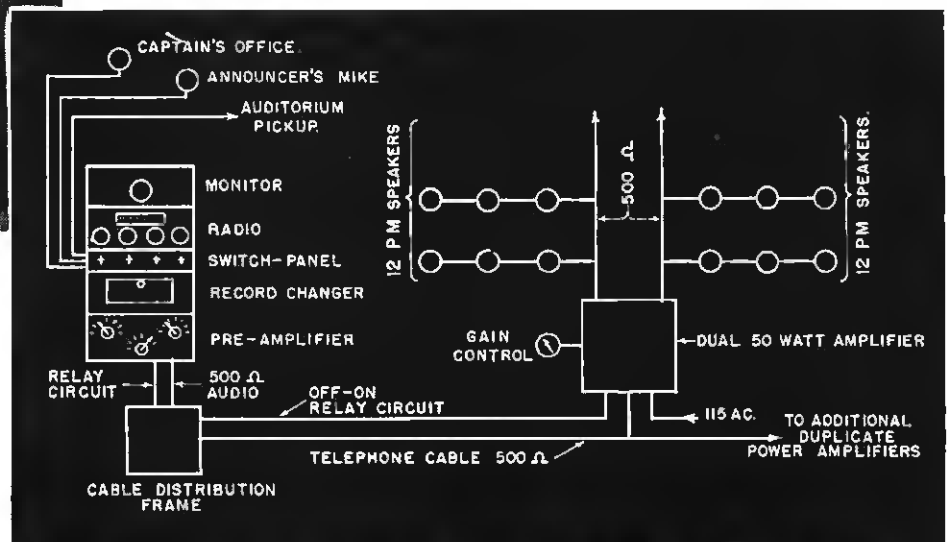

Upper left: A Wave selects first choice for daily recorded variety hour, while companion monitors control cabinet. Above: Sound system layout at St. Albans.

ish Women. The equipment was built by Stromberg-Carlson Company and tailored for the hospital's peculiar needs and installed by the McKee Electric Company, New York, N. Y., Stromberg-Carlson's sound equipment distributors. McKee Electric Company specializes in sound and private telephone installations. Gross Distributors, Inc., cooperated in the installation.

The hospital buildings sprawl over a wide area, covering most of a former golf course. The solution to the space problem was a decentralized system. A pre-amplifier was set up in the all-in-one control station in the administration building and twelve booster amplifiers were scattered throughout the wards and other buildings. These were connected with the control cabinet by telephone lines, which effected a great saving of copper wire.

The sound equipment for this in-

stallation is distributed throughout the buildings and is linked together through a telephone cable which was previously installed. The rack, shown in an accompanying photograph, contains from top to bottom: the monitor speaker, complete FM-AM radio, record changer, pre-amplifier and selector switch panel. The pre-amplifier input will handle two microphones and one phonograph or radio input channels. These channels can be separately controlled by mixer knobs on the front panel. A key-switchboard permits either the radio output or the phonograph pickup output to be connected into the low-gain channel of the amplifier. A microphone cable runs from the auditorium into the switch panel and to one input channel of the pre-amplifier. The other microphone channel can be connected to a local announcement mike. The output of the radio is taken from the second detector and fed to the

REHABILITATION

It Uses Equipment 10 Hours a Day, Aiding Recovery of the Wounded

pre-amplifier. The output of the pre-amplifier is connected back to the first audio stage of the receiver and the audio end of the receiver is used to drive the monitor speaker.

Remote Control

The output of the pre-amplifier which is 500 ohms, is connected to a main distributing frame which is in turn connected to a multi-pair telephone cable. This telephone pair supplies the inputs of twelve dual 50-watt power amplifiers which are located in the various buildings. Each of these dual amplifiers, supplied by Stromberg-Carlson Mfg. Co., drive 24 PM speakers. The input circuits of the dual amplifiers are in parallel while each channel on the output side



Ward patients move right up under loudspeaker to hear the news. Lower left: Equipment used in Purple Heart award ceremony.

supplies 12 speakers on a 500 ohm line. These speakers are mounted in small wooden enclosed baffles which are mounted on the wall in some cases and also in the center of wards.

The volume level on the telephone pair is held at 0 DB and the gain controls on each power amplifier are adjusted to give a very low volume level in all areas.

The power amplifiers can be switched off and on from the pre-amplifier rack by the operator. An additional pair of lines running parallel with the audio circuit supplies low voltage AC to operate a relay at each amplifier to switch it off and on.

A typical ward is approximately 30 ft. wide by 130 ft. long with 11 ft. ceiling. This area is covered by three 8 in. PM speakers mounted in wooden baffle cabinets.

(Continued on page 50)



Decca's Hildegard is heard weekly over the NBC network in "Beat the Band." Lyon & Healy's window in Chicago capitalizes on her characteristic grace with a vertical display and background of classic simplicity.

Continuing to record original casts of current shows and moving pictures, Decca comes up with selections from the MGM musical "Girl Crazy" in their album No. 362, released April 6th. The long-popular melodies of George and Ira Gershwin in this score are given new zest and appeal by Mickey Rooney and Judy Garland in such numbers as "I Got Rhythm," "Bidin' My Time," and "Embraceable You." Cover design is an eye-catcher in bright yellow and orange that reflects the western sunshine in MGM's technicolor movie.

Promotions for the Merry Widow album (No. 364) present a symphony in mauve and include cover blow-up, streamer and counter piece, together with newspaper mats for dealer advertising.

Other attractive sales pieces available on Hildegard recordings in purple and blue have a distinctly continental flavor. One is especially designed to promote "I'll Be Seeing You" and "They're Either Too Young or Too Old," No. 23291. Bing Crosby is also represented in a snappy red and black on white

streamer featuring him in "Poinciana," No. 18586, and Jerry Wald's rendition of the famous tree song, No. 4433.

Not to be overlooked among Decca's current releases is disc No. 23317 of the Personality Series: Helen Forest (new Decca artist) and Dick Haymes singing "Long Ago (and Far Away)" from the Columbia picture "Cover Girl."

Decca dealers can look forward to an album recording of the "Carmen Jones" original cast, a New York musical currently hitting top figures at the box office. In it an all-Negro cast renders the original Bizet score, with modern lyrics by Oscar Hammerstein II. Another forecast is Ethel Smith's recordings of Latin American rhythms on the organ. Miss Smith, recently signed with Decca, will appear in the MGM picture "Mr. Co-Ed."

Columbia's extended promotion of artists' personal appearances and concert engagements adds greater sales impact for dealers to this form of record advertising. If you have not

TIE-INS

Artists' Persona
Moving Pictures

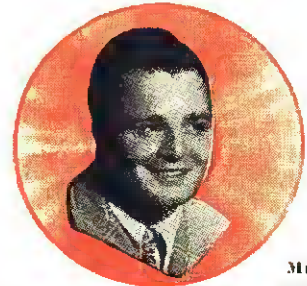

Music-craft's
Phil Brito—tours the Service Camps

already done so, check with your distributor for receipt of this fuller information about artist tie-ins. Extra dealer sales promotion is now available in this connection and your alertness to this offer should reflect in added sales. Ask your distributor about Columbia's Artist Tour Promotion Service for Masterworks, Popular and Okeh artists.

Rich in appeal is one of Columbia's Masterwork offerings this month: Beethoven's Symphony No. 9 in D Minor, Op. 125, Felix Weingartner conducting the Vienna Philharmonic Orchestra and Vienna State Opera Chorus (Set M-MMM-227). This is a natural for promotion to library builders.

In contrasting vein is Columbia's Xavier Cugat's Mexico Album (Set C-98) which includes the popular "Mexican Hat Dance" and "Cocinito."

Columbia's Harry James' recording of "I'll Get By" (No. 36698) has been recently highlighted by the success of the moving picture "A Guy Named Joe." Available April 3rd was No. 36699, Benny Goodman and his orchestra in "After You've Gone" and "At the Darktown Strutters' Ball." No. 36693 offers Ginny Simms with vocal chorus singing "Suddenly It's Spring" and "Irresistible You."

Victor's outstanding movie tie-in of the month is with Universal's film, "Follow the Boys," slated for release April 7th. Jeanette MacDonald sings "I'll See You in My Dreams," Charlie Spivak and his orchestra give out with "Besame Mucho," and Dinah Shore hits the high spots with "Mad About Him Blues." This last is included in her Smart Set album

for Record SALES

Appearances, Broadcasts, Shows, Concerts Are Display Helps for You

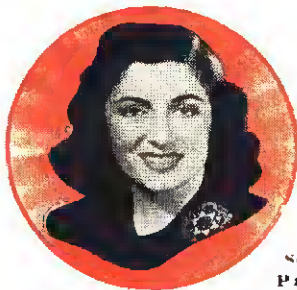

Sonora's
Pauline
Alpert—broadcasts over Mutual



Capitol's
Jo Stafford
—on national network programs



Hit's
Cootie
Williams—makes personal appearances
in vaudeville

April Library Builders

Symphony No. 5 in E Minor
(New World)—Dvorak
Lt. Kije Suite—Prokofieff
Double Concerto—Brahms
Quartet from Rigoletto—Verdi
Victor Herbert Melodies



Radio Centre, New Haven, Conn., takes advantage of artist-tie-in for display in conjunction with the Don Cossacks' concert appearance in that city.

"Musical Orchids." Jeanette MacDonald also sings "Beyond the Blue Horizon" in this picture, and Victor is re-issuing her recording of this song (Victor No. 22514).

The Victor broadcast tie-in of this month is with the Boston Symphony's weekly nationwide broadcast—Saturdays, 8:30 P.M., ETW, on the BLUE network. An 18" x 24" poster featuring the program is supplied by the radio sponsor, Allis-Chalmers Co. Victor offers as a companion piece the 15" x 20" 4-color poster of Serge Koussevitzky, orchestra conductor. In addition, national advertising by the Allis-Chalmers Co. is featuring the broadcast tie-in with Victor records.

One of the better escapes from war's grim reality is the movie, Walt Disney's "Snow White and the Seven Dwarfs." Recently revived in a 50-

city "premiere," it was so well received in Ohio that Governor J. W. Bricker declared the week of February 24 to March 2nd as Snow White Week in the state. Check with your local theatre manager for dates, and your stockroom for Victor set J-8!

● Speaking of musical weeks, don't forget that the 21st observation of NATIONAL MUSICAL WEEK will be celebrated this year from May 7th to May 14th. Its current theme "Music to Foster Unity for the War and the Peace to Follow" is expected to stress the music of Latin American countries, as well as our own. Allied Nations' music may also be included, and the possibilities for window displays are unbounded, as are the tie-ins with the celebrations by churches, schools, libraries, service clubs and

(Continued on page 82)

Victor's sample window display for use in connection with the radio broadcast and Red Seal recordings of the famous Boston Symphony Orchestra.

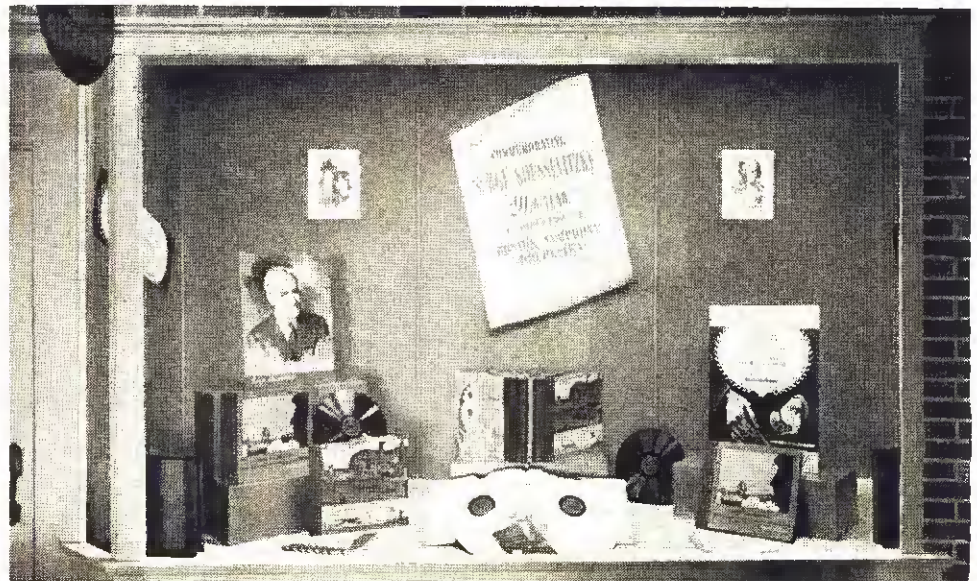



Volume in Disc Sales

R. L. Wallace, left, manager of Oldendorf's Music House, Mt. Carmel, Ill., transacting 1000-record order from G. V. Rockey, vice-president of Meissner Mfg. Co. Mrs. Wallace, center.

Record Store Manager Gives His Public What It Wants Studies His Community for Merchandising Angles

• Recently this publication was asked to give an opinion on what should be an average year for sales of records by a store in a community of 7,000 population. With our tongue in our cheek and without taking into account the variables in merchandising, such as trading area involved, buying power of the respective communities, etc., we estimated conservatively that the local music store manager in such a town should do about \$2,000 worth of record business annually. If he is doing double or triple that total, we said he is doing a "terrific" job.

Here is the story of a small-community music store that is doing a "terrific" business in recordings, by any standard of measurement.

Just before Christmas, a phone call came to R. L. Wallace, manager of Oldendorf's Music House in Mt. Carmel, Ill. The caller asked Wal-

lace how he would like to take an order for a thousand records, most of them to be classical music. Wallace said: "You're not kidding me—I can take your order, and what's more, I can deliver—today!"

Advantage of "Complete Stock"

This singular conversation, remarkable as it was, is somehow characteristic of Oldendorf's. No demand for records, popular or classical, seems to stump Dick Wallace. If he doesn't have what you want, he can get it for you tomorrow (or perhaps, day-after-tomorrow, now that there's a war on), but nine times out of ten he'll have what you want. That's the way it was in December when the Meissner Mfg. Co., radio manufacturer and Mt. Carmel's largest industry, came to Wallace with an

order for a thousand records which the firm wanted to donate to Mt. Carmel High School. Wallace not only took the order in stride, but he actually delivered over 900 of the records from his own stock. These records—98 per cent classical—included symphony orchestras, bands, string ensembles, choral groups, and vocal and instrumental solos.

Not large by comparison with similar stores in larger cities, Oldendorf's at Mt. Carmel has built a unique reputation in sales of phonograph records over a period of many years. The store itself was established by Charles Oldendorf as a combination music and book store, in 1890, dealing in pianos and organs as well as in books and stationery. Eventually, the book and stationery department was abandoned. Phonograph records have been stocked from the earliest days

(Continued on page 110)

MUSIC TO YOUR EARS...

When postwar sales of Home Recording—Radio—Phonograph combinations get back to normal you will want to offer your customers a NEW RECORDIO. Well, you will be able to do just that, for Wilcox-Gay will have ready a new, more sensational RECORDIO. That will be music to your ears!



WILCOX-GAY CORPORATION
CHARLOTTE, MICHIGAN

Manufacturers of the Recordio, Famous Home Recording-Radio-Phonograph Combination

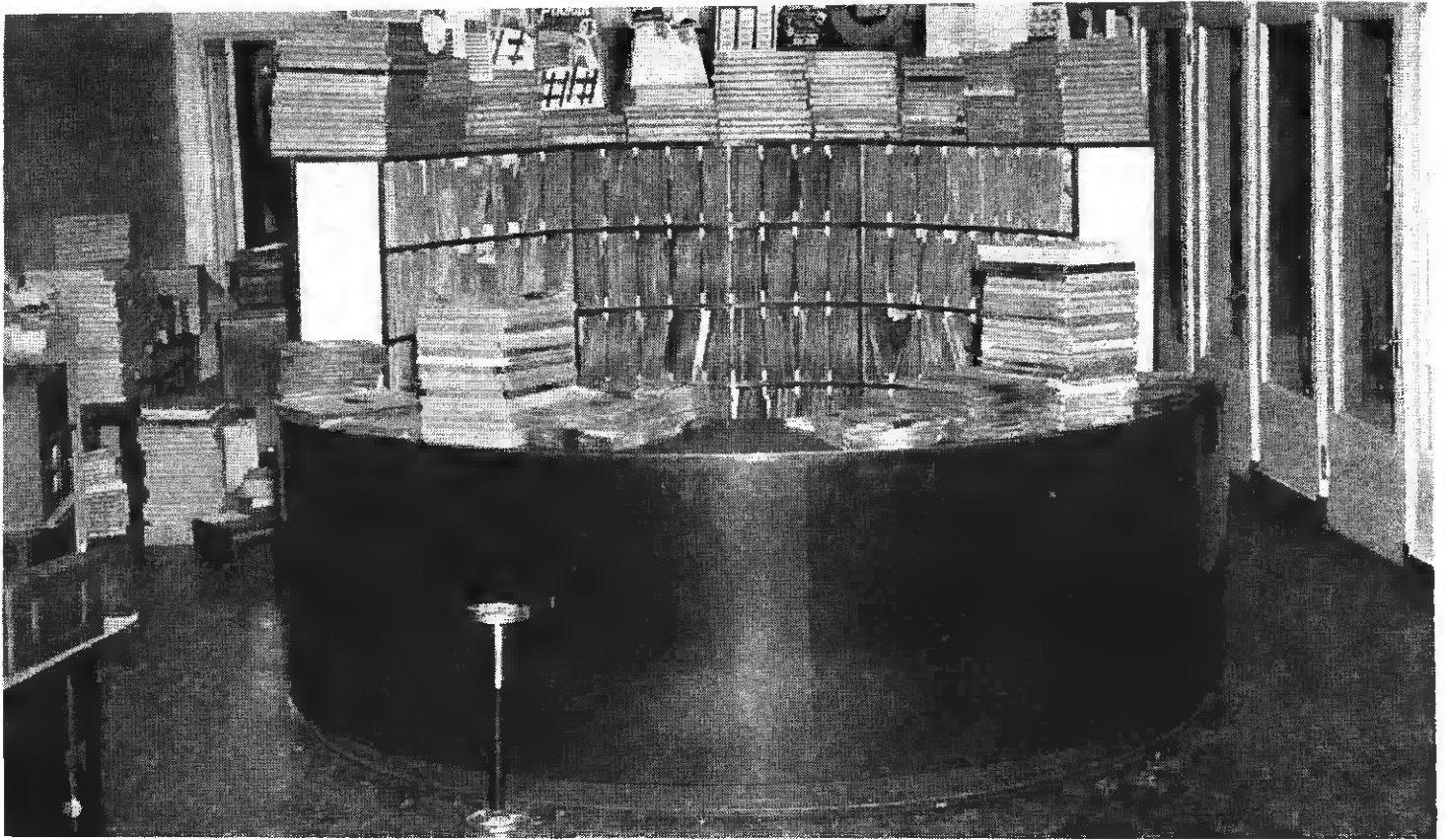

"RECORD BAR"

One-woman Shop Beats Help Shortage with Unique Display

• A unique and most successful music establishment is that run by Mrs. Amelia Rosenstein under the name of The Radio & Record Bar at 519 N. Howard St., Baltimore, Md.

The record "bar" is an ingenious arrangement designed and built to make record merchandising easier for its owner, who operates the shop without further sales help. It is the only shop of its kind in the city operated by a woman.

Step-saver Display

Occupying almost all of the center of the store, the record bar consists of a semi-circular arrangement of record racks. This arrangement, designed to make it easier for Mrs. Rosenstein to serve her customers, does just that. Standing behind the bar, she is able to reach the semi-circular record rack, back of her, and easily procure the requested disc. There is no back-wall shelving in the shop. All records are kept at the "bar", either in the semi-circular rack arrangement, or on the bar in front of the clerk. Customers, if they wish, may select records.

Mrs. Rosenstein is well equipped for her work by experience gleaned from the number of years she had

been associated with her late husband in the music and radio fields. Upon the death of her husband, Mrs. Rosenstein was persuaded by her many friends in the city to keep up at least a part of the business, and the Radio & Record Bar was the result.

Hours Geared to Traffic

The store is opened at 8:30 A. M. daily, and remains open three evenings a week to accommodate the large and ever-growing clientele. The practice of department stores in keeping open one night a week attracts crowds to the shopping district where the Radio & Record Bar is located. Nearby motion picture theatres and a bus terminal also add to the floor traffic of this shop.

With no new radios available, records are the major portion of the business, with popular discs holding first place in sales. Albums run a close second only because they are slower in coming through than the single records.

Record players and phonographs are in stock, and an attractive display of these is featured in the large and beautifully arranged windows across the entire front of the store. Current

radio stock is small. Record cabinet and other record accessory sales are helping to supplement the general volume of business.

The record supply is good, considering the limitations of the times. Like every other retailer, Mrs. Rosenstein's supply is subject to "allotment," but in the overall picture the stock has been consistently satisfactory and continues to be so. Six listening booths are provided for patrons to hear the new numbers.

Supplemental items include novelty lines, arranged in a display case near the door. Greeting cards, soldiers' money belts and kindred articles, while not large in sales volume, add to the intake.

Contacts Distributor

Mrs. Rosenstein is constantly on the alert for merchandise, shops her distributors frequently to keep her stocks well supplied, and finds the jobbers cooperative. They recognize her enterprise and in turn give her good service.

Hats are off to Mrs. Rosenstein and her Radio & Record Bar in Baltimore, and she is rated highly by her competitors in the field.



JUST RECORDED

All the Favorite Selections from
Broadway's Brilliant Revival

THE

MERRY WIDOW

with

**KITTY CARLISLE • WILBUR EVANS
FELIX KNIGHT • LISETTE VEREA**

The Merry Widow Orchestra
and Chorus

Directed by ISAAC VAN GROVE

DECCA ALBUM DA 364
COMPLETE ON SIX 10" RECORDS



Selections Include:

- OVERTURE
- IN MARSOVIA
- MAXIM'S
- FINALE OF ACT 1
- DOWN IN DEAR MARSOVIA
- VILIA
- WOMEN
- LOVE IN MY HEART
- FINALE OF ACT 2
- THE GIRLS AT MAXIM'S
- I LOVE YOU SO
- (The Merry Widow Waltz)
- FINALE

LIST \$5.00
not including
Federal, State
or Local Taxes

Available Now

ORDER FROM
YOUR REGULAR
DECCA BRANCH.



DECCA

DISTRIBUTING CORPORATION



Dover Delivers

No New Radios Left, But Servicemen Keep Sets and Appliances Working!

• There isn't one new radio for sale in Dover, Del., but there are enough skilled radio technicians to keep the sets playing in this city of approximately 6,500 people.

Plagued by the present tube, battery and transportation situation, the servicemen here are hard put to get the work out, but they are doing a big job—and doing it well.

Early in the war, Dover lost some radio shops, but today sees about the same number as in normal times, possibly a few more, according to local radiomen.

The ten-year-old Cosden-Evans Co. on South Bradford Street, specializes in three fields today—radio servicing, records and juke boxes.

Juke Box Service & Record Sales Good

O. A. Evans, the owner, supervises the business in general. Mrs. Evans manages the busy record department, and J. H. Farlow is service manager. Two part-time men are employed, and a high school youth does much of the outside juke box maintenance, performing his duties on the automatic music machines "one hundred per cent", according to Mr. Evans.

Operating the only independent record business in Dover, Cosden-Evans Co. finds disc sales are booming, with the demand for populars and classics about evenly divided. A public address system plugs the sale of records. The speaker is mounted over the store's entrance.

In common with other Dover radio shops, radio repair prices are reasonable. Cosden-Evans Co. finds its repair jobs averaging between \$3.85 and \$5.00. About a third of the sets brought in are battery-operated. The firm does not pick up or deliver work, and does not repair auto radios.

When Cosden-Evans Co. finds circuit-changing the only solution to a repair, the serviceman uses a rubber stamp to print the change made. A rubber stamp printing outfit is employed for this purpose, and the no-



Service manager J. H. Farlow of Cosden-Evans Co. tackles a tough one

tation is conspicuously printed on the set chassis.

Fred W. Erdle has re-opened his shop on So. Governor's Ave., and is now turning out between 25 and 30 jobs a week. About a quarter of these sets are battery-operated.

Erdle Active

Mr. Erdle's shop occupies a building in the rear of his father's watch-repairing establishment. The Erdle radio shop is equipped with the latest test apparatus, and was laid out to provide the utmost efficiency in servicing. Ceiling prices are prominently displayed here. Every customer is given an itemized bill.

In the radio business for ten years, Mr. Erdle has been a National Youth Administration radio supervisor, and a senior radio mechanic for the War Department. He also holds a first class radio telephone license, a second class radio telegraph license, and a Class A "ham" license, W3JNU.

Appliance Maintenance

Earl W. Humphrey, who owns a business on So. Bradford St., founded

22 years ago, is putting in long hours taking care of electrical appliances, oil burners, electric ranges, refrigerators, etc. Well known for the large appliance and radio sales enjoyed by his firm when merchandise was obtainable, Mr. Humphrey has ambitious plans for the postwar period, but in the meantime has practically nothing left for sale in his showroom. He is capably assisted in maintenance work by Millard Biddle.

Appliance Sales High

A short time ago, Mr. Humphrey operated as an electrical contractor, but due to lack of help, was forced to drop this phase of his business. He is attempting to service all of the major and minor appliances he has sold customers, and much new service business is coming his way also. Dover, he reports, is a good community for appliances sales, and despite its comparatively small population, has, according to Mr. Humphrey, over three hundred electric ranges now installed, as well as a large number of refrigerators and oil burners.

Fred W. Erdle works in his recently re-opened shop



TODAY

Philco war research is creating new knowledge and skill for the finer Philco products of tomorrow . . . in radio, phonographs, television, refrigeration and air conditioning.

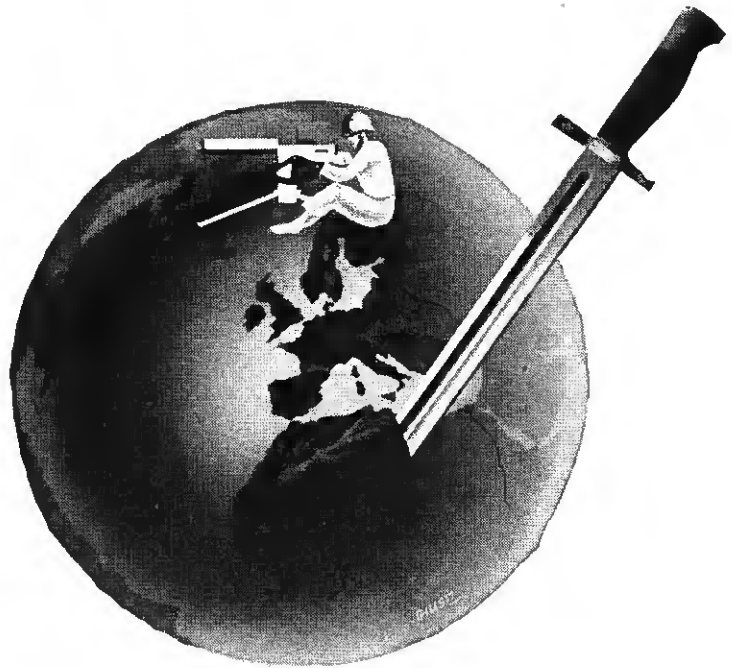

TOMORROW

Philco leadership in engineering, merchandising and promotion will bring new joys to the homes of America . . . and new opportunities for profit to Philco dealers everywhere!

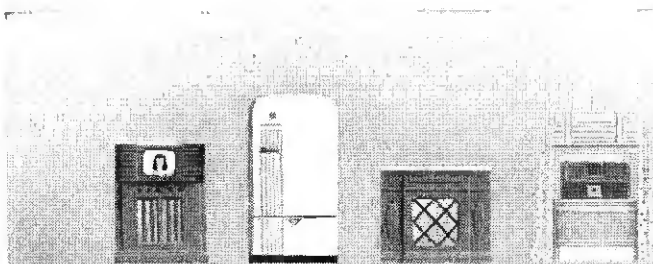

Tune in the RADIO HALL OF FAME, Sundays, 6 to 7 P. M., EWT. Blue Network. The Top Hits of the Show, World, each week.

PHILCO
CORPORATION

BACK THE ATTACK — BUY WAR BONDS

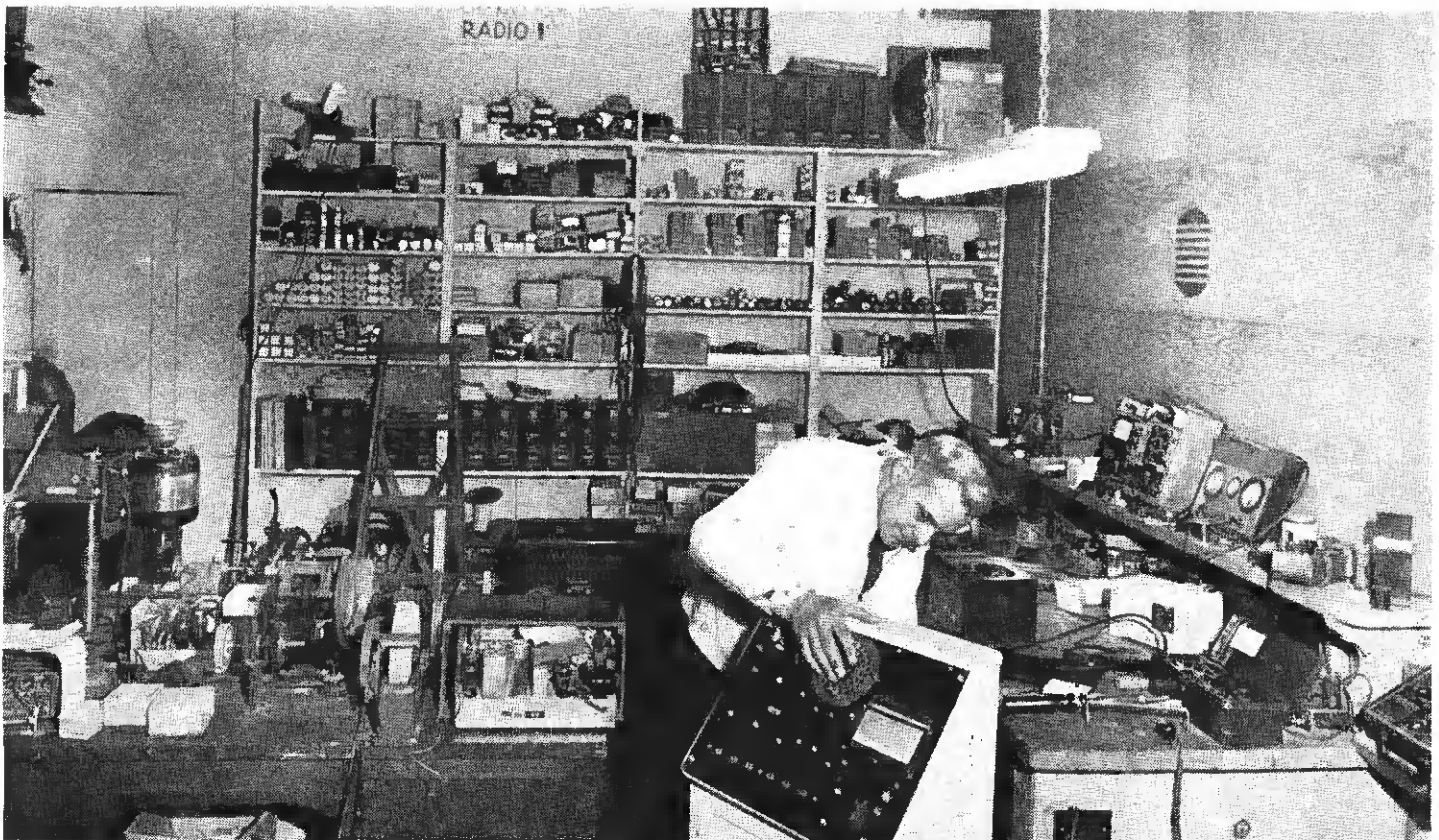

Henry Galbreth, owner of Abington Radio Service, puts finishing touches on reconditioned diathermy oscillator.

Electronic Service

Radioman Finds Profits in Medical and Dental Electronic Repair

• A continuous student of electronics for the past thirty-odd years, Henry Galbreth, owner and operator of Abington Radio Service, 300 Fulton Ave., Hempstead, N. Y., does a lot of electronic equipment maintenance, and specializes in the hospital and dental fields.

In these days when war equipment must take precedence over civilian parts supply in the radio and electrical fields, when even minor replacement parts orders are met with total refusal by the manufacturer, there is money to be made by the radio technician in this kind of repair work, Mr. Galbreth believes.

All kinds of electronic medical apparatus, such as diathermy, x-ray and violet ray machines in doctors' offices and hospitals, and a number of dental units, too, have been in many instances neglected by the skilled radio technician.

Mr. Galbreth suggests that the able repair man interested in devel-

oping this kind of clientele contact the various hospitals and surgical supply houses—as well as the doctors and dentists in his neighborhood. The field is most unlimited, he continues, and, to be very frank, he believes, far more lucrative than the average radio repair.

Maintenance Requirements

The requirements for this electronic work are listed below as outlined by Mr. Galbreth.

- 1) Prerequisite is a complete knowledge of electrical and electronic fields in general;
- 2) Utmost precision in materials and workmanship are paramount factors;
- 3) Promises to medical institutions and individuals that are not going to be kept should be definitely refrained from, if this business is to be retained after the war. This is particularly

true, inasmuch as these people have dealt with the factories previously, and have been driven only by necessity to the extreme of soliciting the services of repair shops.

In obtaining and holding contacts in the work, personal confidence is important. Many of the most skillful surgeons, doctors or dentists are definitely not technical-minded and have very little ability in this line. They like to be able to rely on an able technician for the smooth running of their office equipment.

Mr. Galbreth also does much work for the water companies in his district. Pipe-locating "finders", composed of an oscillator and a receiver, are frequently in need of servicing and continually require attention. Since the majority of the manufacturers of metal locators are on the west coast and factory repairs take that much

(Continued on page 66)



on the threshold of a new Era!

This is an "Electronics" war! Radio and electronics are writing a most vital chapter in the history of modern warfare. Many of the new developments in electronic tubes are military secrets, but in the postwar period the whole world will benefit by the tremendous strides in the engineering achievements and manufacturing methods born of military needs.

Yes, the foundation is being laid *today* for the glorious peacetime era of electronic achievement that will begin on that *tomorrow* when victory is assured. Then, as now, Raytheon will supply electronic tubes with the "Plus-Extra" performance qualities that have built the Raytheon reputation over the years.

When the Peace is won, Raytheon, due to its unique wartime experience, will be better qualified than ever before to supply manufacturers of postwar radios and of industrial electronic equipment with electronic tubes for the most exacting applications.

Raytheon Production Corporation

Newton, Massachusetts • Los Angeles • New York • Chicago • Atlanta



All Four Raytheon Divisions Have Been Awarded Army-Navy "E" Plus Stars

RAYTHEON

High Fidelity
RADIO & ELECTRONIC TUBES



DEVOTED TO RESEARCH AND THE MANUFACTURE OF TUBES FOR THE NEW ERA OF ELECTRONICS

Sound in Rehabilitation

(Continued from page 39)

Two hundred loudspeakers serve the 72 wards, administration buildings, nurses' home, Waves' dormitory, hospital corpsmen's dormitory, laundry, shops and auditorium. Re-entrant projectors of 360 degrees coverage are hung from the ceiling beams of the huge mess hall. There are no headphones anywhere on the system.

There are no individual circuit switches on the system as that would nullify its use in any emergency such as a fire or an air raid. Each amplifier can be cut off from the group, however, and sometimes is if a ward has a patient just back from an operation.

Broadcasts can be made from the central control station, from the office of the commanding officer, Captain Lester L. Pratt, and from the 750-seat auditorium. A special pick-up circuit carries programs from the auditorium back to the main station, while a special switch and relay circuit ready for any emergency connects the skipper's mike with the station.

Operation of the equipment is fairly simple. Wave Ensign Emilie Placatka is program director, assisted by several Waves and sailors, who stand the various watches at the control cabinet while programs are going on. This watch duty consists mostly of switching the controls from radio to

phonograph or turning the radio dial from one station to another as scheduled programs change on the half or quarter hour.

Volume throughout the hospital is kept at a low level, but if special announcements are to be made, the level is raised from the control center. About every two weeks Ensign Placatka checks up on volume.

During an average day of nine and three quarters hours "on the air" the entertainment system provides the patients with nine hours of music, interspersed with three five minute newscasts from radio stations and three fifteen minute news commentator programs. The hospital entertainment starts at 10 A.M., takes a recess from 12:30 P.M. to 2 P.M. (1400 Navy time) and then runs until 9:15 P.M.

Request programs are tops with the boys in the wards. Three mornings a week a 15 minute request program from the auditorium organ is featured. Once a week the hospital orchestra obliges with a half hour request program and five times a week the boys get a full hour of request numbers from the control station record player. Every Thursday from 3 to 4 P.M., or from 1500 to 1600, WQXR devotes "Your Request Program" to the patients at St. Albans. The balance of the programs are broadcasts from the New York area.

When John Wanamaker was once asked what he would be if he could live his life again, he replied:

"I would be a merchant. Why would I be a merchant? Because I know of no better school in which to learn the world, its laws, customs, products, geography, and financial methods, and at the same time serve your city and nation and give education and earning power to the people associated with you, that they may live successful lives. It is a great thing to show people how to work and teach them to live it, and how to honor and advance themselves by honest methods."

Home Appliance Merchants

(Continued from page 37)

the service manager, and here his reports are completed, and then sent to the accounting department.

In addition to insisting that only the best and most careful service be given each set, the management requires employes to see that each receiver is immediately classified—that is, an estimate must be given the customer at once, or if this is not required, the set must be put into the production line.

The versatility of the servicers here, and the efficiency of the repair system, is testified to by the fact that when RADIO & TELEVISION RETAILING reporter called there, Temple of Music had only three radios "tied up" for either lack of parts or lack of classification—and the firm does work for a number of dealers, as well as for their own large retail clientele.

Temple of Music Stores, Inc., was founded in nearby Lynbrook in 1926. Herman S. Busloff is president, Albert I. Sirota, vice president and general manager. Mac Marans is manager of the Rockville Centre store. Sol Busloff operates the Hempstead branch and Mac Sterns is the manager at Freeport.

Foresight in choosing a location has paid dividends to this firm. Seeing that a number of large chain grocery stores were establishing themselves on Sunrise Highway, despite the fact that at that time there was very little foot traffic in the vicinity, Temple of Music opened at their present location, No. 278. Today, foot traffic is very heavy, and in normal times, many cars pass the door, with most of the latter being operated by nearby residents.

NAMESAKE



A bomber is named for the musical, "Winged Victory," so successful on New York's Broadway. Members of the cast witness the event at Mitchel Field. Decca has recorded the original cast and orchestra in several hit tunes from the show. (Album No. 363)

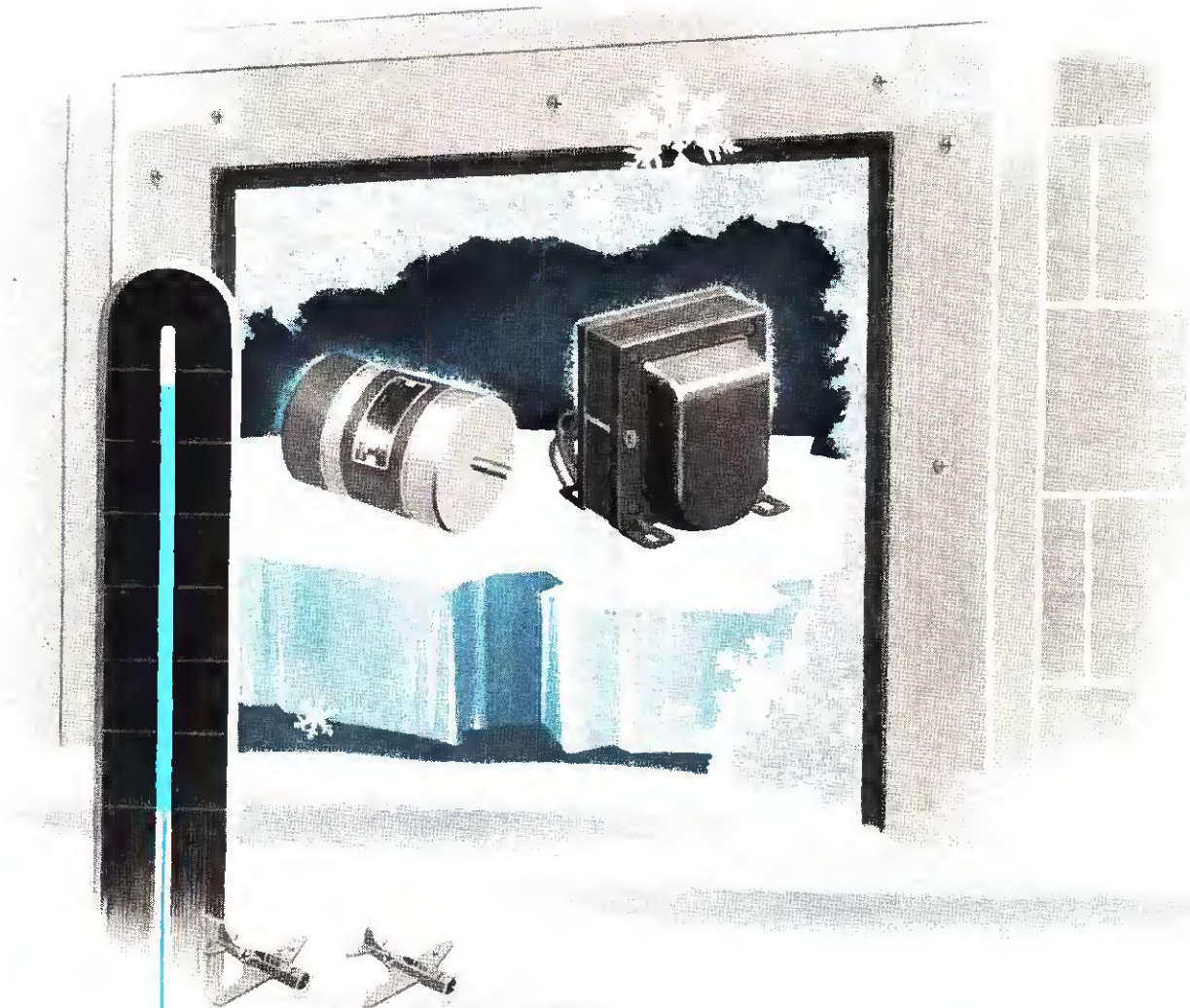

140° cooler inside

There is a piece of the stratosphere just beyond that glass door. The air pressure is less than one-fourth of normal air pressure. And the temperature is 70 degrees below zero.

The Utah parts being tested are proving that their performance will be "as specified," whether they are to operate on the ground or high in the air.

This and other tests which parts undergo in the *complete* Utah laboratory are particularly important in adapting the new electronic and radio developments—in making them militarily and commercially usable—now, and tomorrow!

★ ★ ★

Every Product Made for the Trade, by Utah, Is Thoroughly Tested and Approved

utah

Radio Product Company

Chicago, Illinois

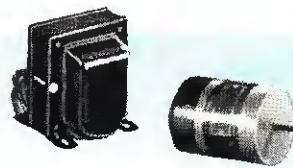

Keyed to "tomorrow's" demands:
Utah transformers, speakers, vibrators,
vitreous enamel resistors, wirewound controls,
plugs, jacks, switches and small electric motors.



"Beach 3 Calling Fire Control 3 ... pinned down by pillbox on right flank!"

★ Landing parties must depend on supporting fire from ships off shore until their own artillery can get into action. By radio communication the Navy's fire is brought instantly to bear on enemy strong points holding up the advance.

When the Marines carry out the tough landing operations for which they are noted, Walkie-Talkies are among the first ashore. *They must get the messages through!* For unfailing power, many depend on *E·L* Vibrator Power Supplies.

Wherever reliability is a "must," *E·L* Vibrator Power Supplies are also proving their other advantages of light weight, small size and high efficiency. They are products of the most extensive research in vibrator power supplies and circuits ever known.

That research has extended the scope and usefulness of vibrator type power supplies beyond all previous conception. Certainly, in the electronic era of peace to come *E·L* Power Supplies will contribute new advances and economies wherever electric current must be changed in voltage, frequency or type.



Electronic
LABORATORIES, INC.

E·L ELECTRICAL PRODUCTS — Vibrator Power Supplies for Communications . . . Lighting . . . Electric Motor Operation . . . Electric, Electronic and other Equipment . . . on Land, Sea or in the Air.



Power Supply using rechargeable, non-spill storage battery for operation of Walkie-Talkie radio equipment. Input Voltage: 4 Volts D.C.; Output: Numerous Voltages, supplying plate and filament requirements of the equipment. Width, 3½"; Length, 6½"; Height, 4½".





Pauline Alpert IN A NEW ALBUM OF PIANO MELODIES

Pauline Alpert takes a piano apart. She babies it, she scolds it, she makes it stand up on its sounding board and holler "Auntie"—and she does it with a mastery that foretells big business with SONORA's Piano Melodies Album. The kind of business any dealer would welcome. Here is classical skill in modern tempo at its peak.

That name SONORA is important. It means that Miss Alpert's deft interpretations live and glow with all the brilliant bell-like clarity of tone for which SONORA Records are noted.

This Album of Piano Melodies is another sure-fire hit in the sensational parade of new, recently recorded SONORA Albums

included in Series E of "Melodies That Will Live Forever". Intensive advertising in leading national magazines is building eager demand for all SONORA releases. Be sure to get the full list of SONORA Albums from your SONORA Record Jobber.

Pauline Alpert Album of Eight Piano Melodies

*Dream of a Doll • Chopsticks • Where or When • Sweet Sue
Hungarian Rhapsody No. 2 (Liszt) • In a Country Garden
Toy Trumpet • Parade of the Wooden Soldiers*

SONORA RADIO & TELEVISION CORP.
325 North Hoyne Avenue • Chicago 12, Illinois

Sonora Records

Clear as a Bell

SWEEP CIRCUITS

Saw-tooth oscillator vacuum tubes in place

• Those who have followed the evolution of cathode ray sweep circuits from a simple RC circuit with a neon lamp, to the modern scanning circuit in a television receiver, know of the advances made as to linearity and ease of synchronization. However, in oscillographic work the tendency is to base circuits around the characteristics of a gas-filled triode, such as a thyratron. The equipment in such an oscillator is rather simple, but the characteristics of this type of discharge tube are altered with voltage, temperature, magnetic fields, etc., so that a permanent calibration is not possible. Also at this time, thyratron replacements are not easy to take care of, and when a tube burns out a makeshift plan is usually resorted to.

Saw-Tooth Oscillator

Numerous circuits have been developed using vacuum tubes in this role, but it generally is found that more tubes are needed to do the job. From an economy standpoint this is not important, however, since the overall cost of several vacuum tubes is usually less than a single gas-filled triode. In converting from a thyratron to an equivalent circuit with vacuum tubes, it is well to remember the two basic characteristics of a thyratron that must be duplicated:

- 1 The tube has substantially infinite impedance for all values of grid voltage up to that value which starts the discharge.
- 2 This impedance falls to a fixed low value when the discharge occurs and remains there until the plate voltage is removed.

A typical time-base or "sweep" circuit is shown in Fig. 1, using a thyratron tube D such as the 884. In this conventional saw-tooth sweep circuit, a capacitor such as C is charged, preferably by constant current, to a voltage which will "breakdown" a gas-filled tube as D. The capacitor is quickly discharged through D until the voltage across C can no longer maintain ionization in the tube at which point the discharge stops and C begins to recharge.

The voltage across C will have a saw-tooth wave shape if C is allowed

to charge to about 1/7 of the full supply voltage. The addition of a pentode as at A in Fig. 1, allows the capacitor C to charge at a constant current rate which further improves the linearity of the saw-tooth wave.

The conventional gas-filled sweep tube will "breakdown" when the grid bias and plate voltage have the correct relationship. In Fig. 2, the characteristic curve for a type 884 thyratron is shown. As the grid is made more negative, the plate voltage must increase to reach the "breakdown" point. By altering the grid bias, the

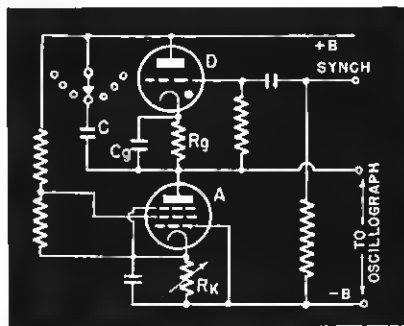

Fig. 1—Basic gas-filled triode saw-tooth oscillator with constant current regulating pentode A for keeping voltage rise across C linear with time

voltage to which C will charge may be changed.

In Fig. 3, a high-vacuum triode, such as a 6J5 may be plugged into the same socket, but another tube B such as a 6SJ7 pentode, must be added to give this 6J5 tube the characteristics of a thyratron. A useful circuit, Fig. 3 is in wide use in Great Britain for both oscillographic and television applications, developed by the A. C. Cossor Company.

Vacuum Tube Circuit

Here, when the tubes are heated up and the capacitor C is just starting to charge, the resistor R_p , in series with the internal impedance of the pentode B, together form a bleeder across the supply, so that the point X is at a definite potential, say 200 volts, which is at the midpoint of the supply potential assumed.

At this time, therefore, the grid of the tube D is 200 volts "down" from the positive point. At the start of the

charging interval the voltage across the capacitor C, is low and the cathode of tube D, therefore, is but a few volts below the positive point. Tube D, therefore, is nonconductive, since its grid is much more negative than the cut-off point. Ultimately, however, the voltage across the capacitor C reaches a value great enough to equal whatever bias is on tube D and plate current will start to flow.

Before this happens, the capacitor C_1 , will have become charged to the whole voltage of the B supply. However, as soon as a voltage drop appears across the resistance R_x , C_1 loses some of its charge, and current flows in the resistor R_2 in a direction that makes the grid of the tube B more negative. This reduces the current through R_p and tube B bleeder combination, and the potential at the point X goes positive by a substantial amount. Tube D, therefore, becomes conductive quite rapidly and (the action being regenerative) an extremely high positive bias appears on the grid of tube D. The capacitor C, therefore, discharges quite rapidly through triode D.

Constant Current Charging

Therefore, this triode D is directly equivalent to a thyratron since it rapidly changes from a nonconductive condition to a good conductor. As soon as the capacitor C has discharged, the initial state of affairs is restored, and the cycle of events starts over again. The pentode combination of tube A produces the constant charging current effect necessary to give linear saw-tooth waves.

The resistor R_p is made variable, as by this means it can be used to determine the charge on C that accumulates before the discharge and thus determines the amplitude of the sweep voltage. This adjustment also effects the frequency, an undesirable condition, but one that is found in the majority of oscillographic time base circuits.

The resistance R_k is the fine adjustment of the sweep frequency of the oscillograph or television circuit. It alters the charging rate of the capacitor C, whose capacitance is altered by a stepped frequency selector switch, the coarse frequency control.

Since a truly linear sweep on an

FOR OSCILLOGRAPHS

circuits using high of gas-filled thyratrons

oscillograph is a matter of great importance when in use in a laboratory, it is well to give some thought to other conditions which determine linearity. A pentode should be selected that has a set of plate characteristic curves as nearly horizontal as possible, and the circuit conditions must be determined so that the tube operation does not extend down into the nonlinear region.

As mentioned above, the pentode A acts as a constant current device. The complete theory by which this action occurs involves an analysis of

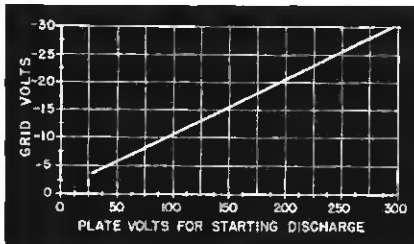

Fig. 2—884 and 885 thyratrons will conduct for any grid and plate voltage value on or below breakdown line

the electrons' habits inside the tube. The electrons emitted by the cathode are drawn away by the effect of the plate voltage and the screen voltage. With the screen grid at its normal positive voltage, its position near the control grid and cathode gives it most of the control over the electrons emitted from the cathode. The positive screen acts as an electrostatic shield between plate and control grid—cathode area. Variations in plate voltage have little effect on the quantity of electrons reaching that electrode, since the electrostatic field produced by the plate voltage does not

extend into the control grid—cathode region. The screen grid also eliminates any space charge in the control grid—plate areas in a pentode. The suppressor grid acts to repel secondary electrons given off by the plate due to bombardment. This secondary electron current (in the case of a tetrode) reduces the normal plate current and gives undesirable characteristics.

It is desirable that the drop across R_k be produced by a current which is more or less fixed. This can be done by sending the bleeder current through R_k in addition to the plate current. Thus it is noted that both R_p and R_k affect the frequency, whereas only R_p affects the amplitude. In order to completely isolate these dual functions, it is possible to couple a second variable resistance unit to the R_p control, connected to increase the current through R_k (which decreases the frequency) at the same time that the resistance of R_p is decreased (which increased the frequency). These effects follow somewhat different rules and the determination of a resistance R_p is a cut and try process.

Blocking Action

Improved results can be obtained with a circuit such as in Fig. 4, if the charging current to the capacitor C is cut off during the interval that the D tube is conductive. This is done by the addition of a capacitor C_k and the resistance R_g as in the sweep circuit of Fig. 4. The same change in potential that produces a negative change on the tube B here produces a similar negative change on the grid of tube A, putting the latter

tube also at its plate current cutoff point and momentarily stopping the charging current. Some improvement in linearity results from the use of a positive voltage on the suppressor grid instead of grounding it to the cathode.

Single Tube Circuit

It is to be seen that this circuit will equal the usual thyatron circuit in action, but in many oscillographs it will be difficult to find space on the chassis for locating an additional tube and its socket. The functions of tubes A and B can be combined in a single tube using the circuit of Fig. 5. This is quite similar to the circuit of Fig. 4 except that the grid of tube D is connected to the screen of the

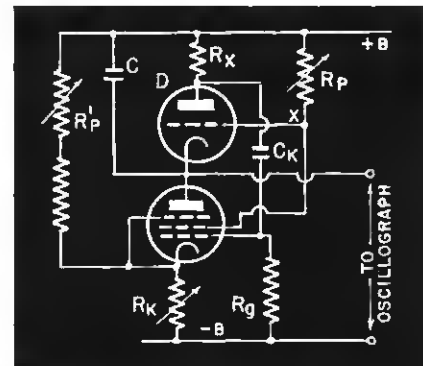

Fig. 5—Two tube version of circuit in Fig. 4. Tube D can be 6J5 and current limit tube, a 6J7 or equivalent

charging tube A permitting the elimination of the third tube B.

The operation of this combination is quite similar to that described for Fig. 3. It will be seen that the cathode, grid and screen grid of tube A, together, form a triode that produces the bleeder circuit that determines the potential of point X, which was referred to in a previous description. It is necessary to avoid using a screen by-pass-condenser on the pentode of this circuit which would absorb the sudden change in screen voltage that triggers off the discharge.

Radio frequency oscillations can occur in these circuits during the interval that the condenser is discharging, that is, during fly back time. The frequency of these oscillations depend on the inductance and capacitance of the condenser C and its

(Continued on page 62)

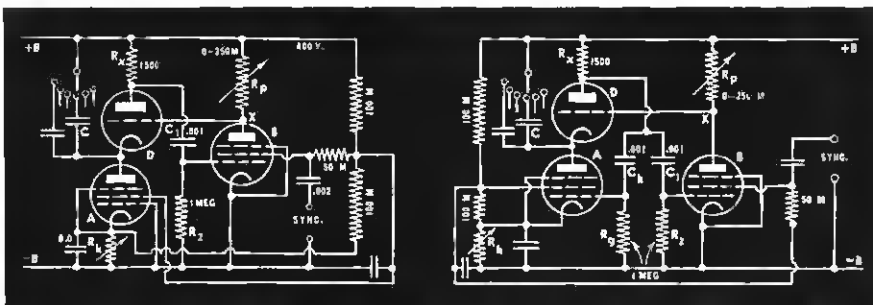

Fig. 3—Vacuum tube at D combined with pentodes A and B produce sawtooth oscillations. Output is available across tube A or capacitor C

Fig. 4—Improved operation of circuit of Fig. 3 is obtained by blocking tube A during discharge of C. Output available across C

RADIO TODAY—

(Continued from page 33)

been able to secure enough gas to make some outside calls, but tries to hold these down to a minimum.

Mr. Newman employs a 17-year-old youth as a servicer, and finds he works out very well.

AUGUSTA, Ga.—Pooser's, 318 9th St., owned by W. J. Pooser, Jr., has been in the radio business in this city for 19 years, and is now specializing in the repairing and sharpening of gardening tools for customers, as well as for resale. This firm requires customers to bring in their repair jobs.

Garden seed is displayed in the store for sale. Whenever a customer brings in a radio repair job that amounts to \$5 or more, 50 cents' worth of garden seeds are given free.

ROCHESTER, N. Y.—Kujawa suggests keeping visitors entirely out of the service shop. Customers are urged to telephone when their radio needs attention. The shop's service truck makes a twice-weekly pick-up, and delivery. All work is serviced at the shop. No credit. Payment is required in advance. No sets may be left or picked up at the shop. Serviceman advises customer one day before repaired set is to be delivered, so someone will be at home.

HOUSTON, Tex.—A limited, but a clean, volume is K. E. Krenzler's way of staying in the radio business and operating at a profit during this war period. Mr. Krenzler runs the Krenzler Radio Service, 2607 Bissonnet St. Although he does get repair work from all sections of the city, he has concentrated on building a solid business in his particular section. He explains, "I have a small organization, but a good one, and we would rather do a limited amount of work, but the kind that will stand up, than to try to hire just any mechanic that comes along and have to do a lot of repair jobs over. We still cling to the old-fashioned idea of giving the best kind of repair service that we can. Our come-backs are very few, and we are able to handle 85 per cent of the repair jobs brought to us. When we have to, we use a smaller or a larger condenser than the original circuit called for, but we can 'make-shift' and do all right.

"We are getting enough parts but not enough tubes. Fortunately, we used to buy, sell and trade a great many used radios, so we are still able to dig out a great many tubes that we can use, and we rewind a lot of coils. By making every possible effort to take care of our community business, we feel that we will be in a solid position for the postwar era."

SAN FRANCISCO, Cal.—A. C. Doughty, for seven years established at 5031 Geary Blvd., has just completed a thorough overhauling and modernizing of the store. This versatile firm offers radio repairs and service, an excellent assortment of records and sheet music. It also houses a circulating library, record accessories and a large variety of greeting cards.

PUNXSUTAWNEY, Pa.—Payne Radio Shop finds little except repairs to go on. Cecil Payne, back from the Army with a service disability discharge, offers an important repair wrinkle to other dealers.

High voltage type tubes are very short, but six-volt tubes are generally available, and filament transformers may be had from junk sets or in the market. Payne uses a small six-volt filament transformer, connected in parallel, for heater voltage. Thus conventional sets using 12SA7, 12SK7, 12SQ7, 50L6 or 35Z5 may be supplied with 6SA7, 6SK7, 6SQ7, 6V6 or 685.

Small output transformers can often be used across the AC line for the filament transformers.

ELGIN, Ill.—John Spalding, operating an appliance business here, is kept very busy these days. He handles radio and other appliance repairs and is working short handed. He has many radios ahead for repairs, some of which are held up for lack of tubes and parts. Customers are so anxious to have items such as washing machines fixed that they bring them to Spalding and call for them when finished. He offers no delivery service or call for repair whatever, except in the case of invalids.

The front office of this shop is neatly arranged with washer parts in special shelves. The same goes for radio tubes. A woman assistant at the counter handles incoming calls and tests tubes. This frees Spalding for repair work and speeds output.

This store has added Coolerators and lamps as new lines. The Coolerators did well last summer and Spalding hopes for good sales this year. Lamps sell well in all seasons.

BUFFALO, N. Y.—National Radio Service recommends carrying a stock of indoor games, retailing from 50c to \$2.50. It claims that indoor games can be played by families while listening to their radios (and uses this suggestion in its newspaper classified ads.) Indoor games are suitable for young and old. With gas and tires rationed interest in games has grown.



TEXARKANA, Texas—Melody Shop's window attracts record buyers with Capitol's talent in a streamlined and effective display.

NEW RCA TUBE GUIDE HELPS YOU SERVICE RADIOS FASTER

16-page Directory lists 304 RCA Receiving Tubes with over 2000 suggested substitutions

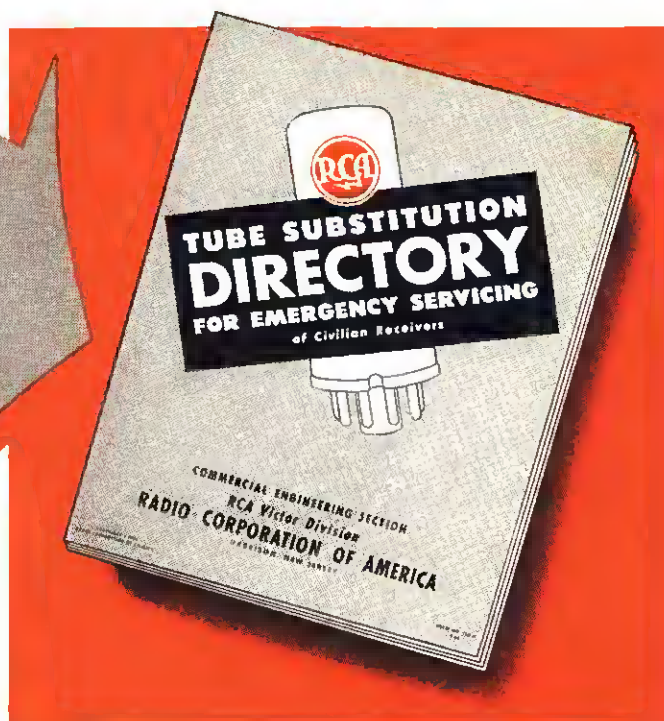

HOT off the press! The most complete Tube Substitution List ever issued by any tube manufacturer! Another great scoop for RCA Service Men and Dealers! Another timely RCA contribution — to help you use available tubes in place of hard-to-get types when you service civilian radio receivers.

With radio Service Men and Dealers, time means money. By showing you how to service radio sets in less time, RCA's new TUBE SUBSTITUTION DIRECTORY puts real, extra dollars in your pocket today!

Here's what's in your Directory:

A listing, in numerical-alphabetical order, of all 304 RCA Receiving Tube types — and in most cases one or more substitution types which can be used as replacements. Notations (with clear, detailed explanations) of the space limitations and the wiring, filament- or heater-circuit, and socket

changes involved in making the substitutions. Sample calculations of series and shunt resistors in heater strings. Suggested substitutions are cross-indexed and keyed to cathode voltages and functional groupings tabulated in the "Classified Chart of Receiving Tubes" which is also included.

Don't fail to get this valuable new RCA Directory at once. Ask your RCA Distributor for a copy today, or fill out coupon below and mail it, with your name and address and 10¢ to cover costs, to RCA, Commercial Engineering Section, 596 South 5th St., Harrison, N. J.

Where else but to RCA can you look for practical, dollars-in-the-pocket support like this?

BUY MORE
WAR BONDS



RADIO CORPORATION OF AMERICA

RCA, Commercial Engineering Section,
596 South 5th St., Harrison, N. J.

Enclosed is 10¢ for TUBE SUBSTITUTION DIRECTORY FOR
EMERGENCY SERVICING OF CIVILIAN RADIO RECEIVERS.
Please mail my copy at once to:

Name.....

Address.....

SALES EXECUTIVES LEARN HOW ADVERTISING BY TELEVISION WILL INCREASE POSTWAR PROSPERITY

Over 1,000 Business Leaders Gather at New York Luncheon to See Actual Demonstra- tions of Television's "Dynamic Salesmanship"

NEW YORK, N. Y., March 14.—The scene . . . a meeting of the Sales Executives Club of New York at the Hotel Roosevelt . . . "Television Day." And so great is the appeal of even the word *television*, it attracted throngs—described by the master of ceremonies as largest in the club's history. In the audience were hundreds of top-flight executives who, in the upbuilding of business after the war, will create millions of new jobs through their sales strategies.

A Trip Into the Future

In his address, Thomas F. Joyce, executive of the Radio Corporation of America, gave a preview of the way advertising by television will *demonstrate* products simultaneously in millions of homes. "Because television has the power to create consumer buying of goods and services beyond anything heretofore known," said Mr. Joyce, "we can count upon its helping to bring about a high level of postwar prosperity in agricultural, industrial and distributive industries, as well as in personal and professional services."

As a special feature, the audience was shown what the magic of *sight* does to radio commercials. In the darkened ballroom, listeners heard an announcer read typical commercials. Then, swiftly, a spotlight stabbed the darkness to light up a stage. Actors now made the commercials come alive as they smiled over a beer, tried to rip overalls or made dirt vanish with a vacuum cleaner. All were simple, familiar sales demonstrations. But the thrill of it was the demonstration of *sight* added to *sound*. This is television!

* * *

Today RCA not only keeps the public informed about television, but as this meeting emphasized, informs business leaders also—executives who will have much to do with the industry's commercial development after the war. In these and other ways RCA is planning ahead, so that when television does get the green light, the sales of television receivers will become an important and profitable part of your business as soon as possible.

W
ILL
ITY



What they saw when the lights came up



HE'S STANDING ON GLASS! But they saw the strength of *this* plate glass.

TUG-OF-WAR! Television SHOWS millions how overalls can take it.



IT SURPRISED THE EXPERTS! In the dark, they heard beautiful music. But when the spotlight went up, all were astonished to see a prodigy of only nine years, Richard Korbil, at the piano.



SEEING'S BELIEVING! The taste of beer is *proved* by a smile!

WATCH THE DIRTY GO! A *visible* demonstration of vacuum cleaner!



RADIO CORPORATION OF AMERICA

RCA VICTOR DIVISION • CAMDEN, N. J.

LEADS THE WAY . . In Radio . . Television . . Tubes . . Phonographs . . Records . . Electronics



DYNAMIC DEMONSTRATOR



BUY MORE WAR BONDS

UNIVERSALLY accepted for practical laboratory and vocational instruction in radio.

Consists of the working parts of a six-tube radio receiver, mounted in proper functional position on a large schematic diagram suitable for use in visual instruction. Jacks are provided for interruption and test of the various circuits. When used with modern radio test instruments, facilitates both qualitative and quantitative analysis of radio circuit conditions—an ideal setup for rapid radio instruction. RCA Dynamic Demonstrators, like the one shown above, are in very extensive use today in practical laboratory and vocational radio training schools. For audio demon-

strations—for service adjustments—for signal tracing technique—for all manner of measuring, checking, testing, analyzing. (NOTE: Currently, deliveries can be made from stock, subject to prior sale, on a priority of A-1-a or higher.) Please address inquiries to Test and Measuring Equipment Section, RADIO CORPORATION OF AMERICA, Camden, New Jersey.

RCA Test and Measuring Equipment
RADIO CORPORATION OF AMERICA



Service De Luxe

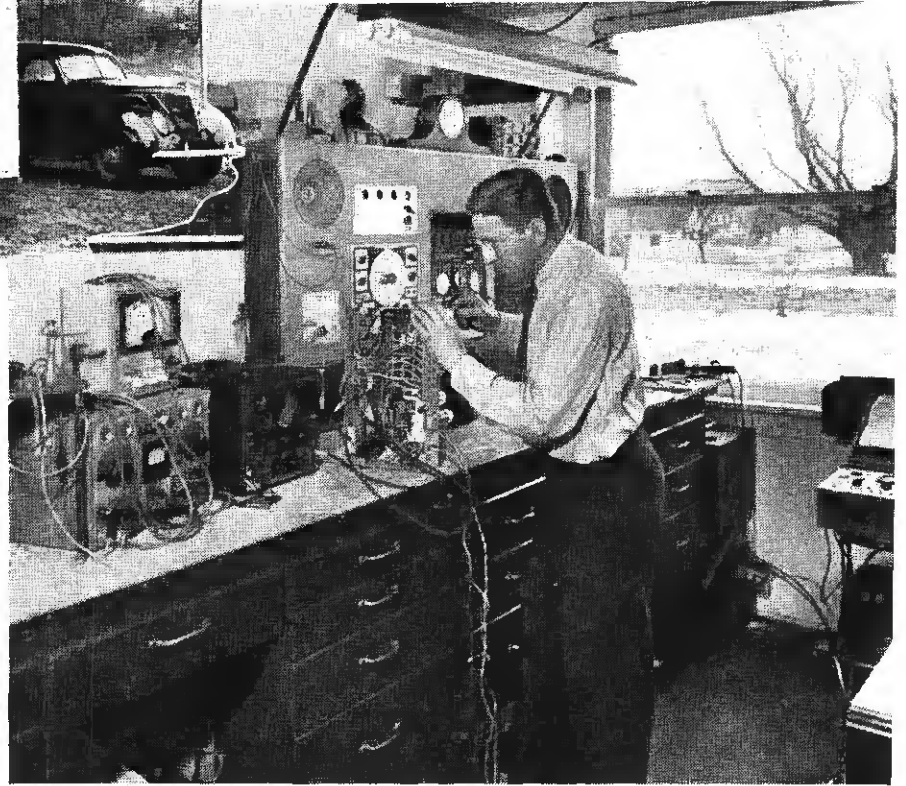

Wertz before his work bench in his immaculate, well-kept shop

Good Work Carefully Done Rewards Servicer With High Calibre Customers

● In business for himself for the past 20 years, Lester F. Wertz, owner of the Wertz Radio Service, 4877 Kutztown Rd., Temple, Pa., continues to do a smart job of servicing in his community, war or no war!

Although Wertz formerly sold some sets, as well, he now does service work only. Specializing in radio reconditioning and repair, he also repairs minor appliances for the home, services record players and does a lot of auto radio work.

Wertz Radio Service is housed in a compact and meticulously clean, well arranged shop that contains the very best in modern lighting and servicing equipment.

Lester Wertz makes calls to do service on receivers in the home and covers a radius of about 15 miles around the town of Temple.

"The word about a good job seems to have a way of getting around!" says Mr. Wertz. He finds that customer confidence in his knowledge and ability to turn out only the best in radio repair has acquired for him

a "preferred list" of clients in the high income brackets. The best equipment in radio in his territory is entrusted to him.

Inspection Charges

Many old sets are being brought down from attics, these days, reports Lester Wertz, inasmuch as tubes for the newer sets are almost impossible to get in any quantity.

RADIO & TELEVISION RETAILING's representative was interested to see the following set up in poster form, on Mr. Wertz's wall: "We reserve the right to make a nominal inspection charge. Locating radio trouble is our business, but no one can predict the time this requires. Parts and service guaranteed 90 days. All repairs cash."

Catching our eye, Wertz smiled. "You may be interested to know that I picked up that idea from another dealer whose story ran in your magazine recently," he said.

The test bench as shown in the accompanying photo contains plenty

of working space. The panel houses a signal generator, multi-meter analyzer, test speakers, and other equipment.

Wertz uses the oscillograph for aligning practically all sets. He finds that it gives more uniform results and saves time when dealing with high fidelity equipment.

In the particular job, on which Lester Wertz is shown working, the customer's complaint on the set was weak response, poor selectivity, and distortion. After giving the set the usual routine check, the cause of the distortion was located and corrected. The signal tracer was used to check the stage-by-stage gain which revealed the necessity for re-aligning. The final job, re-aligning, was then completed with the use of the oscillograph. The automatic record changer used with this particular set also needed adjusting and was corrected to the customer's satisfaction. The changer can be seen on the bench, extreme left, on supports which are used for servicing automatic changers.

Sweep Circuits

(Continued from page 55)

connection wires, and may be 100 megacycles or over.

The presence of such oscillations are sometimes noted in any type of sweep circuit working on the condenser charge-discharge principle, as it is evident that any condenser discharging across a low resistance will produce oscillations. The resistance R_x has a function as outlined in the description of Fig. 3 in addition to its usual job of keeping the discharge rate down to a safe value through the tube.

Quiz for Customers

• Shortages in radio service manpower are a problem in England as well as here. One method to get more jobs done with limited help, is to save time in locating trouble in the set. A good plan is to get full details from the customer, preferably by means of a questionnaire.

Dealer H. J. Evans of Worcester, England, is using the form reproduced here as printed in the *Murphy News*, a publication of Murphy Radio, Ltd. The following is quoted from this article:

The attached Service Questionnaire Form is an idea we have been considering using for some time past, and which has at last got to the actual printing stage. Most service engineers will remember dozens of cases where lack of information regarding customers' complaints has resulted in hours of wasted time; this applies particularly to intermittent faults.

In these days of hurried collections of as many sets as time and petrol will allow, and contact over the counter often having to be left to non-technical hands, it is difficult to have those few words with the knowledgeable member of each household from which the symptoms of the fault can be extracted. Usually some third party hands in the job, or request for service, and either professes entire ignorance of the complaint, or says something like " 'e says it's only a wire come loose."

We propose giving a form only in those cases where details seem vague, and requesting that it be completed by the time we call for the set. With counter jobs the form can either be filled in at once, or returned to us as soon as possible.

This is an idea which should appeal to any one who has tried everything short of "third degree," in his efforts

to extract useful information about the set he is expected to repair. Even if the customer provides only a few of the details called for in the form, the service engineer will have a far better chance of starting the job properly equipped for carrying out the repair. In the case of the customer who revels in forms and fills in all the details, a great deal of serviceman's time may be saved.

There are, of course, customers who panic at anything in the least way resembling an income tax return, and in such cases the form would definitely have a "bad-will value." However, the exercise of a little discretion would soon overcome this difficulty.

Mr. Evans apparently intends to use the form only in cases where there is difficulty in obtaining the necessary information by other means, but there is something to be said for uniformity in these matters, and some dealers

COUNTY MAGNETO		25 SHOBURY, WORCESTER
BY COMPLETING THIS FORM YOU WILL HELP US TO MAKE A SATISFACTORY REPAIR AND AVOID UNNECESSARY DELAY AND EXPENSE		Phone 3053
Name	Address	
Make of Radio	Date	Job No.
WHAT IS WRONG? e.g. No results at all—Very quiet—Crackling noise—Humming noise—Whistling noise—Bad quality—Pop-popping noise (motor buzzing), etc.		
IS THE TROUBLE ALWAYS PRESENT? or only at times, if so how often does it happen?		
IS THE SET LIGHTING UP AS USUAL? ANY SMOKE OR SMELL OF BURNING? HAS IT HAPPENED SUDDENLY or been getting worse for some time?		
IS IT THE SAME ON ALL USUAL PROGRAMMES AND ON ALL WAVE BANDS that is Long Wave—Medium Wave—and Short Wave (if fitted)?		
CAN SET BE MADE TO WORK? by moving any of the knobs, if so which?		
ARE RESULTS NORMAL UNTIL A KNOB IS MOVED? if so, which?		
If the complaint is Excessive HUMMING, WHISTLING or CRACKLING NOISES: please try and answer the following— DOES IT HAPPEN AT ONCE? IS THE SET NORMAL AT FIRST—if so how long before the trouble comes on? DOES THE NOISE ALTER as you tune from one station to another? WILL THE VOLUME CONTROL MAKE ANY DIFFERENCE TO THE NOISE?		
CAN YOU DESCRIBE THE NOISE? e.g. "like an aeroplane," "a screeching noise"		
IF YOURS IS A RADIO-GRAM is the RADIO part faulty, only the GRAM part, or both?		
IF YOURS IS A BATTERY SET—Are you sure the trouble is not due to faulty or run down batteries?		
IF YOURS IS A MAINS SET—Have you tried some other apparatus to see if the supply is getting to the Radio?		
HAS ANYONE (including yourself) ATTEMPTED TO REPAIR THE RADIO LATELY?		
ANY OTHER DETAILS YOU THINK MIGHT HELP		
(WRITE OVER/IF NECESSARY)		
The above information will help us to make a speedy and economical repair. We thank you for your co-operation in completing same.		
STRAIGHT REPAIRS LTD. WORCESTER		

Set-trouble questionnaire for customers to fill out

may prefer to use the form in every case. In normal cases it could be filled in by the person taking in the repair, and by the customer in cases where this seems to be more satisfactory.

The one thing which generally deters a dealer from adopting an idea of this kind is the trouble involved in having the forms set out and printed. Well, the trouble is "on Mr. Evans and his printer" in this case, and there is nothing to stop dealers who are attracted by the scheme from going ahead with it right away.

New JFD Resistance Line Cords

Hard to get line cords are now available in certain ranges from 135 to 560 ohms from JFD Mfg. Co., 4111 Ft. Hamilton Pkwy., Brooklyn 19, N. Y. These cords are not tapped but are complete with plug. Units requiring tapped resistance cords are easily replaced by the plug-in tube resistor unit also available from JFD. The resistance ranges are as follows: 135, 160, 180, 200, 220, 250, 290, 300, 330, 350, 390 and 560 ohms.

21st Edition of Radio Amateur's Handbook Announced

The new 1944 issue of the *Radio Amateur's Handbook*, published by the American Radio Relay League, Inc., West Hartford 7, Conn., has been enlarged and revised particularly in the "theory" part of the book. The chapters on electrical and radio fundamentals have been approximately doubled and the chapter on vacuum tubes has been increased 60%. The construction and adjustment sections show in pictures and diagrams, basic operating principles in receivers and transmitters. A new chapter on Carrier Communication has been added. This field, while new to many radio men and amateurs, is a tried and proven technique used by industrial power companies for communicating and transmitting meter readings, etc., on conventional high voltage power lines. The very complete section on vacuum tube characteristics has been enlarged to include many of the latest types just released. The book has 664 pages, 1,125 illustrations and the price in \$1.00 in continental U.S.A.

Vibrator Starting Trouble

There are many instances reported wherein new vibrators just taken from stock will not start when first installed in the radio receiver. A frequent cause of this trouble is a slight coating of oxide on the points

(Continued on page 65)

from the Smoke of War..

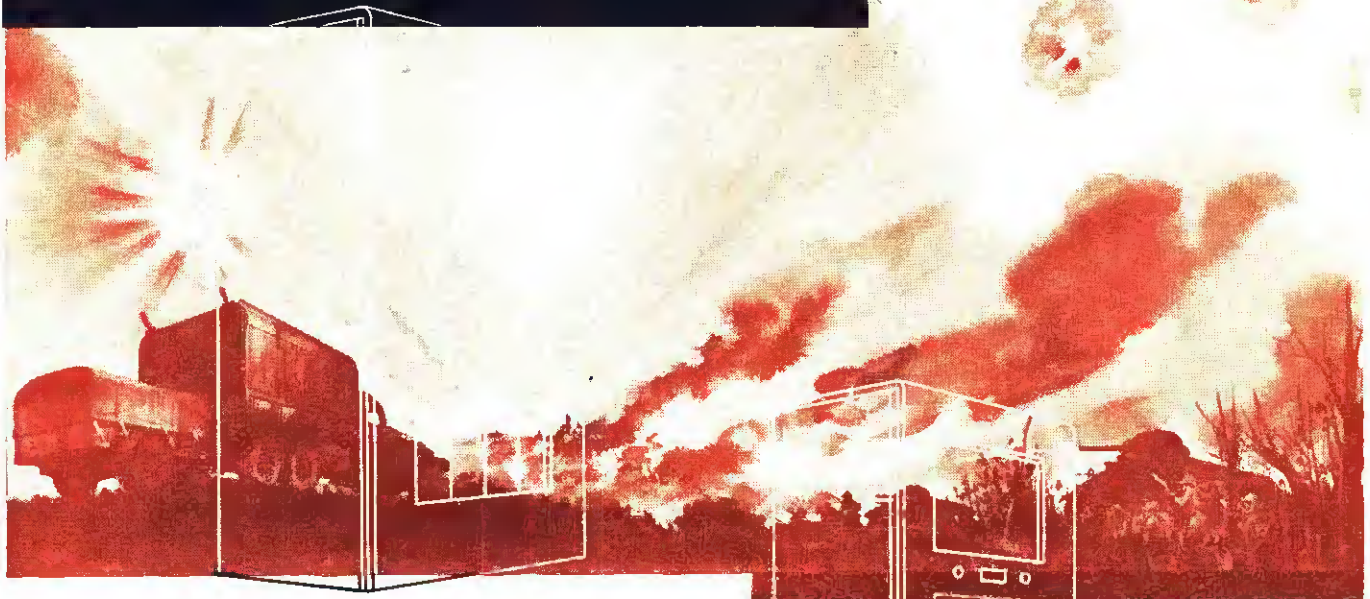

finer Radios for Peace

War's demands for better weapons have added mightily to the progress of radio. Here at Detrola we are in the forefront of it. Detrola engineers are giving their knowledge and experience to the perfection of new and finer electronic equipment. Detrola production workers are learning and employing new short cuts in the mass manufacture of quality products. Our work today is providing us with ideas for a great variety of postwar radio-electronic devices . . . and new ability to translate them into products of finest quality. *Every War Bond You Buy Helps Bring Victory Closer. Buy Another Today.*

DETROLA RADIO

DIVISION OF INTERNATIONAL DETROLA CORPORATION • BEARD AT CHATFIELD, DETROIT 9, MICH.

C. RUSSELL FELDMANN  PRESIDENT

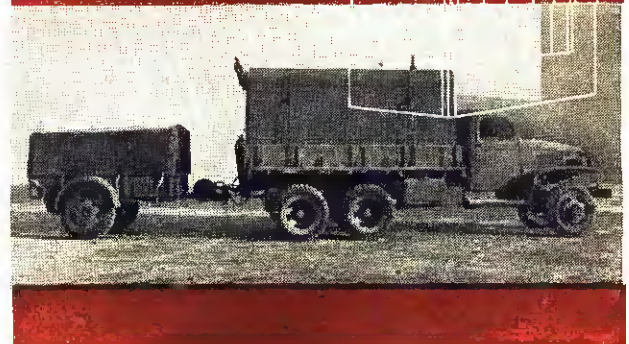
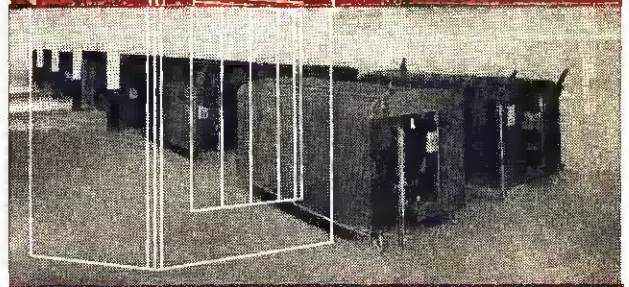

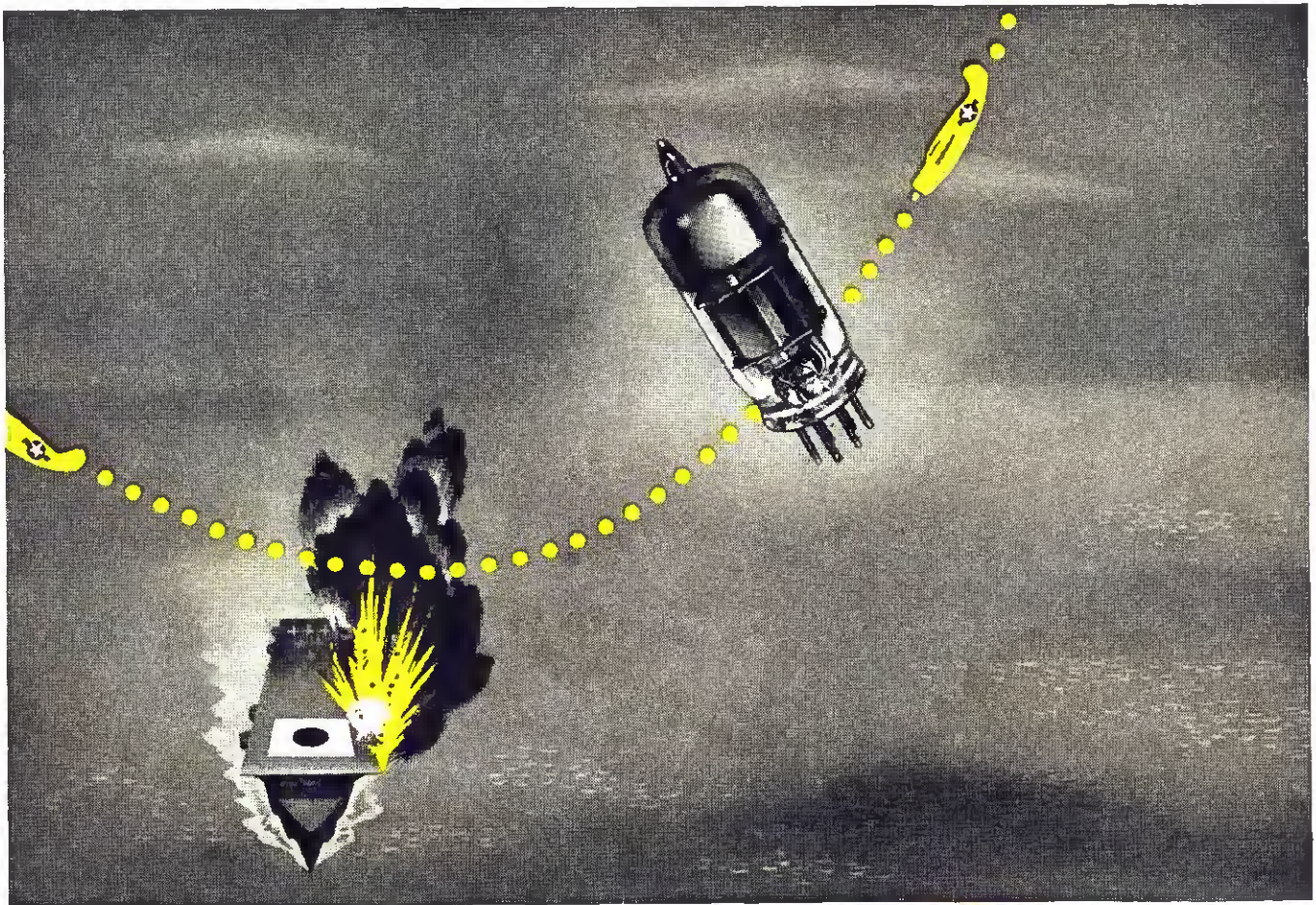

They know their G's

 What is this menace to flying men and their equipment which our scientists call "G's"? And why are N. U. engineers who design tubes for airborne radio and electronic devices taking so much pains these days, to *know* their "G's"?

In a mild form, most of us have felt "G's" at work on a roller-coaster, when we take the turns and hit the dips. However, in high speed flight, with its shifting, twisting, turning, about-face maneuvers—"G's" *really* shake your insides. Think of a dive bomber pilot as he pulls out of a high vertical power dive. That's when

"G's" can become dangerously high. And when there are *too many* "G's"—look out!

Research into the effects of "G's" on the delicate, indeed flimsy filaments and other parts of tubes, has enabled N. U. engineers to provide our armed forces with tubes individually tested to withstand many more "G's" than a pilot or a plane ever has survived. For such battle-tested N. U. Tubes there will be many post-war uses, with profit opportunities for service engineers. *Count on* National Union.

NATIONAL UNION RADIO CORPORATION, NEWARK, N. J.
 Factories: Newark and Maplewood, N. J., Lansdale and Robesonia, Pa.



NATIONAL UNION

RADIO AND ELECTRONIC TUBES

Transmitting, Cathode Ray, Receiving, Special Purpose Tubes • Condensers • Volume Controls • Photo Electric Cells • Panel Lamps • Flashlight Bulbs

(Continued from page 62)

when kept on the shelf over a period of time.

To correct this condition, it is only necessary to remove this oxide film after which no further trouble will be encountered. This is very easily done, using the following method suggested by the Radiart Corp., Cleveland, Ohio.

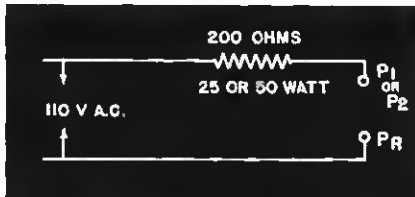

Test circuit to remove oxide film from vibrators.

Connect 110 volts A.C. through a 200 ohm, 25 to 50 watt resistor to the reed (P-R) and to either point "P-1" or "P-2" of the vibrator. Only one of the latter will draw current and actuate the reed. With the vibrator held so that the prongs face you, determine the location of the prongs connected to "P-R," "P-1," and "P-2," and indicate on the drawings referred to in the preceding illustration. It will usually require from one to ten seconds to start the vibrator running and to remove all oxide film from the points. This will not, in any case, damage the vibrator; and after this treatment the vibrator will start and function properly in its normal application. This method may be used to remove oxide film and start any make of shunt-type vibrator. All manufacturers selling a general replacement line employ the shunt-type construction.

Interference from Fluorescent Lamps

The introduction of the fluorescent lamp has brought with it the problem of radio noise which is produced by the rapid interruption of the A.C. arc within the tube. This characteristic is inherent in this form of illuminant, although the magnitude of radio noise will vary with different lamp types and ratings. As long as fluorescent lighting is confined to stores in the business area and to factories or other locations, where radio receivers are not ordinarily used, radio noise may not be a problem. However, with the extension of this form of lighting to the home and to small business places in residential districts, the question of radio noise assumes considerable importance.

The extent to which fluorescent lamps disturb radio reception is dependent upon a number of factors, among which are the strength of the desired signal and the type of receiver antenna. The strength of the signal depends upon the transmitter power of the station being received and the distance between the station transmitter and receiver. Obviously, the stronger the station signal, the less objectionable a given radio noise becomes.

Line Radiation

Radio disturbances from fluorescent lamps reach radio receivers by (1) direct radiation, (2) by radiation from connecting supply lines, and (3) by conduction along supply lines. Unless the conventional radio receiver antenna or lead-in is located within a few feet of the lamp, direct radiation is not serious, although radio receivers using internal loops may require greater separation from the lamp fixture. Usually the radiation from and conduction along supply lines are the most important factors. In order to minimize the effects produced by these forms of radio noise propagation, filters must be installed at the lamp terminals.

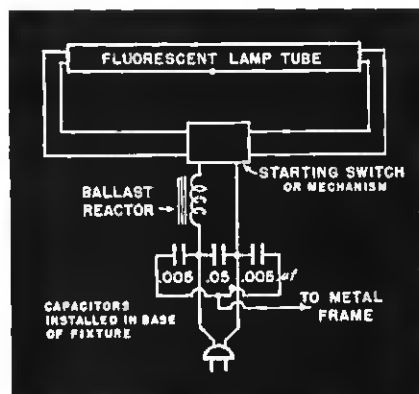

Filter network to prevent line radiation of fluorescent lamp noise.

Some manufacturers incorporate a small capacitor in the starting mechanism of their units. When properly located in the circuit, this capacitor reduces radio noise to some extent. In a great many instances, however, additional measures must be taken to suppress radio noise. Filters are available commercially for this purpose, one type being termed a "Capacitive type filter," which is the simplest and most inexpensive type. There are cases, however, where this type of filter does not give sufficient reduction in radio noise, so that a combined capacitive and inductive filter

must be used to attain the maximum degree of suppression.

Filter Each Unit

In general, it will be necessary to filter each lamp or group of lamps in one fixture, since it is essential that the filter be located directly at the fixture terminals. In making a filter installation, it will be noted that one terminal or lead is to be connected to ground. Ground in this case means primarily the metal frame of the lamp fixture and not a water pipe or other actual ground. If in addition to the so-called ground connection to the metal fixture, an actual ground connection is desired, this may be made provided the "ground" terminal of the filter is connected to the metal fixture with a very short lead.

In the case of small table or desk type lamps, there may not be sufficient room in the base to install a commercial filter. In such cases small short path tubular capacitors, installed in the base in accordance with the diagram shown in Fig. 1, will usually provide ample suppression.* The capacitor should have a 600 volt (D.C.) continuous rating.

Test Data

In Tables 1 and 2 some test data are given, showing the reduction in radio noise for a 15-watt desk type lamp, with and without a filter. Direct radiation with variation in distance from the lamp and radio noise fed into the supply line are indicated.

TABLE 1

Distance in Ft. between Antenna and Lamp	Direction Radiation at 1000 kc	
	Radio Noise Unfiltered	Radio Noise Filtered
1	2,000	85
2	800	30
3	400	14
4	200	—
5	100	—
6	40	—
7	20	—

TABLE 2

†Microvolts of Noise on Supply Line at 1000 kc	
Unfiltered	390
Filtered	19

This material is quoted from an article by C. S. Young in the Edison Electric Institute Bulletin.

*Where the lamp fixture is ungrounded and within reach the capacitance from line to fixture should not exceed .007 μ f.

†Measured in accordance with EEI Publication C9. A report of the Joint Coordination Committee on Radio Reception of EEI, NEMA and RMA.

New Products

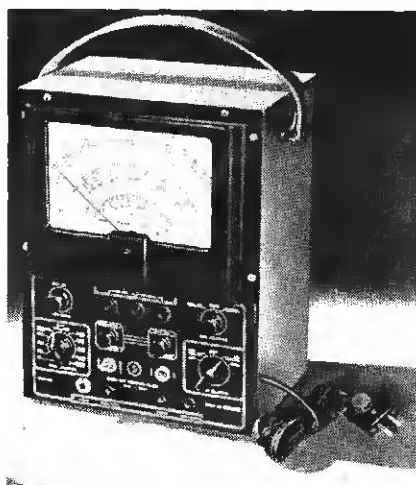

RADIO CITY VT VOLT-OHMMEGOGOR. model 665, tests insulation to 10,000 megohms at 500 volts, also capacitance from 2.5 mmf to 2,000 mf. 13 AC and DC voltage ranges to 6,000 volts. Vacuum tube VM input resistance 16 megohms max. VT Ohmmeter 7 ranges to 1,000 megohms. Radio City Products, Inc., 127 West 26th St., New York 1, N. Y.—RRT.

WIRE-WOUND control, Type 43, measures only $1\frac{1}{8}$ " in diameter by $9\frac{1}{16}$ " behind mounting surface. Bakelite body enclosed by dust-tight metal cap. Alloy contact arm presses against the inside surface of the winding. Supplied with or without switch; in resistance values up to 10,000 ohms; linear tapers only; and is rated at $1\frac{1}{2}$ watts. Clarostat Mfg. Co., Inc., 285-7 N. 6th St., Brooklyn, N. Y.—RRT

SPRAGUE BOBBIN RESISTORS, use ceramic insulated wire construction. Standard tolerance, plus or minus 5 per cent at full wattage. Plus or minus $\frac{1}{2}$ per cent can be provided at lower watt-

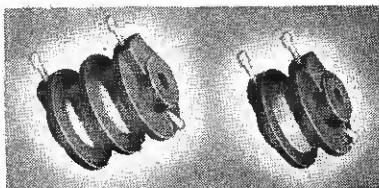

age ratings. Maximum resistance 250,000 ohms in section $\frac{5}{8}$ in. wide, diameter $1\frac{3}{16}$ in. Power rating 2.5 watts. Suitable as meter multipliers and resistance standards. Sprague Specialties Company, North Adams, Mass.—RRT.

BICKLEY KILLFLY, uses high voltage transformer and metal grille, protected by guard, to electrocute flies. Uses 15 watts, size 3 x 6 x 9 in. Bickley Manufacturing Co., Bala-Cynwyd, Pa.—RRT.

POWER AMPLIFIER, Type 101-A. → Excellent low-frequency wave form at high output levels. Inherent noise level 68 db unweighted below full output of plus 47 VU at 2 per cent RMS harmonic distortion. Input impedance of 600 ohms, the gain is 60 db. Using bridging input, the gain is 46 db. Output impedance is adjustable 1 to 1000 ohms. The Langevin Co., Inc., of 37 West 65th St., New York, N. Y.—RRT.



HANDI-EQUIPMENT TRAY, is three-deck sectioned unit for counter display of small items or for service bench use. Unit is 17 in. high. Individual tray sections are removable and three shelves may be rotated around central pivot. Finish, neutral gray krinkle. Handi-Equipment Company, 105-20 New York Blvd., Jamaica 5, N. Y.—RRT.

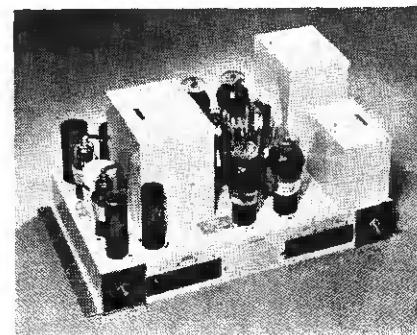

Electronic Service

(Continued from page 48)

longer for the eastern community water companies, the services of a good local radio technician are in great demand. These repair jobs run about \$25 to \$30 an instrument per year.

Service Procedure

In addition to all this, dealer Galbreth does a large volume of repair on radio portables and small sets for the men and women in the Army Air Corps at Mitchel Field, and keeps a large portion of townspeople's receivers "alive".

In this work he observes several rules of his own making, such as: (1) Never charges for testing tubes, as he finds it increases business for him; (2) Will rewind motor armatures, but does it only to accommodate a customer; (3) Rebuilds old sets; (4)

Minimum charge for checking radio is \$1, but if work is done on set this is included in the repair charge; (5) Does a thorough job on repair: for instance, in a bank of four filters, if one is gone, he changes all four, since they are probably slated to go shortly, in any case. While this costs a bit more for parts, the time and money on recalls is saved.

Parts and tubes are, of course, difficult to get. It is not unusual for Mr. Galbreth to spend a whole forenoon rewinding a coil that he cannot replace with a new unit. This is the kind of thing which runs up radio repair costs, but Mr. Galbreth finds that a confidence-inspired clientele has been made to understand that his charges are fair.

After the Victory, dealer Galbreth plans to again stock radio sets, and will add a large record department to his establishment.

What a Life!



"I never test a radio between 2:00 and 2:30. I just hate the programs on at that time!"



Calling All
DEALERS
To Share in
This Great
Post-War Program

CLARION Radio sales—following the war—will be directed through *independent appliance dealers* and *distributors*.

The line is complete and carefully planned—including table models, portables, farm sets, table combinations, consoles and console combinations.

You can satisfy all demands with min-

imum inventory, and be sure of *selling* features to meet every customer need.

Sales promotion helps and advertising will be liberal. *Now* is the time to make certain that the superior CLARION combination of high-grade merchandise and maximum co-operation are *yours* for the post-war period.

*We Invite You to Participate in
Clarion's Bright Peace Time Future!*

Our work for the armed forces and our years of experience in building fine radios will be reflected in the engineering and designing skill applied to civilian production.

This coupon will bring you CLARION'S Radio Preview and 6-Point Post-War Program, with information as to the availability of the CLARION franchise in your locality or territory.

WARWICK MANUFACTURING CORPORATION
4646 WEST HARRISON STREET
CHICAGO 44 ILLINOIS

PLAN WITH CLARION

WARWICK MANUFACTURING CORPORATION
4646 West Harrison St., Chicago 44, Ill.

Please send information and a copy of your Radio Preview.

Name of Firm _____

Street Address _____

City _____ State _____

TODAY IS NONE TOO SOON TO BE
THINKING ABOUT YOUR POST-WAR PLANS

Merchandising Principles

(Continued from page 23)

Watch sales. They are the source of profits. But volume without profit is worse than worthless. The radio retailer who increases his business 75% and then finds a decline of 30% in his profits, should know that there is something wrong. He should remember the good old merchandising formulas: Zero multiplied by any number is still zero and minus times plus is minus. You can sell something at a loss to promote volume at a profit, but you can't continue the loss throughout your volume without going into bankruptcy.

Also, there is such a thing as a radius of profitability. You can sell radios and services so far and make money, but you can't go on indefinitely. There is always a limit and after the war competition will restrict it. Under war conditions dealers have been obliged to ask customers to bring in small sets and take them home. That is the beginning of the restriction of delivery, and some of it may continue into the keenly competitive days after the war. It is also the beginning of self-service, and self-service has been spreading in the grocery trade for nearly a century.

Slide-Rule for Competition

The writer remembers a meeting of merchants some years ago in Buffalo, New York, at which everyone complained of the other fellow's competition. Each one was trying to expand his territory, so that finally nobody was making any money. At the end of the day, when the room was so full of smoke that you had to grope for the door, the leading merchant arose and said, "We don't need an expert from the Department of Commerce to tell us we're losing money, when we send a ten ton truck loaded with unprofitable goods 175 miles down the road. But, the point is, if we don't get that business, somebody else will." The laugh that arose was the only thing that relieved the tension.

In these war days do you feel like complaining about the shortages of labor and materials, priorities, price control and other government regulations? Do you stop to recall what one of the greatest merchants in the history of America said in the aftermath of war difficulties many years ago? When President Grant wanted to make A. T. Stewart Secretary of the Treasury, and Mr. Stewart's enemies said he belonged to the money

interests, Stewart replied, "I will sell out my whole store or give it away if necessary that I might serve my country."

All sound merchandising principles make for profits. Watch all for their effects on profits. But above all watch profits. All rules are made to be broken. Break any, if you are sure you can win by doing so, but be sure beforehand that you will win. Don't count on winning the second time, because you did the first. Don't be afraid to learn from older trades. They have borne the grief. You can have the benefit of their experience.

Appliance Quiz

(Continued from page 29)

brand as yet—depends on distributors."

"Am planning to add a complete line of home appliances."

"We will merchandise a complete line of one make."

"Give all dealers protected territory."

"Franchises should only be given to outlets capable of handling the servicing."

That dealer readers of this publication are extremely aware of the problems in merchandising now confronting them, is obvious from their answers to the survey questions. In this line, it is interesting to scan the entire picture and see how the re-

tailer is going to fit into the postwar selling structure.

The independent retailer—who has always been the *purchasing agent* for his community—has, through present-day emergency servicing to the home, greatly enhanced his position with the consumer. He has gained invaluable good will and confidence. He has ingratiated himself to such an extent with his customers that, by and large, most of them are under definite *obligation* to him.

After the first flurry of postwar buying dies down, and things commence to tighten up, the retailer's importance to the manufacturer will be stressed as never before, because the retailer is the man who selects the lines, selects the models, and sells them to the ultimate consumer.

Must Sell the Retailer

The *strong* dealer can sell a weak line. He can pioneer a line in a comparatively short time, but a manufacturer may well have to spend millions of dollars and years of time to do so. And, in the end, the manufacturer will have to *sell* the line to the dealer in order to get it into the homes of the consumers.

More than ever before, the manufacturer will have to go to the dealer, rather than direct all of his selling facilities toward the consumer.

Dealers are going to be sought after. "Printer's Ink" is cognizant of this fact. A recent item from that publication says: "Competition for dealer outlets will be tougher than battle for nod from customer."

The manufacturer's market is, and always has been, the retailer, and because of the *greatly strengthened* position of the latter today, and the promise of a battle royal for his business tomorrow, the dealer assumes an even more prominent position in the eyes of the alert manufacturer.

Role of Purchasing Agent

The retailer is the community's *purchasing agent* from the manufacturer's viewpoint, and he is the community's *buying agent* from the consumer's viewpoint. In electrical home appliances, the dealer is the keyman between the maker and the taker.

Yes, dealers are studying brands *now* and are selecting them for the buying public. They want to know *now* what lines will be most advantageous to recommend to *their* customers, and what lines will be most *advantageous* for them to sell from a profit and serviceability standpoint.

Wants to Know Who Makes "2nd Line" Appliances

"When electrical appliances are released, it would be a source of very valuable information to have a list of appliance manufacturers who do or do not build a '2nd line' of merchandise for mail order houses 1 and 2. The manufacturer who does not, should add that clause to his franchise—would receive a tremendous amount of dealer good will. Also stop chiseling at its manufacture source.

"We are enjoying \$4000 per month radio service—and receiving, per our estimate—\$1000 per month in advertising from our satisfied customers. This will reflect in tomorrow's business. Yes, 80 per cent of our customers will call back for a new radio-combination, or some kind of appliance. We have, for the past 20 years, been practicing what many dealers are preaching today—honest, efficient, courteous service."

teaching old electrons new tricks

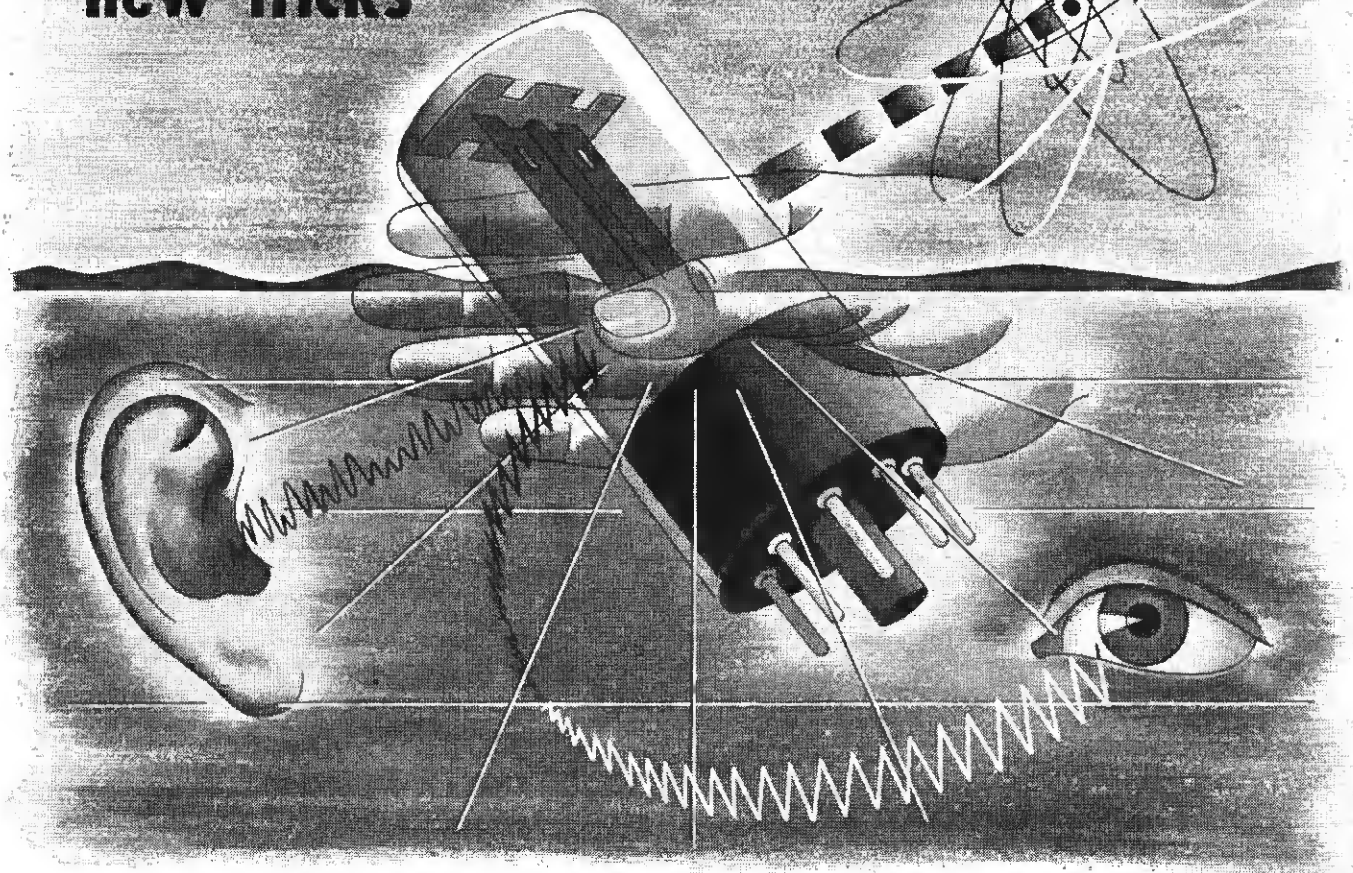

Electrons have always been with us, since the beginning of time. But it was not until the development of radio that they were disciplined and put to work.

Now that the science of electronics has become better understood, these electrons have been taught a lot of new tricks. They have been trained to reproduce images as well as sound, to perform miracles of control in military equipment and industrial machinery. Long hours of research and development have been applied to making electronics a useful force in the fight for Victory.

Delco Radio has worked closely with Army and Navy engineers to help put this relatively new science on a fighting basis. In its laboratories, technical principles have been explored and exploited; in its engineering departments, designs have been evolved to apply these principles; and on its production lines, complete equipment is being manufactured with all the

accuracy and know-how gained through Delco Radio's extensive experience as a large manufacturer of precision radio instruments.

This background of knowledge will continue to serve a useful function in days to come. It holds a promise of important improvements in peacetime radios, and significant developments in new electronic products.

**Put your dollars "in action"
BUY MORE WAR BONDS**

Delco Radio
DIVISION OF
GENERAL MOTORS

LETTERS to the EDITOR

Sees Unfairness in Parts-Meter Distribution

Editor, *Radio Retailing Today*:

I wish to express my thanks for the way *RADIO RETAILING TODAY* has been including extensive articles and good photos of service shops in recent issues. I always enjoy reading about and seeing pictures of other shops. I think many service shop operators would appreciate continued use of these articles and news.

I have a "squawk" to express, and I think many of the other fellows have encountered the same situation.

One of the largest radio and tube jobbers in this area recently shipped several of the 1½ volt series tubes (that I need so desperately for ranchers' radios) to a high school student here. This youngster just "piddles" with radio. He "fixes" a few radios for acquaintances and his father's business friends. His work is inferior.

I have the only legitimate shop in this city of 11,000 serving an area of 100 miles or more.

This aforementioned parts jobber, by his own admission to me, stated that my shop was the only consistent volume account his firm had ever had in my town, and yet they will ship (even scarce supplies) to a high school "punk", or most anyone, when strictly service shops have been unable to obtain the same tubes for many months from any source.

Many shop operators have all their money invested in their businesses; have

spent years learning competent radio service the hard way, and have made radio servicing their life's work.

Is there no way legitimate service shops can obtain protection in the way of discounts and fair distribution of available parts and tubes?

There is a crying need for an investigation and reform of this condition.

Also, the situation concerning test equipment "stinks", to put it bluntly.

Last Fall I waded through unbelievable lengths of pure red tape, and sent application to Washington for a badly needed signal tracer. The applications (required 5 copies) were returned—stamped "Request Denied."

At the same time a local furniture store, with absolutely no service facilities, and only having about 50 tubes on hand, sent in application for a tube tester and their application was O.K.'d. They got a tube tester when they have no real need for one.

What kind of a setup is this, anyhow?

This letter is not to be considered a case of "sour grapes" or peevishness; just a few true facts that I have encountered personally.

I have subscribed to *RADIO RETAILING TODAY* for about 6 years, and have always enjoyed it, especially so in the past 6 months since the articles have focused on the service shops.

I would like to see some trade journal make a thorough investigation of a number of conditions that should be eliminated before it is too late.

WESTERN SERVICER

Dealer Asks Equality in Gasoline Allotments

Editor, *Radio Retailing Today*:

It seems impractical that a radioman who has to carry over 400 tubes, testers and tools, gets the same gas allotment as a salesman, who can use the telephone for business in a good many instances. I know of people who had never used their cars for business and have them listed as salesmen's cars and get a B allowance the same as a radio servicier.

If this angle could be eliminated, maybe others could get more mileage.

A competitor, who uses trucks, and is selling auto converted combinations and servicing them, overlooking most of his former customers, gets plenty of gas from the ODT to sell new merchandise.

Far be it from me to antagonize the OPA, because frankly, I believe in their holding down the prices, if they do it all along the line and don't make one faction stand the entire burden. With so many OPA rules and changes, one can inadvertently make errors. A national periodical should have more influence than a dealer and maybe you can show the OPA that maintenance and repair is more essential than many who get the same B coupon mileage as radio repair men.

PACIFIC COAST DEALER

Use For Music Chart

Editor, *Radio Retailing Today*:

We have been subscribers to your magazine for the last twelve or fourteen years. This in itself is enough to show what we think of your publication.

On page 30 of your December, 1943, issue, you published an article entitled "Library of the Composers." This is the best summary of composer selections we have ever seen.

As we have quite a few customers who have purchased phono-combinations, and have often asked for a summary of what we could suggest in making up a Composer Library for beginners, this article is just what we need.

Would it be possible to furnish us with about 1500 of this article in pamphlet form, or would it be possible to furnish the exact pages of the magazine?

DANIEL F. DOUGHERTY

Louis H. Dougherty Co.,
Wilmington, Del.

Editor's Note:—Since this page of type has been broken up, we have suggested that reader Dougherty have these two pages offset by his local printer. This should not cost more than approximately six or seven dollars per page for the 1,500 copies.

(Continued on page 72)



"I can't rush over every time someone thinks their radio is going bad. Why you might be a hypochondriac!"

ARVIN

Plans Ahead
FOR RADIO TRADE!

WHAT'S COMING from Arvin for the radio trade when civilian production can start again?

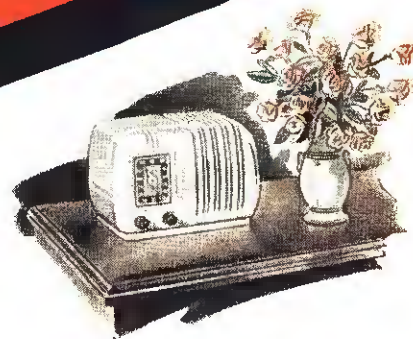

...WITH AN **ARVIN** Radio IN EVERY ROOM

A COZY CHAIR Dad home on leave... dreams... plans for the good days ahead. When peace comes, these planners want a better, larger home—better rights in the pattern of today's dream-plan. And why not—an Arvin radio in every room!

That's not peering through the gates into fairyland. It's just looking toward happier living in a brighter world. Mother can hear her favorite mid-morning drama—in the kitchen. Dad can have his evening sports review—in his den, without disturbing the rest of the family. Jean and

Bill can brush up on their dancing—in the equips room, away from the folks. And every member of the family can tune in a melodic night-cap just before turning out the lights and tucking in the covers.

Of course, Arvin is doing some post-war planning, too—though all present production facilities are engaged one hundred percent in hurrying the end of the war. Then, there'll be an Arvin radio for every room in the home—even better, perhaps, than you imagine—for Arvin is learning some wonderful things from the production of radio equipment for war.

ARVIN is the name of the finest products of NOBLITT-SPARKS INDUSTRIES, INC. COLUMBUS, INDIANA

When you see the name "Arvin" on a product, it means you are getting the best. Arvin is a name that stands for quality and reliability in every product we produce.

INSURE YOUR POST-WAR PLANS WITH WAR BONDS

A Broader Line of radios—large and small sets and combinations—with many developments in “inside engineering” and “outside design” for better performance and appearance appeal. There’ll be other Arvin Products of interest to you, too. **Electrical Appliances**, for example—Arvin will have some fast-sellers—with features that can be merchandised as never before. **It's still too early** to tell you the details. There's still plenty of war work to be done. But remember this—the company back of Arvin Products is in a strong position for the development of merchandise and markets for you—with capital and surplus in excess of \$7,500,000. So . . . keep Arvin in mind in *your* plans ahead.

NOBLITT-SPARKS INDUSTRIES, INC., COLUMBUS, INDIANA



Awarded to the men and women of four of our Columbus plants

Miniature reproduction of one of a series of advertisements appearing regularly in many leading national magazines to keep Arvin in the minds of your future customers.

OFFERING FOR IMMEDIATE DELIVERY

Duotone Miro Point Needles



Enterprising dealers who stock this fast-moving item can offer their customers a needle that will provide more brilliant reproduction than any competitive needle in the same price range. That is a challenging statement! Each Miro Point Needle will play up to 1000 records with the lowest possible degree of surface noise. It has been especially designed to accomplish this and reduce record wear. Miro Point Needles retail at 50 cents each and are available on arresting display cards.

Duotone

799 BROADWAY, NEW YORK 3, N. Y.

Makers of the Five Dollar "Star Sapphire" Needle

(Continued from page 70)

Sky-High Prices Disturb Ohio Radio Servicer

Editor, *Radio Retailing Today*:

Have been offered as high as \$5 each for some of the hard-to-get tubes, but did not sell any at that high price. In fact, I only had 12 to 15 on hand, and am holding them for my local people as I will have to expect them to help me in my business when the war is over. I sell tubes and condensers at the same prices I got in 1941. Get a higher hour rate for service. My business motto is "live and let live."

I also know of a dealer close to this part of Ohio, who had the nerve to ask \$15 for a \$2.95 vibrator tube. Would you call him a real American?

OHIO DEALER.

Virginia Dealer Is Doing a Full-Time Job

Editor, *Radio Retailing Today*:

I read with interest your accounts of radio men in action, and think they are very good, but fail to see very much about the little fellow, who operates in a small community, trying to keep isolated people in touch with the outside world.

I operate in a town of approximately 3,000 population, doing radio, refrigeration and electric appliance service. I have been in the business for the past 20 years, but started here five years ago with "zero."

Today, I have no time to work in a warplant, or go on a strike, because it takes 10 to 18 hours a day for one man to be storekeeper, serviceman, errand boy, stenographer, bookkeeper and general flunky. And this isn't just six days a week—but from Sunday to Sunday. If anyone thinks this isn't a man-size job, let him try it!

I don't need any side lines to keep me busy, because there is plenty of work for me in the business I have built in five counties, including some jobs that come from our Nation's Capital. Haven't had a whole day off in two years—not even Christmas. I attribute my success to practicing the slogan—"A Square Deal for Everybody."

Like many others, the main drawback in radio repairing lies in the tube and battery scarcity. I would also like to know what becomes of those items that are released.

DALE S. TAYLOR

Front Royal, Va.

Editor's Note: Thanks, Dealer Taylor—but let's clear up one point in your interesting letter—many of the fact articles we publish are about the "little fellow" in the small community, though if he's doing an outstanding job today, we feel he's a Big Man in the radio-appliance field. "Size" of the dealer or community has nothing whatever to do with our selection of material for publication. Many of our articles are about communities smaller than yours.

(Continued on page 76)

HAMMARLUND

Radio



* THE SIGN OF QUALITY *

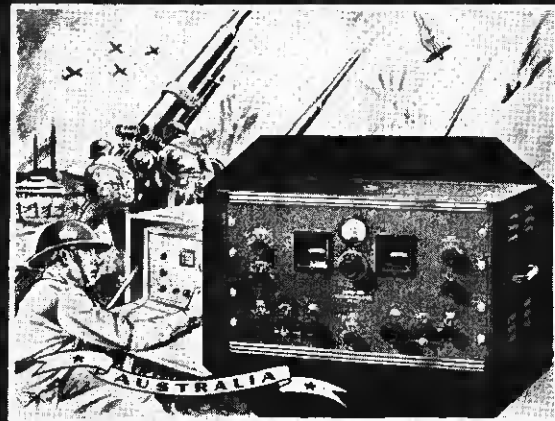
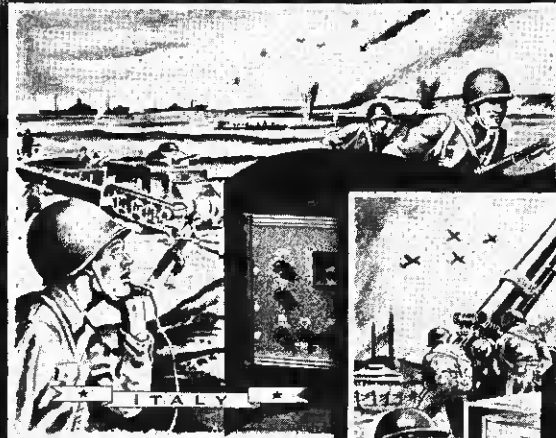

Serving on all our fighting fronts
... the SUPER-PRO "SERIES . 200"

THE HAMMARLUND MFG. CO., INC., 460 West 34th Street, New York, N. Y.

JOBBER OPTIMISTIC

**Many Postwar Plans in Making—
Some Substitute Lines to Be Retained**

Thompson & Holmes Plan Ambitious Postwar Program

Wholesalers Thompson & Holmes, Ltd., San Francisco, Cal., are not only selling substitute lines, such as furniture and household items now, but are planning to retain many of these items in the postwar period, in keeping with the firm's plans for expansion and diversification.

This organization came into being over 20 years ago as a result of the boom in the radio business. The first major line was Majestic, and the firm grew with that brand to become one of the major radio distributors on the West Coast.

The firm of Thompson & Holmes, Ltd., is a consolidation of two former wholesalers, the Frederick H. Thompson Co., San Francisco, and Holmes & Crane, Oakland.

The organization's early activities were confined almost exclusively to radio, but it soon became apparent that good business judgment called for diversification. About 15 years ago, other lines of appliances were taken on.

The program of expansion, and the addition of other lines was continued until Pearl Harbor, when it became apparent that the manufacturing of radios and other appliances would be either greatly curtailed or completely stopped, the firm added various items in the furniture and houseware field.

"The results of our activities during the past several war years have been exceedingly gratifying," says Robert E. Crane, secretary of the company. "Our sales have just about kept pace with the pre-war years and we have enjoyed modest profits."

As far as their future planning is concerned, Thompson & Holmes expect to expand, add new lines, and retain many of the items they now distribute, and they look forward to a big business in radios and appliances as well.

Mr. Crane explains that the planned new activity will necessitate quite an increase in the sales organization. "We don't want to get away from the idea of specialty selling, and in order not to overburden the minds of our salesmen with a lot of items, it is our plan to have at least three separate selling organizations, and split up our various lines with each group of salesmen, so each will have a relatively few things to sell. This will allow each to aggressively concentrate on and promote a few specialty items."



C. Sharrub, vice-president and general manager, Thompson & Holmes, Ltd.

Thompson & Holmes were recently appointed exclusive distributor for the "Universal" appliances, manufactured by Landers, Frary & Clark.

Commenting on the firm's new connection, Mr. Crane said: "We will act as exclusive distributors for Universal major appliances, such as washing machines, vacuum cleaners, electric ranges, etc., and at the same time we will also carry a complete line of Universal small appliances."

"We plan to give Universal the same type of aggressive and intelligent distribution that has characterized our efforts on other lines that we have been so successful with in the past," concluded Mr. Crane.

New Buffalo Firm

A certificate of partnership has been filed in Buffalo, N. Y., for Bars Radio & Electronics Parts Co., 91 Allen St., by Morris and Rose Farber and Alfred and Beatrice Bergman.

Postwar Emerson Meetings

Distributors continue to visit the offices of Emerson Radio & Phonograph Corp., New York, to discuss present problems and postwar aspects. Among those recently there were M. Beckwith, vice-president of Hub Cycle & Radio Co., Inc., Boston, Mass.; R. K. Van Zandt, president of Van Zandt Supply Co., Hunting-

ton, W. Va.; Morey Lasky, president, Mayflower Sales Co., St. Louis, Mo.; Paul Jenkins, president, and K. G. Gillespie, sales manager, of Jenkins Music Co., Kansas City, Mo.; and Herman Goodman, president of Emerson Radio of Washington, D. C.

Oscar Ray Re-elected

Oscar Willard Ray, vice-president of Times Appliances Co., Inc., New York City, has been re-elected for a second term as president of the Photographic Manufacturers & Distributors Assn.

Electrical Apparatus Co. In New Location

Electrical Apparatus Co., formerly at 1018 Commonwealth Ave., Boston, Mass., is now located at its new office building, 1200 Soldiers Field Rd., Boston.

The new offices have complete facilities for the sale and demonstration of the products of the manufacturers represented by this organization. A completely equipped demonstration laboratory, with instruments and other facilities, is in charge of a qualified engineer to furnish information and give demonstrations of

(Continued on page 78)

Returns to Civilian Life



Lieutenant Colonel Harold A. Glasser completes tour of active duty with U.S. Army. Prior to entry into active service, Col. Glasser was appliance division sales-manager of Bruno-New York, Inc.

G.E. IS BUILDING **MORE**

MILITARY RADIO EQUIPMENT

THAN ANY OTHER HOME-

RADIO MANUFACTURER

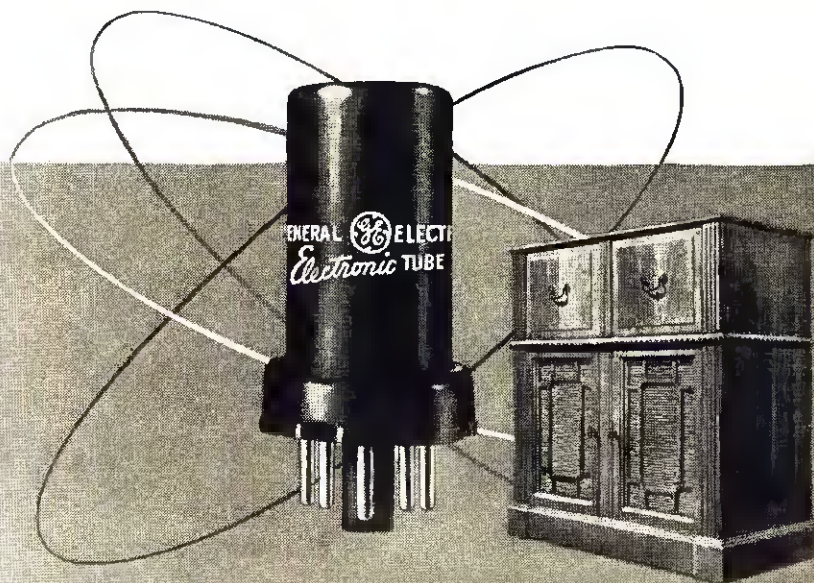

GENERAL  ELECTRIC

FIRST IN RADIO, TELEVISION, AND ELECTRONICS

MEASUREMENTS AROUND THE WORLD



In far off
SIAM

WHEN A CALIBRATION OF .206-INCH IS MADE

it's called a "KABIET"

In the Radio and Electronics Field, far more delicate measurements make it imperative to use calibrating instruments of unflinching accuracy.

THIS EXPLAINS WHY

MONARCH

Measuring—Calibrating—Testing Equipment
is universally accepted for dependable
performance.

Our post-war plans will result in higher
quality for your post-war products!

MONARCH MFG. CO.
2014 N. Major Ave. Chicago, Ill.

(Continued from page 72)

Lots of Scarce Tubes at High Prices, Seen

Editor, Radio Retailing Today:

I was glad to see your article in the February issue under "Washington Wavelength," concerning distribution of tubes, but I don't think enough is being said and done about this. I think the servicemen should get together and protest this good and loud.

I have been buying parts and tubes from at least ten different distributors, and haven't been able to get an #12SA7 tube from any of them for almost a year, and yet I receive letters from obscure and unknown distributors and retailers offering me #12ST7 and other scarce tubes but at 30 to 50 percent more than the list price on popular brand tubes.

For example, #32Z5 tube listing at 90c with all popular manufacturers, is \$1.55 each if you buy from three to six of these tubes. The so-called distributors solicit orders for 100 or more tubes—in fact, some of them won't accept orders for less than fifteen.

If some are able to secure enough "hard-to-get" tubes to accept orders for 100 or more types from one serviceman, why can't the distributors with whom I've spent hundreds of dollars, give me at least one #12SA7 in a year?

JULES WALICKI

*Jules Walicki, Jr.,
Radio Sales & Service,
Pittsburgh, Pa.*

Says "Diverting" Articles Do Not Solve Problems

Editor, Radio Retailing Today:

Would like to register a mild criticism of the content of RADIO RETAILING TODAY. Articles that "brag" of doing the almost physically impossible may be diverting, but they do not help solve such worries as *how* to get enough batteries to keep sets working on the farm, and how to get tubes.

I would like to see more articles and circuits on the use of electronic devices in industry, on sound, on communication systems, on airport control towers, and new apparatus.

W. PELHAM, Mgr.
*Harmony Radio Concern
New Harmony, Ind.*

Editor's note: To Dealer Pelham, thanks for the suggestions. Regarding the "almost physically impossible" articles—unusual things take place during these unusual times. We check as carefully as is possible to maintain accuracy in publishing accounts of what dealers are doing. A few "believe it-or-nots" follow: A one-man shop recently had 300 sets awaiting repair—A servicer, living on a farm, and having no delivery service and *no telephone*, finds hundreds of customers are willing to come to him—a crippled servicer, obliged to use a crutch, picks up and delivers customers' sets, using buses and taxis for transportation—a radio shop owner travels 75 miles a day to work in a warplant; gone 12 hours, then works 3 hours each night in his shop—a servicer, almost totally deaf, doing a good job.

NEW LETTER CONTEST for SERVICEMEN!

**ELEVEN 1st PRIZE WINNERS IN 5 MONTHS
IN CONTEST No. 1!**

Yes, sir, guys, the hundreds of letters received were so swell that *double* first prize winners had to be awarded each of the first four months and there were *triple* first prize winners the fifth and last month . . .

SO — HERE WE GO AGAIN!

Get in on this NEW letter contest—write and tell us your *first hand* experiences with *all* types of Radio Communications equipment built by Hallicrafters including the famous SCR-299!

RULES FOR THE CONTEST

Hallicrafters will give \$100.00 for the best letter received during each of the five months of April, May, June, July and August. (Deadline: Your letter must be received by midnight, the last day of each month.)

For every serious letter received Hallicrafters will send \$1.00 so even if you do not win a big prize your time will not be in vain.

Your letter will become the property of Hallicrafters and they will have the right to reproduce it in a Hallicrafters advertisement. Write as many letters as you wish. V-mail letters will do.

Military regulations prohibit the publication of winners' names and photos at present . . . monthly winners will be notified immediately upon judging.



hallicrafters RADIO

THE HALLICRAFTERS CO. MANUFACTURERS OF RADIO AND ELECTRONIC EQUIPMENT, CHICAGO 16, U.S.A.

THE STANDARD OF QUALITY FOR A THIRD OF A CENTURY



The Ultimate and Exclusive



DYNAMIC MUTUAL CONDUCTANCE

Tube Testers

MEASURING IN MICROMHOS

● HICKOK Tube Testers constitute the ultimate and exclusive in commercial testers. They do more than merely determine the presence or absence of cathode emission. They measure the tube output in MICROMHOS and still secure 100% modulation. Model shown also measures Volts, Ohms, Milliamperes, Capacity, Inductance, Leakage, and Decibels with accuracy. Other models in portable, counter and display types. Get your name and address on file now for new catalog ready soon.

THE HICKOK ELECTRICAL INSTRUMENT CO.
10523 Dupont Avenue, Cleveland 8, Ohio

Pays its own way...

Improves your Radio Service

(Continued from page 74)

all types of electrical units and component for control systems.

Another unusual feature is an Assembly Hall for holding engineering meetings and showing moving pictures and slides of electrical installations, applications and manufacturing processes.

Mid-Lantic "Reps" Get Six New Members

The Mid-Lantic Chapter, Representatives of Radio Parts Manufacturers, announces the following new members: A. S. Van Osten, 109 Erie St., Camden, N. J., and D. M. Gawthrop, 3108 W. Pen St., Phila., Pa. Associate membership were conferred on Lester B. Free, 52 Drexel Bldg., R. H. Williams, 1338 Lincoln-Liberty Bldg., J. C. Muggleworth 1343 Arch St., and J. J. Mahoney, 134 Arch St., all Philadelphia.

The new Mid-Lantic officers are as follows: Sam Jeffries, president; W. S. Trinkle, vice-president; Norman Sewel secretary; J. H. McKinley, treasurer. Delegates to the national convention Jun 6-7, Hotel Stevens, Chicago, are Sam Mac Donald, Doc Lowery and Norma Sewell.

Other "Rep" New

A. S. Detsch, 245 Security Bldg., Portland, Ore., and F. W. Taylor, 14 Brampton Rd., Syracuse, N. Y., have been elected members-at-large.

Robert Milsk, secretary of the Wolverine Chapter, reports that J. P. Davenport and Fred Stevens have been designated as delegates to the national convention.

Russ Hines, James P. Hermans and Elmer Hodges were recently elected delegates to the national meeting of the organization to represent the California Chapter, according to an announcement received from L. Logan, secretary.

Promotions Announced By G. E. Supply Corp.

Charles Webster, for several years appliance sales manager for the Baltimore branch of the General Electric Supply Corp., has been promoted to district manager of appliances for the Chesapeake division of the company. In his new post he will make his headquarters at Washington. The Chesapeake division embraces, Washington, Baltimore and Wilmington, Del.

In assuming this new post, Mr. Webster succeeds C. T. Shropshire, who held the post for many years, and who has been promoted to manager of the Philadelphia branch of the General Electric Supply Corp.

Frank Lambert, for a number of years service manager for the Washington D. C., branch of the General Electric Supply Corp., has been appointed appliance sales manager of the Baltimore branch, succeeding Charles Webster.

(Continued on page 80)

Who'll be your Best Customer?

[AFTER THE WAR]

Here is a beach scene, Summer 194V. From Maine to California it will be duplicated . . .

a boy . . . a girl . . . a companion radio.

It's a far jump from the beaches of Italy or the shores of Kwajalein, but our boys are going to be here, someday soon, we hope. When

Victory comes, they'll come buying portables, home radios, car radios,

combinations and record players. With the finest merchandise that equipment and engineering skill can produce, Trav-Ler will be ready for them. Will you? Now is the time to start planning how to effectively sell this huge market. Future-Minded Distributors . . . you are invited to write regarding future Trav-Ler Karekola sales plans.



No. 3 in a series of advertisements depicting your post-war market for radios, combinations and record players.

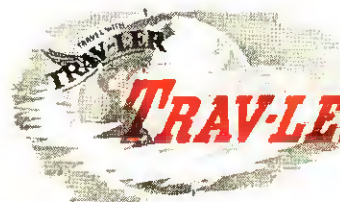

TRAV-LER KAREKOLA RADIO AND TELEVISION CORPORATION

1028-34 W. Van Buren Street, Chicago 7, Illinois
MANUFACTURERS OF QUALITY RADIO AND COMMUNICATION EQUIPMENT

Don't Spare the Horses!

when using

TURNER *Microphones*

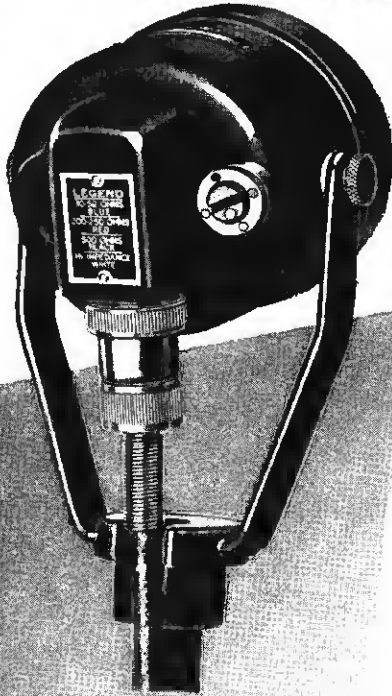

They're Built to "Take It"!

Indoors or out — under any climatic or acoustic condition, the rugged dependability of Turner Microphones is something you can always depend upon. That's why Turners are in such great demand for vital war communications.

GIVE a Turner Microphone the stiffest test you can devise. Use it in any spot, from the finest broadcasting studio to the jungles of the South Pacific, and you'll still be completely satisfied with the beautifully clear, concise and intelligible transmission. "Sound Engineering" combined with rugged construction and stream-lined modern beauty make Turner Microphones first choice of the most critical veterans.

Model U9-S, illustrated, is typical of the dependability and versatility of Turner Microphones. A twist of the switch at the back of U9-S lets you work at your choice of 50 or 200 ohms, 500 ohms or hi-impedance. For full information and prices, write the Turner Co. Now.

*Pioneers in the
Communications field*

The **TURNER** Co.

Cedar Rapids, Iowa



Free

We have a Free
Turner Microphone
Catalog for you.
Write us today.

Crystals Licensed Under Patents of the Brush Development Co.

Crosley Names New Louisiana Distributor

The Electric Supply Co. Inc. of Shreveport, La., has been appointed distributor for the Crosley Corp., in northern Louisiana.

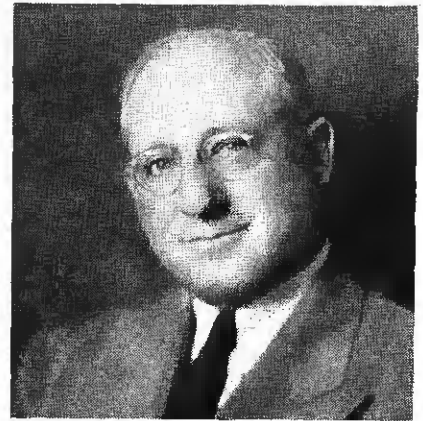

Abry S. Cahn

ana, it has been announced by J. H. Rasmussen, commercial manager of Crosley

The Electric Supply Co. was incorporated in 1937 after having been operated for several years as a partnership between Abry S. Cahn and Henry F. Cahn, co-owners of the Cahn Electric Co., a contracting and retail store in Shreveport which had operated continuously for the past 36 years.

Both Abry S. Cahn, president, and Henry E. Cahn, vice-president of the company, have had 36 years' experience in the electrical business. W. A. Wakema, manager of the company, has had wide experience in electrical jobbing during the past ten years.

Plans New Building

As soon as building conditions permit, The Electric Supply Co. will occupy a new location at 1104-1110 Marshall Street. When remodeled, the new store will have a frontage of 120 ft. in a location six blocks from downtown Shreveport and readily accessible to all parts of the city.

Lehr Co. Changes Name

Lehr Auto & Electrical Supply Co., 16 W. 61st St., New York City, announces a change in the corporate name to Lehr Distributors, Inc. There will be no change in management, personnel or policy.

New Buyers' Guide and Index by Segal Co.

Henry P. Segal Co., 221 Columbus Ave., Boston, Mass., has ready for distribution, "Engineers' and Buyers' Guide and Index," an alphabetical listing of radio, electronic, electrical and similar components, assemblies and material. The booklet also includes other valuable reference material. The Segal organization is a member of "The Representative of Radio Parts Manufacturers."

• HOW WILL
YOU SELL
TELEVISION?

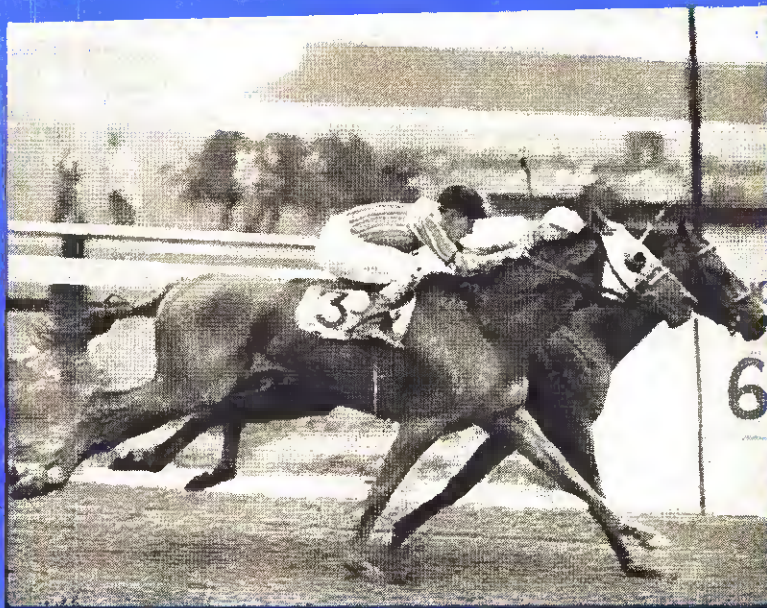

FARNSWORTH PIONEERING POINTS THE WAY!



It's been quite a while since you had a *brand-new kind of product to sell*. But the greatest new merchandise in years — *television* — is on its way!

Farnsworth pioneered in creating modern electronic television. Farnsworth is pioneering in making its market — the market *you* will supply.

Your radio experience will be valuable in selling television . . . the market will be similar. Store demonstration will be more important — new demonstrating techniques will bring people in crowds, help you sign orders. You'll shift from ear-appeal to *eye-and-ear-appeal* . . . with a chance to sell a whole new idea for the home.

Farnsworth advertising is preparing the way. Explaining television in a practical manner. Unfolding the great possibilities. Building confidence. Establishing a trade name — *Farnsworth* — that will help you sell.

Today, Farnsworth's only job is war production — with enlarged facilities and new skills that will stand in good stead when television is available nationally. For home television is coming — after Victory, and as soon as studios and telecasting stations are in operation.

Then your job and ours will be to *sell* television sets — to the ready market our advertising is creating today.

See the Farnsworth television advertisements in April 3 *Newsweek*, April 15 *Collier's*.

**FARNSWORTH
TELEVISION**



• Farnsworth Television & Radio Corporation; Fort Wayne 1, Indiana. Farnsworth Radio and Television Transmitters and Receivers; Aircraft Radio Equipment; the Farnsworth Dissector Tube; the Farnsworth Phonograph-Radio; the Capehart, the Capehart-Panamase.

Thinking of after the War?

We want to make the acquaintance of dealers and distributors alert enough to do their post-war planning now; men and organizations who will recognize the sweeping post-war sales potentials of the high fidelity tape recorders bearing the Fonda name.

Here are a few Fonda features that will explain why our instruments will be in demand—high quality recordings at low cost; continuous recording for eight hours without supervision; automatic instantaneous playback; provides a permanent, indestructible record. The Fonda method of recording is based on our own exclusive patent which is the result of years of engineering and development effort.

Let's start getting acquainted today by dropping us a note requesting our free literature!

Fonda

FONDA CORPORATION
245 EAST 23RD STREET, NEW YORK 10, N. Y.
Designers and Manufacturers of Precision Recording Equipment



The Fonda Recorder
for the Home



The Fonda Recorder
for monitoring by
Commercial Airlines and
Radio Broadcast Stations



The Fonda Recorder
for Industry

Philco Sales Set New High Record

Even after voluntary price reductions totaling \$18,803,929 on Army and Navy work, sales of Philco Corp., last year set a new high record in the company's history by a wide margin, and amounted to \$116,395,598, an increase of 70 per cent over 1942 sales of \$68,505,979, according to the company's annual report signed by John Ballantyne, president and Larry E. Gubb, chairman of the board of directors, which has been released for publication.

Tie-Ins for Record Sales

(Continued from page 41)

many other national and community organizations. In this connection Victor offers dealers a 20" x 20" 2-color poster.

• Sonora releases album MS-460 featuring the Mutual network star, Pauline Alpert, "Sparkling Piano Melodies." "First Lady of the Keyboard" includes in this collection such universal and varied favorites as "In a Country Garden," "Sweet Sue," "Where or When" and "Hungarian Rhapsody No. 2."

• Classic is proud of Hit discs No. 7075, "Tess's Torch Song" and "Now I Know," and No. 7084, "Things Ain't What They Used to Be" and "Cherry Red Blues" (released April 3rd), along with album, "Echoes of Harlem," which includes "Honeysuckle Rose" (to be released shortly), all of which feature Cootie Williams. At present Williams and his orchestra are on vaudeville tour with Ella Fitzgerald and the Ink Spots.

• Musicraft has just completed redesigning its albums with an eye to assisting the dealer in self-service merchandising. New colors and modern designs are paramount. New recording artist for Musicraft is Phil Brito, featured Blue network singer, who lists among his laurels recent selection as pin-up boy by the WACS, and "The boy they would like to get lost with in a jeep" by the girls at General Aircraft. Among his biggest hit recordings for Musicraft: "Little Did I Know," "My Heart Tells Me," "Surrey with the Fringe on Top." His latest: "Besame Mucho," No. 15017.

• Nothing short of a stroke of genius is Capitol's signing of Jerry Colonna, the "wildman" on the Bob Hope NBC network show. He will sing and comment in his own novel fashion to the accompaniment of Paul Weston's Hollywood Orchestra. No news yet as to when these discs will be ready. But we believe they will be worth waiting for!

Custer's Last Stand...

1876: Major General Custer's forces were isolated from reinforcements through lack of communications, which might have successfully averted disastrous defeat.

1944: Today each military unit, regardless of size or location, even the individual soldier can have instantaneous communication through the miracle of modern radio.



Sentinel

The part played by Sentinel's radio-electronic equipment in this war, cannot be told in detail now—except that Sentinel facilities have gone *all out for victory*. Production for military needs has been enormous.

From a civilian standpoint this means new equipment has been added, new skills and methods developed, all of which will be reflected in better, more saleable, more profitable Sentinel products for Sentinel dealers.

SENTINEL RADIO CORPORATION
2020 RIDGE AVENUE, EVANSTON, ILL.

*Quality
Radio Since
1920*

"I USE IT EVERY DAY"*

Well Dad how's your job doing these days. You know the stuff your factory puts out. Well I see it every day and that's no lie. You see at

HE WHO WROTE the above is a switchboard operator in an anti-aircraft battery somewhere overseas. Such outfits have daily contact with communication wire.

Picture this boy's thrill at seeing the old familiar CORWICO diamond trademark so far from home!

We're shipping a lot of wire over there . . . that's why it's so scarce over here . . .

**Excerpt from a letter to William Ogert of Cornish Wire Company from his soldier son, abroad with a fighting unit.*

cornish



WIRE COMPANY, INC.

15 Park Row, New York City, New York

"Made by Engineers for Engineers"

Sees Large Increase in Postwar Appliance Sales

An annual average of 78 per cent more Westinghouse electrical household appliances will be sold during the first 5 postwar years than were distributed in either of the peak years of 1940 and 1941, according to coast-to-coast estimates made by 102 distributors of the company's electric appliance division at Mansfield, Ohio.

The survey covered 13 appliances and was based on the assumption that the first postwar year estimated would be the first year in which industry would be free to produce without restrictions of government control or material shortages.

T. J. Newcomb, sales manager, explained that the postwar business estimates were made to assist Westinghouse appliance factories in making plans for the years to follow the end of the war.

Appliances Show Increase

Following are the average increases in sales of 13 different appliances estimated for the first 5 postwar years as compared to the average sales for 1940 and 1941, with all percentages representing anticipated increases:

Refrigerators, 48 per cent; ranges, 72; water heaters, 118; washers, 97; ironers, 183; fans, 29; vacuum cleaners, 67; small air conditioners, 138; roasters, 36; irons, 58; small appliances, 66; water coolers, 82, and dishwashers, 818.

Hoffman Poster Campaign is Launched

Hoffman Radio Corp., Los Angeles, Cal., has initiated a poster campaign in California, Washington and Arizona. The showing is appearing in 22 cities, with half of the 261 panels illuminated. The campaign is designed to acquaint the trade and the public with the name of the Hoffman Corp., as successors to the Mission Bell and Mitchell-Hughes radio concerns, and also to illustrate the postwar sets as proposed by this company.

Sylvania Workers on Air

Experts in radio tube production and other electronics devices, more than 5,000 employes of Sylvania Electric Products Inc., in Salem, Mass., and nearby towns are enthusiastic broadcasting fans every Saturday night. They have their own program, "Sylvania Showtime", a half-hour variety show aired over WESX in Salem, from the main ballroom of the Hotel Hawthorne.

**BUY
WAR BONDS**

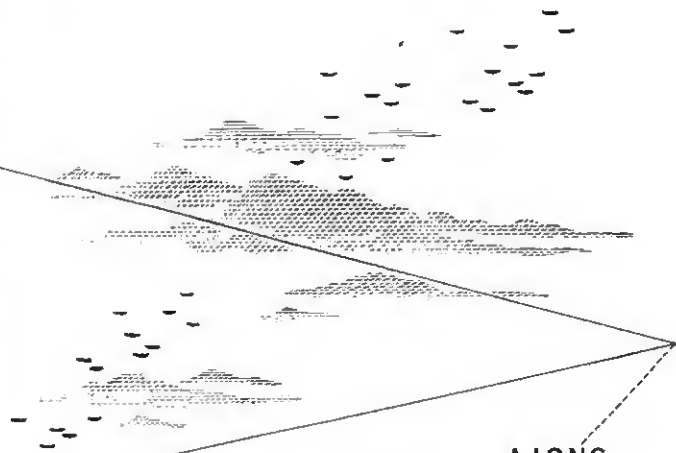

A LONG-
STANDING POLICY
OF NON-DIVERSIFICATION
THAT HAS MADE ZENITH

GREAT YESTERDAY—
GREAT TODAY—

AND WILL MAKE ZENITH

GREATER TOMORROW!

★ This singleness of purpose—Radionics exclusively—is the basic reason why you can be sure of the quality of Zenith's post-war line.

Everything Zenith is making today is for the armed forces or for rehabilitation, but Zenith has never lost sight of the obligation owed to its many distributors and retail dealers. It's one of the chief reasons why we have striven—successfully—to hold our engineering and production organizations intact, why we have not fanned out into other home appliance fields but have chosen to adhere strictly to a policy of

Radionics exclusively—why we have concentrated our every effort toward providing to our entire dealer organization the most valuable *radio* franchise in the country.

Naturally, through our war efforts we have discovered many new techniques and production efficiencies all of which will be adapted to civilian manufacture. Full concentration on the Zenith long distance radios of the future is assured by Zenith's announced policy of "Radionics exclusively"—your guarantee of finer Zenith radios for tomorrow.

ZENITH RADIO CORPORATION
CHICAGO 39, ILLINOIS

★
Better than Cash

WAR SAVINGS STAMPS AND BONDS



Announce Dates for "Reps'" Convention

National secretary David Sonkin, of the Representatives of Radio Parts Manufacturers, has announced that the organization is planning to hold its annual convention in Chicago, June 6 and 7. The board of governors, of which Dan Bittan is chairman, will convene on Tuesday afternoon, June 6 in Room 10 of the Hotel Stevens. The delegates' meeting will follow on June 7, in Room 15. Final arrangements will be posted on the bulletin board in the lobby of the hotel.

In the meantime chapters are naming delegates to the convention, and are also active in scouring new members.

The Chicagoland Chapter recently added to its roster, Alfred Crossley, 549 W. Randolph St., Chicago, Ill. Jules Bencke of 578 Arcade Bldg., St. Louis, Mo., has joined the Missouri Valley Chapter. L. D. Marsh of 110 Battery St., Seattle, Wash., has just been accepted as a member-at-large.

Chapters Elect Delegates

The following delegates to the national convention were designated by the Chicagoland Chapter: Royal A. Stemm, Harry Halinton and Walter Bauman. The New England Chapter will be represented by Raymond Perron and Harrison Reynolds.

Emerson Official Explains Dealers' Postwar Role

According to Charles Robbins, vice president of Emerson Radio & Phonograph Corp., New York City, postwar retailers will play an important part in the dissemination of a greatly increased supply of merchandising due to vastly expanded production facilities.

"Dealers will have to share in the responsibility of moving larger quantities of merchandise through to the consumer," asserted Robbins, "so as to maintain the higher economic tempo that will be necessary to provide jobs to the millions of people essential to continued prosperity."

"There are certain broad programs that retailers can embark upon immediately. They should, for example, make plans for modernization of their stores, both internal and external. Proper display facilities, both in the store and window, should be crystallized and prepared. Effective lighting to enhance the general over-all appearance should be given considerable thought.

"The dealer should give much thought to the installation of a modern up-to-date service department, to the rehiring and training of service and sales personnel, to proper direct mail and other advertising campaigns. In a nutshell, the dealer should begin now in organizing and planning for the type of establishment that will stamp his store as the leading source of supply for civilian goods in his neighborhood," concluded Robbins.

Sentinel Appoints Two

The appointment of two new representatives, well known in the radio field, is announced by Sentinel Radio Corp., Evanston, Ill.

E. J. Goetze, 2020 Walnut St., Kansas City, Mo., has been appointed to cover Kansas, western Missouri and Oklahoma. James Alexander, 3058 N. Pennsylvania Ave., Logansport, Ind., has been named for Indiana, northern Kentucky, southwestern Ohio and southeastern Illinois.

JOINS MEISSNER COMPANY



Oden F. Jester, veteran sales executive, has been named a vice-president of Meissner Mfg. Co., Mt. Carmel, Ill. Mr. Jester recently resigned as sales manager of Utah Radio Products Co., Chicago.

For the extra measure of record-playing pleasure

GAROD PERMATONE PHONO NEEDLES



It's his extra measure of tone and rhythm that has made Shep Fields one of America's favorite orchestra leaders. In Garod Permatone Phono Needles, there's an extra measure, too . . . the extra measure of careful design and construction, which means maximum quality in reproduction. Try them at home. You'll see why dealers say — Garod Permatones for the extra measure of sales and record-playing pleasure.



GAROD RADIO CORPORATION 70 Washington St., Brooklyn 1, N.Y.



History of Communications Number Three of a Series

PRIMITIVE COMMUNICATIONS

An early communications instrument was the Tom-Tom—to prove its efficiency, it is still used by the natives of Africa. Tom-Tom signals are “Beat out” along jungle lined rivers, but even then distance is a handicap, and “repeater” stations are many.

Like all means of communications, other than voice communication, translation of coded signals must take place in which additional skill is required, and another chance of error is presented. As in the case of the Tom-Tom beater: knowledge of the Tom-Tom code was restricted to a special family within the tribe, and was handed down from generation to generation.

Today, Universal Microphones in the hands of the fighting men of the Allied Armed Forces are performing a simple but vital need in electronic voice communications where their quality and efficiency are bringing us one step closer to victory.

< Model T-30-S, illustrated at left, is but one of several military type microphones now available to priority users through local radio jobbers.

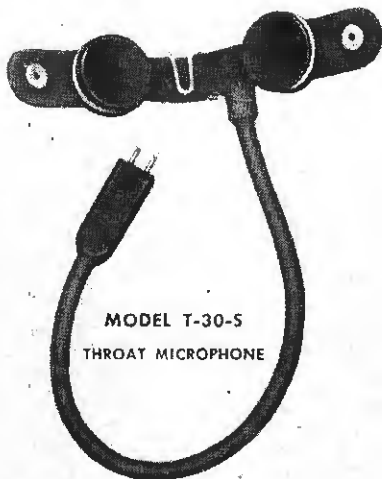

UNIVERSAL MICROPHONE CO., LTD
INGLEWOOD, CALIFORNIA



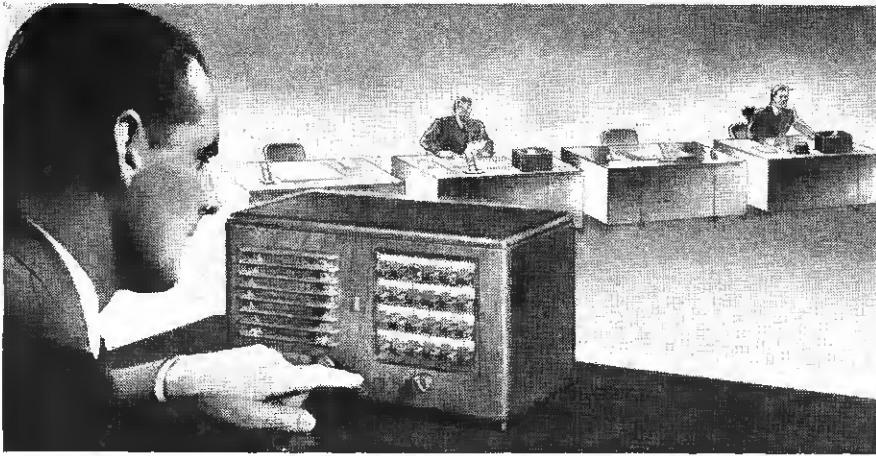

TELE
WEBSTER ELECTRIC
Teletalk *Compensates*
REG. U.S. PAT. OFFICE
for Empty Desks

Every business man in your vicinity is faced with an epidemic of empty desks . . . the need to do more work . . . do it with less help.

Teletalk Amplified Intercommunication can go a long way to increase the productive time of executives everywhere by giving them quick, easy, personal contact with every department of their business.

It will pay you to sell them Teletalk . . . show them the

modern, effective and economical answer to the pressing man-power problem. Teletalk is inexpensive, easy to operate . . . uses the electric light circuit. It is available in just the proper size for either a large or small office or industrial plant.

If you are not now selling Teletalk, you should get in touch with us at once. Write us today. Let us show you how Teletalk can become a profitable addition to your business.

LET'S ALL BACK THE ATTACK—
BUY EXTRA WAR BONDS



Licensed under U. S. Patents of Western Electric Company, Incorporated, and American Telephone and Telegraph Company.

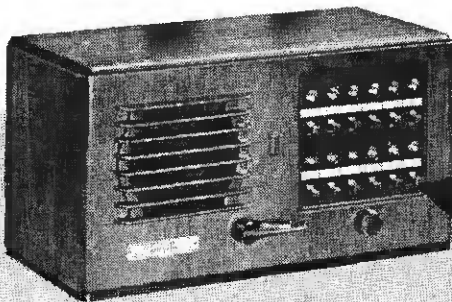

WEBSTER ELECTRIC COMPANY, Racine, Wis., U. S. A. • Established 1909 • Export Dept.: 13 East 40th St., New York (16), N. Y. • Cable Address: "ARLAB" New York City

WEBSTER ELECTRIC

"Where Quality is a Responsibility and Fair Dealing an Obligation"

Three-Bagger "E"



F. A. Poor, founder of Sylvania Electric Products, Inc., with an employee, receiving pennant from Maj. Gen. Wm. H. Harrison, when each of 3 plants won coveted award

New Westinghouse Radio Program on

"Top of the Evening," new radio program featuring the King's Men, the Ken Darby Chorus, the piano duo of Ted Saldenburg and Edward Rebner, and Sally Sweetland, new singing star, is announced by Westinghouse Electric and Manufacturing Co.

The new program, heard Mondays, Wednesdays and Fridays at 10:15 EWT over the Blue Network, features favorite songs of today and yesterday. Information concerning specific Westinghouse products such as motors, electronic applications of various types, lighting and lamps and domestic appliances is given by Gayne Whitman, announcer.

John Charles Thomas will continue to be heard on the Westinghouse Sunday afternoon program with John Nesbitt, Victor Young's Orchestra, and the Ken Darby Chorus.

Norge is Making Line of Victory Gas Ranges

In the same plant in which the company is continuing to turn out a large volume of bottom cowl and other special assemblies for the famous Thunderbolt fighter planes, besides gun turrets for dive bombers, Norge Division of Borg-Warner Corp., has resumed the production of a specified number of kitchen gas ranges, it was announced by Howard E. Blood, president of Norge.

Production of the ranges, which will be shipped to more than 7,000 Norge distributors and dealers throughout the United States, will in no way interfere with production of war materials at the company's Muskegon Heights' plant where the stoves are manufactured.

The ranges will be available to housewives and other consumers through certificates issued by local rationing boards, it was stated.

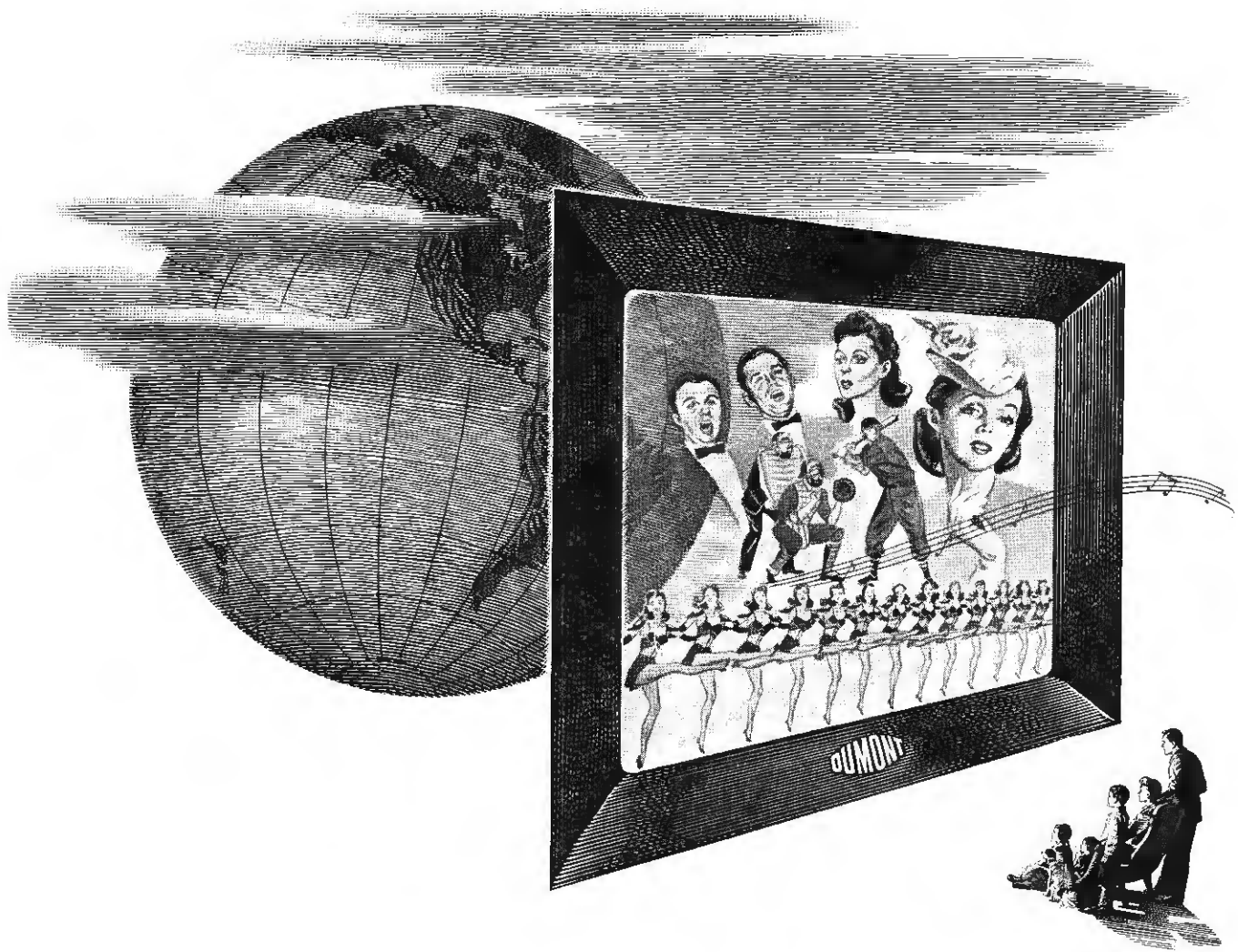

THE BIGGEST WINDOW IN THE WORLD

Each one of your best customers is going to buy a brand-new window for his home—and you're going to sell it . . . sooner than you think.

The new window is the television screen—the biggest window in the world. Through it, a man can *see* the world.

When, shortly after victory, you put DuMont television receiver sets into the homes of your best customers (as someone surely will) you'll be doing right by them . . . and by yourself.

That's because DuMont Receivers will be

technical and artistic triumphs . . . sets of distinction designed for people who want the finest, truest kind of television reception.

When your best customers buy DuMont they're buying a *complete* background in electronic achievement . . . the specialized engineering that has produced the DuMont Cathode Ray Tube and many other outstanding patents.

Preparing for your receiver market is no longer a *distant* opportunity. *Now* is the time. You're welcome to inquire of DuMont.

DUMONT

Precision Electronics and Television



ALLEN B. DUMONT LABORATORIES, INC., GENERAL OFFICES AND PLANT, 2 MAIN AVENUE, PASSAIC, N. J. TELEVISION STUDIOS AND STATION W2XWV, 515 MADISON AVENUE, NEW YORK 22, NEW YORK

New Cardwell Vice-Pres.

Joseph K. Fabel has been elected by the directors of the Allen D. Cardwell Corp., Brooklyn, N. Y., to fill the newly-created office of vice president in charge of sales. Mr. Fabel has resigned the post of assistant district manager, N. Y. section of the Army-Navy electronics production agency.

Stevens With Majestic

John Stevens has become associated with Majestic Radio & Television Corp., Chicago, as an important production executive, according to an announcement by E. A. Tracey, president. Mr. Stevens was connected with the Zenith Radio Corp., since 1924.

Mintz With Admiral Corp.

Seymour Mintz has been appointed director of advertising and publicity for Admiral Corp., Chicago. He succeeds Wally Aeeverman who became sales promotion manager of the company. Mr. Mintz recently resigned as advertising manager of Electric Household Utilities Corp. Previous to that, he was sales supervisor of radios and major appliances for Montgomery Ward retail stores.

To Direct Bendix Sales

J. S. Sayre, president of Bendix Home Appliances, Inc., South Bend, Ind., will take over direction of sales, assuming the former post of Vern Calkins, who has resigned because of ill health.

18 Million Civilian Tubes for 1944 Says WPB

Despite the granting of civilian production for certain consumer durable goods lines, the War Production Board officially stated toward the end of March that there is no early prospect for resumption of manufacturing of radio sets or even of civilian radio home receiver tubes because plant facilities, component parts, labor and raw materials are still required in huge quantities for the continuation of electronic-radio apparatus for the armed forces. However, any forecast, the WPB stated, might be upset at any time by an unexpected turn in military events.

Increase Possible

Surveying the radio tube situation, the WPB emphasized that at least 18,000,000 "MR" (maintenance and repair) tubes are anticipated to be distributed to civilians during 1944. There is a possibility of greater production of civilian home receiver tubes because manufacturers are permitted to produce "over-runs" above their allotted quotas, if their military orders are completed and facilities and labor are available. Much of the credit for this allotment to civilian radio tube production by the WPB with the approval of the armed services, is due to the efforts of Frank H. McIntosh, chief of the Domestic and Foreign Branch of the WPB Radio and Radar Division.

41 Million Tubes Needed

The 18,000,000 tubes, however, represent less than half of the normal replacement in home sets. While it does not view this program sufficient to meet all civilian needs, the WPB does believe this schedule will correct and alleviate the emergency shortages. Actually the number of tubes needed for civilian sets in 1944 is estimated at more than 41,000,000 due to the backlog of demand, longer radio listening hours and the use of old and repaired radios. Under the plan devised by Mr. McIntosh in conjunction with the industry, a more equitable distribution of radio tubes to civilians has been worked out.

Battery Situation

No improvement is also expected in the shipments of dry cell batteries to civilians this year, and the industry is expected to produce about 3,750,000 radio battery packs, the production figure it achieved in 1943. Last year, all but 2 per cent of these batteries went to rural users. The WPB predicts that the quantity of essential civilian batteries manufactured this year will be limited to the capacity of equipment not adaptable for production of military type batteries used in walkie-talkies, bazookas, signal lights, and other war equipment.

KEN-RAD

ELECTRON TUBES



KEN-RAD

EXECUTIVE OFFICES

OWENSBORO · KENTUCKY

EXPORTS 15 MADRE STREET NEW YORK

TRANSMITTING
TUBES

CATHODE RAY
TUBES

SPECIAL
PURPOSE TUBES

RECEIVING
TUBES

INCANDESCENT
LAMPS

FLUORESCENT
LAMPS



WHATEVER YOU WANT IN

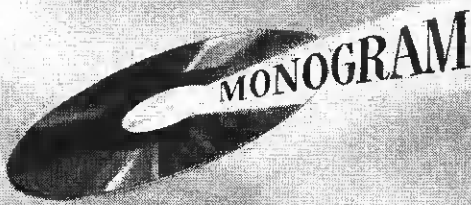

RECORDING DISCS

PRESTO HAS IT . . . the smoothest cutting disc you ever used, easier on your cutting needles, simpler for your less experienced personnel to handle because it doesn't require fussy adjustments of the cutting needle to make a noiseless recording.

PRESTO HAS A DISC FOR EVERY PURPOSE . . . the GREEN LABEL DISC, glass base, for your finest recordings . . . the RED LABEL DISC, glass base, same as the green label but lower priced because it has some tiny imperfection, somewhere, that prevents its being passed as a Presto "first" . . . the MONOGRAM DISC, composition base, for reference recordings, economical both because it costs less and because it's coated with the same high grade recording medium used on the Presto glass base discs. MONOGRAMS won't cause the needle wear experienced with other low priced discs.

PRESTO ALUMINUM BASE DISCS are again

available but only in limited quantity and only for military, government and commercial uses. Broadcasting stations and recording studios may use aluminum discs for recording commercial transcriptions that must be mailed or which must be protected from breakage because of their importance. But it is our prime responsibility to make these discs for the armed forces and release only the excess for commercial use during wartime.

KINDLY ORDER IN ADVANCE OF YOUR REQUIREMENTS. We regret that we are no longer able to clear all disc orders daily. No serious delays but no shipment within the hour on telegraphed orders.



Presto Recording Corporation, New York 19, N. Y., U. S. A.

World's Largest Manufacturers of Instantaneous Sound Recording Equipment and Discs

There are Two Sides

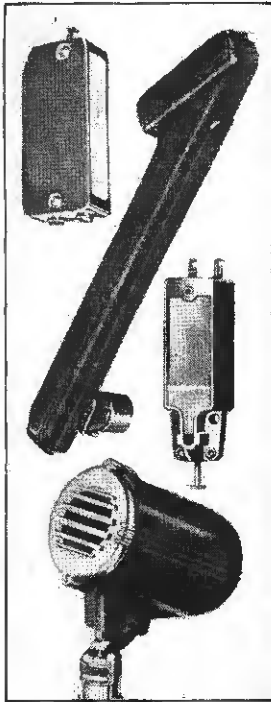

TO EVERY STORY

On the One Side, Astatic continues to manufacture Microphones, Pickups, Cartridges and Recording Heads for various branches of the military service and accredited industrial or public address uses.

On the Other Side, Astatic is using its extensive facilities to manufacture Co-axial Cable Connectors for wartime radio communications and radar equipment.

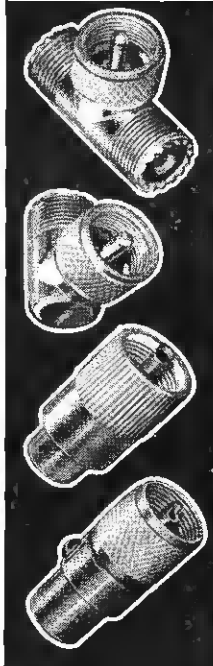

ASTATIC

IN CANADA:
CANADIAN ASTATIC, LTD.
TORONTO, ONTARIO.

THE ASTATIC CORPORATION
YOUNGSTOWN, OHIO

ALLIANCE "Even-Speed" Phono-motors

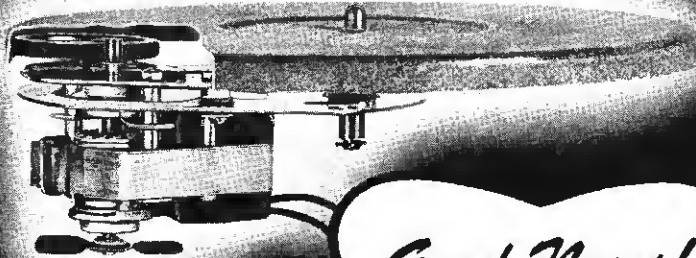

Good News!

ALLIANCE RESUMES PRODUCTION on One Standard Model

• We are now able to return to production of one standard variation of Alliance Model 80 Phono-motor, according to the following definite specifications and on the production plan explained below.

STANDARD SPECIFICATION No. 811—Turntable No. Y-278-S2; 110 Volt, 60 cycle, 9" Model 80
Production must be on the following practical basis under present conditions where there are no large volume priority orders—namely, by accumulating a sufficient quantity of small orders with necessary priority and making periodical single production runs at such time as the quantity of accumulated orders is enough to make this practical. Priority orders (currently AA-3 or higher, with Government Contract Number or Military end use only) must allow delivery time required to obtain a minimum practical production run; to procure material for all orders in hand, and make one production run of the one type standard unit only, for shipment on the various accumulated orders. • Check the above against your requirements, and if you have proper priority, communicate with us.

REMEMBER ALLIANCE—Your Ally in War as in Peace!

AFTER THE WAR IS WON, WE WILL TELL YOU ABOUT SOME NEW AND STARTLING IDEAS IN PHONO-MOTORS

ALLIANCE MANUFACTURING COMPANY
ALLIANCE, OHIO

Talk on Television



Allen DuMont, president DuMont Laboratories, left, and Thomas F. Joyce, RCA Victor, at New York Sales Executives Club meeting, where Joyce spoke of bright outlook for postwar television

Evolution of Prewar Products Seen by Abrams

"Despite the many stories of recent fantastic radio and electronic discoveries, peace-time products immediately after the war will be largely an evolution of prewar products," says Ben Abrams, president of Emerson Radio and Phonograph Corp., New York.

"However, our engineers and laboratories will devote their energies to the development and adaptation for peace-time use of the electronic discoveries and developments now being utilized for winning the war. As soon as postwar conditions make it commercially feasible to do so, we intend to produce and place upon the market those peace-time developments which we find practical and useful," declared Mr. Abrams.

To Make Compact Models

"Emerson has been a pioneer and leader in the field of small radio, and in the firm belief that compact sets will continue to be the backbone of the industry, and to be demanded by the public as the best combination of convenience, technical performance and value, we plan to make compact models of television receivers, small 'FM' radio receivers, table model phonograph and radio combinations, and pocket and portable radio receivers, in addition to the table model electric and farm radio sets. Indications are that the public will be more insistent than ever upon attractive styling of its peace-time products," concluded the Emerson executive.

New Hoffman Engineer

Lewis E. Scott, formerly superintendent of the Resident School of American Television, and more recently industrial engineer with Consolidated Aircraft and Douglas Aircraft, has joined the staff of Hoffman Radio Corp. of Los Angeles, in the capacity of methods engineer.

ENVY OF AN INDUSTRY...

MEISSNER'S FAMED
"PRECISION-EL"



Men of Long Experience: You don't have to be much of a judge of character to know that here's a man who knows his job from A to Z, takes pride in his work. He's typical of the "precision-el" who turn out Meissner's famous line of "Precision-Built" electronics products.

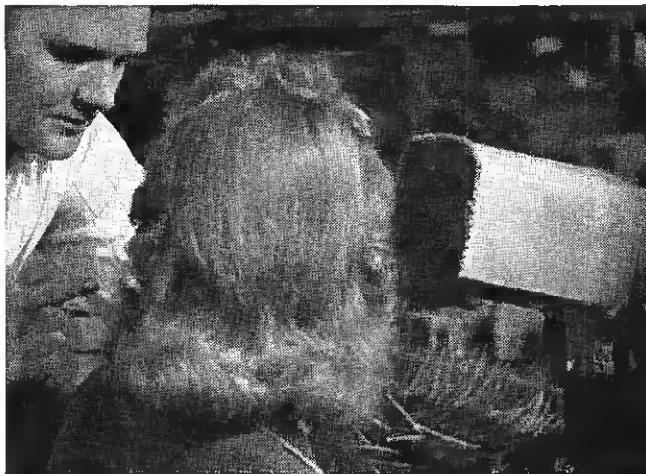

The Meissner "Know How" has long been envied by many in all phases of the electronics industry. There are said to be more electronics technicians per thousand population in Mt. Carmel than in any other American city.



Mighty Unit of America's Might: As far as the camera's eye can reach, it seems, are row upon row of skilled workers engaged in producing vital electronics material for Uncle Sam. This is one unit of the main Meissner plant at Mt. Carmel, Illinois.



Four of a Kind: From miles around Mt. Carmel, entire families have turned to electronics for a place in Meissner's great postwar plans. This family group of four employes, combining many years of varied experience, is about to report at one of the big gates.

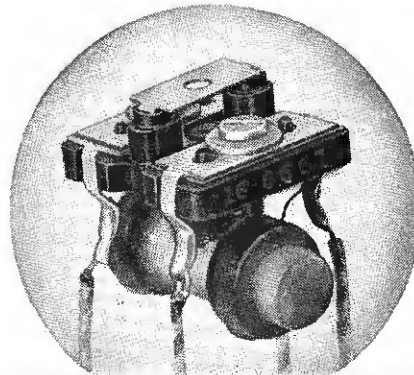

ULTRA COMPACT!

Right — it's Meissner's "mighty midget" — a Cartwheel 1. F. Transformer only 1 3/8" by 1-1/32" by 1 1/4" high! The perfect replacement unit for the many sets using odd shapes and locations for their 1. F. transformers. Excellent, too, for countless AC-DC or Midget type receivers. It's complete with dual trimmers, with one-piece molded plastic trimmer base. Unshielded. For 456-kc only. Our supplies, of course, are limited.



MEISSNER

MANUFACTURING COMPANY • MT. CARMEL, ILL.

ADVANCED ELECTRONIC RESEARCH AND MANUFACTURE

Join the TALK-A-PHONE Jobber Family NOW

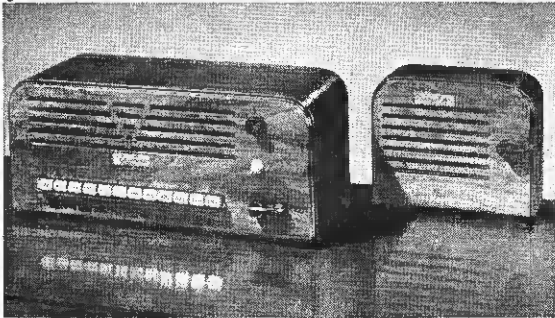

Illustrated above is the Chief—Push Button controlled—a low price-fitting companion to the now famous Super Chief line.

Jobbers, seeking an ideal inter-communication line, should investigate Talk-A-Phone. Especially they should ask for (a) a copy of a colorful new catalog presenting complete specification and reference data. Highly illustrated. (b) Beautiful three color poster illustrating the Talk-A-Phone in use. 3 ft. x 2½ ft., mounted on heavy cardboard for standing.

Here's why Talk-A-Phone is the ideal inter-communication line for Jobbers:

1. Talk-A-Phone offers America's most complete line of inter-communication . . . A unit to fill every need . . . to fit every condition . . . Super Chief, Chief, Deluxe and Standard models.
2. Scientifically designed, on fundamentally sound principles. Manufactured by craftsmen of unusual skill. Rigidly inspected.
3. Modern, inviting appearance. They please the most fastidious executives.
4. An extraordinary value for the price. Acknowledged to offer "most for the money". Sales resistance is low.
5. Talk-A-Phone follows a rigid policy of Jobber Protection.
6. You can get delivery now.

TALK-A-PHONE MFG. CO

1211 WEST VAN BUREN STREET
CHICAGO, ILLINOIS

1. MAKE MONEY TODAY
2. BIG POST WAR OPPORTUNITY
3. EFFECTIVE SELLING HELPS

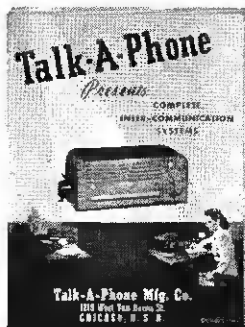

Talk-A-Phone

Get **EVERYTHING!**

Standardize on
STANCOR

Transformers

Call your nearest Stancor Jobber...
or write us for his address

STANDARD TRANSFORMER CORPORATION
1500 N. HALSTED STREET • CHICAGO



Hotpoint Sales Bulletins Popular With Dealers

More than 14,500 retailers have applied for monthly mailings of "Planned Electrical Merchandising," a study of retailing principles aimed at postwar conditions, since the bulletins were first announced in December, according to G. H. Smith, general sales manager, Edison General Electric Appliance Co., Inc., makers of Hotpoint electric appliances.

"The study upon which the bulletins are based includes retailing fundamentals for all lines of business," Mr. Smith said. "Starting with the first bulletin which sums up a discussion of a good store

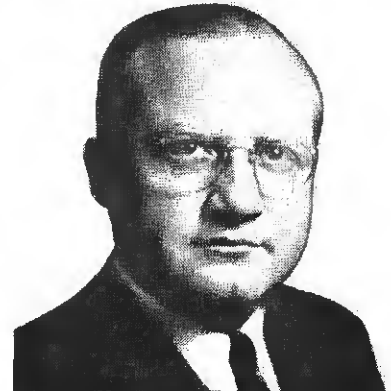

G. H. Smith

Sees his company's sales bulletins aiding retailer in postwar planning

location by listing 23 rules which should be followed in selection, hundreds of facts have been assembled to show how and why given practices must be followed to succeed.

"This is not a study of Hotpoint's business, nor do we mention our policies or products in the bulletins. The material deals with basic retailing procedures which must be followed by retailers, if they are successfully to meet highly specialized competition after the war," Mr. Smith said. "We retained the best retailing authority to prepare these demonstrations of how to sell, display and advertise. Thousands of personal contacts and years of study are behind every fact presented, and an effort has been made to reduce retailing generalities to simple rules of action."

The first six subjects in the series announced are:

1. Plan Now for the Appliance Store that Will Help You Sell.
2. How to Choose a Good Location for an Appliance Store.
3. Planning Your Type of Business.
4. How Customers Know Appliance Stores.
5. Floor Arrangements Which Help You Sell.
6. Advertising Brings Them into the Store.

Dealers not receiving the series are asked to write to the company. They will receive bulletin No. 1 the first month, and the others in succeeding months.

SPRAGUE TRADING POST



A FREE Buy-Exchange-Sell Service for Radio Men

IMPORTANT NOTICE!

We discourage offers to buy or sell anything beyond the O.P.A. ceiling prices, and will not knowingly accept such ads for Sprague Trading Post.

FOR SALE—Crosley 6-B1 6V d-c with built-in vibrator B supply. Tubes test OK. 550 kc. to 17 mc. 3 bands, table model. \$50. L. C. Chapman, Rt. 1, Columbus, Miss.

TUBES TO SWAP OR SELL—Can furnish small quan. most all types of tubes. Prefer trading, but will sell. Need V-0-M, tube checker, all types test eqpt. R. J. Rowell, Apt. 103, 613—5th St. S.W., Birmingham 7, Ala.

WILL SWAP Corona port. typewriter for Hallcrafters S-29, Sky Traveler, Echophone, or other small port. receiver. H. Pilzer, 207 Dickson Bldg., Norfolk, Va.

WANTED—All-wave coils, F-M coils, and any old type battery sets, also 4-gang .000365 tubing cond. M/Sgt. Wm. A. Uporsky, 348th NFS, SAAB, Salinas, Calif.

WANTED—New speaker for #42 Arvin auto radio. C. B. Dibble, Sidney Center, N. Y.

WANTED—D-C voltmeter, 500V min. and higher. Cash. Herbert Mori, 12-6-E, Hunt, Idaho.

WANTED—2nd hand record player, any type; also a-c and d-c voltmeters and ammeters. J. C. Wise, 710 Fifth St., New Martinsville, W. Va.

WANTED—Late tube tester and set analyzer, comb. or otherwise. Supreme or Precision preferred. H. P. Boone, 18 S. Ribberia St., St. Augustine, Fla.

FOR SALE—Electronic Dev. Co. V-0-M, perfect cond., 4" meter, steel case, #34, 3-30-300-600V; R1X100 ohms; 3-30-300 mls. \$27. L. Hill, So. Lewis, 1311 E. Harding, Chicago 23, Ill.

WANTED—Rider's manuals complete. L. D. Pritchard, P. O. Box #320, Pittsfield, Mass.

WILL SWAP Aerovox 95 LC checker for standard Sprague Telohmke. Louis Bauerfeind, Box 125, Hortonville, Wis.

WILL SWAP Astatic JT-30 with JT-40 xtal units, 35T and 60T tubes, 9001, 9002 and 9003 u-h-f tubes, plus cash for modern tube checker or what have you? Everett G. Taylor, 31 S. College, Dayton 7, Ohio.

WANTED—3" oscilloscope, Supreme 546 or RCA 155. Also voltohmmyst. John Cloyd, 507 E. 3rd St., Hamilton, Ohio.

WILL TRADE Smith Corona port. typewriter for Rider's manuals from No. 5 and up, or what have you? Manuel Vasquez, 4609 S. LaFlin St., Chicago 9, Ill.

FOR SALE—Never used: RCA ultra-high freq. tubes, 10-832 @ \$17 ea.; 20-9003 @ \$2.50 ea.; 4-9002 @ \$2 ea.; R.F. ammeter Weston #507, 0-3, \$8.50; Taylor T-20 @ \$2.25. Donald A. Brienen, 970 School Pl., Green Bay, Wis.

WANTED—N.R.I. V-0-M and sig. generator combination or Sprayberry tester put out about 2 years ago. Bill Brown, 12 Clark St., Henderson, Ky.

WANTED—Tube tester in good condition, Superior or R.C.P. Harry Acosta, 140-08 182nd St., Springfield Garden, L. I., New York.

WANTED—Rider's manuals complete, also other radio books and manuals. F. R. Wentz Radio Service, Millerstown, Pa.

WANTED—Professional or semi-pro recorder complete, or less mike or amplifier. L. E. Bartlett, 1 1/2 Bordeaux Place, Asherille, N. C.

WANTED—Hallcrafters S-29 Sky Traveler in A-1 condition, preferably battery-operated. Cash. Sgt. Walter J. Baron, 20613549, Cannon Co. 136 Inf., APO 961. c/o Postmaster, San Francisco, Calif.

WANTED—3" or 5" oscillograph, also frequency modulator. Cash. W. B. Hines, 39 Alden Ave., Portsmouth, Va.

WANTED—New or used Echophone EC-1 complete with tubes. Cash. Lt. Harry E. Merrill, Two Rock Ranch, Petaluma, Calif.

WANTED—Any of following with instructions: Jackson #637, Hickok #510X, Supreme #504A, or Precision #920P. Also Solar QCA condenser checker and tubes: 1A7; 1N6; 1H5; 1B7; 3Q5; 1A5; 12SK7; 12SA7; 12SJ7; 3Z25; 12SQ7; 50L6; 117Z6; 12A8; 12K7; 6A8; also local tube sockets. Cash. Potters Radio Service, P. O. Box 698, Homer, La.

FOR SALE—Phillo sig. generator #077, factory reconditioned. Audio oscillator and radio-freq. coverage in 5 bands, modulated or unmodulated, 120kc to 35.0 mc. \$35. CWO Robert Whipple, George Field, Lawrenceville, Ill.

TUBES FOR SALE—RCA #360, \$25; RCA #211, \$8. Each used only 5 hrs. Lt. E. H. Whittaker, 5243 Ellsworth Avenue, Pittsburg 6, Pa.

WANTED—12SF7; 117P7; 12SA7; 12A8 tubes; also AC DV milliammeter. V. J. Kalcir, 506 West 44th St., Austin, Texas.

WANTED—Sig. generator with output voltmeter, battery-operated similar to Readrite #557. Aris L. Hasford, Double Springs, Ala.

WANTED—Tube tester in good condition. P. M. Barney, 1122 Vine St., Hamilton, Ohio.

WANTED—Tube tester, pocket-size tester, bench tester, etc. W. H. Neaves, 5003 Homer St., Dallas 6, Texas.

URGENTLY NEEDED—Meissner sig. booster in any condition; Rider's vols. 9, 10; 1A7 and 1R5 tubes; any Hallcrafters or Howard receiver with 2-stage RF, crystal phasing and tuning meter; Hy-tron tube characteristics manual, M. J. Blackwell, c/o Marine Hospital Memphis 5, Tenn.

FOR SALE—Majestic super-dynamic speaker G-A, 12", complete, A-1 condition. C. W. Boverer, Rt. 3, Box 293, Winston Salem, N. C.

FOR SALE—30-watt amplifier in new cond., \$40; Triplet tube tester #1210A, no chart, \$10; Readrite tube tester #431 with chart, \$10; five soldering irons; one Yaxley pin plug; Philco wireless station set, like new, \$15; Readrite 3-meter tester #111, \$20; five hand drills, etc. Will consider trade for pocket V-0-M or 2-speed phono motor and turntable. L. R. Benorden, Box 52, Llano, Texas.

WANTED FOR CASH—Supreme or Hickok V-0-M and signal generator. R. H. Dunkin, 117 Sidney St., Longview, Texas.

WILL TRADE Emerson 110 a-c motor, 1750 rpm, pair of #12's, one #11, pair #66's, two pair headphones, Bud oscillator and xmiller parts. Want small Stancor xmiller or similar make. Vernon Robertson, 2018 College St., Columbus, Miss.

FOR SALE—Two 301-0 to 1 mil. Weston meters; 1 Weston 30-0-30 galvanometer; 5 lb. Kester solder; 75 new RCA tubes, all the 6V and some 12V series; 200 resistors; volume controls; by-pass condensers; dial lites; telephone generator hand crank; 300-watt electric soldering iron, etc. E. O. Cole, 3251 W. Madison St., Chicago 24, Ill.

FOR SALE—25-W crystal controlled trans. 3 stages 1250, 1000, 800 V. D.C. power supply, Hallcrafters receiver, vibroplex. McElroy oscillogone, key, milliammeter, voltmeter, ear phones, and ham tubes. Lyle Soray, 231 Langdon St., Toledo 9, Ohio.

WANTED—0-1 mil. meter or smaller. Must be accurate. Also want sig. generator. Will pay cash, or swap tubes, parts, etc. D. Glaser, 229 Amherst St., Brooklyn 29, N. Y.

WANTED—Superior channel analyzer, also Superior tube and set tester #1280. Cash, or will trade brand new Meissner F-M receptor #9-1047A, 8-tube a-c 41.2 to 50.4 mc. Ben Koop, 4320 N. Mobile Ave., Chicago 34, Ill.

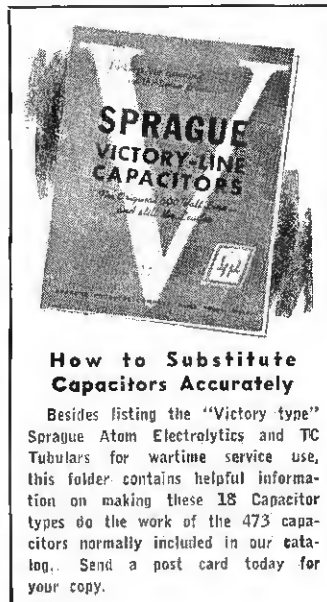

How to Substitute Capacitors Accurately

Besides listing the "Victory type" Sprague Atom Electrolytics and TC Tubulars for wartime service use, this folder contains helpful information on making these 18 Capacitor types do the work of the 473 capacitors normally included in our catalog. Send a post card today for your copy.

WANTED—Complete set Rider's manuals, Superior channel analyzer, and 12-, 35-, and 117-volt tubes. W. G. Cordell, 3921 Shields Blvd., Oklahoma City 9, Okla.

WANTED FOR CASH—Late model tube checker and set tester, counter or portable. Smith Radio & Appliance, 3466 N. Oakland Ave., Milwaukee 11, Wis.

WANTED—Schematic of Truelone AC-DC receiver #DT31, Series A. Cash. C. E. Kelley, 330 Shrewsbury St., Holden, Mass.

WANTED—Good all-wave receiver, Hallcrafters S-20R preferred, but other types accepted. Harold Crosby, Rt. 1, Box 215, Baxley, Ga.

SWAP OR SELL—Superior tube checker, tubes, filters, and cabinets. Want 4.5 reflex camera. Gerald Samokofsky, 527 Bedford Ave., Brooklyn, N. Y.

FOR SALE—R.C.P. #411 Supertester, \$12; Weston #565 3-meter set analyzer. Both in good operating condition. Victor H. Berger, 300 Grandview Ave., Gordon Heights, Wilmington, Dela.

YOUR OWN AD RUN FREE!

This is Sprague's special wartime advertising service to help radio men get needed parts and equipment, or dispose of radio materials they do not need. Send your ad today. Write PLAINLY—hold it to 40 words or less. Due to the large number received, ads may be delayed a month or two, but will be published as rapidly as possible. We'll do everything we can to help you—and the fact that thousands of pieces of Radio-Electronic equipment are in operation today

as a result of sales or "swaps" made through The Trading Post offer convincing proof of the far-reaching effectiveness of this service.

Different Trading Post ads appear monthly in Radio Retailing-Today, Radio Service-Dealer, Service, Radio News, and Radio Craft. Sprague reserves the right to reject ads which do not fit in with the spirit of this service.

HARRY KALKER, Sales Manager

When buying Capacitors—please ask for Spragues by name. We'll appreciate it!

SPRAGUE PRODUCTS CO., Dept. RRT-44, North Adams, Mass.



SPRAGUE CONDENSERS KOOLOHM RESISTORS

Obviously, Sprague cannot assume any responsibility, or guarantee goods, services, etc., which might be exchanged through the above advertisements

Underwood With Majestic Radio Corp.

Carroll E. Underwood, recently resigned from Zenith Radio Corp., has been elected assistant treasurer of Majestic Radio & Television Corp., Chicago, according to an announcement by E. A. Tracey, president.

Spring Housecleaning

Spring housecleaning at the plants of the Universal Microphone Co., Inglewood, Cal., this year includes removal of camouflage paints and nets, and repainting of exteriors, new display signs on outside walls, and neon displays on roofs.

Daniels New Sales Manager for Speed Queen

President H. A. Bumby announces the appointment of Paul J. Daniels, Milwaukee, as general sales manager of Barlow & Seelig Mfg. Co.

Mr. Daniels comes to the Speed Queen organization with a background of 25 years experience in business administration, sales management and organization.

He is well known to the trade, having introduced and supervised the development and national distribution of the Wagner "Komb-Kleaned" sweeper for the past 11 years, with a record of increased distribution and volume each year.

Baker Heads Admiral's Appliance Division

Lee H. D. Baker has recently been appointed vice-president in charge of major appliances of Admiral Corp., Chicago. In this capacity, he will direct and

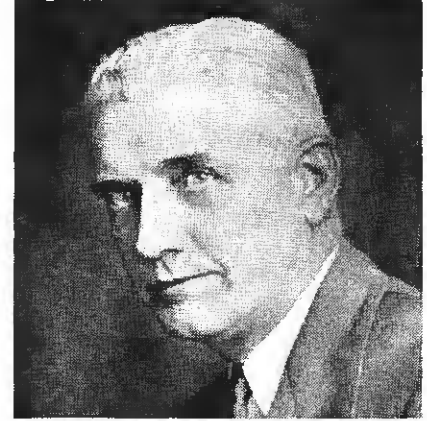

Well-Known Merchandiser

coordinate all activities of the newly acquired Stewart-Warner appliance divisions which will be merchandised under the Admiral name.

Mr. Baker has had years of experience in the merchandising of major appliances. Prior to his association with Admiral, he was sales manager of Gale Products division, Outboard Marine Mfg. Co. Previous to this, he was in charge of manufacturer's equipment sales for Universal Cooler. He was also vice-president of Copeland Refrigeration Corp., from 1934 to 1937.

Announcing the new appointment Ross D. Siragusa, president of Admiral, said: "To insure the same progress we had as radio manufacturers, Mr. Baker's new major appliance division will be supported by an entirely independent staff of designers, research, and production engineers."

Haines Making Wire-wound Resistors

The Haines Mfg. Co., 248-274 McKibbin St., Brooklyn, N. Y., has entered the wire-wound resistor field, according to an announcement by S. H. Harper, chief engineer. A complete line will be offered to industry, and at present the company is building the resistors for Army and Navy use. Catalogs on the new product are now available.

Belmont Aids Blood Drive

50,000 posters reproducing an advertisement for the Belmont Radio Corp., Chicago, currently appearing in national magazines, are being distributed through the 35 blood donor centers of the Red Cross. In the reproduction, Belmont's signature is eliminated from the copy and space is allowed for imprint of the local addresses of the blood donation centers. Belmont assumes the cost of the lithography as a contribution to the war effort.

"THE HELP SITUATION" by Lariat



HERE'S HELP YOU CAN Share with the Services

The members of the radio servicing industry can well be proud of the valuable contribution they have made in preparing technicians for specialized work in the armed forces—even if it hasn't been easy to see your help "come in one door and go out the other."

However, there is one important group of workers that you can share with the services—Rider Books. Used in every branch of our armed force, for the training of radio personnel, these books are also making it possible for civilian servicemen to meet their obligation to "keep 'em playing"—even under today's difficult conditions.

Rider Manuals make it easy to trace the circuit in a faulty receiver. Other data in the thirteen volumes simplify your servicing work. Be sure you have a complete set on each of your benches.

Also check the other Rider Books in the list at the right. They're chock full of proven principles that will further speed your work and enable you to make the most of your opportunities to serve your customers and your country.

RIDER MANUALS (13 VOLUMES)

Volumes XIII to VII.....\$11.00 each volume
 Volumes VI to III..... 8.25 each volume
 Abridged Manuals I to V [1 volume]....\$12.50
 Automatic Record Changers and Recorders 6.00

OTHER RIDER BOOKS YOU NEED

The Cathode Ray Tube at Work
 Accepted authority on subject.....\$3.00
 Frequency Modulation
 Gives principles of FM radio..... 1.50
 Servicing by Signal Tracing
 Basic Method of radio servicing..... 3.00
 The Meter at Work
 An elementary text on meters..... 1.50
 The Oscillator at Work
 How to use, test and repair..... 2.00
 Vacuum Tube Voltmeters
 Both theory and practice..... 2.00
 Automatic Frequency Control Systems
 —also automatic tuning systems..... 1.25
 A-C Calculation Charts
 Two to five times as fast as slide rule..... 7.50
 Hour-A-Day-with-Rider Series—
 On "Alternating Currents in Radio Receivers"—
 On "Resonance & Alignment"—
 On "Automatic Volume Control"—
 On "D-C Voltage Distribution".....90c each

JOHN F. RIDER PUBLISHER, INC.

404 Fourth Avenue, New York 16, N. Y.
 Export Division: Rocke-International Electric Corp.,
 13 E. 40th Street, New York City Cable: ARLAB

RIDER MANUALS

GIVE YOU THE HELP YOU NEED!



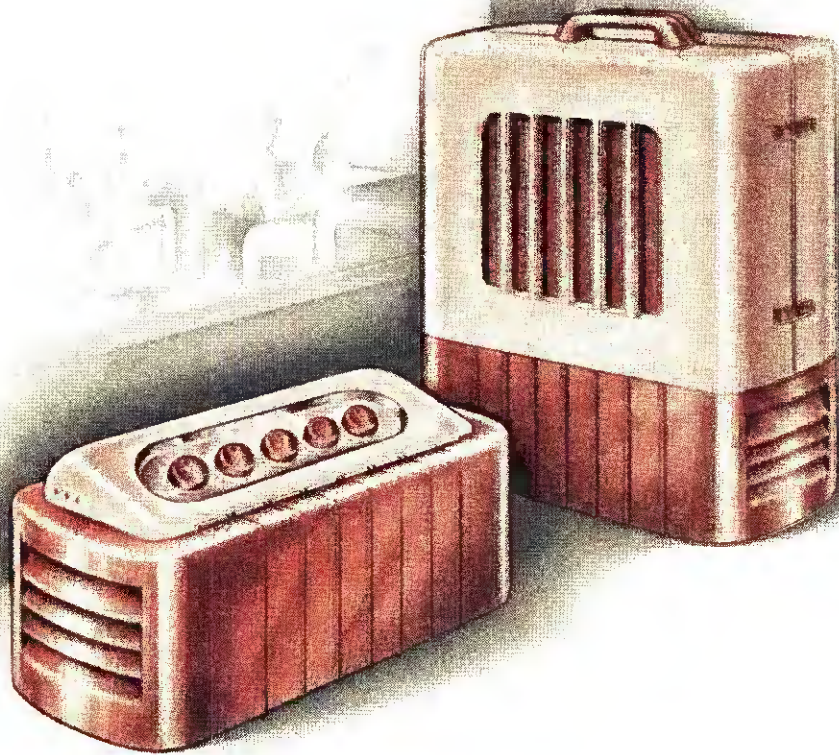

MECK *Sound Equipment*

Neat?—far more than that! For Meck Sound will give you a new concept of performance, as smart as this unique new design. And you can prepare for a new viewpoint on sales opportunity, for tomorrow sound will be Standard Equipment in business, and that will mean big business for you.



NEW YORK: 500 Fifth Avenue
Chickering 4-3545

CHICAGO: 540 N. Michigan Ave.
Delaware 1561

JOHN MECK INDUSTRIES

• CRYSTAL SERVICE • MIRROR-TONE PHONOGRAPHS • MECK SOUND EQUIPMENT • MECK TEST EQUIPMENT

PLYMOUTH, INDIANA, U. S. A.

DUMONT

OIL-FILLED
Ceramic
SEALED
CAPACITORS

For
Dependable
Service
Work

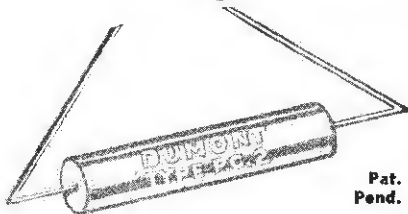

Pat.
Pond.

- For long life in repairs for those expensive high-class service jobs on amplifiers, public address, police and school systems and all good electronics equipment.

All capacitors from .0001 to .25 from 600 volts to 2000 volts.

It is
your duty
to buy
war bonds

Literature and prices
on request

DUMONT
ELECTRIC CO.
MFR'S OF
CAPACITORS FOR EVERY REQUIREMENT
34 HUBERT STREET
NEW YORK, N. Y.

Ellmore Heads Sales for Utah Radio Company

Fred R. Tuerk, president of the Utah Radio Products Co., has announced that W. A. Ellmore, vice president in charge of engineering, assumes the additional duties of heading the sales department



Vice-president W. A. Ellmore

due to the resignation of Oden F. Jester, vice president in charge of sales, who has accepted a position as vice president of Meissner Manufacturing Co.

Well known in the radio industry, Mr. Ellmore has been with Utah for 15 years.

Mr. Tuerk also announced that Chester L. Walker, formerly chief engineer, has been promoted to sales manager in charge of manufacturing and equipment division. Robert M. Karet continues as sales manager of the wholesale and sound division and Frank E. Ellithorpe continues as sales manager of the Carter division.

Dinner for H. C. Bonfig

Over 70 top executives and key men from all departments of Zenith Radio Corp., joined in a welcoming dinner for Henry C. Bonfig at the Palmer House, Chicago. Mr. Bonfig, who resigned his position as vice president of RCA to become vice president in charge of the household radio division of Zenith, was introduced by J. J. Nance, vice president and director of sales.

Second Star for Stromberg Carlson Co.

Three weeks after turning out the greatest month's production in its history, the Stromberg-Carlson Co., Rochester, N. Y., received notice of its award of the second star for the Army-Navy "E" pennant, Wesley M. Angle, president, has announced.

Monaghan Joins Hotpoint

C. P. Monaghan has been named manager of the news and sales training section of Edison General Electric Appliance Co., Inc., makers of Hotpoint Electric Appliances, H. E. Warren, manager, advertising division, has announced.



You're really due a pat on the back. The war effort has made the tools of your profession mighty scarce, but the case is rare that you've failed to keep your customer's radio in operation.

Sure, you've scratched your head over a job that required a substitution. The proper type tube was no longer available. The socket had to be changed, pin connections re-wired. Boy, what fun! But the darn thing worked . . . and did it tickle the set owner! Another receiver snatched from the graveyard.

Thousands of thousands of similar problems are solved daily by you and your brother servicemen. And your sixth sense . . . your test equipment . . . is helping you do the job. We at Supreme are proud that with many servicemen this sixth sense is Supreme Test Equipment.

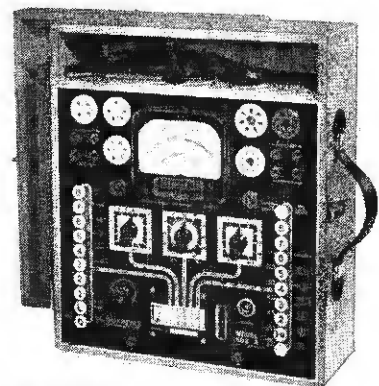

Model 504-A
Tube and Set Tester

Today SUPREME is engaged 100% in war production. When conditions permit, Supreme again will be engaged 100% in producing test equipment that will make YOUR work as a serviceman simpler, surer, faster, more profitable.

SUPREME
SUPREME INSTRUMENTS CORP.
Greenwood, Miss., U. S. A.

Sound Ideas . . .

Sound ideas! On the drafting board . . . in practical engineering . . . in production "know-how". These form a strong union out of which come many Electro-Voice developments. And the latest of these is the Model T-45 "Lip Mike" . . . a noise-cancelling Differential Microphone.

The soundness of Electro-Voice design refinements will be even more effectively demonstrated in peacetime. We have grown up with the field. We know its needs and its possibilities. You may be sure that products born of Electro-Voice ideas will perform a sound function.

Electro-Voice distributors are giving greater understanding to your requirements than ever before. If your limited quantity needs can be filled by any of our Standard Model Microphones, with or without minor modifications, we suggest that you contact your nearest radio parts distributor.

DON'T WASTE WASTEPAPER . . . TURN IT IN TO FIGHT FOR OUR SIDE



Electro-Voice MICROPHONES

ELECTRO-VOICE MANUFACTURING CO., INC.
1239 South Bend Ave. • South Bend 24, Indiana
EXPORT DIVISION: 13 EAST 40th ST., NEW YORK 16, N. Y. — U. S. A. CABLES: ARLAB

POWER for INVASION...

... MEANS BURGESS BATTERY POWER FOR VITAL LIGHTS AND COMMUNICATIONS, LEAVING FEWER BATTERIES FOR YOUR FLASHLIGHT OR RADIO. SO, ALWAYS KEEP THEM IN A COOL, DRY PLACE HEAT WILL SHORTEN THEIR LIFE!

FREE BATTERY SAVER HELPS YOU GET MAXIMUM SERVICE FROM YOUR RADIO BATTERY

Write to BATTERY CO. 43 015

BURGESS BATTERIES
IN THE NATION'S SERVICE
On the Fighting Front—on the Home Front

HOMER G. SNOOPSHAW says:
"When folks understand the many war jobs for batteries, they realize why you can't always supply their needs. Ads like this help explain and remind them that "BURGESS" is the buy-word in batteries."

Named to Sales Post



Arthur F. Gibson has been appointed assistant general sales manager of Stromberg-Carlson Co., Rochester, N. Y. He came with the company in 1912.

Joyce Tells RCA Victor's Distribution Program

Speaking before the post-graduate course for sales executives, at the Roosevelt Hotel, New York, T. F. Joyce, manager, radio, phonograph and television department, RCA Victor division of RCA, explained his company's postwar distribution plans, and discussed wholesale-retail distribution in general. In part, Mr. Joyce said:

"As far as actual sales promotion activities between our company and our specialty distributors are concerned, there is very little of it. Our postwar operation with distributors will be organized, basically, along the following lines:

"1. Supplying the distributor with the products which the public wants and not what the public doesn't want.

"2. A close-working business arrangement with the distributor—operated on facts, figures, market analysis, etc.

"3. A factual analysis of the distributing organization to make certain that the lowest distribution costs prevail.

"4. Supplying the distributor with dealer-to-public sales programs. The goods are not sold until they move from the dealers' hands into the hands of the public.

Costs Must be Cut

"Both the manufacturer and the distributor, as well as the dealer, have an interest—postwar—in reducing the cost of distribution, so that the cost through manufacturer-distributor-dealer channels will be competitive with the cost of distributing goods through mass distributors; i.e., chain stores.

"Chain" Competition

"If the manufacturers, distributors and dealers fail to solve this problem, they must recognize that further inroads will be made into their business by more direct channels. The manufacturer must take the initiative and assume the leadership in developing such programs."

WANTED RADIO REPAIRMAN

Must be thoroughly experienced in all makes and be capable of assuming charge of modern equipped service department.

SALARY \$85 WEEKLY

Plus Commission

Permanent Position Open

Write giving complete details to

CARL'S AUTO ACCESSORIES

162 COURT ST.

WATERTOWN, N. Y.

Workers from essential industries are to provide certificate of availability.



"SEE THIS NEW COMBINATION TELEVISION SET, ELECTRIC REFRIGERATOR AND AIR CONDITIONER"

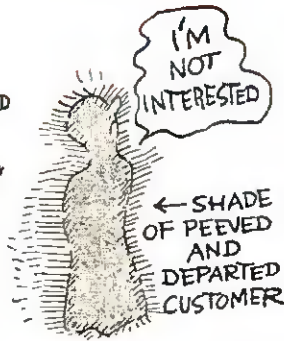
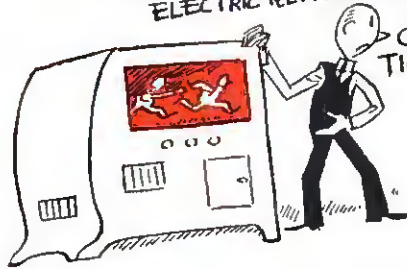

What About Post-War Customer Design? by don herold

We hear an awful lot about the wonderful new products that will appear after the war.

Every factory is designing them or planning to. Every dealer is counting on them to revive his business.

But a lot of factories and dealers are forgetting that customers, as well as products, have to be "planned."

We don't hear enough about post-war customer designing.

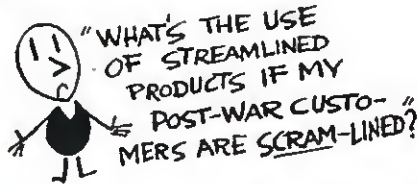

Right now is the time for every radio service man to be "engineering" and blue-printing a nice batch of friendly, receptive, prospective customers for the days to come.

Furthermore, every service man should be doing a whale of a lot of cogitatin' about the post-war products and services he'll be offering to the folks he's warming up now. He'll still be doctoring radios, and maybe he'll also want to sell them their new post-war radios...that is just good

business. And maybe, too, he'll decide to pick up a lot of extra folding money by repairing other electrical equipment in their homes.



Friendly conversation will do wonders to win and keep us customers, even when you can't deliver when and what we want. And it inspires our confidence when you tell us you are using famous parts on our jobs — such as International Resistance Units — whenever you can get 'em.

No. 3 in a series of special messages prepared by America's famous business writer, humorist and cartoonist, Don Herold. . . In sponsoring these Don Herold "broadcasts," IRC pays tribute to the thousands of Radio Service Men who, whenever possible, specify and use IRC resistance units in their work.



INTERNATIONAL RESISTANCE CO.

401 N. Broad St. • Philadelphia 8, Pa.

IRC makes more types of resistance units, in more shapes, for more applications than any other manufacturer in the world.



AMPLICALL

.. KEY TO GREATER
PLANT
EFFICIENCY

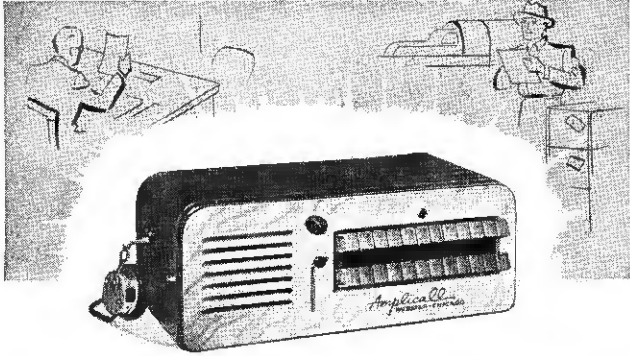

Small, medium and large plants in increasing numbers are finding out through individual on-the-job experiences that **AMPLICALL** Intercommunication, Paging and Sound equipment is the key to an efficiency never before thought possible. Precision craftsmanship, quality materials, perfect tone and dependable day-in and day-out performance are keeping the name **AMPLICALL** out in front. **RAULAND** national advertising too, is keeping the name and exciting story of **AMPLICALL** constantly before one of the largest audiences of top industrial executives of the nation, thus making it possible for **RAULAND** jobbers to increase their present sales and at the same time pave the way to a most profitable future.

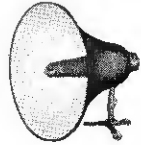
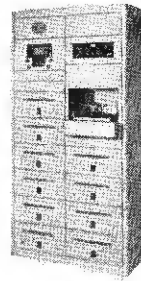

THE RAULAND CORPORATION . . . CHICAGO, ILLINOIS

• *Electroneering is our business* •



RADIO . . . SOUND . . . COMMUNICATIONS

WOMAR

Manufacturers of
RADIO, ELECTRICAL AND
ELECTRONIC COMPONENTS

•

ELECTRONIC PRODUCTS MFG. CORP.
DEXTER, MICHIGAN

Motorola Handie Talkie



Lovely Grace McDonald, featured player in "Gung Ho," poses with a Handie Talkie, originated and developed by Motorola engineers

Philco Gets Another "E"

In recognition of continued excellence in its war production record, the storage battery division of Philco Corp., at Trenton, N. J., has just received its fourth Army-Navy "E" award, it has been announced by M. W. Heinritz, vice president in charge of the division.

To date Philco has received thirteen "E" awards for its outstanding war production record, and the company's operations are at the highest level in its history.

No Rationing for Irons

Electric hand irons, authorized to be manufactured for civilian use, will not be rationed, according to WPB. The controlled production schedule calls for the making of two million irons for civilian use, and 76,000 for the armed forces, Maritime Commission, lend-lease and foreign economic administration.

Resigns from Rola



Lee Golder, who has resigned as secretary and sales manager of the Rola Co., Cleveland, Ohio, had been with company since it was founded

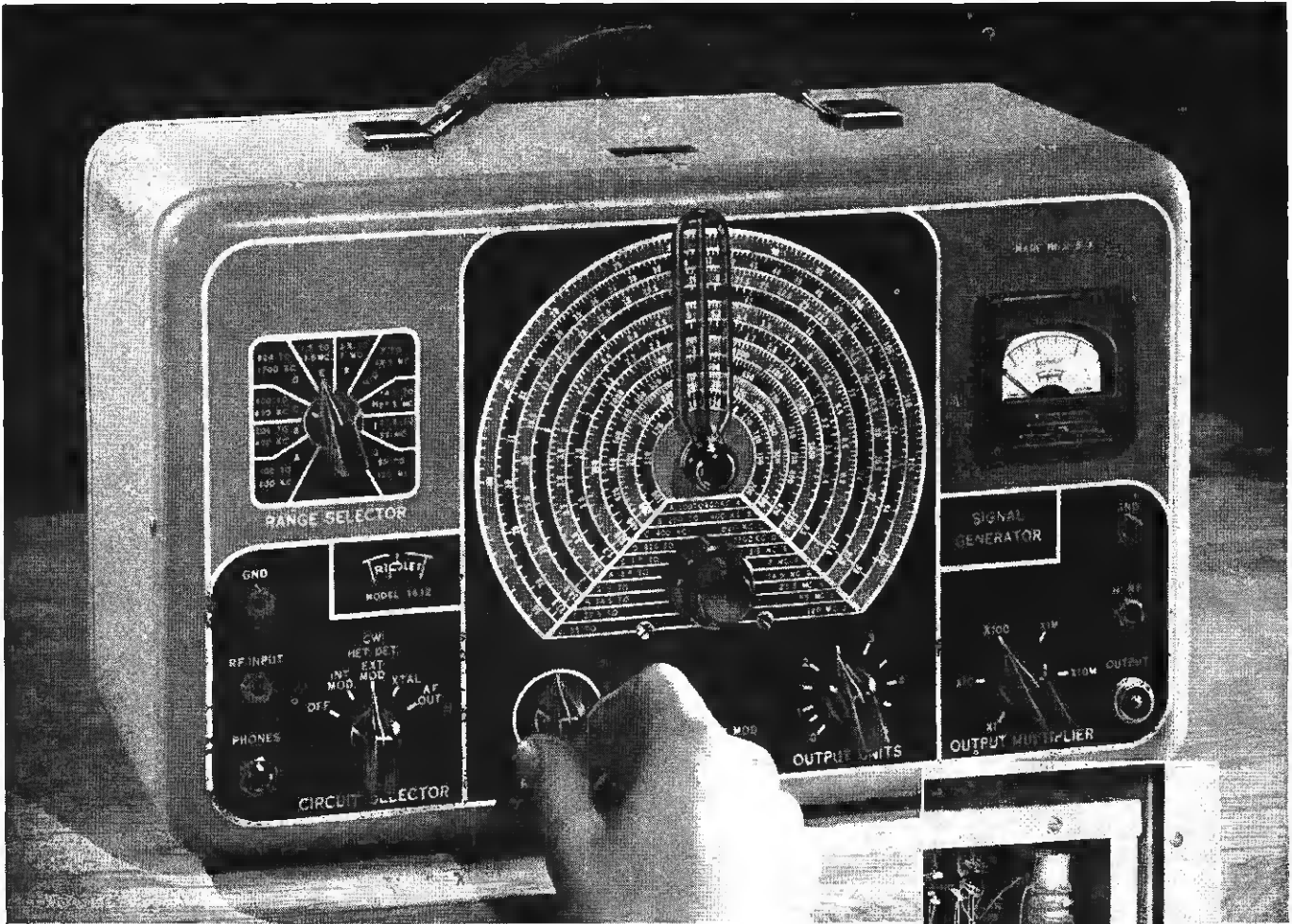

MODEL NO. 1632

Signal Generator

CONTINUOUS COVERAGE — 100 KC. TO 120 MC. • ALL FREQUENCIES FUNDAMENTALS

A complete wide-range Signal Generator in keeping with the broader requirements of today's testing. Model 1632 offers accuracy and stability, beyond anything heretofore demanded in the test field, plus the new high frequencies for frequency modulated and television receivers, required for post-war servicing. Top-quality engineering and construction throughout in keeping with the pledge of satisfaction represented by the familiar Triplet trademark.

Of course today's production of this and other models go for war needs, but you will find the complete Triplet line the answer to your problems when you add to your post-war equipment.

Triplet

ELECTRICAL INSTRUMENT CO.
BLUFFTON OHIO ***

STANDARDS ARE SET BY
TRIPLET

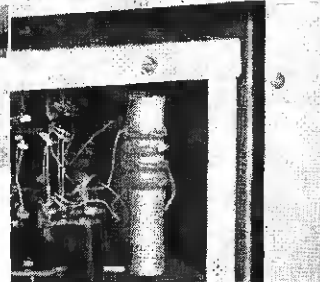

- Triple shielding throughout, Steel outer case, steel inner case, plus copper plating.

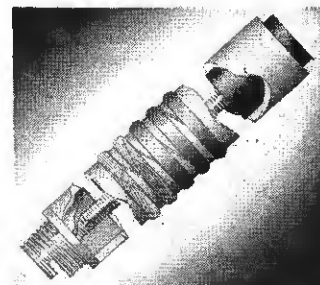

- All coils permeability tuned, Litz wire wound impregnated against humidity with "high-Q" cement.

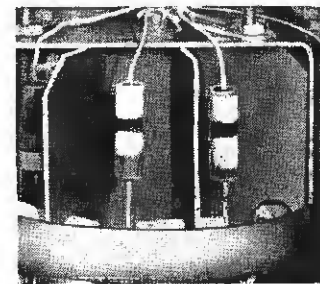

- Note sections individually shielded with pure copper. Entire unit encased in aluminum shield.



Still your best bet for replacements

***Old Man Centralab**
 "Old Man" is right . . . for he is a real "old timer". There is no substitute for experience, and the "Old Man" now, as in the past twenty-two years, is still your best bet.

Centralab

VOLUME CONTROLS



Centralab

Division of GLOBE-UNION INC., Milwaukee

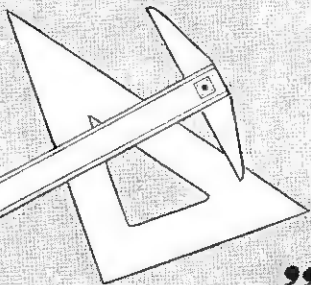

“ IT TAKES INSPIRED ENGINEERING ”
 to build an Amplifier such as this

It is not alone the trim looks and compact convenience of this amplifier which caused it to attain such popularity. Like all Thordarson products, it reflects the right combination of inspired engineering coupled with the highest productive skill, to insure the most in quality at the lowest possible cost.

Thordarson Model T30W20 is a 20-Watt amplifier embodying all of the latest improvements and conveniences which make it adaptable for a wide variety of uses.

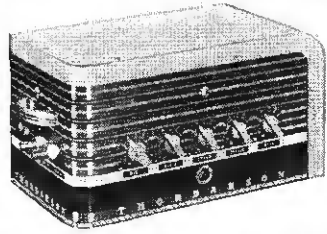

THORDARSON

TRANSFORMER DIVISION
 THORDARSON ELECTRIC MFG. CO.
 300 WEST HURON STREET, CHICAGO, ILL.

Transformer Specialists Since 1895
 ORIGINATORS OF TRU-FIDELITY AMPLIFIERS

Meck Gets RCA and Hazeltine Set Licenses

A Hazeltine license to manufacture radio receiver sets has been issued to John Meck Industries, Plymouth, Ind.

"This is a constructive step in our planning for postwar production," stated John Meck, president, in a recent interview. "We are immensely gratified to have received in recent weeks both RCA and Hazeltine set licenses.

"To us, they represent a challenge and a promise—the challenge to press our war production with renewed vigor until Uncle Sam no longer needs us, and the promise, which we must later fulfill, of finer products and full employment in the peacetime future."

Stromberg Sales Analyst

Edward F. Miller, formerly with the Hickok Manufacturing Co., has joined the Stromberg-Carlson Co., Rochester, N. Y., as radio sales analyst, Wesley M. Angle, president, announced.

New England Jobber Cited for WPB Violations

Cited for receiving radio tubes in violation of the War Production Order L-265, which is designed to conserve all vital electronic equipment, a New England distributor is prohibited from receiving electronic equipment for 3 months and for the next 2 months is restrained from selling such equipment except on orders carrying an AA-1 priority rating, according to a suspension order reported by the WPB.

The suspension action arose from complaints that the company scheduled orders for 7,650 radio tubes, certifying that it was entitled to purchase them under the provisions of Order L-265. The certifications were false, according to WPB, in that the tubes which were ordered were not required to replace tubes which had been delivered to customers out of the firm's inventory in accordance with L-265.

According to WPB, the company received 995 radio tubes, although it had no preferred orders, nor orders bearing preference ratings of A-1-A or higher, nor electronic equipment requiring repair. Therefore, it had no right under Order L-265 to receive tubes except to replace in inventory tubes which it had already delivered against suppliers' certificates. As such deliveries had not been made, the receipt of the radio tubes under these conditions was in wilful violation of L-265, says an official WPB statement. The distributor has appealed the ruling.

Opens New Service Bureau in New York

A new service bureau, a central source of information about its industry, has been opened by the National Electrical Manufacturers Assn., 155 E. 44th St., New York City. Leonard Kebler is president of NEMA, and W. J. Donald is managing director.

More Sold

RECORDS

There are more **Fidelitone** Needles sold than all other long-life needles combined!

Such popularity means greater demand • more sales • faster turnover • greater profits.

UP TO **5000** PLAYS

\$1.00 NET PRICE

Fidelitone
De Luxe
RECORDING POINT
UP TO 5000 PLAYS

PERMO, Incorporated
442 E. CLEVELAND AVE. STE. 10
CHICAGO 20, ILLINOIS

why Radiart Vibrators EXCEL

INTERNATIONAL ASSOCIATION OF ELECTRIC ENGINEERS
RADIART

3. Advanced Production Methods

Radiart Engineers have developed improved production methods for RADIART VIBRATORS and VIPOWERS that assure consistent high quality.

Constant inspection controls over materials, parts and sub-assemblies guarantee perfect operation from each finished product.

Such perfection is doubly necessary now for much of our present production is for our Armed Services.

RADIART VIBRATORS and VIPOWERS justify these rigid production standards by their exceptional performances under severest battle conditions.

Radiart Corporation
3571 W. 62nd. St. CLEVELAND 2, OHIO

ELECTRICITY
For Any Job — Anywhere

For a dependable source of electricity on projects remote from commercial power, Onan Electric Plants are proven leaders in the field. More than half of the armed Forces' total requirements for Power plants are built by Onan.

Gasoline driven. . . . Single-unit, compact design. . . . Sturdy construction. . . . Sound engineering. . . . Suitable for mobile, stationary or emergency service.

Over 65 models, ranging in sizes from 350 to 35,000 watts. 50 to 800 cycles, 110 to 660 volts, A.C.—6 to 4000 volts, D.C.—Also dual A.C.-D.C. output types.

Descriptive literature sent promptly on request.

D. W. ONAN & SONS,
2018 Royalston
Avenue,
Minneapolis,
Minn.

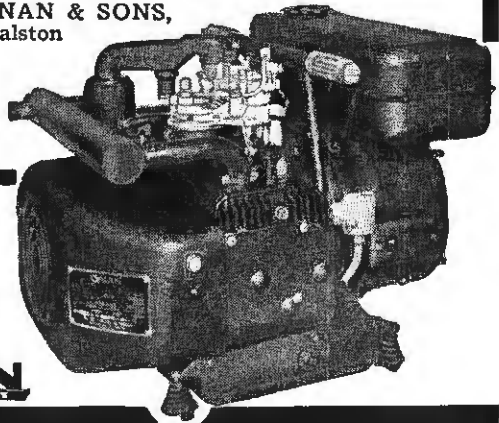

Awarded to each of Onan's four manufacturing plants.



Here's **No. 1** on the Tool
"Hit Parade"

XCELITE



Yes, the name "Xcelite" is a leader among the tools of today—and tomorrow. Combining quality workmanship with originality of design, Xcelite Tools are a "must" in every well stocked tool department. Included in the many practical ideas pioneered by Xcelite craftsmen are Xcelite Screwdrivers with Transparent shock-proof handles . . . Xcelite Detachable-Head Wrenches . . . Xcelite Nut Drivers with shock-proof colored handles indicating size . . . Xcelite Adjustable Socket Wrenches—to name just a few. Many new developments are in the making to step-up your post-war sales! Today, most Xcelite Tools are available on satisfactory priorities—delivery necessarily delayed by war conditions. Details and prices on request. Write Dept. M.

Back the Attack
Buy More
War Bonds

PARK METALWARE CO., INC.
Orchard Park New York

XCELITE QUALITY TOOLS
PREFERRED BY THE EXPERTS



• In keeping with the wartime spirit of minimum types for maximum jobs, Aerovox offers these two "first-aid" servicing items: Type PRS-V Dandees or tubular electrolytics, and Type '84 paper tubulars. They are now available in the standard "Victory Line" ratings taking care of 90% or better of all standard radio set requirements.

AEROVOX VICTORY CAPACITORS

Aerovox Type '84 paper tubulars. Individually tested. Extra-wax-sealed.

D.C.W.V.	CAPACITY
600	.001 mfd.
600	.002 mfd.
600	.005 mfd.
600	.01 mfd.
600	.02 mfd.
600	.05 mfd.
600	.1 mfd.
600	.25 mfd.

Aerovox Dandees Type PRS-V electrolytics. Individually tested. Extra-wax-sealed.

D.C.W.V.	CAPACITY
25	25 mfd.
50	10 mfd.
150	20 mfd.
150	20-20 mfd.
150	50 mfd.
150	20 mfd.
250	10 mfd.
450	10-10 mfd.
450	40 mfd.

● **ASK OUR JOBBER**
Ask for these Aerovox Victory Capacitors to take care of your servicing. Ask for latest Aerovox catalog—or write us direct.

INDIVIDUALLY TESTED

AEROVOX CORP., NEW BEDFORD, MASS., U. S. A.
In Canada: **AEROVOX CANADA LTD., HAMILTON, ONT.**
Export: 13 E. 40 St., New York 16, N. Y. Cable: 'ARLAB'

Phil-American Set for Postwar Radio Market

Phil-American, Inc., makers in peacetime of Philharmonic Radio-Phonographs, will move their entire plant to 528 East 72nd St., New York, where they will occupy more than six times their present space at 216 William St.

This is the fourth expansion of the organization since 1937, when it was founded by Avery R. Fisher as the Philharmonic Radio Co., for the manufacture of high quality radios and phonographs.



Avery R. Fisher

In January of this year, the entire operations of Philharmonic were assumed by Phil-American, Inc., a subsidiary of American Type Founders, Inc. The management and personnel of Philharmonic have continued in the new affiliation, with Mr. Fisher as president and general sales manager; Victor Brociner, vice-president and chief engineer; Stanley Bogart, vice-president and treasurer.

Now fully engaged in the manufacture of military radio, test equipment and naval ordnance, Phil-American will return to the production of Philharmonic Radio-Phonographs when civilian production is resumed, featuring home recording and television. Pre-war prices of Philharmonic instruments ranged from \$250 to \$1200.

Out of Low Price Field

Since postwar plans call for larger production schedules, Mr. Fisher states that prices will probably be lowered, but that Philharmonic will keep out of the low price selling field.

After the war, the Philharmonic will be sold nationally on a selective distribution basis through quality music and radio dealers in key cities. The selection of outlets will be started shortly, according to Mr. Fisher.

Meck Opens N. Y. Office

William W. Montgomery, executive engineer of John Meck Industries, Plymouth, Ind., announces that a New York City office has been opened at 500 Fifth Ave., for expediting materials and as a field office for Meck engineers.

Chester A. Cole, eastern district manager, is in charge.

The Quick-Easy Way to Squeeze Juice

Juice King

HOME JUICE EXTRACTOR

Over 1,000,000 housewives know the convenience of a JUICE KING home juice extractor—know the time and effort it saves in preparing fresh nutritious fruit juices. Just slight pressure to the handle and the rich pulp free juice flows into the glass.

When we whip the Axis Juice King will again be available at your dealers. Remember the name JUICE KING—the finest in home juice extractors.

NATIONAL DIE CASTING CO.

600 North Albany Avenue, Chicago 12, Illinois

THIS JUICE KING AD IS CURRENTLY APPEARING IN . . .

*Good Housekeeping
Ladies Home Journal
Better Homes and Gardens*

Until Victory there will be no Juice Kings manufactured. The large Juice King plant is working "round the clock" for Uncle Sam, producing important precision instruments for the Army Air Force.

In the meantime, Juice King is continuing its national advertising. Advertisements like the one reproduced above will appear in leading women's magazines during 1944.

This Juice King advertising today, is building sales for you tomorrow. Keep your eye on Juice King.

Juice King

home juice extractor

Appliance Jobbers May Set Up Own Division

In announcing the completed program for the National Electrical Wholesalers Association's 36th annual convention and second war conference, to be held in Chicago, April 19-22, Charles G. Pyle, NEWA's managing director points out that the deliberations of the electrical appliance distributor members who will decide upon the organization of their own division within NEWA is of greatest importance.

The campaign, begun late in February, to enlist the membership of electrical appliance distributors has been extremely successful.

These new members are located in numerous important marketing centers from coast to coast, and reflect conclusively the widespread national desire of these leaders in the distribution of electrical appliances to organize a sound aggressive, national Association to represent their broad interests, says Mr. Pyle.

"E" Flag Awarded DuMont Laboratories

Amid a colorful display of flags and decorations, with a huge replica of a DuMont cathode-ray oscillograph, whose screen recorded the speeches and music, the Army-Navy "E" award was made to the Allen B. DuMont Laboratories, Inc., manufacturers of cathode-ray tubes, oscillographs and other electronic equipment, including television transmitters and receivers. The ceremony took place in the Central Theatre, Passaic, N. J. The event was televised, and was also broadcast over WOR.

Many West Coast Homes Without Radio, Says Almy

According to Bob Almy, Sylvania Electric Products Inc., manager of distributor sales, recently returned from an extended tour of the northwestern, southwestern and California sales divisions, the West Coast has been particularly hard hit by the tube shortage. Mr. Almy says:

"I believe that on a percentage basis there are more homes without operative radios on the West Coast than elsewhere in the country. However, I found that our distributors are doing the very best they can to allocate available tube supplies on an equitable basis to their radio service-dealers."

Fire in Norfolk Store

Surplus radio, phonograph and musical instrument stocks were damaged when fire broke out in one of the second floor stock rooms of the Levy-Page Temple of Music store, City Hall and Granby St., Norfolk, Va. The building is protected by a sprinkler system. Though the fire was soon under control, water damage was heavy. The loss in stock and equipment is approximately \$30,000, according to an official of the company.

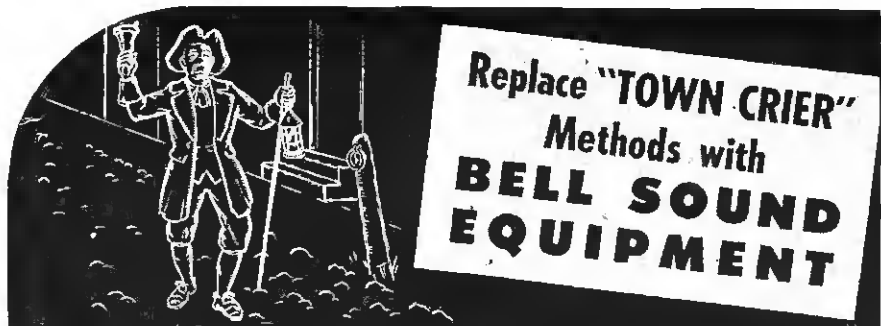

It's the SOUND way to POSTWAR PROFITS

Old-fashioned arrangements for inter-office contacts are as extinct as the "town crier." The pressure of war-rushed production and the manpower shortage have clinched the need for modern "intercom" and voice-paging equipment—their speed, efficiency, convenience and economy will rank them next to the telephone as "musts" in postwar business and industry.

So get set now—with BELL Sound Systems—to sell the most advanced equipment this expanding, profitable field will have to offer. Two types of BELL Sound Equipment already taking the lead in performance and popularity are shown below. They are designed, built and priced to give you the edge on competition.



BELL VOICE-PAGING EQUIPMENT

BELL Voice-Paging Equipment is designed for highest efficiency in industrial installations. The rugged, "tamperproof," compact, standardized units combine to meet individual needs of any type or scope—and are designed for quick, easy rearrangement to meet changing requirements.

BELfone

BELfone offers everything in "intercom" service. All the newest, practical features—and many exclusive ones—are available, including arrangements for private conversations, simplified convenience of operation, and many others.



BELL SOUND SYSTEMS, INC.
1186 ESSEX AVE., COLUMBUS 3, OHIO
Export Office: 4900 Euclid Avenue, Cleveland 3, Ohio



Fourth Revised Edition WARTIME RADIO SERVICE

TUBE SUBSTITUTIONS
REPAIRING BURNED OUT TUBES
CHANGING FARM RADIOS FOR ELECTRIC OPERATION
BEST METHODS FOR MAKING ADAPTORS
\$3.00 Postpaid

The only book of its kind—first job pays for it. You can't afford to figure it out yourself. If you have one of the old books send only \$1.00 and the publisher's imprint on the lower half of the front cover. This latest edition contains 32 pages, including over 300 additional substitutions and other important information. All compiled from practical experience. IR5 always works satisfactorily to replace 1A7—no squeals—late substitutions for many tubes you have in stock or can obtain. Service men all over the country are finding this book an invaluable aid. Buy yours today from your distributor or order direct from

CITY RADIO COMPANY
The RADIO CITY of Phoenix, Arizona
504-506 E. Washington St.

Canadian orders to
Sparling Sales Ltd., Winnipeg Hygrade Radio Ltd., Vancouver

No New Tax on Tubes

According to official information received, there is no additional tax on radio receiving tubes. Some newspapers carried articles to the effect that the new Federal taxes, which commenced April 1, included radio tubes. No new tax has been imposed upon phonograph records either, but incandescent electric lamps and fluorescent tubes are among the many items affected.

Fada Sponsors Program

The Fada Radio and Electric Co., Inc., of Long Island City, N. Y., makers of Fada Radios, has begun sponsorship of Tro Harper's 2:30 p.m. Sunday AP news period over WOR.

Since it is 100 per cent in war work, Fada's commercials on the newscast will be pointed towards keeping the company's name before the public and dealers.

International New Office

International Resistance Company and Connector Corp. has opened sales and customers' service offices at 165 Broadway, New York City. The office is under the management of A. H. Hardwick, assisted by Richard Pollock, Jr.

OFFICERS OF WEST COAST ELECTRONIC MANUFACTURERS ASSN.



Executive councils of both northern and southern California have elected the following officers of the West Coast Electronic Manufacturers Association: President, H. L. Hoffman; vice-president, Jack Kaufman; secretary, Herb Becker, and treasurer, Howard Thomas. Here they are pictured with members of the executive committee:

Top row, left to right, Lew Howard, Peerless Electrical Products Co.; E. Danielson, Remler Co., Ltd.; Leslie Howell, Ghillan Bros., Inc.; James L. Fouch, Universal Microphone Co.; Clayton Bane, Technical Radio Co.; E. P. Gertsch, Air Associates, Inc.

Bottom row, left to right, Herb Becker, Eitel-McCullough, Inc.; H. L. Hoffman, Hoffman Radio Corp.; Jack Kaufman, Heintz & Kaufman, Ltd.; Howard Thomas, Packard-Bell Co.

ESICO

REG. U. S. PAT. OFF.

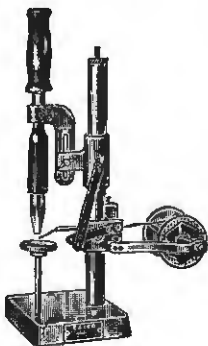

SPOT SOLDERING MACHINE
designed for treadle operation for advancement of iron and solder, leaving operator's hands free for handling of product.



SOLDERING IRONS

are widely used in industrial plants throughout the country. They are designed to withstand the strain of continuous service required of factory tools.

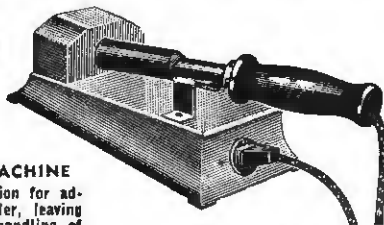

SOLDERING IRON TEMPERATURE CONTROLS
prevent overheating of soldering irons between soldering operations. Irons do not deteriorate when being used. The idle period causes oxidation and shortens life.

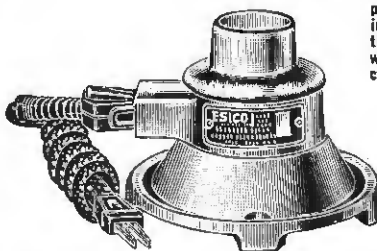

SOLDER POTS

ruggedly constructed pots of various sizes designed for continuous operation and so constructed that they are easily and quickly serviced, should elements have to be replaced.

Write for Catalog

ELECTRIC SOLDERING IRON CO., INC.

234 WEST ELM STREET, DEEP RIVER, CONN.

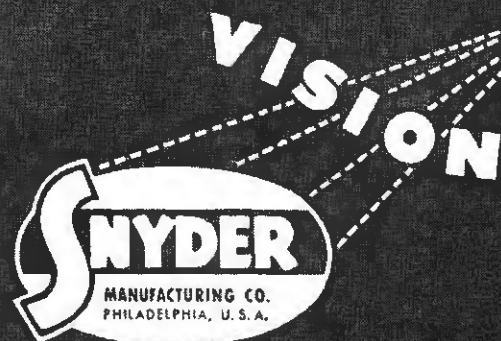

When days of Peace return, our increased facilities and manpower will not only continue in the production of better Radio and Automotive equipment, but will also turn to pioneering other developments to make the post-war period worth while fighting for—Patience—please.

ANTENNAE and Associated Products

Postwar Television Boom Seen by Allen B. DuMont

Addressing a meeting of the American Marketing Assn., in New York, Allen B. DuMont, president Allen B. DuMont Laboratories, Inc., makers of television receivers and transmitters, and owners and operators of W2XWV, stressed the fact that television is not only coming, but will be launched in a big way as soon as the war ends. A portion of Mr. DuMont's address follows:

"Certainly the groundwork has been laid for the commercialized television of the postwar era. We are going to have television in a real big way the moment peace is declared. Everything is set—the production of telesets, the building of tried, tested and proven telecasting equipment, the programming technique, and now the advertising or sponsorship angle. To be more explicit:

"The production of telesets or television receivers can be undertaken on a large scale, and that means reduced costs and lower prices, which in turn means popular demand and volume sales, once the war is over. Indeed, it almost required the war to bring about large scale production of telesets.

"Certain war requirements, notably radar, have created a tremendous demand for cathode-ray tubes which are the very heart of television reception. Where such tubes were made by the dozens in pre-war days, they are now made by the thousands. The advanced equipment and highly skilled personnel that have been producing wartime cathode-ray tubes will obviously be available for television requirements. Likewise with the television receiver proper, which is but a variation of oscillographic equipment used in the war effort.

"Advertisers and advertising men are already convinced that television advertising has real possibilities. They are now cutting their eye teeth on television advertising, and will be ready, so that telecasters will be assured of a source of income whereby to conduct their activities."

Victor A. Irvine



Sales promotion manager for Chicago's Motorola Radio Corp., chooses the "best war plant or war news photo" in exhibit of Chicago Press Photographers Association

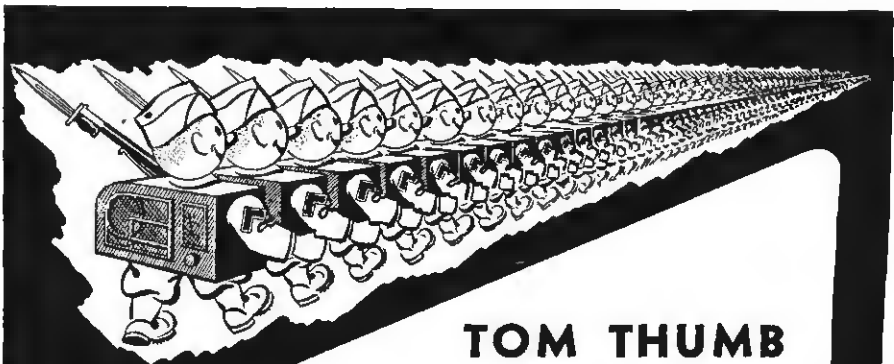

TOM THUMB KNOWS HIS MANUAL OF "ARMS"

—not only the printed version but the unwritten manual for getting into the arms of admiring customers and getting his own arms around a big chunk of the retail radio volume. Tom's captivating behavior in the showroom as in the home, is known to thousands of radio merchandisers who appreciate the importance of volume.

Make your plans NOW to get on the TOM THUMB bandwagon.

Automatic

RADIO MANUFACTURING CO., INC.
122 Brookline Avenue, Boston, Mass.

Serving
the Armed Forces
...AND THE
HOME FRONT, TOO!

- Despite material and manpower difficulties, and our participation in the war effort, we are producing and delivering the Government-approved Victory Line of Condensers. Write for list of Victory items and prices. Shipments are made on L265 Ratings, or better.

For VICTORY Buy
United States War
Bonds and Stamps



POLYMET CONDENSER CO.

699 E. 135th ST., NEW YORK 54, N. Y.



Every Ambitious Business Man Should Read this Free Booklet!

"FORGING AHEAD IN BUSINESS" contains FACTS for all thoughtful, forward-looking men.

This 64-page booklet, of which more than 3,000,000 copies have been circulated, outlines a definite plan of training for your future progress in business.

Said one man who had sent for it:

"In thirty minutes this booklet gave me a clearer picture of my business future than I have ever had before."

Fill in the coupon below and this helpful manual will be sent to you by mail and without cost.

ALEXANDER HAMILTON INSTITUTE
Dept 129, 73 West 23rd Street, New York 10, N. Y.
In Canada, 54 Wellington St., West, Toronto, Ont.
Please mail me a copy of the 64-page book—
"FORGING AHEAD IN BUSINESS."

Name.....

Address.....

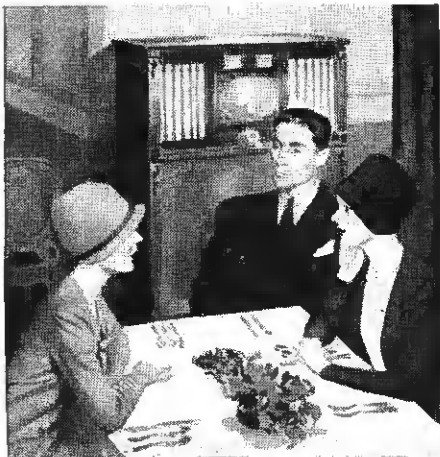

IN THOSE DAYS IT WASN'T CALLED

"Electronics"

... but the "juke box" application of electronics in 1928 was just as revolutionary as some of the electronic war-marvels of today. When the pressure of war work eases, the demand for better electronic devices for home and industry will find seasoned engineering and manufacturing "know-how" at Operadio... where the first commercial portable radio was designed and built!

OPERADIO

Electronic Specialists

OPERADIO MANUFACTURING COMPANY, ST. CHARLES, ILL.

RADIO TUBE ADAPTORS

We manufacture Radio Tube Adaptors and sell at wholesale prices only. Any type adaptor made to order. All types in stock now. Here are some of the adaptors we have:

For	Use
80,5Z3,83	5U4G
12A8	7A8
12SQ7	7C6
12SK7	14A7
12A8	14A7
35Z5	35Z3
12SA7	14A7
12SA7	7A8
1A7	1LA6
1A7	1LC6
25L6	43

Lots of twelve.....\$.55 each
Smaller lots.....\$.75 each
All orders must be accompanied with Signed Limitation Order L-265.

1/3 deposit with order.
Balance of order C.O.D.
Mail order business only.

Manor
Electric & Appliance Co.
3008 W. FULLERTON AVENUE
CHICAGO 47, ILLINOIS

—shipped to him from Boston and Chicago by express just so his customers might receive their instruments exactly on Christmas Day. Charles Oldendorf is retired now, but the spirit and traditions which guided the business successfully for 50 years under his direction are ably carried on by Dick Wallace and his partner, Mrs. Wallace, who have managed the business for the Oldendorf family since 1939.

Large Inventory

Inventories of recorded music have been greatly increased under the Wallace management, and sales volume in records has risen steadily in the past few years. Since 1941, volume in record sales shows a steadily ascending curve. In January record sales were just six times greater than in the same month of 1941. Dollar volume on records has reached four figures in some recent months, excluding December 1943 when the 1000-record order was handled.

Wallace ascribes this steady increase in part to general wartime prosperity, but more than that, he believes that it may be traced directly to the store's motto: "We have what you want." Astonishingly enough, the demand for good recordings of classical music far outstrips the demand for popular records, although in the latter category, too, the store seldom fails its customers. Recently, for instance, Wallace received a shipment of "Oklahoma" albums. Since their arrival, he has had calls for these from customers as far away as Chicago, St. Louis, Evansville.

Consider Your Customer

This policy of having what the customer wants, when he wants it, is basic in Wallace's merchandising philosophy.

The Mt. Carmel school system has one of the finest departments of musical education in the state. The library of recorded music at Mt. Carmel High School is considered one of the best of its kind in the entire country. Since this appreciation for good music has been nurtured in the educational system for 20 years or more, it is only natural that the groundwork thus laid should be reflected in the sales of music in the city's music store.

Community a Sales Factor

Interest of the Meissner firm in the musical life of the city is not a coincidence. When the company decided to move out of Chicago in 1936, the musical traditions of Mt. Carmel had a direct bearing on the city's selection as the firm's future home.



Products of "THE HOUSE OF RESISTORS"

Clarostat is almost 100% on war work.

That's why there are relatively few Clarostat green cartons on your jobber's shelves—only those items essential to wartime servicing.

However, this war won't last forever. And when it ends, those tougher Clarostat resistors, controls and resistance devices will be available to you. Once again those green cartons will be back in full strength on your jobber's shelves to meet your every need. And all of us will be well repaid for having concentrated on the biggest job of all—winning the war.

SEE OUR JOBBER . . .

He's carrying replacement controls and other essential service items. Consult him regarding your wartime servicing problem.



CLAROSTAT MFG. CO., Inc. - 285-7 N. 6th St., Brooklyn, N. Y.

TODAY

*... everything for
our fighting men,*

TOMORROW

**QUAM
SPEAKERS**

*again,
better than ever!*



QUAM-NICHOLS CO
Cottage Grove at 33rd Place, Chicago

**QUAM
SPEAKERS**

This community group alone is a potent factor in the Oldendorf market for recordings, for Meissner employees are all looking forward to that important day, after the war, when their company will begin production on what every one of them believes will be the finest radio-phonograph in America.

The record player at the high school at present is a forerunner of this instrument the company will make after the war. It is the only one that was completed before orders for electronic war materials turned the firm's entire production into Army and Navy channels. Dick Wallace, too, is eagerly awaiting this new machine for in it he sees the grand climax, in his own market area, to the efforts he has been putting into merchandising of records.

Dick Wallace has no special formula to credit for the success of his business in recordings at Oldendorf's. Partly, this increase stems from the increased purchasing power of the community; partly it is due to having what the customer wants.

He estimates he has over 2,500 albums alone in his regular inventory. He uses his two display windows advantageously for seasonal and timely features. Recently he featured a special display in honor of Howard Barlow, who is a native of Mt. Carmel.

In Local Activities

Wallace takes a very active interest, too, in the business and social life of the city in a way that attracts favorable attention to his store. As you might expect, he heads the Citizens' Committee which is cooperating with the high school music department in preparation for the Annual Spring Festival in May, at which Dr. Edwin Franko Goldman of the famous Goldman Band of New York, will be the guest of honor.

In general, the Oldendorf store is well arranged to permit customers to "browse." "Auditioning" of records is supervised by Wallace and Mrs. Wallace, for they feel that their own special knowledge of the machines and of the recordings enables them to bring out the best in any record in which a customer shows interest.

Like most other stores of its kind, Oldendorf's has felt the pinch of wartime restrictions on records. By trying to anticipate the desires of their customers—and they have served many of them for years—the Wallaces are managing, within the limits of their record allotments, to satisfy by far the greater percentage of record requests they receive.

INDEX To Advertisers

	Page
Admiral Corp.	1
Aerovox Corp.	106
Alexander Hamilton Institute	109
Alliance Mfg. Co.	92
Astatic Corp.	92
Automatic Radio Mfg. Co., Inc.	109
Beli Sound Systems, Inc.	107
Burgess Battery Co.	100
Cari's Auto Accessories	100
Centralab	104
City Radio Co.	107
Clarostat Mfg. Co., Inc.	111
Cornish Wire Co.	84
Crosley Corp.	6, 7
Decca Distributing Corp.	45
Delco Radio, Div. General Motors	69
Detrola Radio, Div. International Detroit Co.	63
Dumont Electric Co.	98
DuMont Labs., Allen B.	89
Duotone Co.	72
Electric Soldering Iron Co., Inc.	108
Electronic Laboratories, Inc.	52
Electronic Products Mfg. Co., Inc.	102
Electro-Voice Mfg. Co., Inc.	99
Emerson Radio & Phono. Corp.	12
Fada Radio & Electric Co., Inc.	15
Farnsworth Television & Radio Corp.	81
Fonda Corp.	82
Galvin Mfg. Co.	Cover 4
Garod Radio Corp.	8, 86
General Electric Co.	75
Hallcrafters Co.	77
Hammarlund Mfg. Co., Inc.	73
Hickok Electrical Instrument Co.	78
Hoffman Radio Corp.	16
Howard Radio Corp.	18
Hytron Corp.	5
International Resistance Co.	101
Jackson Electrical Instrument Co.	4
Jensen Radio Mfg. Co.	14
JFD Mfg. Co.	110
Ken-Rad Tube & Lamp Corp.	90
Majestic Radio & Telev. Corp.	2, 3
Mallory & Co., Inc., P. R.	Cover 2
Manor Electric & Appliance Co.	111
Meck Industries, John	97
Meissner Mfg. Co.	93
Monarch Mfg. Co.	76
Muter Co.	110
National Die Casting Co.	106
National Union Radio Corp.	64
Nobliitt-Sparks Industries, Inc.	71
Norge, Div. Borg Warner Corp.	9
Nu-Enamel Corp.	17
Bnan & Sons, D. W.	105
Operadio Mfg. Co.	111
Park Metalware Co., Inc.	105
Permo, Inc.	105
Philco Corp.	47
Polymet Condenser Co.	109
Presto Recording Corp.	91
Quam-Nichols Co.	112
Radiart Corp.	105
Radio Corp. of America:	
RCA Commercial Engineering	57
RCA Test & Measuring Equipment	60
RCA Victor Div.	58, 59
Rauland Corp.	102
Raytheon Production Corp.	49
Rider Publisher, Inc., John F.	96
Rola Co., Inc.	19
Seeburg Corp., J. P.	Cover 3
Sentinel Radio Corp.	83
Signal Electric Mfg. Co.	110
Snyder, Inc.	108
Sonora Radio & Telev. Corp.	53
Sprague Products Co.	95
Standard Transformer Corp.	94
Stromberg-Carlson Co.	20
Supreme Instruments Corp.	98
Sylvania Electric Products, Inc.	13
Talk-A-Phone Mfg. Co.	94
Templetone Radio Co.	10, 11
Thordarson Electric Mfg. Co.	104
Trav-Ler Karenola Radio & Telev. Corp.	79
Triplet Electrical Instrument Co.	103
Turner Co.	80
Universal Microphone Co., Ltd.	87
Utah Radio Products Co.	51
Wamwick Mfg. Corp.	67
Webster Electric Corp.	88
Wilcox-Gay Corp.	43
Zenith Radio Corp.	85

While every precaution is taken to insure accuracy, we cannot guarantee against the possibility of an occasional change or omission in the preparation of this index.

. . . BUT AS FOR ME . . .

169 years ago this month a man arose in the 2nd Virginia Convention and into just nineteen crystal-clear words compressed a question and an answer which will never pass from men's memories. Said Patrick Henry, "I know not what course others may take, but as for me,



give me liberty or give me death."

Patrick Henry's speech carried the convention, and ultimately a young nation was committed to fight for its life—and its freedom, which it valued more. That nation has never since hesitated in the pursuit and defense of freedom, and never will. Today, in freedom's name, America and her allies are fighting a war greater than all the wars of history put together, a war in which the amount of weapons and materials needed surpasses the imagination of most men. But they are being provided and will continue to be provided, with the aid of your War Bonds. It's the extra punch that wins battles—provide it by buying extra War Bonds.



AWARDED TO THE J. P. SEEBURG CORPORATION
FOR OUTSTANDING PRODUCTION OF WAR
MATERIALS IN EACH OF ITS FOUR PLANTS

Seeburg
FINE MUSICAL INSTRUMENTS SINCE 1902

J. P. SEEBURG CORPORATION • CHICAGO, ILLINOIS

When life or death is a matter of Split Seconds

"HANDIE-TALKIE"
Delivers

In a war of vast spaces, swift movement and violent action . . . Radio Communication must not fail. The front line scout, spotting the location and strength of the enemy, gets his vital information back to the command post with split second speed via the Handie-Talkie, the bantam-weight portable two-way radiotelephone. The signalman talks, giving information . . . and listens, receiving instructions.

The Handie-Talkie was conceived and developed by Motorola, makers of Motorola Radios for Home and Car, Automatic Phonograph-Radios, and F-M Police Radiotelephone Systems.

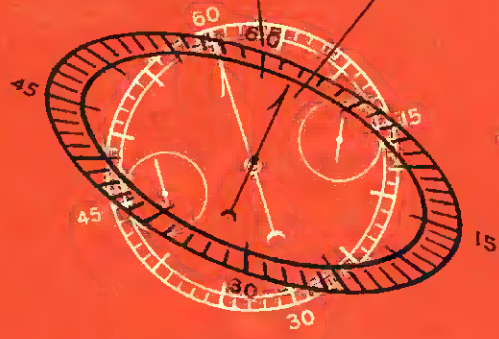

HANDIE-TALKIE
IS ANOTHER
Motorola
Radio
"FIRST"

Motorola
AMERICA'S FINEST RADIO
FOR HOME & CAR
GALVIN MFG. CORPORATION • CHICAGO

