

Radio Retailing

The Business Magazine of the Radio Industry

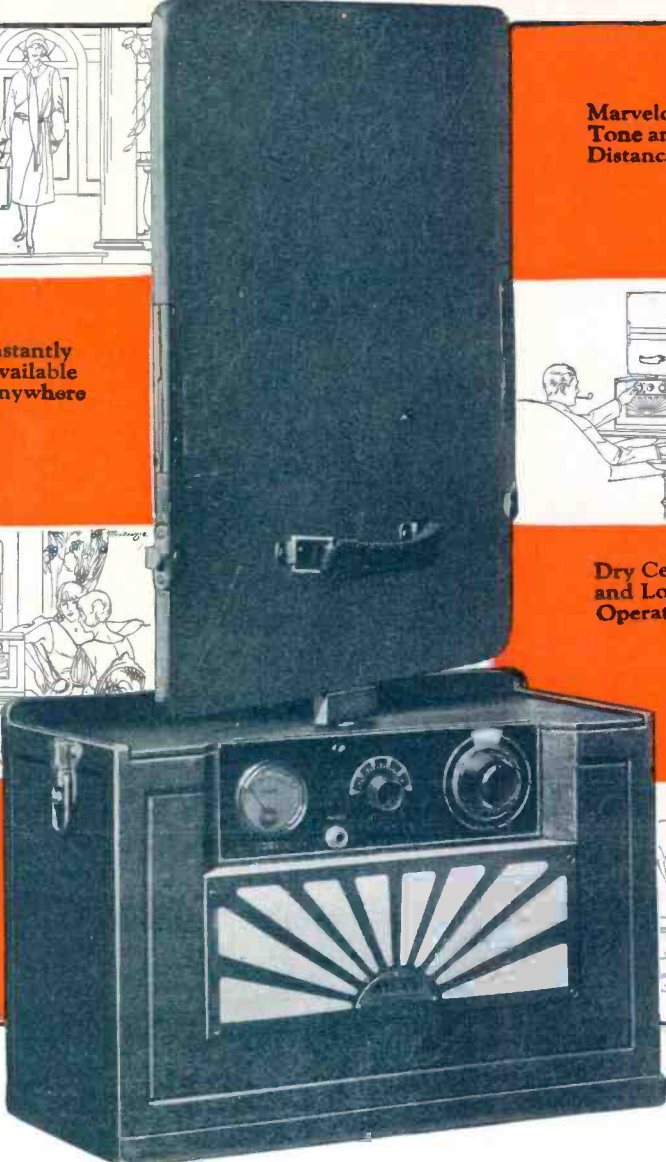

Carried Like a Suitcase

Marvelous Tone and Distance

Instantly Available Anywhere

No Wires or Connections Required

Six Tubes and Speaker in Case

Dry Cell and Loop Operated

Everything Contained in the Case

The Portable Operadio when closed, is a smart compact piece of hand luggage. Entirely self-contained with built-in loud speaker, 6 tubes, (including power tube), loop and extra large dry battery supply. In its tone, range and selectivity it is a triumph of radio engineering.

More Operadios Have Been Sold Than All Other Self-Contained Portables Combined

With the right Portable in your line you can make March and April your biggest selling months. The Operadio is the only entirely successful Portable the industry has produced — proved over a period of years. Your competition has nothing to equal it. Popular — easy to demonstrate — economical to service. Adds months of profitable selling to your radio season. Write today for complete particulars.

OPERADIO

The Original Self-Contained Radio

THE OPERADIO CORP., 8 So. Dearborn Street, CHICAGO

Brandes Cone Speaker,
list \$35

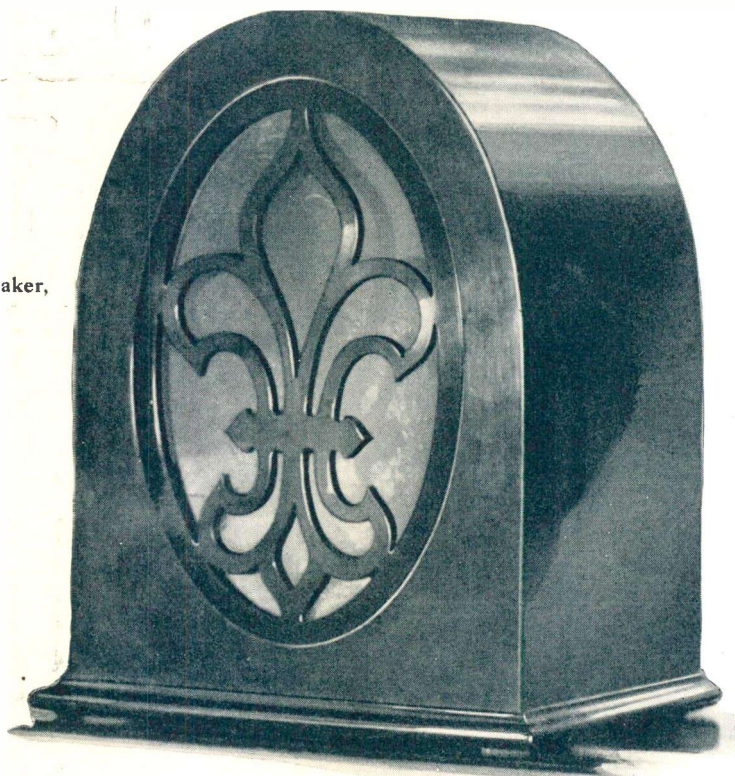

How Can You Advise Your Customers?

How can you recommend the most satisfying speaker until you make this comparison?



Brandes Type H
Horn, list \$18

Order just one Brandes Cone. Make a private comparative demonstration. Learn for yourself how the Brandes experts, with their 17 years of experience in acoustics, have perfected a new-type cone, housing it in a decorative cabinet.

You want to stock the best selling speaker BUT you want also to sell the one which will create delighted customers.

To know for yourself means simply ordering one Brandes Cone—better also include one Horn and one Phonograph Attachment. These three types will be a revelation to you. Let your customers hear them.

This will help you with quicker sales, satisfactory profits and delighted customers.

Canadian and western prices slightly more.

Select a Brandes Speaker pictured here, better one of each, ask your jobber to send it to you or order direct from us and we will forward through the jobber.

Brandes Products Corporation
200 Mt. Pleasant Avenue, Newark, N. J.

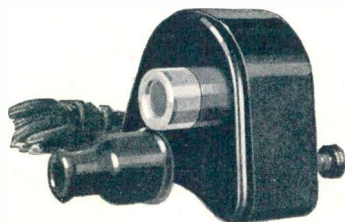

Brandes Phonograph Attachment,
list \$10

Acoustics
by

Brandes

Means the Ultimate in Reproduction

The Best-Known Line of Radio Parts is the Big Allen-Bradley Line

ADDITIONS have been made to the well-known Allen-Bradley line of radio devices whenever a new product was developed that would improve radio reception or make tuning easier. The Allen-Bradley line now includes 10 fast-selling items,

every one of which assures the dealer of quick turnover and substantial profits. For this reason Allen-Bradley parts continue to sell year after year and are building profits and business for progressive dealers. Investigate the Allen-Bradley line, now!

Allen-Bradley Turnover Builds Big Profits

Allen-Bradley Products Are Sold
in Distinctive Checkered Cartons

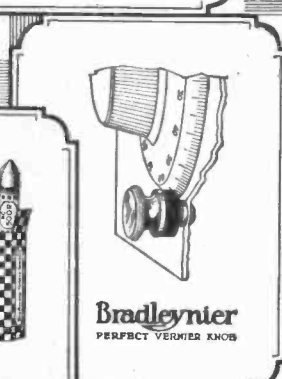
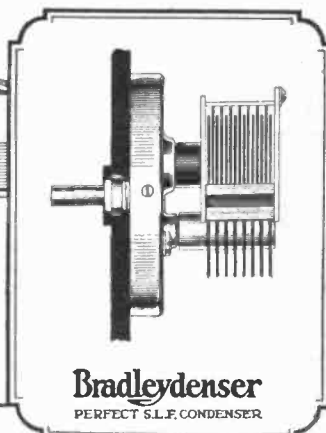
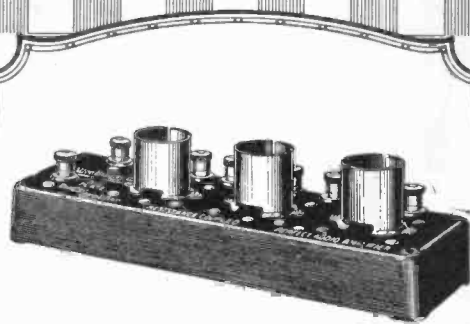
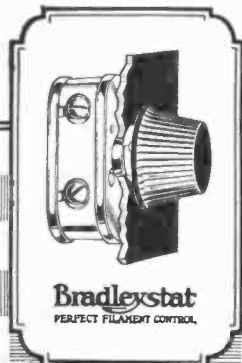

Allen-Bradley Company,
489 Clinton Street, Milwaukee, Wis.

We certainly want to know more
about the Allen-Bradley line.
Please send us your latest complete
literature.

Name

Address



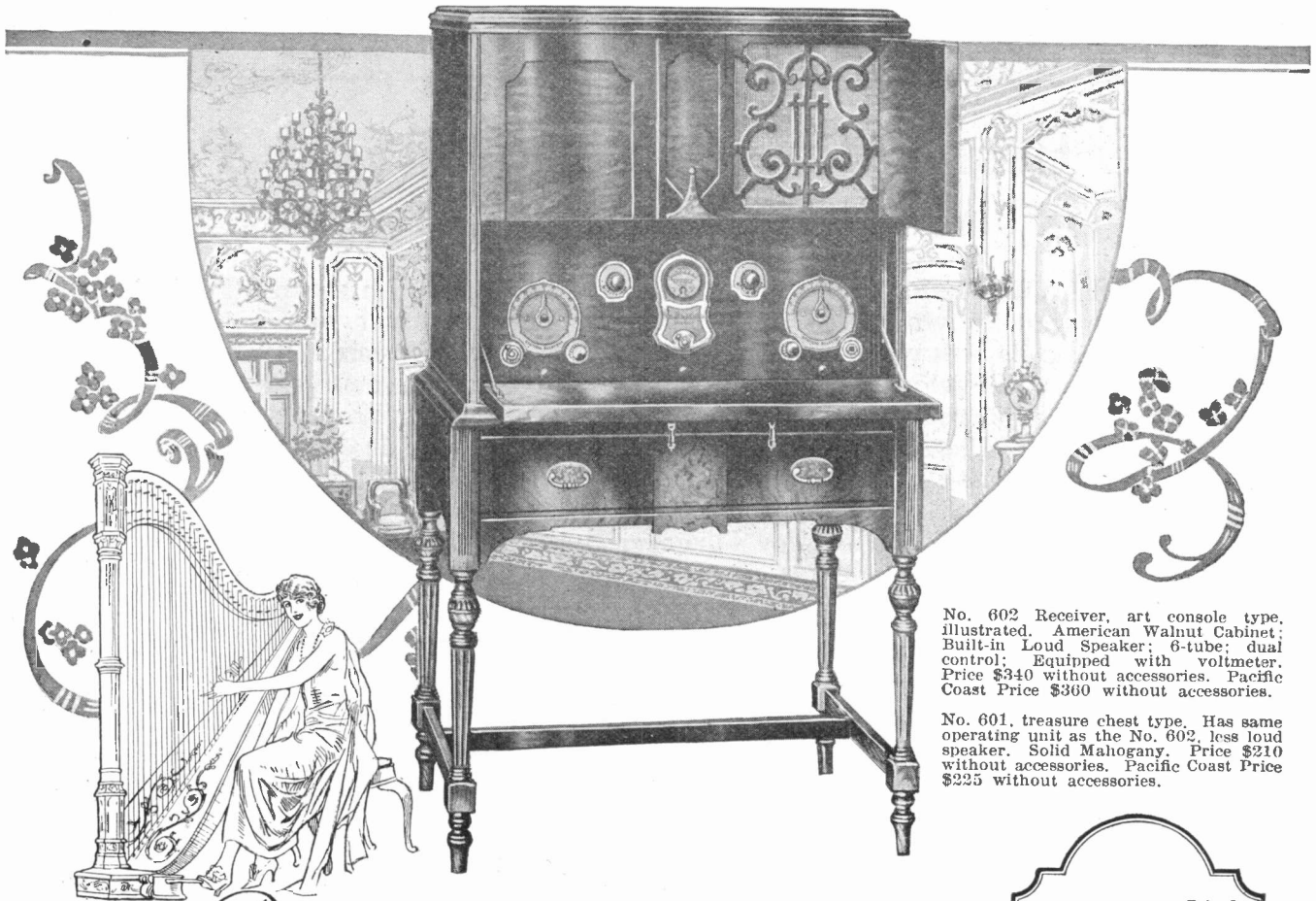

No. 602 Receiver, art console type, illustrated. American Walnut Cabinet; Built-in Loud Speaker; 6-tube; dual control; Equipped with voltmeter. Price \$340 without accessories. Pacific Coast Price \$360 without accessories.

No. 601, treasure chest type. Has same operating unit as the No. 602, less loud speaker. Solid Mahogany. Price \$210 without accessories. Pacific Coast Price \$225 without accessories.

RANGE of TONE

with full Tone Quality

THE melodious notes of the Harp, sweetest of all musical instruments, are faithfully reproduced throughout all their wide compass, by the wonderful Stromberg-Carlson Receiver.

The tone range and tone accuracy of this Receiver will make instant appeal to every one of your prospects who has appreciation of fine music.

Stromberg-Carlson fidelity of tone is the result of many refinements of radio construction developed by Stromberg-Carlson acoustic engineers and to the total shielding of each radio frequency circuit.



Stromberg-Carlson Telephone Mfg. Co.
Rochester, N. Y.

Chicago

Kansas City

Toronto

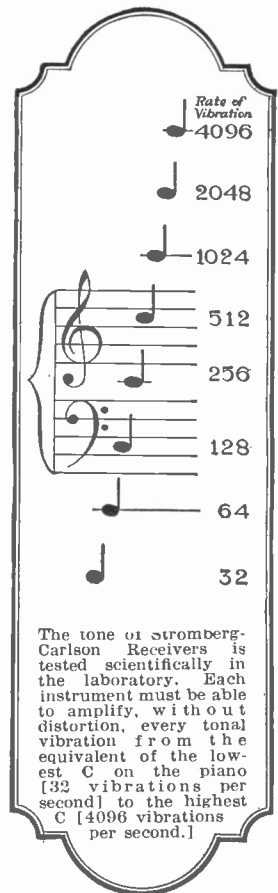

Stromberg-Carlson
Makers of voice transmission and voice reception apparatus for more than thirty years



It is written:

"You can hardly make a friend in a year, but you can easily offend one in an hour."

When you sell a man a Synchronphase you go a long way toward making him a friend for life.

Doctor W.A.

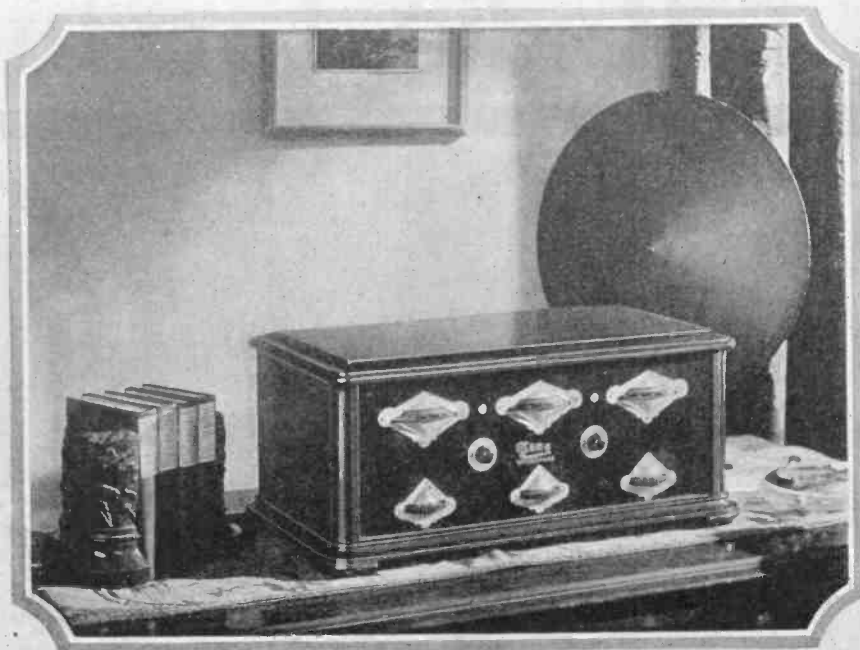

How Many of Your Customers Are "Radio-Wise"?

ISN'T it true that very few radio buyers understand what they see when examining a set? They must depend on your word, and your business success depends much on what you tell them.

Stake your reputation on quality goods. No matter how often or how cheerfully you "make good", defective merchandise reacts against you even more than against the maker, for you are closest to the buyer.

When you sell the Synchronphase you not only have exclusive features that make sales easy and assure satisfactory reception, but also sound construction that prevents the "come-backs" and excessive servicing which eat up profits.

Send for full description.

A. H. Grebe & Co., Inc., 109 West 57th Street, New York
Factory: Richmond Hill, N. Y.

Western Branch: 443 So. San Pedro St., Los Angeles, Cal.

Exclusive Grebe Developments:



Grebe "Colortone"



Flexible Unit Control

Binocular Coils
Reg. U. S. Pat. Off.
and
Low-wave Extension Circuits

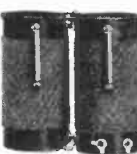

Ask how and why they make Grebe reception so superior and dependable.

This company owns and operates stations WAHG and WBOQ; also low-wave re-broadcasting stations, mobile WGMU and marine WRMU.

The GREBE SYNCHROPHASE

TRADE MARK REG. U.S. PAT. OFF.



All Grebe apparatus is covered by patents granted and pending.

"WINDHAM"

Radio Products

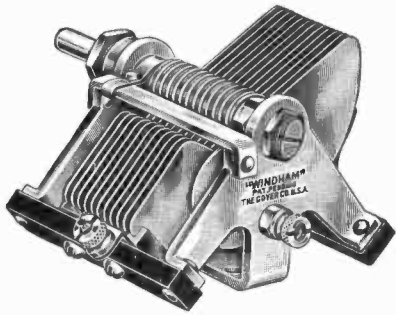

"WINDHAM" CONDENSERS

Small in size, mechanically strong. Has the characteristics so necessary for low radio frequency losses, easy tuning and selectivity. Well adapted to accurate laboratory work as it is to the amateur.

Adjustable brake eliminates counterweights and springs, permits adjustment of bronze cone bearings without altering the balance or alignment. Practical separation on the short wave stations. One hole only required for mounting. Holes for Sub-Panel Mounting.

Made in six standard capacities. Special sizes made to order.

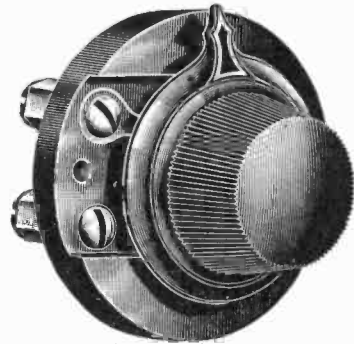

"WINDHAM" BAKELITE RHEOSTAT AND POTENTIOMETER

This Rheostat is made for those who are seeking the better things in Radio. It is made of the best materials the market affords.

The base is of bakelite formed under hydraulic pressure, and designed to retain its original shape beyond the ordinary working temperatures.

The resistance element is special high grade alloy wire, and the smooth working bronze contact arm is operated by a brass spindle moulded into an attractive genuine bakelite knob. All metal parts are nickel plated. One hole only is required to mount upon the panel.

Regular models made in the following resistances—6, 10, 20, 30 ohm, and 200 and 400 ohm Potentiometer.

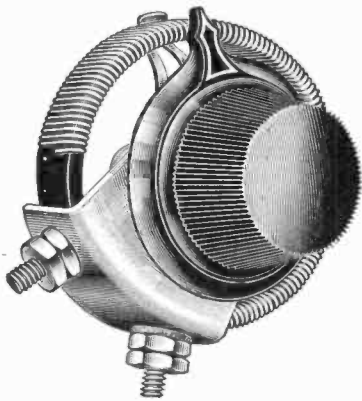

"WINDHAM" RHEOSTATS AND POTENTIOMETERS

Designed to regulate the current within close limits. They have been used under all conditions in a wide variety of receiving sets. Regularly furnished with attractive taper bakelite knob, but a graduated 2-inch dial may be supplied at an additional charge of 25 cents. One hole only is required to mount upon the panel.

A vernier attachment may be supplied. A two-inch composition dial and separate knob furnished for the vernier. For vernier add 50 cents to rheostat list price. Six standard resistances—6, 10, 20, 30 ohms, and 200 and 400 ohm, potentiometer.

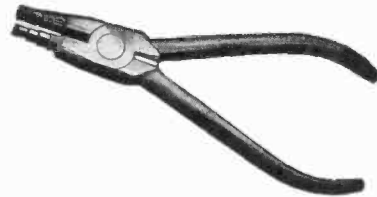

"WINDHAM" WIRE FORMER

A complete and handy tool for electricians, radio set builders and mechanics. It will accurately form loops or eyes for No. 4, 6, 8 and 10 screws, make easy radius and sharp right angle bends, has flat jaws and wire cutters. This tool is made of the best quality steel, dropped forked and carefully tempered in oil.

We guarantee every tool against defects in workmanship and materials and will promptly replace or refund money on any found defective by purchaser.

GUARANTEE

The WINDHAM radio instruments and products are carefully tested for mechanical and electrical defects before leaving the factory and are guaranteed to be in perfect working condition before sent out. We stand ready to replace any instrument that is defective in workmanship or material, or turn it for a new instrument promptly.

The Goyer Co.

Manufacturers

WILLIMANTIC, CONN.

Export Office:

30 Water Street, New York City

Cable Address: "Likex" New York. Codes: Bentleys, A.B.C. 5th Edition, Western Union.

Record Breakers



Clas Thunberg, of Finland, on Jan. 14, 1926 set a new world record by skating two miles in 6 min., 13 4/5 sec. He also established new figures of 5 min., 25 4/5 sec. for 1 3/4 miles and 7 min., 3 sec. for 2 1/2 miles.

Share in the Success of Gold Seal Tubes

OUR dealers in all parts of the country report record breaking sales. Are you sharing in this harvest of quick profits?

Winning on Merit

Gold Seal tubes are winning popular favor because they are actually superior in quality and longer life. And Gold Seal dealers are enthusiastic because of Gold Seal dealer co-operation.

Gold Seal Merchandising Helps You

Gold Seal tubes are carefully packed and shipped—large stocks kept on hand—prompt service. Gold Seal guarantee is liberal—distributors make replacements direct. Gold Seal prices are guaranteed against decline. Gold Seal dealer helps are sales builders.

Tie Up With Gold Seal Now!

Gold Seal tubes are made in all standard types and models

Write today for full particulars of our unusual merchandising policy—of special interest to jobbers, distributors and dealers.

GOLD SEAL PRODUCTS CO., Inc.
250 PARK AVENUE, NEW YORK

Gold Seal Radio Tubes

ALL TYPES
GSX and G.S. 201-A
List Price - \$2.00
GSX and G.S. 199
List Price - \$2.25
GS 199 Large Base
List Price - \$2.25
GSX and G.S. 120
List Price - \$2.50

HIGH POWER
GSX - - - 112
List Price - \$6.50



Gold Seal Tubes last twice as long



Precedent vs. Profit!

*Which one is winning first place .
in your establishment?*

Federal ORTHO-SONIC Retailers are all backing *Profit*—and are winning!

Are you sticking to *Precedent* and packing your stock away in mothballs for the long hibernating period? Or are you a Federal S & S Retailer, receiving splendid factory and wholesaler co-operation, doing a good business and making a *profit*?

If you have not investigated the ORTHO-SONIC proposition, it will pay you to get in touch with the Federal Wholesaler in your district and let him tell you how Federal Retailers make money the year round.

Federal demands no signed contracts from the trade. Federal's word is always sufficient. Federal sales and advertising service—duplicated by no other manufacturer—is put behind Federal Retailers at all times.

You are assigned territories that protect your profits. Discounts allowed permit you to make good money.

In addition, the Federal ORTHO-SONIC line is complete—a model to fit every purse and purpose. The receivers have been acclaimed the greatest advance in radio by music lovers and radio fans alike. They are contained in beautiful cabinets of choice selected woods. And ORTHO-SONIC receivers sell at popular prices.

These are a few of the many reasons why you should join the Federal Retailer Organization. If you do not know the Federal Wholesaler for your territory, write and ask us to tell you how you may join us, and receive the advertising and sales help given preferred retailers on our S & S list.

FEDERAL RADIO CORPORATION, Buffalo, N. Y.

(Division of Federal Telephone and Telegraph Company)
Operating Broadcast Station WGR at Buffalo

Federal
ORTHO-SONIC
Radio

"Rivaled Only by Reality"

STEWART-WARNER

Matched-Unit Radio

Putting It Squarely Up To You!

Instrument
plus Reproducer
plus Tubes plus
Accessories

CHECK up today on the Radio retailers in your community. How many are on the road to permanent success?

How many are headed toward failure, the victims of unsound methods of radio manufacture and distribution? Now, look carefully to your own business.

Are you handling any radio products excepting those of well established, financially strong manufacturers? Are you in danger of being caught in a price cutting war, or of finding yourself suddenly loaded with obsolete stock, due to a manufacturer who cannot "make the grade"?

Or have you the certain assurance of 100% protection against loss, against unfair trade practices of all kinds? Stewart-Warner dealers have!

Our sales plan is actually "Dealer-Made." We know that our success in the radio business depends upon the ability of our dealers to succeed. That's why we made sure our sales proposition was right from every dealer angle.

A Stewart-Warner Radio Dealer Franchise is the insurance policy of your business future. It gives you—

- 1 A full line of highest quality radio products to meet an all year 'round demand.
- 2 The protection of a franchise giving exclusive representation in your locality. And we mean a real franchise, not a "scrap of paper."
- 3 A line built and backed by an institution with 20 years' experience, unquestioned financial strength and a world-wide reputation for fair dealing.
- 4 The protection of dealing direct with the manufacturer. We have no jobbers; we sell only through our own Central Distribution Stations. There's one near you. This means a small investment in stock, because you can always get new stock promptly.
- 5 Protection against price cutting and stock "dumping."
- 6 Protection against your stock being obsolete. There are no "yearly models" of Stewart-Warner Radios.
- 7 An eager consumer acceptance from our tremendous National Advertising Campaign.

Your success as a Radio Dealer is up to you. You must decide between haphazard methods and permanent, profitable business-building.

If you want to take the safe, sure road to lasting success, write today for full information about a Stewart-Warner Franchise in your community.

STEWART-WARNER SPEEDOMETER COR'N
1820 DIVERSEY PARKWAY - CHICAGO, U.S.A.

Stewart-Warner



Model 300
\$65.00



Model 325
\$80.00



Model 305
\$95.00

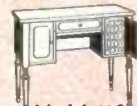

Model 410
\$65.00

Console Table including Built-in Speaker and Battery Compartment, without Radio.



Model 310
\$175.00

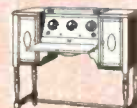

Model 315
\$285.00



Model 320
\$450.00



Model 400
Reproducer
\$25.00



Model 405
\$19.50

Radio Tube
Model S-W
501-A
\$2.00



Tune in Stewart-Warner
Station WBBM, 226 Meters

Mon. - 12-3 a.m., 6-7 p.m. Fri. - 8-10 p.m.
Tues. - 9-12 p.m. Sat. 8-9:30 p.m., 11-2 a.m.
Wed. 8-10 p.m., 12-2 a.m. Sun. - 4-6 p.m., 8-10 p.m.
Thur. - 8-10 p.m. CENTRAL STANDARD TIME

TWELVE MILLION PEOPLE ARE TODAY USING STEWART-WARNER PRODUCTS

A new selling idea for Tungars



This simple wiring diagram shows how to install permanently either the 2 ampere or 5 ampere Tungar. Use it as a sales argument.

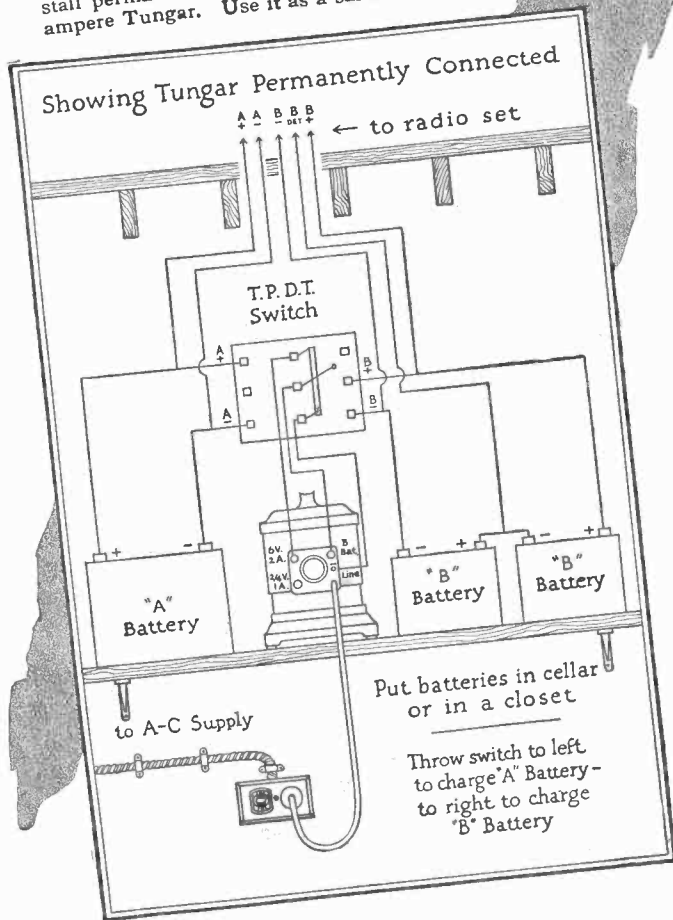

IN addition to selling Tungars you can, if you wish, make another profit by wiring them up for permanent installation. The diagram shows how simple it is. Any radio fan will instantly realize that a Tungar—permanently installed—is the solution to most of his battery problems.

When he signs off at night, all he has to do is throw on a switch. In the morning his battery is charged and peppy. Think of the convenience—and the cost is less than a dime.

Right through the summer, there is a market for Tungars. Stock them and use this permanent connection idea to sell them.

Tungar

REG. U.S. PAT. OFF.

BATTERY CHARGER

Tungar—a registered trademark—is found only on the genuine. Look for it on the name plate.

GENERAL ELECTRIC

GENERAL ELECTRIC COMPANY MERCHANDISE DEPARTMENT BRIDGEPORT, CONNECTICUT

Here's Volume Business for March and April

turn these two
chronic kickers
into buyers

This Ad in



April
Magazines



the man who is tired
of buying B batteries
and flimsy substitutes

Constant-B

appeals to every customer on first sight as a permanent damage-proof investment in B power from the A. C. light socket without batteries. No liquids, no heated filaments—install it and forget it!



Sell it to him for
\$45



the man who demands
something to tune out
his "pet peeve" station

Filtrola

will do it, and do it without extra tubes or controls. He need only tune it once—to drop out permanently his particular "peeve station"—then tune in what he wants with his regular dials



Sell it to him for
\$15



Deliveries
now being made to
Your Jobber

ALL-AMERICAN RADIO CORPORATION, 4221 W. Belmont Ave., Chicago, U. S. A.

E. N. RAULAND, President

Pioneers in the Industry

Sales Offices in

Boston New York Philadelphia Washington Atlanta Pittsburgh Buffalo Detroit
Chicago Minneapolis St. Louis Denver Boise Los Angeles San Francisco Seattle



OWNING AND OPERATING STATION WENR—266 METERS

ALL-AMERICAN

Radio Built for the Years to Come

For impedance coupled amplifiers
sell only a Dubilier By-Pass as a
grid blocking condenser.

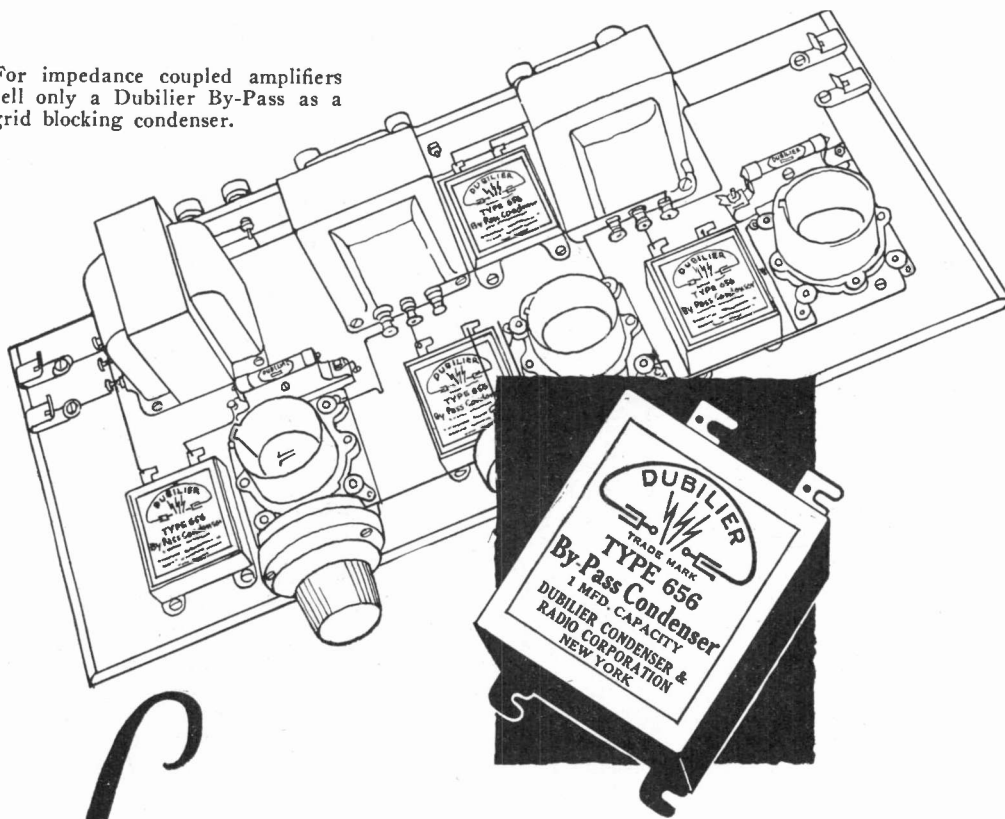

Living tones

Every "radio fan" today seems to have his mind set on a single goal—the true reproduction of "living tones." And in every new development he finds that fixed condensers play a more important part.

Whether it be impedance coupled, resistance or transformer coupled, every audio amplifier can be improved by the use of fixed condensers at critical points in the circuit.

The radio dealer who features Dubilier Micadons and By-Pass Condensers identifies himself with all that stands for the highest quality in radio construction.

Send for booklet, "Fourteen ways to improve your set by the use of Dubilier Condensers"

Address: 4377 Bronx Boulevard, New York, N. Y.

Dubilier

CONDENSER AND RADIO CORPORATION



ELKON TRICKLE CHARGER

Set It **Install It** **Forget It**

Set Owners are Learning

- 1** That the ELKON has no acids, no alkali, no water, no tubes, no moving parts, that it is a "bone dry" trickle charger made of immovable solids....
- 2** That it is noiseless, and does not interfere with other sets....
- 3** That it has a minimum guarantee of 2000 hours without replacing a single part....
- 4** That it keeps your "A" batteries charged, increasing to maximum, tapering to zero—as needed, without attention—that they can really set it—install it—forget it.

Operates from 105-125 v 50-60 cycles. Charges both 4 and 6 volt batteries



The ELKON Rectifier
A bone dry immovable solid.

That is why the ELKON TRICKLE CHARGER is the sensation of radio. For particulars write

ELKON WORKS
Subsidiary of P. R. Mallory & Co. Inc.
Weehawken, N. J. Inc.

Sole licensees under patents pending to Samuel Ruben

Also manufacturers of ELKON CONTACT POINTS of Tungsten, Silver, Platinum, Special Alloys
"ELKONITE" Welding Electrodes and Dies. Molybdenum Sheet Metal Product

SPECIALISTS IN RARE ELEMENT METALLURGY



For Radiola, Victor and Brunswick Super-hets

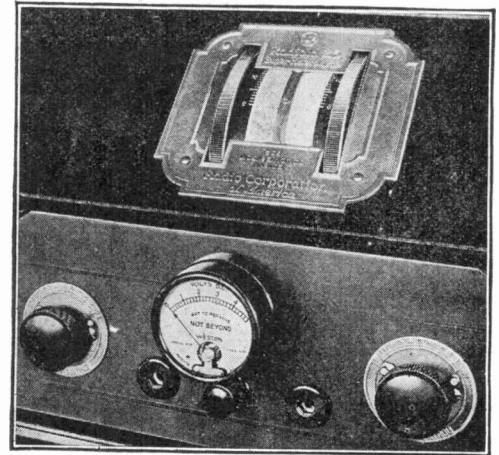
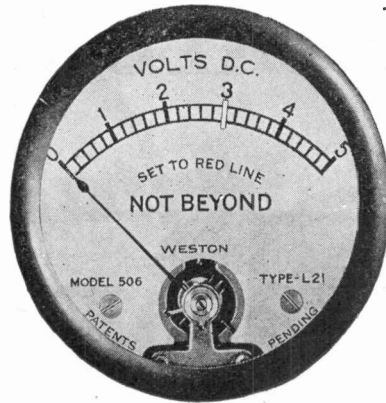
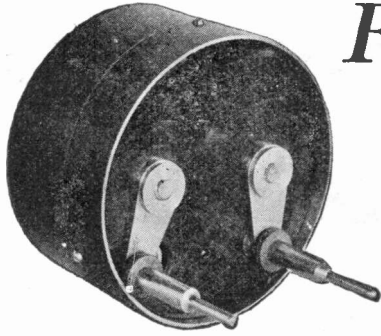

WESTON Pin-Jack Voltmeter

THREE famous radio manufacturers are actually selling this radio instrument for you.

Their superheterodyne models have Voltmeter-Jacks on the panels to receive the Weston Pin-Jack Voltmeter.

This instrument just plugs in—and immediately 90% of all radio receiving troubles cease!

And then—simply turn the battery setting knob until the Voltmeter registers three volts (at the red mark on the dial) and you get best reception, prolonged tube life, lengthened battery service.

Dealers know the reputation of Weston for quality radio instruments—and this Model 506 Pin-Jack Voltmeter is made with all the precision and possesses all the ruggedness for which these instruments are famous.

While production is large, the demands for 506 Pin-Jack Voltmeter have been larger, and you should not delay in getting full dealer information from us and ordering shipments.

*Plugs in—
as easily as the
Radio Plug*



WESTON ELECTRICAL INSTRUMENT CORPORATION
25 Weston Avenue, Newark, N. J.

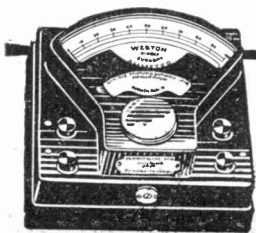

STANDARD THE WORLD OVER
WESTON

Pioneers since 1888

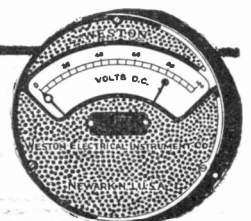

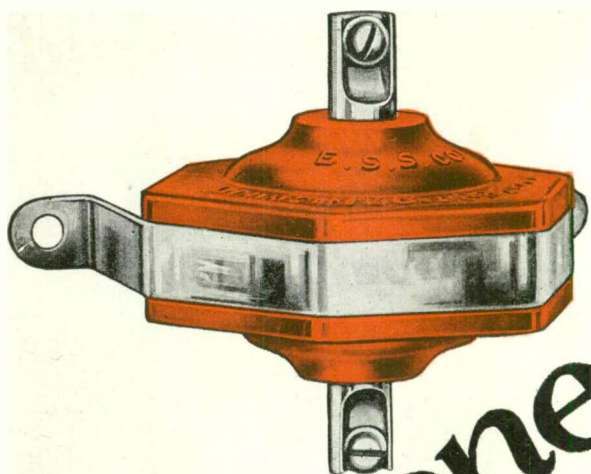

Keystone Arresters

for summer sales!

Do you experience a falling off of radio sales as summer approaches?

With the coming of the warmer weather and its customary electrical disturbances try this summer sales booster—the Keystone Radio Lightning Arrester. Your new customers can be interested in the value of a proved protective device. Your old customers who are replacing crude temporary construction with modern permanent equipment of higher quality, will want a Keystone Arrester.

It's a superior quality product, priced to yield a substantial profit to the dealer, who sells one with every order for antenna material.

ELECTRIC SERVICE SUPPLIES CO.

PHILADELPHIA 17th and Cambria Sts.	NEW YORK 50 Church St.	CHICAGO Illinois Merchants' Bank Bldg.
PITTSBURGH 839 Oliver Building	BOSTON 88 Broad St.	SCRANTON 316 N. Washington Ave.
	DETROIT General Motors Building	
	Lyman Tube & Supply Co., Ltd., Montreal, Toronto, Vancouver.	



KEYSTONE RADIO LIGHTNING ARRESTERS



New counter display carton

Attractive design.
 Made with genuine Bakelite housing.
 Has heavy discharge capacity and no vacuum.
 Weatherproof, dust-proof, damp-proof.
 New display package.
 Extensively advertised.
 Fully approved by Underwriters.
 The most practical arrester for the protection
 of radio antenna.
 The cost of reliable lightning protection is the
 price of this lightning arrester, \$1.50.



Single unit carton



Be sure today's Customers will



It is safest to build for the future on the solid rock of customer satisfaction. The thing that really counts is what your customers think after long use of the radio set or parts you sold them.

Clarity of reception, true tonal values, and distance are dependent upon having all the electrical parts of a radio set adequately insulated. The slightest deterioration of the insulating material used means lowered performance.

The use of Bakelite for the insulation of the radio sets and parts that you sell is an assurance that you will never have complaints because of faulty insulation. Bakelite is made to fixed standards and there is no variation in its properties



BAKELITE

REGISTERED U. S. PAT. OFF.



THE MATERIAL OF A THOUSAND USES

The registered Trade Mark and Symbol shown above may be used only on products made from materials manufactured by Bakelite Corporation. Under the capital "B" is the numerical sign for infinity, or unlimited quantity. It symbolizes the infinite number of present and future uses of Bakelite Corporation's products.



be satisfied a year from now

The insulating value of Bakelite is as high after ten years or more as it is when new. It does not deteriorate. It resists extremes of heat and cold and does not absorb moisture. Its handsome color and finish are lasting—undimmed by time or use.

Ninety-five percent of radio set and parts manufacturers use Bakelite. It is the standard insulation for the radio parts and accessories listed here.



Adapters—Binding Posts—Coils (Forms, Varnish impregnated Coil Mounting Brackets)—Condenser, (Fixed, Variable, Grid Condenser Mountings)—Connecting Shafts—Contact Strips—Crystal Detector Mountings—Dials—Grid Leak Mountings—Head Sets, (Caps, Diaphragms, Housing, Spools)—Jack Ferrules—Jacks—Knobs—Lightning Arresters—Loud Speakers, (Bases, Cones, Horns, Spools)—Panels—Phonograph Attachments (Diaphragm, Housing, Spools)—Plugs—Potentiometer Bases—Rheostat Bases—Sockets—Sub Panels—Tube Bases—Variocouplers—Variometers.

Write for Booklet 39

BAKELITE CORPORATION

247 Chicago Ave., New York, N. Y., Chicago Office 636 W. 22nd St.
BAKELITE CORP. OF CANADA, LTD. 163 Dufferin St., Toronto: Ont.

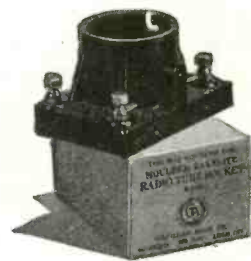

BAKELITE

REGISTERED

U. S. PAT. OFF.



THE MATERIAL OF A THOUSAND USES

The registered Trade Mark and Symbol shown above may be used only on products made from materials manufactured by Bakelite Corporation. Under the capital "B" is the numerical sign for infinity, or unlimited quantity. It symbolizes the infinite number of present and future uses of Bakelite Corporation's products.

ATWATER KENT RADIO



*Let the March winds
blow you trade!*

Here are five facts for your March calendar:

Fact No. 1

February being the best month in the year for radio reception, the second best is—what would you say? December? January? No, March—with April not far behind. The United States Bureau of Standards so reports after a year of testing.

Fact No. 2

In the face of the belief that radio is a fall and winter sport and September the month of the Great Revival, the public bought more sets and speakers last March than in September. Balmy April was as good a sales month as September.

Fact No. 3

Sturdy and reliable Atwater Kent Radio is distinctly year-round Radio.

Fact No. 4

Atwater Kent sales support knows

no slump. Atwater Kent advertising is year round advertising.

Fact No. 5

The Atwater Kent Radio Hour is the weekly concert to which all other radio programs are compared.

* * *

Pretty strong facts? Put them under your hat. Use them on the next customer who tells you he's going to put off his purchase until next season.

Write for illustrated booklet telling the story of Atwater Kent Radio

ATWATER KENT MFG. COMPANY
A. Atwater Kent, President
4733 WISSAHICKON AVE., PHILADELPHIA, PA.

Every Sunday Evening
The Atwater Kent Radio Hour brings you the stars of opera and concert, in Radio's finest program. Hear it at 9:15 Eastern Time, 8:15 Central Time, through:

- WEAF New York
- WJAR Providence
- WEEI Boston
- WCAP Washington
- WSAI Cincinnati
- WCCO Minn.-St. Paul
- WFI Philadelphia
- WOO } alternating
- WCAE Pittsburgh
- WGR Buffalo
- WOC Davenport
- WTAG Worcester
- KSD St. Louis
- WWJ Detroit
- WEAR Cleveland
- WLIB Chicago

Prices slightly higher from the Rockies west, and in Canada



Model 20 Compact, cable attached, \$80



Radio Speaker Model H, \$22

J. ANDREW WHITE,
Contributing Editor
S. J. RYAN,
Merchandising Counsellor
E. E. WHITEHORNE,
Contributing Editor
L. E. MOFFATT,
Associate Editor
PAUL WOOTON, Washington

Radio Retailing

The Business Magazine of the Radio Industry

O. H. CALDWELL, Editor

WILLIAM C. ALLEY,
Associate Editor
H. W. BAUKAT,
Assistant Editor
OVID RISO,
Assistant Editor
RAY SUTLIFFE, Chicago
H. S. KNOWLTON, Boston
C. GRUNSKY, San Francisco

Table of Contents March, 1926

Radio's Splendid Programs Are You Selling Them? <i>How the Dealer May Tie - Up With the Broadcasting of Special Features.</i>	251
Radio Demonstration Properly Made Is a Sale Practically Closed <i>Methods by Which Sales May Be "Put Over" Through Demonstrations, From Start to Finish.</i>	254
Three Examples of the Effective Use of Backgrounds in Show Windows	257
How to Sell Tone Quality <i>An Explanation of Demonstration Ideas That Sell Higher Priced Loud-Speakers.</i>	259
Concentration Of Effort Sells Eight Sets in One Block <i>D. A. Bailey of Troy, N. Y.—Outside Salesman Tells How Concentration Sells Sets.</i>	262
The Four Horsemen <i>How to Control Retail Store Expenses—by S. J. Ryan, Merchandising Counsellor.</i>	264
240 Furniture Dealers Who Are Making a Profit From Radio Tell How They Do It	266
Changes We Have Made in Our Store and Why <i>Physical Store Alterations Which Dealers Have Made to Simplify and Increase Sales.</i>	270
Training The Store Salesmen <i>How to Select and Train the Salesman, by J. Andrew White, Contributing Editor.</i>	273
Radio Our Newest Utility <i>In the Future, No Home Will Be Without Its Radio. Here's Why.</i>	277
Service Methods and Trouble Shooting Ideas Used By Other Men	282
And Now—Here's What Your Editors Think	284
What's New in Radio and Where to Buy It	286
New Service Tools and Equipment for The Radio Dealer's Use	291
How Manufacturers Promote Dealer Sales	292
What the Trade Is Talking About	294

DEPARTMENT OF COMMERCE
BUREAU OF FOREIGN AND DOMESTIC COMMERCE
WASHINGTON

January 19, 1926.

IN REPLY REFER TO 29

Mr. Arthur P. Hirose, Promotion Manager,
Radio Retailing,
McGraw-Hill Company, Inc.,
Tenth Avenue at 36th St.,
New York, N. Y.

Dear Mr. Hirose:

In view of the fact that our 1925 exports of radio products from various countries of the world were nearly \$10,000,000, the importance of foreign trade to our radio industry is readily apparent.

To my mind, one of the big influences in bringing about this rapid growth in our radio export trade is the circulation of our radio journals abroad. It was surprising to me on a recent trip abroad to find how closely radio fans in the countries I visited follow developments in the radio art through subscribing to American radio publications.

Accordingly, I believe that great good can be accomplished through the sending of American radio trade magazines to radio importers and dealers in foreign countries, and feel that such a plan will result in very tangible returns for the radio industry of this country.

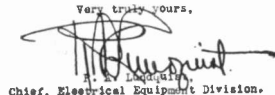
Very truly yours,

A. J. Langford,
Chief, Electrical Equipment Division.

Reaching the Radio Markets of the Whole World

THIS issue of Radio Retailing, and the April and May numbers following it, will be distributed by the publishers to reach radio distributors, radio merchants, radio importers and radio clubs in every country of the world, outside of the United States. This covering of the world markets for radio is, of course, in addition to Radio Retailing's regular coverage of the radio trade of the United States and Canada.

The importance of the export market for radio is being generally recognized by radio manufacturers, and the interest of the United States Bureau of Foreign Commerce is here attested in the present effort of the publishers to stimulate the demand for American radio products abroad.

McGRAW-HILL PUBLISHING COMPANY, Inc., Tenth Ave. at 36th St., New York, N. Y.

JAMES H. MCGRAW, President
JAMES H. MCGRAW, JR., Vice-Pres. and Treas.
MALCOLM MUIR, Vice-President
EDWARD J. MEHREN, Vice-President
MASON BRITTON, Vice-President
EDGAR KOBAK, Vice-President
C. H. TROMPSON, Secretary

Electrical World Journal of Electricity Ingeniería Internacional
Industrial Engineer Engineering and Mining Journal-Press
Chemical & Metallurgical Engineering American Machinist
Electrical Merchandising Power Electric Railway Journal
Bus Transportation Engineering News-Record Coal Age

Copyright, 1926, by McGraw-Hill Publishing Company, Inc.
Cable Address: "Machinist, N. Y."
Annual subscription rate is \$2 in United States and Canada.

WASHINGTON, D. C., Colorado Bldg.
CHICAGO, 7 South Dearborn St.
PHILADELPHIA, Real Estate Trust Bldg.
CLEVELAND, Guardian Bldg.
ST. LOUIS, 713 Star Bldg.
SAN FRANCISCO, 883 Mission Street
LONDON, E. C., 8 Boulevard St.

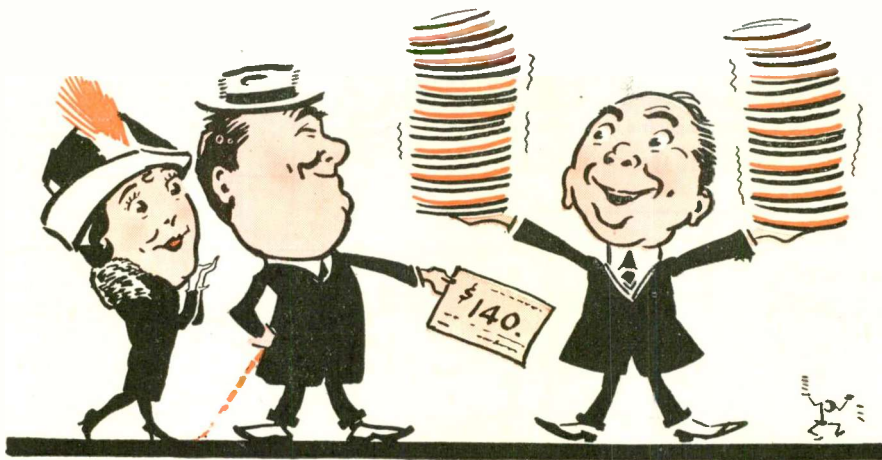

LIST up the features to be heard during any average evening radio program. Then check off these titles on a price-list of phonograph records, and add up the total.

Here is a way to figure the cash value of the radio entertainment that pours in free to every owner of a radio set.

Do You Remind Your Radio Customers that

To Duplicate an Average "Radio Evening" Would Cost \$140 for Phonograph Records?

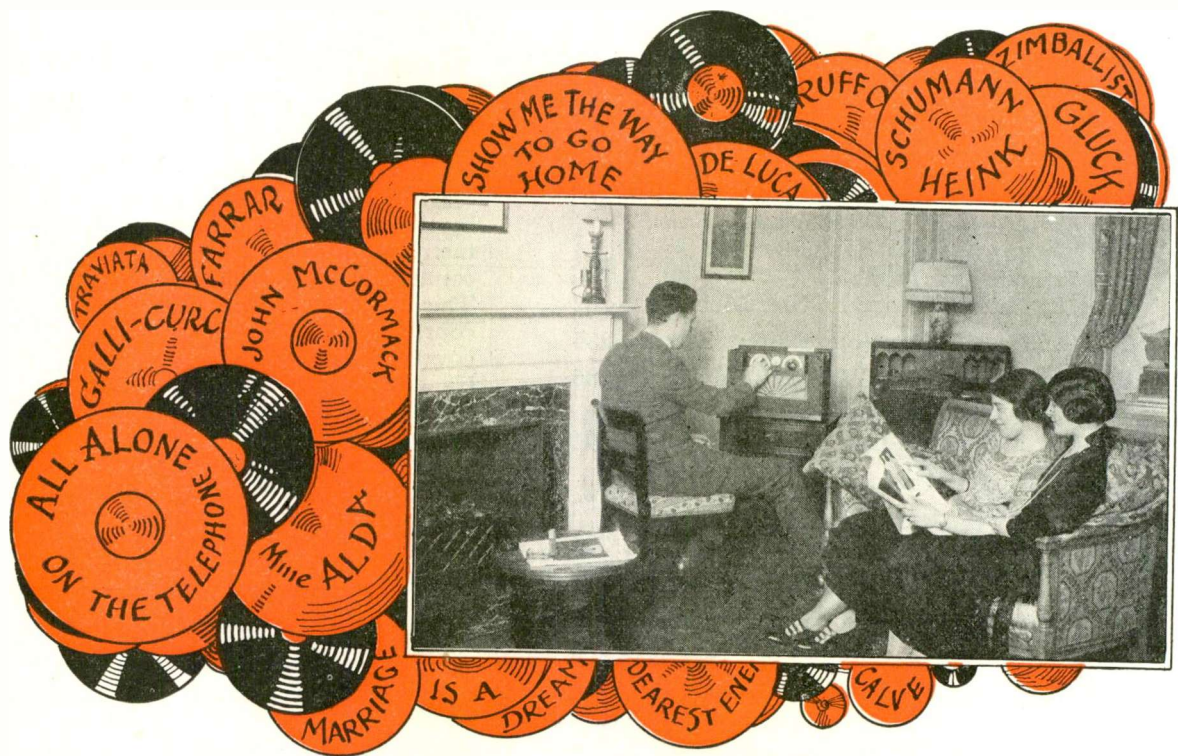

Radio Retailing

With Which Is Incorporated *Electrical Retailing*

VOLUME 3

MARCH, 1926

NUMBER 3

Radio's Splendid Programs— Are You Selling Them?

Nobody would be without a radio set if he fully realized the wonderful character of the nightly programs now on the air

* * *

THE truth of the above will be attested by every present radio listener, by every radio enthusiast, and by every radio dealer. Yet five homes out of six are still without radio receiving equipment.

Must we conclude that the inmates of these radio-less homes do not fully realize "what they are missing"? In newspaper ads, circulars, and window-displays we, as dealers, tell our public about the sets we have to sell, and describe their detail features and advantages.

Phonograph Men Have Long "Sold Artists"

But has the radio trade yet sold its prospects sufficiently on the splendid *program features* which they may expect to hear—and which, after all, comprise their chief and only interest in radio.

Any phonograph dealer who would tell his customers merely about the fine reproducing mechanisms, hand-

some cabinets, and prices of his instruments, while neglecting to talk about the artists and entertainers to be heard thereby, would be missing his principal selling argument.

Yet this is exactly the way in which many radio dealers today fall short in selling radio. They emphasize the excellence of the various parts and circuits, the fine appearance, and the prices of their sets. But too often they slight the most important feature of all—what is heard when the loudspeaker is in operation.

The phonograph trade has long made a point of talking primarily about the artist, the orchestra and the composition. The great growth of phonograph sales indeed dates from the time when the "program" took precedence over the mere machine in the advertising and selling policies of the trade. This page from the phonograph dealer's notebook the radio man can well begin to copy.

For it is in the things he hears "over the air" that the present-day buyer of radio sets is chiefly interested.

When broadcasting first began, everyone sought an opportunity to hear the new wonder of the age. The newspapers saw to that. But throughout the years since, a vast number of men and women have remained unsold, either because they were not properly approached or they refused to buy "machinery" or "experiments." They would not be impressed by mere radio sounds and demanded a reasonable order of excellence in radio programs as the price of their serious interest.

Music Now Appeals to the Most Exacting

The time has now come to sell this great number of doubters and prospects. For the broadcasting programs have attained a standard of excellence which compels the respect and admiration of the most exacting individual. Thus the former sales resistance is largely overcome.

The radio audience itself has in a great measure brought about this change by its improved tastes and demands. For example, its letters to but two well-known stations, WEA and WJZ, have dropped in

Marvelous Features Now on the Air Nightly.

Why Dealers Should Emphasize These to People Who Have No Radio Sets.

How to Use Window Displays and Advertising to Tie Up Sales with Better Broadcasting

Metropolitan Stars on the Radio!



Mme. Frances Alda

FRANCES ALDA

Soprano

TITTA RUFFO

Baritone

FLONZALEY QUARTETTE

Broadcasting from

KDKA, Thursday, 9 P. M.

The concert of these famous singers and the equally noted Quartette will be a source of unalloyed pleasure to you if you have a pure-toned Smith-Jones Receiver in your home.

We can install one of several excellent sets in time for you to hear these artists in your own living room. A ring on the phone will bring a representative; let him explain how easy it is to own a fine radio set and enjoy the many excellent things in the air.

SMITH-JONES SHOP

Main Street and Central Ave.

Phone 777



Mr. Titta Ruffo

HOW THE DEALER CAN ADVERTISE OUTSTANDING PROGRAMS

An example of a newspaper advertisement featuring a coming concert, and showing how the radio dealer can tie up with headline events on the broadcasting programs.

their requests for jazz, from 80 per cent in 1922, to less than 5 per cent last year: jazz being in demand only for dancing, where it rightfully belongs.

World-Famous Names in the Programs

The first reaction of prominent artists against radio performances has passed, and the appearance on broadcasting programs of such soloists as McCormack, Hoffman, Homer, and Seidel, and such orchestras as the Philharmonic and Detroit, has become frequent. So frequent that the radio dealer can almost always promise the most finicky customer the pleasure of hearing some authentic artist or musical organization within a day or so.

Then there are a host of other things of import and interest outside the musical field. Hardly any

important national event takes place without the presence of the all-hearing microphone. There are the market and stock reports so valuable to the farmer and business man, and as these notes are written it is announced that a new station is being erected at the New Madison Square Garden in New York, from which sporting events under the direction of Tex Rickard are to be broadcasted regularly.

The Capitol Theater program on Sunday evenings is always attractive; nor is "Roxy" to be overlooked on Wednesday evenings. And then there are the numerous advertiser's programs offering fine features.

Only if the salesman can discuss intelligently the broadcasting features of the day which appeal to both men and women, is he really prepared to sell receiving sets under new conditions. And he can become familiar with them easily and quickly

by devoting a little time to the weekly summaries of programs and intelligently listening-in himself as often as possible.

Use All the Avenues of Publicity

Now, it is not difficult for the dealer to tie up his sales efforts with the programs, nor is there any mystic formula for the process. The logical thing to do is to utilize every customary means of publicity at the disposal of the dealer—window displays, newspaper advertisements, circulars, direct mailings to selected lists, salesmen's visits, store, home and women's club demonstrations, etc.—and to *interpret and explain the connection between the broadcasted feature and the prospect.*

For instance, merely to insert a note in the local newspaper listing a special feature and allowing a line or two for the dealer's name and address is not availing oneself of the full benefits of broadcasting. The thing to do is to cash in on the great amount of broadcast feature publicity which is often so prominently displayed that few readers can possibly miss it. Consider the effectiveness of an advertisement, such as that illustrated herewith, appearing a few days before the event.

The same idea can be developed at greater length in a direct-mail piece or hand-bill. Note how the dealer's particular service in making the fine concert available to the prospect can be emphasized. That is why the dealer is in business.

The effectiveness of such advertising is augmented by the use of illustrations. It may be possible to obtain pictures of the broadcasting artists from the local newspaper's files or from other available sources. Cuts of sets being featured by the dealer are often good. And if it is possible to use photographs or "line-cuts" of radio home scenes, so much the better.

In Windows and On Store Counters

Pictures of broadcasting stars are always effective in attracting attention to store windows, and should be used whenever possible to accompany window announcements. But consider how much could be accomplished by entire windows dressed for special programs. Every day's program list furnishes countless suggestions for the dealer to exercise his ingenuity.

And inside the store, as well as in

publicity, emphasis should be laid upon the entertainment of which a good radio receiver is the source. If the prospect is sufficiently sold on the pleasures he is about to buy, he will accept almost any price that is not wholly impossible to him.

Indeed it is more important that the salesman know the broadcasting going on in his vicinity than many mechanical details of the receivers he sells. He should never forget that the buyer is primarily interested in entertainment.

Nor should he forget that his own tastes in entertainment are not necessarily those of his customers.

Super-power and link broadcasting are making these radio events available to the majority of listeners in the country. To name a few of these organizations: WJZ, which by virtue of some 46,000 letters received within the first month of its first transmission, considers its local area to be within a radius of 250 miles, has scheduled for the balance of the Winter the Philharmonic Orchestra every Monday evening.

Country-Wide Interconnection of Stations

The WEAf chain, which now includes fifteen stations, continues its Atwater Kent Sunday evening recitals with such artists as Mme. Schumann-Heink and Charles Hackett.

The various hotel ensembles and dance orchestras broadcasting from this station and its associated chains can always be counted upon for good entertainment. Then there are the educational courses of the several universities; the news of markets and stocks so valuable to the farmer and business man; and

the recently instituted reports on Congressional activities. A general tendency is noted among all stations to regularize the broadcasting of these as well as other special features, so that it becomes possible to plan one's radio pleasures some time ahead, just as one plans to take in other events.

Dealers Fail to Take Advantage

It is indeed a far cry from the early broadcasts to these splendid programs of today. The change has been no less phenomenal in respect to quality than to the comparatively short time since which it has come about. Yet in spite of the fact that it is the radio dealer who should profit most from this change, many dealers are found not to take advantage of the new conditions. The average dealer does not use his knowledge of the new broadcasting to utilize it in the expansion of his business; nor does he sell the vast variety of entertainment available to the prospects who are most likely to enjoy it, instead, in many cases he pushes his own preferences.

There is another most important phase of the new radio merchandising: a field in which the broadcasting stations have also progressed, but have not been followed by the mass of dealers. Practically every station devotes a good portion of its time, particularly during the daylight hours, to features which are intimately associated with every woman's immediate personal interests.

So enthusiastic has been the response to these women's features that many stations have instituted both morning and afternoon programs to comply with the demand.

Thus it was found by WJZ that many women outside the city were unable to find time to listen in during the morning. A second women's program in the afternoon was necessary to enable these country women to hear many things of interest and value to them. Both programs are therefore planned with the needs of these particular classes of women in view.

These practical talks of housework, cooking, fashions, home economics, health, care of children, home decoration and what-not, are both interesting in themselves and help to lessen the woman's burden. They are listened to attentively by the fortunate women who have radio sets in their homes. Yet millions of homes are not yet equipped with radio receivers. In his sales appeals the wise merchant will therefore lay more and more emphasis upon the broadcasting features which exert so powerful an attraction to women.

Appeal to the Buyer's Interests

In fact, the dealer's sales appeals today must be directed to the *interests* of his male and female prospects, in contrast with his former mere display for sale of an unusually attractive electrical device. There is nothing original about this suggestion, but the idea behind it appears to have been forgotten by a goodly number of those most concerned. The day of the seller's market in radio is past; the buyer's day has arrived. Those who remain prospects must be sold on the basis of worth-while performance. And only an appeal directed to their genuine interests and desires will secure the response sought.

Do You Realize That—

No One Would Be Without a Radio If He Knew About The Wonderful Things Now on the Air

Here Are Some of the Headliners Appearing on the Programs:

President Coolidge
Ignace Paderewski
Josef Hofmann
John McCormack
Walter Damrosch
Arturo Toscanini
Mme. Schumann-Heink

Mary Garden
Lucrezia Bori
Titta Ruffo
Frances Alda
Louise Homer
Tito Schipa
Drusolina Giannini

Charles Hackett
Dr. S. Parkes Cadman
Irvin S. Cobb
Will Rogers
Philharmonic Orchestra
Sousa's Band
U. S. Marine Band

THE editors of "Radio Retailing" have gathered, from the four points of the compass, "Demonstration Notes" from some of the most successful radio dealers in the country. Here is the "boil-down" of these ideas presented in the following order:

- [1] **Getting the Demonstration**
- [2] **Scheduling the Demonstration**
- [3] **Giving the Demonstration**
- [4] **After the Demonstration**
- [5] **Special Demonstration Room**
- [6] **The "On Trial" Situation**
- [7] **Store Demonstration Facilities**

1

Printed Invitations for "Demonstration Party"

An Illinois dealer sends us the following suggestion: "Why not arrange for a neighborhood demonstration party. Secure permission from some one who is friendly inclined, to use his house for the demonstration.

"Then send neatly printed invitation card to all prospects in the neighborhood. These cards should ask the prospects to come to the demonstration, and should explain that an adequate talk, explaining the fundamentals of radio, will be given at that time. The opportunity to learn something about radio from the lips of an expert will prove tempting bait and will usually bring a number to the demonstration who would not otherwise appear."

Offers \$2.50 in Merchandise to Customers Supplying Leads

The most effective and inexpensive form of advertising for a radio dealer, is the recommendation of a satisfied customer.

One enterprising Denver dealer is-

sues two "introduction cards" to each one of his customers. If this customer, by turning these cards over to friends, thus furnishes the name of a prospect, and the dealer succeeds in making a demonstration and selling this prospect a complete radio receiver, the original customer is given the equivalent of \$2.50 in merchandise. He may choose a I simply have to prove to my customer that the sets I sell will get distance."

state dealer. "If I cannot close the order when I give the demonstration I leave the set for a few more evenings. A good reception night will come along and the set will then sell itself.

DX for Customers "If It Takes All Night!"

"That set you sold me won't bring in Kansas City, but Brown's set, across the street, gets Denver."

A Radio Demonstration Practically

Be Ready to Mail "Rainy Day" Post Cards

Why not have a quantity of "rainy day" postal cards all addressed to your prospect list and ready to drop in the mail box on the morning of, what looks to be, an all day's rain.

Hilliard & Hamill of Rensselaer, Ind., do this and get worth-while returns from it. These cards of theirs read:

"Can't go any place tonight?—Don't know what to do?—Buy a Radio!"

Advertise That You Have a Receiver For Loan

Announce in the local papers that you are willing to loan a first-class radio receiver for use at any public affairs or private parties upon request,—this receiver to be delivered free of charge and to be operated by an expert furnished by the dealer. Such an offer will certainly bring many inquiries.

2

Schedules Demonstrations for Late in the Evening

"I schedule demonstrations for as late an hour in the evening as possible, in order to profit by the better reception conditions," reports a New York

Dealers who have heard that before, please raise your right hand. When Joseph Drake, 460 Central Avenue, Jersey City, N. J., gets a plaintive 'phone call like that he designates a mutually convenient night and, at the appointed time, goes out to the customer's home and proceeds to get DX if it takes "until three in the morning."

"I can't afford to have any sets of mine taking second place to those of some competitive dealer," he says.

Drake makes the date for a Saturday night if possible so that all hands can sleep late the next day. He starts in about 10:30. "If I can get Florida or Texas before the locals sign off, so much the better" he adds, "and if I get a station good and strong I slip off the antenna connection and transfer the ground wire to the antenna binding post. This is a grandstand play. When the customer realizes what he is getting, without an outside connection, it never fails to make a hit."

Drake always takes along a set of tested and matched tubes. These he leaves in the set. He claims that this time and expense is justifiable as the set owner is generally so pleased, when he hears a station 1,000 miles or more away, that he starts right out to boost his wonderful set.

Do Not Offer Excuses

"Do not offer excuses if things don't go right during the demonstration," writes H. R. Smith, Southington, Conn. "The prospect will discount what you say. It is far better to first make certain that conditions are right and that the set is properly installed and in perfect running order—then if noises come in accept them as a matter of fact. This will save a lot of future trouble."

3

Home Demonstration Tips

There are many little "kinks" that the dealer should know about home demonstrations, which on the surface may appear as insignificant, but which are frequently the deciding factors in the demonstration. A dealer in St. Paul,



A good window display is a prime source of leads for demonstrations that turn into sales

Minn., always demonstrates as late in the evening as possible. As is well known, reception usually improves as the hour grows late. He also installs his outfits, if possible, in the afternoon. If this is done prospects do not have to wait for installation "finishing touches" when the demonstration hour arrives.

If the installation must be made at the time of demonstration he makes this job easier and speeds it up by

require the setting up of numerous instruments; to want to try everything, and thereby your customer quite likely becomes a prospect for many other establishments, and the chance of losing the sale is great. The policy employed by the Liberty is to install the set best suited and to readjust the purchase later or change the instrument if some calculation proves faulty.

"Too liberal credit terms are a detriment to the continuation of business,"

Stick to Common Sense Instructions in Plain Language

Only after the sale of the set is closed should the buyer be instructed in the details of its maintenance. He is then already committed to ownership and becomes curious as to his purchase.

The instruction which is now taken as a matter of course is, when wrongly timed, often fatal to a sale. But even now all discussions should be simple, comprehensible, and as free from technicalities as possible.

Properly Made Is a Sale Closed

equipping the A battery leads with large, tension spring, clips. One of these clips, attached to a long flexible wire greatly facilitates making the ground connection.

This dealer also listens in on a pair of head phones before he turns on the loud speaker. He locates the position of several stations in this manner. When the speaker is connected the audience will be struck by the ease and certainty with which one station after another is quickly tuned in. The "squeals" which frequently occur when the operator "fishes" for stations are also done away with by this method.

"Cafeteria Style"—Let's Them Demonstrate Sets to Themselves

The Campbell Electric, London, Ontario, have furnished a room on the second floor of their store for customers' exclusive use. They call it their "Radio Studio." They have a sign prominently displayed on the store entrance door which reads: "Radio Studio Upstairs—Come in and make yourself at home."

Soft carpet, easy chairs, attractive fixtures, and plenty of sets to play with comprise the equipment.

"I leave them alone up there," says Mr. Campbell. "After they bring in four or five stations—sometimes without a bit of instruction—they've sold themselves. All I have to do is to answer questions."

"Store Demonstrations Only" Saves Money, Insists Music Man

More than three-quarters of the radio sales of the Liberty Music House, of Seattle, Wash., are made in the store sales rooms, it is explained. The policy of the firm is to sell in the store, not in the home. No outside salesmen are employed and only those "tips" for business coming from satisfied customers are followed up by outside calls. "The overhead cost of selling in the home is too great," says Mr. Mitchell. I find that those who want home demonstrations are inclined to

Mr. Mitchell states. "Our policy," he adds, "is one-quarter cash payment down and the balance in 10 equal monthly payments, with a five per cent carrying charge equally divided among the ten payments."

4

Find Out What the Prospect Wants

"When giving the demonstration don't talk circuits if the prospect is interested in tonal qualities or distance reception," states a dealer in Salt Lake City, Utah. "I always find out what the prospect wants and confine my selling talk mainly to that particular subject. Instruct your clerks to be on the lookout for this important detail from the minute a customer enters the store," he continues.

"If a man immediately lifts the cover of a set and seems to know something about circuits, this fact is noted and when the home demonstration is being given our man is directed to lay particular stress on the reason why our circuit is best suited for his locality and his local conditions.

"You will find that many people, however, think more of a good tone and a fine appearance than they do about what is inside the box.

"That is why it is so necessary to always use a good loud speaker."

A Good Set Will Sell Itself

A good set will sell itself if it is placed in the home in operating condition. Every middle-class home which lacks radio equipment harbors a live prospect.

With the tremendous publicity radio has had, and the vastly improved programs now being broadcasted, the task of interesting prospects is much simplified. It is not difficult to obtain the average housewife's consent to a free demonstration in the evening, when the entire family can be assembled for an evening's entertainment, and the head of the house is present to O. K. the expenditure and make the initial payment.

5

Steers the Difficult Customer Into the "Turn-over" Room

The radio store of the Central Electric Company, New York city, is located near Times Square, on one of the most expensive pieces of real estate in the world. To pay the rent and make a profit besides, the owners of this establishment are obliged to make the most of every sales opportunity that presents itself. That is why they fitted up a lowly basement as a demonstration parlor. They call it a "parlor" because, although it originally had a concrete floor and a bank of ugly pipes overhead, it is now richly carpeted and curtained, and its walls glisten with panels of silver and gold.

"We call this our 'turn-over' room," explained a member of the firm, "because if we can't close a prospect upstairs we get him down here where



The critical moment in the demonstration comes when the customer herself is encouraged to "tune in" a station

it is quiet and secluded and 'turn him over' to our high-pressure man. Due to this system about one out of every four prospects that were pronounced hopeless upstairs, usually signs on the dotted line before our downstairs man is through with him."

Demonstrates Sets on Mezzanine Floor

It will pay the radio dealer to provide a special room for demonstrating sets, is the opinion of Walter W. Woboshell, who heads the radio department of Hartt & Lane, 68 West Forty-fifth Street, New York City.

"We found that trying to demonstrate on the main floor front was very unsatisfactory," Mr. Woboshell says. "Street noises and distractions from other customers were the main reasons. Our store is so small we didn't have room for booths, but we have a high ceiling, so we added a 'mezzanine.' This floor measures 20x25 ft.

"Of course we haven't any way of establishing the fact but we are quite certain that it is much easier for our salesmen to 'close' when they get prospects up there than it used to be right in front of the street door.

"We prefer a 'mezzanine' to booths," he added, "because booths are so small they don't give the salesman a chance to 'do his stuff.'"

"It's the Product Plus the Salesman's Personality"

"My customers, it seems, cannot definitely make up their minds to buy any particular radio set," writes a mid-western dealer. "Each one insists upon trying out several at his home before thinking of buying. How can this sale stumbling block be overcome?"

Compare this problem with that of the automobile salesman. Few potential car owners have in mind a specific idea of the car they wish. The motor-car salesman must actually plant the idea in the customer's thoughts. He must create in the customer the desire to have, by bringing to his attention every distinctive feature of the product. He must secure his listener's confidence.

In demonstrating radio, as in every other line, it is the *personality* of the salesman, not alone the merit of the product, that makes for successful selling.

Afternoon Broadcasting Enables Minneapolis Dealers to Demonstrate Sets in Stores

The Northwest Radio Trade Association, 301 Tribune Annex, Minneapolis, Minn., has arranged for three separate schedules of afternoon broadcasting over the Gold Medal Broadcast, WCCO. This gives its dealer members in the Northwest better opportunities to demonstrate radio sets in their stores during the daylight hours. With these additional schedules WCCO

is now on the air 7 or 8 times between noon and 5:30 p.m., with various features, and offers nearly continuous broadcasting. An afternoon concert is presented every week day at 3:30 p.m.

How a Canadian Dealer Handles the "On Trial" Situation

That a troublesome sales condition may be turned into an advantage is illustrated in the case of the Virtue Radio Company, 222 King Street, East, Hamilton, Ontario. Discussing the abuse of the "on trial" privilege their manager, N. W. Kittson says:

"We encourage prospects to try out sets in their own homes. It's one of the ways we sell. But we check the tendency of the irresponsible and the insincere to order sets by a very simple method.

"Each applicant for a set on trial must first pay \$7 which is the cost price of the installation of a proper aerial and ground. If the customer doesn't keep our set, his aerial is still good for whatever outfit he finally selects.

Deliberately Refuses "On Trial" Deposit

"Although it is the practice of most radio dealers in this town to demand a deposit on sets sent out 'on trial,' we deliberately refuse to do so," says Paul Wieland of the Model Radio Company, 142 Washington Street, Paterson, N. J. "We purposely request the prospect not to leave a deposit. By so doing we create the impression that we are confident our set will give satisfaction and be retained. 'Time enough to pay us after you have heard it,' we say. This helps us to get demonstrations in the home. We haven't lost a set through abuse of this privilege yet."

Aerial Installation Costs More If Customer Returns Set

The Sport Radio Center, 308 Asylum Street, Hartford, Conn., itemize their installation charge at \$5 if the prospect buys his set from them, but charge \$10 for the aerial and ground connections if he returns the set after the trial demonstration, and buys elsewhere. The effect of this arrangement is quite obvious.

Small Lights Show Customer Which Loudspeaker Is Being Demonstrated

Practically every radio retailer has devised some method by which different receivers can be demonstrated to the customer by merely throwing switches from one to the other. Some

dealers also have provided their demonstration rooms with a similar arrangement for the demonstration of a number of loudspeakers. The difficulty arises, however, that comparison of several speakers grouped closely together is rather difficult, as the customer can not easily tell which one is being operated at the moment.

A New York City radio dealer has found a way to remove this obstacle and at the same time to add to the attractiveness of his store.

He has placed a number of speakers on a shelf, constructed over his sets on demonstration. In front of each speaker is mounted a small automobile parking light. By the use of a simply constructed multipoint switch, one speaker after another can be turned on, and at the same time the light in front of the one in use illuminated. The customer can thus compare the different speakers' operation, by watching these lights.

Can Demonstrate Number of Sets Quickly, in Any Part of Sales Room

L. Bedrosian, a White Plains, N. Y., dealer, has equipped his radio demonstration room with a number of "multi-plug" battery terminals which greatly simplify the demonstration of various sets in rapid succession.

Each demonstration set is equipped with a plug having seven terminals, which are connected to the battery, antenna and ground posts of the set itself.

Located conveniently in the demonstration room are a number of receptacles, having seven corresponding terminals, and connected in turn to a common set of batteries and antenna and ground.

To demonstrate any set on the floor, it is only necessary to insert the attached plug into a receptacle. With one motion, batteries, antenna and ground are either connected or disconnected.

Mr. Bedrosian says:

"I can demonstrate any set, in any section of the room, using one set of batteries. This can be done in a few minutes without fussing with wires, batteries or tubes, making it possible to demonstrate half a dozen different sets to a customer in the time it would ordinarily take to hook up one."

"At the Sign of the Loudspeaker on the Pole"

The Hummer Furniture Company of La Salle, Ill., displays a loud-speaker and advertises its radio department with one master stroke.

E. Charles, the Hummer Company's radio expert, says: "We have mounted a loud-speaker on a pole in front of the store, wiring it to a receiver inside. The set is tuned in on the best program available and an 'open air' concert given to the public."

The loudspeaker on the pole thus becomes a landmark for the store.

Three Examples of the Effective Use of Backgrounds in Show Windows

This background illustrates how a few yards of crepe paper may be made to give the effect of solidity, and change the entire appearance of a window.

The window below gains its "attention value" because of its dominating background. This effect is carried throughout the trim.

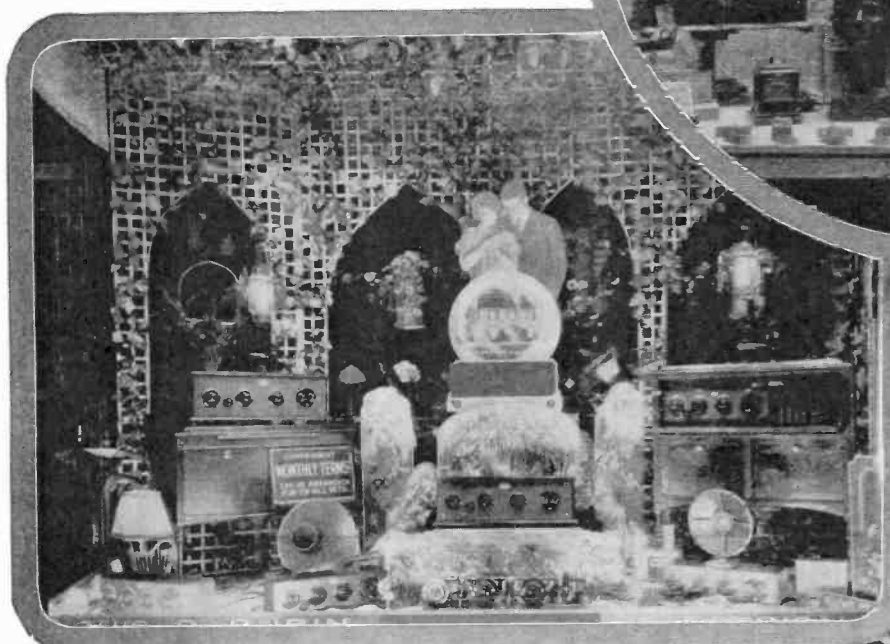
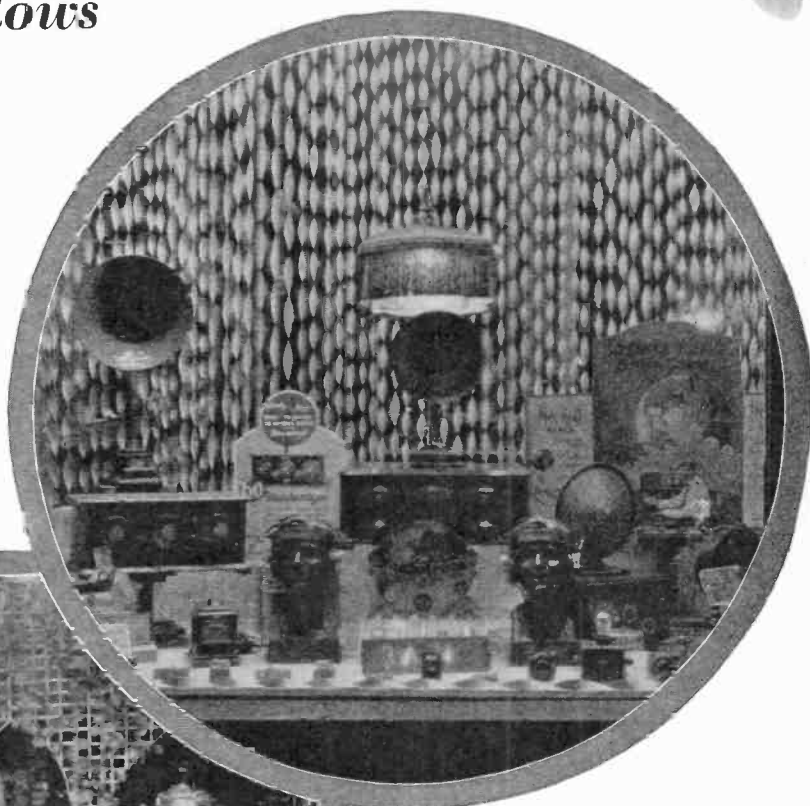

The striking color design background and the row of "bathing girls" pictures in the foreground of this Southern California Radio Company's window, furnish a combination of eye compelling interest which is guaranteed to "stop" the most casual passer-by. The pretty girl—in a bathing suit—is, and always will be, a safe bet as a centerpiece of any window.



Show This to Your Customers. It Explains—
Why the 1926-Model Loudspeakers
“Sound So Much Better”

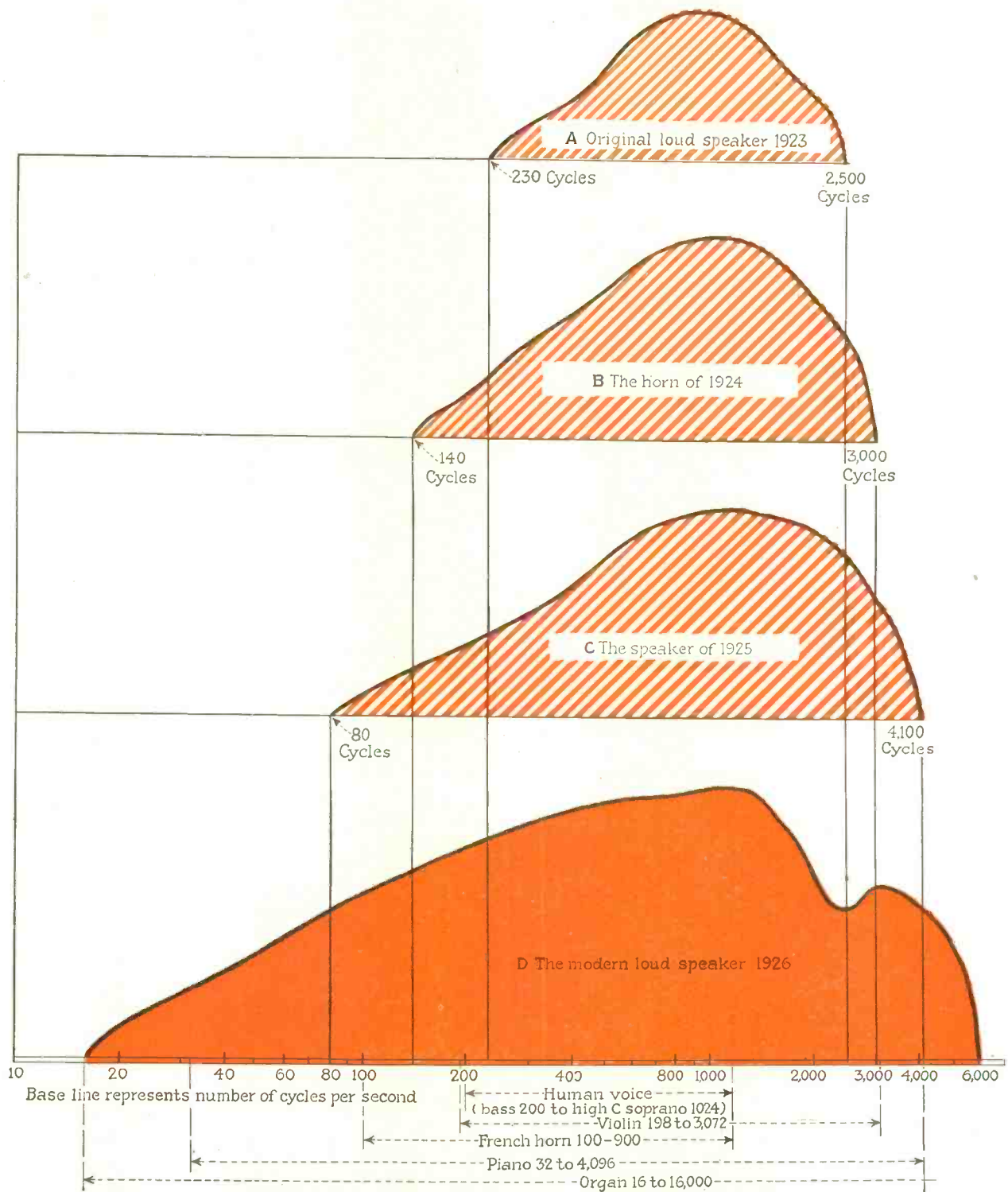

THE early loudspeakers were “tinny” and “phonographic” because, as here shown, they reproduced only a part of the incoming sounds. Especially were they deficient in (a) the deep bass notes at the left, which enrich reproduction, and (b)

the high vibrations at the right, which add timbre. From year to year, loudspeaker improvement has progressed, until now the 1926 models cover, with fidelity and clearness, substantially the whole audible range.

"How to Sell Tone Quality"

BY GEORGE H. JONES

EVERYBODY agrees that the great radio advance of 1925 is improved tone quality. It is featured in advertising and stressed in selling. But the effort of the average retail salesman to sell improved tone quality to the prospect is pitifully inadequate. So-called master salesmen bandy stock phrases with a clumsiness which is the product of ignorance of the subject, while the prospect usually feels that he is the victim of much meaningless selling talk.

"This receiver costs twenty-five dollars more than the one which I have just demonstrated to you. It has the same number of tubes. All the extra cost is in tone quality. Just listen to it and hear for yourself," is one of the standard approaches to the subject.

And then music blares forth from the tonal masterpiece while the salesman smiles benignly and expectantly. If he is sufficiently practiced in the art of smiling, the prospect mechanically and hypnotically smiles also, wondering at the same time whether there is really twenty-five dollars' worth of extra tone quality in the more expensive product.

As a friend of mine aptly put it, you cannot describe the taste of a banana, nor, in the mind of the average salesman, can you describe tonal quality, particularly the fine differences which distinguish one receiving set having good tone quality from another.

The Super-sensitive Ear

But it must be admitted that the ear is conscious of very minute distinctions. You may be listening to an orchestra and be conscious of the fact that *something* is wrong, but only a trained musician can tell specifically what it is.

I once attended a symphony concert with a musician and was conscious through a part of one selection that there was *something* wrong which must have made its composer quiver in his grave. I questioned the musician and he said: "Why, of course. Can't you hear it? One of the violins is playing slightly off key."

Radio Retailing, March, 1926

He regarded me with amiable pity, but I thought my ear was pretty good to distinguish one instrument out of eighty which wasn't doing its job correctly. As a matter of fact, probably about every one in the audience was conscious of something wrong, but only a few could diagnose as discriminatingly as my companion.

If you would sell a receiver costing twenty-five or fifty dollars more to a customer on the basis of superior tone quality, you must be as precise and definite as the musician at the symphony concert. One specific point will carry conviction and will outweigh all the talk about "straight-line frequency characteristic," "proper balance of low tones," "absence of harmonics," and similar phrases, freely used in selling tone quality. Technical terms are absolutely meaningless to a non-technical prospect.

Proper Demonstration Facilities Needed

Particularized selling can be substituted for glittering generalizations if two simple requirements are met. The first is proper demonstrating facilities and the second is specific knowledge of the factors which make tone quality. The first enables you to make the customer conscious of differences in quality between one set and another or one loudspeaker and another, and the second enables you to clinch this feeling by pointing out specifically exactly what these differences are.

In order to test the tonal quality of amplifiers and loudspeakers, I have a switching arrangement in my own laboratory which makes comparison tests simple and easy. There is room for three receiving

The reasons which underlie fidelity of reproduction in both receiving sets and loudspeakers. How to apply them to merchandise better equipment.

sets on the demonstrating table. "A" and "B" battery, antenna and ground connections are available through terminals so that three sets may be wired up at the same time. Clip connectors are used for antenna connection.

Arrangement of Switching Connections

The output of the sets is made available to a small switch panel through a flexible wire and plug of sufficient length to reach any one of the three sets. A master switch on the panel determines whether this output is supplied to a distortion-free amplifier or directly to the loudspeaker circuit. A row of switches enables me to switch to any one of several loudspeakers.

The output of most receivers can be secured through a headphone or detector jack and this is suitable for actuating the distortion-free amplifier. A flip of the master switch cuts out the amplifier. By changing the plug to the loudspeaker jack, the receiving set's audio-frequency amplifier is instantly compared with the distortion-free amplifier as a standard. The diagram shows the wiring arrangement.

The following are the tests which may be performed:

1. **The best loudspeaker for a given set.** By successively switching from one loudspeaker to another, the one best suited to the customer's desires can be quickly determined. It often occurs that a loudspeaker which may be superior with one set is not the one which is best with another, because one loudspeaker may correct the distortion introduced by the audio amplifier while another may exaggerate it. Sometimes the personal taste of one listener may differ from that of another.

2. **The comparative tonal quality of three sets.** By successively changing the plug to the loudspeaker jack of one set after another, clipping the antenna to each set as it is tested, the customer can determine quickly the tonal superiority of one set over another. The receivers should, of course, be tuned to the same station.

3. The comparative sensitivity and selectivity of three sets. By using the distortion-free amplifier, which is sufficiently sensitive to give loud-speaker volume of good quality with the weakest signal audible through headphones, the relative sensitivity and selectivity of three sets can be demonstrated. Oftentimes, for the customer who desires distance, this method of demonstration is superior because it places all sets on an equal basis, so far as these two factors are concerned, regardless of the difference in their audio-frequency amplification.

4. The quality of the audio-frequency amplification of any set. By first plugging in the loudspeaker jack and then changing to the detector jack, at the same time flipping the master switch so that the distortion free amplifier is used, the quality of the audio-frequency system of any set is easily determined. This is of value in selecting your stock of receiving sets as well as selling resistance coupled amplifiers.

The distortion-free amplifier used consists of one stage of impedance coupled amplification, two stages of resistance coupled, the last of which is attained through a power tube.

From an examination of the characteristic curve of a standard impedance amplifier and that of a resistance amplifier, it will be seen that this combination automatically corrects the slight differences in the

characteristics of the two kinds of amplification so that theoretically perfect reproduction is obtained. A standard three stage resistance amplifier, however, is sufficiently good for demonstration purposes.

Although, at first sight, this quick-change switching arrangement may seem not worth the trouble and expense involved in installing it, the startling demonstrations which can be given with it are invaluable in moving a customer to decide on a higher priced receiver. Differences of tone quality are strikingly apparent if demonstrated in rapid succession. But we are not conscious of them after a lapse of time because the ear adjusts itself so quickly to varying tonal characteristics of reproducing instruments.

Knowledge of Nature of Sound Necessary

Your work is not thoroughly done, however, if you leave it to the customer to sell himself on tone quality. You must be able to put into words the specific tonal characteristics which distinguish one set or loudspeaker from another. For this, a little knowledge of sound is necessary.

If you strike a note on the piano sharply and immediately lift your finger from the key after you have struck it, a dampening hammer comes down which stops the string from vibrating. But, if you listen

carefully, you will hear other strings vibrating which give you the impression that the original string has not stopped sounding. Try this on a piano sometime and you can observe this phenomenon for yourself.

The Matter of Harmonics

What happens is this: The strings which are tuned to double, triple, four, five, and six times the frequency of the original note are set in sympathetic vibration. These multiples of the fundamental frequencies are called harmonics. With any musical instrument, harmonics are always set up which are exact multiples of the fundamental or basic frequency.

Second, if you are blindfolded and hear the same pitch or note rendered successively by a piano, flute, violin, cornet, or any instrument you may care to name, you can easily distinguish the different instruments being played. Yet, the fundamental pitch or frequency and the frequency of the harmonics set up by each instrument are identical. For instance, the middle C on the piano and the same pitch with any and all instruments is impressed on the ear by air impulses of a fundamental frequency of 256 and harmonics of 512, 768, 1024 and so on up.

It is the *distribution of energy* upon these identical harmonics which enables us to distinguish between instruments. Thus, the flute, with its clear, piercing tone, concentrates over nine-tenths of the energy on the fundamental and very small fractions of the energy on the harmonics. The violin, on the other hand, puts three or four times as much energy in its third and fourth harmonics as it does in any of the others.

Every instrument has its own way of dividing the energy among the fundamental and harmonics which gives it individuality. It is needless to learn just what these differences are for every instrument, so long as you appreciate the importance of the harmonics and the fact that differences between musical instruments are distinguished by the ear through the energy in the harmonics.

Fundamental Carries the Melody

The fundamental frequencies give you the tune or melody. The harmonics, multiples of the fundamental, enable you to distinguish the various instruments. Hence it is essential that both be faithfully re-

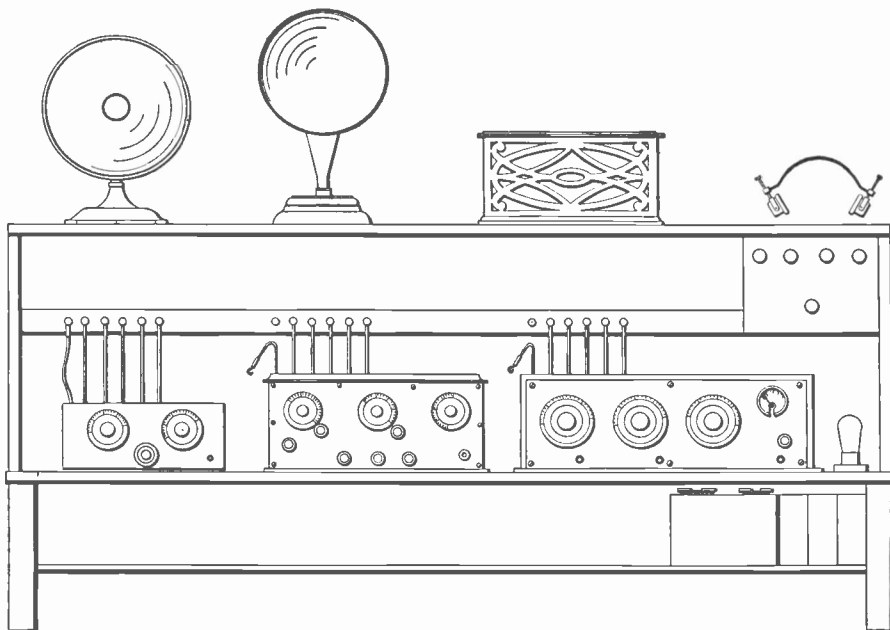

Arrangement of demonstrating table. Loudspeakers on upper shelf, switched in and out by means of upper row of push-pull switches, mounted in control panel at right. Crossbar at center above sets fitted with antenna, ground, and A and B battery connections, so that three or more sets may be

permanently wired in. Spring-clip connectors provided on antenna leads. Sets are placed on main shelf, at convenient height for tuning and inspection, with resistance amplifier at right, cut in and out by master switch, lower center of panel. Shelf below provides room for batteries and charger.

produced. If an amplifier distorts by exaggerating, let us say, frequencies of about 1,500 markedly, and the middle C on the piano is played, the fifth harmonic will be markedly louder than it should be. There will be *something* about the music which does not sound right to the most unmusical person.

All the talk about straight line characteristic of audio-frequency amplifiers and loudspeakers is based on this one point—correct reproduction of fundamental and harmonics. The better broadcasting stations actually transmit fundamentals and harmonics correctly. Any unnaturalness or unfaithfulness of reproduction is usually introduced by the receiving set or the loudspeaker or both.

Appreciating these facts regarding the necessity of faithful reproduction, not only of the fundamental notes but of the harmonics, you can also demonstrate them. When you hear a receiving set from which the reproduction of the piano cannot be distinguished from the banjo when a part of an orchestra, you know that the set does not faithfully reproduce the harmonics.

Demonstrating the Good vs. Bad

You may know that either a piano or a banjo is maintaining the rhythm and time, but, with an inferior set, you cannot determine which it is. Ask the customer who insists on such an inferior set to decide in his own mind whether the instrument being played is a banjo or a piano. Then switch from this set to one which reproduces the harmonics faithfully, by means of the installation we have described.

Oftentimes no talk about tone quality is needed if this manoeuvre makes it strikingly clear that it is a piano and not a banjo or vice versa. There is a fair degree of similarity in the energy distribution among the harmonics of the piano and the banjo, but the differences nevertheless are sufficiently important that a receiving set should be capable of reproducing them.

The soprano voice owes its unpopularity among radio listeners to the fact that, until recently, almost every kind of receiver caused it to sound screechy and painful. But there is nothing inherently wrong with sopranos. This prejudice will disappear as rapidly as receiving sets which reproduce the upper harmonics faithfully come into use.

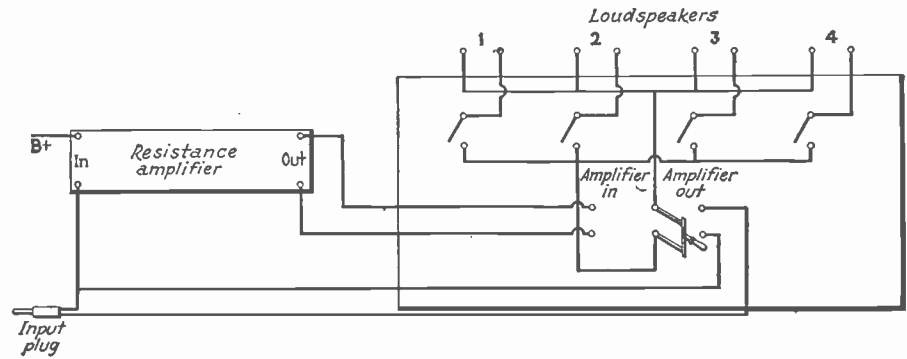

Circuit diagram for switch panel, controlling amplifiers and loudspeakers. The loudspeakers may be permanently wired to the control switches or a row of jacks provided

so that the loudspeaker set-up may be changed. Push-pull switches are preferably employed both for loudspeaker control and amplifier switch.

Lower Harmonics Give Volume, Energy, Richness

Just as the harmonics in the high frequencies furnish the distinguishing characteristic between different musical instruments, the lower ones contribute the volume, the energy and the richness to the tone. Your customer may be able to tell you just what instruments there are in an eight piece orchestra with a set that produces the upper frequencies well, but the music may still sound thin and stringy because few or none of the frequencies lower than 200 cycles are reproduced.

If you are trying to sell a receiver that gives the low frequencies as well as the high frequencies, the organ will make that set stand out above others with a difference as marked as day and night. The low frequencies will make it sound rich and booming, while the set which drops them will sound flute-like and thin, even though it still remains pleasing.

Likewise, the tympani and drum will sound crashing, massive and startling on the good set, while with one which drops out the low frequencies, the drums will sound wooden and the tympani tin-panny. All the music will sound metallic, harsh and grating, instead of soft, smooth and pleasing.

The Time to Make Comparisons

The skillful demonstrator of tone quality, aided by a switch arrangement will know at just what point of a musical selection and just what kind of a program to demonstrate the superiority of one set over another. Just when the organ is coming through, booming over a low and powerful note, he will switch to the inferior make and it is probably not necessary for him to do any sell-

ing by word of mouth to put over the better if more expensive set. On the other hand, if the superiority which he desires to demonstrate is in the higher frequencies, he will wait for a piano, soprano voice or flute to switch from the inferior to the superior set. And he will know what to call to the customer's specific attention if he is faced with one of those rare characters who does not instantly make these discriminations for himself.

Radio is purchased largely for the musical entertainment which it brings. Give your prospects a fair opportunity to appreciate the factors which make that entertainment real and lasting by using particularized selling of tone quality. You will be rewarded by selling more expensive receivers and your prospect by greater radio enjoyment.

Slight Increase in Salesmen's Commission Sells Plugs

J. Weber, manager of the Brooklyn Radio Service Company store, 577 Myrtle Ave., Brooklyn, N. Y., had had about 1,000 loud-speaker plugs on hand for over a month. By offering his store salesmen, who are paid a straight salary, a slight commission of five cents per plug sold, less than three weeks was necessary in which to sell the entire lot.

Mr. Weber says: "If this slight extra commission had not been offered the salesmen, it is quite likely that we would have had our cash tied up in these instruments for some time. By this I do not mean that they do not exert every effort to sell merchandise, but by making it of mutual advantage there is always a much better chance to push 'stickers' off the shelf."

Concentration of Effort Sells Eight Sets in One Block

The Profitable Experience of D. A. Bailey, "Outside Salesman," of Troy, N. Y.—Doesn't Quit a Street Until He Has Checked Up the Possibilities for a Sale With Every Family On It

D. A. Bailey is an outside salesman, not a radio dealer. This season his sales have averaged five sets a week, or about \$2,100 gross business a month. These sales have all originated from Bailey's own efforts "in the field." The experience, therefore, of this live wire should be of considerable assistance, right at this time, to any dealer who is considering the subject of "outside selling."

SEVENTH Avenue, between 102nd and 103rd Streets, Troy, N. Y., is just a nice, comfortable, middle-class block. Most of the houses on it are of the two-family type and rent for about \$50 a month. Thirty-nine average American households, in all, line both sides of the street. Yet—with this material to work on, D. A. Bailey, in two weeks, arranged for ten immediate demonstrations and closed eight of them. "More to follow," he says.

Concentration of effort, is the way he accounts for this record. "Every-

body's interested in radio," he continues, "It's just a question of going to see them. There is no reason these days why any man who is willing to work evenings and who will

Bailey says—

"THE dealer who depends on store trade thinks business is good, but he doesn't fully realize the tremendous interest that exists in radio, or how much more business he could do, until he gets out and makes a house-to-house survey."

follow every lead he can lay hands on cannot make, on a fifteen per cent commission basis, between \$60 and \$100 a week as I am doing."

Bailey is a real radio salesman. He is employed by the Twin City Electric Company, 114 Fourth Street, Troy, N. Y. Originally, the Twin City Electric Company hired Bailey

to sell washing machines, but he found radio so much more attractive that he simply couldn't resist its appeal. Here is the story, in Bailey's own words, of how he sells radio in the home and why he believes in confining his efforts, as much as possible to one block at a time.

Why A Specialty Salesman Took Up Radio

"I was formerly a specialty salesman," says Mr. Bailey, "and I went with the Twin City Electric Company to sell washers, but I had so many people ask me about radio that I just couldn't keep away from it. The boss handles a good set and in less than a week from the time I switched to radio I had four or five sets out 'on trial.' This was about the middle of November. I have been going strong ever since.

"Call it house-to-house selling, canvassing, or whatever you want to," Bailey continues, "The name doesn't matter, but my experience has been that calling at the homes produces results. Just pick a good-looking block and 'dig in.' Take Seventh Avenue, just north of 102nd Street, Troy, for example. It will serve admirably to illustrate how I work one location at a time. I didn't know a soul when I hit that block, so I went to the first house I came to. The woman there wasn't interested in radio. All right, no need to waste more than five minutes on her, when 85 per cent of the people I call on are interested.

"Mrs. Bently, who lived in house number two said she had a very good five-tube set—fair enough—that didn't worry me either, because I knew that only one person in every seven has a good set. The third housewife, Mrs. Tuller, had a small set and was in a receptive mood. I arranged for a demonstration to take place the following evening. From then on I was kept busy on



Thirty-nine families live on this block. Bailey called on every one of them. He found that six had good sets and were perfectly satisfied, but he was able to arrange for ten immediate demonstrations and

closed eight sales within two weeks from the time he started to work this street. He estimates it is good for about five more sales before he gets through. "Concentration" turned the trick.

that same block following up the leads which I secured through this lady and her husband. Perhaps the fact that I suggested, on my first visit, that Mrs. Tuller invite in her friends to hear the set had something to do with the interest I was able to arouse in that neighborhood.

"Of course all her friends didn't live on that one block, and everybody on the block doesn't know Mrs. Tuller. After I called on all the leads I obtained from my first demonstration, therefore, I went back and rang the doorbell of the next 'unknown' on this block.

"I work this way until I have completely covered the street which I select for my activities. The advantages of this method are that you get so well known after a few days' work in the same neighborhood, that you never have any trouble getting an audience.

"Furthermore, you know what the local conditions for reception are in that block, and just what set to recommend and demonstrate. Not having to run all over town is a big help, too—saves time and money. I have even arranged to leave extra tubes, my headphones, testing instruments, and extra aerial equipment at one of the houses in a block while I was working that territory. Thus, I have a little branch store right 'on location.'"

Stick to One Sending Station as Much as Possible

Mr. Bailey considers the demonstration and closing of greatest importance. He has given us his ideas about locating a prospect. "That's easy—it's the demonstration and closing that will make or break an outside man," he states "and when I say demonstration I don't mean 'maybe.'" he adds. Regarding the demonstration Bailey has this to say:

"Put on a real show if you possibly can. First—wait for a good night. Second—tune in a good program with the headphones. Third—stick to that station, if possible. Whatever you do, don't 'fish.' Here's why: If you're getting good tonal volume from one station why take chances of spoiling it? Tell the prospect and his friends the truth, that discriminating people are demanding true reproduction value this year, and that is what you are giving them. If they want to play with the dials, they can do that at some other time. Here's the advantages of this system—(a) good reception; (b) their thoughts are

An Average Week's Work for Bailey

SOLD five sets at an average price of \$118 each.

Put in seventy-five hours following leads, demonstrating sets and in the store.

Net income—on 15 per cent commission basis—\$83.

Obtained nine new names to call on "next week."

centered on one announcer and one program, hence they enjoy it better; (c) don't have to spend as much time on a demonstration. Now don't misunderstand me, you can't stick to one station throughout the entire evening, of course, but always come back to your best station as quickly as possible."

Pinning Down the Triflers

"But doesn't your system get you a lot of professional triflers, Mr. Bailey?" we asked. "My answer to that is that perhaps I do get a few more than the dealer who waits for business to come to him, but I get rid of them quicker, too. I use the same philosophy in closing that I apply in getting prospects—don't waste time on the 'lemons.'" Bailey replied and then gave us these interesting things to think about:

"Just the minute I see that I've got a fusser or a 'dawdler' in tow I proceed to do his thinking for him. In other words I talk right out in meetin'—let him have it straight from the shoulder.

"Well, I don't know, Mr. Bailey, the set isn't quite what I want, but I should like to keep it a few evenings longer," a bird like this will begin.

"What do you want? Mr. Daw-

dle?" I come back. Then I pin him right down.

"Do you expect perfection?"

"No."

"Very well, have you ever heard a better set?"

"No."

"All right—do you want to buy the set?" And right then and there I pull the set and forget about Mr. Dawdle if he doesn't come across and give me his order."

That Bailey has hit upon some sound sales ideas is indicated by his record of sales per week and by the average price per set which he is obtaining. Here is one of his typical weeks:

He sold five sets at an average price of \$118 (does not include installation charge) or a total volume of \$590 worth of business.

Gross commission—at 15 per cent—\$88.50. Deducting \$5.50, for automobile maintenance and operation, this leaves his net earnings for the week, \$83.

Today's Problem Is the Time Factor

"Right now it is a comparatively easy matter to interest people in radio, and to get a set in the home for a demonstration," concludes Mr. Bailey. "For a man who has been up against the problem of closing washing machine and vacuum cleaner sales, getting the signature on the dotted line isn't very much of a task. The selling problems in radio today aren't either of these matters, but have to do with giving a satisfactory demonstration and financing the purchase of enough sets to keep an outside man going. From a personal standpoint finding enough hours in the day and evening to see all the people that want to be shown is my chief difficulty."

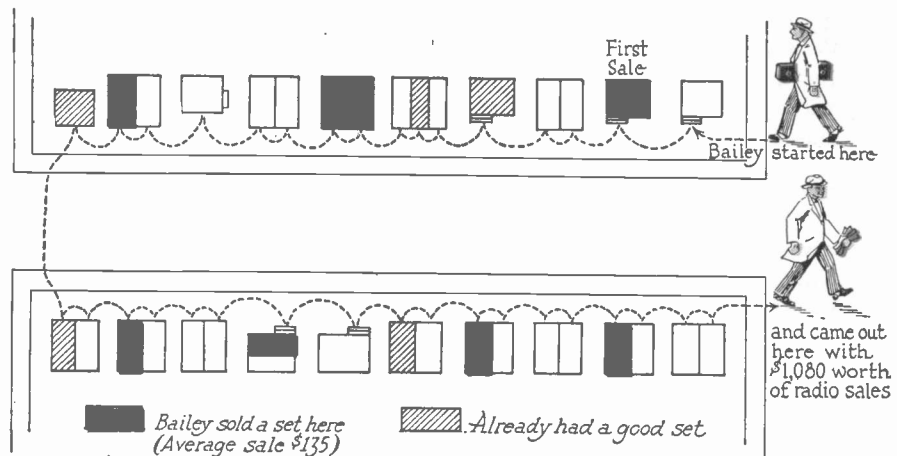

Sold Eight Radio Sets in One Street

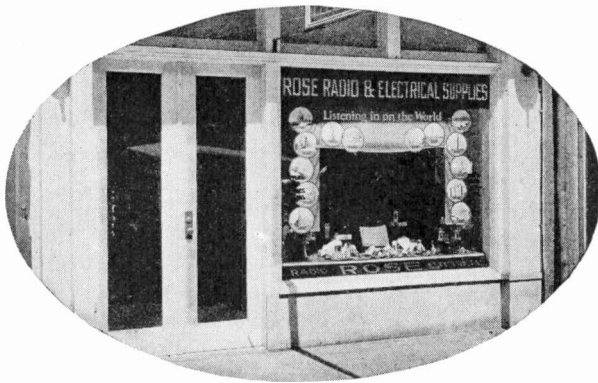

Occupancy

Occupancy expense includes such items as rent, light, heat, water, power, etc., in short, all expenses incurred in occupying the premises.



Selling

Selling expense covers all disbursements made in the selling of merchandise, such as salaries and commissions, demonstrating expenses and delivery costs.

"The Four Horsemen"

Occupancy, Selling, Publicity, and Administration

By S. J. RYAN
Merchandising Counsellor

THE success or failure of a retail operation is governed by the *degree of control* of expense exercised by the management. This is a truism, yet any economist or banker will tell you that the frightfully high percentage of mortality in retail business is due almost entirely to poor management. Conversely, efficient management is the determining factor in a successful enterprise.

The appalling record of business failures is all the more surprising when it is realized that the factors essential to successful operation are readily available for study and *must* be known and their importance appreciated if the enterprise is to flourish.

PRACTICALLY all businesses—and this is particularly true of a new industry like radio—are begun by men who have had previous business contact. Through observation alone they could, in nearly every instance, learn from their previous business connections what to copy and what to avoid.

Unfortunately, all too many managements are obsessed by the factor of *volume*. Volume is important, certainly, as without it a business cannot exist. But unless the *cost* of volume is *controlled*, it will destroy the business! This happens every day.

How can we determine the proper cost? By the

ratio of fixed expense to volume. There are two kinds of expenses in every retail business—those that go on day in and day out regardless of volume—that are immovable—and those that fluctuate with the volume of sales.

The veriest tyro in business can calculate his fixed expenses, but—and here's the rub—he must include *all* of them. Rent, light, heat, power, taxes, interest, depreciation, transportation, and certain fixed minimum salaries constitute the usual immovable expense.

The amount of gross margin per dollar of sales (in radio this is usually the discount from list) is, of course, known. It is, then, only a matter of simple mathematics to calculate the amount of sales necessary to yield a gross margin large enough to absorb the fixed expense. Every business man does this, undoubtedly. Practically all that is necessary is paper and pencil.

The ratio now stands at one to one—a gross margin large enough to equal the fixed expense. This is an impossible condition, of course, because no allowance whatsoever has been made for the inevitable contingencies. There is no factor of safety present. Such a business structure would be unsafe. How many times have you heard a merchant remark: "Well, if I only sell so much I'll come out even" and why is it they so seldom *do* come out "even?"



Publicity

Publicity expense includes the amount spent for newspaper advertising, printing, postage for direct-mail advertising, and outside help and material for window trimming.



Administration

In administrative expense are included the amount paid yourself or someone else as manager of the business, office salaries, collection and office-supplies expenses.

GETTING back to our calculations: The fixed expense and the compensating volume have now been determined. From this point on, use *percentages* in your calculations. This is important. The cost of the merchandise plus the sum of the fixed expenses now equal 100 per cent of the sales volume. A most important point to remember is that not a single penny of merchandise can be sold at any time without a full proportionate share of all the expenses being attached thereto.

This sounds like another "First-Reader" axiom, but every executive of wide experience will tell you that merchants are constantly deluding themselves in this respect. One of the stock phrases of the salesman trying to sell under-margined merchandise is that his article is "just extra business that costs you nothing," etc., etc. Emphatically, there "aint no such animal." Use the percentage of retail sales method as a guard against such merchandising errors.

It is true that all merchandise does not yield the same margin but there must be a compensating benefit to offset this loss (for that is just what it is) such as increased traffic, prestige building, etc., or you are better off without such business. And this benefit should be definitely recognizable. For example, if your cost of doing business is 25 per cent and your desired net profit is 5 per cent (both of *retail sales*), your margin quota is 30 per cent. You have under consideration a proposition which will yield only 25 per cent. You should then be able to see clearly how you can sell an equal amount of merchandise at 35 per cent, or so increase your total volume as to reduce your margin quota to the average figure of the two.

I FEEL perfectly safe in saying that this rule is not usually followed. The result never varies—the expected profit never materializes. Now you can call this dissipated margin or uncontrolled ex-

pense, just as you choose. Probably it impresses itself more firmly if we think of it as uncontrolled expense. What would happen in such an instance is that every dollar of that 25 per cent merchandise would participate proportionately in the total expenses of the business and actually cost more than 25 per cent to sell and leave any margin.

In *theory*, the increased volume would lower the cost percentage of doing business but in *practice* it does not work out that way. Increased volume secured on under-margined merchandise will result in failure. There is more to merchandising than that.

The next step is to split up your expenses into divisions because they are then known and more easily controlled. The percentage system is essential here. Start with your fixed expense and your required minimum volume. You will find your *Occupancy* to be a certain percentage of your retail sales, your *Selling* a definite percentage, etc. At the beginning these percentages will, of course, be based on the minimum volume on which the business can operate. One of your hardest tasks will be to control these percentages, forcing them *downward* constantly and never permitting them to get out of hand.

NURMI, the Flying Finn, taught us a valuable lesson, last year, that can well be applied to our business. He shattered numerous records, many that were thought unbeatable. This was not due to physical endurance alone. As he ran he always held a watch in his hand. He taught us the great value of a *controlled pace*.

Business is a long race and a hard one. The sprinter rarely breaks the tape at the finish line. Go as fast as you can but always control your pace by your expense percentages. Running a business without an accurate knowledge of costs is like sailing a ship without a compass—and just as safe.

240 Furniture Dealers Who Are Making a Profit From Radio Tell Us How They Do It

Store Atmosphere and Store Traffic Big Factors—Volume Increase, This Season, Will Run 10 to 300 per Cent—Furniture Stores Prepared to Do Servicing on Demand

By RAY V. SUTLIFFE

Associate Editor, "Radio Retailing"

How is the furniture trade selling radio?

To get first-hand information—"Radio Retailing" mailed out question blanks to 3,600 retail furniture houses all over the country—concerns known to be handling, or to have recently handled radio. We asked these dealers forty-eight pertinent questions which covered the entire range of radio merchandising methods.

We received 405 replies. Of this number 343 or 84 per cent, said that they handled radio. Seventy-six per cent of this latter group reported an increase in this season's business over that of last, ranging from 10 to 300 per cent. Sixty per cent reported carrying radio at a satisfactory profit. Twenty-three furniture dealers who once carried radio have dropped it.

What methods are the successful ones using? Here is a boiled-down presentation of their replies:

THE furniture man who has had experience in selling radios takes the stand that a radio set should be merchandised the same as a dining-room table, a rug, or a good bed. The furniture trade, in other words, advertises and sells radio as a *household necessity*. This very logical attitude it further confirms by displaying quality radio cabinets in an atmosphere of refinement and amid artistic and dignified surroundings.

Sales practices which do not show a profit are always discounted by the merchant who would benefit from the selling experiences of others. "Are you making a net profit on

your radio business?" was one of the first questions, therefore, we asked these furniture dealers.

"Yes—we are!" 240 replied.

A study of the reasons why these men—representing over 60 per cent of the total number who answered our questions—are selling radio sets and accessories at a profit, clearly shows that it is because they are using sales methods which are aggressive—but not dangerously radical. In other words they do not depart from those sound business practices which they have used, with success, in the furniture game. They employ competent clerks, they will not accept less than 25 per cent of the total cost of the set as a down payment—and then only after a thorough investigation as to the credit responsibility of the customer. These furniture merchants under-

stand the fundamental principles of advertising—the furniture business breeds this knowledge—they use the newspapers therefore to secure radio prospects. These men also keep a record of what it costs them to run their radio department and lastly they *do* render adequate service.

Well Able to Sell Radio

According to the replies *Radio Retailing* received on its survey blanks, the type of salesman who is able to sell a \$500 dining-room suite is the kind of man to have contact with the prospect who comes in to look at radio sets. Frequently, also, a salesman who has completed his sale of furniture to a customer is able to "suggest" a radio set in addition, and to guide the prospect to the radio section of the store. This is the way the furniture dealer promotes radio sales. For the furniture merchant is able to capitalize his regular run of "store traffic," as well as to "cash in" on his store's appearance, and on the experience of his clerks in selling high-priced furniture. "We find it thoroughly satisfactory and desirable to use our furniture men for radio selling," says L. K. Curtis, a Wisconsin dealer and this opinion is expressed generally in the trade.

Replies to *Radio Retailing's* questionnaire also show that there are, on the average, three clerks to each furniture store. This means enough of a store staff to wait on customers promptly. Such ability to handle customers without delay, and with courtesy and intelligence is, apparently, a considerable business-building factor. Sixty-six per cent of the

The Furniture Dealer Who Handles Radio—

Advertises and sells it as a household necessity.

"Stages" his radio cabinets in an atmosphere of beauty.

Employs well-paid clerks.

Carries but two lines.

Gives home demonstrations.

Sells "on time" and insists on a substantial down payment

And—he services.

salespeople selling radio in furniture stores are paid a salary. Twenty per cent work on a straight commission basis and the other fourteen per cent work on a combination of both salary and commission.

Over seventy per cent of the furniture dealers handling radio maintain no outside selling organizations. The rest average a little over one man who is out after business to supplement the sales creating attractiveness of the store itself. Ninety per cent of those dealers who have no regular outside men are prepared to send a man to the home if necessary to follow a lead obtained in the store.

Sales Practices in Furniture Trade

It is quite evident that the furniture dealer who is making a success of radio, fully realizes that he must use certain selling practices which the very nature of the radio game has developed, and which apparently are peculiar unto radio. For example, the majority carry tubes, batteries and other accessories. "It's necessary," says G. V. Taylor of Texas. Seventy per cent quote a price for the set only, and 30 per cent are prepared to make the complete installation. Those who install sets charge flat rates varying from \$5 to \$10.

In the matter of time payments this type of dealer will realize that a radio set is a different credit risk than a piece of furniture. The latter, once sold, "stays sold." While furniture payments average ten to twenty per cent down and the balance in a year to eighteen months, our friends in the furniture industry have raised the ante on radio sets, and practically parallel the practices of other radio dealers in insisting on from 25 to 33½ per cent down, and the balance in 8, 9, or 10 monthly payments. "Sell on time if you have to, and the credit risk is O.K., but insist on prompt payments," is the way a Denver dealer puts it.

By a considerable majority (78 per cent) the answers to our questions on demonstration policy, indicate that furniture dealers are willing to give home demonstrations when called upon to do so.

76 per Cent Reported an Increase

From 10 to 300 per cent increased radio business this season as against that of last, was the report of 76 per cent of the furniture dealers who

handled radio. While but one dealer reported a 300 per cent increase yet 75 per cent estimated a jump of between 50 and 100 per cent. There are very few furniture dealers who have been handling radio for over two years. A study of this question two or three years hence will no doubt show a much slower "rate of increase."

Will the furniture dealer "service" his sets after he sells them? Ninety-seven per cent of our replies stated that he would. In other words that he has organized a radio service department or is in a position to obtain the services of an expert when required. "We service our sets when called upon to do so," is the burden of their song.

Free service running from 30 days to six months and a charge which averages \$1.12 an hour for servicing, when not due to any fault of the set, seems to be the practice of about 80 per cent of those who answered these two questions.

One progressive furniture dealer, who has a very profitable radio department, explains his methods in detail. We quote Max Schutze, president of the Columbia Furniture Company, 213 West Broad Street, Richmond, Va., at length because Schutze's radio policies admirably illustrate how those furniture dealers, who are getting the most out of their radio departments, operate.

Policy of Carrying One Line Proved Successful

"I believe that our policy of carrying but one line has contributed materially to our success," says Mr. Schutze. Another feature that has helped us considerably is that we advertize our sets completely installed, that is, properly hooked up, and fully equipped.

"We advertize the amount of our first down payment as well as our monthly terms. When a customer walks into our store, therefore, he



What the Figures Show

How's Business?

76 per cent reported an increase, in this season's business over that of last, of from 10 to 300 per cent.

And Profits?

60 per cent made a satisfactory profit on radio.

Salespeople

An average of three men to a store. One, at least, thoroughly trained in the fine points of selling radio.

Demonstrations

78 per cent will give home demonstrations—when necessary.

Outside Selling

70 per cent don't do it.

Installations

30 per cent are prepared to erect aërials and make ground

connections. Charge flat rates from \$5 to \$10 for complete installation.

Time Payments

25 to 35 per cent down, balance in eight to twelve months.

Service

97 per cent agree to back up their sets with service. Average charge \$1.25—where an invoice is justifiable.

Kind of Lines

60 per cent favored nationally advertised sets. 40 per cent were influenced by price considerations.

Discounts

30 per cent thought present scale about right. Balance—"should be a little bit bigger."

knows exactly what to expect. We have never sold a set for a down payment at a less amount than advertised. We have yet to repossess our first set.

"We maintain a radio service man who knows his business. We give three service calls free of charge. After this we charge \$1.50 per hour if the fault is not ours."

Kind and Number of Sets Carried

What was the primary factor that influenced your decision as to what kind of sets you would carry? Here was an interesting question *Radio*

Retailing asked these 3,600 furniture dealers because we believed that the entire radio industry would benefit by the answers.

Opinions were not quite evenly divided on this point. Sixty per cent favored the nationally advertised, quality, lines. The other forty per cent thought that the price consideration was of greater importance. "Give the public what it wants. Ours want price," said a Pennsylvania merchant. When it came to the number of lines carried, eighty per cent of the answers indicated that 2½ different makes were regularly carried and twenty per

cent elected to pin their hopes on one line only. But, strange to relate, the grand average of replies to the question "How many lines should a dealer carry?" figured out only 1.6 makes. Evidently many a furniture dealer succumbed to the temptation to carry more lines than his better judgment said that he should.

The Matter of Trade Discounts

As is pretty well known, the furniture trade puts a mark-up of from fifty to one hundred and fifty per cent on its regular merchandise. It has been accused of demanding discounts from radio manufacturers which would permit it to adopt the same practice with respect to radio. It was illuminating, therefore, to find that thirty per cent of the furniture dealers who answered our question about discounts thought that the present scale was "about right."

"Any larger would be injurious," one replied. "The list is high enough as it is," said another. A slight majority thought that the discount should be a little bit longer. "From five to fifteen per cent bigger," as a California merchant put it. "If there weren't so many others selling radio in my town I could get along all right with the present scale of discounts," an Ohio dealer wrote in. This brings us to another question we asked. "Are there too many radio dealers in your territory?"

"Hell, yes!" said a man from Dakota. All the rest agreed but were not so delightfully frank about it.

How Furniture Trade Classifies Various Types of Radio Dealers

"Name the five classes of retailers in the order of their importance that you think will most efficiently handle radio." For their answers to this question, we've got to hand it to the furniture men. They didn't nominate themselves for first place or for second. Here is the composite of their opinion:

Tie for first place,
Radio specialty shops, Music stores,
Hardware stores;
For second place,
Electrical stores;
For third place,
Furniture stores;
For fourth place,
Department stores;
For fifth place,
Auto accessory stores.

From this investigation, it would appear that the rank and file of furniture dealers, who are handling

The National Response of Furniture Dealers Who Handle Radio

Why Do You Handle Radio?

"To increase present business"
Conn.
"Because it's popular"
Mich.
"To keep up with the world"
Ill.
"Brings people into the store"
Ga.

What Kind of Sets?

"The demand is for popular price outfits"
Ga.
"We stock quality cabinets sets only"
Mass.
"We started in with sets priced at about \$130, complete, but we found that for our trade, and in our kind of a store, there was more margin in the higher class 'cabinet' types. We sell less — but make more net profit"
Wis.

Do You Handle Accessories?

"No more than we have to"
Ore.
"The public asks for tubes and batteries"
Utah
"We like the accessory end of the game—easy to sell and good clean profit"
Fla.

Do You Sell on Time?

"Yes, we believe in it"
R. I.
"It's much sounder and more satisfactory than the old time 'charge-it' method."
Calif.
"Certainly—we have to. Radio is not a necessity"
Wash.
"It helps people save"
W. Va.
"Twenty-five per cent down and balance in ten months"
Del.

How About Home Demonstrations?

"Sixty per cent of our sets are demonstrated and 'closed' in the home. This helps us get acquainted and helps us sell furniture, at some other time, to those who meet there."
N. Y.
"You have to come to it sooner or later so we advertise that home demonstrations are our specialty."
Vt.

A Virginia Dealer Sums It Up

"The store with 'home atmosphere,' courteous salesmen and specialized service will sell radio. Today's radio set is an article of furniture in the

What About Window Displays?

"We give one window a month to radio"
Me.
"We generally show a room scene and include furniture"
Nev.
"We have been able to trace many sales to our window trims"
R. I.

How Much Advertising?

"Furniture dealers know that you can't sell furniture unless you advertise it. We have found that the same rule applies to radio"
Mont.
"Ten per cent of our advertising appropriation is reserved for the radio department"
N. Y.
"We give radio one-half column every other day"
Ind.

Do You Place Sets "On Trial"?

"Yes, but for one week only"
Cal.
"We get a payment of \$8 for the aerial installation first"
N. H.
"Only until such a time as we are able to give a satisfactory demonstration"
Idaho

How Do You Pay Your Salesmen?

"The weekly salary covers all our obligations to our men"
Wis.
"A ten per cent 'bonus' has a stimulating effect"
Neb.
"We find a salary plus a five per cent commission on all sets sold works out fine."
Conn.

How Do You Handle Service Calls?

"We pay an outside service man three dollars flat per call. It satisfies both parties"
Ohio
"Maintain our own man and ask \$1.25 an hour for his services — but make call without charge if fault is ours"
Tenn.
"Give three months free service"
Ala.

musical instrument line. We're in the furniture business—we're in the phonograph business and —so it follows that we're in the radio business."



A typical high-class furniture store, showing the way in which many furniture dealers are now displaying their radio sets.

This dealer places his radio cabinets on the main floor, interspersed with other pieces of furniture. He thus surrounds them with

an atmosphere of charm and of beauty. The store is that of the Columbia Furniture Company, Richmond, Va.

radio successfully, are prepared to sell this line the way radio has to be sold — by properly displaying the merchandise in the store, with intelligent salespeople to wait on the trade, by selling "on time" if necessary, by giving home demonstrations and by providing adequate servicing facilities.

Customer Buys "On Time" —Dealer Receives Cash

A credit service which permits the purchaser to buy merchandise "on time" at the cash price, is being advertised in New York newspapers. It is here reported on, in the belief that it may offer a possible method for the sale of radio sets on easy terms.

The service is at present confined to mens' clothing. The advertising announcement in the newspapers reads as follows:

"BUY YOUR CLOTHING ON A LLOYD PURCHASING ORDER"

Men may buy their clothing from the finest stores in New York on the Budget Buying Plan of deferred payments — no interest — no fees — no charges. All we require is that you are employed and can meet your small weekly payments. You pay \$10 at time of purchase and balance in ten weekly payments."

The prospective buyer must first satisfy the financing agent as regards his honesty and his ability to

meet the ten weekly payments. He then pays this "credit service company" his initial deposit of \$10 and receives in return a "purchase order" on the particular clothing store with which the service company is operating. This order entitles him to select any suit he desires, up to the limit of the credit granted him by the service company. The clothing house honors this "order" and sells the customer at the regular cash price: The weekly payments are made by the customer to the service company.

The company offering this service receives its remuneration from the clothing house to whom it directs its "customers." The clothing house figures, no doubt, that this extra

business, which it would not otherwise obtain, and the guarantee of a cash payment in full from the service company within a day or two from the time the suit is purchased, is worth the five or ten per cent commission which it rebates to the service company.

Should Work in Radio Industry as Well

This plan is operating in the clothing business in a satisfactory manner in the opinion of all parties concerned. A similar "set-up" would, no doubt, work out in the radio industry whenever a prospect has an income which would permit him to complete his time payments within a three or four months' period.

"Selling Parts? — Sure!"

"Are you selling parts?" a Brooklyn, N. Y., dealer was asked. "Sure!" we were told. "They are not selling as well as they used to, but I manage to keep them off the shelf by—

DISPLAYING merchandise in kit form rather than separately. In this way the cost of a complete radio set is made to look much smaller.

Suggesting additions for the improvement of the battery

customer's set. Customers are always asked what kind of set they use. Many of the suggested inexpensive methods of improvement are eagerly accepted.

Posting circuit diagrams in the shop, thus keeping home construction in the public eye.

Displaying in the window a sign reading—

"Set builders, bring your troubles to us, we will gladly assist you."

"Changes We Have Made

Re-Arrangements of Furniture and Stock Which Radio Dealers Have Found Resulted in Greater Convenience and Easier Sales

The wise dealer is continually "re-vamping" or adapting his store to suit present needs. Counter arrangements that were originally convenient, prove inefficient—demand for a hitherto un-called for article increases—articles which were formerly sold without any great effort now require pushing. These conditions are always arising, and some change in the arrangement, or "layout" of the store is necessary for best results.

There are many little "kinks" in store arrangement that greatly simplify the work of the dealer and at the same time add to his bank balance, by increasing his business. The suggestions on these pages have been drawn from actual experience.

Demonstration Space Enlarged to Handle Increased Demand for Sets

The entire arrangement of the Webster Radio Company's store, located at 2525 Webster Ave., Bronx, New York City, has been changed, according to J. Tomasiello, the proprietor, because the buying tendency in his neighborhood has steadily inclined toward sets, and away from parts. He has found it advisable, therefore, to enlarge the set demonstration space and decrease that used for the sale of parts and accessories.

Formerly, a long counter, used for the sale of parts and accessories, ran from the front entrance to the rear of the shop, along one wall. With this arrangement, it was impossible to place more than three or four of the larger receivers on the floor.

In order to enlarge the set demonstration space, all but a small section of the counter was discarded, this section being placed across the store, from side to side, about three quarters of the way back from the front entrance. The entire front of the shop is now used for a set display room and the balance of the store, back of the counter and a light partition which has been erected in order to insure privacy, is now used as an office. The few necessary parts and accessories that are still carried, are placed on small shelves, built out from this partition, facing the store interior.

Mr. Tomasiello has arranged a number of his particularly attractive sets in the center of the display room in "island" form, other sets are placed around the walls of the room facing these. In this way more sets can be shown without giving the room a crowded appearance and the special sets are more forcibly called to the attention of the customer.

To Demonstrate Greater Variety of Sets

"Because of limited store space, it was impossible for us to have more than two sets hooked up and ready for instant demonstration, at one time," says J. Weber, manager of the

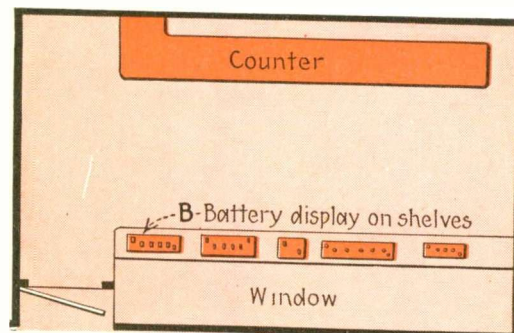

Reminding departing customers of battery needs

Brooklyn Radio Service, 577 Myrtle Ave., Brooklyn, N. Y.

"We found that many customers could not readily make up their minds, unless several different receivers were demonstrated to them, so we removed a counter formerly in the center of the store, placed it on the side, and hooked up a dozen sets in the space it formerly occupied. It is now possible to demonstrate a variety of sets to the customer and clinch the sale then and there.

"Metal shelving has been found much more efficient than the usual wooden racks. It is easier to clean, and compartments can be adjusted to fit merchandise by simply removing a few bolts and moving shelving up or down in slots conveniently provided by the manufacturer."

Shelf Display Up Front Sells B Batteries

F. Dreher, proprietor of the Dreher Radio Store, 315 Amsterdam Avenue, New York City, has put a space usually wasted in the average radio store "to work" selling B batteries for him.

He says: "My store entrance is just to the side of the display window. In back of this window, facing the interior of the store, I have constructed a row of shelves, hinged so that my display may be easily changed. On these shelves an attractive B battery exhibit has been arranged.

"When a customer enters the store, he usually walks up to the

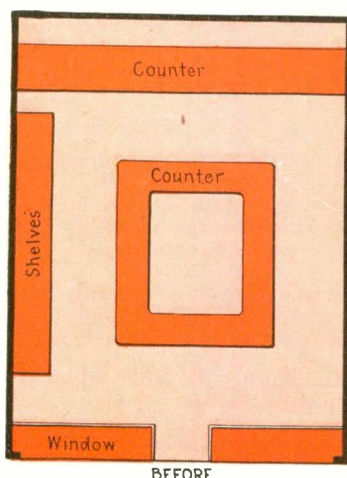

BEFORE

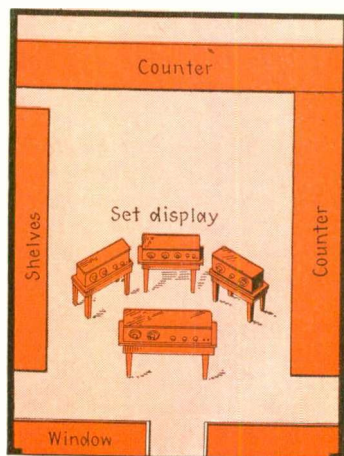

AFTER

Greater variety for set display obtained by removing center counter

in Our Store"—and Why

**Profit from Sales Volume Will Supplement Profit from Lowered Expenses—
Here Are Some "Silent Salesmen" Which Have Proved Their Worth**

counter, buys what he wants, and turns to leave. As he turns around he must look right at our battery shelves, as these are alongside the door. As the customer is usually wondering if he has forgotten anything at this moment, the battery display is brought to his attention at the psychological moment.' Result—Fifteen batteries have 'sold themselves' in the past two days, without the slightest effort on my part to push them."

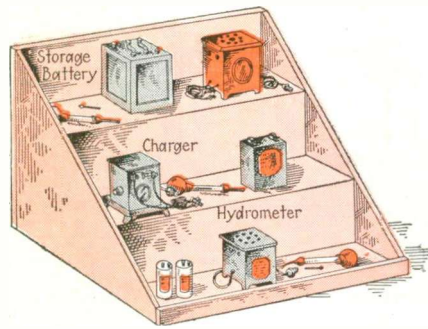

A method of grouping related goods

Customers Separated into Groups

Placing counters and merchandise so that a group of buyers interested in one class of goods do not interfere with those interested in something entirely different, requires a good deal of thought on the part of the merchant.

One St. Louis radio dealer formerly had his sets strung out in a line between the front entrance and the back of the store, paralleling his parts and accessories counter. The customers interested in sets, naturally crowded the aisles and so prevented those interested only in accessories, from approaching the counter.

This dealer has recently rearranged his store and has placed all his receivers in a separate department in the rear. This new arrangement separates buyers into two sections, those interested in sets and those interested in accessories. Quoting the proprietor, "It is now possible for the set buyer to make himself comfortable while listening to a demonstration, and for the parts customer to secure instant service."

Has Put Associated Articles Together

Displaying merchandise to best advantage means more than just placing it in an attractive show case. It means that this merchandise must be displayed in such a way that it accentuates or coaxes along the natural instinct or desire to possess a thing, that is in every customer. The manager of the City Radio

Store, 110 East Forty-second Street, New York City, has grouped his merchandise so that each article on display suggests an accessory that is either necessary or convenient for its care and upkeep.

For instance: It is practically a foregone conclusion that a customer interested in a storage battery will eventually need a battery charger and a hydrometer. Storage batteries, battery chargers and hydrometers are therefore placed together on a specially constructed display platform in the store. A man buying a tuning coil usually needs a variable condenser. If he buys a panel he will be interested in dials to match. All of these things are displayed side by side, the purchase of one naturally leading to the other.

Window Inexpensively Enlarged with Beaver Board

The proprietor of the Court Radio Shop, 108 Court St., Brooklyn, N. Y., was confronted with the not uncom-

mon problem of insufficient window space for the proper display of merchandise.

By extending the window platform, or base, back into the store a few feet, supporting this extension on light wooden uprights, and erecting a painted "beaver-board" panel background, the space was enlarged sufficiently to accommodate a number of the larger radio receivers. This alteration cost approximately \$10. The actual increased value of the window would be difficult to estimate, but it could hardly fall short of a ten-dollar bill.

Banished Counters and Showcases to Make Sales Room "Home-like"

The present tendency in the arrangement of radio stores seems to be leading definitely toward a "homey" arrangement of merchandise and equipment. Just one instance is that of the A & P Radio Store of Jamaica, N. Y.

The proprietor of this shop has entirely eliminated counters, shelves and other business-like equipment, in an effort to create a home-like atmosphere. He has installed easy chairs, attractive floor lamps and other articles of furniture for the "convenience of the customer."

A radio receiver is much more attractive in homelike surroundings.

Makes Entire Store a Showcase

"Why only a show window?" says the manager of the Charles Street

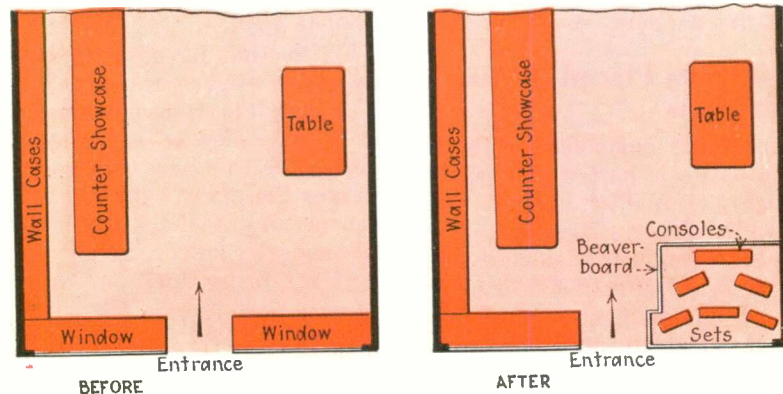

Display window of effective proportions obtained by extending platform

store of Ebeyer & Winteler, New Orleans, La., radio dealers.

"In the ordinary sense of the word, we have no show window. Our entire store interior is visible from the street, and we arrange in it a display of sets and merchandise that would be absolutely impossible in the average store window because of limited space. If window space is enlarged, store space is decreased. It's like 'cutting off your nose to spite your face.'

"If the customer is interested in a set on display, you can't show him its advantages nor can you demonstrate it in a window. You must also have a similar set in the shop. Why not make one set serve the two purposes by utilizing the entire store?"

"Step Background" Makes the Most of Shallow Window

Many dealers are handicapped by having small store windows, and in most such cases these windows cannot be conveniently enlarged. A display arrangement idea that will be valuable elsewhere is used successfully by a Calvert Street dealer in Baltimore.

He has built into his window, a row of shelves, arranged in a series of "steps," and has covered these steps with dark cloth. The first, or lower step faces the window itself.

By placing his parts to be displayed, on these shelves, many more articles can be put into the window without one hiding the other, as each separate row is raised slightly above the one in front.

Small glass shelves, attached to the inside of the plate-glass window by small suction, or vacuum cups, are also used. Articles placed on these shelves are brought within a few inches of the customer's eyes without obstructing his view of the rest of the window.

Console Sets Placed on Raised Platforms

"Attract the customer's attention and the battle is half won," says H. Schweiger, of A. Schweiger & Company, radio dealers, Brooklyn, N. Y.

"We have found that console radio sets are more effectively displayed in our demonstration room, by placing them on platforms raised about six inches from the floor. This additional height is just enough to make the receiver stand out. In other words, it furnishes a setting,

Sets Displayed in Lighted Frames—Helps Customer Decide

In the display room of the Long Island Radio Company, Freeport, N. Y., an unusually attractive set display case has been constructed that eliminates much of the uncer-

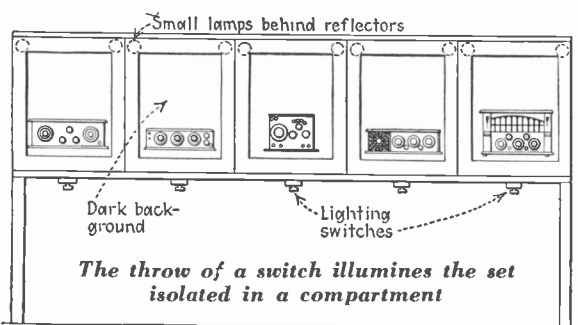

tainty from the mind of the potential radio set owner.

Each set on demonstration is placed in an individual "picture frame" compartment, which is electrically illuminated and lined with dark blue plush. It is possible to bring any one receiver to the attention of the customer, by merely throwing a switch, and illuminating one compartment only.

This display is much more effective than the usual method of placing merchandise on shelves, and is inexpensive to construct. When shown against a dark background of this kind, and properly illuminated, receiver cabinets are given a much "richer" appearance.

Window Shows Merchandise from All Angles

"Have you noticed the way a woman always walks around a console radio set or other article of furniture in which she is interested?" says a Chicago dealer. "She will invariably look at it from every possible angle before making up her mind to buy.

"With this in mind, I have had my store window remodeled so that it is possible for customers to see the sets on display from almost every angle. As this new arrangement increases the size of the window, it is also possible to hold the interest of the passerby longer, by placing more in it for inspection."

Places "Odd Parts" Where Customers Must Pass Them

Every radio dealer, at one time or another, accumulates a number of parts that have failed to move, such

as condensers of odd capacities, patented tuning coils, oddly lettered binding posts, etc. If these parts are kept on the shelf, until customers actually ask for them, it is quite likely that they will not be sold at all.

A Cambridge, Mass., dealer confronted by this problem, placed a "bargain counter" between his set department and the main store entrance, where customers must pass it at least twice, when entering and leaving. On this counter he piled, in no particular order, an assortment of his "stickers" or slow moving parts.

He says: "I have noticed the way people pore over such an assortment of merchandise in a department store, and decided to try it out on radio parts. It has certainly been successful. Parts which would ordinarily remain in stock for months, are being selected and bought, by customers who stop for a minute to glance over the counter. There is a bit of the explorer in every man. If he can be induced in this way to look your stock over, he invariably finds something suited to his particular needs."

Sets Raised to "Eye-Level" of Customers

The Electric Service Shop of Floral Park, N. Y., has constructed a "store salesman" that, quoting W. B. Simpson, the proprietor, "has more than paid for itself in increased radio sales.

"Formerly, our sets were grouped on one side of the store, attracting very little attention," explains Mr. Simpson. "We constructed in the center of the shop, a display case, the top of which is level with the eyes of customers entering the front door. It is now impossible for anyone to miss seeing our radio display, as sets are placed on top of the case at approximately 'eye-level.'

"This addition to our store equipment was made originally as an experiment, but the number of inquiries we have had since its erection has more than repaid us for the expenditure.

"The entire installation of this inside 'salesman' cost us in the neighborhood of \$200.

"The showcase sides were fitted with shelves and sloping glass panels and are used to display small articles, which can be left there indefinitely without fear of having them become dusty and unsalable."

Training the Store Salesman

How to Select the Man—How to Teach Him by Actual Example
—Points in Radio Selling He Should Be Warned Against

By J. ANDREW WHITE*

MEN who can sell are rare enough, but those who can teach others how to sell—try to find them! And the reason for that is, that there are no set rules, no formula, to be studied that will bring about a definite result. Absorption of the principles of sales psychology is interesting and profitable, but after all these are only fundamentals, general guide posts. When it comes to the application, then you are up against the proposition that the individual either *is* a salesman, or he *isn't*. If he hasn't that certain something—call it a gift, for lack of a better word—all the dope, all the time, patience and energy put into instruction is wasted.

There we come to the fine dividing point in the selection of the right men to do radio selling at retail. There is no more vital matter than this, if we are to accept the obvious, that all outstanding business success has back of it a great sales volume.

In the retail radio store, the salesman is the connecting link between the customer and the cash slip, and the effectiveness of advertising or store policies is directly proportionate to the ability of sales people. Patrons become either visitors or purchasers, according to the way they are handled by the man behind the counter or in the demonstration room.

A Test by Which to Pick Salesmen

Now, when I say handled, I don't mean the degree of politeness shown, and that sort of thing. The value of courtesy is so obvious that it can be dismissed in a phrase, it costs nothing and pays big. Handling a customer means making up his mind for him, without his definitely knowing that it has been done. The ability to do this is the distinguishing characteristic of the man who is a natural salesman, or who can be developed into one.

So, in hiring a man for selling,

*Vice-president in charge of store merchandising, Haynes-Griffin Radio Service, Inc., operating retail radio stores in New York and Chicago.

that is the first thing to determine about him. If, when talking to you as an applicant, he doesn't "get across" strongly in your consciousness, doesn't make a dent, so to speak, that he is too valuable a man to let slip by without at least giving him a try-out, the loss won't be very great if you pass him up.

Not All Are Worth the Time to Train

I have seen lots of men who initially lacked strength of personality develop into corking good salesmen after instruction and coaching, but in every instance there was something that made the fellow likeable, even though he did seem to lack force, at first. On the other hand, I have seen a distressing amount of time wasted trying to develop men into salesmen, with the net result that they never got the hang of it sufficiently to repay the boss for all the energy and effort it required.

Now, who is to do the selecting? As a general rule, the boss himself should do the picking. The radio store is the kingdom over which he holds full sway. The type of leadership he gives by close personal contact with those charged with the direct responsibility for its growth will have a lot to do with the eventual outcome when the history of the business comes to be written. For

emphasis, let us separate employees into two classifications: *There are those who make history—the sales force; and there are those who record it—the other clerks.*

Sales volume is the unfailing barometer of growth, and there attention of the master is to be centered; the recording of the result is a different matter, for fixed rules govern there, as has already been shown.

The Boss May Have Sales Sense Without Contact Ability

One of the most successful retail radio merchants I know is, himself, a pretty poor salesman. That is, if you gauge him on his personal skill in separating the customer from his cash when they come into actual contact on the floor of the store. I feel certain he doesn't realize how poor a salesman he is, and how he puzzles the boys who work in the store when he tells them how to handle customers. When his suggestions are tried, they just don't work.

And there is nothing strange about that; he is not naturally a "contact" man, but he has a sales sense that manifests itself in an almost uncanny foresight as to what the public is going to want next in sets, parts and accessories—and right there you have the indication that he is a shrewd appraiser of human nature. From which quality comes an unbeatable ability on his part to weed out the salesmen in any lineup of applicants. I cite this instance as illustrative of the fact that it doesn't necessarily take a salesman to pick a salesman. The boss who has a clear realization that the life-blood of his business is income, isn't likely to make many mistakes in selecting the people to produce it, whether or not he has in himself the exact qualifications he is looking for.

Training a salesman is another story, however.

Fitting a newcomer into an organization—whether it's a one-man show or one with a staff of sales people—and developing him into a real salesman who will get the results the

Train Your Salesmen to:—

Match the set to the customer's purse. This will avoid much unnecessary confusion of the prospect.

Concentrate on one instrument.

Tell the truth about DX reception. Sales made by exaggerating do not usually "take."

Eliminate technical discussion. Sell on performance, reliability and the appearance of the receiver.

boss wants, both in what he sells and how he sells it, means that he should be taken in hand right from the beginning by someone who can illustrate what he wants done by doing it.

That one may be the boss, or it may not; and the best way to determine that is, if at any day or hour the owner can't step out on the floor or go behind the counter and "sell circles" around the best salesman in his employ, then let the best man he has do the training.

Beyond this, any effort to lay out definite specifications as to how to develop a man into a wiz' at moving merchandise seems to be a futile proceeding. There are two distinct types of sales personalities, quick-closers, who make the sale at the first crack or not at all; and confidence-builders, who require more time initially and often don't land the customer until he has come back to the store a second or third time. I have never been able to choose between them, which is the best.

The point is, that either force or patience are inherent in individuals, and this must be taken into careful consideration in developing latent sales ability to its full effectiveness. In those rare cases where the two qualities are found in combination precious little coaching is needed; for there's the man whose sales will top all the others, week in and week out, just as soon as he gets the hang of things around the store!

Discovering Why Sale Is Missed

Little concern need therefore be given to the exact method of developing personalities of sales people; the whole process is one of constant observation on the part of the instructor. In every instance where a sale is missed, he knows the reason why, knows it intuitively and is able to point out to the salesman why the customer walked out of the store without making a purchase, if that happened through any fault of the salesman. It resolves itself into this sort of thing: either the salesman talked too little; talked too much; used too much urge at the wrong time or was silent when the "psychological moment" of decision had arrived—the man who is a seller himself can spot the weakness every time.

It might be difficult for him to explain how he knows, but he does know, and is sure of it; for if he isn't sure, then he is kidding him-

TRAIN the salesmen to find out what price sets customers want.

The more sets demonstrated, the greater the confusion in the customer's mind; and—

If he can't afford a better set, and he hears it demonstrated, good-bye sale!

self that he is a real salesman, and someone else should be delegated to training the newcomer.

There is nothing theoretical about this, as every proven salesman knows; but any attempt at this type of instruction by recitation of salesmanship fundamentals which have been written down in various places is wasted effort, unless by actual demonstration the personal ability of the instructor backs up his analysis of the weakness by putting the next sale across for his pupil. And that's about all that can sensibly be said about dealing with an individual's personality in the preliminary size-up and the development of latent ability. Of major importance, certainly; but the radio retailer like any other merchant cannot hope for a material success unless he is a salesman himself, or realizes that he is not and has somebody around the place who knows that there is plenty of common sense in the guiding points contained within the preceding paragraphs. They can be useful at least to any radio retailer whose sales volume is his weak point and who is seeking the reason why.

Is the Store Back of Salesman's Statements?

Inseparably associated with the personal element in training retail salesmen is the policy under which they are to be trained. With reputable merchants, there is no dodging of the responsibility of the store to stand back of the salesmen's statements. Of primary importance, then, is adoption of the main rules of conduct of the selling end of the business which have been put into effect by the leading retailers of radio, and making these part of the salesmen training.

One of the most difficult things to control is exaggeration of statement. A customer has read somewhere

about the remarkable DX-ing of a skilled amateur, added to which has been a considerable amount of bragging on the part of friends or neighbors of the distances their sets have spanned, and then a scanning of manufacturers' advertisements of sets for coast-to-coast reception, and so on, until, as a novice, he has gained the impression that a radio set isn't of much account unless the whole of the United States can be listened to, any night at will.

The salesman may start off with a conservative and true statement of the reception probabilities of the set under demonstration, but if he sees a possible sale skidding, the temptation is very great to meet the customer's mind on the question and promise a performance that by no stretch of the imagination could be guaranteed.

There simply is no estimating the damage to be done to a store's reputation by this type of loose statement; if a salesman tries it once and gets away with it, he'll do it again. The first time he is caught at it, a warning may do; but for a second offense, there's is nothing to it but to fire him, instantly. There is no sense in such statements, no necessity for making them.

Let Him Tell the Plain Truth About DX Reception

If the customer is told that no set can be guaranteed for any specific distance because of the varying conditions of localities, the construction of the house in which it is to be used and its immediate surroundings, and atmospheric variations which affect reception from night to night, that is the real truth of the matter and the salesman can be taught to say these things with such sincerity and certainty that the intending purchaser immediately acquires a lot of confidence in him, which makes the actual closing of the sale that much easier. It is sufficient to guarantee reception of the local stations, in most cases; then there is no come-back.

In some instances, it may be necessary to go so far as saying that some particular station a few hundred miles away may be heard with regularity—if the customer names that station as one he especially wants to hear, but with the reservation by the salesman that money will be refunded if the receiver doesn't do the trick. If the understanding is clear on that point—and of course

the store's policy must be back of it—not a single sales need ever be lost because of misconceptions about distance-getting. This privilege is not often abused by salesmen, because they ordinarily receive a small commission in addition to their salary, and deductions on account of refunds put the brakes on such return privilege sales automatically.

The understanding should be clear from the start, however, that guarantee of any distance performance is not popular with the boss, and is to be used with great conservatism and only when local reception positively will not satisfy the customer.

Watch What He Says About Servicing

Next in point of difficulty in training the salesman is to hold down his statements in regard to servicing. Policies vary; some stores unconditionally guarantee a set for anything from seven days to six months; others merely echo the manufacturers' warranty over a specified period that it is to be free of mechanical or electrical defects; others go even so far as to assure the customer that no matter what goes wrong at any time up to a certain date there will be a service man sent up to the house and everything will be fixed up hunky-dory without any charge whatsoever.

Now, whatever a store's policy may be in these matters, at least they are clear in the owner's mind. The salesman should know them positively and stick to them absolutely. Where he is likely to weaken is when the prospective customer reports that a competitor is offering service cheaper, or more embracing, or free, or something, and for fear of losing the sale the offer is matched.

As a builder of ill-will for a radio store the undisputed championship must go to the bill later rendered for service or replacement to the purchaser who was originally assured that nothing of the kind would come along. Essential in the coaching of a salesman is the assurance to him that he stands behind a bulwark of sound reason when he meets the customer's story of a competitor being willing to give one of those high, wide, and unlimited guarantees with a calm statement of the manifest absurdities it covers, and how evident it is that the whole thing is worthless.

Next in line comes the task of get-

ting the salesman to drop technical lingo out of his talk, and lifting the lid to show the works. There is no more effective way to cure this common itch for parading knowledge, however, than by having someone who really knows what makes a radio set percolate pull off actual sales in the presence of the wise-one by sticking solely to comments on the cabinet work, the simplicity of control and the reliability of the manu-

facturer, perhaps topping this off by letting the customer sit down in front of the set and work it himself, to show how simple it all is.

Once the salesman really understands that what the intending purchaser really wants is a demonstration, not a discourse, and that technical talk leads either to confusion or time-wasting argument, and the battle is won. It's a hard nut to crack, this one; but once the radio

WHY THEY SUCCEEDED



A \$5,000 Man Should Buy a \$200 Radio

R. C. TODD AND COMPANY of Toronto, Canada, have made a success of the radio business. To quote E. L. Innes, the manager, they have "put it over" largely, because—

Customers are not undersold. Prospects, when known, are scaled in terms of their buying power or income. For example, it is assumed that a man with an annual income of \$5,000 should buy at least a \$200 radio. Sales effort is then concentrated on sets of this price.

Two makes of sets only are handled. Concentration on a few lines has proved more profitable than "dabbling" with a dozen.

Opportunities for home demonstration are particularly sought.

The appearance and tone quality of receivers, rather than DX ability is stressed. This appeals particularly to women.

The display window is left comparatively open, rather than choked with merchandise. In this way the entire shop interior is visible, making a super-display. The customer is brought right *inside*.

The charges for service calls vary, each being considered individually. It is necessary in some cases to render free service, in others a moderate charge is advisable.

The temporary sag in demand for radio sets during the slack, or summer season, is tided over by the sale of automotive accessories. The off season for radio is the on season for motor supplies.

Automotive parts customers may be interested in radio and vice versa.

seller realizes that sets today are being sold on performance and appearance, the struggle is over.

Price, I have saved until the last. Viewed from the angle of competitive underselling it has a lot to do with sales, but not with salesmanship. Where it does enter, however, into the training of salesmen is in the skill which can be developed so that he unerringly leads the person who comes into the store directly to the set which he will decide to purchase.

The Right Price for the Customer's Purse

Radio's slogan is that there is a set for every purse and purpose, and while that makes it convenient to do business in some respects it also leads to the possibility of so confusing the mind of the intending purchaser that he will buy nothing at all. Nothing is more important in radio retail selling than sizing up the customer's probable preferences quickly. It can't always be done by appearances, and the salesman must be taught that the shabbiest person is often a prospect for a higher-priced set than a fashionplate ever will be.

The usual response to the salesman's greeting is a murmured admission on the part of the customer who has just entered the store to the effect that he is just looking around, or that he would like to look at the radio sets, or some similar remark of very general character. It is at this opening point that the salesman gets off to a running start,

or lets himself in for double the work to close the sale.

Smoking Out Price Information

The most important information for him to get, then and there, is some idea of what the customer has in mind to spend. An effective inquiry is, "Is there any particular set you would like to see? I will be glad to demonstrate it for you." If he can get the name of the set, immediately he has some idea of how much money the stranger is figuring on spending for radio. His cue is now, to take him to that particular set, direct, with no loitering on the way. And if that is the set he asked for when he came in, to stick to it and concentrate every effort on selling that, without showing any other.

Oftentimes the skilled salesman can raise the ante, leading the prospect later over to a more expensive set and bringing out its superiorities, but that is nothing for the unskilled salesman to try. In fact, by and large, if the salesman concentrates attention on the first set shown—assuming of course that he has a lead to indicate what amount the customer intends spending—the net result will be more sales in less time than can be accomplished in any other way. This is not an offhand observation; it is with me a proven fact through experience and careful observation.

But there will be many times when the customer will not name any particular set, or perhaps name one that the store does not carry in stock. In the latter case, the prin-

ciple is the same; the name discloses the favored price.

Now, where no set is named, it is still possible to draw out the necessary information quickly. For instance, the salesman remarks pleasantly: "We have quite a few sets, and the prices vary considerably. Be glad to show any or all of them to you, but I feel I can be lots more useful to you and save your time, too, if I had some idea of what you'd like. We have sets at one hundred dollars, for instance, on up to four hundred—" And right there, almost invariably, comes an answer. No, no, the customer doesn't want to spend any such money as that, something around such-and-such a price, is his idea. Then the salesman is ready to go ahead and do an effective job of selling.

Don't Confuse the Mind of the Buyer

Why all this fuss about getting the price dope quickly? Well, it's not a notion; it's experience. It will need no further explanation than drawing attention to two points: The first is, that the more sets are demonstrated the greater is the confusion in the mind of the prospective purchaser; and the second is, that if his purse is attuned to the purchase of one of the cheaper sets and he is given the opportunity of hearing the superior quality of a high-priced one first—good-bye sale!

It would require a manual to cover the whole subject of effective sales training for retail radio, so only fundamentals have been dealt with in this article; and yet there is sufficient foundation in these few points to erect a sound structure for either a larger or steadier sales volume, or both.

Household Ammonia Neutralizes Battery Acid

Even with the greatest of care some acid is always spilled when testing or charging a storage battery. Nothing eats through fabric, spoils finishes, or takes varnish off of furniture quicker than the sulphuric acid solution used in storage batteries. Not only does this solution destroy material but it will also give very severe flesh burns. If ordinary household ammonia is kept near the storage battery, it will be found that liberal application of this upon anything that acid has been spilled will neutralize the action of the acid.

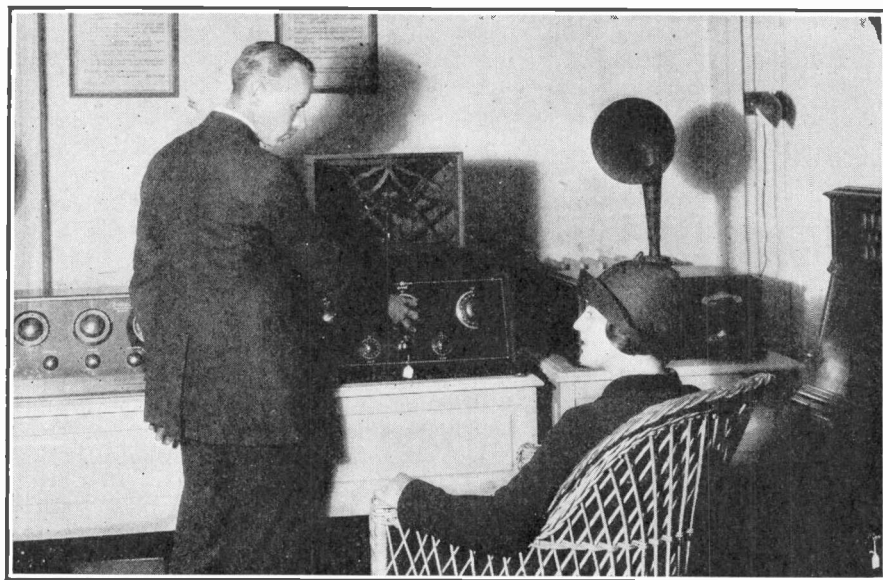

The most important information for the salesman to get, right at the beginning, is how much the customer has in mind to

spend on a radio set. An effective inquiry is, "Is there any particular set you would like to see?"

Radio, Our Newest Utility

The Time is Coming When No Home Will
Be Without Its Radio Set, Any More Than
It Would Be Without Its Daily Newspaper

By M. C. RYPINSKI

Vice-President, Brandes Products Corporation

AS ONE of those who had the privilege of being associated with the beginning of radio broadcasting, and as one who has continued to be intimately connected with the industry, I trust I may not be considered presumptuous if I venture to emphasize what is already becoming evident to those who are thinking constructively about the industry, namely, that radio has reached a new phase in its development.

In the beginning, and because of its almost miraculous potentialities; it gripped the imagination of the public and became the sport or hobby of those who had the means and the urge to take it up.

As time went by, however, it lost some of its novelty and there were those who predicted that radio would be found to be but a passing fad.

A Practical Side of the New Art

Happily, there were others with larger vision who saw that radio had a more practical side.

Some conceived of it as a musical source of entertainment in the home.

Others saw it as a medium of practical utility that could be used to elevate and enlighten the home circle.

The result has been a mixture in our broadcasting of these two elements with the former predominating,—that is the programs have been mainly musical.

The past year has witnessed an important advance in the technique of the art of broadcasting; super-power has been successfully instituted; the program standard has been elevated, receiving sets have been greatly improved, and last, but by no means least, the reproducing element in the chain, viz: the loud speaker, has been brought to a state of perfection which would not have been dreamed of a year or two ago.

In other words, the tools of radio have been brought to such a state of development, that major attention may now be focused on the adequate employment of these tools to the best advantage, and for the permanent good of the public.

Radio is therefore ready to take its place as a utility and to do for the family in the home what the automobile has done for the family outside of the home—broaden its horizon.

Social and Economic Topics

Radio programs of the future will be so full of matters of vital interest to the social and economical life of each and every one of us, that it will become just as much a part of the warp and woof of our lives as the modern newspaper, book, or magazine.

This utility angle may be well illustrated by an event which took place only a few evenings ago.

On this occasion over 20,000 graduates of the Massachusetts Institute of Technology seated at banquet

tables in sixty-seven cities, attended a simultaneous "phantom" radio dinner. It is not known how many others seated in their own homes were also accorded this unusual privilege of "listening in," but it is probable that they numbered several hundred thousand.

In addition to the musical programs, it may be interesting to list a number of examples of strictly utility subjects which are now available to radio listeners almost every day in the week, as follows:

The broadcasting of:

Physical exercises,

Cooking recipes and household hints,

Health talks,

Lectures on every conceivable subject of human interest,

News,

Church services,

Market reports,

Political and economic information,

Weather reports,

Time signals.

For each one of us there is therefore, even now, something sure to be on the air in which we are individually interested, and the time is coming when it will no more be possible for a home to be without its radio set, than for it to be without its newspaper.

If this is to be made imminent, each one of us must do his part.

The Radio Trade's Responsibilities

It is up to the manufacturer to continue the development of better, simpler, and cheaper sets and accessories. He must also find some way by which to contribute to the support of broadcasting if he is not already doing so.

It is imperative that the number of broadcasting stations be reduced, that the use of super-power be extended, that the programs continue to improve, and particularly that the art of program production be developed, with special reference to the utility aspect. Linkage of super-power stations into chains which will blanket the entire country is necessary and inevitable.

The wholesaler and the retailer likewise have a part to play. They must hold up the hands of those who are working for the good of the industry as a whole; whose efforts therefore are constructive and who are thereby contributing to its permanency and stability.

If, and when, all of this is realized in a substantial measure, radio will really come into its own. How much fuller life will then be for the family, especially those who may be denied the means of sharing in these good things except via radio. Their vision will be broadened, their lives brightened, their activities enhanced, all to the benefit of the general welfare.



\$35.

RCA Loudspeaker

MADE BY THE MAKERS OF RADIOLAS
RADIO · CORPORATION · OF · AMERICA

RCA Loudspeaker MODEL 100

QUALITY—and you can prove it. The first demonstration proved it. Every hearing proves it again. Plug it in on one of the new RCA Radiola Super-Heterodynes, with their fine performance — and you can show what it will really do. It renders clearly and without distortion the volume that the power tube can give it. It will sell!



POWER

Model 102
adds a power amplifier for
great volume. (On 50-60 cycle
110 volt A. C.) . . List \$140

RCA Loudspeaker

MADE BY THE MAKERS OF RADIOLAS

NEW YORK · CHICAGO · SAN FRANCISCO

Servicing Methods and Trouble-

Keeping Track of Radio Service Calls

George Blaisdell, owner of the Radio Service Store, Pittsfield, Mass., has developed a simple and effective servicing system that enables him to keep an accurate record of a service call from the time it originates until the job has been billed and paid for. Only two things are required to operate this very practical system. A service inspection ticket and a schedule board. The service ticket is in duplicate and is kept near the telephone. The board is located in the repair room.

When a call for service is received, usually over the telephone, all the information it is possible to obtain is written down on the face of the

be hung on it at the intersection of the day and hour columns which represent the exact time the boss promised that the work would be done.

All that is required to make a board of this kind is suitable wall space and a few small hooks. The advantages of keeping in front of the service man the complete picture of the work ahead of him, and the day and hour that each call must be made, are obvious. "It eliminates 90 per cent of all verbal instructions," says Mr. Blaisdell, "and it enables us to tell instantly how each job stands."

Mr. Blaisdell's explanation of how the service ticket is used is as follows:

When a service man goes out on

enables me to render better service —when promised—and to bill the customer for *all* the time and material which he has received."

Poor Grounds Caused by Pipe Connections

"Say Bill," said the proprietor of a Connecticut radio shop, "Mrs. Smith just called up and said to come over and see what the trouble is with her set. She has the same kind of set as her neighbor in the same block and that neighbor gets Florida and everything. You better go over this evening and see about it."

And so Bill is started off on another trouble hunt. He gets to the house and takes a look at the aerial as he goes in and everything seems all right. The batteries are tested and found to be up, the tubes are checked by means of a standard tube, —and yet the set has no real kick to it. He goes over the connections, every one O.K., yet for the life of him he can get nothing outside of the bigger local stations. Then he thinks of the ground which is made on the steam radiator and fastened with a ground clamp. The pipe is cleaned and yet there is no improvement. At last, in desperation he takes a length of wire and runs an improvised ground to the cold-water pipe in the kitchen. What a difference, the volume is increased and the distant stations come pouring in.

Next day, Bill came back and fixed the ground wire permanently on the water pipe. This shows that too much care cannot be exercised in getting a really good ground connection.

Potentiometers as a Source of Trouble

There seems to be an increased tendency for the manufacturer of tuned radio frequency receivers to place a potentiometer in the circuit to control oscillation. This brings a certain amount of trouble to the service man, but luckily the trouble may be diagnosed without great difficulty. The potentiometer is usually connected in the circuit as shown in the sketch. If it is burned

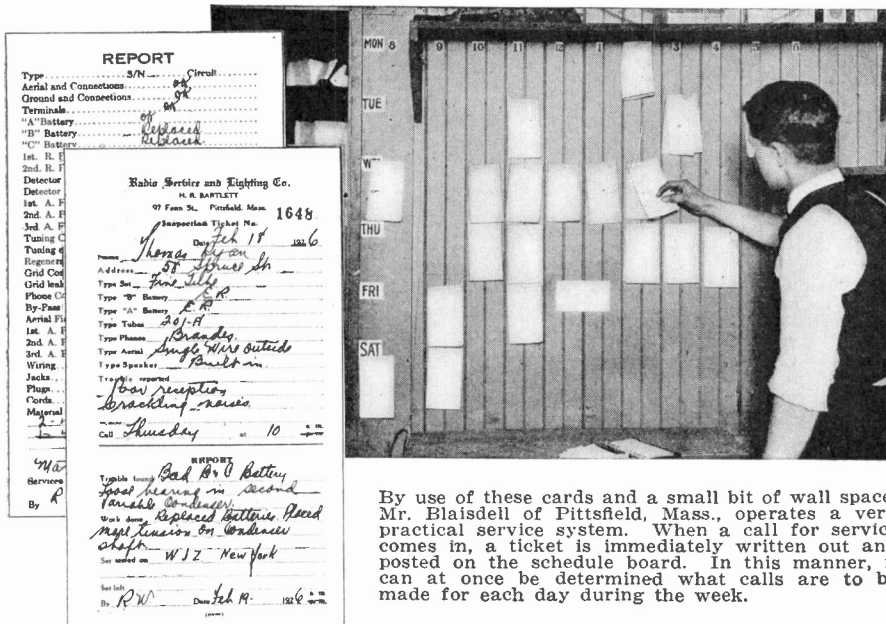

By use of these cards and a small bit of wall space, Mr. Blaisdell of Pittsfield, Mass., operates a very practical service system. When a call for service comes in, a ticket is immediately written out and posted on the schedule board. In this manner, it can at once be determined what calls are to be made for each day during the week.

service ticket. The customer's name and address, type of set, battery and tube equipment, and the "symptoms," are the main points noted. Both copies of this form are then immediately hung on the schedule board in the repair room. This board is divided into six horizontal rows—one for every work-day in the week—and into eleven vertical columns. Each column represents one hour. They are numbered from 8 a.m. to 6 p.m. This board occupies one entire wall, measuring forty-eight inches wide and fifty inches high. It is large enough, therefore, so that the four by six service ticket may

a job, he takes the original copy of the ticket with him, leaving the duplicate copy on the hook. He is required to make a complete report of the trouble, including work done, material used, and elapsed time. To help him make this report, the back of the ticket has printed on it a list of the troubles usually encountered in servicing a set. This report also gives the data from which Blaisdell originates the customer's invoice.

"One thousand service tickets in duplicate and the hooks for the service board cost us \$18.50," says Mr. Blaisdell. "This system has saved hundreds of dollars in that it

Shooting Ideas Used By Other Men

out, or the wire broken at a point such as C, the set will be in oscillation (that is, a squeal may be heard) at all dial settings and the potenti-

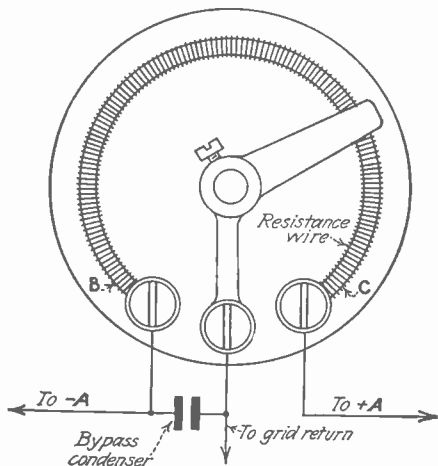

Above is shown the usual method of connecting a potentiometer. To have this instrument burn out is not uncommon. When this happens, replacement is the most satisfactory means of repair.

ometer will have no control over it. This is caused by the fact that the grid bias is negative at all settings. If the break is at B the set cannot be made to oscillate because the bias is positive at all settings. Sometimes when the potentiometer is thrown positive (to the left on most sets) the tubes will dim. This indicates that the bypass condenser is shorted.

Usually when this happens the potentiometer is burned out also, due to the full battery voltage being applied directly to a very short section of the winding.

The best and most satisfactory way of making a repair is to place a new potentiometer in the set, though in some cases the break may be soldered if care is used. A bypass condenser cannot be repaired and the only remedy is a new one.

Overcoming a Set's Tendency to Oscillate

In some cases a receiver of the tuned, radio-frequency type will cause trouble by oscillating (whistling) so badly, especially on the lower wave bands, that it is impossible to get decent reception of the broadcast programs.

In types of sets having the radio-

frequency transformer coils mounted directly in back of and parallel to the variable condenser, the oscillations may be stopped by means of a very simple expedient. Just move the three coils slightly closer to their respective condensers and you will be surprised how quickly the unwelcome oscillations will be reduced or stopped.

This result is caused by a slight additional loss introduced in the coils due to the closer proximity of the coil to the metal end plate of the condenser. These losses are not large enough to make any appreciable difference in the operation of the receiver, and the owner or service man should have no qualms in applying this method. If for some reason it is wished to make the receiver oscillate more it is only necessary to move the coils further away.

Don't Add Acid to Storage Battery Solution

Every once in awhile the old question of storage battery rejuvenation by changing the solution comes up. As far as can be learned there is absolutely no way of charging a battery without the use of an electric current. It just simply cannot be done by changing the acid solution in the battery.

Most of these solutions are made up of a very strong acid and simply give the battery a kick for a short time. The result is that when the battery is charged in the regular way the specific gravity is more than normal for full charge. The plates and separators will be quickly eaten away and the life of the battery is materially shortened. If the battery has been experimented on with such a solution the only remedy, if the solution has not been in too long, is to take all of the acid out of the battery and fill it up with distilled water and place it on a slow charge until no trace of acid shows with the hydrometer.

A new solution of the correct specific gravity can then be added. While the battery is now back to normal, this in no way repairs the damage done, but it does stop excessive deterioration of the separators and plates.

Service Men Guarantee Own Work to This Firm

By R. R. VOORHEES

"Radio means service and there is no use of hoping that it can be dispensed with," says K. A. Crank, of the Hellrung & Grimm Company, St. Louis, Mo. "The thing to do is to make the best of the situation and work out some system that will take the grief out of the servicing of the radio sets that the firm sells. We have done that very thing here in our department and I believe that any other dealer can do the same thing if he will buckle down and follow the system that we use here.

Flat-Rate System Used

"In the first place, practically everything that our service department does is priced on the flat-rate system. For instance, we make a flat-rate charge of \$7.50 for installing a radio set. Service calls are \$2 each. Other servicing is figured on a similar basis. In a few instances we make time charges but they are so rare that they need not be considered. I believe that one solution of many of the troubles that a service department must face is the flat-rate method of making charges. There is no doubt that the customer likes it far better when you can tell him just what his bill will be. This

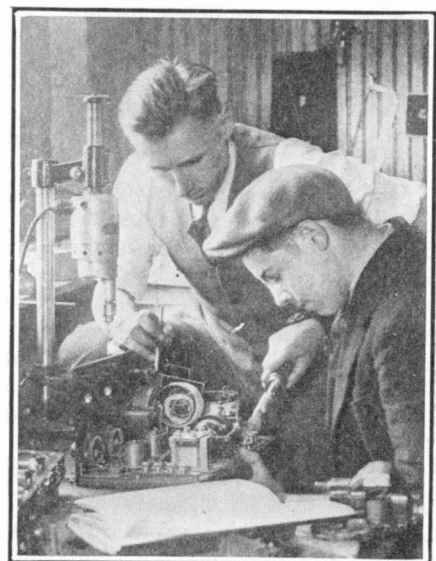

This dealer finds that a little time spent giving free instructions is repaid by the amount of parts he sells. The experimenter, in turn, has the satisfaction of knowing that the completed set has been built with his own hands.

hour-charge system is not in the best of favor with radio fans.

\$1 for Firm, \$1 for Service Man

"But we carry this flat-rate idea a bit further. Not only do we charge our customers a flat rate for all servicing that our men do but our service men also work on a flat rate. For instance, we get \$2 for every service call that our men make. They get \$1 of this \$2 that we collect. We get \$7.50 for making an installation and of this we pay our men \$5. All other servicing charges are based on a similar split with our men. They get that amount and nothing more, regardless of the time it takes them to do the job.

"Then to make the whole thing as near grief proof as possible we insist that our men guarantee their work to us and we in turn will guarantee it to the customer. If a servicing job that one of our men has done goes bad and it is the fault of his work he must do it over without cost to us and naturally without cost to the customer. That makes them careful and almost forces them to do the best work possible.

To be sure it costs the house a bit more to work service men in that way but in the long run it pays because the house gets a better grade of work than where the men are worked on a salary or hour charge basis. In fact we have no trouble getting men to work on this basis because they know that they can earn real money. We have some service men who earn \$200 a month and they wouldn't work on any other basis because they know that they couldn't earn so much in any other way.

Noisy Reception Due To Condenser Connection

Many variable condensers have the rotor connection made by means of friction applied to the end of the shaft. Excessive wear or loosening of the tension screw will cause noisy reception. This will sometimes occur only in certain places on the condenser setting and then again will be found through the entire rotation of the condenser.

Using a flashlight, examine the space in the set directly below the shaft end of the condenser furthest away from the panel. If small particles of metal are seen, it is at once known that there has been excessive wear at the point of contact and that this should be looked after. By



Speeding up service as well as profit can be done by the above illustrated portable shop. This is made by the Electro-Magnetic Tool Company, Cicero, Ill. The service man is here shown cutting a piece of bakelite which is but one of the many things that can be accomplished on this machine.

tightening up on the tension screw it will be found that, in most cases, the noise will disappear. Under no circumstance place oil on this contact.

Running Down Street Light Interference

Locating radio interference, caused by arcing filament terminals in street lamps, was quite a problem until the Municipal Gas Company, Albany, N. Y., hit upon the following plan.

A piece of No. 8 wire about 7 in. long and heavily taped was connected to one terminal on a 15,000-ohm. telephone receiver. The other terminal, well insulated from the first, was brought out from the outer tape layers in a piece of thin flat metal. In order to inspect a circuit the station operator holds the receiver to his ear and with his other hand brings the tape covered electrode near the pilot lamp on a panel of a constant current transformer, feeding the circuit under inspection. The thumb of the hand holding the electrode is pressed down on a metal strip which comes from the layers of tape.

The three usual circuit conditions, which are (1) normal operation, (2) burned out lamp and (3) arcing may be determined by characteristic tones in the receiver. Periodic inspections of circuits by use of this device will result in the checking of radio interference before it has had a chance to cause much trouble.

How To Revive a Tube By Using Two Storage Batteries

For various reasons tubes often become paralyzed just when it is most desired to receive a program. When this happens, a tube rejuvenator is of course, the proper instrument to be used. In case there is none handy, the following method will prove to be very effective.

Borrow a 6-volt storage battery from a neighbor and connect it in series with the storage battery used on the receiving set. Disconnect entirely the B batteries and leave the tubes in their customary sockets. The rheostats should be turned all the way on and then the full voltage of both batteries applied to the set. Leave this on for a period of from 45 seconds to one minute but not longer. Then connect the negative lead so that eight volts is placed on the tubes, remembering that each cell or section of a storage battery delivers approximately two volts. Allow the tubes to burn on this voltage from five to ten minutes. Then connect the set up in the usual manner and it will be found that the tubes will function and the signals will come in as before.

Do not under any circumstances use these voltages with dry-cell operated tubes, as it will mean burnt-out tubes. Dry-cell tubes may be revived however, by using the same time allowance and the same voltage "ratio."

A 25-Cent Instruction Book Saves Much Servicing

It is the experience of most radio dealers that the majority of calls for service originate during the first three weeks of operation of the new set. In most cases they are the result of simple ignorance on the part of the new owner and may be remedied in a moment's time by clearing up some misconception. Occasionally the experimenter will make a wrong connection or otherwise mishandle the equipment so that an actual repair is necessary. Very seldom is anything intrinsically wrong with the set.

Realizing that the expense of servicing is therefore largely one of educating the customer, Gordon Craig of the Gordon Craig Radio shop, Vancouver, B. C., has taken the stand that it is better to expend this money in educating the purchaser of a new set in the first place, rather

than to let him get tangled up with equipment which he does not understand and then to attempt to untangle him later on.

Educates Customer in Advance

In consequence, he takes especial care in explaining the new equipment to the customer, giving what is equivalent to a short course in the elements of radio to any purchaser who is entering this field for the first time. In addition, a small book of instructions, covering the first principles of radio reception and full directions for operating the set are furnished free. The cost of this book to Mr. Craig is some 25c., but it is worth that in direct returns to the store by reason of the saving in later calls for aid. Many of the questions which would ordinarily result in a telephone call and a trip with the service wagon are now solved by consulting the book.

The system has the further advantage that the customer is never allowed to become dissatisfied with his equipment by reason of some mistake of his own. The result has been a real saving in the reduction of servicing costs—and at the same time more satisfied customers.

Pilot Light Saves Soldering Irons and Electricity

How often have you closed your store for the evening and gone all the way home, only to remember as you placed your foot on the front door step, that you had forgotten to turn off the current on your soldering iron, back in the repair shop? When a heating element of this kind is left on all night it is dangerous as well as expensive.

One dealer who has evidently "been there before," in order to prevent a re-occurrence of this in his shop, has connected a red electric light bulb, similar to those used over fire exits, between the wall switch and all his power outlets. Whenever the current is on, this pilot light remains lighted, making it easy to remember when soldering irons are connected.

Removing Excessive Soldering Flux

It is most desirable not to leave any excessive soldering flux on wires sockets or other places in a radio set, as corrosion immediately starts

Your Service Ideas Are Worth Two Dollars

Radio Retailing invites its readers to send in servicing kinks and ideas.

A short description of from 100 to 200 words will suffice. If a sketch will help make the idea clearer, make a rough pencil drawing or send a kodak snapshot.

If acceptable for publication, it will be printed, accredited to you and a crisp new two-dollar bill will be sent you.

in and will eventually cause much trouble. When it is absolutely necessary to use the common types of flux containing acid, be sure that every soldered joint has had sufficient heat applied to drive all the flux out of the interior of the connection and then remove what remains on the outside by means of wood alcohol. It will be found that use of this readily removes any flux or grease on the connection, leaving it bright and clean.

Position of Set Has Marked Effect on Reception

"With loop sets gaining more popularity," says A. E. Kaplan, 2070 Vyse Avenue, New York, "I have found that many families are disappointed with results after the sets are installed. The trouble is due mostly to the location of the set in the room or home and not the fault of the set itself.

Many times when a set is delivered the owner has picked out a 'perfect spot' for the receiver which is soon seen to be near a radiator or hot air register."

Mr. Kaplan has made it a rule to have his men try out the set to be installed in various parts of the room until the location that produces the best results is found. Although this takes a little more time the records prove that the time is well invested and reduces complaints.

This method not only saves the service man's time, and the store's money on call-backs, complaints and

tests, but assures the store of the customer's good-will and recommendation.

Sells Higher-Priced Accessories on Service Calls

"I always carry a few batteries and tubes with me on service calls," says S. Bloomenstein, radio dealer of 651 Manhattan Ave., Brooklyn, N. Y.

"In the majority of cases, trouble is directly due to run-down batteries or defective tubes. If I have these accessories with me, an immediate sale can be made. The customer can be sold higher-priced accessories when they are actually brought to his home, than he would ordinarily buy if compelled to 'shop.'"

Locating a Convenient Ground

Many times it is found that the water pipe is two or three rooms away from where it is desired to install the set. Perhaps there is not even a radiator available. This is very inconvenient as the ground lead of the set must be well concealed in order to preserve the appearance of the room. Remember when you are "up against it" in this way, that the wall plate of the nearest electric light base plug outlet is grounded, making an excellent ground for the receiver. A wire may be easily attached by clinching it under one of the screws that usually hold these plates to the wall.

This plate is *not* in the lighting circuit, but is grounded through the BX cable covering, or insulated casing of the power lines.

Using Interference to Advantage

From the standpoint of radio, the vacuum cleaner and electric fan are usually mere "interference mills." But here's a way in which either of these devices can be made to aid the radio man.

When installing a set, it is bad policy to leave the house before the set has been tested out on a carrier wave of some sort. At times this is impossible owing to the lack of broadcasting stations on the air. In such cases a vacuum cleaner or fan turned on in the same room will furnish enough "carrier wave" to make a test of this kind possible.

And Now—Here's What

General Business at the Peak

THE general business outlook for the coming spring months is a reasonably bright one. The radio trade can take encouragement from the fact that its own sales are being built on a business background that is healthy and promising.

Right now, the business index is at a record level. There has been expansion, but little inflation. Nowhere is any sign of a turn yet apparent, still, as one banking authority puts it "This cycle has advanced sufficiently to indicate conservative policies." In some quarters, therefore, there are predictions of a seasonal slowing down within the next few months.

Good business through June any way, is the general opinion. For reports from all basic industries are uniformly good, and indeed generally optimistic.

Radio Is Revolutionizing the Musical Taste of the Nation

CONSIDER for a moment what a wealth of genuinely meritorious entertainment is now within the reach of everybody—via radio. We are actually witnessing a revolution in the taste of the nation: a musical awakening made possible by radio.

Here is one example. Many people could not go to Carnegie Hall, that temple of American music—so Carnegie Hall was brought into their homes by radio.

The enthusiasm of every live radio dealer cannot fail to be aroused by the service it is possible for him to render in making so much great music available to every person in his city.

He'll Welcome a Call from the Dealer

"THE average set-owner welcomes a visit from the local radio dealer," says Robert Himmel, president of Hudson-Ross, Inc., 116 South Wells Street, Chicago, Ill. "He feels that he can gain much information on radio progress and technical development from the man on the 'firing line.' The dealer should make his visit and appeal in the nature of a personal call. He should, in the conversation, compare recent steps of progress, discuss new features and finally bring the conversation to a point where he can mention a particular accessory or a superior set that he feels his prospect ought to have."

A Money-Making Combination for All Parties

MARKED change of viewpoint toward radio seems to be taking place in the retail phonograph field. It is no special secret that musical instrument retailers, in the main, entered into radio less from choice than as a matter of protection. Broadcasting hit the sales of machines and records a terrific wallop several years ago and it appeared only logical to those who had seen their business rapidly dwindling, to at least try out radio and see what it was all about; to carry broadcast receivers in stock anyhow, and if there was no money

in selling them, then at least to be in position to sense when the public would get over this passing fancy and go back to its first love.

With vision thus restricted it is little wonder that the average of merchandising skill displayed resulted in few if any of the talking-machine men making real money out of radio and that the "carry-it-as-a-sideline" attitude was reflected in red figures on the balance sheet. But things seem due for a change now. Apparently the new combination radio-and-phonograph machines have been received with genuine enthusiasm and both radio and talking-machine men see a union of the two as a basis upon which some real money can be made.

Don't Overlook the Eighty-Dollar Prospect

THE trend this year is toward better sets. Reputable dealers everywhere have stocked their floors with five-, six- and eight-tube cabinets. They are meeting a lively demand for outfits running from \$150 up. We wonder if those dealers who are specializing in the higher price ranges are overlooking another very good bet. Are they passing up an opportunity, not only for additional profit, but for the cultivation of a larger "clientele"? We refer to the so-called "popular" lines of two-tube and four-tube outfits. This group has its own special market—and that market is a very large one.

It will be worth any dealer's time to seriously consider these arguments in favor of carrying also a line of popular priced sets:

They broaden the field of prospects.

They increase the store's list of customers—to whom better sets may eventually be sold.

They attract desirable trade which would otherwise drift to the "gyp."

They provide a suitable line for spring and summer sales—in some cases more desirable than the higher priced portables.

They are readily obtainable—therefore tie up a comparatively small amount of capital and permit quick turnovers.

Improved Loud Speakers Have Created New Sales Opportunities

THE sensitivity, or "tonal quality," of a number of makes of loud-speakers has been so perfected that these speakers now cover practically the entire range of audible sound wave lengths. Improved loud speakers mean better reception. This development tends to further appreciate the value of the radio set to its owner.

In these days, with so much wonderful music coming through the air and with even greater miracles to follow, why should a man put up with an outfit of medium reception ability if he can afford a better one?

Many a set owner thinks he is getting good reception because he hasn't heard the superior tonal qualities of some of these newer loud speakers. Here then, is a chance to add to accessory sales this spring and summer by pointing out these facts to your likely prospects—through the medium of that sales argument which admits of very little "come-back"—the actual demonstration.

Your Editors Think—

Next, Go After the Radio Doubters— There Are a Lot of Them

IN EVERY community there still remains a large class of people who think that "radio has nothing for them"—who declare that they will not buy radio sets "until the programs are improved."

These worthy folk are, here in 1926, giving voice to their impressions formed back in 1923. They are holding on to prejudices three years old,—and usually with more sincerity than good judgment.

The dealer's approach to selling such people on radio must be directed to their interest in genuinely worthwhile entertainment. Such entertainment is now being broadcast regularly.

Radio's present merchandising job is to sell this entertainment, and to recommend receiving combinations which will most faithfully reproduce it.

Intimate knowledge of the worth-while contents of present broadcast programs will make possible the most effective selling appeals.

Selling Radio on Time Payments

SOME radio dealers feel that easy-payment selling cuts down the radio dealer's profits. Yet far from decreasing the dealer's profits, it *increases* them by materially increasing the number of radio prospects he can sell. Statistics show that for every set sold for cash, at least five or six can be sold on time payments.

Stores in almost every city make a feature of selling radio on time payments. Why let this trade go by? Getting into the partial payment method is extremely simple. Go to your banker and find out the nearest office of a contract purchase company. There is one in every city. Then write or visit the office and make your arrangements. You have nothing to lose.

You get a cash payment from the customer and a signed contract. You keep the payment and the credit company buys the contract, paying you cash for the full amount less ten per cent, which they also turn over to you when the contract expires.

Picking the Right Man for the Job

"SELECT the right man and then place him in the right job." That's good advice for the radio merchant. For there is no dealer who should take more care in selecting his store personnel than the radio man. Radio is today seeking definite channels of distribution. Soon it will be stabilized. At the present time there is going on a process of elimination of radio retailers, and those who can best handle their jobs will get the radio business of the future. Much of any store's success depends upon having the proper organization to serve and satisfy the buying public. To build such an organization necessitates great care in selecting a selling staff. Do not fit a square peg in a round hole, or try to. It won't work. Soon it will result in poor service. It will result in merchandise being sold

Radio Retailing, March, 1926

only for the moment, and being returned only to be sold over again. In the end, it will result in a dissatisfied consuming public, ultimately spelling failure for the business itself.

You Can't Spend Your Cake-Money and Save It Too

EARLY in February an Eastern radio manufacturer announced by means of full-page ads in the New York daily papers the adoption of a "manufacturer-to-consumer" policy.

It is difficult to understand how a manufacturer can market his sets at prices 55 to 60 per cent lower than the regular dealer price, and explain the ease with which it is done by pointing to the absence of middlemen—this in spite of the fact that the company has established two retail stores of its own in New York City as distribution points, presumably pays rent for these locations, hires salesmen, and pays them, and in short, assumes all the obligations of a retail dealer; is itself, indeed, its own middleman, with all the latter's expenses, and yet sells its sets at factory prices!

An "Inside" Problem of the Service Man

MICHIGAN radio dealers, writes a Detroit correspondent, are very much disturbed over a recent and very serious menace to the health, morals and working efficiency of their service men, which has reared its ugly head in the Middle West.

"It is no longer possible to do servicing and demonstration work in the evening with any degree of profit," he writes. "Not only do people dislike the presence of service men in their homes during the evening hours but the service men themselves are not able to do their best work under present conditions.

"The amount of liquid refreshment offered to service men by customers is beyond belief and is a menace to them and to the profits of the dealer."

Here, indeed, is a situation to try the souls of the bravest of radio merchants. Outside interference is a hard enough problem for the service man to solve. Why burden him with more from the "inside?"

Benjamin Franklin's Sound Advice on Radio

"NEVER be the first to pick up a new thing, nor the last to drop an old one"—was the advice given by Benjamin Franklin 150 years ago.

His maxim can be well applied to the selling of radio sets by dealers today. "Choose a reliable, well-known, fool-proof line of radio sets, marketed through a good jobbing house, to whom you can go in any difficulties, and then stick by it. If you will simply follow common sense rules that you might apply in other lines, you will make money in the radio game."

Here is some good advice from the Northwest Radio Trade Association that applies to radio dealers elsewhere as well as in Minneapolis, Minn.



What's New in Radio and

This editorial section is prepared purely as a news service, to keep readers of "Radio Retailing" informed of new products on the market.

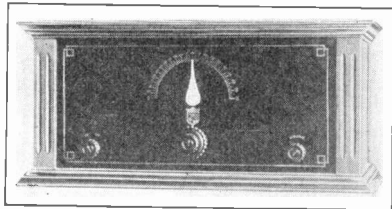

Six-Tube Receiver

Radio Retailing, March, 1926

A six-tube tuned radio frequency receiver is being manufactured by the Simplex Radio Company, Sandusky, Ohio. This set uses a single dial for tuning, and incorporates two stages of tuned radio frequency amplification, detector and three stages of audio frequency amplification. Other than the tuning control, there is a volume control and a stabilizing control. The antenna inductance has been tapped in order to accommodate different lengths of aerial, and provision has also been made for the use of a C battery. A jack is located at the rear of the set for connecting loud speaker or phones. A plug is incorporated at the rear of the set which allows for all battery connections. Audio frequency transformers of 2:1 ratio have been used. Cabinet is of mahogany, finished in Adam brown, the front panel being of bronze with dial figures in old gold. This dial is also accurately calibrated in wave lengths, according to the manufacturer. Intended retail price, without tubes or batteries, \$150.

Five-Tube Receiver

Radio Retailing, March, 1926

Model "B-30" is one of the new line of receivers being manufactured by the Federal Radio Corporation, Buffalo, N. Y. This receiver is of the tuned radio frequency type. Station indicators, micrometer controlled, are located behind glass ports. All delicate parts are completely shielded against mechanical damage and electrical disturbances. Will operate with either dry or storage battery tubes. Overall dimensions are 30 in. x 20 in. x 15 in. and the mahogany cabinet, finished in rich brown tone, is arranged to accommodate all batteries, etc. The new Federal adjustable speaker has also been built into the cabinet. Intended retail price, without accessories, \$130.

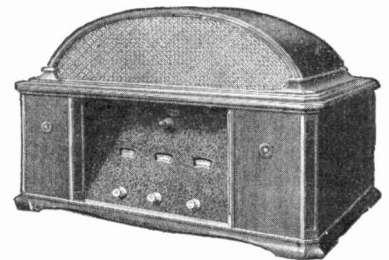

Five-Tube Receiver

Radio Retailing, March, 1926

Model "A-2" is a five-tube tuned radio frequency receiver, which the Ben Radio Corporation, Freeport, Long Island, New York is making. Bakelite is used for insulation throughout and the panel finish is burl walnut, gold engraved. The cabinet is of American walnut. Straight line frequency condensers are used so as to give uniform distribution of wave lengths over the dials. Three major tuning controls are used, as can be seen in the illustration. Intended retail price, less accessories, \$59.

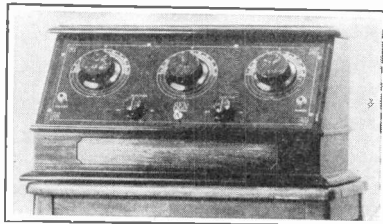

Five-Tube Receiver

Radio Retailing, March, 1926

The illustrated five-tube receiver is the product of the Diamond T Radio Manufacturers, South Bend, Ind. This receiver incorporates two stages of tuned radio frequency, a detector and two stages of audio frequency amplification. Bakelite is used throughout for insulation and all wiring is concealed underneath a sub-panel. The reproducer is built-in as can be seen in the illustration. It is said that this receiver is very selective and that clear faithful tone reproduction is to be had. The intended retail price is \$64.50.

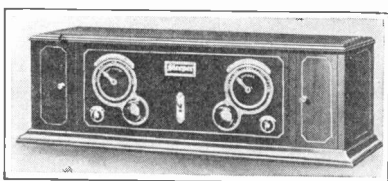
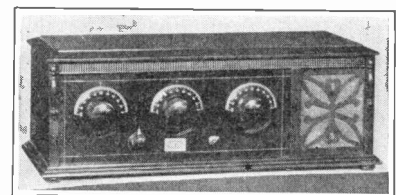

Five-Tube Receiver

Radio Retailing, March, 1926

The illustrated five-tube receiver is being manufactured by the Sleeper Radio Corporation, Long Island City, N. Y. The circuit has two stages of radio frequency, detector and two stages of transformer coupled audio frequency. Two dial control is used with a single condenser tuning the aerial circuit and a double condenser tuning the second radio frequency and detector stages. Mechanical and electrical provisions for UX power tubes in the last stage of radio amplification has been made. The condensers are actuated by a 6 to 1 reduction gear and the scales are calibrated directly in meters, the condensers being true straight line. Overall dimensions are 3 1/2 in. x 11 in. x 11 in. and the cabinet is of solid mahogany. The panel is of 3/32 in. brass finished to resemble oak. This swings outward on bottom hinges making all parts of the set accessible. Intended retail price, less accessories, \$90.



Five and Six-Tube Receivers

Radio Retailing, March, 1926

The illustrated Console receiver is made with both five and six tubes by the Audiola Radio Company, 430 South Green Street, Chicago, Ill. The panel of the six-tube receiver is 7 in. x 21 in. while that of the five-tube receiver is 18 in. x 7 in., both being walnut finish and gold decorated. Two-tone walnut cabinets are used with overall dimensions of 36 in. x 40 in. x 17 in. The reproducer is built-in. Low-loss coils, condensers and sockets of this company's own manufacture are used in the circuit. Three main tuning controls are used. Two stages of tuned radio frequency are incorporated in both sets. The only difference being that the six-tube receiver has one stage of power amplification. The intended retail prices are \$160 and \$135 respectively.

Where to Buy It News of Latest Products Gathered by the Editors

All announcements appearing on these pages are published without advertising considerations of any kind whatsoever.



Loop Receiver in Library Table

Radio Retailing, March, 1926

Illustrated is a Seven-tube, loop operated receiver mounted in a library table, made by Frank R. Porter, 1320 Vermont Ave., N. W., Washington, D. C. The table top measures 26 in. wide by 42 in. long, and may be had in either mahogany or walnut, hand rubbed and finished. The reproducer is of the built-in cabinet type and occupies a space directly below the instrument panel resting upon the shelf. From this position it is readily removed to other parts of the room if desired, ample cord being furnished for this purpose. All batteries are placed on the shelf at the left end of the table, from which point the wires are led in concealed position to the various terminals. This receiver comes complete with seven tubes, two 90-volt B batteries, and one 100-amp. hr., 6-volt storage battery, all fully connected and ready for reception. Intended retail price, \$350.

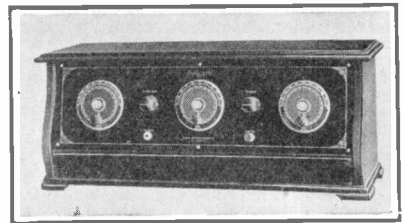

Six-Tube Receiver with Resistance Coupled Amplification

Radio Retailing, March, 1926

The "Melodyne Six" made by the Eaton-Edwards Radio Company, Sag Harbor, Long Island, N. Y., is a six-tube tuned radio frequency receiver, employing two stages of radio frequency amplification, detector, and three stages of resistance coupled audio frequency amplification. The coils are made from Litz wire and are secured against any injury in placing them underneath the sub-panel. Both front and sub-panel are of bakelite, gold engraved. A mahogany cabinet encases the set and has overall measurements of 26 in. x 15 1/2 in. x 11 1/2 in. All visible metal parts are gold finished. Vernier dials are used. Intended retail price, less accessories, \$100.

Five-Tube Receiver With Toroid Coils

Radio Retailing, March, 1926

The Illinois Radio Engineers, Mt. Vernon, Ill., are manufacturing a five-tube, tuned radio frequency receiver, which has a range of from 180 to 550 meters. Overall dimensions of the panel are 7-in. x 24-in., and both front panel and sub-panel are made of Bakelite. Three major tuning controls are used and the coils are of the toroid type. A potential balance control is also used. Intended retail price, \$80.

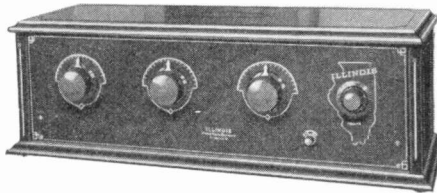

Crosley Introduces Four Additional Radio Receiving Sets

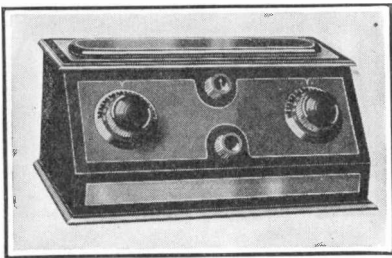

Four-Tube Receiver

Radio Retailing, March, 1926

The Crosley 4-29, illustrated, is a four-tube receiver with a new circuit—one stage of normally non-oscillating radio frequency amplification, regenerative detector controlled by the "Crescendon," with two stages of audio frequency amplification. The Crescendon control of the detector tube is said to be equivalent to one or more additional tubes of radio frequency amplification, giving this receiver selectivity, sensitivity and volume. Two tuning controls are used and the set is intended to cover a wave length band of from 200 to 550 meters when used with an outdoor antenna from 60 to 150 ft. long. Operates on either dry cell or storage battery tubes. The sockets in this set are designed for the UX base. Cabinet is in two-tone mahogany finish with sloping panel, which is of wood. Overall dimensions are 15 1/2 in. x 7 3/4 in. x 8 in. Intended retail price, \$29.

The Crosley Radio Corporation, Cincinnati, Ohio, is also making two other new models, in the RFL-60 and RFL-75—the latter of which is here illustrated. These are five-tube receivers, balanced by means of the Wheatstone bridge method. The circuit consists of two stages of radio frequency amplification, a detector, and two stages of audio-frequency amplification. It is claimed that a high degree of selectivity results from the use of three tuning circuits.

Figures of Pan and Terpsichore have been woven into an artistic design in gold for the panels, which are colored Adam brown. Formica is used in the panels and the cabinets are solid mahogany. Two especially designed audio frequency transformers are said to give unusual volume combined with faithful reproduction. Numerals have been incorporated in the panel design with pointers of rose gold. Intended retail price of RFL-75, \$75; of the RFL-60, \$60.

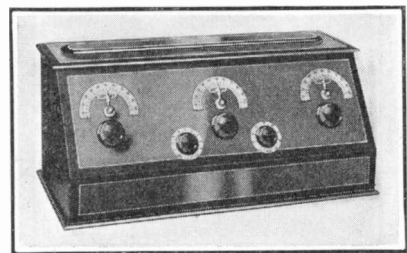
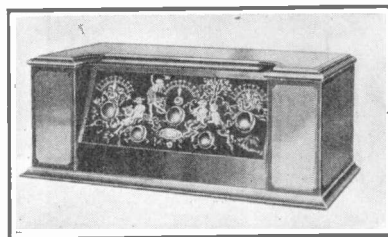

Five-Tube Receiver

Radio Retailing, March, 1926

The illustrated three-dial control, five-tube receiver is known as model 5-38. In this Crosley model, as in the 4-29 regeneration is controlled by means of the Crescendon. This circuit uses two stages of radio frequency amplification, a detector, and two stages of audio frequency amplification. The detector tube and second radio frequency tube are so connected as to be regenerative. An untuned antenna circuit is loosely coupled to the tuning circuit. Overall dimensions are 19 1/2 in. x 8 3/4 in. x 9 1/2 in. This receiver is also designed to cover a range of from 200 to 550 meters. As with the other models this receiver is non-radiating. Either dry cell or storage battery tubes may be used and the sockets are for the UX bases. The cabinet is hardwood, mahogany finished. Intended retail price, \$38.

What's New in Radio and Where to Buy It—

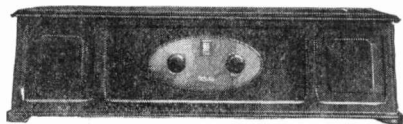

Six-Tube Receiver

Radio Retailing, March, 1926

J. B. Ferguson, Incorporated, 41 East Forty-second Street, New York, is making the Model 8 receiver illustrated. All of the elements which comprise this receiver are mounted upon a rigid aluminum frame. This insures absolute accuracy. The calibrated wavelength drum aids wavelength in tuning besides improving the appearance of the receiver. A single knob accentuates the tuning control driving it at a ratio of 60 to 1. Two stages of balance tuned radio frequency and three stages of audio frequency amplification are incorporated. The antenna coil is tapped in 5 places to make allowances for all sizes of antenna.

Receiving Tubes

Radio Retailing, March, 1926

Radio receiving tubes of the 201-A type are being made by the Hytron Corporation, 19 Oakland Street, Salem, Mass. These tubes are designed for use on a five-volt filament circuit and take from 20 to 100 volts on the plate. They are said to be built to most rigid specifications and triple tested before leaving the factory. The manufacturer guarantees the quality of every tube. Bakelite bases are used in connection with long prongs so that U. X. bases may be used. Tipless construction is also incorporated.

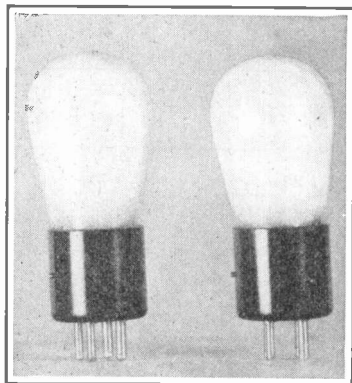

Five-Tube Receiver

Radio Retailing, March, 1926

A five-tube tuned radio frequency receiver is to be found in the type "WC-15," made by the Western Coil and Electrical Company, Racine, Wis. Standard type storage battery tubes are used, and tuning is accomplished by means of two dials. The finish is black irregular crystalline, with gold stripe and engraving. Special finishes of walnut, dark red mahogany, old ivory or blue may be had for \$3 additional. Overall dimensions are 15 in. x 7 in. x 8 in. and the weight is 11 lb. Either inside, outside or lamp socket antenna is recommended for use with this set. Dry-cell tubes may also be used in this circuit if so desired. The intended retail price, less accessories, is \$39.50.

Five-Tube Receivers

Radio Retailing, March, 1926

Known as "Case" are the five-tube receivers being manufactured by the Indiana Manufacturing & Electric Company, 600 Case Block, Marion, Ind. Models 500, 506 and 703 are all three dial control, tuned radio frequency receivers. The latter two are equipped with vernier dials. Although these receivers may be operated on dry cell tubes it is recommended that standard storage battery tubes be used. These receivers are to be used with an outdoor antenna. Model 703 has a built-in reproducer. Intended retail prices are \$65, \$75 and \$170 respectively.



B Battery Eliminator

Radio Retailing, March, 1926

Model 800-A, Super-Ducon, made by the Dubilier Condenser & Radio Corporation, 4377 Bronx Boulevard, New York, is designed for use with sets requiring a potential of 135 volts. The detector tube voltage is variable from 10 to 50, and is controlled by the knob at the top of the instrument, as can be seen in the illustration. Turned clockwise the voltage is increased—counter-clockwise it is reduced. When used with unground loop sets the minus B terminal of the Super-Ducon must be grounded. Overall dimensions are 9 3/4 in. x 8 in. x 5 1/2 in. It is said by the manufacturer that with its average life of 1,000 hr. or more the UV-196 tube used should give satisfactory service for approximately one year. As it is designed to give full wave rectification the tube has two separate filaments. Intended retail price complete, \$47.50.

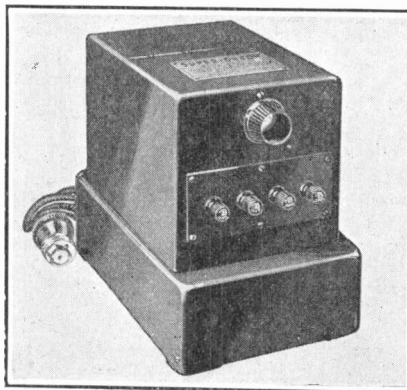

Radio Frequency Transformer

Radio Retailing, March, 1926

"Proudfoot" is the name of the radio frequency transformer being made by the Cruver Manufacturing Company, 2456 Jackson Boulevard, Chicago, Ill. This coil is designed to tune from 200 to 580 meters when used with a .00035 mfd. variable condenser, and a minimum capacity of circuit not to exceed 29 mmfd. Wire is wound on low loss forms which are threaded, insuring that each turn is equal distance from the next one. Threading of forms enables the manufacturer to use bare wire. Legs are provided so that these coils may be mounted on a sub-panel. The illustration shows clearly the neat, solid construction of these coils.

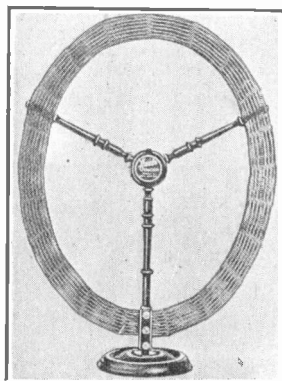
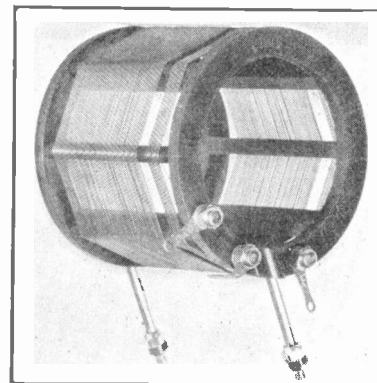

Loop Antenna

Radio Retailing, March, 1926

The Lincoln Radio Corporation, Chicago, Ill., is manufacturing the illustrated loop antenna known as the "Ovaloop." This is provided with a center tap, spring binding posts, is mounted on bakelite and designed to be tuned with a .0005 mfd. condenser. A special feature of this loop is that it rotates around the center spindle, which is securely fastened to the base. The special wire, which is wound in low-loss form is covered with an artistic gold braid and the supports are highly polished. A full guarantee covers this product which has an intended retail price of \$13.50.

News of Latest Products Gathered by the Editors

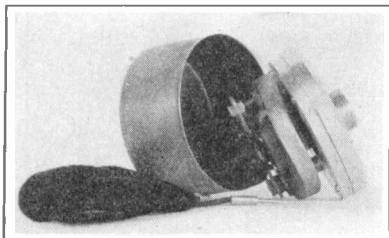

Reproducing Unit

Radio Retailing, March, 1926

The illustrated loud speaker unit is being manufactured by the Holiday Radio Company, Incorporated, Dooly Building, Salt Lake City, Utah. The electrical unit, which is mounted on heavy machined aluminum is encased in a spun brass shell which measures $3\frac{1}{2}$ in. in diameter and is 2 in. deep. The unit is of the balanced armature type and is equipped with large size permanent magnets. Corrugated aluminum is used for the diaphragm which aids in giving faithful reproduction of tone. Intended retail price, \$6.

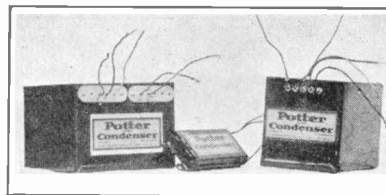

Condenser Units for Filter System

Radio Retailing, March, 1926

The Potter Manufacturing Company, 2004 Sheridan Road, North Chicago, Ill., is manufacturing filter units designed to be used in B battery eliminators with Raytheon tubes. Unit No. 385 has incorporated 2—1 mfd. condensers with a common tap built in one case. These are tested on 1,000 volts d.c. and are securely sealed and well insulated from the case.

Unit No. 350 consists of 2—2 mfd. condensers, 1—8 mfd. condenser and a $\frac{1}{2}$ mfd. condenser and are recommended in circuits using 135 volts plate potential. These are also tested on 1,000 volts d.c.

Unit No. 250 contains condensers of the same capacity as Unit No. 350 but is not designed for as high a voltage, having 650 d.c. tested windings. These units are very well adapted for eliminators as they are easy to mount and compact in form.

Crystal Receiver Contained in Head Set

Radio Retailing, March, 1926

The Petite Radio Corporation, 459 Little Building, Boston, Mass., is manufacturing a complete radio receiver contained in headphones as shown in the illustration. One phone has a series of 8 taps on it by means of which the inductance of the honeycomb coil contained therein may be varied. The other phone contains a crystal detector incorporated within a small fuse-like cartridge. In order to use this device all that is necessary is to connect one of the cord tips to the antenna and the other to the ground. Variations of the switch will bring in the stations. If desired these can be used as an ordinary pair of phones by moving the switch to the end tap at one side. Intended retail price, \$12.

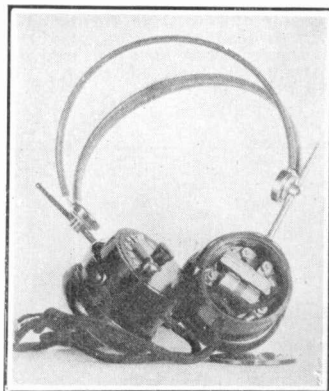

Radio Frequency Coils

Radio Retailing, March, 1926

The illustrated coils are made by the Orbit Coil Company, 6 Howard Street, New York. When tuned by .00037 mfd. variable condenser, these will cover a wave band range of from 200 to 600 meters. The freedom of the coil from foreign substances supporting it is pointed out by the manufacturer and also the manner of bank weave which is said to increase the concentration, thereby gaining in efficiency. For a set of 3 the intended retail price of these coils is \$8.

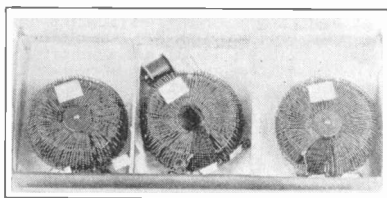

Five-Tube Receiver

Radio Retailing, March, 1926

A five-tube receiver, known as the "Cascade" model is being made by the Nunn-Landon Company, 1115 Fourth Street, Milwaukee, Wis. It is said that the circuit used has a tendency to oscillate up to the point of greatest efficiency, and is there held without introducing any losses. The panel measures 6 in. x 21 in., and is fitted in an attractive walnut cabinet. The intended retail price is \$135.

Push Type Socket

Radio Retailing, March, 1926

A socket of the push type and known as No. 9040 is being made by the Benjamin Electric Manufacturing Company, 120 South Sangamon Street, Chicago, Ill. This socket, embodying all of the shock absorbing features of the "Cle-Ra-Tone" sockets has been designed to accommodate the new standard UX push type base. All tubes of the old style bases except the UV 199 type can also be accommodated. The socket is delicately balanced responding to the slightest vibration which absorbs shocks and vibrations that might otherwise cause noises. Intended retail price, 75c.

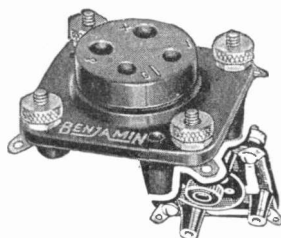

Gold Plated Aerial Wire

Radio Retailing, March, 1926

The Luxem & Davis Manufacturing Company, 6229 Broadway, Chicago, Ill., are now producing 7-strand phosphor bronze wire upon which is said to be seven plates of gold. The feature about this type of antenna wire is that once it is put up securely it may be forgotten as it will not corrode. It is pointed out also that this type of antenna wire is used by high-power sending stations and is in use on all government equipment. It is furnished in 100-ft. coils and has an intended retail price of \$3.

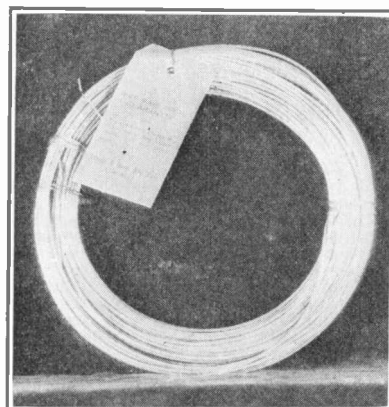

Power Amplifying Tubes

Radio Retailing, March, 1926

The C. E. Manufacturing Company, Incorporated, 702 Eddy Street, Providence, R. I., are making in types E and F tubes designed for the last stage of audio frequency only. The former is a 3-volt tube drawing .125 amp. and taking a maximum plate voltage of 135. The second is a 5-volt tube, drawing $\frac{1}{2}$ an amp. with a maximum plate voltage of 180. It is said that clearer reproduction with increased volume will result by the use of either one of these tubes in the last audio frequency stage. Complete instructions for the most efficient operation is packed with each tube. The bases of these tubes are equipped with prongs designed for use with U. X. bases. Intended retail price of type E, \$2.50; type F, \$6.50.

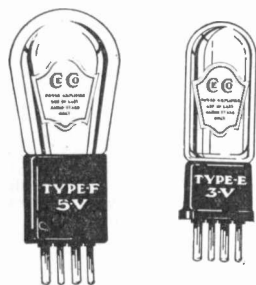

News of Latest Products Gathered by the Editors



Electrolytic B Battery Supply Unit

Radio Retailing, March, 1926

A B battery supply unit using eight electrolytic cells is being marketed by J. Andrew White, 41 West Forty-third Street, New York. This is designed for use on 110-125 volt, 60 cycle current and passes 60 milliamps. A small toggle switch is provided at the bottom, as shown in the illustration, which turns the unit on or off. Due to the extra large size of both the cells and condensers it is said that no overloading will take place and at no time is there any hum present in the receiver. A maximum of 135 volts is furnished for power tubes and there are also three other voltage available for use with radio frequency and detector tubes. Intended retail price, \$38.

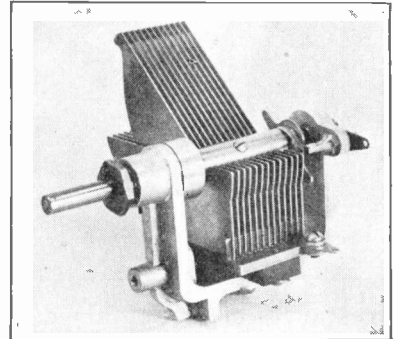

Straight Line Frequency Condenser

Radio Retailing, March, 1926

Being made by the Hammarlund Manufacturing Company, Inc., 424-438 West 33rd Street, New York, is the illustrated straight line frequency condenser. This is designed to simplify tuning, particularly on the low waves. The plates of this condenser are shaped so that they intermesh very slowly at the lower dial readings, and faster at the upper dial readings. This gives the proper change in capacity in order that stations may be evenly distributed on the dial. The frame is of warless aluminum alloy, grounded to the rotor. Hard brass is used for the plates, which are chemically treated against corrosion and securely soldered in individual slots. Permanent alignment is insured by sturdy tie-bars. Adjustable ball-bearings at both ends make easy turning of the rotor shaft. One-hole mounting is provided with an additional anchoring screw. These condensers are furnished in sizes of .00025, .0003, .000375, and .0005 mfd., with intended retail prices of \$1.50, \$4.65, \$4.75 and \$5 respectively.

B Battery Eliminator With Raytheon Tube

Radio Retailing, March, 1926

The B power unit, made by The Modern Electric Manufacturing Company, Toledo, Ohio, has a voltage limit of 150, a capacity of 50 milliamp, and is equipped with a Raytheon tube. The dimensions of this eliminator are 11½ in. x 3¾ in. x 8½ in. and it will handle any set up to 10 tubes. It is designed for use on 110-volt, 60 cycle current. Three voltage taps are supplied which may be used simultaneously with a control for varying the voltage to be used on the radio frequency tubes. The unit is housed in a highly polished steel cabinet, and according to the manufacturer each is tested at 2,500 volts. The life of the tube is indefinite because there is no filament to burn out. Intended retail price complete, \$50.

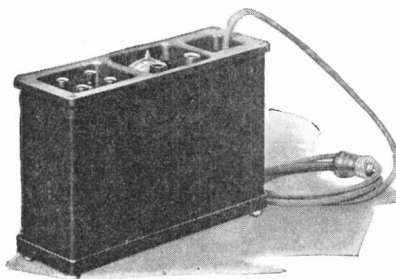

Wave Trap Device

Radio Retailing, March, 1926

The "Thurman Station Separator" is a small wave trap, being made by the Radio Requirements Company, N. W. corner Fifth and Market Sts., Philadelphia, Pa. As can be seen in the illustration this consists of a cone-shaped inductance mounted on a piece of wood 3 in. square. In the center of the cone, coming out of the top is a small control knob by means of which variations in capacity may be accomplished. The cone itself stands 2½ in. high. Inserting this instrument in series with the antenna, where interference is experienced, is claimed to give greater selectivity. Intended retail price, \$1.

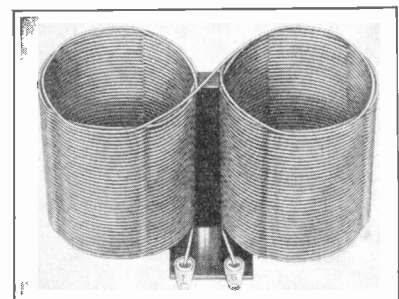
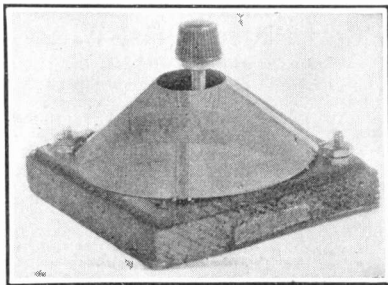

Radio Frequency Transformer

Radio Retailing, March, 1926

A radio frequency transformer by the name of "Lekeless" is being made by the Behjamin Electric Manufacturing Company, 120 South Sangamon Street, Chicago, Ill. Due to the shape of the coil the field is said to be closed, preventing power leakage, making neutralization easy. This transformer can be used in any type of tuned radio frequency circuit and is especially desirable for single control, due to its uniform high inductance and low distributed capacity, according to the manufacturer. It will work satisfactorily with any good .00035 mfd. condenser, and may be mounted in any desired position. Double green silk covered wire is used. Diameter of coil, 1½ in.; overall height, 2¾ in.; width of base, 2½ in. Intended retail price, \$2.50.

Straight Line Frequency Condenser

Radio Retailing, March, 1926

The D. X. L. Radio Corporation, 5769 Stanton Avenue, Detroit, Mich., has developed a straight line frequency condenser known as the "Equa-tune." The plates are soldered solidly together in grooved brass holders, stator and rotor plates may be had silver plated. Contact is made by means of pressure on phosphor bronze spring washers. This condenser is 3¼ in. wide. It is made in capacities of .00025, .00035 and .0005 mfd. with intended retail prices of \$4, \$4.25 and \$4.50 respectively. For silver plating \$1 extra is charged.

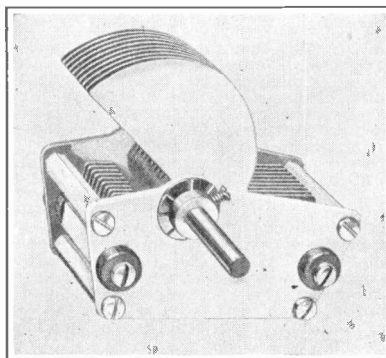



New Service Tools and Equipment for the Radio Dealer's Use

Motor Driven Coil Winder

Radio Retailing, March, 1926

The Eureka coil winder is manufactured by the Eureka Tool and Machine Company, 42 Walnut Street, Newark, N. J. This machine is simple in design, rugged, foolproof, requires no attention, and is said to wind a uniform bobbin. Coasting is prevented by means of a brake so that the bobbins always have the same number of turns and will test very uniformly electrically. A Universal motor with an interlocked switch and anti-coasting brake is used. All the moving parts are packed in grease and the spindle is of ball bearing construction, which is said to be noiseless. Intended retail price, with chuck to fit the bobbin runs, approximately \$200.

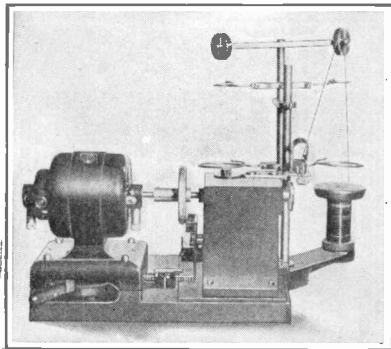

Long Reach Adjustable Radio Wrench

Radio Retailing, March, 1926

A wrench with adjustable jaws designed to fit different sizes of nuts, such as are used on radio sockets, rheostats, condensers, etc., is being manufactured by the William Schollhorn Company, 414 Chapel Street, New Haven, Conn. Pushing the thumb adjustment forward accommodates the wrench jaws to the nut, while pulling it back with the thumb tightens the grip. It may be also used to turn the round, knurled type of nut. This wrench is 9½ in. long and will, therefore, easily reach into the far corners of any set where it may be found impossible to get the hand or fingers.

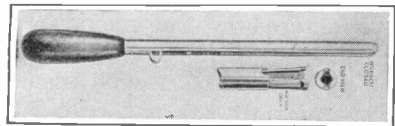

Electric Soldering Iron

Radio Retailing, March, 1926

To overcome trouble from broken cords, the Chapman Machine Company, Terryville, Conn., has equipped the handle of its electric soldering iron with a coil spring cord protector. By use of a new heating element, it is pointed out, about 25 per cent more heat is produced than by previous models. Interchangeable copper points made of pure copper are furnished in three sizes. Extra heating elements, parts and complete instructions for installing may be had for 50c. The intended retail price of the iron, with three tips, is \$3.

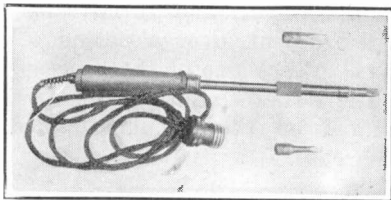

Electric Soldering Iron

Radio Retailing, March, 1926

An electric soldering iron with a pencil point tip for use with fine wires is being made by the Watlow Electric Manufacturing Company, 1320 North Twenty-third Street, St. Louis, Mo. The copper tip is screwed into the brass tube which not only insures good contact with the heating element but makes for a sturdy construction and long life. Ni-chrome wire insulated with asbestos is used for the heating element and can easily be replaced at the factory if necessary. The ⅜-in. diameter is carried from the handle ferrule to the tip. This prevents catching on other wires as might be the case if the tip was of larger diameter. It is designed for use on a 110-125 volt circuit, uses 55 Watts and is 11¼ in. long. Complete with cord and plug the intended retail price is \$1.

Adjustable Panel Hole Cutter

Radio Retailing, March, 1926

A tool to be used for cutting holes of from ½ in. to 3 in., is made by Garrison-Rumely, 3020 Sheridan Road, Chicago, Ill. This is designed to be used in an ordinary carpenter's brace and the adjustment is made by means of the screw shown in the illustration. The cutting edge is glass hard, making it suitable for cutting bakelite. This will be found especially valuable for the some builder to be used where holes are needed to mount voltmeters, switches, jacks, bezels, etc. A hole ½ in. in diameter is first cut, which allows the center of the tool to be inserted in the panel. Dealers are furnished with an attractive display box which contains 12 of these cutters wrapped in an instruction sheet and packed in individual boxes. Intended retail price, 65c.

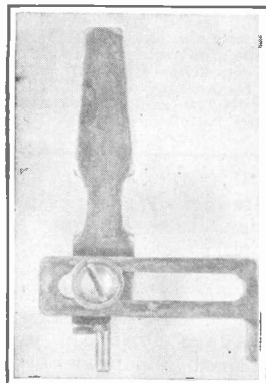

Coil Winding Machine

Radio Retailing, March, 1926

The American Insulating Machinery Company, Fairhill and Huntingdon Streets, Philadelphia, Pa., is making a coil winding machine driven by ¼ horsepower, 110 volt, 60 cycle motor designed especially for radio use. Wire ranging in size from No. 36 to No. 18 may be used on coils wound with 15 and 16 points. Both single and double circuit inductances may be wound at one operation, with outside diameters ranging from 2½ in. to 4½ in. The machine has a winding speed of 50 turns per minute, using either cotton, silk or enamel insulated wire. Over all measurements are: Floor space, 29 in. long by 21 in. wide, height all over 42 in. and net weight 103 lbs., including motor. Motors designed to run on current other than specified above may be had upon request. Intended retail price \$200.

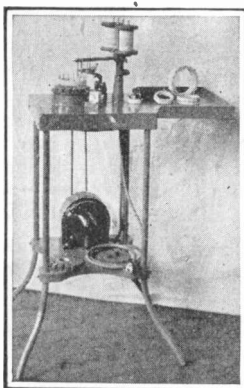

Tube Tester

Radio Retailing, March, 1926

Model 200 tube tester, manufactured by R. M. Peffer, Harrisburg, Pa., is designed to accommodate all types of receiving tubes. The dimensions of this tester are 8½ in. long, 6 in. wide and 2½ in. deep. All batteries are connected externally. With this instrument the dealer would be able to test for open circuits or grounds in phones, amplifying transformers, jacks, coils, etc. The intended retail price is \$30.



How Manufacturers Promote Dealer Sales

New "Dealer Helps" Offered to the Radio Retailer by the Manufacturer to Increase the Merchant's Radio Profits

Manufacturer Pays Half of Dealer's Advertising Costs

A. H. Grebe & Company, 109 West Fifty-seventh Street, Richmond Hill, N. Y., manufacturer of the Synchronphase radio receiver, pays half the cost of dealer advertising in local newspapers and supplies the electrotypes used. These electrotypes are similar to the national advertising material used by the company and by utilizing them the dealer may hook up with a nation-wide schedule.

The company has put aside \$4.65 for each set sold with which to match a similar sum put up by the dealer—in other words it will pay half the advertising bill, providing this amount does not exceed 5 per cent of the net price per set that the dealer pays the distributor. This makes a total of \$9.30 available per set for advertising.

A new mailing circular in the form of a three-page leaflet is now available. The cover of this leaflet is a replica of the Synchronphase and when the first page is turned the effect of lifting the cover of an actual set is given, as a complete view of the interior is shown. When the second page is turned, a complete view of the lower battery compartment is shown, with the method of connection used and the battery arrangement. The last page lists the dial settings of a number of prominent broadcast stations.

On request, large "jumbo" posters will be furnished as well as a number of illustrated catalogues. The entire line of dealer help material is listed for the selection of the dealer in a service catalogue for 1926.

J. B. Ferguson, Inc., 41 East Forty-second Street, New York City, has issued a new catalog which, in an attractive manner, presents in photographic form, the latest Ferguson radio receivers.

Page 292

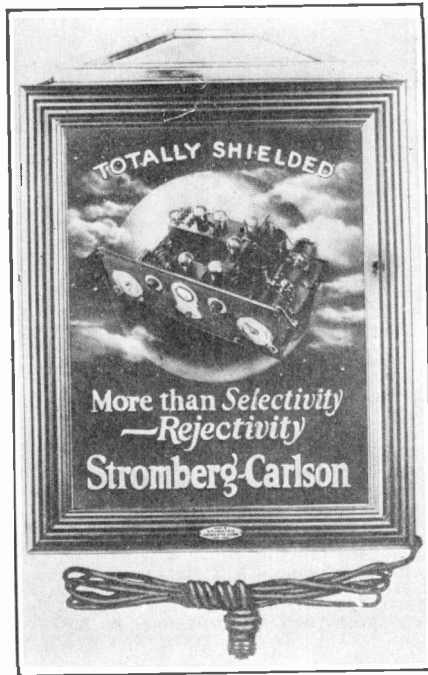

Illustrated is a new animated electric sign, prepared for use of authorized Stromberg-Carlson dealers. This display is equipped with a nine foot electric cable and when connected in the lighting circuit automatically flashes on and off, throwing the word *Rejectivity* and an attractive background into relief.

The Stewart-Warner Speedometer Corporation, 1834 Diversey Parkway, Chicago, Ill., manufacturer of radio vacuum tubes, packs all tubes shipped to dealers, not only in individual boxes but in lots of five. The boxes in which these sets are furnished are attractively colored and may be used as counter displays. The displaying of tubes grouped in this way, rather than singly, has a distinct psychological advantage in encouraging the purchaser to buy five tubes instead of one.

The Turn-it Radio Sales Corporation, 71 Murray Street, New York City, manufacturer of variable grid leaks, supplies twelve individually packed leaks in a handy metal display rack or "dispenser." This rack may be hung on the shop wall and is made in such a way that each leak is visible. When one is sold and removed from the bottom of the rack, those remaining above automatically drop into place, so that articles may be removed one at a time from the holder at the bottom.

Advertising Mailed to Prospects Direct from Manufacturer

A direct advertising service for all authorized Fada dealers has been inaugurated by F. A. D. Andrea, Inc., 1581 Jerome Avenue, New York City.

All dealers carrying this manufacturer's line have been invited to forward a list of their selected set prospects to the factory. Without charge, a series of circulars consisting of catalogues describing the Fada receiver, and three sales letters are sent, over a period of ten days, to each one of these prospects.

The dealer's name and address is printed on the circular mailed in each case.

The De Forest Radio Company, Central Avenue and Franklin Street, Jersey City, N. J., is supplying counter cards for use with tubes which it manufactures. These cards are equipped with a convenient cardboard shelf in which four tubes may be inserted for display purposes.

The Dubilier Condenser & Radio Corporation, Bronx Blvd. at 238th St., New York City, is distributing a well illustrated eight-page booklet in which full information is given regarding the installation and use of the "Super-Ducon" B Battery eliminator. In the back of this booklet is a general index list of seventy popular receivers and information as to installation of the eliminator in connection with each for best results.

The Stromberg-Carlson Telephone Manufacturing Company, 1060 University Avenue, Rochester, N. Y., has put out an animated electric window display sign for the use of all its authorized dealers. This sign is rented to dealers at a nominal cost and may be obtained by writing direct to the Stromberg-Carlson Company at the above address or to their nearest representative, who will supply full particulars.

The Wagner Radio Company, 643 Washington Boulevard, Chicago, Ill., prints a small booklet for use in selling audio transformers which it manufactures, entitled "Matched Tuning Means Better Teamwork."

Radio Retailing, A McGraw-Hill Publication

Furnishes Metal Battery Display Cabinet

A useful dry battery display cabinet is being furnished by the Bright Star Battery Corporation, of Hoboken, N. J., to its dealers.

This cabinet, standing about four feet high and equipped with a number of shelves, is made of steel, and attractively finished in grey enamel. It is shipped to dealers in knockdown form, f.o.b. the factory.

The H. H. Eby Manufacturing Company, Philadelphia, Pa., has brought out a novel counter display for the use of all dealers carrying Eby binding posts. The display is a mammoth wooden reproduction or enlarged 6x10-in. replica of the smaller binding post and is furnished without charge.

The North American Radio Corporation, 1845 Broadway, New York City, distributor of radio receivers and accessories, has recently issued a four-page price list catalogue. Illustrated pamphlets of any items specified in this catalogue are furnished on request.

The Van Horne Company, Franklin, Ohio, manufacturer of vacuum tubes, supplies all dealers handling its product with a data sheet giving full information in connection with each type tube manufactured. Complete data as to impedance, filament consumption, etc., is given. This sheet is made with a special linen-like backing, which prevents tearing and insures a longer life of usefulness.

The Reichmann Company, Chicago, Ill., packs three Thorola tuning coils, which it manufactures, in a small box, the cover of which when opened, makes an effective window display. The coils may be left in the box when placed in the window, thus showing the product itself, as well as the illustration of its use, shown on the box cover.

The Gould Storage Battery Company, Incorporated, New York, has prepared a series of sales helps for its dealers. These consist of a series of 1, 2, 3 and 4 column advertisements for use in local newspapers. A large broadside in

colors notified the dealers of this latest co-operation on the part of the Gould Company. In the broad side are featured the various ads and the cuts that are to be used with them. Window and counter-display cards in three colors have also been prepared, together with a consumers booklet. This material with the cuts, is being furnished to Gould dealers free of charge.

Stevens & Company, 375 Broadway, New York City, has mounted a complete variety of tools manufactured by them for radio use, on a large 2x3-ft. wall display card. This card is furnished with an attractive frame, and tools may be removed from it when sold.

The Carborundum Company, Niagara Falls, N. Y., is mounting twelve carborundum detectors on an attractive window display card. These detectors are packed in individual pasteboard boxes and may be sold to the customer direct from the card.

The Schneitter Radio Company, Fourth and Jule Streets, St. Joseph, Mo., wholesale jobber of radio sets and accessories, has issued a two-hundred page catalogue listing all merchandise carried. All items are well illustrated and prices are given.

The Crescent Tool Company, Jamestown, N. Y., fastens six long-nosed radio pliers to an 8½x11-in. counter display card. This assortment is billed to the dealer at the price of the tools alone.

The Cleartron Vacuum Tube Company, 28 West Forty-fourth Street, New York City, has issued a new booklet in which a brief explanation of the theoretical operation of the radio vacuum tube is given, as well as various photographed processes in the manufacture of these tubes. The last four pages of the booklet are set aside for the listing of various type tubes manufactured and their operating characteristics.

The Diamond Electric Specialties Corporation, 106 S. Orange Street, Newark, N. J., is supplying all its dealers with large cardboard replicas of the Diamond B battery, which may be used attractively as counter displays. This display comes in knockdown form and when assembled forms a monster battery about 2 x 3 ft. in size.

Dealer's Window Sign



This attractive sign furnished by the National Carbon Company of New York City, is finished in brilliant red and blue and may be attached to the show window by means of small rubber suction cups with which it is equipped. The separate sections are joined together by means of small metal links and may be easily removed when new sections are to be substituted.

The Radio Corporation of America, 233 Broadway, New York City, has issued a twelve-page booklet, listing replacement parts for the Radioia 28 receiver. All parts of the receiver are reproduced in this booklet in photographic form, a number being assigned to each one to facilitate description. Prices are not listed, but may be secured at the nearest R.C.A. sales office.

The Consolidated Instrument Company of America, 41 East Forty-second Street, New York City, manufacturer of radio jacks and switches, supplies dealers with a counter display in the form of a small square of plate glass on which is mounted four "Cico" jacks.

The Bridgeport Hardware Manufacturing Company, Bridgeport, Conn., furnishes six screw-drivers, for radio use, on a 10x11-in. card that may be used as a counter display.

The Freed-Eisemann Radio Corporation, Sperry Building, Brooklyn, N. Y., has issued a small pamphlet for use of dealers called "Friendly Advice On How To Buy A Radio."

The Royal Eastern Electrical Supply Company, 114 West Twenty-seventh Street, New York, exclusive metropolitan distributors of the Eagle neodyne has issued a complete parts catalogue of fifty-two pages. This includes all the essentials of radio as handled by the above company.

The Daven Radio Corporation, 158 Summit Street, Newark, N. J., is furnishing dealers with 2x3-ft. counter display cards. These cards are attractively colored and a small pasteboard shelf is provided in the center for the insertion of the Daven resistance amplification unit.

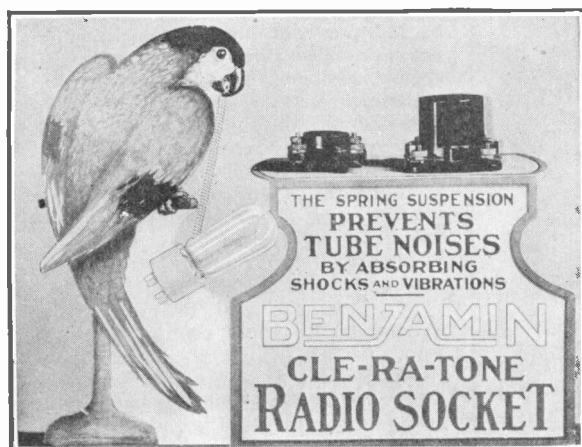

Counter Card Features Spring Suspension

Spring suspension of tube sockets is strikingly emphasized in this counter card, being distributed by the Benjamin Electric Company of Chicago, Ill., for displaying the vacuum-tube sockets which it manufactures. A light spring attached to the bird's beak and the illustrated tube calls attention to the "spring-suspension" idea.

How Radio Gross and Net Increased for 1925 Business

Manufacturers and Jobbers Report to Electrical Credit Association on Factors in Past Year's Sales

Members of the National Electrical Credit Association were asked to comment on radio business conditions for the year 1925, and the results of this study are now made public by Frederick P. Vose, general secretary of the body, with offices in the Marquette Building, Chicago, as follows:

Comments by Manufacturers

All manufacturers reporting indicated an increase in *gross sales*, one as high as 126 per cent increase, but another only a slight increase. Generally gross sales seem to be much over 1924.

This applies also to *net sales*, although there appeared to be somewhat of a larger spread between gross and net sales this year than in 1924.

Gross profit, too, was almost unanimously reported greater, varying from "only slightly" to 102 per cent greater.

The same for *net profit*, although, as in the case of gross sales and net sales, there appears to be a somewhat larger spread in 1925 between gross profit and net profit. The net profit varying from "only slightly greater" to 99 per cent greater.

Most manufacturers reported that jobbers preferred *sets* to *parts*, although this question was not asked and all manufacturers did not express an opinion.

Radio Credit Losses Low

As regarded *credit losses*, manufacturers were about equally divided. One-third reported greater, one-third reported less and the other one-third reported no change. Of those reporting greater, one explained that his credit losses were mostly to fellow manufacturers. Another reporting greater credit losses explained that his loss amounted only to six-tenths of one per cent. It appears, therefore, that radio manufacturers as a class experience very little credit losses.

One-third of those reporting indicated an increase in *manufacturing losses* this year. Another third reported no change, comparatively speaking, and the others reported less or were non-committal. Only one-sixth of those reporting indicated they had produced no new apparatus.

Advertising Outlays Increased

Practically all members reporting indicated an increase in *advertising expense* last year, from only a slight increase to a 90 per cent increase. One-sixth of those reporting indicated a decrease in advertising expense, due to a policy of requiring their jobbers and dealers to share it, in return for exclusive sales territories and other protection and support.

The comments on *sales expense* closely parallel those on advertising expense, except that the *increase* in sales expense was not so great as the increase in advertising expense. Manufacturers who require their jobbers and distributors to share advertising expense reported a decrease in their sales expense for last year.

Most manufacturers felt that the industry was being stabilized or at least that the *tendency was to stabilization*, but one-seventh of those reporting felt that competition was increasing, that drastic price cutting is imminent and that the public expects it.

Practically all those expressing an opinion indicated that *sets* were to be the order of tomorrow rather than *parts*; that parts will be largely left to amateurs in the future, although it was admitted that this demand on the part of amateurs would be great enough to produce an active market, especially since the public in general was still looking for new developments.

All manufacturer members expressed optimism for the future based on the tendency to stabilization, on the increase in public interest, increase in utility of radio and favorable business conditions.

Jobbers Find Radio Booming

The large majority of jobbers reporting were electrical or automotive accessory jobbers. One of the latter reported that the radio this year had eclipsed his auto accessory business ten times in volume. Most of these jobbers indicated they felt radio was very much worth while from their point of view, although one was very emphatic in the opposite view, making good his position by his refusal to handle radio

goods, his argument being "The real buyer of radio is the ultimate consumer who won't buy a radio unless he can see it set up in his own home and then determine whether it suits his requirements as to efficiency, style of cabinet, etc. This service the jobber cannot render, neither is he in a position to consign radios to retail dealers for this purpose.

"The retail dealer is not yet in a position to order a dozen or a hundred sets of any type or style or even make because every customer that comes in wants one like his neighbor or friend who has advised him which to buy, and there are too many styles and makes for him to afford to carry such a stock. Automobiles are not carried or sold by a jobber, but by an exclusive factory agent. The same for vacuum sweepers. By the time radio becomes standardized the article will be more common and the per cent of profit so reduced that the jobber will not care to carry the investment."

Increase Above 30 per Cent

The following figures are submitted by electrical and automotive accessory jobbers handling radio. All those reporting, with one exception, reported a 30 per cent or greater increase last year over the previous year (one a 100 per cent increase) in *gross sales*, with net sales closely paralleling gross sales in *increase* in volume.

Gross profit on the whole did not show the increase that gross sales did, and there was a considerably wider spread between gross and *net profit* than in 1924. Some reporting a decrease of one-third in net profit, although their books showed an increase over 1924 of almost the same proportion in gross and net sales.

Credit losses were in all cases either practically the same or lower, and were extremely nominal.

Trend Is Toward Sets

Prices were generally agreed as lower, where an opinion was expressed, and there was a general feeling prevailing that the distribution of radio was becoming stabilized and that the tendency was very much toward *sets* rather than *parts*.

It was pointed out by one-fourth of those reporting that there was *not the increase* in volume *this year* over last, that 1924 showed over 1923, although there was a very satisfactory increase nevertheless.

While some jobbers reported as high as 121 per cent increase in *advertising expense*, others reported 25 per cent decrease, and most of those reported substantial decrease in *sales and service expense* although there was no unanimity of opinion on this point.

It was generally agreed that in spite of the wider spread between net profits and gross profits, that the handling of radio was very much worth while. Exclusive radio jobbers appear to be highly gratified by the year's business and to have no misgivings as to their economic justification.

All jobbers reporting indicated their feeling that the tendency was toward simplicity and stabilization.

For 1925, Radio Manufacturers' Report—

Gross Sales	Increased, up to 126%
Margin	Increased, up to 102%
Net Profits	Increased, up to 99%
Credit Losses	Low, — down to 0.6%
Advertising Outlays	Increased, up to 90%

What the Trade Is Talking About

White Bill Little Changed by Congress

Late reports of the progress of the White Bill through Congress indicate that it will be reported out of committee with but few changes in form. It is quite possible that there will be a minority report opposing the placing of control in the hands of the secretary of commerce or an advisory committee, but recommending the appointment of a communications committee to sit permanently at Washington to direct all forms of communication, including radio. A resumption of the hearing on the Dill bill is being contemplated by Senator Watson.

The chief point about which debate now revolves is that of the supervision of broadcasting. Control in the hands of one man is looked at askance by many. So also is the idea of a permanent commission by those perennial objectors, congressmen and private citizens alike—to governmental commissions. A committee of private citizens, selected for their capability and knowledge of radio conditions, to act in an advisory capacity to the secretary of commerce is probably the best solution of the problem.

National Music Week and Convention in May and June

A National Music Week, under the auspices of the Music Industries Chamber of Commerce, 45 West Forty-fifth Street, New York City, is scheduled to run from May 2 to 8. The Chamber will furnish stickers, posters, envelope stuffers, and similar publicity aids to music merchants. A nominal charge will cover the cost of such materials.

Merchants connected with the national association of music merchants, or identified by division membership with the chamber, are invited to submit photos of their music week window displays for exhibition at the Music Industries Convention early the following month, week of June 8, at the Drake Hotel, Chicago, Ill.

Department of Agriculture Inaugurates Nation-Wide Farm Service

Three important features of farm service broadcasting, organized by Sam Pickard, chief of radio, were introduced by the Department of Agriculture in February and March. On February 1 a Farm News Digest, made up of items of agricultural news interest, was made available to all stations requesting it. This service is issued twice weekly. A daily service, Fifty Farm Flashes, consisting of broadcast answers given

by agricultural authorities to fifty selected questions put by farmers, was first put on the air by about twenty broadcasting stations on February 15. Divisions of the service are released between 12:30 and 1:00 p.m. daily according to the following schedule: Monday—Livestock; Tuesday—Crops and Soils; Wednesday—Poultry; Thursday—Fruits and Vegetables; Friday—Dairying. Material originating in the Bureau of Home Economics of the department has been broadcast daily since February 15 as a Housekeeper's Half Hour, and on March 1 the department started a Radio Order of Junior Gardeners, introducing Uncle Bert the Garden Expert, who answers questions and conducts informative discussions on gardening topics.

Mary Garden, Opera Star, Makes Radio Debut

One by one, and sometimes in duos and trios, they make their bows. Mary Garden, referred to by proud Chicagoans as "our Mary," is the latest of the famous artists to hold a radio premier. The occasion was the annual dinner of the Fred F. French Companies, a New York realty investment firm, on Monday, February 1. Station WJZ broadcast the program, which included, besides Miss Garden's selections, an address by Fred F. French, and orchestral numbers by the Henry Hadley Orchestra, composed of members of the New York Philharmonic Orchestra.

Commerce Commission Cancels Proposed Freight Increase

The Interstate Commerce Commission has cancelled the proposed freight-rate increase on combined talking-machine and radio sets. The carriers in the official classification had sought to raise the rating of such combined machines from second to first class, retaining the 16,000-pound minimum carload feature, but leaving unchanged the ratings and minimum carload requirements in the southern and western classifications.

Protests from the Music Industries Chamber of Commerce of New York, the Victor Talking Machine Company, the Brunswick-Balke-Collender Company, and the Sonora Phonograph Company resulted in the schedule's having been suspended until February 9, 1926, before which date the commission determined the carriers' proposal to be inconsistent with the ratings maintained by them on other comparable articles, and not reconcilable, likewise, to ratings in force in the southern and western classifications. The suspended schedules were ordered cancelled forthwith.

This decision does not affect the application of Rule 10 of the consolidated classification which provides that for a mixed carload, the rating and weight features of the whole carload shall be the same as that of the article in the car having the maximum rating and the highest minimum weight.

He Makes Radio Draw Pictures



Application of the familiar principle of the "telautograph" to radio, is reported to have been made by C. Francis Jenkins, of Washington, D. C., so that drawings, sketches and handwriting can be reproduced. The

pencil at the distant receiving station is declared to follow the movements of the stylus held in the hand of the operator at the transmitting apparatus and accurate reproductions are thus made.

Prize Awards Made in Edison Radio Play Contest

The committee of judges appointed to award the five hundred dollars in gold contributed by Arthur Williams, vice-president of the New York Edison Company, for the three plays best suited to radio broadcasting, met at the Union League Club late in February to consider the presentations. The committee, composed of Cosmo Hamilton, the English author, B. C. Forbes, editor of *Forbes* magazine, and Earl E. Whitehorne of *Electrical World*, announced the following awards:

To J. F. Ritter, New York City, the first prize of \$250 for his play, "The Return of Diogenes."

To Florence Howard, Rochester, N. Y., the second prize of \$150 for her play, "The Return of Mary Ellen."

To Helen M. Anthony, Washington, D. C., the third prize of \$100 for her play, "Mrs. Rip Van Winkle."

It is announced that Station WJZ will broadcast the plays in the near future.

Canadian Broadcasters Organize

All radio stations in Canada are represented in the new Canadian Association of Broadcasters. The following officers have been elected: J. N. Cartier, CKAC, Montreal, president; M. Johnston, CECA, Toronto, vice-president; A. R. McEwan, Canadian National Railways Radio Department, Montreal, secretary-treasurer; G. M. Bell, CKCK, Regina, and P. H. Combs, CFCA, Toronto, directors.

The announced purpose of the Association is to improve the standard of broadcasting, to promote the interests of the owners of receiving sets, and to spread by means of radio a wider knowledge of Canada, its advantages and opportunities.

Radio Affecting "Movies" in Japan

The growing popularity of radio in Japan is resulting in a steady decline in the public attendance at the movies. American producers say that motion picture theatre receipts are only about 10 per cent of the expected revenue for some pictures, basing the calculation on attendance at theatres last spring before broadcasting was introduced.

Second German Radio Exhibition at Berlin

The marked interest of Germans in the development of radio is shown by the fact that about 400,000 visitors are said to have been in attendance at the second German Radio Exhibition recently held in the exhibition hall on Kaiserdamm, Berlin. Trade Commissioner Theodore Pilger, Berlin, reports to the Department of Commerce. It is understood that relatively little business was transacted, and that from a

Radio Shows and Conventions Announced

March 8-14: Sixth Annual Amateurs' Radio Show at Hotel Pennsylvania, New York City.

May: Radio Manufacturers' Association. Atlantic City, N. J.

June 7: Radio Section, Association Manufacturers of Electrical Supplies. Hot Springs, Virginia.

June 8-15: Music Industries Convention. Drake Hotel, Chicago, Illinois.

September 10-17: Fifth National Radio Exposition. Grand Central Palace, New York City.

September 13-18: Radio Manufacturers' Show. New Madison Square Garden, New York City.

September 27 - October 2: National Radio Exposition. Chicago, Ill.

September 27 - October 2: Northwest Radio Trade Association Fifth Annual Show. Minneapolis, Minnesota.

October 11-17: Radio Manufacturers' Show. Coliseum, Chicago, Ill.

commercial point of view the fair was not successful, although the German radio industry appears to be becoming gradually more independent of foreign parts manufacturers—a tendency which was reflected by the distinctly German models exhibited.

Station at Rugby, England, Nearing Completion

The 1,500-kilowatt station of the British Imperial wireless system is nearing completion at Rugby, England, not far from London. The telephony range of this new station is 5,000 miles, and signals have already been heard in Australia, New Zealand, South Africa, Hong Kong, and Java during preliminary tests. The plant is the center of a ring whose outer bounds are the Marconi beam stations, a system which together covers 900 acres, and at which the whole Imperial wireless system centers.

The *Compañia Radio Chilena* has been licensed by the Chilean government to operate broadcasting stations at Santiago and at Concepcion. The stations will be ready for operation about June 1. That at Santiago, which will be rated at 1,500 watts, will broadcast on a 400 meter wave length, and will have the call letters CMAB.

The *Igranic Electric Company* of London, England, has secured an exclusive manufacturing license from the *Pacent Electric Company*, parts manufacturer, with offices at 91 Seventh Avenue, New York City.

Station WBZ, Boston, Broadcasts Farm Home Service Features

With the increasing appreciation of the educational value of radio to the farmer, broadcasting stations all over the country are giving more time and greater care and effort to programs which are put on the air for the benefit of rural communities. Now every Wednesday night from station WBZ, at Boston, Mass., Professor Monoham of Massachusetts Agricultural College conducts a forum at which answers to questions relating to poultry raising, crops, gardening, home economics and other subjects of interest to farmers, are broadcast.

Women's Club Card Party Broadcast

On Tuesday afternoon, January 26, proceedings of a card party attended by nearly two thousand club women of the United States, many of them of considerable prominence by reason of their philanthropic or social activities, were broadcast from station WRNY, the Hotel Roosevelt, New York City. The event was for the benefit of the City Federation Hotel for Working Girls of Small Wages, one of the most recent philanthropies undertaken by the organized women's clubs of the country. Mrs. Edgar Cecil Melledege, who planned and directed the event, is director of the regular women's club hour which is sent out over WRNY.

Increases Efficiency by Changing Transmitter Location

The removal of the transmitting instruments of station WRNY, the Hotel Roosevelt, New York City, from the eighteenth floor of the building to a location on the roof directly under the aerial has resulted in a power increase of about sixty per cent. Considerable power loss had resulted from the extremely long aerial lead-in necessary under the former arrangement, as well as from the location of the transmitter in a sort of pocket formed by the court of the hotel. Under the new arrangement reception in and about New York has been greatly improved, dead spots and areas of weak reception, which were formerly very numerous, having been largely eliminated.

KDKA's short-wave relay apparatus, utilizing the Piezo effect to overcome the slight frequency shifts, formerly the source of much annoyance, now links it together with three other Westinghouse broadcasting stations, KYW, Chicago, WBZ, Springfield, Mass., and KFKX, Hastings, Neb. The programs are broadcast from KDKA on a wave length of sixty-one meters, and re-broadcast from the several relay stations on their particular wave lengths. Music now goes on the air from the relay stations with as great clarity and as much volume as it does from its original source at Pittsburgh, greatly increasing the area of reception.

Radio Manufacturers' Association Extends Activities

The board of directors of the Radio Manufacturers' Association has approved a budget for 1926 which covers the maintenance of an executive secretaryship, an assistant secretaryship, and a director of publicity. The budget also allows for the establishment of permanent offices in Chicago, where the association now has its headquarters at 123 West Madison Street. B. W. Ruark has been appointed executive secretary, and Charles H. Porter, director of publicity.

The Utica Radio Association, Utica, N. Y., has been conducting a series of bi-monthly lectures for the purpose of educating its dealer members in the finer points of the technical side of radio as well as in better merchandising methods. At a recent meeting, a motion picture entitled "The Audion" was shown and explained by Emerson P. Peck, vice-president of the Utica Gas and Electric Company. Prentis Bailey, who presided, commended the lighting company, in the name of the association, for its educational efforts and for its actual work in eliminating interference noises.

The officers of the association are: *president*, M. H. Johnson, Johnson Electric Corporation; *vice-president*, Emerson P. Peck, *vice-president* Utica Gas and Electric Company; *secretary*, A. C. Stievater, Stievater Electric Company; *treasurer*, John F. Barnard.

The Stromberg-Carlson Telephone Manufacturing Company, Rochester, N. Y., announced at a stockholders' meeting on February 25 that it contemplates changing the capital stock of the company, consisting of 80,000 shares having a par value of \$25, to 320,000 shares having no par value. In other words, it is proposed that four shares of the new stock be issued for each one now held by stockholders. The board of directors announced that the year 1925 had been a particularly profitable one for the company and that stock was selling at \$100 or four times its par value. The company also announced that in addition to the completion of the second wing of the new plant, the foundation of which was laid last year, work will be started this spring on a fourth section.

The Los Angeles Radio Show for 1926 has been set for September 5 to 11, inclusive, it has been announced by A. G. Farquharson, secretary of the newly organized Radio Trades Association of Southern California. As last year, the show will be held in the Ambassador auditorium. Sunday, September 5, has been set aside as a preview for dealers.

J. Chester Johnson, for the past four years vice-president and general manager of the American Radio Exposition Company, has resigned to become associated with U. J. Herrmann and G. Clay-

ton Irwin, Jr., of the Radio Manufacturers' Show Association, whose next Radio World's Fair is scheduled to be held in New Madison Square Garden, New York, from September 13 to 18, inclusive. Mr. Johnson's efforts will be directed particularly toward the conduct of the New York show which is put on by this association.

The Lektophone Corporation, owner of the Hopkins and Farrand patents of the cone-type of radio speaker, announces that the Radio Corporation of America, has just purchased a perpetual license to use the Lektophone patents in the manufacture of cone-type speakers. Licenses to make cone-type speakers embodying Lektophone patents are also in possession of the following companies: Farrand Manufacturing Company, American Bosch Magneto Company, Pathe-Phonograph Company, Stromberg-Carlson Telephone Manufacturing Company, R. E. Thompson Company, J. S. Timmins, Inc. The inventor is Claire L. Farrand, president of the Farrand Manufacturing Company, whose patents on the cone speaker date back to 1918. The original patents for the diaphragm reproducer were filed in 1913 by Marcus C. Hopkins for use in talking machines. Five years later, Mr. Farrand perfected the device for radio reproduction.

Station WGY, the General Electric station at Schenectady, N. Y., is completing arrangements to broadcast programs in the cities of Rochester, Utica, Buffalo and Syracuse. Studios are being established in each city and the programs will be sent to the transmitting station at Schenectady by land wire. WGY is already sending out programs received by land wire from Washington, D. C., New York City, Albany and Poughkeepsie.

Jeremiah K. Cronin, general manager of the Haynes Griffin Radio Service, New York City, has resigned to take charge of the management and insurance department of Potter, Hamilton & Butler, realtors of 9 East Forty-seventh Street, New York City. Mr. Cronin was with the Haynes Griffin organization for more than two years and was responsible for many of its enterprising merchandising campaigns.

Guy H. Robinson, Crosley Radio Headquarters, has moved from 176 N. E. Thirty-ninth Street, Miami, Florida, to 709 N. E. First Avenue, and is putting in a line of household electrical appliances to supplement his radio sales.

The Magnavox Company of Oakland, Cal., has sold the title to its holdings on East Fourteenth Street, leasing occupancy of the buildings however, for a term of years. According to J. C. Sperry, Vice-President of the Company, this property was sold to the Montgomery-Ward Company as it is foreseen that this rapidly growing retail section of the city allows no space for eventual expansion.

The Heyer Products Company, manufacturer of radio accessories, announces the removal of its factory from Montclair, N. J., to larger quarters at 204-6-8 Sylvan Avenue, Newark, N. J. It is said that the new building which has an approximate floor space of 14,000 square feet will enable the company to triple its production under the personal supervision of the president, B. F. W. Heyer.

Electrad, Inc., parts manufacturer with offices at 428 Broadway, New York City, has announced a marketing policy for 1926 that provides for the selling of its products through the distributors only.



Bermuda in winter has much to recommend it over Boston. No wonder, then, that Frank S. Tower, president of the Tower Manufacturing Corporation, plays convoy to such a

smiling family, safely aboard the good (steam) ship Victoria whose port of call is the southern isle where Mr. Tower voyaged for the international broadcast tests.

Increase in Farm Profits Traceable to Radio

Reports from the middle western and Rocky Mountain agricultural districts indicate a growing dependence of the farmer on the services which radio renders him.

From numerous communications received by station KOA at Denver, Col., it is evident that considerable saving has been effected by the cattle men and ranchers in that part of the country by reason of the early arrival by radio of market and crop reports, preceding as they do the newspaper reports of price changes, which were formerly the farmer's guide.

Weather forecasts and warnings by radio likewise have increased greatly the security of ranching and stock raising. Forums identical in plan with those broadcast from other stations serving a rural population are conducted from KOA by George C. Wheeler, managing editor of *Western Farm Life*.

The Diamond State Fibre Company, manufacturer of Celeron and Diamond Fibre, Bridgeport, Pa., has placed C. M. Bogert in charge of the Connecticut territory with offices at South Norwalk, Conn., and W. R. Eisenhans has been transferred from the Bridgeport office to the district managership of Philadelphia, with offices in the Drexel Building.

Station KGW, operated by "The Morning Oregonian," Portland, Ore., is to be equipped with a 1,000-watt broadcasting plant, twice its present power. April 15 is the date set for the beginning of operation under increased power.

Atwater Kent sponsored on Sunday, February 14, the broadcasting of another of the Atwater Kent series of concert programs. The contributing artists on this occasion were Anna Case, leading American soprano, and John Corigliano, violinist.

The Storad Manufacturing Company, Cleveland, Ohio, has been formed by the reorganization of the former Cleveland Engineering Laboratories, Inc. A capital increase has been effected to finance the company's expansion program which takes in the construction of a plant to supply space for the production of the new Storad Automatic Power Supply Unit. The board of directors of the new company is made up of A. M. Baehr, W. K. Fleming, R. B. Clark, and F. J. McDonald.

The Eagle Radio Company, Boyden Place, Newark, N. J., has added to its personnel John J. Kuscher, who is touring the southern states demonstrating Eagle Neutrodyne sets.

Eric H. Palmer of the Freed-Eisemann Radio Corporation, Brooklyn, New York, who has been in Europe as observer during the period of the international broadcast tests, returned to New York on the French liner *Savoie* on Friday, February 6. Besides observing the results of the international tests

while he was abroad, Mr. Palmer visited London, Paris, Geneva, and other important centers where he made a general survey of radio conditions.

The Northwest Radio Trade Association will hold its Fifth Annual Radio Show in Minneapolis, Minn., the week of Sept. 27. Space and booths had been prepared for 160 exhibits, over one hundred of which have been taken by manufacturers and local jobbers.

The Carl A. Stone Company, factory representatives, formerly located at 429 Insurance Exchange Building, has moved its offices to 1050 So. Los Angeles Street, Los Angeles, Cal. The new quarters of the company are larger and are located in the wholesale district of the city.



We have often heard of the street car motorman who spent his entire vacation riding on trolleys. Here we have another instance of a man in love with his work. In this case it is E. T. Cunningham, president of E. T. Cunningham & Company of San Francisco. Mr. Cunningham is evidently delving into the mysteries of why a variometer "various."

The Main Auto Supply Company, Ft. Wayne, Ind., dealers in automobile supplies and radio equipment, has opened a broadcasting station over which a varied program of popular and classical music is given. The station is on the air every Monday and Wednesday night, and every Tuesday, Wednesday, Thursday and Friday from twelve o'clock noon to one P.M. for a musical hour.

The Federal Radio Corporation, Buffalo, N. Y., has announced the appointments of the Salt Lake Hardware Company of Salt Lake City, Utah, and the Southern Radio Company of Jacksonville, Fla., as Federal wholesalers for their respective districts.

The Gibraltar Mercantile Adjustment Company, 220 West Forty-second Street, New York City, has organized the Radio Board of Trade as a branch of its collection and credit reporting service to perform these functions for the radio industry. Edward Salsburg and Alexander M. Leslie, both experienced in the radio field, are the executives of the board.

The New York Edison Company held its third annual radio show during the

first week in February at its show rooms at Irving Place and Fifteenth Street, New York City. Public interest in long distance radio reception, considerably increased by the international broadcasting tests made during the closing week of January, prompted the New York Edison Company to feature six- and eight-tube super-heterodyne receivers.

The Southwest General Electric Company has appointed F. A. Snyder as head of the radio division with headquarters in Dallas, Texas. This firm acts as distributor for the Radio Corporation of America, and carries warehouse stocks in Dallas and Houston, Texas, and in Tulsa and Oklahoma City, Okla.

The Vincennes Phonograph Company of Vincennes, Ind., has been merged with the Radio Industries Corporation by interests that have for some time been in control of the former firm. The new company will retain the name Radio Industries Corporation and engage in the manufacture of receiving sets under the trade name Rivoli. Scott and Keane, New York, will handle sales and promotion for the new company. Officers of the firm are J. S. Watters of Vincennes, president, Irwin Kreiger, vice-president, and S. B. Fleming, treasurer.

The Fromar Company, Atwater Kent distributor in central Pennsylvania, will entertain its dealers on March 1 at the Penn Harris Hotel, Harrisburg, Pa. Interesting subjects will be discussed by factory men from the Atwater Kent plant and from the plants of a number of other standard manufacturers whose products are distributed by Troy B. Wildermuth and his concern, The Fromar Company.

The L. A. Lutz Company, Inc., electrical distributor and jobber of Mahanoy City, Pa., was host at a dinner on Saturday, January 23, to its employees and business associates. The occasion was to mark the opening of the firm's new, modern, fire-proof building.

F. A. D. Andrea, Inc., of New York, has given notice of the departure of H. P. Zopf for Lima, Peru, where he expects to establish a number of Fada agencies. Mr. Zopf had just returned from a similar errand in Mexico and the West Indies. This trip will be more extended, however, and will take him to Chile, Bolivia, Uruguay, Brazil, and Venezuela, as well as to Peru.

The Connewey Electric Laboratories of Hoboken, N. J., manufacturer of Magnatrons vacuum tubes, has appointed Leo Friedman sales manager of the New York district.

Otto Martini, former purchasing agent for the Freed-Eisemann Radio Corporation, Brooklyn, is now with the R. E. Thompson Manufacturing Company, 30 Church St., New York City, as General Manager. The Thompson Manufacturing Company is shortly to move its plant from the location at 66 York Street, Jersey City, N. J., to a new site in Poughkeepsie, N. Y. The New York office will be retained.



The Crosley 4-tube—4-29
in which the Crescendon is equal to one or more additional tubes of tuned radio frequency amplification . . . **\$29**



The Crescendon
—an amazing new volume control exclusive to Crosley sets. Hear it!

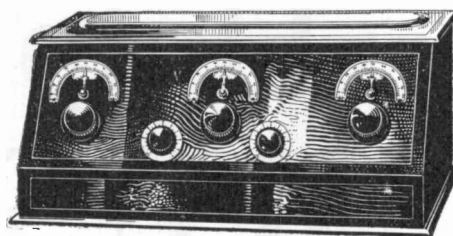

The Crosley 5-tube—5-38
All the volume, selectivity and purity of tone available in the best 5-tube set—plus the Crescendon . . . **\$38**

Widespread Popularity Marks Another Great Success

Spectacular as has been each stride in radio achieved by Powel Crosley, Jr., never before has a Crosley success received such prompt and widespread recognition. Here in the radio plant which has made more radios than any other factory in all the world, every man and machine is going at top speed, every hour is a crowded hour, every night a working day, as the result of orders for the four new Crosley sets.

Even the sweeping success of the Crosley Musicone did not match this merciless demand upon an organization tuned to mass production. With the first demonstrations by Crosley dealers, public approval was expressed in orders that have increased in volume day by day and show no inclination to relax.

This popularity is distributed quite evenly between the four new 4- and 5-tube sets. Thousands who had formerly believed that

worth while reception was exclusive to high priced sets, have found in Crosley 4-29 and 5-38 all that they could ask of radio. The accurate selectivity and pure tone of these instruments would be enough. That magnificent volume achieved through the *Crescendon* is the final touch.

And in Crosley "RFL" types there is a revelation for all. For here true cascade amplification makes its first appearance. Here what was considered *impossible* in expert opinion has been achieved by amplification closely approaching theoretical maximum efficiency per tube!

What a joy to find, and in a low priced set, rare beauty, rich tone, volume subject only to your desire, and no howling at any pitch by any mishandling under any conditions.

Each instrument delights the ear, fires the enthusiasm of the lay technician, converts the staunchest skeptic to love of radio.

If you are a radio dealer—you owe it to yourself to write Dept. 130 for complete details of Powel Crosley, Jr.'s latest and greatest triumph and of the Crosley dealer franchise.

Crosley manufactures radio receiving sets which are licensed under Armstrong U. S. Patent No. 1,113,149, or under patent applications of Radio Frequency Laboratories, Inc.

THE CROSLLEY RADIO CORPORATION, CINCINNATI, OHIO

Powel Crosley, Jr., President

Owning and Operating WLW, first remote control super-power broadcasting station in America



The Crosley 5-tube—RFL-60
A set of marvelous performance and beautified by the artistic decorative panel **\$60**

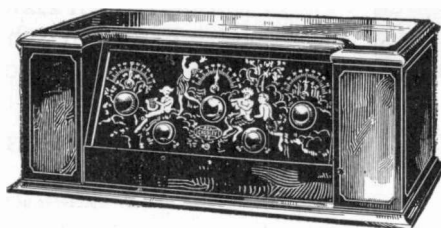

The Crosley 5-tube—RFL-75
Simplicity and speed in tuning, fidelity of tone and decorative beauty, enhanced by the art panel **\$75**

Add 10% to all prices west of the Rockies

CROSLLEY RADIO

BETTER—COSTS LESS

FOR THE ENTERTAINMENT CORNER

Help him get RESULTS

*That's the quickest way to turn
a casual purchaser into a
steady customer*

RADIO owners are after results. Most of them know little about the technical details of their sets—and they care less!

So, if you sell the customer radio parts that *do* give results, and do *not* give trouble, you gain his confidence and, naturally, his steady trade.

That is why radio dealers find the Exide line so profitable. Exide Radio Batteries always deliver the goods—a steady, powerful flow of current so necessary for clear reception. Their dependability and long life often form the basis of lasting customer good-will.

Exide Radio Batteries sell easily. People like to buy something they know. There are few people who *do not* know the Exide name, either from the prominent national advertising or from actual experience with these batteries in the many other fields where Exide has established a reputation for reliability.

There is an Exide Battery for every type of radio set. Build up the customer's confidence in your judgment by recommending the Exide best suited to his needs.

THE ELECTRIC STORAGE BATTERY COMPANY
PHILADELPHIA

Exide Batteries of Canada, Limited, 153 Dufferin Street, Toronto

Exide

RADIO BATTERIES



6-VOLT "A" BATTERY
The rugged, good-looking Exide 6-Volt "A" Battery, in the one-piece case.



4-VOLT "A" BATTERY
Compact Exide "A" Battery for low-voltage tubes. Also made in 2-volt size.



RECTIFIER
Exide Rectifier for economically recharging "B" Battery from your own house current.

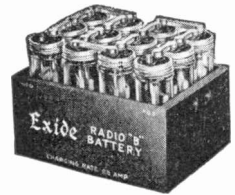

24-VOLT "B" BATTERY
In Glass cells, 6000 milliamperere hour capacity. Also made in 48-volt size.

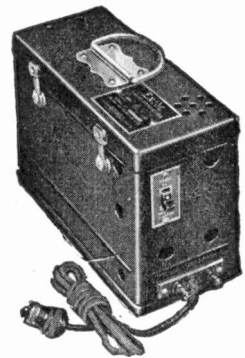

EXIDE RADIO POWER UNIT
(Combination "A" Battery and Charger.) To be kept connected to both light socket and radio set. When switch is raised, radio set is connected, when lowered, battery is automatically placed on charge. Made in two sizes—for sets using 4-volt and 6-volt tubes.

FOR BETTER RADIO RECEPTION, USE STORAGE BATTERIES

Live sellers right now!

These exclusive features mean new big sales—

Radio storage batteries with these new and exclusive features are bound to attract a lot of favorable attention and stimulate battery sales immediately.

The dealers who display them now will benefit first and most, of course.

These storage batteries have been tested and endorsed by many of the leading technical experts. Due to their construction they cannot short-circuit, shed material nor buckle. They are unconditionally guaranteed for one year.

This battery is 4 volts, 12,000 MA for UV 199 tubes. Lists at \$4.00.



The Wonder Cell. This battery replaces the dry cell. Is 2 volts, 12,000 MA. Lists at \$1.50.



This battery is 6 volts for UV 201A for one and two tube sets. Can also be used for larger sets if a turtle charger is used. List at \$4.50.

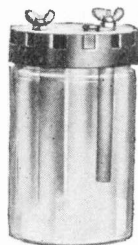
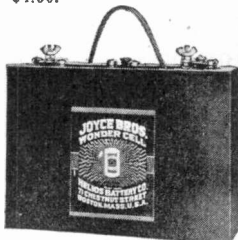

This charger recharges all type "B" Batteries. Lists at \$2.00.

Introductory offer to dealers— 50% discount

Buy your sample order from us. Buy your stock order from your jobber.

The Joyce Bros. Wonder Cell has been patented in America and Europe.

*Distributors, Jobbers, Dealers
Write for details.*

Factory Representatives of Joyce Bros. Products:

Wm. H. Kreeb, 2505 Union Central Bldg., Cincinnati, Ohio. Leonard C. Kohn-Noah Co., 917 Phoenix Bldg., Minneapolis, Minn., Leonard-Kohn Co., 625 Security Bldg., Omaha, Neb. Strimple & Gillette, 169 Jackson Street, Seattle, Wash. Strimple & Gillette, Corbett Bldg., Portland, Oregon. Stephen Brown, Ft. Smith, Arkansas, Park Co., 128 No. Wells St., Chicago, Ill. William Reed Sales Co., 308 E. 17th St., Kansas City, Missouri. L. C. Kohn-Noah Co., 801 Somerset Building, Winnipeg, Canada. I. D. Livingston, 1529 Hutchinson St., Montreal, Canada.

New Joyce Products!

Wonder Cell Filter Circuit

Can be used in conjunction with Bakelite, Tungar, and Rectigon Chargers from 2½ amp. to 5 amps. capacity.

Designed for use with any of the standard rectifiers and smooths out the rectifier current and therefore allows the operation of radio tubes direct from lighting circuit without any humming noises. Approximate dimensions 6½ x 7½ high. Solves the problem of electric radio. List \$19.00.



Trickle Charger

Full Wave Trickle Chargers for charging Joyce Bros. Wonder Cells or other low capacity storage batteries. Can be hooked up to the electric light socket while set is in operation. List \$10.00

Joyce Bros. A Eliminator

Noiseless, Humless, Simple—attach to electric light socket and forget about it. Runs Radio Sets 4 to 12 tubes. Inexpensive to operate. It is the last word in Radio Electric Sets. Made to fit all type sets. List \$40.00.

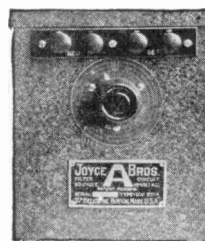

Joyce Bros. Power Unit Type U V 201 A & U V 199

Hooks up to light socket and electrifies your set. Simple, Noiseless and neat. No fuss. No recharging. Simply turn switch. List \$19.50.

JOYCE BROS.

71 Chestnut St., Boston, Mass., U. S. A.

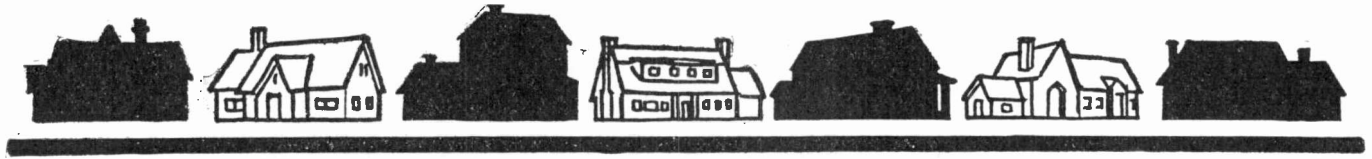

Every other home

*Most of them
want radio, too*

THIRTEEN million phonograph owners—that is the market for the new Magnavox receiver unit listing at \$75 (without accessories) and the Magnavox radio-phonograph reproducer listing at \$12.50.

Not only does this unit offer a ready-made market but it can be sold in combination with new phonographs.

It is the one effective answer to the question of trade-ins of phonographs on radio sets. Advertising of it is being broadcast through widely-circulating newspapers in the leading cities of the country.

Magnavox receiver unit is a standard new Magnavox 5 tube circuit encased in a mahogany drawer. It is easily installed in the record compartment.

Write or wire us or our nearest distributor for full information at once.

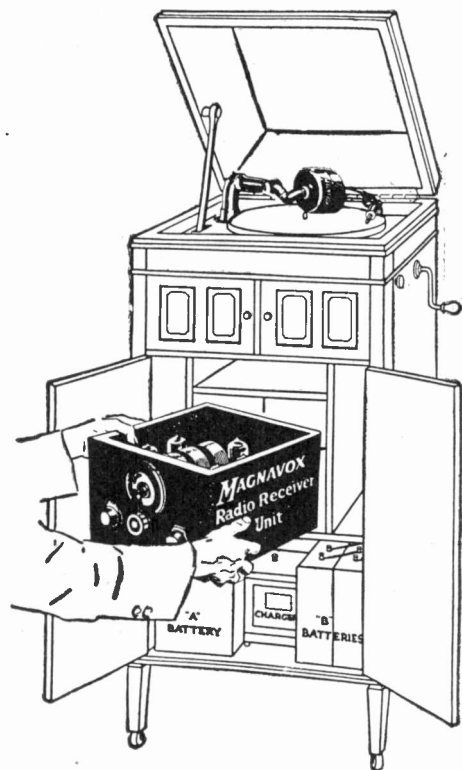

A Spring and Summer Seller

MAGNAVOX sets range in price from \$85 to \$200. They are all of one quality standard. The finest we know how to produce. Operating mechanism of all sets is identically the same. The Magnavox Junior, for instance, gives a quality of reception expected only in high priced sets. It is small, unobtrusive and easily portable. It will have a wide sale as a set for summer seashore and mountain homes.

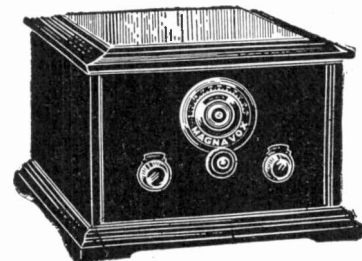

Magnavox Junior—the popular member of the Magnavox line—List \$85



has a phonograph



*Magnavox—first
to perfect single
dial control*

THE radio world is definitely headed toward single dial control. Magnavox pioneered the first successful single dial and still leads the way in its perfection.

Radio has passed beyond the mechanical novelty stage. The public interest is now centered solely in results and appearance, with simple operation as a prime essential. Single dial control makes the Magnavox as easy to operate as a phonograph. Follow the lines of least resistance, anticipate the demands of the future—sell single dial radio—but sell a *dependable* one, Magnavox.

The Magnavox Company

1315 SOUTH MICHIGAN AVE., CHICAGO
OAKLAND, CALIFORNIA

In the radio business since 1911

MAGNAVOX
Radio Sets • Speakers • Tubes

©1926

SPRING
is the same as Fall
with the
Farrand Speaker

YOUR receiver business may be seasonal, but here is a profit-making item that moves day after day, month after month—right through the year. Everybody—all the time—is seeking to improve their reception. The Farrand Speaker is answering this unceasing demand everywhere.

Are
YOU cashing
in?

FARRAND MFG. CO., INC., LONG ISLAND CITY, N. Y.

A WARNING!

to all *Manufacturers, Distributors*
and *Retailers of*

CONE TYPE SPEAKERS

embodying the basic features of the Lektophone Patents

The LEKTOPHONE CORPORATION

Announces that *none* but the following manufacturers are licensed to make cone type radio speakers under its patents Nos. 1,271,527, 1,271,528, and 1,271,529, of July 2, 1918, and other applications:

American Bosch Magneto Corp.
Springfield, Mass.

Farrand Manufacturing Co., Inc.
Long Island City, N.Y.

Pathe Phonograph & Radio Corp.
Brooklyn, N.Y.

Radio Corporation of America
New York City

Radio Foundation, Inc.
New York City

Stromberg-Carlson Telephone
Manufacturing Co.
Rochester, N.Y.

R. E. Thompson Mfg. Co.
Jersey City, N. J.

J. S. Timmons, Inc.
Philadelphia, Pa.

Titanafram Corp.
Jersey City, N. J.

The acknowledged leadership of the cone type speaker over all other types of radio reproducers, and its ever increasing popular demand, has led to the appearance on the market of a number of speakers which infringe upon the Lektophone Corporation patents.

The Lektophone Corporation intends to protect its licensees.

Warning is hereby given that the Lektophone Corporation will prosecute to the full extent of the law, not only manufacturers of, but also distributors and retailers who deal in radio speakers infringing its patents.

The LEKTOPHONE CORPORATION
15 EXCHANGE PLACE, JERSEY CITY, N. J.

Every Set You've Sold Needs UX POWER TUBES

Na-Ald Adapters eliminate rewiring and make winning this profitable market easy

Every set owner wants the increased clarity and volume of UX Power Tubes

HERE is a market ready made for you with a good sized unit sale and a good profit—a profit from tubes—batteries—and from the Na-Ald Adapters and Connectoralds.

See these unit sales possibilities listed below

- For owners of all storage battery sets, Neutrodyne, tuned audio frequency, regenerative, and so forth, sell—

1 UX-112 Tube.....	\$6.50
1 Na-Ald 112 Connectorald.....	1.25
1 B Battery—45 volts.....	3.75
2 C Batteries—4½ volts.....	1.00
Total.....	\$12.50

- For storage battery set owners that want dry battery operation, sell—

4 UV-199 Tubes.....	\$10.00
4 Na-Ald 429 Adapters.....	3.00
Or	
4 UX-199 Tubes.....	10.00
4 Na-Ald 419 Adapters.....	1.40
And	
1 Na-Ald 120 Connectorald.....	1.25
1 UX-120 Tube.....	2.50
1 B Battery—45 volts.....	3.75
1 C Battery—22½ volts.....	1.75
6 Dry cell Batteries.....	2.70
Total.....	\$24.95 or \$23.35

- For owners of Radiola IIIA, sell—

1 UX-199 Tube.....	\$2.50
3 UX-120 Tubes.....	7.50
4 Na-Ald 421-X Adapters.....	3.00
1 10 Ohm Rheostat.....	.60
1 B Battery—45 volts.....	3.75
1 C Battery—22½ volts.....	1.75
Total.....	\$19.10

Other Combinations Possible

- For Radiola superheterodyne semi-portable and for Radiola Super VIII, sell—

1 UX-120 Tube.....	\$2.50
1 Na-Ald 420 Connectorald.....	1.25
1 B Battery—45 volts.....	3.75
1 C Battery—22½ volts.....	1.75
Total.....	\$9.25

- For Radiola superheterodyne portable No. 26 and other dry battery operated sets, sell—

1 UX-120 Tube.....	\$2.50
1 Na-Ald Connectorald 920.....	1.25
1 B Battery—45 volts.....	3.75
1 C Battery—22½ volts.....	1.75
Total.....	\$9.25

ALDEN MANUFACTURING COMPANY

Dept. A 14,
Springfield, Mass.

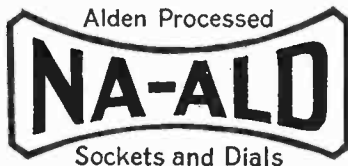

Also Makers of Famous Na-Ald Sockets and Dials

Alden Manufacturing Co.,
Dept., A 14, Springfield, Mass.

Send me complete information on Na-Ald Adapters and Connectoralds.

Name.....

Firm.....

Street.....

City..... State.....

My jobber is.....

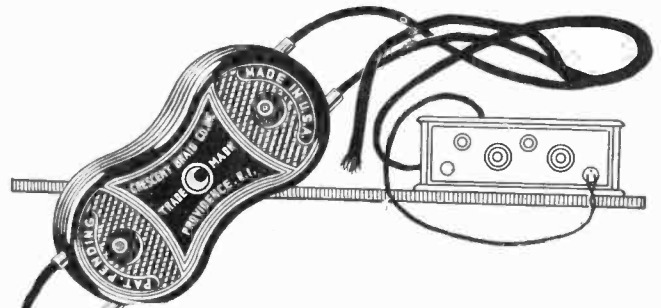

Premier 20ft. Extension Cord

A big demand—a good profit—an all year 'round seller which is bought and used every month in the year.

It enables the user to place his loud speaker in any room.

LIST PRICES—
with Splendid Discounts

\$1.00 for Premier Jr., with connector plug. (Premier Jr. is a serviceable light weight cord.)

\$1.75 for Premier Sr., with connector, beautiful combination of black and gold cord. Also a display card of unusual design for window and counter display.

Premier Jr. in longer lengths—25 ft., \$1.50; 35 ft., \$1.75; 50 ft., \$2.00.

Nationally advertised, yet competing with unknown cords in price and far ahead in quality, packing and service as well as dependability.

Premier Battery Cables
Compete in price—Far ahead in quality.

\$1.00 with clips for "A" storage batteries and lugs for "B" batteries.

75c. with lugs for "A" dry batteries and lugs for "B" batteries.

60c. with leaded terminals for convenient connections everywhere. One to a box and 12 in a counter display carton.

Also 5 wire cable in 100-ft. lengths—10c. per ft. list.

If your jobber should be out of Premier Products tell us. We will have you supplied in 24 hours through our nearest and most convenient distributor.

Crescent Braid Co., Inc. Providence, Rhode Island

Makers of Extension Cords, Battery Cables and Phone Cords for headsets and loud speakers.

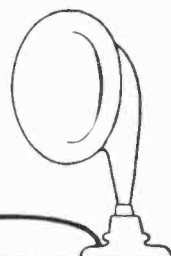

GENERAL RADIO

INSTRUMENTS
for the Scientist or Set-BUILDER

are
the

UNIVERSAL
Standards of Precision

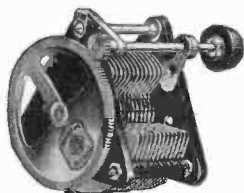

Type 247-H
Geared Condenser
Price \$5.00

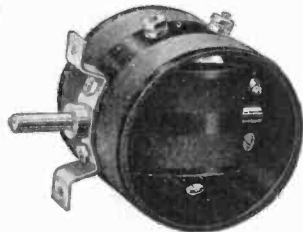

Type 268
Vario-Coupler
Price \$2.75



Type 277-D
Coupling Coil
Price \$1.50



For over a decade General Radio instruments have been universally recognized as the standards of excellence.

They are manufactured by a company which has contributed more laboratory equipment for radio research than any other one company in the history of radio. Nearly all the leading commercial and technical school laboratories throughout the world are equipped with General Radio scientific apparatus.

The same outstanding craftsmanship and materials are embodied in all General Radio parts for use in the construction of broadcast receivers.

Through the merits of design, performance, and price General Radio instruments for the scientist or set-builder are the accepted standards of quality.

Write for our latest catalog 924-R

GENERAL RADIO Co
Cambridge 39,
Mass. U.S.A.



Type 285
Audio Transformer
Price \$6.00



Type 301
Rheostat
Price \$1.25



Type 349
Ux-Tube Socket
Price 50c.

Behind the Panels of Better Built Sets

The New Battery **TITAN**



*Leads
a
Double
Life*

*"Two birds with one stone"
"Two markets with one battery"*

Here's a new appeal that you can make to battery prospects. A combination Radio "A" battery and a Ford battery — all for the price of one.

That's the new Titan 3-R F 11 Battery. An ideal six volt radio "A" battery — 120 amp. hours. Plenty of capacity as a Ford starting and lighting battery. Eleven plates per cell. Rubber case, heavy connectors between cells. Long life because assembled with heavy automobile starting and lighting battery plates.

Titan Radio A-Type R. S. Designed especially for radio service only. 6 volts—rubber case. Sizes 80 to 140 amps.

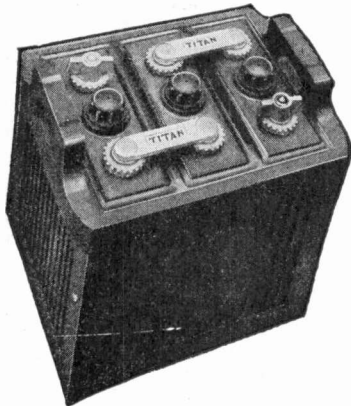

Dealers: Write for our unusual dealer plan, long profits, quick sales, satisfied customers.

GENERAL LEAD BATTERIES COMPANY

2 LISTER AVE.

NEWARK, N. J.

The Home
of TITAN Batteries

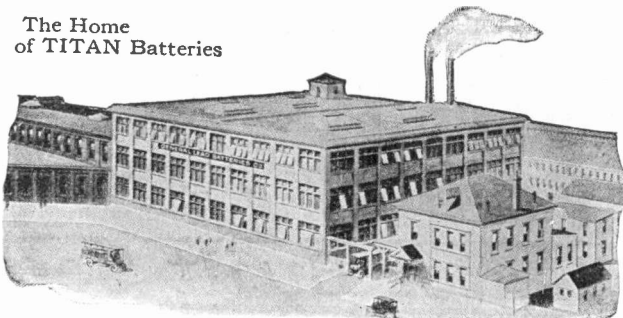

HARTUNG CLIPS

*Continuous Circuit
-Bulldog Grip*



Your Penknife Proves It's Tough!

Take your penknife and cut off a shaving of the lead coating on a Hartung clip. Watch it peel off in a clean, unbroken strip. Compare this tough lead shaving with the brittle fragments you get from ordinary lead coating.

The toughness of this lead skin protects Hartung clips from the ravages of acid and makes them last twice as long as ordinary clips. They have a strong, positive grip, too, and are easy to handle. Send the coupon for your free sample today!

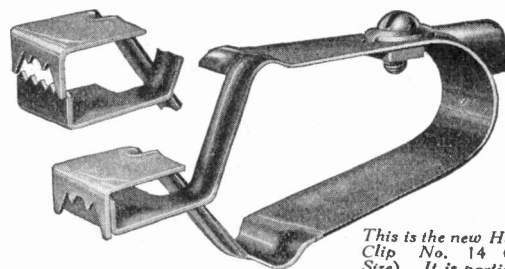

This is the new Hartung Clip No. 14 (actual Size). It is particularly suited to A and B battery charging.

Clip and mail coupon now!

Charles F. Hartung Co.
730 61st St. East, Los Angeles, Calif.

Gentlemen:

Please send me free sample of the new Hartung Clip No. 14. Send also description of your new full line of clips for battery, testing and radio work, and price list.

My jobber on clips is.....

Name.....

Address.....

City..... State.....

Join the leaders at RADIO CENTER!

Radio Center is *the* big move of the year in radio—"The one thing the industry needs most, we're strong for it"—that's the comment of radio leaders all over the country who are reserving space at Radio Center for the permanent display of their complete lines.

Occupying two floors of more than twenty thousand square feet in the famous Bush Building, New York City—in the heart of the world's greatest radio market—Radio Center enjoys the great advantage of a location where remarkable clarity of reception can be had from any of the well-known broadcasting stations.

It is directed by men of wide experience in co-operative merchandising—it is backed by large financial resources—it provides sound-proof offices and demonstration rooms of special construction where radio manufacturers and distributors can enjoy year-round sales facilities of unusual attractiveness.

Progressive radio men everywhere have been quick to grasp this chance—space at Radio Center is being reserved by telegram, by telephone, by letter and in person.

This real opportunity calls for action *now*—don't delay—there is less space available every day—call in person if possible—or wire for space reservations.

RADIO CENTER, INC.

S. HERBERT MAPES, President
Bush Building
130 West Forty-Second Street
New York City

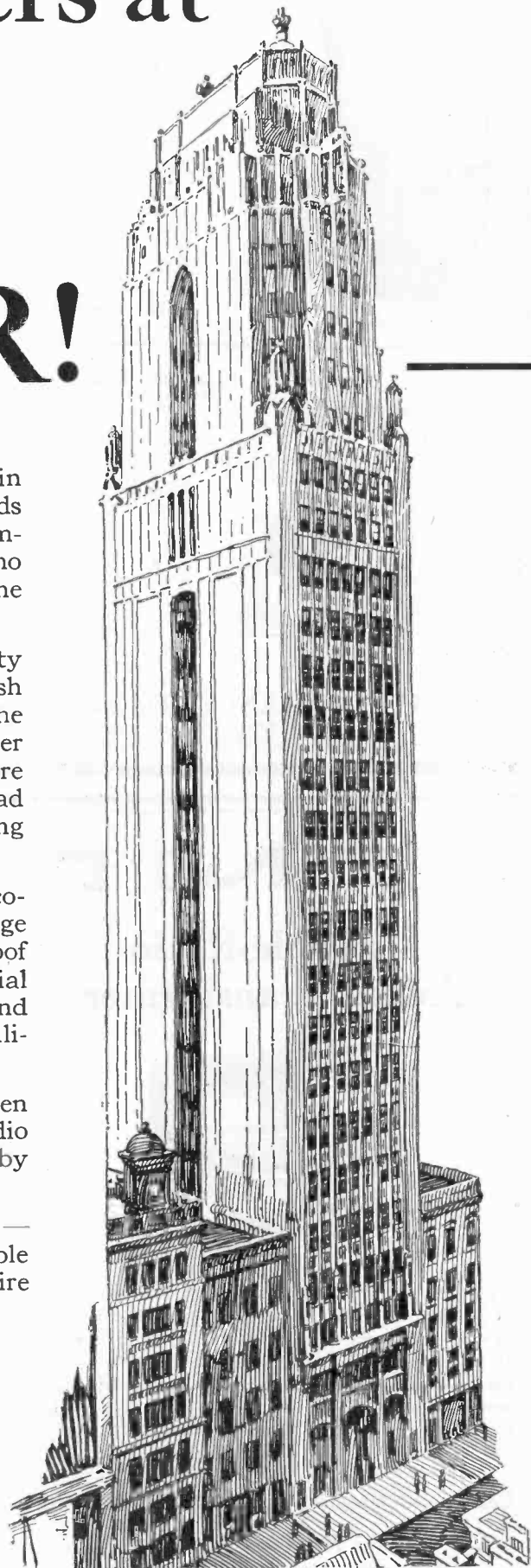



Patents Pending

Tests 3 tubes a minute without error—without calculation!

THE SUPERADIO VACUUM TUBE DYNAMOMETER

What the Dynamometer test does for you!

1. Tells whether tube is a good R. F. Amplifier, A. F. Amplifier or Detector and how good.
2. Tubes may be matched.
3. Measures the performance of the tube.
4. Gives definite measure of the power of the tube.
5. Tells whether or not tubes should be reactivated.
6. Discloses tubes that have been operated with excessive filament voltages.
7. Tells if tubes have been roughly handled.
8. Compares tubes of different manufacturers.
9. Gives Relative Efficiency of any number of tubes.

The following defects in manufacture may be disclosed:

10. Tells if grid is exercising proper control of plate current.
11. Under ageing.
12. Poor filament wire.
13. Low Vacuum.
14. Improper size of tube element.
15. Improperly spaced elements.

The amplification constant, Plate Impedance and Mutual Conductance are obtained directly without calculation.

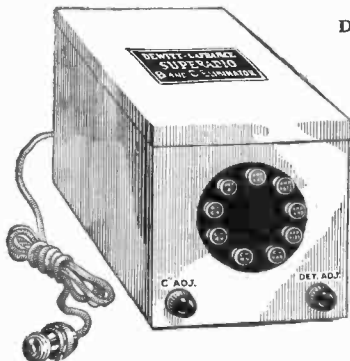

Dependable "B" and "C" Battery Eliminators

Type A Operates ANY type of Receiver at maximum efficiency as well as the new power tubes UX120 and UX112. The Superadio delivers higher voltages and heavier current continuously. Type A is provided with five "B" Taps as follows: precision adjustment of detector voltage variable, 4 to 35 v.; Amp.—45 v.; Amp.—67 1/2 v.; Amp.—90 v.; Amp.—135 v. Three "C" Taps—4 1/2 v., 9 v., and 4-40 v. variable—are available so that the new power tubes may be used at their efficient points. Price \$42.00.

Type B is provided with B taps 90 v., 67 1/2 v., 45 v. and 22 1/2 v. variable. Price \$35.00.

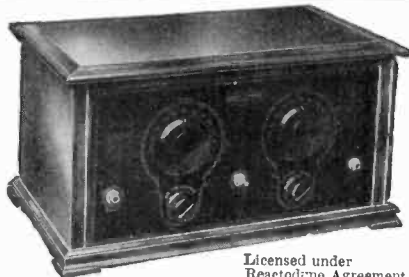

5-Tube Receiver of Advanced Design

Superior engineering has produced this Receiver in which finest results are uniformly obtained. Only 2 dials to tune. Matchless Tone Quality. Price \$56. Low-loss straight-line frequency condensers.

Licensed under Reacto:ne Agreement

Write today for further details on Superadio Products—the result of scientific design and modern production methods.

DEWITT LAFRANCE CO., North Cambridge, Mass.

BOSTON REPRESENTATIVE: Martin, Hartley & DeWitt Sales Co., 99 Bedford St.
CHICAGO REPRESENTATIVE: William A. Welty & Co., 36 So. State St.

COMO

Variable-Ratio Audio-Transformer



This new unit, made by a pioneer manufacturer of high-grade Radio equipment, gives three ratios in one transformer—4 to 1, 6 to 1, and 8 to 1. It permits varying primary impedance to secure the best results in each stage of audio. It may be used as a high-grade impedance in impedance-coupled audio.

Price \$6.00

Dealers and Jobbers write us for full particulars.

COMO APPARATUS CO., Inc.
Kelley St., MANCHESTER, N. H.

Every No. 20 Compact Owner A Prospect for the Console Compact

\$60 LIST

Finished in the very popular Huguenot Walnut

Height 42 in.
Depth 13 in.
Width 26 in.

All wood horn of beautiful tone.



Atwater Kent Dealers:

The new No. 30 Atwater Kent can also be installed in the Console Compact.

Order a Console Compact Today and see how easily it sells.

Liberal Discounts

CRESCENT CHAIR COMPANY
PLYMOUTH, WISCONSIN



This window increased sales

"THIS display created considerable attention, not to mention sales that would not have been made otherwise," says Mr. H. A. Carter, of A. R. Wilson & Co., Ottawa, Ill. See how simple this window is, how easy to do, how dignified. An assortment of Eveready Radio Batteries and display material, two radio sets, three loud speakers, and the window is complete. In it,

the name of the shop and the name Eveready reinforce each other. To the reputation of the store is added that of Eveready Radio Batteries. Such teamwork is mighty profitable. It creates battery and set sales. Order Eveready Radio Batteries from your jobber.

Manufactured and guaranteed by

NATIONAL CARBON COMPANY, INC.
 New York San Francisco
 Atlanta Chicago Dallas Kansas City Pittsburgh
 Canadian National Carbon Co., Limited, Toronto, Ontario

EVEREADY
Radio Batteries
-they last longer

RADIO PEP

B-BATTERY ELIMINATOR

NO TUBES

NO HUM



Buy no more B-batteries!

USE the unlimited supply of cheap, dependable electricity right at hand in your house-lighting circuit.

This can be done with permanent satisfaction with RADIO PEP.

RADIO PEP is the FIRST eliminator to completely solve the problem, as it is the only one made with EIGHT PERFECTED ELECTROLYTIC CELLS, replacing tubes and doing away with all the familiar tube troubles.

Two or four cells overloaded will not give PERMANENCE and POWER—the outstanding characteristics of RADIO PEP.

135 VOLTS are called for by the modern sets and tubes; here you get it year after year without weakening.

For 110-125-volt, 60-cycle alternating current.

Send for particulars and name of our nearest distributor. Price \$38. Money-back guarantee.

PEP MFG. CO., Inc.

33 W. 42nd St.

New York

No Salesmen—No jobbers!



You can buy Aladdin tubes direct from the factory to list at

\$1 (with a good profit for you)

ALADDIN

Type 201-A

"A tube of tubes"

Amplifier and Detector

These are standard tubes. Perfect tubes backed by an iron clad guarantee. They are not seconds.

We have eliminated the usual wasteful distributing methods, thereby affecting an amazing reduction in selling expense.

Try these good tubes. Put them to the test. To offer your trade such a tube at this price is the best kind of merchandising. It is good advertising. Good selling strategy which attracts new people to your store.

Take advantage of the introductory offer below. Mail your order today.

ALADDIN MFG. CO.
55 Hoyt St., Newark, N. J.

Special Offer to dealers only

Standard 201A sold in 1 doz. lots, \$12.00 per doz., less 30% discount, \$8.40 net.

Get 2 Profits Instead of 1

When a Customer buys a WIRT LIGHTNING ARRESTER

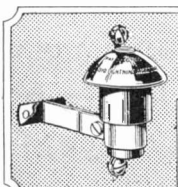

—sell him also a WIRT INSULATOR

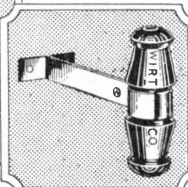

The WIRT Lightning Arrester

is the improved air-gap type.

Listed as Standard by Underwriters Laboratories

The protection is absolute. Made of bakelite, with bakelite "petticoat" which keeps out rain and dust. Brass terminals moulded in bakelite are far enough apart so that there is no leakage. Lasts a lifetime. Sells easily.

WIRT INSULATOR should be installed at the same time. ANOTHER SALE—ANOTHER PROFIT. Push them both.

Wirt Lightning Arrester.....\$1.00
Wirt Insulator......35

The Wirt Lightning Arrester is Listed as Standard by Underwriters Laboratories

WIRT COMPANY
PHILADELPHIA, PENNSYLVANIA
MAKERS OF DIM-A-LITE

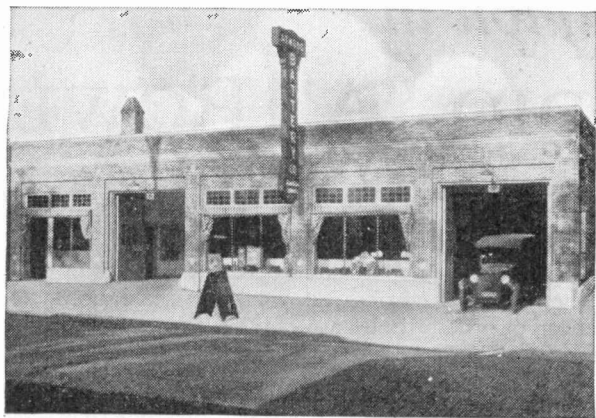

This Company reports
**a wonderful year's
 business with Prest-O-Lite
 Radio Batteries**

THE following letter from the president of the Atwood Battery Company, of Toledo, Ohio, is typical of the success that our dealers everywhere are having with Prest-O-Lite Radio Batteries.

Mr. Ertel writes as follows:

"At the start of this year's radio season I was a little in doubt as to the number of radio batteries I would be able to sell, due to the fact that there were so many very low-priced batteries on the market.

"However, my sales on Prest-O-Lite 'A' Batteries have been averaging several hundred batteries each month and there seems to be no let-up in this business.

"I am most certainly sold on the fine appearance and the high quality of this battery and the results have shown me that quality and service lead.

"Will say that I have had the largest year in the history of my business in all classes of batteries."

(Signed) C. J. ERTEL, *President and Manager*

Letters like this prove conclusively that Prest-O-Lite Radio Batteries are right in themselves, that they are priced right and that the national advertising and merchandising plans back of them are right.

Write us today about the details of our attractive, business-producing dealer proposition. It will increase your business and your profits. Send for it now.

THE PREST-O-LITE CO., INC.
 INDIANAPOLIS, IND.

New York San Francisco
 In Canada: Prest-O-Lite Company of Canada, Ltd., Toronto, Ontario



Prest-O-Lite



**8 out of 10
 Manufacturers
 Know EBY Quality**

The chances are that the receivers you are selling in your store are equipped with Eby Binding Posts. Eight out of ten of the leading radio manufacturers use Eby Binding Posts as standard equipment in their receivers.

National advertising, since the beginning of radio, in the leading radio magazines has been consistently broadcasting the Eby story of quality and service.

Your customers know Eby and your jobber has all of the twenty-seven different markings.



**List Price
 15c.**

**And Now
 The EBY Socket**

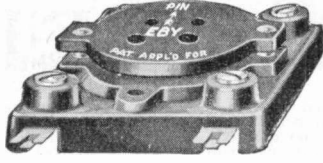

**List Price
 60c.**

The new Eby Quality Socket insures a positive wiping contact at all times. Its ingenious design allows the tube to "float" when in service, thereby reducing microphonic noises and protecting the tube against damage. It also permits interchangeability and other features of the new UX and CX tubes.

Eby Quality Sockets Come Packaged in Convenient Cartons of 10.

If your jobber can't accommodate you—Write to us

**H. H. EBY MFG. COMPANY
 4710 Stenton Ave., PHILADELPHIA, PA.**

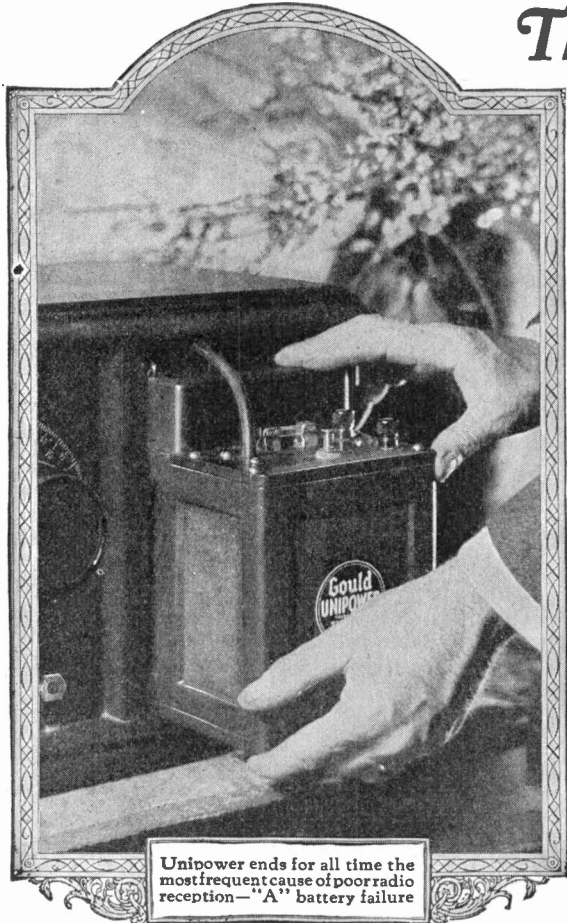

This triumph in RADIO "A" POWER is a sensation in radio sales

DEALERS everywhere are repeating on Unipower. The Gould factories are working extra hours to keep ahead of orders. Sales are climbing even faster than they did in 1925.

If you don't know all about Unipower—ask your jobber. Ask your dealer friends. Here is a product that sells and stays sold. It brings sizeable profits and satisfied customers. Write for special "Dealers' Folder".

Unipower is supplied in two models for use with 110-125 volt A. C. only. Standard models are for 60-cycle. [Special models, 25-50 cycle, are available at slightly higher prices.] All are equipped with special Balkite rectifying element. The 4-volt model is for 199 tubes or equivalent and retails for \$35; the 6-volt, for 201-A tubes or equivalent, retails for \$40. [West of the Rockies, prices are \$37 and \$43.]

The Gould Storage Battery Co., Inc.

250 Park Avenue, New York

Branches: Chicago, Kansas City, San Francisco

Unipower

TRADE MARK

Off when it's on
On when it's off

A Sure Winner With the Trade!

Better Tone, Larger Volume, Compactness—

When you offer your customers this new type of Tuned Radio Frequency Transformer, you offer them merchandise they are glad to buy, for it has many advantages over ordinary toroidal or doughnut coils. And its performance is remarkable.

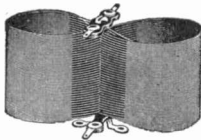

BODINE
TWIN-EIGHT
R.F. TRANSFORMER

The self-contained field of the Twin Eight Coil prevents magnetic interference from other coils, condensers, tubes, etc. Absolutely no distortions. Also, its condensed field and close coupling of primary and secondary windings assures exceptional volume—clarity of tone. And its compactness makes it easy to assemble in the set. Price, each, \$3.00, set of three matched transformers, \$9.00.

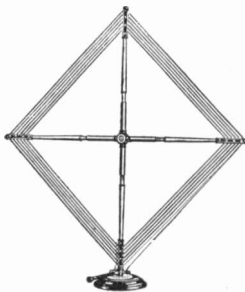

Better Loop Reception

Remarkable selectivity and distance—greater volume—finer tone. The big advantages of the Bodine Folding Loop—advantages made possible by Bodine's basket-weave winding and superior construction throughout. Mahogany finish, wound with green silk wire. Satin silver calibrated dial for logging, concealed hinges; fully collapsible, folding to fit into a box 3½x8x18 in. Price \$8.50 to \$10.00.

BODINE ELECTRIC COMPANY
2242 W. Ohio St., Chicago, Ill.

Speed Up

WITH 12 HOUR CHARGER

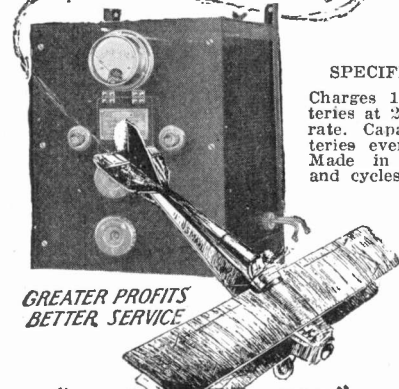

SPECIFICATIONS:
Charges 1 to 15 Batteries at 2 to 12 ampere rate. Capacity 15 Batteries every 12 hours. Made in all voltages and cycles.

GREATER PROFITS
BETTER SERVICE

"TWIN SIX"

Another engineering triumph of the Heyer Products Corporation! Leader of them all.

FULL WAVE TWO BULBS
TRANSFORMER

Balanced and Equalized

ADJUSTMENTS

Coarse and Fine
Same Switch Controls Both Bulbs

EFFICIENCY—84%

Sales Department

CONSOLIDATED EQUIPMENT CORP.

Send
for Catalog

160 GRAND STREET
NEW YORK CITY

Write for
Terms and Prices

A Representative will call on request.

Goodrich Silvertown

The Radio Panel Supreme!

- 1 Easier to drill and machine.
- 2 Better color, lasting lustre.
- 3 Lower free sulphur — no discoloration.
- 4 Higher softening point—no warping.

Goodrich V.T. Sockets Spaghetti Tubing
Radiophone Ear Cushions
Battery Mats
Hard Rubber Tubes for Coils

The B. F. Goodrich Rubber Company
Established 1870 Akron, Ohio

Fleron

AERIAL EQUIPMENT



Lightning Arresters

approved by Underwriters for indoor or outdoor use.

List.....50c & \$1.00



Glass Insulators

Resist change of temperature. Strong and dependable.

List.....20c & 30c



Stand-off Insulators

Keep Lead-in Wire away from building. 2 sizes. List.35c & \$1.25.

Complete Aerial Outfits

Contain everything necessary for the erection of an aerial of high efficiency. List....\$3.50 & \$5.00



Lead-in Bushing

Only device of its kind approved by Underwriters. List\$1.25

The Fleron Line of Radio set accessories is sold by all leading jobbers. *Write for Folder.*

M. M. FLERON & SON, INC.
Trenton, New Jersey

Magic Sales In These Electrad Metallic Leaks and Resistors

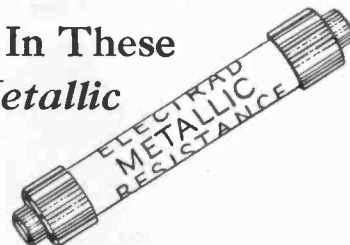

THE final resistance unit everybody has been waiting for. Absolutely noiseless. Non-inductive. Positively and *permanently* accurate. Unvarying under any weather or working condition. Non-hydroscopic. Great current-carrying capacity without overheating or change of calibrated resistance. No paper, fibre or varnish. Resistance element fused on the glass.

You can't go wrong. It will be the biggest selling leak you ever handled. All sizes. List price U. S. 60c, Canada 85c. Write for information.

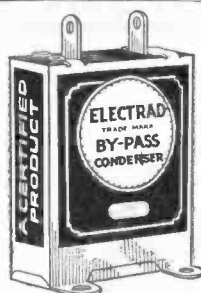

*New and
Better—this*

CERTIFIED
BY-PASS
CONDENSER

YOUR trade needs this quality by-pass condenser. Attractive, lithographed can, packed six in a display container. Here it is. Just study these points of superiority, then you will know why they will remain consistent sellers.

Low power factor, low radio frequency resistance, negligible D.C. leakage. Maximum working voltage 250 A.C. Every condenser certified electrically and mechanically perfect; tested—not by the flash method, which tells nothing—but by one-minute test of 800 volts. Impregnated with paraffin under high vacuum, and sealed with Bakelite of superior quality. Write for information and quotations.

ELECTRAD

428 Broadway, New York *Inc.*

Makers of the Certified Radio Essentials and Accessories
Write for our interesting distributor's proposition.

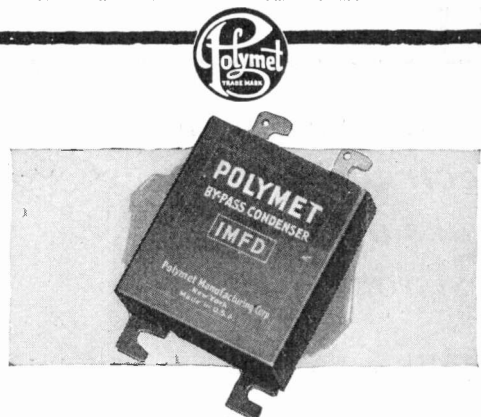

Now — By-Pass Condensers By Polymet!

Polymet made! The same high quality which has led over 100 receiver manufacturers to incorporate Polymet Products in their sets. Manufactured with the latest improved apparatus. Special impregnation process assures maximum durability and long life, and prevents leakage. High breakdown test 800 to 1000 volts.

Made in special sizes for manufacturers—send us your specifications. Put up in standard cans for distributors and dealers. Write today for information and prices.

POLYMET MANUFACTURING CORPORATION
599C Broadway, New York City

"The World's Largest Manufacturers of Radio Parts!"

POLYMET PRODUCTS

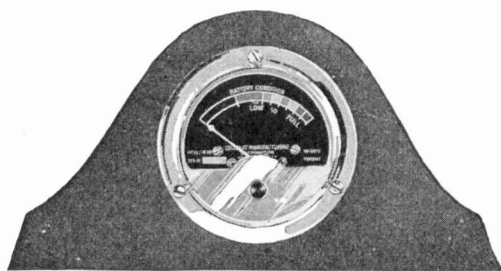

A little battery knowledge is a dangerous thing!

CELL-O-METER

tells you *instantly* more about your battery than hydrometer, voltmeter and ammeter combined.

Use Its Splendid Features To Keep Your Summer Sales Up

The compact little Cell-O-Meter tells you as much in an instant as a whole laboratory full of equipment could. Just press the button.

It is very simple to connect, whether the instrument is set into the panel or whether mounted in the attractive wood base furnished. The wood mounting makes it possible to have a real instrument of this character without boring holes in the panel, and without making the radio front look like a switchboard.

Not only is the Cell-O-Meter accurate, it is made of the materials necessary to keep it accurate after continued use. We have refused to compromise on workmanship or quality of materials in order to cheapen its price.

Dealers write for literature

Several good jobbing territories are open.

CELLOKAY MFG. CORP.

Sales Office—1705 Flatiron Bldg., NEW YORK



-it's in the Tube

You sell radio satisfaction when you sell CeCo Tubes. Whether used as detectors or amplifiers, they deliver maximum results in tone, volume and life.

Our charted tests (results confirmed by laboratories of national reputation), prove CeCo superiority.

Now ready! CeCo Tubes with new type Long PRONG BASES. Also, Power Amplifier Tubes, E (Dry Cell Type), F (Storage Battery), for last stage of Audio Frequency.

Dealers write giving jobbers' name.

C. E. Mfg. Co., Inc.
702 Eddy Street,
Providence, R. I.



HOMMEL'S
ENCYCLOPEDIA
OF RADIO
APPARATUS
466-R

is Free to all dealers
We sell to no others

WHOLESALE EXCLUSIVELY
LUDWIG HOMMEL & CO
929 PENN AVENUE PITTSBURGH, PA.

"It Separates the Stations"

ONE DIAL (One Condenser—Pat. P'nd'g)
Volume—Clarity—Distance—Ruggedness—Beauty

SUPERFLEX

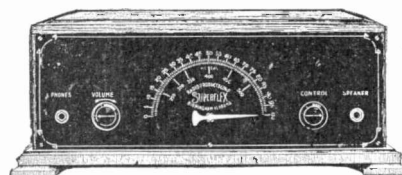

LIST
\$80.00
BARE

DEALERS:—Don't believe US—test one

RADIO PRODUCTS CORPORATION, Inc.
3816 N. 28th St., Birmingham, Alabama
Hemlock 4158



The quality and price for biggest sales

The biggest field for headsets lies among users of multi-tube receivers who want the thrill of getting distance, or who don't want to disturb the household by using the loud speaker.

The famous Superette, selling at this popular price, makes it easy for you to sell headphones to people who only occasionally use headphones.

The Superette is a high quality headset in this popular priced field. It is made with meticulous care and tested with precision instruments before entering our shipping department.

\$1⁹⁵ LIST

Jobbers and Dealers! Here's a worth-while proposition upon which to pick up many extra profits. Write today for literature and particulars.

THE FAMOUS SUPERETTE

NEWTON PRESSED STEEL CO.

13 Hawthorne St., Newton, Mass.

Also manufacturers of the NEWTONE Headset, which Lists at \$3.00

FOR LOCAL AND FOREIGN DEALERS

HEARWELL WINDOW LEAD-IN STRAP

Receives Broadcast, Without Loss



Soldered Terminals. Guaranteed Waterproof and Insulated. 25c. Handsome and Efficient. Sells Well. Write for Discounts.



FORBES SYNTHETIC-"DIAMOND" DETECTOR

A valuable radio invention. This electric process crystal is free from impurities and flaws of the natural crystal. Durable. Power. Volume. No rejects. Each one guaranteed. A Sparking Brilliant. Liberal discounts. Foreign agents wanted.

Hearwell Electric Co., Inc., Boston, Mass., U.S.A.



Super-Ball Antenna For Better Radio

The Super-Ball Antenna is on top in popularity.

The most startling success in Radio History starts its second year shattering all sales records and has made a sensational climb to leadership—Because it is Incomparable.

A Few Basic Features:

1. Increases Selectivity.
2. Clarifies Tone.
3. Non-Directional.
4. Easy to Install.
5. Less Costly to Install.
6. Snow and Ice will not stick to it.
7. Heat has no effect on its conductivity.
8. Cannot Corrode.
9. Accepts Radio frequency signals and rejects a large part of interference from atmospheric or casual electrical disturbances.

List \$10.00

National Distributors

YAH & LANGE

215 E. Water St., Milwaukee, Wis.

Manufacturers

Super-Ball Antenna Co., Green Bay, Wis.

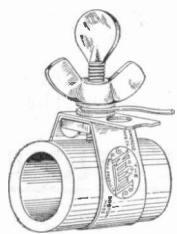

Hook up with THE NIFTY RADIO PRODUCTS

Nifty Ground Clamps

No tools required—no soldering necessary. Made of tinned copper and brass. Easily adjusted to pipes most commonly used. Retail Price 20c. each. 50 in a Nifty Box.



Nifty Lead-ins

Completely weatherproof—pliable—and insulated. No holes to bore. Fits under windows and doors tight closed. 50 in a Nifty Box.

Amoroso Manufacturing Co.
75 High St., Boston, Mass.

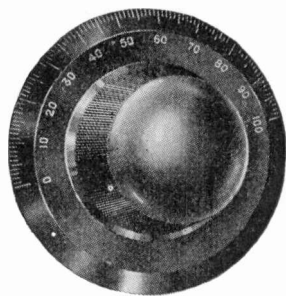

Efficient Service on Molded Parts

MOLDED INSULATION
MADE TO YOUR
SPECIFICATIONS

American Insulator Corp.
52 Vanderbilt Avenue, New York City

The Reason

THE TUBE WITH A SENSIBLE GUARANTEE

REG. U.S. PAT. OFF.
SUPERTRON
A GOOD TUBE

Quality! Performance Dependability

are the factors which made Supertron
the foremost Independent Tube in America !!

The Public buy and enjoy Supertrons because they are assured of satisfaction by a serial number guarantee on each tube for their protection—at their own price; the public demand price—two dollars.

The best dealers sell Supertrons because they give the most satisfaction, the best profit and a permanent good will.

The jobbers who practice their purposes sincerely carry Supertrons to serve their dealers better, because Supertron facts are beyond dispute.

Backed by a rigid policy, substantial organization and clean merchandising.

All Types \$2.00 Each (Canada \$2.75)

SUPERTRON MFG. CO., Inc., Hoboken, N. J.

Export Department, 220 Broadway, N. Y. City



SUPERTRON

A SERIAL NUMBER GUARANTEE

Branch offices in principal cities throughout the United States

Ehlert's Jewel Cabinet

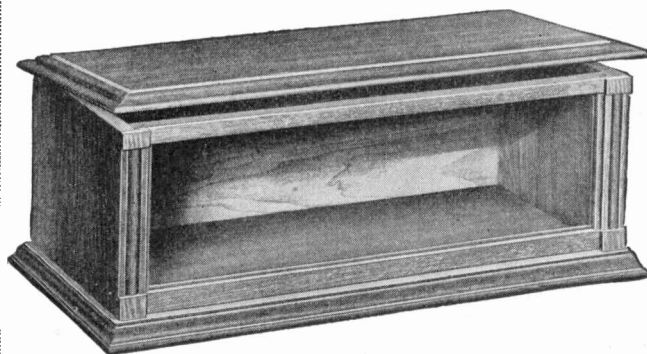

1000 cabinets daily capacity

WE STOCK nine styles of cabinets for standard-size panels.

We build special cabinets to order in quantities for set manufacturers.

EHLERT CABINET COMPANY
Waukesha, Wisconsin

UDELL Radio Cabinets



A good example of our stock line of Radio Cabinets is illustrated at left. UDELL covers a complete range in design, finish and price. Write for complete catalog R-83 and dealer's discounts.

We also build special Radio Cabinets under contract.

Write us your requirements.

THE
UDELL WORKS, INC.
28th Street at Barnes Ave.,
INDIANAPOLIS, IND.

"POSITIONS WANTED"

is the heading under which many excellent positions have been secured through the

"SEARCHLIGHT SECTION"

MEN! Use these columns for good jobs.

EMPLOYERS! Consult these columns for good men.

4 cents a word. Minimum 75 cents an insertion.

0131

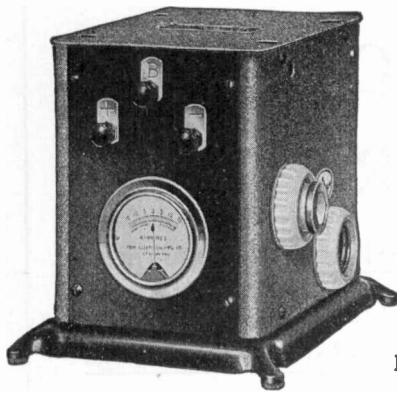

MASTER FORE
Charges both A and B Batteries

Every Radio owner wants the best reception possible. Weak A or B batteries are annoying to say the least. Sell him a Master Fore Battery Charger and win the good will of another customer.

Fill in, clip and mail the coupon now—
TODAY

Manufactured by
Fore Electrical Mfg. Co.
5255 N. Market Street,
St. Louis, Mo.

Sales Department
The Zinke Company
1323 S. Michigan Ave.,
Chicago, Ill.

RADIOGRAM

Fore Electrical Mfg. Co., St. Louis, Mo., Manufacturers, The Zinke Company, Chicago, Ill., Sales Department.

Send me free of charge complete information on how to make more money with the Master Fore.

Name

Address

City

State

More Radio Cabinet Sales

This Standard No. 401 Radio Cabinet was designed to be highly attractive and to be most practical. Users find that it fully meets their needs.

A number of features including spruce wood horn, make this a cabinet you should consider at once.

Made in Antique Brown Mahogany or Antique Burl Walnut finish. Write for dealers' transportation allowance and discount list.

STANDARD PIANO BENCH MFG. CO.
1221-1227 W. Lake St.
Chicago, Ill.

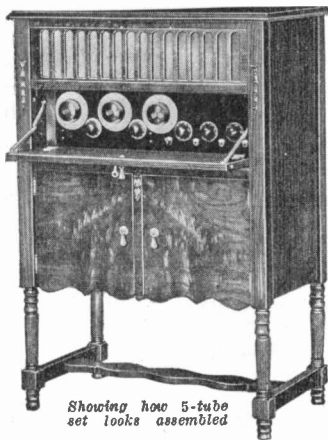

Gets Everything but Noise!

READ THIS CONVINCING LETTER:
Kane Antennae Co. Gentlemen: Your aerial absolutely cuts out all power noise. Before, we could hear an interurban car for 3 miles down the track. Now we get no disturbance whatever. We expect to do a good business.

Signed—H. STAHL & SON, Elkhart, Ind.

Profit In This For YOU—INVESTIGATE

This amazing new Aerial is guaranteed to eliminate all power noises, such as leaky transformers, generators, motor hums, Delco plants, etc. (cuts static, "blooper's," in two. Hundreds of convincing testimonials. Many dealers cashing in.

\$1.00 Brings Blue Prints—working drawings—complete instructions for erecting. Your dollar is refunded on initial order. See for yourself. Get our proposition NOW.

KANE ANTENNAE CO.
Dept. 6038-C, 3343 W. Monroe, Chicago, Ill.

KANE ANTENNAE

INCREASE YOUR PROFITS!

Sell a Table with every Set

Every Radio Owner is a Prospect for a Table. Stock Radio Tables and Make an Extra Profit.

Our line of Radio Tables includes tables for any set in various sizes made in Solid Mahogany, Walnut and Mahogany Finishes in Lacquer and in Varnish. They are an asset to any home.

Over Thirty Years of Furniture Manufacturing Experience is built into these Tables which are made on the same high standard of Quality which has always characterized Watontown goods.



No. 922.

Solid Mahogany. Lacquer Finish. Rubbed Dull.
Top, 18-in.x35-in.
Standard Height—30-in.
Has full length slide which pulls out 12-in. either side of table.
Has ventilator in back covered with dust-proof screen as required by Underwriters Rules for Battery Eliminators.

Watontown Table & Furniture Co.

Incorporated 1893

Watontown, Pa.

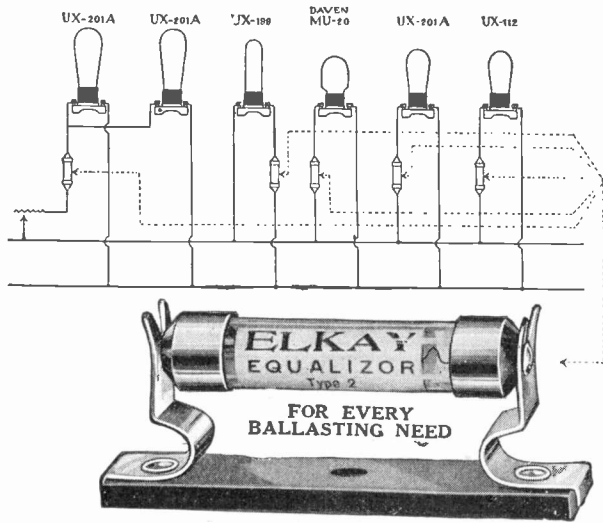

TUBE EQUALIZER SYSTEM

permits use of any combination of tubes in the same set

This System comprises a wide range of flexible filament control Equalizers to slip into spring clips. Equip a set with these clips, and ANY TUBE + THE CORRECT EQUALIZER = 6 VOLTS! With exception of the R. F. stages, no other filament control is needed. A set can be changed instantly from dry cell tubes to big tubes, for instance; and, in these days of UX tubes, the System is ideal. Shown above is a standard tuned R. F. circuit filament line, with four different kinds of tubes equalized to 6 volts. Price of Equalizers, 50c.; with clip, 75c. Write for complete folder on the Elkay Tube Equalizer System.

MANUFACTURERS! Equip your sets with this System. It makes a more flexible, more salable job, and cuts your costs by eliminating rheostats and controls. Write for low-price quantity offer.



ELKAY 5-TUBE SUPER-SELECTOR, \$80

(Equipped with Equalizer System)

Compares favorably in appearance, selectivity, volume, distance and tone quality with sets at twice its price. Has one stage R.F., detector, one stage of transformer coupled amplification and two resistance coupled amplifiers. Only two dials. A radio frequency choke permits same smooth operation on low or high wave lengths. Control over selectivity a distinct departure—an ELKAY invention.

The Langbein-Kaufman Radio Co., Dept. M.
511 Chapel St., New Haven, Conn.



COILS *for* RADIO

- Balloon Honeycombs
- Wave Wound Spirals
- Transformer Windings
- Honeycomb Inductances

*We Wind For The
Manufacturers Only*

COTO-COIL CO.
PROVIDENCE
R. I.

Just Out HARRY ALTER'S RADIO CATALOG

A New, Big Edition
Dealers, Write for a Copy

THE HARRY ALTER CO.

Ogden at Carroll Ave.,
CHICAGO : : ILLINOIS

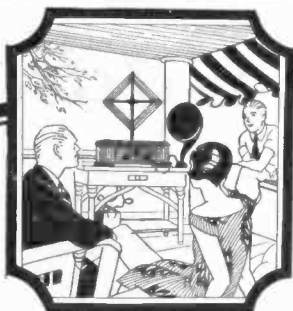

Get Ready for Summer Sales

You can sell a loop receiving set right thru the summer while your competitor stands still, if you are handling the



List Price
\$175

Priess
TRADE MARK
STRAIGHT EIGHT
It's loop operated!

The porch, the living room—anywhere the family or friends gather, the Priess Straight Eight can be brought, because being loop operated, it is semi-portable. Its powerful 8 tubes, even in summer, bring in stations beyond the range of most sets, with a minimum of "static." Go after summer sales with the Priess Straight Eight. It means getting profits out of a supposedly poor radio season.

Write us and we will put you in touch with our distributor in your territory.

PRIESS RADIO CORPORATION
697 BROADWAY  NEW YORK, N.Y.

BIG DISCOUNTS TO DEALERS

There is a lifetime opportunity for making money in radio. Get our new big catalog, see the bargains in standard radio parts, sets, kits at rockbottom wholesale prices. Huge stocks ready for quick shipment. This price list means big profits for you. Wonderful special offers on sets, tubes, batteries. Write for FREE copy before you buy.

Complete Wholesale Price List

W. C. BRAUN COMPANY 34-68 S. Clinton St., Chicago, U. S. A.

DIATRON Radio Tubes

are good because Walter Armstrong made them good.

Ever dependable. The result of 38 years unparalleled experience.

DIAMOND VACUUM PRODUCTS CO.
4049 Diversey Avenue, Chicago, Illinois.

Dealers!

REAL PRICES

We carry in stock at all times the following merchandise—

Electrical Supplies	Chinaware
Furniture	Hardware
Radio	Musical Instruments
Automotive	Leather Goods
Equipment	Sporting Goods
Aluminum Ware	Jewelry
Novelties	

FREE! 1926 complete illustrated catalog just off press. Write for a copy at once. Supply limited.

GENERAL MERCHANDISING CO., INC.
818 Walnut St., Philadelphia, Pa.



Scranton Glass Instrument Co., Inc.
SCRANTON, PA.

Manufacturers of

Battery Testers

A Size and Type for Every Purpose and Every Price

Descriptive information on request

**"Unless the Float Is Right
The Reading Is Wrong"**

Hoyt

RADIO ROTARY METER

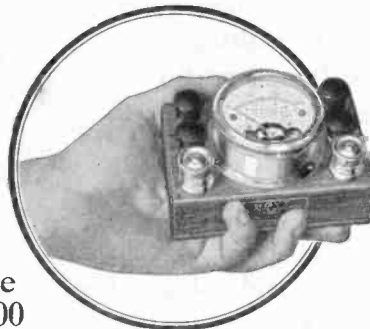

Price
\$24.00

This meter makes 16 different tests on Radio apparatus and batteries, adjusts C battery voltages for distortionless amplification, and will fill every test need of the SERVICE-MAN, DEALER, or RADIO-OWNER.

Our book "The HOYT Radio Rotary Meter" describes these tests in full detail with many illustrations and diagrams.

SEND FOR IT TODAY!

BURTON ROGERS CO.
26 Brighton Ave., Boston, Mass.

Write us for Booklet "Hoyt Meters for Radio"

DIVA—the Wonder Radio

because

that at **\$35** a popular price makes quick sales

there are **No Buss Bars** NO SOLDER Kardonstrip reduces field of resistance

and that **No Service Required** a big saving

Solderless Joints INDESTRUCTIBLE MAKE a big selling point and profits that stay and grow!

Dealers—

Who won the 5 free sets?

Dealers throughout the land responded generously and enthusiastically in submitting new names for the Kardon Radio Set.

DIVA, The Wonder Radio, has been selected as most aptly describing this solderless, serviceless five tube tuned radio frequency set. DIVA it shall be. Look for next issue announcing winner's name and further information.

Jobbers, Dealers,—Write or Telegraph for our Profit Making Plan

THE DIVA RADIO CORPORATION

Successors to

KARDON RADIO CORPORATION

294 East 137th Street

New York, N. Y.

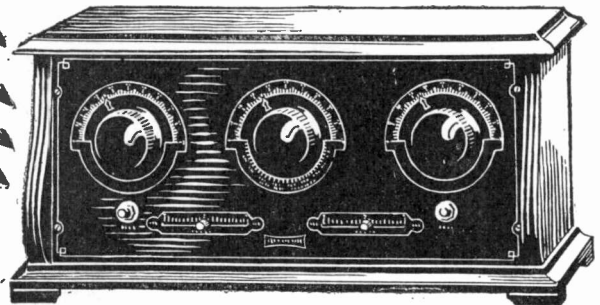

No Other Value Like This

Modern Radio with:

- Speaker built in.
- Selectivity and volume for present day conditions.
- Beautiful cabinet.
- 5 tube tuned radio frequency.

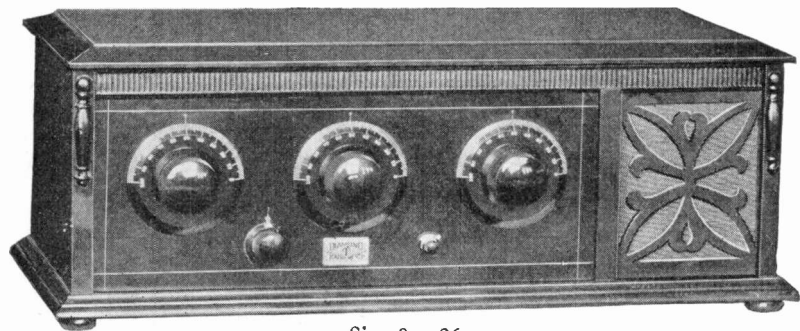

Size 9 x 26

1926 Diamond T "Super Special" Model—\$49.50

Here is a special offer which positively expires April 10th.

To introduce this profit payer to a new dealer we are glad to lose about \$5.00 on a sample set, as its quality and value will make a steady customer of you.

One Sample Set to New Dealer, \$24.75

Only one at this price

Our Guarantee: If this set is not satisfactory or does not meet with your approval we will refund the price paid us without asking any questions if returned within 10 days.

This offer in January and February magazines brought us hundreds of new dealers in all parts of the country. A big percentage have repeated and not one have returned set for refund. Our guarantee is good or this magazine would not accept our copy month after month if they had complaints about us.

We are willing to lose money that you may try this wonderful set, but we ask you to Send Check with Order. Remember this is quality merchandise, both in looks and performance.

Nothing to equal a "Super Special" under \$75.00.

Four other models and all leaders at their price.

We reserve the right to refuse orders if we have a satisfactory dealer in your town.

This is the kind of values that keep Radio Shops open all Summer.

DIAMOND T RADIO MFRS., SOUTH BEND, IND.

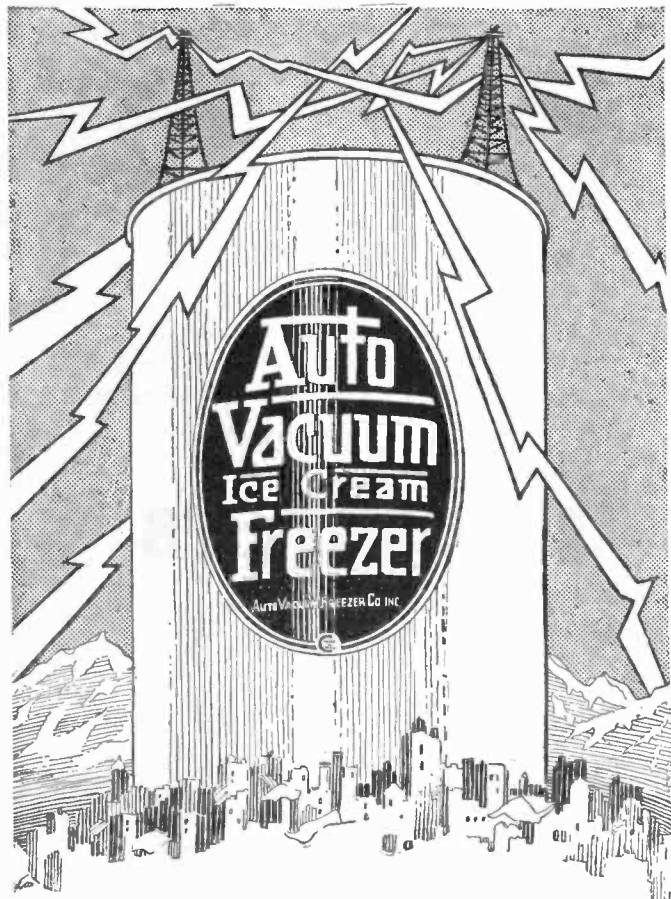

Broadcasting Summer Profits

Here is a patented household specialty with a large established Summer volume—the Auto Vacuum Ice Cream Freezer. Make a display of them and bring people into your store. Tell your customers who buy sets and parts about them. Cash in on the good-will of your Radio business.

The Auto Vacuum Freezer is simple in construction—only three parts. It is neat and sanitary—with a white enamel finish. Fully guaranteed to give absolute satisfaction.

**NO PARTS TO GET OUT OF ORDER
NO CRANKING — NO LABOR
NO FUSS — NO MUSS**

Smooth Delicious Ice Cream

FOUR CONVENIENT SIZES:

1 quart . . \$5.00 list 3 quart . . \$8.00 list
2 „ „ 6.00 „ 4 „ „ 10.00 „

Get on the band wagon. Ask your jobber for full information. If he cannot serve you, write us direct.

AUTO VACUUM FREEZER CO., Inc.
220 West 42nd Street
New York City

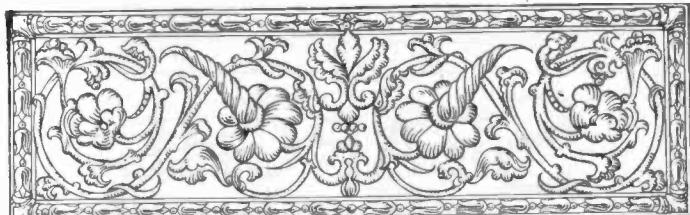

FROST-RADIO

Ask Your Neighbor

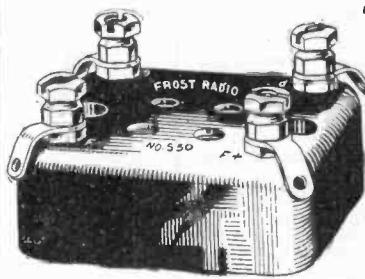

The No. 530 is a rich-looking socket because it is made from real Bakelite. List: 40c

THERE is something new under the sun in radio sockets and adapters—of course it bears the name **FROST-RADIO**. This is the new No. 530 **FROST-RADIO** All-Purpose Socket and the new No. 540 **FROST-RADIO** Adapter—the former the biggest little 40 cent seller ever offered the set builder, and the latter a 25c item which is in tremendous demand right now, and which sells like wild-fire at 25c list.

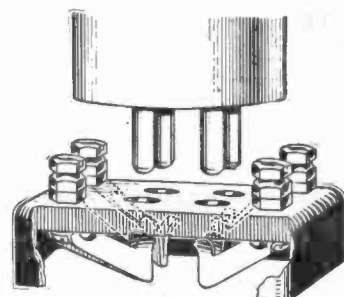

Note the spring construction as revealed by this cut-away view. These sturdy springs are held between cast bosses, and stay put.

The No. 530 **SOCKET** takes all new type tubes. Is moulded from real Bakelite, richly finished in high lustre polish. Has four of the sturdiest springs you ever saw, which grip tube prongs for almost their entire length. This socket is positively self-cleaning—has slotted binding posts fitted with soldering terminals. Looks like a dollar's worth, yet lists at only 40c with usual discounts.

THE No. 540 **ADAPTER** converts present standard sockets to UX-199—CX-299 or UX-120—CX-220 in a jiffy and eliminates tearing set all to pieces to install new tubes. Black Bakelite in polished finish. List price, 25c

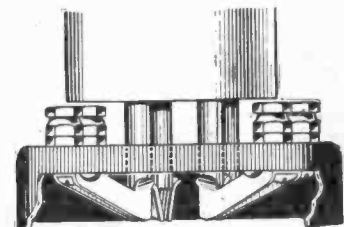

When the tube prongs force spring leaves apart they wipe 'em clean as a whistle. Dirt hasn't a chance to remain long on the prongs or springs here.

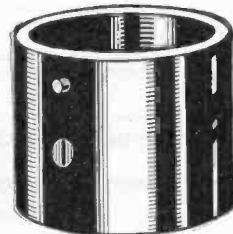

This handy little Bakelite Adapter No. 540 enables your customers to convert standard sockets to UX-199—CX-299 or UX-120—CX-220. List: 25c

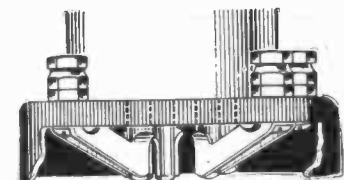

When the tube is inserted each prong is gripped the full length on two sides and held in a vice-like grip. This is a real job of spring designing.

Wire your requirements on these two popular new items. Be first in your neighborhood to fill the already large demand.

HERBERT H. FROST
(Inc.)
314-324 W. Superior St.
CHICAGO, ILL.
New York City Cleveland
Kansas City Los Angeles
Export Office:
314 W. Superior St., Chicago



SEARCHLIGHT SECTION

BUSINESS OPPORTUNITIES—SURPLUS STOCKS

UNDISPLAYED—RATE PER WORD:
 Positions Wanted, 6 cents a word, minimum \$1.25 an insertion, payable in advance.
 Positions Vacant and all other classifications, 10 cents a word, minimum charge \$2.00.
 Proposals, 40 cents a line an insertion.

INFORMATION:
 Box Numbers in care of any of our offices count 10 words additional in undisplayed ads.
 Discount of 10% if one payment is made in advance for four consecutive insertions of undisplayed ads (not including proposals).

DISPLAYED—RATE PER INCH:
 1 to 3 inches.....\$6.65 an inch
 4 to 7 inches..... 6.40 an inch
 8 to 14 inches..... 6.20 an inch
 Rates for larger spaces, or yearly rates, on request.
 An advertising inch is measured vertically on one column, 3 columns—30 inches—to a page.

Radio Retailing

POSITIONS WANTED

HIGH SCHOOL graduate, 22 years old, radio expert; seven years' experience, licensed amateur, desires desirable position with a reliable radio company. Abraham Deaterly, 84 South State St., Westerville, Ohio.

REPRESENTATIVE AVAILABLE

Export Manager
 Now successfully representing several American firms abroad, desires additional line on commission basis; will finance. RA-8, Radio Retailing, Tenth Ave. at 36th St., New York.

SALESMEN WANTED

Salesman Wanted
 If you are a wide awake salesman who has kept step with the manifold changes and improvements effected in radio during the past two years, there's a good job awaiting you somewhere in this ever expanding field. You can find this opportunity through a "Searchlight" advertisement in Radio Retailing.

BUSINESS OPPORTUNITIES

Radio Store Wanted
 If you wish to dispose of your business for any reason the readers of Radio Retailing will be interested in knowing about it. You can reach these men best through advertising in these "Searchlight" columns. Rates above.

Business For Sale
 If you are seeking a going radio business, you can find what you want through an advertisement in these "Searchlight" columns addressed to the Nation's radio retailers.

FOR QUICK SALE

Copper Magnet Wire

300 lbs. net weight, Beldenamel, diameter 40, on spools net weight 2 to 8 ounces.
 HARRY W. DePREZ, Shelbyville, Indiana

Manufacturers!

Locate in Baltimore in this modern concrete structure.

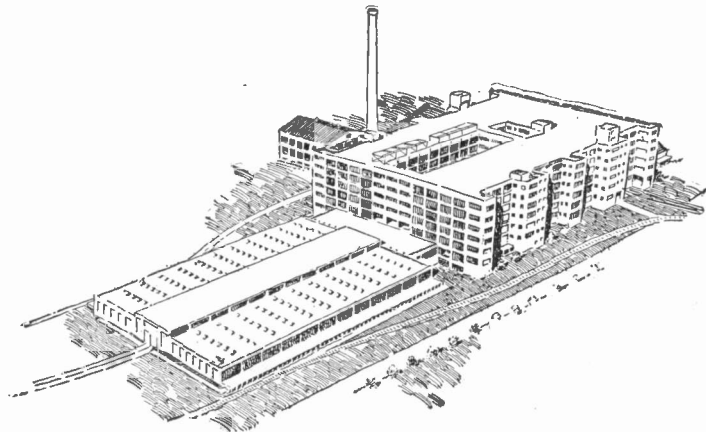

Exceptional daylight floor space immediately available.
 Lowest insurance rates.
 Excellent labor district. Cheap power. Sidings from two trunk line railroads.
 Equipped with "Carrier" Air Conditioning System. Also 40 acres of adjoining land for factory sites.

GIBBS INDUSTRIAL BUILDING
 3500 East Biddle St., Baltimore, Md.

Engrave Panels for Set Builders

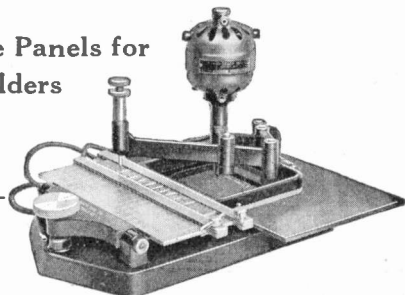

You can earn several dollars an hour engraving panels for amateurs building their own sets.

A low price engraving equipment for engraving the words used on radio panels, trade-marks, and border and corner designs. Will engrave on Hard Rubber, Bakelite, Aluminum and other soft metals. PRICE OF COMPLETE EQUIPMENT \$135.00.

Branch Tool Co., Dept. P, Forestdale, R. I.

MUTER

Dependable Radio Products

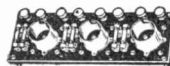

Resistance Amplifiers—
 Completely assembled - - - List \$8.00

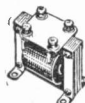

Audio Frequency Transformer
 — Quality at a popular price. - - - List \$2.25

Sold by Leading Jobbers — Ask for Catalog

LESLIE F. MUTER COMPANY
 76th and Greenwood Ave. Chicago, Illinois

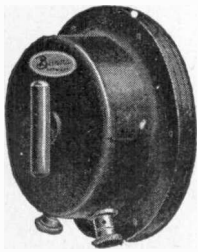

Burns LOUD SPEAKER With Concert Unit

Large size and scientific construction in the Concert Unit gives remarkable tone values which with the special amplifying properties of the Burns horn produce wonderful results.

Burns horn is of a distinctive design with pyralin flare in several handsome finishes.—It pleases the eye as well as the ear.

MANUFACTURERS

American Electric Company

State and 64th Sts., CHICAGO, U. S. A.



"Made in Salem"

Hytron Tubes are the result of 15 years' experience in lamp and tube manufacturing.

Hytron Tubes are made at our own factory.

Hytron Tubes are tested and passed in our laboratories under supervision of technical experts.

201-A or 199
Types

*Exclusive Territories Open
for Distributors*

Hytron Corporation, Salem, Mass.

A POPULAR STANDARD CABINET

No. 325

Quality again, in this Standard Cabinet means it becomes the customer's choice. An exact match for Radioia 25. Can be used for other large dimension sets. Has large, double cabinet space enclosed, and sliding shelf for loud speaker. Doors 5-ply beautiful two tone mahogany.

Finished antique brown mahogany.



No. 325, Cabinet 30 inches high, with 20x33 inch top. Back 3-ply birch. Well made. Artistic. Write for liberal dealers' discounts

STANDARD PIANO BENCH MFG. CO.

1221-1227 W. Lake St., Chicago, Ill.

Radio Dealers WANTED!

If you are the type of dealer who hustles after business, who isn't content to wait for trade to come in but who takes sets out to demonstrate, can talk and sell quality merchandise, and knows Radio values, we have a big proposition for you. Are you that dealer?

50% Discount to Dealers

We manufacture a complete line of high grade receivers and sell to dealers at 50% discount. We are distributors for more than 225 Nationally advertised lines.



FREE Write today for amazing offers, new 112-page catalog and regular monthly catalogs quoting below-the-market prices on latest merchandise—all free. Everything in Radio for less.

AMERICAN RADIO MFG. CO.
1412 McGee St., Kansas City, Mo.

PERRYMAN RADIO TUBES

"Distance without Distortion"

POWER!

Here is the new Perryman Power Amplifier, a power tube with twin-filaments. It develops an abundance of power, yet is as sensitive to control as a finely adjusted throttle.

The same careful engineering and painstaking workmanship that have caused standard Perryman Tubes to be sold as fast as we could make them, assures the success of this twin-filament power amplifier.

Even as the Perryman detector and amplifier types translate voice and music with faithful accuracy so the new Perryman Power Tube adds volume to volume without distortion.

Your Perryman distributor has a stock for immediate delivery. Place your order today.

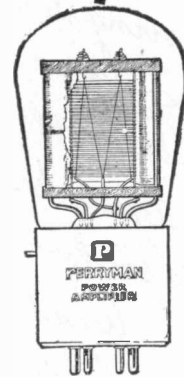

Power Tube

Clear Glass Demonstrating Tube showing Twin-Filament construction of Perryman Power Amplifier.

The familiar and proven principle of supporting filament grid and plate in fixed alignment by means of two bridges is carried out in the Perryman Power Amplifier. In addition, the filament has twin loops which distribute the electron emission over twice the area of the ordinary power tube and permit maximum amplification without choking. The twin tension springs always hold the filaments taut regardless of their operating temperature or their position.

\$6.50 List

PERRYMAN ELECTRIC CO., INC.
LABORATORIES AND PLANT NORTH BERGEN, N. J. SALES AND EXECUTIVE OFFICES 33 W. 60th ST., N. Y. C.

Andrew White "B" Radio Power Supply



J. ANDREW WHITE
Vice President,
Haynes-Griffin Radio
Service, and a lead-
ing retailer. Pioneer
radio editor, the coun-
try's first broadcast
director and veteran
manufacturer.

*Even if reducing the inventory is
the indoor sport right now - but
The cash register must ring, too.
Moving dead stuff isn't the whole
trick; you know that.
The dealer who isn't drawing his
customers back to sell them my "B" unit
is overlooking a bet.
Want something that will more...now?
This unit is the speediest item you've
struck in the past eighteen months.
The public wants to be rid of the
"B" battery nuisance. Try, and see.
P.S. no hum at all.*

J. Andrew White



J. ANDREW WHITE
39 West 43rd Street, New York

Eight cells
passes 60
milli-
amperes.
40% dis-
count to
dealers

135 VOLTS!! \$ 38

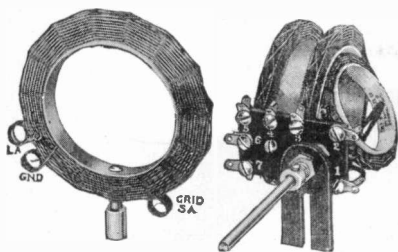

Set Manufacturers!

Have you insured your margin of superiority?

Standards of radio reception are becoming higher with each new year. 1926 models must be an improvement over those of 1925, and they will be.

You realize this fact, and are planning to act on it.

You are well aware that correct coils are vital to good reception. We specialize in such coils. We are producing regularly the most advanced types, built with the famous "Diamond-weave" construction.

Write us concerning your own requirements. We are prepared to furnish better coils for the new sets.

THE F. W. SICKLES COMPANY
140 Union St., Springfield, Mass.

SICKLES

DIAMOND-WEAVE COILS
(Trade Mark registered Aug. 4, 1925)

AMPLION

Product of nearly 40 years' Experience

For Better Radio Reproduction



Increasing demand "for better radio reproduction," augmented by our extensive advertising, has tremendously increased the sales of Amplions. Directly traceable to the nearly 40 years' experience of Allred Graham & Co., England—the originators and oldest makers of loud speaking devices—is the supremacy of the Amplion in sensitivity, volume, clarity and freedom from "chatter."

Six models, equipped with cords and panel plugs, \$12 to \$42.50. Write for "Amplion Pedigree" and proposition to the trade.

THE AMPLION CORPORATION OF AMERICA
Executive Offices: Suite E, 280 Madison Avenue, New York City
Chicago Branch: 27-29 North Morgan Street
In Canada: Burndep of Canada, Limited, Toronto

ALPHABETICAL INDEX TO ADVERTISEMENTS

Page	Page	Page	Page
Aladdin Mfg. Co.....312	Crescent Chair Co.....310	Gold Seal Products Co., Inc....237	Pep Mfg. Co., Inc.....312
Alden Mfg. Co.....306	Crosley Radio Corp.....299	Coodrich Rubber Co., B. F....315	Perryman Elec. Co.....325
All-American Radio Corp.....241		Gould Storage Battery Co.....314	Polymet Mfg. Corp.....316
Allen-Bradley Co.....233		Goyer Co., The.....236	Prest-o-Lite Co., Inc.....313
Alter, Harry Co.....320		Grebe, A. H. & Co.....235	Priess Radio Corp.....321
American Elec. Co.....325	DeWitt-LaFrance Co., Inc.....310		
American Insulator Corp.....318	Diamond T Radio Mfrs.....322	Hartung Co., Charles F.....308	Radio Centre.....309
American Radio Mfg. Co.....325	Diamond Vacuum Products Co.321	Hearwell Electric Co.....317	Radio Corp. of America, 276-277, Back Cover
Amoroso Mfg. Co.....317	Diva Radio Corp.....322	Hommel & Co., Ludwig.....316	Radio Products Corp.....316
Amplion Corp. of America.....327	Dubilier Condenser & Radio Co.242	Hytron Corp.....325	
Apco Mfg. Co...Inside Back Cover			
Atwater Kent Mfg. Co.....248	Eby, H. H. Mfg. Co.....313	Joyce Brothers.....301	Scranton Glass Inst. Co.....321
Auto Vacuum Freezer Co.....323	Ehlert Cabinet Co.....318		Searchlight Section.....324
	Electrad, Inc.....315	Kane Antennae Co.....319	Sickles Co., F. W.....327
Bakelite Corp.....246-247	Electric Service Supplies Co.....245		Standard Piano Bench Co.319-325
Benjamin Electric Mfg. Co.....328	Electric Storage Battery Co.....300	Langbein-Kaufman Radio Co...320	Stewart-Warner Speedometer Corp.....239
Bodine Elec. Co.....314	Elkon Works, Inc.....243	Lektophone Corp.....305	Stromberg-Carlson Tel. Mfg. Co.234
Branch Tool Co.....324			Super-Ball Antenna Co.....317
Brandes Products Corp., Inside Front Cover	Farrand Mfg. Co.....304	Magnavox Company.....302-303	Supertron Mfg. Co.....318
Braun Co., W. C.....321	Federal Radio Corporation...238	Muter Co., Leslie F.....324	
Burton-Rogers Co.....321	Fleron & Son, M. M.....315		Udell Works, Inc.....318
	Fore Electric Mfg. Co.....319	National Carbon Co.....311	
	Frost, Herbert H., Inc.....323	Newton Pressed Steel Co.....317	Watson town Table & Furniture Co.....319
			Weston Electric Inst. Co.....244
Cellokay Mfg. Corp.....316	General Electric Co.....240	Operadio Corp.....Front Cover	White, Andrew J.....326
C. E. Mfg. Co.....316	General Lead Batteries Co.....308		Wirt Company.....312
Ccmo Apparatus Co.....310	General Merchandising Co.....321		
Consolidated Equipment Co.....314	General Radio Co.....307		
Coto Coil Co.....320			
Crescent Braid Co.....306			

Easier Tuning

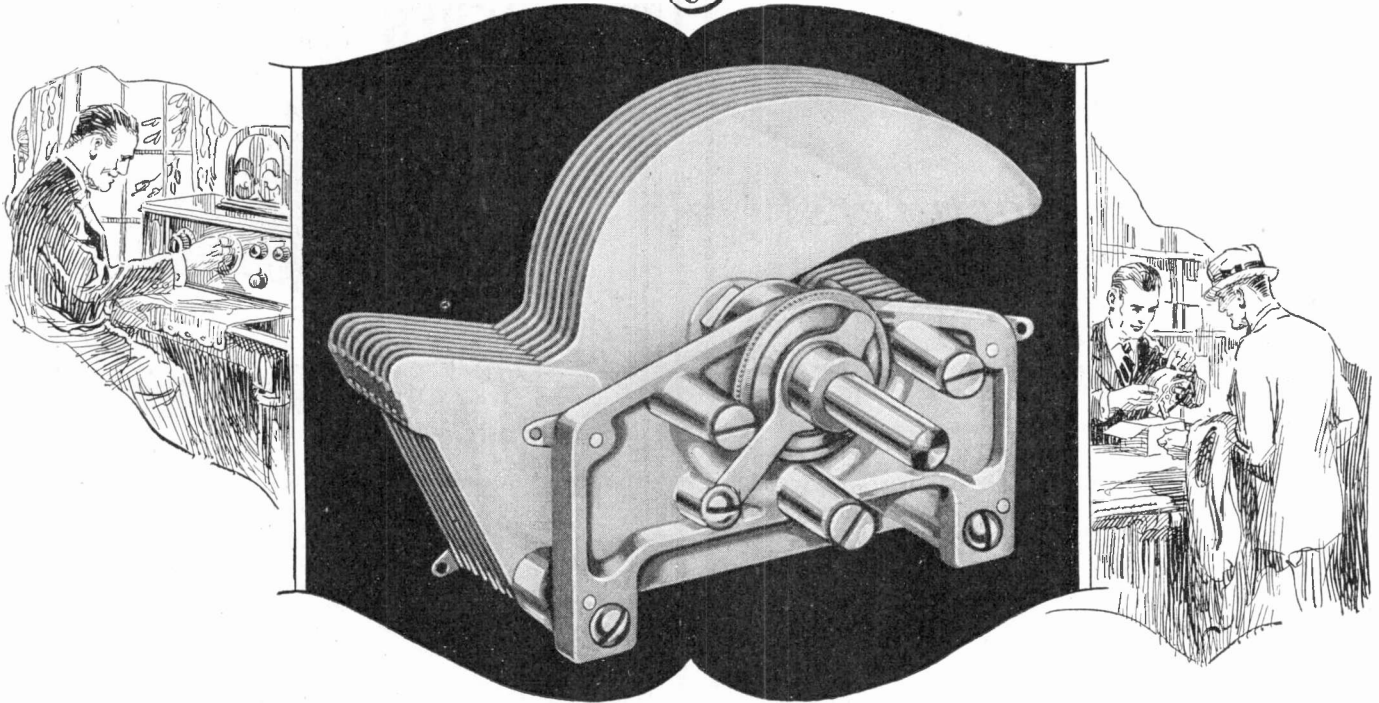

Better Selling

As efficient as it is good looking. A popular model and a big seller, well supported by effective national advertising.

BENJAMIN Straight-Line Frequency Condenser

Spreads the broadcasting frequencies evenly over the entire range of the dial. Makes tuning easier and increases selectivity. Correct design and dimensions, proper placing of highest grade dielectric, elimination of body capacity and absorption losses increases sensitivity. Adjustable turning tentation. Built like a precision instrument to last a life-time. Send for full information and prices.

Benjamin Cle-Ra-Tone Sockets

Stop tube noises by preventing the transmission of outside vibrations into microphonic disturbances. Four springs support the socket—"float" it above the base and absorb all shocks and jars. The new "Push" type Cle-Ra-Tone Sockets are for standard UX and WX tubes.

Patented July 25, 1925; May 2, 1911

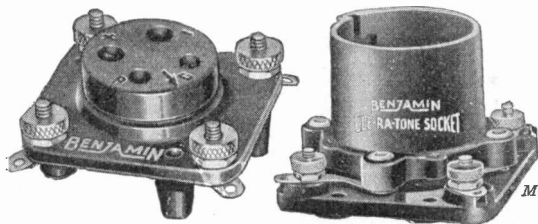

Benjamin Tuned Radio Frequency Transformers

Improvement in tone, volume and selectivity. Low Resistance. Low Distributed Capacity. Space wound, air core; double green silk insulation—the nearest approach to an all-air dielectric construction and the highest type of inductance possible. Put up singly and in sets of three.

Benjamin Electric Mfg. Co.

120-128 S. Sangamon St.
Chicago

247 W. 17th St., New York

448 Bryant St.
San Francisco

Manufactured in Canada by the Benjamin Electric
Mfg. Co. of Canada, Ltd., Toronto, Ontario

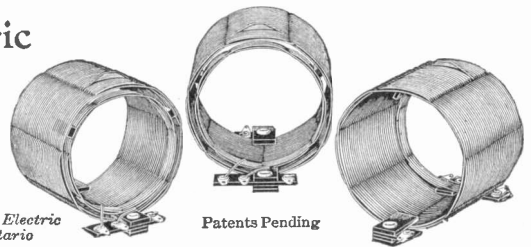

Patents Pending

BENJAMIN

TRADE MARK

**Sales - Greater
than ever - with this
newest **APCO** Product**

The **APCO**

**"B"
SUPER
Battery
Eliminator**

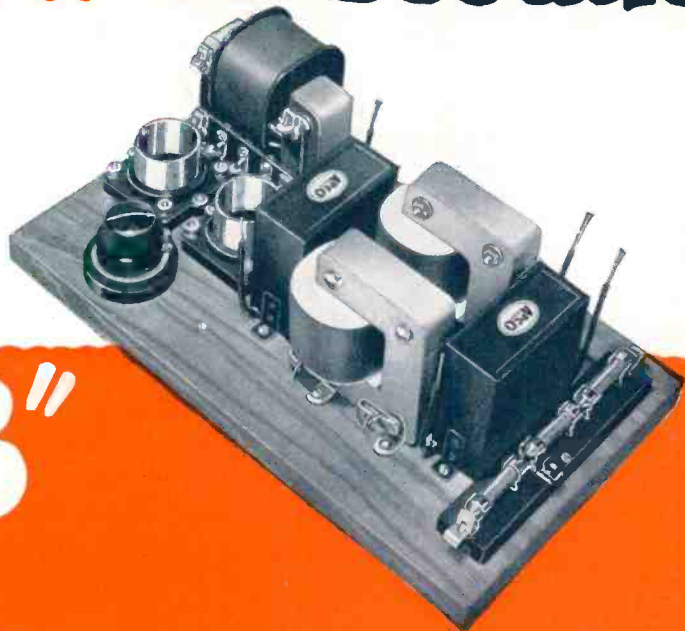

COMplete in open mounting as shown, ready to use except tubes. Ready to attach to lamp socket and deliver up to 135 volts and 40 milliamperes with the smoothness and uniformity of a fully charged "B" battery. Two standard 201-A tubes or one 213-X tube may be used.

The Super "B" Battery Eliminator is the product of two years' specialized experience in a field where Apco is a recognized leader. List, \$36.00.

Apco Manufacturing Company
1245 Eddy Street, Providence, R. I.



APCO Rectodyne No. 66
List, \$44.00



APCO "A" Charger
No. 77. List, \$18.50



APCO "A" Charger
No. 79. List, \$12.50

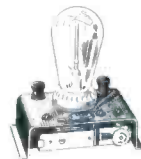

APCO "B" Charger
No. 89. List, \$4.00



Rectron UX-216-B

The new half-wave rectifier tube Rectron UX-216-B has a D. C. output of 65 milliamperes. This tube, which is used in the new RCA Uni-Rectron, to supply power amplification to loudspeakers, has high output—and long life.

**Stock up
now!**



new rectifying tubes

*for longer life —
and higher output*

THE new RCA Rectron UX-213 was especially developed for the Duo-Rectron, the RCA "B" battery eliminator which supplies power up to 135 volts, enough for even the new power Radiotrons UX-120 and UX-112.

This new Rectron is the only full-wave rectifier tube with a D. C. output of 65 milliamperes. It is silent in operation, long-lived, efficient, and rugged.

Rectrons are as readily renewable as Radiotrons, and are carried in stock by first class dealers throughout the country. Just as RCA Radiotrons are the accepted detectors and amplifiers of radio, RCA Rectrons are the standard rectifiers for the delivery of high power D. C. plate voltage from A. C. lines.

RADIO CORPORATION OF AMERICA

New York

Chicago

San Francisco

RCA Rectron

MADE BY THE MAKERS OF RADIOLAS