

A McGraw-Hill
Publication

February
1925

Radio Retailing

Business Magazine of the Radio Industry



Complete Radio Set Specifications

"Ruining the Radio Industry"

Selling Radio House-to-House

What Becomes of the Customer's Radio Dollar?

Matched Tone Headsets sell 'em by tone!

Into 7,500,000 homes goes this old man—to sell Brandes headsets. He appears in the February Brandes advertisements—on full pages in the Saturday Evening Post and many other sales-making magazines.

Into your shop come the radio fans—wanting headsets. Let each one of them listen with a Brandes. Its *matched tone* is the only salesman you need. Hearing will be buying!

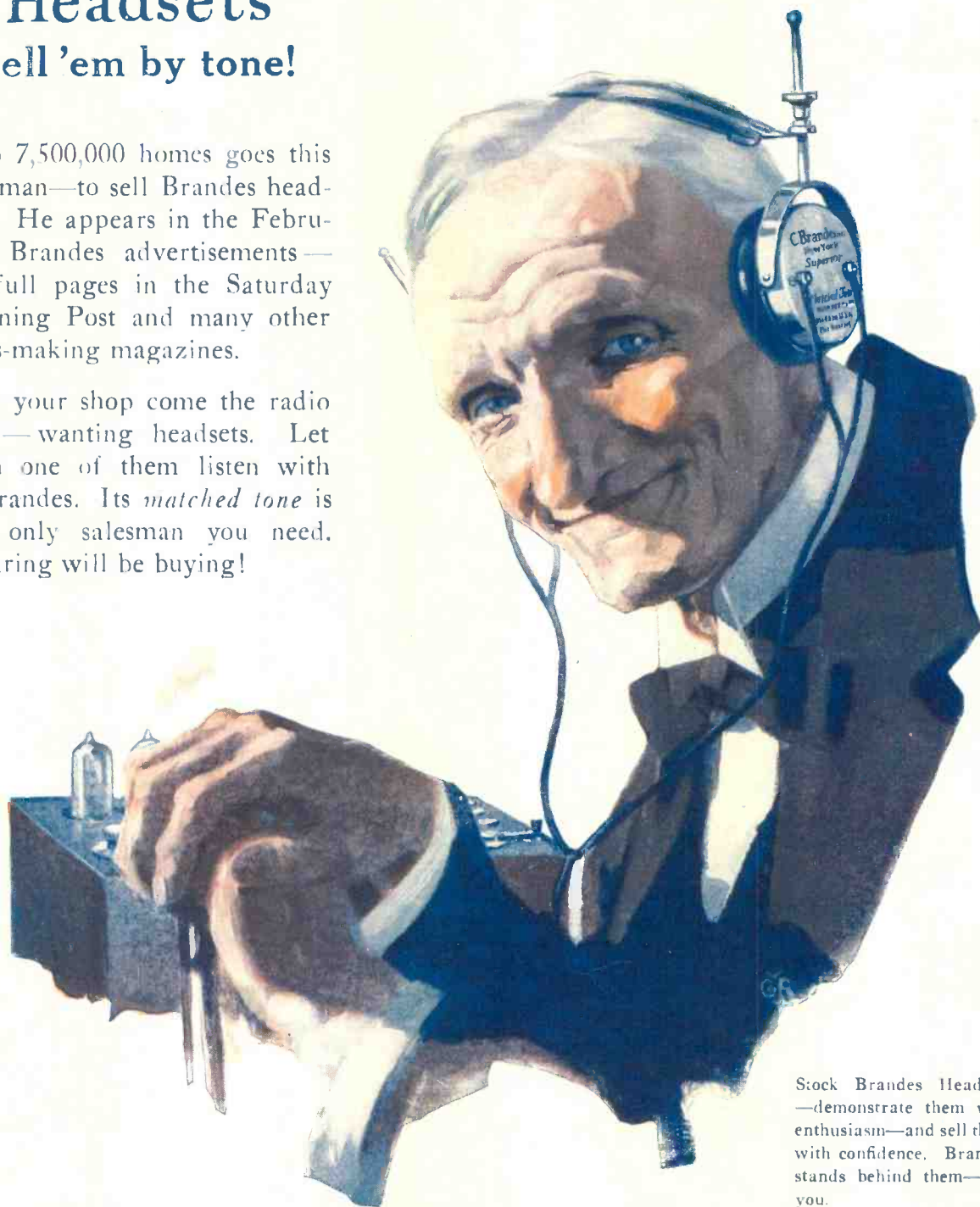

Stock Brandes Headsets—demonstrate them with enthusiasm—and sell them with confidence. Brandes stands behind them—and you.

Brandes

The name to know in Radio

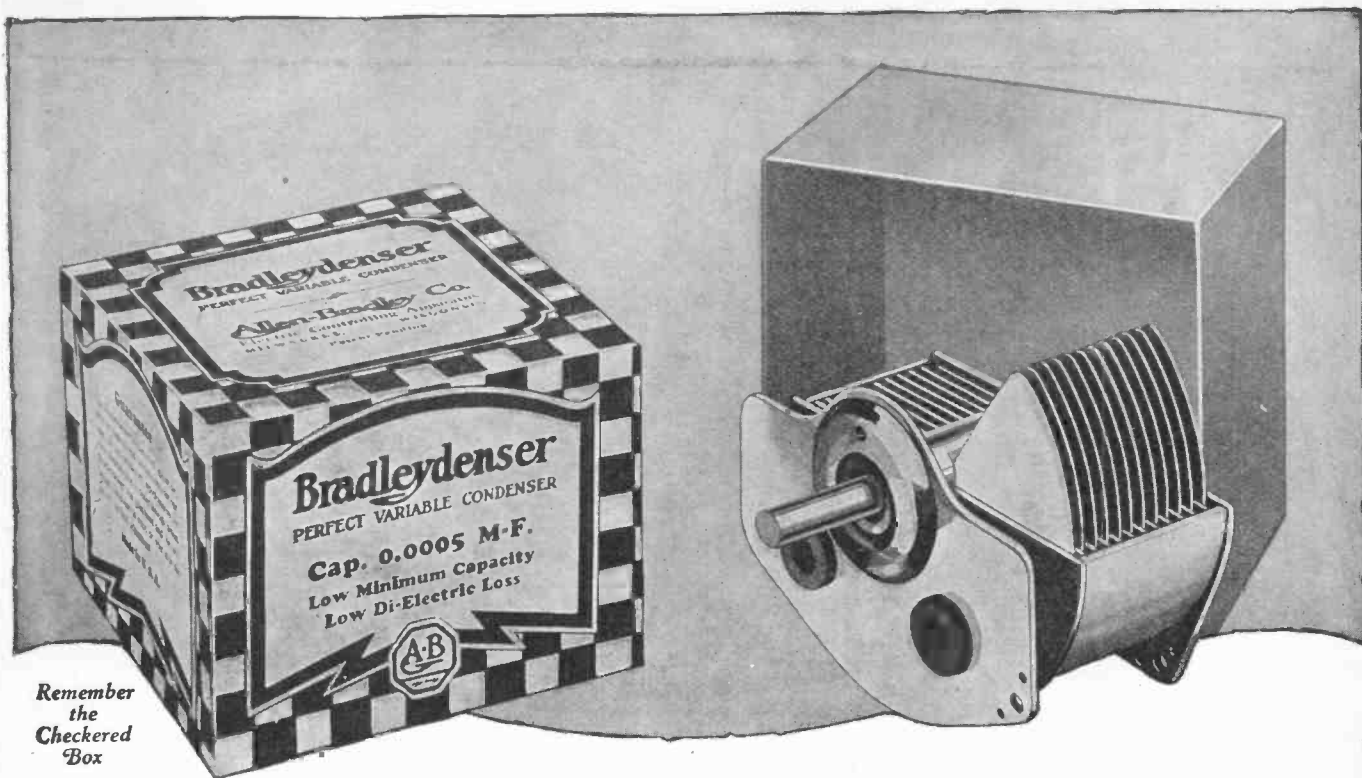

Brass Plates—Soldered Joints—Grounded Rotor

Important Features That Sell the Bradleydenser

The Bradleydenser is a low-loss condenser with many distinctive features that insure long life and high efficiency. For instance, the brass stator and rotor plates are soldered at all joints. The plates cannot become loose, corrode at the joints or work out of alignment. The rotor is mounted on a long sleeve bearing that supports the rotor plates without the use of an outer end-plate. Therefore, the di-electric material is reduced to two small buttons. This means low loss and sharp tuning.

The stator plates are protected with a dust cap that can be detached without tools. The minimum capacity is extremely low, and body capacity effects are greatly reduced. The entire design makes for the highest efficiency in radio receivers.

*Built for
Efficiency*

Allen-Bradley Co.
Electric Controlling Apparatus
489 Clinton St. Milwaukee, Wis.

*Sell the
Bradleydenser*

This filter tuner with resistance-coupled audio amplifier is equipped with Bradleydensers. The tuning is sharp and selective.

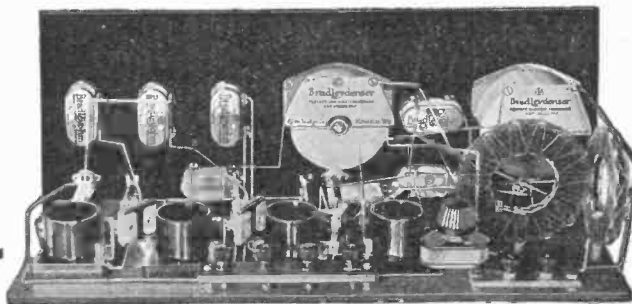

Send for latest sales information on the Bradleydenser. This nationally-advertised condenser will insure satisfied customers and a good profit.



There's compelling force in the Eveready 1925 advertising

THE national advertising campaign on Eveready Radio Batteries for 1925 is the most powerful sales effort ever released in the interest of the radio industry. The tremendous power of the great national magazines, led by *The Saturday Evening Post* with smashing pages in two colors and flanked by every radio-user paper of any importance, is the backbone of the attack. Supplementing this force locally are the great newspapers, covering practically the entire radio market. Firing

like a machine gun, these newspapers will put into circulation during 1925 the staggering total of 421,600,000 Eveready Radio Battery advertisements.

Stock Eveready Radio Batteries—they sell easiest and bring quick profits. Order from your jobber.

Manufactured and guaranteed by

NATIONAL CARBON COMPANY, INC.
NEW YORK

SAN FRANCISCO

Atlanta

Chicago

Dallas

Kansas City

Canadian National Carbon Co., Limited, Toronto, Ontario



Out of the Radio FOG

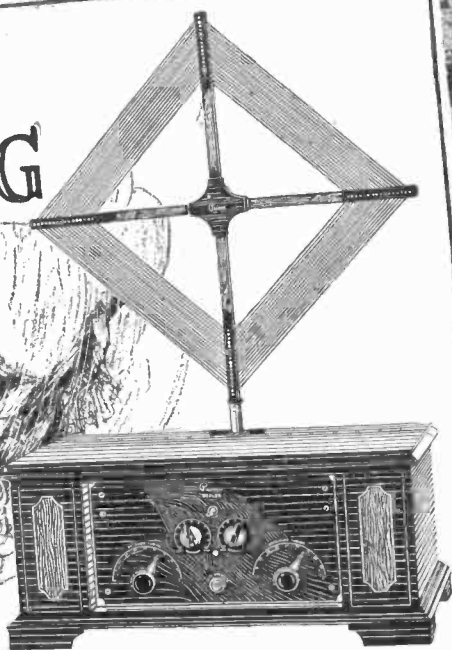

A great receiver for the VOICES of the Great Priess TRADE MARK THE CONCERT GRAND of RADIO

A Five-Tube—Reflex
Circuit—Loop Set
 NOW that you may hear McCormack, Bori, Chaliapin, Elman and the hosts of the great—on the air—you want something more than the ordinary receiver. You want these great artists without the fog of radio sounds to mar their perfect purity and tonal beauty. The PRIESS was designed for this exacting requirement by the nationally-known creator of the reflex radio system.

The PRIESS teloflex detector retains the liquid purity of the original sound without added tube or battery noises. The five tubes operate on the reflex system giving *seven-tube volume and distance capacity*. Indoor loop eliminates static from outdoor aerial and enables you to operate the set anywhere. Simple two-dial control. Solid brass malloy panel. Two-tone mahogany cabinet.

\$145 as illustrated

\$225 in rich console with concealed loop
 Any PRIESS dealer will demonstrate it in your own home if desired.
 Write or phone for booklet if there is no PRIESS dealer near you.

PRIESS RADIO CORPORATION
 695 Broadway

NEW YORK
 Telephone: Spring 4841

*One of a series of
 consumer advertisements
 now appearing*

A New Audience Numbering Millions Awaits This New Set!

Created by
WILLIAM H. PRIESS
originator of the Reflex system

THE millions of opera goers, concert enthusiasts and music lovers who demand SUPER performance from RADIO and will accept nothing else, are the great, new, profitable markets you can cultivate and sell with the SUPER performance of this new set.

Table and Console models.

*Dealers catering to a quality clientele
 are invited to write for further detail.*

PRIESS RADIO, INC.
 695 Broadway
 NEW YORK

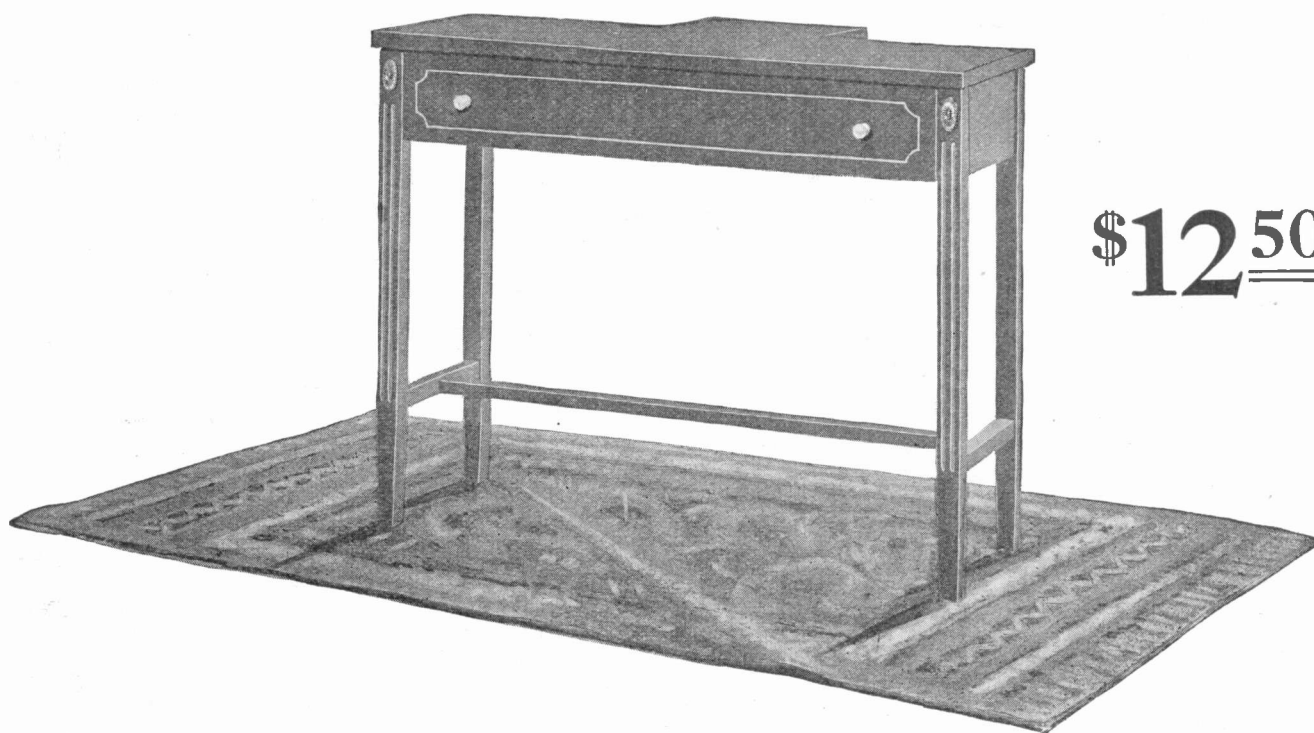

Picture Ten Million "Radio" Homes!

PICTURE for a moment the modern home.

Where do you find the radio receiver? Perhaps on the library table that already shows a scratched surface; or on the dining-room table where it is always in the way; or in one corner on the floor—the worst place possible.

People invest from \$25 to \$300.00 in a radio set—and then it is "kicked" from one end of the house to the other.

A sad condition—but a happy one for the radio dealer. For now he can meet this existing condition with satisfaction to every household and with profit to himself.

How? With the Radio Table, one of the finest pieces of furniture that ever portrayed the master woodworker's skill. The fine mahogany finish has been matched by a grace of line that is at once beautiful and artistic. And the desirabilities of radio have been increased by practical features—the disappearing loud-speaker shelf; the front that opens downward.

The Radio Table answers the problem of where in the home to put the radio set. And it answers this question in a fine, sensible way.

At the present time, these fine tables are being offered to dealers at the very low price of \$12.50.

Watch for our next page, something "New and Different."

Write now for the full information.

The John O. Jesse Manufacturing Co.
Bryan, Ohio

To Radio Dealers:

A new standard of broadcasting; programs that include the leading operatic stars, are opening up another gigantic Radio market. And those programs are doing one other thing—they are making an absolute necessity of one factor that has become a Sleeper characteristic in the minds of the public—Tone Clarity.

The next time you demonstrate a Sleeper Monotrol, call your prospects' attention to a Sleeper's ability to reproduce tone . . . any tone . . . faithfully and truly. The day is coming when Tone will be the one outstanding necessity in Radio reception.

And a Sleeper Monotrol has an unequalled degree of Tone Clarity now.

Sleeper advertising challenges the public to buy on performance only. You will find that demonstration—Sleeper demonstration—is the fastest way to close a sale. Try it!

Sincerely,

John C. Sleeper

Sleeper

MONOTROL

REG. U.S. PAT. OFF.



It's Compact!

SLEEPER RADIO CORP. 439 WASHINGTON AVE. LONG ISLAND CITY N.Y.

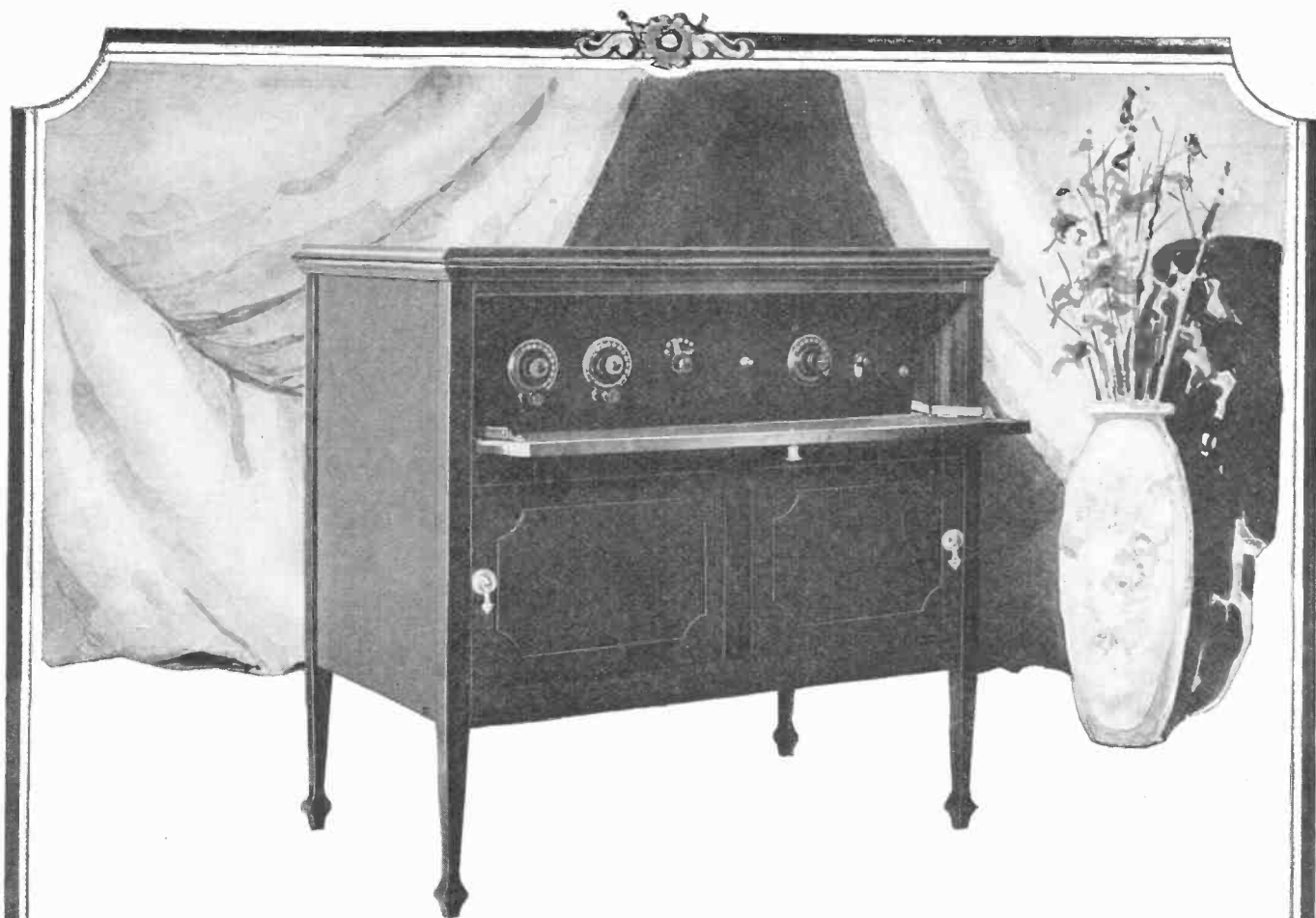

PREMIER

Tone - Quality - Appearance

Reception vs. Adjectives!

The Advent of the World Artist into the Broadcasting Field has made perfect Radio Reception not only a sales help but a public demand.

Premier appears at its best when producing the Classics AS THE ARTIST EXPRESSES THEM. To the music lovers anything short of perfect reproduction of their favorite artist is complete disappointment.

When Radio was first introduced reception of any kind was wonderful, but now Radio Reception must meet the acid test—the reproduction of voices known and loved by millions. Premier welcomes this situation.

Thousands of sales have been lost in the past by the failure of Receiving Sets to give satisfactory reception. Thousands of Receiving Sets have been sold only as a result of master salesmanship. Why not sell a Set that is unexcelled under any condition—a Set for which there is no reason for excuses or super salesmanship? Premier is such a Set. Its reception creates sales which breed good will, establishes word of mouth advertising and leaves profits with the dealer.

Your trade is buying Radio Reception. They will find it in any of the Premier Models.

For the progressive dealer we have a very interesting proposition, including exclusive franchise. Write or wire us today.

The Premier Radio Corporation.
Defiance, Ohio

Radio Distributors and Dealers —

The Gollos Non-Conflicting Sales Policy

The **Gollos Circuit**

a distinctive contribution to the development of the Radio art.

The Gollos Circuit adds a high stabilizing influence to tuned Radio Frequency through its introduction of proper capacities and inductances which greatly increase the grid impact eliminating all howls, squeals and extraneous valve noises. Static, if not at times entirely eliminated, is minimized so that interference from this source is not troublesome. Coastal reception is often obtainable with three tubes, permitting two additional audio frequency for reserve.

will interest you

The Gollos Radio Corporation's non-conflicting sales policy is proving of great interest to distributors and dealers. It offers real protection so that the distributor can operate on a practical, sound and profitable basis. It provides for the dealer so that he reaps full benefit from his radio investment, from the money expended for advertising purposes. The Gollos non-conflicting sales policy is a well organized and uniform plan that becomes at once a valuable asset and extends all the way thru. In addition to advertising matter, Gollos offers dealer protection and a system of furnishing factory sales instructors to build their radio departments into real business producers. This, in an effective manner, strengthens the distributor's position. Territorial arrangements are now being closed. Write or wire for the Gollos proposition.

Gollos Radio Corporation CHAMPAIGN, ILLINOIS

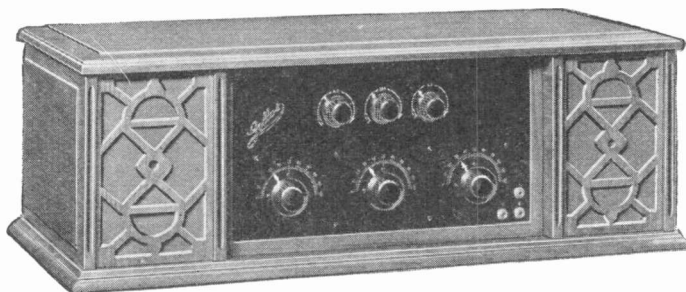

Table Model—5 Tubes

One Radio Frequency, Detector and Three Audio Frequency

We manufacture a complete line of Table, Highboy and Console Models. A feature of Gollos radio receiver is the inbuilt Duoaudion or Double-Horn Loud Speaker. The model illustrated is very compact. The cabinet is truly artistic. Made of American Walnut, highly finished. A striking example of modern design.

Gollos

PARTS—*the backbone of radio!*

**MAR-CO—*the backbone of a
profitable parts business!***

AS RADIO RETAILING pointed out editorially last month, a healthy parts business is the foundation of success in radio. "The parts business is there, and the man who can sell parts is the man who can also sell sets." For it is a known fact that everybody follows the road of the experienced experimenter—*who buys parts!*

"Set builders today are pleasure hunters, not money savers." They want precision far more than they want bargains! And they all know that they get "energy-saving" precision in any MAR-CO instrument!

The MAR-CO line is the widest line of quality instruments. It is consistently advertised, attractively packed, and distributed by one hundred and twenty-five good jobbers. It is the ideal line to form the backbone of a rapidly-moving, successful parts department!

The MAR-CO line of handsomely finished, precision radio instruments, includes Variable Condensers, A. F. Transformers, Plugs and Jacks, Sockets and Rheostats, Resistocouplers, Knife Switches, Battery Switches, Super-vernier-condensers—in fact virtually every standard part that has a *steady* sale. Write today for the complete catalogue. Martin-Copeland Company, Providence, Rhode Island. Branch Offices in New York, Chicago, Boston and San Francisco.



—*The line to concentrate on!*

Music Master Advertising makes Music Master Buyers

Resonant Wood
Insures
Tone Quality

THE reason for Music Master supremacy—reasons based wholly upon proved principles of sound reproduction—are clearly set forth time and again in full-page advertisements in the Saturday Evening Post and other widely circulated national publications, including many of the great daily newspapers.

These publications represent a powerful force to create customer demand. The wide-awake dealer will capitalize this demand for Music Master by making it easy for the prospective purchaser to buy.

Intending buyers pass you door every minute of the day. Do they know that you can supply their Music Master needs? Are Music Masters displayed in your windows and on your counters?

Music Master descriptive folders for circularizing, display signs, transparencies, electros for local advertising—all may be had for the asking. Write to your jobber. If he cannot supply you, write direct to us.

Music Master is the most easily sold and fastest selling item in radio—and it helps you to sell sets, too, and so keeps your customers satisfied. There is no substitute.

Music Master Corporation

Makers and Distributors of High Grade Radio Apparatus

10th and Cherry Streets

Chicago

PHILADELPHIA

Pittsburgh

MODEL VI \$30
14-in. horn

MODEL VII \$35
21-in. horn

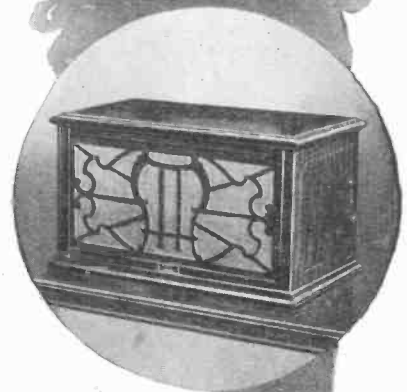
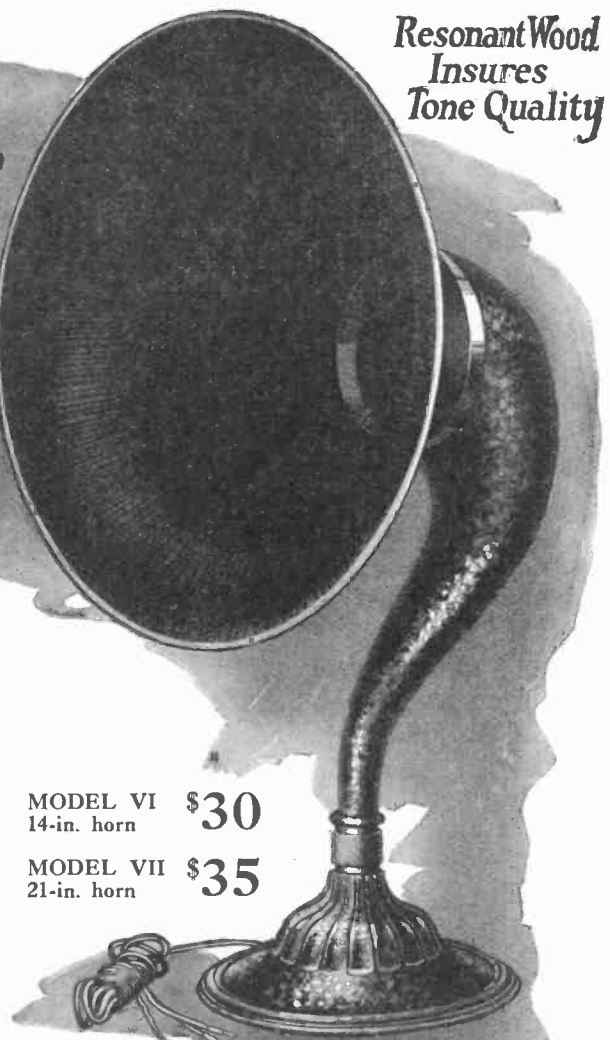

MODEL VIII
Mahogany Cabinet
with "full floating"
horn of nat-
ural wood \$35

Music Master

RADIO REPRODUCER

Connect in place of
headphones.
No batteries needed.
No adjustments.

“Ask Any Technical Engineer” what he thinks of the name “BRISTOL”

For 36 years The Bristol Company has been making Recording Instruments — highly scientific machines that measure in minute degree everything from the withering heat of the electric furnace to the polar cold of an ice plant; the dryness and humidity of the air; the varying densities of liquids; and scores of other properties of matter.

It has always been a religion to make an instrument that will not merely get by a rigid factory inspection, but one that will function on the job without coddling. Many thousands of these sturdy, yet sensitive, instruments are quietly doing their work in the plants of this country.

Every article in your radio stock is somebody's promise to satisfy your most critical customer. Any technical engineer of your acquaintance will tell you whether or not The Bristol Company has a record for making good its promises.

With five Bristol Loud Speakers, retailing from \$12.50 to \$30.00, and Bristol representatives in eight principal cities, you can satisfy every customer who comes to your store. One line — one freight — one responsible house to deal with. Write for bulletins describing Bristol products.

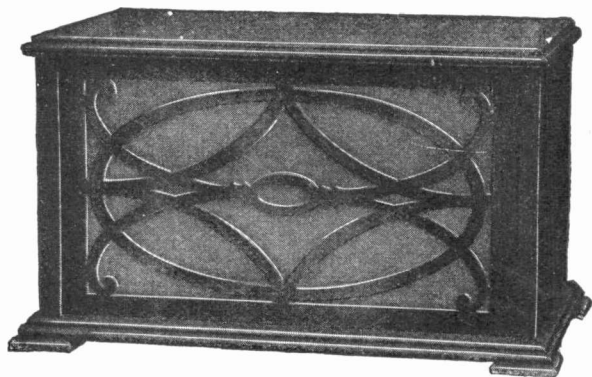

New Cabinet Model \$30

Beautifully finished mahogany. Full floating wooden horn and cast metal throat. Size 17 x 10 x 10½ in.

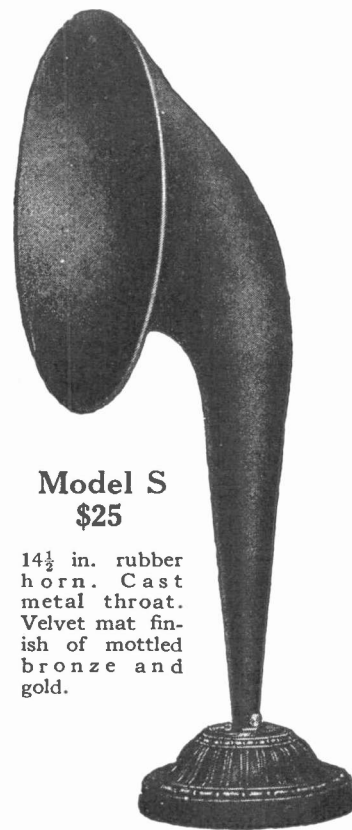

Model S \$25

14½ in. rubber horn. Cast metal throat. Velvet mat finish of mottled bronze and gold.

BRISTOL TRADE MARK AUDIOPHONE REG. U.S. PAT. OFFICE Loud Speaker

The Bristol Company, Waterbury, Conn.



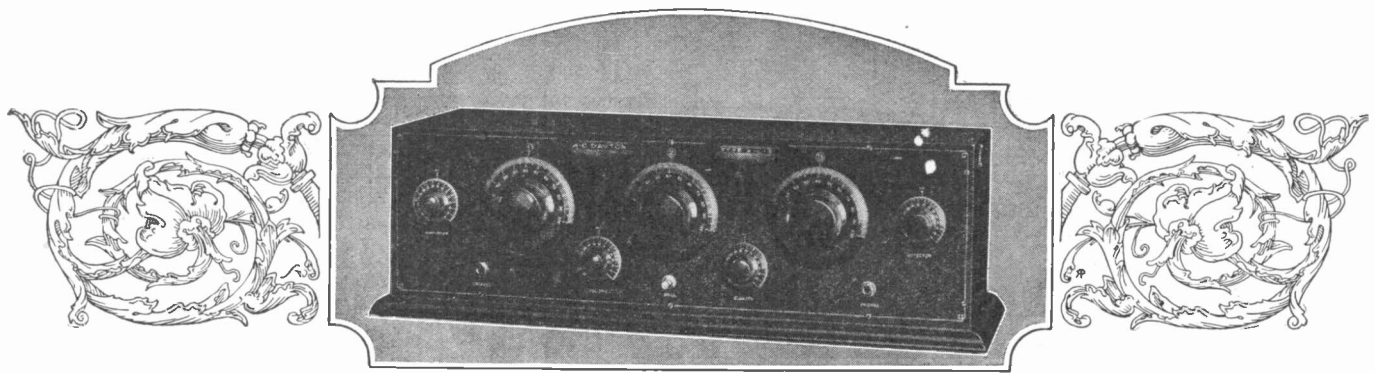

Why do they sell the A-C Dayton XL-5?

ASK any A-C DAYTON Dealer why he chooses to sell the XL-5. "Because it makes money for me," he will say. "It is easy to sell and it *stays sold*."

There's the real answer. *It stays sold!* It consistently backs up our claims for it by actual performance every day. It satisfies the owner, justifying our unreserved guarantee in every way. Of the thousands of sets sold and in use, *less than one-half of one per cent* have been returned *for any cause*.

Electrical and radio dealers who are featuring the A-C DAYTON XL-5 are making money. They are building a solid and profitable business with a high-grade set that is easy to sell, that convinces the prospect by its matchless performance in selectively, volume, distance, and in clear, undistorted reception. The XL-5 is a five-tube Receiver, with tuned radio frequency and balancing control. Its compact, mahogany cabinet is a thing of beauty, adding to its saleability. List price only \$115.00, less tubes and batteries (\$120.00 Denver and West).

May we send you a complete description of this remarkable receiver, along with our liberal dealer proposition?

Proven by Performance

THE A-C ELECTRICAL MFG. COMPANY

DAYTON, OHIO

Makers of Electrical Devices for Over Twenty Years

XL-5 Knock-Down

For those who prefer to build their own receiver, the A-C DAYTON XL-5 is furnished in knock-down form.

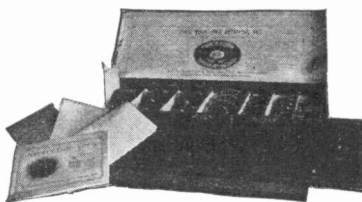

The list price in knock-down form, complete with all parts and directions, is \$72.50 (\$76.50 Denver and west).

A-C DAYTON

XL-5

**If Mozart
could hear "The Magic Flute"
on a FADA Neutrodyne**

—his trained ear would approve the tonal fidelity to the original in his famous old opera. The peculiar charm of this woodwind instrument is caught in all its purity by the famous Fada Neutrodyne. With equal tonal truth, Fada reproduces the deep rolling bass of the pipe-organ.

The Fada Neutrodyne has the range of the 88-key pianoforte. McCormack's pure tenor, Bori's delicious soprano, create the illusion of standing beside the actual artists when you hear them on a Fada set. Bass and baritone voices are reproduced with equal fidelity. Nor does Fada create those raucous distortions that have kept many discriminating folks from investing in radio.

Fada selectivity is one of its chief charms. Turn the dials to predetermined numbers, and in rolls the very station you want to hear—provided the waves from that station are reaching your neighborhood. Fada also excels in distance and volume. In short, Fada is radio at its very, very best.

There are six models to meet every taste and pocketbook. \$75 to \$270. Fada is adapted to either dry-cell or storage-battery tubes, and either indoor or outdoor aerial. Hear Fada. It will be a revelation in radio! Buy your Fada now and be ready to hear the world's famous artists whenever they sing or play for you over the radio.

F. A. D. ANDREA, INC.
1581 JEROME AVENUE, NEW YORK

FADA advertising is a power in the industry

FADA advertising is designed to sell the joy of radio in general, as well as Fada sets in particular. As a leader in the great radio industry, Fada is glad to devote valuable space to the *radio idea*.

Radio programs are getting better and better. Artists of national and international note are bringing their talents to

the microphone. Radio advertising is likewise improving.

Fada advertising is a power in the industry. Speaking through the columns of *The Saturday Evening Post*, with its tremendous circulation, and

through the great metropolitan newspapers, the voice of Fada is carrying far and clear.

Live dealers are turning this advertising to their own profit by co-operating in every way toward its success. Fada has

a complete line to meet every taste and pocketbook. This includes the famous Fada phonograph panel.

FADA Radio

F. A. D. ANDREA, INC., 1581 JEROME AVENUE, NEW YORK

Meet Our Salesman

This is our Salesman. It offers you a sturdy Radio Table at a price within the reach of all your customers.

Owning and operating our own timberlands, saw mills and two large wood-working plants, makes the low prices possible. Eighty years of manufacturing experience are your guarantee of quality.



Top 32-in. x 16-in.
The Pycó Radio Table
 Made of selected hardwood, with Pycowood panel top. Finished in Mahogany or Walnut. Shipped set up and crated, weight 42 lbs.

\$6.00
Dealer's Price



Top 36-in. x 20-in.
Pycó Radio Cabinet Collapsible

Made of hardwood and our own panels. Finished in Mahogany or Walnut. Shipped knocked down and crated, weight 57 lbs.

\$12.00
Dealer's Price

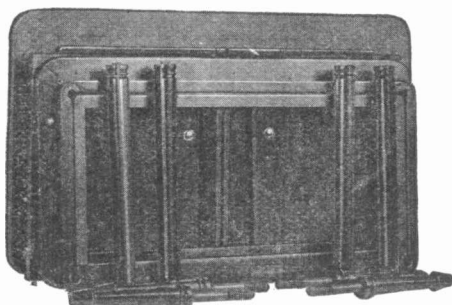

Dealers

Display your Radio Sets with batteries complete on this table.

All goods sold F.O.B. Factory, Orleans, Vermont.

For freight shipment we suggest that you take three tables or cabinets to make the minimum weight. If you want one, have shipment by express.

The Parker-Young Co.
 131 State St.
 Boston, Mass.

Gentlemen:
 Inclosed find check for \$..... Kindly send us
Radio Table at \$6.00 each.
Radio Cabinet at \$12.00 each.
 Also send us your catalogue.
 Very truly yours,

Name

Street.....

City.....State

The Parker-Young Company

131 State Street
 BOSTON, MASS.

The Diaphragm is an Important, Exclusive and Remarkable Feature!

The G-G-H is built on new, different, distinctive principles. All these features were developed by G-G-H engineers. It is impossible for any other "loud speaker" to be *just as good* or *similar to* the G-G-H.

Among these distinctive features none is of greater importance than the G-G-H Constant Tension Diaphragm (patent pending). This diaphragm is "formed" to give a permanent tension in direction of magnet poles. This feature eliminates the usual harshness. A lever permits easy control of air-gap, so that the G-G-H can be adjusted to work in perfect harmony with any receiving set.

With the G-G-H it is possible to obtain greater volume, perfect clarity, and a smooth, pleasing quality of tone. To sell the G-G-H means controlling the "loud speaker" sales in your neighborhood.

*Write at Once for
Full Details and
Particulars of
Big Discounts*

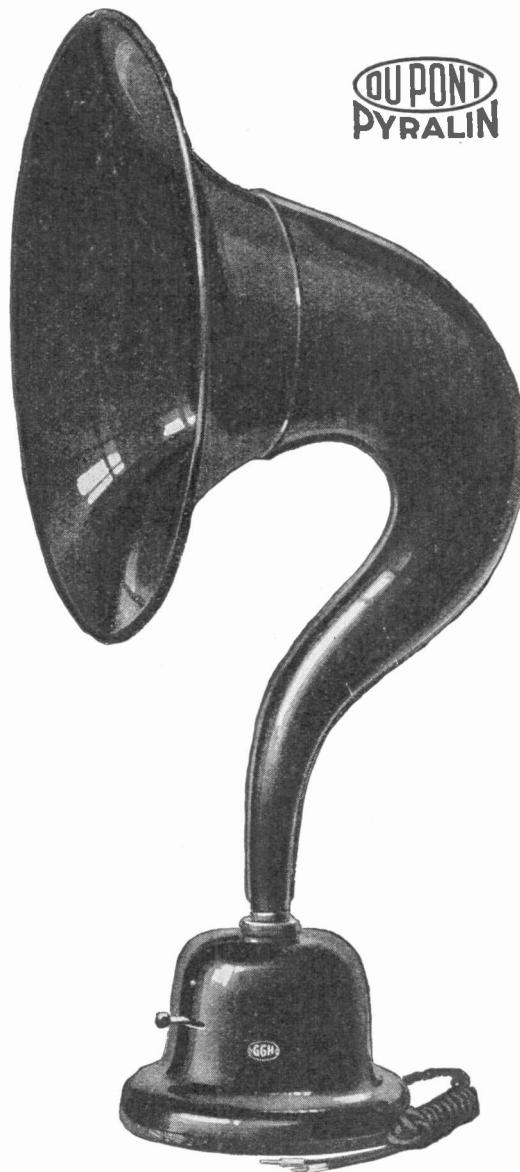

G-G-H REPRODUCER

*Prices that Sell
Profits that Pay*

Ebony Finish.....	\$12.50
Shell Finish.....	15.00
Japanese Pearl.....	17.50
Mother of Pearl DeLuxe.....	20.00

GRIGSBY - GRUNOW - HINDS - CO.
4550 ARMITAGE AVE.
CHICAGO-ILL.

Explore the Air
Farther - Clearer!

Alden
NA-ALO
Processed
DIALS

- 1-Scientific Design
- 2-Prevent Eycatain
- 3-Comfortable Knobs
- 4-Handsome Appearance

Quick and Easy
Tuning

Use them in the set you build
Be sure they're in the set you buy

ALDEN MANUFACTURING COMPANY DEPT. A2 SPRINGFIELD, MASS.



Alden
NA-ALO
Processed
SOCKETS

- 1-Contacts Self Cleaning
- 2-Positive Duo Contact
- 3-Low Loss - Low Capacity
- 4-Alden Processed Bakelite

It's the Contact that Counts

Use them in the set you buy
Be sure they're in the set you buy

ALDEN MANUFACTURING COMPANY DEPT. A2 SPRINGFIELD, MASS.

This Na-Ald Window Display in colors has strong sales-force as well as attractive appearance.

Makes "perfect contact" between your store and Na-Ald advertising

HERE is a way to sell more sockets and dials. Feature the leader — Na-Ald.

You or your salesmen don't have to spend a lot of time explaining their merits. They are already known to radio owners through the wide-spread Na-Ald advertising. Sales are easy and quick.

The Saturday Evening Post, American Boy, all important radio magazines and radio sections of leading newspapers carry Na-Ald Socket and Dial advertisements every month. And now to help you bring into your store more of the Na-Ald sales that our advertising starts, we have prepared the new window display shown above.

Printed in 7 colors, 26 inches high by 32 inches long, this display makes an attractive, arresting appearance in your window. Its striking effect stops people and its convincing sales points draw buyers into your store.

This window display is given free with the fast-moving "Two-Week Sales Unit" of Na-Ald Sockets and Dials.

Write today for particulars. See how readily you can increase profitable socket and dial volume.

ALDEN MANUFACTURING COMPANY
Dept. A2 Springfield, Mass.

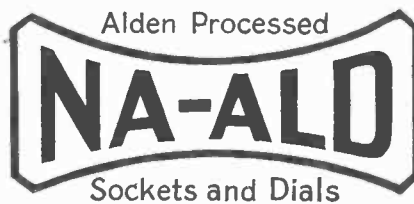

MANY radio owners have...
It's the Contact that Counts

Make Clearer the voice of your Radio

DISTANT points are brought in clearer with more freedom from rasping noises when the contact between tubes and sockets is perfect. You can't have clear radio without clean contact. It's the contact that counts.

Experienced radio owners use Na-Ald De Luxe Sockets because the broad dependable duo-contact and the clean-easy feature insure perfect contact at all times.

With Na-Ald De Luxe Sockets, corrosion—the arch-enemy of clean contact—is easily and quickly removed simply by turning the tube back and forth in the socket. Thus clean, perfect contact is assured at all times—without the bother of removing the tubes and scraping the contact surfaces with sandpaper or file.

Lowest loss and highest insulating qualities the contact surfaces with Na-Ald Sockets are insured in Alden Sockets by using Alden Processed genuine Bakelite.

You can obtain Na-Ald Sockets for all tubes and dials of different sizes at radio, electrical and hardware stores everywhere. Be sure you have Na-Ald Sockets and Dials in the set you already own, build or buy. De Luxe Sockets and Super-Deluxe Dials, 75¢; other Dials and Sockets, 35¢, 50¢, 75¢.

Mail coupon for free booklet "What is Built" SEND for free copy of radio booklet "What is Built" giving a number of the best selected and tested circuits.

ALDEN MANUFACTURING COMPANY
Makers of the famous Na-Ald Sockets and Dials
Dept. E-1, Springfield, Mass.

Alden Processed
NA-ALO
Sockets and Dials

ALDEN MANUFACTURING COMPANY
Dept. E-1, Springfield, Mass.
Name _____
Address _____
City _____ State _____

Reduced reproduction of half-page Na-Ald advertisement in The Saturday Evening Post.

75% More Sales

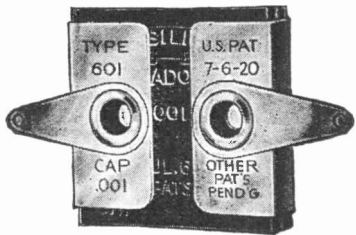

*Micadon—
the standard fixed radio
condenser—35c—75c.*



*Dutect—
a highly sensitive syn-
thetic crystal—30c.*

*By-Pass
Condenser—
for finer, clearer re-
ception — 75c to \$3.75*

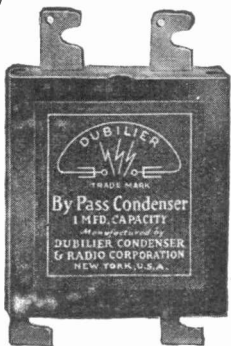

A recent survey made by department stores—our most successful merchandisers—shows that only 25% of their sales are made up of just those things which the customer comes to the store to buy. The remaining 75% of the sales comprise purchases these customers make as a result of what they see in the stores *after* they get in and look over the offerings.

Practically every radio fan uses one or more Dubilier products—a Micadon, a Ducon, a Duratran, a Dutec, a By-Pass Condenser or a Resistance Unit. The radio buyers go to those shops where they know they can get Dubilier Devices.

Stock these devices—and boost the sale of *all* your products.

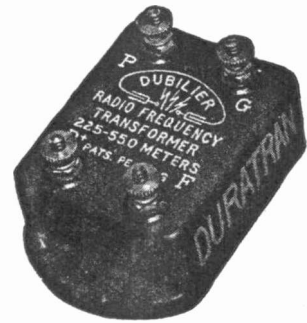

*Duratran—
the efficient radio-fre-
quency transformer —
\$4.00*



*Resistance Unit—
the accurate grid leak—
50c*

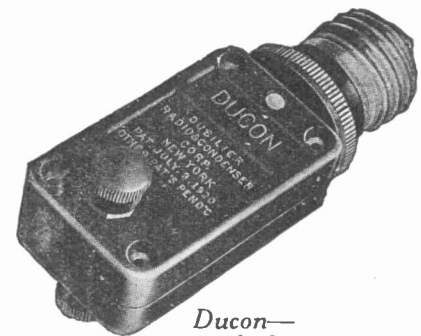

*Ducon—
standard antenna socket
plug—\$1.50*

Dubilier

CONDENSER AND RADIO CORPORATION

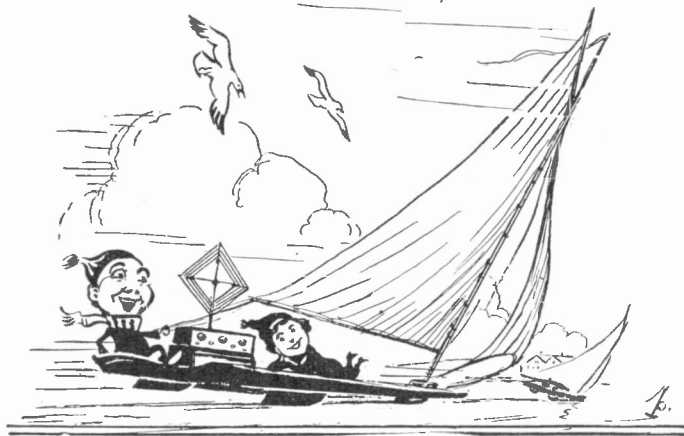

Radio Retailing

The Business Magazine of the Radio Industry

Contents for February, 1925

Cost Figures Will Chart the Way <i>The First Figures Ever Published on the Actual Cost of Retailing Radio Products</i>	131	Radio in Every Room <i>"Wired Outlets in Every Room" Idea Is Being Taken up from Coast to Coast</i>	160
Increasing Radio Earnings <i>Des Moines Dealer Pays Commissions, Sells on Time and Handles Trade-ins to Increase Sales</i>	135	Radio vs. the Theater <i>Concerts by Victor Phonograph Artists Arouse Ire of New York Theater Managers</i>	161
New Profits from Old Customers <i>How a Dealer Keeps Old Accounts Active by Selling Them Radio Before Their Bills Are Paid</i>	137	Dealer Builds Own Radio Craze <i>Home-Made Broadcasting Station Increases Radio Sales for Grand Rapids Merchant</i>	162
The Salesman's "Fourteen Points" <i>Fourteen Fundamental Principles that Every Retail Salesman Should Know</i>	138	Eliminating "Interference" <i>Simple Methods the Dealer Can Use to Get Rid of Those Troublesome Reception Noises</i>	164
What I Would Do If I Were— <i>A Radio Dealer, by William H. Ingersoll A Radio Manufacturer, by S. B. Davega</i>	140	Horns, Cabinets, Cones or Concealments? <i>What Will Be the Design of the Loud Speaker of Tomorrow? Is the Horn Type Doomed?</i>	171
Paving the Way for Door-to-Door Selling <i>The "Hows" and "Whys" of Outdoor Sales Campaigns Clearly and Concisely Explained</i>	142	Servicing the Sale of Radio Sets <i>Four Plans the Dealer May Follow in Deciding His Service Policies. In Two Parts — Part One</i>	173
Ruining the Radio Industry <i>A Bitter "Price War" Among Radio Dealers Has Ruined Business in Providence, R. I.</i>	145	Comments from Readers <i>"Radio Retailing" Receives Hundreds of Letters from Dealers, Jobbers and Manufacturers</i>	176
"The Gyp Must Go" <i>Leaders of the Industry Express Emphatic Opinions Concerning "Gyping" Practices</i>	148	New Products for the Dealer to Sell <i>Latest Sets, Accessories and Parts the Manufacturers Are Putting on the Market</i>	182
Quality Pays <i>San Francisco Dealer Specializes in High-Grade Radio Products and Caters to Prosperous Trade</i>	151	Dealer Helps the Manufacturers Offer <i>How Makers of Radio Apparatus Are Aiding Their Retail Dealers to Bigger Sales</i>	190
Complete Radio Set Specifications <i>Full Information Compiled for the Dealer on Practically All Sets Manufactured</i>	154	What the Trade Is Talking About <i>News and Notes of the Radio Industry Gleaned from the Four Corners of the Country</i>	192

McGRAW-HILL COMPANY, INC., Tenth Avenue at 36th Street, New York

JAMES H. MCGRAW, President
ARTHUR J. BALDWIN, Vice-President
MALCOLM MUIR, Vice-President
E. J. MEBREN, Vice-President
MASON BRITTON, Vice-President
JAMES H. MCGRAW, JR., V.-P. and Treas.
C. H. THOMPSON, Secretary
Cable Address: "Machinist, N. Y."
Copyright, 1925, by McGraw-Hill Company, Inc.

Electrical World Journal of Electricity Ingenieria Internacional
Industrial Engineer Engineering and Mining Journal-Press
Power Engineering News-Record Coal Age American Machinist
Electrical Merchandising Chemical Electric Railway Journal
Bus Transportation Chemical & Metallurgical Engineering
RADIO RETAILING
O. H. CALDWELL, Editor
M. CLEMENTS, W. C. ALLEY, L. E. MOFFATT, Chicago
Contributing Editors EARL WHITEHORNE, L. A. HANSEN
F. R. CLAESS, R. M. DAVIS, O. RISO
H. S. KNOWLTON, Boston P. WOOTON, Washington, D. C.
C. GRUNSKY, San Francisco

WASHINGTON, D. C., Colorado Bldg.
CHICAGO, Old Colony Bldg.
PHILADELPHIA, Real Estate Trust Bldg.
CLEVELAND, Leader-News Bldg.
ST. LOUIS, 713 Star Bldg.
SAN FRANCISCO, 883 Mission Street
LONDON, E. C., 8 Bouverie St.
Annual subscription rate is \$2 in United States and Canada.

Cost of Merchandise
73.3 cents

All Figures Are Based
on amount actually received for
goods (after markdowns have been
taken), and not on manufacturer's
"list retail price" (on which dealer's
discount is ordinarily computed).



What Becomes of the Customer's Radio Dollar?

Analysis of store-operating and selling costs for seven radio departments, in this issue, shows that out of each dollar the customer pays across the counter for radio merchandise, about 73 cents is required to pay the dealer's cost of the merchandise itself, 9 cents goes for clerk hire

and similar selling expenses, 3.7 cents for rent, heat, light, etc., 4.4 cents for publicity, 3.3 cents for buying expense, and 4.3 cents for administration,—leaving, out of the whole dollar, only 1.9 cents for the dealer's profit. What are the corresponding figures for your store?



How Do These Averages Compare With *Your Own* Selling Costs?

Radio Retailing

VOLUME 1

FEBRUARY, 1925

NUMBER II

Cost Figures Will Chart the Way for the Radio Merchant

How Studies of Operating Expenses in Stores Handling Radio, Point Path to Economies and Greater Profits—A Review of Selling Costs in Nine Radio Departments

By LAWRENCE A. HANSEN
Contributing Editor, "Radio Retailing"

"WHAT good are any figures we might keep?" objected one radio-dealer friend of mine, when we got to discussing store records. "A radio inventory valued at \$500 today, may be worth less than \$300 tomorrow." And on this merchant went, in his endeavor to show me why he didn't keep any cost records,—also, why, as I later found out, he didn't make a profit.

Yet the fact that this merchant was losing money proved beyond any question that he needed to know more about the costs of selling. He needed to know more about store management. He needed a guide, and the one guide he needed was *cost figures*. He needed not only such figures on his own store, but he needed those of

other merchants selling what he was selling. He needed to compare his experience with that of others.

For figures are to the merchant what the compass is to the ship's captain. Figures serve to chart the seas of retailing. They tell the dealer where he is headed for—whether the plus or the minus side of the profit-and-loss statement.

When a business is not prospering, there are always reasons. These reasons or causes may be in the operation and management of the store or business itself, rather than the result of any fundamental conditions of the trade or industry. To get quickly at the causes of lack of prosperity, therefore, there is no better method than to compare figures with

successful stores and businesses operating in communities of similar size, and doing a comparable job of selling. And, often a prosperous business may be made even more successful by comparing its operating-cost figures with those of other successful stores.

Such information on store-operating costs, compiled for a group of businesses, will chart the way for other merchants. It shows how others went, and it shows how those others fared.

If they met with success the path is probably safe. If they showed a failure, it definitely marks one route that other merchants should not take.

Radio is being sold today by many

Every Radio Merchant Should Study His Selling Costs— Comparing His Own Figures with Those of Other Radio Dealers

Only by careful study of his costs of store operation and the comparison of these costs with cost figures of similar stores handling radio, can efficient selling methods be developed by any radio dealer.

On the following pages will be found summarized operating

costs in the radio departments of nine department stores—also a simple form which the reader can fill out for analyzing his own store costs and comparing his figures with those for the nine radio departments given.

Readers are also invited to send copies of their own store

operating figures to Mr. Hansen, in strict confidence. He will compare them with corresponding figures for successful radio businesses, and will personally reply under sealed envelope to each reader contributing, pointing out which of their figures seem high and where economies should be effected.

and various kinds of merchants. Aside from the exclusive radio store, there are the electrical dealer and the music dealer. Many sporting goods and hardware merchants also display radio parts in their windows, and a few merchandising druggists show radio sets on their counters.

But among the very first merchants to take up radio on a merchandising basis, were the department stores, and it is with this type of store, because of its longer radio experience and scientific merchandising methods, that we begin our first study.

Nine stores have been selected, situated in nine different cities of the United States. The radio departments of these stores, because of their volume of sales, afford examples worthy of careful study and comparison by even the smallest dealer. The net sales of the several radio departments, reaching from \$28,000 to \$183,000, annually, as they do, coupled with the fact that each department is treated as a unit store, only make the cost figures more valuable to the individual merchant.

Here it may be well to explain that all percentage figures in this discussion are based on the selling price, that is, on the "sales dollar." This is, of course, the recognized practice in all merchandising accounting today.

"The radio sales dollar" we may picture as an American dollar which in the eyes of the merchant is divided into two sections. The larger of these two sections represents the cost of the merchandise sold. The other part is the "margin." This margin should include all expenses, plus a profit. From the experience of these nine stores, there was an averaged merchandise cost of 73.3 per cent in those radio departments which were successful ones. In other words, practically three-fourths or 74 cents out of every dollar spent for radio, was required by the retail merchant to purchase the merchandise itself. Store I as shown in the schedule, reported its merchandise cost as 90.8 per cent. This is particularly interesting but hardly understandable. Its total sales were much better than store H, which reported 76 per cent as its figure, and it is even better than store A with its figure of 73.5 per cent.

The other section of this radio dollar or sales dollar—the margin, averaged 26.7 per cent. The high figure was reached in store F, namely, 28.8 per cent, while the low was in store I, of 9.2 per cent. But here, because the experienced merchant will sense something radically wrong in the management of this particular store, it is not well to take this figure for comparison purposes, but rather to

consider the low as 25 per cent. In fact it might be better to eliminate both this store and store H entirely from the picture. They clearly show one way no merchant should go,

Five Divisions of Expense

For the most part merchandise cost ran fairly equal in all of these departments. This is also true with margin. But in the different expense items which go to make up the total expense of operating the departments there is a wide variation. This may be true because of different methods of allocating expenses. It may be the human element present,—for no two minds may consider an item of expense the same. However, we can make a definite division of the total expense into about five classifications. The standardized system of accounting followed by department stores considers these five divisions as: Administrative, Occupancy, Publicity, Buying, and Selling—which last includes delivery.

Before going further in our analysis it might be well to break these expense classifications up, in order that we may clearly understand what items are included in each one.

All general administrative expenses, including expenses of executives, fall under the administrative division. Bookkeepers' salaries, expenses of the credit department, and

Sales, Profits, Stock-turn, and Operating Costs for

Net Sales =

Store	Gross Sales		Returns and Allowances		Net Sales		Merchandise Cost		Margin		Total Expense		Selling Expense	
	\$	%	\$	%	\$	%	\$	%	\$	%	\$	%	\$	%
A	87,000		16,000	18.5	71,000		52,185	73.5	18,815	26.5	17,750	25.	6,603	9.3
B	238,000		55,000	23.2	183,000		131,211	71.7	51,789	28.3	45,018	24.6	18,666	10.2
C	120,000		22,000	18.2	98,000		72,128	73.6	25,872	26.4	24,304	24.8	7,056	7.2
D	100,000		10,000	10.1	90,000		67,500	75.0	22,500	25.	21,870	24.3	8,370	9.3
E	100,500		17,500	17.5	83,000		61,835	74.5	21,165	25.5	20,335	24.5	8,383	10.1
F	57,500		10,500	18.4	47,000		33,464	71.2	13,536	28.8	11,985	25.5	4,982	10.6
G	137,000		16,000	12.7	121,000		89,419	73.9	31,581	26.1	29,766	24.6	8,470	7.
†Average								73.3		26.7		24.8		9.1
†High	238,000		55,000	23.2	183,000		131,211	75.	51,789	28.8	45,018	25.5	18,666	10.6
†Low	57,000		10,000	10.1	47,000		33,464	71.2	13,536	25.	11,985	24.3	4,982	7.
*H	32,000		4,000	12.2	28,000		21,280	76.0	6,720	24.	8,512	30.4	4,620	16.5
*I	126,000		32,500	25.8	94,000		85,352	90.8	8,648	9.2	26,508	28.2	9,964	10.6

Returns and Allowances are returned merchandise by the customer; Merchandise Cost—includes invoice price plus freight and cartage in; Margin—formerly termed gross profit—includes total store expense and a profit; Selling Expense—includes

selling salaries, supplies for sales department etc.; Buying Expense—all costs incurred in the buying of merchandise and stockroom expense; Publicity Expense—advertising, both newspaper and circular, and window trimming expense with cost

general store expenses are also included in this account.

Occupancy includes all items of expense, such as rent, taxes, proportionate amount of interest on owned buildings, light, heat and insurance.

Costs of advertising in both newspapers and circulars are included in the publicity classification. Interior and exterior display expense, together with window-decorating expense must also be considered as forms of publicity.

Expenses in stockroom, buying merchandise, etc., are included in the buying expense division, while selling expense covers all items incurred in the actual selling of the merchandise. Salesmen's salaries, cost of price tags, sales books, etc., are all examples of selling expenses which are covered by this general heading.

It is next to impossible to get the individual expenses in terms of percentage to the sales dollar for all of these items are classified under the general heading. But the five groups of expenses are covered rather accurately.

When we consider other types of stores we cannot say that the total expense represented as the common figure of 24.8 per cent is high. The general figures for department stores of this size and sales volume show a total of expense of about 27 to 33 per cent. The hardware store shows

an average total expense ranging from about 23 to around 27 per cent.

Studying these items or classifications separately, we find that selling expense is by far the larger, averaging as it does 9.1 per cent, while the highest of any other expense classification, that of publicity, was 4.4 per cent.

A Selling Expense That Is Too High

The high point of sales expense was reached by store H, namely 16.5 per cent, which would seem to my mind to be excessive. Again when we compare the loss sustained by this store of 6.4 per cent, with the average-selling expense we can see something that appears a little out of tune with the other stores' experience.

The difference in expense of 16.5 per cent and the average figure of 9.1 per cent for this classification is very close to 6.4 per cent. This is the percentage of store H's loss. By this I do not mean that if the store cut down its selling expense to the average figure that this loss would be eliminated. I just simply want to point this situation out, and show that by comparing these figures we can lay our fingers very definitely on troubles with the store. Selling expense for one thing is too high, in this individual case.

It is well to remember that by far

the larger amount of selling expense is represented in selling salaries of the clerks. We do not know definitely what this expense is for the radio store, but we can expect probably to find it reaching a figure of about 7 to 9 per cent. This figure though will vary with the type of merchant selling radio and method used in paying salespeople. There are two stores, store C and store G, which seem to suggest the possibility that the department is staffed by female salesclerks. The total selling expense in these two stores is only about 7 per cent. If we were to allow the figure that is most common with hardware store, electrical store, etc., for selling salaries we would find this amount pretty much absorbed. This leaves little for other expenses which fall under this classification. It also leads us to believe that salaries are small.

Selling, however, automatically refers our minds to advertising. The question then comes up—what was the advertising expense in order to create the sales volume? Ordinarily we should expect advertising in stores selling radio to run fairly high. Radio is a new product. The market must be developed. People must be told what a given set will do. This is not so much to create interest in radio, as to meet the contending claims of the numerous sets

Radio Departments of Nine Department Stores

100 per cent

Buying Expense		Publicity Expense		Occupancy Expense		Administrative Expense		Profit and Loss		Ave. Inv. Investment	Cash Disc. on Purchases	Annual Stock Turn
\$	%	\$	%	\$	%	\$	%	\$	%	\$	%	
923	1.3	4,757	6.7	2,698	3.8	2,769	3.9	1,065	1.5	15,348	2.5	3.4
8,052	4.4	4,026	2.2	7,869	4.3	6,405	3.5	6,771	3.7	25,727	2.1	5.1
4,900	5.	4,704	4.8	1,862	1.9	5,782	5.9	1,568	1.6	6,740	1.6	10.7
990	1.1	4,770	5.3	4,410	4.9	3,330	3.7	630	.7	21,093	1.6	3.2
1,162	1.4	4,067	4.9	3,486	4.2	3,237	3.9	830	1.	18,186	2.	3.4
2,115	4.5	987	2.1	2,209	4.7	1,692	3.6	1,551	3.3	6,990	1.9	4.8
6,413	5.3	5,808	4.8	2,057	1.7	7,018	5.8	1,815	1.5	20,771	1.5	4.3
	3.3		4.4		3.7		4.3		1.9		2.	5.
8,052	5.3	5,808	6.7	7,869	4.9	7,018	5.9	6,771	3.7	25,727	2.5	10.7
923	1.1	987	2.1	1,862	1.7	1,692	3.5	630	.7	6,740	1.5	3.2
504	1.8	1,204	4.3	1,092	3.9	1,092	3.9	-1,792	-6.4	7,881	2.0	2.7
1,128	1.2	6,298	6.7	3,290	3.5	5,828	6.2	-17,860	-19.0	44,922	2.3	1.9

of store interior display; *Occupancy Expense*—includes rent, light, heat, water taxes, etc.; *Administrative Expense*—includes executives' salaries, office salaries and expenses, together with all general store expense.

† Include only those stores A, B, C, D, E, F, G, which show a profit.
* These stores show a loss.

now being offered to the public. Competition in manufacturing radio sets is running high. This probably would justify expectations for a rather high advertising expense, in order to create a market for them. But, what do we find? The total cost of publicity, including advertising, store display and window display, averages only 4.4 per cent for these seven successful departments. This figure does not seem excessively high. If we were to segregate advertising from this classification we would probably find it running no greater than three to four per cent. This is quite in line

with the advertising expense in other fields which are pretty well established. Ordinarily the high-point of 6.7 per cent experienced in store A would cause a question. The newness of the industry partly excuses it, yet it is at the danger line. When this item begins to grow this large, the merchant should look to his methods of advertising. Waste advertising may have crept into the program. Advertising running around a figure of five to six per cent may not be pulling sales,—that is, sales which are profitable to the business and commensurate with the expense involved in securing them.

Again, it is interesting to see that the stores with the smaller volume of sales show the higher publicity expense. This is undoubtedly due to the fact that the department may be new. These stores are building a good-will. We might say, they are "breaking into the game." Contrast these departments with those experiencing a larger sales volume, the store with a greater momentum of trade, and one can understand the difference.

Creating demand is one thing, selling to that demand is another, but buying for the demand is quite an-

(Continued on Page 175)

What Becomes of the Customer's Radio Dollar You Collect?

For Your Own Information, Fill Out This Form and Compare Your Results With Those of Other Radio Merchants. A Surprise May Be In Store For You

All Figures Are Based on Annual Business

	\$	%	Averages for Seven Radio Departments,
NET SALES		100	100
<small>Include in this figure the total merchandise you sold that remained sold. Subtract any returned merchandise accepted from customers, together with allowances made, from total sales.</small>			
COST OF MERCHANDISE SOLD			73.3
<small>To get this figure—to your inventory at the first of the year add your purchases for the year. Then deduct your inventory at the end of the year, adding to this any expenditures made for freight and express "in."</small>			
MARGIN (Subtract Cost of Merch. from Net Sales)			26.7
DEDUCT			
RENT AND OTHER OVERHEAD COSTS (Occupancy Expense)			3.7
<small>Include what you spent for rent during the year; for light, heat, water tax, etc.</small>			
BUYING EXPENSE			3.3
<small>Write here what you spent in buying your merchandise, your order blanks, traveling to the market, etc.</small>			
PUBLICITY			4.4
<small>Put here the total amount you spent to trim your windows, for advertising in papers, and in circulars you sent out. Expenses of decorating your store should also be included in this total.</small>			
SALES CLERK HIRE (SELLING EXPENSE)			9.1
<small>How much money did you pay in salaries to your sales force, sale books, price tags, wrapping paper and other miscellaneous selling expenses? Put the total here.</small>			
WHAT DID YOU PAY YOURSELF OR MANAGER (ADMINISTRATIVE EXPENSE)			4.3
<small>Include your salary, your manager's salary, the pay of your bookkeeper, office supplies and expenses.</small>			
TOTAL EXPENSE			24.8
PROFIT OR LOSS			1.9
AVERAGE INVENTORY AT RETAIL PRICE			
<small>Add the inventory January 1, 1924, to the inventory Dec. 31, 1924, both at retail, and divide by two.</small>			
STOCK TURN			
<small>Divide your net sales by your average inventory at retail price.</small>			
	times	5 times.

You will find it instructive and helpful to your business to put down these figures for your own store and compare them with those for the seven radio departments given. Also, if you will send

a copy of your figures to Mr. Hansen in care of *Radio Retailing*, he will return to you an analysis of them, pointing out which of your figures seem high and where economies should be effected.

Your figures, will, of course, be kept in strict confidence, replies being sent you under sealed envelope. This constructive service is wholly without charge to the readers of *Radio Retailing*.

Increasing Radio Earnings

How V. L. Thomas of Des Moines, Ia., Pays His Radio Manager, Grades His Down Payments and Handles Trade-ins, All to the End of Greater Profits

PUBLIC demand for radio equipment has relieved the radio dealer from the necessity of creating markets. The market is there. The dealer who will properly serve the public's radio needs will get his share of the business.

The problem which any dealer has to solve is how to get a good net profit on his radio volume. Keeping his selling cost within reason, wise handling of time payment accounts, service that satisfies the customer without excessive cost to the firm, these are elements that must be controlled. And if the dealer is a busy electrical contractor-dealer, with many other business departments, he must delegate the responsibility to a radio manager.

V. L. Thomas, owner of the Thomas Electric Company, Des Moines, Iowa, has been very successful in his method of handling the profit problems of radio. His basis of success has been to find the right man for radio manager and to get this man interested in profits instead of in volume.

Like all successful contractor-dealers, Mr. Thomas is a very busy man. When, three years ago, he decided to put in radio he knew it was impossible to give it much personal attention. A man to handle radio was essential and this man had to be not only a good salesman, radio service man and demonstrator, but it was essential that he have an eye to the profits as well. When Mr. Thomas got the right man he made his income depend on these profits and not on the gross total of his sales.

Taking the Salesman Into Partnership

The proposition under which the radio man works is, in fact, a partnership in radio department profits. He receives a share of the profit instead of a commission on sales. Radio sales slips are costed and the price listed to show the monthly or weekly profit in radio. The salesman is paid forty per cent of the profit shown. The salesman's share works

out to about fifteen per cent of the gross sales.

But an instance will show that it works for the boss better than a fifteen per cent commission would. Because of obsolescence, a set sometimes has to be sold at a reduced price. As the salesman's commission is reduced as the profit is reduced, he works hard to get the highest price for this obsolete set. It is to his immediate interest to increase the gross profit on the sale.

Should there be a loss on a bad radio account the salesman loses as well as the firm. Therefore, there are no bad radio accounts, so far as the salesman is concerned. He is as keen as the boss to check up on the customer's credit.

The Thomas Electric Company has been selling radio on time for two years and for the same period it has exchanged old sets as part payment on new ones. Both transactions are showing profits and both have been factors in building sales.

In addition to a careful scrutiny of the customer's credit, down payments are graded by the season of the year. The reason is that by

spring the customer will have so large an equity in his set that there is little temptation to allow payment to lapse or the set to be returned.

Down Payments Vary According to Season

In the early fall a set will be sold on a down payment of about fifteen per cent. By Christmas this set commands a down payment of twenty-five per cent. By February this down payment has grown to thirty-three and one-third per cent and on the first of March to fifty per cent. If, by hot weather, the customer has paid two-thirds or more of the price of his set he will either pay it out or if he does revert, the set can be sold again at a profit.

Flexibility is allowed also in the charge for carrying. This charge is usually not less than eight per cent on the total sale. But in the case of a customer of known responsibility who will pay out in a few payments the salesman can reduce this. He also can and does increase this charge to ten per cent if he has reason to think that the customer, while



In the attractive store of the Thomas Electric Company, Des Moines, Ia., radio is shown at his favorite occupation of selling a high priced set. D. Johns, manager of radio sales, is here shown at his favorite occupation of selling a high priced set.

Selling Trade-Ins

Trading in used sets on more expensive new ones has become a big element in selling radio. Thomas has a careful method of handling trade-ins that increases sales without loading him up with second-hand equipment. He doesn't take in the set until he has sold it.

responsible, may be slow in meeting his monthly installments.

This carrying charge added to the selling price becomes a factor in the store profit and consequently in the salesman's profit. The charge made by the bank for discounting the paper is added to the cost and there is usually a profit figure left on carrying the paper.

Taking used sets in exchange has also become an important element in radio sales for the Thomas Electric Company. And a profitable one, too.

Radio fans like to keep up with new set designs. And they drop into the Thomas store to look over the new ones. When such a fan says, "I'd like to have this; suits me better than my set," the Thomas salesman can ask him, "Well, what will you take for the set you have?" A figure is reached and the salesman makes a note to see what he can do for the customer.

Another type of customer comes in looking for a set and after inspecting those offered sometimes can't be sold because he wants something for less money. Right then the salesman can bring up the question of the used set. Showing a photograph of a set marked, say \$275, he can offer this same set, slightly used, for \$150. But he puts it that if the customer is interested the salesman thinks he can get him a used one at that reduced price. The set is a bargain. And after the customer has thought it over, the sale is often closed. The used set is installed in good condition, new tubes and batteries, and the first customer buys a new and higher-priced set.

Thomas has some customers who have bought four sets, trading in each time. Sometimes the Thomas salesman has to do some outside work to sell the used set. A car and a trip twenty-five miles into the country has sold a good many.

On these used set sales it is a rule with the Thomas Electric Company that one or the other of the parties pays full cash. They will carry either the used set sale or the new set sale on time payments but not both. Also, the used set is sold at the same price allowed for it. The profit is a single one coming out of the new set sold. But as a number of new sets sold on this trade-in basis are of the highest priced cabinet type, running \$400 and over, it is very much worth while.

There is only one selling operation involved. By not taking in the used set until it is sold there is no stock of used sets on hand. The customer who trades in does not have to be sold, he sells himself, and often the used set makes a sale that could not otherwise be made.

Pepping Up Summer Sales

There is enough business even during the slow summer months to keep the radio salesman busy and satisfied. The outlying country is especially canvassed during the summer and in addition to the sales made, many prospects are located for fall selling.

The radio salesman does all the demonstrating and much of the service. Anything requiring mechanical service, however, is done by the regular service man and the cost charged to the customer or absorbed by Mr. Thomas.

The salesman sharing in the profits arrangement is eminently satisfactory both to Mr. Thomas and to his radio man. It operates the department at a good profit and with little executive time and thought.

Posts Station Log in Window

The Radio Den, W. B. Ashford, proprietor, Santa Ana, Cal., makes a practice each day of pasting on its main show window a log of the stations that were heard over the establishment's sets during the previous twenty-four hours. Opposite the name of each station is a notation as to how the station came in—whether loud and clear, or whatever way in which it was heard.

This simple little stunt invariably attracts a considerable amount of attention from the radio fans of the city and creates talk about the shop—all of which is of real aid in selling more sets and greater quantities of equipment.

"Free Home Demonstrations" Made Stemle Successful

One way of increasing sales has been successfully tried out by the "Radio Demonstrators" of 219 East First Street, Duluth, Minn. And that is—three days' free trial on any set.

First, a prospect is solicited by telephone, and permission gained to put the set in his home for the free trial. Usually there is no trouble on that point when it is made clear that it won't cost him anything and places him under no obligation.

And A. Walter Stemle, manager, reports that very few sets are taken out, once they are left in for three days. He believes that a "set in the home is worth ten in the store," even if it is not already sold.

Stemle gives his salesmen fifteen to twenty per cent commission on their set sales, varying in accordance with the price of the set, the higher priced sets allowing the higher commission. His radio salesmen must be radio enthusiasts, which may account for the "Radio Demonstrators" large sales during the season. And Stemle gives his customers a wide variety of popular makes to choose from.

The service given by Stemle and his organization is also a big factor in their success. Day and night service is always available to customers and that it is appreciated is shown by the report Stemle makes that many new customers say he was recommended to them by someone whom Stemle has already sold.

Customer Needn't Leave Home

And the best part of the Stemle service idea is that the customer doesn't have to move from his home in order to listen to a radio demonstration. He merely steps to his phone, calls Stemle up, and in a few hours, the aerial is hung and the set fully installed and equipped ready for the home demonstration! And, as has been said before, the set usually stays!

Along the same idea, free radio entertainments are given to fraternal lodges and meetings of social and business organizations, which also lead to more sales.

And—here is an unusual situation—Stemle found that local newspaper advertising results were negligible and it was not until he offered the "free home demonstration idea" that he met with any degree of success.

New Profits from Old Customers

Iowa Furniture Dealer Keeps Old Accounts Profitable by Selling Them Radio Sets Before Their Furniture Bills Are Fully Paid

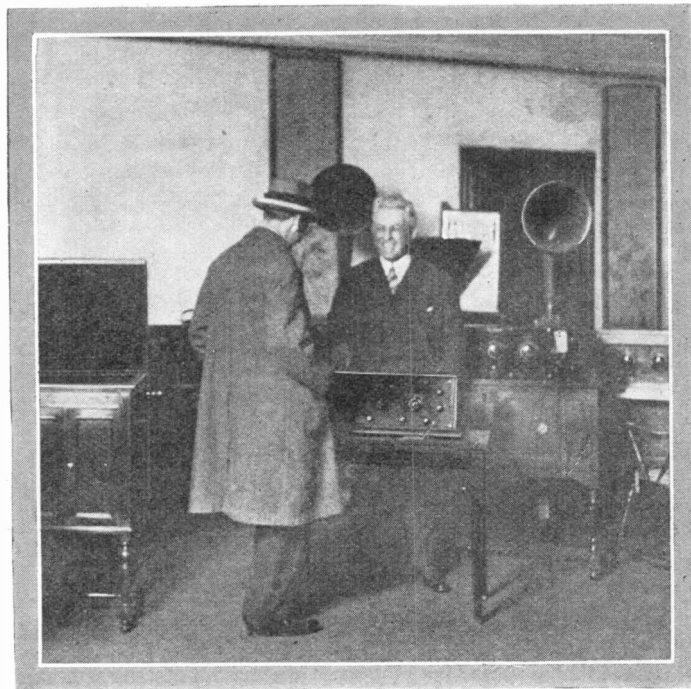

HOW much does it cost to create a new customer? The answer, if anybody knows it, will vary with the type of merchant. It costs the ten-cent store very little and it costs the furniture dealer a good many dollars. But this is true for any merchant: that it costs less to resell an old customer than to make a new one.

Julius Rosenfeld, president of the Continental Furniture and Carpet Company, Council Bluffs, Ia., has been selling more merchandise to old customers for many prosperous years. And he has not found anything better than radio to keep the old customers on the books.

"There is no profit in a closed account," said Mr. Rosenfeld to a representative of *Radio Retailing*. "Good furniture such as we sell does not need frequent replacement. We have the customers, the salesroom, the salesmen and the credit system. We are getting new profits on these assets with radio.

"Radio distinctly belongs in the furniture business. We felt that from the time we first put the line in. And we did not go after it in a half-hearted way. We featured radio in our advertising and our windows. We have given it the best location in the store, directly inside the main entrance. Our stocks are ample and include the most popular types of radio sets and the combination phonograph and radio as well.

"Advertising and window displays have brought in many new customers

but our greatest sales effort and our greatest success have come from concentrating on our old customers. Customers coming in to make a payment cannot overlook the radio display which they must pass to reach the cashier's window. And as they transact their business with the cashier, they notice a sign on each side of the cashier's window. One reads: 'Enjoy Winter Evenings with Radio,' and the other: 'Add a Radio to Your Account.'

"And a salesman is always on the alert to make a demonstration. Even when the customer does not think he is interested, the salesman gets in some missionary work with a comfortable chair to rest in and some good music out of the air.

Calling Up Old Accounts

in his furniture department before they are fully paid up and asking them if they want to add a radio set to their bill is one way an Iowa dealer has made radio give greater profits.

By requiring no additional down payment and putting the price of the set on the time payment bill for other merchandise already bought, this store experiences a quick turnover of sets.

"The big point with the old customers is that they can add a radio set to their account without an additional down payment. When a customer is about paid out on his account for other merchandise we call him up and ask if we cannot send out a radio set for a free demonstration and trial. Sometimes we have sent out a set without asking previous permission, simply notifying the prospect that we are going to entertain him for an evening at our expense.

"They will not be asked to buy, we inform them.

"A salesman gets the stations, they enjoy the experience and usually keep the set. This is made easy for them and for the salesman as they do not have to sign an additional sales contract nor make a new down payment.

"We are secured because when a customer has not yet paid up on a bill of furniture, the radio set goes on the same bill and is secured to us by the lease on the entire bill."

As articles of furniture usually give a greater percentage of profit than do radio sets, Mr. Rosenfeld was asked if the furniture store could sell profitably on the lower percentage.

"The profit is big enough," was the answer. "I can turn over my radio stock about once a month, and because of this fast turnover the radio department can operate profitably on a smaller margin than the slower-moving furniture."

The Salesman's "Fourteen Points"

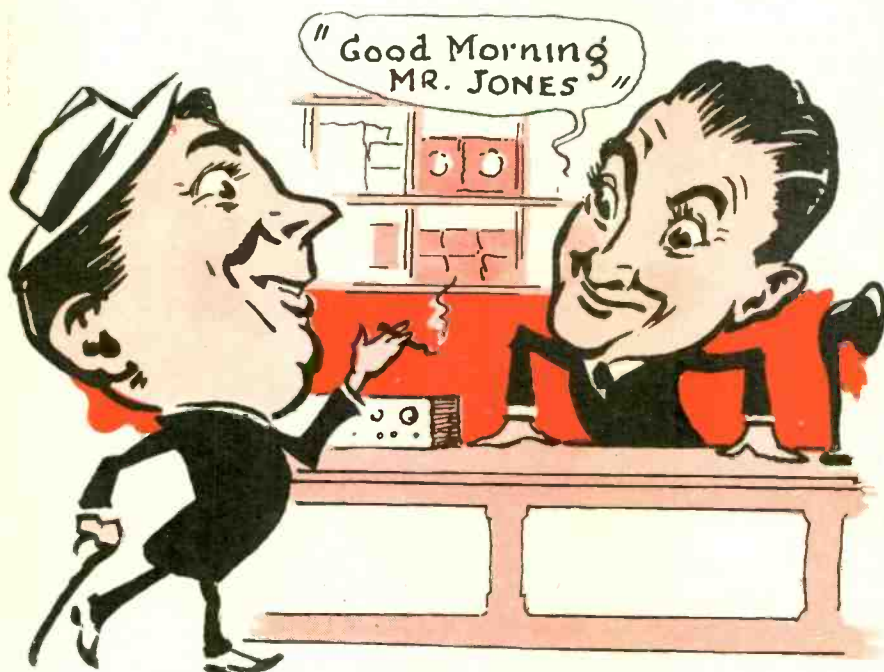

"A Smile is Worth More Than a Frown"

Satisfy the Customer

5. Every sale, large or small, deserves attention. It isn't what you are selling that merits this attention, it is the person to whom it is being sold. The customer must be satisfied. Merchandise should stay sold. Better spend ten minutes explaining a small tube socket and have it stay sold, than have it returned. It costs less and it builds real good will.

Try to Agree

6. "You may be right," is a diplomatic reply. Give the customer the benefit of any doubt. Don't tell them they are crazy, and should know better. Tell them your story, what you believe is the truth about the merchandise you sell. Don't argue. You may tear down in five minutes a good will that has taken years to build, and you may destroy valuable future sales.

Know Your Stock

1. "Know your stock, where it is and what it is," cannot be over-emphasized. Many a sale has been lost by a sales clerk saying, "We haven't it in stock." Many times the article is on the shelf behind some other piece of merchandise. Knowing your stock serves another purpose. It tells you what is on hand and what should be ordered. Sales people should watch it. Don't let a stock get too high or too low.

Be Pleasant

4. "Good morning," said with a smile, is a real greeting. It's warm, it's cordial. There is no iceberg attached to it as there is to the old too familiar greeting of many salespeople today—"Is there anything I can do for you?" It only serves to mark a salesman as dead to his opportunities. There must be something the salesman can do or the customer never would have entered the store. A smile in the place of a frown, a cordial greeting in place of coldness, makes a joy of selling and increases sales.

Remember the Store's Policy

7. Not knowing store policies has spoiled many sales. It has cost stores real money. When a store makes policies, live up to them. But care must be taken with the customer in explaining the store's side. Remember the rule of the merchant, "The customer is always reasonable." If merchandise is returned and you cannot accept it give a very careful explanation.

Study Your Merchandise

2. One of the more important rules for any retailer: "Know the articles you sell." Know what they are made of, where they are manufactured, how they are made. Be able to tell the customer these facts and create the impression that you know your business thoroughly.

Read Advertisements

3. "What paper did you see our advertisement in?" This question marks a slipshod salesman. It is the duty of the sales force to know what the store is advertising. Better still, to know what your competitors are advertising. Reading the advertisements is only one of the early morning jobs.

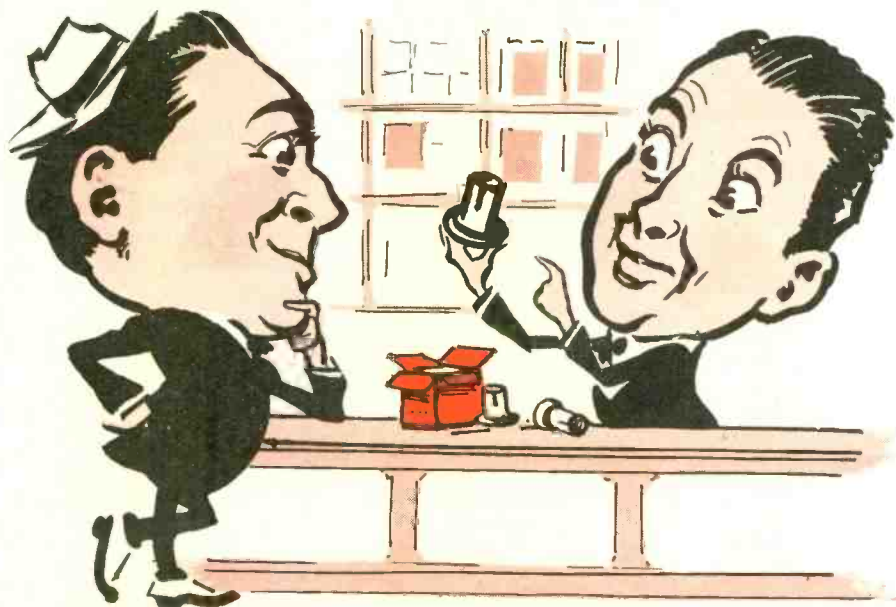

"Take Time With the Smallest Sale"

Here Are the Fundamental Principles Governing Salesmanship That Every Man Who Stands Behind a Retail Counter Should Know

Don't Criticise Competitors

8. Criticising your competitors will do little good as a sales talk. Characterising the competitor as "a gyp," "a cut throat" merchant in your talk with customers will not sell merchandise. Make your sales talk stand alone. Bring out the good points in the merchandise and let the quality and article speak for themselves. Merchandise sold on this basis stays sold and costs less money to sell.

Make Suggestions

9. Suggestions and ideas keep sales on the increase. Don't be afraid to offer ideas. As they come to you, make note of them. Call them to the attention of the manager. One idea by a sales clerk saved a large store around \$15,000 this past year.



"Manufacturers' Booklets Are Profitable Reading"

Don't Be Dumb

10. If a customer asks a question don't answer, "I don't know." If you don't happen to know, find someone who does. Go to the one in charge of your work and get the correct answer. If it is possible that a long explanation will be necessary, return with this person of authority. Introduce him to the customer and leave the rest to him. Remember you are not expected to know everything. But you should be expected to know how you can find out.

Forget Gossiping

11. Don't be a town gossip. Never talk to one customer about another. It is pretty well to remember that a store is a place of business, not a rest room for the discussion of town topics or the happenings of the night before. A gossiping sales force is a black mark for a store.

Go Slowly

12. Many new sales clerks are disappointed if their sales do

not reach the mark of others in the store. There is no reason for it. No store manager expects a newcomer to break all records of the store. Plenty of time should be the rule. Go slowly, learn what there is to learn. Know the executives of the store, where the merchandise is kept. In other words get your feet on the ground before trying to break any records.

Watch Stock Arrangement

13. Use spare moments between sales to keep counters free of merchandise. Arrange the stock which may have been disturbed in making a sale. At this time watch the stock. It may have been sold out during the day. If it is low report it. Dust the showcases. In short, use spare minutes for little housecleaning jobs.

Be Neat

14. Be careful in your dress. Loud ties and "dance hall" styles have no place in a retail establishment. Dark clothes should be the rule. Store work is not the best of white collar jobs, and the personnel should dress accordingly. Keep in mind the fact you are meeting all classes of people.

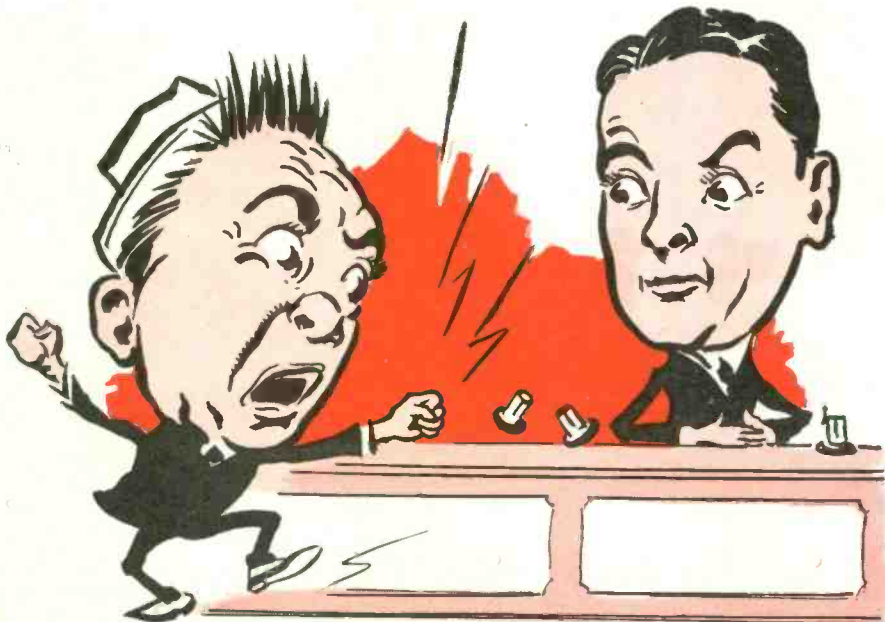

"Never Argue. But Listen Patiently."

What I Would

A Radio Dealer

By WILLIAM R. INGERSOLL,
Vice-President, DeForest Radio Company

Mr. Ingersoll was the man who gave the world "the watch that made the dollar famous"—as spectacular an innovation as has ever come out of a factory. Now he is devoting to radio his genius for market building. He has been president of the Advertising Men's League of New York, chairman of the National Commission of the Associated Advertising Clubs of the World, and Commissioner of Conciliation for the United States Department of Agriculture. He speaks with authority.



IT IS the very theory of civilization that each man should devote himself to the work that he is best capable of doing, and that the successful man must be able to do his work better than other men. Thus the public comes to him for this service in which he is an expert and he prospers. This rule holds true no less in the radio industry than in other walks of life.

Therefore, if I were a radio dealer the first thing I would do would be to make myself an expert in radio, so that I might be sure of possessing greater knowledge and aptitude than the customers who come to me, and I would see that my sales people were well informed. This today demands a good deal, because the typical radio fan knows a lot.

Accurate Stock Keeping

That I take it is the first thing for a dealer to take care of. The second thing I would do if I were a retailer would be to install carefully an accurate stock keeping system so I would know what goods move and which turn over slowly. I would put myself in position to make quick decisions in the selection and handling of my stock.

I would incline to the sale of standard lines to insure the permanency of my business. I would do this because the patent situation, I believe, will play an increasingly important part in radio.

I would have in mind the fact that radio is not a field to enter for the mere sake of quick profit. The time has passed to ride the wave and raid the market. This is the biggest single market development of our times.

I would plan for a life work and organize a business or a radio department in my business that would pay permanently a proper return on my investment. I would find a way to make the volume of sales that would insure that return.

I would give particular attention too to the national advertising of standardized radio and turn it to my advantage in local tie-ups. I would keep in touch with modern trade developments by subscription to the better class of radio trade papers. A trade paper that renders a genuine service to its industry in research and the recording of the news and thinking of the industry and reports the successes, the failures and the dangers that men should know about is a priceless aid to the dealer.

In looking for customers I would go after every family in the community that has an automobile. I would approach them both by mail and personal call. This is a good guide, for every home of moderate means or better is a natural prospect for radio.

Also, I would list every farmer who owns a car or a tractor or shows the slightest sign of life and enter-

prise in the appearance of his farm. We have a great and vital service to render to these farm homes.

I would try to interpret radio to my public very carefully. I would present it not as a fad or a luxury, but as a modern servant to the home, providing a new source of education, news and entertainment, a practical supplement to the newspaper, the telephone and the telegraph. I would impress upon the public the fact that no one today can afford to be out of touch with the new world contacts that radio bring into the household.

Would Not Cut Prices

I would make it my policy not to cut prices except on season-end clean-up sales, for mid-season sales are folly. They undermine the confidence of the public.

So far it seems necessary to slow down in radio sales in summer, but I would put pressure on portable and suitcase sets, on tube, battery and accessory sales, and if the size of the town made it possible I would be an exclusive radio dealer. If in a smaller town, I would combine radio with music or auto accessories.

I would resist as long as I could the taking of trade-ins. Of course, no one knows what will develop here, but a united policy could influence the market to some other disposition of discarded sets.

In my opinion this service element
(Continued on opposite page)

Do, If I Were—

A Radio Manufacturer

By S. B. DAVEGA,
President, Davega United Sports Stores

The eleven Davega United Sports Stores sold over a million dollars' worth of radio in 1924, in New York City. S. B. Davega is president. He started in a small way with one store devoted solely to sporting goods. When radio came, he saw the greater opportunity. The rapid growth of the organization is a tribute to Mr. Davega's ability as a merchant and to the popularity of radio as a merchandising line. His opinion is founded on a broad experience.

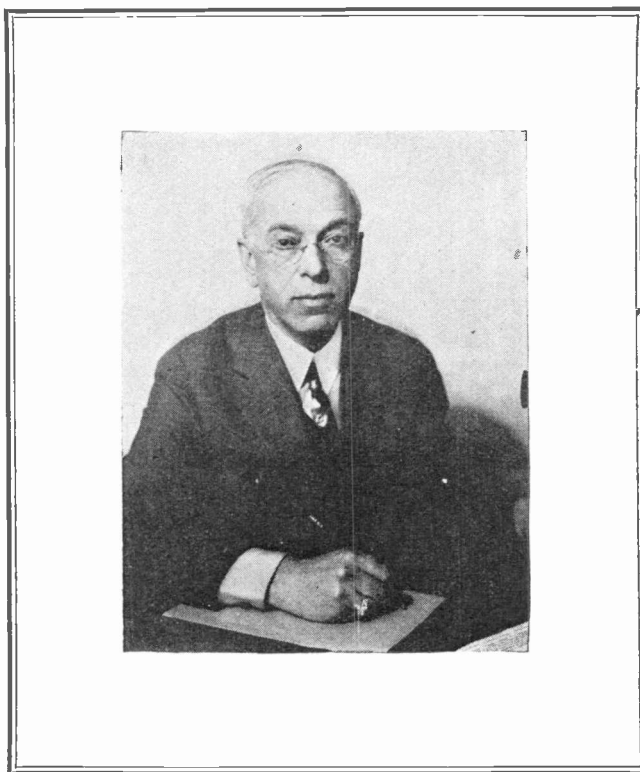

RADIO is young. It has grown fast. Many mistakes in policy have naturally been made. But standard practice is steadily evolving that is gradually going to correct a lot of our troubles. Looking at it from the dealer's standpoint here's what I would do if I were a manufacturer, to try and overcome some of these present ills of the radio industry—

One—I would have as few jobbers as possible, giving over my distribution to strong houses that would cover their territory with thoroughness.

Two—I would try to build up exclusive jobbers who would sell only my line and I would do this by not over-committing my factory so that I could make good on my promises.

Three—I would develop my retail distribution among dealers who ad-

vertise and actually develop local markets. I would pass up the store that will do nothing but sell over the counter.

Four—I would select dealers who also sell another line, preferably talking machines, because that type of store presents a musical atmosphere and is usually provided with listening booths. The dealer also should have one active summer line and therefore the sporting-goods-plus-radio store offers an exceptionally strong set up.

Five—In cities of 10,000 or less where there probably is no regular sporting-goods store, I would select the leading hardware store or electrical supply stores.

Six—I would not sell to dealers who lack the skill and equipment to install and service properly.

Seven—I would not sell too many

dealers and crowd them too close. The day will come I hope, as it came in the talking-machine game, when dealers will have exclusive territories. Meanwhile I would give my dealers ample territory to sell in to aid them toward prosperity.

Eight—I would not sell the "gyp"—by which I mean the dealer who resells standard material under the established price. I would not sell him again.

Nine—I would not over-sell radio and incite the customer to overeagerness to get immediately all distant stations. This automatically sets up a demand for excessive service by the dealer. Rather I would sell the customer stronger on the joys of good service from local broadcasting.

Ten—I would double the usual tests on finished sets if necessary to prevent and avoid trouble in delivered sets. This is what makes trouble all along the line and greatly increases the dealer's service costs.

Undoubtedly today there is an over-abundance of types and styles of radio on the market, bred by the prosperity of the industry—also too many manufacturers, jobbers and dealers. If I were a manufacturer, I would try to get ready and help toward readjustment now. I would protect my jobbers on deliveries. I would protect my dealers from unfair competition from cut-price retailers and overcrowding of territory.

What I Would Do If I Were a Radio Dealer (Continued)

is going to be no less important to radio than it is in selling automobiles. An automobile is no better than the service behind it, and this is no less true in the case of reception sets. Therefore, if I were a dealer I would provide the best possible service to my customers. And yet I would try not to overdo it.

Radio is now in the stage experienced by the automobile when everybody wanted speed. A car that wasn't guaranteed for 60 or 70 miles

an hour was not the thing then, but nowadays people want dependability and comfort. In radio the public demands today long distance reception to an excessive degree. They will trend gradually to an appreciation of tone quality and recognize that after all that is the prime advantage in radio reception.

I see a great future for the radio dealer. If he uses ordinary good business judgment and enterprise he will prosper.

Paving the Way Door-to-Door

Getting inside the prospect's door is one of the most difficult problems confronting the salesman

Have cards printed in imitation of regular theater admission tickets, in the same size and style of type, as illustrated. Mail them to a selected list of prospects. If the dealer will look through the broadcasting programs for the coming weeks he is bound to find something that will serve as an adequate tie-up. Right now it is the concerts given by Victor phonograph artists. Many broadcasting stations are sending out programs that will serve as excellent material for the "admission ticket" idea.



THE future of radio set selling lies with the dealer who goes out after the sales rather than with the one who waits for the business to come to him. There is little argument about this. Business experience in other lines points the way. Phonographs, washing machines, vacuum cleaners, cash registers, all owe their wide distribution and use to years of vigorous and profitable direct house-to-house and office-to-office selling.

There is no one way to manage this kind of business. But there are methods that have produced results and many experiences that have shown what to watch and what to avoid. From a wide contact with successful dealers, not only in radio but in other lines selling direct, *Radio Retailing* is able to collect boiled-down experience and live selling suggestions for the guidance of

the dealer who wants to extend his business and who takes this method of doing so.

One word of warning to the beginner at outside selling.

Don't expect big results overnight. Don't put on all the men you can get. If you do some of them will cost you money. Start with one or two good men, train them carefully to sell your goods in the right way and that is to sell customer satisfaction. Increase your sales force gradually as you create the right kind of salesmen. And, perhaps most important, watch your collections. There is no profit in a sale until the last payment has been made on the time contract.

Picking the Salesman

WHEN radio is sold in the home, the salesman must be the kind of man people will be glad to receive in their homes. A large New York dealer whose business is all through outside salesmen, avoids the "high pressure" type of man. He chooses

his men on the basis of their adaptability to the family circle, this ability being a knowledge of how to conduct themselves properly at an evening's entertainment in the home.

Where to Look for Salesmen

AS THE approach is the first and perhaps the hardest step in making a sale, it follows that an inexperienced salesman with a wide personal acquaintance often sells more merchandise than an experienced salesman working on a cold-turkey basis. A washing machine dealer in Hawthorne, N. J., proved this by interesting a mail carrier in selling for him. The mail carrier knew everybody in a district of some hundreds of families and spent his evenings calling on them. He became a very successful after hours salesman. And when for two consecutive months his evening sales had been over \$1,800 a month, he left the Government service and devoted his entire time to selling. Here is a real suggestion for the radio dealer in enlisting salesmen who can work only in the evenings. Wide per-

for a Successful Sales Campaign

Here is a timely scheme
—and a survey of successful field sales methods in door-to-door selling.

Pick the event, have the cards printed and mailed, and follow it up a few days before the event by sending a salesman to the prospect's home with a set under his arms. Let him make the demonstration right then and there, and if he doesn't succeed in making the sale, send him back at the time of the concert you mentioned. After hearing the concert and realizing they can continue hearing them by purchasing the set, very few prospects will resist the temptation to let it remain.



sonal acquaintance is the first requisite and many a man working during the day will be glad to turn his acquaintanceship into commission checks by selling radio a few evenings a week.

Training the Salesman

THE radio salesman must know his goods. Not that he has to be a radio expert. Many radio experts are in fact not good salesmen. But the salesman must have a working knowledge of the set he sells and he must be thoroughly "sold" on his merchandise.

One of the largest radio dealers in Cincinnati is the Devere Electric Company, which has a large crew of outside radio salesmen. "When we started selling by this method," states S. A. Morsbach, manager of the Devere company, "we advertised for commission salesmen and put the men to work just as we had done on washers and vacuum cleaners. This was quickly seen to be impracticable. The men were not of the right kind and they did not know radio well enough.

"But because we knew the idea

was fundamentally sound and a necessary way to increase radio set business, we sought and found the way to get and train the salesman.

"We now hire men for this work just as carefully as we hire any other regular salesmen and put them on a salary while they are being trained. The training consists of two months of store selling. In two months of behind the counter selling and demonstrating any man can be turned into a good radio salesman.

"Only after this training do we put a man out to sell sets. By this time he knows how to sell and demonstrate, he is sold on the material he is selling and from the fact that he has been selling in the store he has the confidence that he can sell anyone he gets up against.

Watch Your Salesman's Appearance

PEOPLE who live in the better class homes are not only good radio prospects, they are prospects for the high priced sets and they have the kind of credit that makes easy collections. Lyon & Healy, Chicago, please this desirable class

of customer by sending out only salesmen and service men who are neatly dressed and of good appearance. Also the set for demonstration is delivered in a sedan. There is shrewd selling psychology in this. The set is not yet sold and the well dressed courteous men who deliver and demonstrate create an impression highly favorable to the firm they represent.

Canvass the Business District

A SUCCESSFUL dealer in a large middle western city does not canvass house-to-house. His men canvass from office-to-office. As men are the best prospects for radio these salesmen go to the men in their offices during their business hours. The salesman is direct and business-like and asks only for permission to bring out a set to the business man's home and make an evening demonstration. He has a book of photographs but does not try to sell. He concentrates on getting the demonstration. This has proven very successful and it has been found that the same business district can be canvassed regularly over again

with increasing results. Every man is a radio prospect but he may not be ready the first time he is approached.

Leads from Service Calls

SERVICE calls are great producers of leads if the dealer doesn't wait for the customer to kick for service before calling. J. T. Donnelly of Poughkeepsie, N. Y., has a service man call on his new set customers twice a month. This man asks how the set is working and if there is anything wrong, fixes it. There usually isn't and the customer, pleased at the attention, is glad to tell the service man the names of some friends or neighbors who have been over to see the set and who are thinking of buying.

Getting a Deposit Before Trial Demonstration

IN SELLING sets on a free-trial basis, there are some people who will try to take an unfair advantage; people who may be interested in some special broadcasting event and get a set on trial with no intention of keeping it. Lyon & Healy have met this situation by asking a deposit before sending out a set on trial. The moderate amount asked, \$15.50, is no deterrent to the prospect who is really interested in owning a set and it stops the other kind from making the request.

Advertising That Brings Leads

SELLING on leads is, of course, easier for the salesman than a straight canvass. R. C. Bradley, New York, has kept a very large sales force busy on leads, most of which come from newspaper advertising. Varied to avoid monotony, the substance of these ads is about as follows:

"What's the use of running around town looking at sets when one will call on you? Phone us or send us a post card today." Results from these ads have been very good both in the number and character of inquiries. 90 per cent of the prospects have been sold on the first demonstration.

Getting the Procrastinator to Act

ONE of the hitches in selling is the prospect who is interested but wants to put off the demonstration until some indefinite future time. Having a reason why the cus-

House-to-House Sales Campaigns

will be the future method of getting the radio set business, in the opinion of a number of representative radio dealers. Taking this method, step by step, from getting the salesman to completing the sale, *Radio Retailing* has collected an interesting series of hints on how to do it.

Selecting the right type of man for the job, getting him into the home, what his sales talks should be, how he should and should not make the demonstration are a few of the practical things explained for the dealer in this timely review.

tomer should secure the set at once will often get action from these postponers. S. M. Bernheim, Birmingham, Ala., studies the broadcasting programs. When, as frequently happens, an address by a prominent Mason, Shriner or Rotarian is scheduled, Mr. Bernheim's salesmen go hard after the Birmingham members of those organizations. Many sales have been made by this means, as the salesmen have a reason why the prospect should make the purchase.

Let the Prospect Sell Himself

AN OMAHA dealer finds good results in letting the prospect do most of his own demonstrating. "Let the prospect work the set from the start," is his advice. If conditions are unfavorable and he doesn't get all the stations he wants he blames it on his own ignorance and asks for more instruction. The next night the conditions may be perfect and he is completely and thoroughly sold. But if the salesman when demonstrating fails to get perfect results, no matter what the conditions are, the prospect blames the set for it and increases the difficulty of closing the sale.

A Star Salesman's Advice on Demonstration

A SALESMAN who makes one demonstration every evening and who earns as high as \$200 a week

in commissions has this to say about demonstrations.

"The way to sell is to let the set sell itself. Tune in on a good program and if the prospect seems to enjoy it, leave it on. Don't try to 'show off' a set by tuning in on several stations in succession. Clarity of a set is a stronger selling point than range of reception. Don't talk much about the range of the set nor of technical details. These topics invariably lead to difficulty. Get the family comfortably seated in chairs around the set and let the set talk itself into a sale."

Confirm the Contract by Letter

IN SELLING anything on a time payment basis it sometimes happens that there is a dispute over the terms offered by the salesman. The contract is properly made out and signed but the customer claims he didn't read it and the salesman told him something different. The Steves Electric Company, Oshkosh, Wis., has eliminated all difficulty from this source by acknowledging the contract to the customer in a letter which recites all the terms and conditions of the sale. It also makes the request that if everything is not exactly as understood that the customer notify them. This letter makes it extremely difficult for the customer to claim later that there was any special understanding with the salesman.

Guarding Against Returns

NOT all women are pleased when friend husband buys a high-priced radio set. And because of this one big dealer has found it good business and good fellowship as well, to send the bill for the radio set to his customer's office instead of to his home.

The Farmer Offers a Cash Market

THE farmer market is a big field for radio. One of the advantages in selling the farmer is that such sales are all substantially cash sales. The farmer buys his set on time but the dealer gets cash for the sale by discounting the farmer's note at the farmer's own bank. The Reliance Electric Company, Milwaukee, has one salesman who has been averaging \$840 a week in sales and getting the cash by this method. The farmer has credit and will use it to buy the radio set he wants.

"Ruining the Radio Industry"

Dealers of Providence, R. I., Are in the Midst of a Price-Cutting War to See Who Can Sell the Lowest and Hold Out the Longest—Chaos is the Result

By WILLIAM C. ALLEY

"**P**AY Less Here," reads a sign in the window of a radio store in Providence, R. I.

Across the street, pasted on the window of a rival store, is the assertion, "We Are Determined to Sell Radio at the Lowest Prices in Providence."

Around the corner, in the window of a hitherto reputable dealer, is a notice, "We Guarantee to Meet the Lowest Price of Any Reputable Dealer in Providence."

The result? Chaos. Nobody is making money in Providence today. The dealers themselves admit it. Meanwhile the radio-buying public sits back and derides an industry where such practices prevail. How can radio hope to win the respect and admiration of other businesses, or the confidence of the public, when radio dealers resort to such tactics?

Here is, perhaps, the true definition of "gypping." Dealers who cut price simply to bore under the other fellow and determine to sell their goods at the lowest prices in town are ruining the radio industry. They are killing themselves, they are killing other radio dealers and they are giving the radio trade the blackest kind of reputation. These methods should not be tolerated in the radio industry. They can be stopped. But they can be stopped in only two ways—by knowledge of costs and by co-operation.

Co-operation Greatest Need

Co-operation is radio's greatest need. If one jobber or manufacturer makes an attempt to remedy conditions, some other jobber or manufacturer jumps in and throws the proverbial monkey wrench that wrecks the machinery. What kind of an industry can we expect to build up, anyway? When are we going to get wise to ourselves and stop knifing the other fellow simply to add a few more cut-profit dollars to the day's gross sales?

The manufacturer blames the jobber, the jobber blames the dealer and the dealer blames both of them. And each is right. The blame cannot be placed on any one group. All are equally at fault.

The dealer who slashes everything to the bone and tries to establish himself as the lowest-priced house in town is the first at fault. The jobber who continues to sell him is the second at fault. And the manufacturer who sells to the jobber who sells to the gypping dealer is the third at fault. And, the standard price house that cuts its own prices to meet the cut-throat competition is contributing its own share to the general bedlam.

You can hear it said that "it's all very well to talk about stopping it, but how are we going to do it?" The

remedy has got to be a concerted revolt from within the industry against disreputable dealers and against disreputable jobbers, whose sales policies are besmirched with mud, whose advertising reeks with mud and whose mind is filled with the same commodity.

Let's go back to Providence for awhile and find out what's going on there. P. H. Barnett, president of the B. and H. Supply Company, of Providence, and also president of the Rhode Island Radio Dealers' Association, has jumped into the price war, tooth and nail. It is Barnett's window which displays the promise to "meet the lowest price of any reputable dealer in Providence." Heretofore he has never cut a price.

That raises the question immediately, of whether it is or is not a



The kind of stuff that is going on in Providence, R. I., which results in giving radio a black eye in the public's estimation and also causes such a state of confusion that none of the dealers is making money, that

the public is not buying, waiting for still further reductions, and that both the public and the dealers are completely at sea about radio prices and the future stability of the trade in that town.

wise policy to fight cut price competition. Harry Tilley, of the Tilley Radio Corporation, Providence, goes serenely on his way, paying no attention whatever to the price cutting going on all around him, continues selling his merchandise at full list, and reports no falling off in trade.

Personally, I think Tilley is right. A reputable dealer who lowers his prices to meet cut-throat competition is also lowering the standards of his business to the low level of his low competitors. By tarring himself with the same brush the reputable dealer admits himself forced to his knees by his gyping adversaries. He pulls down his reputation and standing and rides in the same boat with the price-cutter.

But Barnett takes the opposite viewpoint.

"Has Killed the Radio Business"

"This price war has absolutely killed the radio business here," he declares. "We were forced to meet the low prices. We simply could not afford not to. Why, people would come into our store and laugh at us for asking list price for a certain article. 'I can get it for half as much around the corner,' they'd say. Were we going to stand by and watch them go around the corner to buy? My answer is 'No.' Fight them, meet their prices until they throw in the

Committing Commercial Suicide

A price war, especially in the trade of radio retailing, is one of the best ways we know to commit commercial suicide. Yet the dealers of Providence, R. I., are at it hot and heavy.

"I sell the lowest," cries one. "All radio prices cut to the bone," declares another. "25 per cent discount on all radio parts," shouts a third.

WHEN IS IT GOING TO STOP? AND WHERE IS THE RADIO INDUSTRY HEADED IF THESE TACTICS ARE CONTINUED?

sponge. After they've lost enough money they'll come to their senses. It's a foregone conclusion that sooner or later they will come to the end of their rope and get out of the radio business.

"Let me tell you of some of the meetings held by the Rhode Island Radio Dealers' Association. Some of the merchants who follow a policy of consistent price-cutting actually got up in the meetings and declared war on the high class houses.

"They said the type of customers they reached demanded the lowest possible prices and they were going to give them what they wanted. Very good. I believe in giving them what they want, too. But we're not in business for love. The margin of profit which list prices allow, is small enough as it is, without cutting it down still further. And radio prices today are not exorbitant. The average buyer can well afford them, and the dealer cannot conduct his business at a profit, in a town the size of Providence unless he gets the full list.

Price of Earphones Changed Four Times in One Day

"Would you believe that the price of a pair of earphones could change four times in the course of a day? Yet that is typical of what is going on here at present. In the morning, a store was selling them for, say, \$4. The actual figures I don't remember. At noon, a competitor put the same make of phones in his window for \$3.50. In the afternoon, it had gone down to \$3 and in the evening they were selling for \$2.50. Now what kind of a way to do business is that?

"Certainly I'm going to fight them. I'm going to fight them until some of us go out of business and I'm not going to be the one who goes out first.

"Passing the Buck"

"I put the blame directly on the manufacturer for this state of disruption. They have had their eyes only on the almighty dollar and have sold their products to too many jobbers. There are far too many wholesale outlets. If the manufacturer would use a little discrimination in placing his products, cut down the number of his jobbers and exercise a closer control of his wholesale outlets, much of this price cutting could be stopped.

"As it is now, the manufacturer cannot find out what jobber is selling to the cut price dealer. With fewer jobbers, he could do so, and his gross sales would not fall off. I venture to say that the fewer jobbers would do a bigger total business than a lot of jobbers each doing a little business.

"Take the Magnavox situation today. A year ago, that was the worst situation in radio. Magnavox was being cut right and left. Then, six months ago, they appointed only one jobber in each territory, with the re-

<p>Why Pay More? Genuine 6-T 8 Tubes Use in place of 201-A \$1.99</p> <p>SINGLE PHONE Good for loud speaker unit 99c</p>	<p>Sale on "B" BATTERIES Bright Star Cytone 45 Volt, large— \$2.43</p>
<p>After stock-taking. Now for our big mark-down prices on sets and radio parts. We buy better and sell lower. If it's anything worthwhile in radio, we have it.</p>	
<p>EVERY ONE TESTED RADIOTRON TUBES</p> <p style="text-align: center;"></p> <p>Always at the lowest prices. See us before you buy.</p>	<p>Atom Audio Transformer \$2.59 Moulded Handmade Bakelite at a bargain price 17c Phone Cords 29c Genuine Bakelite Moulded 6-T 8 Comp. List \$3.00 45 Volt Case 23 7/8" Landscape \$1.97 \$2.45</p>
<p>Magnavox M-1 Loud Speaker, List \$30.00 \$14.95 Woodhorn Loud Speaker, adjustable \$6.79 It's a Wonder</p>	
<p>SALE ON KNOCKDOWN SETS</p> <p>3-tube Ambassador \$16.45 5-tube Neutrodyne 28.95 2-tube Roberts Knockout 18.75 5-tube Freshman Masterpiece 26.45 1-tube Improved Haynes 9.45</p>	
<p>Sale on "B" Batteries 63c up BRIGHT STAR, EVERREADY, CYCLONE At the Lowest Prices</p>	<p>Pico Phones, 3200 Ohms, Reg. \$4.50 \$1.79 N. & E. Phones, 4000 Ohms, List \$7.50 \$4.45 Federal Phones, 3200 Ohms, List \$9.00 \$4.95</p>
<p>Our stock of Cabinets consists of high class Parkway Jewett, knock downs, and mahogany finished. The prices are low. OUR MONDAY SPECIAL, 7x26, MAHOGANY FINISHED \$1.97</p>	

25% Discount
on Radio Parts!

Our entire stock of radio parts is now marked at a 25% reduction. This is an opportunity for you to realize a worth-while saving.

Special Prices on Radio Sets

Fada 160-A Neutrodyne, \$120, Special Price \$85
Kennedy VI, \$105, Sale Price \$78
Palders Reflex, \$130, Sale Price \$100

NOTICE ON RADIO PRICES

Until further notice we will issue a dated receipt for every purchase—our prices will be found as low as any in the city—if you find you could have bought at a lower price from any other reputable dealer—tell us—and we will cheerfully refund the difference.

These newspaper advertisements were clipped from one edition of a Providence newspaper. The large advertisement on the left is from a chain-store organization with a consistent policy of low prices, while the other two were inserted by houses which, in the past, had never resorted to price-

cutting. The small advertisement reads, in part, "if you find you could have bought at a lower price from any other reputable dealer, tell us and we will refund the difference." Is any further comment necessary? It seems to us to speak its own damnation.

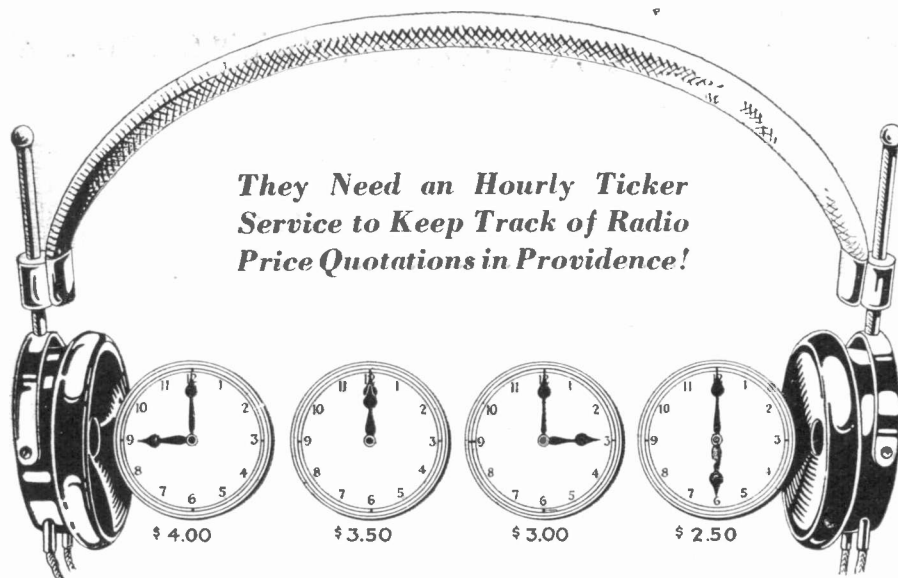

Typical of price conditions in Providence radio stores, as they are today: One morning a pair of earphones was priced at \$4. By noontime, a competitor put the same make of phone in his window for \$3.50. In the afternoon, the first store came back with a reduction to \$3 and at six p. m., the

phones were selling for \$2.50. Had the stores been open in the evening, by midnight they'd probably have been paying the customers a bonus to come in and take the earphones home! All of which accomplishes nothing except to make radio ridiculous in the eyes of the business world.

sult that today, Magnavox is pretty clean. That's the remedy. It is already in actual practice in this line and has been found successful. It's up to the manufacturers."

And that's that. The next step, according to Barnett, must obviously come from the manufacturer. But is that an adequate solution? If not, then what is? Co-operation, for one thing. Education, for another. Education of the dealer in the costs of running his business, education that he cannot operate successfully by cutting prices, education that he is doing as much damage to himself as he is to the rest of the trade, education that healthy competition stimulates business for everyone concerned and that cutthroat competition means ruination.

"A Low Price Sale Is Often an Economic Necessity"

And it must be borne in mind when, and IF, the brooms are gotten out, that a low price sale is often an economic necessity, indulged in by manufacturer and jobber as well as the retailer, upon occasion. To clear shelves or pep up a dull period, a general reduction in price is resorted to by practically every merchant in any line of business.

It is the man who consistently cuts prices, dealer and jobber as well, who slashes as far as he can solely to bore under the other fellow and steal someone's else legitimate trade, against whom the radio industry is up in arms.

Doubles Phonograph Profits by Adding Line of Radio Sets

Swinging into line with the popular demand for radio, Jackson's Furniture Store, at Oakland, Cal., inaugurated a radio department ten months ago, to supplement its business in phonographs. Radio has proven a most profitable line for Jackson's, and a rapid turnover is made in high priced sets as well as in those of average price. Parts are not carried.

"I believe," states William W. Cross, manager of the radio and phonograph department, "that there is no other new product on the mar-

ket which has been taken up by the people as eagerly as radio. But the public is demanding more from radio than it should at the present stage of development. I look for radio to be revolutionized within the coming six months, prices standardized, patents straightened out, and radio put on a firm business basis."

Quality sets sell best in this new department, especially the combinations of radio and phonograph. Table models are also very popular, one model, priced at \$560, is considered the best seller. The man who buys a radio set wants one that will give satisfactory service, therefore the department aims to sell him a set which will give excellent results instead of experimenting with something cheaper.

As a rule the total cost of a quality set is prohibitive to the average person but through the store's credit plan he is able to buy a set which will give him complete satisfaction. Six months are allowed for radio sets and longer terms for combinations.

Service is a very necessary feature in selling radio, Mr. Cross believes. The firm's radio service man is a licensed operator. No service charge is made when the trouble lies with the set and only a slight charge otherwise. A small charge is made for outside aerial installation. After a set has been sold and installed in the home the radio salesman calls and instructs the owner. The salesman does not demonstrate the set to the owner but lets the purchaser do his own demonstrating.

"The important thing in selling radio," he concluded, "is to keep in close touch with the local demand."

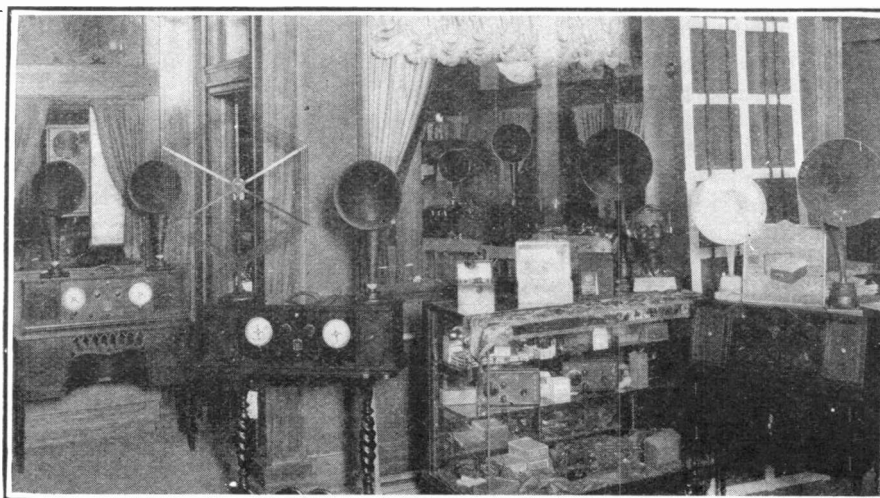

The higher-priced sets sell equally as well as the lower-priced ones in this radio department, according to the manager, Wil-

liam W. Cross. Time payments do it. "The man who buys a set," he says, "wants a good one and is willing to pay for it."

"The Gyp Must Go!"

Education in Dealer Opportunities and Dealer Ethics Will Solve Problem

By E. B. MALLORY

Manager Radio Division, Westinghouse Company, President Radio Section, Associated Mfrs. of Electrical Supplies

I DISLIKE very much to see public use of the term "gyp," which is an expression largely used by members of the radio fraternity to define what seems to me to be a dealer who has not sensed the possibilities in radio, nor has a knowledge of the ethics of one of the most promising professions in the country.

To my mind a clarification of the radio merchandising situation does not involve the elimination of the dealer ignorant of his opportunities and operating on a penny wise, pound foolish policy, but rather the continued education of those dealers who are familiar with the ethics of the profession of merchandising and the vast opportunities of a dealer who conducts his business in an intelligent, progressive and ethical manner.

If the public follow precedent and custom it will not be long before the type of dealer termed as "gyp" will fail through lack of patronage, as a dealer, to continue on a profitable and successful basis in the radio industry. As in any other industry, he must follow the customs and precedents of ages and render service above all things.

The trend of the radio industry indicates quite clearly that dealer's service will be a growing factor from year to year as the radio set of tomorrow will not be an assembly of a few well-known parts whose functions and relations are reasonably well-known to the public. On the contrary, the development in general is toward a complicated, mechanical and electrical device which will require the ministrations of those skilled in its operation and assembly to insure proper installation, and it is my opinion that only those who are capable and willing to render this service can exist as this development progresses.

Fraudulent advertising, misrepresentation of products and other illegal practices should, of course, be definitely and firmly dealt with, but

machinery is available for the prosecution of such illegal practices in the form of the National Vigilance Committee of the Associated Advertising Clubs of the World, a Radio Section of which has recently been formed. The activities of this committee, as in other industries, are too well-known to warrant comment.

It is my suggestion, therefore, that your pages can do the radio industry, the public, and the one to whom your magazine is addressed, namely, the dealer, the most good by developing a full and proper appreciation of the service requirements of the dealer as of paramount importance, and secondary, though of only slightly less importance, proper and adequate representation of products coupled with suitable publicity.

* * *

Prosecute Gyp Misrepresentation Through Better Business Bureau

By E. B. INGRAHAM

Secretary-Treasurer Times Appliance Company, New York

IN GENERAL, a "gyp" is an unscrupulous merchant who misleads the public by misrepresentation, imitation of trade-marks, and other misleading practices. He is a dealer who engages in malicious advertising, such as advertising an article at a very low price, even below cost, for the purpose of attracting customers. This practice invariably destroys the confidence of the public in the trade-marked article. It always seems to me that this practice injures the manufacturer's trade-mark very materially.

The best means we have at present for identifying a "gyp" and for driving him out of the radio business is through the Better Business Bureau. The Better Business Bureau is so organized that it can and will investigate and even prosecute all illegal practices. False advertising, misrepresentation, and other such practices can be eliminated by prompt action on the part of the Better Business Bureau.

I think that other radio dealers could help to do away with "gyp" practices by giving hearty support to the Better Business Bureau and

by keeping an active watch on advertising and reporting all such infractions. *Radio Retailing* can do a great deal to clear up this situation by giving support to the Better Business Bureau and by giving publicity to its activities.

* * *

Manufacturer Estopped By Law From Taking Adequate Action

By M. C. RYPINSKI

Vice-president C. Brandes, Inc., New York City

I BELIEVE that the "gyp" radio dealer will disappear naturally as the public learn to discriminate in their purchases, between dependable merchandise as regularly carried by the responsible dealer who backs up the manufacturer's guarantee and gives 100 per cent service, on the one hand, and the "gyp" radio dealer who cuts prices on popular merchandise to attract trade to his store, in order to sell them inferior merchandise at a profit.

We have endeavored in every possible legal way to control the distribution of our product so that it would not get into the hands of those unscrupulous dealers who were perfectly willing to advertise it at cost or at a loss in order to attract trade, and who, of course, would not carry out our money-back guarantee and render the service that the responsible dealer is qualified to do.

Radio jobbers, however, seem to get panicky with the slightest slackening of demand and liquidate their stocks at ridiculous prices, in many cases approximating their first costs, which stocks are readily absorbed by the "gyp" dealer.

It seems to me that the remedy for this lies more with the individual jobber and dealer than with the manufacturer who is estopped by law from taking adequate action to stop these evil practices.

I suggest that you can help promote a higher standard of merchandising ethics among the distributors by giving as full publicity as possible to the vicious phases of this evil, and drawing particular attention to the business failures which are resulting among those who follow the "gyp" theory.

Emphatic Opinions Expressed by Leaders in All Branches of the Radio Industry

"Radio Leaders Should Protect Public's Interest"

By ALEXANDER EISEMANN
Treasurer, Freed-Eisemann Radio Corporation

THE leaders of radio have a great responsibility to the public. They must protect the interests of the thousands upon thousands of people who now find that radio is indispensable in their homes, that these buyers of radio equipment, knowing little or nothing of the technical side of this new wonder, may receive just values for their hard-earned dollars.

In other words, the clarion call of the radio industry must be to oust the "gyp" wherever such unscrupulous trading is done. It may never be entirely possible to eradicate all merchandising evils (that is the history of every industry), but I feel certain that the vast majority of the public understands that the manufacturers of standard radio apparatus are doing everything within their power to aid in removing all barriers to perfect confidence.

* * *

"Gyps" Are Dealers Who Offer Standard Lines at Cut Prices

By H. F. WILLENBRINK
President The Sutcliffe Co.,
Louisville, Ky.

OUR definition of the gyp dealer would be one who handles and advertises off-brand radio material, and also buys up jobs which sometimes include standard material, quoting cut prices on the entire line.

There is no way that you can prevent this dealer from buying off-brand goods, but if the manufacturers and jobbers would not dispose of their overstock to such dealers, they could be prevented from offering standard goods at cut prices.

Furthermore, if the radio papers could request newspapers not to accept advertising of this kind, it would help to solve the problem to a very great extent.

We think the retail dealer can help the situation by carrying a more representative stock, and we believe they will be willing to do so just as soon as they can feel assured that

there won't be a decline in price every thirty or sixty days.

We are glad to see that *Radio Retailing* has taken up the matter, and believe that you will be able to help a great deal in bettering conditions.

* * *

Fight Gyp With Advertising, Emphasizing Reliability

By O. F. ROST

General Manager, Newark Electrical Supply Company, Newark, N. J.

RESPONSIBLE radio manufacturers should confine their sales to the smallest possible number of distributors; trace every cut price sale that is brought to their attention until they have determined the distributor through whom the article was sold, and then see that the distributor refrains from again selling through the same channel. If manufacturers and jobbers would earnestly see to it that the gyp would find it almost impossible to secure any of the well-known sets and supplies to use as a leader, much can be

accomplished toward the elimination of the gyp.

The reliable radio dealer can do much toward the elimination of the gyp if he will but adopt the practice of "fighting fire with fire," namely—do as much advertising as does the gyp, and instead of advertising price, advertise reliability, honesty and permanency of his establishment. In the final analysis every human being buys an article for the mental satisfaction which comes with possession and, having bought in a first-class store, the infinitely greater sense of confidence and satisfaction will more than make up for the possibly higher price asked by the higher class, reliable dealer.

I personally believe that the only thing that is going to permanently eliminate the gyp is the law of the "survival of the fittest." The industry is undergoing a washing-out process such as the placer miner uses in looking for gold. Most of the irresponsible ones will be washed away in the process and, as gold nuggets remain in the pan, so the honest ones will remain in business.

What Is a Gyp?

Everybody is shouting, "The gyp must go!" That's admitted. But radio's primary problem is to establish clearly the definition of a gyp so that a merchant may not be unjustly accused. The mob spirit, the cry of "Lynch 'em," must not prevail in the radio industry. We must look at the matter sanely and coolly, ascertain the root of the evil and dig it up.

Decide, first of all, and definitely, just what practices may be termed "gypping."

Selling below list price. Is that gypping?

Pushing inferior merchandise. Is that what a gyp does?

Failure to back up his merchandise. Is that part of a gyp's policy?

Dishonest claims concerning what he sells. Is that the brand of a gyp?

Two prices for the same article. Is that how a gyp can be known?

Do all of these factors combined make a gyp? Does one of them, only, make a merchant a gyp? Or perhaps none of these considerations enters into the matter and a gyp can be summed up as a man who is lacking in merchandising ethics and in self-respect. Is that the answer?

"Radio Retailing" throws its columns open for a free discussion of the problem and invites its readers, particularly its dealer readers, gyps included, to express their opinions frankly. In this way, we believe, a constructive help to the radio trade will result.

Address, Editors, "Radio Retailing," Tenth Avenue and Thirty-sixth Street, New York City.

Full Prices and Expert Technical Knowledge Build Dealer's Success

L. Albaum, of Worcester, Mass., Keeps Abreast of Technical Radio Developments and Makes His Store a Source of Authoritative Radio Information

LALBAUM, owner of the Worcester Radio Supply Company, Worcester, Mass., had a hunch three years ago. The hunch was that radio was going to be a whale of an industry. The hunch, as has been proven, was absolutely correct.

From that day to this, Albaum "played" his radio hunches. He built up his business on "hunches," after he invested \$1,500 in his first hunch and watched it grow to \$15,000 in thirty-six months.

His hunches, he declares, are as follows:

1. Know radio thoroughly and believe in it as the biggest thing in the world today.
2. Handle merchandise on a prestige basis and let the price slasher cut his own throat.
3. Handle radio exclusively. If I can't make a go in straight radio, it's time to exit.
4. Know how to buy what sells and gives satisfaction.
5. Give a complete radio service, including transmitting equipment.
6. Give the customer the most for his dollar and keep up interest in the set after it's sold.

Albaum does all of these things. That's why Worcester radio shops may come and go, but Albaum keeps right on in business. His "radio arithmetic" explains his sales policy. It is a slogan he uses in his newspaper advertisements and window displays.

It reads: "Reputable Radio Equip-

ment plus Reliable Radio Dealer Equals Real Radio Satisfaction."

Establishing the prestige of his name and reputation has been the goal for which he has striven.

"I had no 'get-rich-quick' schemes in mind when I opened my radio store," he says. "I determined to establish myself permanently as a radio dealer of the highest standard, and I have consistently striven to do so. The radio dealer who goes into a cut rate business and hopes to make a lot of money by doing a big gross at low prices is following a mistaken policy.

Has Confidence of Fans

"The Worcester Radio Supply Company holds the confidence of Worcester radio fans. They know we are not here today and gone tomorrow, which is the fate of so many cut price stores, and they have learned to look up to our store, not only as a place where radio products of all descriptions, both sending and receiving may be bought, but also as a place where authoritative radio information may be obtained.

"A radio dealer must know radio, everything there is to know about it. He must be looked upon as a radio authority, not as a means of saving a few cents on a radio product. They are willing to pay the full prices I ask because they know they are not

going to get stuck and that I am right up to the minute in technical knowledge, new circuits and the science of radio.

"Also, when I sell a set, I make a ten dollar installation charge and keep up my interest in the set. I don't give any other free service except the factory guarantee, but, on the other hand, when I am in the neighborhood where a new set has been installed, I drop in and inquire how it is working. It takes but a few moments, and creates an excellent impression."

By following this policy of full list prices and radio satisfaction rather than attempting to meet cut price competition, Albaum's monthly gross averages \$3,000, and the market value of his stock has increased exactly ten times in the three years he has been in business.

The radio shop of the future, he believes, will be the high class, full list shop selling radio exclusively. "If you know how to do it," says Albaum, "you can make enough during the season to carry you comfortably over the summer without the necessity of a hot weather sideline."

Baltimore Jobber Launches Billboard Campaign

One of the most up-to-date radio jobbers is the firm of Joseph M. Zamoiski Company, of Baltimore, Maryland, whose billboard advertising commands attention for a radius of fifty miles around Baltimore. This firm uses only preferred locations at the turns of important highways, thus giving a head-on view of the signs. The boards are brightly illuminated so that their value is not lessened at night.

Joseph M. Zamoiski, the head of this concern, has been in the electrical business for many years, but is now, with the able assistance of his son, concentrating entirely upon radio. He has a high-speed crew of salesmen who cover large areas of eastern territory in automobiles. These men are specially trained in Zamoiski policies and methods.

Zamoiski advertising is not limited to billboards. He also uses liberal newspaper space, but confines himself to a wholesale business. A new building, just occupied, was purchased at a cost of a quarter of a million dollars, and is used exclusively for wholesale radio. It is located in the heart of the best wholesale business district.

Radio Enters Billboard Advertising Field



The Joseph M. Zamoiski Company, Baltimore, Md., has launched a billboard campaign for 50 miles in the vicinity of Baltimore. Important highways leading into Baltimore from all directions are lined with

these billboards which are brightly illuminated at night. This type of advertising not only aids Zamoiski but serves to bring the entire subject of radio to the attention of the general public.

"Quality Pays"

E. A. Portal, of San Francisco, Specializes in Higher Grades of Radio Products—
Caters to Prosperous Trade and Cashes in on Its Demand for
Quality Rather Than Low Prices

STARTING business just about two years ago, E. A. Portal of San Francisco has built up an enviable radio business in that city by specializing in what might be called "quality" trade.

His store is located in the main theater district, next door to one playhouse and with another in the same block. One of the well known residence hotels of the city is on the corner. The location is central, between the apartment house district with its concentrated population and unoccupied evenings, and the shopping section which brings always a certain amount of casual trade. From every standpoint, in Mr. Portal's opinion, the situation is ideal. The presence of the hotel alone, he estimates at a value of about \$2,000 a month in the out-of-town trade which it brings to his store.

From the beginning, the shop has specialized in the higher priced sets. The other stores in the neighborhood are mostly specialty shops catering to a high class of trade and his establishment fits in with the tradition. Instead of a window filled with radio parts and mechanical devices, the displays include expensive sets with a background of draperies and hangings, a tasteful use of color and design, and a general home atmosphere of taste and refinement.

No radio parts are carried. This is a business in itself, in Mr. Portal's opinion, and requires catering to a different public, flourishing best in a more purely business location with different merchandising methods and a sales force especially trained to meet the radio fan who builds his own.

On the other hand, sets of all kinds are carried and these are sold at the same price terms as are to be met with elsewhere in town. In other words, the store is not an expensive shop—it sets out to be rather a quality shop. No effort is made to "force" a customer to buy equipment either at a time when he does not wish it, or of a type more expensive than he wishes to buy. He can buy

a crystal set at Portal's if he so desires. It is significant, however, that the average price of sets sold during the past year was \$300 and that a very large number of sets ranging in cost from \$400 to \$500 were sold.

Mr. Portal credits the phenomenal success of the store to many things. This principle of suiting the customer is the beginning of success, in his opinion. The dealer who carries but one line is not in a position to meet the customer's wishes fully and therefore suffers under a certain weakness. The very fact that the customer knows he can get a full assortment here brings him to the store and the more expensive sets

sell themselves through their superior service.

The second cardinal principle of his sales methods is never to oversell a set. Long distance reception is never guaranteed. The customer is always sold on a service that is less than it is reasonable to suppose the set will render. Then when he gets stations even farther away than he expected, he is really satisfied with his purchase. If he is not and feels that he prefers another set, a cheerful exchange is made, even after the equipment is installed in his home.

The third basic element of success lies in the adequate servicing of equipment. An installation charge

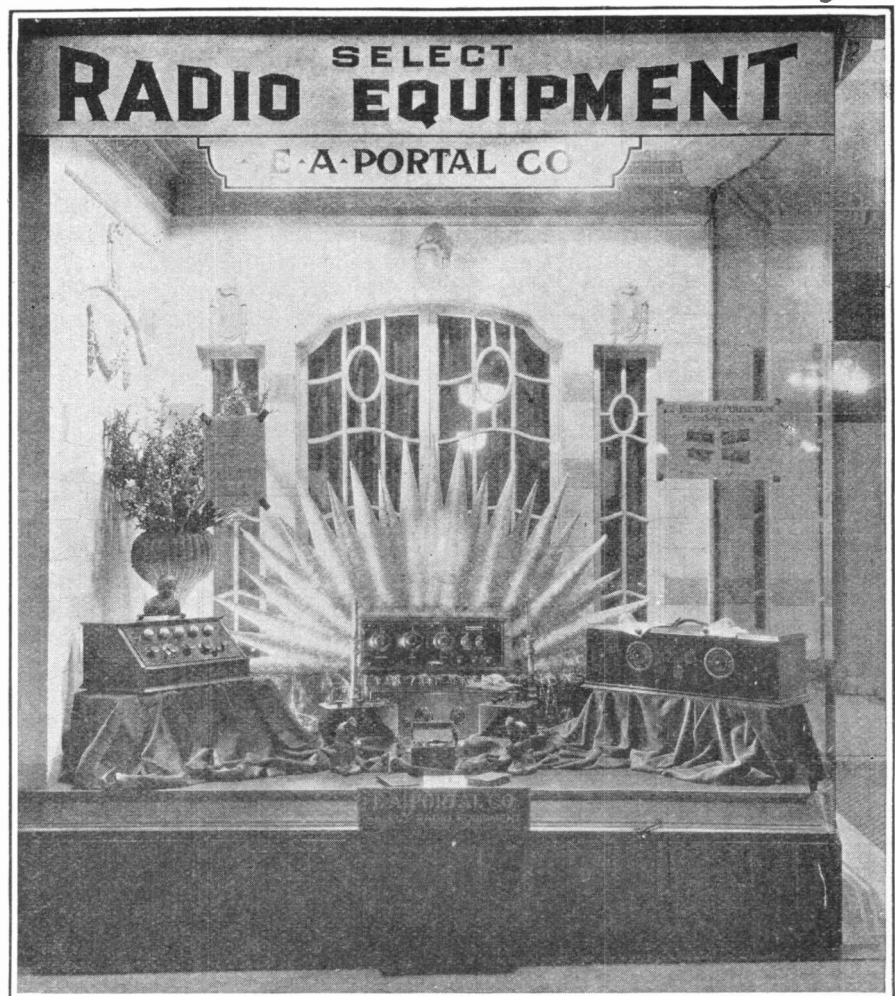

The atmosphere of quiet dignity and refinement conveyed in this window display visualizes the "quality rather than price" policy of this San Francisco dealer. Taste-

fully and attractively decorated in the "home of good taste" style, the display of sets is 100 per cent effective. And they are all expensive models.

of \$10 is made on new sets. This is less than the actual cost, but is made low so as to encourage customers to take advantage of it and to prevent careless amateur setting up of the equipment. Once the set is properly installed and in working order, the guarantee of the firm is behind it.

Replacement of batteries or repairs in this equipment of course involves a proper charge. Should anything go wrong with the machine itself, however, no matter when it was purchased, the Portal service man will call free of charge and repair the damage. This assurance is what sells the customer in many cases. He has perhaps had experience with equipment which did not give satisfactory service and has known the continual drain of repair charges which go with it. Here is a promise that his initial expenditure will be his only one, aside from the operating cost of batteries. On the part of the firm, experience has shown that free service of this kind amounts to very little, for the reason that the equipment sold is of the better type and once in good working order, there is very little opportunity for anything to fail. Three service wagons take care of installation and service work.

Sells Only Sets of Standard Manufacture

In this connection, the store makes a policy of handling only standard sets. Individually-built sets may be excellent, but the advantage of the research work which goes into the manufacture of standard equipment and the security which this ensures are factors of great importance, in Mr. Portal's judgment.

The sale is always followed up after it is made. Before it is consummated the customer has usually been visited in his home—perhaps more than once—and the salesman is thoroughly familiar with conditions. After it is delivered, he usually calls up to see whether it is operating satisfactorily—and repeats this at intervals. This means not only that the sale is a satisfactory one and that the purchaser becomes a source of further business to the store through his friends, but also it accomplishes that most desirable of ends, that of turning the casual purchaser into a regular customer. Record is kept of every set sold and Mr. Portal has concrete evidence of the value of his system through the number of purchasers of crystal sets who have later come in to buy the more

"Get the Quality Trade"

is the advice of E. A. Portal, of San Francisco, who goes after the ones with expensive tastes and sells them the more expensive sets.

The old idea of giving the customer the best set for the least money has died a natural death, he says. Portal has found it pays to take it for granted the purchaser wants to spend three or four hundred dollars.

expensive equipment. It means also, that the purchaser of radio equipment comes back to the Portal shop to buy his batteries. This is an item which Mr. Portal believes too many radio stores overlook, allowing their customers to drift away and to fill their later needs from other sources. He points to a battery replacement business which reaches the figure of \$1,500 per month as an example of the importance of this one item.

No attempt is made to make sales over the telephone, although many orders are received in this way from those who have been interested through sets already sold. Two salesmen are kept in the field, their returns from commissions never falling below \$500 a month.

Much of the demonstration is done in the home—and this work of course, is done mostly in the evening when radio programs are best. The store also keeps open from seven to nine. This is the theater hour when traffic in this district is the heaviest and many customers are brought in at this time.

Very little demonstration work is done in the store itself. For convenience in handling this necessary element in every radio shop however, a series of outlets has been installed in the shop, so that it is possible to connect any equipment with a central battery installation and individual batteries are not necessary with each set.

No particular advertising is done. Announcements are carried in the broadcasting news and some small amount of newspaper space is taken, the total expenditure not amounting to more than \$100 per month. The store itself and its window displays, on the other hand are fully appreciated from their advertising value and

an attractive exhibit is always maintained at the annual Radio Show which is given in the Civic Auditorium of San Francisco.

The best advertisement comes from former customers, is Mr. Portal's contention, and he states that the bulk of his trade comes from prospects sent in or brought in by those who consider themselves his friends because they themselves have been satisfied. The fact that the 1924 business reached a figure three-times that of the previous year and that Mr. Portal anticipates an equivalent increase for 1925, may be looked upon as a tribute to the idea of carrying only quality merchandise.

Unique Advertisement Helps Dealer Sell Portables

"A Roll Call of Portable Sets Sold By Us," was the interesting caption used by an Ohio concern in an advertisement appearing in the columns of local newspapers.

Under this heading the concern gave the names and addresses of all people to whom it had sold portable receiving sets and opposite each name it gave the use to which the purchaser had put the set. For instance, one purchaser had used his portable set on a transcontinental automobile trip. Another purchaser was stated to have used his on a fishing trip. Another took his portable set with him to the farm of his son in another state and there entertained the son's family and friends.

A personalized, localized and highly specific advertisement of this sort is always interesting and entertaining, and the idea helped this dealer to sell more portable sets than a straight ad would have.

The idea can be applied by any dealer, using all of his recent purchasers and how they get the most enjoyment from their equipment.

Five Rules for Dealer Success

BY PIERRE BOUCHERON

- Rule 1—Carry honest and dependable products
- Rule 2—Advertise in local papers to bring people to your store
- Rule 3—Display and demonstrate freely
- Rule 4—Give service if you want "repeat sales"
- Rule 5—There is none

Broadcasting by Operatic and Concert Stars Booms Sale of "Radio Chasses" for Phonographs

The action of the two leading phonograph companies in broadcasting the talent of their operatic and concert stars and the follow-up letters and circulars sent to responding listeners-in are rapidly bringing about a new trend toward combination radio and phonograph sets. Reports from various parts of the country show that the phonograph buying public demands combination units, with the result that a veritable boom in panel mounted radio sets is pending. Several far-sighted radio manufacturers have anticipated this development and are ready with 4-tube and 5-tube radio frequency "chasses."

The cabinet-type phonograph offers a greater potential market than the console-type. Of the former, 5,000,000 have been sold. This style of phonograph lends itself readily to radio adaptation, but as yet only two or three firms have designed drawer-type sets to fit in place of the record shelves. *Radio Retailing* will bring these models to the attention of its readers as they are announced by manufacturers.

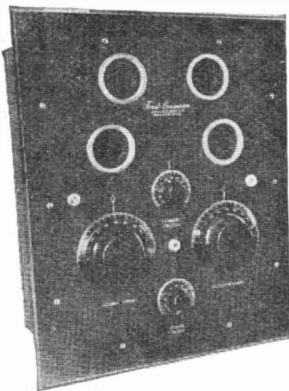

The 4-tube Neutrodyne panels made by Freed Eisemann, New York City, list at \$95. Receiver NR-215 is designed for Victor console Model 215, and receiver NR-400 is designed for Victor console models 400, 405 and 410.

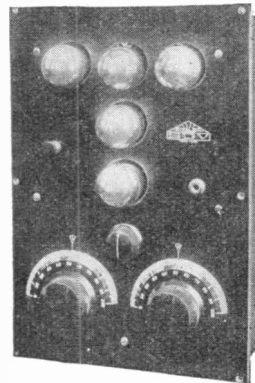

"Engle" SDV is the name of the 5-tube panel made by the Holt Engler Corporation, Brooklyn, N. Y. The panel is 10½ in. x 15 in., and weighs 20 lbs.

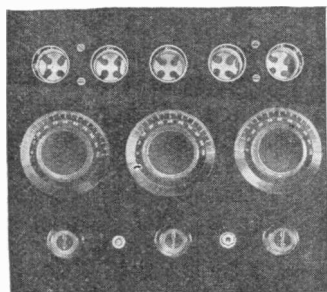

Henry Hyman and Company, New York City, have designed a 5-tube panel suitable for all makes of phonographs. List price is \$85.

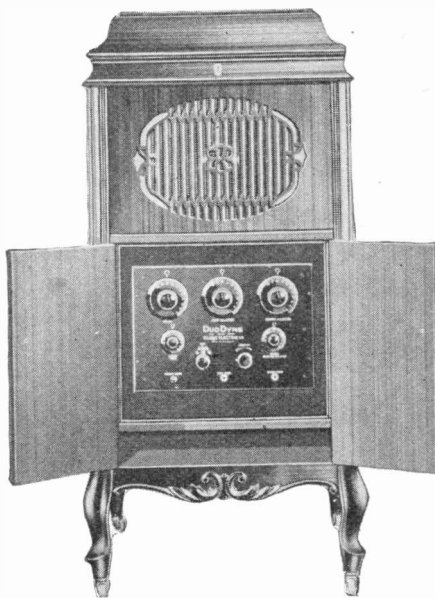

The vertical installation shown above is made by the Globe Electric Company, Milwaukee, Wis. This is made in 4-tube and 5-tube units for vertical or horizontal installations.

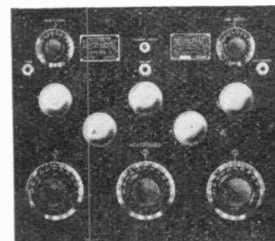

The 5-tube Neutrodyne panel of the Adler Manufacturing Company, Louisville, Ky., is made especially for the "Royal" phonograph. The size is 12½ in. x 15 in. List price is \$135.

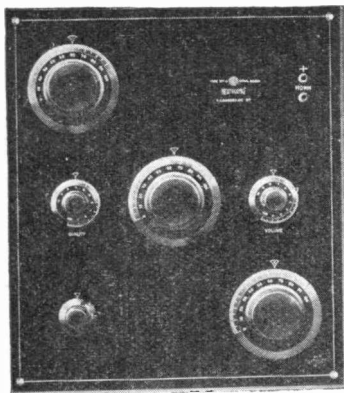

F. A. D. Andrea, Inc., New York City, is making two 5-tube Neutrodyne panels for Victor phonographs. Type 196-A, 15½ x 16½, is for models 400, 405 and 410. Type 197-A, 14½ x 17½, is for model 215.

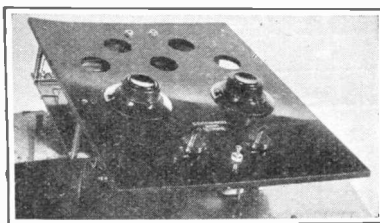

The R. E. Thompson Manufacturing Company, New York City, makes two types of radio panels, both accommodating a 5-tube Neutrodyne. Type P-11-400 (Victor) lists at \$125. Type P-11-215 (Victor) lists at \$115.

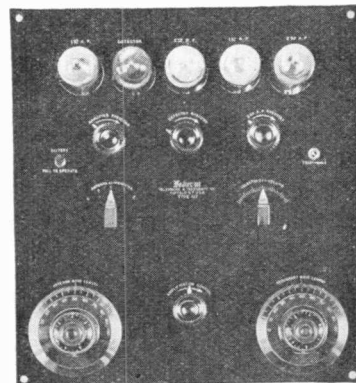

In addition to the two 5-tube panels for Victor models 215, 400, 405 and 410, the Federal Telephone Manufacturing Company, Buffalo, N. Y. is making a 4-tube unit measuring 10½ x 17½ for cabinet phonographs. List price is \$106.

Complete Specifications of Radio Sets—Spring Season, 1925

Manufacturer's Name and Address	Trade Name of Set	Model Number	List Price	Style of Cabinet	Dimensions Over-all	Weight, Lib.	No. of Tubes	Dry Cell or Storage Battery	Detector and Amplifier Plate Voltage	Stages of Radio Amplification	Stages of Audio Amplification	Operates On Aerial Ground or Loop	Type of Circuit
A-C Electrical Mfg. Co., Dayton, O.	Polydyne	NL-5	\$115.00	Table Type	8x24x8½	19	3	Either	90v.	2	2	Yes	T. R. F.
Adams-Morgan Co., 24 Alvin Ave., Upper Montclair, N. J.	"Paragon Paradyne"	No. 2 No. 3 No. 4	27.50 48.50 65.00	Mahogany Mahogany Mahogany	11x5x6½ 16x6½x7½ 20½x7½x8	5½ 9½ 13	1 1 1	Either Either Either	45v. 45-90v. 45-90v.	None None None	1 2 2	Yes Yes Yes	Reg. Reg. T. R. F.
Adler Mfg. Co., 881 Broadway, N.Y.	"Adler-Royal"	199 201	165.00 160.00	Table Type Table Type			3 3	D.C. S.B.	90v. 90v.	2 2	2 2	Yes Yes	Neut. Neut.
Air-way Elect. Appl. Corp., 618 Broadway, Toledo, Ohio	"Air-way" "Air-way" "Air-way" De Luxe	41 51 52	65.00 125.00 375.00	Walnut Walnut Console	8½x16½x8½ 27½x9½x9½ 36x24x21	35	2 3 3	S.B. S.B. S.B.	45-90v. 45-90v. 45-90v.	1 2 2	2 2 2	Yes Yes Yes	T. R. F. T. R. F. T. R. F.
Amber Mfg. Corp., 115 West Broadway, New York	"Marv-o-dyne" "Sky Lark"	512-C	98.00 38.00	Mahogany Mahogany	9x21x10 7½x18½x7½	20 15	3 3	Either Either	45-90v. 45-90v.	2 2	2 2	Yes Yes	T. R. F. T. R. F.
Amer. Etherphone Corp., Detroit, Mich.	"Etherphone" "Etherphone"	RX-3 TR-5	45.00 60.00	Mahogany Mahogany	8x8x13 8x9x27	5 12	2 2	S.B. S.B.	45-90v. 45-90v.	1 1	2 2	Yes Yes	Reflex. Reflex.
Amer. Radio Corp., 6116 Euclid Ave., Cleveland, Ohio	"Arc-Linger" "Arc-Linger" "Arc-Linger"	3A 4 Super 5	70.00 95.00 120.00	Table Type Table Type Table Type	14½x25x12½ 10x27x12 14½x30x12½		2 2 2	S.B. S.B. S.B.	45-90v. 45-98v. 45-90v.			Yes Yes Yes	R. F. (Ref.) R. F. (Ref.) R. F. (Ref.)
Amer. Radio and Research Corp., Medford Hillside, Mass.	Amrad Neutrodyne Amrad Inductroile Amrad Cabinette Amrad Jewel	3500-3 3500-4 3500-6	85.00 100.00 180.00 285.00	Table Type Table Type Console Console	17½x6½x12 17x14x12 12x29x14 15x29x17	14 22 26 38	2 2 2 2	S.B. S.B. S.B. S.B.	221-90v. 221-90v. 221-90v. 221-90v.	1 1 1 1	3 2 2 2	Yes Yes Yes Yes	Neut. R. F. R. F. R. F.
Amerex Elect. Corp., New York	Amerex Ace		59.00	Mahogany	7x18		3	Either	45-90v.	2	2	Yes	T. R. F.
Amer. Specialty Co., Bridgeport, Conn.	"Electrola" Grand	Standard Grand	100.00	Table Type Console	25x10x10 25x23x16	20 30	3 3	S.B. S.B.	45-90v. 45-90v.	2 2	2 2	Yes Yes	T. R. F. T. R. F.
Amisco Products, Inc., 416 Broome St., New York		M.S. 24 M.S. 25	140.00 150.00	Table Type Table Type	23½x8½x8 23½x9½x8	20 22	3 3	S.B. S.B.	45-90v. 45-90v.			Yes Yes	T. R. F. T. R. F.
F. A. D. Andrea, Inc., 1581 Jerome Ave., New York	"Feda" "One-Sixty" "Neutroceiver" "Neutrola" "Neutroceiver Grand" "Neutrola Grand"	160-A 175-A 185-A 175-90-A 185-90-A	120.00 160.00 220.00 210.00 270.00	Mahogany Mahogany Desk Type—L.S. Console Console L.S.	19x8x8 25x12x17 27x21x17 27x44x18 27x51x18	18 35 48 65 80	2 3 2 2 2	Either Either Either Either Either	45-90v. 45-90v. 3v. 45-90v. 45-90v.	2 2 2 2 2	2 2 2 2 2	Yes Yes Yes Yes Yes	Neut. Neut. Neut. Neut. Neut.
Andrews Radio Co., Chicago, Ill.	"Andrews Deresnadyné"	De Luxe L	165.00	Walnut	31x13x11½	45	3	S.B.	45-90v.	2	2	Yes	A. G. and L.
Apex Elect. Mfg. Co., Chicago, Ill.	"Apex"	Super 5	95.00	Desk Type—Walnut	20½x9½x11	21	3	S.B.	20-90v.	2	2	Yes	A. and G.
Appleby Radio Co., 1134 S. Cecil St., Philadelphia, Pa.	"Appleby" "Appleby" "Appleby"	V. XV. X.	135.00 135.00 230.00	Closed Cabinet Open Cabinet L.S.	17½x11½x11½ 17½x11½x11½ 19½x20x12	25 25 40	1 1 1	S.B. S.B. S.B.	90-90v. 90-90v. 90-90v.	2 2 2	2 2 2	Yes Yes Yes	A. and G. A. and G. A. and G.
Armley Radio Co., New York	"Karr Radio"		195.00	Portable	17x14x5½	29	1	D.C.	45-90v.	3	2	Yes	R. F.
Armac Radio Co., 1120 N. Ashland Ave., Chicago, Ill.	"Echophone" "Echophone"	V-3 F-5	50.00 110.00	Table Type Table Type			1 2	D.C. D.C.	45-90v. 45-90v.	2 2	2 2	Yes Yes	A. and G. A. G. and L.
A. and T. Radio Co., Danvers, Mass.	"Babydyne"		10.00	None	6x8	1	1	D.C.	22-45v.	None	None	No	A. and G.
Atwater-Kent Mfg. Co., 4722 Wisconsin Ave., Philadelphia, Pa.	Atwater-Kent Atwater-Kent Atwater-Kent Atwater-Kent	9 10 12	65.00 85.00 105.00 85.00 100.00	Base Board Base Board Base Board Cabinet Cabinet	20x10x6 26x10x6	11 16	2 3 3 3	S.B. S.B. S.B. S.B.	22-90v. 22-90v. 22-90v. 22-90v.	1 2 2 2	2 2 2 2	Yes Yes Yes Yes	T. R. F. T. R. F. T. R. F. T. R. F.
Audiola Radio Co., 430 S. Green St., Chicago, Ill.	"Audiola" "Audiola" "Audiola"	Audiodyne Super Grand Midget	75.00 100.00 45.00 10.00	Portable Portable Portable Portable	21x10x8½ 24x11x9½ 21x10x8½ 7½x5½x4		2 2 1 1	Either Either S.B. D.C.	45-90v. 45-90v. 45-90v. 22½v.	1 2 None None	2 2 None None	Yes Yes Yes No	T. R. F. T. R. F. Reflex Non-Reg.

Company Name	Model Name	Standard-B	23.50	Portable	4x12x24	4	1	Either	22½v.	No	None	No	A. and G.	T. R. F.
Auto Indicator Co., Gd. Rapids, Mich.	"Pocket Radio"		23.50	Portable	4x12x24	4	1	Either	22½v.	No	None	No	A. and G.	T. R. F.
Balt. Hub, Wh. & Mfg. Co., Balt. Md.	"Hobco"	Baby Grand	60.00	Mahogany	20x8	27½	3	S.B.	45-90v.	No	2	Yes	A. and G.	R. F.
Betts & Betts Corp., New York	"Trans-Continental"	T-8	225.00	Two-Tone Walnut	24½x11x16½	1	2	Either	45-90v.	Yes	4	Yes	A. G. and L.	Crystal
Bird Radio Corp., Cincinnati, Ohio	"Biltmore Master"	F-1	6.00	Mahogany	23½x8½x7½	1	3	None	None	No	None	Yes	A. and G.	T. R. F.
Biltmore Radio Co., Boston-30, Mass.	"Brandola"	T-5	68.00	Mahogany	33x13½x13	40	3	S.B.	45-90v.	Yes	2	Yes	A. and G.	T. R. F.
J. F. Brandeis Corp., 37 Oxford St., Newark, N. J.	"Brandola"		125.00	Walnut	10x22x10	23	1	Either	21-90v.	Yes	2	Yes	A. and G.	T. R. F.
P. H. Button, Detroit, Mich.	"Duodyne"	D-100	100.00	Walnut	21x11x12	30	3	S.B.	45-90v.	Yes	2	Yes	A. and G.	T. R. F.
Car Loyd Elect. & Radio Co., N.Y.C.	"Malone-Lemmon"	11	175.00	Table Type	24x10x10	8	2	Either	45-90v.	Yes	2	Yes	A. and G.	Reg.
Chelsea Radio Co., Chelsea, Mass.	Regenodyne	107	75.00	Table Type	8x20x8	20	1	Either	22-90v.	Yes	2	Yes	A. and G.	R. F.
Clearstone Radio Co., Cincinnati, Ohio	"Golderest"	60	60.00	Portable	10x26x10	35	3	S.B.	22-90v.	Yes	2	Yes	A. and G.	T. R. F.
Clapp-Eastham Co., 139 Main St., Cambridge, Mass.	"Radak"	DD	34.00	Leatherette	14½x5x6½	6½	2	Either	22-90v.	Yes	2	Yes	A. and G.	Reg.
Cleveland Prod. Co., Cleveland, O.	"Cleveland"	Gold Seal	38.00	Mahogany	23½x9½x10	17	2	Either	22-90v.	Yes	3	Yes	A. and G.	Reg. R. F.
Colonial Radio Corp., Long Island City, N. Y.	"Colonial"	A-5	120.00	Table Type	7x22x8	15	3	Either	45-90v.	Yes	2	Yes	A. and G.	T. R. F.
Concert Radio Phone Co., 626 Huron Rd., Cleveland, Ohio	"Concert"	17	85.00	Walnut	28½x16x12	40½	2	D.B.	45-90v.	Yes	2	Yes	A. and G.	T. R. F.
Cosmo. Phusi Former Corp., N. Y. C.	"Cosmo"	16	200.00	Walnut	13x19x11	25	1	None	None	None	None	No	A. and G.	Crystal
Crosley Radio Corp., 128 Sassafras St., Cincinnati, Ohio	"Cosmo"	"Sr."	2.50	Portable	7x28x7	25	3	S.B.	45-90v.	Yes	2	Yes	A. and G.	Non-Reg. T. R. F.
Dayton Fan & Motor Co., Dayton, Ohio	"Cosmo"	Grand	120.00	Mahogany	19½x9x8½	30	3	Either	45-90v.	No	2	Yes	A. and G.	T. R. F.
De Forest Radio Co., Central Ave., Jersey City, N. J.	Cosmopolitan	Five	66.00	Mahogany	8½x6x4½	7½	1	Either	22v.	No	1	No	A. and G.	Reg.
Doron Bros. Elect. Co., Hamilton, O.	"Day-Fan"	50	14.50	Mahogany	8x6x4½	21	1	Either	22-67½v.	4½v.	1	No	A. and G.	Reg.
Wm. D. Duck Co., Toledo, Ohio	"Day-Fan"	50-P	16.00	Portable	6x11x4½	9	1	Either	22-67½v.	4½v.	1	Yes	A. and G.	Reg.
Dynamotive Radio Corp., 47 Ninth Ave., New York	"Day-Fan"	51	18.00	Mahogany	6x11x4½	9	1	Either	22-67½v.	4½v.	1	Yes	A. and G.	Reg.
Eagle Radio Co., 27 Boyden Pl., Newark, N. J.	"Day-Fan"	51-P	23.50	Portable	12x12½x8½	10	1	Either	45-90v.	4½v.	1	Yes	A. and G.	Reg.
Ecodyne Radio Co., Irwin, Pa.	"Day-Fan"	52-Special	30.00	Mahogany	6x12½x6	10	1	Either	45-90v.	4½v.	1	Yes	A. and G.	Reg.
Eisemann Magneto Corp., New York	"Day-Fan"	Thru-Ton	35.00	Mahogany Battery	12x14½x8½	10	1	Either	45-90v.	4½v.	1	Yes	A. and G.	Reg. R. F., Ref.
Elgin Radio Supply Co., 207 E. Chicago St., Elgin, Ill.	"Day-Fan"	30A-Special	50.00	Mahogany	20½x9½x12	15	2	Either	45-90v.	4½v.	1	Yes	A. and G.	Reg. R. F., Ref.
Equit. Radio Corp., Hughesville, Pa.	"Day-Fan"	30A-Special	18.00	Mahogany	8½x6x4½	7½	1	Either	22½-90v.	No	2	Yes	A. and G.	Reg.
	"Day-Fan"	O.E.M.-11	90.00	Mahogany	21x8x9	15½	3	Either	22½-90v.	No	2	Yes	A. and G.	T. R. F.
	"Day-Fan"	O.E.M.-7	98.00	Mahogany	21x8x9	15½	3	Either	22½-90v.	No	2	Yes	A. and G.	T. R. F.
	"Day-Fan"	Dayola	125.00	Desk Type	24x15x12	32½	3	Either	22½-90v.	No	2	Yes	A. and G.	T. R. F.
	"Day-Fan"	Daytonia	225.00	Sloping Panel Console (C)	27½x17x21½	72	3	Furn.	22½-90v.	No	2	Yes	A. and G.	T. R. F.
	"Day-Fan"	Daytonia	265.00	Console (C)	42½x16x40½	118	3	Furn.	22½-90v.	No	2	Yes	A. and G.	T. R. F.
	"Radio Phone"	D-12	169.50	Fabrikoid	22½x15½x17½	34½	2	D.B. Furn.	90v.	No	3	Yes	Loop	Ref.
	"Radio Phone"	D-12	184.50	Mahogany	22½x15½x17½	34½	2	D.B. Furn.	90v.	No	3	Yes	Loop	Ref.
	"Radio Phone"	D-12	189.50	Fabrikoid	22½x15½x17½	34½	2	S.B. Furn.	90v.	No	3	Yes	Loop	Ref.
	"Radio Phone"	D-12	204.50	Mahogany	22½x15½x17½	34½	2	S.B. Furn.	90v.	No	3	Yes	Loop	Ref.
	"Radio Phone"	D-17	190.00	Leather	22½x15½x17½	34½	2	Either	90v.	No	3	Yes	Loop	Ref.
	"Radio Phone"	D-17	200.00	Mahogany	22½x15½x17½	34½	2	Either	90v.	No	3	Yes	Loop	Ref.
	"Super-Equidyne"	R-5	125.00	Table Type	28x10x10	60	3	S.B.	45-90v.	Yes	2	Yes	A. and G.	T. R. F.
	"Dynamotive"	R.C.-250	125.00	Table Type	24-7½x8½	17	3	Either	45-90v.	Yes	2	Yes	A. and G.	T. R. F.
	"Dynamotive"	R.C.-250	185.00	Table Type	9x12x15	3	3	Non-D.C.	House Cur.	Yes	2	Yes	A. and G.	T. R. F.
	"Eagle Balanced"	B	235.00	Table Type	9x12x15	3	3	None-A.C.	House Cur.	Yes	2	Yes	A. and G.	T. R. F.
	"Eaglet"	R-13	175.00	Sloping Panel	7½x29x8½	27	3	S.B.	45-90v.	Yes	2	Yes	A. and G.	Neut.
	"Ecodyne"	R-5	75.00	Sloping Panel	8x26x8	15	4	S.B.	45-90v.	Yes	2	Yes	A. and G.	Neut.
	"Ecodyne"	R-5	115.00	Table Type	9x24x9	19	4	S.B.	45-90v.	Yes	2	Yes	A. and G.	T. R. F.
	"Eiseman"	6-D	150.00	Table Type	19½x13½x9½	15½	3	Either	45-90v.	Yes	2	Yes	A. and G.	T. R. F.
	"Elgin Reimartz"	2Lo	125.00	Mahogany	6x15x6	9	1	Either	22½v.	No	1	No	A. and G.	Reg.
	"Elgin Reimartz"	2Lo	32.05	Table Type	6x15x6	9	1	Either	22½-90v.	No	1	No	A. and G.	Reg.
	"Claratone"	S-24	41.80	Table Type	6x15x6	9	1	Either	22½-90v.	No	1	No	A. and G.	Reg.
	"Exlntone"	C-24	51.60	Table Type	6x15x6	9	1	Either	22½-90v.	No	1	No	A. and G.	Reg.
	"Exlntone"	W-25	50.00	Mahogany	6x25	20	3	Either	45-90v.	Yes	2	Yes	A. and G.	T. R. F.
	"Exlntone"	W-25	50.00	Period	6x25	20	3	S.B.	45-90v.	Yes	2	Yes	A. and G.	R. F.
	"Exlntone"	W-25	50.00	Period	6x25	20	3	S.B.	45-90v.	Yes	2	Yes	A. and G.	R. F.

Radio Retailing's

Complete Specifications of Radio Sets—Spring Season 1925—Continued

Manufacturer's Name and Address	Trade Name of Set	Model Number	List Price	Style of Cabinet	Over-all Dimensions	Weight, Lb.	No. of Tuning Dials	Dry Cell or Storage Battery	Detector and Amplifier Plate Voltage	C ⁺ Battery	Stages of Radio Amplification	Stages of Audio Amplification	Operates Loud Speaker	Operates On Aerial Ground or Loop	Type of Circuit	
Federal Tel. Mfg. Corp., Buffalo, N. Y.	"Federal"	110	105.00	Table Type	13x14x11	17	2	Either	45-90v.				Yes	A. and G.	R. F.	
	"Federal"	DX-58	123.00	Portable	9 1/2 x 17 1/2 x 18 1/2	20	3	Either	45-90v.				Yes	A. and G.	R. F.	
	"Federal"	102	140.00	Table Type	10 1/2 x 18 x 10 1/2	35	2	Either	45-90v.				Yes	A. and G.	R. F.	
	"Federal"	61	223.00	Table Type	16 1/2 x 24 1/2 x 12 1/2	35	3	Either	45-90v.				Yes	A. and G.	R. F.	
	"Federal"	59	177.00	Table Type	15 1/2 x 22 1/2 x 11	29	3	Either	45-90v.			2	2	Yes	A. and G.	R. T.
	"Federal"	135	98.20	Phonograph			3	Either	45-90v.			2	2	Yes	A. and G.	R. F.
Ferguson, J. B., 80 Beaver St., New York	"Federal"	200	120.00	Phonograph			3	Either	45-90v.				Yes	A. and G.	R. F.	
	"Federal"	141	150.00	Mahogany			2	Either	45-90v.				Yes	A. and G.	R. F.	
	"Federal"	142	120.00	Mahogany L.S.			2	Either	45-90v.				Yes	A. and G.	R. F.	
	"Federal"	143	230.00	Console L.S.			2	Either	45-90v.				Yes	A. and G.	R. F.	
	"TRF"	3	130.00	Phonograph	9 1/2 x 24 1/2 x 9 1/2	27	2	Either	45-90v.			1	2	Yes	A. and G.	R. F.
	"TRF"	3-V	120.00	Portable			2	Either	45-90v.			1	2	Yes	A. and G.	R. F.
F'n & Dom. El. Com., Inc., N. Y.	"Electradyne"		110.00	Mahogany, L.S.	15 1/2 x 15 1/2 x 14	37	3	None-A.C.	House Cur.	Yes	1	2	Yes	A. and G.	R. F.	
	Freed-Eisemann	NR-5	150.00	Mahogany	13x28x12	17	3	S.B.	45-90v.		2	2	Yes	A. and G.	Neut.	
Freed-Eisemann Radio Corp., 41 Flatbush Ave., Brooklyn, N. Y.	Freed-Eisemann	NR-6	150.00	Mahogany	13x29x12	18	3	S.B.	45-90v.		2	2	Yes	A. and G.	Neut.	
	Freed-Eisemann	NR-7	100.00	Phonograph	12x22x12 1/2	18	2	S.B.	45-90v.		1	2	Yes	A. and G.	Neut.	
Ferris Radio Supply Co., Inc., N. Y.	Ferris Radio, Inc.	NR-215	95.00	Phonograph	14 1/2 x 17 x 11	13 1/2	2	S.B.	45-90v.		1	2	Yes	A. and G.	Neut.	
		3-TR	50.00	Mahogany	19x8 1/2	14 1/2	2	Either	45-90v.	4 1/2 v.	None	2	2	Yes	A. and G.	Neut.
Charles Freshman Co., Inc.	Freshman	"Masterpiece"	60.00	Mahogany	9x21x9	13	3	Either	45-90v.	No	2	2	Yes	A. and G.	T. R. F.	
	Garod Corp.	V	195.00	Sloping Panel Console, L.S.	13 1/2 x 34 1/2 x 11 1/2	25	3	S.B.	45-90v.		2	2	Yes	A. and G.	Neut.	
Giffilan Bros., 1815 W. 16th St., Los Angeles, Cal.	"Garod"	Georgian	400.00	Mahogany	35 1/2 x 16 1/2 x 42 1/2		3	S.B.	45-90v.		2	2	Yes	A. and G.	Neut.	
	"Giffilan"	Rat	135.00	Mahogany	19 1/2 x 7 1/2 x 10		3	S.B.	45-90v.		2	1	Yes	A. and G.	Neut.	
Globe Elect. Co., 14 Keeffe Ave., Milwaukee, Wis.	"Giffilan"	Gn-1	175.00	Desk Type Walnut	10x18x12	35	3	S.B.	45-90v.		2	2	Yes	A. and G.	Neut.	
	"Duodyne"	Gn-2	140.00	Desk Type Walnut	10x26 1/2 x 10 1/2		3	S.B.	45-90v.		2	2	Yes	A. and G.	Neut.	
	"Duodyne"	815	110.00	Table Type	6x21	25	3	S.B.	22-90v.	No	2	2	Yes	A. and G.	T. R. F.	
	"Duodyne"	900	135.00	Table Type	9 1/2 x 28	30	3	S.B.	22-90v.	No	2	2	Yes	A. and G.	T. R. F.	
	"Duodyne"	902	310.00	Console	9 1/2 x 28		3	S.B.	22-90v.	No	2	2	Yes	A. and G.	T. R. F.	
	"Duodyne"	Globe	770	55.00	Portable	6x18	20	2	S.B.	22-90v.	No	2	2	Yes	A. and G.	T. R. F.
Gluck Radio Mfg. Co., New York	Duodyne	772	140.00	Console	38x30	97	2	S.B.	22-90v.	No	1	2	Yes	A. and G.	T. R. F.	
	Duodyne	775	80.00	Table Type	9x16	20	2	S.B.	22-90v.	No	1	2	Yes	A. and G.	T. R. F.	
	Duodyne	860	100.00	Table Type Cabinet	8 1/2 x 23	34	3	S.B.	22-90v.	No	2	2	Yes	A. and G.	T. R. F.	
	Gluckson	RF-5	98.00	Desk Type	12x24x10		3	S.B.	45-90v.	Yes	2	2	Yes	A. and G.	T. R. F.	
A. H. Grebe & Co., Inc., 70 Van Wyck, Richmond Hill, N. Y.	Synchrophase	Mu-1	155.00	Mahogany	9 1/2 x 22 1/2 x 13 1/2	22	3	S.B.	90-90v.	41v.	2	2	Yes	A. G. or L.	T. R. F.	
	Synchrophase	Mu-2	155.00	Mahogany	9 1/2 x 22 1/2 x 13 1/2	22	3	D.B.	90-90v.	41v.	2	2	Yes	A. G. or L.	T. R. F.	
Grimes, D., Inc., New York	David Grimes, Inc.	3XP	85.00	Mahogany	21x16x9	16	3	Either	90v.	No	2	3	Yes	A. and G.	Inv. Duplex	
	Haldorson Radio Receiver	RF-400	75.00	Mahogany	22x9x18	17	2	S.B.	22 1/2-90v.	No	2	2	Yes	A. and G.	T. R. F.	
Hansen Storage Co., 120 Jefferson St., Milwaukee, Wis.	Haldorson Radio Receiver	RF-500	115.00	Mahogany	22x9x18	18	3	S.B.	22 1/2-90v.	No	2	2	Yes	A. and G.	T. R. F.	
	"Nightingale"		32.50	Vertical Sloping Panel	10x6 1/2 x 4	6 1/2	1	S.B.	45-90v.		1	2	Yes	A. and G.	T. R. F.	
	"Nightingale"		57.50	Sloping Panel	8 1/2 x 8 1/2 x 16		2	S.B.	45-90v.		1	2	Yes	A. and G.	T. R. F.	
H. W. Harmon & Sons Co., Grove City, Pa.	"Gold Finch"		75.00	Sloping Panel	23 1/2 x 9 1/2		2	S.B.	45-90v.		2	2	Yes	A. and G.	T. R. F.	
	Amer. Crest		150.00	Table Type	23x8x8		2	S.B.	45-90v.		2	2	Yes	A. and G.	T. R. F.	
Harmony Mfg. Co., Cincinnati, O.	"Harmonson"	IVC	130.00	Table Type	26 1/2 x 10 x 13 1/2		2	Either	D, 20v.	Yes	1	2	Yes	A. and G.		
	"Harmony"	IVC Grand	160.00	Built-in Speaker	26 1/2 x 15 1/2 x 13 1/2		2	Either	A, 45-112v.	Yes	1	2	Yes	A. and G.		
Hartman Electrical Mfg. Co., Mansfield, Ohio	"Harmony"	5	162.50	Mahogany	22 1/2 x 9 x 10		1	S.B.	45-90v.		2	2	Yes	Loop	R. F.	
	"Hartman"	10-A, Adam P.	225.00	Console	43 1/2 x 32 x 14	89	2	D.C.	45-90v.	No	1	2	Yes	Either	T. R. F.	
	"Hartman"	12-A, Adam P.	245.00	Console	43 1/2 x 32 x 14	89	2	D.C.	45-90v.	No	1	2	Yes	Either	T. R. F.	
	"Hartman"	10-A, Ital. Per.	305.00	Console	43 1/2 x 32 x 14	95	2	D.C.	45-90v.	No	1	2	Yes	Either	T. R. F.	
	"Hartman"	12-A, Ital. Per.	325.00	Console	43 1/2 x 32 x 14	95	2	D.C.	45-90v.	No	1	2	Yes	Either	T. R. F.	
	"Hartman"	10-A, Q. Anne P.	295.00	Console	43 1/2 x 32 x 14	95	2	D.C.	45-90v.	No	1	2	Yes	Either	T. R. F.	
	"Hartman"	12-A, Q. Anne P.	315.00	Console	43 1/2 x 32 x 14	95	2	D.C.	45-90v.	No	1	2	Yes	Either	T. R. F.	
	"Hartman"	10-B	135.00	Semi-portable	12 1/2 x 31 x 14	34	2	D.C.	45-90v.	No	1	2	Yes	Either	T. R. F.	
	"Hartman"	12-B	155.00	Semi-portable	12 1/2 x 31 x 14	34	2	D.C.	45-90v.	No	1	2	Yes	Either	T. R. F.	
	"Hartman"	10-C	100.00	Portable	11x25x10 1/2	20	2	D.C.	45-90v.	No	1	2	Yes	Either	T. R. F.	
	"Hartman"	12-C	120.00	Portable	11x25x10 1/2	20	2	D.C.	45-90v.	No	1	2	Yes	Either	T. R. F.	

Company	Model	Weight	Dimensions	Material	Features	Price	Quantity	Notes	Remarks	Reg.
H. Hyman & Co., Inc. 476 Broadway, New York	"Bestone" "Bestone"	165.00 115.00	15x21x10	Sloping Panel, L.S. Sloping Panel, L.S.	2 2	30 30	1 1	45-135v. 45-135v.	A. and G. A. and G.	R. F. R. F.
International Radio Co., New York	"Lark"	7.50	7x11 1/2	Table Type	1	6	None	22 1/2v.	A. and G.	Reg.
Jones Radio Co., Chicago, Ill.	"Symphony"	165.00	23 1/2 x 7 1/2 x 8	Table Type	3	23	None	22 1/2-90v.	A. and G.	Reg.
Colln B. Kennedy Co., 6400 Plymouth St., St. Louis, Mo.	"Kennedy" "Kennedy" "Kennedy" "Kennedy" "Kennedy"	101.75 88.75 105.00 142.50 185.00	13 1/2 x 13 1/2 x 8 16 x 14 1/2 x 9 1/2 16 x 14 1/2 x 9 1/2 21 1/2 x 15 1/2 x 10 1/2 25 x 15 1/2 x 14 1/2	Portable Sloping Panel Sloping Panel Sloping Panel Sloping Panel, L.S.	2 2 2 2 2	25 1/2 15 16 25 40	None None None None None	22 1/2-67 1/2v. 45-90v. 45-90v. 45-90v. 45-90v.	A. and G. A. and G. A. and G. A. and G. A. and G.	Reg. Reg. Reg. T. R. F. Reg.
Kor-Rad Co., 151 E. 58th St., New York	K-40 K-60	140.00 160.00	25 1/2 x 11 1/2 31 x 17 x 11 1/2	Sloping Panel Sloping Panel	3 3	3	2 2	22 1/2-90v. 4 1/2v.	A. and G. A. and G.	T. R. F. T. R. F.
Kodel Mfg. Co., 121 W. 3rd St., Cincinnati, Ohio	E-11 E-12 C-11 C-12 C-13	16.00 22.50 10.00 18.00 28.00	4 1/2 x 5 x 8	Portable Portable Table Type Table Type Table Type	1 1 1 1 1	4 1/2	None None None None None	22 1/2v. 22 1/2-67 1/2v. 22 1/2v. 22 1/2-67 1/2v. 22 1/2-90v.	A. and G. A. and G. A. and G. A. and G. A. and G.	Non-Reg. Non-Reg. Non-Reg. Non-Reg. Non-Reg.
Kilbourne & Clark, Seattle, Wash.	Air Roamer	140.00		Mahogany	3		2	45-90v.	A. and G.	T. R.
Liberty Trans. Co., Chicago, Ill.	"Liberty Sealed Five"	100.00	26x7	Walnut	3	20	2	22 1/2-90v.	A. and G.	T. R. F.
Mercury Radio Prods. Co., N. Y.		165.00		Walnut	3		2	45-90v.	A. G. or Loop	Inv. Duplex
Magnavox Co., 2725 E. 14th St., Oakland, Cal.	TRF-5 TRF-50	125.00 150.00	9 1/2 x 20 1/2 x 14 1/2 14 1/2 x 20 1/2 x 18 1/2	Mahogany Mahogany	1 1		2 2	45-90v. 45-90v.	A. and G. A. and G.	T. R. F.
Mangus Elect. Co., New York	940	65.00	24 1/2 x 11 1/2 x 9 1/2	Mahogany	3	30	2	22 1/2-90v.	A. and G.	T. R. F.
Marwol Radio Corp., New York	A-1	60.00	19x6 1/2 x 9	Mahogany	3	20	2	45-90v.	A. and G.	T. R. F.
Mazda Rad. El. Co., Cleveland, Ohio	"Consomello Grand"	235.00	30x17 1/2 x 13	Console, L.S.	3	50	2	22 1/2-90v.	A. and G.	T. R. F.
Michigan Radio Corp., Fed. Sq. Bldg., Grand Rapids, Mich.	MRC-2 MRC-3 MRC-12 MRC-14	32.50 87.50 57.00 87.00	Sloping Panel Table Type Sloping Panel Desk Type, L.S.	2 2 2 2			None None 1 1	22 1/2-67 1/2v. 22 1/2-90v. 22 1/2-90v. 22 1/2-90v.	A. and G. A. and G. A. and G. A. and G.	Reg. Reg. R. F. R. F.
Midwest Radio Co., Cincinnati, O.	MW	54.50	7x7x24	Table Type	2	20	1	45-90v.	A. and G.	R. F.
Moe Mfg. Co., Fall River, Mass.	"Aladdin"	65.00	17x6 1/2 x 10 1/2	Sloping Panel	3	7	2	45-90v.	A. and G.	T. R. F.
Mohawk Elect. Co., 2220 Diversey Pkwy., Chicago, Ill.	VA X	150.00 250.00	21 1/2 x 16 x 14	Sloping Panel Console	1 1	20	2 2	45-90v. 22 1/2-45v.	A. and G. A. and G.	T. R. F. T. R. F.
Moon Radio Corp., Long Is., City	TA	100.00	15 1/2 x 10 1/2 x 8 1/2	Mahogany	1	15	2	45-90v.	Ground	R. F.
Mu-Rad Labs, Inc., 800 Fifth Ave., Ashbury Park, N. J.	"Murad Triplex" "Mu-Rad"	75.00	23x9x8	Mahogany Mahogany	2 3	36	1 2	22 1/2-90v. House Cu.	A. and G. None	T. R. F. T. R. F.
Murdock Co., Wm. J., Washington Ave., Chelsea, Mass.	"Murdock" "Murdock" "Murdock"	130.00 140.00 100.00	25x11 1/2 x 7 25x11 1/2 x 7 27x15x15	Mahogany Mahogany Mahogany, L.S.	3 3 3	20 20 30	2 2 2	45-90v. 45-90v. 45-90v.	A. and G. A. and G. A. and G.	Neut. Neut. Neut.
Musical Prods. Dist. Co., N. Y.	Federal-Danersk	325.00	15 1/2 x 33 1/2 x 5 1/2	Console Period, L.S.	2		2	22 1/2-135v.	A. and G.	T. R. F.
Nassau Radio Co., 60 Court St., Brooklyn, N. Y.	MIR-60 VR-400 VR-215	130.00 130.00 115.00	7x26 15 1/2 x 17 1/2 14 1/2 x 17 1/2	Mahogany	3 3 3		2 2 2	40-90v. 40-90v. 40-90v.	A. and G. A. and G. A. and G.	T. R. F. T. R. F. T. R. F.
National Air Phone Corp., 18 Hudson St., New York	4-A 5-A 4-B 4-C	65.00 75.00 85.00 150.00	7x26	Mahogany Mahogany Mahogany Mahogany, L.S. Base Board	2 3 3 1 1		1 2 1 1 1	40-90v. 45-90v. 45-90v. 45-90v. 45v.	A. and G. A. and G. A. and G. A. and G. A. and G.	T. R. F. T. R. F. T. R. F. T. R. F. T. R. F.
Operadio Corp., Chicago, Ill.	1925 Model	195.00 C	9x12x17	Leatherette Portable	2	44 (Comp.)	3	45-90v.	A. G. and L.	R. F.
Pathe Phonograph & Radio Corp., 20 Grand Ave., Brooklyn, N. Y.	B-5	90.00 60.00	27 1/2 x 9 x 8 21 1/2 x 9 x 10 1/2	Table Type Table Type	3 3	21	2 2	45-90v. 45-90v.	A. and G. A. and G.	T. R. F. T. R. F.
Penn. Wire Mfg. Co., New Castle, Pa.	"Penn-C Special"	65.00	7x21x9	Table Type	1	15	None	45-90v.	A. and G.	Reg.
Perry Radio Supply Co., 218 Washington Blvd., River Forest, Illinois	Kewpie PA-11 Grand PRD-11 PA-IV	25.00 175.00 50.00 40.00	8 1/2 x 6 1/2 x 6 8 1/2 x 6 1/2 x 6 26 1/2 x 11 13 1/2 x 7 x 6 9 x 7 x 6	Sloping Panel Sloping Panel Mahogany Sloping Panel Sloping Panel	1 None 2 2 None	4 5 30 7 6	None None 3 1 None	22 1/2v. 90v. 60-90v. 60-90v. 45-90v.	A. and G. A. and G. A. and G. A. and G. A. and G.	Non-Reg. Reg. R. F. R. F. Reg.
P. Fanstiehl R. Ser. Co., High Pk., Ill.	P. Fanstiehl	140.00	27x10x8 1/2	Mahogany	7	18	2	45-90v.	A. and G.	T. R. F.
Portola Radio Co., Philadelphia, Pa.	Portola	160.00 C	10 1/2 x 10 1/2	Portable	101	27	3	45-90v.	Loop	R. F.

Complete Specifications of Radio Sets—Spring Season 1925—Continued

Manufacturers Name and Address	Trade Name of Set	Model Number	List Price	Style of Cabinet	Dimensions Over-all	Weight, Lb.	No. of Tuning Dials	Dry Cell or Storage Battery	Detector and Amplifier Plate Voltage	Battery	Stages of Radio Amplification	Operates Loud Speaker	Operates On Aerial Ground or Loop	Type of Circuit
Pontree Radio Lab, 12 Bergen St., Brooklyn, N. Y.	"Engler" "Engler"	S.D.V. S.D.V.	65.00 70.00	Sloping Panel Phonograph	19x9 1/2 x 9 1/2 10 1/2 x 15	30 20	2	Either Either	45-90v. 45-90v.	No No	2 2	Yes Yes	A. and G. A. and G.	T. R. F. T. R. F.
Prezel Radio Mfg. Co., Toledo, O.	"Supertive"		130.00	Sloping Panel	15 1/2 x 22 x 15 1/2	22	3	Either	45-90v.		2	Yes	A. G. and L.	T. R. F.
Premier Radio Corp., Defiance, Ohio	Premier Premier	7-A 7-B	290.00 160.00	Console Table Type			2	Either Either	45-90v. 45-90v.				A. and G. A. and G.	Reflex Reflex
Q-T-Radio Prods. Co., East Or., N. J.	Little Giant	P.T.	60.00	Mahogany	8x8x18	5	3	Either	22 1/2-90v.	Yes	2	Yes	A. and G.	T. R. F.
Radio Corp. of Amer. 233 Broadway, New York	Radiola Radiola Radiola Super "Super-Heterodyne" "Regeno Flex" Radiola	III-A X VIII III	65.00 245.00 425.00 269.00 191.00 35.00	Vertical (C) Slop. Panel, L.S. (C) Console (C) Portable (C) Vertical (C)	11 1/2 x 6 1/2 x 6 21 1/2 x 15 1/2 x 19 1/2 19 x 26 1/2 x 49 35 x 11 1/2 x 11 30 x 11 1/2 x 11 7 1/2 x 6 1/2 x 6	6 1/2 38 93 37 27 3 1/2	1 2 2 2 2	D.B. D.B. D.B. D.B. D.B.	45-90v. 45-90v. 45-90v. 45-90v. 45-90v.	4 1/2 v. 4 1/2 v. 4 1/2 v. 4 1/2 v. 4 1/2 v.	2 2 2 2 1	Yes Yes Yes Yes Yes	A. and G. A. and G. A. and G. A. and G. A. and G.	Reg. Ref. Super-H. Super-H. Reg. Ref. Reg. Ref.
Radio Master Corp. of Amer., Bay City, Mich.	Simpliform Simpliform	100 275 375	135.00 225.00 315.00	Table Type Console Console	26 1/2 x 13 1/2 x 17 34 x 39 x 17 43 x 48 x 18	80 125 175	2 2 2	Either Either	45-90v. 45-90v. 45-90v.		1 1 2	Yes Yes Yes	A. and G. A. and G. A. and G.	R. F. R. F. R. F.
Radio Prod. Mfg. Co. Chicago, Ill.	R. P. M. R. P. M. R. P. M. R. P. M.	50 51 52 53	100.00 110.00 135.00 230.00	Base board Base board Walnut Console	11 x 30 x 5 10 x 30 x 11	13 1/2 24	3 3 3 3	Either Either Either Either	22 1/2-90v. 22 1/2-90v. 22 1/2-90v. 22 1/2-90v.	3-9v. 3-9v. 3-9v. 3-9v.	2 2 2 2	Yes Yes Yes Yes	A. and G. A. and G. A. and G. A. and G.	T. R. F. T. R. F. T. R. F. T. R. F.
Radio-Rite Service Labs. Newark, N. J.	Selectodyne Selectodyne	451 453	17.50 42.50	Mahogany Mahogany	8 x 16 1/2 x 9 9 x 23 x 9		3 3	Either Either	22 1/2-90v. 22 1/2-90v.	Yes Yes	None None	No Yes	A. and G. A. and G.	R. F. R. F.
Radio Supply House, Moline, Ill.	Paramount	X3	20.00	Table Type	7x5		2	D.B.	22 1/2 v.		None	No	A. and G.	Ref.
Rauland Mfg. Co., 2650 Coyne St., Chicago, Ill.	"Alamax"	Junior Senior	42.00 42.00	Open Panel Open Panel	7x9 7x18		1 2	D.B. S.B.	45v. 45-90v.	No No	None None	No No	A. and G. A. and G.	Ref. Ref.
Ramstone Corp., New York, N. Y. 1154 Broadway	Ramstone	Tritube Special	34.50 15.50	Table Type	8 1/2 x 9 x 20 8 x 8 x 12		2 2	Either Either	45-90v. 22 1/2 v.		None None	Yes No	A. and G. A. and G.	Non-Reg. Non-Reg.
Resas, Inc., 112 Chambers St., N. Y.	"Tone-A-Dyne"	5T	78.00	Table Type	7x24x7	30	3	S.B.	45-90v.	4 1/2 v.	2	Yes	A. and G.	T. R. F.
Sears Mfg. Co., 1226 E. 152nd St., Cleveland, Ohio	Acme Reflex Acme Reflex	A B	150.00	Portable Portable	7 x 16 x 8 1/2 7 x 24 x 8 1/2		1 2	S.B. S.B.	45-90v. 45-90v.	Yes Yes		Yes Yes	Loop Loop	Ref.
Simplex Radio Co., 1013 Ridge St., Philadelphia, Pa.	"Simplex" "Simplex" "Simplex" "Simplex"	Travel RX RF	80.00 80.00 120.00	Portable Table Type	10 x 19 x 9 10 x 13 x 9 23 x 8 x 9 1/2	14 14 25	2 2 2	D.B. D.B. S.B.	22 1/2-67 1/2 22 1/2-67 1/2 45-90v.		1 1 2	Yes Yes Yes	A. and G. A. and G. A. and G.	R. F. R. F. R. F. R. F.
E. Singer Co., New York	"Singer Compendyne Recv."		65.00	Mahogany	8 x 10 x 10	25	3	Either	45-90v.	No	2	Yes	A. and G.	T. R. F.
Slagle Radio Co., Fort Wayne, Ind.	"Slagle"	Five	150.00	Table	29 x 11 x 8	40	3	Either	22 1/2-90v.	Yes	2	Yes	A. and G.	T. R. F.
Sleeper Radio Corp., L. I. City, N. Y.	Monotrol	54	130.00	Sloping Panel	18 x 16 x 9 1/2	17	1	Either	90v.	No	3	Yes	A. G. and L.	Inv. Duplex
Sonora Phonograph, Broadway, N. Y.	"Sonoradio"	242	235.00	Console Phonog.	30 x 33 x 19	95	2	D.B.	45-90v.		2	Yes	A. and G.	T. R. F.
Splitdorf Elec. Mfg., Newark, N. J.	Splitdorf	R-200	150.00	Mahogany	34 x 11 x 8 1/2	27	3	S.B.	45-120v.	Yes	2	Yes	A. G. and L.	T. R. F.
Square Deal Radio and Elec. Co. Fenton, Mich.	"Autophone" "Celestaphone" "Harmondyne" Goldtone	III V-3 I	29.50 39.50 49.50 55.00	Walnut Choice Choice Choice	19 x 8 x 9 22 x 10 x 9 20 x 12 x 14 28 x 10 x 11	4 5 8 7	2 4 4 3	S.B. S.B. S.B. Either	45-150v. 22-90v. 22-150v. 22-90v.	No 4 1/2 v. No No	2 None 1 2	Yes Yes Yes Yes	A. and G. A. and G. A. and G. A. and G.	Ref. Non-Reg. R. F. T. R. F.
Stand. Rad. El. Co., Pawtucket, R. I.	"Giblin Broadcast Recv."	RL	125.00	Table Type	22 x 12 x 10 1/2	21	2	S.B.	45-90v.		3	Yes	Loop	R. F.
Stand. Rad. Corp., Worcester, Mass.	"Standardyne"	I	60.00	Mahogany	9 1/2 x 20 x 9	6 1/2	2	Either	45-90v.	No	2	Yes	A. and G.	T. R. F.
Starr Equip. Corp., Brooklyn, N. Y.	"Starr Harmonic"	LD	150.00	Walnut	12 x 24	28	3	S.B.	45-90v.	No	2	Yes	A. G. and L.	T. R. F.
Stromberg-Carlson Tel. Mfg. Co. Rochester, N. Y.	"Stromberg-Carlson"	I-A	180.00 319.00	Table Type Console	28 1/2 x 11 1/2 x 9 32 1/2 x 17 1/2 x 42	44 150	3 3	S.B. S.B.	45-90v. 45-90v.		2 2	Yes Yes	A. and G.	T. R. F. T. R. F.

Company Name	Model	Price	Dimensions	Weight	Material	Features	Power	Controls	Notes	Reg.
Sun Radio Co., Chicago, Ill.	"Sun Set"	150.00		40	Portable					R. F.
Sunbeam Radio Sales Co., N. Y.	"Akradyne"	75.00		20	Mahogany					T. R. F.
Super Antenna Co., Quincy, Ill.	"Super"	210.00		3	Console					R. F.
Supertone Radio Co., McKibben Bldg., Muskogee, Okla.	SRC-4 SRC-4	100.00 100.00	28x9x9 28x9x9	30 30	Mahogany Mahogany					Non-Reg. Non-Reg.
Sypher Mfg. Co., Toledo, Ohio	"Super Reflex"	60.00	15x7x7½	12	Mahogany					R. F.
Tel. Maintenance Co., Chicago, Ill.	"Telmaco"	125.00	8x10x8	26	Portable					R. F.
Telephone Co. of America, 455 W. 42nd St., New York, N. Y.	Telephone Telephone	60.00 225.00	19½x10½x11½ 40x27x18	15 75	Mahogany or Wal. Console, L.S.					T. R. F. T. R. F.
Terlee Elect. Mfg. Co., 445 S. Dearborn St., Chicago, Ill.	Terlee Acme Reflex Acme Reflex	65.00 165.00	9x16x8 9x32x11	31 (P) 68 (P)	Mahogany Walnut					R. F. R. F.
Terrace R. Mfg. Corp., Yonkers, N. Y.	Timson	60.00	19x9x9	15	Mahogany					T. R. F.
Terry El. Co., New Low Falls, Mass.	Terry Neutrodyne	125.00	26x8x8	1	Mahogany					Neutrodyne
Thompson R. E. Mfg. Co., N. Y. 30 Church St., New York, N. Y.	"Grandletter" "Parlor Grand" "Concert Grand"	125.00 145.00 180.00	22½x9½x9½ 22½x10x13 29x14x13½	19½ 22½ 29½	Mahogany Sloping Panel Sloping Panel					Neut. Neut. Neut.
Tuska C. D. Co., 83 Homestead Ave., Hartford, Conn.	Supertone Supertone Tuska Radio	150.00 85.00 35.00	24x13½x9½ 19x9x12 12x6x7	22 17 7	Table Type Table Type Table Type					Super D. Super D. Reg.
Tresco Sales, Inc., Davenport, Iowa	Trescola Trescola Trescola	22.50 22.50 50.00 60.00		2 2 2 2	Sloping Panel Sloping Panel Sloping Panel Sloping Panel					Reg. Reg. Reg. T. R. F.
Thermiodyne R. Corp., Platts., N. Y.	Thermiodyne	140.00	26x9x9	15	Table Type					T. R. F.
United Mfg. & Dist. Co., Chicago, Ill. 9705 Cottage Grove St., Chicago, Ill.	"Unidyne" "Super Unidyne"	75.00 130.00	21½x12x15	24 36	Walnut Walnut					T. R. F. T. R. F.
Vibroplex Co., Inc., 825 Broadway, New York	Martinola Martinola Martinola	20.00 75.00 85.00	9x8x8 23x8x8	6 14½	Table Type Table Type Table Type					Non-Reg. R. F. R. F.
Ware Radio Corp., 529 W. 42nd St., New York, N. Y.	"Ware" "Ware" "Ware"	65.00 150.00 175.00	10½x14x13 21½x8½x10½	22	Table Type Table Type Table Type					Neut. Ref. Neut. Neut.
Wells Mfg. Co., Fond-du-Lac, Wisc.	Westburr	70.00	23x9x10	1	Walnut					R. F.
Westburr, Inc., New York	Westburr	165.00 C	17x13x5½	23	Suit Case					R. F.
Western Coil & Elect. Co., 313 Fifth St., Racine, Wisc	"Radiodyne" "Radiodyne" "Radiodyne" "Radiodyne"	80.00 230.00 150.00 250.00 150.00	22x7x8½ 30x37x19 24½x12x11 30x37x19 24½x12x11	17 50 28 48 28	Table Type Console Table Type Console Table Type					R. F. R. F. R. F. R. F. R. F.
Wolverine Rad. Co., Detroit, Mich.	"Combidyne"	100.00	21½x8½x8	3	Mahogany					T. R. F.
Work Rite Mfg. Co., 1812 E. 30th St., Cleveland, Ohio	"Work-Rite Chum" "Work-Rite Air Master" "Work-Rite Radio King" "Work-Rite Aristocrat"	65.00 120.00 170.00 350.00	21x14x14 22x20x17 42x41x20	25 28½ 80	Sloping Panel Sloping Panel Sloping Panel, L.S. Console, L.S.					Ref. Neut. Neut. Neut. Neut.
World Wireless Corp., New York	"Supér-Four"	65.00	16x8	10	Mahogany					T. R. F.
Wright Rad. Mfg. Co., St. Paul, Minn	"Wright"	50.00	16x8	10	Mahogany					Non-Reg.
Zenith Radio Corp., McCormick Bldg., Chicago, Ill.	"Zenith" "Zenith" "Zenith" "Zenith" "Zenith" "Zenith"	160.00 95.00 224.00 230.00 250.00 300.00 550.00	23½x9½x10½ 20½x13½x8 20½x13½x6 47½x16½x10½ 47½x16½x10½ 47½x16½x10½ 47½x16½x10½	27 19 24	Sloping Panel Portable Sloping Panel Console Console, L.S. Console (2), L.S.					Reg. R. F. Reg. R. F. R. F. T. R. F. T. R. F. T. R. F.



“Radio Concerts in Every Room”

Apartment Houses, Hospitals and Hotels Are Being Equipped for Radio in Every Room—Two Hotels, in New York and Atlantic City, Latest Additions to List

By WILLIAM A. CLARKSON

THE “radio in every room” idea, inaugurated in his own home two years ago by O. H. Caldwell, editor of *Radio Retailing*, is rapidly being taken up all over the country, especially by hospitals, hotels and apartment houses.

Several big apartment houses in New York City and vicinity have already installed central receiving stations, with wires to every apartment, and following the announcement last month that the forty-nine Government hospitals operated for disabled war veterans by the U. S. Veterans’ Bureau are soon to be equipped for radio reception in every room, it is learned that the Waldorf-Astoria Hotel in New York City is to be equipped with similar apparatus and the Western Electric Company is to install receiving sets for ten different channels in a 2,200-room hotel at Atlantic City, N. J.

Centralized receiving is considered a solution to many radio reception problems in the congested sections of the country’s larger cities. The demand for space for aerials is becoming so great that often there is not enough room left on an apartment house roof for even one more strand of wire. And surely no hotel housing permanent guests will permit them to hang an aerial on the roof. The answer is—centralized reception, which permits the listener merely to plug in at the outlet in his room and receive the programs.

The Ritz Apartment at Newark, N. J., has had this system in operation for some time past, as has the

Hudson View Garden Apartments, in New York City. In both cases, the tenant is taxed \$20 a year for the radio service. In the New York City house, 354 apartments are equipped, and the installation, approximating \$20,000, will pay for itself in less than three years.

The Ritz in Newark has only one channel so that but one station may be received at a time. The Hudson View Gardens uses the four-channel system, permitting the reception of three local stations and one DX. This same system is also used in the Longview Hotel, Longbell, Washington, and is being installed in the Tremont Apartments, New York City.

“As Easy as Getting Ice-Water”

The installation to be made at the Waldorf-Astoria Hotel, New York, will differ slightly from that used by the apartment houses. The signals, instead of being amplified at the receiving central, will be put on trunk lines to each room at headset volume. The guest who wants to listen in will phone the desk and the earphones will be forthcoming as quickly as ice-water.

If he wants loud speaker volume, an amplifier and speaker will be sent to him, the rent for the equipment for the evening being but a fraction of the cost of theater tickets.

The installation at the Atlantic City hotel by the Western Electric Company will permit reception from ten different stations. A large power-amplifying unit has been constructed capable of stepping up the

signals to operate 350 loud speakers.

This sort of installation will not hurt the dealer’s sale of sets, it is said, because it is a market that cannot be sold individual outfits. But it does add to the dealer’s market not only for the installations and loud speakers, but also for the wiring jobs in private homes, hotels, hospitals, institution and apartments.

It also opens up another market for the dealer, in two ways, and that is in those hotels and hospitals whose officials do not feel inclined to install radio wiring in every room. The dealer can either rent sets to hospital patients or hotel guests, or he can sell sets to the hotel or hospital authorities, who, in turn can rent them to those desiring them.

This set renting idea is being worked successfully both in hotels and hospitals. The man renting the sets uses a model that is self-contained and inserts a lock in the cabinet so that the instrument cannot be tampered with. The dealer pays the expenses of upkeep and makes a charge for the rental, usually amounting to \$2 a night or \$10 weekly. The hotels and hospitals in any town should be eager to grasp this opportunity to be of service to their guests and the dealer ought to experience little difficulty in securing their co-operation.

The Providence-Biltmore Hotel, at Providence, R. I., is among the first to install the set renting idea for the pleasure and convenience of its guests. More than 40 sets are continually in use at this hotel.

Radio vs. Theater

Operatic Concert by Prominent Artists
Raises Discussion as to Whether Radio
Is Responsible for Theatrical Slump

RADIO EDITOR TAKES ISSUE WITH BRADY

Tells Producer High Prices,
Speculators and Discourtesy
Have Injured Theatres.

ANSWER ADMITS CHARGES

Only Denies Ill-Treatment at Box
Office—McCormack the Cause
of the Controversy.

William C. Alley, associate editor of Radio Retailing, has written a letter to William A. Brady in which he takes exception to Mr. Brady's protest against the radio "appearance" of stars like John McCormack and Mme. Bori. Mr. Brady said the legitimate theatre was suffering from such free performances. Mr. Alley declared that on the contrary not radio but the theatre itself was to blame for the theatre's troubles.

Mr. Alley made two complaints against the theatre—high prices and speculators. He said that he, like many of the public, would like to go to the theatre of

A NEW question is agitating Broadway!

With the radio appearance of John McCormack and Lucrezia Bori, several theatrical managers of New York City visioned their commercial demise and raised a long, loud wail that "radio was causing the death of the theater." The day after the concert, which was a tremendous success, newspapers of the city carried a statement by William A. Brady, prominent New York theatrical producer, that "radio is the greatest menace the theater has ever known."

"The Theater Is Doomed"

"The theater is doomed to extinction," wailed Mr. Brady, or words to that effect, "and here theater managers are sitting back like a lot of humpty-dumpties on a wall and letting this radio business put them out of the running. We've got to do something to fight it or we might just as well all quit."

This precipitated discussion. Discussion not only among the theater managers themselves but also between protagonists of radio against upholders of the drama. Also, some managers took a sane viewpoint of the matter and refused to get at all excited about it, while several interested radio men took the opportunity to point out that radio is probably the least of the reasons for the poor financial year in New York theatrical circles.

First and foremost among radio's protectors, was, of course, *Radio Re-*

tailing. William C. Alley, associate editor, indicted the theater as its own worst enemy, in a written answer to Mr. Brady.

Sensing the news value of the "conflict," most of the city newspapers carried the statements of Mr. Brady, the answer of Mr. Alley and the comments of other theater managers.

Arthur Hammerstein, well-known sponsor of musical comedies, lined up with Mr. Brady and declared war against "the enemy." Mr. Hammerstein ground his teeth, twirled his moustaches, laughed sardonically and chastised the radio industry severely by refusing permission to broadcast any of the musical numbers from his shows, "so there."

John Golden, another prominent producer, flatly disagreed with theat-

rical managers who saw danger in radio, and S. L. Rothafel, the "Roxy" of WEA and allied stations' Sunday evening programs, who broadcasts every week, and, as a result of which, his Capitol Theater in New York, is packed to its 5,000 seating capacity at every performance, laughs out loud whenever he thinks of radio as a "menace."

"If one is looking for distractions which keep people away from the theater," Mr. Golden said, "he must include petting parties, the movies, cross word puzzles, rain, snow and the hired girl's night out. Instead of taking the attitude that radio is a menace, theatrical interests should realize that it can be a great help to the drama. I am already making plans for co-operation, with, instead

(Continued on Page 194)



"HAVE AT THEE, VARLET!"

Rollin Kirby in the New York World



A Dealer Who Built His Own Radio Craze

Home Made Broadcasting Station Keeps Overhead Down by Helping to Build Outside Sales from "Neighborhood" Location

By L. E. MOFFATT

NINETY THOUSAND DOLLARS a year is a good radio business. And when this is done in a "neighborhood" location, it means, with the low overhead due to such an economical location that this volume of business also yields a good net profit. This is the volume and this is the location of the Grand Rapids Radio Company, Grand Rapids, Michigan.

For such a neighborhood dealer the problem of advertising is especially difficult. If the city newspapers are used there is obviously a large waste circulation. The appropriation for advertising that such a dealer can make is not large and the

full advantage must be gotten from all the money spent for advertising.

The Grand Rapids Radio Company has compensated for its location by a great deal of outside selling. Its advertising problem was not so much wanting to get people to come into the store to buy as to make their firm well and favorably known to the people of Grand Rapids in order that its outside salesmen might meet with a favorable reception. Approximately \$2,000 was appropriated for the yearly advertising expense and with this amount what would they use,—broad-sides, newspapers, circular letters or what? The advertising method finally adopted was nothing

less than the installation of a broadcasting station. This sounds financially more ambitious than it actually was. As a matter of fact the entire installation cost about \$2,000. A 20-watt station, it was designed and built by themselves.

Leo L. Robinson and Don L. Gildersleeve the proprietors of this business are radio enthusiasts as well as practical radio men and they have with them two licensed operators with ideas as to what broadcasting equipment should be.

The work of building the broadcasting station and installing the equipment was done during the summer when other business was de-

manding so much time and attention.

Because of the low wattage some of the parts had to be designed and made by themselves. The broadcasting station when finished is so efficient that letters have been received from 25 states reporting reception. This station, WEBK, has been heard in its twice a week broadcasting and its program applauded from Omaha in the West to Boston in the East.

The cost of operation is not excessive and is covered by the charge made to the church and the theater that broadcast through Station WEBK. This charge is \$15 an hour and covers the actual expenses. The church and the theater each broadcasts one evening a week.

As both the licensed operators are kept busy in other work for the company, only a part of their time has to be charged to the station. Fifty per cent is the rate of depreciation set on the station equipment. The station cost \$2,000 which means that \$1,000 a year is charged to depreciation and is the chief advertising expenditure of the company.

There is no studio. The broadcasting equipment is installed in the store of the Grand Rapids Radio Company and connected with the church and the theater by telephone.

Now as local advertising—how has the broadcasting station paid?

It has paid very well. The sale of parts in the store has been greatly stimulated. More small sets are always built where there is local broadcasting, and the small sets that the boy builds converts the family to the large set that father buys.

Station WEBK has made the Grand Rapids Radio Company known and talked about by all the radio fans in the city of Grand Rapids. These radio fans come in to see the broadcasting equipment which, as it is installed in the store, makes it easy for the radio fans to buy his radio needs right there, and he often does.

The radio fan is always welcome at this shop. There is always somebody who can talk to him on any technical matter that he is, at the moment, concerned with and the result is often another steady customer.

These radio enthusiasts who come into the store are also a source of leads for the outside salesman to develop into sales, and everybody in this organization is keen for these leads.

For it is in selling outside the store that the Grand Rapids Radio

Company looks for its greatest growth and has had its best success. Their experience with outside selling goes back to the beginning of this business, which is about two years old and is the reason why, with such an unfavorable location, this company is able to do the very good volume of business which it does.

After a brief experience in selling radio parts bought from a jobber whose stock had been damaged by fire, these two partners, Robinson and Gildersleeve, decided to go into the radio business. Naturally, the question of where they should locate was the first consideration.

Location a Problem

The most attractive locations are always those downtown where traffic is the thickest and where sales opportunities are greatest. It is also the fact that in these locations the rent demanded is often out of proportion to the street traffic and its sales possibilities. When these rents were compared and the locations studied it could be figured how much business would have to be done in order to keep these downtown rents in their proper relations to sales and profit. This would not be so hard in the busy season but these two men had heard that there was a dull period in radio. A seasonal slump. Months when the demand slackened.

And at the time when buying demand would slacken, the rents would keep on at their high altitude just the same. Location alone could not be relied upon to make a good all-year-round business. As these two

men had determined that they were not going to be too much affected by any dull season or slack period, they knew that at the time of slackened demand they would have to get out and sell.

Then why not locate where the rent was low and get out and sell all the year round?

This is what was done. The location of the Grand Rapids Radio Company is out among their customers and prospects. In other words they located not at the community center where rents are high, but out in the center of the community where their customers are. This saves time for the outside men and it cuts the costs of delivery, demonstration and service.

At the start most of the outside selling was done by Mr. Robinson and by Mr. Gildersleeve. Then three salesmen were taken on who have all built substantially for the company and themselves. There has been no "turnover" in salesmen. The salesmen have stuck because they have made good and made money.

Most of the outside selling is done on leads. Old customers are, of course, the chief source of such leads but many leads do come into the store. Selling and demonstrating is done in the evening and in the home and sets are often left for a short trial period. The salesmen find that following up a set newly sold will bring in a number of good leads. While the set is new and the owner is especially enthusiastic with the novelty of it he is one of the best salesmen which the store can have.

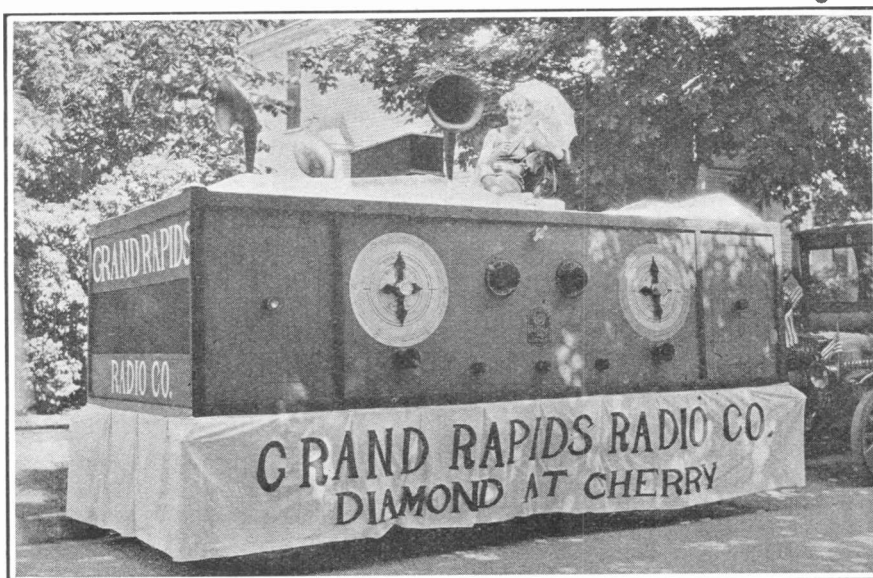

Every time the town that made furniture famous stages a parade, the Grand Rapids Radio Company is right up in front with floats like this one. With the beautiful

blonde riding on top of the set, we don't think many of the witnesses paid a whole lot of attention to the rest of the display. Altogether, it made an effective ad.

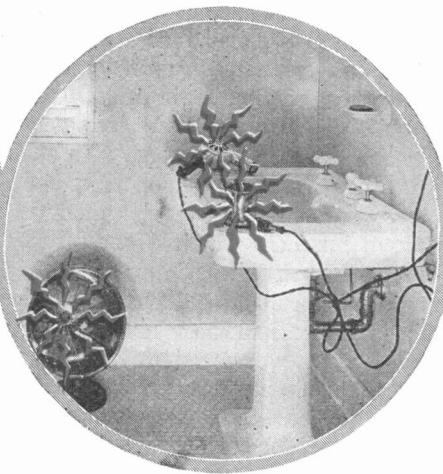
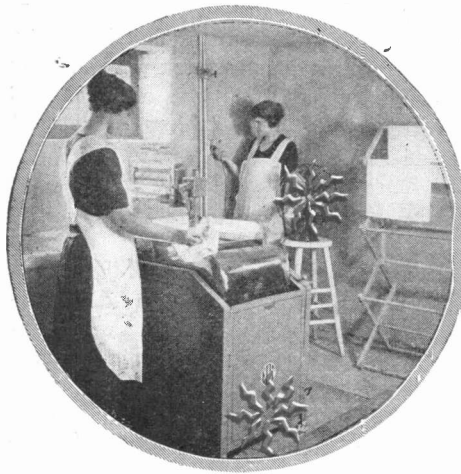

Tiny sparks occurring in motors, lamp sockets, thermostats and other electrical devices are often the causes of exasperating noises in receiving sets. Wash-

ing machines, electric fans, hair driers and vacuum cleaners where operated by motors of the commutator type, produce almost imperceptible sparks under the

motor contact brushes when running. "Interference" from this cause can be minimized by connecting a condenser across the motor leads.

How Dealers Can Eliminate

Troublesome Tiny Sparks in Motors, Lamp Sockets, Thermostats and Other Electrical Appliances Cause Exasperating Noises in Receiving Sets—How to Find and Cure Them

ONE OF the greatest difficulties with which the radio dealer has to contend is "interference," that is, the presence of unwelcome and irritating noises in the receiving set he is demonstrating or servicing. Such "interference" can be divided into four kinds of disturbances:

First—natural "static," which is caused by certain electrostatic conditions of the atmosphere and is practically uncontrollable with the present kind of receiving equipment in use.

Second—"ship interference," produced by obsolete spark sets on vessels, which cause great havoc in broadcast reception along the coasts.

Third—nearby radiating radio receiving sets, with the single-circuit regenerative receiver taking the lead in causing such trouble.

Fourth—local interference set up by tiny sparks or arcs in various electrical appliances, battery-chargers, sign-flashers, trolley cars, and other producers of "man-made static."

It is this last type of "interference" which we shall explain in

detail, for it is this form that is most troublesome to the radio dealer who is located in the congested part of town or city where such interference is at its maximum. It is also a form of interference which he can usually remedy with a little effort.

Few radio merchants really realize the number of good sales that are lost, owing to such interference. Say, for example, a dealer has spent considerable money and has taken

great pains in planning his local advertising campaign, in making an attractive display window, and in training his salesmen. Yet for all that there is this one thing, "local interference," which he probably has not taken precautions against,—especially if he is demonstrating in the customer's home.

A prospective buyer, let us say, is attracted by the display of sets in the dealer's show window, enters, inquires, and is gradually won over

How to Locate Sources of "Interference"

1. If set is noisy, first disconnect the aerial and see if the noise is still produced. If so the trouble lies in the set or batteries.

2. If unhooking aerial stops the interference, the trouble lies outside of the set.

3. Inspect all electrical appliances operating nearby which are most likely to cause interference, such as

electric fans, washing machines, violet ray outfits, sewing machines, ironers, etc.

4. Disconnect each of these, one at a time, and note if the interference is still heard.

5. If so, explore the various light sockets and wiring with the search coil, described in the accompanying article.



Lamps, lamp sockets, and heating devices cause disturbance only if a loose contact exists, intermittently breaking the circuit.



One of the worst producers of "local interference," the violet-ray outfit, can also be remedied by condensers.

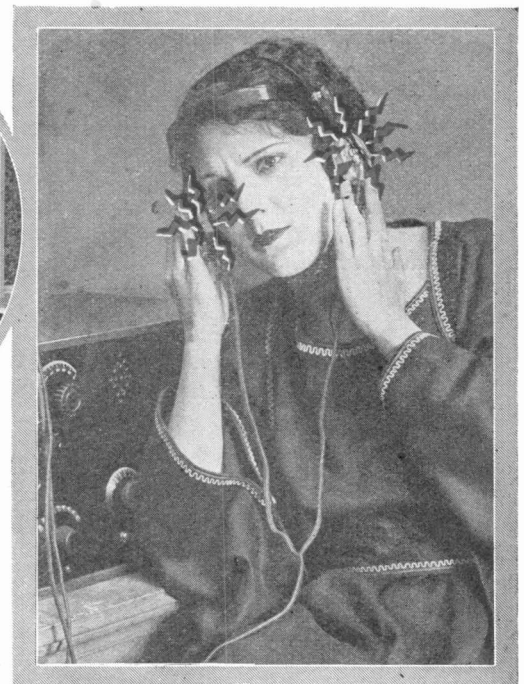

"Interference"

to a buying frame of mind by good salesmanship. All that remains to clinch the sale is a demonstration, and here is where that unforeseen element enters to play havoc with all that has been already accomplished. Music is tuned in on a good loud-speaker and is really enjoyable, the customer appears well pleased and has visions of such entertainment in the chambers of his own home, when—suddenly—gr-r-r crash — bang — bellows forth from the loud speaker, the noise dying away only to repeat itself again and again.

Of course, that was only some unsuspecting person, in the flat above, taking his daily violet-ray treatment, or perhaps the seamstress next door operating her electrically-driven sewing machine. But at any rate it was sufficient to drive the prospective buyer out of the store disgusted and determined to be contented with his law-abiding phonograph, until some future date when radio really reaches a perfected stage. And, of course, not only does this interference sometimes happen during a demonstration in the store, but evening demonstrations in the customer's home may be spoiled in the same way. Interference is also a frequent source of dissatisfaction with sets being used "on trial" or being purchased on an easy-payment plan.

It would be well, therefore, for the radio dealer to get acquainted

with the causes of such interference and to know how to locate and remedy these troubles,—hence the following information is given with the hope that it will prove of value.

While the original source of most such local interference is from electric power lines, yet the currents regularly flowing through these, whether alternating or direct, do not themselves cause any interference, except in a minor way in the case of alternating current lines which induce a continuous audio-frequency hum in the set, if the aerial is very close and runs parallel with the power line. This hum for 60 cycles may be recognized as having the note of middle C on the piano. Such interference, however, is not very common or troublesome, and when it does occur, it can be corrected by placing the aerial at right angles to the power lines.

Arcs or Sparks Cause Noises

When however, any *spark or arc* is produced in any part of the line circuit, radio frequency impulses are generated. It was by means of this phenomenon of spark sources of radio waves that radio communication itself was first made possible as every schoolboy knows nowadays. Spark or arc transmitters therefore proved quite valuable in their day, but sparks or arcs of any kind in 1925 are likely to be sources of great annoyance to radio listeners, when created at any point in electric

power circuits. The radius in which such a spark disturbance can be heard depends upon certain electrical conditions of the circuit, as follows:

First the size of the spark, that is, the larger it is the greater it will transmit, providing all other conditions are the same. Second, the resistance in the circuit will absorb part of the radio-frequency current, the effect of this absorption depending upon the amount of the resistance, and third, the amount of inductance in the line which includes the length of the wire in the circuit.

In some cases local interference is experienced at only a certain wavelength, but in the majority of instances the disturbance is very broad and extends over the whole band of broadcast wavelengths. The interference caused by leaky insulators, badly-bonded street-car rails or jumping trolleys, and other sources of intermittent sparking, is often mistaken for static, due to its rough, unmusical tone. On the other hand the interference due to the sparking rushes of motors used in electrical appliances or in repair shops is of a more continuous and musical sound.

The greatest interference experienced by the radio dealer located in the congested city will be caused by electric motors used to run machinery in near-by stores and factories, by surface cars, by telephone ringers, by electric elevators, by arc

You Can Usually Tell the Cause of Interference by the Kind of Noise

Sparks or arcs, even if so tiny as to be almost indistinguishable, are the sources of practically all "local interference" noises. And a tiny, tiny spark can make a mighty loud noise in a loud-speaker!

Here are some characteristic noises--and their usual origins.

Regular "tattoo"—Commutator motor, leaking insulator, or continuous arc.

Intermittent "musketry fire"—Arcing socket, switch or plug, or other contact,—possibly being jarred by some nearby movement which it reproduces.

Crashing roar—Violet-ray machine. X-ray or other vacuum-

tube discharge. Sometimes starting of induction motor.

Occasional clicks—Thermostat in heating pad or automatic electric iron. Telephone bell. Bad rail-bond or trolley contact.

Musical hum—Induction from nearby alternating-current wires.

lights, by sign flashes and by annunciator systems.

In some cases it is quite simple to find the source of the trouble, as in the case of the surface cars. Such noises usually are first heard in the receiver as a faint crackling sound, becoming louder as the car draws nearer, the maximum volume being heard when the car passes by the store or house.

With a sparking motor located in a near-by factory, the noise will be continuous and of the same intensity throughout the whole day.

Use Loop Aerial to Locate Noise

The best way for locating such interference is by means of a portable loop receiver, the loop being revolved slowly until the noise is loudest. Then it must be determined in which of the two directions the interference is originating. This can be done by moving the set in one of the pointed directions and noting if the noise gets louder or softer, if the latter, it would be a definite indication that the disturbance is coming from the opposite direction and by continuing this operation the faulty motor can be finally located. This same method is used by a number of the large electric power companies for locating defective insulators and transformers.

When the motor that is causing the trouble is found, the commutator and brushes should be inspected. If the commutator is badly grooved and worn, it should be turned smooth in

a lathe. If this is not possible, the remaining remedy is to clean the commutator with sand paper and reset the brushes until the sparking is at a minimum, then connect across the line near the motor a filter composed of two fixed condensers of 1 to 2 micro-farads capacity. These should be capable of standing a high voltage and should be connected as shown in the diagram where the middle point of the condensers goes to the ground.

The radio-frequency currents generated by the sparking brushes will then be by-passed, that is, instead of traveling out over the wires supplying to the motor, which for these currents becomes an aerial system, the oscillations will be short-circuited by the low-resistance path offered by the condensers and the ground. To make this filter even more effective a radio-frequency choke coil can be inserted in one or both sides of the line near the motor. This coil can be composed of 50 to 150 turns of wire wound on a tube, and has sufficient self-inductance to act as a high resistance to the radio-frequency currents, without impairing the flow of power current. It is important, of course, that this wire be of sufficient size to carry the current used by the motor.

For the smaller motors used on household appliances, a $\frac{1}{2}$ micro-farad condenser bridged across the commutator brushes will usually solve 90 per cent of the trouble. The condenser thus receives and absorbs the high-frequency discharges set up by

the tiny sparks between commutator and brushes.

The foregoing remedy, it will be noted, need be applied only to commutator-type motors, like series motors or universal-type motors. Induction motors set up no sparks or radio disturbances, except at the instant of starting,—that is, while the centrifugal switch or starting commutator is in play until the motor comes up to speed. Such induction motors run absolutely silently, so far as radio conditions are concerned.

"Make-and-Break" Devices

The source of interference in violet-ray machines, mechanical rectifiers, and sign flashers, is the making and breaking of part of the house current between two contacts. Even when these contacts are properly adjusted they cause slight arcs and so are great trouble makers. The most effective remedy is bridging the contact points with condensers, as well as inserting one or two choke-coils in the line near the offending machines.

Where the dealer is unable to locate the interference by means of the ordinary loop test previously described, it would be advisable to make up a couple of these radio-current filters as separate units and put them on near-by apparatus which would be likely to cause such interference, until this interference clears up. Mount the filter unit on an insulated base board, with a metal strip

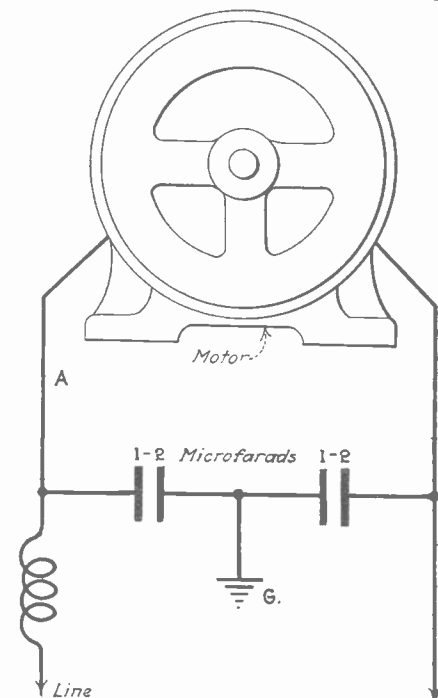

Interference caused by arcing at the brushes of a commutator-type motor can be minimized by connecting condensers across the motor leads, with the mid-point grounded, as shown.

clamping the condensers to the board. Such a unit can be built for a small cost and can be sold at a fair profit to those troubled with interfering electrical appliances in their home.

It sometimes happens that the thermostat control in a heating pad, upon reaching a certain temperature, will arc and therefore create interference. It is quite difficult to discover this trouble, inasmuch as the unit is concealed inside of the pad and the thermostat from all external appearances appears to be working properly. Another common source of interference trouble occurs in defective lamp sockets, especially those having pull-chain switches or dimming adjustments designed only to control say a 40-watt lamp. If a larger lamp is used in such a dimming socket, the heavy current produces excessive heating in the resistance element which in turn chars the insulation and causes minute arcing to occur. This arcing also generates radio frequency waves which radiate from the electric wiring and are picked up by all near-by receiving sets in the form of noisy interference.

Any one of the foregoing, as well as numerous other electrical appliances, used in the customer's home will cause interference, when arcing takes place, however minute and apparently negligible that arcing may be. The radio dealer who sold a set to the customer, is invariably asked to remedy the trouble and this is where

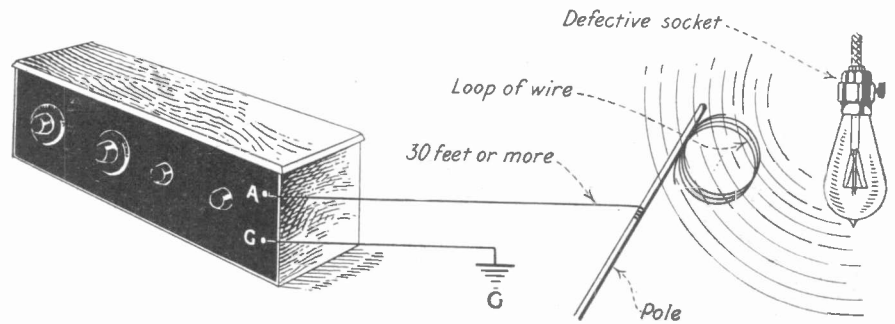

Sometimes an arcing contact in an electric-light socket will defy location by all ordinary methods. In that case a loop attached to a pole and connected to the antenna side of the set, can be carried about the room,

and will show the faulty socket or [appliance] by the increased strength of the "interference" signals as the loop nears the source of the trouble. Careful search will locate the trouble accurately.

his trouble begins. Of course if the dealer will employ a portable loop set, as previously mentioned, it is usually a comparatively simple matter to find the trouble, but such instruments are usually too large and unwieldy to carry when calling. The dealer is likely, therefore, to employ a process of elimination, which while succeeding in the end, consumes a considerable amount of valuable time.

Search Coil Method Is Best to Use

A far more reliable and quicker method is the use of a search coil, which is composed of a length of insulated flexible wire (lamp-cord wire), of at least 30 feet in length. One end of this connects to the aerial binding post on the set, the aerial of course, being disconnected, while about 3 feet of the far end is looped into a small coil (1 to 2 feet in

diameter) and this is attached to a stick or broom handle, which allows the coil to be handled to explore the ceilings, floors and corners. By starting out in different directions and having some one listen in at the set and note whether the interference is louder or fainter, the exact spot may soon be located and the trouble repaired.

In concluding it might be said that practically all cases of local interference may be easily located by the radio dealer by utilizing the above described methods. Where the interference is due to some electrical appliance it may usually be repaired or replaced. If the cause is due to outside power lines, such as leaky insulators or defective lightning-arresters or transformers, the power companies will in most cases be willing to remedy the trouble when notified of its existence and its approximate location.

Have You Some Overstock You Want to Get Rid Of?
"Radio Retailing" Offers a Way Through Its

Radio Dealers' Overstock Exchange

PROBABLY every dealer in the radio business has too much of some item,—"overstocks" in sets, accessories, or parts, that stick on his shelves and cannot be moved to his local customers. Overstocks of this kind may be due to rapid obsolescence in particular lines, or they may be simply the result of having "overbought," through misjudging the radio tastes of the local public at the time.

"Trade-ins" also make up another class of radio merchandise that has been hard to move. To hold these stickers on the dealers' shelves means to tie up costly merchandising space and to go on paying interest charges on profitless stock investment.

But practically all such articles of overstock can find waiting buyers among the

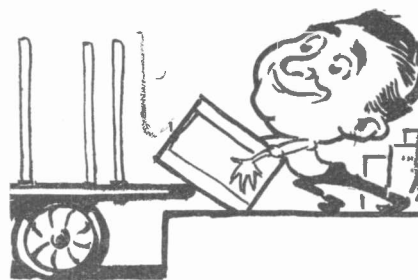

millions of people served by *Radio Retailing's* tens of thousands of dealers. Some other dealer, somewhere, is probably eagerly waiting an opportunity to sell to his customers items you would like to get rid of. How can you reach him to let him know what you have?

Through the pages of "Radio Retailing!"

To help you move such overstocks, *Radio Retailing* is inaugurating a Radio Dealers' Overstock Exchange department.

Through it, you can put your message and offerings before dealers from Key West, Fla., to Nome, Alaska, for the comparatively small charge of \$6.65 or less an inch, depending on the space used. (Count 50 words to the inch.)

Thus you can get rid of merchandise that would otherwise be dead investment, and sell it at a profit. The dealer buys it, sells it, and makes a profit. And the far-away customer gets something he wants and is added to the vast army of pleased radio enthusiasts. Thus each benefits and everybody profits.

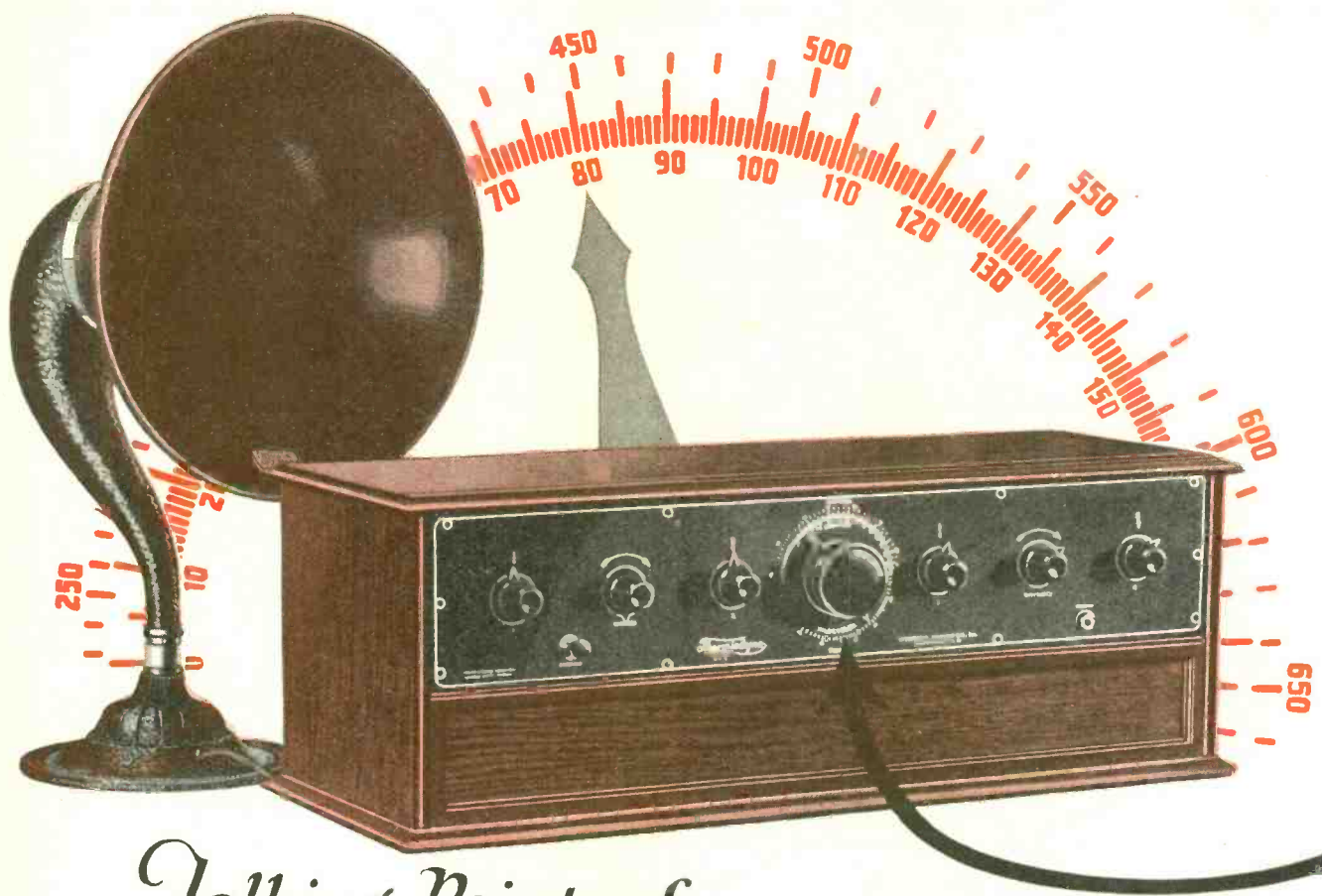

Talking Points of

Thermiodyne

Reg. U. S. Pat. Off.

Pronounced

[Ther-MY-odyne]

Single  Control

Licensed under Trube and other patents pending

1 ONE MASTER CONTROL—calibrated in wave lengths as given in newspaper radio programs.

2 Set master control at wave-lengths of station and it's in—*instantly*. Stations always come in at same settings. Six to ten stations per minute can be brought in with the twist of the wrist.

3 Tunes in stations *before* Detector. No fishing or straining. If it's in the air Thermiodyne will get it.

4 Six tubes. Four refiners to stabilize variations and regulate volume. No howling or distortion.

5 Distant stations not interfered with by local broadcasting. Range of selectivity, thousands of miles.

6 Uses any accessories. Unconditionally guaranteed.

7 Non-technical. Any child can operate accurately and successfully.



WE'RE spending hundreds of thousands of dollars in national and newspaper advertising to tell the public about Thermiodyne's **SINGLE MASTER CONTROL**.

Thermiodyne opens up that vast market comprising the millions of folks who have held off from radio because it was *too complicated* and *too uncertain* of operation.

Thermiodyne is *family* radio—the children can operate it.

Thousands have bought. *Daily*, thousands more are asking dealers for demonstration.

They're sold on the **SINGLE MASTER CONTROL**. Demonstrate *that* and the demonstration is *complete*. Read why on opposite page.

THERMIODYNE RADIO CORPORATION, PLATTSBURGH, N. Y.

Price **\$ 140**
Without Accessories

If you want quick, easy and PROFITABLE sales, write for details of Thermiodyne proposition TODAY. Not much territory left, so hurry!

Which Type of Loudspeaker Do Your Customers Ask For?

RADIO is groping toward perfection in receiving apparatus, and improvements have been made in loud-speaker design, both in appearance and tone quality. Although the original horn type still leads in the matter of gross sales, the trend to the cabinet, cone, and concealment models is clearly seen.

Will the loud speaker of the future be modelled along the lines of one of those on this page or will something entirely new be discovered?

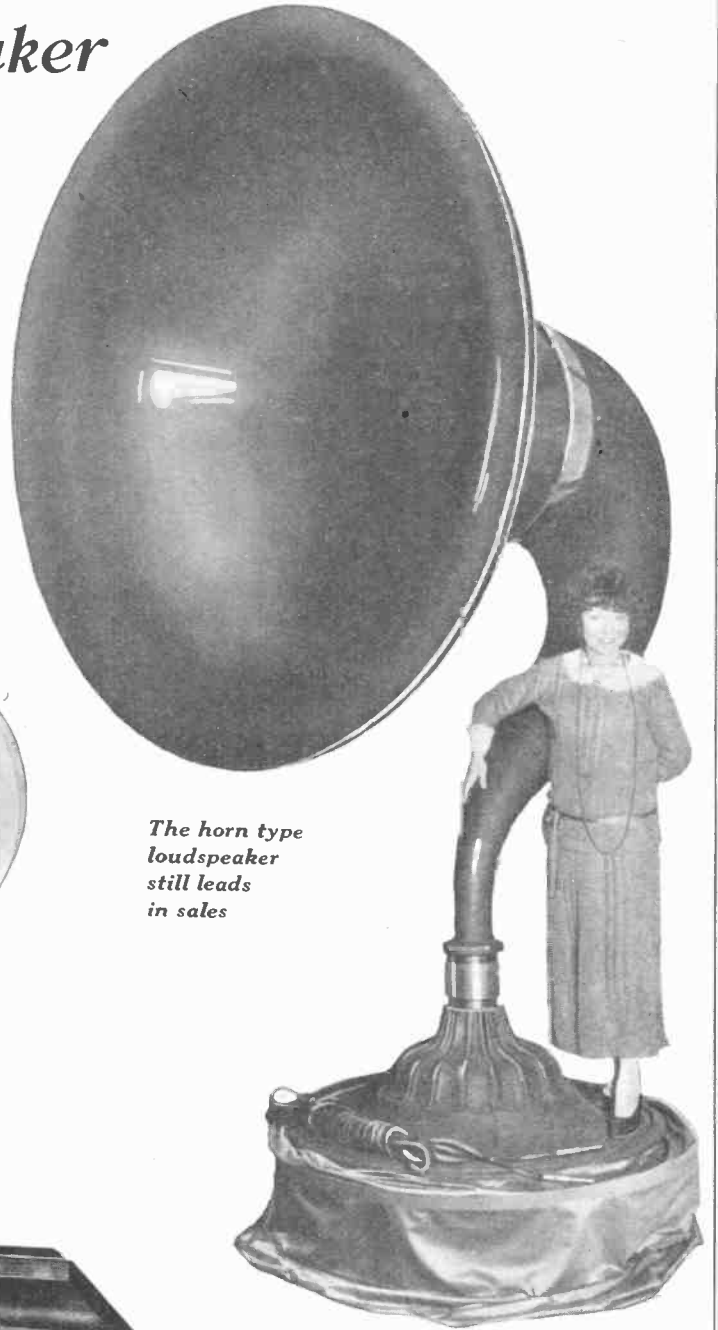

*The horn type
loudspeaker
still leads
in sales*

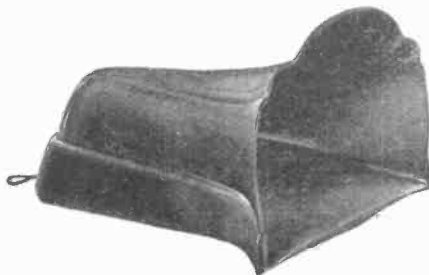
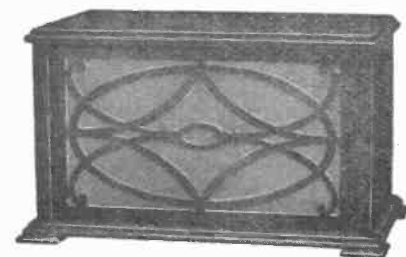
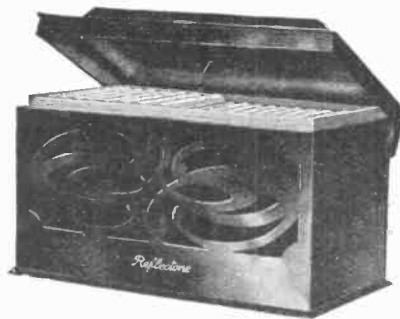
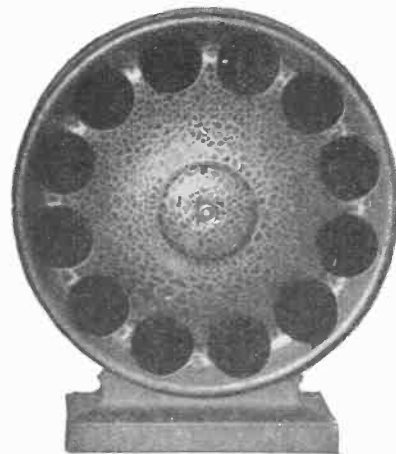

Horns, Cabinets, Cones or Concealments?

The Loud Speaker Design of the Future Presents an Interesting Study—Each of the Various Types Now on the Market Has Its Own Advantages and Disadvantages

EVERYONE admires the new models in loud speakers, but the horns are still going strong!" That is the consensus of opinion concerning our faithful old friend, the horn type speaker.

Cabinet model speakers, cone types, those built in console sets, in electric lamps and other concealments have sprung up in competition with the horn and appear to have dealt him what must eventually prove a death blow, just as the phonograph horns of 1905 gave place to improvements in design and construction.

But despite the inroads into his hitherto exclusive field, he still leads them all in the volume of sales! At the low price stores, it is still the most popular model as it is the lowest in price. At the higher class of stores the cabinet, cone type and concealments are the popular lines, a tour of New York City revealed.

"Cannot Be Made Perfect"

Harold Herbert, whose store, devoted exclusively to radio, is on Forty-sixth Street, a few doors from Broadway, believes that, although there is still an immediate demand for the horn type, it will soon be eliminated, primarily because, in his opinion, it cannot be made a perfect reproducer.

"Present-day taste in loud speakers is toward two very definite things," said Mr. Herbert. "First, quality in reproduction, for which I believe the cone type is best, and, second, beauty in appearance, for which the cabinet speaker has been designed. The horn type is destined to be eliminated, as it is neither an article of beauty nor a perfect speaker. It sends the tone in one direction only, the same fault with the cabinet model, whereas the cone model disseminates the signals in all directions because of the extremely large size of its diaphragm.

"This also makes it a better reproducer for use in concealed places. The trend today is away from anything that looks like radio. Console set models and concealed speakers, adding to, rather than detracting from the beauty of their surroundings, is what the public wants. And the cone type is the most easily adaptable to concealment. Given a receiver that is worthy of it, the cone type will remain unsurpassed for many years to come."

S. F. Nielszen, manager of the radio department of Alexander Taylor and Company, sporting goods, 22 East Forty-second Street, also finds the cone type in popular demand. "The loud speaker market has passed through three distinct periods," Mr. Nielszen declared. "First, the horn type, which seems to have lost its appeal, except for those who want to spend as little money as possible; then the cabinet style which is still in demand, and now the cone model. The cone model is not only attractive in appearance, but gives almost perfect tone quality."

"Everything depends on the ear of the individual listener," says Walter W. Woboshell, radio manager of the Hartt and Lane Electrical Company, Sixth Avenue near 45th

Street, New York. "I find that all types sell about equally as well and the one which, in the customer's personal opinion, is the best reproducer, is the one purchased. Two popular models with us now are the baby type horn and the speaker concealed in an electric lamp."

"Radio speakers are simply following the development of the phonograph horn," in the opinion of C. C. Bohn of the Bohn Electric Company, 820 Sixth Avenue. "I fail to see why the radio industry ever accepted the horn type when they knew what happened in the talking machine trade. The present trend, to an esthetic appearing speaker, concealed in the cabinet, was inevitable."

Wooden Horn Second Best

An interesting observation is made by J. De Fenre, radio manager of the Jones Hardware Corporation, Sixth Avenue and 44th Street. He says, "The most perfect material for tone reproduction is cement, which, however, is not practical for loud speaker purposes. The next best is the wooden horn and then the fibre horn. The cardboard amplifier gives too much vibration, too much of a paper sound. The speaker of the future I believe will be made of wood, built into the set. At present the old horn is the best seller because it is the most economical."

From a technical point of view there has been no radical improvement, but rather a gradual refinement, both electrically and mechanically, in loud speaker design. Most of the instruments now on the market indicate that the manufacturers are paying more attention to the sadly neglected acoustic principles.

The mechanism may generally be divided into two types, first, the bi-polar permanent magnet unit, which is the kind used in all of the

"Speak Up,

thou dolt," said Mr. Shakespeare a few years ago, which advice the present-day radio loud speakers might well take to heart.

A number of loud speaker types are struggling for supremacy. Which one will be able to "speak up" the loudest and establish itself as the ultimate reproducer?

more moderate priced instruments, and second, the balanced armature unit found in the more expensive models. In both of these types of loud speaker units, an adjustable control is usually added as a means of proper balancing with the set.

The cone type speaker, technically, consists of two eighteen inch cones of special parchment paper with their bases cemented together. The point of one cone is cut away so as to leave a circular opening, the edges of which are secured to a metal supporting frame.

This opening is covered with a screen which allows the air to enter and leave as the cone is vibrated. A balanced armature unit is also connected to the supporting frame at this point, its extended lever connecting with the apex of the opposite cone.

In operation, the plate current in the amplifier circuit flows through the balanced armature winding and causes the lever to move and this being connected to the center of one cone causes this and the opposite one to vibrate. Due to the large size of the two cones a considerable amount of air is vibrated.

For this reason, the cone speaker does not give as much volume, nor concentrate the sound, as does the horn type, which is comparable to the results obtained when shouting through a megaphone, or the cabinet speaker, in which the principle of reflected sound is utilized; that is, the receiving unit is in the fore part of the cabinet, the signals being first sent to the back of the speaker whence they are reflected out.

Taking each type of horn, with its advantages and disadvantages, they sum up as follows:

Horn model: advantages, low price, can be used with inexpensive set. Disadvantages: sends signals in only one direction, does not reproduce every signal faithfully, bulky, homely, cannot be easily concealed.

Cabinet model: advantages, beauty, soft tone quality. Disadvantages: sends signals in only one direction, does not amplify every signal faithfully, not easy to conceal.

Cone type: advantages, good appearance, faithful reproduction and amplification of every signal received, disseminates sound rather than concentrating it, easy to conceal. Disadvantages, needs a sensitive set, which will receive and step up the signals perfectly before the cone can reproduce them perfectly.

Tying Up Saint Valentine's Day to Your Radio Window Display

An Attractive Display May Be Made at Slight Cost Out of Red Paper, Cutout Figures and Cardboard



IT IS an established fact that window displays stimulate trade. Each month produces at least one if not more distinct days, to suggest material for attractive display, thus to break the monotony and deviate from ordinary, every-day window dress.

Valentines are no longer confined merely to the paper, candy and flower methods of saying, "Be My Valentine." The day now presents endless possibilities to all merchants, and not even the radio dealer is immune to Valentine Day ideas.

An Easily-Made Display

Reuter's Electric Shop at 120 East Sixth Street, Cincinnati, Ohio, showed a clever window in accord with the day, to display radio goods. From the four corners of the window suspended from the ceiling were

festoons of red paper intermingled with cutout cupids and hearts.

A large red heart of cardboard was hung among these festoons in a conspicuous position a trifle lower. It showed a boy's head bursting the heart in the center, with radio phones on his ears.

On the floor of the window a similar heart appeared with the figure of a golden haired girl peeping through, underneath the heart the rest of the body appeared—a cut-out figure showing frock and feet standing amid a shower of fine red shredded paper which covered the floor of the window.

Upon red drapery in attractive arrangement on the floor and on stands, or slightly raised elevations to permit nice grouping, were radio outfits and parts as well as other electrical apparatus and accessories.

Servicing Radio Sales

A General Discussion of "Radio Sales Service"—Its Past, Its Present, Its Possible Future, and Its Effect on Radio Retailing

By KIMBALL HOUTON STARK

DURING the past three years since radio has become of such national importance, "sales service" has been of great moment to the manufacturer, the distributor, and the retailer of radio receiving equipment. This has been true of factory-built receiving sets as well as of receivers built from "knockdown" sets of parts which the consumer was allowed to assemble and wire in his own home.

In the case of the "knockdown" sets, the directions might not have been understood clearly by the uninitiated radio builder and something invariably would cause the builder to believe that he was not getting the satisfactory operation from the receiver that he should, and that the manufacturer or the distributor or the dealer claimed that he should. The result is that the builder comes back to the dealer that sold the "knockdown" kit with the cry, "I bought this radio set from you, and I certainly expect you to make it work right for me." The same conditions hold true in the case of completed receivers, but in this instance, however, the cry of the consumer is even louder, for here the fault, from the consumer's point of view, is entirely due to the manufacturer or to the dealer who installed the set.

As a result of these various factors which make necessary the servicing of radio equipment, there have gradually grown up several plans of servicing radio receiving equipment which may be tabulated as follows:

- The "No Charge" plan
- The "\$1.00 per Call" plan
- The "Cost per Hour" plan
- The "Yearly Service" plan

To get a general idea of the advantages or disadvantages of these different methods of servicing radio equipment from the manufacturer's, jobber's, and dealer's points of view, and to survey in general the whole

relation of the servicing of radio merchandise to the radio industry are the reasons for this article.

That such an analysis of service conditions is desirable, I am sure is felt in the minds of every radio retailer. For many radio dealers, the discovery of methods by which the cost of "sales service" may be reduced, is one of the greatest things for the better that could happen to the radio industry. This analysis of "sales service" does not attempt to offer a panacea for every radio retailer, having his own individual and local sales conditions, but it does suggest general policies that may be adopted to advantage by practically any radio dealer.

The "No Charge" Plan

This is the simplest of all service plans—in fact, it is one that every merchant unconsciously adopts, one

that he does not discard until the cost of such free service reaches a point where he is by necessity forced to handle his "sales service" in some other way. Possibly the cause of the failure of many radio retailers has been due to the fact that they did not realize that their margin of profit per unit radio receiver sale was not great enough to allow them a justifiable net profit after deducting their total costs of doing business, their sales costs, their advertising costs, their overhead and their "sales service" costs.

In fact, in a great many instances there is no doubt in my mind but that radio retailers have been selling receivers at a net loss to themselves rather than at a profit and that this has been largely due to the abnormal cost of servicing the receivers sold.

Another cause of this "no charge"

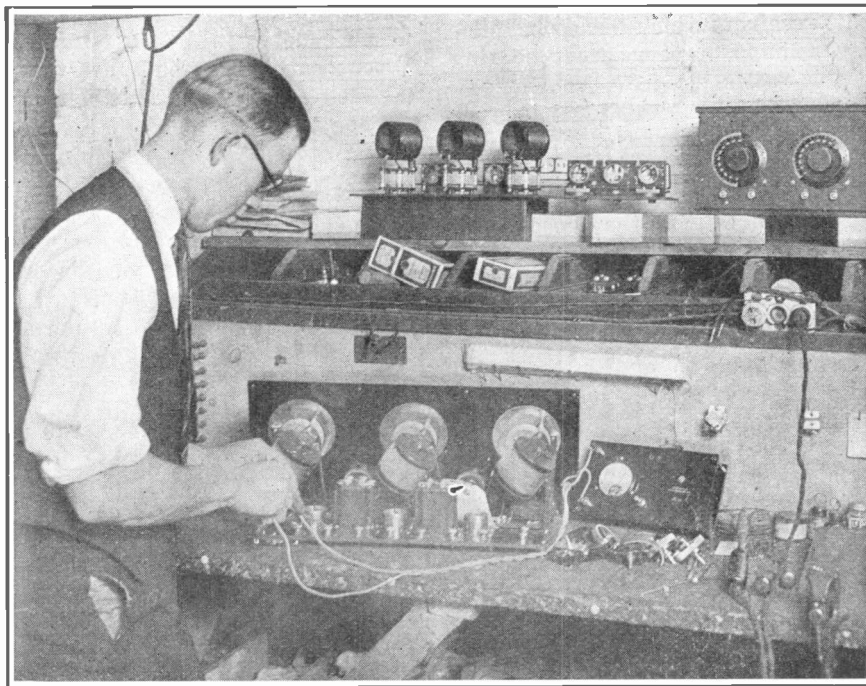

In this picture is shown the service department of R. M. Richter, of Fordham, New York City, which is typical of almost any store's service facilities. If your store

lacks this necessary adjunct to the sale of radio products, you cannot give a complete radio service and so may lose a great amount of valuable trade.

service plan is competition. With the number of radio retailers increasing by leaps and bounds, with competition increasing at the same rate, and with all retailers selling to a certain extent nationally-advertised products, there could be but two possible ways in which one dealer could win out against his competitors: on the basis of cut prices, or on the basis of nationally-advertised prices with increased free sales service.

"The Public Is Willing to Pay"

But most two-fisted American citizens do not want more for their money than they pay for. They are willing to have what they buy equal in value to what they pay for it. They can be educated readily to the knowledge that "sales service" costs the dealer money and that they must pay for it when they purchase a radio receiver.

I noticed in *Radio Retailing* for January, 1925, in the article "Modern Radio Is Merchandise and Needs No Service Man," that at least one radio retailer has seemingly achieved the ideal in reaching the point where the type of equipment he sold initially had such technical and sales superiority that relatively little service needed to be extended to keep the consumer happy. I certainly cannot refute the fact that today if every radio retailer would buy his stock on the basis of the elimination of service as well as on its other points of efficiency that the service problem as a whole would be greatly reduced. It is a fact that the selection of radio receivers which a radio retailer may sell has a very great bearing on the "sales service" problem and can do a great deal to reduce or eliminate "sales service."

"How Much Free Service?"

To get directly to the "no charge" service question, the point involved is "How Much Free Service Can a Dealer Afford to Give on a Radio Receiver Sale?"

Let us take as an illustration a radio receiver sale, including accessories as follows:

1 receiving set	\$295.00
1 storage battery (6-volt, 80-amp.-hour)	20.00
2 "B" batteries (45 volts)	9.50
5 vacuum tubes.....	20.00
1 storage battery charger	20.00
1 antenna equipment.....	2.50
Total	\$367.00

Here is a radio receiver installation having a retail value of \$367.

The Service Problem

embraces four plans, according to Kimball Houghton Stark, author of this article.

They are:

1. The "no charge" plan.
2. The "\$1 per call" plan.
3. The "cost per hour" plan.
4. The "yearly service" plan.

In these articles, Mr. Stark sets forth the basic principles of each system and gives the dealer a complete report on their merits, good or bad.

Assuming a 35 per cent dealer discount, the net cost to the dealer is \$238.55. The difference between his net cost and his selling price is \$128.45. Assuming that the dealer's cost of doing business, including all overhead, etc., is 20 per cent (which figure is relatively low), we may add to the net cost of \$238.55, \$73.40, making the net cost, plus overhead, total \$311.95.

Looking at it from a different angle, we may subtract from the \$128.45, gross profit on the sale, the cost of making that sale, or \$73.40, leaving a net profit to the dealer of \$55.05. That is, on the total investment of the dealer which amounts to \$311.95, the net profit of \$55.05 is approximately 18 per cent. To put one's money in the bank and earn 18 per cent isn't a bad investment, and each radio dealer should realize that the very life blood of his business is dependent upon keeping the dividends earned in percentage per dollar invested as high as possible, and that such costs as "sales service" entails, when such service is rendered on a "no charge" basis, is one of the things that will eat into profits at an abnormal and possibly unappreciated rate.

What "Free Service" Costs the Dealer

Consider for a moment what it must cost any dealer to service radio receivers on a "no charge" basis. Assuming that his service work is handled by an intelligent chap who knows something of technical radio, it is obvious that he cannot be employed at less than \$35 a week. Suppose that any receiver after being in-

stalled at a cost to the customer of approximately \$10, necessitates a hurry call for service—or in other words, that the set doesn't work well—"I am not satisfied with it," and so forth and so forth.

The time consumed in making a service call will probably average, including traveling from retailer's store and back again, three hours. This three hours of the service man's time will cost the dealer approximately \$3. Add to the cost of the service man's time, the transportation expenses, whether by street car or service car or otherwise, and the general operating overhead. This means that each service call will cost the dealer from \$3.50 to \$5. Now if it costs a dealer \$5 to make a service call, it takes only three or four such calls to reduce by one-fourth the net profit on a receiver sale totalling \$367.

Dealer Who Makes No Service Charge Must Watch His Step

The retail dealer who is selling radio sets on a "no charge" service basis must watch his step and watch it carefully. Only by an intelligent understanding of the true value of costs of selling and the costs of servicing, can the radio retailer who would do all that he can for his customer, keep his own costs within the limits in which they must be kept, if his net profit on each individual sale is to earn the most money for him.

In my opinion, the example we have worked out above is representative in every sense of the word as regards number of calls made, but the total retail price of \$367 averages high and the number of calls and the cost per call is low. The retailer should realize that as the retail price goes down, the cost of service goes up in proportion—even as the net profits go down, and it is on the lower-priced receivers, having retail values of from \$50 to \$60 that the most service calls will be necessary, and not on the higher-priced receivers, which require comparatively little "sales service."

(In the next, the March, issue of "Radio Retailing," Mr. Stark will conclude his very interesting exposition of the various plans the dealer may use in servicing the radio sets he sells. Having taken up the "no charge plan," in this article, Mr. Stark, next month, will explain the "\$1 per call plan," the "charge per hour plan," and the "yearly service plan," summing up, finally, the advantages and disadvantages of each system.)

Cost Figures Chart the Way

(Continued from Page 134)

other and very important division of store management.

The average buying expense for these seven stores was 3.3 per cent. Disregarding store I we find that the departments with the larger sales volume have the larger buying expense. This is not out of line with what we might expect. As sales increase buying becomes more complicated. Again, the buyer undoubtedly would have to go to the buying market rather than buy from salesmen coming to the store. That better trained merchandising minds were in charge of the department showing the larger sales volume cannot be doubted. And it costs money to get a good buyer. But it also pays. Turn to their merchandise cost. We find it ranges among the lowest of the group. This then seems to bring out the fact that closer attention was paid to buying than in some of the other departments. Better selection of merchandise was made. Furthermore, the buyer knew his customer-demands.

All through this study store B seems to stand out especially well managed. Its selling expense was only 1.1 per cent above the common figure. Its publicity expense was close to the lowest, and though its occupancy expense was a little higher than the average, its administrative expense was the lowest for the group.

Close Attention to Management Details Brings 3.7 per Cent Profit

Systems had been simplified, yet sufficient administrative attention was given to the department to carry it carefully to a net profit of 3.7 per cent.

This net profit was the highest reached by any of the departments. Without any doubt it shows what sound management will do for a radio store. One other store, which in point of sales and management attracts attention, is store H.

It had a small volume of sales, namely, \$47,000. Its merchandise cost was very low, 71.2 per cent. Its total expense is close to the common figure for the entire seven departments, while its publicity expense was the lowest for the group. Finally the manager accomplished a profit for the store of 3.7 per cent.

Pretty good management. The fact that he had a small sales volume did

not stop this department manager or buyer from keeping his eye on purchasing. Undoubtedly this department was handled by another good merchandising head. A man who knew how to buy in accordance with the demands he created.

All in all we cannot say the profit made on investments, for any of the departments, would lure anyone into selling radio. The fact that the annual turnover for the stores averaged 5 times, seems to answer to some extent why the profit was so low on investments.

Turning to stores H and I we find they experienced a loss of 6.4 per cent and 19.5 per cent respectively. It is also interesting to see that the stock turns for these stores were the lowest.

Style Merchandise Demands Quick Turnover

Stock turnover then seems to point to a way out for the radio merchant, as well as for any other retail merchant, if it is not carried to a point where variety, size, and quantity cannot be offered to the consumer.

"Radio merchandise is worse than any style goods," insists a dealer. This fact itself would seem to demand a quick turnover.

Merchandise should not be allowed

Radio in the "Home Electrical"



A radio set was thus effectively presented in the recent "Home Electrical" display at Tacoma, Wash. Not only was the instrument, one of the most expensive type, on exhibition, but concerts were given for the visitors to the "home." This, in some measure, took the place of the musical programs and lectures usually to be heard at exhibits. This idea focussed the attention of those visiting the house on the whole idea of radio.

to stay on the shelf. It should be sold and purchases should be gaged very closely.

Sales made should be made to stay sold. A store with 25.8 per cent of its gross sales recorded as returns and allowances is not in a healthy condition. To be true it may reflect a large charge business,—a liberal policy with regard to satisfying the customer,—yet when one-fourth of the sales of a store are returned, something is radically wrong with that store's policies and methods.

The sales talk perhaps needs attention. Salesmen may be promising too much as to results. A real sale is a purchase that is kept. Many salesmen can be measured as to their real sales ability by these returned sales. Watch them! If the trouble is with the merchant's policies, change *these*. If trouble is with the sales clerks get at the root of it, but by all means keep this "returned-goods" item down. It is costly. All such sales must be handled twice, and that eats into the profits.

Stores B and F seem to be traveling on safe territory. Still further care and attention to their individual items of expense—a larger stock turn, and they certainly will soon be charting the way for others to follow.

These two stores in particular point the way to better management for other radio merchants. By their experiences radio stores can profit. Compare your figures with theirs. If you happen to be one of the many merchants who answer "I don't keep any," it will be worth while to change your practice.

Compare Cost Figures

Keep such figures on your own business. Then use them as your compass to guide your ship. Adjust them as you find out how other merchants are running their stores and how other merchants have made a greater profit than you have.

And remember the real value of anything is never established until it can be compared with something else. We know whether a store is good or bad only by comparing with another store. Without such a guide no merchant knows how he stands in this race for business and sound profits. He never knows whether he is leading or is falling behind. Only too often is he coming to a slow but sure stop without even ever getting in sight of his goal—without ever seeing his objective—a substantial profit on his radio sales.

"Congratulations!"

Editors, *Radio Retailing*:

I have just spent two hours reading your splendid issue of *Radio Retailing*—12 to 2 a.m. I expected when I started to spend about five minutes but I didn't know then what valuable information was contained between its covers.

F. D. PICKENS,
Janesville, Wis.

Without a doubt *Radio Retailing* is the best radio paper for the radio dealer we have ever read.

KEATING ELECTRIC COMPANY,
Toledo, Ohio.

I am exceptionally pleased with the first issue of *Radio Retailing*. My subscription follows.

THEO. S. BROWN,
Albany, N. Y.

We have been in the radio game three years and *Radio Retailing* is the best we have seen.

ARTHUR B. MENDELL,
Moran, Kan.

Radio Retailing is fine. It is the best magazine I've found.

TOLEDO ELECTRIC & HARDWARE CO.
Toledo, Ohio.

We like *Radio Retailing*. It is just what the dealer needs.

A. E. SOISSON,
Connellsville, Pa.

Radio Retailing is excellent. Keep it up.

CHAS. W. BELT,
Newark, Ohio.

Radio Retailing is so good that I am sending you my subscription today.

GEORGE D. GABRIEL,
Owosso, Mich.

Radio Retailing has a good start. Keep it up. We want you to grow. The January issue is fine.

A. S. LINDSTROM,
San Francisco, Cal.

Radio Retailing is a dandy. It should prove another winner for the McGraw-Hill Company. I hope that its helpful call will be constant through the years of its life so that we may profit by it.

FREDERIC P. VOSE,
National Electrical Credit
Association,
Chicago.

A truly great magazine greatly needed. I have been dealing with McGraw-Hill for years and when they do something it is the best in the field.

J. C. HALVEY,
Cooperstown, N. Y.

Your publication, *Radio Retailing*, is a blessing to the radio industry. Keep up the good work.

JOHN J. CAMPION,
Philadelphia, Pa.

The first issue of *Radio Retailing* certainly reflected general quality and set a mark that will keep even the McGraw-Hill Company stepping.

H. C. KUEBLER,
Kuebler Radio Company,
Toledo, Ohio.

The radio dealers have long needed such a magazine as *Radio Retailing*. It's the best yet.

RICHARD G. DEVANEY,
Sharpsburg, Pa.

Your first issue of *Radio Retailing* was a whale. Keep up the good work. Enclosed find our subscription.

JOHN K. COOPER,
United Electrical Shop,
White Plains, N. Y.

Congratulations. At last there is a real magazine for radio dealers. Without question *Radio Retailing* is by far the best in the field.

S. L. GOODWIN,
Portland, Ore.

Radio Retailing is just the magazine we have been looking for. You have made a wonderful start.

J. H. MOCK,
Springview, Neb.

Radio Retailing is fine. It is just what we need.

LINDGREN & COMPANY,
Chicago, Ill.

The January issue of *Radio Retailing* beats 'em all. The suggestions and pointers are fine.

E. F. RYAN,
Long Branch Radio Shop,
Long Branch, Cal.

Keep up the good work. More power to you. My subscription to *Radio Retailing* follows.

S. M. METZ,
Pontiac Radio Sales,
Pontiac, Mich.

Allow me to compliment the editorial department of *Radio Retailing* on their first issue. This is exactly what the radio industry has needed for some time and I feel certain that it will result in a paper equal to *Electrical Merchandising* in every way in the course of a few years.

L. W. STAUNTON,
C. Brandes, Inc.,
New York City.

Permit me to extend my hearty congratulations on your January issue of *Radio Retailing*, which to my way of thinking is a much needed contribution to radio. I read every page of it with a great deal of interest and shall look forward to forthcoming issues with anticipation.

G. W. WESTON,
Kansas City, Missouri.

Congratulations. *Radio Retailing* is easily the best periodical on radio. We all need it.

H. S. ALLEN,
Portland, Ore.

The first issue of *Radio Retailing* is fine. It is just what I have been looking for.

V. E. WOODWORTH,
Gouverneur, N. Y.

Radio Retailing is the best magazine for the radio dealer.

PROSPECT RADIO SUPPLY HOUSE,
Brooklyn, N. Y.

The first issue of *Radio Retailing* is very good. The articles are some we have been waiting for.

ARNOLD F. WILLIAMS,
Fall River, Mass.

We have just received your publication, *Radio Retailing*, and wish to say that it is the largest help we have ever received along this line.

T. V. COLE,
Wyandotte, Mich.

The first issue of *Radio Retailing* is fine. Keep it going and we of the radio field will be much benefited.

W. HALL MOSS,
Dayton, Tenn.

Excerpts from the Hundreds of Enthusiastic Messages Welcoming "Radio Retailing's" First Issue

This issue of *Radio Retailing* suits me. I congratulate you on your wonderful magazine. It is a very great help to the dealer.

R. H. SCHLECTER,
Freedom, Pa.

Radio Retailing is the best magazine on the subject of radio that I have seen. Keep up the good work.

FULTON DRUG COMPANY,
Chicago, Ill.

Your first issue of *Radio Retailing* was the best of the papers on the American market today.

W. E. FUETTERER,
St. Louis, Mo.

We are sending our check this morning for your valuable paper. It is the best that has come to our desk.

RADIO SERVICE COMPANY,
Stromsburg, Neb.

We are very much interested in your new magazine, *Radio Retailing*. It meets the needs of every radio retailer.

HUSTON & GORMAN ELEC. COMPANY,
Steubenville, Ohio.

I wish to say I think *Radio Retailing* will be of much assistance to all dealers. I like the magazine very much.

WILFRED L. BOENING,
Leicester, N. Y.

Radio Retailing fills a want of radio dealers. I appreciate the first number very much. The articles are interesting and helpful.

B. FLOYD FLICKINGER,
Shepherdstown, W. Va.

We like *Radio Retailing* because it treats of the sales end of radio. The first issue was great.

THEO. J. MULLER & SONS,
Dixon, Ill.

You have a fine magazine and I think that it will be a help to all radio dealers.

DONALD VARNEY,
Exira, Iowa.

Radio Retailing is worth many times the subscription price. No radio dealer should be without it.

C. C. GERBER,
Atchison, Kan.

Radio Retailing is very fine. This issue is a "red hot mamma."

WM. GUSHARD,
D. G. Company,
Decatur, Ill.

RADIO RETAILING, February, 1925

Radio Retailing fills a much needed want. It's sure a good start.

B. T. NORLANDER,
Pittsburgh, Pa.

Please accept our compliments on the first issue of *Radio Retailing*. Facts regarding retailing methods are certainly described pictorially, so that he who runs may read.

ERIC PALMER,
Freed-Eisemann Radio Corp.,
Brooklyn, N. Y.

The first issue of *Radio Retailing* is O. K. and just what retailers need. Have been looking for a magazine like this.

GLENN R. SWANK,
Galva, Ill.

Radio Retailing is the best radio magazine we have read thus far.

PIERCE HARDWARE &
IMPLEMENT COMPANY,
Pierce, Neb.

I enjoyed your magazine very much, because it has more of the human push to it than other trade publications. Inclosed you will find my check for one year's subscription.

ANTHONY S. RAND,
United States Radio-Kraft
Corporation,
New York City.

Just received the January copy of *Radio Retailing*. It looks good to me—more power to the McGraw-Hill Company.

O. R. HENKEL,
Peerless Light Company,
Chicago, Ill.

The Editors
gratefully acknowledge
these and more than 1000 others—

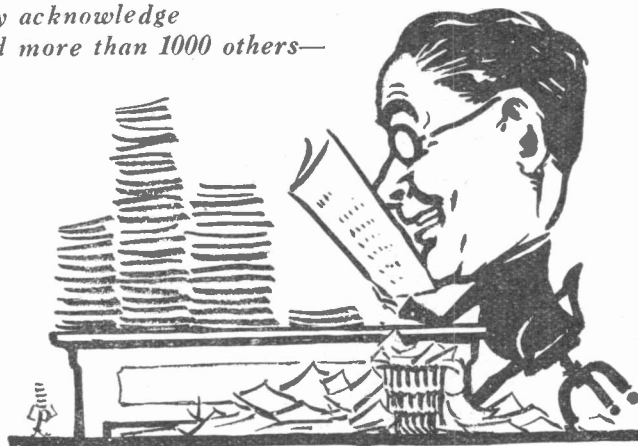

Congratulatory telegrams, letters and messages continue to pour in as we go to press.

Your publication is mighty good. It fills a real gap.

O. H. HOVEY,
Southern Radio Supply Company
Perry, Okla.

Radio Retailing is indeed a valuable contribution, which should be very instrumental in bringing about improvements in the general conditions now existing in the radio industry.

O. FRED ROST,
Newark Electrical Supply Co.,
Newark, N. J.

I have just received the first copy of *Radio Retailing* and want to take this opportunity to congratulate the McGraw-Hill Company on this publication. It is most attractive and should be made to fill a very important position in the radio industry.

ADAMS MORGAN COMPANY,
Upper Montclair, N. J.

We think *Radio Retailing* is one of the cleverest gotten up publications that we have ever seen and we are very anxious to put copies before our twenty-five salesmen, particularly to show them who is selling radio and how.

S. V. ALLTMONT,
Brown-Camp Hardware Company,
Des Moines, Iowa.

The January copy of *Radio Retailing* has been received and I want to congratulate you on the excellence of its material. It is the only radio publication I have seen that I would recommend to radio dealers.

GLOBE ELECTRIC COMPANY,
Milwaukee, Wis.

Six Attractive Displays That Catch



Left—Radio is given the front position in the Forty-Second Street, New York City, store of the Rudolph Wurlitzer Music Company. Dignity and tone are added to the window by displaying the radio merchandise on rich colored velvet. The background of pianos, radio-phonograph combinations and other musical instruments effectively presents the idea that a radio set, also, is primarily a musical instrument.

Right—Although its window display space is limited, the Rousseau Electric Company, of Worcester, Mass., was able to install in it a parlor background. The library table, the books, the easy chair and starling lamps all contributed to the home effect, the final touch being contributed by a life-size doll playing with toys on the floor.



Right — The Hartt and Lane Electric Company, of New York, uses the pyramid effect, built up in tiers, for its display of parts. In this way, there is no crowding and each row of parts gets its full share of attention. The display is made on a background of dark cloth.



and Hold the Attention of Passers-by

Right—The Nebraska Power Company, of Omaha, Neb., conceived the idea of picturing a radio set in a freight car to put across the idea that radio is enjoyable "any time, any where, any place." Two railroad workers, cutout figures, are also shown sitting by a campfire listening to the program. A realistic effect was given to the scene by using red lights for the campfire glow. Attention was centered on the radio set in the freight car door by playing a spotlight on it. The entire layout was made at a cost of \$20.

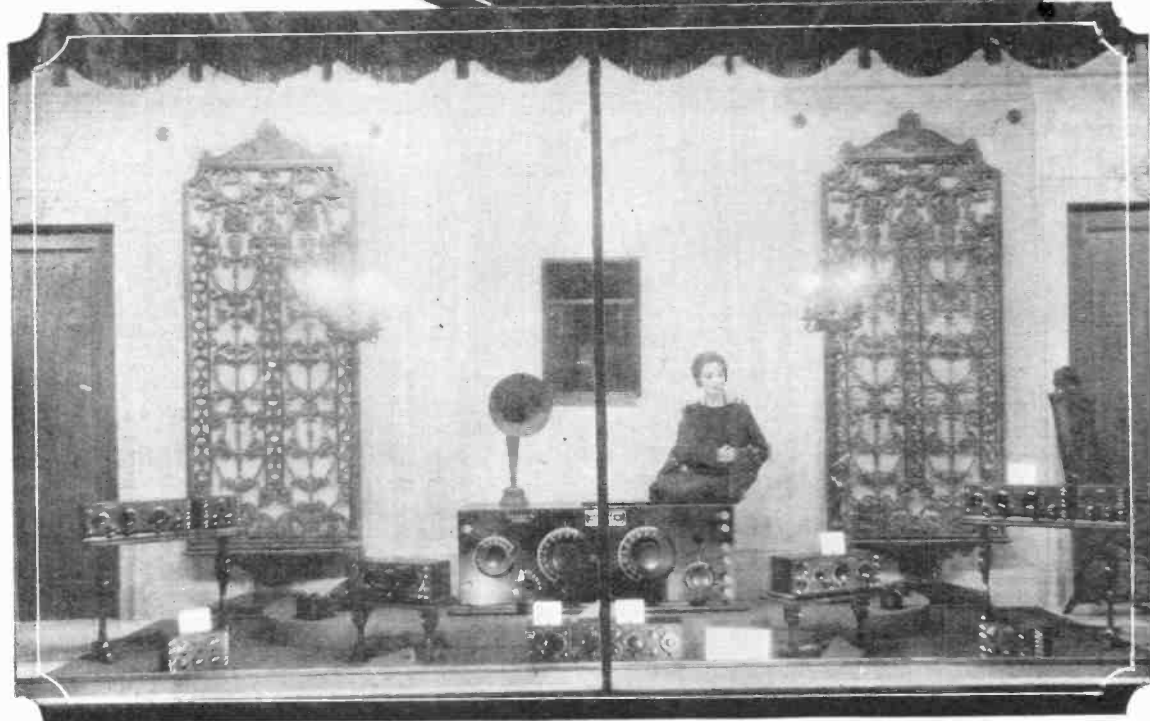
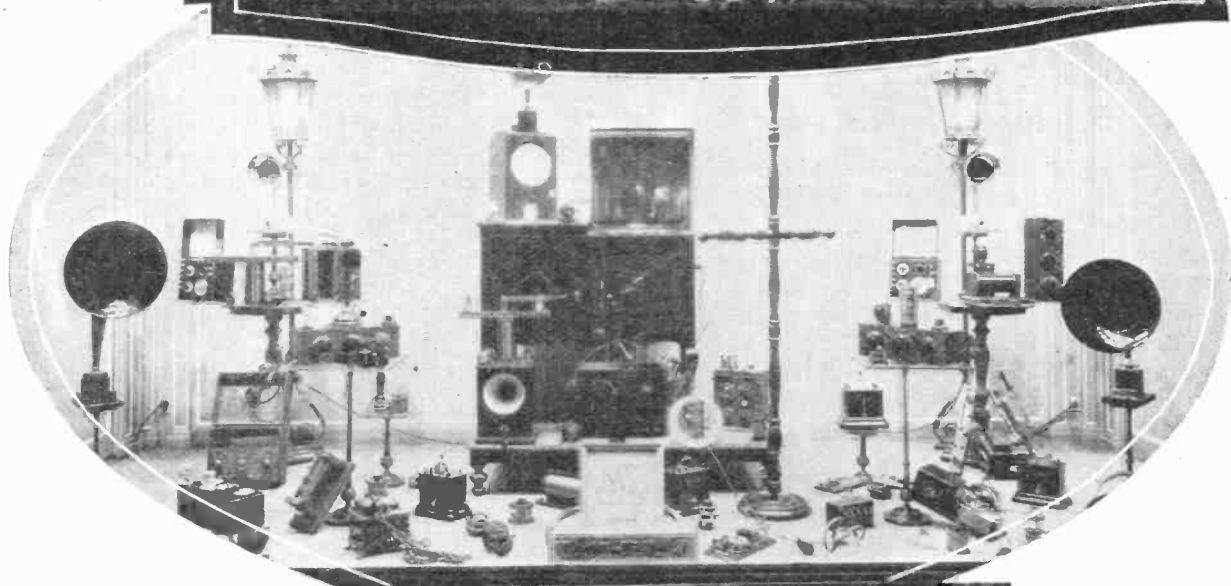
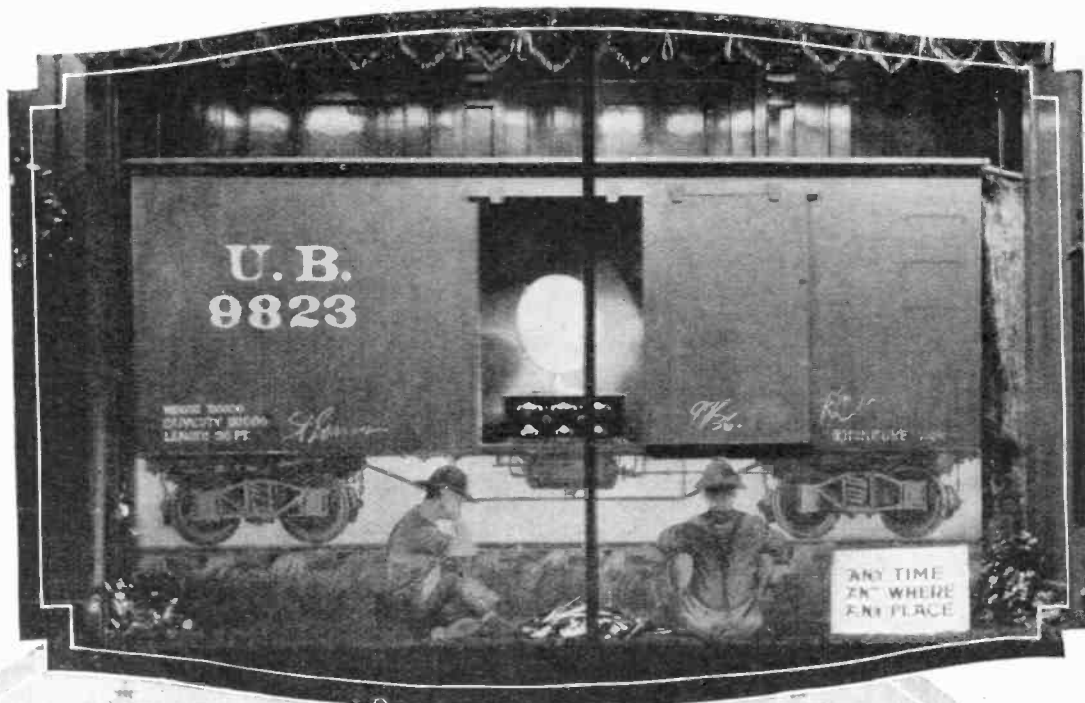

Above and at left—Two radio windows as dressed by two prominent department stores. Above is a neat and well balanced arrangement of sets and accessories, pedestals being used to good advantage. At left is a tastefully decorated "home window," the most striking effect being created by placing a wax figure in the cabinet of a dummy set. It serves as a unique way to present one particular make of receiver.

Radio Retailing

The Business Magazine of the Radio Industry

February, 1925

Public Confidence Will Pick the Radio Dealer of the Future

TOO often, in the past, radio retailing has been anyone's playground. Radio selling has been chaotic. It has been a trade to experiment with, a new way to make money quickly. Unquestionably, time will develop radio retailing to such an extent that it will stand on its own feet as a trade. Present conditions cannot continue. The weeding out process has already begun. The radio dealer of tomorrow will be determined by a natural evolution. He will be the man whose radio selling methods today are creating the public's confidence in him as a merchant and a community leader.

Getting Action on the Discount Evil

ONE of the leading radio and electrical jobbers of Michigan is C. J. Litscher of Grand Rapids. When, a year ago, he announced his 1924 dealer policy, there was great interest in seeing what the result would be. This policy was briefly:

No discounts on radio to industrial customers, friends or anybody else but a radio dealer.

And he set down what he considered a radio dealer to be—did not include those dealers who do not handle radio regularly but who buy one set as a favor for a discount-seeker. The policy was a success. And the evidence is Mr. Litscher's 1925 policy, just announced, which contains this paragraph: "Inasmuch as a discount is a compensation given to the dealer for acknowledged responsibility and service rendered to the user, we will under no circumstances sell radio sets to individuals or industrial plants, but will refer all such inquiries to our authorized radio dealers."

Will You Get That \$15 a Month?

A CALCULATION of the budget of the average medium class American family—that is, the family with \$200 to \$250 a month income, two or three children and possibly a modest home—shows that they have just about \$15 a month spending money over and above the regular expenses of the household.

What do they do with it? Do they spend it for household needs—a new rug, a washing machine or a breakfast nook? Does it go for theater treats or books?

Considering that this average family is the one which makes up the bulk of customers in the radio trade, what chance is there of having the \$15 invested in radio equipment? The problem studied in this way presents several new angles. It shows how the radio business is in competition with all other possible expenditures of that monthly sum and how the purchase of any one

item for, say, \$75, withdraws that family from the market for five months. It suggests also the explanation for the popularity of the time-payment business and furnishes material for thought for the dealer who is fixing his policy in that regard.

What are you doing, Mr. Dealer, in advertising, in window and store displays, in service, that this average householder should turn from all the temptations of his other desires and purchase a radio set from you?

Legislation That Will Aid the Industry

LEADING the fight against the regenerative circuit, which causes so much interference in other sets, a bill has been introduced into the Connecticut Legislature making it contrary to the laws of that State to operate any such set within its boundaries.

This, perhaps foretells the doom of the howling and squealing which have done so much to hinder the enjoyment of a radio set. If this bill passes the Connecticut State Legislature, it stands to reason that other state legislatures will enact similar laws, thus effectively removing one of the greatest barriers to perfection that radio has yet faced. No matter how perfect or expensive a set may be, if a neighbor's "squealer" spoils the reception, that owner's heart is filled with resentment not only against his neighbor but against the whole scheme of radio.

The Connecticut Legislature is to be commended on its far-sighted stand and it is to be hoped the bill will pass and that other legislatures of the country will take similar action.



Know Your Business!

"KNOW your business" is a business man's primary maxim. Too much cannot be said about knowing every minute "in-and-out" of your trade, of studying it, learning it so that no matter what question comes up the answer is ready.

A *Radio Retailing* representative asked a radio dealer the other day if he knew his 1924 gross sales.

"Good Lord, no," was the answer, "I haven't the slightest idea."

Again, the question of stock control came up. He was asked what system of stock control he used. He became enthusiastic immediately.

"Perpetual inventory," he said, "we use red and green cards. I'll show you."

He got the cards and puzzled over them a minute. Then, "Hanged if I know how these things work," he said. "Ask Miss Smith, she takes care of all that."

And yet that man is considered generally a successful dealer. But in a crisis, would you put your money on him to win out? How about yourself? Would you bet on yourself to win out in a crisis? You should be able to shout, "Yes!" Can you?

Good Publicity— and a Worthy Charity

WITH the equipping of hospitals and institutions of all kinds for the reception of radio programs, there arises a new use for the radio set, a new message of hope it can bring to shut-ins and sufferers.

Here is a vast field for the radio dealer to sell. Towns all over the country have already started the ball rolling by inaugurating fund drives to equip their hospitals, sanitariums and charitable institutions with radio sets. The radio dealer can make himself a leader in his town by giving this suggestion to local community leaders.

If necessary, he can donate a set to some home or school for crippled children, or similar institution in his town. It may lead to contracts for the equipping of other homes and hospitals. At all events, it will be a good investment, not only in the dollars-and-cents results it may have, but in the knowledge that the radio man has done his bit to help those less fortunate than himself. It will show that he practices as well as preaches, when he says to his public: "Equip homes and hospitals with radio sets."

Is Yours a Repeat Business?

THE advantage of the dealer in shoes is that side-walks wear out shoe leather. Every so many months the customer is in need of a new covering for his feet, and, if he has been treated well in the store in which he originally traded, he buys again from the same dealer. His is a "repeat" business. Too many dealers in radio equipment are content to look upon a sale made as a sale completed. It is becoming customary to look upon the purchaser of a crystal set as a prospect for one with a wider range—but how many dealers look upon matters of battery replacements as important?

Is it not true that whereas the purchaser of an expensive set almost always goes to one particular firm to make his selection, that he will buy his batteries anywhere, depending purely on the element of convenience to his temporary location? And yet a San Francisco dealer who specializes in the more expensive sets, has found it well worth his while to see that his customers become repeaters, even down to their smallest needs in connection with their radio equipment. His battery replacement business in itself amounts to more than \$1,500 a month—and the secondary returns which come from the allegiance of regular customers is incalculable.

He's Everybody's Guide and Counsellor

IS THE radio merchant simply a salesman, is the man at the counter only a "waiter"? No. He used to be, perhaps, but those days have gone. Radio used to be a novelty, today it has become a necessity.

With the change, the radio dealer has become more than a salesman. He has become a friend and counsellor—or he should be.

"What capacity rheostat is necessary to change from a dry-cell tube to a six-volt tube" is only one of many everyday questions. "Why can't I get such and such a station?" asks another inquirer, and the radio merchant is the doctor. Answers are expected. Not any kind of answer, but replies that will satisfy, conclusions that will eliminate the trouble or solve the problem.

In such answers lie opportunities to plant seeds of confidence. Giving a correct reply to the radio fan, means the establishing of good will on the part of the customer. That is performing a real service.

Service for long has been the foundation on which all business succeeds. Service is the key to any success, whether that of the firm, the individual or the store. And service to the radio fan, planting seeds of goodwill, building confidence in the minds of the public, will lead any radio merchant to increased sales. And increased sales should increase profits.

To Specialize, Not Spread, Lines

"I'VE learned not to carry everything there is in the way of radio sets and parts," said one middle western dealer recently. "I've been taught, by bitter experience, to concentrate on the things that are in universal demand.

"For instance, a crystal of a certain, popular make, that sells for fifty cents and is a household word with every fan, brought in \$3,300 last year. That means we sold 6,600 of these crystals. We specialized on that one make, pushed them to the exclusion of all others, and the result more than upheld our judgment."

This dealer's primary experience with radio, when he stocked "everything there was," is typical of many other dealers, and is a costly lesson to learn. Stock standard, popular merchandise, and in quantities only sufficient to meet your immediate needs. Carry a complete line, but don't burden yourself with five or six brands of the same item that will be in direct competition with each other—that is a lesson that has been learned from older lines than radio and which applies, in its fullest force to the radio merchant.

"Radio Music in Every Room?" Sure!—Through the Hot-Air Registers!



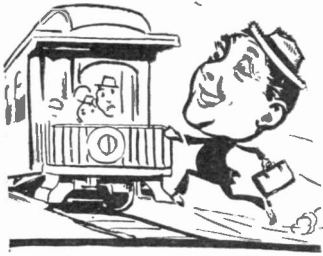

What's New in Radio and

This editorial section is prepared purely as a news service, to keep readers of "Radio Retailing" informed of new products on the market.



Console-Type Receiver

Radio Retailing, February, 1925

The circuit of the new No. 143 console-type receiver announced by the Federal Telephone Manufacturing Corporation, Buffalo, N. Y., is the same as that used in the company's No. 142, table-type receiver. It is a five-tube set housed in the decorative cabinet illustrated. Intended retail price, \$330.

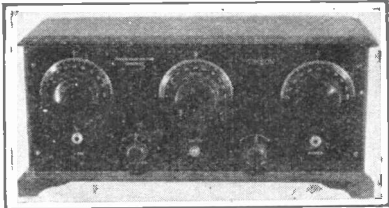

Three-Dial Receiver

Radio Retailing, February, 1925

"Timson" is the name of the receiver illustrated, made by the Terrace Radio Manufacturing Corporation, 26 Dock Street, Yonkers, N. Y. Two stages of radio frequency, detector and two stages of audio frequency are provided. It is designed to operate loudspeaker and to employ aerial and ground. Listed at \$60.

Console-Type Receiver

Radio Retailing, February, 1925

Among the newer decorative radio sets on the market is the Model 52 De Luxe receiver brought out by the Air-Way Electric Appliance Corporation, Toledo, Ohio. It is a five-tube receiver, with built-in loudspeaker and battery compartments. Intended retail price, \$375.

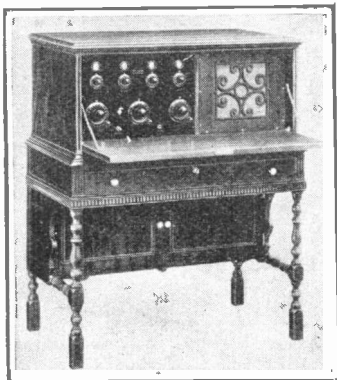

Five-Tube Radio Set

Radio Retailing, February, 1925

The "Baby Grand" five-tube receiver developed by the Baby Grand Radio Manufacturing Company, Brooklyn, N. Y., distributed by the Industries Sales Company, 132 Nassau Street, New York City, is enclosed in a cabinet with piano finish. It has a built-in loudspeaker, a wooden horn using the "Amplion" unit. The "B" batteries and "C" battery can be accommodated in the rear of the cabinet, thus providing an orderly and attractive radio outfit. Intended retail price, \$175.

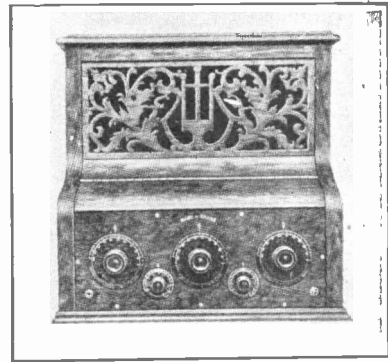

Receiver with Single Dial Control

Radio Retailing, February, 1925

The radio set pictured is known as the "Terafone" Model TA and is marketed by the Moon Radio Corporation, 501 Steinway Avenue, Long Island City, N. Y. It employs two stages of radio amplification, detector and two stages of audio amplification. The detector-plate voltage is variable from 22½ to 90 volts while the amplifier voltage is 90. Enclosed in mahogany cabinet. Intended list price, \$100.

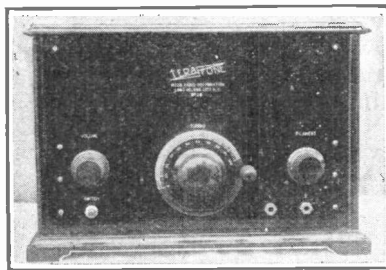

Combination Phonograph and Radio Set

Radio Retailing, February, 1925

The Royal Elizabethan, Model 50, cabinet illustrated houses a phonograph and a five-tube radio set. All batteries fit into the cabinet, thereby eliminating exposed batteries and battery wires. The cabinet may be obtained in walnut or mahogany with all exposed metal parts gold-plated. It is 34½ in. high by 36 in. wide. Intended retail price, \$350.



Five-Tube Radio Set

Radio Retailing, February, 1925

The hook-up of the new No. 51 receiver announced by the Air-Way Electric Appliance Corporation, Toledo, Ohio, is tuned radio frequency, transformer coupled, with two stages of radio frequency, detector and two stages of audio. The set is arranged for either loop or aerial operation. Intended retail price, \$125.

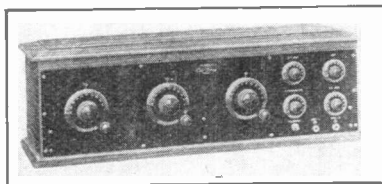

Five-Tube Radio Set

Radio Retailing, February, 1925

The receiver illustrated is the Model 3 set designed by the Sagle Radio Company, Fort Wayne, Ind. The circuit employs two stages of tuned radio frequency amplification, detector and two stages of audio frequency amplification. Jacks are provided for either five or four tube operation. Mahogany Radion panel, with black American walnut or mahogany cabinet, sloping panel. Intended retail price, \$150.

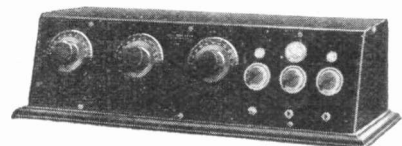

Where to Buy It News of Latest Products Gathered by the Editors

It should be noted that all announcements appearing on these pages are published without advertising considerations of any kind whatsoever.

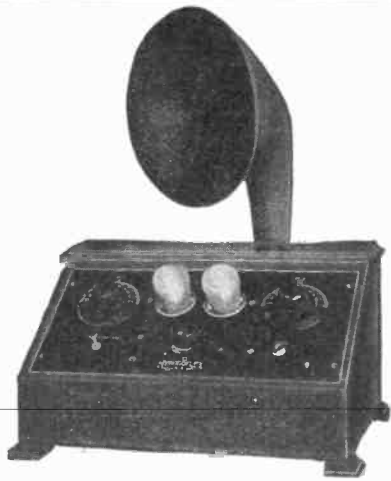

Two-Tube Receiver

Radio Retailing, February, 1925

A two-tube reflex circuit is used in the Model R-2 "Nyaccotflex" receiver made by the New York Album & Card Company, Inc., 23 Lispenard Street, New York City. It is made to operate a loudspeaker and is enclosed in the cabinet illustrated. Intended retail price without accessories, \$32.50.

Radio Receiver

The A. & T. Radio Company, Danvers, Mass., is marketing a new one-tube radio set, the "Babydyne" which is recommended by the manufacturer for use as a portable set as well as for home use. It is 8 in. long by 6 in. wide and weighs 1 lb. The company claims that it can be advantageously coupled with two stages of amplification and will tune in over 1,000 miles. Intended retail price, without the tube, \$10; with tube, phones, batteries, etc., \$15.



Console-Type Receiver

Radio Retailing, February, 1925

Here is an illustration of the FADA "Neutrola Grand," made by F. A. D. Andrea, Inc., 1581 Jerome Avenue, New York City. It is a combination of the FADA No. 185-A five-tube "Neutrola" neutrodyne receiver and the No. 190-A table cabinet. Its approximate overall dimensions are 27 in. long, 51 in. high and 18 in. deep. Built-in loudspeaker. Intended retail price, \$270.

Receiver with Built-In "A" Battery Eliminator

Radio Retailing, February, 1925

No "A" battery is required to operate the "Electradyne" receiver brought out by the Foreign & Domestic Electrical Commodities, Inc., 629 West Twenty-Third Street, New York City, for a built-in "Radio-Powr" unit, operating from the ordinary 110-volt, 60 cycle, a.c. circuit replaces the "A" battery. A special tuned radio frequency, two-tube reflex circuit is employed. The cabinet, which is made of mahogany, has built-in loudspeaker. Intended retail price, including loudspeaker and "Radio-Powr" unit, \$110.

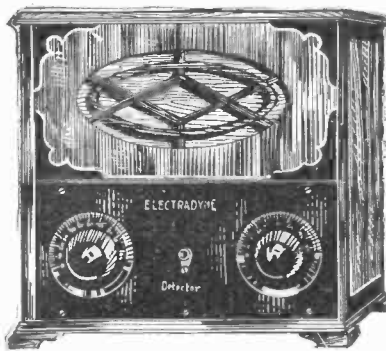

Radio Kit

Radio Retailing, February, 1925

The "Ultradyn" Model L-2 kit of the Phenix Radio Corporation, 3 Beekman Street, New York City, consists of one low loss tuning coil, a low loss oscillator coil, a special low loss coupler, a type "A" "Ultraformer," three type "B" "Ultraformers" and four matched fixed condensers. The "Ultraformers" are air core transformers, designed to pass wave lengths of only 3700 meters. The "Ultradyn" circuit, it is explained, is an improved super-heterodyne, with regeneration added to the "Modulation System." Two-dial control. Intended retail price of kit, \$30. Instruction book, "How to Build and Operate the Model L-2 Ultradyn," 50c.



Radio Set Using Indoor Loop Antenna

The new D-17 receiver announced by the De Forest Radio Company, Jersey City, N. J., is a five-tube set, comprising two stages of tuned radio frequency, one stage of untuned radio frequency, a tube detector and two stages of audio frequency. Tuning is effected through a friction reduction gearing supplemented with one stage of reflexing. Special attention is called to the type of cabinet which provides space for the "A" storage battery and the "B" battery, making the battery equipment self-contained. Enclosed in mahogany or art-leather cabinet, with built-in loudspeaker. Intended retail price, without batteries, in leather cabinet, \$190; in mahogany cabinet, \$200. Model D-17-a, without accessories, \$125.



Console Cabinet

Radio Retailing, February, 1925

A place for everything is found in the radio cabinet designed by the Windsor Furniture Company, 1420 Carroll Avenue, Chicago. It has built-in loudspeaker and compartments for the "A" and "B" batteries and for the charging equipment. The console is 38 in. long, 18 in. wide and 29 in. high and is furnished in two shades, brown mahogany or walnut. Intended retail price, including loudspeaker unit, \$40.

How to File These Items

Every item with its illustration, in this new merchandise section, will fit a standard 3x5-in. filing card. These cards can then be filed, preferably according to the nature of the product, and you will then have a current reference list of all new merchandise as it appears on the market.

If preferred, these items can be pasted on sheets of paper for binding in a loose-leaf catalog or folder.

What's New in Radio and Where to Buy It—

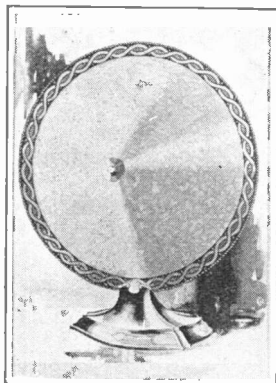

Loudspeaker

Radio Retailing, February, 1925

The attractive appearance of the Farrand-Godley loudspeaker, made by the Farrand Manufacturing Company, 28 South Sixth Street, Newark, N. J., may be seen from the accompanying illustration. The designers claim that with the use of this new type of loudspeaker, every tonal shade of accompaniment, from the second-violins and cellos to all the winds and brasses is faithfully reproduced, especially the tones of the lower scale which are sometimes obscured in a general blare. Intended retail price, \$32.50.

Loudspeaker

Radio Retailing, February, 1925

By a simple movement of the control arm extending from the base of the new "National" loudspeaker developed by the Holtzer-Cabot Electric Company, Boston, Mass., the speaker mechanism is easily adjusted to any kind of receiving set, to all kinds of tubes, and to wet or dry battery, the manufacturer explains. Incorporated in the base is the Audio Filter, an exclusive feature, it is declared, to eliminate side noises, amplify the lower notes and clarify the higher. The horn is made of hard rubber. Intended retail price, \$12.

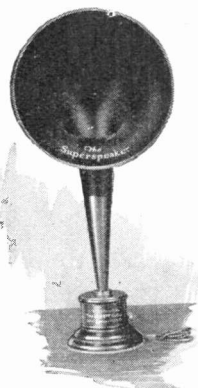

Loudspeaker

Radio Retailing, February, 1925

The Jewett Radio & Phonograph Company, 5680 Twelfth Street, Detroit, Mich., is manufacturing a loudspeaker known as the "Superspeaker." It has 14-in. bell, finished in black satin gloss, high-compression throat, ebony-finished base. It is equipped with adjustment knob to control the tone volume. No extra batteries required. Intended retail price, \$30; "Venico" unit only, with cord, \$12.

Hornless Loudspeaker

Radio Retailing, February, 1925

The No. 540-AW loudspeaker brought out by the Western Electric Company, New York City, is of attractive design and is mounted on a metal stand, suitable for placing on the table of a living room. The cones are approximately 18 in. in diameter and the whole assembly stands about 21 in. high. No additional battery is required to operate this loudspeaker. The impedance of the windings is about 10,000 ohms at average voice frequencies, it is explained, thus adapting it for use with any of the radio sets on the market having two or more stages of audio frequency amplification. Intended retail price, \$35.

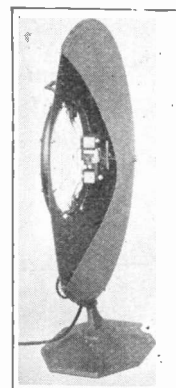

Radio Horn

Radio Retailing, February, 1925

In describing the patented process for making the Hawley horn, Newcombe-Hawley, Inc., 160 North La Salle St., Chicago, explains that its wall construction consists of two hard brilliant surfaces with a soft inner core, the hard surfaces being an integral part of the soft core. All horns have a tendency to vibrate, says the company, and the hard inner surface, in starting to vibrate, is held back by the soft core. The horn cannot sustain any one vibration, it is further explained, and will immediately change with the varying vibrations which are put into the horn by the diaphragm and not carry them over when the rate of this vibration changes with a different note. Hawley horns are supplied to many of the largest radio manufacturers in the country. The company makes a specialty of designing horns to fit all the characteristics of the loudspeaker units with which they are to be used.

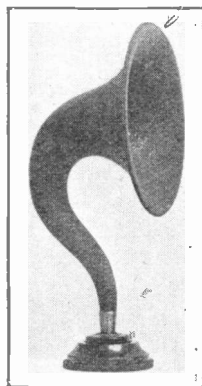

Loudspeaker

Radio Retailing, February, 1925

The Stromberg-Carlson Telephone Manufacturing Company, Rochester, N. Y., is announcing a new No. 2-A loudspeaker which is described by the company as having but one moving unit, the diaphragm. Thoroughly insulated coils, wound a layer at a time and provided with insulating material between each layer so that they will stand up under the highest plate voltage now prevalent, are another feature of its construction. The metal parts and the horn, which is 24 in. high, are finished in oxidized silver. Intended retail price, \$17.50.



Loudspeaker

Radio Retailing, February, 1925

That the wind band instruments used by Sousa were made of special alloy bell brass, with seams silver-soldered and the instruments electro-plated, is pointed out by the Jolley Radio Company, 23 Washington Street, New York City. The company also explains that the horn of its No. 1020 loudspeaker (illustrated) is made of bell brass in the same manner. Intended retail price, \$37.50. A new model of loudspeaker has recently been announced by this company to meet the demand for a popular-priced instrument. The unit contained in the new No. 1225 loudspeaker is the same as that used in the bell brass model, but the horn is composition. Intended list price of No. 1225, \$27.50.

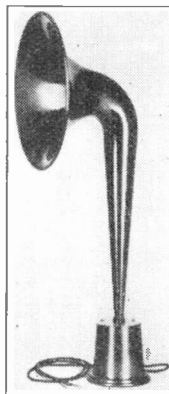

News of Latest Products Gathered by the Editors

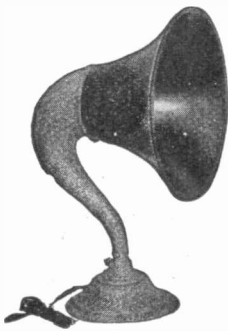

Loudspeaker

Radio Retailing, February, 1925

The sound chamber of the No. 24 loudspeaker brought out by the H. G. Saal Company, 1800-1806 Montrose Avenue, Chicago, is made of cast aluminum. The loudspeaker measures 18½ in. in height and has black crackle finish; the bell is 11 in. wide and is made of black bakelite. Intended retail price, \$20.



Light-Weight Headset

Radio Retailing, February, 1925

For radio folks who object to the headset because of the discomfort caused by the headband when it is donned for any length of time, the Bel-Canto Radio & Telephone Equipment Company, Inc., 872 Broadway, New York City, has brought out a headset that weighs but 5½ oz. It is made without a headband and the ear-phones, which are thin as a watch, are held to the ears by a clamp device. The attachment for the ears is a friction spring made in such a way that it can be taken off and placed in the proper holes which are provided for large and small ears. Ohmage 2,200. Approximate retail price, about \$5.

Loop Aerial

Radio Retailing, February, 1925

Spider-web wound with green or brown silk over phosphor-bronze wire, the "Paramount" loop of the Paramount Radio Corporation, 23 Central Avenue, Newark, N. J., is mounted on a bakelite frame. It is but 15 in. in height and because of its small size and mobility makes greater receivability and directional effect easily possible. Intended retail price, \$12. The illustration shows Steward C. Whitman, president and engineer of the Paramount Radio Corporation, with his new invention.

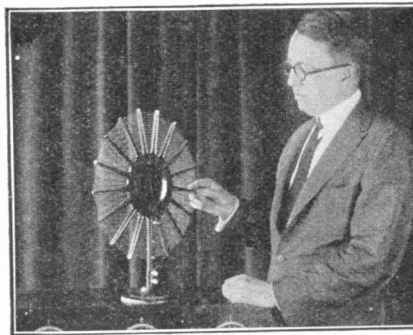

Portable Loop Aerial

Radio Retailing, February, 1925

"Signola" is the name of the portable loop brought out by the Signal Electric Manufacturing Company, Menominee, Mich. It contains 110 ft. of silk-covered wire, wound on formica spreaders, insulating windings from the frame, and folds like an umbrella. The finish of wood parts is dark mahogany while the metal parts are nickel plated. To meet a certain demand, a third tap has been added, the manufacturer explains. Intended retail price, \$8.50.

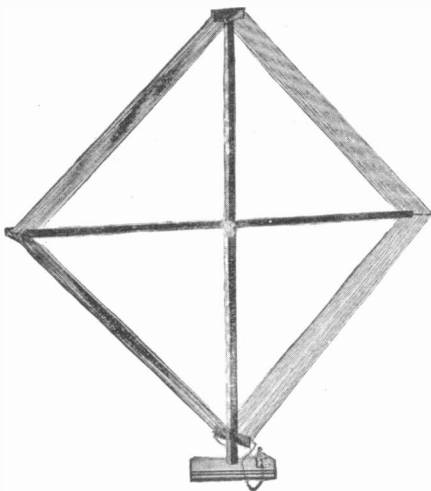

Radio Tube Socket with Spring Lock

Radio Retailing, February, 1925

The B. F. Goodrich Rubber Company, Akron, Ohio, is manufacturing a "V.T." hard rubber radio tube socket which is equipped with a spring lock. Because of this feature the manufacturer explains, the tube can be either inserted and fastened or unfastened and removed without turning or twisting, for the tube locks automatically when inserted. A touch of the lock releases the tube.

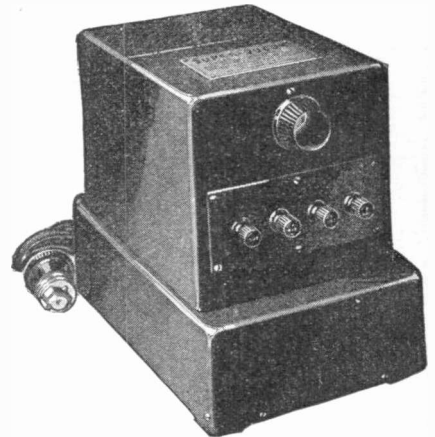

"B" Battery Current Supply Device

Radio Retailing, February, 1925

The improved design of the "Super-Ducon" device to replace "B" batteries, made by the Dubilier Condenser & Radio Corporation, 43 West Fourth Street, New York City, is shown by the accompanying illustration. The "Super-Ducon" is made in two models, No. 800 for use with alternating current and No. 801 for use with d.c. circuits. The intended price, a.c., \$47.50; d.c., \$30.

Radio Outlet

To provide radio reception in every room, from one central receiver, radio outlets are now being built right into the wiring system. A standard H & H wall case or any standard switch box takes the jack-receptacle base, No. 2,139, brought out by the Hart & Hege-man Manufacturing Company, Hartford, Conn. It is wired just like a flush switch and the wall plate, No. 2,137, is the same size as the switch or receptacle plates and may be finished to match. The outlet is designed to take any standard radio plug. Wired into baseboards, tables or other furniture, the loudspeaker or headset may be connected as easily as an electric appliance with a convenience outlet.

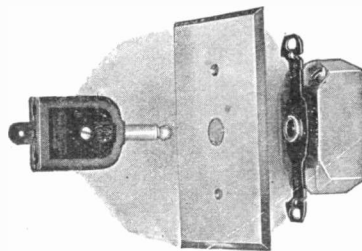

Radio Socket

Radio Retailing, February, 1925

Molded of bakelite, the new radio socket brought out by the Knox Corporation, Galesburg, Ill., is well designed and is made with ample room to mount and allow for soldered connections if desired. The method of gripping the tube is from the side, thereby eliminating all pushing up of the tube, the manufacturer explains. Intended retail price, 75c.

What's New in Radio and Where to Buy It—

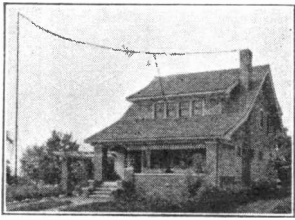

Mast for Radio Aerials

Radio Retailing, February, 1925

The new "Hercules" mast for radio antennae, made by S. W. Hull & Company, 2048 East Seventy-ninth Street, Cleveland, Ohio, is made of steel in sizes to provide 20-ft., 40- or 60-ft. clearance. It can be installed either on the roof of a building or on the ground and is guyed with three wires spaced at equal intervals around the mast. It is shipped knocked down. Intended retail price of the 20-ft. mast, \$10; 40 ft., \$25; and 60 ft., \$45.

Radio Tube

Radio Retailing, February, 1925

The Radio Tube Manufacturing Company, 154 Nassau Street, New York City, is marketing a line of radio tubes, called the "Triple Tone." The tubes are made in the following types. 201A, 5 volt, $\frac{1}{2}$ amp., amplifier and detector; No. 199, 3-4 volts, .06 amp., amplifier and detector; No. 199A, same as 199, with standard base; No. 12, $1\frac{1}{2}$ volts, $\frac{1}{2}$ amp. platinum filament, amplifier and detector; and No. 200A, 5 volts, .1 amp. detector. Intended retail price of all types, \$2.

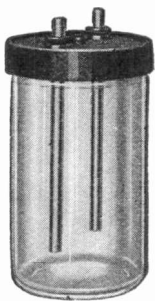

Chemical Rectifier

Radio Retailing, February, 1925

The No. 4 "Storad" charger brought out by the Cleveland Engineering Laboratories Company, 2104 Superior Viaduct, N. W., Cleveland, is designed to charge any number of cells up to twenty-four (48 volts) in series at specified rates. Intended retail price, \$2.75.

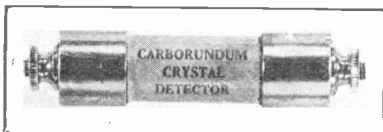

Crystal Detector

Radio Retailing, February, 1925

That it sharpens the tuning and increases the selectivity of the crystal or reflex set is claimed for the Carborundum crystal detector by its manufacturer, the Carborundum Company, Niagara Falls, N. Y. Intended retail price, \$1.50.

"B" Battery Charger

Radio Retailing, February, 1925

Four to six to eight 24-volt batteries may be charged at one time by the "RaBAT" senior charger, declares its manufacturer, the Radio RaBAT Company, 1758 St. Clair Avenue, Cleveland. It is equipped with a patented submerged electrode, designed to automatically cut itself out if charger is improperly connected, causing it to overheat. Intended retail price, \$4.80.

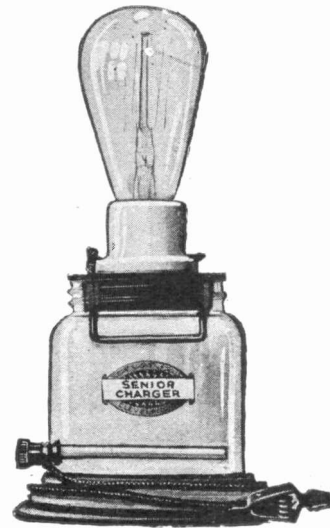

Insulated Bus-Bar Wire

Radio Retailing, February, 1925

Burned out rheostats, it has been found upon investigation, are sometimes caused by defective spaghetti and to the puncturing of the spaghetti by sharp corners on nuts, screws and solder. To overcome this condition and to incidentally prevent short circuits where one wire crosses another, the Alpha Radio Supply Company, Inc., 621 Broadway, New York City, has brought out an insulated bus-bar wire—a spaghetti-covered bus-wire—which consists of an insulating compound applied to a No. 14 B & S round tinned bus-bar wire. The wire is made in 2-ft. lengths and in five colors.



Radio Battery Cord

Radio Retailing, February, 1925

For connecting "A" and "B" batteries to the radio set, the Consolidated Wire and Associated Corporations, Green and Congress Streets, Chicago, has designed a radio battery cord which is packed in a display carton. Each wire is marked in color and the terminals on all wires are made for easy connection. Intended retail price, \$1.

Voltmeter Switch

Radio Retailing, February, 1925

A voltmeter switch for use in connection with a voltmeter for reading voltages of "A" and "B" batteries has been announced by the Yaxley Manufacturing Company, Chicago. The new switch occupies very small space on the panel and is made to mount in a single $7/16$ -in. hole with one nut and to turn in any direction to suit the wiring layout. A designation plate back of the knob pointer indicates which battery is being tested. Intended retail price, \$1.40.

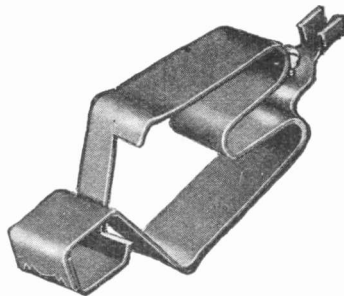
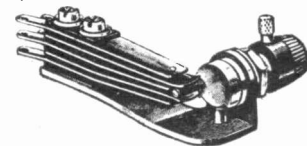

Battery Clip

Radio Retailing, February, 1925

The outstanding features of the new line of battery clips brought out by the H. B. Sherman Manufacturing Company, Battle Creek, Mich., are the one-piece construction of spring steel, coated with hot lead to withstand acid fumes, the handy terminal, the universal jaws, generous size and uniform grip. The clips are made at present in two sizes, No. 50, with a 50-amp. capacity, for use in automotive work in charging storage batteries, and No. 25, for use in charging "A" batteries, although other sizes and styles will be added to the line.

Condenser

Radio Retailing, February, 1925

The Precise Manufacturing Corporation, 254 Mill Street, Rochester, N. Y., has brought out a new instrument known as the No. 1900 "Filtformer" which is a combination radio frequency choke and bypass condenser designed for use in the single-control super-heterodyne circuit.



News of Latest Products Gathered by the Editors

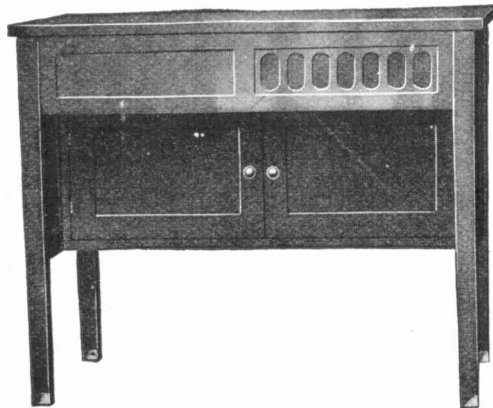

Radio Table

Radio Retailing, February, 1925

The "Signola" table brought out by the Signal Electric Manufacturing Company, Menominee, Mich., is designed to meet the demand for a moderate-priced radio desk. The set is placed on top of the table and compartments for the "A" and "B" batteries are provided. The loudspeaker compartment is fitted with silk-covered grill-work front and loudspeaker horn adaptable to most of the loudspeaker units on the market. Intended retail price, R-501, \$30

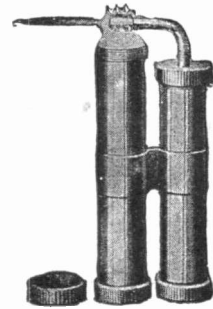

Small Blow Torch for Radio Use

Radio Retailing, February, 1925

The Jas. A. Gaffney Company, Inc., 35 Warren Street, New York City, has brought out an alcohol torch known as the "Acme Automatic" torch. The manufacturer calls attention to the fact that it requires no pumping, priming or blowing; that the heavy tubing used will not contract the heat as quickly as the lighter gage of tubing; and that the heavy knurling of the caps not only acts as a natural base for the torch but enables the user to secure a firm grip when removing. Its size is 5 1/4 in. x 2 3/4 in. and its weight is 7 oz. Intended retail price, \$1.50.

Blow Torch

Radio Retailing, February, 1925

The L. S. Brach Manufacturing Company, 127 Sussex Avenue, Newark, N. J., is now marketing the Self-Acting blow torch formerly sold by the Solderall Company. This torch which is an improved model, is made to generate a blow flame 4 to 5 in. long. The L. S. Brach Manufacturing Company announces that it has taken over the Solderall Company and is now marketing the Solderall line, including the Solderall metal solder put up in collapsible tubes, the Peerless flux and the Rosin Core solder.



Ground Clamp

Radio Retailing, February, 1925

The ground clamp made by the F. R. Zierick Machine Works, 207 Canal Street, New York City, is specially equipped with a lug for fastening the ground lead of the radio set. A guard holds the wire while soldering, and two overlapping ears, bent over the soldered joint, insure a strong mechanical and electrical connection, the manufacturer points out. The clamp is made in two sizes, 6 in. and 9 in., listing respectively, at 5c. and 10c.

Radio Ground Clamp

Radio Retailing, February, 1925

As can be seen from the accompanying illustration, the ground clamp made by the Ekko Company, 111 West Monroe Street, Chicago, Ill., is half-moon in shape. It is made to fit over the pipe (ground) with several notches on the inside to keep the clamp in one position and a threaded screw on the other side. The clamp can be adjusted by tightening up the screw with the fingers, the connection between the clamp and the pipe being made as the point of the screw bites its way into the metal, thus insuring a positive metal contact, it is explained.

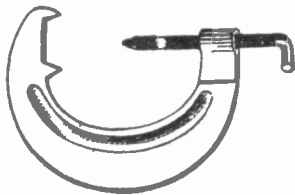

Storage Battery Hydrometer

Radio Retailing, February, 1925

The Biltrite Motor Equipment Company, Inc., 822 Tenth Avenue, New York City, is the manufacturer of the "Biltrite" storage battery hydrometer which is listed at \$1. Replacement parts, including the hydrometer float, glass tube, rubber hand bulb and rubber battery tip may be obtained, the float being listed at 30c. and the other parts at 25c.

Bracket for Radio Aerial

Radio Retailing, February, 1925

The Wm. H. Pearl Company, 425 Harmon Street, Indianapolis, Ind., has designed a drop wire bracket for telephon- and radio wires. To install, it is necessary simply to screw in the hook and hang on the two-piece yoke assembled into porcelain insulator.

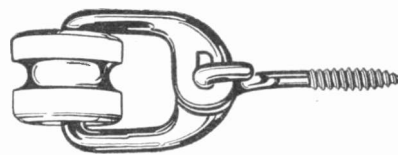

Mica Condenser

Radio Retailing, February, 1925

Because of the special design of the "Micadon" No. 640 mica condenser, it is possible to make it in the wide range of capacities from .00025 mfd. to .02 mfd., its manufacturer, the Dubilier Condenser & Radio Corporation, 43 West Fourth Street, New York City, declares. The size is 2 1/4 in. long by 1 1/4 in. wide. Convenient soldering lugs make it adaptable to the various requirements of radio circuits.

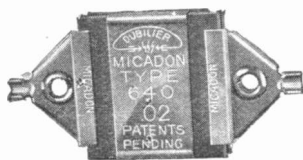

Screw Driver

Radio Retailing, February, 1925

The Coburn Tool Company, Inc., 739 Boylston Street, Boston, Mass., is manufacturing a small screw driver designed to place and start screws in difficult places where the ordinary screw driver would be useless. It is not magnetic, the company explains, and works equally well with screws of any material. The brass cap and handle are knurled to insure a positive grip and the shank is of Shelby drawn steel tubing. The size of the tool is 7 1/4 in. long with 1-in. blade. Intended retail price, \$1.



What's New in Radio and Where to Buy It

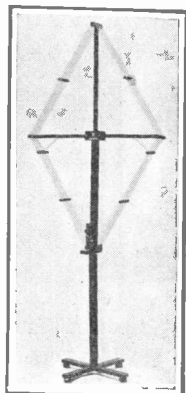

Folding Loop Aerial

Radio Retailing, February, 1925

The multiple coupler switch incorporated in the collapsible loop designed by the C. A. Cook Company, 18 Osborn Street, Cambridge, Mass., has three positions, providing minimum inductance, maximum and medium inductance. For use, it is necessary simply to connect the lead wires to the set, try out all three of the knob positions and finally use the one giving the best results. A compass imbedded in the base plate aids in finding direction. The loop itself occupies a floor space of 13½ in. square although its dimensions are 45 in. x 29 in. Intended retail price, including stand, \$13.50.

Folding Loop

Radio Retailing, February, 1925

The "Duo-Spiral" loop aerial, made by Radio Units, Inc., Maywood, Ill., is now being offered in a folding model, in several different types and ranges. When folded, it can be placed in a box about 18 in. long and 6 in. wide. The loop rotates on the base, so that its directional properties can be fully utilized. The base is provided with a satin silver dial graduated in degrees for calibration. Finished in mahogany and satin silver. Intended retail price, \$8.50.

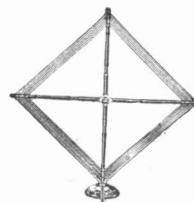

Semi-Completed Radio Set

Radio Retailing, February, 1925

All that the purchaser of an "All-Amaz" receiver must do is wire the set, for the mounting of all instruments on the panel and baseboard and drilling of panels has been completed. Furnished with the semi-finished receiver is a blue print or wiring diagram to guide the purchaser in wiring the set. The "All-Amaz" is made in two models, in one-tube reflex "Junior" and three-tube reflex or "Senior" model. Intended retail price, without tubes or batteries, respectively, \$22 and \$42.



Five-Tube Receiver

Radio Retailing, February, 1925

The specifications of the "Gluckson" receiver, made by the Gluck Radio Manufacturing Company, 115 West Twenty-third Street, New York City, are: Two stages of inherently balanced radio frequency amplification, detector, and two stages of audio frequency; single wire aerial of from 60 to 150 ft., with provisions for both long and short aerials; mahogany cabinet, with Adam Brown finish. Intended retail price, \$98.

Pocket-Size Radio Log Book

Radio Retailing, February, 1925

An imitation leather cover contains enough pages to accommodate 38 stations. It is made by the Fox Company, 247 South Broadway, Los Angeles, Cal., and provides for the indexing of stations so that each station may be readily found when wanted. The book has been suggested as a premium by dealers to accompany purchases of complete radio sets or of de luxe radio sets, as the dealer wishes. Intended retail price, 25c. Fifty books, printed with the dealer's name and address, \$5; 1 doz. books, no special printing, \$1.50.

Five-Tube Knockdown Radio Kit

Radio Retailing, February, 1925

One of the outstanding features of the new No. R-101 tuned radio frequency knockdown set of the Splitdorf Electrical Company, Newark, N. J., is the sub-panel assembly which is completely wired. The audio frequency sockets and transformer are connected to eliminate the possibility of confusion and improper wiring on the part of the user. Included with each set is a pair of Splitdorf headphones, a phone plug, an electric soldering iron outfit and book of instructions. Intended retail price, \$75.

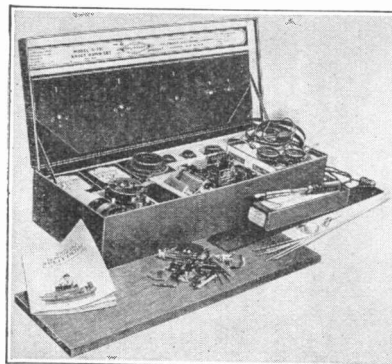

Small Tool Kit

Radio Retailing, February, 1925



The radio worker is always searching around the family tool box for some tools that he can adapt to radio use. Most of the ordinary tools are too large and unwieldy for work on the radio set. An assortment of handy-size tools, with small tin-box container has been brought out by the O. P. Schriver Company, Cincinnati, Ohio. This kit contains one adjustable tool or file handle, a saw, 7 in. long, an ice pick or scratch awl, a screwdriver for large or small screws, a chisel, a tack claw, a gimlet bit, a large brad awl and a small brad awl. The adjustable handle, besides holding these tools, is also made to hold any other small shanked tools.

Radio Socket

Radio Retailing, February, 1925

The base of the new "Noloss" socket brought out by the General Instrument Corporation, 423 Broome Street, New York City, is made of Isolantite which, it is pointed out, has been found to have very desirable properties for radio use. Another feature of the socket is the extra large 5/16-in. diam. sterling silver contacts arranged so as to be self-wiping. Intended retail price, \$1.

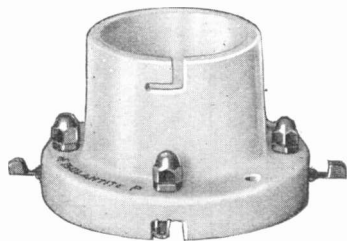

Cabinet-Type Loudspeaker

Radio Retailing, February, 1925

The loudspeaker illustrated is made by the Portola Radio Company, Fifth and Market Streets, Philadelphia, Pa. It is known as Model 1 and is set in a decorative mahogany cabinet. The cabinet measures 5 in. high, 9½ in. long and 8 in. deep and is listed at \$12.50. Model No. 2 is set in a cabinet with legs, is 6½ in. high, and is listed at \$16.



A New Hook-up to Help You Sell Parts

The Eight-Tube Super-Heterodyne Reflex Receiver Designed by Laurence M. Cockaday

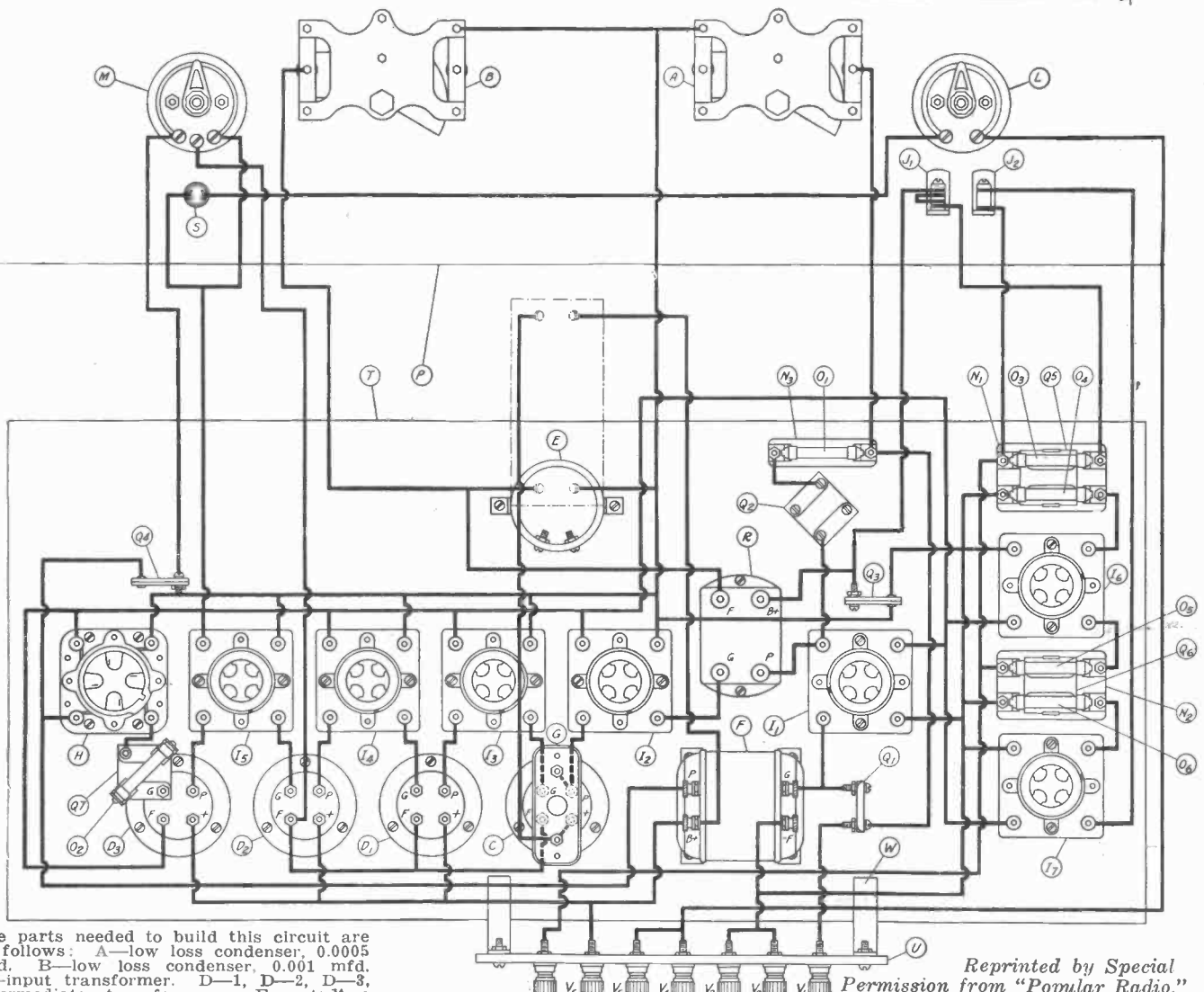
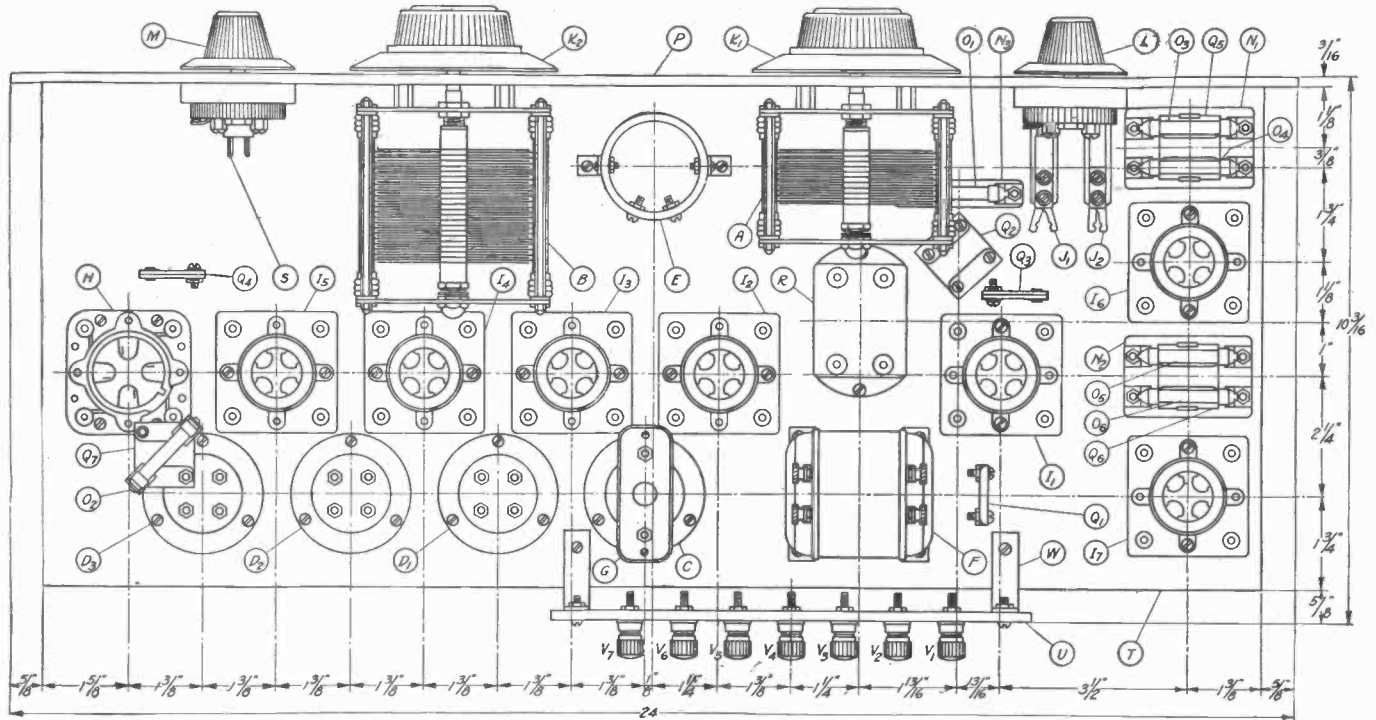

The parts needed to build this circuit are as follows: A—low loss condenser, 0.0005 mfd. B—low loss condenser, 0.001 mfd. C—input transformer. D—1, D—2, D—3, intermediate transformers. E—autodyne coil. F—audio frequency transformer. G—grid condenser, 0.0005 mfd. H—socket. I—1, I—2, I—3, I—4, I—5, I—6, I—7, sockets. J—1, double circuit jack. J—2, single circuit jack. K—1, K—2, four-inch dials. L—2 ohm rheostat. M—400 ohm potentiometer. N—1, N—2, resistance mountings. N—3, grid leak mounting.

O—1, O—2, 5 megohm resistors. O—3, 0.005 megohm resistor. O—4, 0.5 megohm resistor. O—5, O—6, 0.25 megohm resistors. P—panel, 7x24 inches. Q—1, Q—2, 0.0001 mica condensers. Q—3, Q—4, Q—5, Q—6, 0.006 mica condensers. Q—7, 0.00025 mica condenser with grid leak mounting. R—radio frequency trans-

former. S—filament switch. T—baseboard, 9 1/2 inches by 22 1/2 inches by 1/2 inch. U—connecting block, 1 inch by 9 inches by 1/8 inch. V—1, V—2, V—3, V—4, V—5, V—6, V—7, binding posts. W—brass brackets. X—cabinet, 7 by 24 inches, inside deep measurement, 9 1/2 inches. Note—use with loop aerial.

Reprinted by Special Permission from "Popular Radio."

How Manufacturers Promote Dealer Sales

New "Dealer Helps" Offered to the Radio Retailer by the Manufacturer to Increase the Merchant's Radio Profits

Advertised Versus Unadvertised Goods

In its new booklet, "Merchandising Radio," the Alden Manufacturing Company, Springfield, Mass., manufacturer of the "Na-ald" line of radio parts, points out some interesting figures, the result of a survey conducted in one hundred quality stores. This survey, which was originally reported in *Forbes Magazine*, was conducted to determine the real effectiveness of advertising.

Two similar articles, one advertised and the other unadvertised, were placed on sale. No attempt was made by sales clerks to influence the decision of the customers. What actually happened was this:

- 87.6 times the customer bought advertised merchandise
- 6.3 times the customer bought unadvertised merchandise
- 8.8 times the customer showed no preference

And further, when the unadvertised merchandise was priced the lower of the two:

- 60.6 times the customer bought advertised merchandise
- 24.2 times the customer bought unadvertised merchandise
- 12.2 times the customer showed no preference

Included in the booklet, beside catalog descriptions of "Na-ald" products, is a list of the "dealer help" material available to dealers, consisting of a display container, a dial panel and a socket display board.

"How to Sell a Radio Receiver"

"Radio merchandising methods are still so new," says the Sleeper Radio Corporation, Long Island City, N. Y., in its booklet, "How to Sell a Radio Receiver," "that many sets are sold by more or less haphazard methods. This led to much confusion in retail selling, and, while radio distribution has now largely settled into the channels provided by electrical and radio shops, together with phonograph, music and department stores, there

is still much difference in selling methods that can be standardized with advantage to all if each will simply take a merchandising lesson from the other."

The suggestions presented in this manual are based on the actual experience of many different types of stores in different sections of the country. From these experiences are cited (1) a few instances which show how *not* to sell a radio receiver; (2) the broader principles of radio merchandising which stores have found to be the most successful; (3) the questions which most customers will ask concerning the selection of a set.

Here are the fundamental principles of radio merchandising as set down by the Sleeper manual:

1. Always have your demonstration sets hooked up and ready to operate properly.
2. Always permit the customer himself to operate the set.
3. Make every effort to install the set in the customer's own home "on trial."
4. Draw up a time-payment plan; many more sets can be sold when customers can pay "on time."
5. Sell sets which are least affected by unfair competition.
6. Feature your sets vigorously.
7. Sell only sets which stay sold.

"Sell More by Telling More"

"Sell More By Telling More" is the message behind every folder and booklet that a manufacturer issues. At least that is the message of the Atwater Kent Manufacturing Company, Philadelphia, Pa., to its jobbers and dealers. "In these few words," says the company, "are expressed one of the fundamental principles of successful merchandising. Telling more people about the goods you are handling, whether it be through newspapers, direct-by-mail, literature distributed over the counter or any other medium of advertising—that's what counts—for your sales will be in direct proportion to the number of people you reach." This company, by the way, has just issued two new folders, printed in many colors and attractive in makeup.

The Stromberg-Carlson Telephone Manufacturing Company, Rochester, N. Y., also has some interesting window cards, and among several folders and circulars, one telling, in pictures, the joy of a radio in the home.

"Buy With Care—Build With Satisfaction" is the name of a new pamphlet issued by the Cutler-Hammer Manufacturing Company, Milwaukee, Wis. It is known as Publication X-7 and in addition to the line of C-H radio products, also illustrates and describes in particular the new C-H low-loss sockets and the new "Radioloc" locking switch for the "A" battery circuit.

The National Electric Specialty Company, Toledo, Ohio, has issued a pamphlet, No. 15, on its "Vac-M" arresters.

"Turkey-in-the-Straw" Via Radio



The old-time fiddler who was the life of the party and who kept dancers' feet continually stepping, is no more. He has been replaced by radio and may now join in the festivities while someone else provides the music. It is hard to suppress a smile when looking at the new "Red Seal" cutout soon to be released by the Manhattan Electrical Supply Company, 17 Park Place, New York City, for everybody in the group is happy and their merriment is infectious. The display, according to the company's schedule, will be mailed February 13. Folks who enjoyed "Joe O'Connor" and the "Old Lady" last year will welcome their old friends.

A Transformer Display



Transformers, as a rule, are not exactly adapted to artistic display. The window or counter card, with easel back, prepared by the Precise Manufacturing Corporation, Rochester, N. Y., for distribution to its dealers, shows a home tastefully furnished, where everything, including radio requirements, is carefully chosen. The card carries an actual photograph, delicately tinted.

Get Those Indifferent Prospects!

There are a number of folks who are sort of fifty-fifty about radio. They are not exactly opposed to owning a set, neither are they enthusiastic enough to bother to hear a demonstration or to become better informed about the pleasures of listening-in. But once approached and their interest engaged, these prospects develop into full-fledged sales.

One way,—a good way, of reaching the large number of partly-sold people is through a direct mail campaign. To assist the dealer in such a plan, the Radio Corporation of America, Woolworth Building, New York City, has prepared a four-page letterhead on Radiola loudspeakers. These letterheads will be furnished, imprinted with the dealer's name, for a very nominal sum. The letter of course, will not be multigraphed as the dealer may prefer to write his own sales message.

The Klosner Radio Corporation, 1022 East One Hundred and Seventy-Eighth Street, New York City, has prepared for distribution to its dealers a rheostat chart which shows the correct rheostat resistances to choose for every use. The chart is made of heavy cardboard, measuring 11 in. x 14 in., in two colors and is especially adaptable for easy reference by any clerk or customer in a dealer's store. "For long life and good reception," cautions the chart, "burn tubes low and turn them on and off slowly."

"How to Get the Most Out of Your Dry Cell Radio Batteries, 'A,' 'B' and 'C'" is the name of a little booklet published by the National Carbon Company, 30 East Forty-second Street, New York City. Some of the topics discussed are: "How a Dry Cell Works," "How to Select a 'B' Battery," "How to

Test a 'B' Battery," and other topics.

The Music Master Corporation, Philadelphia, is distributing a number of colorful little folders on its headset, cabinet speaker, horn-type loudspeaker, phonograph attachment and loop aerial. The company is also offering a display piece which fits around the horn of its loudspeaker.

The Atwater-Kent Manufacturing Company, Philadelphia, Pa., is issuing some new folders including one entitled "A Land Lubber's Log," one on its general radio line and another, a loudspeaker folder. The company has also available for distribution some colorful window posters.

The Electric Service Supplies Company, Philadelphia, Pa., is distributing a little booklet on the "Keystone" lightning arrester. This sixteen-page booklet gives facts about radio lightning protection, tells how the lightning arrester may affect radio reception and is as well a technical survey of the subject of lightning arresters.

The Kodel Manufacturing Co., 118 West Third Street, Cincinnati, has issued a booklet on its line of Kodel receivers, "Radio for Every Purpose and Any Purse." It has also prepared a huge two-color window hanger showing this entire line.

"How to Build and Operate the Ultradyne Super-heterodyne Receiver" is the title of a new booklet brought out by the Phenix Radio Company, 5 Beekman Street, New York City. It contains 32 pages, illustrated, and gives instructions for drilling, wiring, assembling and tuning the Model L-2 Ultradyne receiver. Price 50c.

They Sell Themselves

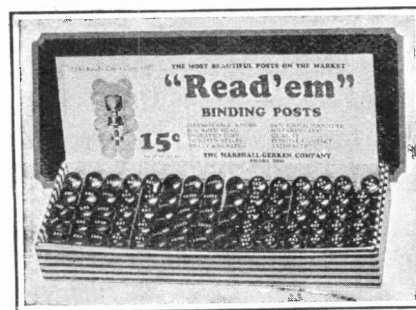

With the manufacturer's co-operation, it is a simple matter for the dealer to acquaint his customers with the various lines of merchandise he is carrying and by an attractive display and well-chosen message to call attention to even the smallest of radio parts. Here is a display of "Read'em" binding posts, a counter carton, made up of seventy-five assorted knobs and distributed by the Marshall-Gerken Company, Toledo, Ohio. Included in the line of binding posts are several with new markings.

The Crescent Braid Company, Inc., Providence, R. I. has available to its dealers an unusually attractive counter card illustrating the use of its 20-ft. radio extension cord. The card has a silver finish, with embossed figures, and lettering in black. It shows a "Premier" cord being used with a radio set, the receiver in one room and the loudspeaker in another, thus enabling the loudspeaker to be placed 20 ft. from the receiver.

The Hartman Electrical Manufacturing Company, Mansfield, Ohio, has recently distributed a very artistic booklet on its line of radio receivers.

A Prize-Winning Window Display from Los Angeles



Radio reaches everywhere. To the home in the city as well as to the little cabin in the mountains the world sends its messages of news and romance. This was the theme of the window display of the Electric Appliance Shop of Los Angeles, Cal., which received one of the prizes in a national display contest, a feature of Radio Week. The window had all the interest of timeliness and local appeal, for the city home shown

was one which was familiar to the community because it had recently been featured as an electrical home exhibit under the auspices of the entire electrical industry and had been visited by some 100,000 people interested in electrical applications to comfort and pleasure. The background with its flashing message gave life to the scene and illustrated its own message by connecting the two pictures.

What the Trade Is Talking About

McGraw-Hill Staff Convention Felicitated by Hoover and Sarnoff

Personal messages from two outstanding figures in radio development were included among the addresses delivered to 450 members of the McGraw-Hill organization, publishers of *Radio Retailing*, *Electrical Merchandising*, and other journals, at the January 30 dinner which closed the three-day convention of the company's editorial and advertising representatives from all parts of the United States, held at the Hotel Pennsylvania, New York City.

Herbert Hoover, Secretary of Commerce, had expected to be present in person but, official engagements preventing his leaving Washington, he addressed to Mr. McGraw the following letter which was read before the meeting:

James H. McGraw, President,
McGraw-Hill Company, New York City,
Dear Mr. McGraw:

I wanted to attend your convention to say a personal word of appreciation for the fine service which you, your company, and your publications, are rendering to American industry. It is a real disappointment to me that I cannot be present.

A big change has come in the spirit of American business and for this change you are in part responsible. I mean the change from rule-of-thumb and laissez-faire, to scientific determination of facts and to a program of action based on facts. The business press is probably the greatest force in making industrial opinion. The schools and colleges have an important place, the trade associations can do much in the fields of production and distribution, the Government bureaus which keep in contact with business can help to promote sound leadership in industrial and economic thinking. All have an important part. But the business press and technical journals are in a unique position and have a unique opportunity. I believe that no organization of technical publications has come nearer to living up to this opportunity than the McGraw-Hill publications under the leadership of Mr. James H. McGraw.

The thought I have in mind is that your great group of journals can not only recognize and support sound industrial leadership; you can also initiate it. The field of your opportunity is practically limitless.

HERBERT HOOVER.

E. J. Mehren, vice-president McGraw-Hill Company, acted as toastmaster. Julius H. Barnes,

past-president of the United States Chamber of Commerce, spoke on "Economic Marketing," and Fred I. Kent, vice-president of the Bankers' Trust Company, New York, discussed world financial conditions growing out of the war and reparations payments.

David Sarnoff, vice-president and general manager of the Radio Corporation of America, took as his topic "Opportunity." To the man with an open mind and alert perception, opportunities, he said, lie on every hand in America, particularly in American industry and distribution processes. Only vision is needed—to see around obstacles, and to convert seeming difficulties into new instruments of usefulness.

Taking an example from the brief history of radio, Mr. Sarnoff pointed out that although lack of privacy in radio transmission had formerly been considered one of the chief drawbacks of the radio art, the great and useful development of broadcasting itself has been possible only because of the very objection once urged that "anybody could tune-in and listen." Even "static," which now occasionally gets in the way of good radio reception, will before long be so thoroughly understood, predicted the speaker, that it can be eliminated as a source of interference and will also actually be

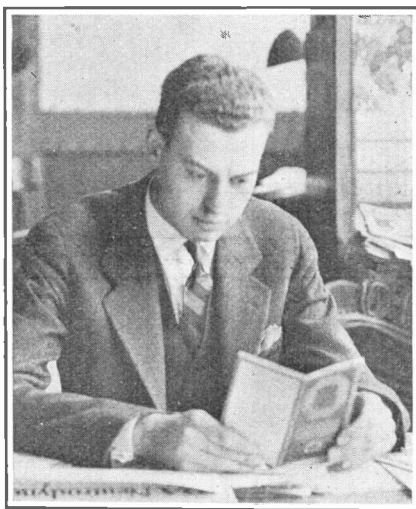

For the past year and a half, Edward E. Laufer has been one of the loyal sales service engineers of F. A. D. Andrea, Inc., of New York City. His technical background as one of the best radio amateurs of the Second Radio District and his general good fellowship have been of tremendous aid in establishing favorable contact with Fada dealers and distributors throughout the South, East and Central West.

harnessed as a new servant of mankind.

Mr. Sarnoff paid a friendly tribute to the work which the McGraw-Hill company, its journals, and its various specialists are doing for American industry and distribution, including the new field of radio where the need today is so great for sound stabilizing influences and for marketing research and accurate knowledge of distribution methods, facts, and costs.

Radio Clubs Benefit the Dealer

If your town has no radio club, there is an opportunity for the progressive dealer to lead in organizing one and cash in on the added sales it will bring to him from the club's members.

Offer your store for the first meeting place, advertise in the local papers, and, no doubt, the editor will give the organization idea space in the news columns as well. If there is one already formed, co-operate with it in every way possible.

Ontario, Canada, has a Radio Club, the objects and aims of which may be used as a model. They are as follows:

To afford opportunity for discussion of radio subjects among members and arrange for talks by authorities on the subject, as well as demonstrations of apparatus by members, manufacturers or dealers.

To encourage the members of the staff to install receiving sets (especially sets which do not radiate), to advise and assist members in the purchase of sets or parts and in connection with constructing of sets and locating troubles.

To help promote radio by all legitimate means and co-operate with other organizations having similar objects; to exert all possible efforts to reduce radiation interference.

To broadcast occasionally.

Novel Radio System for New York Police

The police stations of New York City are to be equipped with radio receiving sets for official business, according to a recent announcement by city officials. A new system has been successfully tried whereby "selective" calls may be made to any particular precinct without the message being picked up by any other precinct. It is expected to prove an invaluable aid in issuing police instructions.

The broadcasting tests were made from Station WNYC by engineers of the Western Electric Company. It was demonstrated that receiving sets under test would not respond when calls were made to other precincts.

Second Radio World's Fair Next September

The definite dates for the Second Radio World's Fair, which is to take place in New York City next fall, have been announced by Directors James F. Kerr and U. J. Herrmann. This year's great international wireless exposition will open September 14 and continue until September 19. It will be held in the 258th Field Artillery Armory, which is located at Kingsbridge Road and Jerome Avenue, the Bronx, New York City, which is the largest building of its kind in America.

The Radio World's Fair of 1925 will outshine the huge exposition held in Madison Square Garden and the 69th Regiment Armory, last September, in almost every respect. This year's show will be at least one-third larger. It will occupy 180,000 square feet of floor space. There will be elaborate displays by 325 radio manufacturers, including 60 of the best known wireless concerns of Europe, South America and the Orient, which is almost one hundred more than participated in the 1924 fair. Fourteen different foreign countries will have exhibits of an official variety.

Among the principal 1925 features will be the first public demonstration of a complete system for the transmission and reception of light, heat and power by radio. Another will be an astounding invention by a Scandinavian which, according to the inventor, will broadcast refrigeration exactly the same as our present day radio stations broadcast programs. "Radio refrigeration," this dauntless inventor insists, will cost less than fifty cents a year.

Government Releases German Radio Patents

The possibility of a radio monopoly in the United States has just been eliminated by the action of the Navy Department in issuing licenses to American manufacturers under the so-called German patents which were purchased by the Navy during the war. The first license was issued on Jan. 8 to the Electrical Research Laboratories of Chicago and it is likely that about 150 other manufacturers will receive licenses.

Los Angeles Holds Radio Exposition

Radio manufacturers, jobbers and dealers combined on the Pacific Coast for the second annual Los Angeles Radio Exposition held in December.

The Los Angeles Exposition was endorsed by the Radio Trades Association of Southern California, and represented not only the leading manufacturing interests but the best known distributors and dealers on the Coast.

The Bel-Canto Radio & Telephone Equipment Company, Inc., is the new name of the company formerly known as the Bel-Canto Manufacturing Company. Its address is 872 Broadway, New York City.

The Standard Metal Manufacturing Company of Newark, N. J., is making radio loud speakers for sale direct to manufacturers, and to be used as built-in speakers for consoles or cabinets. These are all special jobs, designed and built to the manufacturers' specifications.

The Eagle Radio Company, Newark, N. J., has appointed Donald O. Friend assistant to Thomas Smith Loeser, who is chief engineer of the Eagle Company.

Executive Radio Council Plans Annual Show

Final arrangements have been completed for the Fifth Annual Radio Show and Convention under the management of the Executive Radio Council, Inc., to be held in the grand ball-rooms of the Hotel Pennsylvania, New York City, six days extending from March 2 to March 7, general manager F. K. Doscher has announced.

Coming just before the beginning of the supposed slump in the radio trade during the summer months, the March radio show with its first showing of many late models and exclusive features acts as a stimulus for sales.

Radio men from every corner of the country go to New York for the convention held in conjunction with the show. Engineers and technical staffs want to see what others are doing. Manufacturers desire to see what their competitors are offering, and jobbers and dealers want to "get in" on the new lines.

Talking Machine and Radio Men Enjoy Reception

An attendance of 2,000, including the most prominent phonograph and radio dealers of the Metropolitan district, marked the fourth annual dance of the Talking Machine and Radio Men, Inc., held at the Hotel Pennsylvania, New York City, Jan. 19. The Freed-Eisemann Radio Corporation donated one of its finest sets to be used as a prize, the drawing being conducted by Eddie Cantor. An advertising man won the set, Herman Harris, of the W. T. Mullaly Agency.

S. T. Thompson, secretary and general manager of the Duplex Engine Governor Company, Inc., has been elected vice-president of the Duplex Condenser and Radio Corporation, with factory in Brooklyn, N. Y. The business of The Duplex Engine Governor Company has been turned over to the Eisemann Magneto Corporation of Brooklyn, which will continue the production and sale of the Simplex and Turbine Governors.

The Electrical Research Laboratories, Chicago, Ill., have just added to their laboratory staff, J. Elliott Jenkins and Joseph Calcaterra. Both will give their attention to improving and designing radio receiving apparatus. Mr. Jenkins is the holder of patents on several important radio devices and has also installed a number of broadcasting stations. Mr. Calcaterra was technical editor of the radio department of *Popular Science*.

Marconi Urged to Visit America to Witness Latest Broadcasting Wonders

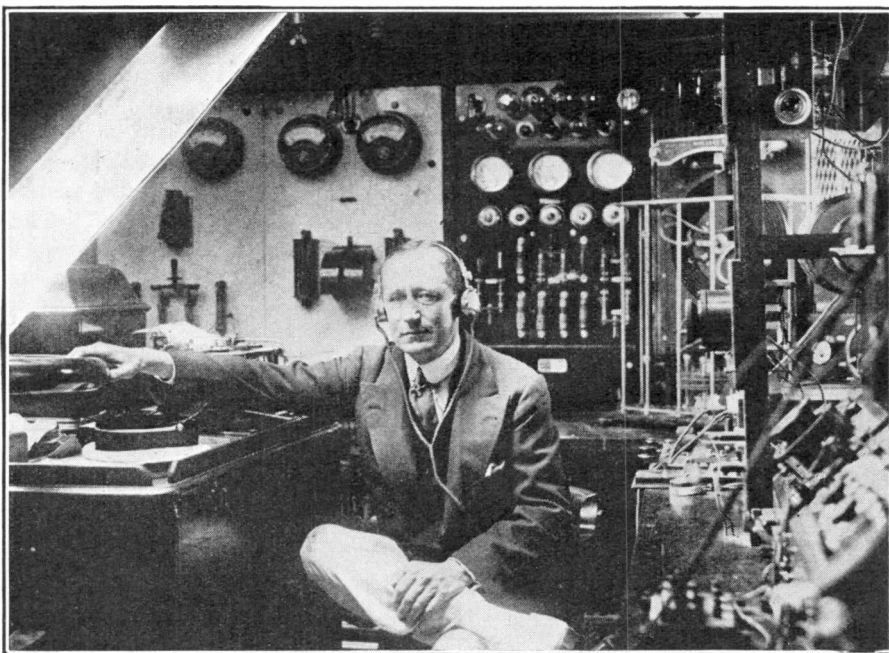

The man who first put radio on the map, William Marconi, has not been a visitor to American shores since broadcasting has really developed and radio has become a topic on everybody's tongue. It is hoped by American admirers to prevail on the great Italian inventor shortly to make another trip to the United States, in order to

witness for himself the results achieved here through tying stations together by wire and by short-wave re-transmission. The picture shows the radio laboratory on board the private yacht of Signor Marconi, where the wizard-owner is still an enthusiastic experimenter, and where much radio history has been made.

Revolutionary Changes Are Not Likely to Come, McDonald Says

Improvements Will Be Made in Mechanical Side of Radio But No Fundamental Developments Are Expected

By E. F. McDONALD, Jr.

President of the National Association of Broadcasters

RADIO has had the most remarkable growth of any industry in the world. Yet I believe that any radical or revolutionary development or changes in radio are very unlikely. From time to time, various new developments are heralded as tending to revolutionize the radio art. Every such rumor naturally has a more or less panicky effect, but when the smoke has cleared away and the reality is apparent, the so-called "new and radical development" is at its best only a refinement.

There are many people today waiting for the perfect radio set. That will never come to pass. Perfection is never reached in any mechanical line of endeavor, but fundamentally radio has already gone as far as the automobile went in twenty years.

There is one side of the radio industry, however, that has been more or less neglected. In the rapid strides which have taken place most of the energy has been devoted to electrical development and mechanical development has been practically ignored. Whatever improvement in radio is to come in the future will not be in the electrical but largely in the mechanical field. Little or no mechanical ingenuity has been displayed in radio so far.

Many of these mechanical refinements, as well as some of the electrical developments have come from amateurs, rather than from professional inventors. The engineers of the various companies producing radio apparatus are always working on improvements, but nevertheless the amateurs very frequently meet success and many of the large radio manufacturing concerns have seen the possibilities of amateurs' work.

In order to further this amateur interest, the Zenith Radio Corporation is willing not only to make arrangements suitable in each case of a deserving development, but also is offering a prize of \$1,000 in gold to the amateur inventor, submitting to its research department the best development or invention during 1925. Stimulation of private effort and the

providing of proper incentives for the focusing of thought on the radio industry should do much to hasten the process of mechanical refinement.

"Standardize," Is Plea of Thermiodyne Head

"We have reached a point in the development of the radio industry when manufacturers, jobbers and retailers must standardize. It is a wonder to me, considering the rapidity with which our industry has grown and the magnitude to which it has grown, that conditions are not more chaotic than they are."

In these words, Leo Potter, president of the Thermiodyne Radio Corporation summed up the present status of the industry as he sees it.

"Bring Order Out of Chaos"

"Standardization will solidify the industry. It will bring order out of chaos. It will decrease our manufacturing and selling costs and let us give consumers better sets for the same money or just as good for less. It will cause a more rapid advancement in radio science just as it has in automotive science. The automobile manufacturers have standardized bearings, bolts, nuts, pistons, axles, shafts, and what not. Their engineers are no longer cluttered up with the obvious. They are centered upon advancement. That is what we have got to bring to our industry—standardization."

Says Radio Progress Will Continue for Many Years

Standardization of radio products will not occur for many years, according to Dr. Alfred N. Goldsmith, of the Radio Corporation of America, in an address delivered before the recent Pan-American Conference on Standardization held at Lima, Peru.

"From time to time in the past, attempts have been made to standardize radio equipment or methods.

It must be admitted that it is confusing to work in a field where, almost from day to day, there are changes in the types of apparatus and the modes of use of equipment. Yet the attempts to standardize radio equipment up to the present have been uniformly unsuccessful.

"Radio circuits, apparatus construction, vacuum tubes, and acoustic reproducing mechanisms, such as loud speakers, are all evolving rapidly, and it will be years before a number of staple forms of radio equipment have been produced and tested to such a degree that standardization will be acceptable and helpful. The radio art is fortunate in having so many potential lines of development, which will compensate for its comparative lack of orderly arrangement at this time."

Radio vs. the Theater

(Continued from Page 161)

of antagonizing, the broadcasting stations.

"The best illustration of the way the two entertainment mediums can be of mutual benefit is best illustrated by the recent operatic concerts by artists under contract to a talking machine company. I think it most unreasonable to assume that radio is an enemy of the theater. It is going to be my policy to co-operate with radio to the fullest possible extent, and the rest rooms of all my theaters are equipped with receiving sets for the enjoyment of the patrons during intermissions."

Florenz Ziegfeld, of the famous "Follies," dismisses the controversy with an enigmatic, "I refuse to get worried," but, nevertheless, took Mr. Alley's hint and reduced the admission prices of two of his current productions.

Meanwhile, the Victor Talking Machine Company, the cause of all the hubbub, reports 60,000 letters from fans praising the McCormack-Bori concert, reports also a tremendous increase in the sale of records by these artists and continues planning more radio concerts by its coterie of operatic stars.

Tube Prices Reduced

Effective immediately, announcement was made February 2 by the Radio Corporation of America and the Cunningham Company, Inc., that the prices on all radio vacuum tubes made by these two concerns are reduced from \$4 to \$3 each.

The Music Master Corporation, Philadelphia, Pa., has placed an order with the Thermiodyne Radio Corporation, Plattsburgh, New York, for 63,000 Thermiodyne receivers. Deliveries are to begin at once and be completed this year.

The Adams-Morgan Company, Inc., maker of Paragon receiving sets has appointed the Music Master Corporation of 128-130 N. Tenth Street, Philadelphia, as distributor. The territory served by the Philadelphia office includes Pennsylvania, New Jersey, Delaware, Maryland, Virginia, and the District of Columbia.

The Independent Radio Manufacturers, Inc., and the Hazeltine Corporation have settled their legal differences with the Freed-Eisemann Radio Corporation, of Brooklyn, N. Y., out of court. The litigation concerned the contractual relationship of the first two companies with the Freed-Eisemann company.

The Scientific Electric and Manufacturing Company, Cincinnati, Ohio, has installed a broadcasting station of the Class "A" type. The power will be 200 watts and the wave length 222 meters. It is planned to re-broadcast distant-station reception three nights a week for the benefit of local fans.

The Pacent Electric Company, New York City, recently brought actions against seven radio manufacturers and two radio dealers in the New York Federal Courts, for alleged infringement of the radio plug patents owned by the Pacent concern. The plaintiff seeks a permanent injunction restraining the defendants from further alleged infringement and also asks that triple damages be assessed in accordance with the provisions of the patent law.

J. F. Quinn, formerly associated with Sears, Roebuck and Company, has joined the Mohawk Electric Corporation, Chicago, Ill., as advertising manager. Mr. Quinn, whose experience in the advertising and merchandising branches extends over a period of many years, will take an active part in the national advertising campaign which Mohawk is launching to introduce its new one-dial five tube receiving set.

Max L. Haas, president of the Haas Electric Company, jobbers, of Cleveland, Ohio, successfully passed the Bar Examinations and was admitted January 10 by the chief justice of the Ohio Supreme Court. Although his wholesale radio business required all his attention during the day, Mr. Haas found time to study law after hours and is now entitled to become a practicing lawyer.

The Winner Radio Corporation, Hendrie and Bolthoff, and the Brunswick-Balke-Collender Company sponsored a radio exposition at the Winter Garden, Denver, Colo., during the week of January 19-24.

The Eagle Radio Company, Newark, N. J., has appointed Thomas Kennedy, Jr., of New York City, assistant sales manager to Albert B. Ayers.

RADIO RETAILING, February, 1925

Latest Financial Developments in Radio Stocks Show Sharp Upward Trend

Interest of Investors and Speculators in Radio Shares Believed
Due to Expected Great Expansion of Industry. Report That
Automobile Company May Manufacture Radio
Sets Stirs Wall Street

WALL STREET, and particularly the Curb Market, has gone almost insane over "the radios," as they are called. New issues coming out every day or so have created an era of wild speculation in any kind of stock connected with the radio industry.

Without doubt the entry of the Victor and Brunswick phonograph people into the broadcasting field has done much to increase prices in stocks, and the Radio Corporation's successful transmission of pictures across the Atlantic created a furore of buying and selling for several days afterward.

Brokers generally seem to feel that radio will reach the rating of a billion dollar industry at no distant date and the latest available statistical information is as follows:

1920	\$2,000,000
1921	5,000,000

1922	60,000,000
1923	120,000,000
1924 (estimated)	350,000,000

This represents an increase of 17,000 per cent and those who are "in the know" are under the impression that radio has only started. There are approximately three million tube sets outstanding as against fifteen million automobiles and ten million phonographs. These figures easily show the potential possibilities of the radio industry and form a basis for the prophesy of a billion dollar annual gross.

At present there are some twenty-eight active radio stocks listed on the New York Stock Exchange or the Curb Market. Nearly every one of these stocks has gone considerably above its original offering price and in some cases the fluctuation has been rather wild. Certain speculators who have gone into "the radios"

Prices of Stocks Closely Related to the Radio Industry

Stock	Div.	Authorized Cap. Stock	1924		Current Market	
			High	Low	Bid	Asked
A. T. & T.	2½Q	900,000,000	134½	121½	134	134½
Apco, A pfd.	2Q	1,250,000			23½	25½
Apco, com.		*65,000				
De Forest		*250,000	28½	5	27	27½
Dubilier		*160,000	68	10½	67	68
Duplex		*62,500	12½	11	15½	16
Federal Tel. Co.		*3,500,000	7½	3	1	3
Freed-Eisemann		*300,000	33½	27½	29½	30½
Chas. Freshman		*225,000			24	25
Gen. Elect.	1Q	185,000,000	322	193½	307	308
Gen. Elect., special	15c-Q	35,000,000	11½	10½	11	11½
Grimes		*300,000			18½	19
Hazeltine		*200,000	48½	13	42	43
Inter-Ocean		*100,000	16½	8½	13	14
Jones Radio		*250,000	10½	7	8	8½
Liberty Radio		*150,000	8	5½	8½	8½
Magnavox		750,000	4	1½	3	5
Marconi of Amer.	5c-Q	10,000,000	15	6	15	20
Marconi of Canada		7,500,000		1	1	2
Marconi of Eng.	15%	18,000,000	12	7	8½	11
Marconi of Eng., pfd.	10%	1,250,000	12	7	8	11
Marconi of Spain		1,750,000	2	1	1	2
Marconi Int. Marine	5Q	7,500,000	8	5	6	8
Radio Corp., com.		*7,500,000	13½	3½	12	15
Radio Corp., pfd.		25,000,000	5	3½	4½	5
Radio Corp., A Com.		*1,500,000	66½	25½	69½	69½
Radio Corp., A pfd.	87½c-Q	25,000,000	50	45½	50	50½
Rova		*150,000	18	9½	12	12½
Sleeper		*110,000	17	15	17½	18
Thermiodyne		*300,000	19½	12	21	22
Thompson Radio		*140,000	21	7	19	20
Ware Radio		*60,000	39½	13½	37	38
Western Elec., pfd.	1½Q	50,000,000	117	111½	113	115½
Westinghouse	1Q	121,000,000	71½	55½	77	77½

*—shares. All others represented in dollars.

Pittsburgh Jobber Moves to New Location

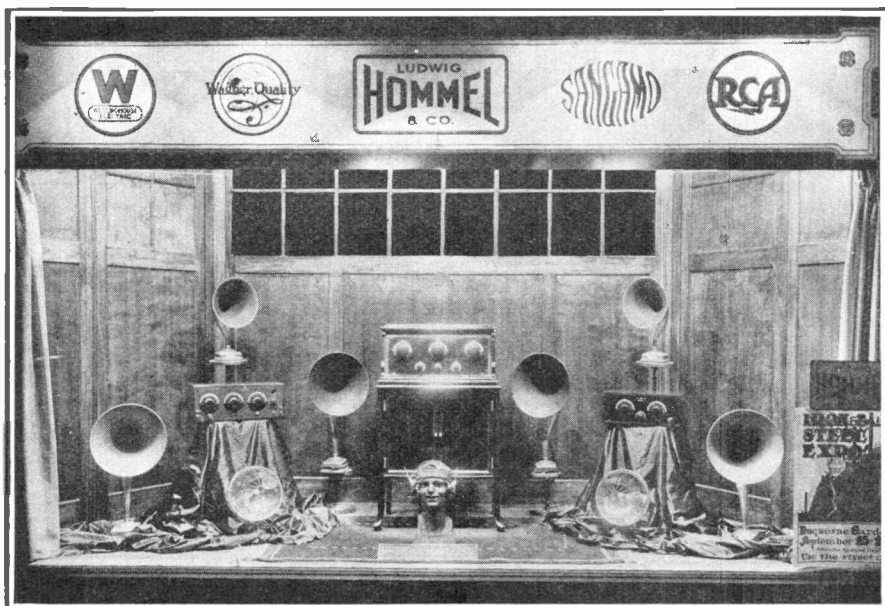

Ludwig Hommel and Company, jobbers of Pittsburgh, Pa., have occupied new quarters in the building at 929 Penn Avenue. Owing to the increased business of this company, larger floor space was required.

The Hommel Company does a wholesale job exclusively, a feature of their policy being to refer any retail customers who

may enter their place of business, to their retail dealers.

The excellent window displays the company makes also attract many retail customers, whom they refuse to sell, feeling that that trade rightfully belongs to their dealers. For the same reason, no newspaper advertising is done.

have come out many thousands of dollars ahead, owing to the wide popular interest in this branch of American industry.

New listings are constantly being offered and examination shows that the following have either just been offered or are about to join the other active radio stocks:

Garod Radio Corporation; manufacturers of neudrodyne receiving sets and several small parts including a glass tube socket.

Apco; chiefly famous for its battery chargers.

National Airphone Corporation; makers of a line of "furniture" sets.

E. R. Smith, president of the Stewart-Warner Corporation is credited with the statement that the company plans immediately to enter the radio field by manufacturing and marketing radio sets of a high order. This company has long held a prominent place in the automobile industry and its entry into the radio field is another evidence of the high place which radio is taking in the nation's business.

The Radio Corporation of America still continues to grow at a tremendous rate and the sales for December and November are estimated at \$22,000,000, which, of course, again establishes a new record for radio. It is announced that the gross sales for the year just past reached

\$54,848,131, as compared with \$26,394,789 in 1923. The net income for 1924 was \$9,503,442, the balance transferred to surplus being \$3,356,651. Since 1921, the growth in sales of this company is estimated at twelve hundred per cent.

Sleeper and Thompson Up

Announcement by the Sleeper Radio Corporation that Lucien Barnes, formerly of the Westinghouse International Company, had been engaged as manager of the export department has assisted considerably in raising the value of the stock of this corporation. Announcement was also made that an extensive advertising campaign had been launched.

Latest information in regard to the Thompson Radio Corporation shows that this concern is making tremendous strides. The sales for December were \$415,655, as against \$203,403 for November, which represents a gain of about 100 per cent. It is generally conceded by brokers that the stock is rather undervalued at its present price.

Music Master Corporation, a new listing on the Curb Market, has an authorized capital of 500,000 shares of no par value of which 450,000 shares will be outstanding. One hundred and fifty thousand shares are being offered at \$20. This company is credited with sales aggregat-

ing \$3,687,947 during 1924. It is generally understood that Music Master and Thermiodyne are closely allied. It is also understood that Percy Rockefeller and other big New York interests have just gone into Music Master.

The Charles Freshman Company, Inc., makers of a popular priced five-tube set, as well as numerous accessories used in radio receivers, has just declared a quarterly dividend of fifty cents a share and an extra dividend of twelve and a half cents a share on the common capital stock. This dividend will be paid to shareholders February 25 and will go to those who are on record at the close of business February 5.

This company has had a remarkable expansion in the radio field, having started with an extremely small capital a few years ago. It is now reported by an officer of the company that their monthly turnover is close to \$1,000,000, with a weekly output of approximately 5,000 sets. The firm has recently purchased a twelve-story loft building on West 40th Street, New York City, where manufacturing and executive forces will be housed.

Powel Crosley, Jr., head of The Crosley Radio Corporation, Cincinnati, Ohio, has gone to Barlow, Mississippi, where he will enjoy his mid-winter vacation in shooting. Yes, he took a Crosley set along too.

The De Forest Radio Company, Jersey City, N. J., announces that Clifford Bucknam, partner in Pynchon & Company, and P. Chauncey Anderson of the law firm of Pendleton, Anderson, Iselein & Riggs, both of New York City, have been added to the De Forest board of directors.

The Revere Electric Company, 439 Plymouth Court, Chicago, is adding a complete line of radio to its regular jobbing stock. A twenty-four page catalog is being distributed to dealers.

The Colonial Radio Corporation, of Long Island City, N. Y., has appointed the following wholesale houses as distributors: Kelly-Howe-Thompson Company, Duluth, Minn.; Dealers' Equipment Company, Chicago, Ill.; and Walters Rubber Company, Mineola, New York.

James N. B. Hill and E. B. McCaffrey have recently been appointed assistant sales managers of the Colonial Radio Corporation.

The United States Radio-Kraft Corporation, of New York City, was one of the pioneer organizations formed for the purpose of financing dealers with their time payment set sales. With the co-operation of a group of bankers, this company makes it possible for the dealer who cannot finance the deferred payment plan, to sell his sets on that basis.

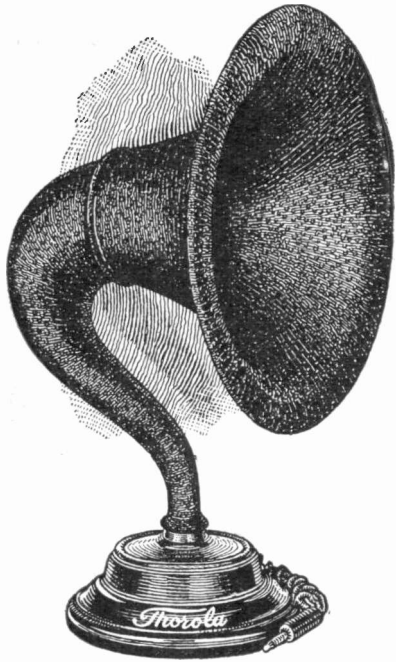

Under the remarkable 10-day Refund Warranty, THOROLA must fulfill every claim—must improve power, range, TONE QUALITY.

THOROLA 4 \$25
 THOROLA 9 (Cabinet) 40
 THOROLA 6
 (Phonograph Attachment) 15

Thorola models require no battery—Simply plug in same as headphones
 THOROPHONE
 (Power Type Speaker) \$45



I had no idea such a speaker could be built

and after putting it through every test, have given up all hope of making it distort or rattle. Have never heard anything that will compete with Thorola for volume, clearness, and tone quality, and gladly commend this unit to all lovers of radio who desire the best there is. (Signed) F. P. Wallou, Station WABM

Radio directors, great musical artists, acoustic specialists, are unanimous on Thorola. Today, with any radio set, Thorola Loud Speaker signifies that the best possible radio is being heard.

Thorola won the cultured ear to radio with betterments direct from the realm of music. The Thorola Controlled Mica Diaphragm was introduced to record sound impulses by the truest method known. The Thorola Separix for the first time sharply preserved overtones, without which there is no real music or natural speech. The Thorola horn of Thorite compound eliminated uncontrolled natural resonance. The exclusive Thorola Synchronizer balances speaker and circuit, an essential of finest radio.

All these inherent superiorities are brought to peak efficiency by the far larger size of the Thorola reproducer, permitting precision construction.

Incomparable in design and construction, Thorola is incomparable in tonal purity and extreme volume. Thorola will make your store headquarters for the most advanced radio entertainment.

REICHMANN COMPANY, 1725-39 W. 74th St., CHICAGO

Thorola

THE SPEAKING LIKENESS

Paragon offers perpetual temptation to old as well as young.



\$27⁵⁰, \$48⁵⁰, \$65

Perfect Popular Price Range

PARAGON prepares you to meet every radio need of the hour. Just as in the past it has always enabled radio dealers to offer the utmost in radio quality, so today it enables them to offer this perfect Paragon quality with the now demanded popular prices.

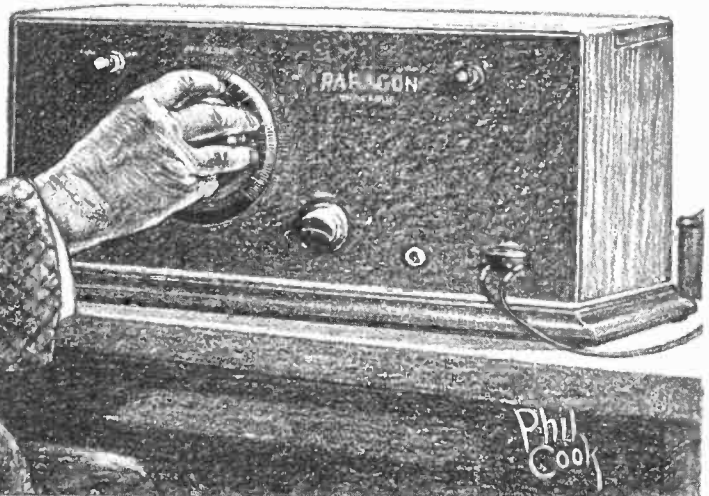

PARAGON RADIO RECEIVERS



Look for the Red Triangle on the Knob

THE NEW PARAGON RECEIVERS are up to the minute. Each of the three new models gives volume, selectivity and a wonderful simplification of tuning. The four-tube set—the Paragon Four—introduces a new non-radiating hook-up, the Paradyne Circuit.

The thousands of these sets put into homes around the holidays are becoming salesmen in turn, creating the biggest sort of demand for the new Paragon line. If you are not already carrying it, write us so that we may have the Paragon Distributor in your territory serve you.

ADAMS MORGAN COMPANY, 14 Alvin Ave., Upper Montclair, N. J.

New Paragon Four

This four-tube set makes a showing that would do credit to a set requiring more tubes and greater battery power. Clear, strong loudspeaker reception over practically unlimited range. New Paradyne Circuit, non-radiating. Simplified tuning—one dial. Mahogany cabinet, 21 inches long.

\$65

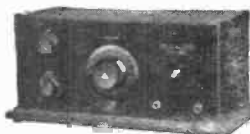

New Paragon Three

This three-tube receiver surprises everyone. Strong loudspeaker reception over remarkable distances. Single tuning dial. Mahogany cabinet, 17 inches long.

\$48⁵⁰

New Paragon Two

Gives great results on the loudspeaker on all stations within moderate range. Phone range almost unlimited. Two tubes. Single tuning dial. Mahogany cabinet, 11 inches long.



\$27⁵⁰

N.B. Prices West of the Rocky Mountains, 10% Additional



The new rugged, good-looking Exide 6-volt "A" battery with one-piece case.

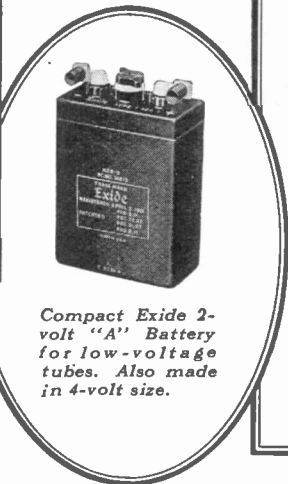

Compact Exide 2-volt "A" Battery for low-voltage tubes. Also made in 4-volt size.



Exide 24-volt "B" Battery in glass jars, 6000 milli-ampere hour capacity. Also made in 48-volt size.

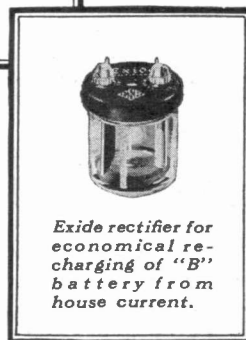

Exide rectifier for economical recharging of "B" battery from house current.

It is no accident— this preference for Exide

These batteries are built especially for radio—behind them is 37 years' experience in storage battery manufacture

THE battery can make or mar radio reception. That is why the far-sighted radio merchant selects his battery stock with care, why the wise fan insists on having batteries he knows and trusts.

That is why dealers and users everywhere are turning to Exide Batteries, made by the world's largest manufacturers of storage batteries.

Long before the days of radio, Exide Batteries were used for every kind of storage battery job. An Exide battery today is the result of 37 years of painstaking development.

For years, vigorous national advertising has been telling millions about Exide Batteries. This year, Exide advertisements in great national magazines and radio publications are showing people why the Exide is the best buy on the battery market.

It pays the radio dealer in cash and reputation to stock and display this complete line of capable, good-looking, fast-selling Exide Batteries.

THE ELECTRIC STORAGE BATTERY COMPANY
PHILADELPHIA
In Canada, Exide Batteries of Canada, Limited
153 Dufferin Street, Toronto

Exide

RADIO BATTERIES

FOR BETTER RADIO RECEPTION USE STORAGE BATTERIES

Red Seal dry batteries for Radio

*The February
Reason why
merchants
handling*

**RED SEAL
BATTERIES**

*make
money!*



*put the "Pep"
in your set*

RED SEAL DISPLAY

*material is selling
Red Seal Batteries!
Quick turnover; small
investment in stock
— hence clear profits.*

A large percentage of our advertising dollars for 1925 is being spent for store advertising material for your use in your windows. The program is a complete Display Service consisting of window displays, counter displays, folders, etc., mailed on a regular monthly schedule. Never before has any Battery manufacturer offered his dealers such a complete and useful Service!

This is the second display piece in the Red Seal Plan for 1925. Every piece is chock-full of interest and attention-getting value. To get this free display material sell Red Seal Dry Batteries—to sell Red Seal Dry Batteries use the display material! Tell your jobber's salesman to put you on the list for the big Red Seal Display Service.

MANHATTAN
ELECTRICAL SUPPLY CO., INC.
NEW YORK CHICAGO ST. LOUIS SAN FRANCISCO

MAKERS OF RED SEAL DRY BATTERIES; MANHATTAN AND RED SEAL RADIO PRODUCTS

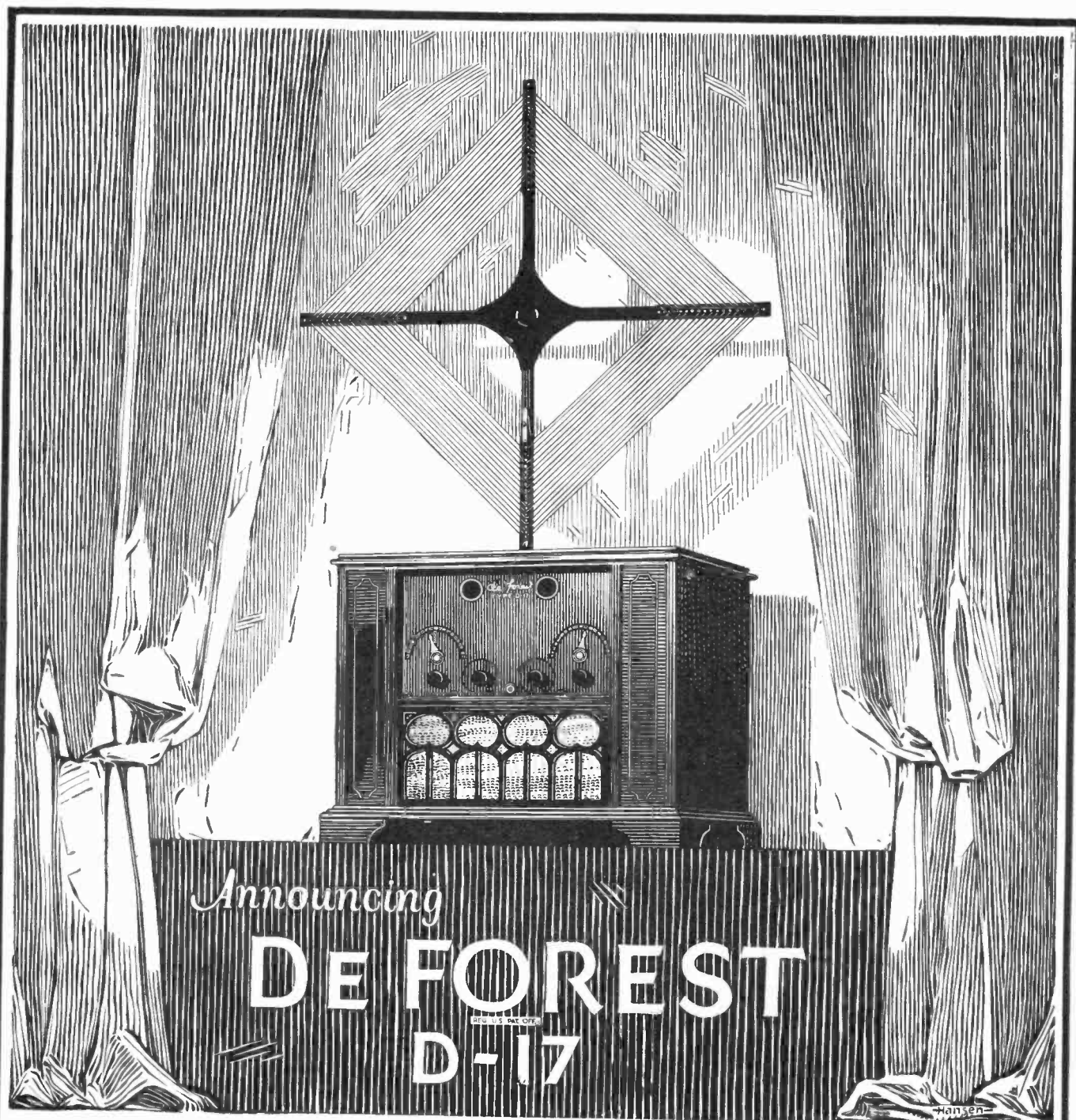

The latest in radio

De Forest leads the field in 1925 with its new D-17. This new instrument has the great features that have made De Forest Radiophones famous alike with experts and the unskilled — plus refinements that simplify its operation, give increased selectivity, sensitivity and distance range.

Note these points:

1. A clear, natural tone common only to De Forest instruments—a tone so rich and pure that the living performer seems to be present.
2. No aerial—no ground wire.
3. Simplicity of operation—detector tube in place of crystal gives immediate results, eliminates all detector adjustments.
4. Disturbing squeals have been eliminated.
5. Both the D-17 and the D-17A can easily be moved from room to room on a tea wagon or carried by hand.
6. A handsome instrument that is a handsome piece of furniture.
7. Lee De Forest, the greatest name in radio, made present-day radio possible.

The D-17 comes in two sizes—one with built-in loud speaker, tubes, loop and space within for A and B batteries; the other, the D-17A (a little smaller) without tubes or loud speaker, but with space for B batteries. Prices from \$125.00 to \$200.00, depending on type and style of cabinet finish. Write us direct for further information and the name of the nearest De Forest distributor.

DE FOREST RADIO COMPANY, Jersey City, N. J.

For Permanence in Radio



You can select a NEUTRODYNE without fear of its becoming obsolete

THE Neutrodyne radio receiver you choose today will still be delivering superlative service years and years from now! The Neutrodyne principle has been tested in the crucible of radio experience. It has been proved beyond question to be scientifically correct. This is your greatest assurance of permanence

Neutrodynes are so highly *Selective* that you can set your dials at predetermined numbers and bring in exactly the station you want to hear, provided that station is on the air. And that same station will always come in at that identical setting. Also you may depend upon this—*with a Neutrodyne*—you can tune out anything that interferes

Neutrodyne for realism

The Neutrodyne is superior in *Tonal Quality*. The skirling notes of the piccolo and the muted brass of the trombone are reproduced with a fidelity that is almost uncanny. Piano is "piano"—not "tin-panno"—on a Neutrodyne. The human voice is that of the living, breathing speaker—as though he stood there in the room beside you. It is difficult to conceive of improvement upon such realism.

The Neutrodyne excels in *Distance*. Be sure of this: if you can't get it on your Neutrodyne, *nobody* can! Neutrodyne picks the air clean. Nothing within range of your aerial (whether outside antenna or indoor) can escape your Neutrodyne. With a Neutrodyne, all the air is a great telephone switchboard. You decide what you want to get—set your dials—and there it is!

Neutrodyne for reliability

Perhaps the greatest virtue of Neutrodyne is its absolute dependability. You may invite guests

If it hasn't this label,
it isn't a Neutrodyne.
It is there for your
protection.



for a "radio evening" without wondering if your Neutrodyne will "perform." Neutrodyne is the set of no apologies; the set of no alibis. With a published program and your Neutrodyne, you can get exactly what you want to hear—and get it *better!*

Have you, perhaps, identified radio with squeals and howls? Be assured, these cat-calls were never created by a Neutrodyne. For a Neutrodyne cannot create squeals. Technically speaking, it cannot "heterodyne." Therefore, the Neutrodyne disturbs neither you nor your neighbors. You hear only what you wish to hear.

Neutrodyne followed broadcasting. Neutrodyne was invented in 1922, after modern broadcasting was established. The three other major receiving systems were invented *previous* to broadcasting. They were made first for dot-and-dash code (radio telegraphy) and adapted later to broadcasting. Neutrodyne was specifically designed to receive the broadcasting of music and speeches. It did not have to be "adapted."

In order to protect the public from fraudulent Neutrodynes, the Hazeltine Corporation was formed, and Professor Hazeltine entrusted his great idea to just fourteen hand-picked, licensed manufacturers. These fourteen radio builders are grouped into one association, known as the Independent Radio Manufacturers, Incorporated. No other manufacturers may use the genuine Neutrodyne principle! Look for the Neutrodyne label on the set you buy.

Hazeltine Corporation (Sole Owner of Neutrodyne Patents and Trade-marks). Independent Radio Manufacturers, Incorporated (Exclusive Licensee of Hazeltine Corporation).

NEUTRODYNE Perfected Radio

Answering the big question in people's minds



"WILL the set I buy today be out of date next month—or even next year?" That is the question that is making many people hold off from buying a radio set. They are waiting for "the ultimate"—waiting for the set that will not become obsolete.

The advertisement reproduced herewith, greatly reduced, answers that question definitely. This advertisement occupies the dominating space of four columns by seventeen inches in the leading newspapers of the great radio centers throughout the United States. It also appears in full-page space in *The Saturday Evening Post*. This means a combined reading audience of twenty-eight million people.

This is just the second advertisement in a gigantic advertising campaign which is broadcasting the truth about Neutrodyne to the great American public. See that you, too, are informed on the many superiorities of this receiving system.

HAZELTINE CORPORATION (Sole Owner of Neutrodyne Patents and Trade-marks). INDEPENDENT RADIO MANUFACTURERS, Incorporated (Exclusive Licensee of Hazeltine Corporation).

Comprising the following firms
American Radio & Research Corp.
F. A. D. Andrea, Inc.
Carloyd Electric & Radio Co.
Eagle Radio Company
Freed-Eisemann Radio Corporation
Garod Corporation
Gilfillan Radio Corporation
Howard Manufacturing Company, Inc.
King-Hinners Radio Co.
Wm. J. Murdock Co.
Stromberg-Carlson Telephone Mfg. Co.
R. E. Thompson Mfg. Company
Ware Radio Corporation
The WorkRite Mfg. Company

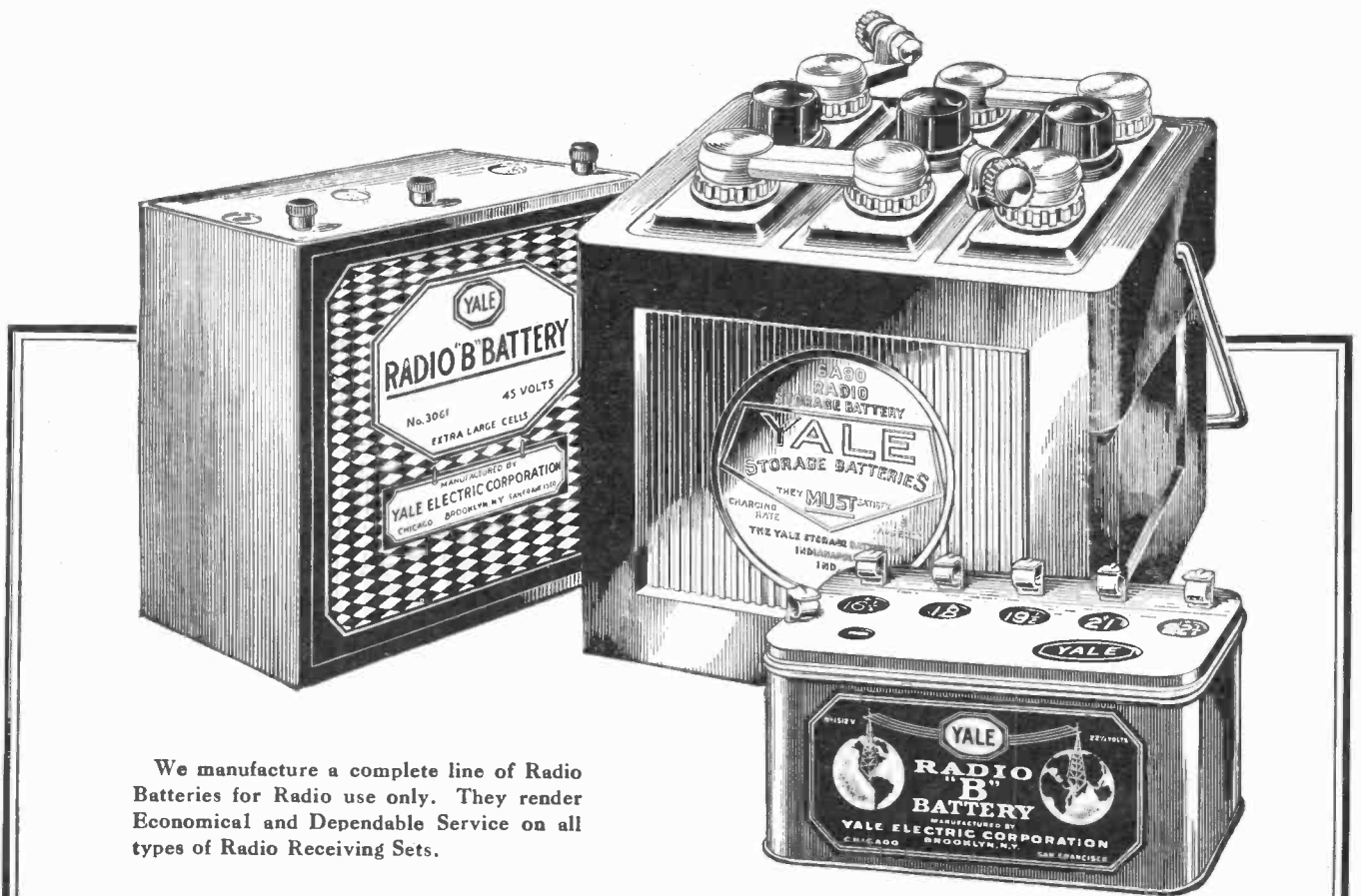

We manufacture a complete line of Radio Batteries for Radio use only. They render Economical and Dependable Service on all types of Radio Receiving Sets.

INVESTIGATE
This Unusual Merchandising Plan
on the sale of
YALE RADIO BATTERIES

YOU will be interested in this plan which will make it possible for you to increase your volume and profit on the sale of Yale Radio Batteries — famous for their Quality.

Communicate with us immediately so that you can benefit on February Battery Sales. This is the peak month for the year.

YALE ELECTRIC CORPORATION

CHICAGO

BROOKLYN, N. Y.

SAN FRANCISCO

Electric light current *which never wears out* replaces B Batteries

The B-Liminator makes electric light circuit suitable for all B Battery use—costs less than a fifth of a cent per hour to operate. It delivers smooth, uniform B current for both detector and amplifier tubes. Voltages can be regulated on all tubes to the fractional part of a volt. This helps to get the very best out of the set.

The newly developed special rectifying tube gives an unlimited number of hours of service in the B-Liminator. Good as B-Liminators were before, this new tube makes them even better.

B-Liminators can be used on any alternating current, 110 volt, 60 cycle electric light circuit—Patented May 15th, 1923.

B-Liminators are being advertised in *Saturday Evening Post*, radio publications and newspapers in principal radio centers. Tie up with this advertising—display B-Liminators and tell your customers about them—thousands are in daily and nightly use on all types of sets. B-Liminators have been endorsed by leading radio authorities.

We'll be glad to send details of our full dealer plan of cooperation—also to supply display material and literature on the B-Liminator.



Timmons B-Liminator. Price \$35 with Timmons Special Rectifying Tube. (Patented May 15, 1923).

TIMMONS RADIO PRODUCTS CORPORATION

GERMANTOWN, PHILADELPHIA



TIMMONS *B-Liminator*

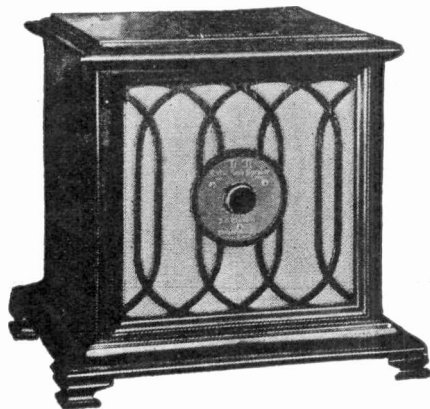

Timmons Talker. Adjustable Type A. List \$35.

Timmons Talker. Non-adjustable Type N. List \$18.

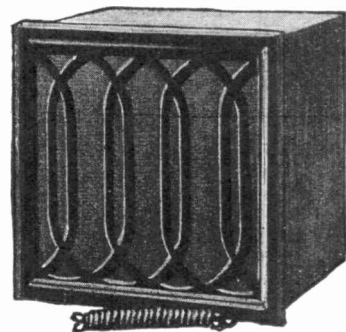

Timmons Talkers

TIMMONS *Radio Products*

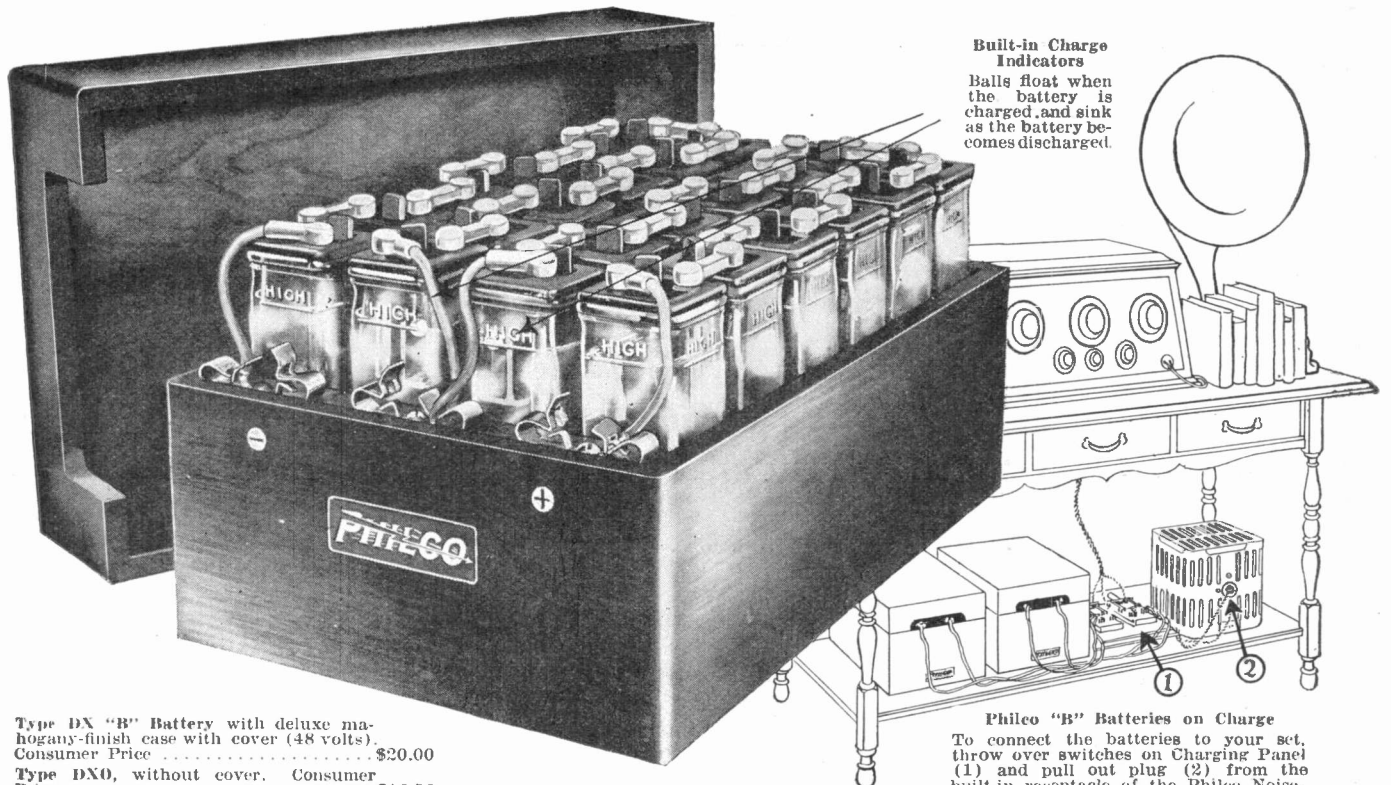

Built-in Charge Indicators
Balls float when the battery is charged, and sink as the battery becomes discharged.

Type DX "B" Battery with deluxe mahogany-finish case with cover (48 volts). Consumer Price \$20.00
 Type DX0, without cover. Consumer Price \$16.50
 "B" Charging Panel, factory wired and ready for use. Consumer Price \$2.75
 Philco Single Charger for all "B" batteries and UD44 "A" batteries. Noiseless. Consumer Price \$9.75
 Philco Double Charger for all "B" batteries and UD86 "A" batteries. Noiseless. Consumer Price \$15.00
 Charger prices include plugs and receptacles.

Philco "B" Batteries on Charge
To connect the batteries to your set, throw over switches on Charging Panel (1) and pull out plug (2) from the built-in receptacle of the Philco Noiseless Charger.

Why radio owners demand Philco Rechargeable Batteries

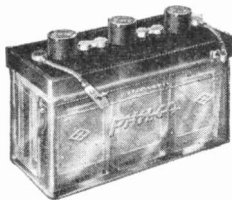

Philco Pressed-Glass Case "A" Batteries

Spray-proof. Stay dry and clean always. Built-in Charge Indicators.
 Type UD86 for storage battery tubes—Consumer Price, \$16.00.
 Type UD14 "a dry cell replacement" enabling you to get better results out of dry cell tubes. Occupies less space than three dry cells and may be installed permanently in the radio cabinet. Consumer Price, \$8.00

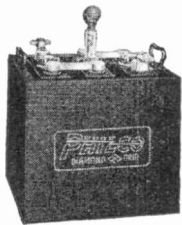

Philco Mahoganyized-Case "A" Batteries

Types—RAR and RW—for 6-volt tubes. Both in beautiful Adam-brown mahogany-finish cases harmonizing with your radio cabinet. Consumer price \$14.50 up.
 Philco Charge Tester—permanently mounted in filler cap, avoids fussing with hydrometer, \$1 extra.

Philco Radio-Batteries—both "A" and "B"—have big exclusive advantages that make storage battery operation not only easy and convenient but far more economical than dry cells.

Clean, Dry and Beautiful. They are assembled in tightly sealed pressed-glass cases—or in wood cases finished in Adam-brown mahogany.

Easily Recharged. With the Philco NOISELESS Charger and built-in receptacles and sockets, you recharge in the living room without changing a wire.

Strong, Hum-free Current. This means clear and distant radio reception, without roar or buzz.

Charge Indicators. These tell at a glance how far a Philco Battery is charged or discharged.

These exclusive advantages—plus Philco national advertising—have created a big consumer demand for Philco Batteries in all parts of the United States.

Philco Batteries are fast-movers—money makers. They are shipped to you CHARGED but absolutely DRY. No charging equipment is needed. Any dealer can handle them just as easily as radio tubes or Victrola Records.

You can buy Philco Radio Batteries from your Jobber or Wholesaler at standard discounts. Order now—or fill out the coupon below and mail to us.

PHILADELPHIA STORAGE BATTERY COMPANY, Philadelphia

PHILCO

DRYDYNAMIC RADIO BATTERIES

Jobbers and Dealers—Philco has brought radio batteries out of the cellar and put them in the living room. Our new Radio Manual tells how. Fill out coupon below and we will mail you a copy.

Name

Street City

State Jobber Dealer

"Electrical Retailing" becomes

Radio Retailing

the McGraw-Hill

Business Magazine of the Radio Industry

Reaching
the retailers
and jobbers
of radio

Enlarged to
standard 9x12 size.
Subscription price
\$2 per year.

FOR the past eighteen months the McGraw-Hill Company has been publishing *Electrical Retailing*—a pocket-size magazine for non-electrical stores carrying electrical appliances and radio equipment. Its readers have been the proprietors of radio shops, hardware stores, music stores, sporting-goods stores, auto-accessory stores and others who stock electrical and radio goods in addition to their regular lines.

But with the rapid growth of radio as a utility

needed in every home, the interest of these "Electrical Retailing" readers in radio above any other electrical line, quickly became apparent. Radio, it developed, is the subject uppermost in these dealers' minds, as it is in the consciousness of the public, today. Responding, therefore, to the demand for more and more radio information in *Electrical Retailing*, radio selling topics had come to occupy a larger and larger place in the pages of the magazine.

"Electrical Retailing" Readers

Wanted More Complete Radio and Electrical Information

ANALYSIS of readers' needs showed, however, that those merchants who were selling radio in worthwhile volume wanted an even more complete radio service than was possible in the limited pages of the pocket-size magazine. *And on the other hand, many of the non-electrical stores having electrical-appliance departments or selling electrical goods in significant quantities, were entering subscriptions to "Electrical Merchandising," "Electrical Retailing's" big brother, in order to get more complete appliance information.*

GUIDED by this marked trend in readers' needs, and by the expressed desire of competent merchandisers for a complete, intensified publishing service in their chosen lines, the McGraw-Hill Company has felt that the largest future usefulness for *Electrical Retailing* required its being reshaped further along the lines it had already naturally taken. Thus it is being made at once into a complete and exclusively-radio publication for all dealers who sell radio sets, accessories and parts.

Comprehensive Paid-Subscription Coverage

Electrical Retailing of the past thus becomes *Radio Retailing*, a standard-size 9x12-inch magazine, with a subscription price of \$2 per year. Already, by characteristically-thorough McGraw-Hill methods, its lists of subscribers are being developed to cover all retail and wholesale outlets for radio, with the purpose of securing complete coverage of the radio-distribution field on a paid-subscription basis.

Meanwhile "Electrical Merchandising" will more effectively serve important de-

partment stores, chain stores, and others selling electrical goods in worthwhile quantities.

Thus through the new *Radio Retailing*, "the business magazine of the radio industry," the thousands of retail and wholesale radio outlets will be served with a complete information service on radio selling, in the same outstanding way that the electrical trade has been served with electrical-selling methods and ideas during the past eight years through *Electrical Merchandising*.

McGraw-Hill Radio Books and Radio Trade Directory

Radio Retailing becomes the third important service rendered the radio trade by the McGraw-Hill publishing organization. The other two are:

McGraw-Hill books on radio and retail selling. These include the following volumes: "How to Retail Radio," "Practical Radio," "The Retail Handbook," "Retail Advertising and Selling," "Radio

Questions and Answers," "Radio Communication," "Radio Engineering Principles," "Elements of Radio Telephony" and many others.

The McGraw-Hill Radio Trade Directory, a classified directory of the radio and allied industries. Issued quarterly, listing all known manufacturers of radio products.



McGraw-Hill Company, Inc., Tenth Avenue at 36th Street, New York

- a
Neutrodyne
 for \$ **100**!

Without
 Loud Speaker
 \$92.50

We will furnish this
 same set without
 loud speaker if you
 wish, \$92.50.

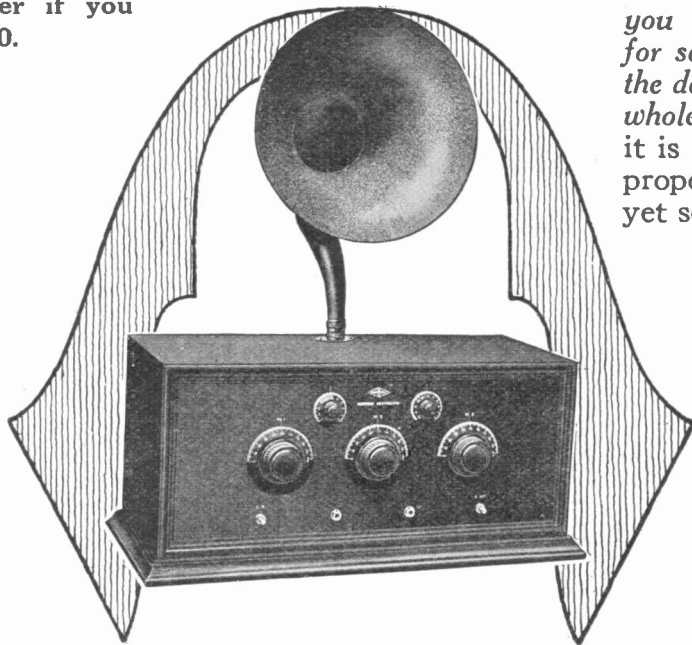

Think of it! A five tube
Murdock Neutrodyne
 with a built-in loud
 speaker.

It isn't a kit. It is a
 standard Murdock in-
 strument of such excep-
 tional quality as the
 name Murdock has stood
 for since 1904.

It has long been our idea
 to bring out such an
 instrument at a price that
 would make sales history.

Here it is!

In a fine mahogany cab-
 inet, with compartment
 for "B" batteries.

*This is a splendid propo-
 sition for dealers and one
 worth looking into before
 you place another order
 for sets. Let us mail you
 the details, and outline the
 whole plan. We believe
 it is the most interesting
 proposition the trade has
 yet seen!*

Wm. J. Murdock Co., Chelsea, Mass.



MURDOCK

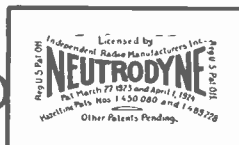



W666. 15 in. Bell

Real Power Amplification! Produces strong, natural tone without blare or chatter. Adjustable to individual set and location conditions. No extra batteries needed.

Radio Material

TRADE MARK

Complete from Aerial Insulator to Ground Clamp

THIS brings together for workable set-building a line of radio-electrically correct parts. All advantages of a standardized line for the Dealer; of interchangeable, electrically-balanced units for the customer. Each unit complements the others; each one helps to sell the others by the guaranteed excellence of its service. 35 years of electrical development-work behind each part — and behind the correct correlating of all parts into "The Complete Line." Send for catalogue 4W — *it clears the air!*

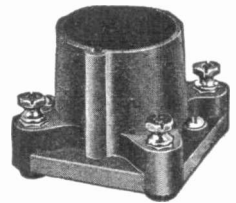

W197
Top View

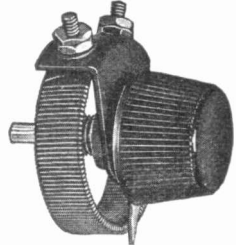

W296

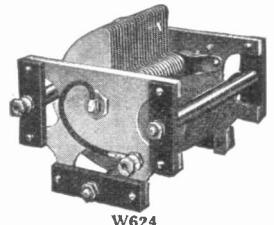

W624

RADIO DIVISION THE HART & HEGEMAN MFG. CO. HARTFORD, CONN.

The After Dinner Speaker Dial Control Rheostats (Plain and Vernier) Low Loss Condensers (Plain and Vernier)
Sockets—All Kinds Dials Variocouplers Variable Grid Leaks Head Sets Variometers Transformers Jacks Plugs

KEYSTONE ARRESTERS

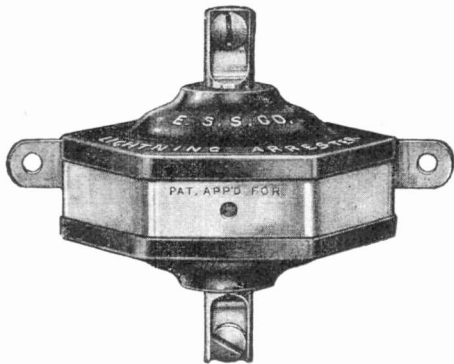

\$1.50 each

Complete with instructions

In Canada

\$2.00

Approved by
the National
Board of Fire
Underwriters.



The only Low Loss Radio Lightning Arresters

(Write for booklet on Low Loss Arresters)

It's easy to sell a lightning arrester, with every sale of antenna material. And when you can offer a Keystone Arrester, which protects without loss of signal strength, you have a most powerful sales talk.

The Keystone Arrester is a strong, sturdy, reliable, low-loss protector required to relieve the antenna system of dangerous accumulations of static or lightning which may result in serious damage. It is manufactured by a company having over 32 years' experience in the design of lightning protective apparatus.

The body of the arrester is made of genuine Bakelite, thus providing the very best insulation between antenna and ground with no loss in the strength of incoming signals. The rugged discharge electrodes are inside the body, where they are in an absolutely water, dust and damp proof enclosure. All metal parts are of brass. The binding posts are of the approved type which do not require cutting the antenna lead-in at the arrester. The lead-in is simply placed under the binding post screw and continued on to set. It is a reliable and efficient device of high quality sold at a popular price.

There's profit in this proposition. Write for full details.

ELECTRIC SERVICE SUPPLIES Co.

Manufacturers of over one and one-half million Lightning Arresters

PHILADELPHIA CHICAGO NEW YORK PITTSBURGH BOSTON SCRANTON
17th and Cambria Sts. Monadnock Bldg. 50 Church St. 829 Oliver Building 88 Broad St. 316 N. Washington Ave.

Remarkable one tube reception—in a set that offers quick profits

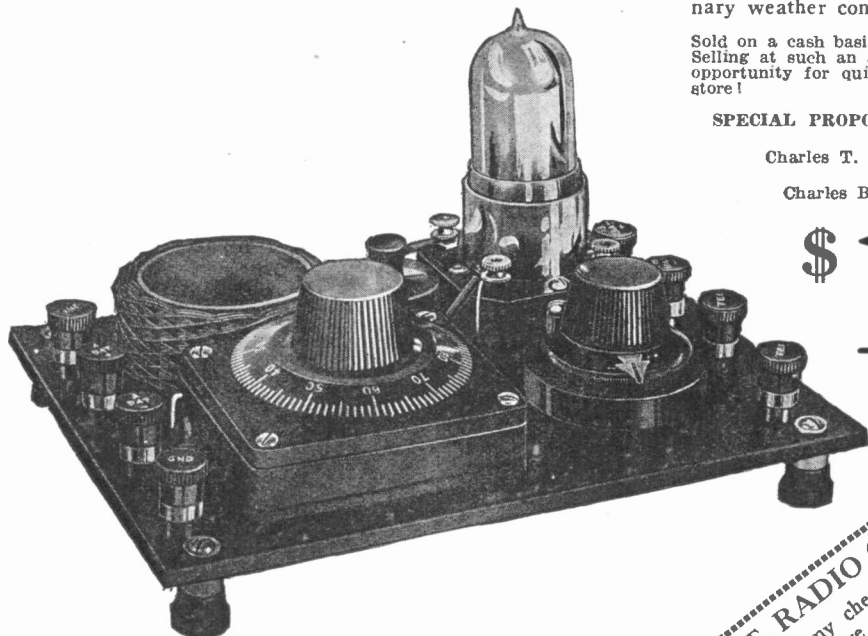

The power, clearness and selectivity of the Babydyne is extraordinary, and at this low price never before equalled! Yet there is no "mystery" about it—just a scientifically balanced hook-up using highly efficient parts and incorporating some new radio improvements.

Uses any amplifier tube. Tunes in distant stations, even 1,500-mile reception being not unusual.

Practically eliminates static.

Tested and approved by Radio Age Institute of Chicago.

WE WARRANT IT for good clear reception under ordinary weather conditions.

Sold on a cash basis with consequent large profit! 40% to dealer! Selling at such an attractive price, the Babydyne offers an unequal opportunity for quick profits. It will draw the crowds into your store!

SPECIAL PROPOSITION TO JOBBERS AND DISTRIBUTORS

Pacific Coast Distributor:
Charles T. Treusser, 933 Geary St., San Francisco
Export Manager:
Charles Bragin, 1416 Broadway, New York City

\$ 10

INTERNATIONAL
BABYDYNE
RADIO RECEIVER
TRADE MARK

LIST

A. & T. RADIO CO., Danvers, Mass.
Here is my check or money order for \$6. Send me postage prepaid one complete Babydyne with absolute guarantee that it is as you say or you will refund my money.

Name
Address

Mail this coupon and see it for yourself! Put one on your counter and watch the fans gather around it. Send for it today!

The new tube with the popular price—

You can sell it at half the usual price, and make a very attractive profit.

A standard tube—a tested and guaranteed tube—at a price that will "bring the world to your door". A strong feature article for attracting attention to your store!

TRIPLE TONE

"Tubes That Are Alive"
Sizes: 201A, 200A, 12, 199

Each tube tested separately on a laboratory radio tube testing machine.

Buying from the manufacturer, you are assured of satisfaction and service—besides the tremendous reduction in price. Write for discounts.

Radio Tube Mfg. Co.
154 Nassau Street, New York City



Tested and Guaranteed

LIST

\$ 2

EACH

Westwyre

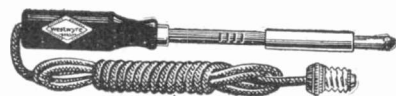

List \$2.50 Junior Model \$1.50

THE WESTWYRE COMPANY
WESTFIELD, MASS.

RADIO DEALERS Price Talks!!!

Write for our new 1925 catalogue just off the press—and get acquainted with "The Livest Jobbers in Penna" we also will be glad to send you free charts showing leading hookups.

RADIO SUPPLY CO.
17 So. 4th St., Philadelphia, Pa.

Gentlemen:
 Please send me your new catalogue of Radio Supplies.
 Please send me your free hookups.

Name
Address

SHINN AMPLITONE BRAIDED AERIAL WIRE

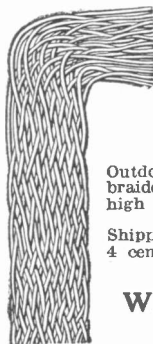

Brings in much greater distance and full radio signals, enabling the receiving set to reproduce the rich volume of voice or music.

THE IDEAL TYPE

Outdoor or Indoor Aerial—made of 17 copper wires braided flat, giving great capacity, low resistance and high tensile strength.

Shipped in packages of 50, 75 and 100 feet, price 4 cents per foot. 33 1/3% discount to dealers.

W. C. SHINN MFG. COMPANY
152 Whiting St., Chicago, Ill.

"Morse Eureka" SPRING GRIP
TRADE MARK
BINDING POSTS

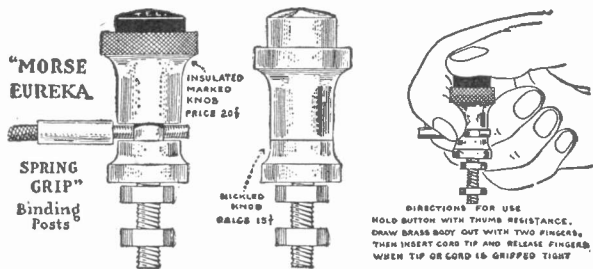

Absolutely the best Binding Posts made. MARKINGS always in Line so can easily be read. Cord Tip easily inserted, and then held in a Positive Grip. Easily released. No screwing or unscrewing, pushing or pulling.

They are made of brass, with polished nickeled or insulated knobs, 24 different markings, as follows:

MARKED BINDING POSTS

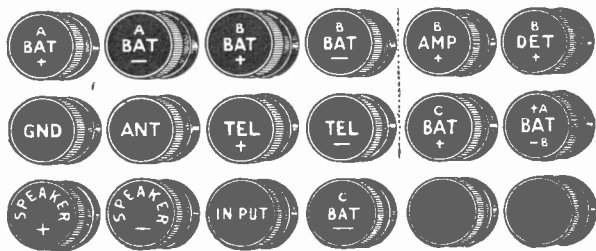

They are packed 10 to a box. 5 boxes in an attractive Display Carton.

Write for Catalogue

Manufactured by

FRANK W. MORSE CO., BOSTON, MASS.

Dealers!
GENERAL RADIO Condensers

Diag \$5.00
Ding \$3.25
Ding \$5.00

Price \$5

**They Ring the Bell
You Like to Hear!**

And when sundown finally breaks the spell of your countless daily bell-ringing journeys, the splendid totals of GENERAL RADIO CONDENSER PROFITS will gratefully sooth your tired feet.

Tie up with the box with the Red Label

Ask your jobber or write us for our new price sheet and new radio catalog.

GENERAL RADIO CO.
Cambridge, Mass.



TRU-FIX
TRADE MARK REGISTERED
RADIO PRODUCTS

**New Vernier Dials
Coming Soon**

Tru-Fix Dials are made of sheet brass .023 of an inch thick. The edge is very thin with a gradual contour to meet the panel and is finished bright nickel with 100 division scale running from left to right etched in surface in-laid with black enamel making Tru-Fix Dial easily read at all times. The Knob is of highly finished Bakelite 1 1/2 in. high with bevel edge at base. Attached to dial with flat spring device made into dial itself.

The New TRU-FIX vernier dials will be completed soon and before you dealers stock your 1925 radio parts, see our new model and get our prices. *It will pay you to wait for our line.* These can be bought at the right price in quantities. Our standard dials have always been popular with the trade *because they correct*, out of alignment, looseness of end play, overbalanced units, loss of tuning adjustments, etc.

We can supply you with our standard dials right now and have an unusual opportunity for jobbers who can buy in large quantities. Dealers ask your jobber.

TRU-FIX RADIO PRODUCTS CO.
42 Maverick Square
East Boston, Mass.

Premier

20 FOOT EXTENSION CORD \$1.75

MFD. BY CRESCENT BRAID CO. INC., PROVIDENCE, R.I.
(Actual size 14x7-in. Colors Silver and Black)

This display card on your counter together with the Premier display box will sell Premier extension cords for you.

The Premier cord comes complete with connecting plug.

The Premier cord has given complete satisfaction as demonstrated by unsolicited letters on file.

At your jobber, or ask us today

Manufactured by the
CRESCENT BRAID CO., INC.
Providence, R. I.

Makers of
Battery Cables, Telephone Cords and Spaghetti Tubing.

Sell More Antenna Wire—

Besides all the people who are buying aerial wire every day, you can sell this special antenna to hundreds who will buy it to improve their reception. Giving the greatest possible capacity and conducting surface, with less resistance, it actually increases range and volume.

There's nearly half a mile of single copper strands in every 100 feet. It makes an excellent indoor antenna too!

Made in copper, tinned copper, enameled copper. Put up in coils of 100 and 150 feet.

Ask your jobber for literature and sales-pulling prices!

Radio Antenna
RADIO ANTENNA

ROSS WIRE COMPANY
 9 Charles Street, PROVIDENCE, R. I.

Note the many strands

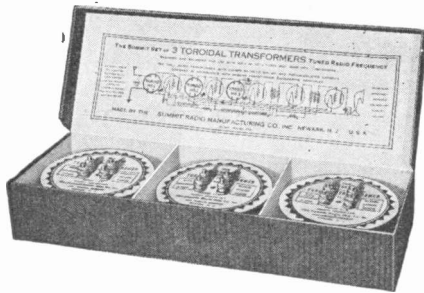
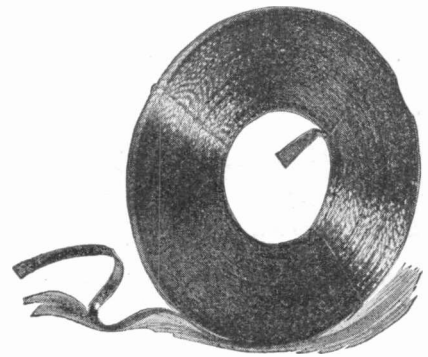
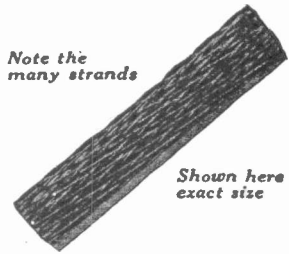

*A seven league stride
 in the refinement of radio*

Eliminates feed-back and leakage—Has no stray field

Step by step the causes of radio losses, noise and the other disturbing factors are being eliminated.

The Toroidal Transformer is the latest step in radio progress, and the only radio transformer with closed magnetic circuit and pre-calculated capacity. It was designed in accordance with modern engineering principles by an engineer who for years has concentrated in this field.

Write at once for a sample set of 3 mated Toroidal Transformers, and enjoy the clearest, finest reception ever.

Sold only in mated sets of 3, packed in a handsome display box with complete instructions and designs, for building the Summit 5 tube Receiver. List \$10.00

Attractive Discounts

The Summit Radio Manufacturing Co., Inc.
 Dept. 16

481 Broad Street, Newark, N. J.

**THE
 SUMMIT
 TUNED RADIO
 FREQUENCY
 TOROIDAL
 TRANSFORMER**

- Low Losses
- Low Distributed Capacity
- Correct Ratio
- Self Neutralized
- Self Balanced

People now like to own their own battery charger—

Here is the battery charger that has been highly successful and one that has found a very responsive market. Show it to your customers and they will at once appreciate its value—they'll soon see the satisfaction obtainable in having a beautiful, fully enclosed battery charger always handy, ready to use, and very economical.

Operates from 110 volt A.C. lamp socket. No bother to use. No bulbs—sloppy liquids or sticking contacts. Here is a really complete charger at a low price. Has WESTON ammeter.

HANDY CHARGER

Ultra Model Charges all A and B Storage Batteries

You'll sell many of these chargers and it will be to your advantage to get the details at once. The list is \$18.00. Liberal trade discounts are in effect. This is the charger designed to appeal to all.

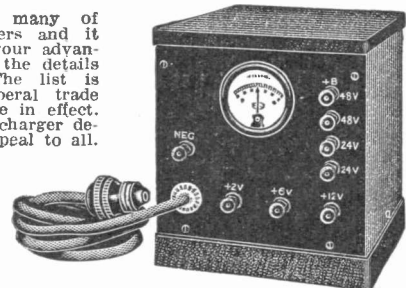

INTERSTATE ELECTRIC CO.
 4339 Duncan Ave., St. Louis, Mo.

Day-Fan

RADIO
A YEAR AHEAD

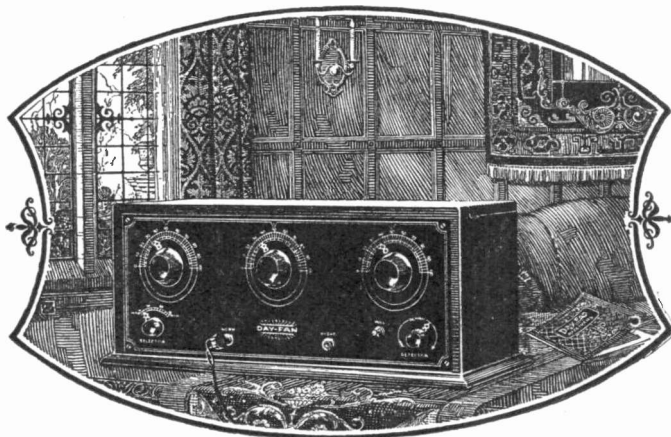

Amazing Simplicity The Set That Is Already Logged

CAN you imagine anything more simple—more practical—than a radio set with all the dial settings exactly identical for any station—regardless of where you live or what antenna you use?

The entire DAY-FAN line, comprising six models ranging in price from \$90 to \$285, is distinguished by this feature.

APPEARANCE. Every DAY-FAN set is a splendid example of the cabinet maker's art. Made of the finest materials, they have a finish and design which harmonize with the surroundings of the most tastefully furnished homes.

VALUE. In everything that you want—long range, selectivity, purity of tone, volume—there is no greater value.

PERFORMANCE. The age of technical discussion and experimenting in radio is past. Today a set must do certain definite things. You may want entertainment, business information, or an educational program. Whatever your desires, a DAY-FAN will get it for you, quickly and easily.

Sold by Leading Radio Dealers Almost Everywhere

The Dayton Fan & Motor Co. Dayton, Ohio

Manufacturers of High-Grade Electrical Apparatus
for 36 years.

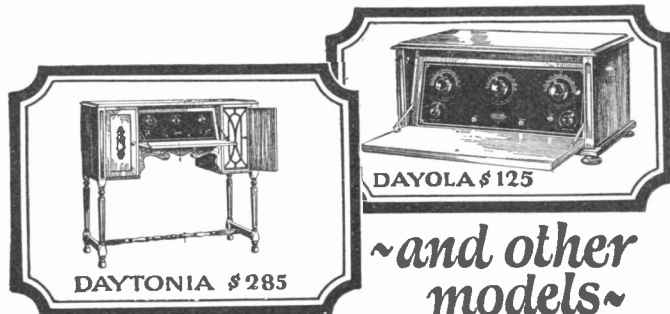

~and other models~

Introducing the ECHOPHONE

Portable
Radio

\$75.00

Without Tubes
and Batteries

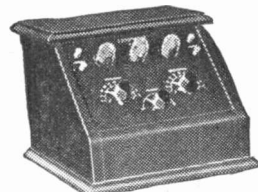

The Echophone "3"
An exceptionally powerful 3-tube set. Uses dry batteries. Two-dial tuning. Range 1800 to 2000 miles. Without Tubes and Batteries... \$50.00

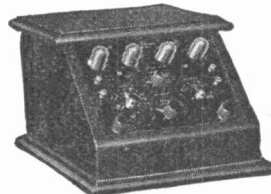

The Echophone "4"
A combined radio and audio frequency four-tube receiver of unusual selectivity. Two tuning dials with special adjustment for volume. May be carefully calibrated for logging new stations. Non-radiating—clear toned, easy tuning. Without Tubes and Batteries... \$75.00



The Light - Weight Heavy - Seller

Here is the ideal portable receiving set!—Weighs only 32 pounds—takes up no more room than an ordinary traveling bag—size 9 in. x 12½ in. x 18 in.;—yet it has the same volume and tone quality as the Echophone cabinet receiver of same capacity.

It uses the same receiving unit—(Echophone "3" or Echophone "4") and operates from a standard 60-ft. stranded wire aerial which automatically winds on a spring reel fitted in a special section of the case.

You will find the case complete with its built-in loud speaker, at \$30.00, an unusually fast selling accessory among purchasers of Echophone cabinet receivers. Write for details and prices. Address—

ECHOPHONE RADIO, INC.
1120 N. Ashland Ave., Chicago, Ill.
Echophone Radio Shop
Long Beach, Calif.
Echophone Sales Co.
156 2nd St., San Francisco, Calif.

ECHOPHONE

Storage Battery Results at Dry Cell Cost

Protects Radio Tubes

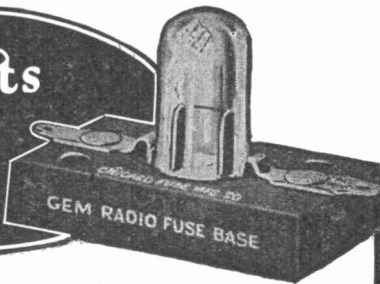

Drop a tool across the wiring in a radio receiving set, or connect the wiring to the wrong binding posts, and zip—the tubes are burned out and \$20.00 or more needlessly wasted.

Tubes can be protected against destruction from short circuits for a few cents by installing the "Gem" Radio Fuse. Then when there's a "short," the fuse blows and the tubes aren't injured. Easily installed.

We are advertising the Gem Radio Fuse in leading radio magazines and in other ways. You are certain to receive scores of calls for this Fuse. Put in a small stock and be ready to make the nice profit you will otherwise lose.

Order from your jobber. If he hasn't put in his stock, give us his name and we will see that you are supplied. Write for interesting booklet.

CHICAGO FUSE MFG. CO.

MANUFACTURERS OF
ELECTRICAL PROTECTING MATERIALS
AND CONDUIT FITTINGS
LAFAYETTE & 15TH STREETS
CHICAGO

"GEM" RADIO FUSE

Makes More Money For You

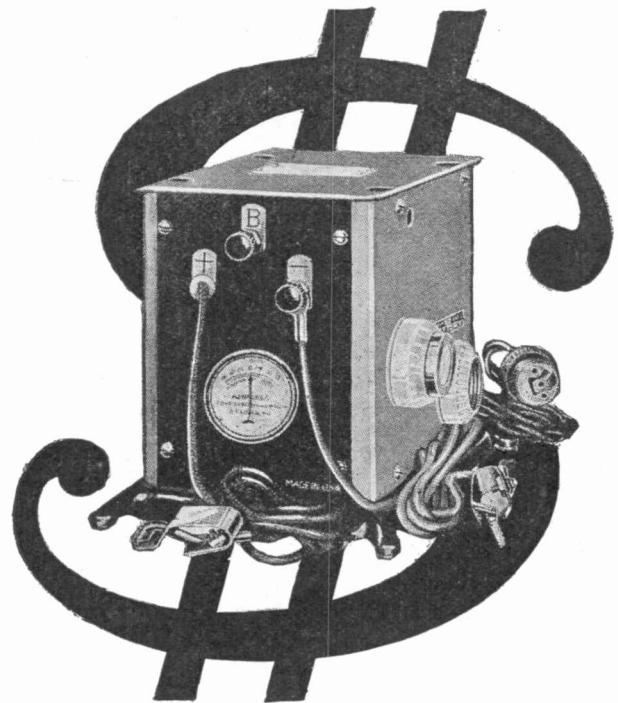

THE Master Fore Battery Charger

Jobbers and Dealers make profit when the Merchandise they handle insures a rapid turnover, with sufficient selling margin. The Master Fore Battery Charger meets these requirements and more. It charges any 6-volt Radio or Automobile Battery, also Radio "B" Batteries up to 48 volts in series and up to 120 volts in multiple. In appearance it is a match for the most expensive Radio Set. Easy to operate, inexpensive and durable. There will be no idle stock on your shelves when you handle the Master Fore.

*Send coupon today, we'll
tell you how it's done*

Manufactured by
FORE ELECTRICAL MFG. CO. 5255 N. Market St.
ST. LOUIS, MO.

Sales Department
THE ZINKE COMPANY 1323 S. Michigan Ave.
CHICAGO, ILL.

ECONOMY SCREW ASSORTMENT

*A complete,
compactly packed
carton for convenience
in display and selling*

Each carton contains twenty individual packages of radio screws, nuts and soldering terminals that meet the requirements of set builders. Our great output enables us to sell these assortments at unusually low cost thus giving you the benefit of real profit. Every set builder is a prospect and will buy—just display this carton and watch the turnover. Every article made of brass and highly nicked. Made right. Correctly designed.

ECONOMY SCREW CORPORATION

Manufacturers of Machine Screws, Nuts,
Washers and Soldering Terminals

5215-17-19 Ravenswood Ave., Chicago, Illinois

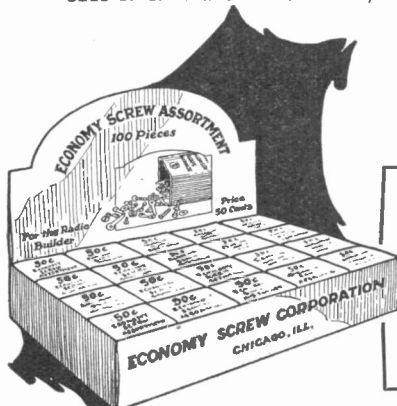

**Jobbers
Dealers**

Get in on this now.
Write and let us
tell you about our
attractive selling
proposition.

RADIOGRAM

Fore Electrical Mfg. Co., St. Louis, Mo., Manufacturers
The Zinke Company, Chicago, Ill., Sales Department

Send me free of charge complete information on how to make more
money with the Master Fore.

Name

Address

City State



To help you
do more business—
make more money—
that's what
Radio Retailing
can do for you!

Think of a
service like that
for only \$1!

Never before during all its years in the publishing of the world's foremost electrical, technical and engineering magazines, has the McGraw-Hill Company made a more attractive offer!

You have in your hand the most valuable publication ever offered the radio dealer. For a limited time you may subscribe to this magazine at a charter subscription price—\$1 a year—12 big issues!

This is the most attractive value for \$1 ever offered the radio retailer! Think of a sales service that will help you during twelve months with information on store management, financing business expansion, ideas on store layouts and window trims, how to advertise, how to handle "trade-ins," how leading radio concerns sell house-to-house, selection of balanced stocks.

In short—a sales service that will give you tried and tested methods for increasing your business and making more money. This is an unparalleled offer in the history of radio. Take advantage of the special charter subscription offer—attach a dollar bill to the coupon and send them in. The regular subscription price is \$2 a year—enroll now as a charter subscriber and save a dollar!

12 Big Issues for \$1 !

RADIO RETAILING

Tenth Ave. at 36th St., New York, N. Y.

The attached payment of \$1 entitles me to a year's subscription—12 big issues—to Radio Retailing.

Pin a dollar _____ here

Name

Address

City State

Name of Company..... Position.....

**Return This
Coupon NOW!**

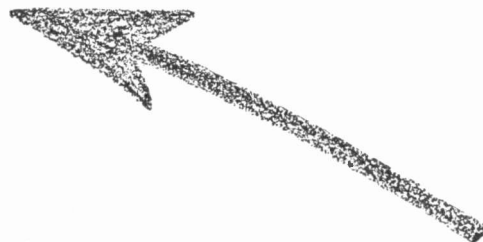

THE ONE CHARGER FOR ALL
RADIO STORAGE BATTERIES

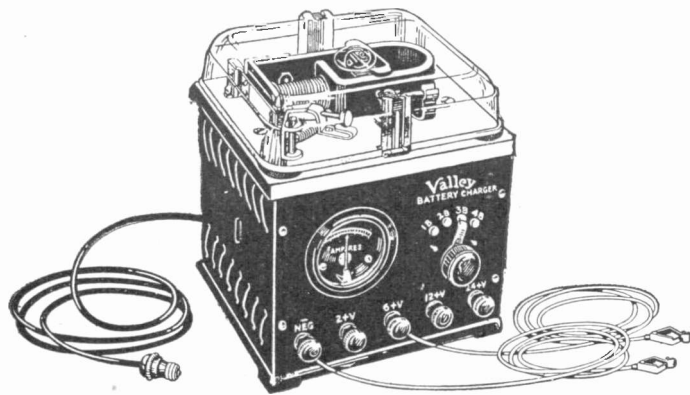

Ten Selling Points
in

Valley Battery Chargers

You'll find ten real selling points in the Valley Battery Charger — ten talking points that give you something vital to say to a prospective purchaser of a Charger:

Here they are:

1. No bulbs
2. No liquids
3. Quiet in operation
4. Cannot harm the battery
5. Efficient. Takes about a dime's worth of current for a full charge.
6. **Correct 6-ampere** charging rate enables the user of a Valley Charger to recharge his battery overnight.
7. Ammeter mounted flush with panel shows if battery is receiving charge and if charging rate is correct.
8. Listed as standard by Underwriter's Laboratories.
9. Has only two wearing parts, the contacts, which can be replaced easily and cheaply. Average life of these contacts is about two years.
10. Built in handsome black case with grained and engraved Bakelite panel and clear glass top which shows simple, patented working parts. Harmonizes with the finest radio receiving sets.

If you are handling the Valley Charger now, learn these features and tell your customers about them. See that your salesmen know this story of the Valley's Ten Points of Superiority.

If you are not handling the Valley Chargers, you are missing sales, that's all. But that's enough for the progressive retailer of radio merchandise. Order from your jobber.

VALLEY ELECTRIC COMPANY

3157 S. Kingshighway - - - - St. Louis, Mo.

New York Philadelphia Chicago Indianapolis
Minneapolis Cleveland Kansas City San Francisco

RADIO RETAILING, February, 1925

Sell headphones
with every set

and keep your sales **SOLD!**



The AMPL-TONE, now selling for \$5, is the only popular priced headset to achieve absolutely clear, equalized tone.

We are now in our own factory, and with greatly increased production facilities we are making sets in such quantity that costs have been revolutionized.

And we have at the same time introduced refinements with AMPL-TONE which because of production handicaps we were unable to utilize before.

We offer the finest of headsets at a price unequalled anywhere on the market, and back it up with a dealer proposition that makes sales profitable sales.

Our Wonderful Phonograph Unit and Attachment—List \$3.00

Unequalled in Tone Quality, Volume or Price

Jobbers and Dealers—write for details



Full 2200 Ohms

AMPL-TONE
GUARANTEED
RADIO HEADSETS

THE UNION FABRIC
COMPANY

Drawer Y
Derby, Conn.

It's Selling Big!

THE NATIONAL REGENAFORMER

This new type of Radio Frequency Transformer has proved so efficient that 90% of the value of amplification calculated by mathematics in laboratory tests is obtained actually in practice, which is more than 3 times the amplification value produced by the usual type of tuned R.F. transformers.

It is incorporated in the Browning-Drake circuit, which has essentially 2 tubes—detector and radio amplifier—to which 2 stages of audio may be added.

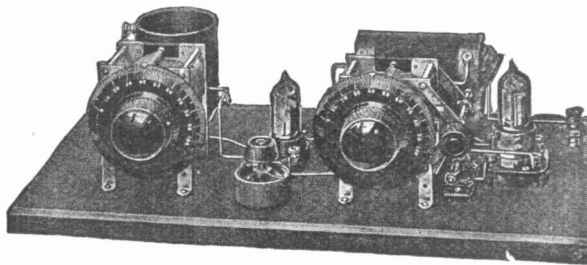

The press has featured it extensively. The dealers who now handle it are selling them with outstanding success.

We are ready to extend distribution

New dealers can now take it on and be assured of responsible deliveries. It is a real proposition. No exaggerated statements are needed to sell it—either in our advertising to you, or on your part to your trade.

Write for literature and discounts, but do it quickly. We will not take on more dealers than can be guaranteed quick service. Write now.

Price of kit for set illustrated..\$22.00
The National Regenaformer and
Coil only, price..... 7.50

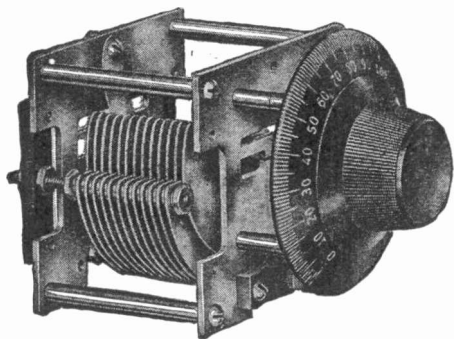

THIS is the National "Velvet Vernier" Condenser and Dial—the most distinctive condenser of all.

Electrically and mechanically it is the finest that scientific principle and painstaking skill can commercially produce. This has been amply proved by its success in sets operated on wave lengths of 15 meters.

The velvety smooth vernier gives perfect reduction over the entire range. No backlash whatever.

Made in four sizes.

Write for Folder and Prices

NATIONAL CO., Inc., Cambridge, Mass.

Established 1914

Engineers and Manufacturers

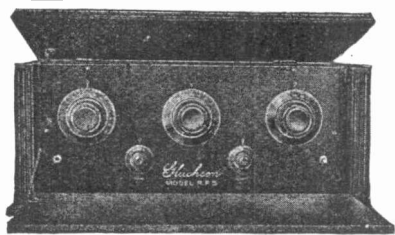

Setting a new standard in radio reception

The Gluckson is undisputedly one of the high achievements in radio.

As a result of its unique construction, absolute stabilization is gained.

Its two stages of inherently balanced radio frequency amplification, detector and two stages of power audio amplification, achieve trueness of reproduction, range and selectivity that are unsurpassed. Highest class parts used throughout.

Write for specifications and full details.

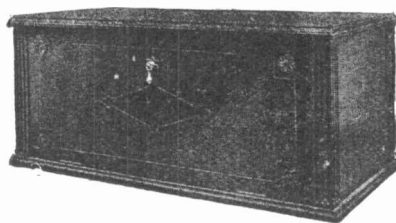

MODEL R F 5
In Distinctive
Solid Mahogany
Cabinet
List \$98

Gluckson

*Beautiful to the Eye
Sweet and Mellow to the Ear*

GLUCK RADIO MANUFACTURING COMPANY
115-117 West 23rd St., New York City

DISTRIBUTORS:
Sanford M. Bookee, 221-225 Fulton St., New York City. Burney Radio Corp., 17 West 60th St., New York City.



**Permanent Cartridge
Detector**

Guaranteed for reflex and all R. F. circuits. Price \$1.00.

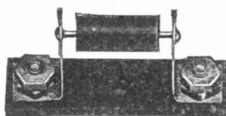

**INDOOR CAGE
ANTENNA**

A highly efficient Antenna System sold on a guarantee of Reliable Reception.

Patented. The Genuine bears the trade mark "Key to the Air." \$2.00. At your dealers—or direct by mail on receipt of price,

STAFFORD RADIO CO., Medford Hillside, Mass.

Send for circuit diagrams of Single Tube Receiver.

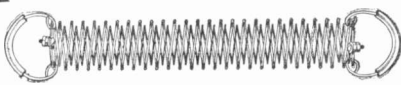

Telephone Cords

High grade Cords for all makes of Headsets and Loud Speakers.

We solicit your 1925 Business

Write for Prices.

Gavitt Manufacturing Co., Inc.
West Brookfield, Mass.

SEARCHLIGHT SECTION

SURPLUS STOCKS—BUSINESS OPPORTUNITIES

UNDISPLAYED—RATE PER WORD:

Positions Wanted, 6 cents a word, minimum \$1.25 an insertion, payable in advance.
Positions Vacant and all other classifications, 10 cents a word, minimum charge \$2.00.
Proposals, 40 cents a line an insertion.

INFORMATION:

Box Numbers in care of any of our offices count 10 words additional in undisplayed ads.
Discount of 10% if one payment is made in advance for four consecutive insertions of undisplayed ads (not including proposals).

DISPLAYED—RATE PER INCH:

1 to 3 inches.....\$6.65 an inch
4 to 7 inches..... 6.40 an inch
8 to 14 inches..... 6.20 an inch
Rates for larger spaces, or yearly rates, on request.
An advertising inch is measured vertically on one column, 3 columns—30 inches—to a page.

Radio Retailing

POSITIONS WANTED

I AM NOT a high powered executive—a super salesman—a miracle worker but I am capable, honest, industrious and intelligent. I am 25 years old, have a good education and 5 years' experience in the merchandising of radio apparatus, over 2 years with one of the largest retail and wholesale radio and electrical supply stores in New York City. Three years assistant sales manager of large radio manufacturer. I am familiar with dealer problems of service, demonstration, window display, advertising, etc. and their solution. I have a large acquaintance in the radio trade and can furnish the best of reference. Can you offer an opportunity where this broad knowledge and wide experience, combined with ability, honesty, and industry, can earn a place in your organization where it can be used to bring mutual benefit? I am at present employed but can change on short notice. PW-2, Radio Retailing, 10th Ave. at 36th St., New York.

SALESMEN WANTED

Salesman Wanted

If you are a wide awake salesman who has kept step with the manifold changes and improvements effected in radio during the past two years, there's a good job awaiting you somewhere in this ever expanding field. You can find this opportunity through a "Searchlight" advertisement in Radio Retailing.

SALESMEN AVAILABLE

Salesman Available

A live-wire radio salesman is seeking a bigger opportunity to demonstrate his ability. This man is now associated with one of the 40,000 dealers served by Radio Retailing and will be watching these columns for information of opportunities offered. If you wish to locate this man, your advertisement here will get his attention.

BUSINESS OPPORTUNITIES

Radio Store Wanted

If you wish to dispose of your business for any reason the readers of Radio Retailing will be interested in knowing about it. You can reach these men best through advertising in these "Searchlight" columns. Rates above.

Business For Sale

If you are seeking a going radio business, you can find what you want through an advertisement in these "Searchlight" columns addressed to the Nation's radio retailers.

TO HELP YOU

LOCATE SELLING OPPORTUNITIES

"Searchlight" Advertising

G-8

Your Overstock is a Dead Investment Move it at a Profit!!!

So long as customers' tastes change; so long as new developments render merchandise obsolete; so long as you accept sets on "trade-ins," you will have overstocks in those particular lines. To hold any or all of these "stickers" on your shelves means that you are tying up costly merchandise space and paying interest charges on a profitless stock investment which might readily be turned into profit.

Sets, accessories and parts that won't sell in one locality are frequently just what customers elsewhere are demanding. Practically all such articles can find waiting buyers among the millions of potential purchasers served by RADIO RETAILING'S tens of thousands of dealers throughout the country.

Recognizing the need and convenience of a National "center" where dealers everywhere can bring their overstocks to the attention of others—or ask for what they wish to buy—we are inaugurating a

Radio Dealers' Overstock Exchange in Radio Retailing

We believe that such an exchange will prove an invaluable service to the radio trade. It will help you as a dealer to sell, at a profit, merchandise that would otherwise be a dead loss. The dealer who buys it, sells it, and makes a profit. And the far-away customer gets something he wants and is added to the vast army of pleased radio enthusiasts. Thus each benefits and everybody profits.

What have you to turn into cash NOW? Get it into the "Exchange" of the next issue of RADIO RETAILING. The cost will be small.

Molded Parts for Radio

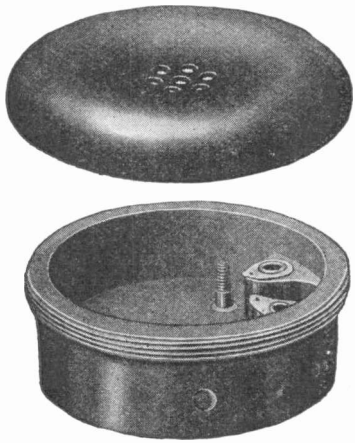

Bakelite and Condensite, produced by a large and experienced Molding Organization.

American Insulator Corp.
52 Vanderbilt Ave., New York City

HARRY ALTER & CO.

OGDEN at CARROLL AVENUES ··· CHICAGO

Wholesale Distributors for

FREED-EISEMANN
RADION
PREMIER
MOHAWK
HOWARD
BURGESS
DUBILIER
ERLA
BRANDES
FRESHMAN
CARTER
ACME
BENJAMIN
HOLD-HEET
APPLETON
SAVE
LIBERTY
SIMPLEX
WADSWORTH
MASTER
MOTOR

And over 100 others

The dealer who makes Harry Alter & Company his wholesaler has at his command complete stocks of the products of America's best known radio and electrical manufacturers. And he enjoys the additional advantage of immediate delivery from these stocks—90% of the orders we receive are shipped the same day.

These are only two of the reasons why dealers in every state in the United States and in 22 foreign countries are buying from Harry Alter & Company to their satisfaction and profit.

L + K Variable Clarifying SELECTOR

Greatly Improves
Any Standard Hook-Up

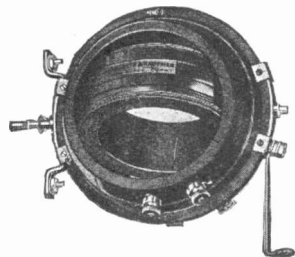

Whether a set is an Erla or any other reflex, an Ultradyne, a R.F. or a Regenerator, you can easily give it that high selectivity and perfect control so necessary where stations interfere.

Just replace variocoupler, fixed coupler, tapped coil, or aerial variometer with an L + K Clarifying Selector and a .0005 variable condenser.

This improvement clears up muffled signals—gives minute selectivity—permits complete control of antenna coupling over the entire B. C. wave band—cuts down antenna losses and strengthens reception—and does away with tapped coils and high loss aerial tuners. \$7.00 list. Jobbers and dealers, write for representation.

LANGBEIN + KAUFMAN L+K
High Grade "Low Loss" Tuning Devices
A Guide to TECHNICAL ACCURACY

DEPT. M., 511 CHAPEL ST., NEW HAVEN, CONN.

*Yes sir, this is it!!!
The Radio assortment
that sells and sells and sells—*

Dealers are daily finding that here is the logical radio fitting assortment. They sell several in the time it takes to sell one ordinary assortment. It's simple to see why. The fittings are popularly priced, each has proven best designed for its purpose. Then there's that unusual Sherman quality to consider. The fittings in this assortment are well proportioned as to number of each so that the assortment sells evenly—no "dead loss" leftovers. Real profit in each assortment. Get details.

H. B. Sherman Mfg. Co.
Battle Creek, Mich.

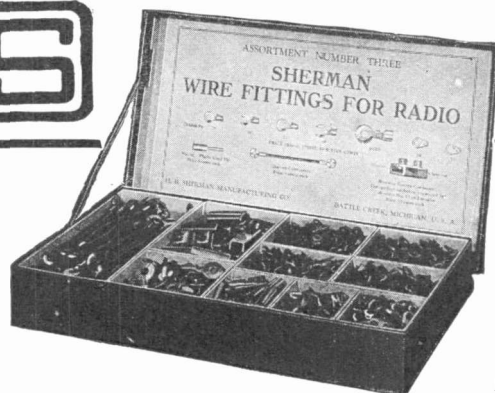

"Order from your jobber"

The Greatest Socket in Radio History!

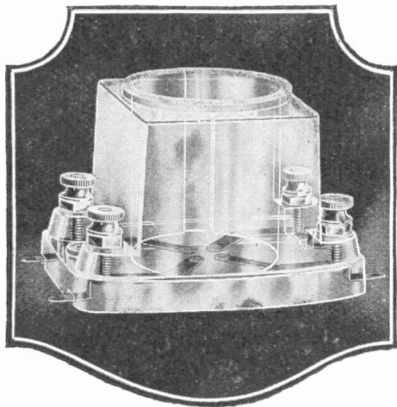

Scientific test has proven glass to be the most effective and reliable insulation available for radio.

After exhaustive research, Duray engineers have developed VIRALON, a special patented glass processed for 100% electrical efficiency.

Countless tests have proven VIRALON to be sturdy and rugged, absolutely heat and moisture proof, and unaffected by those influences that commonly make rubber, rubber derivatives, porcelain or vitreous products so inefficient.

You'll like all the Duray features—the all-glass construction—the one-piece contact strips—the Ezyklean contact spots (eliminates corrosion)—the handy soldering terminals.

Price \$1.25 in attractive cartons.
Packed in Attractive Display Containers holding 10 Sockets.
Jobbers and Dealers—Write for Particulars.

Distributors Wanted Everywhere.

Live Sales organizations will find a big sales' opportunity in Duray All-Glass Sockets. Write for interesting proposition.

DURAY RADIO CORPORATION
Dept. 23, 263 Washington Ave., Newark, N. J.

DURAY

ALL-GLASS

VIRALON

SOCKET

DURAY RADIO CORPORATION, Newark, N. J., Dept. 23

Please send me one Display Container of 10 Duray All-Glass Sockets to retail at \$1.25 each. My discount 35 per cent.

- Bill through the jobber mentioned below, or
 Send C. O. D. Parcel Post.

Name City.....

Address Jobber.....

Radio Leaders

Atwater Kent
Crosley
Fada
Grebe
Thermiodyne
Radiodyne
Magnavox
Federal
Cardwell
Remler
U. S. Tool Co.
Acme
All-American
Jefferson
Dubilier
Cutler Hammer
Carter
Frost
Benjamin
Allen Bradley
Eby
Willard
Powerfield Batteries
Western Electric
Fansteel
Brandes
Goodrich
Am. Hard Rubber

Cunningham Tubes
Burgess Batteries
Brach
Jewell
Belden
Foote
Fahnestock
E. I. Co.
Roller Smith
Pooley Cabinets
Bremer Tully
Raven
Daven
Sickels
Howe
Hope Talking Tape
Apex
Timmons
Bridgeport
Electrad
Hafner
Fleron
Mydar
Copeland
Sterling
Shamrock
Victor
N. Y. Coil Co.

Leading Radio Products Available Through This One Catalog

Write today for our 112 page Radio Catalog, fully illustrating and describing above factory lines. Lowest wholesale price list to dealers. Orders shipped same day received. Practical radio men to handle your business. Our service and large stock enable dealers to turn their stock often.

The Sutcliffe Company
Incorporated
Dept. G, Louisville, Kentucky



THE Gilbert STORAGE "B" BATTERY

Clearer Reception
Greater Distance
More Volume
Noiseless in Action
—the most beautiful "B" Battery made

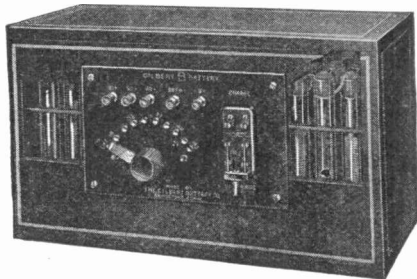

No acids or disagreeable odors. Will stand untold electrical abuse. The alkaline solution has absolutely no chemical action on the nickel-iron elements, adding years of actual service to the battery. Non-sulphating. No buckling of plates. No fear of overcharging.

Its beautifully finished solid American Walnut Cabinet puts a fine battery in a properly distinctive setting.

Note the sturdy durable method of connecting the elements.

For the dealer earnestly seeking the finest in radio to build up his accessories business there is a splendid proposition in The Gilbert Storage "B" Battery. Write today.

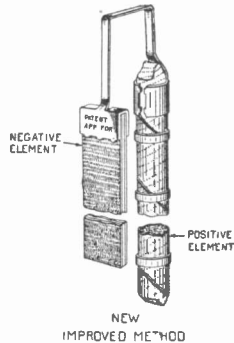

THE GILBERT BATTERY CO.
138 Fayerweather Street
Bridgeport, Conn.



Knockout Reflex Coil No. 8
Price \$4.00 a Set

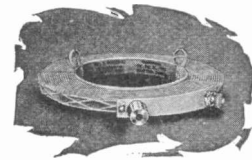

Tuned Transformer Coil No. 14
Price \$2.00

SICKLES DIAMOND-WEAVE COILS

Patented August 21, 1923

COIL HEADQUARTERS

Sickles Diamond Weave Coils are recognized as standard equipment where extreme selectivity is required. They are being specified more and more by the manufacturer who incorporates in the sets which he builds the most efficient parts he can secure.

Among the leading Sickles Coils are the Tuned Transformer Coil for any Tuned Radio Frequency Circuit and the Knockout Reflex Coil for the famous Radio Broadcast Knockout Circuit. There are Coupler and Oscillator Coils and Acme Reflex Tuning Coils.

In addition to these standard coils, we are equipped to furnish special coils for special requirements. Secure maximum efficiency in your sets by including Sickles Diamond Weave Coils for selectivity.

Send for descriptive catalog

THE F. W. SICKLES COMPANY
341 Worthington St., Springfield, Mass.



"Good Will"

—It means everything to you!

Every time you sell a customer Pacent Radio Essentials, you sell him the parts that 40 of the world's leading set makers have selected for their own sets. You're selling him the *best* that his money can buy . . .

In return you have his "good will"—and the profits follow as naturally as day follows night.

Write to-day for your copy of the new Pacent catalogue

PACENT ELECTRIC CO., Inc.
91 Seventh Ave., New York City

Washington Minneapolis Boston
San Francisco Chicago Birmingham
Philadelphia St. Louis Buffalo
Jacksonville Detroit

Pacent
RADIO ESSENTIALS

DON'T IMPROVISE — PACENTIZE

- PACENT Radio Essentials
- Adapters
- Improved Audioformer
- Autoplug
- Coil Plug
- Coil Plug Receptor
- Condensers, Low Loss
- Detector Stand
- Duojack
- Duoplug
- Duo-Lateral Coils
- Headsets, Everytype
- Jacks
- Jack Set
- Radioloop
- Loop Plug
- Loop Jack
- Multiplug
- Plugs
- Potentiometer
- Rheostats
- Resistors, Laboratory
- Sockets
- Twinsadapter, etc., etc.



Stop some service troubles

PUT A DURHAM Grid Leak, variable or metallized fixed, into each set you sell. By thus assuring correct detector grid action, one big service trouble is eliminated.

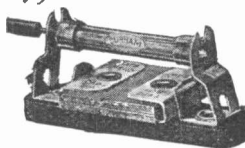

Variable Leak only, 75c.
Base, with cond. clip, 35c.

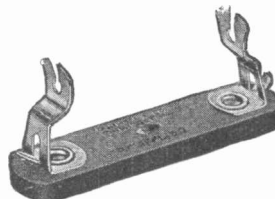

Plain Bases, Single, 30c.
Double, 40c. Single Base
—General Use

DURHAM Grid Leaks

Please your customers with the products that have stood the test of several seasons.

Standard in these sets

Eagle, Eismann, Howard, Thompson, Zenith—and fits all others.

Write for Dealer Plan

DURHAM & CO., Inc.
1936 Market St., Philadelphia,

Prices:
Fixed Metallized, 28 sizes; under 1/4 meg. 75c.; over, 50c.
Variable, 3 sizes, all at 75c.
Plain bases, 30c.
Condenser bases, 35c.
Double bases, 40c.
Resis. Amp. Booklet, 25c.
Canadian Distributors: De Forest Radio Corp., Ltd., Toronto

YAXLEY

APPROVED RADIO PRODUCTS

Are Selling
for Dealers
Everywhere

There's
a
Reason

Convenient packages, on-time deliveries, National Advertising backed by original and correct design and superior construction—

That explains the popularity of Yaxley Approved Radio Products with dealers and consumers everywhere.

Ask your jobber for your price lists and full information or address

Yaxley Manufacturing Co.
Dept. F, 217 N. Desplains St., Chicago

Here's a
NEW
ONE!

—for wiring radio sets.
No. 14 tinned copper wire covered with flexible, varnished insulation, in red, yellow, green, brown and black—called

"CELATSITE"
(Spaghetti Wire)

Looks like "spaghetti" but is smaller and goes into narrower places. Highly dielectric, thoroughly waterproof. Makes the neatest looking set you ever saw. In long envelopes of forty 30-inch lengths to sell at 10c per length. Write for discounts and folder.

Acme Wire Co., Dept. E, New Haven, Conn.

ACME WIRE Makes Better Sets

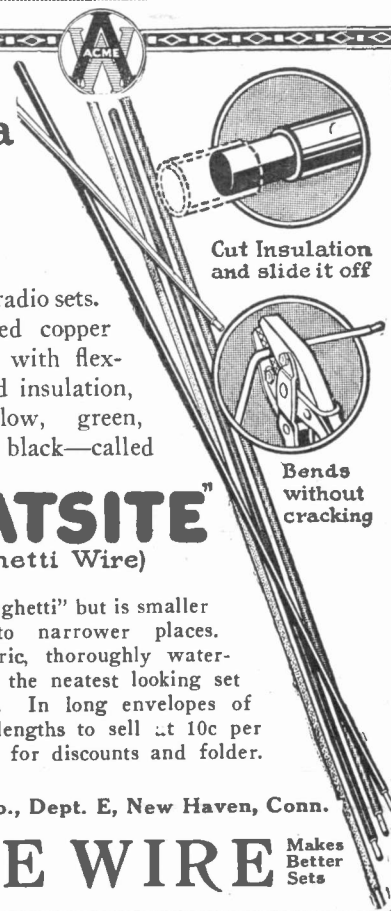

FRESHMAN MASTERPIECE

TUNED RADIO FREQUENCY KIT \$17.50

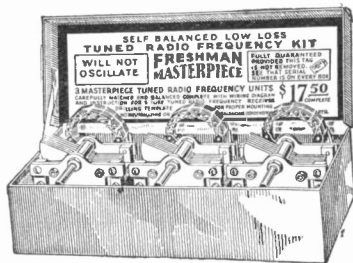

EASY TO BUILD—EASY TO SELL

With the Freshman Masterpiece Kit any one can easily build a five tube radio frequency receiver that will bring in even the most distant stations, with the volume and clarity of locals.

NO NEUTRALIZING OR BALANCING CONDENSERS REQUIRED

Kit consists of 3 Masterpiece Tuned Radio Frequency Units carefully matched and balanced. Complete with wiring diagram and instructions, and drilling template for proper mounting.

No radio stock is complete without Freshman Masterpiece Kits. At \$17.50 list they are good profitmakers for you because they sell quickly and easily. Write for catalog today.

Chas. Freshman Co. Inc.
Radio Condenser Products

Freshman Bldg., 240-248 West 40th St., New York

\$3⁵⁰ LIST!



The Pennsylvania Harmonized Head-Set is the finished product of engineers who have specialized in head-sets for years. In sensitiveness, clarity and faithfulness of reproduction it excels many highest priced sets.

A one-year written guarantee with each pair. 2500 ohms. Weight 12 oz.

Other Pennsylvania Radio Products—

Crystal Receiver Single Tuner, \$3 list.

Reproducing Unit with phonograph attachment, \$5 list.

Crystal Receiver Double Tuner, \$4.50 list.

Type L-32 Head-phones, \$5 list.

The new Pennsylvania Speaker is a beautiful thing to hear—and to see. It combines the rare achievements of faithfully reproducing the human voice, and reproducing orchestra music in such a manner as to bring out the finest detail.

Unbreakable LINOL - FIBRE horn, with handsome molded base. Height 24 in. with a 12 in. bell.

Complete... \$10 list
Horn and base without reproducing unit... \$7 list
Base adaptable for any unit.



Manufactured by

HAMBURG BROS.

620-24-26 Grant Street, Pittsburgh, Pa.

A better deal for you, and
100% satisfaction for your

customers—

TYPE
F201-A

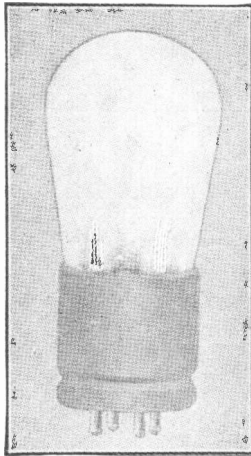

“FEDERAL”

—
GUARANTEED
LIST PRICE

\$4⁰⁰

The Federal Tube, through its vastly improved and *guaranteed* filament, achieves a clarity of tone unequalled in *any* other. Non-microphonic of very rigid construction, and notable for its extremely long life.

You will welcome this *real* tube. Well made by experienced engineers, and soundly backed. You can give your trade a real deal at last.

Generous discounts. Order through your jobber, or direct.

THE SERVICE LAMP CO.
112 Trinity Place, New York City

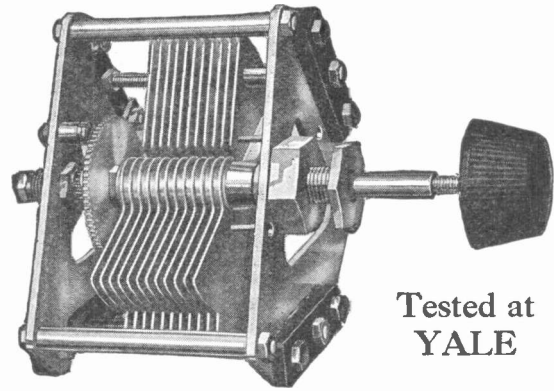

Tested at
YALE

“Built Like a Fine Watch”

LOMBARDI

Low Loss Grounded

Rotor Condensers

One hole Panel Mounting or three screws. Clock Spring Pig Tail Rotor Stops.

Patented Bearings, Tapered and Ball and Thrust type.

Lowest dielectric loss. Geared Vernier takes any size dial. Tested at Sloane Laboratory, Yale University.

Lombardi Multi-Unit Condensers
Double and Triple—Single Dial Control

Plain type \$4.00 to \$5.50. Geared Vernier \$5.00 to \$6.50.

Know the best. Send for literature.

Lombardi Radio Manufacturing Co.
62 Minerva Street, Derby, Conn.

SOCKETS—All Types
DIALS—All Sizes
TRANSFORMERS
VARIOMETERS
INSULATORS
BINDING POSTS
(Character and Plain)

PHONE ADAPTERS
SOCKET BRACKETS
PANEL BRACES
TERMINALS—
Any Finish
BATTERY CLIPS
KNOBS—All Sizes
SWITCH ASSEMBLIES

and other Radio Parts

To Jobbers and Mfrs. Only
Send for Catalog and Prices

“RADIO DEPT.”

WATERBURY BUTTON CO.
Manufacturers Since 1812
Waterbury, Conn.

RADIO DEALER CATALOG
FREE!

Our 1925 Catalog

is being used by thousands of Dealers everywhere as a positive guide to more profitable buying of the kind of radio that is in greatest demand today.

Our financial strength, responsibility and SAME DAY shipping service will help you to “grow with us.”

As we are the largest exclusively wholesale radio organization in the East, our tremendous stocks are representative of the best and fastest selling lines as indicated by nationally known manufacturers.

Consult us first and save on your next order, or the stocking of your new store. Your name on our mailing list will keep you posted and prove a valuable asset. Write today.



Trilling & Montague

Exclusively Wholesale Radio
Merchandisers

49 No. 7th Street, Phila., Pa.

“Grow With Us”

3 Hot Points to Consider—
Set complete,
\$2.50 list. In display
carton with stand, solder and paste.
Mail a sample order. Also one point
Irons at \$1.75. Immediate delivery.

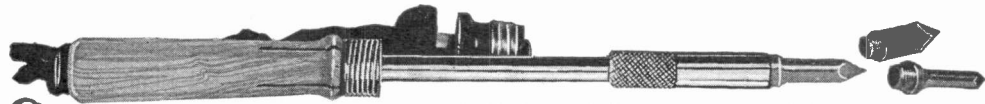

1. An unbreakable heating element guaranteed for one year.
2. Three interchangeable copper points.
3. Never-slip handle construction.

The Chapman Co., Terryville, Conn.

Only reliable products can be
continuously advertised

MANUFACTURERS: Is Your Sales Plan *Complete?*

Two efforts are necessary before a sale can be made.

First the *desire* must be created. This is the job of trade publication advertising—through *Radio Retailing*.

But the job is only half done when desire has been created. The second important half of your sales

task is to place before the buyer at the same moment he is ready to buy all the data he needs to place the order.

Give the radio dealer and jobber this buying information, when they need it, through The Radio Trade Directory. The February issue of The Directory is now being prepared.

The RADIO TRADE DIRECTORY
A McGraw-Hill Publication
471 Tenth Avenue, New York City

ALPHABETICAL INDEX TO ADVERTISEMENTS

Page	Page	Page	Page
A			S
A-C Electric Co.123	Electric Storage Battery Co.199	Lombardi Radio Mfg. Co.222	Searchlight Section217
A & T Radio Co.209	Electric Service Supplies Co.208		Service Lamp Co.222
Acme Wire Co.221		M	Sherman Mfg. Co., H. B.218
Adams Morgan Co.198	F	Manhattan Elec. Supply.200	Shinn, W. C., Mfg. Co.209
Alden Manufacturing Co.127	Fore Electrical Mfg. Co.213	Martin Copeland Co.120	Sickles Co., F. W.220
Allen-Bradley Co.113	Freshman Co., Chas., Inc.221	Morse Co., Frank W.210	Sleeper Radio Co.117
Alter & Co., Harry.218		Murdoch Co., Wm. J.207	Stafford Radio Co.216
American Insulator Corp.218	G	Music Master Corp.121	Summit Radio Mfg. Co.211
Andrea, F. A. D.124	Gavitt Mfg. Co.216		Sutcliffe Co.219
Apco Mfg. Co. Inside Back Cover	General Radio Co.210	N	
	Gilbert Battery Co.220	National Carbon Co.114	T
B	Gluck Radio Mfg. Co.216	National Company, The.216	Thermodyne Radio Corp.168-169
Benjamin Electric Mfg. Co.224	Gollos Radio Corp.119		Timmons Radio Products Corp.204
Brandes, C., Inc. Inside Front Cover	Grigsby-Grunow-Hinds Company.126	O	Trilling and Montague222
Bristol Co.122		Overstock Exchange217	Tru-Fix Radio Products Co.210
	H		
C	Hamburg Bros.221	P	U
Chapman Co.223	Hart & Hegeman Mfg. Co.208	Pacent Elec. Co.220	Union Fabric Co.215
Chicago Fuse Mfg. Co.213	Hazeltine Corporation202	Parker-Young125	
Crescent Braid Co.210		Philadelphia Storage Battery Co.205	V
	I	Preiss Radio Corp.115	Valley Electric Co.215
D	Interstate Electric Co.211	Premier Radio Corp.118	
Dayton Fan & Motor Co.212		Premier Radio Corp.118	W
De Forest Radio Co.201	J		Waterbury Button Co.222
Dubilier Condenser & Radio Co.128	Jesse Mfg. Co., John O.116	R	Westwyre Co.209
Duray Radio Corp.219		Radio Corp. of America, Back Cover	
Durham & Co.220	L	Radio Supply209	Y
	Langbein & Kaufman218	Reichmann Co.197	Yale Electric Corp.203
E		Radio Tube Mfg. Co.209	Yaxley Manufacturing Co.221
Echophone Radio, Inc.212		Ross Wire Co.211	
Economy Screw Corp.213			

SUPERIOR



Cle-Ra-Tone Socket

RADIO



Battery Switch

PARTS

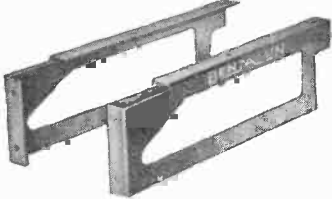

Radio Brackets

FOR



Grid Leak Panel

BETTER

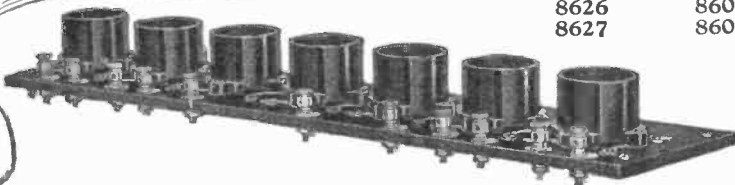

Cle-Ra-Tone Gang Socket and Mounting Shelf

RADIO SETS



Selling Quality Products Brings Profit With Honor

Benjamin Radio Products are accepted everywhere as a real contribution to radio development. They are priced right—they give super satisfaction. Enlarged production facilities enable us to meet the big demand and we are now ready to make immediate deliveries.

Cle-Ra-Tone Sockets

Shock Absorbing—Spring Suspended

Tube holding element "floats" on perfectly balanced springs. Spring supports are not affected by stiff bus wiring. Molded parts of genuine Bakelite. Keeps tubes sensitive only to the radio waves. Keeps microphonic disturbances, due to jars and vibration, out of the receiving set. The Cle-Ra-Tone Socket marked so great an advance in the mechanics of radio reception that it is the choice of the leading manufacturers of high-class sets, and is recommended by the foremost engineers for their most popular hook-ups.

Radio Battery Switch

Lightest and neatest switch made. Mounts in single ¼ inch panel hole. No spacer washers required. Push-pull single contact features give positive contact. When it's in it's off, avoiding accidental cutting in of battery.

Radio Bracket

Gets the wiring out of sight. Adaptable for standard cabinet mounting.

Grid Leak Panel

With the bracket, provides a safe, secure mounting for this important element.

Cle-Ra-Tone Gang Socket and Mounting Shelf

Simplifies construction of the largest receiving sets, and may be used with most of the latest hook-ups. Consists of Cle-Ra-Tone Shock-Absorbing Sockets attached to Bakelite mounting shelf with set of binding posts and markers. There is adequate space for mounting of accessory equipment.

Standard VT Sockets	or UV-199, etc. Sockets	Dimensions of Shelf	No. of Sockets
8613	8603	7 ⁷ / ₈ " x 4 ¹ / ₈ " x 1 ¹ / ₄ "	3
8615	8605	17 ¹ / ₄ " x 4 ¹ / ₈ " x 1 ¹ / ₄ "	5
8626	8606	17 ¹ / ₄ " x 4 ¹ / ₈ " x 1 ¹ / ₄ "	6
8627	8607	17 ¹ / ₄ " x 4 ¹ / ₈ " x 1 ¹ / ₄ "	7

*Ask Your Electrical Supply
or Radio Jobber or write
us giving name of your
supplier*

Benjamin Electric Mfg. Co.

120-128 S. Sangamon St., Chicago

247 W. 17th Street
New York

448 Bryant Street
San Francisco

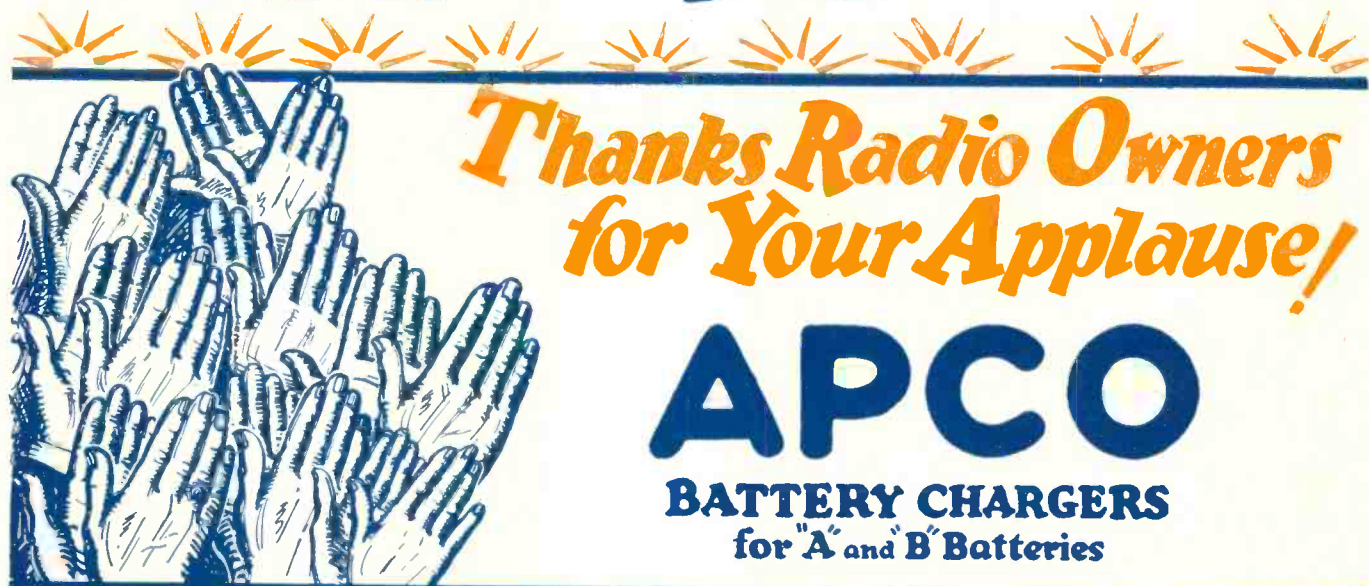
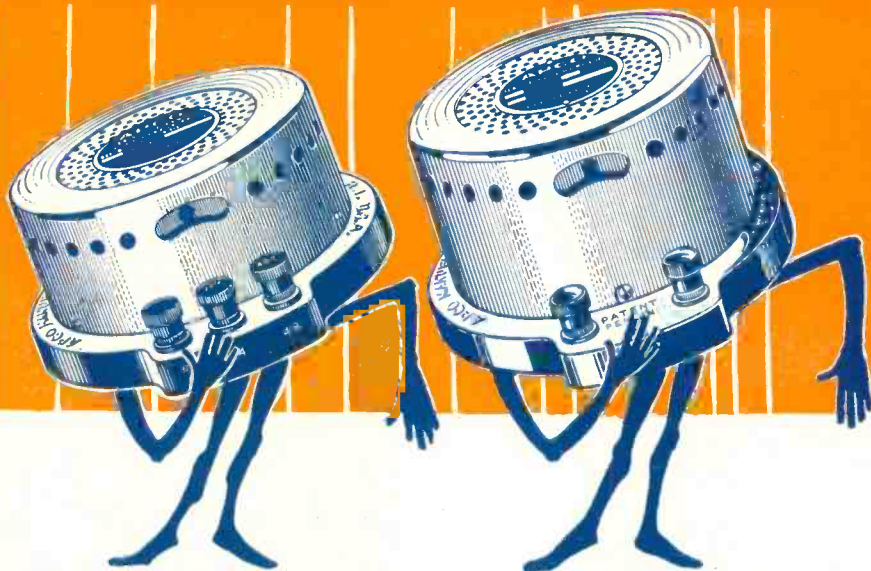

*Thanks Radio Owners
for Your Applause!*

APCO

**BATTERY CHARGERS
for "A" and "B" Batteries**

This "curtain call" is a well-merited tribute to APCO Battery Chargers.

Every radio owner is delighted with the way they perform—so quietly, safely, efficiently. And they are neat, compact and good looking, too.

APCO "A" Charger is of $7\frac{1}{2}$ ampere capacity, self-polarizing, with taper charge. List \$18.50—\$6.00 off to you.

APCO "B" Charger charges 24 or 48 volt "B" storage batteries (or 90 volts in multiple) in ten hours. List \$10.00—\$3.25 off to you.

Order from your Jobber

APCO MANUFACTURING CO., Providence, R. I.

—APCO Branches—

Apco Mfg. Co., 1438 So. Michigan Ave., Chicago
Apco Mfg. Co., Electrical and Export Office, Tribune Bldg.,
154 Nassau St., New York City
Apco Mfg. Co., 2005 E. 15th St., Kansas City, Mo.

Canadian Factory, Apco Canadian Co., Ltd., 3150 Jeanne Mance
St., Montreal
Southwestern Office, M. L. Martin, 2006½ Commerce St.,
Dallas, Texas

Radiola X and Regenoflex

Partners for Real Selling

To the man who wants quality of tone above all things in radio—who wants quality of build—and quality of appearance—sell the Radiola X. One-third of the selling job is already done by the widespread advertising. Another third is done by word-of-mouth fame that the Radiola X has won. Only the last third is left for you. It means quick selling.

To the man who wants the same quality of tone—the same dependable reception—the same big records of performance—but a lower price—sell the Radiola Regenoflex. Win and keep the leadership. Watch the ads. Use them. Send for copies to paste in your windows. Push the Regenoflex and the X. And sell more Radiolas!

"There's a Radiola for every purse"

Radio Corporation of America

Sales Offices:

233 Broadway, New York

10 So. La Salle St., Chicago, Ill.

28 Geary St., San Francisco, Cal.



Radiola X

The Regenoflex circuit in a rich cabinet with its own loudspeaker enclosed. With four Radiotrons WD-11.



This symbol of
quality is your
protection



Radiola Regenoflex

Sensitive, selective, non-radiating. Famous for its tone quality! With four Radiotrons WD-11 and Radiola Loudspeaker.

Radiola

REG. U. S. PAT. OFF.