

HOW TO USE YOUR SPEAKERS FOR STEREO

7 MAC

RADIO & TV NEWS

World's Leading Electronics Magazine

**JULY
1958
35 CENTS**

**COMMUNICATIONS
IN FIRE CONTROL**

(See Page 33)



**BUILD AN ELECTRONIC
IGNITION ANALYZER**

TRANSISTORIZED AUTOMATIC KEY



NEW, IMPROVED



1B3GT

Made possible by

RUGGED, RAYTHEON FLY-BACK LIFE TESTS

At Raytheon, we test tubes to find out how *good* they are, not how bad. Accepted methods of testing tubes like the 1B3GT often resulted in subpar tubes. To improve and maintain the quality of Raytheon 1B3GT Tubes, Raytheon developed an expensive but super-accurate method of life testing these tubes.

Tests on the improved Raytheon 1B3GT far exceeded our expectations. Receiver life tests of the Raytheon 1B3GT showed not a single failure at 600 hours. (No worries about early life tube failure here.) At 1850 hours a sensational 93% of these tubes were still operating at rated efficiency in spite of the fact that *these sets were operated at 10% above their rated line input and cycled on and off every two hours.*

These torturous Raytheon Tube tests not only prove the quality of Raytheon Tubes, they help maintain

that quality. Tubes are constantly checked and tested and any variance in quality is instantly noted and quickly corrected.

That's why you can use Raytheon TV and Radio Tubes with complete confidence in their quality — with full knowledge that you are giving your customers tubes that are RIGHT . . . for Sound and Sight.

New Raytheon 1G3, 1J3 and 1K3 Tubes

are also subjected to the Raytheon Fly-Back Tests — and as a result meet Raytheon's highest standards of quality. Ask your Raytheon Tube Distributor for them.



RAYTHEON MANUFACTURING COMPANY

Receiving Tube and Semiconductor Operations

NEWTON 58, MASS. 55 Chapel Street CHICAGO, ILL. 9501 Grand Ave. (Franklin Park) ATLANTA 6, GA. 1202 Zonolite Rd., N.E. LOS ANGELES 7, CALIF. 2419 So. Grand Ave.

Raytheon makes all these } Receiving and Picture Tubes, Reliable Subminiature and Miniature Tubes, Semiconductor Diodes and Transistors, Nucleonic Tubes, Microwave Tubes.



You Practice SERVING

with Kits NRI Sends



Right now, a solid, proven field of opportunity for good pay is servicing the millions of Television and Radio sets now in use. With NRI's Servicing Course, *without extra charge*, you get NRI kits developed especially to give actual practice with Television-Radio equipment. You build, test, experiment with actual Television-Radio receiver circuits; build, use testing equipment. All equipment is yours to keep.

You Practice BROADCASTING

with Kits NRI Sends



Clearly written NRI lessons teach TV-Radio-Electronics principles. Right in your own home, during spare time, you gain knowledge, get confidence building experience, develop skills needed to get and hold jobs in this vast industry. As part of NRI communications training you build low-power Broadcasting Transmitter, other equipment; train for your FCC Commercial Operator's license. You learn by doing.

I Will Train You at Home in Spare Time to be a TELEVISION-RADIO Technician

TELEVISION Making Jobs, Prosperity



A steady stream of new electronic products is increasing opportunities for TV-Radio Technicians. The millions of Television and Radio sets now in use need servicing. Hundreds of TV and Radio stations on the air offer interesting jobs for Operators and Technicians.

America's Fast Growing Industry Offers You Good Pay, Success



People look up to and depend on the Technician, more than ever before. His opportunities are great, and are increasing. Become a TV-Radio Technician. At home and in your spare time, you can learn to do this interesting, satisfying work—qualify for important pay. NRI is America's oldest and largest home study TV-Radio school with over 40 years' experience and thousands of successful graduates. NRI methods are tested, proved. Successful graduates are everywhere.

Technical Know-How Brings Better Pay, Advancement

NRI TRAINED THESE MEN



"My income has steadily increased in Radio. I have advanced to Chief Engineer of TV Station KTIV."—**A. H. SMITH**, Sioux City, Iowa

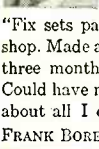

"Fix sets part time in my shop. Made about \$500 first three months of the year. Could have more but this is about all I can handle."—**FRANK BORER**, Lorain, O.



"I've come a long way in Radio and Television since graduating. Have my own business on Main Street."—**JOE TRAVERS**, Asbury Park, New Jersey.



"Before finishing the NRI course I was employed as Studio Engineer at KMMJ. I am now announcing."—**BILL DELZELL**, Grand Island, Nebraska.



New electronic products are boosting the need for more and more trained TV-Radio Technicians. Offices, plants, homes everywhere—are obliged to buy their knowledge and services. For instance, transistor Radios, Color TV, Hi-Fi, were unknown a few years ago. Guided missiles, computing machines, automation would not be possible without this miracle science—Electronics. Police, Aviation, Mobile Two-Way Radio are expanding. The military services reward qualified Technicians with higher rank and pay. To ambitious men everywhere, here is rich promise of fascinating jobs, satisfaction and prestige, increasing personal prosperity.



Start Soon to Make \$10, \$15 a Week Extra Fixing Sets

NRI students find it easy and profitable to start fixing sets for neighbors and friends a few months after enrolling. Use the Tester built with parts NRI furnishes to locate and correct TV-Radio receiver troubles. Picking up \$10, \$15 and more a week gives substantial extra spending money. Many who start in spare time, soon build full time TV-Radio businesses.

Mail Coupon — Find Out What Television-Radio Offer You

You don't have to know anything about electricity or Radio to understand and succeed with NRI courses. And you train in your own home—keep your present job while learning. NRI has developed simplified, practical training methods. Ambitious men can get ahead fast. Many successful NRI men did not finish high school. Mailing the coupon can be one of the most important acts of your life. Do it now. Reasonable tuition, on low monthly payments. Let us send you an actual lesson FREE. Judge for yourself how easy it is to learn. A 64-page catalog gives details of opportunities and training. Address: **NATIONAL RADIO INSTITUTE, Dept. 8GE, Washington 16, D. C.**

Good for Both - FREE

NATIONAL RADIO INSTITUTE,
Dept. 8GE Washington 16, D. C.
Mail me Sample Lesson and 64-page Book, FREE,
(No salesman will call. Please write plainly.)

Name _____ Age _____
Address _____
City _____ Zone _____ State _____

ACCREDITED MEMBER NATIONAL HOME STUDY COUNCIL



Mail Today-Tested Way to Better Pay

RADIO & TV NEWS is published monthly by Ziff-Davis Publishing Company, William B. Ziff, Chairman of the Board (1946-1953), at 434 S. Wabash Ave., Chicago 5, Ill. Entered as second-class matter July 21, 1948, at the Post Office, Chicago, Ill., under the act of March 3, 1879. Authorized by Post Office Department, Ottawa, Canada, as second-class matter. SUBSCRIPTION RATES: one year U. S. and possessions, and Canada \$4.00; Pan American Union Countries \$4.50; all other foreign countries \$5.00.

RADIO & TV NEWS

Reg. U. S. Pat. Off.

Publisher

OLIVER READ, D. Sc., WIET

Editor

WM. A. STOCKLIN, B. S.

Technical Editor

MILTON S. SNITZER

Service Editor

SIDNEY C. SILVER

Associate Editor

P. B. HOEFER

West Coast Editor

EDWARD A. ALTSHULER

Assistant Editor

J. JUSTER

Television Consultant

WALTER H. BUCHSBAUM

Art Editor

HERBERT ASCHER

Art and Drafting Dept.

**J. A. GOLANEK
JAMES A. ROTH
MILTON WHELPLEY**

Advertising Director

JOHN A. RONAN, JR.

Midwest Adv. Manager

W. ROBERT WOLFE

Western Adv. Manager

JOHN E. PAYNE



ZIFF-DAVIS PUBLISHING COMPANY
William Ziff, President; H. J. Morgan-
roth, Vice-President; W. Bradford
Briggs, Vice-President; Michael Michael-
son, Vice-President and Circulation Di-
rector; Victor C. Stabile, Treasurer;
Hershel B. Sarbin, Secretary; Albert
Gruen, Art Director.

Editorial and Executive Offices
One Park Avenue
New York 16, N. Y. OR. 9-7200



MEMBER
INSTITUTE OF



BRANCH OFFICES: Midwestern Office,
434 S. Wabash Ave., Chicago 5, Ill.;
Western Office, Room 412, 215 W. 7th
St., Los Angeles 14, Calif., John E.
Payne, manager.

First in radio-television-audio-electronics

Average Net Paid Circulation 246,225

Radio & Television News • Radio News • Television News Trademarks Reg. U. S. Pat. Off.

CONTENTS

JULY, 1958

VOL. 60 ■ NO. 1

ELECTRONICS—GENERAL

How Small Can They Get? (Editorial).....	W. Stocklin	10
Spot News.....	Washington Correspondent	25
Video Tape—Tape That Takes Pictures.....	Ronald L. Anderson	42
Radiation Detectors—A Technician's View (Part 1).....	Allan Lytel	44
Hi-Fi Anagram.....	James A. Comstock	105

HIGH FIDELITY AND AUDIO

Speakers for Stereo.....	Herman Burstein	29
Is a Loudness Control Necessary?.....	Burt Hines	34
Stereo Control Center.....		38
Simple Transistor Mixer.....	Glenn E. Johnson	47
A Hi-Fi 50-Watt.....		51
3-D Hi-Fi Amplifier.....	A. V. J. Martin	59
Mac's Service Shop (Tape Recorder Tips).....	John T. Frye	62
Automatic Motor Control For Hi-Fi Turntables.....	George F. Andrews	86
Magnetic Recording—1914 Style.....	H. M. Tremaine	90
Hi-Fi—Audio Product Review.....		94
Sound on Tape.....	Bert Whyte	102
Certified Record Revue.....	Bert Whyte	108

TELEVISION-RADIO

TV Circuit Improvements.....	Walter H. Buchsbaum	39
A Parabolic Antenna for U.H.F. TV.....	Harold Harris & Paul Mattern	50
Troubleshooting AM-FM Combinations.....	J. Richard Johnson	52
Operating Costs—Fact and Fantasy.....	William Leonard	54
Service Association of the Month (ARTSNY).....		80
Service Industry News.....		88
Test Bench Puzzler: No. 1.....	Art Margolis	115
Service Notes.....		121

TEST EQUIPMENT

Electronic Ignition Analyzer.....	Dan Peters	48
New Tube Tester Data.....		84

AMATEUR AND COMMUNICATIONS

Communications in Fire Control.....	Lee Zitko	33
This Month's Cover.....		33
Transistorized Automatic Key.....	Roy A. McCarthy, K6EAW	36
Two-Band V.H.F. Converter.....	Everett G. Taylor, W8NAF	60

ELECTRONIC CONSTRUCTION

Designing a Telephone Amplifier.....	Carl David Todd	55
--------------------------------------	-----------------	----

DEPARTMENTS

Letters from Our Readers.....	12	What's New in Radio.....	82
Within the Industry.....	18	Manufacturers' Literature.....	100
Technical Books.....	126		

Copyright © 1958 by Ziff-Davis Publishing Company. All rights reserved.

SUBSCRIPTION SERVICE: All communications concerning subscriptions should be addressed to Circulation Dept., 434 S. Wabash Ave., Chicago 5, Ill. Subscribers should allow at least four weeks for change of address. Include your old address as well as new—enclosing, if possible, an address label from a recent issue of this magazine.

CONTRIBUTIONS: Contributors are advised to retain a copy of their manuscripts and illustrations. Contributions should be mailed to the New York Editorial Office and must be accompanied by return postage. Contributions will be handled with reasonable care, but this magazine assumes no responsibility for their safety. Any copy accepted is subject to whatever adaptations and revisions are necessary to meet the requirements of this publication. Payment covers all author's, contributor's, and contestant's rights, title, and interest in and to the material accepted and will be made at our current rates upon acceptance. All photos and drawings will be considered as part of the material purchased.

GET FREE FACTS

Let DeVry Tech
Prepare You in Spare Time To Be an
Electronics Technician

No Advanced Education Needed

Prepare now to get into one of the fastest-growing, big opportunity fields of the century—one that may give you that better

job you've always wanted, the chance you've always needed.

You may be the boss in your own service shop. The trained man in Electronics is ready to step into one of the most profitable and exciting fields of our times.

More remarkable is the fact that you can get ready in your spare time at home. Or, if you prefer, you can attend day or evening classes in our well-equipped Chicago or Toronto laboratories.

Fill in coupon now! Don't forget—you need no previous technical experience. We will gladly give FREE facts to the man who wants to get ahead. Mail that coupon now! This could be the turning point in your life. Don't let it slip by!

Get FREE Booklet!

Get your free copy of an interesting booklet, "Electronics and YOU." See for yourself how you may take advantage of the opportunities in this fast-growing field.



MAIL TODAY FOR FREE FACTS

DeVry Technical Institute
4141 Belmont Ave., Chicago 41, Ill., Dept. RN-7-0
Please give me your FREE booklet, "Electronics and YOU," and tell me how I may prepare to enter one or more branches of Electronics as listed above.

Name _____ Age _____

PLEASE PRINT

Street _____ Apt. _____

City _____ Zone _____ State _____

Check here if subject to Military Training.

DeVry Tech's Canadian Training Center is located at
2042 626 Roselawn Avenue, Toronto 12, Ontario

PROFITABLE JOB OPPORTUNITIES IN ELECTRONICS:

- Communications • Radar
- Television • Computers
- Guided Missile Control
- Industrial Electronics
- Automation Electronics
- Your Own Service Shop

Employment Service

DeVry Tech's Placement Department is in contact with some of the best-known employers in the Electronics field. The service is free to all graduates — and DeVry Tech's record in helping to place men has been outstanding.

ARE YOU OF DRAFT AGE?

If you are subject to military service, be sure to check the coupon and get valuable information.

CAN YOU DO IT?

Laborers, clerks, farmers, salesmen, men of nearly every calling have taken the DeVry Tech program and today have better jobs or Electronic service shops of their own—REAL PROOF of the effective training offered by DeVry Tech.

27 YEARS' EXPERIENCE!

For over 27 years we have trained many men for better careers. This can mean a great advantage for men like you—practical training KNOW-HOW designed to get RESULTS!

Accredited Member of National Home Study Council

"One of North America's Foremost Electronics Training Centers"



DEVRY TECHNICAL INSTITUTE

CHICAGO 41, ILLINOIS

Formerly DeFOREST'S TRAINING, INC.



KT-500
IN KIT
FORM
74.50

New! Years Ahead!

LAFAYETTE STEREO TUNER KIT

ONLY
\$7.45
DOWN
7.00 MONTHLY



Use it as a Binaural-Stereophonic

FM-AM tuner

Use it as a Dual-Monaural

FM-AM tuner

Use it as a straight Monaural

FM or AM tuner

THE MOST FLEXIBLE TUNER EVER DESIGNED

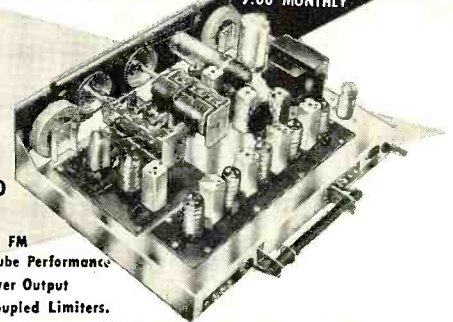

- 11 Tubes (including 4 dual-purpose) + Tuning Eye + Selenium rectifier Provide 17 Tube Performance
- Separately Tuned FM and AM Sections
- 12 Tuned Circuits
- Dual Cathode Follower Output
- Armstrong Circuit with FM/AFC and AFC Defeat
- Dual Double-Tuned Transformer Coupled Limiters.
- 10KC Whistle Filter
- Pre-aligned IF's
- Tuned Cascade FM

More than a year of research, planning and engineering went into the making of the Lafayette Stereo Tuner. Its unique flexibility permits the reception of binaural broadcasting (simultaneous transmission on both FM and AM), the independent operation of both the FM and AM sections at the same time, and the ordinary reception of either FM or AM. The AM and FM sections are separately tuned, each with a separate 3-gang tuning condenser, separate flywheel tuning and separate volume control for proper balancing when used for binaural programs. Simplified accurate knife-edge tuning is provided by magic eye which operates independently on FM and AM. Automatic frequency control "locks in" FM signal permanently. Aside from its unique flexibility, this is, above all else, a quality high-fidelity tuner incorporating features found exclusively in the highest priced tuners.

FM specifications include grounded-grid triode low noise front end with triode mixer, double-tuned dual limiters with Foster-Seeley discriminator, less than 1% harmonic distortion, frequency response 20-20,000 cps \pm 1/2 db, full 200 kc bandwidth and sensitivity of 2 microvolts for 30 db quieting with full limiting at one microvolt. AM specifications include 3 stages of AVC, 10 kc whistle filter,

built-in ferrite loop antenna, less than 1% harmonic distortion, sensitivity of 5 microvolts, 8-kc bandwidth and frequency response 20-5000 cps \pm 3 db.

The 5 controls of the KT-500 are FM Volume, AM Volume, FM Tuning, AM Tuning and 5-position Function Selector Switch. Tastefully styled with gold-brass escutcheon having dark maroon background plus matching maroon knobs with gold inserts. The Lafayette Stereo Tuner was designed with the builder in mind. Two separate printed circuit boards make construction and wiring simple, even for such a complex unit. Complete kit includes all parts and metal cover, a step-by-step instruction manual, schematic and pictorial diagrams. Size is 13 3/4" W x 10 3/4" D x 4 1/2" H. Shpg. wt., 18 lbs.

The new Lafayette Model KT-500 Stereo FM-AM Tuner is a companion piece to the Models KT-300 Audio Control Center Kit and KT-400 70-watt Basic Amplifier Kit and the "Triumvirate" of these 3 units form the heart of a top quality stereo hi-fi system.

KT-500.....Net **74.50**



TINY 6 TRANSISTOR RADIO

• LIGHT • SMALL • SENSITIVE
LOW PRICE HIGH PERFORMANCE

- PUSH-PULL AUDIO OUTPUT FOR FAITHFUL TONE QUALITY
- FULL TONE DYNAMIC SPEAKER
- BUILT-IN FERRITE BAR ANTENNA
- TROUBLE-FREE PRINTED CIRCUIT
- 6 ULTRA-MODERN TRANSISTORS PLUS GERMANIUM DIODE
- SUPERHETERODYNE CIRCUIT
- HIGHLY STYLED PLASTIC CASE
- EARPHONE JACK—BUILT IN—FOR PRIVATE LISTENING
- ECONOMICAL—USES ONLY ONE BATTERY

SIZE: 1 3/8" x 2 3/4" x 4 5/8" WEIGHT: 12 OUNCES

FS-110 — LAFAYETTE "TINY" TRANSISTOR RADIO COMPLETE

with Battery, Carrying Case and EarphoneNet **29.95**

REGULARLY

~~48.50~~

29.95

Including Earphone,
Battery and
Carrying Case

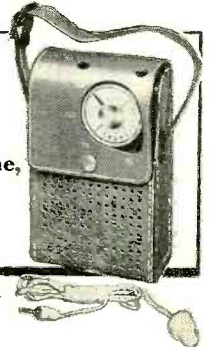

NEW! POWER MEGAPHONE... Portable Sound Broadcaster

- Uses 8 Flashlight Cells
- Completely Self-Contained
- Weighs only 6 1/2 lbs. with Batteries
- High Efficiency Horn Projects Sound 1000 Ft.
- Shoulder Strap for Portability and Ease of Use
- Microphone Detachable On 10-Foot Cord
- For Construction, Auctions, Carnivals, Fire & Police Use
- Also Ideal for Marine, Railroad, Civil Defense, Sporting Events

A power megaphone with many unusual features and many applications. Basically a highly efficient sound projector horn with a built-in microphone, capable of amplifying and projecting the voice with a range of 1000 feet. The microphone is a telephone-type element, easily replaceable, and may be detached and extended up to 10 feet from the horn. The reflex-type horn is extremely light-weight, rubber-rimmed, of strong, sturdy spun aluminum construction with 2 3/4" air column and is supplied with a strap for carrying or placing on the shoulder. A press-to-talk switch on the microphone provides for economy of power use—power is used only when actually talking. No warm-up time required—amplification is instantaneous. A patented non-linear current limiting device restricts current flow to safe levels for longest battery life. Uses 8 size "D" flashlight cells in series with an approximate life of about 10 hrs. of use. Battery housing serves as base for entire assembly. Battery compartment opens easily by means of 2 thumbscrews for battery replacement. Size 17" long overall; horn mouth is 12" diam. Shpg. wt., 8 lbs. less batteries.

PA-13 — Power Megaphone, Less batteries.....Net **29.50**

BATTERIES FOR ABOVE—Burgess No. 2 or RCA

VS036—8 RequiredNet each **.13**



Reg. Value ~~69.50~~

ONLY **29.50**

Self-Contained—
Only 6 1/2 lbs.
**THROWS VOICE
1000 FT.**

SHOULDER
STRAP &
DETACHABLE
MIKE
JUST AIM
& TALK



Lafayette
DEPT
RG **Radio**

165-08 Liberty Ave.
JAMAICA 33; N. Y.

INCLUDE POSTAGE WITH ORDER

NEW YORK, N.Y. 100 6th Ave. Rector 2-8600	BOSTON, Mass. 110 Federal St. HUBbard 2-7850	BRONX, N.Y. 542 E. Fordham Rd. Fordham 7-8813	NEWARK, N.J. 24 Central Ave. MARket 2-1661	PLAINFIELD, N.J. 139 W. 2nd St. PLAINfield 6-4718
---	--	---	--	---

Use Delco Radio Service Parts!

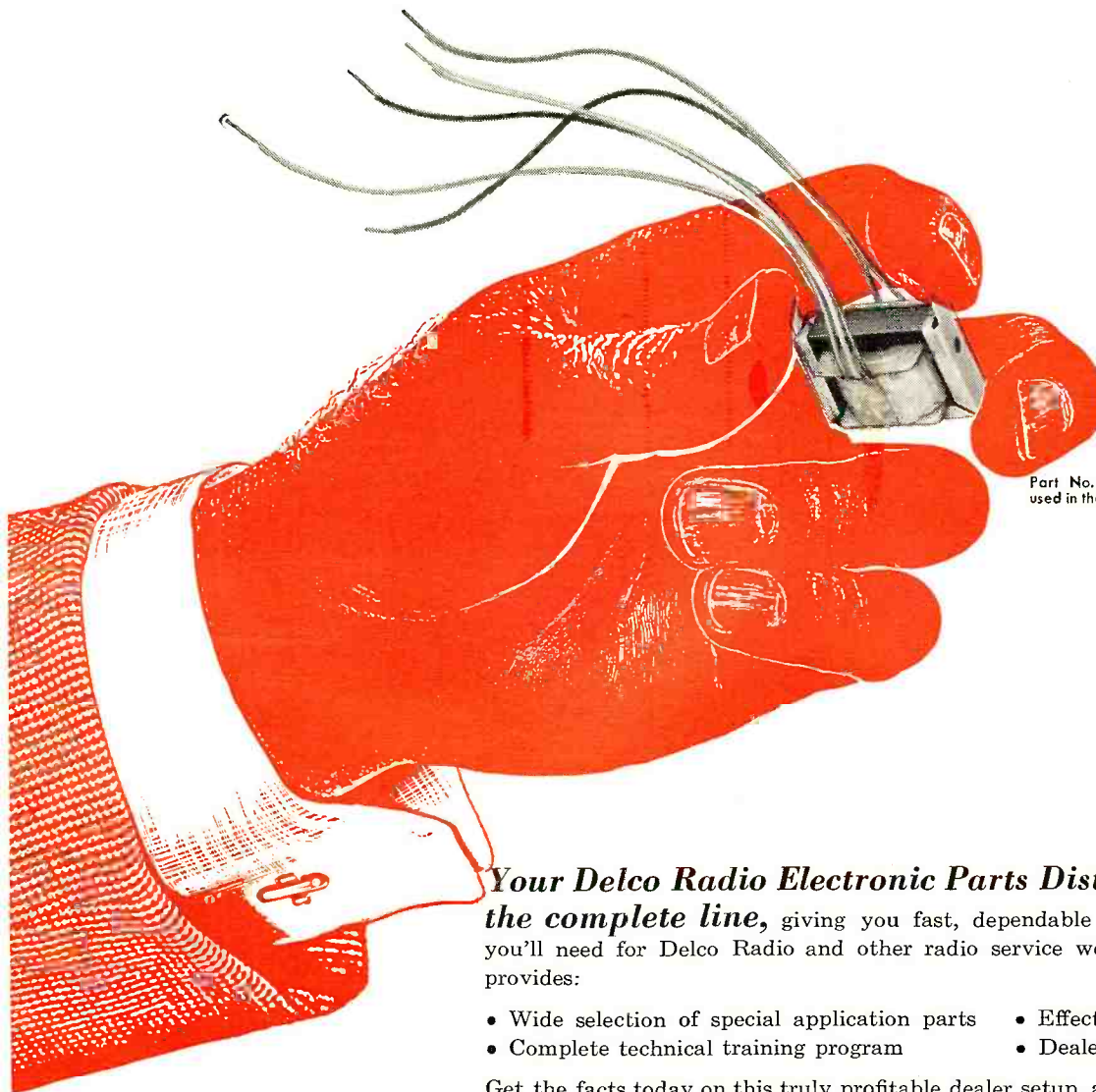

Part No. 7270804—output transformer used in the new Delco Portable Car Radio.

Your Delco Radio Electronic Parts Distributor carries the complete line, giving you fast, dependable service on the items you'll need for Delco Radio and other radio service work. Delco Radio also provides:

- Wide selection of special application parts
- Effective warranty program
- Complete technical training program
- Dealer identification signs

Get the facts today on this truly profitable dealer setup, and grow with General Motors!

Available everywhere through Electronic Distributors associated with . . .



DELCO RADIO

DIVISION OF GENERAL MOTORS, KOKOMO, INDIANA

<p>SPEAKERS</p>	<p>TUNER PARTS</p>	<p>TUBES</p>	<p>IRON CORES</p>
	<p>TRANSISTORS</p>	<p>COILS</p>	<p>RESISTORS</p>
		<p>VIBRATORS</p>	<p>CAPACITORS</p>
			<p>CONTROLS</p>



There's
no question
about it!

IF IT'S AN RCA TUBE...IT HAS TO BE "HEALTHY"!

RCA specializes in the production of "healthy" tubes. Take the RCA-6AX4-GT, for example. It features important built-in safety factors that minimize internal breakdowns and "arc-over", reducing early-hour failures—while providing reliable performance in TV damper circuits. Here are some of the ways RCA builds this "good health" into the 6AX4-GT:

Heater wire has been specially developed to improve welds, thereby reducing early-hour failures due to an open circuit at the weld point. Heater-spacer assemblies are pre-fired to eliminate leakage-producing contamination during tube production. And micas are specially sprayed to control plate-to-cathode leakage.

These are some of the reasons why many designers and manufacturers of TV sets specify RCA's 6AX4-GT—the very same reasons why you should always ask your RCA Tube Distributor to "Ship RCA Only"!



RADIO CORPORATION OF AMERICA
Electron Tube Division
Harrison, N. J.

**RCA Technical
Booklet Available**

RCA Receiving Tubes and Picture Tubes for AM, FM, and Television Broadcast (1275-H) ... includes socket information and useful data for more than 700 tube types. Ask your RCA Tube Distributor for your copy today!



Send for **FREE** booklet and get the

BIG PAYOFF

in **ADIO-TV-ELECTRONICS**

"You might like to know that since I have started this course, my company has given me a \$32.00 a month raise. They seem to think anybody who has enough interest in their job to study at home is worth more money."

—Frank J. Mulvey, 910 124th St., S.,
Renton, Washington

What would a raise of just \$8 a week (\$416 per year) mean to You!

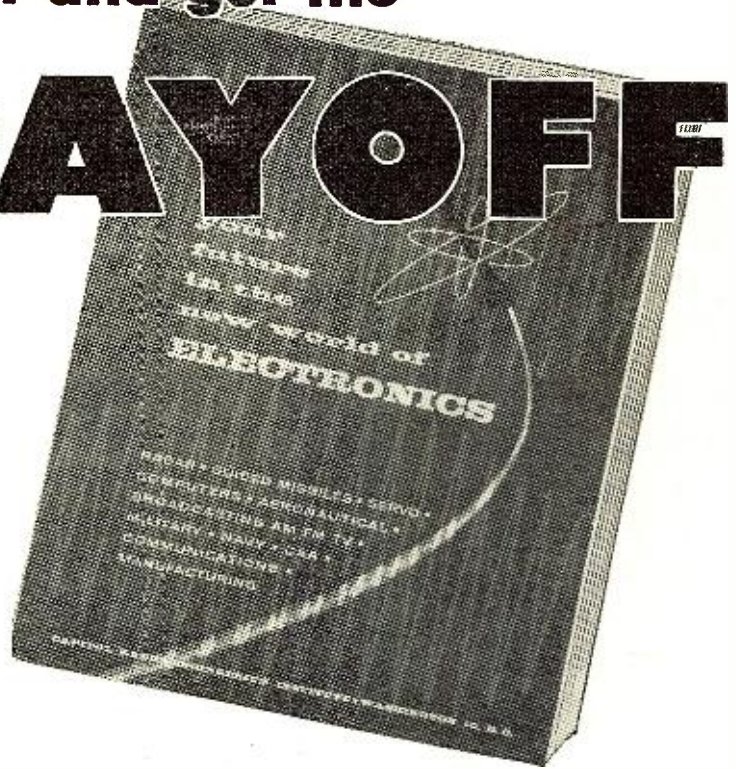

Think of it! Only one \$8-a-week raise (such as Frank Mulvey received) will repay your investment in CREI training, and leave you a substantial profit the very first year! Your increases in pay thereafter are all pure profit, and you'll be prepared for many more promotions and pay raises in the future years of your life!

CASH IN ON THE BIG PAYOFF!

Why let opportunity to make more money pass you by because of lack of training? This booklet describes in detail how CREI training equips you quickly at home to forge ahead into a good paying job—in TV (color, too)—industrial communications—research—aeronautics and scores of other fields in this mushrooming industry.

CREI TRAINING MEANS PROMOTION—PAY INCREASES WITHIN SHORT TIME

Here is just one of the many letters received from CREI students: "In this time of less than two years, I have almost doubled my salary and have gone from wireman to engineering assistant and now to junior engineer. I have CREI to thank."—Frank A. Eckert, 22 Clover Lane, Levittown, Pa.

CREI TEACHES YOU WHAT INDUSTRY WANTS

So leading firms recommend CREI training for their own personnel. Among them are: All American Cables and Radio, Inc.; Canadian Broadcasting Corporation; Columbia Broadcasting System; Gates Radio Company; Federal Electric Corp.; The Martin Company; Douglas Aircraft Co.; U. S. Information Agency (Voice of America); Canadair Limited; Trans-Canada Air Lines; United Air

Lines. Their choice for training of their own personnel is a good cue for your choice of a school.

CREI GRADUATES GET TOP JOBS

CREI maintains constant contact with the electronic industry, and cooperates with employers and graduates in making satisfactory placements. This free service is available to students, as well as graduates.

NAME YOUR GOAL!

CREI training equips you to pass FCC exams, qualify for top jobs; or, start your own business—many a graduate has been launched on a successful, self-owned business career, thanks to CREI.

WHY WAIT? YOU CAN'T LOSE!

You already have practical experience.

Add to it CREI's advanced training and be assured of excellent pay, a bright future and job security in all electronics fields.

You owe it to yourself! Fill out coupon and mail today. No obligation. You'll receive your copy of "Your Future in the New World of Electronics" right away.

CREI ALSO OFFERS RESIDENCE TRAINING IN WASHINGTON, D. C.

... at the same high technical level. Day and evening classes start at regular intervals. Qualified residence school graduates earn degree as "Associate in Applied Science." Check coupon if you prefer residence or home study information ... or write Capitol Radio Engineering Institute, Dept. 117-E, 3224 16th St., N.W., Wash. 10, D. C.

MAIL TODAY FOR YOUR FREE BOOKLET

CAPITOL RADIO ENGINEERING INSTITUTE

ECPD Accredited Technical Institute Curricula—Founded 1927
Dept. 117-E, 3224-16th St., N.W., Washington 10, D. C.

Please send me your course outline and FREE illustrated Booklet, "Your Future in the New World of Electronics" ... describing opportunities and CREI Home Study courses in Practical Electronic Engineering Technology.

- CHECK FIELD OF GREATEST INTEREST
- Radar, Servo and Computer Engineering Technology
 - Electronic Engineering Technology
 - Broadcast (AM, FM, TV) Engineering Technology
 - Television Engineering Technology
 - Aeronautical Electronic Engineering Technology

If you have had a high school education, and experience in electronics—and realize the need of a high-level technical knowledge to make good in the better electronic jobs—you can qualify for CREI home study training. (Electronics experience is not required for admission to CREI Residence School.) Please fill in the following information.

Employed By _____

Type of Present Work _____

Education:

Yrs. High School _____

Yrs. College _____

Electronics Experience _____

Name..... Age.....

Street

City..... Zone..... State.....

Check: Home Study Residence School Korean Veteran

KLEINS

for the ELECTRONICS INDUSTRY

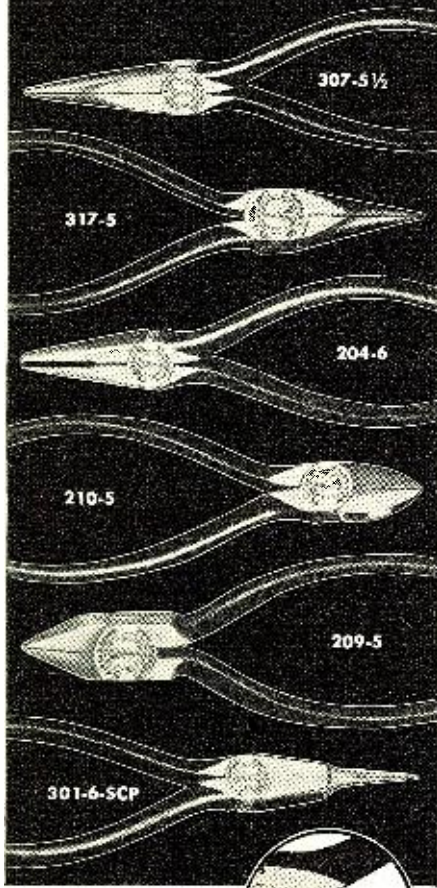

All pliers shown may be had with coil spring to hold jaws in open position. Spring guaranteed for the life of the plier.



Light in the hand... comfortable to use... points carefully matched... knives hand honed—all these features are yours with genuine Klein Pliers.

100 years of engineering skill and manufacturing experience are behind every pair of Kleins you buy.

You will be amazed at how much better a job you can do... how much faster you can do it... when the pliers you use are Kleins.

Foreign Distributor:
International Standard Electric Corp., New York

100 years of service to linemen, electricians and industry is back of this new Pocket Tool Guide No. 100. A copy will be sent to you on request without obligation.



Mathias **KLEIN** & Sons
Established 1857 Chicago, Ill. U.S.A.
7200 McCORMICK ROAD • CHICAGO 45 ILLINOIS

...for the Record

By **W. STOCKLIN**
Editor



HOW SMALL CAN THEY GET?

EVERYONE in the electronics industry should be familiar with the terms "module" and "miniaturization." It all started ten years ago with *Bell Telephone Laboratories'* announcement of the transistor but it wasn't until 1953 that *Raytheon* took the bull by the horns and made the big push with transistors in the hearing aid industry. The effect was instantaneous. The trend spread rapidly to other portions of the electronics industry and as a result the size, weight, and power consumption of equipment was reduced tremendously. Portable radios as we know them today are down to vest-pocket size without any sacrifice of battery life as compared to pre-war days. As a matter of fact, battery life has even been substantially extended with today's transistor sets.

This is the background, but it is far from being good enough today. The words "micro-module" and "micro-miniaturization" are terms that the industry will be thinking about in the future. It is hard for one to believe that there is room for further reduction in size and weight from what we are accustomed to today. On the other hand, we have just seen a diode vacuum tube manufactured by *G-E* that would fit into the shell of a standard triode tube that is no more than $\frac{3}{8}$ inch in height and $\frac{1}{4}$ inch in diameter. This is just a very small part of micro-miniaturization.

The entire program is not just a novelty. After many months of theorizing, experimental design, and manufacturing jointly with American industry, the Army Signal Corps recently placed the first of several extensive development contracts with *RCA* for five million dollars. The day of the single-function component is passing. The key to the future program is the fabrication of extremely small devices known as micro-modules. These are sub-assemblies made up of any number of individual wafers, each wafer measuring .3 inch square and .01 inch thick. Each module provides a specific circuit function and in a radio set it could be an entire stage. Each could, as an example, consist of a diode, coil, transistor, and a number of resistors and capacitors.

This entire program is, of course, directed to the military and was trig-

gered by the urgent need for extremely small size, bulk, and weight of equipment for the Army Signal Corps and certainly for the satellite instrumentation program. It will not stop there. It will certainly run the gamut of all types of electronic data processing equipment and communications equipment and there is no limit in the general field of industrial electronics and aviation. It will be applied to consumer end products such as radios and television sets only if and when the price can be brought low enough to compete with present methods. This is not possible in the immediate future. Actually, there is no specific need for miniaturization in these cases as the sizes of these units are much more dependent on speaker and picture tube dimensions, but there is no reason why the picture tube and speaker could not be separated from the rest of the circuitry.

A whole new concept of manufacture, supply, repair, and maintenance will develop with the widespread acceptance of micro-modular construction.

There will be a substantial increase in the dependability of electronic equipment since micro-modules are extremely rugged and not affected by shock and vibration.

The use of micro-modules will mean greatly simplified servicing and maintenance. An entire module assembly of perhaps 30 to 40 electronic components can be replaced easily without dissipating time and skilled manpower in separately testing individual elements of a stage. If trouble develops, an entire module is removed and replaced.

The supply and replacement problem is reduced since one micro-module will replace many individual components now required to be stocked for replacement purposes.

This is the future and it will affect everyone in the electronic industry from designer, through the distribution channels, and finally to the service technician who is depended upon to keep the equipment functioning.

To those who are in the radio and television field, it may be premature to take immediate action but to those who are in any other branch of the electronic industry, a thought to the future will help present-day planning.

-30-

See The Best Before You Build!

SEE THE AMAZING

ALLIED knight®-kits

IN THE WORLD'S LEADING ELECTRONIC SUPPLY CATALOG

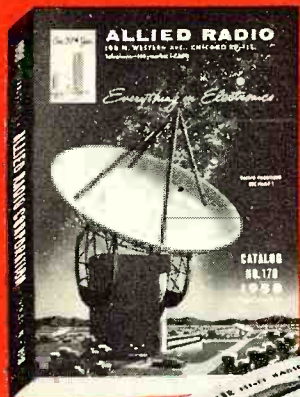

FREE! send for it now

THERE'S A knight-kit FOR EVERY NEED

- LOWEST COST
- EASIEST TO BUILD
- LATEST DESIGN
- FINEST QUALITY

Do-It-Yourself: **SAVE UP TO 50%**

EASY TERMS AVAILABLE

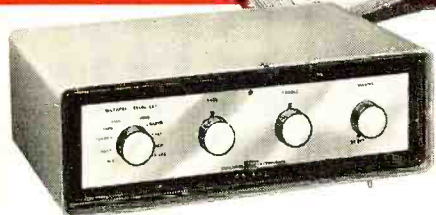

knight-kits:
BEST BUY
HI-FI
KITS

- 18-Watt Amplifier
- 30-Watt Amplifier
- 25-Watt Amplifier
- 20-Watt Amplifier
- 10-Watt Amplifier
- FM-AM Tuner
- FM Tuner
- Preamplifier
- 2-Way Speaker System
- 3-Way Speaker System



knight-kits:
BEST BUY
HOBBY
KITS

- "Space-Spanner" Radio
- "Ocean-Hopper" Radio
- "Ranger" AC-DC Radio
- 2-Way Intercom
- Electronic Lab Kits
- Crystal Set
- Wireless Broadcaster
- 5-Transistor Portable
- 2-Transistor Pocket Radio
- Transistor Lab Kit
- 1-Transistor Radio
- Photoelectric System
- Electronic Photoflash
- Phono Oscillator



knight-kits:
BEST BUY
INSTRUMENT
KITS

- Capacitor Checker
- R/C Tester
- Transistor Checker
- Flyback Checker
- Battery Eliminator
- 5" Oscilloscopes
- Vacuum Tube Voltmeter
- Tube Tester
- VOM's
- RF Signal Generator
- Signal Tracer
- Audio Generator
- Sweep Generator
- R/C Substitution Boxes
- Voltage Calibrator



knight-kits:
BEST BUY
AMATEUR
KITS

- All-Band Ham Receiver
- Self-Powered VFO
- 100 kc Crystal Calibrator
- 50-Watt Transmitter
- RF "Z" Bridge
- Code Practice Oscillator

ALLIED RADIO

404-PAGE ALLIED CATALOG

FREE!

Send for this value-packed catalog featuring the complete ALLIED KNIGHT-KIT line, as well as the world's largest stocks of everything in Electronics. You'll want this valuable, money-saving Buying Guide.



WRITE FOR YOUR **FREE** COPY TODAY

ALLIED RADIO CORP., Dept. 121-G8
100 N. Western Ave., Chicago 80, Ill.

Send FREE 1958 ALLIED 404-Page Catalog

Name _____

Address _____

City _____ Zone _____ State _____

Be sure
it's
a genuine
CHANNELLOCK



Most of them were built around the old type 49 tube and used exactly twelve volts "B+." I believe one of these circuits was called "the 49er." Many hybrid auto receivers use a 12K5 space-charge driver.

CLYDE E. WADE, JR.
Texarkana, Texas

Most of the tubes referred to by author Burgess are brand new types, especially designed for 12-volt operation. Many of our readers will be interested in knowing that the idea is not new, however.—Editor.

* * *

MORE ON RUSSIAN SET

To the Editors:

I noticed the letter in your May issue about a Russian receiver operated from a kerosene-lamp-heated thermocouple. The idea is not new. Thermocouples were used in Germany during the war to operate radio sets.

J. L.
Sudbury, Ontario

To the Editors:

I have just read a letter about the wonderful Russian radio set. I remember in Hungary this idea was tried about 26 years before, but I never heard about vibrator power in a battery operated set.

K. D.
Danbury, Connecticut

To the Editors:

In the November, 1912 issue of "Popular Mechanics" magazine, at the bottom of page 733, there was an article which shows and explains the use of kerosene to make electrical energy for radio purposes. The unit described is approximately 6" wide and 18" long and weighs 6 pounds.

RULISON ARCHER II
Daytona Beach, Florida

Maybe there is nothing new under the sun. For our many readers who wanted more details on the Russian set, watch for our August issue.—Editor.

* * *

SERIES-STRING TV TUBES

To the Editors:

The service problems and test procedures peculiar to TV sets with series filaments impose special burdens on the service industry. The TV industry has reached its great proportions by providing receivers which are reliable and free from trick circuits using popular paralleled filament tubes that are moderately priced as a result of mass production and standardization of types. The elimination of the filament transformer results in a savings to the manufacturer but creates many

OUR FEBRUARY ISSUE

To the Editors:

It is customary to write a letter to the editor only when one is peeved. I am breaking this time-honored tradition; my purpose is to extend congratulations on your February issue. I was particularly interested in the articles on radio astronomy and the electronic photoflash. The former is the type of thing one might expect to find only in a full-fledged scientific publication.

I knew very little about the electronic photoflash, but very little, especially about practical units. Now I know much more about them.

I am certainly pleased to see RADIO & TV NEWS publishing articles such as the above. Keep up the good work.

ROGER M. WILSON, W3EGI
Silver Spring, Maryland

This is the kind of letter we like to get.—Editor.

* * *

VERTICAL-SWEEP CIRCUITS

To the Editors:

I would like to thank you for publishing the article "Facts about Vertical-Sweep Circuits" by Warren Philbrook in your March, 1958 issue.

This article was very informative and I am sure was appreciated by many other readers, some of whom may have learned for the first time some of the puzzling facts on this subject or by others who found it an enlightening review.

I would like to see more articles published, prepared in the same manner, not only on other sections of television receivers, but on other electronic equipment. I especially appreciated the manner in which each component in the illustrated diagram was explained with its proper or improper function.

STEPHEN WIESNER
Cleveland, Ohio

Thanks very much for your comments on the above article. We are planning a series of other articles along the lines you suggest covering other sections of the TV receiver in a similar manner.—Editor.

* * *

TWELVE-VOLT TUBES

To the Editors:

In your March, 1958 issue there is an article "Twelve Volts—Heater and Plate" by Howard Burgess. This is a very interesting article, but the idea of using such low voltages for the "B+" is not new. I'm sure many of you will remember the space-charge receivers of quite a few years ago.

Only Channellock has this reinforced edge for greater strength.

Only Channellock has undercut interlocking non-slip channels.

LOOK FOR THIS TRADE MARK



ASK YOUR
TOOL SUPPLIER
FOR
CHANNELLOCK
PLIERS—
BY NAME

Why? Only Channellock has undercut, interlocking channels that can't slip no matter how tight you grip. Only Channellock has the reinforced tension edge to withstand maximum gripping force. These exclusive features have made the Channellock No. 420 the first choice of skilled mechanics everywhere. So be sure you get only genuine Channellock pliers. Look for the trademark on the handle.



CHAMPION DEARMENT TOOL COMPANY
MEADVILLE, PENNSYLVANIA

FREE from HOWARD W. SAMS!...valuable all-steel file cabinets with your purchase of **PHOTOFACT**—
the world's finest TV-Radio Service Data

FREE! FOR REGULAR PHOTOFACT SUBSCRIBERS

You get your File Cabinets FREE if you are a regular subscriber to PHOTOFACT Folders and buy all new Sets as issued each month. Your Folders come to you in special envelopes, each including a "Bonus Certificate." Sixty (60) of these entitle you to a single-drawer File Cabinet ABSOLUTELY FREE...



FREE! FOR PHOTOFACT LIBRARY PURCHASERS

Get FREE File Cabinets as you complete your profit-building PHOTOFACT Library... here's how:



FREE! Single-Drawer File Cabinet with your purchase of 60 Sets of PHOTOFACT Folders. Cabinet Worth... \$895



FREE! Two single-drawer File Cabinets with your purchase of 120 Sets of PHOTOFACT Folders. Cabinets Worth... \$1790



FREE! Three single-drawer File Cabinets with your purchase of 180 Sets of PHOTOFACT Folders. Cabinets Worth... \$2685



FREE! Four single-drawer File Cabinets with your purchase of 240 Sets of PHOTOFACT Folders. Cabinets Worth... \$3580



NEW EASY-BUY PLAN

It's easy to complete your present PHOTOFACT Library or start a PHOTOFACT Library. Use the EASY-BUY PURCHASE PLAN:

- NO INTEREST
- NO CARRYING CHARGE
- AS LITTLE AS \$10 DOWN
- UP TO 24 MONTHS TO PAY

Get the world's finest TV-Radio Service Data... get FREE File Cabinets with your PHOTOFACT purchases... take advantage of the Easy-Buy Plan. See your Sams Distributor today, or write to Howard W. Sams for full details.

get the full details of the **HOWARD W. SAMS** money-saving way to build your complete profit-making PHOTOFACT Library!

HOWARD W. SAMS & CO., INC.
2203 E. 46th St., Indianapolis 5, Indiana



Send details on your FREE File Cabinet offer and EASY-BUY Plan.

I'm a Service Technician: full time; part time

My Distributor is: _____

Shop Name: _____

Attn.: _____

Address: _____

City _____ Zone _____ State _____

First

from

PACO

Manufacturers of quality electronic equipment in kit form.



TRANSISTOR and Crystal Diode TESTER in kit form

Model T-65 only \$39.95

60% of all 1958 electronic equipment will include transistors and diodes.

PACO, the only test instrument kit line produced under the auspices of a major test equipment manufacturer, is the first to bring you a comprehensive transistor tester in kit form—available at your local distributor. This is the instrument you *must* have to maintain modern electronic equipment!

Produced in accordance with the recommendations of leading transistor manufacturers, PACO's T-65 provides comprehensive tests for I_{ebo} , gain, leakage, shorts, etc., on low, medium and high-power transistors of both the p-n-p and n-p-n types, as well as tetrode transistors.

25 YEARS OF PRECISION KNOW-HOW IS YOURS IN PACO KITS

MODEL V-70 VACUUM TUBE VOLTMETER KIT
• wide-range • peak-to-peak **NET PRICE: \$31.50**

MODEL B-10 BATTERY ELIMINATOR KIT
• less than 0.3% ripple • no external filters required **NET PRICE: \$41.95**

MODEL G-30 RF SIGNAL GENERATOR KIT
• 160 Kc to 240 Mc in 8 bands • 120 Mc fundamental **NET PRICE: \$28.50**

MODEL G-30-PC Same as Model G-30 but with pre-wired and precalibrated front end. **NET PRICE: \$35.50**

MODEL S-50 5" CATHODE RAY OSCILLOSCOPE KIT
• push-pull vertical and horizontal amplifiers. **NET PRICE: \$49.50**

MODEL C-20 RESISTANCE-CAPACITY-RATIO BRIDGE KIT
• 10 mmfd to 2000 mfd • ½ ohm to 200 megohms **NET PRICE: \$20.95**

MODEL T-60 TUBE CHECKER KIT
• full free-point lever selector system **NET PRICE: \$38.75**

MODEL Z-80 RF-AF SIGNAL TRACER KIT
• High gain RF & AF amplifier
• Visual-audible indicator **NET PRICE: \$29.50**

MODEL M-40 HIGH-SENSITIVITY V-O-M KIT
• 20,000 ohms/volt DC • 10,000 ohms/volt AC **NET PRICE: \$31.50**

► Available and on display at leading electronic parts distributors. Write for free descriptive bulletin.

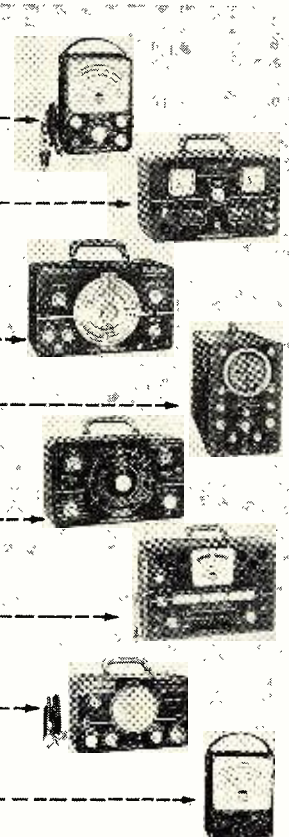

PACO ELECTRONICS CO., INC.

70-31 84th Street, Glendale 27, Long Island, New York

A DIVISION OF **PRECISION Apparatus Company, Inc.**

Export: 458 B'way, N. Y. 13. U.S.A., Canada: Atlas Radio Corp., Ltd., 50 Wingold Ave., Toronto 19

todes. I would not care to commit myself to saying that "Ultra-Linear" is better or worse than "Hartley" operation, but the fact remains that in terms of today's practice, an "Ultra-Linear" amplifier can give a very fine performance indeed. I think, however, it is necessary to point out that you can't run stabilized screen supply with "Ultra-Linear" because the screens are taken to the output transformer primary to give the feedback effect characterizing the system. Yet I think a case could be made out for stabilizing the plate supply as well as that for the screens.

So, then, the justification for making up my 1948 circuit today is found to be only when the constructor does not wish to go to the expense of buying an "Ultra-Linear" output transformer, and if he does insist on making it up, I offer a few minor improvements. For the voltage amplifier, quieter operation will be got by using the *Mullard* EF86 instead of a 6J7, and more power output will be achieved by using two EL34 tubes in the output stage. I don't want to be thought guilty of plugging *Mullard* tubes, but the two types I have just mentioned are very fine tubes.

As to actual constructional details, all that need be mentioned are that the grid, plate and screen stoppers should be soldered directly on to the tube sockets and that all "hot" wires be kept as short as possible. Apart from that no reader can go wrong.

H. H. HARTLEY
London, England

We hope that the above is the final word on the Hartley amplifier, about which we have had so many inquiries.
—Editor.

* * *

AUDIO SWEEP GENERATOR

To the Editors:

An unfortunate error crept into the parts list for the "Audio Frequency Sweep Generator" that appeared in the August, 1957 issue of *RADIO & TV NEWS*.

The value of C_{14} should have been 100 μmfd . rather than .001 μfd . This prevented proper operation of the reactance tube V_{5B} and in turn prevented the oscillation of the v.f.o. V_{5A} . The unit should work after this change.

Some of the constructors of this unit were disturbed by the 60-cycle ripple on the B+. This was not observed in the original unit. However, it may be that since the v.f.o. was not oscillating, it was drawing an abnormal amount of current which upset the normal filtering action. After making the above change, it is suggested that the hum measurement be made again. If the hum is more than can be tolerated, then I can only suggest the use of an eight or more henry choke in series with R_{11} . If desired, a bridge rectifier can be substituted for the half-wave unit shown.

RICHARD GRAHAM
Allendale, New Jersey

-30-

**THIS
DISPLAY
WILL SELL**

**PICTURE
TUBES
FOR
YOU**

**IT'S
BIG,
19" x 23½"**

**IN
FULL
COLOR**

Dr. T. V. SPARK SAYS...

YOU can check your own picture tube

• Tube 3 years old or older?
• Picture lost its brightness?
• Picture come on after sound?
• Look like a photo negative?
• Brown spot in the center?

Silver Vision
ALUMINIZED PICTURE TUBE

**YOU NEED A DEPENDABLE NEW
SILVER VISION PICTURE TUBE...**

from CBS-Hytron, a Division of
Columbia Broadcasting System, Inc.

Get this PA-215 Display Card FREE from your CBS-Hytron distributor



tubes® semiconductors

CBS-HYTRON, Danvers, Mass., A Division of Columbia Broadcasting System, Inc.

win a
dream
trip
for
two



to
the
**BRUSSELS
WORLD'S FAIR!**

win other exciting prizes...
in the big, new Rek-O-Kut contest!

Rek-O-Kut's exciting, new contest is a music-lover's delight! You can win a trip for two to the Brussels World's Fair via Sabena Belgian World Airlines... magnificent Rondine turntables... and turntable arms... just by listening to a Rek-O-Kut demonstration. Simply stop in at your high fidelity dealer, ask him to demonstrate high fidelity reproduction on a Rondine turntable, and fill out an entry blank. There are no puzzles to solve — no jingles to write — no coupons to clip — nothing to buy! You'll be eligible for one of the big contest prizes... and you'll have enjoyed music reproduction at its finest — on a Rondine! Prices from \$59.95.

Selected for display at the American Pavilion, Brussels World's Fair!

For the high fidelity dealer nearest you, write:
REK-O-KUT COMPANY, INC.
38-19 108th Street, Corona 68, New York

Win in the Industry

EDWARD J. WILDER has been promoted to the newly created position of assistant to the sales manager of *Gates Radio Company*, headquartered at the home office in Quincy, Illinois.



His previous position with the organization was that of Northeast regional manager with offices in New York City.

Prior to joining the company, Mr. Wilder was associated with a leading broadcast equipment distributor in New York City. His background also includes sales and station management experience in Virginia and Minnesota.

Mr. Wilder is a member of the Audio Engineering Society and an associate member of the IRE.

* * *

HAROLD W. LINDSAY, manager of industrial design at *Ampex Corporation*, was awarded a fellowship during the recent Audio Engineering Society Convention held in Los Angeles.

The award was given in recognition of Mr. Lindsay's pioneering contributions in the design and development of professional magnetic tape recorders in the United States.

Other contributions made by Mr. Lindsay include design of high speed production equipment for high precision magnetic head devices and industrial styling of professional recording equipment.

* * *

RALPH H. SCHLOTE has been promoted to the position of manager, specialty transformer sales for the *Sola Electric Company*.



Mr. Schlote has been a member of the organization since 1952. Prior to his promotion he served as a sales engineer in the Chicago office of the electronics firm.

A graduate of Marquette University, he holds a Bachelor of Electrical Engineering degree and is a member of the Institute of Radio Engineers.

* * *

ELECTRONIC INDUSTRIES ASSOCIATION is the recipient of this year's National Recognition Award for Association Achievement in the Public Interest presented by the U. S. Chamber of Commerce.

The award, which goes to large trade or professional groups, was given to EIA for initiating a national experiment in closed-circuit television

instruction to 23 primary and secondary schools with 12,000 students in Hagerstown, Md. The national citation was presented as a result of an entry submitted by Executive Vice-President James D. Secrest. It was accepted on behalf of the Association for President W. R. G. Baker by Robert C. Sprague, board chairman of *Sprague Electric Co.*

* * *

CAPTAIN ROLAND A. REUTHER, USN (Ret.), has been named assistant to the vice-president of *Cleveland Institute of Radio Electronics*.



In his new post Capt. Reuther will be in charge of field personnel, working out of the school's main office in Cleveland. He will also supervise development of new marketing and product areas.

Capt. Reuther, who is currently associated with the Institute at its West Coast sales operation, was retired from the Navy last year after 24 years of active service. In addition to considerable sea duty, for which he received the Silver Star Medal among other decorations, he was assigned in the fields of naval personnel and legal administration.

* * *

PYRAMID ELECTRIC COMPANY has moved from North Bergen, N. J., to Darlington, S. C. However, the firm's sales and accounting departments together with its jobber warehouse will remain in North Bergen and its manufacturing operation in Gastonia, N. C. ... **ROHN MANUFACTURING COMPANY** has added a complete new enameling process plant to its recently expanded facilities. Applied as a rust-corrosion preventive finish on the firm's towers and tubing, the coating process has been dubbed "*RohnKote*" ... Regional headquarters for sales of **GENERAL ELECTRIC COMPANY's** line of radio and television broadcast equipment have been established at 16247 Wyoming Ave., Detroit, Mich. ... A modern, air-conditioned plant will be built on a 15-acre site near Roanoke, Va., for use by **INTERNATIONAL TELEPHONE AND TELEGRAPH CORPORATION** to supplement its tube manufacturing facilities ... **SHERWOOD ELECTRONIC LABORATORIES, INC.** has moved to new and expanded quarters at 4300 North California Ave., Chicago, Ill. ... **CBS-HYTRON** and **COLUMBIA RECORDS** have acquired jointly a modern 28,000 square-foot warehouse at 2120 South Garfield Ave., Los Angeles, Calif. ... **TELEMATIC**

HOW TO PASS Your FCC Commercial LICENSE EXAMS*

GET YOUR FCC LICENSE IN A HURRY!

We guarantee
to train you until you receive
Your FCC license
—or your money back

The Master Course in Electronics will provide you with the mental tools of the electronics technician and prepare you for a First Class FCC License (Commercial) with a radar endorsement. When you successfully complete the Master Course, if you fail to pass the FCC examination, you will receive a full refund of all tuition payments.

“License and Good Job . . . Thanks”

“After finishing your Master Course, I passed the FCC exam for the 1st class license. I had my ticket for only one week and I got a job at WOC-TV, AM-FM. Incidentally, WOC is the oldest radio station west of the Mississippi. I sincerely feel that if it weren't for taking your Master Course, I would not have received my 1st class ticket. So I want to take this occasion to again thank you for such a fine, complete and composite study for electronics work.”

Francis J. McManus
Davenport, Iowa

Cleveland Institute training results in job offers like these:

Service Technician:
Man needed in Cleveland, Ohio to service and maintain electronic medical instruments and equipment. Must have a solid knowledge of electronic fundamentals. A car is required. Company benefits include retirement plan.

West Coast Manufacturer:
“We are currently in need of men with electronics training or experience in radar maintenance. We would appreciate your referral of interested persons to us.”

CLEVELAND INSTITUTE OF RADIO ELECTRONICS

Desk RN-19 4900 Euclid Ave. Cleveland 3, Ohio



Accredited by the National Home Study Council

Cleveland Institute of Radio Electronics

Desk RN-19, 4900 Euclid Ave., Cleveland 3, Ohio

We can train you to pass your License Exams if you've had any practical experience—amateur, military, radio servicing, or other. Our proven plan can help put you on the road to success.

• Your FCC ticket will be recognized by employers as proof of your technical ability.

Mail Coupon Now
and get both **FREE**

*good training doesn't cost
. . . it pays!*



Please send Free Booklets prepared to help me get ahead in Electronics. I have had training or experience in Electronics as indicated below.

- | | |
|---|---|
| <input type="checkbox"/> Military | <input type="checkbox"/> Broadcasting |
| <input type="checkbox"/> Radio-TV Servicing | <input type="checkbox"/> Home Experimenting |
| <input type="checkbox"/> Manufacturing | <input type="checkbox"/> Telephone Company |
| <input type="checkbox"/> Amateur Radio | <input type="checkbox"/> Other |

In what kind of work are you now engaged?

In what branch of Electronics are you interested?

Name _____ Age _____

Address _____

City _____ Zone _____ State _____

RN-19

Short description of a Small Efficient TV System...

1 antenna .. IN
8 set lines .. OUT
10 db signal .. GAIN

all with
 the



DISTRIBUTION AMPLIFIER

model DA8-B

approved
 for
 Color-TV

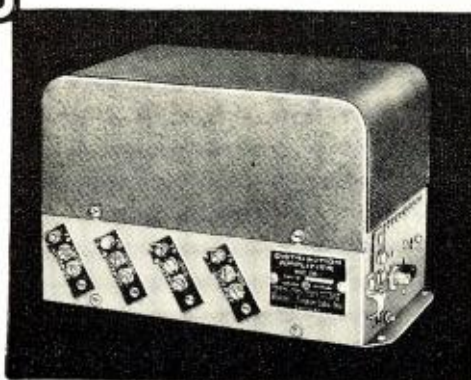

\$94⁵⁰ List

Ideal for garden apartments, motels, TV showrooms, deluxe home installations and other small TV systems. The DA8-B is a broadband, all-channel unit that requires no tuning, impedance matching devices, preamps or other special fittings.

Features and Specifications:

- Low noise all-triode circuit
- More than 10db gain on all VHF Channels
- Inter-set isolation in excess of 22db
- Provision for 75-ohm cable or 300-ohm twin lead
- Prevents overload through 10:1 gain control range
- Built-in power supply
- Designed for continuous duty operation

NOTE: For larger systems, Blonder-Tongue will furnish Free planning service on request.

Sold by Radio-TV Parts Distributors and Jobbers.

Write for Installation Details and FREE Booklet—"TV for 2. or 3. or More"

Dept. RTN-7

BLONDER-TONGUE
LABORATORIES, INC.
 9 Alling St., Newark 2, N. Y.



Manufacturers of TV Cameras,
 TV Amplifiers, Boosters, Converters,
 Accessories and Originators of the
 Masterline and 'Add-A-Unit'
 Master TV Systems.

INDUSTRIES, 251 Lee Ave., Brooklyn, N. Y., has expanded its production quarters from 20,000 square feet to 30,000 square feet . . . **MICHIGAN MAGNETICS, INCORPORATED** has announced the opening of a second plant at Allegan, Mich. . . . Consolidation of all United States research and development activities of *International Telephone and Telegraph Corp.* into a new division to be called **IT&T LABORATORIES** has been made known . . . **HUDSON TOOL AND DIE COMPANY** has completed expansion of production facilities for transistor closures . . . The sales, engineering, and manufacturing operations of the *Méchatrol Division of SERVOMECHANISMS, INC.* have moved into a new 55,000 square foot building at 1200 Prospect Ave., Westbury, Long Island, N. Y. * * *

DON JONSON has been appointed sales manager of *G-C Electronics Manufacturing Co.*, a division of *G-C Textron Inc.*



His new duties include taking charge of all marketing and promotion of the firm's complete line of carbon resistors and thermistors. His experience in the field of electronic sales is expected to be a great asset to the organization in building new distributor-customer sales.

Mr. Jonson comes to the company from the electronic division of the *Elgin National Watch Co.* where he was administrative assistant to the director of sales. * * *

ADOLPH L. GROSS, president of *Adolph L. Gross Associates*, manufacturer's representatives in the electronics industry, died recently of a cerebral hemorrhage at the age of 49.

Mr. Gross had been in the industry 30 years. He was associated with *Hudson Radio, Terminal Radio, and Newark Electric* prior to establishing his own company in 1952.

Representing *Pilot Radio, Wilcox-Gay, BSR, and Sony*, he was also associated with *Audiogersh Corp. and Kingdom Products, Ltd.*

During World War II he was a purchasing agent for several government agencies. * * *

TELEPOWER, a new firm which will design, develop, and produce transistorized electronic equipment to operate on radiated power, has been organized at Silver Spring, Maryland. The firm is headed by Lloyd R. Crump and is located at 12108 Atherton Drive . . . The boards of directors of **HOOKER ELECTROCHEMICAL COMPANY**, Niagara Falls, N. Y., and **SHEA CHEMICAL CORPORATION**, New York, N. Y., have approved a formal agreement for the consolidation of the two companies subject to the approval of the stockholders of each firm. Under the terms of the proposed consolidation the Niagara Falls organization will be the continuing company and its name will be changed

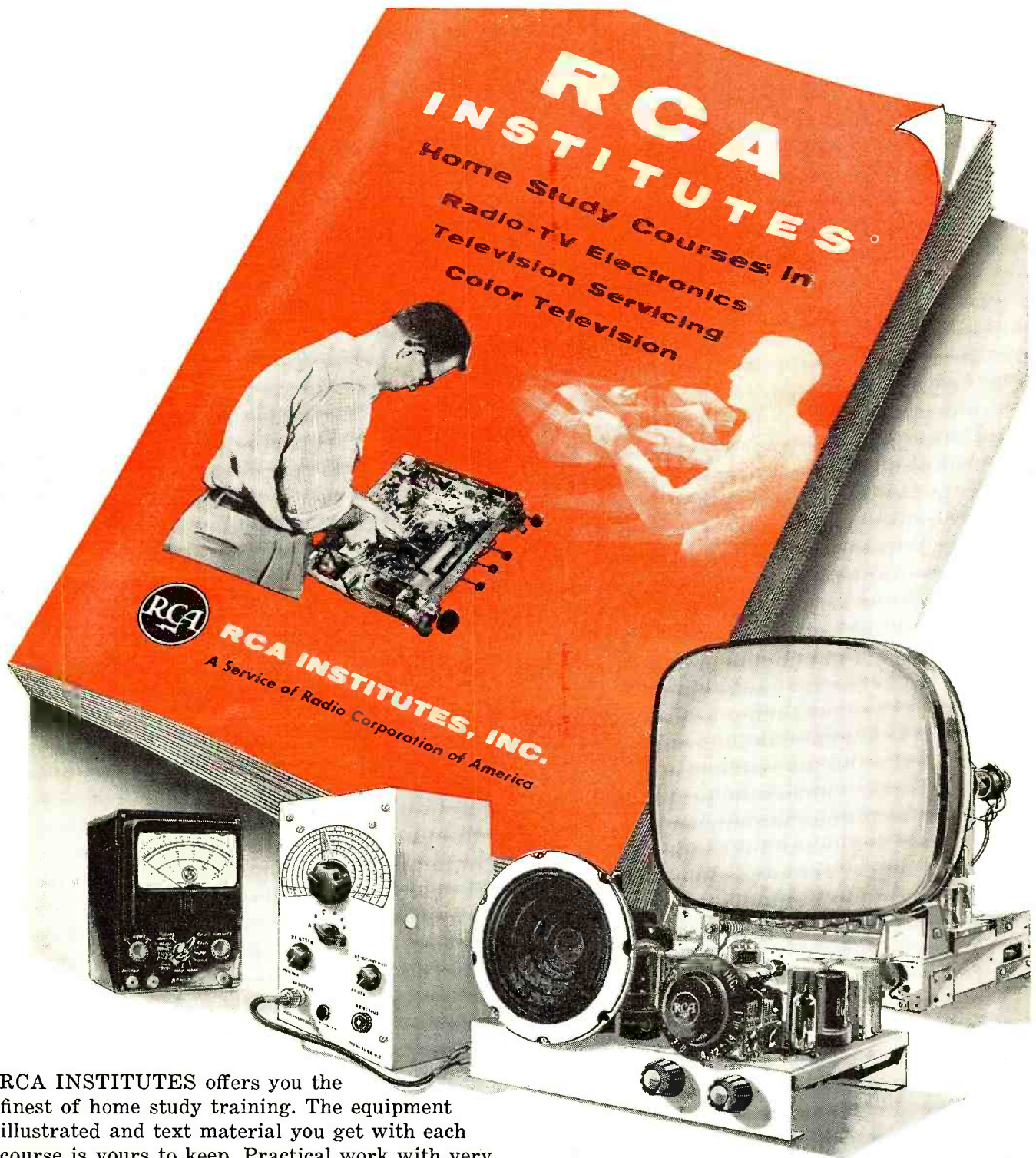

RCA INSTITUTES offers you the finest of home study training. The equipment illustrated and text material you get with each course is yours to keep. Practical work with very first lesson. Courses for the beginner and the advanced student. Pay-as-you-learn. You need pay for only one study group at a time.

**Send for this
FREE Book Now** 

RESIDENT SCHOOL courses in New York City offer comprehensive training in Television and Electronics. Day and evening classes start four times each year.

Detailed information on request

RCA INSTITUTES, Inc. Home Study Dept. RN-78

A Service of Radio Corporation of America

350 West Fourth Street, New York 14, N. Y.

Without obligation, send me FREE 52 page CATALOG on Home Study Courses in Radio, Television and Color TV. No salesman will call.

Name.....
please print

Address.....

City..... Zone..... State.....

Korean Vets! Enter discharge date.....

CANADIANS — Take advantage of these same RCA courses at no additional cost. No postage, no customs, no delay. Send coupon to: RCA Victor Company, Ltd., 5001 Cote de Liesse Rd., Montreal 9, Quebec
To save time, paste coupon on postcard.



**SUITS NEED PRESSING—
MERIT DEFLECTION YOKES
DO NOT!**

Merit deflection yokes are cosine wound TO FORM, not pressed. Pressing can lead to distortion and poor focusing. Pressing after winding frequently causes breakdown.

**MERIT COILS AND TRANSFORMERS HAVE
"BUILT-IN" ADVANTAGES.**

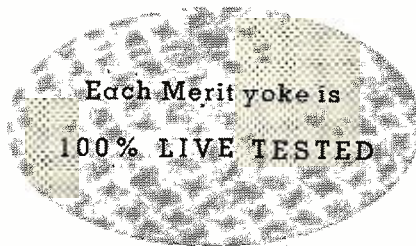
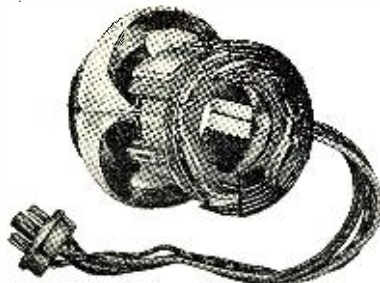



COMPARE IT WITH
MERIT

MERIT COIL AND TRANSFORMER CORP.
MERIT PLAZA • HOLLYWOOD, FLORIDA

to **HOOKER CHEMICAL CORPORATION** . . . Agreement has been reached on terms for the purchase of **MASSA LABORATORIES, INC.** by **COHU ELECTRONICS, INC.** The former will be operated as a division of the parent company . . . **HOFFMAN ELECTRONICS CORPORATION** has signed a working agreement with **HUMPHREY, INC.**, San Diego engineering and manufacturing company. Under the terms of the agreement the electronics firm has acquired a 30 per-cent interest in the San Diego organization for an undisclosed sum and has entered into a licensing arrangement to manufacture products developed by the latter company . . . The City Council of Palm Springs, Calif., unanimously approved the establishment of an electronics research and development organization within the city limits, even though no industry (other than the constructional field) has hitherto been granted a permit to operate. The electronics newcomer is **21ST CENTURY ELECTRONICS, INC.**, which was formed last year in Reno, Nevada, by a group of well-known electronics engineers and scientists for the purpose of undertaking advanced electronic and infrared research and development . . . **HUGHES AIRCRAFT COMPANY** and **MONOGRAM PRECISION INDUSTRIES, INC.** have signed an agreement permitting the latter company to manufacture a new group of microwave devices developed by the aircraft company's research and development laboratories . . . **GENERAL CEMENT MANUFACTURING COMPANY**, a division of **TEXTRON INC.**, has purchased the **AMERICAN MICROPHONE DIVISION** of **ELGIN NATIONAL WATCH COMPANY**. The present sales organization will remain intact and the new division will be known as **AMERICAN MICROPHONE MANUFACTURING COMPANY** . . . John Sanabria has announced his acquisition of **KINE-LAB, INC.**, 3250 Kenilworth Avenue, Berwyn, Ill.

* * *

H. LESLIE HOFFMAN, director and past president of Electronic Industries Association, has been chosen as the recipient of the 1958 EIA Medal of Honor.

Other news from the Association includes the decision by the consumer products division executive committee and tax committee to sponsor an all-out campaign for reduction of the excise tax on radio-TV sets and phonographs from 10 to 5 per-cent.

A special committee of the board has been appointed to investigate and act to curb the rising imports of Japanese-made radios and electronic gear.

Also, the tube and semiconductor division will take over the tube testing laboratory, heretofore operated by **RCA**, and will handle it as an Association service for tube and semiconductor manufacturers.

* * *

ASSOCIATION OF ELECTRONIC PARTS & EQUIPMENT MANUFACTURERS, INC. has announced 15 committees to carry on its activities. The committees, with
(Continued on page 120)

Get into

TELEVISION RADIO-ELECTRONICS



**LEARN ALL 8 PHASES
BY SHOP METHOD**

**OF THE INDUSTRY
HOME TRAINING**

1. Television . . . including Color TV
2. Radio . . . AM, FM
3. Industrial Electronics
4. Communications
5. Sound Recording & Hi-Fidelity
6. Automation
7. FCC License Preparation
8. Radar & Micro Waves

Let National Schools of Los Angeles, a Practical Resident Technical School for over 50 years, train you at home by Shop-Method for unlimited opportunities in All phases of TV, Electronics, Radio.

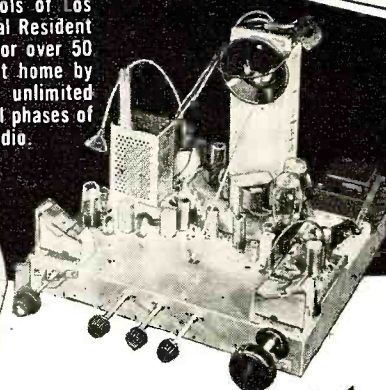

**You get 19 big kits
of equipment!**

**GOOD JOBS . . . MORE MONEY
SECURITY . . . ALL CAN BE YOURS**

YOU are needed in the great modern Television-Electronics industry. Trained technicians are in growing demand, at excellent pay, in sales and service, manufacturing, broadcasting, telecasting, communications, research, and many other important branches of the field. National Schools Master Shop-Method Training, with newly added lessons and equipment prepares you in your spare time right in your own home for these fascinating opportunities. **OUR OUTSTANDING METHOD IS PROVED BY THE SUCCESS OF GRADUATES ALL OVER THE WORLD!**

YOUR TRAINING IS ALL INCLUSIVE

We prepare you for a long list of job opportunities. Thousands of TV and Radio receivers are being sold every day—more than ever before. And, now, Color TV is here. Applications of Electronics in industry—**AUTOMATION**—are growing in tremendous strides. The whole field is alive—opening up new, important jobs rapidly. National Schools complete training program qualifies you in all phases of the industry.

YOU EARN WHILE YOU LEARN

Many students pay for their entire training—and more—with spare time earning. We'll show you how you can, too! Early in your course you receive material that shows you how to earn extra money servicing TV and Radio receivers, appliances, etc., for friends and acquaintances.

YOU GET EVERYTHING YOU NEED

Clear, profusely illustrated lessons, shop-tested manuals, modern circuit diagrams, practical job projects—all the valuable equipment shown above—many other materials and services—consultation privilege with our qualified staff, and Graduate Employment Service. **EVERYTHING YOU NEED** for outstanding success in Electronics.

**INDUSTRY NEEDS YOU. NATIONAL SCHOOLS
WILL TRAIN YOU. SEND FOR FACTS TODAY
NO OBLIGATION.**

YOU LEARN BY SHOP METHOD . . . you do servicing, circuit analysis, and do over 100 down-to-earth experiments. You build a Superhet Receiver and a modern TV Receiver, from the ground up, including a new, big screen picture tube. You also receive a professional, factory-made **MULTI-TESTER**. All of this standard equipment is yours to keep . . . at just one low tuition.

RESIDENT TRAINING AT LOS ANGELES

If you wish to take your training in our Resident School at Los Angeles, the world's TV capital, start NOW in our big, modern Shops, Labs and Radio-TV Studios. Here you work with latest Electronic equipment—professionally installed—finest, most complete facilities offered by any school. Expert, friendly instructors. Personal attention. Graduate Employment Service. Help in finding home near school—and part time job while you learn. Check box in coupon for full information.

Approved for
GI Training



NATIONAL SCHOOLS

LOS ANGELES 37, CALIF.

**FREE!
VALUABLE BOOK
& SAMPLE LESSON
—Just Send
Coupon!**

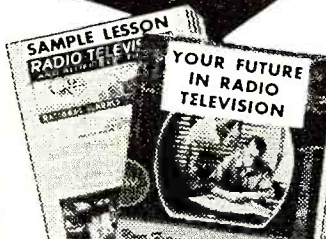

NATIONAL SCHOOLS

TECHNICAL TRADE TRAINING SINCE 1905
LOS ANGELES 37, CALIFORNIA

**GET FAST SERVICE—MAIL NOW TO
NATIONAL SCHOOLS, DEPT. RH-78**

4000 S. FIGUEROA ST. LOS ANGELES 37, CALIF.

Rush free TV-Radio "Opportunity" Book and sample lesson. No salesman will call.

NAME _____ AGE _____

ADDRESS _____

CITY _____ ZONE _____ STATE _____

Check if interested ONLY in Resident School training at Los Angeles.
VETERANS: Give date of Discharge _____

To AVOID amplifier and speaker WASTE...choose from

4 University WIDE-ANGLE SPEAKERS

For uniform dispersion of sound over a wide area

CHOICE OF 5 DRIVERS FOR CLH OR COBREFLEX

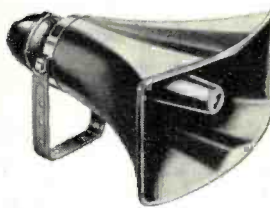

CLH 4½ ft. air column. Exclusive omni-directional bell and mounting bracket helps "tune out" reverberation and "dead spots." \$44.50 list.

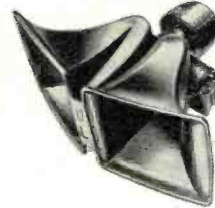

COBREFLEX All die-cast aluminum one piece construction resists a life-time of physical abuse. 2½ ft. air column. \$38.33 list.



CIB Built-in hermetically sealed driver. Excellent for "talk-back." Exclusive Positive-Lok omni-directional mounting bracket. \$42.00 list.



CMIL Smaller than CIB, perfect for voice. Built-in driver packs mighty wallop at low input power. Ideal for close quarter installations. \$29.75 list.



MA-25 \$27.50 list
85-6500 cps. 25 W.



SA-HF \$36.00 list
80-10,000 cps. 30 W.



SA-30 \$47.50 list
built-in matching trans.
80-10,000 cps. 30 W.



PA-HF \$47.50 list
70-10,000 cps. 50 W.



PA-50 \$57.50 list
built-in matching trans.
70-10,000 cps. 50 W.

Only University gives you the choice of speakers you need to ensure greatest economy of amplifier power, equipment and installation costs. No wasteful, "cure-all, do-all" compromises here. Each speaker is designed to do its specific kind of job most efficiently and reliably, with plenty of room for future expansion. Each speaker incorporates many exclusive features to fulfill every possible application. The chart below graphically shows the relative differences between these four speakers in terms of sound out-

put, input power, and low frequency response. Simply choose the intended application and determine the appropriate speakers. Or, depending upon existing operating prerequisites, select the speaker(s) capable of doing the job. That's all there is to it.

NOW AVAILABLE—Free Product Catalog. Or send \$1 for the NEW 64-page University TECHNOLOG, the complete speaker system planning manual. Desk A-6, University Loudspeakers, Inc., 80 S. Kensico Ave., White Plains, N. Y.

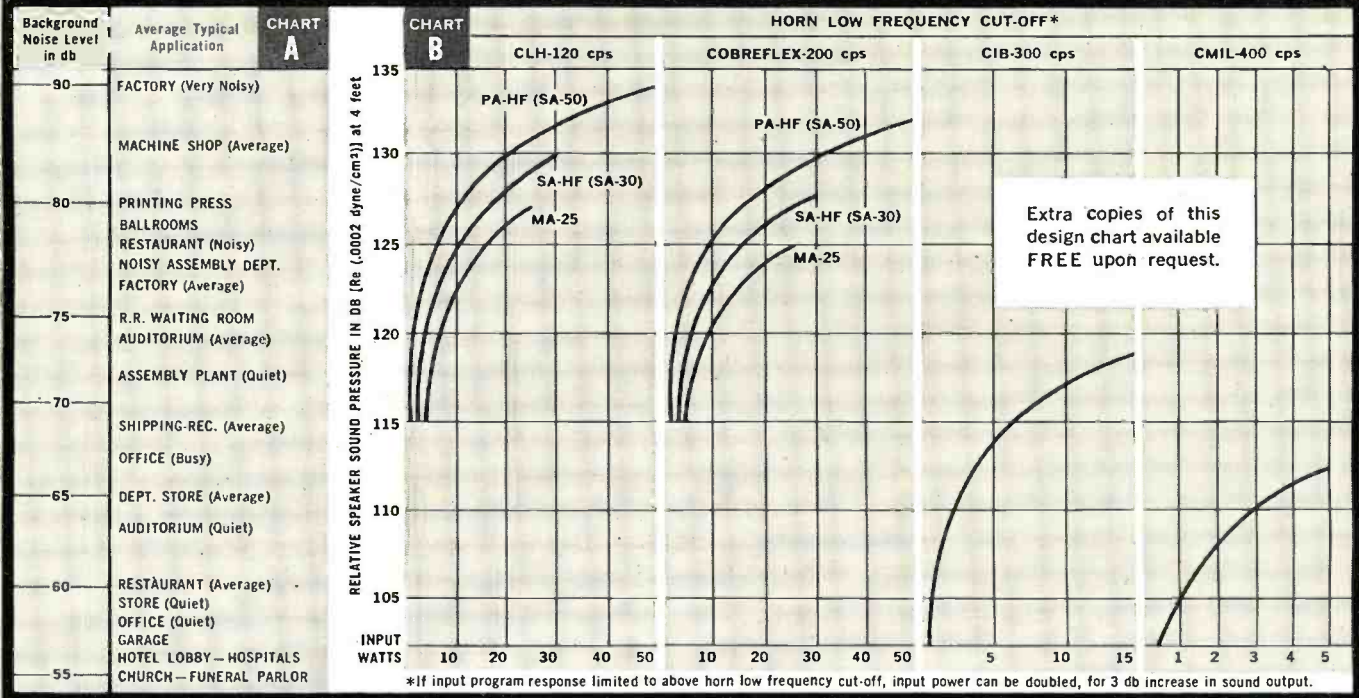

Extra copies of this design chart available FREE upon request.

HOW TO USE THIS CHART

- Determine sound pressure needed by finding noise level from Chart A, add loss of db in Table C and add adjusting factor in Table D.
- Draw horizontal line across Chart B corresponding to the db figure just calculated. This now establishes which speakers can be considered.
- A vertical line drawn to the base of Chart B shows the input power needed for each qualifying speaker.
- Now, further selection may be based upon frequency

response necessary (see Horn Cut-Off, Chart B), initial cost, operating economy and reserve power desired.

5. The CIB and CMIL may also be used in high noise levels by employing several throughout the listening area.

Example: Factory — noise level 90 db, 320,000 cu. ft., live acoustics, music and speech
90 + 25 + 5 = 120 db required

Qualifying speakers are CLH or Cobreflex, with any of the drivers. Final choice is determined by driver characteristics and installation problems. (Send for TECHNOLOG or Product Catalog.)

ROOM VOLUME CU. FT.	INDOORS			OUTDOORS	
	LIVE	NEUTRAL	DEAD	FURTHEST DISTANCE FT.	DB LOSS
1,000	0	3	6	4	0
3,200	5	8	11	8	6
10,000	10	13	16	16	12
32,000	15	18	21	32	18
100,000	20	23	26	64	24
320,000	25	28	31	128	30
1,000,000	30	33	36	256	36

PROGRAM ADJUSTING FACTOR	INDOORS DB	OUTDOORS DB
	SPEECH	4
MUSIC	6	11
MUSIC & SPEECH	5	9

RADIO & TV NEWS

LISTEN

University sounds better





Latest Information

on the Electronic Industry

Spot News

By RADIO & TV NEWS'
WASHINGTON EDITOR

MORE THAN FOUR IN FIVE HOUSEHOLDS NOW HAVE TV—A census survey recently completed by the Department of Commerce reveals that 83 per-cent of all households now have TV sets, as compared with 80 per-cent in April 1957, 73 per-cent in February 1956, and 12 per-cent in April 1950 . . . In addition to the continued spread of TV to more homes, there is also an increase in the proportion of those who have more than one receiver. About 7 per-cent now have more than one TV, compared with 5 per-cent in April 1957 and 4 per-cent in February 1956.

U.H.F. TRANSLATOR INSTALLED AT NEW MEXICO HOLLOWMAN AIR FORCE BASE—The Department of the Air Force has reported that a newly constructed 10-watt TV translator has begun u.h.f. transmissions at the Holloman Air Force Base, near Alamogordo, New Mexico. The station, telecasting on channels 75, 78, and 83, rebroadcasts programs from TV stations KROD-TV, KTSM, and KLIT, El Paso, Texas.

NAVY TV TRANSLATOR ACTIVATED ON GUAM—A channel-10 500-watt translator has been set up on Guam by the Navy. The station is located on Mount Alutom at an elevation said to be sufficiently high to permit island-wide service for the military bases on Guam. Program material consists of retransmissions of signals from Guam's commercial channel 8 station, KUAM at Agana.

FIVE VESSELS JOIN FLOATING MISSILE-SATELLITE TELEMETRY-DATA CHAIN—Five ships, known as CIMAVI (maritime designation for small cargo vessels), big brothers to six FS (freight supply) vessels which started servicing the tracking range about a year ago, are now helping to gather data from missiles and satellites along part of the 5000-mile Air Force Missile Test Range which stretches from Cape Canaveral, Florida to Ascension Island off the west coast of Africa . . . The new net serves to record impact data and chart the flight of intercontinental missiles between St. Lucia Island and the 3000-mile gap to end-of-the-range Ascension.

BBC DEVELOPS VIDEO TAPE RECORDING SYSTEM—A new technique for the recording of TV pictures on magnetic tape, with accompanying sound, has been developed by the research department of the British Broadcasting Corporation . . . Called Vision Electron Recording Apparatus—or VERA—the system has been designed and built by a team of BBC engineers headed by Dr. P. E. Axon and placed in experimental operation at the TV studios of BBC . . . Recordings, it is said, can be cut and the tape joined and played back as soon as the tape has been rewound, or in about six minutes . . . Unlike the system used here, VERA employs a standard grade of magnetic tape, half an inch wide, of the type generally used for sound recording.

REPORTS ON NAVY'S VANGUARD MINITRACK TRACKING AND TELEMETRY NOW AVAILABLE—The radio receiving systems used for tracking and collecting scientific data from the orbiting Vanguard satellite are described in two technical reports released by the Navy . . . One, called Vanguard Report 23, prepared by V. R. Simas and C. A. Bartholomew, is a 31-page booklet and is available from the Department of Commerce for \$1.00. Order identity is PB 131390—OTS . . . The second report, Number 24, also written by Simas, is a 17-page unit, also available from the Department of Commerce as PB 131396 for 50 cents.

AERONAUTICAL SEARCH AND RESCUE STATION PROPOSED—The FCC has served notice that it has proposed the establishment of a new class of station—Aeronautical Search and Rescue Mobile—which would use the 121.6 mc. band.

NEW PUBLIC SAFETY RADIO SERVICE CREATED—A new service—the Local Government Radio Service—for communications essential to local official activities has been ordered by the Commission . . . There are 47 split-channels in the 152-162 mc. band assigned to the new operation.

ON-THE-AIR TV STATIONS CLIMB—Operating TV stations, according to the FCC, now stand at 511; 425 are in the v.h.f. bands and 86 are u.h.f. stations . . . New station grants have gone to Malco Theatres, Oklahoma City, Okla., channel 19 (500-506 mc.), 22.85 kw. e.r.p.; and S. C. Corwin, San Diego, California, channel 27 (548-554 mc.), 129 kw. e.r.p.

-50-

Exciting News From CHANNEL MASTER'S Test Lab!

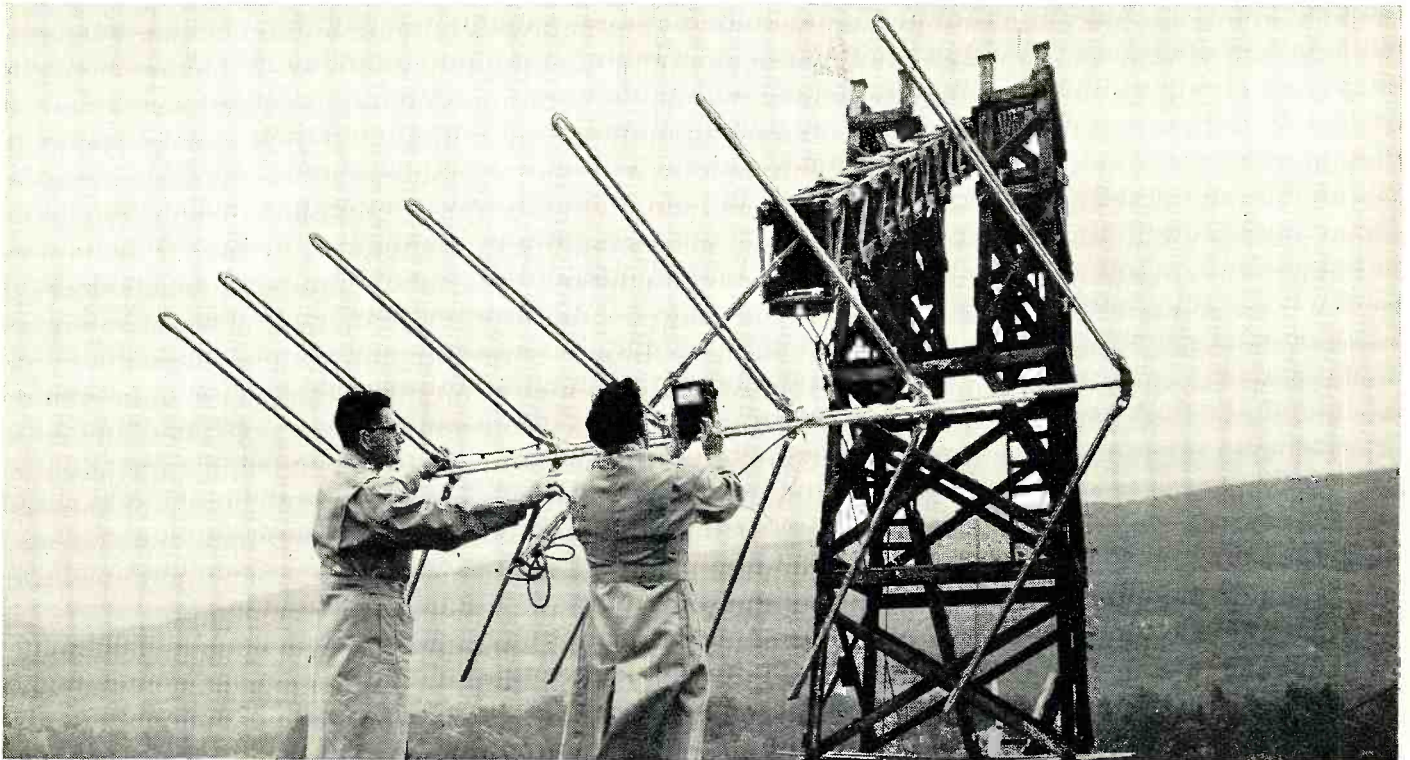

New 350A Series "T-W" Antenna — 7, 5, and 3-element models.

5 New Performance And Durability Features Are Built Into The NEW T-W Antenna

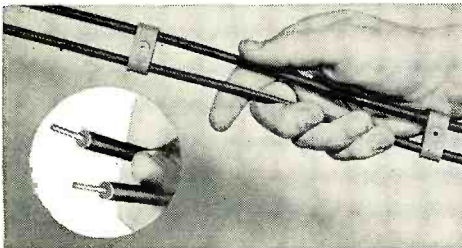

1. New Weatherproof Harness Delivers Peak Performance In All Climates

Give your customers the world's most powerful TV antenna performance . . . and never worry about weather problems. The extra-thick 1/4" virgin polyethylene insulation protects impedance match and electrical efficiency against rain, salt, or sea air. 16 gauge copper conductors. Dealers in coastal areas will particularly go for this new T-W feature.

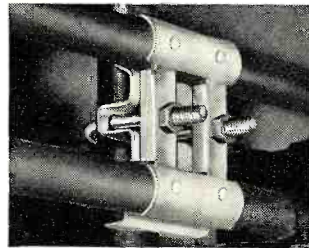

2. New Mast Bracket Installs Faster

A few seconds is all it takes with the new single 3/8" U-bolt. New design mast bracket is really rugged, too. 4 rivets through the bracket and mast secure the antenna permanently in place . . . can't ever twist or slip out of position.

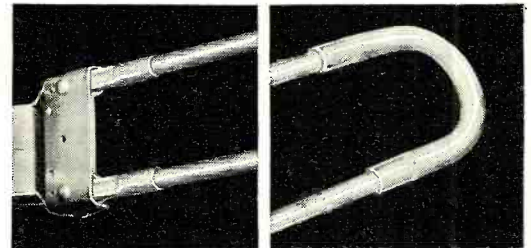

New Ruggedized Elements Provide Extra Durability

3. Seamless 1/2" diameter external sleeves supply "shock-proof" reinforcement of all elements at the brackets.
4. All dipoles are reinforced at the fold with a seamless 1/2" diameter U-bend.
5. 20% heavier wall thickness on all elements.



PLUS FAMOUS "TRAVELING WAVE" PERFORMANCE!
Highest Gains . . . Highest Front-To-Back Ratios of Any VHF Antenna.

CHANNEL MASTER CORP.

ELLENVILLE, N. Y.

The World's Largest Manufacturer of Television Antennas

the experts say... in High Fidelity the best buys are **EICO**®

EICO
KITS and WIRED

BETTER ENGINEERING Since 1945 EICO has pioneered the concept of test instruments in easy-to-build kit form — has become world-famous for laboratory-precision instruments at low cost. Now EICO is applying its vast experience to the creative engineering of *high fidelity*. Result: high praise from such authorities as Canby of AUDIO, Marshall of AUDIOCRAFT, Holt of HIGH FIDELITY, Fantel of POPULAR ELECTRONICS, Stocklin of RADIO TV NEWS, etc. — as well as from the critical professional engineers in the field.†

SAVE 50% Mass purchasing, and a price policy deliberately aimed to encourage mass sales, make this possible.

EASY INSTRUCTIONS You need no previous technical or assembly experience to build any EICO Kit — the instructions are simple, step-by-step, "beginner-tested."

DOUBLE 5-WAY GUARANTEE Both EICO, and your neighborhood distributor, guarantee the parts, instructions, performance . . . as well as *lifetime* service and calibration at nominal cost . . . for any EICO kit or wired unit.

BEFORE YOU BUY, COMPARE At any of 1200 neighborhood EICO distributors coast to coast, you may examine and listen to any EICO component. Compare *critically* with equipment several times the EICO cost — then you judge. You'll see why the experts recommend EICO, kit or wired, as best buy.

† Thousands of unsolicited testimonials on file.

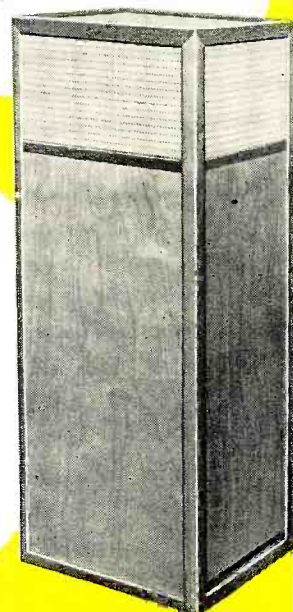

HFS2
Speaker System



HFT90 FM Tuner
with "eye-tronic" tuning



HF61 Preamplifier

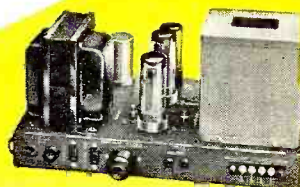

HF60, HF50 Power Amplifiers



HFS2—Speaker System: Uniform loading & natural bass 30-200 cps achieved via slot-loaded split conical bass horn of 12-ft path. Middles & lower highs from front side of 8 1/2" cone, edge-damped & stiffened for smooth uncolored response. Suspensionless, distortionless spike-shaped super-tweeter radiates omni-directionally. Flat 45-20,000 cps, useful to 30 cps. 16 ohms. HWD: 36", 15 1/4", 11 1/2". " . . . rates as excellent . . . unusually musical . . . really non-directional" — Canby, AUDIO. "Very impressive" — Marshall (AUDIOCRAFT). Walnut or Mahogany, \$139.95. Blonde, \$144.95.

HFT90 FM Tuner equals or surpasses wired tuners up to 3X its cost. New, pre-wired, pre-aligned, temperature-compensated "front end"—drift-free. Sensitivity, 1.5 uv for 20 db quieting, is 6X that of other kit tuners. DM-70 traveling tuning eye. Response 20-20,000 cps ± 1 db. Cathode follower & multiplex outputs. Kit \$39.95*. Wired \$65.95*. Cover \$3.95. *Less cover, excise tax incl.

HF61A Preamplifier, providing the most complete control & switching facilities, and the finest design, offered in a kit preamplifier, " . . . rivals the most expensive preamps . . . is an example of high engineering skill which achieves fine performance with simple means and low cost." — Joseph Marshall, AUDIOCRAFT. HF61A Kit \$24.95, Wired \$37.95, HF61 (with Power Supply) Kit \$29.95. Wired \$44.95.

HF60 60-Watt Ultra Linear Power Amplifier, with Acro T0-330 Output Transformer, provides wide bandwidth, virtually absolute stability and flawless transient response. " . . . is one of the best-performing amplifiers extant; it is obviously an excellent buy." —AUDIOCRAFT Kit Report. Kit \$72.95. Wired \$99.95. Matching Cover E-2 \$4.50.

HF50 50-Watt Ultra-Linear Power Amplifier with extremely high quality Chicago Standard Output Transformer. Identical in every other respect to HF60 and same specifications up to 50 watts. Kit \$57.95. Wired \$87.95. Matching Cover E-2 \$4.50.

HF30 30-Watt Power Amplifier employs 4-EL84 high power sensitivity output tubes in push-pull parallel, permits Williamson circuit with large feedback & high stability. 2-EZ81 full-wave rectifiers for highly reliable power supply. Unmatched value in medium-power professional amplifiers. Kit \$39.95. Wired \$62.95. Matching Cover E-4 \$3.95.

HF-32 30-Watt Integrated Amplifier Kit \$57.95. Wired \$89.95.

HF52 50-Watt Integrated Amplifier with complete "front end" facilities and Chicago Standard Output Transformer. Ultra-Linear power amplifier essentially identical to HF50. The least expensive means to the highest audio quality resulting from distortion-free high power, virtually absolute stability, flawless transient response and "front end" versatility. Kit \$69.95. Wired \$109.95. Matching Cover E-1 \$4.50.

HF20 20-Watt Integrated Amplifier, complete with finest preamp-control facilities, excellent output transformer that handles 34 watts peak power, plus a full Ultra-Linear Williamson power amplifier circuit. Highly praised by purchasers, it is established as the outstanding value in amplifiers of this class. Kit \$49.95. Wired \$79.95. Matching Cover E-1 \$4.50.

Prices 5% higher in the West

HF12 12-Watt Integrated Amplifier, absolutely free of "gimmicks", provides complete "front end" facilities & true fidelity performance of such excellence that we can recommend it for any medium-power high fidelity application. Two HF12's are excellent for stereo, each connecting directly to a tape head with no other electronic equipment required. Kit \$34.95. Wired \$57.95.

HFS1 Two-Way Speaker System, complete with factory-built cabinet. Jensen 8" woofer, matching Jensen compression-driver exponential horn tweeter. Smooth clean bass; crisp extended highs. 70-12,000 cps ± 6 db. Capacity 25 w. Impedance 8 ohms. HWD: 11" x 23" x 9". Wiring time 15 min. Price \$39.95.

THE HI-FI EXPERTS SAY:

"For those who have been looking for a well-engineered yet inexpensive power amplifier, the newly-released EICO Model HF20 unit might offer a simple solution to their problem. Not only does this unit provide 20 watts of power but the circuit incorporates a preamplifier and a variety of controls on a single chassis."

William A. Stocklin, Editor, RACIO TV NEWS

"The new EICO 'standard' speaker system . . . produces sound that to my musical ears rates as excellent, from high top to clean low bottom."

Edward Tatnall Canby, AUDIO Magazine

Fill out coupon on other side for FREE CATALOG



HF52, HF20
Integrated Amplifiers



HF12 Integrated Amplifier



HF30 Power Amplifier



HFS1
Speaker System



33-00 Northern Boulevard, L. I. C. 1, N. Y.
Over 1 Million EICO instruments in use the world over.

© 1958

the specs prove it .
your BEST BUY is

EICO®

for COLOR & Monochrome TV servicing

FREE CATALOG

shows you HOW TO SAVE 50%
on 50 models of top quality
professional test equipment.
MAIL COUPON NOW!



NEW!
**TV-FM SWEEP
GENERATOR &
MARKER #368**
KIT \$69⁹⁵ WIRED \$119⁹⁵

Entirely electronic sweep circuit (no mechanical devices) with accurately-biased inductor for excellent linearity. Extremely flat RF output: new AGC circuit automatically adjusts osc. for max. output on each band with min. ampl. variations. Exceptional tuning accuracy: edge-lit hairlines eliminate parallax. Sweep Osc. Range 3-216 mc in 3 fund. bands. Variable Marker Range 2-75 mc in 3 fund. bands; 60-225 mc on harmonic band. 4.5 mc Xtal Marker Osc., xtal supplied. Ext. Marker provision. Sweep Width 0-3 mc lowest max. deviation to 0-30 mc highest max. dev. 2-way blanking. Narrow range phasing. Attenuators: Marker Size, RF Fine, RF Coarse (4-step decade). Cables: output, scope horiz., scope vertical. Deep-etched satin aluminum panel; rugged grey wrinkle steel cabinet.

**NEW! RF
SIGNAL GENERATOR
#324**
KIT \$26⁹⁵ WIRED \$39⁹⁵



150 kc to 435 mc with ONE generator! Better value than generators selling at 2 or 3 times its cost! Ideal for IF-RF alignment, signal tracing & trouble-shooting of TV, FM, AM sets; marker gen.; 400 cps audio testing; lab. work. 6 fund. ranges: 150-400 kc, 400-1200 kc, 1.2-3.5 mc, 3.5-11 mc, 11-37 mc, 37-145 mc; 1 harmonic band 111-435 mc. Freq. accurate to ±1.5%; 6:1 vernier tuning & excellent spread at most important alignment freqs. Etched tuning dial, plexiglass windows, edge-lit hairlines. Colpitts RF osc. directly plate-modulated by K-follower for improved mod. Variable depth of int. mod. 0-50% by 400 cps Colpitts osc. Variable gain ext. amplifier: only 3.0 v needed for 30% mod. Turret-mounted coils slug-tuned for max. accuracy. Fine & Coarse (3-step) RF attenuators. RF output 100,000 uv; AF sine wave output to 10 v. 50-ohm output Z. 5-way jack-top binding posts for AF in/out; coaxial connector & shielded cable for RF out. 12AU7, 12AV7, selenium rectifier; xmfr-operated. Deep-etched satin aluminum panel; rugged grey wrinkle steel cabinet.

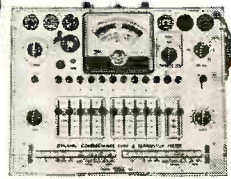

**NEW! DYNAMIC
CONDUCTANCE
TUBE & TRANSISTOR
TESTER #666**
KIT \$69⁹⁵ WIRED \$109⁹⁵

COMPLETE with steel cover and handle.
SPEED, ease, unexcelled accuracy & thoroughness. Tests all receiving tubes (and picture tubes with adapter). Composite indication of Gm, Gp & peak emission. Simultaneous sel of any 1 of 4 combinations of 3 plate voltages, 3 screen voltages, 3 ranges of continuously variable grid voltage (with 5% accurate pot). New series-string voltages: for 600, 450, 300 ma types. Sensitive 200 ua meter. 5 ranges meter sensitivity (1% shunts & 5% pot). 10 SIX-position lever switches: freepoint connection of each tube pin. 10 pushbuttons: rapid insert of any tube element in leakage test circuit & speedy sel. of individual sections of multi-section tubes in merit tests. Direct-reading of inter-element leakage in ohms. New gear-driven rollechart. Checks n-p-n & p-n-p transistors: separate meter readings of collector leakage current & Beta using internal dc power supply. Deep-etched satin aluminum panel; rugged grey wrinkle steel cabinet. CRA Adapter \$4.50

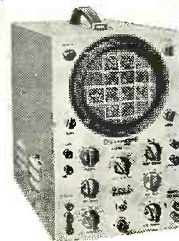

NEW!
**COLOR
and Monochrome
DC to 5 MC LAB & TV
5" OSCILLOSCOPE
#460**
KIT \$79⁹⁵ WIRED \$129⁹⁵
• Features DC Amplifiers!

Flat from DC-4.5 mc, usable to 10 mc. VERT. AMPL.: sens. 25 rms mv/in; input Z 3 megs; direct-coupled & push-pull thruout; K-follower coupling bet. stages; 4-step freq-compensated attenuator up to 1000:1. SWEEP: perfectly linear 10 cps-100 kc (ext. cap. for range to 1 cps); preset TV V & H positions; auto. sync. ampl. & lim. PLUS: direct or cap. coupling; bal. or unbal. inputs; edge-lit engraved lucite graph screen; dimmer; filter; bezel fits std photo equipt. High intensity trace CRT. 0.06 usec rise time. Push-pull hor. ampl., flat to 400 kc, sens. 0.6 rms mv/in. Built-in volt. calib. Z-axis mod. Sawtooth & 60 cps outputs. Astig. control. Retrace blanking. Phasing control.



**NEW! PEAK-to-PEAK
VTVM #232 & UNI-
PROBE (pat. pend.)**
KIT \$29⁹⁵ WIRED \$49⁹⁵

Half-turn of probe tip selects DC or AC-Ohms. Uni-Probe - exclusive with EICO - only 1 probe performs all functions! Latest circuitry, high sensitivity & precision, wide ranges & versatility. Calibration without removing from cabinet. New balanced bridge circuit. High Z input for negligible loading. 4 1/2" meter, can't burn-out circuit. 7 non-skip ranges on every function. 4 functions: +DC Volts, -DC Volts, AC Volts, Ohms. Uniform 3 to 1 scale ratio for extreme wide-range accuracy. Zero center. One zero-adj. for all functions & ranges. 1% precision ceramic multiplier resistors. Measure directly peak-to-peak voltage of complex & sine waves: 0-4, 14, 42, 140, 420, 1400, 4200. DC/RMS sine volts: 0-1.5, 5, 15, 50, 150, 500, 1500 (up to 30,000 v. with HVP probe & 250 mc with PRF probe). Ohms: 0.2 ohms to 1000 megs. 12AU7, 6AL5, selenium rectifier; xmfr-operated. Deep-etched satin aluminum panel; rugged grey wrinkle steel cabinet.

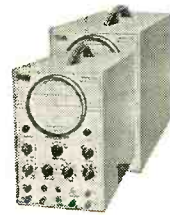

5" PUSH-PULL
OSCILLOSCOPE
#425
KIT \$44.95
Wired \$79.95

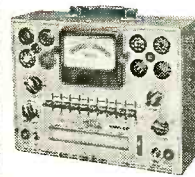

TUBE TESTER
#625
KIT \$34.95
Wired \$49.95
• tests 600 mil series string type tubes
• illuminated roll-chart

Pix Tube Test Adapter\$4.50

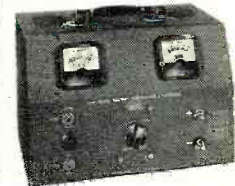

6V & 12V
Battery Elim
& Charger
#1050:
KIT
\$29.95
Wired
\$38.95

Extra filtered for transistor eqpt., #1060:
Kit \$38.95 Wired \$47.95



Sep. hi-gain RF
& lo-gain audio
inputs.
Special noise
locator. Calibra-
ted wattmeter.
KIT \$24.95
Wired \$39.95

DELUXE MULTI-SIGNAL TRACER #147



20,000 Ohms/Volt
V-O-M #565
KIT \$24.95
Wired \$29.95



1000 Ohms/Volt
V-O-M #536
KIT \$12.90
Wired \$14.90



Reads 0.5 ohms
-500 megs, 10
mmfd-5000 mfd,
power factor.

KIT
\$19.95
Wired
\$29.95

R-C BRIDGE & R-C-L COMPARATOR
#950B



VTVM PROBES KIT Wired
Peak-to-Peak\$4.95 \$6.95
RF\$3.75 \$4.95
High Voltage Probe-1\$6.95
High Voltage Probe-2\$4.95

SCOPE PROBES
Demodulator\$3.75 \$5.75
Direct\$2.75 \$3.95
Low Capacity\$3.75 \$5.75

EICO, 33-00 Northern Blvd., R-7
L.I.C. I. N. Y.

Show me HOW TO SAVE 50% on Test Equipment and Hi-Fi. Send me FREE Catalog and name of neighborhood distributor.

Name.....
Address.....
City..... Zone..... State.....

TURN PAGE
FOR MORE
EICO VALUES

EICO®

Send for
FREE CATALOG
now

Prices 5% higher on West Coast.

L.I.C. I. N. Y.

Speakers for Stereo



By HERMAN BURSTEIN

THE ability of stereo to improve the similitude between reproduced sound and the original has been effectively demonstrated at audio shows, high-fidelity salons, special demonstrations, and elsewhere. Progress in the art is reflected by the increasing availability of components needed to bring stereo to the home. Stereo tapes are steadily growing in number and quality, while machines to play them can be had in various brands at various prices. The stereo disc has already made its public debut. Some stereo cartridges are already on the market, with more soon to come. Moreover stereo broadcasts are increasing, by means of an AM and an FM channel, by two FM channels, or, experimentally, by a multiplexing system on a single FM channel.

Until recently it was generally thought that 3-channel sound was needed for a truly successful illusion, while 2-channel stereo, a necessary compromise in the interests of cost and space, was viewed as a watered-down version which is a good deal better than monaural but still appreciably short of the ultimate. However, recent developments indicate that with proper attention to microphone placement in recording and with proper attention to choice, placement, and use of speakers in reproduction, the difference between 3-channel and 2-channel sound can become negligible in the home.

To illustrate, some experiments conducted by personnel of Ampex Corporation showed that although 3-channel reproduction was superior in a large auditorium, the superiority was

What the "stereophile" must know about speaker placement, matching and quality of speakers, and reproduction level.

vastly reduced when the same material was played back in a small auditorium over a 2-channel system; it is to be expected that the small auditorium would more nearly parallel home listening conditions. "... the 3-channel tapes, upon review in a much smaller auditorium of nearly ideal acoustical characteristics, could be shown to have

EDITOR'S NOTE: Because of the great interest in stereophonic reproduction and because of the many differences of opinion as to the proper speaker arrangements to be used for optimum stereo effect, your editors feel that it is important to present as many of the facts as possible. In this article the author has analyzed the views and recommendations of four loudspeaker manufacturers as well as a tape recorder and stereo tape manufacturer in order to present to our readers some guidance concerning the optimum placement of speakers for stereo, the proper matching of speakers, the type and quality of speakers to be used, and the proper level of reproduction to be employed.

negligible advantage over 2-channel tapes. In this corollary experiment, switching apparatus was devised so that, in one position, the three channels were separately presented, while in a second instantaneously available position, identically the same over-all level of sound was presented through two stereophonic channels, the output of the former center channel being mixed equally into each of the two separate outer channels. With a succession of audiences, consisting of

trained musicians, engineers concerned with audio subjects, and lay individuals, no significant accuracy could be found in judgments of the distinction."²

Based upon a mixture of logic and empiricism, progress in the stereo art has reached the stage where desired results can be obtained. Today engineers know how to produce a stereo tape or transmit a live stereo broadcast which makes it possible for the listener to recreate the definition and spaciousness of the original. Completion of the illusion, however, rests very much with the listener. The "stereophile" must pay careful attention to (1) speaker placement, (2) matching of speakers, (3) quality of speakers, and (4) level of reproduction.

This article will deal with these four factors as well as with the factors that create the stereo illusion. This discussion owes a great deal to the opinions expressed by several leaders in the field of sound. Specific thanks are due to the R. T. Bozak Sales Company, Electro-Voice, Inc., James B. Lansing Sound, Inc., Jensen Mfg. Co., and RCA Victor Record Division.

The Stereo Illusion

What is it that enables a stereo set-up to endow the reproduced sound with a three-dimensional quality reminiscent of the original? As we are generally aware, a basic factor is that it

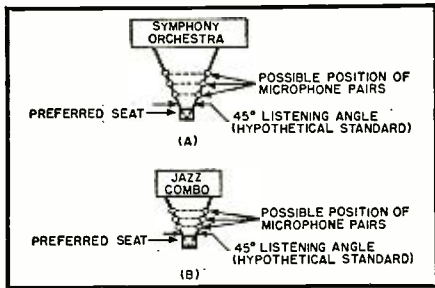

Fig. 1. Relationship between stereo microphones and sound sources in accordance with the "listening angle" principle.

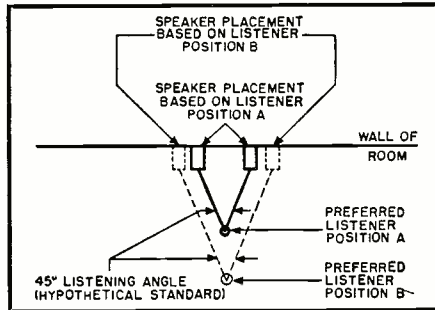

Fig. 2. Optimum placement of the stereo speakers in accordance with the position of the listener and "listening angle."

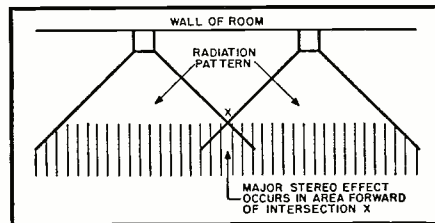

Fig. 3. The relationship of the radiation patterns of speakers to the stereo effect.

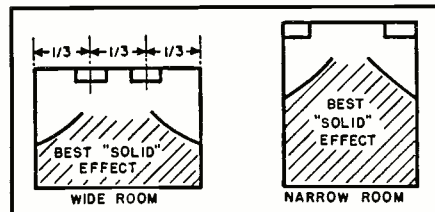

Fig. 4. The Electro-Voice recommendations for the optimum stereo speaker placement.

permits us to distinguish sounds on the left from those on the right, thus providing a dimension of breadth. But there is a good deal more than this to the illusion.

Surprising as it may seem, many of the factors that contribute to stereo are the same as those which enhance the quality of monaural sound, providing a desirable spaciousness, a seeming release of the origin of the sound from the confines of the enclosure. We know that on certain occasions the program material issuing from a conventional sound system has a rounder and fuller character than at other times. Four factors have been listed as contributing to the "stereo" effect both on monaural and stereo systems:³

1. *High signal-to-noise ratio:* To provide virtually complete free-

dom from extraneous distractions, which can easily disrupt the illusion, a high signal-to-noise ratio is required. While a very effective ratio of 55 or 60 db can be attained with first rate equipment, the more usual figure, at least where tape is concerned, is around 40 or 45 db.

2. *Playback reverberation:* Ideally, music requires a reverberation period of about 1.5 seconds. However, few home environments supply this much, so that the listener is dependent, at least in part, upon reverberation supplied by the recording engineer, as discussed in the next point.
3. *Recording reverberation:* Today's trend is to compensate for the less-than-optimum reverberation time of typical listening rooms. Recording engineers are supplying the difference between ideal reverberation time and the estimated period found in the average home. Reverberation may be increased by moving the microphones back from the source, thus increasing the ratio of reflected (reverberated) to direct sound. Or it may be supplied by electronic or mechanical means, such as tape devices and echo chambers.
4. *Playback level:* Ideally, the playback level should approximate the original.

We turn now to that which distinguishes true stereo from monaural, namely the differentiation between left and right. A recent article by Hume⁴ on the subject points out that the ability of humans to locate a sound source has in the past been attributed to one or more of the following differences between the sounds reaching each ear: (1) time delay; (2) phase difference; and (3) amplitude difference. However, Hume has conducted experiments which lead him to state that the value of these differences "is, at best, in confirming a conclusion already reached by the brain. The difference in signals as received that does produce the stereo effect is a difference in waveshape. The head and external ear, because of their size and shape, shadow or filter out certain frequencies. . . . In the head, for example, the frequency is approximately 800 cps and above. The external ear shadows higher frequencies and, because of its angle, from a different direction. It is this shadowing process that produces a difference in waveform in the signals received by the two inner ears and which is used by the

brain to make the perception of direction possible."

Irrespective of the extent to which Hume is correct, there appears to be substantial agreement that the stereo effect depends upon the higher frequencies. Hume refers to 800 cycles as the boundary. *Electro-Voice* attributes the effect to frequencies above 500 cycles.¹ Therefore, as will be seen, primary attention for stereo purposes must be given to that section of the speaker system which reproduces the upper mid-range and treble.

Speaker Placement

Optimum location of speakers for 2-channel stereo depends upon three factors: (1) microphone placement in recording; (2) shape of the listening room; and (3) listener's location in that room. Since there are an infinite number of positions that the recording microphones could occupy, it would seem that optimum speaker location would vary from one stereo program to another. Fortunately, it appears that the problem can be resolved by the "listening angle" principle, attributed to *Ampex*, which postulates a systematic relationship between microphone, speakers, and listener, and permits standardizing this relationship.

"The theory is that the recording engineer sets up his various microphones in such a way that the angle from ideal listener location to the 2-channel pickup points is some generally agreed-on value. About 30-45 degrees seems to be the most common figure. In the reproducing system, the two loudspeakers are separated sufficiently so that a listener will see this same angular distance between the two speakers. Naturally, the farther the speakers are located from the normal listening location, the farther apart they must be . . . to maintain the same angular spread. This theory compensates both for speaker-listener distance and the fact that a symphony orchestra is spread over a much larger area than a small combo. Assuming that a normal concert listener would sit much farther from a symphony orchestra than a jazz lover would (sit) from a small combo in a crowded night club, the angular separation of the two sets of conditions remains fairly constant."⁵

The listening angle principle is illustrated in Figs. 1 and 2. Fig. 1A shows the relationship between a symphony orchestra and a listener in a preferred seat. It also shows several out of an infinite number of microphone locations which would maintain an agreed-on angle, say 45°, between lines drawn from preferred seat to microphones. If the microphones are too close to the orchestra, there is indeed a spreading of sound, but at the risk of losing part of the music issuing from the center of the orchestra. If the microphones are moved too near the listener, then the left-right separation decreases. In between is an optimum point which achieves realistic separation, good left-center-right balance, and a desirable blending of direct and reflected sound

Fig. 5. A corner placement of the stereo speakers is generally not recommended.

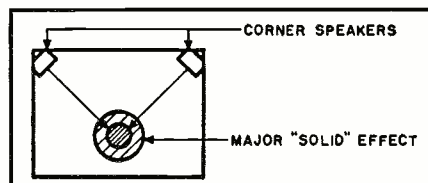

to provide the needed reverberation. Finding this advantageous location is the recording engineer's task.

Fig. 1B is similar to Fig. 1A except that the source is a small jazz group. Although the combo covers less space than the orchestra, the fact that the listener would typically sit much closer to the combo serves to maintain the same angular spread between listener and extremes of the source.

Fig. 2 takes into account the listener's preferred location in the listening room and shows how the speakers would be spaced to maintain a 45° angle between listener and speaker axes. If the listener preferred to sit farther back, then, as shown by dash lines, the optimum speaker location would change.

At this point it is well to interject that although the listening angle principle assumes only two microphones, corresponding to two speakers, some tape recording companies are using three microphones, the third being placed in the center. Subsequently, in preparing a 2-channel master tape, the center channel is mixed with the two outer ones. This enables the engineers to overcome a possible "hole in the center" effect, which has marred some stereo recordings. (Also, the 3-channel tape gives the company an ace in the hole should 3-channel stereo ever take hold to a substantial degree.)

The audiophile should not interpret the listening angle principle to mean that the only suitable listening position is the convergence of the lines forming a designated standard angle between listener and speakers. If the listener moves left, right, or back of the convergence point, the stereo effect will not be destroyed but changed, much as moving to another seat in the concert hall will alter his sensations. Moreover, there are factors which prevent the principle from being as exact in practice as in logic, such as differences between the microphone pickup patterns and the speakers' angular distribution of sound.

It seems fairly well agreed by a number of authorities that once the listener puts a certain distance between himself and the stereo speakers, he will enjoy the stereo effect in virtually any part of the room that maintains this distance. The idea is to get far enough back so that the listener is within the radiation pattern of both speakers, as illustrated in Fig. 3. Fig. 4 shows, as a general rule, how speakers may be positioned for rectangular rooms. Where the speakers face down the narrow dimension of a rectangular room, it is advised that they be spaced so that the axis of each speaker is one-third the distance between side walls. Where the speakers face down the long dimension, it is recommended that they be placed adjacent to each wall.⁹

In the early days of stereo it was thought advisable to place speakers in the corners of the room, as shown in Fig. 5. However, this principle today is generally frowned upon. Thus the

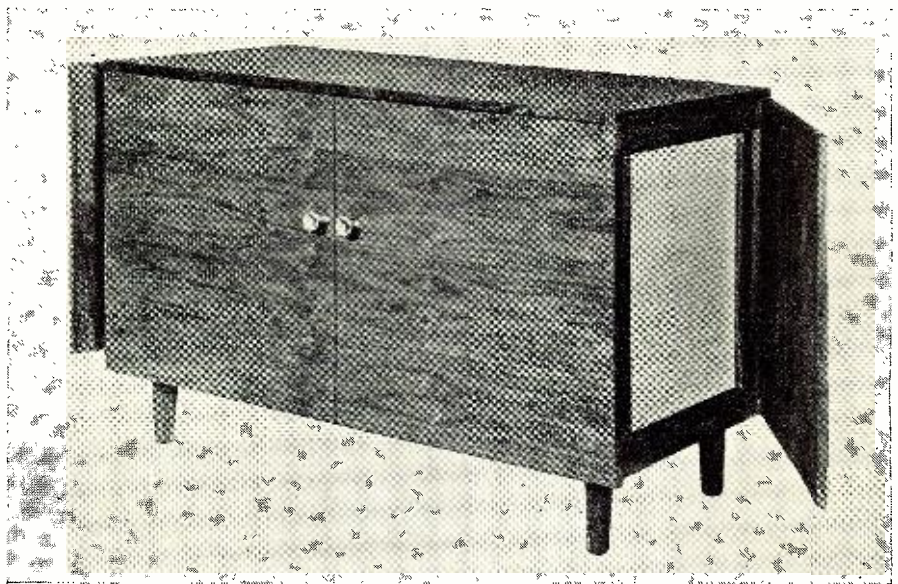

Fig. 6. The Bozak B-304 "Contemporary" complete stereo speaker system in which both stereo speakers are mounted in the same housing. In order to achieve optimum operation, Bozak mounts the speakers facing each side wall, that is, opposite each other, and reflects the sound off the partially open side doors as shown above.

R. T. Bozak Sales Company states, "We feel very strongly that corner placement is not good for stereophonic reproduction."⁶ As explained by *Electro-Voice*, "No speaker manufactured currently has perfect dispersion in the treble and high range so important to stereo. More power is always available down the axis. Therefore, speakers in the corner focus the sound at one point in the room. A . . . concentration of 3 db seems sufficient to localize the effect. . . . An effective means of distributing the sound throughout the listening area is to turn the corner speakers parallel to the side wall so that the treble and very-high frequencies traverse these walls at grazing incidence. This results in a multiplicity of focal points over the widest listening area. Note that considerable distribution in this case is effected by reflection. Perhaps the superior effects thus achieved are due to the even balance of the sound from the two speakers resulting from this diffusion."⁸

A number of speaker systems, among them some of the best, are specifically designed for corners and are out of joint physically and acoustically in any other spot, so that the objection to corner speakers for stereo raises a problem. Inasmuch as the stereo effect depends largely or wholly upon the treble range, the solution consists of turning just the treble unit(s) to face straight down the room instead of at a 45° angle to each wall. Thus the advantage of the corner is retained for best radiation of the important bass frequencies.

The ease of re-orienting the treble units of course depends upon the particular speaker system. For example, *Electro-Voice* has this to say about its "Centurion," "Georgian," and "Patrician," all corner units: "The treble horn and v.h.f. driver only need be rotated 45 to 50 degrees towards the wall adjacent to the listening axis.

This is accomplished with fair ease upon gaining access to the cabinet interior. The exception is the 'Patrician,' in which case the 6HD horn with its T25A driver and T35 tweeter must be extracted and placed at the proper angle (presumably in a decorative housing) on the top of the present cabinet."⁸ Fig. 7 shows the recommended arrangements for the "Georgian" and "Patrician."

Units have recently appeared, either complete audio systems such as the *Ampex* A423 or just speaker systems such as the *Bozak* B-304, which contain both stereo speakers in one housing. Since these housings are necessarily of limited width, the spacing between speakers is not sufficient to achieve a pronounced stereo effect by having the speakers face straight down the room. In a sense, both manufacturers' solutions are the same in that the sound is projected at 45° angles to the left and right of the front panel. But the means of achieving this solution are different. *Ampex* mounts the speakers in cater-corner fashion, as outlined in Fig. 8. *Bozak* mounts the speakers facing each side wall, that is, opposite each other, and reflects the sound off partially open side-doors, as shown in Fig. 6.

In concluding this section, it should be pointed out that not necessarily all views on stereo speaker placement have been represented and that those views which have been presented do not necessarily fit all circumstances. Thus the audiophile who embarks upon stereo reproduction should feel that it is definitely worthwhile experimenting with speaker placement in ways other than suggested here. It is even possible that in certain instances the best location will prove to be a corner one, although the rule says otherwise.

Matching of Speakers

The consensus is that matched

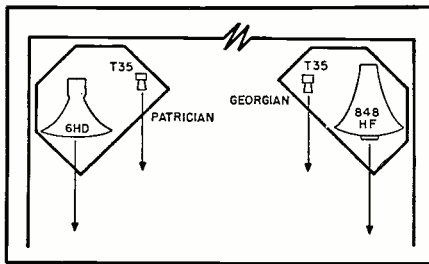

Fig. 7. Electro-Voice recommendations for the reorientation of the treble units in its corner systems for stereo use.

speaker systems are necessary for best stereo effect, although some subscribe to this statement with less emphasis than others. Perhaps the most compelling argument on behalf of matched speakers has to do with eliminating the "hole in the center" feeling that listeners sometimes get when listening to stereo. *Bozak* states, "We attach considerable importance to the use of matched speakers primarily because this is one of the big factors in producing a good center. This is self-evident since the sound that appears to emanate from the center is produced when the two sources are in perfect balance. The balance must be not only in intensity on an over-all basis, but at every individual frequency."⁴

James B. Lansing has additional reasons for recommending matched speakers: "In true stereo reproduction, we feel that consistently good performance can be achieved only with closely matched speaker systems. The idea that one speaker system may reproduce brasses best, while another is perfect for bass viols, is valid but there is no way to guarantee that the recording engineer had the peculiarities of such a combination in mind when he made the recording. Some material will sound excellent on such a mis-matched arrangement, but most of it will be degraded."⁵

However, *Electro-Voice* only goes along with these views with reservations, particularly taking exception as far as bass is concerned. "Identical speakers are not required. However, both speakers should be good ones. An exception can be accommodated relative to bass response if a reversing switch on the speakers is utilized so that the bass side of the orchestra can be switched to the larger, best bass-reproducing speaker. It goes without saying that the treble ranges of both speakers should be of equal quality, although not necessarily identical."³ Presumably *Electro-Voice* has in mind such factors as smoothness, distortion, and angular distribution when referring to equal quality.

At the extreme are those who feel that matching is not only a matter of buying speakers of the same brand and model but also of selecting speaker units of equal characteristics, somewhat as one might match tubes for the push-pull output stage of a power amplifier. For example, a stereo editor has told the writer that he finds the

stereo effect varies substantially according to which pair of speakers he is using, even though they are all very high quality units of one brand and model (over \$150 per speaker, exclusive of enclosure).

Quality of Speakers

A developing art understandably breeds opinions which fuller experience proves wrong. In the field of stereo, one of these "primitive" beliefs was that stereo largely did away with the desirability of high quality, and necessarily expensive, speaker systems. It was thought that stereo masked distortion, ragged response, inadequate bass, and inadequate treble.

No matter how good a monaural speaker system may be, if we listen long enough we will certainly find flaws. (As a matter of fact, after a couple of hours or so one can grow weary of the live performance of a fine orchestra in a fine hall.) At all events, it appears that after one has lived with a stereo system for a while, one becomes just as conscious of speaker inadequacies as in the case of monaural listening. This is confirmed by *Bozak* and *Lansing*:

"It has been held by some workers in this field that many of the offensive effects of distortion are eliminated in stereo systems. This we do not believe to be the case. Conclusions such as those just cited are drawn because the spaciousness and directive qualities of stereo are such an improvement over low quality monaural sources that many of the flaws are overlooked; thus listening fatigue, which is developed subconsciously, is just as likely with low quality speakers in stereo as in monaural. The difference is primarily in incubation time."¹⁵

"It is just as important to use high quality units with a stereo system as it is with any single-source installation. But quality, of course, is not determined by price alone, and the buyer must carefully choose speakers which match his listening preferences and particular room acoustics."⁶

Speaker Level

Many audiophiles have found that on monaural systems they can enhance the illusion of reality by reproducing music at high volume. This is not merely a matter of equalling concert hall amplitude, for it is well known that some audiophiles operate their systems at levels actually above the original. High volume simulates reality by bringing out each voice in the orchestra and perhaps by setting up

Fig. 8. Here is the Ampex method of housing two stereo speakers within one cabinet.

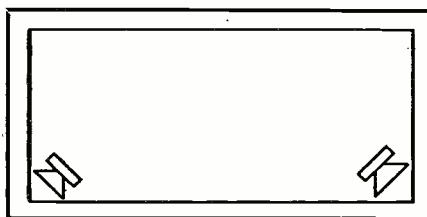

additional reverberation in the listening room.

Opinion seems to be somewhat mixed as to the volume level required for full satisfaction from stereo, although recommendations in the main point to a playback level equalling the original. On the one hand, *Bozak* states, "One advantage that stereo sound does offer over monaural sound is that loudness is not nearly as critical for faithful reproduction. Thus stereo need not be played as loud as monaural for complete musical satisfaction."⁶

However, this statement should not necessarily be interpreted as an endorsement that less than realistic levels will maintain the effectiveness of stereo. It simply says that stereo need not be played as loud as monaural, which is often played above original level.

A more positive case for high-level stereo reproduction is made by *Lansing*: ". . . the 3-D effect is sufficiently arresting to supply some of the 'oomph' which some people try to supply in ordinary systems by boosting the level of reproduction. It is certainly true that with stereo program material it is no longer necessary to boost the intensity above live concert level to hear fine details. But with stereo we feel it even more desirable that material be played at a natural listening level. Most listeners seem to feel that as volume is reduced, the 'realistic' quality vanishes even more quickly than with single channel reproduction. Some stereo recordings of symphonic works sound very much like single channel material until they are played very loud, and then suddenly the whole orchestra opens up and the effect is magnificent."⁵

In the matter of speaker level, there are indications that a woofer-tweeter balance which is suitable for monaural purposes may not be as good for stereo. For one thing, the difference in speaker placement may result in greater absorption of highs by room elements. Thus *Electro-Voice* makes the following recommendation with respect to use of its systems for stereo: "The settings on the treble and very-high frequency attenuators on *Electro-Voice* systems should be advanced to the full 'on' position for stereo reproduction. This is necessary for the preservation of bass-high balance, due to inordinate absorption of the highs by the walls' reflecting."³

Furthermore, in view of the fact that the highs play a major role in the stereo effect, the user may find it desirable to deliberately increase their relative level as a means of bringing out or accentuating this effect.

Conclusions

From what has been said herein it would appear that the individual who wants the utmost that stereo can offer today must go to substantial lengths. Not only must he have two of everything in the audio chain following the stereo source, but he must obtain

(Continued on page 128)

Communications in Fire Control

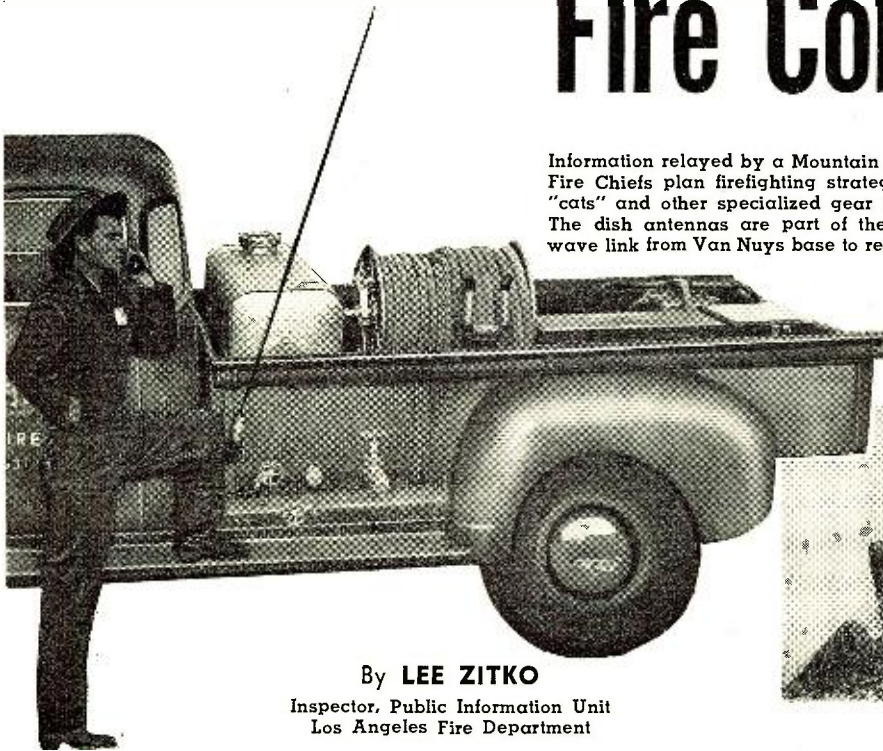

Information relayed by a Mountain Patrolman helps Fire Chiefs plan firefighting strategy and dispatch "cats" and other specialized gear to critical areas. The dish antennas are part of the L.A.F.D. microwave link from Van Nuys base to remote transmitter.

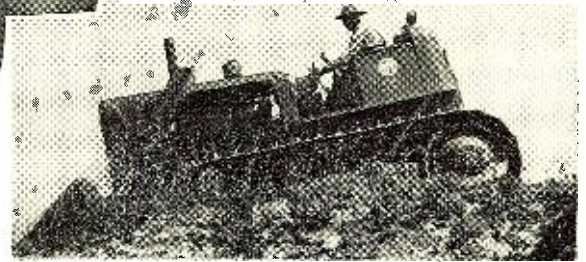

By **LEE ZITKO**
Inspector, Public Information Unit
Los Angeles Fire Department

Radio has changed firefighting from a hit or miss affair to a well coordinated mass attack.

NOWADAYS it works this way: the driver takes another mountain curve and beside him the Battalion Chief says "Roger," claps the handset back in its dashboard cradle, and checks the map book in his lap.

"Patrol Ten's got a three block front moving fast up the west wall at the north end of Hainsely Canyon. Engine and Tank Eighty-Eight ought to be getting close—I'm going to shoot 'em in on Greendale to protect those homes on the crest."

"Patrol One to Engine and Tank Eighty-Eight—go in on Greendale Road to. . ."

But there was a time when it didn't work that way at all. A time when a Fire Chief racing to a brush fire in the Santa Monica mountain range could only guess and wonder about conditions at the fire until he got there. A time when he could only hope his "first-in" companies would be able to calculate the right positions to take up along a fire line whose rugged terrain often blocked their movements from each other's view.

Radio has changed all that.

Radio changed firefighting in Los Angeles' mountain areas from a scattering of blindly anxious defensive battles to a fast-striking, highly coordinated offensive war against the

orange destruction that gnashes at the City's 135 square miles of tinder-dry slopes hundreds of times each year.

Today the Los Angeles Fire Department's elaborate radio communications system virtually turns a mountain brush fire into a huge chessboard at the elbow of the seasoned fire-ground Commander. After his arrival and an initial reconnaissance of the fire area, the Chief quickly picks out a spot suitable for a command post or "base camp," as it is referred to on

the air. This combination temporary headquarters—motor pool—manpower pool—and message center is chosen for its accessibility to other arriving apparatus, its desirable features of terrain, its safety in concentrating men and equipment, and for its topographical adaptability to good radio transmission and reception.

In this area the maps are spread and plans of attack on the fire are laid. Here radio gives the officer in command immediate contact with subordinate Chiefs working various sectors of the fire. In between giving orders, he hears the many uses to which other radio units are put throughout the fire area.

(Continued on page 124)

THIS MONTH'S COVER

LOS ANGELES pays the penalty for its sylvan setting hundreds of times a year when brush fires break out in its 135 square miles of tinder-dry slopes. Radio has changed firefighting into a thing of streamlined precision. The L.A.F.D. communications net includes five base stations, 330 two-way radios installed in equipment, and 38 "Handie-Talkies" which allow chief officers to move about yet keep in radio contact with their men. The cover shows Capt. John E. Cox directing the movement of equipment via his "Handie-Talkie" while Ptl. C. W. Ayers maneuvers the tractor and Ptl. S. P. Jones monitors messages on the radio net. The Patrol rig, which carries two-way radio gear, is a modified one-ton pickup equipped with a 150 gallon-per-minute centrifugal pump. The equipment shown in the photo is typical of the specialized gear designed for such firefighting. (Photo by Peter J. Samerjan)



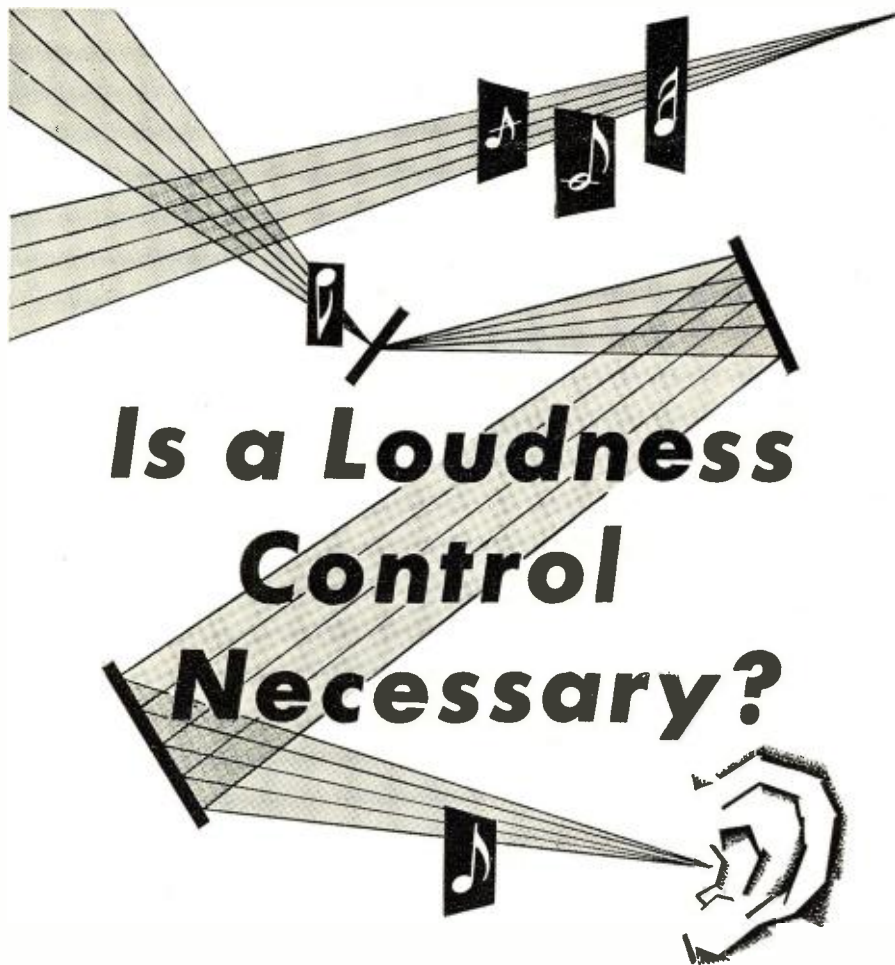

Is a Loudness Control Necessary?

By BURT HINES

The control must be used properly or else it may do more harm than good in the hi-fi system.

CORRECT frequency balance is a key aspect of high-fidelity performance. When music is reproduced below its original level, the problem of balance is complicated by the Fletcher-Munson effect, that is, by the seemingly greater attenuation of bass frequencies as volume is reduced. At low levels it is therefore necessary to employ loudness compensation, which means bass boost. In many or most high-fidelity systems this can be done by means of a loudness control, which attenuates the bass range by a smaller percentage than the mid- and treble-ranges. Lacking a loudness control, the listener can use the bass control for relative emphasis of the bass frequencies when reproducing music at low level.

Despite the great deal that has been written about the loudness control, its proper role in high-fidelity is still a matter of controversy. This is not just a question of theoretical argument but also of practical experience. While some users have been quite pleased with the effects obtained by a loudness control, others have had the

opposite experience and abandoned its use. (Most equipment gives the listener the option of cutting out this control.)

Certainly there is no doubt that loudness compensation is desirable. But there are questions as to the amount of compensation required and the best way to obtain it. A better and fuller understanding of the subject will enable the audiophile to achieve satisfactory compensation, perhaps with or perhaps without the aid of a loudness control, and put him farther along the road to high-fidelity.

Such understanding must take into account all the principal factors involved and their inter-relationships. These factors are:

1. The Fletcher-Munson characteristics of the human ear.
2. The level of the original music.
3. The dynamic range of the original music.
4. The extent to which the original level is reduced when the music is played back in the home.
5. The ambient noise level in the home (environmental noise).

Fig. 1 is the much-discussed Fletch-

er-Munson curves of human hearing. They show explicitly that at soft sound levels the bass frequencies must be produced with much greater intensity than 1000 cycles in order to sound as loud as 1000 cycles. Conversely, it is implicit that if the bass notes are reproduced at the same intensity as 1000 cycles, then at low levels they do not sound as loud as 1000 cycles. Therefore at soft levels we are concerned with restoring the original loudness of bass frequencies as compared with 1000 cycles.

The standard of reference of the Fletcher-Munson curves, namely 0 db, is 10^{-10} watt per square centimeter which is approximately the threshold of human hearing at 1000 cycles under extremely quiet conditions (low ambient noise). The sounds that we ordinarily encounter range from about 40 to 120 db, that is, from 10,000 to 1,000,000,000,000 times as much acoustic power as is encountered at the threshold.

In the case of the treble frequencies, they too do not sound as loud as 1000 cycles for equal intensities. But this is true at *all* levels of reproduction and very nearly to the same degree. Since there is no significant change in loudness relationship as gain is reduced, it is not necessary to boost the treble appreciably at low levels. Thus loudness compensation is essentially and properly concerned only with introducing the correct amount of bass boost at soft levels.

The degree of loudness compensation called for depends upon how much the original level is reduced. This reduction depends upon the original loudness and the level acceptable in the home. The home level depends not only upon personal tastes (and neighbors' tolerance in the case of apartment house dwellers) but also upon the amount of ambient noise, which tends to mask music reproduced at a level lower than this noise.

A detailed examination of these considerations will indicate how much loudness compensation is apt to be required.

It is appropriate to base a discussion of original loudness upon the symphony orchestra, which generally produces the greatest original loudness levels encountered in music and therefore entails the greatest reduction in playback level and the most compensating bass boost. A high-fidelity system capable of supplying adequate compensation for the orchestra will undoubtedly also do so for other music sources.

The softest sounds produced by an orchestra, as heard from a seat well up front in the concert hall, have a level of about 40 db, again employing 10^{-10} watt/cm² as a 0 db reference. The loudest sounds are about 100 to 110 db. The original dynamic range is therefore as much as 60 to 70 db. But a range of this width is seldom, if ever, reproduced by the customary media of high-fidelity, namely FM,

disc, and tape. About the best they can do, because of inherent noise and the problem of running into excessive distortion on loud passages, is to transmit a dynamic range of about 50 to 55 db. 55 db is rather unusual and 45 db is not at all uncommon. For purposes of this discussion, a dynamic range of 50 db is a fair assumption.

To bring the music within the confines of a 50 db dynamic range when recording or broadcasting, the loudest passages are reduced by limiting amplifiers, by having the conductor hold the orchestra in check, by riding gain, or by a combination of these measures. The net result is that while the softest sounds correspond to an original loudness of about 40 db, the loudest are about 90 db—a 50 db range. The average level is about 75 db.

When bringing orchestral music into the home, the problem is to reduce the average level until it is deemed sufficiently quiet, yet maintain the softest sounds at an intensity which will not drop them below the ambient noise and therefore out of hearing. In a city home, the ambient noise is about 40 db. In a quiet home, probably in the suburbs, the ambient noise is about 30 db. In a very quiet home, probably in the country, late at night, the ambient noise level may be as low as 20 decibels.

Let us assume that ambient noise is only 20 db, the most favorable case for good listening. This permits 20 db reduction in the softest sounds (originally 40 db) before they tend to be masked by environmental noise. Perhaps another 10 db reduction is feasible without causing too much of the music to disappear. Thus under the best of conditions 30 db is the maximum feasible reduction that conserves an appreciable portion of the music. Under less favorable circumstances, where ambient noise is 30 or 40 db, a reduction of 30 db would render a substantial portion of the music inaudible.

It was stated that average original loudness of orchestral music is about 75 db. Reduction by 30 db would place the average level at a relatively low 45 db—only 5 db above the noise in a city home. Reduction of the 90 db peaks by 30 db would place them at 60 db, which is about the loudness of conversational speech, quite moderate. In fact, sound levels up to about 75 db—about that of loud conversation—may be considered tolerable in the home, particularly on passages of short duration, as the orchestral peaks are.

All in all, there is good reason to believe that under most circumstances the maximum gain reduction will be on the order of 30 db—one-thousandth of the original sound intensity. Thus an inquiry into the amount of loudness compensation required may be limited to cases where gain is decreased no more than 30 db. If the decrease is greater than 30 db, perhaps as much as 40 db, so much of the music (low-level portions) would be

lost to the ear at all frequencies that it seems pointless to exhibit special concern for the bass frequencies.

While 40 db is the lowest intensity of orchestral sound, this only holds true of the mid-range frequencies, about 1000 to 4000 cycles. On the logical assumption that the bass frequencies have the same minimum loudness as 1000 cycles, then their actual intensity must be a good deal more than the 1000 cycle intensity. Let us pursue this point by taking the case of 40 cycles, which is essentially the lower limit for the great bulk of musical sound. If adequate loudness compensation can be provided at 40 cycles, then it certainly can be provided at all higher frequencies, for the Fletcher-Munson curves show that the problem becomes less acute with increasing frequency (below 1000 cycles).

Fig. 1 shows that when 1000 cycles is at a 40 db intensity level, 40 cycles must be at a 75 db level in order to sound as loud. On the other hand, when 1000 cycles is at 90 db, 40 cycles need only be about 3 db higher in intensity, namely 93 db, in order to sound as loud. Thus, while the intensity level varies from 40 to 90 db at 1000 cycles, it varies from 75 to 93 db at 40 cycles. In other words, a dynamic range of 50 db at 1000 cycles is accompanied by a dynamic range of only 18 db at 40 cycles. The variation at 40 cycles is only 36% as great as at 1000 cycles.

This is a sort of differential action. Proper loudness compensation should conform to this differential. That is, a given change in level at 1000 cycles should be accompanied by a smaller change at bass frequencies. In the

case of a 40-cycle note, the change, as we have noted, should be 36% as great as at 1000 cycles. Conversely, it may be stated that 64% of the loss in gain should be restored at 40 cycles. If 1000 cycles is reduced 30 db, then 40 cycles should be reduced 36% as much, or about 11 db. Conversely, if all frequencies are reduced 30 db, then 40 cycles should be boosted 19 db (leaving a net decline of 11 db); 64% of 30 db is about 19 db.

The bass control in high-fidelity equipment provides a degree of boost which typically reaches a maximum of 17 or 18 db at 40 cycles. In some cases the maximum is as low as 16 db, while in others it may be as high as 20 db. By and large, the bass control will come within 1 or 2 db of providing sufficient bass compensation at 40 cycles when volume is reduced as much as 30 db from original loudness. If the reduction is appreciably less, though still large—say 20 or 25 db—there is no question but that the bass control can provide sufficient boost for correction of the Fletcher-Munson characteristic of the ear.

It may be asked whether the boost curves provided by the bass control correspond exactly to the theoretically required Fletcher-Munson compensation between 40 and 1000 cycles. Probably not. However, the divergence is unlikely to be more than 2 or 3 db at any particular frequency. Taking into consideration that the Fletcher-Munson curves are averages for a number of individuals, there is no guarantee that exact compensation will suit any given individual. It may well be that for some persons the

(Continued on page 110)

Fig. 1. Fletcher-Munson contours of equal loudness level. As the level is reduced, a greater intensity is required at low frequencies for equal loudness.

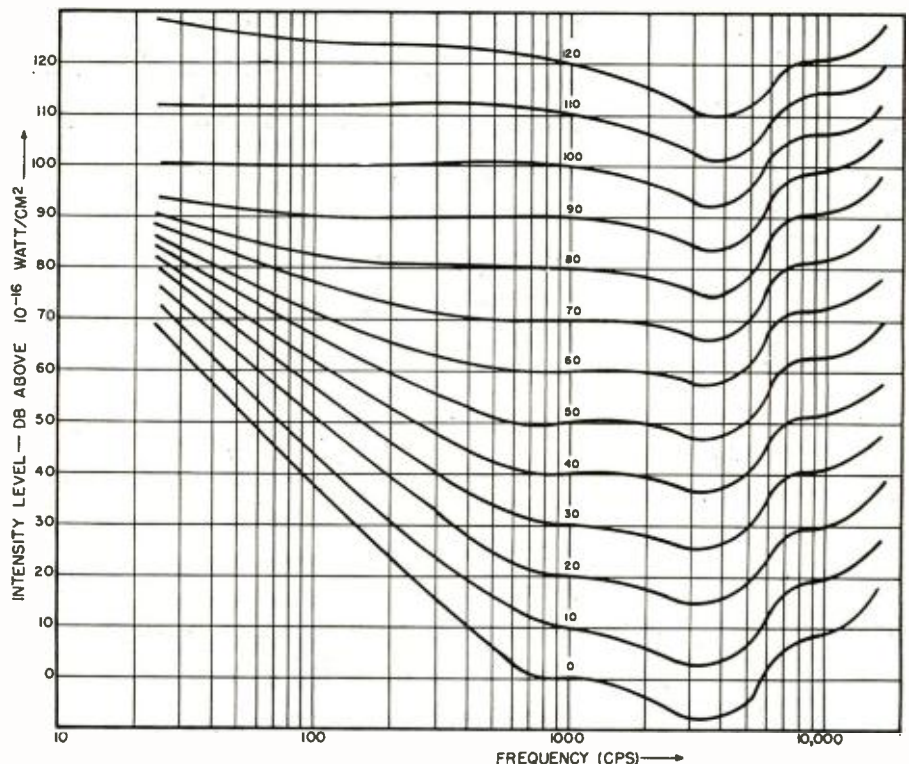

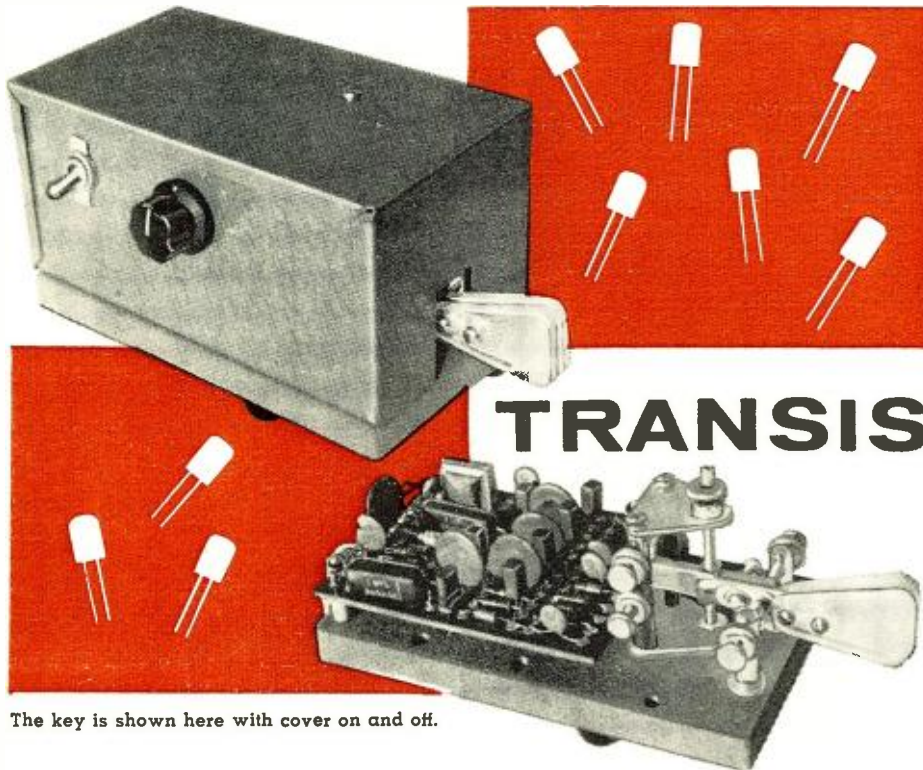

By
ROY A. McCARTHY
 K6EAW

TRANSISTORIZED AUTOMATIC KEY

The key is shown here with cover on and off.

Fully automatic unit uses 7 transistors but can be built entirely on baseplate of key.

AFTER listening to the higher speed QSO's on the amateur c.w. band, one soon realizes that the better sounding and easiest-to-copy signals are generally sent with the aid of an automatic electronic key. It is of interest to note that a fair percentage of these automatic keys are home constructed.

There seems to be three main types in use: those designed around a system of relays, those using a maze of vacuum tubes, or the simpler ones using only a minimum of tubes but requiring tricky adjustments for dot-dash ratio, etc. It is the purpose of this article to describe and explain another type which uses transistors for forming the code characters and keying the transmitter. The advantages of using transistors are many, including low power drain, portability, and reliability due to lack of heating. In addition, small size is easily attained without crowding the components, so that the entire circuit can be built up on the back shelf of a regular speed key.

Referring to the block diagram of Fig. 1 the controlled free-running blocking oscillator is the heart of the timing circuit. The pulses from the blocking oscillator switch the first bistable multivibrator back and forth giving an output of dots and spaces. The second bistable multivibrator, which really makes this a count-of-four circuit combination, operates only on dashes and flip-flops once for every two operations of the first multivibra-

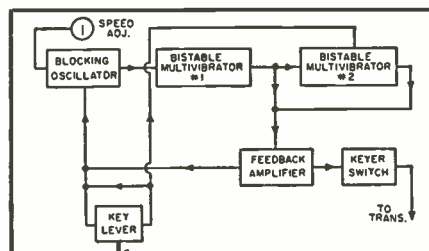
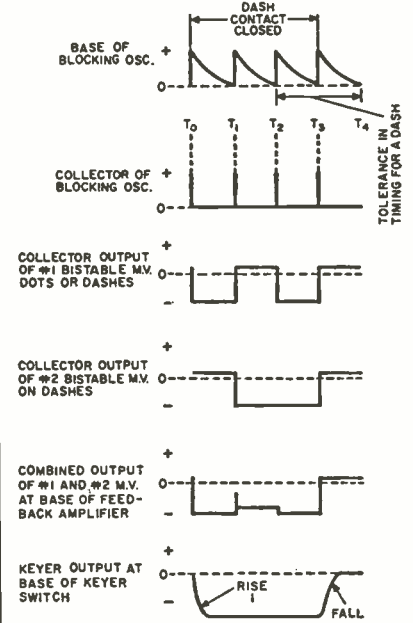

Fig. 1. Block diagram of automatic key.

Fig. 2. Waveforms referred to battery c.t.



tor. Thus on dots the output is only that of multivibrator # 1 which is fed through the feedback amplifier to both the output keyer switch and back to the blocking oscillator. On dashes the outputs of the two multivibrators are added together to produce dashes which are three times the length of the dots. The spaces, as well as the individual or mixed dots and dashes, are self-completing, with the exception of the center portion of a single or end dash. This is an aid to sending, since if the dash contact is accidentally ticked, or held closed only slightly longer than the length of the space following a dash, the result is only an extra dot, which is much less disconcerting than an extra dash would be. The output keyer switch is used to control the transmitter by keying the cathode of a low-power stage, much in the same way as was suggested in the author's article, "Simple Transistor Keyer Unit," in the April 1958 issue.

The waveforms of Fig. 2 show what may be expected at various points in the circuit. Note in particular that for a single dot the blocking oscillator fires twice, once to start the dot and once to finish it. In the combined output of the two multivibrators a small reverse spike is shown at the end of the first third of the dash when the multivibrators are switching. This is wiped out by the waveshaping filter in the output circuit. Also a slight unbalance may be noted in the multivibrators and this is cleared up by the saturated keyer switch acting as an amplitude limiter much as a class C vacuum-tube stage does.

By examining the schematic diagram of Fig. 3 the following conditions

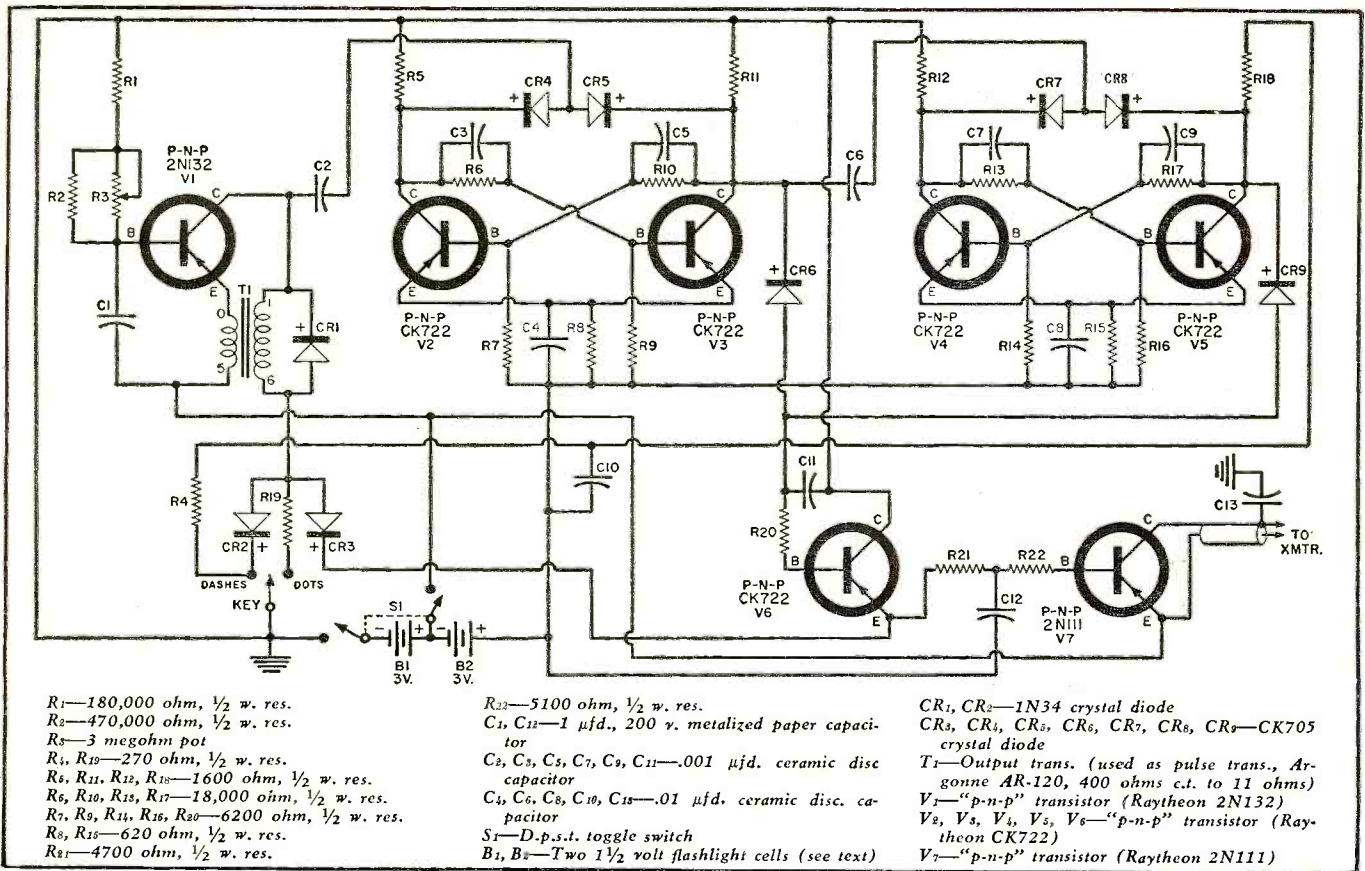

Fig. 3. Here is the complete schematic diagram of the fully automatic transistorized keyer unit described in article.

may be noted. Assuming that the power switch *S*₁ is on and the key is in standby, the blocking oscillator is inoperative due to lack of “B-” supply. In the first multivibrator *V*₂ is cut off and *V*₃ conducting so that the collector of *V*₃ is at a lower, i.e., closer to zero, “B-” potential. This condition must prevail during standby since if the flip-flop happened to be reversed the negative voltage on the *V*₃ collector would be fed through *CR*₆ to the base of *V*₆, causing it to conduct and putting its emitter at the “B-” potential. This would cause the blocking oscillator to fire and reverse the flip-flop to the desired condition.

Also during standby there is no “B-” voltage on the output transistor, *V*₇, of the second multivibrator. Since the base of *V*₁ is not biased now, it also is cut off. And, finally, during standby *V*₆ and *V*₇ are also at cut-off. Incidentally this does not refer to an actual complete cut-off state of the transistors, because there is, of course, a leakage current equal to approximately *I*_{co} times *beta*. Hence, during standby there is a current drain on the order of 2 to 3 milliamperes.

In view of the fact that the blocking oscillator and the two multivibrators are similar to their vacuum-tube counterparts, a detailed description of

their operation will be omitted. Numerous publications are available to those interested in the design problems of the individual circuits. It is felt that an explanation of some of the peculiarities of the over-all circuit would be desirable.

In the blocking oscillator, *R*₃ is the speed control with *R*₁ and *R*₂ added for end limits to make adjustment easier, like a bandspread dial. Capacitor *C*₂, the coupling to the first multivibrator, was purposely made rather small to reduce loading on the blocking oscillator. This low capacity, in conjunction with *R*₅ or *R*₁₁, make up a
(Continued on page 116)

Top view of the board on which all the components are mounted.

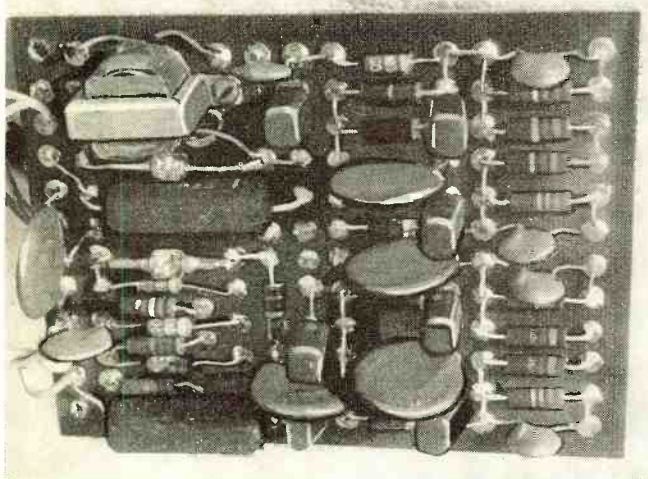

Bottom view of the same board showing wired interconnections.

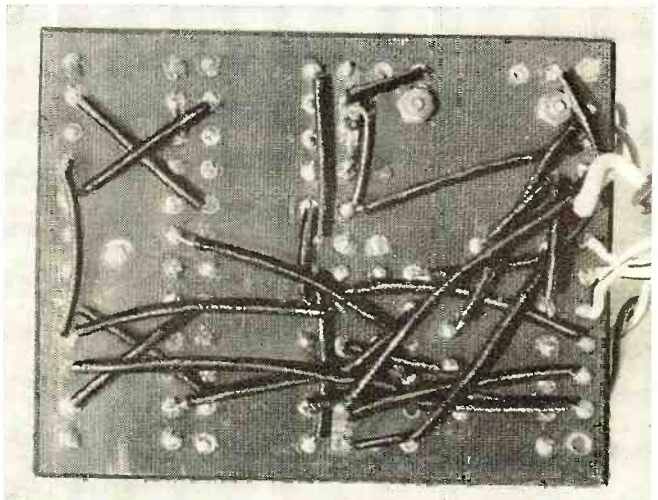

Stereo Control Center

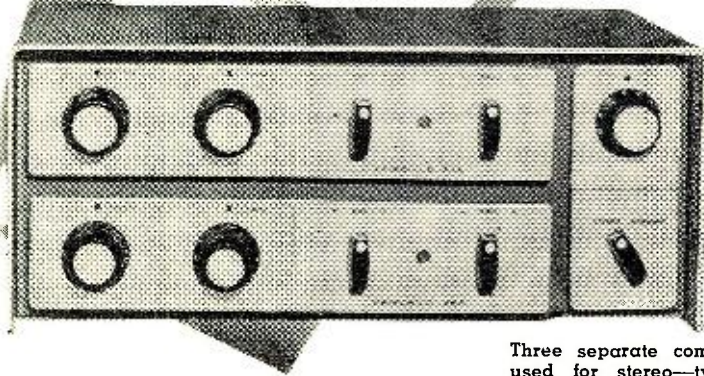

Three separate components are used for stereo—two identical preamplifiers and a control unit.

*Fairchild offers a new stereo control system—
a novel design, compact, and easy to operate.*

THE advent of the stereo disc has, without a doubt, stimulated the entire high-fidelity field. The most common method of achieving stereo is the use of a dual-channel integrated preamplifier with dual power amplifiers, either integrated or separate. This method is certainly advisable for those who have no equipment already on hand.

For those high-fidelity enthusiasts who already have a good monaural system it becomes costly to discard present equipment and start afresh. Actually, there are no problems in using independent preamplifiers and power amplifiers to obtain stereo.

However, for ease of operation it is better to obtain a central control system, one that would provide a master gain control for both channels. There are various ways in which this can be done. Fairchild's method is to use its Model 245 preamplifier along with a power amplifier, if one plans monaural operation. When stereo playback is desired, simply add to the present system an identical preamplifier and power amplifier and the firm's Model 247 stereo converter. This system is novel in that the converter connects in just ahead of the last tube in the preamplifier circuit and to the volume control. This is a very effective way of

obtaining stereo operation. The converter, of course, is designed to be used only with Fairchild Model 245 preamplifiers.

The stereo converter consists of a ganged volume control which permits the simultaneous control of volume in both stereo channels. In addition, a switch is incorporated to combine the two stereo channels into one monaural system. A single-section loudness-control switch converts the volume control to a loudness control.

The Model 245 preamplifier was one of the units that was recently tested in our laboratories. It incorporates the basic functional controls in a straightforward design. As a result, the unit achieves exceptionally good performance and simple over-all
(Continued on page 87)

Fig. 1. Schematic diagram of Fairchild's Model 245 pre-amp. For monaural, just one unit is required. For stereo, it is necessary to obtain another identical unit plus the Model 247 stereo converter. Note that the interconnecting cable connects into the circuit after the second EF86, not ahead or after the pre-amp, as one would expect.

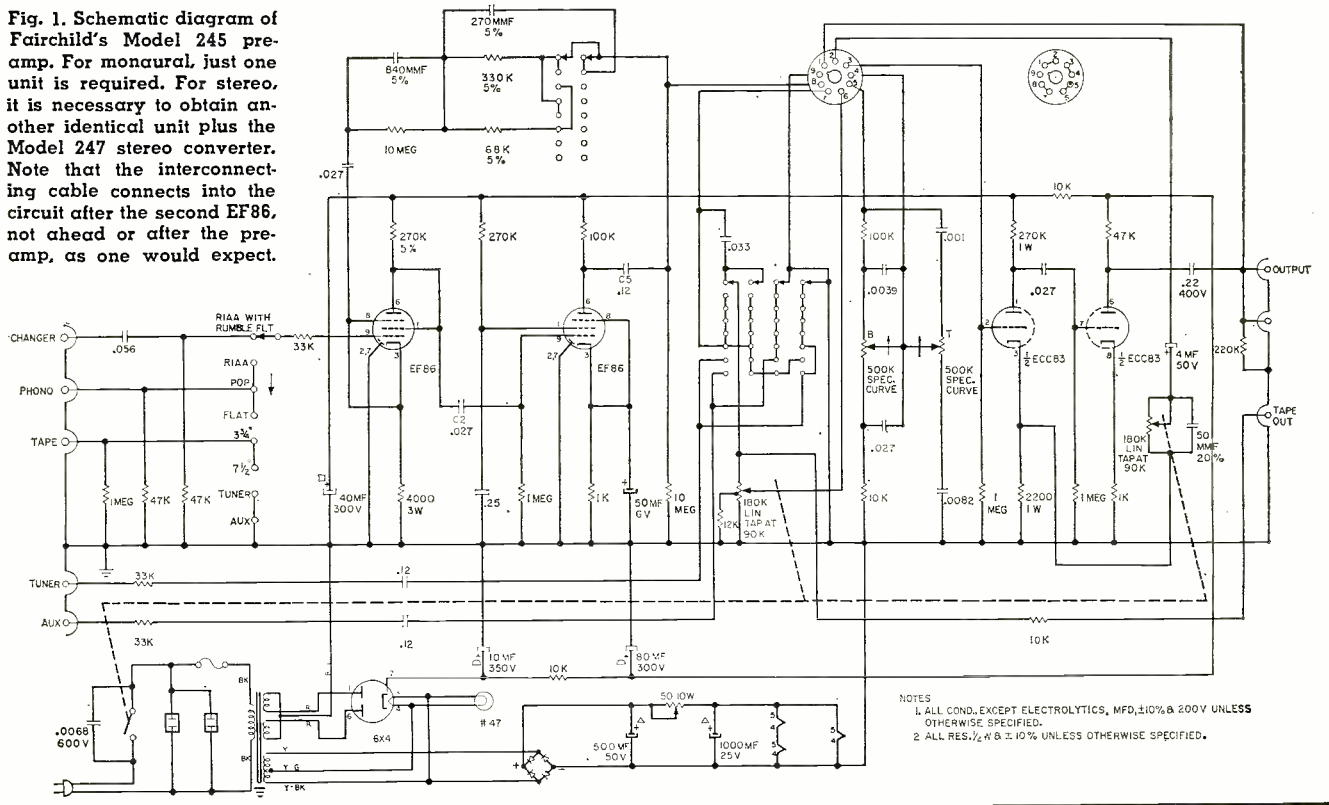

IN ADDITION to troubleshooting and repairing defective TV sets, a service technician is often able to improve the performance of an older receiver by modifying its circuitry slightly. During the last ten years, the author has had occasion to design and redesign, to modify and change back a variety of sets which, for some reason or other, have fallen short of their expected performance.

Often special interference or unique signal conditions make such circuit changes worthwhile even though the receiver is a well designed, properly working unit. At other times, aged components or tubes can be given a new lease on life simply by changing the circuit slightly. Other reasons for circuit changes include increased signal strength due to station power increase, adjacent-channel interference, or simply the installation of a replacement tube or component which is different from the original. We present a number of circuit modifications which have been made successfully, but which require some understanding of TV receivers and, in some cases, certain test equipment.

Blanking Circuits

Most of the recent TV sets already have vertical blanking of the picture tube to keep retrace lines from being visible on low-contrast pictures; some also use horizontal-retrace blanking. Many of the earlier sets do not have blanking circuits and, especially when picture tubes age, retrace lines may become visible and annoying. During the period when the electron beam moves from the bottom back to the top of the screen this trouble is especially noticeable, since several horizontal lines occur which appear as a zig-zag pattern on the screen. This can simply be blanked out by applying a portion of the vertical-retrace signal to the picture tube in such a way as to cut the tube off during the retrace period.

Fig. 1 shows different ways of applying the vertical retrace pulse to the picture tube, depending on the method of video-signal driving employed by the set. Some sets have the video signal going to the cathode, while in others this intelligence goes to the grid of the picture tube. To avoid interference with, or loading of, the video signal, the blanking signal is applied to the tube element which does *not* get the video signal.

When applied to the cathode, the blanking signal must be a positive pulse in order to cut the tube off. The opposite holds true for the control grid. Since the blanking signal is obtained from the vertical-sweep section, the point from which it is taken must be selected to yield the proper signal polarity. At the plate side of the vertical-output transformer the blanking pulse is positive. If, as in Fig. 1A, an autotransformer is used, the signal across the yoke will also be positive. Where a transformer with separate primary and secondary is used, the

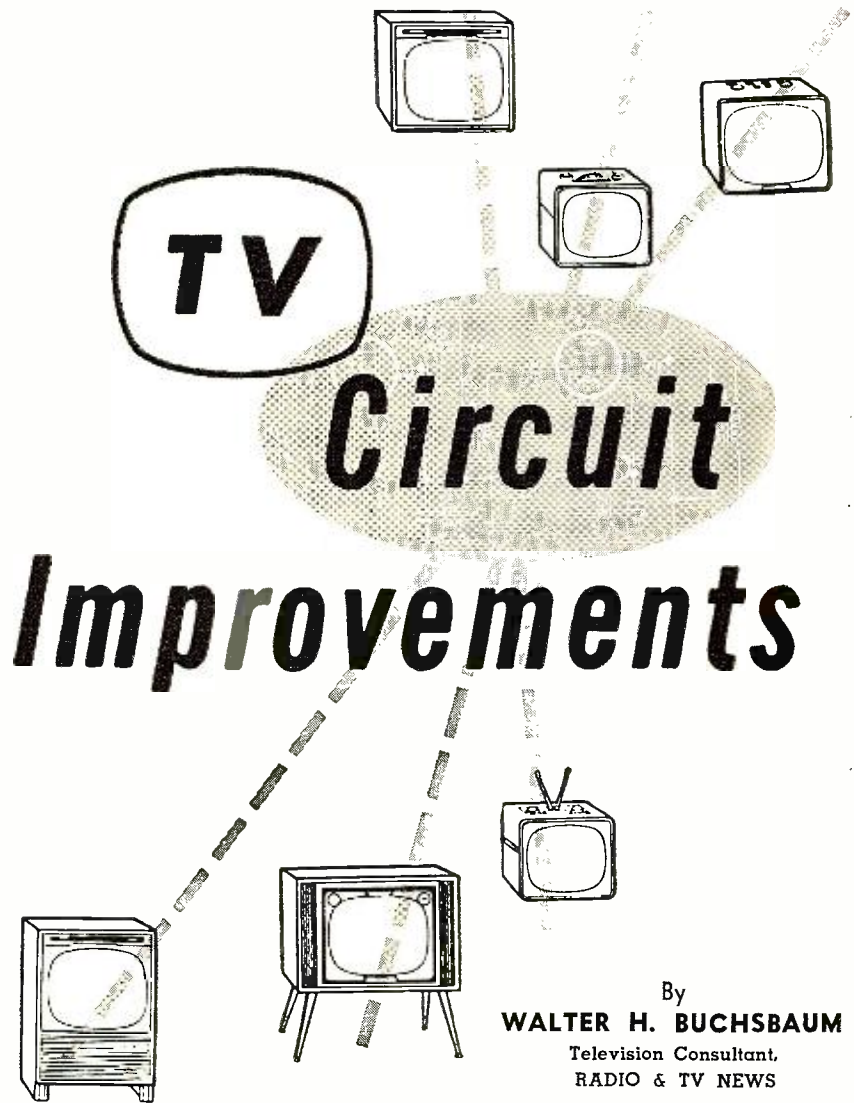

By
WALTER H. BUCHSBAUM
Television Consultant
RADIO & TV NEWS

A wealth of changes for old and new TV sets to enhance performance where aging, outmoded design, or individual reception problems are major factors.

pulse will usually be negative at the secondary and positive at the primary. To get a negative pulse in a set using an autotransformer, the connection

EDITOR'S NOTE: "Stop and proceed with caution," should be the watchword here. Whenever a TV receiver fails to perform up to expectations, the possibility of an out-and-out circuit defect or misadjustment should be investigated thoroughly and eliminated. Only then should changes be undertaken. This is why the decision as to whether alterations are needed is best left to the judgment of a competent, properly equipped technician. This is not the first article of its kind we have seen or published. Nevertheless, it contains many good ideas that have not enjoyed wide circulation before, and its solutions are well thought out. Do you agree?

can be made to the grid of the vertical-output tube.

Coupling capacitors and resistors must be chosen to give a pulse of sufficient amplitude and width to blank out the tube during the entire

retrace period. If the retrace lines are still visible at the top or bottom of the screen, the value of the coupling capacitor should be increased or the value of the shunting resistor or capacitor should be reduced. Figs. 1A and 1B show typical ranges of values for either cathode or control-grid blanking.

In some receivers, the cathode and grid are connected through a diode d.c. restorer network—this might make a simple connection to the vertical-blanking signal impractical. In such cases, the second grid—the accelerating element or first anode—may receive the blanking pulse, as shown in Fig. 1C. There the pulse must be negative and have at least sufficient amplitude to override a good portion of the d.c. potential, which may range from 250 to 450 volts. Sometimes the second grid is bypassed with a capacitor rated at .1 μ f. or

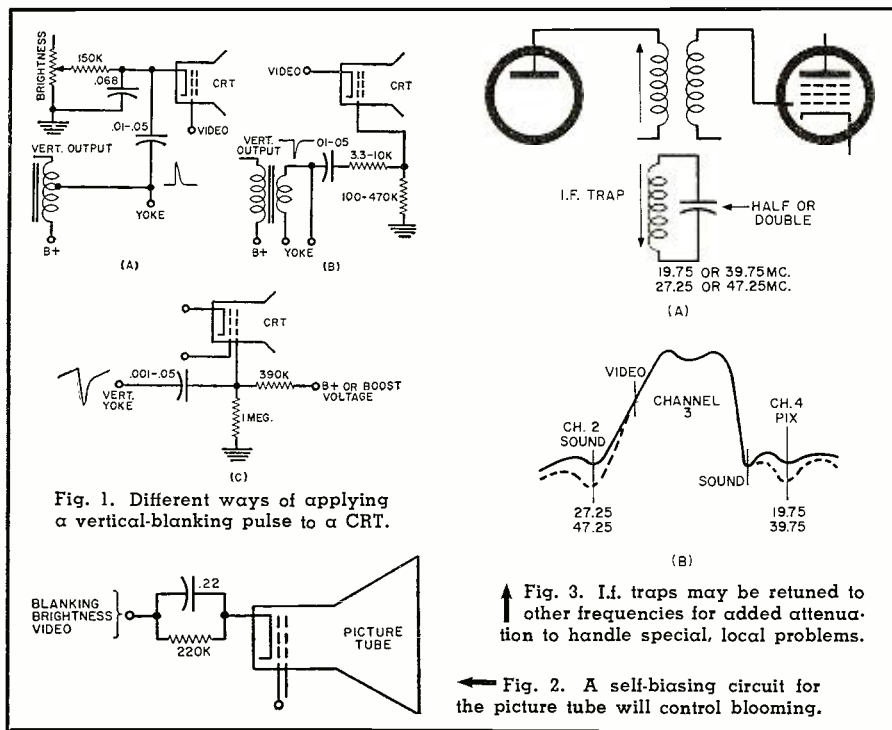

Fig. 1. Different ways of applying a vertical-blanking pulse to a CRT.

Fig. 3. I.f. traps may be retuned to other frequencies for added attenuation to handle special, local problems.

Fig. 2. A self-biasing circuit for the picture tube will control blooming.

larger, which attenuates the blanking pulse. Change that capacitor to a unit of .005 μ f. or smaller.

Occasionally a receiver is encountered which has a vertical-output autotransformer and requires blanking of the second grid. A sufficiently large negative vertical pulse may not be obtainable. One could try to build a single-stage pulse amplifier or, instead, the blanking pulse could be injected at the grid of the last video amplifier. The latter method can cause sync buzz in the intercarrier sound system if the 4.5-mc. signal is taken at the output of the last video stage. A portion of the horizontal flyback pulse can be used then, but capacitor values must be reduced to at least one tenth their original values to avoid loading of the flyback circuit. This latter method requires careful oscilloscope measurement to make sure that horizontal sync, deflection linearity, and pulse width are not affected.

Anti-Blooming Circuit

Blooming usually occurs when the high voltage is not high enough, or when its regulation is so poor that, on bright white, the spot size is enlarged. Slightly gassy picture tubes, washed-out screens, and a generally marginal set may cause this defect. A very simple circuit which usually does wonders in such cases is shown in Fig. 2. This is a simple self-biasing of the picture tube. When blooming occurs, excessive cathode current is drawn, which causes the anode voltage to drop and the spot to bloom. However, when the self-biasing circuit shown in Fig. 2 is added, the excessive cathode current immediately sets up a voltage drop across the new resistor. This voltage drop has the effect of adding to the grid bias of the picture tube

and thereby limits the cathode current. It is the same as if the brightness control were turned down slightly for an instant. The total effect is to eliminate—or at least greatly reduce—the effect of blooming. In some sets, the brightness and contrast controls have to be re-adjusted after the self-biasing circuit is installed.

I.F. Trap Shifting

In some locations, adjacent-channel interference is quite a problem. Often this trouble appears only after the interfering station has increased its radiated power, or a new receiving antenna has been installed which favors the adjacent station. One method of dealing with this type of interference is to align the i.f. traps for maximum adjacent-channel rejection. Most TV sets have traps in the i.f. section to reject the lower adjacent-channel sound and the picture signal of the higher adjacent channel. A typical response curve is shown in Fig. 3B, for Channel 3. Actual frequencies depend on whether a 21- or 41-mc. i.f. section is used, but the spacing and over-all appearance of the response curve is roughly the same for any TV set.

Assume now that the interfering signal originates on Channel 2, and therefore the sound of that channel appears in the picture of Channel 3. The trap tuned to 27.25 mc. may not be sufficient to eliminate the Channel 2 sound completely. At the same time, Channel 4 is not received at all and the 19.75-mc. trap is really unnecessary. An obvious solution is to tune this latter trap to 27.25-mc. as well, and thus to increase the rejection sufficiently to remove the interference from the picture. In many sets, the traps are coils made of heavy bus wire located over or near the i.f. coils and

tuned by a separate slug. The simplest way to increase the frequency of the 19.75-mc. trap would be to tune it, but usually the tuning range does not extend far enough. Changing the tuning capacitor to about half of the original value often does the trick, where frequency must be increased.

It is possible that the situation is reversed and the higher adjacent-channel video signal appears in the sound or even in the picture of the desired channel. Then it would be useful to tune the 27.25-mc. trap down to 19.75-mc. This is simply done by shunting more capacity across it and thereby lowering its resonant frequency. A word of caution: this process of tuning the traps should be performed only when it is possible to observe the entire i.f. response curve. A sweep generator, marker generator, and oscilloscope are required for this modification. The technician will have to watch the response curve carefully and re-adjust various other coils as the traps are changed. Remember that each time a trap is detuned the coil to which it is coupled is also affected and may need touch up.

Increasing I.F. Gain

In some locations, especially on older sets, it may be desired to get the very maximum gain in the i.f. and tuner, even though some slight picture deterioration may also occur. When a receiver already has four i.f. stages, operating at maximum sensitivity, additional i.f. gain may not add anything to the picture, since the noise or snow already is quite strong. In sets using only two or three i.f. stages, however, conditions may arise where increased i.f. gain would give a better picture.

One way to increase i.f. gain is to substitute "hotter" tubes, if possible. Another way is to increase the plate voltage, but usually that is not so easily done. A simple method of boosting i.f. gain is to change the a.g.c. voltage. In many sets, there is a minimum a.g.c. bias of .75 or 1 volt even under weak signal conditions. This can be reduced either by grounding out the a.g.c. bus, connecting a lower value resistor from the a.g.c. bus to ground, or—the most efficient method—by connecting a resistor from "B+" to the a.g.c. bus. This latter circuit is often called "delayed a.g.c." and, in some receivers, is switched on or off with the "local-fringe" switch.

Fig. 4 shows how the "B+" is connected (point A), and also a simple method for getting more gain in the r.f. amplifier stage. Usually the a.g.c. bus going to the tuner is either isolated through a 1000-ohm resistor or else there may be a voltage divider to reduce the bias on the r.f. stage below the level used for the i.f. section. As shown here, the r.f. amplifier could be operated without any a.g.c. at all (the grounded arrow going to point B) or else with greatly reduced bias (the alternate 1000-ohm resistor shown at the same point). In Neutrode and

cascode tuners, the neutralizing adjustment will be affected to some extent by the reduction in bias, especially if the a.g.c. is grounded out. Adding the resistor to "B+" has the advantage of reducing the bias to near zero on weak signals while the full a.g.c. action remains on strong pictures.

Increasing Video Gain

In some sets, a slightly pale, washed-out picture indicates insufficient contrast. Setting the contrast control, changing video-amplifier tubes, and even reducing the brightness may still leave a weak picture, especially in fringe areas. In the latter type of reception, increasing the video gain is often more useful than advancing the r.f. and i.f. gain. This is so because increasing r.f. or i.f. gain often seems to increase noise content more than the picture information.

It also happens that when newer picture-tube types are installed in older sets, the available video gain suddenly appears to be insufficient. The reason for this is that some older tube types did not require as much signal for full contrast. Whatever the reason, in many sets additional video gain can be obtained by minor circuit changes, but it should be understood that this usually will result at least in a theoretical degradation or bandwidth reduction of the picture signal. Usually the full 4-mc. video signal is not used anyway so that a small sacrifice may go unnoticed.

Fig. 5 shows two points at which video gain can be increased. Where the video-amplifier cathode is not bypassed, or has only a small mica capacitor for high-frequency boosting, the addition of a .05- to 1- μ fd. capacitor will increase the gain at all but the low frequencies. By increasing the plate-load resistor, however, the low frequencies are favored and this change often cancels out the cathode bypass effect if both measures are applied at the same time. Increasing the load resistor will increase the overall video signal and, if the increase is too great, the sync circuits, which may obtain their signal from the video stage, could be overloaded. One should therefore make as conservative a change as possible. Another thing to watch for is the wattage rating of the plate-load resistor, since many video tubes often draw enough current to require 4- or 5-watt resistors.

Increasing Picture Width

Insufficient width is a frequent complaint and usually can be cured by tube substitution either in the horizontal flyback section or the "B+" rectifier. In some stubborn cases, no amount of tube changing, voltage checking, and adjustment of the horizontal drive and width controls gives quite enough deflection. Only then should circuit modifications be attempted. Some receivers have a width switch which connects different taps of the flyback transformer into the circuit. This normally is sufficient to

get the correct width. Many sets use a width-control coil which is shunted across a section of the flyback transformer. (EDITOR'S NOTE: *This control has been disappearing rapidly during the last two years.*)

In Fig. 6, a typical circuit is shown, but the changes suggested here will also work on the autotransformer type of flyback. First try adjusting the width coil, when present. If, as is usual, maximum width is obtained with the slug all the way inside the coil, the next step is to disconnect the coil. If the width is still short of the picture-tube edges, connect a capacitor across points A and B where the width control was. This will increase the width and reduce the high voltage slightly. As the value of the capacitor is increased, the effect on the high voltage is also greater. A compromise value must therefore be found which gives good width and also sufficient high voltage.

(If too much capacitance is introduced, the detuning of the flyback circuit that is likely to occur may have other undesirable effects. Horizontal retrace time may be slowed down. In this event, video signal for one line of scan will be fed to the CRT before the electron beam has had a chance to return to the proper starting position. The visual result will be horizontal foldover. Also, operation of the horizontal oscillator and a.f.c. circuit may be affected in some instances.)

A remedy which increases both width and high voltage is to increase the voltage at the screen of the horizontal-output tube. Reducing the screen resistor by shunting another resistor across it is the simplest method. The screen voltage and current rating of the tube should not be exceeded; and it therefore will be necessary to measure the voltage and current. Current is measured easiest

by checking the voltage drop across the cathode resistor and calculating the total tube current by Ohm's Law.

Most 6BG6 tubes can be operated up to 110 ma., while 6BQ6 or 6AU5 tubes should not exceed 100 ma. and 85 ma. respectively. If the cathode resistor is 100 ohms, then the voltage across it should not exceed 11, 10, or 8.5 volts for the 6BG6, 6BQ6, and 6AU5 respectively. For different tube types, check the tube manual. Screen resistors usually have ratings of 2 and often 5 watts; any shunting resistors should therefore be of the same wattage rating to be on the safe side.

Improving Linearity

Vertical and horizontal linearity are controlled by adjustments in the respective sweep sections, and can usually be set to a fairly linear picture. Occasionally it appears that either the vertical or horizontal linearity just cannot be adjusted completely and then some simple circuit changes might be tried. The changes described here will not provide sufficient range in all cases, but they are so easy to try that they are worth the small effort required.

Across each of the vertical-deflection coils, a $\frac{1}{2}$ -watt resistor is usually connected ranging from 470 to 1000 ohms, depending on the type of yoke. As in Fig. 7, either one of these resistors can be increased or decreased to change the linearity at the top or bottom of the picture. In wiring these resistors in place, care must be taken not to short out any portion of the deflection yoke or damage the coil insulation.

Across the "hot" side of the horizontal yoke coil, a 47- μ fd. capacitor or some similar value is often used to damp out oscillations. Changing this capacitor to a larger one, or a com-

(Continued on page 92)

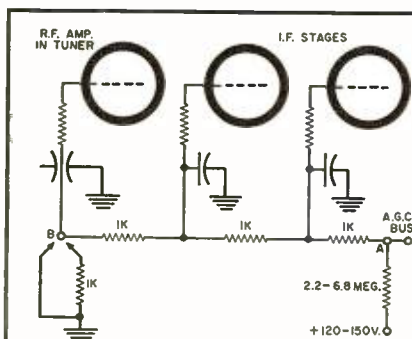

Fig. 5. Changes to increase video gain.

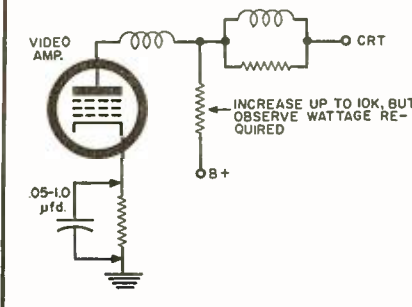
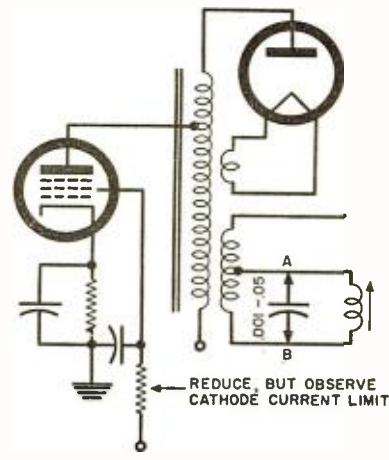

Fig. 4. Changes can be made in the a.g.c. circuit to provide more gain in the r.f. and i.f. stages for fringe use.

Fig. 6. Within limits (see text) width can be increased by adding a capacitor where shown or reducing the output-tube screen-dropping resistor.





Video Tape

Tape That

By **RONALD L. ANDERSON**
 Minnesota Mining & Mfg. Co.

Ten years after magnetic tape was introduced to radio broadcasting, it was introduced to TV broadcasting. Above is the video recorder installed at KING-TV, Seattle, country's first local station to be so equipped.

ONE of the major advances of the electronics industry in the past decade has been the development of video tape recording—a technique which produces “films” for television electronically, rather than photographically.

“Perfection” of such a tape—although certainly further improvements will be made—is even more remarkable when you consider that it was just 10 years ago that tape really came into its own.

April 25, 1948 was the beginning, and it marks the date that the ABC radio network began large-scale use of magnetic tape to record, delay, and then re-broadcast network radio shows to cope with the daylight-saving-time jumble, just as video tape is used in television today.

True, tape had been in use earlier both in Germany and, to a limited extent, in the United States. (*Minnesota Mining and Manufacturing Company* and *Brush Development Company* had paper-backed recording tapes for amateur machines on the market in 1947.) But it was not until ABC's venture that tape proved practical on a large-scale application, meeting truly professional standards.

What made it possible was the development of a new, plastic-backed, high-fidelity recording tape and a newly developed professional tape recorder. Equally significant was the assurance that both could be supplied in sufficient quantity to justify an industry change.

Ampex Electric, as it was then known, developed the machines—patterned largely after the German “Magnetophon” recorder—and *Minnesota Mining* produced a special tape, “Scotch” brand No. 112 tape, tailored to the recorder and, accordingly, similar to the German wartime tapes.

An interesting turn of events, however, was that both the machines and tape were obsolete even before they were put in use, for late in 1947 *3M*

The tape that's used to record TV programs must be very special. Here are some of the reasons why.

had come up with an experimental magnetic tape that employed a red oxide coating. The new material was such an improvement that the same high-frequency response (up to 15,000 cycles per second) at only a quarter the tape speed (7½ inches per second instead of 30 inches per second as required by the German type tape) was obtained. This increased recording time from a half-hour per reel of tape to a full two hours on the 4800-foot reels then in use, and cut costs greatly.

A still further turn of events was that Marvin Camras of Armour Research Foundation, who is frequently referred to as “the father of modern magnetic recording,” actually had invented the red oxide tape prior to *3M* and was accordingly granted the patent. (*3M* is today a licensee under the Camras patent.)

So while the daylight-saving-time

recording venture for radio put tape on the way in the professional recording field, red oxide tape picked up the ball and ran. Not only did it take over the professional field, but paved the way for the development of low-cost, slow-speed, home tape recorders.

How important it was in the home recorder field is evidenced by the fact that in 1947 and 1948, only about 5000 tape recorders were produced, whereas in 1949 the figure jumped to 27,000; in 1950 to 66,000, in 1951 to 84,000 and has been climbing since to over a half-million machines last year.

Since those early days, red oxide tape has been adopted by every segment of the tape recording industry, including the computer, telemetering, and other instrumentation fields.

Video Recording

However, the advent of video re-

Magnified view of small piece of recorded video tape that has been treated to make the tracks visible. Direction of tape motion is up in photo. Picture information is in the transverse lines (with their gradual downward slope from left to right). Accompanying sound is recorded normally along the left edge. Along the right edge is the control track that syncs the tape and record heads.

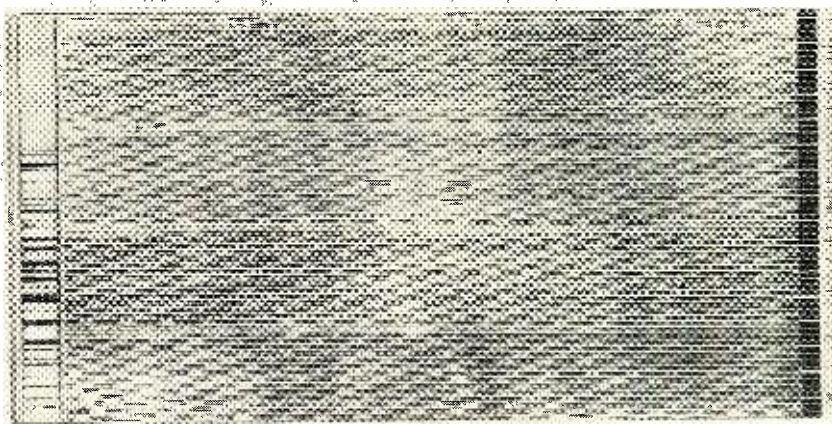

Takes Pictures

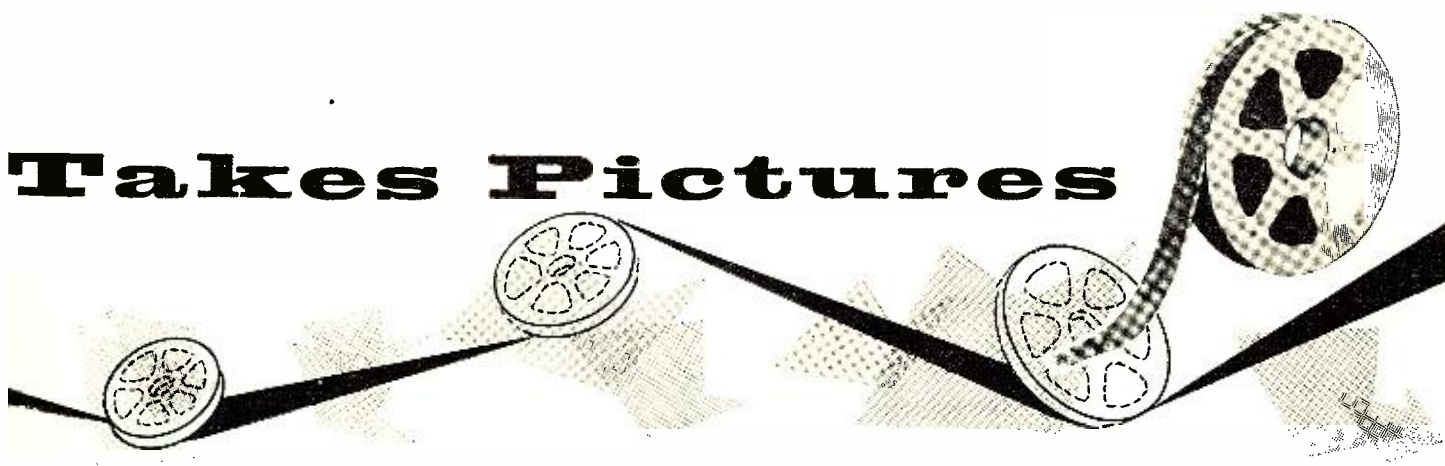

recording introduced new problems that could not be solved readily by the conventional tapes used for recording sound. The video recorders developed by *Ampex* and first shown in 1956 require a special tape with many new properties. Without such a tape, the performance of a video recorder certainly does not live up to all of its expectations.

One of the major differences is in the actual manufacture of video tape and the problems it involves. As Dr. W. W. Wetzel of *Minnesota Mining's* Magnetic Products division explains, "It is necessary to pack about 10 times as much information on the tape in video recording as in sound recording. There you might record 2000 'bits' of information on a single inch of tape track, whereas in video recording, you must record some 20,000."

Since these bits of information are much smaller and thus more difficult to record (wavelengths only .0003" long must be recorded), any dust particle or imperfection in the tape coating only one-tenth that long will cause a signal drop out.

"For example," Dr. Wetzel says, "in recording sound, imperfections up to

.003" might be permissible. In instrumentation recording—as in guided missile work—imperfections as tiny as .0003" may be permissible and not cause drop outs.

"But in video recording, imperfections in the tape as small as .00003" will result in signal drop outs caused by momentary loss of intimate contact between the tape and the recording heads. Imperfections in the oxide coating or even particles of dust which collect on the tape during use may cause them, as will faulty heads on the machines."

At that, to maintain the necessary head-to-tape contact, even with essentially "perfect" tape, it is necessary to exert a head pressure on the tape of about 20,000 pounds per square inch—and that while the heads rotate at more than 14,000 rpm. This creates tremendous friction and results in heat sufficient to soften the binders used in ordinary audio recording tapes.

As a result, in addition to improved manufacturing techniques required to meet these more critical tolerances, new materials must be employed in the fabrication of video tape to insure proper operation.

Because of the rugged operating conditions imposed on the tape (a speed of 15 ips past a rotating disc carrying four equally spaced magnetic heads) a polyester film backing—rather than the more common acetate backing—is used. Its higher physical strength, temperature limits, and increased dimensional stability are important. Then, too, the heads on the video recorders record a track only 10 mils wide. This compares with from 90 mils to 250 mils on conventional sound recorders, and, as a result, requires a special "high potency" oxide coating.

Another difference is special, cross-orientation of the magnetic oxide particles. The particles are acicular, or "rod shaped," and on conventional tape are oriented so they run the long way on the tape. This results in improved magnetic characteristics. However, for the video recorder—which records cross-wise on a 2" wide tape—it was necessary to swing the particles 90 degrees to bring them approximately parallel to the sweep the head makes across the tape. Approximately 64 minutes of program can be recorded on a 12½" reel.

(Continued on page 114)

Video tape must withstand heavy wear and be free from imperfections. Improvements that have been made are shown in the photos below, made at a magnification of 40 times. Early experimental tape at left shows wear and imperfections after only 15 passes of the recording heads. Modern tape, at the right, is still in satisfactory condition after over 300 passes of the video tape recording heads.

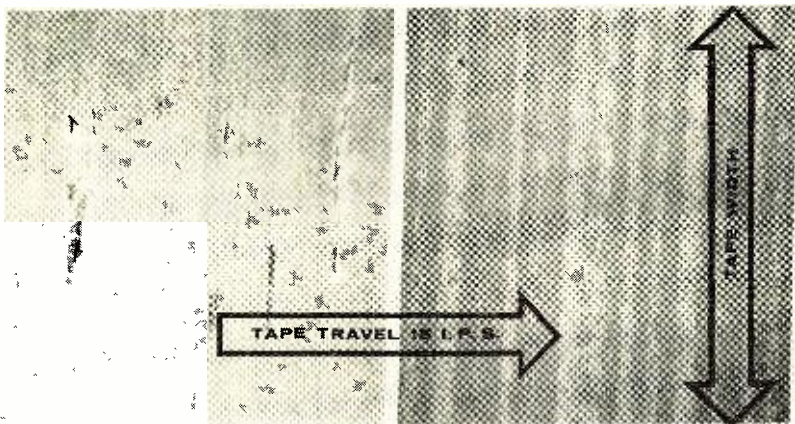

Ampex 200 tape recorder, patterned after German wartime "Magnetophon," enabled radio broadcasting industry to use tape.



RADIATION detectors are natural items for sales, repair, and servicing by radio-TV technicians. The increasing general interest in radioactivity and the requirements of Civil Defense are responsible for the widespread activity in portable radiation detectors. Radioactivity cannot be determined without specialized detection equipment; of recent years many different models of portable detectors have been appearing on the market.

These detectors use some new techniques, in terms of radio and TV circuits, but a part of each detector uses circuits well-known to the service technician.

The servicing and repair of these units, once their principles are understood, are not difficult. They most closely resemble portable radio receivers, in many respects. Some of the many commercial radiation detectors are shown in Figs. 1 to 3.

Types of Radiation

Radiation in the form of radio waves is, of course, familiar—from the lowest frequency of r.f. through v.h.f. and u.h.f. television and up to microwaves as used for communications and radar. Light is radiation much higher in frequency than radio, but it is a special form.

Higher in frequency than light are some of the various types of nuclear radiation. Some chemical elements such as radium and uranium are not stable in their natural state. Their actual physical structure constantly changes through decomposition; during this process energy is emitted by these materials. Energy particles, which are emitted by radioactive materials, are used to detect their presence.

Radiation may result from at least three types of energy particles: these are *alpha* (α), *beta* (β), and *gamma* (γ) rays, as indicated in Table 1.

Alpha rays: These have high energies and a range which is quite short—only a few inches. They are emitted as certain radioactive materials disintegrate to change into new materials. The form of an *alpha* particle has been determined to be that of a helium atom, without the orbit electrons, or the same form as a helium nucleus.

As shown in Fig. 4, there are two electrons in orbits around the helium

RADIATION DETECTORS

A Technician's View

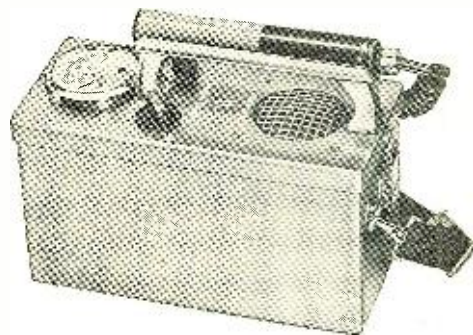
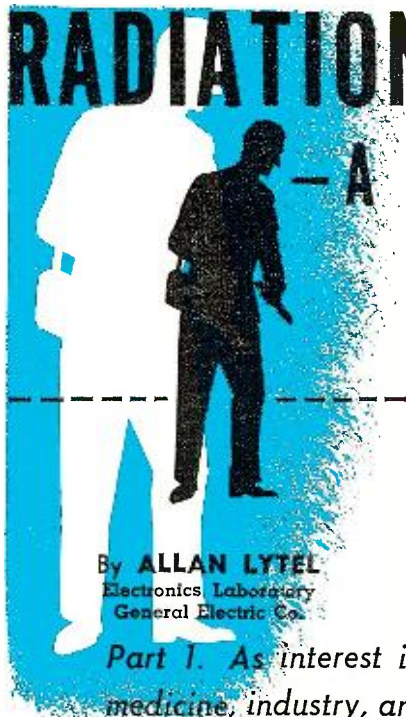

By **ALLAN LYTEL**
Electronics Laboratory
General Electric Co.

Part I. As interest in radioactivity increases in medicine, industry, and among experimenters, less elaborate detectors are reaching the service shop.

nucleus. The nucleus has two protons, each with a positive charge, and two neutrons without any electrical charge. Normally the two negative charges of the two external electrons are balanced by the two positive charges of the protons in the nucleus.

EDITOR'S NOTE: With the increasing use of radioactive materials in industries of all kinds, operation of relatively inexpensive, portable detection equipment is becoming quite widespread. Also, the fact that the government's interest in new deposits of radioactive materials has waned has not dampened the ardor of amateur ore hunters. This summer, many vacationers who will be roaming the country will be carrying along detection equipment. When the latter needs repair or adjustment, any good service technician can handle these relatively simple devices—if he knows what they are about.

However, the particles emitted by radioactive substances are helium nuclei and hence carry a double positive charge. They are easily absorbed however: a piece of ordinary paper will stop *alpha* particles.

Beta rays: These are high-energy electrons of greater force than *alpha*

rays and they travel far greater distances before they are stopped by collision with other materials (including air). *Beta* rays are stopped by about two feet of rock and soil.

Gamma rays: These are electromagnetic radiations of extremely short wavelength. They are a type of *x*-radiation which is very powerful and moves easily through most materials. *Gamma* rays penetrate about 15 times as far as *beta* rays.

Cosmic rays are also significant when dealing with radiation detectors. This is radiation which reaches the surface of the earth from outside the earth's atmosphere. While cosmic rays are not useful in locating radioactive ores, they are nevertheless sensed by radiation detectors and should, therefore, be recognized.

When detection instruments are used, there is always some "background count" due to cosmic rays and the natural radioactivity of the earth. This count is normally between 30 and 50 per minute. Cosmic rays come from outer space and their contribution to

Fig. 4. The typical helium atom.

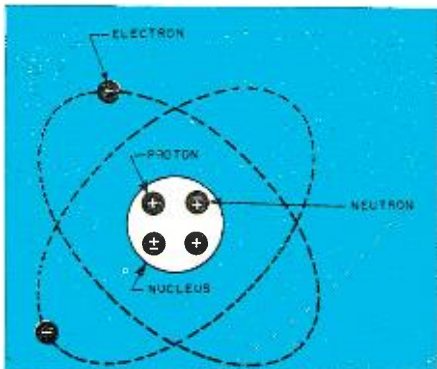

Table 1. The characteristics of three principal types of radiation.

	NATURE	POWER TO IONIZE	POWER TO PENETRATE	DEFLECTION BY ELECTRIC AND MAGNETIC FIELDS	CHARGE
Alpha (α)	Helium nuclei	Strong	Weak	Yes	Positive
Beta (β)	High-speed electrons (like cathode rays)	Less strong	Stronger	Yes	Negative
Gamma (γ)	High-frequency electromagnetic radiation (like x-rays)	Weak	Very strong	No



↑ Fig. 1. EICO Model 803 Geiger Counter.

← Fig. 2. This Geiger Counter, Model F-6, is marketed by Technical Associates.

↓ Fig. 3. Heathkit RC-1 Radiation Counter.

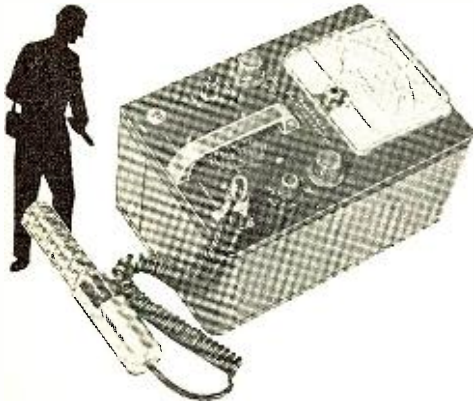

this background count varies from day to day. Also, the count from the natural radioactivity of the earth varies with different locations. A significant indication of radioactive ore is obtained if the count goes up by 50% over the background at a given location. (See "Prospecting for Uranium," available from the U. S. Government Printing Office, Washington 25, D. C. for 45 cents a copy).

Detection Methods

There are many possible methods of detecting radiation. We are here concerned only with those methods whose equipment is "portable."

Two somewhat crude detection methods are the photographic method and the fluorescence test. In the photographic method, ore or other material which is to be tested for

radioactivity is placed on a small piece of metal atop an unexposed photographic film, as shown in Fig. 5. The film is protected from exposure to light. After 24 hours or longer, the film is developed. If the material contains a radioactive substance, there will be an image of the metal plate on the film. The radiation will fog the film except where it was intercepted by the metal. This is the method employed in the "film badges" which laboratory workers wear to measure exposure to radiation.

The fluorescent method is based on the fact that certain materials will glow (or fluoresce) when excited by ultraviolet or "black" light. For example, some watch faces are painted with such materials. Ordinary sunlight contains a small amount of ultraviolet light. When the light source is removed, the luminous paint will continue to give off light. It does the same thing during exposure to sunlight, but the light given off is too faint to see. However, this method cannot be used in daylight. A portable ultraviolet light source can be used as a detector for radioactivity in a dark room.

A more serious limitation is this: some important radioactive materials do *not* fluoresce in their natural state, while some of the materials which *do* fluoresce are not radioactive. Fluorescence can be used, however, by heating a special compound and combining this, while still molten, with the substance to be tested.

The most effective portable radiation detectors now in general use are the Geiger counter and the scintillation counter. Both of these use methods of detection different from those previously outlined.

Geiger-Mueller Tubes

The Geiger counter, built around the Geiger-Mueller tube, is the most widely used low-cost instrument for radiation detection. A typical tube is shown in Fig. 6. A thin wire of tungsten is passed through the open cylinder as indicated. This cylinder is made of thin metal or coated glass. This combination is then placed inside

the other closed cylinder, which is filled with gas. In effect, the tube bears some resemblance to a gas-filled voltage-regulator tube.

A voltage is applied with the central wire positive and the inner cylinder negative. As a particle of radiation enters the tube from the outside, a gas molecule inside the tube loses an electron (negative charge) by collision with the entering particle and thus becomes a positive ion.

The electrons freed by such collisions are attracted to the positive wire but, in their travel, they collide with other gas molecules and produce other free electrons. Thus, for one single particle of radiation, many free electrons are produced. These are all attracted to the positive wire, which acts as a plate or anode just as in an amplifier tube. The total of the arriving free electrons acts as the output current. The positive ions, resulting from collisions which produced the free electrons, are attracted to the negatively charged cylinder. Here they are neutralized since they pick up electrons to make them neutral gas molecules again.

When a single particle of radiation reaches the G-M tube, a rapid multiplication of free electrons occurs. This is the output current. In a very short time, all of the free electrons arrive at the wire and all gas ions arrive at the cylinder. The tube has provided an output and is now ready to react when the next particle enters.

In some cases, external circuits are required to "quench" or turn off this action when it has started. Sometimes this action is controlled by the insertion of a special gas in the tube.

Geiger Counters

Based upon the detection action of the G-M tube many simple, portable, Geiger counters can be built. The design depends upon the nature of the particular tube and the final desired cost. Models are available from the most simple ones to quite complex units with complete amplifiers and several types of detectors.

Fig. 7 is a very simple unit. The d.c. source is a battery with many small

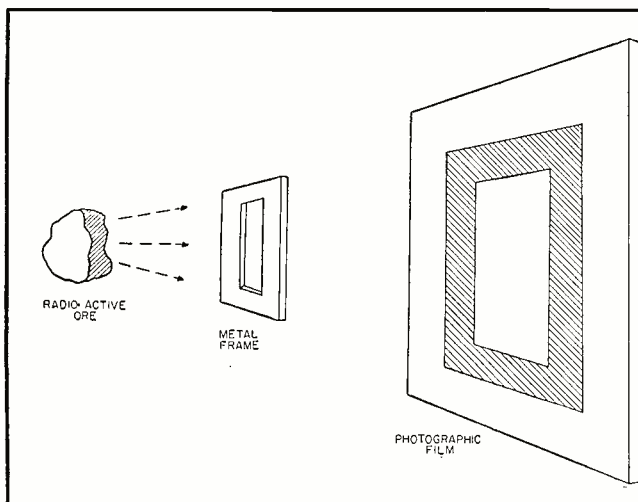

← Fig. 5. A crude test for radioactivity may be performed using a sheet of photographic film.

→ Fig. 7. A simple detector based on the action of the Geiger-Mueller tube.

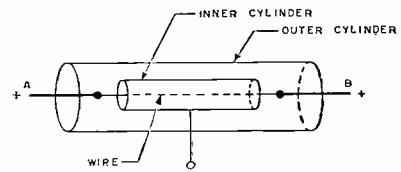
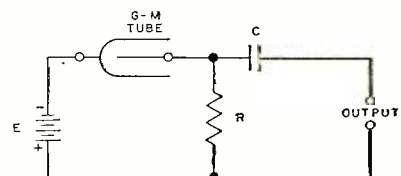

Fig. 6. (Above). A Geiger-Mueller tube.



By
GLENN E. JOHNSON

Simple



Transistor

Mixer

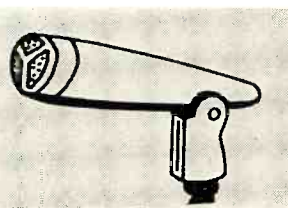
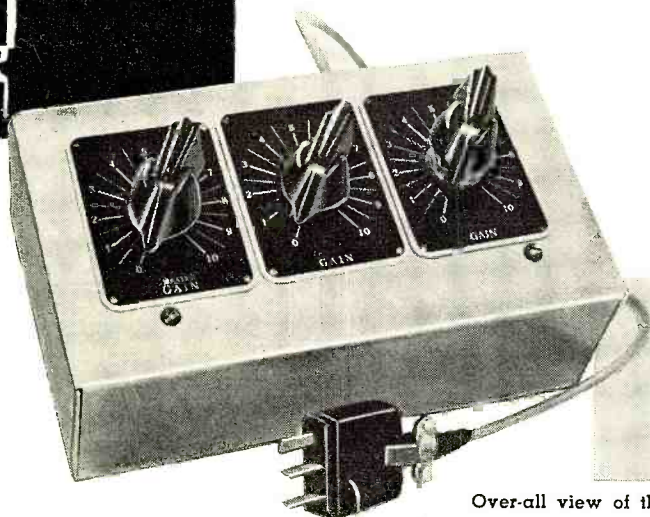
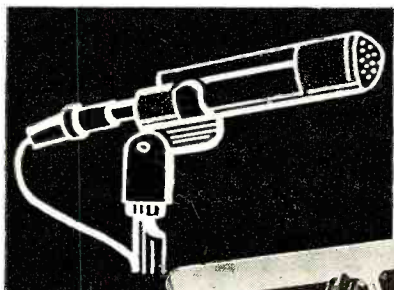

Over-all view of the three-channel mixer.

MANY have faced the problem of mixing several microphone channels into a single input for recording or p. a. work. The mixer to be described is a simple, reliable unit that occupies little space and is ideal for those occasional times when a mixing unit is needed. Some may be surprised by the circuit configuration, even horrified to consider attenuating the extremely low level of a microphone input to an even lower level, and then applying this to a grounded-emitter transistor stage. On the other hand, some may be pleased to note the sim-

Non-critical one-transistor mixer will handle three microphone channels for recording or p.a. applications.

plicity of the circuit in which hardly any component value that is employed is critical.

The input from each microphone is fed to a 47,000-ohm resistor that is terminated in the wiper of a 100,000-ohm potentiometer. At all settings of the level control, the limiting resistors R_1 , R_2 , and R_3 will represent the correct value of terminating load upon

the microphones. At the upper settings of a level control the current is paralleled with that of the other two channels. This current is coupled to the transistor's base where the low impedance, less than 1000 ohms, returns it to ground. Thus the input voltage is changed into a current, variable by the level set of R_1 , R_5 , and R_6 .

(Continued on page 122)

Fig. 1. Complete schematic diagram of the simple three-channel transistor mixer unit.

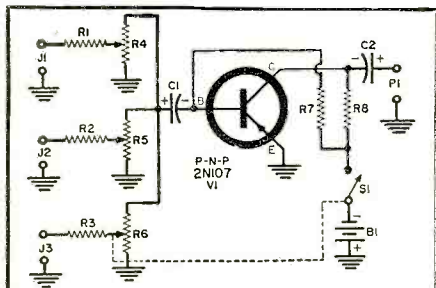

R_1 , R_2 , R_3 —47,000 ohm, $\frac{1}{4}$ w. res. (or selected to correspond to proper termination for the microphones used)

R_4 , R_5 , R_6 —100,000 ohm pot

R_7 —3.5 megohm, $\frac{1}{4}$ w. res.

R_8 —22,000 ohm, $\frac{1}{4}$ w. res.

C_1 , C_2 —10 μ fd., 10 v. elec. capacitor

B_1 —3-volt battery (two penlite cells in series)

S_1 —S.p.s.t. switch

J_1 , J_2 , J_3 —Selected to correspond to cable connectors in use

P_1 —Selected to correspond to connector in use
 V_1 —"p-n-p" transistor (2N107, see text for other suitable types)

Bottom view of the transistorized mixer described above. Parts placement and selection are not critical. All components have been identified in this illustration.

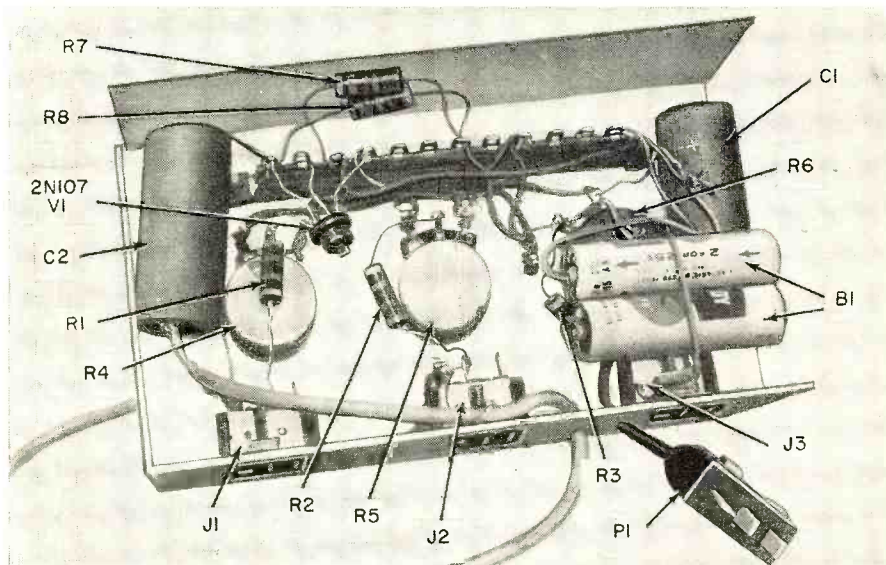

ELECTRONIC

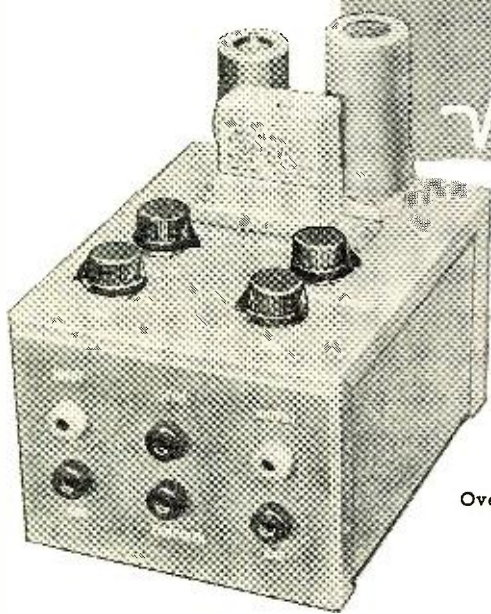

Ignition Analyzer

Over-all view of scope adapter.

By DAN PETERS

Simple adapter for your scope allows you to check up on your car's ignition system.

THE modern automobile carries beneath its hood a gasoline engine perfected to a high degree of refinement when compared to its ancestors. A parallel, although slower, development has been the improvement in ignition systems to meet the severe demands placed upon them.

Unfortunately, however, the test methods used by most ignition mechanics have not progressed nearly as much as the ignition system itself. In an attempt to transistorize the electronic ignition system described in

RADIO & TV NEWS the author soon realized that something better than the common test methods was sorely needed. If it were possible to view the voltage waveshapes existing in the system, much could be learned about its operation. An oscilloscope is the classic tool for analyzing pulse waveforms and seemed the logical choice for ignition analysis. Much to the author's surprise, since he has never seen one in an ignition shop, it was discovered that at least four manufacturers produce oscilloscopes especially

adapted for this work. However, the cost and the high degree of specialization of these instruments ruled out a purchase simply to "monkey with the family car."

The next step was to see if an ordinary scope could be pressed into service as an ignition analyzer.

As a first attempt, the vertical input to the scope was connected, through a capacitive voltage divider, to the output of the ignition coil, as shown in Fig. 1. The voltage waveform applied to the sparkplugs was thus seen stretched along the scope face. Applying an external synchronizing voltage to the scope from the No. 1 plug assures that this plug will always appear at the beginning of the trace. This enables ready identification of all plugs.

While this system provides much of the information supplied by the commercial analyzers, it has one serious disadvantage. Since the waveshapes of all plugs appear on a single line—see Fig. 4—they are crowded together, making analysis difficult. After a brief discussion of auto ignition fundamentals, the author will describe a simple scope adapter which places the waveform of each plug on a separate line.

The wiring diagram of a typical automotive ignition system is shown in Fig. 2. When the ignition points close, the current through the coil primary builds up exponentially, as in any RL circuit. See Fig. 3A. At the instant of point contact a slight oscillation appears in the coil secondary. This oscillation serves no useful purpose in the ignition cycle. The value which the primary current reaches depends upon the battery voltage, the resistance in the circuit, and the length of time the contacts are closed. The last factor is one reason that ignition performance decreases as engine speed increases. At the high rpm's, coil current does not have time to reach an amplitude sufficient to produce a hot spark.

When the points open, the magnetic

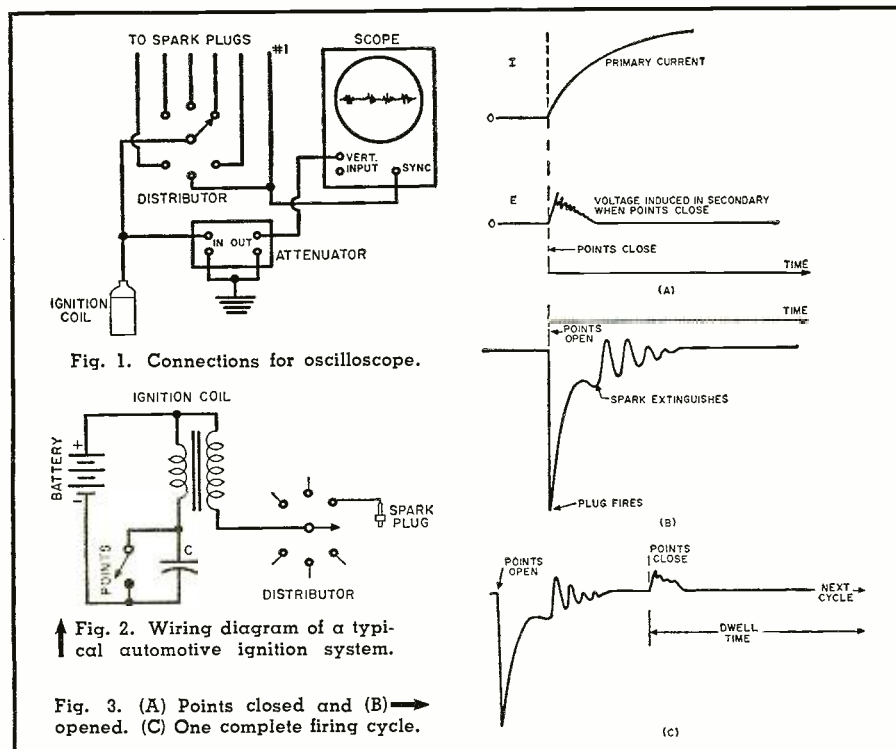

Fig. 1. Connections for oscilloscope.

Fig. 2. Wiring diagram of a typical automotive ignition system.

Fig. 3. (A) Points closed and (B) opened. (C) One complete firing cycle.

Fig. 4. Oscilloscope display for a six-cylinder auto engine.

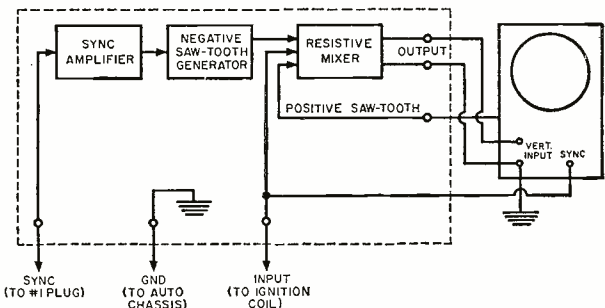

Fig. 5. Adapter block diagram and the scope interconnections.

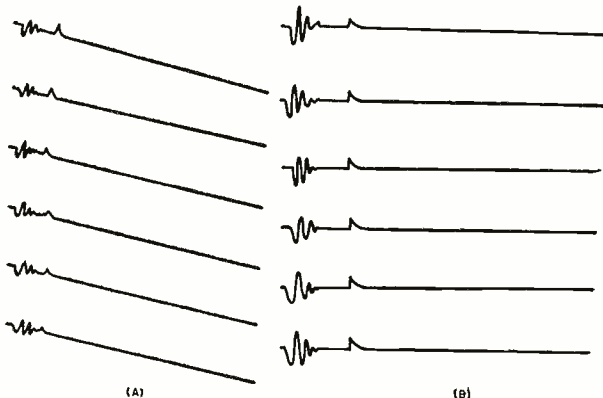

Fig. 6. (A) Uncorrected and (B) corrected six-cylinder pattern.

field about the coil suddenly collapses. The rapidly changing magnetic field induces a very high voltage in the many-turned secondary of the coil. A high voltage is also induced in the primary and it is one function of the capacitor to delay the build-up of voltage across the points. This gives the points a chance to open wide enough to prevent destructive arcing.

When the voltage becomes high enough (Fig. 3B) to cause arcing at the plug, the current through the plug loads the secondary and the voltage drops to a lower value—where it stays until the energy in the coil has dissipated to a point where it is no longer sufficient to maintain an arc. Once the arc is extinguished, the remaining energy is dissipated (in circuit losses) in the form of damped oscillations.

The cycle is repeated when the points once again close. Fig. 3C shows a complete ignition cycle.

After building several adapters designed to place the waveform of each plug on a separate line, the system shown schematically in Fig. 7 was selected as the simplest and most workable.

The block diagram of Fig. 5 will serve to illustrate the principle of operation. In use, the oscilloscope is synchronized to produce a sweep every time the points open. The signal from the coil is passed through the mixer to the vertical input of the scope. This arrangement would result in the waveforms of all plugs being superimposed if it were not for the nega-

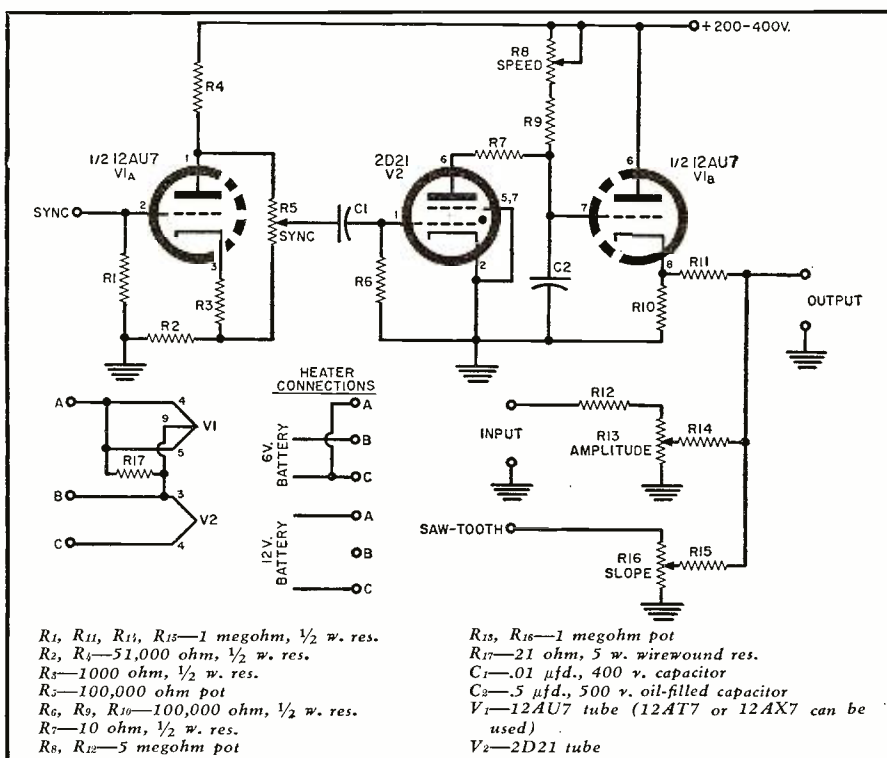

- $R_1, R_{11}, R_{14}, R_{15}$ —1 megohm, $\frac{1}{2}$ w. res.
- R_2, R_4 —51,000 ohm, $\frac{1}{2}$ w. res.
- R_3 —1000 ohm, $\frac{1}{2}$ w. res.
- R_5 —100,000 ohm pot
- R_6, R_9, R_{10} —100,000 ohm, $\frac{1}{2}$ w. res.
- R_7 —10 ohm, $\frac{1}{2}$ w. res.
- R_8, R_{12} —5 megohm pot
- R_{13}, R_{16} —1 megohm pot
- R_{17} —21 ohm, 5 w. wirewound res.
- C_1 —.01 μ fd., 400 v. capacitor
- C_2 —5 μ fd., 500 v. oil-filled capacitor
- V_1 —12AU7 tube (12AT7 or 12AX7 can be used)
- V_2 —2D21 tube

Fig. 7. Car battery supplies heaters, scope supplies the "B+" voltage required.

tive saw-tooth also applied to the mixer. This saw-tooth is synchronized with the No. 1 plug and thus repeats once each engine cycle, or 720 degrees. Fig. 6A shows the resultant waveform for a six-cylinder engine. The

downward slope can be removed by applying a third signal to the mixer. This third signal is a positive saw-tooth at the same frequency as the horizontal sweep. Rather than con-

(Continued on page 101)

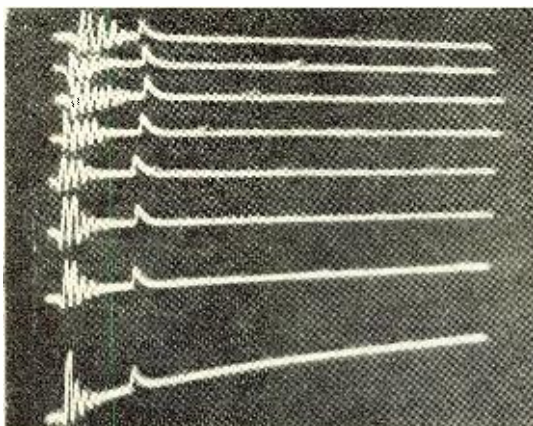

← Fairly normal display from 8-cylinder car with 50,000 miles on odometer and with about 3000 miles since last engine tune-up.

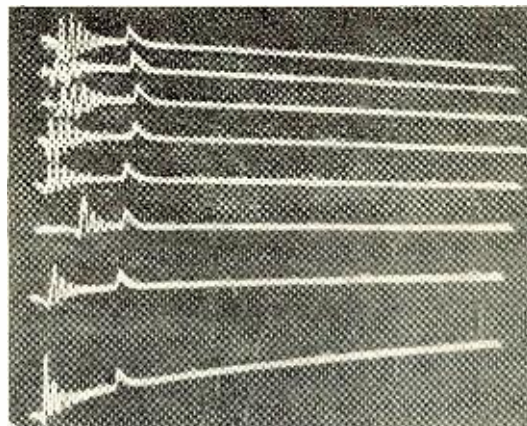

→ Same auto as at left, but with wide spark gap (line 2) and shorted plug (on line 6). Note baseline lengths before oscillations start.

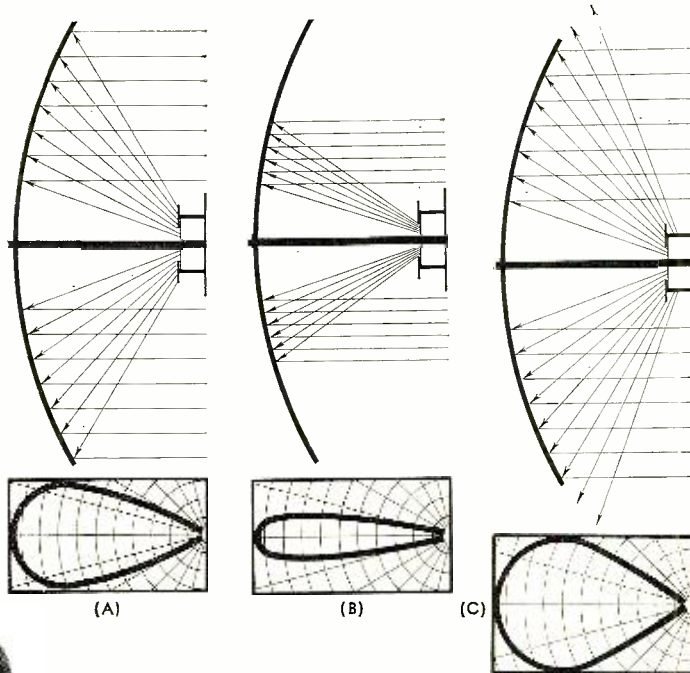
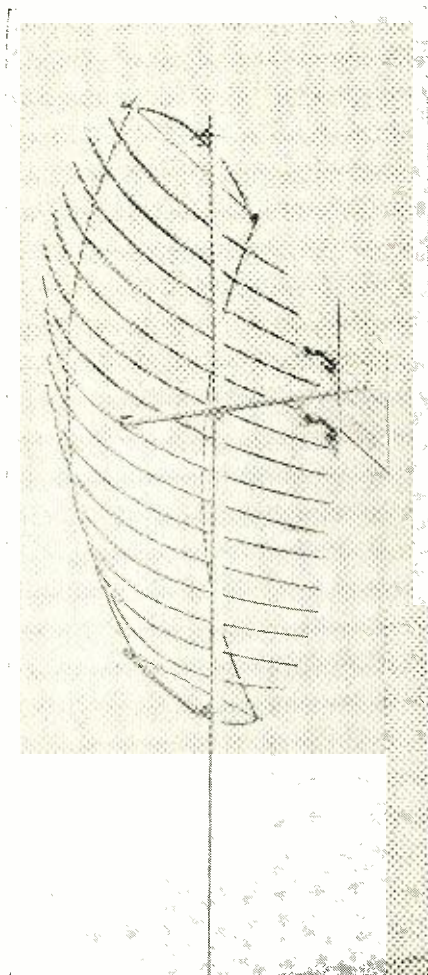

↑ Fig. 1. (A) Ideal pickup of signal by the feed system from the parabolic reflector. (B) Undesired pattern that may develop at higher frequencies. (C) Over-correction may produce this pattern at some frequencies.

← Fig. 2. Final version of the "Para-Scope."

By **HAROLD HARRIS** and **PAUL MATTERN**
Channel Master Corp.

A Parabolic Antenna for U. H. F. TV

A high-gain, all-channel, u.h.f. unit evolves from a principle used in radar and other microwave work.

IT WAS ONCE expected that TV transmission and reception in the u.h.f. range would become an important operation, breaking down the barriers to widespread availability of TV broadcast material. This hope was never realized. In line with the failure of interest to develop in this frequency band, antenna manufacturers and designers have, as a simple matter of economics, neglected some suitable antenna design possibilities.

However, with millions of families within range of u.h.f. stations, a re-examination of this position is certainly worth while, especially since a good antenna could play its own part in broadening the boundaries of the u.h.f. fringe, and thus in encouraging some growth in this range.

With these considerations in mind, the antenna development laboratory of Channel Master Corp. embarked, about a year ago, on a project to develop a

high-gain all-channel u.h.f. antenna. The result is the "Para-Scope," believed to be the first true parabolic antenna for TV reception.

Parabolics have been in use for years in non-TV applications, including radar and radio astronomy. The principle used involves the capture of signal by a curved screen of large diameter and the concentration of signal reflected from this screen onto a feed system at the focal area. The antenna using this principle is shown in Fig. 2, where the curved screen is clearly seen. As may already have been surmised from this photograph, the feeder system consists of more conventional-looking antenna elements. However, since their job is to pick up signal secondarily from the screen, rather than directly from the transmission source, these elements are facing into the screen, with their backs toward the signal source.

While high antenna gain is usually associated with narrow antenna beamwidth, the elements in the feeder system of a parabolic system, paradoxically, must have fairly wide beamwidth in order to pick up signal reflected from the entire surface of the screen. This paradox is not as much of a problem as it appears to be: in a parabolic design it is the screen and *not* the dipole or dipoles in the feeder system that provide the gain.

In short, the problems that come up in conjunction with the feed system involve keeping the beam at *uniform* width for all u.h.f. channels. In the first place, it is true of most broadband antennas that this pickup beamwidth becomes narrower at higher frequencies. Fig. 1A shows how, as a result, a parabolic antenna could work at optimum efficiency at low frequencies, while at higher frequencies (Fig. 1B), narrowing of beamwidth would result in pickup by the feed system from only part of the screen, with much of the signal captured by the curved member going to waste.

While such irregularities are subject to correction in the design of the feed system, this technique must be carried out with great care. One result could be that, at certain frequencies, the dipole or dipoles used would pick up in the manner illustrated in Fig. 1C. Such over-correction would not provide optimum sensitivity either.

Also not to be overlooked in the
(Continued on page 113)

A Hi-Fi 50-watter

RADIO & TV NEWS
LAB TESTED

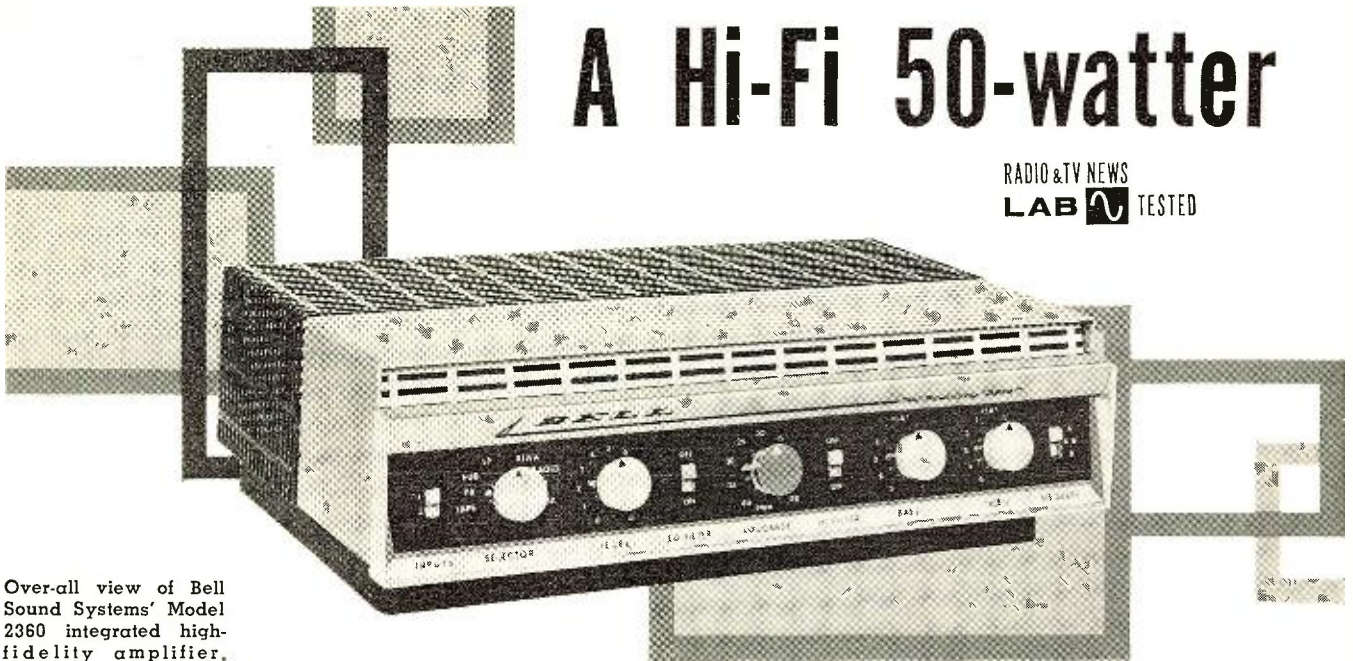

Over-all view of Bell Sound Systems' Model 2360 integrated high-fidelity amplifier.

Attractive design and exceptionally good hi-fi performance characterize this new amplifier.

ALTHOUGH *Bell Sound Systems, Inc.* is not a newcomer to the field of high-fidelity, this is the first opportunity we have had to put one of its units through its paces. Where both the power amplifier and preamplifier are combined on a single chassis, hum and stability generally present quite a problem. We are not considering cost here, which is obviously an important factor since an integrated sys-

tem does cost less than separate pieces. In this case, we were pleasantly surprised in that the over-all tests didn't indicate any instability and hum problems. This unit is extremely

well designed and its housing is attractive enough to fit into any type of living room decor.

The design is based on the use of
(Continued on page 112)

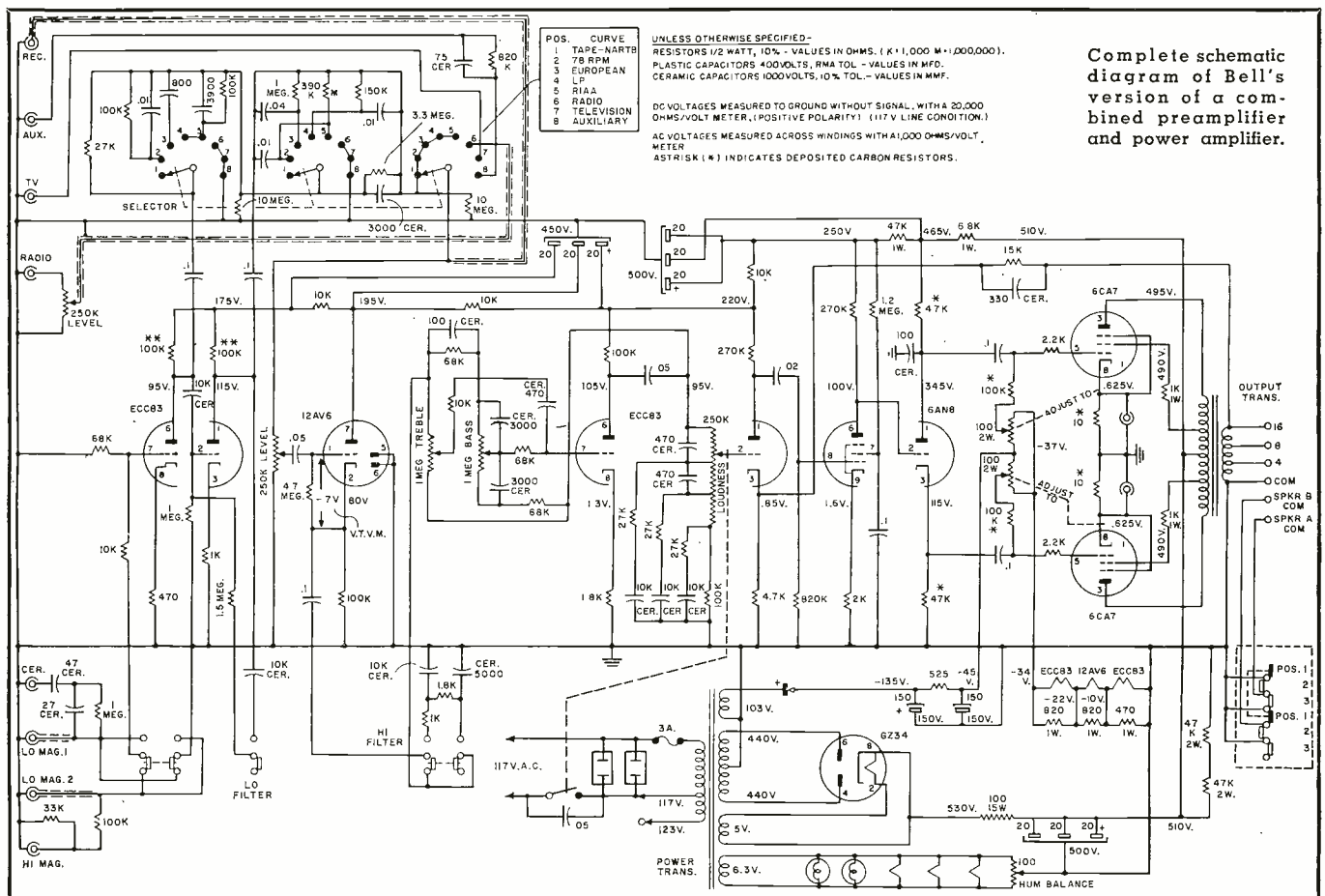

Troubleshooting

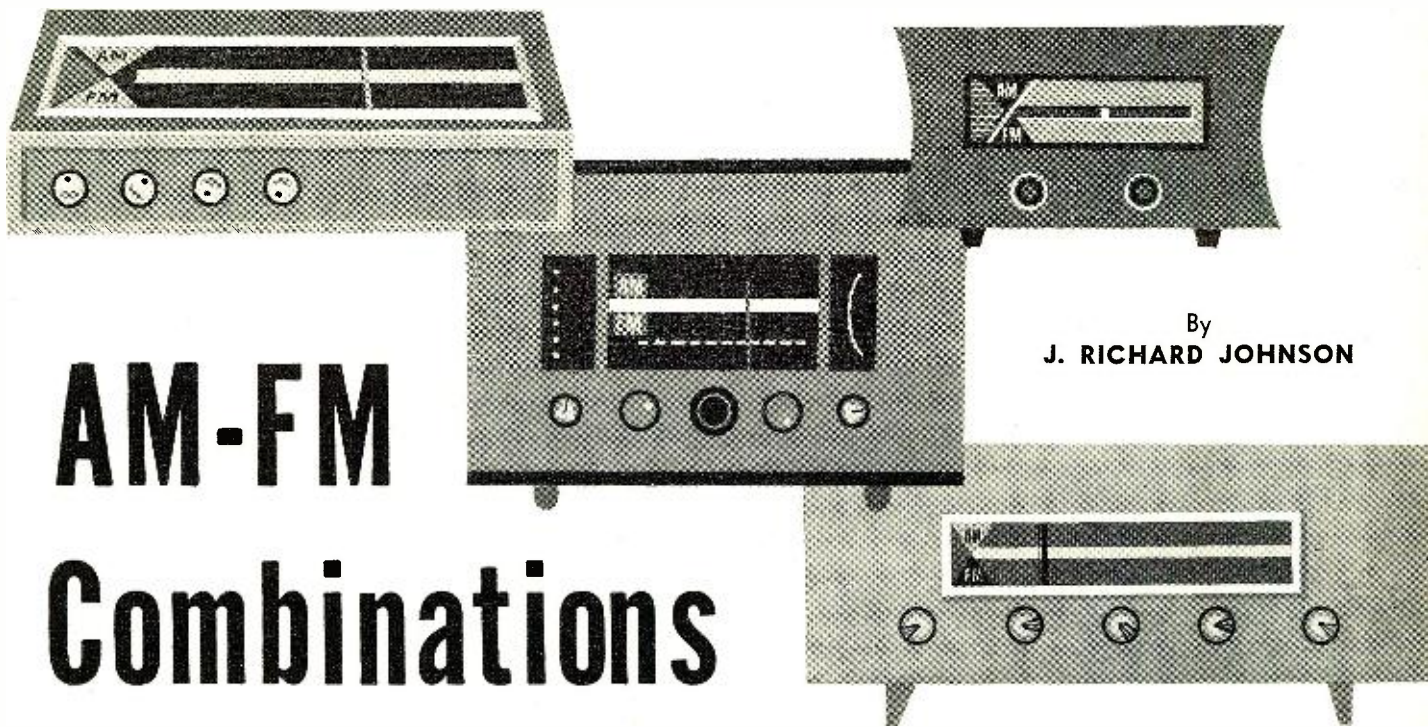

AM-FM

Combinations

By
J. RICHARD JOHNSON

AM-FM tuner and receiver combinations are growing in popularity. Save service time by knowing how circuits used in both sections switch in and out.

BECAUSE there are popular radio programs which can be heard only on AM stations and others which are aired only on FM stations, the AM-FM type of receiver and converter (or tuner) has enjoyed a brisk sale.

The service technician who is familiar with the two individual types of receivers should not have much difficulty in finding his way around the combination type. However, there are certain special features about the way some functions are combined that are not encountered in either an exclusively FM or AM receiver. This article reviews some of the outstanding factors in the combining of the FM and AM functions, with emphasis on application to servicing problems.

Diversity of Ranges

One of the interesting features of the FM-AM receiver is the fact that it must receive signals in each of two widely separated bands of frequencies. Signals in the FM band (88-108 mc.) have frequencies on the order of 100 times those in the AM broadcast band (.54-1.6 mc.). From an ideal, technical point of view, it would be better to provide the FM-AM combination as two completely separate receivers, each one optimized for its own frequency range and type of modulation. However, wide sale and enjoyment by large numbers of people, convenience

of operation, compactness, and reasonable price are factors the manufacturer must consider. For this reason, receiver makers have adopted a number of special methods for making as

EDITOR'S NOTE: *The resurgence of interest in FM reception is doubtless due, at least in part, to the current availability of many moderately priced combination AM-FM sets, many of them only table models. Continuing growth in the hi-fi field has also had its share in selling many units, whether complete receivers or tuners, that combine the circuits for both types of reception. Service technicians are being called upon increasingly to handle these in the shop.*

many components as possible operate during both AM and FM reception.

We all appreciate the great importance of lead length, lead dress, and component placement in receivers operating at frequencies as high as those in the FM broadcast band. Also important is the quality of solder connections, a factor with which the service technician is involved every day.

One thing which we may tend to forget in connection with FM-AM receivers is this: if a tube, component, or circuit is used for FM reception, the quality of the wiring, soldered connections, and component placement must be up to that required for FM operation, even though some parts of the circuit and wiring are used only for AM reception. We must also remember that it is the FM circuit that

is the more critical and alignment checks should always be made *last* on FM reception. If tubes are replaced in sections common to both types of operation, the production tolerances of tube capacitances may not make any noticeable difference for AM reception yet may seriously alter FM alignment.

The relatively high frequency of the FM signals sometimes leads to another problem—oscillator drift. Again, factors in the oscillator circuit which would not affect operation during AM reception can cause serious drift on FM. There are two main reasons for this. One is that, for FM reception, only small values of inductance and capacitance are used in the tuned circuits. This means that stray capacitance and tube capacities are relatively large factors; tuned circuits are sensitive to temperature changes and thus vary the oscillator frequency. The other reason for serious drift problems on FM is that the detector is generally quite critical with respect to the exact frequency of the i.f. signal it receives. Slight shifting of the i.f. signal from the center of the detector response characteristic can cause conspicuous distortion. Since the i.f. depends on the frequency of the local oscillator in the front end, local-oscillator drift becomes immediately apparent. Because of this, many FM receivers (and FM-AM receivers) include an automatic frequency control (a.f.c.) circuit designed to give proper output from the detector. Still the technician must be fully aware of the problem, because a.f.c. circuits can go bad.

It is interesting to note that TV

receivers of modern design, even when operating at a much higher frequency than the FM band (channel 13, 210-216 mc., for example), do not have as much of a sound drift problem as conventional FM receivers. This is because TV receivers now use the inter-carrier principle. The exact frequency of the sound i.f. signal (4.5 mc.) is determined by the spacing between the sound and picture signals as sent from the broadcast station, and these are rigidly controlled by law.

Typical FM-AM Layout

As mentioned, many FM-AM receiver or tuner manufacturers employ components and stages for both FM and AM wherever possible. Examples of typical AM-FM receiver combinations are shown in the block diagrams of Figs. 1, 2, and 3. In the type represented by Fig. 1, only the r.f. amplifier, FM limiter, and the detectors are not shared in AM and FM operation. In the receiver of Fig. 2, the i.f. amplifiers and limiter-AM detector stages are shared. In Fig. 3, only one i.f. amplifier stage and the a.f. amplifier are shared. Most receivers and tuners fall into one of these three categories. Tuners differ from complete receivers in that the a.f. amplifier and output are not included, although some tuners contain preamplifiers and volume and tone controls. Obviously, it is important that the technician make sure what the signal paths in the receiver are before he attempts to service it.

Switching Methods

Also of major importance in troubleshooting is knowing just how an FM-

AM receiver is switched from FM operation to AM operation and *vice versa*. Sometimes the receiver operates satisfactorily on one band and not on the other; sometimes the particular faulty symptoms differ according to the position of the FM-AM selector switch. In either case, knowing how the switching is done allows the technician to come to some quick conclusions in localizing the trouble. Switching methods vary from receiver to receiver, so the schematic of any given unit should be studied carefully. We consider here two examples which give an idea of the kind of methods frequently used.

In most cases, switching is set up to select tuned circuits in the front end. That is, there is a tuned circuit for FM and another for AM, both for a given stage. The FM-AM selector switch connects the proper tuned circuit into the stage. An example of such a stage is given in Fig. 4. In this arrangement, an r.f. amplifier is used for FM only. The converter is switched directly to the loop antenna for AM reception and to the output of the FM r.f. amplifier for FM reception. Another section of the same switch is used to select either the AM or the FM oscillator coil. A third section switches the a.f. amplifier to either the AM detector or the FM detector. Between the converter and the detectors no switching is necessary, because the i.f. stages are coupled through combinations of FM and AM transformers.

Another method of switching is illustrated in Fig. 5. The "B+" supply is switched either to the FM r.f. ampli-

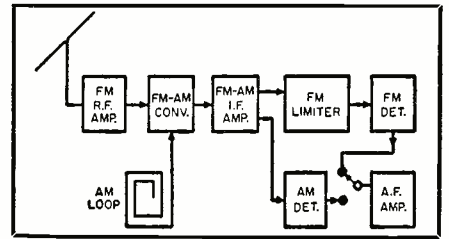

Fig. 1. In this arrangement, only the FM r.f. amplifier, the FM limiter, and the detectors are not common to both AM and FM modes of operation.

fier and converter or to the AM converter. During AM operation, the FM r.f. amplifier and converter, although connected into the circuit, are idle because "B+" is removed from them by the switch. Similarly, in FM operation, the AM converter is idle while "B+" is applied to the FM r.f. amplifier and converter. Notice that the AM and FM channels combine in the i.f. transformer, whose primary windings are separate but whose secondary windings are connected in series in the grid circuit of the first FM-AM i.f. amplifier. The advantage of this type of switching is that the switch does not have to be connected into any of the high-frequency tuned circuits of the front end.

Accordingly, when switch contacts become dirty or damaged, it is less likely that detuning of the resonant circuits will result when this arrangement is used than in the arrangement of Fig. 4. The symptom produced by a defective switch would more likely be either intermittent operation or complete cessation of operation. -30-

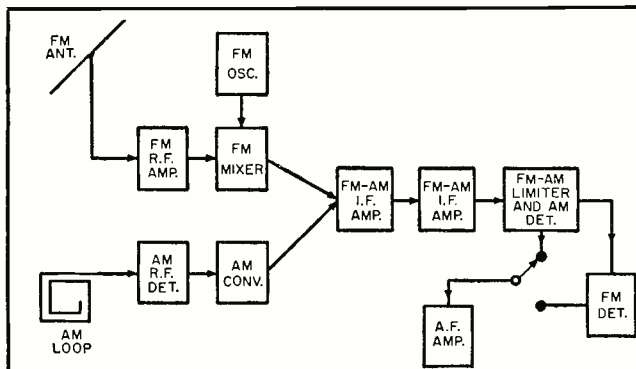

Fig. 2. In this configuration, the i.f. amplifiers are used on both bands, as well as the FM limiter-AM detector.

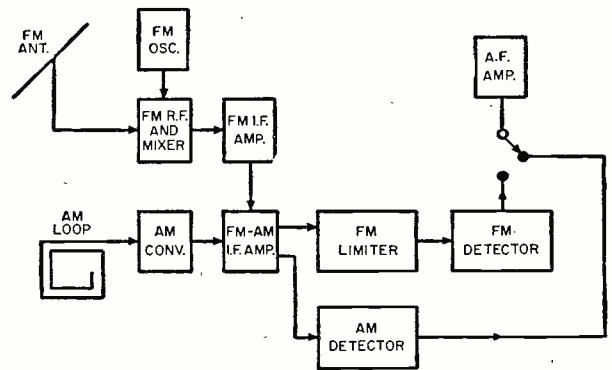

Fig. 3. Only one i.f. amplifier and the a.f. amplifier in this circuit are employed in both AM and FM functions.

Fig. 4. AM or FM tuning components may be switch-selected.

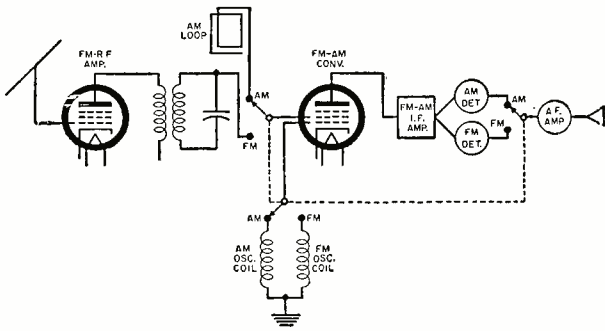
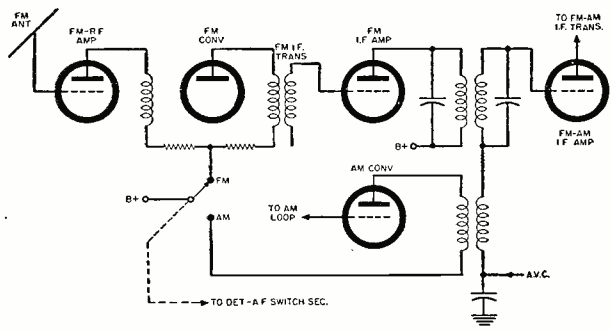
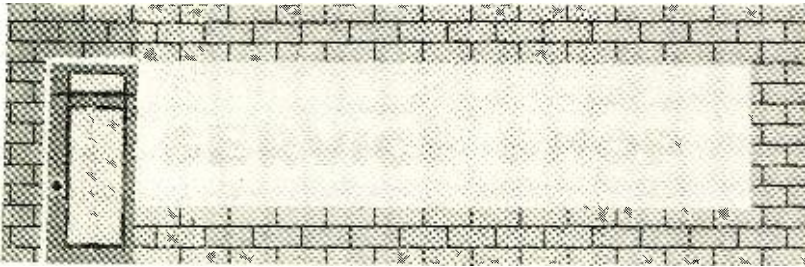

Fig. 5. Stages may be cut in or out by switching of "B+."





Operating Costs

Fact and Fables

By WILLIAM LEONARD

Increased capital requirements and costs of doing business add new burdens to service-shop management.

MOST OF US would pay a pretty good price for a magic formula that would positively produce a worthwhile profit from our businesses every month. That would be particularly true on the first day of those months in which, as we add up the bills we have to pay, we find there is nothing left in the till to pay us for the long hours and the hard work we put in the month before.

The novice in the ranks of independent service dealers usually pushes his way into the business with a lot of optimism and enthusiasm. Without those two essential personal ingredients, he probably never would tackle a business with as many heartaches and pitfalls as that of servicing equipment owned by the general public.

In his early appraisals of the money he will make out of his business, the novice is inclined to rate prospective income high and to minimize the expenses of operating the business. The cost of rent, light, heat, and telephone do not seem to pose a back-breaking overhead burden. If, in a previous job as a field service technician for an established service dealer, he had been turning in from fifty to sixty dollars per day in collections, he pictures himself living in the clover of ten-grand a year personal income as an independent service dealer.

The first jarring notes of the realities of managing an independent business in a highly competitive industry are wafted in as the bills pile up for all the tubes, parts, and supplies that he needed to repair sets. In an industry where the average technician's

tube caddy, stock, and instruments run into an investment of about five-hundred dollars, plus a back-up stock of possibly twice that much, the dealer's inventory requirement adds up to a substantial amount of capital investment. If the new dealer does not have this capital available when he starts his business, he will run into serious financial difficulties in trying to build up his inventory out of profits.

The second series of discordant notes comes in when the novice dealer discovers the extent of the drain on his income for expenses he had glossed over lightly. He discovers that rent, light, heat, and telephone make up only a part of his business operating expenses.

As he checks up on his expenditures at the end of six months, trying to find out what happened to the money, he finds that there are a lot of heads feeding from the trough he set up as a business. Among them he would jot down what he spent for:

Meals away from home, supplies for the shop, small tools, telephone answering expenses, and interest on loans and mortgages.

And he would write down a battery of taxes that would include most, if not all, of the following:

State income tax, Federal income tax, state sales tax, local sales or income tax, personal property tax, unemployment compensation, social security, and licenses and fees.

Then there is the cost of quite an array of insurance policies that he would add to his list of business expenses. Among these would be:

Employer's liability, public liability, fire and storm, burglary, hospitalization and medical insurance for himself and family, life insurance, and insurance on his car or truck.

Since he had to transport his business to his customers' homes, he found that the expense of operating and maintaining his car added up to a substantial sum. These expenses included:

Gasoline and oil, washing and greasing, maintenance, and tire repairs and replacements.

In the course of servicing sets of all makes, he found that he had to have a substantial library of schematics and service information at his fingertips. When he started, he felt he had built up a fairly good library of circuit diagrams, but he found that the industry is changing fast and he had to buy a substantial amount of new literature every month just to keep up with normal changes.

When he started his business, he felt he was sitting pretty with a following of good customers who knew him and had confidence in his ability to take care of their electronic service work. But he soon discovered the factor of attrition in business that slowly eroded his foundation of old customers. To keep his business alive, he had to add new customers regularly. That required advertising and promotion. So he added to his list of operating expenses what he paid out for the following:

Direct-mail advertising, newspaper ads, signs to identify his shop, and telephone directory advertising.

(Continued on page 107)

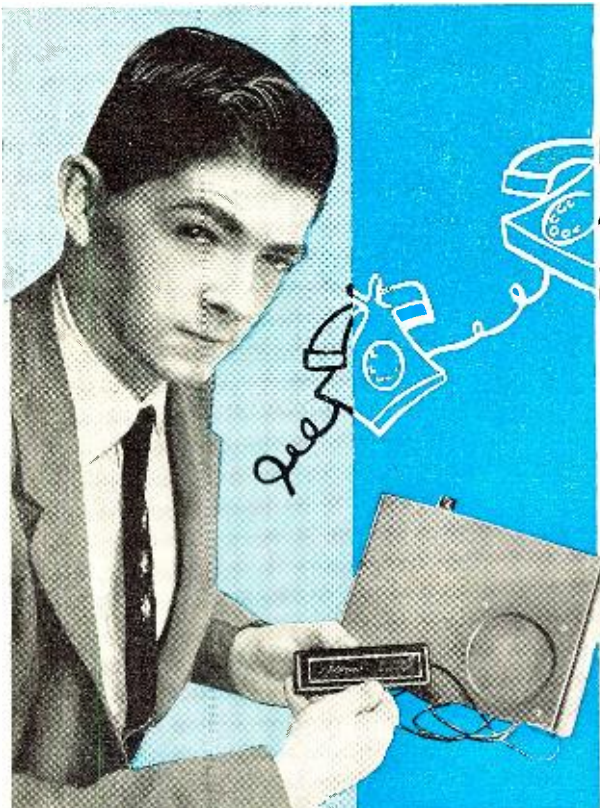

Designing a Telephone Amplifier

This high-gain transistor amplifier features low battery drain and ample power to drive speaker.

By
CARL DAVID TODD
 Semiconductor Products Dept.
 General Electric Company

THERE are many times when a telephone call may concern more than two people. For example, a business phone call may involve a group of people at one end and another group at the other end. Unless there is an extension phone available, it becomes rather difficult for several persons to hear the conversation. Even with the extension, there are cases in which the signal is too weak to allow the extra loading of the second extension, particularly with some long distance calls. A relatively simple device may be built which will allow the conversation to be heard within the room without making any connection to the telephone lines. In addition to its use to allow other people to hear the conversation, it has the advantage of permitting freedom of both hands if the party merely wishes to listen or take notes.

The telephone amplifier to be described is a high-gain transistorized unit which feeds a small loudspeaker. Its excellent sensitivity, ample output power, and low power drain make it a very useful device. The additional feature of negligible warm-up time allows it to be turned on only during the time the telephone is in actual use, thus lengthening the battery life.

In either the base or the wall box of every telephone, there is an induction coil. This coil has sufficient radiation so that if another coil is placed within its magnetic field, a small voltage will be induced in the second coil. It is only

necessary to amplify this small signal sufficiently and feed the output into a loudspeaker or earphone and the pickup system is complete.

Design Considerations

There are several characteristics to be considered when designing a device to be used as a telephone amplifier. The first of these is the sensitivity of the amplifier. The sensitivity required is somewhat dependent on the pickup coil used as well as the distance from the telephone to the coil. It is desirable that the position of the pickup coil not be critical; therefore, an ap-

EDITOR'S NOTE: Here is an article that does more than give the circuit and construction details of a useful and well-performing amplifier. The detailed design procedures used by the author can be applied to many other transistor circuits. Values of component parts can be picked and circuit performance can be predicted as well from the simple approximations given.

preciable amount of reserve sensitivity is required. The sensitivity of the telephone amplifier system is easily controlled by choosing the proper amount of gain for the preamplifier, as will be discussed later.

Another factor which must be considered is the amount of volume which is required of the system. This determines the type of output amplification required. Usually, the actual output required is not very large and, even with inefficient speakers, 200 milliwatts into the speaker will be more than ample.

To provide portability and convenience, it is desirable that the amplifier be battery powered. This places a restriction on the d.c. drain if reasonable

battery life is to be obtained. The use of transistors helps considerably not only because of their low operating power requirements, but because the amplifier may be turned off when not in actual use even if it is needed quite often. The negligible warm-up time required insures that the device is ready for use at the moment that power is applied. Further savings in power drain may be realized by the use of a push-pull output stage which operates very nearly class B. Thus the power drain during lulls in the conversation is small.

The pickup coil consists of many turns of fine wire wound around an iron core. Usually, in the design of coils used for chokes or in transformers, it is desirable to confine the magnetic field of the coil to the core material by the use of closed-loop magnetic cores. However, in the case of a pickup coil, the reverse characteristics are desired. The coil must be able to intercept magnetic fields which are external to itself. This may be accomplished by using a construction like that shown in Fig. 1. The core consists of several sheets of lacquered silicon steel. The winding is approximately 10,000 turns of #39 wire. Neither the size nor number of turns is critical. While it is true that the design of the pickup coil will help to determine the sensitivity of the amplifier system, this may be compensated by choosing the proper gain for the amplifier. Since the coil is fed into a very high gain amplifier, it is desirable to shield the entire coil from hum pickup due to stray capacitance effects. A sheet of copper foil is wound once around the outside of the coil and

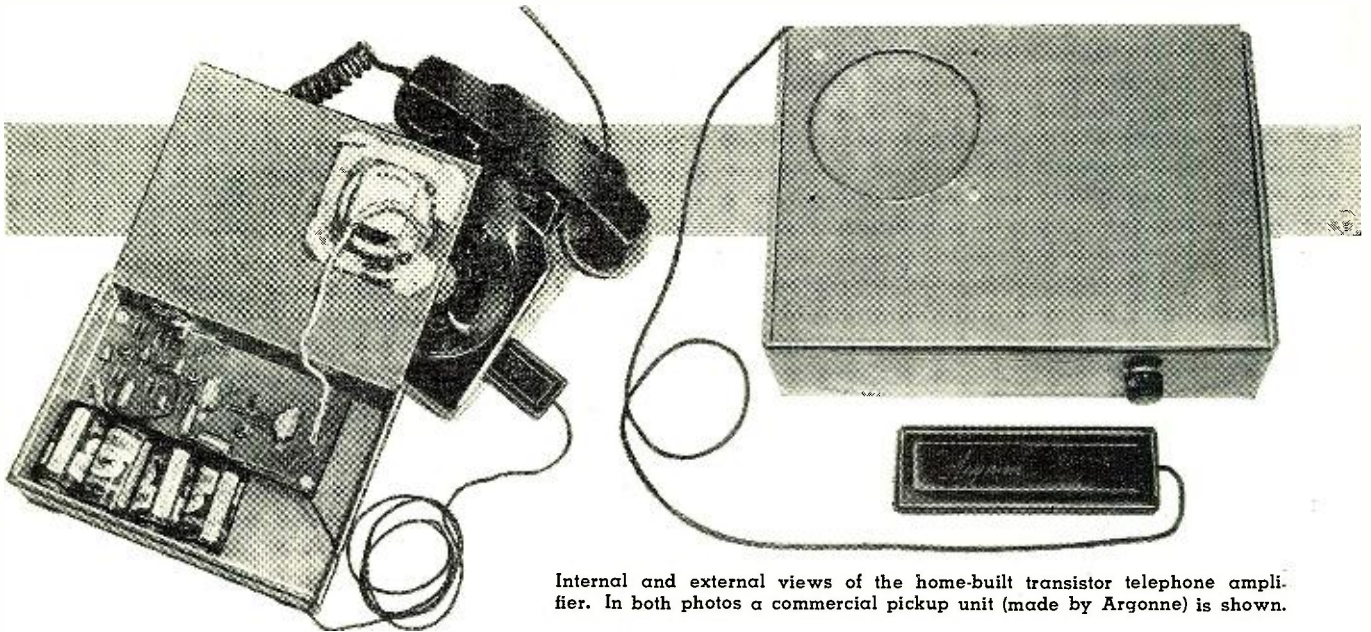

Internal and external views of the home-built transistor telephone amplifier. In both photos a commercial pickup unit (made by Argonne) is shown.

grounded to the shield of the wire leading to the amplifier. The two ends of the copper foil shield must not be allowed to make electrical contact with each other. To do so would decrease the sensitivity of the coil considerably since the effect would be that of a shorted turn. The simple application of lacquer, Cellophane, or tape will prevent this trouble.

If desired, a coil of this type may be purchased commercially.

As previously mentioned, the output stage should be designed to operate close to class B for battery economy. This also allows the use of lower power dissipation transistors than if a class A output stage were used. For the 200-milliwatt output desired, transistors such as the *General Electric* type 2N186 may be used.

For approximate design considerations, the maximum output power will be assumed to be 200 milliwatts and the collector supply voltage will be assumed to be 6 volts. The output power of any amplifier terminated in a load resistor, R_i is given by the relationship:

$$P_o \approx \frac{V_{om}^2}{2 R_i}$$

where V_{om} is the maximum instantaneous output voltage and the output waveform is assumed to be sinusoidal. For a transistor operating at its maximum output power, the maximum output voltage is approximately equal

to the battery voltage. Thus, for a transistor amplifier,

$$P_o \approx \frac{V_{cc}^2}{2 R_i}$$

where V_{cc} is the collector supply voltage.

Since the desired maximum output and the supply voltage are given, the above relation may be solved to find the load resistance.

$$R_i = \frac{V_{cc}^2}{2 P_o}$$

or

$$R_i = \frac{(6)^2}{2 (0.2)} = 90 \text{ ohms per transistor.}$$

The total resistance from collector-to-collector in class B push-pull is four times the load resistance for one transistor, or 360 ohms. For the desired output level of 200 milliwatts, an output transformer which will present a reflected speaker resistance of 360 ohms from collector-to-collector must be used. A smaller resistance will allow greater output and likewise a larger value will decrease the maximum output power. Since less power can be used in this case, an available transformer of 400 ohms, center-tapped, was used.

To minimize the crossover distortion in the push-pull output stage, a small voltage of approximately 0.1 to 0.15 volt must be applied to the bases of the transistors through the input transformer secondary. This voltage may be obtained from a voltage divid-

ing network consisting of two resistors. For best results, it is desirable that the value of the resistors from center-tap to ground be less than 100 ohms.

As a protection against thermal runaway, a small resistor of 8 to 10 ohms should be inserted in each emitter lead. This will decrease the available gain somewhat but will help to stabilize the circuit.

In order to determine the load resistance of the driver stage, the input power required for the push-pull stage must first be calculated. The power gain of the output stage is simply the ratio of the output to the input power:

$$G_c = \frac{P_o}{P_i} = \frac{I_{om}^2 R_i/2}{I_{im}^2 R_i/2}$$

The ratio of the maximum output current to the maximum input current is merely the value of the common emitter amplification factor, h_{FE} at the peak or maximum instantaneous collector current required. The load resistance has previously been chosen as 400 ohms and the base-to-base input resistance of a pair of 2N186 transistors is approximately 1200 ohms. Inserting these values:

$$G_c = h_{FE}^2 \frac{R_i}{R_i} = (30)^2 \frac{400}{1200}$$

$$G_c = 300 \text{ (approximately 25 db).}$$

The input power may now be found by dividing the output power by the power gain of the stage. This gives a value of 0.67 milliwatt, assuming an output power of 200 milliwatts. However, since a load impedance of 400 ohms was chosen rather than the 360 ohms calculated, the maximum output and, correspondingly, the required value of the input power will be somewhat less. To allow for power losses in the transformers and for the slight reduction in gain due to the stabilizing resistors, the required output power for the driver stage will be assumed to be 1 milliwatt.

Since the driver is operated class A

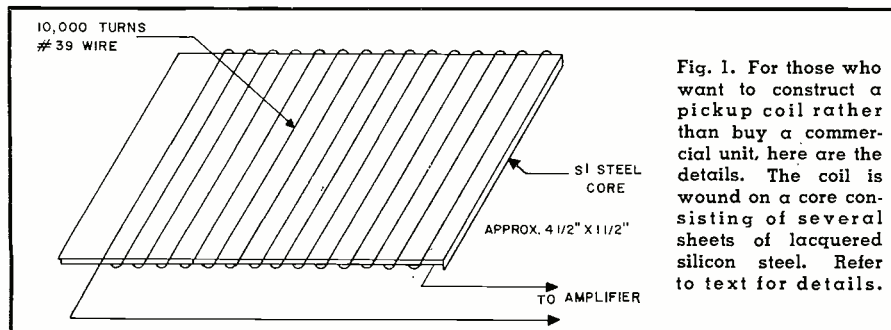

Fig. 1. For those who want to construct a pickup coil rather than buy a commercial unit, here are the details. The coil is wound on a core consisting of several sheets of lacquered silicon steel. Refer to text for details.

with a transformer output, the maximum output voltage is again equal to the supply voltage. However, the supply voltage to be used in the calculations is not the full 6 volts as used before since there will be some voltage drop across the stabilizing resistor of the driver and across the primary winding of the driver transformer. With these in mind, a figure of 3 volts is assumed as a supply voltage. Using the same procedure as before, we find that the desired load resistance is approximately 4500 ohms. The secondary of the driver transformer feeds the bases of the output stage and this should be 1200 ohms base-to-base. An available transformer has a ratio of 10,000 ohms to 2000 ohms center-tapped and may be used here to give a ratio of 6000 ohms to 1200 ohms. This is satisfactorily close enough to the calculated figure of 4500 ohms.

In order to choose the proper bias for the driver, the maximum instantaneous signal swings must be considered. To develop an a.c. signal power of 1 milliwatt across a load resistance of 6000 ohms, a current of roughly 0.4 milliamperes r.m.s. or 0.6 peak is required. This means that a bias current of at least 0.6 milliamperes is required for class A operation. As a usual practice, the actual bias current chosen is made to be somewhat larger than the peak signal swing. This would mean that the bias current for this stage should be somewhat larger than the 0.6 milliamperes. A reserve current swing would prevent possibilities of clipping on strong signals or distortion due to working near non-linear portions of the characteristic curve. Therefore an emitter bias of 2 ma. was chosen.

Bias current is fixed by the standard method of applying a constant voltage to the base and inserting a resistor in the emitter lead. The emitter current is approximately equal to the value of the base-to-ground voltage divided by the value of the emitter resistor. If an emitter resistor of 1000 ohms is to be used, this means that a base voltage of approximately 2 volts is required to give the 2 milliamperes emitter current. It will be noted that when deciding upon the bias current required, the collector current was considered. Here, we bias the transistor by fixing the emitter current. This is reasonable since the two are very nearly equal for transistors with moderate gains.

For good stability, the output impedance of the base voltage source should not be more than two or three times the value of the emitter resistor. It cannot be made too low, however, or there will be excessive signal loss in the bias network. With these facts in mind, a voltage divider consisting of a 3300 ohm and a 6800 ohm resistor was chosen.

The power gain of the driver is given by the expression:

$$G_c = A_i \frac{R_c}{R_i}$$

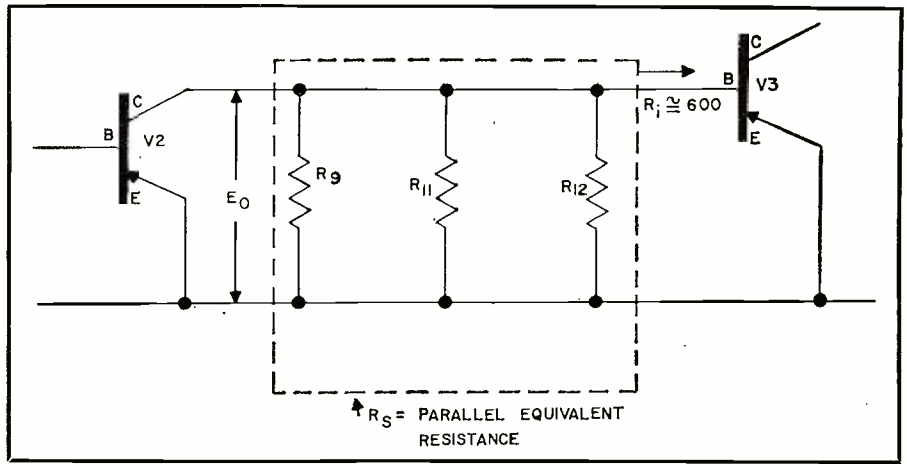

Fig. 2. Interstage coupling equivalent circuit at mid-frequencies.

where A_i is the current gain, and R_i is the input resistance.

For a 2N190 transistor used as a driver, A_i is approximately equal to h_{FE} or 36. For the bias levels chosen, the input resistance of the driver will be roughly 600 ohms. Therefore:

$$G_c \approx \frac{(36)^2 (6000)}{(600)} = 13,000 \text{ or } 41 \text{ db.}$$

Since the power output of the driver is 1 milliwatt, this makes the required power input to the base of the driver transistor 0.077 microwatt.

It will be noted that in the preceding discussion, the input power was specified as power into the base of the driver transistor. Because there are losses in the base bias stabilization network and in the resistor which supplies the collector voltage, the output signal power required of the last stage of the preamplifier will have to be more than 0.077 microwatt.

The bias network, as seen by the signal, is shown in Fig. 2. R_s , the parallel equivalent resistance of the network shown within the dotted line, is 1500 ohms. This value is shunted directly across the 600-ohm input resistance of the following transistor.

The "power gain" of the bias network is given by the relationship:

$$G = \frac{\text{Power delivered to } R_i, P_i}{\text{Power delivered by previous stage, } P_o}$$

The power input to the transistor, P_i is E_o^2/R_i . P_o , the power delivered by the previous stage, is the sum of P_i and the power dissipated in the shunt network, P_s , or:

$$G = \frac{P_i}{P_o} = \frac{P_i}{P_i + P_s} = \frac{E_o^2/R_i}{E_o^2/R_i + E_o^2/R_s} = \frac{R_s}{R_s + R_i} = \frac{1500}{1500 + 600} = 0.715 \text{ or } -1.5 \text{ db.}$$

This signal loss is part of the cost of stability. The actual load resistance as seen by transistor V_i is the parallel equivalent resistance of R_s of the above discussion and R_i of the following stage. For this case, the load resistance is 430 ohms. This means that an additional loss of gain will be caused by the bias network because of decreased load resistance. A compromise must be reached between stability and gain.

Allowing for this loss, the output of

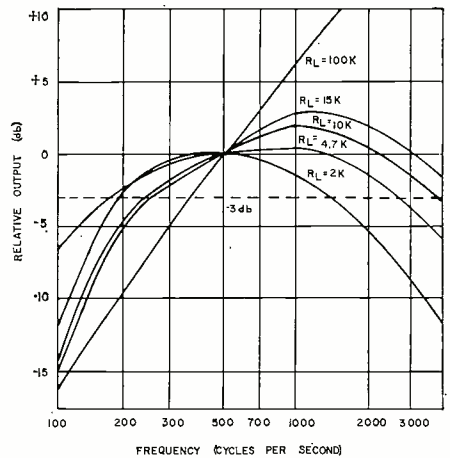

Fig. 3. Frequency response of the pickup coil for several load resistance values.

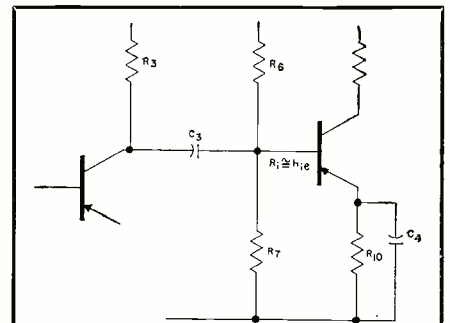

Fig. 4. Typical amplifier stage showing the coupling and bypass capacitors used.

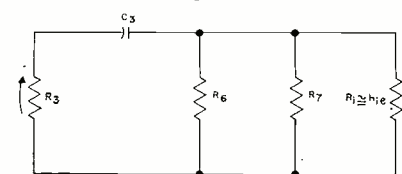

Fig. 5. Equivalent circuit of coupling network of amplifier shown in Fig. 4 if reactance of C_1 is assumed to be negligible.

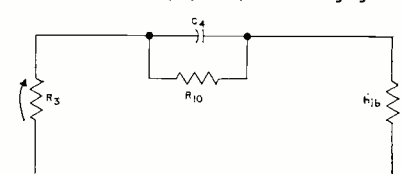
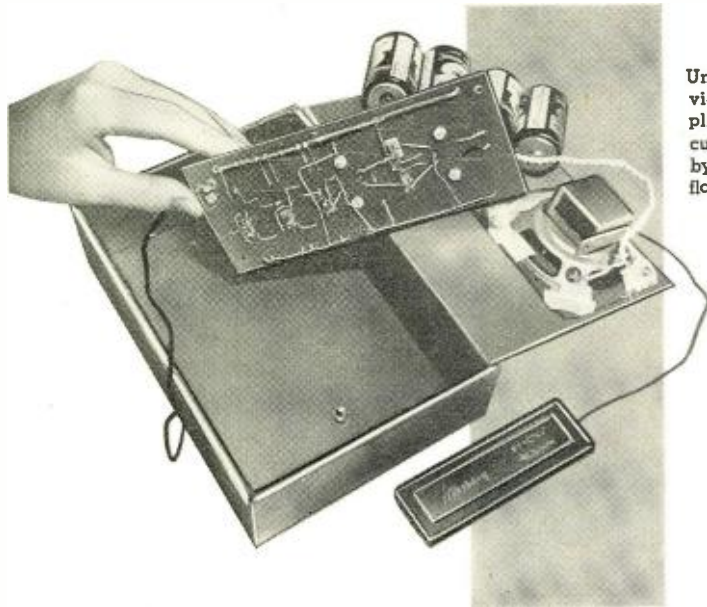

Fig. 6. Equivalent circuit of Fig. 4 if the reactance of C_3 is assumed negligible.



Under "chassis" view of the amplifier. The circuit is powered by four 1½ volt flashlight cells.

the preamplifier stage must be 0.11 microwatt.

The preamplifier must receive the very minute signal from the pickup coil and amplify it to the required level. The pickup coil sensitivity and frequency response are dependent on the load placed across its terminals. In this case, it is the input of the preamplifier. Fig. 3 shows several frequency response curves for different loadings. The zero db reference is taken as the output at 500 cps. The value of loading resistance which seems to give the best frequency response is 4700 ohms. Higher values give greater output but with a higher peaked frequency response. Lower

values give lower output and a severe drop in output above 1000 cps.

Actual measurements on a pickup coil indicate that the average telephone conversation will produce roughly 0.3 millivolt across the 4700 ohm load. This is an input power of about 1.8×10^{-11} watt. Since the preamplifier must supply 0.11 microwatt to the driver, the gain of the preamplifier must be:

$$G = \frac{\text{Output power required}}{\text{Input power available}} = \frac{0.11 \times 10^{-6}}{1.8 \times 10^{-11}} = 6000 \text{ or } 38 \text{ db.}$$

This gain could almost be achieved by a single stage although the input resistance would be far too low. This

means that one common collector or degenerative emitter amplifier stage must be used to obtain the high input resistance required. A standard common emitter amplifier may follow this stage to give the major portion of the power gain.

Since the power handling requirements of the preamplifier are minute, very small bias currents may be used without danger of overloading upon application of signal voltage. If bias currents are too low, however, the gain of the stage will decrease and possibly temperature stabilizing problems may occur. A reasonable value for the emitter bias current for the preamplifier output stage is 0.5 milliampere. Using a 2200-ohm emitter resistor requires a base voltage of approximately 1.1 volt. This is supplied by a voltage divider consisting of a 22,000-ohm and a 4700-ohm resistor. Actually, the current will be somewhat less than the 0.5 milliampere originally chosen but this presents no problem.

For the bias current indicated, and with a collector resistor of 4700 ohms, a collector-to-emitter voltage, V_{ce} , of -2.5 volts will result.

The input resistance of the preamplifier output stage as calculated from h_{ib} (common base, input impedance) and h_{fe} (common emitter, forward current transfer ratio) will be roughly 1700 ohms.

Using the same expression for power gain as for the driver stage,

$$G_o = A_o^2 \frac{R_i}{R_o} \approx \frac{(36)^2 (430)}{(1700)} = 330 \text{ or } 25 \text{ db.}$$

Calculating, as before, the loss in the bias network is found to be 3 db. This increased loss is due, in part, to the increased input resistance obtained with the lower bias current. This means that the input stage must have a gain of about 16 db.

The input resistance required for the input stage is 4700 ohms. This requires either a common collector or a degenerative common emitter stage. A common collector stage would not have sufficient gain.

In the degenerative emitter amplifier, increased input resistance is obtained by inserting an unbypassed resistor R_E in series with the emitter lead. The increase in the input resistance is roughly the product of h_{fe} and R_E . Calculation of the value of R_E will be discussed later.

The required input resistance of 4700 ohms is the parallel equivalent of the base bias stabilization resistors and the input resistance of the input transistor. This means that the values of the bias resistors must be on the order of 10,000 ohms, parallel equivalent, for 3 db loss. Lower values would cause a greater loss.

Since the emitter stabilization resistor should not be much less than one-half or one-third of this parallel equivalent resistance, a value of about 5000 ohms is chosen. An emitter current of 0.3 milliampere is reasonable for this stage. This allows sufficient

(Continued on page 118)

Fig. 7. Complete schematic diagram of the transistorized telephone amplifier.

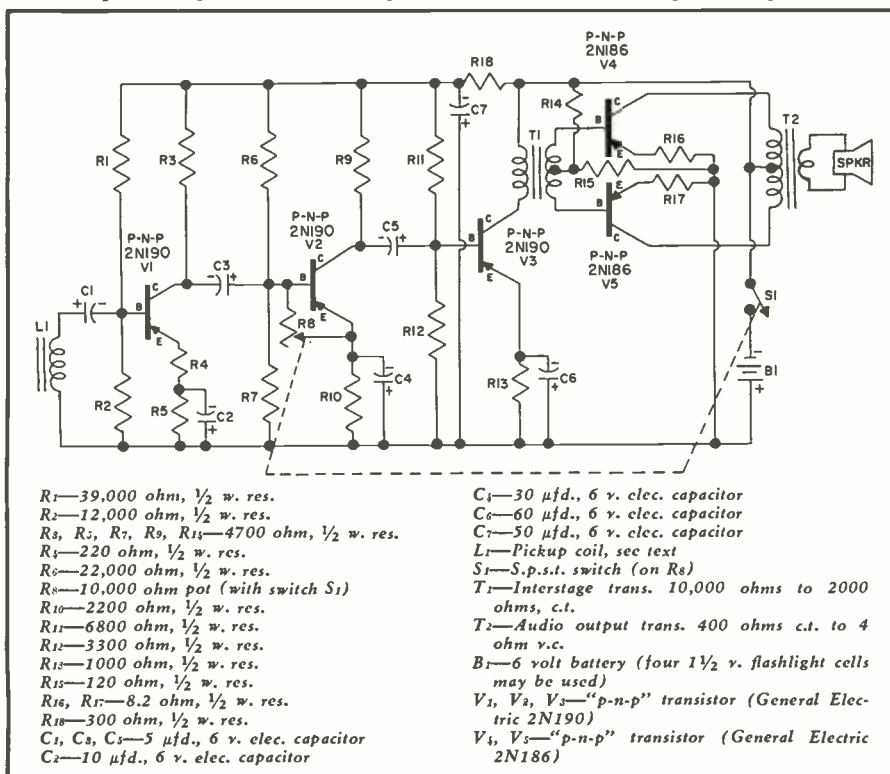

By
A. V. J. MARTIN

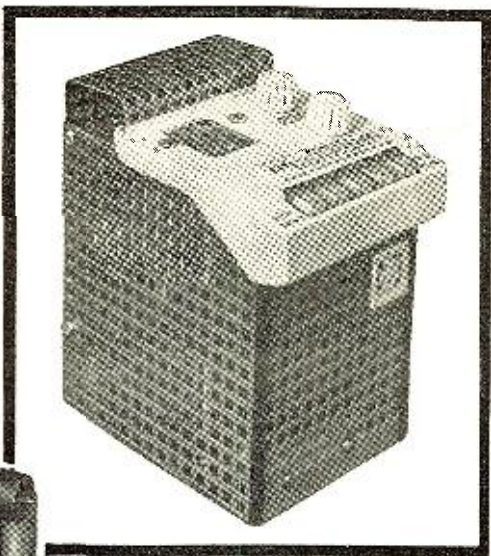
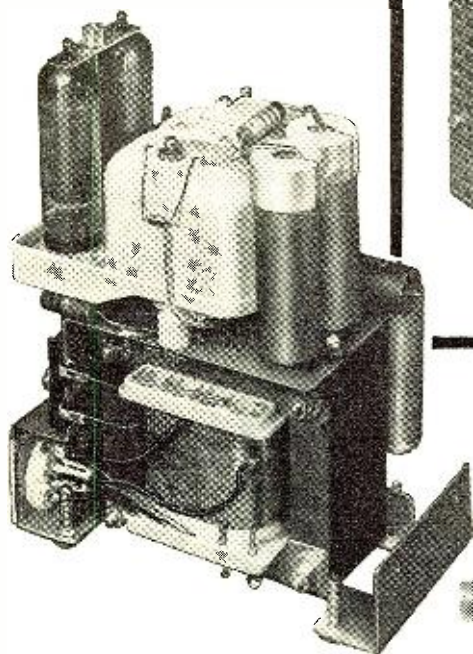

Over-all outside and inside views of the French hi-fi amplifier. Volume and tone controls are provided along with key-board-type tone control switches. In interior view, output tubes, output transformer, and filter capacitors are at top. Power transformer and power plug for auxiliary tuner are below, with preamplifier tube being located behind the power transformer.

3-D

Hi-Fi

Amplifier

New concept in compact, functional equipment design has been used in this French amplifier.

THE actual trend in radio and electronics is toward equipment smaller and smaller, weighing less and less, and ensuring better and better performances. A direct outcome of this philosophy is apparent in the wide choice of miniature parts now available and improving every day. Another facet of designing, however, is the assembling of the parts, whether standard or miniature. Several entirely new methods have been devised, generally taking into account the ease with which they can be adapted for automatic factories.

A highly successful and widely adopted one is printed wiring in one of its several forms. This has the drawback of being two-dimensional and there can be a lot of empty space

above a printed circuit wiring chassis.

A logical extension of the printed wiring principle has led to the modular design where, in fact, one stacks several small printed circuit boards to make better use of the available space. Modules are generally designed on a stage-by-stage basis, and that this leaves large room for improvement is dramatically demonstrated by the three-dimensional assembly technique developed by the French engineer George Henry.

The concept of three-dimensional assembly is a perfectly general one

and can be applied to any equipment and any type of wiring, either using standard, miniature, or else special parts.

Its main characteristic is to consider the completed equipment as a whole, to visualize it in 3-D, and to break it down in a number of basic units.

The complete equipment is designed to be functional and as compact as possible. Strict functionality does not prevent harmony and beauty, as is evidenced by the a.f. amplifier which

(Continued on page 104)

The major components that make up the entire packaged assembly have been separated and labeled in the view shown below.

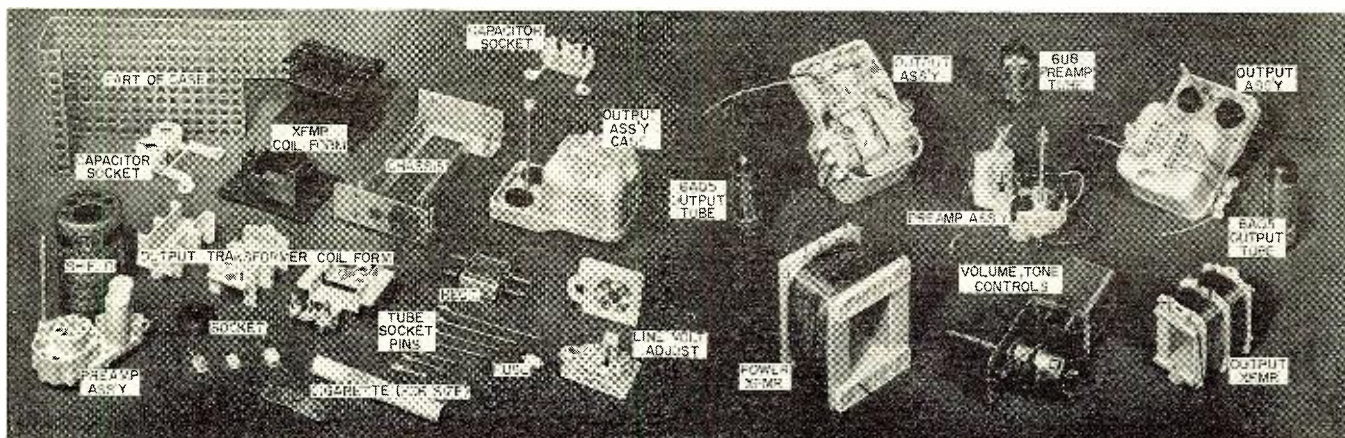

TWO-BAND

V. H. F. Converter

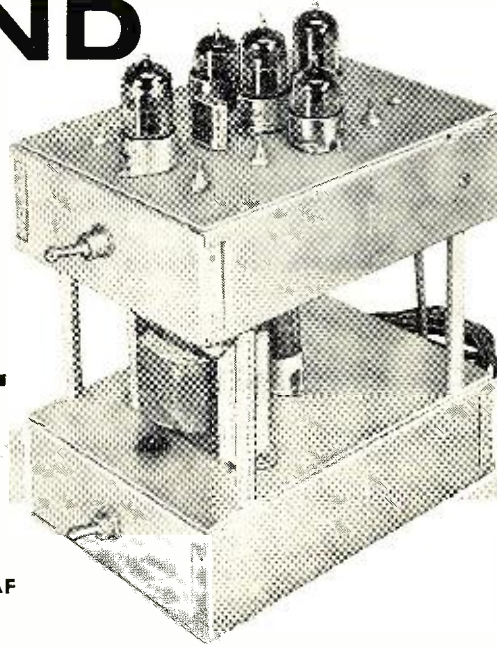

The two-band converter is shown here mounted atop its matching power supply. The two switches shown are for band switching and for the power line.

By EVERETT G. TAYLOR, W8NAF

Construction details on a well-designed two-band converter covering 50 and 144 mc. for serious-minded v.h.f. amateur.

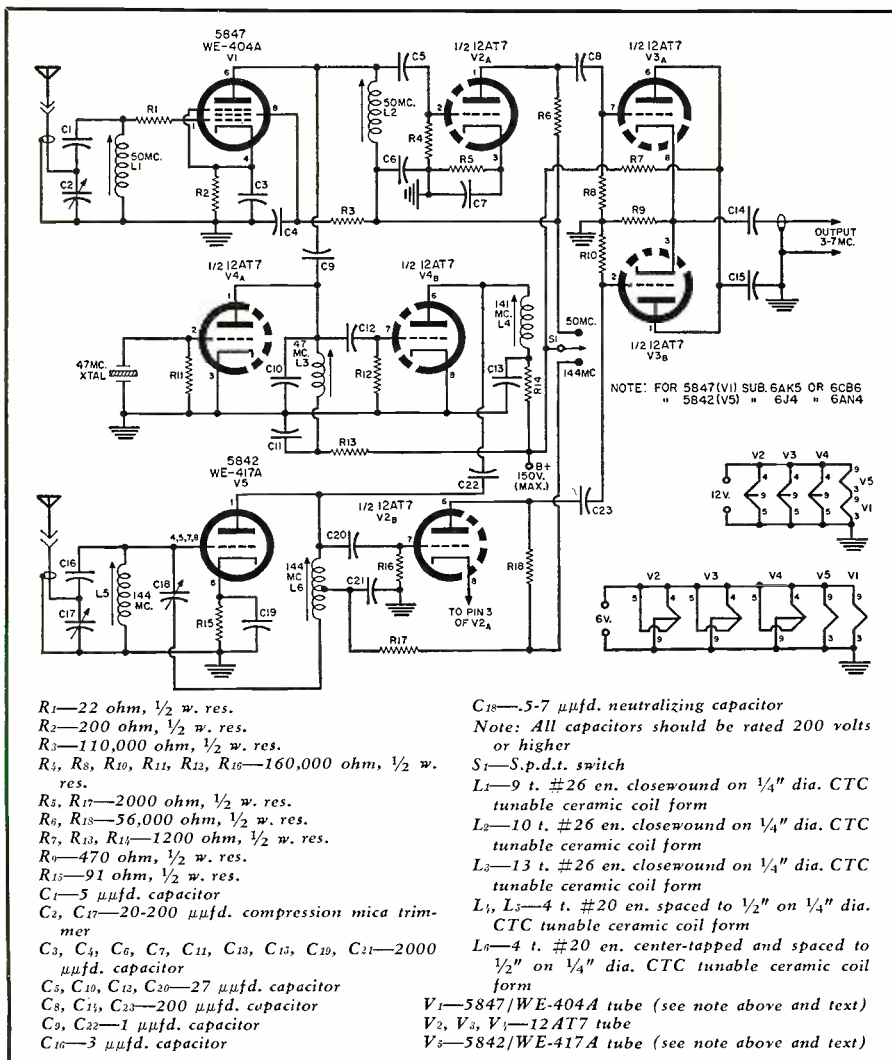

THIS converter was designed for the serious-minded v.h.f. amateur who can operate on the 50 and 144 mc. amateur bands by virtue of having a General Class ticket or a Technician/Novice combination.

The unit is useful for contest work such as the ARRL or CQ sponsored v.h.f. contests held at various times during the year. It will afford the operator an instantaneous check of either band by means of a single switch. The ends of both bands tune to the same frequencies on the high-frequency receiver with which this converter is used. The range is from 3 to 7 mc.

Some readers may question the use of such a low-frequency i.f. but in most receivers we find that the sensitivity is much greater at a lower i.f. than at 7-11 or 14-18 mc., which are the more common ranges. An additional feature of the lower frequency i.f. is that there is less trouble from "feedthrough" in this range as there are fewer high power commercial stations operating in this part of the spectrum.

Some of the local boys who have heard of this converter have questioned the possibility of images while using this low an i.f. but, despite their dire predictions, the images on this converter are nil. About the only case of images that this writer has encountered is from GCA at Wright-Patterson AFB which may be corrected by using a "Tin Can Filter" as described

← Fig. 1. Plate voltage is applied to V1 and V2A for 50-mc. operation. For 144 mc., voltage is applied to V5 and to V2B. Converter output is cathode-coupled.

in the July, 1954 issue of *CQ*. This will eliminate 99% of all images falling in the 2-meter band.

In a few instances, neighboring TV sets with radiating oscillators were observed as causing ITV on 6 meters. We have found that if we use a *Drake* TV-100 low-pass filter between the converter and the antenna most of these "birdies" are eliminated.

As can be noted in the block diagram of Fig. 2, the secret of the dual band capability and the need for only one oscillator is the choice of the 47 mc. overtone crystal. The first half of the oscillator is tuned to the same frequency as the crystal. This affords reception on 6 meters by using the receiver as a tunable i.f. from 3-7 mc., as 47 mc. plus 3 mc. equals 50 mc.

The same oscillator is used to drive a tripler to 141 mc. which supplies the injection to the mixer of the 144 mc. portion of the converter and, in so doing, the receiver again tunes from 3-7 mc., as 141 mc. plus 3 mc. equals 144 mc.

In the author's unit a Navy surplus RAO receiver is used as the i.f. which on "Band 3" tunes upwards from 2.6 mc. providing a 400 kc. region for checking F1 or F2 and sporadic-E openings by observing commercial stations just outside the 6-meter amateur band. This offers an excellent check on band openings.

If your regular communications receiver does not have the 3-7 mc. range, as may be the case if you own a "ham-band-only" type, a surplus BC-454 receiver which tunes from 3-6 mc. can be used for the purpose. This receiver will not cover the entire range of both the 6- and 2-meter bands but the top megacycle does not provide much activity in most areas.

In changing from one band to the other a single-pole, double-throw switch disengages the "B+" from the r.f. stage and mixer of the unwanted band and applies it to the r.f. and mixer stage of the band desired.

Two antenna inputs are used on the converter (Fig. 1) as most of the boys operating on both of these bands use separate beam antennas. The antenna inputs are matched to the r.f. stages by means of the "R-9er" input circuit which is a capacity divider for matching the low impedance of the antenna feedline to the high impedance of the tube. Once this capacity is adjusted it will need no further alterations. The r.f. stages use cathode bias to obtain proper grid voltage.

Separate triodes are used as the cathode follower with the cathodes being tied together at a common output BNC-type of coax connector. It is very important to use coax, such as RG-58 or RG-59, from the converter to the receiver as it eliminates the possibility of picking up stations in the 3-7 mc. range. This lead should be as short as possible with the outside braid serving as a common ground between the converter and the receiver. It is further

(Continued on page 81)

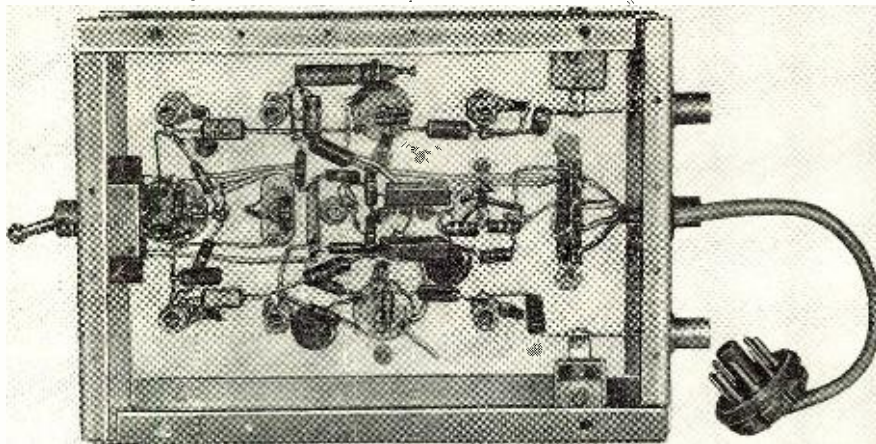

Bottom view of the converter. The bandswitch is visible at the left.

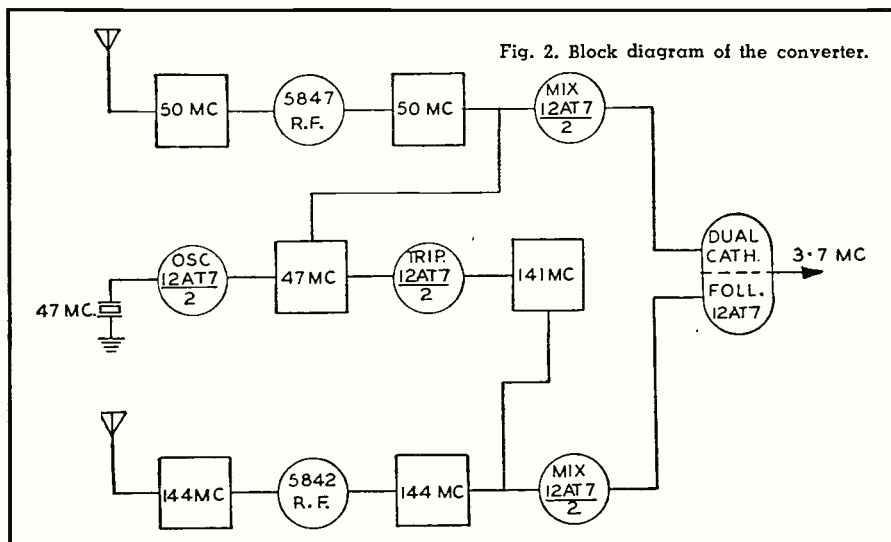
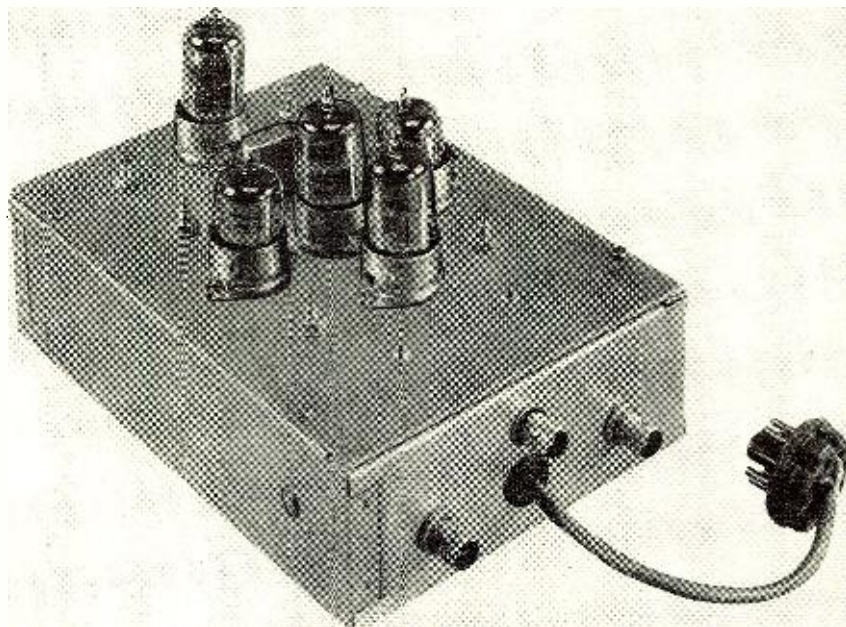

Fig. 2. Block diagram of the converter.

An over-all view of the two-band converter for 50 and 144 mc. use.





By JOHN T. FRYE

TAPE RECORDER TIPS

"THIS isn't going to do my figure a bit of good," Matilda announced as she dug the little wooden spoon deep into one of the chocolate sundaes Barney had brought back with him from a service call. He and Mac, the owner of the shop, were sitting on the service bench. Matilda was perched on a high stool in front of them.

"There you are!" Barney mumbled with his mouth full of ice cream. "Matilda here, with not a surplus ounce, worries about her figure; but when I was buying these sundaes, there were two or three babes standing in line who looked big enough to eat hay."

"Thank you, Barney—I think," Matilda said; "but that wouldn't be a sneaky way of calling me skinny, would it?"

"You know doggone well it's not," Barney said with an aggrieved air. "I wolf-whistle at you every chance I get, don't I? And I'm mighty careful who I whistle at. I've got a reputation for taste to maintain in this man's town."

"Yes, and if you don't stop those leering whistles I won't have a reputation at all," Matilda said with a dazzling smile that belied her reproof.

Mac set his little paper bucket down on the bench beside him and stretched luxuriously. "That really hit the spot this sizzling day, Flame Head. It was mighty thotty of you and it leaves me in a gabby mood. I've been wanting to talk to you about tape recorder servicing. Think you can listen and eat at the same time?"

"I read you loud and clear; over," Barney answered.

"The whole thing is tape recorders have improved tremendously these past few years. They are capable of excellent musical reproduction; and now that the hi-fi crowd has taken them over, we have much more critical customers to satisfy. That means we must be more critical, too, so that every recorder leaving the shop is delivering the best performance of which it is capable."

"Sounds like sense," Barney observed.

"Always start by demagnetizing the heads. Magnetized heads will produce a five to ten db increase in noise and distortion; but what is worse, such heads will gradually erase high frequencies from tape passed over them. I don't want our expensive test tapes ruined by using them on magnetized heads. By the same token, we should explain to the customer that a magnetized head is as bad for his prize tapes as a worn-out needle is for his fine records. Then we should sell him a head demagnetizer.

"Next, use the test tape to check head alignment. Don't forget that if a head is badly out of alignment, such as might occur when a head is replaced or when someone has tampered with the alignment adjustment, false peaks may be found on either side of the true azimuth position. These false peaks, however, will be 15 to 20 db below the correct position; so you will have no trouble locating the true azimuth setting if the adjustment is moved far enough to be sure you are not stopping on one of the false peaks."

"One thing that's always puzzled me is how you check the bias oscillator frequency," Barney said. "The frequency is too low for our grid-dip oscillator to reach; it's below the lowest frequency put out by the r.f. signal generator; and it's higher than the 20,000 top of our sine-wave generator. Just how do you check it?"

"Probably the best way is to feed the audio generator into the horizontal amplifier and the signal from the bias oscillator into the vertical amplifier of the scope. Then adjust the audio generator frequency until you get a stationary Lissajous pattern. In getting this pattern, start at the upper limit of the audio oscillator and come down. The oscillator frequency can then be read as the indicated multiple of the audio generator frequency. For example, if counting loops of the Lissajous figure indicates a 4 to 1 ratio and the sine-wave generator is putting

out 16,000 cycles, you know the oscillator is working on 64 kilocycles. While you're at it, turn on the horizontal saw-tooth sweep and examine the waveshape of the bias oscillator output. It should be close to a true sine wave for best operation.

"Sometimes the service manual gives you the bias or erase voltage that should be present across a head winding. Ordinarily these must be read with a true a.c. v.t.v.m. Make sure that the instrument you use has an upper frequency limit adequate for measuring the oscillator frequency. Some v.t.v.m.'s, intended chiefly for reading line frequencies and audio frequencies, will not give a true indication at the 50-100 kilocycle frequencies involved here. If you're not sure of your v.t.v.m., the scope can always be used with a voltage calibrator to check the amplitude of the voltages with sufficient accuracy.

"Keep in mind, too that some recorders change the voltage across the head with the speed of the tape. For example, one *Bell* recorder specifies 35 volts bias at 7.5 ips, 14 volts at 3 1/4 ips; and 10 volts at 1 1/2 ips."

"What if erase and bias currents rather than voltages are specified?"

"Put a 10-ohm precision noninductive resistor in series with a lead going to a head and measure the a.c. voltage drop across it. Multiply this voltage reading by 100 to get the current in milliamperes. For example, if you get a reading of .3 volt, that means the current is 30 ma."

"Isn't there some quicker way of checking the bias oscillator without going through all that stuff?"

"Well, a quick and dirty check of oscillator performance is to measure the d.c. voltage developed across the grid leak of the oscillator with a v.t.v.m. and compare this reading with the data given in the service manual. If the voltage is too low, try a new oscillator tube and check the other voltages applied to the tube elements against the voltage data supplied in the service sheet. If the voltage is too high, maybe the grid leak has changed value. More likely, the head winding may be open or a switch may be making a poor contact so that the oscillator is running unloaded. If you check the head winding for continuity with an ohmmeter, just remember this d.c. current is certain to magnetize the head; so use the demagnetizer again before running tape across the head."

"What should I use to clean the head and the rubber drive wheels? Some manuals say to use alcohol; others say carbon tetrachloride."

"You know how I feel about carbon tet. That stuff is deadly dangerous when it is used in such a way that you inhale the fumes. However, many manufacturers specify that it be used to clean the tape residue from heads, capstan, and guides. It is a good solvent for the material that collects on these. On the other hand, some manufacturers say *never* to use carbon tet

(Continued on page 117)

**NEW
COMPLETE**

**DIRECT
VIEWING**





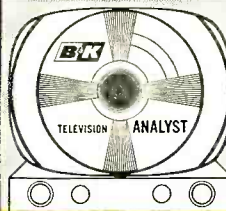
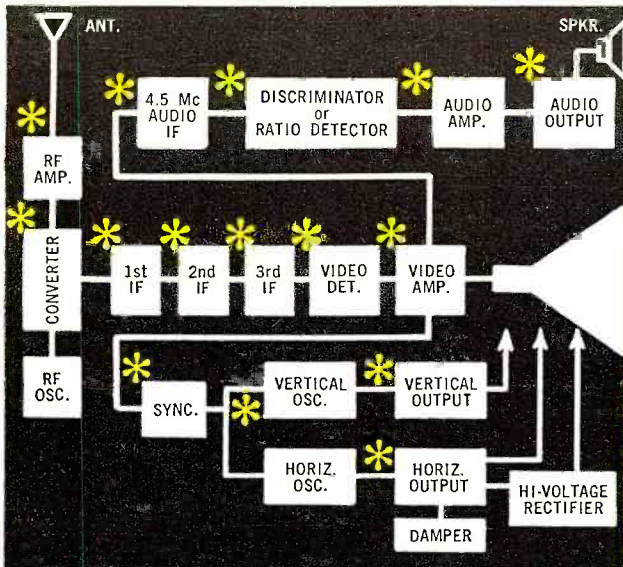

E E V S O N ANALYST

test each stage
SEPARATELY



and watch the
result on the
TV set itself

UNIQUE NEW SIGNAL-INJECTION TECHNIQUE
Saves TV Trouble-Shooting Time and Work

-  **R.F.** Supplies complete r.f. and i.f. signals with video and audio modulation to quickly trouble-shoot each stage in each of the sections of the TV receiver. Enables you to check the r.f. sensitivity and AGC settings of TV receivers.
-  **VIDEO** Reproduces a complete test pattern on the screen of the TV picture tube and injects signals into each video stage of the TV receiver for fast, visual trouble-shooting and correction—anywhere, anytime. Makes it easy to check bandwidth, resolution, shading and contrast capabilities of the TV set.
-  **SYNC** Provides composite signal, sync positive and negative.
- SWEEP CIRCUIT DRIVING PULSES** Provides separate vertical and horizontal driving pulses for trouble-shooting deflection circuits.
- INTERMITTENTS** Test signal injection also aids in locating intermittent troubles.
-  **AUDIO** Provides a 4.5 mc sound channel, FM modulated with approximately 25 kc deviation. (This audio carrier is modulated either from a built-in 400 cycle tone generator, or from your own external audio source.) Injection of the 400 cycle tone signal simplifies trouble-shooting of the audio section.
-  **COLOR** Enables you to trouble-shoot and signal trace color circuits in color TV sets.
Generates white dot and crosshatch patterns on the TV screen for color TV convergence adjustments.
Generates full color rainbow pattern of orange, red, magenta, blue, cyan, green to test color sync circuits, check range of hue control, align color demodulators, etc.
-  **SET ADJUSTMENT** Enables you to check and adjust the vertical and horizontal linearity, size and aspect ratio of television receivers.



NEW



**MODEL
1075**

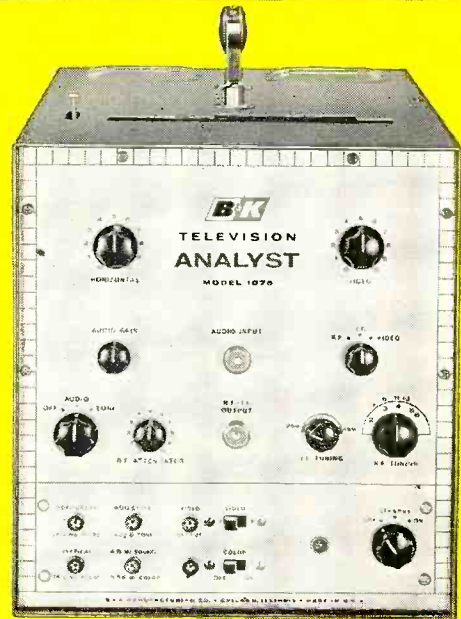

QUICK, DIRECT, COMPLETE TV TROUBLE-SHOOTING

Now, by point-to-point signal injection and test pattern reproduction, you can easily trouble-shoot and signal trace *any stage throughout the video, audio and sweep sections* of black & white and color TV receivers. With the remarkable new Model 1075 B&K TELEVISION ANALYST, you can quickly isolate and diagnose TV troubles (including intermittents). By use of the generated test pattern, you can *actually see* the condition directly on the picture tube of the television set itself. No external scope is needed. The TELEVISION ANALYST is practically a *complete* TV service shop *in one instrument!* Net, **\$259⁹⁵**



See your B&K Distributor or write for Bulletin AP12-N

B & K MANUFACTURING CO.
3726 N. Southport Ave. • Chicago 13, Illinois

Canada: Atlas Radio Corp., 50 Wingold, Toronto 10, Ont.

Export: Empire Exporters, 458 Broadway, New York 13, U.S.A.

"HEATHKITS®

gave me my start and I'm still sold!"

"... they are my lowest cost way to real quality and dependability in electronic equipment of any kind . . .

. . . The clean, modern styling of HEATHKITS make me proud to own them. They make a handsome and useful addition to my workshop.

. . . Rigid quality standards of components used in HEATHKITS assure me of performance equal to or surpassing instruments costing many times more.

. . . after assembling a HEATHKIT myself, I know what "makes it tick" . . . I know that the thoughtful circuitry design and name-brand components used throughout guarantee me years of trouble-free service.

. . . HEATHKITS cost me half as much as ordinary equipment . . . and I get so much more. In assembling my own instruments I am sure of the quality that goes into them. Plus the complete assembly and operating instructions as well as detailed schematics that are at my fingertips for future reference."

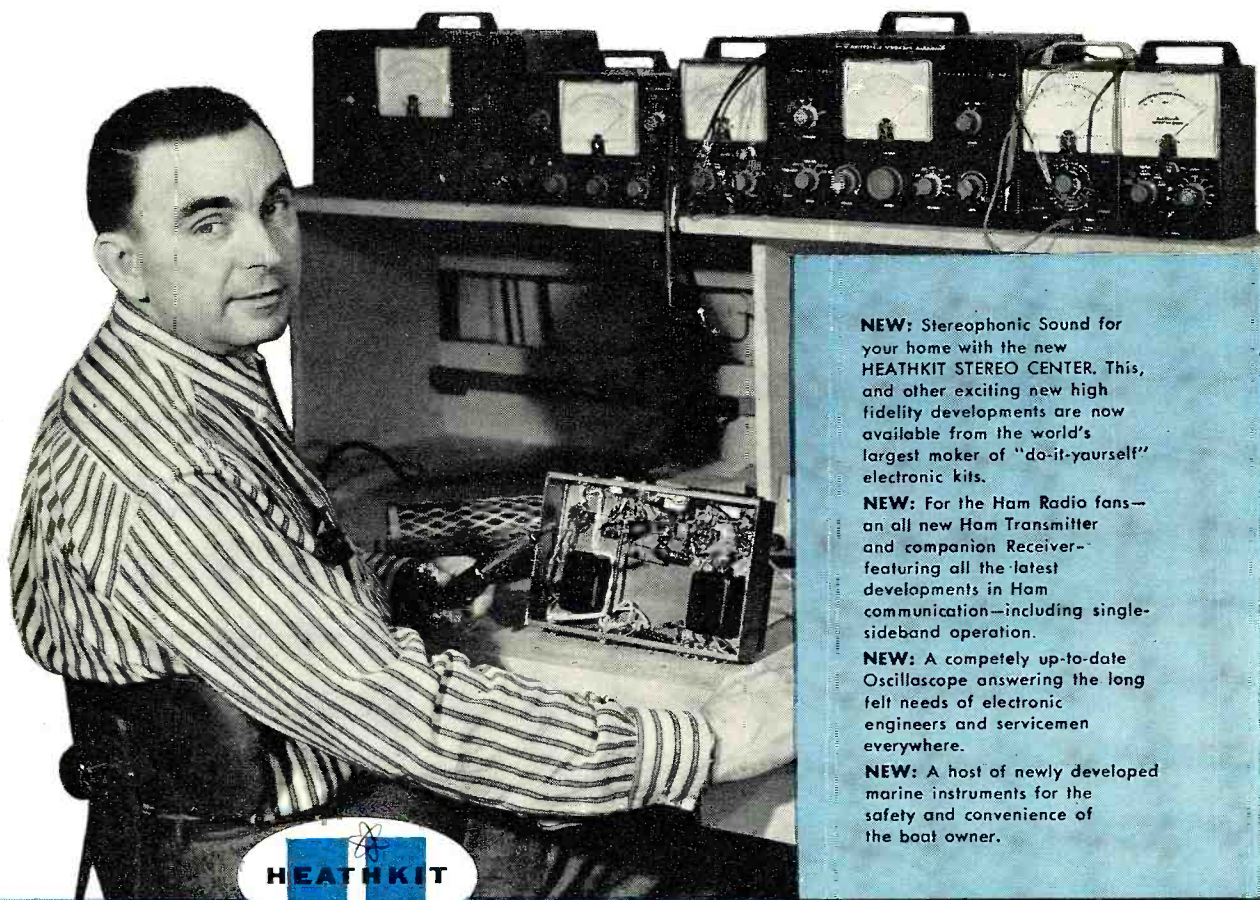

NEW: Stereophonic Sound for your home with the new HEATHKIT STEREO CENTER. This, and other exciting new high fidelity developments are now available from the world's largest maker of "do-it-yourself" electronic kits.

NEW: For the Ham Radio fans—an all new Ham Transmitter and companion Receiver—featuring all the latest developments in Ham communication—including single-sideband operation.

NEW: A completely up-to-date Oscilloscope answering the long felt needs of electronic engineers and servicemen everywhere.

NEW: A host of newly developed marine instruments for the safety and convenience of the boat owner.



HEATH COMPANY Benton Harbor 15, Michigan

H a subsidiary of Daystrom, Inc.

The HEATH TIME PAYMENT PLAN allows you to outfit your whole workshop at one time with needed test instruments while you pay in easy monthly installments.



PROFESSIONAL OSCILLOSCOPE KIT

An exciting development in the Heathkit test instrument line is the introduction of the Heathkit model OP-1 Professional Oscilloscope. Emphasizing complete flexibility in any application, the OP-1 features DC coupled amplifiers and also DC coupled CRT tube un-blanking. The triggered sweep circuit will operate on either internal or external signals and may be either AC or DC coupled. The polarity of the triggering signal may also be selected, and any point on the wave form may be selected for the start of the sweep by using the "triggering level" control. An automatic position is also provided, in which the sweep recurs at a 50 cycle rate, but can be driven over a wide range of frequencies with no additional adjustments. The sweep frequencies are provided by switch-selected base rates of 2 and .2 milliseconds/CM, and 20, 2, and 1 microseconds/CM, in conjunction with a continuously variable 10 to 1 multiplier. Sweep frequencies are calibrated to within 10% at all control settings, and the sweep frequency may be reduced by adding capacity to the "ext. cap" binding post on the front panel. A 5ADP2 flat face CR tube is used for accurate readings on an edge lighted grid screen. A high quality conetic-fernetic CR tube shield prevents stray AC fields from distorting trace. A 12-position vertical attenuator is calibrated in volts-per-CM and the horizontal sweep is calibrated in time-per-CM. Prewired terminal boards are used for rapid, easy assembly of all critical circuits. Simply install and connect the color coded leads. Power supply is transformer operated utilizing silicon diode rectifiers and is fused for protection. Under development for over a year the OP-1 promises outstanding results in any application requiring the use of an oscilloscope.



HEATHKIT
OP-1
\$179⁹⁵

*Here's the scope you've
been waiting for!*

AVAILABLE AFTER JUNE 15



**Laboratory
Performance At Less
Than Utility Scope
Price**

HEATHKIT
O-12
\$64⁹⁵



**A Scope You Will Be
Proud To Own**

HEATHKIT
OM-3
\$39⁹⁵

"EXTRA DUTY" 5" OSCILLOSCOPE KIT

Top quality features at half the cost of ordinary equipment sum up the advantages of this popular kit. Critical observations in your laboratory or shop are handled easily, with clear, sharp pattern displays in every application. Vertical frequency response extends from 3 CPS to 5 mc ± 1.5 db -5 db without extra switching. Response is down only 2.2 db at 3.58 mc. The Heath patented sweep circuit functions effectively from 10 CPS to better than 500 kc in five steps, giving you 5 times the usual sweep obtained in other scopes. An automatic sync circuit with self-limiting cathode follower provides excellent linearity and lock-in characteristics. Extremely short retrace time and efficient blanking action. Both vertical and horizontal output amplifiers are push-pull and the scope incorporates a 1 V peak-to-peak calibrating source, step attenuated and frequency compensated vertical input, plastic molded capacitors and top quality parts throughout. The 11-tube circuit features a 5UP1 cathode ray tube, and provision is made for Z-axis input for intensity modulation of the beam. Frequency response of the horizontal amplifier is within ± 1 db from 1 CPS to 200 kc. Horizontal sensitivity is 0.3 volts RMS per inch. Construction is simplified through the use of two metal circuit boards and precut, cable wiring harness. Shpg. Wt. 22 lbs.

GENERAL PURPOSE 5" OSCILLOSCOPE KIT

For servicing and routine laboratory work this fine kit is a favorite with technicians throughout the country. It incorporates many extras not expected at this low price. Features wide vertical amplifier frequency response, extended sweep generator operation, and improved stability. Frequency response of the vertical amplifier is within ± 3 db from 4 CPS to 1.2 mc. Vertical sensitivity is .09 volts RMS per inch at 1 kc. Sweep generator functions reliably from 20 CPS to over 150 kc. A modern etched circuit board is featured for high stability and reduces assembly time considerably. Standard components are mounted on this board with each position clearly marked preventing wiring errors. Both vertical and horizontal amplifiers are push-pull types. Uses a 5BP1 CRT. Provision for external or internal sweep or sync, built in 1 V peak-to-peak reference voltage and calibrated grid screen. An adjustable "spot shape" control is provided to insure a sharp trace. Input to the vertical amplifiers is through a step attenuated, frequency compensated circuit. The OM-3 is an extremely versatile instrument and has a multitude of practical uses in electronic testing fields. Particularly useful in alignment of television receivers, for testing audio amplifiers and circuits, and checking the quality of modulated RF signals in Ham Radio transmitters. Shpg. Wt. 22 lbs.



Equip Your Service Bench...



HEATHKIT
CD-1 \$59⁹⁵

Cash In Now On Color TV

- ★ 10 VERTICAL COLOR BARS
- ★ CRYSTAL CONTROLLED ACCURACY
- ★ CHOICE OF 6 DIFFERENT PATTERNS

COLOR BAR AND DOT GENERATOR KIT

Colored television is now a reality and as the number of these sets increase the need for a reliable service instrument is apparent. Nothing on the market... in this type of generator has as many features as the CD-1 at such a tremendous price saving. This unit combines two basic color service instruments, a color bar generator, and white dot generator in one versatile portable unit which has crystal controlled accuracy and stability for steady locked-in patterns (requires no external sync leads). Color receivers converged with the CD-1 will still be converged properly on a television program from the station. The 13-tube circuit has been carefully laid out for ease of assembly and provides choice of six different patterns. Produces white-dots, cross hatch, horizontal and vertical bars, ten vertical color bars, and a new shading bar pattern for screen and background adjustments. Variable RF output on any channel from 2 to 6. Positive or negative video output, variable from 0 to 10 volts peak-to-peak. Crystal controlled sound carrier with off-on switch. Voltage regulated power supply uses long-life silicon rectifiers. Kit includes three crystals and test lead, plus an information packed instruction manual covering convergence, and screen and background adjustments of a color TV set. Compare with other generators on the market and you will see that this instrument is loaded with extras and top quality all the way through. Shpg. Wt. 13 lbs.



HEATHKIT
TS-4A \$49⁵⁰

For fast,
easy alignment
of TV sets



HEATHKIT
AG-10 \$49⁹⁵

Sine and
square waves for
countless uses



HEATHKIT
MM-1 \$29⁹⁵

High accuracy
in a
portable meter



HEATHKIT
M-1 \$17⁹⁵

An all-round
meter of
many uses

TV ALIGNMENT GENERATOR KIT

This generator has many special design features for flexible, easy operation and reliability. The all-electronic sweep circuit insures stability and covers 3.6 mc to 220 mc in four bands. Sweep deviation is controllable from 0 to 42 mc. Crystal and variable marker oscillators are built in. Crystal (included with kit) provides output at 4.5 mc and multiples thereof. Variable marker provides output from 19 to 60 mc on fundamentals and from 57 to 180 mc on harmonics. Effective two-way blanking and phasing control also provided. A truly outstanding number of features at a tremendous price saving. Shpg. Wt. 16 lbs.

SINE-SQUARE WAVE GENERATOR KIT

High quality sine and square waves are produced by this generator over a wide range. Frequency response is ± 1.5 db from 20 CPS to 1 mc on both sine and square waves, with less than .25% sine wave distortion, 20 to 20,000 CPS. Output impedance is 600 ohms on sine wave and 50 ohms on square wave (except on 10 volt range). Square wave rise time less than .15 microseconds. Five-position bandswitch—continuously variable tuning—shielded oscillator circuit—separate step and variable output attenuators in ranges of 10, 1 and .1 volts with extra range of .01 volt on sine wave. Shpg. Wt. 12 lbs.

20,000 OHMS/VOLT VOM KIT

This meter is ideal for use in field applications where accuracy is important. Employs a 50 uA $4\frac{1}{2}$ " meter, and features 1% precision multiplier resistors for high accuracy. Requires no external power for operation (batteries supplied). Sensitivity is 20,000 ohms-per-volt DC and 5,000 ohms-per-volt AC. Measuring ranges are 0-1.5, 5, 50, 150, 500, 1500 and 5,000 volts AC and DC. Measures direct current in ranges of 0-150 uA, 15 ma, 150 ma, 500 ma and 15 a. Resistance multipliers are $\times 1$, $\times 100$ and $\times 10,000$. Covers -10 db to +65 db. Batteries and test leads are also included with this kit. Shpg. Wt. 6 lbs.

HANDITESTER KIT

Small enough to carry with you wherever you go, this fine handitester is ideal for use in portable applications when making tests away from the work bench or as an "extra" meter in the service shop, when the main instruments are occupied. The combination function-range switch simplifies operation. Measures AC or DC voltage from 0-10, 30, 300, 1000 and 5000 volts. Direct current ranges are 0-10 ma and 0-100 ma. Ohmmeter ranges are 0-3000 and 0-300,000. Top quality precision components employed throughout. Very popular with home experimenters and electricians. Shpg. Wt. 3 lbs.

with Low-Cost Dependable Heathkits

HEATHKIT

ETCHED CIRCUIT VTVM KIT

The fact that this instrument is outselling all other VTVM's says a great deal about its accuracy, reliability, and overall quality. The precision and quality of the components used in this VTVM cannot be duplicated at this price through any other source. Its attractive appearance as well as its performance will make you proud to own it. A large 4½" panel meter is used for indication, with clear, sharp calibrations for all ranges. Front panel controls consist of a rotary function switch and a rotary range selector switch, zero-adjust and ohms-adjust controls. Precision 1% resistors are used in the voltage divider circuit. An etched circuit board is employed for most of the circuitry, cutting assembly time and eliminating the possibility of wiring errors. It also assures duplication of laboratory instrument performance. This multi-function VTVM will measure AC voltage (RMS), AC voltage (peak-to-peak), DC voltage and resistance. There are 7 AC (RMS) and DC voltage ranges of 1.5, 5, 15, 50, 150, 500 and 1500. In addition there are 7 peak-to-peak AC ranges of 0-4, 14, 40, 140, 400, 1400 and 4,000. Seven ohmmeter ranges providing multiplying factors of x 1, x 10, x 100, x 1000, x 10 k, x 100 k and x 1 megohm. Center scale resistance readings are 10, 100, 1000, 10 k, 100 k ohms, 1 megohm and 10 megohms. A zero-center scale db range is also provided. Battery and test leads included with kit. Shpg. Wt. 7 lbs.



HEATHKIT
V-7A
\$24.50

**World's largest selling
VTVM kit**

- ★ LARGE EASY-TO-READ 4½" 200 UA METER
- ★ 1% PRECISION RESISTORS EMPLOYED FOR HIGH ACCURACY



HEATHKIT
C-3 **\$19.50**

**Checks all types of
condensers accurately**



HEATHKIT
T-4
\$19.95

**Locate faults quickly
by tracing signals**



HEATHKIT
SG-8 **\$19.10**

**Easy-to-build—prewound
and calibrated coils**

CONDENSER CHECKER KIT

Check unknown condenser and resistor values quickly and accurately. Capacity measurements are made in four ranges of .00001 mfd-.005 mfd; .001 mfd-.5 mfd; .1 mfd-50 mfd; 20 mfd-1,000 mfd. Checks paper, mica, ceramic, and electrolytic condensers. Leakage test provides switch selection of five polarizing voltages, 25 volts to 450 volts DC to indicate condenser operating quality under actual load conditions. Electron beam "eye" tube indicates balance and leakage. A spring return test switch automatically discharges condenser under test and eliminates shock hazard to the operator. Measures resistance from 100 ohms to 5 megohms in two ranges. Shpg. Wt. 7 lbs.

VISUAL-AURAL SIGNAL TRACER KIT

Here is a brand new signal tracer completely re-designed with compact dimensions and new circuit layout. Features built-in speaker and electron beam "eye" tube for signal indication and a unique noise locator circuit. Ideal for use in A.M. FM and TV circuit investigation. RF and audio inputs are provided in one convenient probe with switch on probe to select either input. Useful for checking microphones, phono cartridges, record changers, tuners, etc. Makes a handy substitution speaker for servicing TV sets at the shop. Transformer operated for safety and high efficiency. Complete with test leads and informative construction manual. Shpg. Wt. 6 lbs.

RF SIGNAL GENERATOR KIT

Save valuable time in aligning RF tuned circuits of all kinds with this easy-to-use kit. Also a quick way to trace signals in faulty RF, IF and audio circuits. Designed for general service applications—the SG-8 covers 160 kc to 110 mc on fundamentals in five bands, and from 110 mc to 220 mc on calibrated harmonics. The entire oscillator circuit is built on a special sub-chassis, using prewound and calibrated coils. No further calibration is required so it is ready to use as soon as construction is completed. RF output is in excess of 100,000 microvolts, controlled by both step and continuously variable controls. Complete with output cable and instructions. Shpg. Wt. 8 lbs.

HEATH COMPANY • a subsidiary of Daystrom, Inc. • **Benton Harbor 15, Mich.**

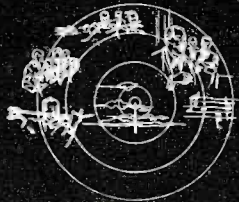

Enjoy Rich 3 Dimension Sound...

Beautifully Styled with Plenty of Room for the Most Complete Stereo System

AVAILABLE IN THE FOLLOWING MODELS:

Model SE-1B—Stereo Equipment Cabinet (birch)

Model SE-1M—Stereo Equipment Cabinet (mahogany)

Model SC-1BR—Stereo Wing Speaker Enclosure (birch—right end)

Model SC-1BL—Stereo Wing Speaker Enclosure (birch—left end)

Model SC-1MR—Stereo Wing Speaker Enclosure (mahogany—right end)

Model SC-1ML—Stereo Wing Speaker Enclosure (mahogany—left end)

HEATHKIT
SE-1

PRICE TO BE
ANNOUNCED

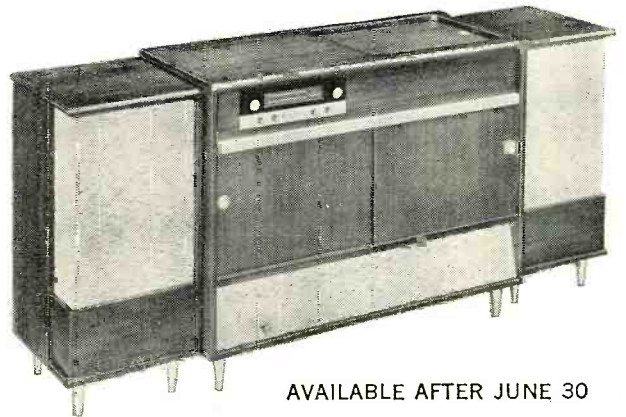

AVAILABLE AFTER JUNE 30

STEREO EQUIPMENT CABINET KIT

Imagine!...Stereophonic sound in your own home. This superbly designed cabinet holds all of your hi-fi stereo equipment and lends striking elegance to your living room. The attractive gold and black panels, trim and hardware brilliantly highlight the overall effect. Rich toned grille cloth, flecked in gold and black, complements the cabinet. The unit has ample room provided for an AM-FM tuner, tape deck, stereo pre-amplifier, amplifiers, record changer, record storage and speakers. Beautifully grained $\frac{3}{4}$ " solid core Philippine mahogany or select birch plywood is used for construction. The top features a shaped edge and sliding top panel for easy access to the stereo tape deck and stereo preamplifier. Sliding doors are employed for convenient front access to the

changer and record storage compartment. All parts of the cabinet are precut and predrilled for simple assembly. The speaker wings and center cabinet may be purchased separately if desired. Note: the kit is delivered equipped with panels pre-cut to accommodate Heathkit components and also blank panels to cut out for your own equipment. Measurements of the individual component areas follow: tape deck and preamplifier area 20 $\frac{3}{4}$ " L. x 17 $\frac{3}{4}$ " W. x 10" D., record changer area 21" W. x 16" D. x 9 $\frac{5}{8}$ " H., record storage area 22 $\frac{5}{8}$ " W. x 14 $\frac{1}{2}$ " H. x 12 $\frac{1}{2}$ " D., speaker wing area (inside) 14" W. x 29 $\frac{1}{2}$ " H. x 15 $\frac{3}{4}$ " D., AM-FM Tuner-area 20 $\frac{1}{2}$ " W. x 5 $\frac{1}{4}$ " H. x 14" D., amplifier (2 areas) 15 $\frac{1}{4}$ " W. x 10 $\frac{3}{4}$ " H. x 13 $\frac{1}{4}$ " D.

Model HH-1B Birch
Model HH-1M Mahogany
Now only **\$299⁹⁵** each



The Same Superior Performance
At a New Low Price

HEATHKIT
SS-2 **\$39⁹⁵**



OPTIONAL LEGS
EXTRA

Economical Hi-Fi For Your Home

"LEGATO" HI-FI SPEAKER SYSTEM KIT

The increasing sales of the Legato has made more economical quantity production possible so we are passing the savings on to you by offering you this magnificent speaker system at a reduced price. Truly a "queen" among hi-fi speaker systems, the Legato was specially designed to meet and surpass the most stringent requirements of high fidelity sound reproduction. Two 15" Altec Lansing low frequency drivers cover frequencies of 25 to 500 CPS while a specially designed exponential horn with high frequency driver covers 500 to 20,000 CPS. A unique crossover network is built in making electronic crossovers unnecessary. Internal reflections are absorbed by splayed back panel and a 3" fiber glass lining. The Legato emphasizes simplicity of line and form to blend with modern or traditional furnishings. Cabinet construction is $\frac{3}{4}$ " veneer surface plywood in either African mahogany or white birch and measures 41" L. x 22 $\frac{1}{4}$ " D. x 34" H. All parts are precut and predrilled for easy assembly. Shpg. Wt. 195 lbs.

"BASIC RANGE" HI-FI SPEAKER SYSTEM KIT

True high fidelity performance at modest cost make this basic speaker system a spectacular buy for any hi-fi enthusiast. The amazing performance of this popular kit is made possible by the use of high quality speakers in an enclosure specially designed to receive them. The cabinet is a ducted port bass reflex type enclosure 11 $\frac{1}{2}$ " H. x 23" W. x 11 $\frac{3}{4}$ " D. It features an 8" mid range woofer to cover 50 to 1600 CPS and a compression-type tweeter with flared horn covering 1600 to 12,000 CPS. Both speakers are by Jensen. The adjustable flared tweeter horn allows speaker to be used in either upright or horizontal position. The cabinet is constructed of $\frac{1}{2}$ " veneer surfaced plywood suitable for light or dark finish of your choice. All wood parts are precut and predrilled for easy assembly. Shpg. Wt. 25 lbs.

Attractive brass tip accessory legs convert SS-2 into attractive consolette. Legs screw into brackets provided. All hardware included. Shpg. Wt. 3 lbs. No. 91-26 \$4.95

with a Heathkit Stereo System



HIGH FIDELITY STEREO TAPE DECK KIT

For your unparalleled enjoyment in the world of stereophonic sound Heathkit brings you an all new stereo tape deck. This tape deck is a precision engineered instrument providing monaural record/playback, and stereo playback of prerecorded tapes. Incorporates three separate heads, erase-record-stereo playback (stacked). The mechanical tape deck assembly is supplied complete. You build only the record and playback circuit employing two etched circuit boards for ease of wiring. Low noise EF-86 tubes in input stages and efficient push-pull bias-erase oscillator insures complete freedom from hum and noise in recording and playback. Provision made for 3¾ and 7½ IPS tape speed selected by a push button. Deck handles up to 7" reels of tape. Other features are: provision for monitoring tape while recording, built in VU meter for proper recording level, pause control for editing tape, "fast forward" and "rewind" control. Frequency response at 7½ IPS tape speed is ±2 db from 40 to 12,000 CPS, at 3¾ IPS speed 40 to 6,000 CPS. Signal-to-noise ratio is 55 decibels with less than 1% total harmonic distortion. NARTB tape playback equalization. A safety interlock button prevents accidentally switching to record position causing erasure of recorded tapes. Shpg. Wt. 33 lbs.

Model TR-1C monaural tape deck incorporates all of the features described for the model TR-1D with the exception of stereo playback. \$131.95.

No. C-TR-1C conversion kit converts model TR-1C to include stereo function of model TR-1D. \$15.95.



HEATHKIT
TR-1D \$143⁹⁵

**Preassembled Tape Mechanism . . .
You Build Only Electronic Circuit**

AVAILABLE AFTER JUNE 30

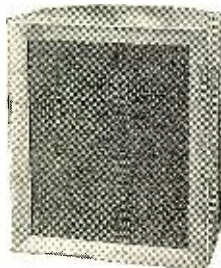

HEATHKIT
SS-1B
\$99⁹⁵

**Fill out the Hi-Fi Range
of Your SS-2 Speaker**

"RANGE EXTENDING" HI-FI SPEAKER SYSTEM KIT

This is not a complete speaker system in itself, but is designed to extend the range of the SS-2. The SS-1B uses a 15" woofer and a small super tweeter to supply the very high and very low frequencies to fill out the response of the basic SS-2. The SS-2 and SS-1B when used together, form an integrated four speaker system. The SS-2 and SS-1B combination provide an overall response of ±5 db from 35 to 16,000 CPS. The kit includes circuit for crossover at 600, 1600 and 4,000 CPS. Impedance is 16 ohms and power rating is 35 watts. A control is also provided to limit output of super tweeter. The handsome cabinet measures 29" H. x 23" W. x 17½" D. Constructed of beautiful ¾" veneer surface plywood. Complete step-by-step instructions make this kit easy to build. No wood-working experience required. Shpg. Wt. 80 lbs.

AVAILABLE AFTER JUNE 30

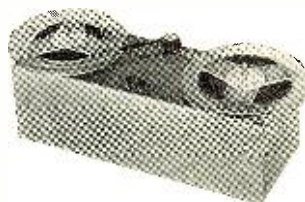

HEATHKIT
SW-1 PRICE TO BE
ANNOUNCED

Save Time Rewinding Tape

"SPEEDWINDER" KIT

This handy device leaves your tape recorder free for operation while it rewinds tape at the rate of 1200' in 40 seconds. Prevents unnecessary wear to the tape and recorder by eliminating wear against guides and heads. It will handle up to 10½" tape reels as well as 800' reels of 8 and 16 millimeter film. A very useful aid to operators of movie projection equipment. The Heathkit Speedwinder features an automatic shutoff which prevents whipping of tape when it has rewound. A manual shutoff is also provided. An automatic braking device is built in for protection against power failure. Driven by a heavy duty four pole motor. Handsome cabinet is constructed of furniture grade plywood. Step-by-step instructions are provided to make this kit easy to assemble even by one with no experience.



HEATHKIT
TK-1 \$99⁹⁵

**All The Tools You Need For
Building Heathkits**

COMPLETE TOOL SET

A clear illustration of just how easy Heathkit building is. The pliers, diagonal sidecutters, two screw drivers and soldering iron are all the basic tools you need for building practically any Heathkit. Pliers and sidecutters are equipped with insulated rubber handles. The American Beauty soldering iron has a replaceable tip to facilitate cleaning. All the tools are of top quality case hardened steel for rugged duty and long life. With these simple, inexpensive tools in your hand you need not be afraid to tackle the most elaborate kit. The manual included with this handy kit provides you with many useful tips on the use and care of your tools. It shows the all important step of making proper solder connections. A truly worthwhile investment for the beginner in electronic kit building. Shpg. Wt. 3 lbs.

HEATH COMPANY • a subsidiary of Daystrom, Inc. • Benton Harbor 15, Mich.



Plan Your Hi-Fi System...

AVAILABLE AFTER JUNE 30



**HEATHKIT
SP-2** **PRICE TO BE
ANNOUNCED**

Model SP-1 (monaural)
Model SP-2 (monaural-stereo)
Model C-SP-1 (converts SP-1 to SP-2)

**Control both stereo
channels simply
and conveniently**

MONAURAL-STEREO PREAMPLIFIER KIT

This expertly designed preamplifier provides all the controls required for either standard monaural (single channel) or stereo (dual channel) sound reproduction. Features building block design... you can start with a basic preamplifier and add a second channel for stereo later on, without rewiring. Second channel plugs in for fast conversion. The complete model SP-2 (stereo) features twelve separate inputs, six on each channel with input level controls. Six dual-concentric controls consist of: two 8-position selector switches, two bass, two treble, two volume level and two loudness controls, a scratch filter switch and a 4-position function switch (separate on-off switch). The function switch provides settings for stereo, two-channel mix, channel A or B for monaural use. Inputs consist of tape, mike, mag phono, and three high-level inputs. Tape input has NARTB equalization and input selector provides for RIAA, LP, 78 record compensation. EF86 tubes are used in the input stages along with hum balance controls to assure low hum and noise. Two cathode follower outputs with level controls provided in addition to two separate tape outputs for stereo recording. A remote balance control with twenty feet of cable allows balancing the stereo system from listening position. Construction is greatly simplified through the use of two printed circuit boards (one in each channel) and encapsulated printed circuits. The beautiful vinyl clad steel cover has leather texture in black with inlaid gold design. Built-in power supply.

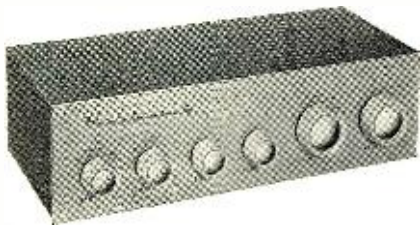

**HEATHKIT
WA-P2**
\$1975

**Finger-tip controls for
your operating convenience**

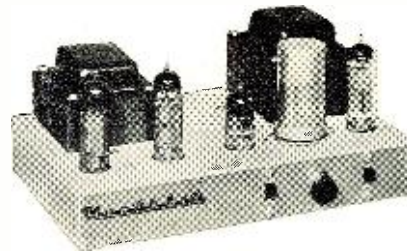

**HEATHKIT
UA-1**
\$2195

**A low cost
versatile performer**

"MASTER CONTROL" PREAMPLIFIER KIT

Designed as a control center for basic amplifiers, the WA-P2 provides you with true high fidelity performance for the finest audio systems. Five switch-selected inputs accommodate a record changer, tape recorder, AM-FM tuner, TV receiver, microphone, etc., each with level control. Provision is also made for a tape recorder output. Ideal for "remote" installations, the WA-P2 features a low impedance cathode-follower output circuit allowing greater length of output lead. Full frequency response is obtained within $\pm 1\frac{1}{2}$ db from 15 to 35,000 CPS and will do full justice to the finest available program sources. Equalization is provided for records through separate turnover and roll-off switches for LP, RIAA, AES, and early 78's. A special hum balance control allows setting for minimum hum level. Power for operation is required from basic amplifier or external source. Shpg. Wt. 7 lbs.

"UNIVERSAL" 12-WATT AMPLIFIER KIT

A true high fidelity performer in every sense of the word, the UA-1 makes an ideal basic amplifier for any hi-fi system and is a perfect addition to gear your present hi-fi system for stereo sound. Uses 6BQ5, 6EL84 push-pull output tubes for less than 2% harmonic distortion throughout the entire audio range (20 to 20,000 CPS) at full 12 watt output. The on-off switch is located right on the chassis and an octal socket is provided for connecting a preamplifier for remote control operation. The specially designed output transformer provides excellent stability and frequency response. Taps for 4, 8 and 16 ohm speakers, with switched damping for "unity" or "maximum" on the 16-ohm tap. An input level control is provided for use in wired music systems where a preamplifier is not required. This versatile unit is the latest addition to the fine line of Heathkit basic amplifiers. Shpg. Wt. 13 lbs.

With Flexible Heathkit Components



DELUXE AM-FM TUNER KIT

Outstanding features in both styling and circuitry are combined in this 16-tube deluxe AM-FM combination tuner to bring you the very finest in program sources, for your listening enjoyment. Features include three circuit boards for easy construction and high stability—prewired, prealigned FM front end—built-in AM rod antenna—tuning meter—AFC (automatic frequency control) with on-off switch and flywheel tuning. AM and FM circuits are separate and individually tuned making it ideal for stereo applications. Cathode follower outputs with individual controls are provided for both AM and FM. Other features include variable AM bandwidth, 10 kc whistle filter, tuned-cascode FM front end, FM AGC and amplified AVC for AM. The unique IF limiter design automatically provides the number of limiting and IF stages required for smooth non-flutter reception. The silicon diode power supply is extremely conservatively rated and is fuse protected assuring long service life. A tuning meter shows when the station is tuned-in for clearest reception on AM or FM. Use of three circuit boards greatly simplifies construction of circuit, you do only a minimum of wiring. All IF transformers and coils are prealigned so it will be ready to operate as soon as construction is completed. Appearance of this top-quality unit is further enhanced by the vinyl-clad steel cover in black with inlaid gold design. A multiplex jack is provided for addition of converter unit to receive multiplex stereo broadcasts on FM. A top dollar value.

AVAILABLE AFTER JUNE 30

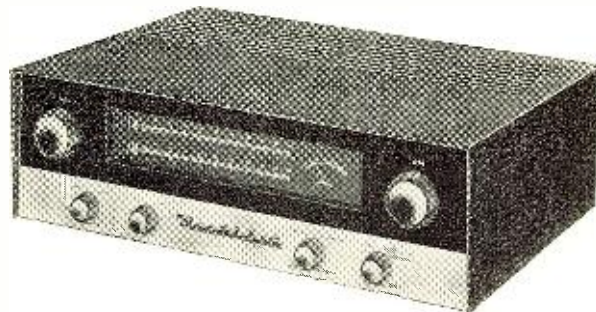

HEATHKIT
PT-1 \$89⁹⁵

**A deluxe AM-FM
tuner combination
loaded with extras!**



HEATHKIT
BC-1A
\$25⁹⁵

Wide range broadcast reception

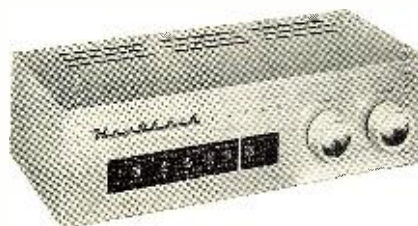

HEATHKIT
FM-3A
\$25⁹⁵

Enjoy static-free FM entertainment

HIGH FIDELITY AM TUNER KIT

This AM tuner was designed especially for high fidelity applications. It incorporates a special detector using crystal diodes, and the IF circuit features broad bandwidth to assure low signal distortion. Audio response is ± 1 db from 20 CPS to 9 kc, with 5 db of pre-emphasis at 10 kc to compensate for station rolloff. Sensitivity and selectivity are excellent and the tuner covers the entire broadcast band from 550 to 1600 kc. Quiet performance is assured by a 6 db signal-to-noise ratio at 2.5-uv. Prealigned RF and IF coils eliminate the need for special alignment equipment. Incorporates AVC, two outputs, two antenna inputs, and built-in power supply. Edge-lighted glass slide rule dial for easy tuning. Your "best buy" in an AM tuner. Shpg. Wt. 9 lbs.

HIGH FIDELITY FM TUNER KIT

FM programming, your least expensive source of high fidelity will provide you with years of real enjoyment. This beautifully styled FM tuner features broad-banded circuits for full fidelity and better than 10 uv sensitivity for 20 db of quieting to pull in stations with clarity and full volume. Covers the complete FM band from 88 to 108 mc. Stabilized, temperature-compensated oscillator assures negligible drift after initial warmup. A ratio detector provides high-efficiency demodulation without sacrificing hi-fi performance. IF and ratio transformers are prealigned, as is the front end tuning unit, making special alignment equipment unnecessary. Edge-lighted glass slide rule dial for easy tuning. You need not wait to have FM in your home at this low price. Shpg. Wt. 8 lbs.

HEATH COMPANY • a subsidiary of Daystrom, Inc. • Benton Harbor 15, Mich.

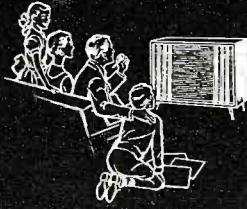

You can be sure you're buying High Fidelity

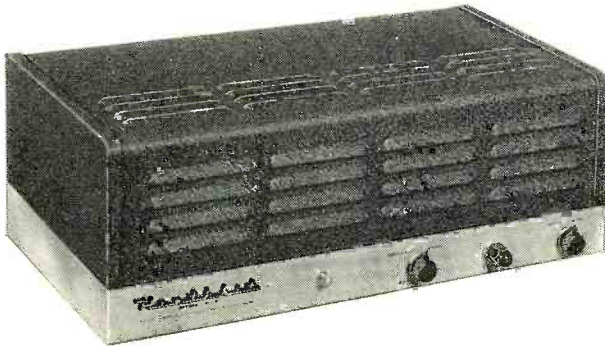

HEATHKIT
W-7M

\$54⁹⁵

**55 watts of hi-fi power at
only \$1 per watt**

- ★ BEAUTIFULLY STYLED IN BLACK AND GOLD
- ★ UNITY OR MAXIMUM DAMPING

**"EXTRA PERFORMANCE"
55 WATT HI-FI AMPLIFIER KIT**

Another Heathkit first! An honestly rated high power amplifier with many top quality features at less than a dollar per watt. Full audio output is conservatively rated at 55 watts from 20 CPS to 20 kc with less than 2% total harmonic distortion throughout the entire range. Unique paired output connections permit instant switch selection of "unity" or "maximum" damping factors for all 4, 8 or 16 ohm speakers. Each output has an optimized current feedback circuit for unity damping so that there will be no compromise in performance when any of the impedances is used. This current feedback circuitry is entirely shorted out when not in use to obtain the highest possible damping factor. Features include level control and "on-off" switch right on the chassis plus provision for remote control from preamp, etc. Famous "bas-bal" circuit conveniently balances EL-34 output tubes. These heavy duty push-pull tubes operate into a high quality tapped-screen transformer designed especially for this unit. A 70-volt output on the transformer provides for P.A. or large music systems. The silicon diode power supply features a protection device that controls current until tubes have warmed up, greatly increasing service life of all components. The stylish black and gold case measures 6" H. x 8½" D. x 15" W. Convenient pilot light on the chassis. Thoughtful circuit layout makes this kit easy to build. Dollar for watt you can't beat this buy. Shipped express only. Shpg. Wt. 28 lbs.

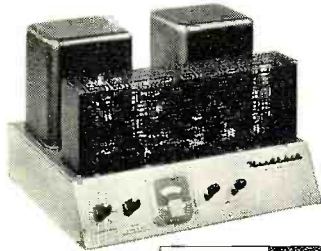

HEATHKIT
W-6M

\$109⁹⁵

**Plenty of Reserve Power
Without Distortion**

"HEAVY DUTY" 70-WATT HI-FI AMPLIFIER KIT

Here is an amplifier that will provide the extra "push" needed to drive any of the fine speaker systems available today, for truly fine performance at any power level. Silicon-diode rectifiers are used to assure long life and a heavy duty transformer gives you extremely good power supply regulation. Variable damping control provides optimum performance with any speaker system. Quick change plug selects 4, 8 and 16 ohms or 70 volt output and the correct feedback resistance. Frequency response at 1 watt is from 5 CPS to 80 kc with controlled HF rolloff above 100 kc. At 70 watts output harmonic distortion is below 2%, 20 to 20,000 CPS and IM distortion is below 1%, 60 and 6,000 CPS. Hum and noise 88 db below full output. Metered balance circuit. Designed especially for easy assembly and years of dependable service. Shipped express only. Shpg. Wt. 52 lbs.



HEATHKIT
W-5M

\$59⁷⁵

**Top-Flight Performance
for the Critical Listener**

25-WATT HI-FI AMPLIFIER KIT

Considered top value in its power class by leading independent research organizations, the W-5M incorporates all the design features required by the super critical listener. Features include a specially designed Peerless output transformer and KT66 tubes. The circuit is rated at 25 watts and will follow instantaneous power peaks of a full orchestra up to 42 watts. A "tweeter saver" suppresses high frequency oscillation and a new type balancing circuit facilitates adjustment of the "dynamic" balance between output tubes. Frequency response is ±1 db from 5 CPS to 160,000 CPS at 1 watt and within 2 db from 20 to 20,000 CPS at full 25 watts output. Harmonic distortion is less than 1% at 25 watts and IM distortion is 1% at 20 watts (60 and 3,000 CPS, 4:1). Hum and noise are 99 db below 25 watts for truly quiet performance. Rich black and gold colored styling. Shipped express only. Shpg. Wt. 31 lbs.

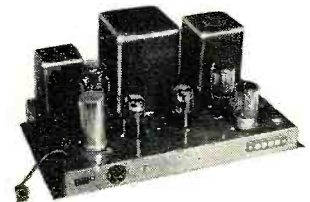

HEATHKIT
W4-AM

\$39⁷⁵

**Faithful Sound Reproduction
with Minimum Investment**

20-WATT HI-FI AMPLIFIER KIT

This fine amplifier will amaze you with its outstanding performance. It features a true Williamson circuit with extended frequency response, low distortion, and low hum levels. Enjoy true hi-fi with only a minimum investment compared to other units on the market. 5881 tubes and a special Chicago-Standard output transformer are employed to give you full fidelity at minimum cost. Frequency response extends from 10 CPS to 100 kc within ±1 db at 1 watt assuring you of full coverage of the audio range. Clean, clear sound amplification takes place in circuits that hold harmonic distortion at 1.5% and IM distortion below 2.7% at full 20 watt output. Hum and noise are 95 db below full output. Taps on the output transformer are at 4, 8 or 16 ohms to match the speaker system of your choice. An outstanding performer, this investment will bring you years of listening enjoyment. Shipped express only. Shpg. Wt. 28 lbs.

All basic amplifiers recommended for use with model WA-P2, SP-1 or SP-2 preamplifiers

...When You Buy Heathkit

HEATHKIT

"BOOKSHELF" 12-WATT AMPLIFIER KIT

The model EA-2 combines eye-pleasing style and color with many extra features for high quality sound reproduction. This fine amplifier provides full range frequency response from 20 to 20,000 CPS within ± 1 db. Harmonic distortion is less than 1% at full 12 watt output over the entire range (20-20,000 CPS). IM distortion is less than 1.5% at 12 watts with low hum and noise. Miniature tubes are used throughout the advanced circuitry, including EL84 output tubes in a push-pull tapped-screen output circuit using a special designed output transformer. Transformer has taps at 4, 8 and 16 ohms. The model EA-2 has its own built-in preamplifier with provision for three separate inputs, mag phono, crystal phono and tuner. The mag phono input features RIAA equalization. Separate bass and treble controls are provided with boost and cut action. A special hum-balance control assures quiet operation. The luxury styled cabinet has a smooth simulated leather texture in black with inlaid gold design and is constructed of vinyl plastic bonded to steel. It resists scuffing, wear, abrasion, and chemicals. The front panel features brushed-gold trim and buff knobs with gold inserts for a very pleasing appearance. An amber neon pilot lamp indicates when the amplifier is on. Cabinet measures 12 1/2" W. x 3 3/16" D. x 4 3/8" H. making it suitable for use on a bookshelf, end table, etc. High quality is emphasized throughout for performance matching amplifiers costing many times more. Shpg. Wt. 15 lbs.



HEATHKIT EA-2 \$27⁹⁵

Combines beauty, style and quality

- ★ LESS THAN 1% DISTORTION AT FULL OUTPUT OVER ENTIRE AUDIO RANGE.
- ★ BUILT-IN PREAMPLIFIER



HEATHKIT A9-C \$35⁵⁰

A Bargain Package of Power and Performance

GENERAL-PURPOSE 20-WATT AMPLIFIER KIT

The A9-C combines a preamplifier, main amplifier and power supply all on one chassis providing a compact unit to fill the need for a good high fidelity amplifier with a moderate cash investment. Designed primarily for home installations, it is also capable of fulfilling P.A. requirements. The preamplifier section features four separate switch selected inputs. Separate bass and treble tone controls offer 15 db boost and cut. A true high fidelity performer, the A9-C covers 20 to 20,000 CPS within ± 1 db. Front panel is detachable, and can be installed on the outside of a cabinet where the chassis comes through, for custom installations. A fine unit with which to start your hi-fi system. Shpg. Wt. 23 lbs.

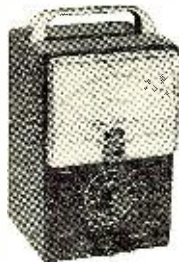

HEATHKIT AV-3 \$29⁹⁵

Invaluable for Hi-Fi Testing

AUDIO VTVM KIT

Critical AC voltage measurements are made easy with this high quality vacuum tube voltmeter which emphasizes stability, broad frequency response and sensitivity. Features large 4 1/2" 200 microampere meter, with increased damping in the meter circuit for stability in low frequency tests. Extremely high voltage range handles measurements from a low value of 1 millivolt to a maximum of 300 volts. AC (RMS) voltage ranges are: 0-.01, .03, .1, .3, 1, 3, 10, 30, 100 and 300 volts. Db ranges cover -52 to +52 db. Employs 1% precision multiplier resistors for maximum accuracy. High input impedance (1 megohm at 1,000 CPS). Frequency response is essentially flat from 10 CPS to 200 kc. Shpg. Wt. 6 lbs.



HEATHKIT AW-1 \$29⁵⁰

Measure Exact Power Output

AUDIO WATTMETER KIT

Here is a fine meter to accurately measure output wattage. Five power ranges cover 0-5 mw, 50 mw, 500 mw, 5 w and 50 w full scale. Five switch selected db ranges cover -10 db to +30 db. All indications are read directly on the large 4 1/2" 200 ua meter. Frequency response is ± 1 db from 10 CPS to 150 kc. External or internal load resistors are selected with convenient front panel switch. Non-inductive load resistors are built in for 4, 8, 16 or 600 ohms impedance. Precision multiplier resistors are used for high accuracy and incorporated a crystal diode bridge for wide-range frequency response. Modern styling and convenient front panel design. Cabinet is ventilated to allow efficient cooling of load resistors. Shpg. Wt. 7 lbs.

HEATH COMPANY • a subsidiary of Daystrom, Inc. • **Benton Harbor 15, Mich.**



Easy to Buy - Easy to Build - Easy to Use...



CONTEMPORARY
Model CE-1B Birch
Model CE-1M Mahogany



TRADITIONAL
Model CE-1T Mahogany

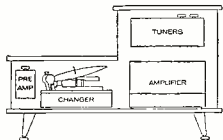

HEATHKIT
CE-1
\$43⁹⁵
each

CHAIRSIDE ENCLOSURE KIT

This Chairside Enclosure lets you combine all of your hi-fi equipment into one compact control center and, at the same time add a beautiful piece of furniture to your home. The CE-1 is designed to house the AM and FM tuners (BC-1A and FM-3A) and the WA-P2 preamplifier along with the majority of record changers which will fit into the space provided. Adequate room is available in the rear of the unit to house any of the Heathkit amplifiers designed to operate with the WA-P2. The enclosure is flexible enough to give you a large choice in component installation. If only one tuner and the preamplifier are used, the two units can be installed in the tilt-out drawer, or if more convenient, either unit can be placed in the space provided in front of the changer compartment. The tilt-out shelf can be installed on either right or left side and the lift-top lid is similarly designed to lift from either side depending on your choice during construction. Good ventilation is achieved through appropriately placed slots in the bottom and back of the enclosure. Overall dimensions are 18" W. x 24" H. x 35½" D. The changer compartment measures 17¾" L. x 16" W. x 9¾" D. All parts are precut and predrilled for easy assembly and attractive hardware is supplied to match each style. The contemporary cabinet is available in either mahogany or birch and the traditional cabinet is available in mahogany only. Furniture grade plywood can be finished to your taste. Shpg. Wt. 46 lbs.

Combine all your Hi-Fi equipment
in this attractive cabinet



HEATHKIT
AG-9A \$34⁵⁰



HEATHKIT
AA-1 \$49⁹⁵



HEATHKIT
HD-1 \$49⁵⁰

Your own source of
Hi-Fi audio signals

3 Audio test instruments
in one compact unit

Check amplifier
distortion quickly

AUDIO SIGNAL GENERATOR KIT

The model AG-9A is "made to order" for high fidelity applications, and provides quick and accurate selection of low-distortion signals from 10 CPS to 100 kc. Three rotary switches select two significant figures and a multiplier to determine audio frequency. Incorporates step-type and a continuously variable output attenuator. Output indicated on large 4½" panel meter, calibrated in volts and db. Attenuator system operates in 10 db steps, corresponding to meter calibration, in ranges of 0-.003, .01, .03, .1, .3, 1, 3 and 10 volts RMS. "Load" switch permits use of built-in 600-ohm load, or external load of different impedance. Output and frequency indicators accurate to within ±5%. Distortion less than .1 of 1% between 20 and 20,000 CPS. Shpg. Wt. 8 lbs.

AUDIO ANALYZER KIT

Complete high fidelity testing facilities are yours in the AA-1. It combines the functions of three separate instruments; an AC VTVM, audio wattmeter and a complete IM analyzer with filters and high and low frequency oscillators built in. VTVM ranges are: 0-.01, .03, .1, .3, 1, 3, 10, 30, 100 and 300 volts (RMS). Db scale reads from -65 to +52 dbm. Wattmeter ranges are: 15 mw, 1.5 mw, 15 mw, 150 mw, 1.5 w, 15 w and 150 w. IM scales are 1%, 3%, 10%, 30% and 100% full scale. Provides internal load resistors of 4, 8, 16 or 600 ohms. Combining and consolidating functions reduces the number of test leads and controls required for the same test. Complete instructions are provided for easy assembly, also, valuable information on use of instrument. Shpg. Wt. 13 lbs.

HARMONIC DISTORTION METER KIT

Valuable in both designing and servicing of audio circuits, the HD-1 used with an audio signal generator, will accurately measure harmonic distortion at any or all frequencies between 20 and 20,000 CPS. Distortion is read on panel meter in ranges of 0-1, 3, 10, 30 and 100% full scale. Full scale voltage ranges of 0-1, 3, 10 and 30 volts are provided for the initial reference settings. Signal-to-noise ratio is measured on a separate meter scale calibrated in db. Features high input impedance (300,000 ohms) and 1% precision resistors in the VTVM voltage divider circuit for excellent sensitivity and accuracy. High quality components insure years of dependable service. Complete instructions provided for easy assembly and operation. Shpg. Wt. 13 lbs.

Heathkits are Your Best Dollar Value



TRANSISTOR PORTABLE RADIO KIT

The overwhelming sales of this outstanding transistor portable have made a substantial price reduction possible... in addition, an all new plastic molded case adds the finishing touch to the exceptional circuitry. Six name-brand (Texas Instrument) transistors are used for extra good sensitivity and selectivity. The 4" x 6" PM speaker with heavy magnet provides excellent tone quality. Use of this large speaker and roomy chassis make it unnecessary to crowd components adding greatly to the ease of construction. Transformers are prealigned so it is ready for service as soon as construction is completed. A touchup in alignment is easily accomplished on a station by following simple instructions in manual. Alignment tool furnished. Has built-in rod-type antenna for reception in all locations. Six standard size "D" flashlight cells are used for extremely long battery life (between 500 and 1000 hours) and they can be purchased almost anywhere. Cabinet is two-tone blue molded plastic with pull-out carrying handle. Dimensions are 9 1/2" L. x 7 1/4" H. x 4" D. Shpg. Wt. 6 lbs.

Model XR-1-L: Identical to XR-1-P except in genuine leather case. Rich, warm sun-tan tone. Leather carrying strap included. Shpg. Wt. 7 lbs.

Leather Case: can be purchased separately if desired. Fits all XR-1P's and XR-1's. No. 93-1. Shpg. Wt. 3 lbs. \$6.95.



MODEL XR-1-L
\$34⁹⁵

HEATHKIT
XR-1-P **\$29⁹⁵**

Newly designed plastic case . . . new low price!

- ★ 4" X 6" SPEAKER FOR "BIG SET" TONE
- ★ LONG BATTERY LIFE (500 to 1000 Hours)



HEATHKIT
CT-1
\$7⁹⁵

Test condensers right in the circuit



HEATHKIT
DF-1 **\$54⁹⁵**

Pin-point your exact location



HEATHKIT
FD-1 **\$35⁹⁵ each**
(6 volt model FD-1-6)
(12 volt model FD-1-12)

Detects gas fumes



HEATHKIT
MC-1
\$42⁹⁵

Save your boat batteries

IN-CIRCUIT CAPACI-TESTER KIT

Check most capacitors for "open" or "short" right in the circuit with this handy kit. Detects open capacitors from about 50 mmf up, not shunted by an excessively low resistance value. Checks shorted capacitors up to 20 mfd (not shunted by less than 10 ohms). (Does not detect leakage nor check electrolytic condensers.) Employs a 60-cycle frequency for the short test and a 19 megacycle frequency for the open test. Uses electron beam "eye" tube for quick indication. Test leads included. Shpg. Wt. 5 lbs.

TRANSISTOR RADIO DIRECTION FINDER KIT

This transistor radio compass will double as a portable radio. Covers the standard broadcast band from 540 to 1600 kc. Ideal for use aboard boats and also on land by hunters, hikers, etc. A directional high-Q ferrite antenna rotates from the front panel to obtain a fix on a station. A 1 ma meter serves as null and tuning indicator. Prealigned IF transformers—six transistor circuit. Powered by tiny 9-volt battery with spare included. Dimensions 7 1/2" W. x 5 3/8" H. x 5 3/8" D. Shpg. Wt. 5 lbs.

FUEL VAPOR DETECTOR KIT

Protect your boat and passengers against fire and explosion with one of these fuel vapor detector kits. Indicates the presence of fumes on a three-color "safe-dangerous" meter scale and immediately shows if it is safe to start the engine. A pilot lamp shows when the detector is operating. Easy to build and install, even by one not having previous experience. Operates from your boat battery. The kit is complete with heavy-duty neoprene insulated cable, and includes spare detector unit. Shpg. Wt. 4 lbs.

MARINE CONVERTER KIT

Charge 6 or 12 volt batteries with this marine converter and battery charger. A panel mounted 25 ampere meter continuously monitors the charging current. Moisture and fungus proofed for rugged marine use. Convection cooling prevents unsafe temperature rise. The MC-1 has no moving parts, tubes nor blowers to wear out or break. Mounting brackets are supplied for easy installation on any boat. Ideal for keeping batteries fully charged or to supply extra current for appliances. Shpg. Wt. 16 lbs.

HEATH COMPANY • a subsidiary of Daystrom, Inc. • Benton Harbor 15, Mich.



New Styling - New Features...



HEATHKIT
TX-1 **\$229⁵⁰**

Complete Versatility for Top-Notch Amateur Communications

- ★ NEWLY DESIGNED VFO—ROTATING SLIDE RULE DIAL
- ★ MODERN STYLING—PROVISION FOR SSB ADAPTER

"APACHE" HAM TRANSMITTER KIT

Fresh out of the Heath Company laboratories, the brand-new "Apache" model TX-1 ham transmitter features modern styling and the latest in circuitry for extra fine performance. The "Apache" is a high quality transmitter operating with a 150 watt phone input and 180 watt CW input. In addition to CW and phone operation, built-in switch selected circuitry provides for single-sideband transmission through the use of a plug-in external adapter. These SSB adapters will be available in the near future. A compact, stable and completely redesigned VFO provides low drift frequency control necessary for SSB transmission. A slide rule type illuminated rotating VFO dial with vernier tuning provides ample bandspread and precise frequency settings. The bandswitch allows quick selection of the amateur bands on 80, 40, 20, 15 and 10 meters. (11M with crystal control). This unit also has adjustable low level speech clipping and a low distortion modulator stage employing two of the new 6CA7/EL-34 tubes in push-pull class AB operation. Time sequence keying is provided for "chirpless" break-in CW operation. The final amplifier is completely shielded for greater TVI protection and transmitter stability. Die-cast aluminum knobs and front panel escutcheons add to the attractive styling of the transmitter. Pi network output coupling matches antenna impedances between 50 and 72 ohms. Shpg. Wt. 115 lbs.

\$50.00 deposit required on C.O.D. orders. Shipped motor freight unless otherwise specified.



HEATHKIT
DX-20 **\$35⁹⁵**

An Ideal Code Transmitter

DX-20 CW TRANSMITTER KIT

Designed especially for CW work, the DX-20 features high efficiency at low cost. An ideal rig for the novice or advanced-class CW operator. Plate power input is 50 watts, and covers 80, 40, 20, 15, 11 and 10 meters with single knob bandswitching. Features a single 6DQ6A tube in the final amplifier stage and a 6CL6 as a crystal oscillator. Pi network output circuit matches various antenna impedances between 50 and 1000 ohms and reduces harmonic output. Top-quality parts are featured throughout, including "potted" transformers, etc., for long service life. Complete shielding to minimize TVI. Removable metal pull-out plug on left end of cabinet provides access for crystal changing. Very easy to build with complete instructions supplied. Shpg. Wt. 19 lbs.



HEATHKIT
DX-100 **\$189⁵⁰**

You'll be Proud to Own This Outstanding Performer

DX-100 PHONE AND CW TRANSMITTER KIT

Well known for its high quality and fine performance the DX-100 features a built-in VFO, modulator, and power supply, complete shielding to minimize TVI, and a pi network coupling to match impedances from 50 to 600 ohms. RF output is in excess of 100 watts on phone and 120 watts on CW, for clean strong signals on all ham bands from 10 to 160 meters. Single knob bandswitching and illuminated VFO dial and meter face add real operating convenience. RF output stage uses a pair of 6146 tubes in parallel, modulated by a pair of 1625's. High quality components are used throughout, such as potted transformers, silver-plated or solid coin silver switch terminals, aluminum-heat dissipating caps on the final tubes, copper plated chassis, etc. Shpg. Wt. 107 lbs.

\$50.00 deposit required on C.O.D. orders. Shipped motor freight unless otherwise specified.



HEATHKIT
DX-40 **\$64⁹⁵**

Phone & CW Facilities at Low Cost

DX-40 PHONE AND CW TRANSMITTER KIT

An outstanding buy in its power class the DX-40 provides both phone and CW operation on 80, 40, 20, 15, 11 and 10 meters. A single 6146 tube is used in the final amplifier stage to provide full 75 watt plate power input on CW, or controlled carrier modulation peaks up to 60 watts for phone operation. Modulator and power supplies are built in and single-knob bandswitching is combined with the pi network output circuit for complete operating convenience. Complete shielding to minimize TVI. Provision is made for three crystals. A four-position switch selects any of the three crystals or a jack for external VFO. Crystal sockets are reached through access door in rear of cabinet. High quality D'Arsonval movement panel meter. Shpg. Wt. 25 lbs.

For Real Ham Enjoyment



"MOHAWK" HAM RECEIVER KIT

Here is a ham receiver that any radio operator would be proud to own. The "Mohawk" has all the functions required for high quality communications with clear, rock-steady reception on all bands. This 15-tube receiver features double conversion with IF's at 1682 kc and 50 kc and covers all of the amateur frequencies from 160 through 10 meters on seven bands with an extra band calibrated to cover 6 and 2 meters using a converter. Receiver accommodations are provided for these converters which will be available in Heathkits soon. The "Mohawk" is specially designed for single-sideband reception with crystal controlled oscillators for upper and lower sideband selection. A completely preassembled, wired and aligned front end coil assembly assures ease of construction and top performance of the finished unit. Other features include five selectivity positions from 5 kc to 500 CPS, bridged T-notch filter for maximum heterodyne rejection, and a built-in 100 kc crystal calibrator. The set provides a 10 db signal-to-noise ratio at less than 1 microvolt input. Front panel features S meter, separate RF, IF and AF gain controls, T-notch tuning, T-notch depth, ANL, AVC, BFO, bandswitch, tuning, antenna trimmer, calibrate set, calibrate on, CW-SSB-AM, receive-standby, upper-lower sideband, selectivity, phone jack and a wide band rotating slide rule type vernier tuning dial with easy to read calibrations. Shpg. Wt. 90 lbs. \$50.00 required on C.O.D. orders. Shipped motor freight unless otherwise specified.



HEATHKIT
RX-1 **\$274⁹⁵**

Now in Kit Form a Top Quality Ham Band Receiver

- ★ PREWIRED AND ALIGNED FRONT END COIL ASSEMBLY.
- ★ CRYSTAL CONTROLLED OSCILLATORS FOR DRIFT-FREE RECEPTION.



HEATHKIT
B-1 **\$8⁹⁵**

Get Proper Match Between Transmitter and Antenna

BALUN COIL KIT

Unbalanced coax lines used on the most modern transmitters can be matched to balance lines of either 75 or 300 ohms impedance by using the model B-1 Balun Coil Kit. Can be used with transmitters and receivers without adjustment over the frequency range of 80 through 10 meters, and will handle power inputs up to 200 watts. Cabinet size is 10" square by 5" D. and may be located any distance from the transmitter or antenna. A protective cover is supplied to prevent damage in outdoor installations. Shpg. Wt. 4 lbs.



HEATHKIT
AM-2 **\$15⁹⁵**

Measure Standing Wave Ratio

REFLECTED POWER METER KIT

The match of your antenna transmission system can be checked by measuring the forward and reflected power or standing wave ratio from 1:1 to 6:1 with this fine unit. Designed to handle a peak power of well over 1 kilowatt of energy the AM-2 may be left in the antenna system feed line at all times. Band coverage is 160 meters through 2 meters. Input and output impedances for 50 or 75 ohm lines. No external power required for operation. Cabinet size is 7 $\frac{3}{4}$ " x 4 $\frac{1}{16}$ " x 4 $\frac{3}{8}$ ". Shpg. Wt. 3 lbs.



HEATHKIT
VX-1 **\$23⁹⁵**

Eliminates Hand Switching

ELECTRONIC VOICE CONTROL KIT

This unique device allows you to switch from receiver to transmitter merely by talking into your microphone. . . you get the advantage of "telephone-type conversation" as in single sideband but with regular AM transmission. The unit is adjustable to all conditions by sensitivity controls provided. A variable time delay control changes the "hold" time. Provision is made for receiver and speaker connections and also for a 117 volt antenna relay. Built-in power supply. Complete instructions provided. Shpg. Wt. 5 lbs.



HEATHKIT
PM-1 **\$14⁹⁵**

Quick Check of Transmitter Operation

RF POWER METER KIT

This self contained unit requires no power for operation. You simply place it close to the transmitter antenna to sample the RF field which is then indicated on the panel meter. Operates with any transmitter having an output frequency between 100 kc and 250 mc, regardless of power. Sensitivity is 0.3 volts RMS full scale, and a special control on the panel allows for further adjustment of the sensitivity. Measures 3 $\frac{3}{4}$ " W. x 6 $\frac{1}{4}$ " L. x 2" D. An easy way to put your mind at ease concerning transmitter operation. Shpg. Wt. 2 lbs.

HEATH COMPANY • a subsidiary of Daystrom, Inc. • Benton Harbor 15, Mich.



Choose from a wide variety of Heathkits

DUAL-CHASSIS 20 WATT HI-FI AMPLIFIER KIT



Model W3-AM
(Shpg. Wt. 29 lbs.)

\$49⁹⁵

12" UTILITY SPEAKER



Model 401-6
(Shpg. Wt. 7 lbs.)

\$7⁵⁰

ALL-BAND RADIO KIT

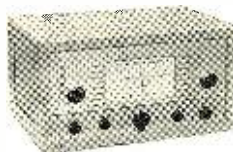

Model AR-3
(Shpg. Wt. 12 lbs.)

\$29⁹⁵
(less cabinet)

CRYSTAL RADIO KIT



Model CR-1
(Shpg. Wt. 3 lbs.)

\$7⁹⁵

BROADCAST BAND RADIO KIT



Model BR-2
(Shpg. Wt. 10 lbs.)

\$18⁹⁵
(less cabinet)

ELECTRONIC CROSSOVER KIT



Model XO-1
(Shpg. Wt. 6 lbs.)

\$18⁹⁵

"Q" MULTIPLIER KIT



Model QF-1
(Shpg. Wt. 3 lbs.)

\$9⁹⁵

"AUTOMATIC" CONELRAD ALARM KIT

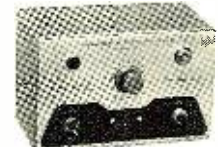

Model CA-1
(Shpg. Wt. 4 lbs.)

\$13⁹⁵

GRID DIP METER KIT



Model GD-1B
(Shpg. Wt. 4 lbs.)

\$21⁹⁵

VIBRATOR POWER SUPPLY KIT



6 volt Model VP-1-6
12 volt Model VP-1-12
(Shpg. Wt. 4 lbs.)

\$7⁹⁵
ed.

VARIABLE FREQUENCY OSCILLATOR KIT

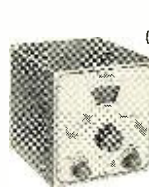

Model VF-1
(Shpg. Wt. 7 lbs.)

\$19⁵⁰

PROFESSIONAL RADIATION COUNTER KIT



Model RC-1
(Shpg. Wt. 8 lbs.)

\$79⁹⁵

ISOLATION TRANSFORMER KIT



Model IT-1
(Shpg. Wt. 9 lbs.)

\$16⁵⁰

ELECTRONIC SWITCH KIT



Model S-3
(Shpg. Wt. 8 lbs.)

\$21⁹⁵

REGULATED POWER SUPPLY KIT



Model PS-3
(Shpg. Wt. 17 lbs.)

\$35⁵⁰

VOLTAGE CALIBRATOR KIT



Model VC-3
(Shpg. Wt. 4 lbs.)

\$12⁵⁰

DIRECT-READING CAPACITY METER KIT

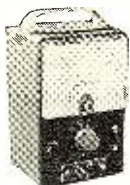

Model CM-1
(Shpg. Wt. 7 lbs.)

\$29⁵⁰

TUBE CHECKER KIT



Model TC-2
(Shpg. Wt. 12 lbs.)

\$29⁵⁰

EASY TIME PAYMENTS

AVAILABLE FOR YOUR CONVENIENCE...

Any order totaling \$90 or more can be paid for in small monthly payments (send for complete details).

RESISTANCE SUBSTITUTION BOX KIT



Model R5-1
(Shpg. Wt. 2 lbs.)

\$5⁵⁰

CONDENSER SUBSTITUTION BOX KIT



Model CS-1
(Shpg. Wt. 2 lbs.)

\$5⁵⁰

CATHODE RAY TUBE CHECKER KIT



Model CC-1
(Shpg. Wt. 10 lbs.)

\$24⁹⁵

LABORATORY RF GENERATOR KIT



Model LG-1
(Shpg. Wt. 16 lbs.)

\$48⁹⁵

"Q" METER KIT



Model QM-1
(Shpg. Wt. 14 lbs.)

\$44⁵⁰

DECADE CONDENSER KIT

Model DC-1
(Shpg. Wt. 3 lbs.)

\$16⁵⁰

DECADE RESISTANCE KIT



Model DR-1
(Shpg. Wt. 4 lbs.)

\$19⁵⁰

...to Fill Your Exact Needs

HEATHKIT

PORTABLE TUBE CHECKER KIT



Model TC-2P
(Shpg. Wt. 15 lbs.)

\$34.50

**TV PICTURE TUBE TEST ADAPTER*
FOR TC-2 AND TC-2P**



Model 355
(Shpg. Wt. 1 lb.)

\$4.50

BINDING POST KIT

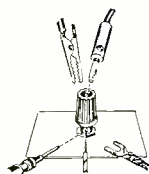

Model 362
(Shpg. Wt. 1 lb.)

\$4.00

BATTERY TESTER KIT



Model BT-1
(Shpg. Wt. 2 lbs.)

\$8.50

**ELECTRONIC IGNITION
ANALYZER KIT**



MODEL IA-1
(Shpg. Wt. 20 lbs.)

\$59.95

SCOPE PROBES

Scope Demodulator Probe Kit



Model 337-C
(Shpg. Wt. 1 lb.)

\$3.50

Low Capacity Probe Kit

Model 342
(Shpg. Wt. 1 lb.)

\$3.50

VTVM PROBES



30,000 Volt DC HV
Probe Kit No. 336
Shpg. Wt. 2 lbs. **\$4.50**



Etched Circuit RF
Probe Kit No. 309-C
Shpg. Wt. 1 lb. **\$3.50**



Peak-to-peak Voltage
Probe Kit No. 338-C
Shpg. Wt. 2 lbs. **\$5.50**

ENLARGER TIMER KIT



Model ET-1
(Shpg. Wt. 3 lbs.)

\$11.50

IMPEDANCE BRIDGE KIT



Model IB-2A
(Shpg. Wt. 12 lbs.)

\$59.50

**"LOW RIPPLE" BATTERY
ELIMINATOR KIT**



Model BE-5
(Shpg. Wt. 21 lbs.)

\$39.95

**ELECTRONIC ANALOG
COMPUTER KIT**

Fult Computer Group C

\$945.00



Write for free folder.

Free
Catalog

Send for this
informative
booklet
describing these
and many other
do-it-yourself kits.

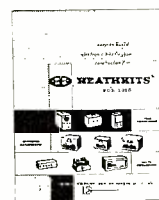

**ORDER DIRECT BY MAIL . . . from the
WORLD'S LARGEST MANUFACTURER**

OF ELECTRONIC INSTRUMENTS IN KIT FORM

Save 1/2 or more over equivalent ready-made products by buying direct and assembling them yourself. You gain priceless knowledge through complete and informative construction manuals.



HEATH COMPANY A Subsidiary of Daystrom, Inc. **BENTON HARBOR 15, MICH.**

**ORDER
BLANK**

NOTE: All prices and specifications subject to change without notice.

Enclosed find () check () money order for. Please ship C.O.D. () postage enclosed for _____ pounds.

On Express orders do not include transportation charges—they will be collected by the express agency at time of delivery.

On Parcel Post Orders include postage for weight shown. All prices are NET F.O.B. Benton Harbor, Michigan, and apply to Continental U.S. and Possessions only.

Name _____
Address _____
City & Zone _____ State _____
(PLEASE PRINT)

SHIP VIA
 Parcel Post
 Express
 Freight
 Best Way

QUANTITY	ITEM	MODEL NO.	PRICE
		POSTAGE	
		TOTAL	

SEND FREE Heathkit Catalog

UNBEATABLE!

SPAULDING

"STRATO-TOWER"

FEATURING THE

ALL NEW SCREW ANCHOR BASE

1. No Concrete Necessary
2. Completely Self-Supporting
3. Unconditionally Guaranteed
(Base more satisfactory than concrete or your money back)
4. Absolutely No Hole To Dig
5. Fast Installation . . . Base in 15 Min., Tower in 90 Min. (2 men)
6. One Base Fits All Tower Sizes To 48 Ft.
7. Tower Completely Galvanized
8. All Riveted Construction
9. Beaded Channel Leg (Will not rust inside like tubular type towers)

No. X40B (ILLUSTRATED)
40 FT. HIGH
LIST **\$99.95**

OTHER MODELS FROM 8 FT. TO 64 FT.

U. S. Patent No. 2806560

How
Tower
Mounts
On
Screw
Anchor
Base

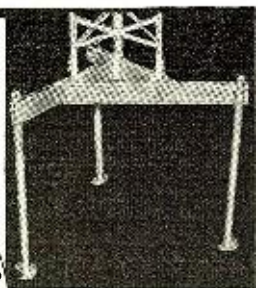

WRITE

today for complete literature and details on where to get Spaulding Strato-Towers for TV—Ham—Civil Defense—Industrial Communications.

SPAULDING PRODUCTS COMPANY

550 West Barner Street • Frankfort, Indiana

IN CANADA: Delhi Metal Products Co., Delhi, Ontario

Service Association of the Month



ASSOCIATED RADIO-TV SERVICEMEN OF N. Y.

TEN YEARS is a long time, as far as service-association life goes. Thus ARTSNY—Associated Radio-Television Servicemen of New York, Box 32, Brooklyn 32, New York—has every right to be proud of its history, which dates back more than a decade. Actual attempts at organizing the group date back to 1932. Lasting results were not achieved until 1947, when the founders finally saw their faith and perseverance justified. The group was incorporated the following year, becoming the first radio-TV service organization to achieve the status in N. Y. State.

Distinctive, if not unique, is the sys-

wishes to support the association activities, by virtue of a vocational or avocational interest. He is entitled to receive ARTSNY publications, attend special clinics, all open meetings, and certain lecture meetings, but he cannot use the organization's emblem, vote, or enjoy other membership benefits. With this broad base, ARTSNY has been able to pick up 450 interested members in New York City.

This organization elects officers every December. The present roster includes Marty Boxer, president; Max Liebowitz, executive secretary, Phil Goldfarb, treasurer; Peter La Presti,

Service Editor
RADIO & TV NEWS
1 Park Avenue
New York 16, New York

We want to tell you more about our association. Please send us your questionnaire.

Name of Association.....

Mailing Address

Name of President or Corresponding Sec'y.....

Would you like us to feature your association here? Send in the coupon!

tem of membership set up by this body of New York City service technicians and dealers. While most service associations tend to restrict membership to operators in business for themselves, ARTSNY, looking ahead to the future of service and the frequent injections of new blood that are inevitable, has established four classes of membership. An individual who has had at least four years of full-time professional experience and can pass written and oral tests is eligible to become a "technical member." On the other hand, anyone who maintains a service establishment may become a "business member" without a test.

No test is required for "apprentice membership," into which category fall those with less than four years experience, including students of electronics and graduates of schools. This grade of membership may not be retained for more than three years, at the end of which time the apprentice will usually have qualified for one of the two levels of membership already noted. If he has not, he reverts to the newest class of membership ARTSNY has set up, "associate membership."

The associate member is an individual who sympathizes with and

v. p., technical chapter; and Charles Edwards, v. p., business chapter.

Regular meetings are held on the third Thursday of every month, but this does not include the popular and practical TV service clinics held in member shops and other activities. The "ARTSNY Newsletter," official publication, appears once a month. The president and technical vice-president are its editors.

The ARTSNY "Code of Ethics," which each member must sign, sets forth the technical, business, and ethical obligations the service technician or dealer must observe with respect to his customers. Pioneered by the New York group, this code has been used as a model by a number of associations throughout the country.

Striving for increased interchange and cooperation among service associations, as well as between service and other aspects of the industry, ARTSNY has worked with or help set up many other groups. It is presently a member of the Empire State Federation of Electronic Technicians' Associations. Future plans call for an employment service, products testing, financial assistance to members, and group insurance.

—50—

RADIO & TV NEWS

Two-Band Converter

(Continued from page 61)

recommended that you add a coax fitting to the receiver antenna input and shield the regular antenna terminals if it is of the "doublet" type.

A word here about the tubes used. The author has found that a single *Western Electric WE-417A* provides enough sensitivity on 2 meters to outperform many of the commercial converters on the market. This converter uses a single 417A plate-neutralized triode in the 2-meter r.f. stage but a 6J4 or a 6AN4 may also be used, with a loss of perhaps 6 to 10 db of sensitivity. The noise figure is on the order of 2.2 db measured with a "Mega-Node" noise generator. The sensitivity measured .16 μ v. at 10 db down.

The 2-meter r.f. stage is neutralized with one of the filament leads disconnected and a signal of 146 mc. fed into the antenna connection from an r.f. signal generator. The neutralizing capacitor is tuned to minimum signal as indicated on an output meter across the voice coil of the speaker on the receiver.

The only unusual feature of the 50 mc. r.f. stage is the use of a 22-ohm swamping resistor in the grid circuit of the WE-404A. This tube has such a high g_m that this is the only way to make it settle down without a lot of extra shielding. A prototype model was built using shielding between the grid and plate circuits but it performed no better than the model with the above-mentioned resistor incorporated.

All cathode and "B+" bypass capacitors should be good quality disc ceramics. Particular attention should be paid to keeping the ground leads as short as possible to eliminate "current loops" which may cause unwanted oscillations and difficulties with neutralization of the 144 mc. r.f. stages. All other fixed capacitors should be good grade silver mica or ceramic. The resistors may be of any wattage from $\frac{1}{4}$ watt up and should have at least a 10% tolerance rating.

The power supply requirements for this converter are 125 volts at 50 ma. See Fig. 3. The transformer used in the power supply is a *Stancor* type PA-8421 which in addition to a 6X4 tube with both diode sections tied together in a half-wave circuit, a 40-40 μ fd., 150-volt filter capacitor, and a 1000-ohm resistor make up the entire power supply circuit.

Fig. 3. Circuit of the separate supply.

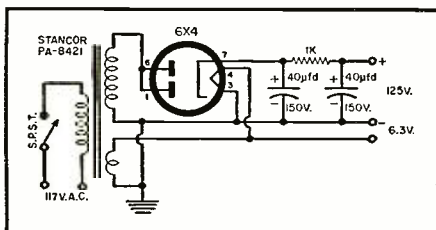

FABULOUS RADIO BARGAIN!

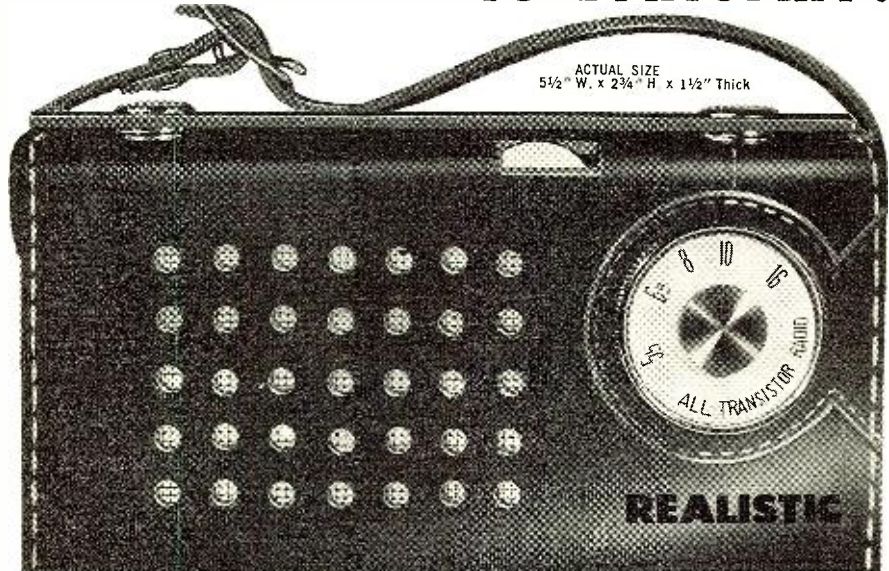

6 TRANSISTOR RADIO

Completely encased in top grain leather!

Equals or Exceeds \$40-\$50-\$60-\$70 Radios!

- ★ Free! Earphone and Jack, plus Built-in Speaker!
- ★ 6 Hi-Gain Transistors plus Germanium Diode!
- ★ Super-High Audio Gain: Drives Speakers to 12"
- ★ No Short-Life Flashlight Batteries! 1 Mercury Cell!

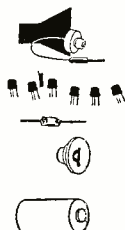

\$26⁹⁹

Radio: Q-6277
Ship. 3 lbs.

9V Battery
Q-2502 75c
Ship. 4 Oz.

Best-Performing, Best-Looking, Lowest-Priced 6-transistor set we've ever seen! Miracle Realistic "Little Six" defies comparison at twice the price! Has built-in loudspeaker, earphone with case, printed circuitry and more than enough audio output to drive 12" speakers! Sensitive ferrite antenna. Plays on one 9 V mercury cell or equal. Money-back guaranteed to be the best transistor radio value available!

RADIO SHACK CORP.

* Mail Orders: 157 WASHINGTON ST., BOSTON 3, MASS.
Stores: BOSTON, and 230 CROWN ST., NEW HAVEN, CONN.

RADIO SHACK CORPORATION

167 Washington St., Boston 3, Mass.

..... Send FREE 1958 Catalog

..... Q-6277 Radio @ \$26.99

..... Q-2502 Battery @ 75c

..... Check or M.O. Encl.

Name _____
Address _____
City _____ State _____ R-7

\$29.95
ppd

Send for it today!

NEVER BEFORE AT THIS LOW PRICE!

Precision, battery-operated
transistorized portable

TAPE RECORDER

Weights only 2 lbs. 8"x7"x2"
(imported from West Germany)

Preston-engineered—Records, plays back, erases. Variable speed controls. Operates on 4 ordinary C-batteries. Uses standard $\frac{1}{4}$ " 1-mil or $\frac{1}{2}$ -mil tape. Playback time about 15 min. Patented motor mount provides for forward and reverse winding; stopping with instantaneous braking action, taking up all slack tape; preventing tape from spilling. Voice can be dubbed and superimposed on music or other voice recording (and vice versa). Fine, durable, high-quality components. Complete instructions.

Serviceemen—Dealers! Every service call an easy sale after a simple demonstration. Renders same functions as machines costing many times as much.

Unconditionally guaranteed for 90 days against mechanical defects. 10-day money-back guarantee. RTN-7

FILNOR PRODUCTS CO. 1 Park Ave., N.Y. 16, N.Y.

What's

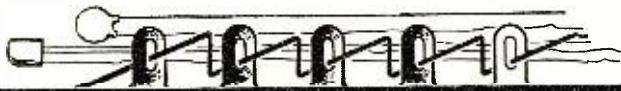
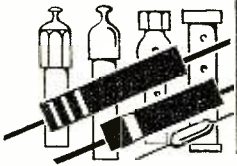

New in Radio

TINY POCKET RECEIVER

Stat, 9551 W. Pico Blvd., Los Angeles 35, Calif. is now offering a miniature all-transistor pocket radio receiver which retails for under \$20.00.

The receiver measures $3\frac{1}{2}$ " x $2\frac{1}{16}$ " x $1\frac{1}{8}$ " and weighs 5 ounces including the batteries. The circuit features a



"sensi-tuning" control plus a built-in antenna for maximum earphone volume. A booster lead is included for fringe area reception.

The receiver is housed in a modern, high-impact plastic case which is available in ivory, two-tone ivory with pink, ivory with charcoal, or ivory with turquoise.

For further details on this unit, write the manufacturer direct.

RUBBER COAT SPRAY

Electronic Chemical Corp., 813 Communipaw Ave., Jersey City, N. J., has recently introduced a new rubber coating which can be sprayed from a can.

The "No-Noise Rubber Coat Spray" produces effective insulation and complete protection for TV, radio, FM and auto wiring as well as for antennas. Among its features are insulation where applied; protection for indefinite time; prevention of arcing, shorting, and corrosion; and thorough waterproofing. The spray is non-inflammable and contains no plastic.

NEW PHOTOCONDUCTORS

Clairex Corporation, 50 W. 26th St., New York 10, N. Y., is now offering a complete line of small photoconductors which are available from stock.

The twelve units comprise a combination of four types of cadmium sulphide and cadmium selenide polycrystalline photoconductive materials with four types of enclosures—two in plastic and two in glass, with the glass types hermetically sealed.

A four-page folder lists the units, range of spectral response, resistance,

etc. on the line. Write the company direct for a free copy.

MYLAR CAPACITOR KITS

Cornell-Dubilier Electric Corporation of South Plainfield, N. J., has assembled a representative assortment of its "Mylar" tubular capacitors in a kit for the benefit of technicians handling TV, radio, and electronic service work.

The compact, clear plastic dispenser contains an assortment of 80 "PM" type capacitors in the most popular sizes, ratings, and quantities for quick and efficient servicing requirements. The technician pays only for the capacitors as the case is given free.

Information on either the kit deal or the complete "PM" line is available from the company's distributors or direct from the manufacturer.

TINY NEW G-E TUBES

A new low-noise military receiving tube which measures $\frac{1}{2}$ " long and $\frac{1}{2}$ " wide has been developed by the General Electric Company's receiving tube department, Owensboro, Ky.

The Type 7077 is a high-mu triode of planar construction intended primarily for use in grounded-grid circuitry in



communications, radar, and navigation equipment. The amplification factor is 80, power gain 14.5 db, and noise figure 5.5 db. It will operate at frequencies up to 1200 mc.

Sample quantities are being released to designers with production quantities available on request from the manufacturer.

TEMPERATURE CONTROLLER

The Control Devices Division of Minneapolis-Honeywell, 2747 Fourth Ave., South, Minneapolis, Minn. has developed a transistorized amplifier relay system for the remote control of temperature in industrial applications.

The low-cost system consists of a compact transistorized amplifier which serves as the temperature controller and a vibration-proof mounting containing a thermistor which acts as the sensing element. The thermistor mounting and relay can be located up to two miles apart.

Mountings for the thermistors are

available in a wide variety of sizes and shapes to fit any application. They can be as small as $\frac{3}{32}$ " of an inch in diameter by 2" long. The mountings can withstand blows from a hammer without damage to the sensing element.

The system, R7079A, has been accepted for listing by Underwriters' Laboratories.

PORTABLE "DYNA-QUIK"

B&K Manufacturing Co., 3726 N. Southport Ave., Chicago 13, Ill., is now

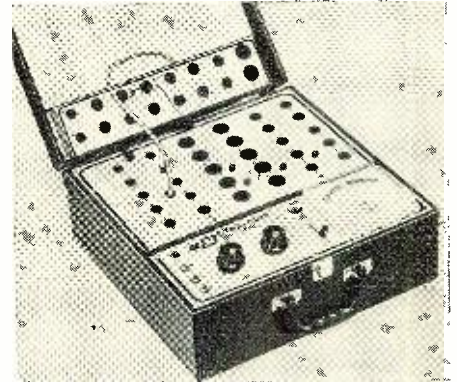

offering a portable version of its dynamic mutual conductance tube tester as the Model 500B.

The new instrument enables service technicians to quick-check most of the TV and radio tubes usually encountered in everyday service work. It makes a complete tube test in seconds, covering the average set in a few minutes. The "Dyna-Quik" tests tubes for shorts, grid emission, gas content, and leakage as well as measuring true dynamic mutual conductance.

A single switch operates the entire instrument. There is no multiple switching and no roll charts. The settings for the most popular tube types are listed on a quick-reference chart inside the cover.

Housed in a luggage-type leatherette-covered carrying case, the unit is easily portable. Bulletin TAD-18, available from the manufacturer, provides complete information on the unit.

NEW MOTOROLA MOBILE

The Communications and Industrial Electronics Division of Motorola Inc., 4501 W. Augusta Blvd., Chicago 51, Ill.,

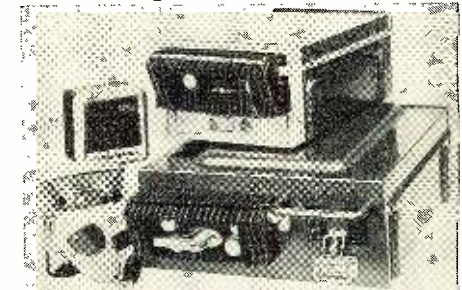

is now on the market with a 100-watt mobile radio which features a fully transistorized power supply.

Designed for operation in the 25-54 mc. band, the new unit incorporates four transistors to replace both the vibrator and dynamotor. Black-finned, highly effective heat sinks are used

to conduct heat from the externally mounted transistors for optimum operation.

The new "T-Power" radiophones can be operated from any 12-volt primary power source with either positive or negative ground. Models are available with a conventional noise squelch or with the company's exclusive "Dual-Squelch Private Line Circuit" which eliminates all co-channel nuisance messages as well as other interference.

For further information on the 100-watt unit as well as other models in the "T-Power" line, write Dept. T of the company.

PORTABLE CHECK TUBE

Sylvania Electric Products Inc., Seneca Falls, N. Y., has announced the release of a completely portable 110-degree television picture tube designed as a universal check tube.

The new tube is a 8" lightweight rectangular model which features automatic self-focusing and non-ion-trap



construction, factors which result in simplified application and considerable time saving.

As a safety feature and to achieve universality in application, no external conductive coating is used. This eliminates the need for discharging the tube before handling.

Designated as the Type 8YP4, the new tube comes in a distinctive carrying and storage carton with handle, making it ideal for use in the shop, truck, or home. It is equipped with a conventional base to withstand repeated connecting and disconnecting and a convenient adapter is supplied to convert the tube to a rigid pin base.

"FAST-CHECK" TUBE TESTER

Century Electronics Co., Inc., 111 Roosevelt Ave., Mineola, N. Y., has just released a new model of its "Fast-Check" tube tester to the service industry.

Known as the Model FC-2, the new unit tests any tube in ten seconds without the necessity for setting multiple switches or consulting a roll chart. Two settings enable the technician to check for quality, inter-element shorts and leakage, gas content, and life expectancy of over 600 tube types including TV tubes, CRT's, series-string TV tubes, 0Z4's, magic-eye tubes, gas regulators, special-purpose, hi-fi, and even foreign tubes. The instrument covers most of the ordinary tubes in use today.

Forty-one long-lasting phosphor-

bronze tube sockets accommodate all present and future tube types. A large d'Arsonval-type meter is extremely sen-

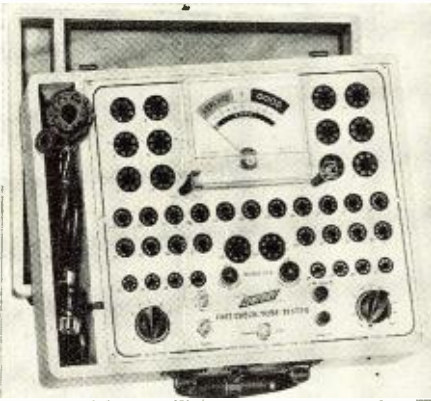

sitive yet rugged and fully protected against accidental burn-out. The tester is line-isolated and includes line voltage compensation. Pin straighteners for 7- and 9-pin tubes are mounted on the panel.

REACTANCE SLIDE RULE

Shure Brothers, Inc., 222 Hartrey Ave., Evanston, Ill. has just issued an improved, easy-to-read version of its reactance slide rule.

A single setting of the slide rule solves such problems as resonant frequency, capacitive reactance, inductive reactance, and coil "Q" and dissipation factor. The rule has been widely used for many years in schools and by radio technicians and electronic engineers. It is useful for solving problems of filter design, oscillator tank circuits, transformer design, amplifier design, coupling circuits, and frequency loss in microphone circuits due to additional cable lengths.

The slide rule, re-designed in red and black, is available for 75 cents if ordered direct.

COMPACT "TUBE-SAVER"

Wuerth Tube-Saver Corporation, 9025 Livernois, Detroit 4, Mich., has announced the availability of a new compact "Tube-Saver," the Model 125.

Designed to provide low-cost surge protection for TV, radio, and hi-fi equipment, the new unit will handle all elec-



tronic equipment drawing 100 to 275 watts, 117-volts a.c. or d.c.

The device limits the surge current until tube heaters are warmed sufficiently to accept full voltage without damage. In addition, "B+" voltages are temporarily held down to prevent cathode stripping.



NOW AVAILABLE
... a quality line of
exact replacement magnetic
tape heads ...

INCLUDING STEREO!

You owe it to your Customers-



5B20



5L20U



3L20S



5L20U



7EM12

TO INSPECT AND REPLACE RECORDING HEADS BEFORE TONAL BRILLIANCE IS LOST

In five-hundred hours or less of operation, high frequency response can fall off to a measurable degree due to the abrasive action of the tape passing over the head in the presence of normal amounts of dust in the air. If visual inspection discloses excessive wear on the active surface of the head, your customer will appreciate your replacing this unit with an MM head to enhance his listening pleasure and protect his tapes.

THE MICHIGAN MAGNETICS LINE . . .

NO.		LIST PRICE
5B20	Stereo	\$22.50
5B20LS	Stereo	22.50
10B20LS	Stereo	22.50
5L20U		8.50
3L20S		7.50
	Also replaces 2L35 & 2M40	
10L17		8.50
10L17S		7.50
	Also replaces 9L20S & 10M20A	
40EM12		6.00
7EM12		6.00

Order today

OR WRITE FOR ANY ADDITIONAL INFORMATION YOU MAY REQUIRE!



Michigan Magnetics, Inc.

VERMONTVILLE - MICHIGAN

DISTRIBUTOR INQUIRIES INVITED

HARVEY'S

MID-YEAR HAM EQUIPMENT SALE

HERE'S YOUR CHANCE

... to get the buy of your 'amateur' life. Harvey Radio Company, New York's leading Ham Center's mid-year sale is now on. Whether you're a ham who has pounded a key for years or one who has just received his novice license, this is a 'buy' opportunity. Each item has received W2DIO's careful attention—visual inspection, aircheck and equipment approval. Nothing has been overlooked to achieve your complete satisfaction.

MODEL	GONSET CONDITION	PRICE
3025B—2-Meter Communicator 6V.	New	150.00
3057B—2-Meter Communicator 12V.	New	175.00

HARVEY-WELLS		
T90—Mobile or Fixed Transmitter	Display Model	135.00
R9A—Mobile or Fixed Receiver	Display Model	125.00
CMA-50—Preamplifier	New	10.00

BARKER & WILLIAMSON		
5100 Transmitter	Display Model	320.00
650 Matchmaster	Display Model	39.50
651 Matchmaster	Display Model	39.50

SONAR		
120 M Transmitter	New	90.00

JOHNSON		
240-301-2 Pacemaker Transmitter	Display Model	395.00
240-500-2 500 Watt Transmitter	Display Model	750.00
240-102-2 Viking II	New	250.00

HALLICRAFTERS		
HT-31 Linear-Pair of Push-Pull 811's	New	295.00
HT-33 1-KW SSB Linear	Like New	625.00

ELDICO		
MD-40P 40-Watt Modulator Kit	New	35.00
SSB-500 1/2 KW Linear	New	395.00
SSB-100A Exciter-Transmitter	Like New	475.00

COLLINS		
32V-3	Like New	495.00
32V-2	Excellent	395.00
32V-1	Very Good	295.00

If your address is APO or FPO, you can be assured of the safe, rapid shipment of every Harvey product. From the time your order is received to its prompt delivery, every detail will be given our personal attention.



MAIL ORDERS SHIPPED
SAME DAY AS RECEIVED

Established 1927
HARVEY RADIO CO., INC.

103 West 43rd St., New York 36, N. Y.
JUdson 2-1500

New Tube Tester Data

Additional settings for new tubes and picture tubes to add to your Allied Knight-Kit testers.

KNIGHT-KIT MODELS 83YX142 AND 83YX143

TUBE TYPE	A	B	C	U	D
2B3	3	2	100	0	2
	(Good tube reads 10)				
2B5-Tests 1-2	1-1	2	22-22	13-68	45-45
3BN4	2	3	20	27	136
4BC8	2	4.2	20	12	34
4BC8-Test 2	2	4.2	20	67	48
5BE8	2	5.0	20	12	35
5BE8-Test 2	2	5.0	20	679	358
5BQ7A	2	5.0	19	12	34
5BQ7A-Test 2	2	5.0	19	67	48
5BZ7	3	5.0	19	12	34
5BZ7-Test 2	3	5.0	19	67	48
5CL8	2	5.0	21	12	34
5CL8-Test 2	2	5.0	21	679	48
6BA8A	3	6.3	20	23	14
6BA8A-Test 2	3	6.3	16	789	46
6BUS	1	6.3	20	2789	15
6BUS-Test 2	1	6.3	20	2367	15
6BV8	2	6.3	20	23	15
6BV8-Test 2	1	6.3	60	9	57
6BV8-Test 3	1	6.3	60	6	58
6CM7	2	6.3	22	18	59
6CM7-Test 2	2	6.3	24	67	35
6CW5	3	6.3	16	126789	34
9AU7	2	5	23	12	345
9AU7-Test 2	2	5	23	67	458
12AB5	3	12.6	23	1368	57
12AC6	1	12.6	21	256	47
12AD6	1	12.6	32	6	12357
12AD6-Test 2	1	12.6	32	567	123
12AE6	1	12.6	22	17	23
12AE6-Test 2	1	12.6	40	6	23
12AE6-Test 3	1	12.6	40	5	23
12AF6	1	12.6	34	56	1237
12AJ6	1	12.6	20	17	23
12AJ6-Test 2	1	12.6	38	6	23
12AJ6-Test 3	1	12.6	38	5	23
12AL8	1	12.6	22	1	59
12AL8-Test 2	1	12.6	38	26	357
ECC81	2	6.3	21	12	39
ECC81-Test 2	2	6.3	21	67	89
ECC82	2	6.3	25	12	39
ECC82-Test 2	2	6.3	25	67	89
EZ81	3	6.3	20	1	34
EZ81-Test 2	3	6.3	20	7	34

Picture Tubes*:

21ACP4A/AMP4A	1	6.3	21	26	78
21ALP4A	1	6.3	21	26	78
21AMP4A	1	6.3	21	26	78
21ATP4	1	6.3	20	256	78
21ATP4A	1	6.3	21	26	78
21AUP4A	1	6.3	21	26	78
21AVP4A	1	6.3	21	26	78
21ZP4B	1	6.3	21	26	78
24CP4A	1	6.3	24	26	78
24DP4A	1	6.3	21	26	78

*These new picture tubes can be checked on the Knight-Kit Tube Checkers when used with the 83Y141 Picture-Tube Adapter. The instructions supplied with the adapter apply to these settings.



The data that launched thousands of careers is yours FREE

► TELLS how you can be successful in **ELECTRONICS . . . including:**

Servomechanisms . . . Computers . . . Radar . . . Automation . . . Aeronautical Electronics . . . Broadcasting . . . Communications and Manufacturing, and the Electronic Principles Associated with Guided Missiles, Telemetry, Astronautics, and Instrumentation.

Send for your Free Copy today!

This is a brand new edition of the book which has launched thousands of men on good-paying careers in radio-TV-electronics.

It brings you completely up to date—answers important questions on newest career developments in electronics, including Radar, Guided Missiles, Servomechanisms, Computers, as well as Aeronautical Electronics, Broadcasting (AM, FM, TV), Military, Navy and CAA Electronics, Communications and Electronics Manufacturing.

This book, "Your Future in the New World of Electronics," also shows you how CREI Home Study leads the way to greater earnings in the booming electronics world.

However, CREI does not promise you a "snap." With accredited technical school curricula such as CREI offers, you must study to convert your ambition into technical knowledge which you can sell in the fabulous field of Electronics. Since its founding in 1927, CREI has provided thousands of professional electronics men with technical education. During World War II, CREI trained thousands for the Armed Services. Leading firms recommend CREI training for their own personnel. Among them: United Air Lines, Canadian Broadcasting Corporation, Trans-Canada Airlines, Douglas Aircraft Co., The Martin Co., Columbia Broadcasting System, All-American Cables and Radio, Inc., Gates Radio Co., Canadair, Ltd., Federal Electric Corp., and U. S. Information Agency (Voice of America).

CREI courses are prepared by recognized experts, in a practical, easily understood manner, and constantly revised to meet the new electronic challenges of our time. You get the benefit of time-tested study assignments under the personal supervision of a CREI staff instructor. Your studies are accomplished on your own time, during hours selected by you, and controlled by your own willpower. This complete training is the reason that graduates find their CREI diplomas keys-to-success in even the most advanced of electronic applications. CREI alumni hold top positions in America's leading firms. At your service

is the CREI Placement Bureau, which maintains constant contact with electronic industry, and cooperates with employers and graduates in making satisfactory placements. This free service is available to students, as well as graduates. Fill out the coupon below completely and mail it now. We'll promptly send you your free copy of "Your Future in the New World of Electronics." The rest—your

future—is up to you!

CREI also offers residence training in Washington, D.C. at the same high technical level. Day and evening classes start at regular intervals. Qualified residence school graduates earn degree as "Associate in Applied Science." Check coupon if you prefer residence or home study information . . . or write, Capitol Radio Engineering Institute Dept. 117Y, 3224—16th Street, N.W. Wash. 10, D. C.



VETERANS: If eligible for training under the new G.I. Bill of Rights, check the coupon for full information.

INDUSTRY CALLS FOR CREI TRAINING BY NAME . . . SO SHOULD YOU!

← Here you see an actual help wanted ad from the *San Francisco Examiner*, one of many which specify "CREI or equal" training. This shows that industry approves CREI training, even insists on it.

FILL OUT AND MAIL TODAY—BEFORE YOU FORGET IT!

CAPITOL RADIO ENGINEERING INSTITUTE

ECPD Accredited Technical Institute Curricula—Founded 1927
Dept. 117-Y, 3224 16th St., N.W., Washington 10, D. C.

Please send me your course outline and FREE illustrated Booklet "Your Future in the New World of Electronics" . . . describing opportunities and CREI home study courses in Practical Electronic Engineering Technology.

- CHECK FIELD OF GREATEST INTEREST
- Radar, Servo and Computer Engineering Technology
 - Electronic Engineering Technology
 - Broadcast (AM, FM, TV) Engineering Technology
 - Television Engineering Technology
 - Aeronautical Electronic Engineering Technology

Name _____ Age _____
 Street _____
 City _____ Zone _____ State _____
 Check: Home Study; Residence School; Korean Vet

If you have had a high school education, and experience in electronics—and realize the need of a high-level technical knowledge to make good in the better electronic jobs—you can qualify for CREI home study training. (Electronics experience is not required for admission to CREI Residence School.) Please fill in the following information.

EMPLOYED BY _____
 TYPE OF PRESENT WORK _____
 EDUCATION:
 YEARS HIGH SCHOOL _____
 YEARS COLLEGE _____
 ELECTRONICS EXPERIENCE _____

Automatic Motor Control For Hi-Fi Turntables

By **GEORGE F. ANDREWS**

Sound-operated relay, with adjustable delay, turns off phono motor if audio is missing for more than 15 seconds.

MOST owners of manual hi-fi turntables, while well satisfied with the wowless, rumble-free operation obtained, have probably encountered the same problem as the author, *i.e.*, after placing a 12-inch LP album on and settling back to enjoy the pleasant sounds, a sudden distraction such as the telephone, children's squabble, wife, etc., calls you away.

Thinking you will surely return before the album is finished, you depart. Forty-five minutes later, you suddenly remember that the machine is still running and you hurry back to find the needle grinding its life away on the last groove. Having repeated this scene numerous times, the device to be described evolved. Before the final design was adopted, the possibility of using a photocell circuit to shut off the turntable was investigated; but, due to the difference in location of the final groove on different sizes and brands of recordings, it was ruled out, and the following system was devised.

In effect, it is a sound-operated relay, with an adjustable delay time, which is set to turn off the turntable motor if the audio signal is missing for more than fifteen seconds. This allows the device to distinguish the

pauses between selections on an album from the actual end of the recording. One toggle switch is the only operational control and its function is to select either the *automatic* feature or normal *manual* operation of the turntable motor.

One of the main requirements was that the control should involve no direct connections to the amplifier, since a true hi-fi addict will tolerate nothing which might load or alter the response of his equipment. Thus, it was decided to use "air coupling," the necessary signal being picked up by a four-inch PM speaker placed inside the existing enclosure, at the same time insuring that extraneous room sounds do not prevent the relay from operating.

A transistor preamp was desirable, but the use of batteries in any form was not, since the unit should be able to be installed and then require no further attention. Therefore, the transistor stage is operated from a simple internal power supply. The switching is done by a 2D21 miniature thyatron with d.c. on its plate so that, once fired, it will remain conducting until the operator restarts the motor.

Use is made of standard, inexpensive parts throughout and after three

months of daily use, operation is still positive and without fault. Referring to the diagram, circuit operation is as follows: When the hi-fi system is playing, a small signal is picked up by the PM speaker "mike" and applied through T_1 (an ordinary a.c.-d.c. radio audio output transformer, 2500 ohms-to-voice coil, connected in reverse) to the base of the transistor. This stage is used in the grounded-emitter configuration which results in a low input impedance for a correct match to T_1 . Circuit constants are chosen so that limiting occurs in this stage in order to present a constant level output to the following stage, thus insuring that the delay time remains the same for different listening levels. The transistor output is coupled through T_2 (a standard 1:3 midget interstage audio transformer) to the diode and thence to the RC circuit in the grid of the thyatron.

Here the amplified, limited signal is rectified by CR_1 and negatively charges C_3 to hold V_2 cut off. Should the incoming signal cease, C_3 starts to discharge through R_2 (which is adjustable to cover a range of zero to approximately 35 seconds delay) and when the grid potential decays to -2 volts, the thyatron conducts and closes RL_1 , in turn operating RL_2 , which stops the turntable motor. V_1 remains conducting until S_1 is opened, thus restoring the circuit to its original condition and restarting the motor.

The power supply is a conventional half-wave selenium type, and the transistor "B-" (*p-n-p* transistor) is obtained by rectifying the 6.3-volt thyatron filament supply with a 1N34 diode and its associated filter capacitor. Almost any available plate relay can be used for RL_1 , since the limiting factor would be the current capability of the power supply used. With the 125-volt supply shown, the 15,000-ohm plate load resistor limits the current to approximately 15 ma., which is the rating of the midget power transformer used. The two NE-2 lamps are for pilot lamps only and are not necessary for proper circuit operation. Wiring is not critical and the unit may be built with ease on a 2" x 4" x 6" chassis.

After construction the first adjustment is the proper placing of the pickup speaker in the enclosure to insure adequate signal at normal listening level to limit in the transistor stage. This can be observed with an oscilloscope at the collector of the CK722, or with a v.t.v.m. on the grid of V_2 . If the latter method is used, the pickup speaker should be placed close enough to the hi-fi speaker so that increasing the volume no longer increases the bias. The final adjustment is with R_2 to set the delay time. Fifteen seconds has been found best to cover all types of musical selections without premature operation of the relay.

The switching circuit of this device could easily be altered to turn off the whole system or perhaps control some other useful function. Its adaptability to other equipment will be left to the ingenuity of the reader.

Complete schematic diagram and parts listing for the automatic motor control unit.

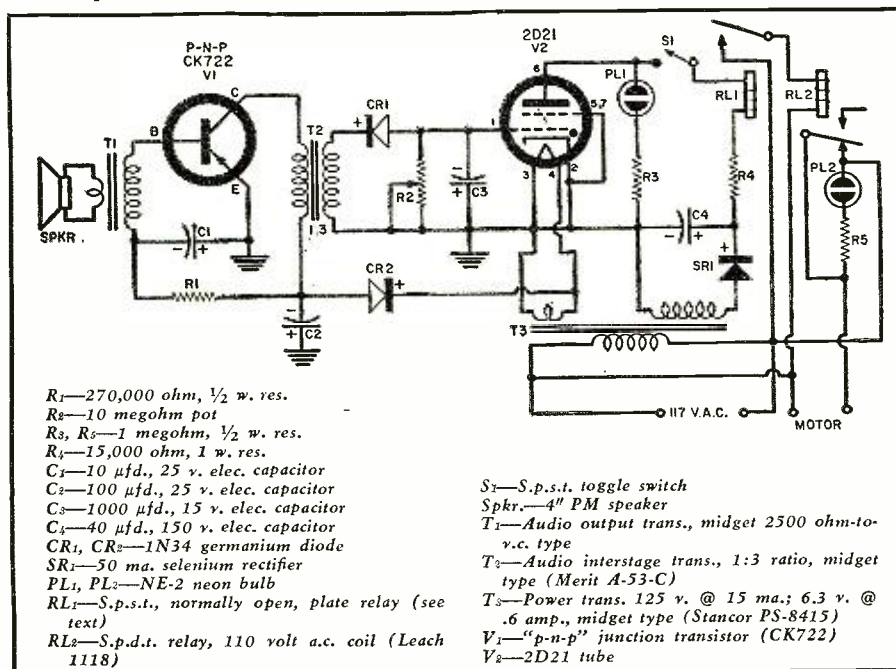

Stereo Control Center

(Continued from page 38)

operation. See Fig. 1 for a complete schematic diagram of the unit.

It has provision for five separate inputs: magnetic (turntable), magnetic (record changer), tape, tuner, and auxiliary. Three separate outputs are provided: tape and two audio in parallel. The basic controls are volume and "on-off" switch, bass, treble, and selector-equalizer. The eight-position selector-equalizer switch has several functions. It selects the signal source (changer, turntable, tape head playback, radio tuner, or auxiliary). It also serves as a four-position equalization switch for record playback (RIAA with rumble filter, RIAA, pop, and flat), or it selects equalization for 3.75, 7.5, or 15 ips tape playback.

The over-all sensitivity for 1 volt output for phono and 3.75 ips tape is .00062 volt: auxiliary and tuner, .182

volt: and 7.5 and 15 ips tape, .00115 volt.

Hum and noise for all inputs, either shorted or open, is approximately -55 db from a 1-volt reference.

The frequency response at the 1-volt output level is ± 6 db from 20 to 15,000 cps.

Bass control provides a variation of -14.4 db and +15 db at 30 cps.

The treble control provides a variation of -17.2 db and +9.6 db at 15,000 cps.

RIAA equalization is within $\pm .25$ db from 30 to 15,000 cps of the standard.

Both the IM and harmonic distortion figures came out especially low. For tuner input with 1 volt applied and 1-volt output, the IM distortion is .09%. With a .5-volt input and 2 volts output the IM is .125%. The harmonic distortion, taken under the same input and output conditions as for IM distortion, is .13% and .15% respectively at 20 cps; .12% and .18% respectively at 20,000 cps; and .09% and .14% respectively at 1000 cps.

Fig. 2. Complete wiring diagram of the tubeless stereo converter, Model 247.

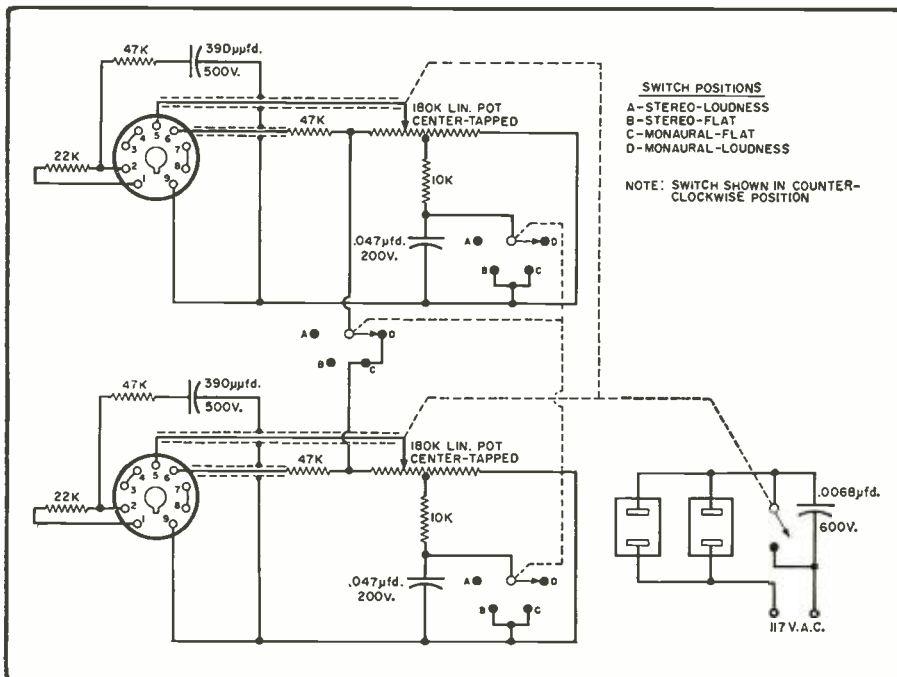

View of one of the preamplifiers with cover removed. The adapter plug shown in the top left-hand corner makes the proper internal wiring connections for monaural operation. For stereo this plug is removed and the interconnecting cable completes the circuit for stereo operation.

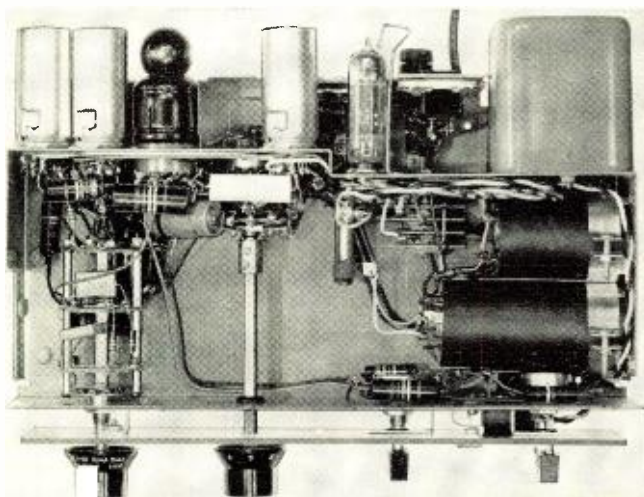

HOW TO BUILD A Transistorized 40-watt supply

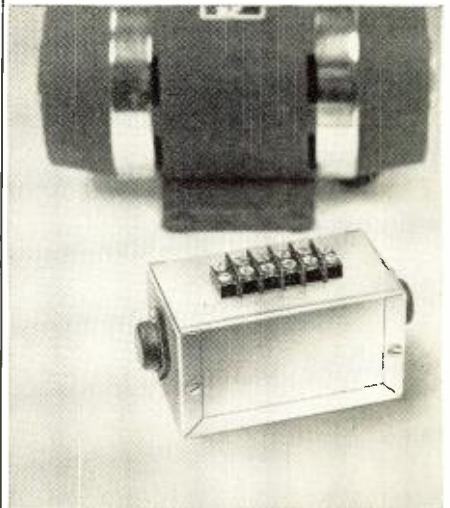

Easy to build, this modern power supply is as big in performance as it is little in size. Two CBS 2N256 power transistors, operating from a 12-volt battery, deliver 450 and 250 volts simultaneously. Combined output is 40 watts continuous service.

Features: compact and light... 85% efficient... instant-starting... cool-running... long-lived. No moving parts... vibrationless, noiseless and troublefree. You'll find this supply ideal for mobile or portable transmitter and/or receiver, sound system, etc.

Free Bulletin E-279 gives complete how-to-build-it details. Get it today with your 2N256 transistors from your CBS Tube distributor.



2N256...\$1.50
 2N255...\$1.35

CBS-HYTRON

Semiconductor Operations, Lowell, Mass.
 A Division of
 Columbia Broadcasting System, Inc.



You can have this

ILLUSTRATED
FREE BOOK
32 page



Shows You — Tells You
about the wonderful career opportunities
in the world's fastest growing
interdependent industries:

• **AERONAUTICS**
• **ELECTRONICS**

Tells how you can take your place in a surprisingly short time, at Big Pay and with a Future Unlimited, alongside the hundreds of successful Northrop graduates. They are employed by many of the country's leading companies on such projects as:

**Electronic Computer Planning,
Missile Flight Test Engineering,
Design of Servomechanisms,
Design of Rocket Powerplants,
Celestial Guidance Systems,
and many more.**

It will cost you nothing but a postage stamp to find out about the wonderful future open to you, and about the great demand for Northrop Institute graduates.

APPROVED FOR VETERANS



Northrop
Aeronautical Institute
An Accredited Technical Institute
1185 W. Arbor Vitae Street
Inglewood 1, California

NORTHROP AERONAUTICAL INSTITUTE
1185 W. Arbor Vitae Street, Inglewood 1, Calif.
Please send me immediately the Northrop catalog, employment data, and schedule of class starting dates. I am interested in:

Electronic Engineering Technology
 Aeronautical Engineering Technology
 Aircraft Maintenance Engineering Technology
 Master Aircraft and Engine Mechanic
 Jet Engine Overhaul and Maintenance

Name..... Age.....
Address.....
City..... Zone..... State.....
Veterans: Check here for Special Veteran Training Information.



DURING the months immediately ahead, some of the service industry's leading annual gatherings will take place. The best known of these popular service conventions are the annual clinic and fair sponsored by the Texas Electronic Association and the national NATESA convention. Dallas, Texas, will be the host city for the T. E. A. fair, while delegates to the NATESA convention will meet in their headquarter city of Chicago.

Both of these annual affairs will feature leading industry figures as speakers at their technical and business forums and panels. The subject matter covered at each of the sessions will be the result of careful selection by service-committee members to insure that all subjects will be of timely and specific interest to electronic service dealers and technicians.

The professional manner in which these conventions are handled is an excellent criterion of the growth in business stature that has occurred in the independent service industry during the past ten years. Another measure of this remarkable growth is the uniformly high caliber of the men who take time away from business to attend these important events.

Among the noteworthy changes that have occurred with service dealers during the past decade is the steadily growing willingness to discuss actual business operating problems with competitors. This one development alone has done much to raise the sights of dealers on the practical aspects of running their service shops as businesses. Obviously this development is due entirely to the efforts of dealers working in their local associations. When they found that their first cautious efforts in discussing their problems paid off handsomely in the dividends of factual ways to handle them, they willingly broadened the scope of the personal business-management problems they presented for discussion at their meetings.

Another indication of this progress of service as an industry has been the gradual acceptance of the truth that issues can be debated without attacking the personalities involved. Dealers have come to recognize and accept the fact that much of the TV service industry's bad public reputation is due to the poor business and public-relations practices of the dealers themselves. Out of this recognition has come association programs that are designed to improve the customer-relations practices of member shops.

Dealers who have never attended one of these service-sponsored major

clinics, fairs, or conventions are delightfully surprised at the wealth of information they acquire when they participate in their first one.

TSA Re-names Heinzman

With the re-election of Karl Heinzman of *H & M Television* as president for another year, the Television Service Association of Michigan changed its bylaws to establish five distinct districts in its area, with each district headed up by a vice-president.

Each of these five TSA districts will hold its own monthly luncheon meeting. The purpose of the new plan is to provide a "grass roots" approach to the problems of the individual areas in Detroit and suburbs—problems that are often peculiar to a given area. It is hoped the area meetings will result in a larger turnout of members and also encourage members to bring up and discuss problems they might hesitate to broach at larger, general membership meetings.

The change also enables TSA to name additional vice-presidents in districts that may subsequently affiliate with the association. It would allow dealers in suburban and neighboring small communities to become a part of TSA, if they so desire, and have their own vice-president representing them on the board of directors. All officers, including the new vice-presidents, are automatically board members. The board also named new heads for TSA's standing committees.

New officers, in addition to Mr. Heinzman, are: Samuel J. Mooney of *General Television Labs.*, secretary, and Mike Dallen of *Dallen Television*, re-elected treasurer.

The five new vice-presidents and their districts are: Southwest—Steve Raboczky of *Southwest Radio & Television Lab.*; Northwest—Charles D. Judd of *Judd Electronics*; North—Tom Taber of *Taber Radio & Television Service*; East—Edward J. Brown of *Visual Electronics*; and Central—Charles March of *Vutronic Electronics*.

The members selected to head standing committees are: Association Activities—Isa Katuah of *New Center Electronics*; Public Relations—Eugene Zecman of *Personalized Television Service*; Industrial Relations—John Keppinger of *Grosse Pointe Radio & Television*; and Educational—Dan Fodor of *Fodor Radio & Television*.

Mr. Heinzman also appointed Hal Chase of *Chase Television* to head the TSA Grievance Committee, a post which must be held by a former TSA president. Mr. Chase was also retained

as editor of the monthly "TSA News."

ESFETA Elects

Robert Larsen of *Windsor TV Service*, Rosedale, N. Y., was elected president of the Empire State Federation of Electronic Technicians Associations, Inc., at their recent annual meeting.

Other officers named to serve during the coming year include Irving J. Toner of Buffalo, as vice-president; George Carlson of Jamestown, as secretary; Dan Hurley of Syracuse, as treasurer; and Frank Kurowski of Mohawk Valley, as sergeant-at-arms.

Atlanta Election

In its recent annual election, the members of the Radio-Television Service Association of Greater Atlanta, Inc., selected Kermit M. Smith of *Decatur Radio & Television Service*, to serve as president for the coming year. The retiring president, Joe Mull of *Mull Television Service*, was elected treasurer of the association.

Other officers elected include: L. J. Webber of *Webber's Radio & Appliance Co.*, first vice-president; W. H. Steed the *Radio Doctor*, second vice-president; M. Daniels of *Fulton Appliance Service*, third vice-president; and Pierce McGee of *McGee's Television & Radio Service*, secretary.

Members elected to the Board of Directors include: Red Tarsa of the *Riteway Television Co.*, chairman; Marvin Cochran of *Atlanta Electronic Service*; W. T. Edwards of the *Radio-Television Co.*; and Arthur Powell of *Powell Electronics*.

Elkhart, Ind. Officers

Wayne Clem of Elkhart, Indiana, was recently elected president of the Television Bureau of Elkhart at their annual meeting. Named to serve with him were: Willis Roberts of *Suburban Radio & Sound*, as vice-president; Harry Carmien of *Carmien's TV*, as secretary; and Dean R. Mock, of *Mock's TV*, as treasurer.

Members elected to serve on the Board of Directors include: Wilbur Wenger of *Wenger's TV*; John Gray and Floyd Menges of *Acme-Gray TV*; and Lamarr Zimmerman, Jr., of *Zimmerman's Service, Inc.*

MARDA of Muskegon

In a spirited election, members of MARDA of Muskegon elected a twelve-man Board of Directors to guide the association during the coming year.

Members selected to serve on the Board include: C. Ashley, R. Warner, F. Mayo, and D. McPhall, for three-year terms; C. Nienhuis, G. Mihalovits, J. Sienkiewicz, and M. Greisback, for two-year terms; and J. Kelley, K. Stults, N. Sargent, and J. Van Randwyck, for one-year terms.

The board named the following of its members to handle the executive positions: C. Ashley, president; R. Warner, vice-president; D. McPhall, secretary; and J. Sienkiewicz, treasurer.

Just 2 settings on the NEW

Model FC-2

FAST-CHECK TUBE TESTER

tests over 600 tube types completely accurately... **AND IN SECONDS!**

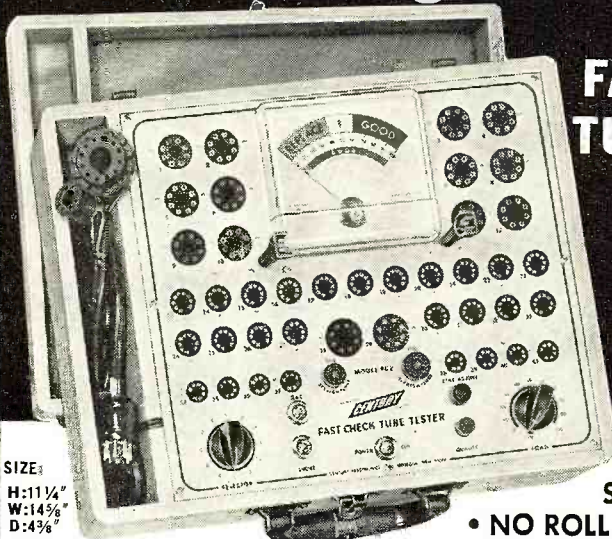

SIZE:
H: 11 1/4"
W: 14 5/8"
D: 4 3/8"

NEW Special compartment to accommodate line cord and CRT Test Adapter cable

CANNOT BECOME OBSOLETE

Engineered to accommodate all future tube types... new tube listings furnished periodically.

TRY THE FC-2 BEFORE YOU BUY IT!

Shipped on approval for **FREE 10 day trial... No obligation to buy**

EASY TO BUY IF YOU'RE SATISFIED!

Pay in small monthly payments at net cash prices... **no financing charges**

MODEL FC-2—housed in rugged oak carrying case complete with CRT adapter, tube listings... only **\$69.50** Net

GUARANTEED FOR 1 FULL YEAR

This extremely low price is made possible only because YOU ARE BUYING DIRECT FROM THE MANUFACTURER

• NO MULTIPLE SWITCHING
• NO ROLL CHART CHECKING

The FAST-CHECK enables you to save valuable time and eliminate unprofitable call backs. You earn extra money and win confidence by showing your customer the actual condition and life expectancy of the tube on the large meter scale of the FC-2. The extra tubes you will sell each day will pay for the FAST-CHECK in a very short time.

WIDE RANGE OF OPERATION

- Checks quality of over 600 tube types... more than 99% of all TV and radio tubes, including the newest series-string TV tubes, auto 12 plate-volt tubes, OZ4s, magic eye tubes and gas regulators.
- Checks inter-element shorts and leakage.
- Checks for gas content.
- Checks for life expectancy.

IMPORTANT FEATURES

- ✓ Checks each section of multi-section tubes and even if only one section is defective the tube will read "Bad"
- ✓ 41 long lasting phosphor-bronze tube sockets accommodate all present and future tube types—cannot become obsolete
- ✓ Less than 10 seconds required to test any tube
- ✓ Large D'Arsonval type meter is extremely sensitive yet rugged—is fully protected against accidental burn-out
- ✓ Line isolated
- ✓ 7-pin and 9-pin straighteners conveniently mounted on panel
- ✓ Quick reference tube chart lists over 600 tube types
- ✓ Line voltage compensation

NEW A specially designed PICTURE TUBE ADAPTER cable is now part of the FC-2... making it a highly efficient CRT Tester-Rejuvenator. This feature eliminates the need of carrying extra instruments and makes the FC-2 truly an all-around tube tester. The adapter enables you to check all picture tubes (including the new short-neck 110 degree picture tubes) for cathode emission, shorts and life expectancy... also to rejuvenate and restore cathode emission of weak picture tubes.

"You've really made tube testing a snap"... "I've almost got the cost of the Fast-Check paid off with the extra money I've made, and it's only 2 weeks since I received it"... "It's easier to use than you said"... "I wouldn't ever want to be without it"... "I use it in the shop and take it along on every call!"

WHAT SERVICEMEN* are SAYING ABOUT THE FC-2

*Names on request

MAIL COUPON NOW—NO MONEY REQUIRED WITH ORDER

CENTURY ELECTRONICS CO., INC. 111 Roosevelt Avenue Dept. 207, Mineola, N.Y.

Please rush the new Model FC-2 FAST-CHECK TUBE TESTER for a 10 day trial period. If I am not completely satisfied I will return the instrument within 10 days without further obligation. If fully satisfied I agree to pay the down payment within 10 days and the monthly installments as shown. No financing charges are to be added. Should I fail to make payment when due, the unpaid balance shall become due and payable at once.

BUDGET TERMS: Pay \$14.50 within 10 days after receipt of instrument. Balance \$11.00 monthly for 5 months, plus shipping charges.

PREPAID TERMS: Enclose \$69.50 with coupon as payment in full and Century will pay all shipping costs. 10 day money-back guarantee.

Name.....

Address.....

City..... State.....

ABSOLUTELY NO RISK ON YOUR PART

LIQUIDATING MOBILE RADIO EQUIPMENT

Manufactured by the famous
LINK RADIO CORP.

TYPE 2210 FM MOBILE EQUIPT.

152-162 MC FOR 6 V. OPERATION
Current Regulations, Phase Modulation
FM Transmitter-Receiver with 6 V. Power Supply mounted in a single case 17" L x 8" W x 6" H. Power output 6 V.: 10-15 watts; 12 V.: 15-20 watts. A single power supply furnishes plate current alternately to both the transmitter and receiver. In one compact unit are included all the necessary control features, volume control, squelch adjustment, receiver and transmit pilot lamps and primary fuse. Universal mounting facilities permit installation in almost any desired location. Used, checked out, ready for operation with cables, accessories and antenna (as illustrated below) **\$129.50**
Crystals & 12 V. Conversion Kits Available.

TYPE 2365 FM MOBILE EQUIPMENT

25-40 or 30-50 MC FOR 6 V. OPERATION
Current Regulations, Phase Modulation
Same specifications as 2210 above, except freq. range 25-40 Mc. Power output 6 V.: 30 watts; 12 V.: 35-40 watts. Used, checked out, ready for operation with cables and accessories (as illustrated at left) less antenna... **\$99.50**
Crystals, antennas & 12 V. Conversion Kits Avail.

ORDER TODAY AT THESE SENSATIONAL LOW PRICES!

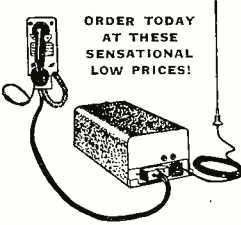

Crystals, antennas & 12 V. Conversion Kits Avail.



FM MOBILE EQUIPT.—TYPE FMTR FOR 6 VOLT OPERATION

Complete assembly designed for mobile 2-way communication on the 20-44 Mc band. Consists of Radio Transmitter 55-UFM, Power Supply Type VPA-3A, Radio Receiver Type 11-UF, and accessories (less antenna assembly) for accomplishing an operating 2-way mobile communication system. Designed normally to derive all its primary energy from 6-volt, 3-cell lead storage battery. Used checked out with cables & accessories. **\$99.50**
less antenna...
Crystals, antenna, 12 V. Conversion & PMC Kits. (Write for detailed description or see our Radio News ad, June/58 Issue.)

6V FMTR EQUIPMENT

Removed in working condition from one of our larger law enforcement agencies. With cables & controls. Less tubes and crystals. **\$59.50**
Used, as is...

BC-221 Frequency Meter

Real Value! QUANTITY IS LIMITED—so first come first served. They are just like new, with original calibration charts. Range 125-20,000 KC with crystal check points in all ranges. Complete with crystal and tubes. **\$119.50**
MODULATED TYPE \$139.50
MODULATED TYPE with AC Power Supply 159.50
These Frequency Meters are factory tested, checked for frequency alignment and GUARANTEED.

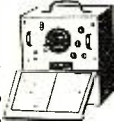

J-38 KEY

Mounted on black bakelite base, 4 3/4" x 3", easily attached to operating desk. Has jumper strip, binding posts and circuit closing switch; full adjustable, 1/16" solid silver keying contacts. Metal parts are cadmium-plated. **\$1.29**
New
J-45 Key with metal knee band. Brand new. **\$2.95**



HEADSETS

HS-23 high impedance, brand new \$4.55
HS-33 low impedance, brand new with cord and PL-54 plug... **\$4.65**



COMMAND EQUIPMENT

BC-454 Receiver, 3-6 mc, good used \$8.29
BC-456 Modulator, new, \$1.95
BC-457 Trans., 4 to 5.3 mc, good used... \$5.75
BC-458 Trans., 5.3 mc to 7 mc, good used... \$5.75
BC-696 Trans. 3-4 mc, good used... \$6.95
BC-602 Control head for SCR-522, new... \$1.29
Plugs for above Command Sets, PL-152-A or PL-156-A \$0.55

OUR RETAIL DEPARTMENT IS OPEN ALL DAY SATURDAYS

Immediate delivery. Include 25% deposit with order—balance C.O.D. 50c HANDLING CHARGE ON ALL ORDERS UNDER \$5.00. All shipments F.O.B. our warehouse, N.Y.C.

PLATT ELECTRONICS CORP.

20 MURRAY ST., NEW YORK 7, N. Y.
Telephone: COrthand 7-2575

Magnetic Recording — 1914 Style

By **H. M. TREMAINE**
Chief, Sound Division
USAF Lookout Mountain Laboratory

One of the early devices for detecting oscillating currents. Old-time "brass-pounders" will recall it!

THE art of magnetic recording and reproduction has advanced to a point where, without a doubt, it is the finest method of recording and reproduction known today. Yet, how many people know that Valdemar Poulsen invented magnetic recording in 1898 or that Marconi used magnetic recording and reproduction for the detection of wireless signals prior to 1914?

An interesting bit of historical information was recently brought to light while the author was looking through a copy of the "Handbook of Technical Instruction for Wireless Telegraphists," authored by J. C. Hawkhead and published by the *Marconi Press Agency Ltd.*, London, England, 1914.

This work describes the *Marconi "Magnetic Detector"* used for the detection, recording, and reproduction of wireless signals. A photograph of the instrument, taken from the book, is shown in Fig. 1. To quote from the Handbook regarding the known methods of detecting wireless signals: "Different devices are adopted for rendering the oscillating currents detectable. The best known method is by means of an instrument known as a magnetic detector."

In this instrument, a band consisting of 70 strands of No. 40 d.s.c. (double-silk-covered) soft-iron wire was kept moving around two ebonite (a form of hard rubber) pulleys by a clockwork mechanism in the base of the instrument. The velocity of the soft-iron band was 1.6 meters-per-

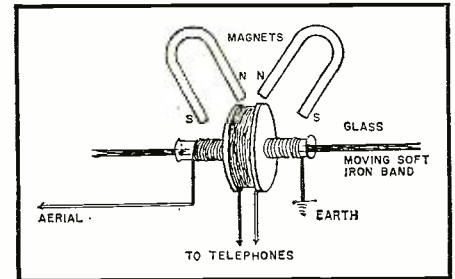

Fig. 2. Basic magnetic detector mechanism.

minute or approximately 1 inch-per-second.

The soft-iron band was braided in the form of a rope and passed through two coils, as shown in Fig. 2. The primary winding was connected between the aerial and ground, the secondary to a pair of headphones.

Again quoting from the Handbook: "The band of soft-iron wire passes in front of the poles of two permanent horseshoe magnets. Now the particles of iron become small magnets under the influence of the lines-of-force (from the magnets) and, as the band is moving, it has the power to drag the lines-of-force in the direction of its motion. As the particles of iron pass from the influence of a north pole to that of a south pole, the direction of magnetism is changed. But this change in magnetism does not take place in time with the change in the force producing it. That is to say, the particles do not change their magnetism until sometime after they

Fig. 1. The Marconi "Magnetic Detector" for detecting, recording, and reproducing wireless signals. The parts shown are: A, Adjusting screw for varying tension of iron band; B, Telephone condenser plugs; C, Telephone condenser; D, Ebonite discs; E, Iron band; G, Glass-fronted cover; H, Winding handle for clockwork; L, Clockwork control; M, Magnet; P, Primary coil; and S, Secondary coil. Refer to text.

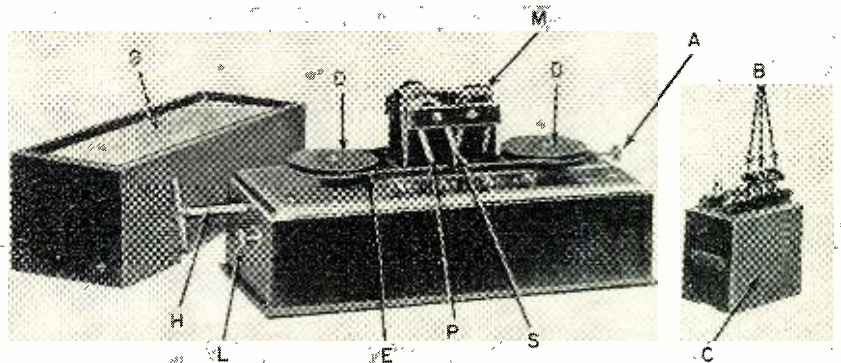

CDR ROTORS

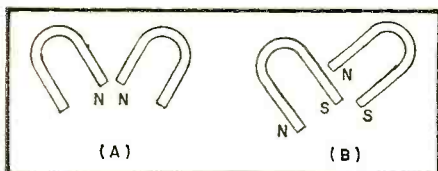

Fig. 3. Detector magnetic arrangement, showing the two recommended positions.

have passed the point where the influence of the opposite pole is being exerted. If an oscillating current be passed through a coil of wire wound around the moving band where it passes in front of the magnets, it has the effect of causing the lag in magnetism to disappear.

"A second coil of much greater number of turns is wound over the first and a pair of telephones connected to its extremities. When the transmitting station sends out a train of waves, oscillating currents are set up in the receiving aerial, which pass through the primary coil and cause a sudden change in the state of magnetization of the moving iron band. This change induces a current in the secondary, which passes through the coils of the telephone and causes a vibration of the diaphragms. Thus, as long as the sparks take place at the sending station, corresponding changes will take place in the magnetism of the moving band and the diaphragms will be kept in continuous vibration. If the sparks be made having long and short periods representing dots and dashes of the Morse Code, sounds of corresponding duration are heard in the telephones."

Fig. 3 shows two recommended positions for the permanent magnets and an explanation of their effect on the moving iron band. Again to quote: "The usual position of the magnets with respect to the coils is shown in Fig. 3A where it is seen that the like poles are together. This arrangement results in a slight hissing sound being produced in the telephones all the time the band is moving. If the magnets are re-arranged as shown in Fig. 3B, this hissing or breathing effect is eliminated and, at the same time, the sensitivity of the receiver is lessened. The matter of arrangement is largely one of personal choice. Many operators claim the breathing effect renders the reading of weak signals difficult and that the latter arrangement is better."

Two sets of magnets and coils were provided for the magnetic detector, the second set for use in case of failure of those normally employed.

It doesn't take an engineer to appreciate the vast strides that have been made in magnetic recording techniques in the forty-odd years that have elapsed since this equipment was considered to be the last word in recording and reproducing gear, but it is interesting to see just how far advanced were the ideas of the period. Many "brass-pounders" of that era probably recall the magnetic detector with nostalgia.

—50—

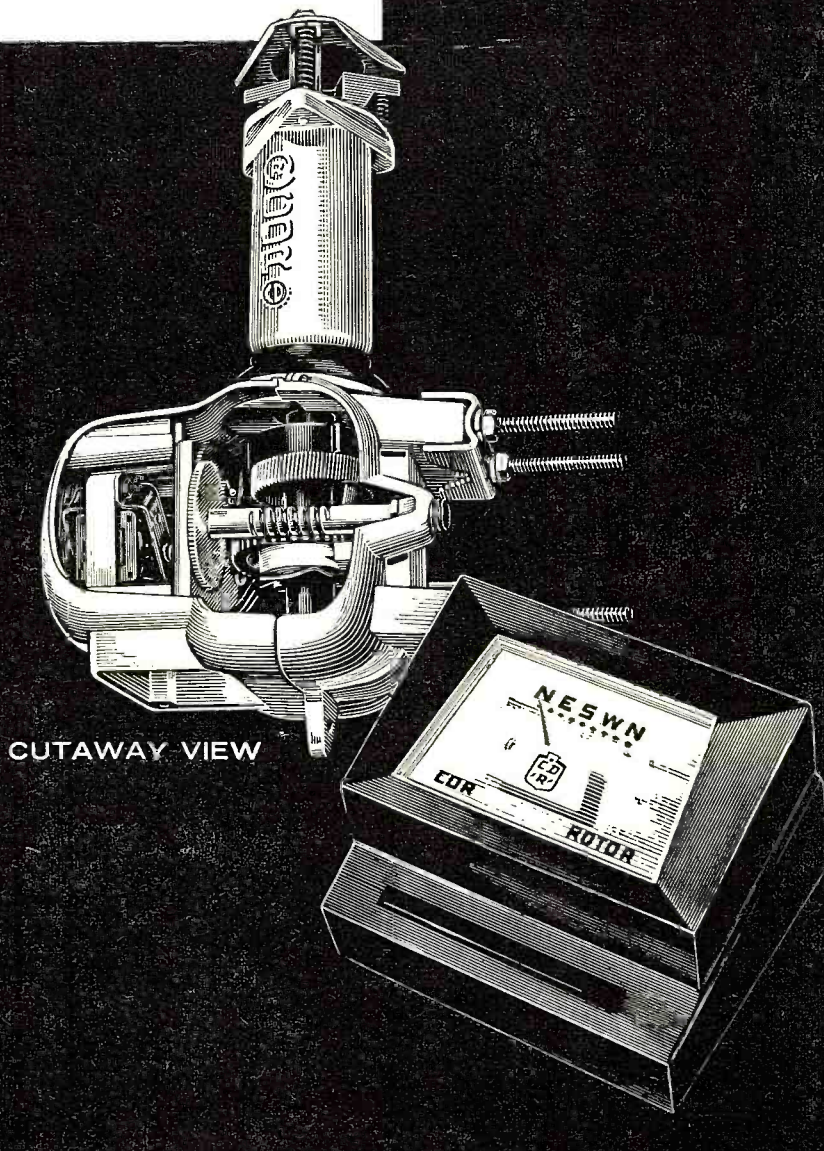

All new features

Completely designed from the ground up, CDR Model TR-15 and TR-16 Rotors have features never before available in the popular price range. Check these refinements and you'll see why: Quick mounting mast collet... speedy installation (no loose parts to assemble)... self-centering sawtooth clamps take masts up to 1½" O.D.... instant locking prevents drift... mechanical brake releases magnetically... instantly reversible... makes complete revolution in 45 seconds... meets JAN salt water test... great strength thrust bearing support... low weight... completely weather-sealed... fits standard towers... streamlined to reduce wind resistance... mahogany or blonde finish control box. Get full details today from your local CDR distributor.

CORNELL-DUBILIER ELECTRIC CORP.
South Plainfield, New Jersey

THE RADIART CORPORATION
Indianapolis, Indiana



CDR Antenna Rotors

Old Hands at Dependability

www.americanradiohistory.com

Hi-Fi-Audio

Product Review

"HI-TONE" TAPE RECORDER

American Geloso Electronics, Inc., 312 Seventh Ave., New York, N. Y. is handling distribution of the new 7½ pound tape recorder recently introduced by *Societa Per Azioni Geloso* of Milan, Italy.

The recorder which measures 9½" wide, 5½" high, and 5½" deep has a power output of 2 watts. It uses four tubes plus selenium rectifier and will record at either 1⅞ or 3¼ ips. The

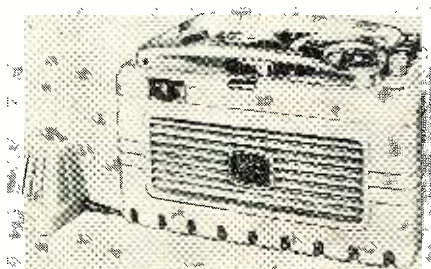

unit incorporates eight controls which handle record, stop, play, rewind, fast forward, speed selector, line-voltage adjust, and modulation level functions.

At the low speed the unit will record 90 minutes with 1 mil tape and 120 minutes with ½ mil tape while at the higher speed recording times are 45 and 60 minutes respectively with 1 mil and ½ mil tapes. Frequency response is 100 to 4500 cycles at 1⅞ ips and 80 to 6000 cycles at 3¼ ips. Two external jacks are provided.

A booklet on this new recorder is available from the U. S. distributor on request.

ALTEC 40-WATT AMPLIFIER

Altec Lansing Corporation of Anaheim, Calif. has just announced the availability of a new 40-watt amplifier, the 350A.

Featuring a 70-volt output for multiple speaker application, the amplifier is equipped to handle an accessory



input line-matching transformer which adapts it for use with professional mixing and recording equipment.

The premium power tubes used in the circuit have gold-plated grids and are rated for 100-watt capacity, en-

abling the unit to provide full rated performance even under fluctuating line voltages. Frequency response is ± 1 db from 5 to 100,000 cps.

SONOTONE STEREO UNIT

Sonotone Corporation of Elmsford, N. Y. has announced the availability of a new ceramic phonograph cartridge which plays the new stereophonic records as well as all present discs.

The basis of the new cartridge is a special coupling device which, through a single needle, breaks down the composite stereo groove motion and recreates the two original recording signals. The cartridge also offers a built-in rumble suppressor, jewel-tipped styli, and "flip under" replaceable needles.

Voltage output of the "8-T" will provide a signal strong enough to drive the amplifiers without requiring the use of separate preamps. The needle for the stereo side is ⅞ mil.

RONETTE STEREO CARTRIDGE

Ronette Acoustical Corporation of Lynbrook, N. Y. is now on the market with a stereo cartridge, the "Bino-fluid."

The dual-element cartridge is completely compatible with both monaural

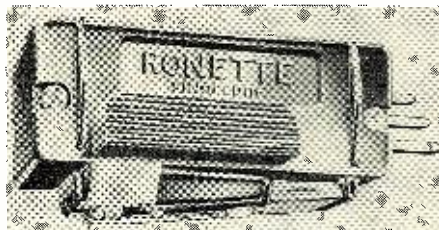

and stereo discs. It may be used in both original equipment and replacement applications. Lateral and vertical compliances are 3.5×10^{-6} cm/dyne. Optimum stylus pressure is 4 to 6 grams. According to the company, frequency response is flat from 20 to 12,000 cps with a roll-off at 14,000 cps. The cartridge uses a clip-on stylus.

PANEL-MOUNTING KIT

Dyna Company, 617 N. 41st St., Philadelphia 4, Pa. is currently offering an inexpensive accessory kit designed to be used with the firm's "Dynakit" preamplifier.

The new kit includes a special brass escutcheon plate, a pair of nickel-plated mounting brackets, and hardware which enables the user to mount the preamp on panels of any thickness up to 1½".

No screws are necessary to mount the kit and no mounting hardware is

visible from the front. Only a rectangular hole is required in the panel without need for extensive cabinet work or carpentry to close tolerances. Once the panel opening is made, installation or removal of the preamplifier can be done without the use of tools.

LAFAYETTE AM-FM TUNER

Lafayette Radio, 165-08 Liberty Ave., Jamaica 33, N. Y. has recently introduced the LT-25 FM-AM tuner as a companion piece to its LA-22 12-watt amplifier.

The tuner is supplied complete with

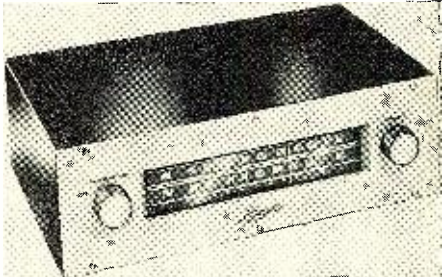

cabinet and provides such features as temperature-compensated oscillator plus a.f.c. for low drift on FM as well as a.f.c. defeat for tuning in weak FM stations. The design incorporates the Armstrong FM circuit with limiter and a Foster-Seeley discriminator.

FM frequency response is 20 to 20,000 cps ± 1 db and AM response is 20 to 5000 cps ± 3 db. There are built-in antennas for both AM and FM.

The cabinet measures 4" high.

FOUR-TRACK STEREO TAPES

Ampex Corporation of Redwood City, Calif. has announced that low-priced, high-quality four-track 3¼ ips stereophonic tapes will be commercially available this summer.

The company also announced that all of its "A" series stereophonic tape recorders now in the field and those in production can be converted, for full compatibility, to reproduce both the new four-track 3¼ ips tapes and existing two-track 7½ ips tapes.

NEW TUBE FOR HI-FI

The Electron Tube Division of *Radio Corporation of America*, Harrison, N. J. has introduced a new high-peak power tube of the glass-octal type which has been designed specifically for use in push-pull power amplifier circuits of hi-fi audio equipment.

The 7027 is capable of delivering high power output at low distortion. Two of the tubes in class AB₁ push-pull service, with 450 volts on the plate, can handle up to 50 watts of audio power with only 1.5 per-cent distortion.

TAPE STROBE

Scott Instrument Labs, 17 E. 48th St., New York 17, N. Y. has developed a unique stroboscopic device for checking the tape speeds of all tape recorders and players now on the market.

The "Tape Strobe" quickly and accurately indicates the correct or in-

correct tape transport speed. The unit consists of a precision-mounted wheel housed in a machined aluminum yoke such that the user may apply it directly to the moving tape. Under 60-

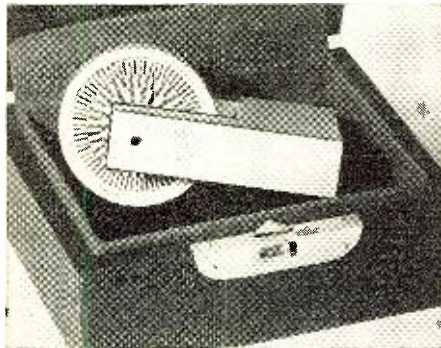

cycle light sources, reference marks on the wheel disc appear to stand still if the tape is moving past the capstan at the correct speed.

The instrument comes complete with a sturdy carrying case.

MINIATURE SPEAKER SYSTEM

To meet the needs of those living in cramped quarters, *Telematic Industries* of 251 Lee Ave., Brooklyn 6, N. Y. has developed a miniature speaker system which is being offered in

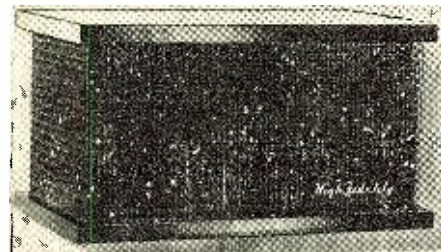

four decorator woods; mahogany, walnut, blonde, or ebony.

The "Minstrel" utilizes the entire air chamber, through dynamic air coupling, as a phase-matching transformer to provide optimum results from both the low and high ends. The enclosure measures a mere 9" x 9" x 16" and can be used in practically any location. The system will handle 10 watts continuous and provides a frequency response of 50 to 15,000 cps. Impedance is 4 ohms.

Write the manufacturer direct for additional details on this compact unit.

UNIVERSITY "DEBONAIRE"

University Loudspeakers, Inc., 80 S. Kensico Ave., White Plains, N. Y. has just introduced a new lowboy high-fidelity speaker system and enclosure which has been designed with special emphasis on living room decor.

Currently available in three versions, all of the systems operate on the phase inversion principle. Custom finished in mahogany, blonde, or walnut, the over-all dimensions are 27 3/8" wide, 16" deep, and 25 3/8" high, including the legs.

The "Debonaire-12" consists of a three-way system made up of the basic C-12W 12" woofer, the H-600 reciprocating flare horn with T-30 driver, and the UXT-5 super tweeter which carries the treble range out to

July, 1958

DYNAK PREAMPLIFIER

Acclaimed as the finest available—by laboratory test or critical listening—in money-saving kit form!

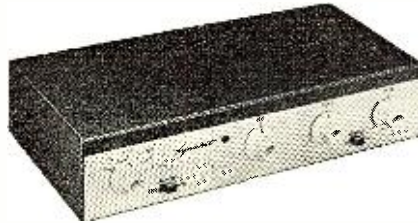

This handsome new control unit gives crystal clear, noise-free reproduction from any modern program source. Its unique all-feed-back design by David Hasler sets a new standard of preamplifier performance. The design of the Dynakit preamplifier is a synthesis of outstanding features which produce smoother, more natural sound.

ONLY **34⁹⁵**_{net}

(Slightly higher in the West)

**NEW!
DYNAKIT
STEREO CONTROL KIT**
ADDS COMPLETE STEREO CONTROL FUNCTIONS TO TWO PREAMPLIFIERS FOR ONLY... **\$12⁹⁵**
DATA SHEET AVAILABLE ON REQUEST

DYNACO, INC.

617 N. 41st St., Phila. 4, Pa.

Export Division:
25 Warren St., New York 7, N.Y.

★ Unequaled performance

Actually less than .1% distortion under all normal operating conditions. Response ± 5 db 6 cps to over 60 kc. Distortion and response unaffected by settings of volume control. Superlative square wave performance, and complete damping on any pulse or transient test.

★ Easiest assembly

All critical parts supplied factory-mounted on XXXP printed circuit board. Eyeleted construction prevents damage to printed wiring. This type of construction cuts wiring time by 50% and eliminates errors of assembly. Open simplified layout offers complete accessibility to all parts.

★ Lowest noise

Integral dc heater supply plus low noise components and circuitry bring noise to less than 3 microvolt equivalent noise input on RIAA phono position. This is better than 70 db below level of 10 millivolt magnetic cartridge.

★ Finest parts

1% components in equalization circuits to insure accurate compensation of recording characteristics. Long life electrolytic capacitors and other premium grade components for long trouble-free service.

★ High flexibility

Six inputs with option of extra phono, tape head, or mike input. Four AC outlets. Controls include tape AB monitor switch, loudness with disabling switch, full range feedback tone controls. Takes power from Dynakit, Heathkit, or any amplifier with octal power socket.

★ Outstanding appearance

Choice of bone white or charcoal brown decorator colors to blend with any decor. Finished in indestructible vinyl coating with solid brass escutcheon.

Descriptive brochure available on request.

Pat. Pending

**Amazing New Handbook
Takes The "Headache"
Out of TV Trouble Shooting**

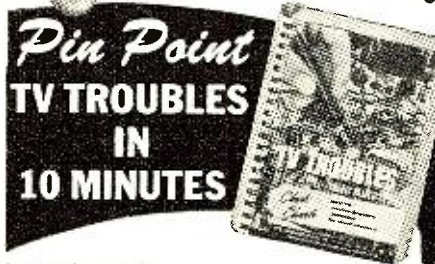

**SAVES TIME . . .
ELIMINATES GUESSWORK!**

Now, a simple, practical way to accurately spot the cause of trouble in any TV set, FAST! Quick, easy-to-understand tests tell you in which of 5 TV set sections to find the cause of trouble. Fool-proof Check Charts help you locate the exact trouble spot at once, from as many as 700 possibilities. Book fits easily into your tool kit for handy on-the-job use. Over 300 spiral bound fast reference pages with 50 time-saving Check Charts; dozens of easy to understand diagrams and tests; explanations of circuits and designs. The hours and aggravation this amazing handbook can save you on a single servicing job more than pay its low price!

USE IT ON 7 DAYS FREE TRIAL!

Send no money, just the coupon. We'll rush your copy on FREE TRIAL. After 7 days, send only \$3.95 plus postage or return the book and owe nothing. Act NOW!

MAIL COUPON NOW!

Educational Book Publishing Div.
COYNE ELECTRICAL SCHOOL, Dept. 78-RT
500 S. Paulina St., Chicago 12, Ill.

Rush TV handbook for 7 days FREE TRIAL per offer.

Name Age

Address

City Zone State

Check here if \$3.95 enclosed. We pay postage. 7-day money-back guarantee.

"NOISE" BIG 3
Beware Of Cheap Substitutes!



**NO-NOISE NEW
RUBBER COAT
SPRAY**

- Insulates where applied
- Protects indefinitely
- Prevents arcing, shorting, corrosion
- Waterproofs thoroughly
- Non-inflammable
- Contains no plastic

6 Oz. Spray Can

\$3²⁵

Net To Servicemen

**NO-NOISE
VOLUME CONTROL
and
CONTACT RESTORER**

• Cleans • Protects
• Lubricates
**NOT A CARBON TET
SOLUTION**

2 Oz. Bottle 6 Oz. Spray Can

\$1⁰⁰

Net To Servicemen

\$2²⁵

Net To Servicemen



**NO-NOISE
TUNER-TONIC**

With PERMA-FILM

- Economical—a little does a lot.
- Cleans, lubricates, restores all tuners, including water type.
- Non-toxic, non-inflammable
- Use for TV, radio and FM

6 Oz. Aerosol Can

\$3²⁵

NET to Servicemen



ELECTRONIC CHEMICAL CORP.
813 Communipaw Avenue Jersey City 4, N. J.



ready
for
STEREOPHONIC
records
GLASER-STEERS
GS-77

With the availability of stereophonic records, the requirements for turntable and record changer quality become more critical than ever before. Yesterday's 'bests' may no longer be good enough. All previously acceptable units must now be re-examined in the light of the new quality demands imposed by stereo.

That the Glaser-Steers GS-77 should be ideally suited for stereo is no mystery. It is simply the result of strict adherence to rigid precision standards, and permitting no compromise in quality. This is evident in every feature of the GS-77.

The Tone Arm, by reason of optimum mass distribution and free pivot suspensions, exhibits no resonance in the audible spectrum. And tracking error is virtually eliminated. In addition, the arm counterbalance is so designed that the stylus pressure between the first and tenth record in a stack does not vary beyond 0.9 gram. These characteristics virtually eliminate vertical rumble (to which stereo is sensitive).

Turntable Pause is an ingenious GS-77 innovation designed for added record protection. During the record-change cycle, the GS-77 turntable comes to a complete halt, and doesn't resume motion until the stylus has come to rest in the lead-groove of the next record. This completely eliminates the grinding action which takes place where records are dropped onto a moving turntable or disc—more important than ever because of the delicate grooves of stereo records.

The GS-77 is the perfect record changer for stereo as it is for conventional monaural high fidelity. Only \$59.50 less cartridge & base.

GLASER-STEERS CORP.
20 Main Street, Belleville 9, N. J.

Please send me complete information on the GS-77.

NAME _____

ADDRESS _____

CITY _____ ZONE _____ STATE _____

17,500 cps. The N3 "Acoustic Baton" three-way network uses 700 cps for midrange and 5000 cps for treble crossover.

The "Debonaire-15" uses a two-way 15" Diffaxial speaker, the Diffusicone-15, with the H-600 and new Hyper-sonic T-50 driver. The EN-1215 "Debonaire" is an enclosure without the speaker system. It permits the user to choose and install his own speaker system. It includes a versatile baffle board arrangement which accommodates just about any variation of 1-, 2-, or 3-way systems employing a 12" or 15" basic speaker.

MARANTZ 30-WATT AMP

Marantz Company, 25-14 Broadway, Long Island City 6, N. Y. has added a 30-watt power amplifier to its line of audio equipment.

The Model 5's circuit is based on the company's 40-watt design and provides 30 watts continuous and 60

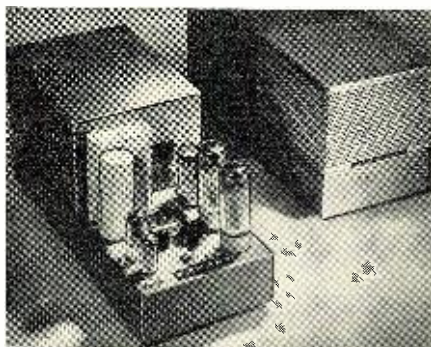

watts peak output. Any of a number of desired damping factors can be obtained by the addition of two specified resistors, with installation instructions included. The circuit is of the "Ultra-Linear" type but can be converted to triode operation with two connection changes.

The amplifier measures 6" x 15" x 7 1/2" with a gold finished perforated cover grille available at extra cost.

DELUXE AUDIO PLUG

Cannon Electric Company, P. O. Box 3765, Terminal Annex, Los Angeles 54, Calif. is now offering an improved version of its "XLR" plug for audio applications.

The new design, according to the company, offers protection against disagreeable mechanical noise by means of resilient inserts with rubber cushioning ribs and positive latching mechanism.

Other features of this deluxe audio plug are serrated finger grips for easy separation, improved adjustable clamps, improved cable relief bushings, more space for wiring, and satin nickel finish. The bushings and cable clamps accommodate the full range of mike cables.

JENSEN CARTRIDGES

Jensen Industries of Forest Park, Ill. has entered the phonographic cartridge field with a complete line of 32 units.

The new units feature a simplified needle changing method, plus a built-

in needle guide. Each cartridge carries a permanent printed identification as to the correct needle to be used.

According to the company, the 32 units in the line are designed to replace 80 per-cent of the cartridges now on the market.

REDESIGNED AMPLIFIER

Dynamic Electronics—New York, Inc., 73-39 Woodhaven Blvd., Forest Hills, N. Y. has just released its new

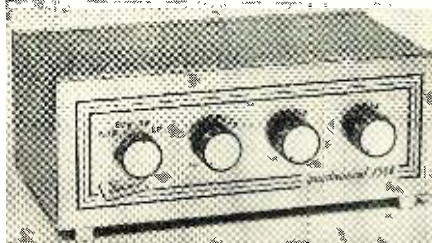

model Q1500PA 12-watt amplifier with built-in preamp, a redesigned and improved version of the Q1500.

Rated at 12 watts, the new unit has a frequency response of 20 to 20,000 cps. Peak output is 18 watts. There are separate bass and treble controls, a tone-compensated loudness control, record compensator and auxiliary tap, built-in power outlet, three input jacks, multiple output taps for matching 4, 8, and 16 ohms, and five tubes.

Housed in a satin copper finished cabinet, the unit measures 11" x 4 1/2" x 7" and weighs 8 1/2 pounds.

"COMPASS-1" SPEAKER SYSTEM

Kingdom Products Ltd. of 514 Broadway, New York 12, N. Y. is in production on its unique "Compass-1" speaker system which employs a 12" woofer and 360-degree omnidirectional tweeter.

The cabinet is custom built and is available in either mahogany or walnut. It comes complete with 4" legs

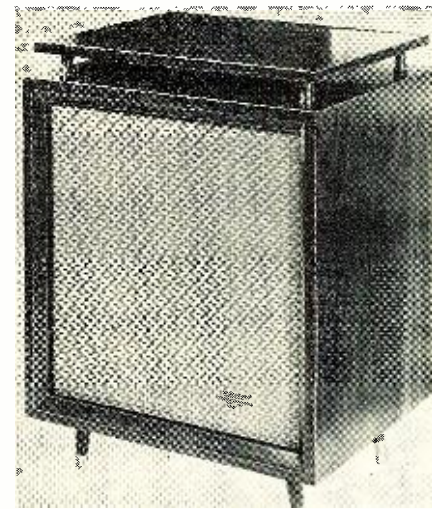

having polished brass ferrules. To permit complete flexibility of placement anywhere in a room, the back of the cabinet is covered with a grille cloth so the unit can be used as a room divider.

The tweeter is placed at the top of the unit to provide complete coverage

in any direction. The 12" woofer covers the frequency range from 20 to 14,000 cps while the tweeter output is said to be flat within ± 5 db from 2500 to 18,000 cps. The system will handle the output of a 50-watt amplifier on normal program material.

"DEBUTANTE" SPEAKER SYSTEM

Ruxton Electronics Company, 11168 Santa Monica Blvd., Los Angeles 25, Calif. is now marketing an inexpensive and compact speaker system which has been tradenamed "Debutante."

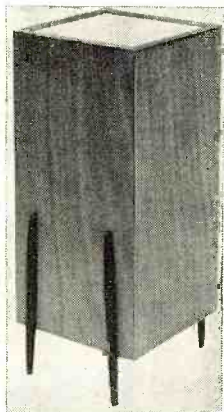

Designed to be used with any power amplifier of 15 watts or higher rating, the system provides a frequency response of from 40 to 19,000 cps. Impedance is 8 ohms and the unit will handle 10 watts of normal program material and 15 watts peak.

The cabinet measures 29" high by 12" x 14" wide or deep, depending on the positioning of the legs. It is available in honey-nut, mahogany, silver beige, or special finishes.

AUDIO CATALOGUES

STEREO BOOKLET

Fairchild Recording Equipment Co., 10-40 45th Avenue, Long Island City 1, N. Y. has announced the availability of a new booklet which covers stereo sound and stereo discs in particular.

The pamphlet traces the history of stereo discs from the earliest days in 1931 to the latest developments. It fully explains how stereo sound on discs is produced and how it should be reproduced in the home.

Copies of this booklet are available without charge from the manufacturer at the above address. Ask for Booklet "K-3."

PARTRIDGE TRANSFORMERS

M. Swedgal Electronics, 258 Broadway, New York 7, N. Y. is currently offering copies of a new 4-page booklet which illustrates and describes the complete line of high-fidelity output transformers made by Partridge Transformers Ltd. of London.

The publication describes the P-5000 series which is available in 20- and 35-watt models, each of which is offered in four types with various anode-to-anode loads and "Ultra-Linear" taps. Details on power transformers and chokes designed to be used with these output transformers are also included.

For a copy of the booklet and additional details on the line, write the firm's sole United States sales agent at the above address. They will be happy to forward a copy of the brochure to those who are interested in the components.



Write for the latest Oxford catalog



OXFORD Components, Inc.
 Subsidiary of Oxford Electric Corp.
 556 West Monroe Chicago 6, Ill
 Export: Roburn Agency, New York City
 In Canada: Allco Radio Corp., Ltd., Toronto

MAKE SURE IT FITS!

OXFORD SPEAKERS

When you order a speaker (for replacement or original installation), demand units that meet your most exacting needs.

Each OXFORD SPEAKER is "tailor-designed" to actually "fit the application."

The next time you specify speakers, make certain they fit the job by selecting OXFORD . . . unsurpassed quality for over thirty years.

<p>RADIO & TV SPEAKERS</p>  <p>OXFORD Speakers are used by more original set manufacturers — find out why!</p>	<p>OUTDOOR SPEAKERS</p>  <p>For rugged, steady performance under any conditions, OXFORD Weather-proof speakers will meet the need.</p>
<p>DUAL CONE HI-FI SPEAKERS</p>  <p>Oxford's newest development to provide maximum performance. For Hi-Fi and rear deck applications.</p>	<p>PORTABLE RADIO SPEAKERS</p>  <p>More Oxford speakers are used in portable sets than ever before . . . there must be reasons!</p>

BUILDING A HI-FI SYSTEM?

Send Us Your List Of Components For A Package Quotation

WE WON'T BE UNDERSOLD!

All merchandise is brand new, factory fresh & guaranteed.

AIREX RADIO CORPORATION

64 Cortlandt St., N. Y. 7, CO 7-2137

PARTIAL LIST OF BRANDS IN STOCK

Altec Lansing
 Electrovoice
 Jensen
 University
 Acoustic Research
 Janszen
 Wharfedale
 Viking
 Concertone
 Bell • Lee • G.E.
 Weathers
 Harman-Kardon
 Eico • Pilot
 Sherwood
 Acrosound
 Fisher
 Bogen
 Dynakit
 H. H. Scott
 Pentron
 Ampro • VM
 Revere
 Wollensack
 Garrard
 Miracord
 Webster
 Collaro
 Thorens
 Rek-O-Kut
 Norelco
 Fairchild
 Pickering

Full Line of Cabinets

LEARN

Television
 RADIO-COLOR-TV
 Electricity
 ELECTRONICS
 IN THE GREAT SHOPS OF COYNE

TRAIN QUICKLY! OLDEST, BEST EQUIPPED SCHOOL OF ITS KIND in U.S.

Veterans and Non-Veterans — Get practical training in top opportunity fields. Prepare now for a better job and a real future. Advanced education or previous experience not needed. Employment service to graduates.

Enroll NOW—Pay Later

Finance Plan and Easy Payment Plan. Also Part Time Employment help for students. Training in Refrigeration and Electric Appliances can be included.

FREE BOOK Clip coupon for Big Free Illustrated Book. No obligation and No Salesman Will Call. Act NOW.

B. W. Cooke, Jr., President
COYNE
 ELECTRICAL SCHOOL
 OPERATED NOT FOR PROFIT
 Established 1899
 500 S. Paulina, Chicago
 Dept. B8-6C

B. W. COOKE, Jr., Pres.
 COYNE Electrical School
 500 S. Paulina St., Chicago 12, Ill. Dept. B8-6C

Send FREE BOOK and full details on:
 TELEVISION-RADIO
 ELECTRICITY-ELECTRONICS

NAME.....
 ADDRESS.....
 CITY.....STATE.....

Superior's New
Model 82

RAP D ES ER

The Very Best Value in Multi-Socket Tube Testers!

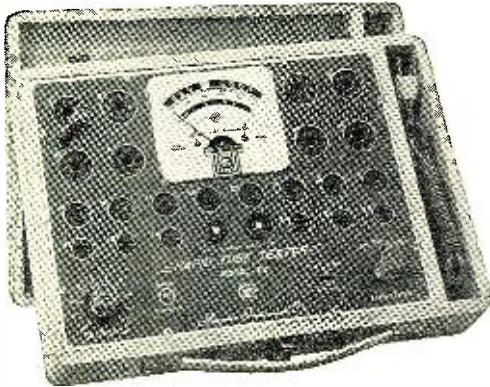

Production of this Model was delayed a full year pending careful study by Superior's engineering staff of this new method of testing tubes. We don't expect it to replace conventional testers but if you want to try this new type of tester, you can do no better than mail the coupon

Primarily, the difference between the conventional tube tester and the multi-socket type is that in the latter, the use of an added number of specific sockets (for example, in Model 82 the noval is duplicated eight times) permits elimination of element switches

- ★ Dual Scale meter permits testing of low current tubes.
- ★ 7 and 9 pin straighteners mounted on panel.
- ★ All sections of multi-element tubes tested simultaneously.

on the facing page. Don't let the low price mislead you! We claim Model 82 will outperform similar looking units which sell for much more—and as proof, we offer to ship it on our examine before you buy policy.

thus reducing testing time and possibility of incorrect switch readings. To test any tube, you simply insert it into a numbered socket as designated, turn the filament switch and press down the quality switch—THAT'S ALL! Read quality on meter. Inter-element leakage, if any indicates automatically.

FEATURES:

- ★ Use of 22 sockets permits testing all popular tube types and prevents possible obsolescence.
- ★ Ultra-sensitive leakage test circuit will indicate leakage up to 5 megohms.

\$36⁵⁰

Superior's New Model TW-11

STANDARD PROFESSIONAL

TUBE TESTER



- Tests all tubes, including 4, 5, 6, 7, Octal, Lockin, Hearing Aid, Thyatron, Miniatures, Sub-miniatures, Novals, Sub-minars, Proximity fuse types, etc.
- Uses the new self-cleaning Lever Action Switches for individual element testing. Because all elements are numbered according to pin-number in the RMA base numbering system, the user can instantly identify which element is under test. Tubes having tapped filaments and tubes with filaments terminating in more than one pin are truly tested with the Model TW-11 as any of the pins may be placed in the neutral position

when necessary.

- The Model TW-11 does not use any combination type sockets. Instead individual sockets are used for each type of tube. Thus it is impossible to damage a tube by inserting it in the wrong socket.
- Free-moving built-in roll chart provides complete data for all tubes. All tube listings printed in large easy-to-read type.

NOISE TEST: Phono-jack on front panel for plugging in either phones or external amplifier will detect microphonic tubes or noise due to faulty elements and loose internal connections.

EXTRAORDINARY FEATURE

SEPARATE SCALE FOR LOW-CURRENT TUBES—Previously, on emission-type tube testers, it has been standard practice to use one scale for all tubes. As a result, the calibration for low-current types has been restricted to a small portion of the scale. The extra scale used here greatly simplifies testing of low-current types.

The Model TW-11 operates on 105-130 Volt 60 Cycles A.C. Comes housed in a beautiful hand-rubbed oak cabinet complete with portable cover.

\$47⁵⁰
NET

Superior's New
MODEL 77

VACUUM TUBE VOLTMETER

WITH NEW 6" FULL-VIEW METER

Compare it to any peak-to-peak V. T. V. M. made by any other manufacturer at any price!



- ✓ Model 77 completely wired and calibrated with accessories (including probe, test leads and portable carrying case) sells for only \$42.50.
- ✓ Model 77 employs a sensitive six-inch meter. Extra large meter scale enables us to print all calibrations in large easy-to-read type.
- ✓ Model 77 uses new improved SICO printed circuitry.
- ✓ Model 77 employs a 12AU7 as D.C. amplifier and two 9006's as peak-to-peak voltage rectifiers to assure maximum stability.

- ✓ Model 77 uses a selenium-rectified power supply resulting in less heat and thus reducing possibility of damage or value changes of delicate components.
- ✓ Model 77 meter is virtually burn-out proof. The sensitive 400 microampere meter is isolated from the measuring circuit by a balanced push-pull amplifier.
- ✓ Model 77 uses selected 1% zero temperature coefficient resistors as multipliers. This assures unchanging accurate readings on all ranges.

SPECIFICATIONS

• DC VOLTS—0 to 3/15/75/150/300/750/1,500 volts at 11 megohm input resistance. • AC VOLTS (RMS)—0 to 3/15/75/150/300/750/1,500 volts. • AC VOLTS (Peak to Peak)—0 to 8/40/200/400/800/2,000 volts. • ELECTRONIC OHMMETER—0 to 1,000 ohms/10,000 ohms/100,000 ohms/1 megohm/10 megohms/100 megohms/1,000 megohms. • DECIBELS—10 db to +18 db, +10 db to +38 db, +30 db to +58 db. All based on 0 db = .006 watts (6 mw) into a 500 ohm line (1.73v). • ZERO CENTER METER—For discriminator alignment with full scale range of 0 to 1.5/7.5/37.5/75/150/375/750 volts at 11 megohms input resistance.

AS AN AC VOLTMETER

Measures RMS values if sine wave, and peak-to-peak value if complex wave. Pedestal voltages that determine the "black" level in TV receivers are easily read.

AS A DC VOLTMETER

The Model 77 is indispensable in Hi-Fi Amplifier servicing and a must for Black and White and color TV receiver servicing where circuit loading cannot be tolerated.

AS AN ELECTRONIC OHMMETER

Because of its wide range of measurement leaky capacitors show up glaringly. Because of its sensitivity and low loading, intermittents are easily found, isolated and repaired.

Model 77 comes complete with operating instructions, probe and test leads. Use it on the bench—use it on calls. A streamlined carrying case, included at no extra charge, accommodates the tester, instruction book, probe and leads. Operates on 110-120 volt 60 cycle. Only.....

\$42⁵⁰
NET

EXAMINE BEFORE YOU BUY!

USE APPROVAL FORM ON NEXT PAGE

The Most Versatile All-Purpose Multi-Range Tester Ever Designed!

Superior's New Model 79

SUPER-METER

WITH NEW 6" FULL-VIEW METER

A Combination **VOLT-OHM MILLIAMMETER.**
Plus **CAPACITY, REACTANCE, INDUCTANCE AND DECIBEL MEASUREMENTS.**

Also Tests **SELENIUM AND SILICON RECTIFIERS, SILICON AND GERMANIUM DIODES.**

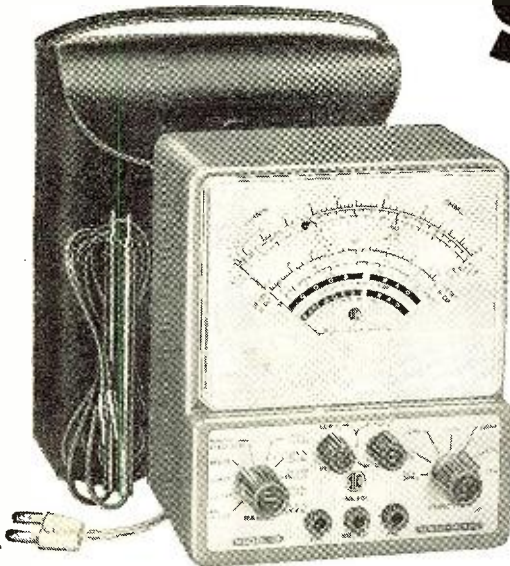

Model 79 completely wired and calibrated with test leads and portable carrying case sells for only \$38.50. Positively no extras to buy.

The Model 79 represents 20 years of continuous experience in the design and production of SUPER-METERS, an exclusive SICO development.

In 1938 Superior Instruments Co. designed its first SUPER-METER, Model 1150. In 1940 it followed with Model 1250 and in succeeding years with others including Models 670 and 670-A. All were basically V. O. M.'s with extra services provided to meet changing requirements.

Now, Model 79, the latest SUPER-METER includes not only every circuit improvement perfected in 20 years of specialization, but in addition includes those services which are "musts" for properly servicing the ever increasing number of new components used in all phases of today's electronic production. For example with the Model 79 SUPER-METER you can measure the quality of selenium and silicon rectifiers and all types of diodes—components which have come into common use only within the past five years, and because this latest SUPER-METER necessarily required extra meter scale, SICO used its new full-view 6-inch meter.

Specifications

- ✓ D.C. VOLTS: 0 to 7.5/15/75/150/750/1,500.
- ✓ A.C. VOLTS: 0 to 15/30/150/300/1,500/3,000.
- ✓ D.C. CURRENT: 0 to 1.5/15/150 Ma. 0 to 1.5/15 Amperes.
- ✓ RESISTANCE: 0 to 1,000/100,000 Ohms. 0 to 10 Megohms.
- ✓ CAPACITY: .001 to 1 Mfd. 1 to 50 Mfd.
- ✓ REACTANCE: 50 to 2,500 Ohms, 2,500 Ohms to 2.5 Megohms.
- ✓ INDUCTANCE: .15 to 7 Henries, 7 to 7,000 Henries.
- ✓ DECIBELS: -6 to +18, +14 to +38, +34 to +58.

The following components are all tested for QUALITY at appropriate test potentials. Two separate BAD-GOOD scales on the meter are used for direct readings.

- ✓ All Electrolytic Condensers from 1 MFD to 1000 MFD.
- ✓ All Selenium Rectifiers.
- ✓ All Silicon Rectifiers.
- ✓ All Germanium Diodes.
- ✓ All Silicon Diodes.

Model 79 comes complete with operating instructions and test leads. Use it on the bench — use it on calls. A streamlined carrying case included at no extra charge accommodates the tester, instruction book and test leads.....Only

\$38⁵⁰
NET

SHIPPED ON APPROVAL NO MONEY WITH ORDER — NO C. O. D.

Try any of the instruments on this or the facing page for 10 days before you buy. If completely satisfied then send down payment and pay balance as indicated on coupon. No Interest or Finance Charges Added! If not completely satisfied return unit to us, no explanation necessary.

MOSS ELECTRONIC DISTRIBUTING CO., INC.
Dept. D-484, 3849 Tenth Ave., New York 34, N. Y.

Please send me the units checked on approval. If completely satisfied I will pay on the terms specified with no interest or finance charges added. Otherwise, I will return after a 10 day trial positively cancelling all further obligation.

Model 82 Total Price \$36.50
\$6.50 within 10 days. Balance \$6.00
monthly for 5 months.

Model TW-11 Total Price \$47.50
\$11.50 within 10 days. Balance \$6.00
monthly for 6 months.

Name

Address

City Zone State

All prices net, F.O.B., N.Y.C.

Model 77 Total Price \$42.50
\$12.50 within 10 days. Balance \$6.00
monthly for 5 months.

Model 79 Total Price \$38.50
\$8.50 within 10 days. Balance \$6.00
monthly for 5 months.

for graduate engineers
interested in acquiring

SYSTEMS EXPERIENCE



Through intensive formal training and assignments of one to two years duration, Hughes Field Engineers obtain an over-all knowledge of the most advanced airborne electronic weapons systems in tactical use and under development. They become familiar with complete systems, including digital computers, microwave equipment, high gain parabolic antennas and analog computers in their operational development.

E.E. or Physics graduates of accredited universities may investigate by writing:

the West's leader in advanced electronics

HUGHES

Scientific and Engineering Staff

**RESEARCH & DEVELOPMENT
LABORATORIES**

*Hughes Aircraft Company
Culver City, California*



Manufacturers' Literature

TUBE PRICING CHART

Tung-Sol Electric Inc. has just published a wall-type chart, "Suggested Retail Prices of Electron Tubes for Radio and TV," which it is offering as a service to the industry.

The 11" x 14" chart shows, in easy-to-read form, the industry recommended retail prices for 839 electron tubes used in radio, television, and high-fidelity applications. This includes virtually all known entertainment types available in today's domestic market.

Service technicians and those engaged in selling tubes at retail to the public may obtain a copy of this chart from the firm's authorized distributors.

CCTV APPLICATIONS

General Precision Laboratory, 63 Bedford Road, Pleasantville, N. Y. has announced the availability of a new 8-page illustrated brochure entitled "How Many Jobs?"

The publication covers a complete line of industrial television equipment for business and industry, shows different types of cameras, control units, monitors, accessories, and projection systems, and discusses the varied applications for such gear.

The manufacturer will supply copies of this publication without charge on request.

INTERCHANGEABILITY CHART

The Receiving Tube Department of *General Electric Company*, Owensboro, Ky. has published an interchangeability chart which lists the essential characteristics of its thirty-four high reliability "Five Star" tubes and the standard miniature prototypes which they can directly replace.

The chart (No. ETI-1572) is being handled by the firm's authorized tube distributors and may be had on request.

RECTIFIER HANDBOOK

The Rectifier Division of *Sarkes Tarzian, Inc.*, 415 N. College Ave., Bloomington, Ind. has just issued a completely revised edition of its "Silicon Rectifier Handbook."

Although this 40-page publication is priced at \$1.00 a copy, the company is making it available to RADIO & TV NEWS' readers without charge. The publication covers the theory of operation, how silicon rectifiers are made, forward and reverse characteristics, operating temperatures, and complete descriptions of the various rectifiers in the company's line.

When writing for a copy of Cata-

logue No. 67, indicate that you are a reader of this magazine in order to take advantage of the "no-cost" offer.

NEW HEATHKIT CATALOGUE

Heath Company of Benton Harbor, Michigan has just released a new 24-page catalogue which pictures and describes its complete line of "build-it-yourself" kits.

Included are items of interest to radio amateurs, audiophiles, service technicians, boating enthusiasts, experimenters, and those who are interested in or work with electronic gear. In addition to listing the features of each kit, the catalogue contains an order blank and complete instructions for obtaining any of the kits.

CAPACITOR GUIDE

Tobe Deutschmann Corp., Indianapolis, Ind. has announced the availability of its new twist-prong capacitor "Selector and Stock Sequence Guide" for the speedy selection and identification of stock.

To be posted on counters and capacitor storage racks, the Guide is designed to assist dealers and service technicians in simplifying their stock-keeping chores.

Jobbers may obtain a copy of this streamlined guide by contacting their representatives or by writing the manufacturer direct.

RECORDING SATELLITE SIGNALS

Audio Devices, 444 Madison Ave., New York, N. Y. has just published a two-color, 12-page booklet entitled "You Can Record the Satellites" which it is offering to radio amateurs and others interested in sharing in one of the "greatest scientific experiments of all time."

The booklet, which includes diagrams and charts, describes how to adapt basic equipment to tune in the transmitters in the "Vanguard" and "Explorer" satellites, including those now circling the earth and those planned for the future; how to record the information on magnetic tape and interpret the data received; methods for accurate timing of recordings; and how to contact satellite information headquarters to determine the value of particular recordings.

The information in the booklet was assembled with the help of the U. S. Naval Research Laboratory and the Jet Propulsion Laboratory at Cal Tech. The booklet is available without charge from *Audiotape* dealers or by mail from the company at a charge of 10 cents a copy to cover handling.

-30-

Attention Photographers
**THE SECRET OF
 "BUYING SMART"**
 costs you only a Dollar!

You've noticed how some people seem to have a knack for buying photo equipment. Before they go into a store they know the kind of equipment they want, the manufacturer, model, features, and the price. They've compared beforehand . . . and saved themselves time, effort and money.

What's the secret? For many it's the *Photography Directory & Buying Guide* . . . a handsome catalog of all photographic equipment on the market compiled by the editors of *Popular Photography*. It tells you everything you want to know about more than 5,000 products, from cameras and lenses to film and filters—for black and white or color, for movie or still photography. The cost? Only \$1.00.

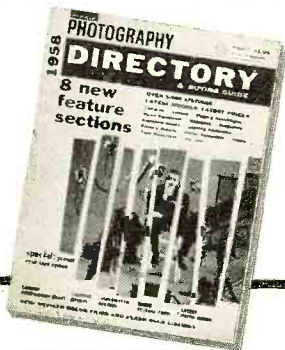

**1958 Edition
 Has These
 Extra Features**

Besides listing over 5,000 new photo products (and illustrating more than 1,000 of them), the 1958 *Photography Directory & Buying Guide* includes helpful, simplified **CAMERA COMPARISON CHARTS**. These charts compare the prices, shutter ranges, lens speeds and other features of over 300 press, 35mm and reflex cameras. In addition, a special 16-page section on **FOTO FACTS** gives data and figures on filters, films, lenses, exposure and conversion scales. An exclusive bonus, **PHOTO SHORTCUTS** points out ways to save money when you shoot, light, print and process. A section on **PORTRAIT LIGHTING SETUPS** lists tested diagrams for lighting a model. As additional features, the 1958 *Photography Directory* suggests sample **MODEL RELEASE FORMS** and a roundup of the **LATEST BOOKS ON PHOTOGRAPHY**.

The new *Photography Directory* is now on sale. This 1958 Edition, priced at only \$1.00, will sell fast! So to insure yourself of a copy, pick one up at your newsstand or photo dealer's now.

ZIFF-DAVIS PUBLISHING CO.
 434 S. Wabash Avenue
 Chicago 5, Illinois

July, 1958

Ignition Analyzer
 (Continued from page 49)

struct another saw-tooth generator, the voltage is borrowed from the oscilloscope. In the author's case, the voltage was obtained from one of the horizontal-amplifier grids.

The test leads to the coil output and No. 1 plug need not make physical contact. Since the secondary voltage is quite high, a few turns of test lead wire wrapped around the ignition wiring offers enough capacitive coupling to provide substantial signal.

The layout of the adapter is not at all critical and almost any chassis will do. However, for those who may wish to duplicate the author's unit, the following construction details are given. A 3" x 4" x 5" Bud "Fleximount" case serves as both chassis and case, as shown in the photo. To provide a "professional" appearance, two engraved nameplates were purchased from *Radio Stationers* of Brandywine, Maryland. These plates are available on order and may be obtained by asking for the "ignition analyzer plates." Test lead connections are via banana jacks and the power-supply connections enter through a rear-mounted *Jones* barrier strip.

To aid the builder in interpreting the displays he will obtain, a troubleshooting chart is given in Fig. 8. The two scope displays show two conditions in an eight-cylinder engine. A few minutes' use will enable many ignition troubles to be determined.

It is advised that you do not wait until trouble develops before using the adapter, because use on properly functioning systems will develop the familiarity necessary for proper interpretation of the displays. Other applications will suggest themselves with use, for instance, feeding the unit with the output of a microphone will aid in finding difficult-to-locate engine noises since the exact position of the noise during the engine cycle is easily determined.

Fig. 8. Troubleshooting chart.

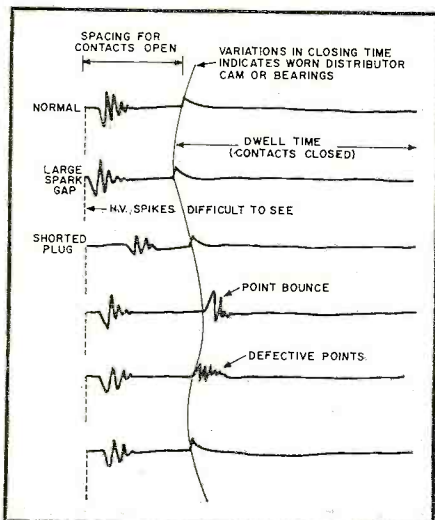

Leading Set Makers
 Specify Tung-Sol

High
 IN PERFORMANCE



BLUE CHIP
 QUALITY

Leading Independent
 Service Dealers
 Choose Tung-Sol

LOW
 IN CALLBACKS

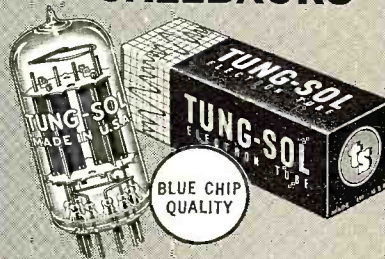

TUNG-SOL[®]
 Magic Mirror Aluminized
 PICTURE TUBES
 RECEIVING TUBES

ELECTRON TUBE DIVISION
 TUNG-SOL ELECTRIC INC., NEWARK 4, N. J.

**UNEXCELLED
PERFORMANCE
IN LESS THAN
2 HOURS**

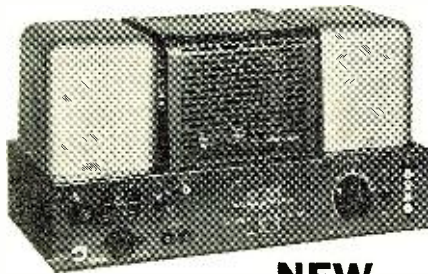

**NEW
Ultra-Linear II
AMPLIFIER**

**World-famous circuit in
an easy-to-assemble kit**

ENTIRE CIRCUIT including all tubes, filter capacitors, and resistors pre-assembled on an extra heavy printed circuit board . . . built and pretested by Acro.

COMPLETE AMPLIFIER assembled in less than two hours.

OUTPUT and POWER TRANSFORMERS specially designed and built by Acro for the Ultra-Linear II circuit.

NEW HYBRID FEEDBACK provides realistic amplification that insures unequalled stability and excellent square wave response on all types of output loads.

PRICE \$79.50 complete with all components. \$109.50 wired and assembled (slightly higher in West).

60 WATTS continuous output, instantaneous peak power of 120 watts.

EFFECTIVE DAMPING CONTROL variable between 0.5 and 10 for optimum speaker match . . . does not change volume, may be switched out for fixed damping factor of 15.

1M DISTORTION less than 1% at 60 watts.

HARMONIC DISTORTION less than 1% between 20 CPS and 20 KC at power output within 1 DB of 60 watts.

OUTPUT TUBES EL-34 or 6CA7. Simple bias adjustment permits use of 6550 or KT88's.

Stereo-Philes! Two for the price of one Assemble a pair of high quality Ultra-Linear II kits for less than the cost of a comparable factory-built amplifier.

Write for information on Ultra-Linear II amplifier and complete Acro line of high quality output transformers.

ACRO PRODUCTS COMPANY
369 SHURS LANE, PHILADELPHIA 28, PA.

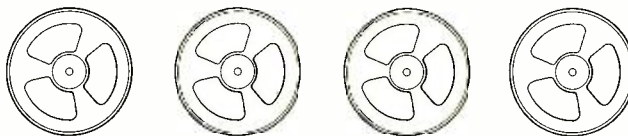
S 
Sound on Tape

By BERT WHYTE

MUCH interest has been aroused by disclosure of the *RCA* and *Shure Bros.* four-channel, "half-track stereo" playback heads and systems. The ability to split a stereo track like a regular half-track monaural tape plus the 3 3/4 ips speed of vastly improved frequency response, has paved the way for really competitive prices on stereo tape. However, in addition to the enthusiasm, there have been yowls about the factor of compatibility with present type stereo tapes and playback machines.

Much of the distress was caused by the *RCA* push on a magazine or cartridge type of deal which would completely obsolete present machines. *Shure* has taken the viewpoint that compatibility is a "must," even with the four-channel system. As a result of a recent development, it would now appear that both systems will be in use with a certain degree of compatibility.

Ampex has just announced, (much to the relief of many A-series owners) that they will have an adapter kit available which will enable the regular Series A *Ampex* machines to be shifted to a modification of the existing 3 3/4 ips drive system and the replacement of the normal half-track head with the new *Ampex* four-channel stereo head. Cost of the kit, including installation, is said to be a little more than 70 dollars. The significant thing here, of course, is that while it is nice that *Ampex* A owners will be protected, it shows the handwriting is on the wall. In other words, you will probably see four-channel tapes and the machines and modification kits for existing machines at the Fall Audio Shows. A certain sign and good precursor of this is the fact that *Ampex* is also busy at work on dubbing machines for the four-channel tapes!

Your reporter is going to Europe to visit the various music centers and studios and I hope to have some interesting poop for you (and longer columns) when I return.

**MUSSORGSKY
NIGHT ON BALD MOUNTAIN
FALLA**

RITUAL FIRE DANCE
Vienna State Opera Orchestra conducted by Hermann Scherchen. Westminster SWB7036. Price \$6.95.

This is stereo music of the type designed to gladden the hearts of the

audiophile. The orchestral canvases are big, with sound to match. Whether the performances here are good—and they are—or not is almost an academic question in the face of such exciting stereo as this little tape offers. A fine balance between orchestral detail and spacious acoustics gives a very live sound of compelling realism. Directionality, depth perception, stage breadth, frequency and dynamic range, and general cleanness are all contributing elements. A particularly good tape for the library of the stereo novice, affording him a chance to evaluate his stereo system at a reasonable price.

COMPOSER'S HOLIDAY

Les Brown and his Orchestra. Capitol ZC32. Price \$12.95.

RALPH FLANAGAN IN HI-FI

Ralph Flanagan and his Orchestra. Victor BPC83. Price \$8.95.

Among the pop stereo tapes this month these two are the standouts. Each is very definitely big-band stuff, with plenty of multi-mike mix and much artificial, but highly effective, control of depth perspective and direction. Musically they are at variance, with Brown's group a hard drivin' very "swingy" type and Flanagan espousing the smoother, large ensemble, more danceable type of thing. Brown has some very fine arrangements of his numbers, which evidently were done with stereo in mind, while Flanagan's program draws heavily on his Glenn Miller-derived style, which lets the stereo chips fall where they may. Whichever direction your pop taste takes, you can't go wrong with either of these fine tapes.

Here are some other fine stereo tapes recommended for light summer listening:

YOUNG IDEAS

Ray Anthony and his Orchestra. Capitol ZC34. Price \$12.95.

The popular trumpeter is in great form here with a collection of fine standard ballads, played in an eminently danceable style and with a group of cellos adding an unusual filip to the orchestration. Very bright clean sound, good punchy brass.

WILD ABOUT HARRY

Harry James and his Orchestra. Capitol ZC29. Price \$12.95.

And who isn't wild about the trumpet of the great James? This is a very upbeat album featuring Harry in

plenty of solo work, mostly of the real goin' kind. A heavyweight tape for big-band sound, generally clean, with just a shade overload in some of the very high level passages.

OVERTURE

Hollywood Bowl Symphony conducted by Felix Slatkin. Capitol ZF36. Price \$12.95.

"William Tell" is on this and so is the ubiquitous "Poet and Peasant," but the star of this typical summer-time "concert in the park" is the "1812 Overture." This is not the most perceptive performance in the world, but boy does this sound out! The acoustic treatment and the pickup make for a spectacularly live sound.

ANTHEIL

BALLET MECANIQUE

Los Angeles Contemporary Music Ensemble conducted by Robert Kraft. Omegatape ST6009. Price \$9.95.

This music was one of the scandals of the early '30's. Patrons were outraged with this cacophonous music depicting the mechanical age. The score called for the sound of an airplane motor and on this fine version an actual stereo pickup of an airliner is featured and against the din of the myriad percussion instruments, you can follow the sound of the plane back and forth across the room between your speakers. Fairly clean and free from distortion, it makes an interesting novelty to play for a visiting sound "bug."

-30-

HAM MEETS SCHEDULED

SHERIDAN Radio Amateur League will play host to this year's Wyoming Hamfest at the South Fork Recreational Area, 18 miles west of Buffalo, Wyo., on U.S. 16, July 12th and 13th. Cabins and camp sites will be available.

The program will include a banquet, contests, transmitter hunts, and prizes. Registration, including banquet, is \$4.50. Register with W7QPP, 362 E. Loucks St., Sheridan, Wyoming.

-30-

THE Annual West Gulf Division Convention of the ARRL will be held in Oklahoma City, Okla., on July 25th, 26th, and 27th at the Biltmore Hotel.

The pre-convention party, which includes a dinner and a dance, will cost \$2.50. The convention, which will include two dinners and a dance as well as various technical talks and special-interest meetings, will cost \$9.50.

Reservations should be made through the ACARC Convention Committee, Box 5-W, Oklahoma City 12, Okla. Sponsor of this year's convention is the Aeronautical Center Amateur Radio Club, Inc.

-30-

THE Twenty-first Annual Hamfest of the South Hills Brass Pounders & Modulators has been scheduled for Pittsburgh's South Park Totem Pole Lodge on August 3, from noon to 6 p.m.

The committee has planned games for young and old, prizes galore, a swap shop, and display of commercial radio equipment. Preregistration is \$1.50 with \$2.00 tariff at the door. Advanced registrations should be made with William Guthrie, W3LDB, 4949 Roberta Dr., Pittsburgh 36, Pa.

-30-

190 TO 9050 KC ALL BAND RECEIVER

AIRCRAFT • WEATHER • BROADCAST MARINE • FOREIGN • MOBILE AMATEUR — 40, 75, 80 & 160 METERS

NAVY ARB/CRV 46151—Four Band, Six Tube Superhet—Local and remote tuning and band change, illuminated dial, sharp and broad tuning, AVC, CV, provisions for operation of DU-1 Loop. Complete with tubes: 1/12SA7, 1/12A6, 4/12SF7, & 24 Volt Dynamotor. Size: 8" x 7" x 16". Conversion for 12 Volt or 115 V 60 cycle available.

Price, USED: **\$18.95**
 ABOVE—Converted to 12 Volt, with Dynamotor (No Electric Band Change) **\$26.95**
 Conversion for 115 Volt 60 cycle with Spin Dial, Phone Jack, CW, Vol. Control, On & Off Switch (all on front panel)—KIT of PARTS, with Instructions **\$10.00**
 Conversion—as Above—for 12 Volt DC—Kit of Parts, with Dynamotor **\$10.00**
 Remote Control Box **\$2.00** Tuning Knob, for large splined shaft... **\$1.00**
 Remote Control Head **2.00** T-Shaft Adapter f/remote & local tuning. **1.50**
 Remote Control Shaft **1.50** Plugs only f/Rec. or Control Box... Ea. **1.00**
 Cable, with Plugs... **2.75** New Spin Knob f/converting tuning direct **1.00**

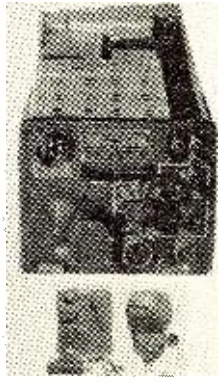

TEST OSCILLATOR

Test Oscillator—low power Trans. or Het Freq. Meter for 75 MC. Crystal control. Modulation 400, 1300 & 4000 cycles. Battery operated 1.5 V & 90 V. Tubes: 1/1A5, 3/1C5; Weston 3" Meter measures Batt. Crystal, Doubler, Tripler & Modulation on 0-10 MA, 0-2 VDC & 0-100 VDC Scale. Used for checking Marker Beacon Rec. & Trans. Chassis only—no case—part of BC-376 Test Set. Price, With Tubes & Crystal... **\$14.95**
 Price, less tubes and crystal... **\$8.95**
 BC-357 MARKER BEACON RECEIVER—75 MC. with Tubes: 12C8 & 12SQ7 & sensitive relay which operates when signal is received. Operating voltage 24 VDC. Prices: NEW... **\$5.95**; USED... **\$3.95**

MODULATOR AUDIO AMPLIFIER

Modulator Audio Amplifier with variable audio modulation 200 to 4000 cycles, Diode Bias, Sweep-time, Pulse delay, & Width Controls. Standard 19" rack mounting, 115 Volt 60 cycle voltage regulated power supply. 20 Tubes: 14/12SN7, 1/5U4, 3/VR-150, 1/6L6 & 1/6X5. **\$19.95**
 PRACTICE CODE TAPE SETS—15 Reels in Wood Case... **\$18.95**

Price, USED: **\$18.95**

PRIVATE TELEPHONE SWITCHBOARD

BD-7 PORTABLE TELEPHONE SWITCHBOARD—Six private lines or extra party lines for use up to 20 miles. Hand ringing magneto type, using flashlight batteries. Automatic signal, night light & alarm. Desk type cabinet with folding, adjustable legs. Wt.: 60 lbs. Size, with legs folded: 18" x 12" x 14". Complete with Headset & Chest Mic. NEW: **\$24.95**— **\$14.95** USED Telephone Handset \$3.00 Extra

Extension Phones for use with above: EE-8 Field Telephone, in canvas carrying Case—Used... **\$14.95** RM-29 Wall Phone—New... **\$ 9.95** Telephone Wire—outdoor or indoor, 500 ft. **\$4.95**—2500 ft. **\$19.95**. (Specify type when ordering).

AC POWER SUPPLY

BC-603—683—3050 Plug in type, interchangeable with Dynamotor. No conversion to Rec. except adding On & Off Switch to front panel. Supplies 220 VDC 80 MA & 24 VAC 2 A. KIT of PARTS: **\$10.50**; Wired: **\$14.95**

THE WORLD'S FINEST SURPLUS BARGAINS!

For Details on Items Previously Advertised—SEND for FREE CATALOG #M-58!

TRANSMITTERS—RECEIVERS:	DYNAMOTORS:
SCR-522 Trans.-Rec. 100-156 MC AM... Used: \$29.95	12/625 VDC 225 MA DM-35 N: \$14.95 U: \$11.95
BC-1335 FM—27 to 38.9 MC—w/Pow. Sup... U: 24.95	12/220 VDC 80 MA DM-34 N: 4.95 U: 2.95
BC-604 FM—20 to 27.9 MC—Used: \$14.95 —New: 19.95	12/540 VDC 450 MA DA-12 N: 14.95 U: 11.95
BC-684 FM—27 to 39.1 MC—Used: \$14.95 —New: 19.95	12/440 VDC 200 MA N: 12.95 U: 9.95
BC-3050 FM—30 to 50 MC—10 MC Spread—New: 29.95	6/640 VDC 260 MA G.E. Reconditioned 12.95
BC-603 FM—20 to 27.9 MC—Used: \$14.95 —New: 19.95	6/420 VDC 200 MA G.E. Reconditioned 9.95
BC-683 FM—27 to 38.9 MC—Used: \$24.95 —New: 29.95	For Other Dynamotors—Send for List!

Address Dept. RN • \$5.00 Order Minimum, & 25% Deposit on C.O.D.'s • Prices are F.O.B. Lima, Ohio

FAIR RADIO SALES 132 SOUTH MAIN ST. LIMA, OHIO

ENGINEERING DEGREES

E.E. Option Electronics or Power
 Earned through Home Study Residence classes also available
 (Operating as a College of Engineering only at present)
 5719R Santa Monica Blvd. Hollywood 38, California

QUAL-KITS ARE EASIEST!

H-F Amplifier Kit **\$28.50**
 H-Fr AM-FM Tuner Kit **\$28.95***

And they have the finest features and specs. Fully illustrated step-by-step 28-page manual makes assembly a snap!
 WRITE FOR FREE CATALOG! *10% Federal Tax.
QUALITY ELECTRONICS
 319 Church Street Dept. T-7 New York 13, N. Y.

MOTOROLA CAR RADIOS

Custom-designed to Fit YOUR Car! **LOW PRICES!**

The Finest in Styling and Performance

- Custom-designed pushbutton and manual sets
- Complete line of transistor-powered models
- Universal models . . . two types of tuning

Over 2,000 radios in stock at all times
 Quick Delivery
 Send for complete catalog

Liberty Auto Radio, Inc.
 191 East 161 Street • New York 51, N. Y. • LUdlow 8-7111

VACUUM CONDENSER SPECIAL

Jennings JCS-2A
25 MMF 10 KV.....ea. **\$2.95**

MICROAMMETER SPECIAL

2 1/2" 0-50 Microamps. (Scale 0-5.) Each **\$4.95**

MOBILE DYNAMOTORS

SMALL SIZE
Input 1 1/2 to 12 Volts. Output 425 V.
@ 375 Ma. Each **\$12.95**

FILAMENT TRANSFORMERS

Primary 115V. or 230V.-60 Cy. Sec. 6.3 V. @
20 Amps. Size: H-4 1/2" x W-4" x
D-3 1/2" Each **\$3.50**
Primary 110 Volts 60 cycle. Secondary 2 1/2 V.
10 amps 10,000 V. Insulation. Suitable
for pair of 866 tubes. **\$3.95**

CHOKE—FULLY CASED

10 HENRY 80 Mil (unshielded) 90c
6 HENRY 150 Mil \$1.50
8 HENRY @ 200 Ma 1.95
4 HENRY 300 Mil 2.95
8 HENRY 500 Mil 5.95

OIL CONDENSER SPECIALS BRAND NEW

2 MFD 600 VDC .50	4 MFD 2000 VDC 3.50
4 MFD 800 VDC .75	6 MFD 2000 VDC 4.95
6 MFD 800 VDC .95	6 MFD 2000 VDC 2.50
8 MFD 600 VDC .95	4 MFD 2500 VDC 4.95
10 MFD 600 VDC 1.19	1 MFD 3000 VDC 1.85
12 MFD 600 VDC 1.50	4 MFD 2000 VDC 6.95
1 MFD 1000 VDC .60	1 MFD 7500 VDC 6.95
2 MFD 1000 VDC .85	5 MFD 7500 VDC 2.95
4 MFD 1000 VDC 1.35	1 MFD 12,500
8 MFD 1000 VDC 1.95	1 MFD 15,000 VDC 29.95
10 MFD 1000 VDC 2.95	1 MFD 15,000
12 MFD 1000 VDC 3.25	VDC 34.50
1 MFD 1200 VDC .45	1 MFD 25,000 VDC 69.50
1 MFD 1500 VDC .75	10 MFD 330 AC. 1.95
2 MFD 1500 VDC 1.10	15 MFD 440 AC. 2.50
4 MFD 1500 VDC 1.95	8 MFD 660 AC. (2000 DC) 2.35
8 MFD 1500 VDC 2.95	
1 MFD 2000 VDC .85	
2 MFD 2000 VDC 1.50	

REDMOND BLOWER

110V. 60 cyc. .3 Amp. 1600 Rpm. 3 3/4" Blower
wheel—Outlet 2" Diameter. Suitable for
cooling Transm. tubes, etc. ea. **\$7.95**
2 for \$15.00

ELECTRICAL TESTER

AC-DC PROBE—2 METERS IN PROBE
1 meter measures Voltage 55, 110, 220, 440.
Second meter indicates whether AC or DC, and
if DC, polarity at tip of probe. ea. **\$5.50**
PRICE

SIGMA 5F RELAY

16,000 ohm in dual 8,000 ohm coils. (Can be
paralleled) SPDT adjustable silver contacts. Ad-
justable armature tension. Operates on 500
microamperes or less. Ultimate in a sensitive
relay. Ideal for precision control
work ea. **\$3.95**
Write for quantity prices.

RELAYS

Sealed Claire SPST. Norm. closed 3000 ohm
coil 4 ma. **95c**
Claire Telephone Relay 11,300 ohm coil
DPDT cont. 10 amp 125V. Sens. 4MA. ea.
Hermetically Sealed Relay Coil 110V AC
60 cy SPDT Contacts 5 Amps ea. **\$3.95**
110 V. AC DPDT **\$1.85**
Contacts 10 Amps **\$1.75**
110 V. AC TPDT **\$1.95**
Contacts 5 Amps **99c**
6 Volt DC **\$1.35**
DPDT H.S. **\$1.05**
12 Volt DPDT DC Relay **\$6.95**
Each **\$2.50**
12 Volt DPST Advance Relay **\$1.25**
Each **\$1.10**
Cramer Time Delay Relay, 220V 60 cy.
45 sec. adj. 2 pole DT. ea. **\$2.50**
G.E. Plug in Relay 5 prong 10,000 ohm
coil 1 mil SPDT ea. **\$1.25**
Telephone type relay 12 V. DC @ 10 ma.
triple pole single throw. Normally open.
G.E. Relay control, contains 8000 ohm
relay, sensitivity 2 mils. 10 for \$9.25. ea. **\$1.10**

PANEL METERS

G.E., WESTINGHOUSE, W.E., SIMPSON, etc.
2" METERS
0-200 Ma DC 2.95
0-500 Mil DC 2.95
1-0-1 Amps DC 2.95
0-10 Amps DC 2.95
0-25 Amps DC 2.95
15-36 Volts DC 1.99
0-50 Volts DC 2.95
0-150 V. AC 3.49
0-4 Amps RF 2.95
3" METERS
0-100 Micro (Scale 0-3) 5.95
0-1 Mil DC (0-3 1/2 KV scale) 4.50
0-5 Mil DC 3.95
0-10 Mil DC 3.95
0-50 Mil DC 3.95
0-100 Mil DC 3.95

MISCELLANEOUS SPECIALS

N.E. 51 NEON LAMPS, Box of 10 ea. \$1.00
50 OHM 6 watt (Non-Inductive) ea. 35c
3-12 MMF Erie Ceramic Trimmers 21c
Replacement 6" phone cord for Standard
Headsets 35c
OHMITE CAP SWITCH Model 608 D.P. ea. \$8.95
4-Throw, 100 Amps AC ea. \$8.95
Write for quantity prices on all special items

All merchandise sold on a 10 day money back guarantee basis

Min. Order \$3.00—25% with Order—F.O.B. New York

PEAK

ELECTRONICS COMPANY

66 W. Broadway, New York 7, N. Y., WO-2-5439

3-D Hi-Fi Amplifier

(Continued from page 59)

will be described presently. Indeed, it leads to new and frequently very satisfying forms. Many considerations have to be taken into account, for example, heat problems or induction or coupling possibilities. The best design is frequently a happy balance between conflicting requirements.

To make maximum use of the available space, the basic units sometimes have complicated shapes. This may be due also to the necessity of facilitating, as far as possible, assembly and wiring and also maintenance and eventual replacement. Complicated shapes are no problem whatsoever; the corresponding parts are molded in plastic, and the assembly recalls, in a simpler way, those Chinese games where a number of odd looking pieces can be assembled to make an honest cube.

Molded plastic is light, cheap, and ideally suited to mass production.

The fundamental principles of 3-D assembly will best be illustrated by an example.

A.F. Amplifier

The unit shown here is a push-pull output ("Ultra-Linear" type) audio-frequency amplifier, with one stage of preamplification and one driver combined in a single 6U8 tube. The output pair can be a number of types: EL84, 6AQ5, 6BQ5, etc.

This small standard amplifier passes sinusoidal signals from less than 10 to more than 200,000 cps. Its power output of 4 watts is obtained for a 0.5 volt input signal in the "Hi-Fi" position. The maximum feedback is 44 db. For a 0.5 watt output power, distortion is less than 0.5% from 20 to 1500 cps. Intermodulation distortion, using 50 and 6000 cps in a 4/1 ratio, is 0.25% for 0.2 volt input signal. These are minimum performances.

Assembly

The complete amplifier is shown in the photographs. Its over-all dimensions are: height 6", width 3 1/2", depth 5". It will be noted that the originality in design is accompanied by originality in appearance.

The two knobs are the volume and tone controls. The keyboard switch on front has five keys. From left to right: the first one is the main switch; the second and third are the hi-fi (full feedback) position, and switch respectively out and in a treble-cut capacitor, thus giving "treble" and "bass" positions; the fourth and fifth are the high gain (partial feedback) positions, with the same arrangement for treble and bass positions.

The socket is destined to feed an associated AM-FM tuner. It provides heater and plate voltages. It is visible on the front of the high-fidelity amplifier's cabinet.

The main part in this amplifier, as

in any audio amplifier, is the output transformer. The performance just indicated would be impossible to obtain within the small space occupied by the transformer if it were not for the use of grain oriented laminations. However, the usual C or E cores, too costly, have been replaced by an original arrangement. The laminations are cut in rectangular shapes of increasing length, bent in U fashion, and interleaved with a large amount of overlap. Symmetrical sandwich windings are resorted to, to ensure balance between the two halves of the transformer. The assembled transformer is then inserted in its plastic case. This case is one of the unique parts which have been designed 3-D fashion. It comprises not only the case for the transformer, but also a molded subchassis for the output stage. The sockets are molded in and the various pin contacts clip in place; they carry "tails" of different lengths, which replace the connecting wires.

The transformer coil form is molded and a center partition separates the two half-windings. This form is made of two identical halves, the mold being then cheaper.

A similar process is used for the simple power transformer coil form; moreover, this form is also made of two identical halves.

All the extruded parts can be made in a number of plastics and different colors are used to enhance the overall effect.

Another complex special part is the preamplifier block, which contains the preamplifier tube socket and all associated components in "tailored" recesses. A cylindrical shield encases the tube and its wiring.

A sub-element which is not molded, but encased in a square shielding can, is the input and feedback circuits assembly, including the volume and tone controls. A number of smaller molded parts had to be developed for the purpose.

The photograph of the completed amplifier shows how these parts assemble together to give a really compact piece of equipment. Even so, enough space has been left available to permit the eventual addition of a 12AX7 preamplifier stage for low-level inputs, in another version of the amplifier.

Future Developments

The 3-D assembly process is evidently best suited to mass produced equipment. This is why the firm B.T.H., which exploits the new technique, began to apply it to audio amplifiers and to AM, FM, and AM-FM receivers, which enjoy a wide home market.

However, it is apparent that the idea can profitably be extended to professional or semi-professional equipment. No doubt then that 3-dimensional equipment will successfully meet the challenge of the fourth dimension, and that is the important dimension of time.

—50—

HI-FI ANAGRAM

By JOHN A. COMSTOCK

IF YOU know the true meaning of the term "hi-fi," how familiar are you with the many expressions used in this growing branch of radio-TV-electronics? If you have an average lay knowledge of the subject, you should be able to whiz through this puzzle with no difficulty.

(Solution on page 129)

ACROSS

1. Speaker board.
4. Treble speaker.
8. Three-dimensional sound effect.
9. Network which separates bass and treble frequencies and transmits them to different speakers.
11. Recorder utilizing an iron oxide-coated ribbon, for storage of intelligence.
13. Unit of weight for phono stylus pressure.
15. Electrical network designed to accept, reject, or reduce certain frequencies.
16. The general character of reproduced sound as it affects the ear.
17. Bass speaker.
20. Record playing device.
21. Pertaining to hearable frequencies.
22. Dual-channel sound system utilizing two signal sources, amplifiers, and a dual headphone system.
24. Electro-acoustical unit that converts current variations into sound waves.

DOWN

1. Speaker enclosure which employs phase inversion and speaker loading for maximum bass reproduction.
2. Ability to reproduce faithfully.
3. Control which permits balancing sound according to room acoustics and individual taste.
4. A hi-fi program source.
5. Type of phono cartridge which permits playing of both standard and micro-groove recordings.
6. What a cathode-follower introduces.
7. Term meaning capable of being perceived by the organs of hearing.
10. A sound ratio.
12. Abbreviation for network.
14. Tape recorder designed exclusively for single-channel recording and reproduction.
18. Type of speaker.
19. Low-frequency sound.
23. Abbreviation for audible frequencies.

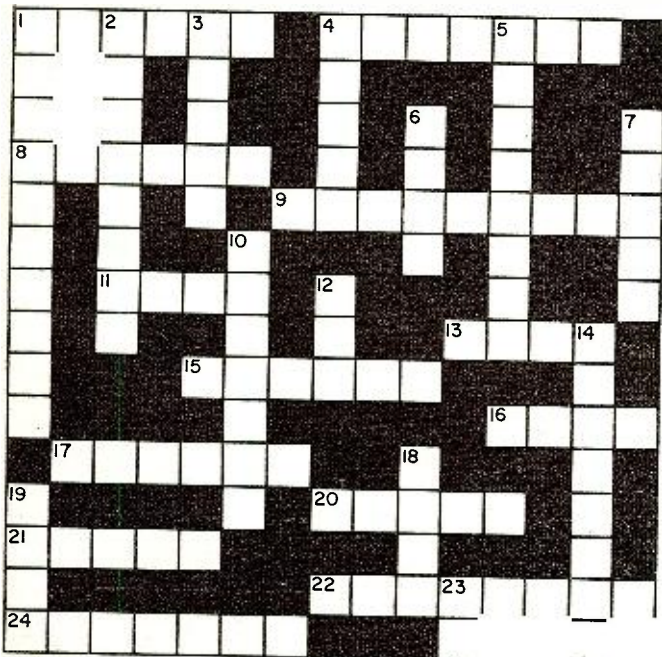

July, 1958

RADIO and ELECTRONICS TRAINING AT HOME

BUILD 16 RADIO

CIRCUITS with DELUXE

1958 Progressive
RADIO "EDU-KIT"

Reg. U.S.
Pat. Off.

PRACTICAL ^{only}
HOME \$22.95
RADIO
COURSE



NOW INCLUDES
★ 12 RECEIVERS
★ TRANSMITTER
★ SIGNAL TRACER
★ SIGNAL INJECTOR
★ CODE OSCILLATOR

- * No Knowledge of Radio Necessary
- * No Additional Parts or Tools Needed
- * Excellent Background for TV
- * School Inquiries Invited
- * Attractively Gift Packed

FREE EXTRAS

• SET OF TOOLS • RADIO & ELECTRONICS TESTER • ELECTRIC SOLDERING IRON • TESTER INSTRUCTION MANUAL • MEMBERSHIP IN RADIO-TV CLUB; CONSULTATION SERVICE • HI-FI GUIDE • QUIZZES • TV BOOK • FCC AMATEUR LICENSE TRAINING • RADIO BOOK • PRINTED CIRCUITRY • PLIERS-CUTTERS • ALIGNMENT TOOL • WRENCH SET • CERTIFICATE OF MERIT • VALUABLE DISCOUNT CARD

WHAT THE "EDU-KIT" OFFERS YOU

The "Edu-Kit" offers you an outstanding PRACTICAL HOME RADIO COURSE at a rock-bottom price. Our kit is designed to train Radio & Electronics Technicians, making use of the most modern methods of home training. You will learn radio theory, construction, servicing, basic Hi-Fi and TV repairs, code, FCC amateur license requirements.

You will learn how to identify radio symbols, how to read and interpret schematics, how to mount and layout radio parts, how to wire and solder, how to operate electronic equipment, how to build radios. Today it is no longer necessary to spend hundreds of dollars for a radio course. You will receive a basic education in radio, worth many times the small price you pay, only \$22.95 complete.

THE KIT FOR EVERYONE

The Progressive Radio "Edu-Kit" was specifically prepared for any person who has a desire to learn Radio. The "Edu-Kit" has been used successfully by young and old in all parts of the world by many Radio Schools and Clubs in this country and abroad. It is used for training and rehabilitation of Armed Forces Personnel and Veterans throughout the world.

The Progressive Radio "Edu-Kit" requires no instructor. All instructions are included. Every step is carefully explained. You cannot make a mistake.

PROGRESSIVE TEACHING METHOD

The Progressive Radio "Edu-Kit" is the foremost educational radio kit in the world, and is universally accepted as the standard in the field of electronics training. The "Edu-Kit" uses the modern educational principle of "Learn by Doing," to illustrate the principles which you learn.

You begin by examining the various radio parts included in the "Edu-Kit." You then learn the function, theory and wiring of these parts. Then you build a simple radio. With this first set, you will enjoy listening to regular broadcast stations, learn theory, practice testing and troubleshooting. Then you build a more advanced radio, learn more advanced theory and techniques. Gradually, in a progressive manner, and at your own rate, you will find yourself constructing more advanced multi-tube radio circuits, and doing work like a professional Radio Technician.

Included in the "Edu-Kit" course are sixteen Receiver, Transmitter, Code Oscillator, Signal Tracer and Signal Injector circuits. These are not unprofessional professional wiring and soldering on metal chassis, plus the new method of radio construction known as "Printed Circuitry." These circuits operate on your regular AC or DC house current.

In order to provide a thorough, well-integrated and easily-learned radio course, the "Edu-Kit" includes practical work as well as theory; troubleshooting in addition to construction; training for all, whether your purpose in learning radio be for hobby, business or job; progressively-arranged material, ranging from simple circuits to well-advanced topics in Hi-Fi and TV. Your studies will be further aided by Quiz materials and our well-known FREE Consultation Service.

THE "EDU-KIT" IS COMPLETE

You will receive all parts and instructions necessary to build 16 different radio and electronics circuits, each guaranteed to operate. Our Kits contain tubes, tube sockets, variable electrolytic, mica, ceramic and paper dielectric condensers, resistors, tie strips, coils, hardware, tubing, punched metal chassis, Instruction Manuals, hookup wire, solder, etc.

In addition, you receive Printed Circuit materials, including Printed Circuit chassis, special tube sockets, hardware and instructions. You also receive a useful set of tools, a professional electric soldering iron, and a self-powered Dynamic Radio & Electronics Tester. The "Edu-Kit" also includes Code Instructions and the Progressive Code Oscillator, in addition to the F.C.C.-type Questions and Answers for Radio Amateur License training. You will also receive lessons for servicing with the Progressive Signal Tracer and the Progressive Signal Injector, and a High Fidelity Guide and Quiz Book. Everything is yours to keep.

J. Statistis, of 25 Poplar Pl., Waterbury, Conn., writes: "I have repaired several sets for my friends, and made money. The "Edu-Kit" paid for itself. I was ready to spend \$240 for a course, but I found your ad and sent for your Kit."

UNCONDITIONAL MONEY-BACK GUARANTEE

The Progressive Radio "Edu-Kit" has been sold to many thousands of individuals, schools and organizations, public and private, throughout the world. It is recognized internationally as the ideal radio course.

By popular demand, the Progressive Radio "Edu-Kit" is now available in Spanish as well as English.

It is understood and agreed that should the Progressive Radio "Edu-Kit" be returned to Progressive "Edu-Kits" Inc. for any reason whatever, the purchase price will be refunded in full, without quibble or question, and without delay.

The high recognition which Progressive "Edu-Kits" Inc. has earned through its many years of service to the public is due to its unconditional guarantee upon the maintenance of perfect engineering, the highest instructional standards, and 100% adherence to its Unconditional Money-Back Guarantee. As a result, we do not have a single dissatisfied customer throughout the entire world.

ORDER FROM AD—RECEIVE FREE BONUS RESISTOR AND CONDENSER KITS WORTH \$7.00

- Send "Edu-Kit" Postpaid. I enclose full payment of \$22.95.
- Send "Edu-Kit" C.O.D. I will pay \$22.95 plus postage.
- Send me FREE additional information describing "Edu-Kit." Also send FREE Radio, TV & Hi-Fi Books worth \$1.50. No obligation.

Name.....
Address.....

Progressive "EDU-KITS" Inc. 1186 Broadway, Dept. 79E
Hewlett, N. Y.

RADIO ELECTRONIC SURPLUS

BC683 FM RECEIVER



27-39 mc. Equipped with 10 push buttons for selecting channels. Cont. variable tuning over the entire range. Unit complete with tubes, built-in loud speaker, squelch circuit, head phone jacks, schematic diagram on bottom of case. Approx. weight 34 lbs. Used, good.....\$12.50 each
12- or 24-volt D.C. Dynamotoreach \$3.95

BC603 FM RECEIVER

Same description as BC683 except that range is 20-27 mc. This unit complete with tubes. Like New.....each \$6.95
Manual with schematic for BC603 & BC604each \$1.00 each

BC684 TRANSMITTER

(Used with BC683 receiver.) Used, good...\$4.95 each
CRYSTALS (set of 80) for BC604 transmitter...\$5.00

DM35 DYNAMOTOR

Input 12 volt D.C., 18.7 amps. Output 625 volts, 225 ma. Used, good.....\$9.95 each
FT237 RACK for above receivers and transmitter\$4.95

BC1335 2-CHANNEL FM TRANSCEIVER



30-39 mc. This unit is complete with 18 tubes operating from either 6 or 16 volts D.C. (Self-contained power supply). Crystal control, sensitive superhet circuit. Approx. dimensions 11" x 10" x 6". Approx. weight 24 lbs. Unit complete with tubes, schematic diagram and pre-testing instructions. Like New.....each \$22.50

BC659 FM TRANSCEIVER

29-40 mc, 2 channels, crystal control. Unit complete with tubes, built-in speaker and dual meter for testing filament and plate circuit. Approx. dimensions 16" x 13" x 7 1/2". Like New.....each \$6.95
Manual with schematic for BC659.....each \$1.00

NT-6 WILLARD 6-VOLT STORAGE BATTERY



Rated 2.4 amp. hr. Approx. dimensions: 3 1/2" l. x 1 3/4" w. x 2 1/8" h. Weight: 1 lb. 3 oz. (plastic case) Dry charged PRICE \$2.50 ea.

ELECTROLYTE
Pint Bottle with Filler Bulb \$1.00

500 KC CRYSTALS IN FT241 HOLDER

(54th harmonic type). \$1.00 each, 6 for \$5.00 postpaid



AN/CRC-7 VHF TRANSCEIVER



With voice or transmit tone, used with air-sea rescue work. Crystal controlled. 140.58 mc. Used, good. See Conversion Data April '58, CQ \$15.00 each (less battery)

44 POSITION STEPPING SWITCH

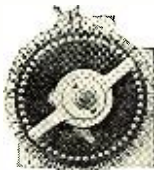

With automatic reset. 24 volt A.C. Dimensions 4 1/4" x 4 1/4" x 3" deep. Mfgd. by Wico. \$3.00 each

Five for \$12.50 postpaid

RG-8/U (52 OHM) 100 FT. Roll \$5.95 per roll
RG-11/U (75 OHM) 200 FT. Roll With Connectors \$7.95 per roll

NO C.O.D.'s. REMIT FULL AMOUNT WITH ORDER. ALL PRICES F.O.B. PASADENA.

C & H SALES CO.

2176 E. Colorado St. - Pasadena 8, Calif.

Radiation Detectors

(Continued from page 46)

the signal pulses, then feeds them to the grid of V_3 . The two stages of amplification have a sensitivity of approximately .1 volt and limit at an input of .25 volt.

V_3 and V_4 together form a multivibrator oscillator. (Note the common cathode resistor of 15,000 ohms.) The control grid of V_3 is returned to a positive point on a voltage divider connected between "B+" and ground, causing V_3 to conduct. Current flow through the common cathode resistor is sufficient to cut off V_4 . V_4 is only allowed to draw current during the short operating cycle following each negative input trigger. The "Range" switch connects capacitors between the plate of V_3 and the grid of V_4 and, together with the common cathode resistor, provides the necessary cross-coupling. The capacitors switched between the two tubes determine the period of time the multivibrator will remain in its unstable state. This, in turn, determines the average current flowing through the meter. The meter is calibrated in both counts per minute and milliroentgens per hour.

The transistor oscillator uses a small output transformer as the oscillatory inductance. Its operating voltage is obtained from the voltage drop across a bypassed portion of the plate load resistance for V_4 . Thus voltage is present only during the unstable state following the input trigger pulse. A small loudspeaker, connected directly across the output-transformer secondary, reproduces the audio tone generated by the transistor oscillator.

Two flashlight cells for the heaters and a 67 1/2-volt "B" battery (such as is used in many portable radios) supply all operating voltages. The power-supply subassembly obtains operating voltage from the 67 1/2-volt "B" battery. However, its built-up output voltage is greater than 1200 volts, but is regulated at 900 volts for use with the Geiger-counter probe.

When the instrument is turned off, the "Range" switch puts a short across the meter for protection. A "time constant" circuit has been incorporated to give added flexibility to the counter, allowing a meter time constant of 1/2 second to 10 seconds. The 1/2-second position of the "time constant" switch is used when the detector is being moved about rapidly, as when locating a source of radioactivity. The 10-second position is used for accuracy in assessing amounts of radioactivity once a source is established.

The corona voltage-regulator tube, V_5 , is used to regulate the output voltage of a high-voltage, low-current power supply. When two coaxially positioned cylindrical electrodes are enclosed in a gas-filled envelope and a d.c. potential is applied between them in such a direction that the inner electrode is positive with respect

to the outer, the unit may be considered as a variable resistor which is very current sensitive. The volt-ampere relations will exhibit three distinctly different regions of operation, as illustrated in Fig. 10A.

The exact values of voltage and current for any one of these regions are determined by electrode dimensions as well as the nature of the gas and pressure. If the tube is designed for operation in the glow region, the characteristic curve may pass through the corona region quickly.

These three areas of operation may be distinguished by the location of light visible in the tube. The corona will appear around the anode, while the glow appears adjacent to the cathode. The arc is visible between the two.

Corona tubes are useful for high-voltage, low-current application; glow tubes for medium voltages and currents; the arc involves higher currents and lower voltages. As a voltage regulator, the corona tube is connected across the load whose voltage is to be regulated. A graph showing its characteristics in this function is given in Fig. 10B.

The counter tube, mounted in the probe, is a gas diode. The ions and electrons produced within the tube by the entering particles are accelerated by the electrode potential and produce other ions. The discharge spreads throughout the tube in this manner. The electrons, which are collected rapidly, account for the rise time of the pulse.

Counter tubes are classified according to the type of radiation which they are designed to measure, which may determine their wall thickness and the material of which they are made. The 6306 tube used in the Geiger Counter Probe Model GC-1 is designed for accurate gamma counting in this instrument. The aluminum shell, although only 0.11 millimeter thick, is very strong. The tube will operate satisfactorily even after being accidentally dented. (To be concluded)

Fig. 10. Operating regions (A) of the regulator tube used in the Heath counter. Graph (B) shows regulation curve.

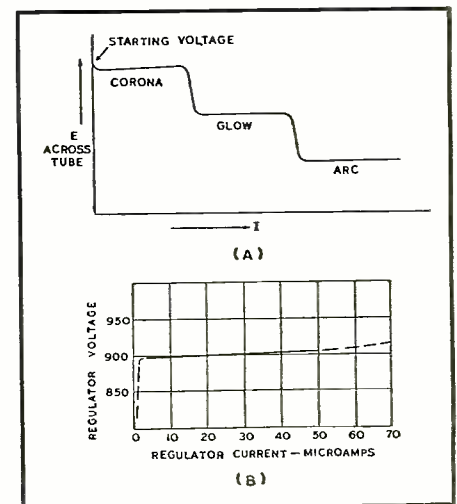

3
new
STEREO-
FIDELITY
components
by

Pilot



SP-210 • Stereo Preamplifier
\$89.50 less power supply
P-10 Power Supply \$15.00

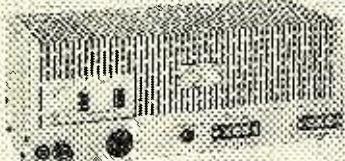

SA-232 • Basic Stereo Amplifier
Total Power Output:
64 watts peak
Has power tap off for SP-210
\$89.50

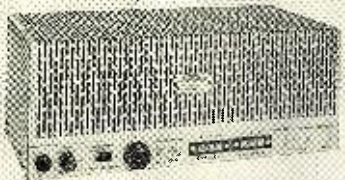

SA-260 • Basic Stereo Amplifier
Total Power Output:
120 watts peak
Has power tap-off for SP-210
\$119.50
prices slightly higher in West

Pilot Radio Corporation DD-7

37-06 36th St., L. I. C. 1, New York

Please send literature covering
Pilot Stereo Components.

NAME _____

ADDRESS _____

CITY _____ ZONE _____ STATE _____

Electronics manufacturer
for over 39 years.

Certified
RECORD REVUE

By BERT WHYTE

BY THE time this issue reaches you, the major record companies will have released their first stereo discs. After much hearsay and conjecture, my spies inform me that it's almost a 100% sure thing that the stereo discs from the majors will make their formal debut at the National Association of Music Merchants' Convention in July. I reported this to you last month as "rumor" . . . this month the position has "firmed up" and all indications are that the age of the stereo disc will begin in July. Meanwhile, several other smaller firms have reached the marketing stage with their stereo discs.

Anyone who has read this column over the past years knows that I have always championed the cause of stereo, in all of its various manifestations. I say this because, I certainly don't want anyone to feel that I am normally given to throwing cold water on ideas. But after listening to some of the first stereo discs from some of the smaller labels, you'll pardon me if I take vanilla. Maybe some of this stuff sounds good on the cheap jury-rig type of stereo systems, but I assure you that on any kind of reasonably good component hi-fi stereo disc set-up, the results from many of the discs have been shockingly bad.

Now mind you, I'm not knocking a guy just because he wants to get a product out in the field and start coining loot. Nothing wrong with that. But whether you're selling apples or stereo discs, the principle is the same . . . if you don't have a good product that offers good value you'll soon be out of business. And it's very easy to dismiss this by just saying "who cares" or "that's tough." Trouble is, in a deal like the stereo disc, disillusionment about a bad product could lead to public boycott of stereo discs in general. And for those who would scoff at this possibility, you would be surprised at the number of stereo discs which have already been sold. Sure, these people represent a minuscule percentage of the public who buys records, but never forget the power of word-of-mouth.

Remember the lesson of color TV. Here, too, the percentage of people who had color sets was very tiny in the over-all market. But the majority of these set owners had trouble with their color and from that tiny fraction of discontent the color fiasco was born. I will be the first to admit that today's color set still is not the perfected device that it should be. But there are many people who have color sets which work very well. Yet in most areas, color TV is unjustly maligned . . . because, "my brother Joe bought one and it was a dog," "Mary Jones told me that her sister had a set and there was always trouble with it," etc., etc. *ad infinitum*.

Perhaps you may feel that I am exaggerating and that when the majors bring out their stereo discs the problem will take care of itself. This is only partly true because as-

suming it were wholly true, the majors would have to turn out perfect records. That because they are "majors" their stereo discs will automatically be perfect is sheer wishful thinking. The point and the root of all this is that most of the small companies do not have their own equipment to cut stereo masters and the majors who do own equipment do not necessarily have all the answers on stereo cutting. My attitude is this . . . I want stereo discs just like everybody else . . . I think the industry needs them to keep the recession at bay and I think the market potential for them is tremendous. But much as I would like to see the discs come from the majors in July, I feel there is little to be gained and much harm to be done if bad stereo discs are released. It would seem that many of the independent studios that do the cutting for the small labels have a lot to learn about cutting a stereo disc, nor, as pointed out, is the major necessarily guiltless on this point. It is equally obvious that companies which do perfect the cutting of a stereo disc will gain an important market advantage. Let us hope that, target date or not, cool heads will prevail in the industry and no one will release stereo discs to the public until and unless they have been thoroughly "debugged."

Your reporter is leaving for an extensive tour of Europe where I'll be visiting all the music festival spots. I hope to be able to visit a number of recording companies and hi-fi manufacturers. If it can be all worked out, I hope to be able to give you an idea of what is happening in the hi-fi sphere in Europe and what plans are afoot on European stereo discs. And you have a nice vacation and remember not to leave vinyl discs in the open sun in a convertible or in a closed car during the hot weather. If you forget, your discs will make the best warped skeet targets you ever saw . . . I know because I pulled this goof myself!

SCHUBERT

SYMPHONY #7 IN C
Cleveland Orchestra conducted by George Szell. Epic LC3431. Price \$3.98.

George Szell was always a highly regarded conductor, but many people felt that he was too stiff and inflexible—a rather "cold" conductor. What happened there is no way of knowing, but about a year ago this "stiffness" began to be leavened with a bit more humanity and warmth and his recordings and concert appearances were notably improved. Today he seems to have undergone a virtual transformation as he is really storming the conductorial heights with critically acclaimed

The opinions expressed in this column are those of the reviewer and do not necessarily reflect the views or opinions of the editors or the publishers of this magazine.

concert performances and an ever increasing appreciation of his recordings.

This recording is a good case in point. Without laboring the point that there are several fine performances on LP, this present version must be accorded top spot. It is brilliantly conceived, with just tempi, superb phrasing and dynamic expression, and with Szell providing an understanding and insight that is rarely met with in performances of this work.

The playing of his Clevelanders can only be described as "splendiferous" and their precision in ensemble work is a fine tribute to Szell. The sound, too, is about the most expansive and well wrought of any of the recordings. All orchestral elements are clean and well balanced and the mixing was a happy compromise between orchestral detail and acoustic perspective spacious enough to maintain a good sense of presence. You may have three other versions of the Schubert C Major, but believe me, this is worth a listen.

SUPPÉ OVERTURES

Halle Orchestra conducted by Sir John Barbirolli. Mercury MG50160. Price \$4.98.

Here is a whole stable full of rearing war-horses including such as the "Light Cavalry," "Jolly Robbers," "Pique Dame," "Morning, Noon, and Night in Vienna," "The Beautiful Galatea," and last but not least the most infamous potboiler of them all . . . the "Poet and Peasant Overture." Frankly, I was quite prepared to be bored to death, but Sir John is incredible . . . he plays these old gassers as if he were inspired and with the huge impact of some very fine Mercury sound, I was nearly bowled over!

They whoop and holler and get up a great deal of steam, but Sir John never lets the reins rest too lightly in his hands and he achieves some wondrous sonorities. Mercury has an engineering ball with these boiler-factory scorings and it is really quite a spectacular recording. Clean throughout, with fine acoustic balance and bright sparkling orchestral detail, this is a good record for a little hi-fi on a hot July evening.

ENCORE PLEASE, SIR JOHN!

Halle Orchestra conducted by Sir John Barbirolli. Mercury MG50161. Price \$4.98.

This is more of the same general persuasion as above, but there are a few compensating items like Purcell's "Trumpet Voluntary" and Chabrier's "Marche Joyeuse." Sir John tackles these with equal and astonishing relish and it is quite a commentary on conducting of numbers like these. The sound is equally felicitous and, all in all, it's a pleasant record that makes fine summer fare.

GEORGE LONDON ON BROADWAY London 5390. Price \$4.98.

When you can get an artist of the stature of George London, a man who has sung the lead in Met Opera productions of "Boris Godounov," to lend his magnificent voice to hit numbers from such shows as "Oklahoma," "South Pacific," "My Fair Lady," and "Carousel," to name a few that are on this disc . . . brother you're a good A and R man. But make no mistake, London evidently didn't have to be unduly coaxed and his approach to these songs in no way smacks of condescension. His singing of these songs is quite straightforward . . . there isn't the usual sound of an operatic voice trying to break out of the restrictive bonds of a pop song. He has terrific projection, a great deal of sincerity, and of course his natural talent of one of the most richly resonant voices on the concert stage today. Listen to this voice and what it can do with pop numbers and then try to listen to the mewlings and cater-

July, 1958

When Converting Your Phono to Stereo...Use

The ERIE AUDIO-AMPLIFIER KIT

featuring
"PAC" and an ERIE
Printed Wiring Board

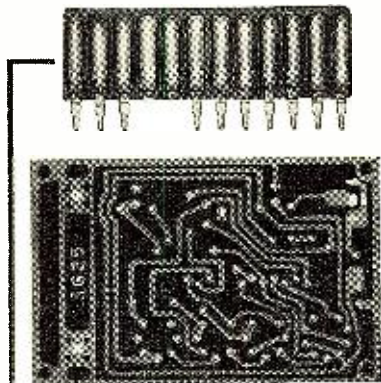

With these Plug-in Components:

- ERIE "PAC" (Pre-Assembled Components)
- ERIE PRINTED BOARD
- OUTPUT TRANSFORMER
- FILTER CAPACITOR
- VOLUME CONTROL and SWITCH
- TUBE SOCKETS
- CAPACITORS
- TONE CONTROL
- TUBES

SPECIFICATIONS FOR ERIE STANDARD AUDIO-AMPLIFIER

- Frequency Response: 30 cycles to 12,000 cycles +0, -3.5 db.
- Sensitivity: 0.56 volt RMS (input at 1 KC) for 2 watt output.
- Power Output: 2 watts • Input Impedance: 2 megohms.
- Output Impedance: 4 ohms • AC Power Consumption: 17 watts.
- Overall Dimensions: 6 5/8" L x 4 3/8" W x 3 7/8" H • Shipping Weight: 2 lbs.



MODEL
PAC-AMP-1

See and hear it at
your local distributor
or Write for
nearest source.



COYNE
TRAINS YOU
IN SPARETIME
AT HOME

COYNE
QUALITY
TRAINING
AT LOWEST
COST

TELEVISION

RADIO-COLOR TV

Only from famous COYNE do you get this modern up-to-the minute TV Home Training. Easy to follow instructions—fully illustrated with 2150 photos and diagrams. Not an old Radio Course with Television tacked on. Includes UHF and COLOR TV. Personal guidance by Coyne Staff. *Practical Job Guides* to help you EARN MONEY QUICKLY IN A TV-RADIO SALES AND SERVICE BUSINESS—part time or full time. COSTS MUCH LESS—pay only for training—no costly "put together kits."

SEND COUPON FOR FREE BOOK

SEND COUPON BELOW for Free Book and full details including EASY PAYMENT PLAN. NO COST OR OBLIGATION—NO SALESMAN WILL CALL.

B. W. COOKE, JR. **COYNE** FOUNDED 1899
PRES. ELECTRICAL SCHOOL

A TECHNICAL TRADE INSTITUTE OPERATED NOT FOR PROFIT
500 S. Paulina Dept. B8-H6 Chicago 12, Illinois

COYNE ELECTRICAL SCHOOL
Television Home Training Div.
500 S. Paulina St., Chicago 12, Ill., Dept. B8-H6

Send FREE BOOK and details of your Television Home Training offer.

Name _____
Address _____
City _____ State _____

terado Trav-Electric

MOBILE POWER CONVERTERS

Give You
110 A.C. HOUSE CURRENT ANYWHERE
You Drive or Cruise

LIST
For 6 and 12 Volt Car Batteries—Capacity: 15 to 200 W-ahy **\$12.95 UP**

NO INSTALLATION
Just plug into cigar lighter on dash of car, truck, or boat—and away we go

- OPERATE PORTABLE TV,
- SMALL DO-IT-YOURSELF
- TOOLS WHEREVER NEEDED

One of the great conveniences of our electronic age

101 USES

- PORTABLE TV
- DICTIONATION
- ALL ELECTRIC SHAVERS
- DO-IT-YOURSELF HOBBY TOOLS

See Your Electronic Parts Dealer or Jobber

terado COMPANY

DESIGNERS & MFRS. OF ELECTRONIC EQUIPMENT SINCE 1937
1058 RAYMOND AVE., ST. PAUL 14, MINNESOTA
IN CANADA: ATLAS RADIO CORPORATION LTD. ONTARIO

Tele-Vue

COMMUNICATIONS

TOWERS

FIT EVERY NEED

AMATEUR

HOME TV

INDUSTRIAL

Sturdy, dependable towers with exclusive design features. Easy to erect, easy to service . . . priced right.

Used by thousands—Hams, Signal Corps, Civil Defense, TV homes, communications and industry.

3 series—home TV telescopic, amateur telescopic, sectionals for industrial use.

ADJUSTABLE ROTOR POST

MOUNTING INSIDE TOP SECTION

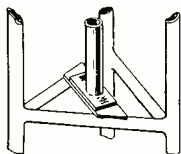

Mounting post to accommodate AR 22, C-D-R "HAM-M" and others, standard equipment on sectionals and models 30R, 40R and 50R hinged base or layover towers.

Enamel Finish or HOT DIPPED GALVANIZED AFTER ASSEMBLY. Superior design gives a clean uncluttered appearance.

Low shipping cost—will not exceed \$10 anywhere in U. S. on most telescopic models. Most areas \$5.00.

Export: Minthorne 15 Moore St., New York
Cable: Churchin, New York

TELE-VUE Towers, Inc.
701-707 49th St., So. St. Petersburg, Fla.

FREE BROCHURE RTN-2

Mail this coupon for full information

- Amateur Distributor
 Dealer Industrial

Name _____

Address _____

City _____ State _____

Prices subject to change without notice

waulings of so called "hit artists." The comparison is quite uncomfortable. The recording quality is equal to the demands of the artist and is wonderfully clean. This would make a nifty number for a summer night party.

BEETHOVEN
SYMPHONY #6 (PASTORALE)
Philharmonic Promenade Orchestra of London conducted by Sir Adrian Boult. Vanguard VSR1014. Price \$4.98.

This is one in the complete series of the Beethoven symphonies Sir Adrian is currently recording for Vanguard. This is a good recording which is neither markedly inferior to any in the catalogue, nor markedly superior. Although I should qualify this by stating that soundwise this must be regarded as one of the very top efforts. Sir Adrian plays it close to the vest here, displaying little in the way of eccentricities. Thus it is a fairly linear performance which is pleasant, but is in no way "heaven storming." Fine clean strings here and lovely woodwind sound. The acoustic balance is very well done.

HOCH UND DEUTSCHMEISTER
KAPELLE
Conducted by Julius Herrmann. London LL1744. Price \$4.98.

These Deutschmeister boys really get around! This is London's entry and we have already had the Westminster and Angel recordings of this group. I personally can take a limited amount of oompah-oomph, but I must admit that these people are first-class musicians. The program is well balanced, with liberal sprinklings of waltzes and marches. Of all the recordings thus far, this would seem to have the edge in terms of sound, although the Westminster is good too. This has, I think, a shade more presence and better articulation.

COMMAND PERFORMANCE
The Jazzpickers, featuring Red Norvo. EmArcy MG36123. Price \$3.98.

In case someone on one of these hot July nights should want some "cool" music, this should fill the bill. The Jazzpickers are an unusual instrumental jazz group featuring, of all things, a flute and cello. They are "progressive" and a very accomplished bunch. On this disc they team up with the redoubtable Red Norvo and his vibes and come up with some fine music and interesting sounds. The music as noted is of the "cool" school . . . a little more so in this case, with some very modern tonalities in evidence.

Norvo is, as always, a paragon on the vibes. He falls in with this group as easily as if he had been playing with them for years. The program is a few standards, mostly originals, and all arranged by leader Harry Babasin. Soundwise this has the clean-cut, very distinctive crispness that EmArcy strives for with this group. My only quibble is a slightly too heavy string bass. Not for everyone this, but good for the folks whose taste in classics leans towards the moderns.

PURCHASE PROTECTION

THE current status of the stereo disc has left many audiophiles in such a state of uncertainty that Shure Brothers, Inc. has put forward a plan permitting the hi-fi fan to "have his cake and eat it."

The company has announced that persons buying either its monaural professional Dynetic phono cartridge or its studio Dynetic phono reproducer now can exchange it, up to December 31, 1959, for its stereo counterpart and receive a credit of 75% of the original purchase price toward the new audio component. Fair enough!

Loudness Control

(Continued from page 35)

particular bass rise characteristic obtained from a tone control will provide more satisfactory compensation.

The loudness control seems frequently to be a source of complexity and confusion. The original idea behind this control was to eliminate the bass and treble controls by a single substitute, which would automatically vary the frequency balance in accordance with gain setting. Unfortunately, the automatic action may not be correct unless the user plays nothing but one record over and over. Typical equipment requires that maximum position of the loudness control correspond to original loudness of the music. Therefore a gain control is provided to achieve this correspondence. But the original loudness varies from one type of program material to another, and the sound level varies from one FM station to another, from one disc to another, and from one tape to another. Moreover, if one's FM tuner has a ratio detector instead of Foster-Seeley discriminator, then level will also vary with station strength. As a result of these differences in original loudness and in program source level, re-adjustment of the gain control setting is necessary in order to obtain the theoretically correct Fletcher-Munson compensation.

In addition, the change in gain setting involves a very important and not too simple judgment on the listener's part, namely the sound level in his home which corresponds to the sound level that he would have heard at the original performance. Incorrect judgment and a wrong setting of the gain control means that he is getting some kind of bass boost other than Fletcher-Munson compensation.

Finally, use of the loudness control, if one desires to make it operate correctly, involves the following steps:

1. Turn gain control down.
2. Turn loudness control to maximum.
3. Turn gain control up until level is estimated to approximate the original. (This may have undesirable consequences if practiced late at night.)
4. Turn loudness control down to desired listening level.
5. Adjust the bass control for the deviation of the particular listener's ear from the Fletcher-Munson average characteristic or for other reasons (discussed later).
6. Repeat the procedure for every new selection, change in station, etc.

As an alternate for the audiophile, the gain control may be set to the desired or permissible level and then the bass control (and the treble one, too, if desired) may be adjusted until the results please the ear. In systems employing speakers with good low-frequency response, seldom will the

listener have recourse to full bass-boost at low levels in order to restore the original frequency balance.

As far as the writer can see, the loudness control has one advantage: It leaves the bass control free to provide bass-boost over and above that required for Fletcher-Munson compensation at very low levels. Such additional boost might be desired for several reasons, such as: (1) the preference of the listener for music with greater accent on the bass than in the original performance, (2) deficiency of bass in the program source, (3) deficiency of bass in the audio equipment, most likely in the speaker.

On the other hand, this advantage might easily be overcome if bass controls were designed to supply somewhat more boost than they presently do. If boost could attain something like 25 to 30 db at 40 cycles, this would handle any situation. —30—

AN ELECTRONIC SIREN

By EDWARD H. DINGMAN

WHEN the need for a fire siren arose at the plant in which the author is employed and cost and emergency power requirements precluded the purchase of a commercial unit, the following simple circuit was designed as a substitute. It gives a realistic siren sound whose volume can be governed by the volume control setting of the factory's p.a. system.

The circuit is, in effect, a double neon tube oscillator. Assuming a discharged condition at the start, the following action takes place. C_1 starts charging through R_1 . When the voltage level has reached a value to break down the neon bulbs, PL_1 and PL_2 , C_2 is charged. As soon as the voltage on C_2 reaches a certain value, PL_1 and PL_2 are extinguished. In the meantime, C_2 is charging C_3 through R_3 . When the voltage level reaches the breakdown value of PL_2 , C_3 discharges via the path through PL_3 . R_2 is adjusted for whatever cycling rate of the siren is desired.

Because of the effect of coupling on the required frequency, it is desirable to use a low-impedance to high-impedance coupling transformer. However, capacity coupling can be used if a very small unit of approximately one-tenth the value of C_3 is selected. This will require a high-impedance, high-gain stage following it.

As neon bulbs vary in characteristics, some experimentation with resistor values may be required. Use only oil or paper capacitors in this construction. Since current drain is low, $\frac{1}{4}$ watt resistors will be suitable. —30—

Schematic diagram of electronic siren.

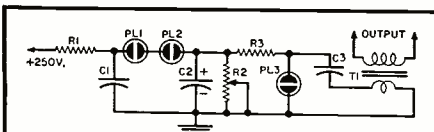

- R_1 —500,000 ohm, $\frac{1}{4}$ w. res.
- R_2 —10 megohm pot
- R_3 —1.2 megohm, $\frac{1}{4}$ w. res.
- C_1 —1 μ f., 400 v. oil or paper capacitor
- C_2 —10 μ f., 400 v. oil capacitor
- C_3 —0.001 μ f., 400 v. capacitor
- T_1 —Coupling trans. Any unit with primary impedance of 100 ohms or more to highest available secondary impedance. (UTC SO-1 "Subouncer" is suitable)
- PL_1, PL_2, PL_3 —NE-2 type neon bulb



Leo I. Meyerson
WØGFQ

Leo Says: "OF COURSE!
Your Best Buy is from

ON THIS NEW

hallicrafters SX-101 MARK III

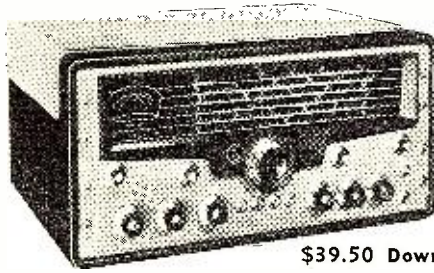

\$39.50 Down

\$395 Net Only **\$22⁷²** per mo.

Utmost mechanical and electrical stability. Complete coverage of 7 amateur bands: 160, 80, 40, 20, 15, 11 and 10 meters. Exclusive crystal-controlled upper/lower sideband selection. S-meter functions with AVC off/on. Tee-notch filter. Built-in crystal calibrator. Antenna trimmer, dual conversion, full gear drive, five steps of selectivity from 500-5,000 cycles, band in use illuminated.

Send for Complete Information Today!

World Radio!

- ★ **EASY PAYMENT**
We finance our own paper, offering a really easy payment plan. You can be working your new equipment from World Radio while you pay. Only simple credit information is required.
- ★ **ONLY 10% DOWN**
On any item over \$25, you pay just one-tenth down. World Radio does everything in its power to make it easy for the ham to buy. Why not try us?
- ★ **COMPLETE STOCKS**
The foremost lines of major manufacturer are stocked here at World Radio. No waiting for factory shipment, no lie-up in getting your order.
- ★ **TOP TRADE INS**
Our reconditioned list is the bible of the industry. This means that hundreds of hams trade at World Radio, proving our offer of the best trade around the country. Ask for a quote!
- ★ **FAST SERVICE**
Our location in the center of the U. S., our large processing plant and shipping department, all mean prompt, same day service to you. You get what you want, at once!
- ★ **PERSONAL ATTENTION**
World Radio is geared for individual service and counsel. No card organizer here; but top ham personnel to advise with you when you ask for a literature or merchandise.

FREE 1958 Catalog

200 pages, hundreds of illustrations, 15,000 top value items write for yours, today!



Please send me Free Catalog . . . and complete info on Hallicrafters SX-101. R 7/7

NAME: _____

ADDRESS: _____

CITY & STATE: _____

KEEP CANDEE HANDY!

- ★ Domestic, foreign and export buyers,
- ★ hams, industrials, commercial agents:
- ★ Count on J. J. CANDEE for reliable
- ★ new and used surplus communication
- ★ equipment and airborne electronics—
- ★ all sold retail—at wholesale prices!
- ★ Inquiries solicited—and answered fast!

DM-35 DYNAMOTOR

Depot re-pack. Like new. **\$9.95**
With spare brushes. Each . . . **\$17.50**
Save by buying 2 for . . . **\$17.50**

AN/APR-1 RECEIVER

Frequency: 40-1000 MC. Removed from aircraft. Includes receiver and three tuning units. **\$29.95**

APN-4 LORAN EQUIPMENT

Marine or airborne. Long range navigational gear to determine exact position of ship or plane up to 1200 miles from base. Includes Scope and receiver. Complete with tubes, crystals Only **\$19.95**

VOLT-OHM METERS

Manufactured by Simpson and Weston. Measures resistance voltages and milliamperes. With test leads and carrying case. Like new. **\$8.95**
Ea.

Order a pair of them and save. 2 for . . . **\$17.50**

NEW WALKIE-TALKIE CHASSIS—BC-611

Really F.B. for making your own Walkie-Talkie! With antenna. Does not contain coils, crystal or tubes. Each **\$6.95**
2 for only **\$12.00!**

HEADSET SPECIALS!

HS-23: Hi impedance. Leather covered head-band. New, with cushions. **\$4.49**
Get two for only **\$8.49** Ea.
HS-33: Low impedance. With extension cord. Brand new. **\$5.49**
Each only **\$9.95**

INTERPHONE AMPLIFIER

AM-26/AIC. 28 VDC. Complete with dynamotor and tubes. Excellent cond. **\$5.95**
2 for **\$10.00** Each

RG8U CO-AX CABLE BARGAIN

Brand new. Marked. With connectors. **98c**
25 ft.

All items FOB, Burbank, Calif., and subject to prior sale without notice. In Calif. add 4%.

J. J. CANDEE CO.

4002 W. Burbank Blvd., Burbank, California
Phone: Victoria 9-2411

NEW! IMPROVED!

SENCORE TRC4 TRANSISTOR CHECKER

Another
Sencore
Time-
Saver

America's newest,
most popular test
instruments

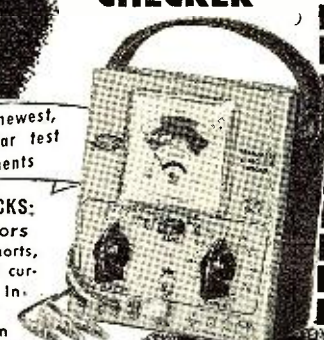

NOW CHECKS:

- ★ Transistors for opens, shorts, leakage and current gain. Includes new gain test on power transistors.
- ★ Crystal Diodes checks forward to reverse current ratio on all diodes.
- ★ Selenium Rectifiers checks forward and reverse currents.

Controls are accurately set for each transistor by referring to replaceable set-up chart on rear. Test leads or socket provides for fast hook-up. See your parts distributor.

SIMPLE TO OPERATE
ONLY \$17.95
Dealer Net
Cannot become obsolete. Approved by leading manufacturers.

SENCORE Mfg. by **SERVICE INSTRUMENTS CORP.**
171 OFFICIAL RD., ADDISON, ILL.

Cut out this ad now for further information

SURPLUS BUYS

PORTABLE AUDIO AMPLIFIER—1141F. Used with 625 mine detector. Compl. w/tubes, schem., cable. L.N. 12x4x4. 9 lbs. \$3.95
DUAL RECEIVER RACK (ARC-5)—Br. new \$1.95
5933/807W—ruggedized version of 807. Br. New—Sylvania Boxed \$1.59, 2 for \$3.00, dozen \$15.00
ARC-5 XMTR. 3-4MC—gd. cond. \$4.95

TRIPLETT MICROAMMETER—0-500 u/a Dc. 2 1/2" rd, bakelite case, white scale—ea. \$3.95
G. E. METER—DW41. 2 1/2" rd, 0-500 mils., New \$2.95
METER—0-1 Mil (8KV scale) 3 1/2" rd, Marion—new \$3.95

LEACH RELAY #1154—115VAC—DPST—New. Boxed \$1.95
PLATE TRANSFORMER—Pri.: 115V-60CPS. Sec.: 550-0-550 220MA. (conservative) Collins cased. Each \$6.95

COAX RELAY Advance #3305—Coil 100VDC. With matching coax connectors. New. \$5.95
NAVY PATCH CORD—2PL-55 type plugs on short cable. 49¢—5 for \$2.00

T40-APS/18 TRNSVR—115V—800 Cy—829 B Final. Blower, Relays, Metered—Br new 20 lbs. \$39.95
2AP1—RCA Boxed. \$1.95

BC-730C—CONSTANT OUTPUT AMPLIFIER—115V-60CPS input, use w/XMTR. to prevent overmodulation—Limits output to 1DB of 6 milli-watts to 600 Ohm line—Metered—Like new, 20 lbs. \$24.95

BC-1056B RECEIVER—Input 115V-60CPS. Contains 14 tubes, meter, 115VAC—DPDT relay—30MC IF strip—35 lbs—L. N. \$17.95
SCOTT COMMUN. RECEIVER—Input 115V-60CPS—5 band—Freq. 80KC-550KC; 1.9MC-24MC—BFO—good op. condition—80 lbs. \$59.95

NATIONAL COMMUN. RECEIVER—Input 115V-60CPS—6 bands—Freq. 200KC-20MC—BFO—Good op. cond'n—60 lbs. \$59.95

INTERPHONE BOX—BC1362—Compl. w/handset H22 A/V. Coil cord, plugs, set of spare parts—Waterproof housing 12" x 9" x 4 1/2"—LF8 mobile—New—30 lbs. \$9.95

OAP-1 WAVEMETER GENERATOR—Input 115V-60CPS—148-262MC—BC221 type—Scale and dial—Good condition. \$19.95
HI-POT 0-5KV—Input 115V-60CPS—Industrial instrument Type P-2—Exc. condition. \$99.50

REX RADIO SUPPLY CO.
 88 Cortlandt St.
 New York 7, N. Y.
 In the Heart of New York's Radio Row.

QUANTITY BUYERS

- AGGRESSIVE JOBBERS
- LABORATORY SUPPLIERS
- INDUSTRIAL DEALERS

An opportunity to buy at maximum savings
 • Monthly listings of hot items keyed to your needs • Standard brands • Below manufacturers' cost.

WE OFFER—IMMEDIATE DELIVERY, PHONE COLLECT FOR TECH. INFO.

- *****
 * Electrolytic Condenser—1200 mfd, 25-VDC, Ind. boxed. Lots of 100—25¢ ea. *
- *****
 * Fenwal Thermo Switch — Cat. #1700-501, Ind. boxed. Lots of 50—\$1.00 ea. *
- *****
 * Coax Cable—9' length of RG11/U with male plug PL259 on each end. Ind. boxed. Lots of 100—35¢ ea. *
- *****
 * Carbofilm Res. 1% — 1/2, 1 or 2 Watt (top makes) not assorted, good sizes, brand new, full leads. *
- *****
 * Lots of 10,000—\$5.00 per 1000 *
- *****
 * Silver Ceramicon Trimmer—Erie Type #NPOTS2A—3—12 mmf—500 VDC For Sale in Lots of 1000 for \$85.00 *
- *****
 * TUBES — Special Purpose — TUBES *
- *****
 * 2C4—Sylvania, boxed—100 for \$25.00 *
- *****
 * 5933/807W—Syl. 100 for \$85.00 *
- *****
 * 2AP1—RCA, boxed — 100 for \$90.00 *
- *****
 * Variable Condensers *
- *****
 * 100 MMFD—23 Plate—2.5 Kv Gap—Hammarlund—100 for \$75.00 *
- *****
 * 140 MMFD—W/Shaft—100 for \$40.00 *
- *****

GREENWICH SALES CO.
 59 Cortlandt St., N. Y. 7, N. Y. ★ DI 9-3813

A Hi-Fi 50-Watter

(Continued from page 51)

seven tubes: a 12AV6, a 6AN8, a GZ34, two ECC83's, and two 6CA7's. The 6CA7 output tubes are the ones that are supplied by *Amperex* and are identical to the *Mullard* EL-34's which have become extremely popular in audio circuits in the past several years.

There are five master operating controls: an eight-position selector-equalizer switch (tape, 78's, EUR, LP, RIAA, radio, TV, and auxiliary); level; loudness; bass; and treble. Additional slide switches are included to switch the low and high filters in and out of the circuit; a three-position speaker selector (either one of two, or both); a two-position input selector (one position is for tape, low magnetic or ceramic cartridges and the other position is for tape, low magnetic or high magnetic cartridges).

Following are the specifications which we measured on one of the units:

Sensitivity: .112 volt for 50 watts output on both radio and TV inputs; .015 volt for high magnetic; .44 volt for auxiliary; .32 volt for ceramic; and .0055 volt for low magnetic.

Hum and Noise: -63 db from 2 watts output with both shorted and open circuited auxiliary input.

Frequency Response: ±1 db from 12 to 27,000 cps at 2 watts output and 11 to 23,000 cps at 50 watts output.

High Filter: -5 db at 5 kc., -9 db at 10 kc., and -15.5 db at 20 kc. This is an extremely satisfactory roll-off and is particularly useful since this filter works with any input.

Low Filter: 0 db at 100 cps, -4 db at 30 cps, and -6 db at 20 cps. This is quite a sharp roll-off and is effective in eliminating any possible phono motor rumble. This particular circuit is only operative when using the phono input.

Equalization: ±1.3 db from 30 to 15,000 cps from the standard recom-

mended RIAA phono playback curve. **Bass Control:** -24 db to +13.5 db at 30 cps from minimum to maximum positions respectively.

IM Distortion: With 60 and 6000 cycles at a ratio of 4:1, the IM distortion is .23% at 2 watts equivalent sine-wave output and .76% at 50 watts. For 1% IM, which we consider maximum permissible, the power output available is 52.9 watts.

Harmonic Distortion: At 2 watts output, .2% at 20 cps, .014% at 1000 cps, and .26% at 20,000 cps. For 2% harmonic distortion, maximum power output is 44 watts at 20 cps and 35 watts at 20,000 cps. For 50 watts output, the harmonic distortion is 1.48% at 1000 cps.

The performance specifications, as indicated, are characteristic of a high-quality component. Such performance shows that considerable effort went into the original design and that there was no skimping on parts used to save cost.

There is only one specification which might be criticized and that is the maximum power output available at 2% harmonic distortion. The figures we obtained are considerably lower than those published by the manufacturer. There is a possible explanation for this. Most manufacturers quote distortion figures obtained when using the 16-ohm output tap. Since all our tests are made using the 8-ohm output, it is to be expected that our figures would not show up as well. This is quite normal with circuits of this type and we have run into this same situation in other amplifiers. An explanation for this behavior is that the feedback loop is taken from the 16-ohm output tap and the values chosen for the feedback network are optimized for this load. It is to be expected that when other loads are used, the performance of the amplifier would not then be precisely the same. For those who use this amplifier with a 16-ohm load, the distortion figures would be more favorable than those indicated by our tests.

-30-

Top view of amplifier with cover removed. Note particularly the clever design which physically separates the power and the pre-amplifier circuitry.

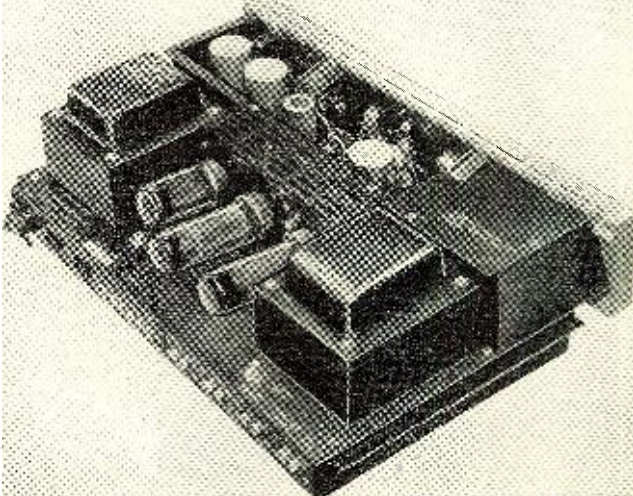

60
NEW PROJECTS FOR
"DO-IT-YOURSELFERS"
 In the NEW EDITION of the
ELECTRONIC
EXPERIMENTER'S
HANDBOOK



IMPORTANT NEWS: The new 1958 Edition of the *Electronic Experimenter's Handbook* is now on sale. If you like to build useful, profitable electronic devices, pick up a copy of the new *Handbook* now.

60 Devices . . . Nearly 200 pages
. . . a Practical "File" of Electronics
Ideas and Information

- FOR YOUR HI-FI.** Presence control. Hi-fi crossover. Filter. Electrostatic speaker system. Mixer equalizer. Spare amplifier. \$5 coax. Oval-Flex speaker enclosure. Junior hi-fi. Hardware store crossover.
- RECEIVERS.** Shirt pocket transistor superhet. Superregen unit. Miniature VHF ear. Junkbox BC receiver. Etched circuit two-tuber.
- FOR YOUR HOME.** Invisible light door opener. Picnic power amp. DS supply for AC/DC motors. Installing a back seat speaker. Light-operated relay. Transistorized intercom. Radio intercom.
- FOR YOUR DARKROOM.** Audio photometer. Transistor slave flash unit. Photographer's electric pencil. Light distributor. Darkroom timer. Enlarger exposure meter.
- FOR YOUR HAM SHACK.** Simple shortwave receiver. VHF explorer's receiver. 70-watt transmitter. Double your Heathkit AT-1 output. Code practice set. Antenna tuner. Transistor 10-meter receiver.
- FOR YOUR WORKSHOP.** Economy signal generator. Simple oscilloscope calibrator. Rejuvenator for dry cells. \$14 signal tracer. Transistor checker. Capacitor meter. Low-cost multi-tester. Transistorized signal tracer. Buzzer-type power supply.
- FOR THE KIDS.** IQ tester. Electronic worm digger. Model spaceship. Game computer. Transistorized phonograph amplifier. Coin-operated oscillator.
- SPECIAL PROJECTS.** Solar battery experiments. Electronic anemometer. Varistrobe. Detectorscope. Simplified etched circuits. Car rattle locator. Simple burning tool.

NOW ON SALE
Only \$1
 Pick up your copy today at your
 newsstand or radio parts store

ZIFF-DAVIS PUBLISHING CO.,
 434 S. Wabash Ave., Chicago 5, Ill.

A Parabolic U.H.F. Antenna
(Continued from page 50)

feed system is the fact that, if pickup is to be obtained uniformly from the surface of a uniformly curved screen, the horizontal and vertical pickup patterns must be similar to each other in shape. The horizontal pickup pattern of a dipole is normally in the shape of a figure 8: that is, it is bidirectional, picking up equally well from front and rear. The vertical pickup pattern is normally circular or omnidirectional. In this application, each pattern should ideally take the form of a single forward lobe facing into the curved screen.

One important measure taken to give the feed system the desired characteristics was to use a small, flat screen to back up a dipole. This cut out the rear lobe completely. While it had only a negligible effect on the already satisfactory forward lobe of the horizontal pattern, it completely changed the circular, vertical pattern to a broad, single lobe similar in shape to the horizontal one. Stacking a pair of dipoles in the feed system narrowed the vertical pattern still more, bringing it even closer to the horizontal pattern in shape.

Concerning the smaller, flat screen, which is at the rear of the feed system although at the forward side of the entire array, there are other points of interest. In addition to the role already noted, it eliminates pickup of direct signal at the rear of the dipoles. Since the dipoles operate on the concentrated, indirect signal reflected from the curved screen, a directly received signal at their rear could arrive out-of-phase with the principal signal. Since such a signal could produce cancellation and other unfortunate effects, it is clearly undesirable.

Elimination of sensitivity at the rear of the dipoles is helpful in another respect: it increases forward pickup of the dipoles, in the direction of the parabolic reflector.

Despite its great importance to the entire system, the flat screen had to be designed to achieve the objectives already noted without being made too large. If its size were considerable, it would have blocked off an appreciable area at the center of the parabolic reflector from receiving the desired signal.

Size of the parabolic screen was also carefully considered. Antenna gain depends primarily on the area of this member. A diameter of 6 feet was chosen to provide exceptional gain on all u.h.f. channels, while still permitting practical size. In its final version, the antenna takes up no more mast space than stacked v.h.f. designs also used for fringe-area reception. Made of lightweight aluminum and pre-assembled, it presents no great installation problems, yet it helps u.h.f. transmissions leap greater distances.

Your choice of school is highly important to your career in



INDUSTRIAL ELECTRONICS



RADIO-TELEVISION



ELECTRONICS COMMUNICATIONS

Become an
ELECTRICAL ENGINEER
or an
ENGINEERING TECHNICIAN
at
MSOE in Milwaukee

Choose from courses in:

ELECTRICAL ENGINEERING
 Bachelor of Science Degree in 36 months—
 Communications or Electrical Power.

ENGINEERING TECHNOLOGY
Associate in Applied Science degree in 18 months—
 Electronics Communications
 Electrical Power or Computers.

MSOE—located in Milwaukee, one of America's largest industrial centers—is a national leader in electronics instruction—with complete facilities, including the latest laboratory equipment, visual aid theater, amateur radio transmitter—offers 93 subjects in electrical engineering, electronics, radio, television, electrical power, and electricity.

Advisory committee of leading industrialists. Courses approved for veterans. Over 50,000 former students. Excellent placement record. Previous educational, military, and practical experience is evaluated for advanced credit.



QUARTERS BEGIN SEPTEMBER, JANUARY, MARCH, JULY

Choose wisely—your future may depend on it. Mail coupon today!

MILWAUKEE
SCHOOL OF ENGINEERING

Dept. RT-758, 1025 N. Milwaukee St.
 Milwaukee, Wis.
 Please send free illustrated career booklet (please print)

I'm interested in.....
 Name..... Age.....
 Address.....
 City..... State.....
 Are you eligible for veterans educational benefits?.....
 Discharge date.....

MOBILE-RADIO MAINTENANCE



CAN MEAN

A BETTER HOME...
A BIGGER CAR...
AND MONEY
IN THE BANK!

It's a rapidly growing industry that practically guarantees a high, regular income to qualified independent servicemen. Thousands of new transmitters are licensed each month—and must have regular maintenance...plus periodic FCC checks. The usual method of payment is a service contract which provides for retainer fees.

To learn about rates . . . typical contracts . . . and take home pay . . . send for the free booklet "HOW TO MAKE MONEY IN MOBILE-RADIO MAINTENANCE".

In addition to your present test equipment you'll want these Lampkin meters.



LAMPKIN 105-B
FREQUENCY METER
RANGE 0.1 TO 175 MC.
AND UP
PRICE \$220.00

LAMPKIN 205-A FM
MODULATION METER
RANGE 25 TO 500 MC.
PRICE \$240.00

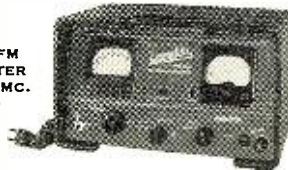

MAIL THE COUPON TODAY!

LAMPKIN LABORATORIES, INC.
MFM Division, Bradenton, Florida

At no obligation, please send me free booklet, technical data on Lampkin meters, and time-payment plan details.

Name _____
Address _____
City _____ State _____

LAMPKIN LABORATORIES, INC.
MFM Division
BRADENTON, FLORIDA

RAD-TEL TUBE CO.

JAN from 24¢
TU 4

Send for Catalog!

CHEST MICRO-PHONE TDI \$1.95
3-position switch
impedance 200 ohm.

86" FOLDED DIPOLE TV ANTENNA \$1.95

With 92" reflector: complete ready for pole and 300 ohm wire. Limited quantity.

POWER TRANSFORMERS \$1.95 ea.
260-260V 52MA 6.4 @ 2.3A
256-256V 54MA 6.4 @ 2.4A
280-280V 300MA 5@5A, 6.9@6A
320-320V 130MA 5@3A, 6.4CT 3A

HIGH QUALITY BI-PASS CONDENSERS \$2.95
Kit of 25
Consists of 11 600V, 1 400V and 13 200V. Semi-molded tubular paper or mylar dielectric.

Write Dept. RN-7 for FREE Catalog of Tubes and Parts



55 Chambers Street, Newark 5, N. J.

Subject to prior sale. No C.O.D.'s. Allow for postage.

TAPES YOU CAN TRUST!

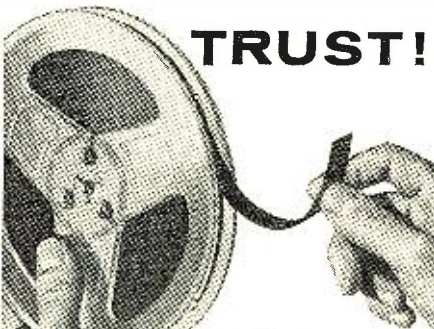

Enjoy professional quality at popular price!



Scotch Magnetic Tape

THE TERM "SCOTCH" IS A REGISTERED TRADEMARK OF 3M CO., ST. PAUL 6, MINN. EXPORT 99 PARK AVE., N.Y. CANADA LONDON, ONT. © 3M CO., 1956.

MINNESOTA MINING AND MANUFACTURING COMPANY
...WHERE RESEARCH IS THE KEY TO TOMORROW

Video Tape

(Continued from page 43)

According to 3M, however, which so far is the only tape manufacturer offering video tape in commercial quantities, the major difference in tape for video and audio is in the binder—the material which holds the oxide particles together and which also binds them to the tape backing.

The oxide is a form of pigment which is mixed with a binder, then is coated on the tape backing. The tape is then dried in ovens which cause the solvents in the binder to evaporate, leaving the oxide particles permanently bonded in place.

Again, however, under the severe pressures and temperatures imposed by the revolving heads of the recorder, no conventional binder will last more than a few plays. The high temperatures soften the binder, making the tape surface tacky and the rotating heads rip into it, creating gouges and furrows. Once this occurs, it works like a chain reaction and tiny particles of oxide which have been ripped out gather on the heads and drop outs become severe.

"It was when we were able to come up with a harder, more durable binder—coupled with improved manufacturing techniques—that we were finally able to produce usable video tape," Dr. Wetzel says.

At that, the firm reports more than half of the video tape it produces is rejected in the factory. Dr. Wetzel philosophically calls that a considerable improvement over a run made nearly a year ago, however, when only three rolls of video tape were usable out of a run of 100 rolls, with the other 97 rolls of the \$306-a-roll tape proving worthless.

CBS TRANSISTOR COURSE

CBS-Hytron Sales Corporation of Danvers, Mass. is sponsoring a new transistor course which has been prepared by A. C. W. Saunders for service technicians and interested experimenters.

The course consists of ten lessons with the company supplying correction and advisory service and awarding a certificate of proficiency upon satisfactory completion of the course.

Although no components are supplied for performing the experimental projects, all parts are readily available from local parts distributors.

The course covers semiconductor theory, fundamental transistor circuitry, biasing methods for transistors, typical transistor amplifiers, push-pull transistor amplifiers, transistors in radio receivers, basic transistor oscillators, transistorized power supplies, and transistor parameters.

The extensive use of line drawings and other illustrative material helps to amplify the text for the benefit of the student working on his own.

Distribution of the course and requests for further information are being handled by local CBS tube representatives.

Test Bench PUZZLER: No.

By ART MARGOLIS

How would you have handled this front-end problem?

THIS CASE history is the kind that comes up whenever TV technicians get together and begin to compare their experiences with "dogs." Before looking at the solution on page 129, can you spot trouble from the information given?

The symptoms popped up on an RCA KCS48T. The symptoms: no audio, no video, but a good raster.

The fact that the oscillator-mixer (a 6J6) was out was established with little trouble. A check of the tube showed some of the elements to be shorted together, putting "B+" to ground. A check of voltages at the empty socket of the 6J6 showed no "B+" on the plates (points 1 and 2, Fig. 1).

A check of the "B+" line showed that R_{202} (100 ohms, point 3) was open. After it was replaced and cold resistance from the plates to ground seemed normal, a new 6J6 was installed. The set appeared to operate properly when first turned on with the new tube in place.

During a check-out run, however, some trouble developed. The 6J6 became unusually hot and R_{202} ran warm. Since an apparently abnormal

heat condition is just a matter of degree, it was decided to make more exact voltage readings. Sure enough, there were 52 volts at point 1 instead of 96; 90 volts at point 2 instead of 135; and 48 volts at the screen of the 6CB6 r.f. amplifier (point 4) instead of 84.

The mixer bias check provided an important clue. Instead of being -2.1 volts, it was just about zero (point 5). This explained why, lacking bias, the 6J6 was drawing the heavy current that overheated it and the 100-ohm resistor, R_{202} .

Now, why should these plate and screen voltages be running so low? Of course, the increased current due to the lack of bias might drop them to some extent; but it would not drop all three of them to such a great extent.

The 375-volt supply point (point 6) was checked. It was right on the button. The 120-volt "B+" feed (point 7) was also checked. It, too, was just about perfect. All right, then, where had the vanished voltage gone? It's all right in front of you in Fig. 1! Give it a try before turning to page 129 for the answer.

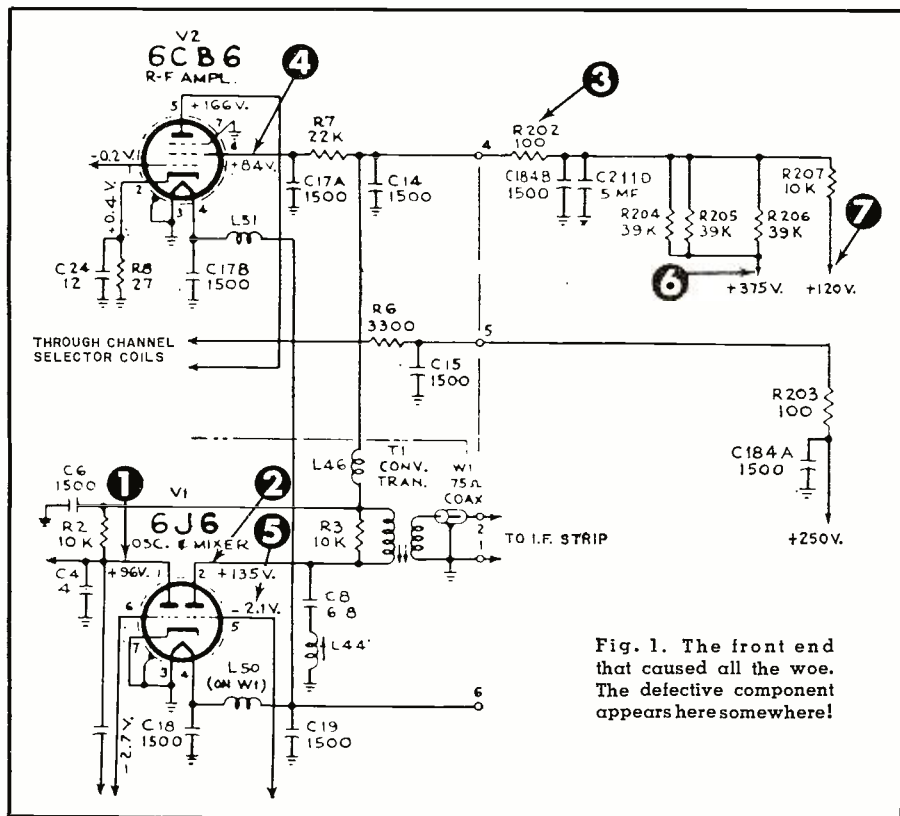
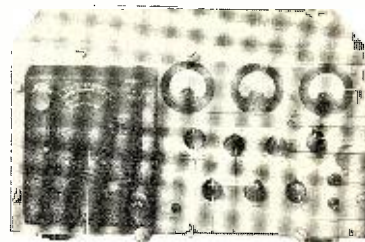

Fig. 1. The front end that caused all the woe. The defective component appears here somewhere!



VHF UHF

RDO RECEIVER

Navy Receiver. Similar to APR4, however more versatile having input metering, DB output meter, automatic noise limiter and greater selectivity and sensitivity. Complete w/tubes, three plug-in tuning units, connectors and tech. manual. 110VAC 60 cycle operation. Brand New..... **\$159⁵⁰**

RCA SIX TUBE all purpose super het RECEIVER covering 195 KC to 9000 KC including weather lighthouse, aircraft radio range broadcast, marine and amateur 160 meter, 80 meter, 75 meter and 40 meter, with tubes, 24 volt dyno. and schematic. EXC..... **\$17⁹⁵**

Accessories for remote tuning, \$5.00 per set. 8" x 10" x 18", ship. wt. 40 lbs.

AMPLIFIER—Easily converted to 6 watt mobile P.A. Complete with 3 6V6 and 12 Volt dynamotor (250 volt—50MA output). Exc..... **\$345**
2 for\$6.00

AN/APN-9 LORAN RECEIVER inc. long range navigation unit. 12 or 24 volt. inst. UNUSED..... **\$195⁰⁰**
APN 4B Complete, Brand New.....\$89.50

BC-659 FM Receiver-transmitter, xtal controlled, two channels, freq. range 27-38.9, 9 mc. 13 tubes, built-in speaker, dual meter \$6⁹⁵
for testing filament and plate circuits. EXC.....\$10.95
Brand New.....\$12.95

BC 683. Ten Channel Push-button on continuous tuning FM RECEIVER 27 to 39 Mc complete with/tubes, speaker, squelch circuit. EXC..... **\$12⁹⁵**
BC 603. Same as above except to 20 to 27 Mc. Brand New\$12.95
Exc.\$6.95
Used\$4.95
Ideal for spare parts
12 Volt Dyna for above receivers. Exc. \$2.95

BC669. Six Channel Crystal Controlled, 50 Watt Radio Telephone, 1600 to 4500 KC. Ideal for boats or land station, less power supply. Exc.\$79.50
Used\$59.50
BC 453. Command receiver 190 KC-550 KC complete w/tubes and dynamotor. Exc.....\$12.95

WRITE FOR LATEST FLYER

R W ELECTRONICS

2430 S. Michigan Ave., Dept. N, Chicago 16, Ill.



THE MULTIPLE OUTLET BOX YOU'VE ALWAYS WANTED.

Features include fused plug, pilot light, control switch, six sturdy outlets, heavy-duty line cord. Attractive brown hammertone metal case.

Available at all leading parts distributors.

CBC C.B.C. ELECTRONICS CO., INC.
2601 NORTH HOWARD ST.
PHILADELPHIA 33, PENNA.

ANNUAL JULY SELL-A-BRATION!

PENNY SALE!



of OUR 6 MOST POPULAR "PAKS"

- CERAMIC CONDENSERS 75 for 88c 150 for 89c
- PRECISION RESISTORS 30 for 88c 60 for 89c
- DISC CONDENSERS 30 for 88c 60 for 89c
- GERMANIUM DIODES 6 for 88c 12 for 89c
- CARBON RESISTORS 75 for 88c 150 for 89c
- TRANSISTOR SOCKETS 6 for 88c 12 for 89c

YOUR CHOICE OF ANY POLY-PAK LISTED BELOW FREE WITH EACH \$10 ORDER!

Save \$3 to \$30 on Each of These World-Famous **POLY-PAKS** **1** EACH

- SUN BATTERY, HUNDREDS OF USES.
- 4 HORSESHOE MAGNETS.
- 3 VARI-LOOPSTICKS, 540-1600 kcs.
- 2 VARIABLES, 1 1/2" sq. 10-365mf.
- TV STEEL MIRROR, 12 x 10"
- 4 G-ENGINES herm. seal DIODES.
- 10 3-SECOND TIMERS.
- 60 HI-Q RESISTORS. 1 lb.
- 50-FT. "ZIP" CORD. 2 lbs.
- 5 25' ROLLS "micro" WIRE. 1 lb.
- 250-FT. HOOKUP WIRE. 2 lbs.
- 4 1/2" FAN MOTOR. 1 lb.
- SIGMA 10,000 ohm MINI RELAY.
- 40 WOLDED CONDENSERS. 2 lbs.
- 20 PRINTED CIRCUITS. 1 lb.
- 5 "RED" DIAL LITES. 1 lb.
- VEE-DEE-ROOT COUNTER 0-9999.
- 4 TUBE SOCKETS. 2 lbs.
- 1" SQ. CRYSTAL MIKE.
- "MICRO" MOTOR. 1 1/2" VDC.
- 20 INSTRUMENT KNOBS. 1 lb.
- 2000 PCS. HARDWARE. 2 lbs.
- 6 SILICON DIODES. 1 lb.
- 10 POWER SWITCHES. 115 VAC.
- 40 PRINTED CIRCUIT PARTS. 2 lbs.
- 60 COILS & CHOKES. 2 lbs.
- 15 VOLUME CONTROLS. 2 lbs.
- 50 PLUGS, RECEPTACLES. 2 lbs.
- 6 FERRITE CORES. 2 lbs.
- 40 POWER RESISTORS. 3 lbs.
- 10 TUBULAR CONDENSERS. 3 lbs.
- 60 TERMINAL STRIPS. 1 lb.
- 1 MINI-METER. 0-6A. AC. 1 lb.
- 40 HI-Q CONDENSERS. 2 lbs.
- 8-PC. NUTDRIVER SET. 1 lb.
- 50 RADIO, TV KNOBS. 2 lbs.
- 10 "POLY" BOXES. 1 lb.
- 100 RADIO PARTS.
- 75-PC. RESISTOR ASST. 2 lbs.
- 25-PC. CONDENSER ASST. 2 lbs.
- 2 PNP TRANSISTORS. \$5 Value.
- 10 MICRA CONDENSERS. 2 lbs.
- 15-PC. TWIST DRILL SET. 1 lb.
- 40 SUBMINI RESISTORS. 1 lb.
- 10 ELECTROLYTICS. 1 lb.

SATISFACTION GUARANTEED

BIG BUYS in 'MINI' TYPE

- MICROSCOPE, 100-200-300 POWER \$3.99
- TELEGRAPH KEY, BAKELITE BASE, CHROME \$1.19
- PIC TUBE BRITENER, parallel, series 88c
- 3-SPEED ARM, w/cart, & sapphire needle \$2.99
- TELEPHONE PICKUP COIL, REC. MFGS \$1.99
- 1 1/2" SUBMINI PM SPEAKER, 30 ma \$1.99
- PILLOW SPEAKER, crystal. Cord, plug \$2.69
- CRYSTAL HEARING AID PHONE, cord, plug \$1.19
- 5,000-ohm MINI PHONE, cord, plug \$1.69
- BAROMETER, 5" round, chrome \$3.88
- COPE-SAW-DRILL-REAM BIT, for all drills \$1.19
- SCOOP! 4 HAMMERS, 10" wood handles \$1.19
- TRANSISTOR TRANSFORMER, 20K to 1K; 10K to 2KCT; 500CT to 3.2 ohms... each \$1.39
- 0 to 1 ma METER, 1 1/4" SQUARE \$3.99
- 0 to 50 microA METER, 1 1/4" SQUARE \$5.99
- TURNER MIKE, crystal. Hand, desk, stand. 100-8000 cps. s. cable. \$2.98
- 0-60 MINUTE TIMER, with alarm \$1.00
- 12-HOUR SPACE CLOCK, operates on 1 1/2VDC pen-lite battery \$1.98
- LENK SOLDERING GUN, 115VAC, for fine work. Easy-grip, incl. tip. \$4.99

HOW TO ORDER Check items wanted. Return entire ad w/check or MO. including sufficient postage; excess returned. C.O.D. orders, 25% down; rated, net 30 days. Print name, address, amount money enclosed, in margin. (Canada postage, 45c 1st lb., 28c ea. add'l. lb.) EXPORT ORDERS INVITED.

LEKTRON 133 EVERETT AVE. CHELSEA 50, MASS.

Automatic Key (Continued from page 37)

differentiating (peaking) network. This, in turn, makes necessary the insertion of steering diodes CR_1 and CR_2 . Although other triggering methods could be used on the multivibrator it was felt that the arrangement shown was more reliable for high speed switching. R_{10} is a last minute addition to correct for a slight difference in the pulse rate on dots and dashes. This difference was caused by the surge current of the blocking oscillator flowing through the isolation diode, CR_3 , on dashes. An AR-120 output transformer was used as a pulse transformer solely because it was on hand and seemed to handle the job well, giving pulses with a very fast rise time. The second multivibrator is an exact duplicate of the first one, with the exception that the collector voltage of V_5 is keyed on dashes through a delay network consisting of R_1 and C_{10} . This delay is long enough so that on sending a dash the second multivibrator does not flip on the first pulse but waits for the time period of one dot before reversing. Without this delay the first dash of a series is only two units long, rather than three. The two diodes, CR_5 and CR_6 , couple the signal from the multivibrators to V_6 , an emitter follower that supplies feedback through CR_3 to the blocking oscillator to cause it to put out one more pulse after the key lever is released, completing the sequence. The output of V_6 is also coupled through an RC network to V_7 , the keyer switch stage. The waveshaping gives a bit more rounded code than is generally used, but with automatic sending this is desirable.

The r.f. filtering is provided by C_{11} and C_{13} , as well as by careful filtering of the key leads at the transmitter. The amount of r.f. filtering and shielding required will depend on the individual transmitter power and antenna system.

Since various switching transistors are becoming more readily available, sockets were provided in the blocking

oscillator and output stages for future experimentation. A Raytheon 2N111 is used at present in the output stage because of its low leakage current. The 2N111 is used to key the cathode of a 6CL6 buffer stage running at its normal c.w. ratings. A 2N132 is used in the blocking oscillator, replacing the CK722 shown in the photographs which was found to be defective, causing a "warm-up" drift. The circuit is flexible enough to accommodate any inexpensive transistors and diodes.

The power supply uses four small flashlight cells about 1" x 2". Although the total drain is on the order of six or eight milliamperes, penlite cells were avoided in the interest of reliability.

Since the author had a regular "bug" mechanism available, it was decided to use this as the base for construction. Hence the cabinet or shield cover dimensions were preset at about 3 1/2" wide x 6 3/8" long x 3" high. The front of the "bug" was included in the shield to preclude the possibility of r.f. pickup on the contact posts. It was found that a piece of fiber board 3 1/4" wide x 4 1/4" long was a practical size for the component board. The eyelet board with jumper wire type of construction was chosen for simplicity and ease of wiring. The top cover is in three sections, a lift-off top with the power supply batteries mounted inside by a metal clamp and two sides which are fastened to the base with machine screws. A "mouse hole" is provided in the front for the key lever. The original dot contact was moved up front opposite the dash contact and a "dress up" paddle was made from scrap lucite. A professional ham-mertone finish on the cold rolled steel cover completes the construction of the unit.

In learning to use the key, practice and more practice seems to be the answer. A few attempts to go right on the air will quickly demonstrate that it's best to have a regular straight key handy for tuning up and for explaining why you suddenly sound like a "lid." But an automatic electronic key soon grows on one and, once it is mastered, radio operating is much more enjoyable. -30-

A top view of the automatic key is shown here with cover off. It was found that a piece of fiber board 3 1/4" wide x 4 1/4" long was a practical size for the mounting of all the components.

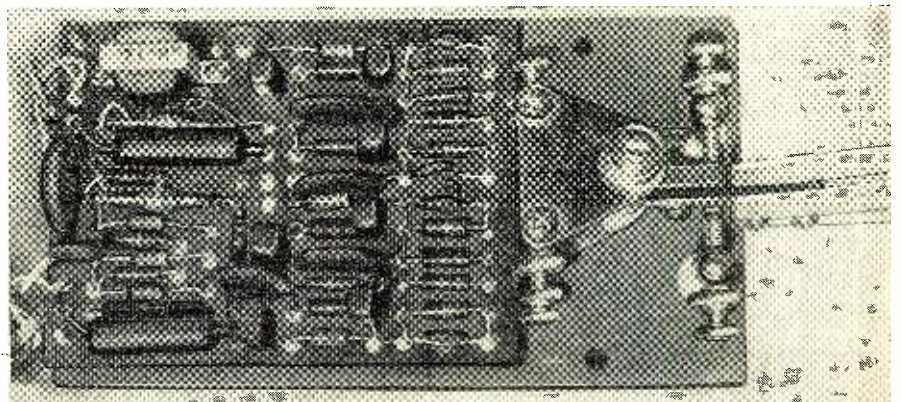

Mac's Service Shop
(Continued from page 62)

on any of the rubber drive wheels or pressure rollers. They insist that alcohol be used in such places. Still others say that carbon tet is perfectly all right for use in these places. I suspect that the difference lies in the kind of rubber used. Always follow the manufacturer's instructions to the letter. When in doubt, I believe it is safer to try alcohol."

"Check," Barney said as he spooned the last drop of his sundae from the paper bucket.

"Many of the recorders have a hum balance control," Mac went on; "and there's a lot more to adjusting this than just twisting a screw. In the first place, the recorder should be in completely assembled operating condition when this adjustment is made. This adjustment is intended to 'buck out' various sources of hum induced from motor, transformer, choke, and other parts of the recorder.

"But even if the tape recorder is all together, you still have to be sure that it is not picking up hum from some external source, such as an electric clock motor, a fluorescent lamp ballast, etc. The way to check on this is to note whether or not the level of the hum changes when the tape recorder is moved about. If it does, you can be sure it is coming from an external source."

"Seems to me trying to judge the hum by ear would be pretty tricky."

"Don't try it. Hook our a.c. v.t.v.m. across the speaker voice coil and set it to a low range. Usually the hum should be less than .1 volt with the volume and tone controls full on. Keep your eye on the meter while making all checks and adjustments regarding hum. It will give a more sensitive indication than your ear. Try reversing the line cord, too, and adjust the hum control again. If the hum can be reduced to a lower level with the cord in one way—due, no doubt, to some of the fields cancelling themselves out—adjust the hum control with the plug in this way and mention to the customer that the hum will be lower when the plug is properly inserted."

"One final question: is there any easy way to run down the source of wow?"

"Not really. There are some things that help. One is to have the tape transport mechanism arranged where you can see it while a tape with a steady tone is passing across the heads. Watch carefully and see if you can detect a connection between the wow and the rotation of the capstan, pressure roller, or speed roller. If you can spot any such relationship, the battle is half won. All you have to do then is find out why that particular bit of the mechanism is running at an uneven speed."

"OK," Barney said. "Now that I've had food for the body and food for the mind, I'm rarin' to go!"

WE TRADE HIGHER!

IT'S EASY TO DO BUSINESS WITH WALTER ASHE!

1. Just tell us what factory-built gear (made since 1945) you have to trade, and what new gear you wish to purchase. You'll get our top dollar quote by return mail.

2. When the deal is made, you ship your equipment to us by prepaid express or, if express is not available, by prepaid truck. We check it at once and, in most cases, your new gear is on its way to you within 24 hours after we receive your trade-in.

SEND FOR OUR BIG FREE 1958 CATALOG

144 PAGES
THE
"TREASURE CHEST"
OF VALUES



SPARKY SAYS

**HEY! LOOK!
HOW ABOUT THIS?**



WANT RECONDITIONED GEAR AT LOW COST? SEE WALTER ASHE!

WRITE FOR FULL DETAILS ABOUT OUR TIME PAYMENT PLAN

All prices f. o. b. St. Louis

Walter Ashe
RADIO CO.
1125 PINE ST. - ST. LOUIS 1, MO.

WALTER ASHE RADIO COMPANY
1125 Pine Street, St. Louis, Mo.

OUR 36TH YEAR

Rush "Surprise" Trade-In Offer on my.....
for.....
(show make and model number of new equipment desired)

Send new FREE 1958 Walter Ashe catalog. RN-7-58

Name.....
Address.....
City..... Zone..... State.....

ENGINEERING Home Study Courses

Courses written by world authorities in all branches of engineering. Step-by-step instructions using methods proved successful by thousands of our graduates. One hour each day in your spare time will start you off to higher pay, security, prestige. Check the course you are interested in and we will send you a complete outline of the course with a booklet describing the Institute and our advanced methods of teaching. Send to:

**CANADIAN INSTITUTE OF SCIENCE
AND TECHNOLOGY LTD.**
#674 Century Bldg.

412, 5th St. N. W.	Washington, D. C.
Civil Eng.	Electrical Eng.
Surveying	Radio
Architecture	Electronics
Forestry	Television
Mining	Aeronautical Eng.
Structural	Aircraft Engineer
Mechanical Eng.	Navigation
Industrial Eng. &	General Education
Management	Chemical
Refrigeration	Mathematics
Heating	Journalism
Drafting	Accounting
Plastics	

Name.....
Address.....
City..... State.....

Canadians: Send to Canadian Institute of Science & Technology Limited, #674 Garden Bldg., 263 Adelaide St. West, Toronto, Ontario.

A.... Always
B.... Buy
C.... Columbia

FREE! SUMMER '58 CATALOGUE!
32 pages of the greatest buys ever offered! Get your copy today—and save!

HS-23 HI IMPEDANCE HEADSET
8,000 ohms - De Luxe Air Force Style. Leather covered headband. Side-mounted cord. **\$3.95**
New
CD-307 EXTENSION CORD for above.
Excellent..... **.49**

BC-191 TRANSMITTER
12 V. Input power: 700 watts. Freq.: 1500 to 12,500 kc. Self-contained modulation. Can be used for CW or phone.
Excellent, like new. ONLY..... **\$14.95**

RA-34 POWER SUPPLY
For above BC-191. 110 V or 220 VAC. Input: 60 cye. Output: 1000 VDC @ 350 MA continuous duty. Also 12 VDC @ 25 A.
Excellent. A great buy!..... **\$65.00**

JULY ONLY! BC-611 HANDY-TALKIE CHASS.
Brand new, boxed, crystal controlled, 3-6 MC. WITH ANTENNA (less tubes, coils, etc.).
Excellent..... **\$7.95**

BC-652 MARINE RECEIVER: 2-6 MC. 8-tubes superhet, 2 bands. Built-in freq. crystal calibrator and 12 VDC dynamotor. Compact, needs no conversion, mfg. by G.E.
Excellent condition..... **\$14.95**

FM MOBILE
R-237/VR RECEIVER. 30-40 MC. 6 VDC. 15-tube, double superhet! Looks like standard Motorola mobile installation. Size: 18x10x11". Excellent, like new. Complete with all tubes & self-contained power supply.
..... **\$19.95**

BC-342 RECEIVER SPECIAL!
Freq. 1.5-18 MC. 6-bands superhet. 2 RF stages. Extremely sensitive. Power requirement: 110 VAC, 60 cye. Excel.
checked out..... **\$79.50**

T-208 FM SIGNAL GENERATOR
Aligns FM communication equip. RF alignment: 1.9-4.5 MC. RF alignment: 19-45 MC. FM deviation adjustable from 0-50 Kc. Operates on 110 VAC, 60 cye. or 12 VDC.
Excellent condition..... **\$49.50**

T-17 AIR FORCE HAND MIKE
200 ohm carbon mike. Known for years as the best! NEW, ORIGINAL BOX.
ONLY..... **\$4.95**

RA-62 POWER SUPPLY
For SCR-522 Transceiver. 110 V. or 220 VAC. 60 cye. Output: 300 VDC @ 260 MA. Also 150 VDC @ 10 MA and 12 VDC @ 5 amps. Excellent. Reduced to..... **\$49.50**

All Orders FOB Los Angeles. 25% deposit required. All items subject to prior sale. NOTE: MINIMUM ORDER \$3.00. WRITE TO DEPT. R.

Columbia

ELECTRONICS
2251 W. WASHINGTON BLVD.
LOS ANGELES 18, CALIFORNIA

STAN-BURN

CATHODE RAY TUBE SPECIALS ONE YEAR GUARANTEE

G.E.	Type	STAN BURN	G.E.	Type	STAN BURN
\$15.80	10BP4	\$10.00	\$24.75	17LP4	\$18.00
19.10	12LP4A	13.95	37.00	10AP4A	24.00
	12QP4	11.50	28.35	20CP4A	18.95
30.25	12UP4	15.00	33.60	20CP4B*	21.95
20.75	14CP4	13.75	36.00	21AP4	25.00
	15DP4	14.50	29.75	21EP4A	20.15
33.75	16AP4	18.50	34.85	21EP4B*	23.25
32.20	16BP4	18.75	31.95	21YP4A	21.15
33.75	16GP4	18.75	37.00	21MP4	26.25
23.50	16KP4	15.75	29.75	21YP4	22.00
28.40	16RP4A	18.75	31.95	21YP4A	22.00
31.50	16LP4A	16.25	28.30	21ZP4	21.00
31.50	16WP4	16.25	33.60	21ZP4B*	24.00
23.50	17BP4	18.75	100.00	24AP4	56.00
28.40	17BP4B*	18.75	48.40	24CP4A*	38.00
30.75	17CP4	20.50	50.00	24DP4A*	39.00
33.90	17GP4	21.50			

*ALUMINIZED—INQUIRE FOR ANY TUBE TYPE NOT LISTED. STAN-BURN CRT TUBES RCA LICENSED—MFD. BY LINCOLN. All orders of 6 or more STAN-BURN CRT are subject to additional 10% discount. PRICES SUBJECT TO CHANGE WITHOUT NOTICE.

WHY PAY MORE?

Top brand nationally adv. merchandise in this and other Radio & TV mags. is yours at low, low cost. Send us your list, and we'll ship you the best of item. Write for '58 catalogs to Dept. RTV-7 today.

GENERAL ELECTRIC RECEIVING TUBES

Brand New—1 Year Guarantee—Boxed

O24	83	6K6GT	1.13	12SA7	1.45
1B3GT	1.38	6SN7GT	1.25	12SK7	1.33
5U4CA	1.55	6X4GT	1.03	12SO7	1.18
6AG5	1.25	6W4GT	1.15	35W4	.68
6AU6	1.00	12AU7	1.18	35Z5GT	.90
6BQ6A	1.25	6X5	1.25	6X5	.03
6BG6A	3.10	12BE6	1.03	50LEGT	1.15

Additional 10% Discount in Lots of 10 Assorted!
WRITE FOR COMPLETE PRICE LIST

MASCO "SMALL TALK" INTERCOM

For Home, Office and Factory
This 3-tube intercom comes complete with 50 ft. cable, ready to operate, nothing more to buy. Can be used AC or DC, has volume control with on-off switch, pilot light, talk listen switch. Can be left open for baby sitting or dictation. UL Approved. **ONLY \$18.75**

HI-FI DIAMOND NEEDLES—1 Yr. Guar.

Diamond needles reduce record wear and needle noise thus retaining full frequency response and tonal qualities of your records for a longer period of time.
SINGLE DIAMOND needle \$6.95
DIAMOND SAPP dual needle \$7.95
Shipment PPD. (specify cartridge make)

RECORD CHANGERS

- COLLARO TC-340 4 speed changer... \$36.75
- COLLARO RC-440 4 speed changer... 40.67
- COLLARO TC-540 4 speed changer... 45.57
- GARRARD RC-88 4 speed changer... 53.41
- GARRARD RC-98 4 speed changer... 66.15
- FREE wood mounting base, record wiping cloth and 45 RPM spindle with all orders for Collaro and Garrard changers, with this ad.
- VM 4 SPEED HI-FI CHANGER—Model 1210 with Ronette or Astatic flip-over cartridge... \$22.95
- MONARCH Model UABU 4 SPEED AUTO. INTERMIX CHANGER less cartridge \$19.85
- WEBCOR 4 SPEED CHANGER with turn-over cartridge... \$23.95
- RONETTE (phono fluid) cartridge flip-over type... \$2.98
- SONOTONE cartridge, flip-over... \$2.98
- 45 RPM SPINDLE for V.M. or Monarch... \$1.98
- WOOD MOUNTING BASE for V.M. or Monarch... \$3.95
- MOUNTING BOARD unfinished for V.M. or Monarch... \$1.50
- NEW GENERAL ELECTRIC HI-FI VARIABLE RELUCTANCE CARTRIDGE. Replaces discontinued RPX050 type. Full range reproduction 20-20,000 cycles. Four gram tracking force for minimum record and stylus wear.
- 4G050—Dual Sapphire needles... \$8.77
- 4G052—Diamond, Sapphire needles... \$18.99

KITS!

We stock the following manufacturers complete line of kits—see Advertisers Index for reference pages.
EICO QUALITY CABINART
DYNA BOGEN ELECTRO-VOICE
ARKAY GRONIMES TECHMASTER

All domestic orders will be shipped prepaid and on your list. Order by Mr. and Model No. of item.

YOU NAME IT—WE HAVE IT

Complete line of T.V. & Radio receiving tubes, coils, trans., controls, antennas & accessories—No Minimum Order—DEALER DISCOUNTS! Thousands of satisfied Hi-Fi enthusiasts and dealers will vouch that STAN-BURN GIVES THE BEST DEAL POSSIBLE!

EXPORT INQUIRIES AND OFFERS INVITED
Terms: 20% with order. Balance C.O.D. All Prices F.O.B. NEW YORK Warehouse.
Write for our latest price list and Hi-Fi Catalog RTV-7. All Prices Subject to Change Without Notice.

STAN-BURN RADIO and ELECTRONICS CO.

558 CONEY ISLAND AVE. • B'KLYN 18, N. Y.

Telephone Amplifier

(Continued from page 58)

collector voltage for the resistance values specified.

A voltage divider consisting of a 39,000-ohm and a 12,000-resistor, in conjunction with the 5000-ohm emitter resistor, produce the desired emitter current.

The parallel equivalent resistance of the two base bias resistors is 9200 ohms. This means that the actual input resistance of the transistor must be 9600 ohms to give the over-all input resistance of 4700 ohms.

The input resistance of the transistor is:

$$R_i \approx h_{ie} (R_E + h_{ib})$$

At the 0.3 milliamperes emitter current, h_{ib} is roughly 75 ohms. Also, at this current h_{ie} has dropped to about 29 for a 2N190 transistor. The above expression may be solved for R_E and proper values substituted to give a value of R_E of 255 ohms. A 220-ohm resistor would be close enough for practical use.

Gain for this stage is:

$$G = A_v^2 \frac{R_i}{R_t} \approx \frac{(29)^2 (865)}{(9600)} = 75.5 \text{ or } 19 \text{ db.}$$

Subtracting the 3 db loss in the bias resistors gives an over-all gain for this stage of 16 db which is the amount needed.

It will be noted that in the design of all of the stages, the coupling capacitors and the bypass capacitors have been assumed to be a complete short circuit to the a.c. signals present. This is a valid assumption for a certain range of frequencies if the proper values of capacitance have been chosen.

To simplify the discussion, the effects of the coupling capacitor and the emitter bypass capacitor of an amplifier, such as shown in Fig. 4, will be considered separately.

First, neglect any effect of C_4 . An equivalent circuit is shown in Fig. 5. It may be seen that the loss due to the coupling capacitor, C_3 , will be approximately 3 db at the frequency at which the reactance of C_3 is equal to the sum of the load resistance R_s and the parallel equivalent of R_6 , R_7 , and R_t of the following stage. If the amplifier is to be used with the pickup coil whose frequency response is shown in Fig. 3, a low-frequency cut-off frequency of 100 cps for the amplifier is more than ample.

Using the above method for calculating the value of a coupling capacitor required to give a 3 db loss per stage at 100 cps, a value of 0.3 microfarad is found to be sufficient in all cases. A value of 5 microfarads will almost eliminate the effects of a coupling capacitor at the frequency range used.

The equivalent circuit, showing the effect of the bypass capacitor in the amplifier of Fig. 4, is shown in Fig. 6. Here R is the parallel equivalent of R_3 , R_6 , R_7 multiplied by the quantity

$(1 + h_{fb})$. (The parameter h_{fb} is the common base forward current transfer ratio.) A loss of 3 db would be caused by C_4 at the frequency at which the magnitude of the equivalent impedance of C_4 and R_{10} is equal to the sum of R and h_{ib} . Since the sum of R and h_{ib} is usually 1000 ohms or more, the effect of R is negligible.

Performing the necessary calculations to satisfy this requirement, and again assuming a 3 db loss per stage at 100 cps, the required values of C_2 , C_4 , and C_5 in the diagram of Fig. 7 are approximately 3, 15, and 30 microfarads respectively. It should be recognized that these values would give a 9 db loss for the three stages. To aid the low-frequency response, actual values of 10, 30, and 60 microfarads may be used.

As seen from the schematic diagram of Fig. 7, the circuit for the telephone amplifier is quite simple and straightforward. The signal from the induction pickup coil is amplified by a four-stage audio amplifier which feeds the loudspeaker.

The transistor amplifier includes stabilization networks which serve two main purposes. First, the use of such networks helps to fix the operating point of the transistor, thus eliminating the necessity of adjusting the bias of each transistor. Second, the stabilizing networks help to prevent the major shifts in operating point which would occur at elevated temperatures. Of particular importance from this standpoint is the output stage. Without the emitter stabilizing resistors, an elevation in ambient temperature could increase the power dissipation of the two output transistors sufficiently to cause thermal runaway. This occurs whenever the collector dissipation is sufficiently increased due to a rise in ambient temperature. This increased dissipation causes increased power dissipation which completes a positive feedback loop. Without proper stabilization, the gain of the loop may exceed unity with damaging results to the transistor.

A decoupling network consisting of resistor R_{18} and capacitor C_7 was necessary to prevent oscillation due to the relatively high gain amplifier. There is a small amount of d.c. voltage loss across the resistor but its effect is negligible.

Power for the telephone amplifier is derived from four standard flashlight cells. Since the unit is normally used only intermittently and even then the current drain is on the order of 10 to 30 milliamperes, depending on the volume level at which it is operated, the life of the batteries is quite long. If space is at a premium, smaller batteries could be used. In this case, the battery life would also be decreased.

To hear a telephone conversation by use of the telephone amplifier, it is only necessary to bring the induction pickup coil near the telephone. While there is an optimum position for the best performance, this is not critical.



Name your own 7 WONDERS OF THE WORLD

and visit them all
FREE VIA **TWA**
TRANS WORLD AIRLINES
U.S.A. • EUROPE • AFRICA • ASIA

Just list any 7 places, people, or events in the world that you would most like to visit and photograph, and you can win this fabulous contest!

TWA-TRANS WORLD AIRLINES will fly you to the 7 world wonders of your choice in luxurious comfort aboard a JET-STREAM* airliner!

AMERICAN EXPRESS will make all arrangements for first class accommodations through its worldwide Travel Service! Your expenses will be covered by safe, convenient, American Express Travelers Cheques, spendable everywhere!



POPULAR PHOTOGRAPHY magazine reveals how you can get aboard this exotic magic carpet . . . with full details of the most unique contest ever—in the current issue.

Read complete details in
POPULAR PHOTOGRAPHY
. . . on sale now.

*JETSTREAM IS A SERVICE MARK OWNED EXCLUSIVELY BY TWA

At full gain and assuming a reasonably strong signal, the conversation may be picked up when the induction coil is a foot or more from the coil in the telephone base. The gain of the amplifier should not be turned to maximum if the speaker is placed anywhere near the telephone handset since audio feedback from speaker to mouthpiece may cause a very objectionable squeal. Since the mouthpiece of the telephone is somewhat directional, it is wise to point it away from the speaker to further minimize the possibility of squealing. Of course, if earphones were used in place of the speaker or if the speaker were in another room, there would be small possibility of trouble of this sort.

In this article, many approximations were used to simplify the design, but the errors caused are less than the variations of transistor and component parameters from unit to unit.

-50-

POOR MAN'S 6146 REPLACEMENT

By STAFFORD E. DAVIS, W5HDM

ALMOST all modern low- and medium-power commercial transmitters are using 6146 tubes as their power amplifiers. These vary in power from 75 to 300 watts, depending on the power supply, and whether one or more 6146 tubes is used. Although these transmitters work very well, the cost of replacing a defective 6146 is quite high.

After replacing one or two of these tubes at a cost of approximately \$5.00 each, the average amateur will begin to wish that his transmitter used a less costly tube in the final. There is another tube that can be used in place of the 6146 at a considerable reduction in cost. This is the old reliable 807.

By constructing a very simple adapter socket and plug (as shown in the diagram) the 6146 and 807 can be interchanged. The only change necessary in the transmitter wiring, is to lengthen the plate leads. This is necessary because the 807 is slightly longer than the 6146. Using two replacement 807's in a DX-100, no difference in operation or efficiency was noted on any amateur band.

A new 807 sells for approximately \$3.00, however there are a large number of surplus 807 tubes on the market selling for around \$1.10 and even less. When compared with the \$5.00 tag of the 6146 this is quite a saving.

-50-

Wiring for socket adapter is shown here.

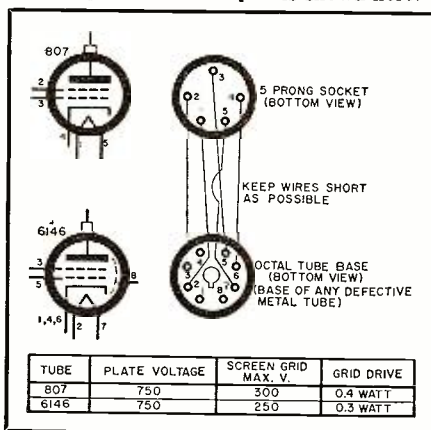

Get

Your First Class Commercial F.C.C. LICENSE in 12 Weeks!

F.C.C. License—the Key to Better Jobs

An FCC commercial (not amateur) license is your ticket to higher pay and more interesting employment. This license is Federal Government evidence of your qualifications in electronics. Employers are eager to hire licensed technicians.

Learn by Mail or in Resident Classes

Grantham School of Electronics specializes in preparing students to pass F.C.C. examinations. Correspondence training is conducted from Washington and Hollywood; resident DAY and EVENING classes are held in both cities. Either way, we train you quickly and well—NO previous training required. A beginner may qualify for his first class F.C.C. license in as little as 12 weeks.

Here's a few of our recent graduates, the class of license they got, and how long it took them:

Name	License	Weeks
Michael Aperio, 916 Townsend, Chester, Pa.	1st	12
A. Giaquinta, 404 Dale, Silver Spring, Md.	1st	12
John Ward, 407 E. Cowden Ave., Midland, Tex.	1st	10
Charles Page, Gen. Delivery, Yuma, Ariz.	1st	16
F. T. Verga, 538 - 7th St., Buffalo, N. Y.	1st	12
E. H. Siddall, 13351 Magnolia, Van Nuys, Calif.	2nd	8
G. C. Patschke, 3220 Conn. Ave. NW, Washington, D.C.	1st	12
Harold Jones, P. O. Box 705, Alamogordo, N. Mex.	1st	13
Norman Cook, 130 Olive St., Neodesha, Kan.	1st	12
Henry Best, 1003 Vermont St., Fremont, N. C.	1st	11

The Grantham

Communications Electronics Course

offers you complete preparation for F.C.C. examinations required for a first class F.C.C. license. Even though it is planned primarily as preparation for F.C.C. examinations, it is not a "cram course" but prepares you by TEACHING you electronics.

OUR GUARANTEE

If you should fail the FCC exam after finishing our course, we guarantee to give you additional training at NO ADDITIONAL COST. Read details in our free booklet.

FCC-TYPE EXAMS

FCC-type tests are used throughout the Grantham course. Constant practice with these FCC-type tests helps you prepare for the actual FCC examination.

TWO COMPLETE SCHOOLS: To better serve our many students throughout the entire country, Grantham School of Electronics maintains two complete schools—one in Hollywood, California and one in Washington, D. C. Both schools offer the same rapid courses in FCC license preparation, either home study or resident classes.

MAIL TO SCHOOL NEAREST YOU

(mail in envelope or paste on postal card)

Grantham Schools, Desk 86-K

1505 N. Western Ave. Hollywood 27, Calif. OR 821 - 19th Street N.W. Washington 6, D. C.

Please send me your free booklet telling how I can get my commercial F.C.C. license quickly. I understand there is no obligation and no salesman will call.

Name

Address

City State

I am interested in: Home Study. Resident Classes

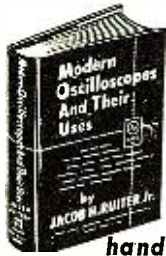

GET MORE WORK OUT OF YOUR OSCILLOSCOPE

Learn to service
ANY radio or TV
faster . . . with the
handiest instrument of all!

Here, in a greatly enlarged edition, is THE book that really shows you how to use oscilloscopes!

Clearly as A-B-C, MODERN OSCILLOSCOPES AND THEIR USES tells you exactly when, where and how. You learn to locate either AM or FM radio or television troubles in a jiffy. Even tough realignment jobs are made easy. No involved mathematics! Every detail is clearly explained—from making connections to adjusting circuit components and setting the oscilloscope controls. And you learn to analyze patterns fast and RIGHT!

ENLARGED 2nd EDITION!

Includes Color TV 'Scope Data

Includes latest data on use of 'scopes in color TV, industrial electronics, teaching . . . even in atomic energy work. Over 400 pages and over 400 clear pictures. Dozens of pattern photos make things doubly clear . . . even for beginners!

PRACTICE 10 DAYS FREE!

Dept. RN-78, RINEHART & CO., Inc.
232 Madison Ave., New York 16, N. Y.

Send new 2nd edition of MODERN OSCILLOSCOPES AND THEIR USES for 10-day examination. If I like book, I will then send \$6.50 (plus postage) in full payment, or return book postpaid and owe you nothing. (SAVE! Send \$6.50 with order and we pay postage. Same return privilege with money refunded.)

Name

Address

City, Zone, State

Outside U.S.A.—Price \$7.00, cash with order only. Money back if you return book in 10 days.

NOW—faster, easier ball-bearing drive for GREENLEE chassis punches

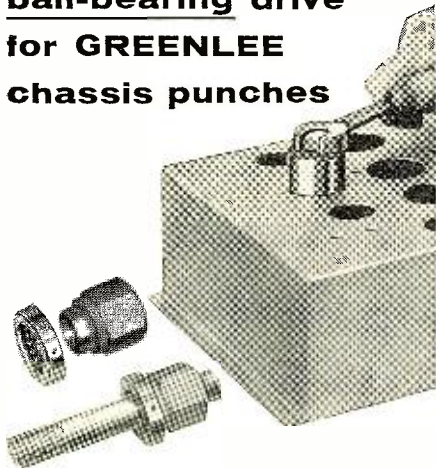

New GREENLEE Ball-Bearing Drive Nuts and Drive Screws reduce friction and make it easier than ever to cut smooth, accurate holes with GREENLEE No. 730 Round Radio Chassis Punches. The new faster drives are available for all round-type GREENLEE Punches sizes 11/16" through 2-25/32". Operate with ordinary wrench for quick socket openings, etc., in metal, Bakelite, or hard rubber.



GREENLEE TOOL CO.
1887 Columbia Avenue
Rockford, Illinois

120

Within the Industry

(Continued from page 22)

the officers, directors, and Past Chairmen Council, will be responsible for the group's program in both industry relations and intra-membership activities.

Committee chairmen include: Industry Coordinating, Francis F. Florshheim, *Columbia Wire & Supply Co.*; Industry Relations, Mike Remund, *Jensen Industries*; Program and Attendance, Dave Rice, *Electronic Publishing*; Membership, Jay Greengard, *Waldom Electronics*; Educational, Norman Ackerman, *Perma-Power Co.*; Credit, Jack Reesor, *Jensen Mfg. Co.*; Conference Coordinating, Ernie Necker, *Argos Products*; Social, Irving Rossman, *Pentron Corp.*; Survey, Herb Bowden, *Service Instruments*; Publicity, W. L. Larson, *Switchcraft*; Industrial Distribution, Ralph M. Hill; Special Projects, Robert Svoboda; Catalogue, Ralph M. Hill; Finance, Kenneth A. Hathaway; and Nominating, A. N. Haas, *Bud Radio*.

E. H. TAYLOR has been named to the newly created position of manager of product and market development by *DuKane Corp.* . . . **Tenney Engineering, Inc.** has named **SAUL S. SCHIFFMAN** chairman of its board of directors . . . **BERN MARSHALL** has been promoted to the position of technical coordinator, and **AL PICCIRILLI** appointed to coordinate traffic on the shipping and receiving ends of the purchasing function at *Blonder-Tongue Laboratories, Inc.* . . . **THOMAS M. STUART** has joined the *Hallcrafters Company* in the newly created post of sales promotion manager of amateur equipment. . . . **STANLEY M. SURLOW** has been added to the sales department of *Pioneer Electronics Corp.* . . . **W. HARRISON FAULKNER, JR.** has been elected vice-president for engineering and development, *Tracerlab, Inc.* . . . **CHARLES C. SILVA, JR.** has been named director of process engineering at *Clevite Transistor Products* . . . The appointment of **D. O. REINERT** to the new position of manager, mobile and microwave service sales, technical products department, has been announced by *RCA Service Company* . . . *Audio Devices, Inc.* has appointed **GERARD CAFARO** and **GEORGE KULPER** as sales engineers for its new rectifier division . . . **E. A. FREIBURGER** has been appointed general manager of *Concertapes, Inc.* . . . **JOHN A. MCCORMICK** has been named manager of system sales for two-way radio units made by the *General Electric* communication products department . . . **MERLE W. KREMER** and **GERALD L. MORAN** have been appointed divisional vice-presidents of *Sylvania Electric Products Inc.* . . . **ROBERT STRICH** has been named chief engineer for the Los Angeles division of *Cannon Electric Company* . . . **MILTON WISOFF** is now executive sales manager of *Pyramid Instrument Corp.* . . . **JOSEPH R. OWEN** has been ap-

pointed manager of advertising and sales promotion for *General Electric's* specialty electronic components department . . . **KENNETH W. CONNOR** has been named to the newly created post of manager of sales management development for *Sylvania Home Electronics*, a division of *Sylvania Electric Products Inc.* . . . *Michigan Magnetics, Inc.* has named **GROVER J. BEACH** sales manager and **WAYNE C. COLE** controller . . . **CARROLL M. WHITE**, manager of the Electronic Industries Association's mobile radio communication division, has resigned to accept the position of executive secretary to the Special Industrial Radio Services Association (SIRSA) . . . **GILBERT E. GUSTAFSON**, vice-president in charge of engineering, *Zenith Radio Corp.*, died after a brief illness . . . *British Industries Corporation* announces the death of **JAY H. QUINN**.

* * *

HERB GERSON has been named assistant advertising manager of *Blonder-Tongue Laboratories, Inc.*



In his new position he will administer the company's advertising and publicity activities in trade, dealer, and consumer media. He will also assist the sales manager, Joseph H. Kerner, in sales promotional activities.

Mr. Gerson came to the firm from *Conti Advertising Agency*. Prior to this position he was employed by two other agencies as an account executive and in traffic and production.

* * *

WILLIAM R. MINCK, a University of Wisconsin graduate student, has been awarded the National Electronics Conference fellowship for the 1958-59 academic year.

Mr. Minck, 23, was chosen in a national competition. He is currently studying towards his master's degree in electrical engineering, having received his bachelor's degree from the University of Notre Dame.

The fellowship award, worth \$2500, is the second to be given under a program recently adopted by the NEC for sponsoring advanced study in electronics.

Sponsors of the Conference are the American Institute of Electrical Engineers and the Institute of Radio Engineers. The Electronic Industries Association and Society of Motion Picture and Television Engineers are also participants.

* * *

DR. ALLEN B. DU MONT, chairman of the board of directors of *Allen B. Du Mont Laboratories, Inc.*, has been presented with the award of "Engineer of the Year" by the New Jersey Society of Professional Engineers.

Dr. Du Mont was honored not only for his achievements leading to TV but for engineering developments that led to electronic devices such as radar, loran, and oscilloscopes.

-30-

WANTED!

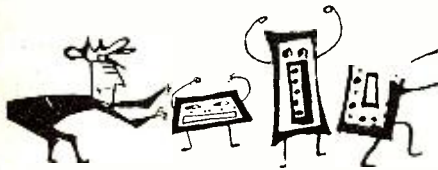

Equipment, components or parts!

THE more than 245,000 readers of RADIO & TV NEWS are always in the market for a good used equipment buy. So, if you have something to sell, let RADIO & TV NEWS readers know about it in our classified section.

It costs very little: just 50¢ a word, including name and address. Minimum message: 10 words. For further information, write:

Martin Lincoln
RADIO & TV NEWS
One Park Avenue
New York 16, New York

college grads get ahead faster!

... have higher incomes ... advance more rapidly. Grasp your chance for a better life. Share rewards awaiting college men. Important firms visit campus regularly to employ Tri-State College graduates. Start any quarter. *Approved for Vets.*

Bachelor of Science degree in 27 months

Complete Radio Engineering courses (TV, UHF, FM, Electronics). Also Mechanical, Civil, Electrical, Chemical, Aeronautical Engineering. In 36-months a B.S. in Business Administration (General Business, Accounting, Motor Transport Management). Superior students faster. More professional class hours. Small classes. Enrollment limited. Beautiful campus. Well-equipped labs. Prep courses. Enter Sept., Jan., March, June. Earnest capable students (whose time and budget require accelerated courses and modest costs) are invited to write Jean McCarthy, Dir. Adm., for Catalog and book "Your Career in Engineering and Commerce."



GET YOUR COMMERCIAL TICKET EASIER WITH ...

Kaufman's

RADIO OPERATOR'S LICENSE Q AND A MANUAL

now available 6th EDITION up to the minute

The BEST book for FCC License Preparation Covers elements 1 thru 8.

The only book with complete discussion of answers to every technical question in the FCC Study Guide. Makes it very easy to answer multiple choice questions.

Used by leading schools and industry. Only \$6.60 at jobbers, bookstores or direct from:

JOHN F. RIDER PUBLISHER, INC.
116 West 14th Street, New York 11, N. Y.

EXPECTING AN ORDER?

You'll get it quicker if your postal delivery zone number is on the order blanks, return envelopes, letterheads.

The Post Office has divided 106 cities into postal delivery zones to speed mail delivery. Be sure to include zone number when writing to these cities; be sure to include **your** zone number in **your** return address —after the city, before the state.

July, 1958

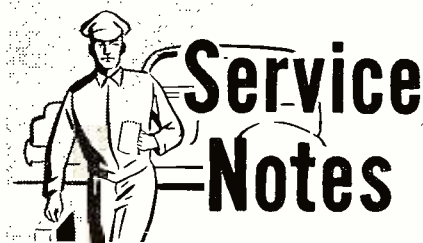

HORIZ. DRIFT, WESTINGHOUSE

The horizontal hold may drift out of lock-in range after an hour or more of operation on some V-2373-1 chassis. Your first check, if you run into this problem, should be of the 10,000-ohm, 2-watt resistor located between the socket of the 17DQ6 and the selenium diode for the a.f.c. system. An under-chassis view of this portion of the receiver is shown in Fig. 1. As the

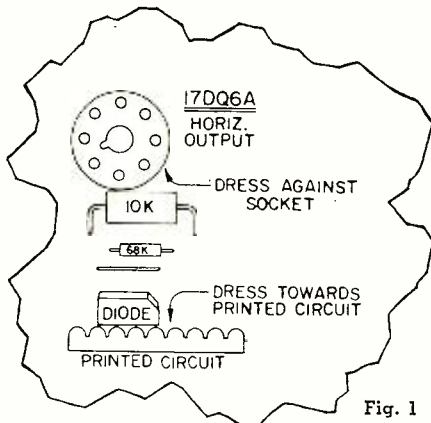

Fig. 1

resistor heats, it can influence operation of the a.f.c. circuit because of the physical proximity.

The solution to this one simply is to dress the resistor away from the diode by pushing it up against the 17DQ6 socket, and also to dress the diode away from the resistor, as shown.

TUNING SHIFT, ZENITH

It sometimes happens that a receiver appears to show a tendency to shift tuning on a single channel, although there seems to be no instability on others. In chassis 27F20, 28F20, 28F21, 28F22, 28F23, 28F25 and others using similar tuners, this difficulty of the oscillator in holding its adjustment is usually caused by fine particles that have broken loose from the oscillator adjustment screw. When the turret is switched from one channel to another, these small pieces change position, affecting tuning of the strip with which they are associated.

The adjustment must be screwed out entirely to correct this condition. Then blow the shavings out, preferably with an air gun. If the fault is still not cured, the entire channel strip should be replaced.

HOFFMAN: VERTICAL JITTER

Some TV sets using chassis 301, 302, 303, 306, 307, and 308 may reveal a tendency toward vertical jitter when operated in the fringe area, although vertical stability of these same receivers is entirely satisfactory for non-



Demand the finest in Electronic Test Equipment—EMC, of course. You get the most quality per measurement dollar!

NEW! EMC Model 301 Speedi Tube Tester

Checks tubes in seconds. Checks shorts, leakages, and quality. Over 375 tubes, including 024, now listed. New listings available. Checks and rejuvenates Picture Tubes with Model PTA (Picture Tube Adaptor), at only \$4.50. Model 301P (illustrated),

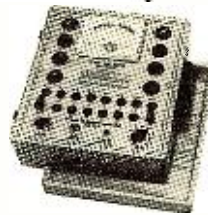

with 4 1/2" meter & oak. Carrying case \$47.50
Kit 33.20
Model 302C, (with 7 1/2" meter) 62.90
Kit 47.90

NEW! EMC Model 108 Handi Tester

The only appliance and auto battery tester in its price class to use a D'Arsonval, instead of an iron vane type meter. Gives exclusive advantages of maximum accuracy and scale length, and minimum battery replacement cost ... at no added charge. Complete with test leads and instruction manual.



Wired \$15.95 Kit 12.95

NEW! EMC Model 905-6A Battery Eliminator, Charger, and Vibrator Checker

A MUST for auto radio service. Features continuously variable voltage output — in either 6 or 12 volt operation. Checks all 6 or 12 volt vibrators.



Wired \$67.90 Kit 44.90

NEW! EMC Model 601, Wide Band Oscilloscope for Color & Monochrome TV

Features full 5 mc band with push-pull vertical amplifier with sensitivity .02 volts per inch, retrace blanking amplifier for clearer pictures, and multivibrator sweep from 15 cycles to over 75 kilocycles. Wired and tested ...\$117.90

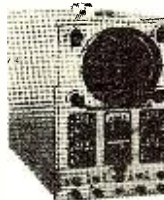

NEW! EMC Model 206P Dynamic Mutual Conductance Tube Tester

The lowest priced mutual conductance tube checker on market. Checks tubes for microhm value and gas content. Completely flexible switching. Your best buy in a quality tube tester. (Hand rubbed Carrying Case) ...\$83.50

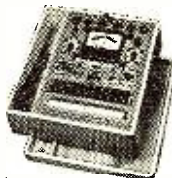

Yes, tell me more, send me—FREE—RN-7 a detailed catalog of the complete EMC line.

NAME _____

STREET _____

CITY _____ STATE _____

EMC

Electronic Measurements Corp.
625 B'way • New York 12, N. Y.
Ex. Dept. 370 B'way, N. Y. 13

ORDER by MAIL and SAVE! TV PICTURE TUBES

10BP4	\$ 7.95	17BP4	\$10.95	21AMP4	\$19.95
12LP4	8.95	17CP4	17.00	21ATP4	20.95
14B/CP4	9.95	17GP4	17.60	21AUP4	20.95
16DP4	14.95	17HP4	13.60	21EP4	14.95
16EP4	15.90	17LP4	13.60	21FP4	15.95
16GP4	15.90	17QP4	11.95	21WP4	17.30
16KP4	10.95	17TP4	19.30	21YP4	15.95
16LP4	10.95	19AP4	19.30	21ZP4	14.95
16RP4	10.95	20CP4	13.90	24CP4	23.95
16WP4	15.20	20HP4	17.95	24DP4	26.95
16TP4	10.95	21AP4	22.10	27EP4	39.95
17AVP4	15.20	21ALP4	20.95	27RP4	39.95

27"-6 month guarantee—all others 1 year. Aluminized Tubes \$5.00 more than above prices. These prices are determined to include the return of an acceptable similar tube under vacuum.

ALL PRICES FOB CHICAGO, ILLINOIS. Deposit required, when old tube is not returned, refundable at time of return. 25% deposit required on COD shipments. Old tubes must be returned prepaid. We ship anywhere.

WRITE FOR COMPLETE LIST.

— PICTURE TUBE OUTLET —

3032 MILWAUKEE AVE.
CHICAGO 18, ILLINOIS
Dickens 2-2048

ENGINEERING

Prepare for unlimited opportunities of the Electronic Age! Earn your B.S. DEGREE IN 27 MONTHS in Aeronautical, Chemical, Civil, Electrical or Mechanical Engineering; in 36 MONTHS in Mathematics, Chemistry, Physics. Intensive, specialized courses. Comprehensive training in electronics, television, advanced radio theory and design, math, nuclear physics and electronic engineering. Engineering Science preparatory courses. Low rate. Graduates in demand. Spacious campus; 20 bldgs., dorms, gym, playing field. Earn part of your expenses in Fort Wayne while studying. G.I. approved. Enter Sept., Dec., March, June.

B.S. DEGREE IN 27 MONTHS

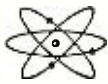

INDIANA TECHNICAL COLLEGE

978 E. Washington Blvd., Fort Wayne 2, Indiana
Please send me free information on B.S. ENGINEERING DEGREE IN 27 MONTHS as checked.

Electronics Chemical Aeronautical
 Civil Mechanical Electrical

B.S. DEGREE IN 36 MO. IN Math. Chem. Physics

Name
Address

FOR THE BIGGEST BATCH . . . of blockbusting buys in electronics

get our new, free, 32-page

Catalogue No. 117! It's terrific!

ARROW SALES, INC.

Sales-Showrooms:
Western: 7035 Laurel Canyon, No. Hollywood, Calif.
Central: 2534 S. Michigan Ave., Chicago 16, Ill.
Mailing Address: Box 3007, No. Hollywood, Calif.

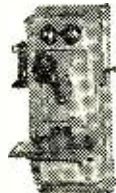

Genuine OAK WOOD Antique TELEPHONES!

As is \$9.00 complete. Tested working order \$12.00. Shipments FOB Simpson, Pa. Write for free list.

Telephone Engineering Co.
Dept. RT7 Simpson, Pa.

TAPE RECORDERS

HI FI COMPONENTS
Tapes—Accessories
UNUSUAL VALUES
Send for Free Catalog

DRESSNER
69-02 RA-174 St.
Flushing 65, N. Y.

MERITAPE

Low Cost, High
Quality Re-
cording Tape—
in boxes or
cans.

fringe use. Under weak-signal conditions however, a change in the vertical circuit can be made to eliminate this jitter. The existing integrator network, consisting of R_{601} , R_{602} , C_{603} , and C_{604} , is first removed. A single-unit integrator plate (Hoffman Part No. 9695) is then connected into the circuit as shown in Fig. 2. Some receivers bearing the model numbers noted

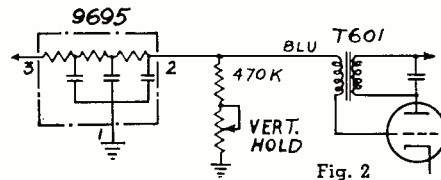

Fig. 2

already have this change incorporated in them. Since this change should not be necessary except in areas where the available signal is very weak, other possible causes should be checked first if jitter occurs in other circumstances.

RIGHT-HAND PIX CURL, G-E

Receivers in the "U2" series may show some tendency to develop curling of the picture along the right-hand edge of the raster. Operation of the horizontal-output circuit may be improved to eliminate this curl with a simple change. This is done by breaking the connection from terminal 1 of

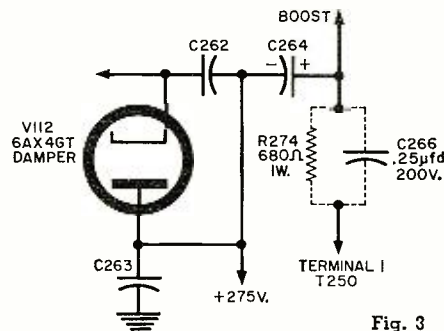

Fig. 3

horizontal-output transformer T_{250} to capacitor C_{264} in the boost circuit, and inserting a resistor shunted by a capacitor at this point, in the manner shown in Fig. 3. The resistor (R_{274}) is a 1-watt, 680-ohm unit. The capacitor (C_{266}) is a .25- μ fd., 200-volt unit.

KAYE-HALBERT: LIN. CONTROL

In some cases, overheating of the vertical-linearity control in receivers using chassis 263, or damage to this control, or other symptoms, may indicate that excessive current is being drawn through this potentiometer. This difficulty can be remedied by replacement of the unit with one better suited for this circuit and by another slight revision. After the control has been removed, replace it with a 2000-ohm, 2-watt, wirewound, linear-taper potentiometer. Kaye-Halbert Part No. 138 may be used. In addition, the 220-ohm, 1/2-watt resistor in the cathode circuit of the vertical-output tube should be removed and replaced. A convenient replacement for this component is made by placing two 1200-ohm, 1-watt resistors in shunt. —30—

Simple Transistor Mixer

(Continued from page 47)

The current is amplified by the transistor and appears as a voltage variation that is developed across the load resistor R_s .

The over-all voltage gain from input to output is about 8, depending upon the gain of the transistor used. The current drawn under operation is slight, 50 μ a. The output impedance is not low enough to allow for extreme lengths of cable, but without having a vu meter its usefulness at remote positions for adjusting volume levels is ruled out. Alongside a recorder or p.a. amplifier it functions without trouble, although lengths of cable up to 50 feet would cause no loading of the output circuit.

There is little that is critical in the construction of this circuit. Almost all of the values involved have a wide latitude that will allow proper operation. Although this mixer was limited to three input channels, there is no reason why it could not function with as many as 20 identical input circuits. The limiting resistors, R_1 , R_2 , and R_3 can be changed to other values to correspond to the correct termination of any particular microphone, although as the value is increased the gain will correspondingly decrease. This is partly offset by the fact that a lighter loading on the microphones results in a greater voltage output. Both C_1 and C_2 will function with lower values of capacitance, 1 μ fd. being the lower limit. The controls R_4 , R_5 , and R_6 also may have any value between 50,000 and 500,000 ohms. From all this it can be seen that this is a lovely project to build from junk box parts.

The only item that requires attention is the selection of R_7 and the transistor. The transistor must have a low noise level. The 2N107 used in the circuit was not selected for its extremely low noise level, but because it was available from the parts box and functioned satisfactorily. The noise level is just discernible above the thermal noise of the tape recorder used with the mixer. It was not annoying enough to warrant the purchase of a low-noise unit. A 2N190 would give a lower noise level as well as increasing the over-all gain.

The bias resistor, R_7 , selects the operational point for the transistor. It only becomes important when an output voltage of 300 millivolts or more is desired. The value should be adjusted until the load resistor R_s shows a voltage drop of 1 volt (measured on a v.t.v.m.) when the transistor is cold. You can test its function when warm by pinching the body of the transistor with the fingers for a minute. Body heat will warm it up sufficiently to see if the voltage drop has increased to too large a value. It should not go beyond 2 volts. Stabilization was not considered necessary since the output level will always be low and there is prac-

GET INTO EL CTRONICS

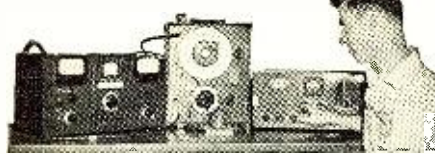

V.T.I. training leads to success as technicians, field engineers, specialists in communications, guided missiles, computers, radar and automation. Basic and advanced courses in theory and laboratory. Associate degree in electronics in 29 months. B.S. in electronic engineering obtainable. ECPD accredited, G.I. approved. Graduates in all branches of electronics with major companies. Start September, February, Dorms, campus. High School graduate or equivalent. Catalog.

VALPARAISO TECHNICAL INSTITUTE
Dept. RD Valparaiso, Indiana

Wholesale Only SELLING

Receivers, Transmitters, Radar, Special Purpose Tubes, Relays, Meters, Switches, Connectors, Rectifiers, Transformers, Motors & Generators, Wiring Cable, Instruments and All Electronic Components.

RADIO & ELECTRONIC SURPLUS

14000 BRUSH STREET

Detroit 3, Mich. TO 9-3403

GOVERNMENT SURPLUS KITS

Electronic and Electro-Mechanical Parts

Tremendous assortment of Army-Navy surplus, either stripped from equipment or still packaged in brand new condition. EXPECT TO BE DELIGHTED! Selectronics includes items usually unheard of in bargain kits. While all kits are different, they include such items as:

Resistors	Tubes	Timers
Condensers	Sockets	Counters
Transformers	Bulbs	Relays
Chokes	Switches	Meters
Rectifiers	Solenoids	Setlays

... Plus many, many other kinds of electronic parts & equipment.

KIT "A"

35-40 lbs. \$4.95

KIT "B"

100 lbs. \$9.95

FOB Philadelphia, Pa. Purchase Price refunded if not completely satisfied.

SELECTRONICS 1206-18 South Napa Philadelphia 46, Pa.

30 Watt Hi-Fi Super Lin Kit

AMP-PREAMP with TRANSISTORIZED FRONT END

FREQUENCY RESPONSE: ± 1 db 10-40,000 cps.
TUBES: uses (1) 6AU6, (1) 12AU7, (1) 12AU7, (2) 6X4's, (1) 5Y4-GB.

SHIPPING WEIGHT 26 lbs. FL-30 \$42.00

Sale Price. F.O.B. N.Y. Send for Free Catalogue write Dept. RN CUTICK ELECTRONICS HI-FI RADIO T.V. PARTS 171 Washington St., Worth 2-5866, New York 7, N.Y.

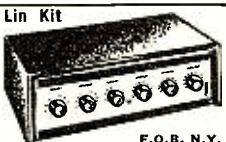

TAPE RECORDERS

WHOLESALE PRICES

HI-FI COMPONENTS

NATIONAL BRANDS

WRITE FOR FREE CATALOGUE

CARSTON

215-RD E. 88 ST. NEW YORK 28, N. Y.

BARGAIN HUNTING? TV SERVICEMEN!
Write for SENSATIONAL CATALOG
HENSHAW RADIO SUPPLY
3619 TROOST KANSAS CITY, MO.

tically no danger of over-loading the transistor in this circuit.

The mixer is constructed in a 6¼" x 3½" x 2½" box chassis. The unit is small, yet there is no crowding, allowing the use of standard size components. After mounting the potentiometers and the input microphone jacks, a terminal strip is placed on the opposite side of the chassis. The selection of input jacks should correspond to the type of plug that will be encountered in use. The output is fed into a three-foot cable that conveniently connects into the input of the equipment with which the mixer will be used. Three lugs were selected on the terminal strip; the first became the collector terminal, than a lug was skipped to correspond to the spacing of the transistor terminals. This helps to prevent confusion when connecting in the transistor. The next terminal becomes the base and the third the emitter connection. After all the wiring is completed the transistor is connected to the three terminals, again remembering to keep the unit cool, with long-nose pliers conducting heat away from the leads as they are soldered into the circuit.

This mixer has proved to be very serviceable. It will take abuse yet functions with little attention. —30—

SERIES HEATER TV SET HINTS

By DOMENIC RIPANI

HERE'S a little trick that can bring back lost picture brightness in some of those "worn-out" TV sets with series heaters. With 16 or more tubes connected in series, it is easy for heater voltages to re-establish themselves incorrectly, when tubes have aged, and quite often the picture tube heater voltage may drop as low as 3 volts. Although a usable picture may still be obtained at that voltage when the screen is quite active, the picture becomes dim if the screen has seen long service.

To remedy this, disconnect the picture tube from the rest of the heater circuit and connect it to a small filament transformer. Connect together the leads which had wired the picture tube heater to the heater string of the TV set. This will not materially affect the voltage distribution across the other tubes. If more brightness is desired, the heater voltage may be stepped up to 7 or 8 volts, but this will result in reduced picture tube life.

Other heater changes can be made at the same time, if desired, for improved results. Recently, a local store was about to discard a 12-inch *Coronado* TV set because "it was too expensive to fix." After claiming the set, the author not only wired up the picture tube to a filament transformer (after discovering that the heater voltage distribution was all wrong) but also installed a double-winding transformer and tied in all 6-volt tubes to it. In this particular case the audio output tube, a 25L6, was directly replaced by a 6V6 and it also was tied to the filament transformer. The remaining high-voltage heater tubes were connected in series and tied to the power line. Results were beyond expectation and the set has operated for about six months now with a clear, steady picture. —30—

EARN MORE!

MAKE FASTER, EASIER

AUTO RADIO REPAIRS

These Howard W. Sams

"AUTO RADIO" MANUALS SHOW YOU HOW!



Most complete auto radio service data available: Schematics, voltages, resistance readings, alignment, chassis photo views keyed to components, replacement parts recommendations—everything you need to know for quicker, easier servicing. Each volume, 8½ x 11".

AR-7. Covers 56 auto radio models produced in 1957. Only.....\$3.75

AR-6. Covers 77 models produced during 1955-56. Only.....\$3.95

AR-5. Covers 96 models produced during 1954-55. Only.....\$3.50

AR-4. Covers 61 models produced during 1953. Only.....\$3.00

AR-3. Covers 83 models produced during 1950-52. Only.....\$3.00

AR-2. Covers 73 models produced in 1949-50. Only.....\$3.00

GET EXTRA HELP WITH SAMS "AUTO RADIO REMOVAL" MANUALS

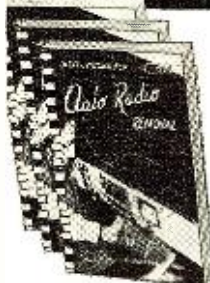

Solves the toughest problem in auto radio servicing—shows fastest ways to remove radio, power supply and speaker units. Covers all standard and sports model cars. 5½ x 8½".

ARR-57. Covers all 1957 cars.
ARR-56. Covers all 1956 cars.
ARR-55. Covers all 1955 cars.
Each Volume, only.....\$2.95

SEE THESE BOOKS AT YOUR SAMS DISTRIBUTOR OR MAIL COUPON

SEND TODAY

FREE TRIAL COUPON

Howard W. Sams & Co., Inc., Dept. 1-G8
2201 E. 46th St., Indianapolis 5, Ind.

Send me book(s) checked at right for 10 days FREE examination. In 10 days I will pay for the book(s), plus a few cents delivery cost, or return postpaid.

We pay delivery if you remit with coupon; same return privilege.

AR-7 AR-3
 AR-6 AR-2
 AR-5 ARR-57
 AR-4 ARR-56
 ARR-55

Name _____

Address _____

City _____ Zone _____ State _____

(Outside U. S. A. priced slightly higher)

Advance **BUY of the MONTH!**
POWER SUPPLY KIT BARGAIN!
 Primary 115V, 60 Cy. Sec. 415.0-415V. @ 200 Ma. 6.3V @ 6 Amp., 6.3V @ 1 Amp., 5V @ 3 Amp., 20V @ 6 Amp. Std. Mounting, plus 8 H.V. 200 Ma choke and two 10 mfd oil condensersKit **\$7.50**

RELAYS
 110 VAC
 3 PDT ceramic, leach #1773.25
 DPDT Allied BD-type2.79
 3 PST hvy. dty. Dunco, 30-amp. cont.4.39
 5 PST hvy. dty. Dunco4.79
 12 VDC DPDT plus SPST
 10 amp contact. 1.39
 SIGMA 4F. sens. 24VAC or 6VDC. 1.49
 w/tsfmr for 110 VAC1.89

SPECIAL !! **SOLENOID**
 RG-8/U CO-AX CABLE 115V 60 Cyc cont. 52-ohm Imped. 100-ft. length **\$5.75**
 115V 60 Cyc cont. duty. 18 Lb. pull. Each **\$4.95**

STEPPING RELAY **STEP UP-DOWN TRANSFORMER**
 Resettable type, 3 deck position with and mist. 1A and 1B contact at reset position. Stepping coil 24 VDCea. **\$8.95**
 750 Watt 110/220 V. 60 cycle. ea. **\$5.95**

TRANSFORMERS
 6.3 V FILAMENT 1 Amp.\$1.19
 35 Amp.\$7.80
 20 Amp.3.95
 10 Amp.2.19
 5 1/2 Amp.1.99
 3 Amp.1.89
 2 1/2 V Sec. 10 Amps. 110 V Pri. Excellent for pr. of 866's\$3.95

SCOOP! **JENNINGS VACUUM CAPACITORS, 25 Mmf @ 10 KV. Each. \$4.50**

OIL CONDENSER BARGAINS
 1 Mfd 600 VDC \$.25
 2 Mfd 600 VDC .45
 4 Mfd 600 VDC .75
 10 Mfd 600 VDC 1.10
 25 Mfd 600 VDC 3.40
 20 Mfd 650 VDC 2.75
 1 Mfd 1000 VDC .60
 2 Mfd 1000 VDC 1.20
 4 Mfd 1000 VDC 1.25
 10 Mfd 1000 VDC 1.75
 15 Mfd 1000 VDC 2.45
 4 Mfd 1500 VDC 1.75
 6 Mfd 1500 VDC 2.45
 8 Mfd 1500 VDC \$2.95
 10 Mfd 1500 VDC 3.75
 2 Mfd 2000 VDC 1.50
 12 Mfd 2000 VDC 2.75
 15 Mfd 2000 VDC 4.50
 1 Mfd 3000 VDC 1.85
 2 Mfd 4000 VDC 5.75
 4 Mfd 4000 VDC 12.75
 1 Mfd 5000 VDC 3.25
 2 Mfd 5000 VDC 8.75
 1 Mfd 6000 VDC 5.95
 5 Mfd 10000 VDC 40.00
 1 Mfd 12500 VDC 28.50

SPECIAL! PANEL METERS
 2" METERS
 0-120 Ma RF with external Thermo-couple3.95
 0-250 Ma3.95
 0-300 VAC3.95
 3" METERS
 0-150 VAC\$4.95
 0-15 DC KV 3" w/ shunt\$8.95
 0-3 1/2 KV with shunt\$6.95
 2" Dual scale w/high and low/switch 0-150V. DC. 0-7 1/2 V. DC\$3.95

115V 60 Cyc. Blower 120 CFM. Each **\$9.95**
 Cramer Synchronous Motor 115V 60 cyc. 1 RPM. Each **\$2.95**

0-200 MICROAMMETER 2", Mounted in Rubber case with cable. Ea. **\$2.95**
 DU MONT POWER TRANSFORMER 950 V. CT 300 ma; 2 6.3 V. @ 5 Amps; 2 5 V. @ 4 Ampsea. **\$7.50**

G. E. RELAY CONTROL
 (Ideal for Model Controls, Etc.)
 Contains a sigma magnet, 8,000 ohm. relay (trips at less than 2 MA), high impedance choke, bi-metal strip, neon pilot and many useful parts. The sensitive relay alone is worth much more than the total low price of **\$1.25** Each10 for **\$9.95**

Signal Corps Earphones Hi-Impedance Dual Headset, complete w/ Headband & Cord. Used -terrific Value Per Set **\$1.79**
 2 for \$3.25
 Selenium Rectifiers 30-36 VDC input, 24-28 Vac output. 5 Amps\$4.50
 2 Amps\$2.19
 1/2 Amp\$1.19
 150 Ma 110V. **\$1.29**

Min. Order \$3.00-25% with order F.O.B. New York 10 DAY GUAR. PRICE OF MDSE. ONLY

Advance Electronics
 6 West Broadway • New York 7, N. Y. • REctor 2-0270

SCHEMATICS—CONVERSIONS FOR SURPLUS GEAR
NEW LIST DI MANY ADDITIONS!
 Send stamped, self addressed envelope for List D. Add 25c for chart explaining AN nomenclature. DO IT TODAY!
 R. E. BOX 1220
 GOODHEART BEVERLY HILLS, CAL.

HOME SENDING SPEED
RECEIVING SPEED
 Be a "key" man. Learn how to send and receive messages in International Morse code. Communicate with operators around the globe. Learn at home quickly through famous Candler System. Used by best operators. Qualify for Amateur or Commercial License. Write for FREE BOOK. CANDLER SYSTEM CO., Dept. 2-H, Box 9226, Denver 20, Colo., U.S.A.

Fire Control
 (Continued from page 33)

Big hose-laying, brush-clearing "cats" are swung into action by the press of a button on a "Handie-Talkie." Fire crews are yanked from the path of treacherous spot fires by a mobile radio transmission originating high on the hill above them. That vital boost in water pressure comes just in time because a pumper engineer "got the message."

Operating with four principal land stations located in various quarters of the City's 454 square miles, plus a fifth dispatch point in the heart of the Mountain Patrol area, the L.A.F.D. radio communications net utilizes a primary frequency of 33.9 megacycles and a secondary frequency of 33.7 megacycles. Each of these base stations controls two 300-watt transmitters, the second being used, in compliance with FCC requirements for emergency radio operations, as a spare. Three of the stations control their transmitters remotely by microwave, each with telephone circuits providing a standby safety factor.

The 330 mobile two-way radio units on engines, pumpers, ladder trucks, and every conceivable piece of special fire apparatus have approximately 60 watts output and a range within the city limited only by characteristic line-of-sight operation. The 38 "Handie-Talkies" carried in command cars, which allow Chief Officers to move about on foot and still keep radio contact, have a range up to 5 miles under good conditions.

When the fast moving radio traffic of a large, major brush fire threatens to bog down amid a heavy flow of messages from other simultaneous fires in the city, high level command

Motorola's new transistorized "Handie-Talkies" are similar to the units used by the Los Angeles Fire Department for two-way communication between Fire Chiefs and key personnel. The unit shown is from the "H" series. It is available for either the 25-54 mc. or the 144-174 mc. bands. The r.f. output is 1.5 watts. The set comes with a handset and uses a standard dry battery power pack. The unit shown on this month's cover employs tubes while the set pictured here is completely transistorized.



units at the brush fire, by a flip of the switch to the secondary frequency, are afforded a closed net on which to carry on uninterrupted.

The pride and joy of the electronic technicians of the Fire Department's Bureau of Supply and Maintenance is the new communications truck being designed and largely built by their own hands. This unit, with its two dual-frequency base transmitters of 125 watts output each is, in effect, a sort of portable base station. With chairs and counter space inside to accommodate a dispatcher, a technician, and a couple of Command Officers, it promises greatly increased efficiency for command post operations at large brush fires. Unique features of the rig include a radioteletype system for alternate means of ordering equipment, etc., and a public address system with a radius reach of up to a quarter of a mile. The latter will prove useful in the urgent, bustling atmosphere of a command post area.

To tune in on the L.A.F.D. fire emergency net when the air is really hot with messages is to hear a marvel of net discipline in action. So well trained are the 2860 firemen who appreciate and depend on radio for vital coordination of their work that messages rarely conflict and those of top urgency find a natural priority with no formal net supervision.

But, of course, it has to be that way. For when a perspiring, open-shirted Fire Chief wants a bulldozer to cut a break on the crest before that fire jumps, he wants it now! And he gets it—by radio!

JOBS IN ANTARCTICA
THE National Bureau of Standards, Central Radio Propagation Laboratory at Boulder, Colorado would like to receive applications from qualified persons who are interested in operating upper atmosphere scientific recording equipment at one of five Antarctic stations during 1959.

Application on Standard Form 57, obtainable at local Post Offices, should be submitted immediately to Section 82.10, National Bureau of Standards, Boulder, Colorado. Applicants should have a degree in Electrical Engineering or Physics, with two or more years of practical experience in electronics OR two years technical education leading to an engineering or physics degree, plus four years practical experience in electronics. The practical experience can include active amateur radio experience.

Appointments will be made in grades GS-9 to GS-12, salary range from \$6250 to \$8645 per annum, plus 25 per cent ice differential. Training will commence during July 1958.

Personnel will leave for Antarctica during October or November 1958 and return to the U. S. in January or February 1960. Travel will be paid from home to Boulder for training, to Antarctica and return to home in U. S.

Here is an opportunity for the adventurous who enjoy travel and want to be an active participant in the International Geophysical Year activities.

VIDEO ELECTRIC COMPANY says: DOWN WITH RISING COSTS OF ELECTRON TUBES OVER ONE MILLION USED TUBES TO SELECT FROM at only

Each and every tube is tested by our supplier under actual operating conditions in Radio, FM, Hi-Fi, Industrial Equipment and Television Chassis or Intricate Testing Equipment for Mutual Conductance and Life Test.

Below is a Partial List of Over Three Hundred Popular Types!
Write for Free Complete List and Order Blank!

0A2	5AX4GT	6BC5	6L7	717	19
0B2	5AZ4	6BC7	6N7	7N7	19A4GT
0Z4	5BK7	6BD8	6Q7	7Q7	19BG6G
1A5GT	5BR8	6BD6	6S4	7X7/XXFM	19J6
1A7GT	5BQ7	6BE6	6S8GT	7Y4	19T8
1B3GT	5C68	6BF5	6SA7	7Z4	24A
1C5GT	5J6	6BF6	6SB7Y	12A8	25AV5
1H4G	5T8	6BG6G	6SC7	12AB5	25AX4
1J6	5U4G	6BH6	6SF5	12A05	25BQ6
1H5GT	5U4GA	6BJ6	6SF7	12AT6	25D86
1L6	5U4GB	6BK5	6SG7	12AT7	25L5GT
1N5GT	5U8	6BL7GT	6SH7	12AU6	25W4GT
1Q5GT	5V4G	6BN6	6SJ7	12AV5	25Z6
1R5	5V6GT	6BQ6GT	6SK7	12AV6	26
1S5	5X8	6BQ7	6SL7GT	12AV7	35A5
1T4	5Y3GT	6BS8	6SN7GT	12AX4GT	35B5
1T5GT	5Y4G	6BK7GT	6SQ7	12AX7	35C5
1U4	6A7	6BY5G	6SR7	12AZ7	35L6GT
1U5	6A8	6BZ6	6SS7	12B4	35W4
1V2	6AB4	6BZ7	6T4	12BA6	35Y4
1X2	6AC7	6C4	6T8	12B6	35Z4GT
2A3	6AF4	6C5	6U4GT	12BE6	35Z5GT
2A7	6AG5	6C6	6U8	12BF6	36
2AF4	6AG7	6CB5	6V3	12BH7	37
3A15	6AH4GT	6CB6	6V6	12BK5	39/44
3AU6	6AH6	6CD6G	6W4GT	12BQ5	42
3AV6	6AK5	6CF6	6W6GT	12BQ7	43
3BC5	6AL7	6CG7	6X4	12BV7	45
3BE6	6AM8	6CL6	6X5	12BY7	50A5
3BN6	6AN8	6CM6	6X8	12CA5	50B5
3BY6	6AQ5	6CN7	6Y8G	12DQ6	50C5
3BZ6	6AQ6	6CS6	7A4/XXL	12F5	50C6
3CB6	6AQ7GT	6DE5	7A5	12F6	50L6GT
3CF6	6AR5	6DQ6	7A6	12G7	50X6
3C56	6AS7G	6DT6	7A7	12H7	50Y6
3DT6	6AT6	6E5	7A8	12I6	56
3L4	6AT8	6F6	7B4	12J6	57
3Q4	6AU4GT	6F8	7B6	12K7	58
3Q5GT	6AUSGT	6H6	7B7	12LA7	58
3S4	6AUG	6J4	7C4	12M7	71A
3V4	6AU8	6J5	7C5	12N7GT	75
4BC8	6AV5GT	6J6	7C6	12O7	76
4BQ7A	6AV6	6K7	7C7	12P7	77
4BZ7	6AW8	6K6GT	7E5	12Q7	78
5AM8	6AX4GT	6K7	7E6	12R7	80
5AQ5	6AX5GT	6K8	7E7	12S7	84/6Z4
5AS8	6B4G	6L6	7F7	12T7	117LGT
5AT8	6BA6		7F8	12U7	117N7GT
5AU4	6BA7		7G7/1232	12V7	117P7GT
5AV8			7H7	12W7	117Z3
5AW4				12X7	117Z6



GUARANTEE: We guarantee to replace FREE for one (1) year any tube purchased from us which fails to function efficiently under actual operating conditions. Refunds will be made promptly for any defective merchandise.

WE HAVE OVER 1000 USED TV SETS

At All Times In Our Huge Warehouse
Buy one or more of these WORKING TVs to sell or use as your own second set!
All sets in GOOD WORKING condition!
Your Choice—Console or Table Model

10" . . . \$23.00	17" . . . \$46.00
12" . . . \$28.00	19" . . . \$58.00
14" . . . \$33.00	20" . . . \$64.00
16" . . . \$40.00	21" . . . \$72.00
24" . . . \$99.00	

When ordering TVs, state whether table model or console is desired. Also, preference on make of set. All TVs sent railway express F.O.B. Newark. On any quantity, WIRE or CALL today!

SEND for our FREE complete TUBE & PARTS LIST and order blank.

FREE Bonus Antenna Given with Any TV Set Order!!	FREE RCA "Cheater" Cord Given with Any Tube Order of \$7.00 or More!!
--	---

FREE POSTAGE

in U.S.A. and Territories on orders over \$5.00. 25¢ handling charge on orders under \$5.00. 25% deposit required on C.O.D.'s. Please send approximate postage or freight on Canadian and foreign orders. Subject to prior sale.

Phone
HUMboldt 4-9848

VIDEO

ELECTRIC COMPANY
79 CLINTON PL. NEWARK, N. J.

INFRARED SNIPERSCOPE TELESCOPE & PARTS

See in the dark—without being observed. War surplus Sniperscope M-2. Contains the famous IP25A Image Tube. Gov't cost about \$1200. Used for industrial plant security; research lab experiments; infrared photography; spectroscopy, etc. Instrument complete, ready to use. Includes Power Pack, infrared light source. Will operate from 6 V auto battery. Battery or transformer available.



Stock No. 85,053-DU . . . Shipping **\$150.00**
weight approx. 12 lbs.

f.o.b. Barrington, N. J.
Order by stock No.—Send check or M.O.—money-back guarantee!

Save still more money! Build your own Sniperscope! We will furnish instructions—parts, including: Power Packs, IP25A image tubes, light units, filters, etc. For details—request FREE Catalog "DU."

SPECIAL! INFRARED IP25A IMAGE TUBE
Stock No. 70,127-DU \$9.95 pstd.
Order by stock No.—Send check or M.O.—money-back guarantee!

COLOR TV TUBESCOPE
Saves time, effort in alignment of color dot pattern.
Stock No. 50,139-DU . 22 power . \$24.50 pstd.
Order by stock No.—Send check or M.O.—money-back guarantee!

GET FREE CATALOG "DU"
America's No. 1 source of supply for experimenters, hobbyists. World's largest variety of Optical Items. Bargains galore. . . . War Surplus—Imported—Domestic! Microscopes, Telescopes, Satellitescopes, Color TV Tubescopes, Infrared sniperscopes and Parts, Prisms, Lenses, Reticles, Mirrors and dozens of other hard-to-get Optical Items.

WRITE FOR FREE CATALOG DU
EDMUND SCIENTIFIC CO.
BARRINGTON, NEW JERSEY

**TREMENDOUS SAVINGS ON
PRECISION RESISTORS**
Manufactured by leading company.
1% tolerance carbofilm, HiStability,
Low temperature co-efficiency. New,
Popular Ohmage.
5 lb. assortment of 1/2, 1 and
2 watts \$5.00
10 lb. assortment \$9.00
Please include postage with order.
UNITED SALES COMPANY
537 State Street Ithaca, New York

**ONE BIT FOR ALL DRILL
SAW • REAM
CUT**
Handiest drill bit made. Use on any electric drill, lathe, drill press, etc. Made of finest, American hi-speed steel, 3 3/8" long, 1/2" diameter. Has 2 side-cutting sections. Cuts steel, wood, plastic, aluminum, etc. 3 types specify types wanted. (1) All purpose, (2) Wood. (3) Heavy metal. \$2.45 each 3 for \$7.00—Post paid. Money back guaranteed. Buy from your dealer or send check or Money Order TODAY.
**BEAVER
HI-SPEED
DRILL BITS**
Jobber & Dealer
Inquiries Invited

BEAVER DRILL & TOOL CO.
3008-T McGee Trafficway Kansas City, Mo.

**HAVE GEAR? WILL BUY!!!
WANTED!** All types of lab test equipment: X, S, K bands, Signal Generator, slotted lines, power meters, bridges, etc. Anything in aircraft communications equipment—and ALL TYPES of vacuum tubes.
We pay top prices—fast!
V. & H. RADIO-ELECTRONICS
2033 W. Venice Blvd., Los Angeles 6, Calif.

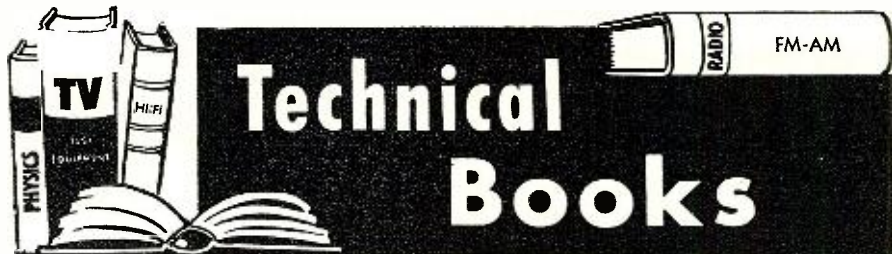

"THE RADIO AMATEUR'S HANDBOOK" compiled by ARRL Staff. Published by the *American Radio Relay League*, West Hartford, Conn. 584 pages plus tube data charts and catalogue section. Price \$3.50. 35th Edition.

Some time during the life of this edition, the three-millionth copy of the amateur's "bible" will go to a ham, experimenter, student, or engineer.

The volume has been revised to include new equipment which has appeared on the market this past year. Complete chapters are devoted to receiver and transmitter construction for both Novice and experienced hams. Additions to the v.h.f. section include high-powered amplifiers and beam antennas. Extensive material on radioteletype machines and circuits has been included in order to stimulate the use of this mode of transmission.

Since no serious amateur would attempt to operate without a copy of the "Handbook" in his shack, this new edition needs no "plugs" from any reviewer to get that three-millionth copy out!

"COMMERCIAL RADIO OPERATOR'S LICENSE GUIDE—ELEMENT 3" by Martin Schwartz. Published by *American Electronics Co.*, 1203 Bryant Ave., New York 59. 122 pages. Price \$1.75. Paper bound.

This is the third in the publisher's series of books for would-be operators. The study guide covers the elements involved in the preparation for radio-telephone and radiotelegraph license examinations and includes sample FCC-type practice exams.

The sample examinations incorporate multiple-choice questions and should be of great help to those preparing to take the tests.

"CARE AND REPAIR OF HI-FI" by Leonard Feldman. Published by *Cowan Publishing Corp.*, New York. 152 pages. Price \$2.50. Paper bound.

This is the first in a new series of books to be devoted to audio electronics for the hi-fi enthusiast and technician. This volume covers amplifiers, preamps, and associated circuits. The companion volume, due later in the year, will deal with tuners, tape recorders, pickups, microphones, speakers, etc.

The book is divided into twelve chapters which cover the technician and hi-fi, component failures, separate preamps, tone controls, loudness controls, the cathode-follower in hi-fi, equalization, power amplifiers, voltage amplifiers, phase inverters, power output stages, and transformers and im-

pedance matching. A buyers' guide and index covering the schematics in the book complete the volume.

Written especially for technicians and knowledgeable audiophiles, an understanding of tube circuitry is requisite. Mathematics and pure theory are held to a minimum but the reader should know how to read schematics and use various pieces of test equipment.

"COLOR TV PRINCIPLES AND PRACTICES" compiled and published by the Electronic Components Division, *General Electric Co.* 135 pages. Price \$5.00. Spiral bound.

Designed for the service technician who is interested in acquiring a basic knowledge of the nature of light and color as well as of color television receiver circuitry, this new "course" by *General Electric* offers an amazing amount of vital information in a relatively few pages.

Lavishly illustrated and written in down-to-earth style, this material is suitable for self-instruction as well as classroom use. Any practicing television technician who is thoroughly familiar with black-and-white circuitry will have no trouble assimilating the color material as presented. The three chapters on color TV receiver circuits are especially valuable since the text emphasizes those circuits which differ from the more familiar monochrome components. The section on troubleshooting the "CL" color chassis is illustrated in full color, with 18 different "problems" discussed and pictured.

Technicians interested in getting a jump on their competition by being ready for color when it hits their areas will find this practical volume extremely helpful. The company's tube distributors are handling the book.

"FOUNDATIONS OF WIRELESS" by M. G. Scroggie. Published for "Wireless World" by *Iiffe and Sons Ltd.*, London. 376 pages. Price 15 s. (by mail 16s/4d).

Since 1936 several generations of electronic students have been "weaned" on Scroggie and this enlarged and completely revised seventh edition will find an eager new audience ready to welcome the author's concise and witty exposé of radio and electronic basics.

The author assumes that his "students" have no previous technical knowledge and are not too familiar with higher mathematical procedures. His treatment is elementary to the point that the book is entirely suitable



Send for FREE Olson Catalog!
Fill out coupon below and mail.

BOGEN

AMAZING
OFFER
from...

OLSON

BUY THE BOGEN AC-10
AND GET THE JENSEN DX-120 **FREE**

Reg. \$55.00

BOGEN AC-10



Reg. \$25.50

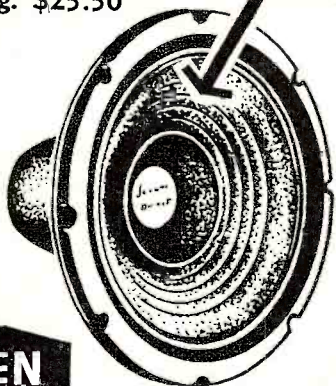

**JENSEN
DX-120**

JENSEN DX-120 DUAX SPEAKER. Now! Thrill to the tremendous tone quality and velvet smoothness of the hi's and lo's this Jensen DX-120 commands as it glides through its paces. Two carefully coordinated cones driven by one voice coil are combined to attain the extended range response in this single 12" speaker. Large 2" aluminum piston and disperser cone produce crisp, bell-clear highs. Jensen multi-ribbed woofer cone yields full bodied, rich bass and powerful mid-range response. Uses new high energy DP-alnico 5 permanent magnet. Magnet weight 1 lb. Voice coil 16 ohms. Frequency response 40 to 13,000 cps. Rated at 20 watts.

OLSON STOCK NO. 5-314..... **\$25.50**

BOGEN MODEL AC-10. This beautiful 10-watt Hi-Fi amplifier is custom styled and tailor engineered to the audiophile's fondest expectations. Separate bass and treble controls and the unique Bogen Loudness Contour Selector which allows you to choose the most suitable volume levels without loss of high or low frequencies. Instant front panel selection of popular tape and record equalizations. Rated at 10 watts with a peak power of 20 watts. Response: 20 to 20,000 cps +1 DB. Rumble filter built in. Inputs for tuner, magnetic or crystal phono, tape and auxiliary. 3 output impedances: 4, 8 and 16 ohms. Tube line up: 1 - 12AX7/ECC-83, 1 - 6U8, 2 - 6AQ5, 1 - EZ-80. In black metal cabinet, with contrasting black and gold control panel. Size: 12½" x 8¾" x 4". For 117 Volts AC, 60 cps.

OLSON STOCK NO. AM-97..... **\$55.00**

GET BOTH FOR... \$55

MAIL YOUR ORDER TO:

OLSON RADIO WAREHOUSE

T-78 Forge Street — Akron 8, Ohio

SEND BOTH — Bogen AC-10 and the FREE Jensen DX-120 for only \$55.00 plus shipping cost for 38 pounds.

SHIP VIA:

- Parcel Post
- Express
- C. O. D.

\$5 deposit on C.O.D.'s.
Pay balance on arrival.

Send FREE Olson Catalog only

**OLSON
STORES IN:**

AKRON.....73 E. Mill Street
CHICAGO.....4101 N. Milwaukee Ave.
CLEVELAND.....123 N. Western Ave.
CLEVELAND.....2020 Euclid Ave.
PITTSBURGH.....5918 Penn Ave.
MILWAUKEE.....423 W. Michigan
BUFFALO.....711 Main Street

NAME _____
ADDRESS _____
CITY _____ ZONE _____ STATE _____

Olson Radio Warehouse

**T-78 FORGE STREET
AKRON 8, OHIO**

HQ for the 5 TOP QUALITY brands of

TV & RECEIVING TYPE

UBES

AT SENSIBLE PRICES!

TUBE SPECIALS

10KP7 ... \$12.00 C1B/3C31 ... \$2.50 100TH ... \$7.75
 750TL ... 27.50 35TG ... 1.75 WE-350B ... 1.75
 304TH ... 17.50 803 ... 1.50 355A ... 9.00
 304TL ... 17.50 866A ... 1.50 CBS-6004 ... 1.00

AND OTHERS—WRITE

• Individually Boxed • First Quality Only
 WRITE FOR LATEST TUBE CATALOG FREE!

We stock over 1000 types including Diodes, Transistors, Transmitting and Special Purpose types

2-COLOR TUBE CARTONS

Keeps your tube stock neat. New safety partition prevents tube breakage. Distinctively lithographed in glossy red and black. The most distinctive tube carton available today. Minimum quantity: 100 of any one size. Write for case lot prices. Packed 1000 to case. F.O.B. N. Y. C.
 SIZE For Tube Per 100
 Miniature ... 6AUG, etc. ... \$1.00
 GT ... 6SN7GT, etc. ... 1.25
 Large GT ... 1B3GT, etc. ... 1.50
 Large G ... 5U4G, etc. ... 2.00



WHITE GLOSSY BOXES

Completely blank. No printing or color. Otherwise same as above. Same high quality, same low prices. Specify "WHITE" when ordering. When color is not stated, 2 color cartons will be shipped.

**Equipment & Component
 Specials**

- Bud 77" Panel Space Relay Racks. Standard 19" amateur width—17" deep. Deluxe grey-crackle finish—louvered side panels—top and bottom—back door with double lock—brand new in original wrappings—complete with hardware — shipped knocked-down — F.O.B. N. Y. C. An excellent buy at \$35.00.
- 3" Panoramic Adapter—operates on 110 VAC 60 CPS—I.F. Frequency Adjustable 450 to 475 KCS Sweep Width ± 100 KCS—Model RCC Condition, Clean, Used. ... \$59.50
- 5" Panoramic Adapter—115 or 230 VAC—50 CPS Sweep width ± 5000 KCS—Clean, Used Condition Model RDP. ... \$79.50
- University Labs 10 Watt Outdoor Loudspeaker, 8 Ohms—300 to 5000 CPS—Brand New Boxed—with Mounting Bracket and 10 Foot Rubber Cord and Amphenol Connector made for Navy—Black finish—finest construction—Excellent for portable Megaphone Amplifier. ... \$12.95
- Portable Microphone, Sound-Powered (Requires no Batteries) with chest plate and strap. Brand New, Black Finish with On-Off Switch Button—Complete w/25 Foot Rubber Cord & Connector—Finest Navy Construction. New. ... \$4.75
- 6 Henry—500 MA. Chokes—26 OHMS D.C. Resistance. New—Open Frame. ... \$3.95 (3 for \$9) Grey-Commercial Finish.
- Eldico TR-1 TV Transmitter—4E27A Modulated By 811's—Wired All Bands—300 Watts AM & CW. ... \$275.00
- TR-1 Kit—813 Modulated by 811's Complete with RF Section with Speech Amplifier & Modulator with 866A 1500 Volt Power Supply Kit (Less Tubes). ... \$99.50
- 8 Henry Choke—500 MA—Hermetically sealed —D.C. Resistance 44 Ohms. ... \$7.95
- Hewlett-Packard Audio Oscillators complete with case, all in used clean condition. Model 200B \$80.00, Model 200C \$85.00, Model 200D \$95.00
- B & W Model No. L-1001A Linear Amplifier Brand New in Sealed B & W Original Carton ... \$240.00
- 28 Volt—10 Amp Xmfrr-Pri; 115 vac/60 CPS ... \$4.50
- Little Gem Xmfrr—Brand new compact. 19000 Ohms to 600 Ohms Plate to Line Xmfrr, approx. 2" round x 2 1/4" high. Pri. rated at 10 mils. Can also be used as line to grid xmfrr. Individually boxed. .69¢ each (10 for \$4.00).
- 6 Volt Vibrapack—New Unused. Delivers 300 Volts D.C. @ 100 ma. approx. (regular net over \$30.00) Special \$9.95

• 1958 VACATION NOTICE •
 Closed from June 21st Until July 7th.

TERMS: 25% deposit with order, balance C.O.D. All merchandise guaranteed for cost of merchandise only. F.O.B. N.Y.C.

Subject to price variation and stock depletion
 We are near Prince St./BMT Station, Spring St./IRT Station. Open Monday thru Saturday. Thousands of unadvertised specials. Come in and browse around.

**BARRY ELECTRONICS
 CORP.**

512 Broadway, Dept. RN, N.Y. 12, N.Y.
 Phone: WALKER 5-7000

for home study or beginning radio and electronic courses for any age group.

The subject matter has been expanded to cover transistors, television, and other developments of fairly recent vintage. There is a completely new chapter on amplification as well as a new and enlarged chapter on radiation and antennas.

The appendix includes a listing of alternative technical terms, a chart of symbols and abbreviations, circuit symbols, and a decibel table to make the text self-contained for the student user. A canvass of a few "old timers" in the field will readily convince the beginner that this text is indeed considered one of the "bibles" of elementary radio and electronics. —30—

Speakers for Stereo

(Continued from page 32)

speakers that are of high quality and matched in their sound characteristics, he must place them properly in relation to the dimensions of his room and listening position, and he must operate them at suitably high levels in order to produce a three-dimensional illusion.

Yet this should not discourage those who would like to get into stereo on a modest, relatively inexpensive basis. Pleasing results can still be obtained with moderate-priced speakers, less than optimum placement, and reasonably reduced playing levels. It is a rule in audio that one pays a good deal for a slight improvement. Conversely, by accepting a tolerable sacrifice in performance, one can achieve a substantial saving.

The writer has long been among the skeptics who doubted that 2-channel stereo could match the stunning effect produced by binaural sound (via earphones), although he did not deny the superiority of stereo over monaural. However, what he has heard and seen in the past year cause him now to believe that a wholly convincing stereo effect can be achieved under the proper circumstances with only two speaker channels. The stereo art has emerged sufficiently from infancy so that it is

now worthwhile for the audiophile to consider bringing stereo into his home.

True, the art is still quite young and no doubt the next two or three years will bring considerable advances, some of which may revise today's thinking. But this does not seem to be a valid reason for putting off one's initiation into stereo, particularly on the part of those venturesome spirits who prefer to be active participants in a new development rather than mere on-lookers.

The writer is reminded of the early years of TV, the late 1940's, when some viewers paid a high price for a 7- or 10-inch screen and had little but wrestling and old cowboy movies to watch. Today's viewer typically watches a 21-inch screen and has a great variety of fare to draw upon, yet it is doubtful that TV addicts of the 1940's experienced any less a thrill than today's audience. Because stereo will be better in 1960 is not enough reason, for some, to postpone first-hand acquaintance with stereo, even though their speaker setups are not all that they might be.

REFERENCES

1. Burstein, Herman: "Stereo Tape Comes of Age," *Radio-Electronics*, November, December 1956.
2. Sletted, Walter T. & Snyder, Ross H.: "Acoustical and Electrical Considerations in Symphony Orchestra Reproduction," *Audio*, January 1957.
3. Electro-Voice, Inc.: "Application of Electro-Voice Speaker Systems to Stereo Reproduction," *E-V Technical Bulletin No. 1*.
4. Hume, Howard F.: "A New Concept on the Physiological Aspect of Stereophonic Sound," *Audio*, March 1957.
5. Correspondence from James B. Lansing Sound, Inc.
6. Correspondence from R. T. Bozak Sales Company.

—30—

PHOTO CREDITS

Page	Credit
31	R. T. Bozak Sales Co.
33	Official photos, Los Angeles Fire Dept.
38, 87	Fairchild
42, 43	Minnesota Mining & Mfg. Co.
44	Technical Associates
45 (top)	Electronic Instrument Co.
45 (bottom)	Heath Company
50	Channel Master Corp.
51, 112	Bell Sound Systems, Inc.
55, 56, 58, 116	General Electric Co.
90, 91	Marconi Press Agency Ltd.
124	Motorola Inc.
128	Arrow Sales Inc.

Arrow Sales, Inc. has just moved into this handsome warehouse-showroom at 7035 Laurel Canyon Blvd., North Hollywood, California. In addition to a large retail department where the public is served, the 45,000-square-foot building includes a hangar-sized room to meet the needs of amateurs, Civil Defense, Civil Air Patrol, experimental, and research personnel. The company handles a complete line of parts and equipment.



**Answer to Puzzle
appearing on page 105.**



SOLUTION TO BENCH PUZZLER NO. 1

(See page 115)

WITH the information already obtained, it was decided that a systematic check of components in the "B+" string, which seemed to be ailing, was in order. Since it was already known that the tube short had burned out one resistor (R_{202}) in the string, the other resistors seemed like a logical starting point. The logic paid off!

Note the three 39,000-ohm resistors (in the diagram below) in parallel with each other. One of them had increased to 2 megohms. Here, then, was the culprit. The resistance of the combination of R_{204} , R_{205} , and R_{206} had thus doubled from the original 13,000 ohms to 26,000 ohms. The missing voltage was being lost across this increased resistance. To be safe, all three of these resistors were replaced by a single 13,000-ohm unit having a

higher power rating. All voltages returned to normal. Oscillator slugs were re-adjusted. The set has been playing steadily ever since. -30-

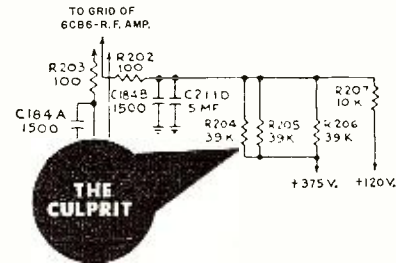

Have you come across an interesting service job lately? Send it to the "Puzzle" Editor, RADIO & TV NEWS, using this format. We will pay for items used at regular rates. Others will be returned.

CLASSIFIED

RATE: 50¢ per word. Minimum 10 words. September issue closes July 10th. Send order and remittance to: RADIO & TV NEWS, 1 Park Ave., N. Y. C. 16, N. Y.

RADIO ENGINEERING

ELECTRONICS! Associate degree—29 months. Technicians, field engineers, specialists in communications, missiles, computers, radar, automation. Start September, February. Valparaiso Technical Institute, Dept. N, Valparaiso, Indiana.

ENGINEERING Degrees, **EE** Option Electronics earned by home study. Residence classes also available. Pacific International University (operating as a college of engineering only at present), 5719-C Santa Monica Boulevard, Hollywood 38, California.

FOR SALE

TELEVISION & Radio Tubes, Parts and Supplies at low prices. One year Guarantee. Write Hi-Quality Tube Co., Inc., 284 Lafayette St., Rahway, New Jersey for Free price list. Distributorship openings.

DIAGRAMS for repairing radios \$1.00. Television \$2.00. Give make, model. Diagram Service, Box 672-RN, Hartford 1, Conn.

RADIO & TV Tubes at manufacturers prices. Guaranteed—Send for free price list, Edison Electronic Tube Co., Menlo Park, N. J.

GOVERNMENT Sells—Surplus Electronics; Walkie-Talkies; Transceivers; Test Equipment; Oscilloscopes; Radar; Voltmeters; Misc.—Fraction of Army costs—Buy direct now from U. S. Government—"Depot List & Procedure" \$1.00—Brody, Box 8-RT, Sunnyside 4, New York.

TUBES—TV, Radio, Transmitting And Industrial Types At Sensibly Low Prices. New, Guaranteed. 1st Quality, Top Name Brands Only. Write For Free Catalog or Call Walker 5-7000, Barry Electronics Corp., 512 Broadway, New York 12N, N. Y.

TELEVISION Sets \$11.95. Plus shipping. Jones TV, 147 High, Pottstown, Pa.

DIAGRAMS! Repair Information! Radios—amplifiers—recorders \$1.00. Televisions \$1.50. Give make, model, chassis. TV Miltie, Box 101RA, Hicksville, New York.

SWITCHES, 2 Pole Cutler Hammer. 25¢ ea. Amplifiers, with five 717A Tubes \$2.50. 50 assorted resistors, relays, condensers, etc. for \$1.00. Full credit if not 100% satisfied. All prices F.O.B. our address, Ray Bridge Surplus, 2001 Bayshore Highway, Redwood City, Calif.

LABORATORY Oscilloscope New 5 MC direct from factory guaranteed. Kit price \$142. Write for free literature. Electronic Industries, Patterson, New York.

1" MINIATURE Meters: All stock ranges available, free literature; Alco Electronics, Lawrence, Mass.

IDEAL receiver for boating, fishing \$9.95. Hoey & Co., Hayward Airport, Hayward, Calif.

WANTED

CYLINDER and old disc phonographs. Edison, Conqueror, Idella, and Oratorio models. Berliner Gramophones and Zono-o-phones, Columbia cylinder Graphophones, and coin-operated cylinder phonos. Want old catalogues and literature on early phonos prior to 1919. Will pay cash or trade late hi-fi components. Classified Box 50 % Radio & TV News, 1 Park Ave., N. Y. C. 16, N. Y.

CASH Paid! Sell your surplus electronic tubes. Want unused, clean transmitting, special purpose, receiving, TV types, magnetrons, Klystrons, broadcast, etc. Also want military & commercial lab test and communications gear. We swap too, for tubes or choice equipment. Send specific details in first letter. For a fair deal write, wire or telephone: Barry, 512 Broadway, New York 12, N. Y. Walker 5-7000.

WANTED: Receiver R5/ARN-7, MN-62A Transceivers, RT18/ARC-1, AN/ARC-3, BC-788C, I-152C, Collins, Bendix equipment, Test Sets, Dynamotors, Inverters. We pay highest prices. Advise quantity, condition, price first letter. Aircraft Radio Industries, Inc., 70 East 45th St., N. Y. 17, telephone LExington 2-6254.

LABORATORY Quality Equipment and Military Surplus Electronics bought, sold. Engineering Associates, 432 Patterson Road, Dayton 9, Ohio.

HIGH FIDELITY

PRICE? Try ours! Everything in HI-FI. Factory-sealed components. Write right now. Audion, 64-62T Booth St., Rego Park 74, N. Y.

DISGUSTED with "HI" HI-FI Prices? Unusual Discounts On Your High Fidelity Requirements. Write Key Electronics, 120 Liberty St., New York 6, N. Y. EVergreen 4-6071.

WORLD Renowned Hartley Speakers now available to Dealers, Servicemen, Custom Installers, lowest franchise requirements in high fidelity. Write Hartley Products Company, 521 East 162 Street, New York 51, N. Y.

DISCOVER our "Six Unique Services" on Hi-Fi; Stereo. Exceptional values. Write The Silver Trumpet, 406R Walnut, Alexandria, Indiana.

REPAIRS & SERVICING

ALL Makes High Fidelity Speakers Repaired. Amprite, 70 Vesey St., N. Y. 7, N. Y. BA 7-2580.

TAPE & TAPE RECORDERS

RECORDERS, HiFi, Tapes, Free Wholesale Catalog. Carston 215-R East 88 St., N. Y. C. 28.

TAPE Recorders, hi-fi components, tapes. Unusual Values. Free catalog. Dressner, 69-02 R, 174 St., Flushing 63, N. Y.

DISCOUNTS to 50%, recorders, tapes, hi-fi components, consoles, photograph equipment. Request specific prices only. Long Island Audio & Camera Exchange, 3 Bay 26th Street, Brooklyn 14-N, N. Y.

AMPREX, Concertone, Crown, Ferrograph, Presto, Tandberg, Pentron, Bell, Sherwood, Rek-O-Kut, Dynakit. Others. Trades. Boynton Studio, 10RT Pennsylvania, Yonkers, N. Y.

ELECTRICAL EQUIPMENT & SUPPLIES

TV-RADIO Servicemen! Amazing electronic machine instantly reproprocesses tubes. Portable. Guaranteed. International Tube Repair, Box 924, Maywood, N. J.

BUSINESS OPPORTUNITIES

HIGH Paying Jobs, Opportunities, foreign, USA. All trades. Companies pay fare. For information Write Dept. 59L, National Employment Information, 1020 Broad, Newark, New Jersey.

START a fast growing, money making business. Operate a self-service tube tester route spare or full time. No selling. Stores make money for you every open hour. Send for Free booklet describing this proven business. Century Electronics, 111-H Roosevelt Avenue, Mineola, N. Y.

CORRESPONDENCE COURSES

USED Correspondence Courses and Books sold and rented. Money back guarantee. Catalog free. (Courses bought.) Lee Mountain, Pisgah, Ala.

INSTRUCTION

USED Correspondence Courses, Educational Books Bought, Sold, Free Catalog, Vernon, Summerville, Ga.

RECORDS

PHONOGRAPH Records cheap, postpaid. Catalogue. Paramount, Box 242-N, Williamsport, Penna.

MISCELLANEOUS

DECALS—Trademarks, Service, Sales, etc. Write Allied Decals, Inc., 8378 Hough, Cleveland, Ohio.

"TAB" Tubes Tested, Inspected, Boxed

New and Used Gov't & Mfgs.
Surplus! 6 Mos. Guarantee! No Rejects—
Orders \$10+ Receiving types only ppd 48 states

0A2	.80	6B16	.72	12A76	.59	117Z3	.69
0B2	.72	6B17	.99	12A77	.89	117Z6	1.10
0C3	.84	6B17	1.95	12AUG	.63	2C51	2.65
0D3	.80	6B86	1.08	12AU7	.69	2D23	.68
0Z4	.50	6B06	1.13	12AX7	.79	3D23	5.00
1A7	1.00	6BZ7	1.25	12BA6	.65	717A	5/51
1B3	.78	6C4	.49	12BA7	.99	4-125	29.00
1R5	.78	6C5	.63	12B6	.66	4-125	29.00
1S4	.78	6CB6	.80	12BB6	.59	4E27	7.00
1T4	.78	6CD6	1.49	12BF6	.59	4PR60	29.50
1U4	.68	6H6	.59	12BH7	.99	4X150	19.00
1U5	.89	6J7	.59	12C7	1.00	4X250	35.00
1X2A	.68	6J6	.59	12BZ7	.99	4X500	38.00
3Q4	.68	6K6	.59	12CU6	1.45	5BP1	3.98
3Q5	.86	6K7	.79	12SA7	.69	5BP4	1.98
3S4	.58	6L5	1.19	12SO7	.75	388A	1.00
3V4	.99	6S4	.59	12SH7	.89	100T	7.00
5R4	1.25	6S8	.99	12SJ7	.75	250T	20.00
5U4	.59	6SA7	.69	12SK7	.75	388A	1.00
5V4	.89	6SB7	1.19	12SQ7	.69	418A	14.00
5Y3	.59	6SC7	.89	19B66	2.15	450T	43.00
6AB4	.59	6S07	.79	19T8	1.16	807	1.10
6AC7	.79	6S17	.69	6V2G6	1.19	808	1.00
6AG7	.89	6S17	.69	25L6	.72	809	3.00
6AH6	.99	6S17	.72	25W4	.77	810	10.00
6AK5	.69	6S17	.89	25Z5	.72	811	3.00
6AL3	.89	6S17	2.19	25Z6	.72	812	3.00
6AQ5	.66	6SQ7	.74	EL34	3.49	813	9.00
6AU7	3.00	6SR7	.79	EL37	2.49	814	2.45
6AT6	.49	6T6	.99	35L6	.59	815	2.50
6AU4	1.29	6U8	.98	35W4	.52	829B	8.00
6AU5	1.19	6V6	1.39	35Y4	.69	832A	7.00
6AU6	.69	6W4	.79	35Z5	.89	866A	1.60
6AX4	.79	6W6	.69	35Z6	.89	866B	1.60
6BA6	.59	6X4	.39	50B5	.69	5879	1.20
6BA7	1.00	6X5	.49	50C5	.69	5881	2.70
6BD6	.69	6Y6	.89	50L6	.69	6550	3.90
6BE6	.89	7N7	.89	K766	3.29	8762	1.00
6BG6	1.50	12AL5	.59	75	.89	5654	1.00
6BH6	.79	12AQ5	.75	80	.59	5894	0.00

Write for Complete Tube List! Discounts to QOV. Buyers
TUBES WANTED! WE BUY! SELL & TRADE!

NEW "TEKSEL" SELENIUM FULL WAVE BRIDGE RECTIFIERS. ONE YEAR GTD!

AMF	18VAC	36VAC	72VAC	144VAC
CONT.	1.40C	2.80C	5.60C	11.20C
1AMP	\$ 1.30	\$ 2.00	\$ 4.90	\$ 9.45
2AMP	2.15	3.00	6.25	12.30
3AMP	2.90	4.00	8.60	16.75
6AMP	4.80	6.00	11.70	23.40
10AMP	6.10	12.15	26.30	48.90
15AMP	9.90	19.00	40.00	66.60
24AMP	15.00	29.45	57.50	108.45



NEW GTD RADIO & T.V. RECTIFIERS

35MA 40c @ .6 for \$2; 65MA 45c @ .5 for \$2;
75MA 49c @ .5 for \$2; 100MA 59c @ .6 for \$3;
150MA 70c @ .8 for \$5; 250MA 79c @ .6 for \$4;
300MA 89c @ .5 for \$2; 500MA 1.10 @ .5 for \$5;
400MA \$1.10 @ .5 for \$5; 500MA \$1.35 @ .4 for \$5;
65MA/260V \$1.10 @ .5 for \$5; 100MA/260V \$1.25 @ .9 for \$10; 100MA/150V \$1.10 @ .156V \$1.75, 3/55. Order \$10. Postpaid 48 States!

New Silicon Radio & TV 500MA/280VAC/
400p.p.v. Rectifier W/mt. \$1.50 @ .5 for \$6.50, 40 for \$46
Orders \$10. Postpaid 48 states!



HAMS NEW TRANSISTORIZED "TABPAK"

12 VDC to HI-VDC POWER SUPPLY!!!
Kit or Assembled. Filtered, small in size! Quiet! Light Wgt.! Input 12 to 14VDC (Low Idle Current) Output 450ctap @ 250VDC at up to 150ma/65 watts. Int.
"TABPAK" Assembled TR39CB.....\$35
"TABPAK" Kit TR39CK.....\$30



NEW TPSK2 DC POWER for TRANSISTORS!!

Transistors! Filtered Power Supply Kit used to power transistor circuits, amplifiers, etc. Delivers 12VDC at 2AMPS filtered less than 0.5% ripple or 28VDC at 1A TPSK2 Kit \$18; TPS2W assembled & wired \$24.
115VAC Inpt. Transformer & Full Wave Bridge Rectifier for 12VDC @ 2AMP @ 40 RECFRAN KIT RT1K.....\$4.50
RT1W Assembled & Wired.....\$8.50
RT2C Kit 12 or 18VDC at 6 AMPS.....\$9.00
RT2W Assembled & Wired.....\$14.75



BCK-1 Battery CHARGER KIT. 1to4Amps charges 2-4-6 & 12 volt Batteries.....\$9.95

DIAMOND PHONO-NEEDLES Postpaid 48 States!

REGISTERED ONE YR. GUARANTEED BY THE MFR!
ALL MAKES LP&78—ONE DIAMOND.....\$6
TWO DIAMOND \$14; DIAMOND & SAPPHIRE.....\$8
PLEASE SEND CARTRIDGE NAME & NUMBER

NEW VR11 "GE" PHONO CARTRIDGES!!

Postpaid 48 States!
4G061/LP or 4G063/78 DIAMOND.....\$16
4G060/LP&78 TRI-PLAY SAPPHIRE.....\$8.59
4G032/LP&78 TRI-PLAY DIAMOND & SAP.....\$18
4G053/LP&78 TRI-PLAY DIAMONDS.....\$26

FINEST HI-FI RECORDING TAPE

1200 Ft.—7" Reel **\$1.45** Lots of 3
Money Back Gtd.

Highest quality controlled plastic base tape made by new Erin process. Precision coated & Silt. Gtd. Constant output. Splice Free. Freq. 7 1/2 IPS
40-15KC Oxide Wind In.
New 1st Quality "Mylar" 2400 Ft.—7" Reel Ferro Erin Gloss Process Recording tape. \$4.49, 3 for \$12



KITS! "TAB" THE BEST KITS!

Kit 35 Precision Resistors	Kit 35 Power Resistors
Kit 18 Switches	Kit 75 Mica Cond's
Kit 3 Transistor Transf.	Kit 6 Crystal Diodes
Kit 150 Carbon Resistors	Kit 8x25 ft. Hookup Wire
Kit 42 Panel Lamps	Kit 100 Fuses
Kit 12 Electronic Cond's	Kit 10 Ceramic Cond
Kit 15 Volume Controls	Kit 18 Rotary Switches
Kit 36 Tube Sockets	Kit 6 Crystals & Holders
Kit 50 Tubular Cond's	Kit 65 Inductors & Coils
Kit 500 Lugs & Eyelets	Kit 6 Microswitches
Kit 10 Xmit Mica Cond's	Kit 10 Wheat Lamps
Kit 5 Lbs. Surprise Kit	Kit 40 Insulators
Kit 10 Xmit Mica Cond's	Kit 25 Insulated Resist.
Kit Encapsulation Fluid	Kit TV Knobs
Kit Volume Control Fluid	Kit Glyptal Cement &

BUY 10 KITS GET ONE FREE! EACH KIT 99c

"TAB" TERMS: Money Back Guarantee! Our 14th year. \$2 min order F.O.B. N.Y.C. All shipping charges or for C.O.D. 25% Dep. Prices shown subject to change.

111KR LIBERTY ST., N. Y. 6, N. Y. Catalog
Write for PHONE: RECTOR 2-6245

INDEX OF Advertisers

JULY 1958

[While every precaution is taken to insure accuracy, we cannot guarantee against the possibility of an occasional change or omission in the preparation of this index.]

ADVERTISER	PAGE	ADVERTISER	PAGE
Acro Products Company.....	102	Michigan Magnetics, Inc.....	83
Advance Electronics.....	124	Milwaukee School of Engineering.....	113
Airex Radio Corp.....	97	Minnesota Mining and Manufacturing Company.....	114
Allied Radio Corporation.....	11	Moss Electronic Distributing Co., Inc.....	98, 99
Arrow Sales, Inc.....	122	National Radio Institute.....	3
Ashe Radio Co., Walter.....	117	National Schools.....	23
B & K Manufacturing Company.....	63	Northrop Aeronautical Institute.....	88
Baltimore Technical Institute.....	107	Oelrich Publications.....	107
Barry Electronics Corp.....	128	Olson Radio Warehouse.....	127
Beaver Drill & Tool Company.....	126	Oxford Components, Inc.....	97
Blonder-Tongue Labs., Inc.....	20	Pacific International University.....	103
C.B.C. Electronics Co., Inc.....	115	Paco Electronics Co., Inc.....	16
CBS-Hytron.....	17, 87	Peak Electronics Company.....	104
C & H Sales Co.....	106	Picture Tube Outlet.....	122
Canadian Institute of Science and Technology Ltd.....	117	Pilot Radio Corp.....	108
Candee Co., J. J.....	107, 111	Platt Electronics Corp.....	90
Candler System Co.....	124	Popular Photography Contest.....	119
Capitol Radio Engineering Institute.....	9, 85	Popular Photography Directory.....	101
Carston.....	123	Postal Zone Information.....	121
Century Electronics Co., Inc.....	89	Progressive "Edu-Kits" Inc.....	105
Champion De Arment Tool Company.....	12	Quality Electronics.....	103
Channel Master Corp.....	26	RCA Institutes.....	21
Cleveland Institute of Radio Electronics.....	19	RW Electronics.....	115
Columbia Electronics.....	117	Radiart Corporation, The.....	91, 92
Cornell-Dubilier Corporation.....	91	Radio & Electronic Surplus.....	123
Coyne Electrical School.....	95, 97, 109	Radio & TV News Classified, Advertising Information.....	121
Cutick Electronics.....	123	Radio Corporation of America.....	8
Delco Radio.....	7	Radio Shack Corporation.....	81
DeVry Technical Institute.....	5	Rad-Tel Tube Co.....	114
Dressner.....	122	Raytheon Manufacturing Company.....	SECOND COVER
Dynaco Inc.....	95	Rek-O-Kut Company, Inc.....	18
Edmund Scientific Co.....	126	Rex Radio Supply Company.....	112
EICO.....	27, 28	Rider Publisher Inc., John F.....	121
Electronic Chemical Corp.....	95	Rinehart & Co., Inc.....	120
Electronic Experimenter's Handbook.....	113	Sams & Co., Inc., Howard W.....	15, 123
Electronic Measurements Corp.....	121	Selectronics.....	123
Erie Resistor Corp.....	109	Service Instruments Corp.....	111
Fair Radio Sales.....	103	Sonotone Corporation.....	14
Filtron Products Co.....	81	Spaulding Products Co., Inc.....	80
Glaser-Steers Corp.....	96	Sprayberry Academy of Radio-Television.....	13
Goodheart, R. E.....	124	Stan-Burn Radio and Electronics Co.....	118
Gratham Schools.....	119	"TAB".....	130
Greenlee Tool Co.....	120	Telephone Engineering Company.....	122
Greenwich Sales Co.....	112	Tele-Vue Towers, Inc.....	110
Harvey Radio Company, Inc.....	84	Terado Company.....	109
Heath Company.....	64, 65, 66, 67, 68, 69, 70, 71, 72, 73, 74, 75, 76, 77, 78, 79	Texas Crystals.....	107
Henshaw Radio Supply.....	123	Tobe Deutschmann Corporation.....	93
Hughes Aircraft Company.....	100	Triplet Electrical Instrument Corporation.....	THIRD COVER
Indiana Technical College.....	122	Tri-State College.....	121
Klein & Sons, Inc., Mathias.....	10	Tung-Sol Electric.....	101
L. R. Electronics Corp.....	107	United Sales Company.....	126
Lafayette Radio.....	6	University Loudspeakers.....	24
Lampkin Laboratories, Inc.....	114	V. & H. Radio—Electronics.....	126
Lektron.....	116	Valparaiso Technical Institute.....	123
Liberty Auto Radio, Inc.....	103	Vide Electric Company.....	125
Mallory & Co., Inc., P. R.....	FOURTH COVER	World Radio Laboratories.....	111
Merit Coil & Transformer Corp.....	22		

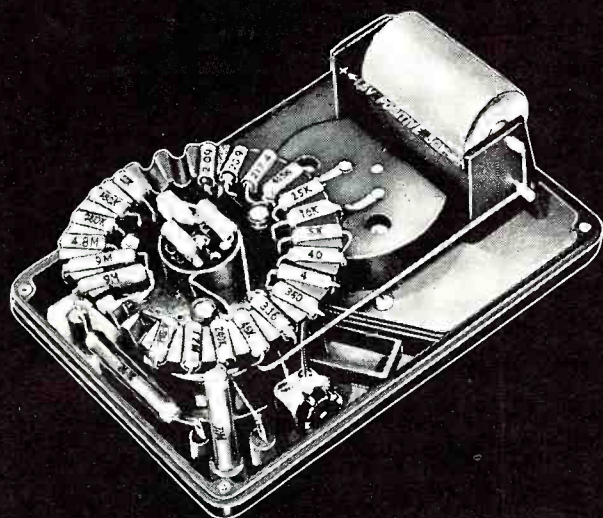

new... most easy to read



- Clear, unbreakable, shadowless front for instant wide vision.
- 5 to 500,000 cps on A.C.
- Continuous resistance reading from 0.1 ohms to 100 megohms.
- Polarity reversing switch.
- *Only one* (king-sized) switch selects both circuit and range—minimizes wrong settings, burnouts.

Only Triplett affords you such a wide choice of VOMs. Whatever your application—broad or limited—there is a Triplett VOM particularly suited for it.

the mighty nine + two

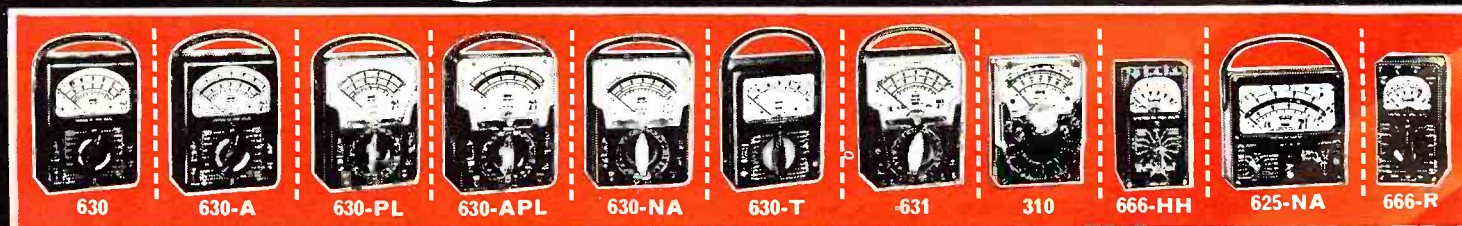

TRIPLETT ELECTRICAL INSTRUMENT COMPANY • BLUFFTON, OHIO



Box Seat Behind Home Plate *... with Mallory Mercury Batteries*

Today's pocket-size transistor radios, powered by tiny, dependable Mallory Mercury Batteries, make available a world of news, entertainment and pleasure . . . anywhere.

LISTENING to the baseball game beside a favorite fishing stream is just one example of how today's compact transistor radios add to enjoyment. Helping make their tiny size and high performance most practical is the "teaming up" of the transistor and unique Mallory Mercury Batteries.

Product of pioneering Mallory research, these amazing mercury batteries compress into miniature size all the performance of larger, conventional batteries—and more. Unlike ordinary dry cells, they show little loss of power when not in use . . . give steadier output . . . last far longer. In addition to eliminating the nuisance of frequent battery changes, they bring out the *best* in transistor performance.

At work in a variety of applications, from nearly-invisible hearing aids to guided missile control equipment, these versatile, dependable batteries are part of a complete family of battery systems developed by Mallory for personal, commercial and military uses. They are constantly finding new applications that bring increased convenience . . . improved performance.

Whether you are a service engineer, hobbyist or one of the millions who enjoy radio listening outdoors, you're sure to get the best in performance and value when you use Mallory Mercury Batteries.

