

SPECIAL SERVICE FEATURE ISSUE

RADIO & TELEVISION NEWS

MARCH

1954

35 CENTS

In Canada 40¢

IN THIS ISSUE

NEW TV DESIGNS FOR 1954

FUNDAMENTALS OF COLOR TV

SERVICING TAPE RECORDERS

TRENDS IN AM RECEIVERS

TV TEST EQUIPMENT

**THE CHROMATIC
COLOR PICTURE TUBE**

**TRANSISTORIZED
APPLAUSE METER**

**"SELF-COMPLETING"
ELECTRONIC KEY**

"DIFFUSICONE-9" ENCLOSURE

E-V MODEL 666 MICROPHONE

(See Page 63)

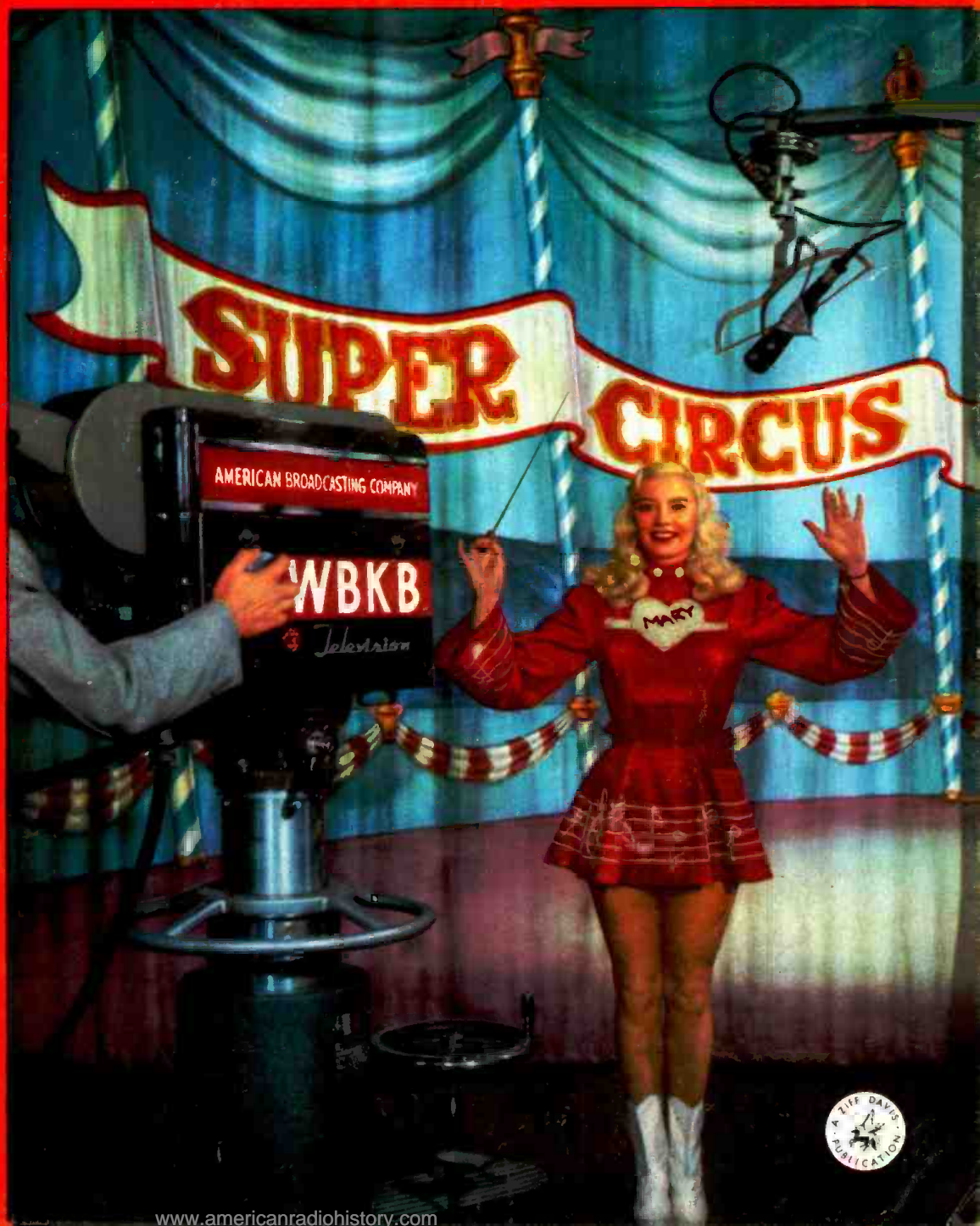

SERVICE DEALERS!



Ask your
TUBE DISTRIBUTOR
how you can get the

time and money saving new **RAYTHEON BROW-LITE**

Here's another sensational *Raytheon first*. It's a different kind of flashlight that sheds a new light on Radio-TV servicing — makes it faster, easier, more profitable.



RAYTHEON BROW-LITES are available through your Raytheon Tube Distributor. Ask him how to get a supply for you and your men.

Here's why Service Dealers from coast to coast are hailing the RAYTHEON BROW-LITE:

- **FREES BOTH HANDS** — work is easier, faster
- **DIRECTS LIGHT AUTOMATICALLY**—you see what you look at in a clear, bright light
- **USES STANDARD PARTS** — 1½ volt penlite batteries and 3 volt penlite bulb
- **ANYONE CAN USE IT** — fits easily above glasses
- **EASY TO CARRY** — folds compactly to pocket size
- **REPLACES FLASHLIGHTS** — easier, safer to use
- **DURABLE** — made of rugged plastic



RAYTHEON MANUFACTURING COMPANY

Receiving Tube Division
Newton, Mass., Chicago, Ill., Atlanta, Ga., Los Angeles, Cal.

Excellence in Electronics

RECEIVING AND PICTURE TUBES • RELIABLE SUBMINIATURE AND MINIATURE TUBES • SEMICONDUCTOR DIODES AND TRANSISTORS • NUCLEONIC TUBES • MICROWAVE TUBES

I'll Train You For Your FCC License

Training plus opportunity is the *perfect combination* for job security, good pay, advancement. A Federal Communications Commission Commercial Operator's License puts you in line for a good job in Radio or Television Broadcasting, Police, Marine, Aviation, Mobile or Micro-Wave Relay Radio. Mail Coupon for 64-page book *free*. It will give complete facts about my Communications Course.

You Build This Transmitter

with parts I send. Use it to get practical experience. Put this station "on the air." Perform procedures required of broadcasting station operators, conduct many experiments, make practical tests.

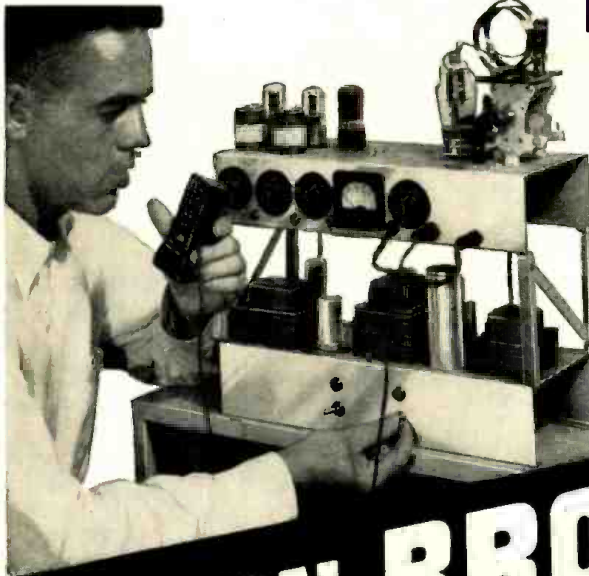

LEARN BROADCASTING by PRACTICING at Home in Spare Time

Get Practical Experience on Circuits Common to Radio & TV

Ever think HOW FAST Radio-Television Communications is changing, developing, growing? Have you considered what this amazing progress can mean to you?

Even without Television the industry is bigger than ever before. Over 115 million home and auto radios, 3000 radio stations, about 200 TV stations with hundreds more being built. Expanding use of Aviation and Police Radio, Micro-Wave Relay, Two-Way Radio for buses, taxis, etc. makes opportunities for Communications Technicians and FCC licensed operators. New jobs, more jobs for beginners! Better jobs, better pay for experienced men!

Television Is Today's Good Job Maker

Over 25 million television sets are in use. Thousands more being sold every week. Good TV jobs opening for Technicians, Operators everywhere. The time to act is NOW! Start learning Radio-TV communications. America's fast growing industry offers good pay, a bright future, security. If you are a beginner, my course can help you get FCC License, prepare for the job

J. E. SMITH, President
National Radio Institute
Washington, D. C.

has trained more men for Radio-Television than any other man. OUR 40TH YEAR.



MY COURSE INCLUDES TELEVISION

you want. If you've had some training in Radio or Radar, or as a Licensed Operator, my course modernizes—increases the value of your knowledge.

Includes New Developments

Mail coupon now for facts about my practical course in Radio-Television Communications. Let me send you my FREE book. See the nine big Kits of Parts I send that "bring to life" theory you learn. You get practical experience by working on circuits common to both Radio and Television; also lessons on TV principles. Read about the Transmitter you build and operate, about the Electronic Multitester you get. All equipment is yours to keep. My graduates are filling jobs, making good money in both Radio and Television. Remember, the way to a successful career in Television is through experience in Radio.

Mail Coupon for Book FREE

Send today! See what my Communications course is like. Find out how I get you ready for a brighter future, better earnings, more security in Radio-Television. Send coupon now in envelope or paste on postal. NO OBLIGATION. NO SALESMAN WILL CALL! My book sent to you FREE, tells the full story. J. E. SMITH, President, Dept. 4CE, National Radio Institute, Washington 9, D. C. Our 40th year.



YOU BUILD this Transmitter Power Supply used in the basic experiments in RF and AF amplifiers, frequency multipliers, buffers, etc.



YOU MEASURE current, voltage (AC, DC and RF), resistance and impedance in circuits with Electronic Multitester you build. Shows how basic transmitter circuits behave; needed to maintain station operation.



YOU PRACTICE setting up code, amplitude and frequency modulation circuits (put voice, music, etc., on "carrier signals" you produce). You learn how to get best performance.

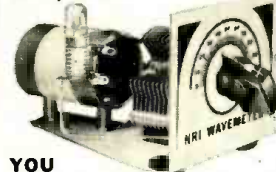

YOU BUILD this Wavemeter and use it to determine frequency of operation, make other tests on transmitter currents.

SERVICING TRAINING ALSO AVAILABLE

If you prefer a good-pay job in Radio-Television Servicing . . . or your own money-making Radio-Television Sales and Service Shop, I'll train you at home. My famous Servicing Course also includes many Kits of Parts. You use them to get PRACTICAL EXPERIENCE with circuits common to Radio and Television. I also show you how to make \$10, \$15 a week or more EXTRA MONEY fixing neighbors' Radios while training. Full information in my 64-page book . . . Mail coupon.

Training Leads to Jobs Like These

| | | |
|---|--|---|
| BROADCASTING Chief Technician Chief Operator Power Monitor Recording Operator Remote Control Operator | GOVERNMENT RADIO Operator in Army, Navy, Marine Corps, Coast Guard Forestry Service Dispatcher Airways Radio Operator | AVIATION RADIO Plane Radio Operator Airport Transmitter Operator |
| SHIP AND HARBOR RADIO Chief Operator Assistant Operator Radiotelephone Operator | POLICE RADIO Transmitter Operator Service Technician | TELEVISION Pick-Up Operator Voice Transmitter Operator TV Technician Remote Control Operator |

I TRAINED THESE MEN



"My position with WNBT is video control engineer on the RCA color project. I owe a lot of my success to your textbooks."—Warren Deem, Maiverne, N. Y.



"I am a technician at WTOP in Washington and I like it very much. Most of my radio knowledge was from N.R.I."—John Britto, Hyattsville, Md.



"A former employer recommended N.R.I. training. Now employed as transmitter operator at WKBO."—Albert Herr, New Cumberland, Pa.

AVAILABLE TO
VETERANS
UNDER G.I. BILLS

MAIL NOW-BOOK FREE

MR. J. E. SMITH, President, Dept. 4CE,
National Radio Institute, Washington 9, D. C.
Mail me your 64-page Book, FREE. (No salesman will call. Please write plainly.)

Name..... Age.....

Address.....

City..... Zone..... State.....

VETS write in date of discharge

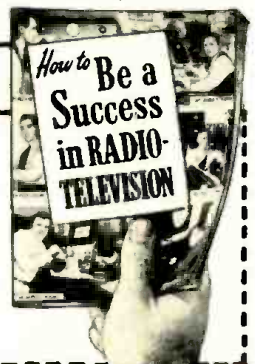

RADIO & TELEVISION NEWS is published monthly by Ziff-Davis Publishing Company, William B. Ziff, Chairman of the Board (1946-1953), at 64 E. Lake St., Chicago 1, Ill. Entered as second-class matter July 21, 1948, at the Post Office, Chicago, Ill., under the act of March 3, 1879. Authorized by Post Office Department, Ottawa, Canada, as second-class matter. SUBSCRIPTION RATES: Radio & Television News—one year U. S. and Possessions, and Canada \$4.00; Pan-American Union countries \$4.50; all other foreign countries \$5.00. Radio-Electronic Engineering Edition—One year U. S. and Possessions, and Canada \$6.00; Pan-American Union countries \$6.50; all other foreign countries \$7.00. Postmaster—Please return undelivered copies under form 3589 to 64 E. Lake St., Chicago 1, Ill.

Editor and Asst. Publisher
OLIVER READ, D.Sc., WIETI

Managing Editor
WM. A. STOCKLIN, B. S.

Technical Editor
H. S. RENNE, M. S.

Service Editor
CHARLES TEPFER

Assistant Editors
P. B. HOFER
M. C. MAGNA

Television Consultant
WALTER H. BUCHSBAUM

Short-Wave Editor
KENNETH R. BOORD

Art Editor
FRANK SAYLES

Draftsmen
A. A. GANS, W2TSP
J. A. GOLANEK

Advertising Manager
L. L. OSTEN

Midwest Adv. Manager
JOHN A. RONAN, JR.

Western Adv. Manager
JOHN E. PAYNE

RADIO & TELEVISION NEWS

First in radio-
television-audio-electronics

Average Paid Circulation over 230,000

Radio News Trademark Reg. U. S. Pat. Office • Television News Trademark Reg. U. S. Pat. Office.

CONTENTS

MARCH, 1954

| | | |
|---|-------------------------------------|-----|
| Looking Ahead..... | Harold J. Schulman | 43 |
| New TV Designs for 1954..... | Robert B. Gary | 44 |
| Crystal Substitute..... | J. G. Donald | 47 |
| TV Test Equipment—How To Choose, How To Use..... | Robert G. Middleton | 48 |
| Latest Trends in AM Receivers..... | M. S. Kay | 50 |
| The Chromatic Color Picture Tube..... | Walter H. Buchsbaum | 52 |
| Power Amplifier Output..... | Joseph F. Sodaro, W6ZRT | 54 |
| The "Diffusicone-8" Enclosure..... | Abraham B. Cohen | 55 |
| Let's Look at Changers..... | Perry Sheneman | 56 |
| Home-Built U.H.F. Antennas..... | Robert H. Hawkins | 58 |
| Know Your 1954 Stewart-Warner TV Receivers..... | H. B. Massie | 59 |
| E-V Model 666..... | Howard Souther & Louis R. Burroughs | 63 |
| Television Troubleshooting Methods..... | John K. Frieborn | 64 |
| How Is Your Training Program?..... | J. H. Hazlehurst | 66 |
| New Communications Receiver..... | | 67 |
| Fundamentals of Color TV—Color Analysis (Part I)..... | Milton S. Kiver | 68 |
| Building a Multimeter..... | Robert Hilliard | 71 |
| Superregenerative Transistor Receiver..... | Joseph M. Hughes, W9VHJ | 72 |
| Servicing Tape Recorders..... | William Rockwell | 74 |
| Certified Record Revue..... | Bert Whyte | 76 |
| 1954 TV Receiver Characteristics..... | | 77 |
| How's Your Rumble?..... | James A. Mitchell | 78 |
| "Self-Completing" Electronic Key..... | Jack D. Gallagher, W5HZB | 80 |
| A Transistorized Applause Meter..... | Louis E. Garner, Jr. | 82 |
| TV-Radio Service Technician Associations..... | | 85 |
| Mac's Radio Service Shop..... | John T. Frye | 86 |
| Wireless Operators of Old..... | C. Howard Bowers | 90 |
| New TV Stations on the Air..... | | 132 |
| A Feedback Loudness Control..... | Ray C. Williams | 134 |
| Service Hints on Stewart-Warner TV Sets..... | | 158 |
| Radio-TV Service Industry News..... | | 160 |
| New TV Grants Since Freeze Lift..... | | 166 |



COVER PHOTO: Mary Hartline, lovely queen of ABC's "Super Circus" as she would look on color television. The microphone visible at the top right is an Electro-Voice Model 666. For details on this unit, see page 63. (Ektachrome by Mickey Pallas)

ZIFF-DAVIS PUBLISHING COMPANY

President
B. G. DAVIS

Vice-Presidents
H. J. MORGANROTH
M. H. FROELICH

Secretary-Treasurer
G. E. CARNEY

Circulation Manager
M. MICHAELSON

BRANCH OFFICES
CHICAGO (1)
64 E. Lake St., AN 3-5200
LOS ANGELES (14)
Statter Center, 900 Wilshire Blvd., Mich. 9856

DEPARTMENTS

| | | | | |
|--------------------------|-------------|----|--------------------------------|-----|
| For the Record..... | The Editor | 8 | Manufacturers' Literature..... | 106 |
| Spot Radio News..... | | 14 | What's New in Radio..... | 112 |
| Within the Industry..... | | 28 | Technical Books..... | 124 |
| Short-Wave..... | K. R. Boord | 84 | New TV Products..... | 136 |



COPYRIGHT 1954
(All Rights Reserved)
ZIFF-DAVIS PUBLISHING COMPANY
Editorial and Executive Offices
366 Madison Ave., New York 17, N. Y.
VOLUME 51 • NUMBER 3



Member
Audit Bureau of
Circulations

SUBSCRIPTION SERVICE: All communications concerning subscriptions should be addressed to Circulation Dept., 64 E. Lake St., Chicago 1, Ill. Subscribers should allow at least four weeks for change of address.

CONTRIBUTIONS: Contributors are advised to retain a copy of their manuscripts and illustrations. Contributions should be mailed to the New York Editorial Office and must be accompanied by return postage. Contributions will be handled with reasonable care, but this magazine assumes no responsibility for their safety. Any copy accepted is subject to whatever adaptations and revisions are necessary to meet the requirements of this publication. Payment covers all author's, contributor's, and contestant's rights, title, and interest in and to the material accepted and will be made at our current rates upon acceptance. All photos and drawings will be considered as part of the material purchased.

RADIO & TELEVISION NEWS

**NOW... GET EVERYTHING YOU
NEED TO LEARN AND MASTER**

TELEVISION

RADIO-ELECTRONICS

...AT HOME!

Use REAL commercial-type equipment to get practical experience

Your future deserves and needs every advantage you can give it! That's why you owe it to yourself to find out about one of the most COMPLETE, practical and effective ways now available to prepare AT HOME for America's billion dollar opportunity field of TELEVISION-RADIO-ELECTRONICS. See how you may get and keep the same type of basic training equipment used in one of the nation's finest training laboratories... how you may get real STARTING HELP toward a good job or your own business in Television-Radio-Electronics. Mail the coupon today for complete facts—including 89 ways to earn money in this thrilling newer field.

D. T. I., ALONE, INCLUDES BOTH MOVIES and HOME LABORATORY In addition to easy-to-read lessons, you get the use of HOME MOVIES—an outstanding training advantage—plus 16 big shipments of Electronic parts. Perform over 300 fascinating experiments for practical experience. Build and

Get information packed publication FREE!

keep real commercial-type test equipment shown at right.

89 WAYS TO EARN MONEY IN TELEVISION RADIO-ELECTRONICS

MODERN LABORATORIES
If you prefer, get all your preparation in our new Chicago Training Laboratories—one of the finest of its kind. Ample instructors, modern equipment. Write for details!

MILITARY SERVICE
If you're subject to military service, the information we have for you should prove very helpful. Mail coupon today.

ACT NOW! MAIL COUPON TODAY!

DEVRY TECHNICAL INSTITUTE
4141 BELMONT AVE., CHICAGO 41, ILL.

RN-3-K

I would like your valuable information-packed publication showing how I can get started toward a good job or my own business in Television-Radio-Electronics.

Name..... Age.....
Street..... Apt.....
City..... Zone..... State.....



21 INCH
Build and keep this BIG DTI Engineered TV set—easily converted to U.H.F. (DTI offers another home training, but without the TV set.)

Here's the REAL THING!

SET UP YOUR OWN HOME LABORATORY

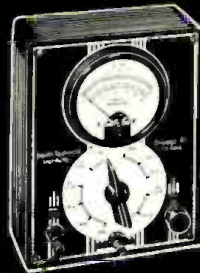

Multimeter



Oscilloscope

HOME MOVIES



"ONE OF AMERICA'S FOREMOST TELEVISION TRAINING CENTERS"

DEVRY TECHNICAL INSTITUTE
AFFILIATED WITH
DEFOREST'S TRAINING, INC.
CHICAGO 41, ILLINOIS

They look alike...

...but what a difference!



These RCA types today give you . . .

RCA receiving tubes provide the superior performance and reliability usually associated with higher priced specialty designed types. That's because RCA receiving tubes are constantly being improved to meet the changing requirements of radio and television applications.

For instance, the RCA-5U4-G features a new electrolytic coating on its channel filament which produces a uniform, hard emitter, leading to greatly increased life over the older version.

Or take the RCA-6W4-GT. This type now uses a new RCA-developed carbonized plate-coating material which has improved heat-dissipating properties, thus contributing to longer tube life and increased reliability.

The RCA-6AL5 now utilizes double helical heaters to insure low hum and pinched cathodes to minimize cathode shift within the mount. These features make possible greatly reduced microphonics.

The superior performance of *regular* RCA receiving tubes—at *regular* prices—eliminates unnecessary call-backs, assures you of greater customer satisfaction, results in increased profits for you.

When you sell a receiving tube, your reputation and profit depend on its *performance and reliability*.

1 1 1

So, you just can't afford to buy anything less than the best in receiving tubes . . . and that's RCA.

Longer Life



Superior Performance



At No Extra Cost



RADIO CORPORATION of AMERICA
ELECTRON TUBES
HARRISON, N. J.

HERE ARE
31 REASONS
WHY THE

hallicrafters SX-88

is the hottest ham news in years!



SX-88

SELECTIVITY—
For the first time, selectivity
from 10 kc to 250 cycles in six steps.
Compare with ANY other receiver!

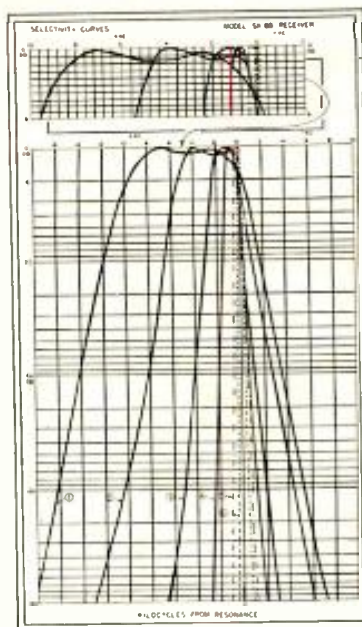
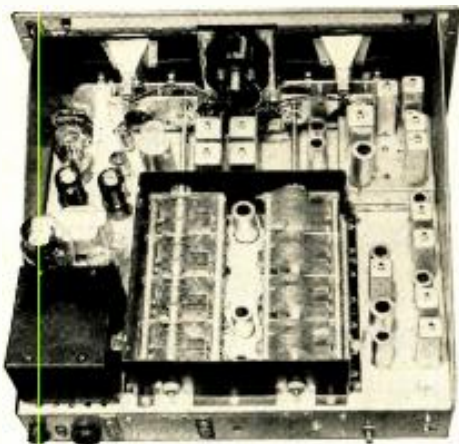

1. Heavy gauge steel welded chassis for mechanical stability.
2. Full precision gear drive for main and band spread tuning.
3. Six position Band Width Control (selectivity) from 250 cycles to 10 kc.
4. 10 watt inverse feed back and push-pull audio output.
5. Exalted B.F.O. for tops in single side band reception.
6. Buffer amplifier in B.F.O. circuit.
7. Antenna trimmer.
8. Amplified and delayed A.V.C.
9. Built-in 100 kc calibration crystal.
10. Second conversion oscillators crystal controlled.
11. Inertia tuning (fly wheels both dials).
12. Full frequency coverage from 535 kc. to 33 mc.
13. Calibrated electrical band spread 160, 80, 40, 20, 15, 11, and 10 meters.
14. Logging scales on each tuning shaft.
15. Dial locks on each tuning shaft.
16. Tuning dial indicators resetable from front panel for maximum calibration accuracy.
17. Auxiliary A.C. socket on rear of chassis.
18. Illuminated band-in-use indicator.
19. Illuminated S meter.
20. Dual S meter calibration S units and microvolts.
21. Auxiliary power socket plus .6 amps at 6.3 volts and 10 ma at 150 volts for accessories.
22. Standard 8 $\frac{3}{4}$ " by 19" panel for rack mounting if desired.
23. 50 kc i.f. output jack via cathode follower for teletype converter, etc.
24. Five position response control (tone control).
25. Two r.f. stages (Bands II to VI).
26. 17 tubes plus voltage regulator, ballast tube and rectifier.
27. Automatic noise limiter circuit.
28. Phono Jack.
29. Audio output transformer for 3.2, 8, 500/600 ohm loads.
30. Fuse for overload protection.
31. Auxiliary sensitivity control permits monitoring of local transmissions in standby position.

hallicrafters

World's Leading Exclusive Manufacturer of Communications and
High Fidelity Equipment, Radio and Television

4401 West Fifth Avenue, Chicago 24, Illinois • Hallicrafters Ltd., 51 Camden Street, Toronto, Canada

MARCH, 1954

THE BEAUTIFUL **E-V**
Peerage
 SOUND EQUIPMENT CONSOLE

Compactly houses
 Tuner, Amplifier & Changer



**Makes it Easy to Enjoy
 the Hi-Fi System You Want**

Specifically designed by E-V to house any of the popular tuners, amplifiers and record changers. Makes it easy for anyone to install with ordinary tools all the components needed for true High Fidelity sound. Available in lustrous Tropical Mahogany or sparkling Blonde Korina. Size: 29 $\frac{3}{4}$ " high, 20 $\frac{1}{2}$ " wide, 18 $\frac{3}{4}$ " deep.

Cabinet, less tuner, amplifier and changer.

MAHOGANY... Audiophile Net \$ 96

BLONDE ... Audiophile Net \$102

Send for Bulletin No. 189.

Note how the PEERAGE complements an E-V folded-horn speaker enclosure. The simple, graceful lines harmonize with all E-V enclosures and blend with any contemporary setting.



No finer choice than

Electro-Voice

BUCHANAN · MICHIGAN

Export: 13 E. 40th St. N.Y. U.S.A. Cables: Arlab

For the **RECORD.**

BY THE EDITOR

TALKIES, TELEVISION, AND TAPE

THE history of our industry will some day record the year 1954 as one of the most competitive periods of tremendous technical achievements in the field of electronics. The past year concluded with many developments still in the experimental stage. One, well-known to millions of moviegoers, was the mad race to win public acceptance of a particular 3-D system. All in all, we've witnessed many showings on all shapes and sizes of screens and have listened intently to an even greater number of sound systems. Some of these have provided a spatial effect—depending on the individual seating location. Others have simulated, to some degree, a stereophonic effect by employing multitrack audio channels into widely separated loudspeakers.

We've drawn some conclusions and perhaps the most definite is that stereosound techniques have reached only the half-way mark on the road to binaural reproduction or its effect.

The peculiar and unfortunate technical requirements for true 3-D motion pictures with binaural sound are well-known to the physicist and the audio engineer. But the public simply will not accept the fact that it must be encased in a network of earphones and polaroid glasses to watch 3-D and listen to binaural sound for any length of time, with the attendant discomfort and fatigue that results.

The public has accepted the new screen techniques as providing realism and perspective for the picture. Audio systems used with *Cinemascope* and *Cinerama* have done wonders to educate the public to the need for better sound. These recordings have about twice the frequency response of conventional theater sound and a wider dynamic range of musical scores greatly enhances the action. We feel that the public will support any screen technique that provides the ingredients of high-fidelity sound and wide-screen optical effects. Of the two—audio needs the most attention. It will be interesting to see which system wins greatest public favor. The small movie houses simply do not lend themselves, acoustically, to the requirements of wide range audio at high volume levels. This is just one of many obstacles that must be met in the ensuing year.

And, this is the year when color tele-

vision emerges from the laboratory as a full-fledged giant in our industry. Hand-in-hand with live telecasts in color will be rapid development of electronic photography. Certainly one cannot overlook the tremendous contributions of *Crosby Enterprises* and *RCA* engineers in making such rapid progress in video recording on magnetic tape. Those of us who witnessed the first *RCA* demonstration of "recorded color TV" will, in years to come, remember the occasion as representing a new era of photography for industry, the theater, and the home.

We've been in on many "firsts" in reporting technical achievements of our electronics industry. But, we don't recall any "preview" that represented a development that was so highly refined and one that was capable of rousing such great enthusiasm as the one at Princeton. There's little doubt that our future home movies will be photographed on magnetic tape and that the visual and audio information will be "played back" through our television sets for the entire family to see and hear.

Another important use for magnetic tape is the control device developed by *G-E's* engineers. This machine is a tape record-playback device that directs a machine operation on a process cycle from information recorded on the magnetic tape. A machinist, skilled in an operation, performs the functions of operation on the original piece of work.

Each motion of this correctly executed operation is recorded on the tape as a result of translation to electrical signals *via* selsyns. Playback of the tape then duplicates the operation of the machine and an identical part is thus produced. The tape can be stored until needed to re-fill an order. In its present stage of development any control or motion that can be operated from electrical signals can be done with this tape playback control device.

There is an almost unlimited horizon for applications of magnetic tape in fields of sound and signals. Any device that can be controlled by electrical signals in conjunction with selsyn motors can be controlled *via* signals recorded on magnetic tape.

The year 1954 certainly will see rapid progress made in each of the three T's—talkies, television, and tape. O.R.

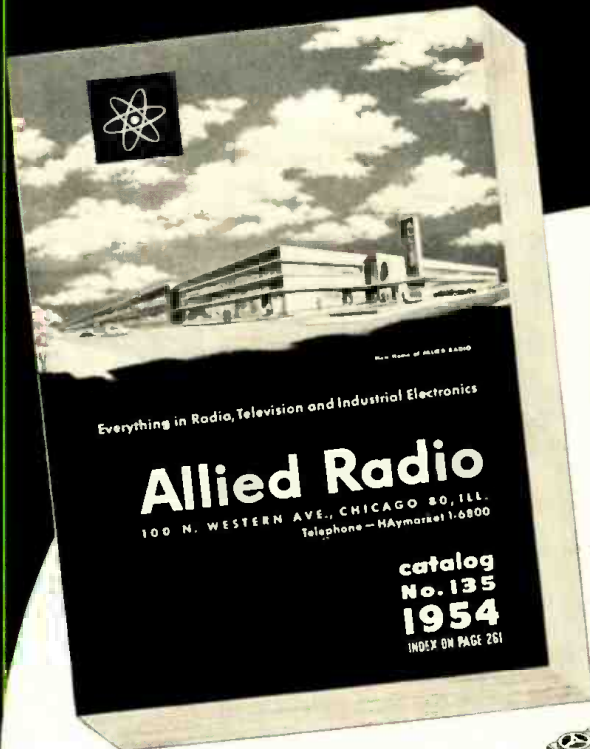

the only **COMPLETE** catalog
for Everything in TV, Radio
and Industrial Electronics

FREE value-packed

1954 ALLIED 268-PAGE CATALOG

The World's Largest Stocks

- TV and Radio Parts
- Test Instruments
- High-Fidelity Equipment
- Custom TV Chassis
- AM, FM Tuners and Radios
- Recorders and Supplies
- P.A. Systems, Accessories
- Amateur Station Gear
- Builders' Kits, Supplies
- Equipment for Industry

Fastest Service in Electronic Supply

SEND FOR THE LEADING
ELECTRONIC
BUYING GUIDE
FREE!

NEW HOME OF
ALLIED RADIO
ultra-modern facilities
TO SERVE YOU BEST



EASY PAY TERMS

Use ALLIED'S liberal Easy Payment Plan—only 10% down, 12 months to pay—no carrying charge if you pay in 60 days. Available on Hi-Fi and P.A. units, recorders, TV chassis, test instruments, Amateur gear.

TV and HI-FI SPECIALISTS

To keep up with developments in High-Fidelity and TV, look to ALLIED. Count on us for all the latest releases and largest stocks of equipment in these important fields. If it's anything in High-Fidelity or Television—we have it in stock!

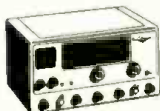
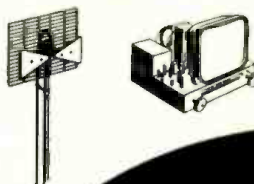

SEND FOR IT TODAY

Get ALLIED'S latest catalog—268 pages packed with the world's largest selection of quality equipment at lowest, money-saving prices. See all the latest releases in custom TV chassis, TV antennas and accessories; AM and FM tuners and radios; everything in High-Fidelity custom components; latest P. A. Systems and accessories; recorders and supplies; Amateur receivers, transmitters and station gear; specialized industrial electronic equipment; test instruments; builders' kits; huge listings of parts, tubes, tools, books—your choice of the world's most complete stocks of quality equipment. ALLIED gives you every buying advantage: speedy shipment, expert personal help. Lowest prices, assured satisfaction. Get the big 1954 ALLIED Catalog. Keep it handy—and save time and money. Send for your FREE copy today.

**SAVE ON EVERYTHING
IN ELECTRONICS**

ALLIED RADIO
World's Largest Electronic Supply House

ALLIED RADIO CORP., Dept. 1-C-4
100 N. Western Ave., Chicago 80, Illinois

Send FREE 268-Page 1954 ALLIED Catalog

Name _____

Address _____

City _____ Zone _____ State _____

Quality is an elusive thing. Engineers measure it... copywriters glorify it... salesmen describe it. But the final test is actual performance. If a product is the best in its field, those who know quality will accept no other.

That is the story of Pickering's new 260 Turnover Cartridge.

Introduced only months ago, it is already a leader among magnetic cartridges. It has won that position because it is the nearest thing to perfection yet produced. Here are the combined advantages it offers:

The nearest Thing to Perfection



A simple flip of the handy lever and you're ready to play any favorite that fits your mood—whether it's standard or microgroove.

1. HIGHER OUTPUT—Better overall signal-to-noise ratio.
2. LOWER OVERALL DISTORTION—Less intermodulation distortion with wider frequency response.
3. MINIMUM TRACKING FORCE—Lowest practical tracking force for both microgroove and standard recordings.
4. HIGHER COMPLIANCE—Compliance of moving elements is the highest practical, consistent with best-quality transcription arms and changers.
5. LOWER MOVING MASS—Lowest of any comparable magnetic cartridge.
6. TWO DIAMOND STYLI—For longer record and stylus life and greatest economy.

These design features have real meaning to those who understand that quality reproduction depends on components which meet professional standards. If you want the best that high fidelity can offer, ask your dealer to demonstrate the new 260 Turnover Cartridge. You, too, will hear the difference!

PICKERING and company incorporated • Oceanside, L. I., New York



PICKERING PROFESSIONAL AUDIO COMPONENTS

“For those who can hear the difference”

... Demonstrated and sold by Leading Radio Parts Distributors everywhere. For the one nearest you and for detailed literature; write Dept. C-4

New CBS-Colortron

NOW IN MASS PRODUCTION



Unique photographic process, like photoengraving, uses aperture masks as negatives to print consecutively the red, green, and blue phosphor dots (250,000 of each) on CBS-Colortron screens.

After tri-color screens are printed, aperture masks are temporarily removed and face plates move on to critical inspection for screen imperfections.

COLOR TV IS COMING . . . faster than you think. The revolutionary new CBS-Colortron . . . a practical color picture tube . . . hastens the day. Already it is in lower-cost, mass production . . . made possible by its simplified, advanced design.

As in black-and-white tubes, the CBS-Colortron's screen is deposited directly onto the inside of its face plate. A unique photographic technique makes this possible. Because each aperture mask serves as a negative to print its tri-color screen, perfect register of mask and screen is automatically achieved

and maintained. The rugged, simple, light-weight mask sharply reduces assembly and exhaust problems. And the spherical design of mask and screen simplifies convergence circuitry and adjustment.

The CBS-Colortron is now a 15-inch, round tube. But, as soon as tooling is completed, it will be made in larger sizes. Watch for the new CBS-Colortrons. You'll see plenty of them soon. And you'll be sold on sight by their logical simplicity . . . their superior performance . . . their many advantages.

CBS-Colortron OFFERS MANY ADVANTAGES



Cross-section (face plate, aperture mask, funnel, tri-color electron gun) shows simplicity of CBS-Colortron and its adaptability to low-cost, mass production.

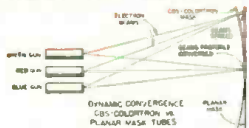

Spherical screen and aperture mask of CBS-Colortron simplify convergence and focus. Electron beams remain in focus over entire surface of screen.



Light-weight (6 oz.), rugged, simple aperture mask of CBS-Colortron minimizes problems of exhaust, handling, and assembly.

COMPLETE CBS-Colortron DATA FREE!

Take a look into the future. Write today for complete information on CBS-Colortron 15HP22: Construction . . . operation . . . application . . . installation and adjustment . . . electrical and mechanical data. Four packed pages . . . free!



CBS-HYTRON, Main Office: Danvers, Massachusetts

Manufacturers of Receiving Tubes Since 1921

A Division of Columbia Broadcasting System, Inc.

A member of the CBS family: CBS Radio • CBS Television • Columbia Records, Inc. • CBS Laboratories • CBS-Columbia • and CBS-Hytron

RECEIVING • TRANSMITTING • SPECIAL-PURPOSE • TV PICTURE TUBES • GERMANIUM DIODES AND TRANSISTORS
MARCH, 1954

Now

G-E TUBES ARE SERVICE-TESTED

IN INDIANAPOLIS: Howard W. Sams & Co., Inc. regularly checks the performance of current-production G-E tubes in all popular TV chassis, at various line voltages.

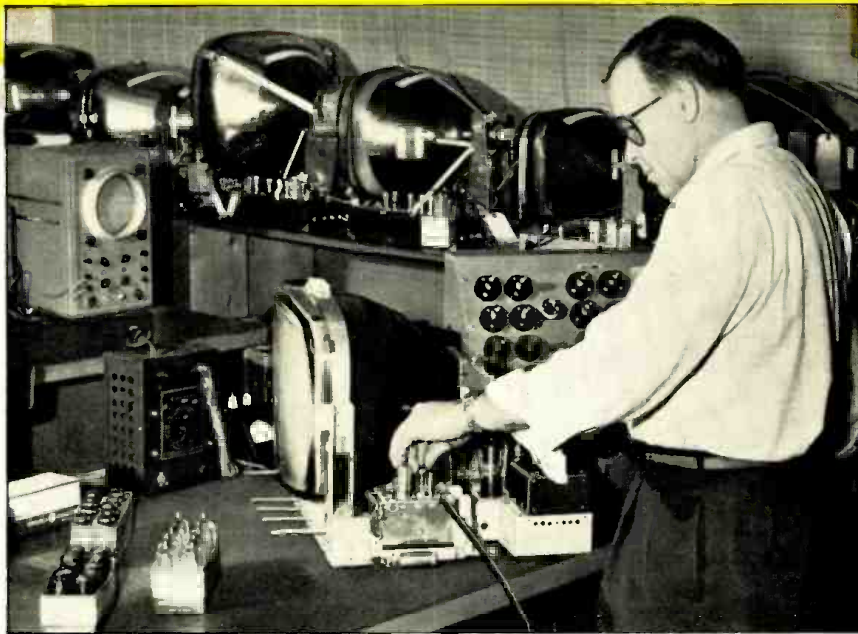

● A Howard Sams staff member tests General Electric tubes in one of a series of TV chassis of different makes. The pre-heating panel at right makes it possible to have up to 30 tubes ready at one time for substitution and test.



Simplify your tube requirements, reduce service call-backs, with G-E interchangeable tubes!

SINCE September, 1953, the nationally-known Howard Sams TV-radio technical organization has checked G-E receiving tubes for servicing interchangeability.

A number of tubes of each type are selected periodically for test. The tubes are fully representative of normal production—their performance ranges all the way between top and bottom limits of the permissible variation in tube characteristics. The tubes are all tested

at various line voltages in TV chassis of different makes. Their performance is accurately checked by instruments. When a tube fails to operate satisfactorily in any chassis, that fact is noted in the detailed report sent by Howard Sams to General Electric.

Based on these reports, G.E.—as described at right—takes prompt corrective steps that help give you tubes you can install successfully in every make receiver!

FOR TV-SET INTERCHANGEABILITY!

AT GENERAL ELECTRIC: the Howard Sams reports are carefully studied for ways in which G-E tubes may be improved for wider usefulness in servicing.

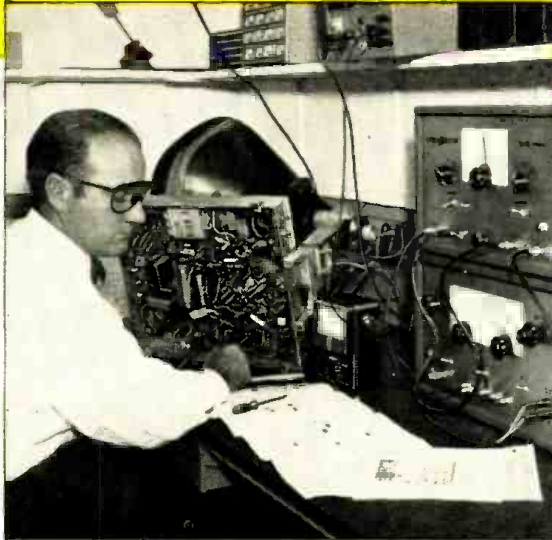

● A General Electric tube engineer—with a Howard Sams analysis before him—re-checks tube performance in the same make of chassis where difficulties were reported.



● A General Electric executive micro-inspects a tube structure, to determine whether or not manufacturing or test requirements need to be changed.

Ever-better quality is the aim of G-E tube manufacture and testing!

So that G-E tubes will give superior service in *all* receivers, G.E. exhaustively studies each case of unsatisfactory performance reported by Howard Sams.

First, a cross-section of General Electric tubes of that type is tested in the same make TV chassis where trouble was encountered. Afterwards, tubes other than G-E are substituted and checked.

By comparison and analysis, any G-E tube performance fault is established and isolated. The cause then is determined by laboratory investigation, and corrective steps follow immediately. These may take the form of an improvement in manufacture or inspection, or revised tube test specifications.

Result: you are always installing *better G-E tubes*. Your General Electric tube distributor is your source for a product that is constantly being improved in quality and interchangeability. *General Electric Co., Tube Department, Schenectady 5, New York.*

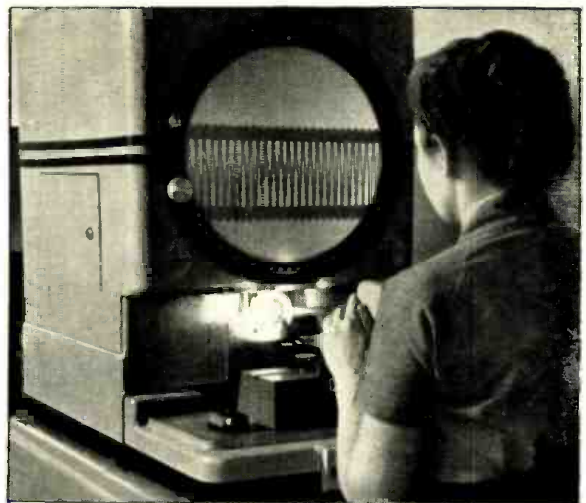

● A General Electric plant employee checks a tube grid, using a comparator that greatly magnifies the component which is to receive special attention.

GENERAL  **ELECTRIC**

161-1A1

NEW LIFE FOR OLD RADIOS

NEW

SUPEREX

Vari-Tenna®

Modern replacement for old-fashioned hank of wire and antenna coil.

- Boosts sensitivity and gain up to 25 times.
- Pulls in hard-to-get-stations.

50,000,000 old and inexpensive radio sets now in use NEED a VARI-TENNA . . . including many of your own customers'. Superex Vari-Tenna gives all the power and reception of modern sets . . . lets you hear stations never before available.



\$1.25
List

and EXTRA power for all radios

NEW

SUPEREX

ENERGIZED

Ferri-Loopstick®

List \$1.50

Even brand new radios, still equipped with old-fashioned loop antennas, can benefit from this "hot" loopstick. Adds 20% gain to even the powerful Ferri-Loopstick. Q up to 350, will outperform any coil with a core 3 times its length. 1-hole snap in mount; self-locking vinyl adjustment collar.



Popular enough to be imitated

Recommend these compact, highly sensitive money makers.

Grayburne

FERRI-LOOPSTICK®

List 75c

Pulls in stations strong and clear. Customers rave over performance.

Grayburne

VARI-LOOPSTICK®

List \$1.00

Same as Ferri-Loopstick with variable micrometer adjustment.

BE SMART! Boost your reputation as a technician . . . make handsome profits. Recommend Superex products to your customers on every call.

SupereX successor to Grayburne
23 Atherton St., Yonkers, N. Y.

Spot Radio News

★ Presenting latest information on the Radio Industry.

By RADIO & TELEVISION NEWS'
WASHINGTON EDITOR

COMPATIBLE COLOR TV, now blessed with the official seal of Uncle Sam, found itself steeped in affectionate phrases of approval as the public announcement of the historic decision appeared. Said the Commission: "The accomplishment of a compatible color television system that can operate within a 6-megacycle bandwidth is a tribute to the skill and ingenuity of the electronics industry."

In supporting industry through its approval, the FCC declared that it had decided to adopt the new system because there is . . . "virtual unanimity" that the proposed standards are . . . "fundamentally capable of producing satisfactory color television pictures . . ." and in addition there is . . . "also substantial agreement" . . . that they . . . "have a potential for growth."

The Commissioners also declared that the system will . . . "furnish incentive and stimulus to manufacturing and research organizations to devote their efforts to the equipment problems . . ." and that history . . . "has demonstrated that American industry is capable of devising practical and economical equipment on a mass production basis . . ." which would eventually reduce the price of receivers and other equipment. The new approach would also afford the consumer, the Commissioners added, a . . . "greater degree of freedom than would an incompatible system in choosing whether or not to purchase a color receiver . . . since the public will, in any event, continue to receive program material in monochrome."

In a concurring statement, Commissioner Robert Lee said that he would like to consider the decision . . . "a milestone in the fast-moving electronics industry." In his opinion, the . . . "defects and shortcomings that may now exist will evaporate in the coming months as industry takes on mass production." Continuing, he declared: "The first automobile had many defects. An airplane going on the assembly line immediately takes on some aspects of being outmoded as experience teaches us new improvements and better methods of production. We would never learn the new short-cuts if we kept the basic idea on the drawing board." Our economy, he felt, will . . . "get a tremendous boost from this development."

"I am delighted at long last to have

had a small part in putting the show on the road," he concluded.

In another concurring view, Commissioner George Sterling noted that he was certain that both larger and cheaper color receivers . . . "with controls having the ease of adjustments of current monochrome receivers will be made available to the public within the next two to three years; the time necessary to establish a color television broadcasting service of any consequence."

Commander E. M. Webster also applauded the decision, but issued a stern warning to industry, noting that the adoption of the standards creates . . . certain receiver problems which must be recognized . . . Receiver manufacturers, he went on to say . . . "are obligated to the public to incorporate . . . refinements beyond those in monochrome receivers necessary to suppress adequately aggravated receiver radiation and overcome the greater susceptibility to interference, particularly in the region of the color subcarrier."

The report and order, a 22-page affair supplemented by a comprehensive review of the system's operation, presented some intriguing facts, heretofore not too well known. In a commentary on station costs, the Commission said that color broadcasters will have to spend over \$187,000 for equipment that will permit them to network color programs, and colorcast slides, color films, and live color. To transmit color film, stations will require a 16-mm film chain and miscellaneous gear. For live pickup, at least one three-tube color camera will be needed, and the price offered covers but one unit; it was noted, generally two or more cameras are required for live telecasts. In addition, stations will also require remote equipment, which will add many thousands of dollars to the cost.

The controversial subject of convertibility also received a frank explanation in the report. The Commission declared that . . . "No practical converter has been demonstrated, nor does it appear that proponents of the proposed signal specifications have any current plans for the production of converters."

Describing receivers and their costs, the Commission reported that they were well aware of the fact that the new sets would be high priced and fall

NOW! Use Your Present Signal Generator

NEW!

For UHF!

PHILCO Signal Generator Adapter

(VHF to UHF)

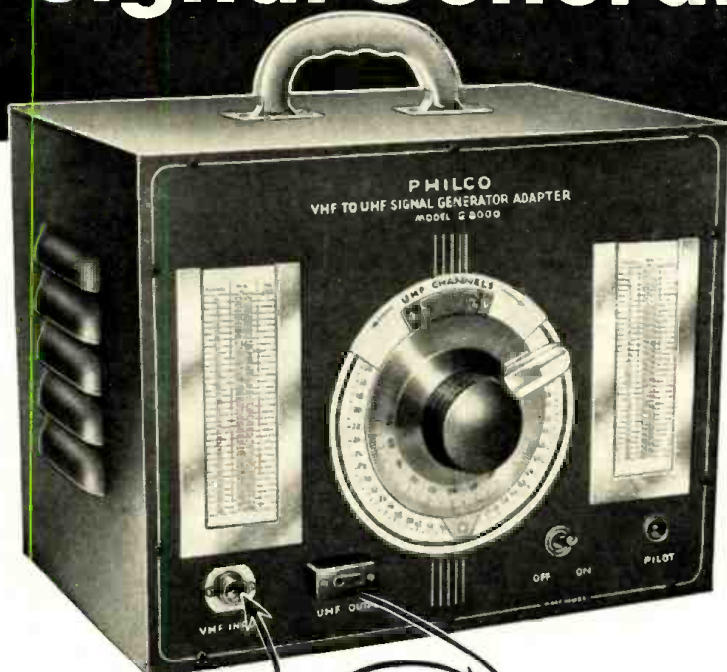

VHF INPUT
60 MC

UHF OUTPUT
SIGNAL

Individually Calibrated For Extreme Accuracy

Now produce UHF signals for TV receiver tests at a fraction of the cost of a UHF generator. Individual calibration guarantees extreme accuracy of UHF frequency. Any VHF signal generator output at 60 MC is converted by the PHILCO Model G-8000-C to UHF. The VHF sweep or marker signal beats against the UHF oscillator, producing UHF signals with the same characteristics as the VHF input signal. It's economical . . . it's a *PHILCO exclusive!*

Look at These Philco Features . . .

- 1 The VHF signal generator output attenuator controls the UHF output signal level.
- 2 Precision Vernier Dial for accurate re-settings.
- 3 Each unit is hand calibrated.
- 4 Functions as an external UHF converter by connecting UHF antenna transmission line to generator's output terminal and connecting lead to TV receiver tuned to 60 MC Channel 3.
- 5 High UHF levels, excellent stability, no drift.

5" High Gain Oscilloscope Model S-8202.

Gives rugged, general purpose performance. 60 CPS phasing of sweep generator presentations. Wide sweep range (up to 100KC) gives extreme flexibility in sweep circuit trouble shooting.



**AVAILABLE THROUGH YOUR PHILCO DISTRIBUTOR
ON A NEW SPECIAL PAYMENT PLAN**

Take advantage of the great
SHARE and PROFIT Program
on Philco Receiving Tubes
Parts and Accessories
NOW AT YOUR PHILCO DISTRIBUTOR



Win a McIntosh Amplifier and Compensator and \$500 cash*!

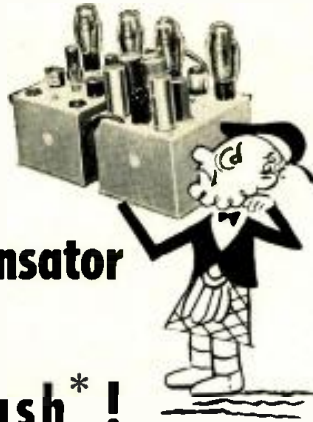

Mac needs your help! He needs a name for the famous McIntosh output transformer circuit. Just by naming it you can win one of six big prizes. Names may be either technical, for example, "Bicoupled", or non-technical like "Perfectone".

Your McIntosh dealer can supply

you with a folder that tells all about the McIntosh circuit. Get one, it will make it easy for you to win. Your entry blank is in the booklet.

Six Big Prizes!

1st prize, a McIntosh 50W2 50 watt Amplifier, a McIntosh C-108 Audio Compensator and \$500 cash*; 2nd prize, McIntosh 50W2 50 watt Amplifier and C-108 Audio Compensator; 3rd prize, McIntosh A-116, 30 watt Amplifier and C-108 Audio Compensator; 4th prize, McIntosh A-116, 30 watt Amplifier; 5th prize, McIntosh C-108 Audio Compensator and D-101 Power Supply; 6th prize, McIntosh C-104 Audio Compensator and D-101 Power Supply.

*If you are the first prize winner, McIntosh's Chief Engineer will install your equipment and assist you in the selection of other components.

The McIntosh Circuit

At right is a drawing of the patented McIntosh output transformer circuit which is not available on any other amplifier. See your Hi-Fi dealer and find out why McIntosh amplifiers guarantee substantially less than 1/2% distortion at all frequencies 20-20,000 cycles even at full power output. Hear the difference — the difference can be your suggested name. All you have to do then is name it, and you can have it . . . IF you're one of the lucky winners!

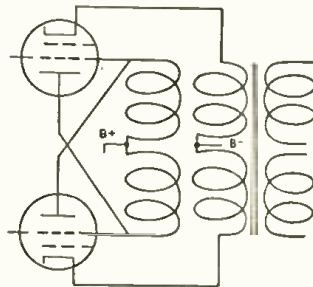

"Name the McIntosh Circuit" Contest Rules

1. Send in as many entries as you wish. There is nothing to buy, but each entry must be mailed separately, and should be accompanied by an explanation of 25 words or less as to why you think this name fits the circuit or its performance. Entries may be on a postcard, plain sheet of paper, or better still, the entry blank in the booklet available at your hi-fi dealer.
2. All entries are to be mailed to: McIntosh Laboratory, Inc., Post Office Box No. 5822, Cleveland, Ohio, by midnight March 31, 1954.
3. Entries will be judged on the basis of aptness and originality. The decision of the Contest Judges will be final. In the event of a tie, duplicate prizes will be awarded. All entries become

the property of McIntosh Laboratory, Inc. and will not be returned.

4. The contest is open to all residents of the U.S. and Canada only, and is valid only where permitted by Federal, State and Provincial laws. Your entry must be postmarked not later than midnight, March 31, 1954.
5. Employees of McIntosh Laboratory, Inc., their representatives, advertising agency or families are not eligible.
6. Winners will be announced in HIGH FIDELITY Magazine as soon as possible after May 1, 1954. A complete list of winners will be sent to you about May 15, 1954, if a self-addressed, stamped envelope is enclosed with your entry.

McIntosh

LABORATORY, INC.
BINGHAMTON, N. Y.

Makers of the World's Finest Amplifiers and Compensators

Manufactured under patent numbers 2,646,487; 2,545,788; 2,654,058; 2,477,074

in the luxury-price brackets of from \$800 to \$1000. Unfortunately, they added, the high cost is caused by the complex three-gun tube, which presently is valued at from \$175 to \$200 at the set-makers' level; this tube, a 15-inch model, provides an 11½-inch picture.

Since the Commission released its statement, several very significant tube cost and size developments have appeared on the scene. It has been reported that it has now become possible to produce a 19-inch tri-color, 3-gun tube, which can provide a 15- to 16-inch picture. A nationally-known laboratory has also demonstrated the practicability of a single-gun tube that can produce a 17-inch picture, and be sold at a substantially lower price than the 3-gun smaller-face model. Commenting on this tube, the lab officials declared that it has good light efficiency, assures automatic registration due to color switching near the phosphor screen and minimizes the problem of convergence. Model shown was a 22-inch round type; it was explained that a 21-inch rectangular version will be available soon, and this will probably be followed by a 24-inch model, which will provide 18- and 21- to 22-inch pictures, respectively.

THE ANNUAL REPORT of the Commission, always bulging with valuable information, was equally complete in its '53 version, replete with vital data and statistics. Noting that as the nineteenth year of the Commission closed (June, '53), there were nearly 1,100,000 radio authorizations on its books, the report said that over 235,000 of these were for safety and communications purposes on land, sea, and air, and almost 5500 were for broadcast. Radio station authorizations covered the use of about 600,000 transmitters, of which more than 430,000 were for mobile purposes.

The growing utilization of radio by industry was reflected by nine types of services now operating, for which there are nearly 17,000 authorizations, involving the use of over 127,000 transmitters. These services concern power, petroleum, forest products, relay press, motion picture, agriculture, radio-location/land, and special industrial.

Authorized ham stations were said to number over 112,000. It was noted that the popularity of the new Novice class operator license prompted the issuance of nearly 10,000 licenses during the fiscal-year period ending June 30, '53.

The field engineering and monitoring division of the Commission revealed that they had received over 20,000 complaints on interference; almost twice as many as in '52. Most of the broadcast-interference complaints were due to increased TV operation and the high susceptibility of its reception to interference. Other complaints involved interference from industrial, scientific and medical equipment, and even community antenna systems. Many odd cases of interference were also reported. To illustrate, in the

RADIO & TELEVISION NEWS

ADVANCE! Raise your earning power—learn RADIO-TELEVISION-ELECTRONICS by SHOP-METHOD HOME TRAINING

GOOD JOBS AWAIT THE TRAINED RADIO-TV TECHNICIAN

There is a place for you in the great Radio-Television-Electronics industry when you are trained as National Schools will train you at home!

Trained technicians are in growing demand at good pay—in manufacturing, broadcasting, television, communications, radar, research laboratories, home Radio-TV service, and other branches of the field. National Schools Master Shop-Method Home Training, with newly added lessons and equipment, trains you in your spare time, right in your own home, for these fascinating opportunities. OUR METHOD IS PROVED BY THE SUCCESS OF NATIONAL SCHOOLS TRAINED MEN, ALL OVER THE WORLD, SINCE 1905.

EARN WHILE YOU LEARN

Many National students pay for all or part of their training with spare time earnings. We'll show you how you can do the same! Early in your training, you receive "Spare-time Work" Lessons which will enable you to earn extra money servicing neighbors' and friends' Radio and Television receivers, appliances, etc.



Signal Generator

Audio Oscillator

T. R. F. Receiver

National Schools Training is All-Embracing

National Schools prepares you for your choice of many job opportunities. Thousands of home, portable, and auto radios are being sold daily—more than ever before. Television is sweeping the country, too. Co-axial cables are now bringing Television to more cities, towns, and farms every day! National Schools' complete training program qualifies you in all fields. Read this partial list of opportunities for trained technicians:

Business of Your Own • Broadcasting
Radio Manufacturing, Sales, Service • Telecasting
Television Manufacturing, Sales, Service
Laboratories: Installation, Maintenance of Electronic Equipment
Electrolysis, Call Systems
Garages: Auto Radio Sales, Service
Sound Systems and Telephone Companies, Engineering Firms
Theatre Sound Systems, Police Radio
And scores of other good jobs in many related fields.

TELEVISION TRAINING

You get a complete series of up-to-the-minute lessons covering all phases of repairing, servicing and construction. The same lesson texts used by resident students in our modern and complete Television broadcast studios, laboratories and classrooms!



MASTER ALL PHASES!

Get Master Shop-Method Home Training from an Established Practical Resident School with its own Training Shops, Laboratories, Studios — almost 50 Years of Successful Experience in Training Ambitious Men.

We Bring National Schools To You!

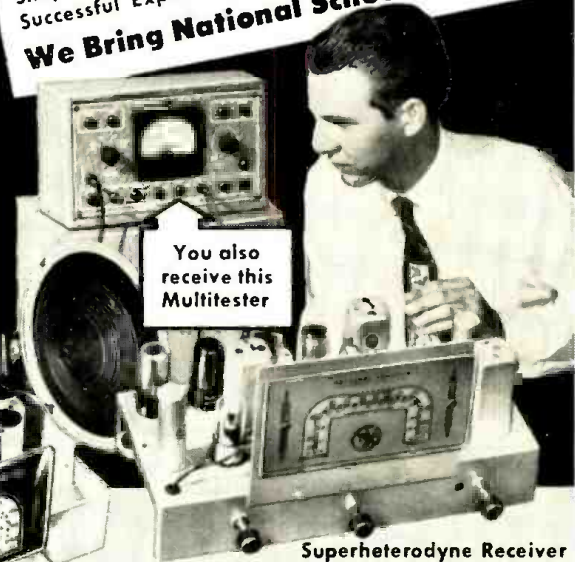

You also receive this Multitester

Superheterodyne Receiver

LEARN BY DOING

You receive and keep all the modern equipment shown above, including tubes and valuable, professional quality Multitester. No extra charges.

FREE! RADIO-TV BOOK AND SAMPLE LESSON!

Send today for National Schools' new, illustrated Book of Opportunity in Radio-Television-Electronics, and an actual Sample Lesson. No cost—no obligation. Use the coupon now—we'll answer by return airmail.

APPROVED FOR
VETERANS
AND
NON-VETERANS
Check coupon below

Both
Resident and
Home Study
Courses Offered!

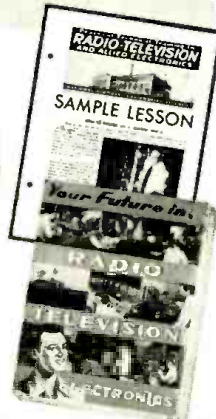

NATIONAL SCHOOLS

LOS ANGELES 37, CALIFORNIA • ESTABLISHED 1905
IN CANADA: 811 W. HASTINGS STREET, VANCOUVER, B.C.

GET FACTS FASTEST! MAIL TO OFFICE NEAREST YOU!

(mail in envelope or paste on postal card)

NATIONAL SCHOOLS, Dept. RH-34

4000 S. Figueroa Street or 323 West Polk Street
Los Angeles 37, Calif. or Chicago 7, Ill.

Send FREE Radio-TV Electronics book and FREE sample lesson. No obligation, no salesman will call.

NAME _____ BIRTHDAY _____ 19 _____

ADDRESS _____

CITY _____ ZONE _____ STATE _____

Check here if interested in Resident School Training at Los Angeles.
VETERANS: Give Date of Discharge _____

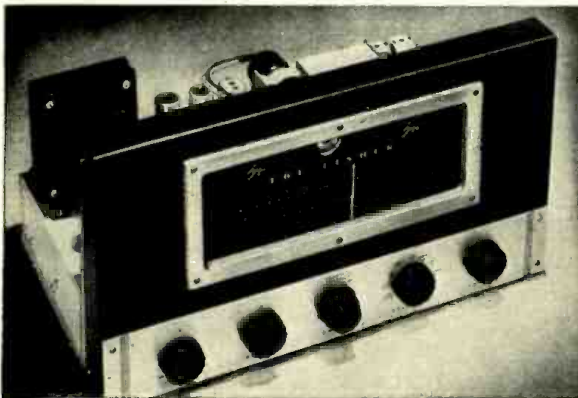

New!
*And
Terrific!*

FISHER

SERIES "70"

■ When the FISHER 50-R Tuner and 50-A Amplifier first appeared, two things promptly happened. We were besieged with orders; as well as with requests (from those with limited space) for a tuner with audio control facilities and preamplifier. Many also wanted a low-cost, high output, quality amplifier. It took us time, but here they are. *And they're tops!*

FISHER FM-AM Tuner MODEL 70-RT

■ Features *extreme sensitivity*: (1.5 mv for 20 db of quieting), works where others fail. Armstrong system, *adjustable AFC* plus switch, *adjustable AM selectivity*, separate FM and AM front ends. Complete shielding and shock-mounting on main and subchassis. Distortion less than 0.04% for 1 volt output. Hum level: better than 90 db below 2 volts output on radio, better than 62 db below output with 10 mv input on phono. Two inputs. Two cathode-follower outputs. Self powered. Six controls: BASS-AC, TREBLE, VOLUME, LOUDNESS, CHANNEL and EQUALIZATION, TUNING. \$184.50

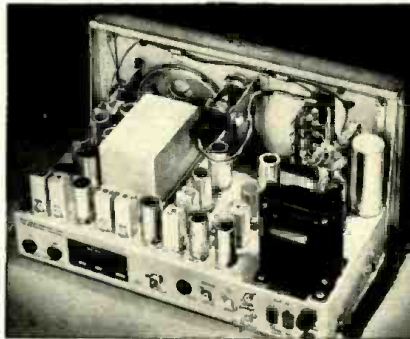

FISHER 25-Watt Amplifier 50-WATT PEAK

■ The FISHER Model 70-A Amplifier offers more *clean watts* per dollar at its price than any amplifier made—25 *clean watts* for only \$99.50! The 70-A costs no more than "basic" 10-watt units, but has 150% *greater power!*



■ High output (less than 1/2% distortion at 25 watts; 0.05% at 10 watts). IM distortion less than 0.5% at 20 watts; 0.2% at 10 watts. Uniform response ± 0.1 db, 20-20,000 cycles; 1 db, 10-50,000 cycles. Power output constant within 1 db at 25 watts, 15-35,000 cycles. Hum and noise virtually non-measurable (better than 95 db below full output!) Four separate feedback loops, unique cathode and screen feedback circuit. Outstanding transient response. 8 and 16 ohm outputs. SIZE: 6 3/4" x 10 1/4" x 6 1/8" high. \$99.50

PRICES SLIGHTLY HIGHER
WEST OF ROCKIES

Write for full details

FISHER RADIO CORP.

39 EAST 47th STREET • N. Y.

spring of '53, interference caused to the International Airport, in East Boston, was traced to a partly broken 4400-volt power cable inside a metal conduit on a high-line pole 2 1/2 miles from the airport.

Reviewing the uses of radio by police, the Commission pointed out that as of June 30, over 8000 police stations held licenses to operate. A normal police radio station, it was noted, consists of a base station, usually located at police headquarters, and a group of radio-equipped cars. These cars may include not only official police cars, but also ambulances and emergency vehicles used to clear highways of obstructions.

The ever-increasing demand for two-way communications, taxing the capacity of the spectrum, also received a thorough analysis in the yearly report. A development that was said to offer considerable promise in alleviating some of the congestion was channel-splitting. The net result of such splitting would be to provide more channels in the same amount of space. It is hoped that during '54 it might be possible to introduce this new technique. The great problem that faces the Commission in introducing the new approach, however, is how such a change-over can be made, especially in the more crowded parts of the spectrum, without too rapid obsolescence of equipment already in use. Supplementing its channel-splitting study, the Commission has initiated a frequency utilization investigation looking toward a reevaluation of the frequency requirements of communication services.*

Citizens radio service has also begun to show signs of real life, the annual review revealed. Due to the absence of equipment, the service had been stalemated. In the past year, however, this service has experienced a boom due in part to the availability of commercial gear, and also to the widespread acceptance and use of the recently added 27.255-megacycle frequency, which is available, among other things, for the control of objects such as model airplanes. To encourage further the development and manufacture of low-cost transmitters for this service, the Commission has proposed to relax technical standards applicable to low-powered equipment of the walkie-talkie type.

As of June 30, close to 4000 authorizations had been issued for the Citizens radio service band.

AS A MEANS of helping FM broadcasters improve their financial situations, and at the same time make further use of the FM broadcast band, the Commission has issued a proposal to
(Continued on page 165)

* Since the above report was prepared, the Commission has issued a new allocation plan for the 450-460 mc. band. Under the revised program, industrial services were assigned frequencies from 451.05 mc. at 100 kc. intervals to 451.95 and from 456.05 to 456.95 mc.; land transportation services received 452.05 to 452.95 mc. and 457.05 to 457.95 mc. ranges; public safety services were given 453.05 to 453.95 and 458.05 to 458.95 mc. bands; and domestic public services were placed in the 454.05 to 454.95 and 459.05 to 459.95 mc. area.

NEW

BARRIER DISC INSULATOR
BARRIER DISC INSULATOR
BARRIER DISC INSULATOR
BARRIER DISC INSULATOR

WALSCO

Imperial

INTRODUCING the greatest advance in Conical antennas ... it's the all-new WALSCO *Imperial*. Featuring a new "barrier disc" insulator with 2 inches of air space between the terminals to prevent shorts. Soot deposits, dirt, moisture, salt, etc., cannot affect this insulator. The WALSCO *Imperial* will therefore maintain *lasting* high gain performance anywhere, regardless of weather conditions. Contact surfaces and terminals will never rust or oxidize. Front end hardware is *stainless steel* to prevent corrosion losses permanently.

IN 4 YEARS

Front end elements are pre-assembled to holding plates which are fastened to the insulator with one wing nut. Less than 2 minutes to assemble.

MOST REVOLUTIONARY CONICAL ANTENNA

3 year unconditional guarantee!

WALSCO

Guaranteed lasting high gain on all VHF channels

ELECTRONICS CORPORATION

3602 Crenshaw Blvd., Los Angeles 16, Calif.



PUZZLE PICTURE: Find the guy who just got a WALTER ASHE "Surprise" Trade-In



NEW HALLCRAFTERS SX-71.
Less speaker. Net \$249.95



COLLINS 75A-3 with 3KC mechanical filter. Less speaker. Net \$530.00



NEW HALLCRAFTERS SX-88.
Dual conversion, high selectivity.
Less speaker. Net \$595.00



ELMAC AF-67 TRANSMITTER. VFO or crystal controlled. Phono or CW transmitter, ideal for home or for underdash mobile operation. Complete with tubes. Net \$177.00



ELMAC MOBILE RECEIVER. Dual conversion, 10 tubes, BFO, noise limiter, covers all amateur bands 10 through 160 meters plus BC band.

| | | |
|---------------|--------------|--------------|
| Model PMR-6A | For 6 volts | Net \$134.50 |
| Model PMR-12A | For 12 volts | Net \$134.50 |



JOHNSON VIKING II TRANSMITTER
KIT. Net \$279.50
JOHNSON VIKING II. WIRED
AND TESTED. Net \$337.00



MILLEN GRID DIP METER
Model 90651. Net \$61.50

All prices f. o. b. St. Louis • Phone CHestnut 1125

Walter Ashe
RADIO CO.
1125 PINE ST. • ST. LOUIS 1, MO.

FREE CATALOG!

WALTER ASHE RADIO COMPANY
1125 Pine Street, St. Louis 1, Missouri

R-3-54

Rush "Surprise" Trade-In Offer on my _____
for _____
(show make and model number of new equipment desired)

Send new FREE 1954 Catalog.

Name _____

Address _____

City _____ Zone _____ State _____

**Send
for
your
copy
today**

Here's your Opportunity

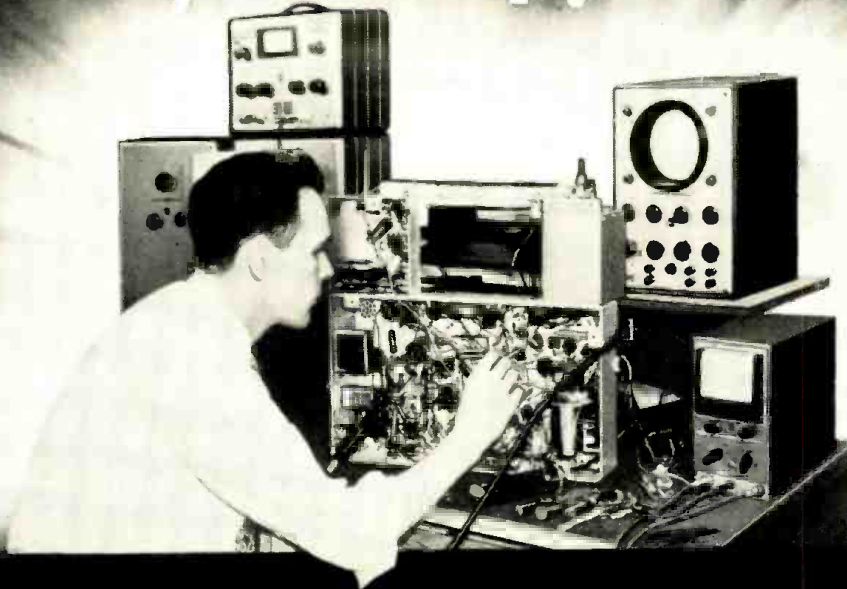

**to prepare for a good job or a business
of your own in TV SERVICING**

ARE YOU SATISFIED with the position you now hold? Do you feel you're worth more money? Are you pleased with yourself, your work, your associates . . . and your future? What does the next year hold for you . . . and the year after that?

Are you content merely to plod along through the best years of your life . . . or do you want to get into more pleasant work . . . hold a well-paid job . . . perhaps establish your own business?

If you are looking for a REAL opportunity . . . If you want to GROW with a GROWING INDUSTRY . . . If you want to grasp the success that should be yours, then we say to you, study TV Servicing.

Everyone knows that Television is the fastest growing industry today. Opportunities are going begging for men who have

the training and ability to grasp them. Now is the time to start on the road to success in TV Servicing.

Study at Home in your spare time

The RCA Institutes Home Study Course in TV Servicing is easy to learn. You progress rapidly, step by step, as you learn the procedure of servicing and trouble-shooting TV receivers and installing TV antennas. Hundreds of pictures and diagrams help you understand the how-it-works information and the how-to-do-it techniques.

A Service of Radio Corporation of America

The RCA Institutes TV Servicing course was written and planned by instructors with years of specialized experience in training men. You get up-to-the-minute information, too, because you study right at the source

of the latest developments in Television. Your lessons are carefully examined and accurately graded by competent teachers who are interested in helping YOU to succeed.

RCA Institutes is licensed by the University of the State of New York . . . an affiliate member of the American Society for Engineering Education . . . approved by leading Radio-TV Service Organizations . . . approved by Veterans Administration.

It costs so little to gain so much

RCA Institutes makes it easy for you to take advantage of the big opportunities in TV Servicing. The cost of the TV Servicing Home Study Course has been cut to a minimum. You pay for the course on a pay-as-you-learn unit lesson basis. *No other home study course in TV Servicing offers so much for so little cost to you.*

RCA Institutes conducts a resident school in New York City offering day and evening courses in Radio and TV Servicing, Radio Code and Radio Operating, Radio Broadcasting, Advanced Technology. Write for free catalog on resident courses.



RCA INSTITUTES, INC.
A SERVICE OF RADIO CORPORATION of AMERICA
350 WEST FOURTH STREET, NEW YORK 14, N.Y.

SEND FOR FREE BOOKLET—Mail the coupon—today. Get complete information on the RCA INSTITUTES Home Study Course in Television Servicing. Booklet gives you a general outline of the course by units. See how this practical home study course trains you quickly, easily. Mail coupon in envelope or paste on postal card.



MAIL COUPON NOW!

RCA INSTITUTES, INC., Home Study Dept. RN354
350 West Fourth Street, New York 14, N. Y.

Without obligation on my part, please send me copy of booklet "RCA INSTITUTES Home Study Course in TELEVISION SERVICING." (No salesman will call.)

Name _____ (please print)
Address _____
City _____ Zone _____ State _____

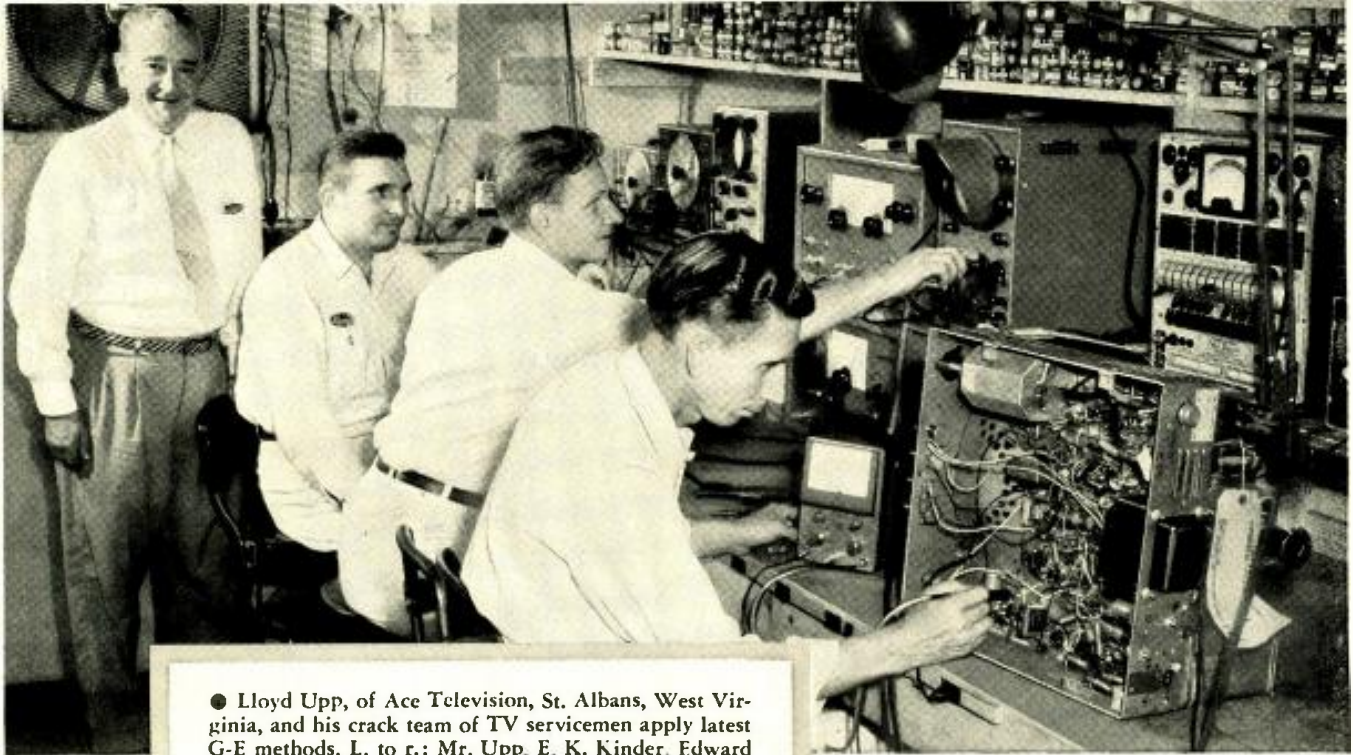

● Lloyd Upp, of Ace Television, St. Albans, West Virginia, and his crack team of TV servicemen apply latest G-E methods. L. to r.: Mr. Upp, E. K. Kinder, Edward V. Sharp and Charles W. Morris.

"G-E FIELD CLINICS ESSENTIAL" SAYS SUCCESSFUL SERVICE DEALER

**Boost Your Sales With Up-To-Date G-E Service Methods!
Attend the Next General Electric Field Clinic Near You!**

"THOSE G-E field engineers' service meetings sure promote efficient operation of our service department," says Lloyd Upp. Take advantage of G-E Field Clinics. Learn how you can improve your service operation and your profits.

General Electric Field Engineers are holding clinics throughout the country.

They are open to *all* TV Servicemen—*absolutely without charge!* G-E engineers demonstrate simple ways to diagnose and correct TV troubles—and answer your questions on all phases of TV service.

Contact the service manager at your G-E TV distributor now! Tell him to sign you up for the next clinic in your area.

General Electric Company, Radio and Television Department, Electronics Park, Syracuse, New York.

You can put your confidence in—

GENERAL  ELECTRIC



WANT MORE PAY? MORE SECURITY? A JOB WITH FUTURE UNLIMITED?

VETERANS! CIVILIANS! NO EXPERIENCE NECESSARY!

Go Into TELEVISION

I'll train you at home... in your spare time

for better-pay jobs in TV

L. C. Lane, B.S., M.A.
President: Radio-Television Training Association
Executive Director: Pierce School of Radio & Television

LEARN MORE

I give you ALL the practical training you need to qualify for the highest-paid technician jobs in TV.

RADIO-FM-TV TECHNICIAN TRAINING

No experience necessary! You learn by practicing with equipment I send you. It's easy! I give you the same successful guidance that has helped hundreds of men towards a TV career. Many started with only grammar school training.

FM-TV TECHNICIAN TRAINING

Saves you months if you have previous Armed Forces or civilian radio experience! Train at home. I give you kits, plus equipment to build BIG SCREEN TV RECEIVER, and FREE FCC COACHING COURSE! Everything AT NO EXTRA COST!

OPTIONAL: TWO WEEKS TRAINING IN NEW YORK CITY AT NO EXTRA COST!

You get two weeks, 50 hours, of intensive Laboratory work on modern electronic equipment at our associated school in New York City — Pierce School of Radio and Television. And I give you all this AT NO EXTRA COST whatsoever, after you finish your home study training in the Radio-FM-TV Technician course and FM-TV Technician Course.

FREE FCC COACHING COURSE!

Important for BETTER PAY JOBS requiring FCC License. You get this training AT HOME and AT NO EXTRA COST! Top TV jobs go to FCC licensed technicians.

NEW! PRACTICAL TV CAMERAMAN & STUDIO COURSE!

(For men with previous radio and TV training)

I train you at home for an exciting high pay job as the man behind the TV camera. Work with TV stars in TV studios or "on location" at remote pick-ups! A special one-week course of practical work on TV studio equipment at Pierce School of Radio & TV, our associate resident school in New York City, is offered upon your graduation.

VETERANS!

MY SCHOOLS FULLY APPROVED TO TRAIN VETERANS UNDER NEW G.I. BILL! If discharged after June 27, 1950—CHECK COUPON! Also approved for RESIDENT TRAINING in New York City at Pierce School of Radio and Television... qualifies you for full subsistence allowance up to \$160 per month. Write for details.

RADIO-TELEVISION TRAINING ASSOCIATION

52 EAST 19th STREET, NEW YORK 3, N. Y.

Licensed by the State of New York • Approved by the VA

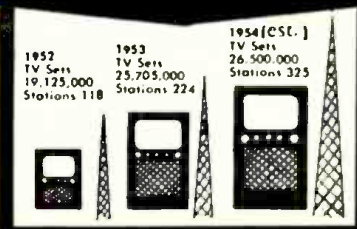

PROOF! TV NEEDS THOUSANDS OF TECHNICIANS!

TV is coming into practically every community. More than 2,000 new TV stations authorized in this country alone! Thousands of new studios being planned and built. All kinds of new equipment coming on the market. Millions of new TV-set owners will need servicing. It's the rich field of the future with money-making opportunities NOW... if you get in on the ground floor. There just won't be enough TV Technicians to go around. It's your chance of a lifetime for GOOD EARNINGS in a TOP JOB or YOUR OWN BUSINESS!

yours to build and keep!

EARN MORE

MORE MONEY AND A CAREER ARE WAITING FOR YOU HERE!

Earn while you learn by repairing TV sets for friends and neighbors. Many of my students make up to \$25 a week in spare time... pay for their entire training this way... start their own money-making service business. When they complete training and go into TV full time, their earnings zoom into big figures! My graduates are now working at RCA, NBC-TV, CBS-TV, DUMONT TV and numerous other TV studios and plants.

GET MORE



Enough equipment to start your own home Laboratory! You learn by doing. I give you ALL the equipment. You build and keep a professional GIANT SCREEN TV RECEIVER complete with mammoth picture tube (takes any size up to 21 inch)... also a Super-Het Radio Receiver, RF Signal Generator, Combination Voltmeter-Ammeter-Ohmmeter, C-W Telephone Transmitter, Public Address System, AC-DC Power Supply, and more! 15 full Kits! All tubes supplied, too!

Public Address System



C-W Telephone Transmitter



Combination Voltmeter-Ammeter-Ohmmeter



Super-Het Radio Receiver



RF Signal Generator

YOU GET ALL 4 FREE!

Just by mailing coupon. Try the Sample Lesson. Read how and where you can make big money in TV... easily!



MAIL THIS COUPON NOW! No Salesman Will Call!

Mr. Leonard C. Lane, President
RADIO-TELEVISION TRAINING ASSOCIATION
52 East 19th Street, New York 3, N. Y. Dept. T-3B

Dear Mr. Lane: Mail me your NEW FREE BOOK, FREE SAMPLE LESSON, and FREE aids that will show me how I can make BIG MONEY IN TELEVISION. I understand I am under no obligation and no salesman will call.

(PLEASE PRINT PLAINLY)

NAME _____ AGE _____
ADDRESS _____
CITY _____ ZONE _____ STATE _____

I AM INTERESTED IN:

- Radio-FM-TV Technician Course
- FM-TV Technician Course
- TV Cameraman & Studio Course

VETERANS!
Check here for Training under NEW G.I. Bill

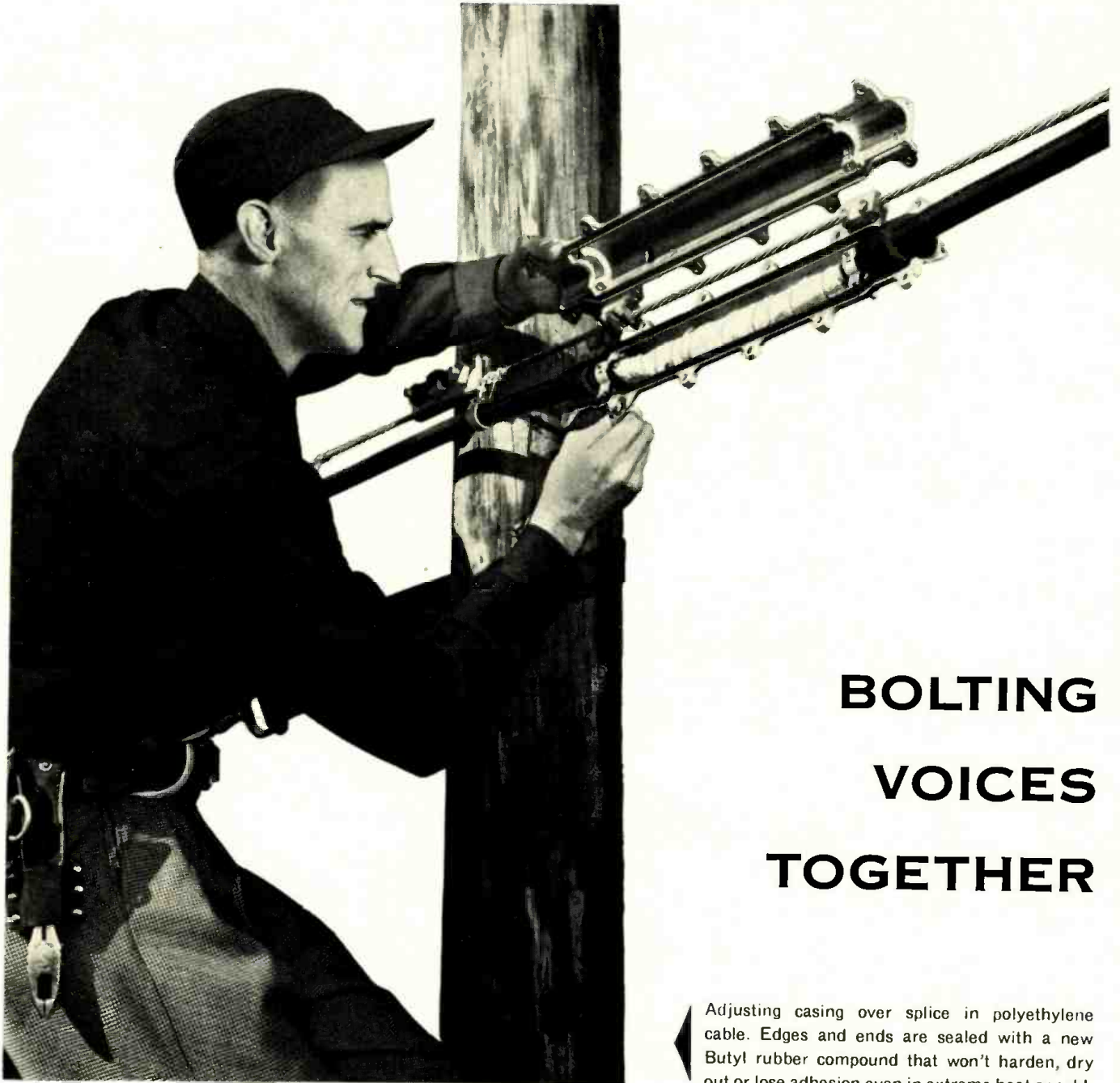

BOLTING VOICES TOGETHER

Adjusting casing over splice in polyethylene cable. Edges and ends are sealed with a new Butyl rubber compound that won't harden, dry out or lose adhesion even in extreme heat or cold.

More than ever, light, flexible polyethylene sheathed cable developed by Bell Telephone Laboratories is providing speedy answers to the demand for more telephone service.

But at thousands of splices, the sheath must be thoroughly sealed against moisture. Laboratories engineers developed a protective casing which is quickly and simply bolted in place. The edges and ends of the casing are *permanently* sealed with a new compound developed by Laboratories rubber chemists.

Now, economical polyethylene cable can be installed much faster and at lower cost. Here is another example of how Bell Laboratories continually finds ways to keep telephone service high in quality, while the cost stays low.

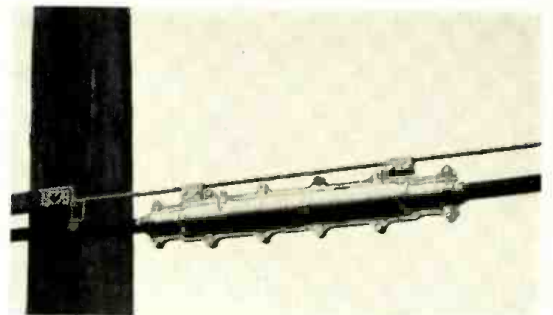

CLOSED CASING IN PLACE

BELL TELEPHONE LABORATORIES



EXPLORING AND INVENTING, DEVISING AND PERFECTING, FOR CONTINUED IMPROVEMENTS AND ECONOMIES IN TELEPHONE SERVICE

RADIO & TELEVISION NEWS

Let me send you FREE
the entire story

Just fill out the coupon and mail it. I will send you, free of charge, a copy of "How to Pass FCC License Exams," plus a sample FCC-type Exam, and the amazing new booklet, "Money-Making FCC License Information."



EDW. H. GUILFORD
Vice President

I can train you to pass your FCC License Exams in a minimum of time if you've had any practical radio experience—amateur, Army, Navy, radio servicing, or other. My time-proved plan can help put you, too, on the road to success.

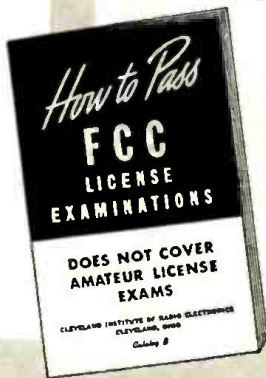

How to Pass FCC COMMERCIAL Radio Operator License Exams

FREE

Tells where to apply and take FCC examinations, location of examining office, scope of knowledge required, approved way to prepare for FCC examinations, positive method of checking your knowledge before taking the examination.

GET YOUR FCC TICKET IN A MINIMUM OF TIME

Get this Amazing Booklet FREE



TELLS HOW

HERE IS YOUR GUARANTEE

If you fail to pass your Commercial License exam after completing our course, we guarantee to continue your training without additional cost of any kind, until you successfully obtain your Commercial license, provided you first sit for this examination within 90 days after completing our course.

WE GUARANTEE

TO TRAIN AND COACH YOU AT HOME IN SPARE TIME UNTIL YOU GET

YOUR FCC LICENSE

If you have had any practical experience—Amateur, Army, Navy, radio repair, or experimenting

TELLS HOW

TV ENGINEERING INCLUDED IN OUR TRAINING & COACHING

Our Amazingly Effective JOB-FINDING SERVICE

Helps GIRE Students Get Better Jobs

Here are a few recent examples of Job-Finding results

GETS FIVE JOB-OFFERS FROM BROADCAST STATIONS

"Your 'Chief Engineer's Bulletin' is a grand way of obtaining employment for you graduates who have obtained their 1st class license. Since my name has been on the list I have received calls or letters from five stations in the southern states, and am now employed as Transmitting Engineer at WMMT."

Elmer Powell, Box 274, Sparta, Tenn.

GETS CIVIL SERVICE JOB

"I have obtained a position at Wright-Patterson Air Force Base, Dayton, Ohio, as Junior Electronic Equipment Repairman. The Employment Application you prepared for me had a lot to do with my landing this desirable position."

Charles E. Loomis, 4516 Genesee Ave., Dayton 6, Ohio.

GETS AIRLINES JOB

"Due to your Job-Finding Service, I have been getting many offers from all over the country, and have taken a job with Capital Airlines in Chicago, as Radio Mechanic."

Harry Clare, 4537 S. Drexel Blvd., Chicago, Ill.

OURS IS THE ONLY HOME STUDY COURSE WHICH SUPPLIES FCC-TYPE EXAMINATIONS WITH ALL LESSONS AND FINAL TESTS.

Your FCC Ticket is recognized in all radio fields as proof of your technical ability.

TELLS HOW

Employers make

JOB OFFERS Like These to Our Graduates Every Month

Letter from nationally-known Airlines. "We would also appreciate if you would place the following additional advertisement in your bulletin—Wanted—Superintendent of Communications . . . Salary \$666.66 per month."

Letter from nationally-known airplane manufacturer. "We need men with electronic training or experience in radar maintenance to perform operational check-out of radar and other electronics systems . . . starting salary . . . amounting to \$329.33 per month."

These are just a few examples of the job offers that come to our office periodically. Some licensed radiomen filled each of these jobs . . . it might have been you!

HERE'S PROOF FCC LICENSES Are OFTEN SECURED IN A FEW HOURS OF STUDY WITH OUR COACHING at HOME in SPARE TIME

| Name and Address | License | Lessons |
|--|-----------|---------|
| Lee, Dorothy 2210 1/2 Wilshire St., Bakersfield, Calif. | 2nd Phone | 16 |
| Clifford E. Voot Box 1016, Dania, Fla. | 1st Phone | 20 |
| Francis X. Foerch 36 Bayler Pl., Bergenfield, N. J. | 1st Phone | 38 |
| S/Sgt. Ben W. Davis 317 North Roosevelt, Lebanon, Ill. | 1st Phone | 28 |
| Alfred Schoell 110 West 11th St., Escondido, Calif. | 2nd Phone | 23 |



Get All 3 FREE

MAIL COUPON NOW

CLEVELAND INSTITUTE OF RADIO ELECTRONICS

Desk RN-62
4900 Euclid Bldg., Cleveland 3, Ohio
(Address to Desk No. to avoid delay)

I want to know how I can get my FCC ticket in a minimum of time. Send me your FREE booklet, "How to Pass FCC License Examinations" (does not cover exams for Amateur License), as well as a Sample FCC-type exam and the amazing new booklet, "Money-Making FCC License Information."

Tell me how I can get a TV Engineering Course without additional charge.

NAME

ADDRESS

CITY..... ZONE..... STATE.....

Paste on 2-cent post card or send air mail

CLEVELAND INSTITUTE OF RADIO ELECTRONICS

CARL E. SMITH, E. E., Consulting Engineer, President
Desk RN-62—4900 Euclid Bldg., Cleveland 3, Ohio

Bill Clemens says—
 Midget Radio Service (a 3-Man Shop)
 129 S. Elizabeth St., Lima, Ohio

*"TRIPLITT 660 saves us
 50 to 100 man hours
 per month."*

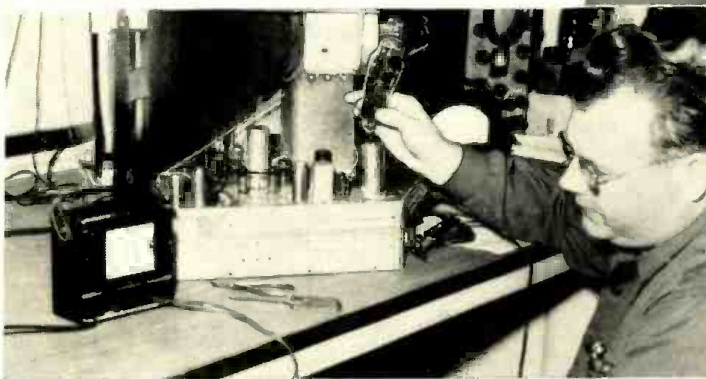

1. ISOLATING THE TROUBLE—Plug the power cord of the chassis into LOADCHEK and note the reading. With your eye on the large meter remove the rectifier tube and you can tell immediately which side of the tube the trouble is on. You have already eliminated 50% of your probing time.



2. LOCATING THE SHORT—With Loadchek you can quickly check the shorted side, part by part, without laying down tools or picking up test leads. Here, the trouble was a short in the transformer, spotted without having to warm up set. Overloads are found the same way.

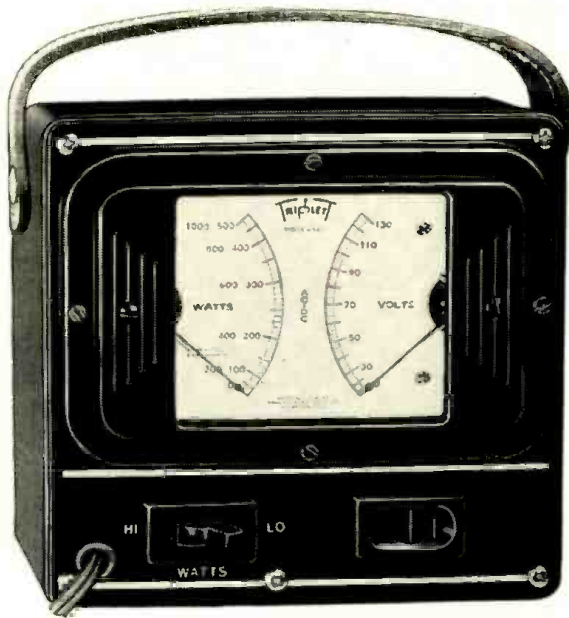

Locates trouble in a hurry

The above pictures illustrate but one of the many time-saving uses of Triplitt 660 Loadchek. This versatile instrument accurately measures power consumption, enables you to see instantly any deviation from normal load, without disconnecting a single part... finds trouble in a hurry.

For Radio and TV servicing—for almost any kind of electrical trouble-shooting—LOADCHEK saves hours of painstaking work every day. At its moderate cost no service technician can afford to be without it. Try one today—and see! Write for free booklet.

TRIPLITT ELECTRICAL INSTRUMENT CO., BLUFFTON, OHIO, U.S.A.



Triplitt

Suggested U. S. A. DEALER NET \$29⁵⁰
 Price subject to change without notice.



**TRAIN FASTER—TRAIN BETTER—TRAIN EASIER
IN 10 MONTHS—OR LESS—FOR
RADIO-TELEVISION**

Our 21st Year Training Men for Greater Incomes and Security in Radio-Television

**I SEND YOU
18 BIG KITS**

of Radio Television parts and equipment. Much of your training will be actual construction and experimentation . . . the kind of truly PRACTICAL instruction that prepares you for your Radio-Television career.



Frank L. Sprayberry
President
Sprayberry Academy
of Radio

NEW! NO OBLIGATION PLAN

**You Have No Monthly Payment Contract to Sign
Pay For Your Training as You Earn and Learn**

You can get into Radio-Television, today's fastest growing big money opportunity field, in *months* instead of years! My completely new "package unit" training plan prepares you in as little as 10 months or even less! *No monthly payment contract to sign—thus NO PISK to you!* This is America's finest, most complete, practical training—gets you ready to handle any practical job in the booming Radio-Television industry. Start your own profitable Radio-Television shop . . . or accept a good paying job. I have trained hundreds of successful Radio-Television technicians during the past 21 years—and stand ready to train you, even if you have no previous experience! Mail coupon and get all the facts—FREE!



**Valuable Equipment Included
With Training**

The new Sprayberry "package" plan includes many big kits of genuine, professional Radio-Television equipment. You perform over 300 demonstrations, experiments and construction projects. You build a powerful 6-tube 2-band radio set, multi-range test meter, signal generator, signal tracer, many other projects. All equipment and lessons are yours to keep . . . you have practically everything you need to set up your own profitable Radio-Television service shop.

Earn Extra Money While You Learn!

All your 10 months of training is IN YOUR HOME in spare hours. Keep on with your present job and income while learning. With each training "package" unit, you receive extra plans and "Business Builder" ideas for spare time Radio-Television jobs. New television stations everywhere, open vast new opportunities for trained Radio-Television Technicians—and those in training. If you expect to be in the armed forces later, there is no better preparation than practical Sprayberry Radio-Television training.

YOU BUILD the Television set and the powerful superhet radio receiver shown above. IN ADDITION to the other test units shown here (many are not shown because of lack of space). All equipment I send you is **YOURS TO KEEP.**

Approved for Veterans under the G.I. Bill

SPRAYBERRY ACADEMY OF RADIO 111 NORTH CANAL ST. Dept. 25-G, Chicago 6, Ill.

**MAIL COUPON
TODAY!
NO OBLIGATION**

I invite you to get all the facts—
**FREE TO YOU 3 BIG
RADIO-TELEVISION BOOKS**

I want you to have ALL the facts about my new 10-MONTH Radio-Television Training—without cost! Rush coupon for my three big Radio-Television books: "How to Make Money in Radio-Television," PLUS my new illustrated Television Bulletin PLUS an actual sample Sprayberry Lesson—ALL FREE. No obligation and no salesman will call. Mail coupon NOW!



SPRAYBERRY ACADEMY OF RADIO, Dept. 25-G
111 North Canal St., Chicago 6, Ill.

Please rush to me all information on your 10-MONTH Radio-Television Training Plan. I understand this does not obligate me and that no salesman will call upon me. Be sure to include 3 books FREE.

Name..... Age.....

Address.....

City..... Zone..... State.....

The C-800 is here
to bring you new
record performance!



the new
craftsmen 800

FM-AM TUNER

with built-in phono
preamplifier and
record equalizer

Now—Craftsmen brings you a tuner that matches all your finest records . . . is setting new records for versatility, too. The C-800 is further evidence that Craftsman leadership in high fidelity is something you can put your finger on, something you can hear.

- Front-panel-selected equalization for AES, LP or EUROPEAN recording characteristics. Inverse feedback compensated dual-triode phono preamp for correct turnover and roll-off characteristics.
- Improved AM reception. Wider bandwidth for better fidelity, and sharper IF bandpass "skirts" for greater selectivity.
- Double-shadow tuning eye and AFC (no drift) on FM simplifies tuning. Front-panel AFC cut-out for tuning weak stations.
- Efficient new layout. Bottom plate, completely shielded chassis minimize oscillator radiation, assure tuner isolation.
- Cathode follower audio output for remote installations; 2 volts at less than 1/2% dist. Detector output also has cathode follower for recording applications.
- Bass and treble controls continuously variable from attenuation to boost—flat position clearly marked. Selector positions: FM, FM with AFC, AM, TV, LP, AES, EUR, and SPore.
- Mahogany-finish wood cabinet available.

HIGH FIDELITY—LOW COST! C.400 audio amplifier offers 10 watts ± 1 db., 15—20,000 cps., less than 1% distortion. New streamlined chassis design.

Write
today for
information

THE RADIO

craftsmen INC.

Dept. R-3, 4401 N. Ravenswood Ave.
Chicago 40, Ill.



Within the INDUSTRY

LOUIS DE LA FLEUR of the Federal Communications Commission staff has joined RETMA as manager of the newly-established international department of the Association.

He has been with the FCC since 1940 when he began as an assistant monitoring officer in Baltimore, later becoming chief of the investigating section of the Commission's Radio Intelligence Division in 1946. He subsequently served as chief of the frequency utilization and requirements branch and since 1947 has been assistant chief of that division.

He has served as a member of various U. S. delegations at international conferences. In his new post he will assist RETMA members engaged in export trade.

* * *

D. W. GUNN has been appointed general sales manager of electronic products for *Sylvania Electric Products Inc.*, succeeding **Harold P. Gilpin** who has retired.



In his new post Mr. Gunn will be responsible for the sales of products of the radio and television tube divisions and the electronics division.

He joined the company in 1931 as a factory engineer at the Salem plant, became a sales engineer for the firm in Chicago in 1936, and since that date has worked successively as a quality engineer, supervisor of quality control, eastern district sales engineer, east central district engineer, and assistant to the general sales manager. Until his new appointment he has been assistant general sales manager of the electronic products sales division.

THE VICTOR DIVISION of RADIO CORPORATION OF AMERICA has started construction on a group of ultra-modern buildings which will serve as administration and laboratory headquarters for its home instrument and service company activities. The project will be located on a 58-acre tract in the Cherry Hill section of Camden, N. J. . . . **HELIPOT CORPORATION**, California manufacturer of precision potentiometers, has opened a new eastern plant in Mountainside, N. J. The 20,000 square foot plant will house manufacturing, showroom, and regional office activities . . . **JAMES B. LANSING SOUND, INC.** has moved into a new building adjoining its main building which will be retained for production facilities. The mail address will continue to be 2439 Fletcher Drive, Los Angeles 39, Calif. . . . **SHALL-**

* * *

CROSS MANUFACTURING CO. of Collingdale, Pa. has recently completed a building program which provides for completely modernized and larger offices as well as increased production and engineering facilities . . . **G. C. WILSON & CO.**, designer and manufacturer of electronic timers, has moved its offices and plant from Chatham, N. J. to 1950 Eighth Ave. in Huntington, W. Va. . . . **CHANNEL MASTER CORPORATION** of Ellenville, N. Y. recently opened a \$1,500,000 TV antenna plant with a production potential of over four times its present factory. The new plant has 115,000 square feet of floor space and has six separate assembly lines to supplement the two assembly lines in the old plant, which will remain in operation . . . **DAVIS ELECTRONICS** of Burbank, California, has established two new regional plants to provide faster antenna deliveries. The plant at 8933 Brookville Rd., Silver Spring, Maryland will supply the eastern seaboard while a plant at 5725 N. Central Ave. in Chicago will supply the midwest market . . . **MAJESTIC RADIO & TELEVISION DIVISION** has acquired an additional manufacturing plant at 41 Water Street near its main Brooklyn plant. The new structure adds 50,000 square feet of production and warehousing space . . . **ROHN MANUFACTURING COMPANY** has added a 5000 square foot addition to its plant in Peoria, Ill. This is the third addition to the original plant and gives the firm approximately 24,000 square feet of floor space for the manufacture of TV and communication towers.

* * *

LEO HAHN has been promoted to the post of national radio sales manager of *Emerson Radio and Phonograph Corporation*.



He has been in charge of sales in the Central Atlantic states and will now head the radio department in the company's sales division. He will coordinate all radio sales and merchandising by working in close association with the company's regional sales managers, district salesmen, and distributors' sales personnel.

* * *

RCA SERVICE COMPANY has developed a comprehensive color training and educational program which will be made available to the entire TV service industry.

The program will provide complete information on the theory and practice of installation and service for color television receiving equipment to the serv-

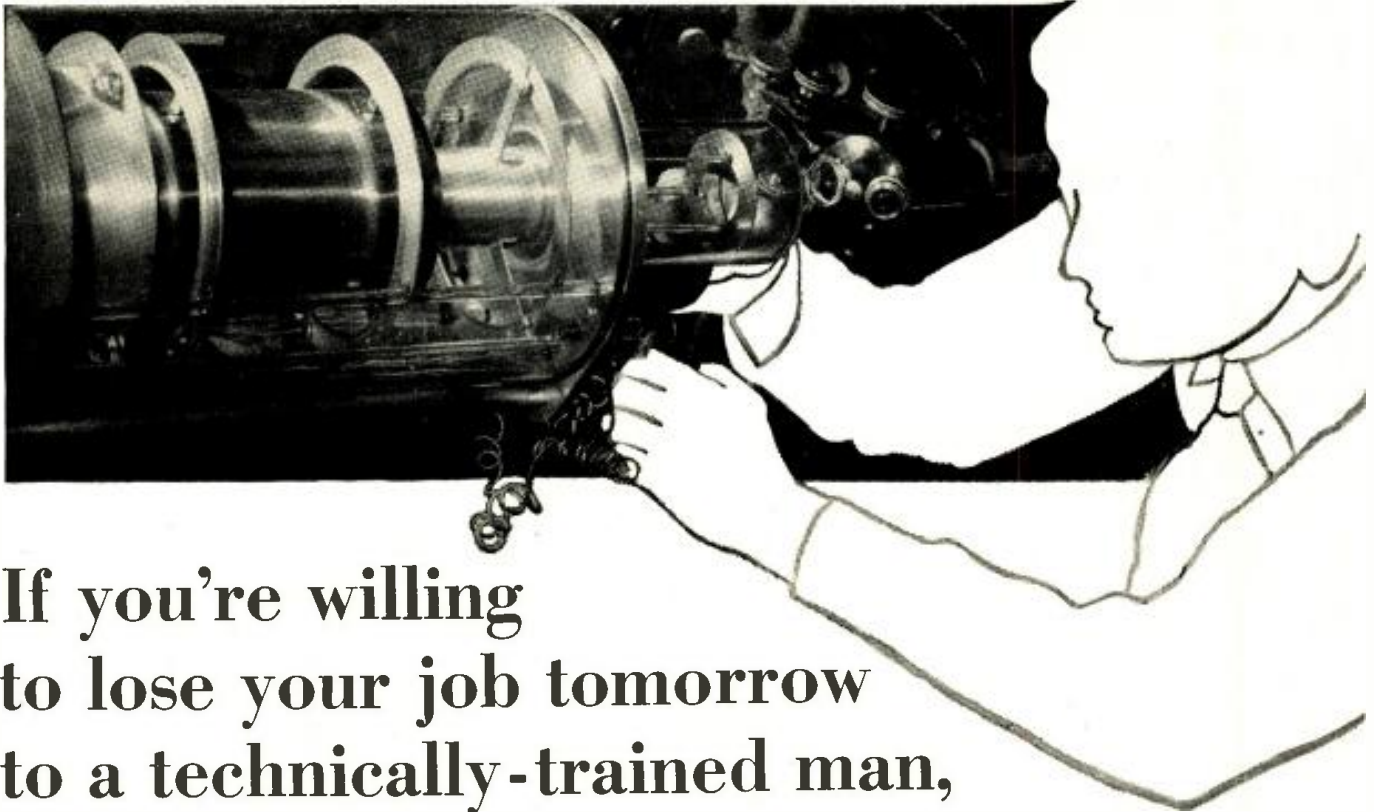

**If you're willing
to lose your job tomorrow
to a technically-trained man,
turn the page, Mister**

But, if you're interested in an honest-to-goodness career in the vigorous young electronics industry, here's how you can step ahead of competition, move up to a better job, earn more money, and be sure of holding your technical job even if the brass is firing instead of hiring.

The "how" is CREI training in radio-television-electronics.

You don't have to be a college graduate. You *do* have to be willing to study—at home. You can do it while holding down a full-time job. Thousands have. Since 1927 CREI has provided alert young men with the technical knowledge that leads to more responsibility, more job security, more money. More than a quarter century of experience qualifies CREI to train you.

What qualifies *you* for CREI? If you have a high school education, you're off to a good start. If you have a knack for math, so much the better. If you are currently working in some phase of the electronics industry, you'll get going faster. But remember this: CREI starts with fundamentals and takes you along at your own speed. You are not held back by a class, not pushed to keep up with others who have more experience or education. You set your own pace. Your CREI instructors guide you through the lesson material and *grade* your written work personally. You master the fundamentals, then get into more advanced phases of electronics engineering principles and practice. Finally you may elect training at career level in highly spe-

cialized applications of radio or television engineering or aeronautical radio.

How good is CREI training? Here are a few ways to judge. Ask an electronics engineer if you know one. Ask a high-school or college physics teacher. Ask a radio station engineer. Check up on our professional reputation: CREI home study courses are accredited by the Engineers' Council for Professional Development; CREI is an approved member of the National Council of Technical Schools. Ask personnel managers how they regard a man with a CREI "ticket." Look at this partial listing of organizations *that pay CREI* to train their own personnel: All American Cables & Radio, Inc., Canadian Aviation Electronics, Ltd., Canadian Broadcasting Corporation, Columbia Broadcasting System, Hoffman Radio Corp., Machlett Labs., Glenn L. Martin Co., Magnavox Co., Pan American Airways, Atlantic Division, RCA Victor Division, United Air Lines. Finally, ask a CREI graduate to tell you about our Placement Bureau, which currently has on file more requests for trained men than we can fill.

What's the next step? The logical one is to get more information than we can cram into one page. The coupon below, properly filled out, will bring you a fact-packed hooklet called "Your Future in the New World of Electronics." It includes outlines of courses offered, a resume of career opportunities, full details about the school, and tuition details. It's free.

Note: CREI also offers Resident School instruction, day or evening, in Washington, D.C. New classes start once a month. If you are a veteran discharged after June 27, 1950, let the new GI Bill help you obtain resident instruction. Check the coupon for more data.

CAPITOL RADIO ENGINEERING INSTITUTE

An Accredited Technical Institute • Founded in 1927

3224 16th Street, N. W. Dept. 113A Washington 10, D. C.

Send **no** money for "Your Future in the New World of Electronics" and course outline.

CHECK FIELD OF GREATEST INTEREST

- Practical Radio Engineering
- Broadcast Radio Engineering (AM, FM, TV)
- Practical Television Engineering
- Aeronautical Radio Engineering
- TV, FM & Advanced AM Servicing

Name.....

Street.....

City..... Zone..... State.....

Check— Residence School Veteran

Exciting New Performance . . . Superb Cabinet Craftsmanship

THE PERMOFLUX

Fortissimo

2-Way Speaker System with "DUAL DRIVING POINT" Horn Design

Now Brings You

FULL RANGE HIGH FIDELITY
At Either Low or High Volume Level

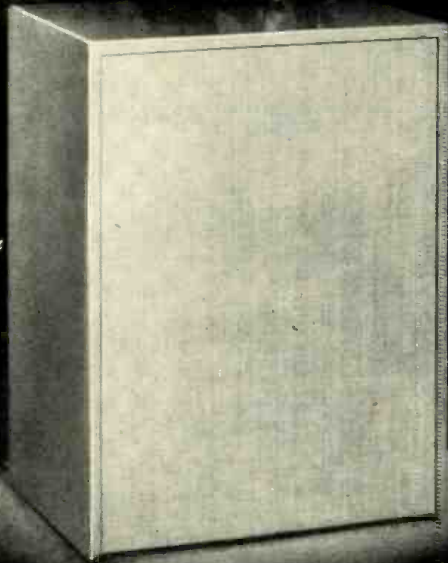

Perfection
in Cabinetry
by
*Contemporary
American
Furniture*
in
Mahogany or
Korina Blonde.

Unique "New Dual Driving Point" Enclosure Design, employing Dual Eight inch woofer system, surpasses bass and mid-range performance of finest conventional 12 and 15 inch systems. Satin smooth highs are added by specially designed Super Tweeter.
Beautiful modern cabinet styling . . . precision constructed of carefully selected veneers . . . hand rubbed to a lustrous enduring finish . . .

New . . . Diminutive 2-Way Speaker System

THE PERMOFLUX

Diminutive

Exclusive New Design . . . combines full high fidelity performance with minimum cabinet size and low cost. Angled speaker mounting assures correct distribution of sound regardless of placement. Perfect for Binaural when used in pairs.



Two Royal 6 inch Speakers and Super Tweeter housed in choice of Mahogany or Blonde enclosure.

See your Hi-Fi dealer for demonstration; also hear the New Super Royal Speaker (8, 12 and 15 inch sizes).

For complete descriptive literature write to . . .

Permoflux CORPORATION

4918 West Grand Avenue • Chicago 39, Illinois

West Coast Plant

4101 San Fernando Road • Glendale 4, California

ice industry even before the first commercial color sets reach the public. The program is divided into four major elements.

One is a series of two-day technical clinics to be held in 65 key cities. The clinics will be conducted by technical specialists of the company, using textbooks, test equipment, and other instructional materials developed especially for these clinics. Service dealers and technicians in each city will be invited to attend.

The second phase is a comprehensive textbook "Practical Color Television for the Service Industry." The third area of assistance will be a home-study course, while the fourth aid is a series of test equipment designed for use with color sets.

* * *

DAVID J. HOPKINS has been named director of sales for *CBS-Columbia*, the manufacturing division of *CBS*.



Mr. Hopkins resigned his position as director of sales and advertising for *Emerson Radio and Phonograph Corporation* to take his new post. During

World War II, he served for three and a half years with the Naval Air Arm in the Pacific Theater, attaining the rank of Lieutenant Commander.

* * *

CLIFFORD SHEARER has been named advertising manager of *Radio Merchandise Sales, Inc.* His duties will include handling all advertising and sales promotion material . . . *CBS-Hyltron* has promoted **CHARLES F. STROMEYER** to the position of executive vice-president. He was formerly chief engineer and assistant to the president and later vice-president in charge of manufacturing and engineering . . . **COLE H. PILCHER** has been named director of industrial relations of *Sylvania Electric Products Inc.* He succeeds **HOWARD L. RICHARDSON** who was recently named vice-president in charge of engineering operation . . . **A. MELVIN SKELLETT**, vice-president in charge of manufacturing and engineering for *National Union Radio Corporation*, has been elected to the board of directors of the firm . . . *Emerson Radio and Phonograph Corporation* has appointed **M. F. BLAKESLEE** to the post of director of distributor relations, a newly-created post with the company . . . **DONALD H. ROGERS** has been appointed chief engineer of *Blonder-Tongue Laboratories* of Westfield, N. J. He was formerly associated with *Western Electric* and *Utility Electronics* . . . **JOHN A. CURTIS** has been appointed general sales manager of the *Westinghouse Electronic Tube Division* . . . **ALBERT J. FRANKEL** has been promoted to the post of purchasing agent for *CBS-Columbia*. He was formerly chief buyer . . . **RALPH R. STUBBE** is the new chief engineer of *General Instrument Corporation*. He will make his headquarters at the company's Elizabeth, N. J. plant . . . **JE-**

RADIO & TELEVISION NEWS

Another Outstanding Service Success Story...

with SYLVANIA!

From Basement Repair Shop
to prosperous Service Business...
featuring Sylvania Tubes, Parts
and Promotion Programs!

The steady and substantial growth of the Ball Television and Radio Service, from basement shop to the large handsome brick building, shown below, is a tribute to the fair practices and alert policies of the owner, Mr. Ted Ball.



Early photo of Ball Radio Service Shop.

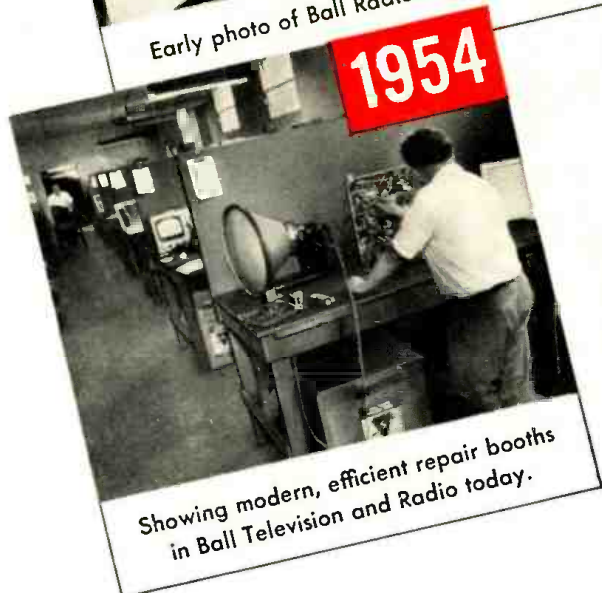

Showing modern, efficient repair booths
in Ball Television and Radio today.

Says Mr. Ball: "My men are as skilled and experienced as any you'll find anywhere, and each is instructed to do the best job possible with the best of parts... and that, of course, includes Sylvania Tubes."

Ted Ball is another important Radio-TV Service Manager that appreciates the quality performance, dependability, and the nation-wide high reputation of Sylvania products.

Mr. Ball also knows about the business-boosting power of Sylvania's promotion and display offers. Find out how Sylvania can step up *your* business. Your friendly Sylvania Distributor is ready and anxious to give you full cooperation. Call him today.

SYLVANIA

Sylvania Electric Products Inc., 1740 Broadway, New York 19, N. Y.



In Canada: Sylvania Electric (Canada) Ltd., University
Tower Bldg. St. Catherine St., Montreal, P. Q.

LIGHTING • RADIO • ELECTRONICS • TELEVISION

You can build a reputation on Tung-Sol® Quality



TUNG-SOL makes
All-Glass Sealed Beam Lamps,
Miniature Lamps,
Signal Flashers,
Picture Tubes, Radio, TV,
Special Purpose Electron Tubes,
Semiconductor Products.



TUNG-SOL ELECTRIC INC.
Newark 4, New Jersey

Sales Offices: Atlanta, Chicago, Columbus, Culver City (Los Angeles), Dallas, Denver, Detroit, Newark, Seattle

ROME V. DEEVY has been appointed director of industrial relations for *National Union Radio Corp.* . . . **BRUCE K. ARNOLD** has been appointed engineer for the eastern division of *Cannon Electric Company* after twenty-years' experience in production and engineering at the company's Los Angeles factory . . . **BOB MIDDLETON**, formerly with *RCA* and *Precision Apparatus*, has joined the sales-engineering division of *Simpson Electric Company* of Chicago. He will conduct a series of lectures for technicians throughout the country . . . **JOHN P. TANSEY** has been appointed national service manager of *Motorola's* communications and electronic division . . . **SAM GROSSMAN**, associated with *Wholesale Radio Parts, Inc.*, Baltimore distributing firm, died suddenly at his home at the age of 50. He had been in the electronics field for 30 years and was an active ham with the call W3FT . . . **DAVID C. McNEELY** has been named sales manager of *Helipot Corporation*. He will make his headquarters at the company's South Pasadena, California plant . . . **P. R. DAWSON** has retired from *Tung-Sol Electric, Inc.* after 34 years with the firm. He plans to make his home in Florida. At the time of his retirement, he was staff assistant to the general sales manager of the company . . . **JOHN R. HUTSELL** has been appointed general sales manager of *The Sealtron Corporation* of Cincinnati . . . **STANLEY ADAMS** has been named general manager of the Chicago plants of *Standard Coil Products Co. Inc.* He was formerly manager of the company's plant at Bangor, Michigan . . . **C. H. FRITZ** is the new assistant sales manager of *Shallcross Manufacturing Company* of Collingdale, Pa. For the past seven years he was with the company's engineering and sales departments . . . **GEORGE R. LOUX** is the new vice-president in charge of manufacturing for the *National Company, Inc.* He was formerly with *Federal Telephone and Radio Company, General Instrument Company, Sylvania*, and *RCA* . . . **HAROLD P. GILPIN**, general manager of the electronic sales division of *Sylvania Electric Products Inc.* has retired after 21 years of service with the company . . . **CHARLES G. SHERWOOD**, director of purchases for *Federal Telephone and Radio Company* has been named a vice-president of the company . . . **MAURICE SCHOENBRUN** has been promoted to the post of director of cabinet engineering for *CBS-Columbia* . . . **ERNEST B. LOVEMAN**, for many years vice-president and general manager of *Philco* Television Broadcasting Division, died recently in the reception room of the firm's headquarters plant in Philadelphia. He was 58 . . . **OTTO C. BIXLER**, director of engineering and research for *Magnecord, Inc.*, has been elected vice-president of the firm. He joined the company in 1951 as chief engineer . . . *Schwab Brothers Corporation* of New York City has announced the appointment of **JOSEPH K. NOLL** as vice-president in charge of the firm's mica division . . . *Phen-O-Tron, Inc.* has

named **RICHARD D. SCHOTTER** vice-president and **JACK BAYHA** chief engineer of the company's new printed circuit plant in New Rochelle, N. Y. . . . **VERNE ROBERTS** has been named distributor sales manager of *I.D.E.A.* of Indianapolis.

* * *

JOHN C. MARSHALL has been elected a vice-president of *Arvin Industries, Inc.* and appointed director of sales for the firm's radio-television sales division.



Joining the company in 1928 soon after his graduation from DePauw University, Mr. Marshall has spent his entire business life in sales work. For the past several years he has been director of sales of the company's special products division. He has also served as a member of the firm's board of directors since 1947.

* * *

WORKSHOP ASSOCIATES DIVISION of Norwood, Mass. has changed its name to the **GABRIEL ELECTRONICS DIVISION** of **THE GABRIEL COMPANY**. The change was required to reflect the broadened scope of the division's operation . . . John R. Wells, formerly a partner of **WELLS & WINEGARD**, television accessory manufacturer, has established a new television antenna manufacturing firm in Burlington, Iowa, **WELCO MANUFACTURING COMPANY** . . . **COLLINS RADIO COMPANY** of Cedar Rapids, Iowa has organized a wholly-owned Canadian subsidiary, **COLLINS RADIO COMPANY OF CANADA, LTD.** with offices at 74 Sparks St. in Ottawa, Ontario . . . **SIGHTMASTER CORP.** has acquired the complete fuse operation of **GENERAL FUSE CO.** of South River, N. J. . . . **RADIO MERCHANDISE SALES, INC.** has acquired the controlling interest in **AMES MFG. CORP.**, manufacturers of a complete line of wire products, and in **JEB SALES CORPORATION**, producers of a television rotator . . . **CHESAPEAKE INDUSTRIES, INC.** of New York has purchased the **ALLEN D. CARDWELL MFG. CORP.**, electronics firm with plants in Plainville, N. Y. and Stamford, Conn.

* * *

E. P. GERTSCH has been elected chairman of the West Coast Electronic Manufacturers' Association's Los Angeles Council for 1954.

Serving with Mr. Gertsch are R. G. Leitner of *Packard-Bell* as vice-chairman and Gramer Yarbrough of *American Microphone Company* as secretary-treasurer.

New directors include Ed Grigsby, *Altec-Lansing Corp.*; Don Duncan, *Helipot Corp.*; W. V. Phillips, *Hoffman Radio Corp.*; and Thomas J. Walker, *Triud Transformer Mfg. Co.*

* * *

GENERAL ELECTRIC COMPANY'S Tube Department has received its fifth award for its public relations program on behalf of the service industry.

RADIO & TELEVISION NEWS

Here's the Most Compatible Line of Matched Hi-Fi Components

in the industry today!



*Custom Music
Ensemble*



Dual Coaxial Speaker A1-400



Preamplifier-Control Unit A1-200



Power Amplifier A1-300



Baton Tone Arms:
A1-500 (12")
A1-501 (16")



Speaker Enclosure (Blond,
Mahogany or Unfinished
Veneers) A1-406

From stylus to speaker General Electric designs...engineers...and manufactures more of its own components than any other company. The result: matched equipment worthy of the name! Forget about stocking many different brands and offer customers *one integrated sound system* that minimizes distortion.

Remember, you are already a sales step ahead with the famous General Electric cartridge. No other high quality line is as complete...as preferred...as outstanding in performance and price as G-E! And, people everywhere who listen once to the complete Custom Music Ensemble then look at its low price tag, sell themselves. To go places in the Hi-Fi business...go all the way with G.E.! For complete information, mail the coupon below, today.

G-E VARIABLE RELUCTANCE CARTRIDGES



New Stylus



Worn Stylus

Why you should use a G-E Diamond Stylus Cartridge.

All records cause stylus wear. The result: reduced record life and performance. Tests conducted on diamond styli have run hundreds of hours with no audible distortion and only highlights on the styli to indicate visible wear.

General Electric Company, Section R934
Electronics Park, Syracuse, New York.

Send me information on all units in the G-E high-fidelity equipment line.

NAME

ADDRESS

CITY.....STATE.....

GENERAL  **ELECTRIC**

8

TUBES

8

BIG FEATURES



NC-88

THE *World Master*

NO OTHER RECEIVER GIVES YOU SO MUCH AT THE PRICE!

No other broadcast and shortwave receiver gives you 8 tubes plus rectifier at this moderate price! And no other receiver offers you all 8 of these big performance features:

- (1) Calibrated bandspread for 80, 40, 20, 15, 11 and 10 meter bands (on large, indirectly-lighted lucite scales), with minimum parallax
- (2) delayed AVC, (3) exceptional sensitivity,
- (4) new miniature tubes used exclusively,
- (5) antenna trimmer, (6) outstanding selectivity,
- (7) 8 tubes plus rectifier, (8) most compact.

Covers 540 kcs. to 40 mcs. in 9 bands (5 bandspread, 4 general coverage).

Has tuned RF stage, 2 IF stages, 2 audio stages with phono input and tone control.

Built-in speaker with provision for external speaker if desired.

\$119.95

FREE! Catalog of National receivers and components. Write Dept. RN-354.



TUNED TO TOMORROW

National



EST. 1914
NATIONAL COMPANY, Inc.
MALDEN, MASSACHUSETTS

The National Alliance of Television and Electronic Service Associations presented its award to the firm for the second straight year, citing the Tube Department "for outstanding service to television service management in creating better customer relations."

Previous awards include those from NATESA, Associated Radio and Television Service Dealers, Inc. of Columbus, Ohio, The Federation of Radio Servicemen's Associations of Philadelphia, and RTG of Boston.

* * *

JOHN N. PHILLIPS has been named manager of color television products



engineering for *General Electric Company's* radio and television department while Carroll R. Miner has been appointed to a similar post for monochrome products.

The two new appointments are part of the firm's reorganization plan to gear the television product engineering department for the mass production of color television receivers.

Mr. Phillips graduated from Union College in 1940 and joined the company immediately following his graduation.

Mr. Miner has been with *G-E* for 25 years and was a member of the original engineering group at Schenectady in 1934. Until recently he was manager of TV product engineering.

* * *

DeVRY TECHNICAL INSTITUTE is the new name for the television, radio, electronics school formerly known as *DeForest's Training, Inc.*

The renamed school will occupy new quarters at 4141 W. Belmont Ave. in Chicago.

* * *

WORLD RADIO LABORATORIES, Council Bluffs, Iowa distributor, suffered a disastrous fire on January 3rd which completely destroyed its store.

According to Leo Meyerson, head of the firm, plans have now been completed for moving into a new ultra-modern fireproof plant at 3415-27 W. Broadway, Council Bluffs. The new building contains 30,000 square feet of floor space plus an additional 30,000 square feet of customer parking area.

Mr. Meyerson also announced that no attempt would be made to salvage equipment from the burned out building and that all equipment would be new, as will be all components used in reconditioning ham gear in the Used Amateur Equipment Division.

Copies of the company's 1954 catalogue are available from the company at its new address.

* * *

DALMO VICTOR COMPANY, San Carlos, California electronics firm, has been sold to *Textron Incorporated*, a textile firm.

Dalmo Victor has become a subsidiary of the parent company but will continue under present management.

-30-

\$50,000 IN PRIZES

... easy to win

503 PRIZES!

\$2000 - 1st prize

\$500 - 2nd prize,

\$100 - 3rd prize

100 - \$10 prizes,

400 - \$5 prizes

HOW TO WIN

To win one of these 503 prizes all you have to do is complete in 25 words or less "I like Pyramid capacitors because _____" You fill in this statement on a Pyramid contest entry blank which can be obtained from any electronic parts jobber selling Pyramid capacitors. You have this entry blank countersigned by your jobber or one of his salesmen and forward it to us attached to a Pyramid Dry Electrolytic Capacitor box top—the top being the part which carries the description of the item. There is no limit to the number of entries which you may make in this contest but each entry must be accompanied by a box top. Full rules for the contest appear on the entry blank.

It's so easy. Here is the kind of statement that might win:

"I like Pyramid capacitors because they always check out perfectly and don't deteriorate and so I know I won't have to call back at my expense."

"I like Pyramid capacitors because the line is so complete that I can always get what I need and don't have to worry about an off-brand capacitor."

PYRAMID



PYRAMID FEATURES:

- 1 Only one quality—the best at no premium. All Pyramid capacitors are made of materials commanded by rigid military specifications.
- 2 All Pyramid capacitors are non-hygroscopic.
- 3 Highest quality insulator material used in all production results in low leakage factor.
- 4 Exclusive non-contamination technique guarantees close tolerances and no deterioration. Peak performances for life.
- 5 Pyramid capacitors operate unchanged at ambient temperature of 85° centigrade.
- 6 Designed by service technicians across the country for their requirements.
- 7 Individually packaged for protection.
- 8 Permanently legible, high visibility ratings on each item.
- 9 100% absolute electronic inspection before shipment.

Pyramid is in its 10th year as a leading manufacturer of high-quality capacitors.

PYRAMID ELECTRIC COMPANY

1445 HUDSON BOULEVARD
NORTH BERGEN, N. J.

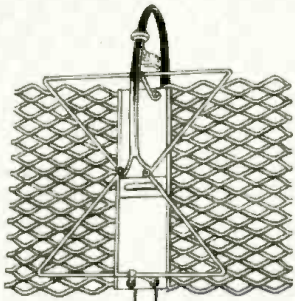

Model UW-2

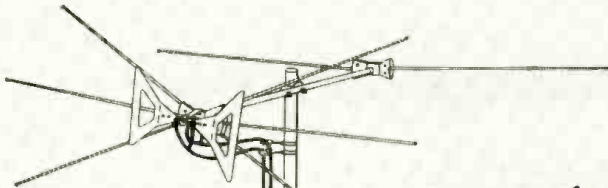

Model VU-1

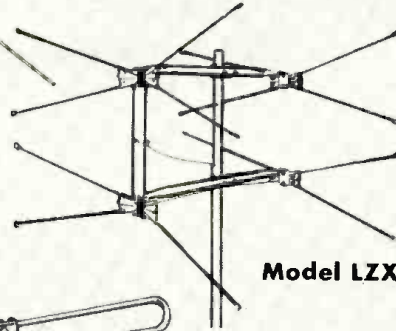

Model LZX-2L

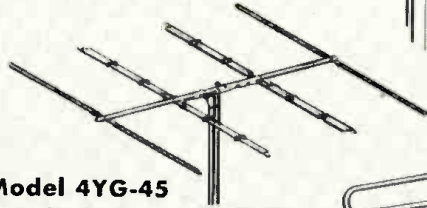

Model 4YG-45

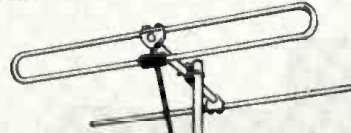

Model 92-FM

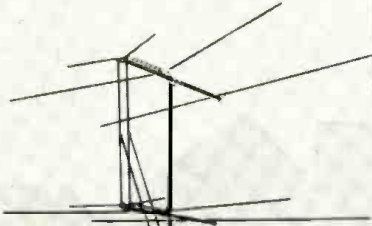

Model V-8

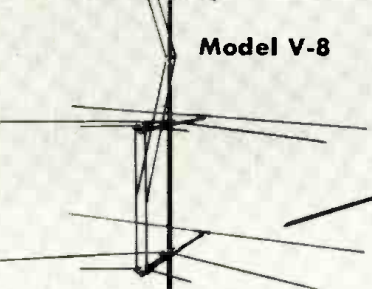

Model HL-4

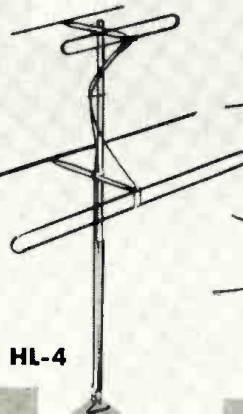

Model K8-2

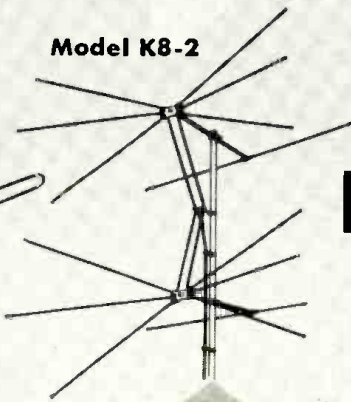

Model 93-FM

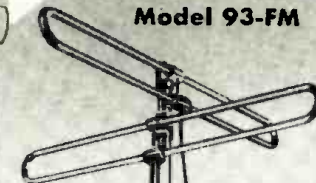

Model S-6

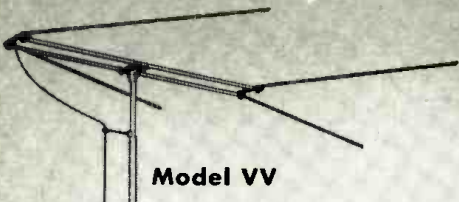

Model VV

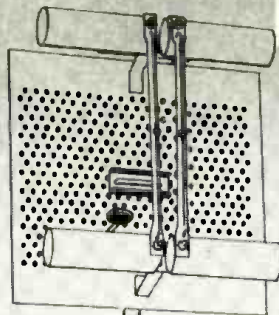

Model U-4

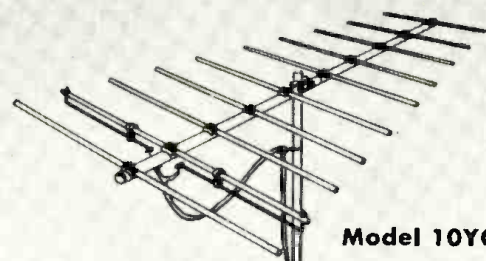

Model 10YG

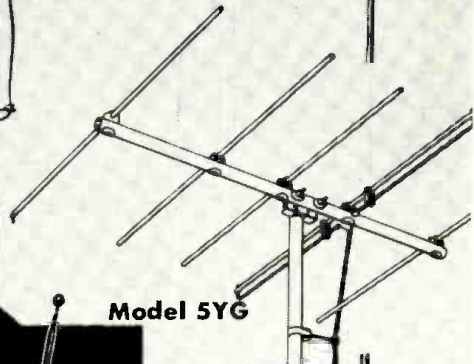

Model 5YG

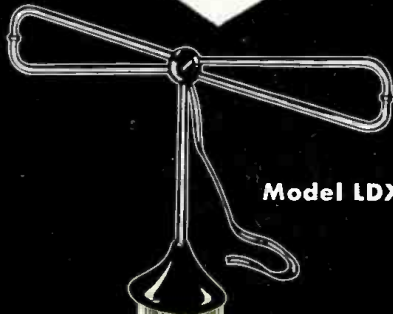

Model LDX-1

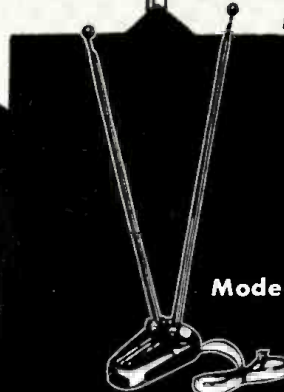

Model CT-231

RADIART

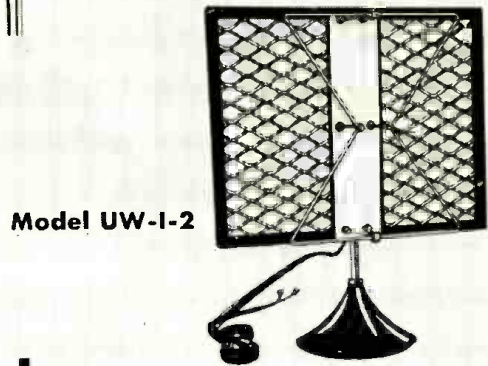
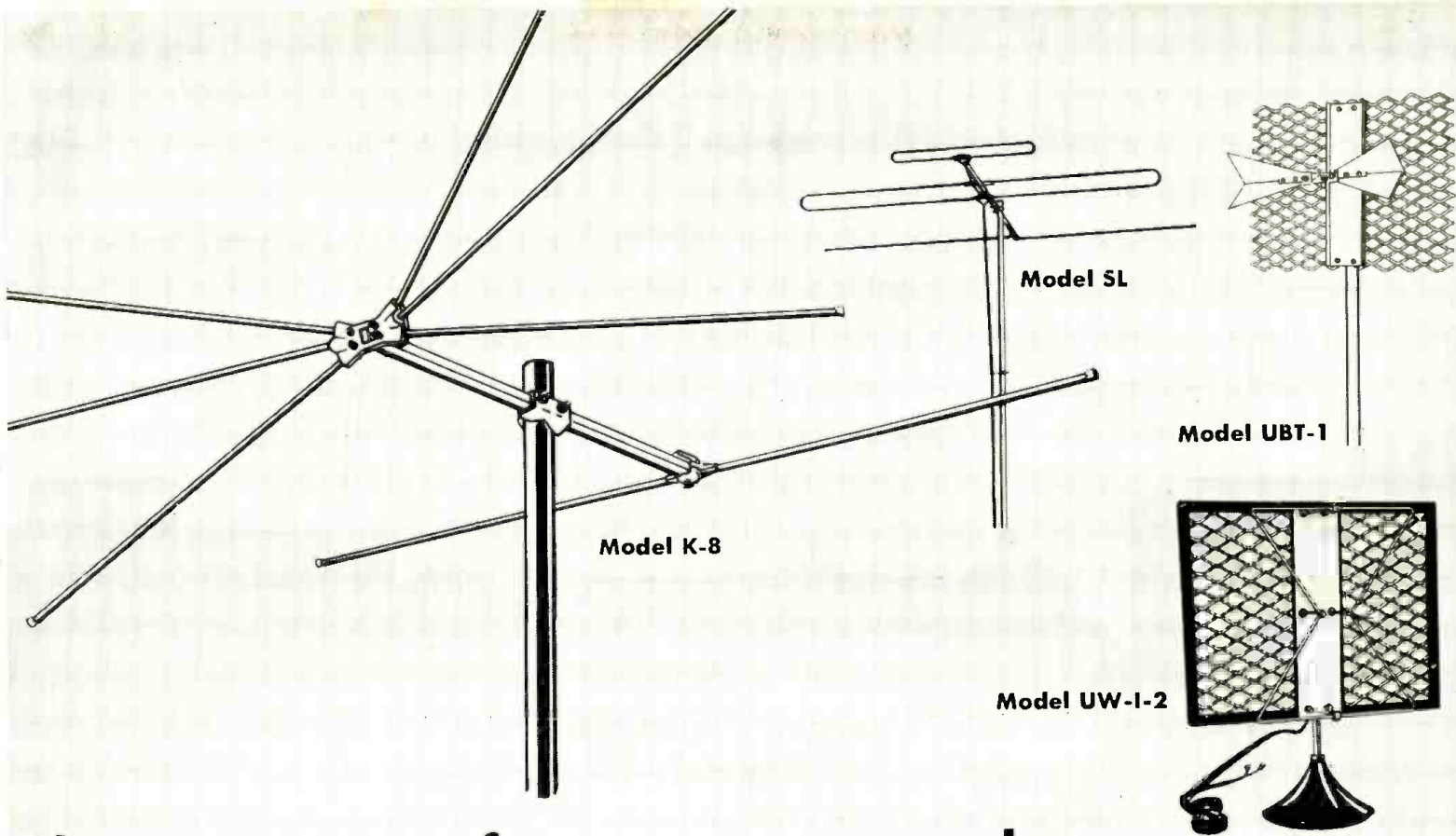

has a type for every need ...

a design for every application

UHF and VHF ANTENNAS

Ready For Immediate Delivery

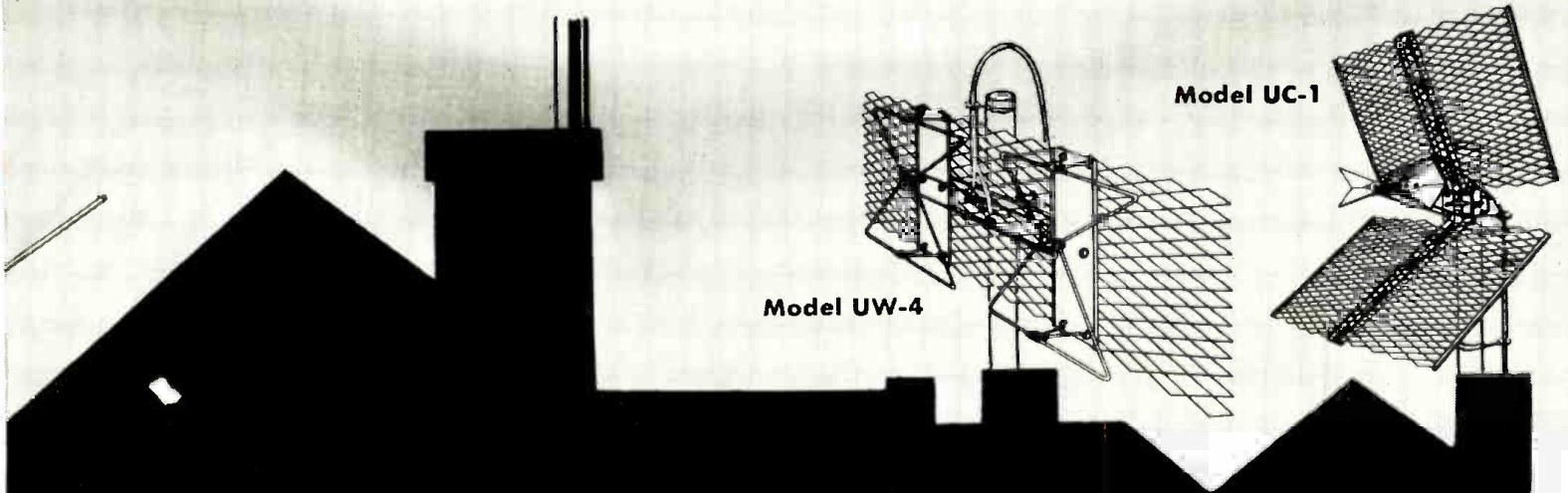

THE **RADIART** CORPORATION
CLEVELAND 13, OHIO

TV ANTENNAS * AUTO AERIALS * VIBRATORS * ROTORS * POWER SUPPLIES

The New SYLVANIA SERVICE POLYMER

TYPE 301



REDUCE SERVICE TIME READ DIRECT PEAK TO PEAK VOLTAGES

The new AC input circuit provides for full wave rectification to give you direct "P-P" readings of symmetrical and asymmetrical waveforms. This feature has been included in the new Polymer to aid in measuring signals of a complex nature. A point to point search quickly localizes circuit failures and minimizes service time.

QUICK, ACCURATE MEASUREMENT OF COMPLEX WAVE FORMS



COMPOSITE VIDEO SIGNAL
Plate of video amplifier
(75 volts P-P)



COMPLEX WAVE FOR TRIGGERING
Grid of vertical oscillator
(180 volts P-P)



COMPLEX WAVE FOR DEFLECTION
Plate of vertical output tube
(700 volts P-P)

ENGINEERED BY SYLVANIA ... world famous in electronics
STYLED BY SUNDBERG & FERAR ... leaders in industrial design

LABORATORY PRECISION ACCURACY FOR DIRECT MEASUREMENT OF...

- ✓ P-P voltages from .2v to 2800v.
- ✓ DC voltages of plus or minus polarity from .05v to 1000v.
- ✓ AC voltages from .05v to 1000v.
- ✓ DC current from 50 Micro-amps to 10 amps.
- ✓ Resistance from .5 ohm to 1000 megohms.
- ✓ Decibels from -20 db to +61.4 db.

COMPARE THESE DELUXE FEATURES

- ✓ Peak to Peak Scale.
- ✓ New Sylvania 7" Meter Movement.
- ✓ Lighted Scale.
- ✓ Sylvania Patented Linearity Circuit.
- ✓ 17 Megohm Input Impedance.
- ✓ Shielded AC Lead.
- ✓ Screw-on Connectors.

AVAILABLE THROUGH YOUR
SYLVANIA RADIO TUBE DISTRIBUTOR

Sylvania Electric Products Inc., Radio and Television Division

WILLIAMSPORT, PENNSYLVANIA

The eye-opening event of the radio-electronic new year!

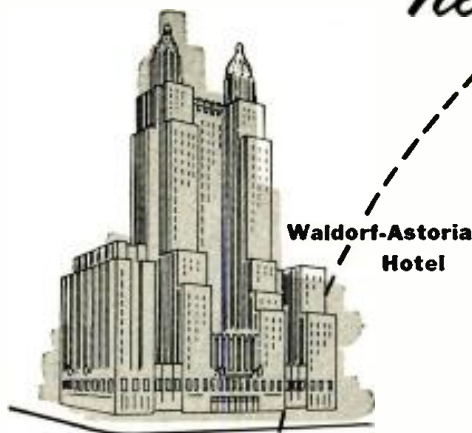

Waldorf-Astoria
Hotel

For the past 12 months the vast, fast-growing radio-electronic industry has been preparing for 4 great days — March 22-25. This is when the IRE National Convention and Radio Engineering Show — the biggest and best ever — will take place in New York City. Be sure to join the other radio-electronic men — nearly 40,000 are expected — who will come, see and appraise the show at which all that is new will be unveiled.

A practical summary of radio-electronic progress will be unfolded at 54 technical sessions during the four-day period. 243 scientific and engineering papers, grouped by related interests, will be presented during these sessions, more than half of which are organized by IRE professional groups. Actually, you will be attending 21 conventions fused into one. New York's finest meeting facilities are provided — the Waldorf-Astoria Hotel plus 3 huge halls in Kingsbridge Armory. Transportation between the two locations is quick, easy — by subway and bus service.



Kingsbridge Armory

At the show you will find over 600 firms "spotlighting the new" in their high-interest product exhibits. These will extend over a mile and a half along avenues appropriately named for radio elements: "Instruments," "Components," "Airborne," "Radar," "Transistor," "Audio," "Microwave," etc. These exhibits, an education and revelation in themselves, fill the four-acre space of the great Kingsbridge Armory ... and can be viewed throughout any one or all of the four days.

Admission is by registration only, and serves for the four-day period. For IRE members the cost is only \$1.00. For non-members it is a low \$3.00, covering sessions and exhibits. Social events have been carefully planned. These are priced separately.

March 22-25, 1954

**is the date! New York is the city
where the radio-electronic event
of the year will take place.
Come! See! Enjoy!**



THE 1954
IRE NATIONAL CONVENTION
AND
RADIO ENGINEERING SHOW
THE INSTITUTE
OF RADIO ENGINEERS
1 EAST 79th STREET, NEW YORK CITY

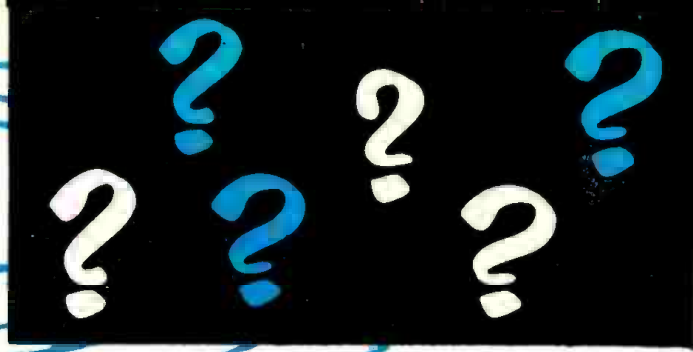

HOW CAN I,
 *A Dealer*

GET TO THE BOTTOM OF THIS BIG CONTROVERSY OF "WHOSE ALL-CHANNEL ANTENNA OUTPERFORMS WHOSE?"

DO AS THOUSANDS OF OTHER DEALERS ARE DOING...

Test the super "KATYS" Yourself!

Find out for yourself, in your own area, why KAY-TOWNES can honestly guarantee that a super "KATY" will outperform any other all-channel TV antenna on the market today!

If we were in your shoes, with a local Dealer-Service reputation to protect . . . and add to . . . we would do exactly as you should do! WE WOULD RUN OUR OWN PERFORMANCE TESTS ON THE SUPER "KATYS"!

In the next few months, many of our competitors are going to attempt to copy the "KATYS" . . . just as they did our "BIG JACK". We have already taken the necessary steps to stop them . . . and to protect our dealers. This is the price forced upon us, because of our recognized leadership in the field of "fringe area" antenna design.

When you stop to think, it is easy to understand why KAY-TOWNES is so far ahead of the pack. While the others have been busy "commercializing" strictly on production

to satisfy the huge demand, KAY-TOWNES has been working toward the "reception perfection" demanded by today's more cautious buyers of Television!

4½ YEARS OF DEVELOPMENT, with our resources and energies trained upon the objective of designing and engineering the world's finest TV antenna, has produced the SUPER "KATYS". What the SUPER "KATYS" will do toward the betterment of Television enjoyment is a foregone conclusion.

Look for KAY-TOWNES' big consumer ads appearing in *Life Magazine* . . . *Country Gentleman* . . . *Progressive Farmer* . . . and many other of the leading home publications!

The combined readership of all these publications will add up to more than 30,000,000 individual readers in the most productive "fringe areas" in America! Think what this means in terms of selling help for you!

It's a fact...

The amazing, "long-distance", photo-clear reception performance of the KAY-TOWNES SUPER "KATYS" makes all other all-channel antenna designs as obsolete as the 7-inch screen!

THE SUPER "KATYS" WILL PROVE . . . THE BEST SET IS ONLY AS GOOD AS ITS ANTENNA!

WHO CAN I BELIEVE

Who IS TELLING THE TRUTH ABOUT TV ANTENNA PERFORMANCE... *and who isn't!*

WE CAN ONLY ANSWER FOR OUR OWN ANTENNAS . . .
AND THEN LEAVE THE ENTIRE QUESTION UP TO YOUR OWN
GOOD, QUALIFIED JUDGMENT!

THE NEW, KAY-TOWNES SUPER "KATYS" ARE POSITIVELY
GUARANTEED TO OUTPERFORM ANY OTHER ALL-CHANNEL
ANTENNA ON THE MARKET TODAY!

This is an absolute fact, and not simply an advertising statement! In our search for a perfect All-Channel Antenna design we have, in the past 4½ years, developed countless arrays *with ability to perform as well and often better than any competitive design available.* We didn't stop there!

The more we probed into the secrets of TV reception, the more convinced we became that with the *right research and study, the right engineering and experimentation* we could finally develop a truly amazing and outstanding TV Antenna. We didn't stop until we did just that!

We've crossed and recrossed our engineering trails many times. We've made every test and check possible. We stake our reputation and future on the positive GUARANTEE we make for the KAY-TOWNES SUPER "KATYS"!

What does this Guarantee mean to You... a Dealer?

First of all, it means that we are absolutely sincere with you! It means that we are willing to stand behind the Super "KATYS" with all the resources at our command. It means that you can finally SELL an All-Channel TV Antenna you can depend on to do the best possible receiving job for any installation!

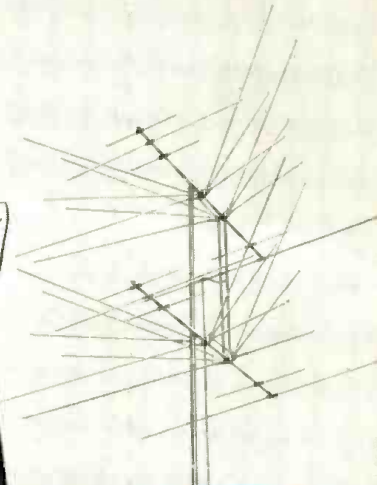

KAY-TOWNES
ANTENNA COMPANY
ROME, GEORGIA

KAY-TOWNES
Super KATY-2
2-Bay
PATENT PENDING

Recognized leaders in the field of fringe area antenna design
www.americanradiohistory.com

NOW... 2 SENSATIONAL EICO SCOPE VALUES!

NEW AMAZING FEATURE PACKED
7" PUSH-PULL OSCILLOSCOPE

Only **EICO** Has All These Features

- VERTICAL FREQ. RESPONSE: flat ± 2 db 10 cps - 1 mc
- VERTICAL SENS.: .01 volts rms/inch
- HOR. FREQ. RESP.: flat ± 0 db 10 cps - 200 kc, -4 db at 500 kc
- HOR. SENS.: .3 volts rms/inch
- SWEEP RANGE: 15 cps-100 kc
- 3-STEP FREQ. COMPENSATED ATTENUATOR eliminates freq. distortion, overloading.
- CATHODE FOLLOWER inputs to both amplifiers
- PUSH-PULL outputs in both amplifiers
- RETURN TRACE BLANKING
- INT. VOLTAGE CALIBRATOR
- V & H TRACE EXPANSION & CENTERING: 1.5X full screen without distortion.
- DIRECT CONNECTION to vert. CRT plates.
- PHASING CONTROL of internal 60 cps sine wave sweep.
- AT FRONT PANEL: intensity mod. input; 60 cps, sawtooth outputs.



MODEL 470K
KIT \$79.95. WIRED \$129.50.

EICO EXCLUSIVE! 5" PUSH-PULL SCOPE, 425K, Amazing feature-packed economy-priced Wired, \$79.95.

- PUSH-PULL V & H amplifiers. Sens: 0.5-1 rms v/in. Useful to 2.5 mc.
- SWEEP: 15 cps-76 kc. Z-axis intensity modulation. Dual trace positioning controls.



SCOPE VOLTAGE CALIBRATOR KIT 495K KIT \$12.95. WIRED \$17.95.

- Sq. wave output at power-line freq. with full-scale readings of .1, 1, 10 or 100 V. peak-to-peak.
- Accuracy $\pm 5\%$ of full-scale on each range.

6V & 12V BATTERY ELIMINATOR KIT 1050K KIT \$29.95. WIRED \$38.95.



- DC output: 0-8 V or 0-16 V.
- Continuous current rating: 10 A at 6 V, 6 A at 12 V.
- Intermittent current rating: 20 A at 6 V, 12 A at 12 V.
- Separate Voltmeter & Ammeter.

New! EICO SCOOPS!

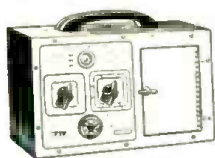

CATHODE RAY TUBE CHECKER 630K, WIRED \$24.95 KIT, \$17.95.

- Checks all types of TV picture and C.R. tubes in the set or carton. Bridge measurement of peak beam current (proportional to screen brightness).
- Detects shorted & open elements.

BAR GENERATOR 352K, WIRED \$19.95 KIT, \$14.95

- Enables rapid adjustment of TV picture V & H linearity without hard-to-find station-transmitted test pattern.
- Produces 16 V or 12 H bars. Operates on TV channels 3, 4, or 5.



RTMA RESISTANCE SUBSTITUTION BOX 1100K WIRED \$9.95 KIT, \$5.50.

- Enables rapid substitution of resistances from 15 ohms to 10 megs in decade multiples of 15, 22, 33, 47, 68, 100 ohms.
- Uses 36 standard 1 watt, $\pm 10\%$ RTMA resistors.



221K VTVM KIT \$25.95. WIRED \$49.95.

- AC & DC volts: 0-5, 10, 100, 500, 1000 V (30 KV with HVP-1 probe).
- 5 ohm ranges from .2 ohm to 1000 megs.
- DC input Z 26 megs.
- $4\frac{1}{2}$ " meter movement in can't-burn-out circuit.
- 1% mult. resistors.



HIGH VOLTAGE PROBE \$9.95

- Extends range of VTVMs & voltmeters to 30 KV.



PIX TUBE ADAPTER
for Tube Testers \$4.50.
Checks TV picture tubes while in set.

625K TUBE TESTER KIT \$34.95. WIRED \$49.95.



- Illum. gear-driven "Speed Rollchart."
- New lever-action switches for individual testing of every element.
- Tests all conventional & TV tubes.

COUNTER CABINET for above: add \$10.00 to Kit or Wired Prices.

360K SWEEP GEN. KIT \$34.95. WIRED \$49.95.

- Continuous coverage of all TV & FM freqs. from 500 kc to 228 mc.
- Sweep width variable 0-30 mc.
- Crystal marker oscillator, variable amplitude.

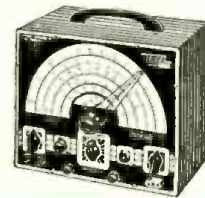

214K VTVM KIT \$34.95. WIRED \$54.95.



- Large $7\frac{1}{2}$ " meter, can't-burn-out circuit.
- AC/DC volts: 0-5, 10, 100, 500, 1000 (30 KV with HV Probe).
- 5 ohms ranges from .2 ohm to 1000 megs.
- DC input Z 26 megs.
- 1% mult. resistors.

950A-K R-C BRIDGE & R-C-L COMP. KIT \$19.95. WIRED \$29.95.

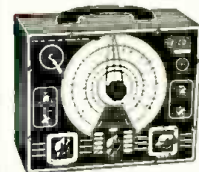

- Measures & tests all resistors; .5 ohm to 500 megohms.
- Every type condenser, 10 mmf to 5000 mfd.
- 0-500 DC voltage source for capacitor leakage testing.

NOW! ONLY EICO KITS & WIRED INSTRUMENTS Gives You LIFETIME SERVICE & CALIBRATION GUARANTEE*

*at less than our cost of handling (See EICO Guarantee Card enclosed with each Kit & Instrument).

171K RES. DECADE BOX KIT \$19.95. WIRED \$24.95.

- Resistance values from 0 to 99,999 ohms with 0.5% precision.
- All resistors have 0.5% accuracy

DECADE CONDENSER BOX KIT 1180K KIT \$14.95. WIRED \$19.95.

- All capacitors precision silver mica, accuracy $\pm 1\%$.
- Range from 100 mmf - 0.111 mfd in steps of 100 mmf.
- Smooth-action positive detent ceramic switches.

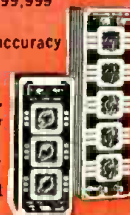

Prices 5% higher on West Coast. Specifications and prices subject to change without notice.

315K DELUXE SIG. GEN. KIT \$39.95. WIRED \$59.95.



- Covers range of 75 kc to 150 mc.
- 7 calibrated scales: accuracy better than 1%.
- Bandsread vernier tuning.
- 4-step RF shielded output multiplier: constant output Z.

565K MULTIMETER KIT \$24.95 WIRED \$29.95.

555K MULTIMETER KIT \$29.95 WIRED \$34.95.
(1% precision resistors)



- 20,000 Ω/V ; 31 ranges.
- DC/AC/Output volts: 0-2.5, 10, 50, 250, 1000, 5000.
- DC Current: 0-100 ua; 10, 100, 500 ma; 10 A.
- Ohms: 0-2K, 200K, 20 meg.

377K SINE & SQUARE WAVE AUDIO GEN. KIT \$31.95. WIRED \$49.95.



- Complete sine wave coverage, 20-200,000 cps in 4 direct-reading ranges.
- Complete square wave coverage, 60-50,000 cps.
- Cathode follower output circuit.

145K SIG. TRACER KIT \$19.95. WIRED \$28.95.



- Audibly signal traces all IF, RF, Video & Audio circuits from ANT to SPKR or CRT in all TV, FM, AM, etc. without switching.
- Germanium crystal diode probe responsive to over 200 mc.
- Integral test speaker.

536K MULTIMETER KIT \$12.90. WIRED \$14.90.

526K MULTIMETER KIT \$13.90. WIRED \$16.90.



- 1000 Ω/V ; 31 ranges
- DC/AC volts: Zero to 1, 5, 10, 50, 100, 500, 5000.
- DC/AC Current: 0-1, 10 ma; 0.1, 1 A.
- Ohms: 0-500, 100 K, 1 meg.

320K SIG. GEN. KIT \$19.95. WIRED \$29.95.

322K SIG. GEN. KIT \$23.95. WIRED \$34.95.



- Fundamentals 150 kc to 34 mc, harmonics to 102 mc.
- 5-step band switching.
- Colpitts audio oscillator generates 400 cps pure sine wave voltage.
- Permits pure RF, modulated RF, or pure AF.

Write NOW for FREE latest Catalog R-3

See our I.R.E. Booth No. 209-211. Ask your jobber for FREE EICO business building decals.

Separate Assembly & Operating Manuals supplied with each EICO KIT!

You build EICO Kits in one evening, but... they last a lifetime!

SAVE OVER 50%! See the famous EICO line TODAY, at your local jobber.

AMERICAN INSTRUMENT CO., Inc., 84 Withers Street, Brooklyn 11, N. Y.



LOOKING AHEAD

By **HAROLD J. SCHULMAN**

Chairman, Service Committee, RETMA

An appraisal of the status of servicing today, and of the new opportunities for service technicians in u.h.f. and color TV, hi-fi, and tape recording.

RIGHT at this moment more than thirty million television receivers are plugged into handy wall sockets. A simple "twist of the wrist" and a "window on the world" is brought into being in thirty million homes.

Ten years ago, you could have been a millionaire and still not have been able to enjoy the magic of big screen television that we take for granted today. This modern miracle was made possible by teamwork such as exists in no other industry. Receiver manufacturers conceived and produced this wonder-child. The broadcasters give it its daily sustenance. And service technicians keep it alive. Without the combined efforts of these main segments of our industry, television as we know it today could not come to pass. The service technician is not just a repairman, installer, or tinkerer. He is a most important member of the team helping to make electronic developments enrich the lives of all of us.

What can we look forward to in television service? With the FCC approval of compatible color, this question almost answers itself. But let's for the moment look back a bit to see where we are today.

Television service has passed through several distinct stages. The first, or introductory stage, featured factory sponsored or controlled one-year service contracts. Many manufacturers, either through their own organizations or their distributors, encouraged the sale of factory service contracts. This led to the build-up of giant service companies, some good—some bad.

Changing times brought the decline of the large service company. A number of factors helped this along. Receiver prices came down. The cost of a service contract thus looked high in relation to the cost of the set. Design improvements and competitive conditions also combined to encourage the consumer to risk owning a set without service contract coverage. Also, too many service companies were closing their doors, leaving angry contract owners with nothing more than worthless pieces of paper to show for their money.

All this led to a trend away from the service contract. Independent service technicians, some of them former employees of the larger companies, started taking over more of the available service work on a charge-per-call basis. Moderate-size service companies and dealer service organizations completed the group then handling the country's service requirements. This is mostly on a charge-per-call basis.

Of course, there are occasional exceptions where a large well-managed service organization survived and thrived. But the trend is definitely to smaller organizations and independent service technicians. It is interesting to note that even a major factory service organization is pulling in its large-scale horns. A trade report says that it is selling or closing its service company branches in cities with less than 100,000 population.

While the consolidation of this trend was going on, u.h.f. bounced on the scene. The educational process started all over again. Experienced service technicians had to learn new techniques. Newcomers in newly opened areas really had to scratch around a bit to get things rolling right.

H. J. SCHULMAN—studied electronics at Syracuse University and business administration at N. Y. U. During the war, served in the Air Force doing radar maintenance and teaching radar. After the war, had a retail radio and TV sales and service business in New York. Was TV service manager for Admiral distributor in New York City, and has been Director of Service at Allen B. Du Mont Labs. for past three years. Co-authored a TV troubleshooting course for a correspondence school, and assisted in the preparation of a TV booklet for the New York City Better Business Bureau, subsequently adopted by the Radio-Electronics Television Manufacturers Association.



New u.h.f. antennas had to be put up. The tricks played by different transmission lines had to be mastered. The "why's" and "wherefore's" of strips, converters, and all-channel tuners had to be learned.

To add to the national work load, some v.h.f. stations switched channels in line with FCC recommendations. Set owners in these areas usually found some change in their reception. Sometimes it was better, sometimes worse. Where it was worse, the service technician heard about it.

That the service technician has been able to keep up with the changing scene—and for the most part, very admirably—is attested again by the latest Elmo Roper survey. Again Roper concluded that the overwhelming majority of television set owners was pleased with the service they received when they needed it.

This is a great tribute to the men in the service field. Thirty million television receivers—600 million television sockets with tubes that can, and often do, go bad, all in operation today, give us a feeling of confidence that the service industry will be able to meet new challenges with flying colors.

The service technician can be expected to take on increasing work on hi-fi equipment and tape recorders. But the main problem will still be black-and-white television in existing and ever increasing markets. Much emphasis will be in u.h.f. as more and more u.h.f. transmitters hit the air.

The main challenge, of course, will be color. This year can be called the "Year of Preparation" for color TV service technicians. The main emphasis at this point should be towards acquiring a good theoretical understanding of the NTSC signal.

At this writing there are no production line color sets available. This means that no one has reliable statistics or experience on color sets as they will roll out of the factories this fall.

Early indications show that for the most part the same broadband antennas used in black and white will be suitable for color. Narrowband antennas, or those with sharp dips at the color subcarrier frequency, may cause some trouble and will have to be watched carefully.

The installer will have to learn how to insert the color tube in the cabinet. According to current information, color picture tubes will most likely be shipped out of the cabinet. The installer will also have to set up a new series of color adjustments as well as spend more time teaching the customer how to tune in (Continued on page 143)

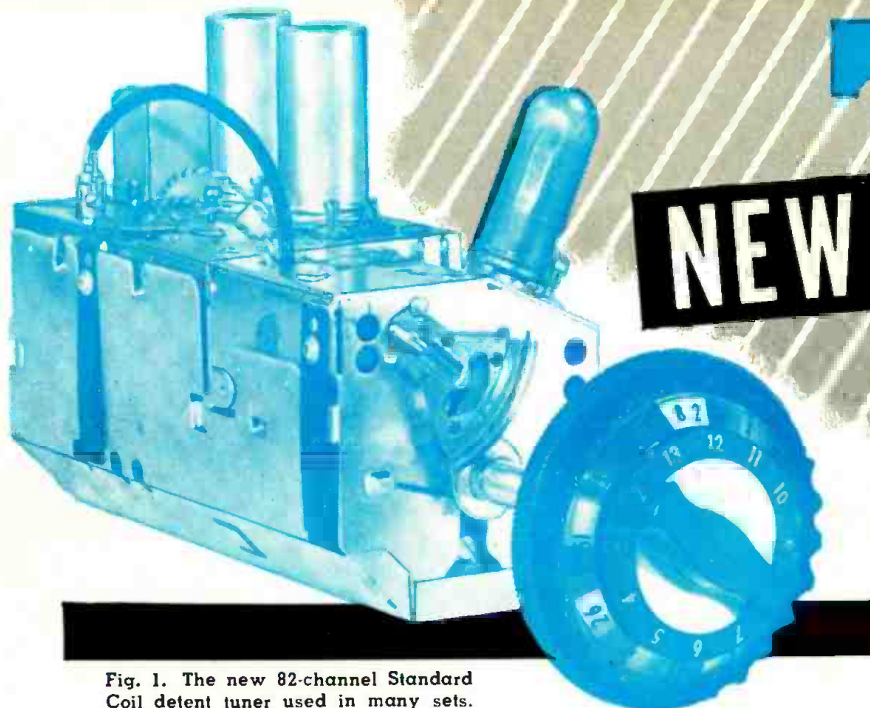

Fig. 1. The new 82-channel Standard Coil detent tuner used in many sets.

WITH the somewhat confused and uncertain market conditions caused partly by the advent of color TV and partly by the general slack in business, the television industry has prepared its 1954 models with great care. Shying away from radical innovations, most manufacturers have emphasized price, quality, and ease of servicing in their new designs. Most models feature time-tested electronic circuits, with improved mechanical design, and better layout for easier servicing and simpler assembly methods. Two new electrical features appear in almost every major TV line; high-fidelity sound, and a full u.h.f.-v.h.f. band tuner.

High fidelity has proven to be such good business that many TV manufacturers have diverted some of their facilities to radio-phonograph combinations, while others offer TV receivers with greatly improved sound quality, phono attachments, AM-FM combinations, etc. There are even TV sets on the market using two speakers, push-pull output amplifiers, and connections for tape recorders and record players.

The second feature, an 82-channel tuner, is incorporated in most of the better lines. The September 1953 issue of *RADIO & TELEVISION NEWS* described the *Standard Coil Products* 82-channel detent tuner which is used in TV sets made by *Admiral*, *Emerson*, *Hoffman*, *CBS-Columbia*, *Majestic*, *Olympic*, *Packard-Bell*, *Stewart-Warner*, and several others. The outstanding features of this tuner are the fact that it is a single conversion system, uses straight detent turret switching, and permits selection of each of the 82 channels simply by setting the two concentric dials until the desired channel number appears. This tuner is shown in Fig. 1.

Most of the other 82-channel tuners consist of a detent-type v.h.f. tuner, and a continuous-type u.h.f. tuner. These, however, were fairly common in 1953 models.

Before discussing individual new de-

signs, the subject of color receivers deserves some mention. At the time of publication color TV sets are still as scarce as solid gold *Cadillacs*. During the second half of 1954, however, some color receivers will appear at the dealers. From current engineering plans it appears that practically all major manufacturers will use basically the same circuit, a type of "630" of the color variety. In a subsequent issue a detailed description of this first color receiver will appear, but for the present only some of its features can be mentioned.

The first color receivers will use a shadow mask tube, either the *RCA* tri-color tube, which is being produced by other manufacturers as well, or the *CBS-Hytron* "Colortron" which is a simplified version of the *RCA* tube. Most color receivers will use 82-channel tuners. It is expected that the color decoder section will be a separate sub-chassis, probably identical in all sets, and eventually as standardized as TV tuners. The i.f. section of all color sets will use the 41 mc. band and feature "bridged-T" rejection filters of great efficiency. The i.f. response curve must be flat to 4 mc. from the video carrier while the sound i.f., 4.5 mc. from the video carrier, must be at least 60 db down to avoid sound interference. These requirements will focus special attention on i.f. alignment both at the factory and by the service technician. Practically all aspects of the color sets will be new, but space does not permit a detailed discussion here.

New Electronic Designs

Instead of producing different TV receiver models for normal reception areas and for fringe areas, most manufacturers incorporate some type of adjustment for sensitivity in a single model. Two major systems are used to get better fringe area performance. One system makes use of a switch or potentiometer to set the level for the a.g.c., the other system concentrates on improving the sync action in the

presence of noise or weak sync pulses.

In Fig. 2 are shown two versions of the *Admiral* "DX Range Finder." The a.g.c. system in Fig. 2A is a simple diode type and the "DX Range Finder" control sets the d.c. level of the bias voltage. The cathode of the a.g.c. diode is biased positively by the action of the voltage divider R_{222} and R_{221} , the contrast control. When maximum contrast is desired, the cathode of the video amplifier is grounded, putting the entire 1000 ohms of R_{221} in series with the a.g.c. diode and making the a.g.c. cathode quite positive. In addition to this variable voltage divider, a fixed network R_{214} and R_{215} also has control over the d.c. level at the a.g.c. diode cathode. The total effect of these two voltage dividers is to allow an increase in positive delay voltage, and therefore a decrease in a.g.c. bias when the contrast control is turned up. The potentiometer R_{215} together with R_{214} , C_{209} , and C_{210} form the time constant of the charging network for the a.g.c. diode. When R_{215} is set for maximum resistance, the developed a.g.c. bias will correspond to the peak sync pulse level of the video carrier, a condition desired in strong signal areas. As R_{215} is reduced, the time constant becomes shorter until the developed bias corresponds only to the average video carrier voltage. The reduced bias will provide more i.f. gain; at the same time, the short time constant does not allow the a.g.c. to be affected by strong noise pulses. The result is that both sensitivity and noise immunity are adjustable for each location.

In Fig. 2B is shown the a.g.c. circuit for the *Admiral* 22F series. In this chassis a keyed a.g.c. system is used and the "DX Range Finder" control sets the grid bias level of the a.g.c. tube. The grid bias of this tube controls the final a.g.c. voltage, but is determined itself by the amplitude of the horizontal sync pulses applied to the grid. Resistors R_{231} and R_{232} form a voltage divider controlling the d.c. bias on the a.g.c. tube. By adjusting R_{232} the final a.g.c. level is set, just as in the circuit of Fig. 2A.

In many other receivers, such as the 1954 *Majestic*, the fringe control simply consists of an additional resistor in the a.g.c. bias network which is switched in or out to reduce or increase the total bias. A variation of

DESIGNS FOR 1954

By
ROBERT B. GARY

A few new circuits and improved mechanical layout for better serviceability are the highlights of 1954 sets.

the fringe switch is found in the new *Westinghouse* V2240 chassis which uses a triode in a keyed a.g.c. circuit. In this unit the a.g.c. cathode is at 140 volts positive for local stations, allowing a certain a.g.c. voltage as determined by the flyback pulse and the composite video signal amplitude. For fringe operation a resistor in series with the cathode is shorted out by the fringe switch and the cathode potential is increased to 150 volts. This reduces the tube current and therefore the a.g.c. bias.

A second type of fringe area improvement is illustrated in Fig. 3, the sync pulse clipper used in the 1954 *Raytheon* models. The 6BE6 pentagrid tube receives two different video signals, one from the 2nd detector and the other from the video amplifier. The signal from the detector is applied to the control grid and is positive in polarity. The gating grid receives a much stronger negative signal from the video amplifier. By setting the d.c. voltage on the control grid, the level of clipping is set so that only the top of the sync pulse is passed by this tube. Since the tube can conduct only during the sync pulse period, noise pulses occurring during the video portion of the signal cannot pass the tube. Resistor R_{101} , called the "sync stabilizer" permits adjusting the operating level for the sync clipper tube for optimum performance in a particular area.

The new *Emerson* receivers feature a very effective sync stabilizing system which actually amplifies and inverts noise pulses so that cancellation of noise pulses is possible. When a noise pulse is greater in amplitude than the horizontal synchronizing pulse, it is amplified in a triode section and then fed back, in opposite polarity and slightly stronger than the original signal. The cancellation of strong noise pulses results in more stable sync action. For fringe area operation a potentiometer and "on-off" switch permit both a fine and rough level setting to determine at just what amplitude the noise inverter tube should function. This tube's bias level is set by the fringe compensator so that the tube is cut off for sync pulses, but any pulse higher than the sync level will set off the cancellation scheme. A similar noise cancellation system, but without the adjustable features, is found in the new *Philco* TV models.

Another new feature in many 1954 models is the higher i.f. of 41 to 45 mc. Although a few of the 1953 TV sets used these new frequencies, practically all manufacturers have switched to the higher i.f. for 1954. An increasing number of TV manufacturers use the new *RCA* printed circuit i.f. strip. For the service technician the higher i.f. range means a whole new set of interference problems, mostly due to local police broadcasts which are often in the 40 mc. band. (See article on TV interference in the July 1953 issue of *RADIO & TELEVISION NEWS*).

Concerning the printed circuit i.f. section, good grounding is essential in all alignment and troubleshooting because the entire i.f. assembly is subject to regeneration and oscillation.

In tune with the economy and power conservation policy followed in most late models, most manufacturers have arranged the d.c. power distribution for maximum efficiency and minimum losses in bleeder resistors. A typical example of this is shown in Fig. 4, the "B+" circuit of the *Admiral* 19B1 receiver series. In this system there is a total of five different branches for the d.c. power. The fuse is used to protect the high voltage flyback and "B+" boost voltage, isolating any breakdown in this section.

Mechanical Features

The 1954 *Zenith* models have two rather unique features as shown in Fig. 5. The speaker is retractable and can

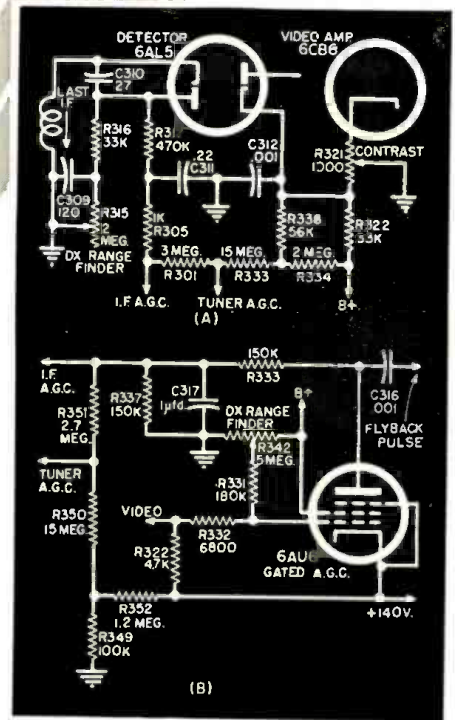

Fig. 2. *Admiral*, among others, uses a potentiometer to regulate the sensitivity of the receiver for fringe and normal viewing. The circuit in (A) is from the 19B1 series, the circuit in (B) is from the 22F chassis.

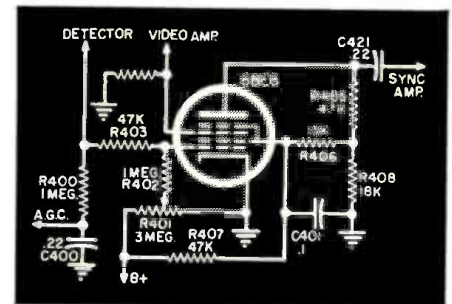
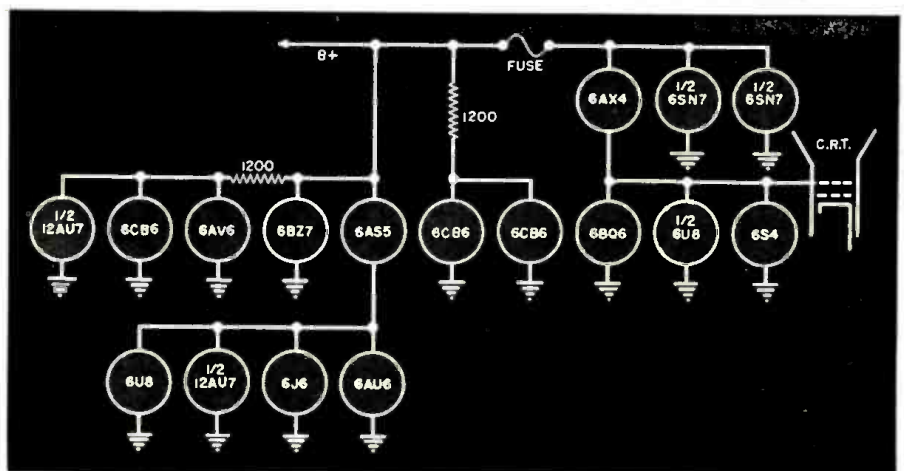

Fig. 3. Circuit of sync clipper used in *Raytheon's* 1954 TV receiver line.

be pushed out of sight when the set is not in use. One advantage of this design is the compact cabinet size and the fact that the impression is given that the sound originates directly from the screen. This is some improvement

Fig. 4. The "B+" distribution diagram for the *Admiral* 19B1 series chassis.



over the usual practice of mounting the speaker on the side, at the rear. A drawback is the fact that the mechanical arrangement for the retracting of the speaker is subject to various defects and although good sound is claimed by the manufacturer, the lack of any sort of baffle is hardly an improvement.

The second unique feature of the *Zenith* line is the channel selector. As seen in the illustration of Fig. 5, the selected channel lights up in large numbers at the center of the dial. This is a good sales feature since it makes it possible to see the operating channel number in the dark and at a distance. For the service technician this presents another possible mechanical troubleshooting for, in addition to burned out pilot lights, the switching arrangement is subject to friction and wear.

As mentioned in the beginning of this article, most manufacturers have also made some efforts to include features in their 1954 models which will appeal to the service technician since

it is now understood that many sales are the result of the service technician's recommendation.

Among the "service engineered" new 1954 models is the *Stewart-Warner* "Thunderbolt" line as shown in Figs. 6 and 7. Fig. 6 shows a cleverly designed U-bracket which supports the deflection yoke assembly and at the same time permits the service technician to turn the chassis upside down for easier servicing. This bracket can also be used as a handle for pulling the chassis from the cabinet, carrying it, resting the chassis on either side, and rolling it over as might be needed. In addition, the U-bracket eliminates the customary center bracket which usually makes some of the tubes hard to reach. The circuit layout of this chassis is designed for greatest accessibility, all tubes can be reached with the receiver in the cabinet, and high-voltage fuse replacement can be effected from the rear without soldering or removing the chassis.

A further boon to the technician is

the fact that both deflection yoke and high-voltage transformer can be replaced from the rear of the receiver, without soldering connections. Fig. 7 shows how to disconnect and remove the flyback transformer. All connector plugs are color coded to avoid errors.

Many other TV manufacturers use plug-in arrangements for the focus coil and deflection yoke to allow for easier replacement, and accessible fuses are also found frequently. The new *Majestic* receivers even use two separate fuses in snap-on holders. One fuse, a 3 amp. type, protects the entire receiver, while a regular ¼ amp. fuse is used for the high-voltage section.

Since many TV sets sold in 1954 will have u.h.f. channels added or may require changing of tuner coil plates, several leading TV manufacturers provide access doors underneath the tuner assembly. *Majestic* and *Packard-Bell* receivers, as well as other popular brands, have a small trap door, set into the cabinet bottom of the table models for this purpose. It will usually be necessary to remove the tuning knobs and adjust the oscillator frequency with a tuning rod from the front panel. In many cases where the tuning slug has been pushed in too far during adjustment it will no longer be necessary to remove the entire chassis for correction.

Another good idea in TV design is the use of a removable safety glass on the front of the cabinet. While many manufacturers have used this in the past, it is only now gaining widespread acceptance. Some receivers, like the new *Packard-Bell* models, use a tilted safety glass, mounted on soft rubber, which is easily removable and can be cleaned and replaced without affecting any other part of the television receiver.

Surveying the innovations for 1954 we find that they include many welcome features which are expected to ease the burden of the service technician. A number of manufacturers have obviously consulted their service departments before settling on any new design and the result will be felt by both manufacturer and customer. Other features are based on economy, such as the fairly widespread use of selenium rectifier supplies instead of the more expensive power transformer and tube combination.

Most components and circuits have already become standardized and apparently few actual improvements are possible at this time. It is more economical to use a proven system for which all parts are readily available than embark on new developments which usually require special components and a lot of expensive engineering, field testing, and modifying afterwards.

The trend in TV picture tubes is definitely towards the 21, 24, and 27 inch sizes. The new popular screen will be at least 21 inches. A good quantity of 27-inch tubes in economy style cabinets is also expected to be marketed.



Fig. 5. Shown here are an ingenious speaker arrangement and channel dial.

Fig. 7. The plugs used in this receiver make flyback replacement easier.

Fig. 6. The new Stewart-Warner sets include bracket on which to rest set when it is turned over for troubleshooting and repair.

CRYSTAL SUBSTITUTE

By
J. G. DONALD

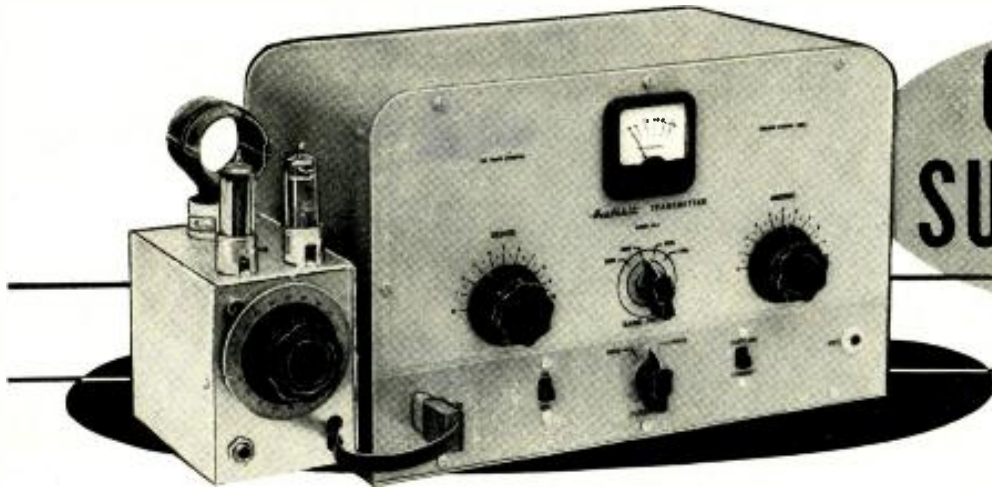

Fig. 1. The v.f.o. and transmitter set-up. The author uses his unit with a Heath Model AT-1 transmitter kit, but it will work with other transmitters.

WHILE crystal-controlled transmitters are usually the most economical to build or buy, they are not always desirable for use in crowded areas of the amateur bands. A simple v.f.o. is just the thing to avoid interference, especially when applied to low-powered transmitters and limited antenna space. Since a v.f.o. can be a tremendous help, it is worth the time spent in constructing one.

A typical v.f.o. and transmitter set-up is shown in Fig. 1.

The Heath Model AT-1 transmitter kit was chosen because of its economy and bandswitching facilities. Power for the v.f.o. is supplied by the transmitter through an octal socket mounted on the rear of the chassis.

A series-tuned Colpitts oscillator circuit is used as shown in Fig. 2. The grid coupling condenser which is usually used in this type of circuit has been omitted because the circuit will work with or without it. The 6AQ5 miniature tube, mounted to the right of the 0A2 regulator, uses less space in the 3"x4"x5" aluminum box than the equivalent 6V6.

Oscillations are prevented by operating the v.f.o. on 160 meters and its output on 80 meters. The oscillator coil is a standard Bud OCL-160 which fits a five-prong socket. The oscillator plate coil is resonant about the middle of the 80-meter band and requires no tuning.

Instead of mounting the series resistor inside the v.f.o. box, it was mounted between pins four and five of the v.f.o. power output socket on the transmitter chassis. This eliminates heat accumulation in the v.f.o. box. The plate voltage for the v.f.o. is obtained from pin 5 on the socket instead of pin 4. In case this particular transmitter is not used, provisions should be made to mount the resistor outside the box, preferably inside the transmitter chassis.

The key jack on the front of the oscillator unit is not used. Originally, the oscillator was to be keyed for break-in operation. But since the

(Continued on page 122)

Build this compact v.f.o. for your crystal-controlled transmitter. The unit uses standard parts throughout.

R_1 —100,000 ohm, 1/2 w. res.
 R_2 —12,000 ohm, 10 w. wirewound res. (see text)
 C_1 —50 μ fd. var. cond.
 C_2 —100 μ fd. var. cond.
 C_3, C_4 —.001 μ fd., 600 v. cond.
 C_5 —.01 μ fd., 600 v. cond.
 C_6 —100 μ fd. mica cond.
 L_1 —160 m. osc. coil (Bud OCL-160)
 L_2 —#30 en., 7/8" long, closewound on 1/2" form
 RFC_1 —2.5 mhy. r-f. choke
 P_1 —Octal plug
 P_2 —2-circuit plug, to fit crystal socket
 SO_1 —Octal socket
 V_1 —6AQ5 tube
 V_2 —0A2 tube

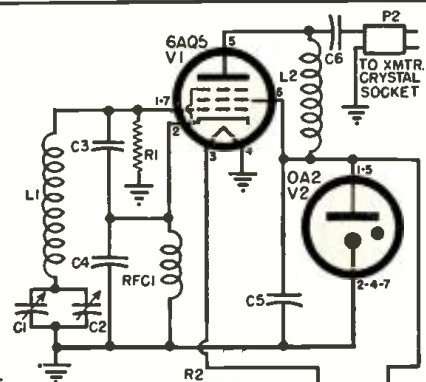
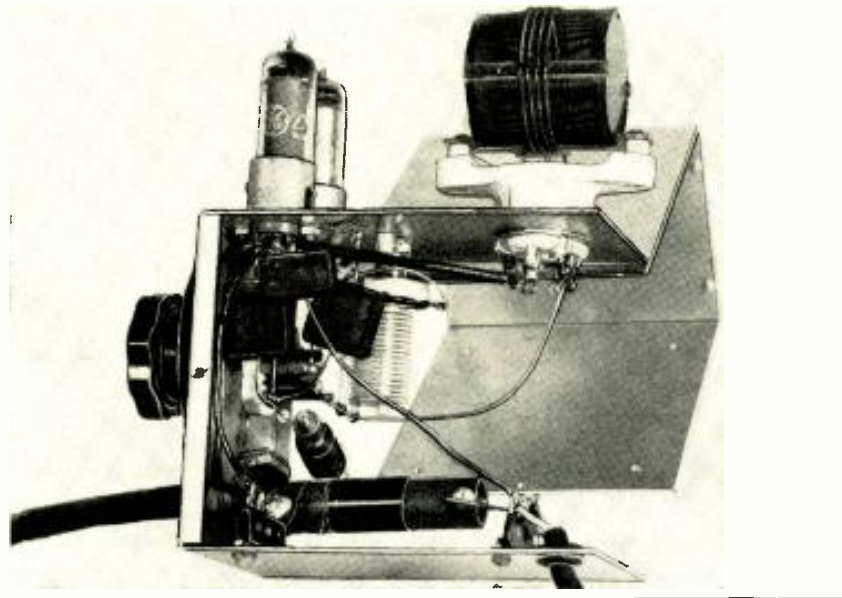

Fig. 2. Schematic of the "crystal substitute," a series-tuned Colpitts oscillator.

Fig. 3. Interior view of the v.f.o. box shows component layout. Placement of the parts is not too critical and almost any component arrangement can be used. Condenser adjustments are made from top of box.





TV TEST EQUIPMENT

By

ROBERT G. MIDDLETON

Author, "TV Troubleshooting Guide"

PERHAPS less than in any other trade do the five senses of the TV technician directly serve their possessor. Occasionally an overloaded resistor, arced transformer, or shorted condenser may make itself evident to the sense of smell; some faults announce themselves to the sense of hearing as noisy, distorted, or weak sound; other faults display their character in the form of picture distortions; overheated transformers, tubes, and resistors are evident to the sense of touch; and some gross mechanical failures, such as broken leads, may be directly visible. In the main, however, the majority of faults which occur in a TV chassis can be revealed only by means of suitable test equipment. The components of a TV chassis appear quiescent and uninformative to the unaided eye, but when investigated with suitable instruments exhibit myriads of rapid electrical actions. Oscilloscopes, vacuum tube voltmeters, and similar instruments are extensions of sense, particularly the sense of sight, which enable the operator to peer into the innermost activities of electrical circuits.

Sweep Generators

Among the major circuits of a TV receiver are the tuned signal circuits, comprising the r.f. mixer and i.f. amplifiers. Practically all receiver service data provides average response curves of voltage vs frequency for these circuits, and responses of the type shown in Fig. 1 are quite familiar to most TV technicians. Less well known, perhaps, are the requirements for suitable sweep generators for such applications. In general, the r.f. circuits of the receiver impose the severest demands upon a sweep generator and the user of the instrument is concerned with the following performance factors:

1. Is the sweep generator a true r.f. sweeper, or is it primarily an i.f. sweeper, relying upon harmonic output for high-band coverage?
2. Does the sweep generator have sufficient output on the high channels to obtain satisfactory scope deflection?
3. Is the attenuator satisfactory for r.f. sweeping, providing control of the output voltage without distorting the response curve at various settings?
4. Most important of all, is the output voltage from the sweep generator flat within plus-or-minus 10% over the swept band?

The output from an r.f. sweep generator should be at least 0.1 volt on channel 13. The gain of a front end is usually least on the high channels, but if the stated amount of output is available, a reasonable amount of scope deflection can be obtained, even if the front end is not in peak alignment at

the outset. The gain on channel 2 is usually about double the gain of the front end on channel 13, hence, the full output of the generator is not required for low-band alignment.

The attenuators should be of low-impedance construction, to avoid resonances and partial resonances which cause lack of flatness in the output at various operating frequencies. The flatness of a sweep generator is easily tested with the aid of a crystal demodulator probe and scope, as shown in Fig. 7A. The pattern which is obtained on the scope screen will be quite flat over the swept trace as in Fig. 7B, if the output voltage from the sweep generator is uniform over the swept band. However, the swept trace will be uneven, or wavy as in Fig. 7C, if the output voltage from the sweep generator is not uniform. The extent of nonuniformity is usually observed with respect to a zero-volt reference line; there are various methods of obtaining zero-volt reference lines, but the usual method is to use the retrace-blanking function provided by many sweep generators.

Some caution should be observed, however, when checking the output from very simple types of beat-frequency sweep generators, since the output is often a mixed output, comprising feedthrough frequencies from the beating oscillators, sum and difference beat frequencies, and harmonics

of these frequencies. In consequence, the flatness check is not necessarily valid unless the operator utilizes suitable output filters to remove the unwanted frequencies. It is quite possible, for example, for the fundamental output from a sweep generator to be quite flat, while the second-harmonic output may be far from flat, due to partial resonances in the output system. For this reason, the operator should be certain to study the circuit diagram of the sweep generator before tests are made, and to provide suitable filters, if required. Sometimes low-pass filters are built into the generator, and sometimes they are provided as accessory units. In other cases, the technician will have to make use of 75-ohm filters which have been designed primarily for other applications.

Oscilloscopes

A common misconception concerning scopes for use in alignment work is that 4 mc. bandwidth is believed to be required. Nothing could be farther from the facts of the matter, and no other application of the scope requires less bandwidth than does visual alignment. The chief point to keep in mind is that a visual response curve, as shown in Fig. 2, for example, is a demodulated response, and belongs to the same general class of waveforms characterized by a 60-cycle square wave. Such waveforms are properly

Fig. 1. Tuned circuit response shown on scope, using a sweep generator.

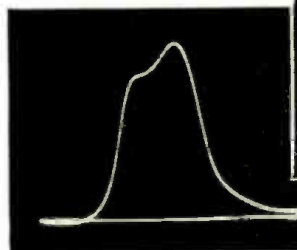

Fig. 2. A demodulated h.f. response curve for a tuned circuit.

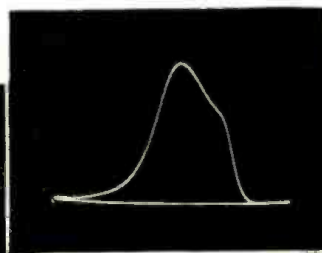
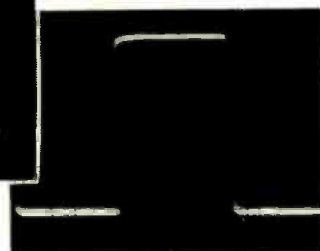

Fig. 3. 60-cycle square wave. Such waveform demands good i.f. response.



RADIO & TELEVISION NEWS



Since test gear represents a major investment for the technician, its selection requires careful planning.

displayed by scopes having vertical amplifier response down to 20 cycles per second. The upper frequency limit need not be more than 1 kc. In fact, when the upper frequency limit is high, such as 2, 3, or 4 mc., the marker indication will be very poor. This matter is reserved for later discussion.

It is sometimes asked why the low-frequency response of a scope must extend down to 20 cycles per second to properly reproduce a 60-cycle square wave. The reason for this requirement is that the phase characteristic of the vertical amplifier is just as important as the frequency characteristic. Unless the phase characteristic is linear, the reproduced square wave will exhibit tilt, and the phase characteristic cannot remain linear at 60 cycles unless the frequency response is sustained to 20 cycles, or lower.

The sensitivity of a scope used in visual-alignment work should be relatively high, in order to obtain satisfactory pattern displays in r.f. alignment work. It has been seen that a sweep generator may have limited output on the high band, and this deficiency can be compensated, to some extent, by using a high-gain scope. Many present-day service scopes provide a sensitivity of 10 millivolts per inch, which is ample for alignment work.

Marker Generators

Practical considerations limit the

Fig. 4. The appearance of a beat marker or "birdie" on an i.f. response curve.

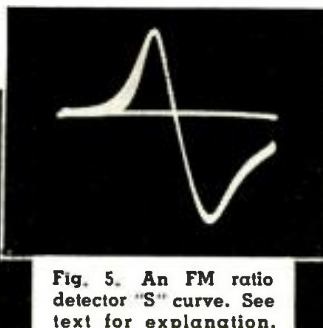

Fig. 5. An FM ratio detector "S" curve. See text for explanation.

accuracy of frequency indication which can be obtained from sweep generators, and limit the extent of horizontal linearity which can be realized, as well as the accuracy of the sweep-width calibration. If these three functions could be maintained to a high degree of accuracy, a marker generator would not be required. However, a marker generator is almost always utilized in practical work.

A typical beat marker, or birdie, is shown in Fig. 4. The marker is obtained by mixing the output from a signal generator, termed a marker generator, with the FM sweep signal. A beat occurs in the circuits under test, and the zero-beat point, or maximum marker excursion, corresponds to the dial indication of the marker generator. Unless the bandwidth of the scope is restricted, the marker will appear very broad and fuzzy on the response curve. Sharp markers, such as seen in Fig. 4, can be obtained when using wideband scopes by shunting a fixed condenser of suitable value across the vertical input terminals of the scope.

The accuracy of the marker depends upon the type of circuit which is under test. For general i.f. alignment work, a generator which is accurate within $\pm 2\%$ is usually satisfactory. However, the accuracy required for sound i.f. and ratio detector work, as illustrated in Fig. 5, is very strict, and very few

Fig. 6. Curve with spurious markers caused by faulty set and/or test equipment.

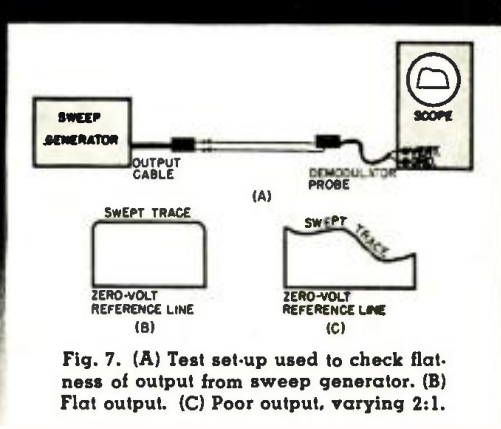
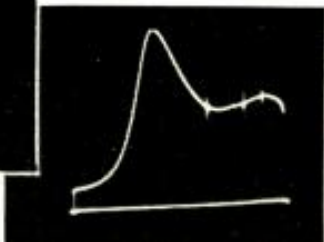

Fig. 7. (A) Test set-up used to check flatness of output from sweep generator. (B) Flat output. (C) Poor output, varying 2:1.

marker generators can meet the requirements. The majority of test equipment manufacturers recommend that the technician utilize a 4.5 mc. marking crystal, instead of a generator, for this application. Many marker generators and sweep generators contain 4.5 mc. crystal oscillators to meet this requirement. However, if the marker generator provides for calibration checks, it is often possible to use the generator output for sound i.f. work. The accuracy of calibration should be within ± 1 kc.

One of the difficulties encountered in ratio detector marking is the AM rejection of the circuit, which wipes out the marker from the center of the "S" curve, as seen in Fig. 5. The visibility of the marker can be improved in double-ended ratio detector circuits by opening the stabilizing condenser during the alignment. In the case of single-ended ratio detector circuits, the most practical method of marking is provided by a bypass marker injector which develops the beat marker independently of the tuned circuits in the receiver.

Spurious markers, shown in Fig. 6, often arise to plague the user of sweep and marker generators. In most cases, the spurious markers are caused by beating of spurious outputs from the generators, although improper test conditions can also give rise to spurious markers. For example, if the local oscillator is not disabled during i.f. alignment, harmonics of the local oscillator frequency will almost certainly cross beat with harmonics of the sweep and marker generators to produce spurious markers and spurious sweeps which distort the shape of the i.f. response curve.

When running r.f. response curves, the local oscillator must be kept in operation to avoid distortion of the response curve as a result of improper mixer bias. Hence, the operator is sometimes troubled with cross beats of oscillator output with sweep and marker voltages and their harmonics. However, these sources of difficulty are much less frequent than in i.f. work. Unless the sweep generator has a very

(Continued on page 144)

LATEST TRENDS IN

By M. S. KAY

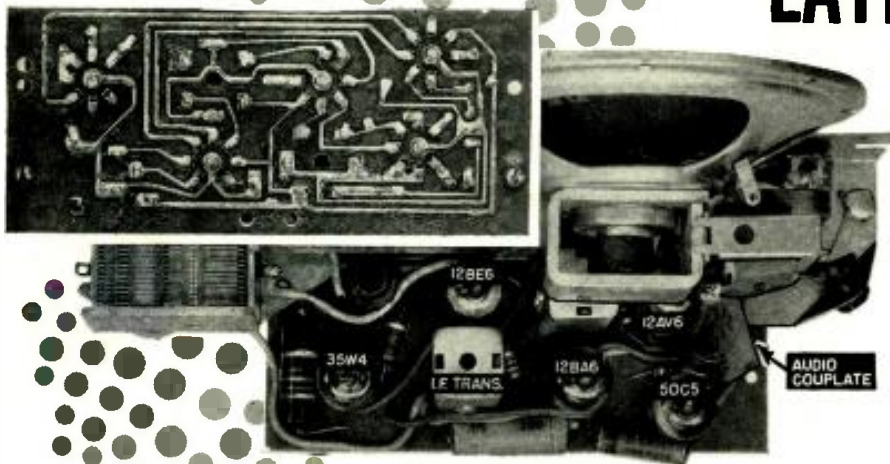

Fig. 1. Top and bottom views of an AM receiver which uses printed circuitry. Note that in this chassis all components are on one side and the wiring on the other.

The "new look" in radio sets with ferrite antennas and printed circuitry requires some new service techniques.

EVERYONE has been so preoccupied with television these last few years that not much attention, editorial or otherwise, has been given to radio. Yet it takes but a glance at current statistics to reveal that radio production is greater than ever, more numerous by far than television.

What has happened to radio since it was so abruptly shunted aside by the onslaught of television back in 1946? Basically, as far as circuitry is concerned, very little. However, there have been some significant changes made in components and it may not be amiss at this time to examine these in some detail.

The first item to strike you upon examination of current sets is the change in tube types. Thus, where we used to find such tubes as a 12SA7 (converter), 12SK7 (r.f. and i.f.), 12SQ7 (detector, a.v.c., and 1st audio), 50L6 (output), and 35Z5 (power supply), we now find such miniature replacements as a 12BE6 (converter), 12BA6 (r.f. and i.f.), 12AT6 (detector, a.v.c., and 1st audio), 50C5 (output), and 35W4 (power supply). The miniature

tubes are more compact and generally possess slightly lower ratings than their predecessors; otherwise they are comparable to the tubes they have replaced.

Alternate tubes for some of those just mentioned include a 12BD6 for the i.f., and a 35C5 for the power output. The choice of the latter tube is frequently governed by what tubes have been used in the prior stages and what total voltage is required by their heaters in series. Thus, if we have a 12BE6, 12BA6, 12AT6, and 35W4, then the 50C5 will round out the combination with a total series heater requirement of 121 volts. On the other hand, if we desire to add a 12BA6 r.f. amplifier, then the total required heater voltage rises to 133 volts, which is far in excess of what is commercially available. Under these conditions, it is wiser to substitute a 35C5 for the 50C5.

In battery receivers, the current tube line-up is as follows: 1U4 (r.f. and i.f. amplifiers), 1R5 (converter), 1U5 (detector, a.v.c., and 1st audio), and 3V4 (audio output). There are,

of course, other tubes which can be and occasionally are used, such as the 1V6 (mixer and oscillator), 1AH4 (i.f.), 1AJ5 (detector, a.v.c., and 1st audio) and 3S4 (output). However, most battery receivers utilize the first set of tubes noted.

A second important change in recent years has been the substitution of ferrite-rod antennas for the flat air-core loop antenna. This change, while principally made in portable and table-model sets has, to a limited extent, also been made in console receivers. The principal advantages of the ferrite-rod antennas stem from their reduced size (important primarily in portable sets) and their greater operating efficiency, the latter arising from the higher "Q" of these units.

The flat air-core loop antenna has a fairly large area (approximately 20 square inches) and for optimum reception it must be oriented so that the ends are pointing toward the received signal. The most common position of this antenna in a portable receiver is within a hinged lid and when the set is to be operated, the lid is swung into an upright position away from the receiver cabinet.

When a ferrite-rod antenna, Fig. 6, is employed, it is generally mounted near the top of the receiver and does not have to be oriented for the best signal reception. Another feature of the ferrite-rod antenna is its ease of adjustment to obtain the correct inductance. This might be required in the manufacture of the set or when a ferrite-rod antenna is either being used to replace an air-core loop or simply another, defective ferrite unit. The adjustment is carried out by varying the position of the coil along the ferrite rod. A 10 per-cent change in inductance will be obtained by varying the coil position over the range of

Fig. 2. (A) Printed circuit consisting of four condensers, as used in an AM receiver. (B) Same circuit as shown in (A) rearranged to show where the four condensers would normally appear in the circuit if a printed circuit were not used.

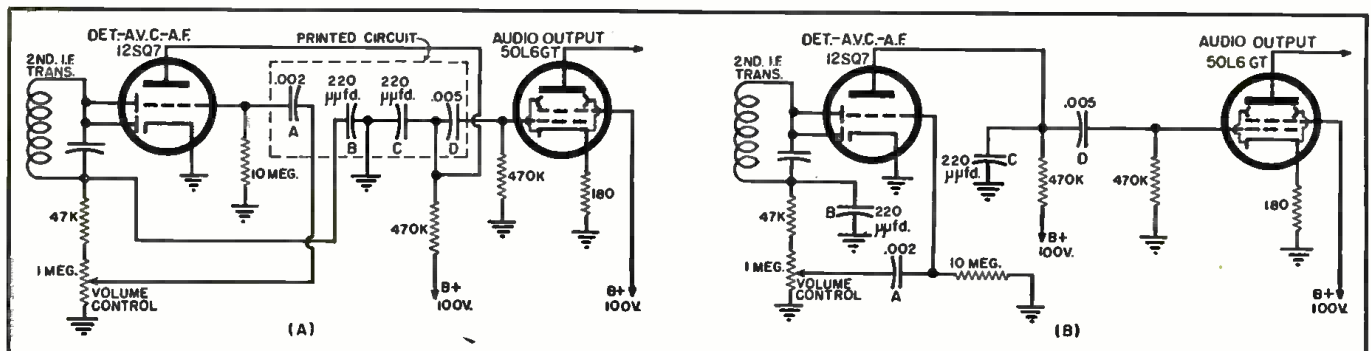

AM RECEIVERS

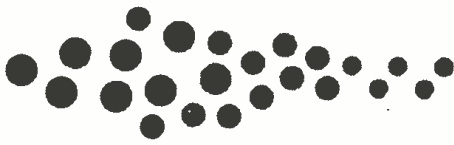

plus or minus one-quarter inch on the rod.

Incidentally, every one of the radio receivers now using an air-core loop can be converted to a ferrite-rod antenna. In many instances the greater "Q" of this unit will revitalize the set remarkably, improving not only the set sensitivity, but also its signal-to-noise ratio. Commercial units are available for less than a dollar at any parts jobber, and come complete with a mounting bracket having a pre-drilled hole for single fastener mounting. To obtain best results with these antennas, mount them as far as possible from any metallic surfaces or components. Ferrous metals will introduce more loss than nonferrous metals (such as aluminum, copper, and brass). After the unit is mounted in the set, the ferrite rod is moved back and forth until the best signal is obtained.

Printed Circuits

One of the major electronic developments of World War II was the miniaturization of condensers and resistors through the use of printed circuits. Since printed circuit manufacturing techniques have been discussed in past issues of *RADIO & TELEVISION NEWS*, no explanation will be given here except to state that through the use of these circuits, "it has been possible to simplify the manufacture of radio receivers.

The chief application of printed circuit components in radio sets has been in the network between the diode detector and the grid of the audio amplifier. See Figs. 3 and 5. The circuits are available with a variety of condenser and resistor values and with a number of components. For example, one of the simplest printed circuits in use replaces the two bypass condensers and series resistor in the load circuit of the diode detector. See Fig. 4. The printed circuit has three wires: one goes to ground while the other two are connected between the volume control and the bottom of the secondary winding of the output i.f. transformer. The circuit is symmetrical, and once the ground wire is established, either one of the two remaining wires may be connected to the volume control. The remaining wire is then attached to the i.f. transformer.

There is, of course, no limit to the complexity of these printed circuits and they may contain as many condensers and/or resistors as any par-

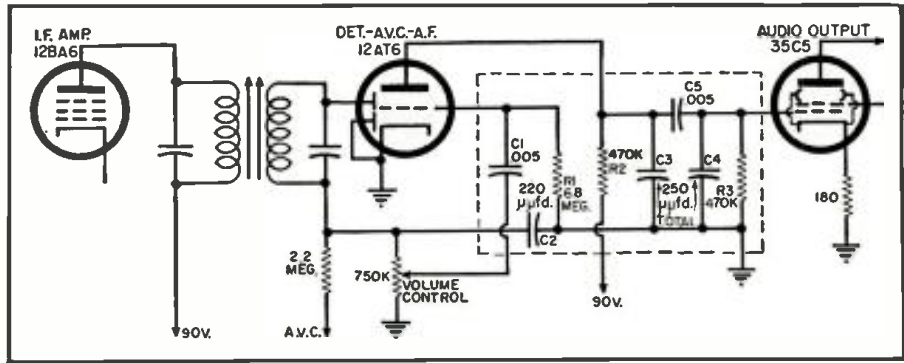

Fig. 3. In this partial schematic, a single printed circuit unit replaces five condensers and three resistors in the audio amplifier stages of set.

ticular application requires. Thus, in Fig. 2A, the printed circuit unit contains four condensers ranging in value from 220 $\mu\text{fd.}$ to .005 $\mu\text{fd.}$. The first condenser, .002 $\mu\text{fd.}$, serves to couple the volume control to the grid of the 1st audio amplifier. The second condenser, 220 $\mu\text{fd.}$, bypasses the i.f. voltage around the detector load resistors. The third condenser, another 220 $\mu\text{fd.}$ unit, serves in a similar capacity at the plate of the audio amplifier. The fourth and final condenser, .005 $\mu\text{fd.}$, couples the audio signal from the plate of the 12SQ7 to the grid of the 50L6.

When the condensers are arranged as shown in Fig. 2A (in order to bring out the fact that they are all contained within the same printed circuit), their position in the receiver tends to be obscured. A rearrangement of the circuit to the form shown in Fig. 2B makes their individual purposes more evident.

A printed circuit containing five condensers and three resistors is illustrated in Fig. 3. C_1 , couples the volume control to the audio amplifier; C_2 is an i.f. bypass for the diode load circuit; C_3 and C_4 are similar i.f. bypass units for the plate circuit of the audio amplifier and the grid circuit of the audio output stage; C_5 couples the audio voltage from the audio amplifier to the audio output. In the resistor section there is R_1 , the grid resistor for the audio amplifier, R_2 , the plate resistor of this stage, and R_3 , the grid resistor of the following audio output stage. For what would be eight parts requiring sixteen leads to be soldered, we now have only one small component with seven leads. The savings under such an arrangement are obvious, and all this without any impairment of operation.

There are many other configurations that these printed circuits can take,

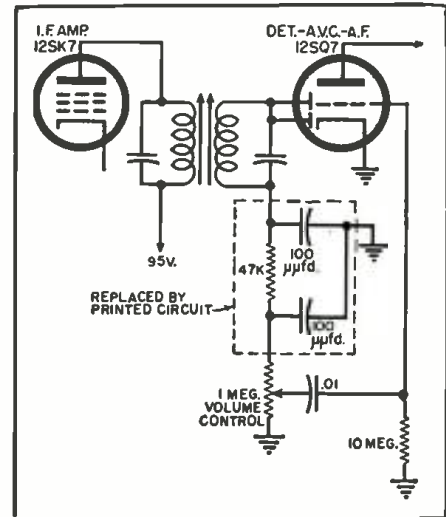

Fig. 4. Partial diagram of an AM receiver showing the components that can be replaced by a printed circuit.

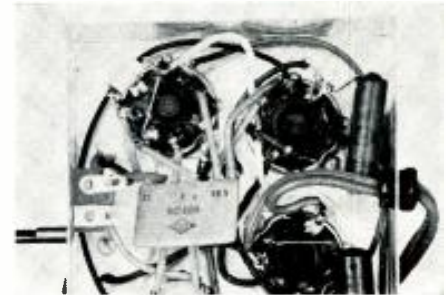

Fig. 5. The printed circuit used here has several resistors and condensers.

but those discussed are representative.

Printed Wiring

Another form of printed circuitry is the printed wiring which has recently been adapted to midget AM receivers. (Continued on page 181)

Fig. 6. A ferrite-rod antenna as installed on a midget radio receiver chassis.

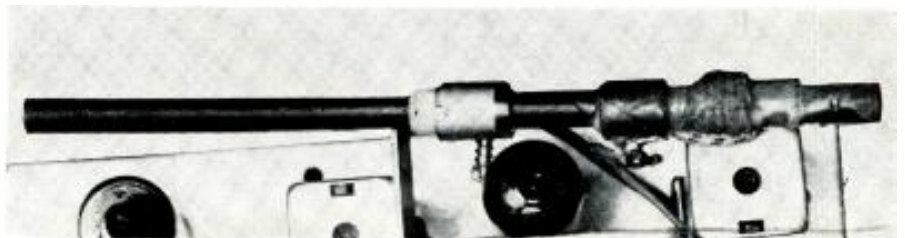

THE CHROMATIC

By WALTER H. BUCHSBAUM

Television Consultant

RADIO & TELEVISION NEWS

Report on the construction, operation, and progress of the "Chromatron," a single-gun picture tube for color TV

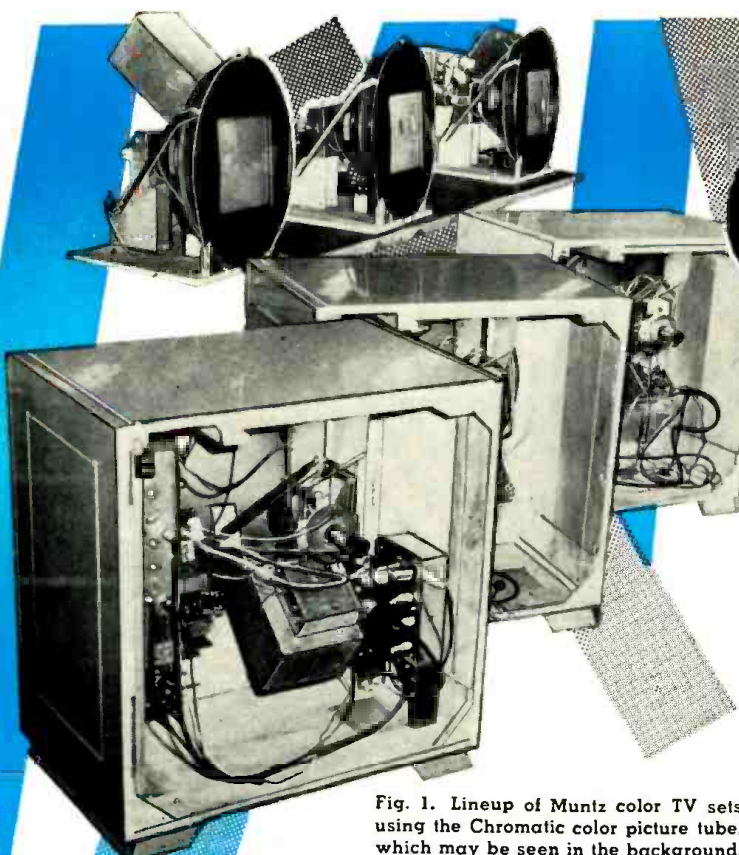

Fig. 1. Lineup of Muntz color TV sets using the Chromatic color picture tube, which may be seen in the background.

WITH the inauguration of color TV receiver manufacturing, the problem of color picture tubes is again receiving much attention. RADIO & TELEVISION NEWS reported some time ago on the tri-color tube both as developed by RCA and as simplified by CBS-Hytron. Now it is possible to give some of the details concerning another type of color picture tube. This latter type, based on the ideas of Dr. E. O. Lawrence of the University of California, was publicized as being a "simple" and inexpensive rival of the RCA tri-color tube. The actual development work on the tube and associated circuits was taken over by Chromatic Television Laboratories, Inc., a subsidiary of Paramount Inc. The tube described here is not necessarily the final design. Further improvements and changes are currently under development.

The current model of this color picture tube has been named the "Chromatron" and a complete 22-inch unit is shown in Fig. 1. The neck and flared portion of the tube are essentially the same as for other metal envelope picture tubes, but the cone is made in two parts to permit separate assembly of the color screen. Although the "Chromatron" is a round picture tube, the color structure is rectangular and occupies less than the full screen space. Picture width of the tube shown is 16 inches; the remaining screen space is taken up by the frame and mounting flanges required for the color structure. Fig. 2 shows the color structure in its frame before being assembled into the complete "Chromatron." In the manner of assembly this is very similar to the RCA tri-color

tube which also contains a separate color structure, frame, and flanges. While the RCA system employs three electron guns, the "Chromatron" uses only a single gun, but it would be possible to use three guns.

The deflection components used for the "Chromatron" are essentially the same as used for black-and-white picture tubes. This is a considerable ad-

van-

vantage over the RCA design which requires complex deflection yokes, a purity coil, and convergence and centering adjustments. The simplification at the neck of the tube is possible in the "Chromatron" because the complete color switching section is part of the color screen structure.

tube which also contains a separate color structure, frame, and flanges. While the RCA system employs three electron guns, the "Chromatron" uses only a single gun, but it would be possible to use three guns.

The deflection components used for the "Chromatron" are essentially the same as used for black-and-white picture tubes. This is a considerable ad-

color dots are arranged in the correct sequence and the colored picture is the composite of the amount of light coming from a large number of dots.

The "Chromatron" uses lines of colored phosphor instead of dots and a special wire screen behind the phosphor strips makes the electron beam dance back and forth between the color strips to produce, effectively, a series of color dots. Fig. 4 shows the principle of the "Chromatron" color structure. A number of vertical strips are laid out, each containing a colored phosphor. The color sequence is arranged so that a green strip falls between each red and blue one. Behind the phosphor is a fine wire grid, so spaced that an electron beam passing between two wires will hit the green phosphor if there is no voltage between the wires.

The phosphor screen is aluminum backed, just as in some types of black-and-white picture tubes, and the aluminum backing is connected to a terminal outside the tube. If a voltage is applied between the two wire grids and the aluminum backing, a series of electron lenses will be set up between the wires and the screen. These lenses help to focus the electron beam so that a sharp spot is obtained on the screen. Although the focusing produced by these lenses is not as effective as the focusing coil or electrostatic focus element back in the electron gun, this "post deflection focus" (PDF) system has a considerable effect on the size of the spot. Because the acceleration of the electrons in the beam is so high near the screen, the focusing potential required is much greater than at the electron gun.

EDITOR'S NOTE: Although, to date, most manufacturers of color TV receivers have designed their color TV sets for use with the 3-gun color tube, as produced by RCA, CBS-Hytron, and others, a large segment of the industry is investigating the possibility of using a single-gun tube such as described in this article. This tube is based upon the invention of Dr. E. O. Lawrence, and the development work of the Chromatic Television Laboratories. Engineers, manufacturers, and all others concerned in the color television industry are divided on which type of tube will predominate in the future. Each has its advantages and disadvantages.

Which tube will be more popular? This depends upon which tube will result in a more simplified circuit, lower over-all set production cost, lower picture tube cost, and which tube will give the better picture. Although there is no reason why both the 3-gun tube and the single-gun tube cannot live side-by-side, in the final analysis, the public will decide as to which will be more popular.

The RCA tri-color tube has a screen consisting of small dots of colored phosphors each of which lights up either in red, green, or blue. These

COLOR

PICTURE

TUBE

In addition to the focusing potential, another voltage can be applied between the set of wires located behind the red and the blue phosphor strips. Depending on the polarity and magnitude of this voltage, the electron beam will be deflected from striking the green strips and hit the red or blue strips.

The color of the spot is therefore determined by the instantaneous voltage between the two sets of wire grids, while the size of the spot is determined by the d.c. voltage between the aluminum backing and the electrical center of the two wire grids. This is similar to the application of centering voltage in an electrostatic deflection cathode-ray tube. In the simplified sketch of Fig. 5, the condition is illustrated where the electron beam hits a green strip because no potential exists between the red and blue wire grids. If a positive voltage is applied to the red wire grid, for example, the electron beam would be deflected slightly more to the left and hit a red phosphor strip.

In addition to the deflecting action of the two wire grids, the electron beam is also moved by the vertical and horizontal deflection coils located around the neck of the tube. It should be understood that the action of the two wire grids is on the order of a minute jiggling motion, superimposed on the horizontal and vertical sweep movement of the electron beam. The colored phosphor strips, the wires, and the spacing between the wires are all so small that from the standard viewing distance individual colors are not discernible.

For operation under the NTSC standards for all electronic color TV, the color switching rate for the wire grids is 3.58 mc., the frequency of the color subcarrier. Rigid standards are needed to maintain the phase relationship between the three color components since it is this relationship which delivers the color or chromaticity information.

To switch at this rate raises some problems when we consider that the wire grids contain considerable capacity and require quite some power to move the electron beam sufficiently. The d.c. voltage on the wires for focusing is on the order of 5000 volts and

the a.c. switching signal must, accordingly, be strong, usually about 500 volts. In one practical demonstration the driving power was about 25 watts. To increase the efficiency of the system somewhat an external inductance was used to resonate the approximately 1200 $\mu\text{mfd.}$ capacity due to the wire grids.

The problem of driving the wire grids, however, is being solved by new driving methods and a modification in the design of the "Chromatron." One approach is to move the grid wires further away from the screen and, thus, reduce the capacity. This would help to reduce the required driving power considerably. In addition to the switching circuits it is also necessary to key the cathode or control grid of the electron gun so that only the red picture information or brightness level exists during the instant that the electron beam hits the red phosphor, and so on for the other colors. To accomplish this, the output of the three video

amplifiers are switched, each delivering its signal, in turn, to the picture tube.

A block diagram of the circuitry needed to utilize the "Chromatron" (Continued on page 156)

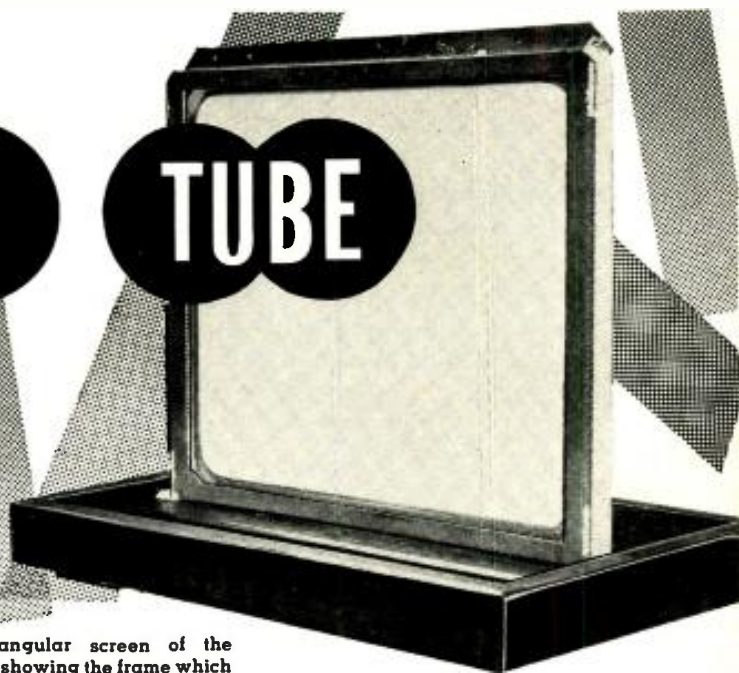

Fig. 2. Rectangular screen of the "Chromatron" showing the frame which holds the color grid wires in place.

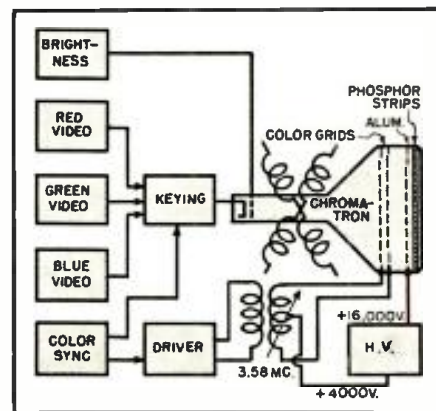

Fig. 3. Simplified block diagram of the circuits required with the "Chromatron."

Fig. 4. Representation of the "Chromatron" phosphor screen showing the grid arrangement behind the color strips.

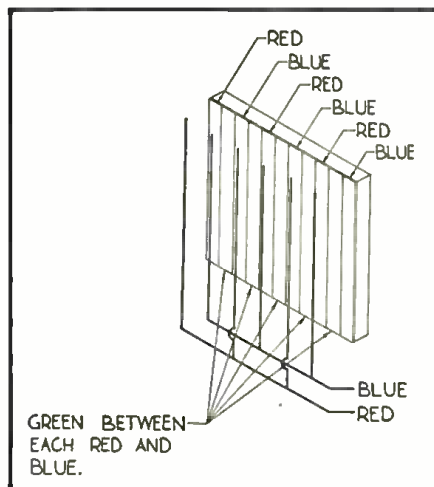
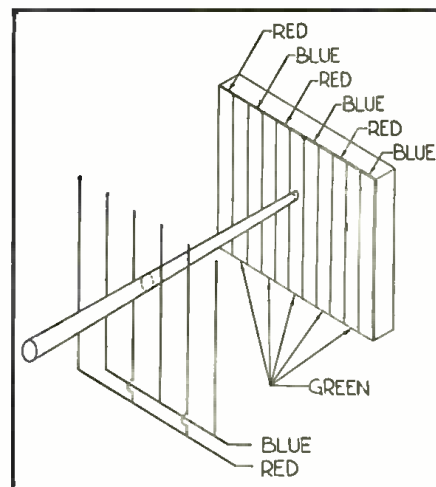

Fig. 5. Electron beam excites green phosphor strip when no deflecting voltage is fed to the blue and red grid wires.



POWER AMPLIFIER OUTPUT

By JOSEPH F. SODARO, W6ZRT

Simple nomograph for determining power output versus efficiency for tubes of a specified plate dissipation rating.

POWER amplifier tubes are rated by maximum allowable plate dissipation. By this system of rating, the 100 watt tube is a tube which will dissipate 100 watts at the plate. However, this tube may generate from 25 to 500 watts in the circuit. This power output difference depends upon the circuit efficiency. Efficiency, in turn, depends upon the amplifier class and operation. For example, the class C amplifier is more efficient than the class A amplifier. Also, a class C amplifier with adequate

excitation and plate voltage has higher efficiency and output than one with inadequate excitation or plate voltage. "Watts output" is an important figure to the amateur. It is the purpose of this article to present a simple, rapid method of estimating output in terms of allowable plate dissipation. Such an estimate is made possible by the calculator shown in Fig. 1.

The dissipation-output calculator of Fig. 1 is used by simply placing a straightedge across the scales through an anticipated or known amplifier class or efficiency. The class C amplifier is at the top of the group with an efficiency range of 60 to 80 per-cent. Sometimes 85 to 90 per-cent is given as an upper limit. Class B amplifiers have efficiencies from 50 to 60, class AB from 40 to 50, and class A from 20 to 35 per-cent. The class B linear amplifier has an average efficiency of about 30 per-cent, reaching 50 to 65 per-cent at full output. The high-efficiency Doherty amplifier has an average figure of 60 per-cent.

The power output calculator has been designed for estimating maximum output when maximum allowable plate dissipation and efficiency are known. This calculator can be used during transmitter planning to determine the power output to be expected when a certain tube is operated in a certain class of amplifier. The chart can also be used to estimate dissipation power for values of efficiency and output. Another application of this graph is the determination of circuit efficiency when input and dissipation powers are known. In general the nomograph can be entered on any two scales and an answer read on the third scale.

On the left side are the power dissipation scales. On the right side are the power output scales. In order to meet all amateur transmitter power requirements, these scales have several ranges. Thus the low power range (LO) runs from zero to 10 watts, medium (MED) to 100 watts, and high (HI) to 1000 watts. It is only necessary to remember to read both dissipation and output on scales of the same range. Thus, use LO with LO, MED with MED, and HI with HI.

All scales are linear. Thus, the midpoint between two scale values is the midscale value. Notice that while the power dissipation scale increases downward, both the power output and efficiency scales increase upward. The first major division on both outer scales is subdivided into ten smaller divisions. Each of these is one unit. Thus, the fourth division from zero is 0.4 on "LO," 4 on "MED," and 40 on "HI."

Using the Calculator

To use the calculator simply locate values on two scales, place a straightedge such as a plastic rule through these values, and read the answer where the rule intersects the other scale. A straight line can be drawn through the three points if desired. A piece of black thread is an excellent nomograph indicator.

As an example, assume that a tube capable of dissipating 20 watts is on hand and we wish to know what outputs can be expected from this tube when used in a radio-frequency power amplifier. Since this would be a class C amplifier we place the straightedge indicator across 20 on the "MED" dissipation scale and 60 per-cent on the "E" scale and read an output (*Continued on page 121*)

Fig. 1. Dissipation vs output calculator. See text on its use.

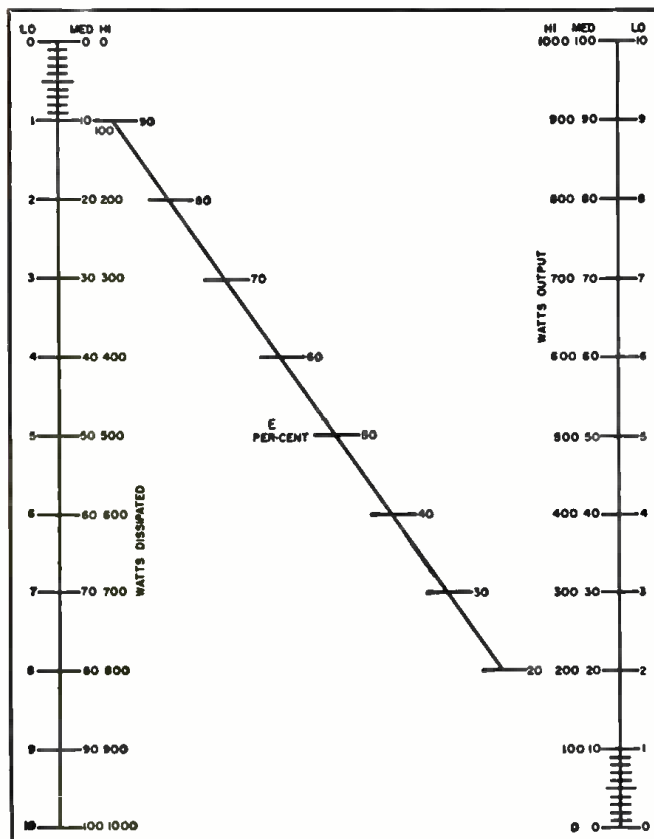

Table 1. Dissipation multiplying factors for rapidly estimating the power output of a given tube. Their use is covered in text.

| FRACTION | EFFICIENCY PER-CENT | MULTIPLYING FACTOR |
|----------|---------------------|--------------------|
| 1/4 | 25 | 1/3 |
| 1/3 | 33.3 | 1/2 |
| 1/2 | 50 | 1 |
| 2/3 | 66.6 | 2 |
| 3/4 | 75 | 3 |
| 4/5 | 80 | 4 |
| 5/6 | 83.4 | 5 |
| 6/7 | 85.7 | 6 |
| 7/8 | 87.5 | 7 |
| 8/9 | 88.9 | 8 |
| 9/10 | 90 | 9 |

The "DIFFUSICONE - 8" ENCLOSURE

By
ABRAHAM B. COHEN
University Loudspeakers, Inc.

Over-all view of enclosure for the University "Diffusicone-8", shown without finish.

Designed for an 8-inch speaker, this cabinet received considerable attention at last year's N.Y. Audic Fair.

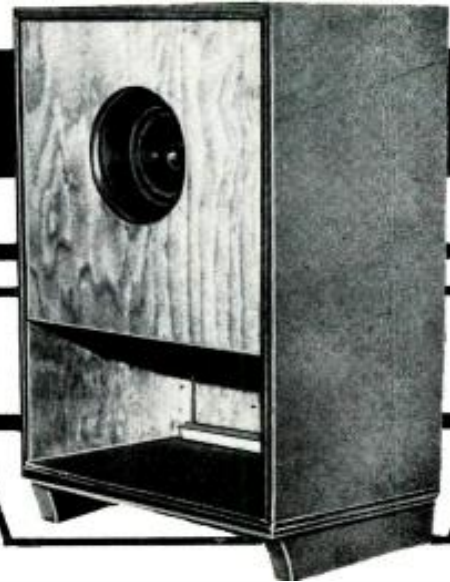

OPTIMUM performance of a loudspeaker is obtained when it is mounted in the proper enclosure. The enclosure and the loudspeaker must be matched to each other. A 6-inch speaker doesn't require a seven cubic foot cabinet, nor will a two cubic foot cabinet suffice for a 15-inch woofer. The University cabinet for the "Diffusicone-8" was designed to provide the proper load match for this speaker. Since this speaker is a high-efficiency, extended-range radiator, it requires a cabinet that will:

- (a) allow its extended high frequencies to spread into the room without obstructions due to bends or folds in the cabinet;
- (b) do justice to the high-level, low-frequency output of which the speaker is capable; and
- (c) be modest in size compatible with the performance requirements of the "Diffusicone-8"

Requirement (a), calling for an unobstructed path for the high frequencies, makes it mandatory that the enclosure and the speaker constitute a "direct radiator" combination, rather than a horn type. The final design of this enclosure resulted in essentially a bass reflex type of cabinet with the important addition of a horn load applied to the port of the enclosure. Thus, what looks like an exceptionally large port for a bass-reflex cabinet of this size is actually the mouth of the horn which feeds from the proper size port located at the rear bottom of the enclosure. The addition of the horn to the port permits smoother low frequency radiation than is possible from a simple port aperture. This condition holds because the efficiency of radiation of low frequencies rises as the size of the radiating opening becomes larger. Thus, since the mouth of the horn is more compatible, dimensionally, with the wave length of the low frequencies than is the smaller sized port, the horn adds a considerable measure of improvement to the performance of the bass reflex cabinet.

Inasmuch as this horn mouth lies at the bottom of the cabinet structure, the floor of the room acts as a natural extension of the horn walls which effect still further aids the low-frequency efficiency. The relatively small size of the enclosure allows it to lie flat

against a room wall or in the corner. Due to the high efficiency of the "Diffusicone-8," the sound pressures developed within the enclosure for the lower frequencies require that the cabinet be constructed of heavy rigid
(Continued on page 150)

Mechanical details of cabinet construction. Although any 8-inch speaker can be used, its design and performance characteristics are based on the use of the University "Diffusicone-8" speaker. The cabinet is simple to build and is, fundamentally, a bass reflex cabinet with a horn flare. The entire upper section of the cabinet should be Kimsul lined. All inside corners are re-inforced by using 1/2" square wood strips glued and screwed to the sides of the cabinet. Dimensions for the legs are not given and can be designed to suit the builder or omitted.

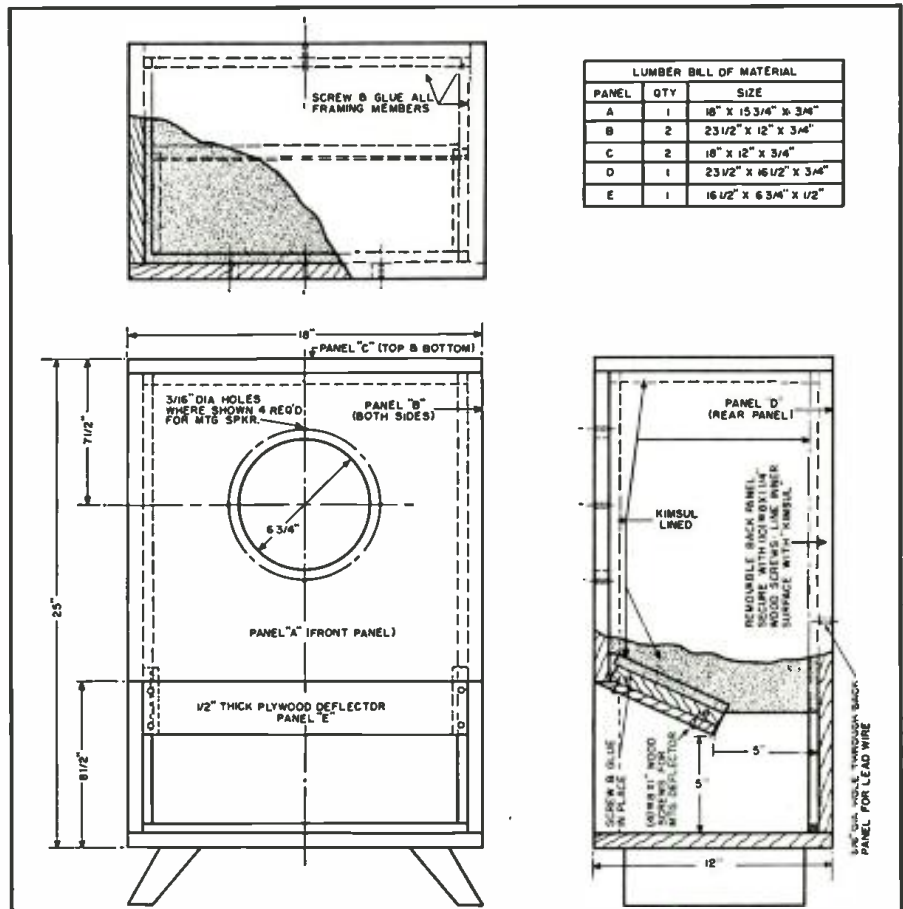



LET'S

LOOK

AT

CHANGERS

A profitable source of service income is available to the service technician with some mechanical aptitude.

THE versatility and popularity of record changers presents a challenge and a new responsibility to the electronic service technician. In addition to thinking in electronic terms, he must think in terms of gears, cams, motors, and mechanical devices, so he can meet successfully the service requirements for a television-radio-phonograph combination.

Fortunately, to master the servicing of record changers does not call for learning the theory of mechanics. If the service technician can learn to focus his attention on the particular section that is giving trouble, refrain from trying to make a diagnosis by observing the mechanism as a whole, and exercise patience, he will be able to solve most of the problems that face him.

To most people, most record changers look alike, and so there is a natural assumption that they are alike and operate the same way. This is an erroneous impression. Every record changer has a motor, a tone arm, a spindle, and its function is to play records. However, in spite of all this apparent similarity, the working parts are different and each record changer has its own particular set of problems.

Many record changers, although made by the same company, appear under different brand names, so the ones discussed here have been selected because they represent different types of units.

For a record changer to accomplish its task it must have the following sections:

1. An indexing or tone arm set-down assembly
2. A motor and speed reduction system
3. A trip and reject system to start the change cycle.
4. A record drop mechanism to furnish a new record.

Regardless of the brand of record changer, it will have to index (set the

tone arm to the proper start position) correctly for 7", 10", and 12" records. How is this accomplished? The *Admiral* RC600 uses a set-down index assembly, shown in Fig. 1, containing slots for each size record.

The tone arm mechanism is made to fall into the proper slot by a control finger extending above the changer base which feels the edge of the record played. Failure to index correctly must be attributed to one of these two parts. For instance, the control finger may be bent so that it does not feel the edge of the record, or there may be an obstruction in the slot in which the tone arm shaft rides as it lets the tone arm down to the record.

The *V-M* 950 record changer also uses a control finger rising above the changer pan to feel the size of the record to be played. See Fig. 3. The finger does not control the set-down index assembly by feeling the edge of a record, but rather by the height to which it travels. Twelve inch records have a separate selector to control the index assembly. The actual setting down of the tone arm on the record is accomplished by the tone arm shaft sliding down the inclined angle of a cam. If index trouble in this record changer is not solved by the adjustment screw under the tone arm, it may be because the control finger is bent so that it rises too high above the changer base.

In the *Motorola* RC36 record changer the location of the index position is determined by the manual movement of the record support shelf. The record support shelf (see Fig. 2) is geared to the index set-down cam. This set-down cam is positioned correctly so that when the tone arm assembly is moved inward, it will stop at the proper record size. The actual setting down of the tone arm on the record is accomplished by the tone arm shaft riding down the inclined section of the cam assembly.

Failure to index correctly, if only by a narrow margin, may be corrected by the index adjustment screw located at the inside rear of the tone arm. More complex servicing information on this problem will be given in a future article.

Motor and Speed System

The modern motor is electronically balanced, has powdered metal bearings, requires very little service, and is a mighty sturdy and reliable piece of equipment. When the record changer is ready to be discarded because it is obsolete or worn out, the motor is still going strong.

The need for service arises in the linkage between the motor and the turntable, where the 1750 rpm of the motor is reduced to 78, 33 $\frac{1}{3}$, and 45 rpm for the turntable. The turntable not only must rotate accurately, but must also supply power to the rest of the mechanism. Different methods are used.

For example, the *Zenith* S14028 record changer has the motor shaft contacting a drive wheel lying horizontally that furnishes the power (see Fig. 4). An idler wheel riding vertically between the turntable bottom and the drive wheel provides the friction necessary to turn the turntable. The speed of the turntable is controlled by changing the position of the idler wheel on the drive wheel. When the idler wheel is moved inward, it will rotate more slowly. This is because the inside of the drive wheel moves more slowly than the outer edge.

In the *RCA* 960282 series, only one wheel between the motor shaft and turntable rim provides the friction to turn the turntable. Speed is controlled for the different rpm records by the motor shaft itself. The motor shaft is different from the ordinary pencil-like variety in that it has enlarged sections, similar to the shaft used by *Philco* and shown in Fig. 5. Moving the idler wheel to different places on the shaft controls the speed by the principle that the outside of the larger shaft moves more rapidly than the outside of the narrower shaft.

The method used in the *Webcor* 106



changer is that of an idler wheel furnishing the friction, but the turntable speed is changed by placing a pulley between the idler wheel and the motor shaft. The circumference of the pulley placed between the idler wheel and the motor shaft determines the turntable speed. Another type of speed reduction system using pulleys and a belt drive is shown in Fig. 6.

Service requirements differ with the type of speed reduction used. One principle, common to all, is that the turntable speed and power depend upon friction coupling between the motor shaft and the turntable. Naturally, any loss of friction means incorrect turntable speed and loss of power to pull the mechanism through its change cycle. This loss of friction can be due to oil or grease on the idler wheel, pulleys, or turntable rim. The spring that holds the idler wheel to the motor shaft, or, in the case of *Webcor* type units, the idler wheel to the pulley, may be weak. A worn idler wheel or pulley, or any binding of a pulley or idler wheel on the shaft on which it turns, also are possible causes of trouble. A small thing like removing the gloss from an idler wheel or pulley may solve the problem.

The most important single service on any type of speed reduction system is a good cleaning, preferably with alcohol.

Reject and Trip Section

In any automatic device, every part is essential. It is true that the smallest washer or nut can cause even a well designed machine to fail. The trip and reject system is the very heart of the record changer. Because it is so important to the operation of a record changer, it stands to reason that its function must be perfect. There is no room for error here, and here lies the greatest single cause for complaint.

The reject system performs two important jobs. The most important is the control of the playing cycle; i.e., the reject system must allow the record player to play through an entire record before beginning the change cycle. The second job of the reject system is to release power from the turntable to the main cam which, in turn, operates the change cycle. These two operations work together, and one is dependent upon the other.

The most important service for the trip and reject system is a good cleaning, just as in the speed reduction

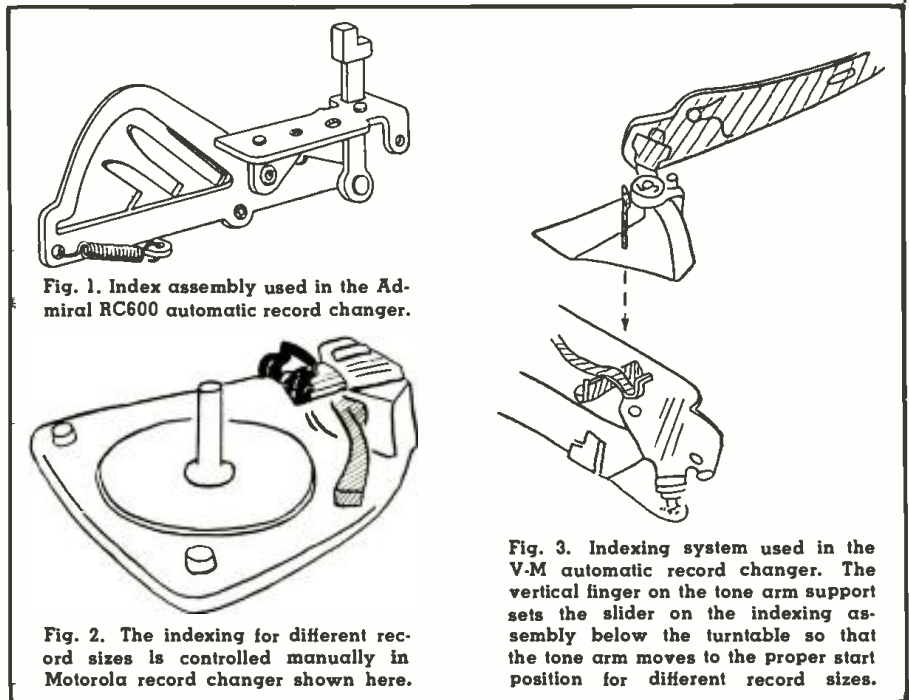

Fig. 1. Index assembly used in the Admiral RC600 automatic record changer.

Fig. 2. The indexing for different record sizes is controlled manually in Motorola record changer shown here.

Fig. 3. Indexing system used in the V-M automatic record changer. The vertical finger on the tone arm support sets the slider on the indexing assembly below the turntable so that the tone arm moves to the proper start position for different record sizes.

system, for dirt and grease will cause malfunction.

Practically all changers use a velocity trip method which means that they take full advantage of the oscillating grooves in the center of the record. The reason this method is popular is because the trip and reject can be controlled irrespective of the type of record played, whether it has more or less than normal playing time.

Although the velocity trip and reject is common to all record changers, the principle and method vary with each manufacturer.

One RCA record changer has spiral

grooves on the turntable to operate the change cycle. Here, the trip causes a plunger to jump into the spiral and start the change cycle. A *Zenith* changer uses a solenoid that becomes activated by the trip and permits the change cycle to begin. A weighted cam in a *Philco* model is released by the trip action and permits the record changing mechanism to operate.

Obviously, the repair required is dependent upon the type of reject mechanism. For instance, in the *Zenith*, first determine if the solenoid is being activated by the trip finger. If it is

(Continued on page 104)

Fig. 4. A vertical idler wheel (not shown) rides on the upper face of the horizontal drive wheel in the Zenith speed system. The position of the idler wheel on the drive wheel determines final speed. →



↑ Fig. 5. The Philco motor and speed reduction system uses a single drive shaft working against another shaft with three different size pulleys for various speeds.

Fig. 6. Admiral and V-M speed reduction system using a set of pulleys with a belt drive from the motor armature shaft. →



HOME-BUILT U.H.F. ANTENNAS

By ROBERT H. HAWKINS

Details on four collinear arrays for channels 14-30, 31-47, 48-64 and 65-83.

Antennas may be built in an evening.

The author's antenna for u.h.f. reception on channel 43.

THE licensing of many new TV stations in the u.h.f. range has brought with it many "growing pains" for the TV set owner. Some antennas work well in one area, others work better for another location. Should we use round lead-in wire or wire of the oval cross section? Many such questions arise as a community learns to live with its new u.h.f. station.

This article covers an easily-built

antenna that has helped improve reception for TV set owners who were about to conclude that their sets or converters just didn't work for u.h.f. reception. There is nothing new or original about the basic design used. It's a collinear array, the same design as used by amateur radio operators for many years. The only things that have been done to adapt this simple design for u.h.f. television

use is to determine the proper element lengths and spacings and mount the antenna for horizontal polarization.

The antenna shown in the photograph is specially cut for channel 43, but, using the dimensions shown in the chart, antennas can be constructed which will cover the u.h.f. channels as indicated. Four antennas are listed and they are so spaced throughout the u.h.f. television spectrum that they will give adequate coverage for the entire band. The antennas are broadbanded enough to cover more than the seventeen channels assigned to each of the antennas A, B, C, and D. Choose the one which comes closest to the channel of the u.h.f. station in your area and it should help you achieve reception equal to or better than that obtained by your neighbors. It's always a source of pride to say, "I built it myself," so here is how you can build yourself a good u.h.f. antenna in a single evening.

Constructing the antenna requires few tools, a small amount of material, and not much time. The elements can be made from $\frac{1}{4}$ " aluminum welding rod or $\frac{3}{8}$ " diameter aluminum tubing. (Either size seems to work equally well; the larger diameter makes the antenna a little more broadbanded.) Cut them to length as shown in the diagram, four driven elements and four reflectors. Flatten one end of each element about 1" in from the end and drill two holes as shown, using a #29 drill. Make four insulator strips from fiber, or preferably polystyrene, as shown. Two wooden spacers are required to separate the driven elements from the reflectors. After two assemblies consisting of two driven elements and two reflectors each are

(Continued on page 143)

Mechanical details for building receiving antenna for the u.h.f. television bands.

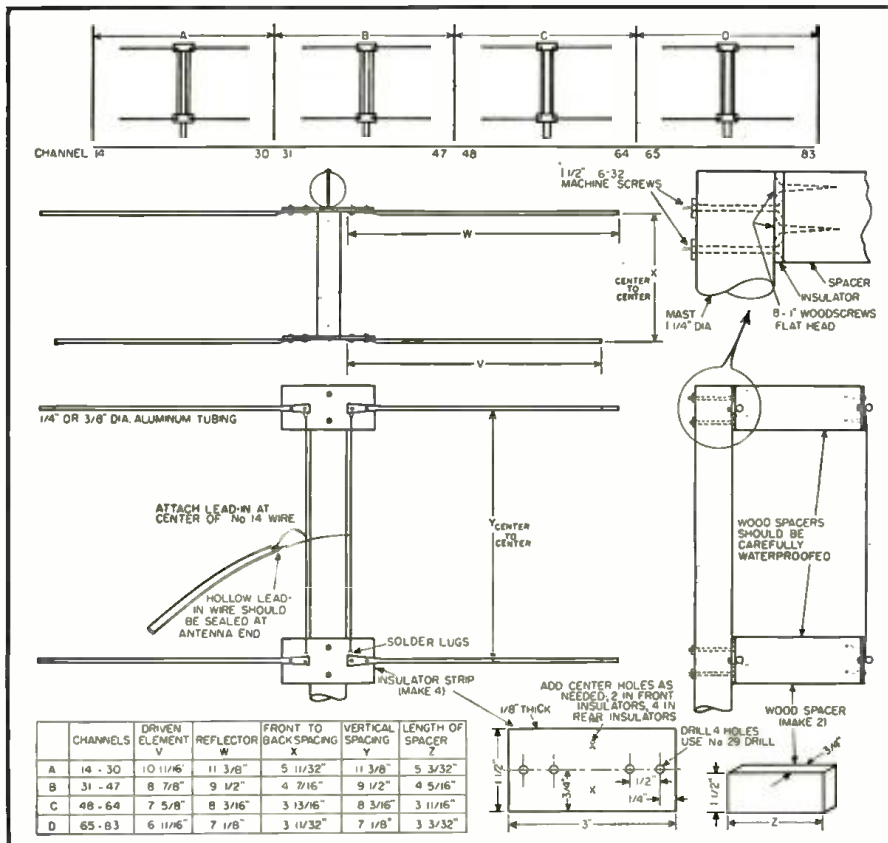

KNOW YOUR 1954

STEWART-WARNER

TV RECEIVERS

By

H. B. MASSIE

Field Engr., Stewart-Warner Electric



Fig. 1. Rear view of the Stewart-Warner 9340 series TV chassis.

ALL THE 1954 Stewart-Warner television receivers incorporate the "Thunderbolt" chassis that will be used with 21-inch, 24-inch, and 27-inch picture tubes. There are two basic chassis: one incorporates a turret-type v.h.f. tuner which can be adapted to u.h.f. by inserting a set of strips in the tuner for the particular u.h.f. channel involved, the other utilizes an all-channel turret-type tuner and additional new circuitry. The latter chassis, the 9340 series, containing a 21-inch picture tube, will be discussed.

All the "Thunderbolt" chassis incorporate many new features which simplify servicing, such as the positioning of receiving tubes on the chassis to allow for easy replacement. (See Fig. 1.) Also, plug-type connections are used for the flyback transformer and deflection yoke so that they can be replaced without the use of a soldering iron or removing the chassis from the cabinet. A special-type chassis bracket is used which allows for easy removal of the chassis from the cabinet as well as allowing the chassis to be turned upside down for servicing. (See Fig. 2.)

Tuner

The all-channel turret-type tuner furnished with the 9340 series sets is of the latest design, and is capable of tuning all standard television channels in the v.h.f. and u.h.f. range from channels 2 to 83. It consists of two separate chassis joined together as a unit. The front section tunes the u.h.f. stations, channels 14 to 83, and incorporates two preselector stages, a 6AF4 or 6T4 tube as the oscillator, and a 1N82 crystal as the mixer. The rear section performs a dual function in that it tunes all the v.h.f. stations, and

Another complete analysis of a popular 1954 TV set including the schematic diagram and alignment data.

operates as a 41-mc. i.f. amplifier when the receiver is tuned to any u.h.f. channel. It incorporates a 6BZ7 or 6BQ7A tube as a cascaded r.f. amplifier for v.h.f. operation and as a 41-mc. i.f. amplifier for u.h.f., and a 6U8 as the oscillator-mixer. In the u.h.f. position, the oscillator section of the 6U8 tube is rendered inoperative.

Fine tuning of both the v.h.f. and u.h.f. channels is performed by the same control. The shaft of the fine tuning control rotates two separate pieces of dielectric material simultaneously between two separate sets of condenser plates, one set connected to the u.h.f. and the other to the v.h.f. oscillator tank circuits. The front-

panel oscillator adjustment is merely a screw adjustment similar to that used in many v.h.f. turret-type tuners. The adjustment tool should be a non-metallic screwdriver at least 9 inches long, so it can make contact with the v.h.f. oscillator slug which is located in back of the u.h.f. section.

The selection of a u.h.f. channel is accomplished in a dual manner. Rotation of the u.h.f. turret, which is accomplished by turning the middle knob, sets into position a coil assembly that can be tuned through a range of 10 channels with the front knob. Eight different coil assemblies are used and they are easily removed for replacement. There are nine settings of the u.h.f. turret, one of which is blank, containing no coil assembly. For v.h.f. operation, the u.h.f. turret is placed in the blank position.

The u.h.f. signal entering the tuner is first fed through a high-pass filter, consisting of condensers 402A and 402B and inductances 403 and 404, which attenuates all frequencies below 470 mc. See Fig. 4. It is then coupled to the first preselector circuit, which consists of a coil connected between terminal "F" and a condenser plate.

From here the signal is coupled through condenser 406 to the second preselector stage which consists of a coil connected between terminal "H" and a condenser plate. One condenser plate is common to both preselector stages and is grounded through terminal "G." These preselector coils and

(Continued on page 62)

Fig. 2. The special chassis bracket on Stewart-Warner's TV sets makes removal from the cabinet very simple.



VIDEO I. F. ALIGNMENT

| STEP | SIGNAL GENERATOR | | OUTPUT INDICATOR | CONNECT TO | ADJUST | REMARKS |
|------|--|---|--|-------------------------|--|---|
| | FREQUENCY | CONNECT TO | | | | |
| 1 | 45 mc., 10 mc. sweep. 42 mc. and 45 mc. markers | Pin 1 of V ₃ Output of sweep generator (loosely coupled) | Oscilloscope or/and a V.T.V.M. through a 10,000-ohm resistor | Pin 2 of V ₄ | Primary and secondary of 3rd i.f. transformer for maximum, with even plateau between markers. Connect a detuning clip to pin 5 of V ₂ | Short antenna terminals together. Sweep generator output at detector should be 1 volt maximum. Place 1000 μfd. condenser across oscilloscope terminals. |
| 2 | 45 mc., 10 mc. sweep. 42 mc., 43.5 mc., and 44.9 mc. markers. | Pin 1 of V ₂ through a 100-μfd. condenser. Output of sweep generator (loosely coupled) | Same as above | Same as above | Primary and secondary of 2nd i.f. transformer for maximum—with even plateau between markers. 43.5 mc. marker in center. | Remove detuning clip. Connect negative terminal of 3-volt bias battery to a.g.c. line at point "D" (Fig. 3) on i.f. strip, positive side to chassis. |
| 3 | 41.25 mc. unmodulated | Pin 1 of V ₁ | Same as above | Same as above | Sound i.f. trap for minimum | Disconnect a.g.c. bias battery. |
| 4 | 47.75 mc. unmodulated | Pin 1 of V ₁ | Same as above | Same as above | Adjacent sound i.f. trap for minimum | |
| 5 | 45 mc., 10 mc. sweep. 42.5 mc. and 44.5 mc. markers | Pin 1 of V ₁ Output of sweep generator (loosely coupled) | Same as above | Same as above | 2nd i.f. grid coil and 1st i.f. plate coil for maximum with even plateau between markers | Reconnect a.g.c. bias battery as in step 2. |
| 6 | 39.75 mc. unmodulated | Top of raised tube shield on V ₁₉ | Same as above | Same as above | Adjacent picture i.f. trap for minimum | Disconnect a.g.c. bias battery. |
| 7 | 45 mc., 10 mc. sweep | Top of raised tube shield on V ₁₉ | Same as above | Same as above | 1st i.f. grid coil and converter plate coil (458, see Fig. 5) for curve below: | Reconnect a.g.c. bias battery as in step 2. |

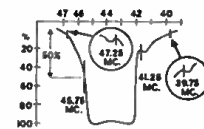

SOUND ALIGNMENT

| | | | | | | |
|----|---------------------|---|---------------|---|--|---|
| 8 | 4.5 mc. unmodulated | Pin 2 of V ₄ through a 1000-μfd. condenser | V.T.V.M. | Pin 11 of picture tube through high-frequency probe or detector network shown in Fig. 8 | Sound trap, coil 49, for minimum | Set contrast control to maximum counter-clockwise. Remove one of 6CB6 i.f. tubes. |
| 9 | Same as above | Same as above | Same as above | Pin 2 of V _{14A} through a 10,000-ohm resistor, using negative meter lead. Positive lead to ground | Top of transformer 158 for maximum | Reinsert 6CB6 tube. |
| 10 | Same as above | Same as above | Same as above | Same as above | Bottom of transformer 158 for maximum | |
| 11 | Same as above | Same as above | Same as above | Same as above | Transformer 153 for maximum | |
| 12 | Same as above | Same as above | Same as above | Junction of two series 68,000-ohm resistors from pin 2 of V _{14A} to ground. Positive meter lead to junction of resistor 161 and condenser 162 | Top of transformer 158 for zero between a positive and a negative peak | 68,000 ohm resistors are added to V _{14A} circuit for alignment only. |

Table 1. Condensed alignment procedure for the Stewart-Warner 9340 TV chassis. Before alignment, cut out the r.f. oscillator by setting the tuner to an inoperative channel and placing a piece of tape over the first two tuner drum contacts.

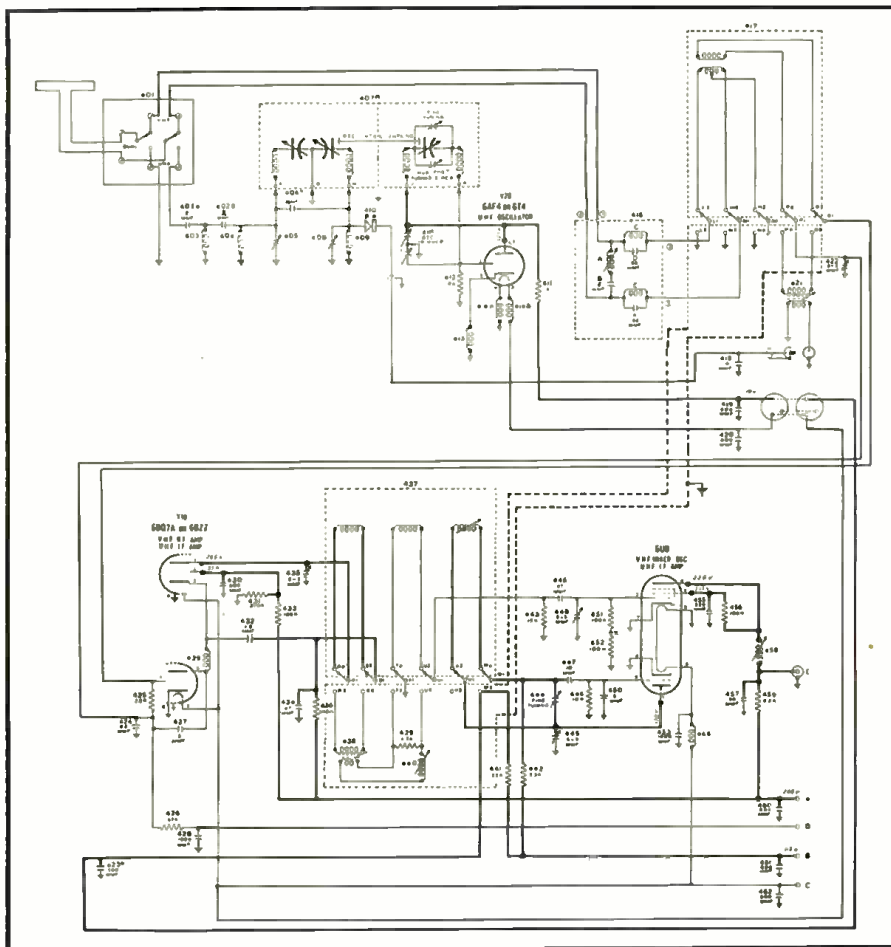

Fig. 4. Schematic diagram of the 82-channel turret tuner, furnished with the 9340 series Stewart-Warner TV chassis, shown set on a v.h.f. channel.

condenser plates are mounted on a single form and are tunable through a range of 10 channels. Selection of any one channel is effected by varying the amount of dielectric between the condenser plates. Additional tuning for alignment purposes is accomplished by adjusting condensers 405 and 408, and by either compressing or expanding the preselector coils.

A 6AF4 tube is operated as the u.h.f. oscillator, and its tank circuit consists of two condenser plates and a coil connected to each plate. These are mounted

on the same form as the preselector coils and form a complete coil assembly which is tunable through a range of 10 channels in the same way as the oscillator. In addition, the frequency range of fine tuning on all u.h.f. channels is approximately 2 to 3 mc.

Auxiliary fine tuning is accomplished by adjusting a metal slug between the oscillator-condenser plates on the coil form. On some tuners, auxiliary fine tuning is performed by a screw mounted on the face of the u.h.f. drum, which varies the capacity between the oscil-

lator plate and ground. On other tuners this auxiliary fine tuning screw is mounted on the coil form. Adjustment of this screw changes the capacity between the oscillator condenser plates. As before, additional tuning, for alignment purposes only, can be accomplished by either compressing or expanding the oscillator coils.

The output of the oscillator is capacitively coupled to the second preselector coil. The coupling is in the form of a short piece of wire, one end of which is close to one of the oscillator condenser plates while the other end is close to the second preselector plate. Note that no physical contact is made with either plate.

The oscillator frequency and u.h.f. signal are then fed to a 1N82 crystal, 410, operating as a u.h.f. mixer. This action produces the desired i.f. frequency of 41 mc. which is fed through a coaxial cable to the primary of transformer 421 which is mounted on a 41-mc. contact board. This board maintains electrical contact in the circuit of the 6BZ7 and 6U8 only when the tuner is set for u.h.f. operation, and is switched in by a cam action on the rear of the u.h.f. drum which, at the same time, breaks contact between the v.h.f. drum and its associated circuit. The secondary of transformer 421 is connected to the input circuit of the 6BZ7 tube, which is now operating as a 41-mc. amplifier. The 6BZ7 tube is a dual triode, and is connected in the circuit as a direct-coupled, grounded-grid amplifier. Transformer 438 couples the output from the plate (pin 1) of the 6BZ7 to the grid input of the pentode section of the 6U8 tube, which operates as a 41-mc. amplifier during u.h.f. operation. Transformers 421 and 438 and coil 440 are all mounted on the 41-mc. contact board. Note that in u.h.f. operation, terminal V3 on the 41-mc. contact board is left open, removing plate voltage from the triode section of the 6U8 tube, which makes this section of the tube inoperative. Signal output from the 6U8 is coupled through the plate coil, 458, to a coaxial socket on the tuner and then fed to the receiver's i.f. amplifiers.

For v.h.f. channel selection, the u.h.f. turret must be rotated until the blank setting is detented into position. This occurs when the middle knob shows the letters "v.h.f." in an upright position or when the flat of the middle shaft is in its uppermost position. With the drum in this position, there is no connection to the u.h.f. drum, which makes the u.h.f. oscillator inoperative. At this time the 41-mc. contact board is switched out of the circuit, and the v.h.f. drum is placed into operation. The desired v.h.f. channel selection is now brought about by turning the front knob which rotates the v.h.f. drum. This drum contains two sets of easily removable coil assemblies for each v.h.f. channel.

In v.h.f. operation, the antenna signal is first fed to a 41-mc. trap network, 416, which is tunable from the

Fig. 5. Top view of the 82-channel turret tuner showing the major parts.

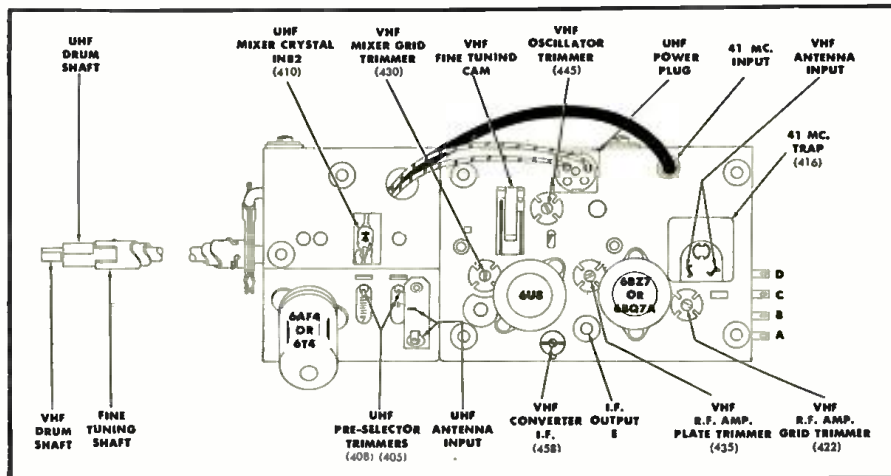

EV

MODEL 666

By

HOWARD SOUTHER & LOUIS R. BURROUGHS

Electro-Voice, Inc.

Fig. 1. The new Electro-Voice Model 666 in the special shock absorber unit for boom work. A desk stand is also available.

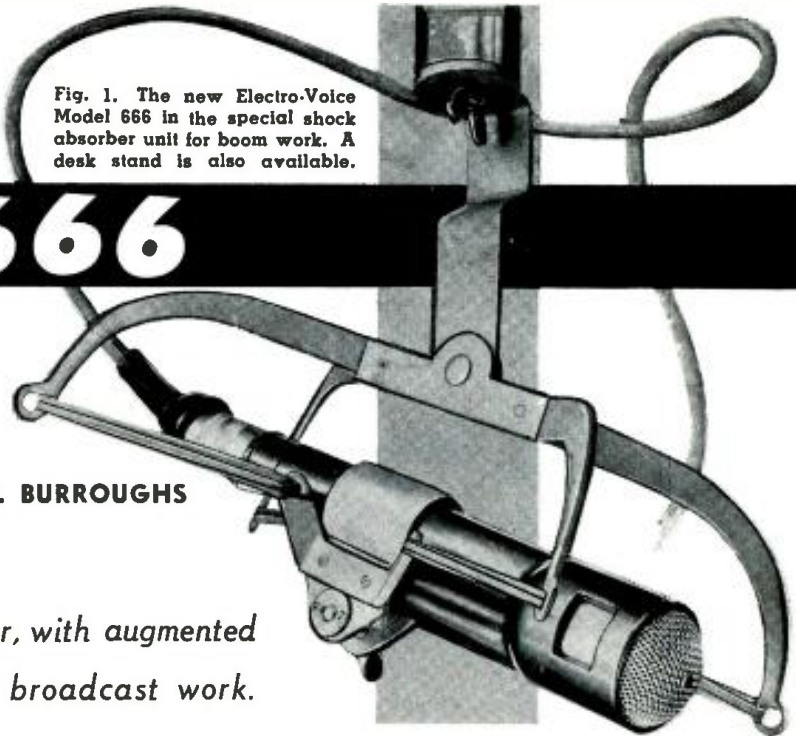

Details on a new wide-range transducer, with augmented cardioid characteristics, for use in broadcast work.

NOW, all the advantages of a pressure-operated type dynamic microphone, *i.e.*, wider range response, greater sensitivity, and extreme ruggedness, are available in a cardioid microphone—the new *Electro-Voice Model 666*.*

Despite the overwhelming superiority of the dynamic type in all of the aforementioned categories, in the important field of unidirectional design, up to now engineers have not been able to use it for wide-range applications. This new development in the unidirectional field extends the high-frequency response, permits elimination of ribbons, and does not have a characteristic boominess in the high bass region, caused by the proximity effect, when used close to the sound source. In the field of microphone design, the successful application of the dynamic principle to a microphone of outstanding characteristics is a truly major advance.

It is highly advantageous to have a unidirectional or cardioid pickup pattern in a microphone. In broadcast work it is generally desirable to exclude audience sounds and other noise not originating from the performers. It is also helpful if vocalists, with their respective microphones, can be placed near or in front of the orchestra with minimum orchestral pickup to confuse balance and sometimes override the singer. A directional microphone also prevents undue reverberation caused by reflected sound impinging from walls and reflective surfaces not a part of the performing area.

It is also necessary, in telecasting, to exclude the sounds caused by the movements of camera crews and noisy equipment. The preservation of an intimate quality in speech despite a fairly distant microphone position, out of the camera's range, can be achieved

only by a directional microphone. Further, rapid movement of a ribbon microphone can cause deformation or failure of the fragile ribbon. Increased ribbon sag can, in some cases, decrease the response resulting in non-uniform operation between microphones of the same model. Most essential, the development described herein presents adequate and uniform cardioid action throughout the entire range. In the region below 150 cps and above 4 kc., the improvement in the Model 666 is particularly noticeable and important because unwanted noise exists in the extreme bass region. Also, the ear is sensitive to the higher frequencies in speech, dolly squeaks, audience movements, and other extraneous noise to be found in the last two octaves.

Because of these new and stringent demands on microphone performance, it was obvious that the industry needed a lightweight, rugged microphone which could provide high and uniform front-to-back discrimination. Simplicity of design was also required to provide stable operation. Susceptibility to shock and wind noise had to be reduced and the size had to be small to eliminate shadows and make the microphone as unobtrusive as possible. A microphone which meets these requirements will be described.

* Patent Pending

Design and Operation

The Model 666 is 7½" long, 1⅝" at its largest diameter and 1" at its smallest diameter. The microphone is supplied with an integrated blast filter and magnetic shield and weighs only 11 ounces. Accessories for use with this model include a small, heavy cast stand and an inconspicuous shock mount for boom work.

The output level of the microphone is —57 db below 1 milliwatt operating in a sound field of 10 dynes/cm.². Output impedances are available at 50, 150, and 250 ohms with a matching strap provided internally in the barrel of the unit.

The frequency response range, Fig. 2, is substantially uniform throughout the entire spectrum. The front-to-back signal discrimination is no less than 14 db at any frequency and averages 25 db throughout the spectrum in the back hemisphere.

The shape of the microphone, Fig. 1, is the result of fundamental functionality. The two tubes extending from the rear of the head cavity include sound entrances. These sound entrances, in combination with the openings directly behind the diaphragm, form part of three separate acoustic paths, all of different lengths. Each path is carefully calculated to pass sound over only that part of the spec-

(Continued on page 150)

Fig. 2. Frequency response of the Model 666. See text for discussion of response.

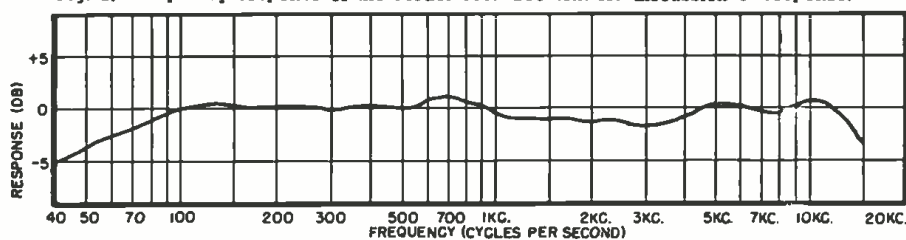

TELEVISION

TROUBLESHOOTING

METHODS

By JOHN K. FRIEBORN

How systematic is your troubleshooting? Review the techniques described here for better TV servicing.

"IS THE television receiver you are trying to outthink an *Ultravision* Model 2020 with a purple shamrock on the rear chassis apron and does it show people with short legs and long heads? Replace the vertical amplifier tube and/or C_{20} ."

This service hint may be valuable to you unless the only *Ultravision* Model 2020 that ever tried to get the best of you had a *green* shamrock and showed people with long legs and flat heads.

You say you want something that you can use a bit more often? How about this? "If the sound produced by a given receiver is all right, but there is something wrong with the picture, then the trouble is in one of the parts of the receiver which affect the picture but not the sound."

Too general, you say, and it doesn't tell you what to do? That isn't the half of it; sometimes such "obvious" statements are, from a practical point of view, not even true and television receiver troubles are not where they should be.

Both of the types of information mentioned do have their uses, of course. Sometimes the specific cure does refer to the receiver and trouble you have—or it can be applied to another receiver if you know enough to make the necessary changes. As for the general suggestions, they may be all you have to start with. Of course, going beyond them does require you to know how they apply to the particular receiver with which you are dealing.

Fortunately, there are many other

methods known to service technicians which can be used to find many different troubles in almost any type of receiver; this article will describe some of them.

Most—if not all—of the available techniques for finding troubles in television receivers can be divided into three types: 1. interpreting symptoms and tracing the functioning of the receiver to localize the trouble logically; 2. checking for particular faults which are known to occur frequently; and 3. checking components and adjustments which are easy to check.

Logical tracing of the receiver's functioning begins, of course, with observation of the symptoms. First, though, have the set-owner turn the set on, adjust it, and show you what is wrong with it. The fault may be in his (or her) methods. This also will avoid looking for the wrong trouble.

Sound Section

With one exception, the sound-producing functions of a television receiver are practically identical with those of an FM receiver. In addition, a TV receiver must separate the video signal from the sound. When it does not do so completely, we have the well-known video buzz, one of the most annoying troubles to the set-owner and often one of the hardest for the service technician to find. Actual direct function-tracing in this case is difficult. The best approach is to check each point in the circuit where the fault could be, since there are not very many of them.

First, check the sound i.f. tuned cir-

cuits by adjusting them to reduce the buzz. If no improvement is produced by manipulating a particular trimmer, return it to its original position. Second, in an intercarrier receiver, check the video i.f. tuned circuits which are intended to reduce the amplitude of the sound signal entering the video detector. (This requires specific knowledge of the receiver's i.f. alignment.) Third, also in an intercarrier receiver, if the sound is separated from the video signal after one or more stages of video (not video i.f.) amplification, check on the possibility of cross modulation in a video stage because of a weak tube, improper bias, or overloading. Fourth, in any receiver, if the buzz is most noticeable with a strong signal, check the possibility that the mixer tube is drawing grid current, thus offering a varying load which frequency modulates the oscillator. The cure is either to reduce the signal input to the mixer or rewire the circuit to apply a.g.c. bias to its grid. If nothing suggested here does any good, the service technician may console himself—though not his customer—with the thought that many intercarrier receivers of a couple of years ago had a buzz "built-in." The seat of the trouble was a distorting video stage as mentioned in the third suggestion. The cure requires redesign of the receiver, with the sound take-off immediately after the video detector and an additional sound i.f. stage.

Picture Section

In dealing with picture faults, the first step is the hardest: determining exactly which function is not correct. We must recall just what functions are required to produce the picture and examine each one separately. Those functions are: 1. light production, 2. focusing, 3. beam modulation, 4. vertical deflection, 5. horizontal deflection, 6. vertical synchronizing, and 7. horizontal synchronizing.

If the screen is dark or less bright than normal, the trouble is one of the following: heater voltage low or absent, cathode worn, ion trap magnet misadjusted, improper electrode voltage (grid bias and first-anode potentials are possibilities as well as the high voltage), phosphor worn, or other picture tube fault such as loose connection in base.

To check focusing note the width of the scanning lines. They should be as narrow as possible and well-separated from each other, over as much of the area of the screen as possible. Inadequate focusing may be due to improper adjustment of ion trap magnet, improper position of focus coil or magnet, or (in case of focus coil) faulty focus-control, current- or voltage-dividing network.

Beam-modulation faults, indicating improper video signal delivered to the picture tube grid-cathode circuit, are of many different types. "Snow," interference, "ringing," and lack of signal are the principal defects.

"Snow" usually is said to be caused

by a weak signal, but it would be more accurate to say that a weak signal does not override the "snow," which is always present but not visible in the presence of a strong signal. If the signal actually is not weak, the fault may be in the antenna system (insufficient gain, loose connection), or in the r.f. section of the receiver (loose connections, corroded contacts, weak tubes, improper voltages).

A regular pattern superimposed upon the picture indicates an interfering signal. Some clue to the source usually can be obtained by computing the frequency of the interference. If horizontal bars are produced, multiply one-half the number of bars (dark and light), from the top of the picture to the bottom, by 60 cycles. In Fig. 1, two bars are present, so that interference is due to a 60-cycle signal (in this case, hum in the video amplifier or picture-tube circuit). If the bars are vertical or diagonal, multiply one-half the number of bars by 15,750 cycles. The pattern shown in Fig. 2 contains about 120 bars, allowing for the entire width of the screen (Fig. 2 shows only part of the screen) and the horizontal retrace, and the interfering signal is about 1 mc. This effect could be produced either by a 1-mc. signal injected into the video amplifier, or a signal 1 mc. more or less than the video carrier frequency injected into the r.f. or video i.f. sections.

The pattern in Fig. 5 is not caused by an external interfering signal. Note that the bars are not straight and do not cover the entire screen. This effect is caused by "ringing"—oscillation, possibly in the video amplifier, but usually in the video i.f.

A useful technique for diagnosis of faults in the receiver's response to video signals is to draw (or imagine that you have drawn) a picture of the waveshape which would produce a portion of one line as it appears on the screen and as it should appear. (See Fig. 3.) Poor response to either high or low frequencies may be due to misalignment of the video i.f. amplifier or to faulty components in the video amplifier. Poor low-frequency response can be further localized by noticing the effect of manipulating the fine tuning control. If no setting of the control gives adequate low-frequency response, the fault is in the video amplifier. Poor high-frequency response cannot be localized so easily, but usually it is due to i.f. misalignment.

One case of variation in light on the screen is not caused by a grid-cathode signal in the picture-tube circuit at all. (See Fig. 6.) This is due to "ringing" in the horizontal deflection circuit, causing each line to be folded back upon itself. (See Fig. 4.)

Most vertical and horizontal deflection faults, causing insufficient size or nonlinearity, produce easily recognizable effects on the picture. On the other hand, it may be difficult to tell whether certain other faults are in the deflection section or in the synchronizing section of the receiver. Faults in



Fig. 1. Pattern produced on TV screen by 60-cycle hum interference in video.

either one may cause vertical "rolling" or horizontal "tearing." The test is to adjust the hold control very carefully and note the effect. If the picture can be brought into proper synchronization, even momentarily, without going to either extreme of the control's range, the frequency-controlling parts of the deflection circuit are OK and the trouble is in the synchronizing circuits.

Checking the Stage

When a fault has been isolated to a section of the receiver, the faulty stage can be found by signal tracing or signal injection. The most adequate signal tracer for the deflection and synchronizing stages—and even for the video amplifier—is an oscilloscope. For other stages, suitable voltmeters and signal generators can be used. At two points in the receiver, the faulty stage cannot be found by simple stage-to-stage tracing: the mixer and oscillator, and the horizontal a.f.c. circuit. In both cases, two inputs are required to produce the proper single output.

Oscillation of the oscillator can be verified by measuring the developed grid bias in receivers where a test point is provided. If the measurement is made without the benefit of a special test point, precautions must be taken so that the loading effect of the meter will not disturb the functioning of the oscillator. Such a measurement in any case tells nothing about the frequency of oscillation. The frequency may be checked with a frequency meter if available or the functioning of the receiver may be observed using a substitute signal from a signal generator.

The faulty component within a stage

Fig. 5. "Ringing" interference is caused by oscillation in video i.f. amplifier.



Fig. 2. One-megacycle interference produces this beat pattern on picture tube.

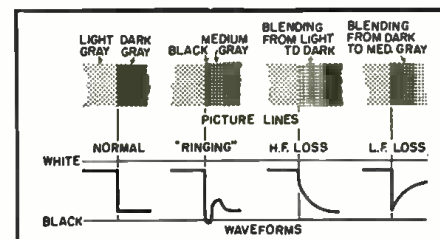

Fig. 3. Matching the appearance of a picture line on the CRT with the type of signal waveform that produces it.

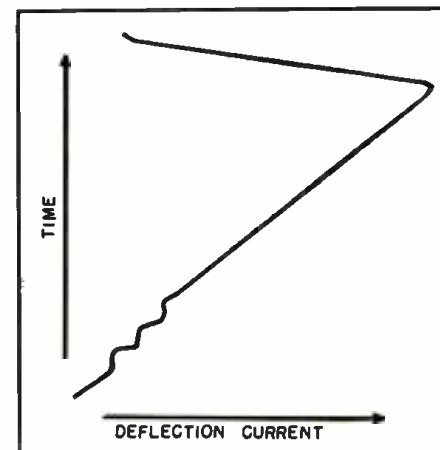
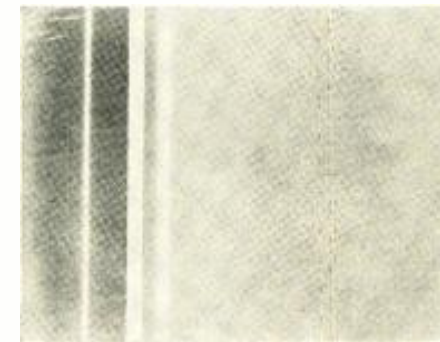

Fig. 4. Horizontal deflection waveform producing vertical lines as in Fig. 6.

can be found by the direct and indirect methods common in troubleshooting: tube replacement, voltage and resistance measurements, condenser bridging, etc.

The systematic method described for localizing the trouble to a section, to a stage, then to a component, sounds
(Continued on page 149)

Fig. 6. Vertical white lines caused by oscillation in horizontal sweep circuit.





Bench consultations, group instruction, and lectures yield advanced TV training.

HOW IS YOUR TRAINING PROGRAM?



By
J. H. HAZLEHURST
Business Consultant

ANY owner of a service shop, if he keeps records on employee "turn-over," is aware of the "fluidity" of his shop force, particularly his field men. In a general way, he is also aware of the fact that the staff needs training. In some of the larger shops time may be set aside during which training sessions are held. It is the exceptional owner, however, who has any realization of how much such training periods cost him or, alternately, how much the lack of such formal training costs him in lost time and inefficient servicing.

Unfortunately this is not a problem that the shop owner can take or leave alone. In this respect it is like public relations. The shop owner cannot decide whether he will or won't have a public relations program. He has one. His only decision is whether it will be good or bad. The same is true of training. Whether or not it is recognized, every shop owner has a training program. Any owner or shop foreman who is called to confer with a bench man on a problem set is spending time and money in training. When several men are in a discussion, during working hours, over a "dog," the shop owner has just spent money in training. When a repaired set bounces, some of the money spent in making it good can be charged to training if that is any satisfaction to the shop owner. If you are in the radio and TV servicing business, you are also in the training business whether you know it or not and whether you want to be or not.

If the training challenge is to be met properly, it must be met on two fronts—the industry front and the individual front. Let's consider the industry side first. Perhaps few busy people in the service game realize the extent to which training programs have grown within the electronics industry in general. Consider the phenomenal growth of the organizations supplying service information. Actually, these are "training aids" and the demand for them and the "how-to-do-it" books has increased to an unbelievable extent since the old radio

Do you have an efficient training program for the radio and TV service technicians in your shop? If not, you stand a chance of losing your key men.

days. The correspondence and home study schools have increased in size and number. Schools with residence courses are still jammed with students. Every manufacturer has field men who put on training meetings covering everything from antennas to test instruments. Most of these are excellent, but the overlap in material is very great. If a shop owner took on all these programs, his men would never be at the bench or out making home calls. It is no wonder, then, that the practical shop man looks with a chilly eye on the eager beaver who wants him to have his men attend a hot meeting, say, by a tube manufacturer.

The fact is that the training aspect of the servicing field is in the same state as the manufacturing branch of the industry in the days when some wanted to scan from left to right and some from right to left, and everyone had his own notion of the proper number of lines per frame and frames per second. The solution to that problem was the NTSC. It is my opinion that the solution to at least a great part of the current training rat race lies in an analogous mechanism for the service field.

Logically, this should be spearheaded by the national associations in the service industry. It is doubtful, though, if this is a practical answer at the present time owing to the fact that these associations do not have the full backing of the service shops of this country, nor do they have the funds to undertake such an enterprise. The greatest weakness of the servicing industry is that it has not yet developed the leadership necessary to make it an integrated segment of the industry that is both vocal and intelligently powerful. Certainly, the leadership is there somewhere, and in time it will

assert itself, but meanwhile, it is probably going to be up to the manufacturers to supply the needed unification and streamlining of the welter of training efforts now being made. While this may not be the manufacturer's responsibility, it would be to his advantage to do it. Many a manufacturer has discovered that while it is not his responsibility to do sales training at the retail level, it nevertheless pays off in increased profits.

Much has been said about service charges being high. At the same time, shop owners generally are not getting wealthy. It is very possible that a disproportionate share of the service dollar goes to cover inadequate, faulty, or uneconomical training. If so, a solution to the problem would be reflected in increased profits to service shops, manufacturers, and might even benefit the public in lowered charges. Certainly there are enough dollars being spent in the service field today to pay the costs of such a study and undertaking.

This, then, is the problem of the industry at large, and I believe that the industry will eventually recognize it. Meanwhile, the individual shop has its own job to do. Each shop is an individual enterprise with its own characteristics and no pat formula can be set up to fit them all. There are basic principles, though, that must be recognized as fitting all shops from the largest to the smallest. The first is to realize that training programs are probably here to stay. A shop owner must acknowledge the fact that he must provide some form of training and then try to make it a controlled item. He must study the training tools available in his area, pick out those with the least overlap and the least amount of specialized commercial

(Continued on page 172)

NEW COMMUNICATIONS RECEIVER

THE new National Model NC-88 is a good example of a communications-type receiver of high performance and rugged dependability. It has been designed to fill the needs of many varied classes, from the amateur and short-wave listener to the many commercial services and civil defense groups. Eight miniature type tubes plus rectifier are utilized in a modern superheterodyne circuit with a continuous frequency coverage of 540 kc. to 40 mc. Both voice and radiotelegraphy reception are provided to permit world-wide coverage over the entire range. The complete frequency coverage of the NC-88 is separated into four bands, with the entire main tuning dial and the 10, 11, 15, 20, 40, and 80 meter amateur bands on the bandspread dial calibrated directly in megacycles. A logging scale on the bandspread dial permits relative calibration of bandspread tuning anywhere within the range of the receiver, while clear markings on both dials, including location of the new civil defense frequencies, contribute to ease of operation.

A phono jack has been installed on

the rear of the chassis to accommodate most types of record players in use today, permitting the receiver to be used for music reproduction. Audio is delivered to the built-in loudspeaker, while a two-position tone switch gives the listener his choice of crisp treble or rich bass response. The delayed automatic gain control circuit compensates for fluctuations in the strength of the received signal due to

atmospheric conditions, etc., while an extremely effective automatic noise limiter circuit provides maximum suppression of most types of objectionable noise.

Audio output is provided by the built-in five-inch permanent magnet loudspeaker or at the headphone jack located on the front panel. The headphone load impedance is not critical,

(Continued on page 148)

Details on a receiver of good performance and rugged dependability which covers all bands 540 kc. to 40 mc.

Schematic diagram of the National Model NC-88 communications receiver for amateur, s.w., commercial, and civil defense use.

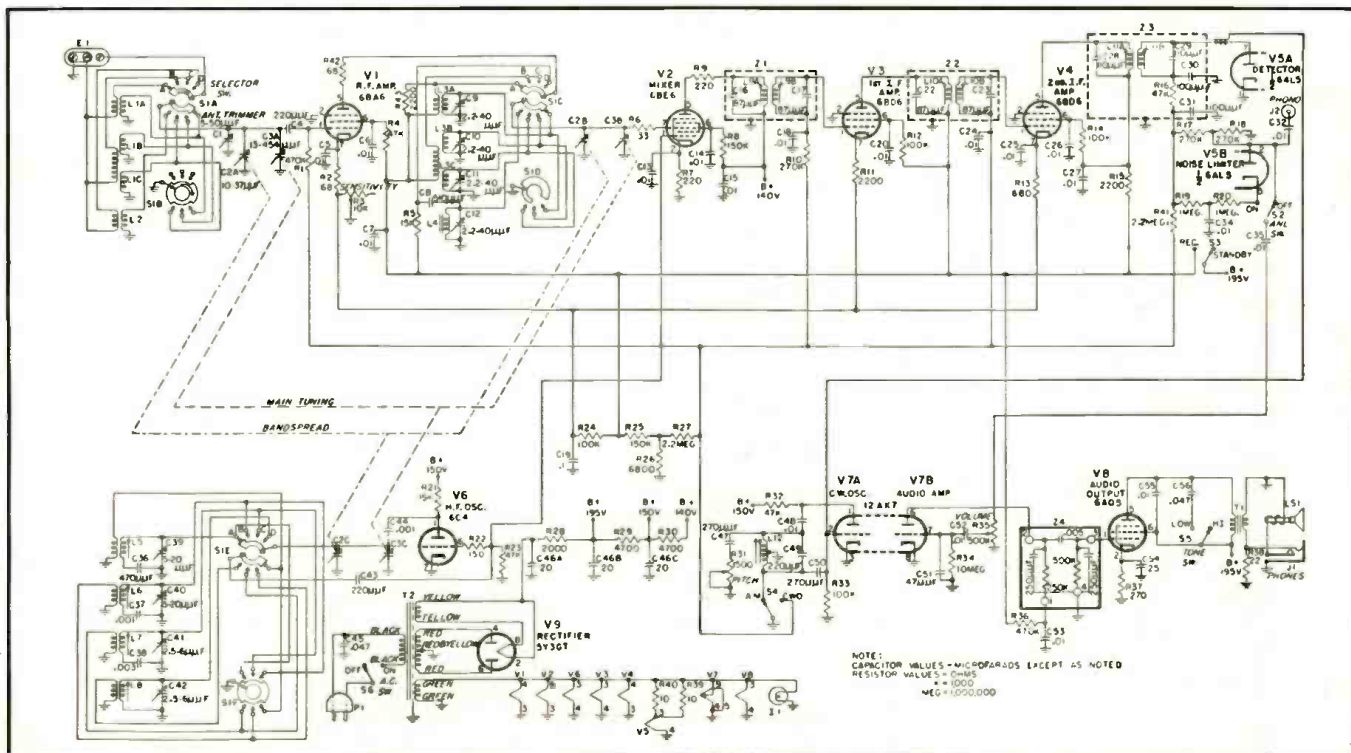

FUNDAMENTALS OF

COLOR TV

Part I. For fundamentals and their application in

television for radio and TV service technicians.

MILTON S. KIVEN

Pres., Television Communications Institute

COLOR forms one of the most intimate contacts in our everyday life—we wear colored clothes, we use colored objects, we live in colored houses, and we eat colored food. Yet, in spite of this close contact with color, most people have only a casual knowledge of the nature of color or of color mixing. To the television technician, color possesses added significance because of its application in color television. Such terms as color primaries, hue, saturation, chromaticity, and luminance will be commonly used in any description of a color television receiver, both from the standpoint of operation and of service. What do these words mean? How do they tie in with color television? These are some of the questions the service technician will be confronted with and now, while the art is still young, is as good a time as any to learn about them.

Let us start off with color primaries. Anyone who has ever experimented with projector lamps has discovered that when different colored lights from several projectors are combined, the resultant color seen by an observer will differ from the color of any of the projected beams. Thus, for example, yellow can be formed by combining red and green light; white light can be produced by combining red, green, and blue. The color of the light formed will appear to the eye as a complete color and the eye will be unable to distinguish the various components of the mixture that united to form the new color.

This method of color formation is illustrated in Fig. 1A. Two circles of colored light are projected onto a screen and positioned so that they overlap to some extent. Within the overlapping region, a new color will be produced by the addition of color "A" and color "B." Where the circles of light do not overlap, each light will retain its original color. If a third circle of light is added, as shown in Fig. 1B, then a maximum of seven colors can be obtained. These would be: color "A," color "B," color "C," color "D" (formed from "A" and "B"), color "E" (formed from "A" and "C"), color "F" (formed from "B" and "C"), and color "G" (formed from "A," "B," and "C")

and each would differ from the other. In the areas where the circles of light overlapped, the eye would not be able to distinguish each of the colors forming the mixture, but instead would see the final color produced. Thus, color "A" and "B" would not appear to the eye as color "A" and color "B," but as some new color which we can call color "D." The same would be true of each of the other combinations.

The number of different colors that can be formed by the use of three colored lights, as shown in Fig. 1B, will depend upon the colors chosen. Experience has indicated that the colors red,

With the addition of more and more colors to our mixing scheme, the reproducible range would widen somewhat. Obviously, however, a line must be drawn and the use of three colors has been standardized. The three colors chosen, red, green, and blue, are thus referred to as the "primary" colors although, as we shall see, the use of the word primary has been widely misinterpreted to mean that red, green, and blue will, in various combinations, reproduce all colors. This is only in a special instance.

The reason why three primaries were chosen, in preference to say four, probably stems from the belief that the eye behaves as though it contains three sets of nerves, with each set of nerves responsive to a different portion of the visible spectrum. Thus, one set of nerves has its greatest sensitivity in the blue region; another set is most sensitive in the green region; and the third set is most sensitive to red. Whether or not three sets of nerves actually exist has never been absolutely established. However, since the eye reacts as though such a condition does exist, it is reasonable to work on the assumption that it does.

The theory which serves to explain the ability of the human eye to distinguish various colors can also be employed to explain color blindness. In the eyes of a color-blind person, all of the color sensitive nerves or retinal cones react in the same way to all colors. Hence, when colored light is viewed by these people, all three sets of nerves are similarly stimulated and the same result is obtained as though equal amounts of red, green, and blue light were intermixed. The color seen would be white, or some intermediate shade of grey. These people can distinguish between dark and light, but no more.

There are also people whose retinal cones differ sufficiently to see some of the colors, but not all. These people are known as partially color blind. Perhaps the best known instance of this is green and red color blindness. In the eyes of these people green or red appears grey. Fortunately, however, over 90 per-cent of the population have normal vision, which means

EDITOR'S NOTE: Although color television is a commercial reality, few TV service technicians will have the opportunity to install or work with sets for some time to come. In the meantime, the service technician can ground himself thoroughly on the fundamentals of the subject so as to be prepared when color TV sets become widely available. This article is the first of a series that will attempt to present all the background necessary for the servicing of color TV receivers. Actual schematic diagrams of color TV sets will be analyzed when they become available and once the fundamentals of color TV have been thoroughly covered. Of course, other articles in RADIO & TELEVISION NEWS will present the latest advances in color TV as they occur.

blue, and green, when combined with each other in various proportions, will produce a wider range (or gamut) of colors than any other combination of three colors. Note, however, that if we used four different colors in our mixing process, we could produce an even greater number of different colors.

Fig. 1. (A) A new color is formed between color "A" and color "B" as a result of mixing color "A" and color "B". (B) Adding three original colors, "A", "B", and "C", results in four new ones.

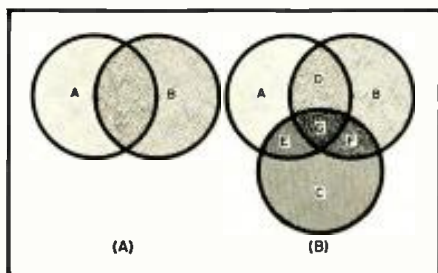

COLOR ANALYSIS

that they are able to distinguish between all of the spectrum colors.

A diagram which is very convenient to use for color mixing is the tongue-shaped (or horseshoe-shaped) curve shown in Fig. 2. (Another name for this curve is chromaticity diagram.)

Around the perimeter of this curve are listed numbers that range from 400 at the lower left-hand corner to 740 at the farthest point to the right. These figures represent the wavelength of various spectrum colors in millimicrons. Thus, purple (violet) extends from approximately 400 to 450, blue extends from 450 to 500 millimicrons, green extends from 500 to 570 millimicrons, yellow extends from 570 to 610 millimicrons, orange extends from 590 to 610 millimicrons, and red extends from 610 to 740 millimicrons.

Any point not actually on the solid-line curve but within the diagram represents not a pure spectrum color but some mixture of spectrum colors. Since white is such a mixture, it, too, lies within this diagram; specifically, at point "C." This particular point was chosen at an international convention in England and is generally referred to as "illuminant C." Actually, of course, there is no specific white light, since sunlight, skylight, and daylight are all forms of white light and yet the components of each differ considerably. The color quality of a conventional black-and-white television receiver tube is represented by some point in the central region of the diagram about point "C."

The chromaticity chart lends itself readily to color mixing because a straight line joining any two points on the curve will indicate all the different color variations that can be obtained by combining these two colors additively. Thus, consider a line drawn connecting points "R" and "G" representing certain shades of red and green respectively. See Fig. 3. If there is more red light than green light, the exact point representing the new color will lie on the line, but be closer to "R" than "G." Point "R" might be such a color. On the other hand, if a greater percentage of green light is employed, the color will still lie on the line connecting "R" and "G," but now, it will be closer to "G" than "R." Point "G" might be such a color. This same line of reasoning can be carried out for any two colors on the chart.

(On the screen of a three-gun tri-color picture tube we can carry out the same experiment by turning off the blue gun and permitting only the electron beams from the green and red guns to reach the phosphor-dot screen. As one beam, say that from the red gun, is made more intense, the resultant color on the screen shifts closer to red. On the other hand, if the red gun is turned down and the green gun beam is turned up, the resultant color takes on more and more of a greenish cast. When both guns are producing beams of equal intensity, yellow will be seen.)

Point "C," in the central region of this diagram, is taken to represent white or daylight. If we draw a line between point "C" and any point around the curve, we have a mixture of white light and a particular spectrum color. Thus, in Fig. 4, a line connects point "C" and green at 545 millimicrons (point "A"), indicating a mixture of white light and spectrum green. If the amount of white light is zero, then the pure spectrum green will be produced. As white light is added, the hue of the green changes and the point representing this mixture moves along the line toward point "C." We might consider this as diluting the green, causing it to become lighter and lighter.

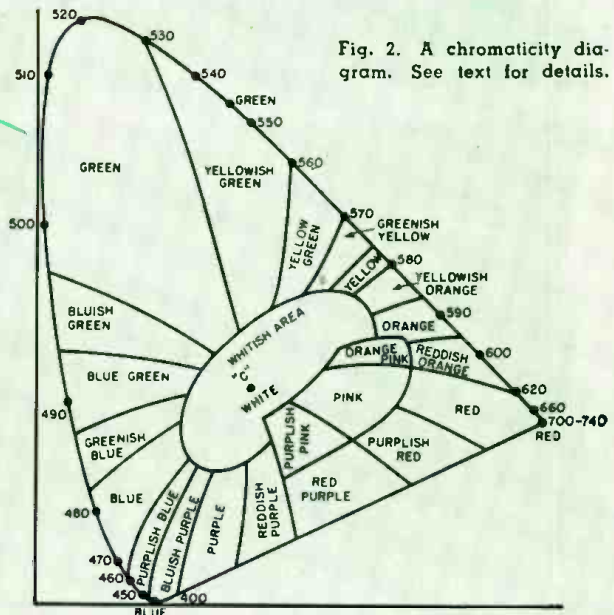

Fig. 2. A chromaticity diagram. See text for details.

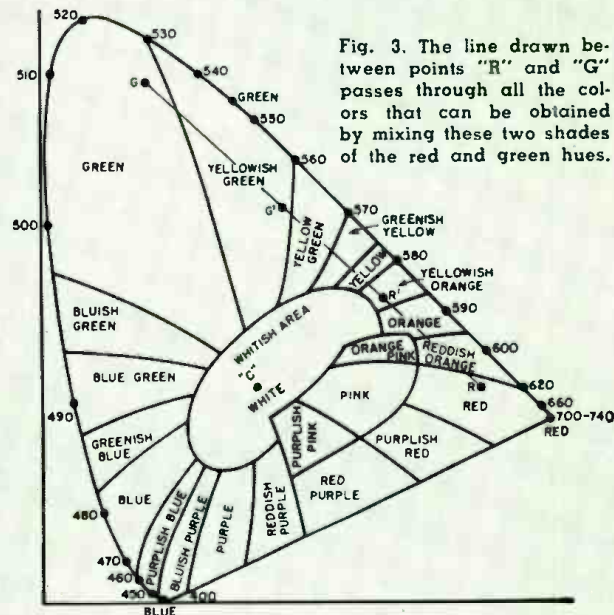

Fig. 3. The line drawn between points "R" and "G" passes through all the colors that can be obtained by mixing these two shades of the red and green hues.

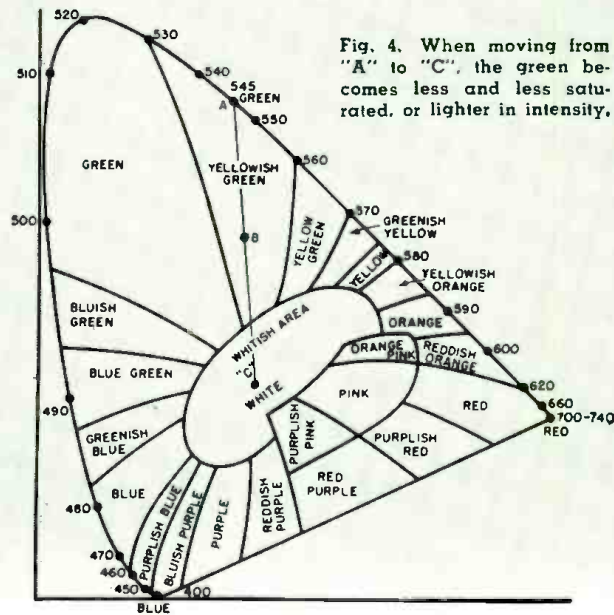

Fig. 4. When moving from "A" to "C," the green becomes less and less saturated, or lighter in intensity.

(In a color tube, we dilute a solid color, say green, by adding more red and blue. The red and blue combines with some of the green to form white, thereby reducing the intensity or depth of the green.)

It is possible to specify the saturation of a color by its distance from point "C." Thus, consider point "B" in Fig. 4. This is half way between point "C" and point "A" and represents a mixture of green diluted 50 per-cent with white light. The saturation of the green at point "B" is 50 per-cent. Had the distance between point "C" and point "B" been 75 per-cent of the total distance between point "C" and point "A," we would have stated that the saturation of the color at point "B" was 75 per-cent. By moving point "B" closer and closer to the spectrum curve, its purity increases until it becomes 100 per-cent at the curve—point "A." By moving point "B" closer to point "C," its saturation decreases. At point "C," the saturation is said to be zero.

In connection with saturation, the word hue is frequently heard. Hue represents colors such as red, green, orange, etc. It is associated with color wavelength and when we label a certain color as green, or orange, or red, we are specifying its hue. Thus, hue refers to the basic color as it appears to us, while saturation tells us how deep the color is. If the color is highly saturated we say that it is a deep color, such as deep red, or deep green. If it contains a considerable amount of white light, we say it appears faded or pale, as a faded red or a pale green. Hue and saturation are psychological terms representing the observer's impression of a color and hence they cannot be defined as precisely as wavelength.

At the bottom end of the chromaticity curve, on the line drawn from deep blue to red, there is a series of colors which are combinations of red and blue in various proportions. These

range from bluish purple to purplish red. It can be seen that this line completes the curve of Fig. 2. However, this line should not be considered in the same sense as the rest of the curve. It does not contain any spectrum colors but only combinations obtained from mixing spectrum colors. Because of this, the region at the back end of this tongue-shaped curve is known as the region of non-spectral colors. The boundaries of this region are obtained by drawing dotted lines from point "C" to red at 700 millimicrons and from point "C" to blue at 450 millimicrons. The remainder of the diagram above these dotted lines is known as the region of spectral colors. The entire diagram is known as the domain of real colors.

One further term used in connection with this diagram is complementary color. Any two colors which can by themselves form white are known as complementary colors. Thus, in Fig. 5, the line connecting point "F" with point "G" passes through point "C" and hence, the colors at "F" and "G" are said to be complementary to each other.

We have previously seen that a line drawn between two points representing two different colors contains all of the combinations that can be derived using those two colors. If, now, we wish to determine what range or gamut of colors can be obtained from any three given colors (say "R," "G," and "B"), we would draw connecting lines to each of the colors. See Fig. 6. The result is a triangle. We can produce any color within this triangle by various combinations of the three colors, "R," "G," and "B."

The wavelengths of "R," "G," and "B," chosen for television fall near 610 millimicrons for the red, near 540 millimicrons for the green, and near 470 millimicrons for the blue. These are actually the values used for the triangle drawn in Fig. 6 and by studying this diagram you can see the extent of

the color range obtainable on a color television receiver. Note that colors not included within the triangle will not be reproduced by any combination of the three primary colors chosen.

This, of course, brings us back again to the statement made previously, that three primary colors cannot reproduce all colors simply by adding the three primary colors together. In color television, of course, only those colors which can be produced by adding the primaries together can be considered, this being the only practical approach possible.

The choice of suitable primary colors for television depends principally upon what type of color phosphors can be obtained for the receiver picture tube. Originally it was felt that the color picture would be traced out on a black-and-white screen and then the light passed through a color filter to present the observer with the "color" image. This was the method employed in the CBS system and in the early forms of the RCA system. However, with the development of a color tube, phosphors are employed which emit colored light directly, leading to a less cumbersome system physically and a more efficient system optically.

A considerable amount of research work is being done on evolving phosphors which will provide as wide a gamut of colors as possible. In recent tubes, a willemite phosphor ($Zn_2SiO_4:Mn$) was used for the green, a sulphide phosphor ($ZnS:Ag:MgO$) for the blue, and a third phosphor, $Zn_3(PO_4)_2:Mn$ for the red. These primaries provide a fairly wide range of colors, as seen in Fig. 6. By comparison, the area covered by printing inks is much smaller. It may be that as the art advances, the color range of the phosphors will be extended, although the colors now obtainable are wholly satisfactory.

When the NTSC system of color television was under development, a considerable amount of research was

(Continued on page 157)

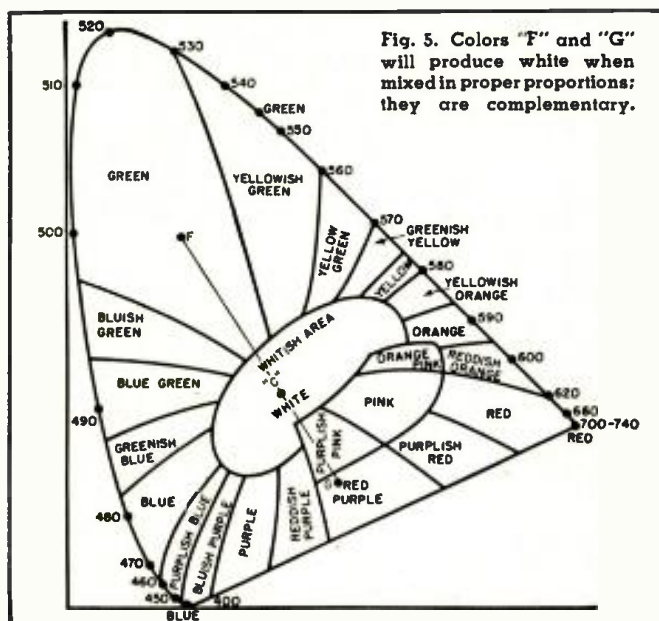

Fig. 5. Colors "F" and "G" will produce white when mixed in proper proportions; they are complementary.

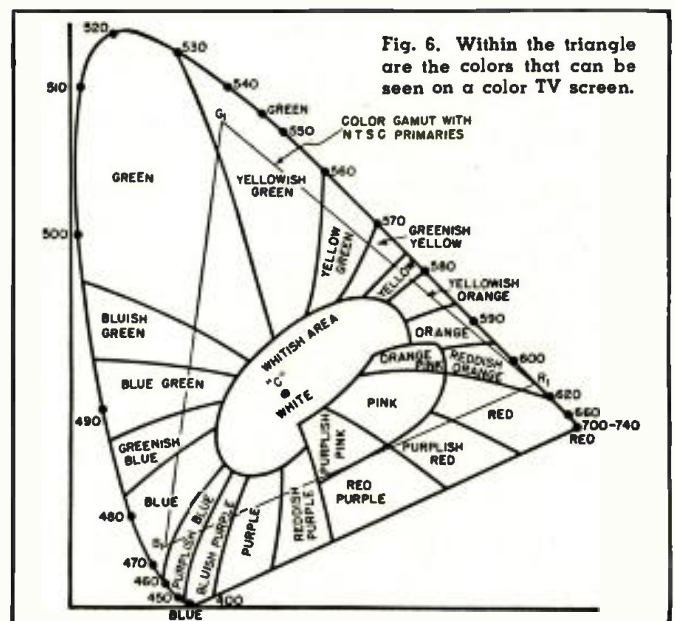

Fig. 6. Within the triangle are the colors that can be seen on a color TV screen.

BUILDING A MULTIMETER

By **ROBERT HILLIARD**
Robert Hilliard Company

Build this compact, versatile test instrument. A 0-1 ma. meter, with its scale redrawn, is used for this unit.

CONSTRUCTION articles describing various sorts of multimeters have been more plentiful than unique. Generally these units consist of a low-range milliammeter with a switching system and multipliers which permit a number of different functions to be read on a single indicator.

The circuit of the multimeter to be described is novel in several respects. Among the unique features is resistor R_1 in Fig. 1A. Its function will be discussed in some detail later in the article. The a.c.-d.c. switching system is rather unorthodox in that the input of the bridge system is floating across the meter in the d.c. position. Although this does offer a shunt of several thousand ohms across a 100-ohm meter circuit, its effect is negligible and the savings offered by the resulting simplified switching arrangement are worthwhile.

The balance of the circuit consists of a current-type ohmmeter in the $R \times 100$ position and a voltage divider system in the $R \times 1$ position. Two current scales are provided, one covering the 0-10 ma. range and the other the 0-100 ma. range. These two scales are sufficient for most multimeter applications.

The four voltage ranges are provided by series multipliers in the positive meter leg. All functions are selected by a two-deck, non-shorting type, 11-position wafer switch and the d.p.d.t. a.c.-d.c. switch. The output is read directly across a 500-ohm line through the 0 to 10 volt a.c. position and the db scale. An external .25 μ fd. condenser is used if a d.c. component is present.

The components used in this circuit were chosen for their ready availability at most radio wholesale houses. Stock values are used throughout and most junk boxes will yield the bulk of the items needed. Naturally the builder may have to series or parallel a resistor or two to obtain exact values but this is common practice and is entirely acceptable in this construction.

The first step in assembling the multimeter is to prepare the front panel as shown in the photograph since all parts are attached to it. The holes are drilled for the components and the template supplied with the 0-1 ma. meter used to locate the meter cut-out. If you already have the meter or have obtained a surplus unit you will have

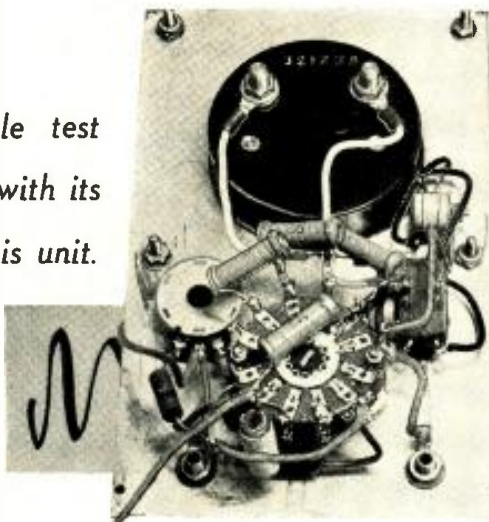

Two views of the meter panel on which all component parts are mounted.

to make a template for your meter out of paper.

When the holes are drilled and all burrs removed, a coat of primer is applied followed by a coat or two of enamel. Auto body gunmetal grey was used in the author's model. When completely dry, the surface was satin finished by rubbing it lightly with fine steel wool. Rub in one direction only for professional-looking results. The switch plate decal was then positioned over the holes provided in the panel.

Next, the meter was disassembled and the new scale (Fig. 2) was cemented in place on the reverse side of the dial plate. This was done to preserve the original scale for future reconversion should the need arise. The location of this scale is very important and this operation must be performed carefully.

When the face is mounted the meter is re-assembled and installed in the

panel. The rest of the components are now installed on the panel as indicated in the left-hand photograph. The selector switch is placed in the center hole in such a way that its two stack screws run laterally and the pole connectors are on the right, as viewed from the back. The a.c.-d.c. switch is in the right-hand upper hole and the rheostat is placed in the left-hand upper hole. The jacks are located in the two 5/16" holes at the bottom.

After the parts have been mounted, you are now ready to begin wiring. Care should be taken to provide good solder joints and to keep the leads short and dressed. If a 5000-volt range is employed, be sure to take the necessary precautions regarding high-voltage insulation.

The battery leads consist of two four-inch lengths of wire. One lead is connected to the center post of the
(Continued on page 174)

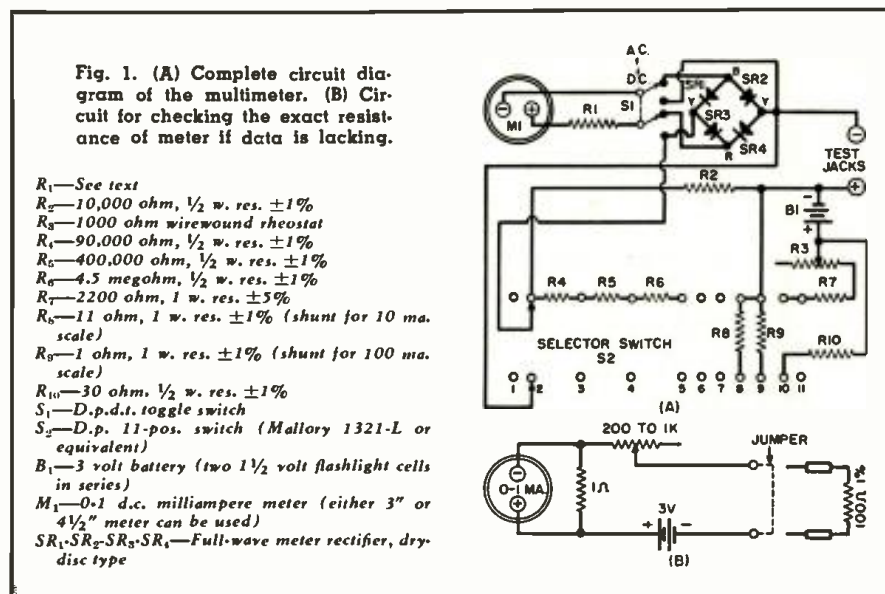

SUPERREGENERATIVE TRANSISTOR RECEIVER

By
JOSEPH M. HUGHES
W9VHJ

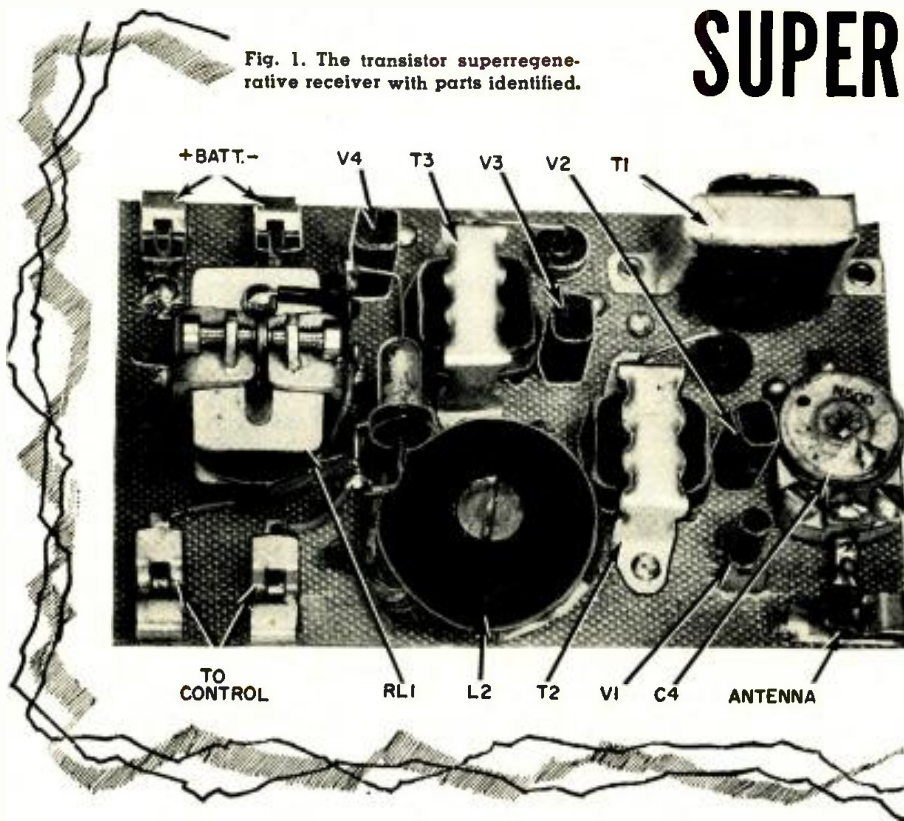

This small transistor receiver for model control features negligible battery drain and is fairly easy to construct.

NOTHING in recent years has captured the interest of the electronics fraternity quite like the introduction of the transistor. Although first announced in 1948, it was not until very recently that reliable units in large quantities were brought within the reach of all of us. Today there are perhaps 20 or 30 firms manufacturing both point contact and junction types and their products are available at almost any large radio supply store. Surely this field of development is still in its infancy and we can be certain that the future will bring many new types of transistors with characteristics to meet the requirements of practically any application.

The recent issues of this and other technical magazines have pretty well covered the principles of operation of the point contact type and the junction type transistors. However, most of us feel that the best way to become familiar with a new device is to incorporate it in something we build ourselves, measure its characteristics, and observe its performance. This article will describe an interesting, practical application of both types of presently-available transistors.

My hobby, for a number of years, has been building and flying radio-controlled model airplanes. Many different types of radio receivers have been used during this period. Each has its good points and its bad features. The requirements for this kind of service are much the same as for any really portable equipment. Light

weight, of course, is of prime importance, not only in the receiver itself but particularly of the batteries required for operation. This is the same as saying the current consumption must be held to an absolute minimum if reasonable life is to be obtained with lightweight batteries. The sensitivity must be as good as possible because usually an inefficient receiving antenna must be used. The receiver must be able to absorb a lot of mechanical punishment. You can imagine the shock to which this equipment is subjected when a model plane dives into the ground from several hundred feet altitude under full throttle. Still, a well constructed receiver in a properly designed mounting will survive this sort of treatment. These requirements point very strongly toward

what is perhaps the simplest type of receiver, the superregenerative.

One of the most foolproof versions of a superregenerative receiver for model airplanes was described by Howard McEntee in the September 1951 issue of *RADIO & TELEVISION NEWS*. It consists of a superregenerative detector, a stage of audio amplification, and a biased detector operating a relay. Three subminiature tubes are used. The characteristic rushing noise output of the detector in the absence of an incoming signal is amplified and by grid rectification is used to bias the final tube to cut-off. When a signal (unmodulated carrier) is received, the rushing noise from the superregenerative stage disappears. The bias is removed from the last stage and the plate current increases. This operates a sensitive relay in the plate circuit and its contacts are used to energize the control mechanism.

An application such as this looks like a "natural" for transistors. They are light in weight, consume no heater power which means a great saving in battery weight, and have a much longer expected life than any vacuum tube. This is some compensation for their greater initial cost. They too are practically free from microphonic noise which can become a problem when the equipment is subjected to severe vibration as it is in model airplane use. Even the shock from a crash landing should mean nothing to a transistor.

The picture, however, is not quite as rosy as it seems. Most radio control operation is done either on the 50-54 mc. amateur band, the Citizens Band at 460-470 mc., or the new "license free" spot frequency at 27.255 mc. At this time there are no transistors generally available which will operate at any of these frequencies although several manufacturers have models under development which are capable of oscillating at frequencies higher than 100 mc. There are several point contact transistors presently on the market which will operate satisfactorily up to 3 or 4 mc. The equipment to be described operates on the

Fig. 2. Response of audio amplifier stages.

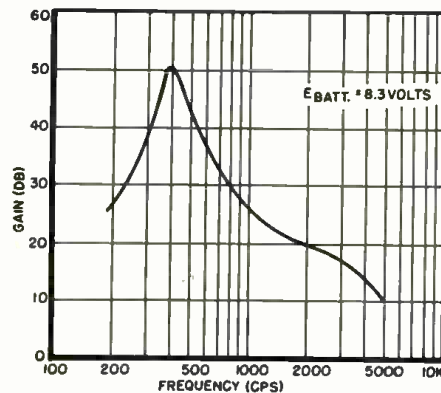

160-meter amateur band. Currently available junction transistors are primarily suited for audio frequency use because of very limited high frequency response.

There is another consideration which must not be overlooked. Transistors are inherently much noisier than vacuum tubes. For example, most point contact transistors have a noise figure around 50 db, while the figure for junction transistors is around 20 db. The noise figure for a good vacuum tube is on the order of 4 to 6 db. Without going into detail we can see that any transistor amplifier we build will be inherently much noisier than a vacuum-tube amplifier with the same amount of gain. This, then, will be one of the factors which determine the minimum signal level our receiver will be able to distinguish from the noise created within the receiver itself. It should be remembered that noise power is a function of bandwidth, so by reducing the bandwidth of our system this difficulty may be somewhat minimized.

When transistor amplifier stages are cascaded we must also remember that they are essentially power amplifiers. The low-impedance input circuit actually absorbs power from the driving source so some form of matching device, usually a transformer, must be used to efficiently couple the high-impedance output circuit of one stage to the low-impedance input of the next stage. This is quite different from the conventional class A vacuum-tube stage where the input circuit approaches infinite impedance at audio frequencies. Typical power gain for a junction transistor stage is 30-40 db while a single tube stage may have a theoretical power gain of infinity but will easily realize 70-80 db gain in practice. Remember we are speaking of *power* gain. Obviously a high-gain amplifier will need more stages if transistors are used than it would if tubes were used.

Fig. 1 is a photograph and Fig. 3 is the schematic diagram of the receiver. V_1 is a point-contact transistor with a usable current gain up to about 3 mc. The superregenerative stage is essentially a Hartley oscillator. However, the transistor in a grounded-base circuit such as this does not produce a phase reversal between input and output voltages as a tube would do. This is the reason the tap on the tank circuit coil is coupled to the input circuit, rather than the bottom of the coil as is done in vacuum-tube Hartley oscillator circuits. The stage operates as a self-quenched superregenerative detector with the values of R_1 , C_1 , C_2 , and the resistance of the primary winding of T_1 , determining the quench frequency. Although this frequency is not critical it must be somewhat greater than the highest modulation frequency the receiver will be expected to handle. On the other hand the quench frequency must not be so high that the superregenerative stage can not operate with discrete bursts of oscilla-

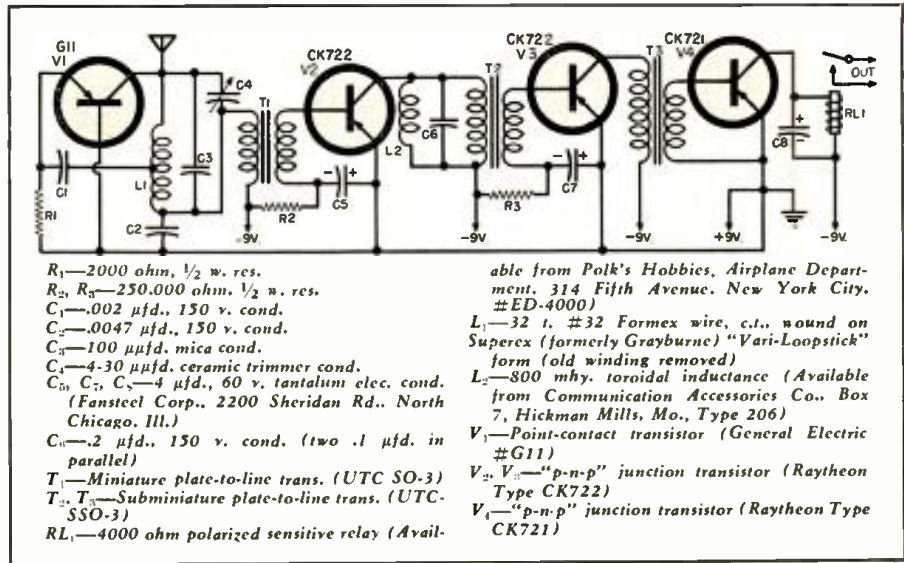

Fig. 3. Schematic of superregenerative transistor receiver for model airplane control.

tion. The presence of an incoming signal increases the quench frequency in this type of operation. This brings about a condition of "coherence" which shows up as multiple resonance peaks in the selectivity curve when the incoming signal is extremely strong and the quench frequency is too high.

V_2 is a conventional grounded-emitter stage of audio-frequency amplification with about 30 db maximum gain. The base current is approximately 50 μ a. and the collector current .3 ma. L_2-C_6 is a parallel-resonant circuit tuned to 400 cps bridged across the primary of the output transformer. L_2 is an 800 mhy. toroidal inductance which has a "Q" of about 15 at this frequency. This resonant circuit across T_2 results in maximum gain at 400 cps and yet gives appreciable discrimination against the noise inherent to V_1 (random in frequency) and to the quench frequency which in this case is around 10 kc. V_3 is a conventional amplifier stage. The over-all gain as a function of frequency of these two stages is shown in Fig. 2. If this re-

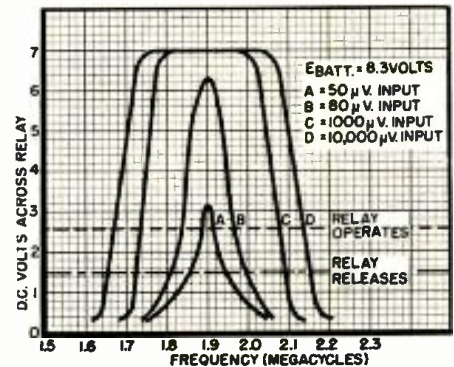
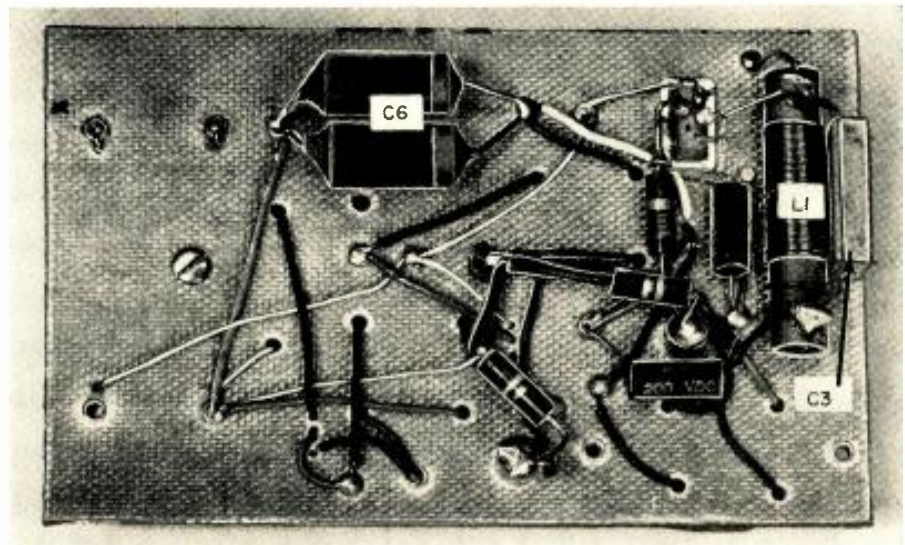

Fig. 4. Selectivity curves for the superregenerative receiver for various inputs.

ceiver were to be used for voice-modulated signals the resonant circuit would be eliminated at some sacrifice in signal-to-noise ratio.

V_4 operates essentially as a class B amplifier or a "plate" detector. When there is no input signal the collector current is very low, only a few microamperes. The negative half cycles of
 (Continued on page 91)

Fig. 5. Underchassis view of transistor receiver showing simplicity of the wiring.



SERVICING

TAPE

RECORDERS

By **WILLIAM ROCKWELL**
Authorized Factory Service Company, Inc.

Whether you are interested in servicing tape recorders as a business, or in repairing your own machine, this article will give you some valuable tips you can use.

IN THE past few years the home-type tape recorder has gained tremendous popularity and, as a result, there have been at least thirty-five different machines manufactured to date, with the list still growing. What does this mean to the radio and television technician? He can continue his present line of servicing and forget that tape recorders exist; or he can familiarize himself with the different types of machines on the market, and in so doing, he can add tape recorders to his list of services and add new avenues of profit to his business.

To date there have been few, if any, articles written on home tape-recorder service and, as a result, the service technician has been stymied because of the lack of information. That is the purpose of this article—to acquaint the service technician with some of the troubles he can expect to encounter when servicing these machines.

A tape recorder consists of three basic sections:

1. The recording amplifier
2. The playback amplifier
3. The tape transport mechanism

In the home-type tape recorder, the recording and playback amplifier are one, with the different functions selected by a "record-listen" switch. This switch, when in the "record" position, connects the record and playback coil in the head assembly (one coil performs both functions) to the output of the amplifier which supplies the audio voltage to be recorded. In this position, the switch also converts the output stage to an oscillator, usually 30 to 50 kc., to provide bias for the recording head and also erase current for the erase coil in the head. (On some machines a separate bias and erase oscillator is used.) Equalization is also inserted in the amplifier to compensate for frequency response characteristics of the head and tape speed. This

equalization is in the form of high-frequency boost. This increases the signal-to-noise ratio of the recording during playback.

In the "playback" position, the recording coil in the head assembly is connected to the input of the amplifier. The bias oscillator is converted back into an output stage, and the high-frequency boost is removed. The equalization in the "playback" position is different than in the "record" position. The high-frequency response is attenuated to retain the balance of the original program material, and the low-frequency response is boosted. The low-frequency equalization is accomplished during playback rather than during recording to prevent the low-frequency components from saturating the tape.

Now we come to the mechanical side of the subject which, in most cases, will be the main source of repairs. This is because the tape recorder is subject to all the woes of any mechanical device. These are: 1. dirt, 2. wear, and 3. lubrication.

A tape transport mechanism must meet certain requirements and perform certain functions in order to qualify for the exacting job it has to perform:

1. Its speed must be constant (wow and flutter held to a low value)
2. It must be quiet in operation
3. It must be able to stand a fair amount of abuse

All this must be accomplished and still keep the machine at a price the public can afford. At the present state of the art, it is simple to produce an amplifier whose response is flat to 8000 cps which, in most cases, is the upper limit at a tape speed of $7\frac{1}{2}$ " per second. It is not quite so simple, however, to produce a good mechanism that meets the aforementioned requirements.

A tape transport mechanism consists of the following basic sections:

1. A capstan and flywheel assembly which pulls the tape past the record-and erase-head assembly at a constant rate of speed, usually $3\frac{3}{4}$ " or $7\frac{1}{2}$ " per second. This capstan and flywheel assembly is driven by a fairly heavy motor through a rubber idler wheel. The tape is held against the capstan by a spring-loaded rubber pressure roller, and against the heads by a pressure-pad assembly. See Fig. 1.

2. A take-up spindle assembly. This take-up spindle is usually driven by the motor that drives the flywheel through some form of clutch. See Fig. 2. This clutch is needed because the diameter of the take-up reel is constantly changing as it takes up tape, causing it to pull more tape with each revolution, but, the capstan will only feed the tape at a constant rate, so the clutch supplies the necessary slip-page.

3. A rewind spindle assembly. This can be driven from the flywheel by a belt or from the motor shaft by a rubber idler wheel. See Fig. 3.

Mechanical Servicing

As stated previously, most of the troubles encountered will be in the tape transport mechanism. The most common offenders will be the rubber wheels used to drive the different moving parts. These wheels will become glazed and start slipping or they will wear and get lumpy, causing wow and flutter. The rubber pressure roller will become foul with oxide from the tape and start to slip. If any oil gets on any of the rubber wheels, they will be ruined.

Wheels that have become glazed after considerable use can be restored by cleaning with alcohol or by holding a piece of fine sandpaper on the wheel while it is running. Be careful not to remove too much rubber if sandpaper is used. Wheels that have had oil on them must be replaced. Cleaning will not help, since oil gets into the pores of the rubber and will seep out.

Motors should be lubricated with one or two drops of No. 10 motor oil. Be sure that no oil gets on any of the

driving surfaces. Cams and levers should be lubricated with a small amount of light grease on the bearing surfaces only. If possible, refer to the manufacturer's lubrication instructions.

The pole pieces in the recording head or heads are also subject to considerable wear. The tape used for magnetic recording is coated with a metal oxide which acts as a fine abrasive, something like crocus cloth. When the pole pieces wear down, the machine will not record and erase properly because the gap dimensions change, causing low volume, poor high-frequency response, and incomplete erase.

Examine the pole pieces with a jeweler's loupe or magnifying glass and notice if the gap is worn or uneven. The "record" gap should be a very fine line, and the spacing along the full length of the gap should be even. The "erase" pole piece has a gap about four or five times the size of the "record" gap, and this also should be even along the full length of the gap. A sure check would be to compare an old head with a new one.

Improper recording and erasing can also be caused by a dirty head. Be sure the head is free from all oxide that may come off the tape. When replacing heads or pole pieces, they must be peaked for maximum high-frequency response. This is done by running a test tape with 7500 cps recorded on it, made on a machine known to be good, and slowly rocking the head back and forth until maximum response is obtained. Then lock the head in position.

Wow and flutter can be traced by listening to its rate, and watching for drive wheels or pulleys that turn at the same rate. For example, a fast flutter would not be caused by a pressure roller that turns at a slower speed than the rate of flutter. Speed should be checked by making a recording of music with piano or wind instruments and listening for wow and flutter. There are instruments made for the measurement of wow and flutter, but these instruments are priced at approximately \$500 and therefore, are out of the reach of the average service technician. A 1000-cycle note can also be used for these checks, and after listening to this note on a number of machines the service technician will be able to determine whether the machine is operating properly.

Some precautions to observe when servicing are the following:

1. Don't over-lubricate.
2. Don't use carbon tetrachloride to clean rubber wheels as this will ruin them. Use alcohol.
3. Don't wash oilite bearings in any type of solvent. If you do, you will remove all oil from the pores of the bearing.
4. Don't use magnetized tools near the recording heads. Be careful not to scratch or mar the pole pieces.
5. Don't check heads with an ohmmeter unless absolutely necessary, or the

heads will become heavily magnetized and cause a high hiss in the background of the recording. If the head does become magnetized, use a head demagnetizer, which should be available from any large supply house that sells recording equipment. If one is not available, place the head near a strong 60-cycle a.c. field, and slowly reduce the field to zero. Do this a number of times.

Make sure the tape being used on the recorder has the correct wind. Tape comes in two winds; "A" wind, which has the oxide wound facing the hub of the reel, and "B" wind, which has the oxide wound facing away from the hub. After threading the tape through the machine, the oxide or dull side of the tape should be against the heads.

Electrical Servicing

All of the troubles encountered in the amplifier of a tape recorder will respond to conventional servicing techniques. One of the common sources of trouble is the bias-erase oscillator. When this does not function, the machine will not erase and the recordings will be low in volume and very distorted. A quick check can be made by placing a neon bulb on the plate of the oscillator and also on the leads going to the head. If the bulb glows, you can be reasonably sure the oscillator is working. Also, check for worn or dirty pole pieces as they will give the same type of symptoms.

For exact voltage and resistance values, refer to the manufacturer's service manual. When replacing noisy resistors, especially in the low-level stages, be sure to shunt the heat of the soldering iron away from the new resistors, otherwise the new resistors will be as noisy as the old ones. To shunt the soldering iron heat away from the resistor either use a pair of long-nose pliers from the resistor lead to the chassis, or an alligator clip to the chassis.

Following is a list of a few of the tools and lubricants which will be needed in addition to the tools found in the average service shop:

1. A complete set of *Allen and Bristol* wrenches.

Fig. 1. The head assembly and capstan of a typical tape recorder. Note that the head assembly includes the record-playback and erase heads in one unit.

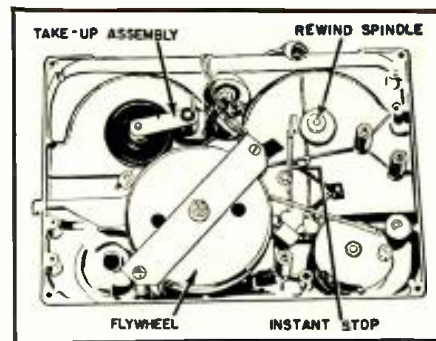
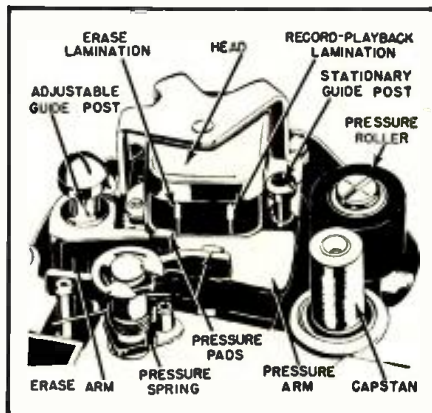

Fig. 2. Shown here is a typical method of using a flywheel for driving the take-up reel of a tape recorder. The flywheel is coupled to the motor via an idler.

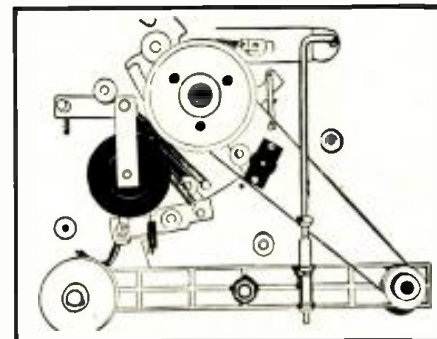

Fig. 3. The rewind spindle in the lower right is driven by means of a chain belt from the motor in the system shown here.

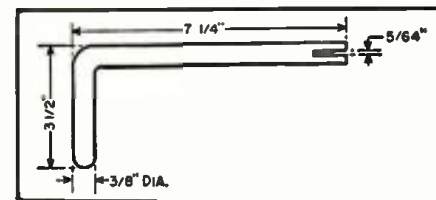

Fig. 4. Dimensions for a bending tool useful for entering inaccessible places in the tape recorder for slight adjustments.

2. A set of small sized open-end wrenches.
3. A bending tool (see Fig. 4) for getting into otherwise inaccessible places in the tape recorder works, for slight bending when necessary.
4. A good test tape containing a 7500 cps note for head alignment.
5. A head demagnetizer.
6. A light grade of grease or lubricant.
7. No. 10 motor oil.
8. Penetrating oil for freeing frozen bearings.
9. Alcohol for cleaning rubber drive wheels and belts.
10. Carbon tetrachloride for cleaning metal parts.
11. A complete set of tape recorder service manuals available either from the manufacturers directly, or from some of the various radio and television service manual and book publishers.

The service technician interested in the theory of magnetic tape recording should read some of the excellent books on this subject appearing in recent years, as well as magazine articles which will keep him up to date.

Certified RECORD REVUE

By BERT WHYTE

THE term "Certified" in the title of this column may puzzle some readers who missed the first review when it was introduced last year. For the benefit of these readers and as a restatement of our basic policy, we hasten to explain. As you know, we name the equipment used in reviewing the recordings each month. The naming of this equipment does not necessarily constitute an endorsement of this particular equipment. If we seem to use one certain brand of equipment more consistently than any other, it is primarily for reasons of convenience. In other words, the material is at hand and is familiar enough to quickly and thoroughly test. That is what "Certified" means. Each link in the chain of reproduction, from pickup to speaker is checked and rechecked to make absolutely certain that everything is in perfect operating condition. It is only fair to evaluate a recording when this situation exists. It is not right to impose the possibility of defective equipment when reviewing records. Listening to phonograph records is a subjective thing at best; to accuse a record of being inherently distorted, when the distortion actually stems from poor equipment, is to do the manufacturer of the recording and the public a great disservice. Still another factor is important in reviewing records and that is the acoustical environment.

It is said most people listen to records under "living room" conditions. This is a somewhat misleading term, since the size, shape, reflection, and absorption characteristics of walls and floors and the type of furnishing are all variables, and what is true in 10,000 rooms isn't necessarily true in 10,000 other rooms. The brightness of a recording can be changed by such a simple thing as whether the drapes in a room are open or closed! It is because of this that we published a listing of the acoustic conditions under which recordings were reviewed.

I have moved since the first appearance of this column and will list herein my present acoustical conditions: room 26 x 15 ft., 20 ft. of drapes along one wall which may be left at full 20 ft. or reduced to 6 ft. A hard reflective wall with a speaker in each corner, a hard wall opposite speaker wall, extra large (16') sectional sofa, several other up-

holstered chairs, wall-to-wall carpeting, conventional plaster ceiling. This is a considerably better room for listening than my previous one. Just "live" enough with barely 2-3 seconds reverberation time. Some people I know like a little longer reverb period. That's because they haven't lived with binaural! Believe me, binaural sound in a room with a reverb period over 3 seconds can drive you goofy!

In playing monaural material, disc and tape, I use both speakers phased properly to give me a diffuse sound source. Well, that's my new set-up. If you have a comparable room and equipment of equal quality and your hearing is "normal," you should get just about the same results as I do. However, I must stress again the great number of variables and the subjectivity of listening to music. What is golden to my ear may be garbage to yours and *vice versa*. All I, or any other critic, can do is to call your attention to what is an *apparent* fault or virtue in a given recording. That a critic should make his analysis under as carefully controlled conditions as possible, goes without saying. It's a pity so few adhere to this line of reasoning:

Equipment used this month: *Weathers*'s pickup and arm, *Rek-O-Kut* T12H turntable, *Fisher* Master Audio Control, two 30-watt *McIntosh* amplifiers, two *Jensen* G-610 Triaxial speakers in a *Read* "Fold-a-flex" enclosure.

RAVEL
CONCERTO IN D MAJOR FOR THE LEFT HAND FOR PIANO AND ORCHESTRA
CONCERTO IN G MAJOR FOR PIANO AND ORCHESTRA

Jacqueline Blancard, pianist, with L'Orchestre de la Suisse Romande conducted by Ernest Ansermet. London LL797, frr curve. Price \$5.95.

This recording may come as quite a surprise to a great many people since *London* has already issued an LP with the identical repertoire. Of course the other LP was issued in the very early days of *London's* entry into the long-play field and it left something to be desired in the way of sound quality. *London* is to be commended once again for "upgrading" an existing part of its

The opinions expressed in this column are those of the reviewer and do not necessarily reflect the views or opinions of the editors or the publisher of this magazine.

catalogue with this new recording. Those of you who feel a little "put-out" with this state of affairs since you already own the older version, should really take heart that a magnificent new recording of these Ravel works is available. If you liked the music enough to buy the older job, then you'll really go for the new one. It's a far better effort than the previous disc. Soundwise it's one of the best piano recordings on LP. There was no flutter in piano tone that I could detect and *what tone!* Here is truly exciting piano. Properly percussive in a score that calls for prodigious percussiveness and yet a piano that can sing as well. The orchestral accompaniment is something wonderful to hear with splendid, solid bass and sharp biting brass. The opening woodwinds in the "Left Hand" are a marvel of sonority. The jazzy, percussive figurings of the "G Major" are crisp and clean with plenty of punch. Both concerti are played with verve and spirit by Mme. Blancard. On the older disc Mme. Blancard shared honors with another fine pianist, Nicole Henriot.

This new recording arrived just about the time I was able to hear Mme. Henriot play the "G Major" with Mitropoulos and the N. Y. Philharmonic in concert. Strangely, there was little to choose between Mme. Henriot's interpretation and that of Blancard. Blancard's was perhaps more academic, more linear than the volatile reading of Henriot. Other than that, both pianists displayed brilliant technique coupled with solid musicianship. (A note in passing but it always seems to me that the Ravel piano concerti are apparently the exclusive province of women pianists. I cannot recall a male interpretation of these works for a long, long time.)

Mr. Ansermet is a particularly astute gentleman when it comes to conducting Ravel. His readings are always masterful and most obviously a labor of love. In these recordings he chose just the right tempi and was able to keep his orchestra well in hand. The *frr* curve reproduced well with no cut or boost necessary in treble or bass. Surfaces in my copy were quiet. In every respect a superior recording.

MOZART
SYMPHONY #38 IN D
SYMPHONY #34 IN C

Chicago Symphony Orchestra conducted by Rafael Kubelik. Mercury "Olympian" MG50015, AES curve. Price \$5.95.

As noted last month this is Rafael Kubelik's swan song with *Mercury* and the Chicago Symphony. It is rather fitting that he leaves us with this splendid reading of "The Prague," a score always dear to the heart of a son of Bohemia. That Mr. Kubelik has made his mark in phonographic history is not surprising. His previous efforts for *Mercury* in a very catholic repertoire have been outstanding. I was sorry to hear of Mr. Kubelik's col-

(Continued on page 151)

1954 TV RECEIVER SPECIFICATIONS

The electrical and mechanical specifications listed below are of direct aid to service technicians. This list will be continued in forthcoming issues to include all major manufacturers.

| MFR. | CHASSIS | TUBES | | | | | | VIDEO I.F. FREQ. (MC.) | H.V. ⁴ (KV.) | U.H.F. PRO-VISION | POWER (WATTS) | SPECIAL FEATURES | |
|----------|---------|-------|-------------------|--------------------|----------------|--------------------|-------|------------------------|-------------------------|-------------------|---------------|------------------|-------|
| | | TUNER | I.F. ¹ | VIDEO ² | AUDIO | SWEEP ³ | P.S. | | | | | | CRT |
| ADMIRAL | 19B1 | 6BZ7 | 6CB6 | 6AL5 | 6AU6 | 12AU7, 6S4 | 5U4G | 17" | 25.75 | 15 | Strips | 185 | |
| | 19F1 | or | 6CB6 | 6CB6 | 6AL5 | 6SN7GT, 6BQ6GT | 1B3GT | 21" | 25.75 | 15 | Strips | 185 | |
| | 19F2Z | 6BC5 | 6U8* | | 6AV6 | 6AX4GT, 6U8* | | 21" | 25.75 | 15 | Strips | 185 | 8, 9 |
| | 19A2 | 6J6 | | | 6AS5 | | | 21" | 25.75 | 15 | Strips | 185 | |
| | 19D2 | | | | or | | | 21" | 25.75 | 15 | Strips | 185 | 9 |
| | 19G2 | | | | 6Y6G | | | 24" | 25.75 | 18 | Strips | 185 | |
| | 19S1 | | | | | | | 17" | 25.75 | 15 | 11 | 195 | |
| | 19J1 | | | | | | | 21" | 25.75 | 15 | 11 | 195 | |
| | 19B2 | | | | | | | 21" | 25.75 | 15 | 11 | 195 | |
| | 19E2 | | | | | | | 21" | 25.75 | 15 | 11 | 195 | 9 |
| | 19K2Z | | | | | | | 21" | 25.75 | 15 | 11 | 195 | 8, 9 |
| | 19H2 | | | | | | | 24" | 25.75 | 18 | 11 | 195 | |
| | 19T1 | | | | | | | 17" | 45.75 | 15 | 11 | 195 | |
| | 19L2 | | | | | | | 21" | 45.75 | 15 | 11 | 195 | |
| | 19L2Z | | | | | | | 21" | 45.75 | 15 | 11 | 195 | 8 |
| | 19M2 | | | | | | | 21" | 45.75 | 15 | 11 | 195 | 9 |
| | 19N2Z | | | | | | | 21" | 45.75 | 15 | 11 | 195 | 8, 9 |
| | 19W1 | | | | | | | 21" | 45.75 | 15 | 11 | 195 | |
| | 19R2 | | | | | | | 24" | 45.75 | 18 | 11 | 195 | |
| | 22F2 | 6BZ7 | 6CB6 | 12AT7* | 12AT7* | 6SN7GT, 12AU7 | 1B3GT | 21" | 25.75 | 17.5 | Strips | 200 | |
| | 22F2Z | 6J6 | 6CB6 | 6CL6 | 6AU6 | 6S4, 6AL5 | 5U4G | 21" | 25.75 | 17.5 | Strips | 200 | 8 |
| | 22A3Z | | 6AG5 | 6AU6 | 6AL5 | 6SN7GT, 6BQ6GT | | 21" | 25.75 | 17.5 | Strips | 200 | 8 |
| 22D3Z | | or | | 6AV6 | 6AX4GT | | 21" | 25.75 | 17.5 | Strips | 200 | 8, 9 | |
| 22G2 | | 6AU6 | | 6V6GT | | | 21" | 25.75 | 17.5 | 11 | 235 | | |
| 22G2Z | | | | | | | 21" | 25.75 | 17.5 | 11 | 235 | 8 | |
| 22B3Z | | | | | | | 21" | 25.75 | 17.5 | 11 | 235 | 8 | |
| 22J2Z | | | | | | | 21" | 45.75 | 17.5 | 11 | 235 | 8 | |
| 22H3Z | | | | | | | 21" | 45.75 | 17.5 | 11 | 235 | 8 | |
| 23E1Z | 6BZ7 | 6CB6 | 12AT7* | 12AT7* | 6SN7GT, 6AV5GT | 1B3GT | 24" | 25.75 | 19 | Strips | 235 | 8 | |
| 23B1Z | 6J6 | 6CB6 | 6AU6 | 6AU6 | 12AU7, 6AL5 | 5U4G | 27" | 25.75 | 19 | Strips | 235 | 8 | |
| 23F1Z | | 6AG5 | 6CL6 | 6AL5 | 6SN7GT, 6CD6G | 5U4G | 24" | 25.75 | 19 | 11 | 235 | 8 | |
| 23C1Z | | | | 6AV6 | 6V3 | | 27" | 25.75 | 19 | 11 | 235 | 8 | |
| 23H1Z | | | | 6V6GT | | | 24" | 45.75 | 19 | 11 | 235 | 8 | |
| 23J1Z | | | | | | | 27" | 45.75 | 19 | 11 | 235 | 8 | |
| ANDREA | VN-21 | 6BK7 | 6CB6 | 1N105 | 6AU6 | 12AX7, 12AU7 | 5U4 | 21ZP4A | 45.75 | 15 | Strips, | | |
| | | 6J6 | 6CB6 | 6AH6 | 6AL5 | 6S4, 12AU7 | 5U4 | | | | or | 180 | 10 |
| | | | 6CB6 | 6AU6 | 6AV6 | 6BQ6, 6AX4 | 1B3 | | | | 11 | | |
| | | | 6CB6 | | 6K6 | | | | | | | | |
| CAPEHART | CX-37 | 6BQ7 | 6CB6 | 1N64 | 6X8* | 6BE6, 12AU7 | 5U4G | 17LP4 | 45.75 | 14 | Strips | 210 | 5, 10 |
| | | 6J6 | 6CB6 | 6X8* | 6BN6 | 12AU7, 6BF6 | 1B3GT | 21EP4A | | | | | |
| | | | 6CB6 | 6AQ5 | 6BK5 | 6V6GT, 6BQ6GT | | 21EP4B | | | | | |
| | | | 6CB6 | 6AU6 | | 6W4GT | | 21ZP4B | | | | | |

1. Video i.f. tubes only. 2. Includes detector and a.g.c. 3. Includes sync section and a.f.c. 4. CRT 2nd anode voltage. 5. Removable safety glass. 6. Local-fringe a.g.c. adjustment. 7. High-fidelity sound. 8. Aluminized picture tube. 9. TV-radio-phono combination. 10. Built-in antenna. 11. 82-channel tuner. 12. Adjustable dial light. *Part of tube is used in another section.

(Continued next month.)

HOW'S YOUR RUMBLE?

By

JAMES A. MITCHELL

A HIGH-FIDELITY fan was describing his new speaker system, "It sounds terrific! The highs are there. The bass is solid. But when we come to a quiet part in the music there is some infernal background noise like someone upstairs moving furniture. It seems that I have acquired a rumble problem." This experience is becoming a common one as speakers with improved bass response come into general use. Unless we learn to select and adjust audio equipment for low noise and rumble, good audio reproduction will not be enjoyed.

The main source of rumble is the mechanical movement of the turntable. However, each part of the audio system (Fig. 4) can greatly influence the amount and kind of low-frequency noise actually heard. For example, speaker baffles such as open back phonographs which do not produce much response below 75 cps seldom produce rumble. The new corner horns and other improved baffles extend bass response as far as 30 cps. Whether rumble will be objectionable with these speakers depends on the quality and condition of the rest of the equipment, the room acoustics, and the listening habits of the user. With these conditions constant, the lower the response of the speaker system the more rumble will be heard.

From point of view of rumble many amplifiers have too good a low frequency response. I have seen amplifiers which will drive a speaker cone back and forth in rhythm with each turn of an eccentric 78 rpm record. Such amplifiers make tremendous demands on turntables and records. Do not assume that because rumble cannot be heard that it cannot affect your sound. The speaker movements due to rumble can be below the response of the baffle so are not heard, yet they can drive the voice coil into the non-linear extremes of motion and produce intermodulation distortion. Sometimes the reduction in distortion with elimination of the rumble is noticeable.

The preamplifier used has a great



Fig. 1. Measuring the rhythm of turntable rumble to locate source.

How to establish the causes of low-frequency noise in wide range record playing systems and corrective steps to apply.

effect on rumble because it is the bass boost in the record equalization circuit of the preamp which amplifies the low frequency noise so much. To provide the correct compensation for records with a 500 cps turnover recording curve the preamp must boost 50 cps 20 db more than 1000 cps and 25 cps 26 db more than 1000 cps. Fig. 2 shows the equalization curves of two preamplifiers. Curve B is the *G-E* SPX-001, a moderately priced unit for home use. Curve A is the *Brociner* A-65 set on the 500 cps turnover position. This is a precision unit for use with wide range equipment. Note the large difference in bass amplification, over 12 decibels below 40 cps. Each of these units has an optimum use, but on wide-range equipment the amount of rumble heard will be very different.

Preamplifiers are often the source of some low-frequency noise themselves. Hum is a common problem. Tube noise can cause trouble because of the high amplification of the low frequencies.

Fig. 2. Low-frequency equalization for two well-known commercial preamplifiers.

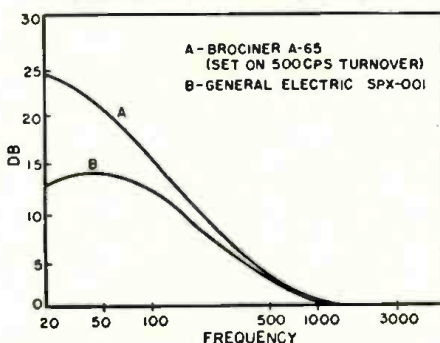

Nearly all modern pickup cartridges have excellent bass response. One major cause of emphasized rumble is the tendency of some cartridge arm combinations to have a resonant peak in the low frequencies. This often happens with the short, light arms which are common on record changers. One good way to test for arm resonance is to measure the output of the amplifier while playing a test record with a good low-frequency sweep. The *Cook* Series 10 has such a band extending down to 35 cps. Playing it at 33 rpm allows you to test down to 15 cps. With a *G-E* cartridge in one record changer arm a peak of about 5 decibels was found at 26 cps. While this is of no consequence in a limited-range system it can greatly increase the rumble in a wide range system. The same *G-E* cartridge in a long professional arm showed no such resonance.

When we consider the demands we have made on the turntables with our modern recording systems it is not surprising that we hear rumble. The microgroove record has about 260 lines-per-inch and a maximum groove "wobble" of about 3 thousandths of an inch. Now since bass frequencies are recorded at constant amplitude, a vibration of 3 thousandths of an inch at any bass frequency will be a rumble as loud as the maximum recording level. If the vibration in the turntable is 3 ten-thousandths of an inch the rumble will be 20 db below the maximum recording level or about the average loudness of the music. This is plenty objectionable. If you want the rumble to be 30 db below the average recording level, and this is just acceptable for wide range systems, the

vibration is limited to one hundred-thousandth of an inch! Vibration in the turntable can originate in the motor, the drive wheels and bearings, the rubber drive idler, and the turntable rim and bearings. In order for the vibration to be heard it must be transmitted to the record surface and must be in a direction that produces response in the pickup. Sometimes changing the position of an arm relative to the turntable can lower rumble.

Rumble Measurements

In analyzing a rumble problem in a hi-fi installation it is worthwhile to make certain measurements of the low-frequency noise level as this can help to locate the sources of the trouble and indicate the type of correction needed. The equipment required is simple. An audio test record such as the Cook Series 10 or the *Dubbings* phonograph test record can provide the recorded source of tones. An audio oscillator can also be useful. The preferred meter is an a. c. vacuum-tube voltmeter such as the *Heathkit* AV-2. An a. c. multimeter can be used if measurements are made on the 500 ohm output of the amplifier. The meter must be capable of measuring flat to 20 cps. The set-up is shown in Fig. 1.

First, it is good practice to determine the actual low-frequency response of the preamplifier and amplifier using the oscillator. This will tell if the preamp has proper, insufficient, or excessive equalization. It should be noted that rumble measurements can only be compared from one audio system to another when exactly the same response and equalization are obtained.

Now to measure the various sources of low-frequency noise connect the proper size resistor in place of the speaker and connect the a. c. voltmeter across the resistor. See Fig. 3. Put the test record on and track the 1000-cycle tone as a reference. Adjust the volume level so that a meter reading is obtained within the power limits of the amplifier and preferably 50 db above the lowest meter reading that can be made. Set this reference level without the interference of rumble. If your tone control does not affect the 1000-cycle tones turn the bass down when adjusting the level. Record the reference level in decibels and return the bass control to normal for the rest of the measurements. Now without change in gain place the stylus in an unrecorded groove. The *Dubbings* record has a specific band for this. Record the level in decibels and report the total noise and rumble as decibels below the reference level.

To determine the amount of noise contributed by the various parts of the equipment make the following tests, without change in the volume control.

Amplifier Noise: Disconnect the preamp from the amplifier being careful to leave no ungrounded leads to the input. Record the noise level in decibels.

| Low-Frequency Limit of Speaker System | Moderate Volume—Background Music | Moderate Volume—Critical Listening | Listening Conditions Full Volume—Critical Listening | Full Volume—Bass Boost Critical Listening |
|---------------------------------------|----------------------------------|------------------------------------|---|---|
| 50-70 cps | -10 | -20 | -25 | -30 |
| 40-50 cps | -15 | -25 | -35 | -40 |
| 30-40 cps | -20 | -30 | -40 | -50 |

Expressed as db below standard recorded tone

Table 1. Noise and rumble for turntables or changers for various listening conditions.

Normally this should be 60 decibels or more below the reference. Higher readings are indicative of faulty tubes or improper design.

Preamplifier Noise: Reconnect the preamplifier but disconnect the lead from the pickup. Set the equalization to 500 cps turnover if it is adjustable. Record the meter reading as db below the reference. The reading should be between -35 db for home type equipment to -60 db for the best professional types.

Induced Hum in the Pickup: Plug in the pickup. Turn on the turntable and hold the pickup directly over but not touching the record. The increase in noise over the previous reading is due to hum induced in the pickup. Check the shielding on the pickup lead. Also make sure that the turntable and arm are well grounded and that the unit is not close to unshielded transformers.

External Vibration: Place the pickup in a record groove with the turntable turned off. Any increase in noise when the pickup is placed in the groove, compared to being held just above it, indicates external vibration. Better spring mounting of the turntable can help reduce this rumble.

Turntable Motor Vibration: Remove the idler drive wheel from the record changer or turntable so that the phono motor can be turned on without the turntable rotating. Place the stylus in a record groove and turn the motor on. The increase in noise over the previous two readings is a measure of motor quality and condition. One way to tell if the motor bearings are worn is to make this same reading with a new unit of the same type substituted.

Turntable Rotation Vibration: Replace the idler drive wheel and with the turntable going place the stylus in the unrecorded groove of the test record. Record the total noise and rumble. The increase in noise level over the previous reading is the noise and rumble due to the rotation of the

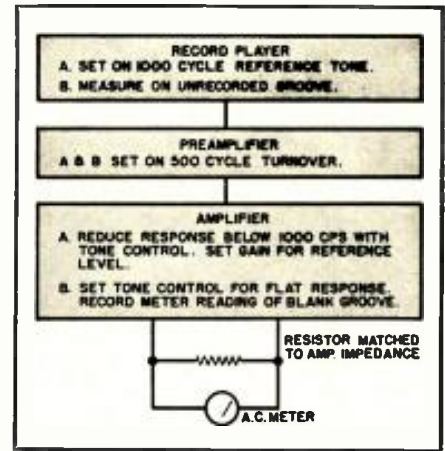

Fig. 3. Block diagram of the low-frequency noise and rumble test set-up. See text.

| Accumulated Sources of Noise | High-Fidelity Systems* | | | |
|---|------------------------|-----|-----|-----|
| | A | B | C | D |
| Main Amplifier | -60 | -60 | -72 | -72 |
| Preamplifier | -38 | -38 | -21 | -44 |
| Induced Hum in the Pickup | -33 | -36 | -18 | -39 |
| External Vibration | -32 | -36 | -18 | -39 |
| Turntable Motor Vibration | -18 | -31 | -12 | -29 |
| Turntable Rotation Vibration (Total Noise and Rumble) | -14 | -29 | -8 | -26 |

* See text for description of systems
Db below standard recorded reference tone

Table 2. Noise and rumble measurements.

turntable and the idler drive. This is usually the largest source of rumble after the motor and is an indication of the condition and quality of the bearings, drive surfaces, and roundness of the idler. It is common experience to have the meter show considerable variation during this reading. This is due to uneven roughness of the drive wheels and turntable rim. It is often possible to detect the location of rough spots on the rim by watching the rhythm of the meter movement and the turntable revolutions.

Table 2 lists a series of rumble and noise measurements for typical equipment. (Continued on page 168)

Fig. 4. Factors affecting low-frequency noise and rumble in record playing systems.

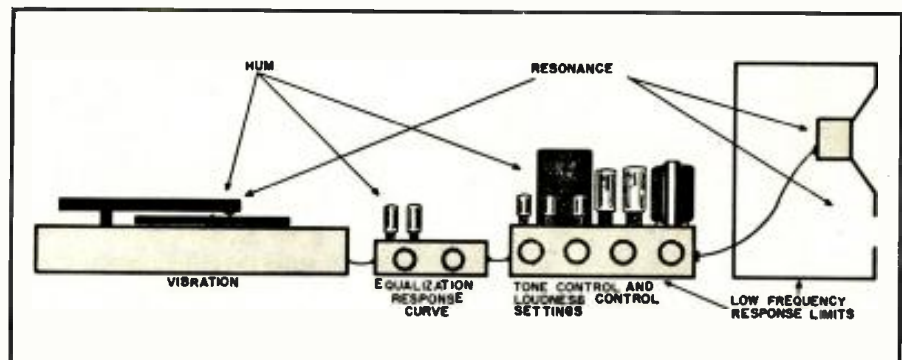

"SELF-COMPLETING" ELECTRONIC KEY

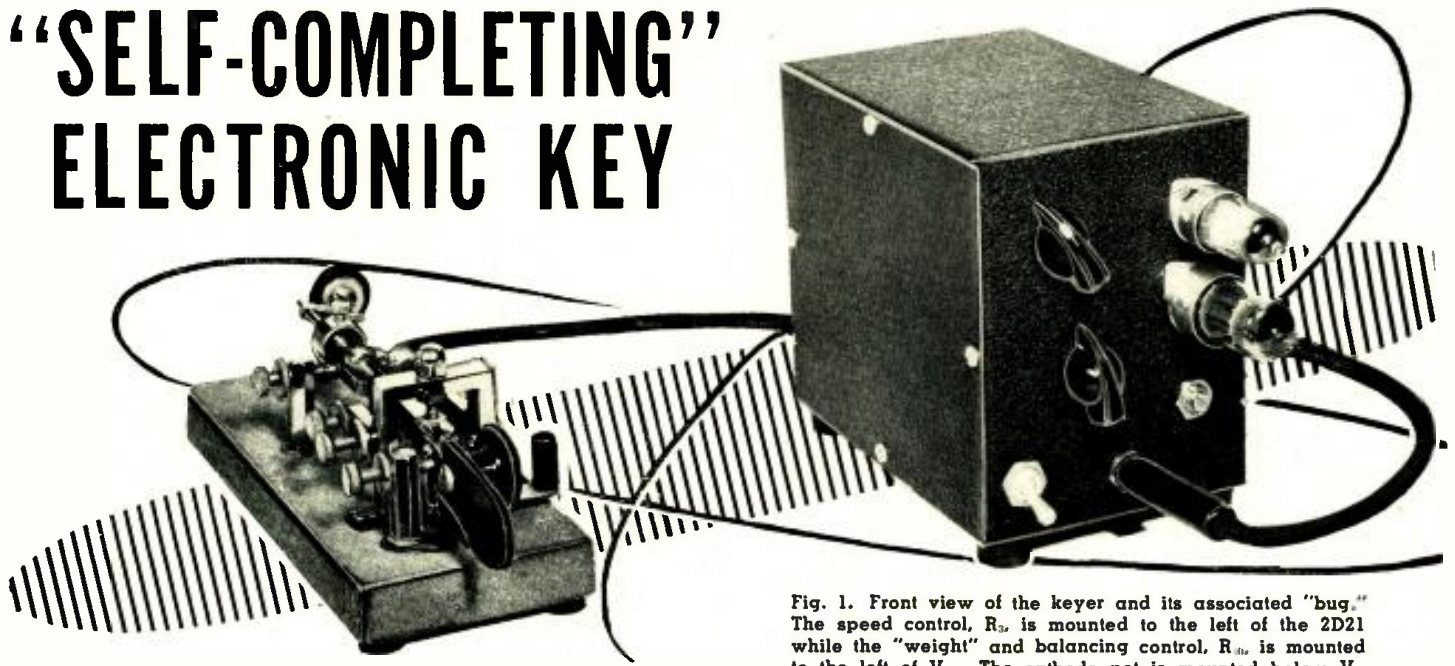

Fig. 1. Front view of the keyer and its associated "bug." The speed control, R_s , is mounted to the left of the 2D21 while the "weight" and balancing control, R_w , is mounted to the left of V_2 . The cathode pot is mounted below V_2 . Jack, J_s , is mounted to the right of the "on-off" switch.

By JACK D. GALLAGHER, W5HZB

Construction details on an economical keyer which requires no elaborate mechanical changes in the "bug" used with it.

DURING the past few years numerous electronic keys have been described which were designed to reduce strain on the operator and to improve the character of the transmitted signal. The operation of the earlier models was based on the action of a multivibrator, electronically connected to a keyer tube, or connected through a d.c. amplifier to a keyer tube. The plate circuit of the keyer tube was connected to a relay, which keyed the transmitter. The dot-to-dash ratio was governed by the difference in condenser capacities, which was controlled by a contact on the switching mechanism. Unless the operator used exact timing, clipping of signals resulted.

Later models of electronic keys eliminated the multivibrator circuit in favor

of a circuit consisting of two relays interconnected between vacuum tubes which caused the keying relay to operate in a more precise manner. The dot-to-dash ratios were improved and the feature of self-completing dots and dashes aided the operator tremendously. It was now impossible to cut dots and dashes short by improper timing, since the circuit was designed to complete one operation before another could be started. Of course, the main disadvantage with this circuit was the two relays that had to be adjusted. Other disadvantages were the number of parts, the number of tubes used, and the power supply requirements.

In order to provide a simpler, more economical keyer, the author described a circuit in the January, 1953 issue of

RADIO & TELEVISION NEWS which used only one relay and provided the self-completing action through the use of a small thyratron. However, in order to use the "bug," a few mechanical changes were necessary. Providing extra contacts, insulating contact screws, and other modifications destroyed the future usefulness of the "bug" as a semi-automatic key.

The "bug" modification for the keyer described in this article does not destroy its usefulness as a semi-automatic key, nor are there any complicated mechanical changes to be made. No additional contacts are necessary, and there are no insulating problems.

A brief description of the circuit and the photographs will make clear its simplicity and ease of construction. The pulse circuit consists of a 2D21 thyratron gas tube, V_1 , connected to the timing circuit and the grid of a cathode coupler. The 8.2 megohm resistor connected to the grid of V_1 is returned to the cathode. This resistor causes a small negative "contact" potential when the circuit is completed by closing the key. In order to make the "bug" operate without contact additions, the electrical connection is removed between the dot and dash contact posts. The dot contact post is connected to the grid of V_{2A} , and the dash contact post is connected to the ungrounded terminal of C_1 . The frame of the "bug" is connected to the plate of the 2D21. When the key is in the neutral position, the voltage builds up on the timing circuit, consisting of C_1 , R_s , and R_w . The condenser, C_1 , becomes charged since this section of V_2 has zero grid bias. The cathode of V_{2A} is connected to the grid of V_{2B} through 27,000 ohms. The voltage drop through this resistor causes approximately three volts positive bias on V_{2B} , which results in a heavier plate current flow in this section of the tube. The keying re-

Fig. 2. Close-up view of the "bug" showing the three-conductor cable fastened to the spring arm stop with a cable clamp. See text for details on key modifications.

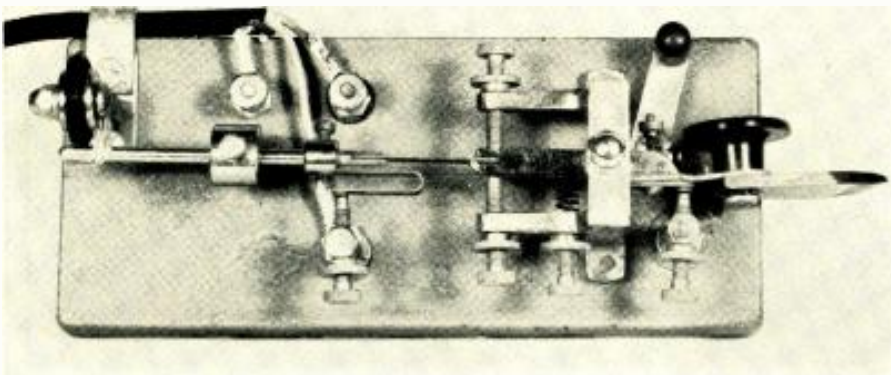

lay is connected from the plate of V_{2B} to the arm of a "balancing" potentiometer, R_{10} . In the idle condition, the balancing potentiometer is adjusted for zero voltage across the relay winding.

Operating the "bug" lever to the dash position causes the following action:

1. The timing condenser is grounded through V_1 .

2. Since the voltage is above the firing point, the tube fires and immediately discharges the timing condenser and grounds the grid of V_{2A} .

3. As the timing condenser is discharged, the voltage across V_1 reaches the extinguishing point and will not fire again until the voltage has risen to the firing point. (This action of the thyatron provides the self-completing action in this circuit.)

4. As the grid of V_{2A} is momentarily grounded through V_1 , the plate current of V_{2A} is cut off. This causes the voltage across the cathode load resistor and the timing circuit to decrease.

5. Since this timing circuit is connected to the grid of the second section of V_2 , the decrease in voltage will cause the grid of V_{2B} to become negative with respect to its cathode. V_{2B} is momentarily cut off.

6. The relay is in one arm of a Wheatstone bridge circuit, and in the idle condition the voltage across the relay winding is adjusted to zero. When dashes are being made, the bridge is unbalanced, and the voltage at the plate of V_{2B} rises. This change in voltage causes the relay to operate.

As soon as the voltage across V_1 reaches the extinguishing point, the circuit tends to resume its idle circuit condition. The grid-to-cathode voltage of V_{2A} drops toward zero causing the plate current to flow through the tube which recharges the timing circuit. As long as the dash contacts are closed, the thyatron will reach the firing point and repeat the operation.

When dots are made, the following action takes place:

1. The operation of the "bug" to the dot position places R_2 in series with the plate of the pulse tube, V_1 , and the timing condenser, C_1 . The operation of the thyatron is not affected since it will fire and extinguish as the voltage between its plate and cathode rises and falls.

2. The voltage discharged from the timing condenser is a different value because of the voltage drop across R_2 . The grid of V_{2A} is grounded through V_1 .

3. Since the timing condenser is not discharged as completely as it was in the case when producing dashes, the condenser recharges in a shorter interval of time. Holding the dot contact closed results in the same action as that described for producing dashes, except that the circuit now produces shorter relay contact closures, or dots.

Within certain limits, the adjustment of R_2 to values other than 33,000 ohms will result in different dash-to-dot ratios. Higher values of plate voltage than that shown in the diagram may

(Continued on page 146)

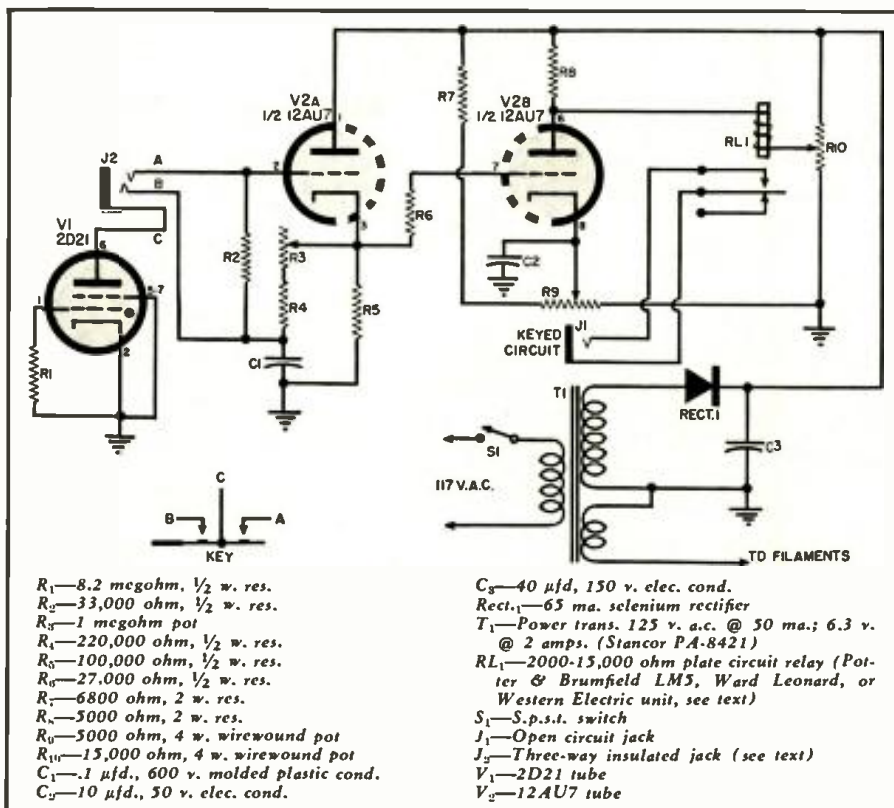
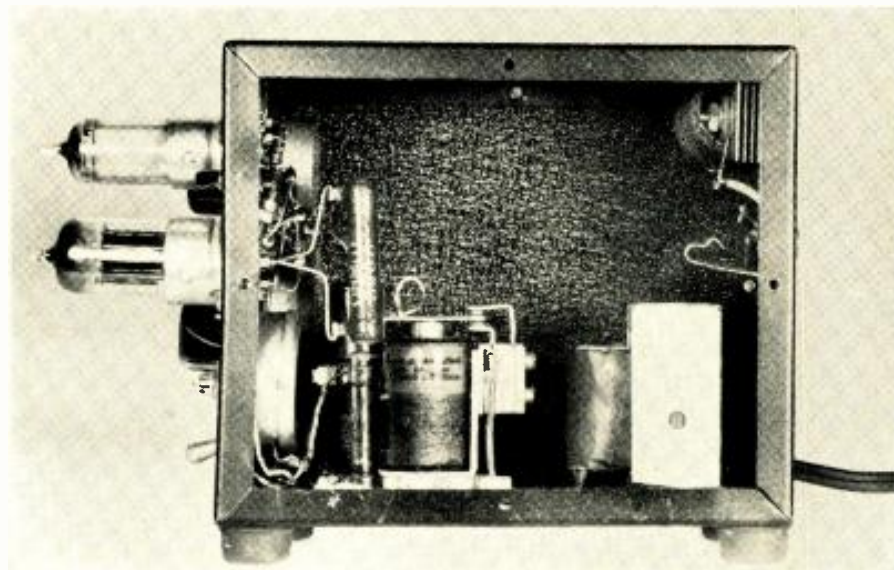

Fig. 3. Complete schematic of keyer. A 2D21 thyatron was selected for its small size.

| RELAY TYPES (See Text) | CONDITION | V_{2A} | | | V_{2B} | | |
|--|-----------|----------|----|----|----------|----|----|
| | | 1 | 2 | 3 | 6 | 7 | 8 |
| Ward Leonard adjustable 2000 ohm coil | Key Up | 138 | 65 | 96 | 78 | 46 | 43 |
| | Dots | 142 | 23 | 30 | 96 | 30 | 30 |
| | Dashes | 142 | 16 | 24 | 105 | 23 | 28 |
| Western Electric non-adjustable 4000 ohm coil | Key Up | 138 | 66 | 97 | 82 | 47 | 44 |
| | Dots | 142 | 23 | 30 | 105 | 30 | 31 |
| | Dashes | 144 | 16 | 24 | 112 | 23 | 28 |
| Surplus "BK-35" adjustable 13,000 ohm coil | Key Up | 138 | 65 | 96 | 78 | 46 | 43 |
| | Dots | 142 | 23 | 30 | 105 | 30 | 31 |
| | Dashes | 142 | 16 | 24 | 114 | 23 | 28 |
| Potter & Brumfield adjustable 10,000 ohm coil | Key Up | 138 | 64 | 97 | 78 | 46 | 43 |
| | Dots | 142 | 23 | 30 | 103 | 30 | 31 |
| | Dashes | 142 | 16 | 24 | 112 | 23 | 28 |

Table 1. Voltage readings for the four different types of relays tried by the author.

Fig. 4. Side view of keyer. Contact spacing adjustment on relay is indicated here.



A TRANSISTORIZED APPLAUSE METER

By LOUIS E. GARNER, JR.



Fig. 1. Over-all view of the transistorized applause meter. It measures 4" x 6" x 4 1/4" and is battery-operated.

Build this compact unit for rental or "loan." It can be used as an output meter or for sound-survey work.

WITH the increasing general interest in square-dance competitions, amateur shows, and similar contests, the radio-TV service shop is frequently in a position to pick up extra money or to obtain good publicity by renting or lending and installing p.a. systems, record players, and juke boxes. General practice is to rent the systems or equipment to clubs and money-raising groups, and to "lend" the systems to churches and similar charitable organizations.

At such contests, prizes are often awarded on the basis of "audience reaction." The only fair way to determine audience reaction to a particular act is by means of the impartial judgment of an electronic applause meter. In this way, there is no possibility of favoritism on the part of the emcee, nor any question as to the fairness of decisions.

Since the radio-TV service shop may be called on to furnish or operate the p.a. system, it is only natural that it also be requested to supply or obtain an applause meter or similar device. Commercial applause meters may not only be difficult to obtain locally but quite expensive, so the service organization handling such work may find it worthwhile to consider building its own instrument.

In choosing the design for such an instrument, several features are desirable. The applause meter should be self-contained, compact, light weight, sensitive, easy to use, and, preferably, independent of both the power line

and the p.a. system. These last two features are important because the instrument may sometimes be used outdoors where power is not available or in small groups where a p.a. system is not needed.

The instrument shown in Fig. 1 comes close to meeting all of these requirements. It is completely self-contained. No extra "mike" or other pickup is required. It is compact as the over-all dimensions are only 4"x6"x4 1/4". It is quite sensitive, yet easy to operate and use—only three simple controls are provided. It is battery operated and no power line connections are necessary!

These features have been made possible by utilizing *p-n-p* junction transistors in the design of the instrument.

Circuit Description

The complete schematic diagram for the transistorized applause meter is given in Fig. 2. The basic circuit consists of a two-stage transformer-coupled transistor amplifier followed by a single stage combination amplifier-detector. A built-in crystal microphone cartridge (Mic.) serves as the pickup.

In operation, audio signals picked up by the microphone are applied to the primary of transformer T_1 , a step-down unit used to match the high impedance of the crystal microphone to the low input impedance of the first transistor amplifier stage.

In order to adjust the gain of the

instrument for different sized audiences, a simple step-type attenuator, consisting of rotary switch S_1 and resistors R_1 , R_2 , R_3 , R_4 , and R_5 , is provided between the secondary winding of T_1 and the input to the CK721 amplifier stage.

The audio signal obtained from the "arm" of S_1 is applied through coupling condenser C_1 to the base of the transistor, connected as a conventional "grounded-emitter" amplifier. This basic circuit has been used throughout the instrument as it provides good gain and permits a single battery power source to be employed.

Resistor R_6 serves as the "base return" resistor. Connected to the negative terminal of the power supply, it establishes the base current "bias" for the first stage.

Transformer T_2 is used to match the high output impedance of the first stage to the low input impedance of the second stage, a CK722 "grounded-emitter" amplifier. The primary winding of this transformer serves as the collector load for the CK721 stage.

Coupling condenser C_2 offers a low impedance path for the audio signal to the base of the CK722 amplifier, yet prevents the secondary winding of T_2 from acting as a d.c. short from base to ground. R_7 is the base return resistor for the second stage; again, the value of this resistor determines the base "bias" current.

Condenser C_3 serves to bypass the higher frequency components of the audio signal and thus to reduce the effects of high-pitched whistles on the final meter reading. This condenser also reduces, to some extent, the amplitude of the noise "hiss" generated by transistor amplifier stages.

If desired, crystal headphones may be inserted in the monitor jack, J_1 , coupled to the second amplifier stage through condenser C_4 . This provision permits the operator to hear the signal as picked up by the applause meter.

Transformer T_3 serves to perform a function similar to that of T_2 , that is, its primary winding serves as the collector "load" for the second amplifier stage, and it is used to match the high output impedance of one stage to the low input impedance of the next.

C_5 serves as the coupling condenser to the last stage, a CK722 transistor operated without base "bias" current. Note that base resistor R_8 is returned directly to ground rather than to "B—".

When a transistor amplifier is op-

erated without base "bias" current, it acts to rectify as well as to amplify the applied signal. Thus, collector current depends directly on the amplitude of the applied audio signal and this current is indicated on the microammeter, M_1 .

Provision is made for "smoothing out" the peaks of audio signals by means of a large capacity bypass condenser, C_6 , across the meter. The use of this filter is optional with the operator, since it may be thrown out of the circuit by means of switch S_2 .

Power for the entire instrument is obtained from a single 6 volt battery, B_1 , controlled by a s. p. s. t. power switch, S_2 .

Construction Hints

The assembly and wiring of the instrument are straightforward and should present no problem to the skilled technician. The placement of major parts is apparent from the interior view of the instrument given in Fig. 3. The microphone cartridge and the input transformer (T_1) are mounted on the back panel.

A small chassis is used for the transistor circuits. An under chassis view is not shown because the final wiring, with the author's layout, must be done with the chassis in place.

The subminiature transformers are held in place by small "Z" brackets.

Wiring and layout are not especially critical, and the builder may modify the layout shown or choose a new one to suit his own requirements. Care should be taken to follow good audio practice, that is, leads should be kept reasonably short and the "input" and "output" portions of the instrument should be kept well separated.

Although the author's model has been assembled in a standard sloping panel utility box, another type cabinet may be preferred by the builder. Almost any small metal box will serve well in this capacity; a Bud "Minibox" is a good choice.

The transformer leads are identified by color-coded wires—the proper connections are shown in Fig. 2 for the transformers specified in the parts list.

In rare instances it may be found necessary to readjust the values of the "base return" resistors R_6 and R_7 for optimum results with a particular transistor. To do this experimentally, connect an audio sine-wave generator to the input and an oscilloscope to the output of the stage to be checked. Adjust the value of the resistor for best gain with minimum distortion, but in no case choose a value which permits the collector current to rise above 5 ma.

The builder can use one of two methods when installing the transistors. He may either use sockets or wire the transistors directly into the circuit. Should sockets be preferred, standard 5-pin subminiature tube sockets are suitable.

If the transistors are to be soldered in position, however, special care

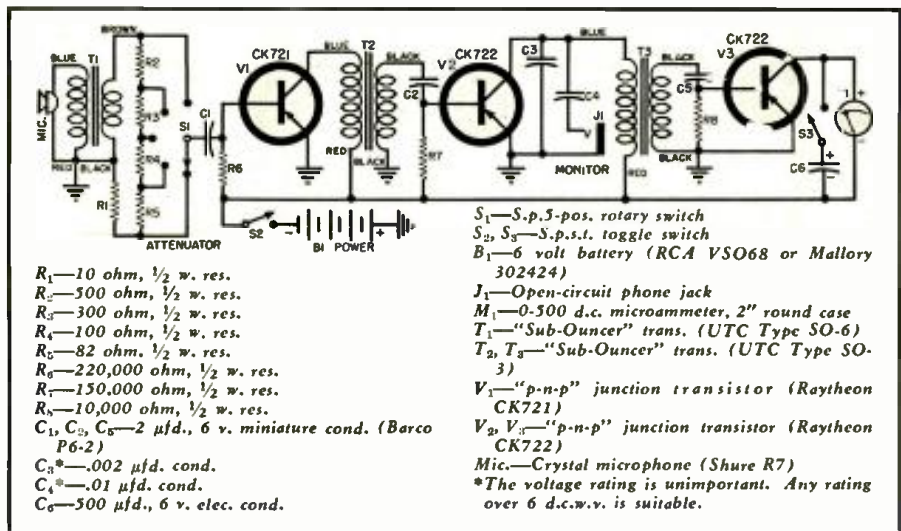

Fig. 2. Complete schematic of the transistorized applause meter. The "p-n-p" type junction transistor has been used in this construction. Three are required.

should be exercised to complete the soldering as quickly as possible to avoid possible damage by overheating these expensive components.

Circuit Modifications

A considerable number of modifications in the basic applause meter circuit are possible to meet the special needs of the individual builder. However, because the number of possibilities is so large, only a few suggestions are outlined here.

First, the monitor circuit may be eliminated entirely if desired. Simply remove C_4 and J_1 . No other circuit changes are necessary.

Another meter may be substituted for the 0-500 microampere unit specified in the parts list without making any other circuit changes. An 0-100

microammeter will provide increased sensitivity, while less sensitivity will be obtained with a 0-1 ma. unit. Irrespective of the meter chosen, however, care must be taken to set the attenuator so that serious overload will not occur. The exact setting will vary with different sized audiences.

In the author's model, the resistors in the attenuation network (R_1, R_2, R_3, R_4 and R_5) were chosen arbitrarily and no attempt was made to provide a precise degree of attenuation at each switch position. This method was employed since the instrument is used only to indicate relative peaks and exact meter readings are unimportant.

Some builders might prefer that the attenuator switch provide precise steps of attenuation, either in terms
 (Continued on page 120)

Fig. 3. Rear view of instrument. Microphone and transformer are mounted on the panel.





International SHORT-WAVE

Compiled by KENNETH R. BOORD



THIS month's ISW Department finds a heavy file of reports from listeners all over the world who obviously have had good luck with their DX-ing.

Albania—Radio Tirana, 7.850A, noted opening *English* session 1400. (Pearce, England)

Andorra—Radio Andorra, 5.990, noted 1730 with recordings. (Sarembe, Va.)

Anglo-Egyptian Sudan—Radio Omdurman, 7.093A, noted with news 1115 on Sun., Wed. (Pearce, England) Heard on 6.593A at 2315-2345, all-Arabic; best after 2330. (Stark, Texas)

Angola—Luanda, 11.862, varies its announcements; at times still says "Radio Clube de Angola," at others "Radio Angola," and sometimes "Radio Angola, Emissor Nacional." Noted around 1500-1530 and later. (Pearce, England)

Argentina—LRS, 9.316, *Radio Splendid*, noted 2115 with piano selections. (Tandrow, Calif.) News noted 1800A over LRA, 15.345. (Smits, Minn.) Heard on this outlet 1800-2000 to North America. (Vokral, N. Y.) *Radio El Mundo*, LRX, 9.660, 7.5 kw., LRX1, 6.120, 10 kw., is scheduled 0530-2235. (Kahan, Calif.) LRY, 9.76, heard 2215 at excellent level. (del Rosario, Hawaii)

Australia—VLA15, 15.200, noted 2200 at excellent strength in Hawaii. (del Rosario) VLC9, 9.615, noted at strong level 0700-0845. (McGrath, Iowa) VLM4, 4.917, Brisbane, heard 0410-0450 at good level in Home Service. (Morris, Pa.)

Austria—Radio Wien, 9.664, Vienna, noted 0330 with light musicals. Appears now to identify as "Radio Osterreich." *Blue Danube Network*, 9.617, Salzburg, noted with program preview 1025. (Pearce, England) This one is heard at fair level as late as 1100-1200. (Siggs, Sweden)

Azores—Ponta Delgada, 4.865, noted to 1900 closedown. (ISWL, England) CSA92, 11.090, heard with music 1530-1538. (Morris, Pa.)

Bechuanaland—ZNB, 8.230, Mafeking, is heard in Sweden 1200-1300. (Radio Sweden)

Belgium—ORU, 9.745, Brussels, noted with recordings, announcements in Portuguese at 1618. Heard on 6.000 at 1700 with Spanish for Latin America. (Pearce, England) Heard closing 0805 on 11.805, fair level; noted on 21.510 with fair signal 0700 when reception improves (may change beam then).

(Gillett, Australia) Heard on 9.767A with interval 1300, French language. (Smits, Minn.) Noted on 15.335 at 1200 in German. (Sarembe, Va.)

Belgian Congo—Radio Congo Belge, Leopoldville, lists OTM1, 6.295, 0000-0130, 0515-0730, 1130-1600; OTM2, 9.380, 0000-0130, 1130-1600; OTM4, 11.720, 0515-0730; OTH, 9.210, 0530-0700, 1130-1330; OTH, 11.670, Sun. only 0500-0700. (Cody, Ireland, others) The 9.380 outlet is good level to 1600 closedown in French, but does have occasional CWQRM. (Jannis, S. C.) Good level when checked 0040. (Barnard, Calif.)

Brazil—ZYK3, 9.565, *Radio Jornal do Comercio*, Recife, Pernambuco, is good level in the United Kingdom when presents "Brazil Calling" (*English*) weekdays 2005-2030 (Sun. 1630); ZYK2, 6.085, ZYK32, 11.825, and ZYK33, 15.145, are also used. *Radio Cultura do Sao Paulo*, 6.165A, is being heard well in Canada around 2330 when announces in *English* and asks for reception reports, says will send a "novelty" reply from Radio Cultura, Avenida Sao Goao 1285, Sao Paulo, Brazil; no longer uses 9.745. *Radio Bandeirante*, ZRY77, 6.185, and ZRY78, 11.925, is scheduled now 0400-1100, 1600-0030. (ISWC, London, others)

Radio Record, 9.505, Sao Paulo, heard 1700 with news in Portuguese. (Mesquita e Sousa, Portugal) *Radio Tamandare*, ZYK21, 3.265, heard 1905-1930; *Radio Clube de Para*, PRC5,

This young SWL who became a ham is Edward R. Buchholz, W9VBZ of Milwaukee, Wis. Shown are Ed's NC-125 receiver; his transmitter—a Johnson Viking; a Johnson v.f.o.; and the Milwaukee Radio Amateur's Club "Novice Trophy" presented to Ed for the year 1952. His transmitter usually runs 100 watts on the 20- and 75-meter bands. His antenna is a 125-foot center-fed, half-wave, running E-W about 50 feet in air.



4.865, heard 1904-2058 sign-off; *Radio-difusora Amazonas*, ZYSS, 4.805, heard 1900-2130 sign-off; *Radio Quitandinha*, ZYP23, 5.045, noted 1630-1700. (Miemois, Finland)

British Guiana—ZFY, 3.220A, Georgetown, *Radio Demarara*, noted 1845-1915. (Hill, Mass.)

British Honduras—Radio Belize, 3.300, noted 1925-2000 with *English*, then Spanish news, weather report, and talk in *English*; heavy CWQRM. (Morris, Pa.; Kirby, Mo.)

Bulgaria—Radio Sofia, 9.700, heard well with news 1745. (Roemer, Ky.; Smits, Minn., others) Noted on 7.671A in *English* 1625-1640 through CWQRM. (Morris, Pa.; Keith, N. Y.)

Burma—Radio Rangoon, 4.774, noted with *English* 0915-1015. (Miemois, Finland)

Canada—CJCX, 6.010, Sydney, Nova Scotia, has increased power from 1 to 5 kw. (*WRH*) Heard with news, weather report 0705-0715, then music. (Greco, N. J.) BED, 7.320, Edmonton, Alta., noted 1430, bad QRM, QSB. (Bellington, N. Y.)

Cape Verde Islands—CR4AA, near 7.398, Praia, noted signing on in Portuguese 1500. (Pearce, England) Has news in Portuguese 1545, 1630. (Mesquita e Sousa, Portugal)

Ceylon—VOA relay, 9.57, noted opening 0830 with "Star-Spangled Banner." (Bellington, N. Y.) *Radio Ceylon*, 11.975, heard 0930-1030 and later at good level. (Jones, N. C., others) Strong at 1100 (Lund, Iowa) Heard on 15.120 in *English* 2030-2330, announces 7.190 in parallel. (Crowell, Pa.)

China—Radio Peking, measured 15.058, noted with Chinese at dictation speed 2050; at 2100 had time pips, fair level. (Ferguson, N. C.) Heard on 10.210AV with setting-up exercises 1820, parallel 9.060A. (Niblack, Ind.) Heard on 7.450A in native 1820-1915, good level at times; CWQRM. (Morris, Pa.) Peking is being heard on 6.105, 6.200, 9.010A, and 10.200 to sign-off 1334A; on 11.96 at 2200 in *English* with 15.06 announced as in parallel. (Morgan, Calif.)

(Continued on page 126)

(Note: Unless otherwise indicated, all time is expressed in American EST; add 5 hours for GCT. "News" refers to newscasts in the English language. In order to avoid confusion, the 24 hour clock has been used in designating the times of broadcasts. The hours from midnight until noon are shown as 0000 to 1200 while from 1 p.m. to midnight are shown as 1300 to 2400.) The symbol "V" following a listed frequency indicates "varying." The station may operate either above or below the frequency given. "A" means frequency is approximate.

TV-RADIO SERVICE TECHNICIAN ASSOCIATIONS

Listed below, by state, are the various TV-radio technician associations in the United States and Canada. Service technicians wishing to obtain more information about their local associations should write direct to one of the officers listed.

CALIFORNIA

Long Beach Radio Technicians, Inc., P.O. Box 4085, Long Beach 4—Joseph Martin, Pres.; Merlyn Cochems, Sec'y.

Bureau of Home Appliances of San Diego County, Electric Bldg., San Diego 1—Robert D. Halvorson, Pres.; J. Clark Chamberlain, Sec'y-Mgr.; J. Holloway, Chm. Electronics Div.

San Diego County Electronic Ass'n, Inc., P.O. Box B, Old San Diego Station, San Diego 10—Frederick Palmer, Pres.

Society of Radio & Television Technicians, Inc., P.O. Box 126, Van Nuys—Jimmie Scarsborough, Pres.; Morris Blumbaum, Sec'y.

COLORADO

Rocky Mountain Radio-Television Guild, Inc., 8201 West Grandview, Arvada—Milo G. Scram, Pres.; Tom Sampson, Sec'y-Treas.

FLORIDA

Radio & Television Technicians Guild of Florida, Inc., 8909 N.W. 22nd Ave., Miami—Shan Desjardins, Pres.; Clarence C. Gunn, Sec'y.

ILLINOIS

Greater Chicago Television Service Industry, 135 S. LaSalle St., Chicago 11—Charles Custer, Pres.; M. G. Mackay, Sec'y.

National Alliance of Television & Electronic Service Ass'ns, 5908 S. Troy St., Chicago 29—Frank J. Moch, Pres.; Jack McDowell, Sec'y-Gen.

National Appliance & Radio-TV Dealers' Assn., 1141 Merchandise Mart, Chicago 54—Wallace Johnston, Pres.; Victor P. Joerndt, Sec'y.

Television Installation Service Ass'n. of Illinois, 5908 S. Troy St., Chicago 29—Frank J. Moch, Pres.; Ruben Saxner, Sec'y.

INDIANA

Radio & Television Service Engineers Ass'n., Inc., 1624 W. 9th St., Anderson—Joe Groves, Pres.; E. J. Deilks, Sec'y.

Radio-TV Service Dealer Ass'n., % Snyder Radio Service, 728 11th St., Columbus—Ralph R. Dwenger, Chm.; J. E. Snyder, Sec'y-Treas.

Radio Servicemen's Ass'n., 701 Hess Ave., Evansville—Wayne Stephan, Pres.; Albert J. Bosler, Sec'y-Treas.

Fort Wayne TV-Radio Appliance Ass'n., 112 East Washington, Fort Wayne 2—Ray Adams, Pres.; Edward H. Sharkey, Sec'y.

IOWA

Radio Technicians Ass'n., 515 Church St., Ottumwa—Jerry Brown, Sec'y.

MARYLAND

Certified Television & Electronics Ass'n. of Maryland, 2861-3 W. Franklin St., Baltimore 23—Harry O. Johnson, Pres.; Jerry Jacobson, Sec'y.

MASSACHUSETTS

Radio Television Technicians Guild of New England, 212 Massachusetts Ave., Ar-

lington 78—Ben Sims, Pres.; James Stine, Sec'y.

Association of Television Service Engineers, 18 Jackson St., Cambridge—I. Werlin, Pres.; Russell J. Cummings, Sec'y.

Radio Television Technician's Guild of New England, Inc., P.O. Box 1307, Fall River—Jim Shipley, Pres.; Alfred A. Feisal, Sec'y.

MICHIGAN

Television Service Ass'n. of Michigan, 16311 Grand River, Detroit 27—Harold Chase, Pres.; M. Wright, Sec'y.

Radio Technicians Ass'n., P.O. Box 773, Kalamazoo—Paul M. Goecke, Pres.; James Thayer, Sec'y.

Oakland County Electronic Ass'n., 286 State St., Pontiac—John Stefanski, Pres.; James H. Hampton, Sec'y.

MINNESOTA

Radio Servicemen of America, 1010 Second Ave., S., Minneapolis—A. R. Trovall,

Rochester Radio & Television Servicemen's Ass'n., 505 11th St., N.W., Rochester—George McKinzie, Pres.; V. Norman, Sec'y.

MISSOURI

Television Service Engineers, Inc., 307 Shukert Bldg., 1115 Grand, Kansas City—Albert A. Richards, Pres.; Ray Crawford, Sec'y.

Ass'n. of Television Service Companies of Greater St. Louis, Inc., 1724 S. 39th St., St. Louis 10—Vincent J. Lutz, Pres.; Morton Singer, Sec'y.

NEBRASKA

Nebraska Electronic Service Ass'n., 1617 S. 17th St., Lincoln 2—H. M. Tanquary, Pres.; T. M. Duffield, Sec'y.

NEW JERSEY

Radio Servicemen's Ass'n., Inc., 72 S. Olden Ave., Trenton 9—George Owens, Pres.; Louis E. Peoples, Sec'y.

NEW YORK

Buffalo Radio Institute Alumni, 45 W. Mohawk St., Buffalo—Albert Licata, Pres.; Philip Oehler, Sec'y.

Radio Technicians Ass'n., Inc., 657 Broadway, Buffalo 12—Ted J. Telaak, Pres.; Clarence Jax, Sec'y.

Radio Television Service Ass'n. of Western N. Y., Station E., Box 28, Buffalo—Ferdinand J. Lynn, Pres.; John G. Wick, Sec'y.

Long Island Electronic Technicians Ass'n., 88 4th St., Oceanside, L.I.—William Carey, Pres.; H. F. MacFarland, Exec. Sec'y.

Long Island Television & Radio Technicians Guild, 23 Broadway, Hicksville, L. I.—John A. Wheaton, Pres.; Henry Wawryck, Sec'y.

Radio Technicians Guild of Rochester, N. Y., Inc., 703 Temple Bldg., Rochester 4—Alfred L. Best, Pres.; Francis G. Stoffel, Sec'y.

Associated Radio-Television Servicemen of N. Y., Inc., 855 Midland Ave., Yonkers—Max Leibowitz, Pres.; Arthur Rhine, Exec. Sec'y.

OHIO

Associated Radio & Television Service Dealers, 2552 N. High St., Columbus—Sam Oppenheimer, Pres.; Robert Tyo, Sec'y.

Electronic Technicians Ass'n. of Toledo, 626 Pleasant Place, Toledo 9—Vern B. LaPlante, Chm.; Orville G. Shanteau, Sec'y.

OKLAHOMA

Oklahoma City Television & Radio Service Ass'n., 2909 N.W. 23rd St., Oklahoma City—H. O. Eales, Pres.; Harry E. Dent, Sec'y-Treas.

PENNSYLVANIA

Lehigh Valley Radio Servicemen's Ass'n., Radio Station WSAN, 39 N. 10th St., Allentown—Claude Kramer, Pres.; Ed Ehrhitz, Sec'y.

Federation of Radio Servicemen's Ass'ns. of Pa., Carbondale—Milan J. Krupa, Chm.; Leon J. Helk, Sec'y.

Alle-Kiski Chapter of the National Appliance & Radio-TV Dealers Ass'n., P.O. Box 283, Brackenridge—Penny Martin, NARDA Rep.

Conestoga Television Ass'n., 915 New Holland Ave., Lancaster—Lewis I. Mengle, Pres.; Robert G. Wiegand, Sec'y.

Joint Electronics & Radio Committee on Service, Lewis Tower Bldg., Philadelphia—Paul V. Forte, Exec. Sec'y.

Philadelphia Radio Service Men's Ass'n., Inc., 1307 W. Rockland St., Philadelphia 40—Samuel Brenner, Pres.; Fred Cohen, Sec'y.

Television Contractors Ass'n., Lewis Tower Bldg., 15th & Locust Sts., Philadelphia 2—Albert M. Haas, Pres.; Martin Weinberg, Sec'y.

Television Servicing Dealers Ass'n., 6021 Ogontz Ave., Philadelphia—Louis J. Smith, Pres.; Martin Benoff, Sec'y.

Radio Servicemen's Ass'n. of Luzerne County, P.O. Box 309, Wilkes-Barre—William Morgan, Jr., Pres.; Milan J. Krupa, Sec'y.

RHODE ISLAND

R. I. Radiomen's Business Ass'n., P.O. Box 800, Providence 1—Hugo Olobri, Pres.; Edward Oliver, Sec'y.

TEXAS

Fort Worth Radio & Television Ass'n., Inc., 1610 Eighth Ave., Fort Worth—Truett Kimzey, Pres.-Dir.; J. W. Williams, Jr., Sec'y-Treas.

Texas Electronics Ass'n., 511 Hemphill St., Fort Worth—Leonard R. Smith, Pres.; Luther Bradley, Sec'y.

Texas Electronic Technicians Ass'n., P.O. Box 15011, Houston—Ed Grange, Pres.; M. Chaplinsky, Sec'y.

(Continued on page 164)

Editor's Note: Although every attempt has been made to make this list as complete as possible, some groups may have been omitted. If the officers of any such group will send in the exact name, address, and list of officers, we will be happy to include this information in one of our future issues.

Mac's RADIO SERVICE SHOP

By JOHN T. FRYE



TAPE RECORDERS

THE express truck was just driving away from the service shop as Barney returned from his lunch hour, and the youth, who had more curiosity than Dr. Kinsey, immediately hurried inside to find out what new equipment Mac could be purchasing. The boss already had the instrument out of the box and sitting on the service bench, and he was unwrapping some small parts that had been packed with it.

"Hey!" Barney exclaimed, "that's a mighty neat looking tape recorder. Is it for the shop?"

"Yep," Mac answered. "Our old one is pretty well worn out; furthermore, home tape recorders have improved a lot since that one was made. The features of this *Ekotape* 205 represent many of the advances found in most late model recorders."

"Such as . . ." Barney led him on.

"Such as the ability to record at either 3.75 or 7.5 inches-per-second and being able to switch instantly from one speed to the other with proper equalization of the playback amplifier being cut in automatically for either speed. It is a dual-track machine that can put two full hours of program on a seven-inch reel and has a fast forward and rewind for quickly spotting a particular section of the recording. When a program is being taped, it can be heard through the recorder speaker or this can be cut out. There is a full range tone control for boosting either the bass or highs during playback. There is a high-level input jack and a patch cord for taking a recording from any radio, TV, or phono player by simply clipping the ends of this cord directly to the voice coil connections. The same jack, of course, could be used with a shielded cord for taking the program from a high impedance

source, such as directly across the volume control or from the output of a phono cartridge.

"As I mentioned, many of these features are found in practically all late model recorders; but here is something in this one that appeals to me for our uses." As he said this, Mac inserted a small device in an opening in front of the recorder and pushed it gently with his thumb. Instantly the reels that had been moving the tape through the recording head stopped going around. As his thumb released the gentle pressure, the reels started revolving again.

"This manual control of tape movement allows you to stop and start the tape instantly at any time while recording or playing back without disturbing any of the other controls. I figure it will be most handy for dictating. A fellow can say a sentence and then stop the gadget while he thinks up another."

Mac removed the hand control and inserted the end of a flexible tube that went down to a foot treadle affair resting on the floor. When he pressed on this with his foot, the tape could be stopped and started again as readily as with the hand control.

"This foot control is a good companion for the hand control," Mac explained. "It allows you to control the recorder while your hands are busy doing something else. For example, Matilda can use it to take down on the typewriter a letter I have dictated on the tape. She can let the tape run for a few words at a time and then hold it while she puts these down, and so on."

"You whizzed something by me awhile ago," Barney complained. "What was that business about different am-

plifier compensation for each speed?"

"Well, you must know the response curves of an uncompensated tape recording would never serve as a high-fidelity fan's pin-up. It looks like a sort of lopsided parabola with the lows falling away from the peak more gradually than do the highs. By increasing the speed of the tape, we can increase the frequency of this peak response point. In fact, the relationship is a direct one, with the peak response frequency being doubled by doubling the tape speed."

"Hold it!" Barney commanded. "Why?"

"Suppose we used light-sensitive tape instead of magnetic and employed a neon lamp shining through a narrow slit on to the tape as our recording head. When the light was bright, the tape in front of the slit would be turned black; when the light was out, the tape would remain white. Now if we use a low-frequency sine wave to excite the neon lamp, the moving tape will be transformed into alternate bands of white and black. As we increase the frequency of our exciting signal, the width of these bands will decrease until they become narrow vertical lines. Finally, as the frequency goes higher and higher, the alternate lines of black and white will become so narrow that they merge together. Holding our exciting frequency at this point, however, we can double the speed of the tape and so double the width of the lines, making them again easily distinguishable. Only when the exciting frequency is doubled will they merge together once more. Since the recording head prints magnetically on the tape in precisely the same way that this apparatus would print photographically, you can see why increasing the tape speed increases the potential high-frequency response."

"Yes, and I also see why different amplifier compensation would be required to flatten out the curves for each speed. You would need less high-frequency compensation at the higher speed. Right?"

"Right," Mac applauded; "and while this picture is still fresh in your mind, perhaps we had better talk about the importance of head alignment in playing tapes recorded with a recording head that is different from the playback head. Since most home recorders use the same head to perform both jobs, this is not very important as long as the machine is used only for playing tapes recorded on that machine; but now it looks as though we are on the brink of a new era in which there will be a lot of exchanging of tapes."

"What makes you think so?"

"For one thing, it is becoming quite a fad to exchange tapes between recorder fans. In fact there is an organization called *Tape Respondents, International*, with headquarters just that sort of thing. Then I saw in 'Time' a few weeks back where both *Pentron*

(Continued on page 170)

FIRST
... in
more ways
than one!



First On The Market . . . more than 20 years ago Mallory produced the first commercial Vibrators.

First As Original Equipment . . . today Mallory produces more Vibrators for set manufacturers than all other makes combined.

First With Servicemen . . . surveys show that Mallory Vibrators are preferred and used by 5 out of 6 servicemen.

Your Work Is Right The First Time when you use Mallory Vibrators. The patented, tuned mechanism assures completely dependable performance . . . always. Ask for Mallory Vibrators by name.

**Cover 75% of Your Replacement Needs
with just 6 Mallory Vibrators!**

Ask your Distributor about Mallory Deal 2448 which includes these 6 fast moving Vibrators.

And be sure you have a copy of the current Mallory Vibrator Guide. It is a complete cross reference listing and service guide—the most recent edition of a publication serving servicemen for nearly 25 years.

P. R. MALLORY & CO. Inc.
MALLORY

CAPACITORS • CONTROLS • VIBRATORS • SWITCHES • RESISTORS
RECTIFIERS • POWER SUPPLIES • FILTERS • MERCURY BATTERIES
APPROVED PRECISION PRODUCTS

P. R. MALLORY & CO. Inc., INDIANAPOLIS 6, INDIANA

over **100,000**
already installed!



CHANNEL MASTER'S fabulous
CHAMPION*

the world's most powerful
all-channel VHF antenna
—OUT-PERFORMS AND OUT-SELLS THEM ALL!

Never before in the history of television has an antenna received such an overwhelming reception. Channel Master's CHAMPION — in a few short months — has rocketed to the top as the nation's most-wanted, best-selling, best-performing VHF antenna!

CHAMPIONSHIP Performance: Only the CHAMPION has the unique new "Tri-Pole", a triple-powered dipole system in which the Low Band dipole also functions as three dipoles tied together, in phase, on the High Band.

All-aluminum. Assembles faster than a 5-element Yagi! The CHAMPION is another great contribution of the Channel Master Antenna Development Laboratories.

CHAMPIONSHIP Promotion: The CHAMPION is the antenna America knows best!

- Publicized in leading magazines!
- Outstanding dealer Cooperative Advertising Program!
- Free newspaper mats, window streamers and TV film commercials!

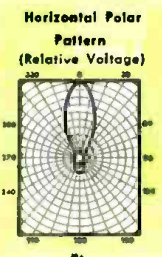
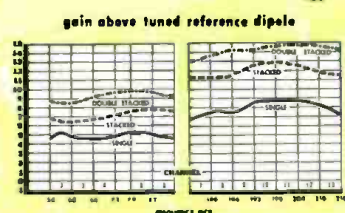
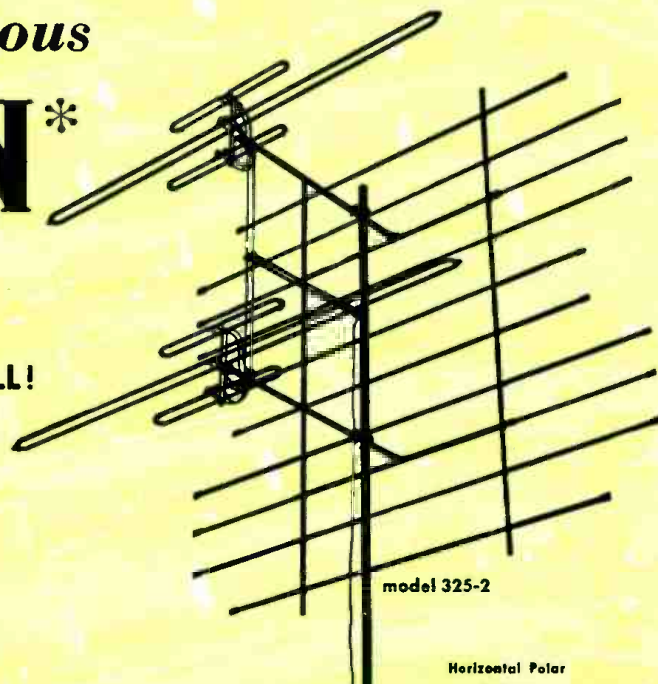

THE STACKED CHAMPION OUT-PERFORMS

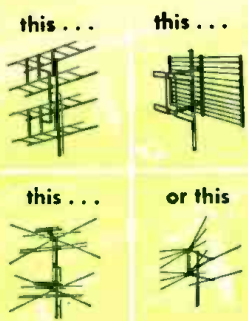

THE STACKED CHAMPION PROVIDES:
11-13 DB High Band gain
6 1/2-7 1/2 DB Low Band gain

| Model No. | | List Price |
|---------------------------|---------------|------------|
| 325 | Single Bay | \$20.83 |
| 325-2 | 2-Bay | \$42.36 |
| 325-4 | 4-Bay | \$88.89 |
| Separate Stacking Harness | | |
| 325-3 | 2-Bay Harness | \$ 2.08 |
| 325-5 | 4-Bay Harness | \$ 4.17 |



CHANNEL MASTER CORP.
ELLENVILLE, N. Y. WORLD'S LARGEST MANUFACTURER OF TELEVISION ANTENNAS

*pat. pending

TIE SEPARATE ANTENNAS TO ONLY ONE TRANSMISSION LINE

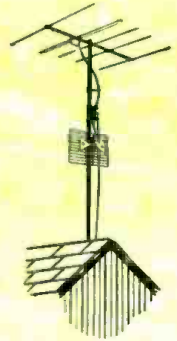

CHANNEL MASTER inter-action filters

Only Channel Master filters are permanently sealed in a block of moisture-proof, high melting-point electrical wax, locked in an attractive styrene case.

- Single lead
- No switching
- No signal loss
- No inter-action, effective isolation.

New!
VHF only
TENNA-TIE

model no. 9033-A



Use with leads of any length!
New, specially designed High and Low Pass filters entirely eliminate the need for critical lead lengths! This new, extremely effective circuit makes the TENNA-TIE the most effective filter of its type now available.
— only \$3.50

VHF-UHF
ULTRA-TIE

model no. 9034



JOINS — separate VHF and UHF antennas for use with a single lead.

SEPARATES — VHF and UHF signals at the set or converter where separate terminals are provided.

"Free-space" terminals.

new low price — \$3.75

VHF-UHF
TRIPLE-TIE

model no. 9035



Ties together all three TV reception bands:

1. Low Band VHF
2. High Band VHF
3. All UHF

High and Low Pass filters enable the Triple-Tie to adapt all Hi-Lo VHF installations to UHF — quickly and effectively. "Free-Space" terminals for perfect all-weather UHF reception.

new low price — \$4.86

THE ANTENNA IN COLOR TELEVISION

by Harold Harris, Vice President, Sales and Engineering

Now that color telecasting is a reality, we will see an ever-increasing flow of color sets to the consumer. Although much is being said and written on the subject of color sets, many unanswered questions remain about the role of the television receiving antenna in color television.

Will present antennas work on color?

Will a special antenna be needed?

The results of thorough laboratory and field tests made by engineers of the Channel Master Antenna Development Laboratories show that practically all present TV antenna types will perform satisfactorily on color. Gain variations as high as 3 DB across one channel can be tolerated. When this figure is exceeded blurring or smearing of the picture may occur. Although there are certain antennas on the market which do have excessive gain variation, this is not the case of the vast majority of present installations.

There are also indications that fringe area color reception may be more critical. This may necessitate the use of fringe area antennas in areas closer to the TV station.

In the nation's most advanced television research laboratory, Channel Master antennas have always been designed for full band width and minimum variation in gain on any one channel.

For this reason, every Channel Master antenna which you have installed in the past, as well as the ones you install today, will provide reception of outstanding quality when color TV comes to your area.

Channel Master antennas were the antennas selected for the tests which led to the F.C.C.'s approval of the National Television Standards Committee color system.



**Positive
connections
every time**



with
new
**Centralab
Precision**

**Attachable Terminal
HI-VO-KAPS®**

When it comes to high-voltage capacitors, you just can't beat CRL Precision Attachable Terminal Hi-Vo-Kaps for dependability. Here's why:

They are 100% factory-tested at twice rated working voltage — withstand continuous overload up to 40,000 v.d.c.

Terminals and taps have heavy 8-32 thread—cannot strip or break off, when terminals are tightened.

Terminals seat flat at bottom of tap. No gaps between terminals and capacitor body — no possibility of corona.

Positive mechanical bond between stub terminals and internal electrodes prevents loosening, when terminals are attached.

Keep a stock of CRL Precision Attachable Terminal Hi-Vo-Kaps on hand. Separate packaging of terminals and capacitor body lets you buy only the terminals you need. See your Centralab distributor.

Send coupon for bulletin 28-2 on CRL Precision Attachable Terminal Hi-Vo-Kaps.

Centralab

CENTRALAB,
A Division of Globe-Union Inc.
910C E. Keefe Avenue, Milwaukee 1, Wisconsin
Send bulletin 28-2 on CRL Precision
Attachable Terminal Hi-Vo-Kaps.

Name _____

Company _____

Address _____

City _____ Zone _____ State _____

D-1954

WIRELESS OPERATORS OF OLD

By C. HOWARD BOWERS

OLD TIME Wireless Operators are being heard from all over the country! If you were a commercial operator around 1912, send us a brief resumé of your career as we would like to share your experiences with our readers.

This month we were privileged to hear from J. F. Hammel, Vista, California, who spun this yarn of service and adventure to his friend E. H. Mariner. "JF," as he is known to his friends, started out in San Francisco in 1912 after attending the old Marconi Wireless School.

Our new operator's first ship was a lumber schooner, the "SS Wolverton," followed by several freight and passenger vessels of the *Admiral* Line. Starting pay was \$30 a month plus room and board. "Board" was usually restricted to the petty officers' mess adjoining the crew's galley and "room" was that portion of the ship of least use for anything else!

Most of the West Coast operators seemed to have a yen for Alaska and "JF" was no exception as in 1913 he served aboard two lumber schooners in that area. During 1914, however, our Arctic-minded friend made his first voyage away from the U. S. coast and sailed to Chile on the "SS Cuzco" with lumber, returning with nitrates to California. In 1915 he made a European cruise on a *Grace* Line ship. He returned to the Alaska run in 1917.

"JF" continued as a wireless operator until 1937 when he fell into evil ways and became a purser. The list of ships on his service record was longer than a king size cigarette when he quit the sea in 1947 and succumbed to his dreams of a chicken ranch in southern California where he hopes they do not become cheaper by the dozen!

Fred H. Zolin

While the majority of those engaged in professional work start as amateurs and wind up as professionals, the reverse is true in the case of Fred H. Zolin of Milwaukee. He started out as a professional telegrapher for *Western Union* about 1910 and did a little dabbling in wireless on the side. Fred was one of the many "boomer" operators and by 1914 he had drifted south to New Orleans and his first glimpse of the Gulf. His first sniff of salt water so stimulated his sea-going appetite that he obtained a First Class Commercial License and packed his bag and hammock.

He signed on the good ship "Alabama" bound for Frontera, Mexico. The ship had just undergone repairs and his first chore was to muck out the wireless shack. The gear was *Telefunken* with a quenched gap—something new to our tyro "sparks." The Chief Mate had to be contacted

every time juice was wanted and no one aboard knew the ship's call. Anyway, when the rig was finally cranked up and a general call sent out, our friend promptly received a QRT from a British warship lying off Vera Cruz and what could be sweeter.

His stretches at sea were usually followed by *Western Union* assignments and in 1917 Fred joined the Navy as First Class Electrician's Mate and was sent to London where he served on Admiral Sims' staff in communications. After World War I he served on Herbert Hoover's American Relief Commission and held posts in Paris, Venice, Trieste, and Vienna.

Returning to the States in 1919, Fred again accepted employment with *Western Union* at Milwaukee, Wisconsin, where he is now assistant operations chief. He is also a big-shot amateur radio operator on the side and has served two terms as president of the Milwaukee Radio Amateur Club. This alone is no small job as the club has over 300 members. It might also be added that our friend is still going strong and that he celebrated his "39th" birthday last Christmas Day. Continued success to Fred H. Zolin.

John O. Ashton

Switching signals across the country, we now pick up the story of another old timer, John O. Ashton of 2261 St. Francis Drive, Palo Alto, California.

This old time wireless operator has collected more "fruit salad" than General Marshall ever thought of. It all started in (hold your hat) 1901 when "JO" and his uncle tuned in the now famous "S" signals from Marconi's colleagues in Poldu, Cornwall, in fact the same signals that Marconi and his assistants, Kemp and Paget, were receiving in Newfoundland.

During 1910 "JO" and his friend and colleague, Earl Ovington, demonstrated Professor Tesla's high-frequency apparatus at Madison Square Garden, N. Y., and during the same year he installed his counterpoise antenna on Ovington's small *Bleriot* monoplane and conducted the first two-way radio communication with a plane aloft.

Our fast-moving friend obtained his "Certificate of Skill" in 1912 and became a regular operator atop 42 Broadway in New York City. Later he sailed on *United Wireless* equipped ships and others operated by *United Fruit*. He became an instructor and later an engineer in Latin America and South America. He taught radio school in four different foreign countries. He took post-graduate wireless engineering instructions in Berlin under Professor Braun, inventor of the *Braun* tube from whence come our TV tubes.

In 1913 he was a sales representative
RADIO & TELEVISION NEWS

for Lee DeForest in the distribution of *Audion* tubes. He is a member of the IRE, the National Association of Trade Executives, African Explorers Society, Pioneer Radio Station Owners, Association of Research and Development Directors, to name a few.

He is now a consulting engineer and in his spare time he is preparing a series of books on the history and development of radio and electronics covered by his own experience.

Our best wishes to "JO."

-30-

Transistor Receiver

(Continued from page 73)

an input signal cause collector current to flow. This pulsating current filtered somewhat by C_c operates the sensitive relay in the collector circuit. Although the class A efficiency of a junction transistor closely approaches the theoretical 50%, in this application we are interested in getting the maximum power output, irrespective of distortion, so the class B operation is much more attractive. The relay, manufactured in England, is a lightweight, sensitive device ideally suited for model airplane work. It weighs about one ounce, has a 4000-ohm winding, and operates on about 3 mw. of power. It features a balanced armature operating in the field of a permanent magnet and is highly resistant to vibration.

The sensitivity of this receiver is surprisingly good. A 40 microvolt signal, modulated 50% with a 400 cycle tone, is sufficient to operate the relay. Any signal greater than 100 microvolts will drive the last stage to saturation which delivers about 12 milliwatts into the relay. With only 3 milliwatts needed to operate the relay this gives a comfortable margin of safety.

The current drawn from the 9-volt battery is about 2 ma. for the V_1 and 3 ma. each for V_2 and V_3 . This is a total power consumption of about 23 milliwatts under standby conditions. An incoming signal increases this drain to 50 mw. but then we are delivering 12 mw. to the relay. This is a phenomenal saving of power when we consider that most vacuum-tube receivers of this type consume at least 150 mw. of filament power alone. This receiver is normally operated from six of the smallest available flashlight batteries connected in series.

A 10-watt mobile transmitter feeding into a 12-foot loaded vertical whip antenna was used for range checks. A three-foot vertical antenna was used on the receiver. Operation on the ground was satisfactory at $\frac{1}{4}$ mile so the range in the air should be more than adequate.

This receiver is not offered as the ultimate for this type of service because its performance leaves much to be desired. The author hopes, however, that this description will stimulate additional activity in the use of transistors in radio receiver applications.

-30-



THE FISHER HI-LO FILTER SYSTEM • MODEL 50-F

FISHER

Hi-Lo Filter System

■ Here it is at last—America's first electronic *sharp cut-off* Filter System. Suppresses turn-table rumble, record scratch and distortion, etc., with the *absolute minimum* loss of frequency response. *Separate* low and high frequency cut-offs. Can be used with *any* tuner, preamplifier, amplifier, etc. No insertion loss. Uniform response 20-20,000 cycles, ± 0.5 db. Self-powered. All-triode. Beautiful plastic cabinet. **Only \$29.95**

FISHER

Preamplifier-Equalizer

■ Now, professional record equalization facilities are within the reach of *every* record collector. THE FISHER Model 50-PR, like its big brother (Model 50-C) is beautifully designed and built. **Only \$22.95**

THE FISHER PREAMPLIFIER-EQUALIZER • MODEL 50-PR



OUTSTANDING FEATURES

- Independent switches for low-frequency turnover and high frequency roll-off.
- 16 combinations.
- Handles *any* low level magnetic pickup.
- Hum level 60 db below 10 mv input.
- Uniform response 20-20,000 cycles, ± 1 db.
- Two triode stages.
- Full low frequency equalization.
- Output lead any length up to 50 feet.
- Beautiful plastic cabinet, etched brass control panel.
- Completely shielded chassis.
- Built-in AC switch.
- Jewel indicator light.

Write for full details

FISHER RADIO CORP.

39 EAST 47th STREET • N. Y.

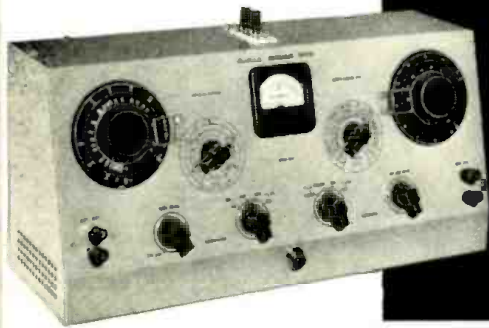

Heathkit IMPEDANCE BRIDGE KIT

MODEL IB-2

\$59⁵⁰

SHIPPING WT.
15 LBS.

Features

- Simpson 100-0-100 microampere meter.
- Completely AC operated.
- Built-in phase shift generator and amplifier.
- Battery type tubes, no warm-up required.
- Newly designed two section CRL dial.
- Single knob D, Q, and DQ functions.
- Special impedance matching transformer.
- New modern cabinet styling.
- 1/2% precision resistors and silver mica condensers.

Another new, outstanding instrument design so typically characteristic of Heathkit operation in producing high quality instrument kits at the lowest possible price. A new, improved model Impedance Bridge kit featuring modern cabinet styling, with slanted panel for convenience of operation and interpretation of scales at a \$10.00 price reduction over the preceding model. Built-in adjustable phase shift oscillator and amplifier with all tubes of the battery operated type completely eliminates warm-up time. The instrument is entirely AC line operated. No bothersome battery replacements.

The Heathkit IB-2 Impedance Bridge Kit actually represents four instruments in one compact unit. The Wheatstone Bridge for resistance measurements, the Capacity Comparison Bridge for capacity measurements, Maxwell Bridge for low Q, and Hay Bridge for high Q inductance measurements. Read Q, D, DQ all on one dial thereby eliminating possible confusion due to the incorrect dial reference or adjustment. Only one set of instrument terminals nec-

essary for any measurement function. Panel provisions provided for external generator use.

A newly designed two section CRL dial provides ten separate "units" switch settings with an accuracy of .5%. Fractions of units are read on a continuously variable calibrated wire-wound control. A special minimum capacity, shielded, balanced impedance matching transformer between the generator and the bridge. The correct impedance match is automatically switch selected to provide constant load operation of the generator circuit. The instrument uses 1/2% precision resistors and condensers in all measurement circuits.

The new Heathkit IB-2 provides outstanding design features not found in any other kit instrument. The single low price includes the power supply, generator, and amplifier stages. No need to purchase separate instrument accessories in order to obtain the type of operation desired.

Heathkit AUDIO WATTMETER KIT

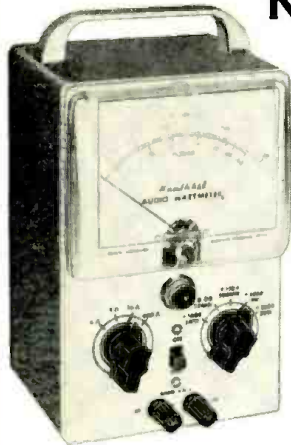

MODEL AW-1

\$29⁵⁰

SHIPPING WT.
6 LBS.

A new Heathkit design for the audio engineer, serious hi fi enthusiast, recording studio, or broadcast station; the Heathkit Audio Wattmeter Kit. This specialized instrument instantly indicates the output level of the equipment under test without requiring the use of external load resistors. All readings are taken directly from the calibrated scales of a 4 1/2" 200 microampere Simpson meter.

The Heathkit Audio Wattmeter features five full scale power measurement ranges from 5 milliwatts up to 50 watts with db ranges of -15 db to +48 db. The instrument has a power measurement rating of 25 watts continuous and 50 watts maximum for intermittent operation. Non-inductive resistance load impedances of 4, 8, 16, and 600 ohms are provided through a panel impedance selector switch. Frequency effect is negligible from 10 cycles to 250 kc. A conventional VTVM circuit utilizes a 12AU7 twin triode tube. The meter bridge circuit uses four germanium diodes for good linearity.

With the Heathkit AW-1 desired information can be obtained instantly and conveniently without bothering with the irksome scrups and calculations usually required. Useful for power curve measurements, frequency response checks, monitoring indicator, etc. Convenient calibration directly from 110 volt AC line source. This new instrument will help to supply the answers to your audio operating or power output problems.

Heathkit LABORATORY GENERATOR KIT

MODEL LG-1

\$39⁵⁰

SHIP. WT.
16 LBS.



Another welcome new addition to the popular line of Heathkit instruments, the Heathkit Laboratory Generator. Specifically designed for flexibility of operation, accuracy and versatility beyond the performance level provided by the conventional service type generator. Frequency coverage of the Colpitts oscillator is 150kc to 30mc in five convenient ranges with provisions for internal or external modulation up to 50%, and .1 volt RF output throughout the frequency range. Panel mounted 200 microampere Simpson meter for RF "set reference level" to provide relative indication of RF output. Individually shielded oscillator and shielded variable and step attenuator provide flexible control of RF output.

The circuit features a 6AF4 high frequency oscillator, a 6AV5 amplifier with grid modulation, 12AU7 400 cycle oscillator and modulator, OB2 voltage regulator tube, and a selenium rectifier for the transformer operated power supply. The smart professional instrument appearance and over-all flexibility of operation will prove a decided asset to any industrial or educational laboratory. The Heathkit Laboratory Generator sets a new level of operation, far superior to any instrument in this price classification.

HEATH COMPANY • Benton Harbor 15, Mich.

THE MOST *Outstanding* OSCILLOSCOPE IN HEATHKIT HISTORY

NEW MODEL O-9

OSCILLOSCOPE KIT







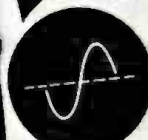

MODEL O-9

\$59.50

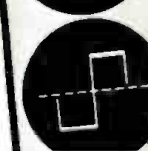
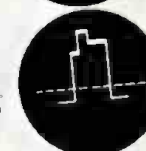
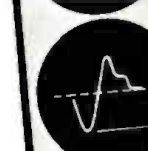
SHIPPING WT.
28 LBS.

Check THESE FEATURES

| | | | |
|--|--|--|--|
|  | Voltage regulated for rock steady traces—complete freedom from bounce and jitter. |  | Built-in 60 cycle sweep and phasing control—a necessity for TV service work. |
|  | Wide band width down only 6 db at 3mc—reproduces 500 kc square wave and up to 10 mc sine wave. |  | New production 5U1 CR tube by RCA gives finest trace available for complex, hard-to-see wave forms. |
|  | Acts as peak-to-peak vacuum tube voltmeter—measures directly on calibrated screen—built-in calibrator voltage. |  | Properly compensated cathode follower vertical input controls trace reproduction at any input level. |
|  | Retrace blanking amplifier eliminates confusion and gives clear concise picture of viewed wave form. |  | New ready formed and laced wiring harness eliminates unsightly and time consuming work of assembly. |

Announcing the newest addition to a brilliant series of Heathkit Oscilloscopes, the outstanding new model O-9 instrument. This Oscilloscope features a brand new 5U1 cathode ray tube for really fine hairline focusing, good intensity and freedom from halation.

NEW FEATURES

Efficient voltage regulation system maintains rock steady trace stabilization. New retrace blanking amplifier circuit—amplifier band width further extended through efficient circuitry. Calibrated 1 volt peak-to-peak reference—wiring simplified by ready laced and formed wiring harness—new phasing control.

GOOD DESIGN

Terminal board for quick access to deflection plates—provisions for Z axis input—astigmatism control—balanced push-pull deflection amplifiers—internal sync on either positive or negative peaks.

VERTICAL AMPLIFIER

High impedance input with 6AB4 cathode follower, twin triode 12AT7 Cascade amplifier, 6C4 phase splitter and 12AT7 push-pull high gain deflection amplifier. Sensitivity .025 volts per inch.

HORIZONTAL AMPLIFIER

Five position input switch for choice of external input—line sweep—line sync—internal sync and external sync. Uses 12AU7 input stage, half as triode phase splitter driving 12AT7 push-pull high gain deflection amplifier. The remaining half of the 12AU7 used as retrace blanking amplifier.

POWER SUPPLY

New heavy duty internally shielded 100 milliampere power transformer. Efficient high voltage filtering system—voltage regulation completely eliminates trace bounce or jitter.

The Heathkit O-9 is the ideal general purpose oscilloscope for educational and industrial use. Radio and TV servicing and any other application requiring the instantaneous reproduction and observation of actual wave forms.

Heathkit LOW CAPACITY PROBE KIT



No. 342

\$3.50

SHIP. WT. 1 LB.

Oscilloscope investigation of high frequency, high impedance or broad band width circuits requires the use of a low capacity probe. The Heathkit Low Capacity Probe features a variable capacitor to provide the necessary degree of instrument impedance matching.

Heathkit SCOPE DEMODULATOR PROBE KIT



No. 337-B

\$3.50

SHIP. WT. 1 LB.

In applications such as trouble shooting TV, RF, IF and video stages, the frequency ranges encountered require the demodulation of signals before oscilloscope presentation. The Heathkit Demodulator Probe will fulfill this function and readily prove its value as a service accessory.

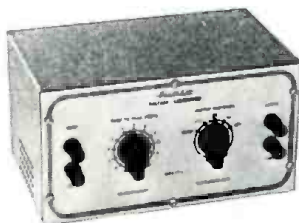

MODEL VC-2

\$11.50

SHIP. WT. 4 LBS.

Heathkit VOLTAGE CALIBRATOR KIT

The Heathkit Voltage Calibrator provides a convenient method of making peak-to-peak voltage measurements with an oscilloscope. Peak-to-peak voltages are read directly on the calibrated panel scales in the range of .01 to 100 volts peak-to-peak. A convenient "signal" position on the panel switch can be used to by-pass the calibrator and apply the signal directly to the scope input.

Heathkit ELECTRONIC SWITCH KIT

The basic function of the Heathkit S-2 Electronic Switch kit is to permit simultaneous oscilloscope observation of two separate traces which can be either separated or super-imposed for individual study. Continuously variable switching rates in three ranges from less than 10 cps to over 2000 cps. Individual gain controls for each input channel and a positioning control.



MODEL S-2

\$23.50

SHIP. WT. 11 LBS.



Heathkit VACUUM TUBE VOLTMETER KIT

MODEL V-6

\$24⁵⁰

SHIPPING WT. 6 LBS.

The beautiful Heathkit Model V-6 VTVM, the world's largest selling kit instrument, now offers many outstanding new features in addition to retaining all of the refinements developed and proven in the production of over 100,000 VTVM's. This is the basic measuring instrument for every branch of electronics. Easily meets all requirements for accuracy, stability, sensitivity, convenience of ranges, meter readability, and modern styling. It will accurately measure DC voltages, AC voltages, offers tremendous ohmmeter range coverage, and a complete db scale for a total of 35 meter ranges.

New 1½ volt full scale low range provides well over 2¼" of scale length per volt. Upper DC scale limit 1,500 volts. DC ranges 0-1.5, 5, 15, 50, 150, 500, 1,500 volts full scale. AC ranges 0-1.5, 5, 15, 50, 150, 500, 1,500 (1,000 volts maximum). Seven ohm-

meter ranges from .1 ohm to 1,000 megohms. For added convenience a DC polarity reversing switch and a center scale zero adjustment for FM alignment.

The smartly styled, compact, sturdy, formed aluminum cabinet is finished in an attractive gray crackle exterior. The beautiful two-color, durable, infra-red, baked enamel panel further adds to the over-all professional appearance.

Top quality components used throughout. 1% precision resistors — silver contact range and selector switches — selenium rectifier — transformer operated power supply. Individual calibration on both AC and DC for maximum accuracy. DB scale printed in red for easy identification, all other scales a sharp, crisp black for easy reading. A variety of accessory probes shown on this page still add further to over-all instrument usefulness.

Features

- ✓ New 1½ volt full scale low range
- ✓ 1,500 volt upper limit DC range
- ✓ Increased accuracy through 50% greater scale coverage
- ✓ High impedance 11 megohm input
- ✓ Center scale zero adjust
- ✓ Polarity reversal switch
- ✓ 1% precision resistors
- ✓ Clearly marked db scales

Heathkit 30,000 VOLT DC PROBE KIT

For TV service work or any similar application where the measurement of high DC voltage is required, the Heathkit Model 336 High Voltage Probe Kit will prove invaluable. A precision multiplier resistor mounted inside the two-color, sleek, plastic probe body provides a multiplication factor of 100 on the DC ranges of the Heathkit 11 megohm VTVM. The entire kit includes precision resistor, two-color plastic probe, tip connector spring, test lead, phone plug panel connector, and complete assembly instructions.



No. 336

\$4⁵⁰

SHIP. WT.
2 LBS.

No. 338-B

Heathkit PEAK-TO-PEAK PROBE KIT



\$5⁵⁰

SHIP. WT. 2 LBS.

Now read peak-to-peak voltages on the DC scales of the Heathkit 11 megohm VTVM. Readings can be directly made from the VTVM scale without involved calculations. Measurements over the frequency range of 5 kc to 5 mc. Use this probe to extend the usefulness of your VTVM in radio and TV service work. The Peak-to-Peak Probe Kit features the new polished aluminum housing with two-color polystyrene probe ends. Detailed assembly sheet including instructions for probe operation.

Heathkit RF PROBE KIT

The Heathkit RF Probe used in conjunction with any 11 megohm VTVM will permit RF measurements up to 250 mc, ± 10%. A useful, convenient accessory for those occasions when RF measurements are desired. The RF probe body is housed in the new, smartly-styled polished aluminum probe body featuring two-color polystyrene probe ends and a low capacity flexible shielded test lead. The kit is complete with all necessary material and a detailed assembly sheet as well as instructions for probe operation.



No. 309-B

\$3⁵⁰

SHIP. WT. 2 LBS.

Heathkit AC VACUUM TUBE VOLTMETER KIT

MODEL AV-2

\$29⁵⁰

SHIPPING WT.
5 LBS.

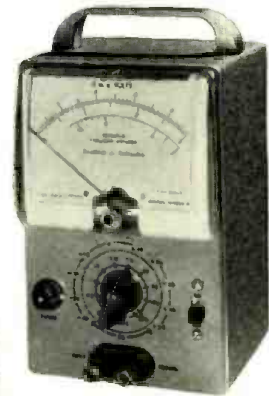

The new Heathkit AC VTVM that makes possible those sensitive AC measurements required by laboratories, audio enthusiasts, and experimenters. Especially useful for hum investigation, sensitive null detection, phono pick-up output measure-

ments, making frequency response runs, gain measurements, ripple voltage checks, etc. Low level measurements are easy to make because of the complete voltage coverage of the instrument and the one knob operation.

The large 200 microampere Simpson meter has clearly marked and easy to read meter scales. Ten voltage ranges covering from .01 rms full scale to 300 volts rms full scale, with frequency response ± 1 db from 20 cycles to 50,000 cycles. Instrument input impedance 1 megohm, ten db ranges from -52 db to +52 db. For stability and good linearity characteristics the meter bridge circuit features 4 germanium diodes. Attractive instrument styling, a companion piece for the popular Heathkit VTVM and the new AW-1 Audio Wattmeter.

HEATH COMPANY • Benton Harbor 15, Mich.

RADIO & TELEVISION NEWS

CHECK THESE *Features*

- ✓ 20,000 ohms per volt DC sensitivity, 5,000 ohms per volt on AC
- ✓ Polarity reversal switch
- ✓ 1% precision multiplier resistors
- ✓ 50 microampere 4½" Simpson meter
- ✓ Meter ranges for service convenience
- ✓ New resistor ring-switch assembly
- ✓ Total of 35 meter ranges
- ✓ New Modern cabinet styling

NEW *Heathkit*
**MULTIMETER
KIT**

MODEL MM-1

\$26⁵⁰

SHIPPING WT. 6 LBS.



The most important Heathkit announcement of the year, the new 20,000 ohms per volt Heathkit Multimeter, Model MM-1. The universal service measuring instrument, accurate, sensitive, portable, and completely independent of AC line supply. Particularly designed for service use incorporating many desirable features for the convenience of the service man. Full 20,000 ohms per volt sensitivity on DC ranges — 5,000 ohms per volt sensitivity on AC — polarity reversal switch, no bothersome transferring of test leads — 1% precision multiplier resistors — large 4½" recessed non-glare 50 microampere Simpson meter — conveniently slanted control panel — recessed safety type banana jacks — standard universally available batteries — rugged practical sized cabinet with plastic carrying handle, and a total of 35 calibrated meter ranges.

RANGES

Voltage ranges selected entirely for service convenience. For example 1½ volt full scale low range for measuring portable radio filament voltages, bias voltages, etc., 150 volt full scale range for AC-DC service work, 500 volt full scale range for conventional transformer operated power supply systems. Complete voltage ranges AC and DC, 0-1.5—5—50—150—500—1,500—5,000 volts. DC current ranges, 0-150 microamperes—15 milliamperes—150 milliamperes—500 milliamperes—15 amperes. Resistance measurements from .2 ohms to 20 meg-

ohms x 1 x 1,000 x 10,000.
DB coverage from -10 db to +65 db.

CONSTRUCTION

Entirely new design permits assembly, mounting and wiring of precision resistors on a ring-switch assembly unit. The major portion of instrument wiring is completed before mounting the ring-switch assembly to the panel. No calibration procedure is required, all precision resistors readily accessible in event of replacement.

CABINET

Strikingly modern cabinet styling featuring two piece construction, durable black Bakelite cabinet, with easy to read panel designations. Cabinet size 5½" wide x 4" deep x 7½" high. Good cabinet physical stability when operated in vertical position.

The Heathkit MM-1 represents a terrific instrument value for a high quality 20,000 ohms per volt unit using all 1% deposited carbon type precision resistors. Here is quality, performance, functional design, and attractive appearance, all combined in one low priced package.

Heathkit
BATTERY TESTER KIT



MODEL BT-1

\$8⁵⁰

SHIP. WT.
2 LBS.

The Heathkit Battery Tester measures all types of dry batteries between 1½ volts and 150 volts under actual load conditions. Readings are made directly on a three color Good-Weak-Replace scale. Operation is extremely simple and merely requires that the test leads be connected to the battery under test. Only one control to adjust in addition to a panel switch for "A" or "B" battery types. The Heathkit Battery Tester features compact assembly, accurate meter movement, and a three deck wire-wound control, all mounted in a portable rugged plastic cabinet. Checks portable radio batteries, hearing aid batteries, lantern batteries, etc.

Heathkit
HANDITESTER KIT



MODEL M-1

\$14⁵⁰

SHIPPING WT.
3 LBS.

The Heathkit Model M-1 Handitester readily fulfills major requirements for a compact, portable volt ohm milliammeter. Despite its compact size, the Handitester is packed with every desirable feature required in an instrument of this type. AC or DC voltage ranges full scale, 0-10—30—300—1,000—5,000 volts. Two ohmmeter ranges, 0-3,000 and 0-300,000. Two DC current measurement ranges, 0-10 milliamperes and 0-100 milliamperes. The instrument uses a Simpson 400 microampere meter movement, which is shunted with resistors to provide a uniform 1 milliampere load on both AC and DC ranges. Special type, easily accessible, battery mounting bracket — 1% deposited carbon type precision resistors — hearing aid type ohms adjust control. The Handitester is easily assembled from complete instructions and pictorial diagrams. Necessary test leads are included in the price of this popular kit.

HEATH COMPANY • Benton Harbor 15, Mich.



New Heathkit 12 Volt BATTERY ELIMINATOR KIT

MODEL BE-4

\$31⁵⁰

SHIPPING WT.
18 LBS.

CHECK THESE *Features*

- ✓ Either 6 or 12 volt operation
- ✓ Continuously variable voltage output
- ✓ Constant ammeter and voltmeter monitoring
- ✓ Automatic overload relay — self-resetting
- ✓ Two 10,000 mf condensers
- ✓ New 18 disc split type heavy duty rectifier unit
- ✓ Fuse protection

Here is the new Heathkit Battery Eliminator necessary for modern, up-to-date operation of your service shop. The Heathkit Model BE-4 furnishes either 6 volts or 12 volts output which can be selected at the flick of a panel switch. Use the BE-4 to service the new 12 volt car radios in addition to the conventional 6 volt radios.

This new Battery Eliminator provides two continuously variable output ranges, 0-8 volts DC at 10 amperes continuously, or 15 amperes maximum intermittent; 0-16 volts DC at 5 amperes continuously or 7.5 amperes maximum intermittent. The output voltage is clean and well filtered as the circuit uses two 10,000 mf condensers. The continuously variable voltage output feature is a definite aid in determining the starting point of vibrators, the voltage operating range of oscillator circuits, etc. Panel mounted meters constantly monitor voltage and cur-

rent output and will quickly indicate the presence of a major circuit fault in the equipment under test. The power transformer primary winding is fuse protected and for additional safety an automatic relay of the self-resetting type is incorporated in the DC output circuit. The heavy duty rectifier is a split type 18 plate magnesium copper sulfide unit used either as a full wave rectifier or voltage doubler according to the position of the panel range switch.

Here is the ideal battery eliminator for all of your service problems and as an additional feature, it can also be used as a battery charger. Another new application for the Heathkit Battery Eliminator is a variable source of DC filament supply in audio development and research. More than adequate variable voltage and current range for normal applications.

Heathkit VIBRATOR TESTER KIT

Your repair time is valuable, and service use of the Heathkit Vibrator Tester will save you many hours of work. This tester will instantly tell you the condition of the vibrator being checked. Checks vibrators for proper starting and the easy to read meter indicates quality of output on a large Bad-?-Good scale. The Heathkit VT-1 checks both interrupter and self rectifier types of vibrators. Five different sockets for checking hundreds of vibrator types.

The Heathkit Vibrator Tester operates from any battery eliminator capable of delivering continuously variable voltage from 4 to 6 volts DC at 4 amperes. The new Heathkit Model BE-4 Battery Eliminator would be an ideal source of supply.



MODEL VT-1

\$14⁵⁰

SHIPPING WT.
6 LBS.

NEW Heathkit VARIABLE VOLTAGE ISOLATION TRANSFORMER KIT

The new Heathkit Isolation Transformer Kit provides line isolation for AC-DC radios (not an auto transformer), thereby eliminating shock hazard, hum problems, alignment difficulties, etc. The output voltage is variable from 90 to 130 volts AC and is constantly monitored by a panel mounted AC volt meter. Use it to increase AC supply voltage in order to induce breakdown of faulty components in circuits thereby saving service time. Use it also to simulate varying line voltage conditions and to determine the line voltage level at which oscillator circuits cease functioning, particularly in three-way portable radios. Rated at 100 watts continuous operation and up to 200 watts maximum intermittent operation. A useful radio and TV service tool.



MODEL IT-1

\$16⁵⁰

SHIP. WT. 9 LBS.

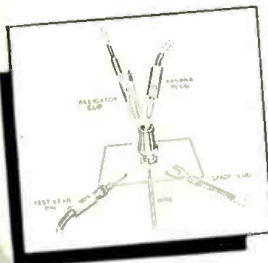

Heathkit BINDING POST

Binding post kit now available so that standardization of all instrument connectors is possible. This new, five-way binding post will accommodate an alligator clip, banana plug, test lead pin, spade lug, or hook-up wire. Sold in units of 20 binding post assemblies. Each assembly includes binding post, flat and shoulder fiber washers, solder lug, and nut. 120 pieces in all. Kit 362, \$4.00.



Heathkit TECHNICAL APPLICATION BULLETINS

An exclusive Heathkit service. Technical application bulletins prepared by recognized instrument authorities outlining various combinations of instrument applications. Available now with 40 four-page illustrated bulletins and an attractive flexible loose-leaf binder. Only \$2.00. (No c.o.d. on this item, please.)

HEATH COMPANY • Benton Harbor 15, Mich.

CHECK THESE *Features*

- ✓ INCREDUCTOR controllable inductor sweep
- ✓ TV and IF sweep deviation 12-30 mc
- ✓ 4 mc- 220 mc continuous frequency coverage
- ✓ Oscillator operation entirely on fundamentals
- ✓ Output in excess of 100,000 microvolts
- ✓ Automatic amplitude circuit
- ✓ Voltage regulation
- ✓ Simplified operation

NEW *Heathkit*
**TV ALIGNMENT
GENERATOR
KIT**

MODEL TS-3

\$44.50

SHIPPING WEIGHT
18 POUNDS

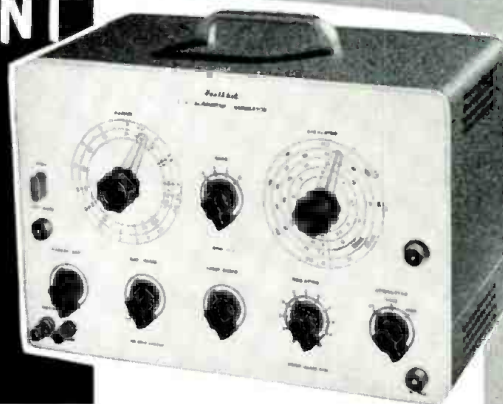

Proudly announcing an entirely new, advanced model TV and FM Sweep Generator, the Heathkit Model TS-3. This new design provides features and combinations of functions not found in any other service type instrument. Every design consideration has been given to the requirements of the TV service man to provide a flexible, variable sweep source with more than adequate RF output and complete frequency coverage throughout the TV and FM spectrum.

The frequency range of the TS-3 is from 4 mc to 220 mc in four switch selected ranges. All frequency ranges are overlapping for complete coverage. A particularly important feature of the instrument is that the oscillator operates entirely on fundamentals, thereby providing complete freedom from spurious oscillation and parasitics normally encountered in beat frequency type oscillators. This circuitry assures a much higher total RF output level and simplifies attenuation problems.

The new TS-3 features an entirely new principle of sweep operation. Sweep action is entirely electronic with no moving parts or electro-mechanical devices so commonly used. The heart of the sweep system is a newly-developed INCREDUCTOR controllable inductor. With this system, the value of inductance of each oscil-

lator coil is electrically varied with an AC control current, and the inductance variation is achieved by a change in the magnetic state of the core on which the oscillator coils are wound. This system provides a sweep deviation of not less than 12 mc on all TV frequencies, and up to a maximum of 30 mc on TV IF frequencies. The high RF output level throughout the instrument frequency range overcomes the most common complaint of the older type sweep generators. A new, automatic amplitude control circuit maintains the output level flat to ± 2 db throughout the instrument range. For convenience of operation a low impedance 50 ohm output is used.

Operation of the instrument has been simplified through the reduction of panel controls and separate panel terminals provide for external synchronization if desired. The circuit uses a voltage regulator tube to maintain stable instrument operation. A built-in variable oscillator marker further adds to flexibility of instrument operation. Provisions are also made for the use of an external marker, such as your service type signal generator, if desired. Use the Heathkit TS-3 for rapid, accurate TV alignment work, and let it help you solve those time consuming, irksome problems so frequently encountered.

NEW *Heathkit*
SIGNAL GENERATOR KIT

MODEL SG-8

\$19.50

SHIPPING WEIGHT
8 POUNDS



Announcing the new Heathkit Model SG-8 service type Signal Generator, incorporating many design features not usually found in an instrument in this price range. The RF

output is from 160 kc to 100 mc in five ranges, all on fundamentals, with useful harmonics up to 200 mc. The RF output level is in excess of 100,000 microvolts throughout the frequency range.

The oscillator circuit consists of a 12AT7 twin triode tube. One half is used as a Colpitts oscillator, and the other half as a cathode follower output which acts as a buffer between the oscillator and external load. This circuitry eliminates oscillator frequency shift usually caused by external circuit loading.

All coils are factory wound and adjusted, thereby completely eliminating the need for calibration and the use of additional calibrating equipment. The stable low impedance output features a step and variable attenuator for complete control of RF level. A 6C4 triode acts as a 400 cycle sine wave oscillator and a panel switching system permits a choice of either external or internal modulation.

The transformer operated circuit is easy to assemble, requires no calibration, and meets every service requirement for an adjustable level variable frequency signal source, either modulated or un-modulated.

NEW *Heathkit*
BAR GENERATOR KIT

MODEL BG-1

\$14.50

SHIPPING WEIGHT
6 POUNDS



The Heathkit BG-1 Bar Generator represents another welcome addition to the fast growing line of popular Heathkits. The

station transmitted test pattern is rapidly disappearing, and the bar generator is the logical answer to the TV service man's problem in obtaining quick, accurate adjustment information without waiting for test patterns.

The Heathkit BG-1 produces a series of horizontal or vertical bars on a TV screen. Since these bars are equally spaced, they will quickly indicate picture linearity of the receiver under test. Panel switch provides "stand-by position" — "horizontal position" — "vertical position." The oscillator unit utilizes a 12AT7 twin triode for the RF oscillator and video carrier frequencies. A neon relaxation oscillator provides low frequency for vertical linearity tests. The instrument will not only produce bar patterns but will also provide an indication of horizontal and vertical sync circuit stability, as well as overall picture size.

Instrument operation is extremely simple, and merely requires connection to the TV receiver antenna terminal. The unit is transformer operated for safety when used in conjunction with universal or transformerless type TV circuits.

HEATH COMPANY • Benton Harbor 15, Mich.



NEW *Heathkit* TUBE CHECKER KIT

MODEL TC-2

\$29⁵⁰

SHIP. WT. 12 LBS.

The new Model TC-2 Heathkit Tube Checker features many circuit improvements, simplified wiring, new roll chart drive and illumination of roll chart. The instrument is primarily designed for the convenience of the radio and TV service man and will check the operating quality of tubes commonly encountered in this type of work. Test set-up procedure is simplified, rapid, and flexible. Panel sockets accommodate 4, 5, 6, and 7 pin tubes, octal and loctal, 7 and 9 pin miniatures, 5 pin Hytron and a blank socket for new tubes. Built-in neon short indicator, individual three-position lever switch for each tube element, spring return test switch, 14 filament voltage ranges, and line set control to compensate for supply voltage variations, all represent important design features of the TC-2. Results of tube tests are read directly from a large 4½" Simpson three-color meter, calibrated in terms of Bad-?-Good. Information that your customer can readily understand. Checks emission, shorted elements, open elements, and continuity.

The use of closer tolerance resistors in critical circuits assures correct test information and eliminates the possibility of inaccurate test interpretation. Improvement has been made in the mechanical roll chart drive system, completely eliminating diagonal running, erratic operation, and backlash. The thumb wheel gear driven action is smooth, positive, and free running. As an additional feature, the roll chart is illuminated for easier reading, particularly when the tube checker is used on radio or TV home service calls.

Wiring procedure has been simplified through the extended use of multi-cable, color coded wires, providing a harness type installation between tube sockets and lever switches. This procedure insures standard assembly and imparts that "factory built" appearance to instrument construction. Completely detailed information is furnished in the new step-by-step construction manual, regarding the set-up procedure for testing of new or unlisted tube types. No delay necessary for release of factory data.

The new Heathkit Tube Checker will prove its value in building service prestige through usefulness—simplified operation—attractive professional appearance. Don't overlook the fact that the kit price represents a savings of \$40.00 to \$50.00 over the price of a comparable commercially built instrument. At this low price, no service man need be without the advantages offered by the Heathkit Tube Checker.

CHECK THESE NEW *Features*

- ✓ Simplified harness wiring
- ✓ Improved, smooth, anti-backlash roll chart action
- ✓ Optional roll chart illumination
- ✓ Individual element switches
- ✓ Portable or counter style cabinet
- ✓ Spare blank socket
- ✓ Contact type pilot light test socket
- ✓ Simplified test set-up procedure
- ✓ Line adjust control
- ✓ 4½" three-color meter

New

HEATHKIT PORTABLE TUBE CHECKER KIT

MODEL TC-2P

\$34⁵⁰

SHIP. WT. 14 LBS.



The portable model is supplied with a strikingly attractive two-tone cabinet finished in rich maroon, proxylin impregnated, fabric covering with a contrasting gray on the inside cover. Detachable cover, brass-plated hardware, sturdy plastic handle help to impart a truly professional appearance to the instrument.

PORTABLE TUBE CHECKER CABINET as described above will fit all earlier Heathkit TC-1 Tube Checkers. Shipping weight 7 lbs. Cabinet only, 91-8, \$7.50.



Heathkit TV PICTURE TUBE TEST ADAPTER

No. 355 **\$4⁵⁰**
Ship. Wt. 1 Lb.

The Heathkit TV Picture Tube Test Adapter used with the Heathkit Tube Checker will quickly check for emission, shorts, etc., and determine picture tube quality. Consists of standard 12 pin TV tube socket, four feet of cable, octal socket connector, and data sheet.

Heathkit POWER SUPPLY KIT



MODEL PS-2

\$33⁵⁰

SHIPPING WT.
17 LBS.

The Heathkit Laboratory Power Supply features continuously variable, regulated voltage output with good stability under wide load variations. A 4½" Simpson plastic enclosed panel mounted meter provides accurate meter output information of voltage or current. All panel terminals completely isolated from the cabinet. Separate 6.3 volt AC supply at 4 amperes for filament requirements. Ripple component exceptionally low, stand-by switch provided to eliminate warm-up time of the five tube circuit.



LABORATORY AND SERVICE SHOP BOOKLETS

"Planning Your Service Business" by John T. Frye, and "Establishing the Industrial Electronics Laboratory" by Louis B. Garner, Jr., are booklets available to Heathkit customers at no charge. These booklets, written by nationally recognized authorities, outline the various requirements and considerations for establishing your own service business or for setting up an industrial electronics laboratory. Full attention is given to various details that are frequently overlooked when projects of this nature are undertaken. Just write in to the Heath Company requesting your free copy, or attach a memo to your next order.

HEATH COMPANY • Benton Harbor 15, Mich.

RADIO & TELEVISION NEWS

CHECK THESE *Features*

- ✓ Visual and aural signal tracing
- ✓ Two channel input
- ✓ High RF sensitivity
- ✓ Unique noise locator circuit
- ✓ Calibrated wattmeter
- ✓ Substitution test speaker
- ✓ Utility amplifier
- ✓ RF, audio probes and test leads included

Heathkit VISUAL-AURAL
SIGNAL TRACER

KIT

MODEL T-3

\$23⁵⁰

SHIPPING WEIGHT
10 POUNDS



An entirely new type of signal tracer incorporating a combination of features not found in any other instrument. Designed expressly for the radio and TV service man, particularly for the servicing of AM, FM, and TV circuits. Here in a five tube, transformer operated instrument are all of the useful functions so necessary for speedy, accurate isolation of service difficulty.

This new signal tracer features a special high gain RF input channel, used in conjunction with a newly-designed wide frequency range demodulator probe. High RF sensitivity permits signal tracing at the receiver antenna input. A separate low gain channel and probe available for audio circuit exploration. Both input channels are constantly monitored by an electron ray beam indicator, so that visual as well as aural signal indications may be observed. The instrument can also be used for comparative estimation of gain per stage.

A decidedly unusual feature is a noise localizer circuit in conjunction with the audio probe. With this system, a DC potential is applied to a suspected circuit component and the action of the

voltage in the component can be seen as well as heard. Invaluable for ferreting out noisy or intermittent condensers, noisy resistors, controls, coils, IF and power transformers, etc. A built-in calibrated wattmeter circuit is very useful for a quick preliminary check of the total wattage consumption of the equipment under test. Separate panel terminals provide external use of the speaker or output transformer for substitution purposes. Saves valuable service time by eliminating the necessity for speaker removal on every service job. The terminals also permit the utilization of other shop equipment, such as your oscilloscope or VTVM. The T-3 Signal Tracer can be used as a high gain amplifier for checking tuners, record changers, microphones, phono crystals, etc.

Don't overlook the interesting service possibilities provided through the use of this new instrument and let it work for you by saving time and money. The kit is supplied complete with all tubes, circuit components, demodulator probe, audio probe, and additional test leads.



Heathkit
DECADE RESISTANCE KIT

MODEL DR-1 The Decade Resistance Kit provides individual switch selection of resistance values using twenty 1% resistors providing a choice of 1 to 99,999 ohms in 1 ohm steps. Ceramic wafer switches, silver-plated contacts, smooth, positive detent action, baked enamel panel, and handsome, polished birch cabinet.

\$19⁵⁰

SHIP. WT.
4 LBS.

Heathkit
DECADE CONDENSER KIT

The Heathkit Decade Condenser Kit features silver mica, precision condensers with a rated accuracy of $\pm 1\%$. Capacity values are arranged in three decades from 100 mmf to .111 mf in steps of 100 mmf. Ceramic wafer switches with silver-plated contacts and smooth detent action. Useful in laboratory work, for circuit development.

MODEL DC-1

\$16⁵⁰

SHIP WT.
4 LBS.

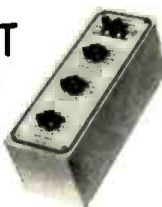

Heathkit RESISTANCE
SUBSTITUTION BOX KIT



MODEL RS-1

\$5⁵⁰

SHIP. WT.
2 LBS.

The Heathkit Resistance Substitution Box provides individual switch selection of any one of 36 RTMA 1 watt 10% standard value resistors, ranging from 15 ohms to 10 megohms. Many applications in circuit development work, and also in radio and TV service work. Ideal for experimentally determining resistance values and for quickly altering circuit operating characteristics. Entire unit housed in attractive Bakelite cabinet, featuring the new universal type Heathkit binding posts to simplify circuit connections.

Heathkit
CONDENSER CHECKER KIT



MODEL C-3

\$19⁵⁰

SHIPPING WT.
8 POUNDS

Use the Heathkit C-3 Condenser Checker to quickly and accurately measure those unknown condenser

and resistor values. All readings are taken directly from the calibrated panel scales without requiring any involved calculation. Capacity measurements in four ranges from .00001 mf to 1,000 mf. Checks paper, mica, ceramic, and electrolytic condensers. A power factor control is available for accurate indication of electrolytic condenser measurements. A leakage test switch with switch selection of five polarizing voltages, 25 volts to 450 volts DC, will indicate condenser operating quality under actual load condition. The spring return leakage test switch automatically discharges the condenser under test and eliminates shock hazard to the operator.

Resistance measurements can be made in the range from 100 ohms to 5 megohms. Here again all values are read directly on the calibrated scale. Increased circuit sensitivity coupled with an electron beam null indicator increases overall instrument usefulness.

For safety of operation the circuit is entirely transformer operated and the instrument is housed in the attractive, newly-styled Heathkit cabinet, featuring rounded corners, and drawn aluminum panel. The outstanding low kit price for this surprisingly accurate instrument includes necessary test leads. Good service shop operation requires the use of this specialized instrument, designed for the express purpose of determining unknown condenser values and operating characteristics.

HEATH COMPANY • Benton Harbor 15, Mich.



Heathkit AMATEUR TRANSMITTER KIT

MODEL AT-1

\$29.50

SHIPPING WEIGHT
16 POUNDS

CHECK THESE NEW Features

- ✓ Single knob band switching
- ✓ Pre-wound coils
- ✓ Metered operation
- ✓ 52 ohm coaxial output
- ✓ Crystal or VFO excitation
- ✓ Built-in power supply
- ✓ Rugged, clean construction

Here is the latest Heathkit addition to the ham radio field, the AT-1 Transmitter Kit, incorporating many desirable design features at the lowest possible dollar-per-watts price. Panel mounted crystal socket, stand-by switch, key click filter, AC line filtering, good shielding, etc. VFO or crystal excitation — up to 35 watts input. Built-in power supply provides 425 volts at 100 ma.

This kit features pre-wound coils, single knob band switching, 52 ohm coaxial output, plug in chassis provisions for VFO or modulator and rugged clean construction. Frequency range 80, 40, 20,

15, 11, and 10 meters. Tube line-up 6AG7 oscillator-multiplier, 6L6 amplifier-doubler, 5U4G rectifier. Physical dimensions 8 1/8" high x 13 1/8" wide x 7" deep.

This amazingly low kit price includes all circuit components, tubes, cabinet, punched chassis, and detailed construction manual. The ideal kit for the novice just breaking into ham radio. It can be used later on as a stand-by rig or an all band exciter for higher powered transmitter.

NEW Heathkit ANTENNA COUPLER KIT

New Heathkit Antenna Coupler, specially designed for the Heathkit AT-1 Transmitter. The Antenna Coupler can be used with any 52 ohm coaxial input — up to 75 watts power. Low pass filter with cut-off frequency of approximately 36 mc — L section tuning network — neon tuning indicator — rugged, compact construction — transmitter type variable condenser, and high Q coil are all outstanding features. The AC-1 has both inductance and capacity tuning for maximum operating versatility. Dimensions 8 1/8" wide x 4 3/8" high x 4 7/8" deep.



MODEL AC-1

\$14.50 SHIP. WT.
3 LBS.

Heathkit ANTENNA IMPEDANCE METER

Use the Heathkit Antenna Impedance Meter for measuring antenna impedance for line matching purposes — adjustment of beam antennas — phone monitor, etc. It will determine antenna resistance at resonance, match transmission line for minimum SWR, determine receiver input impedance, and provide a rough indication of SWR. Precision resistors, germanium diode, 100 micro-ampere Simpson meter. Dial calibrated from 0-500 ohms. Shielded aluminum cabinet. 7" long x 2 1/2" wide x 3 1/4" deep.



MODEL AM-1

\$14.50
SHIP. WT. 3 LBS.

Heathkit COMMUNICATIONS RECEIVER KIT

MODEL AR-2

\$25.50 SHIP. WT.
12 LBS.



Here is the new receiver kit you have repeatedly asked for, the Heathkit Communications Receiver. The perfect companion piece for the AT-1 Transmitter kit. Many outstandingly desirable features have been incorporated in the design of the AR-2; such as, electrical bandspread for logging and tuning convenience — high gain miniature tubes — IF transformers for high sensitivity and good signal to noise ratio — separate RF gain control with optional automatic volume control or manual volume control, in addition to the conventional audio gain control. Noise limiter — stand-by switch — stable BFO oscillator circuit — headphone jack — transformer operation, etc., all contribute to a high performance standard.

Frequency coverage is continuous from 535 kc to 35 mc in four ranges. For added convenience, various ham bands have been separately identified in respect to their relative placement on the slide rule tuning scale. A chassis mounted, 5 1/2" PM speaker is included with this kit. Tube line up 12BE6 mixer oscillator, 12BA6 IF amplifier, 12AV6 detector AVC audio, 12BA6 BFO oscillator, 12A6 beam power output, 5Y3GT rectifier.

RECEIVER CABINET

Proxylin impregnated, fabric covered, plywood cabinet with aluminum panel designed expressly for the AR-2 Receiver. Part 91-10, shipping weight 5 lbs., \$4.50.



IMPROVED Heathkit GRID DIP METER KIT

\$19.50 SHIP. WT.
4 LBS.

MODEL GD-1B

The invaluable instrument for service men, hams, and experimenters. Useful in TV service work for alignment of traps, filters, IF stages, peaking compensation networks, etc. Locates spurious oscillation, provides a relative indication of power in transmitter stages, use it for neutralization, locating parasitics, correcting TVI, measuring C, L, and Q of components, and determining RF circuit resonant frequencies. With oscillator energized, useful for finding resonant frequency of tuned circuits. With the oscillator not energized, the instrument acts as an absorption wave meter. Variable meter sensitivity control, head phone jack. 500 microampere Simpson meter. Continuous frequency coverage from 2 mc. to 250 mc. Pre-wound coil kit and rack, new three prong coil mounting. 6AF4 high frequency triode.

Two additional plug-in coils are available and provide continuous extension of low frequency coverage down to 355 kc. Dial correlation curves included. Shipping weight 1 lb., kit 341, \$3.00.



HEATH COMPANY • Benton Harbor 15, Mich.

CHECK THESE *Features*

- ✓ First popular priced Q Meter
- ✓ Reads Q directly on calibrated scale
- ✓ Oscillator supplies RF frequencies of 150 kc to 18 mc
- ✓ Calibrate capacitor with range of 40 mmf to 450 mmf with vernier of ± 3 mmf
- ✓ Measures Q of condensers, RF resistance, and distributed capacity of coils
- ✓ Many applications in design and development work
- ✓ Useful in TV service work for checking deflection yokes, coils, chokes, etc.

Heathkit
"Q" METER
KIT

MODEL QM-1

\$44.50

SHIPPING WT. 14 POUNDS

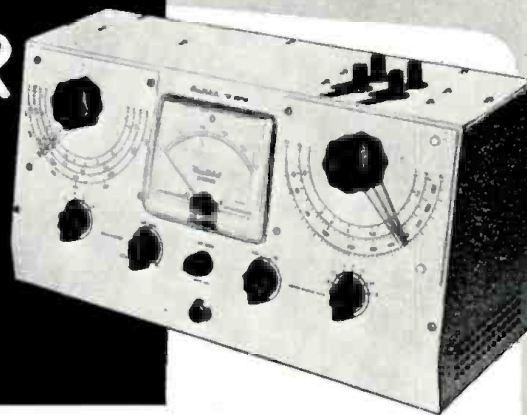

Another outstanding example of successful Heathkit engineering effort in producing a Q Meter Kit within the price range of TV service men, schools, laboratories, and experimenters. This Q Meter meets RF design requirements for rapid, accurate measurement of capacity, inductance, and Q at the operating frequency and all indications of value can be read directly on the meter calibrated scales. Oscillator section supplies RF fre-

quencies of 150 kc to 18 mc. Calibrate capacitor with range of 40 mmf to 450 mmf, with vernier of ± 3 mmf.

Particularly useful in TV service work for checking peaking coils, wave traps, chokes, deflection coils, width and linearity coils, etc. At this low kit price research laboratory facilities are within the range of service shops, schools, and experimenters.

Heathkit INTERMODULATION ANALYZER KIT



MODEL IM-1

\$39.50

SHIPPING WT. 17 POUNDS

The Heathkit IM-1 is an extremely versatile instrument specifically designed for measuring the degree of inter-action between two signals in any portion of an audio chain. It is primarily intended for making tests of audio amplifiers, but may be used in other applications, such as checking microphones, records, recording equipment, phonograph pick-ups, and loud-speakers. High and low test frequency source, intermodulation unit, power supply, and AC vacuum tube volt meter all in one complete instrument. Per cent intermodulation is directly read on the calibrated scales, 30%, 10%, and 3% full scale. Both 4:1 and 1:1 ratios of low to high frequency easily set up. With this instrument the performance level of present equipment, or newly developed equipment can be easily and accurately checked. At this low price, you can now enjoy the benefits of intermodulation analysis for accurate audio interpretation.

Heathkit AUDIO GENERATOR KIT

A Heathkit Audio Generator with frequency coverage from 20 cycles to 1 mc. Response flat ± 1 db from 20 cycles to 400 kc, down 3 db at 600 kc, and down only 8 db at 1 mc. Calibrated, continuously variable, and step attenuator output controls provide convenient reference output level. Distortion is less than .4% from 100 cps through the audible range. The ideal controllable extended frequency sine wave source for audio circuit investigation and development.



MODEL AG-8

\$29.50

SHIP. WT. 11 LBS.

Heathkit AUDIO OSCILLATOR KIT

Sine or square wave coverage from 20 to 20,000 cycles in three ranges at a controllable output level up to 10 volts. Low distortion, 1% precision resistors in multiplier circuits, high level output across entire frequency range, etc., readily qualify this instrument for audio experimentation and development work. Special circuit design consideration features thermistor operation for good control of linearity.



MODEL AO-1

\$24.50

SHIP. WT. 11 LBS.

Heathkit
AUDIO FREQUENCY METER KIT



MODEL AF-1

\$34.50

SHIP. WT. 12 LBS.

The Heathkit Audio Frequency Meter provides a simple and convenient means of checking unknown audio frequencies from 10 cycles to 100 kc at any voltage level between 3 and 300 volts rms with any non-critical wave shape. Instrument operation is entirely

electronic. Just set the range switch, feed an unknown frequency into the instrument, and read the frequency directly on the calibrated scale of the Simpson 4 1/2" meter.

Heathkit
SQUARE WAVE GENERATOR KIT



MODEL SQ-1

\$29.50

SHIP. WT. 12 LBS.

The Heathkit Square Wave Generator provides an excellent square wave frequency source with completely variable coverage from 10 cycles to 100 kc. This generator features low output impedance of 600 ohms and the output voltage is continuously variable between 0 and 20 volts, thereby providing the necessary degree of operating flexibility. An invaluable instrument for those specialized circuit investigations requiring a good, stable, variable square wave source.

HEATH COMPANY • Benton Harbor 15, Mich.

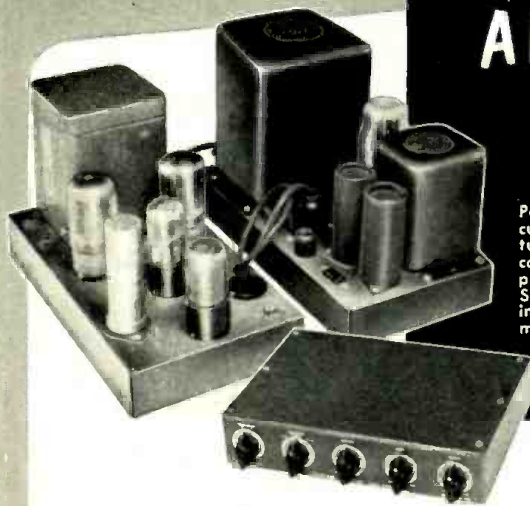

Heathkit WILLIAMSON TYPE AMPLIFIER KIT

MODEL W-2

Particularly designed for custom installations, featuring separate cable connected units for simplicity of installation. Sheet metal work finished in attractive gray hammer-tone for smart appearance. All control shafts of the adjustable length break-off type.

\$69.50

PRICES OF COMBINATIONS

W-2 Amplifier Kit including main amplifier, power supply, and WA-P1 Preamplifier Kit. Shipping Weight 37 lbs. Shipped Express only. **\$69.50**

W-2M Amplifier Kit includes main amplifier and power supply. Shipping Weight 29 lbs. Shipped Express only. **\$49.75**

WA-P1 Preamplifier Kit only. Shipping Weight 6 lbs. Shipped Express or Parcel Post. **\$19.75**

When selecting an amplifier for the heart of your high fidelity audio system, investigate the outstanding advantages offered by the Heathkit Williamson Type Amplifier. Meets every high fidelity audio requirement and makes listening to recorded music a thrilling new experience. This outstanding amplifier is offered with optional output transformer

operation, providing either the conventional triode output circuit or the new extended power circuitry in which the screen supply voltage is obtained from separate transformer primary taps. Frequency response within ± 1 db from 10 cycles to 100 kc. Tube complement—6SN7 cascade amplifier and phase splitter, 6SN7 push pull driver, two 5881 push pull power amplifiers, one 5V4G cathode type rectifier.

Matching preamplifier available providing three switch selected inputs, correct compensation, and individual bass and treble tone controls. Uses 12AY7 (or 12AX7) preamplifier—12AU7 tone control amplifier.

Particularly designed for the novice kit builder and requires no specialized knowledge or equipment for successful assembly and operation.

NEW Heathkit 20 WATT High Fidelity AMPLIFIER KIT

MODEL A-9A



\$35.50

SHIP. WT. 18 LBS.

A new 20 watt high fidelity amplifier, designed especially for custom audio installations demanding clean reproduction, adequate power, and flexibility to meet individual requirements. Separate treble and bass tone controls provide up to 15 db boost or cut. Four switch selected inputs, each with the necessary compensation for the service desired. Output transformer impedances of 4, 8, and 16 ohms. Preamplifier, tone control, and phase splitter circuits utilize 9 pin twin triode miniature tubes for low hum and noise level. Two 6L6 push pull power output tubes provide full 20 watts power. Frequency response ± 1 db, 20-20,000 cycles. Total harmonic distortion 1% (at 3 db below rated output). Tube line-up: 12AX7 preamplifier, 12AU7 voltage amplifier and tone control, 12AU7 voltage amplifier and phase splitter, two 6L6 push pull pentode power output, 5U4G rectifier. Truly outstanding amplifier performance coupled with low cost.

NEW Heathkit BROADCAST BAND RECEIVER KIT

Another new Heathkit for the student, beginner, or hobbyist. If you have ever had the urge to build your own radio receiver, this kit warrants your attention.

New high gain miniature tubes and IF transformers provide excellent sensitivity and good signal to noise ratio. A built-in ferrite core rod type antenna has been provided. A chassis mounted $5\frac{1}{2}$ " PM speaker provides excellent tone and volume. Convenient phono input. Can be operated either as a receiver or tuner. Simplified construction manual outlines circuit theory. Ideal for students. Tube line-up: 12BE6 mixer oscillator, 12BA6 IF amplifier, 12AV6 detector-AVC-first audio, 12A6 beam power output, 5Y3GT rectifier.

CABINET — Proxylin impregnated fabric covered plywood cabinet. Shipping weight 5 lbs. Part number 91-9, \$4.50.



MODEL BR-2

\$17.50 SHIP. WT. 11 LBS.

Heathkit ECONOMY 6 WATT AMPLIFIER KIT

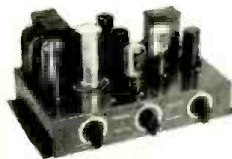

MODEL A-7B

\$15.50

SHIP. WT. 10 LBS.

The new Heathkit Model A-7B Amplifier offers many unusually fine features not normally expected in this low price range. Either of the two input circuits may be individually switch selected for phono or tuner operation. Separate bass and treble tone controls. Output impedances of 4, 8, and 15 ohms. Push pull beam power output stage for balanced reproduction. Excellent voltage gain characteristics, good frequency response, and full 6 watts power output. 12J5 amplifier, 12SL7 second amplifier and phase splitter, two 12A6 beam power output, one 5Y5 GT rectifier.

A-7C incorporates preamplifier stage with special compensated network to provide necessary gain for operation with variable reluctance or low output level phono cartridge. Circuit is properly compensated for microphone operation. \$17.50.

Heathkit FM TUNER KIT

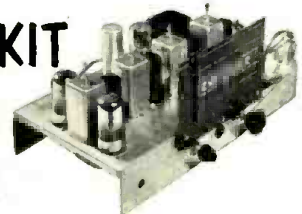

MODEL FM-2

\$22.50

SHIP. WT. 9 LBS.

The Heathkit FM-2 Tuner was specifically designed for simplified kit construction. Can be operated through the "phono" portion of your radio or with a separate amplifier. The kit features a pre-assembled and adjusted tuning unit, three double tuned-IF transformers, and a discriminator transformer in an 8 tube AC operated circuit. Frequency coverage 88 to 108 mc. Experience the thrill of building your own FM tuner and at the same time enjoy all of the advantages of true FM reception.

Free CATALOG

Write for free catalog containing latest price information, schematics, specifications, and descriptions of all Heathkits.

HEATH COMPANY • Benton Harbor 15, Mich.

BARRYMOUNTS



C-2045
C-2060
C-2070
C-2090

45¢
each
\$35/100

UPRIGHT OIL CONDENSERS

| CAP. | PRICE | CAP. | PRICE |
|----------------|--------|----------------|-----------|
| 220VAC/600VDC | \$1.29 | .1-1 4800 WVDC | \$4.79 |
| 15 | 3.49 | 1 6000 WVDC | |
| 330VAC/1000VDC | | .1 | 53.69 |
| 15 | \$3.79 | 115-.15 | 3.89 |
| 6 | 1.25 | 1.5 | 10.98 |
| 1000 VDC | | 1.5 | 7000 WVDC |
| 5 | .69 | 1-1 | \$3.79 |
| 5-5 | 1.19 | 1 | 9.95 |
| 1 | 1.49 | 8000 WVDC | |
| 4-1.5 | 2.19 | .075-.075 | \$3.79 |
| 1.5 | 1.39 | 10K VDC | |
| 1500 WVDC | | .1 | \$8.95 |
| 4 | \$1.95 | .0016 | \$7.95 |
| 1.5 | 1.59 | .015 | \$9.50 |
| 2 | 1.79 | .015 | \$9.50 |
| 2000 WVDC | | .25 | 20K VDC |
| 1 | \$1.79 | 1 | \$85.00 |
| 2500 WVDC | | .5 | \$65.00 |
| .5 | \$2.98 | | |
| 4000 WVDC | | | |
| .15 | \$6.95 | | |

MOBILES! C. D. MEN! CAP!!

IDEAL DYNAMOTOR — CONVERTS EASILY TO SUPPLY UNIT DELIVERING

12 Volt Input OR 6 Volt Input
610 V @ 150 MA OR 300 V @ 90 MA
325 V @ 125 MA OR 160 V @ 110 MA
Brand New with Conversion Data.....\$3.75

DYNAMOTORS

| TYPE | INPUT VOLTS | AMPS | OUTPUT VOLTS | AMPS | PRICE |
|-----------|-------------|------|--------------|------|--------|
| DM 418 | 14 | 6.2 | 330 | .170 | \$6.75 |
| DM 33A | 28 | 7 | 540 | .250 | 3.95 |
| BD AR 93 | 28 | 3.25 | 375 | .150 | 7.50 |
| 23350 | 27 | 1.75 | 285 | .075 | 3.95 |
| B-19 Pack | 12 | 9.4 | 275 | .110 | 8.95 |
| DA-3A* | 28 | 10 | 500 | .050 | |
| | | | 300 | .280 | 6.95 |
| | | | 150 | .010 | |
| | | | 14.5 | 5 | |
| 5053 | 28 | 14 | 280 | .060 | 3.95 |
| PE 73 CM | 28 | 19 | 1900 | .250 | 22.50 |
| BD 69† | 14 | 2.8 | 220 | .08 | 12.95 |
| D-402† | 13.5 | 12.2 | 300 | .200 | |
| | | | 8.8VAC | | 12.50 |
| SP 175 | 18 | 3.2 | 450 | .06 | 4.49 |
| DM 25† | 12 | 2.3 | 250 | .05 | 6.95 |

* Less Filter
† Used. Excellent
* Replacement for PE 94.

INVERTERS

PE-218-H: Input: 25/28 vdc. 92 amp. Output: 115v. 350/500 cy 1500 volt-amperes. NEW.....\$37.50
PE-206: Input: 28 vdc. 36 amps. Output: 80 v 800 cy. 500 volt-amps. Dim: 13"x5 1/2"x10 1/2". \$22.50
NAVY COR-211095: Input 22.30 VDC/75-60A. OUTPUT: 115V/400 CY. 1 KVA/8.7A. RPM: 4800. With coupling provision for motor. Brand New. Original packing.....\$150.00

SELENIUM RECTIFIERS

| Current (Con-tinuous) | 18/14 Volts | 36/28 Volts | 54/42 Volts | 130/100 Volts |
|-----------------------|-------------|-------------|-------------|---------------|
| 1 Amp. | \$1.38 | \$2.15 | \$3.70 | \$8.50 |
| 2 Amps. | 2.20 | 3.60 | 5.40 | 10.50 |
| 2 1/2 Amps. | | | 6.75 | 13.00 |
| 4 Amps. | 4.25 | 7.95 | 12.95 | 25.25 |
| 6 Amps. | 4.75 | 9.00 | 13.50 | 33.00 |
| 10 Amps. | 6.75 | 12.75 | 20.00 | 44.95 |
| 12 Amps. | 8.50 | 16.25 | 20.50 | 49.00 |
| 20 Amps. | 13.25 | 25.30 | 38.00 | 79.50 |
| 24 Amps. | 16.25 | 32.00 | 45.00 | 90.00 |
| 30 Amps. | 20.00 | 38.50 | | |
| 36 Amps. | 25.00 | 48.50 | | |

* F. W. Bridge

INTERPHONE AMPLIFIER

Easily converted to an ideal inter-communications set for office, home or factory. Original. New w/conversion diagram.....\$4.75



INTERPHONE TRANSFORMER SET

Rig Your own interphone. Kit consists of 1-Input Transformer (Matches 4 or 6 OHM SPKR to Grid) and 1-Output Transformer (Matches 50L6, 35L6, 25L6, etc., to 4 or 6 OHM Speaker Set of 2 XMRs. ONLY.....\$1.00

RECTIFIER TRANSFORMERS

Pri: 115V. 60 Cy. Sec: 28V/3.1A. 26V/8.4A 7.3V/1.4A.....\$12.95
Pri: 210/215/220/225/230/235/240V. 60 Cy.. 1 Phase Sec: 11/10/7.5/5VCT @ 35A.....\$19.50
Pri: 115V 60 Cy. Sec: 8.1V @ 1.5A.....\$1.39
Pri: 115V 60 Cy. Sec: 18.5V @ 5A.....\$2.79

12-14V SUPPLY KIT

Delivers 12.14VDC at 3.5A from 115V. 60 cy.. Kit contains 1—Transformer Rated 18.5V, 4A. 1—Selenium Rectifier. F. W. Bridge.....\$6.35

Send M.O. or Check. Shipping Chgs. C.O.D.
COMMUNICATIONS EQUIPMENT CO.
131 Liberty St. Dept. N-3 New York City 7, N. Y.

Let's Look at Changers

(Continued from page 57)

being activated, then determine what mechanical part is binding or not operating, causing failure to trip. On the *Philco*, first see if the weighted cam is dropping to engage the main gear when the trip finger releases it.

Close observation and patience are needed when service is required in the trip and reject system. Each changer is different and has to be approached from a different view. When it is known what the particular record changer is supposed to do, it is not hard to find out what it is not doing.

The Record Drop

Modern record changers use a record drop. The records rest on a record support and centerpost or just on the centerpost itself. The bottom record slides down the centerpost when it is needed. Older changers either used two record supports, slid the records off a stack on the turntable, turned them over, or used other various combinations; but the modern method is much easier on the records, quicker, and simpler.

In modern changers, the records are either pushed off or pulled off. For example, the *Zenith* record changer has a little finger, called an ejector cam, that slides up into the center hole of the record and rotates outward pulling the record off the rest on the centerpost (see Fig. 7C). To service a record dropping failure on this changer, check the ejector cam to see if it enters the center hole properly and rotates far enough to pull the record off. From there, check the ejector lever and link assembly under the turntable that causes the ejector cam to move.

On a *Webcor* changer, a different approach is necessary, for in this changer the records are pushed off the spindle. The record support shelf moves forward and pushes the bottom record off the centerpost rest (see Fig.

7A). If the records are not pushed off properly, the trouble is in the record support shelf. It may be turned so that the record does not rest on it evenly, or perhaps the rocker arm assembly needs adjustment or service to move the record shelf forward or backward to make the record fit.

On the *V-M* record changer, still another method is used. Here the records rest entirely upon the centerpost. The record support is used merely to balance the records in position. An ejector cam reaches out of the centerpost and pushes the bottom record off the shelf on which the records rest. See Fig. 7B. Check for a bent centerpost or perhaps a worn ejector cam if record dropping troubles develop in this changer.

The *RCA* 45 rpm record changer uses an entirely different type of record drop than any of the other changers described before. A set of separator knives and record shelves is mounted in the large diameter centerpost of the changer. The knives are located one record thickness above the shelves. At the start of the record drop operation, the shelves are moved out of the centerpost, underneath the record stack, and the knives are moved in to allow one record to drop on the shelves. Then, the knives are moved out, to hold up the rest of the records, and the shelves move in to drop the single record on the turntable. All of this is accomplished by the centerpost rotation about a separator shaft with flat surfaces.

This article has described briefly the most important parts of a record changer. The motor turns the turntable, the record plays, it trips, and the change cycle brings the tone arm out of the way while a new record drops and the tone arm comes to rest on the new record. Sounds simple, doesn't it? Well, record changer servicing is fairly simple if attention is focused on the section needing service, and not on the maze of gears, levers, springs, etc.

Future articles will cover detailed field and bench service on all late model record changers.

Fig. 7. Three popular record drop mechanisms. In (A), the record support shelf does the pushing. in (B) and (C), the centerpost does the dropping.

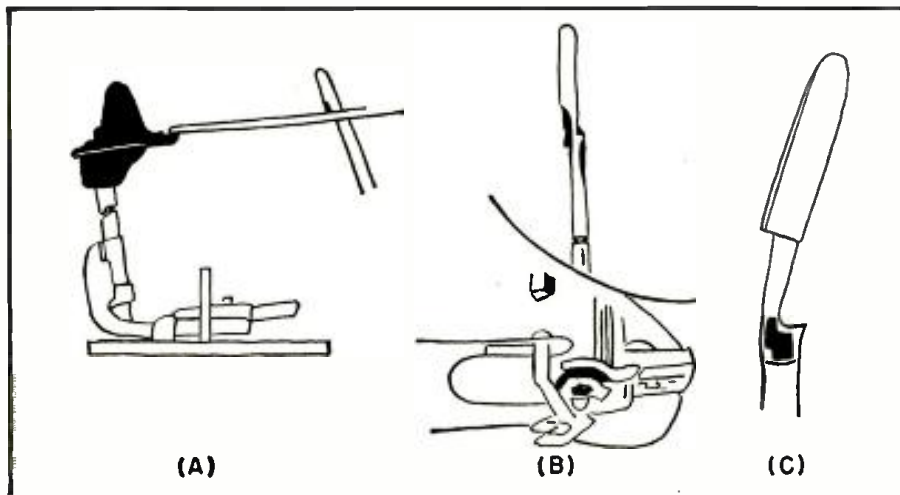

Now a

COLOR

TELEVISION

HOME STUDY COURSE

by RCA Institutes



"Color Television is here—not around the corner, or in the developmental labs, but here! The big question now is . . . Are You ready for Color TV?"

"You may now have a successful TV servicing business. When color sets come to your bench for servicing, will you be able to handle them?"

"Color Television is a vast new field, embodying entirely new concepts . . . principles of light and vision, radically new circuitry."

First Home Study Course in Color TV

Now is the time to prepare. Now, for the first time, you can train yourself for the

opportunities in this brand-new field. The just-announced RCA Institutes Home Study Course is the *first* home study course covering all phases of color television. Offered only to those already experienced in radio-television servicing, it explains the "why" of basic theory, as well as the "how-to-do-it" of servicing techniques.

Planned and written by RCA instructors, the entire course is based on the practical experience of RCA engineers—the men who have pioneered in the research and development of color television since the very first color experiments, many years ago.

Remember when black-and-white television first became a reality? Overnight, the demand for men who knew television grew. Even now, a shortage of qualified servicemen exists. Think, then—of the even greater demand for servicemen who will understand the many additional problems of color reception!

Costs so little to gain so much

RCA Institutes makes it easy for you to prepare yourself now for color television. Not only is the cost of the home study course for qualified servicemen extremely low, but you pay for the course on a pay-as-you-learn basis.

RCA Institutes conducts a resident school in New York City offering day and evening courses in Radio and TV Servicing, Radio Code and Radio Operating, Radio Broadcasting, Advanced Technology. Write for free catalog on resident courses.

Send for **FREE Booklet**—Mail the coupon, today. Get complete information on the RCA INSTITUTES Home Study Course in Color Television. Booklet gives you a general outline of the course lesson by lesson. See how thoroughly you can learn Color TV. Mail coupon in envelope or paste on postal card.

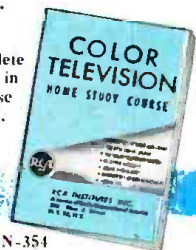

MAIL COUPON NOW!

RCA INSTITUTES, INC., Home Study Dept. RN-354
350 West Fourth Street, New York 14, N. Y.

Without obligation on my part, please send me copy of booklet "RCA INSTITUTES Home Study Course in COLOR TELEVISION." (No salesman will call.)

Name _____ (please print)

Address _____

City _____ Zone _____ State _____



RCA INSTITUTES, INC.
A SERVICE OF RADIO CORPORATION of AMERICA
350 WEST FOURTH STREET, NEW YORK 14, N. Y.

If you want professional sound quality



Sound engineers know that the selection of a fine amplifier, pickup and speaker system is only part of the story; that unless the turntable is of equal quality, music reproduction must suffer. That is why they insist on such high standards for turntable performance.

do as the professionals do...

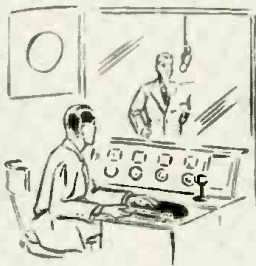

Rek-O-Kut precision turntables are made to conform to the highest standards in the professional field, and they certainly represent the finest you can use in the home. A Rek-O-Kut turntable will make all the difference in the world. The finer your present system, the more apparent the improvement will be. Whether you select the deluxe T-12H or the standard LP-743, the entire performance of your sound system will become a new and thrilling experience.

use a

REK-O-KUT

precision turntable



Rek-O-Kut Precision Turntables are priced from \$59.50. Write for specifications and descriptive literature to Dept. J-12

The REK-O-KUT COMPANY

Manufacturers of Professional Disc Recorders and Specialized Sound Systems.

38-01 Queens Boulevard, Long Island City 1, New York
Export Division 458 Broadway, New York, U.S.A. Cables: Morhanex
In Canada: Atlas Radio Corp., Ltd., 560 King Street, W., Toronto 2B

Now Ready! New Sprayberry Book!
**"HOW TO CONVERT TV SETS
for LARGER PICTURE TUBES"**



Covers Step-by-Step Method
for Converting any TV Receiver

This new book opens exceptional extra money opportunity for the alert serviceman . . . converting older small screen TV sets to modern, large screen 17", 21" or 24" receivers. Fully illustrated with diagrams, charts and pictures. Covers every step: planning, wiring, final adjustment. Special introductory price—50¢. Mail coin (no stamps please) today.

SEND
Only
50¢

SPRAYBERRY ACADEMY OF RADIO
111 N. Canal St., Dept. 49-G, Chgo. 6, Ill.

FACTORY REPAIRS

ON ALL MAKES AND TYPES OF
TEST EQUIPMENT

Write for BIG NEW FREE Catalogue

GENERAL ELECTRONIC DIST. CO.

98 PARK PLACE, NEW YORK 7, N. Y.

World's Only Recorder of its Kind WALKIE-RECORDALL 8-LB SELF-POWERED BATTERY RECORDER

- AUTOMATIC UNDETECTED RECORDING up to 4 hrs. Records noiselessly in or out of closed briefcase, containing hidden mike while walking, riding, flying. Conferences, lectures, dictation, 2-way phone. Permanent, unalterable, indexed recording at only 3¢ per hr.
- PICKS UP WITHIN 60 FT. RADIUS
- VOICE ACTIVATED "SELF-START-STOP"
- NO WIRES OR PLUGS.

MILES REPRODUCER CO., INC.
812 Broadway, N. Y. 3, N. Y. Dept. RN-2

Manufacturers' Literature

The bulletins reviewed in this section are for your convenience; unless otherwise indicated they are available to all our readers. For prompt attention write directly to the manufacturer for literature described.

TUBES AND ACCESSORIES

AmpereX Electronic Corporation, 230 Duffy Ave., Hicksville, N. Y., has released a "library reference edition" of its complete catalogue.

Prepared for the benefit of engineers, the new publication provides a permanent and easy reference-record of every electronic tube and tube accessory manufactured by the company for communication, industrial, rectification, amateur, electro-medical, and special purpose applications.

This 578-page manual is bound in a loose leaf ring binder with a permanent plasticized cover. The manual, priced to sell at \$2.00, will be made available to qualified engineers. For a copy, write on your business letterhead to Myron Smoler of the Sales Engineering Division of the company.

RECTIFIERS FOR COLOR TV

The Rectifier Division of *Sarkes Tarzian, Inc.*, 415 N. College Ave., Bloomington, Ind., has issued a four-page brochure entitled "Selenium Rectifiers for Color Television."

The booklet includes data on seven of the company's rectifiers suitable for color TV applications along with circuit diagrams illustrating these applications. In addition, information on the company's new plug-in rectifiers is provided with dimensional details and related socket data.

PIPE LOCATORS

Fisher Research Laboratory, Inc., 1961 University Ave., Palo Alto, California, is now offering a 4-page brochure on its "M-Scope" line of locators.

The bulletin explains the operation of these units and illustrates the various models available from the company. Included in the line are pipe and cable finders, leak detectors, box locators, and water level indicators. Literature is available on each of these units individually.

"WALL CATALOGUE"

A novel wall catalogue listing "bread-and-butter" condensers and containing a handy pocket for distributor order cards and "want lists" has been announced by *Sprague Products Company*, 51 Marshall St., North Adams, Mass.

Designed to give the technician a handy reference for the most frequently needed condensers, it also provides him with a means of noting his needs

RADIO & TELEVISION NEWS

NO INTEREST!!

Buy on our radically new
Time Payment Plan

NO CARRYING CHARGES!!



Measures 6 1/4" x 9 1/2" x 4 1/2"

Superior's new
Model 670-A

SUPER METER

A COMBINATION VOLT-OHM MILLIAMMETER PLUS
CAPACITY REACTANCE INDUCTANCE AND DECIBEL MEASUREMENTS

SPECIFICATIONS:

D.C. VOLTS: 0 to 7.5/15/75/150/750/1,500/7,500 Volts
A.C. VOLTS: 0 to 15/30/150/300/1,500/3,000 Volts
OUTPUT VOLTS: 0 to 15/30/150/300/1,500/3,000 Volts
D.C. CURRENT: 0 to 1.5/15/150 Ma. 0 to 1.5/15 Amperes
RESISTANCE: 0 to 1,000/100,000 Ohms to 10 Megohms
CAPACITY: .001 to 1 Mfd. 1 to 50 Mfd. (Quality test for electrolytics)
REACTANCE: 50 to 2,500 Ohms, 2,500 Ohms to 2.5 Megohms
INDUCTANCE: .15 to 7 Henries 7 to 7,000 Henries
DECIBELS: -6 to +18 +14 to +38 +34 to +58

ADDED FEATURE:

The Model 670-A includes a special **GOOD-BAD** scale for checking the quality of electrolytic condensers at a test potential of 150 Volts.

The Model 670-A comes housed in a rugged, crackle-finished steel cabinet complete with test leads and operating instructions.

\$28⁴⁰ NET



Superior's new
Model TV-11

TUBE TESTER

SPECIFICATIONS:

- ★ Tests all tubes including 4, 5, 6, 7, Octal, Lock-in, Peanut, Bantam, Hearing Aid, Thyatron, Miniatures, Sub-Miniatures, Novals, Sub-minars, Proximity fuse types, etc.
- ★ Uses the new self-cleaning Lever Action Switches for individual element testing. Because all elements are numbered according to pin-number in the RMA base numbering system, the user can instantly identify which element is under test. Tubes having tapped filaments and tubes with filaments terminating in more than one pin are truly tested with the Model TV-11 as any of the pins may be placed in the neutral position when necessary.
- ★ The Model TV-11 does not use any combination type sockets. Instead individual sockets are used for each type of tube. Thus it is impossible

to damage a tube by inserting it in the wrong socket.

- ★ Free-moving built-in roll chart provides complete data for all tubes.
- ★ Newly designed Line Voltage Control compensates for variation of any Line Voltage between 105 Volts and 130 Volts.
- ★ **NOISE TEST:** Phono-jack on front panel for plugging in either phones or external amplifier will detect microphonic tubes or noise due to faulty elements and loose internal connections.

The model TV-11 operates on 105-130 Volt 60 Cycles A.C. Comes housed in a beautiful hand-rubbed oak cabinet complete with portable cover.

EXTRA SERVICE—The Model TV-11 may be used as an extremely sensitive Condenser Leakage Checker. A relaxation type oscil-

lator incorporated in this model will detect leakages even when the frequency is one per minute.

\$47⁵⁰ NET

SUPERIOR'S NEW MODEL TV-40



C.R.T. TUBE TESTER

A complete picture tube tester
★ for little more than the price of a "make-shift" adapter!!

★ Tests all magnetically deflected tubes . . . in the set . . . out of the set . . . in the carton!!

The Model TV-40 is absolutely complete! Self-contained, including built-in power supply, it tests picture tubes in the only practical way to efficiently test such tubes: that is by the use of a separate instrument which is designed exclusively to test the ever increasing number of picture tubes!

EASY TO USE:

Simply insert line cord into any 110 volt A.C. outlet, then attach tester socket to tube base (*Ion trap need not be on tube*). Throw switch up for quality test . . . read direct on Good-Bad scale. Throw switch down for all leakage tests.

- SPECIFICATIONS:**
- Test all magnetically deflected picture tubes from 7 inch to 30 inch types
 - Tests for quality by the well established emission method. All readings on "Good-Bad" scale.
 - Tests for inter-element shorts and leakages up to 5 megohms.
 - Test for open elements.

Model TV-40 C.R.T. Tube Tester comes absolutely complete—nothing else to buy. Housed in round cornered, molded bakelite case. Only

\$15⁸⁵ NET

MOSS ELECTRONIC DISTRIBUTING CO., INC.
Dept. B-95, 3849 Tenth Ave., New York 34, N. Y.

Name.....

Address.....

City.....Zone.....State.....

- MODEL 670-A..... Total Price \$28.40 \$7.40 down payment. Balance \$3.50 monthly for 6 months.
- MODEL TV-11..... Total Price \$47.50 \$11.50 down payment. Balance \$6.00 monthly for 6 months
- MODEL TV-40..... Total Price \$15.85 \$3.85 down payment. Balance \$4.00 monthly for 3 months.
- I enclose \$..... as down payment.
- Ship C.O.D. for the down payment.

Please send me the units checked. I am enclosing the down payment with order and agree to pay the monthly balance as shown. It is understood there will be no carrying interest or any other charges provided I send my monthly payments when due. It is further understood that should I fail to make payment when due, the full unpaid balance shall become immediately due and payable.



6

REASONS WHY HI-FI FANS DEMAND THE FAIRCHILD SERIES 215 DIAMOND CARTRIDGE WITH HIGH COMPLIANCE

Instantly—there's a startling improvement in sound when record collectors switch to the FAIRCHILD Series 215. Listeners who have just discovered high-fidelity—and seasoned audiophiles both hear a new *presence* in recordings.

Only FAIRCHILD's *moving coil design* can give such unequalled performance. Compare—and you too will agree that the start of any high-fidelity system must be the *high Compliance FAIRCHILD Series 215*.

- 1—Brings true-to-life color to high piano chords.
- 2—Releases new low frequency tones.
- 3—Smooth linearity—lower apparent surface noise.
- 4—Reduces tone arm resonance greatly.
- 5—Preserves record quality—reduces stylus wear.
- 6—Eliminates—completely—listening fatigue caused by tracking distortion.

All of this at an unbelievably low price — \$37.50

And investigate these FAIRCHILD products, too!



The NEW Model 240 Balanced-Bar Preamplifier-Equalizer offers typical FAIRCHILD quality, a wide latitude of control, extreme operating simplicity, correct record equalization and decorator styling. Net to user — \$98.50

The NEW Model 280 Plug-In Type Pickup Arm brings professional quality into the home with minimum size, unusual pivoting method, low bearing friction and accepts all standard makes of cartridges. Net to user — \$29.50



SEE YOUR AUDIO DEALER or for free folder write:
FAIRCHILD RECORDING EQUIPMENT
8th Ave. & 154th STREET, WHITESTONE, L. I., N. Y.

GET INTO ELECTRONICS

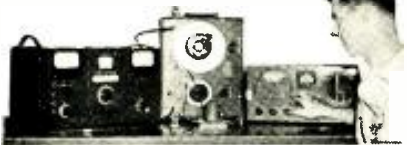

You can enter this uncrowded, interesting field. Defense expansion, new developments demand trained specialists. Study all phases radio & electronics theory and practice: TV; FM; broadcasting; servicing; aviation, marine, police radio. 18-month course. Graduates in demand by major companies. U.S. or equivalent required. Begin Jan., March, June, Sept. Campus life. Write for catalog.

VALPARAISO TECHNICAL INSTITUTE
Dept. RD Valparaiso, Indiana

FREE LEARN TV

Assemble a TRANSVISION TV KIT in easy stages. Pay as you wire—only \$39 for Starting Package #1. Learn while building a superb 17" to 21" screen TV Set with latest features. Ideal for fringe areas, adaptable to UHF. No technical knowledge required. Catalog describes 6 great TV KITS.

Write today to Educational Dept. at—
TRANSVISION, INC., Dept. HO, NEW ROCHELLE, N. Y.

SCHEMATICS—CONVERSIONS FOR SURPLUS GEAR

NEW LIST! MANY ADDITIONS!
Send stamped, self addressed envelope for List C. Add 25c for chart explaining AN nomenclature.

R. E. BOX 1220
GOODHEART BEVERLY HILLS, CAL.

for either mail, telephone, or distributor-salesman orders.

Details on the "C-452 Hanging Wall Catalogue" are available from the company.

"EICO" KITS

Electronic Instrument Co., Inc., 84 Withers St., Brooklyn 11, New York, has issued a 12-page catalogue covering the "Eico" line of kits and factory-wired instruments.

The 30 kits and 33 factory-wired instruments available in the line are pictured and described in detail in this new publication. Complete specifications are given on each instrument in order to enable service technicians, students, engineers, and distributors to select the correct instrument for the job to be done.

A copy of this catalogue will be forwarded without charge upon request.

HICKOK BROCHURES

The Hickok Electrical Instrument Company, 10524 Dupont Ave., Cleveland 8, Ohio, now has available two brochures covering its v.t.v.m. and tube testers.

Form 209A2, a four-page booklet, lists technical specifications and uses of the company's multi-purpose Model 209A capacitance tester and v.t.v.m.

The four-page Form TT5A1 describes ten of the company's dynamic mutual conductance tube testers including those for the radio and TV technician as well as laboratory models. Graphic explanation of the dynamic mutual conductance test is also included.

SWITCH CATALOGUE

The Disc Department of *Erie Resistor Corporation*, Erie, Pa., has issued a new catalogue which gives a full description, illustrations, and specifications on its new line of switches.

Twenty-five item numbers are catalogued, including single and multiple section rotary switches in shorting and non-shorting types, lever action switches, and general purpose switches.

SERVICE PUBLICATION

Simpson Electric Company is sponsoring a new bulletin for television technicians, "*The Technician's Time-saver*."

The new publication is written by Bob Middleton, author of many books and articles dealing with TV servicing. The purpose of the publication is to show effective shortcuts in TV servicing and more practical applications for electronic test equipment.

A complimentary subscription, at no cost or obligation, may be obtained by writing direct to *Simpson, c/o Service Department, Howard W. Sams & Co., Inc.*, 2201 E. 46th St., Indianapolis 5, Indiana.

TRANSISTOR BATTERIES

Burgess Battery Company, Freeport, Illinois, has published a four-page folder covering its developments in the field of transistor batteries.

SCOOP of the Month ---

BC1267 TRANSMITTER AND RECEIVER

154 to 186 Mcs., 1KW pulse oscillator, superhet circuit, 2 RF stages, and 5 stagger tuned IF's, includes 21 tubes; 2C26(2), 3E29/829B(1), 6AG5(7), 6CA4(1), 6E5(1), 6H6(1), 6AK5(3), 6J5(2), 6SN7(1), 6V6(1), 9006(1); can be easily converted to 2 meter converter and outboard amplifier, ship. wt. 75 lbs., complete with conversion instructions (NOTE: 3E29/829B is worth \$10.00 alone).

excellent condition **\$14⁹⁵** (less tubes) **with 21 tubes \$24⁹⁵**



BROADCAST BAND and AERO

Ideal for Use in Boats, etc.

MN-26-C Remote Controlled Navigational Direction Finder and communications receiver. Manual D.F. in any one of three freq. bands, 150 to 1500 KC. 24 V. Self contained dynamotor supply. Complete installation, including receiver, control box, loop, azimuth control. Left-Right Indicator, blues, loop transmission line and flex. shafts, oper. & main. manual.

ALL UNITS BRAND NEW EXCEPT CONTROL BOX

MN-26-Y 150 to 325 KC. 325 to 695 KC. 3.4 to 7 megacycles, comp. installation..... \$69.50
 MN-26-C alone, like new..... 24.95
 MN-26-Y as is less tubes..... 4.95
 MN-20-E Loop, Brand New..... 6.95
 MN-22 Crank drive, New..... 2.50
 MN-26L1 Receiver exc. freq. 150-1250 KC. 2.9-6mc..... 59.50

Low Freq. Crystals—FT 241 A for SSB, lattice filter, 1/2" spc. 54th harm channels listed by fund. Fractions omitted.

See previous Radio-TV News issues for frequencies 49c each 10 for \$3.00

POWER YOUR RIG FROM AC

RA-34 RECTIFIER. Makes a ground xmit of BC-191, the 12V version of BC-375-E. Convert BC-375-E to 12V by changing heater link switches and relay connections, power it with RA-34. Input 105-125 or 210-250V, 60 cy. Outputs: For plates, 1000V filtered dc at 350 ma; for relay and mike, 12V filtered dc at 2.4 A; for heaters, 12V ac at 14.25 A. Used condition. F.O.B. \$159.75

BC-433 RADIO COMPASS RECEIVER

200 to 1700 KC, used, excellent condition less tubes \$19.95
 used, as is, less tubes and cover, \$6.95
 excellent for parts only \$4.65
 BC-434 Control box for above. Brand new \$4.65
 Used 1.79

VHF TRANSCEIVER

Ideal substitute for SCR-522, freq. range 140-144 mc, crystal controlled, 10 watts. The receiver section has two individual RF sections, feeding a common 3 stage 10mc IF amplifier. Both RF sections may be operated simultaneously, or either one individually. The receiver unit has 13 tubes. The transmitter is of straight forward design. Transmitter unit has 7 tubes, one 2-832 as final modulated by a pair of 6L6 and push-pull. Complete unit in case less tubes, and diagram less dynamotor. EXCELLENT CONDITION \$9.95
 WITH TUBES \$19.95

TG-5 Portable Telegraph set—used \$3.95
 3 for 7.00
 new 5.95
 2 for 11.00

A SWEET OSCILLOSCOPE DEAL

ASB-7 Radar Indicator Unit: For conversion to test scope or for use as modulation monitor. Has standard test-scope CRT tube, H Cent. V Cent, Brill, Foc, Gain, and range selection switch. External power source was used. Tubes: 4-6AC7, 3-6H6, 1-5H7P. Condition good. NEW \$9.95

BEAM-ROTATOR

Reversible beam rotator motor 8500 rpm, attached to gear reduction box which drops speed to 120 rpm—used \$1.95
 3 for \$5.50

Hundreds of items in stock. WRITE FOR NEW BULLETIN AND PRICES. Shipments F.O.B. warehouse. 20% Deposit on orders. Minimum order \$5.00. Illinois residents, add regular sales tax remittance. Prices subject to change without notice.

AMPLIFIER can be easily converted to 100w outboard amplifier \$1495
 complete with 3E29/829B and conversion data.....

CONVERTER can be easily converted to 2 meter converter, \$995
 with conversion data.....

METER 0-1kw 4" Panel Meter..... \$395
 0-100ma

BC-620 TRANSMITTER-RECEIVER UNIT

FM transmitter-receiver, crystal controlled, two channels, freq. range 20-27.9 mc. 13 tubes, dial meter for testing filament and plate circuits. PE-117 Power supply for above, complete, like new..... \$39.25
 PE-117 Power supply for above, complete, like new..... \$17.95

RECEIVER

Battery powered heterodyne receiver, 75-150 mc—brand new..... \$10.95

BC-929-A

Contains power supply 110 V. 400 cycles, has 7 tubes such as 3C11, brand new, complete with tubes. Each \$19.95

BC-746 TUNING UNIT

Plug-in transmitter tuning unit from Army Walkie-Talkie. Contains antenna and tank coils, tuning condenser, transmitting and receiving crystals. Ideal transmitter foundation..... ONLY \$1.29

CONDENSERS

Oil filled—1 ufd at 3600 v..... \$1.95 ea.
 2.22 at 1000 v..... \$1.75 ea.

ID6/APN4

Made to operate in conjunction with Radio Receiver R-9C 1/4IN-4. Unit includes 13 tubes, one 5" scope tube, crystal controlled standard oscillator, sweep circuits, marker pulses. Excellent cond. \$42.50

MIKES and HEADSETS

T-26 Telephone chest unit with P-1 Western Electric Transmitter \$2.39
 HS-33 Low Impedance Headset exc. \$2.95 new \$5.45
 HS-23 Headset used 1.89 new 4.50
 CD-307 Ext. cord for HS-23-33 like new .79 new 1.29
 Throat Mike—T-30..... new .98
 Lip Mike—Navy Type..... new .98
 CW-49505 High Impedance headset complete with headband Used 98c
 T-45 Lip Mike. New..... \$1.75
 HS-30, miniature headset. Used \$1.49, new 2.49

WOBUlator

BUILD TV-FM-AM SWEEP GENERATOR

You can build "Versatile Sweep Frequency Generator" with APN-1 magnetic units..... \$ 5.95
 R-120F Beacon Receiver..... 9.95
 TS-184/Al Test Set..... 39.50
 IE-10A-SC1522 Test Unit..... 29.00
 I-222-Signal Generator..... Used, exc. 95.00

11 TUBE UHF TUNABLE RECEIVER 214-258 mc. less tubes..... \$7.95
 With conversion diagram to 220.

RA-52 RECTIFIER

Transtat controlled to produce high voltage DC from 110 VAC 60 cycle source. Up to 11,500 VDC @ 50 W. Metered high voltage (0-15 KV) and current (0-20 MA). \$69.95
 Exc. in stock—write.

| | As Is | With | |
|--|--------|---------|----------|
| | Tubes | Tubes | New |
| BC-454 3 to 6 mc..... | — | \$11.95 | — |
| BC-455 Receiver, 6 to 9 mc..... | — | 9.95 | — |
| BC-456 Modulator..... | \$2.95 | 4.95 | \$7.95 |
| BC-458 Transmitter, 5.3 to 7 mc 2.95 | — | — | — |
| BC-459 Transmitter, 7 to 9 mc 7.95 | — | — | — |
| Control boxes, racks, mounts, connectors for above in stock—write. | — | — | — |
| MG-149F excellent condition..... | — | — | \$ 89.50 |
| MG-149H excellent condition..... | — | — | 129.50 |
| MG-153 Inverter (3 phase)..... | — | — | 89.50 |
| PE-206, Inverter, like new..... | — | — | \$11.95 |
| PE-218, inverter, excellent condition..... | — | — | 24.95 |
| BC-640..... | — | — | \$695.00 |
| BC-639 with RA 42 rectifier..... | — | — | 225.00 |

NATIONALLY ADVERTISED TUBES

5BP1 ..\$3.29 3BP1 ..\$3.29 5AP1 ..\$3.29
 3 for \$9.00 3 for \$9.00 3 for \$9.00
 All Brand New In Original Cartons
 304TL ..\$5.95 808 ..\$1.95
 830-B ..\$1.59 720BY ..\$29.50

QUANTITY PRICES AVAILABLE!

1625, 1626, 33, 34, 954, CK1005, 6Z7G, 9002, 9006, 1619, 955, 9004, 12A6, 1F4, 1F5, 211, 6F5, 1A6, 1629, 19, 50.

10 for \$3.00

RT7/APN-1 TRANSCEIVER UNIT

Used as an altimeter, it may be converted for signaling control circuits, etc. Used, less tubes, as is \$4.95

RT/34 APS 13 TRANSCEIVER—Used as a tail warning radar on 415 MC. Containing a 30MC IF Strip and various other parts, these units have been stripped of RF sections and all tubes, but are an excellent buy if only for parts \$4.95 and IF Strip. Used..... \$4.95

R-1/ARR-1—220 MC converted with minor alterations becomes a high gain converter with two stages of RF amplification—(complete with diagram). New..... \$4.95

ALL THREE ABOVE ITEMS FOR \$7.50

BEAM ANTENNA SELSYN TRANSMITTER and indicator, per set..... \$12.00

BC-684 FM Transmitter, 27-38 mc..... \$14.95

used, exc. \$11.95

BC-604 FM Transmitter, 20-27 mc..... \$11.95

used, exc. \$11.95

LOOK WHAT YOU GET FOR \$14.95

- 350 feet of continuous length of 50 ohm coaxial cable
- 100 feet of same coaxial cable
- Easily type attenuator
- 6 short lengths of RG8U with connectors and sockets
- In wooden case—shipping weight 30 lbs.—all for \$14.95

BC 347 Interphone Amplifier..... \$2.95

I-70 Tuning Meter..... .89

APS 13 UHF Antenna, Pair..... .99

I-97 Bias Meter..... \$3.95 4.95

BC 1066 B—150 to 225 MC Portable Receiver adaptable to many amateur uses. Used..... \$5.95

One Tube Interphone Amplifier—Small compact aluminum case fully enclosed. 2 1/4"x3 1/4"x5 3/4". Less Tube..... 79c

BC 709 Battery operated lightweight interphone amplifier. Complete with tube and shock mount, but less battery..... New \$3.95

DYNAMOTORS

DYNAMOTORS: The best dynamotor for conversion to 6V. Multiple windings! After conversion you get choice of 110 or 250 v. at 50 MA or 250 v. at 100 MA. Complete dope sheet furnished. BRAND NEW (See "CQ" Aug. issue) \$4.65

DM-28—Dynamotor for BC-318—28V DC at 1.25 amps in 220 V at 70 MA output Good \$4.95

DM-32A—Dynamotor for Command Receiver 28V at 1.1 input 250V at 90 MA output Used 2.95 New 7.50

DM-33—Dynamotor for Command Transmitters—Used \$2.95

D-101 Imp. 27V 1.75 Amp. output 285 VC .075 amp..... each \$1.95

3 for \$5.00

PE-94..... each \$1.95

PE103—6V Dynamotor..... Used \$22.95

BC-1033 62-80 mc reevr. Like new, less tubes, exc. 9.95

BC-1023 brand new with tubes..... 9.95

SCR-625—FAMOUS ARMY MINE-DETECTOR For Prospectors, Miners, Oil Companies, Plumbers, etc. This unit is being offered now at a considerable reduction in price. Recently advertised at \$79.50 it is now available in the same brand new wrappings in suitcase style carrying case (less batteries). New \$59.50

SCR-522—Transceiver, complete in case with top bracket, less tubes \$29.95

RU-19—Receiver. Complete control box and coils—brand new.....ea. \$17.95

BC375, exc. \$49.50

BC191, exc. 49.50

TU5, exc. 14.95

BD77, used, exc. 14.95

BUY NOW! **R W ELECTRONICS**

Dept. N, 2430 S. Michigan Ave., Chicago 16, Ill.

PHONE: Calumet 5-1281-2-3

BUY NOW!

NEW PROBES!

FOR VTVM'S & SCOPES

- FULLY SHIELDED
- SHOCK-MOUNTED TERMINAL BOARD
- SWIVEL ACTION
- ALL PARTS ACCESSIBLE
- COLOR CODED

Only EICO Probes Have All These Features!

SCOPE DEMODULATOR PROBE
MODEL PSD
KIT \$3.75 WIRED \$5.75

LOW CAPACITY PROBE MODEL PLC
KIT \$3.75 WIRED \$5.75

DIRECT PROBE MODEL PD
KIT \$2.75 WIRED \$3.95

VTVM RF PROBES MODEL PRF-11 OR 25
For any 11 or 25 megohm VTVM
KIT \$3.75 WIRED \$4.95

PEAK-TO-PEAK PROBES
MODEL PTP-11 OR 25
For any 11 or 25 megohm VTVM
KIT \$4.95 WIRED \$6.95

SENSATIONAL HIGH VOLTAGE PROBE
MODEL HVP-2
ONLY... \$4.95
FOR VTVM'S & VOM'S

See these amazing probe values at your jobber today. Write now for free catalog PR-3 Turn to our full-page ad on page 42 this magazine.

EICO®
ELECTRONIC INSTRUMENT CO., Inc.
84 WITHERS STREET, BROOKLYN, NEW YORK

"All above probes
Pat. App. for."

The folder describes the requirements for batteries used in transistor circuitry. Typical batteries are illustrated and described.

For a copy of this folder write Transistor Engineers in care of the company.

RMS CATALOGUE

Radio Merchandise Sales, Inc., 2016 Bronxdale Ave., New York 62, N. Y., has published a new catalogue which illustrates and describes the company's complete line of TV antennas and accessories.

Catalogue 55 is a 32-page, multi-colored publication which is fully indexed by product groupings. It includes information on packaging and shipping weights as well as the company's gain reference chart.

MID-AMERICA BULLETIN

Mid-America Co., Inc., 2412 S. Michigan Avenue, Chicago 16, Illinois has recently published a 28-page bulletin which lists TV, radio, electronic and related components for manufacturers and wholesalers.

Designated as Bulletin No. 1053, the new publication is available only to recognized manufacturers and jobbers and will be sent on letterhead request from such organizations.

RADIO-PHONE LINE

Roland Radio Corp., 716 S. Columbus Ave., Mt. Vernon, N. Y., is now offering a 4-color, 4-page brochure covering its 1954 line of radios and radio-phonograph combinations.

Each model in the line is shown in a close-up view and specifications accompany each illustration. The back cover leaves space for a dealer imprint.

SPEAKERS AND CABINETS

Kingdom Products Ltd., 23 Park Place, New York 7, N. Y., has issued a four-page catalogue covering "Lorenz" speakers and "Kingdom" cabinets and combinations of the two components.

In addition to providing complete technical details on these items, the new publication carries a page of construction notes giving mechanical specifications on a series of speaker enclosures.

A copy of "Music Comes Alive" is available on request.

"EDU-KITS" BROCHURE

Progressive "Edu-Kits" Inc., 497 Union Ave., Brooklyn 11, N. Y., has issued a new booklet describing its 1954 radio "Edu-Kit," a home-study course in kit form.

Literature on radio and TV servicing also accompanies this brochure which is available from the company. Address all requests to Mr. R. Nevins.

CONVERSION CHART

The Cinema Engineering Co., Division of Aerovox Corporation, 1100 Chestnut St., Burbank, California has issued an audio power conversion chart which will be supplied without charge on request.



the **UHF**
Granco
CONVERTER
has Everything!

No other converter offers all these essential functions to the degree that Granco does, regardless of price. Model LCU (only \$29.95 list) features: **COAXIAL TUNING...** The most efficient UHF tuning system known. Precision-ground metal slug sliding in and out of precision-ground glass tube for mechanical and electrical accuracy. No troublesome noise-producing wiper contacts. Highest stability. Provably better UHF reception.

FINE TUNING...

No "on-again off-again" tuning with Granco. Fine tuning is simple and positive with the high-ratio single tuning knob. Permits "on the button" tuning without need of a safecracker's touch!

PRESELECTION...

Tuning circuits reject unwanted signals and images—only the desired channel is tuned in. A "must" in areas having two or more channels, UHF or VHF. Granco preselection means cleaner, sharper, more pleasing pictures.

AMPLIFICATION...

Low-loss tuning and associated circuitry, plus true high-gain amplification of only the tuned-in channel, provides the finest reception in TV.

Ask for
DATA

from your distributor or from us direct. Then compare Granco UHF converters with all other brands. Better still, make your own comparative tests. You're the judge!

GRANCO
PRODUCTS, INC.,
36-17 20th Ave., Long Island City 5, N. Y.
AVAILABLE AT LEADING JOBBERS

Printed in card form for hanging on the wall or placing under glass tops of desks, the chart contains three columns, *i.e.*, power level in watts, power level in db, and voltage across a 600-ohm line.

The tabulation may be used in converting from the old db system to dbm by adding 7.78 db or converting from dbm to the old system by subtracting 7.78 db. Other conversions may also be performed with the chart, complete instructions for which operations are given on the chart.

AUDIO GEAR

The *Dubbings Company, Inc.*, 41-10 45th St., Long Island City, N. Y., has issued a hi-fi catalogue covering products handled by its new high-fidelity sales department.

Pictured and described are a series of tuners for AM and FM, record players, turntables, pickup arms, cartridges, amplifiers, preamps, speakers, speaker enclosures, tape recorders, disc recorders, microphones, television chassis, phonographs, "basic" audio packages, and test records.

RECTIFIER HANDBOOK

Federal Telephone and Radio Company has issued a second edition of its "Selenium Rectifier Handbook."

This 80-page edition contains a representative listing of the selenium rectifiers made by the company for radio and TV use. It also covers rectifier designs and power supply circuits for such applications as phonographs, audio amplifiers, amateur radios, mobile gear, photocell amplifiers, intercom systems, and other d.c. supply requirements.

Servicing and troubleshooting information is provided in easy-to-use form. The handbook, which is priced at 50 cents a copy, is available from the company's distributors or from the company direct at 100 Kingsland Road in Clifton, N. J.

LAFAYETTE AUDIO

Lafayette Radio, 100 Sixth Avenue, New York 13, N. Y., has just issued a 48-page catalogue comprising a comprehensive listing of high-fidelity music system components.

In addition to illustrating some custom installation ideas, the catalogue pictures and describes amplifiers, tuners, preamps, cabinets, binaural amplifiers, record changers, "packaged" installations in various price ranges, speakers, tone arms and cartridges, tape recorders, recorder accessories, and remote-control TV sets for custom installation.

AUTO RADIO REPLACEMENTS

P. R. Mallory & Co., Inc., P. O. Box 1558, Indianapolis, Ind., has issued an 11-page auto radio replacement control manual which covers most auto radios made since 1946.

The data is listed by manufacturer's make and model, control use, *Mallory* replacement controls and special bushings and switches.

MARCH, 1954



"Of the very best!"

—HIGH FIDELITY MAGAZINE

FISHER

SERIES "50"

It is only natural that more than one manufacturer will claim *his* product is the best. For that reason it remains for *you* to be the judge. We say—*demand the specs.* Then check workmanship, performance and beauty of appearance. If you do all these things, the answer will inevitably be . . . THE FISHER SERIES "50." There is no finer made.

THE FISHER Master Audio Control SERIES 50-C

■ "One of the finest units yet offered to the enthusiast or audio engineer." —*Radio and TV News.* Can be used with *any* amplifier. IM distortion virtually non-measurable. Complete, professional equalization settings and tone controls; genuine F-M loudness control; five inputs, five independent input level controls, two cathode follower outputs. Self-powered.

Chassis, \$89.50 • With blonde or dark cabinet, \$97.50

THE FISHER FM-AM Tuner MODEL 50-R MODEL 70-RT

■ Features *extreme sensitivity* (1.5 mv for 20 db of quieting); *low distortion* (less than 0.04% for 1 volt output); *low hum* (more than 100 db below 2 volts output.) Armstrong system, *adjustable AFC* with switch, *adjustable AM selectivity*, separate FM and AM front ends (shock-mounted), cathode follower output, fully shielded, aluminum chassis, self-powered. \$164.50
Model 70-RT, same as Model 50-R, but including tone controls, phonograph preamplifier-equalizer, and loudness balance control. \$184.50

THE FISHER 50-Watt Amplifier MODEL 50-A

■ Truly the world's finest all-triode amplifier, yet moderately priced. 100-watt peaks! Less than 1% distortion at 50 watts (.08% at 10 watts.) IM distortion below 2% at 50 watts. Uniform response within .1 db from 20 to 20,000 cycles; 1 db, 5 to 100,000 cycles. Hum and noise more than 96 db below full output. Quality components throughout. \$159.50

Prices slightly higher west of the Rockies

WRITE TODAY FOR COMPLETE SPECIFICATIONS

FISHER RADIO CORPORATION • 39 EAST 47th STREET • N. Y.

NOW!
GET BETTER
HI-FI RESULTS
at less
cost!

512 pages
203 illus.
Price \$7.50

**HIGH FIDELITY
TECHNIQUES**

By John H. Newitt
Staff, Mass. Inst.
of Technology



**CASH IN on
HI-FI service
and
custom-building
PROFITS!**

**THE BIG BOOK THAT
Shows You How!**

- Judging hi-fi equipment
- What to avoid
- Loudspeakers
- Bass-reflex
- Distortion
- Baffles
- Overhang
- Woofer-tweeters
- Sound-proofing
- Grillwork
- Output transformers
- Circuits
- Crossover frequencies
- Volume expansion
- Noise suppression
- Negative feedback
- Pre-Amps
- Equalizers
- F-M tuners
- Records
- Recording
- Avoiding chatter
- Turntables
- Pick-ups
- Design charts

Building tips . . .
and dozens of
other subjects

Here, by one of the nation's leading experts, is the complete "know how" of high fidelity . . . from theory and circuits to commercial equipment; from methods and authentic technical data to home-building, custom building and service.

HIGH FIDELITY TECHNIQUES shows you what to do—how to do it—what mistakes to avoid—which methods and equipment should prove best for your particular purpose. Written especially for listeners, home and commercial installation builders, experimenters and service technicians, it is a complete, easy to understand guide to this vast new hobby that is sweeping the nation.

Whether you want to specialize in the work or simply build a high-fidelity installation for your own use, the book will guide you every step of the way; help you get better results at less cost; and give you a full understanding of the many different methods, components and equipment that are debated whenever hi-fi fans get together.

From beginning to end, HIGH FIDELITY TECHNIQUES is chock full of how-to-do-it building tips, ideas and service data of the most helpful sort. Read it 10 days FREE. You be the judge!

10-DAY FREE EXAMINATION

Dept. RN-34, RINEHART & CO., Inc.
232 Madison Ave., New York 16, N. Y.

Send HIGH FIDELITY TECHNIQUES for 10-day FREE EXAMINATION. If I like book, I will then promptly send \$7.50 plus postage in full payment. Otherwise, I will return book postpaid and owe you nothing!

Name
Address

City, Zone, State
OUTSIDE U.S.A.—Cash only, price \$8.00. Money back if book is returned in 10 days.

WHAT'S *New in Radio*

The products described in this column are for your convenience in keeping up-to-date on the new equipment being offered by manufacturers. For more complete information on any of these products, write direct to the company involved.

HI-FI ENCLOSURE

Now in production by *Angle Genesee Corp.*, manufacturers of high-quality cabinets, is the *Read "Fold-a-flex"* loudspeaker enclosure. The original "Fold-a-flex" design first appeared in the October, 1953 issue of *RADIO & TELEVISION NEWS*. An improved folded horn structure has extended the low frequency response materially.

This enclosure, on which patents are



pending, may be used with a 12" or 15" coaxial loudspeaker, as a full 2-way system with woofer and tweeter or a full 3-way system comprising woofer, mid-range horn, and high-frequency tweeter. An isolated compartment, for horns and tweeters, has its own mounting baffle and is available precut to accommodate standard units.

The "Fold-a-flex" incorporates three adjustable ports. These are set, by the user, to provide a choice of: 1. folded horn, 2. infinite baffle, or 3. bass reflex. The reflex port is fully adjustable to the acoustical requirements of any 12" or 15" loudspeaker.

Optimum performance (corner or wall position) is insured in any room with any of the popular high-fidelity speakers. The company is producing the "Fold-a-flex" in traditional or modern cabinetry and in a wide selection of finishes.

Full information and price will be sent promptly on request to the company at 107 Norris Drive, Rochester 10, N. Y.

HEAVY-DUTY ROTATOR

The *Trylon Tower Division* of *Wind Turbine Co.*, West Chester, Pa., is now offering a heavy-duty rotator that is capable of handling the largest beam antennas used in amateur, commercial, and military communications systems. The rotator supports single- or two-

band arrays weighing up to 200 pounds and accommodates two coax, ribbon, or open-wire transmission lines without switching by means of separate low-leakage noise-free couplings.

The unit is driven by a special 1/25 h.p. motor that is instantly reversible for continuous rotation in either direction. The reduction gear train consists of two worm-and-spur gear sets having an over-all ratio of 2400 to 1 to prevent backlash during high winds.

Complete specifications are available from the manufacturer.

PRECISION RESISTORS

Hycor Company, Inc., 11423 Vanowen St., North Hollywood, California, is in full-scale production on the Type 10 wirewound resistor, a molded-in-plastic unit.

The new unit is the first production type to be offered by the company in its new series "H" group of hermetically sealed resistors. It is rated at 1.4 watts at ambient temperatures up to 125 degrees C. Dimensions are 1/4" diameter by 13/32" long. It is supplied in resistances from .1 ohm to 300,000 ohms at tolerances as close as 1/20th of 1 per-cent.

Descriptive material on this and other type resistors up to 1 watt is contained in Bulletin "H."

NEW TRANSISTOR

The Receiving Tube Division of *Raytheon Manufacturing Company*, 55 Chapel St., Newton 58, Mass., has announced the addition of a low-noise junction transistor to its line of *p-n-p* junction transistors.

The new type, CK727, has an aver-



age noise factor of 13 db, an average alpha of .97, and an average power amplification of 37 db.

Full details on this new transistor are given in a data sheet which is available from the Technical Information Service of the company.

COMPACT POWER SUPPLY

The *Allied Engineering Division*, Connecticut & Richards Ave., South Norwalk, Conn., is currently offering its Model 302 power supply.

The new unit is designed to conserve bench space as it is housed in a cab-



**YOU GET BUSHELS OF
\$\$\$ IN SAVINGS
WHEN YOU BUY FROM B-A!**



**IT'S
FREE
1954
CATALOG**

**BURSTEIN-APPLEBEE CO. Dept. M,
1012-14 McGee St., Kansas City 6, Mo.**

- Send Free B-A Catalog No. 541
 My order attached for items in this ad.

\$..... enclosed.

Name.....

Address.....

City.....

State.....

**B-A'S
LITTLE TUBE MAN SAYS:**

"For the finest quality at the lowest prices you're always better off at B-A. It's dollar value that counts and that's what you get when you look to B-A for your every electronic need."

**AMAZING BARGAIN
WILLARD Rechargeable
6-Volt
STORAGE BATTERY
\$6.50
VALUE! **\$1.39****

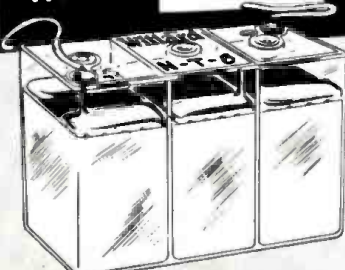

**TRANSPARENT PLASTIC CASE
Size 3 1/2" W. x 1 3/4" D. x 2 3/8" H.**

LOTS OF USES
Experimenters, laboratories, etc. will find numerous applications for this midget storage battery. Rated 6 volts but can be easily ganged in multiples of 2 for 12 volt use and in multiples of 4 for 24 volt use. Provides 2.4 amp/hour. Popular for use in photo-flash units, as a source of DC power for alarm systems, etc.

**EASY TO STOCK—NO
DETERIORATION**
These batteries are dry—there is no acid in them... the vent holes are sealed. Electrolyte is put in when ready for use (standard 1.275, available everywhere at low cost). Battery becomes charged when put in use and is rechargeable like any standard storage battery. Simple factory-printed instructions on each battery. 3" wire leads spot soldered to battery terminals. Shpg. wt. 2 lbs.

EVERYONE IS NEW AND PERFECT
This sensational low price made possible by another B-A hot buy.
No. 3A166
Each..... **\$1.39** For..... **\$4.88**
Case Lots of 36..... **\$39.88**

**DON'T MISS THIS SPECIAL PURCHASE!
POPULAR - MAKE CONTINUOUS DUTY
1/4-INCH PORTABLE ELECTRIC DRILL**

**\$29.95
LIST VALUE**

\$16.88

**SAVE \$4.00 FROM
REGULAR WHOLESALE PRICE**



- Popular Jacobs Geared Key Chuck
- Industrial Type Motor, Rated 2 Amps Under Load
- Precision Ball Bearings
- Lightweight—Weights Only 3 Lbs.

Not another drill on the market with so many desirable features at such a colossal low price. Modern in every aspect. A natural for every Serviceman, TV Installer, Electrician, home maker, etc. **Why the Reduced Price?** The manufacturer in a desire for expanding retail sales in hardware stores and the like is now providing the same drill only with a mirror finish in place of the satin finish. Not desiring to duplicate his stock with two drills of the same mechanical specifications, but of different finishes, he looked to B-A—so here it is exactly as offered elsewhere except for the finish, at a terrific saving to you. Quantities limited. Order Now.

Uses quality components throughout. The industrial capacity motor is engineered for continuous trouble-free duty with smoothness contributed by the precision ball bearings. Has sufficient power for drilling in hard woods or metals without stalling. Built-in work light focuses on work in dark recesses of cabinets, in attics when installing antennas and wiring, anywhere better visibility is required for more accurate drilling. Aluminum die-cast housing. 7 1/2" heavy duty 3 cond. cord with grounding terminal for operating on 110-120 volts AC-DC. Wt. 3 lbs.
No. 37A302. **SPECIAL EACH..... \$16.88**

CHECK THIS SENSATIONAL VALUE!

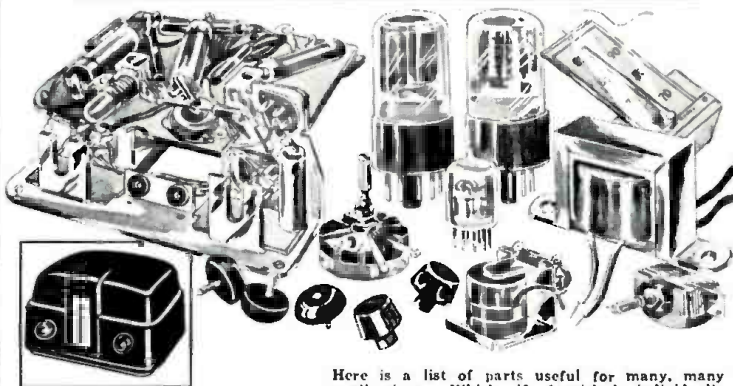

99c
FOR CHASSIS AND PARTS

\$2.88
COMPLETE WITH TUBES AND CABINET

- 1—115 V. 6.3 V., 1 AMP FIL. TRANSFORMER
- 1—S.P.S.T. SENSITIVE PLATE RELAY
- 1—S.P.S.T. SWITCH
- 1—ELECTROLYTIC CONDENSER
- 1—POTENTIOMETER
- 6—CARBON INSULATED RESISTORS
- 7—WIRE-WOUND RESISTORS
- 3—TUBE SOCKETS
- 4—PAPER TUBULAR CONDENSERS
- 1—CHASSIS AND HARDWARE

Here is a list of parts useful for many, many applications. Which if furnished individually would regularly cost many times the Crazy Low Price we show. Originally intended as Thyatron Remote Controls for Electric Blankets... but now available at a mere fraction of original cost because the maker had more controls than he could make blankets. Comes completely assembled—can be modified for various remote control uses or easily taken apart for the high quality parts alone.

Others offer these identical units as Big Bargains, and truly so, at up to double our prices. Order from B-A Now while they last at the Ridiculous Low Prices below.
Complete Assembly, including 1—6SL7GT, 1—6SN7GT, 1—GL5662 and Plastic Cabinet as pictured. Shpg. wt. 3 1/2 lbs.
No. 18B53
Special Each..... **\$2.88** 10 Lots Each..... **\$2.50**
*No. 18B48 as above, except less tubes and cabinets. Shpg. wt. 2 lbs.
Special Each..... **99c** 10 Lots Each..... **89c**

**DELUXE REAR SEAT AUTO SPEAKER
KIT**

\$5.95

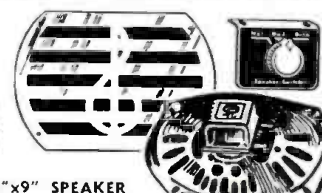

INCLUDES LARGE 6"x9" SPEAKER

Consists of top quality 6x9" Alnico V heavy magnet PM Speaker, Chrome finished Grille with flocked screen, Centralab dual Speaker Switch Kit, and all necessary mounting hardware. No. 22B58. Shpg. wt. 3 lbs.
Complete as Listed Above..... **\$5.95**



BURSTEIN-APPLEBEE CO.

**1012-14 MCGEE ST.
KANSAS CITY, MO.**

**TERMS: F.O.B. Kansas City. Remit with order,
include postage for parcel post shipments.**

Installing Speakers?

INSIST ON *Utah*

Your one complete

SPEAKER SOURCE

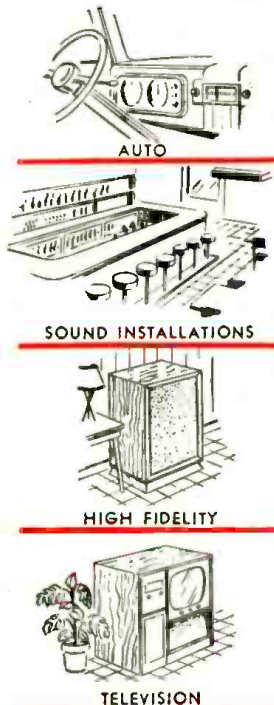

Whether you are making a sound installation in a church, school, tavern, factory or office—or a replacement in an automobile, radio or television set—insist on the tops in the speaker field—insist on Utah Pre-tested speakers.

A Utah speaker is as close to you as your telephone—all leading jobbers handle Utah—because Utah has the widest line of speakers available to the trade—is your one complete speaker source.

The name Utah on a speaker signifies the finest quality in design, engineering, production and performance.

Repeat sales—customer satisfaction—is assured when you insist on and install a Utah Pre-tested speaker.



Radio Products Co., Inc.

1350 MONROE STREET
HUNTINGTON, INDIANA

Export Dept. Rocke International Corporation—N.Y. C.

A WHOLLY OWNED SUBSIDIARY OF NEWPORT STEEL CORPORATION

inet measuring just 8" x 5" x 5½". Two outputs are available: from 150 to 350 volts at 0-80 ma. with either positive or negative grounded to the chassis, and from 0-150 volts at 0-5 ma. with positive internally connected to the negative of output 1.

Ripple is less than 3 millivolts and



the ambient temperature range is 0-40 degrees C. Operating voltage is 105-125 volts r.m.s., 50-60 cycles, 150 watts maximum.

Further information on this unit and a copy of the company's d.c. power supply catalogue are available on request.

PLUG-IN UNITS

Langevin Manufacturing Corporation, 37 West 65th St., New York 23, N. Y. is now marketing two plug-in units which have been designed for applications where space is at a premium.

The Type 5208 plug-in power supply is designed to be used with the 5000 series of miniature plug-in amplifiers. Input is 105-130 volts, 50-60 cycles, single-phase a.c. The d.c. output is 300 volts, 90 ma. continuous. The unit measures 10¼" long x 2⅝" wide x 3" high.

A companion plug-in amplifier, the Type 5117, is also available. The new unit is a two-stage, push-pull, fixed gain amplifier rated at 8 watts. Designed to be mounted on relay racks or in consoles, the amplifier has the same

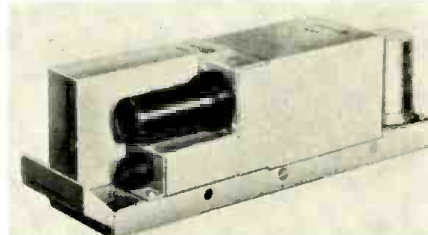

dimensions as the power supply unit. The amplifier uses two 5879 miniature tubes and two 6V6's. Gain is 55 db.

A catalogue on the company's amplifiers, power supplies, and transformers is available on request.

SPECIAL COMPONENTS

Transvision, Inc. of New Rochelle, N. Y., has set up a special transformer and coil manufacturing division which will design, engineer, and manufacture short transformer and coil runs.

The coils include such items as high-

RADIO & TELEVISION NEWS

CORONA RADIO KITS

EASY TO BUILD • EDUCATIONAL
EXCELLENT RECEPTION

Broadcast
Superhet
Kit

\$14.75

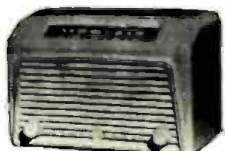

ROCKET 115K—Latest Single Band superhet circuit for ultimate in sensitive reception and tonal quality. Kit includes all necessary parts, punched chassis, attractive bakelite mahogany cabinet, built-in loop antenna, iron core IFs, big 5" Alnico V speaker tubes: 12SK7, 12SA7, 12SO7, 50L6, 3Z5. Automatic vol. control, beam power output, Tunes 540 to 1700 Kc. Simple step-by-step instructions included.

Plaza 812K 2-Band AC-DC Super Kit...net \$20.75
Globemaster 814K 3-Band Super Kit...net \$24.75
All kits supplied less wire and solder. Please include 25% deposit with C.O.D. orders. Dept. N-3.

CORONA RADIO & TV CO.
136 LIBERTY ST., NEW YORK 6, N. Y.

YOUR TESTER DAMAGED?

Let Douglas Repair It
Contractors to U. S. Government
Repairs and calibration by skilled craftsmen on all makes of Meters, Sig. Gens., Testers, etc. Prompt service. All work guaranteed. For immediate estimate send instrument by P. O. Ins. to

DOUGLAS INSTRUMENT LABORATORY
Electrical Instrument Repairers
176 Norfolk Avenue Boston 19, Mass.

Be a "key" man. Learn how to send and receive messages in code by telegraph and radio. Commerce needs thousands of men for jobs. Good pay, adventure, interesting work. Learn at home quickly through famous Candler System. Quality for Amateur or Commercial License. Write for FREE BOOK. CANDLER SYSTEM CO. Dept. 2-C, Box 928, Denver 1, Colo., U.S.A.

Now! RAD-TEL Tubes & Parts At Savings!

Wafer Rotary Switch Kit

A choice combination of single, double, etc., from 2 to 8 positions. Special kit of 10



\$139

Smashing Reductions on FP CONDENSERS

All famous makes. Save plenty on these top quality FP Condensers. Made by leading manufacturers. You can't miss—these values are hits no matter how you look at them!



\$1.99

CERAMICON KIT

1 kit of 50 assorted ceramic discs, biplates, tubular condensers. All condense popular sizes, used in T.V. and P.M. sets. A MUST kit



List price \$10.00
\$1.99

Hi-Watt RESISTOR KIT

Consisting of 5, 10, 15 and 20 watt vitreous type resistors by Ward, I. R. C., etc. A top-flight buy!



Assortment Kit of 20
List price \$15
\$1.95

FILTER CONDENSER

20-20 Mid, 450 V. Color-coded leads. Ideal for use where impossible to use metal cans. For top performance at a give-away price. List price \$2.40.



49c

BIAS CONDENSERS

Sangamo, Aerovox, Cornell-Dubilier
500 mid 12V
List Pr. \$2.35 ea.
Pkr. of 10...**\$2.95**
SPECIAL
4-50 mid 8-100 VDC
Kit of 7...**\$1.29**

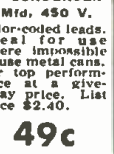

CAN ELECTROLYTICS

Mfd. by SPRAGUE, AEROVOX, PHILCO, Etc.

| Capacity | DC Working Voltage | Price |
|-------------|--------------------|-------|
| 40-40-40 | 450-450-25 | \$.99 |
| 250-1000 | 10-6 | .49 |
| 40 | 450 | .49 |
| 60-10-10-20 | 450-450-450-150 | .89 |
| 80-40-10 | 450-450-450 | .99 |
| 20-8-8-8 | 450-450-450-250 | .59 |
| 80 | 500 | .79 |
| 15-15-20 | 450-450-25 | .59 |
| 40-10-100 | 450-450-200 | .79 |
| 10-20 | 450-25 F.P. | .39 |
| 10-8-8-8 | 450-450-450-150 | .49 |

Philco TV BOOSTER

Made by PHILCO, famed for quality and precision communications equipment. Completely self-contained, including 2 tubes for High Channels and 1 for Low Channels and selenium rectifier plastic cabinet in factory-sealed cartons, complete with instructions



In Lots of 3...**\$9.95**
List price...**\$10.95**

25 Paper BY-PASS CONDENSERS

An assortment of 25 by-pass condensers, made by leading manufacturers. Top quality. Most popular sizes and voltages. Values .005 to 2 MFD 200 to 1000 VDC.



Kit of 25...**99c**

Hi-Voltage POWER SUPPLY

4500 VOLTS 6 MA. 12AU7 oscillator, 1B3 rectifier completely wired, enclosed in shielded metal case, removable cover. Use as B.F. high voltage supply.



BRAND NEW!
Kit of 2 tubes for above...**\$2.95**

Kit of 10 Assorted Electrolytic Condensers

Consists of singles, doubles, triples and quadruples, all of popular voltages and capacities—all standard popular brands.

\$2.39

FLY BACK TESTER

"A Must for every Serviceman!" Fast, sure horizontal shooting test sensitive to as small a defect as a 1 turn short. Tested while in receiver! Tests continuity of speaker's switches, etc.



Your Price **\$39.95**

VARIABLE CONDENSERS

Mfd. by Philco, Radio Condenser, etc. contains 2 separate sections for AM and 2 for FM with paddle condensers. Attached a slug tuned high frequency coil whose plunger is geared in condenser shaft. Pulley type drive wheel... 89c



3 Gang Superhet with drum pulley and padders... 79c
Complete with padders and drive... 89c

ALL BRAND NEW PARTS!

FILAMENT ISOLATION TRANSFORMER

6.3 V @ 1.2 A



For damper use with 6W4, etc. High voltage insulation between primary and secondary to withstand high voltage surge. Can be used for general replacement.79c
List price—**\$1.75**

TRIMMER KIT

Compression type mica for radio, P.M., T.V. Very few duplications. Don't let this chance pass you by!
25 FOR... 99c

Vertical OUTPUT TRANSFORMER

Very popular used in most T.V. sets. Well known manufacturer. Matches vertical output tube to the deflection yoke. 10 to 1 ratio. A terrific buy on a top performer... 95c
List price—**\$4.50**



BIG SAVINGS YOU CAN'T PASS BY! 70° YOKE

Mfd. by TODD, SICKLE & other top makers. Very good value, makes conversion profitable and simple. Get one while they're still around! . . . \$2.50
1 Watt. 25-2 Watt. All new, all clean. Good value. . . . \$1.50
55° YOKE... 99c

70% to 90% OFF ON TUBES!

All Tubes Individually Boxed—1 Year Guarantee—1 Day Service!

| Type | Price | Type | Price | Type | Price |
|--------|-------|--------|-------|------------|-------|
| 0A2 | .74 | 6BK7 | .80 | 12AY7 | .99 |
| 0B2 | .81 | 6BL7GT | .83 | 12BA6 | .38 |
| 0C3 | .72 | 6BN6 | .59 | 12B7 | .60 |
| 0D3 | .70 | 6SQ6GT | .90 | 12BD6 | .45 |
| 0Z4M | .55 | 6BQ7 | .90 | 12BE6 | .39 |
| 1A5 | .30 | 6BZ7 | .90 | 12BF6 | .39 |
| 1A7GT | .47 | 6C4 | .37 | 12BH7 | .63 |
| 1A2 | .62 | 6C5 | .39 | 12BY7 | .65 |
| 1B3GT | .68 | 6C6 | .58 | 12BZ7 | .65 |
| 1B7 | .30 | 6CB6 | .44 | 12C8M | .34 |
| 1C5 | .43 | 6CD6 | 1.11 | 12CM | .63 |
| 1E7 | .66 | 6E6 | .39 | 12J5GT | .42 |
| 1G6 | .24 | 6F5GT | .39 | 12K8 | .59 |
| 1H4 | .30 | 6F6 | .59 | 12Q7 | .59 |
| 1H5GT | .49 | 6G6 | .52 | 12S8GT | .62 |
| 1L4 | .46 | 6H6GT | .41 | 12SA7GT | .65 |
| 1L6 | .59 | 6J5GT | .43 | 12SF5 | .50 |
| 1LA4 | .59 | 6J6 | .52 | 12T7M | .67 |
| 1LC5 | .59 | 6K5 | .47 | 12SK7M | .63 |
| 1LE3 | .59 | 6K6 | .37 | 12SL7GT | .47 |
| 1LW5 | .59 | 6K7GT | .44 | 12SN7GT | .52 |
| 1P5GT | .57 | 6L6 | .64 | 12SQ7GT | .56 |
| 1Q5GT | .58 | 6L7M | .68 | 12SR7M | .49 |
| 1R5 | .49 | 6Q7 | .45 | 12T6GT | .38 |
| 1S4 | .59 | 6S4 | .79 | 12X7M | .59 |
| 1S5 | .43 | 6S5 | .79 | 14A5 | .59 |
| 174 | .49 | 6S8GT | .53 | 14H7 | .59 |
| 1U4 | .49 | 6SA7GT | .43 | 14W7 | .30 |
| 1U5 | .43 | 6SD7GT | .41 | 14J7 | .30 |
| 1V | .53 | 6SF5GT | .46 | 14W7 | .30 |
| 1X2A | .63 | 6SG7GT | .41 | 19B6 | .95 |
| 2A3 | .30 | 6SH7GT | .41 | 19C7M | .70 |
| 2A4G | .24 | 6S7GT | .41 | 19T9 | .69 |
| 2W3 | .38 | 6SK7GT | .41 | 19V8 | .79 |
| 2X2 | .59 | 6SL7GT | .48 | 24A | .39 |
| 3A4 | .45 | 6SN7GT | .52 | 25AV5GT | .83 |
| 3E5 | .46 | 6S07GT | .37 | 25BQ6GT | .79 |
| 3Q4 | .48 | 6SR7GT | .45 | 25L6GT | .39 |
| 3Q5GT | .49 | 6S57GT | .39 | 25W4GT | .59 |
| 3S4 | .49 | 6T4 | .56 | 25Z5 | .66 |
| 3V4 | .51 | 6U4 | .60 | 26 | .45 |
| 5U4G | .50 | 6U4 | .60 | 27 | .39 |
| 5W4GT | .50 | 6U5 | .44 | 35 | .58 |
| 5Y3GT | .37 | 6U6 | .59 | 35B5 | .40 |
| 5Z3 | .45 | 6U8 | .61 | 35C5 | .39 |
| 5Z4 | .59 | 6V6GT | .39 | 35L6GT | .41 |
| 6A4 | .48 | 6W4GT | .44 | 35W4 | .37 |
| 6A5 | .86 | 6W6GT | .44 | 35Z3 | .59 |
| 6AG7M | .90 | 6X4 | .37 | 35Z4 | .47 |
| 6A7 | .48 | 6X5GT | .37 | 35Z5GT | .47 |
| 6AG7M | .99 | 6X8 | .75 | 36 | .39 |
| 6AH4 | .57 | 6Y6G | .48 | 41 | .42 |
| 6AH6 | .73 | 7A4 | .47 | 42 | .44 |
| 6AJ5 | .65 | 7A5 | .69 | 45 | .55 |
| 6AK5 | .55 | 7A6 | .69 | 45 | .55 |
| 6AL5 | .38 | 7A7 | .69 | 45Z3 | .44 |
| 6AQ5 | .39 | 7A7F | .53 | 45Z5 | .49 |
| 6AQ6 | .37 | 7B4 | .44 | 50B5 | .43 |
| 6AR5 | .37 | 7B6 | .69 | 50C5 | .39 |
| 6AS5 | .50 | 7C4 | .59 | 50L6GT | .61 |
| 6AT6 | .37 | 7C5 | .59 | 50Y7 | .50 |
| 6AU4GT | .68 | 7E5 | .59 | 53 | .24 |
| 6AU5GT | .82 | 7E6 | .30 | 55 | .49 |
| 6AU6 | .38 | 7E7 | .59 | 57 | .58 |
| 6AV5GT | .83 | 7H7 | .59 | 58 | .60 |
| 6AV6 | .37 | 7L7 | .59 | 70L7GT | .97 |
| 6AX4GT | .53 | 7T7 | .70 | 75 | .44 |
| 6B4 | .64 | 7Y6 | .69 | 77 | .57 |
| 6BA6 | .99 | 7Z4 | .59 | 78 | .47 |
| 6B7 | .57 | 12A8GT | .61 | 80 | .35 |
| 6B8 | .49 | 12A5 | .37 | 83V | .68 |
| 6B8 | .49 | 12A5 | .37 | 85 | .59 |
| 6B8 | .49 | 12A5 | .37 | 117L7 | .99 |
| 6B8 | .49 | 12A5 | .37 | 117Z3 | .37 |
| 6B8 | .49 | 12A5 | .37 | 80T | .99 |
| 6B8 | .49 | 12A5 | .37 | 86G4 | 1.39 |
| 6B8 | .49 | 12A5 | .37 | 1274 | .30 |
| 6B8 | .49 | 12A5 | .37 | 2050 | .89 |
| 6B8 | .49 | 12A5 | .37 | 1000FM | .59 |
| 6B8 | .49 | 12A5 | .37 | Hi-Po #567 | 1.39 |

Horizontal Output TRANSFORMER

Type 204T1
A horizontal Output Transformer designed for deflection circuits employing rf-operated high voltage supplies. Intended for 50% magnetic deflection kinescopes. Used with RCA Deflecting Yokes 201D1, 201D2, 201D3 or 201D12.
List price—**\$13.95**



HIPO TV rectifier tube

replaces the 5U4 tube directly. Makes pictures bigger, brighter, sharper and increases the gain in TV receivers.
HIPO 587... **\$1.39**



Kit of 50 MICA CONDENSERS

All popular sizes of mica condensers. In regular and kit construction. For FM and TV use... **\$1.95**
List price—**\$12.50**



American Makers Kit of 100 Insulated RESISTORS

50-10 and 10-25. 25-1 Watt, 25-2 Watt. All new, all clean. Good value. . . . \$1.68
List price—**\$15.00**

Hi-Voltage T.V. CONDENSERS

500 mmfd 10KV. \$.39 ea.
500 mmfd 15KV. .49 ea.
500 mmfd 20KV. .49 ea.
500 mmfd 30KV. 1.59 ea.



OLD FASHIONED SAVINGS!

TUBE REJUVENATOR

Fixes all makes of picture tubes. Completely automatic. Easy to install. No tools needed. For A.C. parallel circuit. Available for all sets. . . \$1.29
YOUR OLD PICTURE TUBES ARE STILL USEFUL
List price—\$5.95
Everyone is a potential user—10 for \$12.90



Army - Navy HEADSETS

Individually boxed. Very sensitive. Meets both Army and Navy specifications.
Ea. per set... **\$2.95**
List price—**\$18.00**



Volume Control Kit

Kit of 10 includes 3 wire-wound, 2 dual post, 5 carbon
The price of one (1) for the quantity of ten (10). Short and long shaft.
PKR Kit... **\$1.79**



SPEAKERS—All Standard Brands, Dynamic

| Size | Ohms | Price | 5.5" | 38 | 1.49 |
|-------|-------------------------------|-------|------|----|------|
| 3" | 1000 | 79c | | | |
| 4" | 1800 | 79c | | | |
| 5" | (tapped at 300) | 79c | | | |
| 6" | (auto speaker) | 99c | | | |
| 10" | 2500 | 1.49 | | | |
| 4 x 6 | 1800 | 99c | | | |
| 4 x 6 | 2750 | 99c | | | |
| 5 x 7 | 1000 | 99c | | | |
| 5 x 7 | 1800 | 99c | | | |
| 5 x 7 | 2750 | 99c | | | |
| 6" | 90 | 1.49 | | | |
| | (with 6K8 output transformer) | | | | |
| 8" | 880 | 1.95 | | | |
| | (with 6V8 output transformer) | | | | |



Kit of BATTERY PLUGS

Polarized, 3, 4, 5, etc.
50 for... **\$1.69**

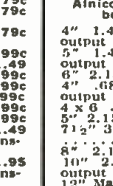

Knob Kit (Choice Groups!)

Assortment of home, auto, and T.V. knobs. All colors—plastic, wood and bakelite knobs. . . \$1.29
Base of 50...
Super Base of 10 extra value... \$1.95
Sells from 12c to 18c each.



SOLDER LUG STRIPS

Kit of 48—very usable assortment of solder lug terminal strips. Brand new. Unusually fine value!
Comp. Kit of 48... **89c**
List price \$4.00



T.V., RADIO, and F.M. COIL KITS

Kit for television service men and experimenter consisting of wide coil, peaking coil, 4.5 m.c. ratio detector, and 21.9 m.c. IF coil.
TV. Standard kit of ten (10)... **99c**
TV. Super value; not duplicated... **\$1.85**
Broadcast and short-wave, midget to multi-band replacement coils.
BC. Standard kit of ten (10)... **99c**
BC. Super value; not duplicated... **\$1.85**
Kit of 25... **\$1.85**
Kit includes RF, Osc., IF, and detector coils.



TERMINAL STRIPS

Assortment of 50 terminal strips (screw type). Kit contains wide selection to meet every design.
Kit of 50... **89c**
2, 3, 4 and 5 screw strips.



Send for Free Illustrated Parts Catalog

Please send full remittance. Allow for postage and save COD charges! We'll refund all unused monies.



RAD-TEL TUBE CO.

Ph. Essex 5-2947, Dept. RN-3, 115 Coit St., Irvington 11, N. J.



Everything
you need
at your fingertips — in

Centralab

Rotary Switch Kits

Centralab Switch Kits contain *all* the parts you need to assemble almost any standard or special switch for low-power application — stock sections, indexes, and hardware. There are five different kits packed in attractive steel cabinets.

1. KIT No. 1000 — Miniature Phenolic Switches — 68 miniature phenolic sections, 15 complete miniature index assemblies, plus hardware and four-drawer metal cabinet. Net \$48.00

2. KIT No. 2000 — Miniature Steatite Switches — 39 miniature steatite sections, 12 complete index assemblies, plus hardware and four-drawer metal cabinet. Net \$48.00

3. KIT No. 1500 — Standard Phenolic Switches — 33 standard phenolic sections, 16 basic index assemblies, plus hardware and four-drawer metal cabinet. Net \$30.00

4. KIT No. 414 — Master Standard Phenolic Switch Kit — 111 standard phenolic sections, 31 complete index assemblies, plus hardware and large three-drawer metal cabinet. Net - - \$105.00. Send for Bulletin 42-138.

5. KIT No. 419 — Master Standard Steatite Switch Kit — 81 standard steatite sections, 27 complete index assemblies, plus hardware and large three-drawer metal cabinet. Net - - \$111.00. Send for bulletin 42-138.

Your Centralab distributor can furnish kits and kit replacements from stock. You pay only for parts — there's no charge for the cabinet. Get your kits soon

Send coupon for
Centralab Catalog 28



Centralab

CENTRALAB
A Division of Globe-Union Inc.
910C E. Keefe Avenue, Milwaukee 1, Wisconsin

Send me the material I have checked
 Catalog 28 Bulletin 42-138

Name _____

Company _____

Address _____

City _____ Zone _____ State _____

P-1754

frequency air cores, multilayer solenoids, peaking, synchro-winding, television r.f., TV i.f., etc., while transformers including audio, power, high voltage, pulse application, synchro, etc., will be made available.

Sketches and blueprints may be sent to the division for estimates. A 4-page brochure on this new service is also available.

1-KW. BALUNS

Barker & Williamson, Inc., 237 Fairfield Ave., Upper Darby, Pa., is now offering a new line of 1-kw. baluns designed to solve the many problems involved in matching feedline systems of radio transmitters to fixed or rotary antennas.

Three of the new baluns have been designed for use with beam antennas employing "T" matching sections. Available in models for 20, 15, or 10 meter input, their input is designed to match a 75-ohm unbalanced feedline system, while the output, in combination with a "T" section, matches 100 ohms.

The remaining baluns in the line are for use with half-wave, folded dipole antennas. Designed for an input of 75 ohms unbalanced to an output of 300 ohms balanced, a total of five models is available for operation on 80, 40, 20, 15, or 10 meters.

Bulletin 700, giving complete details on these units, is available from the company's dealers or the company direct.

LOW-COST INTERCOM

Mark Simpson Mfg. Co., Inc., Long Island City 3, N. Y., is now offering an inexpensive two-station intercom which has been designated as the *Musco* "Small Talk."

The system comes complete with a 50-foot cable. The master unit features an "on-off" switch with volume control, an "on-off" pilot light, and a separate "press-to-talk" switch. The remote unit has a "press-to-talk"



switch which allows the remote station to originate calls to the master station as well as answer calls from a distance up to 40 feet.

The unbreakable all-metal cabinets measure 6½" x 4½" x 4¾".

REPLACEMENT RECTIFIERS

Federal Telephone and Radio Company, Clifton, N. J., has introduced a new "universal" line of selenium rectifiers designed for replacement in any radio or television receiver now equipped with this component.

The new line of four models is available in packages of 12 and 24 to the carton. The rectifiers are of eyelet construction and come equipped with

mounting hardware for simplified installation. The four units are: 1236A rated at 300 ma.; 1238A rated at 350 ma.; 1241A rated at 400 ma.; and 1237A rated at 500 ma.

Additional information on these rectifiers is available from local distributors.

¼-INCH TAPE RECORDER

The Stancil-Hoffman Corporation, 921 N. Highland Ave., Hollywood 38, California, has introduced a new ¼" tape recorder-reproducer, the Model R5.

Designed for either standard rack mounting or portable carrying case op-



eration, it is available at two speeds (7½" or 15") with a frequency response flat ± 1 db to 7500 and 15,000 cycles. The total distortion is 1% with a signal-to-noise ratio of better than 50 db.

When rack mounted the unit occupies a total rack space of 22¾" and has a tape reel capacity of 2500 feet.

BX CRYSTAL

Biley Electric Company, Union Station Building, Erie, Pa., is now offering its "Bantam BX" crystal for use in subminiaturized communications equipment.

The new crystal is hermetically sealed and has wire leads. The range is 15 mc. to 100 mc. It has the same performance characteristics as MIL types CR-23 or CR-32.

The unit may be wired into a miniature socket or soldered to a printed circuit terminal board. Bulletin 46, containing additional technical information on the unit, is available on request.

WIREWOUND CONTROLS

Clarostat Mfg. Co., Inc. of Dover, N. H., is now offering an improved version of its Series 43 wirewound potentiometer.

Known as the Series 43c, the new units feature an improved wiper arm contact and end termination. The new contact allows higher resolution, more intricate tapers, and tighter tolerances in over-all resistance and linearity. Terminals are directly fastened to the winding, insuring low contact resistance. The collector and terminal are now in one piece, eliminating rivets as mechanical fasteners and current conductors.

The new series is available in resistances from 1 ohm to 10,000 ohms at

RADIO & TELEVISION NEWS

2 watts. Taps and various tapers are available. A choice of shafts, switching arrangements, and assemblies is available. At present they are being offered as initial-equipment units only.

TROPICALIZED CONDENSERS

Micamold Radio Corp., 1087 Flushing Ave., Brooklyn, N. Y., is now offering a line of molded tubular condensers known as "Tropicaps."

Designed for superior resistance to extreme humidity and ability to withstand severe mechanical and thermal shock and total immersion, the line is available in all standard capacitance and voltage ratings.

Bulletin 106, giving complete engineering data on these units, is available from the company.

PRINTED CIRCUIT TRANSFORMERS

Microtran Company, 2117 Mott Avenue, Far Rockaway, N. Y., has developed a line of miniature transformers which have been especially designed for use with printed circuits.

These units, which range in power handling capacities from 8 milliwatts to 2 watts, are designed with special soldering tabs so that they may be inserted in a printed circuit terminal board and mounted and connected by means of dip soldering.

Resin impregnation is used to insure the strength characteristics required of units of this type. The company will supply additional details on request.

PERSONAL SPEAKER

Wright-Zimmerman of New Brighton, Minn. is now offering a personal speaker for radio and television applications.

Designed especially for the hard of hearing, the speaker can be clipped



against the speaker terminals of any receiver and placed on the back of a chair or across the viewer's shoulder in a convenient position to the ear.

NEW CONNECTOR LINE

Two battery or portable mating receptacles and plugs, equipped with center polarized pins and sockets, have been introduced by *H. H. Buggie, Inc.* of 726 Stanton St., Toledo 4, Ohio for application to walkie-talkie equipment and other similar electronic items.

Both types feature eight contacts. No. 2411 receptacle is pressurized to withstand 5 psi. It is 1 1/8" in diameter and 3/8" thick and is designed for panel

... it pays to all there is to KNOW about RADIO and TV!

COMPLETE COLOR TV STORY

INTRODUCTION TO COLOR TV
by Kaufman & Thomas
Complete story on NTSC color TV system. Explains color TV receiver circuit — how color receiver differs from black and white; how single and triple gun color tubes differ from black and white picture tubes. Answers all questions on present day color TV. 128 (5 1/4 x 8 1/4") pages, illus. \$2.10

HIGHLIGHTS OF COLOR TELEVISION
by J. R. Locke, Jr.
New basic concepts. Shows how the color TV receiver differs from black and white. A "must" for the service technician, engineer, student. Discusses "colorimetry", the NTSC color signal — special problems at the color receiver, such as matrixing and color synchronous detection. 48 (5 1/2 x 8 1/2") pages, illus. \$.99

HOW TO INSTALL AND SERVICE AUTO RECEIVERS
by Jack Darr
Practical, detailed instructions on how to install and service all types of automobile radios. Where to run lead-ins, how to install antennas, eliminate noise, and methods for vibrator testing. Furnishes a complete list of tools, spare parts and other equipment in addition to business procedures for setting up an auto radio shop or service department. 128 (5 1/2 x 8 1/2") pages, illus. \$1.80

SERVICING TV VERTICAL & HORIZONTAL OUTPUT SYSTEMS
by Harry Thomas
Complete explanation of how vertical and horizontal output systems function. Discusses all types of circuits used in TV receivers — waveforms encountered, construction of components, component constants, requirements and troubleshooting. For the TV service technician and TV servicing student. No other book in print offers equivalent coverage of the subject. 140 (5 1/2 x 8 1/2") pages, illus. \$2.40

New RIDER BOOKS out this month!

service technicians experimenters • students

TV MANUFACTURERS' RECEIVER TROUBLE CURES
VOL. 1, VOL. 2, VOL. 3, VOL. 4, VOL. 5
Positive cures for TV troubles!
VOL. 1, 115 (5 1/4 x 8 1/4") pages..... \$1.80
Covers 12 brands, Admiral through Dumont.
VOL. 2, 117 (5 1/4 x 8 1/4") pages..... \$1.80
Covers 11 brands, Emerson through Jackson.
VOL. 3, 119 (5 1/4 x 8 1/4") pages..... \$1.80
Covers 16 brands, Kaye-Halbert through Philco.
VOL. 4, Over 115 (5 1/4 x 8 1/4") pages..... \$1.80
Covers 10 brands, Philharmonic through Shaw TV.
VOL. 5, Over 120 (5 1/4 x 8 1/4") pages..... \$1.80
Covers 12 brands, Sparton through Zenith.

ONE SERVICE JOB WILL MORE THAN PAY THE COST OF THIS SERIES OF BOOKS!

HOW TO TROUBLESHOOT A TV RECEIVER
by J. R. Johnson..... \$1.80

HOW TO USE SIGNAL AND SWEEP GENERATORS
by J. R. Johnson..... \$1.80

TV TROUBLESHOOTING AND REPAIR GUIDE BOOK
VOL. 2 by R. G. Middleton..... \$3.30

TV TROUBLESHOOTING AND REPAIR GUIDE BOOK
VOL. 1 by R. G. Middleton..... \$3.90

GUIDE TO AUDIO REPRODUCTION
by David Fidelman..... \$3.50

OBTAINING AND INTERPRETING TEST SCOPE TRACES
by J. F. Rider..... \$2.40

TV SWEEP ALIGNMENT TECHNIQUES
by Art Liebscher..... \$2.10

ENCYCLOPEDIA ON CATHODE-RAY OSCILLOSCOPES AND THEIR USES
by Rider and Usland..... \$9.00

SECOND SUPPLEMENT, RECEIVING TUBE SUBSTITUTION GUIDE BOOK
by H. A. Middleton..... \$.99

FIRST SUPPLEMENT, RECEIVING TUBE SUBSTITUTION GUIDE BOOK
by H. A. Middleton..... \$.99

RECEIVING TUBE SUBSTITUTION GUIDE BOOK
by H. A. Middleton..... \$3.00

UHF TELEVISION ANTENNAS & CONVERTERS
by A. Lytel..... \$1.80

HOW TO USE METERS
by Rider..... \$2.40

HIGH FIDELITY SIMPLIFIED
by Weiler..... \$2.50

IN CANADA, ALL PRICES APPROXIMATELY 10% HIGHER.

WRITE FOR COMPLETE RIDER CATALOG
Buy these books now from your jobber, bookstore — if not available from these sources, write to:

JOHN F. RIDER PUBLISHER, INC.
480 Canal Street, New York 13, N. Y.

Export Agent: Roburn Agencies, Inc. 39 Warren Street New York 7, New York

West Coast Office: 4216 20 W. Jefferson Blvd. Los Angeles, California

Cable Address: Roburnage N. Y.



SH!

SH!

QUIETROLE

TRADE MARK REG. U.S. PAT. OFF.

**ELIMINATES NOISE
THE SAFE* CLEAN WAY!**

**"The ORIGINAL
NON-INFLAMMABLE
NON-CONDUCTIVE
LUBRICANT CLEANER"**

QUIETROLE quiets noisy television and radio controls, switches* and other moving parts.

REMEMBER . . . there is NO substitute for quality . . . SH! . . . QUIETROLE eliminates noise, the clean safe* way.

NO GUM! NO GOO! NO GRIME!

Carried by recognized jobbers . . . everywhere!



Available in 3 sizes:
2 oz., 4 oz., 8 oz.

*Unequaled for TV front end switches. Contains no "thinner".

manufactured by

**QUIETROLE
COMPANY**

Spartanburg, South Carolina

mounting with a spanner ring. The mating plug, No. 2413, is equipped with a hood having a pull ring and right-angle cable clamp.

The HHB No. 2412 receptacle has a square flange for panel mounting. The dimensions are $1\frac{1}{16}$ " center-to-center holes. Over-all thickness is $\frac{3}{8}$ ". The mating plug, No. 2611, has the same specifications as the No. 2413.

"GUIDE-A-TUBE

S/C Laboratories, Inc., 37 George Street, Newark, N. J., is in production on a newly-patented service aid which has been tradenamed "Guide-A-Tube."

The new unit is a low-loss plastic wafer designed to insure quick, safe, and simple insertion of miniature tubes into their sockets. The wafer is slipped over the tube pins and then the tube can be inserted into the socket with the ease of an octal, according to the company. The device is also said to reduce microphonics and prevent tube breakage.

TEST PROBE

Mic-Con, Inc., 521 Lehigh Ave., Union, N. Y., has introduced a new test probe which provides for instantaneous connection in any electronic circuit irrespective of space or size.

The new probe features a push-to-operate mechanism which frees the operator's hands without disturbing adjacent circuitry. This clip-on mechanism is combined with a chrome-plate hardened steel hook which fits over circuit wiring.

A four-page brochure on this probe is available on request.

PARTS CABINET

Aurora Equipment Company's *Equipment Division*, Aurora, Illinois, has added six new storage cabinets to its line of equipment for service shops, dealer, and distributor stockrooms.

The new units combine drawers for small parts and drawers for tiny parts in a single cabinet. The small parts drawers measure $5\frac{1}{2}$ " wide x 11" deep



x $3\frac{1}{8}$ " high and are regularly furnished with two flush-fitting adjustable dividers. The tiny parts drawers measure 11" wide x 11" deep x $1\frac{1}{4}$ " high and can be divided into 28 separate adjustable compartments. Any two of the drawers for tiny parts are interchangeable with any two of the small parts drawers.

"SIGNAL SENTRY"

E. F. Johnson Company, Waseca, Minn., has developed a new product of interest to the amateur.

Known as the "Signal Sentry" the new unit is designed to perform four major station functions. It operates on all of the amateur bands to 50 mc. and

requires no tuning after initial adjustment. It monitors radiotelephone signals, monitors c.w. signals, acts as an "on-the-air" indicator, and provides for break-in by automatically muting the audio system of the receiver with



which it is used. It can also be used as a code practice oscillator.

Supplied completely wired and tested, it requires only two tubes and can be powered by the receiver power supply.

REMOTE VOLUME CONTROL

Controla-Tone Company, 111 No. Tacoma Ave., Tacoma 2, Washington, is in production on an inexpensive remote control volume control which can be used with either radio or television receivers.

The new unit is a rheostatic volume control which connects to one of the speaker wires in the set. Volume can be set at any level desired by the user.

Simple installation instructions are packed with each unit and installation can be completed in a matter of minutes.

TUBE CADDY

Windsor Electronic Tube Co., 1515 Sheepshead Bay Road, Brooklyn 35, N. Y., is now offering a sturdily-built tube caddy which is capable of holding all the necessary tubes, meters, and tools for servicing in the home.

This compact and light caddy is fully described in an illustrated bulletin which the company will send free on request.

TAPE SPLICER

Cousino, Inc., 2321 Madison Ave., Toledo 2, Ohio has just introduced a new splicing device for magnetic recording tape.

The back of the splicer, formed in plastic, is provided with an adhesive mounting material for firmly attaching it to the tape recorder or work table.

The splice is quickly and neatly accomplished by pressing the tape ends into a groove, overlapping each other about one-half inch. No clamps are necessary, edge friction holding the tape in place. The ends are then trimmed by running a blade through a guide slot and pressing the splicing tape over the joint. The company will send a free folder on request. -50-

THE Original

WRENCH WITH THE SCREWDRIVER ACTION!



SPINTITE
REG. U. S. PAT. OFFICE

120 STYLES and SIZES

for

- ASSEMBLY WORK
- REPAIR WORK
- RADIO
- TELEVISION
- INDUSTRIAL
- AIRCRAFT



STEVENS WALDEN, Inc.
WORCESTER 4, MASS.

Applause Meter (Continued from page 83)

of voltage gain or db level. In such a case, new resistors may be chosen for this network. Refer to *Federal's* "Reference Data for Radio Engineers" for the necessary design formulas.

A continuously variable attenuator control may be provided if desired. Simply use a standard 1000 ohm potentiometer in place of *S*₁ and its associated resistors.

If the completed instrument is to be used in other than "applause meter" applications, the builder may wish to provide frequency selective filter networks so the frequency response of the amplifier can be adjusted for special measurements. Again, filter network design data will be found in the handbook mentioned previously.

Calibration: As long as the instrument is used only as a peak-reading device, there is no need for meter scale calibration, either in db or in other terms, and none is provided in the model. Should the builder wish to use the instrument for absolute sound level measurements, however, not only will scale calibration be necessary, but the attenuator switch will have to provide precisely known amounts of attenuation.

Meter calibration is best carried out by borrowing a standard sound-survey meter or similar instrument and obtaining comparative readings. The final calibration may either be a chart or curve or, if preferred, a new scale may be prepared for the meter itself.

Applications

To use the completed instrument as an applause meter, place it on a small stand or table with the microphone facing the audience. Set the attenuator switch (*S*₁) in the maximum attenuation (minimum signal) position. The meter switch (*S*₂) may be set either in the "filter" or "peaks" position, as preferred by the individual operator, but the switch position should be left fixed during any series of tests.

The power switch should now be turned "on." The meter reading should be noted during the program and the attenuator switch adjusted for a one-third to one-half full-scale reading during a particularly good "hand" and before actual "voting" takes place. As an alternative, the audience may be asked for a good "hand" before the program starts, and the attenuator switch adjusted at this time.

Once set, the switch is left in position until all contestant "voting" is completed.

In some cases it may be desirable to have two or three "judges" to note the meter reading during voting to avoid any possibilities of error.

In addition to its use as an applause meter, the completed instrument has many other possible applications. For example, when placed in front of a

12 V. DYNAMOTOR
(D. W. Thomas Engineering, Inc.)
NEW! Guaranteed. Ready to use. Continuous duty ratings. Gray finish. 10" Lx. 2 1/2" x 1 1/2" x 1 1/2" H. 1224-1 400V, 350 ma. 1224-2 600V, 200 ma. Either. **\$9.95**
(Less base.) ...
Add \$6.00 for base box containing starting relays & filters as shown. Shipping wt. 1 1/2 lbs.; with base, 1 3/4 lbs.

12 V. RECEIVER DYNAMOTOR
Same as the 24V dynamotors on the back end of your 274-N or ARC-5 command receivers, except that these are made for 9 or 14 volts. Same base plate and plug connections. Output 250V 60 ma. **\$5.95**
DY-1/ARR-2X, like new, checked out.

GENERATOR-ALTERNATOR SPECIAL
120V AC PLUS 28.5V DC
Two units in one package, each complete in itself: the removable centrifugal slip clutch and the generator-alternator. Clutch maintains armature speed of 2400 rpm for drive speeds varying between 2400 and 4200 rpm. Output: 120V, 800 cy. 1 ph., 1080 VA plus 28.5 v. 25 A DC. Drive it from engine or electric motor. With diagram and instructions. **\$24.50**
New.
(Freight prepaid)

VOLTAGE REGULATOR (Carbon pile) for above.
New. **\$2.95**

200 AMP 24 V. GENERATOR
For marine—aircraft—farm—amateur—summer home—battery charging—welding—etc. Heavy Duty 24-30 VDC. 4400-8000 RPM. G.E. type 2CM-81B2 (Air Forces #1). Excellent condition. A \$47.50 value for only. **\$24.50**
(Freight prepaid)

- MARINE RADIO**
- 1.) Our marine division announces the ALL NEW 1954 G.L. SEA KING, a complete FCC-approved 100-watt xmtr-receiver in one compact case, one-knob control. Time-tested circuitry in a miniaturized package. Write for info.
 - 2.) Command receiver 1.5-3 mc in back with dynamotor, ready to go, with leads for hook-up in brought out. Use also as the extra receiver necessary to monitor 2182 KC. 12 W01. **\$49.50** 24 VOLT. **\$39.50**
 - 3.) Good and reliable unidirectional Direction Finder DU-1 remodeled to Hothouse—beacon—lower half of Broadcast Band—and entire Marine Band. Goes ahead of any receiver. New with instructions. **\$47.50**
 - 4.) Bulkhead speaker in neat compact louvered-metal cabinet, with transformer to match easiest output loads. Specify 4K or 600 ohms. **\$5.95**
 - 5.) 6 Volt Radiophone! 2 xtal-controlled channels, brand new Jefferson-Travis, 5-watt output, with mike, built-in speaker. Less xtals. **\$69.50**

TV GLO-TEST
Sensational new test instrument for TV, radio, and hi-fi technicians, hams and X-perimenters! Only 1 control, no switches, no batteries! 3 1/2" x 1 1/2" x 1 1/2" in. OVER 50 USES! Great for testing picture tubes, capacitors, selenium rectifiers, 10 & hi resistance continuity, transformers, coils, tubes. Measures AC & DC voltages from 0 to 50 kv. NEARLY ORIGINAL BOX. With test leads and instructions. **\$14.95**

MINIATURE 6 V. WET BATTERIES
The famous NT-6 Willard 2.4 AH, 6 volt battery. A standard for model control, etc. Plastic case, only 3 1/2" long, 1 1/2" wide, 2 1/4" high. Uses standard electrolyte. New. Boxed. EA. ... **\$1.49** 4 for. **\$5.45** CHARGER. **\$2.45**

OUNCER TRANSFORMERS, one for mike to push-pull grids, flat 30 to 15,000 CPS; other for push-pull output, tapped sec., turns 14:1. In unit for resistors, condensers, etc. BOTH FOR ONLY. **98c**

\$45.00 HI-FI HEADSET AT \$7.95
Uses annular grooved plastic fibre cones with voice coils in speakers, and padded cushion ear muffs to obtain spacing for correct acoustical load. Gives finest music reproduction, 600 ohms. Checked out with freshly laundered ear pads and long flexible fabric cord with phone tips. (Shpg. wt. 3 lbs.) **\$7.95**

MODEL 27-Z TESTER
(Made in Japan)
\$9.95
(Plus 25c shipping)
RANGES: AC and DC volts 0-5/25/250 /500. DC MA 0-1/10/100/250. Ohms 0-10K, 100K. Black bakelite panel, metal case. Manufacturer claims extreme accuracy and our spot checks show them to be within 1%! Here is a meter to be proud of!
METER: 0-1 MA. New. 2" Rd—(Japan). **\$3.95**

12-CHANNEL TV FRONT END FOR \$1.19
Famous "Silver Circle" tuner, with original factory instructions. Use for 2-meter receivers, etc. The TV bargain of the year! Factory rejected for minor damage. Less tubes. \$1.19 each, 3 for \$2.95 (Shipping wt. each 3 lbs.) Tubes, shields and knobs for above. **\$1.25 set, 3 for \$3.00**

WAKE UP TO MUSIC
Brand new clock movement only. Beautiful Telechron modern chrome-ring design with red numerals and white setting knobs. 6 amp switch normally closed, with instructions for easy changeover to normally open. Don't miss this terrific buy! Add 75c **\$2.95** for postage and handling.

G. L. ELECTRONICS, INC.
905 S. Vermont Ave., Los Angeles 6, Calif.
Minimum Order \$5.00 Total. 25c cartons. Required All Prices F.O.B. Los Angeles, Calif. Buyers Add Sales Tax
GET ON OUR MAILING LIST
"OPEN MONDAY NITES 'TIL NINE"

receiver's loudspeaker, it may be used as a "no connection" output meter. Good results can be obtained in this application if the background noise level is not too high.

When calibrated, the instrument may be used as a sound-survey meter and, in this application, is useful for checking noise levels in offices, stores, schools, and factories. In many cases, the background noise level has a definite effect on workers' efficiency.

When used in conjunction with a fixed audio signal source, the instrument will permit tests of the comparative sound absorption qualities of different types of draperies, acoustic tile, and floor coverings.

Installers of p.a. systems could use such an instrument for checking sound distribution in a particular installation, both to insure adequate coverage and to prevent "loud spots."

These suggestions cover only the more obvious applications, however. The reader will undoubtedly think of many additional applications both in regard to his own work and of a general nature.

Power Amplifier Output (Continued from page 54)

of 30 watts direct on the "MED" output scale. This means with minimum efficiency we can expect an output of 30 watts from this tube. By pivoting the indicator on 20 and passing through the efficiency range for class C amplifiers we read increasing outputs finally reaching 80 watts at 80 per-cent.

On the other hand, assume that 5 watts of r.f. driving power is required and a buffer of adequate plate dissipation must be selected. Place the indicator on 5 on the "LO" power output scale and on 70 per-cent on the "E" scale. We read a dissipation of slightly more than 2 watts on the "LO" dissipation scale. Pivoting on 5 down toward 60 per-cent we see an increase in dissipation allowance to over 3 watts. Thus, while a 2 watt operating at good efficiency will do, a 3 or 3½ watt would be a safer choice.

It should be remembered when estimating power output that coupling networks may also dissipate power. Generally, these circuits can be made highly efficient by good design and construction, and these losses can be neglected in the estimate. Also remember that push-pull amplifiers have an allowable dissipation of twice the single tube value.

Table 1 is a tabulation of multiplying factors for various amplifier plate efficiencies. A rule-of-thumb for quick mental estimates can be deduced from this table. Notice that if the numerator and the denominator of the efficiency fraction are consecutive integers such as 4/5 or 6/7 the output multiplier is the numerator of this fraction. This rule applies for efficiencies of ½ or more. For

OUTSTANDING for HIGH FIDELITY!

COLLINS TUNERS and RECEIVERS

AUDIO PRODUCTS CO.

BUY DIRECT AND SAVE

Two ALL NEW Complete Kits for Every High-Fidelity Need

Collins Audio Products Co. is an equal opportunity employer with Collins Radio Co.

Each Collins Tuner Kit is complete with punched chassis, tubes, power transformer, power supply components, hardware, dial assembly, tuning eye, knobs, wire, etc., as well as the completed sub-assemblies: FM tuning units, AM tuning units, IF amplifiers, etc., where applicable. All sub-assemblies wired, tested and aligned at the factory make Collins Pre-Fab Kits easy to assemble even without technical knowledge. The end result is a fine, high quality, high fidelity instrument at often less than half the cost—because you helped make it and bought it direct from the factory.

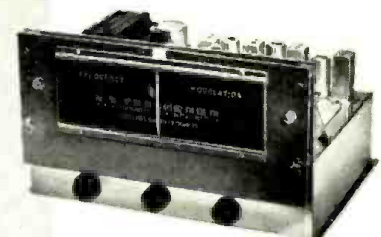

FM Tuner Kit **\$55**

The FM-11 tuner is available in kit form with the IF Amplifier mounted in the chassis, wired and tested by us. You mount the completed RF Tuning Unit and power supply, then after some simple wiring, it's all set to operate. 11 tubes: 6J6 RF amp, 6AG5 converter, 6C4 oscillator, 6BA6 1st IF, (2) 6AU6 2nd and 3rd IF, (2) 6AU6 limiters, 6AL5 discriminator, 6AL7-GT double tuning eye, 5Y3-GT rectifier. Sensitivity 6 to 10 microvolts, less than ½ of 1% distortion, 20 to 20,000 cycle response with 2DB variation. Chassis dimensions: 12½" wide, 8" deep, 7" high. Illustrated manual supplied. Shipping weight 14 lbs.

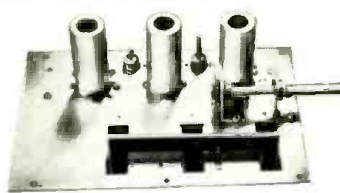

FMF-3 Tuning Unit **\$15²⁵**

The best for FM. The most sensitive and most selective type of "front end" on the market. 6 to 10 microvolts sensitivity. Image ratio 500 to 1. 6J6 tuned RF stage, 6AG5 converter, 6C4 oscillator. Permeability tuned, stable and drift-free. Chassis plate measures 6½" x 4½". In combination with the IF-6 amplifier, the highest order of sensitivity on FM can be attained. Tubes included as well as schematic and instructions. Draws 30 ma. Shipping weight FMF-3: 2½ lbs. Dial available @ \$3.85.



IF-6 Amplifier **\$19⁷⁵**

A remarkable value! 6 tubes are used in the IF amplifier: 6BA6 1st IF, (2) 6AU6 2nd and 3rd IF's, (2) 6AU6 limiters and 6AL5 discriminator. High gain, wide-band response (200 KC) for highest fidelity. 20 to 20,000 cycles. Distortion less than ½ of 1%. Draws 40 ma @ 220 volts. Chassis plate dimensions: 11 7/16" x 2½". Shipping weight: 3 lbs.



AM-4 Tuning Unit **\$24⁵⁰**

Tops in AM superhet performance! A 3-gang tuning condenser gives 3 tuned stages with high sensitivity and selectivity. Assembly is completely wired, tested and aligned ready for immediate use. Frequency coverage 540 KC to 1650 KC at a sensitivity of 5 microvolts. Tubes 6BA6 RF amplifier; 6BE6 converter; 6BA6 IF amplifier and 6AT6 detector. Draws 30 ma @ 220 volts. Mounts on a chassis plate measuring 4" x 7¾". Shipping weight 2½ lbs. Dial available at \$3.85.

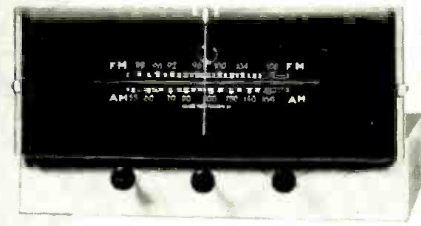

FM/AM Tuner Kit **\$77⁵⁰**

The original 15 tube deluxe FM/AM pre-fab kit redesigned on a smaller chassis. The tuner now measures 14" wide by 12" deep by 7½" high. This attractive new front and dial assembly opens up new applications where space is at a premium. Kit includes everything necessary to put it into operation—punched chassis, tubes, wired and aligned components, power supply, hardware, etc. Kit comprises FMF-3 tuning unit, IF-6 amplifier, AM-4 AM tuning unit, magic eye assembly and complete instructions. All tubes included. Shipping weight 19 lbs.

MAIL COUPON TODAY

To: Collins Audio Products Co. Inc. P.O. Box 368, Westfield, N. J. Tel. Westfield 2-4390. RN-3

FM Tuner Kit FM/AM Tuner Kit Slide Rule Dial Assembly FMF-3 Tuning Unit IF-6 Amplifier AM-4 Tuning Unit

NAME _____

ADDRESS _____

CITY _____ STATE _____

Amount for Kit \$ _____ See weights, add shipping cost \$ _____

Total amount enclosed \$ _____ Check Money Order

WHEN YOU THINK OF TUNERS, THINK OF COLLINS AUDIO PRODUCTS

SUPERIOR'S NEW MODEL TV-40 C.R.T. TUBE TESTER



- ★ A complete picture tube tester for little more than the price of a "make-shift" adapter!!
- ★ Tests all magnetically deflected tubes . . . in the set . . . out of the set . . . in the carton!!

SPECIFICATIONS:

- Tests all magnetically deflected picture tubes from 7 inch to 30 inch types
- Tests for quality by the well established emission method. All readings on "Good-Bad" scale.
- Tests for inter-element shorts and leakages up to 5 megohms.
- Test for open elements.

EASY TO USE:

Simply insert line cord into any 110 volt A.C. outlet, then attach tester socket to tube base (Ion trap need not be on tube). Throw switch up for quality test . . . read direct on Good-Bad scale. Throw switch down for all leakage tests.

Model TV-40 C.R.T. Tube Tester comes absolutely complete—nothing else to buy. Housed in round cornered, molded bakelite case.

\$15⁸⁵ NET

AT YOUR
RADIO PARTS
JOBBER

Write Dept. RN-3 for catalog of complete line.



SUPERIOR INSTRUMENTS CO.
2435 White Plains Road New York 67, N. Y.

The Magneraser* Perfect Magnetic Tape Eraser



**100% Erasure Guaranteed
WITHOUT REWINDING**

You no longer need a cumbersome and costly tape demagnetizer. The Magneraser* has all the features necessary for quick, efficient and absolute erasure of any recorded reel of tape. No matter what tape recorder you are using, or how severely the tape is overloaded, the Magneraser* is guaranteed to eliminate completely all recorded signal and bring the background noise level 3 to 6 db. below that of new unused tape.

You can carry the Magneraser* from room to room and use it wherever you have an AC outlet. To operate, simply place the Magneraser* on top of the reel of tape and move it once around. Within seconds, the complete reel is wiped perfectly clean.

Size 4" dia., 2½" high; Weight 2½ lbs.; Operating current 90 to 130 volts, 25 to 60 cycles; Power consumption 60 watts. Furnished with 8 ft. cord, molded rubber plug, and operating instructions. See your local dealer or write directly to factory. Net Price \$18.00

AMPLIFIER CORP. of AMERICA
398 Broadway, N. Y. 13, N. Y.

*T.M. Reg. U.S. Pat. Off.

For Values You Know Check These from

\$\$\$ HARJO \$\$\$

APS 13 COMPLETE 420 MC RADIOPHONE

when converted with our easy-to-follow schematics and instructions. Range in most cases equal to 2 meters. Fine for short-distance communication, ranches, farms, etc. \$4.95

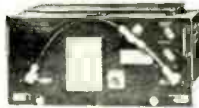

\$14.95 value

Complete with RF sections, conversion booklet, and 30 MIC I.F. strip, lens tubes, dynamotor.

CERAMIC CONDENSERS

Kit of 100 asst'd. Brand new. Stand. and brands. \$10 value. \$1 postpaid

SPECIAL VALUE

934 Acorn Tubes & Sockets. All New. 4 sets **\$1**

METER BARGAIN

0-1 MA Full Scale 3-inch Aircraft Instrument Type. Simple conversion sheet furnished. Tops for "S" meters. VOM, experimental use. Check this price and see if you can afford to pass it up! **\$149** 3 for \$4 ppd.



Brand New POWER TRANSFORMERS

110 V. 60 cyc. primary
150 V. 30 MA secondary
6-3-1 AMP. FIL.
FB for grid dip kits, test equipment, etc. 4 for **\$3.00** **79¢**

SPLINED TUNING KNOB—only 59¢ ea.

Really hard-to-find, but we have it. Fits BC-453, BC-454, and other 274N receivers. **\$17.95**

SCOPE TRANSFORMERS—\$2.95

Prim. 110 V. 60 cyc.
Secondary 3500 V., 25 ma., 10 KV ins.
Shipping wt. 15 lbs.

Attn: Schools, Labs, Mams! WE PAY MORE for Radio Parts, Equipment! Cash in surplus—or trade. Write now.

Write for FREE Surplus Catalog

Thousands of items not listed. If you don't see it, write.

All shipments F.O.B. warehouse.

HARJO SALES CO. Dept. RB

4109 Burbank Blvd., Burbank, Calif.
P. O. Box 1187, Magnolia Park Sta.
Cable: Harjo Phone: Rockwell 9-2411

efficiencies of ¼ and ½ notice that the multiplying fraction is the same with the denominator diminished by one. For example, if a tube of 250 watts maximum allowable plate dissipation is operated at ¼ efficiency (75 per-cent) the output is 3 x 250 or 750 watts. At ½ efficiency (33.3 per-cent) the output is ½ x 250 or 125 watts.

The analytical basis for the nomograph in this article is as follows:

If P_o is power output, P_i is power input, and E is efficiency,

$$E = P_o/P_i \dots \dots \dots (1)$$

and:

$$P_i = P_d + P_o \dots \dots \dots (2)$$

if P_d is the power dissipated in the amplifier. Substituting eq. (2) in (1)

$$E = P_o/(P_d + P_o)$$

rearranging, $P_o = EP_d/(1-E) \dots (3)$

-30-

Crystal Substitute

(Continued from page 47)

transmitter was wired to key both stages as described in the step-by-step assembly instructions, the oscillator signal on 80 meters does not interfere with listening on that particular frequency. On forty meters the signal is hardly noticeable.

The transmitter is tuned the same way that it would be tuned when using a crystal. However, care should be exercised in setting the oscillator within the amateur bands. This can be done quite easily with a calibrated receiver or by listening for other amateurs on either side of the frequency which you wish to use. If more band-spread is wanted, remove two of the rotor plates from the 50 µfd. tuning condenser, or substitute a smaller condenser. Of course, on forty meters the dial division coverage will be less than half of the 80-meter band, so make the adjustments carefully.

In the photograph of Fig. 1 showing the v.f.o. and transmitter, the oscillator coil seems to be too close to the transmitter cabinet. This does not affect the operation of the v.f.o., nor does it affect its stability. The oscillator coil should be mounted as far away from the tubes as possible to prevent heat drift.

The photograph of the inside of the v.f.o. box (Fig. 3) shows the arrangement of components. Placement of parts is not too critical and almost any arrangement can be used. The 100 µfd. padding condenser is mounted so that screwdriver adjustments can be made from the top of the box. Inserting and removing the screwdriver when making adjustments should not cause too much change in the setting of the oscillator frequency.

No trouble should occur by following the general v.f.o. layout shown in the photographs. Careful placement of parts and normal construction procedure will provide a compact, stable v.f.o.

-30-

FACTS

NOT JUST CLAIMS

**FACT- 53 CLAIMS GRANTED
IN 5 UNITED STATES PATENTS—**

#2,585,670; 2,609,503; 2,625,655; 2,644,091; 2,661,423, others pending.

FACT- These antennas positively receive ALL channels 2-83 from ALL directions without a rotor motor.

FACT- These antennas have consistently OUT-GAINED and OUT-PERFORMED all others in actual public demonstrations.

FACT- These antennas will unquestionably OUT-PERFORM all others, on YOUR roof, with YOUR set, or YOUR money back.

FACT- SAVES YOU MONEY. Eliminates rotor motor, uses only ONE transmission line, uses only ONE antenna for both UHF & VHF—and only ONE simple, quick installation.

FACT- Perfect pictures have consistently been received as far as 3 times the guaranteed distances.

FACT- ONLY one antenna, ONLY one transmission line, ONLY one installation. You solve once and for all your PRESENT and FUTURE antenna problems.

**MONEY BACK GUARANTEED
TO RECEIVE *All* CHANNELS
2-83 FROM *All* DIRECTIONS
AND POSITIVELY OUTPERFORM
All OTHER ANTENNAS WITH
OR WITHOUT A ROTORMOTOR**

Guaranteed
60 mi UHF
60 mi VHF



SUPER 60

LIST PRICE
\$36.75
SEE YOUR
JOBBER

Guaranteed
100 mi VHF
30 mi UHF



ULTRA 750

LIST PRICE
\$43.50
SEE YOUR
JOBBER

**9 POSITION
ELECTRONIC
ORIENTATION
SWITCH**



PRICE INCLUDES

Antenna arrays - necessary stacking bars - 9 position switch - switch-to-set coupler - necessary hook-up harness - 7 1/2" stand-offs Individually boxed in mailable carton.

**NEW POLYMICALENE
4 CONDUCTOR TRANSMISSION LINE**

- Low Loss External Air Dielectric
- Matched Impedance
- Eliminates End Sealing
- Eliminates Condensation
- Up to 50% Less Loss Than Tubular When Wet
- Easily Spiraled
- No Breaking or Shorting
- Patents Pending - T. M. Reg.

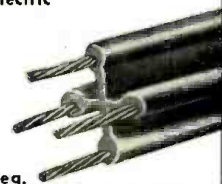

ALL CHANNEL ANTENNA CORP.,

70-07 Queens Blvd., Woodside 77, N. Y.

Hickory 6-2304



you're on easy street
with **PHOTOFACT**
**FIELD SERVICE HINTS &
TROUBLE-SHOOTING AIDS**

EXCLUSIVE Trouble-Shooting Aids
—in each and every PHOTOFACT TV Folder—applicable to the particular receiver covered by the Folder. Describes trouble symptoms—tells where to look for them; explains new or unusual circuits used in the receiver. Specific, invaluable time-saving help!

NOW—included in each and every PHOTOFACT TV Folder! Invaluable time-saving guide and reference for adjustments and services you can perform on the specific receiver in the customer's home—right down to safety-glass cleaning tips. Helps eliminate costly chassis-hauling back to shop...

22 other exclusive features consistently in every PHOTOFACT Folder—the world's best data for faster, more profitable servicing...

NOW! GET THE PROOF FOR YOURSELF!

FREE We'll send you a Free Photofact TV Folder—just ask us for it!

Learn for yourself how PHOTOFACT pays for itself by earning bigger profits for you! We'll send you the proof—a FREE specimen PHOTOFACT TV Folder that shows all the features found consistently and exclusively ONLY in PHOTOFACT. Send for your FREE specimen TV Folder now. Examine it. Compare it. You'll see why PHOTOFACT belongs in your shop! And you'll want to ask your parts distributor about the pay-as-you-earn-plan. Only \$25 down brings you the entire PHOTOFACT Library. Write for FREE specimen TV Folder—learn now how to earn more!

HOWARD W. SAMS & CO., INC.
2203 E. 46th St., Indianapolis 5, Ind.

HOWARD W. SAMS & CO., INC.

Technical
BOOKS

"GUIDE TO AUDIO REPRODUCTION" by David Fidelman. Published by John F. Rider Publisher, Inc., New York. 228 pages. Price \$3.50. Paper bound.

This is a companion volume to Harold D. Weiler's "High Fidelity Simplified" (Rider) which was written for the audiophile without technical background. This book is addressed to the experimenter, engineer, and technician. The approach is more technical than the previous volume and delves into the "why's and wherefore's" more deeply.

The text material covers the high-fidelity reproduction of sound, sound principles, sound reproducing systems, input and pickup units, audio amplifier theory, practical audio amplifier circuits, a.f. networks and corrective circuits, loudspeakers and loudspeaker enclosures, complete hi-fi systems, magnetic recording, and the measurement of quality of audio reproduction.

Readers of this magazine are long familiar with the author's style as he has contributed numerous articles on audio subjects. They will find that, like his articles, this book is written in easy-to-understand style. The text material is lavishly illustrated and amplified by means of photographs, circuit diagrams, and graphs.

Those who install, service, or build audio equipment will find this volume a welcome addition to their bookshelves.

"MOST-OFTEN-NEEDED 1953 RADIO DIAGRAMS" compiled by M. N. Beitman. Published by Supreme Publications, Chicago. 192 pages. Price \$2.50.

This is the thirteenth volume in the "radio" series published by Supreme.

As is the case with the previous volumes, this new publication reproduces factory service data as supplied by the manufacturers represented. Included are AM and FM radio receivers, auto radios, portables, combination sets, record changers, and receivers employing printed circuits.

The products of approximately thirty-five companies are covered in this particular volume.

"RADIO DATA CHARTS" by R. T. Beatty, revised by J. M. Sowerby. Published by Iliffe & Sons, Ltd., London. Available in the U. S. from The British Book Centre, 122 E. 55th Street, New York 22. 91 pages. Price \$1.75.

This book is a series of 43 nomographs covering data required in the design of radio receivers.

These nomographs originally appeared in the British technical journal, "Wireless World", and have been assembled in this convenient form for reference purposes.

The charts cover such items as frequency and wavelength; inductance,

capacity, and frequency; self-inductance; r.f. coil windings; reactance of coils or condensers; transformer design; choke and transformer design; etc.

The only "equipment" required to utilize any of the nomograms is a straightedge. All the desired data can then be read directly.

For the engineer, the experimenter, or the hobbyist who likes to "roll his own" either as a vocation or an avocation, this book should be invaluable.

"DATA AND CIRCUITS OF TELEVISION RECEIVING VALVES" by J. Jager. Published by Philips Technical Library, Eindhoven. Available in the U. S. from Elsevier Press Inc., 402 Lovett Blvd., Houston 6, Texas. 215 pages. Price \$4.50.

This is the third in the current Philips series dealing with electronic tubes and covers the tubes encountered in modern television receivers.

The discussion centers around tubes made by Philips in Holland for receiving sets operating on European standards. In this respect the text is not directly applicable to U. S.-made receivers but the basic engineering data contained in the book as well as the receiver circuitry will be of interest to all in the television field.

The book is divided into three sections. The first discusses each type of tube and provides full information on applications and correct operating conditions. The second section covers typical circuits while the third contains a short description of various measuring instruments suitable for testing, troubleshooting, etc.

"TECHNIQUES OF TELEVISION PRODUCTION" by Rudy Bretz. Published by McGraw-Hill Book Company, New York. 464 pages. Price \$10.00.

This is a comprehensive handbook for the studio engineer and technician as it covers all of the equipment and materials used in producing television programs.

The book is divided into twenty chapters which deal with the television cameraman, cameras, and camera handling; TV lenses; cutting; switching equipment; technical limitations and the production problems involved; graphic materials; projection equipment; mirrors and prisms; composite shots and the illusion of space; special effects with graphic materials; studio effects; electronic effects; television scenery, make-up, and lighting; audio problems in TV; and remote pickups.

The author has prepared this material based on the assumption that personnel at the average television station (non-network originating station) has to "double in brass." Many "engineers" in smaller stations are vitally involved in "production" and vice versa and the author rightly feels that a broadening of the scope of both the "engineers" and "production man's" job is a natural process to insure close coordination in all facets of programming.

We predict that this book will be-

come a "standard" in the production field as the material covered is primarily basic and, on the whole, not subject to obsolescence even in the face of the imminence of widespread color telecasting.

* * *

"RADIO AMATEUR QUESTION & ANSWER LICENSE GUIDE" compiled and published by *American Electronics Company*, 1203 Bryant Ave., New York. 32-pages. 50 cents. Paper bound.

This compact handbook carries sample questions and answers for Novice, General, and Technician classes of license examinations.

The material is divided into sections, one covering the Novice class and the balance the General and Technician classes. Practice questions cover the basic electricity, power supplies, transmitters and receivers, and rules and regulations elements for the Novice class and the same elements for the other two classes with the addition of the element covering vacuum tubes and audio amplifiers.

* * *

"UHF TELEVISION ANTENNAS AND CONVERTERS" by Allan Lytel. Published by *John F. Rider Publisher, Inc.*, New York. 113 pages. Price \$1.80. Paper bound.

This is a practical handbook for the television service technician. It explains in easy-to-understand terms just how the various u.h.f. conversion systems work and how to select and install suitable antennas to be used with sets operating in the ultra-high television bands.

The book is divided into seven chapters dealing with conversion systems and installation problems, transmission lines, antennas, converter circuits, single-channel converters, full-range converters, and all-channel tuners.

The author describes and discusses some commercial units as typical of the units available. The lavish use of circuit diagrams and photographs enhances the value of this work as a guide to servicing procedures.

Any technician familiar with v.h.f. receiver circuitry will be able to handle the material in this book. Treatment is non-mathematical and explanations are lucid.

READERS' BOOK SERVICE

AT THE suggestion of many of our readers, who either live in communities which do not have adequate bookstore facilities or who would like to enjoy the convenience of receiving their books by mail, we have established a Book Department in this magazine.

This department will be able to supply its readers with any book in print in our field. Each month it will carry advertisements featuring a number of important radio-TV-audio-electronics titles, new and old, issued by leading publishers of this country.

We hope that our readers will find this new department helpful and that you will take full advantage of its facilities.

MARCH, 1954



FOLLOW ARROW FOR BIGGEST STOCK AT LOWEST PRICES

- RADAR—TRANSMITTERS
- RECEIVERS — TUBES — PARTS

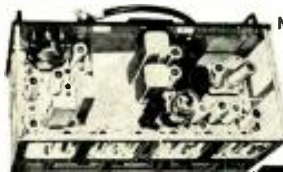

Sensational New Year buy! UHF TRANSMITTER-RECEIVER

Frequency range 415-420 MC. Receiver uses 13 tubes. 5 Stages of 30 MC. IF amplifier. With schematic. Less dynamotor and tubes. Excellent condition. Never before offered at this money-saving price! **\$5.95**



C.A.P. SPECIAL BC-625 VHF TRANSMITTER
 Freq. range 100-156 MC. With tubes & crystals, with conversion dope. Used, good condition. (See Nov/53 (Q)) **\$9.95**

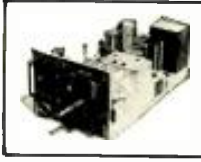

UHF Transmitter
 450-710 MC. Tunable Transmitter, 10 W. output. Two 368-type tubes as push-pull oscillators. Wide band video amplifier. Less tubes, with schematic. Excellent condition... **\$8.95**

I-83 COMPLETE DYNAMOTOR TESTING PANEL WITH METERS. EXCELLENT CONDITION..... \$49.50

T6-10 TELEGRAPH KEYING AMPLIFIER. EXC. CONDITION..... \$22.50

R-28/ARC-5 RECEIVER
 100-156 MC. With tubes. Excel. cond..... \$45.00

MOTOROLA MODEL TR 20-18 MOBILE 2-WAY RADIO. Used condition..... \$150.00

RADAR TEST EQUIPMENT
 TS-3, TS-12, TS-13, TS-15, TS-33, TS-34, TS-35, TS-36, TS-45A1M3.

| COMMAND EQUIPMENT (SCR-274N) | | | |
|---|--------|--------|--|
| | Used | New | |
| BC-442 ANTENNA RELAY. Less cond. | \$1.95 | | |
| BC-451 TRANSMITTER CONTROL BOX | | \$1.50 | |
| BC-450 3-RECEIVER REMOTE CONTROL BOX | | 2.95 | |
| MC-219 MECHANICAL DRIVE SHAFT. Per length | | 2.95 | |
| BC-496 2-POSITION RECEIVER CONTROL BOX | | 2.95 | |
| BC-454 RECEIVER, 3-6 MC. With tubes | 12.95 | | |
| BC-455 6-9 MC RECEIVER. With tubes | 9.95 | 14.95 | |
| BC-457 TRANSMITTER, 4-5.3 MC. With tubes | | 9.95 | |
| BC-458 TRANSMITTER, 5.3-7 MC. With tubes | \$9.95 | | |
| MC-211 90° ANGLE COUPLING UNIT | | \$0.95 | |
| FT-234 MOUNTING RACK for single transmitter | 2.95 | 3.50 | |
| FT-226 MOUNTING RACK for 2 Command Xmters | | 3.95 | |
| FT-221 MOUNTING PLATE for FT-220 | | 1.50 | |
| FT-220 MOUNTING RACK for 3 receivers | 2.25 | 3.95 | |
| FT-225 MOUNTING PLATE for BC-456 | | 2.25 | |
| BC-456 MODULATOR. For SCR-274 | 5.75 | | |
| Complete set of 4 tubes for transmitter | | 1.25 | |

Miscellaneous Specials! HAVE YOU ANY NEW OR USED RADIO GEAR TO SELL? FOLLOW ARROW FOR TOP PRICES!

BC-223 TRANSMITTER. With tubes and one tuning unit. Excel. cond. \$49.50
 RM-12 WITH HANDSET. Excellent cond. 35.50
 RM-13 LESS HANDSET. Good cond. 24.95
 T-48 DESK STAND MIKE. New. 4.95
 LIP MIKE. Navy type. New.98

6 VOLT DC CARTER DYNAMOTOR
 Complete 6 v DC dynamotor power supply. Input 5.5 v DC. output 350 v DC @ 150 MA. Mounted on a 6 x 4 x 3 chassis with 2 each 4 mfd. 600 v. cap. 1 each filter choke and starting relay. Like new **\$17.50**

BC-1023 75 MC. MARKER BEACON RECEIVER. Complete with tubes, mig. roc. NEW. 10.95
 PE-125 POWER SUPPLY: Operates on 12 or 24 v. battery. NEW \$17.95

CCT-52233 NAVY COMMAND TRANSMITTER
 2.1-3 MC. New, with tubes..... \$14.95
 250 TL TUBE..... Ea. \$9.95 Per Pair \$17.00

INDUSTRIAL CORPORATIONS
 We carry one of the most complete stocks in U. S. of Military Electronic Equipment, Test Equipment, and Aircraft Electronics. Call or write for NEW catalogue.

ARROW SALES, INC.
 Mailing Address: P. O. Box 3878-R, N. Hollywood, Calif.
 Office-Warehouse: 7460 Varma Ave., N. Hollywood, Calif.
 Cable Address: ARROWSALES - POplar 5-3810

\$5.00 MINIMUM ORDER ACCEPTED. All items subject to prior sale. All shipments F.O.B. warehouse. Calif. residents add tax with remittance. 20% deposit required. Please specify shipping instructions with order. EQUIPMENT WANTED! Highest prices paid for all types of Electronic Gear!

WORLD'S LARGEST MANUFACTURER
OF CUSTOM BUILT TELEVISION

MATTISON

SILVER ROCKET 630 CHASSIS

Featuring *Synchromatic Tuning*
NO DRIFT UHF-VHF-DX

ONLY THE MATTISON 630 ELIMINATES DRIFTING APART OF PICTURE AND SOUND ON UHF, VHF and DX RECEPTION. SELECT YOUR CHANNEL . . . SOUND IS AUTOMATIC. (Synchromatic tuning is an exclusive Mattison 630 Circuit)

Tube Complement:
29 tubes
3 rectifiers
1 CRT

SILVER ROCKET
630 Chassis with
built in UHF Tuner

33

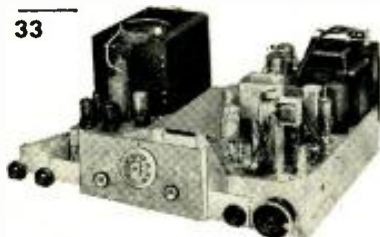

All Channel UHF Tuner

UHF Cascade I.F. amplifier adds additional I.F. stage. Very important because UHF transmitters operate with moderate power and RECEIVER must be sensitive to give top notch UHF performance.

SILVER ROCKET 630 CHASSIS
• with **TUNEABLE**

BUILT-IN BOOSTER
for Better DX Reception

Tube Complement:
28 tubes
3 rectifiers
1 CRT

Select Your
Channel
SOUND IS
AUTOMATIC!

32

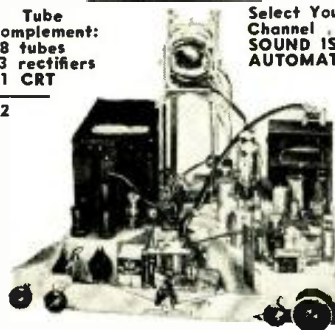

All Channel Booster

Broad band single knob control pre-amplifier built in to eliminate long leads which may cause regeneration and attenuation of signal.

ONLY THE MATTISON 630 CHASSIS HAS AN ALL CHANNEL TUNEABLE BUILT-IN BOOSTER THAT INCREASES SIGNAL STRENGTH UP TO 10 TIMES.

ALL CABINETS MADE IN MATTISON'S OWN CABINET FACTORY. AVAILABLE IN EVERY FINISH AND STYLE. WRITE FOR COMPLETE CATALOG.

DEALERS! SERVICE DEALERS! Here is your opportunity to become the "important" TV Dealer in your area for THE FINEST CUSTOM-BUILT LINE OF TV RECEIVERS. FREE!! Write for Mattison's merchandising portfolio explaining the "UNASSEMBLED PLAN" and "\$1,000,000 FLOOR PLAN."



Manufactured with integrity

When you buy from Mattison you need only one source of supply! You can buy a Mattison Chassis, a Mattison Cabinet or a complete Mattison TV Set!

Mattison Television & Radio Corp.
10 West 181st St., Dept. RN, N. Y. 53, N. Y.

International Short-Wave

(Continued from page 84)

Colombia—Bogota, 6.000, noted 2200-2300 with Spanish news, music. (Zerosh, Pa.) HJKH, 5.070, Sutatenza, announces 5.070 and 1580 kc., closes with National Anthem 2100; announced Sun. opening as 0800; on Sat. has "La Accion Cultural Popular esta en Marcha" before closedown; good level; all-Spanish. (Kahan, Calif.) NNRC reports *Radio Continental*, HJKE, 4.835, Bogota, logged 2105-2200 in Spanish.

Costa Rica—TIFC, 9.645, noted 2300-2330 Sun. with "Old-Fashioned Revival Hour." (Tandrow, Calif.) Heard closing 0005; requested reports to "Lighthouse of the Caribbean," Box 1307, San Jose, Costa Rica. (Smith, Ga.)

Cuba—*Radio Reporter*, COCW, Prado 53, Havana, lists 6.330 (measured 6.314), at 0600-2400, 1 kw. (Roberts, Conn.) COKG, 8.955, Santiago, noted at high level 1530. (Grenell, Ohio)

Czechoslovakia—Prague, 9.504, noted signing on *English* session 0715; ran to 0740. (Pearce, England) Heard on 7.255 at 1930-2000 with news for North America. (Smits, Minn., others)

Denmark—Copenhagen, 15.165, strong 0700-1000; *English* 0950; is beamed to South Asia. (Saylor, Va.; Kirby, Mo.; Earnhardt, N. C., others)

Ecuador—HCJB, 9.745, noted ending Russian 0100, continuing in Spanish. (Wilcox, Mo.; Milnes, Ore., others) Heard on 17.890 to Europe with Swedish 1535. (Saremba, Va.)

Egypt—*Radio Cairo*, 15.315, noted 0915 with Arabic music; closed 0930 after call in Arabic. (Pearce, England) Noted on 11.965 with Arabic music 1445. (Ferguson, N. C., others) The 9.475 outlet is strong around 1500. (Mitchell, N. Y.; Zerosh, Pa., others)

El Salvador—YSUA, 6.100A, San Salvador, noted in Spanish 2130-2230. (Kahan, Calif.) San Salvador, 9.55A, noted closing in Spanish 2330. (Zerosh, Pa.) YSS, 6.010, heard with marimba music and announcements in Spanish at 2310 to closedown 0006 (Roberts, Conn.) YSWW, Santa Ana, noted best 2030-2100. (Stark, Texas) YSAXA, 11.950, noted 1540-1600, good level. (URDXC)

Ethiopia—*Radio Addis Ababa*, 15.047AV, noted with news some days 1315-1325, then dance music with *English* vocals. (Zerosh, Pa.) Seems to have recorded music 1330-1400 with announcements in *English*. (Earnhardt, N. C.)

Finland—Revised schedules of Helsinki include to South America 0430-0550 on 15.190, 17.800; to North America 0600-0800 on 15.190, 17.800; from 0700 also on 9.555. (WRH)

France—Paris, 9.550, noted 0400 with music. (Tandrow, Calif.) Noted closing 1600 on 7.105. (Zerosh, Pa.; Ferguson, N. C.) Heard on 5.955 in Spanish to 1645 closedown. (Stark, Texas) Noted closing 0715 on 21.740. (Gillett, Australia) Excellent on 15.400 closing 1000. (Bishop, Ohio)

French Equatorial Africa—Radio Brazzaville, 11.970, 9.440, has French-*English* lesson ("The French Have a Word For It") at 1445-1500; news to Far East on these channels 1100. (Pearce, England)

French Guiana—*Radio Cayenne*, 6.205, noted with news in French 1800 (by woman); poor level and with QRM from Rome, 6.210. (Huttemeyer, N. J.; Mercier, France)

French West Africa—*Radio Dakar*, 9.560, noted with call and news in French 1500; at 0200 with recordings. (Pearce, England) Heard 0100-0300, 0700-0900, 1300-1900. Heard opening 0130 with "La Marseillaise" on 4.950; good level to 0300 tune-out. (Nilsson, Sweden; Morris, Pa.) Noted on 11.896A in French 1355-1550 and later. (Roberts, Conn.)

Germany—Cologne, 11.795, noted 1210-1224 fade-out. (Miller, Ga.)

Greece—The Greek station near 7.088 has been identified as Jannina; strong with recordings when tuned 1300. (Pearce, England) *Forces Station*, 7.420, Athens, is very good strength to 1704 closedown. (Buggins, England)

Greenland—OZL, 7.570, noted 0900-0945 with Danish or Icelandic and playing popular music. (Cody, Ireland)

Guatemala—TGNA, 5.952, noted 1750 with musical program. (Ferguson, N. C.) Heard closing *English* 2345. (Mitchell, N. Y.) TGNB, 9.668A, noted recently parallel TGNA, 5.952 with Spanish-*English* lesson 1900. (Bellington, N. Y.)

Haiti—*Radio Haiti*, 4VHW, 5.840, and 4VRW, 10.070A, is scheduled 0700-2200 weekdays, 0930-1800 Sun.; QRA is Radio Haiti, P.O. Box 737, Port-au-Prince. (ISWC, London) *Radio Commerce*, 4VC, 9.485, noted from before 0700 (probably still opens 0630) and still on the air at 1710. (Ferguson, N. C.) Heard closing 2300 on 6.095A in French and *English*, followed by National Anthem. (Zerosh, Pa.) 4VEH, 9.667A, good level beginning *English* 0805. (Bishop, Ohio) *Radio Citadelle*, 4VWA, 6.300, Cap Haitien, noted 2058-2205 closedown in French. (Roberts, Conn.)

Hawaii—VOA relay, 6.195, excellent 0515. (Reidler, Pa.)

Holland—*Radio Nederland*, 9.59, good level with *English* 1100. (Lund, Iowa) Noted on new 9.745 channel 1145 with Arabic, parallel 9.59. (Bellington, N. Y.)

Honduras—HRTL, *Radio Tela*, 6.035, is on the air daily except Sun. 0900-2300; has American music and songs 2120-2200. (ISWC, London) HRXW, 6.110A, Comayagueia, noted fair level closing 2300. (Niblack, Ind.)

Hong-Kong—ZBW3, 9.525, Victoria, noted with BBC news relay 0600. (Morgan, Calif.)

Hungary—*Radio Budapest*, 9.833, noted 2215-2230 in *English* with world news. (Rugel, Kansas)

India—Madras, 4.920, noted with news relay from Delhi 1030. Also at that time from Delhi, 9.750A, 4.760A. (Pearce, England) Heard closing on

precise *Presents*
the Lowest Priced Factory Wired
VACUUM TUBE VOLTMETER
 NO. 909W CONVENTIONAL MODEL



- 1% Ceramic precision Resistors
- Coax DC connector
- FM zero alignment scale
- Burn-out proof circuit



- DC input 25 Meg.
- Rugged oversize 4 1/2" meter
- Power transformer used
- 3-tube circuit



NOW ONLY
37.50 Available in kit form No. 909K **25.98**

precise *is first again . . .*
New Revolutionary
VOLTAGE REGULATED V.T.V.M.



- Rugged, oversize 7 1/2" meter
- 1% Ceramic precision Resistors
- FM zero alignment scale
- Coax DC connector
- Burn-out proof circuit
- DC input 25 Meg.
- Compact design
- Power transformer operated (No Selenium Rectifier used)
- 4 tube circuit
- Measures 8 x 11 x 6

No. 9071K—Kit **\$35.95**
 No. 9071W—Wired **\$49.95**

NEW IMPROVED VERSIONS
of famous precise **SCOPES**



PRECISE MODEL 308B

- Full 8 1/2" tube designed specially for this model
- Voltage regulation
- High frequency—Low frequency—Normal frequency—Synchronization Circuit
- Separate intensifier anode
- Deluxe version of Model 300B

308BK—Kit Form **\$129.95**

308BW—Factory Wired **\$239.50**

Model 300B—Full 7 1/2" scope with many deluxe features

300BK—Kit Form **\$94.95**
 300BW—Factory Wired **\$199.50**

IT'S COMING— *Watch for the New, Revolutionary*
precise TUBE TESTER
 WHICH CHECKS BOTH EMISSION & **G_M** SEPARATELY

SEND FOR COMPLETE CATALOG

Send 20% deposit with order, balance C.O.D., or, check or money order in advance.



All orders are shipped on the same day received

3211-13 Washington Street
 Jamaica Plain 30, Mass.

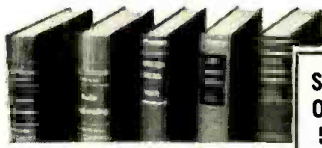

SAVE \$10 ON THESE 5 BOOKS

SPECIAL OFFER on this COMPLETE RADIO ENGINEERING LIBRARY

• 5 Volumes • 3872 Pages • 2770 Illustrations

NOW offered at a special low price, the Radio Engineering Library brings you almost 4000 pages of tested methods, standards, data, and accepted practice. This Library will help solve hundreds of problems for designers, researchers, engineers, and students in any field based on radio. Books cover circuit phenomena, networks, tube theory, amplification, measurements, etc.—give specialized treatment of all fields of practical design and application.

SET INCLUDES: Eastman's Fundamentals of Vacuum Tubes, 3rd Ed.; Fernan's Radio Engineering, 3rd Ed.; Everett's Communication Engineering, 2nd Ed.; Hunt's High Frequency Measurements, 2nd Ed.; and Henney's Radio Engineering Handbook, 4th Ed.

SPECIAL LOW PRICE—EASY TERMS

SAVE \$10.00—Regular price of books is \$47.50; when bought as a set, you pay only \$37.50, and on easy terms.

10-DAY FREE TRIAL

McGraw-Hill Book Co., Dept. RTN-3, 327 W. 41 St., N. Y. C. 36

Send me for 10 days' FREE trial, the RADIO ENGINEERING LIBRARY. If not satisfied I will return books. Otherwise I will send \$7.50 plus delivery charges, then \$6 a month for 5 months. (We pay delivery if you send \$7.50 first payment WITH coupon; same return privilege.)

Name Street City Zone State Employed by RTN-3 This offer applies to U. S. only

READ RADIO & TELEVISION NEWS Every Month

7.155 in English to Great Britain, Ireland 1644. (Ferguson, N. C.) Heard to South, East Africa 2300-0010 on 15.130, 11.870; to Far East on Sat., Sun. in English 0715-0730 over 9.670, 7.155, very strong signals in Tokyo. (Wada, Japan) Heard in French 1500 over 4.940. (Buggins, England) Noted in Calif. on 6.075 from around 0930 to after 1000 with English announcements. (Morgan, Balbi, Calif.)

Indo-China (Vietnam)—"The Voice of Vietnam," 9.620, has English 0930; Radio Dalat, 7.265, has French 0630-0730, closes 0745 with interval signal by native instrument; Radio Hue, 7.205, is heard 0815-0900 in French and with music, then closes with National Anthem. (Japanese Short Wave Club) Radio France-Asie, Saigon, is heard on 9.750A to Europe in French 1035-1100, then English to 1130A when closes with "La Marseillaise." (Pearce, England; Mesquita e Sousa, Portugal, others)

Iran—Radio Sanandaj broadcasts on 6.755 from 0830; heard in Germany. (ISWC, London)

Israel—Tel Aviv, 9.009A, opens 1415. (Nblack, Ind.) Sent verification form letter and listed "Voice of Zion" relay in English 1615-1700. (Lusty, Ont.) 4XB44, "Galei Zahal," heard at fair level 1345 on 6.705A with Western music. (Nattugglan, Sweden)

Italy—Rome noted on 7.290 signing on English 1330 to Great Britain; said parallel over 15.400, 11.80. (Pearce, England) Noted in English to North America from 1920A on 9.575. (Geiselbrecht, Texas; Zerosh, Pa., others) On 11.810 with news 1330-1345, good level. (Saylor, Va.) With news 2130-2145 on 7.290. (Zerosh, Pa.) Rome closes 0435 to Australia, New Zealand on 21.560, but opens again 0450 in Indonesian. (Gillett, Australia)

the sensational ADAPHONE

... It's a remote control SILENT LISTENER ... It's a Hi-Fi extension HEARING AID



At last... a precision instrument that brings radio and TV listening pleasure to the hard of hearing, without raising the normal loudspeaker volume And perfect for normal hearing folks who want to watch TV or listen to radio without any sound to annoy others. List Price \$19.95 complete. Write Dept. RN-3 for illustrated literature.



ADAPHONE is easily attached to any TV or radio set. Enables the hard of hearing to hear programs perfectly without disturbance to other listeners.

FENTON COMPANY 15 Moore Street • New York 4, N. Y.

When Answering Advertisements Say You Saw It In RADIO & TELEVISION NEWS

—RECEIVING TUBES—

| Type | Price | Type | Price | Type | Price | Type | Price | Type | Price | Type | Price | | | | | | | | |
|-----------|-------|--------|-------|-------|-------|--------|-------|-------|-------|------|-------|--------|-----|---------|-----|-------|-------|--------|------|
| 0A2 | .89 | 2A6 | .49 | 6BZ7 | .85 | 6K8 | .69 | 6SQ7 | .41 | 7M7 | .59 | 12BE6 | .49 | 12SN7GT | .58 | 47 | .89 | 1B24 | 1.90 |
| 0A3/VR75 | .99 | 2A7 | .64 | 6C4 | .37 | 6K8G | .65 | 6SR7 | .45 | 7J7 | .75 | 12B7 | .45 | 49 | .39 | 1N23 | 1.95 | 31 | 1.90 |
| 0A4G | .65 | 2B7 | .52 | 6C4 | .58 | 6L5G | .79 | 6S57 | .45 | 7K7 | .57 | 12B7V | .75 | 50 | .87 | 2C40 | 6.95 | 32L7GT | 2.95 |
| 0B2 | .39 | 3A4 | .44 | 6C5G | .45 | 6L6 | .72 | 6S7 | .45 | 7L7 | .69 | 12B7 | .71 | 51 | .87 | 2C44 | .89 | 34 | .89 |
| 0B3/VR90 | .95 | 2X2A | 1.15 | 6C6 | .45 | 6L6C | .69 | 6T7G | .79 | 7M7 | .62 | 12C8 | .39 | 52 | .87 | 2D21 | 1.09 | 35C5 | .37 |
| 0C3/VR105 | .98 | 3A4 | .44 | 6C8G | .85 | 6L6GA | .69 | 6T8 | .65 | 7Q7 | .56 | 12E8GT | .69 | 53 | .87 | 3D21A | 1.75 | 35W4 | .33 |
| 0D3/VR150 | .83 | 3A5 | .60 | 6D6 | .45 | 6L7G | .59 | 6U7G | .40 | 7B4 | .58 | 12F5 | .49 | 54 | .87 | 3D21B | 7.95 | 35Z5GT | .35 |
| 0E | .48 | 3A8 | .60 | 6D6 | .57 | 6L7 | .79 | 6U7 | .40 | 7B4 | .58 | 12F5GT | .49 | 55 | .87 | 3D21C | 14.50 | 36 | .39 |
| 1A4P | .39 | 3B7 | .39 | 6E5 | .98 | 6N7G | .62 | 6V6GT | .39 | 7V7 | .85 | 12G7 | .58 | 56 | .87 | 3D21D | 2.85 | 37 | .39 |
| 1A5GT | .46 | 3C4 | .44 | 6F5 | .45 | 6R7 | .49 | 6W4 | .45 | 7W7 | .85 | 12K7 | .58 | 57 | .87 | 3D21E | 1.75 | 39 | .39 |
| 1A6 | .39 | 3LF4 | .79 | 6G5 | .45 | 6R7 | .49 | 6W4 | .45 | 7W7 | .85 | 12K7GT | .58 | 58 | .87 | 3D21F | 2.21 | 39/44 | .45 |
| 1A7 | .44 | 3Q4 | .44 | 6G6 | .45 | 6S7 | .45 | 6X7 | .35 | 7Y7 | .91 | 12J7GT | .58 | 59 | .87 | 3D21G | 4.49 | 42 | .41 |
| 1A8S | .39 | 3SQ5GT | .44 | 6G6 | .45 | 6S7 | .45 | 6X7 | .35 | 7Y7 | .91 | 12J7GT | .58 | 60 | .87 | 3D21H | 7.90 | 43 | .41 |
| 1A9 | .51 | 3S5 | .43 | 6G6 | .45 | 6S7 | .45 | 6X7 | .35 | 7Y7 | .91 | 12J7GT | .58 | 61 | .87 | 3D21I | 7.50 | 44 | .41 |
| 1B3 | .49 | 3V4 | .44 | 6G6 | .45 | 6S7 | .45 | 6X7 | .35 | 7Y7 | .91 | 12J7GT | .58 | 62 | .87 | 3D21J | 4.85 | 46 | .49 |
| 1B5 | .26 | 5T4 | 1.28 | 6G6 | .45 | 6S7 | .45 | 6X7 | .35 | 7Y7 | .91 | 12J7GT | .58 | 63 | .87 | 3D21K | 2.50 | 48 | .49 |
| 1C5GT | .45 | 5AR4 | .82 | 6C4 | .37 | 6K8G | .65 | 6SR7 | .45 | 7J7 | .75 | 12B7 | .45 | 49 | .39 | 4A6A | 2.40 | 50 | .49 |
| 1C6 | .35 | 5V4G | .82 | 6C4 | .58 | 6L5G | .79 | 6S57 | .45 | 7K7 | .57 | 12B7V | .75 | 50 | .87 | 4A6B | 3.40 | 51 | .87 |
| 1C7G | .39 | 5W4 | .45 | 6C5G | .45 | 6L6 | .72 | 6S7 | .45 | 7L7 | .69 | 12B7 | .71 | 51 | .87 | 4A6C | 3.50 | 52 | .87 |
| 1D5GT | .44 | 5K4 | .45 | 6C6 | .45 | 6L6C | .69 | 6T7G | .79 | 7M7 | .62 | 12C8 | .39 | 52 | .87 | 4A6D | 1.50 | 53 | .87 |
| 1D7GT | .39 | 5Z3 | .36 | 6C8G | .85 | 6L6GA | .69 | 6T8 | .65 | 7Q7 | .56 | 12E8GT | .69 | 53 | .87 | 4A6E | 6.50 | 54 | .87 |
| 1D8GT | .77 | 5Z4 | 1.03 | 6C9G | .85 | 6L6GA | .69 | 6T8 | .65 | 7Q7 | .56 | 12E8GT | .69 | 54 | .87 | 4A6F | .58 | 55 | .87 |
| 1E4 | .29 | 6A6 | .47 | 6C9G | .85 | 6L6GA | .69 | 6T8 | .65 | 7Q7 | .56 | 12E8GT | .69 | 55 | .87 | 4A6G | 2.50 | 56 | .87 |
| 1E7GP | .35 | 6A7 | .82 | 6D5 | .98 | 6N7G | .62 | 6V6GT | .39 | 7V7 | .85 | 12K7 | .58 | 56 | .87 | 4A6H | 1.90 | 57 | .87 |
| 1F4 | .78 | 6A8 | .66 | 6D6 | .45 | 6S7 | .45 | 6X7 | .35 | 7Y7 | .91 | 12J7GT | .58 | 57 | .87 | 4A6I | 2.90 | 58 | .87 |
| 1F5G | .34 | 6B4 | .49 | 6D6 | .45 | 6S7 | .45 | 6X7 | .35 | 7Y7 | .91 | 12J7GT | .58 | 58 | .87 | 4A6J | .39 | 59 | .87 |
| 1G4GT | .34 | 6B7 | .75 | 6D6 | .45 | 6S7 | .45 | 6X7 | .35 | 7Y7 | .91 | 12J7GT | .58 | 59 | .87 | 4A6K | 1.10 | 60 | .87 |
| 1G6GT | .45 | 6B8 | .99 | 6D6 | .45 | 6S7 | .45 | 6X7 | .35 | 7Y7 | .91 | 12J7GT | .58 | 60 | .87 | 4A6L | 7.50 | 61 | .87 |
| 1H4G | .25 | 6AC7 | .72 | 6D6 | .45 | 6S7 | .45 | 6X7 | .35 | 7Y7 | .91 | 12J7GT | .58 | 61 | .87 | 4A6M | 9.90 | 62 | .87 |
| 1H5GT | .48 | 6AF4 | .88 | 6D6 | .45 | 6S7 | .45 | 6X7 | .35 | 7Y7 | .91 | 12J7GT | .58 | 62 | .87 | 4A6N | 9.90 | 63 | .87 |
| 1H6GT | .38 | 6AF5 | .88 | 6D6 | .45 | 6S7 | .45 | 6X7 | .35 | 7Y7 | .91 | 12J7GT | .58 | 63 | .87 | 4A6O | 9.90 | 64 | .87 |
| 1J6G | .65 | 6AC5 | .40 | 6D6 | .45 | 6S7 | .45 | 6X7 | .35 | 7Y7 | .91 | 12J7GT | .58 | 64 | .87 | 4A6P | 9.90 | 65 | .87 |
| 1J6GT | .65 | 6AG7 | .95 | 6M6 | .49 | 6SA7 | .49 | 6T7 | .49 | 6T7 | .49 | 6T7 | .49 | 65 | .87 | 4A6Q | 9.90 | 66 | .87 |
| 1L4 | .43 | 6A15 | 1.49 | 6M6GT | .55 | 6S7 | .45 | 6X7 | .35 | 7Y7 | .91 | 12J7GT | .58 | 66 | .87 | 4A6R | 9.90 | 67 | .87 |
| 1L4 | .74 | 6A5 | .55 | 6J5 | .49 | 6S7 | .45 | 6X7 | .35 | 7Y7 | .91 | 12J7GT | .58 | 67 | .87 | 4A6S | 9.90 | 68 | .87 |
| 1L6 | .79 | 6A5S | .36 | 6J5GT | .38 | 6S07GT | .35 | 7A07 | .35 | 7A07 | .35 | 7A07 | .35 | 68 | .87 | 4A6T | 9.90 | 69 | .87 |
| 1L8A | .79 | 6A5S | .36 | 6J5 | .49 | 6S7 | .45 | 6X7 | .35 | 7Y7 | .91 | 12J7GT | .58 | 69 | .87 | 4A6U | 9.90 | 70 | .87 |
| 1L8B | .79 | 6A5S | .36 | 6J5 | .49 | 6S7 | .45 | 6X7 | .35 | 7Y7 | .91 | 12J7GT | .58 | 70 | .87 | 4A6V | 9.90 | 71 | .87 |
| 1L8S | .79 | 6A5S | .36 | 6J5 | .49 | 6S7 | .45 | 6X7 | .35 | 7Y7 | .91 | 12J7GT | .58 | 71 | .87 | 4A6W | 9.90 | 72 | .87 |
| 1L8C | .79 | 6A5S | .36 | 6J5 | .49 | 6S7 | .45 | 6X7 | .35 | 7Y7 | .91 | 12J7GT | .58 | 72 | .87 | 4A6X | 9.90 | 73 | .87 |
| 1L8D | .79 | 6A5S | .36 | 6J5 | .49 | 6S7 | .45 | 6X7 | .35 | 7Y7 | .91 | 12J7GT | .58 | 73 | .87 | 4A6Y | 9.90 | 74 | .87 |
| 1L8E | .79 | 6A5S | .36 | 6J5 | .49 | 6S7 | .45 | 6X7 | .35 | 7Y7 | .91 | 12J7GT | .58 | 74 | .87 | 4A6Z | 9.90 | 75 | .87 |
| 1L8F | .79 | 6A5S | .36 | 6J5 | .49 | 6S7 | .45 | 6X7 | .35 | 7Y7 | .91 | 12J7GT | .58 | 75 | .87 | 4A6A | 9.90 | 76 | .87 |
| 1L8G | .79 | 6A5S | .36 | 6J5 | .49 | 6S7 | .45 | 6X7 | .35 | 7Y7 | .91 | 12J7GT | .58 | 76 | .87 | 4A6B | 9.90 | 77 | .87 |
| 1L8H | .79 | 6A5S | .36 | 6J5 | .49 | 6S7 | .45 | 6X7 | .35 | 7Y7 | .91 | 12J7GT | .58 | 77 | .87 | 4A6C | 9.90 | 78 | .87 |
| 1L8I | .79 | 6A5S | .36 | 6J5 | .49 | 6S7 | .45 | 6X7 | .35 | 7Y7 | .91 | 12J7GT | .58 | 78 | .87 | 4A6D | 9.90 | 79 | .87 |
| 1L8J | .79 | 6A5S | .36 | 6J5 | .49 | 6S7 | .45 | 6X7 | .35 | 7Y7 | .91 | 12J7GT | .58 | 79 | .87 | 4A6E | 9.90 | 80 | .87 |
| 1L8K | .79 | 6A5S | .36 | 6J5 | .49 | 6S7 | .45 | 6X7 | .35 | 7Y7 | .91 | 12J7GT | .58 | 80 | .87 | 4A6F | 9.90 | 81 | .87 |
| 1L8L | .79 | 6A5S | .36 | 6J5 | .49 | 6S7 | .45 | 6X7 | .35 | 7Y7 | .91 | 12J7GT | .58 | 81 | .87 | 4A6G | 9.90 | 82 | .87 |
| 1L8M | .79 | 6A5S | .36 | 6J5 | .49 | 6S7 | .45 | 6X7 | .35 | 7Y7 | .91 | 12J7GT | .58 | 82 | .87 | 4A6H | 9.90 | 83 | .87 |
| 1L8N | .79 | 6A5S | .36 | 6J5 | .49 | 6S7 | .45 | 6X7 | .35 | 7Y7 | .91 | 12J7GT | .58 | 83 | .87 | 4A6I | 9.90 | 84 | .87 |
| 1L8O | .79 | 6A5S | .36 | 6J5 | .49 | 6S7 | .45 | 6X7 | .35 | 7Y7 | .91 | 12J7GT | .58 | 84 | .87 | 4A6J | 9.90 | 85 | .87 |
| 1L8P | .79 | 6A5S | .36 | 6J5 | .49 | 6S7 | .45 | 6X7 | .35 | 7Y7 | .91 | 12J7GT | .58 | 85 | .87 | 4A6K | 9.90 | 86 | .87 |
| 1L8Q | .79 | 6A5S | .36 | 6J5 | .49 | 6S7 | .45 | 6X7 | .35 | 7Y7 | .91 | 12J7GT | .58 | 86 | .87 | 4A6L | 9.90 | 87 | .87 |
| 1L8R | .79 | 6A5S | .36 | 6J5 | .49 | 6S7 | .45 | 6X7 | .35 | 7Y7 | .91 | 12J7GT | .58 | 87 | .87 | 4A6M | 9.90 | 88 | .87 |
| 1L8S | .79 | 6A5S | .36 | 6J5 | .49 | 6S7 | .45 | 6X7 | .35 | 7Y7 | .91 | 12J7GT | .58 | 88 | .87 | 4A6N | 9.90 | 89 | .87 |
| 1L8T | .79 | 6A5S | .36 | 6J5 | .49 | 6S7 | .45 | 6X7 | .35 | 7Y7 | .91 | 12J7GT | .58 | 89 | .87 | 4A6O | 9.90 | 90 | .87 |
| 1L8U | .79 | 6A5S | .36 | 6J5 | .49 | 6S7 | .45 | 6X7 | .35 | 7Y7 | .91 | 12J7GT | .58 | 90 | .87 | 4A6P | 9.90 | 91 | .87 |
| 1L8V | .79 | 6A5S | .36 | 6J5 | .49 | 6S7 | .45 | 6X7 | .35 | 7Y7 | .91 | 12J7GT | .58 | 91 | .87 | 4A6Q | 9.90 | 92 | .87 |
| 1L8W | .79 | 6A5S | .36 | 6J5 | .49 | 6S7 | .45 | 6X7 | .35 | 7Y7 | .91 | 12J7GT | .58 | 92 | .87 | 4A6R | 9.90 | 93 | .87 |
| 1L8X | .79 | 6A5S | .36 | 6J5 | .49 | 6S7 | .45 | 6X7 | .35 | 7Y7 | .91 | 12J7GT | .58 | 93 | .87 | 4A6S | 9.90 | 94 | .87 |
| 1L8Y | .79 | 6A5S | .36 | 6J5 | .49 | 6S7 | .45 | 6X7 | .35 | 7Y7 | .91 | 12J7GT | .58 | 94 | .87 | 4A6T | 9.90 | 95 | .87 |
| 1L8Z | .79 | 6A5S | .36 | 6J5 | .49 | 6S7 | .45 | 6X7 | .35 | 7Y7 | .91 | 12J7GT | .58 | 95 | .87 | 4A6U | 9.90 | 96 | .87 |
| 1L9A | .79 | 6A5S | .36 | 6J5 | .49 | 6S7 | | | | | | | | | | | | | |

Jamaica—Radio Jamaica, 3.36, is good level to 2300 closedown; at times has QRM. (Jannis, S. C.)

Japan—The 7.180 outlet of Radio Japan is heard 0030 with news. (Tandrow, Calif.) Also good on 9.695 in parallel. (Stein, Calif.) When this was compiled, Radio Japan was being heard on 11.725 in Eastern USA in beam to South America 1700-1800 in Spanish, Portuguese, Japanese. (Ferguson, N. C.; Niblack, Ind., others) JBD3, 15.225, is fair 2200 to 2300 sign-off, in Japanese. (Morgan, Calif.)

Kenya Colony—VQ7LO, 4.855, Nairobi, is heard 1000-1500; 1300 BBC news relay; 1315 local news, then music; leaves air 1400 Sun. (ISWC, London)

Lebanon—Radio Beirut, 8.036, noted from 1415 tune-in to 1500 with Arabic, then music; news in Arabic 1520-1530 sign-off (Sun.) with National Anthem. (Saylor, Va.)

Libya—The Forces Broadcasting Service, Benghazi, has been using 0.5 kw. on 4.782 and 4.965; further tests with 7.5 kw. were to begin soon; scheduled 0000-1600; QRA for reports is FBS, Middle East No. 5, Benghazi, Cyrenaica-Libya. (ISWC, London) In verifying, asked for further reports; not audible lately. (Pearce, England)

Malaya—BFEB5, 11.820, noted to around 0900. (Stark, Texas) With news 0430. (Balbi, Calif.)

Mexico—XEVC, 9.630A, Mexico City, announces "XEV y XEVC, La Voz y Expression de Mejico," has news in Spanish weekdays 2315. (Kahan, Calif.)

Mozambique—CR7BU, 4.920, Lourenco Marques, is heard in the United Kingdom to 1600 (Sat. to 1700) through heavy CWQRM; CR7BV, 4.872A, has programs in Portuguese 1300-1615. (ISWC, London) News in Portuguese noted on this one 1500. (Mesquita e

Sousa, Portugal) The 11.742AV channel is being heard again from 2300 in English. (Niblack, Ind.)

Nicaragua—YNBH, 6.547, Radio Panamericana, noted going past 2405 lately. (Stark, Texas)

Norway—Radio Norway, 11.735, noted Sun. with English ("Norway This Week") 1200-1215A. (Roemer, Ky.) Heard on 11.850A at 1050-1100 with church music (Karrer, Pa.) Good level on 7.210 at 2000-2100. (Zerosh, Pa.)

Okinawa—The VOA relay is now scheduled over 6.145 at 0500-0945 to China-Korea. Noted by Ballou, Calif., strong at 0555 on measured 6.1463.

Pakistan—Radio Pakistan, 17.710, noted with news 0330. (Cushen, N. Z.) Heard over 7.010, 6.235 with slow-speed news 1310-1330, opening on these channels 1445 to Turkey. (Pearce, England) Heard on 5.990A with news 1015. (Morgan, Calif.)

Panama—HOLA, 9.505, Colon, noted in English 1630. (Jannis, S. C.) Radio Baru, David, is still on 6.045 and goes past 2045. (Stark, Texas)

Peru—Radio Nacional del Peru, OAX4R, 15.150A, Lima, has special broadcast to Europe and North America 1200-1400 and requests reports; announces in English, French, Spanish. (ISWC, London) Heard closing on OAX4T, 9.562, at 2400 in Spanish, English, French, followed by National Anthem. (Smith, Ga., others)

Philippines—DZH7, 9.73, Manila, heard as early as 0100, signing off 0145 and returning around 0245; DZH9, 11.855, audible with fair level then. (Balbi, Calif.) DZH5, 9.69, noted at nice level with news 0615. (Saylor, Va.)

Poland—Radio Warsaw noted near 5.93 and 6.192 (varies as high as 6.197) with news 1730-1800; with English 1400, 1500 on 6.025. (Pearce, England)

The RCA Color TV Dynamic Demonstrator, which will be used by the RCA Service Company to explain the operation and servicing of color TV to service technicians, is shown here as it was unveiled at the Chicago convention of the National Alliance of Television & Electronic Service Associations. Mr. E. R. Klingemann who helped develop this working model of a color TV set into which troubles may be introduced and their effect on the picture demonstrated, is shown as he lectured to an audience of 300 service technicians.



New replacement control
helps you provide hi-fi reproduction
at low-volume levels



Centralab's new

**SENIOR
COMPENTROL***
with level-set

**Combination volume control
and Printed Electronic Circuit***

**There's nothing else like it for
improving tone performance**

Now, Centralab's new Senior Compentrol with level-set lets your customer control bass and treble range to suit himself — something he cannot do with an ordinary compensated volume control. A universal unit, Senior Compentrol replaces any value without additional amplification. You install it easily and quickly — make money on the job.

Be set to cash in on today's increasing awareness of tonal qualities by your customers. Get several Senior Compentrols from your Centralab distributor — net price, \$4.50.

Centralab also has a Junior Compentrol. It is furnished in 1/2 and 1 meg., plain and switch types, for use in radio sets (5 or more tubes, AC or DC), audio amplifiers, or phono combinations.

Send coupon for 20-page booklet 42-182 telling the whole Compentrol story — or Centralab Catalog 28.

Centralab
*Trademark

CENTRALAB,
A Division of Globe-Union Inc.
910C E. Keefe Avenue, Milwaukee 1, Wisconsin
 Send Catalog 28.
 Send Compentrol bulletin 42-182.

Name _____
Company _____
Address _____
City _____ Zone _____ State _____

**FOR THOSE WHO SEEK THE ULTIMATE
IN HIGH FIDELITY CABINETS**

**Your Music System
Housed Within A Furniture Setting**

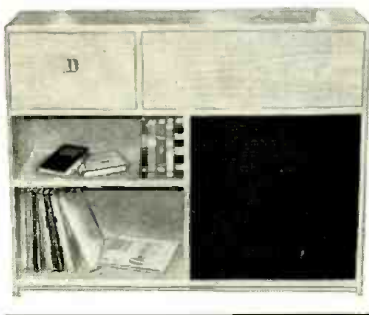

Handsomely styled in the finest woods, both models are available in Mahogany on Birch, Natural Birch or Unfinished Birch.

Here's a bookcase cabinet that provides ample room for the housing of a record changer, tuner, amplifier and speaker... plus a music library.

MODEL 90: Overall dimensions: 35 1/2" H., 48" W., 16" D. Tuner compartment: 11" H., 29" W., 15" D. Baffle area: 5 cu. ft.

MODEL 91: Similar in size to Model 90. Contains adjustable record shelves in place of speaker baffle at no extra charge.

Finished **\$125*** net
White Birch—Unfinished **\$96*** net

*Net prices, slightly higher West and South

Precision Manufactured High Fidelity Cabinets of Character

G & H WOOD PRODUCTS CO.
75 NORTH 11th STREET, BROOKLYN 11, N.Y.



PIONEERS IN RADIO FURNITURE FOR HIGH FIDELITY EQUIPMENT

New Guaranteed TUBES Standard Brands

| | | | | | |
|-----------|--------|-----------|-------|----------|-------|
| 0A2 | \$0.90 | 3C45 | 12.50 | 726A | 12.00 |
| 0A3 VR75 | 1.10 | 3E29 | 11.95 | 801A | .49 |
| 0A4G | 1.00 | 3FP7 | 1.75 | 802 | 2.95 |
| 0B2 | 1.10 | 3GP4 | 3.95 | 803 | 3.95 |
| 0C2 VR105 | .95 | 5Y7 | 3.95 | 804 | 10.95 |
| 003 VR150 | .85 | 4C27 | 9.50 | 805 | 3.25 |
| 1A3 | 1.00 | 4C28 | 35.00 | 807 | 1.65 |
| 1B23 | 8.50 | 4C35 | 19.50 | 811 | 2.90 |
| 1B24 | 9.50 | 4-125A | 22.50 | 812 | 3.50 |
| 1B27 | 12.50 | 4K150A | 27.50 | 813 | 10.95 |
| 1D21 5N4 | 4.50 | 5B1 | 4.50 | 814 | 2.95 |
| 1N21B | 2.50 | 5C22 | 37.50 | 829 | 8.95 |
| 1N22 | 1.25 | 5FP7 | 1.95 | 829B | 9.95 |
| 1N23 | 1.25 | 5R4GY | 1.25 | 830B | 2.75 |
| 1N23B | 3.25 | 5R4WG | 2.25 | 832A | 8.95 |
| 1N34A | .75 | 6AK5 | .89 | 833A | 27.50 |
| 1N38 | 1.50 | 6AL5W | 1.50 | 836 | 3.50 |
| 1N63 | 2.15 | 6A57C | 3.50 | 837 | 1.45 |
| 1N69 | .69 | 6SN7WGT | 1.75 | 866A | 1.20 |
| 2C39 | 12.50 | 15E | 12.50 | 872A | 2.95 |
| 2C40 | 7.50 | 15R | 7.79 | 884 | 1.25 |
| 2C51 | 4.25 | FC57 | 14.95 | 931A | 5.50 |
| 2D21 | 1.25 | KK60 1641 | 2.25 | 954 | .33 |
| 2E22 | 2.75 | 100TH | 9.50 | 955 | .49 |
| | | | | 956 | .49 |
| | | | | 957 | .49 |
| | | | | 958A | .69 |
| | | | | 959 | 1.95 |
| | | | | 991 | .39 |
| | | | | 1005 | 1.69 |
| | | | | 50-32006 | 1.95 |
| | | | | 1616 | .90 |
| | | | | 1625 | .39 |
| | | | | 1626 | .39 |

SPECIAL Vacuum Capacitors

| | |
|--------|---------|
| 50-15 | \$ 7.50 |
| 50-32 | 12.50 |
| 12-32 | 10.00 |
| 100-20 | 14.50 |

| | | | | | |
|----------|--------|-----------|-------|-------|------|
| 2E24 | 4.65 | 250TH | 16.50 | 2050 | 1.30 |
| 2E25A | 4.50 | 304TL | 7.95 | 2051 | 1.10 |
| 2K25 | 26.50 | 307A RK75 | 3.95 | 5670 | 1.50 |
| 2E26 | 2.95 | 393A | 6.95 | 5702 | 2.95 |
| 2K28 | 28.50 | 394A | 3.95 | 5718 | 5.95 |
| 2K45 | 110.00 | 446A | 1.19 | 5726 | 2.00 |
| 2K48 | 95.50 | 701A | 4.50 | 5814 | 1.75 |
| 3A4 | .75 | 703A | 3.50 | 5844 | 4.50 |
| 3A5 | 1.25 | 705A | 1.50 | 8012 | 1.95 |
| 3B22 | 2.95 | 707B | 13.95 | 8025A | 4.95 |
| 3B24 | 4.75 | 715B | 7.50 | 9001 | 1.25 |
| 3B26 | 3.50 | 717A | .90 | 9002 | .98 |
| 3C24 24G | 1.50 | 723A B | 16.95 | 9025 | .98 |
| 3C33 | 12.50 | 724B | 2.75 | 9003 | 1.50 |

Complete line of Receiving Tubes. Thousands of other types of Transmitting Tubes. If you don't see it, WRITE. Prices subject to change without notice. Californians add sales tax. Add postage to order. Minimum order—\$3.00.

VEEDER ROOT COUNTER

S figure. Adds ten for each revolution of shaft in one direction; subtracts ten for each revolution in opposite direction. Size 3 1/2" x 1 1/2" dovetail mounting; lever arm removable.



ONLY **1.25** ea.
Quantity Discounts

FREE! Write for new complete Catalog just off presses.



ELECTRONICS
Dept. R-B
7552 Melrose Ave.
Los Angeles 46,
California

STOP VOLUME CONTROL NOISE!

"NO NOISE"

New 6 oz. Spray Can

Net to Servicemen **\$2.25**

CONTAINS AMAZING NEW **PERMA-FILM**

- ★ CLEANS! ... dirt and oxidation immediately on contact.
- ★ LUBRICATES! ... one drop eliminates scratch, hum and noise.
- ★ PROTECTS! ... assures continued top performance.

Perfect Contact Restorer—cleans & restores volume controls, band switches, push button assemblies, electrical contacts. NO NOISE is not a carbon tet solution.

"NO NOISE"

2 oz. bottle. Net to Servicemen **\$1.00**

Available in 8 oz. bottles and quart cans. Nearest distributor—or write

ELECTRONIC CHEMICAL CORP.
813 Communipaw Ave., Jersey City 4, N. J.

Heard opening 1501 on 6.195 with *English* for Europe, fair level. (Bellington, N. Y.)

Portugal—Lisbon, 6,374, noted 1700-1830 with Portuguese news, music. (Zerosh, Pa.) Overseas Service is now scheduled 0600-0800, 0945-1200, 15.030; 1230-1530, 11.836, 11.996; 1600-1830, 11.960, 11.996; 1900-2100, 5.976, 6.374, 9.746. (WRH) Heard recently on 9.795A around 1340 parallel 9.740. (Earnhardt, N. C.; Bellington, N. Y.)

Portuguese India—Radio Goa, 9.610, now seems to have "The Catholic Hour" in *English daily* 1100-1130; closes down 1230. (Pearce, England)

Portuguese Guinea—CQM, Bissau, has been reported heard in Sweden and Belgium testing on 9.380 from 1640 to 1800 closedown. (Radio Sweden)

Reunion—St. Denis is using 4.820, 7.170 in French 2130-2245, 0300-0430, 0900-1330 weekdays, and 2300-0000, 0130-0530, 0900-1330 Sun. (Scheiner, N. J.)

Roumania—Radio Bucharest, 9.254A, noted 1447 with news by man and woman. (Ferguson, N. C.) Heard opening on 9.57 at 1200 preceded by interval signal and a long march sung by chorus; then appeared to use Roumanian. Heard with *English* 2200-2230 to North America; good level but with bad QRM at times. (Saylor, Va.; Bellington, N. Y.)

Sao Tome—Radio Clube de Sao Tome e Principe, CR5SB, 17.677A, noted Sun. 0700-0800, very weak level in Portuguese. (Mesquita e Sousa, Portugal) CR5SC, 4.807, heard 1530-1600 closedown. (Miemois, Finland)

South Africa—SABC noted "calling Africa" closing 1535 on 11.937; news 1500. (Pearce, England)

Spain—FET1, 7.006, Valladolid, noted 1815 with variety program of music; faded out before 1830; all-Spanish; "Transmite Emisora La Radio Puerto Santa Maria," 7.210A, noted 1740 with varied recordings. (Pearce, England) Madrid, 9.363, noted with *English* to North America 2215-2245A. (Irvine, Texas, others) And 1800-1840A. (Parrish, Ga.; Connelly, O., others) A new station is Radio Falange de Villanueva, 7.015, at 1500-1615; relays news in Spanish from Madrid at 1600. (WRH)

Sweden—Radio Sweden, 7.210, noted 1300 with *English* for Africa. (Pearce, England) Heard with news 1930 over 6.065. (Roemer, Ky., others)

Switzerland—Home Service noted over HER22, 3.985, at 1645 with music. Noted opening in *English* to Great Britain, Ireland 1345 on 6.055, 9.665. (Pearce, England) This beam is heard well 1345-1530 closedown over the 9.665 outlet. (Smits, Minn., others) The 11.865 outlet noted opening 1015 at good level. (Welch, Mass.) The 9.535 channel is noted 1325 with news in German. (Saremba, Va.)

Taiwan—"Voice of Free China," Taipei, noted on 11.735 in *English* 0045 asking for reception reports. (Gillett, Australia) Taipei, 9.785, heard with Western music 0500-0600, good level. (Balbi, Calif.)

Tangier—Radio Africa, 7.193, noted

with Spanish songs 1700; intermittent QRM. (Pearce, England) *Pan American Radio* uses 1178 kc., 7.290 at 0400-2000 in six languages. (WRH)

Thailand—Radio Thailand, 11.670, noted 0855 with Home Service relay; closes 0920. (Pearce, England) With news 0500-0520, in Overseas Service, then with program for Thai Forces in Korea. (Churchill, Calif., others) The North American transmission on 11.670 at 2315-0015 is audible in Australia. (*Radio Australia*) This transmission is seldom if ever heard in North America, however.

Trieste—British Forces Station, 15.125, is heard in Sweden around 1500.

Trinidad—Radio Trinidad, 6.085, Port-of-Spain, noted with popular recordings, time checks 0505-0525. (Morris, Pa.) Lists this outlet at 0500-1700; 3.275 at 0500-2200. (Hardwick, N. Z.)

Vatican—HVJ, 11.685, is coming in fair to good with *English* 1000-1015; and on Tue. only with further *English* 1030-1045 (to India, Pakistan, Ceylon). (Miller, Ga., Saylor, Va., others) Noted closing 0545 on 21.740, very good level; schedule on this channel seems *irregular*. (Gillett, Australia) Noted on 9.646A with *English* 1315-1330, good level but with QRM. (Niblack, Ind.)

Venezuela—YVLK, 4.970, Caracas, *Radio Rumbos*, noted closing 2230 with National Anthem; on Mon., Thurs., at 2230 has "Luz de Luna y Sombras." (Kahan, Calif.) YVMF, 4.800, Maracaibo, noted 2230 closing with *English* and Spanish announcements, says "Goodnight, God bless you, and very happy dreams;" asks for reception reports. (Niblack, Ind.) YVMQ, *Radio Barquisimeto*, 4.940, noted 1935 with heavy QRM. (Hill, Mass.)

Yugoslavia—Radio Yugoslavia is using 6.100, 7.200 at 1645 with news. Recently tested on 6.100 at 0400-0800. (Pearce, England) Heard 2230 with strong signal in Texas. (Frazier)

Special DX Broadcast

At press time, tentative arrangements had been made for your short-wave editor, Ken Boord, to present a program of Passion Week and Easter organ melodies, by tape transcription, in a special DX broadcast dedicated to short-wave listeners throughout the world. The program will be aired over TGNA ("Telling the Good News Abroad"), the radio voice of the Central American Mission, Apartado 601, Guatemala City, Guatemala, Central America, at 2315-2345 EST on Saturday, April 17 (Easter Sunday, April 18, 0415-0445 GMT), over TGNE, 9.668, and TGNC, 11.850.

Harold Van Broekhoven, director of TGNA, airmails that *all correct reception reports will be verified by a QSL card and a mimeographed letter which tells of the work of TGNA—sent by airmail.* "We appreciate it when the listener encloses an IRC," he says, "but we will not make this a requirement."

* * *

Press Time Flashes

A station in Arabic noted on 11.720

MARCH, 1954

TRAIN *for* TELEVISION

in 3 easy steps!
Learn more to earn more!

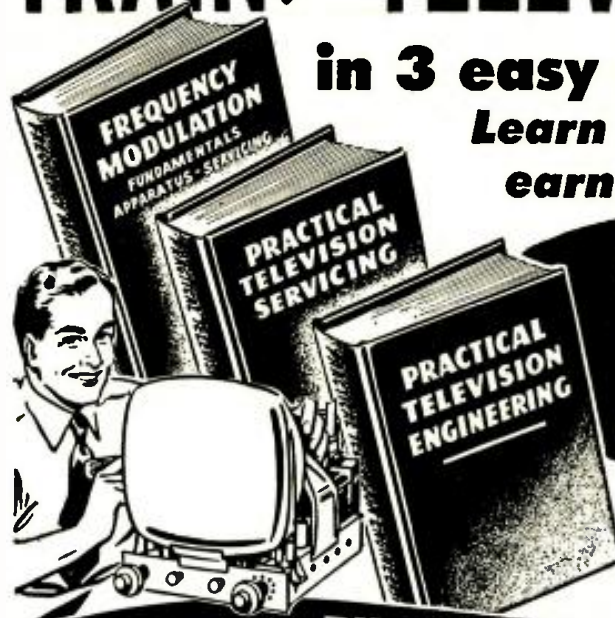

ONLY \$15.50

for the complete training (all 3 books)

5 Months to Pay!

The famous RINEHART TV LIBRARY

●1—FREQUENCY MODULATION (F-M) The "heart" of TV sound

This essential book gives you complete training in F-M . . . the subject so frequently neglected in Television training and whose problems so often "stumps" service technicians. F-M, of course, is the system used for TV sound and on which many other developments are based. You learn all about F-M control circuits, receivers, transmitters, mobile equipment, detectors, amplitude limiters, antennas, etc. Clear explanations of F-M test equipment and how to use it are invaluable to busy service men. Book sold for \$5.00 if bought separately. Use coupon.

●2—PRACTICAL TV SERVICING

What to do . . . how to do it

After studying this famous book, you'll find even the most puzzling TV servicing problems greatly simplified. You'll work better, faster—more profitably! Actual service case histories make things amazingly clear. Dozens of illustrations and pattern photos explain details step by step. You learn how TV differs from radio, how receivers operate and, above all, how to service them properly. Other subjects include wiring details, component replacement data, testing tips, fringe area reception hints, improving picture linearity and dozens of other vital TV service subjects. Price \$4.00 if bought separately. Use coupon.

●3—PRACTICAL TV ENGINEERING

Basic training for the "big money" field

The "know-how" so clearly presented in this big 700-page book can help you forge quickly ahead of the average student! In particular, it takes you right into the TV station, outlines broadcasting problems, shows how the work is done . . . from camera chains to lighting . . . from the cathode ray tube to oscilloscopes . . . from video amplifiers to power supplies . . . from ordinary transmission and reception to the very latest UHF, VHF and color television developments. Ideal for general TV training . . . a "MUST" for those who hope to enter the glamorous field of telecasting. 385 illustrations. Price \$7.50 separately.

**RECEIVERS... TRANSMITTERS...
FM . . . COLOR and dozens of other subjects**

Good training for television doesn't need to cost you a lot of money!

These 3 great books make it easy for you to study to get ahead in this fast-growing industry . . . at **absolute minimum cost**. No lessons to wait for! No wasted time!

The Rinehart TV Library is not a "series" or course containing a lot of costly or unnecessary material in which you are not interested. Each book is an authentic, complete and intensely practical guide to a different phase of television and related training. Add all 3 together and you have a broad, specialized knowledge that can help fit you for any one of a number of good-pay jobs . . . from FM and television service to work as a TV broadcast station technician, camera operator, sales engineer, etc. They're easy to understand and up-to-date . . . even to acquainting you with the latest developments and problems in **COLOR TELEVISION** transmission and reception.

SAVE \$1 . . . pay as you learn

There's no need to send any money. You don't even pay the postman when the books arrive. Read them for 10 days . . . then make a worthwhile cash saving if you decide to buy! Bought singly, these books cost \$16.50. Under our special offer for all 3 you save \$1—and have 5 months to pay besides.

You can't lose on this offer!

10-DAY FREE TRIAL

Dept. RN-34, RINEHART & COMPANY, Inc.
232 Madison Ave., New York 16, N. Y.

SAVE \$1 . . . ORDER COMPLETE SET!

Send me the RINEHART TELEVISION LIBRARY (all 3 books) for 10-DAY FREE TRIAL. If not what I want, I will return them postpaid at the end of 10 days and owe you nothing. If I keep the books, I will then mail \$3.50 as my first payment and send you \$3 a month thereafter for four months until the special price of \$15.50 is paid. (Outside U.S.A. Price \$16.50, cash only—same 10-day return privilege.)

TO ORDER BOOKS SINGLY

Enclosed find \$_____ for books checked; or send C.O.D. and I will pay Postman. In either case, I may return books postpaid in 10 days and you guarantee to refund my money.
 FREQUENCY MODULATION \$5.00 (\$5.50 outside U.S.A.) **PRACTICAL TV SERVICING** \$4.00 (\$4.50 outside U.S.A.)
 PRACTICAL TELEVISION ENGINEERING \$7.50 (\$8.00 outside U.S.A.)

Name

Address

City, Zone, State

Your Employer

HARVEY

The House of Audio



The New Model 70-RT
FISHER
FM-AM TUNER
With Preamp-Equalizer,
Tone and Loudness Controls

The Fisher Model 70-RT is a complete, self-contained high fidelity front-end system. Not only does it provide the means for the finest reception of both FM and AM radio broadcasts, but embodies the necessary preamplification for use with high quality magnetic phono pickups. The equalizer control with 4 compensating positions enables matching to the characteristics of all record types. Frequency response: 20 to 20,000 cycles ± 1 db. Other features include: Variable AFC Control Switch, Broad and Sharp AM Auxiliary Input. Continuously variable Bass and Treble controls permit up to 15 db boost or attenuation at 50 and 10,000 cycles respectively.

Complete with tubes **\$184.50**



THE
NEW **REL**
Precedent
FM TUNER

Unquestionably the finest FM tuner ever made. This successor to the famous 646B incorporates every important advance developed in the art of FM reception. Sensitivity is 2 microvolts for better than 40db quieting. Frequency response is 30 to 40,000 cycles ± 1 db. Waveform distortion is less than .5% for 100% modulation. Provides 2-volt output to high impedance, and 2 volts to 600 ohms. Front panel includes slide-rule dial, tuning meter, signal strength meter, tuning control, radio frequency and audio gain controls, and power switch. Power supply is self-contained. Supplied complete with tubes.

Chassis only for custom installations) **\$325.00**

Relay Rack Model..... **335.00**

Cabinet Model
(Mahogany, Walnut or Blonde) **360.00**

THE
NEW **CORONATION**
30-WATT
SUPRA
LINEAR
AMPLIFIER

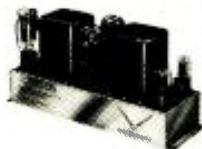

An advanced version of the Williamson with several important circuit modifications. Through the use of matched, high-quality components, and an output transformer, specially designed and wound for the unit, the Coronation has achieved unusually fine performance.

Frequency Response: 10 to 100,000 cycles ± 1 db. Power Response: 20 to 20,000 cycles $\pm .25$ db. Intermodulation Distortion is less than .15%, and Harmonic Distortion less than .1%, at 15 watts, Class A-1 operation. Power supply is self-contained, with outlet for furnishing power to a pre-amp unit. Uses KT-66 output tubes.

May be operated from tuner, preamp, high-level pickup, tape recorder, or other sound source. Operates any speaker system, 8-16 ohms. Hum and noise level is 96db below full output. Dimensions: 15 x 4 1/4 x 7 1/8 inches.

Complete with tubes **\$92.50**

Anywhere in the world —

order by mail direct from Harvey. Enclose estimated shipping charge. Excess will be refunded.

NOTE: Prices Net, F.O.B., N.Y.C.
Subject to change without notice.



Harvey
RADIO COMPANY, INC.

103 W. 43rd St., N.Y. 36, N.Y. • JU 2-1500

around 0930 with Eastern-type music is believed to be ZJM7, Limassol, Cyprus. (Ferguson, N. C.) *Radio Cultura*, 6.165A, Sao Paulo, Brazil, noted with *English* around 2310 and 2325; asked for reports. (Niblack, Ind.) *Indonesian Air Force Station*, Djakarta, 11.945A, heard opening 0425 with plane sounds, followed by American musical program; signs off 1030.

The Japanese Short Wave Club, Box 29, Sendai, Japan, is eager to increase its membership throughout the world; its monthly bulletin is *all-English*; details can be had by writing *direct* to the club. Miller, Ga., reports AFRS relay station in Puerto Rico heard on 7.800A with news 1800. At press time, Pearce, England, noted that *Radio Beirut*, 8.036, Lebanon, appeared to have *dropped its English* session 1000-1100; was using Arabic then.

Radio France-Asie, Saigon, Indo-China (Vietnam), noted *moved* from 6.225 to 6.17. (Balbi, Calif., Gillett, Australia, others) Latest schedules list *English* for India, Asia on 7.230, 1830-1900; 11.935, 2030-2045; 11.935, 0900-1115; and with *new "French by Radio"* session to Australia on 15.430 on Tue., Thur., Fri, 0345-0400, to India, Southeast Asia on 11.935 on Sun., Wed., Fri., 1045-1100. (Catch, Eng-

land) *Radio Tirana*, 7.850, Albania, now has *English* 1400, 1700 (WRH)

At press time, "*Deutsche Welle*," Cologne, Germany, was scheduled 0530-0830 to Far East, 11.795, 15.275; 0930-1230 to Near East, 7.290, 11.795; 1300-1600 to Africa, 7.290, 11.795; 1700-2000 to South America, 2030-2330 to North America, 5.980, 7.290. (WRH) Press dispatches from South Korea indicate that *Radio Pusan* was destroyed by fire. Operated on 7.935A. *Back on the air?* (NNRC) *English* news is scheduled from AIR, India, 1930-1940, 9.755, 7.170; 2310-2320, 15.130, 11.870; 0235-0245, 17.740, 15.380; 0835-0845, 11.790, 9.565; 1045-1055, 15.210, 11.790.

Saudi-Arabia plans to have its *new* 100 kw. transmitter completely installed by the end of 1954; then will use Turkish, *English*, other languages in addition to Arabic. (Scheiner, N. J.) TGNA, 5.952, TGNB, 9.668, are used for *English* 2200-2345; asks for reception reports to Box 601, Guatemala City. (Cook, Calif.)

Acknowledgment

Thanks for the fine reports, fellows! Keep them coming to Kenneth R. Boord, 948 Stewartstown Road, Morgantown, West Virginia, USA. Good listening! - - - - - K. R. B.

NEW TV STATIONS ON THE AIR

(As of February 25, 1954)

The following new stations bring the lists published in previous issues up to date.

| STATE, CITY | STATION | CHANNEL | FREQUENCY RANGE (IN MC.) | VIDEO WAVELENGTH (IN FT.) | VIDEO POWER* (IN KW.) |
|------------------------------|----------|---------|--------------------------|---------------------------|-----------------------|
| Arkansas Little Rock | KARK-TV | 4 | 66-72 | 14.61 | 100 |
| California San Francisco | KSAN-TV | 32 | 578-584 | 1.7 | 81 |
| Florida Fort Myers | WINK-TV | 11 | 198-204 | 4.93 | 12 |
| Jacksonville | WJHP-TV | 36 | 602-608 | 1.63 | 120 |
| Georgia Augusta | WRDW-TV | 12 | 204-210 | 4.79 | 117 |
| Idaho Boise | KBOI-TV | 2 | 54-60 | 17.8 | 16.5 |
| Illinois Harrisburg | WSIL-TV | 22 | 518-524 | 1.9 | 10.5 |
| Michigan East Lansing | WKAR-TV† | 60 | 746-752 | 1.32 | 245 |
| Saginaw | WNEM-TV | 5 | 76-82 | 12.74 | 24 |
| Minnesota Duluth-Superior | WDSM-TV | 6 | 82-88 | 11.8 | 100 |
| Mississippi Meridian | WCOC-TV | 30 | 566-572 | 1.73 | 251 |
| New Hampshire Manchester | WMUR-TV | 9 | 186-192 | 5.25 | 112 |
| New York Schenectady | WTRI TV | 35 | 596-602 | 1.65 | 262 |
| North Carolina Wilmington | WMFD-TV | 6 | 82-88 | 11.8 | 53.7 |
| South Carolina Anderson | WAIM-TV | 40 | 626-632 | 1.57 | 166.6 |
| Utah Salt Lake City | KUTV | 2 | 54-60 | 17.8 | 27.5 |
| Virginia Danville | WBTM-TV | 24 | 530-536 | 1.85 | 22.5 |
| Wyoming Cheyenne | KFBC-TV | 5 | 76-82 | 12.74 | 5.2 |
| Alaska Anchorage | KTVA | 11 | 198-204 | 4.93 | 3.22 |
| Canada Montreal | CBMT | 6 | 82-88 | 11.8 | 43.8 |
| Vancouver, B. C. | CBUT | 2 | 54-60 | 17.8 | 2.5 |

WJDT-TV, channel 3, Jackson, Mississippi, has changed its call letters to WLBT-TV.

*From Station CP application. †Educational, Michigan State College. The frequency of the video carrier = 1.25 + channel lower freq. limit. Total number of TV stations now on the air in U. S.: 369 (131 of which are u.h.f.).

BARGAINS FROM "WHOLESALE RADIO"

FREE!

THE HOTTEST VALUE-
PACKED BULLETIN
IN THE MAILS!

Over 153,000 subscribers
buy and save through
**WHOLESALE RADIO'S
F. Y. I.
BULLETIN
EVERYTHING
IN RADIO • TV
HI-FI SOUND**

WRITE TODAY!
Get Latest Issue
Just Off The Press!



**Equal To \$75 Motorized
TV Aerial Systems**
360° SUPER DIRECTRONIC
Electronically Rotates in All Directions
VHF-UHF CHANNELS 2-83

Exclusive Snyder
Engineering and
design cuts costs to **\$24.95**

**ALL CHANNEL UHF
BOW TIE & REFLECTOR**
Channels 14-83

All pre-assembled. Just unfold, tighten and erect. Hi-tensil aluminum bow. All-welded steel screen, all-weather zinc-plated. U clamp included. Model UHF-5.

UHF-5 **\$1.49**
UHF-6 BOW TIE with Corner Reflector **\$3.49**

**SPECIAL! "STANDARD COIL"
REPL. CASCODE TV TUNER**
Series TV-2000 For High Profit Replacement

Has tube complement of 6J6 osc and conv. and a 6HQ7 or 6HZ7 as IF amp. Designed for inter-carrier circuit and also adaptable for split sound IF circuits such as the "630" and similar types. by use part - XM-752 trap assembly. (Available separately.) IF is adj. 19 to 26 mc. Adaptable to UHF. Shaft length .42" overall.

XM-752 TRAP ASSEMBLY **\$1.14**
UHF STRIPS. Available for Standard Coil tuners. Specify channel no. and series designated by letter such as F, G, Q, etc. stamped on each strip of your present tuner. Set (inc. & ant) **\$7.50**

Stop Fiddlin' With Your Indoor Antenna!!!
**UHF/VHF DIRECTRONIC
INDOOR TV ANTENNA**

Filet of beam selector switch electronically rotates antenna for clearest picture on any channel instantly. Equal to outdoor antenna in metropolitan areas. Channels 2 to 83.

Model 3D **\$6.95**
Lots of 3 **\$4.95** each Lots of 6 **\$3.95** each Lots of 25 **\$3.40** each

SNYDER BROAD BAND YAGIS

- Higher Gain Than Conventional Yagis
- For Fringe and Ultra Fringe

High signal level for sharp, bright pictures. Hi-tensil 3/8" aluminum elements: 7 on low band; 9 on high band. Complete with universal U clamps.

RB2-6 for Ch. 2 thru 6 **\$9.95**
RB7-13 for Ch. 7 thru 13 **\$4.95**

**NOW! TEST CONDENSERS
WITHOUT REMOVING THEM
FROM THE CIRCUIT!**
**SPRAGUE KT-1 KWIK-TEST
CAPACITOR CHECKER**

Turns trouble-shooting hours into seconds. Checks condensers for opens, shorts, intermittents. **RIGHT IN THE CIRCUIT.** Checks bypass, coupling or filters 30 mmf. to 2000 mf. even when in parallel with resistor. A must for profitable servicing of TV receivers **\$34.50**

WHOLESALE RADIO PARTS CO., Inc.

311 W. BALTIMORE ST., BALTIMORE 1, MD.

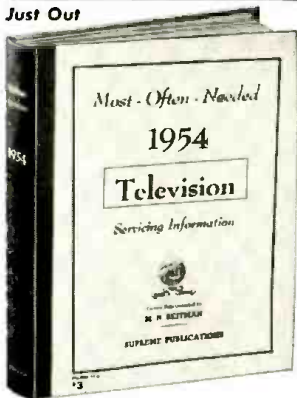

This newest giant volume of the **Supreme TV Manuals** covers 1954 factory data on all popular television sets of all makes. There are explanations of new circuits, 192 pages of alignment procedure, test patterns, response curves, pages of waveforms, voltage charts, service hints, production changes, and dozens of double-spread circuit diagrams. Manual-style binding (opens flat). Special price, only **\$3**

New SUPREME 1954 TV Manual

FULL YEAR'S TV MATERIAL IN A GIANT VOLUME — \$3

COVERS ALL POPULAR SETS

This new **Supreme 1954 TV manual** has all the required service material on every popular television set of every important manufacturer. Here is helpful, practical, factory-prepared data that will really make TV servicing and adjustment easy for you. More pages, more diagrams, more service data per dollar of cost. This new giant TV manual and previous volumes for other years have complete circuits, alignment facts, test patterns, response curves, service hints, recommended changes, voltage charts, waveforms, and many double-page diagram blueprints. Here is your TV service material to help you do more expert work quicker: and priced at only \$3 and \$2 per manual covering a whole year of material. See coupon below for complete list of all eight TV volumes, from 1947 to 1954, and the 1953 UHF Converters manual. Order for a 10-day trial.

AMAZING BARGAIN OFFER

The 1954 TV Manual is another amazing value offered by **Supreme Publications**. This mammoth television servicing manual at only \$3, or the TV manuals for previous years for only \$3 and \$2 each, are super bargains and defy competition. There is nothing else like them. Each manual is a virtual treatise on practical television repairs. By normal standards, each such large manual packed as it is with practical facts, hundreds of illustrations, diagrams, charts, photographs, and expensive extra-large blueprints, should sell for \$10—but as **SUPREME** special values they are priced at \$3 and \$2 each. Only a publisher who sold over one million TV and radio manuals can offer such bargains based on tremendous volume-sales. Be ready to repair any TV set by having in your shop all **Television Manuals** listed in coupon. Or try the new 1954 TV Manual to see what an amazing bargain you get for only \$3. Send no-risk trial coupon.

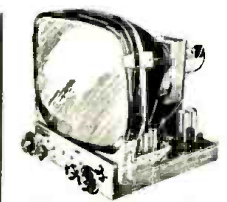

The repair and adjustment of sets is really simple with **Supreme TV service manuals**. Every set is covered in a practical manner that will simplify troubleshooting and repair. This is the help you need to find toughest faults in a jiffy. Each \$3 volume covers a whole year of material. Be wise, buy **Supreme Manuals** only once each year instead of spending dollars every week for not needed data.



Supreme Publications
Available from Leading Parts Jobbers

RADIO DIAGRAMS

Here is your complete source of all needed **RADIO** diagrams and service data. Covers everything from most recent radios to pre-war old-timers: home radios, auto sets, combinations, changers, and portables. Sensational values, still sold at pre-Korean prices. Only \$2 for most volumes. Every **Radio** manual contains large schematics, all needed alignment facts, parts lists, voltage values, trimmers, dial stringing, and helpful service hints. All volumes are large in size, 8 1/2 x 11 inches, about 192 pages. See coupon at right for a complete list of these low-priced manuals.

NO-RISK TRIAL ORDER COUPON
SUPREME PUBLICATIONS, 1760 Balsam Rd., Highland Park, ILL.

| | |
|--|---|
| <p>Radio Diagram Manuals</p> <p><input type="checkbox"/> Latest 1953 Manual, \$2.50</p> <p><input type="checkbox"/> 1952 Radio</p> <p><input type="checkbox"/> 1951 Diagrams } EACH</p> <p><input type="checkbox"/> 1950 Manual } \$2.50</p> <p><input type="checkbox"/> 1949 Radio</p> <p><input type="checkbox"/> 1948</p> <p><input type="checkbox"/> 1947</p> <p><input type="checkbox"/> 1946</p> <p><input type="checkbox"/> 1942</p> <p><input type="checkbox"/> 1941</p> <p><input type="checkbox"/> 1940</p> <p><input type="checkbox"/> 1939</p> <p><input type="checkbox"/> 1926-1938 Manual, \$2.50</p> <p><input type="checkbox"/> Master INDEX only 25c</p> | <p>Send TV manuals checked <input checked="" type="checkbox"/> below and Radio manuals at left. Satisfaction guaranteed or your money back.</p> <p><input type="checkbox"/> New 1954 Television Servicing Manual, only... \$3.</p> <p><input type="checkbox"/> 1953 TV Manual, \$3. <input type="checkbox"/> 1953 UHF Units, \$1.50</p> <p><input type="checkbox"/> 1952 Television Manual, \$3. <input type="checkbox"/> 1951 TV, \$3.</p> <p><input type="checkbox"/> 1950 Television Manual, \$3. <input type="checkbox"/> 1949 TV, \$3.</p> <p><input type="checkbox"/> 1948 TV, \$3. <input type="checkbox"/> 1947 TV & FM, only \$2.</p> <p><input type="checkbox"/> I am enclosing \$..... Send postpaid.</p> <p><input type="checkbox"/> Send C.O.D. I am enclosing \$..... deposit.</p> <p>Name:</p> <p>Address:</p> |
|--|---|

PRICED AT ONLY \$2 EACH

AIREX'S 1954 Co-Channel

630 FA-2A with Genuine FM
Armstrong Sound System

READY FOR COLOR CONVERTER

3 MONTHS

RMA
GUAR.
ON ALL
PARTS

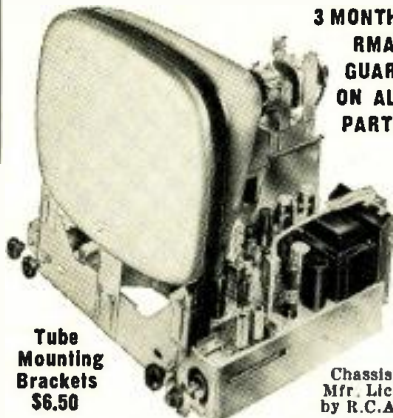

Tube
Mounting
Brackets
\$6.50

Chassis
Mfr. Lic.
by R.C.A.

CHECK THESE EXCLUSIVE FEATURES

- 10 WATT push-pull audio output. Frequency range from 40 to 12,000 cycles • 3 position fringe area switch • Delayed gated AGC system • Standard Coil Cascade Tuner prevents radiation • Retrace Blanking Circuit allows you to raise the brightness without the annoying vertical retrace lines • Heavy duty front focus control • Automatic gain control potentiometer allows you to adjust the threshold sensitivity as low as 4 microvolts & still keep the full 4 MC band width • Improved sync amplifier • Improved automatic brightness control • Set aligned for 21.9 MC. New Ham band will not interfere • Improved fused high voltage power supply gives full 14.5 KV under load. Will handle all picture tubes up to 24 inch round with full sweep • Improved video amplifier has a gain of 40 • All moulded plastic condensers give long life & trouble-free operation • Easily adapted to new UHF stations in 2 minutes by just changing a strip in the tuner • Extra heavy duty power transformer with large safety factor • 6CB6 tubes in Video IF to give full gain • Extra filtering in power supply for hum & ripple-free operation • Phono Connection & switch on chassis allows you to play your phonograph or tuner through the built-in 10 watt hi-fidelity amplifier • Extra heavy duty focus coil, which runs cool • Full focus cosine yoke.

THE ONLY CHASSIS WITH 10 WATT
PUSH-PULL AUDIO OUTPUT AT

\$169⁹⁵

Fed. Tax
Included

Less C.R. Tube
and Brackets

Complete with 12" ROLA Hi-Fi Speaker
With UHF 83 Channel Converter—\$211.90
Detailed Service Manual & Schematic—\$1

COMBINATION SAVING!

- 630 FA-2A Chassis
 - 21" Picture Tube
 - Mah. Console Cabinet
- With mask, glass, tube mtg brackets FOR THE 3 UNITS

This Month
Only
\$249⁹⁵
Fed. Tax
Incl.

TV PICTURE TUBE SALE

- Standard Brands, Factory New, Guar. 1 year.
- 17" Tube...\$27.95
 - 20" Tube...\$34.95
 - 21" Tube...\$38.95
 - 24" Tube Round (Guar. 9 Mos.)...\$79.95
 - 24" Rect...\$59.95
 - 27" Tube Rect...\$79.95
- Rimk and Sleeve for 24" Round...\$ 7.50

630 CHASSIS
FOR 24" & 27" RECT.
OPERATION **\$189⁹⁵**
PRICE
Not push pull audio

TV GOLD PLASTIC MASKS

- 16" and 17".....\$ 4.99
- 20" and 21".....\$ 7.95
- 24".....\$14.95

630 UHF
converter... **\$34.95**

BARGAIN CABINET BUY

Beautiful mahogany console cabinet cut for 630 FA-2A Chassis. Complete with mask, glass & tube mounting brackets

\$49.95

In Stock.....\$59.95

Send for complete cabinet brochure

FREE—New TV—HI-FI PARTS CATALOG

All merchandise brand new, factory fresh, guaranteed. Mail & phone orders filled upon receipt of certified check or money order for \$25 as deposit on TV chassis. 20% on other items. Balance C.O.D., F.O.B. factory N. Y. Prices & specifications subject to change without notice. NO FED. TAXES TO PAY.

AIREX RADIO CORP.

SHOWROOM: 171 Washington St., N. Y. 7
Gramercy 7-9245
MAIL ORDER: 400 Lafayette St., N. Y. 3

A FEEDBACK

LOUDNESS CONTROL

By RAY C. WILLIAMS

Biophysics Dept., Medical College of Va.

A low output impedance as well as high- and low-frequency compensation characterize this compact control.

LOUDNESS controls which compensate for physiological characteristics of the human ear, as shown by the Fletcher-Munson curves, are considered a "must" by most high-fidelity enthusiasts.

Such a control should have the following features: simplicity, compensation for both high and low frequencies, constant mid-frequency gain when compensation is switched in or out, continuous variability, and low output impedance. A loudness control which incorporates all of these features is shown in Fig. 1.

The basic circuit consists of a two-stage resistance-coupled amplifier with cathode-follower output. A feedback loop consisting of C_2 , R_3 , R_4 , and

Fig. 1. Diagram of feedback loudness control.

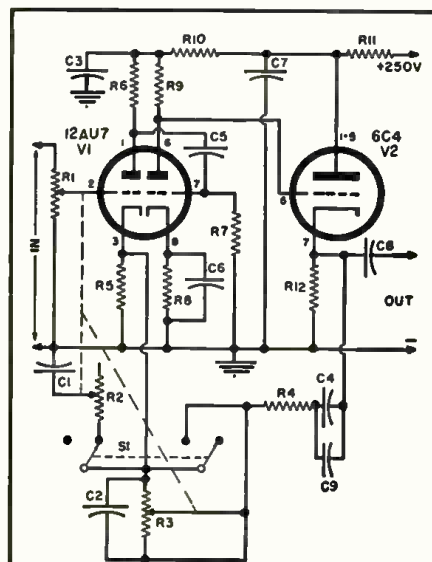

- R_1 —500,000 ohm linear-taper pot
- R_2 —3000 ohm linear-taper pot
- R_3 —250,000 ohm audio-taper pot
- R_4 —3300 ohm, $\frac{1}{2}$ w. res.
- R_5 —1000 ohm, $\frac{1}{2}$ w. wirewound res.
- R_6 , R_7 —47,000 ohm, $\frac{1}{2}$ w. res.
- R_8 —470,000 ohm, $\frac{1}{2}$ w. res.
- R_9 —1000 ohm, $\frac{1}{2}$ w. res.
- R_{10} , R_{11} —4700 ohm, $\frac{1}{2}$ w. res.
- R_{12} —27,000 ohm, $\frac{1}{2}$ w. res.
- C_1 —.05 μ f., 400 v. cond.
- C_2 —20 μ f., 450 v. elec. cond.
- C_3 —20 μ f., 150 v. elec. cond.
- C_4 —20 μ f., 150 v. elec. cond.
- C_5 —.1 μ f., 600 v. cond.
- C_6 —50 μ f., 25 v. elec. cond.
- C_7 —.25 μ f., 400 v. cond.
- C_8 —.01 μ f. ceramic cond. (shunt for C_2)
- S_1 —D.p.d.t. switch
- V_1 —12AU7 tube
- V_2 —6C4 tube

* All three pots ganged into a single unit. See text.

COLUMBIA

will never be undersold!

12 V. 25 AMP DELCO-REMY MOBILE

GENERATOR

Fair, used cond. Never before sold at this
sensationally low price,
Stock up! **\$3.95**

R-54/APR-4 COMPLETE UHF RECEIVER: With
tuning units—TN-18, 17, 18, 19, 54, Freq. 38,
4,000 MC. Like New, Guaranteed...\$1,250.00

SCR-518 UHF ELECTRONIC ABSOLUTE ALTIMETER.
Terrible for conversion to 420 Mc and citizen's bands.
Consists of transmitter, receiver, indicator, power
supply, control boxes, rails with plugs, mounts,
etc. Less tubes. BRAND NEW. With schematic. Auto-
matic. Never before priced so low. ONLY **\$19.95**
WARD-LEONARD RHEOSTAT, 12.5 ohms, 10 amps,
600 V. Maximum. Excel. cond.\$1.29

RADAR CONTROL BOX

Consists of one 0-25 ma, 2 1/2 in. round meter,
PLUS a raft of miscellaneous parts. New.
Has 400 cycle variac
SPECIAL SALE PRICE **\$5.50**

NEW 6 V. FILTERED CARTER MOBILE POWER SUP-
PLY. Output, 350 V. @ 150 mils. SPECIAL.
ONLY **\$14.50**

APS-13 "Tail End Charley" TRANSMITTER
420 MC. UHF, 5 stages of 30 MC. IF amplifier. Com-
plete with RF & IF section & schematic less tubes
and dynamotor. Good cond.\$4.95
MINIATURE 6 V. WET CELL BATTERY, With 6 V.
rev. DC motor, F.H. for R/C boat. 3 1/2 x 2 1/2 x 1 1/2
Battery less motor, \$1.45 for motor...\$2.59

SLASH PRICE TUBE BUYS!

58P4...\$2.95 6L6C...\$.49 6AK5...\$.60
6SN7...\$.75 6AC7...\$.62 829B...\$.75
ARR-1 RECEIVER: For conversion to 220 MC. With
schematic. See Jan/19 Radio News for conversion
Good condition. ONLY **\$3.99**
PE-104 VIBRATOR SUPPLY. Part of BC-654. Trans.
Rec. 6 or 12 V. input. Output: positive: 6, 14
and 84 VDC; negative: 1.4, 6, 12, 51 VDC. New
with spare parts.\$9.95

METER: 0-25 ma. 2" rd. Weston New. Down to

ONLY **\$2.49**
METER: 0-15 V. AC. 2" rd. Westinghouse.
New.\$2.95
METER: 0-6 amps RF 2" rd. Westinghouse.
New.\$3.49
WESTERN ELECTRIC METER: 100.0-100 scale.
0-1 ma. each side of zero. 3" rd. New **\$3.95**
DUAL METER INDICATOR: Has 2 individual
elements each perpendicular to the other.
One has 110 microamperes movement; other
—210 microampere movement. Makes ter-
rific "95" meter or field-strength meter.
Dim.: 3 1/2 x 3 1/2 in. New.\$3.95
0-2 MIL METER, 2" panel type. New boxed
Each **\$3.95**

HS-33 LOW IMPEDANCE HEADSETS. Used...\$1.99

SOULD POWERED HANDSETS **\$10.95**

Brand New, Ea.\$10.95
PER PAIR\$19.95

SCR-183 12 V. RECEIVER & TRANSMITTER! Covers
aircraft, marine and ham bands with proper coil. Has
2 coils, 2 control boxes, tuning head, flex cable, rack
and shock mount! Plus 12 V. Dynamotor! Individual
parts worth \$25.35. Approx. 25w. output. EXCEL.
COND. Plus schematic **\$12.95**

NEW LOW PRICE.....\$12.95

ARC-5 OR 274-N TRANSMITTERS

All pre-tested & guaranteed!

- 2.1-3 mcs. Brand new **\$19.95**
- 3-4 mcs. With tubes **25.00**
- 4-5.3 mcs. With tubes **7.50**
- 5-7 mcs. With tubes **6.95**
- 7-10 mcs. With tubes **14.50**

ARC-5 OR 274-N RECEIVERS

Equipped with Tuning Knobs

- 10-35 kc. **\$19.95**
- 1.5-3 mcs. Like new **24.50**
- 3-4 mcs. Brand new **22.50**
- 4-5.3 mcs. With tubes **7.95**
- 5-7 mcs. With tubes. Used **7.95**
- New **14.95**
- 6-0.1 mcs. Used. Less tubes **5.95**
- BC-456 274-N Modulator. Less dyna-
motor. Excel. cond. **3.99**
- 12 V. COMMAND RECEIVER DYNAMO-
TOR. New **12.95**

Plus All Accessories Needed for Above.
Conversion dope available on request.

Write Today—and ask for
FREE CATALOGUE!

All orders F.O.B. Los Angeles. 25% deposit required.
All items subject to prior sale. Note New Address.
Dealer Inquiries Invited.

COLUMBIA ELECTRONIC SALES

2251-53 W. Washington Blvd., Los Angeles 18, Calif.
Come in and visit our new, larger centrally located
warehouse-store!

AMAZING!

NOW IN ONE INSTRUMENT
TROUBLE-SHOOTER

FOR RADIO AND TELEVISION

With this instrument, you can analyze every circuit; test any tube or condenser; and make continuity tests to find faulty parts. It takes the puzzle out of TV, shows you everything you need to know to TROUBLE-SHOOT any radio or TV set. Custom built on production line. Free information.



TELE-DIAGNOSIS CO.
THE HOME OF FINE INSTRUMENTS
155 West 72nd Street New York 23, New York

C_1 , is connected between the cathode-follower output and the cathode of the input stage. C_1 is a 20 μ f., 150 v. electrolytic shunted by a .01 μ f. ceramic condenser and is used for d.c. blocking only. C_2 - R_2 give low-frequency compensation and when shunted by C_1 - R_2 compensates for the high frequencies. The control element is a three-gang potentiometer and is made of the IRC type "Q" and multisections having the values indicated in the parts list.

When the control element is at the maximum clockwise position, C_2 is shorted by R_2 making the feedback loop resistive. Shunt condenser C_1 is in series with R_2 and has little or no effect, the result being a two-stage amplifier having a flat frequency response. When the control element is turned counterclockwise, the reactance of C_2 becomes increasingly large at frequencies downward from 1500 cycles. C_1 becomes an increasingly effective shunt at frequencies upward from 1500 cycles. The reduction of the feedback fraction at the low and high frequency ends, with the mid-frequency fraction remaining constant, results in a marked increase in gain at the low and high frequency ends of the spectrum. Obviously, varying degrees of compensation will be obtained when the control element is turned between these two extremes. Switch S_1 simply shorts C_2 - R_2 and opens the circuit of the shunt condenser C_1 to make the feedback loop resistive, resulting in a flat amplifier.

In the maximum counterclockwise position the gain at 1500 cps is 14 db; at 30 cps is 38 db.; and at 15 kc. is 26 db. In the maximum clockwise position the gain from 30 to 15,000 cps is 14 db.

This loudness control can be incorporated into new or existing equipment or built as a separate unit. All grounds should be tied to a common point and the plate supply voltage should be well filtered.

-30-

REPAIRING TUNING SLUGS

By CHARLES ERWIN COHN

THE screw slots on the tuning screws of slug-tuned coils are not usually very strong, and sometimes one of the nibs breaks off, making the slot useless. This most often happens when the slug turns hard, and a repair must be made to enable convenient tuning.

This can be easily done by first breaking off the other nib with a pliers and smoothing the end of the screw with a file. After that, a hex nut of the proper size is screwed on so that its surface is flush with the end of the screw, and solder is flowed on the end to hold the nut securely. Then the coil can be tuned with a socket wrench or "Spintite."

-30-

Method for salvaging tuning slugs.

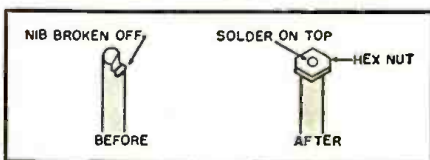

MARCH, 1954

BEST ALL-AROUND TESTER ON THE MARKET

USE IT FOR:

- TV SETS
- RADIOS
- TRANSMITTERS
- BROADCASTING EQUIPMENT
- HOME APPLIANCES
- TWO-WAY RADIO COMMUNICATIONS SYSTEMS
- PHONE LINES
- AIR CONDITIONING SYSTEMS
- STARTER CONTROLS
- AUTO IGNITIONS, GENERATORS, BATTERIES
- MOVIE EQUIPMENT
- PANEL INSTRUMENTS
- TV CAMERAS
- AUTO LIGHTING SYSTEMS
- GENERATORS
- VOLTAGE SOURCES
- "HAM" RADIO EQUIPMENT
- CABLES
- CONNECTORS
- AUDIO FREQUENCY SOUND CURRENTS

and write for your complimentary copy of "1001 Uses for the Simpson Model 260" . . . 50 pages of uses.

RANGES:

20,000 OHMS PER VOLT DC
 1,000 OHMS PER VOLT AC
 VOLTS, AC AND DC: 2.5, 10, 50, 250, 1,000, 5,000
 OUTPUT: 2.5, 10, 50, 250, 1,000
 MILLIAMPERES, DC: 10, 100, 500
 MICROAMPERES, DC: 100
 AMPERES, DC: 10
 DECIBELS (5 RANGES): -12 TO 150 DB
 OHMS: 0-2000 (12 OHMS CENTER), 0-200,000 (1,200 OHMS CENTER), 0-20 MEGOHMS (120,000 OHMS CENTER)

SIMPSON ELECTRIC COMPANY

5200 W. North St., Chicago, 44 • Estebrook 9-1121

In Canada: Bach-Simpson, Ltd., London, Ont.



Simpson
 Model 260
 VOLT-OHM-MILLIAMMETER

\$38.95 Dealer's net.

HEADSET SALE!

HS-33 \$4.50 each
 HS-23 \$4.00 each

PLUG PL68 WESTERN ELECTRIC
 ON CORD 50c each

BRAND NEW

TALLEN CO., Inc., Dept. RN
 159 Carlton Avenue, Brooklyn 5, New York

RADIO ENGINEERING DEGREE IN 27 MONTHS

Radio engineering is a big field. There's room for you in it—if you're good. Get first-class training at Indiana Tech. Intensive, specialized course, including strong basis in mathematics and electrical engineering, advanced radio theory and design, television, electronics. Modern laboratories. Low rate. Also B.S. DEGREE IN 27 MONTHS in Aeronautical, Chemical, Civil, Electrical and Mechanical Engineering. G.I. Government approved. Enter March, June, September, December. You can earn part of your expenses right here in Fort Wayne while you are studying.

INDIANA TECHNICAL COLLEGE

934 E. Washington Blvd., Fort Wayne 2, Indiana
 Please send me free information on B.S. Engineering Degree in 27 months as checked.

- Radio-Television Aeronautical
 Civil Mechanical Electrical

Name
 Address

135



15 or 12 in.
Bass Reflex Cabinet

High Fidelity at moderate cost*

Every essential for superb tone— $\frac{1}{2}$ " wood sides, $\frac{1}{2}$ " acoustic lining, 4.3 cu. ft. capacity, heavy construction (wt. 31 lbs).

But moderate cost with leatherette covered sides. Hand rubbed solid mahogany or blonde hardwood around front adds genuine richness. Compare it with any other and see for yourself. Only \$45.00 net (slightly higher west of Rockies).

Send for **FREE Folder**



*By makers of famous TV Tube Caddy®



NEW TV PRODUCTS on the Market

U.H.F. GENERATOR

Industrial Television, Inc., 369 Lexington Ave., Clifton, N. J., is now offering a u.h.f. television generator which is designed to speed u.h.f. set installation and service and provide



the required u.h.f. signal in locations where u.h.f. stations are not in operation.

The IT-130R uses the signal from a v.h.f. station and translates it to a u.h.f. signal on any channel. In using the equipment to demonstrate u.h.f. receivers when the signal is not available, it will permit customers to compare receiver sensitivity, ease of tuning, channel designation display, switching methods, etc.

Complete technical details on the IT-130R are available from the company on request.

NEW ANTENNAS

Channel Master Corporation, Ellenville, N. Y., has developed a new u.h.f. corner reflector, the Model 409. The new unit features optional 2-way mounting which permits the reflector to be mounted either behind or in front of the mast, depending on installation conditions.

Falcon Electronics Company of Quincy, Illinois, is now offering a new and improved version of the yagi for all-v.h.f. band use. The "88" has 5 elements on the low channels, 4 on the highs, and combines the best features of the conical with the high gain and sharp directivity of the yagi. Complete details are available on request.

JFD Manufacturing Co., Inc., 6101 Sixteenth Ave., Brooklyn 4, N. Y., has added two antennas to its u.h.f. line. The "Golden Rig" corner reflector is designed for fringe reception of channels 14 to 83. It is braced four ways to eliminate ghost-producing vibration. The second antenna is the UHF312 "Ultra Yagi" which has been designed for deep-fringe reception of single u.h.f. channels. The company will supply additional details on either of these antennas on request.

Technical Appliance Corporation of Sherburne, N. Y., is in production on

a high-gain, all-channel colinear yagi for v.h.f. Tradenamed the "Trapper," it incorporates newly-developed phasing elements which multiply the effectiveness of the driven elements on high-band channels, according to the company. The antenna comes completely assembled.

HIGH-VOLTAGE CONTROL

Clarostat Mfg. Co., Inc. of Dover, N. H., is now offering a new high-voltage, high-resistance, composition-element control, the Series 51.

Used to control voltage for electrostatic-focus television picture tubes, the Series 51 can be used with three-gun tubes in color television.

Housed in a low-loss phenolic case with a phenolic disc back that separates the terminals for maximum insulation, the control withstands 10,000 volts d.c. breakdown test between terminals and mounting bushing. It measures 2" in diameter by $\frac{5}{8}$ " deep. It is available in resistance values from 5000 ohms to 50 megohms linear and is rated at 1 watt.

Additional information is available in the company's Engineering Bulletin No. 119, which will be forwarded on request.

TV TEST EQUIPMENT

The Hickok Electrical Instrument Company, 10524 Dupont Ave., Cleveland 8, Ohio is currently introducing a series of test instruments designed to facilitate television servicing.

Among the new equipment is the Model 697 u.h.f. sweep alignment generator which provides fundamental output on all channels from 14 to 83. The generator features a piston-type attenuator which meets the most critical requirements for accurate attenuation. It provides minimum loading effects of u.h.f. circuits under alignment.



Technical details on this equipment are contained in Form 697 available on request.

The company is also introducing the Model 690 u.h.f.-v.h.f. marker generator which covers frequencies from

4.25 to over 225 mc. on fundamentals with a .25-volt r.f. output. It provides dual markers with any TV sweep generator.

The third item of equipment is the Model 691 heterodyned marker adder which is designed to be used with any sweep marker equipment that has an output of 50,000 microvolts or more. The Model 691 provides a marker visible at all times and will not change in amplitude or distort the response curve in any way.

BOGEN BOOSTER

David Bogen Co., Inc., 29 Ninth Avenue, New York 14, N. Y., has introduced a new u.h.f. television booster, the Model UHB.

According to the company, the new booster increases the reception range



for TV sets operating on channels 14 to 83 inclusive. A gain of 13½ db is obtainable at the lower frequencies while 8 db gain is available at the high end. The noise figure is 11 db at the low-frequency end and 15 db at the high end.

The Model UHB is housed in a compact case which has a vernier-type dial with a pointer behind a screened glass faceplate. A single knob controls the operation of the booster which is automatically turned on and off by the set by means of a thermal-type relay.

A data sheet covering this booster is available from the company.

COMPONENTS FOR COLOR

The Tube Department of Radio Corporation of America, Harrison, N. J. has announced that electronic components for color TV will be available in production quantities soon.

Production schedules will be geared to meet the needs of manufacturers who are expected to produce an estimated 100,000 color receivers in '54.

Under present plans, seven of the more critical components will be produced initially. They include the deflection yoke, high-voltage transformer, and several types of focus and convergence coils, all designed to be used with the company's tri-color picture tube.

The components will be made at the firm's Camden, N. J. plant.

"MIRROR-BACK" TUBE

CBS-Hytron of Danvers, Mass. is in production on a new "Mirror-Back" picture tube, the 21FP4C.

This tube, which may be used to

MARCH, 1954

irish ...The Tape That Mirrors the Original Sound

GREEN BAND Professional



The Finest Tape Your Recorder Can Use...

Just as the reflection of a perfect mirror is faithful to the original image, in every detail, so too does IRISH Green Band RECORD, RETAIN, and REPRODUCE the original sound with flawless fidelity.

Instruments will reveal that IRISH Green Band offers lower noise level, uniform sensitivity, minimum amplitude variation, less distortion. But instrument tests are only the landmarks of good design and production. The final proof is in the hearing. To appreciate the quality of IRISH Green Band Tape, it must be listened to and compared with other tapes on the same recorder.

You will find that the only limitation to IRISH Green Band quality is the limitation of the tape recorder itself... it is the finest tape your recorder can use.

irish GREEN BAND professional

is fast becoming the choice of audio engineers in broadcast stations, recording studios and wherever sound quality is of paramount importance.

1200 feet on plastic reel.....\$ 5.50
2400 feet on metal or
fiberglass reel 12.85

One day you will surely use IRISH . . .
so write today for free test sample reel.



irish BROWN BAND for POPULAR PRICED RECORDERS

IRISH Brown Band, expressly designed for home and office recorders. Reproduces with true fidelity the frequency range from 100 to 8000 cycles. A high quality, plastic base tape for the price of ordinary paper tape!

1200 feet, plastic base, on
plastic reel.....\$3.75

At all leading radio parts distributors

ORRADIO INDUSTRIES, INC.

OPELIKA 6, ALABAMA

World's Largest Exclusive Magnetic Tape Manufacturer

EXPORT DIVISION: Merban Exporting Corp., 458 Broadway, New York, N. Y.

SOUND RECORDING

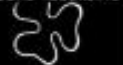

CROWN BROADCASTER PORTABLE TAPE RECORDER



Now for the first time—true broadcasting quality priced low enough for all to enjoy. Six years development has resulted in the only recorder of its price meeting NARTB broadcasting standards.

3 speeds—1 1/2", 7 1/2", 3 3/4"
± 2 db 30-11000 cps at 7 1/2"/sec.
3 motor mechanism. 2 inputs
less than .25% flutter and wow
20 watt hi-fi amp. built in
8" 10 watt speaker built in

Write today for free brochure to Dept. R3
Dealer Inquiries Invited

INTERNATIONAL RADIO & ELECTRONICS CORP. • ELKHART, INDIANA

Builders of Broadcast Equipment Since 1938

CRYSTALS

LARGEST STOCK IN THE WORLD

NOTE!

HUGE PRICE REDUCTIONS! FREE GIFT OFFER BELOW

COMPLETE SET—80 CRYSTALS
 Ranging from 370-516 Kc., 54th Harmonic, INCLUDING 500 Kc. & 455 Kc. crystals. Only... Per set **\$6.95**

COMPLETE SET—120 CRYSTALS
 Ranging from 370-540 Kc., 72nd Harmonic, PLUS 500 Kc. & 455 Kc. crystals. Only... Per set **\$9.95**

200 KC. CRYSTAL... Ea. \$1.75
 500 KC. CRYSTAL... Ea. .75
 1,000 KC. CRYSTAL... Ea. 2.75

All above crystals in FT-241-A HOLDERS 1/2 in. pin SPC.

FREE WRIST COMPASS—On request with every \$15.00 order for crystals.

MISCELLANEOUS BEST BUYS

3-STAGE UNIT. Will make a terrific 2-meter converter. Consists of: 1 out stage, 1 RF stage & 1 mixer stage. New... **\$2.95**
ULTRA-VIOLET COCKPIT LAMP. Used... **1.95**
PILLOW SPEAKER. Used... **1.95**
SOUND POWERED 2-WAY COMMUNICATION SET. With 50 ft. of wire. Pair type. Excellent. **\$3.35**
24V. TRANSFORMER. Pri. 110 V. @ 2 amps. New... **\$1.95**

SPECIAL! 12 V. 35 AMP GENERATOR
 Ideal for mobile rig. Used. ONLY... **\$3.95**

SILVER CIRCLE TUNER. Used. Ea. **\$1.25** 3 for... **\$2.95**

ARW-2 Remote Control Receiver

10-channel audio-tone receiver. Ideal for radio control, garage door opener, lawn mower, model boat and many other electronic control devices. Here are some of the parts it contains: ten 10,000-ohm resistors, 10 audio filter sections, 14 standard size tubes, 2 crystals, 24 V. power supply. Plus many other useful items. ALL NEW. An unbeatable value at ONLY... **\$27.50**

PE-73 DYNAMOTOR. Used... **\$3.49**
BARBEQUE MOTOR. AC. New... **9.45**
CHOKER. 16 Henry 0.45 amp. New... **6.95**
400 ASSORTED SILVER MICA CONDENSERS. New, mounted 10 to a strip. All for... **\$1.95**

SPECIAL COMBINATION!

WILLARD 6 V. Plastic storage battery for model control equipment. Uses standard electrolyte. NEW. (Orig. sold for \$2.49.) PLUS REVOLVING MIDGET MOTOR. Operates on 11-6 V. at top speed of 10,000 R.P.M. (Orig. price \$1.95). NEW. BOTH units now only... **\$2.75**

All merchandise sold as is. Prices net. F.O.B. Los Angeles. All items subject to prior sale.

J. J. GLASS ELECTRONICS CO.
 1615 S. MAIN STREET
 LOS ANGELES 15, CALIF.

replace the 21FP4, is an aluminized tube with low-voltage, electrostatic focus. Electromagnetically deflected, it incorporates an all-glass, rectangular bulb, and a gray-glass, cylindrical face plate that provides greater contrast and a reflection-free viewing surface.

The 21FP4C has an electron gun designed for use with a single-field, external ion-trap magnet. It also has an outer conductive coating which, when grounded, serves as a high-voltage filter condenser.

U.H.F. HI-PASS FILTER

A u.h.f. hi-pass filter, the HP2, has been announced by *Service Instruments Company* of 422 South Dearborn St., Chicago, Ill.

The new unit is designed to pass u.h.f. frequencies with less than 1 db



attenuation and reject all v.h.f. frequencies from 45 to 50 db. According to the company, the HP2 filter eliminates FM interference on u.h.f., airport interference on strips, i.f. feed-through, and prevents channel 5 or 6 from interfering on dual-conversion, all-channel tuners.

NEW PICTURE TUBES

The Tube Department of *General Electric Company*, Schenectady, N. Y., has announced two new 21" television picture tube types whose 90-degree deflection angles make them about 3" shorter than corresponding narrower-deflection types.

The tubes, types 21ACP4 and 21ACP4-A (aluminized), are both glass, rectangular types. Both tubes are 20" in over-all length, allowing in-

COMPACT • INEXPENSIVE



Tracks 'em down dead or alive!

Amazing, new, indispensable electrical tester takes guess-work out of electrical troubleshooting. Signal light in tip at point of contact assures fast, accurate results. Popular, practical Desco Circuitracer... DEVELOPED FOR THE SERVICE MAN! Can be used to quickly locate grounds, opens and shorts in both dead and live circuits, ac or dc. Check these added features: ✓ Tests tube filament; plates, screens; vibrators and output voltages, relays, switches, fuses, controls. ✓ Tests condition of wiring and devices in all types of electrical systems, with power on or off.

Rugged, yet conveniently small. Weighs only 2 1/2 oz. ONLY \$3.95. Money-back guarantee. Order yours TODAY. (Jobber inquiries invited.)

DESCO MFG. CO.

605 E. WALNUT, PASADENA 1, CALIF.

EASY TO LEARN CODE

It is easy to learn or increase speed with an Instructograph Code Teacher. Affords the quickest and most practical method yet developed. For beginners or advanced students. Available tapes from beginner's alphabet to typical messages on all subjects. Speed range 5 to 40 WPM. Always ready—no QRM.



ENDORSED BY THOUSANDS!

The Instructograph Code Teacher literally takes the place of an operator-instructor and enables anyone to learn and master code without further assistance. Thousands of successful operators have "acquired the code" with the Instructograph System. Write today for convenient rental and purchase plans.

INSTRUCTOGRAPH COMPANY

4711 SHERIDAN ROAD, CHICAGO 40, ILLINOIS

3 in 1

LIGHTNING ARRESTER

JFD MANUFACTURING CO.
 BROOKLYN 4, NEW YORK

ULTRA LOW LOSS DESIGNED FOR HIGHEST UHF GAIN

DON'T RUIN your installation with a lightning arrester of high insertion loss. Install the arrester that's an asset instead of a liability to your UHF or VHF installation—the JFD "3-IN-1" with the ultra low loss compensating coil circuit. Thousands of installations prove the "3-IN-1" gives the lowest insertion loss of any arrester in use today. Patented strain-relief lips and patented saw-tooth washers are exclusive JFD extras at no extra cost.

Write for Form 210.

No. AT110 with hardware for wall or window sill... **\$1.50 list**
 No. AT110S with UL approved stainless steel mounting strap... **\$1.75 list**

U. S. Patent Nos. 2,654,857; D-159,330

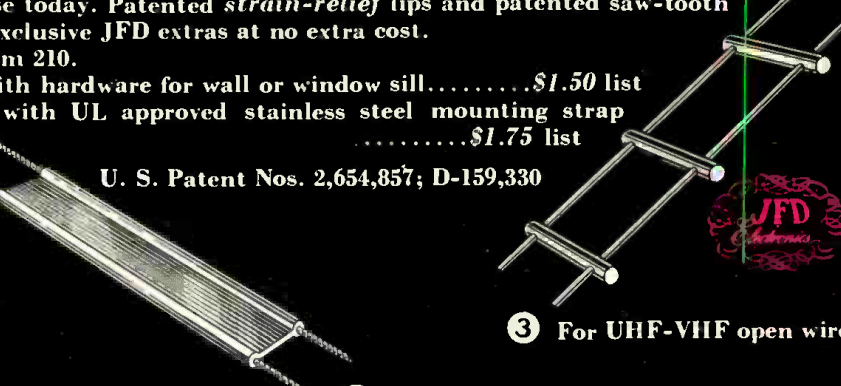

① For all UHF or VHF tubular twin leads

② For VHF flat twin leads

③ For UHF-VHF open wire

KESTER



Since the most important single step in Radio-Television Servicing is soldering . . . it's just plain good sense to use the best — KESTER SOLDER . . . Key Name in Solder for More Than 50 Years.



KESTER SOLDER COMPANY
4235 Wrightwood Avenue • Chicago 39, Illinois
Newark 5, New Jersey • Brantford, Canada



SOLDER

**EARN MORE MONEY—
BE A PROFESSIONAL
TELEVISION
SERVICE
TECHNICIAN**



STEP INTO THE TOP PAY \$5,000—\$10,000 A YEAR CLASS. 7 MONTHS' SHOP TRAINING QUALIFIES YOU.

If you want to reach your goal as a Successful Service Technician you will need plenty of "KNOW HOW" to qualify for the better servicing jobs or profitable shop ownership.

SEND FOR FREE BOOK TODAY!

WESTERN TV offers real experience on live equipment in our BIG SHOPS AND LABORATORIES in the shortest practical time under expert instructors. Graduates are in big demand because they have the "field experience" necessary for immediate "bench" or supervisory positions. You learn every phase of Radio and TV servicing (AM, FM, VHF, UHF). WTI men win fast promotion . . . can demand better pay . . . develop highly profitable businesses of their own with the latest and most PRACTICAL PERSONALIZED TRAINING BEHIND THEM. You concentrate all your time on being a PROFESSIONAL TV SERVICE TECHNICIAN — non-essential math and engineering theory omitted. YOU CAN EARN WHILE YOU LEARN. Special Finance Plan. APPROVED FOR VETERANS. Find out how you can get into the TOP PAY GROUP — Send for this fact-packed book NOW!

WESTERN TELEVISION INSTITUTE America's Leading Television Servicing School

Western Television Institute Dept. R-34
341 W. 18th St., Los Angeles 15, Calif.
Without obligation, please send FREE fully illustrated booklet. (No salesman will call.)

NAME _____ AGE _____
ADDRESS _____
CITY _____ ZONE _____ STATE _____

SPECIAL VALUES

- 783 Output Power Meter General Radio. Like New \$225.00
- 3200-3370 mc. Like New 400.00
- LR-1 Signal Generator 160-30,000 KC. 115VAC. 60 cy. with xtal calibration. Exc. 1,000.00
- Model 225X Hickok Universal crystal controlled Signal Generator. Like New 125.00
- Model 290C Hewlett Packard Audio Generator Exc. 100.00
- Du Mont 208B Oscilloscope Exc. 125.00
- Model 230 Clough Brengle AC Cap. & Res. Tuning Ratio Bridge Exc. 45.00
- Type 726A General Radio Vacuum Tube Voltmeter New 125.00
- 804C Federal or General Radio Signal Gen. 8-830 mc. Exc. 300.00
- RC-221 or IM Prod. Meter Exc. 99.50
- RC-221AK with modulation Exc. 150.00
- General Electric Dual Regulated Power Supply Type STA9 New 300.00
- Type 721A Precision Wavemeter General Radio. 16 KC. to 50 mc. Exc. 175.00
- A LARGE STOCK OF ARC-1, ARC-3, ART-13, AP-34A, AP-34B, APR-4, ARB, BC-312, BC-342, BC-348, BC-433G, BC-611, BC-1806, CRT-3, 156A, 1222, 1E-19A, 1E-35A, 1E-36A, SCR-284, SCR-522, SCR-578, SCR-625, TCS, T19/AP25, TS-34/AP, TS-100/AP, TS-184/AP, 14C, Plugs and Sols. SUBS PUR*
Kay Elec. Mega-Sweep Exc. 250.00
Kay Elec. Mega-Trigger Exc. 100.00
Bounton Q-Meter 160A 50KC. to 75MC. Exc. 400.00
* PUR—Price upon request.

WANTED

All types of radio and electronic surplus. We especially need: APA10, APN9, APR4, ARN4, ARC1, ARC3, ART13, ATC, BC221, BC342, BC348, BC611, BC721, BY12, BY17, 1100, 1310 to 1318, MC140F, MC140H, PU14, R5/ARN7, R5A/ARN7, SCR718C, TCS, TN16, TN17, TN19, TN54, TS3, TS13/AP, TS33, TS35, TS45, TS75, TS76, TS102, TS147/CP, TS148/CP, TS173, TS174, TS175, TS250, TS251, TS323, 11CT, 1F, 1G, 5CT, 5DG, 5F, 5G, 6DG, 6G, 11V, 60 c.p.s. Selenium, and all types of Hewlett Packard, General Radio Co., Measurements Corp., Bounton Radio, Ferris, Leeds & Northrup, and other test equipment. Please state accurate description, condition, and your lowest price. Explain modification, if any. We pay freight charges.

NEW SPRING CATALOG NOW AVAILABLE

PHOTOCON SALES

417 N. Foothill Blvd. Sycamore 2-4131
Pasadena 8, Calif. RYan 1-6751
CABLE: Photocon, Pasadena.

signed for capacitive loads of 600, 700, and 750 ma. and are produced for maximum input voltage ratings of 130, 172, and 195 volts r.m.s. The construction of this series differs from regular radio and TV selenium rectifiers.

A bellows-type spring contactor, as used in industrial rectifiers, is employed in the assembly of this series. This contactor affords a lower forward drop, lower temperature rise, and longer life, according to the company.

Bulletin ER-178 Supplement covers the electrical and mechanical specifications on all of the units in the series and is available on request.

"UHF-LAMP"

Metal Products Corporation, 807 Northwest 20th St., Miami, Florida is now offering an all-channel, indoor



u.h.f. antenna enclosed in a table lamp which is designated as the "UHF-Lamp."

The antenna-lamp comes in a variety of color combinations and gives a subdued, light for television rooms. Tests made in five south Florida cities have shown that the antenna-lamp gives good reception in favorable locations up to five miles from low-powered u.h.f. TV stations.

The company will provide additional details on this and other antennas in its line upon request.

REPLACEMENT FLYBACKS

The Standard Division of Chicago Standard Transformer Corporation, Addison and Elston, Chicago 18, Illinois, has added three exact replacement flybacks for Sylvania receivers.

The new units, A-8227, A-8228, and A-8229, cover almost 90 per-cent of all Sylvania production up to 1953. They are supplied as coil and core for quick, easy installation to the original brackets which are a permanent part of the chassis. New filament leads are packed with each transformer.

Stancor Bulletin 478 lists over 170 Sylvania models and chassis using these transformers. It is available without charge from the company's distributors or the company direct.

TRANSMISSION LINES

Fenton Company, 15 Moore St., New York 4, N. Y., has introduced two new transmission lines designed to provide better TV reception by reducing interference pickup.

Known as "Fentube-Airspaced" and "Twistube," the new lines have one plain and one Formvar-coated pure copper conductor. The former has one common covering tube which is firmly fused to the spiral cords. Since there is practically no dielectric between conductors, all of the advantages of an open wire line are incorporated without its disadvantages.

The "Twistube," besides being airspaced, incorporates the added feature of being transposed to equalize the average proximity and thus the capacity of both conductors in relation to the mast and other grounded objects.

SIGNAL EQUALIZER

Tele-Matic Industries, Inc., 1 Joralemon St., Brooklyn, N. Y., has introduced an automatic signal equalizer designed for locations where the signals from the low-frequency channels cause overloading and the high-frequency channels are not strong enough to tolerate any attenuation.

The Model AT-25 provides maximum attenuation of the low-frequency channel and minimum attenuation of the high-frequency channel without upsetting the impedance of the receiver.

TUNER REPLACEMENT KIT

Standard Coil Products Co., Inc. has announced the availability of a new tuner replacement kit which contains the small tuner parts which may be needed by the service technician.

Included are 104 of the most-called-for parts for servicing TV-200, TV-1500, TV-2000, and TV-2200 series tuners made by the company. The majority of parts are individually boxed, permitting the distributor to place the contents in stock or to sell the kit as a complete item to his service trade.

CHANNEL SELECTOR

Tech-Master Products Co., 443 Broadway, New York 13, New York, has announced (Continued on page 142)

NEW SUPER POST TOWERS FOR TELEVISION ANTENNAS IN FRINGE AREAS

TOWERS OF STRENGTH TO LAST A LIFETIME

Self-supporting tower built up of galvanized steel sections. No guy wires necessary. Easy to erect. Safe and resistant to high wind. Available in heights 47 ft., 60 ft., 73 ft., 87 ft., and 100 ft., with bases in proportion.

FRINGE AREA TV BUYERS MUST HAVE SPECIALLY BUILT TOWERS FOR CLEAR RECEPTION

Tower and the TV set go hand in hand as a package sale to rural TV buyers. Provides an extra sale and profit to dealers. An excellent fast selling accessory for jobbers and dealers.

TERRITORIES OPEN FOR JOBBER DEALER FRANCHISE

Write for complete structural details, packing, prices, discounts, and territorial assignment.

MANUFACTURED BY

AERMOTOR CO.

Dept. 6103, 2500 Roosevelt Road, Chicago 8, Illinois
BUILDERS OF STEEL TOWERS SINCE 1888

Available in Heights from 47 ft. to 100 ft.

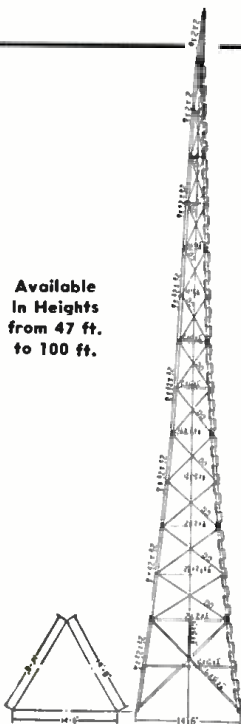

MARCH, 1954

Attention!! • EXECUTIVES • SALESMEN • PUBLIC OFFICIALS
• POLICEMEN • FIREMEN • OUTDOOR MEN
REPORTERS • FIELD INSPECTORS • DOCTORS • LAWYERS, ETC.

Dictate in your CAR

with **ATR**

INVERTERS

for changing your battery current to **A.C. Household CURRENT**

Anywhere . . .
in your own car!!



Announcing!
NEW MODELS
NEW PRICES

EASY TO INSTALL
EASY TO OPERATE

ATR INVERTERS . . . especially designed for operating standard 110 volt A.C. Tape Recorders, Wire Recorders, Dictating Machines and Electric Razors IN YOUR CAR.

A VALUABLE TIME SAVER FOR:

There is an ATR INVERTER for most applications for inverting D.C. Voltages (ranging from 6 volts D.C. to 220 volts D.C.) to 110 volts A.C. . . . Specially Designed for operating A.C. Radios, Tape Recorders, Wire Recorders, Dictating Machines, Electric Razors, Record-Changers, Television Sets, Amplifiers, Address Systems, Radio Test Equipment and most small electrical and electronic devices FROM D.C. VOLTAGES IN AUTOMOBILES, BUSES, TRUCKS, SHIPS, TRAINS, PLANES AND IN D.C. DISTRICTS.

Additional information available upon request.

- TRAVELLING SALESMEN—Dictate reports in your own car. Send your dictated reports in duplicate to your home office or sales manager.
- FIELD INSPECTORS & INVESTIGATORS—Dictate your field inspection reports in the field—on the spot. Give the complete story factually and completely. Include your clients recordings also.
- DOCTORS—Dictate and record your house calls on the completion of your call while everything is fresh in your mind. Have these records for transcription by your office girl.
- LAWYERS—Record evidence in the field of your client's premises. Obtain factual and complete witness reports, etc.
- EXECUTIVES—Dictate in your car all business matters while on trips for pleasure or business.
- PUBLIC OFFICIALS—Dictate complete field reports in your car. Obtain recorded opinions and expressions of Mr. Public in the field. Dictate your business reports while traveling.
- POLICE SQUAD CARS—Dictate accident reports right on the scene complete and factual. Include witness recordings at the same time. Have the complete story available by dictation.
- FIRE TRUCKS—Dictate your fire reports factually and complete on the scene and include witness reports. Have the complete story.
- AMBULANCES—Dictate complete reports of your ambulance run. Include witness recordings, etc.
- ADVERTISING AGENCIES—Use AC operated animated or illuminated displays in or on the car.
- FISHERMEN & HUNTERS—Use your electric razor on Camping trips, operating in your car. Also small home radios and other electrical or electronic items.
- CAMPERS—Make your camping and outing trips more exciting using mis-masters, tape recorders, or wire recorders operating from your car battery.
- WAREHOUSE & MATERIAL HANDLERS—Dictate your inventory and material handling reports on the scene, in the warehouse, yard, or wherever you may be.

Announcing!

NEW ATR INVERTERS

New models New features New prices

WRITE FOR NEW FREE LITERATURE

See your jobber or write factory

✓ NEW MODELS ✓ NEW DESIGNS ✓ NEW LITERATURE

"A" Battery Eliminators, DC-AC Inverters, Auto Radio Vibrators



AMERICAN TELEVISION & RADIO CO.
Quality Products Since 1931

SAINT PAUL 1, MINNESOTA—U. S. A.

BECOME AN ELECTRICAL ENGINEER



**Bachelor of Science Degree
in 36 months.**

Major in Electronics or Power.
Now, prepare for a career in
these rapidly expanding fields.

This school will prepare you to become an engineer, technician or service man. Previous military, academic or practical training may be evaluated for advanced credit.

Enter Both Radio and Television

In 12 months you can attain the *Radio-Technician's* certificate. An added 6 months course qualifies you for the *Radio-TV Technician's* certificate and the Degree of "Associate in Applied Science." The Technician's course is the first third of the program leading to a Bachelor of Science Degree in Electrical Engineering with a major in Electronics.

Also offered: 12-month Radio-TV service course; 12-month Electronics or Electro Technician Courses; 6-month Electrical Service Course and 3-month refresher and general preparatory classes.

Terms Open April, July, Sept., January

Famous for its Concentric Curriculum. Faculty of specialists. 50,000 former students. Annual enrolment from 48 states and 23 overseas countries. Non-profit. 51st year. Courses approved for Veterans. Residence courses only.



MILWAUKEE SCHOOL OF ENGINEERING

MILWAUKEE SCHOOL OF ENGINEERING
Dept. RN-354 1025 N. Milwaukee
Milwaukee 1, Wisconsin

Send: Free 45-page "Your Career" booklet
describing Electrical Engineering Courses;
 Booklet on Careers in Radio-TV.

I am interested in.....
name of course

Name..... Are.....

Address.....

City..... Zone... State.....

If veteran, indicate date of discharge.....

that owners of any 630-type television receiver as well as owners of the company's Models 2430, 2431P, 2430-9, 1930, and C-30 sets, can obtain full 70-station u.h.f. coverage with these receivers by means of a newly-introduced u.h.f. selector.

The Model TV101-U fits into the front recess that is common to all 630-type chassis, thereby requiring no cabinet alterations. Mounting is simple, requiring only two internal connections and the antenna lead. One knob, continuous-tuning covers the entire u.h.f. spectrum.

ANTENNA "ORIENTOR"

Mosley Electronics, Inc., 8622 St. Charles Rock Road, St. Louis 14, Mo., has designed a new aid for TV installers which facilitates u.h.f. and v.h.f. antenna orientation.

Called the "Orientor," the new device consists of two pocket-size units comprising an isolation network that permits the single transmission line to carry the signal to the television set and return the video signal without interaction and with little or no insertion loss.

The video signal can be read in terms of relative strength by means of a portable v.o.m. In this way the in-

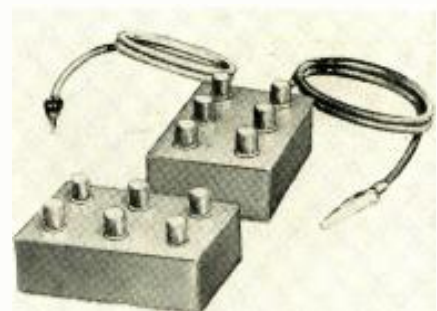

staller on the roof can tell when the TV set is achieving maximum video signal.

Installers are invited to write for a descriptive folder, Form 903. Address all requests to the company direct.

NEW STANDOFF INSULATOR

A new strap-type standoff insulator that accommodates all standard television transmission lines has been announced by *Insuline Corporation of America*, Long Island City, N. Y.

A low-loss polyethylene grommet in the eye of the device holds flat twin-lead ribbon, tubular twin-lead, oval-tubular lead, or coaxial cable securely. An adjustable steel strap permits the insulator to be used on any pipe from 3/4" to 1 1/2" in diameter. The assembly is quickly tightened by means of a captive tension nut, through which the threaded end of the insulator screw-eye passes. All metal surfaces are heavily zinc plated.

FLYBACK CHECKER

Radio City Products Company, 152 W. 25th St., New York, N. Y., is now offering a new instrument for testing the condition of flyback transformers

and yokes in the horizontal output circuit of TV receivers.

Known as the Model 123 "Flybacker," the new unit detects a single shorted turn or a number of shorted



turns in both flybacks and yokes. It also shows up short-circuited windings. A large front meter indicates, on a "good-bad" scale, the condition of the unit.

"SILVER ROCKET" 630 CHASSIS

Mattison Television and Radio Corp., 10 West 181st St., New York 53, N. Y., is now in production on a new 630 chassis which features "synchromatic" tuning.

The new tuning feature was designed to synchronize picture and sound with co-channel circuits. Picture and sound tended to drift apart in extreme fringe areas or on the new u.h.f. channels. The viewer can now tune for the best picture and the sound is adjusted automatically.

The company will forward a booklet on this and other new chassis in the series upon request to the engineering department of the company.

TV LINE INSULATOR

JFD Manufacturing Company, Inc. of Brooklyn 4, N. Y. has introduced a new standoff insulator which has been trademarked "PAL."

Designed for u.h.f. requirements, the new insulator eliminates the necessity



of removing the grommet from the standoff or threading the lead-in through the grommet.

Electrically, this insulator maintains the critical distance between lead-in and metal standoff which prevents impedance mismatch. The new-design insulator is available in every type of the company's standoffs.

Looking Ahead

(Continued from page 43)

his new color television receiver. The importance of this is emphasized by one manufacturer who says his three-gun picture tube can be damaged if the chroma (color) control is advanced too far on a strong signal.

Since all these practical considerations may change as set designers whip production models into shape, the important thing to spend time on now is color fundamentals. What are colors? How is a full color picture formed on the face of a color tube? Of what does the composite signal consist? How do these signals flow through a basic set? These are the questions a good technician will try to answer even before he gets to see a color set.

Much material is being published on color these days. If the service technician doesn't choose his study material carefully he runs the risk of becoming more confused than enlightened. Don't spend too much time with authors who seem more intent on dazzling you with their brilliance rather than work sufficiently hard in presenting their material so you can understand it.

The color system, when understood, will be simple to you. If you choose carefully the material you study it won't be too difficult to absorb.

Color sets will probably be available in limited quantities for consumer purchase this fall. At first, we can look forward to direct interest and even some control of service on the part of some manufacturers. But then there is no doubt that, as time goes on, color receivers, just like their black-and-white brothers, will be serviced principally by servicing dealers and independent service technicians. First there will be an increase in service contracts—then a levelling off.

What with color, hi-fi, tape recorders, and the additional growth of u.h.f. and new markets, the service technician can look forward to a busy and exciting future. I hope you get your share of the rewards.

U.H.F. Antennas

(Continued from page 58)

completed, mount them on the 1 1/4" diameter aluminum tubing. Space the assemblies one above the other according to the dimensions shown on the chart. Two straight lengths of #14 tinned copper wire are used to connect the driven elements only, as shown.

Attach the 300-ohm lead-in as shown at the exact vertical center of the two copper wires. Be sure to seal the open end of the hollow lead-in wire or you may find water running out of your set or converter some rainy night. When all the joints are tightened and all soldering completed, spray the entire antenna with plastic spray or varnish it with waterproof varnish.

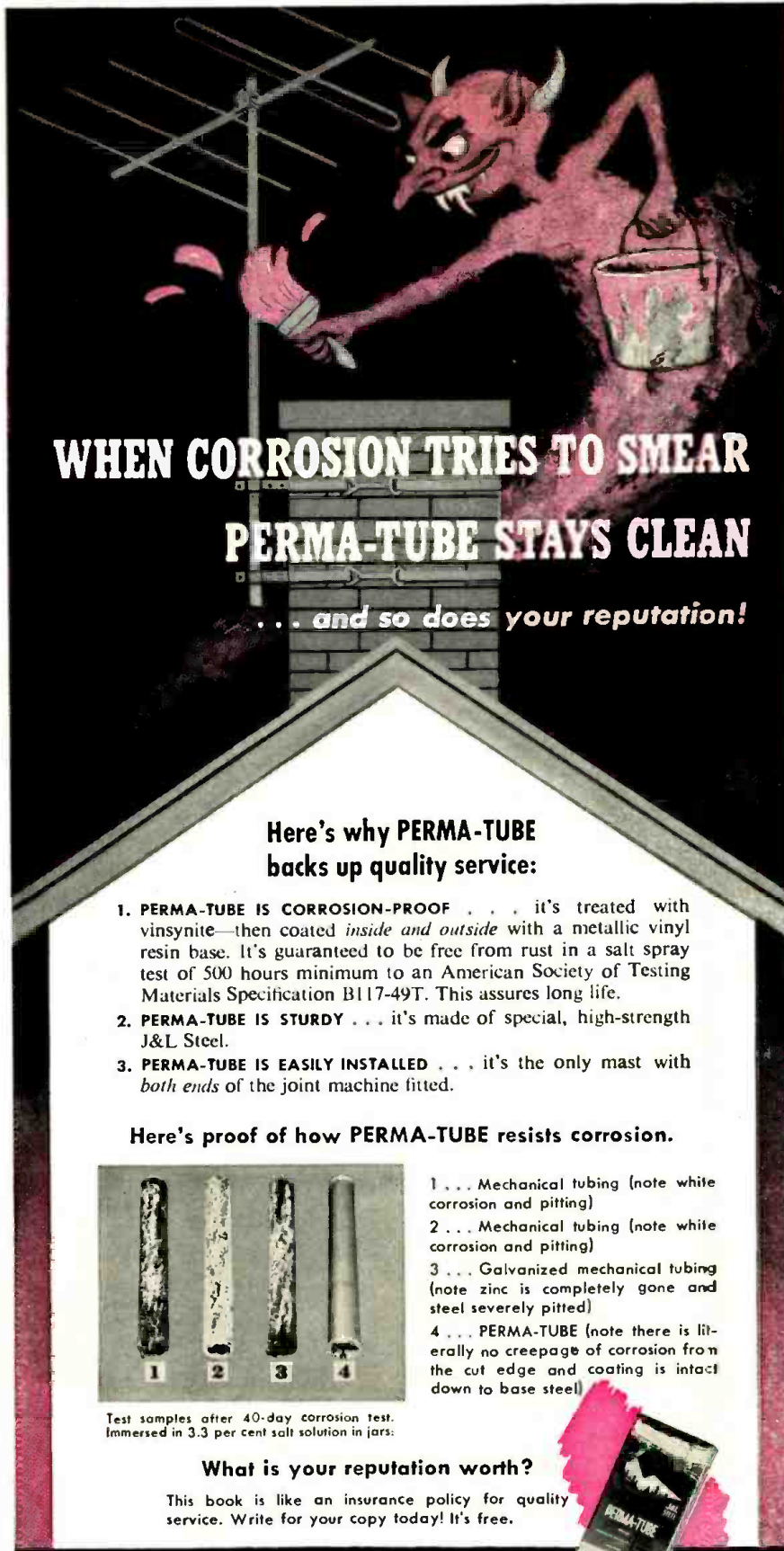

WHEN CORROSION TRIES TO SMEAR PERMA-TUBE STAYS CLEAN

... and so does your reputation!

Here's why PERMA-TUBE backs up quality service:

- PERMA-TUBE IS CORROSION-PROOF** . . . it's treated with vinsynite—then coated *inside and outside* with a metallic vinyl resin base. It's guaranteed to be free from rust in a salt spray test of 500 hours minimum to an American Society of Testing Materials Specification B117-49T. This assures long life.
- PERMA-TUBE IS STURDY** . . . it's made of special, high-strength J&L Steel.
- PERMA-TUBE IS EASILY INSTALLED** . . . it's the only mast with *both ends* of the joint machine fitted.

Here's proof of how PERMA-TUBE resists corrosion.



- 1 . . . Mechanical tubing (note white corrosion and pitting)
- 2 . . . Mechanical tubing (note white corrosion and pitting)
- 3 . . . Galvanized mechanical tubing (note zinc is completely gone and steel severely pitted)
- 4 . . . PERMA-TUBE (note there is literally no creepage of corrosion from the cut edge and coating is intact down to base steel)

Test samples after 40-day corrosion test. Immersed in 3.3 per cent salt solution in jars.

What is your reputation worth?

This book is like an insurance policy for quality service. Write for your copy today! It's free.



J&L STEEL

Jones & Laughlin Steel Corporation
Dept. 495, 3 Gateway Center, Pittsburgh 30, Pa.
Please forward a copy of your "PERMA-TUBE" booklet.

Name _____
Company _____
Address _____

BASIC NEW HIGH FIDELITY DISCOVERY

**Revolutionary
acoustics principle
for enclosures!**

The Karlson Ultra-Fidelity Enclosure is NEW! It embodies an original sound principle—the first such basic invention in years. The Karlson, using the Exponential Coupler, creates a profound sound improvement over all other makes, regardless of price or size.

MODEL 15M



Blond and Mahogany
\$11760

The Karlson Ultra-Fidelity Enclosure is only 34½ inches high, but outperforms horns thirty feet long. Its dimensions are less than 6 cubic feet yet it outdoes a 2700 cubic foot infinite baffle! See and hear the Karlson—unmatched in performance, craftsmanship and beauty.

SPECIAL KIT!

MODEL 15PK

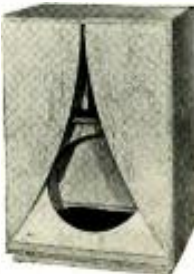

¾" Plywood Kit
\$45.

The Karlson Ultra-Fidelity Rough Plywood Kit. 34 precision cut pieces, exactly routed sides, no special tools required for quick assembly.

NOTE: Buy kit intact—making parts at home extremely difficult.

SPECIFICATIONS OF ENCLOSURES

Size: 34½ x 22½ x 18. Specially designed internal chamber with front and back speaker loading. Fundamental coupling below 25 cycles. Designed for co-axial speakers.

If not yet available at your Hi-Fi dealer, order direct. For further information, write to:

KARLSON ASSOCIATES

INCORPORATED
Receiving Dept.

1379 EAST 15 ST. • B'KLYN 30, N. Y.

TV Test Equipment (Continued from page 49)

large number of spurious outputs, the operator will note few spurious markers on the r.f. response curve.

Spurious markers are especially troublesome when running video amplifier response curves, because numerous harmonics of the marker generator fall within the video passband when the curve is being marked at lower frequencies. For this reason, absorption markers are used to a considerable extent in video amplifier checks. Some sweep generators have absorption marking facilities built in.

Volt-Ohm-Milliammeters

The volt-ohm-milliammeter, or v.o.m., is basically a simple instrument, but is nevertheless the backbone of many a service operation. The v.o.m. is surpassed in usefulness only by the vacuum tube voltmeter.

Circuit loading is a problem in v.o.m. application, and in this respect, the 20,000 ohms-per-volt instrument is superior to the 1000 ohms-per-volt meter. In turn, the 100,000 ohms-per-volt v.o.m. imposes the least circuit loading of any nonelectronic voltmeter.

The prime consideration in choosing a volt-ohm-milliammeter, aside from circuit loading, is the accuracy of indication. In this regard, it is a fairly good rule that one gets what he pays for. The higher priced instruments utilize meter movements with higher full-scale accuracy, and the multiplier resistors are manufactured to higher tolerances. A typical medium priced instrument may have a full-scale accuracy of ±2%, and multiplier resistors with a tolerance of ±1%. The end result is a full-scale accuracy of ±3%.

The beginner sometimes falls into the error of assuming that if the full-scale accuracy is ±3%, any voltage value indicated on the scale will be accurate to within this tolerance. Such an assumption is completely false. An example will illustrate the fallacy of this argument: If the voltmeter is operating on the 100-volt range, the full-scale accuracy of the meter will be ±2 volts. When the pointer reads full scale, or 100 volts, it is true that the accuracy of the meter movement is within ±2%. But consider the situation in which the pointer reads 25 volts on the 100-volt scale; the accuracy is still ±2 volts, which means that the true voltage falls somewhere between 23 and 27 volts—but this is an accuracy of only ±8%! The advisability of using a voltmeter on the lowest possible range is apparent.

Isolating probes cannot be used successfully with a v.o.m., because the relatively large current drain of the instrument entails excessive loss of voltage across the isolating resistor. Furthermore, an isolating resistor which is chosen to provide direct readings on one range, will read incorrect-

STAN-BURN EPA-D-KE

CATHODE RAY TUBE SPECIALS

| One Year Guarantee | | |
|---------------------------------|----------------------------|-----------|
| G. E. | STAN-BURN | STAN-BURN |
| * 7JP4 \$17.10 | 10BP4 \$10.50 | |
| * 10BP4A 19.25 | 12LP4 12.50 | |
| * 10FP4A 24.00 | 12LP4A 14.50 | |
| * 12KP4A 27.10 | 12QP4 12.50 | |
| * 12LP4A 21.70 | 12JP4 12.50 | |
| * 12QP4A/B1014 | 12UP4A 15.00 | |
| Dumont 21.00 | 14CP4 17.00 | |
| * 12UP4B 28.75 | 15DP4 18.50 | |
| * 14CP4 24.50 | 16KP4 18.50 | |
| * 15DP4/B1014 | 16DP4 or A 18.50 | |
| Dumont 23.75 | 16JP4 or A 18.50 | |
| * 16AP4A 30.95 | 16CP4 or A 18.50 | |
| * 16DP4A (N.U.) 25.25 | 16FP4 18.50 | |
| * 16GP4 or B 31.25 | 16WP4 18.50 | |
| * 16KP4/16RP4 24.20 | 16AP4 19.00 | |
| * 16CP4A 78.50 | 16AP4A 23.00 | |
| (Aluminum) 28.75 | 16EP4 19.00 | |
| * 16JP4A (N.U.) 25.25 | 16EP4A 23.50 | |
| * 16LP4A 28.50 | 16GP4 or A 21.00 | |
| * 16WP4A 26.50 | 17BP4 19.50 | |
| * 16GP4B 31.25 | 17CP4A 21.60 | |
| * 17BP4A 24.00 | 17GP4B 22.60 | |
| * 17CP4A 23.90 | 19FP4 23.00 | |
| * 17CP4B 23.90 | 19FP4A 24.00 | |
| (Aluminum) 29.00 | 19AP4 23.90 | |
| * 19AP4A 41.50 | 19AP4A 24.90 | |
| * 20CP4 34.50 | 20CP4 26.00 | |
| * 20LP4 37.50 | 21AP4 26.50 | |
| * 21AP4 42.00 | 21EP4 26.50 | |
| * 21EP4A 36.35 | 24AP4 49.00 | |
| * 24AP4A 78.50 | | |

QUANTITY CRT USERS

We will give you a 10% allowance if you ship them to us Prepaid. 10 CRT's minimum shipment. WRITE FOR DETAILS.

| ANTENNA SPECIALS | | |
|---|------|------------------|
| * RED DOUBLE "V" Antenna \$2.19 | 1-5 | 6 or more \$1.98 |
| * 10 ELEMENT CONICAL DOVELEDED INSERTS 2.98 | 2.98 | 2.79 |
| * Folded Hi Straight Low Quick Rig 1/2" elements 4.25 | 4.25 | 3.25 |
| * WINDOW CONICALS 4.95 | 4.95 | 3.75 |
| * 5 FOOT SWEGGED79 | .79 | .69 |
| * MASTS 10 FOOT PLAIN 1.39 | 1.39 | 1.29 |
| * NEPCO MASTS 1.69 | 1.69 | 1.49 |
| * TV WIRE 42 Mil. 300 OHM \$ 9.95 M Ft. | | |
| 55 Mil. 300 OHM 11.95 M Ft. | | |
| 72 OHM COAXIAL 35.00 M Ft. | | |

* CHASSIS 630 TECH-MASTER Model C40 with Cascade Tuner \$149.50

* OPEN FACE CABINET 42.00

* TAPE RECORDERS IN STOCK

* PENTRON — Model 9T3C — 2-speed Tune Indicator Write for Price.

* RADIO CRAFTSMAN Model C400—Hi-Fi Amplifier Net 42.90

* Model C10—AM-FM Tuner Net 131.80

* Model C500—Williamson Amplifier Net 99.50

* We also carry MASCO—BOGEN—PILOT, etc., Amplifiers, Pre-Amps, FM Tuners and WESTER Tape Recorders.

* 6x9 PM Speaker \$ 3.98

* 7" PM Speaker 3.98

* 70" Yoke 1.98

* 630 Vert. output 1.98

* 630 Vert. output 1.29

* 630 Vert. output 1.29

* 630 Vert. output 1.29

* 630 Vert. output 1.29

* 630 Vert. output 1.29

* 630 Vert. output 1.29

* 630 Vert. output 1.29

* 630 Vert. output 1.29

* 630 Vert. output 1.29

* 630 Vert. output 1.29

* 630 Vert. output 1.29

* 630 Vert. output 1.29

* 630 Vert. output 1.29

* 630 Vert. output 1.29

* 630 Vert. output 1.29

* 630 Vert. output 1.29

* 630 Vert. output 1.29

* 630 Vert. output 1.29

* 630 Vert. output 1.29

* 630 Vert. output 1.29

* 630 Vert. output 1.29

* 630 Vert. output 1.29

* 630 Vert. output 1.29

* 630 Vert. output 1.29

* 630 Vert. output 1.29

* 630 Vert. output 1.29

* 630 Vert. output 1.29

* 630 Vert. output 1.29

* 630 Vert. output 1.29

* 630 Vert. output 1.29

* 630 Vert. output 1.29

* 630 Vert. output 1.29

* 630 Vert. output 1.29

* 630 Vert. output 1.29

* 630 Vert. output 1.29

* 630 Vert. output 1.29

* 630 Vert. output 1.29

* 630 Vert. output 1.29

* 630 Vert. output 1.29

* 630 Vert. output 1.29

* 630 Vert. output 1.29

* 630 Vert. output 1.29

STAN-BURN RADIO and ELECTRONICS CO.
(C.S.S. THEATRE BLDG.)
1697 BROADWAY • NEW YORK 19, N.Y.

**ENJOY 3 COLOR TELEVISION
FILTER SCREEN NOW**
Changes dull eye-straining black and white pictures into beautiful color tones. Screen to attach. No tools used. Helps eliminate glare. Order direct. Send \$1 for screen size up to 16" — \$1.25 size 17" — \$1.50 size 20" — \$2 size 21" — \$2.50 size 24" — \$3 size 27" (Also available are single solid color screens in blue, green, or amber.) Prices on solid color screens are 10% less. We pay postage except on C.O.D. orders. Satisfaction guaranteed. Inquiries from dealers also welcomed.
Zingo Products, Johnstown 19, New York

**REVOLUTIONARY
NEW TYPE TV ANTENNA WINS!
THE OCTO-TENNA**
proves superior against all competition in 97 out of 100 comparison tests in difficult signal areas.
DEALERS: This is IT!
Contact C. R. DERR CO.
1018 TAYLOR AVE. VALLEJO, CALIF.

ly on the next higher range, because the input resistance of the instrument is not constant. The input resistance on any one range is equal to the full-scale value of the range times the ohms-per-volt rating of the instrument; for example, a 100,000 ohms-per-volt instrument has an input resistance of 1 megohm on the 10-volt range, but an input resistance of 10 megohms on the 100-volt range.

The V.T.V.M.

Most v.t.v.m.'s have automatic protection against burnout, which avoids severe damage to the instrument when applied across excessively high voltages. Aside from this important feature in practical work, a v.t.v.m. provides high input resistance on low-voltage ranges, which makes it possible to measure a.g.c. voltages, signal-developed grid bias, and plate-voltage values in pentode amplifier circuits. Almost all service v.t.v.m.'s are designed with an isolating probe for use on the d.c. ranges, so that d.c. voltages can be measured in the presence of high-frequency a.c.

The input resistance of a v.t.v.m. is constant (usually at 10 or 15 megohms) so that when a high-voltage d.c. multiplier probe is used with the instrument, the probe can be used on the low-voltage ranges as well as on the high-voltage ranges. Thus, a v.t.v.m. can be used not only to measure the second anode voltage of a picture tube, for example, but can also be used to measure relatively low d.c. voltage values in the presence of high-voltage a.c. pulses, such as the plate voltage of a horizontal oscillator tube. In the latter application, the high-voltage d.c. probe is being used as an a.c. filter, and the d.c. voltage attenuation is incidental; because of the constant input resistance provided by the v.t.v.m. the probe reads directly on any scale, indicating 1/100 of the applied d.c. voltage.

Many present-day service v.t.v.m.'s provide for measurement of peak-to-peak voltage values. Some instruments have a built-in peak-to-peak voltage indicating network, while others obtain peak-to-peak indication by means of an external probe. The built-in arrangement has an advantage in that higher voltages can be accommodated without damage to the instrument, but has the disadvantage that the input capacitance is somewhat higher, with correspondingly greater circuit loading.

The ohmmeter function of the electronic ohmmeter built into the service v.t.v.m. is superior to that of the v.o.m., since resistances as high as 1000 megohms can be measured with an ohmmeter battery of only 1.5 volts. This is a great advantage, since various delicate circuit components can be damaged by higher voltages.

The accuracy of a v.t.v.m. is seldom as high as that of a v.o.m., but against this, are the advantages afforded by electronic protection against overload, and wider measuring facilities. —30—

MARCH, 1954

WE'RE IN OUR NEW BUILDING!



Leo I. Meyerson
WØGFQ



We are now operating from our new ultra-modern electronics building — geared for greater efficiency and faster, more complete PERSONALIZED service than ever before!

HALLICRAFTERS S-40B \$119.95 | HALLICRAFTERS SX-88 \$595.00



\$954 Per Month
(12 months)

\$12.00 CASH DOWN

Communication receiver with built in speaker covering 540-Kc to 44 Mc in four bands. One RF stage, 2 IF stages.



\$4730 Per Month
(12 months)
\$59.95 CASH DOWN
\$32.42 18 MONTHS

Dual Conversion Receiver 535-33.3-Kc in 6 bands. 2 RF stages, variable 6 position band width selectivity, 250 cycles to 10 Kc. 10 watt audio output. 17 tubes plus voltage regulator, ballast tube and rectifier.

HALLICRAFTERS RECEIVERS AVAILABLE FOR IMMEDIATE SHIPMENT

| MODEL NUMBER | 12 MONTHLY PAYMENTS | DOWN PAYMENT | CASH PRICE | MODEL NUMBER | 18 MONTHLY PAYMENTS | DOWN PAYMENT | CASH PRICE |
|--------------|---------------------|--------------|------------|--------------|---------------------|--------------|------------|
| S-38C | \$3.97 | \$ 5.00 | \$ 49.95 | S-76 | \$10.90 | \$20.00 | \$199.95 |
| S-53A | \$7.95 | \$10.00 | \$ 99.95 | SX-62 | \$19.07 | \$35.00 | \$349.95 |
| S-72 Port | \$8.74 | \$11.00 | \$109.95 | SX-71 | \$13.62 | \$25.00 | \$249.95 |
| S-77A | \$9.54 | \$12.00 | \$119.95 | HT-20XMTR | \$24.50 | \$44.95 | \$449.50 |



FREE 1954 CATALOG

WRITE—WIRE
PHONE 2-0277

Get your BIG NEW 1954 WRL CATALOG, offering the greatest selection of radio and television equipment, parts and supplies for the Novice, Experimenters, Hams and Professionals.

WORLD RADIO LABORATORIES R-3
3415-27 W. Broadway
Council Bluffs, Iowa

Please send me:

- 3' x 4' U.S. Radio Map 25c
 New Catalog
 Used Equipment List
- WRL XMTR Info
 SX-88 Info
 S-40B Info
 NEW LOG BOOK 25c

Name _____

Address _____

City _____

State _____

HELP WANTED!

This established radio & television manufacturing firm in Western New York has openings for:

Test Engineers
Technicians

Trouble Shooters
Aligners

Applications should contain details of past experience. Write to

Personnel Manager, H. E. Dudley

STROMBERG-CARLSON COMPANY, Rochester 3, New York

INVENTORY SALE!

DEDUCT 10% FROM ALL PRICES FOR THIS MONTH ONLY.

WESTON METERS

Model 301, RECTIFIER TYPE
0-150 Volts AC, 1000 ohms per volt AC, \$9.95 Ea.
Round bakelite case.
NEW! BOXED10 for \$89.95

OTHER WESTON MODEL 301—

0-100 Microamp DC (Spec. Scale) \$10.95
0-200 Microamps DC 9.95
0-10 Volts DC (1000 ohms/v) 7.95
0-1 Ma (KV Scale) 7.95
0-50 Ma DC 7.95
0-1.5 Mills DC 7.95

MODEL 731

0-200 Microamps (Spec. Scale) 9.95
0-1 Ma (0-100 Scale) 8.95

MODEL 506

0-200 Microamps 7.95
0-1 KV with Mult 7.95

WESTERN ELECTRIC METERS

3 1/2 Inch round

100-0-100 Microamps DC 8.95
0-1.5 Ma DC 5.95

WESTINGHOUSE METERS—Model NX35

0-500 Microamps (0-100 Scale) 6.95

GENERAL ELECTRIC

0-150 Volt AC—Model AO 22 7.95
0.3 Amp RF w/thermo—Model D044 7.95
0.5 Amp RF w/thermo—Model D044 7.95
Running Time, 99,999 Hours, 115 V., 60 cy. 10.95

WESTON FREQUENCY METER

Model 814, 300 to 450 cycles, 100 to 125 Volts. Regular Price \$100.00.

Our Price, Brand New **\$39.95 EA.**

G. E. RELAY CONTROL

(Ideal for Model Controls, Etc.)

Contains a sigma midget 8,000 ohm, relay (trips at less than 2 MA), high impedance choke, bi-metal strip, neon pilot and many useful parts. The sensitive relay alone is worth much more than the total. **\$1.25 Each 10 for \$9.90**
low price of

Panel Meters

NEW GOVT SURPLUS STANDARD BRANDS 2" METERS
DB meter—10 to +20 \$3.49
0-80 ma DC 3.49
3" METERS
0-200 Microamps \$6.95
0-400 Microamps 5.95
0-500 Microamps 5.95
0-200 Millamp 4.50
0-250 Millamp 4.50
0-1000 Millamp 4.50
0-1.5 Volts AC 4.95
0-3 Volts AC 4.95
4" METERS
0-200 Microamps \$8.95

OIL CONDENSERS

4 MFD—600 VDC95
2 MFD—1000 VDC95
6 MFD—1500 VDC 2.95
2 MFD—2000 VDC 2.50
4 MFD—2000 VDC 5.50
2 MFD—2500 VDC 3.95
3 MFD—4000 VDC 5.95
1 MFD—5000 VDC 3.95
2 MFD—5000 VDC 5.95
50 MFD—330 VAC 6.95
1 mfd 750VDC 1.75
1 MFD 20 KVDC 49.95
15 MFD 5 KVDC 49.95
8 mfd 60 VAC 2.95

NON-INDUCTIVE RESISTORS

Ohmite, 250 Ohm, 100 Watt. **\$9.95**
Special, 5 for \$25.50

FILTER CHOKES

4 Henry, 500 ma DC., fully cased. Cracked Insulators, guaranteed O.K. electrically. Each **\$2.95**

SOLA CONSTANT VOLT TRANSFORMERS

Input 95-125 V 60 Cy Output Regulated 115V
250 VA \$33.65
500 VA 48.65
1 KVA 79.95

NATIONAL "S" METER

2", Illuminated Scale. Marked "Tune for Max." 0-1 MA movement. BRAND NEW **\$2.95**

WIRE WOUND RESISTOR KITS

25 assorted 10 Watt \$1.95
25 assorted 20 Watt 2.50
50 assorted 5, 10, 20, and 50 Watt 4.95

WIRE WOUND RESISTORS

Stock too long to list. We can supply most sizes, so order what you need.
10 Watts. From 1 Ohm to 70K Ohms \$.15
20 Watts. From 4 Ohms to 50K Ohms20
25 Watts. From 1 Ohm to 100K Ohms30
50 Watts. From 5 Ohms to 100K Ohms40
100 Watts. From 50 Ohms to 100K Ohms50

ADJUSTABLE SLIDER, WIRE WOUND

10 Watts from 1 Ohm to 10K \$.25
25 Watts from 20 Ohms to 2.5K35

EIMAC VACUUM CONDENSERS

6 MMF 32 KVDC (VC 6-32) \$ 9.95
12 MMF 32 KVDC (VC 12-32) 10.95
50 MMF 32 KVDC (VC 50-32) 12.95
100 MMF 5 KVDC G.E. 4.95

Min. Order \$3.00—25% with Order

PEAK ELECTRONICS CO.

66 West Broadway, New York 7, N. Y.
Phone WO rth 2-5439

Electronic Key

(Continued from page 81)

make it necessary to increase or decrease this resistor for a correct two-to-one ratio. The higher the value of R_2 , the greater the dash-to-dot ratio. The value of R_2 shown in Fig. 3 gave a two-to-one ratio as determined by an electric counter. The ratio can be determined fairly close by ear, or by slowing the key down so that dots and dashes can be counted. Experience has shown that for correct adjustment, the ratio should be determined by counting rather than by listening to the relay clicks or an oscillator.

The photographs show the general construction procedure followed. Although the parts were mounted in a 4" x 5" x 6" metal box, a 5" x 7" x 3" aluminum chassis would be easier to drill.

In the photograph of Fig. 1 the speed control, R_3 , was mounted to the left of the 2D21. The "weight" and balancing control, R_{10} , was mounted to the left of the 12AU7, V_2 . The cathode potentiometer was mounted below V_2 . In order to accommodate the three wire connection to the "bug," a three way plug and jack were used. The jack, J_2 , is mounted to the right of the "on-off" switch, and insulated from the chassis.

The photograph of the "bug," Fig. 2, shows the three-conductor cable fastened to the spring arm stop with a cable clamp. The connection to the dash contact post is made below the bug after the strap from the dash contact post to the dot contact post was removed. By loosening the dot contact post, enough clearance between the metal washer and the stud can be obtained to accommodate a solder lug. To keep the spring arm from bouncing when dots are being made, a rubber band was used to keep the end of the spring arm against the spring arm stop. Only the necessary "bug" modifications are shown, and the reader will undoubtedly have ideas on how to adjust his own "bug." However, for a better "feel" the spacing between contacts should be closer than normally used with a "bug."

The circuit can be easily adjusted by using a vacuum tube voltmeter and an ohmmeter, or combination test instrument.

First, hold the "bug" lever to close the dot contact, and connect the v.t.v.m. between the cathode of V_{2A} and ground. Adjust the speed control potentiometer, R_3 , until a varying voltage is noticed on the meter. Set the speed control so that the meter pointer is nearly steady. Note this value.

Next, place the v.t.v.m. across the cathode of V_{2B} and ground. The dot contact should still be closed. Adjust R_2 to give the same average voltage as before.

Release the "bug" lever and connect the v.t.v.m. across the relay winding with the positive meter terminal to the plate end of the relay winding. Adjust

the balancing potentiometer, R_{10} , to show zero voltage across the relay. Momentarily ground the grid of V_{2B} and note the voltage.

Close the dot contact and adjust R_2 until half of this reading is obtained. The relay may not operate at this time.

Set the v.t.v.m. or ohmmeter to indicate $R \times 10$, $R \times 100$, or $R \times 1000$ and calibrate it in the usual manner. Connect the ohmmeter across the armature and keying contact of the relay. Hold the dot contact closed as before and adjust the relay to give mid-scale indication on the ohmmeter. This generally will insure proper adjustment of the relay. Now close the dash contact on the "bug" and note that the ohmmeter indicates about three-quarters full scale or three-fourths of the way toward the "zero ohms" end of the scale. Rechecking the voltages and rebalancing, as described, will insure that proper adjustments have been made.

If the relay is a non-adjustable type, use the "weight"-balance control, R_{10} , to give the mid-scale indication.

If the dash-to-dot ratio is too great, a lower value of resistor should be tried between the grid of V_{2A} and the timing condenser. Due to the circuit elements in the keying circuit of the transmitter, the "weight" control, R_{10} , should be used in adjusting the transmitted signal.

Relays

Voltage readings under various conditions for four different types of relays are shown in Table 1. These readings were obtained after each relay was connected in the circuit and adjusted as previously described. The voltages shown in the chart, which should be the same, will vary one or two volts depending upon the power line voltage at the time the readings were taken.

The relay marked "BK-35," which was found as a surplus item, is ideal for this circuit, but three others were also checked for performance and ease of adjustment. The *Ward Leonard* relay was purchased about seven years ago, but could not be found in any of the present day catalogues. However, a catalogue number 25038 marked on the relay might be helpful in locating a similar one from the manufacturer. Since it is constructed along the same lines as the "BK-35" relay, it is easy to adjust the contact spacing and spring tension. On the other hand, the only method of adjusting the contact spacing on the *Potter & Brumfield* type LM5 is to bend the back contact down with a pair of pliers. The amount of bend required is shown in the photograph of Fig. 4. The spring tension is adjusted by means of a screw at the top of the relay. The distance between the armature and the pole piece should be about the thickness of a sheet of good-grade typewriter paper for best results. After a few repeated adjustments, this relay worked as well as the others. The *Western Electric* relay is a sealed, non-adjustable type, polar relay which fits a standard octal socket. Since it is sealed-in-glass mercury con-

tact switch whose characteristics are fixed by its design and manufacture, no adjustments are necessary for keying purposes. It was included in the list to show that a non-adjustable type relay having a medium coil resistance would work satisfactorily. However, the relay should be a sensitive plate relay with a winding of from 2000 to 12,000 ohms.

The circuit shown was designed for economy, low supply voltage; a minimum of parts; and ease of adjustment. The low priced semi-automatic key was purchased from the *Electric Specialty Mfg. Co.*, Cedar Rapids, Iowa. As long as the plate voltage does not vary over 10% higher or lower (20% total) the "weight"-balance control, R_{in} , and the speed control will adjust the circuit for different voltages. The only reason for using the 2D21 instead of the larger 2050 was to conserve space.

In closing, the writer wishes to thank W5FRE for his assistance in the construction of the keyer. —30—

RUMBLE FILTER

By DAVID KESSEL

THE current trend toward improved low-frequency response in amplifiers and speaker systems has resulted in a corresponding increase in the audibility of so-called turntable rumble. This is especially true of the average system in which a three-speed changer and a loudness control are used.

The most economical method of reducing response below 40 cycles is the insertion of a parallel "T" section between the equalizer tube and the next (high impedance) stage. Unfortunately the mathematics involved in the computation of circuit components for the "T" filter seems to discourage many experimenters.

The author has tested several "T" filters and found that a circuit with a resonant frequency (frequency of minimum response) of 8 cycles eliminates practically all of the Garrard and Webster-Chicago rumble with little effect on frequencies above 40 cycles. The response is down 5 db at 25 cycles; 20 db at 10 cycles; and 20 db at 5 cycles. Apparently most rumble occurs between these frequencies. If this filter is connected in the preamp with a d.p.d.t. switch, the decrease in speaker vibration with the filter switched in is immediately noticeable. —30—

A simple turntable rumble filter.

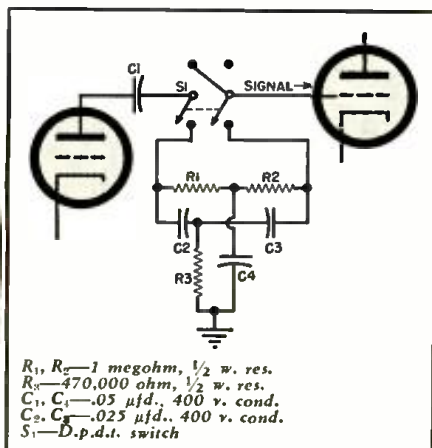

A fascinating field! A great future! A good job or independence in a business of your own! TV is growing by leaps and bounds—1227 new communities, 1845 new stations given "go-ahead". Trained men are worth their weight in gold!

COYNE HAS TRAINED MORE SUCCESSFUL MEN

Thousands of successful men trained at COYNE—the largest, oldest, best-equipped school of its kind (established 1899). A Coyne-trained man is a top-trained man. Coyne methods require no advanced education or previous experience.

TRAINING TAILORED TO MEET YOUR NEEDS

Resident Shop Training—You can learn on real equipment in the Great Shops of Coyne. Learn quickly—easily at Coyne. Practical Technical method gives practical experience on massive outlay of full-size equipment plus necessary technical training. Finance Plan whereby you can enroll now and pay most of tuition later. Also Monthly Payment Plan especially designed for K-Vets. If you need part-time work to help out with living expenses while at COYNE, we'll help you get it. Coupon brings FREE BOOK and details.

OR

Coyne Tested Home Training—To those who cannot come to the Coyne shops here in Chicago, we offer modern, up-to-the-minute training designed to meet Coyne standards. Practical, down-to-earth, easy to follow, step-by-step instruction. So practical, you can quickly be earning money in

B. W. COOKE, President FOUNDED 1899

COYNE ELECTRICAL SCHOOL

A TECHNICAL TRADE INSTITUTE CHARTERED

NOT FOR PROFIT

500 S. Paulina Street, Chicago 12, Dept. 34-HR5
ELECTRICITY • RADIO • TELEVISION • REFRIGERATION • ELECTRONICS

Television and Radio while learning—personal supervision by Coyne Staff—men who know TELEVISION AND RADIO, AND KNOW HOW TO TEACH IT—and the cost is low—you pay only for training—no costly extras. Send coupon below for Picture Folder and full details, including easy Payment Plan.

MAIL COUPON FOR FREE INFORMATION

Fill in and mail coupon, TODAY. Check the training you're interested in. If you want information on both, check both. Complete details will come by return mail. No cost—No obligation—No salesman will call.



B. W. COOKE, President
 COYNE ELECTRICAL SCHOOL
 500 S. Paulina Street, Chicago 12
 Dept. 34-HR5
 Send details of your offer on training checked below. This does not obligate me and no salesman will call. I am interested in:
 TELEVISION-RADIO HOME TRAINING
 TELEVISION-RADIO IN COYNE SHOPS
 Name
 Address
 City State

TUBES

RCA, G.E., SYLVANIA, CBS
AT TREMENDOUS SAVINGS OVER
REGULAR WHOLESALE

OTHER TUBES AVAILABLE AT SAME LOW, LOW PRICES

| Latest Code | Dates | Boxed | Fully RTMA | Guaranteed |
|-------------|-------|-------|------------|------------|
| 024 | .62 | 6A5 | .63 | 6C86 .76 |
| 183 | .95 | 6AQ5 | .76 | 6CD6 1.98 |
| 1X2 | 1.06 | 6AU6 | .67 | 6J6 .92 |
| 5U4 | .63 | 6AV6 | .60 | 6K6 .65 |
| 5Y3 | .48 | 6BA6 | .71 | 6SN7 .85 |
| 6AB4 | .80 | 6BG6 | 1.98 | 6S4 .73 |
| 6AC7 | 1.25 | 6BK7 | 1.28 | 6V6GT .75 |
| 6AG5 | .83 | 6BQ6 | 1.42 | 6W4 .70 |
| 6AH6 | 1.40 | 6BQ7 | 1.42 | 12AT7 1.05 |
| 6AK5 | 1.30 | 6BZ7 | 1.52 | 12AU7 .85 |
| | | | | 50L6 .75 |

| Brand New Pix Tubes | Full One Year Guarantee | | |
|---------------------|-------------------------|----------------|-------|
| 10BP4...10.50 | 10.00 | 16RP4...18.50 | 16.00 |
| 12LP4...12.50 | 12.00 | 17BP4...19.50 | 17.00 |
| 12LP4A...13.50 | 12.00 | 17CP4...21.00 | 18.00 |
| 16AP4...19.00 | 17.00 | 19AP4...25.00 | 20.00 |
| 16AP4A...24.00 | 17.00 | 19AP4A...24.00 | 20.00 |
| 16DP4/A...17.50 | 16.00 | 20CP4...25.00 | 20.00 |
| 16GP4...20.50 | 17.00 | 21EP4...27.00 | 21.00 |

STUART ELECTRONIC DISTRIBUTORS

Dept.—R12

Minimum Order \$10.00

149-09 Union Turnpike
Flushing 67, N. Y.

Olympia 8-3553, 4352

TERMS: 25% Check or Money Order, Balance C.O.D., F.O.B. New York. Satisfaction Guaranteed.

Bargain in Broadcast Quality TAPE RECORDER MECHANISM

38.75



Model 90 "Ultra-Audio" tape transport mechanism complete with high quality record-erase-playback dual track head, 110 volt, 60 cycle induction motor, rewind, accessories and hi-quality plastic base recording tape.

USE WITH ANY HI-GAIN AMPLIFIER

The "Ultra-Audio" tape transport mechanism comes complete with convenient terminals and full instructions which permit its application to your present amplifier, phono-radio, or other audio unit, for the making, reproduction and erase of tapes, just as any standard tape recorder. This machine is ideal for the hi-hi enthusiast, the experimenter, the radio ham, or commercial user. It is identical to that provided for our commercial outlets. Little experience is required to follow simple instructions and comprehensive circuit diagrams to connect to almost any radio or audio unit for full life-like performance.

Records—Reproduces—Erases, At Two Speeds

Simple change over parts furnished permit operation at either 7 1/2 or 3 3/4 inches per second speeds. A number of circuit diagrams with clear instructions are provided to enable even the novice to construct special amplifiers, etc., at minimum cost to obtain results comparable to that of recorders selling for many hundreds of dollars. Machine will operate with any amplifier capable of being excited by crystal pickup or magnetic phono, and with most radios. Unit comes complete, ready to connect and use. Provided with convenient mounting lugs. The fine professional appearance of this unit will make any user proud to display his "Ultra-Audio" Model 90. MONEY BACK GUARANTEE.

The Model 90 tape transport mechanism was initially developed by the engineers of the Ultra-Audio Broadcasting System for our own use to provide an extremely rugged and simple unit with sufficient mechanical stability to meet commercial and broadcast requirements. It was felt that such design could be achieved by following a careful program of simplicity and removing many of the "frills" at a cost much lower than we were compelled to pay for so-called "professional" units and eliminate a great deal of the constant servicing, repair, and adjustment expense of such units as were available to us.

Available at no cost to the purchasers and users of Ultra-Audio Broadcasting System equipment are the full facilities and services of our engineering staff.

FIRST COME—FIRST SERVED

ORDER FROM
EQUIPMENT-SERVICE DIVISION

Ultra-Audio Broadcasting System
BOX 243, SAN DIEGO (12), CALIFORNIA

(Shipped pre-paid on cash with order—otherwise charges collect. 1/2 cash with order on all C.O.D.'s.) All orders subject to possible two weeks' delay.

Communications Receiver

(Continued from page 67)

permitting use of a wide variety of headphones. The speaker is silenced when the headphones are inserted into the jack. A larger external speaker, with an impedance of 4-8 ohms, may be plugged into the headphone jack if so desired.

Two slide-rule tuning dials are used, one the main tuning dial and the other the bandsread tuning dial.

The main tuning dial has four scales marked "A," "B," "C," and "D" corresponding to the four bands of frequencies tuned by the NC-88, the position of the red dot on the "selector" switch indicating which of these scales is to be read. Heavy white lines have been placed on certain portions of the short-wave bands corresponding to important frequencies along with a letter to designate the agency which uses each. That is, the letter A above a heavy white line indicates a band used chiefly by amateurs, while the letter F denotes use by foreign countries, the letter S, ships, and P, police. There are also small white circles at various points on the scales enclosing an identifying number or letter. These circles indicate the correct setting of the main tuning dial pointer when bandsread tuning is to be used on that band. They are discussed in the paragraph on bandsread tuning. The two circles enclosing the letters CD on the broadcast band, however, indicate the two civil defense frequencies and are dealt with in the paragraph on those frequencies.

The "bandsread" dial has five scales calibrated directly in mc. plus a logging scale graduated from 0 to 100. These scales are identified by a letter to indicate the receiver band to be used for a particular amateur band and a number to indicate the amateur band being tuned, with the exception of the logging scale which is identified by the word "log." Six principal amateur bands have been calibrated on the dial, the "log" scale serving for calibration purposes on any other band within the range of the receiver.

Recently the Federal Communications Commission authorized the frequencies 640 and 1240 kc. for use by broadcast stations in the event the United States should be placed under threat of air attack. In that event all transmitters will be required by law to immediately cease all operation, with broadcast stations resuming operation only on those two frequencies. Accordingly, these frequencies have been clearly marked on the "A" scale of the NC-88 and are identified by circles enclosing the letters, "CD." To receive either of these two frequencies place the receiver in operation for the broadcast band and set the bandsread pointer on the "set" mark. Then set the "main tuning" dial pointer in the center of either of the two circles and the receiver will be set up for proper reception of emergency bulletins. —30—

Editors and Engineers PUBLICATIONS



RADIO HANDBOOK
THE GREAT
ONE-VOLUME
LIBRARY OF RADIO
INFORMATION
734 PAGES!

RADIO HANDBOOK, GIANT 13TH EDITION. A one-volume library of radio information with extensive, simplified theory. Detailed how-to-build-it data on dozens of items of practical radio equipment. Book No. E&E-RH13...\$6.00*

BETTER TV RECEPTION (in fringe and low-signal areas). **NEW SECOND EDITION.** The standard guide for installation technicians. A popular text for TV enthusiasts. Book No. E&E-TR2...\$2.50*

SURPLUS RADIO CONVERSION MANUAL, VOL. 1. Practical conversions. Write for list of contents. Book No. E&E-SM1...\$2.50*

SURPLUS RADIO CONVERSION MANUAL, VOL. 2. Companion to Volume 1. Book No. E&E-SM2...\$2.50*

WORLD'S RADIO TUBES (BRANS' VADE MECUM). NEW 9TH EDITION. Lists over 15,000 tubes from every tube making country. Printed in 16 languages. Book No. E&E-VM9...\$5.00*

RADIOTELEPHONE LICENSE MANUAL. Typical study questions with concise answers for any commercial U.S.A. radiotelephone operators license. Book No. E&E-RL1...\$3.75*

*Plus any tax.

BUY FROM YOUR DISTRIBUTOR
ADD 10% ON DIRECT MAIL ORDERS TO
EDITORS AND ENGINEERS, Ltd.
BOX 4895, SANTA BARBARA, CALIF.
Proceeds from sales to BAKER & TAYLOR, HAWAII, N. H.

STAY ON THE AIR WHEN POWER FAILS...with an ONAN Electric Plant



**AUTOMATIC
START & STOP**

Model 10EL, 10KW A.C.

When storms, floods, or fires interrupt electricity and force you off the air, you lose listeners and income. Guard against loss, assure vital public service during emergencies by installing an Onan Electric Plant. Onan Standby Electric plants serve many network and private stations. Gasoline driven automatic models to 50,000 watts.



PORTABLE ELECTRIC PLANTS FOR MOBILE RADIO USES
Supply A.C. power for broadcasting at scene of events. Light in weight. Can be carried by hand or in trunk of car. A.C. models: 400 to 3,500 watts.

Write for **FREE Folder**

D. W. ONAN & SONS INC.
7901 University Avenue
Minneapolis 14, Minnesota

TV Troubleshooting Methods
(Continued from page 65)

good, but what if it doesn't work? For example, what if signal tracing shows all of the stages of the suspected section to be all right? We may have suspected an innocent section; signal trace other sections which could possibly be guilty and, as a last resort, signal trace the supposedly "innocent bystanders."

What if all of the components in the suspected stage check all right? You guessed it: check the components in other related stages.

Why not just check all of the components and adjustments in the receiver on every job and forget all about the systematic procedure? It may be all right in theory, but what good is it if it may not always work? The answer is that it does work often enough to save most of the time which would otherwise be spent on random checking of components and adjustments. Also, it can be combined with the other two techniques previously mentioned.

Faults which occur frequently enough to be worth checking on even without any definite indication are: bad tubes, blown fuses, and poor connections in the antenna system. These things can also be included among those easy to check, along with visible faults such as broken components and open or shorted wires, and the effects of manipulating the various controls and adjustments, of tuning to a different channel, or of operating the receiver at a different time or in a different location.

A practical troubleshooting procedure should include steps such as the following, subject to modification depending on the indications observed and the available equipment:

1. Have set-owner demonstrate and describe trouble.
2. Observe effects of front-panel controls and adjustments. (Any adjustment whose manipulation does not produce an improvement should be returned to its original position.) Check back-of-chassis adjustments, antenna connections, and anything else accessible.
3. By functional analysis, determine section probably faulty.
4. Remove back cover, insert a.c. interlock bypass ("cheater" cord). Adjust ion trap magnet. (They usually need adjustment.) Check whether all tubes are lighted. Refer to tube location guide and replace tubes in suspected section. If no replacement parts except tubes are immediately available, check other tubes.
5. If vacuum tube voltmeter, test-point adapters, and replacement parts other than tubes are available, make voltage and resistance measurements from top of chassis in suspected section and compare with service data. Refer to circuit diagram to determine component probably faulty.
6. Take chassis out of cabinet and to shop. Refer to hints regarding the

MARCH, 1954

TG-34A KEYER

PORTABLE

● 115 or 230 V. @ 50 to 60 cycle—KEYER TG-34A is an automatic unit for reproducing audible code practice signals previously recorded in ink on paper tape. By use of the self contained speaker, the unit will provide code practice signals to one or more persons or provide a keying oscillator for use with a hand key. The unit is compact, in portable carrying case, complete with tubes, photo cell, and operating manual. Size: 10¹/₁₆" x 10¹/₂" x 15¹³/₁₆". Shipping weight: 45 lbs. **BRAND NEW**—in Original Box—While They Last—Only: **\$14.95**

NEW: \$24.95—USED: \$19.95
TG-10 KEYER: Same function as TG-34A, only larger, using 2/6N7—2/6L6—2/6S17—1/5U4G Tubes and 1/923 Photo Cell. Housed in standard Metal Cabinet, can be removed for 19" rack mtg. Size: 11" H x 24" W x 18¹/₂" D.
NEW: \$29.95 • USED: \$19.95

TRANSFORMERS—110 V. 60 CYCLE PRI:
5 Volt CT-25A—10,000 V. Ins. OPEN FRAME—5" x 5" x 4¹/₂".....\$7.95
6.3 V. 1 Amp.....1.25 24 V. 1 Amp.....1.95
24 V. 1/2 Amp.....1.50 24 V. 6.5 Amp.....5.95
6—24—or 30 Volt 8 Amp.....2.95

ANTENNA EQUIPMENT

MAST BASES—INSULATED:
MP-132 BASE—Illustrated at left—1" heavy coil spring, 2" insulator. Overall length: 11¹/₂". Weight: 2³/₄ lbs. Price.....\$3.95
MP-S-33 BASE—Insulated type with heavy coil spring and 5" dia. insulator. Requires 2" hole for mounting. Weight: 9 lbs.\$5.95
MP-48 BASE—Insulated type base with heavy coil spring. Requires 1³/₄" mounting hole. Weight: 11 lbs.\$6.95
MP-37 BASE—Insulated type with heavy coil spring; 7" dia. insulator; requires 1³/₄" hole for mounting. Weight: approx. 10 lbs.\$8.95
MAST SECTIONS FOR ABOVE BASES:
Tubular steel, copper coated, painted in 3 ft. sections, screw-in type. MS-53 can be used to make any length with MS-52-51-50-49 for taper. Any section, @ 50c each. Larger Diameter Section: MS-54.....\$1.25

COAXIAL CABLES:
RG-8/U (SPECIAL) 51.5 ohms. Same size as RG-8/U. Prices: 1 to 100 ft. @ \$c per ft.—100 to 500 ft. @ 7¹/₂c per ft.—500 to 1000 ft. @ 7c per ft.—1000 ft. Rolls @ 6¹/₂c per ft.
RG-34/U—71 ohms, 145 ft. length.....\$15.00

DYNAMOTORS

HEAVY DUTY MOBILE DYNAMOTOR:
14 V. INPUT—Output: 1030 VDC 260 MA. Tapped 515 V. 215 MA. use @
6 V DC INPUT—500 V. 175 MA. While they last—DM-42.....Excel. Cond.: \$14.95.....New: \$20.95

| INPUT VOLTS: | OUTPUT VOLTS: | MA. | STOCK No. | PRICES USED: | NEW: |
|--------------|---------------|-----|-----------|--------------|-------|
| 14 VDC | 230 | 90 | DM-21 | 9.95 | |
| 14 | 330 | 150 | BD-87 | 6.95 | 8.95 |
| 14 | 250 | 50 | DM-25 | 6.95 | 8.95 |
| 14 | 1000 | 350 | BD-77 | 22.50 | 30.95 |
| 28 | 230 | 100 | DA-1A | 3.95 | 5.95 |
| 24 | 250 | 60 | DM-32 | 2.95 | 6.95 |
| 24 | 575 | 160 | DM-33 | 2.95 | |
| 28 | 210 | 125 | DY-22 | 7.95 | |
| 24 | 220 | 80 | DM-53 | 3.95 | |
| 28 | 1000 | 350 | PE-73 | 8.95 | |
| 14 | 172 | 138 | DM-40 | 6.95 | 8.95 |
| 28 | 250 | 60 | PE-86 | 2.75 | 8.95 |
| 12 or 24 | 500 | 50 | USA/0515 | 4.95 | |
| 12 or 24 | 275 | 110 | USA/0516 | 4.95 | |
| 12 | 150 | 100 | DM-310X | 4.95 | 7.95 |
| 6 or 12 | 500 | 160 | PE-103 | 29.95 | 39.95 |
| 12 | 230 | 90 | PE-133 | 6.95 | 8.95 |
| 18 | 450 | 60 | SP-175 | 3.00 | 4.95 |

PE-101 DYNAMOTOR—6 or 12 Volt. (Reprints of original CQ conversion articles—Oct. & Dec., '52 issues—furnished.) This is the Dynamotor the Hams have been talking about! Easily adapted to supply 625 V. @ 150 MA. and 325 V. 125 MA. @ 12 Volts— or 300 V. 90 MA. and 160 V. 110 MA. @ 6 Volts
NEW: \$4.95

Address Dept. RN • Minimum Order \$5.00 • Prices F.O.B., Lima, Ohio • 25% Deposit on C.O.D. Orders

FAIR RADIO SALES 132 SOUTH MAIN ST. LIMA, OHIO



FREE CATALOG

LISTING HUNDREDS OF TRULY EXCEPTIONAL "BUYS"—WRITE FOR YOUR FREE COPY NOW!

NEW—LOW—LOW PRICES

ARC-5 COMMAND EQUIPMENT:

R-25/ARC-5 Rec. 1.5 to 3 MC. No Tubes...Used: \$14.95
R-26/ARC-5 Rec. 3 to 6 MC. No Tubes...Used: 7.95
R-27/ARC-5 Rec. 6 to 9 MC. No Tubes...Used: 6.95
R-28/ARC-5 Rec. 100 to 156 MC. No Tubes...Used: 12.95
T-20/ARC-5 Trans. 4 to 5.3 MC.....New: 16.95
T-22/ARC-5 Trans. 7 to 9 MC.....Used: 14.95

274-N COMMAND EQUIPMENT:

BC-454 Rec. 3 to 6 MC.....Used: \$10.95
BC-455 Rec. 6 to 9 MC.....Used: 9.95
BC-458 Trans. 5.3 to 7 MC.....Used: 9.95
BC-459 Trans. 7 to 9 MC.....Used: 14.95
BC-456 Modulator.....Used: 2.95
FT-225 Mtg. F/BC-456.....Used: 50c.....New: .95
FT-220 3 Rec. Rack.....Used: \$1.50.....New: 2.50
FT-221 3 Rec. Shock.....Used: .50c.....New: .95
BC-450 3 Rec. Cont. Box.....Used: \$1.50.....New: 2.00
BC-451 Trans. Cont. Box.....Used: \$1.00.....New: 1.50
PLUG—Male for rear of Rec. or Trans......55
DM-32 Dynamtr F/Rec. 24V. Used: \$2.95.....New: 6.95
DM-33 Dynamtr F/Modulator & Trans.....Used: 2.95

SOUND POWERED HEAD AND CHEST SET

Navy Type—No Batteries Required—Ideal for TV Antenna Installations and many other uses. 20 Ft. Cord. Used: **\$5.95** EA.



TELEPHONE WIRE FOR THE ABOVE

COMBAT TYPE—2 Cond. Twisted, Rubber Covered, Medium Weight, W-130.....@ .01c per Ft.
FIELD WIRE—2 Cond. Twisted, Weather-Proof, Heavy Duty, W-110—525 Ft. Roll... **\$4.75**
COPPER WELD WIRE—Weatherproofed, 2 Cond. Solid, 1200 Ft. Roll. \$10.00, Per Ft. @ .01c per Ft.

AERIAL WIRE—Phosphorus Bronze #16 Stranded, 200 lb. test. Weatherproof, 150 Feet **\$1.50** on Reel. RL-3 with Clips

BLOWERS—115 VAC 60 CYCLE

SINGLE TYPE: (Illustrated at left) 100 CFM. 2¹/₂" intake; 2" outlet. Complete size: 5" x 6". Order No. 1C939.....\$8.95
DUAL TYPE: 100 CFM. 4" intake; 2" Dis. Each Side, Complete Size: 8" x 6". Order No. 1C880.....\$13.95
COMPACT TYPE: 108 CFM. Motor built inside squirrel cage. 4¹/₂" intake; 3¹/₂" x 3" Dis. Complete size: 4¹/₂" W x 8³/₄" H x 8¹/₂" D. Order No. 2C067.....\$14.50
FLANGE TYPE: 140 CFM. 3¹/₂" intake; 2¹/₂" Dis. Complete size: 7¹/₂" W x 7¹/₂" H x 6¹/₂" D. Order No. 1C807.....\$13.95
FLANGE TWIN: 275 CFM. 4¹/₂" intake; 3¹/₂" x 3" Dis. Complete size: 11³/₄" W x 8³/₄" H x 8-1/16" D. Order No. 2C069.....\$21.95



TRANSVISION FIELD STRENGTH METER

*Finest
at
Any Price*



For 110V AC,
and BATTERY
OPERATION

**SAVES 50% OF
INSTALLATION COST**

Works from antenna
(no TV set needed)

FINEST because: Each Meter is individually calibrated in microvolts on every channel. Widest range—10-50,000 microvolts. 12 channel selector. Multiplier switch for weak signal areas.

Pays for itself on 3 or 4 jobs. Measures relative picture signal strengths **directly from antenna.** Determines best antenna system and orientation. Checks receiver re-radiation (local oscillator.) Identifies signals—TV, FM, TVI. Easy to operate, light, rugged. Many other exclusive features.

*Model FSM-4, for 110V AC only. Complete with tubes. Wt. 13 lbs. net \$69.

Model FSM-4B, for Battery Operation and 110V AC. Wt. 13 lbs. net \$89.

TRANSVISION, INC.
NEW ROCHELLE, N. Y.

\$69
NET*

A MUST IN
FRINGE AREAS

**UHF
OR
VHF**

10 DAY TRIAL:
Try these fine instruments for 10 days. Then, if you return them, your cost less 10% (our cost of re-packaging) will be refunded.

Test & Repair CRTs

Make BIG PROFITS this EASY way:

Every Service Shop needs these Transvision instruments. Can be used while picture tubes are in sets or cartons. Choice of 4 types:

TESTER-REACTIVATOR-SPARKER: 3 instruments in 1. Measures cathode emission; locates shorts between elements; locates high resistance shorts (leakage) as high as 3 megohms. Gives rapid check of gas condition of tube.

Reactivates film lines—renews brightness and detail. Sparks out electrical leakage. net \$24.95

TESTER-REACTIVATOR: 2 instruments in 1. Similar to the above, but without the sparking function. net \$19.95

TESTER-SPARKER: 2 instruments in 1. Sparks out electrical leakage between elements—saves many picture tubes and small tubes. Provides variable 8,000-14,000V D.C. supply; useful for analyzing hard-to-solve deflection problems. net \$25.95

SPARKER: Eliminates leakage between elements in C.R.T.s and small tubes. net \$18.95



Transvision, Inc., New Rochelle, N. Y., Dept. N3

Send me _____
 Enclosed find \$_____ deposit. Balance C.O.D.
 My JOBBER is _____
I accept your 10 Day Trial terms.

Name _____
Address _____
City _____ State _____

JOBBER INQUIRIES INVITED

receiver and trouble at hand, if any are available from published data or your own records. Continue signal tracing and component checking if necessary.

7. Make record of receiver type, symptoms, and cause, so that you will have a hint available next time.

This procedure should be supplemented by a few precautions:

1. Do not change permanently any component or adjustment unless the benefit is immediately obvious.

2. Do not correct any trouble without giving some thought to what may have caused it, especially in a case of burned-out fuses, transformers, resistors, tubes, etc.

3. Do not be sure that a change in a component or adjustment has removed the actual cause of a trouble unless you understand how it could have done so.

Electro-Voice Model 666

(Continued from page 63)

trum for which it is designed and, by proper acoustic delay elements, a crossover from one acoustic path to another is achieved smoothly and uniformly. This principle of varying the front-to-back distance is now established as the "Variable D."

The Model 666 is unique in that "boominess" is totally absent on close talking. Variations in bass sensitivity

"Diffusicone-8" Enclosure

(Continued from page 55)

plywood paneling with all sections well glued and screwed. Internal damping is provided by "Kimsul" insulation.

This cabinet has created such wide interest during public demonstrations that it has been exhibited without the decorator's finishing touch (as in the photograph) in order to satisfy the countless listeners that there was only one 8-inch speaker working during the demonstration. The home constructor will of course want to put the finishing touches to the cabinet as best suits his needs. The important factor concerning the acoustics of this finish is the grille cloth that covers the face

below 100 cps due to the proximity effect are less than ± 2 db when the unit is used from 6 inches to 5 feet. Close talking is facilitated by the insensitivity of pressure-operated dynamic elements to "blooming" from explosive labial sounds, such as those found in the letters "P" and "B." Complete insurance against excessive blooming is effected by the integral blast filter. The blast filter obviates the necessity for wind bags on exterior shots.

This freedom from blooming and proximity effects allows the microphone to be used closer to the vocalist, announcer, or soloist for still further discrimination against unwanted sounds than would be possible with a conventional unidirectional microphone.

TV CONFERENCE

THE Eighth Annual Television Conference, sponsored jointly by the Cincinnati Section of the IRE and the Professional Group on Broadcast and Television Receivers, will be held in Cincinnati on Saturday, April 24th.

The subject of the conference will be "Black and White and Color TV and UHF." Meetings will be held in the Engineering Society of Cincinnati Bldg. at McMillan St. and Woodburn Avenue.

Advance registrations for the conference, including hotel, luncheon, and banquet reservations, should be addressed to J. A. Purdy, 7520 E. Miami River Road, Hamilton, Ohio. Others may register at the Conference if desired.

of the speaker. The *University "Diffusicone-8"* employs the patented high-frequency diffusing element which disperses the high frequencies over a wide angle. Thus, whatever grille cloth is used should be selected more on the basis of acoustic transparency rather than artistic appearance. A good rule of thumb to use in selecting a grille cloth is that the cloth be about 50% optically transparent. If these precautions concerning the physical construction of the cabinet are followed, then the combination of the enclosure and the "Diffusicone-8" will give clean strong bass reproduction with well balanced middles; and if the proper grille cloth is used the top end of the spectrum will be completed through the extended-range, wide-angle, high-frequency performance of the diffusion system.

Response frequency characteristics of enclosure using the "Diffusicone-8" speaker.

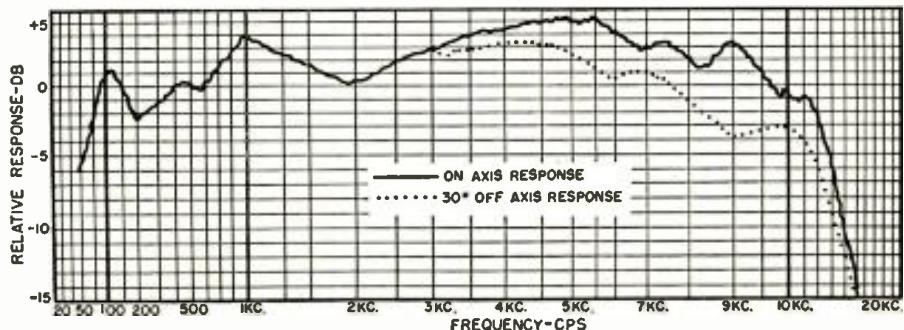

Certified Record Revue
(Continued from page 76)

lapse while conducting the Israel Philharmonic recently. It is typical of the man that he drive himself to a state of exhaustion in his striving for perfection. The same relentless spirit is evidenced in his reading of these Mozartian gems. There are some who may object to a "big hall sound" for Mozart. I don't think this argument is valid here because the spaciousness of the recording is coupled by a fabulous amount of inner detail. I don't think I am exaggerating when I say that this is perhaps the finest sounding Mozart on records. The silken beauty of the strings, the bubbling capriciousness of the clean and articulate woodwinds are a joy to the ear. This is what true high-fidelity recording can do for the classical repertoire.

There is many a person who doesn't like Mozart, who would certainly be won to his cause by this superb reproduction. In "The Prague," Mr. Kubelik has chosen to follow the broad melodic lines and polish and burnish the highlights of the whole by meticulous attention to tempi and dynamics. He is never overly fussy, neither is he sloven of detail. I think it fairly safe to say that his reading ranks with that of Sir Thomas Beecham and I've no doubt there will be many who will prefer it, sacrilegious as this may seem. The "34th in C" is an unjustly neglected work. A thoroughly delightful piece it fairly froths and bubbles with the effervescent reading afforded it by Mr. Kubelik. He recognizes the work for what it is; a light-hearted exposition on "much-ado about nothing." Again the work benefits from the superb fidelity of reproduction.

The AES curve reproduced the record perfectly with no necessity for tone control adjustment. Surface noise was almost non-existent. A wonderful farewell performance by Rafael Kubelik for *Mercury*. I trust we have not seen nor heard the last of Mr. Kubelik in this country.

VIVALDI

LAS PASTORELLA; SONATA FOR FLUTE, BASSOON AND HARPSICORD IN A MINOR; CONCERTO FOR FLUTE, OBOE, AND BASSOON IN G MINOR; SONATA FOR OBOE AND HARPSICORD IN C MINOR; CONCERTO FOR FOUR INSTRUMENTS IN F MAJOR

Jean-Pierre Rampal, flute; Robert Gendrec, violin; Pierre Pierlot, oboe; Paul Hongne, bassoon; Robert Veyron-Lacroix, harpsichord. Haydn Society HSL-82, NARTB curve. Price \$5.95.

A collection of works by one of the greatest of Italian composers, Antonio Vivaldi. Now don't get up on your hind legs and run away! I know that the idea of anything like this strikes terror into you lovers of the hi and the fi. But hold on! There is some really good stuff here if you'll just take the trouble to listen. This admittedly is

check THESE N. J. R. T. TUBE PRICES 70% to 90% OFF LIST

Guarantee
ALL NJRT TUBES ARE BRAND NEW AND FULLY GUARANTEED FOR ONE YEAR

| Type | Price | Type | Price | Type | Price |
|-------|-------|--------|-------|----------|-------|
| 1A7GT | .45 | 6AK5 | .75 | 6L6 | .62 |
| 1B3GT | .67 | 6AL5 | .37 | 6R7 | .49 |
| 1H5GT | .38 | 6AQ5 | .37 | 654 | .38 |
| 1L4 | .50 | 6AQ8 | .36 | 658GT | .51 |
| 1N5GT | .62 | 6AT6 | .37 | 65A7GT | .41 |
| 1R5 | .48 | 6AU4GT | .70 | 65D7GT | .39 |
| 1S5 | .40 | 6AUG | .40 | 65K7GT | .39 |
| 1T4 | .48 | 6AV6 | .37 | 65L7GT | .49 |
| 1U4 | .48 | 6AX4GT | .55 | 65N7GT | .50 |
| 1U5 | .40 | 6BA6 | .40 | 65Q7GT | .37 |
| 1X2 | .65 | 6BA7 | .57 | 6T8 | .57 |
| 3A4 | .43 | 6BC5 | .49 | 6U8 | .59 |
| 3L4 | .49 | 6BD6 | .45 | 6V6GT | .38 |
| 3Q4 | .48 | 6BE6 | .37 | 6W4GT | .42 |
| 3Q5GT | .48 | 6BGG | 1.20 | 6W6GT | .45 |
| 3S4 | .48 | 6BH6 | .45 | 6X4 | .35 |
| 3V4 | .50 | 6BJ6 | .41 | 6X5GT | .35 |
| 5A24 | .50 | 6BK7 | .89 | 7E6 | .35 |
| 5U4G | .45 | 6BL7GT | .65 | 7F8 | .63 |
| 5Y3GT | .39 | 6BQGT | .70 | 12A5 | .40 |
| 5Z3 | .45 | 6BQ7A | .92 | 12AT6 | .35 |
| 5Y4G | .39 | 6B27 | .95 | 12A7 | .65 |
| 6A3 | .57 | 6C4 | .39 | 12AUG | .38 |
| 6A6 | .49 | 6CB6 | .45 | 12AUV | .55 |
| 6AB4 | .42 | 6CD6G | 1.15 | 12AV6 | .50 |
| 6AF4 | .92 | 6F6 | .45 | 12AV7 | .60 |
| 6AF6 | .75 | 6J5 | .40 | 12AX4GT | .55 |
| 6AC5 | .47 | 6J6 | .50 | 12AX7 | .55 |
| 6AJ5 | .73 | 6K6GT | .37 | 12BA6 | .40 |
| | | | | 12B7 | .37 |
| | | | | 12B8 | .49 |
| | | | | 12BE6 | .41 |
| | | | | 12BH7 | .65 |
| | | | | 12BY7 | .65 |
| | | | | 12BZ7 | .65 |
| | | | | 12SA7 | .58 |
| | | | | 12SK7 | .58 |
| | | | | 12SL7GT | .49 |
| | | | | 12SN7GT | .50 |
| | | | | 12SQ7 | .55 |
| | | | | 12SR7met | .55 |
| | | | | 12V6GT | .50 |
| | | | | 19B6GG | 1.15 |
| | | | | 19T8 | .75 |
| | | | | 25BQGT | .75 |
| | | | | 25L6GT | .40 |
| | | | | 25W4GT | .45 |
| | | | | 25Z6 | .37 |
| | | | | 35A5 | .49 |
| | | | | 35B5 | .38 |
| | | | | 35C5 | .38 |
| | | | | 35L6GT | .45 |
| | | | | 35W4 | .37 |
| | | | | 35Z3 | .43 |
| | | | | 35Z5GT | .45 |
| | | | | 42 | .40 |
| | | | | 43 | .53 |
| | | | | 45 | .53 |
| | | | | 50B5 | .41 |
| | | | | 50C5 | .41 |
| | | | | 50L6GT | .59 |
| | | | | 70L7GT | 1.07 |
| | | | | 76 | .42 |
| | | | | 117Z3 | .39 |
| | | | | 117L7GT | 1.19 |
| | | | | 807 | 1.25 |

T.V. PIX TUBE BRIGHTENER \$1.39
For T.V. sets where voltage supply is low AC LINE BOOSTER with safety fuse \$5.95 and switch

FREE FIVE 1L4 TUBES INDIVIDUALLY CARTONED LIST \$11.25 WITH EVERY ORDER OF \$25.00 OR MORE.
Many 7 volt types not listed. All tubes individually boxed. For orders under \$10 add \$1 handling charge. Tubes offered subject to prior sale. Prices subject to change. All orders shipped F.O.B. 2% discount if full remittance accompanies order. 25% deposit on c.o.d. shipments.
SEND FOR FREE TUBE LISTING.

NJRT TUBE CO.
NEW JERSEY TELEVISION SUPPLY CO.
Sole Distributor of NJRT Tubes
906B WESTFIELD AVE., ELIZABETH, N. J. EL. 3-6166

Now! HANDLE TELEVISION SERVICE THIS NEW "SHORT CUT" WAY!

Spot TV troubles at a glance . . . Fix 'em twice as fast!



NEW! PIX-O-FIX No. 2 JUST OUT!
Users of PIX-O-FIX No. 1 were so enthusiastic about it that No. 2 has now been issued to include 23 TV receiver troubles not previously covered. Get both at bargain price of only \$2 . . . a saving of 50¢!

PIX-O-FIX TV TROUBLE FINDING GUIDES
by Ghirardi & Middleton

The looks of the picture on a bad TV receiver can tell you at a glance what is wrong. PIX-O-FIX not only make this easy—but also show how and where to make the needed repairs.

PIX-O-FIX No. 1.—Identified 24 common troubles by actual TV screen photos. Gives 192 causes and 253 remedies for these troubles. Price separately, \$1.25.
PIX-O-FIX No. 2 (New)—Covers 23 additional troubles not included in No. 1. Together, the 2 volumes are a comprehensive guide to easy "picture analysis" servicing of any TV set. Price separately, \$1.25.

SPECIAL OFFER! Get both PIX-O-FIX No. 1 and No. 2 for only \$2. Use coupon. OUTSIDE U.S.A. \$1.50 each. \$2.50 for both. Same return privilege.

Cut TV testing time to minutes! Make repairs fast and right!
Just turn the dial of the Ghirardi PIX-O-FIX. When the TV screen image in the PIX-O-FIX "window" matches the image on the set you're repairing . . . you've got your clue as to what is wrong! PIX-O-FIX then gives you all causes of this particular trouble plus the section of the receiver in which it has probably happened. Next you get step by step repair instructions. Usually, the component likely to be faulty is specified. Quick tests to apply to it are explained—or parts substitution recommended where this is the best procedure.
The two PIX-O-FIX units cover 47 different kinds of TV trouble—just about anything you're ever likely to be called on to fix. Operation is simple and easy. Our money-back Guarantee protects you fully.

10-DAY MONEY-BACK GUARANTEE

Dept. RN-34, RINEHART & COMPANY, Inc.
232 Madison Ave., New York 16, N. Y.
Enclosed find \$. . . for which please rush the following:
 PIX-O-FIX No. 1 (\$1.25) PIX-O-FIX No. 2 (\$1.25)
 Both PIX-O-FIX No. 1 and No. 2 at the special price of only \$2.00 for two.
If not satisfactory, I will return PIX-O-FIX postpaid in 10 days and you guarantee to refund the purchase price.
Name
Street
City, Zone, State

THE *American* IDEA



"To find and follow the better way" . . . Out of the vision of Dr. George Ellery Hale came the great "American Idea" that resulted in the creation of the "Glass Giant of Palomar"—world's largest telescope—to gather new light from the farthest stars for the searching eye of science.

With us, the "American Idea" is, by directed effort and applied know-how, to continue to lead in bringing you electronic products of the highest quality.



INSIST ON
AMERICAN
REPLACEMENT
CRYSTAL
CARTRIDGES

Send for FREE catalog 46



American microphone co.

370 South Fair Oaks Ave. • Pasadena, 1, Calif.

music for the more musically mature, but it is not all that formidable. The "La Pastorella" is a lovely work that sparkles like wine in the Italian sun. The quality of woodwind playing found here is exemplary.

Each man is a virtuoso of his chosen instrument and it is evident from the good time they are having that they enjoy this spritely work of Vivaldi. The other works are combinations for the various woodwinds and are splendid examples of Vivaldi's amazing technical facility. Most are in sonata form and show clearly Vivaldi's penchant for contrast in his writing. He made daring innovations for his day, elevating the oboe from the obscurity of the orchestral whole to a solo instrument for which he wrote some exceedingly clever (and difficult) music. The reproduction throughout is very good indeed, the lone violin displaying no annoying edginess, and the woodwinds sibilant, snarly, sonorous as the score demands. A record to be treasured by students and others who appreciate this resurrection of some unjustly neglected Vivaldi. The NARTB curve needed a few db of bass boost to reproduce satisfactorily and the surfaces were a little "ticky"

STRAVINSKY THE RAKE'S PROGRESS

Hilde Gueden, Blanche Thebom, Eugene Conley, Mack Harrell, Martha Lipton, Norman Scott, Paul Franke, Lawrence Davidson, soloists with Metropolitan Opera Association orchestra and chorus conducted by Igor Stravinsky. Columbia SL125, NARTB curve. Price \$11.90.

The advent of any work by Stravinsky is usually cause for much excitement and anticipation. When I heard reports some years back that he was working on a new opera, I made a particular point of watching for news of its completion and premiere. I was somewhat disappointed when the U.S. was bypassed in favor of Venice for the premiere which took place on Sept. 11, in 1951. I was further disappointed by the mixed reaction of the critics, and knew that I would never be satisfied as to its worth until I had heard it myself. By the time "The Rake's Progress" arrived at the Metropolitan, so much had been written *pro* and *con* about this opera, that tickets were a hard thing to come by and I never did get to see or hear the Met production. All this is by way of telling you of the happy appearance of this controversial opera on 2-12" Columbia LP's. Ah! The wonders of the age of LP! Not only is this the same Metropolitan production, but Stravinsky himself has been retained to conduct.

Has my wait been worthwhile? Decidedly yes! I can't agree with many of the European critics who rapped it for eclecticism, for lack of dramatic cohesion and goodness knows what else. I feel that if you analyze what Stravinsky had in mind here and what has been produced, you will come to the logical conclusion that this represents but a further extension of

a musical philosophy Stravinsky has been developing for some time now. Certainly it smacks of the Mozartian and Italianate. He has been integrating his amazing genius for polyphonic and polyrhythmic writing with 18th century elements ever since he wrote "Pulcinella." So the fact that he produces an opera essentially 18th century in character should come as no surprise to the musically literate.

I think what is really the basis of much criticism is a sort of wishful thinking, a desire for Stravinsky to return to his "wild" period, which produced "LeSacre du Printemps" and "Petrouchka." One cannot blame these people altogether, for I too would like to see Stravinsky produce at least one more work in this genre before he leaves this vale of tears. Well, come what may, I like this present effort and I think many of you will agree. The libretto by famed poet W. H. Auden and Chester Kallman is a moral fable with a pretty familiar story line, owing much to Hogarthian elements.

Space will not permit more than the briefest of story outlines: Boy and girl are in love. Boy wants money sells soul to devil. Carouses wantonly and degenerates morally, devil comes to claim boy's life, but loses out as girl proclaims her love and boy his, and he is saved. Boy goes mad and is committed to Bedlam. Mad love scene ensues between boy and girl and boy finally dies. (I suggest you read the jacket for a far more lucid description of the opera than I have just tendered you!)

The cast is an excellent one with special bows to Eugene Conley for his portrayal of "The Rake" and Mack Harrell as "Nick Shadow" (the devil). Blanche Thebom is delightful as "Baba the Turk," but I was a little disappointed in the character of "Anne," "The Rake's" love, as sung by Hilde Gueden. I felt that a more ingenuous quality was needed in keeping with the story line.

The music is unusually scored since there are no trombone or tuba parts and this gives the trumpets the job of maintaining the bass line. The entire score reminds you more of a chamber concertante than anything else, but nevertheless is not wanting in power and expression when the need arises. The reproduction is top notch, for both vocal and orchestral elements. Strings are smooth and a fine orchestral balance is maintained by Stravinsky. Spaciously recorded but fortunately not so much so that the vocalists are obscured. The fact that the opera is sung in English adds to its attractiveness and the inclusion of a libretto makes for easy understanding. All in all, a major phonographic event and highly recommended. The NARTB curve needed no tone control alteration. The only thing I might quibble about is a good deal more of anticipatory tape echo than is usual. Somebody running too "hot" on the vu meter?

ALBINONI
CONCERTO FOR ORCHESTRA IN D MINOR
CORELLI-GEMINIANI
CONCERTO GROSSO #2
SAMMARTINI
VIOLIN CONCERTO #2
SYMPHONY IN G
Italian Chamber Orchestra conducted by Newell Jenkins. Haydn Society HSL74, NARTB curve. Price \$5.95.
ROSETTI
HORN CONCERTO IN E FLAT MAJOR
BOCCHERINI
SYMPHONY IN F MAJOR

Italian Chamber Orchestra conducted by Newell Jenkins. Haydn Society HSL79, NARTB curve. Price \$5.95.

These two records are further evidence that the Haydn Society is not above venturing into other musical fields than that which is the province of Papa Haydn. Which is a healthy trend, for ultra-specialization can be a dangerous drug which dulls the creative mind. These discs represent #1 and #6 of a series entitled, "Italian Classical Symphonists." Here the Haydn Society has done itself proud in bringing to light a whole group of 18th century Italian composers whose works are comparatively obscure. These are not in the category of what I call "desperation repertoire." In other words they have not been recorded merely because they were never previously recorded. There is a great deal of the trite and the banal being committed to LP these days, most of which is hardly worth wasting vinylite on even for musicological purposes.

Although one might gain the impression that there is too much recorded herein of similar line and invention, such is not the case. The music ranges from the rich contrapuntal textures of Albinoni to Geminiani's masterful transcriptions of his great teacher Corelli and his concerti grossi, to Sammartini and his symphony which was not really a symphony in conventional form as we know it, but which actually anticipated and fathered the sonata. All of these works are played expertly and with considerable elan by Newell Jenkins and the properly Italianate orchestra. Again, this is not fare for the hi-fi; by which I mean to say that there are no booming basses or tinkling triangles. But the fidelity of reproduction is nevertheless of the very top quality, with a warm, rich string tone and excellent acoustics. The NARTB curve was slightly bass deficient, but responded to a few db of boost. Surfaces were quiet.

THOMAS MIGNON
Genevieve Moizan, Janine Michean, Libero De Luca soloists with chorus of Le Theatre Royal de la Monnaie, Brussels. L'Orchestre National de Belgique conducted by Georges Sebastian. London LLA15, frrr curve. Price \$17.85.

It looks like this must be the month for opera! I know there will be rejoicing with this new version of "Mignon," since it is the first complete recording

Windsor TUBES

RADIO & TV RECEIVING

TESTED and GUARANTEED for **PEAK PERFORMANCE**

WHAT EVERY SERVICEMAN SHOULD KNOW. . . . No tube checker reading of "Good" can positively insure that a specific tube will function perfectly in a TV set . . . only a substitution test in an actual set will do that! This is particularly true of tubes used in power and sweep circuits, deflection amplifiers, oscillators, reactance modulators, etc.

YOU PLAY IT SAFE when you buy Windsor tubes—because every tube we ship has been carefully pre-tested in a radio or TV set for **PEAK PERFORMANCE** under actual operating conditions. So we unconditionally guarantee every Windsor tube in accordance with the Standard Warranty: full replacement of any defective tube within 90 days of purchase, excepting only burnouts and breakages. Each tube is attractively packaged in individual carton.

BUY—AND SELL—WINDSOR TUBES, WITH CONFIDENCE

| Type | Each | Type | Each | Type | Each | Type | Each | Type | Each |
|-------|-------|--------|------|--------|------|---------|------|---------|------|
| IA7GT | \$.67 | 3V4 | 1.00 | 6BD5GT | .98 | 6Q7GT | .55 | 7B6 | .52 |
| IB3GT | .89 | 5R4GY | .44 | 6BD6 | .54 | 6S4 | .51 | 7AH7 | .65 |
| IH5GT | .51 | 5U3G | .44 | 6BE6 | .51 | 6S8GT | .75 | 7A17 | .70 |
| IJ6 | .93 | 5V4G | .83 | 6BF5 | .66 | 6SA7GT | .57 | 7B4 | .64 |
| IL4 | .63 | 5Y3G | .37 | 6BF6 | .43 | 6SC7 | .63 | 7B5 | .51 |
| IL6 | .66 | 5Y3GT | .32 | 6BG6G | 1.47 | 6SD7 | .55 | 7E5 | .85 |
| ILA4 | .82 | 5Y4G | .43 | 6BH6 | .63 | 6SF5GT | .66 | 7E6 | .65 |
| ILA6 | .80 | 6ABGT | .68 | 6J16 | .53 | 6SH7GT | .52 | 7E7 | .65 |
| ILB4 | .82 | 6AR4 | .51 | 6K5 | .76 | 6SJ7GT | .52 | 7F7 | .69 |
| ILC5 | .80 | 6AC5GT | .82 | 6BK7 | .97 | 6SK7GT | .55 | 7F8 | .87 |
| ILC6 | .80 | 6AG5 | .59 | 6BL7GT | .94 | 6SL7GT | .68 | 7G7 | .95 |
| ILD5 | .80 | 6AH4 | .68 | 6BN6 | .98 | 6SN7GT | .59 | 7H7 | .61 |
| ILE3 | .80 | 6AH6 | .89 | 6BO6GT | .98 | 6S07GT | .46 | 7J7 | .65 |
| ILG5 | .80 | 6AK5 | 1.05 | 6B07 | .92 | 6T8 | .35 | 7K7 | .83 |
| ILH4 | .80 | 6AL5 | .44 | 6C27 | 1.09 | 6U4GT | .60 | 7L7 | .65 |
| ILN5 | .80 | 6AQ5 | .51 | 6C4 | .41 | 6U8 | .86 | 7N7 | .62 |
| INSGT | .63 | 6AQ6 | .47 | 6CSGT | .60 | 6V3 | 1.09 | 7Q7 | .62 |
| IR4 | .85 | 6AQ7 | .75 | 6C86 | .58 | 6V6GT | .51 | 7R7 | .70 |
| IR5 | .82 | 6AR5 | .42 | 6CD6G | 2.04 | 6W4GT | .50 | 7S7 | .90 |
| IR4 | .67 | 6AS5 | .55 | 6D6 | .63 | 6W6GT | .63 | 7V7 | .92 |
| ISS | .52 | 6AT6 | .42 | 6E5 | .72 | 6X4 | .37 | 7W7 | .99 |
| IT4 | .62 | 6AU5GT | .85 | 6F5GT | .54 | 6X5GT | .36 | 7X6 | .62 |
| IU4 | .81 | 6A16 | .47 | 6H6GT | .55 | 6Y6G | .64 | 7Y4 | .45 |
| IU5 | .51 | 6AV5 | .85 | 6J5GT | .44 | 7A4 XXL | .57 | 7Z4 | .50 |
| IX2A | .74 | 6AV6 | .41 | 6J6 | .46 | 7A5 | .70 | 12A76 | .53 |
| 2X2 | 1.43 | 6AX4 | .72 | 6I7 | .70 | 7A6 | .57 | 12A77 | .75 |
| 31F4 | .76 | 6BRG | .93 | 6K6GT | .45 | 7A7 | .58 | 12A78 | .47 |
| 304 | .66 | 6BA6 | .50 | 6K7 | .70 | 7A8 | .56 | 12A79 | .58 |
| 305GT | .72 | 6BA7 | .66 | 6L6G | .88 | 7AD7 | 1.05 | 12A80 | .87 |
| 3S4 | .61 | 6BC5 | .58 | 6L6GA | .88 | 7AF7 | .63 | 12A81 | .77 |
| | | | | | | | | 12A82 | .67 |
| | | | | | | | | 12A83 | 2.15 |
| | | | | | | | | 12B4 | .66 |
| | | | | | | | | 12B4A | .50 |
| | | | | | | | | 12B4B | .66 |
| | | | | | | | | 12B6 | .52 |
| | | | | | | | | 12B6E | .52 |
| | | | | | | | | 12B7 | .69 |
| | | | | | | | | 12B7V | .77 |
| | | | | | | | | 12C6GT | .48 |
| | | | | | | | | 12SA7 | .57 |
| | | | | | | | | 12SH7T | .47 |
| | | | | | | | | 12SK7GT | .53 |
| | | | | | | | | 12SL7GT | .67 |
| | | | | | | | | 12SN7GT | .59 |
| | | | | | | | | 12SQ7GT | .46 |
| | | | | | | | | 14A7 | .51 |
| | | | | | | | | 14F7 | .68 |
| | | | | | | | | 14B6 | .50 |
| | | | | | | | | 14C5 | .85 |
| | | | | | | | | 14R7 | .7 |
| | | | | | | | | 14E6 | .70 |
| | | | | | | | | 14E7 | .84 |
| | | | | | | | | 14F7 | .69 |
| | | | | | | | | 14F8 | .99 |
| | | | | | | | | 14J7 | .85 |
| | | | | | | | | 14N7 | .75 |
| | | | | | | | | 14Q7 | .62 |
| | | | | | | | | 14S7 | .80 |
| | | | | | | | | 14S7 | .80 |
| | | | | | | | | 19B6G | 1.3 |
| | | | | | | | | 19T8 | .87 |
| | | | | | | | | 25B0G6T | .9 |
| | | | | | | | | 25L6GT | .53 |
| | | | | | | | | 25W4GT | .53 |
| | | | | | | | | 25Z6GT | .46 |
| | | | | | | | | 35A5 | .55 |
| | | | | | | | | 35P5 | .53 |
| | | | | | | | | 35C5 | .73 |
| | | | | | | | | 35I6GT | .52 |
| | | | | | | | | 35W4 | .33 |
| | | | | | | | | 3Z5GT | .33 |
| | | | | | | | | 50A5 | .55 |
| | | | | | | | | 50B5 | .52 |
| | | | | | | | | 50C5 | .52 |
| | | | | | | | | 50L6GT | .52 |
| | | | | | | | | 50L7Z3 | .43 |
| | | | | | | | | 11Z6GT | .75 |



FREE!
WINDSOR
TUBE CADDY

The most practical Service-Aid ever designed for the radio and TV repairman. This ideal television carry-all now offered free with every purchase of \$160.00 or accumulated purchases totaling \$160.00 within 90 days. (You get carry credit memo with each purchase.)
Windsor Tube Caddy may also be purchased outright for \$14.95.

- Carries approximately 125 tubes including meters and tools.
- 16 3/4 inches long x 8 1/4 inches wide x 1 3/4 inches high.
- Weights only nine pounds.
- Runned v constructed with heavy leatherette cover, inq. strong plastic handle, nickel plated hardware, and reinforced with metal clamps.

DON'T MISS THIS SENSATIONAL OFFER!

25% Deposit with Order. All merchandise F.O.B NYC. For orders less than \$10. Add \$1 handling cost. Deduct 2% if full remittance accompanies order. All merchandise subject to prior sale and price changes without notice.

WRITE FOR ADDITIONAL TUBE TYPES AND PRICES. We also stock Special Purpose and Transmitting Tubes at similar savings! Dept. N-3

Windsor ELECTRONIC TUBE CO.
1515-N SHEEPSHEAD BAY ROAD, BROOKLYN 35, N. Y.

JUST SEND \$1
for YOUR CHOICE
OF THESE BARGAINS!

CRYSTAL HEARING AID MIKE only \$1
40 MICA CONDENSERS (Assorted) only \$1
45 CERAMIC CONDENSERS (Assorted) only \$1
75 RESISTORS (Assorted) only \$1

YOUR CHOICE OF ANY 3 OF THESE HEARING AID TUBES } ONLY \$1
502X - 501X - 501AX - 502AX }

3 MINIATURE HEARING AID CHOKES } ONLY \$1

Send check or money order—WE PAY POSTAGE

PHILIP GLICK & CO.
256 Greenwich St. New York 7, N. Y.

RECORDING TAPE (Plastic Base)
40% OFF (NEW)
WASHINGTON, D. C. WHERE ELSE WOULD THERE BE MORE RED A TAPE?

● 1200 ft. plastic tape with plastic reel included.
● Each reel individually boxed.
● Choice of nationally famous top quality brands such as:
Wetear (2806) 3:20; Reeves (SPN-12) 3:20; Audio (1251) 3:25; Scotch (111-A) 3:25; Panamoistic (713-A) 3:25; Irish, Professional grade (211) 11P-A; 3:30.
● FREE! A 7.95 tape carrying case included with purchase of 12 new tapes!

★ ★ ★ ★ ★
USED RECORDING TAPE (PLASTIC BASE)

1.99 for 7"—1200 foot
.99 for 5"—600 foot
.59 for 4"—300 foot
.39 for 3"—150 foot
Plastic reels included with all above sizes

New empty plastic reels in boxes for easy labeling. 3" 10c; 4" 22c; 5" 24c; 7" 29c; 7" Professional reel (2 1/4" hub) 39c ea. EMPTY BOXES: 3" 3c; 4" 5c; 5" 5c; 7" 10c ea.

We carry all brands of new tape, recording blanks, tape recorders, etc. at low prices. PLEASE INCLUDE SUFFICIENT POSTAGE.

COMMISSIONED ELECTRONICS CO.
2503 Champlain St. N.W., Washington 9, D. C.

PRIZE CONTEST!

Name Our Newest TV Service Book

(now in preparation)

WIN VALUABLE CASH PRIZE!

Many other prizes, including cash, test instruments, TV magazine subscriptions, etc.

ABSOLUTELY NO OBLIGATION!

We want best name. Send coupon below for full particulars.

NEW! 1954 TV CONSULTANT TV Serviceman's Silent Partner



New, easy-to-use way to solve toughest TV troubles. UHF sect. Includes conversions, installations and servicing. Modern alignment methods shown by pictures, diagrams and simple directions. Tell exactly what to do and how to do it. Practical pointers on use of all TV Test Instruments. Over 300 pix, raster and sound symptoms. Detailed directions tell where and how to find faulty parts. Over 135 RAPID CHECKS, many using pix tube as trouble locator. 125 illustr. of scope wave forms, diagrams, station patterns, show various defects—take mystery out of TV servicing. **NO THEORY—NO MATH—NO FORMULAS**—just practical service info. covering all types of TV sets. **Only....\$2**

terms, show various defects—take mystery out of TV servicing. **NO THEORY—NO MATH—NO FORMULAS**—just practical service info. covering all types of TV sets. **Only....\$2**

NEW! 1954 TV TUBE LOCATOR ALL PIX TUBES LISTED!



Money-making Time Saver tells which tubes to replace to cure every type of tube trouble. Over 135 such TV troubles, listed with clear charts for quickly locating the faulty tubes. Copyrighted TROUBLE INDICATING TUBE LOCATION GUIDES for over 3000 most popular models from Admiral to Zenith plus PIX TUBES used in each model! 1947 to 1953 models. A storehouse of valuable TV servicing info. priced very low for large volume sales. **Only....\$1**

NEW! Trouble Shooting PIX GUIDE incl. TV TERMS Explained

Set. 1 is a fully illustrated GUIDE to off-recurring Pix faults. Causes and cures explained. Copyrighted Trouble Indicating Illustrated chart tells where troubles start in typical TV set—illustrations show resulting faulty TV pictures. Set. 2 explains hundreds of TV terms in non-technical language. SPEEDS UP TV SERVICING—HELPS YOU DO A BETTER JOB FASTER! **Only....\$1**



NEW! TV TROUBLE TRACER

VOL. 1 & 2 NOW READY!

70 Common TV troubles traced to source and cured. Copyrighted trouble indicating tube location guides covering over 1200 most popular TV models. Many models different from those shown in TV TUBE LOCATOR. Each contains over 70 illustrations and tube location guides. Forty most common picture troubles illustrated, with symptoms described, causes given and remedies prescribed.

Vol. 1 only 50c Vol. 2 only 50c



H. G. CISIN, PUBLISHER

Order from your Jobber today, or if not stocked, write to

HARRY G. CISIN, Dept. R-3
Amagansett, New York

Enclosed find \$ Send

- TV Consultant TV Locator
 TV Pix Guide TV Tracer, Vol. 1
 TV Tracer, Vol. 2

Itush full particulars about PRIZE CONTEST!

Name

Address

City Zone State

on LP. Lovers of this comic opera have had to content themselves with excerpted highlights, not very satisfying to the opera addict. Of course the mere fact that a complete recording of "Mignon" exists does not gain for it immediate acceptance. Among the most canny buyers of records is the opera fan. He's from Missouri and wants to be shown! He can allay any fears he might have with regard to this version herein reviewed. It is a magnificent achievement from any standpoint. Genevieve Moizan as "Mignon" is absolutely splendid, Janine Micheau as "Philine" is her usual brilliant self, and Libero De Luca entirely convincing as "Wilhelm." There might have been a happier choice than Rene Bianco as "Lothario," but he is competent enough as are the other remaining soloists.

The ensemble work is among the finest I've ever heard in an opera. Georges Sebastian conducts, with authority, a better-than-average orchestra and in general keeps a firm but guiding hand on all the forces he commands. The sound is up to the high standards that *London* has set in its opera recordings. String tone is warm and vibrant, percussion very clean and accurate, soloists are projected with splendid clarity. "Big hall" acoustic perspective.

It is interesting to note the unique new method of packaging multi-disc sets that *London* has developed. Enclosed in the usual box-type album, between the inside cover and the record itself is a cube of foam rubber. This cube is somewhat larger than the space between album cover and disc. As a consequence, when the album is in a closed position, the cube compresses and holds the disc quite firmly in its inner shuck. This, of course, is of more practical importance in the shipping of an album to its distribution point. A clever little idea and one that seems to pay off, as there was a minimum of scratches and surface noise in the review copy sent to me. The *ffrr* curve reproduced the disc perfectly with controls flat.

MOUSSORGSKY

PICTURES AT AN EXHIBITION
Philadelphia Orchestra conducted by Eugene Ormandy. Columbia ML4700, NARTB curve. Price \$5.95.

PICTURES AT AN EXHIBITION
Chicago Symphony Orchestra conducted by Rafael Kubelik. Mercury MG50000, AES curve. Price \$5.95.

Many readers have asked for a comparative review on these discs, ever since the Ormandy version appeared. Whew! You guys don't mind putting me on the spot, do you? These are just about the toughest two discs in the LP catalogue to compare. Why? Well, let it be understood from the start that these two recordings are absolutely tops, each in its own way. As far as fidelity of reproduction is concerned, each is extremely wide range with no particular advantage of one over the other. The *Mercury* disc is now famous

COMMUNICATIONS RECEIVERS



Contains All Components

FEATURES:

- 2 Watt P. P. Audio
- Amplified AVC
- Voltage Regulated Oscillator Supply
- Noise Limiter
- Beat Oscillator
- Air Tuned R.F. Trimmers
- 2 Stage Permeability Tuned 455 KC I.F. Plus Crystal Filter
- Phone Jack — Built-in Stand-by Relay
- Operates on 105 to 125 Volts AC or DC Power Source
- Frequency Range 200 KC to 400 KC and 450 KC to 19 MC in Six Bands
- 40:1 Gearing Ratio Dial Drive
- 11 Tubes Plus Selenium Rectifier
- 65G7 RF Amp.
- 65B7Y Mixer
- 2-65G7 I.F.
- 6H6 2nd Det & N. L.
- 65F7 AVC Amp.
- 6SL7 BFO & 1st Audio
- 6SL7 Phase Inverter
- P.P. 25LGGT Audio
- VR-75 Voltage Regulator
- Full Vision Calibrated Dial
- Cabinet 19 1/2" high x 10 1/2" deep
- Finished in fine grain black wrinkle
- Front panel silk screened to identify each control

FRONT PANEL CONTROLS

- Tuning
- R.F. Gain
- Audio Gain
- BFO-AVC Switch
- BFO Pitch
- Power On-Off
- Stand-by
- Noise Limiter On-Off and Control
- Antenna Trimmer
- Crystal Filter On-Off
- Crystal Phasing
- Selectivity
- Band Change Switch
- Calibrated Dial Face

COMPLETE KIT—This kit is complete with every part necessary to assemble into a finished receiver, including tubes and cabinet. Chassis is punched and marked. Mount the parts, wire it, align it and you have a fine receiver of commercial appearance, that can't be beat for 3 or 4 times the price. Parts layout, schematic diagram and alignment instructions are supplied.

SPECIAL Complete Kit **59.50** KIT PRICE EACH

Shpg. weight 45 lbs. Shipped express only. F.O.B. Chicago and subject to change without notice.

Signal Corps HS-18 replacement units, consisting of 2 type R-14 series connected units with PL-54 plug. 8000 ohm impedance. Per set. **\$1.50**

HEAD PHONES

Famous Signal Corps type P-20 high-impedance (24,000 ohm) head phones. Complete with 6 foot moulded rubber cord. PL-55 plug and head band. Brand new at a bargain price of **\$3.95**

ORDER TODAY!

TERMS: 25% Deposit with order. Balance C.O.D.

BOULEVARD ELECTRONICS, INC.

Mail Order Address:
1229 W. Washington Blvd., Chicago, Ill.
Store Address: 4054 W. Belmont Ave., Chicago, Ill.
RADIO AND TELEVISION SUPPLIES

RADIO and TELEVISION ELECTRONICS



in all Technical Phases
New Classes (Day and Evening) Start 1st of Dec., Mar., June, Sept.

Free Placement Service for Graduates
For Free Catalog write Dept. RN-54

RCA INSTITUTES, INC.

A Service of Radio Corporation of America
350 WEST 4TH ST., NEW YORK 14, N. Y.

TV TRADE-IN SETS

- Philco • Emerson • GE • Admiral
- Motorola • Tele-King • Others
- 10"—\$17; 12" to 17"—\$20 up

Send check or money order now!
List available—Add \$5 for packing

WASHTEK SERVICE CO.
1501 Boston Road, Bronx, N. Y. DA 3-9261

as the initial effort in their "Olympian Series," which also saw the inauguration of the single *Telefunken* mike-over-the-podium pickup. *Columbia* has made some constructional changes (what they are I haven't the vaguest idea) in the Academy of Music in Philadelphia. I presume these constructional changes were accompanied by new pickup techniques. So what is the essential difference between the two recordings, and which do I prefer? The *Mercury*, and for the following reasons. Tempo. This is a matter of performance you say. But, this is a peculiar circumstance in which the type of repertoire we are dealing with actually sounds different when played at various tempi. I thought Mr. Ormandy lost a great deal of the punch and the sonority of "Pictures" by conducting at a much faster pace than Kubelik. Acoustics and dynamic range; here is perhaps the crux of the whole matter. As I said, both recordings are recorded with equal fidelity. But the *Mercury* disc was recorded in the fortuitous acoustic environment of Orchestra Hall in Chicago. The combination of the repertoire and the acoustics made one of the most sonorous discs yet heard. The weight of the brass was tremendous and the percussion unbelievably solid. May I point out that this theory of repertoire and acoustics has been pretty well borne out by subsequent recordings made by *Mercury* in Orchestra Hall.

Take, for instance, Brahms "First Symphony" as recorded by the same orchestra and conductor, in the same hall. Yes, it is a very good recording, but no where near as sensational soundwise as the "Pictures." Many a hi-fi fan went to hear Kubelik play the Moussorgsky piece when the Chicago Symphony was at Carnegie Hall in N. Y. (contrary to popular belief, hi-fi fans do go to concerts). They heard the same splendid performance as on the disc, but most were disappointed in the sound. Of course! No two halls are alike as to acoustics and the acoustics of Orchestra Hall in Chicago just seem to go with "Pictures at an Exhibition," like ham with eggs.

You must remember that all the foregoing is just this reviewer's personal opinion. I have no doubt that there are many who prefer the Ormandy version. It is a splendid recording, but to me the more exciting result is the Chicago disc. The *Columbia* disc does have one advantage over the *Mercury* and that is the bonus of an excellent performance of Stravinsky's "Firebird Suite" on the flip side of the 12" disc. The *Mercury* version of "Pictures" occupies both sides of a 12" LP and those who have to watch their pennies a little closer than most may prefer the bonus value of the *Columbia* disc. Well, that's it. I am mentally cringing from the weight of wrathful letters I know will descend on my head for this review. But them's my views, Podner, an' I'm stickin' with 'em!

That is the "bag" of recordings for this month. Happy listening!

NOW EICO® brings you A LABORATORY SCOPE AT A PRICE YOU CAN AFFORD!

Now you can enjoy all the tremendous advantages of trouble-shooting with the greater speed, precision and visual meaning which only an oscilloscope gives you. With the EICO 5" Scope you can:

- Visually align TV, FM and AM sets
 - Visually signal trace and trouble-shoot every stage of any electronic device
 - Visually analyze complex waveforms
- All without disturbing circuits

425K 5" Push-Pull Scope KIT \$44.95. Wired \$79.95.

NEW 3 PROBES make 3 INSTRUMENTS of your EICO Scope

DEMODULATOR PROBE KIT \$3.75. Wired \$5.75 — For signal tracing every stage of TV, FM and AM sets.

LOW CAPACITY PROBE KIT \$3.75. Wired \$5.75 — For broad bandwidth and high impedance circuits.

DIRECT PROBE KIT \$2.75. Wired \$3.95 — For voltage and current measurements and general analysis.

Special introductory price, set of three PROBE KITS \$9.95. Wired \$14.95



Compare these specifications with scopes selling at many times the EICO economy price!

- Push-pull Vert. & Hor. amplifiers
- Full-screen V & H centering controls
- Intensity (Z-axis) mod.
- 6.3 volt AC, 60 cps test signal output

- Direct connections to deflection plates
- V & H Freq. Resp: 5 cps — 500 kc; usable to 2.5 mc.
- V Sens: .05 to .1 volts rms/inch
- V & H input imp: 1 megohm
- Multivibrator Sweep Generator Range: 15 cps — 75 kc
- Tubes: 2-5Y3, 2-6J5, 3-6SN7, 1-5" CRT.



See this amazing Scope value at your jobber today. Write NOW for FREE Catalog SR-3 describing the complete EICO line. Turn to our full-page ad on page 42 of this magazine.

ELECTRONIC INSTRUMENT CO., INC.
84 Withers Street, Brooklyn 11, N. Y.

Dealers—Servicemen—ATTENTION! Tremendous Bargain

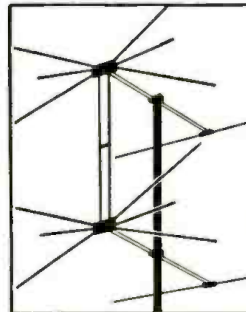

in
CONICALS
2-BAY
16-ELEMENT
CONICAL
ARRAY
With Hi-Band
Adapters
Sturdy 3/8" Element

\$4.99 Each
In Lots of Three
Single Lots \$5.30

Never before has National Electronics had a BARGAIN like this. We made a special purchase in order to get these sensational prices. And this array has everything. This conical 2-bay 16-element array provides ultra-high fringe reception. Includes sixteen 3/8 inch aluminum type aluminum elements, including hi-band adapters for greater gain on the high channels and is complete with one pair of stacking bars to each array. These are packed in cartons of three 16-element arrays per carton, with the rods, at \$14.95 per carton. When purchased in single 16-element arrays, separately boxed—your cost is \$ 5.30 each

3 Two-Bay Arrays per carton without the Rods 13.50 carton

4 Bay Ultra-Fringe Stacking Assembly for Above—Model 4B \$1.95 set

FAMOUS ROCKET ZOOM-UP TOWERS

• Sturdy • Reliable • Easiest Installation

Economize with Rocket Zoom-up Towers. Offers quickest, easiest way to make an installation up to 50'. Each section telescopes inside the other—to erect, simply slide out each section in its turn—insert bolt thru section below—tighten to keep mast from turning. Each tower complete with guy rings, bolts, and mounting base suitable for peak or flat roof. Handsome and sturdy. Rocket Zoom-ups offer you economy and long life. Order by size.

20' \$ 9.95 30' \$15.95
40' 19.95 50' 29.95

UHF STRIPS Now available for Standard Coil tuners. To order, specify channel No. and series designated by letter, such as F, G, Q, etc., stamped on each strip of your present tuner. (Set consists of one. & ant.) **\$7.50 Ea.**

NEW SPRING CATALOG AVAILABLE
Includes Sensational Profit Sharing Point Plan

NEW SUPER FRINGE MOTORLESS DIRECTRONIC VHF-UHF CHANNELS 2-83

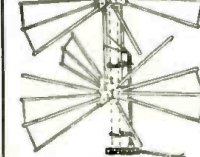

Model AX-524
ONLY \$23.50
YOU SAVE 50% ON
AVERAGE INSTALLATION

- Reception From All Directions
- No Motors Needed

New Super Directronic is Electronically Beammed in all directions by directronic selector switch at receiver. Hi-gain 24-element array eliminates need for motors. Kit complete with 75' popular Tri-X cable, Directronic Switch, Matched Stacking Bars and Universal U-Clamp.

ROCKET BROAD BAND YAGIS

- SENSATIONAL GAIN
- SENSATIONAL PICTURES IN FRINGE AND ULTRA FRINGE AREAS

Switch to Yagi Broad Band Hi-Gain Antennas! These new Yagis give you Yagi reception on the 5 low-band and 7 hi-band channels—no restriction to one single channel. A two-bay array will perform even a 10 or 12-element single channel Yagi. Price is sensationally low. Complete servicemen's array includes 1 double selector, 2 folded inductors, 3 directors. Universal mast clamp. Easy-to-assemble quick rig construction.

Model RB 20—Ch. 2 thru 6-7-element \$10.95 ea.
Model RB 715—Ch. 7 thru 13-8-element 5.95 ea.
Matched Stacking Bars 1.25 ea.

HI-GAIN BOW-TIE REFLECTOR
For UHF \$1.95 Each
High gain at low cost. Completely pre-assembled. Easily stacked for fringe use.

2 Bay with the rods \$ 4.40
4 Bays with stacking harness 9.95
Lots of 6—individually carton-toned 10.95

ALL PRICES F.O.B. CLEVELAND, OHIO
Do not remit more than complete purchase price. Pay shipping charges on receipt of goods. 25% deposit on all C.O.D. orders please. Money-back guarantee. Prices Subject to Change Without Notice

National Electronics
OF CLEVELAND
THE HOUSE OF TV VALUES
103 Delco Building Cleveland 3, Ohio

**SPECIAL-OF-THE-MONTH
SCR-522 RECEIVERS**

less oscillator assembly, frequency shifter and tubes. Contains all Coils, Transformers, Resistors, Condensers and other valuable parts. **SPECIALLY PRICED \$7.95 each**



**R-47/ARN-5
Glide-Path Receiver**

R-47 is a single-channel Glide-Path Receiver tunable from 330 to 340 mc. Excellent condition, less tubes. Operates on 24 VDC **\$9.95**

SPECIAL!

20 LBS. of ASSORTED RADIO PARTS
A terrific buy at only **\$1.99**



TUBES BRAND NEW! JANI BOXED! TUBES

| | | |
|--------------------|--------------------|--------------------|
| 1B2269c | 114B29c | 84129c |
| 2B2249c | 215A09c | 84317c |
| 2C2609c | 221A29c | 86419c |
| 2C28A15c | 316A29c | 102619c |
| 3B221.19 | 3B8A59c | 719319c |
| 30039c | 471A1.19 | 000269c |
| 7C459c | 5221.19 | E114849c |
| 12K6V39c | 722A99c | RK3499c |
| 13R39c | 801A19c | VR9214c |
| 39/4429c | 82639c | VT12715c |

TELEGRAPH KEYS

| | |
|---------------|--------|
| J37 | \$1.50 |
| J38 | 1.50 |
| J41 | .98 |
| J45 | 3.95 |

**SCR-274N
COMMAND
and
ARC-5
EQUIPMENT**



| | | | |
|-----------------------|--------------|---------|---------|
| RECEIVERS | USED | USED | NEW |
| BC-453—190 to 550 KC. | \$29.95 | | \$49.95 |
| BC-454—3 to 6 MC. | | | 24.35 |
| BC-455—6 to 9 MC. | 5.95 (as ls) | \$13.95 | 19.95 |
| 1.5 to 3 | | | 34.95 |

| | | | |
|---------------------------|------|-------|-------|
| TRANSMITTERS | | | |
| A-958—21 to 3 MC. | | | 29.95 |
| BC-457—4 to 5.3 MC. | | 14.95 | 29.95 |
| BC-458—5.3 to 7 MC. | 9.95 | 14.95 | 29.95 |
| BC-459—7 to 9.1 MC. | | | 24.95 |
| 7-15 ARC 5—500 to 800 KC. | | | 29.95 |

| | | | |
|--|------|------|------|
| ADDITIONAL EQUIPMENT | | | |
| BC-456 Modulator | | | 7.29 |
| BC-450 Control Box (3 Receiver) | 1.49 | 1.95 | |
| BC-451 Control Box (Transmitter) | 1.29 | 1.79 | |
| BC-442 Relay Unit (ANT.) | | | 5.69 |
| Plugs: PL-147, 148, 151, 152, 153, 154, 156—EACH | | 1.25 | |
| Flexible Shaltine with gear to fit receivers | | | 2.69 |
| 3 Receiver Rack | 1.79 | 2.29 | 2.98 |
| 2 Transmitter Rack | 1.69 | 2.39 | 3.97 |
| Single Transmitter Rack | | | 3.97 |
| DM-33 Dynamotor for Command Set. | | | 3.95 |
| Mounts for Above Racks | 1.95 | | |

Field Telephones
Army surplus. Plus, completely reconditioned and electrically tested, using 2 flashlight cells and a pair of interconnecting wires. GUARANTEED. **\$21.95**

SPECIAL!
45 Henry 60 ma 625 ohm. LIMITED QUANTITY OF THESE CHOKES **\$1.25**

HEADSETS

| | |
|---|--------|
| HS-29 high impedance. BRAND NEW with ear pads. | \$4.65 |
| HS-33 low impedance. BRAND NEW with ear pads, cord and PL54 plug. | 5.65 |
| CD-307A Cords, 6 ft. NEW | \$1.49 |
| H-16/U high impedance. Includes two receiving units | 3.95 |
| HS-16 high impedance—used. | .98 |

BC-221 Frequency Meter
Real Value! QUANTITY IS LIMITED—so first come, first served. They are just like new, with original calibration charts. Range 125-20,000 KC with crystal check points in all ranges. Complete with crystal and tubes. **\$139.50**
MODULATED TYPE \$169.50
MODULATED TYPE with AC Power Supply 189.50
These Frequency Meters are factory treated, checked for frequency alignment and GUARANTEED.

MINIMUM ORDER \$2.00
Immediate Delivery—Send 25% deposit on C.O.D. orders. All shipments F.O.B. N.Y.C. (N.Y.C. residents add sales tax to your remittance.)

PLATT ELECTRONICS CORP.
Dept. A, 489 Broome St., N. Y. 13, N. Y.
PHONES: WO 4-0827 and WO 4-0828

Chromatic Color Tube

(Continued from page 53)

with the NTSC color TV system is shown in Fig. 3. The four video sections, containing the brightness and the three color signals, are required for the NTSC color system since the fine picture detail is transmitted on the brightness signal, and for color information each requires a separate amplifier. For the color signals, the amplifiers are relatively narrow-band stages, but for the brightness signal a 3.5 to 4 mc. bandwidth is desirable. Not shown in Fig. 3 is the synchronous detector which supplies the brightness and color signals. Also omitted are the vertical and horizontal deflection circuits.

The keying section is required to switch the output of each of the three color stages onto the single electron gun. In the RCA tri-color picture tube this is not necessary since each color channel is connected to one of the three electron guns. The tri-color tube is essentially a simultaneous device, while the "Chromatron" breaks the simultaneous NTSC system into a dot-sequential picture.

The operation of the color grids and their associated circuits is shown in some detail in Fig. 3. In order to maintain the d.c. focus potential between the two color grids and the aluminized phosphor backing, a center-tapped coil is required to make this potential equal at both grids. In Fig. 3, it is assumed that the secondary of the output transformer is resonated with the color grid capacity and properly matched to the primary for maximum transfer.

The driver stage can be a power amplifier driven by a voltage amplifier which, in turn, is driven by the color synchronizing oscillator. This 3.58 mc. oscillator is controlled by means of a keyed a.f.c. system from the color synchronizing burst transmitted after each horizontal synchronizing pulse in the

composite color signal. In order to obtain true color rendition it is absolutely essential that the frequency remain constant and no phase shift or distortion be introduced.

The high voltage section of the "Chromatron" is somewhat different than for the RCA tri-color picture tube. Good regulation of the anode voltage is not required for the "Chromatron" whereas it is for the tri-color tube.

At the time of writing, several demonstrations of the "Chromatron" have been given. When demonstrated with the NTSC color TV system the "Chromatron" itself appears fairly good. The pictures on one of the tubes appeared to have considerable red streaking which apparently was due to the red phosphor's long persistence. This feature can be remedied by using a different red phosphor. At a viewing distance of about 10 feet, the individual lines are not visible and the viewer sees only the complete color picture.

One interesting aspect of the line structure is the fact that the lines and the grid wires behind them can be oriented either vertically or horizontally and both types of tubes have been tested. It was found that when the colored phosphor lines are in the same direction as the horizontal scanning lines the color moire pattern is much less visible at closer viewing distances. The actual width of the color phosphor lines has not been definitely set, but tubes with strips as narrow as 0.010 inch (10 mils) have been built. When these strips are applied horizontally, the resulting line structure is fine enough to enable the viewer at ordinary distances to see the complete color picture exclusively.

Chromatic Television Laboratories and some other tube manufacturers are developing improved tubes. Some of the planned improvements include much narrower phosphor strips, permitting a greater number of strips and therefore better resolution. Color grids will be made of finer wire and a better

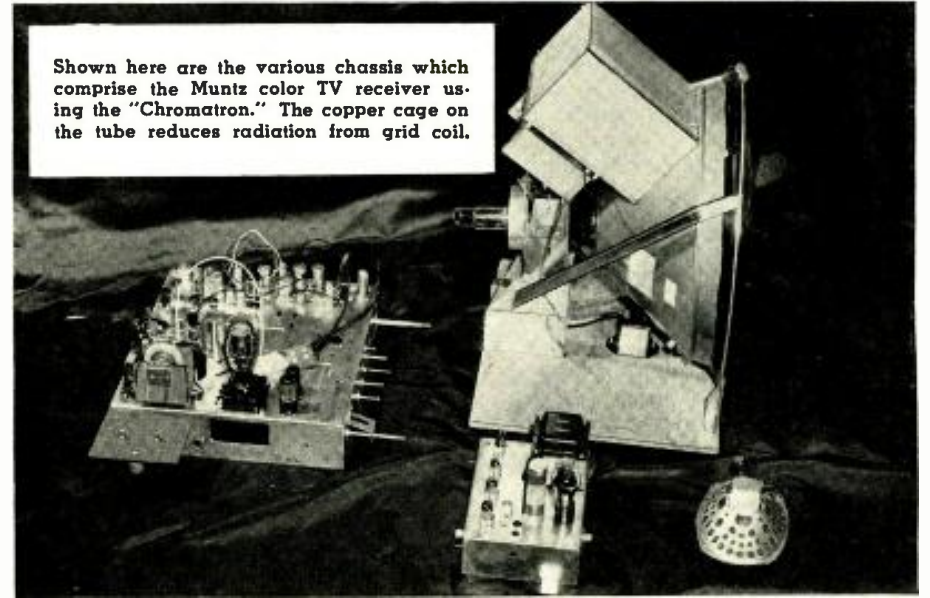

Shown here are the various chassis which comprise the Muntz color TV receiver using the "Chromatron." The copper cage on the tube reduces radiation from grid coil.

20-20 PLUS!

S-256-Q
Output
Transformer

±1 db 10—100,000 cps
40 watts 30—40,000 cps

10 watts at 10 cps
20 watts at 15 cps

Insertion loss
0.4 db

Pri: 5,000ΩCT
Sec: 16, 12, 8, 4, 2Ω

May be operated between
halved or doubled
impedances



Write
today
for the
Peerless
Catalog

PEERLESS
Electrical Products

A DIVISION OF



9356 Santa Monica Blvd., Beverly Hills, Calif.
161 Sixth Avenue, New York 13, New York

set of colored phosphors is under consideration. The problem of the persistence of the phosphors can be solved when a color combination is found which produces the correct primary colors and has equal brightness and persistence under the same accelerating potential. In the sample tubes demonstrated so far, the correct phosphor combination was lacking, but some fairly good pictures were observed with a compromise arrangement of phosphors. —50—

Basic Color TV (Continued from page 70)

done on how much color the average human eye really sees. This work, in conjunction with other data which has appeared from time to time, brought forth several very interesting facts.

1. The theory that vision is a three-color process is true only when the object viewed is relatively large. On a television screen, this refers to objects which are produced by video frequencies from 0 to .5 mc.

2 For medium-sized objects, say those produced by .5 mc. to 1.5 mc. video frequencies on a television screen, only two primary colors are needed. Blues and yellows are among the first colors to lose their color and become indistinguishable from gray within this range.

3. For very fine detail, say those reproduced by video frequencies from 1.5 to 4.0 mc., all people with normal vision are color blind. In other words, all that is seen are shades of brightness.

The conclusion to be drawn from the foregoing is that 4 mc. color is not necessary. All we require is color up to 1.5 mc. And even within this range, we need all three colors only to .5 mc. and only two primaries for the color signal extending from .5 mc. to 1.5 mc. In the formation of the NTSC signal, these facts were put to use by employing one color signal, called the "Q" signal, with a range from 0 to .5 mc. and a second color signal, called the "I" signal, with a bandpass from 0 to 1.5 mc. The rest of the video picture, containing all of the fine detail, is reproduced in black-and-white by a monochrome signal and the eye is none the wiser. As a matter of fact, a full color television signal consists of a 0 to 4 mc. monochrome video signal (just as we have in black-and-white broadcasting) plus a color subcarrier containing the "I" and "Q" color signals mentioned previously. It has been truly said that the NTSC system is a "colored" television system.

The monochrome signal possesses such alternate names as brightness signal and luminance signal. The color portion is frequently referred to as the chrominance signal.

In the next article of this series we will see how the NTSC color signal is formed and of what it consists.

(To be continued)



**NEW! THE ONLY
COMPLETE BOOK ON
TELECASTING!**
covers every phase

"Principles & Practices of TELECASTING OPERATIONS"

by HAROLD E. ENNES

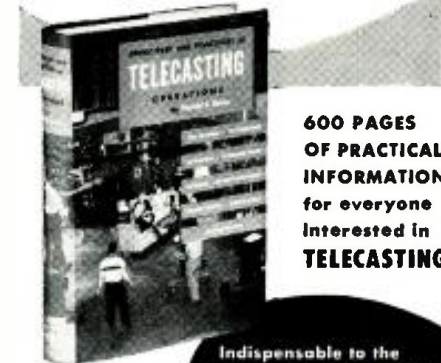

**600 PAGES
OF PRACTICAL
INFORMATION
for everyone
Interested in
TELECASTING**

top reference
on Telecasting

Indispensable to the
Engineer, Production Man,
Director, Technician, and
to all Students of
the Video-Audio Art

CONTENTS:

A Partial List of Authoritative Chapters:

Basic Telecasting Equipment; The TV Camera; The TV Control Room; Fundamentals of TV Studio Lighting and Equipment; Network Program Relay Systems; TV Operational and Maintenance Practices; Technical Production of TV Shows; Field Equipment and Microwave Relays; Analysis of Video and Audio Transmitting Plants; Technical Definitions — PLUS HUNDREDS OF OTHER SUBJECTS

Here, in one complete, easy-to-understand volume is the whole fascinating story of Telecasting operations. Whether you are a Chief Engineer, Production Director or Technical Director; if you are now working in or planning to work in TV, or if you are simply interested in Telecasting, this book is *meant* for you. Here is practical, useful information that makes you familiar with the equipment and techniques used in Telecasting, tells you *everything*—answers all your questions about TV production and transmission. If you work or are interested in Telecasting, you'll want this vast wealth of reliable information—you'll want this book in your library. Order your copy today!

600 Pages, 450 Illustrations
6" x 9"
Hard Covers **\$7.95**

**ORDER
TODAY!**

Order from your electronic parts distributor or bookstore, or write direct to Howard W. Sams & Co., Inc. 2203 E. 46th St., Indianapolis 5, Ind.

My (check) (money order) for \$..... enclosed. Send the following:..... copy(ies) of "Telecasting Operations" (\$7.95 per copy).

Name.....

Address.....

City.....State.....

SERVICE HINTS ON STEWART-WARNER TV SETS

Terrific Transmitter-Receiver Buy! FAMOUS BC-645 450 Mc.—15 Tubes



BRAND NEW, in original carton! Easy to convert for phone or CW 2-way communication, covering these bands: 420-450 Mc Ham Band, 450-480 Mc fixed or Mobile, 460-470 Citizens Band, 470-500 Mc TV experimental. Contains 15 tubes: 6-7F7, 4-7W7, 2-7E6, 2-6F6, 2-955, 1-WE-316A. Size 10 1/2 x 13 1/2 x 4 3/4". Wt. 25 lbs.

BRAND NEW
\$39.50
each

CONVERSION DIAGRAM INCLUDED!

PE-101C DYNAMOTOR for above BC-645..... **\$4.85**

UHF ANTENNA ASSY. for above BC-645..... **\$2.45**

HEADSETS

| | Excellent USED | BRAND NEW |
|--|----------------|-----------|
| HS-23 high impedance | \$2.95 | \$4.75 |
| HS-33 low impedance | 2.45 | 5.75 |
| HS-30 low imp (featherwt) | 1.49 | 4.95 |
| W-16 U high imp (2 units) | | |
| CD-307A cords, with PL55 plug and JK26 jack, 8' long | | 1.19 |

SCR-522 BARGAIN OFFER!

SCR-522 Xmitter less tubes \$22.50 **\$32.50**
with tubes.....
SCR-522 Recvr less tubes \$19.50 **\$24.50**
with tubes.....

MICROPHONES

T-17 Shure Handmicke 200-ohm carbon single button. Press-to-talk switch, 5' cord & plug. BRAND NEW..... **\$7.95**
Used, excellent..... **\$5.50**

BC 605 INTERPHONE AMPLIFIER

Can be easily converted to an intercom. set—ideal for office, home or factory.
New..... **\$5.25** Like New..... **\$3.95**



| Type | USED | Excellent BRAND NEW |
|---|---------|---------------------|
| BC-453 Revr. 190-550 Kc. | \$21.50 | \$28.50 \$44.50 |
| BC-454 Revr. 3-6 Mc. | 10.50 | 12.50 24.95 |
| BC-455 Revr. 6-9 Mc. | 10.95 | 12.95 17.95 |
| BC-456 Modulator | | 2.75 5.75 |
| BC-457 Xmtr. 4-5.3 Mc. | 13.50 | 18.50 29.50 |
| BC-458 Xmtr. 5.3-7 Mc. | 8.50 | 9.75 29.50 |
| BC-459 Xmtr. 7-9.1 Mc. | 14.95 | 16.50 24.50 |
| BC-450 3 Revr. control box | | 1.49 1.95 |
| BC-451 Xmtr. control box | | 1.25 1.49 |
| 3 Receiver rack | | 1.79 2.95 |
| 2 Transmitter rack | | 1.59 3.25 |
| Single Transmitter rack | | 1.59 3.25 |
| ARC-5 T-23 Transmtr. with tubes. Brand New..... | | \$49.50 |

ARMY FIELD PHONES

Type EES—Talk as far as 17 miles. Dependable 2-way communication. Each phone complete with ringer and handset. Excellent Condition. Your cost..... **\$22.25**

DC AMMETER 0-15 Amps

A terrific buy! 3 1/2" easy reading scale. 75 divisions. Black plastic case 4 1/2 x 5 1/4 x 2 1/4". Rubber covered test clip leads plus black metal carrying case with hinged cover. Brand New. Wonderful for automotive, battery charging, general test work. Value **\$4.59**
\$25. All yours for only

Sensational Buy! BC-221 FREQUENCY METER

JUST LIKE NEW! Limited quantity, first come, first served! Range 125 to 20,000 Kc. with crystal check points in all ranges. Complete with tubes, crystal, calibration charts.
YOUR COST..... **\$129.50**
Modulated BC-221-AK BRAND NEW..... **\$210.00**
Complete.....
These Frequency Meters are factory treated, checked for frequency alignment and GUARANTEED.

SELSYN 2J1G1

Operates from 57 1/2 V 400 cycles. New, tested. Conversion diagram for 110 V AC included.

BRAND NEW..... **\$4.50** per pair

WILLARD 6-VOLT MIDGET STORAGE BATTERY

3-amp hr. BRAND NEW. 3 3/8" x 1-13/16" x 2 3/8". Uses standard electrolyte..... **\$2.65**
WILLARD 20 AMP. HR. BRAND NEW..... **\$2.69**

DYNAMOTORS

| Type | Input | Output | Exc. | Brand New |
|--------|-----------|--------------|--------|-----------|
| DM-32A | 28V 1.1A. | 250V .05A. | \$4.90 | \$7.50 |
| DM-33A | 28V 5 A. | 575V .16A. | 2.25 | 3.95 |
| | 28V 7 A. | 540V .25A. | | |
| DM-40 | 14V 3.4A. | 172V .138A. | 7.40 | 9.50 |
| DM-28 | 28V | 224V .07A. | 3.95 | 6.95 |
| PE-73 | 28V 20A. | 1000V .350A. | 9.50 | 12.50 |

Please include 25% Deposit with order—Balance C.O.D. MINIMUM ORDER \$3.00. All Shipments F.O.B. Our Warehouse N.Y.C. Dept. N-3

G & G Radio Supply Co.

51 Vesey St., New York 7, N. Y. CO 7-4605
Branch: 16 W. Kinzie St., Chicago, Ill.

9120, 9121 & 9122

Poor horizontal linearity.

If it is sometimes difficult to obtain the correct horizontal linearity through adjustment of the horizontal linearity, horizontal drive, and width controls, change condenser 280, in the return lead of the horizontal output transformer (red lead from terminal 6 to deflection yoke), from .1 μ fd. to .25 μ fd.

9124-A

Critical horizontal hold.

This condition may be due to an increase in the value of resistor 258, which should be 3900 ohms, in the plate circuit (pin 2) of V_{10} , 6SN7GT horizontal multivibrator. Check this resistor and if its ohmic value has increased above 10%, replace it with another 1/2-watt, 10% tolerance unit.

Also check resistor 263, in the other plate (pin 5) circuit of this tube. The value of this resistor should be 270,000 ohms.

9127

Picture centering trouble.

If it is impossible to center the picture without producing neck shadow, apply the following circuit modifications:

1. Disconnect the yellow lead of the focus coil socket from the 340-volt "B+" supply, and reconnect it to the red lead coming from pin 7 of the deflection yoke socket.
2. Disconnect resistor 363 (12,000 ohm, 2 watt) in the screen circuit (pin 8) of the horizontal output tube (6CD6G) from the 340-volt "B+" supply, and reconnect it to the red lead coming from pin 7 of the deflection yoke.

9200 SERIES

Poor vertical hold.

In weak signal areas, or in areas with a great deal of external electrical interference, do the following to improve the vertical sync stability:

1. Change resistor 160, in the plate circuit (pin 6) of the 12AU7 phase splitter (V_{12B}), from 3300 ohms to 6800 ohms.
2. Change resistor 219 (from pin 6 of the 12AU7 phase splitter to terminal 1 of the vertical integrator network), from 56,000 ohms to 27,000 ohms.

Squeal.

During the receiver warm-up period, a high-pitched squeal may be emitted. This comes from the horizontal multivibrator, and can be eliminated by doing the following:

1. Change condenser 174, in the plate circuit (from pin 2 to pin 4) of the 6SN7GT horizontal multivibrator

(V_{11}), from 470 μ fd. to 390 μ fd.

2. Change resistor 177 (connected to pin 5 of V_{11}), from 330,000 ohms to 680,000 ohms.
3. Change resistor 235 (connected to pin 2 of V_{11}), from 3900 ohms to 3300 ohms.
4. Add a 270,000-ohm, 10%, 1/2-watt resistor from pin 5 of V_{11} to the 315-volt "B+" supply.

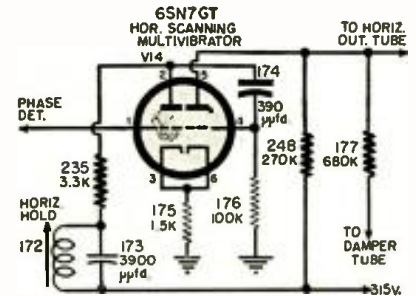

See accompanying diagram for new circuit.

9202

Vertical bending.

In moderate or strong signal areas, vertical bending may be encountered. To overcome this action, insert a 27,000-ohm isolating resistor in the plate circuit of the 12AU7 phase splitter. This resistor should be inserted between the plate (pin 6) of the 12AU7 and lead 1 of the vertical integrator printed circuit.

9204

Picture centering trouble.

If it is impossible to center the picture without producing neck shadow, disconnect the yellow lead of the focus coil socket from the 315-volt "B+" supply, and reconnect it to the red lead coming from pin 7 of the deflection yoke.

9300 SERIES

Poor horizontal hold.

If the horizontal hold action is critical, follow the procedure outlined below:

1. Check to see that condenser 131 is a silver mica 820- μ fd. unit with $\pm 5\%$ tolerance.
(See accompanying diagram.)

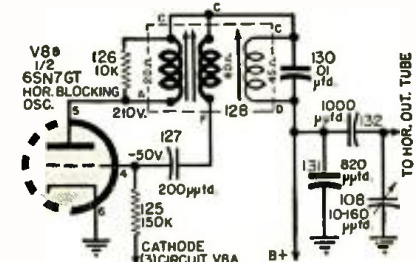

MR. SERVICEMAN and TECHNICIAN

*Thanks for
Your Acceptance*

THE
KIRBY
Model 98
**ORIGINAL FLYBACK
TRANSFORMER
TESTER**

Has PROVEN ITSELF!



Patent Applied for

- Takes the Guesswork Out of Horizontal Sweep Circuit Servicing
- Saves Time
- Inexpensive
- Easy-to-Operate

Detects shorted turns in Flyback Transformer and indicates as low as one shorted turn.

Tests transformer while in Television Receiver.

Also tests continuity on yokes, coils, speakers, switches, etc.

Suggested Dealer Net Price

\$39⁹⁵

SEND FOR FREE INFORMATION

KIRBY PRODUCTS CORPORATION

20 East Herman Street, Philadelphia 44, Pa.

"How to Test Flyback Transformers" Instruction Manual

"Specification and Data Sheets"

Name _____

Address _____

State _____ RTN

2. Check to see that condenser 130 is other than a *Sangamo* type (red body). This .01- μ fd. condenser should be the type supplied under the *Stewart-Warner* Part No. 512311. Do not use a substitute.
3. If the receiver has a "horizontal range" trimmer condenser, it should be screwed closed.
4. If a 6SN7GTA tube is used as the horizontal a.f.c. locking oscillator (V.), replace it with a 6SN7GT.
5. Turn the receiver on and allow it to operate for fifteen minutes.
6. Set the horizontal hold control, on the front of the receiver, to its counter-clockwise position.
7. Remove the 6BE6 gated sync separator tube from its socket. This will cause the receiver to lose both horizontal and vertical sync.
8. If it was necessary to replace condenser 130, the receiver will probably be far off of horizontal frequency. This should be corrected by adjusting the bottom slug of the syncro-guide transformer (Part 128) until the picture "hunts" horizontally. The picture will remain intact and slide from side to side across the screen. If condenser 130 was not replaced, do not adjust the bottom slug of transformer 128, but do adjust the top slug for "hunting."
9. Plug the 6BE6 tube back into its socket, and set the front control of the receiver to the center of its range.

21-INCH RECEIVERS

Dark spot on CRT.

A round dark spot, approximately 4 inches in diameter, may appear in the center of the picture tube on some of these receivers. This spot is due to the fact that the picture tube is too close to the safety glass. An electrostatic discharge to the glass reduces the high voltage on the picture tube in a small area, and the dark spot results.

To remedy this, loosen the chassis-mounting bolts, and slide the chassis back as far as it will go. —30—

Howard W. Sams (center) president of the firm bearing his name, accepts the "Friend of Service Management" plaque of the National Alliance of Television-Electronic Service Associations on behalf of his company. Frank J. Moch of Chicago, president of NATESA (right) looks on as Mr. Sams shows the plaque to Fred Colton, NATESA's eastern central vice-president and chairman of the board of the Associated Radio & TV Service Dealers of Columbus. More than 100 civic leaders and electronics executives attended the recent ceremonies.



*Your most
trouble-free
replacements*

for old-style mica and ordinary tubular capacitors

Centralab
Standard Tubular

BC HI-KAPS®

600 V.D.C.W. — 1600 V.D.C.W. — 3000 V.D.C.W.
For bypass, coupling, and general use

Any way you look at it, BC Hi-Kaps are "just what the doctor ordered!"

- They're small in size — have convenient radial leads.
- They fit easily, without tricky bending.
- They let you make close-coupled low-inductance connections — and fast.
- They operate at temperatures where ordinary tubulars fail — up to 85° C.
- They withstand extreme humidity.
- They're color-coded per RETMA and JAN specifications.
- They're conveniently packaged—5 or 25.

Have plenty of BC Hi-Kaps on hand to replace old-fashioned capacitors. Your Centralab distributor has complete stocks — see him soon.

Send coupon
for Centralab
Catalog 28.



Centralab

CENTRALAB,
A Division of Globe-Union Inc.
910C E. Keefe Avenue, Milwaukee 1, Wisconsin
Send Centralab Catalog 28.

Name _____

Company _____

Address _____

City _____ Zone _____ State _____

D-854

**INTERNATIONAL
RECTIFIER
CORPORATION**

EL SEGUNDO
CALIFORNIA

**RADIO TV
TYPE
SELENIUM
RECTIFIERS**



**NOW
AVAILABLE
AT
YOUR
FAVORITE
JOBBER**

**Widest Range
in the Industry**

Ask for Bulletin JRP-2

**INTERNATIONAL RECTIFIER
CORPORATION**

1521 E. Grand Ave., El Segundo, Calif. - Phone: DRegos 4-6261
CHICAGO: 205 W. Wacker Drive - Phone: Franklin 2-3889
NEW YORK: 501 Madison Avenue - Phone: Plaza 5-8665

RADIO-TV Service Industry News

**AS REPORTED BY THE
TELEVISION TECHNICIANS LECTURE BUREAU**

IN RESPONSE to the many inquiries that have been sent to the Bureau, a survey is now being completed that will provide the required information for a chart of standard labor charges for radio and phonograph service. Readers who would like to be notified when these charts are available should send a stamped, addressed envelope to TTLB Information Service, P. O. Box 1321, Indianapolis 6, Indiana, and request information on the Standard Radio Service Labor Charges Chart (RSL-1).

Color TV Service Charges

It will probably be a long time before the independent service industry will be called upon to install and service color television receivers. The set manufacturers will go into the production of color sets very cautiously. Field experience must be acquired both on the stability of circuitry under a great variety of operating conditions and the range of the likes and dislikes of the general public on color variation and deviation.

The early sets will be prototype models that will be closely watched in service by factory field service engineers and distributor service personnel. Even if color picture tube production should build up faster than is currently anticipated, production runs of color sets, which will carry high list prices, will be very limited.

The industry generally anticipates that color receivers will require far more service attention than monochrome receivers even after circuits and components have been perfected to the point where large-scale production is possible.

Quite naturally, charges for contract and C.O.D. service on color receivers will be determined through experience when thousands of sets are in use. But as a starting point, all sets that will be sold in the early days will probably have a mandatory 90-day parts and service warranty which the purchaser must buy and some may even require the purchase of a 1-year parts and service warranty. How much will set purchasers have to pay for these parts and warranty agreements?

Those best qualified to judge the

service requirements of color sets during the early stages, say that the average 90-day parts and service warranty will cost the purchaser about ninety dollars and the 1-year service contract and parts warranty will cost him about \$295.00. These estimates do not include the installation of an antenna.

Adequate Service Charges

It should be obvious to every service shop operator who handles TV service that he must assume part of the responsibility for educating the set-owning public to pay adequate charges for TV service. Those who still live under the illusion that they can continue to advertise home service calls for \$2.50 or \$3.00 and make up the difference in loaded tube and parts bills will find more and more realistic operators urging set owners to demand the old tubes and parts removed from their sets. As service customers become wise to the padded parts and tube gimmick, men who have promoted their businesses on the basis of small charges for home service will find themselves squeezed into an impossible position.

All of the factors involved inadequate pricing of service labor are now so well known that there is no reason why anyone should offer to perform TV service at a lower price than it can be given—honestly—and return to the business the sort of income a competent technical business has a right to expect.

The bulk of the income of a service business must come from the sale of labor. Records show that where adequate labor charges are levied for service, and the parts and tubes charged for are held to those really required to service the sets, 80% of the service income comes from labor charges and only 20% from the sale of replacement parts and tubes. In other words, each ten dollars of service income includes \$8.00 for a service technician's time and \$2.00 for the parts used in repairing the sets.

How much is experienced technical labor worth? If you are a top-flight technician operating your own service business how much "take home pay" should you expect to get from your

REAL SAVINGS! AT PART-MART

SPECIAL! INDUCTUNER

Way below wholesale cost for this popular 3-gang tuning device! For replacement or in own designs for TV and FM receivers and boosters. Continuous tuning from 52-120 mc and 175-216 mc with 4 turns of shaft. Size, 4 1/8" x 2 1/8". Shaft length 3". Wt.: 3 lbs., No. LC108. **\$2.19 EA.**



LOTS OF 3
\$2.19 EA.

12" P.M. SPEAKER

A quality speaker made by R.C.A. for use in the finest sets. Alnico V centerless ground magnet. Seamless cone. Extended Frequency Range. Voice coil 3.2 Ohms. Maximum power output 10 Watts. Wt. 4 lbs. No. LC106. **\$3.49 EACH**



LOTS OF 3
\$3.19 EA.

70° DEFLECTION YOKE

Latest design focus corrected 70° yokes at lower than wholesale cost. Can be used on all CR tubes up to 21". Inductance: 10.6 mh. Horizontal; 44 mh. Vertical. Will replace most 8 to 14 mh. yokes. Wt. 3 lbs. No. LC107. **\$1.29 EA.**



95c EA.
LOTS OF 3

\$1.29 EA.

LINE VOLTAGE TESTER

NEW! Just what you need! An inexpensive, accurate line voltage tester that will give you instantaneous readings right at the receptacle. NO WIRES—NO ASSEMBLY . . . JUST PLUG IN! Swivel head for easy reading. AC only. Reads 0-150 Volts ± 5%. Precision-made. Steel case. Wt. 1 lb. Stock No. SC113. **\$3.00 EA.**



ADJUSTABLE ION TRAP

New! with adjustable feature which allows magnetic field to be varied between 32-55 gauss. Will replace old style ion traps having specific magnetic fields. One universal ion trap to take care of all your needs! Wt. 8 ozs. No. SC111. **38c EACH**



3 FOR \$1.00

TV TUBE "BRITENER"

Extend life of Picture tube with this newly designed rejuvenator! Increase cathode emission and improve brightness-contrast. Fits all makes of TV tubes. Takes one minute to plug into any set having parallel-wired filaments. No tools or soldering. Fully automatic. Wt. 1 lb. No. SC112. **\$1.35 EACH**



LOTS OF 3
\$1.25 EA.

JEWELERS' EYE LOUPE

Finest quality loupe. Made of highly ground and polished, clear optical glass and toughest plastic case. Triple-plus magnification at 3" focussing distance. Every electronic technician can use one. No. GC115. **79c EA.**



Write for Additional Listings
INCLUDE POSTAGE—Excess Promptly Returned
TERMS: F.O.B., N.Y.C.—MIN. ORDER \$3.00—
25% Deposit on C.O.D. Orders. SAVE C.O.D.
CHARGES—REMIT IN FULL PLUS POSTAGE. Ex-
cess Promptly Returned. SUBJECT PRIOR SALE.

business to warrant the application of your time, energies, training, and experience *plus* all of the risks involved in running a business of your own?

Last November, the *RCA Service Company* completed a new contract with its employees' union which provided for the following wage schedule:

| | per week | hours |
|--|----------|-------|
| Chief Technician | \$115.00 | 40 |
| Journeyman Installation & Service Technician | 95.00 | 40 |
| Apprentice Installation & Service Technician | 50.00 | 40 |

The schedule for apprentices provides for regular increases in the wages paid apprentice technicians every six months until, after 42 months of satisfactory performance and progress, they will receive the journeyman's scale of \$95.00 per week.

How good a TV service technician do you consider yourself to be? Do you demand of your business that it pay you \$115.00 per week for yourself and family and a return on your investment in equipment, tools, and supplies? If you are running a one-man TV service business and want that business to pay you \$115.00 per week for working eight hours per day for five days a week, you will have to get \$8.56 net income from each service call you make, and you must average 7 calls regularly every day.

Although most one-man TV service operators work six days per week and ten or more hours per day, few of them are able to consistently average 35 service calls per week. The determining factor is not the number of hours per day or days per week a man works, but what he is able to accomplish in completed service jobs during the time he is available to work.

A great many studies have been made to determine the minimum size, in personnel, a service organization must be to operate profitably, and the optimum size for most efficient and profitable operation. The conclusion reached is that for most cases, a three-man operation is a minimum organization. Generally, where less than three men are employed, the time lost in handling non-income producing details of the business make it impossible for the one- or two-man shops to handle enough income-producing business to pay incomes commensurate with the technical skills of the men who operate the business. That this conclusion is sound is evidenced by the very high mortality rate among one- and two-man shops.

What will color TV demand in organization size for efficient and profitable operation? The following predictions by Paul V. Forte in a recent issue of the "Almo Broadcaster," published by the *Almo Radio Company* of Philadelphia, may prove significant:

"Take the green out of your eye, the red from your face, and don't be blue. The new year will be a colorful one, and particularly in the television industry.

"From its inception, television has been a turbulent business and nine-

Here's how to GET MORE WORK OUT OF YOUR Oscilloscope!



A complete, easily understood guide to using the handiest, most profitable service instrument of all
MODERN OSCILLOSCOPES AND THEIR USES

By Jacob H. Ruiter, Jr.
of Allen B. Du Mont Laboratories, Inc.
326 pages, 370 illustrations. Price \$6.

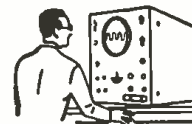

'SCOPE EXPERTS
get better jobs
. . . bigger pay!

Oscilloscopes are gold mines for servicemen who learn to use them fast, fully and accurately on all types of work—AND HERE AT LAST IS A BOOK THAT REALLY SHOWS YOU HOW. In clear, easily understood terms, it teaches you when, where and exactly how to use the oscilloscope . . . how to interpret patterns . . . how to use your 'scope to handle tough jobs easier, faster, and better. It contains no involved mathematics—no complicated discussions. Instead, it gets right down to "brass tacks" in explaining how oscilloscopes operate. Then you learn exactly how to use them in lab work and on all types of AM, FM and television service—from locating troubles to handling tough realignment jobs.

WORK EASIER—BETTER—FASTER!

Each operation is clearly explained step by step. You learn to determine just where and how to use the 'scope on a specific job; how to make connections and adjust the circuit components; how to set the controls; and HOW TO ANALYZE OSCILLOSCOPE PATTERNS fast and accurately. 370 illustrations including dozens of pattern photos make things doubly clear.

No other type of specific service training can mean so much to you in boosting your efficiency and earning power! Send coupon NOW for 10-day FREE examination!

**PRACTICE
10-DAYS
FREE!**

Dept. RN-34, RINEHART & Company, Inc.
232 Madison Ave., New York 16, N. Y.
Send MODERN OSCILLOSCOPES AND THEIR USES for 10-day FREE EXAMINATION. If book is satisfactory, I will then send you \$6.00 promptly in full payment. If not, I will return book postpaid in good condition and owe you nothing.

NAME

ADDRESS

CITY, ZONE, STATE

OUTSIDE U.S.A. \$6.50, cash only. Money back if you return book within 10 days.

PART//MART
ROCKVILLE CENTER L. I., N. Y.

MARCH, 1954

ARGYLE
again revolutionizes
TV installation
business... one look
shows you
how

The Argyle Mast Type Universal Standoff combined with the new Argyle Mast-Lok clamp permits the best installation possible. Is stronger, more versatile—clamps will not slip or loosen...entire installation is done in a few seconds.



a must
for UHF...
you need it
for VHF too!

- Now—Argyle introduces Mast-Lok... the clamp used in conjunction with the Universal Mast Type Standoff. Available at no difference in price. The strongest, quickest, and most positive method of securing standoffs to the mast... heavy duty steel with a re-inforced cantilever clamp.
- Improves Reception... rigid engineering and lab tests prove that the New Argyle Universal Standoff tends to substantially reduce coupled-in effects and related evils in the line.
 - Big Time Saver... you can actually save 75% of your installation time.
 - No Threading—use any type of wire at all... Flat, Tubular, Open, Rotor—When ordering MAST-LOK with Argyle Universal Standoffs*—add letters MC after model number of standoff... Separately model AMC-12.

ARGYLE ELECTRONICS CO.
8 West 18th Street, New York 11, N. Y. · CH 2-2093

ROUND, SQUARE, KEY and "D"
OPENINGS QUICKLY MADE
with Greenlee
Radio Chassis Punches



Save hours of hard, tedious work... cut accurate holes in chassis for sockets, plugs, controls, meters, panel lights, etc. with GREENLEE Punches. In 1-1/2 minutes or less make a smooth hole in metal, bakelite or hard rubber up to 1/16" thick. Easy to operate... simply turn with ordinary wrench. Wide range of sizes. Write for details. Greenlee Tool Co., 1883 Columbia Avenue, Rockford, Ill.



QUARTZ CRYSTALS

FT-243—093" PIN DIA.
.486" PIN SPC.—FOR HAM AND GENERAL USE

| | |
|-------------------------------|-------------------------------|
| 4035 5437 5950 6800 7610 7900 | 1015 3840 6473 7100 8025 8475 |
| 4080 5485 5973 6806 7625 7906 | 1110 3885 6475 7125 8050 8500 |
| 4165 5500 6240 6875 7640 7925 | 1915 3940 6500 7140 8073 8575 |
| 4190 5660 6250 6850 7641 7940 | 1930 3955 6506 7150 8075 8550 |
| 4280 5675 6273 6875 7650 7950 | 1940 3990 6550 7175 8100 8575 |
| 4300 5700 6275 6900 7673 7973 | 1950 6000 6573 7200 8125 8600 |
| 4330 5706 6300 6925 7675 7975 | 2065 6025 6575 7250 8140 8225 |
| 4397 5725 6325 6950 7700 8206 | 2125 6050 6600 7300 8150 8650 |
| 4490 5740 6350 6975 7706 8225 | 2257 6075 6606 7306 8173 8700 |
| 4495 5750 6373 7450 7720 8250 | 2940 6100 6625 7325 8175 8733 |
| 4535 5773 6375 7473 7725 8273 | 3500 6125 6640 7340 8200 |
| 4735 5780 6400 7475 7740 8275 | 3640 6140 6650 7350 8340 |
| 4840 5806 6406 7500 7750 8300 | 3680 6150 7000 7375 8350 |
| 4830 5840 6425 7506 7773 8325 | 3720 6175 7025 7400 8380 |
| 4950 5852 6473 7525 7775 8630 | 3735 6200 7050 7425 8400 |
| 4980 5873 6675 7540 7800 8683 | 3760 6440 7073 7440 8425 |
| 5030 5875 6700 7550 7825 8690 | 3800 6450 7075 8000 8450 |
| 5205 5880 6706 7573 7840 | |
| 5300 5906 6725 7575 7850 | |
| 5385 5925 6750 7600 7875 | |
| 5379 5940 6775 7606 7875 | |

49c each - 10 for \$4.00

Low Frequency—FT-241A for 53B, Lattice Filter etc., .093" Pins, .486" SPC., marked in Channel Nos. 0 to 79, 54th Harmonic and 270 to 389, 72nd Harmonic. Listed below by Fundamental Frequencies, fractions omitted.

| | |
|---------------------------------|-------------------------------|
| 370 393 414 436 498 520 400 459 | 5910 2030 2220 2390 3120 3520 |
| 372 394 415 437 501 522 440 461 | 6370 2045 2258 2415 3150 3550 |
| 374 395 416 438 502 523 441 462 | 6450 2052 2260 2435 3155 3570 |
| 375 396 418 441 503 525 442 463 | 6470 2082 2282 2532 3215 2945 |
| 376 397 419 483 504 526 444 464 | 6497 2105 2290 2545 3232 3955 |
| 377 398 420 484 505 527 445 465 | 6522 2125 2300 2557 3237 3970 |
| 379 401 422 485 506 529 446 466 | 6547 2131 2305 2660 3250 3995 |
| 380 402 423 486 507 530 447 468 | 6610 2145 2320 2660 3252 3995 |
| 381 403 424 487 508 531 448 469 | 7350 |
| 383 404 425 488 509 533 450 470 | 7380 |
| 384 405 426 490 511 534 451 472 | 7390 |
| 385 406 427 491 512 536 452 473 | 7480 |
| 386 407 429 492 513 537 453 474 | 7580 |
| 387 408 430 493 514 538 454 475 | 7810 |
| 388 409 431 494 515 455 476 | 7930 |
| 390 411 433 495 516 456 477 | |
| 391 412 434 496 518 457 479 | |
| 392 413 435 497 519 458 480 | |

49c each—10 for \$4.00 99c each — 10 for \$8.00

PLEASE ADD 20c POSTAGE FOR EVERY 10 CRYSTALS OR LESS

| | |
|-------------------------------|--|
| CR-1A SCR 522 1/2" P 1/2" SPC | FT-171B BC-510 2 Banana Plugs 3/4" SPC |
|-------------------------------|--|

Special—200 KC or 500 KC in FT241A Holder, \$1.79 each

teen-fifty-four will have more than its share of turbulence. This is inherent in growth and the business will grow faster than it ever did before, despite some rumors to the contrary. More important, the growth will bring about healthy changes that will hurt some but bring great benefits to the majority.

"Color is to be feared only by the ignorant, no matter what phase of the television business he handles. Our immediate interest, however, lies in its effect on the television service business. We would like to discuss this effect in the form of predictions for the year, a pleasant practice in which we all indulge around the first of the year.

"We predict:
"1. This year will be the beginning of the end for the greatest majority of the individual TV servicemen, particularly those who operate from home or after hours of normal business. The intricacy of color television will require more facilities, resources, equipment, and organization in its service than an individual can provide.

"2. There will be many mergers of service businesses as individuals and small groups realize the necessity and desirability of pooling resources. Efficiency and economy of operation will be demanded by the consumer when he begins to realize the cost of both color and u.h.f. service. As you know, u.h.f. is scheduled to be with us in Philadelphia soon and the lack of consumer education on this score will be seriously felt by service people.

"3. The shortage of really competent service technicians will become even more painfully apparent in the coming year. The larger service organizations will take unusual steps to hold those they have and develop the potential in others where and when they must.

"4. Service trade organizations will become bigger and more influential as service technicians and business operators begin to realize, fully, a proper concept of their functions. That these associations can and will do a job that the individual service operator can't begin to do in his relations with the consumer and the industry will become too obvious to be passed over lightly, as in the past.

"5. Manufacturers and distributors will give more and more attention to the needs of the service industry than they have in the past. They will do this for a very good reason: because it is good business. They are beginning to realize the value of the goodwill of service people, especially as it begins to reflect on balance sheets in the sale of receivers, parts, tubes, and related equipment.

"Mark these predictions! Some of them began to take form months ago but they are still almost shapeless masses. Color television will be the catalytic agent that will make them stand out sharply."

Service in 1954
At the turn of the year, the industry generally was jittery over the possible

TO THE

E. E.

OR

**PHYSICS
GRADUATE**

WITH EXPERIENCE IN

RADAR

OR

ELECTRONICS

HUGHES RESEARCH AND DEVELOPMENT LABORATORIES ARE ENGAGED IN A CONTINUING PROGRAM FOR DESIGN AND MANUFACTURE OF ADVANCED RADAR AND FIRE CONTROL SYSTEMS IN MILITARY ALL-WEATHER FIGHTERS AND INTERCEPTORS.

YOU WILL serve as technical advisor in the field to companies and government agencies using Hughes equipment.

TO BROADEN your field of experience in radar and electronics you will receive additional training at full pay in the Laboratories to become thoroughly familiar with Hughes radar and fire control equipment.

AFTER TRAINING you will be the Hughes representative at a company where our equipment is installed; or you will direct operation of Hughes equipment at a military base.

THE GREATEST advancements in electronics are being made in this sphere because of military emphasis. Men now under 35 years of age will find this activity can fit them for future application of highly advanced electronic equipment.

HUGHES

RESEARCH AND DEVELOPMENT LABORATORIES

SCIENTIFIC AND ENGINEERING STAFF

Culver City, Los Angeles County, Calif.

Assurance is required that relocation of the applicant will not cause disruption of an urgent military project.

effect of color television on the sale of black-and-white sets. The industry had produced TV receivers throughout 1953 at the annual rate of about 7 million sets and there were some fears that a drastic cutback would take place when the public started to sit on its purse strings and wait until they could buy color sets. Forecasts by industry authorities, though, were very optimistic for business this year. Typical of these forecasts that are of special interest to the independent service industry are the following made by G-E's Dr. W. R. G. Baker:

"I believe the industry can look forward to these developments in 1954:

"1. A strong demand for monochrome television station equipment and receivers with the addition of about 200 new TV stations during the year, bringing the total to 550 in operation by the end of 1954.

"2. Introduction of limited color telecasting opening a new market area for broadcast equipment and receivers.

"3. Industry to distributor sales of 5,200,000 monochrome and 100,000 color TV receivers, and continued strong demand for radio receivers with industry production of about 7,600,000 home and portable radios.

"4. Further improvement in monochrome TV picture tubes, intensified research and development in tubes for color TV, and continued growth in total tube sales by the industry."

While industry attention will be focused on color television, service technicians will be offered many training programs to apprise them of the technical aspects of compatible color TV and the installation and servicing requirements for color TV sets. However, color television will not add any appreciable volume of business to the activity of independent servicing during the coming year. As a matter of fact, it may be two years before the service industry has an opportunity to service any considerable quantity of color TV receivers.

Industry thinking about the effect of color TV on the production and sales of other home entertainment electronic devices was more or less summed up in the year-end report of Robert W. Sprague, chairman of the Board of Directors of RETMA:

"With good merchandising, I believe the industry should be able to sell at least 6 million television sets and 10 million or more radios in 1954 unless incomes generally drop more sharply than now seems likely. Most manufacturers feel that black-and-white TV sets will continue to constitute the bulk of the set sales for years to come. All agree that relatively few color receivers will be available in 1954, and that these, of necessity, will be very high priced and will have screens that are small in comparison with the larger screen black-and-white sets available at a third the price or less.

"Certainly, color TV programs will be distinctly in the minority for a long while despite understandable ballyhoo that will attend color broadcasts in

TRANSVISION

makes this greatest of TV offers—backed by

MONEY-BACK GUARANTEE:

\$88 TV SERVICE INSTRUMENT **\$39⁹⁵** VALUE FOR—

NEW TV Component Tester performs functions you've always wanted. Look what you get:—
FLYBACK TESTER, value.....\$39.00
SELENIUM RECTIFIER TESTER, val. 29.00
CRT TESTER and REACTIVATOR, val. 20.00

Total Instrumentation, value..... 88.00
ALL 4 in 1 great instrument, net..... 39.95



NEVER BEFORE SUCH GREAT VALUE. For only \$39.95 you get 4 testing-and-repair instruments all in one! Compact, weighs only 3 lbs. Does things never been done before! Pays for itself quickly. Prove it yourself—

TRY IT for 10 DAYS on Money-Back Guarantee:

10-DAY TRIAL: Try this Transvision TV COMPONENT TESTER for 10 days. Then, if you are not 100% satisfied, you may return it. Your purchase price, less 10% (our cost of handling and re-packing) will be promptly refunded.

TRANSVISION, INC. • NEW ROCHELLE, N. Y.

— RUSH THIS COUPON NOW —

TRANSVISION, INC. NEW ROCHELLE, N. Y.

DEPT. RN-34 NEW ROCHELLE, N. Y.

Send _____ TV COMPONENT TESTERS @ \$39.95.

Enclosed find \$_____ deposit. Balance C.O.D.

Enclosed find \$_____ in full.

I accept your 10 Day Trial terms.

Name _____

Address _____

City _____ State _____

My Joiner is _____

JOBBER INQUIRIES INVITED

ALMO PROUDLY PRESENTS

precise

KIT AND WIRED
INSTRUMENTS

NOW
IN
STOCK

EXCLUSIVE...

precise

MODEL #308

8 1/2"

SCOPE

KIT \$129⁵⁰

#308W \$229.50

No other oscilloscope, at any price, can meet all the specifications of this electronic masterpiece.

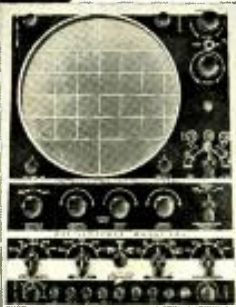

- VERTICAL FREQ. RESPONSE—Flat $\pm 1\frac{1}{2}$ db DC thru 5 MC.
- SENSITIVITY—Greater than 10 millivolts push-pull (3.9 Millivolts/CM)
- BLANKING—60 cycle or 120 cycle Blanking through Blanking amplifier circuit.
- SWEEP RATE—Linear sweeps from 1 cycle to 80 KC in 5 ranges. (1-10 uses Ext. C.) DRIVEN and RECURRENT sweeps.
- MAGNIFIER—Expands and magnifies signal up to 10 times.
- PUSH-PULL—Output in both amplifiers.
- CRT—The latest type 8 1/2" NEW tube a PRECISE EXCLUSIVE.
- VOLTAGE REGULATED.
- ANODE INTENSIFIER—a PRECISE FIRST.
- INTERNAL CALIBRATOR

NEW 7" OSCILLOSCOPE

MODEL #300K \$94.95

MODEL #300W \$199.50

LOWEST PRICED IN ITS FIELD

NEW MODEL #909

VACUUM TUBE VOLTMETER

FACTORY \$37⁵⁰
WIRED

Model 909 Vacuum Tube Voltmeter. 1% Ceramic precision Resistors; Coax DC connector; FM zero alignment scale; burn-out proof circuit; DC input 25 Meg. Rugged oversize 4 1/2" meter.
MODEL #909 KIT... \$25.98



OTHER PRECISE TEST INSTRUMENTS AVAILABLE

- 907 — 7 1/2" VTVM — Kit \$38.98 • Wired \$58.98
- 610 — RF SIG. GEN. — Kit \$23.95 • Wired \$39.95
- 630 — RF-AF TV MARKER — Kit \$33.95 • Wired \$53.95
- 635 — AF SINE, SQ., PULSE GEN. — Kit \$33.50 • Wired \$52.50
- 468 — RESISTANCE DECADE BOX — Kit \$18.95 • Wired \$24.95
- 478 — CAPACITY DECADE BOX — Kit \$18.95 • Wired \$24.95
- 912 — RF PROBE — Wired and Calib. \$4.25
- 960 — 10-1 CA. PROBE — Wired \$5.95
- 999 — HIGH VOLTAGE PROBE — Wired \$6.95

ALMO RADIO CO.
509 ARCH ST. & 6205 MARKET ST.
Philadelphia, Pa.
6th & ORANGE STS. • Wilmington, Del.
4401 VENTNOR AVE. • Atlantic City, N. J.
1133 HADDON AVE. • Camden, N. J.
219 Highland Ave. • Salisbury, Md.

1954. Sponsors will be slow to spend money for color programs which so few persons will be able to see, except in black-and-white.

In the meantime, there is a whale of a lot of service work to be done on radios, phonographs, and other electronic devices that are widely used in homes and businesses. In many areas, service operators who have been making a fringe living competing for TV service business have ignored the tremendous need for service on radio sets, phonographs, and wire and tape recorders.

In one city recently checked by your editors, a dealer in office equipment had found it necessary to hire a technician to repair wire and tape recorders in order to protect his market for these devices which he was selling for use as dictating machines. Within six months the service end of his business had grown so much that he had to add a second technician. The increased service business came from owners of recorders who learned about his recorder service facilities. Within eighteen months the profit from his recorder service department exceeded the profit he was making from the sale of new recorders.

During this same period in this same city several dozen service operators were knocking themselves out competing for TV service business at \$2.50 per call, slowly starving themselves out of business—blind to the immense pool of profitable service business that was available in radio, phonograph, and recorder repairs.

There are two ways to merchandise service. One is to wait for service business to come to you, the other is to go out after business. The first way is the negative way. It lets your business wobble up and down at the whim of customers who call on you as a last

resort and then want good service fast and cheap.

The second way—going out after business—is a positive way. When you merchandise your business that way it puts you in command of it. You are in a business that is unusual in this respect—you have a 100% market for your services. There is hardly a home in your market area right now that doesn't need the services you have to sell on some piece of electronic equipment now in use—or shelved for service. It may be a TV set, a radio set, or a phonograph.

How do you go out after business? It's simple in a business like yours with a 100% market so clearly defined. Use a simple, inexpensive, direct-mail program. Ask your parts jobber about the direct-mail programs the tube manufacturers have prepared for you. They are good, effective, and inexpensive.

—30—

Technician Associations

(Continued from page 85)

UTAH

Utah Ass'n. of Radio & Television Servicemen, 418 Frick Bldg., 23 E. 1st S., Salt Lake City 1—John F. Burns, Pres.; Robert J. Magness, Sec'y-Treas.

WASHINGTON

The Northwest Appliance & Television Ass'n., 714 American Bldg., Seattle 4—Keith Davis, Pres.; L. Edward Smith, Exec. Sec'y.

CANADA

Victoria & Island Chapter of the Radio Electronic Technicians Ass'n., 783 Fort St., Victoria, B.C.—Dave Banfield, Pres.; George D. Percy, Sec'y.

Radio Electronic Technicians Ass'n., P.O. Box 391, Winnipeg, Manitoba—N. Weibe, Pres.; V. Sexton, Sec'y.

—30—

Greatest Tape Buy Ever!



1200 FT. REEL Genuine
Plastic Base RECORDING TAPE

\$189

C.O.D. accepted per roll plus postage

LAFAYETTE made a terrific deal with one of the leading manufacturers of recording tape to supply us with their regular tape

which sells for almost twice our price. WE GUARANTEE ABSOLUTE SATISFACTION OR YOUR MONEY BACK. The finest, professional-quality recording tape obtainable. Highest performance for thousands of playings. Red Oxide Base in a smooth, uniform coating; greater signal strength; with maximum fidelity; uniform frequency response from 40-15,000 cps at 7 1/2" per second; and freedom from background noise and distortion. Each reel is individually boxed.

LAFAYETTE RADIO

Dept. RC-1
NEW YORK 13, N.Y.
100 Sixth Ave.

FREE! Lafayette's new 48 page catalog. Includes tape recorders, high fidelity equipment. Write today!

BRONX 58, N.Y.
542 E. Fordham Rd.
BOSTON 10, MASS.
110 Federal St.

PLAINFIELD, N.J.
139 W. 2nd St.
NEWARK 2, N.J.
24 Central Ave.

Spot Radio News
(Continued from page 18)

relax its present rules. Specifically, the present minimum of 42 hours of operation would be reduced to 36, and secondary or subsidiary licenses would be offered to those engaged in non-broadcast services which involve special programming on a simplex basis during non-broadcast hours using an ultrasonic (beep) signal to activate special receivers owned or rented by commercial and industrial establishments for the purpose. Secondary licenses would also be available for additional program transmission on a multiplex basis during regular broadcast hours to individuals and organizations who have the necessary multiplexing receivers. These possibilities, it was said, embrace functional music (background, storecasting, and transit-casing), and such appropriate supplemental programming as news, music, time and weather announcements, which would further utilize the FM frequencies, and provide sources of additional income for FM broadcasters. They would not, however, cover such activities as dispatching services, etc. Nor could the FM licensee lease or otherwise delegate such special authorization.

The decision to ease the rules represents quite a turnabout, for only a few years ago it was pointed out that beep operations were inconsistent with basic statutes of the broadcast law, and that technically the licensees had given away the power to alter their service to meet the changing needs of the public because they had entered into contracts to provide subscribers with planned music. The Commission also cited that the elimination of sponsorship, station identification, and other announcements from reception by subscribers, although made to the general public, violated the law, since the requirements of the Act contemplate transmission of such information to the station's entire audience and not to the broadcasting of a tone which prevents a portion of the audience from hearing the announcements.

The change in heart was prompted by a reconsideration of the legality of such broadcasts and the serious economic groove in which the FM broadcasters find themselves. Of the 53 independent FM stations reporting in '52, only six showed a profit; five had net incomes before Federal income taxes of \$2000 or less, the highest income being \$4600. The Commission also noted that 87% of the 616 FM stations on the air were operated by AM licensees, the large majority of which provided the FM service as a bonus.

On the basis of their review of the FM picture, the Commission added, they believed that it might be possible to provide for a more effective use of the frequency space now assigned for FM, making possible the rendering of new and useful services, and enabling

Let MILTON S. KIVER Help You Prepare For U.H.F.-TV, Color And...



Easy to TRAIN AT HOME This Practical Way!

Men with the right training in Television Servicing are in big demand... pull down big pay. T.C.I. TRAINS YOU RIGHT with easy-to-follow technical training designed by servicemen, for servicemen! You learn practical, professional type Television Servicing without leaving your present job. Included are money-making extras such as set conversion, master antenna installation, U.H.F.-TV NTSC Color System and field servicing short cuts. You can start earning Television money after the first few lessons. You learn to test, trouble shoot and repair all types of TV sets the proven, practical way!

HERE'S HOW YOU GET EXPERIENCE!

You train on your own large screen modern television receiver, furnished as part of your course. This set is yours to keep! As an optional feature you can get two weeks of actual field experience out on service jobs and on the repair bench for Chicago's largest independent servicing organization. You learn Television Servicing by actually doing Television Servicing... you get the practical know-how you need to qualify for BIG MONEY in this fast-growing field! Age is no barrier. Many TCI students are over 40!

VETERANS!
T.C.I. is approved for G.I. training under Public Law 550. Check coupon.

ACT NOW! Mail coupon for FREE Catalog and SAMPLE LESSON. Write TODAY!

TELEVISION COMMUNICATIONS INSTITUTE

605 W. Washington Blvd., Dept. AY, Chicago 6, Ill.

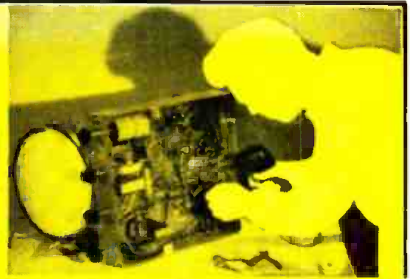

YOU GET and keep modern large screen Television receiver.

YOU DO actual testing, servicing, trouble shooting and repairing

BEGINNERS! LEARN ABOUT NEW BASIC TV COURSE!

You don't need radio experience for practical, home-study training in Basic Television. Start earning money on TV after first few easy lessons. Check coupon for details.

MAIL NOW FOR FREE BOOKLET

MILTON S. KIVER, President
TELEVISION COMMUNICATIONS INSTITUTE
605 W. Washington Blvd., Dept. AY,
Chicago 6, Ill.

Rush full facts on practical TV training. I am not obligated. Salesman will not call.

Name Veterans! check here

Address

City Zone State

BEGINNERS check here for information on Basic Television Course.

BARGAINS • BARGAINS • BARGAINS

| STANDARD BRANDS | | TUBES | | All Brand New Individually Boxed FAR BELOW WHOLESALE COST! | |
|-----------------|------|-------|------|--|------|
| 024 | .66 | 6AC7 | 1.29 | 6SL7 | .96 |
| 1A7 | .87 | 6AG5 | .89 | 6SN7 | .86 |
| 1B3 | .93 | 6AG7 | 1.24 | 6XQ7 | .86 |
| 1H5 | .73 | 6AH6 | 1.39 | 6Y8 | 1.09 |
| 1N5 | .82 | 6AK5 | 1.44 | 6UR | 1.14 |
| 1R5 | .79 | 6AK6 | .93 | 6V6GT | .71 |
| 1S5 | .79 | 6AL5 | .71 | 6W4 | .73 |
| 1T4 | .77 | 6AQ5 | .79 | 6W6 | .91 |
| 1U4 | .78 | 6AR5 | .85 | 6X4 | .62 |
| 1U5 | .78 | 6AR6 | .73 | 6X5 | .89 |
| 1V2 | .99 | 6AS5 | .83 | 6XR | 1.09 |
| 1X2A | 1.89 | 6AT5 | 1.00 | 6Y5 | .71 |
| 30A | .89 | 6AU5 | .71 | 6Z5 | .89 |
| 30Q5 | .99 | 6AV6 | .71 | 6N7 | .87 |
| 30S | .77 | 6AW5 | 1.00 | 6Y7 | .77 |
| 30T | .89 | 6AX5 | .71 | 6Z7 | .87 |
| 3V4 | .82 | 6AV6 | .63 | 6L6GA | 1.39 |
| 5V4 | .65 | 6BA6 | .82 | 6SA7 | .73 |
| 5V4 | .65 | 6BA7 | .93 | 6SC7 | .84 |
| 5Y3 | .49 | 6BC5 | .86 | 6SH7 | .84 |
| 6AR4 | .79 | 6BC7 | 1.04 | 6S17 | .66 |
| 6AR7 | .99 | 6BE6 | .74 | 6SK7 | .72 |
| | | | | 12AV7 | 1.14 |
| | | | | 12AX7 | 1.06 |
| | | | | 12AZ7 | 1.59 |
| | | | | 12BA6 | .72 |
| | | | | 12BE6 | .78 |
| | | | | 12BH7 | .98 |
| | | | | 12CA7 | .83 |
| | | | | 12CK7 | .79 |
| | | | | 12DL7 | .99 |
| | | | | 12EN7 | .91 |
| | | | | 12EQ7 | .69 |
| | | | | 12F7 | 1.29 |
| | | | | 12G6 | .73 |
| | | | | 12H6 | .78 |
| | | | | 12J6 | .79 |
| | | | | 12K6 | .79 |
| | | | | 12L6 | .73 |
| | | | | 12M6 | .53 |
| | | | | 12N6 | .74 |

INTERCOM SPECIAL

Now you can own an intercom that has a thousand uses at a price you would normally pay for a kit. This intercom comes housed in sturdy cabinets completely wired and ready to operate. Unit consists of one master, one sub station and fifty feet of two wire cable. Ideal for home as baby sitter. Perfect for office or factory. Order now as quantities are limited.

CASCADE TUNER

\$1699 LOTS OF 3 \$17.95 each

Factory aligned ready to use. Complete with tubes and instructions.

THREE-SPEED PORTABLE RECORD CHANGER
33 1/3, 45, 78 RPM

Now for the first time at this low, low price a 3 speed V.M. Changer complete with 3 tube high quality amplifier. This unit uses the newest type V.M. Changer with automatic shut-off. Changer Inter-mixes 10" and 12" records at any speed. Turnover crystal cartridge with 2 permanent needles. Amplifier has tone and volume control. When last record has played changer and amplifier automatically shut off. Unit comes housed in beautiful rich maroon leatherette carrying case with white heading. Plays 10-12" and 12-10". AC only.

Shipped Railway Express only. 22 lbs. shipping wt. **\$4699**

List Price \$89.95. YOUR COST

WEN ELECTRONIC SOLDERING GUN

250 Watts. Choice of red, green, black. Lots of 3 **\$971** each \$8.64

STEVE-EL ELECTRONICS CORP.
Dept. RN-3 61 Reade St., New York 7, N. Y. COrtland 7-0086

BUILD 15 RADIOS AT HOME ONLY

With the New Improved 1954 \$19.95
Progressive Radio "EDU-KIT"

NOW INCLUDES
SIGNAL TRACER
and
CODE OSCILLATOR

- FREE TOOLS WITH KIT
- ABSOLUTELY NO KNOWLEDGE OF RADIO NECESSARY
- NO ADDITIONAL PARTS NEEDED
- EXCELLENT BACKGROUND FOR TELEVISION
- 10-DAY MONEY-BACK GUARANTEE



WHAT THE PROGRESSIVE RADIO "EDU-KIT" OFFERS YOU

The "Edu-Kit" offers you a Home Radio Technician Course at a rock-bottom price. You will learn how to identify Radio Symbols and Diagrams; how to build radios, using regular radio schematics; how to wire and solder in a professional manner. You will learn how to operate Receivers, Transmitters, and Audio Amplifiers. You will learn how to service and trouble-shoot radios. You will learn code. You will receive training for F.C.C. license. In brief, you will receive a basic education in Radio exactly like the kind you would expect to receive in a Radio Course costing several hundred dollars.

THE KIT FOR EVERYONE

It is not necessary that you have even the slightest background in science or radio. The "Edu-Kit" is used by young and old; by radio schools and clubs; by Armed Forces Personnel and veterans for training and rehabilitation. No instructor is required. Instructions are complete, simple and clear. You cannot make a mistake.

PROGRESSIVE TEACHING METHOD

The "Edu-Kit" uses the principle of "Learn by Doing." Therefore you will build radios, perform jobs, and conduct experiments to illustrate the principles which you learn. You begin by learning the function and theory of each of the radio parts. Then you build a simple radio. Gradually in a progressive manner, you will find yourself constructing more advanced multi-tube radio sets, and doing work like a professional Radio Technician. The "Edu-Kit" instruction Books are exceedingly clear in their explanations, photographs and diagrams. These sets operate on 105-125 V. AC-DC.

The Progressive Radio "EDU-KIT" is Complete. You will receive every part necessary to build fifteen different radio sets. Our kits contain tubes, tube sockets, chassis, variable condensers, electrolytic condensers, mica condensers, paper condensers, resistors, line cords, selenium rectifiers, the strips, coils, hardware, tubing, etc. Tools are included, as well as an Electrical and Radio Tester. Complete, easy-to-follow instructions are provided. In addition, the "Edu-Kit" now contains lessons for servicing with the Progressive Signal Tracer, F.C.C. instructions, quizzes. The "Edu-Kit" is a complete radio course, down to the smallest detail.

TROUBLE-SHOOTING LESSONS

Trouble-shooting and servicing are included. You will be taught to recognize and repair troubles. You will build and learn to operate a professional Signal Tracer. You receive an Electrical and Radio Tester, and learn to use it for radio repairs. While you are learning in this practical way, you will be able to do many a repair job for your neighbors and friends and charge fees which will far exceed the cost of the "Edu-Kit." Our Consultation Service will help you with any technical problems which you may have.

FREE EXTRAS

• Electrical & Radio Tester • Electric Soldering Iron • Book on Television • Radio Trouble-Shooting Guide • Membership in Radio-TV Club • Consultation Service • Quizzes • F. C. C. Training

ATTRACTIVELY GIFT PACKED

MAIL TODAY Your Order Shipped Same Day Received

- Send me the "Edu-Kit" with Money-back Guarantee—include All FREE extras.
- Check or M.O. enclosed—postage prepaid
 - C.O.D. (U. S. Only)—I will pay postage
 - Send further information
- Outside U.S.A.—No C.O.D.'s; send check on U.S. bank or intern'l M.O. for \$19.95. Postage prepaid. "Edu-Kit" for 210-250 V. AC/DC \$22.45.

NAME _____
ADDRESS _____

PROGRESSIVE "EDU-KITS" INC.

497 Union Ave., Dept. RN-28, Brooklyn 11, N.Y.

FM broadcasters to alleviate, in part, their financial difficulties.

Commissioner Frieda Henneck did not agree with her fellow Commissioners that the new proposal was a logical one. And in a biting dissent, she said that the new plan, in her opinion, amounts to a reallocation of the FM band, and "... no amount of emphasis that ... the aim ... is not conversion of the band to some new specialized non-broadcast service ... will change this result."

Continuing her blast, Madam Commissioner added: "If the spectrum space allocated to FM broadcasting is excessive, or not fully utilized by that service and capable of accommodating the services, all persons interested in radio communications should be given an opportunity to apply for the use of these frequencies. As it is, only FM licensees would be the beneficiaries of this proposal, for only they would be eligible for the proposed SCA (Subsidiary Communications Authorization) to engage in non-broadcast operations. In my opinion, it has not been shown that it would be in the public interest so to restrict the scope of what essentially is a proposal for a new allocation of 20 megacycles of spectrum space."

The proposal to convert the FM band to private non-broadcast use may give FM licensees a windfall from the public domain, the fiery Commissioner added. She viewed the use to which the FM band can be placed through multiplexing as virtually unlimited. "While the Commission emphasizes that the pri-

mary use of the band is to remain FM broadcasting," added Commissioner Henneck, "by the very nature of the manifold uses, such as multiplexing, functional music, storecasting, transit-casting, and all other services lying between functional music operation and taxicab dispatching service, FM broadcasting may well be relegated to a subsidiary position. This is certainly a case of the tail wagging the dog."

PREDICTIONS citing the number of stations that would be on the air, offered early in '53, were shattered and splattered as the year came to a close. For instead of the mere 75 stations that it was said would perhaps begin telecasting during '53, the records showed that 225 had joined the television-broadcasting bandwagon, bringing the total number of on-the-air stations to nearly 360. (As this column was being prepared stations appearing in the table below received permits.)

And if somewhat the same processing pace is maintained in '54, at least 200 to 250 more stations are expected to come on the air during the new year.

The records also show that about two-thirds of the new stations were ultra-high operated.

A possibility that station spacing may be altered, permitting more channels to some cities, was set aside by the Commission, who felt that it would not be wise at present to revise any assignment principles. Requests for such changes came from those who

NEW TV GRANTS SINCE FREEZE LIFT

Continuing the listing of construction permits granted by FCC since lifting of freeze. Additional stations will be carried next month.

| STATE | CITY | CALL | CHANNEL | FREQUENCY (mc.) | POWER (Video) |
|----------------|-------------------------------|----------|---------|-----------------|---------------|
| California | Palm Springs | KPAL† | 14 | 470-476 | 13.275 |
| " | San Diego | | 21 | 512-518 | 186 |
| D.C. | Washington | | 50 | 686-692 | 95.2 |
| Florida | Clearwater | | 32 | 578-584 | 93.5 |
| " | Miami | WMIE-TV | 27 | 548-554 | 200 |
| " | Miami | WINZ† | 33 | 584-590 | 182 |
| Georgia | Thomasville | | 6 | 62-88 | 6.03 |
| Illinois | Chicago | WOPA-TV† | 44 | 650-656 | 205 |
| Kentucky | Lexington | WLAP† | 27 | 548-554 | 247 |
| Maryland | Baltimore | WSID† | 18 | 494-500 | 85.2 |
| Michigan | Traverse City | WPBN-TV | 7 | 174-180 | 51.3 |
| Missouri | Joplin | KSWM† | 12 | 204-210 | 58.9 |
| " | Kirksville | KBIZ† | 3 | 60-66 | 100 |
| Minnesota | Duluth | KDAL-TV | 3 | 60-66 | 100 |
| New York | Bloomingtondale (Lake Placid) | | 5 | 76-82 | 3.55 |
| " | Carthage | | 7 | 174-180 | 190 |
| North Carolina | Asheville | WLOS | 13 | 210-216 | 170 |
| Ohio | Cleveland | | 19 | 500-506 | 220.3 |
| Oklahoma | Ada | KEOK | 10 | 192-198 | 251 |
| " | Enid | | 5 | 76-82 | 100 |
| South Carolina | Spartanburg | WORD-TV | 7 | 174-180 | 316 |
| Tennessee | Jackson | WDXI-TV | 9 | 186-192 | 56.2 |
| Texas | Amarillo | KLYN-TV | 7 | 174-180 | 5 |
| " | Corpus Christi | | 43 | 644-650 | 37.1 |
| " | San Antonio | | 12 | 204-210 | 316 |
| Utah | Provo | KOVO | 11 | 198-204 | 64.6 |
| Virginia | Richmond | WTOB-TV† | 29 | 560-566 | 17 |
| Washington | Seattle | | 20 | 506-512 | 200 |
| Wisconsin | La Crosse | WKBT | 38 | 614-620 | 18.2 |

*ERP = (effective radiated power, kw.). † = Call letters to be announced

**In DETROIT it's
AARON ELECTRONICS**
6025 Mt. Elliott, Detroit 11, Michigan



TG-10 CODE KEYS

Self-Contained Automatic unit for code practice signals from an inked type recording. Complete with 7 tubes and electric eye: Audio freq. output of 800 CPS-Size: 11 x 24 x 18 1/2"—110-220 VAC 60 cy.-78 RPM motor can be used for a turntable—Power unit **\$29.95** can be used for a P.A. system—wt. 6 1/2 lbs.—NEW

TG-10 KEYS—same as above—used **\$19.95**

TG-34-A KEYS

Like above—more Compact. See Feb. Adv. for picture and details **\$24.95**

PROP PITCH MOTOR—24 to 33 VAC or DC (4 amp)—Reversible, only 3 wires required—7000 to 1 gear reduction—Stops free swing—approx. 3/4 RPM—1/4 H. P. Motor—Rugged gear train and sturdy thrust bearings—wt. 6 1/2 lbs. **\$15.50**

TRANSTAT VOLTAGE REGULATOR—Type RH—115 VAC 400 cy.—.72 KVA—output 75 to 120 V @ 8 Amp—black wrinkle finish metal case—wt. 11 lbs. New **\$5.95**

CARDWELL 7 GANG TUNING CONDENSER—Type CA-235, 30-1 Dual gear ratio—Split cap. of 200 Mfd and 100 mfg—out of BC-223 Xmir, which tunes from 2 mc to 5.2 mc—New **\$2.95**



**RT-48 TPX-1
TRANSCIVER
EXPERIMENTERS
IDEAL FOR UHF
157 TO 187 MC**

Contains Video Ampl. sweep circuits, 17 tubes,

plugs and many misc. parts—in case with lid, wt. 47 lbs. Priced only at a fraction of original cost.

New **\$14.95**

TYPE T-3074 UHF TRANSMITTER 180-220 MC—British made with pr. of tuned lines and 2 VT 90 British tubes. See Feb. Adv. for Cut & Details. New **\$14.95**

Tuning Units from BC-375 xmir. contains—2 vernier dials—2 RF chokes—2 4-pos. cer. sw.—X 3—var. conds.—cer. flex. couplings—etc. **\$2.25**

BC-300-A Antenna Units—contains: 1-5 pos. hi-voltage band sw.—vernier dial, etc. **\$2.95**

RM-29 WALL PHONES—similar to EE-8, but in metal case—less handset **\$6.95**

PERMEABILITY TUNER—has osc. coil—ant. coils—ideal for 5 tube superhet—schematic diagram enclosed—New 4th ea. 6 for **\$2.00**

BATTERY CHARGER METER—0-10 dc amp—New. 49c

H5-23 HEADSET—hi-impedance—practically new **\$2.95**

H-16 U HEADSET—8000 ohms. **\$2.95**

CO-605 CORD—with PL-55 plug—6 1/4 cord—C-410 x xmir. **\$1.25 ea.**

WIRE KIT—each individually packaged in one carton with a gr. wt. 4 lbs.—consists of: 25 ft. POWER CORD—2 cond. ±18 AWG stranded copper wire—rubber covered—ideal for extension cord—5 rolls ±30. 10 strands HOOK-UP wire—class insul. 5 Env. of 1 doz. per env. shake-proof washers. **\$1.95**

110 VAC 60 CY BLOWER—1525 RPM—Type L—Model 3571—App. 100 cu. ft. dis.—3 1/4 intake—2" outlet—motor size 3 1/2"x3"—Has mounting bracket and heating element. **\$7.95**

ASSORTMENT OF HOME-AUTO-RCVR KNOBS—all colors Plastic—wood—bakelite—Box of 100. **\$1.75**

TECH. MANUAL for BC-221 Freq. Meter. **\$1.25**

FTR HALF-WAVE RECTIFIER—Input: 72 VAC. Output: 56 VDC @ 75 ma.

FTR HALF-WAVE RECTIFIER—Input: 26 VAC. Output: 10.5 VDC @ 40 ma.

EITHER RECTIFIER. 50c ea. 10 for **\$4.00**

25% With order—balance including postage C.O.D. Michigan residents please add 3% sales tax.

felt the mileage-spacing ruling should be modified to include a five-mile tolerance instead of the fifteen-mile limitation now on the books; rule now makes a channel available for an unlisted community within 15 miles of the listed city.

A NEW ERA in TV and radio reporting from Washington was ushered in shortly after the new year, when after more than sixteen years of waiting, a huge remodeled room with sparkling new studios on the gallery floor of the Senate wing on the U.S. Capitol was opened.

Now, instead of being shuttled about and crowded in a nook, radio and TV networks, four major film services, and 35 individual radio stations and special news services can use a new TV studio which is 20 by 15 1/4 feet, or either of four radio rooms.

The refurbished gallery, technically known as G-25, is next door to the press gallery. Many interviews with Congressmen will be forthcoming hereafter from these new studios. Some might be live, some filmed, and some taped. To the broadcasters who initiated the move and to the 83rd Congress who appropriated the money (\$33,000), everyone is grateful for this change; a glowing tribute to the maturity and dominance on the American scene radio and TV has achieved. . . L.W.

EDISON HAM AWARD

J. STAN SURBER of Peru, Indiana has been named the outstanding ham of 1953 and awarded the "Edison Amateur Radio Award" by General Electric Co., sponsor of award.

W9NZZ was named for his service as "nailman" for servicemen stationed at Arctic weather stations. Surber was nominated in 112 letters from 28 states and 5 foreign countries. **-30-**

A wife can watch a variety show while her husband enjoys a different program at the same time on the same screen on the new Du Mont "Duoscopic" television receiver. Viewing is done through polaroid glasses or polaroid panels. By reversing the glasses or panels, the viewer can choose the alternate of the two programs tuned in. Individual earphones are used to separate the sound portions of the programs. A remote control unit permits the viewer to listen to either of the two programs.



for every
audio
need

**CANNON
PLUGS**



P SERIES

you can hear
the difference



XL SERIES



D SERIES



UA SERIES



O SERIES



X SERIES



K (TV) SERIES



XK SERIES

CANNON ELECTRIC

Since 1915

Factories in Los Angeles, Toronto, New Haven
Representatives in principal cities. Address
inquiries to Cannon Electric Co., Dept. 145,
Los Angeles 31, California.

SAVE 65%

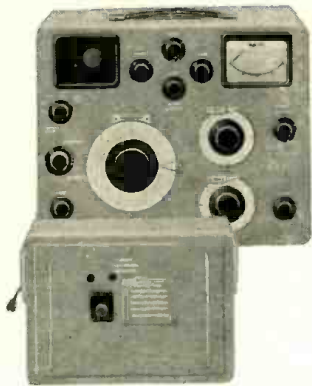

Marconi SPECTRUM ANALYZER TF 890-1

Frequency: 9000 - 9650 mcs
Attenuation: 0-27 db. calibrated
Power: 110-120-220-240V 40-100 cps
A precision laboratory or portable instrument which may be used as a SPECTRUM ANALYZER, SIGNAL GENERATOR, WAVE METER, POWER METER, FREQUENCY METER, for measuring pulse width, cw spectrum width, or any X band test within this frequency. Set is supplied with power supply and complete kit of adapters, wave guide, attenuator and all accessories.



TS-78/A1 PHANTOM ANTENNA

for AN/ARC-3 & SCR-274N
Newly Manufactured by

Associated Industries
IMMEDIATE DELIVERY!

Technical Manuals

We recently purchased, from the government, a large quantity of technical and operating manuals on **RADIO, RADAR and AIRCRAFT** equipment. Send for our listings.

SCR-291

Direction Finder

Frequency: 1.5 - 30 mcs.
Power: 115V - 60 cy. Single Ph.
Semi-portable radio direction finder using U-Adcock antenna system. Visual bearings are received on 5" cathode ray tube with illuminated azimuth scale. Designed for location of gun installations, radio stations and portable transmitters.

IMMEDIATE DELIVERY
COMPLETE INSTALLATION
Write for Further Technical Data

Certified - Guaranteed

All equipment is sold with our certified, unconditional guarantee, checked and tested in our own shop. We are a recognized and approved supplier for Foreign and U. S. Govt. Agencies. We invite your inquiries for supply of technical data.

ASSOCIATED INDUSTRIES
CABLE ADDRESS *Arnic* LOS ANGELES
6855 TUJUNGA AVENUE
NORTH HOLLYWOOD, CALIF.

How's Your Rumble?

(Continued from page 79)

ment. Column A shows the results on one hi-fi set-up using a record changer, a wide range amplifier and a corner horn speaker. The rumble on this system was definitely noticeable at moderate volume levels and very objectionable at high levels. The greatest increase in noise occurs from the vibration of the phono motor. Nothing was found wrong with this motor and when a new unit of the same type was substituted a change in vibration noise of only 1 db was noticed. Thus the rumble in this system was pretty much due to the vibration inherent in this particular type of motor. Column B shows the performance of this same system when an improved type turntable was substituted. The rumble dropped to a level which was just detectable at high-volume listening.

Column C shows the results of these tests on another system. This set-up uses a record changer, a wide range amplifier, and a large bass reflex cabinet. It is obvious from the data that hum or noise from the preamplifier is a problem. The large increase in noise when the turntable is rotated is an indication of a rough turntable rim or idler wheel. The rhythm of the turntable noise coincided with the revolutions of the idler wheel rather than the turntable. Replacement of a noisy tube in the preamplifier and a thorough cleaning of the record changer plus installation of a new idler drive wheel produced the results of column D. The rumble level was considerably improved and satisfactory.

Now it should be made clear that we have not really measured the noise level from each of the components by this method. We have simply seen how noise accumulates as it proceeds through the equipment and this is helpful in telling where the abnormal conditions lie. With a little experience in this method it is easy to size up the noise and rumble problem in a high-fidelity system.

General Considerations

In analyzing a rumble problem the first step is to have it demonstrated to you under actual listening conditions. A few checks of the control settings plus some discussion will enable you to tell if (1) the listener is very critical, (2) if he likes music very loud, (3) or if he likes tremendous bass boost. Each of these three points lowers the amount of rumble which can be tolerated. You can also tell from your knowledge of equipment how low the bass response of the speaker goes. Careful listening will tell if the speaker has a peaked bass response or an over-resonant boom. If either of these troubles is present it would simplify the rumble problem and improve the over-all sound to correct them first.

The main question to be answered

RCA MI-2475 SOUND POWERED PHONES

NEW EXPORT PACKED
Shipping weight 5 lbs.



complete with 22' rubber covered cable press to talk switch are light weight, the mic is on a swivel boom that can be moved to any position in front of face. Cost \$52 ea.

Price **\$13⁹⁵** Ea.

AC-METER 0-150VAC Weston or West, 2" R. **\$3.25**
WESTON 301 1.5 KVDC W/external West. Res. \$7.95
GE 3" R PSA-001 scale 10 mil & 5 KVDC. 4.95
RF AMPS 2.5 37 R. MacIntock. 4.00
MAGNETRON 2J21A \$7.95, 725A \$5.95, 820 & 832 \$5.95, 829A \$6.95, 803 2.50
SCOPE TUBES 6CP1 \$4.95, 6BP4 \$4.00, 3AP1 3.95
TV PICTURE TUBES 141P4 \$16.00, 10RP4 10RP4 10T14 Raytheon 5V1, brand new, Guar. 18.95
MOTOR 4 hole shaded pole induction 120 RPM G.I. 1/70 HP running torque 12 oz. Inches Max \$12.00 F/Inch wire or disc recording. 3.50
HEADSET TELEX monostat Alod. 2570 rez. 14.00 4.95
MICROPHONE SHURE 707A & 834B desk stand 4.95
RECTIFIERS Fed. Sel. 403D2787 150 Mill 180V. 75
CIRCUIT BREAKERS Helmenann Cat. 0711 5 amp 115VAC curve D. 1.00
WIRE HOOKUP #18 solid grey W.E. 1200 ft. roll 3.50
TA-128 trans. osc. section 4 channel new spec. 4.95
L&S Navy Waterproof speakers brand new each 9.95
RM-29A REMOTE TEL. new W/canvas case & TEST SET 1-236 for AC DC and Ohms with Prods 3.95
MN-26C DF RECEIVER 150 to 1500 KC with 12 tubes dyn. and tuning motor new condition. 23.50
BC1023A 75 meg beacon rec. W/tubes sensitive relay shock mount brand new W/Inst. book. 10.95
CURRENT RELAY West. 2 to 1 amp DC type A1 with glass cover Reg. \$28.00 brand new spec. 4.95
SPRAGUE 2A2 2MFD 600 VDC oil filled round ea. 75
SPRAGUE 34430 2MFD 750 VDC oil filled ea. 85
CD RC15B9 2MFD 600 VAC 1250 VDC oil filled 1.25
CD T36010 1 MFD 600 VDC oil filled. 75
CD TYPE 86 NICA .01 2500 VDC. 5000 VDC. 1.75
AROVOK AT Hi-Kenol A 1 1000 VDC. 2.95
XTALS 500 KC standards CR-2B/U special. 1.00
Include postage with order. Min. order \$3.00
New address: BARTO, PA.
McCONNELL'S Phone: BALLY 5-3621

ARKAY

world's finest radio kits
Write for free Brochure
RADIO KITS, INC., 120 Cedar St., N. Y. 6

DON'T THROW OLD RADIOS AWAY!

Here's the data you need
to fix them FAST and r-i-g-h-t!

There's a "secret" to repairing old radios fast and profitably and this big **RADIO TROUBLE-SHOOTER'S HANDBOOK** is it!

Just look up the old make and model you want to fix. This manual-size, 3 1/2 pound, 744-page Ghirardi handbook tells what the trouble is likely to be . . . and shows you exactly how to fix it. No useless testing! No wasted time! Even beginners can handle jobs "slick as a whistle."

THE ONLY GUIDE OF ITS KIND!

Cuts service time in half!

Included are common trouble symptoms and their remedies for over 4,300 models of home and auto radios and record changers. Actual case histories cover practically every model made by 202 manufacturers between 1925 and 1942—Airline, Apex, Arvin, Atwater Kent, Belmont, Bosch, Brunswick, Clarion, Crosley, Emerson, Fada, G-E, Kolster, Majestic, Motorola, Philco, Pilot, RCA, Silvertone, Spartan, Stromberg and dozens more. Gives how-to-do-it data on SPECIFIC jobs—NOT general theory. Includes hundreds of pages of invaluable tube and component data, service short cuts, etc.

---TRY IT 10 DAYS . . . at our risk!---

Dept. RN-34, RINEHART & CO., Inc.
232 Madison Ave., New York 16, N. Y.
Send Ghirardi's **RADIO TROUBLE-SHOOTER'S HANDBOOK** for 10-day free examination. If I decide to keep book, I will then remit the full price of only \$6.50 plus a few cents postage. Otherwise, I will return book postpaid and owe you nothing.

NAME.....
ADDRESS.....
CITY, ZONE, STATE.....

is, can the rumble be fixed by working on the equipment and replacing defective parts or must a higher quality turntable be obtained. Measurements of the rumble and noise content can help to answer the question. The data in Table 1 is an approximation of various rumble levels suitable for different types of installations. This may be helpful to the inexperienced.

In general, record changers have a rumble content of -10 to -35 db when measured on wide-range equipment. Turntables cover the range of -25 to -55 db. Some of the best record changers have rumble content lower than some good turntables. However the best turntables are the most quiet and dependable types of apparatus for critical installations. In setting up a new high-fidelity installation with a wide range speaker the best choice of record playing equipment is a good turntable and arm if the listener does not already have a collection of 78 records. There is really very little need for a changer if you are mainly interested in LP records. However if a record changer is

desired for 78 or 45 rpm records and you are still critical of rumble there are three choices. First you can very carefully select a record changer. Some models are quite low in noise. It is a good plan to make listening tests and measurements on a few competitive models in the actual installation. A second plan is to install a dynamic noise suppressor to control rumble. The third choice is to install both a changer and a good turntable. This is often done in custom home audio systems where it is to be used by several members of the family, some preferring the changer for dance and pop music and the turntable for serious listening.

Though we have heard about rumble for many years the new advances in the audio art extending the low-frequency limit of sound equipment have highlighted this problem. Careful equipment selection and maintenance on the part of the audio amateur or service technician can do much to control rumble and increase enjoyment from home sound systems.

-30-

SIMPLIFYING V.T.V.M. CALIBRATION

By KENNETH P. AURELIUS

PROBABLY most people who use vacuum-tube voltmeters have, at some time or other, had occasion to recalibrate them because of jarring or aging of components. This process usually involves removal of the chassis from the cabinet.

In the "Eico" unit shown in the photograph, I drilled four holes on the top of the cabinet to obviate the need for removing the chassis. The template shown in the diagram was used to locate the holes. If other types of meters are to be so treated, you simply invert the chassis and make the necessary measurements on the top of the cabinet for the correct location of the holes.

All of the holes are 5/16 inch in diameter. Snap-button hole plugs are inserted to keep the dust out. These plugs are color coded for easy identification. With my v.t.v.m., I used the following color codes: - d.c. calibration (black); + d.c. calibration (red); a.c. zero (no color); and a.c. calibration (green).

A long handled screwdriver or alignment tool may be used to calibrate the meter. To see the slot in the potentiometer, an adjacent snap-button plug can be removed and, by using a flashlight, the operation is easily visible.

Template used to locate calibration holes in Eico Model 221 vacuum-tube voltmeter.

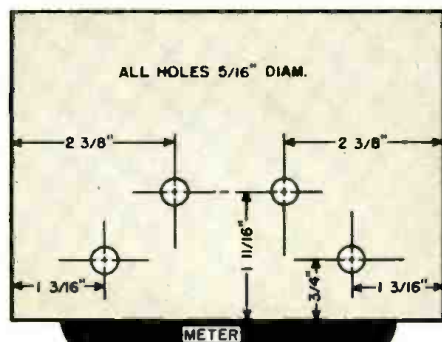

MARCH, 1954

The few minutes spent in drilling the cabinet pays off handsomely in time saved later on.

-30-

The color-coded holes in the v.t.v.m. cabinet. Screwdriver is inserted through the proper hole to recalibrate the instrument.



NEW for TV

NOW

operate 2 TV sets from
1 antenna at same time
(VHF-UHF)

WITH BOOST
IN
SIGNAL STRENGTH

WALDOM Electronic

Duo-Tenna

TV DISTRIBUTION AMPLIFIER



Install
anywhere indoors.

- Booster effect improves picture quality in "fringe" as well as metropolitan areas.
- Reduces existing noise and "snow" conditions.
- When used with single UHF Converter, converts TWO sets to UHF.
- Broad band width. (Ideal for color telecasts.)
- Save cost and installation of second antenna.
- Easily installed.

It will PAY you to get the
whole story . . . Write to —

WALDOM
ELECTRONICS INC.

911 Larrabee St.

Chicago 10, Ill.

169

Every Sound heard right!



MODEL 1502
\$445.00



Concertone

"... just like being there..."

lets you hear them all

THE ONLY TAPE RECORDER UNDER \$1000 WITH ALL THESE PROFESSIONAL FEATURES:

- Separate playback head permits monitoring direct from tape while recording.
- Uses 10½ inch professional reels without extension arms.
- Three motors for superb tape motion.

DESIGNED SPECIFICALLY FOR CUSTOM SOUND SYSTEMS

Get complete details now. See your Audio Distributor or write for Bulletin Number 3-M01.



Berlant Associates

4917 W. Jefferson Boulevard Los Angeles 16, California

**MOGULL'S BUCK
S-T-R-E-T-C-H-I-N-G
BARGAINS!**

TIMER MOTORS

Haydon synch. type 1600A. 110V. 60 Cy., 1RPM. Brand New. Stock No. N-M494. SPECIAL \$2.49

HOT SHOT BATTERIES (60% OFF!)

Burgess 9 volt batteries type 4F611. Tested OK. Brand New. Dated 1944. Stock No. N-BAT. \$1.49

MOBILE ANTENNA AND REEL

50 Ft. braided copper wire on pocket size, finger rewind reel. Phenolic case fully encloses wire. Silver plated brass mount-contact mounts with single ¼-20 screw. Meas. 2½" x 2½" x ¾" thick. Brand New in orig. boxes. A "reel" buy! Stock No. N-M162. \$2.49

3" ALARM BELL & TRANSFORMER

Edwards 24 volt, chrome plated warning bell on black enam. cast alum. base. 3-hole flush mtg. Complete with 2 Amp. 24 V. xfmr. 110V. 60 Cy. pri.) New. in orig. boxes. Stock No. N-GRX. Combination special \$2.75
3" bell only. Stock No. N-M33898
24V., 2Amp. Xfmr. only. Stock No. N-M649. 1.98

OIL CONDENSER SPECIAL!

15 MFD—600 Volts DC. Westinghouse No. CAY-481758-10. 6 for \$15.85; 10 for \$24.95. NET EACH \$2.79

DYNAMOTOR BARGAINS!

Receiving type ZA/USA-0516. 12 or 24 volts DC input. OUTPUT: 12V. @ 3A./275V. @ 110 ma. Stock No. N-M114. Brand New \$4.95
Xmtg. type ZA/USA-0515. 12 or 24 V. DC input. OUTPUT: 500V. @ 50 ma. Stock No. N-MX14. Brand New \$4.95
Generator type DC-77365C (Delco. Pioneer. Wincharger). 12V. DC input. OUTPUT: 275V. @ 110 ma./500V. @ 50 ma. Stock No. N-M230. Brand New—orig. boxes \$8.95
Minimum order \$5.00 FOB our NYC warehouse. Quotation requests invited.

**alexander
mogull**
company
17 WARREN STREET • NEW YORK 7, N. Y.
WOrth 4-0865

**POWER TRANSFORMERS FOR SELENIUM
RECTIFIERS OR FILAMENTS. PRIMARIES
115V 60 CYCLES.**

| | |
|----------------------------------|---------|
| 12.6VCT/2A/2500V INS. | \$ 2.79 |
| 25.2VCT/1A/2500V INS | 2.79 |
| 12.6V/7A or 25.2V/3.5A/2500V INS | 6.17 |
| 26VCT/3A/2000V INS | 4.11 |
| 104VCT/3A/2000V INS | 11.76 |
| 78V TAP 26V/52V/6A/2000V INS | 22.34 |
| 13V/12A/2000V INS | 7.06 |
| 104VCT/6A/2000V INS | 24.69 |
| 156V TAP 130V/3A/2000V INS | 23.52 |
| 130V TAP 104V/12A/2000V INS | 70.56 |
| 156V/6A/2000V INS | 41.16 |
| 36VCT/10A/2000V INS | 15.87 |
| 72VCT/10A/2000V INS | 29.40 |

**RACK PANEL CABINETS
BLACK CRACKLE FINISH**

| Size | Panel Space | Price |
|-------------------------|-------------|---------|
| #42 42-1/16 x 22 x 17/4 | 36¾ x 19 | \$27.25 |
| #47 47-5/16 x 22 x 17/4 | 42 x 19 | 31.20 |
| #66 66-9/16 x 22 x 17/4 | 61¼ x 19 | 40.50 |
| #82 82-5/16 x 22 x 17/4 | 77 x 19 | 48.75 |
| #10 10½ x 21½ x 15 | 8¾ x 19 | 9.70 |
| #14 14 x 21½ x 15 | 12¼ x 19 | 11.88 |
| #15 15¾ x 21½ x 15 | 14 x 19 | 12.20 |
| #19 19¼ x 21½ x 15 | 17½ x 19 | 15.70 |
| #28 28 x 21½ x 15 | 26¼ x 19 | 18.45 |
| #36 36¾ x 21½ x 15 | 35 x 19 | 20.45 |

Grey Crackle Furnished on Request—Same Price.

**RACK PANELS
BLACK CRACKLE FINISH**

| Size | Steel | Aluminum |
|------|------------|----------|
| 1¾ | .63 | \$.73 |
| 3¾ | .70 | .99 |
| 5¼ | .88 | 1.50 |
| 7 | .99 | 1.80 |
| 8¾ | 1.25 | 2.15 |
| 10½ | 1.48 | 2.70 |
| 12 | 1.75 | 3.15 |
| 14 | 1.99 | 3.63 |
| 15¾ | 2.25 | 3.99 |
| 17½ | 2.48 | 4.45 |
| 19¼ | 2.75 | 4.88 |
| 21 | 3.05 | 5.25 |
| 26¼ | on request | |
| 35 | on request | |

Grey Crackle Furnished on Request—Same Price.

All prices F.O.B. our warehouse New York
LEEDS RADIO CO.
75 Vesey St. Dept. A New York City 7

Mac's Service Shop
(Continued from page 86)

and Webcor were planning on releasing pre-recorded tapes of classical music."

"Why does a head not in alignment hurt?"

"Suppose we want to play that photographically printed tape we were talking about," Mac said. "Let's say our playback mechanism consists of a bright light shining through a very narrow slit onto the tape and that this reflected light excites a photoelectric cell that works into our amplifier. Light falling on a white section of tape excites the cell to maximum; when it falls on a black section, the excitation is minimum. When a low frequency recording passes the slit of light, the output of the light cell swings back and forth from a maximum to a minimum at a rate that faithfully reproduces the low note.

"Suppose, though, that we try to reproduce the frequency that printed the tape with the finest distinguishable lines. If the slit through which the light shines is in precise alignment with the lines themselves, the reflected light will be turned on and cut off cleanly by the movement of the fine lines beneath the slit. On the other hand, suppose the slit is canted so that it makes an angle with the lines. Now, long before we reach a frequency at which the lines themselves run together, the slit of light will cease to fall entirely upon a single white or black line. Instead, it will fall across adjacent lines so that part of a white line and part of a black line will always be beneath the slit. That means that the reflected light can never rise to the maximum or fall to the minimum value it attained when proper head alignment allowed all the light to fall upon a single white or black line. In other words, improper head alignment results in a loss of high frequencies. Of course, if the same head is used for both recording and playback, then alignment will matter little, for the recorded lines will have to match the angle of the head, even though both are tilted from the vertical."

"How do you know when a head is in proper alignment?"

Before answering Mac opened a cabinet and took out a roll of tape on a special 5" reel.

"This," he said, "is an alignment tape specifically prepared for head alignment by the Toogood Recording Company of Chicago. The recorded signal is .001 inch in wavelength and will reproduce at 7500 cycles-per-second at 7.5 i. p. s. or 15,000 cycles at 15 i. p. s. The signal is vertically aligned on the tape to a tolerance of 1½ minutes of arc. While the tape has been recorded the full width, it can be used effectively on dual-track machines because great care has been taken to make sure the edges of the tape are cleanly recorded. This is

NEWARK

Recommends



WILCOX-GAY

Model 3A10 Tape Recorder

Combines all popular recording features. Two speeds, 3 1/4 and 7 1/2" per second. Simple push-buttons for forward, reverse, record, stop and play. Records from mike, external radio or phonograph, or other source. High speed forward and reverse. Neon recording level indicator. High quality 5x7" oval speaker. Jack for external speaker. Attractive portable case, 12x14x9". With take-up reel and microphone. For 110-120 v, 60 cycles AC. Shpg. wt., 26 lbs.

119.97

75F003. NET

Wilcox-Gay 3F10 HI-FI Recorder

Deluxe tape recorder with features as above, but has push-pull amplifier to deliver 6 watts output. Resp: ±3db, 75-7500 cps. at 3 1/4"; ±3db, 55-10,500 cps. at 7 1/2". Two neon indicators, full range tone control, compensated volume control, storage compartment for tape and accessories. Size: 18 1/2 x 12 3/4 x 10 5/8". Shpg. wt., 25 lbs.

133.30

75F007. NET

Special Selections

- Pentron 9T3C. 2-Track, 2-Spd Recorder. 74F909. Shpg. wt., 27 lbs. 139.50
- Garrard RC-80. 3-Speed Record Changer 73F510. Shpg. wt., 18 lbs. 45.08
- Newark Portable 3-Spd Record Changer. 73F910. Shpg. wt., 23 lbs. 47.50
- Newark Portable 3-Speed Phonograph. 73F903. Shpg. wt., 9 lbs. 22.50
- RCA WV-97A. Senior VoltOhmyst. 62F000. Shpg. wt., 10 lbs. 67.50
- Triplet 666-HH. Volt-ohm-milliammeter. 62F208. Shpg. wt., 3 lbs. 24.01
- Simpson 260. Set Tester (Roll Top). 62F303. Shpg. wt., 9 lbs. 45.96
- Hallierafters S38C. All-wave Receiver. 98F005. Shpg. wt., 11 lbs. 49.95
- National SW-54. Superhet Communications Receiver. Covers 540kc to 30 mc. 98F318. Shpg. wt., 10 lbs. 49.95
- Brush Mike. Hi-Z. At Special Price. 54G350. Shpg. wt., 1 1/2 lbs. 5.95
- Wireless Mike. With built-in midget transmitter. Plays thru any radio within 50 feet. No wiring required. With batteries. 27F576. Shpg. wt., 3 lbs. 6.50
- Drake 905. Popular Soldering Gun. 33F056. Shpg. wt., 4 lbs. 11.02
- Weifer S-500. Heavy duty Solder Gun. 33F128. Shpg. wt., 3 3/4 lbs. 9.75

FREE! NEWARK'S

NEW CATALOG
No. 56

Latest Releases in
High Fidelity, Radio
TV and Electronics.



Order from Department R-3

FOB Chicago. Include Shipping Charges and Insurance.

NEWARK

ELECTRIC COMPANY

223 W. Madison St., Chicago 6, Illinois

MARCH, 1954

necessary since many half-track heads run over the edge of the tape and would give a false reading if the recording at the edges was inaccurate.

"To align the head of a home recorder, you simply play this tape at 7.5 i. p. s. and adjust the position of the head by the means provided until maximum output is indicated by an audio wattmeter inserted in the external speaker jack or by an ordinary output meter connected across the speaker voice coil. Let me say here and now, though, if you ever erase a single foot of this tape, you had better take to the hills. Furthermore, never rewind the tape or run it forward at high speed for fear of stretching it. After you are through making your alignment test, reverse the reels and let the tape wind back on this reel at playing speed."

"Is there anything else I ought to watch in working on recorders?"

"One thing comes to mind. I note some manufacturers specify carbon tet for cleaning rubber drive wheels and others say to use alcohol. Probably the cleaning agent recommended depends on the kind of rubber used, and any other cleaner may soften or damage the rubber. Always stick exactly to the cleaner recommended in the service data.

"In general, never let a recorder go out without cleaning the head thoroughly. This is something home recorder owners are likely to overlook, and it has tremendous effect on the quality of the recording. Check tape speeds with a timing tape. After this has been running for a few seconds, count the proper timing intervals that pass a certain point in exactly a minute. If the speed is off more than one full interval in this length of time, find out why. Always check all tape moving controls thoroughly, making sure they work easily, that the tape is stopped without putting excessive strain on it, and that there is no tendency to spill the tape.

"Make a short recording at an excessively high level and see if the erase head will take this off completely. If not, measure the erase voltage delivered to the head and compare this with what the service data says it should be. If that is all right, make sure the tape is held firmly against the erase head by the pressure pad. If nothing is wrong here, you are probably up against a bad head. Substituting a good head is the best test for that."

"How about checking for wow?"

"Special equipment is needed to measure wow accurately, but you can easily make a rough check by recording a frequency of about one-thousand cycles and then listening to it being played back. You are almost certain to hear some wow on home recorders, but it should not be very pronounced. You will soon learn how much to expect.

"A rough frequency check can be made by recording a good record containing a wide range of sounds. A good piano piece constitutes a tough test. If

NOW!...a complete guide to Wire & Tape Recording

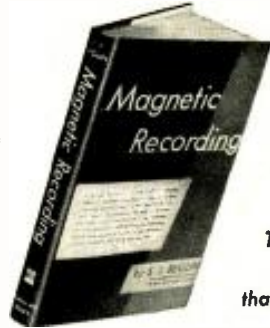

for
**HIGH-
FIDELITY
RESULTS**

There's more to this
fascinating subject
than you may suspect!

MAGNETIC RECORDING

By S. J. Begun

242 pages, 130 illustrations. Price \$5.00

for
Home
Entertainment
Movies
Broadcasting
Amateur Radio
Secret
Communications
Speech
Scrambling
Professional
Recording
Transcriptions
Telegraphy and
Telephony
Automatic
Announcing
Magnetic
"Memories"
Recording
Transients
Chronoscopes

... and many other
uses that make this
one of the fastest-
growing phases of
the electronic in-
dustry.

Here's your "Open, Sesame!" to a fast-growing branch of electronics in which far too few have specialized to date! Whether recording is your hobby or your business, this book will pave your way to better results, new techniques and effects.

From simple wire or tape recorders for home entertainment to complicated equipment and processes used in secret services, movies, industry and elsewhere, MAGNETIC RECORDING brings you complete, how-to-do-it data. From basic circuits to components; from commercial and home built equipment to its operating and service problems, you get the latest information and expert guidance. And, chances are, you'll be amazed at the opportunities for recording specialists in this steadily expanding field.

Starting with the fundamentals of magnetism and acoustics you progress rapidly to the advanced phases of the art. Biasing methods, distortion, reproducing heads, erasing, artificial reverberation (echoes), amplification, instrumentation and measurements and helpful analyses of modern commercial recording equipment, are but a few of the subjects covered. Dozens of schematics, block diagrams, cross-sections and under-chassis photos make things easy to understand and are invaluable guides in selecting new equipment or building your own.

READ IT 10 DAYS ... at our risk!

Dept. RN-34, RINEHART & CO., Inc.
232 Madison Ave., New York 16, N. Y.
Send MAGNETIC RECORDING for 10-DAY FREE EXAMINATION. If book is O.K., I will then promptly remit \$5.00 in full payment. If not, I will return it postpaid and owe you nothing.

Name

Address

City, Zone, State

Price outside U.S.A. \$5.50—cash only.
Money back in 10 days if you return book.

THE SYMBOL OF
Quality
IN TRANSFORMERS



dollars
AND
sense...

Triad quality costs no more, and those who buy Triad Transformers get what they pay for.

Superior design—finer materials—precise workmanship—distinctive appearance—continuous and unfailing service. All these contribute to the recognized value of Triad products.

Industry expects and gets—from Triad the finest transformers made.

Triad Transformers are sold by select jobbers in principal cities. Write for Catalogs TR-53A & TV-53A.



4055 Redwood Ave., Venice, California



this sounds good on playback, the recorder response may be considered satisfactory. For a better test, record 1000, 50, 100, 500, 1000, 2500, 5000, 7500, and 10,000 cycles in that order from our audio generator, keeping the input level constant as measured with the a.c. v.t.v.m. Plug the audio wattmeter into the external speaker jack with the proper load resistor switched into use. Now, with the first 1000 cycle note being played, set the volume control so that a convenient value of output is obtained well below the maximum output rating of the amplifier. One watt should be satisfactory. Note down the reading produced on the wattmeter by each frequency. The departure of these values from the 1000-cycle reading can be converted into decibels and compared with the manufacturer's claims. Of course the tone control should be in the 'flat' position while taking the readings."

"You must be expecting to do quite a bit of recorder service."

"I am. RCA predicts that schools alone will buy 50,000 tape recorders this year. More and more families are finding new uses for them around the home. I consider them easier to work on than record changers. One reason I bought this new job for the shop was so that we would have a reasonable standard of home recorder performance always at hand. On top of that, it is sometimes a great help to be able to play a recording made on a doubtful machine back on one known to be good, and *vice versa*. This allows you to spot whether the trouble is in the recording or playback system, or both. Now here are some good books on tape—"

"Oh no you don't!" Barney shouted. "You've already made a bookworm out of me by loading me down with those now-here's-something-you-ought-to-read things; but I'll be darned if you're going to make a tapeworm out of me!"

-30-

Training Program
(Continued from page 66)

content, and then budget a fixed amount of shop time for these training efforts. It won't be perfect, and it will have bugs, but it is a first step. And, as the Chinese say, a journey of a thousand miles begins with one step. In his planning, a shop owner should overlook the fact that he may be training for a competitor or that the employee so trained may leave him. That is a separate problem. He must consider only the problem of where a dollar of training will get more than a dollar of good quality production.

The second thing for the shop owner to recognize and work at is the principle known to all good personnel men, namely, that all aspects of personnel control interlock and affect one another. It does no great good to provide good training if your policies are such that men don't like to work for you. Training dollars are wasted if you hire poor material to begin with. The market for technicians is not so free that there is unlimited choice in hiring, but the owner must do the best he can. Based on the material available he must set up the training that best fits his shop needs and those of his men. Then he must take a long, hard look at his general personnel policies. Here he must be competitive, not only with other service shops, but with other opportunities that his men might seek. Here are the questions that a professional personnel man asks about his company. Are my wages in line with those of other possible employers of my men? Is my vacation or sick leave policy in line? Does my sales promotion keep my men on a full time job, or do I have to lay them off during the summer? Do I have the equipment I should? Does a man working for me feel he is learning and

Allied Radio Corp. recently played host to the Chicago Acoustical and Audio Group at the association's regular dinner meeting. The 150 diners were treated to a demonstration of stereophonic sound in Allied's dining rooms. The demonstration involved the use of three of the company's "Golden Knight" 24-watt amplifiers, three Electro-Voice "Regency III" speaker systems, an Ampex special 3-channel tape recorder, and Ampex stereophonic recorded tape. The same meeting also included a lecture and demonstration on new ceramic cartridges for high-fidelity use by Howard Souther of Electro-Voice, a "black curtain test" of a series of speakers, and a binaural sound demonstration from tape.



growing? Do my men feel that there is opportunity for advancement if they produce for me? If a company can meet the problems posed by these questions, it will not only keep its people, but can demand and get a full measure of work from them.

This is particularly true of the more seasoned men in the shop—the ones who have done some jumping around and perhaps tried a shop of their own and discovered it was no bed of roses. These are the wheel horses of any organization and the ones most costly to lose. Generally, these men place a high value upon security, and more and more companies are studying deferred compensation programs to bring stability to this important group of key men.

There is a general belief in industry that the small company cannot do the same things that the big company can do. This is a stubborn and erroneous idea. The small shop may have to do it differently, or on a more simplified scale, but basic principles apply to all working organizations regardless of size, and to be successful, management must give time to broad policy.

This problem is not an easy one. No management problem is. We cannot give a detailed blueprint here, but the broad approach outlined represents a method of attack that will bring success to the management that believes in it and is persistent in its pursuit.

The shop management that applies these techniques of manpower development need not fear that it will carry its competitors' training burden. It will be working and training for its own profit and its own public acceptance. Furthermore, it will be doing its individual share in the development of a great industry.

-30-

NOISE SUPPRESSION

By ROBERT A. THOMASON, W4SUD

IN THE belief that other readers of this magazine would be interested in my recent experiments on vehicular noise suppression in late model ('49-'53) Ford trucks for the Texas Gas Transmission Corporation, of which I am communications foreman, I'd like to pass on these tips.

After reducing ignition and regulator noise to a tolerable level, I found the noise still much higher than was desirable. With the help of a coaxial feed link, tied to the antenna terminals of a 50 mc. receiver, I found most of the noise was coming from the electrical oil pressure gauge (meter block unit).

Also guilty, but to a lesser degree, were the electrical temperature and gas gauges. The noise sounded like someone scratching the antenna with a knife blade. I found that by using .01 μ fd. disc ceramic condensers, the noise was effectively bypassed at all three points.

These condensers should be installed with as short leads as possible. The ground side was soldered while the other lead was tightened under the screw terminal. I then tried this same technique on my 4 mc. mobile station with equally good results.

W4MGT, with the Kentucky State Police, reported good results after installing a condenser on the oil gauge.

-30-

MARCH, 1954

ALL RADIO AND TV TYPES

CLOSE OUT SET MANUFACTURERS' INVENTORY TUBES

Standard Brand Warranty • BRANDED • Bulk or Individually Boxed

| | | | | |
|-----------------------|----------------------|----------------------|---------------------|---------------------|
| 0A4G \$.50 | 6AC768 | 6C649 | 6T861 | 12Z339 |
| 0Z449 | 6AG546 | 6CB642 | 6U749 | 19BG6G . . . 1.49 |
| 1B3GT59 | 6AH688 | 6CD6G 1.08 | 6U869 | 19T861 |
| 1B24 4.95 | 6AK579 | 6E576 | 6V6GT41 | 25AV5GT . . 1.05 |
| 1L447 | 6AL534 | 6F6GT54 | 6W4GT41 | 25BQ6GT . . .79 |
| 1R546 | 6A0538 | 6H649 | 6W6GT41 | 25L6GT . . .42 |
| 1S452 | 6A0649 | 6H6GT49 | 6X449 | 25Z6GT . . .49 |
| 1S538 | 6A5562 | 6J499 | 6X5GT43 | 3329 |
| 1T446 | 6AT636 | 6J5GT34 | 7R759 | 3429 |
| 1U446 | 6AU636 | 6J651 | 12A639 | 35B546 |
| 1U538 | 6AV5GT79 | 6J7G49 | 12AT631 | 35C546 |
| 1X2A52 | 6AV636 | 6K6GT36 | 12AT757 | 35L6GT . . .42 |
| 2E22 1.45 | 6BA633 | 6K7G49 | 12AU634 | 35W432 |
| 2X2A31 | 6BA776 | 6L6GA99 | 12AU752 | 35Z5GT . . .33 |
| 3A833 | 6BC546 | 6SA759 | 12AV788 | 50B546 |
| 3B24W 2.95 | 6BE649 | 6SA7GT61 | 12AY772 | 50C546 |
| 3D625 | 6BF569 | 6SC781 | 12BA652 | 50L6GT . . .42 |
| 3B26 1.95 | 6BF669 | 6SF558 | 12BE642 | 117Z349 |
| 3Q469 | 6BG6G 1.16 | 6SG759 | 12BH753 | 801A19 |
| 3Q5GT55 | 6BM646 | 6SH765 | 12H649 | 803 2.95 |
| 3S446 | 6BJ646 | 6SJ754 | 12J729 | 814 2.95 |
| 3V446 | 6BL776 | 6SK769 | 12SA7GT . . .59 | 832A 4.95 |
| 4C35 24.95 | 6BN672 | 6SK7GT69 | 12SG761 | 836 2.95 |
| 5F14 9.95 | 6BQ676 | 6SL7GT59 | 12SH749 | 866A 1.49 |
| 5U4G49 | 6BQ776 | 6SN7GT46 | 12SK7GT . . .49 | 5670 1.45 |
| 5Y3G36 | 6C431 | 6SN7GT46 | 12SN7GT . . .46 | 5718 4.95 |
| 6A635 | 6C541 | 6S07GT49 | 12SQ7GT . . .49 | 6101CT . . .4.95 |
| 6AB769 | 6C5GT41 | 6SR749 | 12SR749 | 9003 1.10 |

More than 400 types in stock—Include all your needs when ordering.

MINIMUM ORDER: \$10.00. Terms: 25% with order, balance C.O.D. Please include postage. All prices subject to change without notice. F.O.B. New York City, mail order division.

TRANSAMERICA ELECTRONICS CORP.

120 LIBERTY STREET NEW YORK 6, N. Y.

(Advertisement)



"Joe dropped the
JENSEN NEEDLE . . .
we've got to find it."



FINGER STOCK

Electrical Weather-Stripping
by Eimac —

Now Available!

Silver-plated, spring alloy, pre-formed finger stock especially suited for electrical "weather-stripping" for TVI-proofing cabinet access doors, etc. Also ideal for making coaxially constructed tube connections and many other uses. Available in 17/32", 31/32", and 1 1/8" widths.

- Write for new Eimac Catalogue Summary showing Eimac tubes and other accessories.



Eimac
ELECTRONIC INDUSTRIES

EITEL - McCULLOUGH, INC.
San Bruno, California

GUARANTEED TELTRON TUBES LOWEST PRICES EVER

All of our tubes are individually boxed and unconditionally guaranteed for one year.

To insure your complete satisfaction and to do away with costly "call backs" all Teltron tubes have been "set tested."

| TYPE | PRICE | TYPE | PRICE | TYPE | PRICE | TYPE | PRICE | TYPE | PRICE |
|-------|-------|--------|-------|--------|-------|---------|-------|---------|-------|
| 1A7GT | .53 | 6AB4 | .43 | 6BQ6GT | .83 | 6U8 | .76 | 12SK7GT | .45 |
| 1B3GT | .62 | 6AQ5 | .52 | 6BQ7 | .85 | 6V6GT | .48 | 12SN7GT | .56 |
| 1H5GT | .51 | 6AJ5 | .98 | 6BZ7 | .95 | 6W4GT | .43 | 12SQ7GT | .38 |
| 1L4 | .51 | 6AK5 | .96 | 6C4 | .41 | 6W6GT | .53 | 19B6GQ | 1.48 |
| 1L6 | .51 | 6AL5 | .43 | 6CB8 | .51 | 6X4 | .37 | 19T8 | .71 |
| 1N5GT | .51 | 6AQ5 | .48 | 6CD6G | 1.63 | 6X5GT | .38 | 25BQ6GT | .82 |
| 1R5 | .51 | 6AT6 | .37 | 6F6 | .42 | 12AL5 | .43 | 25L6GT | .41 |
| 1S5 | .43 | 6AU6 | .43 | 6J6 | .61 | 12AT6 | .37 | 25W4GT | .43 |
| 1T4 | .51 | 6AV6 | .37 | 6K6GT | .38 | 12AT7 | .71 | 25Z6GT | .38 |
| 1U4 | .51 | 6AX4GT | .60 | 6L6G | .78 | 12AU6 | .43 | 35B5 | .48 |
| 1U5 | .43 | 6BA6 | .56 | 6L6GA | .78 | 12AU7 | .58 | 35C5 | .48 |
| 1X2A | .65 | 6BA7 | .58 | 654 | .41 | 12AV7 | .73 | 35L6GT | .41 |
| 3Q4 | .53 | 6BC5 | .48 | 658GT | .65 | 12AX4GT | .60 | 35W4 | .33 |
| 3Q5GT | .61 | 6BE6 | .48 | 65A7GT | .45 | 12AX7 | .61 | 35Z5GT | .33 |
| 354 | .48 | 6BG6G | 1.18 | 6SK7GT | .45 | 12BA6 | .46 | 50B5 | .48 |
| 3V6 | .48 | 6BH6 | .51 | 6SL7GT | .60 | 12BE6 | .46 | 50C5 | .48 |
| 6U4G | .43 | 6BJ6 | .51 | 6SN7GT | .60 | 12BH7 | .61 | 50L6GT | .50 |
| 6Y3GT | .39 | 6BK7 | .78 | 6SQ7GT | .38 | 125A7GT | .45 | 117Z3 | .33 |
| 8Z3 | .42 | 6BL7GT | .78 | 6T8 | .71 | | | | |

FREE

\$5.00 list value Bonus Box of Radio & TV components including resistors, condensers—push pull transformers and many other items with each order of \$25.00 or more.

Minimum order \$10.00. 25% deposit on C.O.D. orders—Save parcel post charges. Orders accompanied with full remittance will be shipped prepaid anywhere in continental U.S.A.—All orders subject to prior sale.

We have hundreds of tube types in stock—you may order any type at similar savings.

Send for Free complete tube listing

SPECIAL

while they last
.39c Each
10 for \$3.50

| TYPE | TYPE | TYPE | TYPE | TYPE |
|-------|-------|------|-------|-------|
| 1A4P | 1E7GT | 19 | 34 | 39/44 |
| 1G6 | 1E7GT | 19 | 34 | 39/44 |
| 1C7G | 1E4 | 1E2H | 38 | 46 |
| 1D5GP | 1H4G | 22 | 35/51 | 49 |
| 1O7G | 2A7 | 33 | 36 | 1P5G |

These specials are brand new in their original cartons.
Order now.

TELTRON ELECTRIC COMPANY

P.O. Box 107-A, Harrison, New Jersey

Phone: Waverly 6-1339

PREMAX

GROUND PLANE ANTE NNAS



For Races Jobs

A fully adjustable type with secure-locking elements which may be set for 20 to 40 meter operation or for 40 to 60 meters. All-aluminum construction, waterproof cable housing, standard 1/2-inch threaded sleeve for mounting. Ask your jobber or write for special Bulletin.

Premax Products

Division of Chisholm-Ryder Co., Inc.

5423 HIGHLAND AVE., NIAGARA FALLS, N. Y.

The COMPLETE line

OR Double-Reentrant Projectors

Paging & Talk-Back Speakers

for EVERY

ALNICO-V-PLUS Driver Units

Dual Speakers

Public Address need!

Tweeters

WRITE NOW for FREE Catalog 553

FULL-GRIP, VELVET-ACTION Mike Stands

ATLAS

SOUND CORP.

1446 39th St., Brooklyn 18, N. Y.
In Canada: Atlas Radio Corp., Ltd., Toronto, Ont.

Building a Multimeter

(Continued from page 71)

1000-ohm rheostat and the other to the positive test jack.

The switch legs are numbered from 1 to 11. These run counterclockwise from the pole connectors. The top deck to which the series resistors for the voltage multipliers are attached is the one nearest you when the instrument is on its face. The lower deck is immediately adjacent to the panel.

The wooden case for the meter was made from a piece of 1/4" maple, 2 1/2" wide and 30" long. Simple rabbet joints were used and the box assembled using glue and brads. The top edges were rabbeted 1/16" deep for the panel recess and the bottom edges rabbeted 1/4" for the plywood back.

The two size "C" flashlight cells were secured to the back by means of a metal strap 5/8" x 2" and a 1 1/4" No. 8 screw. The connections to the battery were made through two miniature *Fahnestock* clips soldered to the positive and negative poles. Four 3/8" No. 4 screws were used to hold the completed meter in its case.

The reason for resistor R_1 , mentioned earlier, is to facilitate the use of stock value shunts for the two current ranges and to make it an easy matter to match any 0-1 ma. meter of 100 ohms or less to this circuit. R_1 is equal to the meter's internal resistance subtracted from 100 ohms. In other words, if you have a meter with an internal resistance of 55 ohms, R_1 will be 45 ohms. These meters vary, depending on the manufacturer, so if you are not positive of the exact resistance of your meter use the following method to determine it:

1. Install the new meter scale.
2. Wire the circuit shown in Fig. 1B using short, heavy leads.
3. Place a jumper across the test jacks and carefully adjust the meter to full scale deflection.
4. Remove the jumper and insert the 100-ohm resistor.
5. Read the meter resistance directly on the "Ohms" scale.

Caution: Do not attempt to measure the resistance of an instrument with an ohmmeter as the former is ex-

Fig. 2. Scale calibration for the multi-meter discussed. This could be photostated and increased in size to fit either a 3 or 4 1/2 inch meter. The 3" meter scale is 2 5/16" wide and the 4 1/2" meter scale is 3 11/16" wide. See Editor's Note at end of article regarding the availability of a commercially drawn scale for meter.

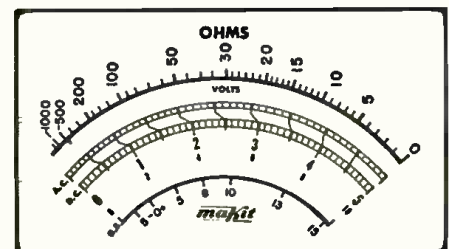

HI-FI BUY!

NEW

STANCOR-WILLIAMSON

Amplifier

Kit \$49.50 Wired \$69.50
(Complete with all parts, Punched chassis and tubes)

Finest in sound, yours for very little cost. Only takes you a few hours to put together. Over 5,000 already built and successfully performing. Frequency responses: flat from 20-20,000 cycles at both 0.5 and 8 watt levels. 0.1 distortion at 8 watts. Power supply and amplifier mounted on individual chassis. Kit is complete with 5 tubes (2—6SN7, 1—5U4 and 2—807), 2 punched chassis, Stancor Hi-Fi Output transformer A-8054, assembly instructions and all other necessary parts for amplifier and power.

PICTURE TUBES

| | WESTINGHOUSE | |
|-----------|--------------|---------|
| | Tung-Sol | Liberty |
| 10BP4A | 19.25 | 11.00 |
| 12LP4A | 21.70 | 14.20 |
| 14CP4 | 24.50 | 16.50 |
| 16AP4A | 30.95 | 21.60 |
| 16DP4A | 28.20 | 20.60 |
| 16GP4 | 31.25 | 21.60 |
| 16KP4 RP4 | 28.20 | 18.00 |
| 17BP4A | 23.90 | 18.00 |
| 17CP4 | 23.90 | 21.60 |
| 20CP4 | 32.50 | 27.00 |
| 21EP4 | 37.35 | 32.50 |
| 24AP4A | 78.50 | 65.00 |

ANTENNAS

V. Antenna . . \$1.95 Window Con. . . 3.50 each
 10 EL. Con. . . 2.75 each Indoor V. Antenna . . 1.19 each

MASTS

5 ft. swedged . . . 65c each 10 ft. seamless . . . 1.25

WIRE

55 mil. 300 ohms. 10.95 70 mil. 300 ohms. 12.95

SPEAKERS

4" P.M. 1.29 5" P.M. 1.39
 6" x 9" P.M. 3.49

CONDENSERS

50x30 150V .39 ea. 50x50 150V .49 ea.
 KINE TUBE REJUVENATOR 95c each
 GRANCO UHF Converter \$29.95

25% deposit must accompany all orders. Balance C.O.D. All prices F.O.B. New York City. If remittance is made with order, you can deduct 2%. \$1.00 handling charge for orders under \$5.00. Subject to prior sale.

ACE ELECTRONICS, INC.

2281 Nostrand Ave. BROOKLYN 34, N. Y.
 CLOVERDALE 3-8010

SPEAKER RECONING

Complete line Cones, Spiders, Rings and Voice Coils. Custom Built Voice Coils. Low prices. Write for Parts List and Reconing information.

WESTERN ELECTRONICS CO.

3164 West Colfax Denver 4, Colo.

BARGAIN HUNTING? **RADIO SERVICEMEN!**
 Write for SENSATIONAL CATALOG
HENSHAW RADIO SUPPLY
 3619 TROOST KANSAS CITY, MO.

MARCH, 1954

tremely delicate and the current flowing in the circuit is on the order of 90 to 100 ma. which would cause serious damage to the milliammeter under test.

The critical eye will note a built-in compromise or two, such as the fact that a 10,000-ohm resistor was used in a 1000 ohms-per-volt circuit to provide the 0-10 volt range. Actually, this value should be 9900 ohms with a 100-ohm meter resistance but since the difference of 100 ohms is only 1 per-cent, it was considered a worthwhile risk since the stock 10,000 ohm value is easier to obtain than the 9900-ohm resistor.

There is a slight loss of accuracy in the a.c. position but it is less than the 5 per-cent usually quoted for multi-meters of this type. To correct these minor shortcomings, a complex switching system and an additional bank of resistors would be required which would result in an increase in both cost and building difficulty. The circuit, as shown, was decided upon as the most practical for these reasons.

Editor's Note: For those who wish to lend a "professional" appearance to their instruments a kit, containing meter scales (for either 3" or 4 1/2" meters), front panel decals, and a builder's manual is available from Robert Hilliard Company, Box 549, Inglewood, California. The kit is \$1.00 postpaid in the U. S. When ordering specify whether the scale is to be used with a 3" or a 4 1/2" meter.

STANDOFF CONNECTOR

By OTTO WOOLLEY, WØSGG

TRYING to take coaxial output from standoff insulators often results in a makeshift arrangement or mutilated cable. Using the simple adapter diagrammed here makes a firm, solid connection that may be removed or installed in a moment's time.

Construction of this unit is simply a matter of drilling any suitable piece of insulating material to fit the standoff centers, mounting the coax output connector, as shown, with suitable short connecting wires or ribbons.

If the unit is to be changed often, the use of wing nuts on the standoff insulators will be helpful.

A simple adapter which will provide a solid connection to standoff insulators.

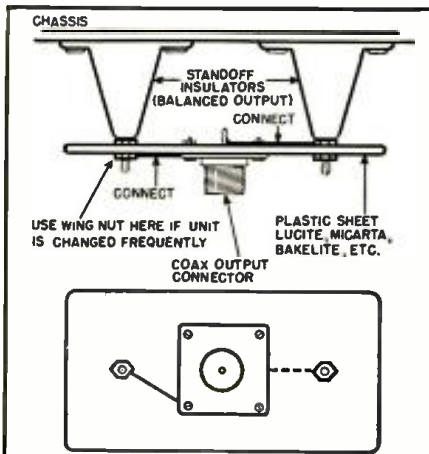

In one box
 ... all the parts you need for a fast, profitable installation



Centralab

Dual-Speaker Switch Mounting Kit

Helps you cash in on the growing trend to dual speakers

There's nothing else to buy, when you have this handy Centralab kit. You're all set to do a profitable job of switching between dual speakers, such as auto rear-seat and front-seat speakers and remote phono speakers. See for yourself—look at what you get:

- 1 Dual speaker switch
- 1 Etched mounting bracket and dial
- 1 White, split-knurled pointer knob
- 2 Self-Tapping, sheet-metal mounting screws
- Complete installation instructions.

Keep several Centralab Dual-Speaker Switch Mounting Kits on hand. Get them from your Centralab distributor now.

Send coupon for Centralab Catalog 28.

Centralab

CENTRALAB, A Division of Globe-Union Inc. 910C E. Keefe Avenue, Milwaukee 1, Wisconsin Send Centralab Catalog 28.

Name _____
 Company _____
 Address _____
 City _____ Zone _____ State _____

P-754

Trav-Electric

DC to AC

CURRENT CONVERTERS
for Land... Sea... Air

JUST PLUG INTO CIGAR LIGHTER ON DASH

Change 6 or 12 Volt D. C.
to 110 Volt A. C. - 60 cycle



Operates Test Equipment,
All Electric Shavers

SIZE: 2" x 2" x 3 1/2"

Trav-Electric MIDGET

Model 6-11160, 60 Cycle, 10-15 Watts

\$11.95

List



- OPERATES
- Test Equipment
 - Turntables
 - Lights
 - Short, Long Wave Radios
 - Portable Phonographs
 - Electric Shavers, etc.

SIZE: 2 1/2" x 2 1/2" x 4 1/2"

Trav-Electric SENIOR

Model 6-1160, 60 Cycle, 35-40 Watts

\$15.95

List



- OPERATES
- Curling Irons
 - Radios
 - Turntables
 - Small Dictating Machines
 - Test Equipment,
 - Electric Shaver
 - Portable Phonographs

SIZE: 4" x 5" x 6"

Trav-Electric MASTER

Model 6-51160, 60 Cycle, 40-50 Watts

\$24.95

List



- OPERATES
- Wire Recorders
 - Amplifiers
 - Soldering Iron
 - Radios
 - Dictating Machines
 - Turntables
 - Small Electric Drill
 - Electric Shaver

SIZE: 4" x 5" x 6"

Trav-Electric SUPER

Model 6-71160, 60 Cycle, 60-75 Watts

\$37.95

List

FULLY GUARANTEED
See your Jobber or Dealer

Terado COMPANY

ST. PAUL 14, MINNESOTA

In Canada Write: Atlas Radio Corp., Ltd.
560 King St. West, Toronto 28, Ont.

Export Sales Division: Scheel International, Inc.
4237 N. Lincoln Ave., Chicago 18, Ill., U.S.A.

Cable Address—Harsheel

Stewart-Warner TV Sets

(Continued from page 62)

top of the tuner. (see Fig. 5). The output of this trap is then coupled to the individual antenna coil sections as shown in Fig. 4. The balance of operation of the v.h.f. section of this tuner will not be discussed since it is similar to a standard v.h.f. cascode-type turret tuner.

Signal output from the mixer is coupled through the converter plate i.f. coil, 458, to a coaxial socket and then fed to the receiver's i.f. amplifiers.

Video and Sound Stages

An intercarrier-type i.f. system, containing printed circuit wiring and transformers, is used in the 9340 series chassis. It is a 3-stage i.f. assembly, having a sound carrier of 41.25 mc., and a picture carrier of 45.75 mc. The first two stages are connected as cascode amplifiers, similar to those utilized in the latest type tuner circuitry, and will be discussed in their entirety in a subsequent paragraph.

The transformers, traps, and all components are mounted on a printed wiring panel, and the unit is then dip soldered to provide connection between the components. Whenever any parts have to be replaced, it is suggested that a pencil-type soldering iron be used to prevent excessive heat from destroying the printed circuit wiring. The adjustment screws for the alignment of i.f. transformers and traps are all located on one side of the strip. (See Fig. 6.)

The i.f. transformer between the tuner and the first i.f. amplifier consists of an M-derived bandpass filter. Trapping of the adjacent channel picture i.f. carrier is obtained by one section of this transformer, which highly attenuates frequencies of 39.75 mc. See Fig. 3. Between the first i.f. amplifier and the second i.f. amplifier, another M-derived bandpass filter is used. It consists of transformers 16, 25, and 22 which are mounted in three separate cans. Trapping of the sound i.f. carrier and adjacent channel sound carrier is achieved by transformer 22, which highly attenuates frequencies of 41.25 mc. and 47.75 mc.

Before proceeding further, let us examine the circuitry between the first i.f. amplifier (V₁) and the second i.f. amplifier (V₂). Although voltage is present at the plate of V₁, there is no actual connection to "B+." Also, a.g.c.

Fig. 6. Side view of the video i.f. strip showing major alignment points.

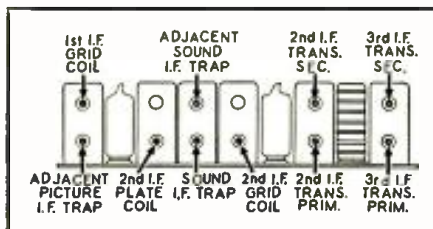

PRE-SPRING SALE PRICES SLASHED

T.V. TUBES—ROCK BOTTOM PRICES

In lots of 6 each No. only

6B6G . . . 89c 6B6E . . . 57c 1L4 . . . 45c 6X5 . . . 36c
1986G . . . 89c 6A05 . . . 38c 1T4 . . . 45c 6SA7 . . . 42c
1986E . . . 89c 6D9 . . . 51c 6B6G . . . 36c 6AT8 . . . 38c
6C8B . . . 39c . . . 37c 6V6GT . . . 38c 6BA6 . . . 38c
6AK5 . . . 63c 6Y8 . . . 55c 6AX4 . . . 52c 6BE8 . . . 38c

Tube Special—Broken Keys—Electrically Perfect
12AB6 . . . 29c; 4 for \$1.00 12M8 . . . 49c; 7 for \$3.00
Tube Sale—247-55-27-85-31-50 . . . 6 for \$1.75
RCA UV876 Tubes 50c

Operadio 10 in. 7500, 9000 ohm Dyn Speaker, \$3.49
N.D. Silver Contact Trans. Keys 1.00
Isolantite Octal Panel Clamp Sockets 3c ea.
100 Assorted Resistors \$1.95
1 Mfd., 1,000V Oil Filled Cond. 75c

2 Gang Var. Cond. 456 K.C. with Osc. Section,
2 3/4 in. Pulley on 3/8" Shaft 49c
Westinghouse Kuprox Rectifier 0.64 Amp. 2B
Volts. Reg. \$11.00 ea. Special \$1.95

BRAND NEW 10" PHONO RECORDS—Ass't.
Jazz—Popular, Rhythm—Jazz—Please specify.
12 for \$1.79 or 24 for \$3.00 or 50 for \$5.75

Single Pole—10 Pos. 2-Gang Switch 29c
Grind Your own Crystals. Pure Brazilian Quartz. Various sizes and thicknesses. 1/4 lb. pkg. . . . \$1.00

4-Tube Drilled Chassis. 4 1/2" x 6 1/2" x 1 1/2". 29c each
Signal Corps Phones—2 M. Ohms (8 M. Ohms
Imp.) Brand new. \$1.75
2 Ft. Ext. Cord (and Plug) 40c

2 3/4" x 4" Bake. Panel Mounting—5 Res.; 6 Mica Cond.;
2 Choke Coils 49c
30 M.H. R.F. Choke Coil 27c ea.; 4 for \$1.00
7 Ft. Und. APP. AC Line Cord 20c

Miniature 9 pr. Sockets 7c Ea.; 60c Doz.
RCA 4" x 8" Oval P.M. Speakers \$1.75
5x7" Oval 1700 Ohm Dyn. Speaker \$1.69

TUBULAR ELECTROLYTICS

20-20 MFD. 150 V. 49c 30-30 MFD. 150 V. 57c
40-40 MFD. 150 V. 59c 80-80 MFD. 150 V. 78c

Low-Loss Short Wave
Lock Type Air Trimmer
Variable Condensers
4x8 Oval 1M Ohm
Spkr. \$1.69

D.P.D.T. SLIDE
TOGGLE
SWITCH 15c
4x6 Oval 500 Ohm
Spkr. \$1.69

1,000 OHM WIRE WOUND POTENTIOMETER 15c
30 HY-FILTER CHOKE SHIELDED New. \$1.25
PIEZO CRYSTAL HOLDERS .24 for \$1.25; \$3.50 per C

RCA Band Switches—
3 gang. 3 pos. 3 band. 30c 6 gang. 4 pos. 4.5 band. 40c
Trimmer-Padder Ast.—all isolantite—singles, dual;
triples—100 Ass't. \$2.25

ATTENTION! Prospectors. Explorers for Hidden Treasures!
Construct a U.S. Army Type of Metallic Mine
Detector Amplifier. Amplifier unit only (less tubes
and batteries) with cables, headphones cord, and Jack.
Army wiring diagram. Type AN/PHS. \$3.95

Philco push button Rotary Switch Double Pole 35c
DRILLED CHASSIS FOR 5-6 tubes 5" x 10" x 1 1/2". 25c
PHONE JACKS—OPEN & CLOSED AUTO 18c
SALE—PHONO RECORD ALBUMS—12" comp. 15c;
10" comp. 15c; 4 comp. 20c; 12 comp. 69c

VULCAN HEAVY DUTY 100 WATT SOLDERING IRON.
Buy for U.S.N.—Brand New—Sells for
\$8.50 OUR PRICE \$2.99

MINIMUM ORDER \$3.00—NO C.O.D.
SHIPMENTS—PLEASE INCLUDE POSTAGE
NEWARK SURPLUS MATERIALS CO.
324 Plane Street, Dept. MA, NEWARK 1, N. J.

URGENT! URGENT! ELECTRONIC TUBES

We Pay Spot Cash for:

Radio, TV—all types—State types,
quantities, condition of merchandise,
quantities and price.

TELEVISION MATERIALS CORP.

120 Liberty St., New York 6, N. Y.

CO 7-4307

\$2.95 EACH OR 2 FOR \$5.00!

Genuine Telephone Company Unlight
telephone complete with cord in Tested and
Guaranteed condition. For inter-communication
or extension. Complete line of tele-
phones and parts, inter-communication systems,
switchboards, handsets, magneto and
dial telephones, etc. Write for free list.
C.O.D. orders accepted. All shipments F.O.B.

TELEPHONE ENGINEERING CO.
Dept. 3C Simpson, Pa.

Interested in Microwaves?

Subscribe now to the Radio Electronic Engineering Edition of Radio & Television News. The April issue of the Engineering Section will contain a wealth of information on various aspects of microwaves.

This special Edition is available by subscription only. One year, \$6.00; two years, \$9.00; three years, \$10.00.

RADIO-ELECTRONIC ENGINEERING
366 Madison Ave., New York 17, N. Y.

is present at the grid of V_2 , yet the grid of V_1 is the only i.f. return to the a.g.c. supply. If we examine the circuit closely, it will be noted that the cathode of V_2 is connected to the plate of V_1 through resistors 29 and 17 and transformer 16. Therefore, these two pentodes are connected in series across a common "B+." Since each tube contains internal resistance, we also think of these tubes as two resistors in series. Therefore, the voltage at the plate of V_1 is the voltage applied to the plate of V_2 , less the voltage drop across this tube, and resistors 29 and 17. In order that the potential between the grid and cathode of V_2 remain within design standards, a steady state voltage is applied to the grid of V_2 by the use of a voltage divider network, consisting of resistors 27 and 23.

To explain how a.g.c. voltage is applied to the grid of V_2 , let us assume zero a.g.c. voltage on the grid of V_1 . The current through both tubes is large at this time and the circuit is so designed that the voltage at the cathode side of resistor 26 is 130 volts. The voltage divider network maintains 130 volts at the grid of V_2 . Since there is no difference in potential between the grid side of resistor 26 and the cathode side, no current will flow through this resistor; hence, no bias on the tube. When a.g.c. voltage is applied to the grid of V_1 , current through this tube is decreased, which produces a greater voltage drop across V_1 . Therefore, the cathode side of resistor 26 has a higher potential than 130 volts. There is now a difference in potential between the grid and cathode sides of resistor 26, causing current to flow through this resistor, producing a bias on V_2 .

Two primary reasons are involved for this type of circuit. Under normal arrangements, the plate circuit of V_1 and V_2 would be returned to the 120-volt supply. If this were done, the 120-volt supply would vary considerably, depending upon the area in which the receiver operates since the a.g.c. bias applied to the first two i.f. stages determines the current drain. Upon checking the circuit further, it will be noted that V_{15} (sound output tube) is connected in parallel with filter condenser, 89. Therefore, any variation in current drain of the first two i.f. tubes must pass through V_{15} ; hence, an appreciable change in the 120-volt supply, obtained from the cathode of V_{15} , would occur when current varies. Also, this large current variation through V_{15} makes it difficult to design a good sound output stage. By using the cascaded type of circuit for the first two i.f. stages, both of these conditions are alleviated.

Between the second i.f. amplifier and the third i.f. amplifier, and between the third i.f. amplifier and the crystal detector (1N64), double-tuned, mutually-coupled transformers are used. The output of the third i.f. amplifier is coupled to the cathode of the crystal detector, which supplies a negative signal to the grid of the video amplifier (V_4). As will be noted in

MARCH, 1954

384,000 MOBILE-RADIO RIGS NEED MAINTENANCE!

Make frequency and FM deviation checks on unlimited numbers of channels with just these 2 meters!



LAMPKIN 105-B MICROMETER FREQUENCY METER

Uses one crystal to measure all transmitters from 0.1 to 175 mc. Gives readings of percent error from assigned frequencies. Acts as precision CW signal generator for receiver final alignment.

PORTABLE—Width less than 13" . . . weight less than 14 lbs., each.

MEET FCC REQUIREMENTS—for mobile-service checks.

For low prices . . . and technical data . . . mail coupon today!



LAMPKIN 205 FM MODULATION METER

Direct indication of peak voice deviation, 0-25 kc positive or negative. Tunable 25-200 mc. in one band. Doubles as relative field-strength meter. Built-in speaker. Jack for oscilloscope.

LAMPKIN LABORATORIES, INC.
MFM DIVISION
BRADENTON, FLORIDA

Without obligation, please send me data on Lampkin meters.

Name _____
Street _____
City _____ State _____

LAMPKIN LABORATORIES, INC.
Bradenton, Florida

SAVE!!! 10" PICTURE TUBES!!!

10BP4 & 10FP4—STANDARD BRANDS, 90 DAY GUARANTEED!

All perfect, unsealed cartons, **\$7.95** WHILE THEY LAST!

RADIO & TV TUBES UP TO 80% OFF!!! 90 DAY GUARANTEE. Standard brands, unsealed cartons. STOCK UP NOW! . . . THOUSANDS OF OTHER TUBES AVAILABLE AT SAME SAVINGS!!!

#24, 26, 27, 34, 41, 42, 55, 56, 89 or 6K7 29¢

#1A6, 1C6, 1W4, 1W6, 1J6, 5U4, 5Y3, 5V4, 8B7, 6C5, 6F5, 6G5, 6L5, 6K6, 6B07, 6BQ7, 6R7, 3B25, 76, 77, 78, or 80 39¢

#1A7, 1L4, 2A3H, 6A8, 6AG5, 6AU6, 6BE6, 6CB6, 6F6, 6H6, 6J6, 6J8, 6S47, 6SK7, 6W4, 7A4, 7A7, 6SN7, 7AG7, 7B6, 7C5, 7C6, 7G7, 7Y4, 125N7, 25L6, 35, 37, or 45 49¢

#1B3, 1LC6, 1W4, 1LE3, 2A5, 2A6, 5V4, 6A3, 6A6, 6AG7, 6AJS, 6B8, 6BQ6, 6AC7, 6L7, 6S07, 6SFS, 6T8, 6U7, 7C7, 12A6, 12AU7, 12AT7, 50, 58 or 81 69¢

#V105, VR150, 6BGG, 6L6, 7B8, 7Q7 or 10 98¢

421A \$1.95 VT-52 (45 spec) 39¢
5881 1.95 1619 39¢
168098 1624 \$1.49

G-E TUNGAR BULBS . . . #206501 2amp.; #12X825 2amp.; #195528 2amp.; #289881 .6amp.; #20X 672 2amp. EACH \$1.49

MARCH SPECIAL BUYS . . .
6" PM SPEAKER (G-E), Heavy duty Alnico slug \$2.95
IGNITION SUPPRESSORS—mouted elbow type .15
1N21B—ca. \$1.85 1N23—ca. \$1.20
CRYSTAL DIODES . . . 1N21—ca. 89¢ . . . 10/\$7.50

STOP!! LOOK!!
SAVE!!
. . . with the NEW "Jumbo Radio Electronics Parts Kit"

Check full of: SWITCHES, SOCKETS, WIRE, RESISTORS, CONDENSERS, COILS, CONTROLS, PHOTOFACTS, TV PARTS & DIAGRAMS, ETC., ETC.

Shpg. wt. **\$3.95**
20 lbs.

"DIRECT FACTORY SPEAKER REPAIRS SINCE 1927"
Min. order \$3.00. 20% deposit req. on all C.O.D.'s.
Please add sufficient postage—excess refunded.

LEOTONE Radio Corp.
67 Day Street
New York 7, N.Y.

FASTER EASIER more PROFITABLE operation

RADIO'S MASTER NEW! 1954 EDITION

- 1370 pages
- Over 85,000 items
- Over 8,000 illus.
- Completely indexed

GET INTO THE MASTER HABIT!

\$1.95 at your parts distributor. Publisher's price \$4.50

Have complete access to the many thousands of products vital to your daily sales and service operations. In the customer's home, across the counter or on the bench, you'll value the Master's thoroughly complete descriptions, specs, illustrations and prices . . . all systematically organized in 18 big sections for instant reference. Increase your sales . . . sell directly from the Master. Facilitate your stock problem . . . use the Master for jiffy comparison of all electronic products. The Master is the only Official Buying Guide for the TV-Radio-Electronics industry. It contains unabridged catalog data direct from the manufacturers. For buying and selling—the Master gives you all the needed facts in a single volume.

Over 100,000 in active daily use. Get into the Master habit. Order your copy today!

Just a few of the products included: Tubes — Test Equipment — Tools — Transformers — Capacitors — Resistors — Relays — Coils — Antennas — Recording & PA Systems — Hardware — Transmitters — Receivers — Kits — Wire — Cable . . . and thousands of allied products!

Eliminate incomplete Small Catalogs and Loose Literature

UNITED CATALOG PUB., INC.
110 LAFAYETTE ST. NEW YORK 13, N.Y.

LEADING TELEVISION DEALER TELLS YOU THE VALUE OF KRYLON



● "I use Krylon on the high voltage sections of TV receivers, and on the antennas as well. It does a good job, cuts down contract calls, and I know it gets the word around about my servicing reliability."—Edwin G. Schaffer, President, Edwin G. Schaffer Company, 7920 Frankford Avenue, Phila., one of the Quaker City's most progressive television organizations.

KRYLON 100% Acrylic Spray is a crystal clear, high dielectric strength coating in a push-button dispenser. For all high voltage sections and component parts of television receivers. Because of its weather-proofing qualities, it is ideal for coating antennas, lead-ins, etc.

"The most important handyman in the TV industry."



KRYLON, INC.

2038 Washington Ave., Phila. 46, Pa.

Krylon also available in Bright Aluminum, Flat Black, Glossy Black, Touch-Up White and Bright Gold

At TV Jobbers Everywhere

Special Sale, Brand New, Well Known Make TV BOOSTERS

Handsome Maroon Metal Cabinet **\$9.10** ea.

Mahogany Wood Cabinet With TV Set Receptacle **\$11.30** ea.

UNCONDITIONALLY GUARANTEED

Famous push-pull 6J6 circuit, 72-300 ohms input and output, tunable channels 2 to 13 Shipped Parcel Post Prepaid

Terms—C.O.D. or Cash with Order ORDER FROM

JOHN B. KRIGBAUM
1445 N. Gulick Ave. Decatur, Illinois
LIMITED QUANTITY—ORDER NOW

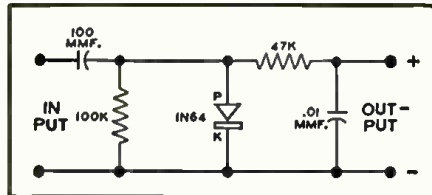

Fig. 8. The detector network used with v.i.v.m. for step 8 in alignment table if h.f. meter probe is not available.

through the 6A4Q5 increases, resulting in a lower cathode voltage. The bias is then automatically decreased, increasing the gain of the tube. When the set is operated in a strong signal area, the reverse occurs. Therefore, in strong signal areas, the gain of this stage is minimum and in weak signal areas maximum, yet within design standards for minimum sound distortion.

Sync Stages

The composite video outputs of both the video detector and video amplifier are applied to the gated sync separator stage (V_c). The tube used is a 6BE6 heptode and, in addition to sync separation, it acts as a noise canceller. If we momentarily assume that the first grid (pin 1) is removed, this tube will act as a normal sync separator. Operation of this type of circuit is poor in the presence of noise bursts which are in excess of the sync pulse, as the noise will cause a larger amount of grid current to be drawn. This results in a bias increase bringing about a decreased sync pulse level and, in some instances, a complete loss of sync output. Also, the output still contains the noise pulse which will trigger the sweep oscillator circuits at the random rate of this noise. Both of these limitations bring about poor holding action.

In the gated system used, a composite negative signal is applied to the first grid (pin 1) at the same time the composite positive signal is applied to the second grid (pin 7). Except for polarity and amplitude, both of these signals are identical in shape. The signal applied to the second grid is always larger in amplitude, resulting in a negative sync output. The first grid is biased so that the tube will cut off whenever its voltage becomes slightly more negative than the sync pulse amplitude. Therefore, whenever a noise pulse whose amplitude is in excess of the sync pulse reaches the first grid, the tube cuts off. It then becomes impossible for the second grid to draw current due to the noise, as well as preventing noise pulses in excess of the sync pulse appearing in the output. If, by chance, the noise is riding on the sync pulse, this circuit will eliminate the noise as well as the sync pulse. Fortunately, this will not occur very often, so that the flywheel action of the horizontal oscillator circuit keeps the oscillator in sync for several periods. From the output of this stage, the sync signal is coupled to the sync amplifier (V_{ra}), which merely amplifies

SERVICE TECHNICIANS: FOR YOUR SHOP!

THE COMPLETE

PHOTOFACT SERVICE DATA LIBRARY

(world's best TV-Radio service data)

in this one handy file cabinet

YOURS FOR ONLY

\$25 DOWN
NO CARRYING CHARGES

1. If you now own some Sets of PHOTOFACT Folders, you can COMPLETE your present library this EASY-PAY-WAY
2. If you've never used PHOTOFACT, you've never realized your full earning power. Put this file cabinet with its 220 Sets of PHOTOFACT Folders to work... starting right NOW!

YES, ONLY \$25 DOWN PUTS THE COMPLETE PHOTOFACT LIBRARY IN YOUR SHOP...

COVERS OVER 17,000 TV, RADIO, RECORD CHANGER, RECORDER AND AMPLIFIER MODELS



SEE YOUR PARTS DISTRIBUTOR TODAY FOR FULL DETAILS

HOWARD W. SAMS & CO., INC.
INDIANAPOLIS 5, INDIANA

SOLVE your hi-fidelity problems with
University
CONE
SPEAKERS
-HIGHEST QUALITY!
-LOWEST COST!



MODEL 6201 - COAXIAL SPEAKER SYSTEM. Now generally acknowledged to be industry's finest value in a high quality 12" speaker. TRUE coaxial dual range system comprising clean sounding woofer with heavy exclusive Alnico 5W magnet, DRIVER TYPE tweeter with "Reciprocating flares" wide angle horn, and BUILT-IN crossover network complete with "Balance" control.

DIFFUSICONE-12 - WIDE RANGE WIDE ANGLE 12" SPEAKER. Exclusive "diffusicone" design utilizes the benefits of dual-horn loading, radial projection and diffraction principles to achieve unsurpassed quality and sound distribution from a single unit speaker. Enjoy full fidelity ANYWHERE in the room . . . of a surprisingly reasonable cost.



DIFFUSICONE-8 - WIDE ANGLE 8" SPEAKER. Same as the Diffusicone-12 except in 8" size. Remarkable fidelity and exceptional sensitivity and power handling capacity make this a truly outstanding eight. Ideal for use where space is limited, and is also a perfect selection for a mid-range speaker in 3-way systems.

MODEL 6200-EXTENDED RANGE 12" SPEAKER. Designed for general applications, capable of highly efficient FULL-BODIED response throughout the operating spectrum. May be used with equal facility to improve commercial radio, TV, phono sets, high quality sound re-inforcement in night clubs, churches, schools, etc., or as a woofer. The 6200 must be heard to be appreciated.



MODEL C-15W-DUAL IMPEDANCE RANGE 15" WOOFER. Brand new low frequency reproducer embodying many exclusive advance features. Its superior response and acoustic output is due, in part, to a newly University-developed cone and voice coil suspension system permitting the greatest axial movement ever achieved. The incredibly low distortion results from a new magnet assembly.

There is a UNIVERSITY Tweeter for every application and pocketbook. Write for descriptive illustrated literature. Address Desk

University
LOUDSPEAKERS INC
 80 SO. KENSICO AVE., WHITE PLAINS, N. Y.

the sync pulse and inverts its polarity for proper use with the horizontal and vertical oscillator stages.

The horizontal oscillator and associated frequency control system consists of a blocking oscillator and pulse-width type a.f.c. circuit. A 6SN7GT tube is used for this purpose. Tube V_{MA} acts as the frequency control section, comparing the horizontal oscillator frequency with that of the incoming sync pulses. The comparison frequency originates from two sources, the output of the horizontal oscillator itself, and a portion of the horizontal output from a tap on the flyback transformer. The position of the feedback pulse on the sync determines the current drain in this section of the tube. Since resistor 117 in the cathode of V_{MA} is also common to the grid of the blocking oscillator (V_{NB}), a change in current drain in V_{MA} , produced by a change in frequency of the feedback pulse, will be felt as a voltage change on the grid of V_{NB} , altering its frequency. The horizontal hold control, 123, varies the plate voltage of V_{MA} , which changes the current through the tube; hence, altering the voltage across resistor 117.

The saw-tooth output of the horizontal oscillator is coupled to the horizontal output stage which utilizes a 6BQ6GT tube (V_{H}). A flyback transformer of the auto-transformer type is connected to the output of V_{H} . Through this transformer, in association with the deflection yoke, high voltage is developed as well as boost voltage. Horizontal damping is provided by a 6AX4GT tube (V_{11}), and the width control is located in the plate circuit of this tube. In series with the plate circuit of this tube is the quarter-amp fuse. Horizontal retrace blanking is provided by reshaping a portion of the horizontal output and connecting it to the grid of the picture tube.

The low-voltage power supply in this chassis utilizes a 5U4G tube (V_{12}) which is operated as a full-wave rectifier and the output is separated into four distinct voltage sources. The primary of the power transformer contains a 4-amp slow-blow fuse. The heaters of those tubes, whose cathodes contain a higher-than-normal voltage potential, are returned to the 120-volt supply through isolating resistor 83. This will avoid the possibility of a cathode-to-heater short due to a large potential difference.

Before proceeding to the alignment of this receiver as outlined in Table 1, be sure to do the following:

1. Insulate the oscillator contacts on the tuner strip to render the oscillator inoperative. Use cellulose tape on the first two contacts from the front of the drum assembly.
2. Short the antenna terminals together with a jumper wire.
3. Keep the marker generator output at a level that provides a readable marker but does not distort the curve on the scope.
4. Proceed to step 1, Table 1. -30-

THE NEW TV DYNATRACER

ONLY \$4.95 Ppd. or C.O.D. + Chgs.

- TRACES TV SIGNALS AND VOLTAGES
- LOCATES DEFECTIVE COMPONENTS
- REQUIRES NO ADDITIONAL EQUIPMENT

This sensationally new piece of test equipment is ideal for trouble-shooting television sets in the home or in the shop. The "DYNATRACER" will out-perform more expensive testers and should pay for itself on the very first repair.

A Must for Every TV Technician

SPECIFICATIONS: The "DYNATRACER" is a self-powered quality test instrument designed to trace TV signals through any Video, Sound, Sync, AFC, Horizontal or Vertical Sweep Circuit—will isolate trouble to a stage or component.

ADDED FEATURE: The "DYNATRACER" will also trace voltages (30/500 V. AC/DC) and instantly locate open, shorted, intermittent or leaky (up to 20 MEGOHMS) condensers, resistors, coils, XFormers, etc.

Instructions and Trouble-Shooting Book Enclosed

10 DAY MONEY-BACK GUARANTEE

Cut out advertisement . . . attach name and address with \$5.00 bill, check or money order and mail to

Century ELECTRONICS CO.
 8509-21st Ave., Dept. 21 1, Brooklyn 14, N. Y.

TELEVISION

PREPARE FOR A GOOD JOB!
 BROADCAST ENGINEER
 COMMERCIAL OPERATOR (CODE)
 RADIO SERVICING

Television Servicing

(Approved for Veterans)
SEND FOR FREE LITERATURE
BALTIMORE TECHNICAL INSTITUTE
 1425 EUTAW PLACE, BALF. 17, MD.

Coils & Kits for THEREMIN

Described in Jan. issue of this Magazine (reprint upon request)

- *Pretested coil assemblies: Pitch Control Coil \$2.95, Volume Control Coil \$2.95, Fixed Oscillator Coil \$2.50, R.F. Transformer (T1) \$1.50, or all 4 for ONLY \$8.95. (Plus 1 lb. postage. We refund overpayments.)
- *Kit containing all parts for construction of the Theremin. Chassis comes completely punched.
- *Complete step-by-step wiring instructions and large, easy-to-read diagrams are included. Shipping wt. 25 lbs. OUR PRICE \$59.95 (less cabinet) plus postage.
- *Completely assembled and tested Theremin housed in a beautiful hand polished mahogany cabinet. 25 lbs. OUR PRICE \$87.95.
- *ONE YEAR GUARANTEE.

R. A. MOOG CO. 51-09 Parsons Blvd. FLUSHING, NEW YORK

ASK YOUR JOBBER for

Carleo PARTS KITS

Amazing values! All new, standard brands, guaranteed perfect. Most popular items for every need. At your jobber's. Catalog sheets on request. Carl Cordover & Co., 100 Warren St., New York 7, N. Y.

FREE: Display Rack for Jobbers

COURSES OFFERED

- Radio Technician • F.M. & T.V. Tech.
- Electronic Tech. (Radar) • Electrical Insp.
- Radio Comm. (F.C.C. Lic. Prep)

Write for Free Booklet

LINCOLN SCHOOL
 of Radio & Television, Inc.
 1851 B'way, N. Y. C. • CI 6-5300

RADIO & TELEVISION NEWS

Trends in AM Receivers
(Continued from page 51)

In essence, the printed wiring replaces the hookup wire formerly employed to connect the various portions of the circuit together. In these receivers, the printed wiring is permanently fixed to the plastic chassis base by a photoengraving process. See Fig. 1. Normal components, such as resistors, condensers, and coils are then soldered into position. For tubes, appropriate holes are drilled into the panel and then clips are inserted in these holes. The tube pins fit into these clips and thereby make electrical contact with the rest of the circuit.

There are several different methods of fabricating these printed wires. *Motorola*, for example, places the printed wires on both sides of the plastic base and components are mounted on each side. The metal printing extends through holes on the chassis, connecting circuits on the front with those on the rear. *Admiral*, on the other hand, places all of its wiring on one side and all the components on the other side. This permits them to do away with hand soldered connections. After the components (with the exception of the tubes) have been mounted and their wires pulled through holes in the chassis to appropriate points on the printed wiring side, the underside is dipped into a large solder "bath" or pot. This secures the component leads to the printed wiring. The excess solder is then brushed off (literally) and any excess lead length clipped.

Troubleshooting and parts replacement will in general be the same as for receivers wired with hookup wire. However, there are certain precautions to observe when parts must be replaced. These are as follows:

1. Do not use too large a soldering iron when changing parts. 60 watts or less is recommended. Do not use a soldering gun.

2. To remove a defective component, apply the tip of the soldering iron to the point of connection. Keep the soldering iron on the connection just long enough to melt the solder, then quickly tap the chassis against the service bench to shake the solder away from the connection. After the solder is removed, untwist or separate connections. A pick will be helpful for this. After disconnecting wires or lugs, carefully remove components from the top side of the chassis.

Motorola recommends that i.f. transformers, the tuning condenser, volume control, oscillator coil, or the electrolytic condenser be removed by immersing all the lugs simultaneously into a small soldering pot. The component may then be lifted off the chassis easily. *Motorola* feels that the soldering pot is superior to the soldering iron because, with the latter, plated connections may be pulled loose from the chassis.

3. To prevent tube breakage, remove

Amplifier SENSATION OF THE YEAR
the **H. H. SCOTT "99"**



\$99.95 net

"best amplifier for the money I've ever owned"
Other owners say: (owner's comments on returned guarantee tags)
"amazed at its performance—idea of fully encasing the amplifier is brilliant—a group of twelve persons, upon hearing this amplifier, judged it the best dollar for dollar buy on the market — more than satisfied — I am sure every owner is as proud as I am of his 99-A amplifier."
FREE BOOKLET

An Expert Says:
"the little Scott, amusingly designed to resemble a control unit alone, has few rivals in the feature of flexibility, regardless of price."
C. G. Burke, *NEW TRENDS IN AUDIO*
"Saturday Review" Dec. 26, 1953

HERMON HOSMER SCOTT, INC. 385 PUTNAM AVENUE, CAMBRIDGE 39, MASSACHUSETTS

AUDELS TV-RADIO SERVICE LIBRARY

HERE IS LATE INFORMATION IN A HANDY FORM FOR RADIO AND TELEVISION REPAIRMEN, SERVICEMEN AND STUDENTS



2 VOLS. \$6 COMPLETE \$1 A MONTH

AUDELS T.V.-RADIO SERVICE LIBRARY—Highly Endorsed—1001 Facts—Over 1552 Pages—625 Illustrations, Diagrams of Parts. Presents Important Subjects of Modern Radio, Television, Industrial Electronics, P.M., Public Address Systems, Auto, Marine & Aircraft Radio, Phonograph Pick-Ups, etc.



IT PAYS TO KNOW!

The Basic Principles—Construction—Installation—Operation—Repairs—Trouble Shooting. Shows How to get Sharp, Clear T.V. Pictures. Install Aerials—How to Test. Explains Color Systems, Methods of Conversion, Terms, etc. Includes Ultra High Frequency (U.H.F.)—Valuable for Quick Ready Reference & Home Study. Tells How to Solve T.V. & Radio Troubles—Answers Your Questions.

Get this information for yourself. 7 DAY TEST—ASK TO SEE IT!

MAIL ORDER

AUDELS Publishers, 49 W. 23 St., N.Y. 10, N.Y.
Mail AUDELS T.V. RADIO SERVICE LIBRARY 2 Vols. \$6 on 7 days free trial, if O. K. I will remit \$1 in 7 days and \$1 monthly until \$6 is paid. Otherwise I will return them.

Name _____
Address _____
Occupation _____
Employed by _____ RN

Concord's BUY OF THE MONTH

Sensational SELF POWERED 2 WAY PHONE SYSTEM



\$4.50 PAIR

Sensitive 2 way phone system Operate with telephone like clarity over distances of up to one mile. Phones made of rugged, shockproof Dow Styron with self-contained 1 1/2 Volt flashlight battery. Has full size 1 1/2 carbons mike 24 carat gold plated. Complete with push to talk switch, spring clip-plate and wall brackets. Without a doubt, one of the most sensational service, office or home items ever offered. Complete with batteries. \$4.50
Two conductor twisted pair weatherproof wire for above. .2¢ per ft 100 ft. \$1.50

FREE! NEW 1954 CATALOG! 1954!

A complete, comprehensive listing of all your electronic requirements. Bursting with SPECIAL VALUES

CONCORD RADIO, 53 Vesey St., N. Y. 7, Dept N3

Please send . . . sets of phones at \$4.50 ea.
 Enclosed find \$ in complete payment. Minimum 20% deposit with C.O.D.
 Send new 1954 CONCORD CATALOG!

NAME _____
ADDRESS _____
CITY _____ ZONE _____ STATE _____

CONCORD RADIO • 53 VESEY ST. NEW YORK 7, N. Y. • Digby 9-1132

Smaller in Size-Greater in Efficiency!

The FAMOUS
SUB-MINIATURE
K-TRAN*
I.F. TRANSFORMER
 ONLY 1/2" SQUARE BY 1 1/2" HIGH
 Over-all, Inc. Terminals, 1-15/16"



THE FAMOUS "K-TRAN" I.F. TRANSFORMER HAS NOW BEEN MINIATURIZED. For the first time we are now able to supply a 455 KC intermediate frequency transformer which has all the desirable features of the conventional size I.F. and smaller than a miniature tube. Through the use of a Ferrite shell core material these Sub-Miniature I.F. Transformers offer the gain and bandwidth characteristics previously obtained only in larger I.F. assemblies.

It is now possible to construct personalized receivers smaller than ever before. These transformers may be used with sub-miniature tubes where sockets are not required.

| Catalog No. | Net Price |
|-----------------------------------|-----------|
| 10 - C1 455 KC Input Transformer | \$1.50 |
| 10 - C2 455 KC Output Transformer | \$1.50 |

(Available through your local distributor)

* Manufactured under "K-TRAN" patents of Automatic Mfg. Co.

J. W. MILLER COMPANY
 5917 South Main Street • Los Angeles 3, California

Canadian Representative: Atlas Radio Corporation, Ltd. 560 King Street, W. Toronto 2B, Canada

MORE JOBS than graduates
 Demand for our engineering graduates exceeds supply. Effective placements. Study in this world-famed college established 1884. Quarters start March, June, Sept., Jan. Approved for Korean Vets.

Bach. Sci. degree in 27 months
 Complete Radio Eng. courses . . . TV, UHF and FM. Also Mech., Civil, Elec., Chem., Aero. and Adm. Eng.; Bus. Adm.; Acct. Small classes. Well-equipped labs. Modest costs. Prep. courses. Write Jean McCarthy, Director of Admissions for Catalog and Campus View Book.

Electronic Engineers
 Excellent opportunity for professional growth and advancement. Interesting and challenging.

TRI-STATE COLLEGE
 1634 College Avenue, Angola, Indiana

\$

WE PAY CASH
 for all types of
MILITARY ELECTRONIC EQUIPMENT
 Top Dollar for:

- BC-348 RCVRs (Bonus on Q & R Models)
- ART-13 & any accessories
- BC-788 (Bonus on C Model)
- I-152 (Bonus on C Model)
- RADAR EQUIPMENT (Specify full name plate info)
- DIRECTION FINDING EQUIP. (Specify full name plate info)
- TEST EQUIPMENT (Specify full name plate info)

Plus anything you have not listed here. Send complete description of your equipment to:

V & H RADIO & ELECTRONICS
 2033 W. Venice Blvd., Los Angeles 6, Calif.
 Phone: REpublic 3-1127

them before any parts are replaced. Also, when a tube is pulled out, pull it straight out. Wiggling the tube from side to side, a customary procedure in other sets, may cause a tube clip to bend and lead to subsequent poor contact.

4. Before installing replacement components, clean the solder from the connection point so that the leads or lugs can be pushed through the holes in the chassis panel. To avoid running solder into adjacent leads of the printed circuit, use as little solder as possible.

Resistors and condensers may be replaced quickly by clipping out the defective part and soldering the new part to the connecting leads remaining from the original part.

An open or damaged section of printed circuit wiring can be replaced by soldering a jumper of ordinary hookup wire across the connection points. To eliminate the need for complete tube socket replacement, defective tube socket pin clips may be replaced individually.

The chassis of most printed-wire receivers are connected directly to one side of the power line. To avoid possibility of damage to test equipment or to printed circuit wiring, do not place the chassis directly on a metal service bench, tools, or other metal objects.

When taking voltage readings or making resistance measurements, use test leads with needle point prods to avoid possibility of short circuits between sections of the printed circuit wiring.

PHOTO CREDITS

| Page | Credit |
|----------------------|------------------------------------|
| 44 | Standard Coil Products Company |
| 46 (Fig. 5) | Zenith Radio Corporation |
| 46 (Figs. 6 & 7), 59 | Stewart-Warner Corporation |
| 50 | Admiral Corp. |
| 51, 159 | Howard W. Sams & Co., Inc. |
| 52, 156 | Muntz Television, Inc. |
| 53 | Chromatic Television Laboratories |
| 55 | University Loudspeakers, Inc. |
| 63 | Electro-Voice, Inc. |
| 65, 129 | Radio Corporation of America |
| 66 (center top) | Central Television Service |
| 67 | National Company |
| 71 | Robert Hilliard Company |
| 167 | Allen B. DuMont Laboratories, Inc. |
| 172 | Allied Radio Corp. |

Lafayette's Greatest Values!

NOW! PHILCO BOOSTER
MODEL TB-3 In original factory sealed cartons. Money back guarantee!

~~\$39.50~~
 1st
\$12.50 ea.
\$11.50 ea.
 in lots of 3
 Shp. Wgt. 5 lbs. ea.

The Philco Television Booster Model TB-3 is a high quality, push-pull, wide-band radio-frequency amplifier designed to amplify r-f signals in the television bands. This unit employs two 6J6 tubes as r-f amplifiers, uses a selenium rectifier in a self contained power supply. Channels 2 through 13.

Include postage with your order. C.O.D.'s accepted.

LAFAYETTE RADIO

Dept. RC

Talk about tuners!
THE STANDARD CASCADE TUNER TOPS 'EM ALL!

\$14.95 ea.
\$14.25 ea.
 in lots of 3

BRAND NEW! GUARANTEED!

The No. 1 Tuner in the trade. Lafayette is out front with this red-hot STANDARD COIL CASCADE TUNER deal. Lafayette made a buy—we paid cash—and you get the saving! Regular dealer price \$24.50. Servicemen, now is the time to stock up and save! Size: 4 3/4" x 3 1/4" x 6 1/4" supplied with 6J6 and 6BQ7. Stock No. TL-11. Shp. wt. 4 lbs.

Unbelievable Price!
WESTERN ELECTRIC HEARING AID

Reg. price ~~\$185.00~~
Our price \$14.95

Brand new, in original Western Electric's jeweler's case. Supplied with receiver, receiver cord, battery cord and plug (less batteries). Money back guarantee. Act now while they last! Uses Burgess XX30E and 8R batteries at \$1.55 per set.

FREE! Lafayette's new bargain packed catalog. Write today!

NEW YORK 15, N.Y. | BOSTON 10, MASS. | NEWARK 2, N.J. | BROOKLYN 58, N.Y. | PLAINFIELD, N.J.
 100 Sixth Ave. | 110 Federal St. | 24 Central Ave. | 542 E. Fordham Rd. | 139 W. 2nd St.

ERRATUM

Several readers have written us that they are finding it difficult to obtain the Stanwyck LHO-2 coil specified in the parts list accompanying the "Theremin" article in the January issue. This number is a manufacturer's part number. Its replacement number is the Stanwyck 3582 ringing coil and it is under this number that you will find it at your parts distributors. The Stanwyck 37416 may also be used in this application. If the 3582 is used change the i.d. of L₁-L₂ from 1 1/4" to 1 1/8" and L₁-L₂ from 9/16" to 1/2". Change the resistance of L₁ from 30 to 20 ohm.

Condenser C₁₁ in the schematic diagram accompanying "Foolproof 2-Band Transmitter" (page 116, December 1953) should have a value of .001 μfd., 600 volts. The value was omitted from the parts list.

XCELITE Hand Tools

PREFERRED BY THE EXPERTS

"Sure I'm Guilty BUT . . ."

who could resist "borrowing" that swell new Xcelite Standoff Insulator Plier! It's the easiest way yet for tightening and loosening Standoff Insulators. Great all-purpose plier too!

"If only I'd Known . . ."

"I could have bought a 10" Plier for only \$4.35, less dealer discount, at my Xcelite Distributors."

Brand-New Xcelite No. 64 is slip-proof, tough—with rib joints and jaws fully drop-forged.

Remember—Xcelite makes a complete line of screwdrivers for radio and TV men, too.

See Your Dealer NOW!



XCELITE, INCORPORATED

(Formerly Park Metalware Co., Inc.)
Dept. E ORCHARD PARK, NEW YORK

Canadian Representative
CHARLES W. POINTON
1926 Gerrard St. E. TORONTO, ONT.

For Originality
LOOK TO XCELITE



NOW... enjoy luxurious hi-fi remote control!



with the beautiful *Rauland*

LIBRETTO remote control



Now you can have complete remote control of your present High Fidelity Music System with the LIBRETTO! This amazing control is completely self-powered and capable of operation several hundred feet from the amplifier. Uniquely fashioned in the form of a luxuriously bound book (only 8 3/4 x 11 x 2" thick). Backbone lifts for easy access to controls. Operates in either horizontal or vertical position. Controls: 1. Crossover; 2. Roll-off; 3. Volume; 4. Bass; 5. Treble. Adapter available for simple connection to your present system. Gives you the ultimate in luxurious Hi-Fi.

See the LIBRETTO at your Hi-Fi Dealer, or write for full details

RAULAND-BORG CORP.
3515 W. Addison, Dept. B, Chicago 18



Classified

Rate 50c per word. Minimum 10 words

RADIO ENGINEERING

COMPLETE radio, electronics theory & practice; television; broadcasting; servicing; aviation, marine, police radio. 12 or 18 months. Catalog. Valparaiso Technical Institute, Dept. N, Valparaiso, Ind.

FOR SALE

ISOLATION transformer 35w 117v sec. 117 or 135 plus 6.3v .45a tap. 3 lbs. \$1.95 plus postage. Removed from new equipment. Surplus bought. Empire Electronics Co., 409a Ave. L, Brooklyn 30, N. Y.

DIAGRAMS—Radio \$1.00; record changers, recorders \$1.25. Television with service data \$2.00. Where model unknown, give part numbers. Kramer's Radio Service, Dept. S53, 36 Columbus Ave., New York 23, N. Y.

TAPE Recorders, Tapes, Accessories. Unusual Values. Dressner, 624-R East 20th St., N.Y.C. 9.

CIRCUIT Diagrams will save your precious time. Radio \$1.00. Television \$2.00. Give make and model. Carleton Radio, 39 Daniel, East Hartford 8, Conn.

MANUFACTURER'S Closeout. 4 sectional—28 1/2 feet Stainless Steel aerial masts. Size of tubing O.D.—Maximum 1 1/4"—Minimum 3/8". Price \$19.95 F.O.B. Newark. C.O.D. Quality Discounts. Maxnor Metal Company, 235 Ridgewood Ave., Newark, N. J.

ALUMINUM tubing, angle and channel, plain and perforated sheet. Willard Radcliff, Postoria, Ohio.

FREE: Get our monthly electronic lists. Dick Rose, Everett, Wash.

TV-FM antennas. All types including UHF. Mounts, accessories. Lowest prices. Wholesale Supply Co., Dept. H, Lunenburg, Mass.

BC-221 Power supply (also TS-174, TS-175) 115V, replaces batteries, guaranteed new \$33.50 1'PD. Crest Equipment Corp., 34-R Herkimer Place, Brooklyn 16, N. Y.

USED television sets \$25. Jones, 1115 Rambler Ave., Pottstown, Pa.

HALLICRAFTERS SX-71 Top Condition. Regular \$249.95 for \$169.95 cash. F.O.B. Wes Eckhardt, Ritzville, Wash.

WILLIAMSON Amplifiers—buy direct from manufacturer—\$56.00 up. Write Long Island Sound Co., 19 Bennett Place, Amityville, N. Y.

"ELECTRIC Eye" Equipment. Kits, photoelectric cells, relays, etc. Lowest prices! Write—Universal Electronics, 709 Grove, Buckroe Beach, Virginia.

WORKING Televisions, \$30 up. W4API, 1420 South Randolph, Arlington, Virginia.

USED Radio Vibrators Rejuvenated \$1.25 each 30 day guarantee. Radio Products Service, Box 591, Springfield, Ohio.

WANTED

AN/APR-4, other "APR-," "ARR-," "TS-," "IE-," ARC-1, ARC-3, ART-13, everything surplus; Tubes, Manuals, Laboratory equipment. Describe, price in first letter. For Sale; Reconditioned Watthour Meters, four for \$10.00. Engineering Associates, 434 Patterson Rd., Dayton 9, Ohio.

WILL buy all ART-13/type T-47A \$200.00; ART-13/type T-47, \$150.00; BC-348 unmodified \$65.00, BC-348 modified \$50.00; APN-9 \$200.00; ARC-3 complete \$600.00; R77 receivers \$300.00; ARC-1 \$300.00; BC-312 \$60.00; BC-342 \$60.00. Ship via Express C.O.D., subject to inspection to: H. Finnegan, 49 Washington Avenue, Little Ferry, N. J.

CORRESPONDENCE COURSES

USED correspondence Courses and Books sold and rented. Money back guarantee. Catalog free. (Courses bought.) Lee Mountain, Pisgah, Ala.

AMATEUR radio is fun. Fifty pages, easy to understand, code and theory for Novice Class license. \$1.00. Satisfaction guaranteed. Radiographic, 3246 North Orange, Chicago, Ill.

PASS amateur theory exams. Check yourself with sample FCC-type questions & novice & general class examinations. All for only 50c. American Electronics, 1203 1/2 Bryant Ave., New York 59, N. Y.

BUSINESS OPPORTUNITIES

BUY Wholesale 25,000 items. Catalog 25c. Matthews, 1472-R6 Broadway, N. Y. C. 36.

MISCELLANEOUS

SPEAKERS repaired, wholesale, guaranteed. Jobbers wanted. Anprite Speaker Service, 70 Vesey St., New York City 7.

FREE money saving bargain list. 10 MFD/600WV Oil Capacitor 98c; RCA 3AP1A \$1.95; add postage. Mark Electronic, 1888 Randell Ave., Bronx 72, N. Y.

RECORDING Fans—Join world-wide club; swap tapes, make friends everywhere! Details free. P. O. Box 1404-G, San Francisco, Calif.

24 PAGES Plans "1-tube Receiver" (record 12,000 miles) with 6 issues "Radiobuilder" \$1.00. Laboratories, 328-H Fuller, Redwood City, California.

BUILD your own electronic organ, or miniature electric brain. Details free. Jim Kirk, W6DEG, 1552 Church St., San Francisco 14, Calif.

QSL-SWL Cards. Rainbows, multicolors, Supergloss, Samples 10c. QSL Press, Passaic, N. J.

THE BEST FOR THE LEAST!!!

The KELTON Company, makers of the world's finest Hi Fidelity phonograph, now have a complete line of speaker and enclosure combinations designed by Henry C. Lang, leading acoustical scientist. These are complete units ready to attach to your set. Each unit is acoustically tested as part of the production process.

The COMPANION—Net \$34.50
Designed specifically to get the most from TV sets and AC-DC radios. The addition of the COMPANION will add octaves of sound to the least expensive radio. Also an ideal PA or extension speaker. Available in either corner or bookshelf cabinet.

The AMBASSADOR—Net \$69.75
Designed for use with 10 watt or larger amplifiers. Acclaimed by leading musicians and engineers as the finest reproducer available REGARDLESS of SIZE or COST.

The DIPLOMAT—Net \$59.75
Acoustically identical to the AMBASSADOR but housed in plain birch cabinet for bookshelf installation.

ALL MODELS ARE UNCONDITIONALLY GUARANTEED

Dealers: write for literature on the fastest selling speaker and enclosure in America.

The KELTON Co., Inc.

Dept. R
55 Amory Street Boston, Massachusetts

Sensational Saving For
STANDARD BRAND users
OF THE 5 TOP-LEADING
TUBE MANUFACTURERS

- FULLY GUARANTEED
- INDIVIDUALLY BOXED
- FIRST QUALITY

NO SECONDS OR REMAINS "BARGAINS" YOU CAN PLACE YOUR CONFIDENCE IN OUR DEPENDABLE, NEW TUBES.

Tube Orders Over \$25.00, with full remittance, PREPAID to you in U.S.A.

| Type | Net | Type | Net | Type | Net |
|-----------|-------|-----------|-------|------------|-------|
| 0A2 | .30 | 6BA6 | .60 | 12BD6 | .75 |
| 0B2 | .30 | 6BC5 | .69 | 12BE6 | .64 |
| 0C3/VR105 | .91 | 6BE6 | .63 | 12BH7 | .85 |
| 0D3/VR150 | .89 | 6BGG | 1.79 | 12BY7 | 1.05 |
| 0Z4 | .50 | 6BH6 | .80 | 12BZ7 | 1.10 |
| 1A7GT | .77 | 6B16 | .85 | 12SA7 | .70 |
| 1B3GT | .85 | 6BK7 | 1.10 | 12SF5 | .70 |
| 1B27 | 11.50 | 6BL7GT | 1.00 | 12SG7 | .85 |
| 1H5GT | .77 | 6BN6 | 1.20 | 12SH7 | .63 |
| 1L1 | .50 | 6BQ6GT | 1.17 | 12SJ7 | .55 |
| 1L6 | .95 | 6BQ7A | 1.23 | 25K7 | .61 |
| 1LA6 | 1.10 | 6BY5G | 1.95 | 12SL7GT | .65 |
| 1L81 | 1.10 | 6C27 | 1.28 | 12SN7GT | .95 |
| 1LW5 | 1.10 | 6C4 | 1.00 | 12SO7GT | .75 |
| 1N5GT | .95 | 6C6 | .50 | 12SR7 | .69 |
| 1N21B | 1.80 | 6CB6 | .55 | 12SX7GT | 1.10 |
| 1N23B | 2.25 | 6CD6G | 1.30 | 14F7 | 2.75 |
| 1N34A | .75 | 6CU6 | 2.10 | 25B6G | 2.05 |
| 1N48 | .50 | 6D5 | .75 | 25B6GT | 1.25 |
| 1N54 | .75 | 6F7 | 3.00 | 25L6GT | .85 |
| 1R4 | .59 | 6F5 | .59 | 25W4GT | .45 |
| 1R5 | .75 | 6F5GT | .68 | 25Z5 | .70 |
| 1R3 | .70 | 6F6 | .70 | 25Z6GT | .59 |
| 1T4 | .75 | 6F6G | .80 | 28D7 | 1.35 |
| 1U4 | .50 | 6F8G | .85 | 35A5 | .65 |
| 1U5 | .75 | 6G6 | .85 | 35B5 | .90 |
| 1V | 1.05 | 6H5 | .62 | 35C5 | .65 |
| 1V2 | .90 | 6J1(RCA) | 5.10 | 35L6GT | .45 |
| 1X2A | .85 | 6J5 | .50 | 35W4 | .45 |
| 1Z2 | 3.25 | 6J6 | .75 | 35Z3 | .79 |
| 2C51 | 3.90 | 6J7 | .75 | 35Z5GT | .48 |
| 2E26 | 3.40 | 6K4(Sylv) | 2.25 | 35A5 | .75 |
| 2E30(Hyt) | 2.05 | 6K4A | 2.75 | 50B5 | .65 |
| 2I39 | 7.95 | 6K6T | .80 | 50C5 | .65 |
| 2I61 | 37.50 | 6K7 | .69 | 50L6GT | .85 |
| 2I62 | 33.00 | 6L6G | 1.10 | 80 | .66 |
| 2K28 | 27.55 | 6L6GA | 1.10 | 81 | .66 |
| 2X2 | .45 | 6L6M | 1.25 | 81V | .15 |
| 3A4 | .59 | 6L7 | .80 | 84G24 | .55 |
| 3B7H | 9.00 | 6N7M | .70 | 11Z23 | .75 |
| 3B7 | .39 | 6Q7GT | .80 | 11Z76 | .98 |
| 3B28 | 4.25 | 6S4 | .58 | 11VT4C | .98 |
| 3C23(GE) | 8.50 | 6S7M | .98 | Surplus | 7.75 |
| 3C24/24G | 1.15 | 6SA7 | .64 | 10A(WE) | 1.50 |
| 3Q4 | .89 | 6SC7 | .88 | 10T4(WE) | 3.50 |
| 3Q5GT | .90 | 6SD7GT | .80 | 40B4(WE) | 2.50 |
| 3B4 | .75 | 6S7 | .88 | 803 | 3.25 |
| 3L4 | .90 | 6SH7 | .88 | 805 | 2.95 |
| 3V4 | .75 | 6S17 | .65 | 809 | 1.50 |
| 4E24 | 4.50 | 6SK7 | .61 | 81A | 2.35 |
| 4D22 | 18.50 | 6SL7GT | .65 | 81A | 3.80 |
| 5A4 | 1.55 | 6SN7GT | .75 | 815 | 1.20 |
| 5D21 | 11.95 | 6S7 | .88 | 830B | 2.75 |
| 5H4GY | 1.50 | 6T8 | .88 | 866A | .80 |
| 5U4G | .56 | 6U8 | .80 | 866A(JAN) | 1.25 |
| 5V4G | .92 | 6V3 | 1.15 | 866A | .80 |
| 5W4G | .80 | 6V6GT | .61 | (CBS) | 1.75 |
| 5X40 | .75 | 6W4GT | .59 | | |
| 5Y36T | .44 | 6W6GT | .75 | | |
| 6A1GT | 1.10 | 6X5GT | .85 | | |
| 6A14 | .65 | 6X8 | .69 | | |
| 6A17 | .95 | 7A7 | .75 | | |
| 6A17 | 1.04 | 7A8 | .69 | | |
| 6A14 | 1.39 | 7B6 | .75 | | |
| 6A15 | .71 | 7B7 | .75 | 955 | .42 |
| 6A17 | 1.10 | 7B8 | .75 | 991/NE16 | .50 |
| 6A14GT | .80 | 7C4 | .69 | CK1005 | .75 |
| 6A15 | .88 | 7C5 | .69 | 1616 | .88 |
| 6A15 | 1.30 | 7C30 | 85.00 | 1622/6L6M1 | .95 |
| 6A15 | .79 | 7E5 | .39 | 1625 | .35 |
| 6A16 | .98 | 7F7 | .83 | 1626 | .38 |
| 6A13 | .55 | 7F8G | 1.50 | 1629 | .25 |
| 6A14 | 1.50 | 7H7 | 1.10 | 2050 | 1.40 |
| 6A15 | .55 | 7J7 | 1.20 | 5516(Hyt) | 2.25 |
| 6A16 | .73 | 7Q7 | .98 | 5528/C6L | 5.80 |
| 6A15 | .70 | 12A7 | .50 | 5654 | 2.25 |
| 6A16 | 1.95 | 12A77 | .80 | 5656 | 10.00 |
| 6A17 | 3.75 | 12A7U | .79 | 5670 | 3.25 |
| 6A18 | .48 | 12AV6 | .50 | 5687 | 2.95 |
| 6A16 | .59 | 12AV7 | .90 | 5691 | 7.00 |
| 6A15GT | 1.10 | 12AW6 | .88 | 5693 | 6.25 |
| 6A16 | .48 | 12AX7 | .70 | 5814 | 1.55 |
| 6A14GT | .72 | 12AY7 | 1.90 | 9002 | 1.10 |
| 6A15GT | .80 | 12B4 | .98 | 9004 | .33 |
| 6B8 | .75 | 12B6 | .65 | 9006 | .29 |

Large Quantity
872A(GE) 3.25
10 for 29.50

Above is only a partial listing of our huge stock. Types not listed may be ordered at approx. the same savings. Many new special purpose types in stock. FOR RUSH ORDERS OF \$75 OR MORE, PHONE COLLECT.

AUTHORIZED DISTRIBUTORS
CBS-HYTRON EIMAC WESTINGHOUSE

KARLSON SPEAKER ENCLOSURES
In Stock—Blonde or Mahogany—Kits and
To order media available.
Write for Special Prices.

TUBE CARTONS
Two-Colored Cartons With New Safety Partitions
Prevents Tube Breakage. This Super-Gloss Red and
Black Carton is the Most Distinctive Box Available
Today.
SIZE EACH
Miniature (6AU6, 6AL5, etc.) \$0.1
GT (6SN7, 6W4, etc.) .0125
LARGE GT. (1B3, 6BQ6G, etc.) .015
LARGE G (5U4G, 6BQ6G, etc.) .02
Minimum—100 in any one size.
Quantity prices on request.
FREE SAMPLE, if requested on your letterhead.

BARRY
ELECTRONICS CORP.
136 F Liberty Street, N.Y. 6, N.Y. REctor 2-2562
Terms: 2 1/2% with order, balance C.O.D.
All merchandise guaranteed. F.O.B. N.Y.C.

INDEX OF Advertisers

MARCH 1954

[While every precaution is taken to insure accuracy, we cannot guarantee against the possibility of an occasional change or omission in the preparation of this index.]

| ADVERTISER | PAGE | ADVERTISER | PAGE |
|--|-----------------------------|--|------------------------------|
| Aaron Electronics | 167 | Leotone Radio Corp. | 177 |
| Ace Electronics, Inc. | 175 | Lincoln School of Radio & Television, Inc. | 180 |
| Aermotor Co. | 141 | Mallory & Co., Inc., P. R. | 87, 4th cover |
| Airex Radio Corp. | 134 | Mattison Television & Radio Corp. | 126 |
| All Channel Antenna Corp. | 123 | McConnell's | 168, 176 |
| Allied Radio Corp. | 9 | McGraw-Hill Book Co. | 128 |
| Almo Radio Co. | 164 | McIntosh Laboratory, Inc. | 16 |
| Altec Lansing Corp. | 157 | Miles Reproducer Co., Inc. | 106 |
| American Microphone Co. | 152 | Miller Co., J. W. | 182 |
| American Television & Radio Co. | 141 | Milwaukee School of Engineering | 142 |
| Amplifier Corp. of America | 122 | Mogull Company, Alexander | 170 |
| Argos Products Company | 136 | Moog Co., R. A. | 180 |
| Argyle Electronics Co. | 162 | Moss Electronic Distributing Co., Inc. | 107, 122 |
| Arkay Radio Kits, Inc. | 168 | National Company | 34 |
| Arrow Sales, Inc. | 125 | National Electronics of Cleveland | 155 |
| Ashe Radio Co., Walter | 20 | National Radio Institute | 3 |
| Associated Industries | 168 | National Schools | 17 |
| Atlas Sound Corp. | 174 | Newark Electric Company | 171 |
| Audel Publishers | 181 | Newark Surplus Materials Co. | 176 |
| Baltimore Technical Institute | 180 | New Jersey Television Supply Co. | 151 |
| Barry Electronics Corp. | 184 | Onan & Sons, Inc., D. W. | 148 |
| Bell Telephone Laboratories | 24 | Orradio Industries, Inc. | 137 |
| Berlant Associates | 170 | Part Mart | 161 |
| Boulevard Electronics, Inc. | 154 | Peak Electronics Co. | 146 |
| Burstein-Applebee Co. | 113 | Philco Corporation | 36 |
| CBS-Hytron | 11 | Photo Sales | 140 |
| Candler System Co. | 114 | Pickering & Company Incorporated | 10 |
| Cannon Electric | 167 | Permoflux Corporation | 30 |
| Capitol Radio Engineering Institute | 29 | Platt Electronics Corp. | 156 |
| Centralab | 90, 116, 129, 159, 175, 178 | Premax Products | 174 |
| Century Electronics Co. | 180 | Premier Radio-TV Supply | 119 |
| Channel Master Corp. | 88, 89 | Progressive "Edu-Kits" Inc. | 166 |
| Cisin, H. G., Publisher | 154 | Pyramid Electric Company | 35 |
| Cleveland Institute of Radio Electronics | 25 | Quietrol Company | 118 |
| Collins Audio Products Co. | 121 | RCA Institutes, Inc. | 21, 105, 154 |
| Columbia Electronic Sales | 134 | R W Electronics | 109 |
| Commissioned Electronics Co. | 153 | Radiart Corporation, The | 15 |
| Communication Equipment Co. | 104 | Radio Corporation of America | 6 |
| Concord Radio | 181 | Radio Craftsmen, Inc., The | 28 |
| Corover, Carl, & Co. | 180 | Radio & Television News Book Service | 185 |
| Corona Radio & TV Co. | 114 | Radio-Television Training Association | 23 |
| Coyne Electrical School | 147 | Rad-Tel Tube Co. | 115 |
| DeForest's Training, Inc. | 5 | Rauland-Borg Corp. | 183 |
| Derr Co., C. R. | 144 | Raytheon Manufacturing Company | 2nd cover |
| Desco Mfg. Co. | 138 | Rek-O-Kut Company, The | 106 |
| Douglas Instrument Laboratory | 114 | Rider Publishers, Inc., John F. | 117 |
| Editors & Engineers, Ltd. | 148 | Rinehart & Co., Inc. | 112, 131, 151, 161, 168, 171 |
| Eitel-McCullough, Inc. | 173 | Sams & Co., Inc., Howard W. | 124, 157, 179 |
| Electronic Chemical Corp. | 130 | Sect, Inc., Hermon Hosmer | 181 |
| Electronic Instrument Co., Inc. | 42, 110, 155 | Simpson Electric Company | 135 |
| Electron Tube Wholesalers, Inc. | 128 | Sprayberry Academy of Radio | 27, 106 |
| Electro-Voice | 8 | Stan Burn Radio & Electronics Co. | 144 |
| Fair Radio Sales | 149 | Standard Surplus | 39 |
| Fairchild Recording Equipment Corp. | 108 | Steve-El Electronics Corp. | 165 |
| Federal Telephone & Radio Company | 109 | Stevens Walden, Inc. | 120 |
| Fenton Company | 128 | Stromberg-Carlson Company | 147 |
| Fisher Radio Corporation | 18, 91, 111 | Stuart Electronic Distributors | 145 |
| G. & G. Radio Supply Co. | 158 | Sun Parts Distributors, Ltd. | 162 |
| G. & H. Wood Products Co. | 130 | Superex Electronics Corp. | 14 |
| G. L. Electronics, Inc. | 120 | Superior Instruments Co. | 122 |
| General Electric Co. | 12, 13, 22, 33 | Supreme Publications | 133 |
| General Electronic Dist. Co. | 106 | Sylvania Electric Products, Inc. | 31, 38 |
| Glick & Co., Phillip | 153 | "TAB" | 186 |
| Goodheart, R. E. | 108 | Tallen Co., Inc. | 135 |
| Granco Products, Inc. | 110 | Tee Vee Supply Co. | 127 |
| Greenlee Tool Co. | 162 | Tele-Diagnosis Co. | 134 |
| Hallcrafters | 7 | Television Communications Institute | 165 |
| Harjo Sales Co. | 122 | Television Materials Corp. | 176 |
| Harvey Radio Company, Inc. | 132 | Teltron Electronics Co. | 174 |
| Heath Company | 92 thru 103 | Terado Company | 176 |
| Henshaw Radio Supply | 175 | Transamerica Electronics Corp. | 108, 150, 163 |
| Hughes Research and Development Laboratories | 163 | Transvision, Inc. | 172 |
| Indiana Technical College | 135 | Triad Transformer Corp. | 26 |
| Institute of Radio Engineers, The | 39 | Triplet | 182 |
| Instructograph Company | 176 | Tri-State College | 32 |
| International Radio & Electronics Corp. | 137 | Tung-Sol Electric, Inc. | 148 |
| International Rectifier Corporation | 160 | Ultra-Audio Broadcasting System | 177 |
| International Resistance Company | 3rd cover | United Catalog Pub., Inc. | 180 |
| JFD Manufacturing Co. | 138 | University Loudspeakers, Inc. | 180 |
| JSH Sales Co. | 130 | Utah Radio Products Co., Inc. | 114 |
| J. J. Glass Electronics Co. | 138 | V & H Radio & Electronics | 182 |
| Jensen Industries, Inc. | 173 | Valparaiso Technical Institute | 108 |
| Karlson Associates Incorporated | 144 | Waldom Electronics, Inc. | 169 |
| Kay-Townes Antenna Co. | 40, 41 | Walsco Electronics Corporation | 19 |
| Kelton Co., The | 183 | Washtek Service Co. | 154 |
| Kester Solder Company | 140 | Western Electronics Co. | 175 |
| Kirby Products Corporation | 159 | Western Television Institute | 140 |
| Krignaum, John B. | 179 | Wholesale Radio Parts Co., Inc. | 123 |
| Krylon, Inc. | 179 | Windsor Electronic Tube Co. | 153 |
| Lafayette Radio | 164, 182 | World Radio Laboratories | 145 |
| Lampkin Laboratories, Inc. | 177 | Xcelite | 183 |
| Leeds Radio Co. | 170 | Zingo Products | 144 |

Announcing

A NEW SERVICE FOR READERS OF

Now, in the radio-TV-audio-electronics field, from theory to production and servicing, RADIO & TELEVISION NEWS BOOK SERVICE will get any book for you. Whether it is listed below or not, we will make every effort to fill your requirements. Just send name of book and remittance (Sorry, no COD's) and books will be sent at once. No extra charge for postage and handling.



RADIO-TELEVISION

200. HOW TO USE SIGNAL AND SWEEP GENERATORS. By J. Richard Johnson. A practical handbook for the service technician, the radio amateur and the experimenter. Emphasis is on how to use the equipment, not on why it works. Lavishly illustrated, it gives test uses and discusses problems and their solutions in using this equipment. \$2.00

201. PRACTICAL TV ENGINEERING. By Scott Holt, New 2nd Ed. A definitive work with new chapters on color, u.h.f., and v.h.f. Mfg. and sales engineers, broadcast engineers, students, and tech workers will all find this book an invaluable aid to a thorough understanding of this booming medium. 730 pages. \$7.50

202. NOLL'S TV for RADIOMEN. By Edward M. Noll. One of the most widely used of all books on TV theory and construction, book is in simple non-mathematical terms and gives practical instruction on installation, alignment and adjustment. \$8.00

203. PRINCIPLES AND PRACTICES OF TELECASTING OPERATIONS. By Harold E. Ennes, 600 pages, 450 illus. \$7.95

204. BASIC TELEVISION ENGINEERING. By Bernarb Grob. 592 pages with 415 illustrations covering scanning, synchronizing, video signal, brightness control, DC Reinsertion, Picture, Tube Alignment, picture tubes, VHF and UHF transmission and reception. \$7.50

205. HOW TO TROUBLESHOOT A TV RECEIVER. By J. Richard Johnson. A step by step guide for newcomers. \$1.80

206. UHF TELEVISION ANTENNAS AND CONVERTERS. By A. Lytel. Latest information on all types, covers latest UHF installation techniques. \$1.80

207. AUDELS TV-RADIO SERVICE LIBRARY, 2 vols. \$6.00

208. MODERN OSCILLOSCOPES AND THEIR USES. By Jacob H. Ruiter, Jr., 360 pages, 370 illus. \$6.00

209. ESSENTIALS OF RADIO. By Slurzberg & Osterheld. \$6.75

210. TELEVISION ENGINEERING. By Fink, 2nd Ed. \$8.50

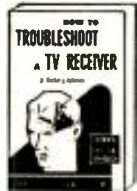

ELECTRONICS

211. INDUSTRIAL ELECTRONICS: An Introduction to Modern Industrial Electronic Practice. By Dr. R. Kretzman. \$5.50

212. TELEVISION: The Electronics of Image Transmission. By Zworykin and Morton. Television in all its technical aspects. Includes valuable information for installing TV stations. 646 pages. \$8.50

213. ELECTRICAL ENGINEERS HANDBOOK, Vol.

2. By Pender and McIlwain, 4th Ed. Covers the field of communications, including facsimile, TV, FM and pulse techniques. Contains information on optics, 1,618 pages. \$8.50

214. ELECTRONICS FOR COMMUNICATION ENGINEERS. By Markus and Zeloff. Covers circuit diagrams, formulas, graphs, etc. 879 pages. \$10.00

215. ELECTRONIC MEASUREMENT. By Terman

and Pettit. New, completely revised edition of "Measurements in Radio Engineering". Tells how to solve measurement problems in radio and electronic engineering. Covers measurement of audio frequencies, determining tube co-efficients, measurement of noise figures on the oscilloscope, measuring line parameters, making time interval measurements, measuring power using bolometer and calorimeter methods, measuring field patterns of antennas. \$10.00

AUDIO

216. A GUIDE TO AUDIO REPRODUCTION. By David Fidelman. An A to Z explanation of the reproduction of sound. Discusses all phases of systems and requirements plus design, construction, assembly, and testing of systems and components. Explains in detail the circuitry of preamplifiers and amplifiers; complete discussion of phono cartridges, tuners, microphones, loudspeakers and enclosures. For the radio and TV service technician, engineer and experimenter. Companion volume to Weiler's High Fidelity Simplified. 250 pages. \$3.50



217. HIGH FIDELITY TECHNIQUES. By John H. Newitt. For the engineer, home builder of audio gear, service technician, studio personnel and professionals in the audio field. 12 chaps. in easy to read language. \$7.50

218. RECORDING AND REPRODUCTION OF SOUND, 2nd Ed. By Oliver Read. A complete presentation of the entire subject of sound. Discusses modern theory and methods used in the recording and reproduction of sound, based upon years of experience and research. Includes charts and Appendix. 810 pages. \$7.95

219. AUDIO AMPLIFIER MANUALS. Produced by Howard W. Sams. Four volumes from 1948 to 1952 covering a wide variety of amplifiers, tuners, and recorders, plus associated equipment used in high-fidelity systems. Includes circuit diagrams, parts lists, etc. (Specify year desired when ordering.) Each \$3.95

220. ELEMENTS OF SOUND RECORDING. By Frayne and Wolfe. Covers everything in sound recording from the nature of sound to stereophonic recording. \$9.50

221. HIGH FIDELITY SIMPLIFIED, 4th Ed. By Harold D. Weiler. A non-technical explanation of hi-fi techniques and the necessary components which constitute a hi-fi system. Covers the latest tape recorders and the newest types of enclosures and speaker systems. 208 plates. \$2.50

222. HOME MUSIC SYSTEMS. By Edward T. Canby. How to assemble parts at greatest savings. \$4.00

223. HIGH FIDELITY HANDBOOK. By Greene, Radcliffe and Scharff. A virtual encyclopedia of step by step instructions, hundreds of diagrams that make it easy, inexpensive to select, install, assemble, and enjoy your own HI-FI system for records, tape, FM, AM, TV. Expert guidance in layman's language. \$4.50

CLIP AND MAIL THIS COUPON NOW

RADIO & TELEVISION NEWS BOOK SERVICE, Dept. R
201 East 57th Street, New York 22, N. Y.

I enclose \$..... for which please ship postpaid books circled or indicated below. If not satisfied I can return them within 5 days for refund.

200 201 202 203 204 205 206 207 208 209 210 211
212 213 214 215 216 217 218 219 220 221 222 223

Any book not listed..... \$.....

Name.....

Address.....

City.....Zone.....State.....

ALL ORDERS SHIPPED POSTPAID. Sorry, no COD's. Add 3% sales tax with orders for N. Y. C. delivery; add 25¢ per title for delivery outside U.S.A., except for APO's.

NO. 1

CHOICE

of service technicians for

TV CONTROLS*



*Not Claims! Not Predictions!
But Plain Facts! More Service
Technicians prefer IRC TV Controls
than the next 2 brands combined.
Proved by unbiased, authoritative,
independent surveys.*



**ASK FOR *IRC* TV CONTROLS...
MOST SERVICE TECHNICIANS DO!**



INTERNATIONAL RESISTANCE COMPANY

415 N. Broad Street, Philadelphia 8, Pa.

In Canada: International Resistance Co., Ltd., Toronto, Licensee

Wherever the Circuit Says 

PROVED from coast to coast

In every UHF area, Mallory Converters bring clear, trouble-free all-channel reception to thousands and thousands of families. Make sure your customers get this **PROVED PERFORMANCE**.

Mallory UHF Converter



Prove to yourself that the Mallory Converter can be a profit-maker for you. Ask your Mallory distributor for details on the Mallory 88 Converter. It's a fast-seller... easy to install... and performance is outstanding.

P. R. MALLORY & CO. Inc.
MALLORY

CAPACITORS • CONTROLS • VIBRATORS • SWITCHES • RESISTORS
RECTIFIERS • POWER SUPPLIES • FILTERS • MERCURY BATTERIES

APPROVED PRECISION PRODUCTS

P. R. MALLORY & CO. Inc., INDIANAPOLIS 6, INDIANA