

RADIO & TELEVISION NEWS

ANC

DECEMBER
1952
35¢

In Canada 40¢

IN THIS ISSUE

INTERNATIONAL TV IS HERE

U. H. ANTENNAS

MULTI-BAND V. F. O.
MOBILE TRANSMITTER

MAGNETIC PICKUP PREAMP

CARRIER CURRENT INTERCOM

TV INTERMITTENTS

CASCADE-CASCADE ON
2-METERS

HI-FI SPEAKER DESIGN

A CAPACITANCE RELAY

SELL PORTABLES YEAR-ROUND
(See Page 44)



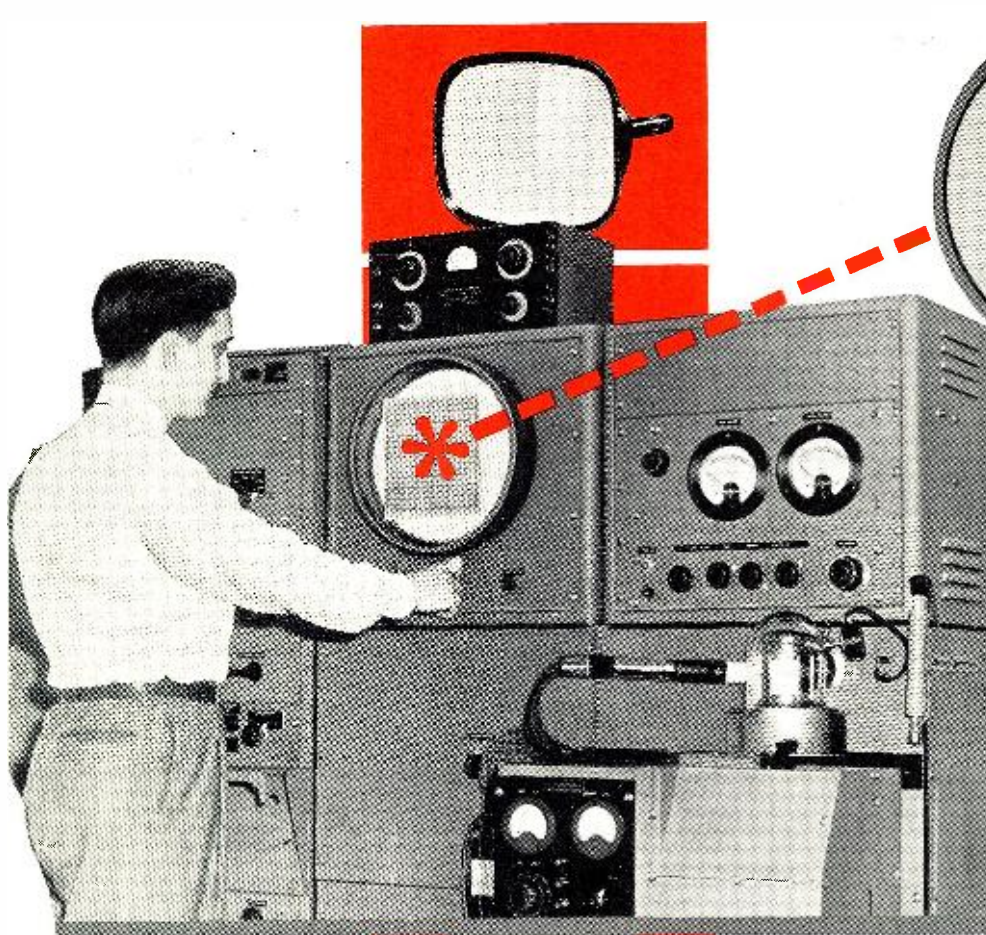

Electrical "pictograph" shows the white is right!

How we get  that's just right

for RCA picture-tube screens

MIX BLUE AND YELLOW paint and you get green. But mix "blue" and "yellow" phosphors and you get *white* . . . or what appears white to the eye. So it is that the fluorescent screen of a picture tube consists of about two billion tiny "blue" and "yellow" luminescent crystals. By the principle of *color addition*, the colored light from the individual crystals stimulates the eye to give the *impression* of white light.

The problem is you can get white that is yellowish, or white that is bluish . . . depending on the blend of the "blue" and "yellow" phosphors. Getting a white that's *just right* for picture-tube screens is

no easy trick. It calls for extremely precise *color control* of the phosphor.

RCA does it with a *spectroradiometer*. This instrument permits very accurate measurement of the *shade* of the "blue" and "yellow" phosphors. Based on this information, batches of "blue" and "yellow" phosphors are selected and blended to give the desired shade of white. Each blend is tested in a pilot run of picture tubes, and these tubes are also measured on the spectroradiometer. Only when a pilot run shows the desired white is a blend approved for production use. Result: "Off-color" picture tubes never reach your shop.

RCA's constant vigilance at all stages of manufacture is your assurance that only top-quality RCA Kinescopes leave the factory. In this way, RCA closely guards its own reputation . . . *and yours as well.*

With RCA Receiving Tubes, as well as RCA Kinescopes, TOP-QUALITY CONTROL makes the difference.



RADIO CORPORATION of AMERICA
ELECTRON TUBES
HARRISON, N. J.

TMK. ®

NEW

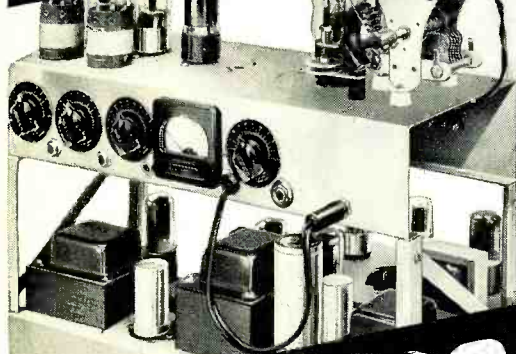

I'LL TRAIN YOU FOR YOUR FCC LICENSE

A Federal Communications Commission Commercial Operator's License puts you in line for a good job in Radio or Television Broadcasting, Police, Marine, Aviation, Two-way, Mobile or Micro-wave Relay Radio. Mail coupon below for 64-page book FREE. It will give you complete facts about my NEW Communications course.



YOU BUILD THIS TRANSMITTER

with parts I send. With this Transmitter you practice how to put a station "on the air." You perform procedures demanded of Broadcast Station Operators, conduct many experiments, make many practical tests.

LEARN COMMUNICATIONS by PRACTICING at Home in Spare Time



YOU BUILD this Transmitter Power Supply used in the basic experiments in RF and AF amplifiers, frequency multipliers, buffers, etc.

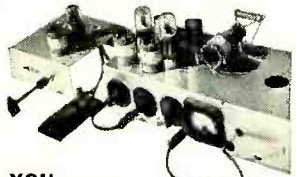

YOU PRACTICE setting up code, amplitude and frequency modulation circuits (put voice, music, etc., on "carrier signals" you produce). You learn how to get best performance.

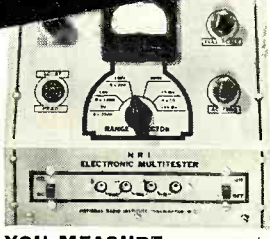

YOU MEASURE current, voltage (AC, DC and RF), resistance and impedance in circuits with Electronic Multitester you build. Shows how basic transmitter circuits behave; needed to maintain station operation.

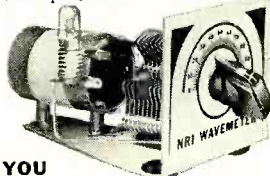

YOU BUILD this Wavemeter and use it to determine frequency of operation, make other tests on transmitter currents.

Get Practical Experience on Circuits Common to Radio & TV

Ever think HOW FAST Radio-Television Communications is changing, developing, growing? Have you considered what this amazing progress can mean to you?

Even without Television the industry is bigger than ever before. 105 million home and auto radios, 2900 Radio Broadcasting Stations, 108 TV Stations with 1800 more now authorized. Expanding use of Aviation and Police Radio, Micro-Wave Relay, Two-Way Radio for buses, taxis, etc. makes opportunities for Communications Technicians and FCC Licensed Operators. New jobs, more jobs for beginners! Better jobs, better pay for experienced men!

Television Is Today's Good Job Maker

In 1952, over 18,000,000 homes had TV sets. More are being sold every day. The "Freeze" on building new TV stations has been lifted. The time to act is NOW! Start learning Radio-TV communications. America's fast growing industry offers good pay, a bright future, security. If you are a beginner, my course can help you get FCC License, prepare for the job you

J. E. SMITH, President National Radio Institute Washington, D. C.

For 38 years, the leader in training men for Radio-Television.



MY COURSE INCLUDES TELEVISION

want. If you've had some training in Radio or Radar, or as a Licensed Operator, my course modernizes, increases the value of your knowledge.

Includes New Developments

Mail coupon now for facts about my practical course in Radio-Television Communications. Let me send you my FREE book. See the nine big Kits of Parts I send that "bring to life" theory you learn. You get practical experience by working on circuits common to both Radio and Television; also lessons on TV principles. Read about the Transmitter you build and operate, about the Electronic Multitester you get. All equipment is yours to keep.

My graduates are filling jobs, making good money in both Radio and Television. Remember, the way to a successful career in Television is through experience in Radio.

Servicing Training Also Offered by N. R. I.

If you prefer a good-pay job in Radio-Television Servicing . . . or your own money-making Radio-Television Sales and Service Shop, I'll train you at home. My famous Servicing Course also includes many Kits of Radio Parts. You use them to get PRACTICAL EXPERIENCE with circuits common to Radio and Television. I also show you how to make \$5, \$10 a week or more EXTRA MONEY fixing neighbors' Radios while training. Full information in my 64-page book. . . . Mail coupon.

Mail Coupon for Book FREE

Send today! See what my Communications course is like. Find out how I get you ready for a brighter future, better earnings, more security in Radio-Television. Send coupon now in envelope or paste on postal. NO OBLIGATION, NO SALESMAN WILL CALL! My book, sent to you FREE, tells the full story. J. E. SMITH, President, Dept. 2 NE, National Radio Institute, Washington 9, D. C. Our 39th year.

Training Leads to Jobs Like These

- | | | |
|---|--|---|
| BROADCASTING
Chief Technician
Chief Operator
Power Monitor
Recording Operator
Remote Control Operator | GOVERNMENT RADIO
Operator in Army,
Navy, Marine Corps,
Coast Guard
Forestry Service
Distatcher
Airways Radio Operator | AVIATION RADIO
Plane Radio Operator
Airport Transmitter Operator |
| SHIP AND HARBOR RADIO
Chief Operator
Assistant Operator
Radiotelephone Operator | POLICE RADIO
Transmitter Operator
Service Technician | TELEVISION
Pick-Up Operator
Voice Transmitter Operator
TV Technician
Remote Control Operator |

I TRAINED THESE MEN

 "My position with WNET is video control engineer on the RCA color project. I owe a lot of my success to your textbooks."—Warren Deem, Malverne, N. Y.

 "I am a technician at WTOP in Washington and I like it very much. Most of my radio knowledge was from N.R.I."—John Britto, Hyattsville, Md.

 "My first job was with KDLR, obtained for me by your Graduate Dept. Now in charge of Radio Equipment for Police Dept."—T. S. Norton, Hamilton, O.

 "A former employer recommended N.R.I. training. Now employed as transmitter operator at WKBO."—Albert Herr, New Cumberland, Pa.

MAIL NOW-BOOK FREE

MR. J. E. SMITH, President, Dept. 2 NE National Radio Institute, Washington 9, D. C.

Mail me your 64-page Book about Radio and Television Communications opportunities and training. (No salesman will call. Please write plainly.)

Name..... Age.....
Address.....
City..... Zone..... State.....

Approved Under G. I. Bill

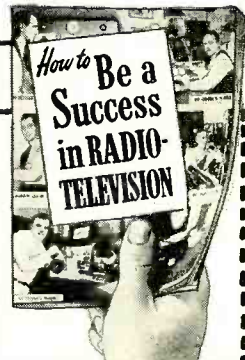

RADIO & TELEVISION NEWS is published monthly by the Ziff-Davis Publishing Company at 185 N. Wabash Ave., Chicago 1, Ill. Entered as second-class matter, July 21, 1948, at the Post Office, Chicago, Ill., under the act of March 3, 1879. Authorized by Post Office Department, Ottawa, Canada, as second-class matter. SUBSCRIPTION RATES: Radio & Television News—one year, U. S. and Possessions, Pan-American countries, and Canada \$4.00; all other foreign countries \$5.00; Radio-Electronic Engineering Edition—one year, U. S. and Possessions, Pan-American countries, and Canada \$6.00; all other foreign countries, \$7.00. Postmaster—Please return undelivered copies under form 3589 to 64 E. Lake St., Chicago 1, Ill.

Editor
OLIVER READ, D.Sc., W1ETI

Managing Editor
WM. A. STOCKLIN, B.S.

Technical Editor
H. S. RENNE, M.S.

Service Editor
CHARLES TEPPER

Assistant Editors
P. B. HOEFER
M. C. MAGNA

Television Consultant
WALTER H. BUCHSBAUM

Short-Wave Editor
KENNETH R. BOORD

Staff Artist
FRANK SAYLES

Draftsman
A. A. GANS, W2TSP

Advertising Manager
L. L. OSTEN

Midwest Adv. Manager
JOHN A. RONAN, JR.

Western Adv. Manager
JOHN E. PAYNE



COVER PHOTO: A portable radio is a happy thought for any gift-giving occasion. The recipient of this RCA Victor Model 2B400 "personal radio" beams her obvious pleasure. Gown by "Perfect Neglige," New York City. (Ektachrome by Photo Associates)

Chairman of the Board and Publisher
WILLIAM B. ZIFF

President
B. G. DAVIS

Secretary-Treasurer
G. E. CARNEY

Vice-Presidents
H. J. MORGANROTH
Production Director

LYNN PHILLIPS, JR.
Advertising Director

H. G. STRONG
Circulation Director

BRANCH OFFICES
CHICAGO (1)
185 N. Wabash, AN 3-5200
LOS ANGELES (14)
Staller Center, 900 Wilshire Blvd., Mich. 9856

First in
radio-television-electronics
Average Paid Circulation over 220,000

RADIO & TELEVISION NEWS

Reg. U.S. Pat. Off.

Radio News Trademark Reg. U. S. Pat. Office • Television News Trademark Reg. U. S. Pat. Office.

CONTENTS

DECEMBER, 1952

International TV Is Here.....	A. V. J. Martin	31
A Preamp for Magnetic Pickups.....	William Creviston	34
U.H.F. Antennas.....	Milton S. Kiver	36
Multi-Band V.F.O. Mobile Transmitter.....	Loren C. Watkins, Jr., W5JXO	39
Sell Portables Year-Round.....		44
A Carrier-Current Intercom.....	Irving Gottlieb	45
Locating TV Intermittents.....	Walter H. Buchsbaum	46
The Cascade-Cascode on 2 Meters.....	Robert B. Tomer, W1PIM	48
A Novel Capacitance Relay.....	Richard Graham, W2PDI/1	50
DX Television.....	Stan Johnson, W0LBY	52
Mac's Radio Service Shop.....	John T. Frye	54
A Duo-Diode Modulation Monitor.....	J. Lucas, DL4ZY & D. Peters, DL4VJ	55
Hi-Fi Loudspeaker Design.....	Abraham B. Cohen	56
A Meterless V.T.V.M.	Louis E. Garner, Jr.	60
Mobile Radio (Part 4).....	Leo G. Sands	62
Radio-TV Service Industry News.....		128
Radio & Television News Index (Vols. 47-48).....		145

DEPARTMENTS

For the Record.....	The Editor	8	Short-Wave.....	K. R. Boord	59
Spot Radio News.....		16	Technical Books		66
Within the Industry.....		24	What's New in Radio.....		78
New TV Products.....		140			



COPYRIGHT 1952
ZIFF-DAVIS PUBLISHING COMPANY
Editorial and Executive Offices
366 Madison Ave., New York 17, N. Y.
VOLUME 48 • NUMBER 6



Member
Audit Bureau of
Circulations

SUBSCRIPTION SERVICE: All communications concerning subscriptions should be addressed to Circulation Dept., 64 E. Lake St., Chicago 1, Ill. Subscribers should allow at least two weeks for change of address.

CONTRIBUTIONS: Contributors are advised to retain a copy of their manuscripts and illustrations. Contributions should be mailed to the New York Editorial Office and must be accompanied by return postage. Contributions will be handled with reasonable care, but this magazine assumes no responsibility for their safety. Any copy accepted is subject to whatever adaptations and revisions are necessary to meet the requirements of this publication. Payment covers all author's, contributor's, and contestant's rights, title, and interest in and to the material accepted and will be made at our current rates upon acceptance. All photos and drawings will be considered as part of the material purchased.

RADIO & TELEVISION NEWS

NOW... get EVERYTHING YOU NEED to help you EARN while you LEARN

TELEVISION

RADIO - ELECTRONICS

THOUSANDS of successful graduates PROVE that here is one of today's most **EFFECTIVE WAYS** to master Television

- (1) at HOME . . . or
- (2) in one of nation's finest TV training laboratories

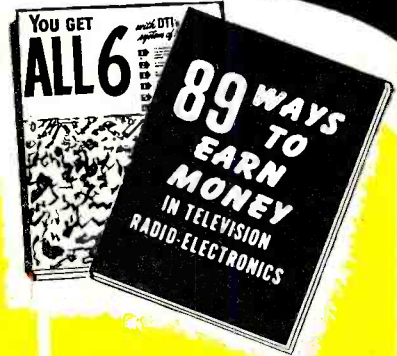

Mail coupon today for these FREE publications showing HOW and Where real money is being made in TELEVISION

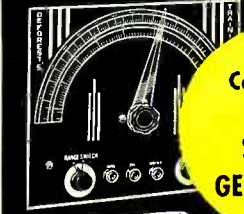

Commercial type **SIGNAL GENERATOR**



Jewel Bearing **MULTI-METER**



High Quality **OSCILLOSCOPE** a "must" for TV service

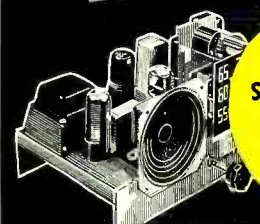

6 tube Superheterodyne **RADIO SET**

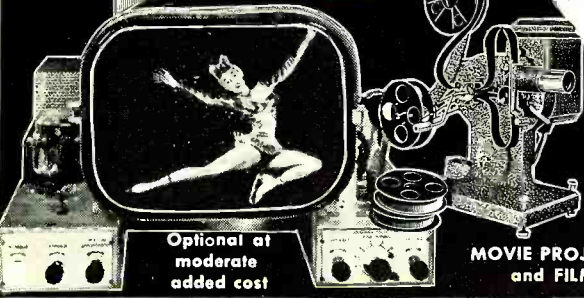

Optional at moderate added cost

MOVIE PROJECTOR and FILMS

Looking for a chance to earn REAL MONEY... to get a really interesting job or your own business... and above all, to enjoy the peace of mind and satisfaction that comes from knowing your future is tied in with one of America's most promising opportunity fields? Then mail the coupon at once! Find out about one of today's most WONDERFULLY EFFECTIVE ways to prepare you to enjoy all of these advantages in America's amazing, multi-billion dollar opportunity field of Television-Radio-Electronics.

Now you can have your own HOME LABORATORY

Using the D.T.I. Way, no previous experience is needed. You can get laboratory type training (1) at home in spare time—or (2) full time training in one of nation's finest TV training laboratories. The home method includes EVERYTHING YOU NEED to learn-by-doing. You work over 300 experiments from 16 big shipments of parts which you keep. This includes building and keeping the valuable commercial type test equipment shown at the left—ideal for helping you EARN while you learn. You also get easy-to-read, well-illustrated lessons. And to help you master important fundamentals faster, easier, better, you get D.T.I.'s remarkable and exclusive home training advantage—learn-by-seeing HOME MOVIES.

Mail Coupon TODAY!

But why not get ALL the facts about D.T.I.'s wonderful training programs... about the top flight Employment Service available to all graduates... about the special advantage that may be yours if called to military service? Mail coupon today. We believe the late facts we have are really going to surprise you.

ONE OF AMERICA'S FOREMOST TV TRAINING CENTERS
— Established 1931 —



DeFOREST'S TRAINING, INC., Dept.— RN-12-1
2533 N. Ashland Ave., Chicago 14, Ill.

I would like valuable, information-packed folders showing how I may get started toward a good job or my own business in Television-Radio-Electronics.

MAIL TODAY

Name _____ Age _____
Street _____ Apt. _____
City _____ Zone _____ State _____

De FOREST'S TRAINING, INC.
AFFILIATED WITH
De VRY Technical INSTITUTE
CHICAGO 14, ILLINOIS

1902-1952



**ELECTRICAL AND ELECTRONIC
WIRES AND CABLES**

*—For the Automotive, Appliance, Motor,
Radio, and Television Industries*

Belden Manufacturing Company
Chicago 80, Illinois

RADIO & TELEVISION NEWS

Finally! No More TV Interference Problems!

The New Hallicrafters HT-20 is T.V.I. proofed!*

Here's the news you've been waiting for—a medium power transmitter (100 watts) that solves the problem of television interference once and for all. The Hallicrafters HT-20 is the answer. Completely tested in the lab and in the field, here is a transmitter that is truly T.V.I. Proofed*.

This is not simply a revamped design, but completely new circuitry to meet this problem. Physically, too, the entire transmitter is new from the massive, two-piece, completely rigid chassis to the electrical air cooling system of the final amplifier tube.

See this newest Hallicrafters—get the complete story of the finest transmitter, dollar for dollar, on the market today. Or write Hallicrafters direct for full details.



Check these features!

- 100 watts carrier power with high level (Class AB2) modulation on any band.
- Continuous coverage, with overlapping bands, from 1.7 to 30 mc.
- Compact, efficient design. Amazing for its power. The HT-20 is 20½" long, 11¾" high and 16¾" deep.
- Weight of transmitter, in cabinet, 105 pounds.
- All transformers and chokes operate "cool"—maximum temperature rise of 40 degrees. This means fewer replacements, long operating life.
- Operates equally well from relay rack or in cabinet on table top.
- Uses 117 volts, 60 cycle AC.
- Moderate cost.

* **T.V.I. PROOFED**—means that this transmitter has circuitry specifically designed to eliminate spurious and harmonic energies that result in television interference.

World's Leading
Manufacturer of Precision Radio, Television
CHICAGO 24, ILL.

hallicrafters

meet 85%
of your
replacement
needs with
these TRIAD
Television
Components

There are 23 Triad Television Replacement items listed below. They will take care of 85% of your service needs. Always keep a supply on hand. They eliminate excessive inventories, speed servicing and simplify reordering. Your Triad jobber carries them in stock. Call him today.



Y-12

DEFLECTION YOKES:

Y-11 Y-19
Y-12 Y-20
Y-17



TYPE P

**HORIZONTAL OUTPUTS:
(Flybacks)**

D-1 D-15
D-11 DA-20
D-14



CASE Y

**VERTICAL BLOCKING
OSCILLATORS:**

A-97X A-97Y
A-97K



CASE X

FILTER CHOKES:

C-11X C-21X
C-13X C-23X
C-17X

VERTICAL OUTPUTS:

A-99X A-103X
A-101U A-107X
A-102X

Write for Catalogs TR-52A and TV-52A



For the RECORD.

BY THE EDITOR

AUDIO INTEREST REACHES NEW HIGH

TO THOSE of us who are in a position to observe the Audio Industry, it becomes more apparent than ever that the impact of audio on the public has reached major proportions. And those of us who are charged with the responsibility of maintaining a balanced technical publication need only to look at the daily mail to confirm our own belief that as far as the theory, construction, and applications for audio equipment are concerned, there is an ever-increasing interest and a continually expanding market.

The recent Audio Fair in New York gave us an opportunity to actually talk to many of our readers. We discussed their varied interests and problems. As a result, these personal contacts proved what we already surmized—that audio interest in all phases—theory, construction, and application—is on the increase. Some of those to whom we talked were newcomers who only during the last year realized the importance of good, sound equipment. Many of them are buying or intend to buy their equipment and assemble it into well thought-out sound systems. There are others who would rather construct their equipment from the very basic units on up. Regardless of whether they buy or build, their interests are of great importance to the entire audio industry. With an ever-increasing interest there is only one answer—a continually expanding market.

With the exception of television, audio ranks high in reader interest and preference. For example, we recently mailed an extensive questionnaire to one out of every ten of our readers. In this survey, we asked the reader to indicate his preference for feature articles and for departments. We also asked him to check subjects in which he had no interest. It was extremely gratifying to the editors that a high percentage of those receiving the questionnaire took the necessary time to complete the extensive listings and to return them to us for compilation. The purpose of the questionnaire was two-fold. First, to give the reader an opportunity to state his preference for articles in each facet of electronics. Second, to determine his specific activity or profession in the industry.

There are more than 220,000 technicians and others purchasing RADIO & TELEVISION NEWS each month. We sampled in excess of 22,000 individuals. Many have written to the editors requesting the results of the survey. While the final tabulations have not been made at this writing, we are able to give you some of the highlights

which are indicative of the average reader of this publication. He is 30 years of age and actively engaged in some phase of electronics. He has been a reader of RADIO & TELEVISION NEWS for over five years and shares his copy with others. He has shown greatest interest in the following: television (theory and practice), television servicing, radio (AM-FM theory and practice), audio (construction data), audio (theory and practice), radio servicing, microwaves, industrial electronics, and amateur radio (theory, construction, and practice).

In addition, he prefers to read the following monthly departments: Mac's, For The Record, What's New, Technical Books, TV Products, Manufacturers Literature, and Service Industry News.

We asked for the principal classification of our readers and find that approximately 73,000 are engaged in full time radio and television servicing, more than 50,000 are active in the communications field and over 42,000 are in equipment manufacturing. While these are the principal classifications shown on the lists, there are, in addition, another 10,000 dealers, approximately 8000 teacher-instructors, 6000 parts manufacturers, and nearly 4000 distributor-jobbers.

We also questioned our readers as to their special interests and hobbies in addition to their regular occupations. Heading the list are the more than 95,000 readers specifying an active interest in audio. They show greatest interest in the following: amplifier construction, tape recording, custom installations, and high-fidelity listening. The average audio reader values his equipment at approximately \$500 and states that he will spend approximately \$200 for new equipment in the next 12 months. This in itself represents a very lucrative market for those engaged in the merchandising of audio. It also indicates a good taste in quality components.

It is gratifying, too, to observe a steady increase in audio circulation resulting from our efforts to continue to publish outstanding articles on each phase of the audio art.

Our sincere thanks go to our more than 220,000 monthly readers and to our valued advertisers, both of which have combined to make RADIO & TELEVISION NEWS the most widely read publication in its field.

The editors will continue in their efforts to bring you the very best possible coverage of our industry. The information compiled from our survey will serve as a guide in the planning of future issues. O.R.

**THE ONLY COMPLETE CATALOG FOR EVERYTHING IN
TELEVISION, RADIO AND INDUSTRIAL ELECTRONICS**

your 1953

ALLIED free!

**236-PAGE CATALOG
complete...value-packed**

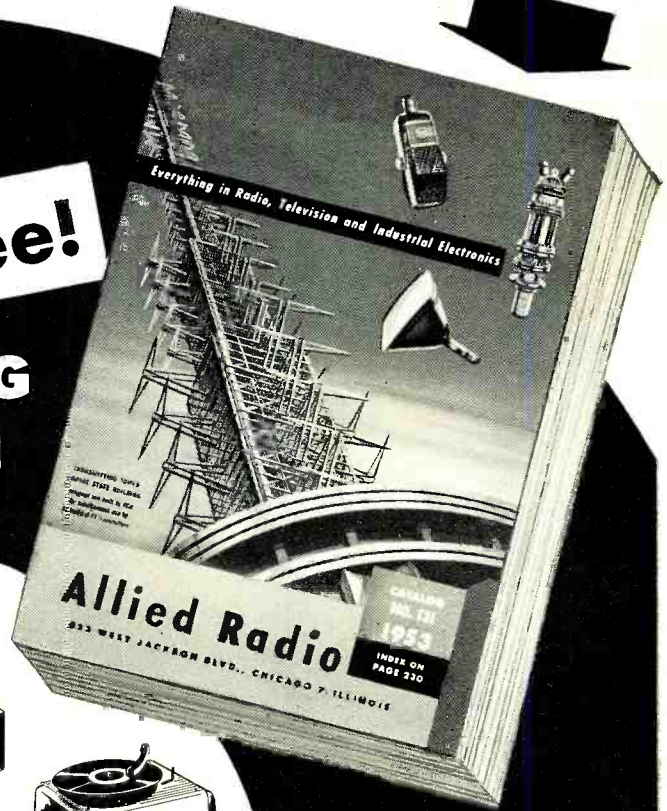

Send for it Today!



Here's the *one* authoritative, complete Buying Guide to *Everything in Electronics*—packed with the world's largest selections of quality equipment at lowest, money-saving prices. See the latest in TV, AM and FM receivers; High-Fidelity Custom Sound components; latest P.A. Systems and accessories; recorders; Amateur receivers, transmitters and station gear; specialized industrial electronic equipment; test instruments; builders' kits; huge listings of parts, tubes, tools, books—the world's *most complete stocks* of quality equipment.

ALLIED gives you every buying advantage: speedy delivery, expert personal help, lowest prices, liberal time payment terms, assured satisfaction. Get the latest 1953 ALLIED Catalog. Keep it handy—and save time and money. Send for your FREE copy today!

the world's largest stocks

- TV and Radio Parts
- Test Instruments
- Hi-Fi and P.A. Equipment
- Television & Home Radios
- Recorders and Supplies
- Amateur Station Gear
- Builders' Supplies
- Equipment for Industry

quick, expert service

EVERYTHING IN ELECTRONICS

ALLIED RADIO
World's Largest Radio Supply House

free

**Send Today for Radio's
Leading Buying Guide**



EASY-PAY TERMS

Take advantage of ALLIED'S liberal Easy Payment Plan—Radio's best terms—only 10% down, 12 months to pay—no interest if you pay in 60 days. Available on Hi-Fi and P.A. units, recorders, TV chassis, test instruments, Amateur gear, etc.

TV & HI-FI SPECIALISTS

To keep up with developments in TV and High-Fidelity, look to ALLIED! Count on us for *all* the latest releases and largest stocks of equipment in these important fields. If it's *anything* in Television or High-Fidelity equipment—we have it in stock!

ALLIED RADIO CORP., Dept. 1-M-2
833 W. Jackson Blvd., Chicago 7, Illinois

Send FREE 236-Page 1953 ALLIED Catalog

Name _____

Address _____

City _____ Zone _____ State _____

For fastest, safest use **CENTRALAB**

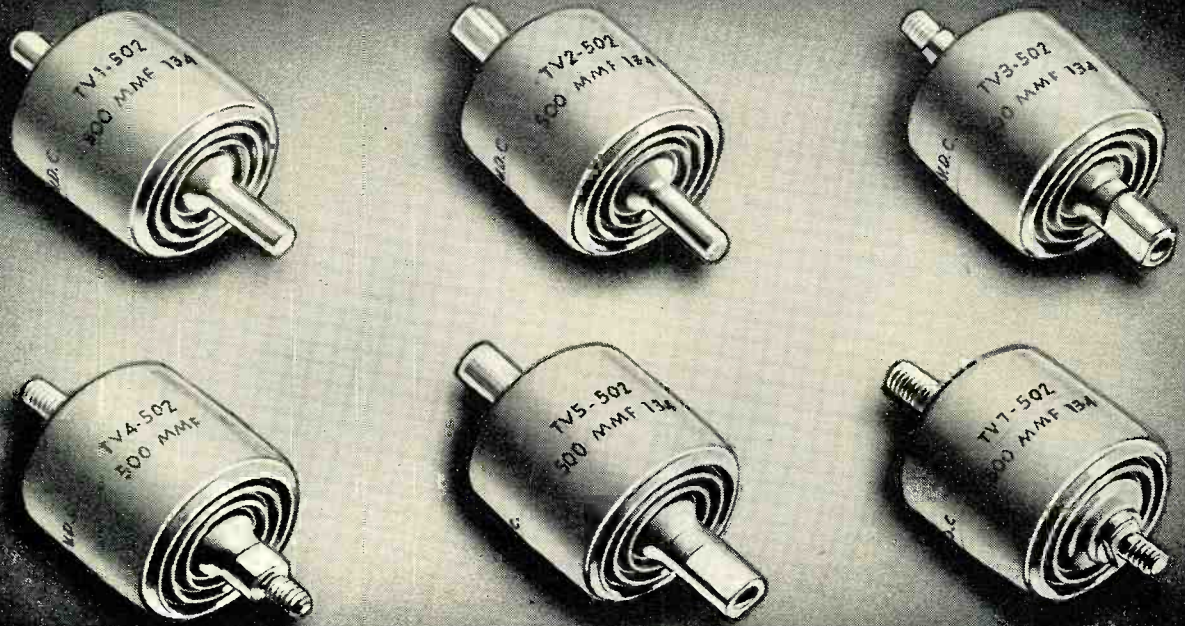

CHECK THESE ACTUAL DIMENSIONS

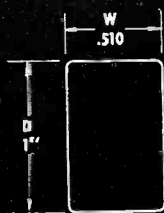

10,000 WV STYLE

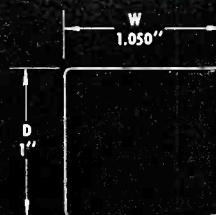

20,000 WV STYLE

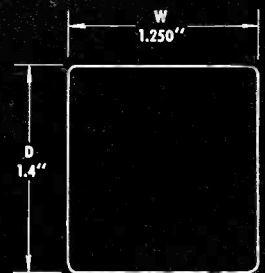

30,000 WV STYLE

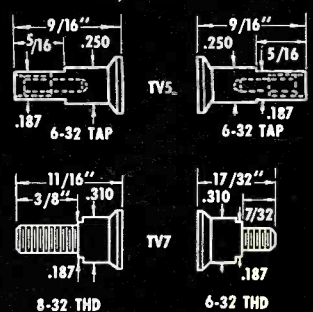
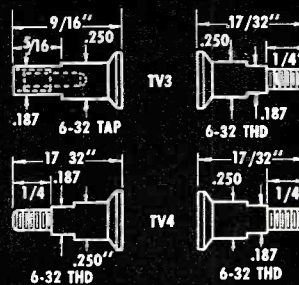
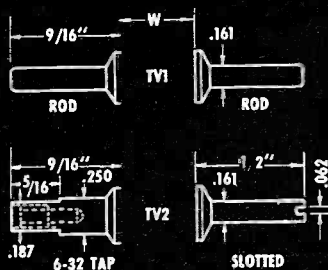

guaranteed service TV HI-VO-KAPS

Compare voltage tests, ease of service, prices . . .
you'll choose **CENTRALAB TV HI-VO-KAPS** every time

ARE you on safe ground when you guarantee TV high voltage service? You are — if you use Centralab TV Hi-Vo-Kaps. Designed for exact replacement according to original manufacturer's specifications, they're *factory assembled*. There's no need for a service man to fumble with "kits" . . . putting parts together . . . doing the manufacturer's job. That means no unseen air gaps between terminal and capacitor body . . . no shorting . . . safe, positive connections *every time*.

And when you check CRL voltage guarantees, you'll see

why Centralab Hi-Vo-Kaps withstand continuous overload up to twice rated working voltage. *Every unit is individually tested at the factory!*

Take a good look at price, too. Here's further proof that Centralab Hi-Vo-Kaps are your best buy. What's more, they're packaged and marked for ease of identification and better stock control. Each unit is individually cartoned, ready for use. Five individual cartons per standard display pack. For additional information, ask your distributor, or mail coupon for copy of Catalog 28.

Check these specifications

- **POWER FACTOR** — At 1 MC or 1 KC, initial 1.5% maximum; after 95% humidity, 2% maximum. Returns to initial upon drying.
- **LEAKAGE RESISTANCE** — Initial, 5000 megohms; after 100 hours at 95% humidity, 1000 megohms. Returns to initial upon drying.
- **TOLERANCE** — Minus 20%, plus 50%.
- **BODY SIZES** — 501 (10,000 V.D.C.W.) 1" dia. x .625" long. 502 (20,000 V.D.C.W.) 1" dia. x 1.050" long. 503 (30,000 V.D.C.W.) 1.4" dia. x 1.250" long.
- **TERMINALS** — Brass, cadmium plated. Three combinations available on type 501, 10,000 V.D.C. units. Six combinations on type 502, 20,000 V.D.C. units. Type 503, 30,000 V.D.C. units are available only with 2 type TV1 stud type terminals.

VOLTAGE D.C.W.	CAP. MMF	CRL CAT. NO.	VOLTAGE D.C. TEST	TERMINALS
10,000	500	TV1-501	20,000	2 Rod
10,000	500	TV2-501	20,000	1 Slot, 1 Tap
10,000	500	TV3-501	20,000	1 Tap, 1 Thread
20,000	500	TV1-502	40,000	2 Rod
20,000	500	TV2-502	40,000	1 Slot, 1 Tap
20,000	500	TV3-502	40,000	1 Tap, 1 Thread
20,000	500	TV4-502	40,000	2 Male Thread
20,000	500	TV5-502	40,000	2 Female Tap
20,000	500	TV7-502	40,000	1 8-32 thd, 1 6-32 thd
30,000	500	TV1-503	48,000	2 Rod

Centralab

A Division of GLOBE-UNION INC.

900 E. Keefe Avenue • Milwaukee 1, Wisconsin
In Canada, 635 Queen Street East, Toronto, Ontario



CENTRALAB, A Division of Globe-Union Inc.
910 East Keefe Avenue, Milwaukee 1, Wisconsin
Please send me a copy of the new Centralab Catalog 28.

Name.....
Company..... Title.....
Address.....
City..... State.....

It splits seconds even faster

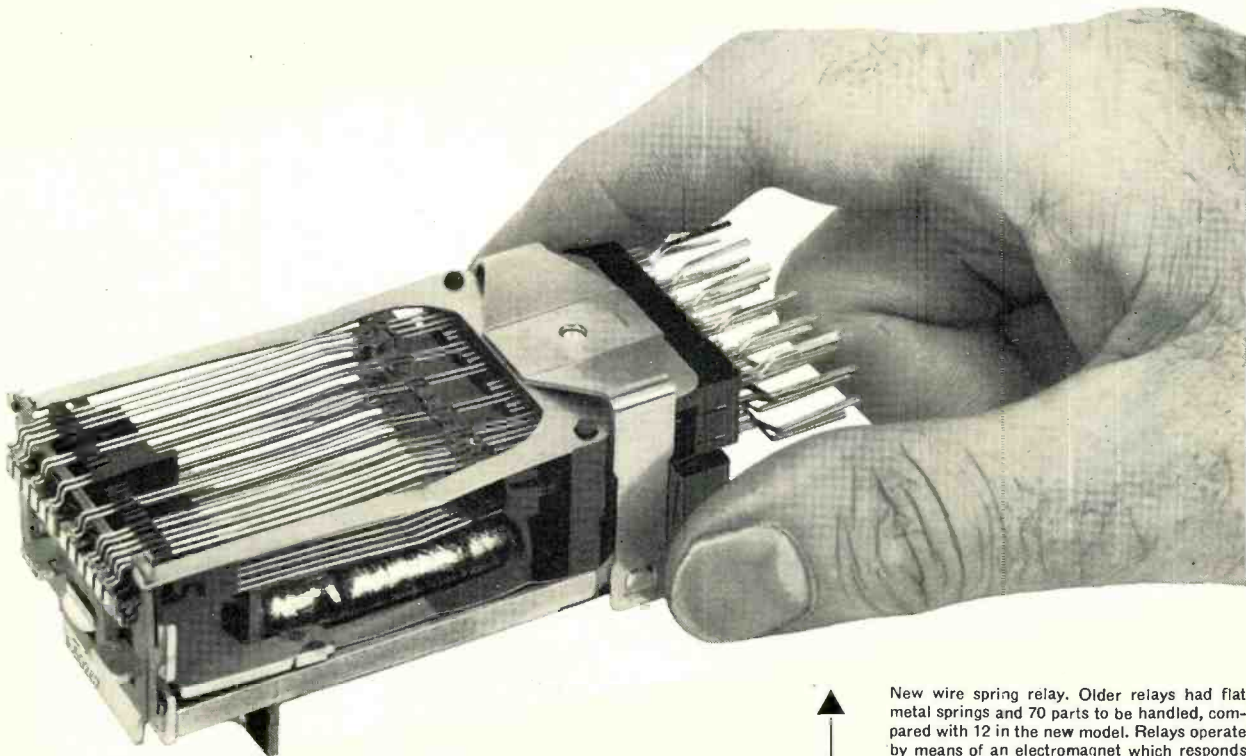

IN A split second, relays, which are high-speed switches, set up dial telephone connections. Then they are off to direct the next call. Yet even this speed is too slow for Bell Laboratories scientists in quest of still faster switching.

Scientists and engineers devised a new relay—the wire spring relay—and worked out the production problem with Western Electric, manufac-

turing unit of the Bell System. This is twice as fast, uses less power and costs less to make and maintain.

With speedier relays, switching can be done with less equipment . . . and calls go through faster. The wire spring relay is a practical example of how Bell Telephone Laboratories and Western Electric pool their skills to improve telephone service while keeping its cost down.

New wire spring relay. Older relays had flat metal springs and 70 parts to be handled, compared with 12 in the new model. Relays operate by means of an electromagnet which responds to high-speed pulses.

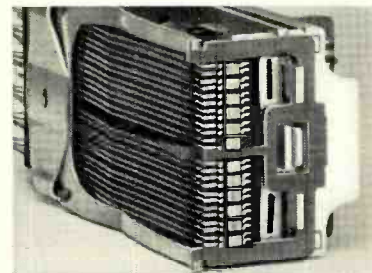

New relays must be able to operate one billion times—equal to once-a-second for 30 years. Employing a sound recorder as a precision vibrator, Bell scientists learned to evaluate the effect of sideways motion on relay life. Such rubbing motion is limited to one-thousandth of an inch in the new relays.



Dynamic Fluxmeter, developed by Bell Laboratories, indicates flux build-up in intervals of 25 millionths of a second. Precise information like this was essential to higher speed operation.

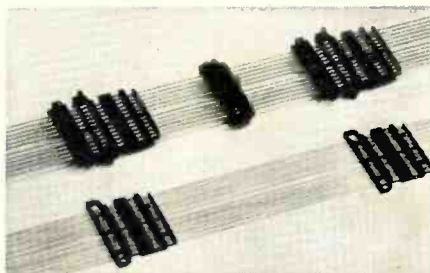

Relay springs as they come from Western Electric molding machine, before being cut apart for use. Molding technique saves time and money . . . makes possible the maintenance of precise adjustment.

Bell Telephone Laboratories



IMPROVING TELEPHONE SERVICE FOR
AMERICA PROVIDES CAREERS FOR CREATIVE
MEN IN SCIENTIFIC AND TECHNICAL FIELDS

RADIO & TELEVISION NEWS



TRAIN **FASTER**—TRAIN **BETTER**—TRAIN **EASIER**
 IN 10 MONTHS—OR LESS—FOR
RADIO-TELEVISION

Our 21st Year Training Men for Greater Incomes and Security in Radio-Television

**I SEND YOU
 18 BIG KITS**

of Radio Television parts and equipment. Much of your training will be actual construction and experimentation . . . the kind of truly PRACTICAL instruction that prepares you for your Radio-Television career.



Frank L. Sprayberry
 President
 Sprayberry Academy
 of Radio

NEW! NO OBLIGATION PLAN

**You Have No Monthly Payment Contract to Sign
 Pay For Your Training as You Earn and Learn**

You can get into Radio-Television, today's fastest growing big money opportunity field, in *months* instead of years! My completely new "package unit" training plan prepares you in as little as 10 months or even less! *No monthly payment contract to sign—thus NO RISK to you!* This is America's finest, most complete, practical training—gets you ready to handle any practical job in the booming Radio-Television industry. Start your own profitable Radio-Television shop . . . or accept a good paying job. I have trained hundreds of successful Radio-Television technicians during the past 21 years—and stand ready to train you, even if you have no previous experience! Mail coupon and get all the facts—FREE!



**Valuable Equipment Included
 With Training**

The new Sprayberry "package" plan includes many big kits of genuine, professional Radio-Television equipment. You perform over 300 demonstrations, experiments and construction projects. You build a powerful 6-tube 2-band radio set, multi-range test meter, signal generator, signal tracer, many other projects. All equipment and lessons are *yours to keep* . . . you have practically everything you need to set up your own profitable Radio-Television service shop.

Earn Extra Money While You Learn!

All your 10 months of training is IN YOUR HOME in spare hours. Keep on with your present job and income while learning. With each training "package" unit, you receive extra plans and "Business Builder" ideas for spare time Radio-Television jobs. New television stations everywhere, open vast new opportunities for trained Radio-Television Technicians—and those in training. If you expect to be in the armed forces later, there is no better preparation than practical Sprayberry Radio-Television training.

YOU BUILD the Television set and the powerful superhet radio receiver shown above. IN ADDITION to the other test units shown here (many are not shown because of lack of space). All equipment I send you is **YOURS. TO KEEP.**

SPRAYBERRY ACADEMY OF RADIO 111 NORTH CANAL ST. Dept. 25-R, Chicago 6, Ill.

**MAIL COUPON
 TODAY!
 NO OBLIGATION**

SPRAYBERRY ACADEMY OF RADIO, Dept. 25-R
 111 North Canal St., Chicago 6, Ill.

Please rush to me all information on your 10-MONTH Radio-Television Training Plan. I understand this does not obligate me and that no salesman will call upon me. Be sure to include 3 books FREE.

Name..... Age.....

Address.....

City..... Zone..... State.....

I invite you to get all the facts—
**FREE TO YOU 3 BIG
 RADIO-TELEVISION BOOKS**

I want you to have ALL the facts about my new 10-MONTH Radio-Television Training—without cost! Rush coupon for my three big Radio-Television books: "How to Make Money in Radio-Television." PLUS my new illustrated Television Bulletin PLUS an actual sample Sprayberry Lesson—ALL FREE. No obligation and no salesman will call. Mail coupon NOW!



Approved for Veterans under the G. I. Bill

**SMASH
HIT!**

TERRIFIC ACCEPTANCE GREET'S THE NEW

**TRIO
ZIG-ZAG**
(Patent Pending)

TV ANTENNA

The sensational new TRIO ZIG-ZAG TV ANTENNA has already proven its superiority in the field. Thousands of installations have given a new high in TV reception, especially in ultra-fringe areas. Word of mouth has done the rest. TRIO'S plant capacity, taxed to the limit in an effort to supply the amazing demand for the ZIG-ZAG ANTENNA series, is being greatly expanded. Very soon now, your ZIG-ZAG ANTENNA will be supplied, and it's well worth waiting for.

ZIG-ZAG ANTENNAS have replaced every known type of installation and TRIO is proud to report that in EVERY instance the ZIG-ZAG ANTENNA has out-performed them all, even the tried and true TRIO dual-channel yagi.

TV listeners are finding that with a ZIG-ZAG ANTENNA they are no longer tied down to just one or two channels, but are getting excellent reception on channels never seen before. ZIG-ZAG ANTENNA is truly HOT on all VHF channels.



**TRIO ZIG-ZAG
TV ANTENNAS**

available in 8 different models, provide a new high in all-channel performance for any area, from metropolitan to ultra-fringe. Tremendous gain, sharp directivity, excellent match to 300 ohm line, sturdy vibration-proof construction and fast, easy installation tells the rest of the TRIO ZIG-ZAG ANTENNA story.

SEE THEM at your JOBBERS. WRITE for CATALOG.



TRIO ROTATOR

A worthy companion to the ZIG-ZAG ANTENNA. Tested and proven under every conceivable condition of load, weather, strain and stress. Two motors, one for each rotation direction. Positive electrical stops prevent damage of over-rotation. Positive brake action, no drift even when supporting heavy arrays in 80 MPH winds. Precision built of finest materials and UNCONDITIONALLY GUARANTEED by TRIO for TWO YEARS. SMARTLY STYLED DIRECTION INDICATOR has easy to read dial face and easy to use finger touch control. A beautiful instrument you'll be proud to own.

These ZIG-ZAG ANTENNAS provide the ultimate in extreme fringe area reception. ZZ12L provides 12-14 db. gain on Channels 2 thru 6. ZZ16H has a gain of 14 db. on Channels 7 thru 13. These antennas have very narrow forward lobe, high front to back ratio, provide high rejection in areas with co-channel interference.

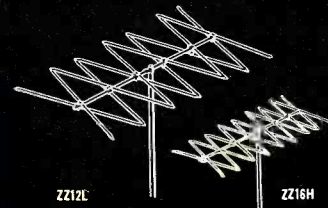

ZZ12L

ZZ16H

Where maximum gain is not necessary these normal fringe model ZIG-ZAG ANTENNAS are ideal. Model ZZ8L has a gain of 9 db. average on Channels 2 thru 6. The ZZ8H provides an 11 db. gain on Channels 7 thru 13. Forward lobe patterns comparable to good multi-element single channel yagi.

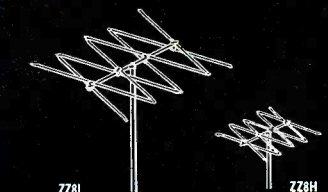

ZZ8L

ZZ8H

For near fringe area reception these ZIG-ZAG ANTENNA models provide 8-9 db. gains on all Channels 2 thru 13. ZZ6L covers Channels 2 thru 6 and Model ZZ6H covers Channels 7 thru 13. Both models have patterns similar to those of cut to channel yagis.

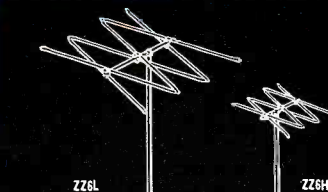

ZZ6L

ZZ6H

These ZIG-ZAG ANTENNAS provide ALL CHANNEL reception with only ONE antenna bay. Model ZZ6A is designed for near fringe area reception of all Channels 2 thru 13, with an average gain of 9 db. Model ZZ4A is for use in suburban areas, providing an average gain of 6 db. on all Channels 2 thru 13.

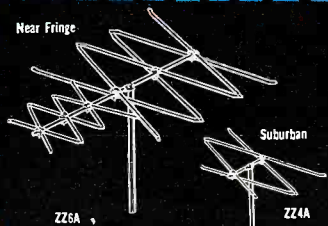

ZZ6A

Suburban

ZZ4A



TRIO MANUFACTURING COMPANY

GRIGGSVILLE, ILLINOIS



Kansas City, Mo. Service, and where to obtain it, is featured in this poster that works fulltime for the serviceman whose name and number show prominently at center. Floodlighting increases the board's usefulness.

Now-for the first time-

FULL-SIZE BILLBOARD ADVERTISING FOR TV-RADIO SERVICEMEN!

Another G-E "first!" Colorful 24-sheet posters spotlight the serviceman's name and phone number—tell owners *who to call for service!*

● Coast to coast, big G-E-tube posters in full colors are answering the query of TV-radio owners: where can I go for reliable, experienced service? Simultaneously, the billboards meet the serviceman's need to tell customers where his shop is located, how to phone him.

G-E-tube posters are a thrifty and productive advertising medium for the serviceman. Hundreds of postings already have been contracted for. They are located where customers-to-be see them, and their large size assures attention. In every case, the serviceman's name, address, and phone number appear in bold type in the center of the poster.

Assisted energetically by G-E tube distributors, G.E. is proud to have pioneered this business-getting aid for servicemen! *Tube Dept., General Electric Co., Schenectady 5, N. Y.*



York, Pa. Beside a busy street, this board is seen, read, and remembered by thousands of TV-radio owners who walk or drive past.

GENERAL  ELECTRIC

161-1A6

SPINTITE

REG. U. S. PAT. OFFICE



120
STYLES
and
SIZES

THE
ORIGINAL
WRENCH
WITH THE
SCREWDRIVER
ACTION

for

- ASSEMBLY WORK
- REPAIR WORK
- RADIO
- TELEVISION
- INDUSTRIAL
- AIRCRAFT



STEVENS WALDEN, Inc.
WORCESTER 4, MASS.

Spot Radio News

★ Presenting latest information on the Radio Industry.

By RADIO & TELEVISION NEWS'
WASHINGTON EDITOR

THE ULTRA-HIGHS, described on a host of occasions in Washington as the sparkling band which would truly launch a glittering gateway to a new TV world, saw this vivid prediction suddenly come to life in Portland, Oregon, just as the Fall made its debut.

In a surprise move, the Commission granted Herb Mayer permission to put his Channel 27 station on the air on an interim basis, using the experimental transmitting gear sent from Bridgeport, Conn., with an effective radiated power (erp) of 17.6 kilowatts. The full approved erp of 88 kilowatts, from a 5-kilowatt transmitter, is expected to be available sometime next year.

The station's prexy, thrilled by the honor of not only being the first u.h.f. telecaster, but the first TV station to go on the air in the northwest, dined and wined local retail and civic leaders, distributors and advertising men at a reception and luncheon, and then brought everyone to the transmitter site in the western hills of the city. On view was a 14-bay antenna about 1300-feet above sea level, and a cinder-block house serving as home for the 1-kilowatt transmitter.

The initial results were noted as impressive, with an 87-dbu signal hitting the city of Portland, a 74-dbu * signal covering the adjacent cities of Vancouver, Washington; St. Helens and Oregon City, Oregon, and 64-dbu signals reaching Salem, Oregon and Longview, Washington.

At this writing, over 5000 sets were reported to have been installed. It was believed that the quantity would be tripled and quadrupled within a matter of weeks.

CONTINUING ITS WHIRLWIND pace, the FCC has sent approvals to nearly a score more applicants for TV construction permits, bringing the total to 63, commercial interests receiving 54 and educational 9, and announced that processing will continue on 170 mutually exclusive applications on hand, and thereafter, for a limited time, would only handle the baskets of pending noncompetitive bids.

The south retained its lead in the new-grant race, and is expected to hold this favored position for many, many weeks. Among the southern

cities approved for TV were Jackson, Mississippi; Columbia, South Carolina; Montgomery, Alabama; and Roanoke, Virginia.

Jackson won Channel 25 and the transmitter there will be operated by *Mississippi Publishers* on a power of 205 kilowatts. WCOV in Montgomery, owned by *Capital Broadcasting*, received Channel 26 and will pump out 88-kilowatt signals. Columbia was quite fortunate, receiving two grants. One went to WCOS, the property of *Radio Columbia*, who will use Channel 25 and a power of 89 kilowatts. WNOK, a *Palmetto Radio Corp.* station, received Channel 67, and will transmit with a power of 680 kilowatts. There were a pair of grants approved for Roanoke, too, with one a u.h.f. assignment (Channel 27) and another on Channel 10. The ultra-high award was won by WROV, *Radio Roanoke*, who will telecast on 105 kilowatts. WSLs, a *Roanoke Broadcasting* property, will use Channel 10 and a power of 250 kilowatts. *Little Rock Telecasters* in Little Rock, Arkansas, were told that they would be able to operate on Channel 17 with a power of 22 kilowatts. KMJ, a *McClatchy Broadcasting* station, in Fresno, California, will have a TV affiliate also and operate on Channel 24 with a power of 105 kw. Denver, the first city to win approval for a TV station since the freeze lift, also won a u.h.f. approval. Awarded to *Mountain States Television* for Channel 20, TV-casting will be via a 89-kw. transmitter. Another grant was also issued to Harrisburg, to WHP, who will have Channel 55 and use a power of 240 kilowatts. In Youngstown, *Polan Industries*, who had submitted a plea for a channel change, was awarded Channel 21 and a power of 170 kilowatts. The *Washtenaw Broadcasting Co.*, operators of WPAG, in Ann Arbor, Mich., were authorized to proceed with their construction of Channel 20 station operating on 1.75 kilowatts. Channel 39 in Rockford, Ill., will be operated by the *Winnebago Television Corp.*, and a power of 15.5 kilowatts will be used.

Based on estimated commencement dates, cited in the grants, some of the ultra-high stations are expected to be

* A "dbu" represents field strength in db above one microvolt-per-meter.

RADIO & TELEVISION NEWS

the greatest Yagi of them all
JFD 10-ELEMENT "Baline" YAGI

***12 db** (gain of stacked JFD BALINE over a tuned folded dipole)

***9½ db** (gain of single JFD BALINE over a tuned folded dipole)

*These figures have been verified by the Hazeltine Corporation, world famous research laboratory. All JFD gain figures are based on a reference tuned folded dipole. Beware of exorbitant gain figures which are not based on any reference level.

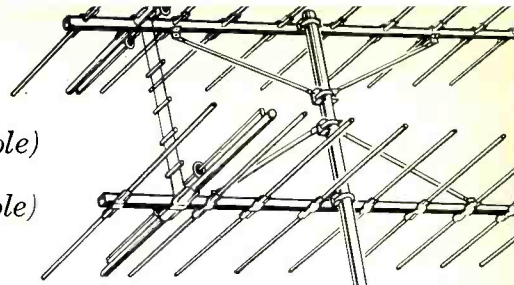

illustrated: JFD No. 10Y2S-10Y6S
 Low Band Stacked Baline Yagi

ACTUAL FIELD TESTS PROVE IT

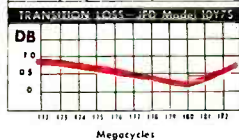
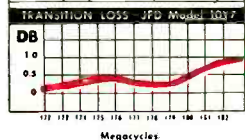
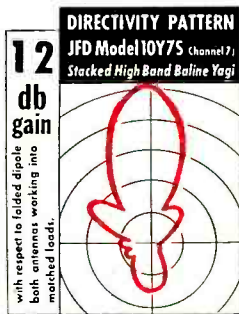
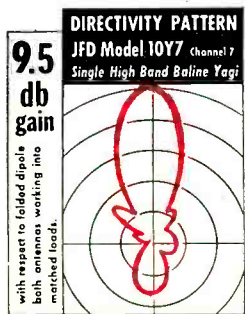

Single JFD High Band BALINE Yagis		
Channels	Models	List Price
7-13	10Y7-10Y13	\$13.85
Stacked JFD BALINE Yagis		
Channels	Models	List Price
2	10Y2S	\$63.70
3	10Y3S	63.70
4	10Y4S	56.90
4-5	10Y45S	67.80
5	10Y5S	56.90
6	10Y6S	51.40
7-13	10Y7S-10Y13S	27.70

Include JFD Baline matching transformers at no extra charge

Single JFD Low Band BALINE Yagis		
Channels	Models	List Price
2	10Y2	\$31.85
3	10Y3	31.85
4	10Y4	28.45
4-5	10Y45	33.90
5	10Y5	28.45
6	10Y6	25.70



The antenna sensations of the Nation!

JETENNA... the conical with jet-action assembly
 ...no other fan conical assembles so fast, performs so well!

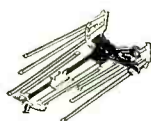

1. Pre-assembled JFD JeTenna as packaged. Note its compactness of construction and craftsmanship of design.

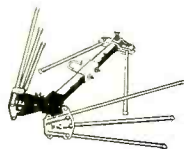

2. As the JeTenna swings open, dipole elements fan instantly into exact position by riding along unique fulcrum indices.



3. JeTenna elements lock into position effecting 35° forward inception angle and 40° dipole angulation for greater signal pickup. Reflectors snap into place for quick tightening by wing nuts.

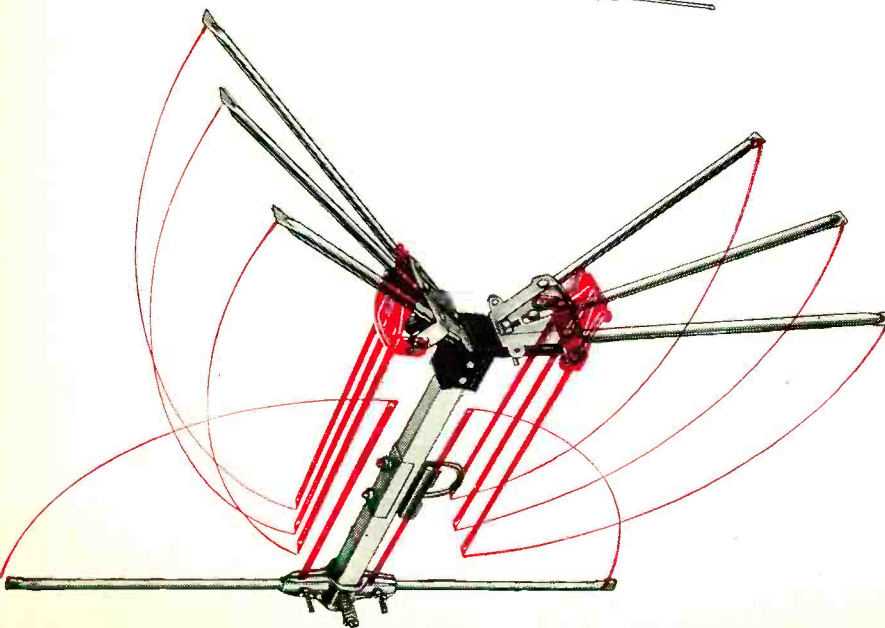

Series with 1" seamless aluminum square crossarm and 3/8" diameter aluminum elements reinforced with Fibreglas dowels.			
No. JET160	Single Bay	Up to 8.8 db*	\$12.50 list
No. JET161	2 Bay	Up to 12.5 db*	\$26.40 list
No. JET164	4 Bay	Up to 15.5 db*	\$56.80 list
Series with 1" seamless square aluminum crossarm and wood doweled butt-seam aluminum elements.			
No. JET660	Single Bay	Up to 8.8 db*	\$ 9.75 list
No. JET661	2 Bay	Up to 12.5 db*	\$20.70 list
No. JET664	4 Bay	Up to 15.5 db*	\$45.40 list

*Performance tested and figures verified by the Hazeltine Corporation, Little Neck, N.Y. World Famous Research Laboratory.

JFD MFG. CO.
 BROOKLYN 4, N. Y.
 BENSONHURST 6-9200



Someone would love to give you a WELLER Gun for Christmas



And someone else would love to get a Weller Gun from you! Handy to give—dandy to get—Weller Guns delight every hobbyist and homemaker. Because you can do so many jobs with a Weller—faster, easier, neater! Drop a hint to your wife that you want a Weller Gun. And put Weller Guns on your Christmas list, too. You won't have to shop for them; your nearby Radio and Electronic Parts Distributor has these famous tools.

INSTANT HEAT
means no delay—
no wasted time
or current.



DUAL HEAT
Switch instantly
to high or low heat
to suit job.

EXCLUSIVE TIP-GRIP
assures full constant heat
longer tip life.

DUAL SPOTLIGHTS
let you see clearly—
even in dark corners.

SHATTER-PROOF HOUSING
PERFECT BALANCE—LONGER REACH



**LOW-COST,
REPLACEABLE TIPS**
Change in just a few moments.

**The real
JACK-OF-ALL-TRADES**

For fast, easy soldering—repairing furniture finishes—model railroading—removing gold hardened putty—mending rain spouting—making costume jewelry—cutting rubber and composition floor tile—dating and regrooving auto tires—dozens of other jobs.



READY PACKAGED FOR CHRISTMAS GIVING
WELLER Guns come "ready-to-give"—in colorful Christmas gift wrappings. Your nearby Radio and Electronic Parts Distributor has them on display. Visit his store and try the sharpshooting WELLER Electric Gun for yourself. You'll find it the ideal Christmas gift—to give or to receive.

**4
MODELS**
from **\$8.95**

**WELLER
ELECTRIC GUN
Model WD-135**

Weller

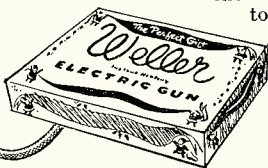

810 Packer Street
Easton, Pa.

EL CTRIC GUNS Better From Grip to Tip!
The Finest Soldering Tool for the Finest Craftsmen

on the air as this issue comes off the press, and most in the early part of '53.

BRIDGEPORT, CONNECTICUT, for nearly three years the ultra-high proving ground in the east, may soon return to its prized status, through the facilities of Channel 43, which will be operated by *Southern Connecticut and Long Island Television Company*. According to the prexy of the new station, Philip Merryman, who owns WICC, arrangements have been made with the suppliers of the transmitting gear, to field test all of the lab developments evolved by the manufacturer, following the pattern employed by RCA at their experimental setup.

The new station is expected to cover an area that will include Waterbury as well as the eastern part of Long Island, plus fringe New York, offering coverage to about 2,000,000 viewers.

This transmitter is also expected to begin operation before the New Year is welcomed in.

THE RUMBLE OF DISSATISFACTION among prospective new-station operators seeking better assignments, which just rippled the air during the early post-freeze days, has begun to gain db and in some instances produce waves of rocking blasts. In Lancaster, Pa., and Nashville, Tenn., the roar has been deafening.

The commotion in these areas stems from the requests of WLAN of Lancaster and WMCT in Nashville. In the latter case, the Commission acknowledged that it had erred in its assignment for that area and deleted Channel 5 from Nashville, to satisfy the minimum 190-mile co-channel separation from the transmitter site of WMCT-TV, Channel 5 being allocated to Old Hickory, Tennessee, about 11 miles from Nashville. In explaining their change of plan, the Commission admitted that they did not realize that a 187.5-mile separation existed between Nashville and WMCT's (Memphis) transmitter location.

The WLAN case had not been solved at this writing, and may involve weeks of deliberation. The operators of the station had asked the Commission to consider the frequency shift of WGAL-TV (who had received a Channel 4 renewal in the summer) from Channel 4 to 8, and appeared before the U. S. Court of Appeals seeking relief. Then the plea was dropped when the Commission disclosed that Channel 8 had not been firmly assigned and WLAN would be able to compete for the assignment. Subsequently, the Commission told the station that it would have to appear in a comparative hearing to review the requested shift, but allowed WGAL-TV permission to operate on Channel 8. The hearing plan was severely criticized by Commissioner George Sterling who declared that the competitive sessions will cause
(Continued on page 120)

RADIO & TELEVISION NEWS

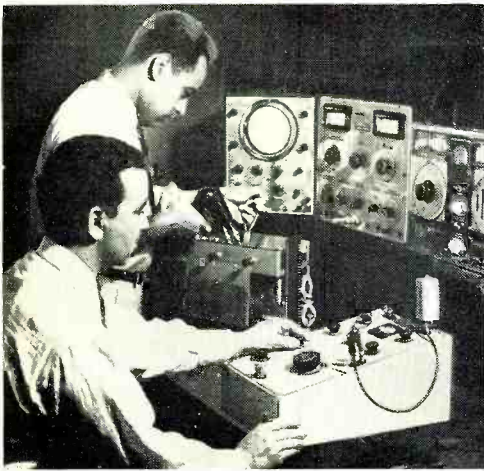

EARN MORE MONEY AS AN EXPERT
 Get Shop-Method Training at Home in **RADIO TELEVISION ELECTRONICS**
One Master Course - One Low Tuition
LEARN ALL PHASES - EARN WHILE YOU LEARN

AS A NATIONAL SCHOOLS GRADUATE THERE'S A PLACE FOR YOU IN THIS EXPANDING INDUSTRY...Never before such a demand for you! For *never before* such a *growing* industry as today's Television, Radio and other Electronic fields. This industry needs you... **TODAY...** and it needs you as a *trained* man... the kind of man you will be as a National Schools graduate. So don't wait. Start your National Schools training **NOW...** and enjoy big money, job security, **SUCCESS!**

LEARN from EXPERTS! BE A SUCCESSFUL MAN YOURSELF! You learn from men who are themselves successful Radio, Television and Electronics technicians. You learn the *practical* way... by *doing*... with equipment we send you. **And you advance quickly, step by step. Get ALL the facts from FREE book and sample lesson. Mail coupon below NOW. Absolutely no obligation.**

You can qualify FAST for these big-pay jobs...plus many more

Radio Station Technician • Your own Sales and Service Shop • District Service Manager • Inspector Technician • Aircraft Radio Inspector • Special Govt. Positions • Service Specialist • Sound Truck Operator • and many others!

ONLY NATIONAL SCHOOLS GIVES YOU THIS PROFESSIONAL MULTI-TESTER

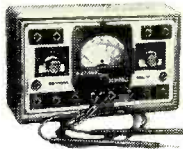

Ready to use. Easy to operate. Light enough to carry on service calls.



DRAFT AGE? National Schools training helps you get into special service classifications—get higher grades, better pay!

NATIONAL SCHOOLS GRADUATES IN BIG DEMAND. You'll find National Schools graduates in good jobs everywhere. For these are the jobs National Schools *trains* you for. Such complete, shop-method home training can be *your* ticket to success...your key to the job happiness you've always wanted. It's up to you. Mail coupon **NOW!**



All yours at no extra cost!

GET YOUR TRAINING FROM THE RADIO-TV CAPITAL OF THE WORLD

Let National Schools —a *resident* technical trade school for nearly 50 years—train you at home for today's unlimited opportunities in Radio-TV.



FRIENDLY GUIDANCE AS STUDENT AND GRADUATE. Our special Welfare Department is constantly at your service. Helps you with your technical and personal problems. Gives you the benefit of its wide industry contacts and experience in helping you after graduation. **Write National Schools, 4000 South Figueroa St., Los Angeles 37, California.**

NATIONAL SCHOOLS APPROVED FOR G. I. TRAINING
 Los Angeles, Calif. • Est. 1905 • In Canada: 193 Hastings St., Vancouver, B.C.

YOU GET ALL THE PARTS INCLUDING TUBES for this superheterodyne receiver... and lots of other equipment...to keep!

NATIONAL SCHOOLS, Dept. RH-122
 4000 South Figueroa Street
 Los Angeles 37, California

Mail in envelope or paste on postal card

Send me **FREE** book "My Future in Radio-Television and Electronics." Also a **FREE** sample lesson. I understand no salesman will call on me and that there is no obligation.

NAME _____ AGE _____
 ADDRESS _____
 CITY _____ ZONE _____ STATE _____
 VETS! Check here if you are a veteran.

ACT NOW

Don't put it off! Mail coupon NOW!

performance proven



Vec-D-X takes the lead in UHF antennas—just as it did in VHF. Whatever the area—single channel, multi-channel, combination UHF-VHF, primary or fringe—there's a performance proven VEE-D-X antenna or combination of antennas that will provide brilliant reception. All Vec-D-X antennas for UHF were developed and extensively field-tested with the experimental UHF transmitter (KC2XAK) located at Bridgeport, Connecticut (since 1949)—and only 60 miles from the Vec-D-X development laboratory. So, be safe—be sure with Vec-D-X performance—proven UHF antennas.

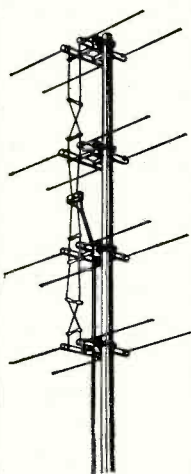

THE UHF COLINEAR

A high gain all-channel fringe area antenna. Here is the mighty mite of all-channel UHF reception and considered by a leading TV set manufacturer as the finest UHF antenna yet perfected. Rugged four-bay construction of solid aluminum elements with fiberglass cross arms. List \$11.10 Also available in side-by-side stack.

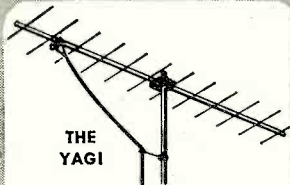

THE YAGI

Single channel primary and fringe area antenna. A rugged, efficient 12-element yagi that delivers 14 db gain. Unusual band width of 60 mc. Boom constructed of tough-as-steel weather-resistant fiberglass with solid aluminum elements. List \$7.65

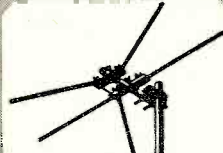

THE VEE-D-X "V"

All-channel primary area antenna. Excellent broad band characteristics. Supplied as a straight UHF antenna or with Vec-D-X Mighty Match for use in combination with a VHF antenna using a single transmission line. The plain "V" lists \$2.75



VEE-D-X UHF ADAPTING BRACKET

Permits addition of UHF antenna to existing VHF installation. Can be mounted three different ways to mast or antenna boom. Fast, easy, inexpensive to install. Supplied plain (list \$1.50) or with Mighty Match MM-30 (list \$5.50)



VEE-D-X MIGHTY MATCH (Model MM-30)

Provides a most efficient method of combining VHF-UHF antenna systems with a single transmission line. Entirely automatic in action. Employs new printed circuit filters. List \$4.00

VEE-D-X ALL-CHANNEL UHF-VHF ANTENNAS

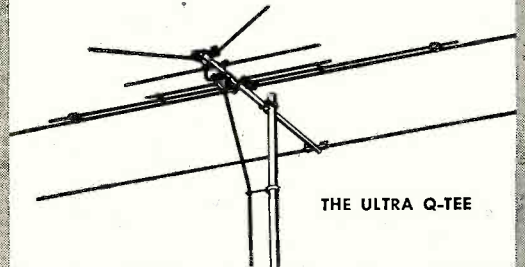

THE ULTRA Q-TEE

THE ULTRA Q-TEE and its new companion the **ULTRA Q-TEE Suburban** combine both UHF and VHF into a single antenna using a single transmission line. Both contain eight patented* printed circuit channel separators. The Ultra Q-TEE is designed for primary areas and will receive all channels 2-83 VHF-UHF. Lists for \$14.25

*Lic. A.A. K. Pats. 2,422,458; 2,282,292; 2,611,086; others pending.

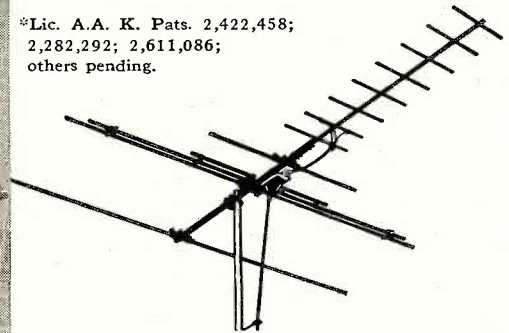

THE ULTRA Q-TEE SUBURBAN is designed for all-channel VHF and fringe area UHF. Lists for only \$17.60

FREE!

UHF ANTENNA GUIDE

An authentic guide to UHF antenna systems. Tells how, what, and where for every area. Mail coupon for your copy.



THE LaPOINTE-PLASCOMOLD CORPORATION
Rockville, Connecticut

Gentlemen:

Send.....copies of your UHF Antenna System booklet

NAME

ADDRESS

CITY..... ZONE..... STATE.....

RADIO & TELEVISION NEWS

YOU

make more money
when you replace with

RAYTHEON PICTURE TUBES

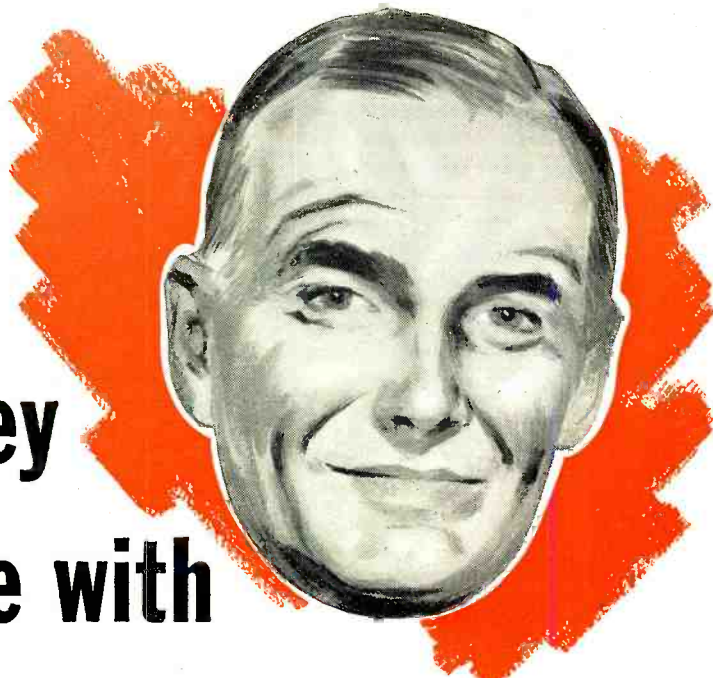

**RAYTHEON PICTURE TUBES
GIVE YOU ALL THESE ADVANTAGES:**

A brand new tube — Raytheon makes only new tubes of finest quality. Raytheon Picture Tubes have new glass, new guns, new screens.

Top quality — Raytheon Picture Tubes are the precision products of a multi-million dollar concern that has specialized in the design, development and manufacture of only top quality electron tubes for more than 26 years. During all this time RAYTHEON has never compromised with quality.

A thoroughly tested tube — Raytheon Picture Tubes and their components are given 101 rigid quality tests and checks to insure electrical and mechanical perfection.

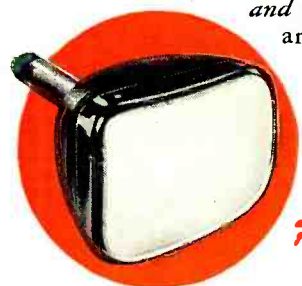

Right... for Sight!

An established brand name — Raytheon Picture Tubes don't need to be "sold" to your customers — thanks to Raytheon's national advertising and reputation for making only the finest quality tubes.

Service — Raytheon Picture Tubes are readily available through your Raytheon Tube Distributor.

A 1-year warranty — Raytheon Picture Tubes are guaranteed for 1 year from date of installation — a warranty backed by Raytheon — one of America's leading tube manufacturers.

**THESE RAYTHEON PICTURE TUBE
ADVANTAGES ADD UP TO:**

Satisfied customers — Raytheon Picture Tubes will give your customers the finest picture, the finest performance possible. They'll build your reputation as a competent and thoroughly dependable Service Dealer — put you in line for repeat business and the business of your customers' friends.

More profit! — You'll save time on replacement jobs when you use Raytheon Picture Tubes because you work with complete confidence that their quality is uniform and will complement your skills. Saving time means more profit for you.



Excellence in Electronics

RAYTHEON MANUFACTURING COMPANY

Receiving Tube Division
Newton, Mass., Chicago, Ill., Atlanta, Ga., Los Angeles, Calif.

RAYTHEON MAKES ALL THESE:

RECEIVING AND PICTURE TUBES • RELIABLE SUBMINIATURE AND MINIATURE TUBES • GERMANIUM DIODES AND TRANSISTORS • NUCLEONIC TUBES • MICROWAVE TUBES

BUY DIRECT
AND SAVE

COLLINS OFFERS

FOR YOUR

COLLINS "PRE-FAB" TUNERS and RECEIVERS

4 ALL NEW Complete Kits
for Every High-Fidelity Need

ASSEMBLE YOURSELF AND SAVE

Each COLLINS KIT is complete with punched chassis, power transformer, power supply components, hardware, dial assembly, tuning eye, knobs, wire, etc. As well as the completed sub-assemblies: FM tuning units, IF amplifiers, power amplifiers, etc. where applicable. With all sub-assemblies wired, tested and aligned at factory, no specific skills are required. Hundreds of satisfied customers report that even without technical knowledge COLLINS Pre-Fab Kits are easily assembled and obtain wonderful high-fidelity performance. Modernize your old radio or sound reproduction system with a COLLINS Tuner or Receiver.

Unsurpassed COLLINS workmanship makes this astounding announcement possible—A mighty proud FIRST FOR COLLINS!

The Famous COLLINS FM-11 NOW IN KIT FORM FM TUNER KIT

IF Amplifier mounted and
wired right in Chassis.

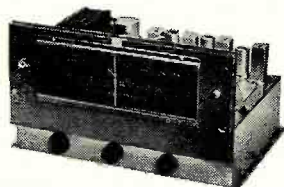

\$55

A terrific value in an FM tuner! 11 tubes. Formerly sold for \$87.50. Nothing has been changed. The tuner is available in kit form with the IF Amplifier mounted in the chassis and wired and tested by us. You mount the RF Tuning Unit, power supply and after some simple wiring, it's all set to operate. If you had a million dollars, you couldn't buy a finer tuner than this COLLINS unit. It's the best at a really fair price! Buy direct and save! Tube lineup: 6J6 RF amp, 6AG5 converter, 6C4 oscillator, 6BA6 1st IF, (2) 6AU6 2nd and 3rd IF, (2) 6AU6 limiters, 6AL5 discriminator, 6AL7-GT double tuning eye, 5Y3-GT rectifier. Sensitivity 6 to 10 microvolts, less than 1/2 of 1% distortion, 20 to 20,000 cycle response with 2DB variation. Chassis dimensions: 12 1/2" wide, 8" deep, 7" high. Shipping weight 10 lbs.

The New 1953 Model Redesigned Smaller Chassis

FM-AM TUNER KIT \$77⁵⁰

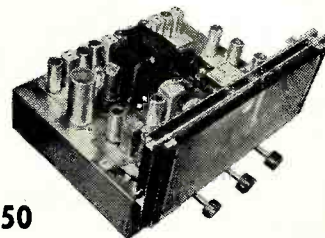

The original 15 tube deluxe FM/AM pre-fab kit redesigned on a smaller chassis. The tuner now measures 14" wide by 12" deep by 7 1/2" high. This attractive, new front and dial assembly opens up new applications where space is at a premium. Kit includes everything necessary to put it into operation—punched chassis, tubes, wired and aligned components, power supply, hardware, etc. Kit comprises FMF-3 tuning unit, IF-6 amplifier, AM-4 AM tuning unit, magic eye assembly and complete instructions. All tubes included. Shipping weight 17 lbs.

A New Addition To The Pre-fabs!

FM RECEIVER KIT

Tuning Eye and ALL Tubes Included

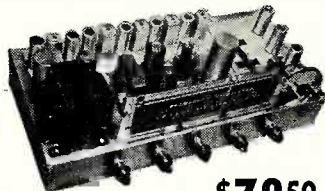

\$78⁵⁰

New! A complete 15 tube pre-fab Receiver Kit requiring only an antenna and speaker for operation. Where space is at a premium, the COLLINS Custom FM Receiver Kit can be conveniently mounted in a book shelf or end table with a remote speaker. Highly sensitive and selective, the COLLINS FM receiver will pull in those distant FM stations with clarity and fidelity. Kit includes all necessary parts for assembly and operation: punched chassis, dial assembly, power supply, tuning eye, wired and aligned components, all tubes and complete instructions. 6 to 10 microvolt sensitivity, IF band width 200 KC, 20 to 20,000 cycle response, low distortion, 6 watts output. Bass and treble tone controls, phonograph input. Tubes: 6J6 RF amp., 6AG5 converter, 6C4 oscillator, 6BA6 1st IF, (2) 6AU6 2nd and 3rd IF, (2) 6AU6 limiters, 6AL5 discriminator, 12AU7 1st audio, 6SN7-GT 2nd Audio, (2) 6K6-GT push-pull power output. Order today for the best FM package you'll ever find! Shipping weight 20 lbs.

Another New Star in the Pre-Fab Galaxy

FM-AM RECEIVER KIT \$89⁵⁰



New! Another COLLINS FIRST. A complete FM/AM receiver kit on one chassis, with power amplifier capable of delivering 6 watts of high fidelity audio into a loud speaker. Tops in quality, easily recognizable in the fine workmanship and first grade materials. Kit includes all necessary parts for assembly and operation: punched chassis, dial assembly, power supply, tuning eye, wired and aligned components, all tubes and complete instructions. 20 microvolt sensitivity on FM, 10 on AM. Shipping weight 20 lbs.

COLLINS AUDIO PRODUCTS CO. is in
no way affiliated with Collins Radio Co.

WHEN YOU THINK OF TUNERS —

A COMPLETE LINE LISTENING PLEASURE . . .

BUY DIRECT
AND SAVE

Selected Basic Components
For Those With Special
Applications

Coupled with tremendous popular demand for COLLINS Complete Pre-Fab Tuner and Receiver Kits, we have also supplied many users with many of the individual components shown below. These units, as well as being parts of the kits shown on the opposite page, are also available separately to builders and those who experiment and who wish to use their own chassis or special layouts. Each assembly is completely wired, tested and aligned ready for immediate use. In buying these COLLINS custom components direct from our factory, you save many dollars and are assured of the highest manufacturing standards. All prices include tubes. Diagrams and instructions furnished with each unit. Operating voltages are all that are necessary to place these units in operation!

FM IF AMPLIFIER



FM 10.7 MC, IF-6 Amplifier. **\$19⁷⁵**

A remarkable value! 6 tubes are used in the IF amplifier: 6BA6 1st IF, (2) 6AU6 2nd and 3rd IF's, (2) 6AU6 limiters and 6AL5 discriminator. High gain, wide-band response for highest fidelity. 20 to 20,000 cycles. Distortion less than 1/2 of 1%. Chassis plate dimensions: 11 1/8" x 2 1/2". Shipping weight: 3 lbs.

FM TUNING UNIT SPECIAL

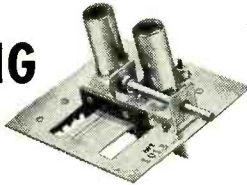

. . . at a
NEW
LOW
PRICE
\$10

A precision FM tuning unit for a ten dollar bill! Permeability-tuned, 88 MC to 108 MC, stable and drift-free. Two tubes: 6AG5 converter, 6C4 oscillator. Sensitivity 20 microvolts. Used with 10.7 MC IF amplifier such as our model IF-6. Compact, small, light in weight, and adaptable to many, many FM applications. Chassis plate measures 4 1/2" x 4 1/2". Aligned, tested and calibrated—ready to operate. Tubes included as well as schematic and instructions. Shipping weight FMF-2: 2 lbs. Dial: 2 lbs.

Slide Rule Tuning
Dial Assembly **\$3.85**

COMPLETE FM TUNER CHASSIS (RD-1C and Slide Rule Dial) **\$28⁵⁰**

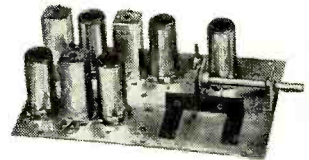

Only Power Supply and
Amp. Required.

The COLLINS RD-1C FM tuner chassis is unique in the field. A whole, compact FM tuner that fits in the palm of your hand. Convert AM sets to FM/AM receivers for only a few dollars! Unlimited applications where space is at a premium. So compact that you can get two in a cigar box! Use in conjunction with your phonograph amplifier. Full frequency response to 20,000 cycles. Sensitivity 20 microvolts, Permeability tuned. Tuning unit and IF amplifier on the same chassis plate. Tubes: 6AG5 converter, 6C4 oscillator, (2) 6AU6 IF amplifiers, 6AL5 in new ratio detector circuit. Shipping weight 2 1/2 lbs. Dial: 2 lbs.

FM TUNING UNIT

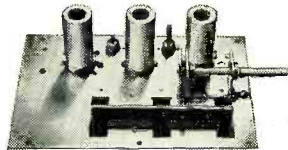

FMF-3 FM
Tuning Unit **\$15²⁵**

Slide Rule Tuning
Dial Assembly **\$3.85**

The best for FM. The most sensitive and most selective type of "front-end" on the market. 6 to 10 microvolts sensitivity. Image ratio 500 to 1. 6J6 tuned RF stage, 6AG5 converter, 6C4 oscillator. Permeability tuned, stable and drift-free. Chassis plate measures 7" x 4 1/2". In combination with the IF-6 amplifier, the highest order of sensitivity on FM can be attained. Tubes included as well as schematic and instructions. Shipping weight FMF-3: 2 1/2 lbs. Dial: 2 lbs.

AM TUNING UNIT

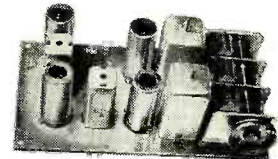

Tubes Included **\$24⁵⁰**

Tops in AM superhet performance! A 3-gang tuning condenser gives 3 tuned stages and consequently higher sensitivity and selectivity. Assembly is completely wired, tested and aligned ready for immediate use. Frequency coverage 540 KC to 1650 KC at a sensitivity of 5 microvolts. Tubes: 6BA6 RF amplifier; 6BE6 converter and oscillator; 6BA6 IF amplifier and 6AT6 detector. Mounts on a chassis plate measuring 4" x 7 3/8". Shipping weight 2 1/2 lbs. Dial: 2 lbs.

MAIL
COUPON
TODAY

To: Collins Audio Products Co. Inc.
P.O. Box 368, Westfield, N.J.
Tel. Westfield 2-4390

- | | | |
|--|---|---|
| <input type="checkbox"/> FM Tuner Kit | <input type="checkbox"/> FM/AM Receiver Kit | <input type="checkbox"/> IF-6 Amplifier |
| <input type="checkbox"/> FM/AM Tuner Kit | <input type="checkbox"/> FMF-2 Tuning Unit | <input type="checkbox"/> RD-1C Tuner & Dial |
| <input type="checkbox"/> FM Receiver Kit | <input type="checkbox"/> FMF-3 Tuning Unit | <input type="checkbox"/> AM-4 Tuning Unit |

Amount for Kit \$ _____

See weights, add shipping cost \$ _____

Total amount enclosed \$ _____ Check Money Order

FROM:

NAME _____

ADDRESS _____

CITY _____ STATE _____

— THINK OF COLLINS AUDIO

Trav-Electric

\$15⁹⁵
LIST

Model 6-1160

**MIGHTY
MIDGET
CONVERTER**

*Just plug into
Cigar Lighter on Dash*

**Converts 6 volts D.C. to 110
volts A.C. 60 cycles 40 watts.**



PORTABLE PHONOGRAPH

Ideal for phonographs and turntables at beach, or picnic.



IN THE CAR - IN THE TRUCK

Radios, short wave or broadcast bands in car, truck and cabin, etc.

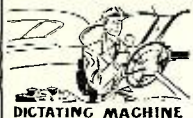

DICTATING MACHINE

Small dictating machines . . . ideal for salesmen, business or professional men.

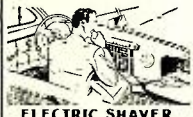

ELECTRIC SHAVER

Electric shaver works beautifully when it is plugged into Trav-Electric. A great time saver.



IN BOATS

Boats—the 110 volts A.C. operates radios, lights, etc.



AT PICNICS - OUTINGS

Ideal for outdoor musical entertainment from table radio to phonographs, including most wire and disc recorders.

**Fully Guaranteed
THOUSANDS IN USE**
See your Electronic Dealer or
Jobber, or write direct



Model 6-1160

Size 2 1/2" x 2 1/2" x 3 1/2"

TERADO Company

Mfrs. of Precision Equipment
1068 Raymond Ave., St. Paul 14, Minn.

Within the
INDUSTRY

THE 1953 PARTS SHOW has been scheduled for May 18th through 21st at the Conrad Hilton Hotel in Chicago, according to the recent announcement by Samuel L. Baraf, newly-elected president of the Electronic Parts Show Corporation.

The 1953 Parts Show will run from Monday through Thursday, from 10 a.m. to 6 p.m., with a supplementary program of seminars patterned after those at the 1952 Show. Both the Exhibition Hall and fifth and sixth floors of the hotel will be utilized again in 1953 and, in addition, a new section will be added to the Exhibition Hall area to accommodate an estimated forty more booths.

* * *

HAROLD G. GULLIKSEN recently joined *Electro-Voice, Inc.* as an industrial designer and art consultant to the company's advertising department . . .

JACOB J. MUCHER, one of the founders of *Clarostat Mfg. Co., Inc.*, passed away recently at the home of his daughter. He and his two brothers founded the company in 1921 and Mr. Mucher served as the treasurer and chief tool designer of the firm for twenty-five years . . . **DOUGLAS C. LYNCH** has been elected vice-president in charge of sales for *The Brush Development Company*. He will be responsible for the sale of all company products . . .

Waldom Electronics, Inc., Chicago manufacturer of replacement cones and field coils, has elected **FRED R. ELLINGER** to the post of president. He succeeds the late **JEROME PRINCE** in the post . . . **SEYMOUR MINTZ**, advertising director of *Admiral Corporation* has been elected vice-president in charge of advertising . . . **L. E. COTSEN** has been named manager of renewal sales for *Tung-Sol Electric Inc.* of Newark. He was formerly manager of the company's eastern division sales office, a post which is now being filled by **WALTER R. OHLSEN** . . . **EDWIN L. WHITE**, chief of safety and special radio service bureau, Federal Communications Commission, has been appointed a Colonel in the Civil Air Patrol with duties as Communications Advisor to the National Commander, Major-General Lucas V. Beau, N.C. . . . **THOMAS H. MOSS** has been named assistant sales manager of *The Turner Company*. He will be in charge of all phases of the recently-expanded sales program of the company's microphones and television boosters, including sales promotion, advertising, distributor relations, and customer service . . . **WILLIAM L. THIBADEAU** has returned to *Starrett Television Corporation* as general sales manager after an absence of two years during which he was man-

ager of national sales for *Sheraton Television Corp.* . . . **STANLEY BERNSTEIN** has been named executive vice-president and general manager of *Electrical Tower Service, Inc.*, Peoria firm specializing in the installation and erection of radio and communication towers and antennas . . . **WILLIAM J. SHANAHAN** is the new technical director of *Skiatron Electronics & Television Corporation's* system of pay-as-you-see-television. He will be directly responsible for all technical phases of the company's recently-announced public tests. He was formerly associated with *Hazeltine Corporation* . . .

LOUIS RIFKIND, president of the *Associated Distributing Corporation* of Baltimore, died recently in that city. His son, David, vice-president and general manager of the firm, will continue to operate the business . . . *Hoffman Sales Corporation* of Los Angeles has named **JOHN F. HERBST** to the post of sales manager. He was formerly western regional sales manager for the *Allen B. Du Mont Laboratories, Inc.* . . . **E. B. HARRISON** is the new general sales manager of the *Peerless Electrical Products Division* of *Altec Lansing Corporation* of Beverly Hills. He will direct the sales of the division's products and act as a consultant on transformer design . . . **DONALD MACGREGOR**, vice-president in charge of manufacturing for *Zenith Radio Corporation*, has been elected president of *Webster-Chicago Corporation*. He succeeds **R. F. BLASH** who has been named chairman of the board.

* * *

HAROLD A. JONES has been promoted to the newly-created post of manager of the Technical Information Center for *Motorola Inc.*

In his new capacity Mr. Jones will direct the production and distribution of all technical publications covering the sales promotion, sales training, public relations, and service activities of the division. He holds a BS in Electrical Engineering and is a member of Eta Kappa Nu, the honorary electrical engineering society.

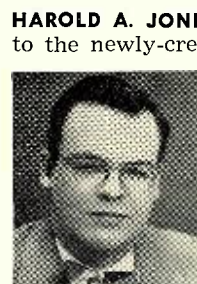

* * *

ALLIED SOUND CORPORATION has been formed under the direction of Irving Greene, well-known audio consultant. The new firm is occupying quarters at 115 West 45th Street, New York, which have been designed solely for the sale and demonstration of the various components that comprise a home music system . . . **PHILCO CORPORATION**

* * *

RADIO & TELEVISION NEWS

CBS HYTRON NEWS FOR YOU...

ABOUT NEW CBS-HYTRON DIODES

CBS-Hytron guarantees its new germanium diodes *moisture-proof* . . . trouble-free. Germanium wafer is soldered directly to the base . . . no plating to flake. Universal design follows joint Army-Navy specifications. You can clip or solder these diodes into circuit. Ten popular CBS-Hytron types are ready for you. See your CBS-Hytron jobber. Or write direct for catalogue and interchangeability chart.

TECHNICAL DATA
CBS-Hytron Germanium Diodes

Type No.	Min. Forward Cur. (MA) + IV	Max. Inv. Cur. (MA) -50V	Peak Inv. Voltage 25° C
1N48	4.0	.850	85
1N51	2.5	1.067	50
1N52	4.0	.15	85
1N63	4.0	.05	125
1N64	Special video detector tested at 44 mc. Complete data on request.		
1N65	2.5	.20	85
1N69	5.0	.05	75
1N70*	3.0	.025	125
1N75	2.5	.05	125
1N81*	3.0	.01	50

*1N TYPES

Permanent X molded into end of case marks connection to germanium . . . which corresponds to cathode of vacuum tube.



New, attractive tuck-away carton fully protects CBS-Hytron germanium diodes. Note unbent leads and convenient data on inside cover.

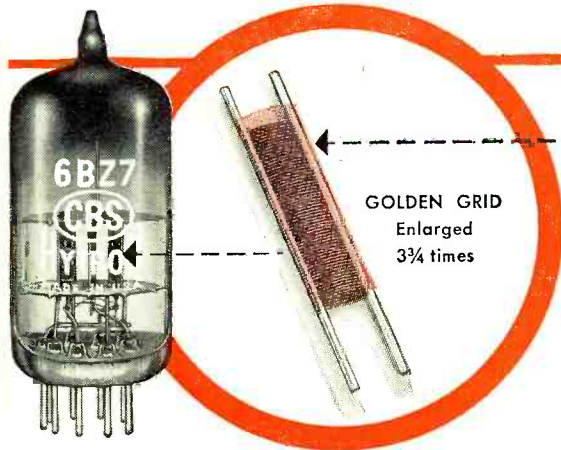

ABOUT CBS-HYTRON GOLDEN GRIDS

Hidden gold in CBS-Hytron tubes? Yes, since 1944. CBS-Hytron first used gold-plated grids in the 6AK5. Later in many transmitting types: 2E25A, 2E30, 3B4, 5516, etc. Now you will find them also in the 6BZ7, 6BQ6GT, 12A4, 12BY7, etc.

Why? Gold kills unwanted emission. Even mounted very close to a hot cathode, a CBS-Hytron gold-plated grid does not give *primary* emission. Like a sponge the gold also soaks up stray electrons. Wipes out *secondary* emission too. And foreign material vaporized onto the grid during exhaust is absorbed harmlessly by the gold plating.

Such deluxe processing costs money. But it gives you better tubes. That is why CBS-Hytron has ignored the cost. Has specified gold-plated grids for years.

ABOUT NEW, FREE CBS-HYTRON TV GUIDE

Like the popular CBS-Hytron Miniature Guide, the new CBS-Hytron Reference Guide for Television Picture Tubes is *complete*. Gives all important data . . . as well as basing diagrams . . . for 164 types. Includes *all* magnetically deflected picture tubes . . . regardless of make. Also shows electrical interchangeability of similar types.

You need this complete . . . accurate . . . helpful Guide. Keep abreast of today's confusing variety of TV picture tubes. Get the new CBS-Hytron TV Guide now. It's *free*. At your CBS-Hytron jobber's. Or write direct today.



DANVERS, MASSACHUSETTS

Here are the headphones you asked for



You headphone users have always known just what you want—flat response, high sensitivity, low distortion, rugged construction, lightweight, comfortable design. Now for the first time, all of these features are combined in a single headphone designed around the exclusive BIMORPH CRYSTAL* drive element. These outstanding, new headphones result from Brush pioneering and experience in acoustics and electronics.

- Exceptionally flat frequency response
- Exceptional bass response
- Low distortion
- Lightweight—designed for comfortable wear
- Sensitivity is approximately 6.3 dynes/cm²/volt at 1000 cps.
- Exclusive METALSEAL CRYSTAL* for protection against high humidity
- Impedance of 100,000 ohms at 1000 cps.
- No transformer required
- Multiple installations are readily made

Available from your local radio parts jobber in three styles: Double headset, Single headset and Lorgnette style.



Brush Microphones—Superior Brush crystal microphones are available in five models. See them at your dealer.

* Trade Mark Registered

THE **Brush**
DEVELOPMENT COMPANY
3405 Perkins Avenue • Cleveland 14, Ohio



Piezoelectric Crystals & Ceramics
Magnetic Recording Equipment
Acoustic Devices
Ultrasonics
Industrial & Research Instruments

has announced the formation of a separate Radio Division to handle all phases of the company's activities in the home and auto radio field. William H. Chaffee is the newly-appointed vice-president of this division.

* * *

F. D. MEADOWS has been appointed general sales manager of the *Dage Electric Company* and the *Dage Electronics Corp.* of Beech Grove, Indiana.



A major in physics and chemistry, Mr. Meadows was graduated from Phillips University with an AB degree. He also attended the University of Oklahoma, taking graduate work in communications.

He joins the *Dage* organization after 12 years' association with *Radio Corporation of America* where he served in the engineering, sales, and administrative departments. He has worked with broadcasting and television equipment distribution since 1947.

In his new post he will be responsible for the company's nation-wide sales program.

* * *

A. D. PLAMONDON, JR., who has been chairman of the RTMA board of directors since his election at the June convention, has assumed the additional duties of president of the association.

The Board of Directors also elected Glen McDaniel, who recently resigned as RTMA president, to the post of general counsel and promoted General Manager James D. Secrest to the post of executive vice-president. Mr. McDaniel succeeds Judge John W. Van Allen who retires after 25 years' service to the association.

* * *

NEDA has named its 1952-53 slate of officers, according to the announcement made by L. B. Calamaras, executive vice-president of the distributor association.

W. D. Jenkins of *Radio Supply Co.*, Richmond, Va., was named president; Dahl W. Mack, *Scranton Radio & Television Supply Co.*, Scranton, Pa., is the new first vice-president; Gerald E. Murphy, *Electronic Supply Corp.*, Battle Creek, Michigan, will serve as second vice-president with Max I. Epstein, *Federated Purchaser*, New York City as treasurer and J. Howard Klein, *All-State Distributing Co.*, Dallas, Texas, as secretary.

Aaron Lippman, *Aaron Lippman & Co.*, Newark, New Jersey, was unanimously re-elected chairman of the board.

* * *

RADIO ELECTRIC SERVICE CO. OF PENNA., INC. has opened a new high-fidelity and commercial sound studio at 7th and Arch Streets in Philadelphia.

Offering advanced facilities for display and demonstration, the new studio is divided into three sections. One
(Continued on page 120)

RADIO & TELEVISION NEWS

Here's your Opportunity

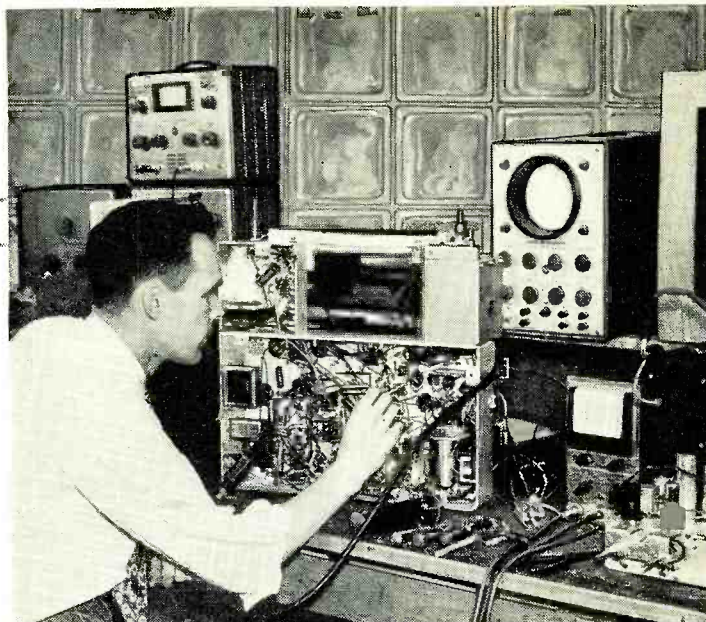

to prepare for a good job or a business of your own in TV SERVICING

There are today more good jobs open in TV Servicing than there are trained and experienced men to fill them. Yes, thousands of opportunities exist now for good-pay jobs offering employment security for years and years to come. Thousands of TV Servicing jobs are going begging. Do you want one of them?

Experts agree, that because of the critical shortage of trained and experienced TV Servicemen, and the tremendous future growth of the industry, no vocational field today offers more opportunities than TV Servicing.

The Big New Industry with a Great Future

Television is just in the beginning stages of its big industrial boom. Look at these amazing facts:

- Within a few years over 1000 TV stations will be telecasting compared with 108 TV stations now on the air.
- Nearly one-half of all families living within the present TV areas do not yet own TV receivers.
- The new trans-continental video network plus better and more interesting programs plus larger viewing screens and color TV will increase the installation of new receivers, will induce present owners of 12-inch and smaller size viewing screens to buy newer model receivers.
- The power increases of many existing stations and improved reception range of current receivers will result in receivers being installed and serviced in the fringe areas of present stations.
- Under the FCC proposal, over 70 per cent of all communities will be served by UHF channels exclusively. This means TV servicemen must know UHF receivers before the new UHF stations in their area are opened.
- No one yet knows how great the industrial TV market will be.

- Lifting the freeze on new TV stations will open many new TV areas and will improve the coverage of existing areas. The result will be an enormous demand for TV receivers.

RCA Institutes conducts a resident school in New York City offering day and evening courses in Radio and TV Servicing, Radio Code and Radio Operating, Radio Broadcasting, Advanced Technology. Write for free catalog on resident courses.



RCA INSTITUTES, INC.
A SERVICE OF RADIO CORPORATION of AMERICA
350 WEST FOURTH STREET, NEW YORK 14, N.Y.

December, 1952

RCA Institutes Home Study Course prepares you for a Career in TV Servicing

The addition of the RCA Institutes TV Service Training to your present radio-electronics experience will qualify you to step out and grasp the golden opportunities that now exist in television—America's fastest growing industry.

Learn at home—in your spare time—while you study the practical *how-to-do-it* techniques with *how-it-works* information. Easy-to-read and easy-to-understand lessons under the supervision of RCA engineers and experienced instructors quickly train you to qualify for the many good jobs now waiting for trained TV servicemen. Don't pass up this lifetime opportunity for financial security and a bright future in TV. Learn TV Servicing from RCA—pioneers and leaders in radio, television and electronic developments.

Send for FREE BOOKLET

Mail the coupon—today. Get complete information on the RCA INSTITUTES Home Study Course in Television Servicing. Booklet gives you a general outline of the course by units. See how this practical home study course trains you quickly, easily. Mail coupon in envelope or paste on postal card.



MAIL COUPON NOW!

RCA INSTITUTES, INC., Home Study Department RN-1252
350 West Fourth Street, New York 14, N. Y.

Without obligation on my part, please send me copy of booklet "RCA INSTITUTES Home Study Course in TELEVISION SERVICING." (No salesman will call.)

Name _____ (please print)
Address _____
City _____ Zone _____ State _____

OHMITE®

Little Devil® RESISTOR ASSORTMENTS

FOR RADIO-TV SERVICEMEN



WITH HANDY

PLASTIC CABINET

ALL FOR THE PRICE OF RESISTORS ALONE!

Here's a handy all-plastic resistor cabinet that's a real timesaver for the radio-TV serviceman. This handsome, sturdy cabinet has five drawers, with eight compartments in each drawer. Each compartment is individually labeled—making it easy to locate the right resistor and to maintain visual stock control. The cabinet is extremely compact—only 9" long, 4¾" high, and 5¼" deep. Dovetail joints permit cabinets to be stacked one on top of another.

Factory packed in each cabinet is an assortment of 150 (½-watt) or 125 (1 or 2-watt) carefully selected Ohmite "Little Devil," individually marked, insulated composition resistors, in the 40 values (10 ohms to 10 megohms) most frequently used by servicemen.

These assortments are offered at the price of the resistors alone—the cabinet being furnished without extra cost. Order from your jobber.

OHMITE MANUFACTURING COMPANY

4885 W. Flournoy Street, Chicago 44, Illinois

QUANTITIES AND RESISTANCE VALUES

QUANTITY			OHMS	QUANTITY			OHMS	QUANTITY			OHMS
CAB-10	CAB-2	CAB-3		CAB-10	CAB-2	CAB-3		CAB-10	CAB-2	CAB-3	
1	1	10	5	3	1000	3	1	33,000	10	10	0.47 meg.
1	1	15	1	1	1500	5	5	39,000	1	1	0.68 meg.
1	1	27	1	1	2200	10	10	47,000	10	10	1.0 meg.
1	1	47	3	3	2700	3	1	68,000	1	1	1.5 meg.
5	1	100	10	5	4700	1	1	82,000	1	1	2.2 meg.
1	1	150	1	1	6800	10	10	0.1 meg.	3	1	2.7 meg.
3	1	270	10	10	10,000	5	5	0.15 meg.	1	1	3.9 meg.
1	1	330	3	3	15,000	3	1	0.22 meg.	1	1	4.7 meg.
3	1	470	5	5	22,000	10	10	0.27 meg.	1	1	6.8 meg.
1	1	680	10	10	27,000	3	1	0.33 meg.	1	1	10.0 meg.

Be Right with **OHMITE**

RHEOSTATS • RESISTORS • TAP SWITCHES

RADIO & TELEVISION NEWS

Extra profits
for service-
men!

NOW you can add UHF to the thousands of VHF Super Fans presently installed in your area, with Channel Master's exclusive new Ultra-Dapter, Model No. 414. In 5 minutes you can convert any Super Fan into an all-channel VHF-UHF antenna. See your distributor for details.

VHF *and* UHF

Now! Get all 82 channels
with the
new

CHANNEL MASTER ULTRA FAN

model no. 413

Write for literature on Channel Master's new complete line of UHF antennas including such models as these:



Ultra Bow
Model No. 401

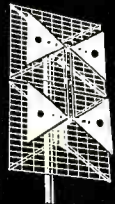

Ultra Bow with
screen reflector
Model No. 403

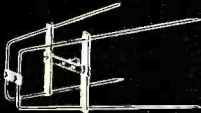

Ultra Vee
Model No. 404



Today's most advanced
ALL-VU* antenna.

*All VHF, All UHF

Featuring:

- **2 great antennas in 1 —**
A genuine, high gain Super Fan on VHF, and an all-channel Triangular Dipole and reflector for peak UHF reception.
- **Electronic inter-action filter —**
Automatically isolates VHF and UHF bands, eliminates inter-action. Ultra Fan operates with only a *single* transmission line to TV set.
- **"Free space" terminals —**
Channel Master's exclusive UHF "free space" terminals prevent accumulation of dirt and moisture which gradually reduce picture quality in ordinary UHF installations.
- **Famous Channel Master engineering —**
The Ultra Fan is an *integrated* VHF-UHF antenna that give uniformly high gain over all TV channels, from 2 through 83.

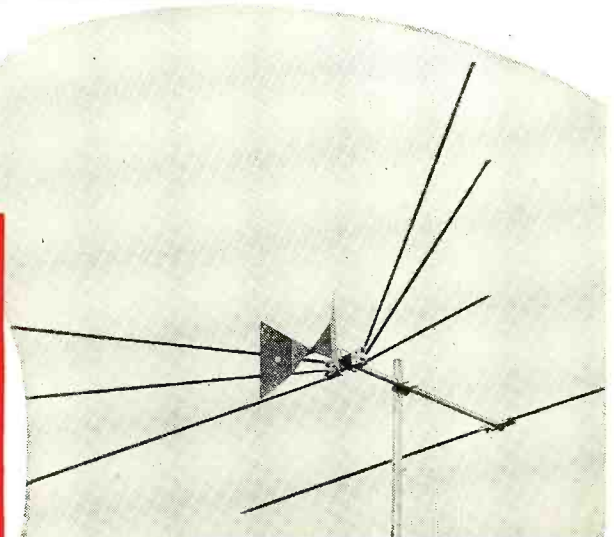

HORIZONTAL POLAR PATTERNS
(Relative Voltage)

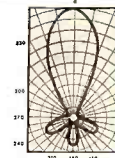

Channel 2

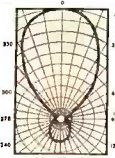

Channel 10

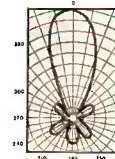

Channel 60

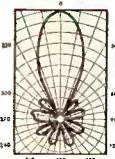

Channel 77

GAIN CURVES

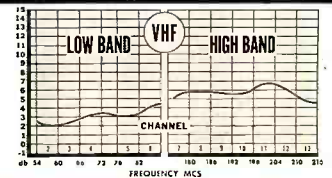

Can be stacked for
additional gain.

CHANNEL MASTER CORP. ELLENVILLE, N. Y.

MEMBER



Everybody's talking about the new Pyramid Imp!

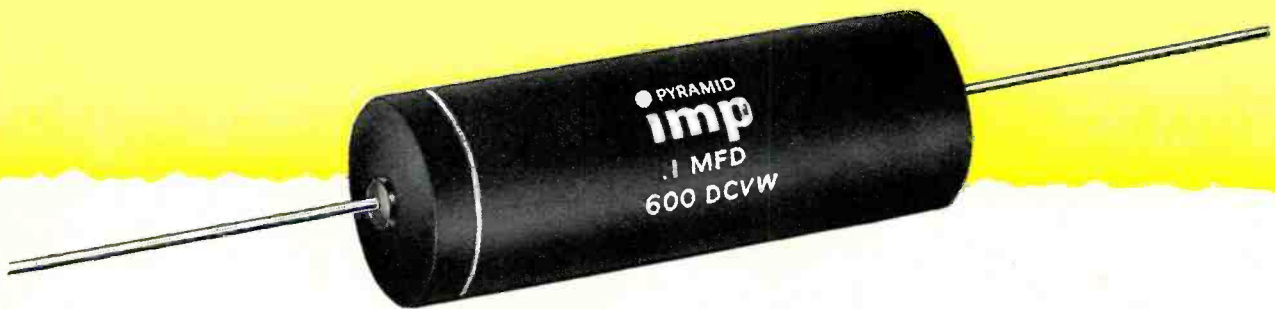

All over the country service-engineers are praising the newest and finest molded tubular paper capacitor—the Pyramid IMP!

here's why—



IMPS ARE REALLY RUGGED!
The tough thermo-setting plastic will take an astounding amount of abuse—yet IMPS will still look and perform like new!

IMPS WON'T FREEZE OR MELT! They'll operate faithfully in temperatures ranging from -40°C . to $+100^{\circ}\text{C}$. (212°F .)—and that's the boiling point of water!



IMP LEADS CAN BEND AND BEND! Tinned leads that are really securely anchored—you'll be amazed at how much punishment they'll take without breaking!

IMPS ARE MOISTURE-PROOF! No moisture can get through the varnished plastic case, or even through the lead anchor-points.



IMPS are available in all popular ratings in 200, 400 and 600 volt ranges. See your local distributor.

If you haven't tried the new IMP, send for your free sample today—use this handy coupon



PYRAMID ELECTRIC COMPANY
1445 Hudson Boulevard
North Bergen, New Jersey

Name.....

Company.....

Address.....

City.....Zone.....State.....

RADIO & TELEVISION NEWS

INTERNATIONAL TV IS HERE

Details on a precedent-making hook-up between Great Britain, France, and Belgium, including data on standards conversion.

FOR the first time in history, seven transmitters, working on three different standards, and covering three countries (France, Great Britain, and Belgium) were linked together to telecast the same international programs for a full week, ending on July 14th, the French national day.

This achievement, which was enthusiastically received by all viewers, was made possible through the close cooperation of *Radiodiffusion et Television Francaise (R.T.F.)* and the *British Broadcasting Corporation (B.B.C.)*.

The transmissions made use of the existing facilities in France and Great Britain—in particular, full use was made of the Paris-Lille television link and of the coaxial and Hertzian cables linking the four British transmitters.

Between Lille and London, a chain of four microwave relays was set up and went straight across the Channel.

While this might be considered a well-established technique, there remained one important point to be covered. Great Britain uses a 405-line standard while France has an 819-line standard. Thus, there had to be, somewhere in the chain from Lille to London, a transformation of standards.

Similarly, since the old French standard of 441 lines is being kept in operation in Paris until 1958 a second conversion was necessary in Paris to change from the 819-line standard to the 441-line standard to feed the two Paris transmitters.

The Converter

Engineers on both sides of the Channel have been busy these past few years trying to solve the problems involved in the conversion of standards.

Many solutions have been advanced—some subtle, some ingenious, and some extremely complex. The final answer is surprisingly simple and seems to be a case of Christopher Columbus' celebrated egg.

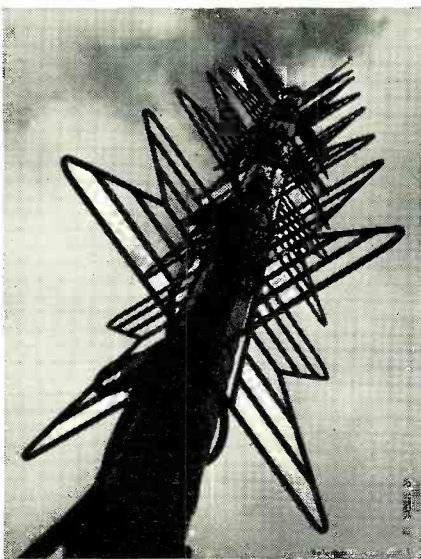

(Left) Close-up of the 185.25 mc. turnstile antenna. (Above) Antenna array atop the Eiffel Tower in Paris, France.

By

A. V. J. MARTIN

Editor, "Television"
Paris, France

In the final version, a high-quality receiver displays a good 819-line picture which is then picked up by a 441- or 405-line camera. It is as simple as all that!

In reality, the procedure is not quite as simple as it seems. The phosphor on the tube must have a decay time such that the picture will be "stored" long enough for scanning by the camera, but this time must not be too long or there would be some smearing in the case of rapidly moving objects.

The decay time used is comparable to that necessary to scan a single frame. This decay time is obtained through the use of a zinc beryllium silicate phosphor having an exponential decay characteristic such that the brightness falls to 28 per-cent of its original value in 1/50th of a second.

The frame frequency is 50 cps in France and Great Britain. Of course, the system works one way—only when the receiver displays a high-definition picture to be transformed into a lower definition standard.

This same system could not be used for transmitting programs from the British standard to the French standard since the 405-line picture is inferior in quality to the French standard, whose over-all definition is four times better.

Two of these simple CRT-camera converters were in use during the

French-British television week—one at the Eiffel Tower (converting the 819 lines into the 441 lines) and the other at Cassel (converting the 819 lines to the 405-line standard).

Four mobile pickup units, installed in cars, were used for outside pickups and to supplement coverage from the Paris studios. All of the pickups were made on 819 lines. The mobile equipment was linked to the control room through 9000 mc. relays.

The 819-line video signal was sent direct to the high-definition Paris transmitter atop the Eiffel Tower and to the relay transmitter in Lille. It was also transformed to 441 lines and fed to the old medium-definition transmitter at the Eiffel Tower.

The relay from Paris to Lille uses two intermediate stations. At Lille, the 819-line signal was radiated over the local high-definition transmitter, over northern France and the southern part of Belgium. A high-quality receiver installed at Cassel received the Lille programs and this part of the link was supplemented by a microwave link as a standby.

The 819-line picture coming from Paris was finally displayed on the receiver in Cassel where the French part of the transmission ended and that of the *B.B.C.* began.

At Cassel, the 819-line picture was converted into 405 lines and then sent across the Channel to London by



Control Room No. 2 in the studios of Radiodiffusion et Television Francaises.

microwave relay, using three intermediate stations.

It was radiated by the 45 mc. transmitter at Alexandra Palace, London and the signal was piped through the coaxial link to the regional transmitters of Sutton Coldfield and Holme Moss. From Manchester, near Holme Moss, the program was sent to the Scottish transmitter of Kirk O'Shotts through the seven-station microwave link.

Pickup Equipment

Besides the standard studio equipment, four mobile units were used in the transmissions:

1. A *Pye* mobile unit using four image-orthicon cameras. This equipment was loaned for the duration of the experiment.
2. A *Radio-Industrie* mobile unit which was especially constructed for the occasion and incorporated three image-orthicon cameras.
3. The regular *R.T.F.* car for outside pickups with its two super-icoscope cameras (*Radio-Industrie*).
4. A new *R.T.F.* hand-carried "trunk" unit with two photicon cameras, put in use for the first time (*Thomson-Houston*).

Three microwave relays, operating on 9000 mc. and made by the *Compagnie des Compteurs*, linked the outside equipment with the Eiffel Tower.

There the signal was demodulated, amplified, controlled, and applied simultaneously to the 819-line transmitter, the Paris-Lille microwave relay, and the 819/441 converter.

Paris Transmitter

The 819-line high-definition transmitter is located on the fourth floor of the Eiffel Tower in the room that Eiffel called his "salon" and reserved for his own use.

The picture carrier is on 185.25 mc. and the sound carrier is 174.1 mc. Both used amplitude modulation.

The total width of the channel is

14 mc., the video transmitter working on the vestigial upper sideband principle.

The antennas are installed on the topmost part of the tower and comprise an array of four turnstiles—shortly to be replaced by a 6-bay diplexed array. Horizontal polarization is used.

The official service radius is on the order of 50 miles (80 km.) but the practical coverage is much greater.

The 819-line standard has been adopted as the official French standard and will be used by all stations, existing or projected, that form the French television chain.

Medium-Definition Unit

Prior to the adoption of the high-definition standard, Paris had a transmitter working, since 1938, on 441 lines.

This transmitter will be kept in service until 1958 to give the owners of the old 441-line receivers their

money's worth in programs. These receivers are now considered obsolete in view of the low quality pictures provided by such relatively low lineage.

The 441-line transmitter is located at the foot of the Eiffel Tower and radiates the picture on a 46 mc. carrier and sound on a 42 mc. carrier. The total bandwidth of the channel is 8 mc., both sidebands being transmitted. Peak powers are 30 kw. for the video and 20 kw. for the aural.

A 5-inch coaxial cable runs from the transmitter to the fourth floor of the Eiffel Tower which supports an array of dipoles for the picture frequency and another array for the sound frequency. These antennas are vertically polarized.

Usually the 441-line program is different from the material carried over the 819-line transmitter, except for star studio features where two sets of cameras are used. This, incidentally, is rather a nuisance from a production standpoint.

During the French-British television week, a 819/441 line converter was used and was installed in the 441-line transmitter building. It proved so successful that it will undoubtedly remain in operation.

The converter was developed by *Radio-Industrie*, a French firm.

Paris-Lille Relay

At Paris, the 819-line signal is fed to a microwave transmitter, the first of the chain that links Paris to Lille on a wavelength of 30 centimeters (approximately 900 mc.).

This radio link, which uses two intermediate stations at Villers-Cotterets and Saily-Saillisel (near Peronne), is regularly used to transmit television programs from Paris to the Lille transmitter.

This link is an experimental one and will soon be replaced by a permanent link which is currently under construction.

The three "hops" are: from Paris to Villers-Cotterets, 44 miles (70 km.); from Villers-Cotterets to Saily-Saillisel, 50 miles (80 km.); and from Saily-Saillisel to Lille, 42 miles (67 km.).

The sound (30 to 15,000 cps) and vision (0 to 15 mc.) signals are transmitted simultaneously, both by frequency modulation. The deviation ratio is 30 for the sound and 1 for the vision.

Each transmitter has an output power of 5 watts and feeds a dipole placed at the focus of a parabolic dish reflector 3 meters in diameter. This gives a 25 db gain. The half-power point width of the beam is 8 degrees which allows easy siting (and eventually some swaying of the parabolas in the wind). The starting point of the radio link is the dish antenna on the third floor of the Eiffel Tower and the end point is at the Lille belfry, some 100 meters high.

The two intermediate stations are unattended and remotely controlled. All of the equipment is mounted on

Details of the various transmitter installations at the Eiffel Tower. See text.

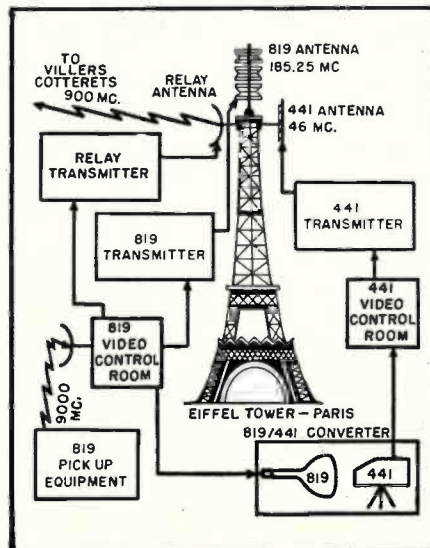

a steel tower 75 meters high. This equipment comprises a receiving antenna, a first frequency changer, an i.f. amplifier (68 to 102 mc.), a second frequency changer, which transposes the frequency to the 900 mc. band, a power amplifier, and a transmitting antenna. It will be noticed that there is no demodulation but double-frequency changing.

The first intermediate station receives on 940 mc. and transmits on 905 mc. while the reverse is true for the second intermediate station.

Lille

The signal received from Paris over the radio link is detected and used to modulate the Lille 819-line transmitter which is similar to the Paris transmitter and operates on the same frequencies. The geographical separation was considered to be sufficient to permit this type of operation.

Besides serving the one million French citizens in the Lille region, this transmitter covers a considerable area of Belgium where the programs are enthusiastically received.

The transmitter and local studio are located in the Lille belfry while the antennas are atop the building, 100 meters above street level.

During the French-British television week, a temporary radio link (working on approximately 9000 mc.) was installed by R.T.F. between Lille and Cassel and was modulated at Lille by the signal coming in from Paris.

Cassel

The 9000 mc. relay (*Campagne des Compteurs*) ended at Cassel where the video signal was delivered to the B.B.C., who took over the liaison from there.

The Lille-Cassel 9000 mc. relay was paralleled with direct reception of the Lille television transmitter, only 30
(Continued on page 118)

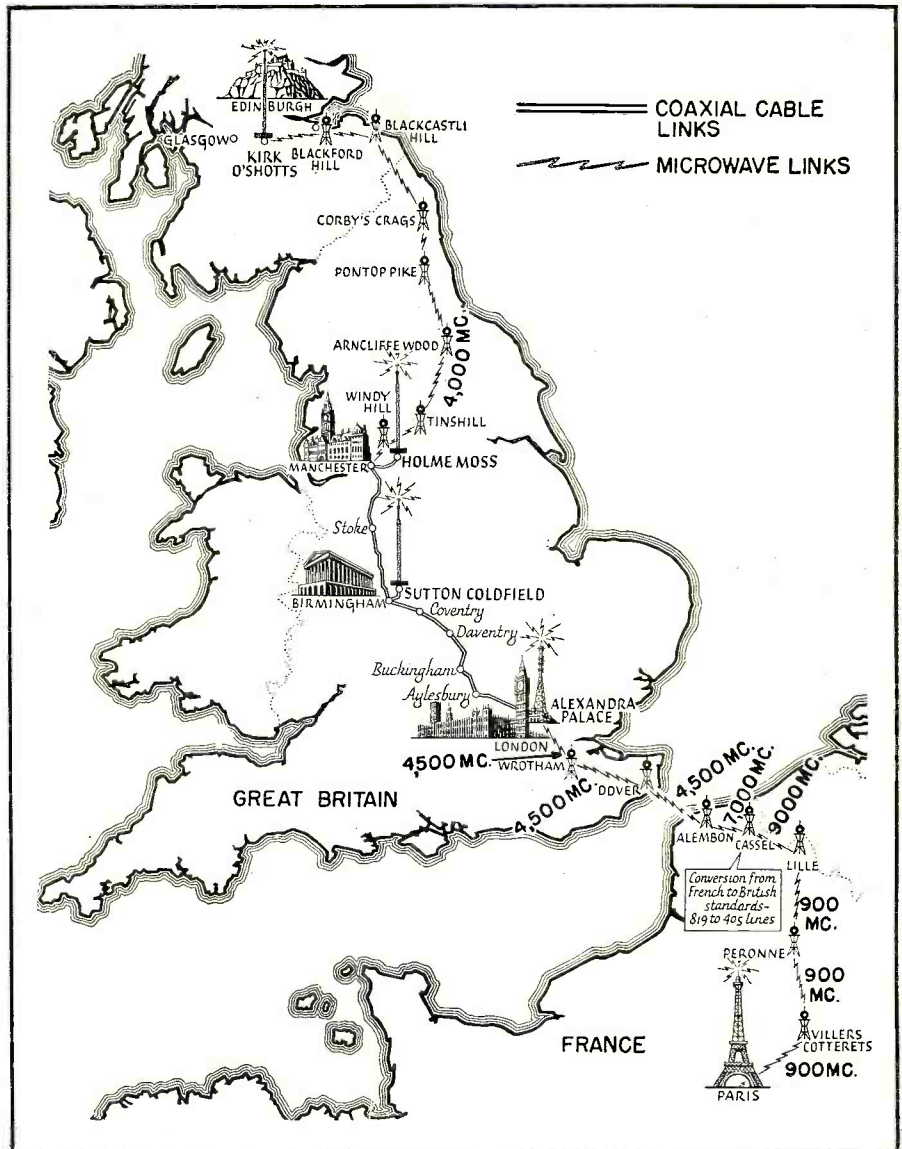

How the television signal was routed from Paris to various television transmitters in Great Britain. Both coaxial cable and microwave relays were used.

Close-up view of the relay station at Villers-Cotterets, one of the relay points between Paris and Lille.

The receiving antenna on the roof of the Mount Cassel building. Antenna is beamed toward the Lille station.

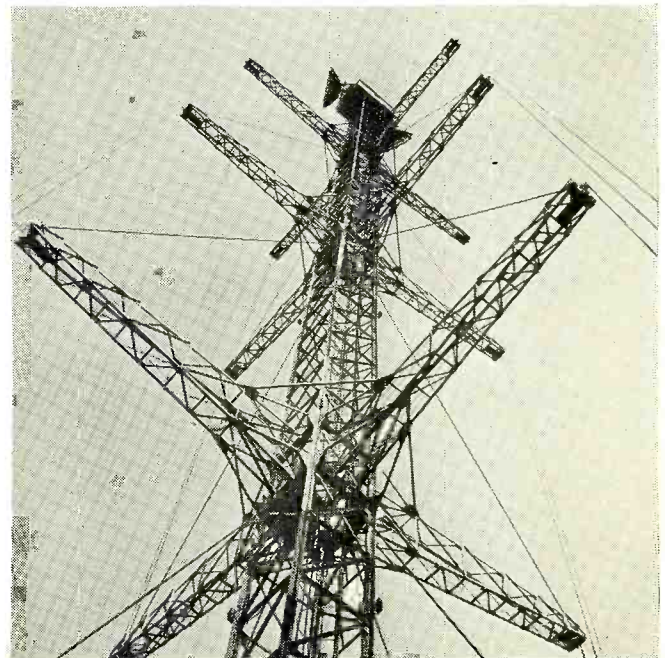

A PREAMP FOR MAGNETIC PICKUPS

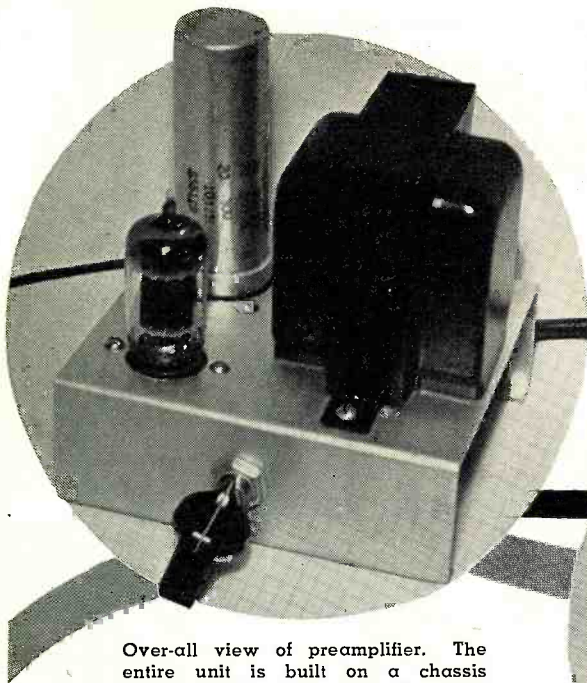

Over-all view of preamplifier. The entire unit is built on a chassis measuring 4" x 4" x 1½". Its small size poses no installation problems.

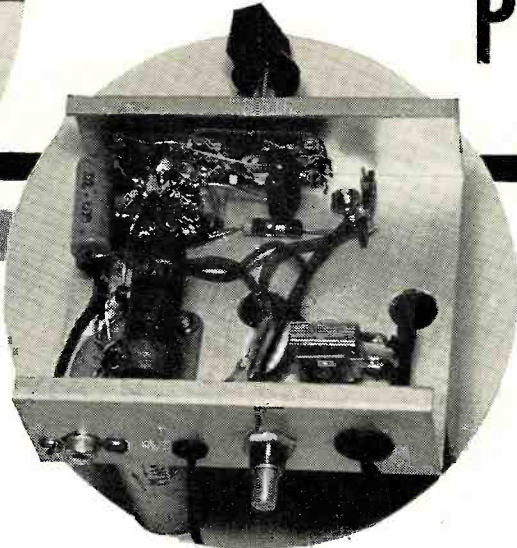

Underchassis view of preamplifier showing compact layout. Small size components were used throughout to minimize bulk of unit.

By

WILLIAM CREVISTON

Details on an easy-to-build unit which uses a single tube and incorporates a selenium rectifier type power supply.

HUM and distortion are not unknown in preamplifiers for magnetic phonograph pickups, despite the considerable engineering time that has been spent on their design. The problem is to amplify a 1 to 10 millivolt signal, putting in a 20 db bass boost, in as clean and quiet a manner as possible. Three basic circuits for doing this are known. Two of them are in general use in this country, but the third is popular mainly in England, having been employed in some new circuits described by D.T.N. Williamson in the May, 1952 issue of "Wireless World." This circuit is the basis of the preamplifier described here, in a form duplicating the main external characteristics of the *G-E* and similar preamps but giving better performance with fewer parts.

Basic Circuits

Let's run through the three methods of getting the bass boost. The first method is the one used by *G-E* and others in their manufactured units. Fig. 3A shows the circuit with the trimmings left out. The bass boost is accomplished by the resistors R_1 and R_2 and condenser C_1 , drawn in heavy lines. At high frequencies, the condenser C_1 looks like a short circuit, and the signal level is knocked down about 8 times by the voltage divider R_1 , R_2 . At bass frequencies, C_1 looks like an

open circuit; the signal doesn't know R_2 is there, and goes on its unattenuated way from the plate of the first triode to the grid of the second triode.

The tube is usually a metal 6SC7 double triode, which is considered less "hummy" than the more common (nowadays) 6SL7. The metal shell reduces hum, too, when there is a power transformer nearby. Any other appropriate tube could be used.

The second widely-used circuit is the two-stage feedback system, shown simplified in Fig. 3B. The bass equalization is in a feedback loop, shown in heavy lines, from the plate of the second stage to the cathode of the first stage. At high frequencies, C_1 looks like a short circuit, and the over-all gain is knocked down by a factor depending on resistors R_1 and R_2 . At

very low frequencies, C_1 looks like an open circuit and there isn't any negative feedback, hence more gain.

This circuit has two advantages over the first circuit: lower distortion at high frequencies, and low output impedance, due to the negative feedback. This permits one to use a long shielded cable on the output without much loss of high frequencies.

It has the disadvantage, however, that the first stage cathode is off ground to the extent of 2200 ohms, and cannot be bypassed. This makes the hum problem worse. The output of *G-E*, *Pickering*, and such pickups is 10 millivolts at 1000 cycles, but only around 1 millivolt at 60 cycles. Hence the hum level must be very low indeed. The only reason why preamplifier hum is not more noticeable in practice is that it tends to be masked by turntable rumble.

The third circuit, shown simplified in Fig. 3C, combines the benefits of negative feedback with the advantage of a bypassed or grounded cathode. We get low distortion and at the same time realize the full low-hum potentialities of our tube.

The negative feedback runs from the plate of the triode right back to the grid, through R_2 and C_1 . For this type of feedback to work, the signal source must, in general, have a low impedance, *e.g.*, be a magnetic pickup cartridge. In series with the source is a resistor R_1 , conveniently 100,000 ohms. The feedback ratio is determined by the two resistors, R_1 and R_2 . At high frequencies the negative feedback is in force. At low frequencies C_1 has a high reactance and the gain is

Fig. 1. Response curves of preamplifier using the plate-grid type of feedback.

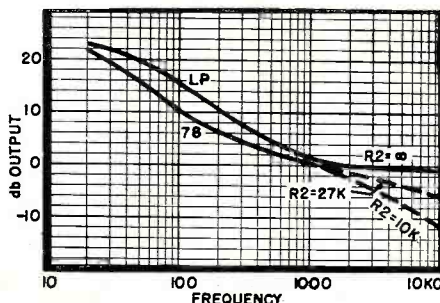

the gain of the stage without feedback.

This scheme was first described by J. Ellis in England², then by L. Fleming⁴, and most recently used by Williamson³. All these versions use a single pentode which lacks the gain to bring U. S. magnetic pickup levels up to the desirable value of 1 volt. The present circuit in complete form employs a dual triode with adequate gain.

Complete Circuit

Fig. 2 is the complete circuit and Fig. 1 the frequency response curves. The first stage, V_1 , has the plate-grid feedback network R_1, R_2, C_1 . With C_1 in the circuit alone the turnover frequency is about 800 cycles. A switch is provided to lower the turnover to 400 cycles, shunting condenser C_2 across the original condenser C_1 . The bass boost curves follow the recommendations of John Goodell¹. The feedback loop is connected to the far side of the interstage coupling condenser, partly because it includes condenser C_4 in the feedback loop, giving a trifle more bass, and partly because it gives the little condensers C_2 and C_1 a bit less d.c. voltage to worry about.

The second stage V_2 is just an ordinary straight resistance-coupled amplifier. "Contact potential" bias is used throughout. It works at least as well with high-mu tubes as does cathode-resistor bias. Some authorities say it is better.

The operation of the plate-grid feedback system requires a source impedance that is low compared to the 100,000-ohm series-input resistor R_1 . Magnetic pickups work fine with it. Crystal pickups do not.

Fig. 1 shows the two bass boost curves obtained with the values of C_1 and C_2 shown in the diagram. Some high-frequency cut is needed with most recording characteristics, and this is generally accomplished by shunting the magnetic pickup with a resistance of somewhere around 20,000 ohms. It is a good scheme to terminate the pickup cartridge in 22,000 ohms as shown at R_2 , and then depend on the main amplifier tone control to adjust the high end to the particular record. Goodell's excellent article¹ should be referred to for further details on particular equalization characteristics.

Power Supply

Fig. 2 shows a self-contained power supply, although power can be drawn from the main amplifier if this is convenient. The power transformer used is one of those handy little jobs made for powering TV boosters. A small selenium rectifier and a three-section electrolytic complete the parts list. Particular note should be taken of the hum-balancing pot, R_8 . If this pot. is adjusted for minimum hum, the hum level can be as low as 5 microvolts referred to the first grid, or about 50 db below average signal level. This is an improvement of 10 to 20 db over the hum level with a fixed centertap.

Filament voltages almost always run too high when a power transformer filament winding is under-loaded. In this case a 3.3 ohm resistor R_0 was required to bring the heater voltage to the desirable value of 6.0 volts.

Tube Types

The 12AT7 or 12AY7 can be used interchangeably in this amplifier. Contrary to the impression in some quarters, the high-mu ($\mu = 100$) 12AX7 is not a good equivalent for the low-noise 12AY7. The "AX" has a much higher mu and lower G_m than the "AY," and a set of load resistors and biases that is right for one is not optimum for the other. The 12AT7 is electrically very close to the 12AY7, however. In many cases the 12AT7 is as quiet too. Following a note by L. Fleming in his article on hum control⁵, the writer tried half a dozen 12AT7's for hum level and found that four of them were actually quieter, humwise, than the 12AY7 sample available. Of the other two AT's, one was slightly "hummier" than the AY and the other was badly microphonic.

Design Principles

Anyone with an audio oscillator and a scope, or anyone with just the desire to fiddle with parts values, may be helped by these simple rules on the design of the bass equalizing network. Referring to Figs. 1 and 2, the gain of the first stage V_1 at extreme bass frequencies (e.g., 20 cycles) is simply the stage gain of the triode, which is about 30. The high frequency gain, above 1000 cycles (ignoring high frequency drop due to R_2 , which is a different subject) for the first stage is approximately the ratio of the sum of R_1 and R_2 to R_1 . For example, if R_1 is 200,000 ohms and R_2 is 100,000, the high-frequency stage gain will be about 3. The

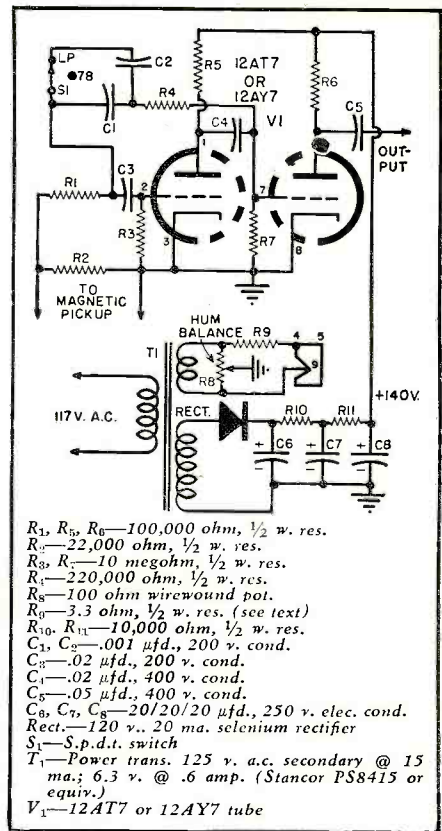

Fig. 2. Circuit diagram of self-powered, high-quality preamp. Bass boost is by plate-to-grid feedback; cathodes grounded.

turnover frequency is about where the capacitive reactance of feedback condenser C_1 (or C_2) is equal to the resistance R_1 . These three considerations determine the whole low frequency end of the curve. The rise rate of the curve is automatically 6 db per octave, because it is determined by a single reactive component, C_2 .

The preamplifier shown in the photo (Continued on page 102)

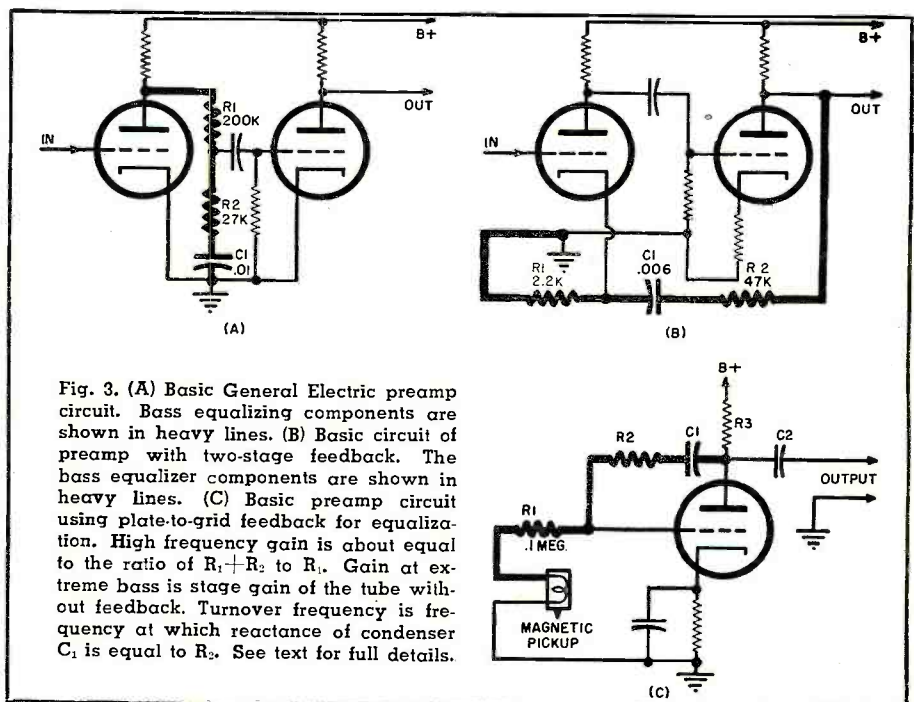

Fig. 3. (A) Basic General Electric preamp circuit. Bass equalizing components are shown in heavy lines. (B) Basic circuit of preamp with two-stage feedback. The bass equalizer components are shown in heavy lines. (C) Basic preamp circuit using plate-to-grid feedback for equalization. High frequency gain is about equal to the ratio of $R_1 + R_2$ to R_1 . Gain at extreme bass is stage gain of the tube without feedback. Turnover frequency is frequency at which reactance of condenser C_1 is equal to R_2 . See text for full details.

U.H.F.

ANTENNAS

By

MILTON S. KIVER

Pres., Television Communications Institute

Part I. "How-to-do-it" information on the selection and installation of antennas for coverage of the newly-opened u.h.f. bands.

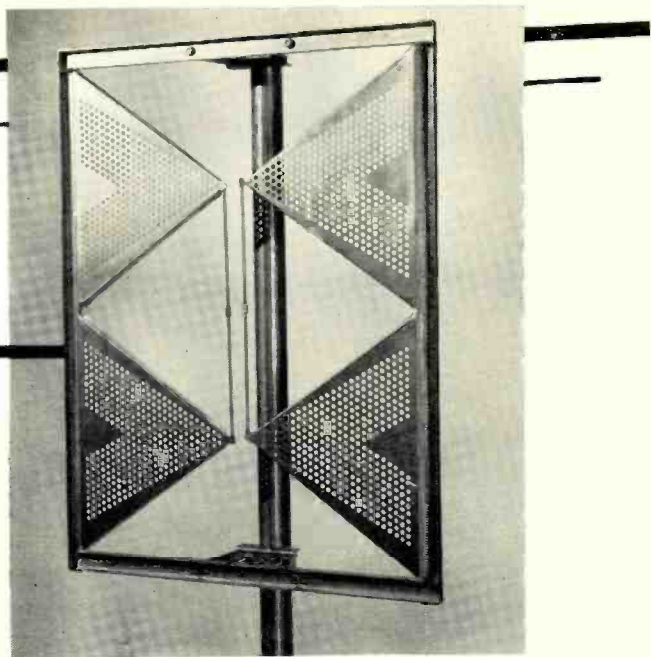

Fig. 1. A two-stacked fan dipole for u.h.f. reception.

COMMERCIAL telecasting has been with us now for almost seven years and although great progress has been made in both broadcasting and receiving equipment, the dependency of the receiver upon its antenna remains as great now as it did back in 1946. Without an antenna, very few sets are capable of providing satisfactory pictures. In general, the best pictures are produced when the antenna is roof mounted (or otherwise positioned at some outside point).

For seven years, we have been concerned with 13 channels extending from 54 to 88 mc. and from 174 to 216 mc. A certain number of antennas have been developed which are capable of good performance within these frequencies. Now, however, we are faced with expansion into the u.h.f. television band (470-890 mc.) and the problems of reception which are encountered with v.h.f. television receivers are intensified. Power for u.h.f. is quite difficult to generate, losses in signal travel between station and receiver are greater, and the ability of the receiver to amplify within this region is considerably poorer. Faced with this situation, the television technician can appreciate how important the antenna becomes. It can truly be said—without qualification—that your success in dealing with u.h.f. receivers will depend more upon your installation know-how than upon your u.h.f. circuit know-how!

To deal with these difficulties, a host of antennas have been developed. Some of these arrays resemble those with which we are familiar, but there are many which will be strange to the television technician. To develop an understanding of these antennas and what can be expected of them, it may first be best to start with the simple half-wave dipole. Not only are many arrays nothing more than elaborations

of the dipole, but when comparisons are made between the gains of different arrays, the dipole is the standard against which these comparisons are made.

The half-wave dipole response pattern is shown in Fig. 4. Note that a signal is best received from a direction which is at right angles (or broadside) to the antenna wires. As the angle made with the 0-180 degree line increases, the strength of the received signal decreases until, when we are facing one end of the antenna, signal reception is poorest. The dipole, then, is a directional antenna since it receives energy best from the broadside direction and poorest (or not at all) off the ends.

When we swing the dipole antenna around, the whole response pattern swings with it. Suppose the ends of the antenna are pointing east and west; maximum response will be obtained then from signals coming from the north and south. If we swing the antenna 90°, the ends will be pointing north and south and maximum signal reception will be obtained for signals coming from the east and west.

The response of a dipole, as shown in Fig. 4, retains its figure-8 shape even when the signal frequency is raised until it is double the value to which the antenna was originally cut. At twice the original frequency the two large lobes (or halves) of the figure-8 may be somewhat narrower, but the over-all appearance of the response curve remains essentially the same.

However, when an antenna is employed to receive signals whose frequencies exceed twice the fundamental frequency for which the antenna was cut, side lobes appear. Fig. 3A shows the response of a dipole cut for 55 mc. Figs. 3B, C, and D show what the pattern becomes at 85 mc., 175

mc., and 195 mc. In the four-lobed patterns of Figs. 3C and 3D, signals coming from any one of these four directions will induce maximum voltage in the dipole. Note, too, that none of these four lobes point in the same direction as the original two lobes and this might require a different positioning of the antenna. Finally, multi-lobed patterns make the antenna more susceptible to ghosts and other interfering signals.

The number of lobes will increase as this antenna is used to receive higher and higher frequency signals. Also, there is a tendency for the larger lobes to break up into a series of smaller ones. The illustration in Fig. 5 brings this out clearly and shows why it is generally not advisable to use v.h.f. antennas to receive u.h.f. signals. Not only does the array lose much of its directivity, but even a reflector appears to exert little influence in cutting down the number of lobes. There are some exceptions to this behavior, and these will be brought out later.

(The fact that the response pattern of an array changes with frequency is one that is not fully appreciated by many technicians. It explains, for example, why an array must be turned one way for signals of one frequency and then turned to another direction for signals of another frequency. It could also explain why the signals of one station might be strongly received while the reception of another station located in the same general direction might be poor. Obviously there are also other reasons for unequal signal reception.)

Now, it was stated that v.h.f. antennas are not usually suitable for use at u.h.f. However, if we reduce the dimensions of the v.h.f. antenna, or in other words, raise its resonant frequency, then it will possess the

same pattern at u.h.f. as it does at v.h.f. The figure-8 pattern of a 55-mc. dipole is the same as the figure-8 pattern of a 550-mc. dipole. In each case, both dipoles are cut to their resonant frequencies and we are not using a 55-mc. antenna to capture 550-mc. signals.

At u.h.f., the wavelength is much smaller than at v.h.f. Since antennas are cut according to wavelength, this means that the physical dimensions of a half-wave dipole at 550-mc. will be 1/10 of what it is at 55 mc. This smaller physical size is convenient, because it permits easier handling, a simpler supporting structure, and lower cost. It can also be employed to advantage by permitting the addition of more elements to the array. The purpose of an antenna is to intercept as much of the passing signal energy as possible. Obviously, the greater the physical size of the array, the greater the amount of energy intercepted and the more signal the set receives. Because of this, fairly elaborate arrays will be more in evidence at u.h.f. than they are at v.h.f.

Gain. The two most important characteristics of any antenna array, from the standpoint of the technician, are its gain and directional response. The power gain of an array is the ratio of the signal power which this array develops to the signal power which a thin half-wave dipole develops at the same location. Thus, a gain of 10 means that the array would develop 10 times as much power as a half-wave dipole antenna placed at the same point.

Many times, the decibel (db) is used as the unit of gain. In this case, since power is being employed, the formula is:

$$db = 10 \log_{10} \frac{P_1}{P_2}$$

A ratio of P_1 to P_2 of 100 would give the equivalent decibel rating of 20. This follows from the fact that the $\log_{10} 100 = 2$, and 2×10 equal 20 db. The 0 db line is taken as the gain of the reference dipole adjusted to resonance at each different frequency. Thus, suppose that we are told that a certain array has the gain curve shown in Fig. 6. At 500 mc., the gain of this antenna is 6 db greater than a half-wave dipole, cut to 500 mc., and placed in the same position as this array. At 600 mc., this array has a gain of 8 db greater than a half-wave dipole, cut to 600 mc. The same is true for all points along the gain curve.

Directivity. When speaking of the directivity of a directional antenna, we mean the sharpness with which the signal is confined or directed to a particular direction. It may, in a sense, be compared with the selectivity of a receiver in allowing one signal to pass through and rejecting all others. The more selective the set, the sharper and more peaked its tuning curve. In radio sets, sharp selectivity can usually be attained only

when several tuning circuits are used in conjunction with each other. One coil and condenser combination, by itself, would not be adequate. It is much the same with antennas. Ordinarily, several radiators must be used before a highly directive pattern is obtained. Just one or two elements, by themselves, might show definite directive effects, but these would not be as clear cut as those obtained if a greater number of elements are used.

When speaking of antenna directivity, the term "beam angle" is often employed. Beam angle is the angle between the two points on a response curve at which the signal voltage is .707 (or 70.7%) of its maximum value. In Fig. 2, the angle between points A-B, or the angle θ , is the beam angle for this response curve. At each of these points (A and B), the signal strength is .707 of its value at point C.

The half-wave dipole is the simplest type of v.h.f. antenna and it is like-

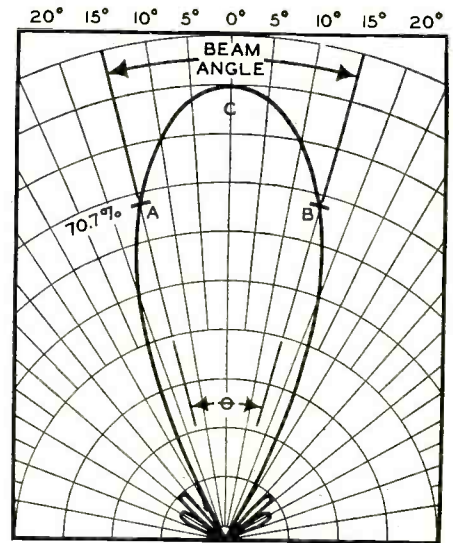

Fig. 2. An illustration of the standard definition of the term "beam angle."

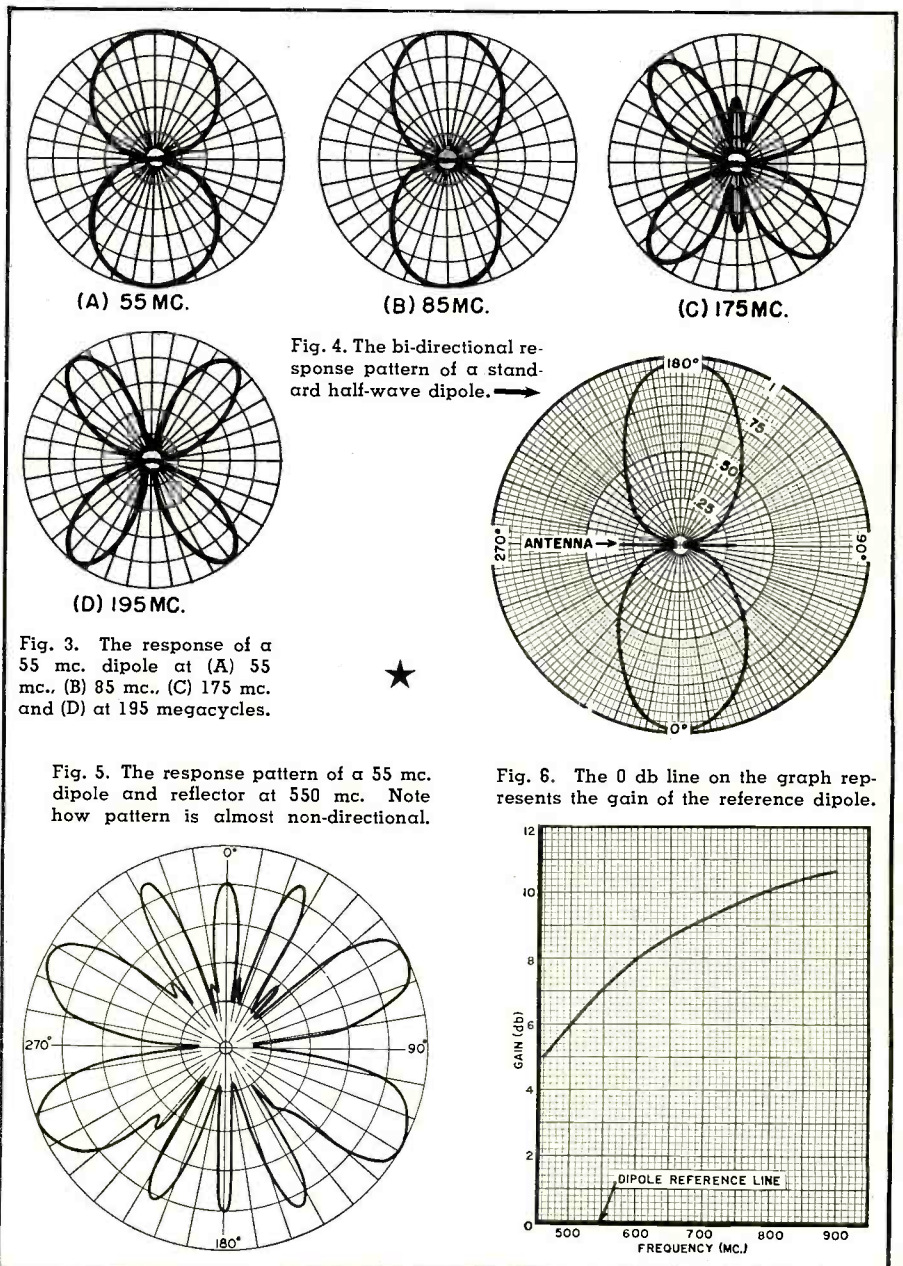

Fig. 3. The response of a 55 mc. dipole at (A) 55 mc., (B) 85 mc., (C) 175 mc. and (D) at 195 megacycles.

Fig. 4. The bi-directional response pattern of a standard half-wave dipole.

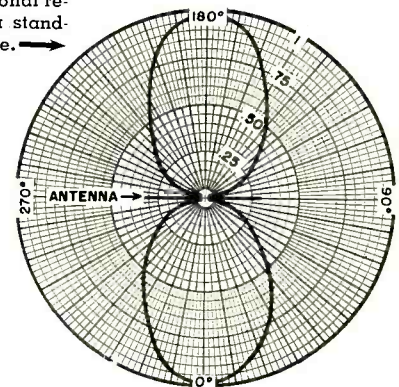
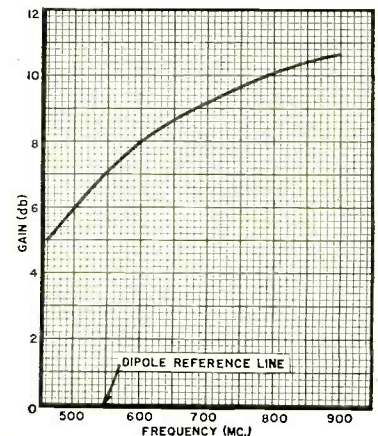

Fig. 5. The response pattern of a 55 mc. dipole and reflector at 550 mc. Note how pattern is almost non-directional.

Fig. 6. The 0 db line on the graph represents the gain of the reference dipole.



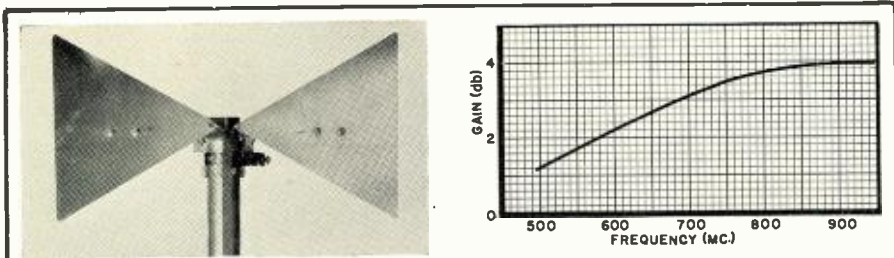

Fig. 7. (Left) A commercial-type fan antenna. (Right) The gain curve of the unit.

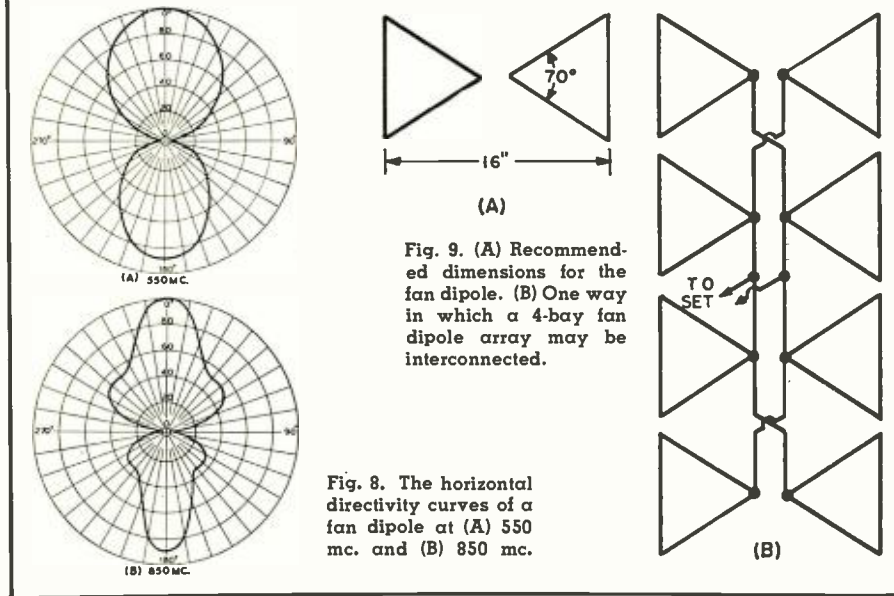

Fig. 9. (A) Recommended dimensions for the fan dipole. (B) One way in which a 4-bay fan dipole array may be interconnected.

Fig. 8. The horizontal directivity curves of a fan dipole at (A) 550 mc. and (B) 850 mc.

wise the simplest u.h.f. antenna. However, to increase its effective surface area, the unit is constructed of two triangles of metal, supported by a suitable insulator. See Fig. 7. By using triangular sheets of metal instead of rods, the unit becomes a broadband affair, capable of receiving all signals within the u.h.f. television band (470—890 mc.). The response pattern of the fan dipole retains its figure-8 pattern at both the upper and lower ends of the band. See Fig. 8. This behavior might have been anticipated in view of the fact that the highest frequency is not quite twice as great as the lowest frequency.

Because of its somewhat altered

construction, the fan dipole is capable of greater gain than the conventional dipole using thin rods. This increase, however, is quite small and, in consequence, the fan dipole provides satisfactory reception only in strong signal areas where there are relatively few ghost signals.

The impedance of a fan or triangular dipole varies with the corner angle of the dipole section. To best match 300-ohm balanced lead-in lines, the corner angle should be about 70°. See Fig. 9A. Also recommended for greatest gain is an over-all dipole length of 16 inches.

*As recommended by antenna engineers at RCA (Johnson), JFD, and other manufacturers.

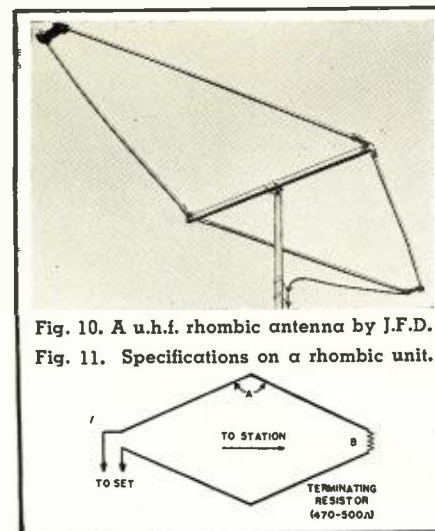
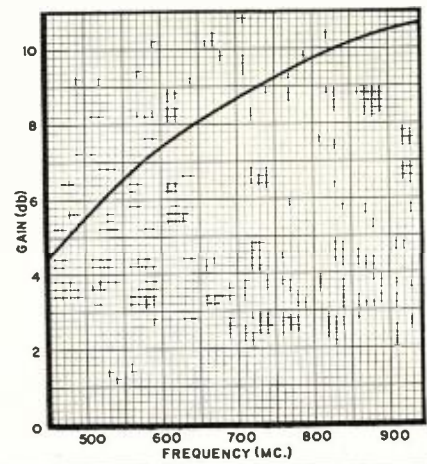

Fig. 10. A u.h.f. rhombic antenna by J.F.D.
Fig. 11. Specifications on a rhombic unit.

Fig. 12. Gain characteristics of the rhombic antenna shown in the photo of Fig. 10.



Fan dipoles can be stacked two high, as shown in Fig. 1, and four high, to provide increased gain. For the 2-bay unit, the gain varies from a low of 4.5 db at 500 mc. to a high of 8.3 db at about 850 mc. With a 4-bay array, the gain limits are 7 and 10.4 db.

In all the curves shown, 300-ohm twin-lead transmission line was connected to the antennas to conduct the signal to the receiver. For a single fan dipole, the 300-ohm line attaches directly to the narrow ends of the triangular sheets. For the two stacked fan dipoles, two small rods connect similar ends together (as shown in Fig. 1) and the 300-ohm twin-lead would attach to the center points of these rods. In the 4-bay array, the arrangement shown in Fig. 9B would have to be used. These matching systems are similar to those used with v.h.f. arrays.

Rhombic Antennas

The rhombic antenna has been used to some extent for v.h.f. reception in weak signal areas. It has broad band-pass properties, is uni-directional, possesses a sharply defined directivity pattern, and is capable of good gain. That it is not extensively employed at v.h.f. is due principally to the fact that its dimensions are quite large and the array neither lends itself to rotation by a rotator, nor to limited spaces such as apartment building rooftops where more than one array might be installed.

The specifications for a rhombic antenna are given in Fig. 11. The length of each of the four sides (also known as legs) should be at least several wavelengths long. In fact, the longer each side, the greater the gain and the sharper the horizontal directivity pattern of the array. The angle at A varies with the length of the legs, but it generally falls between 110-130 degrees. For legs which are 2 wavelengths long, an angle of 100° is recommended; for legs 3 wavelengths long, the angle is 120°; and for 4 wavelengths long, it is 130°. If the wires at point B are simply connected together, the array is bi-directional. But if, as is more usual, a carbon resistor having a value of 470 to 500 ohms is inserted at this point, the response pattern becomes uni-directional. The input impedance at the other end is equal to the value of this resistor, but connecting a 300-ohm twin-lead here will, for all practical purposes, serve very nicely with some slight loss in gain. (Open-wire transmission line has an impedance of 450 ohms and will produce a better match.)

Rhombic antennas, because of their broadband properties, can be used easily over a 2 to 1 frequency range. Their gain (as shown for u.h.f. array in Fig. 12) enables them to be used in relatively weak signal areas. Their sharp directivity patterns (their beam angle is on the order of 25° or less) indicate that they would be extremely

(Continued on page 108)

MULTI-BAND V.F.O.

MOBILE

TRANSMITTER

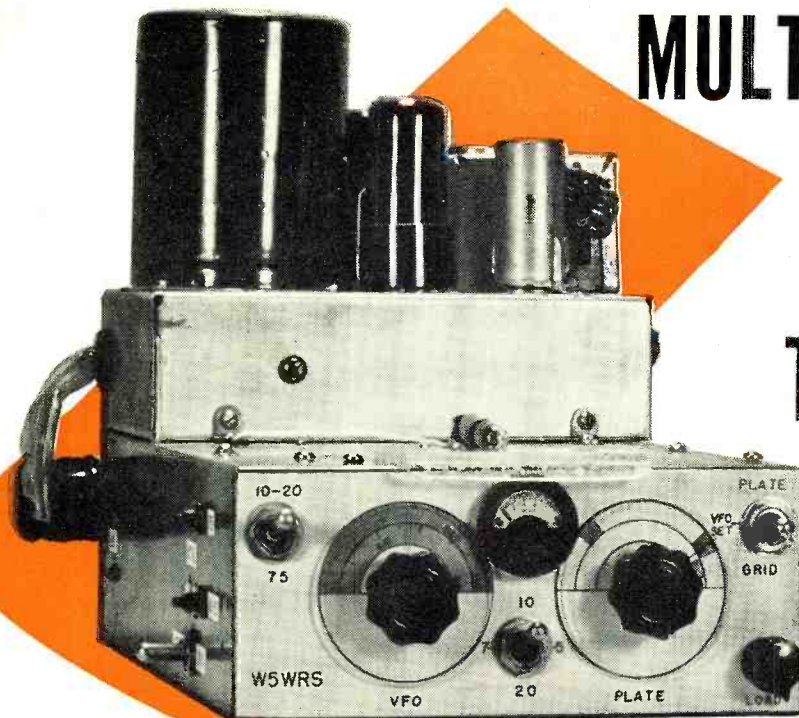

Fig. 1. Front view of the complete 30-watt v.f.o. transmitter. A multi-band tank circuit and front-panel loading control add to operating convenience.

By

LOREN C. WATKINS, JR.

W5JXO

Construction details on a versatile mobile transmitting installation. Features include multi-band operation, two tubes in the r.f. section, bandswitching, v.f.o. or crystal frequency control, and a high-efficiency audio system. Several interesting modifications of the auto receiver are also described in some detail

A COMPLETE mobile transmitting installation which embodies most of the desirable features of performance and operating convenience that characterize the usual fixed-station installation is not only possible but highly practical. This article describes the installation made by Earle Fletcher, W5WRS, as adapted to a 1951 model *Chevrolet* sedan. The rig pictured is a battle-scarred veteran of many thousands of miles of travel and has provided reliable communications under nearly any condition that a mobile station would normally encounter.

Experience has shown that the planning stage for a mobile installation should include consideration of the entire system—including the power source, transmitter and receiver control system, receiver modifications, etc.—as a coordinated scheme if the utmost in convenience, performance, and operating enjoyment is to be had.

The power input to the transmitter final amplifier should be limited to about 30 watts if undue battery trouble is to be avoided. As low as 15 watts input power, with a really good audio system and a resonant antenna, will do a surprisingly good job of communicating, even on the 75-meter band.

The R.F. Unit

The entire r.f. portion of the rig

uses only two tubes, V_1 and V_2 (Fig. 3). The 6AG7 works in a conventional electron-coupled Colpitts oscillator, with one grid tank working on 3.8 mc. and the other grid tank operating on 7.0 mc. The 6AG7 doubles to give 20 meter operation, or quadruples for 10 meters. The 2E26 final amplifier works straight-through on all three bands. Seventy-five meter crystals are used for that band, and 40 meter crystals are used for 20- or 10-meter output. The v.f.o. main tuning condenser, C_1 ,

should be set at its minimum capacity position for crystal operation, although the crystal may actually be "rubbered" over a small frequency range if desired. Trimmer condensers C_1 and C_2 set the upper frequency limit to which the v.f.o. will tune, and C_3 and C_4 are the band-spreading condensers.

Align the v.f.o. circuit by setting C_1 at minimum capacity; adjust C_1 or C_2 for the proper output frequency at the high-frequency end of the band; and then adjust C_3 and C_4 for bandspread over the entire dial on 75 meters, and nearly so on 10 meters. When calibrating the 10-meter scale keep in mind the harmonic relationship between 20 and 10 meters, so that none of the 20-meter band will be lost on the low frequency edge. In other words, adjust C_1 for the high end of 10 meters, and C_3 for the low end of 20 meters. The 20-meter calibration will occupy about one third of the dial because of the relatively narrow band.

The grid coils are located near the main tuning condenser, with trimmers C_1 and C_2 mounted on the left edge of

Fig. 2. Installation of the versatile mobile rig in a 1951 *Chevrolet* sedan. The modulator chassis projects up under dash at rear of the r.f. chassis.

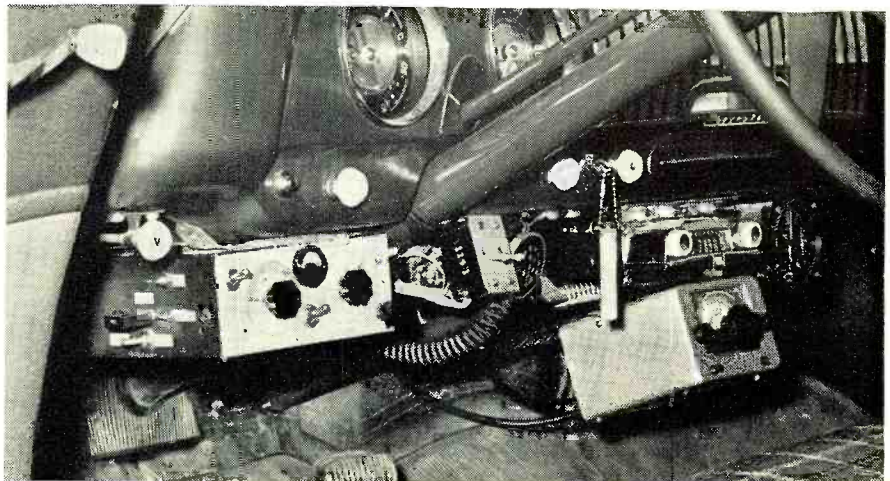

the chassis near the crystal socket. C_5 and C_6 are soldered with heavy leads directly from C_7 to S_2 . All of the v.f.o. components should be mounted as rigidly as possible and the wiring done with heavy bus-bar wire, remembering that the transmitter will be subjected to considerable shock and vibration in the automobile. The stability and drift characteristics of the v.f.o. are quite adequate, even on 10 meters.

Coils L_3 and L_4 are mounted on a small bracket in the approximate center of the v.f.o. compartment. A toggle switch of the center-"off" variety switches the coils for doubling to 14

mc. or quadrupling to 28 mc. in the 6AG7 plate circuit. The coils are self-resonant with the stray capacity in the circuit and are sufficiently broadband that no loss of grid drive occurs when tuning the v.f.o. across an entire band. Adequate drive is obtained on 3.8 mc. without an additional tuned circuit. If more than 2.5 ma. of grid drive is obtained when these coils are peaked, a 1-watt carbon resistor of the proper value to reduce the grid current to 2.5 ma. (with the final amplifier loaded) should be shunted directly across each coil. Values of 10,000 ohms or less will probably be found to be in the proper range.

The 2E26 output tank circuit is of the multi-band type and requires no switching. All three bands are tuned by a single 180-degree rotation of C_{15} . The 75-meter band will tune near maximum capacitance, and the 20-meter band will also tune near maximum capacitance but at slightly less capacity than 75 meters. The 10-meter band will tune near minimum capacitance. One important precaution is to see that the 75- and 20-meter bands do not tune at exactly the same spot on the dial, as excessive harmonic output would result. This can be corrected by removing a turn or two of wire from the high fre-

Fig. 3. Complete circuit diagram and parts list covering the multi-band mobile transmitter. See Figs. 4, 7, and 8 for other circuit data.

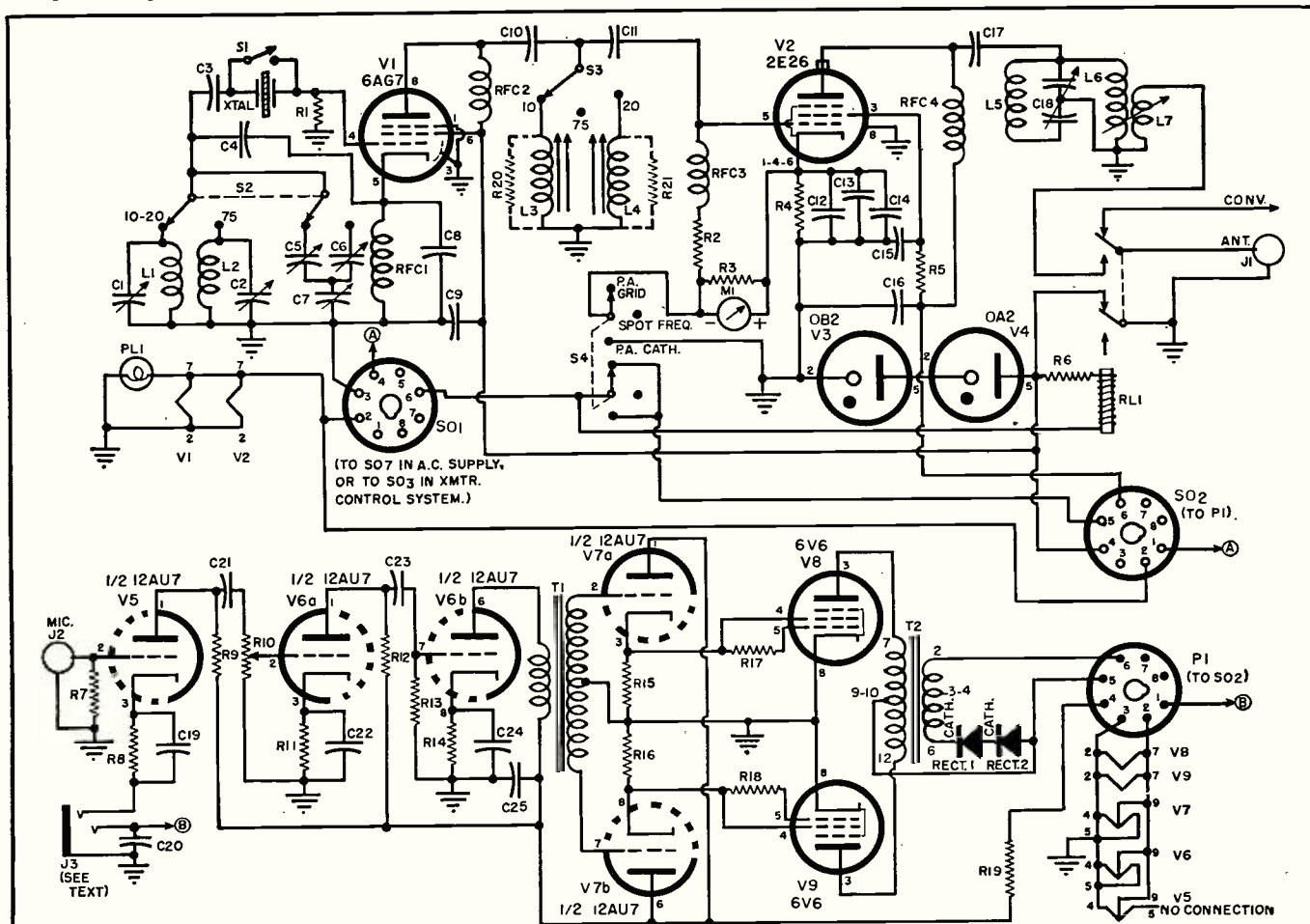

- R_1 —47,000 ohm, 1/2 w. res.
- R_2 —22,000 ohm, 1 w. res.
- R_3 —5 ma. meter shunt
- R_4 —95 ma. meter shunt
- R_5 —35,000 ohm, 20 w. wirewound res.
- R_6 —2500 ohm, 50 w. wirewound res.
- R_7 —1 megohm, 1/2 w. res.
- R_8 —1000 ohm, 1/2 w. res.
- R_9 —50,000 ohm, 1 w. res. (low-noise, metallic-film type. Continental Carbon X or equiv.)
- R_{10} —250,000 ohm, audio-frequency taper pot.
- R_{11} —1800 ohm, 1/2 w. res.
- R_{12} , R_{13} , R_{14} —100,000 ohm, 1/2 w. res.
- R_{15} —470,000 ohm, 1/2 w. res.
- R_{16} —820 ohm, 1/2 w. res.
- R_{17} , R_{18} —22,000 ohm, 1/2 w. res.
- R_{19} —1000 ohm, 1 w. res.
- R_{20} , R_{21} —See text
- C_1 , C_2 , C_3 , C_4 —4-80 μ fd. mica trimmer
- C_5 —100 μ fd. silver mica cond.
- C_6 —200 μ fd., silver mica cond.
- C_7 —50 μ fd. midget variable air cond.
- C_8 —1000 μ fd. silver mica cond.
- C_9 , C_{10} , C_{13} , C_{15} —0.05 μ fd., 500 v. disc ceramic cond.
- C_{12} —0.1 μ fd., 500 v. disc ceramic cond.
- C_{13} , C_{14} —0.01 μ fd., 500 v. disc ceramic cond.

- C_{16} , C_{17} —0.02 μ fd., 1250 v. mica cond.
- C_{18} —140/140 μ fd. variable air cond. (Bud MC Dual, Type 912A)
- C_{19} , C_{20} , C_{21} —25 μ fd., 25 v. elec. cond.
- C_{22} —0.05 μ fd., 500 v. mica cond.
- C_{23} —0.02 μ fd., 500 v. mica cond.
- C_{24} —16 μ fd., 450 v. elec. cond.
- S_1 —S.p.s.t. toggle sw.
- S_2 —D.p.d.t. toggle sw.
- S_3 —S.p.d.t. toggle sw., center-"off" type
- S_4 —D.p.d.t. toggle sw., center-"off" type
- J_1 —Motorola-type jack (Cinch No. 81F)
- J_2 —Shorting-type microphone connector (Amphenol 75-CL-PCM1)
- J_3 —Three-way microphone jack
- SO_1 , SO_2 —Octal socket
- P_1 —Octal plug
- PL_1 —6.3 v. pilot lamp
- RL_1 —D.p.d.t. relay, 117 v.a.c., 445 ohm d.c. resistance (Allied Control Type BO)
- $RECT.1$, $RECT.2$ —100 ma. selenium rectifier
- M_1 —0-1 ma. midget meter, 1" mounting hole
- RFC_1 , RFC_2 , RFC_3 —2.5 mhy., r.f. choke (National R-50)
- RFC_4 —2.5 mhy. r.f. choke (National R-100)

- T_1 —1:3 ratio audio interstage trans. (Chicago 1N-14, see text)
 - T_2 —Multi-match 15-watt modulation trans. (UTC Type CVM-O)
 - L_1 —9 t. 1" dia., 16 t. per-inch (#3015 "Mini-inductor")
 - L_2 —24 t. 1" dia., 16 t. per-inch (#3015 "Mini-inductor")
 - L_3 —7 t. #24 en., closewound on 3/8" dia. slug-tuned ceramic form (Cambridge Thermionic)
 - L_4 —31 t. #26 en., closewound on 3/8" dia. slug-tuned ceramic form (Cambridge Thermionic)
 - L_5 —14 t. 1" dia., 8 t. per-inch (#3014 "Mini-inductor")
 - L_6 —21 t. 1" dia., 16 t. per-inch (#3015 "Mini-inductor")
 - L_7 —8 t., 1/2" dia., 16 t. per-inch (#3003 "Mini-inductor")
- Xtal.—See text
 V_1 —6AG7 tube
 V_2 —2E26 tube
 V_3 —OB2 tube
 V_4 —0A2 tube
 V_5 , V_6 , V_7 —12AU7 tube
 V_8 , V_9 —6V6 tube

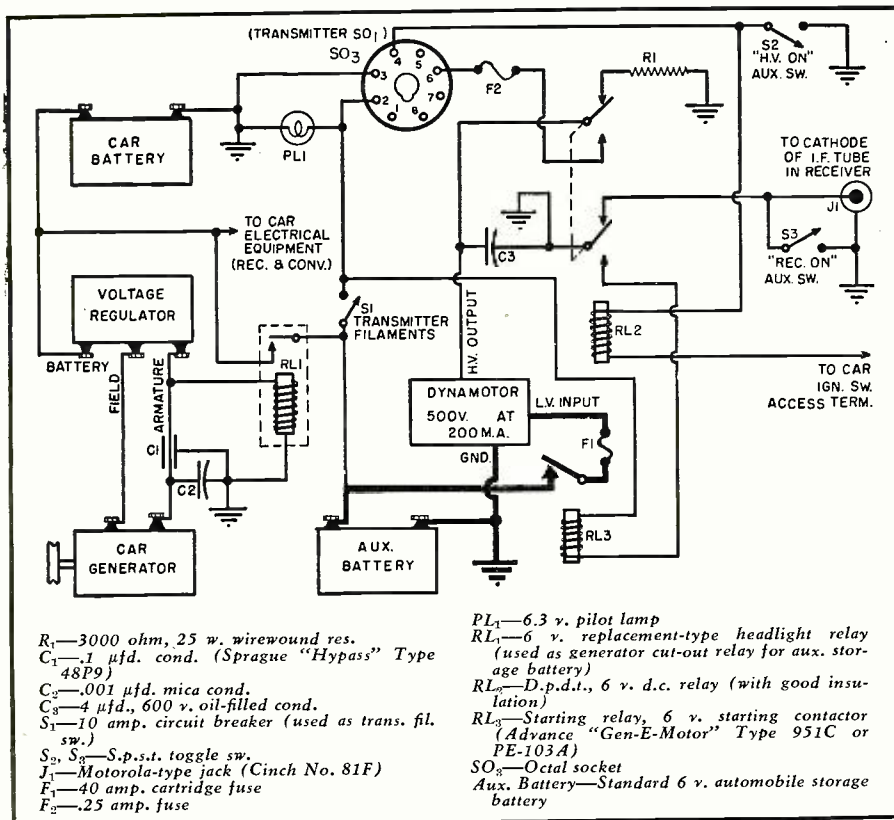

Fig. 7. Schematic of the transmitter control system. The auxiliary cut-out relay and battery may be omitted and connections made directly to regular auto battery.

within a standard 7 x 12 x 3 inch steel chassis. The v.f.o. and plate tuning dials are made from 1/16-inch plastic stock and are 2 1/4 inches in diameter. They are cemented to the knobs, which have been filed smooth on the back side. The dial calibrations and switch markings are made on white Bristol board, cut to cover the entire front of the chassis and cemented to it.

The front panel is illuminated by an edge-lit piece of clear plastic, 1/4-inch

thick. The plastic is heated in boiling water and a right-angle bend made along one side. The bend will direct the light down on the panel front. The edge of the plastic nearest the pilot lamp has notches sawed in it to pick up the light and distribute it evenly throughout the plastic. The result is pleasing and adequate.

The Modulator Unit

The class B modulator utilizes type

Fig. 8. Circuit diagram of the a.c. power supply which is capable of operating the complete mobile radio installation, including auto receiver and converter.

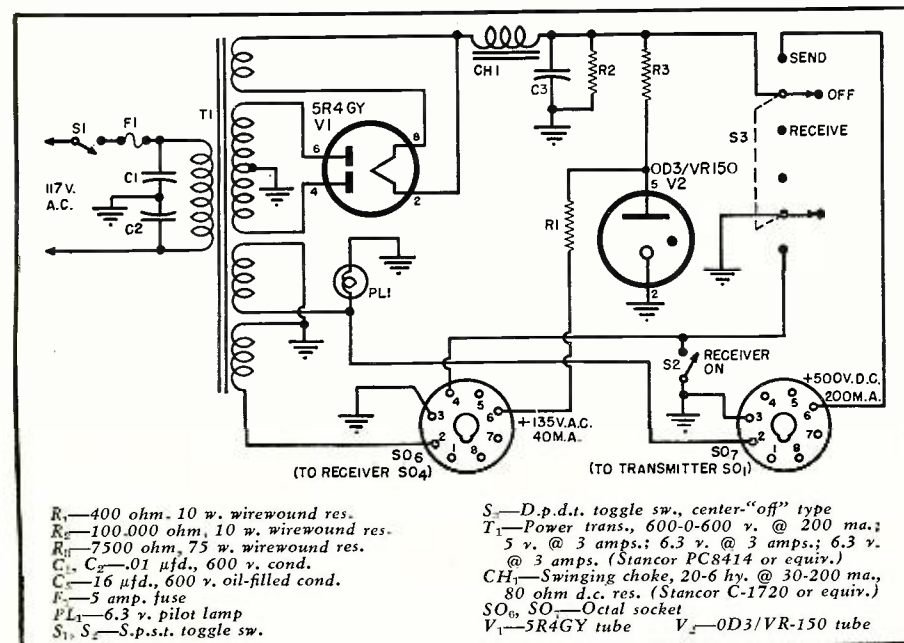

6V6 tubes in the popular zero bias circuit. Driving power for the output stage is furnished by the cathode-follower driver stage, V₁. The interstage transformer, T₁, shown in the photographs is physically larger than necessary, as it was originally installed on an experimental basis and never removed. A smaller unit, such as the Chicago IN-14, will operate perfectly and occupy much less space.

The speech amplifier input tube may be replaced by a 6C4, if desired, although we have used one-half of a 12AU7 so that it would be necessary to carry only a 12AU7 and a 6V6 as modulator spares. Note that the heater of the unused half of the 12AU7 is not connected into the circuit. Crystal or high-impedance dynamic microphones are plugged into J₂, and carbon microphones into J₃. When J₂ is in use, a shorting plug must be kept in J₃ to complete the V₅ cathode circuit to ground. If it is desired to use a push-to-talk type microphone at J₂, this connector should be replaced with a two-pin connector and the control lead connected to the tip of J₃, or directly to pin 1 on P₁.

The T₂ terminal connections (Fig. 3) are for the CVM-O modulation transformer and are connected to provide the proper impedance match between the 17,000 ohm plate-to-plate load of the 6V6's and the 8000-ohm load of the class C final amplifier, for the maximum input of about 30 watts.

Two selenium rectifiers in series with the secondary of the modulation transformer provide automatic high level negative peak clipping. This is not the best system for increasing the average audio power but is simple, effective, and highly dependable for mobile work. The values of condensers C₁₆ and C₁₇ have been adjusted to provide attenuation of the audio frequencies above 3000 cps, thereby effectively filtering the clipping harmonics and maintaining a narrow transmitted bandwidth. Since clipping acts to overemphasize the bass frequencies, condensers C₂₁ and C₂₃ have been adjusted to provide attenuation below about 300 cps.

Several models of this modulator, using the type CVM-O transformer, have delivered over 20 watts of sine-wave power into an 8000-ohm load resistor. This would indicate that the transformer is conservatively rated. The 6V6's draw about 15 ma. resting current, which increases to approximately 70 ma. for 20 watts sine-wave output power (500 volts plate voltage). The speech amplifier draws a total of 15 ma., making a total resting current of only 30 ma. The 6V6's are operated well within ratings, except for plate voltage, and no trouble of any kind has been experienced with voltage breakdown.

The entire modulator is constructed on a standard 5 x 7 x 2 inch steel chassis.

Receiver Modifications

Most late-model auto receivers em-

ploy a vibrator power supply circuit similar to the one shown in Fig. 4. To permit either a.c. or battery operation, it is necessary to break the leads marked "X" in the schematic and bring them out to an octal socket mounted on the receiver case. A jumper plug is kept in the socket for normal battery operation. W5WRS chose to silence the receiver on "transmit" by merely opening the i.f. tube cathode ground connection, which is an effective method.

The beat frequency oscillator tube, V_1 , and associated components are mounted on a small bracket and bolted inside the receiver case, with the b.f.o. "on-off" switch, S_3 , located so as to be accessible from the front. To adjust the b.f.o., tune in a station for maximum signal strength; then turn on the b.f.o. and adjust C_2 for zero beat. The b.f.o. is almost a "must" for v.f.o. operation.

A simple, but effective, noise limiter may be installed by connecting a 1N34 crystal diode, in series with a toggle switch, across the power output tube head has fixed bias applied to its grid instead of cathode bias as shown, merely connect the switch to the bottom end of the grid resistor instead of to ground.

Another extremely satisfying modification is to have the auto receiver crystal-controlled on the 1440 kc. output frequency of the converter (assuming a tunable type is used, such as the Gonset "Tri-Band"). The converter dial calibration is then always accurate, and time is saved in not having to make a critical tuning adjustment of the receiver dial, especially on those receivers not equipped with push-buttons. With the 1895 kc. crystal in the circuit, tune the receiver dial to the general region of 1440 kc. and the crystal will suddenly lock in and control the oscillator frequency. The 1440 kc. converter output will then produce the desired 455 kc. i.f. frequency. The auto receiver dial may be rocked back and forth over a quite wide range for peaking the input circuits for maximum response; a beneficial procedure since few receivers are perfectly aligned. The crystal and its "in-out" switch, S_1 , should be mounted as close as possible to the converter tube, and the switch should be operated by drilling a hole in the handle and inserting an extension rod, if necessary.

The Control System

The control system shown in Fig. 7 is designed around the popular PE-103A dynamotor, but other dynamotors or vibrator supplies may be used with equal success. Switches S_2 and S_3 are mounted on a small dash bracket, along with RL_2 , R_1 , and J_1 . RL_2 cannot be energized unless the auto ignition switch is turned on. The ground return is then made either by the microphone push-to-talk switch, or the auxiliary dash switch, S_2 . The contacts on RL_2 provide the ground re-

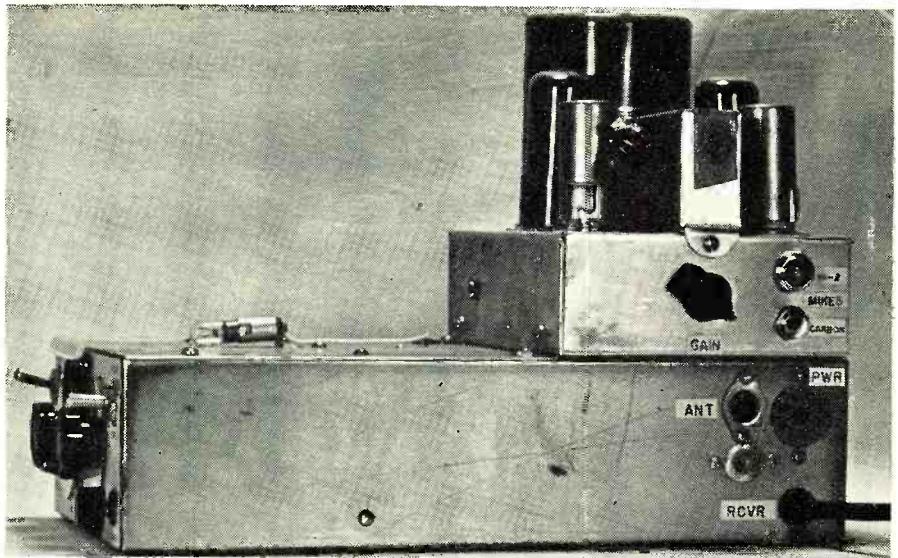

Fig. 9. Right-side view of unit showing transmitter power and antenna connectors.

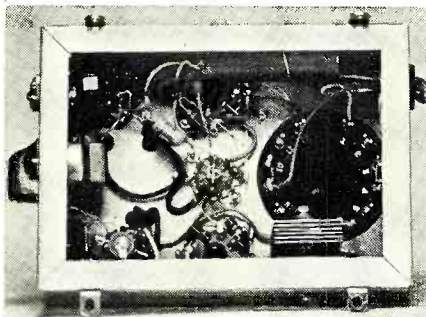

Fig. 10. Bottom view of modulator unit. The selenium rectifiers are stacked on one bolt and mounted with insulated washers near modulation transformer. Parts layout in this circuit is not critical.

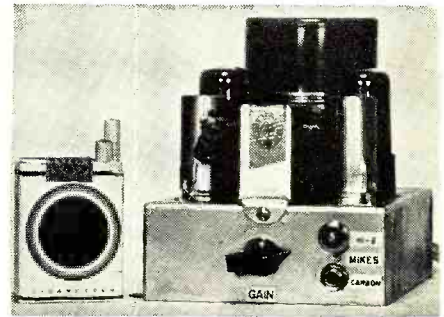

Fig. 11. The compact, but powerful, modulator may be removed from the r.f. chassis and mounted remotely at any convenient location under dashboard of automobile. See text for complete details.

turn for the cathode circuit of the receiver i.f. tube on "standby," or the ground return for the dynamotor starting-relay coil, RL_3 , on "transmit." The auxiliary switch, S_3 , permits the receiver to be turned on for zero beating or monitoring purposes while the

transmitter is on. RL_3 cannot be energized unless the main filament circuit breaker, S_1 , is closed. One set of contacts on RL_2 connects the dynamotor high voltage output—and bleeds filter condenser C_3 —to ground on "standby."

(Continued on page 134)

Fig. 12. Left-side view of transmitter showing crystal socket, crystal-v.f.o. switch, and cable between the modulator chassis and radio frequency chassis.

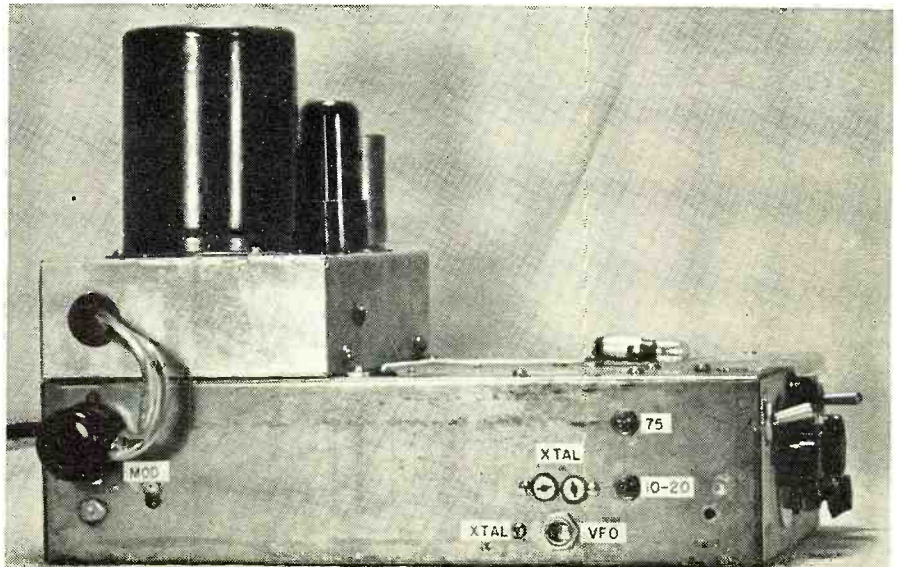

SELL PORTABLES YEAR-ROUND

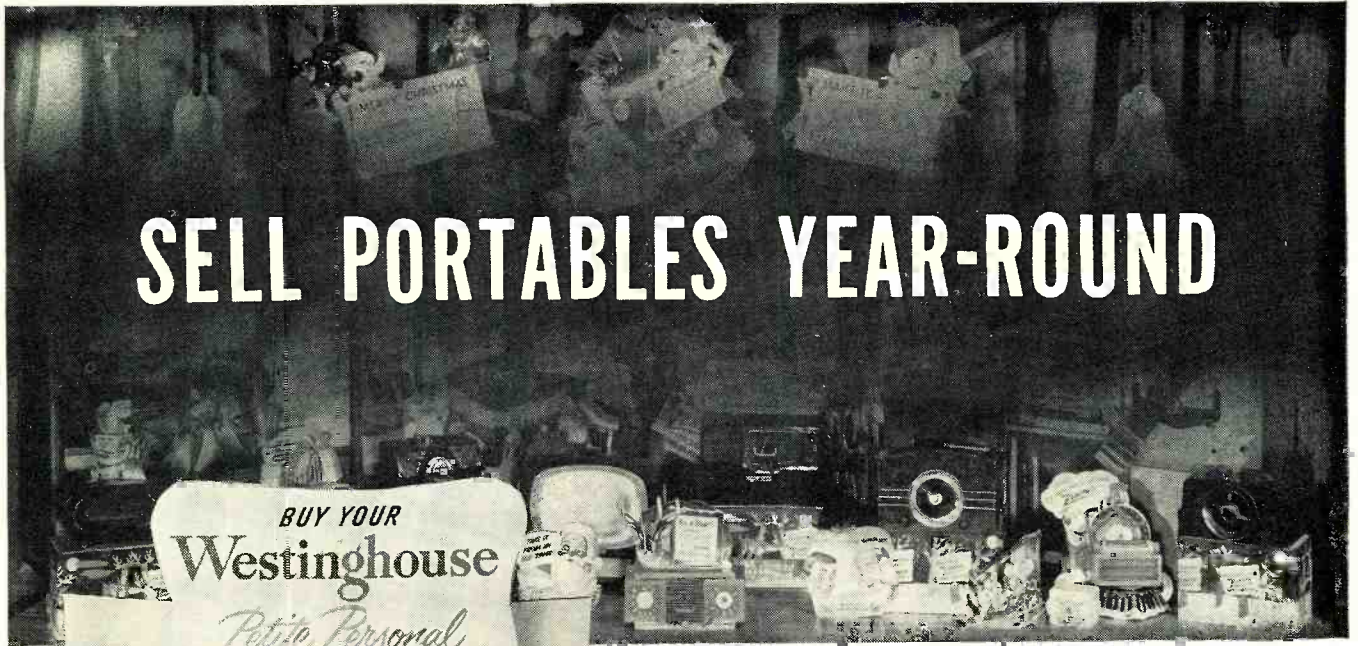

A seasonal display, such as this effective Zenith window, helps to promote the sale of portables the year-round instead of just in the summer.

Portables can be merchandised profitably both summer and winter. Climb on this "gravy train".

FOR too long the portable radio has been considered a seasonal stepchild. You either made your "killing" during the spring and early summer months or you just weren't in the portable business. Time, however, has made changes even in the selling processes of portable radios. At least, no longer does the manufacturer think of limited, seasonal horizons when his mind turns to portables. Most dealers as yet are not so inclined.

Probably no definition more aptly describes a portable than the one subscribed to by this writer—"the radio away from home." The recent technical advances made in their design have given portables a greater range than ever before. Longer lasting batteries have made them more economical. The passing years have also set aside the idea that summertime means vacation-time. Today a great many people take their time-off during the winter months, either at southern beaches or snow-imbedded resorts. Thus, there are many winter vacationers who are in the market for portables. Probably typical of the unseasonal marketing is the front cover shot; it was taken on a hot July afternoon. Certainly if a Christmas tree can be promoted in July, a portable can be promoted in December.

Recognizing the change in trend, manufacturers of portables are preparing merchandising programs based on year-round selling. A look at dealers' windows gives a practical indication of the portable trend. More and more
(Continued on page 105)



This Westinghouse display is only one of the many such sales aids available from radio manufacturers.

Hallicrafters offers a new model portable for holiday market.

This Emerson-Pan-American tie-in is aimed at the travel market.



RCA Victor finds a ready market for its portables during the Christmas-gift season.

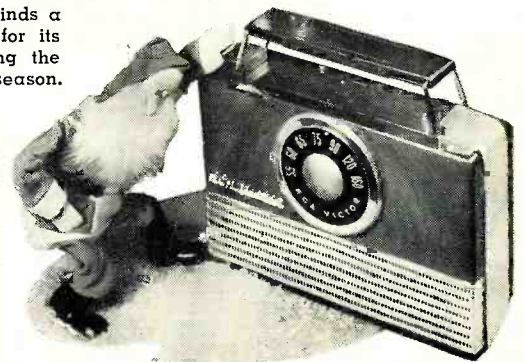

A CARRIER-CURRENT INTERCOM

By

IRVING GOTTLIEB

Complete construction details for building a trouble-free intercom system which requires no interconnecting wires.

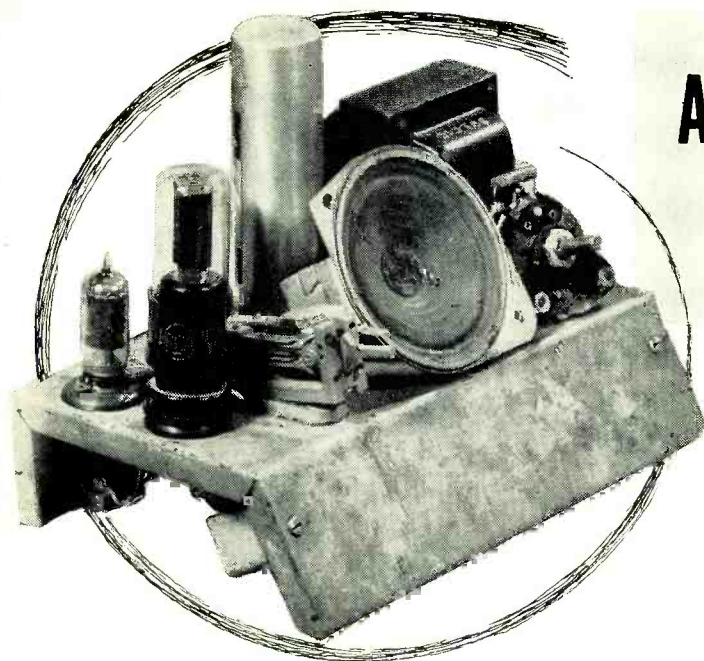

Front view of the home-built intercom with cabinet removed to show the parts layout. Two such units are required in the system. The speaker is the "mike" on "transmit."

THE DEVICE to be described provides a simple means for communicating between rooms or sections of a dwelling, or even between buildings. The medium of transmission is neither radiant energy nor the bothersome wire connections used in conventional intercommunication systems. Instead, the a.c. power lines are utilized as the connecting link between the transmitter and receiver. Thus, to establish communication between two points, it is merely necessary to plug two identical units into the wall socket, one at each station. Both units are normally receivers, but are converted into transmitters when a spring-loaded switch is actuated whenever the operator wishes to speak.

The presence of the power line frequency would make it quite difficult to use the lines as a feeder for the actual audio frequencies. However, by employing a modulated radio frequency, discrimination against the relatively low power line frequency is easily accomplished. The power line then becomes a low characteristic impedance transmission line and the transmitter and receiver tank circuits, in conjunction with the line, resemble the link-coupled resonant circuits often used in amateur transmitters. The power line is not a good radio-frequency transmission line. Most of the radio-frequency energy injected into a power line is dissipated in poor dielectric material, electric appliances, transformers, and meters. Nevertheless, a moderate amount of transmitting power and suitable amplification in the receiver will result in sufficient compensation for these losses and render good communication possible over the distances involved. The carrier frequency is approximately 150 kilocycles. Although other frequencies could be employed, rapid attenuation

results if we use frequencies much higher than this. At lower frequencies there is less attenuation, but trouble is encountered from line noises due to motors, power frequency harmonics, leaky insulators, etc. The "Q" of the resonant circuit is necessarily low in order to accommodate the sideband energy. As a consequence, a very low carrier frequency will not provide

high discrimination against line interference. If the experimenter desires to deviate from the chosen carrier frequency, these facts should be kept in mind.

Two identical units should be constructed from the schematic diagram of Fig. 1. The circuit consists of three tubes, one of which is a rectifier. During "receive," a germanium diode functions as a detector with the remainder of the receiver comprising a

(Continued on page 138)

Fig. 1. Complete circuit diagram of communicator. Two such units are required.

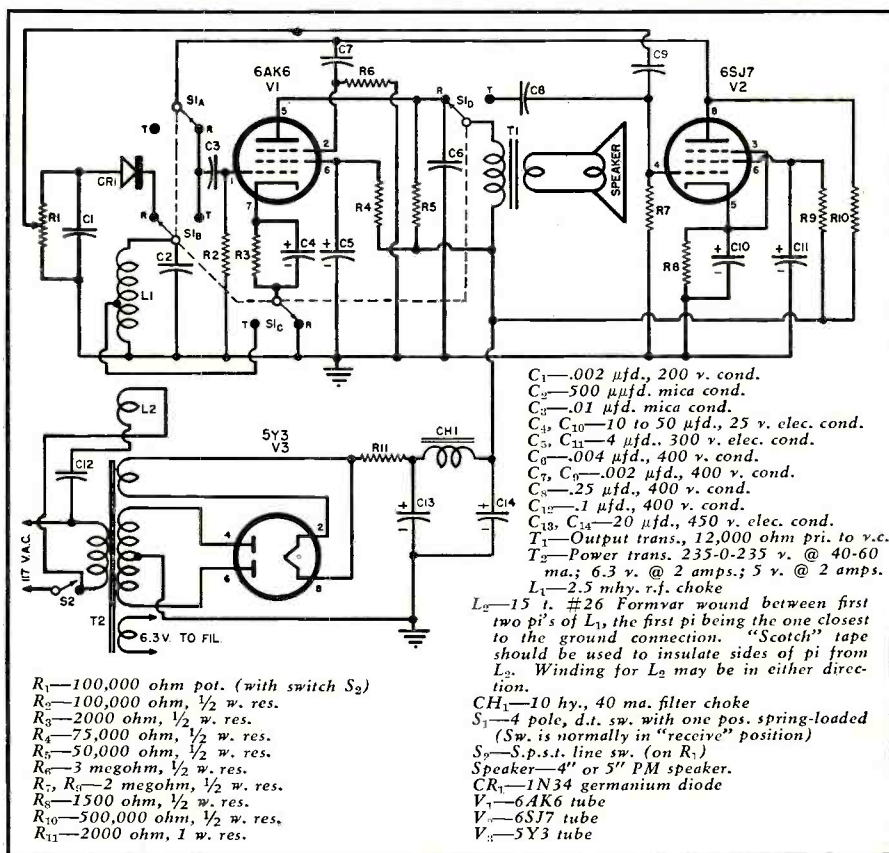

LOCATING

TV

INTERMITTENTS

By

WALTER H. BUCHSBAUM

Television Consultant
RADIO & TELEVISION NEWS

Hints on combating the most time-consuming and annoying service problem encountered by the television technician.

THE dread of every radio technician is the set that plays only intermittently. With the increased complexity of the television receiver, the intermittent defects are correspondingly more difficult to locate and repair. Our readers are all familiar with the set that suddenly goes dead but gives excellent pictures as soon as the technician enters the house. The customer complains that his receiver appears to go bad only at certain hours, or will play only for half an hour at a time, or loses the picture every time Junior jumps down the stairs. All these are symptoms of an intermittent defect and most technicians warn the owner that intermittents are hard to find and usually run into a higher repair bill than a more definitive defect. Difficulties of this type can be overcome by using a methodical approach and a few simple tricks known to many experienced technicians. In this article we present the most efficient and direct method for eliminating intermittents using a minimum of instruments and time.

Localizing the Defect

When a TV set has good sound but nothing appears on the screen we naturally need not check the sound section. We know that the defect must be in the picture sections only. In the same manner we can localize the intermittent defect. Fig. 2 shows the block diagram of a typical TV receiver and the various sections which perform different functions. Depend-

ing on how the intermittent defect appears, it is possible to determine the section in which it is most likely to occur. Table 1 lists the most frequently encountered intermittents and the section in which they usually originate.

Once the section in which the intermittent occurs is determined, the actual culprit can be found by two different methods. The first and sometimes the fastest is to replace suspected parts. This is only expedient in cases where only a few parts can cause the defect as in keystoneing where another deflection yoke can quickly be substituted and there is a good likelihood that this will cure the defect. Where a number of tubes and their circuits are suspected it is not practical to replace all of them at once. The second method must be applied which consists of finding the guilty component by causing the in-

Fig. 1. A simple circuit for supplying variable a.c. to check intermittents caused by either high or low power line voltage.

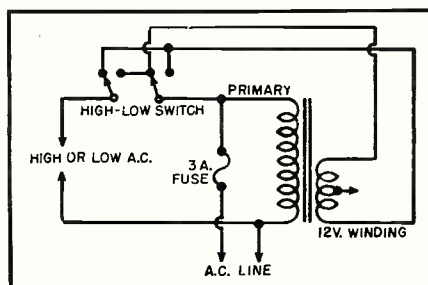

termittent at will. But the difficult part about most intermittent defects is that they occur at apparently random intervals and it is too time consuming to sit and wait until a part breaks down. The main trick in servicing such intermittents is to reproduce whatever causes the breakdown and then locate the defective part.

Types of Intermittents

Intermittent defects are due to any of these causes.

1. Mechanical: This includes poor solder joints, broken wires, loose elements, microphonic tubes, intermittent tubes, loose metal parts inside the chassis, connections almost touching ground or other terminals, poor socket contact, broken or charred insulation, etc.

2. Thermal: Heat causes expansion of metal parts and often produces a mechanical intermittent due to near-shorts, or near breaks in wiring. In addition, heat affects the electrical operation of resistors and condensers. Electrolytic condensers and oil filled types are especially susceptible to heat. The electrolyte may dry up or wax insulation may melt, both of which result in changed capacitance and therefore distortion or circuit failure. Carbon resistors may increase as much as 50% in resistance value under excessive heat and selenium rectifiers show a greater tendency to arc or break down under heat.

3. Voltage: Abnormally high or low voltages, either due to line voltage variations or defective power supplies, can cause intermittents. In many instances safe voltage ratings of parts can be approached or exceeded; however, incorrect voltage on some tubes can cause tube failure. In the high voltage section excessive voltage can cause arcing or corona and insufficient flyback voltages may reduce picture size or lower brightness. Low filament voltage means less amplification through each tube, weaker pictures, and shorter tube life.

4. Humidity: This factor usually affects only the HV section and certain types of condensers. High humidity can cause arcing, corona, and HV breakdown where the insulation is barely sufficient in dry conditions. Humidity also affects paper type condensers having a not too substantial wax coating. A combination of humidity and salt content, found near the seashore, is often responsible for corrosion of chassis or other metal parts causing poor electrical contact and therefore mechanical intermittents.

The most vexing type of trouble is usually the one that takes place in the customer's home, but fails to show up on the service bench. The reason for such intermittents lies in the different operating conditions in the home. Where a mechanical intermittent is observed it is simple enough to duplicate the effect. Jarring the set, banging the bench or rapping individual tubes and parts will help locate

this type of defect. Heat intermittents can also be brought out without too much trouble in the shop and, by supplying different voltages to the set, conditions of varying line voltage can be simulated. Excessive humidity presents a problem, but with a little ingenuity almost any humidity condition can be simulated.

Mechanical Intermittents

Whenever the defect can be traced directly to such mechanical actions as floor vibration, jarring the set, moving a chair, banging a door, switching stations, closing windows, or any other commonplace action which might give some mechanical shock to the chassis, a mechanical intermittent exists. The conventional way of locating it consists of first tapping each tube lightly with a finger, screwdriver handle, or a tube tapper. If none of the tubes appear defective the entire set is jarred repeatedly in the hope that the intermittent defect will become permanent and can then be located by regular troubleshooting procedures. Finally the chassis is inspected closely, individual parts are tapped or pulled until, by chance, the defect is found.

To speed up this procedure we suggest a little thought first as to which section of the receiver could possibly cause the observed defect. Connecting a meter to the "B plus" bus will show if the voltage varies greatly during the defective period. This will automatically limit the possible defects to only a few parts in the set. Here are some mechanical intermittents which are a bit unusual and tricky. If the picture tube appears defective or intermittent try rotating, tapping, or tilting it. Sometimes small pieces of the internal coating get loose and cause shorts in the electron gun. Shaking these fragments toward the bulb of the tube will make them harmless unless the tube is again tilted back. If the tube pins appear intermittent in any tube, apply a soldering iron to each pin for at least two minutes. This will cause the internal solder joint to be solid again. Occasionally it appears that no possible bad connection can be found at all and many such defects are cured by applying a heavy duty iron to every ground connection to insure good contact.

Thermal Intermittents

When the defect appears only after the set has been operating for a while the defect is most likely due to heat. In order to bring such defects into the open it is best to try and localize it to the particular section which goes bad. If the "B plus" is affected the most frequent offender is one of the electrolytic condensers. Substituting a good one, in turn, for each suspected one and letting the set heat up is quite time consuming. Many technicians keep an infrared heat lamp on their benches to reproduce the temperature in the cabinet after a long warm-up period. The heat from such a lamp can be quite intense and could

INTERMITTENT	SECTION
Sound and raster	"B plus" supply, filament shorting
Sound	Audio amp. volume control, sound i.f.
Weak sound	Audio output tube, coupling condenser
Distorted sound	Audio coupling condenser, audio "B plus" filter or bypass condenser, discriminator
Hum	Transformer lamination vibration, video amp. audio filter or bypass, discriminator
Raster	HV, horiz. osc., brightness control, video amp., picture tube
Picture (raster OK)	Video amp., tuner contact
Loss of horiz. sync	Horiz. a.f.c., sync section, horiz. osc.
Loss of vertical sync	Sync section, integrating network, vert. osc.
Loss of both	Sync section, video amp., HV arcing
Change in width	Horiz. sweep, horiz. osc., HV
Change in height	Vert. sweep, vert. osc.
Change in both height and width	HV, "B plus" supply, horiz. sweep
Change in brightness	HV, brightness control, horiz. sweep, video amplifier
Flashing	Video amp., antenna, tuner
Picture overload	Picture i.f., a.g.c. system
Keystoning (trapezoidal raster)	Deflection yoke, horiz. or vert. sweep
Loss of focus	Focus control, "B plus" supply, first anode voltage, HV

Table 1. The most frequently-encountered intermittents and where they originate.

damage parts if left on too long. We recommend putting the heat lamp about a foot away from the suspected part and leaving it on for no longer than 15 minutes. Another use for this heat lamp will be to bake out moisture from HV components before applying new insulation, as described later.

If it seems impossible to localize the intermittent and it is desired to heat up the entire set, the simplest method is to utilize the regular receiver cabinet. Covering all ventilating holes with a blanket or taping them up will prevent ventilation and insure quick heat build-up, thereby hastening the intermittent condition. If the line voltage is increased at the same time the heating will be still more rapid and intense. Whenever a heat run is made it is good practice to connect the set to the a.c. line through a 3 amp. fuse to protect the set in the event excessive current is drawn.

In addition to electrolytics, selenium rectifiers are also very sensitive to heat. Under excessive heat the rectifiers are subject to arc-over or bubbling on the coated side which eventually

means high resistance and lowered "B plus" voltages. The smell of a defective selenium rectifier, however, is always a quick and sure clue to this type of intermittent.

Earlier we mentioned that carbon resistors increase in resistance with heat. The difficult part about locating such a defect is that usually the "cold" resistance is within ratings and measurements must therefore be made while the resistor is hot. Applying the infrared lamp while the ohmmeter is connected will quickly locate this type of intermittent.

Whenever a heat intermittent is suspected be sure to check also for a mechanical failure. Frequently the expansion due to heat causes near-shorts, poor solder joints and other mechanical defects in the wiring. Melted insulation, discolored resistors or condensers are all a sign of overheating and often cause mechanical defects.

Voltage Intermittents

Defects due to low a.c. line voltage are most frequent in the HV and sweep section. Perhaps the most com-

(Continued on page 134)

Fig. 2. Block diagram of an intercarrier TV set showing the various sections.

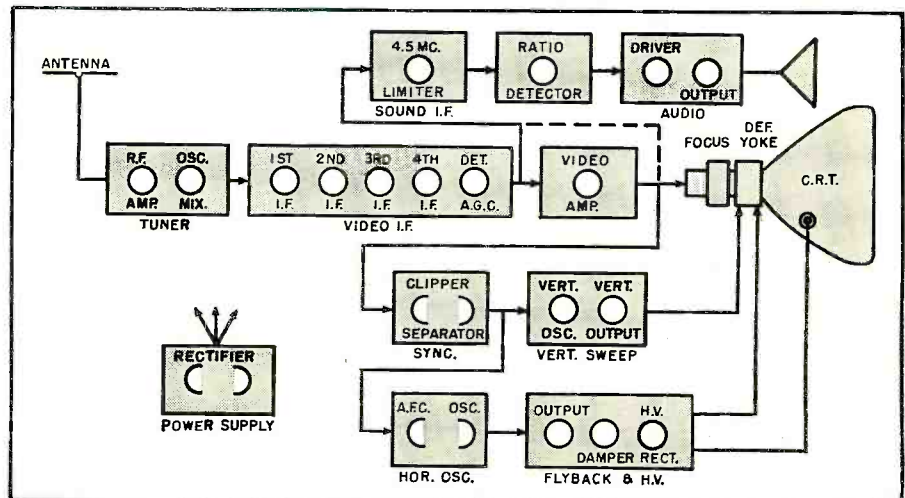

THE CASCADE-CASCADE ON 2 METERS



Fig. 1. Over-all view of the cascade-cascade for 2-meter operation.

By

ROBERT B. TOMER, W1P1M

Details on a crystal-controlled, bandpass converter which permits bandspread tuning on communication receiver dial.

PROGRESS in the development of the v.h.f. bands has been paced, for the most part, by the progress made in receiving equipment. For many years, the standard equipment for ham use above 30 megacycles was the superregenerative receiver. There are still those today who cling to the legendary theory that a superregenerative receiver will do about as well as the best superhet, and with much less trouble. Soon after World War II, the majority of these superregen addicts broke down and obtained a 522, thereby learning just how good a v.h.f. superhet could be. The advent of the 522's brought about a major change in the thinking and in the equipment of most v.h.f. men. They doomed the modulated oscillator to the same fate as the Dodo bird—extinction, in other words. With the combination of better receivers and better transmitters, the range and effectiveness of the v.h.f. bands were immediately improved. Such things as regular reception under all conditions, between points 100 or more miles apart, became common practice.

More recently, there has emerged a new trend, or phase, in the develop-

ment of v.h.f. communication. This is the low-noise converter in combination with a standard communications receiver as the i.f. As this trend develops, it is working the same revolution in v.h.f. performance brought about by the 522's some five years ago. There is little room for improvement in transmitters at this time; however, the improvement which can be achieved by a well-designed, low-noise converter is truly remarkable.

There are several types of converters and each has certain advantages.

For ease of classification, they may be grouped as follows: 1. Tuned r.f.—tuned oscillator; 2. Bandpass r.f.—tuned oscillator; and 3. Bandpass r.f.—crystal oscillator.

In the first type, we have what might be called the theoretically ideal design. Such a unit would provide the maximum possible selectivity and, therefore, the lowest noise figure, theoretically at least. However, the design and construction of such a device poses many serious problems. The mechanical problem of gang-tuning three or four r.f. circuits, together with an oscillator; the phys-

ical problem of obtaining short leads; low inductance tuning condensers; adequate shielding between stages; and lastly, but by no means least, the problem of obtaining a drift-free local oscillator, are all very discouraging and tend to turn one away from this approach.

The second classification has many devotees and rightly so, because it has much to recommend it. Perhaps the only drawback is the problem of obtaining a stable oscillator. The degree of stability required depends very much on the selectivity of the receiver used as the 2nd i.f. If maximum selectivity and complete freedom from drift are desired, the answer lies in the third classification of converters.

In the crystal-controlled, bandpass converter, the communications receiver is used as a tunable 2nd i.f. The dial of the communications receiver is the only tuning control and the receiver is used exactly the same as if it were tuning any of the low-frequency channels. The operator has the advantage of bandspread tuning which eliminates the customary critical tuning of the local oscillator in the second type of converter mentioned. Another advantage which will be described in more detail later is the fact that by the proper choice of the injection frequency, the communications receiver dial becomes automatically a frequency calibrated, direct-reading dial for the band you are working. No searching for stations of known frequency to determine the band edges, or the tuning range of the system.

In considering a converter of the type to be described, it is well to consider the separate sections, such as r.f. amplifier, mixer, oscillator-multiplier, and impedance matching transformer, as individual problems in order that they may be studied in more detail.

In general, the major problem in the design of r.f. amplifiers for v.h.f. work is noise. This noise is the noise which is generated largely in the tubes themselves. We would all like a receiver which was completely noiseless until we connected the antenna and then we would like to have the only noise

Fig. 2. (A) Original circuit using transformer coupling. (B) Simplified circuit in which T has been eliminated and an r.f. choke substituted and made series-resonant with the cathode-to-ground capacity (C_{H-K} , shown dotted) in the circuit.

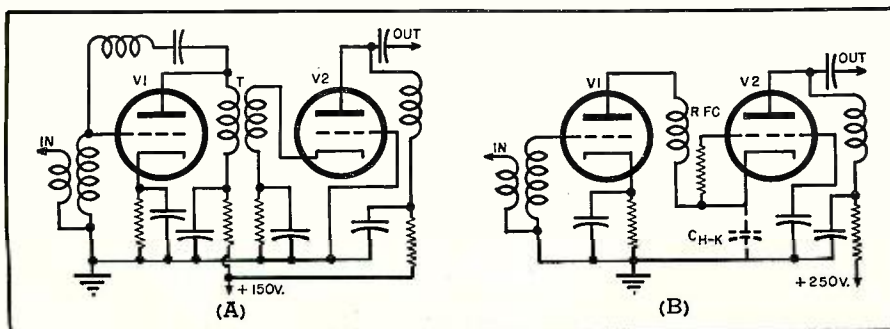

that of signals. This utopian situation may be impossible to achieve; however, we can go a long way toward that goal by reducing the known sources of noise in the receiver. Pentodes, although they offer high gain, are, almost without exception, considerably noisier than triodes. This is due, in large measure, to the additional elements within the tube, each of which contributes some part of the noise. The use of triodes has been restricted, however, because of the high grid-to-plate capacity which tends to cause oscillation. Neutralization can be resorted to; however, this is often quite critical and may be very difficult to achieve when a band of frequencies must be tuned. Any tendency toward regeneration is undesirable since this too increases the noise.

By now, most hams have heard of the cascode circuit for r.f. amplifiers which came out of World War II radar designs. In this circuit, a triode, conventionally connected, drives a grounded-grid triode to achieve a very high order of gain with low noise. The input triode is prevented from oscillating, in the original circuit, by a parallel resonant circuit, consisting of the grid-plate capacity across a small inductance. This LC combination is made resonant at the center of the passband and is broad enough to extend well beyond the band on either side. The high impedance thus created neutralizes the voltage fed back from the plate to the grid which would normally cause oscillation. Another feature of the original circuit was a transformer for coupling the plate of the first triode to the cathode of the grounded grid triode. Both of these devices, although relatively simple, are extra components and serve as additional complications. In the cascade-cascode, they are eliminated in the manner shown in Fig. 2B resulting in a much simpler circuit.

The r.f. choke shown in Fig. 2B is made series resonant with the cathode-to-ground capacity of V_2 at the operating frequency of the amplifier. This low impedance path so reduces the plate-to-ground impedance of V_1 that feedback from the plate-to-grid of V_1 is negligible. The construction of this choke is not critical and its effect covers a wide band of frequencies either side of its resonant frequency. The second simplification is in the elimination of the coupling transformer, T , shown in Fig. 2A, between the plate of V_1 and the cathode of V_2 . This is accomplished by direct coupling the d.c. from V_2 to V_1 and increasing the supply voltage from 150 to 250 volts. The resulting circuit is even more simple when it is reduced to actual wiring since most of the connections are made between the socket terminals themselves and adjacent terminals or ground.

The circuit shown in Fig. 2B is the basic one used in the cascade-cascode. Two cascodes are used in series, cascaded, to provide higher gain, greater circuit simplicity, easier bandpassing.

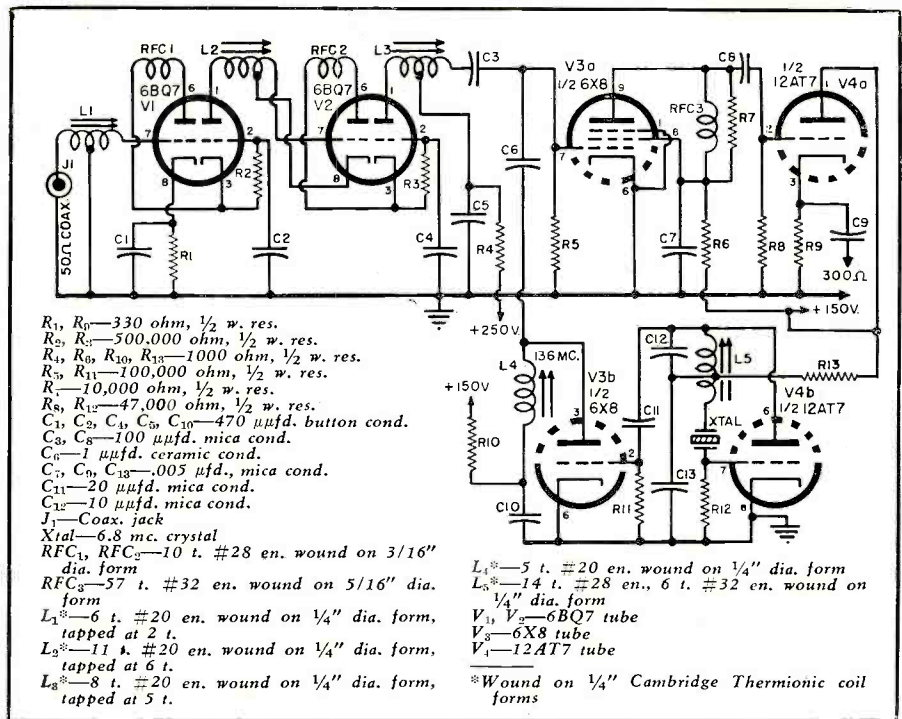

Fig. 3. Complete circuit diagram of the cascade-cascode converter for 2-meters.

The resulting r.f. amplifier provides gains almost unbelievable a few years ago. Two of the latest type television r.f. amplifier tubes are used so that although four triode sections are employed, only two tubes are needed for this part of the converter.

The method of coupling deserves some study since it is largely responsible for the excellent bandpass characteristics of the amplifier. Three double-tuned transformers are used in the amplifier portion of the converter. This permits stagger tuning and makes possible a flat response throughout the 4 mc. 2-meter band, with rapid drop off on either side, with approximately 1 mc. to spare. To see how these double-tuned transformers work, it is necessary to refer to Fig. 4.

Fig. 4A shows a conventional, double-tuned transformer such as those

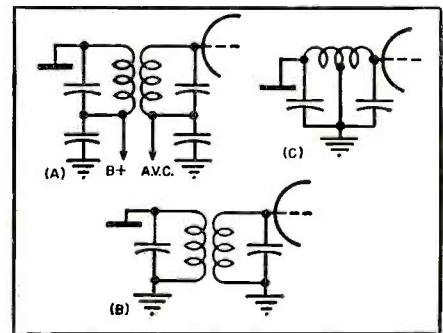
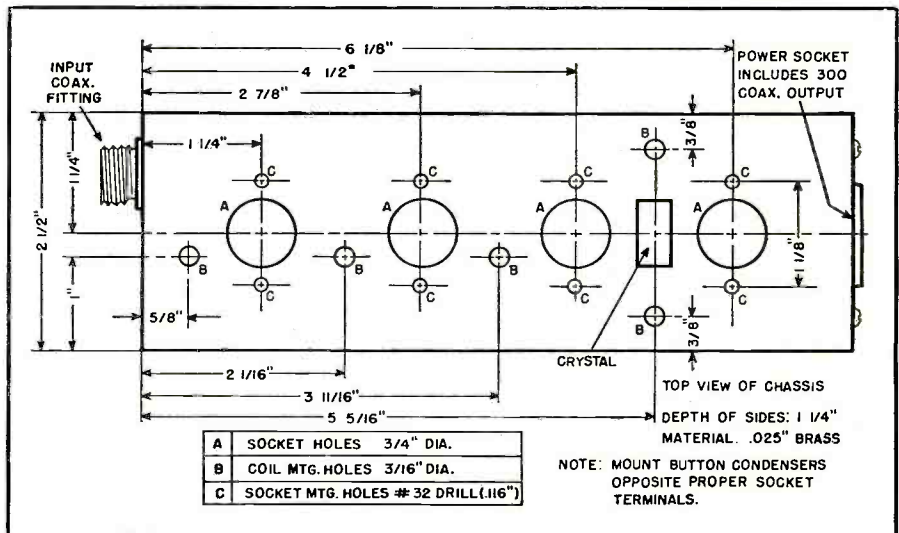

Fig. 4. (A) Conventional, double-tuned transformer. (B) The i.f. or r.f. equivalent circuit. (C) Same circuit redrawn to show two coils wound on the same form, centertapped.

encountered in most i.f. amplifiers. Fig. 4B shows the circuit, neglecting (Continued on page 124)

Fig. 5. Layout for converter chassis. Arrangement should be followed exactly.



A NOVEL CAPACITANCE RELAY

By

RICHARD GRAHAM. W2PDI/1

THE capacitance relay or alarm has long been known and used in industrial plants to handle counting and sorting operations. It has found use in various businesses in connection with door openers and advertising displays. It has been employed as a burglar alarm, to guard dangerous areas of machines, and even as a foul line indicator in bowling alleys. However, its use in the home has never been widespread. Probably the main reason for its non-acceptance is simply one of economy. Most published circuits to date have used eighteen to thirty-five watts for filament power alone. Actually, there are few home applications that would justify continuous operation at this rate. The circuit to be described consumes less than two watts—an amount that will be barely noticeable on the electric bill. Thus, the uses to which this device can be put are limited only by the constructor's imagination. The unit has been used successfully by the author as a training device for the family cat. It developed that the cat had taken a fancy to a particular chair and derived great satisfaction in using it as a scratching board. This, of course, called for immediate action and the capacitance relay was called upon. The feeler antenna, placed under the chair, warned of her approach to the chair, thus steps could be taken before any damage was done. The cat eventually got the idea and we all lived happily ever after.

Before the circuit operation is described in detail, it might be well to describe and define a capacitance relay. Specifically, it is a device which is actuated by any change in the capacitance relation between the feeler antenna and its surroundings. The amount of change the device will tolerate is the "sensitivity." Further, the definition of capacitance describes what type of change will actuate the device. We know from the definition of capacitance that capacitance depends upon the dielectric, the effective area of the plates, and the distance between the plates. The feeler antenna can consist of a piece of wire, a fence, a screen, or a machine, as one plate; the surrounding earth and metal objects as the other plate. A change in the capacitance can be caused by the approach of a human or animal or any metallic object such as an automobile or other machine.

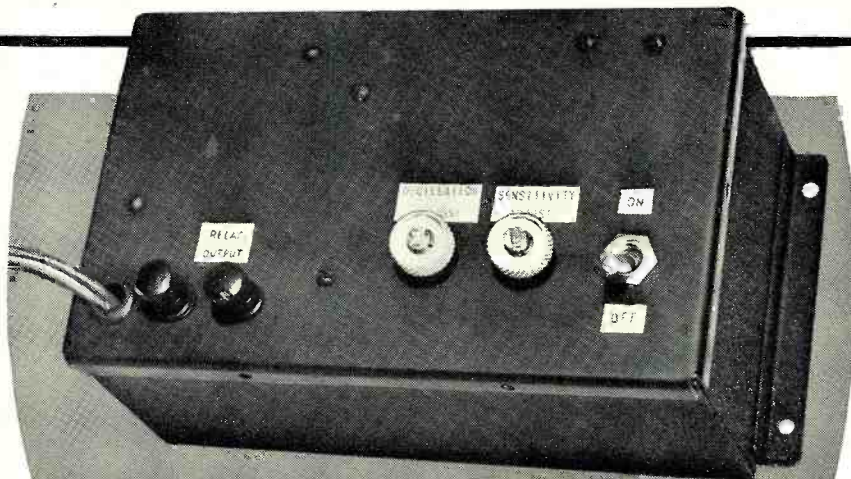

Front panel view of the capacitance relay. The entire unit can be housed in a case measuring $7\frac{1}{2} \times 4\frac{1}{2} \times 3\frac{1}{4}$ inches. A single 12AT7 tube is required.

Construction details on a unit which is designed for continuous operation and draws only 2 watts.

Circuitwise, the capacitance relay consists of three separate circuits, namely, an r.f. oscillator, a diode rectifier, and a relay amplifier. The oscillator portion, which is really the heart of the device, consists of a straightforward Hartley oscillator. However its conditions of operation differ from those of the usual or conventional oscillator where stability under changing load is the chief consideration. In this circuit the grid condenser, C_2 , is adjusted so that the unit is oscillating very weakly, i.e., the oscillator has not reached the equilibrium condition which allows it to maintain a relatively constant output with a varying load. This latter condition is obtained by making the grid condenser a high reactance for the r.f. frequency used. By reducing the capacitance of the grid condenser (with the circuit still oscillating), we find that the r.f. output of the oscillator is quite sensitive to variations in feedback caused by any change in the capacitance of the feeler antenna to ground.

This changing r.f. oscillator voltage, due to a variation in feeler antenna capacitance, can be reflected as a d.c. current change by rectifying the r.f. and applying the resulting negative d.c. voltage to the grid of a triode relay amplifier. In this case, the diode rectifier consists of a 1N34 germanium diode and the oscillator and relay amplifier are combined in one envelope in the form of a 12AT7 dual triode.

Even though the oscillator grid condenser C_2 is adjusted so that oscillation is very weak, the rectified d.c. voltage measured across R_2 may be from 9 to 16 volts. This is beyond the grid cut-off voltage for the 12AT7 which is approximately 3 volts. Thus it becomes necessary to use a potentiometer

to adjust the grid voltage of the relay amplifier to cut-off or slightly less, according to the desired sensitivity. By adjusting the potentiometer R_2 so that the voltage applied to the grid is far beyond cut-off, it becomes necessary to make a greater capacitance change to reduce the r.f. voltage and consequently the negative grid bias on the relay amplifier to a value low enough to cause current to flow and thus close the relay. Under these conditions, the relay is relatively insensitive. Adjusting potentiometer R_2 to a value so that the relay amplifier is conducting slightly (but not enough to close the relay) will result in maximum sensitivity. Now only a small capacitance change will be necessary to reduce the amplifier grid bias enough to close the relay. Actually, the oscillator grid control C_2 also controls the sensitivity to some extent and, in practice, it will be found that the two will interact. However the use of a potentiometer gives the device much greater flexibility. This gives C_2 the job of adapting the oscillator to whatever feeler antenna might be used and to obtain the desired intensity of oscillation.

As can be seen from the circuit diagram, the a.c. line voltage is applied directly to the tubes. Thus the oscillator portion oscillates on only half of the a.c. cycle. The resistor-condenser combination R_2, C_3 must then maintain the negative voltage on the grid of the relay amplifier during the negative half of the a.c. cycle when the oscillator is not oscillating. The condenser C_3 must also serve another purpose besides that of d.c. filter for the rectified r.f. oscillator voltage. It must also serve as a sort of "shock absorber" for line voltage fluctuations,

thus preventing the relay from closing every time a refrigerator or oil burner starts. This RC combination also determines the reaction time of the whole device, that is, the speed with which it will respond to a capacitance variation. For example, if your particular application requires that the device go off only for capacitance changes that last, say, from a half to one second, it would be necessary to increase the capacitance of C_3 from the value shown. This value is most easily determined by experiment. The values for C_3 (.01 $\mu\text{fd.}$) and R_2 (2 megohms) provide fairly good stability for the usual line fluctuations and give a fairly fast reaction speed.

The previous discussion on reaction time also partially applies to the relay coil and its parallel condenser. In this case the value of 1 $\mu\text{fd.}$ was chosen to eliminate relay chatter and buzz. If a lower resistance relay is used, a larger value condenser will be necessary.

One of the novel features of this device is the method of obtaining the filament voltage. A 3 $\mu\text{fd.}$ condenser is used in series with the filament across the line to produce the necessary twelve volts for the 12AT7. This provides real economy over the usual series-filament voltage dropping resistor. This latter method of obtaining filament voltage would consume a total of almost 18 watts while the condenser method uses only 1.8 watts. It also provides a saving in space and weight over a transformer. A 3 $\mu\text{fd.}$ condenser might be rather large, but at most, it's less than half the size of a filament transformer. Needless to say, an electrolytic condenser cannot be used for this application.

An intelligent discussion of the sensitivity of a unit such as this is difficult, especially without knowing the application and hence the type of feeler antenna to be used. In one case it might consist of a short piece of wire while in another case it might consist of a large machine or wire fence. In the beginning of this article we discussed the fact that among the factors determining capacitance is the effective area of the plates. Thus the sensitivity will not be as great if the feeler antenna is merely a six-inch piece of wire rather than, say, a window screen used as the feeler antenna. However it is not as simple as that. The residual capacitance this feeler has to ground also determines the sensitivity. For example, if the feeler antenna has a residual capacitance of 50 $\mu\text{fd.}$ and a person's approach a certain distance away introduces a change of 10 $\mu\text{fd.}$, the resultant change in oscillator feedback will be much greater than if the residual capacitance were 200 $\mu\text{fd.}$ and the person's approach introduced 10 $\mu\text{fd.}$ as before. This can be readily seen if the grid coupling condenser and the residual capacity are visualized as being in series as a capacitance-voltage divider. Then for a lower residual capacity, the grid coupling condenser will have a lower

value. Hence a small grid-to-ground capacitance change will produce a greater voltage change in the capacitance divider. This voltage change is actually an oscillator feedback change.

The purpose of the photographs showing the unit as constructed by the author is not to suggest that the unit be built in exactly the same manner, but rather to point out some features which the constructor may wish to include. The whole unit is built on an aluminum cover made to fit an old surplus junction box measuring $7\frac{1}{2} \times 4\frac{1}{2} \times 3\frac{1}{4}$ inches. To avoid any body capacitance difficulties when setting the equipment in operation, the antenna post was brought through the side while the operating controls are on the top of the opposite edge. If the operator's body capacitance is included when the equipment is set up, the unit will have less sensitivity. When the operator moves away from the unit after setting it up, his body capacitance is subtracted from the residual capacitance. This increases the feedback and consequently the negative voltage on the grid of the relay amplifier.

Both rotor and stator of the oscillator grid condenser C_2 must be insulated. This operation can be simplified somewhat by using a ceramic or mica trimmer and adjusting it with an insulated rod. However that insulated rod always seems to be lost when needed most. By using an air trimmer and insulated coupling, adjustments may be made with an ordinary screwdriver.

The coil for the unit was wound on a one-inch diameter bakelite rod and consists of enough turns of number 36 enamel wire to fill $2\frac{1}{4}$ inches with a tap brought out at the center or $1\frac{1}{8}$ ". This inductance, in combination with 70 $\mu\text{fd.}$ for C_1 , will place the oscillator on approximately 550 kc. The exact frequency used is not too critical. Because of the low frequency and be-

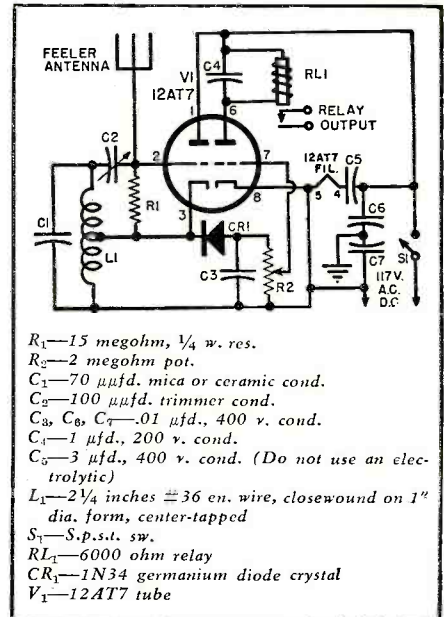

Complete circuit diagram of the capacitance relay. Standard parts are employed.

cause the oscillator is just barely oscillating, no radiation or interference problems exist.

Since the unit was built into a metal case, in order to avoid any danger of serious shock and fuse-blowing, neither side of the line was connected to the case. However to eliminate hand capacity effects it is necessary to place the case at a.c. ground. This is accomplished by means of the two .01 $\mu\text{fd.}$ condensers from each side of the line to the case (C_6 and C_7).

The adjustment of C_2 and R_2 can be set up quickly and easily with the aid of a d.c. vacuum tube voltmeter, however the use of such an instrument is not essential. If a v.t.v.m. is available, it can be set to measure the negative d.c. voltage from the detector, that is, (Continued on page 139)

Top chassis view of relay with cover removed to show the compact parts layout.

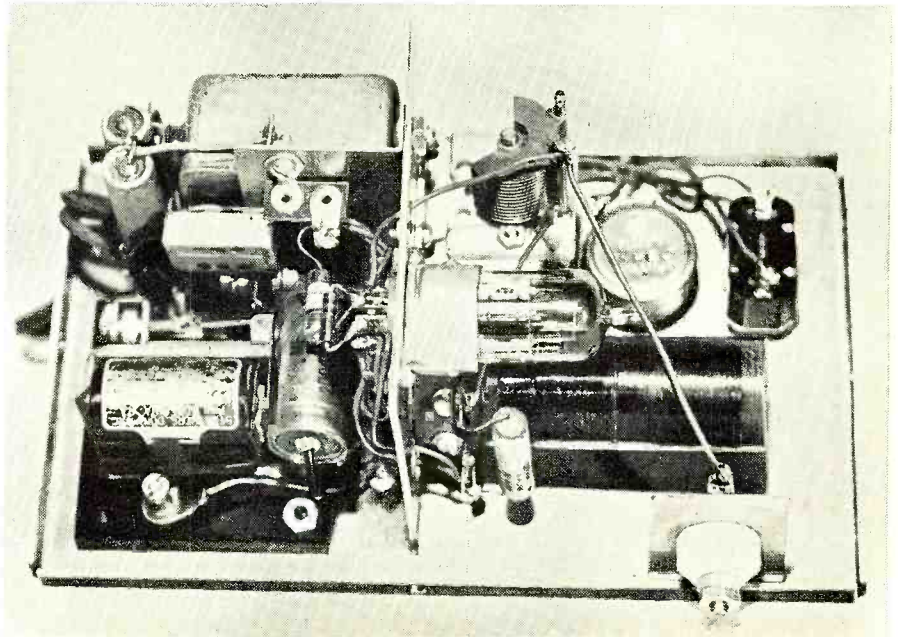

DX TELEVISION

By
STAN JOHNSON, WØLBV

THERE are cowboys on Peachtree Street in Atlanta, Georgia—the Johnsons know, because we've seen them. The only thing remarkable about this fact is that we saw them from Denver—via a television signal loosed from the transmitting tower of WSB in Atlanta—months before Denver had a television station of its own!

Because Denver was one of the most television-hungry cities in America—the largest to be caught by the “freeze” without a station—it became the center of an extremely active group of television DX-ers—of whom the writer was one. From the experience of this group has come some practical ideas to help *you* pull in long distance television—and enjoy one of the few real thrills left in radio.

The writer's interest in television DX was sparked by work on an article which appeared in RADIO & TELEVISION NEWS this past year—and dealt with DX-ing by a service technician in Longmont, Colorado. After seeing what *could* be done, it was inevitable that the Johnson family would acquire a television set, despite the fact that at that time it appeared television for Denver was a long ways away.

The set, however, was nothing fancy. It couldn't be—because it had to be lugged from San Francisco, where the writer happened to be on business. Furthermore, there was a little matter of explaining to the XYL that a television set was something the household could not do without, and that those new drapes for the bedroom could wait.

(How to sell an XYL an idea like this will be discussed later—so read on!)

At any rate, the set chosen was a little second-hand 7-inch *Admiral*, which sold for \$50.00. Sharpies, with time to shop, have been known to buy similar 7-inch sets for \$25.00 or less.

The little set managed to survive the trip all right—and was brought home and hooked up—in late January. Wonder of wonders—for a few fleeting seconds one memorable Sunday morning—it brought in a picture.

But all of the dope said that sporadic “E” reception wouldn't begin until May—and unfortunately, the dope was right. For weeks the little set produced nothing—although by this time the XYL was becoming interested enough to monitor Channel 2 several times a day—and the Num-



Jim Livesay, WØTRP, has logged over 20 DX television stations. This new “hobby” has gained a tremendous following in the U. S.

Despite the fact that TV stations are springing up all over the U.S., television DX-ing still has many ardent adherents.

ber Two Son had learned to say something which sounded like “no pictures today, Mommy.”

Meanwhile, the OM, being the conservative type, had decided that a booster might be a good idea, so had parted with another \$10.95 to buy a “bargain” 6J6 booster.

Then, one evening—May 3rd—the 10-meter phone band came alive with a bang on “short skip.” So it was time to check the theory that if 10 meters was open, Channel 2 should not be far behind.

Bright and early Sunday morning the little TV set was turned on. And there it was—intermittent—fading—but a picture: KPRC in Houston, Texas.

Because the picture seemed to be a bit muddled-up, it was decided that the home-brewed V-beam being used was probably causing ghosts—so a standard TV antenna (Dubl-V) was hastily erected on a rotating mast assembly—and we were ready to try again.

The next chance came on May 9, and the XYL reported that the picture still displayed people with three heads—so the OM knew that he had a service job on his hands. It turned out to be nothing more complicated than replacing the horizontal oscillator tube.

One fact was already apparent—the wire V-beam, which cost less than \$2.00 to erect, was a lot better than

the smaller Dubl-V. And it became evident from checking with other hams and TVL's in the city that the big V-beam has the pleasant habit of brewing up signals when large stacked TV arrays, and much hotter receivers, weren't doing a thing.

The V-beam was about as simple as an antenna could be—consisting of two wires (see diagram) fed with a feeder on one end. An open wire line (the original was homemade but the *Gonset* line would be ideal) was used to tie the antenna to the set.

Fine on Channel 2—which after all is fairly low frequency. But surely a standard TV antenna would do the job better when the higher frequencies opened up.

On May 17 they did—with a bang—signals coming in as high as Channel 5. In every case the V-beam outperformed the TV antenna—in *any direction*—and the average held true all summer long. Further cross-checking with other listeners showed that the beam was staying in there with the best of them—and out-performing all but the best.

Exactly *why* the writer doesn't know. However, here is a theory, for what it is worth.

Big stacked arrays have as their basic purpose concentrating reception at *very* low angles—a factor which is probably more important than sheer gain in fringe area reception. But TV

DX is fairly high angle. And a wire V-beam is a fairly wide angle device—capable of receiving from a number of angles—and from many different directions. Likewise, having a lot of wire out seems to give better over-all efficiency—or as one practical soul put it—gets a “better grip on the ether.”

However, the V-beam does have one serious disadvantage—it picks up signals from many different directions at the same time. And until you have seen TV stations pile up five deep on the same channel you don't know what interference is.

So—in the writer's opinion—the best answer for the antenna problem is to put up a V-beam for best reception when signals are coming in chiefly from one area. And then have a rotating array, with an antenna with a fairly good front-to-back ratio, to allow selection should there be several stations coming in on the same channel but in different directions.

So much for antennas. But when do TV signals come in?

Again there is much opinion in all of this. But the opinion of Denver listeners—and their logs—seem to show a definite pattern.

The writer's own log clearly gives the morning hours the nod during the summer season of '52, with a lot of signals coming in as early as 7 a.m.—with 10 a.m. being a particularly good time. Relatively few signals were logged at noon—but the afternoon hours showed more signals—and the early evening second only to the morning.

All of this boils down to the fact that there might be signals to be heard (or seen!) almost any time—so it would be nice to know when to listen.

As mentioned earlier, it seemed to the writer that monitoring the 10 meter phone band was an easy way to get a tip-off on good skip conditions. And the experience described previously was no fluke—not once in months of listening did TV DX come in at a time when there was no short skip on 10 meters. However—unfortunately—many times skip did come in on 10 when TV was dead to the world.

Even so, the cue, obviously, is to watch 10 meters. If that band is dead for short skip (reception under 1000 miles) go shoot pool, or mow the lawn, or something, for TV DX probably won't happen. But when the 10 meter band comes alive with short skip signals, get a can of beer and stay with the TV set, because something is probably going to happen.

If you are an experimenter at heart you may want to test another theory—not the writer's this time, but that of one of the champion “DX-ers” among the several hundred in Denver who did a lot of listening—or watching: Jim Livesay, WØTRP.

Jim, who is an engineer, and whose background includes several years as an officer in the Signal Corps, is now general engineer for the Colorado Central Power Company. In this ca-

capacity, part of his job is to keep an eye on the company's high frequency radio gear, operating on 47.94 megacycles, used to maintain communication with company trucks.

Jim noticed during 1950 that during the summer months quite frequently “skip” signals from other services would interfere with local communication. He reasoned that if 47 megacycles would come alive, so should Channel 2, and on the strength of that idea bought a TV set.

In '51 he received stations intermittently throughout most of the summer—and during December and early January of '52 had some excellent reception. His receiver is a 17" Admiral—with a good booster and a parasitic array, cut for Channel 3. The antenna, a yagi, is a bit unusual in that the tubing used is quite large in diameter, the idea being to get as wide a band of response as possible, in order to cover the low frequency channels. (The limitations of any parasitic array in frequency coverage are one of the reasons the writer chose two types of driven arrays.)

Livesay's carefully-kept log shows one highly-interesting thing: in Denver, at least, almost invariably sporadic “E” skip during '52 came during times of high barometric pressure—and since the barometer would go up first, it served to give some warning that conditions were about to be favorable.

Never once, according to Jim, was skip received when barometric pressure was low. He doesn't regard his observations as at all conclusive—but perhaps other DX-ers will test it further.

Jim was one of the first DX-ers in the Denver area, and when his activities became known through a news story in the *Denver Post*, he became



TV DX stations are not necessarily weak. Some pound through like locals. Here's proof, in the form of a picture of KPRC's (Houston) pattern as received in Denver.

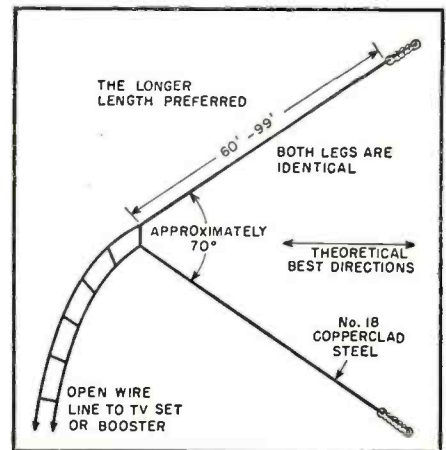

Top view of WØLBV's TV DX antenna.

the unofficial “Paul Revere” of a network of listeners. When the 47.94 megacycle signals at the power company began to show signs of skip, he would give his attractive wife, Trudy, a ring—and she would watch for signals to appear. If they did, she would, in turn, call others in the “network”

(Continued on page 104)

With this simple receiving gear—a three-year-old 7" TV set and “bargain” booster, plus a good antenna, author has picked up stations from Pittsburgh to the Pacific.

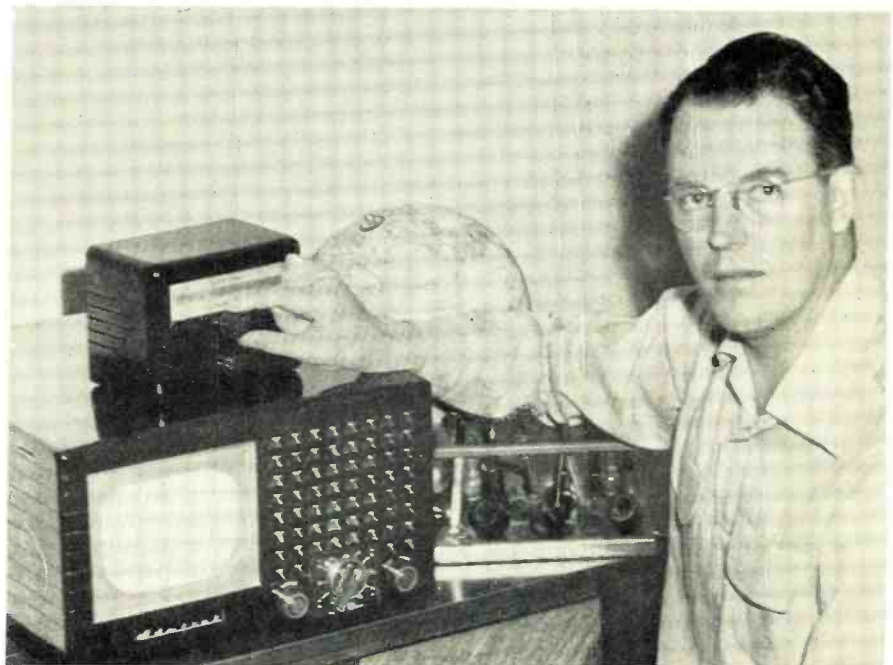

MAC'S RADIO SERVICE SHOP

By JOHN T. FRYE

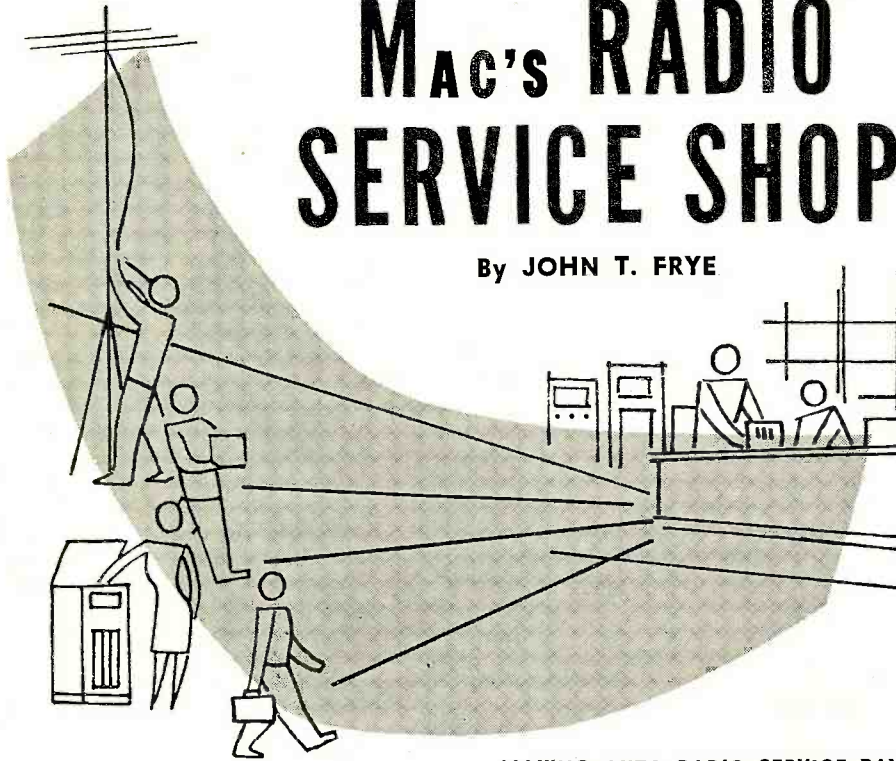

MAKING AUTO RADIO SERVICE PAY

"MAN, what a fine snowstorm this is!" Barney exclaimed as he stamped into the service shop on a blowy December morning.

Mac, his boss, looked up thoughtfully from the blueprints he had been inspecting to the flushed face and sparkling eyes of the youth and slowly said, "You'd never guess how old that remark suddenly makes me feel. I can barely remember back to when I used to think the first snowstorm of the year was exciting fun. Now, thanks to the Age of the Automobile, it is just a darned nuisance. When I see those big fat flakes starting to drift down, all I can think of are icy streets, stalling at the curb, tire chains, and dented fenders."

"What a cheerful outlook!" Barney commented. "Let's change the subject, quick. What are the blueprints about?"

"There's no escape from the auto albatross there," Mac grinned. "These prints are of the addition to the shop that is going to be built back there on the alley in the very near future. Intended for our new auto radio repair department, it will be a full twenty-four by twenty-four feet and will have two overhead doors opening out on the alley."

"Sounds like a lot of room for only two stalls."

"I want plenty of room," Mac retorted. "I want to be able to throw the doors of both cars wide open and still be able to get between them, in front of them, and behind them with the service-bench-on-wheels that is going to be a feature of the shop."

"Why all this sudden interest in auto radio service?"

"As you know, I have long felt that

this branch of service was being neglected; but the thing that really started me thinking about it in earnest was the publication of a recent survey. This survey revealed that for every three radios operating in the home, a fourth was used on the highway. In the past half-dozen years, the number of auto radios has zoomed up from seven and a half million to *twenty-seven and a half million*. 92.4% of all postwar cars are radio equipped. If things keep on at this rate, that means that nearly five million new auto radios will roll off the production line next year."

"Yeah," Barney said with mounting enthusiasm, "and we know the competition is not too keen. As we were saying a while back, it is becoming harder and harder to get an auto radio set fixed. Radiomen don't like to fool with them."

"And not without reason," Mac conceded. "Taking the set out of the car and putting it back is often hard, dirty, hot work to which the radio technician is not accustomed and at which he is not too adept. On top of that auto radio service requires the stocking of many specialized and slow-moving parts; it means that the shop must add special equipment such as vibrator-testing apparatus, special power supplies, heavy-duty drills, and punches or saws for cutting holes in the body, firewall, etc. New techniques must be learned, too, for auto radio service requires a knowledge of auto ignition systems, an understanding of the production and suppression of electrical noise, and a mastery of the vibrator-type of power supply that is foreign to house radio and television servicing.

"Still worse, though, has been the fact that in the past many radiomen came to believe that no money was to be made in auto radio service. For one thing so much time was consumed in taking the set out of the car and putting it back. In many modern cars this is really a major operation. The customer, thinking in terms of having his house radio repaired, often yelled long and loud when he found that putting a fifty-cent coupling condenser in his car receiver cost him ten dollars while he could have the same condenser put into his a.c.-d.c. house receiver for three-fifty. But the technician knew that he could service half a dozen midget sets while he was fixing that one auto radio receiver, and he could do this comfortably at his bench instead of having to stand on his head and bark his knuckles trying to get the blankety-blank automobile set to go back where it belonged."

"Wait up!" Barney commanded. "You're taking the bloom right off my first enthusiasm for this expansion project. Every discouraging word you say about how hard auto radio service is sinks right home on this boy, for he likely will be the one taking 'em out and putting 'em back. But if you can't make money in the business, why are we going into it?"

"I didn't say money *couldn't* be made. I said many radiomen thought it couldn't—and it probably can't as long as auto radio service is treated as a sort of poor relation and is denied the time and thought and equipment this branch of the service requires. Especially it can't be made to pay as long as you refuse to be realistic about charging for it. And don't break out in a cold sweat at the prospect of doing a little work for a change. While it's true I'll expect you to do your share of the actual repair work, I'm hiring another man to do all the removal, replacement, and new installation of sets."

"Who dat?"

"A young garage mechanic I know whose specialties have been ignition system maintenance and body work. I wanted a man who really knows his way about automobiles and feels at home with a wrench in his hand—one who can work just as well with his back on a creeper as he can standing on his feet. The purely mechanical jobs that look so hard and awkward to us will be a lead-pipe cinch to such a fellow; moreover, he will be a great help in running down those noise problems that are finally traced back to some fault in the ignition system itself."

"You said something about charges. Are you really going to pour it on?"

"No, but I'm going to see to it that charges for auto radio service actually reflect the costs of that department. In other words, I'll not allow the radio and television department to carry the auto service department. The bill for an automobile radio repair job will consist of two separate charges: first,

(Continued on page 125)

A DUO-DIODE MODULATION MONITOR

By

J. LUCAS, DL4ZV and D. PETERS, DL4VJ

THE modulation monitor described in this article was designed and constructed as a simple, low cost unit which would indicate 100% negative peak modulation on plate modulated transmitters, without using a high voltage diode as commonly used in negative peak indicators. It was further desired to have the monitor indicate at 100% regardless of the power input, plate voltage, or loading of the modulated stage without necessitating any readjustment of the monitor.

Neon indicators were chosen because they are capable of instantaneous indication, thus the indication is not affected by the mechanical lag of meters. Furthermore, the flash of a lamp will attract the operator's attention more than a meter pointer passing a given point.

After constructing the original model it was decided to incorporate a second indicator lamp which would flash at a value which could be set anywhere below 100% modulation. In the authors' unit this second lamp is set at 80%, and the mike gain is adjusted to have the 80% lamp flash consistently and the 100% lamp flash on occasional peaks. This feature satisfies an inherent human desire to be assured of sufficiently heavy modulation, without actually overmodulating.

The modulation monitor, as seen in Figs. 1 and 3, is built in two sections. The greater portion of the circuit is built into the transmitter.

The indicator lamps and meter are mounted in a 3 x 4 x 5 inch utility box making a neat compact unit to place on the operating table. The reader, of course, is not limited to the type of construction used by the authors. The components could be included in any unit which is used on the operating table, such as the speech amplifier, v.f.o., etc.

The schematic diagram of the unit is shown in Fig. 2. It can be seen that the diodes are connected backwards,

Fig. 1. Neon lamps are cemented in plastic mount. Leads run through holes behind the lamps and terminate behind panel. Meter is used for reading modulator plate current.

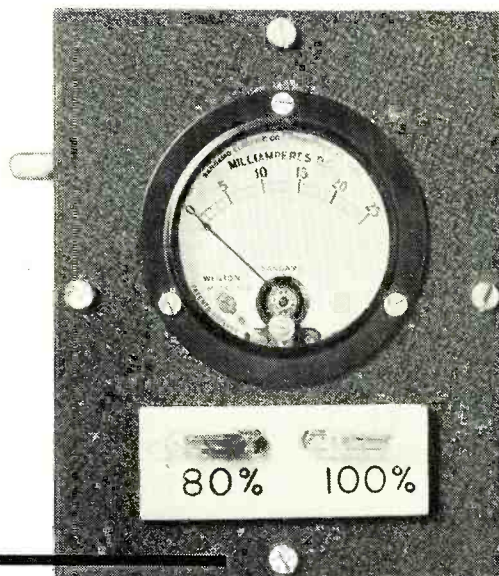

Low-voltage diodes and neon lamps are used to indicate predetermined percentage of modulation and overmodulation.

compared to the usual diode-type negative peak indicator. Therein lies the reason for the ability to use a low voltage diode.

To explain the operation we will analyze lamp NE_1 ; however, the discussion will also apply to NE_2 because both units are identical. R_1 is connected to the junction of the modulator transformer and the cold end of the plate tank. Provided the voltage at this point remains more positive than the voltage at the arm of R_3 , the diode V_1 will conduct. It can be seen that R_1 and V_{1a} are effectively series resistors when V_{1a} is conducting. Its resistance is a small fraction of R_1 and almost all of the plate voltage will be dropped across R_1 . As the voltage at the cold

(Continued on page 144)

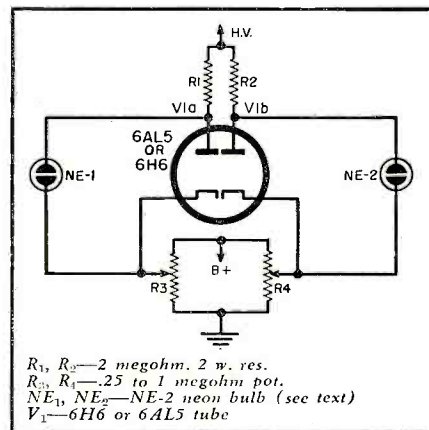
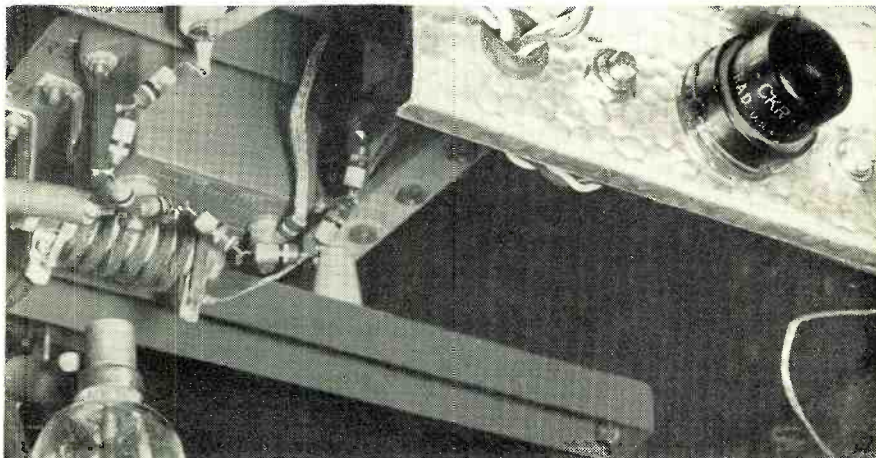

Fig. 2. Complete circuit diagram for the duo-diode modulation monitor unit.

Fig. 3. The diode and its associated resistors shown mounted on the rear of a BC-610. "B-plus" for R_3 and R_4 and filament power are taken from the exciter deck. Note that composite resistors R_1 and R_2 are made up of 1/2 watt resistors in series to prevent arc-over from the high-voltage point to the diode end.



HI-FI LOUDSPEAKER DESIGN

By ABRAHAM B. COHEN
University Loudspeakers Inc.



Fig. 1. The "Diffusicone" system of wide-angle high-frequency dispersion.

Details on a new loudspeaker design which features a replaceable basket-diaphragm and wide-angle dispersion.

acteristic of a high-fidelity loudspeaker. Equally essential to high fidelity is the wide-angle distribution of the high frequencies.

High-frequency sound radiates from a simple diaphragm in the form of a fairly sharp beam. The higher the frequency, the more sharply is this beam defined. A plot of the acoustic pressure output of a simple type of diaphragm for, say 10,000 cycles-per-second would show a rapid drop of energy as measurements were made off-axis of the speaker. This condition is shown in Fig. 2. An amplifier that behaved in this manner would surely not be classified as a high-fidelity unit, however, this is essentially the characteristic frequency droop which will pertain to a high-fidelity system which uses the usual type of a single, wide-range speaker. The fidelity of the system would appear to be continuously deteriorating as the listener moves away from directly in front of the speaker. In a practical sense, the higher the frequency range of the speaker, the less relative high-frequency energy will be heard. This is an acoustic paradox which must be met and overcome.

There are solutions to this problem that lead one to multi-speaker systems where the high frequencies are separated from the low frequencies by means of suitable frequency-dividing networks. The separated high frequencies are subsequently radiated by tweeter horns especially designed to disperse these high frequencies over a wide angle. In cases of space limitation, or where economic considerations must govern the choice of the speaker,

wide-angle diffusion of high frequencies may be realized from a diaphragm type of loudspeaker employing a high frequency diffusion system like that illustrated in Fig. 1. This system is descriptively known as a "Diffusicone."

This high-frequency diffusion system is made up of an on-axis horn load, an angularly displaced concentric horn load, and a diffraction ring which terminates this latter horn. This diffusion system is placed in the central area of a matched twelve-inch diaphragm and is effective in producing wide-angle, high-frequency sound distribution from a single, direct-radiator type of speaker. High frequencies are radiated for the most part by the apex area of the diaphragm. Consequently, to increase the efficiency of a loudspeaker for the high frequencies, the most natural area of the diaphragm to modify is the apex area. Accordingly, this diffusion system is located in this diaphragm apex section. A cross-section of this system in place is shown in Fig. 3. Element "A" is a direct axial horn load; element "B" is a radially displaced concentric horn load; element "C" is a diffraction ring across the mouth of this latter horn; and element "D" is a duralumin diaphragm which energizes the diffusion system.

Horn Loading and Efficiency

One way of increasing the acoustical efficiency of any diaphragm is to horn load it. When a diaphragm energizes the narrow end (the throat) of a horn, all the sound pressure from the diaphragm is concentrated at this narrow end. At this point in the horn the sound pressure is high, but it displaces only a small volume of air. At the large end of the horn (the mouth) the sound pressure has had a chance to spread out over a large area. Consequently at this terminal end of the horn, the sound pressures have been reduced, but a correspondingly larger volume of air is displaced.

This effect is analogous to transformer action where the primary winding has a low voltage with high current, while the secondary winding has a high voltage with low current. If the secondary of this transformer is properly matched in im-

IN THESE DAYS of advanced electronic design, it is fairly easy to obtain an audio amplifier that has built into it any electrical characteristic that one may desire. There are pentode output types; there are triode output types. There are amplifiers that are flat from 10 cycles-per-second to 200,000 cycles-per-second; and there are amplifiers whose frequency range at either end may be raised or lowered at will. There are dynamic noise suppression circuits; and there are amplifiers with built-in record compensation equalizers. Name the characteristic you desire, and it will probably be available. If what you want does not exist, just wait a short while. Our advanced electronic experts will soon pop up with the answer.

In contrast, advanced design in loudspeaker practice has not been as apparently spectacular. Loudspeakers are, in the main, mechanical devices. To the electronic engineer, then, the subject of advanced mechanical design may not appear very glamorous on the surface. However, since these advanced electromechanical improvements are so intimately tied in with electronic devices, it is only fair to the reader who is well versed in electronics to present data on the new and radical innovations in modern loudspeaker design, which will aid him in getting the most out of his expensive and advanced electronic reproducing equipment. The factors that go into a high-fidelity speaker of the single diaphragm type and the advanced solutions for some of the more difficult problems of designing such a loudspeaker will be discussed in this article.

Wide-Angle Dispersion

Wide frequency range is commonly recognized as one fundamental char-

Fig. 2. Relative response of a 12" piston as a function of off-axis angle for a frequency of 10,000 cycles-per-second.

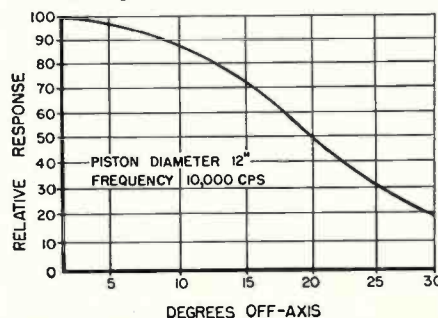

pedance, then maximum power is transferred from the primary source to the secondary load. Similarly a horn may be considered to be an acoustic matching transformer which, through its large mouth, gets a good grip on the atmospheric load into which it radiates its energy. A better impedance match between the "large area" atmosphere and the small area diaphragm is thus obtained. This results in more acoustic output from the diaphragm than when the diaphragm has to grab hold of the atmosphere around it without benefit of an "acoustic lever" such as a horn. Because of this inherent efficiency, horn loading is invariably used where maximum acoustic output is desired for a given available power into the diaphragm of the driver unit, such as in public address systems. Horn loading is now the trend for low frequency reproducers because of its inherent high-efficiency loading characteristic as compared to the direct-radiator type of baffling.

Fortunately, horn loading shows no preference as far as frequency is concerned. Low frequencies, which are long in wavelength, require large horns. High frequencies, which are short in wavelength, are satisfied with small horns. At the frequency range in which we are interested—the high frequencies—the size of the horn necessary to provide an adequate loading effect becomes small enough so that it may be fixed to the central area of the diaphragm without upsetting the major piston action of the diaphragm. Thus the diaphragm proper may continue to function unrestrained as a unified piston for the low frequencies. However, for the high frequencies which are in the main generated in the apex area, the diaphragm is transformed into the multi-horn "Diffusicone" element.

The Diffusion System

The theory of operation of this diffusion system may be understood by referring to Fig. 3. The "Diffusicone" element is so proportioned that it splits the area of the radiating apex into two equal parts. These two equal parts, in turn, feed the two horns of the system—the inner horn "A," and the outer concentric horn "B." This radiating apex which energizes the two horns is a rigidly braced duralumin dome. This dome is located at the very area of the diaphragm where the voice coil vibratory driving force is applied. There is no intervening energy absorption element between the voice coil support and the dome. Accordingly the high-frequency energy developed by the voice coil will be imparted, without loss, directly to this rigid dome. Consequently, this dome area becomes one of the most efficient areas of available high frequency power. It will, in turn, transfer this high-frequency energy with minimum loss of acoustic pressure to the two concentric horns which are energized by it.

Horns transmit the major portion of their energy in the direction of the acoustic axis. The acoustic axis of horn "A" lies on dead center of the speaker. The acoustic axis of the outer horn "B" is determined by the direction of sweep of the diaphragm wall and the direction of the wall of horn "A." Because of the specially chosen sweep curve of the outer diaphragm proper (which will be treated later) the resultant acoustic axis of horn "B" is at a considerable angle to the central horn axis, as indicated in Fig. 3. Because the axis of horn "A" is dead center, this horn will cover the central portion of the total field. The outer horn, because of its angularly displaced acoustic axis, will cover a side zonal area. This side coverage will extend beyond the angular dispersion that would take place if the directive effect of the horn were not present.

The central horn mouth terminates in free space. The outer horn terminates in a diffraction ring. The purpose of this diffraction ring is to provide still wider angular dispersion of the high frequencies that would normally flow from this horn, even though its acoustic axis is already angularly displaced. As can be seen in the photographs, this diffraction ring consists of a series of equally spaced apertures across the mouth area of the outer concentric horn. The characteristics of transmission of sound through apertures depend upon the wavelength of the sound and the size of the aperture through which the sound passes. If the hole size is large compared to the wavelength of sound, the wave front will emerge in a fairly concentrated beam (Fig. 4A). If the hole size is small compared to the wavelength, the aperture will become a "pin-hole" source of sound which will, in turn, give rise to a widely divergent spherical wave front (Fig. 4B).

In the diffraction ring under discussion, located at the mouth of the concentric horn, there is a plurality of

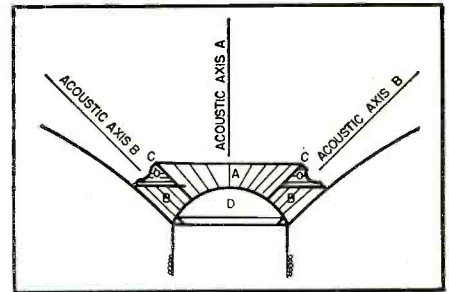

Fig. 3. Cross-section of "Diffusicone" system showing the acoustic axis of the horns.

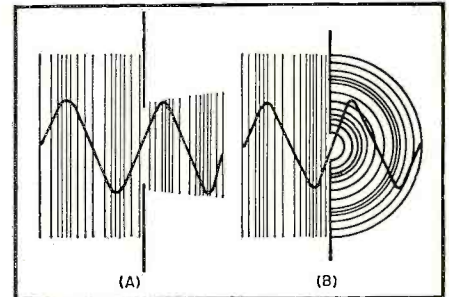
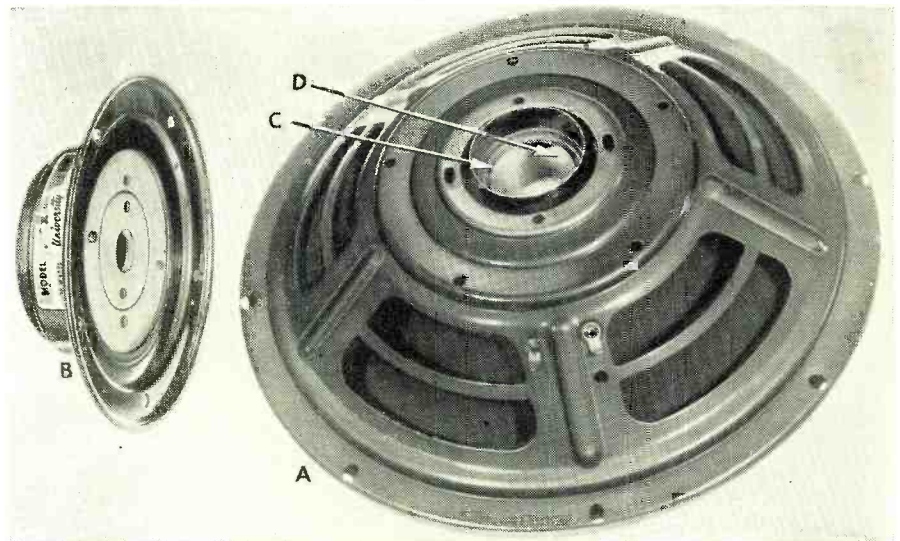

Fig. 4. Diffraction ring principle. (A) An aperture large compared to wavelength will beam sound while (B) an aperture small compared to wavelength will disperse it.

such acoustic "pin-holes." These apertures become, in turn, new transmission sources for the high-frequency sound arriving at the mouth of this outer horn. On emerging from these "pin-hole" sources, the sound from each aperture source will be spherically scattered over an individual wide spherical angle. These individual spherical radiations from each hole source all add together to produce a more uniform hemispherical radiation from the mouth of the outer horn. The combined effect of the angular orientation of this outer horn and the hemispherical radiation from its mouth due to the diffraction ring is to further increase the angular dispersion from the outer horn. The end result of this integration of coaxial direct horn, an-

Fig. 5. (A) Replaceable basket assembly showing (B) removable magnet structure, (C) rib-reinforced dural coil form, and (D) dural apex diaphragm.



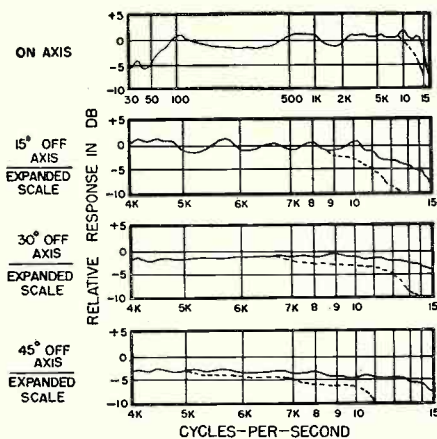

Fig. 6. Comparison of performance between "Diffusicone" system (solid line) and a similar speaker without this feature (dotted).

gular concentric horn, diffusion ring, and apex drive, compared to a speaker of similar construction but not employing this diffusion system, is shown in Fig. 6.

Diaphragm-Basket Assembly

Since a high-fidelity speaker is usually used in conjunction with other fine equipment, it is only right that there be added to the specifications for such a speaker the matter of protection for the user's investment in his speaker. To this end there has been engineered the unique feature of easy separation of the basket assembly from the magnetic housing. This provision makes possible continued laboratory-tested performance when and if replacement of the diaphragm becomes necessary because of accidental damage—for accidents do happen even to the finest of equipment. For instance, the output transformer of the amplifier may develop a short between the secondary winding and the primary high voltage and burn up the voice coil of the loudspeaker. Or perhaps in making a cabinet change the installation man may accidentally poke his screwdriver through the cone of the speaker, or the handle of a vacuum cleaner may tip over and fall into the diaphragm of the loudspeaker. Whatever the cause, the speaker will need repair.

When such repair becomes necessary, it is all important that the rehabilitated speaker be as good as new, so that the system will have the same acoustic properties which sold the purchaser on the speaker in the first place. With the replaceable diaphragm-basket assembly, as shown in Fig. 5, any doubts concerning performance are eliminated.

When it becomes necessary to replace the cone assembly, the user may make the change himself with absolute certainty that his work will result in the equivalent of a new speaker. The magnetic "power house" may be easily replaced by removing five screws that hold the canned magnetic structure to the basket. A complete replacement basket may then be installed on the magnetic structure in perfect alignment by means of auto-

matic centering devices built into the basket assembly and the magnetic pot structure. This substitution may be made with a screwdriver without resorting to spacing shims, cements, or elapsed time to allow cements to dry. As soon as the basket is replaced, it is immediately ready for use.

Circuit Efficiency

It is important to emphasize the function of the available magnetic flux which will drive the speaker, and how the magnetic efficiency may be increased. The common type of magnetic circuit uses either slug and ring structures (Fig. 7B), or slug and yoke assemblies (Fig. 7C). These latter types generally require heavy iron keepers or yokes to complete the magnetic circuit. These return circuits are secured in place by either bolts or cement, or are arc welded.

Fig. 7A shows the cross-section of a magnetic circuit design which, because of the shape, is termed the (*University*) "W" magnet. The inherent shape of the "W" magnet provides its own return magnetic circuit except for the cover plate (which is common to all the circuits) in which the magnetic air gap is placed. Breaks and joints in the "W" magnetic circuit are thus at an irreducible minimum. There is but one mating surface between the magnet and the cover plate assembly and this assembly is secured to the magnet by the strength of the magnetic force itself.

The application of this principle of reduction of mating surfaces in the magnetic circuit results in reduced reluctance losses. Such losses are always present to a large degree at the multiple joints of the alternate types of magnetic assemblies. In addition to decreasing the reluctance losses in the magnetic circuit, the presence of only

one mating surface reduces the stray magnetic fields and surface magnetic leakage. Greater concentration of the magnetic energy in the voice coil gap will thus result for the pound and a half of *Alnico V* "W" magnet where these reluctance and leakage losses have been eliminated.

The cover plate, which is the sole addition to the magnetic circuit, is made up of an outer ring and an inner disc of high permeability "Armco" iron, permanently affixed to each other by means of a welded support that holds the outer ring and inner disc in perfect alignment. The unity of this cover plate assembly provides absolute assurance that no matter how the magnet may shift (if it could) with respect to the cover plate, the magnetic gap relations will remain unchanged.

Conversion Efficiency

High voice coil gap flux manifests itself in greater efficiency of the loudspeaker. The more powerful the magnetic "power house," the higher will be the conversion efficiency of the speaker. If there were no magnetic circuit at all, the diaphragm would not move irrespective of the amount of electrical power fed into the voice coil. In such a case, the conversion efficiency would, of course, be zero. However, if an external magnetic field were introduced around the voice coil, the voice coil would begin to move and the conversion efficiency of the speaker would rise accordingly. The more dense this external field becomes, the greater the degree of interaction between the field flux and the flux due to the voice coil current. This increased reaction results in increased conversion efficiency.

Because of this stepped-up efficiency of the speaker, the amplifier may be operated at much lower gain settings to obtain the desired acoustic output. With the amplifier operating conservatively, more distortion-free operation may be expected. Should sudden tone bursts or peaks occur, the amplifier will then be capable of reproducing these peaks without driving itself into areas of amplitude distortion. These sudden peaks, short though they may be, represent many times greater power level than the average power under normal program conditions. The ability of the loudspeaker to reproduce these sudden surges of high input without incurring physical damage is, in part, a function of the flux in the air gap.

If a peak power of thirty watts was fed into the voice coil of a loudspeaker around whose voice coil there was a comparatively weak magnetic field, the voice coil would hardly be impelled to move at all. Very little acoustic work will have been performed, and all the power fed into the speaker will have been dissipated in the form of heat within the voice coil. On the other hand, where a heavy flux field exists, the voice coil will be

(Continued on page 112)

Fig. 7. (A) The "W" magnet structure. (B) A ring magnet structure. (C) The slug magnet.

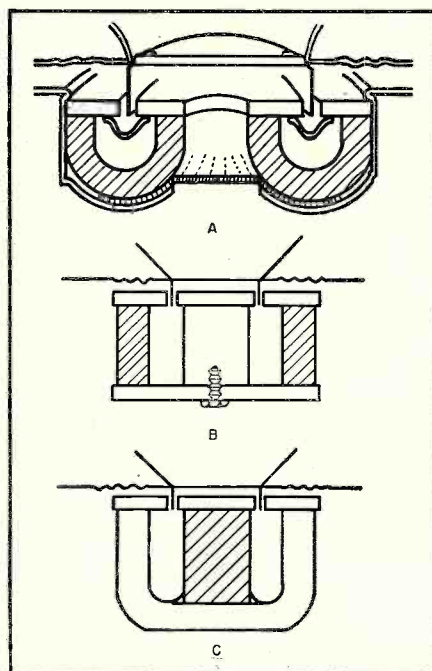

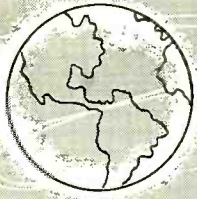

International SHORT-WAVE

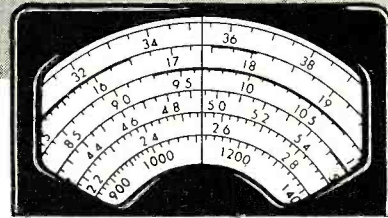

Compiled by **KENNETH R. BOORD**

IT IS a pleasure this month to dedicate the *ISW DEPARTMENT* to *Nordwestdeutscher Rundfunk* (Northwest German Radio), Rothenbaumchausse 132/134, Hamburg 13, Germany. We are grateful to officials of NWDR for the material furnished, and to *ISW DEPARTMENT* monitor René Rastorfer, New York, for his translation of this material.

NWDR broadcasts on medium-wave, short-wave, FM, and has recently started experimental telecasts (according to *World Radio Handbook*, the picture is 189.25, sound 194.75). All programs are in German. Identification is "Hier ist der Nordwestdeutsche Rundfunk Hamburg." Interval signal is a motif from the first movement of Brahms' 4th Symphony, played from Hamburg on two oboes, Cologne on two horns, Berlin on two clarinets, and Hannover on two trumpets. Verification is by QSL card or letter; reports should be sent to Nordwestdeutscher Rundfunk, "Technische Hererpost," Hamburg 13, Germany.

Short-wave transmitters are listed for 6.270, 7.290, 9.735, 11.975, 15.275, 17.815, 17.845. While the short-wave transmitters until recently were beamed to various areas (such as Southeastern Europe, North America, or the Near East), the station's officials point out that all short-wave transmitters will operate with omnidirectional antennas until further notice. Schedules are listed 2300-0600, 6.270, 11.795, 15.275, 17.845; 0600-1100, 7.290, 11.795, 15.275, 17.845; 1100-1900, 7.290, 9.735, 11.795, 17.815. Location of the short-wave transmitters is Norden. Power on short-wave varies from 0.35 to 20 kw., according to WRH.

Hamburg, the key station of the NWDR network, operates two 100 kw. transmitters. Built by *Telefunken*, they differ considerably from each other construction-wise. The older transmitter—dating back to 1934 and operating on 904 kc.—is not, however, appreciably less efficient than the one installed in 1940 with a frequency range from 500 to 1500 kc.

The antenna system consists of a modern, self-radiating metal tower 200 meters (656 ft.) high which also mounts the FM and TV aeriels. It replaces the wooden tower which until recently was used to support a vertical antenna of one-quarter wavelength. An alternate array, to which either of the two transmitters may be

switched, consists of three horizontal three-wire antennas suspended from three round steel masts. An extensive ground system that covers an area of 200 meters (656 ft.) in diameter, in a cobweb fashion, completes the antenna system.

Aside from Hamburg, medium-wave transmitters are located in Berlin, Bonn, Flensburg, Hannover, Herford, Kiel, Langenberg, Obenburg, Osterloog, and Osnabruck, with main studios in Hamburg, Cologne, and Berlin. FM transmitters are situated in Hamburg, Langenberg, Cologne, Hannover, Berlin, and in a steadily-growing string of smaller localities.

Administered by an Executive Council of 16 members—composed of the minister-presidents of Nordrhein-Westfalen, Niedersachsen, and Schleswig-Holstein, the burgomaster of Hamburg, and representatives from public life—under a British Military Government statute dated January 1, 1948, NWDR operates 20 hours daily. Within the area it covers, there are four million receivers registered. NWDR estimates its domestic audience at 12 million listeners.

Our best wishes go to NWDR and its personnel.

* * *

Club Notes

England—Arthur Bear, secretary, International Short-Wave Club, informs me that SWL's throughout the world are welcomed to membership "in this great radio friendship circle," and that he always will be glad to forward a sample copy of *ISWR*, the club's monthly bulletin, to those who ask for it. This club was founded in the United States back in 1929. QRA is 100, Adams Gardens Estate, London, S.E. 16, England.

Present members of the Council of the International Short-Wave League, 123, Sturla Road, Chatham, Kent, England, include J. Cowles (president), F. Baldwin (general secretary), A. Seymour (council secretary), T. W. Eaton, P. Bush, R. Aldridge, E. Alban, H. Clear, and R. Patrick; technical adviser is H. E. Smith; traffic manager

(Note: Unless otherwise indicated, all time is expressed in American EST; add 5 hours for GCT. "News" refers to newscasts in the English language. In order to avoid confusion, the 24 hour clock has been used in designating the times of broadcasts. The hours from midnight until noon are shown as 0000 to 1200 while from 1 p.m. to midnight are shown as 1300 to 2400.)

The symbol "V" following a listed frequency indicates "varying." The station may operate either above or below the frequency given. "A" means frequency is approximate.

is N. Foord; assistant secretary is V. Baldwin. Motto of this club is "We Span the Globe" and its monthly house organ is called "Monitor."

USA—Officers chosen by the United 49'ers Radio Society are Edward I. Broome, president; James Zaloudek, first vice-president; Charles E. McCormick, Jr., second vice-president; Mrs. Julia Boice, secretary; James R. Pickering, treasurer; William McKenna, chaplain; Anson M. Boice, editor; John J. Flanagan, Jr., assistant editor.

The Empire City Short-Wave Listeners Club was organized recently in New York by Michael Marinaro; QRA is 715 Ditmas Avenue, Brooklyn 18, New York.

* * *

This Month's Schedules

(Note: Some stations are still changing to winter schedules; hence, in some cases you may find current schedules to be *one hour later* than listed herein.—K.R.B.)

Afghanistan—*Kabul Radio*, Afghan Broadcasting System, is being heard on 9.975 around 1145 with news to around 1155; on Sundays the news is followed by a program of "listeners' requests" and closedown varies around 1218-1220. Normally, has no signature tune. (Pearce, England)

(Continued on page 84)

A portion of the elaborate antenna system used by Nordwestdeutscher Rundfunk of Hamburg. NWDR broadcasts on medium-wave, short-wave, and FM in addition to TV frequencies.

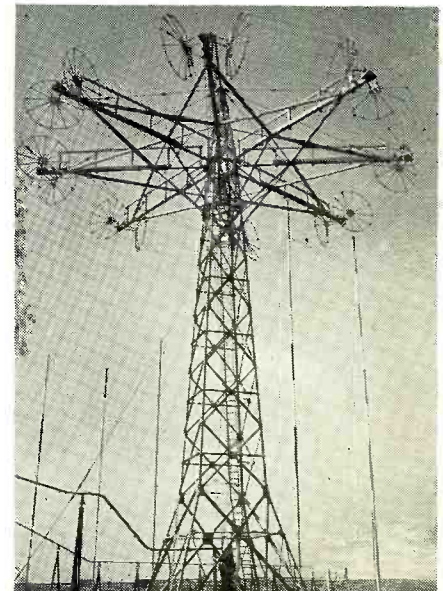

A METERLESS V.T.V.M.

By

LOUIS E. GARNER, JR.

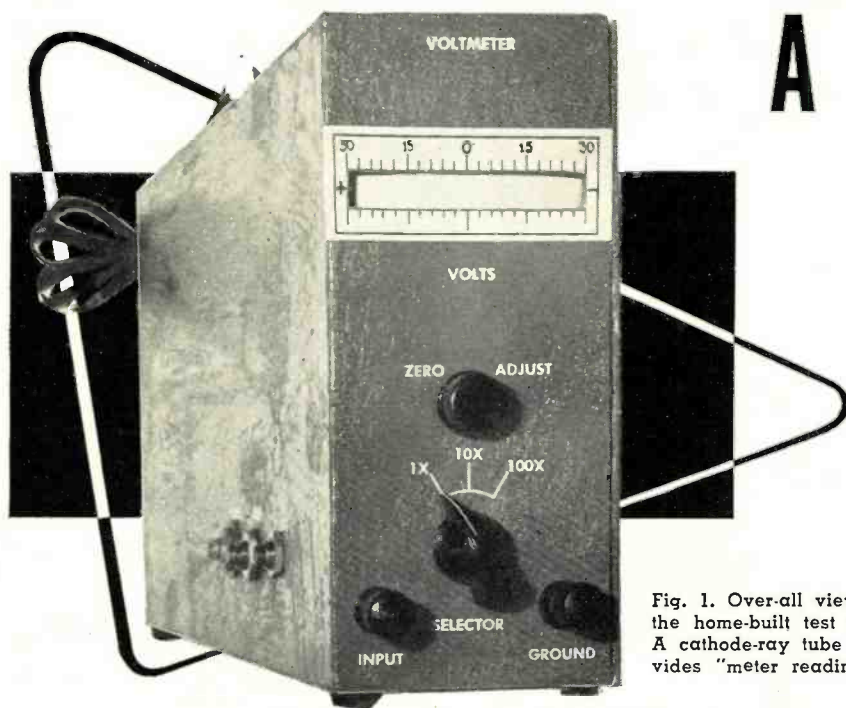

Fig. 1. Over-all view of the home-built test unit. A cathode-ray tube provides "meter readings."

The construction and application of an easily-built, high input impedance v.t.v.m. which features a direct-reading slide-rule scale and no meter. It is a "true" v.t.v.m. in that the slide rule indicating scale is a vacuum tube.

FROM the experimenter's and home builder's viewpoint, v.t.v.m. circuits often suffer from several disadvantages. First, in almost every case, a sensitive meter is required (usually a 500 microamp movement, or better). Not only are such meters expensive, but with present-day shortages, they are likely to prove hard to locate unless a "DO" rating is available.

In addition, circuits are likely to prove complicated, especially where the instrument incorporates a polarity reversing switch, provision for "zero center" readings, and provision for a.c. measurements as well as d.c. voltage readings. The input impedance, while high, is generally limited by the maximum permissible input resistance to the grid of a tube. Because of this, most v.t.v.m. circuits have a maximum input impedance of around 11 megohms.

All of these factors may tend to discourage the home builder unless he can purchase the instrument in "kit" form.

Fundamentally, the majority of commercial "vacuum tube voltmeters" are not truly vacuum tube instruments. Rather they are "vacuum tube-operated voltmeters" in the sense that the indicating device itself is not a vacuum tube but a conventional meter. The author, in an effort to design a "true" vacuum tube voltmeter, found that he had, at the same time, eliminated most of the disadvantages described above.

The final version of the voltmeter,

shown in Fig. 1, features a 3" direct-reading scale, a slide-rule dial, a 33 megohm input impedance, low input capacity, a zero-center scale (which may be easily changed to give either a "left" or "right" zero position), direct reading of peak-to-peak a.c. volts without switching or special calibration, and an extremely simple circuit—all of this without a meter.

Circuit Description

As seen in Fig. 2, the "Meterless V.T.V.M." is essentially a cathode-ray tube circuit. The d.c. operating voltages are obtained from a conventional power supply circuit using a half-wave rectifier, with filtering provided by R_1 and C_2 .

A small receiver power transformer is used with only one-half the high-voltage secondary winding employed. This gives a comparatively low accelerating voltage, thus permitting increased sensitivity. The author used a 3" cathode-ray tube. Where a larger tube (5") is employed, the entire secondary winding of the transformer may be used.

The grid of the CRT is connected to the most negative point of the "B" supply, while the cathode is connected to potentiometer R_{10} , in the voltage divider. This permits the cathode voltage to be adjusted with respect to grid voltage so that the grid is always negative with respect to the cathode. Thus, R_{10} serves as an "Intensity" or brightness control.

Potentiometer R_7 is used to adjust

the relationship of the first anode and accelerating anode voltages and thus serves as the "Focus" control.

Centering of the electron beam on the screen of the CRT is accomplished in the usual fashion by applying a fixed d.c. voltage to the horizontal and vertical deflection plates, respectively, by means of R_2 and R_3 . Since the horizontal deflection plates are used for voltage measurement, R_2 becomes the "Zero Adjustment" control and is mounted on the front panel of the instrument.

Except for the "Range Selector" control, SW_2 , and the power switch, SW_1 , all other controls ("Vertical Centering," "Focus," "Intensity") are adjusted when the instrument is first set up and calibrated and then left as is. Thus, these controls may be mounted inside the instrument, along a side panel, or at any other convenient location.

To provide the vertical "hairline" indicator for the slide-rule dial, a small a.c. voltage is coupled from the high voltage secondary winding through condenser C_1 to one of the vertical deflection plates. C_1 and R_5 act as a voltage divider to keep this voltage comparatively low.

As we have seen, one of the horizontal deflection plates is connected to an internal adjustable d.c. source which acts as the "Zero Adjustment" control. The voltage to be measured is connected to the other horizontal deflection plate through a voltage divider consisting of R_{11} , R_{12} , and R_{13} , with the exact proportion of the input voltage determined by the setting of SW_2 , the "Range Selector" switch.

In operation, a thin, vertical hairline appears across the scale shown in Fig. 1. This indicator may be adjusted to fall right across the center "0" indication by means of the "Zero Adjustment" control. Now, when a positive voltage is applied to the input terminals, the hairline moves immediately to the right of "0," with the exact amount of deflection proportional to the applied voltage. The movement of the indicator is instantaneous as the voltage is applied, and there is absolutely no "hunting"—the indicator stops exactly at the point indicating the applied voltage. Since the elec-

tron beam used as an indicator is virtually inertialess, there is no need to worry about "damping" or other problems that beset the meter designer.

In a similar fashion, if a negative voltage is applied to the input, the same type of indication is obtained, but the indicator movement is to the left.

Should the applied voltage be sufficient to move the indicator completely off the scale, simply turn the "Range Selector" switch to the 10X or 100X position and use a multiplying factor. There is no need to worry about "slamming" the needle pointer or accidentally burning out the meter movement, as in the case of v.t.v.m.'s using a conventional meter movement.

Construction Hints

Most of the construction details of the author's instrument are visible in Fig. 3. The prospective builder may use a layout similar to the author's, or may employ his own.

Since no high frequencies are present in the circuit, distributed wiring capacities and lead length are not too important and the builder need not be concerned about these items. Nor need he worry especially about lead dress. Just use conventional wiring techniques.

In the case of the input circuit, however, reasonable care should be taken that short direct leads are used, with all wires well above "ground" and away from other leads. This is to insure a low input capacity and thus to make the instrument more useful for measuring high frequency a.c. voltages.

The power transformer should be located as far away from the CRT as is practicable, and care should be taken to experiment with its exact orientation. Pick a position which will give minimum hum on the screen of the CRT. In this respect, the author found it convenient to wire the circuit completely, leaving the power transformer unmounted, but with sufficiently long leads to permit experimentation with its position. After turning on the instrument, the power transformer may be shifted in position and orientation until the best place is found on the chassis.

To obtain the "slide-rule" dial scale, a narrow slot is cut in the front of the cabinet or chassis, and the cathode-ray tube mounted behind this. Thus, only a portion of the screen face is used (see Fig. 1).

The author decided to use a long, narrow cabinet. Since no commercial cabinet fitting this description was available, a standard 3" x 7" x 15" chassis was employed. A bottom plate covered one side, and the narrow end was used as the "front" of the cabinet. Rubber feet along the bottom edge, a carrying handle, gray wrinkle paint, and decals completed the "professional" instrument shown in Figs. 1 and 3.

Although a 3RP1 tube was used by the author, and is specified in the parts list, any cathode-ray tube is suitable.

A 1" tube, a 2" tube, any other 3" tube, or, for those desiring a long scale, even a 5" tube, may be used with excellent results. When using a tube other than that specified, minor modifications in the resistors used in the voltage divider circuit may be necessary.

Reference to a tube manual will indicate which set of deflection plates for a particular cathode-ray tube are the most sensitive (require the least applied voltage for a given deflection). This set of plates should be used for the "horizontal" plates of the "Meterless V.T.V.M."

Adjustment and Calibration

Once the wiring is completed and checked, the instrument is ready for adjustment and calibration. An individual hand-drawn scale must be used, but since the scale is linear and drawn in a straight line (rather than along the arc of a circle), preparing the scale is a comparatively easy task.

To adjust the instrument, first short the input terminals. Plug in the v.t.v.m. and turn on the power.

After allowing the instrument to warm up for a few seconds, turn up the "Intensity" control until a line appears somewhere on the face of the CRT. Adjust the "Intensity" control for desired brightness.

Now turn the tube until the line on its screen is aligned vertically across the slot representing the "slide-rule" scale. Adjust the "Vertical Centering" control until the line is properly centered on the screen of the CRT, and the "Focus" control until a sharp, properly focused image is obtained. The "Vertical Centering," "Intensity," and "Focus" controls are now left fixed in position.

The instrument is now ready for calibration. Before calibration is possible, the user should decide whether he prefers a "zero-center," a "left-zero" or a "right-zero" scale. The "Zero Adjustment" knob on the front of the instrument (R_2 in Fig. 2) is then adjusted to bring the vertical indicator line to the proper position.

A paper or thin cardboard scale, with a slot corresponding to the slot in the

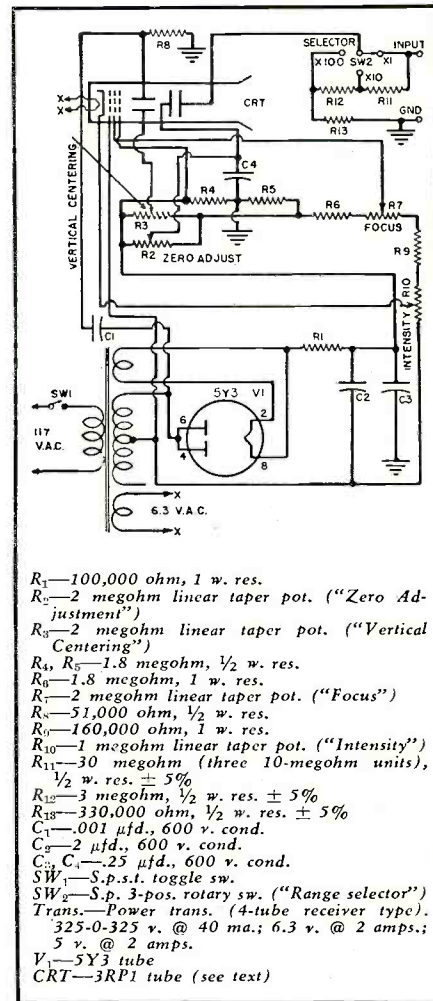
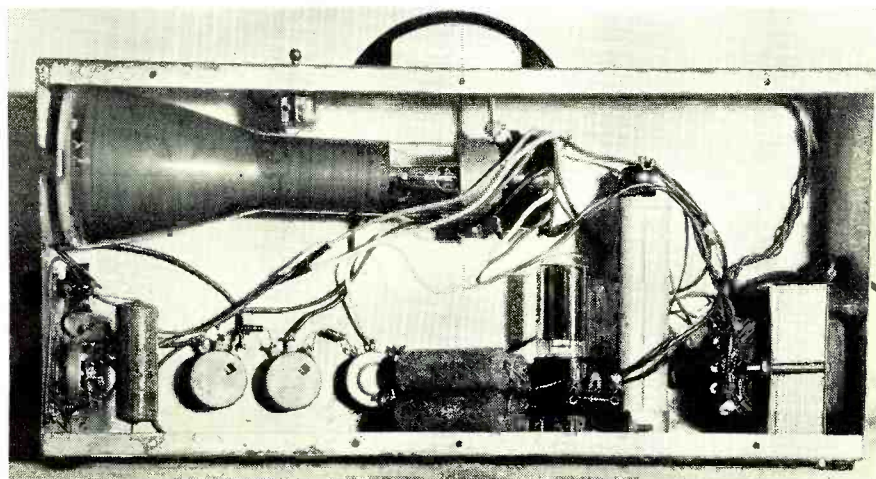

Fig. 2. Complete schematic diagram of "Meterless V.T.V.M." It is easy-to-build.

front of the cabinet, is mounted on the front of the instrument, using rubber cement or Scotch tape. The "zero position" is lightly marked on the scale with a pencil.

Now, apply known d.c. voltages to the input of the instrument, using either a standard voltage source, or a variable d.c. voltage together with a calibrating standard meter. Lightly mark the indicator deflection obtained (Continued on page 137)

Fig. 3. Chassis side view. Any size housing, depending on CRT employed, can be used.





This compact Bendix installation takes little room in the luggage compartment.

MOBILE RADIO

By
LEO G. SANDS
Bogue Railway Equipment Division

Part 4. Concluding article covers data on test gear and special equipment needed to service mobile radio units.

THE rapid expansion of mobile radio has prompted many radio technicians to enter this field. There is still a great shortage of competent mobile radio servicing establishments and room exists in the field for qualified and responsible technicians.

Servicing mobile radio equipment requires no more skill than that required to properly service television receivers. Mobile radio equipment is not as complex as a television receiver. However, a greater sense of responsibility is required of the service technician because mobile radio equipment must stand more rigorous and continuous service and is capable of causing serious interference to others. The prime requisite for the mobile radio technician is that he must hold a radio operator's license. First or second class radiotelephone or radiotelegraph licenses are valid for this purpose. It is true that a technician may service mobile radio equipment without a license provided he does not make adjustments to a transmitter except under the supervision of a licensed operator. However, a person incapable of passing the fairly simple examination for a radio operator's license could hardly be considered qualified to service mobile radio equipment.

In addition to holding a license, the technician should be thoroughly familiar with v.h.f. theory and practice. He must understand multi-stage transmitters, superheterodyne receivers, FM, squelch circuits, and automotive electrical systems.

A standard broadcast receiver can be serviced by a competent technician with but few tools or instruments. A screwdriver and a wet-finger voltmeter are sometimes all he needs. Servicing mobile radio equipment requires the proper tools and adequate test equipment. By adequate test equipment is meant laboratory-quality test equipment. A signal generator, for example, for the alignment of v.h.f. r.f. circuits and i.f. circuits must be accurately calibrated, very stable, and its output must be controllable down to a fraction of a microvolt. Several manufacturers offer suitable signal generators designed specifically for this purpose. It might be possible to squeak by with an inexpensive signal generator intended for servicing home receivers, but this practice is certainly not recommended.

Specific instructions for aligning mobile receivers are furnished by the manufacturers. There are no general methods as equipment designs differ

widely. The service technician should follow the manufacturer's instructions exactly. If the manufacturer, for example, states that a frequency modulated signal generator and an oscilloscope are to be used for alignment of the intermediate frequency stages, it is wise to do so. Peaking of an i.f. amplifier which should be "flat-topped," for example, will destroy the performance characteristics built in by the manufacturer.

The mobile radio shop should be equipped with a tube tester for sifting out obviously bad tubes. However, the typical tube tester used in a radio repair shop may not reject tubes which are unsatisfactory for further use in a precision v.h.f. receiver or transmitter. The substitution method with a very weak signal fed into the receiver is likely to reveal more tube defects than a standard tube tester. In r.f. and i.f. circuits, it is a good idea to check the alignment when substituting tubes to make sure that small mechanical differences in the tubes have not caused misalignment.

Most mobile radio manufacturers build or distribute special test meters for servicing their own brands of equipment. The use of this special test equipment is recommended because often the mobile equipment itself contains the multipliers and shunts for the test meter and the use of a substitute meter may cause erroneous readings.

The employment of a dummy antenna when tuning the transmitter is necessary to prevent interference to others operating on the same or adjacent frequency. It is better to buy a suitable dummy antenna than to make one because simple as it may seem, a dummy antenna that will match the transmitter output is a precision device that took a lot of engineer hours to design.

There are r.f. wattmeters available which not only measure transmitter output but also serve as dummy antennas. A frequency meter is required for checking the output frequency of the transmitter. A modulation meter is also required so that the frequency deviation of the transmitter may be

measured. FCC rules require licensees to measure transmitter frequencies at regular intervals by approved methods. It is also necessary that frequency deviation be measured to make sure the transmitter frequency does not swing beyond legal limits.

The mobile radio service shop should also be equipped with a reliable source of 6 volts d.c. to permit testing of mobile radio transmitters and receivers used in automobiles. If truck, bus, or railroad radio equipment is to be serviced a source of 12-volt d.c. power is also required. Some railroad radio equipment requires 32, 64, or 117 volts d.c. for operation.

A storage battery and a charger will sometimes suffice. However, where a large volume of work is to be done, a rectifier unit or motor generator set should be used. Where 6, 12, 32, 64, and 117 volts d.c. is required, a motor generator set like the *Bogue* RT-100 will provide the necessary voltages at ample current to permit piping the power to several outlets at work benches.

A monitor receiver is another useful tool. It should be capable of being tuned continuously across the band or by plug-in crystals to the frequencies at which the transmitters to be serviced are to be operated. Unless a really good screen room is used, some signals will be radiated which might cause interference. Therefore, it is wise to monitor the channel before turning on the transmitter, even when using a dummy antenna.

Most of the servicing of mobile radio equipment is performed in the shop. When a vehicle is brought in for a radio check, it is customary to replace the radio equipment with a spare unit to avoid tying up the vehicle.

When installing a new or spare unit in a vehicle it is suggested that the alignment of the receiver's first r.f. stage and the transmitter's final r.f. stage be checked to compensate for any difference in characteristics between the mobile antenna system and the dummy antenna used in the shop.

A portable field strength meter which may consist of a quarter-wave antenna, crystal diode, r.f. filter, and a microammeter can be used to check the output and alignment of the mobile transmitter. The field strength meter is usually placed a few feet from the vehicle where it can be seen while adjustments are made.

Some knowledge of automotive electrical systems is required of the mobile radio technician so he can instruct automotive electricians on proper adjustments in case he doesn't do so himself. When adjustments are made to the charging generator regulator to provide adequate charging current, care should be taken to prevent the voltage across the battery from rising too high. Although high charging current is available for longer periods of time, excessive voltage will shorten the life of the tubes and mobile radio equipment.

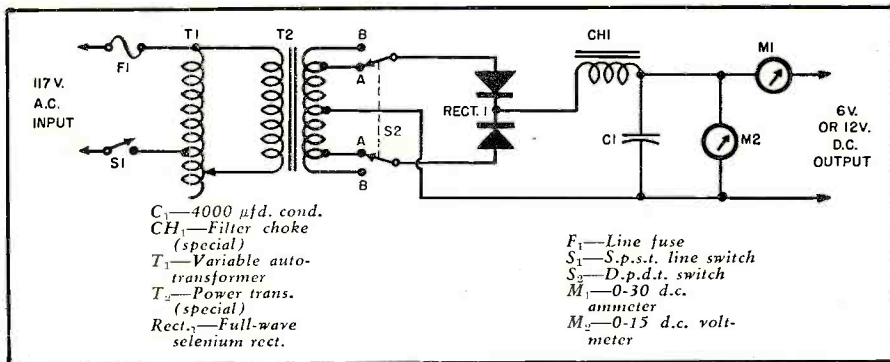

Schematic diagram of a power supply suitable for bench testing mobile radio gear.

Jigs and wiring harnesses for all types of equipment serviced
 Regulated power supply to provide 6 volts d.c. (12 v. optional)
 Dummy antenna (several types may be needed depending on units)
 Test meter (use type prescribed by the equipment manufacturers)
 R.f. wattmeter
 R.f. signal generator
 V.T.V.M. and V.O.M.
 Tube tester
 Oscilloscope
 Field strength meter
 Monitor receiver
 Modulation meter

Table 1. Minimum shop equipment needed for servicing mobile radios.

Diagnosing ignition noise is another art which is usually learned through experience. This is not often a major problem with v.h.f. equipment particularly when using FM. However, noise does occur which reduces the effective sensitivity of the receiver and requires knowledge of ignition systems for correction.

Railroads generally utilize their own personnel for maintaining radio communications equipment. However, in some cases this work is farmed out on a contract basis. Usually, the radio service contractor does not service the radio equipment on board rolling stock. He assumes responsibility for servicing the radio equipment before it is installed and after it has been removed from a caboose or locomotive by railroad personnel. Prospective service contractors interested in doing

business with railroads should contact the railroad's chief communications officer who usually has the title of Superintendent of Communications or Superintendent of Telegraph on the larger roads.

Component failures occur less frequently in mobile radio equipment than in home radio and television receivers. This is because mobile radio equipment is designed for commercial service and because the customer is willing to pay a higher price for superior quality equipment. Furthermore, the maker would soon find his equipment unsaleable if component failures occurred frequently.

The performance requirements of mobile radio equipment are rigorous compared with domestic receivers. The receiver, for example, must be able to operate satisfactorily on sig-

Motorola's 25-50 mc., 30 watt base station transmitter being bench tested.

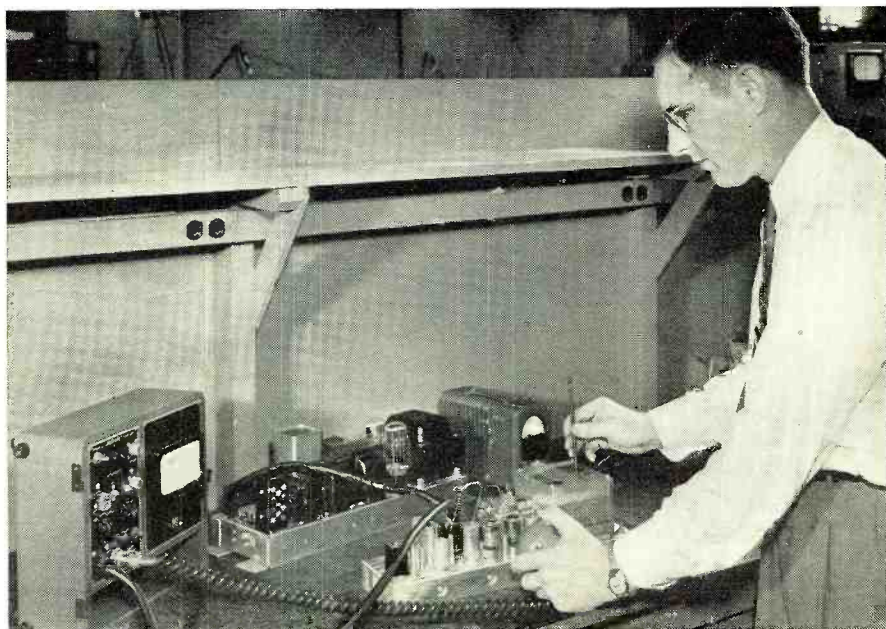

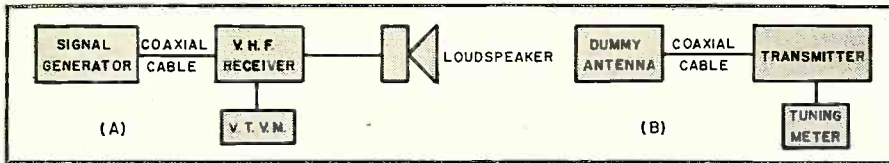

(A) Set-up for aligning mobile FM receivers. A v.t.v.m. is used to measure limiter voltage. (B) Set-up for aligning transmitters. Meter is switched to various circuits.

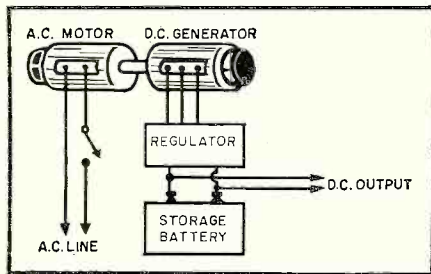

A rotary type power supply designed for the bench testing of mobile equipment.

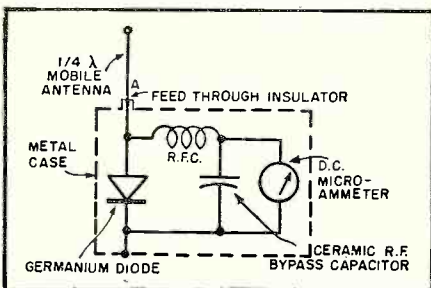

Diagram of a portable field strength meter for aligning mobile transmitters.

nals on the order of a fraction of a microvolt and it must do so consistently. Its local oscillator circuit must be very stable to prevent loss of sensitivity or selectivity because of drift. Likewise, the i.f. amplifier must not drift. Simple as these requirements may sound, at the very high frequencies heat and other factors contribute to instability so extreme care must be exercised in the design of equipment and selection of components.

Because of rigid stability requirements, it is important that the mobile radio service technician use exact re-

placement parts when replacing defective components, especially in r.f. and i.f. circuits. Use of a replacement part of the same value and operating rating but differing physically or in some minute way may cause difficulties not easily compensated for or diagnosed. Furthermore, a replacement part should be installed in exactly the same manner as the original. In r.f. circuits particularly, a lead one-half inch too long or a part placed one-quarter of an inch too near or too far from a critical "hot" circuit might cause feedback, instability, detuning or some other undesirable phenomena.

It is not always possible to obtain exact replacement parts, especially on short notice, so the technician will have to exercise good judgement in selecting a substitute.

Some of the irregularities which require the most frequent attention of the mobile radio technician are: worn out vibrators; defective tubes; need for realignment; squelch adjustment; external wiring failures; defective microphones; defective components; and blown fuses.

Most of the troubles encountered in vehicular radio installations seem to occur during the first 60 days of service which is the shakedown period when bugs and other vagaries are generally ironed out. After that, failures occur mostly because of wear or abuse. During the shakedown period, the equipment should be checked every two or three weeks with special attention to tuning trimmers. It is not to be construed that all new installations can be expected to be troublesome. However, experience has demonstrated that vehicles newly equipped with two-way radio are brought to the shop for checking more frequent-

ly than vehicles previously radio equipped.

Fuses blow because excessive current has been passed through them. As protective devices, this is their function. Fuses in mobile radio equipment are sometimes found open for no apparent reason, particularly in plate supply circuits. Obviously a short circuit or overload caused the fuse to blow but when the set is brought to the shop, everything except the fuse checks out as satisfactory. It has been found that momentary short circuits between the elements of one of the final r.f. stage power amplifier tubes in the transmitter has caused the fuse to blow. This is a difficult thing to diagnose. Tapping of the tube when under load might reveal the culprit. The cure is to replace the tube, which when on the bench may appear to be normal but when subject to the shock it encounters in the trunk of an automobile, may become shorted.

Much of the mobile radio equipment now in service will not meet current FCC requirements although use of the equipment is permitted under existing licenses for a limited time. Should ownership of the equipment be transferred, it would not be possible to obtain licenses for the use of the equipment until it had been modified to meet FCC regulations.

In many cases, it is possible to modify this early type of mobile radio equipment in the mobile technician's shop without returning the equipment to the factory. By writing to the manufacturer, it is generally possible to obtain modification kits and explicit modernization information.

With the Citizens Radio Service opening up, slowly but surely, the field for the mobile radio service technician is widening. Many have entered the mobile radio field and some have already left it. Only those that provide competent service can survive in this branch of radio because the customer generally depends on his mobile radio equipment as a business tool which is useful only when it performs properly.

-30-

Lampkin Laboratories' Type 205 FM modulation monitor. It indicates maximum frequency deviation in mobile FM transmitters.



The Lampkin Type 105-B micrometer frequency meter. It is used to measure the center frequency of AM or FM transmitters.



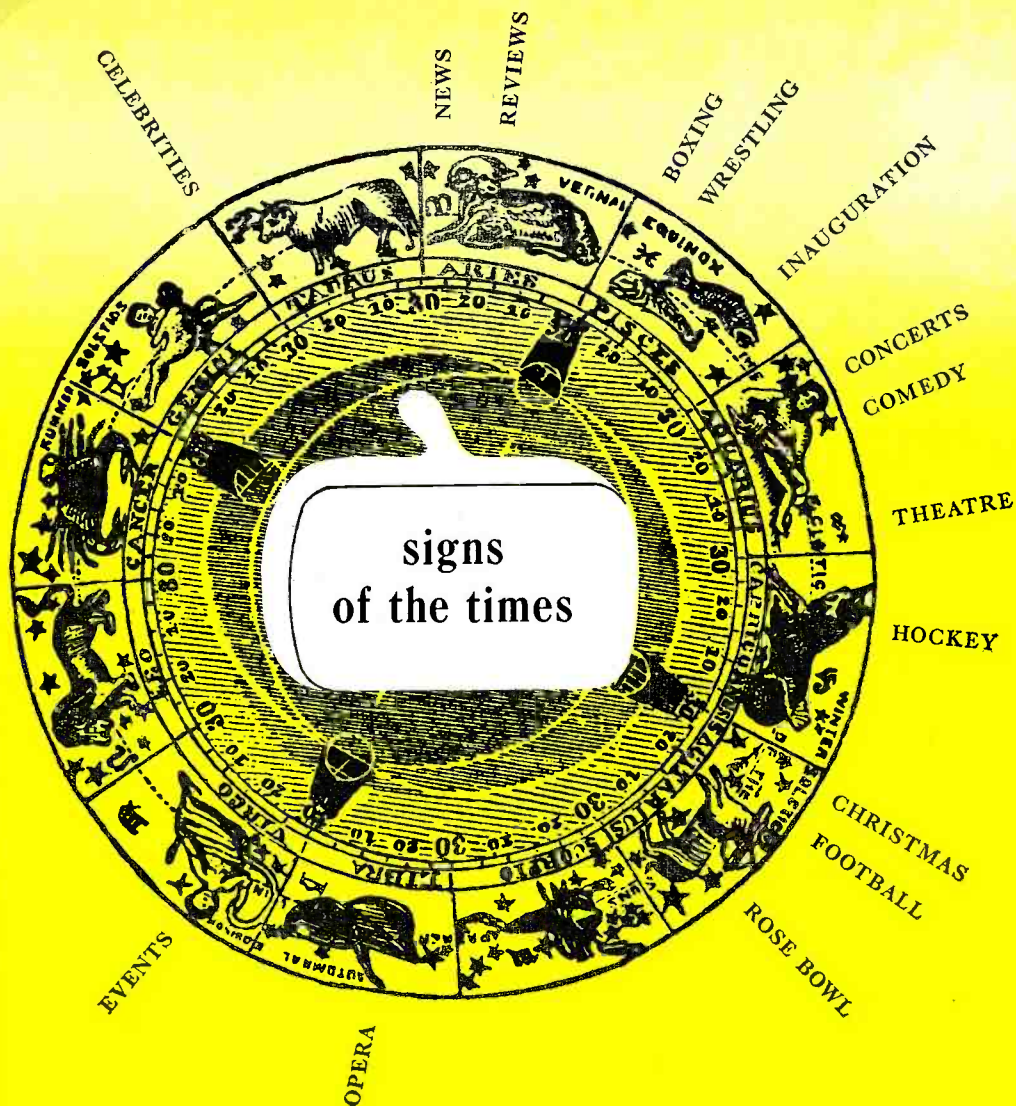

burton browne advertising

The stars show quality ascendant in the TV set owner's mind. *Follow your stars*—give the set owner the best picture tube replacement—Rauland. Your Rauland jobber anticipates your need today with a complete stock. The Rauland Corporation, 4245 N. Knox Avenue, Chicago 41, Illinois. MUlberry 5-5000.

RAULAND

PERFECTION THROUGH RESEARCH



\$39.00 NET*

15 or 12 in. Bass Reflex Cabinet

*Craftsmanship
in Cabinets*

New—with more style and better tone at half the price. Fits finest surroundings, yet economically engineered. ½-in. cellufoam acoustic lining. Solid hardwood picture-frame front. Brahma-grain matching leatherette on top and sides. Blonde or mahogany, same price. Ask your Parts Jobber or write for specification sheet.



**NEW BASS REFLEX
CORNER BAFFLE**

Gives more effective coverage, looks better on wall. ½-inch cellufoam acoustic lining. Blonde or mahogany, same price.
12" spkr.\$8.55 Net*
8" spkr.\$5.10 Net*



WALL BAFFLES

Argos craftsmanship with resonant tone. Reinforced for extra strength. Blonde or mahogany, same price.
Up to 12" spkr.\$2.34 to \$4.65 Net*

*Slightly higher west of Rockies



Technical
BOOKS

"DIRECT-CURRENT MACHINERY" by Charles S. Siskind. Published by McGraw-Hill Book Company, Inc., New York. 310 pages. Price \$6.00.

This textbook is written for the student of electrical engineering and with this audience in mind the author has produced a clear and straightforward presentation covering up-to-date direct current machines.

Separate chapters are devoted to discussions of the dynamo, armature windings, generator principles, motor principles, armature reaction, interpoles and compensating windings, generator characteristics, generator operation and performance, motor characteristics, the control of motors, efficiency and ratings of dynamos, special machines and their applications, and commutation.

The text material is lavishly illustrated with photographs and diagrams. The necessary mathematical formulas are carefully derived so that the student can proceed step-by-step to the solution. In many instances the problems are worked out in their entirety to permit self-checking. Answers to the problems included with each chapter are also provided.

A fairly comprehensive bibliography is included for those interested in additional data on the subject.

Although written at a college level, the serious student should be able to handle the subject matter working alone and on his own.

* * *

"MOST-OFTEN-NEEDED 1952 RADIO DIAGRAMS AND SERVICING INFORMATION" compiled by M. N. Beitman. Published by Supreme Publications, Chicago, Illinois. 168 pages. Price \$2.50. Paper bound.

This is Volume 12 in the series and covers all of the best-known radio receivers made during the last year. Included are AM and FM receivers, portables, auto radios, combination sets, and record changer units.

Diagrams and servicing information on units manufactured by 38 different companies have been included in this manual. Like the previous volumes, the material is presented in its most concise and usable form. Alignment procedure, dial stringing data, correct voltage readings, and a complete circuit diagram are included for each receiver.

As all extraneous material has been eliminated in compiling this manual the 168 pages are literally crammed with usable data.

* * *

"TV CONSULTANT" by H. G. Cisin. Published by Harry G. Cisin, 200 Clinton St., Brooklyn 2, New York. 70 pages. Price \$2.00. Paper bound.

This is an up-to-date and enlarged edition of the author's "Rapid TV Trouble Shooting Method," published

some years ago. The method for tracking down service faults in the television receiver is the same but has been expanded to include over three hundred commonly-encountered troubles.

A new section of the book includes details on streamlined alignment procedures which have been developed in the service shop under actual working conditions. An important feature of this section deals with the correct way to use v.t.v.m.'s, sweep generators, and oscilloscopes.

The book contains more than 125 illustrations and lists a total of 135 "rapid checks," many of which are made without instruments, using the picture tube as a guide.

If the user of this book will study the instructions for applying the author's method of servicing, there is no reason why the beginning technician as well as the old timer can't locate service faults easily and rapidly.

* * *

"TELEVISION" by F. Kerkhof & W. Werner. Published by Philips Technical Library, Eindhoven, Holland. 475 pages. Price \$7.75. Available in the U. S. from Elsevier Press Inc., 402 Lovett Blvd., Houston 6, Texas.

This is truly a monumental work on the subject of television and its associated techniques. Written for the engineer and advanced service technician, the authors have provided a comprehensive introduction to the physical and technical principles of television.

Since this book is to be distributed in English-, German-, Dutch-, and French-speaking countries, all of the television systems presently in operation are discussed in the text.

It is difficult to do more than suggest the scope of this work in a brief review but suffice it to say the authors have managed to convey a wealth of information to the reader in a relatively few pages.

While the treatment of the subject is mathematical, the reader with a limited knowledge of mathematics will not experience any undue difficulty in handling the text material.

For the serious technician and TV engineer, this book offers a solid foundation on the principles of the art.

* * *

"RADIO SPECTRUM CONSERVATION" by The Joint Technical Advisory Committee, sponsored by IRE and RTMA. Published by McGraw-Hill Book Company, Inc., New York. 216 pages. Price \$5.00.

This is a report of a study made into the problem of spectrum utilization and a recommendation regarding the handling of this serious and growing threat to all types of radio services.

The book, with the exception of a single chapter on propagation, is written in non-technical language so that the lay reader may derive as much benefit from the text as the engineer.

-30-

Check these ADVANTAGES FOUND Only in HEATHKITS

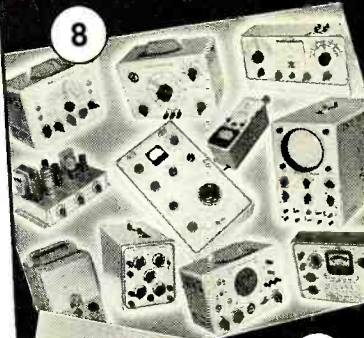
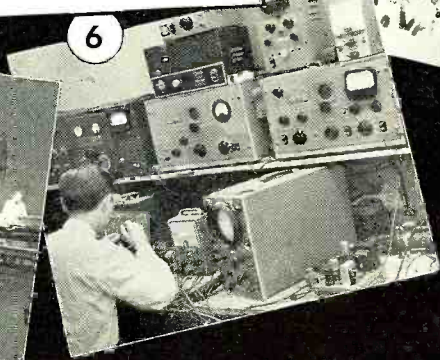
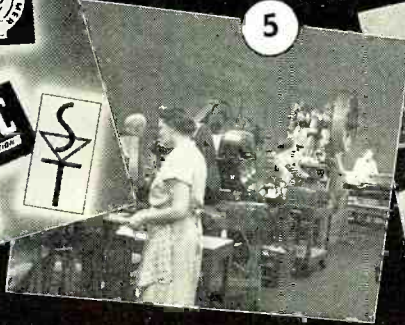
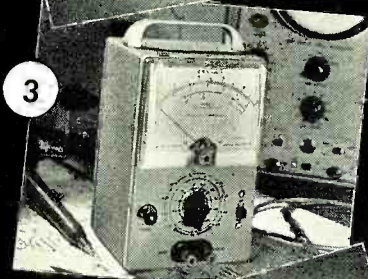
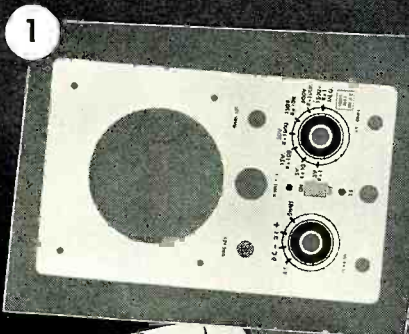

1. **Baked Enamel Lifetime Finish Panels** — Oven baked finishes for maximum durability and freedom from marks, scratches and discoloration. Panels that can really take service shop and laboratory abuse.
2. **Save Money** — You save all expensive factory wiring costs when you build your own. And, direct factory to customer sales eliminate all middle man profits. You can have a complete Heathkit laboratory or service shop for what one or two pieces of ready built equipment cost.
3. **Modern Styling** — New "fitted panels" and formed cabinets with rounded corners present a smart, professional appearance. Dignified appearance for prestige.
4. **Quality Components Used Throughout** — Heathkits use well known, time and quality tested components such as Simpson, Chicago Transformer, Wilkor, Allen-Bradley, Altec-Lansing, Centralab, Cinch, Oak, Grigsby-Allison, Mallory and many others.
5. **Extensive Factory Facilities** — Shearing, punching, forming, spot welding, etc. is done right in our own plant — controlled production for highest quality and less cost to you.
6. **Extensive and careful engineering** — A staff of engineers working in a modern, well equipped laboratory carefully develop Heathkits according to highest engineering practices. Your assurance of accurate, up to the minute instruments.
7. **Complete Kits** — All the parts are right in the kit — you get all tubes, controls, no transformers, meters — everything — no other components to buy. And no cutting, punching, or painting necessary — it's all done for you. Heathkits go together easily and smoothly.
8. **Only Complete Line** — Over 30 kits available — Heathkits form the only complete line of kit-form test equipment on the market. Kits for hams, engineers, service men, schools and audio enthusiasts.
9. **Detailed, Complete Instruction Manuals** — Comprehensive manuals tell you exactly how to build your Heathkit. Manuals contain easy-to-follow instructions, clear, large pictorials, schematic, detail drawings, etc. They make construction easy, fun, and educational.

Nine New Heathkits This Year!

EXPORT AGENT
ROCKE INTERNATIONAL CORP.
13 E. 40th ST.
NEW YORK CITY (16)
CABLE: ARLAB-N.Y.

The HEATH COMPANY
... BENTON HARBOR 15, MICHIGAN

NEW Heathkit "Q" METER KIT

• A HIGH QUALITY Q METER AT LOW COST.

MODEL QM-1

SHIPPING
WT. 12 LBS.

\$39⁵⁰

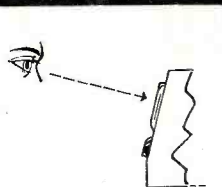
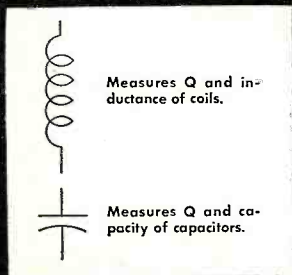

Slant face cabinet for ease in reading the meter.



• First Q METER within the price range of all.

• Read Q's of 0-500 directly on calibrated scale.

• Stable oscillator supplies R.F. frequencies of 150 kc to 18 megacycles.

• Calibrated capacitor with range of 40 mmf to 450 mmf with vernier of ± 3 mmf.

• Simple, easy operation.

• Can be used to measure small inductances or capacitors.

• Measures Q of condensers, RF resistance and distributed capacity of coils.

• Measures capacity by substitution, capacity by resonance, inductance by resonance.

• Slanted panel for convenient operation.

Another outstanding example of progressive HEATHKIT engineering. Now a highly desirable Q METER within the price range of all laboratories, schools and experimenters. No longer is it necessary to deny yourself the many measurement advantages offered by this instrument.

Use the new HEATHKIT Q METER for the following simple basic measurements: capacity by substitution, capacity by resonance, inductance by resonance and Q at the OPERATING frequency all can be read on the calibrated scales. The method used to obtain information regarding the Q of condensers, RF resistance, distributed capacity in coils, etc., is only slightly more involved. In the HEATHKIT Q METER, the generated RF signal is coupled through a cathode follower and injected across a low impedance condenser which is included in the resonant circuit under test. Large $4\frac{1}{2}$ " 50 microampere Simpson meter reads Q directly. The resonating condenser and vernier condenser are calibrated in mmf for substitution method capacity tests. The resonating condenser is also calibrated in effective capacity for resonance tests. The inductance calibration serves for rapid determination of the approximate inductance of a coil. The HEATHKIT Q METER has a generator frequency range of 150 kc to 18 megacycles. Vernier capacity covers ± 3 mmf and the resonating condenser is calibrated from 40 mmf to 450 mmf actual capacity or 40 mmf to 350 mmf effective capacity. Meter reads Q directly up to 250. Higher and lower full scale readings can be obtained by varying the injection voltage levels.

The entire kit consists of 12AT7, 6AL5, 6C4, OD3 and 6X5 tubes, 50 microampere Simpson meter, power transformer, cabinet and all other parts necessary for construction as well as instructions for assembling, testing and operation of the completed instrument.

Heathkit DECADE RESISTANCE KIT

The HEATHKIT DECADE RESISTANCE KIT is widely used by schools, experimenters and laboratories because of the extremely wide resistance range offered and the useful, dependable service provided. The DECADE consists of 5 rotary 2 deck ceramic wafer switches with silver plated contacts and twenty 1% precision resistors in a circuit which provides the resistance range of 1 ohm to 99,999 ohms in 1 ohm steps. The HEATHKIT DECADE RESISTANCE KIT is simple to construct and is housed in a beautiful polished birch cabinet with an attractive panel. The DECADE will furnish years of accurate trouble-free service.

Individual decade sections of above can be purchased separately for special applications.



MODEL DR-1
SHIPPING
WT. 4 LBS.

\$19.50

NEW Heathkit DECADE CONDENSER KIT

Extremely useful in all experimental and design work such as determination of condenser values for: compensating networks, filters, bridge impedances, tuned circuits, etc. Uses all precision silver mica condensers within $\pm 1\%$ accuracy. Values run in three decades from 100 MMFD to 0.111 MFD in steps of 100 MMFD. Smooth acting, positive detent, highest quality ceramic wafer switches make all capacitor values easy to set up and keep losses to a minimum. Low loss dielectric terminal board mounts on outside of panel for easy cleaning. Heathkit binding posts accommodate a wide variety of test leads. Comes complete with all parts, including polished birch cabinet.

Individual decade sections of above can be purchased separately.

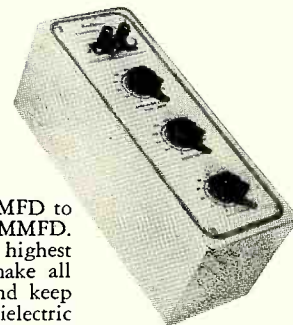

MODEL DC-1
SHIPPING
WT. 4 LBS.

\$16⁵⁰

EXPORT AGENT
ROCKE INTERNATIONAL CORP.
13 E. 40th ST.
NEW YORK CITY (16)
CABLE AREA-N.Y.

The **HEATH COMPANY**

... BENTON HARBOR 15, MICHIGAN

NEW *Heathkit* OSCILLOSCOPE KIT

• NEW WIDE BAND VERTICAL AMPLIFIER ± 2 DB 10 CYCLES TO 1 MC.



Direct plate connections for modulation tests.



Displays TV sync pulses correctly.



Useful to 5 mc.



Good square wave response at 100 kc.

MODEL O-8

SHIPPING
WT. 29 LBS.

\$43.50

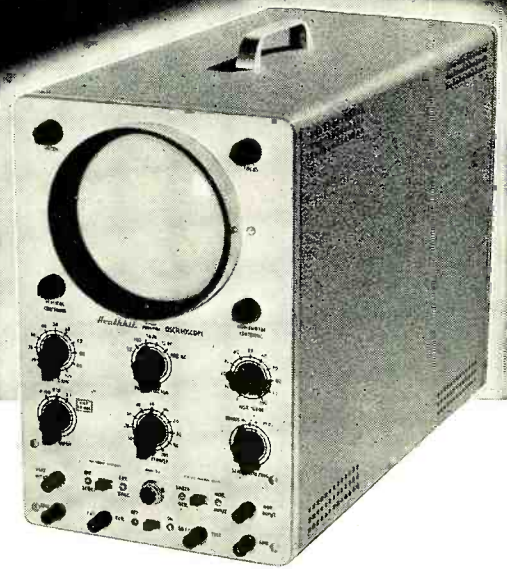

- New wider band vertical amplifier ± 2 db from 10 cycles to 1 megacycle useful to over 5 megacycles.

- High sensitivity in vertical amplifier. .025 volts RMS per inch deflection.

- New 3 step input attenuator input ranges X1, X10, X100.

- New 5CP1 intensifier type tube for greater brilliance.

- Terminal board and rear cabinet opening provisions for direct connections to deflecting plates.

- Newly styled formed and ventilated aluminum cabinet.

- Wide band sweep generator, 15 cycles to over 100 kc. Will synchronize with 5 megacycle signal.

- 10 tube circuit featuring push pull operation of vertical and horizontal amplifiers.

- Internal synchronization on either positive or negative peaks.

- Reproduces faithfully the front and back porches of TV sync pulses. Excellent square wave reproduction to over 100 kc.

- Optional Intensifier kit available for 2200 volt operation.

Proudly announcing the new 1953 HEATHKIT Model O-8 OSCILLOSCOPE featuring the finest performance ever offered in this extremely popular kit instrument. Improved wider band vertical amplifier featuring a new 3-step input attenuator affording smooth control of the excellent .025 volts per inch vertical sensitivity. Possibility of overloading the vertical input circuit is minimized. Greater band width in the vertical channel is a decided advantage to TV service men. Permits clear observation of all TV sync pulse detail and excellent square wave reproduction over 100 kc. 5CP1 intensifier type CR tube provides a brilliant trace with normal accelerating voltages. A handsome, ventilated cabinet with smooth rounded corners and a snug fitting drawn panel adds to the smartly styled professional appearance. Longer life is assured through cooler instrument operation. Push pull output stages in both vertical and horizontal amplifiers for balanced deflection of the spot. All of the many fine features of the previous model have been retained. Rear cabinet access to terminal board for direct connection to CR plates. The entire kit of all 10 tubes, parts, cabinet and panel as well as detailed construction manual for assembly and operation of the instrument included.

INTENSIFIER KIT: For extreme trace brilliance in special applications such as photography, group demonstrations or operation in brightly lighted areas an optional Intensifier kit providing 2200 volt operation of the CR tube is available. Kit includes high voltage filter condenser, high voltage selenium rectifier, etc. \$7.50.

Heathkit

SCOPE DEMODULATOR PROBE KIT



Trouble shooting or aligning TV, RF, IF and video stages requires demodulation of high frequency signals before Oscilloscope observation. The HEATHKIT SCOPE DEMODULATOR PROBE KIT was specifically developed for this application. Kit consists of a probe housing, crystal diode detector circuit, shielded cable and spade lugs. Assembly is simple and the probe will quickly prove its usefulness as an Oscilloscope accessory.

No. 337
SHIP WT. 1 LB.
\$4.50

NEW *Heathkit* VOLTAGE CALIBRATOR KIT



MODEL VC-1
SHIPPING
WT. 5 LBS. **\$9.50**

Use the Heathkit Voltage Calibrator with your oscilloscope to measure peak-to-peak TV complex waveshapes. TV manufacturer's specifications indicate correct peak-to-peak voltages and this kit will permit making these important measurements.

A big help to engineers in circuit work. Makes peak-to-peak voltage measurements of complex waveshapes of all kinds. Flat topped semi-square wave output of calibrator assures fast and easy measurement of any voltage between .01 and 100V peak-to-peak.

The Voltage Calibrator can remain connected to your oscilloscope at all times for instant use. "Signal" position connects signal under study directly through calibrator and into scope input circuit for direct observation. Eliminates transferring leads from calibrator. *A wonderful scope accessory.*

Heathkit ELECTRONIC SWITCH KIT



MODEL S-2
SHIPPING
WT. 11 LBS.

\$19.50

A few dollars spent for this accessory will increase the usefulness of a scope immeasurably. An electronic switch will open up a whole new field of scope applications for you. The S-2 allows TWO SIGNALS to be observed at the SAME TIME — this important feature allows you to immediately spot phase shift, clipping, distortion, etc. The two signals under observation can be superimposed or separated for individual study. Each signal input has an individual gain control for properly adjusting scope trace patterns. Has both coarse and fine frequency controls for adjusting switching time. Multivibrator switching frequency is from less than 10 cps to over 2000 cps in three overlapping ranges. Kit comes complete including 5 tubes, power transformer, all controls, instruction manual, etc. *Every scope owner should have one!*

EXPORT AGENT
ROCKE INTERNATIONAL CORP.
12 E. 40th ST.
NEW YORK CITY (16)
CABLE ARIAB-N.Y.

The **HEATH COMPANY**

... BENTON HARBOR 15, MICHIGAN

Heathkit
VACUUM TUBE

VOLTMETER KIT

• NEW 1½ VOLT RANGE ON 1953 VTVM.

MODEL V-6

SHIPPING
WT., 7 LBS.

\$24.50

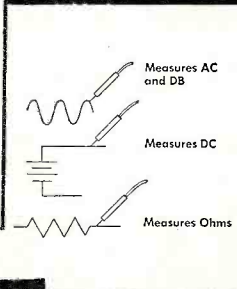
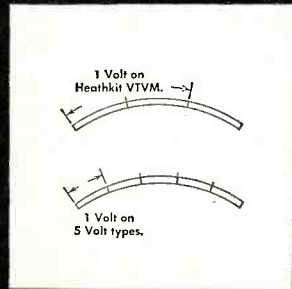
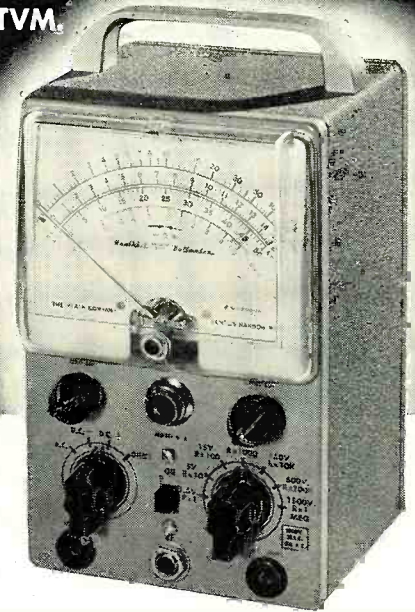

- New 1½ volt low range gives over 2" of scale per volt instead of less than ¾" found on 5 volt range type.
- Increased accuracy due to expanded scales.
- New 1500 volt DC high range gives 50% greater coverage.
- Seven ranges in all. 1½, 5, 15, 50, 150, 500 and 1500 volts DC (1000 volts maximum AC only).
- Provides proper service ranges 150 volts for AC DC work and 500 volts for AC type service.
- High input impedance, 11 megohms minimizes circuit loading.
- Variety of accessory probe kits available.
- 1% precision resistors in multiplier circuits.
- 200 microampere Simpson meter.
- Center scale zero adjust.
- Transformer operated.
- Test leads included.
- New cabinet styling.
- Large, clearly marked meter scales indicate ohms, AC volts, DC volts and DB.

The 1953 Heathkit V-6 VTVM has improved ranges! The lowest range has been moved way down to 1.5V full scale. This gives 3½" of actual scale length for the 1.5V covered — that's 2½ inches per volt!! Now you can make your low level measurements faster and with greater accuracy.

And the upper range has been moved up. Readings up to 1500V DC can be readily made with new, improved VTVM — plus readings up to 1000V on AC. Higher ranges for extended use.

New vertical chassis mounting gives added chassis space for really easy wiring — no tight corners to worry about. Uses only highest quality components throughout. Simpson 200 microampere meter movement combined with 1% precision resistors in multiplier circuit insure highly accurate and dependable readings.

AC and DC voltage ranges are 0-1.5V-5V-15V-50V-150V-500V-1500V. (1000V max. reading on AC) — a total of seven ranges for convenient, accurate readings. Instrument also measures resistance from .1 ohm to over 1 billion ohms in seven handy ranges of RX1, X10, X100, X1000, X10K, X1 Meg., — all convenient multiples of 10 with no skips. Has Db scale in red for easy identification.

New panel has rough baked on enamel finish for freedom from scratches and maximum durability. Modern styled, formed, compact cabinet with rounded edges and crackle finish is truly handsome.

Comprehensive, detailed instruction manual with step-by-step instructions, figures, pictorials, etc. makes assembly a cinch.

Be sure and look over the special accessory VTVM probes below — for added usefulness.

Heathkit R. F. PROBE KIT
SHIP. WT. 1 LBS. **\$5.50**
No. 309
Extends RF range of HEATHKIT 11 megohm VTVM to 250 megacycles ± 10%.

Heathkit 30,000 V. D.C. PROBE KIT
SHIP. WT. 2 LBS. **\$5.50**
No. 336
Provides DC multiplication factor of 100 for any 11 megohm VTVM.

Heathkit PEAK TO PEAK VOLTAGE PROBE KIT
SHIP. WT. 2 LBS. **\$6.50**
No. 338
Reads on DC scale of any 11 megohm VTVM 5 kc to 5 megacycle range.

NEW Heathkit BATTERY TESTER KIT

The new Heathkit Battery Tester measures all types of dry batteries between 1½ volts and 150 volts under actual load conditions. Readings are made directly on a three-color GOOD-WEAK-REPLACE scale that your customers can readily understand. Operation is extremely simple and merely requires that the leads be connected to the battery under test. Only one control to adjust in addition to a panel switch for A or B battery types.

The Heathkit Battery Tester features compact assembly. An accurate meter movement and wire wound control mount in the portable, rugged plastic case.

Use the BT-1 to check portable radio batteries, hearing aid batteries, lantern batteries and photo flash gun batteries.

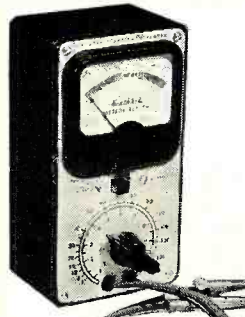

MODEL BT-1
SHIPPING WT. 3 LBS.
\$7.50

Heathkit AC VACUUM TUBE VOLTMETER KIT

A new AC VTVM that makes possible those sensitive AC measurements required by laboratories, audio enthusiasts and experimenters. Ten full scale ranges of .01, .03, .1, .3, 1, 3, 10, 30, 100 and 300 volts RMS. 10 DB ranges from -52 to +52 DB. Frequency response within 1 DB from 20 cycles to 50 kc. Simpson 200 microampere meter with large plainly marked meter scales. Precision multiplier resistors. Two amplifier stages using miniature tubes. A unique bridge rectifier meter circuit and a clean layout of parts. Order the AV-2 today and become acquainted with the interesting possibilities offered by this instrument.

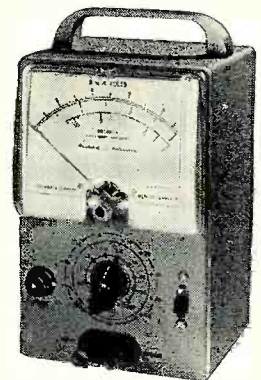

MODEL AV-2
SHIPPING WT. 5 LBS.
\$29.50

EXPORT AGENT
ROCKE INTERNATIONAL CORP.
13 E. 40th ST.
NEW YORK CITY (16)
CABLE AR148-N.Y.

The HEATH COMPANY

... BENTON HARBOR 15, MICHIGAN

NEW *Heathkit* GRID DIP METER KIT

• CONVENIENT ONE HAND OPERATION.

Indicates frequency of energized circuits.

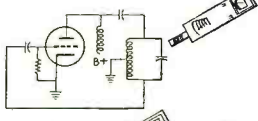

Indicates frequency of de-energized tuned circuits.

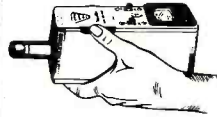
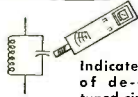

Complete unit easily held and operated with one hand.

MODEL GD-1

SHIPPING WT. 4 LBS.

\$19⁵⁰

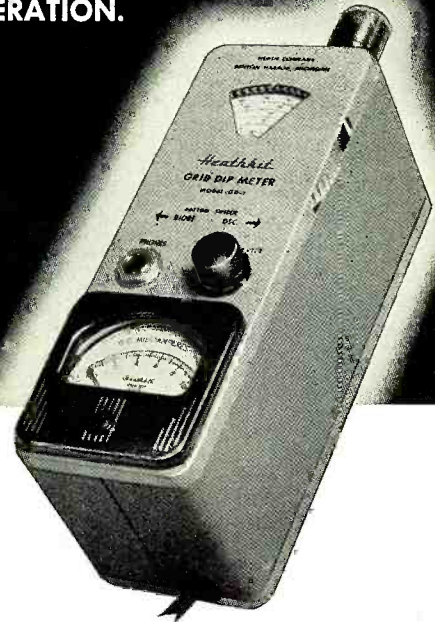

- New GRID DIP METER with assembled calibrated coils.
- Uses quality Simpson 500 microampere meter.
- One hand operation, extremely compact, Only 2½" wide by 3" high by 7" long.
- Variable meter sensitivity control.
- Uses newest type 6AF4 high frequency triode in a Colpitts oscillator circuit.
- Continuous coverage from 2 megacycles to over 250 megacycles in 6 ranges.
- Head phone monitoring jack.
- AC power transformer operated for maximum safety.

Here is the GRID DIP METER KIT you have been asking for. This new HEATHKIT instrument is compact, highly sensitive and easy to use. Housed in a handsome formed aluminum cabinet—rounded corners—durable oven baked finish on panel and cabinet. The entire instrument can be easily held and operated in one hand, tuning accomplished with the thumb wheel drive. This excellent design feature leaves the other hand entirely free for making circuit adjustments. The instrument with many applications — with oscillator energized, use it for finding the resonant frequency of tuned circuits, locating parasitics, determining characteristics of filter circuits, roughly tuning transmitter stages with power off, and neutralizing transmitters. Useful in TV and radio repair work for alignment of traps, filters, IF stages, peaking and compensation networks within the 2 to 250 megacycle range. With the oscillator not energized, the instrument acts as an absorption wave meter and indicates the frequency of radiating power sources. Locates spurious oscillations, as a relative indication of power in various transmitter stages, etc. (Head phones not included). Complete kit includes plug-in coils, tube, all necessary parts and detailed assembly and instruction manual.

Heathkit IMPEDANCE BRIDGE KIT



MODEL IB-1B
SHIPPING
WT. 15 LBS.

\$69⁵⁰

The HEATHKIT IMPEDANCE BRIDGE is especially useful in educational training programs, industrial laboratories and for experimental work. Use it for measuring AC and DC resistance value of resistors,

determination of condenser capacitance and dissipation factor, finding coil inductance and storage factor, electrical measurements work, etc. Quality components: GR 1000 cycle hummer, GR main control, Mallory ceramic wafer silver plated contact switches, ½% precision resistors, etc. The basic circuit is a self powered, 4 arm bridge. Choice of Wheatstone, Capacitance comparison, Maxwell or Hay bridge circuits. Resistance from 10 milliohm to 10 megohm. Capacitance 10 mmf to 100 mfd. Inductance 10 microhenry to 100 henries. Dissipation factor .002 to 1. Storage factor (Q) 1 to 1000. The IMPEDANCE BRIDGE has provisions for external generator use for measurement at other than the 1000 cycle level. Take the guess work out of electrical measurements. The HEATHKIT IMPEDANCE BRIDGE mounted in a beautiful polished birch cabinet with large easy reading panel calibrations will furnish years of accurate, trouble free measurement service.

Heathkit HANDITESTER KIT

The HEATHKIT Model M-1 HANDITESTER fulfills requirements for a portable volt ohm milliammeter. This kit features precision 1% resistors, 3 deck switch for trouble free mounting of parts, specially designed battery bracket, smooth acting ohms adjust control, beautiful molded bakelite case and a 400 microampere meter movement. 5 convenient AC and DC voltage ranges as follows: 10 - 30 - 300 - 1000 - 5000 volts. Ohms ranges 0 - 3000 and 0 - 300,000. DC milliammeter ranges 0 - 10 milliamperes and 0 - 100 milliamperes. The instrument is easily assembled from complete instructions and pictorial diagrams. Test leads are included. Carry the HEATHKIT M-1 HANDITESTER in your tool box at all times for those simple jobs and eliminate that extra trip for additional testing equipment.

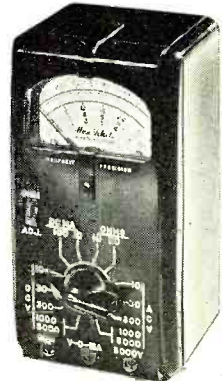

MODEL M-1
SHIPPING
WT. 3 LBS.

\$13⁵⁰

EXPORT AGENT
ROCKE INTERNATIONAL CORP.
13 E. 40th ST.
NEW YORK CITY (16)
CABLE ARLAB-N.Y.

The **HEATH COMPANY**

... BENTON ARBOR 15 MICHIGAN

NEW
Heathkit

AUDIO GENERATOR KIT

• RANGE EXTENDED TO 1 MEGACYCLE

MODEL AG-8

SHIPPING
WT. 16 LBS.

\$29.50

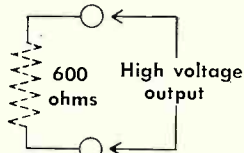

Low impedance output
High voltage output



Sine wave output
from 20 cycles to 1
megacycle.

- Improved design — new low price.
- Frequency coverage in five ranges from 20 cycles per second to 1 megacycle.
- Response flat 1 DB from 20 cycles to 400 kilocycles. Down 3 DB at 600 kilocycles. Down only 8 DB at 1 megacycle.
- Five calibrated output voltage ranges, continuously variable 1 mv, 10 mv, 100 mv, 1 v, 10 v.
- Low impedance output circuit. 600 ohms.
- Distortion less than .4 of 1% from 100 cycles per second through the audible range.
- New HEATHKIT universal type binding posts.
- Durable infra-red baked enamel panel.
- Transformer operated for safe operation.
- Sturdy, ventilated steel cabinet.

A new Audio Generator with features heretofore found in only the most expensive generators. Such features as complete coverage from 20 cycles to 1 Mc — response flat ± 1 db from 20 cycles to 400 Kc, down 3 db at 600 Kc and down only 8 db at 1 Mc.

And it has calibrated output . . . Calibrated continuously variable and step attenuator output controls allow you to easily set calibrated output voltage. Moreover, distortion is less than .4 of 1% from 100 cps through the audible range.

Oscillator section consists of a two stage resistance coupled amplifier (6SJ7 and 6AK6) utilizing both positive and negative feedback for oscillator operation and reduction of distortion. Oscillator section drives a cathode follower output power amplifier (6AK6) which isolates the oscillator from variations in load and presents a low impedance output (600 Ohms). Power supply is transformer operated and utilizes 6X5 rectifier with 2 sections of RC filtering.

An unbeatable dollar value — for here is an audio generator with wide frequency coverage, excellent frequency response, stepped and continuously variable calibrated output, high signal level, low impedance output, and low inherent distortion.

Heathkit AUDIO FREQUENCY METER KIT

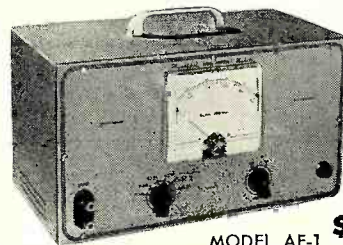

MODEL AF-1

SHIPPING
WT. 15 LBS.

\$34.50

The HEATHKIT AUDIO FREQUENCY METER provides a simple and easy way to check unknown audio frequencies from 10 cycles to 100 kc between 3 and 300 volts RMS. The instrument features 7 ranges for accuracy and wide coverage. The meter itself has a quality 200 microampere Simpson movement and large clearly marked scales. The AUDIO FREQUENCY METER is transformer operated and features a voltage regulator tube to maintain constant plate voltage on the second stage. Kit supplied complete with all necessary construction material and a detailed construction manual.

NEW *Heathkit* AUDIO OSCILLATOR KIT

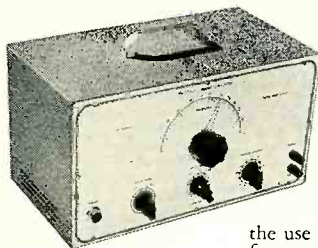

MODEL AO-1
SHIPPING
WT. 14 LBS.

\$24.50

A new Audio Oscillator with both sine and square wave coverage from 20 to 20,000 cycles . . . An instrument designed to completely fulfill the needs of the audio engineer and enthusiast — Has numerous advantages such as high level output (up to 10V obtainable across the entire range), distortion less than .6%, and low impedance output.

Special design features include the use of a thermistor in the second amplifier stage for keeping the output essentially flat across the entire range.

A cathode coupled clipper circuit produces good, clean, square waves with rise time of only 2 microseconds. Oscillator section uses 1% precision resistors in range multiplier circuit for greatest accuracy.

You'll like the operation of this fine new kit.

Heathkit SQUARE WAVE GENERATOR KIT

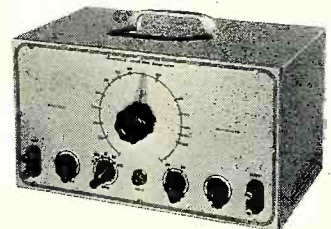

MODEL SQ-1
SHIPPING
WT. 14 LBS.

\$29.50

The HEATHKIT SQUARE WAVE GENERATOR is an excellent square wave frequency source with wide range coverage from 10 cycles to 100 kc continuously variable. This feature makes it useful for TV and wide band amplifier work as well as audio experimentation. The output voltage is continuously variable between 0 and 20 volts. The circuitry consists of a multivibrator stage, a clipping and squaring stage and a cathode follower low impedance output stage. The power supply is transformer operated and utilizes a full wave rectifier circuit with two sections of filtering. Another excellent HEATHKIT value at this remarkable low price. Kit includes all necessary construction material as well as complete instruction manual for assembly and operation.

EXPORT AGENT
ROCKE INTERNATIONAL CORP.
13 E. 40th ST.
NEW YORK CITY (16)
CASE 82184 N.Y.

The **HEATH COMPANY**

... BENTON HARBOR 15, MICHIGAN

NEW *Heathkit* VISUAL-AURAL SIGNAL TRACER KIT

• NEW NOISE LOCATOR AND WATTMETER CIRCUITS.

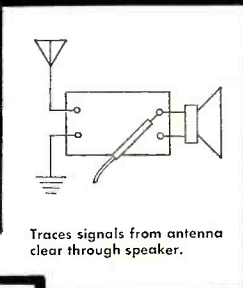
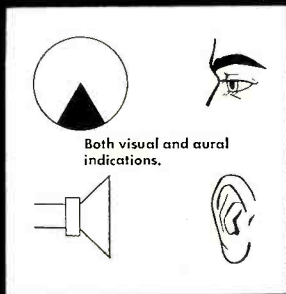

MODEL T-3

SHIPPING
WT. 8 LBS.

\$22⁵⁰



- Permits visual signal observation as well as aural operation.
- Two separate input channels.
- Tremendous RF channel sensitivity. Adequate for actual signal detection at receiver input.
- Separate high gain RF and low gain audio channels.
- A unique and useful noise locator circuit.
- Built-in calibrated wattmeter.
- Two separate shielded probes for RF and audio application.
- Additional test leads supplied.
- Substitution test speaker and output transformer eliminates necessity for speaker removal in service work.
- Utility amplifier. Check record changers, tuners, microphones, instrument pickups, etc.
- VTVM and Scope panel terminals.
- 5 tube transformer operated circuit.

The new HEATHKIT VISUAL AURAL SIGNAL TRACER represents one of the most convenient and useful instruments the service man can use in AM, FM and TV service work. The electron ray beam indicator constantly monitors both input channels for visual observation of the signal. Now, see and hear the signal level for easier estimation of signal strength and gain per stage in a receiver circuit. Separate high gain channel and special shielded demodulator probe for RF circuit work. Low gain channel for audio circuit investigation and for use as a noise locator. In this feature, approximately 200 volts DC is applied to a suspected circuit component and the action of the voltage in the component can be seen and heard to determine satisfactory operation. This feature alone will prove tremendously helpful in locating the source of objectionable noises in coils, transformers, resistors, condensers, cold solder joints, controls, etc. A convenient wattmeter permits rapid preliminary check for voltage distribution circuit breakdown as well as transformer failures. Use the T-3 as a universal test speaker and substitution transformer and save service time by eliminating the necessity for speaker removal on every service call. Additional service uses are: as a utility amplifier for checking the output of record changers, tuners, microphones, instrument pickups, etc. Separate panel terminals permit utilization of other shop equipment such as your Oscilloscope or VTVM. Entire kit supplied complete with 5 tubes, all necessary construction material along with a detailed step by step instruction manual for the assembly and operation of the instrument.

NEW *Heathkit* CONDENSER CHECKER KIT

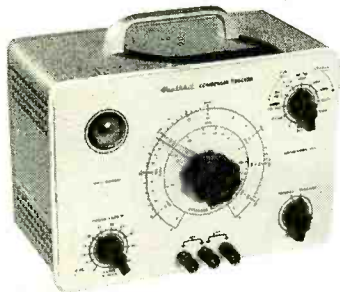

MODEL C-3
SHIPPING
WT. 7 LBS.

\$19⁵⁰

Announcing the new improved Model C-3 HEATHKIT CONDENSER housed in a new smartly styled professional appearing cabinet featuring rounded corners and snug fitting drawn panel. Adequate provisions for ventilation insures longer instrument life through cooler operation. Use the C-3 to accurately measure those unknown condenser and resistor values. All readings of condensers and resistors are read directly on the calibrated scales. Range of condenser measurements is from .00001 mfd to 1000 mfd. Calibrated resistance measurements can be made from 100 ohms to 5 megohms. A leakage test with a choice of 5 DC polarizing voltages will quickly indicate condenser operating quality under actual voltage load conditions. The spring return leakage test switch automatically discharges the condenser under test and eliminates shock hazard. An electron ray beam indicator tube is used in a new leakage test circuit for added sensitivity. The instrument is transformer operated for safety and will prove an extremely welcome addition to your shop equipment. The kit is furnished complete with all necessary parts, test leads and includes a step by step detailed construction manual for assembly and operation.

Heathkit TV ALIGNMENT GENERATOR KIT

MODEL TS-2
SHIPPING
WT. 20 LBS.

\$39⁵⁰

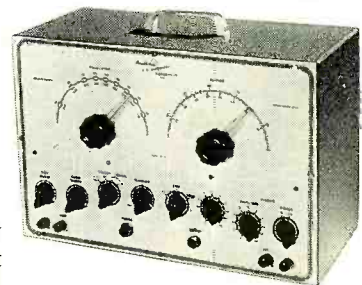

Here is an excellent TV ALIGNMENT GENERATOR designed to do TV service work quickly, easily and properly. The Model TS-2 when used in conjunction with an Oscilloscope provides a means of correctly aligning TV receivers. The instrument furnishes a frequency modulated signal covering in 2 bands the range of 10 to 90 megacycles and 150 to 230 megacycles. An absorption type frequency marker covers from 20 to 75 megacycles in 2 ranges; therefore you have a simple, convenient means of checking IF's independent of oscillator calibration. Sweep width is variable from 0 to 12 megacycles. Other excellent features are horizontal sweep voltage controlled with a phasing control — both step and continuously variable attenuation for setting the output signal to the desired level — a convenient stand by switch — and blanking for establishing a single trace with a base reference level. Make your work easier, save time and repair with confidence. Order your HEATHKIT TV ALIGNMENT GENERATOR now.

EXPORT AGENT
ROCKE INTERNATIONAL CORP.
13 E. 40th ST.
NEW YORK CITY (16)
CABLE: ARIAB-N.Y.

The **HEATH COMPANY**

... BENTON HARBOR 15, MICHIGAN

Heathkit TUBE CHECKER KIT

MODEL TC-1

SHIPPING
WT. 12 LBS.

\$29.50

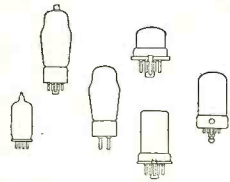
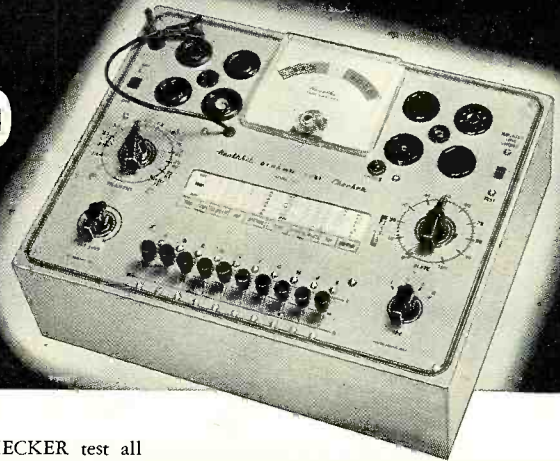

Checks 7, 8, 9 prong tubes, octals, loctals, 7 and 9 prong miniatures, 5 prong Hytrons, pilot lights.

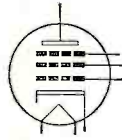

Checks for opens, shorts, emission, filament and filament tap continuity.

- Beautiful counter type birch cabinet.
- 4½" Simpson 3 color meter.
- Simplified setup procedure.
- Built-in gear driven roll chart.
- Checks emission, shorted elements, open elements and continuity.
- Complete protection against obsolescence.
- Sockets for every modern tube.
- Blank for new types.
- Individual element switches.
- Contact type pilot light test socket.
- Line adjust control.

PORTABLE TUBE CHECKER KIT MODEL TC-1P

Same as TC-1 except supplied with polished birch cabinet (with removable lid) instead of counter type cabinet. Shipping weight 14 lbs. **\$34.50**
No. 365 Polished Birch Tube Checker Cabinet only. Shipping Weight 7 lbs. **\$7.50**

With the HEATHKIT TC-1 TUBE CHECKER test all types of tubes commonly encountered in AM-FM and TV receiver circuits. Test setup procedure is simplified, rapid and flexible. Tube quality is read directly on a beautiful 4½" Simpson three color BAD - ? - GOOD scale that your customers can readily understand. Panel sockets accommodate 4, 5, 6 and 7 prong tubes, octals, loctals, 7 and 9 prong miniatures, 5 prong Hytrons, a blank socket for new tubes and a contact type socket for quick checking of pilot lights. Built-in gear driven roll chart for instant reference. Neon short indicator, individual three position lever switch for each tube element, spring return test switch, line set control to compensate for supply voltage variations. At this low price, no service man need be without the advantages offered by the HEATHKIT TUBE CHECKER.

Heathkit TV PICTURE TUBE TEST ADAPTER

Use your HEATHKIT TUBE CHECKER with this new TV TEST ADAPTER to determine picture tube quality. Check for emission and shorts, independent of TV power supply. Consists of standard 12 pin TV tube socket, 4 feet of cable, octal socket connector and data sheet. Quickly prove TV picture tube condition to yourself and your customer.



No. 355
Ship. Wt. **\$4.50**
1 lb.

Heathkit RESISTANCE SUBSTITUTION BOX KIT



MODEL RS-1
SHIPPING
WT. 3 LBS.

\$5.50

NEW HEATHKIT RESISTANCE SUBSTITUTION BOX KIT provides switch selection of any single one of 36 RTMA 1 watt 10% standard value resistors, ranging from 15 ohms to 10 megohms. This coverage available in 2 ranges in decades of 15, 22, 33, 47, 68 and 100. Housed in rugged plastic cabinet featuring new HEATHKIT universal type binding posts. The entire kit priced less than the retail value of the resistors alone.

Heathkit BATTERY ELIMINATOR KIT

A clean 6 volt d-c supply source is definitely required for successful automobile radio servicing. Has a continuously variable d-c output from 0 to 8 volts. It can be safely operated at a steady 10 ampere level and will deliver up to 15 amperes for intermittent periods. The voltage output terminals are completely isolated from the chassis to accommodate additional service applications such as supplying bias voltages or d-c substitution voltages for battery operated tube filament circuits.

The output of the Battery Eliminator is constantly monitored by a d-c voltmeter and a d-c ammeter. The circuit features an automatic overload relay of self resetting type. For additional protection, a panel mounting fuse is provided. Build this kit in a few hours and pocket a substantial savings.

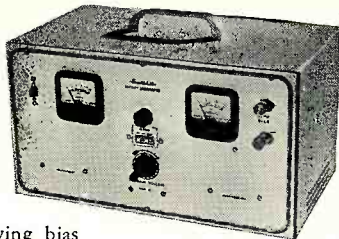

MODEL BE-3
SHIPPING
WT. 20 LBS.

\$24.50

Heathkit VIBRATOR TESTER KIT

Repair time is valuable, and the Heathkit Vibrator Tester will save you hours of work. Instantly tells the condition of the vibrator under test — and the check is thorough and complete. Checks vibrator for proper starting, and the easy-to-read meter indicates the quality of output on large BAD-GOOD scales. Tests both interrupter and selfrectifier types of vibrators. Five different sockets for checking hundreds of vibrators.

Operates from any battery eliminator capable of delivering continuously variable voltage from 4 - 6V at 4 amps. The Heathkit BE-3 Battery Eliminator is ideal for operating this kit.

Faulty vibrators can be spotted within seconds and you're free to go on to other service jobs.



MODEL VT-1
SHIPPING
WT. 7 LBS.

\$14.50

EXPORT AGENT
ROCKE INTERNATIONAL CORP.
13 E. 40th ST.
NEW YORK CITY (16)
CALL 42168 N.Y.

The **HEATH COMPANY**

... BENTON HARBOR 15, MICHIGAN

Heathkit SIGNAL GENERATOR KIT

MODEL SG-7

SHIPPING
WT. 7 LBS.

\$19.50



Modulated or unmodulated RF output.

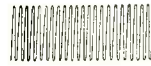

400 cycle sine wave output.

- Step attenuated RF output.
- 6 to 1 vernier dial ratio.
- Turret mounted coil sub-assembly.
- Pre-calibrated and adjusted coils.
- Hartley RF oscillator circuit.
- Colpitts oscillator 400 cycle sine wave output.
- Modulated or unmodulated RF output.
- Frequency coverage on fundamentals 160 kc to 50 megacycles in five ranges. 51 megacycles to 150 megacycles on calibrated harmonics.
- RF output in excess of 100,000 microvolts.
- Audio output 1½ to 2 volts.
- AC transformer operated.
- Professionally styled cabinet.
- Infra red baked enamel panel.

The new HEATHKIT Model SG-7 SIGNAL GENERATOR easily fulfills requirements for a controllable, modulated or unmodulated source of variable frequency. A convenient 400 cycle sine wave output is available for audio work. All RF oscillator coils are precision wound and adjusted to calibration before shipment thereby assuring maximum accuracy. The coils, band switch and tuning condenser all mount as a turret assembly so as to offer the advantage of short wiring leads and easy mounting of parts. The RF output circuit is of the low impedance type obtained by the use of cathode coupling to the output jacks. The level of RF output is varied by means of the RF step and RF output control. Use the HEATHKIT SG-7 as an RF signal source modulated or unmodulated for radio repair, laboratory work, experimental testing, 400 cycle sine wave audio testing, checking RF stages, alignment of both AM and FM IF stages, marker generator for TV alignment, etc. The kit is transformer operated and utilizes miniature tubes for ease in handling high frequency. Panel jacks and a convenient switching system permit either external or internal modulation. The entire kit is supplied complete with tubes and all necessary material as well as a detailed step by step instruction manual for the assembly and operation of the instrument.

Heathkit INTERMODULATION ANALYZER KIT



MODEL IM-1
SHIPPING WT.
18 LBS.

\$39.50

The HEATHKIT MODEL IM-1 is an extremely versatile instrument specifically designed for measuring the degree of interaction between two

signals caused by a specific piece of apparatus, or a chain of equipment. It is primarily intended for tests of audio equipment but may be used in other applications such as making tests of microphones, records, recording equipment, phonograph pickups and loud speakers. Use it for checking tape or disc recordings, as a sensitive AC voltmeter, as a high pass noise meter for adjusting tape bias, cutting needle pitch or other applications. High and low test frequency source, intermodulation section, power supply and AC voltmeter all in one complete unit. Percent intermodulation is directly read on three calibrated ranges, 30%, 10% and 3% full scale. Both 4 to 1 and 1 to 1 ratios of low to high frequencies easily set up. At this low kit price YOU can enjoy the benefits of Intermodulation analysis for accurate audio interpretations.

Heathkit LABORATORY REGULATED POWER SUPPLY KIT

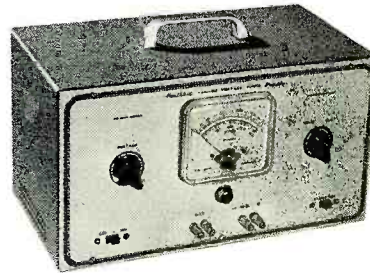

MODEL PS-2

SHIPPING
WT. 20 LBS.

\$29.50

New HEATHKIT LABORATORY POWER SUPPLY provides continuously variable regulated DC voltage output from 160 volts to 400 volts depending on load. Panel terminals supply separate 6.3 V. AC supply at 4 amperes for filament circuits. A 3½" plastic cased panel mounted meter provides accurate metered output for either voltage or current measurements. Exceptionally low ripple content of .012% admirably qualifies the HEATHKIT LABORATORY POWER SUPPLY for high gain audio applications. Ideal for laboratory work requiring a reference voltage for meter calibration or for plotting tube characteristics. In service work, it can be used as a separate variable voltage supply to determine the desirable operating voltage in a specific circuit. Use it as a DC substitution voltage in trouble shooting TV circuits exhibiting symptoms of extraneous undesirable components in plate supply circuits. Entire kit, including all 5 tubes now available at this low price.

EXPORT AGENT
ROCKE INTERNATIONAL CORP.
13 E. 40th ST.
NEW YORK CITY (16)
CABLE APLA-N.Y.

The **HEATH COMPANY**

... BENTON HARBOR 15, MICHIGAN

Heathkit WILLIAMSON TYPE AMPLIFIER KIT

The new HEATHKIT WILLIAMSON TYPE AMPLIFIER, incorporates the latest improvements described in Audio Engineering's "Gilding the Lily." 5881 output tubes and a new Peerless output transformer with additional primary taps afford peak power output of well over 20 watts. Frequency response ± 1 db from 10 cycles to 100 kc. allows reproduction of highs and lows with equal crispness and clarity. Harmonic and intermodulation distortion have been reduced to less than $\frac{1}{2}$ of 1% at 5 watts. This eliminates the harsh unpleasant qualities which contribute to listening fatigue. Make this amplifier the heart of your radio system to achieve the fine reproduction that is the goal of all music lovers.

The HEATHKIT PREAMPLIFIER (available separately or in combination with the amplifier kit) features inputs for magnetic or low level cartridges, crystal pickups and tuners, turnover control for LP or 78 type records, individual bass and treble tone controls each providing up to 15 DB of boost or attenuation. Special notched shafts on preamplifier controls and switches adaptable to custom installation. The preamplifier can be mounted in any position and a liberal length of connecting cable is supplied. No radio experience is required to construct this amplifier. All punching, forming, or drilling has already been done. The complete kit includes all necessary parts as well as a detailed step by step construction manual with pictorial diagrams to greatly simplify the construction.

ACROSOUND TRANSFORMER OPTION. If desired, the output transformer with the kit will be the Acrosound output transformer, type TO-300. The use of this transformer permits ultra-linear operation as described in Audio Engineering's "Ultra-Linear Operation of the Williamson Amplifier."

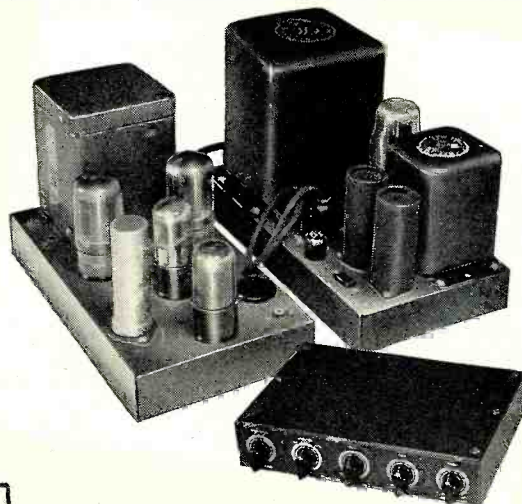

Heathkit FM TUNER KIT

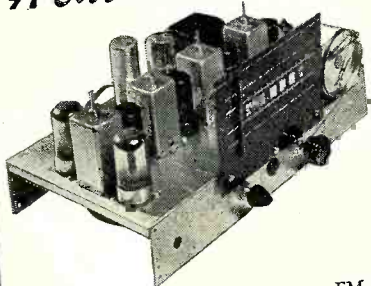

MODEL FM-2
SHIPPING
WT. 9 LBS.

\$22.50

The HEATHKIT MODEL FM-2 TUNER specifically designed for simplified kit construction features a preassembled and adjusted tuning unit. Three double tuned IF transformers and a discriminator transformer are used in an 8 tube circuit. Smooth tuning is obtained through a 9 to 1 ratio vernier drive using a calibrated six inch slide rule type dial. The usual frequency coverage of 88 to 108 megacycles is provided. Experience the thrill of building your own FM tuner. Operate it through your amplifier or radio and enjoy all the advantages of true FM reception. Transformer operated power supply to simplify connections to all types of audio systems. The kit is supplied complete with all 8 tubes and a necessary material required for construction. A complete instruction manual simplifies assembly and operation.

PRICES OF VARIOUS COMBINATIONS

W-2 Amplifier Kit (Incl. Main Amplifier with Peerless Output Transformer, Power Supply and WA-P1 Preamplifier Kit) Shipping Weight 39 lbs.	\$69.50
W-2M Amplifier Kit (Incl. Main Amplifier with Peerless Output Transformer and Power Supply). Shipping Weight 29 lbs. Shipped express only	\$49.75
W-3 Amplifier Kit (Incl. Main Amplifier with Acrosound Output Transformer, Power Supply and WA-P1 Preamplifier Kit) Shipping Weight 39 lbs. Shipped express only	\$69.50
W-3M Amplifier Kit (Incl. Main Amplifier with Acrosound Output Transformer and Power Supply) Shipping Weight 29 lbs. Shipped express only	\$49.75
WA-P1 Preamplifier Kit only. Shipping Weight 7 lbs. Shipped express or parcel post.	\$19.75

Heathkit ECONOMY 6 WATT AMPLIFIER KIT



MODEL A-7
SHIPPING
WT. 10 LBS.

\$14.50

The HEATHKIT Model A-7 amplifier features beam power, push pull output with frequency response flat $\pm 1\frac{1}{2}$ DB from 20 to 20,000 cycles. Separate volume, bass and treble controls. Two input circuits, output impedances of 4, 8, and 15 ohms. Peak power output rated at full 6 watts. High quality components, simplified layout, attractive gray finished chassis, break off type adjustable length control shafts and attractive lettered control panel.

THE MODEL A7A amplifier incorporates a preamplifier stage with special compensated network to provide the necessary voltage gain for operation with variable reluctance or low output level phono cartridges. Excellent gain for microphone operation in a moderate powered sound system..... **\$16.50**

Heathkit HIGH FIDELITY 20 WATT AMPLIFIER KIT

The HEATHKIT MODEL A-8 amplifier kit was designed to deliver high fidelity performance with adequate power output at moderate cost. The frequency response is within ± 1 DB from 20 to 20,000 cycles. Distortion at 3 DB below maximum power output at 1000 cycles is only .8%. The amplifier features a Chicago power transformer in a drawn steel case and a Peerless output transformer with output impedances of 4, 8, and 16 ohms available. Separate bass and treble tone controls permit wide range of tonal adjustment to meet the requirements of the most discerning listener. The amplifier uses a 6SJ7 voltage amplifier, a 6SN7 amplifier and phase splitter and two 6L6's in push pull output and a 5U4G rectifier. Two input jacks for either crystal or tuner operation. The kit includes all necessary material as well as a detailed step by step construction manual.

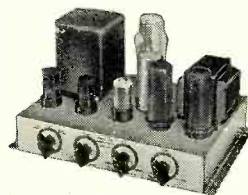

MODEL A-8
SHIPPING WT. 19 LBS.

\$33.50

MODEL A8-A features an added 6SJ7 stage (preamplifier) for operating from a variable reluctance cartridge or other low output level phono pickups. Can also be used with a microphone. A 3 position panel switch affords the desired input service. **\$35.50**

EXPORT AGENT
ROCKE INTERNATIONAL CORP.
13 E. 40th ST.
NEW YORK CITY (16)
CART. ARAB-N.Y.

The HEATH COMPANY

... BENTON HARBOR 15, MICHIGAN

Heathkit SUPERHETERODYNE RECEIVER KITS

- High gain dual iron core tuned type IF transformers
- AC transformer operation for safety
- Continuously variable tone control
- Sturdy punched and plated steel chassis
- Ideal for custom installation
- Full AVC action
- Inverse feedback for improved frequency response
- Kit supplied with all necessary construction material except speaker and cabinet. (Available separately if desired).

6 tube all wave circuit.
3 ranges, continuous coverage 550 kc to over 20 megacycles, shipping wt. 11 lbs.

Model AR-1
\$23.50

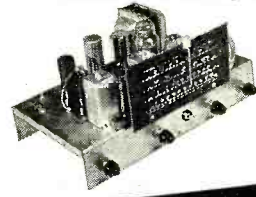

5 tube broadcast band
550 to 1600 kc coverage,
shipping wt. 11 lbs.

Model BR-1
\$19.50

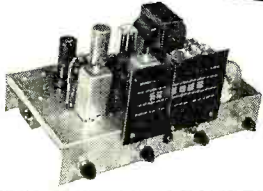

Two excellent radio receiver kits featuring clean design and open layout for simplified construction. Satisfy that urge to build your own radio receiver and select the model which meets your requirements. Both receivers feature continuously variable tone control, a radio phono switch and phono input and an AC receptacle for the phono motor. A six inch calibrated slide rule type dial with a 9 to 1 ratio vernier dial drive insures easy tuning.

SHIPPING INFORMATION

ON PARCEL POST ORDERS include postage for weight shown and insurance. (We insure all shipments.) Don't worry about sending more than the correct amount — if you send us too much, every extra cent will be promptly returned.

ON EXPRESS ORDERS do not include transportation charges. They will be collected by Express Agency on delivery.

ORDERS FROM CANADA must include full remittance for merchandise.

Orders processed on the same day received. Customers notified of unavoidable delay.

U. S. postal or express money orders, bank drafts or checks are acceptable. Do not send loose coins or stamps.

ALL PRICES SUBJECT TO CHANGE WITHOUT NOTICE

EXPORT AGENT
ROCKE INTERNATIONAL CORP.
12 E. 40th ST.
NEW YORK CITY (16)
CALIF. AREA - N.Y.

The HEATH COMPANY

... BENTON HARBOR 15, MICHIGAN

ORDER BLANK



From _____

SHIP VIA

- Parcel Post
- Express
- Freight
- Best Way

(PLEASE PRINT)

QUANTITY	ITEM	PRICE	QUANTITY	ITEM	PRICE
	Heathkit Oscilloscope Kit—Model O-8 (29 lbs.)	\$43.50		Heathkit Square Wave Gen. Kit—Model SQ-1 (14 lbs.)	\$29.50
	Heathkit Intensifier Kit (O-8 only) No. 339 (1 lb.)	7.50		Heathkit AC VTVM Kit—Model AV-2 (5 lbs.)	29.50
	Heathkit Voltage Calibrator Kit—Model VC-1 (5 lbs.)	9.50		Heathkit Intermodulation Analyzer Kit—Model IM-1 (18 lbs.)	39.50
	Heathkit Electronic Switch Kit—Model S-2 (11 lbs.)	19.50		Heathkit Regulated Power Supply Kit—Model PS-2 (20 lbs.)	29.50
	Heathkit Scope Demodulator Probe Kit No. 337 (1 lb.)	4.50		Heathkit Handitester Kit—Model M-1 (3 lbs.)	13.50
	Heathkit T.V. Alignment Generator Kit—Model TS-2 (20 lbs.)	39.50		Heathkit Decade Resistance Kit—Model DR-1 (4 lbs.)	19.50
	Heathkit Q Meter Kit—Model QM-1 (12 lbs.)	39.50		Heathkit Decade Condenser Kit—Model DC-1 (4 lbs.)	16.50
	Heathkit Grid Dip Meter Kit—Model GD-1 (4 lbs.)	19.50		Heathkit Impedance Bridge Kit—Model IB-1B (15 lbs.)	69.50
	Heathkit VTVM Kit—Model V-6 (7 lbs.)	24.50		Heathkit Battery Tester Kit—Model BT-1 (3 lbs.)	7.50
	Heathkit RF Probe Kit No. 309 (1 lb.)	5.50		Heathkit Resistance Substitution Box Kit—Model RS-1 (3 lbs.)	5.50
	Heathkit HV Probe Kit No. 336 (2 lbs.)	5.50		Heathkit F.M. Tuner Kit—Model FM-2 (9 lbs.)	22.50
	Heathkit Peak-to-Peak Volt. Probe Kit No. 338 (2 lbs.)	6.50		Heathkit Broadcast Receiver Kit—Model BR-1 (11 lbs.)	19.50
	Heathkit Visual-Aural Signal Tracer Kit—Model T-3 (8 lbs.)	22.50		Heathkit Three Band Receiver Kit—Model AR-1 (11 lbs.)	23.50
	Heathkit Condenser Checker Kit—Model C-3 (7 lbs.)	19.50		Heathkit Amplifier Kit—Model A-7 (10 lbs.)	14.50
	Heathkit RF Signal Generator Kit—Model SG-7 (7 lbs.)	19.50		Heathkit Amplifier Kit—Model A-7A (10 lbs.)	16.50
	Heathkit Tube Checker Kit—Model TC-1 (12 lbs.)	29.50		Heathkit Amplifier Kit—Model A-8 (19 lbs.)	33.50
	Heathkit T.V. Tube Adapter No. 355 (1 lb.)	4.50		Heathkit Amplifier Kit—Model A-8A (19 lbs.)	35.50
	Heathkit Battery Eliminator Kit—Model BE-3 (20 lbs.)	24.50		Williamson Type Amplifier Kit (Type. Shipped express only)	
	Heathkit Vibrator Tester Kit—Model VT-1 (7 lbs.)	14.50		WA-P1 Preamplifier Kit (7 lbs.) (Shipped exp. or p.p.)	19.75
	Heathkit Audio Generator Kit—Model AG-8 (16 lbs.)	29.50			
	Heathkit Audio Oscillator Kit—Model AO-1 (14 lbs.)	24.50			
	Heathkit Audio Frequency Meter Kit—Model AF-1 (15 lbs.)	34.50			

*Please ship C.O.D. Postage enclosed for _____ lbs. Enclosed find Check Money Order for _____

WHAT'S *New in Radio*

For additional information on any of the items described herein, readers are asked to write direct to the manufacturer. By mentioning RADIO & TELEVISION NEWS, the page and the issue number, delay will be avoided.

CRAFTSMEN TUNER

The Radio Craftsmen, Inc., 4401 N. Ravenswood Avenue, Chicago 40, Illinois, has announced the availability

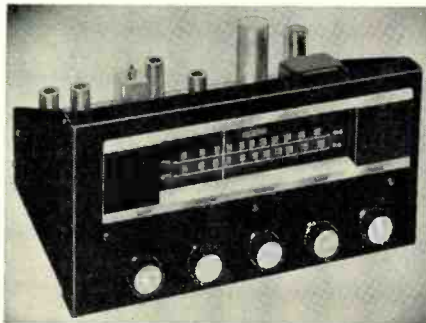

of a new high-fidelity AM-FM tuner for custom installation applications.

The model C800 incorporates a front panel selected equalization for AES, LP, or European recording characteristics. Also featured is a double-shadow tuning eye, front panel control for a.f.c. cut-out when tuning weak stations, and continuously variable bass and treble controls from 15 db boost through 15 db attenuation with flat position clearly marked.

The new unit has 15 tubes and can be mounted in the same panel formerly cut for a RC10 or C10 tuner.

SPEAKER BAFFLE

Permoflux Corporation, 4900 W. Grand Avenue, Chicago 39, Illinois, has added a new speaker baffle to its line of audio products.

The CH-16 dual-eight speaker baffle represents a new approach to high-fidelity reproduction in that two eight-inch speakers can be mounted and connected for parallel operation in the corner horn enclosure.

In addition, the baffle provides

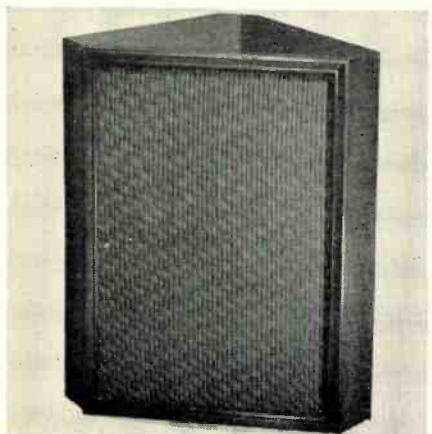

enough space to permit a single twelve-inch speaker to be mounted in lieu of the eight-inch units if the user

desires. An alternate mounting board is supplied for this purpose.

The new enclosure is 31½" high, 25½" wide, and 14" deep. It is currently available in blonde and mahogany finishes. A data sheet giving complete details on the CH-16 is available from the company without charge.

COMPACT TRANSMITTER

Radio Laboratories, Inc. of 1846 Westlake Avenue North, Seattle 9, Washington, has introduced a new transmitter which has been especially designed for marine, aeronautical, and fixed station use.

The "75" permits any two frequencies to be monitored simultaneously, using the crystal receiver for one and the tunable receiver for the other. The crystal receiver features a new



improved noise limiter, a variable squelch circuit, plus automatic blanking of the tunable receiver.

The transmitter features eight independent, separately tuned channels for maximum efficiency. There is 35 watts of audio available for paging, public address, or deck horn operation.

A data sheet giving complete technical specifications on the "75" is available on request.

STEPDOWN TRANSFORMERS

Hindle Transformer Company Inc., Woods Church Road, Flemington, New Jersey is introducing a new line of stepdown transformers for use in operating standard radio, television, or other electrical equipment from 220 to 240 volt lines.

At the present time, two types are available. The Type BT is recommended for use where the transformer is mounted as part of the equipment or appliance. This unit is supplied with flex leads for both the input and output.

The Type SS is completely enclosed

in a steel housing and is suggested for high humidity conditions or where a corrosive atmosphere exists.

A bulletin giving information on the proper selection of stepdown transformers as well as other data with respect to their uses is now available on request.

COMBINATION TESTER

Southwestern Industrial Electronics Co., P. O. Box 13058, Houston 19, Texas is currently marketing a new



combined ohmmeter and leakage tester, the Model C-3.

This new unit is a compact, portable instrument which has been designed for production testing of transformers and condensers. It has a useful range of 1 ohm to one million megohms. The four "ohms" ranges are powered by a 1½ volt battery. The six "megohms" ranges apply a maximum of 105 volts to the unit under test, providing indication of insulation resistance or dielectric leakage.

Accuracy is ±3% of full-scale deflection for all ranges except the highest megohm range which is ±5%. The front panel is black-anodized and is equipped with a welded-aluminum case which measures 10" x 6½" x 6½", finished in gray wrinkle-baked enamel.

A data sheet on the Model C-3 is available on request.

"TOGGLE" FUSE PULLER

Star Fuse Company, Inc., 235 Canal Street, New York, New York, has developed a modern fuse puller which is now available to the trade.

Featuring a toggle action for double leverage and greater gripping strength, this new fuse puller enables technicians to pull fuses from the tightest clips without danger of slipping or twisting. The design also permits the replacement of fuses in the panel box without slippage.

The unit is 7½" long, weighs 2 ounces, and fits all fuses up to 100 amps. It has a dielectric strength of 4000 volts after 24 hours' immersion in salt water.

AUDIO OSCILLATOR

Waveforms, Inc., 333 Sixth Avenue, New York 14, New York, is now marketing its wide-range audio oscillator which is said to incorporate several

Which Do You Want?



Better Pay



A Nice Home



A New Car



Greater Security



Happy Vacations and Travel

Get Your FCC Ticket
Then Use Our
Amazingly Effective
Job-Finding Service
To Get a Better Job



EDW. H. GUILFORD Vice President
I can train you to pass your FCC License Exams in a minimum of time if you've had any practical radio experience—amateur, Army, Navy, radio servicing, or other. My time-proven plan can help put you, too, on the road to success. Just fill out the coupon and mail it. I will send you free of charge, a copy of "How to Pass FCC License Exams," plus a sample FCC-type Exam, and the amazing new booklet, "Money Making FCC License Information."

How to Pass FCC Commercial Radio Operator License Exams

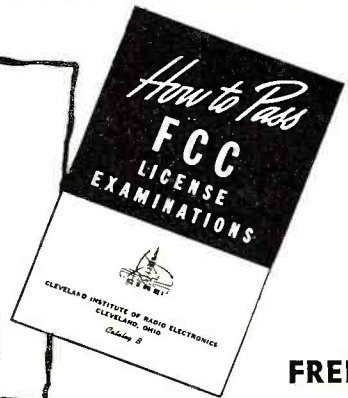

FREE

Tells where to apply for and take FCC examinations, location of examining offices, scope of knowledge required, approved way to prepare for FCC examinations, positive method of checking your knowledge before taking the examinations.

Get this Amazing Booklet FREE

TELLS HOW -

WE GUARANTEE TO TRAIN AND COACH YOU AT HOME IN SPARE TIME UNTIL YOU GET YOUR FCC LICENSE

If you have had any practical experience—Amateur, Army, Navy, Radio Repair or Experimenting

HERE IS YOUR GUARANTEE
If you fail to pass your Commercial License exam after completing our course, we guarantee to continue your training without additional cost of any kind, until you successfully obtain your Commercial License, provided you first sit in 90 days after completing our course.

TELLS HOW -

Our Amazingly Effective JOB-FINDING SERVICE

Gets Better Jobs for Graduates Here is just one recent example of Job-Finding Results

GETS FIVE JOB-OFFERS FROM BROADCAST STATIONS
"Your 'Chief Engineer's Bulletin' is a grand way of obtaining employment for your graduates who have obtained their 1st class license. Since my name has been on the list I have received calls or letters from five stations in the southern states, and am now employed as Transmitter Engineer at WMMT."
Elmer Powell, Box 274, Sparta, Tenn.

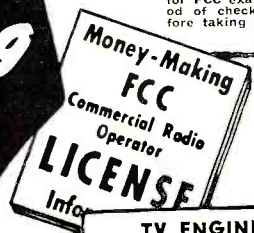

Ours is the Only Home Study Course Which Supplies FCC Type Examinations with All Lessons and Final Tests.

TV ENGINEERING INCLUDED IN OUR TRAINING & COACHING

TELLS HOW -

Employers Make JOB OFFERS Like These to Our Graduates Every Month!

Long distance Phone from Chief Engineer, Broadcast Station, Georgia. "Need 1st class licensed man immediately; salary \$65 for 40 hour week."
Letter from Chief Engineer, Broadcast Station, Penna. "We are in need of a broadcast engineer with first class license. Experience not necessary and starting pay is \$50 per 40 hour week."

These are just a few examples of the job offers that come to our office periodically. Some licensed radioman filled each of these jobs . . . it might have been you!

HERE'S PROOF FCC LICENSES ARE OFTEN SECURED IN A FEW HOURS OF STUDY WITH OUR COACHING AT HOME IN SPARE TIME

Name and Address	License	Lessons
Lee Worthy 2210 1/2 Wilshire St., Bakersfield, Cal.	2nd Phone	16
Clifford E. Vogt Box 1016, Dania, Fla.	1st Phone	20
Francis X. Foorch 38 Beuler Pl., Bergenfield, N. J.	1st Phone	38
S/Sgt. Ben H. Davis 317 North Roosevelt, Lebanon, Ill.	1st Phone	28
Albert Schoell 110 West 11th St., Escondido, Cal.	2nd Phone	23

CLEVELAND INSTITUTE OF RADIO ELECTRONICS
CARL E. SMITH, E. E., Consulting Engineer, President
Desk RN-47, 4900 Euclid Bldg., Cleveland 3, Ohio

Your FCC Ticket is recognized in all radio fields as proof of your technical ability.



Get All 3 FREE

MAIL COUPON NOW

CLEVELAND INSTITUTE OF RADIO ELECTRONICS
Desk RN-47, 4900 Euclid Bldg., Cleveland 3, Ohio
(Address to Desk No. to avoid delay)

I want to know how I can get my FCC ticket in a minimum of time. Send me your FREE booklet, "How to Pass FCC License Examinations" (does not cover exams for Amateur License), as well as a sample FCC-type exam and the amazing new booklet, "Money-Making FCC License Information."
 Tell me about your Television Engineering Course.

NAME
ADDRESS
CITY ZONE STATE

Paste on 2 cent postcard or send air mail



24 VOLT TRANSFORMERS

For operating surplus gear, toy trains, gadgets, etc. Operates from 115V, 60 cy., supplies 24 VAC at 1.2 Amp., herm. sealed and cased. A Great Buy at only **\$1.49**

POWER TRANSFORMERS

Comb. Transformers—115V/50-60 cps input

CT75B	600-0-600V/6A	2X5VCT/6.2A, 6.3VCT/3A, 6.3V/3A	\$12.95
CTJ5-2	600VCT/2A	5V/6A	8.95
CT-15A	550VCT	.085A 6.3V/6A, 6.3V/1.8A	2.85
CT-164	4200V/0.02A/12KV	Test, 5VCT/3A/12KV Test, 6.3V/0.6A/5400V Test	12.95
CT-341	1050 10 MA.—625V @ 5 MA, 26V @ 4.5A 2x2.5V/3A, 6.3V @ 3A		16.95
CR-825	360VCT	.340 A 6.3VCT/3A, 6.3VCT/3A	3.95
CT-626	1500V	.160 A 2.5/12, 30/100	9.95
CT-071	110V	.200 A 33/200, 5V/10, 2.5/10	4.95
CT-367	580VCT	.050 A 5VCT/3A	2.25
CT-99A	2x110VCT	.010 A 6.3/1A, 2.5VCT/7A	3.25
CT-403	350VCT	.026 A 5V/3A	2.75
CT-931	585VCT	.086 A 5V/3A, 6.3V/6A	4.25
CT-610	1250	.002 A 2.5V/2.1A, 2.5V/1.75A	4.95
CT-456	390VCT	30 MA 6.3V/1.3A, 5V/3A	3.45
CT-180	800VCT	100 MA 6.3V/1.2A, 5V/3A	4.95
CT-931	585VCT	86 MA 5V/3A, 6.3V/6A	4.95
CT-442	525VCT	75 MA 5V/2A, 10VCT/2A, 50V/200MA	3.85
CT-720	550-0-550V/250 MA, 6.3V/1.8A		8.95
CT-43A	600-0-600V/.08A, 2.5VCT/6A, 6.3VCT/1A		6.49
CT7-501	650VCT/200 MA, 6.3V/8A, 6.3V/5A		6.49
CT-444	230-0-230V/.085A, 5V/3A, 6V/2.5A		3.49

Filament Transformers—115V/50-60 cps input

Item	Rating	Each
FT-674	8.1V/1.5A	\$1.10
FT-157	4V/16A, 2.5V/1.75A	2.95
FT-101	6V/.25A	.79
FT-924	5.25V/21A, 2x7.75V/6.5A	14.95
FT-824	2x26V/2.5A, 18V/1A, 7.2V/7A, 6.4V/2A	8.95
FT-463	6.3VCT/1A, 5VCT/3A, 5VCT/3A	5.49
FT-55-2	7.2V/21.5A, 6.5V/6.85A, 5V/6A, 5V/3A	8.95
FT-986	16V @ 4.5A or 12V @ 4.5A	3.75
FT-38A	6.3/2.5A, 2x2.5V/7A	4.19
FT-A27	2.5V/2.5A, 7V/7A, TAP 2.5V/2.5A, 18KV TEST	18.95
FT-608	6.3V/3A/750V Test	1.79
FT-873	4.5V/.5A, 7V/7A	2.19
FT-899	2x5V @ 5A, 29KV Test	24.50

RECTIFIER TRANSFORMERS

Pri: 115V, 60 Cy. Sec: 28V/3.1A, 26V/8.4A	
7.3V/14A	\$12.95
Pri: 210/215/220/225/230/235/240V, 60 Cy., 1 Phase	
Sec: 11/10/7.5/5VCT @ 35A	\$19.50
Pri: 115V 60 Cy. Sec: 20V @ 10A	3.95
Pri: 115V 60 Cy. Sec: 8.1V @ 1.5A	1.39

UNIVERSAL SUPPLY KIT

Delivers 230V @ 40MA DC. From 110/220VAC. 60 Cy. Kit Consists of 1-1TX Transformer, 1-5 Hy @ 40MA Choke, 2-8MFD @ 450V Filter, Cond. 1-6x5 Tube. A great buy at only **3.95**

SELENIUM RECTIFIER

F. W. BRIDGE

UP TO 18 VAC IN—	
UP TO 14 VDC OUT—	
2A.....	\$ 2.50
4A.....	4.00
6A.....	6.00
10A.....	7.50
12A.....	9.00
24A.....	18.00
UP TO 36 VAC IN—	
UP TO 28 VDC OUT—	
1A.....	\$ 3.00
2A.....	4.00
5A.....	10.00
10A.....	14.50
12A.....	18.00
24A.....	36.00
UP TO 54 VAC IN—	
UP TO 42 VDC OUT—	
2A.....	\$ 6.50
4A.....	8.50
UP TO 120 VAC IN—	
UP TO 100 VDC OUT—	
2A.....	\$11.00
10A.....	48.00
12A.....	60.00

NON-POLAR CAPACITORS

A.C. ELECTROLYTICS

CAP.	VAC.	PRICE
13-15	220—	\$1.20
20-24	110—	1.00
26-30	220—	1.35
43-65	110—	1.25
43-48	110—	1.25
50-75	110—	1.25
53-60	220—	1.50
61-69	320—	1.60
64-72	110—	1.25
72-87	110—	1.25
75-84	110—	1.25
88-106	110—	1.50
107-129	110—	1.65
130-157	110—	1.75
130-150	70—	1.50
130-180	110—	1.85
158-191	110—	1.85
161-180	110—	1.75
189-210	110—	1.95
200-220	110—	1.95
270-300	110—	2.10
324-360	110—	2.40
378-420	175—	3.00
432-480	110—	2.75
485-540	110—	2.85

STEP-DOWN TRANSFORMERS

210-250V PRI—
110-120V SEC

Watts	Price
300.....	\$ 7.49
500.....	10.95
1000.....	19.95
1500.....	24.95



Send M.O. or Check. Shipping Chgs. C.O.D.
COMMUNICATIONS EQUIPMENT CO.
131 Liberty St. Dept. N-12 New York City 7, N. Y.

improvements in stability and precision.

Known as the Model 510-B, the new unit exhibits frequency changes of less than .5% with line voltage variations



from 95 to 130 volts and less than 1% with temperature variations of 0 to 150 degrees F. Standard calibration accuracy is 2%, but accuracy of 1% is available on special order.

The unit measures 6" high, 4 1/4" wide, and 5" deep, covers a range of from 18 cps to 1.2 mc.; has distortion under .2% over most of the useful range; and a constant output within ± .5 db. A 600/150 ohm line matching transformer is available.

Literature on the Model 510-B will be forwarded on request.

STORAGE TRAY

Walter L. Schott Company is currently introducing a novel "storage tray" which is now available to service technicians through the company's regular jobbers.

The new trays are designed to hold up to 20 sliding-lid plastic containers thus enabling technicians to keep small hardware items neatly stacked and readily available.

The descriptive label, showing the item and part number, appears on each box for quick identification of all items stored in the tray. The tray can be mounted on the wall or placed on a shelf or work table.

This tray is being offered with the Walsco "50 Line" of hardware and details on how this unit may be obtained are available from the company's jobbers.

TECHNICIAN'S TOOL KIT

A seventeen-unit radio and television technician's tool kit which features slip-on deep-wall socket wrenches in eight sizes from 1/4" to 3/16" is now available from Tele-Scopic Products Inc., 111 W. 42nd Street, New York 36, New York.

Called the "Tele-Tool Kit," the new kit also features a ratchet wrench and an extension shaft which enables technicians to reach screws and nuts which are located in inaccessible spots. The screwdriver blades, which are part of the kit, consist of three regular blades (large, medium, and small) and two recessed head sizes. A heavy-duty amber handle is provided, as well

as a strong plastic roll-up container with electronically welded durable plastic pockets.

Further information is available at distributors or from the company direct.

LIQUID PLASTIC

A new clear liquid methyl methacrylate plastic which provides good insulation for radio, television, and electronic components and wiring is now available in pressurized containers, according to the announcement made recently by United Technical Laboratories, Morristown, New Jersey.

The new plastic is applied as a spray to reduce electrical leakage. "Plastik-707" is unaffected by exposure to acids, alkalis, chemical fumes, the sun, weather, or salt spray. It is supplied in pressurized twelve ounce cans or in bulk in pints, quarts, and gallons, without pressure for brush application.

NEW CORNER HORN

Brociner Electronics Laboratory, 1546 Second Avenue, New York 28, New York has added a new corner horn to its line of loudspeakers.

The Model 4 utilizes two horns to cover the audible range. The smaller of the two, which has its mouth at the grille at the upper part of the speaker, covers the middle register and the treble range (150 to 20,000 cycles). These frequencies are uniformly distributed throughout the listening space by a uniquely designed reflector-type horn.

The range below 150 cycles is derived from the back of the driver unit through a folded horn whose mouth is



directly below the speaker structure. The driver unit is a twin-cone speaker having a field magnet that produces a flux of 20,000 gauss in the gap. A 6-inch cone capable of very large excursions without introducing distortion covers the bass range and the middle register. Working through a mechanical crossover network built into the cone system, a second, smaller cone reproduces the range above this, to the limits of audibility.

The Model 4 is available in natural mahogany and measures 42" high, 32 1/4" across the front, and 24" diagonal into the corner.

NO INTEREST!!

Buy on our radically new Time Payment Plan

NO CARRYING CHARGES!!

— OUR POLICY —

All merchandise offered on a "try-before-you-buy" basis. If the item you order does not meet with your approval, you may return it, no explanation necessary.

All merchandise offered on easy terms at the net cash price with no interest charges added!

Superior's New Model 770

VOLT-OHM MILLIAMMETER

Sensitivity—1000 ohms per volt



Model 770 is an accurate pocket-size V.O.M. Measures only 3/16" x 5/16" x 2 1/4".

Uses latest design 2% accurate 1 Mil. D'Arsonval type meter. • Same zero adjustment holds for both resistance ranges. It is not necessary to readjust when switching from one resistance range to another. This is an important time-saving feature never before included in a V.O.M. in this price range. • Housed in round-cornered, molded case. • Beautiful black etched panel. Depressed letters filled with permanent white. Insures long-life even with constant use.

Specifications:
6 A.C. VOLTAGE RANGES:
 0-15/30/150/300/1500/3000 Volts.
6 D.C. VOLTAGE RANGES:
 0-7.5/15/75/150/750/1500 Volts.
4 D.C. CURRENT RANGES:
 0-1.5/15/150 MA. 0-1.5 Amps.
2 RESISTANCE RANGES:
 0-500 Ohms 0-1 Megohm.

\$14.90 NET The Model 770 comes complete with self-contained batteries, test leads and all operating instructions.

Superior's New Model TV-11 TUBE TESTER



Operates on 105-130 Volt 60 Cycles A.C. Hand-rubbed oak cabinet complete with portable cover **\$47.50 NET**

• Uses the new self-cleaning Lever Action Switches for individual element testing. Because all elements are numbered according to pin number in the RMA base numbering system, the user can instantly identify which element is under test. Tubes having tapped filaments and tubes with filaments terminating in more than one pin are truly tested with the Model TV-11 as any of the pins may be placed in the neutral position when necessary. • Uses no combination type sockets. Instead individual sockets are used for each type of tube. Thus it is impossible to damage a tube by inserting it in the wrong socket. • Free-moving built-in roll chart provides complete data for all tubes. • Phono jack on front panel for plugging in either phones or external amplifier detects microphonic tubes or noise due to faulty elements and loose external connections.

Superior's New Model 670-A SUPER-METER

A COMBINATION VOLT-OHM MILLIAMMETER PLUS CAPACITY REACTANCE INDUCTANCE AND DECIBEL MEASUREMENTS

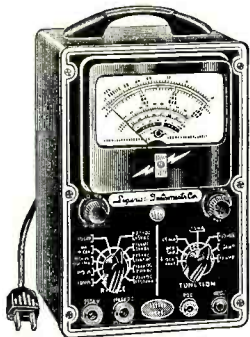

The Model 670-A comes housed in a rugged, crackle-finished steel cabinet complete with test leads and operating instructions. Size 6 1/4" x 9 1/2" x 4 1/2".

SPECIFICATIONS:
D.C. VOLTS: 0 to 7.5/15/75/150/750/1,500/7,500 Volts
A.C. VOLTS: 0 to 15/30/150/300/1,500/3,000 Volts
OUTPUT VOLTS: 0 to 15/30/150/300/1,500/3,000 Volts.
D.C. CURRENT: 0 to 1.5/15/150 Ma. 0 to 1.5/15 Amperes.
RESISTANCE: 0 to 1,000/100,000 Ohms to 10 Megohms
CAPACITY: .001 to 1 Mfd. 1 to 50 Mfd. (Quality test for electrolytics)
REACTANCE: 50 to 2,500 Ohms, 2,500 Ohms to 2.5 Megohms
INDUCTANCE: .15 to 7 Henries 7 to 7,000 Henries
DECIBELS: -6 to +18 +14 +38 +34 to +58

\$28.40 The Model 670-A includes a special GOOD-BAD scale for checking the quality of electrolytic condensers at a test potential of 150 Volts.

Superior's New TV BAR GENERATOR



Power Supply: 105-125 Volt 60 Cycles. Power Consumption: 20 Watts. Channels: 2-5 on panel, 7-13 by harmonics. Horizontal lines: 4 to 12 (Variable). Vertical lines: 12 (Fixed). Vertical sweep output: 60 cycles. Horizontal sweep output: 15,750 Cycles.

Throws an Actual Bar Pattern on Any TV Receiver Screen!!

Two Simple Steps:

1. Connect Bar Generator to Antenna Post of any TV Receiver.
2. Plug Line Cord into A.C. Outlet and Throw Switch.

RESULT: A stable never-shifting vertical or horizontal pattern projected on the screen of the TV receiver under test.

TV Bar Generator comes complete with shielded leads and detailed operating instructions. Only **\$39.95 NET**

New Model 200 AM and FM SIGNAL GENERATOR

Provides complete coverage for A.M.-F.M. and TV alignment

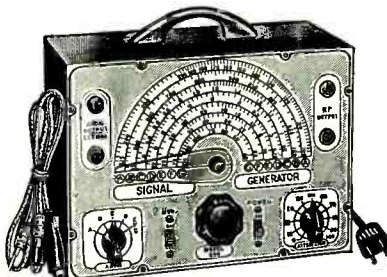

* Tubes used: One 954 as oscillator; one 954 as modulated buffer amplifier; T-2 as modulator; 7193 as rectifier.

• R.F. Frequency Ranges: 100 Kilocycles to 150 Megacycles. • Modulating Frequency: 400 Cycles. May be used for modulating the R.F. signal. Also available separately. • Attention: The constant impedance attenuator is isolated from the oscillating circuit by the buffer tube. Output impedance of this model is only 100 ohms. This low impedance reduces losses in the output cable. • Oscillator circuit: Hartley oscillator with cathode follower buffer tube. Frequency stability is assured by modulating the buffer tube. • Accuracy: Use of high-Q permeability tuned coils adjusted against 1/10th of 1% standards assures an accuracy of 1% on all ranges from 100 Kilocycles to 10 Megacycles and an accuracy of 2% on the higher frequencies.

The Model 200 comes complete with output cable and operating instructions **\$21.85 NET**

NEW TIME PAYMENT PLAN ORDER BLANK

MOSS ELECTRONIC DISTRIBUTING CO., INC.

Dept. B-40, 38 Murray Street, New York 7, N. Y.

Please send me the units checked below. I am enclosing the down payment with order and agree to pay the monthly balance as shown. It is understood there will be no carrying, interest or any other charges, provided I send my monthly payments when due. It is further understood that should I fail to make payment when due, the full unpaid balance shall become immediately due and payable.

- MODEL 770 Total Price \$14.90
\$2.90 down payment. Balance \$2.00 monthly for 6 months.
- MODEL TV-11 Total Price \$47.50
\$11.50 down payment. Balance \$6.00 monthly for 6 months.
- MODEL 670-A Total Price \$28.40
\$7.40 down payment. Balance \$3.50 monthly for 6 months.
- TELEVISION BAR GENERATOR Total Price \$39.95
\$9.95 down payment. Balance \$5.00 monthly for 6 months.
- MODEL 200 Total Price \$21.85
\$5.85 down payment. Balance \$4.00 monthly for 4 months.
- I enclose \$..... as down payment.
- Ship C.O.D. for the down payment.

Signature.....

Name.....

Address.....

City..... Zone..... State.....

IT'S MCGEE FOR T.V. MATERIAL BOOSTERS FM AM CHASSIS RECORD PLAYERS

THE ORIGINAL STANDARD COIL TV TUNER \$12.95 ANOTHER MCGEE SCOOP

Five millions of this 12-channel Standard Coil tuner now in use. The popular model with clip-in channel inductors and concentric fine tuning shaft. You save over 50%. Price includes tubes. Stock No. SC-947, \$12.95 each; 2 for \$25.00. Choice of 27" or 3 1/2" length insulated shaft. Used on Emerson Model 650D, 655, etc. Filaments connected in series (12 volts) and shunted .6 amp drain for AC-DC TV sets. Priced with tubes 6A5 or 6BC and 6A6. Stock No. SC-948, \$13.95 each; 2 for \$27.00. Available with either 3", 3 1/2", or 5" shaft length. Filaments are in parallel for 6.3 volt AC operation. Price includes tubes 6A5 or 6BC5 and 6A6. Note: Both tuners have IF coil attached for intercarrier sets. For sets with separate sound we suggest using the converter coil on the following stage. (Diagram furnished with each tuner.) Bakelite channel selector knob with embossed channel markings, 59c extra.

STANDARD COIL TUNERS FOR ADMIRAL SETS \$13.95

2 tube Standard Coil tuners for Admiral TV sets. Price includes tubes; 6A65 or 6BC5 and 6A6. Brand new. For intercarrier models; No. 94C-1, 5 1/4" shaft. No. 94C-2, 2 7/8" shaft. For separate sound models; No. 94C-1, 5 1/4" shaft. No. 94C-2 and -3, 5 1/2" shaft. No. 94C-18-4, 5" shaft. (Numbers listed are Admiral part numbers.)

3-TUBE SARKES-TARZIAN T.V. TUNER \$9.95

This popular Sarkes-Tarzian Type 3 tuner is widely used, 13 channel rotary type switch with individually tuned coils. Price is complete with diagram and three tubes: 6C4 osc., 6BH6 R.F. and 6A65 mixer. Regular factory price \$12.95. Each tuner is wired ready to hook up to a video and sound IF strip. May be used with either inter-carrier or separate sound IF circuits. Has built-in converter coil but is fine for frequency control. Sarkes-Tarzian TV tuner, with 3 tubes. Net price, \$9.95 each. Specify shaft length, either 2 7/8" or 4 3/4".

RCA 201E1 T.V. TUNER \$7.95

Terrific buy on this RCA tuner. We have a limited quantity of the famous original 201E1, 13 channel completely wired and tested TV front end tuners. Ready to connect to your TV video I.F. strip. Offered at a sacrifice. Price was \$44.00. Now only \$7.95 each, with tubes. Each tuner in good condition but has been repaired. Stock No. RCA-13P. TV front end tuner. Converter coil type for separate sound as well as inter-carrier. Complete with 3-676 tubes, \$7.95. Specify shaft length desired, either 2" or 4".

GENUINE STANDARD COIL T.V. BOOSTER \$11.95

Not Surplus, But Right From The Factory

Latest Model B-51 Standard Coil Television Booster. McGee makes another lucky purchase and as usual, passes the saving on to you. The famous Model B-51, 12 Channel Standard Coil TV booster, which is self-powered by 110 volt AC operation. In stock, \$11.95 each. Brand new, factory cartoned and fully guaranteed by McGee. This top quality single stage booster utilizes printed high frequency circuits, for improved performance on all channels. Uses 6A5 tube. Average gain, 6 to 7 volts on low channels and 5 or 6 on high channels. No distorting of picture or sound. Has extremely low noise factor. Continuous one-tuning channel selector control switch for off-on and by-passing 300 ohm lead-in to set. Modern design, dark brown plastic cabinet, 8" x 4 1/2" x 4 1/2". Made for 110 volt, 60 cycle AC operation. Shipping weight 5 lbs. Model B-51. Sale price, \$11.95 each, or buy 2 for only \$22.00.

MCMURDO SILVER BOOSTER \$10.95

Sensational value. Continuously variable inductance type tuner, from channel 2, including the FM band, through channel 13. This booster is self-powered by 110 volt AC operation. In stock, \$10.95 each. Brand new, factory cartoned and fully guaranteed by McGee. This top quality single stage booster utilizes printed high frequency circuits, for improved performance on all channels. Uses 6A5 tube. Average gain, 6 to 7 volts on low channels and 5 or 6 on high channels. No distorting of picture or sound. Has extremely low noise factor. Continuous one-tuning channel selector control switch for off-on and by-passing 300 ohm lead-in to set. Modern design, dark brown plastic cabinet, 8" x 4 1/2" x 4 1/2". Made for 110 volt, 60 cycle AC operation. Shipping weight 5 lbs. Model B-51. Sale price, \$10.95 each, or buy 2 for only \$22.00.

1952 MODEL ASTATIC \$19.10

New Astatic "Scanafan" TV booster with improvements to make the booster the most powerful and sensitive. Minimum noise with maximum gain. Balanced cascaded circuit with 6J6 and 6BQ7. Input and output for 300 ohm line and 300 ohm output to the TV set. Single knob tuning. Attractive plastic case. McMurdo Silver Super Sontic TV FM booster, Stock No. GP-6B. Shipping weight 5 lbs. McGee's terrific sale price, \$10.95 each, two for \$20.00.

1952 MODEL REGENCY \$19.10

New Regency DB-520 TV booster with exclusive circuit stabilizer and newly designed cabinet only 4 1/2" x 6 1/2" x 1 1/2". Improved circuit with push-pull 6B8 is equal to the best cascade circuits and has higher gain. Matches 72 or 300 ohm. Net price \$19.10.

20 IN. CONV. KIT \$29.95

Our 20" conversion kit includes a 6-month guaranteed 20HP4, 20" rectangular blackface picture tube, plus a 14,000 volt G.E. built high voltage flyback transformer, plus a matched 70" cosine yoke, plus a 14" plexiglas gold trimmed mask and suggested diagram. The picture tube is the latest electro-static focus type that requires no focus coil. Shipped via air express or truck only. Ship. weight, 40 lbs. Stock No. 20-TP, net price, \$29.95.

14-INCH CONVERSION KIT \$19.95

Our 14" conversion kit includes an RCA 14CP4, 14" rectangular blackface tube, plus a 14,000 volt G.E. built flyback, plus a 70" cosine yoke, plus a 14" plexiglas gold trimmed mask. Offered at the very low price of only \$19.95. Suggested diagram furnished. Ship. weight, 20 lbs. Via express or truck only. Stock No. RC-14X, net price, \$19.95.

17-INCH CONVERSION KIT \$24.95

Our 17" conversion kit includes a 6-month guaranteed 17HP4 blackface rectangular picture tube, plus a G.E. built 14,000 volt flyback, plus a matched 70" cosine yoke, plus a gold trimmed 17" plexiglas mask, and suggested diagram. The 17HP4 is the latest electro-static focus tube that requires no focus coil. Shipped via air express or truck only. Stock No. 17-TP4, Net price, \$24.95.

3-STATION INTERCOM MASTER, \$14.95

USE UP TO 3-SUB STATIONS, \$4.49 EACH

A red-hot intercom master value. A full 3 tube, 110 volt AC-DC master, with 3 station selector switch and easy accessible volume control. Small compact size, 5" x 6" x 6 1/2" high. Makes an attractive intercom installation. May be used with from one to three of our G-4T substations described below. Intercom master is quiet at all times, except when press-to-talk switch or call-back switch at one of the subs is pressed. Shipping wt. 5 lbs. Stock No. KA-3, master station, less tubes. Net \$14.95. Stock No. G-4T, brown plastic substitution, with Alnico V PM speaker and call-back switch. May be purchased with or without master station. Shipping weight 2 lbs. Net \$4.49 ea. 3 wire plastic intercom cable, 100 ft. \$1.95; 500 ft. \$8.95.

3-SPEED PORTABLE ELECTRIC PLAYERS

TWO NEW MODELS

\$21.95 \$18.95

\$21.50—LOTS OF 3—\$18.50

PLAYS ALL 3 SPEEDS

ALL 3 SIZES

New 1952 model 7843-X electric portable player has crystal pickup with all-purpose, 3-speed needle and brown reptile grain leatherette cover. Ship. wt. 10 lbs. Sale price, \$18.95 each, lots of 3, \$18.50.

Deluxe model 8532-X electric portable player has tone control and flip-over crystal cartridge with two needles for playing LP and standard records. Tan leatherette cover. Ship. wt. 11 lbs. Sale price, \$21.95 each, lots of 3, \$21.50 each. Both models are housed in sturdy wood cases covered with durable leatherette material. They have powerful 3-tube amplifiers with full-size Alnico V dynamic speakers and volume controls. Plays all 3 speeds, 78, 45 and 33 1/2 RPM and all 3 sizes, 7", 10" and 12" records.

McGEE RADIO COMPANY

Prices F.O.B. K.C. Send 25¢ deposit with Order, Balance Sent C.O.D. With Parcel Post Orders, include Postage

ESPEY 12-TUBE FM-AM CHASSIS, \$64.50

- ★ BUILT-IN PRE-AMP FOR G.E. VARIABLE RELUCTANCE PICK-UP
- ★ WIDE RANGE AUDIO
- ★ WHY NOT ORDER WITH A COAXIAL SPEAKER AND A RECORD CHANGER? SEE OUR SPECIAL OFFERING

McGee's new 1952 model 12-tube FM-AM chassis. Latest design with phono inputs for all types of record players, crystal or G.E. variable reluctance. Receives standard broadcast 550 to 1700 kc and FM 88 to 108 mc. Wide range audio response (push-pull 6V6 output) and bass boost tone control. Loop antenna for broadcast and 300 ohm line type FM antenna may be selected. Attractive slide rule dial. Chassis size, 13 1/2" x 9" high and 9" deep. Complete with tubes: 6BE6, 6BA6, 6BA6, 12A7T, 6SH7, 6AL5, 6SQ7, 6SQ7, 12A7T, 2-6V6GT and 513GT rectifier. Shipping weight 20 lbs. Stock No. 70-X. Espey 12-tube FM-AM chassis. Sale price, \$64.50, less speaker. Output matches voice coil of our 12" or 15" coaxial speakers.



ESPEY DEAL (1), \$104.95

Espey 7-C chassis complete with 12" coaxial PM speaker CU-14Y and VM-950 G.E. 3-speed changer equipped with a G.E. turnabout variable reluctance cartridge. A better music system than you can find anywhere. Espey Deal #1. Sale price \$104.95. With 15" coaxial PM speaker P15-CR instead of CU-14Y, \$10.00 extra.

ESPEY DEAL (2), \$118.95

Espey 7-C chassis complete with 12" coaxial PM speaker CU-14Y and the Garrard 3-speed changer equipped with a G.E. variable reluctance turnabout cartridge. Our best home music system. Espey Deal #2. Sale price \$118.95. With 15" coaxial PM speaker P15-CR instead of CU-14Y, \$10.00 extra.

ESPEY DEAL (3), \$138.95

Espey 7-C chassis complete with THREE 12" coaxial PM speakers CU-14Y (these three 12" coaxial speakers give a cone area equal to an 18" speaker) and a Garrard 3-speed changer with G.E. variable reluctance turnabout cartridge. Espey Deal #3. Sale price \$138.95.

CAPEHART CABINET, \$79.95

BLANK OR CUT TO FIT ESPEY CHASSIS

Buy this cabinet with Espey chassis and the VM changer listed above and have a fine radio-phonograph combination for less than the value of either cabinet alone. This beautiful cabinet was intended for a Capehart \$800.00 combination. It is the finest possible furniture quality cabinet workmanship, 37" high, 40" wide and 17" front to back. Hinged top, 25 1/2" lid covers the changer compartment and 14 1/2" is the width of the radio compartment. Changer mounting panel is furnished inlaid in the cabinet. Hinged door swings open for Espey chassis. Baffle is cut to hold 2-12" speakers. Made of top quality walnut veneer. 7/8" material used throughout. Shipped with truck rail or express only. Shipping weight, 160 lbs. Stock No. C-175, with panel cut to fit Espey 7-C, \$79.95. Stock No. B-175B, with blank changer and radio panel, \$79.95. Buy 2-12" 32 oz. Alnico PM speakers for use in this cabinet for only \$15.00 (\$7.50 each).

McGEE'S \$62.50 LIST 15" COAXIAL SPEAKER, \$21.95

21 OZ. ALNICO V MAGNET—5" TWEETER

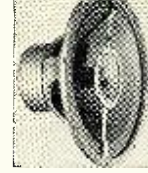

This is the finest 15" coaxial PM speaker value that we have ever offered. It is the finest of famous manufacturers of fine speakers. The 15" speaker has a 2 1/2" x 1 1/2" Alnico V magnet, 21 oz. of 68 oz. of the Alnico 3 type magnet. The cone is free floating, of one piece construction. It will reproduce low frequencies down to 20 cps. The 5" tweeter is coaxially suspended and has a wood cone to reproduce only the high frequencies. It will respond up to 17,500 cps. The high-pass filter is concealed under the pot cover, leaving only two wires to connect both 5" tweeter and woofer to any transformer or high fidelity radio, or high fidelity music lover's amplifier. Stock No. P15-CR. Shipping weight 15 lbs. Net price \$21.95.

12" COAXIAL SPEAKER, \$12.95

McGee offers the new 1952 model 12" coaxial PM speaker. Quality you would put in your finest sets if you were a manufacturer, 12" woofer has 6 oz. of Alnico V magnet. Tweeter is coaxially suspended and has a metal diffuser. High pass filter is under the pot cover. Only two wires to connect to your radio or audio amplifier, 8 ohm with 18 watt peak and 10 watt average. Shipping weight 8 lbs. Response from 30 to 17,500 cps. Stock No. CU-14Y, Sale price \$12.95 each; 2 for \$25.00.

12" JENSEN PM, \$15.95

Another McGee Scoop! Jensen Concert 12" 14 1/2" oz. Alnico V magnet PM speaker. 8 ohm voice coil. Will take 25 watt audio. You save dollars on this speaker. It is a terrific value to sell. Shipping weight 8 lbs. Stock No. P-12P, Sale price \$15.95; 2 for \$30.00.

TERRIFIC COMBINATION CABINET SALE

29.95



Originally intended for an Admiral 14" TV combination. Made of mahogany veneer, 32" wide, 35 1/2" high and 22" deep. Offered at a sacrifice for the very low production cost. Upper left door is made to swing down, opening record changer compartment, 14 1/2" x 13 1/2" x 20" deep. Upper right door swings open for the TV compartment. (Note: The TV chassis area is only 14 1/2" wide and 15 1/2" high, 20" deep, limiting the size of TV chassis to a 14" set.) Panel is cut to fit the Admiral. Up to a 12" speaker may be mounted in the lower right section. Lower left section has hinged door and is for record storage. Brass hardware and matching grill cloth. Shipping weight 60 lbs. Stock No. A-330 mahogany TV combination cabinet. Special Price, \$29.95. Blank panel overlay for cut out TV panel, \$3.95 extra.

CAPEHART CABINET FOR 1000 SET—ONLY \$99.95

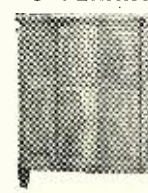

99.95



EITHER WALNUT OR MAHOGANY Beautiful finest quality walnut combination radio-phonograph cabinet, 42" high, 42" wide and 22" deep. Made for Capehart's finest combination, selling for \$200.00. Cabinet cost manufacturer over \$200.00. Has highly polished mahogany wood panels. Made of 3/4" material. Top 1 1/2" solid stock. Cabinet weighs approximately 175 lbs. The changer radio and speaker grill all have hinged doors. Radio compartment on right hand side is 14" high and 11 1/2" wide. Made to mount changer or recorder mechanism. Front 10" of top over the changer compartment is hinged to fold back for easy access to the changer. Both radio and changer compartments come with uncut blank panels. Speaker down automatically after 37.00. Complete with 12" x 12" speaker and matching grill cloth. Shipping weight, 275 lbs. Stock No. K-275 Capehart combination cabinet. Net price \$99.95. SPECIFY, when ordering, whether you want Walnut or Mahogany. Note: This cabinet has a very large record changer compartment. It is suggested that you obtain a selective record changer from a juke box operator and make a selective radio-phonograph combination.

G.I. 3-SPEED CHANGER WITH G.E. \$22.95

VARIABLE RELUCTANCE TURN-ABOUT CARTRIDGE



Another tremendous McGee Scoop! Brand new General Instrument 3-speed automatic record changer. Complete with RPX-050 G.E. variable reluctance cartridge with turn-about stylus. Plays all 3 speeds automatically: 7 1/2", 10" or 12" records. Has reject button, repeats last record, and size 12 1/2" records. Shipping weight 14 lbs. Stock No. 700-GE. Scoop price, \$22.95.

GI 3-speed changer same as above, but with Webster flip-over twin needle cartridge. Stock No. GI-700. Sale price, \$21.95 each.

WEBSTER CHICAGO MODEL 100-2 ONLY \$26.95



For the first time we offer the world famous Webster-Chicago model 100-2. Features a newly designed spindle, that drops the records flat; air-cushioned to the turntable. Pickup arm sets down automatically after the last record is played. Plays all records automatically, 33 1/2, 78 and 45 rpm. New balanced tone arm with Electro-Voice Tilt-A-Matic cartridge with dual needles. Ord. McGee price \$37.00. McGee's terrific sale price \$26.95 each. Base size 12" x 12 3/4". Shipping weight 14 lbs.

TELEPHONE VICTOR 9045. WRITE FOR FLYER 1422 GRAND AVE., KANSAS CITY, MISSOURI

McGEE'S \$250,000 PUBLIC ADDRESS SYSTEM SALE!

FEATURING 3-SPEED PHONO AND TWIN 12" ALNICO V SPEAKERS
IMMEDIATE SHIPMENT AT UP TO 60% SAVINGS!

5 Trailer loads—over \$250,000 worth of underwriters lab. approved public address systems on sale at McGee for a fraction of the original price. Purchased from one of the largest mail order companies in the United States. These amplifiers are made of the finest material to U. L. standards for 105 to 125 volt 60 cycle operation. Compare their weight with other amps and you can see for yourself. Follow our ordering instructions for immediate delivery.

HOW TO ORDER: Send full remittance and you save the added C.O.D. collection fee, or if you wish include a 25% deposit and the shipment will be made C.O.D. for the balance. All prices F.O.B. Kansas City, Missouri. Specify whether you wish shipment to be made by Express or Truck. Amplifiers are not mailable.



28 WATT \$150⁰⁰ LIST PORTABLE P.A. ON SALE \$69⁹⁵

3-SPEED PHONO TOP—TWO 12-INCH SPEAKERS
7-TUBES PUSH PULL 6L6'S HEAVY LEATHERETTE
COVERED PLYWOOD PORTABLE CASES
CRYSTAL MIKE \$8.95 EXTRA

STOCK NO. AP-28X. Portable 28 watt public address system. You get a 7 tube heavy duty push pull 6L6 amplifier with inputs for 2 mikes either crystal or dynamic with separate mixing volume controls. One phono input. Fully variable tone control high fidelity, wide range frequency response. The heavy duty output transformer has taps for 4, 8, 16, 125, 250 and 500 ohm speaker connections. Two heavy duty 12 inch alnico V PM speakers, each with 25 feet of speaker cable. Each speaker is mounted in separate carry-up case. Each case has a snap on back and is large enough to give good speaker baffling. Each case is 21 x 16 x 13 inches. One is used to carry the amplifier. A 3 speed phono motor and pick up is mounted in the top of the amplifier to play 33 1/2, 45 and 78 RPM records. This portable P.A. system will put out 20 watts all day long and 28 to 30 watts peak audio. McGee offers you this \$150.00 list portable P.A. system at a terrific saving.

STOCK NO. AP-28X complete portable PA system with 3 speed phono and speakers as pictured (less mike) ship, wt. 71 lbs. \$69.95. Electro Voice model 910 \$28.50 list crystal mike with 20 feet of cable and desk stand \$8.95 extra.

Floor type mike stand instead of desk stand \$4.95 extra.
(SEE OFFERING TO THE RIGHT FOR WALL SPEAKERS INSTEAD OF THE PORTABLE SPEAKERS.)

28-WATT AMPLIFIER WITH 12-INCH WALL SPEAKERS

The 28 watt amplifier shown to the left is also offered without the portable speakers. In their place we will ship two Seeburg walnut wall baffles with two heavy duty 12 inch alnico V magnet PM speakers and 500 ohm line matching trans. Stock No. SS-28R 28 watt amplifier with 3 speed phono top with two 12 inch wall speakers \$69.95. Extra 12 inch wall speakers \$11.95. Model 910 Electro Voice mike \$8.95 extra. Floor stand \$4.95 extra.



50 WATT \$250⁰⁰ LIST PORTABLE P.A. ON SALE \$99⁹⁵

3-SPEED PHONO TOP—TWO 12-INCH SPEAKERS
10 Tubes — 4 6L6's
Heavy Plywood Tan Leatherette Covered Cases

STOCK NO. AP-60X. Portable 50 watt public address system. You get a 10 tube amp with (4-6L6) push pull parallel 6L6 output tubes. Inputs for two mikes either crystal or dynamic, with separate mixing type volume controls. One phono input. Twin tone controls one for bass the other for treble high fidelity wide range frequency response. The heavy duty output trans. has taps for 4, 8, 16, 125, 250 and 500 ohm speaker connections. Two super heavy duty 12 inch 20 oz. alnico V magnet PM speakers with 25 foot cables and plugs. Each speaker is mounted in large separate cases, one is used to carry the amp. Each case is 21 x 21 x 13 inches with removable snap on backs. Twice the ordinary size to give proper speaker baffling. This is the most powerful portable PA system we have ever offered. Most 4-6L6 amps of this size and weight are rated 60 watts. This amp will put out 40 watts all day long and 50 to 60 watts with ease. Equipped with a 3 speed phono motor and pick up to play all records, 33 1/2, 45, 78 rpm. \$250.00 list value. Ship, wt. 100 lbs.

STOCK NO. AP-60X portable PA system as pictured less mike. Sale price \$99.95. Reg. \$45.00 list Electro voice model 610 dynamic mike with 20 feet of cable and desk stand \$11.95 extra.

If floor stand is desired instead of the desk stand add \$4.95.
(SEE OFFERING TO THE RIGHT FOR WALL SPEAKERS INSTEAD OF THE PORTABLE SPEAKERS.)

DYNAMIC MIKE \$11.95 EXTRA

50-WATT AMPLIFIER WITH 12-INCH WALL SPEAKERS

The 50 watt amplifier shown to the left is also offered without the portable speakers. In the place we will ship two Seeburg walnut wall baffles with two super heavy duty 12 inch alnico V pm speakers with 500 ohm line matching trans. Stock No. SS-60X 50 watt amplifier with 3 speed phono and 2 12 inch wall speakers \$99.95. Extra 12 inch dynamic mike \$11.95 extra. Floor stand instead of desk stand \$4.95 extra. Extra 12 inch speakers and wall baffles \$14.95.



10 WATT \$90⁰⁰ LIST PORTABLE P.A. ON SALE \$42⁹⁵

STOCK NO. AP-11X. A 5 tube 10 watt (14 watts peak) push pull 7C5 U. L. approved amplifier with wide range frequency response. Inputs for one mike and one phono. Separate mixing volume controls. Fully variable tone control. Heavy plywood leatherette covered case is equipped with a heavy duty 10 inch Alnico V magnet PM speaker. The amp fits inside the speaker case. Case size 21 x 16 x 13 inches has removable snap on back, (note, this portable system has only one speaker whereas the 28 and 50 watt models shown above have two). The top of the amplifier is equipped with a 3-speed phono motor and pick up for all records, 33 1/2, 45, 78 rpm—this portable PA system has a list value of \$90.00. Offered by McGee at a terrific saving.

STOCK NO. AP-11X. 10 watt portable PA system with 3-speed phono. Ship wt. 41 lbs. Sale price as pictured less mike \$42.95. Crystal mike with non removable desk stand \$3.95 extra.

3-Speed Phono Top—Heavy Plywood, Tan Leatherette Case
10" Alnico PM Speaker—Crystal Mike
\$3.95 Extra

The 10 watt portable PA system shown on the left is offered less the phono top. Specify stock No. AP-11NO. Sale price \$34.95 less mike. Crystal mike with non removable desk stand \$3.95 extra.



BRUSH CRYSTAL EAR PHONE \$5.49
With Control

Simply clip on to the speaker voice coil of any radio or TV set or to an audio amplifier. No soldering necessary. Listen in privately to your favorite programs. The tiny Brush crystal ear phone fits your ear just like a regular hearing aid ear piece. A small remote control box enables using 20 ft. from the radio or TV set. Has its own separate volume control and small matching transformer built-in to operate the crystal from any speaker voice coil. Ideal for hospitals, homes, hundreds of other uses. 10 times more comfortable to wear than conventional earphones. Stock No. BH-500 includes Brush crystal ear piece, remote control box, 20 ft. of cable and instructions. Sale price, \$5.49 complete. Brush crystal ear phone with 36" cord. Stock No. BR-51, \$2.95. (You connect it like any crystal earphone, diagram furnished.) Accessory kit includes volume control with switch plus coupling capacity and instructions, 99c extra.

CROSLY RADIO WITH 45 RPM CHANGER \$29.95
5 tube superhet radio (540 to 1600 kc Broadcast) using 12SA7, 12SK7, 12SO7, 50L6 and 35Z5 tubes. Automatic changer for up to 8 45 RPM records (6 1/2" only). Brand new in original factory cartons. Only 100 to sell at the terrific low price of \$29.95. Shipped Express only. Shipping weight 23 lbs. Mahogany cabinet 13" x 16" x 8 1/2" high. Lid covers 45 RPM changer (will not play 78 or 33 1/2 RPM records). Ideal for children and grown-ups alike. Model No. 10-145M. \$29.95.

T.V. RADIO NEWS SPECIAL \$9.95
3 Flybacks and 3 deflection Yokes for \$9.95. You get 3 deflection yokes, 2-70" disks, and 1-55" yoke, and 3 horizontal flyback transformers. 2 General Electric 14,000 volt ceramic core 70" and curvy model Philco. The G.E. flyback cost regularly more than our price for the complete deal. Stock No. 33YK. Ship, weight, 5 lbs. Radio News Special, only \$9.95.

T.V. COMPONENT DEAL #CGE \$12.95
Here is a terrific TV parts deal for those who repair TV or for the builder and experimenter. You get a Meissner 12-channel TV tuner, a Crosley 5-tube video IF strip, a 14KV G.E. horizontal output transformer, plus a standard 4-wire vertical output transformer, plus a 70" ceramic deflection yoke (no tubes included). It's worth \$20.00. Our sale price, only \$12.95.

TERRIFIC FLUORESCENT FIXTURE SALE

IS YOUR SERVICE DEPT. PROPERLY LIGHTED? SAVE 50% ON THIS 4-LIGHT FIXTURE \$12.95, TWO FOR \$25.00 WITH LAMPS

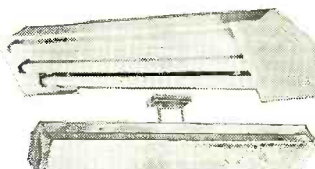

TOP ILLUSTRATION: This is the finest value in a fluorescent fixture that we have ever offered. Constructed of heavy gauge metal with lustrous white enamel finish. Furnished with General Electric 36", 30 watt white fluorescent lamps. Fixture may be mounted next to the ceiling or suspended on chains. These fixtures are beautifully constructed. Use them over your service bench, in your display room or in your office. Brand new in factory cartons properly packed for shipment. These fixtures sold for up to \$30.00. We bought 6 truck loads and are passing our bargain on to you. Why pay more than this to modernize your shop. Shipping weight 23 lbs. each. Shipped via Express, Rail Freight or Truck only. Stock No. MK-430 fixture complete, Net \$12.95; 2 for \$25.00.

DELUXE MODEL WITH GLASS, \$14.95; CEILING CANOPY, \$1.95

Bottom Illustration

Deluxe Model No. MK-430X, same as No. MK-430 described above with the exception that it has translucent glass over the lamps to diffuse the light. **CEILING CANOPY** that is shown, \$1.95 extra. Shipping weight 33 lbs. Net price \$14.95; 2 for \$28.00.

Canopy for suspending either of the above fluorescent fixtures 30" from the ceiling. For use where it isn't advisable to mount fixture flush or suspend it on chains. Canopy kit is complete with stamped metal box cover with hardware for mounting to any outlet box and 2-30" lengths of 3/8" extra enamel tubing. Ship, wt. 6 lbs. Fixture canopy kit, No. 1-30, \$1.95.

McGEE RADIO COMPANY

Prices F.O.B. K.C. Send 25% Deposit with Order, Balance Sent C.O.D. With Parcel Post Orders, Include Postage

TELEPHONE VICTOR 9045. WRITE FOR FLYER 1422 GRAND AVE., KANSAS CITY, MISSOURI

YOUR BEST TV SERVICING GUIDE

\$3.25

TELEVISION AND F-M RECEIVER SERVICING

gives you practical information on antennas and transmission lines, complete alignment and servicing instructions. How to diagnose, locate, and correct common troubles as well as install sets for best reception. 248 pages, illustrated.

And Don't Miss

- TELEVISION SIMPLIFIED (Kiver).....\$6.50
- F-M SIMPLIFIED (Kiver)..... 6.50
- U.H.F. RADIO SIMPLIFIED (Kiver).... 4.50

D. VAN NOSTRAND COMPANY, INC.

Order from your parts jobber today, or write direct to D. Van Nostrand Company, Inc., 250 Fourth Avenue, New York 3, New York.

Please send me the following books:

- Television Servicing Television Simplified
- F-M Simplified U.H.F. Radio Simplified

I enclose \$.....

Name

Address

City

RTN-12a2

International Short-Wave

(Continued from page 59)

Albania—Radio Tirana, 7.850A, noted with news 1600. (Pearce, England) Begins *English* session 2348A. (Kary, Pa., Saylor, Va., others)

Algeria—Radio Algerie, 9.57, noted with news in French 1645. (West, Va.) Noted in Arabic on 6.145 at 1530. (*Nat-tugglan*, Sweden)

Andorra—Radio Andorra, 5.990, heard at 1620 at strong level in England with popular and old-time tunes; had frequent announcements in Spanish by woman. (Catch) Noted in New York at 1900 in Spanish. (Pelegri)

Anglo-Egyptian Sudan—Radio Omdurman, 7.004A, noted in Arabic from 1130; stronger on 9.735A in parallel. (Pearce, England) Heard on these channels with Arabic 2315-2345. (Bellington, N. Y., Kary, Pa.)

Angola—Radio Clube de Angola, Luanda, is scheduled 0100-0215 (Sun. 0300-0500), 0630-0830, 1230-1630 (Sun. to only 1530) on CR6RA, 4.869, 0.25 kw., CR6RL, 7.142, 1 kw., and CR6RN, 1 kw.; the 10 kw. outlet on 11.862 with slogan "*Voz de Angola*" is on the air 1330-1730. (WRH) (On Sundays may close 1530.—K.R.B.)

Argentina—LRS, 11.880, Buenos Aires, noted 1525 with program of Argentina music, during French transmission to Europe; fair level in Brit-

ain. (Catch) LRY, 9.76, is noted by Cushen, N. Z., Ferguson, N. C., others, to 2400 closedown; Ferguson also noted this one at 0452 with weather report and other information; announced for LR3 and continued with news in Spanish; R8 signal.

LRS, *Radio Splendid*, was noted recently on 9.740A to after 0815; another day, however, was found back on 9.320. (Stark, Texas) Has been heard evenings (*EST*) by Bellington, N. Y.; best time to try is on *Mondays when HCJB is off the air.*

Latest schedules from SIRA are 1000-1200 Portuguese to Brazil, 15.345; 1200-1500 French to France, 15.345; 1505-1700 Spanish to Europe and America, 15.345; 1730-2000 *English* to Eastern North America, 9.690; 2000-0100 Spanish to Caribbean, 9.690; 0700-0845 Spanish to Latin America, 15.290; 1300-1545 Spanish to Latin America, 15.290; 2100-2300 Spanish to Latin America, 15.290; 2300-0100 *English* to USA, 15.290; 0800-1300 Portuguese to America, 15.345; 1730-2000 *English* to England, 1400-1500 German to Europe, 1500-1600 Italian to Italy, 1600-1700 Spanish to Europe and America, 1700-2230 Portuguese to Brazil, and 2300-0100 Spanish to America, 11.880.

Belgian Congo—OTC, 9.655, Leopoldville, is fine strength in Illinois when relaying ORU, Brussels, with *English* to North America 2200-2400. (Black)

Brazil—Radio Nacional, PRL9, 6.147, Rio de Janeiro, noted 1850 with very

COMPLETE RADIO, TELEVISION AND AMPLIFIER KITS AT MCGEE

3-WAY PORTABLE KIT

\$15.95



A NEW '52 MODEL

New 1952 Model 3-way personal portable radio kit. Operates on 110 Volts AC-DC or 67 1/2 B. Receives broadcast 550 to 1650 KC. A conventional 2-gang superhet with 456 KC iron core I.F.s. Incorporates the new super gain stick loop antenna. All plated chassis. Lab. approved circuit—matched parts. Price includes all parts, tubes, diagram, Alnico V PM speaker. A factory quality kit. Stock No. PR-4T, shipping weight 7 lbs. The complete kit, less batteries, \$15.95. 67 1/2 V. B, \$1.59; 1 1/2 V. A, 39c extra.

Build Your Own \$7.95

Phono-Mike Broadcaster

Kit Model DE-GR. With this simple kit, you can build a 3-tube phono oscillator that also has a mike input. Will broadcast over any radio, within your home, (about 75 feet) from 1000 to 1500 kc. Inputs for crystal mike or crystal phono pickup. Fader control fades from mike to record. Ideal for a home P.A. system, baby listener and home entertainment. A complete kit of parts including tubes. Kit Model DE-GR. Net price, \$7.95. DE-GRWT, wired and tested. Net price, \$9.95. Crystal mike and desk stand, \$4.95 extra. Concated microphone units only 1" in diameter and 1/4" thick. Specify hidden mike when ordering. Stock No. T-001. Net, \$3.95 extra.



8-Tube Hi-Fi Amplifier Kit \$29.95

A complete kit, including tubes; 3-7E5, 2-7B7, 2-6A3, plus rectifier diagram and photos. Inputs for radio tuner or any kind of phono pickup (crystal or G.E. variable reluctance) and either crystal or dynamic mike. Output matches 8 ohm voice coil. Twin electronic bass and treble tone controls with range selector switch for either juke box quality with heavy bass response or brilliant symphonic range. Response 18 to 20,000 cps. 8 tube all triode amplifier kit, complete with tubes. Shipping weight 25 lbs. Model TX5. Net \$29.95.



10-Watt Hi-Fi Amplifier Kit \$14.95

A complete kit of parts including tubes 12AX7, 12AU7, 2-50L6, plus rectifier, diagram and instructions to build a high fidelity twin tone control audio amplifier with bass and treble boost. Inputs for radio tuner, crystal and crystal phono pickup. Output matches 8 ohms. Response from 50 to 15,000 cps. Chassis ready punched. Ventilated cover. Straight forward circuit with twin triode gain stages and 2-50L6 tubes in push-pull. Size, 5 1/4" x 10" x 5 1/2" high. Model AP-10R, ship. wt. 8 lbs. Sale price \$14.95.



10-TUBE RADIO KIT \$29.95

10 tube broadcast radio chassis kit, complete with tubes; 2-6SK7, 6SA7, 6H6, 6SQ7, 2-12A7, 2-6V6 plus rectifier diagram and instructions. 3 gang superhet with 8" slide rule dial. Chassis size, 12 1/2" x 10" x 6 1/2" high. Features push-pull 6V6 high fidelity output. Output matches 3 to 8 ohm voice coil speakers. Inputs for G.E. variable reluctance or crystal phono pickup and crystal mike. Heavy duty power transformer. Model BR10 low kit less speaker, shipping weight 18 lbs. Net \$29.95.

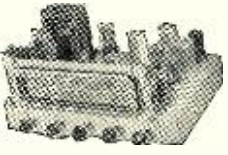

6-TUBE 2-BAND KIT \$14.95

Popular with schools and colleges for training. 6 tube AC-DC 2 band radio kit with plastic cabinet. Receives broadcast and 6 to 18 mc shortwave. Full 2 gang superhet with 5" speaker and slide rule dial. A complete kit with tubes; 12SK7, 12SK8, 12SK7, 12SQ7, 35L6 and 35Z5, diagram and instructions. Factory quality. Cabinet size 12" x 5 1/2" x 4 1/2". Shipping weight 12 lbs. Model ME6-2. Net \$14.95.

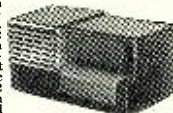

5-TUBE AC-DC KIT \$12.95

Model RS-5. A 5 tube AC-DC straight broadcast kit, housed in the same cabinet as ME6-2 above. Complete with tubes. Shipping weight 10 lbs. Net \$12.95.

AC POWERED BROADCAST TUNER KIT \$12.95

A self-powered, 3-gang superhet tuner kit with R.F. stage. This complete kit is furnished with a diagram, photos and tubes. 6AU6 R.F., 6BE6 oscillator R.F., 6AU6 I.F. detector, 6AL5 diode. AVC, plus rectifier. Connect to any audio amplifier. Ideal for use with our S-2020 or 7x5 amplifier kits. Chassis size, 9 1/2" x 4 1/2" x 4 1/2" high. Shipping weight, 7 lbs. Broadcast tuner kit Model BT-38X. Net price, \$12.95.



25-Watt Weather-Proof Out-Door Speaker

\$28.95

25-Watt Horn \$28.95

8" PM AND LEATHERETTE BAFFLE, \$4.95 LOTS OF 10, \$4.75

The finest Leatherette Baffle we have ever offered. New self-supporting plastic grill material. Baffle is covered with metalizing grill. Opened with a good heavy duty 8" Alnico V PM speaker with 3.2 ohm voice coil. Stock No. 818. Speaker and Baffle, \$4.95 ea. Lots of 10, \$4.75. 8" Baffle only. Stock No. NV-8, \$2.29 ea.; 10 for \$19.95.



17, 20" T.V. Kit \$59.95 Less Tubes

A complete kit of parts to build an AC transformer operated television chassis for use with a 17" or 20" rectangular picture tube. The 12 channel Sarks-Farzian tuner is ready wired, as is the 4 tube video IF strip. Circuit is of the conventional design. Do not buy this unless you understand Television. It is difficult to wire. We furnish schematic. Kit model WT-20. Ship. wt. 40 lbs. less all tubes. Net \$59.95. Kit of 22 tubes, less picture tube \$16.95. 17" 17BP4A, \$19.95. 20HP4, \$25.00.

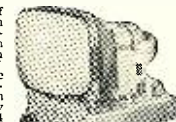

50-WATT BOOSTER AMP. \$39.95

2-Mike Pre-Amp \$12.95 Extra. Not a Kit, but a Manufactured Amp.

50-WATT BOOSTER

A sensational value. 50 watt booster amplifier with push-pull parallel 6L6 output tubes. Connect to your present amplifier as a booster or use with the PR-2X pre-amp to add the use of 2 mikes and one low level input. The booster amplifier has one input jack and with 1 volt input gives low level of audio. Booster has a 6 lb. potted case high fidelity output transformer, matches speaker with 4-8-16 ohm voice coil, also 60 ohm and 250 ohm line. Booster has 2.25 mill power supply with 5U4 rectifier. Price includes tubes: 4 6L6, 7N7 and 5U4. The two variable controls are for master volume control and bass boost tone control. Size 8 x 6 1/2 x 14 1/2. Stock No. PA-55N. Shipping weight 26 lbs. Sale price \$39.95 ea. Pre-amplifier plugs in directly to the PA-55N Booster amplifier. It enables use of 2, Crystal or Dynamic Mikes plus one low level input. Furnished with 4 foot cables and plugs for remote control of the 55 watt Booster Amplifier. Small chassis size 5 x 3 1/4 x 4". Stock No. PR-2X, with tubes 7F7 and 7N7. Net price \$12.95 ea.



ORDER FOR USE WITH ANY P.A. SYSTEM OFFERED ON MCGEE'S 3 PAGES OF ADVERTISING

25-WATT HORN 25-Watt Driver and 3 1/2-foot air column re-entrant Trumpet. The standard type trumpet and driver you see the most. Drivers are 100% weatherproof, horn is spun aluminum, offered to you at a considerable savings. Stock No. MA-33. Shipping weight 20 lbs. Net price \$28.95.

McGEE RADIO COMPANY

Prices F.O.B. K.C. Send 25¢ Deposit with Order, Balance Sent C.O.D. With Parcel Post Orders, Include Postage

TELEPHONE VICTOR 9045. WRITE FOR FLYER 1422 GRAND AVE., KANSAS CITY, MISSOURI

AIREX 630FA*

ACCLAIMED BY THOUSANDS! ONLY AT AIREX THE MOST POWERFUL Fringe Area TV CHASSIS MADE

THE CHASSIS THAT TELEVISION ENGINEERS AND SERVICEMEN ARE BUYING FOR THEMSELVES

This amazingly advanced 32 tube TV chassis is years ahead in engineering and gives you the ultimate in TV viewing and listening pleasure. To assure you trouble free TV our engineering staff has incorporated into the "630 FA" design the experiences of hundreds of TV servicemen and engineers. Receiving range includes stations up to 200 miles away. Nothing has been spared to bring you the finest of TV chassis. Only the best and most expensive parts are used. There is no other chassis that compares with the "630 FA" * for fringe area reception.

The only chassis with Push-Pull Audio Output at

\$164.95

Less GR Tube & Brackets

Complete with 12" ROLA Hi-Fi Speaker (Fed. tax incl.)
AND FREE SERVICE MANUAL & SCHEMATIC

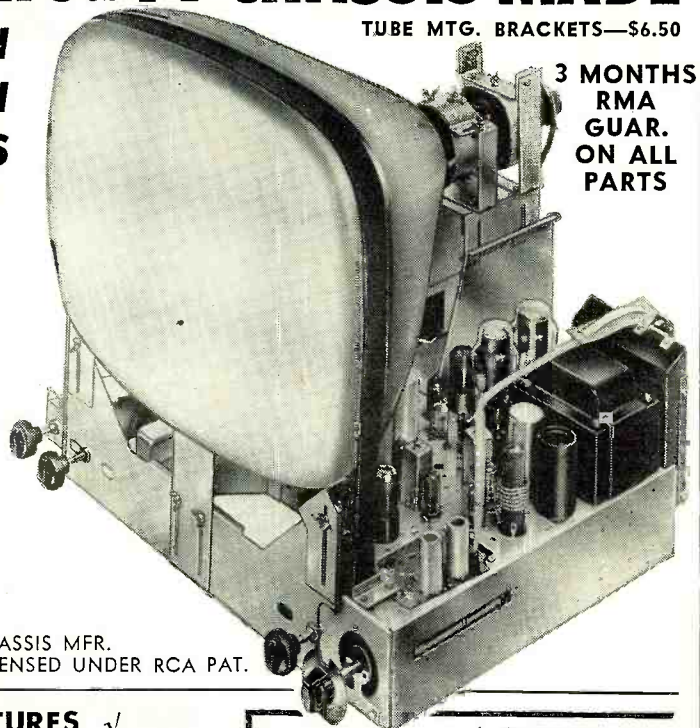

TUBE MTG. BRACKETS—\$6.50

3 MONTHS
RMA
GUAR.
ON ALL
PARTS

CHASSIS MFR.
LICENSED UNDER RCA PAT.

✓ CHECK THESE EXCLUSIVE FEATURES ✓

- 10 WATT push-pull audio output. Frequency range from 60 to 12,000 cycles • Link coupled Standard Coil Cascade Tuner prevents radiation • Retrace Blanking Circuit allows you to raise the brightness without the annoying vertical retrace lines • Heavy duty front focus control • Automatic gain control potentiometer allows you to adjust the threshold sensitivity as low as 4 microvolts & still keep the full 4MC band width • Separate high & low frequency sync amplifiers • Set aligned for 21.75 MC. New Ham band will not interfere • Improved fused high voltage power supply gives full 14.5 KV under load • Will handle all picture tubes up to 24 inch with full sweep • Improved video amplifier has a gain of 32 • All moulded plastic condensers give long life & trouble-free operation • Easily adapted to

- new UHF stations in 2 minutes by just changing a strip in the tuner • Extra heavy duty power transformer with large safety factor • 6CB6 tubes in Video IF to give full gain • Extra filtering in power supply for hum & ripple free operation • Color connection on chassis which is adaptable to the cathode follower circuit of color converter • Phono Connection & switch on chassis allows you to play your phonograph or tuner through the built-in 10 watt hi-fidelity amplifier • Extra heavy duty focus coil, which runs cool • Tuner can be removed up to 25 feet • Full focus cosine yoke.

ESPEY FM-AM 12-TUBE CHASSIS
with RCA 12" 201S1 Speaker. \$69.50

**SAVE 50% RAM
CONVERSION KIT**

Up to & including 24". Has 15 KV flyback, 70° cosine yoke, Special width coil, 10W resistor. Complete with schematic. Reg. \$23.95. **\$11.95**

**STANDARD COIL
CASCODE TUNER**

Complete with tubes & instructions. High gain, low noise. **\$23.97**

**Regency Booster
MODEL
DB520
Deluxe** **\$19.11**

**UHF SLUGS FOR
ALL STATIONS**

\$9.40

For standard coil tuner. Complete instructions with each set. Simple to install. No tools necessary. For Each Station

BARGAIN SPECIALS! BRAND NEW

- TV Telescopic Mast complete with hardware, guy wire and base... 30 ft., \$14.95; 40 ft., \$19.45
- Alliance Antenna Rotors... ATR, \$20.49; Directional, \$26.29
- Garrard RC80 3-speed changer with astatic turnover cart. \$42.30
- Presto Call Intercom—2 units, with 100 ft. wire... \$24.95
- Standard coil contact cleaners. Self-cleaning action. Set of 4... \$1.50

Save 50%—Brand New in Factory Sealed Cartons SILVERTONE

PORTABLE AMPLIFIERS

Complete with carrying case, 12" speaker, microphone and cable.

- 10 Watt... \$42.50
- 20 Watt (Turntable & 2 speakers) \$74.95
- 40 Watt (Turntable & 2 speakers) \$109.95

SENSATIONAL SPECIAL OFFER OF THE AIREX SUPER DX COMPLETE TV SETS . . . THE FINEST SET VALUE IN ITS PRICE CLASS

These outstanding sets were specially designed to meet our rigid specifications to assure you many pleasant hours of trouble free TV at an unequalled price. The mfr. is licensed by RCA. RMA guarantee. All you have to do is plug in and play.

Includes These Features

- Has standard coil Cascade tuner that brings in reception up to 200 miles
- 20 tubes • Large HI-FI speaker
- Hand rubbed, satin finished genuine mahogany cabinet • AGC • Moulded plastic condensers • Black, glareless picture tube, guaranteed for 6 months
- Adaptable for UHF and color • Synchronized FM audio system • 5 hour heat run at factory • Factory wired, aligned and tested • Mounted in cabinet.

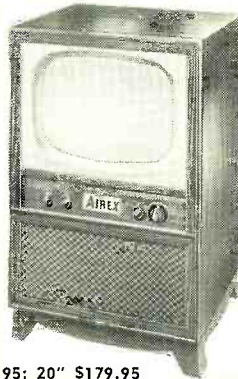

TABLE MODELS—17", \$154.95; 20" \$179.95
CONSOLES—17", \$174.95; 20", \$199.95

TV TUBE EXTRA STANDARD BRANDS FACTORY NEW

1ST QUALITY—GUAR. 1 YEAR

17BP4... \$27.95 | 21" TV tube... \$39.95
20" TV tube... 34.95 | 24" TV tube... 64.95

**RING & SLEEVE
FOR 24" TUBE... \$7.50**

**TV GOLD PLASTIC MASKS
FOR CUSTOM INSTALLATION**
16" and 17"... \$4.95 24".....\$14.95
20" and 21"....\$7.95

38 BARGAIN-PRICED CABINETS FOR THE "630" & OTHER CHASSIS

Send for FREE folder and price list. Full line table models, consoles, consolettes and TV-Radio Phono combinations. Many styles. Mahogany, blonde, etc.

Complete Service Manual
For "630FA" or Super 630DX—\$1

SEND FOR FREE NEW TV PARTS &
HI-FI AUDIO EQUIPT. CATALOG

All merchandise is brand new, factory fresh & fully guaranteed. Mail & phone orders filled upon receipt of certified check or money order for \$25 as deposit on TV chassis. 20% on other items. Balance C.O.D. P.O.B. N. Y. Prices subject to change without notice. No Fed. taxes to pay. Prices lower than QPS Regs.

AIREX RADIO CORP. 171 Washington St., N.Y.C. 7, N.Y.
Phone WOrth 2-4029

SEND POSTCARD TO BE
PUT ON FREE MAILING LIST

1000 Kc mounted crystals \$2.95
RCA 100 watt 115 volt
line noise filter..... **\$1.95**

XMAS SPECIALS

20 watt PP 6L6 output transformer,
to standard VC, completely
shielded upright case..... **\$1.95**

ZA BAND PASS FILTERS, 60, \$1.25
90 or 150 cy. each.....

OIL CAPACITORS

5 MF 235VAC	\$0.95	16 MF 1500VDC	\$6.95
10 MF 330VAC	2.95	2 MF 2000VDC	2.25
14 MF 275VAC	3.48	4 MF 300VDC	4.50
4 MF 600VDC	.69	8 MF 2000VDC	5.50
8 MF 1000VDC	2.95	2 MF 300VDC	3.95
35 MF 1000VDC	7.50	3000 MF 3V elect.	.39
2 MF 1500VDC	1.85	1000 MF 30V ELE:	.39

5 HY 300 MA CHOKES, 70 OHMS, 2 KV insulation, new \$2.99. **\$25.00**

115V POWER SUPPLY KITS 60 CY

A 600VCT 93 MA, 6.3V 3A, 5V 2A, 8 HY 100 MA CHOKES (2 ea.); 8X8 MFD 600 VDC OIL CAPACITORS **\$5.95**

B PLATE TRANSFORMER 740VCT 305 MA, 3V 6A, 6.3V 3A, DUAL FIL TRANSFORMER: 4.6 HY 310 MA CHOKES (2 ea.); 8X8 MFD 600 VDC OIL CAPACITORS **\$12.50**

115V POWER TRANSFORMERS 60 CY

58 V Half Wave	3A	5V 2A	8 HY 100	2.95
68 to 83 V Half Wave	1.5A			1.25
300 V Half Wave	.02A			2.75
495 VCT 145 MA	6.3V 3A, 5V 3A			2.95
685 VCT 95 MA	6.3V 3.5A, 5V 2A			2.95
700 VCT 100 MA	5V 3A, 2.5V 10A			2.25
740 VCT 185 MA	6.3V 4A, 5V 3A			5.95
800 VCT 200 MA	6.3V 3A, 5V 2A			5.95
680 VCT 300 MA				2.95
740 VCT 305 MA				4.50
750-600-600-750 VDC	225 MA			10.50
3600 VCT 350 MA				29.50
5400, 5800, 6200 VCT	110 MA			29.50

CHOKES

6 HY 50 MA	\$.39
9 HY 95 MA	1.15
7 HY 125 MA	1.49
8 HY 150 MA	1.95
11 HY 200 MA	2.95
15 HY 250 MA 80 ohm. cased	3.95
4-16 HY 200 MA (Swinging)	4.99
3 HY 250 MA 15 ohm. cased	5.99
5 HY 300 MA 70 ohms	2.99
8 HY 400 MA 110 ohms	5.59
8 HY 450 MA 80 ohms	6.50
6 HY 400 MA 55 ohms	7.25
.05 HY 3A 1 ohm	0.00
.02 HY 3A .5 ohm cased	4.95

115V FILAMENT TRANSFORMERS 60 CY

2.5 VCT 10A, 10 KV Insulation, Cased	\$4.50
5V 4A 2.5 KV Insulation	1.99
5.0 V 6A, 6.3 V 6A	3.95
5.0 V 12A, 2.5 KV Insulation	5.95
5.0 VCT 20A, 2.5 KV Insulation	6.85
5.0 VCT 30 A, 2.5 KV Insulation	7.50
6.3 VCT 3A, 2.5 KV Insulation	2.25
6.3 VV 6.3 V ea. at 4A	2.95
6.3 VCT 6A, 2.5 KV Insulation	1.15
10 VCT 10A, 2.5 KV Insulation	6.00
Dual 25V 1 Amp	1.95
34-41V 1A	1.45

IN34 GERMANIUM DIODES
10 for \$3.95, 100 for \$35.00

HEARING AID TESTER

DYSONIC hearing aid tester, tests type 503, 503 submin; hearing aid tubes, batteries, cords etc. Complete with G.E. 3" SQUARE METER (0-1MA) engraved bakelite panel, tube socket etc. Only **\$12.95** Less portable case.....

SIGMA SENSITIVE 3 Prong Plug in relay, polarized coil 3000 ohms D.C. Operates on 2-4 MA SPDT contacts. Ideal for use with electric eye, control of model hobby equipment, etc. May be used directly in plate circuit of amplifiers, etc. Removable dust cover permits finer adjustment of contacts. \$2.95. **\$25.00**

POCKET MULTIMETER

SUPREME type 542 pocket multimeter 5000 ohm/volt 3" meter (Mfg. by TRUMPH, SU-PREME) 24 AC/DC ranges measures up to 1500VDC. complete with test leads, batteries & 90 day guaranteePrice each **\$14.95**

ZA GLIDE PATH RECEIVER, NEW, BLACK CRACKLE ALUMINUM CASE 6"x7"x12", complete with shock mount, 3 (6) 6C6 tubes, resistors, capacitors, etc. Ideal for building test equipment, mobile X-mitters, etc. **\$3.95**

TV COLOR ADAPTER converts sweep frequencies of present TV sets to requirements of color sweeps to permit viewing on black and white receivers. Unit comes housed in attractive brown cabinet, completely wind ready to operate, including cables and simple instructions, \$1.79 each. **\$.99**

FUSES

2A 3AG	100/2.49	30A	4AG	100/2.45
10A 4AG slo-blo	100/2.49	35A	4AG	100/2.75
10A 4AG	100/2.45	40A	4AG	100/2.75
15A 4AG	100/2.45	50A	B	100/1.99
20A 4AG	100/2.45	100A	B	100/1.99

TUBES 2E24\$2.49 | 304TL\$6.95
3E29 9.95 | 872A 3.95

POLY TECH

Dept. 122, 919 Dawson St., New York 59, N. Y.
Send for Bulletin
Murray Hill 6-2650

New! Up-to-date!



TELEVISION SERVICING

by Walter H. Buchsbaum

Get this brand new, complete handbook for sure-fire working knowledge of TV installation, maintenance and troubleshooting. Tells you step-by-step procedures for audio IF alignment, video IF alignment, aligning RF amplifiers, mixers, oscillators, etc. All possible defects classified for ready reference, thoroughly analyzed to show what is wrong and why... and what to do to correct the defect. No mathematical knowledge needed! Practical, authoritative, up-to-the-minute, the perfect handbook for set owners, trainees, and repairmen.

340 pages
170 illustrations



Symptoms of defective operation easily recognized, quickly corrected by illustrations, diagrams and how-to-do-it facts in this new book.

USE IT 10 DAYS FREE

Coupon below brings you "Television Servicing" on FREE trial for 10 days, without obligation. Mail it NOW.

PRENTICE-HALL, Inc., Dept. M-RTN-1252
70 Fifth Ave., New York 11, N. Y.

Send me, for 10 DAYS FREE TRIAL, "Television Servicing." I will return it in ten days and pay nothing—or keep it and send \$1.35 down (plus postage) and \$2 monthly for 2 months.

NAME.....
ADDRESS.....
CITY..... STATE.....

SAVE! Send \$5.35 with this coupon, and we'll pay postage and packing.

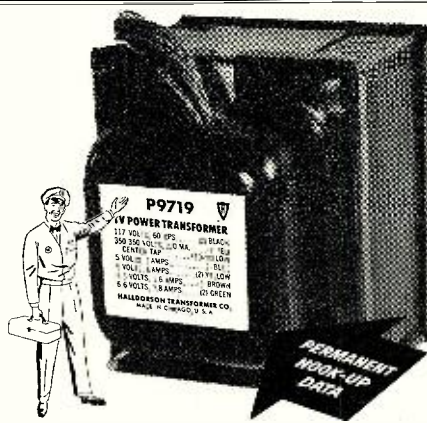

**Where You Need it!
When You Need It!**

NOW—no more halted work, no more writing to the factory for missing instruction sheets. Tough identifying labels giving complete application and hook-up data are affixed to all Halldorsen components. This provides maximum convenience in original installations or re-use at some later date. The same data appears on each box for instant identification.

This is only one of Halldorsen's many aids designed to save your valuable time. Look to Halldorsen for the biggest variety of transformer components, plus the newest for TV. Ask your distributor for your copy of Halldorsen's great new catalog and TV Replacement Guide... today. The Halldorsen Transformer Co., 4500 N. Ravenswood Ave., Chicago 40, Ill. Dept. RN-1



HALLDORSON

QUALITY Transformers SINCE 1913

Intex Co., Inc., 136 Liberty St. New York 6, N.Y. Cable Address: Intexcom, N.Y.

strong signal when identified in Portuguese. (Catch, England) Heard on this channel around 1815-2300 or 2310. (Levy, N. Y.) PRL7, 9.72, signs off around 1730. (Bellington, N. Y.)

PSL, 7.935, Rio de Janeiro, noted 1745-1800 when signed off with "A Voz de Brasil" and National Anthem. (URDXC) ZYB9, 15.155, Radiodifusora Sao Paulo, noted 1445 with dance music, songs; Radio Tupi, 15.370, Rio de Janeiro, heard with sports commentary in Portuguese when tuned 1430. (Pearce, England) "Brazil Calling" (English) is noted 1930-1955 on 11.825; 2000-2025 on 9.565 from Recife, Pernambuco. (West, Va.) Wants reports on reception of this English feature. (Niblack, Ind.)

ZYK21, 3.265, Recife, Radio Tamandare, noted 1920 with Brazilian music and announcements in Portuguese; fair level but with bad CWQRM; also heard another Brazilian at that time around 3.320, perhaps ZYJ21? (Catch, England)

Radio Cultura, 9.740A, Sao Paulo, noted when tuned as early as 0444; strong signal with musical program. (Ferguson, N. C.) Heard identifying at 2103. (Bellington, N. Y.)

British Guiana—ZFY, 5.980A, Georgetown, noted with news 1945. (Niblack, Ind.) Recently was measured on 5.982 at 1910; previous measurement was 5.9808. (Oskay, N. J.)

British New Guinea—VLT7, 7.280, Port Moresby, heard signing off 0759 at good level. (Ferguson, N. C.)

British Somaliland—Radio Somali, Hargeisa, informs that its broadcasting hours are 0815-0930 on 7.125 (WRH)

Bulgaria—Radio Sofia noted with news 1600 on 7.671, 6.070; strong on both channels. (Catch, England) The 7.671 outlet heard with news 1500. (Bellington, N. Y.)

Canada—CHNX, 6.130, Halifax, Nova Scotia, is noted 1530-1600 at good level and in the clear. (Machajewski, N. Y.)

Cape Verde Islands—CR4AA, Praia, noted on 7.114A in parallel with 5.890A around 1530; QSL card lists 5.895 and 42 m. (Pearce, England) Heard on these channels to 1700 close-down. (Kary, Pa., Bellington, N. Y.) Heard on the 7.114A outlet from 1500. (Black, Pa.)

Ceylon—In Radio Ceylon's daily session called "Eventide Echoes" at 1130 on 11.975, a Bing Crosby recording of "A Perfect Day" is used, after which the announcer says "good-night," and the station closes 1145 with "Strike Up the Band." Is a "regular" in Britain. (Catch) Signs on 2045 on this channel with "Strike Up the Band;" relays BBC news 2100.

China—A station believed to be Chungking is heard in Melbourne on 11.022 at reasonably good strength 0700 in Chinese; like most other (Communist) Chinese outlets, has noticeable hum on the carrier. (Hutchins, Radio Australia) Radio Peking, 10.260, noted 1020 with woman in Chinese, possibly news, at dictation speed.

(Continued on page 90)

HOW YOU CAN *plan for success* IN TV-ELECTRONICS

Send today for this free CREI booklet

YOU have a greater chance for success if you sincerely believe that success doesn't just *happen*. For every man who reaches the top on luck or looks, tens of thousands come up the "planned" way. The "planned" way means outlining your objectives, choosing the means of reaching your objectives, and having a positive ambition to succeed. You must plan your TV-Electronics career carefully, because these are fields where the rewards go to the man with technical knowledge.

When you read CREI's fact-packed booklet, called "Your Future in the New World of Electronics," you will get a complete picture of the electronics industry—where it is going—and how you can go forward with it.

This is a field expanding so rapidly that the most optimistic experts fall short in their predictions.

Consider the 2,980 radio stations and the 111 TV stations now operating plus the 2,073 more made possible by the FCC "unfreeze." Consider the 18,626,860 TV sets and over 100,000,000 radios now in operation. Consider the gigantic defense orders for electronic equipment and installations.

Consider the thousands of radio-equipped fire and police departments; the radio-equipped railroads; the hundreds of cities with 2-way radio service for cars and cabs; the wide-ranging field of aviation communications—radio-controlled aircraft, navigation-and-traffic control, airport stations.

Consider the maritime world with its radar and navigation aids, fathometers, ship-to-shore and ship-to-ship communications. Think of electronic heating, Fax and ultra-Fax electronic medicine, electronic computers, and all the industrial applications of electronic know-how.

Then think of the unlimited number of positions to be filled—in development, research, design, production, testing and inspection, manufacture, broadcasting, telecasting, and servicing. Luck won't get you a job. Contacts won't. Knowledge *will*. You will have knowledge if you prepare now—if you are alert enough and ambitious enough to obtain that knowledge—if you take two minutes to send for "Your Future in the New World of Electronics" and then follow the plan it describes.

This helpful book shows you how CREI Home Study leads the way to greater earnings through the inviting opportunities described above. However, being an accredited technical school, CREI does not promise you a "short-cut." You must translate your willingness to learn into salable knowledge—via *study*. CREI knows what it means to grow along with a booming industry. This year CREI is celebrating its 25th Anniversary. Since 1927 CREI has provided thousands of professional radiomen with technical educations. During World War II, CREI trained thousands more for the Armed Services. Leading firms now use CREI courses for group training in electronics at company expense; among them are United Air Lines, Canadian Broadcasting Corporation, Trans-Canada Airlines, Sears Roebuck & Co., Bendix Products Division All-American Cable and Radio,

and
find
out!

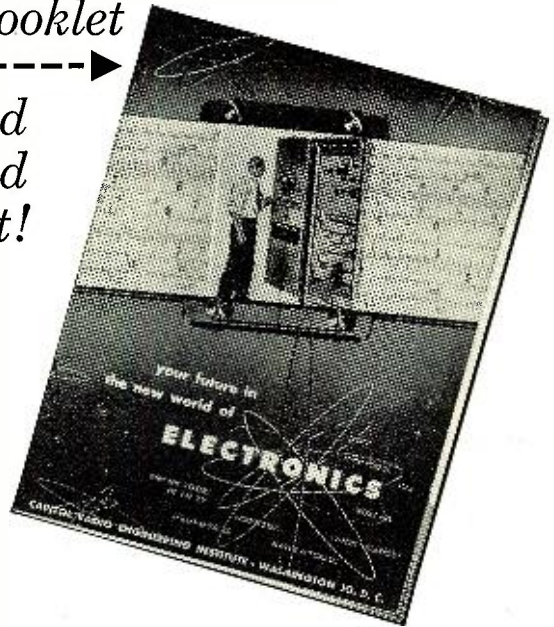

Inc., and RCA-Victor Division and Machlett Laboratories.

CREI courses are prepared by recognized experts, in a practical, easily-understood manner. You get up-to-date study materials; your work is under the personal supervision of a CREI Staff Instructor who *knows* and *teaches* you what industry needs. You choose your own hours of study *at home*. Upon completion you join the many CREI graduates who have found their diplomas keys-to-success in Radio, TV and Electronics. CREI alumni hold many top positions in America's leading firms.

At your service is the CREI Placement Bureau which finds positions for students and graduates. Although CREI does not guarantee jobs, the bureau now has more requests for

personnel than it can fill.

Talk to men in the field and check up on CREI's high standing in electronics instruction. Determine for yourself right now that your earnings are going to rise with your knowledge—and that you will rise *with* this booming industry. All this CREI offers you, provided you sincerely want to learn. Fill out the coupon and mail it today. We'll promptly send you your free copy of "Your Future in the New World of Electronics." The rest—your future—is up to you.

CREI resident instruction (day or night) is offered in Washington, D. C. New classes start once a month.

VETERANS: If you were discharged after June 27, 1950—let the new G.I. Bill of Rights help you obtain CREI resident instruction. Check the coupon for full information.

MAIL COUPON FOR FREE BOOKLET

CAPITOL RADIO ENGINEERING INSTITUTE

Dept. 1112D, 16th & Park Rd., N.W., Washington 10, D. C.

Send booklet "Your Future in the New World of Electronics" and course outline.

CHECK TV, FM & Advanced AM Servicing Aeronautical Radio
FIELD OF Practical Television Engineering Engineering
GREATEST Broadcast Radio Engineering (AM, FM, TV)
INTEREST Practical Radio Engineering

Name

Street

City..... Zone..... State.....

If residence school in Wash., D. C., preferred, check here

OLSON'S PENNY PROFIT POLICY MEANS GREATER BARGAINS

GIANT 3-SPEED RECORD CHANGER SALE!



IMPERIAL DELUXE MODEL
STOCK NO. RA-69
Equipped with single needle, with precious metal long-lasting tip. Plays all speeds—Records 33 1/3, 45 and 78 RPM. Retail price \$47.50. Shpg. wt. 1.5 lbs.
Single, each \$19.99
In lots of 3, each, only \$18.99

3-SPEED GENERAL INSTRUMENT AUTOMATIC RECORD CHANGER

Automatically Changes All Sizes—7", 10" and 12"
All Speeds—33 1/3, 45 and 78 RPM

All the finest features are incorporated in these General Instrument Record Changers. Records Slide Gently down the center spindle. There is no wobble, no scrape, no slip. No chance of damaging your records. The newly-designed controls are so simple, they explain themselves. No instructions needed. All moving parts in every General Instrument Changer are factory adjusted thus insuring years of trouble-free performance.

These Changers are precision-built by craftsmen who have had years of experience. Every Changer is brand new—in original factory-sealed cartons—and guaranteed 100% by Olson and the manufacturer. Here is one of Olson's most sensational bargains. Believe us—you can't go wrong.

Changer can be connected to any radio or amplifier. Equipped with clever "touch-plate"—a slight press and you can reject or skip a disc and go on to the next one. Has perfect cast parts. Here's a Changer you'll be proud to demonstrate to your friends. You can sell plenty of them too. Operates on 115 Volts AC, 60 cycle. Base size 12"x12 1/2". 5 1/4" above plate and 3 1/2" below. Take your choice of either model.

COMPLETE 3-SPEED RECORD CHANGER AMPLIFIER KIT

Easily Assemble Your Own Automatic Record Player

Stock No. AS-71
FOR ONLY \$29.99

SEE WHAT YOU SAVE
Regular List Price Complete Kit \$47.50
3-Speed Changer \$47.50
Amplifier (Wired) 7.50
Set of 3 Tubes 4.55
5" Heavy Duty Speaker 4.00
Output Transformer 1.75
Mounting Base (Pre-Drilled) 8.50
Mounting Hardware55
Total List Price \$74.35

Here's an outfit that normally retails at \$74.35. Save yourself a pile of money and have fun assembling your own 3-Speed Automatic Record Player. It's easy—can be assembled by anyone in just 30 minutes. All holes are drilled and all mounting hardware is provided. The Amplifier is completely wired. All you have to do is attach the Changer and Speaker wires. Shpg. wt. 20 lbs.

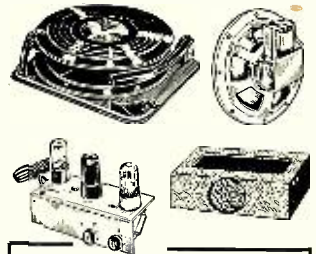

You Get Everything You Need to Easily Assemble Your Own 3-Speed Automatic Record Player. Kit Includes:

- GENERAL INSTRUMENT IMPERIAL DELUXE CHANGER (Model RA-69—as described to left).
- 5" PM HEAVY-DUTY SPEAKER AND OUTPUT TRANSFORMER.
- 3-TUBE AMPLIFIER COMPLETE WITH TUBES
- MOUNTING BASE—WITH HARDWARE & INSTRUCTIONS

HI-FI DELUXE MODEL

STOCK NO. RA-113
Equipped with "Turnover" cartridge and dual needle. One side for 33 1/3 and 45 RPM discs and other side for 78 RPM discs. Both sides equipped with precision metal long-lasting tips. Regular retail price \$52.50. Shpg. wt. 15 lbs.
Single, each \$29.99
In lots of 3, each, only \$21.99



Slotted Super Space Line LOWER LOSS 300 OHM W-115
500 Ft. Spool Single, Ea. \$7.95
Lots of 2, \$7.50 EACH

This slotted 300 ohm TV line is made to standard specifications in such a manner as to provide maximum air spacing while maintaining the desirable strength and durability of the usual 300 ohm twin line. Color: Brown, with 22 strands of copper, pure polyethylene 55 mil wdg. Never offered before at such a low price. ORDER EARLY—while supply lasts. Shpg. wt. 7 lbs.



WIRE AT LESS THAN COST OF ROPE
500 Foot \$2.95
Spool, Only

You get a big 500 foot spool of 2 Conductor plastic insulated stranded copper wire, No. 22 Flexible—for all around use. Intercom connection between stations, speaker extensions, ground wire, burglar alarm systems, etc. Here's your chance to get this fine zip-apart wire at less than cost. Think of it—you pay about 1/2¢ per foot. Brother, That's a Bargain! Shpg. wt. 3 lbs.

OLSON SMASHES KINESCOPE PRICES GUARANTEED!

Here are real bargains in Picture Tubes. Prices that would be impossible except for the fact that Olson made a cash deal on THREE SOLID RAILROAD CARS full of PICTURE TUBES. This is one of the biggest deals that we have ever made and we pass the savings on to you. We promised not to advertise the manufacturer's name, however, every tube is guaranteed, is in the original factory-sealed carton and bears the manufacturer's name. Express only. Shpg. wts.: 12LP4—18 lbs., 16KP4—20 lbs., 17BP4—22 lbs., 19AP4B—23 lbs., 20CP4—31 lbs.

12LP4A	Round, Dark Face, Glass Envelope. Retail Price \$31.00	\$17.95
16KP4	Or 16RP4. Rectangular Glass Envelope, Dark Face. Retail Price \$37.50	\$20.95
17BP4A	Rectangular Dark Face, Glass Envelope. Retail Price \$37.50	\$20.95
19AP4B	Round, Etched Dark Face, Metal Envelope. Retail Price \$65.00	\$29.95
20CP4	Rectangular Dark Face, Glass Envelope. Retail Price \$59.00	\$29.95

NEW LATEST 1953 MODEL ESPEY

12-TUBE AM-FM RADIO CHASSIS

COMPLETE: With Tubes, Loop Antenna Escutcheon, Knobs, Etc.

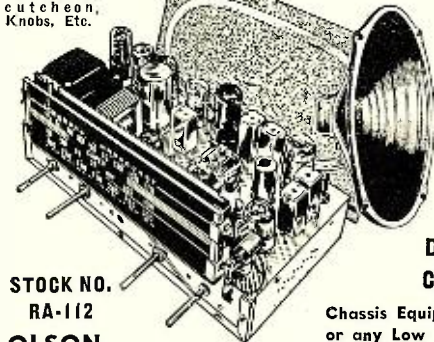

COMPLETE WITH 12" MAGNAVOX SPEAKER

LOOK HOW YOU SAVE
12" Magnavox Speaker. \$ 20.00
12 Tube AM-FM Chassis. 130.00
Regular List Price. . . . \$150.00

DESIGNED FOR QUALITY CUSTOM INSTALLATIONS

Chassis Equipped with Built-In Pre-Amp for GE or any Low Output Variable Reluctance Pickup

Here's a deal for you! Don't pass it up. We got a terrific bargain by paying cash on the barrel-head. Olson passes it on to you. If we went out to duplicate this offer WE COULD NOT DO SO TODAY. Order Your Outfit Now!

LOOK AT THESE FEATURES: You get a full size AM-FM Chassis including 12 tubes (4 are dual purpose, thus giving you the equivalent of 15-tube performance). Push-Pull Output Audio Stage delivers 10 Full Undistorted Watts. Improved FM Circuit, drift compensated. Built-in Automatic Volume Control. Inverse Feed-back. High-Fidelity assured on both AM and FM channels. Full Range Combination Bass-Treble Tone Control. Slide Ratio Dial is indirectly illuminated. Equipped with Loop-Antenna for AM, and Folded Dipole Antenna for FM.

Has Input Jack for both Crystal Cartridge Tone Arm or any Magnetic Low Voltage Cartridge. Also has Microphone Input for Public Address use. Fully licensed under both RCA and Hazeltine Patents.

Receives standard AM broadcast 550 to 1700 KC and FM 88 to 108 MC. The FM Circuit includes an aperiodic RF Amplifier Stage, 2 Stages of High-Gain Intermediate Frequency Amplification and an advanced design Ratio Detector Circuit which provides Low Noise Level between stations, freedom from AM interference, ease of tuning and ample gain.

High-Fidelity Reproduction is assured through well-engineered Circuits and the use of High Quality Parts throughout.

TUBE COMPLIMENT: 1-6BE6, 2-6BA6, 2-12AT7, 1-6SH7, 1-6AL5, 2-6SQ7, 2-6V6GT and 1-5Y3GT. Wide Frequency Response is assured by the Push-Pull Output Stage. Chassis size 13 1/2" wide x 9" high x 9" deep. Complete with Tubes, Knobs, Front Escutcheon, Mounting Hardware and Full Size Layout Template. Operates on 115V AC 60 Cycle.

The 12" Magnavox PM Speaker is of the Highest Quality and is found in the most expensive Console Radios. You can depend upon it to render life-like tone when connected to the chassis. All metal parts are heavily chromium plated. Full Size Heavy Alnico 3 Magnet is permanently centered. Core is Full Frequency Construction and the Voice Coil is Fully Dustproofed both inside and out. A Rare Combination such as this AM-FM Chassis and Magnavox 12" PM Speaker is hard to find. Here is truly a generous offer. ORDER YOUR OUTFIT TODAY! Be the envy of everyone who hears the magnificent performance of Radio at Its Best. Original Factory-Sealed Cartons. Shpg. wt. 25 lbs.

COMPLETE TV ANTENNA

A complete stacked array. Made by a famous manufacturer whose name and brand is on every factory sealed carton. Look what you get: 2 Six-element conical dipoles, 1 pair of 2 Five-foot mast sections, 60 ft. 300 ohm twin line, 5 Standoff insulators, 1 mounting base, 1 guy wire, 1 clamp, hardware. Elements are highest quality aluminum. Reg. list price is \$31.95. Shpg. wt. 15 lbs. Express only.

Stock No. AU-24
\$11.99
Complete Set

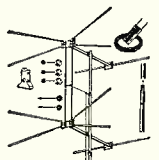

GENUINE GE GERMANIUM DIODES

STOCK NO. X-294 • TYPE IN-64 • Single, each, 70¢
Lots of 10, each, only 60¢
General Electric Germanium Diodes. Will withstand shock and vibration. Free from microphonics. Very stable in operation. Vacuum fitted with a flexible wax material chemically and electrically inert which seals the vital germanium wafer against moisture and contamination. Save Money and get your Diodes from Olson. 100% Guaranteed.

✓ CHECK-OFF BARGAINS! ✓

W-78, OPEN WIRE TV Line. 100 Ft. Only	\$466	W-109, MICROPHONE CABLE. 100 Ft. Only	\$450
W-79, OPEN WIRE TV Line. 250 Ft. Only	\$1095	W-113, RECORDING WIRE, 15 Min., 1800 Ft. Lots of 10, Ea. . . .	79¢
X-288, 807 POWER TUBES Stock Up Now. Only	\$149	W-114, RECORDING WIRE, 30 Min., 3600 Ft. Lots of 10, Ea. . . .	\$129
W-74, MICROPHONE CABLE. 50 Ft. Only	\$295	RA-58, 6 AMP. BATTERY CHARGER for All 6 V Batteries . . .	\$1295

USE HANDY ORDER BLANK ON NEXT PAGE



OLSON RADIO WAREHOUSE • 275 E. Market St., Akron 8, Ohio

TEST-ADJUST T L VISION SETS at YOUR Convenience

Even Without Station Test Pattern or in Remote, Weak Signal Areas



SUPREME MODEL 665

Net Price \$389.50

The SUPREME COMPOSITE VIDEO GENERATOR provides the same type of sync and blanking signal as the TV station—even the equalizing pulses. In addition, it incorporates a video section which generates a special test pattern for analysis and adjustment of TV sets. Other patterns or pictures can be presented by using auxiliary equipment connected to the special "gated" video input section of this versatile instrument. The Model 665 should not be confused with the cross-hatch or bar-pattern generators. The Supreme Model 665 supplies a COMPOSITE VIDEO SIGNAL.

Every TV station sends a COMPOSITE VIDEO SIGNAL when telecasting a program or a test pattern. This COMPOSITE VIDEO SIGNAL is composed of—(1) a synchronizing and blanking signal to lock the free running raster into a frame of two interlaced fields, and—(2) a video signal to control the amount of light and produce the picture (which may be a program scene or a test pattern for analysis purposes).

A television set will produce a picture only when it is supplied with a COMPOSITE VIDEO SIGNAL. To check any TV set properly, you must have a COMPOSITE VIDEO SIGNAL.

Why lose time and money waiting for that ideal scene or test pattern to check a TV set? In fringe or weak signal areas, you are strictly in the "driver's seat" with a SUPREME COMPOSITE VIDEO GENERATOR. Write SUPREME, Inc., Dept. 1, GREENWOOD, MISSISSIPPI for descriptive folder.

Since 1927

SUPREME

Testing Instruments

"SUPREME BY COMPARISON"

TUBE TESTERS • OSCILLOSCOPES
SIGNAL GENERATORS • MULTI-METERS
FOR RADIO AND TELEVISION

Supreme, Inc., Greenwood 1, Mississippi

DON'T MISS THESE

MOBILE DYNAMOTORS (SMALL SIZE—BRAND NEW)

5.6 volts input, 425 volts @ 375 MA output **\$27.95** ea.
11.5 volts input, 425 volts @ 375 MA output **\$19.95** ea.

G.E. RELAY CONTROL

(Ideal for Model Controls, Etc.)
Contains a sigma midget 8,000 ohm, relay, (trips at less than 2 MA), high impedance choke, bimetal strip, neon pilot and many useful parts. The sensitive relay alone worth much more than the total low price of..... **\$1.25** each, 10 for **\$9.90**

WESTINGHOUSE OIL CONDENSER

10 M.F.D.—1000 VDC (Marked 440 VAC) **\$1.95** each
—A terrific bargain at.....

FILTER CONDENSER BARGAIN

8x8 M.F.D. 600 vdc oil compound filled. NEW, but scratched. Only..... **.95** each

MICROAMMETER BARGAIN

Basic 0-200 UA D.C. (0-10 Scale) Rectifier type, reads 0-1 VAC. Ideal for GRID DIP METERS, F.S. METERS, etc. Removed from equipment..... **\$2.95** each

PANEL METERS

0-10 MA AC.....	2.95	50 mfd 600 vac	\$4.95
0-4 AMP RF.....	2.95	3.75 mfd 60 vac	2.45
3" METERS.....		15 mfd 1000 vdc	4.95
0-200 Microamp.....	6.95	1 mfd 1500 vdc	.89
0-500 Microamp.....	5.95	1 mfd 2500 vdc	1.75
0-2 MA.....	4.95	1 mfd 3600 vdc	1.95
0-2.5 AMP RF.....	4.95	.1 mfd 7500 vdc	1.95
0-200 MA.....	4.95	.02 20,000 vdc	9.95
0-100 VDC (1MA).....	5.95		
0-200 VDC (1MA).....	5.95		
0-250 VDC (1MA).....	5.95		
0-15 KVDC (500 UA) with multiplier.....	9.95		
0-200 UA.....	6.95		
0-50 UA.....	12.95		

OIL CONDENSERS

50 mfd 600 vac	\$4.95
3.75 mfd 60 vac	2.45
15 mfd 1000 vdc	4.95
1 mfd 1500 vdc	.89
1 mfd 2500 vdc	1.75
1 mfd 3600 vdc	1.95
.1 mfd 7500 vdc	1.95
.02 20,000 vdc	9.95

H.D. FILTER CHOKES

6 Hy 90 ma.....	\$.79
6 Hy 500 ma.....	4.95
4 Hy 1 Amp, 10KV insulation.....	22.50

WIRE WOUND RESISTORS

5 watt ohms: 25-50-84-200-2500.....	\$0.09 ea.
10 watt ohms: 25-40-1325-2K-4K.....	.15 ea.
20 watt ohms: 150-300-750-1K-1.5K, 2.5K-2.7K-10K-20K.....	.20 ea.
30 watt ohms: 100-2500-5300-18K.....	.22 ea.

PEAK ELECTRONICS CO.

378 Great Neck Rd., Great Neck, New York
Phone Great Neck 2-0082

SUPER VALUE!



0-1 MA DC
4" SCALE
Only **\$5.95** ea.

2 FOR ONLY \$11.00

Greatest meter value ever offered! Sensitive 1 MA DC basic movement may be used for any type of current or voltage meter. Big 4" scale calibrated 0-1 for easy fractional readings. Rectangular bakelite case with corner mounting holes mounts flush on panel, projects 2" forward. Nothing behind panel except meter terminals. Meter case measures 4 1/2" high, 5 3/4" wide. These meters are slightly used but have been thoroughly checked and reconditioned. We guarantee them for absolutely top performance. Don't delay; order now! No more available after present supply is sold!

25% with order—
balance C.O.D., F.O.B. Chicago

NATION WIDE RADIO

572 W. Randolph Street Chicago 6, Ill.

(Catch, England) Has improved signal in Eastern USA after 0630 lately. (Harris, Mass.) Peking, 7,500, signs on daily 1645 with Communist March, then has setting-up exercises. Heard signing on in English at 0400 on 15.060AV, news follows. (Pearce, England) The 7,500 channel is noted by Saylor, Va., in Chinese around 0600-0800 fade-out; has both male and female announcers.

Colombia—HJFC, "La Voz de America," 6.010, sent letter verification via airmail; listed HJFH on 4.875. (Pearce, England) HJAG, "Emisora Atlantico," 4.905, Barranquilla, broadcasts in Spanish daily 1000-2300, Sundays to 0100. (ISWC, London) HJFK was recently noted on 6.100 to 2300 sign-off; is "La Voz Amiga," Pereira, listed 6.095 but which has varied to 6.108 in the past. Recently heard Radio Manizales moved to 6.110 from 6.225; believe sign-off is 2300. (Stark, Texas) Bogota, 6.200A, Radio Nacional, noted lately at 2145 with "English by Radio." (Niblack, Ind.)

Costa Rica—TIDCR, "La Voz de la Victor," San Jose, sent QSL card; listed frequencies of 625 kc. and 9.615 (4 kw.); QRA is Apartado 3611, San Jose, Costa Rica. (Pearce, England) Radio Athenea, 11.972A, noted at fair level around 0845-0915. (West, Va.)

Cyprus—ZJM6, 6.790, Limassol, Asharq-al-Adna, noted 1144-1215. (Nattugglan, Sweden)

Czechoslovakia—Prague, 9.55, has a new session in English for North America 2300-2330. (Bellington, N. Y.) Heard on 9.504 with Spanish daily 0100. (Pearce, England) Has been noted in Stockholm on a new channel of 5.485 in Spanish 1820-1834 sign-off. (Radio Sweden)

Denmark—Copenhagen, 15.165, noted with clock chiming at 0900, signing on for India-Malaya in English. (Pearce, England) Noted yet to North America 2030-2130 and 2200-2300 over OZF, 9.52. (Saylor, Va., others)

Dominican Republic—HI2T, 9.730A, noted with English session 2100-2110, continued in Spanish; good level in N. Y. (Lubell) HI1N is heard some evenings (EST) on 6.043. (Stark, Texas) HI1Z, Radiodifusora Nacional, heard on 6.112 at 1932-2100. (Pelegrini, N. Y.)

Ecuador—What appears to be a new Ecuadorean is noted on 6.830A to 2302 sign-off; announces as "Radio Commercial." (Kary, Pa., Bellington, N. Y.) HCJB, 15.115, noted with English at 1645. (Pivnik, N. Y.)

Egypt—Hawthorne, Australia, says SUX, 7.865A, Cairo, is heard at excellent level around 1600. (Radio Australia) Bellington, N. Y., recently heard this one opening 2257 when man started to chant in Arabic; good level but had CWQRM, QSB. Cairo, 11.815, is widely heard signing on 1320 with news in French; has news in English 1330; noted by Boice, Conn., signing off recently 1647.

El Salvador—Radio Victoria, 11.765, San Salvador, was measured on this channel recently at 2015; had strong



SOLD THE MOST

(FROM COAST-TO-COAST)



People Buy Most What They See Most!

**36 MILLION VIEWERS
AROUND 70 TV STATIONS
SEE ALLIANCE TV
DEMONSTRATIONS!**

BECAUSE THEY'RE

SEEN THE MOST!



The Buying Impulse is there—why not Tap it?

Alliance TV spots Convince, Demonstrate and pre-sell! Newspaper ads fit each market! Alliance TV products are sold the most because they're seen the most!

Place your orders now for the NEW Alliance Cascamatic Booster with the Famous "California Circuit!"

This Fully Automatic, 3-tube TV Booster pre-tuned to all VHF channels mounts instantly on back of set—another companion item to Alliance Tenna-Rotor and Tenna-Scope, the selective, single-control Booster.

ALLIANCE MANUFACTURING COMPANY • ALLIANCE, OHIO

Become an ELECTRICAL ENGINEER in 36 MONTHS

Bachelor of Science Degree — Major in Electronics or Power

It is estimated by 1955 there will be at least two positions for every engineering and technician graduate. This college offers a tested plan that permits you to enter these vast employment opportunities at an early date. Save a valuable year through optional year-round study. Receive *advanced credit* for prior training gained in the armed forces, other schools or field experience.

ENTER BOTH RADIO AND TELEVISION 12 months or one-third of the B. S. degree course (Electronics major) — also brings you the *Radio Technician's* certificate. An added 6-month course qualifies you for the *Radio-TV Technician's* certificate. Recent developments open unlimited opportunities for TV technicians and engineers.

MILWAUKEE SCHOOL OF ENGINEERING

NONPROFIT • FOUNDED IN 1903



THE PROVEN "UNIT CHASSIS SYSTEM" of teaching was developed here. It "breaks down" the TV set by stages. You learn every component of all types and makes — and are prepared for future design changes, including the advent of color.

12-MONTH TELEVISION SERVICE COURSE... trains for good servicing jobs and shop ownership in the shortest practical time under expert instructors.

Terms open January, April, July, October. Over 48,000 former students from all states and 23 overseas countries. Faculty of trained specialists. Modern laboratories and equipment.

Write for free 110-page catalog, 48-page pictorial booklet "Your Career" and "Occupational Guidance Bulletins."

Milwaukee School of Engineering
Dept. RN-1252 1025 North Milwaukee
Milwaukee 1, Wisconsin

Without obligation send Catalog for Electrical Engineering, B. S. Degree, major in Electronics; Power; "Your Career"; Occupational Guidance Bulletin on: Radio-TV; Electrical Power; Welding; Heating, Refrigeration, Air Conditioning; Mechanical Engineering, B. S. Degree; Preparatory; Television Service.

Name.....Age.....

Address.....

City.....Zone.....State.....

If veteran, indicate date of discharge.....

VISIT THE BLOOD BANK

ANOTHER NEW PRODUCT
IN THE **ACCEPTED!**
APPROVED!

LINE OF 67 POPULAR ITEMS
Make Sure—Make it Master



NEW MASTER DELUXE

2-METER COAX ANTENNA — MODEL NO. 214

MASTER MOBILE'S engineers have designed a Superior New, Ruggedly Constructed, Vertically Polarized, Coaxial Antenna in the frequency range of 140 to 170 Megacycles.

Features: Completely waterproofed • furnished with approximately 10 ft. of 72 OHM Coax Cable • smart design enhances the appearance of any vehicle • very attractive highly polished chrome finish • delivered complete — ready for quick, simple installation.

Mounting Types: Type 1, on-side — with 2 brackets furnished — as shown. Type 2: on master mount (No. 132X or 140X). Mounts sold separately. Complete Antenna: Featured at **\$15.95** Plus Postage. Approx. Ship. Wt. — 3 lbs.

Master Mounts: No. 132X **\$9.85** No. 140X **\$7.65**

2-METER STANDARD MODEL — NO. 114 COAX VHF ANTENNA — At a Popular Price FOR OPEN TYPE VEHICLES using 140 MC. to 165 MC. Mounts any convenient place with standard MASTER MOUNTS. Baked enamel finish. With 10' Coax Cable and 18" Adjustable Section. NET—ONLY \$9.95. At Leading Distributors or Write

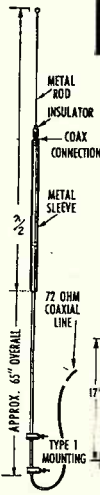

Master Mobile Mounts, Inc.

P.O. BOX 1817 • LOS ANGELES 36, CALIFORNIA

WAREHOUSE AND SHIPPING ADDRESS: 1306 30ND STREET

IF IT MOVES
OR
ROLLS
USE



The Original and Most Reliable Product You Can Use for

QUIETING NOISY CONTROLS AND SWITCHES AND ALL OTHER MOVING PARTS SINCE 1947

IT HAS BEEN THE STANDARD AND PREFERRED PRODUCT OF ITS KIND IN THE INDUSTRY

NON-CONDUCTIVE — NON-INFLAMMABLE

WHY TAKE CHANCES WITH CHEAP IMITATIONS WHEN A FEW CENTS MORE WILL BUY QUIETROLE

2 oz. 4 oz. 8 oz.

ORDER FROM YOUR DISTRIBUTOR

MFD. BY

QUIETROLE COMPANY

SPARTANBURG SOUTH CAROLINA

signal in N. C. (Ferguson) YSC, 6.095, noted 0015-0030 with music and news in Spanish. (Pelegri, N. Y.)

England—The BBC has revised its schedule for the Pacific Service to 0300-0345 on 9.825, 9.690, 11.820, 11.955. (Cushen, N. Z.)

Ethiopia—*Radio Addis Ababa*, 15.048AV, is still noted to 1302 closedown; heard recently 1100 with call in French, then talk in that language by man; at 1130 began usual Amharic program of music and vocals; had talk in Amharic at 1230; on a Sunday was noted with *English* religious broadcast in progress at 1045, then went into French at 1100. (Pearce, England) Announces as "This is Radio Addis Ababa in the heart of Africa, the Voice of Ethiopia."

Falkland Islands — Port Stanley, 3.400, 0.25 kw., will increase power in 1953 to 5 kw. (WRH, others)

Finland—Helsinki now has *English* news at 0700 on 15.190; news in French 0715, recordings to 0745 when has news in Finnish; is audible in parallel on 9.555, but can not be heard on 17.800. (Pearce, England) Has *English* for North America on these channels 2200, French 2220. (ISWC, London)

France—Paris, 17.850, noted signing on in French 0145. (Pearce, England)

French Camerouns—According to Malmo DX-aren, Sweden, *Radio Douala* is heard on 9.150 with music at 1440; has CWQRM.

French Equatorial Africa—*Radio Brazzaville*, 15.595, noted in French at 0715 and signing off 0723 with "La Marsellaise." (Ferguson, N. C.) Schedule for *English* sessions includes 0030 on 11.970, 9.440 to Western North America, Europe; 0515 on 15.595, 9.440 to Middle East, Africa; 1100 on 11.970, 9.440 to Far East; 1315 and 1550 on 11.970, 9.440 to Europe, Africa; 1745 on 11.970, 9.440 to Eastern North America; on Sundays 1315 and 1745 and Mondays 0030 has "Africa Today," facts and events on the Dark Continent. (WRH)

French West Africa—*Radio Dakar*, 9.560A, announcing as *Radiodiffusion Francaise Afrique Occidentale*, signs on 0200 with French march, gives call in French, and then has an all-African dialect program of news, talks, native music and songs; scheduled to close 0315; a separate program in French is audible 0200 on 11.896A. (Pearce, England) The 9.560A channel is noted 1550-1730; news in French 1645. (Sutton, Ohio) Bellington, N. Y., confirms report from Pearce that signs on 0200 on this channel.

Germany—RIAS, 6.005, Berlin, noted 0100. (Pearce, England) Hamburg, 7.290, noted with popular American music 1830-1900, then slow-speed news in German to closedown which varies 1907-1915; RIAS, 6.005, Berlin, is heard 0000-0050, with news in German 0030. (West, Va.) Baden-Baden, 6.322, noted poor to fair 1700-1800 with recorded music, then news in German to 1815 closedown. (Kary, Pa.)

Greece—A Greek station noted on

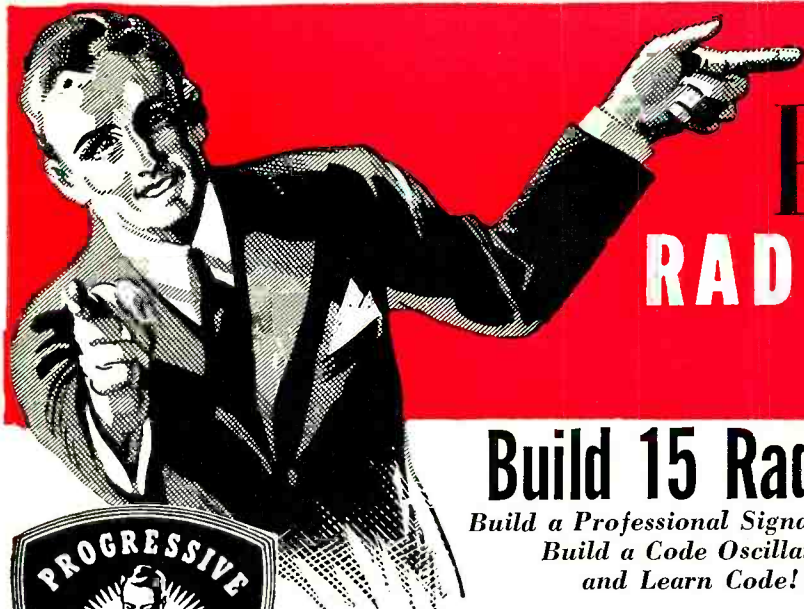

LEARN PRACTICAL RADIO AT HOME!



Build 15 Radios

Build a Professional Signal Tracer
Build a Code Oscillator
and Learn Code!

COMPLETE, FOR ONLY
\$19⁹⁵

FREE!

- ELECTRICAL AND RADIO TESTER
- RADIO TELEVISION SERVICING LESSONS
- BOOK ON TELEVISION
- MEMBERSHIP IN RADIO-TELEVISION CLUB
- ELECTRIC SOLDERING IRON
- CONSULTATION SERVICE
- QUIZZES

10-DAY MONEY BACK GUARANTEE

ABSOLUTELY NO PREVIOUS TRAINING NEEDED • FREE TOOLS • NO ADDITIONAL PARTS REQUIRED
YOU KEEP ALL PARTS, TOOLS, INSTRUCTIONS • AN EXCELLENT BACKGROUND FOR TELEVISION

LEARN TROUBLE SHOOTING . . . THEORY . . . WIRING . . . CODE!

WHAT THE NEW IMPROVED 1953 PROGRESSIVE RADIO "EDU-KIT" OFFERS YOU

The Progressive Radio "Edu-Kit" offers you a home study course at a rock bottom price. Our kit is designed to train Radio Technicians, with the basic facts of Radio Theory and Construction Practice expressed simply and clearly. You will gain a knowledge of basic Radio Principles involved in Radio Reception, Radio Transmission and Audio Amplification. You will learn how to identify Radio Symbols and Diagrams; how to build radios, using regular radio circuit schematics; how to mount various radio parts; how to wire and solder in a professional manner. You will learn how to operate Receivers, Transmitters, and Audio Amplifiers. You will learn how to service and trouble-shoot radios. In brief, you will receive a basic education in Radio exactly like the kind you would expect to receive in a Radio Course costing several hundreds of dollars.

THE KIT FOR EVERYONE

The Progressive Radio "Edu-Kit" was specifically prepared for any person who has a desire to learn Radio. The Kit has been used successfully by young and old in all parts of the world. It is not necessary that you have even the slightest background in science or radio.

The Progressive Radio "Edu-Kit" is used by many Radio Schools and Clubs in this country and abroad. It is used by the Veterans Administration for Vocational Guidance and Training.

The Progressive Radio "Edu-Kit" requires no instructor. All instructions are included. All parts are individually boxed, and identified by name, photograph and diagram. Every step involved in building these sets is carefully explained. You cannot make a mistake.

THE PROGRESSIVE RADIO "EDU-KIT" IS COMPLETE

You will receive every part necessary to build 15 different radio sets. This includes tubes, tube sockets, variable condensers, electrolytic condensers, mica condensers, paper condensers, resistors, tie strips, coils, tubing, hardware, etc. Every part that you need is included. In addition these parts are individually packaged, so that you can easily identify every item.

TROUBLE-SHOOTING LESSONS

Trouble-shooting and servicing lessons are included. You will be taught to recognize and repair troubles. While you are learning in this practical way, you will be able to do many a repair job for your neighbors and friends, and charge fees which will far exceed the cost of the Kit. Here is an opportunity for you to learn radio and have others pay for it. You build a Professional Signal Tracer which alone, is worth more than the price of the complete Kit.

THE PROGRESSIVE TEACHING METHOD

The Progressive Radio "Edu-Kit" comes complete with instructions. These instructions are arranged in a clear, simple and progressive manner. The theory of Radio Transmission, Radio Reception, Audio Amplification and Servicing by Signal Tracing is clearly explained. Every part is identified by photograph and diagram; you will learn the function and theory of every part used.

The Progressive Radio "Edu-Kit" uses the principle of "Learn By Doing." Therefore you will build radios to illustrate the principles which you learn. These radios are designed in a modern manner, according to the best principles of present-day educational practice. You begin by building a simple radio. The next set that you build is slightly more advanced. Gradually, in a progressive manner, you will find yourself constructing still more advanced radio sets, and doing work like a professional Radio Technician. Altogether you will build fifteen radios, including Receivers, Amplifiers, Transmitters, Code Oscillator & Signal Tracer.

THE PUBLIC APPROVES!

COMMENTS FROM SATISFIED USERS OF THE PROGRESSIVE RADIO "EDU-KIT"

VETERANS ADMINISTRATION,
PHYSICAL MEDICINE REHABILITATION SERVICE,
WASHINGTON, D. C.

"This morning I was showing the Progressive Radio 'Edu-Kit' to one of our representatives from our Branch Office in Richmond, and already he wants me to purchase some for his hospitals. . . As indicated in previous correspondence, I took the Progressive Radio 'Edu-Kit' to our Veterans Administration Hospital at Fort Thomas, Kentucky. Both instructors and patients worked them, and they proved quite satisfactory."

ROBERT L. UFF,

1534 Monroe Ave., Huntington, W. Va.

"Thought I would drop you a few lines to say that I have bought a Progressive Radio 'Edu-Kit' and was really amazed that such a bargain can be had at such a low price. I have already started repairing radios and radio-phonographs. Friends were really surprised to see me get into the swing of it so quickly. The trouble-shooting tester that came with the kit is really swell, and finds the trouble if there is any to be found. Everything you say about your kit is true."

DOMINICK STRACUZZA,

111 Clarence St., London, Ontario.

"I am very satisfied with the Progressive Radio 'Edu-Kit' which I bought from you. I did not know anything about radio, but now I feel as though I have been in the radio business for years. Your kit is simple and educational. I enjoy working with it."

Order your Progressive Radio "EDU-KIT" Today, or send for further information.

Postage prepaid on cash orders—C.O.D. orders accepted in U. S. A.

BECOME A RADIO AMATEUR



GET A WELL-PAYING JOB



GO INTO A PROFITABLE BUSINESS



PROGRESSIVE ELECTRONICS CO.

497 UNION AVE., DEPT. RN-12

BROOKLYN 11, N. Y.

Complete Stocks SPRAGUE HYPASS Capacitors

Sprague Hypass . . . the really effective three terminal network capacitor for TVI-proofing.

.1 mfd.—250V AC	\$1.56 net
.005 mfd.—600WV, DC	1.29 net
.01 mfd.—600WV, DC	1.41 net
.005 mfd.—1000WV, DC	1.44 net
.01 mfd.—1000WV, DC	1.56 net
.005 mfd.—2500WV, DC	1.74 net
.01 mfd.—2500WV, DC	1.86 net
.002 mfd.—5000WV, DC	1.92 net

JOHNSON VIKING MOBILE KIT

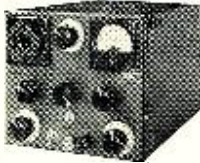

Brand new . . . inputs up to 60 watts with 100% modulation. Band switching, gang tuning, xtl control, easy assembly, low cost.

Less tubes and crystals \$99.50 net

SPECIAL PURCHASE 6J4 HF TRIODES

Here's an opportunity to obtain these excellent HF triodes at a fraction of their regular \$8.05 price. Brand new, standard brand. Only \$2.95 ea.

MORROW GC-10 NOISE FILTER

The new generator noise filter for 10 meter operation. Simply installed . . . effective. . . \$3.95 ea.

NOVICE 500V POWER SUPPLY KIT

Here is all the makin's for a sweet little power supply suitable for 807's. Includes: Power transformer, 2—4mfd, 600V oil filled condensers, 1—10 henry choke, 1—5U4 rectifier, 1—socket, 1—chassis, line cord, power switch and terminal board. Supply output voltage is 500 volts at 200 ma. Only \$16.95 kit

SPLINED TUNING KNOB FOR 274N RECEIVERS



An exclusive O-R item manufactured for us. Fits BC-453, BC-454 and other 274N receivers. This is a really hard-to-obtain item. Only . . . 89c ea.

TRANSFORMERS-CHOKES:

325-0-325 @ 225 ma. 6.3 @ 5A. 5V @ 3A. Pri. 110V, 60 cy AC. Size, 4 1/8" x 4 1/8" x 3 7/8". Only \$6.95 ea.

Isolation transformer. Useful for AC-DC supplies. Pri. 117V, Sec. 120V, AC. at 50 ma. Also 6.3V at 1/2 amp. Only \$1.80 ea.

Isolation transformer. Pri. 117V AC. Sec. 120V, AC. at 50 ma. Also 6.3V at 2 amps.

920-0-920 or 740-0-740 AC @ 200 ma. Pri. 115V, 60 cycle, AC. Upright shielded case. Excellent for 807's. Only \$10.80 ea.

5V. 25A. Pri. 115V. 60 cy. AC. A real rugged job excellent for 304TL—4-250A etc. Limited quantity. Only \$4.50 ea.

2.5V @ 10A AC. 10,000V insulation. Pri. 115V AC only \$3.39 ea.

350-0-350 @ 300 ma. 6.3 @ 4A. 6.3 @ 8A. 5V @ 3A. Pri. 115V, 60 cy. AC. . . . only \$7.95 ea.

450-0-450 @ 200 ma. Pri. 115V, 60 cy. AC. 5V @ 3A, 6.3 @ 5 amp. In shielded case. Only \$8.90 ea.

350-0-350 @ 350 ma. 6.3 @ 10A. 5V @ 6A. Pri. 115V, 60 cycle. Only \$8.95 ea.



110V, AC POWER SUPPLY FOR ANY 274-N RECEIVER

Just plug it into the rear of your 274-N RECEIVER . . . any model. Complete kit and black metal case, with ALL parts and diagrams. Simple and easy to build in a jiffy. Delivers 24 volts plus B voltage. No wiring changes to be made. Designed especially for the 274-N receiver. Only \$8.95.

Filament trans. for 274N receivers. Pri. 110V, 60 cy. AC. Sec. 24V @ .6A. An excellent buy at \$1.95 ea.

Minimum order \$2.00. All items subject to prior sale. All prices subject to change without notice. 20% deposit must accompany all orders. balance C.O.D.

OFFENBACH-REIMUS
1564 MARKET STREET
SAN FRANCISCO, CALIF.

measured 7.948 at 1430 is believed to be Kozanis; closed 1530; another Greek station is heard at that time on measured 7.554. (Pearce, England)

Radio Athens, 7.300, is often at good level in Britain around 0100-0200. (Pearce) Noted on this channel with news 2300; opens 2230 with march. (Ferguson, N. C., others) Is now using 9.607 again, replacing 11.717A, to North America 1900-2000; news around 1935. (Niblick, Ind., others) Larissa, 6.745, heard with news in Greek 2330, poor level in Pa. (Kary)

Guadeloupe—Basse-Terre, 7.447A, is heard at weak strength with much CWQRM some days around 1830-2000 sign-off; takes relay of French news from Paris 1830-1900A. Closes with "La Marseillaise." (Kary, Pa., Stark, Texas, others)

Guam—Radio Free Asia relay is heard over KUJ2, 9.490A, at 0845 in English. (ISWC, London) Is scheduled except Mon. at 0700-0920. (WRH)

Guatemala—According to newspaper dispatches, station TGO-TGOA, "La Voz de las Americas," was recently completely destroyed by fire; TGOA has not been present lately on 6.101. (Robbins, Ind., via URDXC) TGJA, 5.990, Radio Nuevo Mundo, is heard well as early as 1900; has harmonic on 11.980. (Niblack, Ind.) Harmonic can be heard mornings (EST).

TGNA, 5.9525, noted with English identification recently 2215 when said 9.668 was in parallel; could not be found on 11.850, so must be using 5.9525 instead at that time now. (Bellington, N. Y.) The 9.668 channel is good level in Iowa at 2200-2230. (Lund)

Haiti—ISWC, London, says 4V2H, Port-au-Prince, is a new station operating on 6.200A; heard around 1200 on Sundays and from 1600 weekdays in French. This may be the Haiti outlet noted by Stark, Texas, signing off 2200. Brunell, Sweden, says Haiti on 6.197A is audible around 1715-1900 and that most of the program consists of Spanish and North American music and advertisements, not much French music. Stark says the Haiti

stations on 10.007A and 6.178 both announce as "Radio Haiti"; the 10.007A outlet is probably 4VRW, "the wanderer," up from around 9.986A.

4VEH, 9.624V, Cap-Haitien, noted with good signal in Spanish 0630-0800, English 0800-0833 sign-off; on Sundays has additional English sessions 0730, 2030. (West, Va.) Recently was measured as 9.6374. (Okay, N. J.)

A QSL letter in English from 4VM, La Radiodiffusion Haitien, 6.005, Port-au-Prince, listed 4VM, 6.010, and 4VYM, 1250 kc.; gave schedule of weekdays 1200-1500, 1800-2130, Sundays 1100-1500. (Paterson, Ga.)

Holland—December schedules for English from Radio Nederland are 0430-0510 to Australia, New Zealand, Pacific Area, 21.48, 17.775, 15.22, 6.025; 1100-1140 to South Asia and Africa, 11.73, 9.59, 6.025; 1630-1710 to Europe, North America, 9.59, 6.025; 2130-2210 to North America, 9.59, 6.025; sessions are listed "weekdays" only in GMT so may be off Saturdays (EST), that is, for the 2130-2210 beam, The "Happy Station Sessions" on Sundays only are scheduled 0530-0700, 21.48, 17.775, 15.22, 6.025, to Far East, Pacific Area, Europe; 1100-1230, 15.22, 11.73, 6.025, to Near and Middle East, Europe; 1630-1800, 9.59, 6.025, to South and Central America, and 2130-2300, 9.59, 6.025, to North America.

Honduras—"La Voz de Atlantida," 6.235, noted 2215. (Pelegri, N. Y.) HROW, 6.675, Radio Monserrat, is heard at good level from 2100 onwards. (Norman, Ga.)

Hong-Kong—ZBW3, measured 9.524, noted at good strength just before 0730 with Chinese session; at 0730 takes relay, also Chinese, from BBC. (Hutchins, Radio Australia) Heard occasionally 0600 when has BBC news relay. (Kary, Pa.)

Hungary—Radio Budapest noted with English for North America 1715 on 9.833, 11.910A, 7.220. (Pearce, England, others)

India—VUC2, 4.800, Calcutta, noted 1145 with native music, bad CWQRM at times, poor level in Britain. Delhi, 4.960, heard 1155 with light music,

Some of the transmitting equipment used by Nordwestdeutscher Rundfunk, Hamburg, Germany. Much of the apparatus used by NWDR was made by Telefunken of Germany.

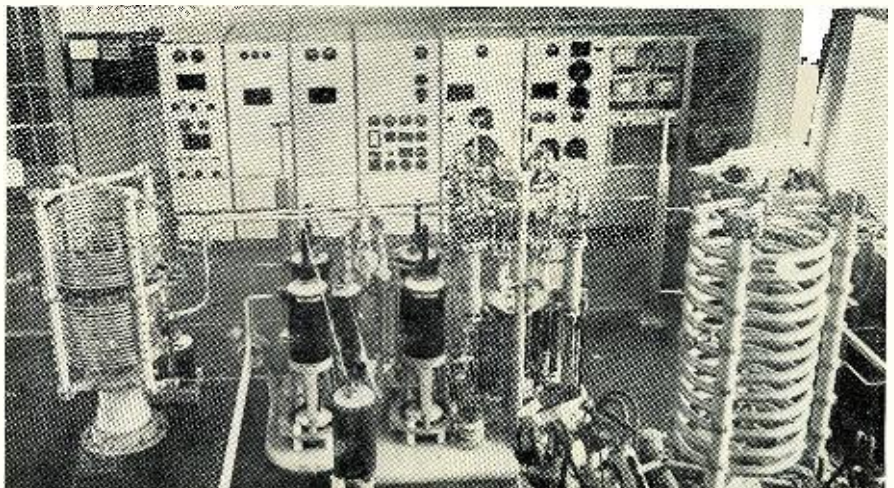

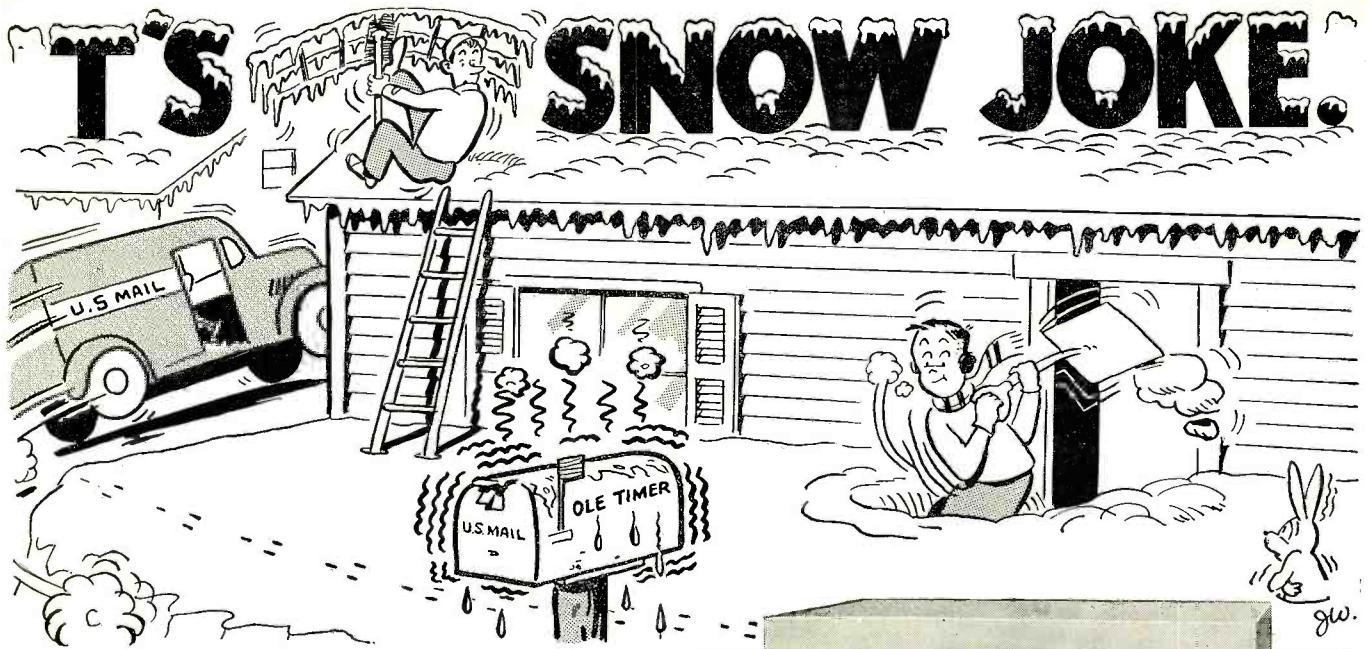

**You're Money Ahead In Any Season
With a "SURPRISE" Trade-In**

At Walter Ashe it's never too cold for a "hot" trade-in deal on your used (factory-built) test and communication equipment. For fast action, use the convenient coupon to tell us what you have to trade and to indicate your choice in new equipment. Then, keep an eye out for the postman and make a bee line for the mailbox to obtain our money-saving offer. Get your trade-in deal working today!



JOHNSON VIKING II TRANSMITTER KIT. Complete with tubes. Shipping weight 85 lbs. Only \$279.50

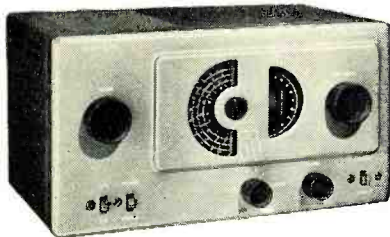

HALLICRAFTERS S-38C
Shpg. wt. 14 lbs. Only \$49.50



HALLICRAFTERS S-40B
Shpg. wt. 32 lbs. Only \$99.95



NATIONAL SW-54
Shpg. wt. 10 lbs. Only \$49.95



NATIONAL NC-183D less spkr.
Shpg. wt. 65 lbs. Only \$369.50



HALLICRAFTERS SX-71 less spkr.
Shpg. wt. 51 lbs. Only \$199.50



HALLICRAFTERS S-76 less spkr.
Shpg. wt. 46 lbs. Only \$169.50

Phone CHestnut 1125
All prices f. o. b. St. Louis

Walter Ashe
RADIO CO.
1125 PINE ST. • ST. LOUIS 1. MO.

---FREE CATALOG!---

WALTER ASHE RADIO CO.
1125 Pine St., St. Louis 1, Mo. RN-12-52

Rush " Surprise" Trade-In Offer on my _____
(indicate make and model number of used equipment)

for new _____ (identify by model number)

Send new 1953 catalog.

Name _____
Address _____
City _____ Zone _____ State _____

**Send
for
your
copy
today**

AUDELS TV-RADIO SERVICE LIBRARY

HERE IS LATE INFORMATION IN A HANDY FORM FOR RADIO & TELEVISION REPAIRMEN, SERVICEMEN & STUDENTS

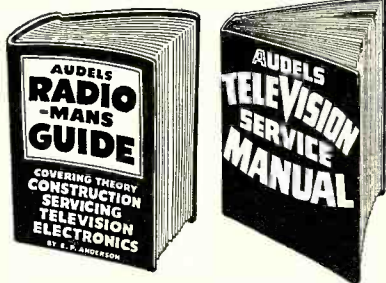

2 VOLS. \$6 COMPLETE \$1 A MO. IT PAYS TO KNOW!

AUDELS T.V.-RADIO SERVICE LIBRARY presents the important subjects of Modern Radio, Television, Industrial Electronics, F.M. Public Address Systems, Auto, Marine & Aircraft Radio, Phonograph Pick-Ups, etc. Covers Basic Principles—Construction—Installation—Operation—Repairs—Trouble Shooting. Shows How to get Sharp, Clear T.V. Pictures. Install Aerials—How to Test. Explains Color Systems & Methods of Conversion. 1001 Facts—Over 1260 Pages—625 Illustrations—Parts & Diagrams—Valuable for Quick Ready Reference & Home Study. Tells How to Solve T.V. & Radio Troubles—Answers T.V. & Radio Questions.

Get this information for Yourself.
7 DAY TEST—ASK TO SEE IT!

MAIL ORDER

AUDEL Publishers, 49 W. 23 St., N. Y. 10
Mail AUDELS T.V. RADIO SERVICE LIBRARY 2 Vols. \$6 on 7 days free trial. If O.K. I will remit \$1 in 7 days and \$1 monthly until \$6 is paid. Otherwise I will return them.

Name _____
Address _____
Occupation _____ RN
Employed by _____

RADIOS
1, 2 & 3 band Electric and/or battery

TELEVISION
AC/DC Operation

TEST INSTRUMENTS
Write for FREE Catalog

ARKAY—Radio Kits, Inc.
120 Cedar St., New York 6, N. Y.

then identifies in *English* 1200 and 1230, closes after clock chimes 1230; has QRM from Soviet outlet on 4.9575. VUD2, 3.495, noted 1205 with native music. Delhi, 4.940, heard 1210. VUD5, 15.190, is good level for news 0830; the 5.960 outlet is heard at 1745-1800 with Indonesian to Indonesia. (Catch) AIR noted to Europe in *English* 1345-1445 on 11.780, 9.570, 7.120. (Pearce, England) Bellington, N. Y., believes the 31-m. outlet is rather 9.565. Pearce recently noted AIR ending session in *English* to Southeast Asia 0330 on 17.705, signing on 0230 on 15.160 another day.

AIR, 17.760 (may be as low as 17.740), noted ending Cantonese session 0815 when identified in *English*. (West, Va.) Heard on 11.792 at 2050 in native session. (Ferguson, N. C.)

Indo-China (Vietnam) — Radio France-Asie, Saigon, is noted irregularly on 6.115 around 0830-0930; often has QRM; evidently has replaced the 9.75A outlet. (Balbi, Calif.) Noted in Britain on 9.754A signing on 1700 with "La Marseillaise" to Europe; has news in French, then at 1723 songs with orchestra; at 1735 has "Knightsbridge March" to introduce *English* session of news, music, to 1757, when plays "Knightsbridge March" again and signs off after call in French; announces next *English* for 1830 over 7.230. (Pearce, England) "The Voice of Vietnam," now moved from 7.090 to 7.290 has *English* from 0930 to closedown 1000. (Wada, Japan, via WRH)

Iran—EPB, 15.100, Teheran, noted with Eastern-type music 1428; news 1500; jammed at 1515 when had program in Russian. (Ferguson, N. C.)

Iraq—*Radio Baghdad*, 11.725A, can be heard some days signing on 2300A in Arabic. (Niblack, Ind., Bellington, N. Y.)

Ireland (Eire)—WRH says *Radio Eirrean*, Dublin, is using 15.120 and 9.595 for newscasts 1230-1250 and

1610-1630 (by this time may be on winter schedule of *one hour later*).

Israel—Tel Aviv, 9.010A, noted with *English* program ("Voice of Zion," relayed from Jerusalem) at 1515-1545; had French 1500; some QRM. (Lubell, N. Y.) Has *English* newscasts 0545 and 1415 on 9.010A, 6.830. (Radio Amateur, London) "Voice of Zion," P. O. Box 754, Jerusalem, Israel, issues a weekly program bulletin in *English* and French. (ISWC, London) A letter from the station says that soon will use a *new* 50 kw. transmitter. (Martin, R. I.) 4XB44, 6.725, Tel Aviv, *Galei Zahal*, is heard in Sweden around 1300-1400. (*Nattugglan*, Sweden)

Italy—Rome noted to Pacific with news, commentary from 0400 sign-on to 0440 closedown on 17.80; announces 21.56 and 15.40 in parallel. Noted with *English* for British Isles signing on 1245 on 11.81, 9.63. (Pearce, England) Is good level in Virginia at that time on these channels with news. (West) Rome, 7.110, still has Russian 2215, leaves the air 2245. (Kary, Pa.) Rome, 11.905, noted signing off 1755 with severe CWQRM. (Shaw, Fla.)

Ivory Coast—Kary, Pa., has received word from *Radio Abidjan*, Service de l'Information, Le Chef du Service de l'Information, Abidjan, Ivory Coast, that schedule on 7.210 currently is 1330-1600 weekdays, 1300-1600 Sundays.

Jamaica—*Radio Jamaica* definitely is still using 4.950 mornings (noted 0600 with "Church in the Wildwood" session) although has moved back to 3.360 for its evening beam (closes 2300 with "God Save the Queen"). (Kary, Pa., Bellington, N. Y., others)

Japan—*Radio Japan* sent this schedule—to North America 0000-0100, JOA6, 15.135, and JOB4, 11.705; to North China 0600-07000, JOA3, 9.675, and JOB2, 7.180; to Central China 0700-0800, JOA3, 9.675, and JOB2, 7.180; to Philippines-Indonesia 0900-



Regency

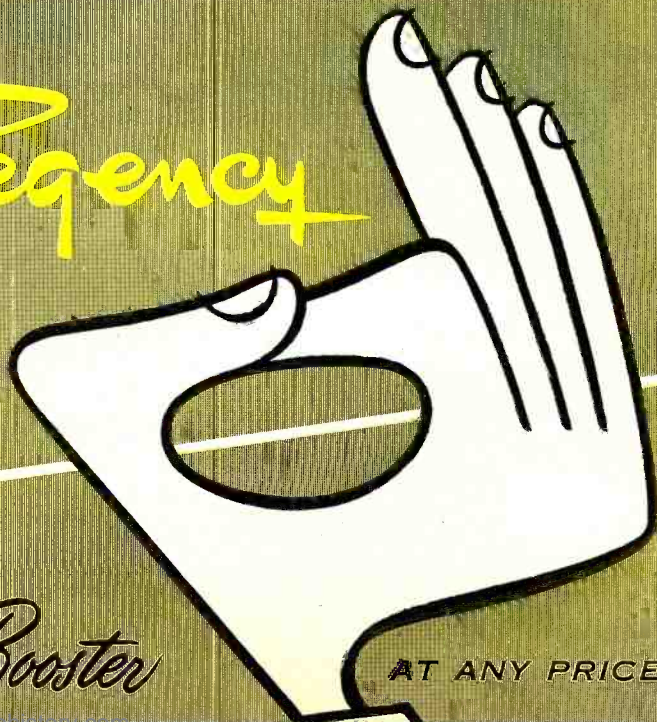

Largest Selling Booster

AT ANY PRICE!

1000, JOA3, 9.675, and JOB4, 11.705; to India-Pakistan 1030-1130, JOA3, 9.675, and JOB4, 11.705. (Ferguson, N. C.)

Kenya Colony—Nairobi, 4.855, noted 1445 with orchestral records, 1500 time pips, then signed off with "God Save the Queen." Sent schedule for 863 kc. and 4.855 as Mon.-Fri. 0500-0600, 1000-1500, Sat. 0500-0610, 1000-1500, Sun. 0200-0600, 1000-1400. (Pearce, England)

Lebanon—Radio Beirut, 8.036A, is heard in Australia at very good strength around 1600. (Hawthorne, via Radio Australia)

Liberia—ELBC, 6.025A, noted signing off 1845 at weak level in Ind. (Ni-black)

Luxembourg—Radio Luxembourg is now scheduled in Flemish on 15.350 at 0600-0800; in English on 6.090 at 1300-1800. (WRH)

Madagascar—Radio Tananarive, 9.515, noted signing on 2230 in French after "La Marseillaise," then with setting-up exercises in that language.

Malaya—Radio Malaya, Kuala Lumpur, noted at fine level giving the "9:30 p.m. news from Singapore," at 0900 in parallel with Radio Malaya, Singapore, on 7.205A. BFEBs, Singapore, is heard relaying BBC's "Radio Newsreel" 0900 on 7.12; 11.955 is not audible at that time but is at good strength 1100 with BBC news relay. (Balbi, Calif.) BFEBs noted on 15.435 at 1000 relaying BBC; also at 1030 on 11.955 with "English by Radio" session; announced was using 17.755 and 15.435 to India-Pakistan, and 11.955 and 7.120 to Burma-Thailand. (Catch, England) Heard on 17.755 at 0500 relaying BBC when announced also was using 9.69, 6.10. (Pearce, England) The Blue Network of Radio Malaya is heard by Pearce on 7.200A at 1032 with dance music and closing 1100 with "God Save the Queen."

BFEBs, Singapore, QSL'd by card; officials stated they only QSL reports of a technical nature and of such length of time as to be assured that it is not freak reception, and that they do not QSL reports of transmitted program matter only; QRA is British Far Eastern Broadcasting Service (BBC), Singapore, Malaya. (URDXC)

Manchuria—Mukden, 7.665, is noted around 1640-1655 when is swallowed in QRM: (Kary, Pa.)

Mexico—XEHH was noted recently on 11.923 at 1907 tune-in; may have moved from 11.880. (Bellington, N. Y.)

Monaco—Radio Monte Carlo, 9.785, is heard some days around 1545-1730; has news in French 1700-1705. (West, Va.) Appears now to have religious broadcasts in English on Thursdays around 1730-1800 on both 9.785, 6.035. (Bellington, N. Y.)

Mozambique—ISWL, Britain, reports CR7BG, 9.855, at 1230 with musical session.

New Caledonia—The new 6.000 channel (scheduled 0200-0540A) of Radio Noumea was measured in Melbourne recently as 6.000324. (Radio Australia)

New Low Prices!

MIKES and HEADSETS

HS-33 Low Impedance Headset, exc. \$2.95 new \$4.95	
HS-23 Headset used \$2.95 new \$4.95	
CD-307 Ext. cord for HS 23-33 like new .79	
Throat Mike—T 30... New .98	
Lip Mike—Navy Type... New .98	
Extension Cord and Switch Assembly for lip and throat Mikes... New .98	
CW 49505 High Impedance headset complete with leather headband and rubber cushions... Used 98c	
T-17, Microphone... new \$5.95	
HS-38... exc. \$1.95 new 2.29	
HS-30, miniature headset... new 2.49	

DYNAMOTORS

14 Volt input—285 output... \$ 4.95
DM 53A... used exc. 19.95
DM 53A... new 7.95
PE 109... new 89.50
BD 83... used exc. 8.50
BD 77... new 39.95
PE 73... used 8.95
PE 98... new 75.00
DM 34... used exc. 9.95
DM 35... used exc. 19.95
DM 36... used exc. 9.95
DM 37... used exc. 14.95
DM 28... new 5.95
used exc. 2.95

TUBES

90 DAY GUARANTEE	304TH... \$5.95
16JP4... \$16.95	830B... 1.69
16DP4... 16.95	805... 2.69
14CP4... 16.95	9001... .99
	9002... .59
	9003... .98
	6AJ5... 1.89
	4AP10... .95

DYNAMOTOR PE-101C

The best dynamotor for conversion to 6v. Multiple windings! After conversion you get choice of 190 or 350 v. at 50 MA or 250 v. at 100 MA. Complete dope sheet furnished. \$4.65 BRAND NEW (See "CQ" Aug. issue)

WOBULATOR

BUILD TV-FM-AM SWEEP GENERATOR

(See Dec. Radio & TV News)
You can build "Versatile Sweep Frequency Generator" with APN-1 magnetic units... \$5.95

RT7/APN1 TRANSCIEVER UNIT—Used as an altimeter, it may be converted for signaling control circuits, etc. Complete with 14 tubes and dynamotor they are in good used condition at the amazingly low price of... \$17.95 Used, less tubes, with wobulator... 9.95

BC 604 FM TRANSMITTER
20-27MC used, exc... \$12.95

MISCELLANEOUS EQUIPMENT

MS-49 to 56, each 39c
RM-29... 8.95
FL 8 used, exc... 1.95
BC 906 each... 9.95
BC 347 each... \$1.95
RL 42 each... 3.95
BC433 less tubes 12.95 with tubes 19.95

SELSYN TRANSMITTER

Loop Motor and Autosen Transmitter Assembly for matching to I-82 Indicator. Used, excellent condition.
ONLY \$5.95 Complete with Indicator... \$14.95

AIRBORNE EQUIPMENT

Designed for Aircraft

T-85/APT-5 UHF Transmitter Radar Set AN/APT-5 operates on 80 or 115 volts A. C. at 400 to 2600 cycles requiring 640 volts amperes at 0.90 power factor. Complete with all tubes. Brand new in original packing.
A TERRIFIC BUY AT ONLY \$149.50

SCR 625 Famous Army Mine-Detector

For Prospectors, Miners, Oil Companies, Plumbers, etc.

This unit is being offered now at a considerable reduction in price. Recently advertised at \$79.50 it is now available in the same brand new wrappings in suitcase style carrying case (less batteries) at **\$59.50** WHILE THEY LAST! Used, like new, \$39.50

SCR-274N COMMAND and ARC-5 EQUIPMENT

RECEIVERS	AS IS	EXC. USED	NEW
BC-454—190 to 550 KC.	(Less tubes)	(With tubes)	
BC-454—3 to 6 MC	\$10.95	\$23.95	
BC-454—6 to 9 MC	4.95	11.95	\$16.95
BC-454—9 to 12 MC	4.95	11.95	
TRANSmitters			
BC-457, 4 to 5.3 MC	4.95	7.95	
BC-458, 5.3 to 7 MC	4.95	6.95	
BC-459, 7 to 9.1 MC	10.95	14.95	
ADDITIONAL EQUIPMENT			
BC-150 Modulator	2.25	2.75	5.75
BC-450 Control Box (3 Receiver)		1.75	2.55
BC-151 Control Box (Transmitter)		1.69	2.29
BC-442 Relay Unit ANT With Condenser		2.79	3.50
Without Condenser		1.29	2.95
Plugs: PL-147, 148, 151, 152, 153, 154, 158			
Each		1.25	
Flexible Shafting with Gear to fit receivers			2.45
3 Receiver Rack		2.29	2.98
2 Transmitter Rack		2.39	3.97
Single Transmitter Rack		2.25	2.95
DM-32 Dynamotor for Command Set	2.25	3.25	7.95
DM-33 Dynamotor for Command Set		2.95	3.95
Shoek Mfg. for 3 Receiver Rack, 2 Trans. Rack, Modulator or Ant. Relay Unit		1.95	2.45

MONTHLY SPECIAL SURPRISE PACKAGE

20 pounds of assorted radio parts. A real value at... **\$1.95**

TUBES 10 for \$3.50

12SR7	6SL7	1N5	Your choice of these nationally advertised tubes.
1613(6F6)	6V6	3B7	
9006	1N5	6C4	
6Z7G	1626	6AL5	
211	954	5Y3	
6H6	625	12H6	

RT/34 APS 13 Transceiver used as a tail warning radar on 415 MC. Containing a 30MC IF Strip and various other parts, these units have been stripped of RF sections and all tubes but are an excellent buy if only for parts and IF Strip. Used... \$4.95

BC 624 receiver (SCR 522), less tubes, 100 A 156... used \$19.95
BC 625 transmitter (SCR 522) less tubes, used 14.95
SCR 522 transceiver, complete in case with top bracket, less tubes... 29.95
Transceiver—140-144 mc, 2 meter, used, excellent condition, less dynamotor, with tubes... only 24.95

BROADCAST BAND & AERO



MN-26-C Remote Controlled Navigational Direction finder and communications receiver. Manual DF in any one of three freq. bands, 150 to 1500 KC. 24 V. Self contained dynamotor supply. Complete installation, including receiver, control box, loop, azimuth control. Left-Right Indicator, plugs, loop transmission line and flex. shafts.

BRAND NEW... \$69.50
MN-26-Y 150 to 325 KC, 325 to 695 KC, 3.4 to 7 megacycles, comp. installation... \$69.50
Receiver alone... 35.95
MN-26-C alone new... 39.50
MN-26-C or MN-26-Y as is less tubes... 13.95
With tubes, Used good... 24.95
MN-20-E Loop, Brand New... 6.95
MN-52 Crank drive, New... 2.50

BC375 TRANSMITTER \$19.95

TUNING UNIT 8, 9, 10 FOR BC375, used, \$2.95 ea. exc. cond.

WANTED!

All TS, APR, APS, ARC, ARN, ART, SCR, R89 and BC equipment... write today! Quote lowest prices in your first letter

WRITE FOR PRICES

BC1033	BC376	LP21LM
BC939	BC638	TS67
APS13	RA42	TS61
ARN7	RA52	TS92
SCR269F&G	RTA1B	BC1277
SCR619	TA2J	BC191
BOONTON SIG.	CRT3	BC1287
GEN. I. 26 B	MP10	APR-4
TS 100/AP		

Shipments FOB warehouse. 20% Deposit on orders. Minimum order \$5.00. Illinois residents, add regular sales tax to remittance. Prices subject to change without notice.

R W ELECTRONICS

Dept. N, 1712-14 S. Michigan Ave., Chicago 16, Ill.

PHONE: HARRISON 7-9374

*"For those who can hear the difference"
Listen....*

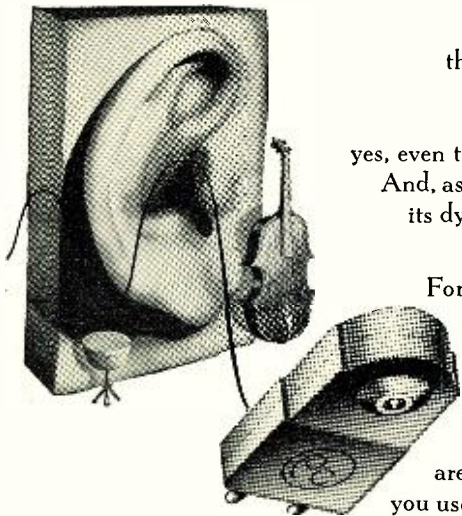

it comes to you
in the subtle shading of a piano...
in the clean brilliance of violins,
the purity of a flute. Your ear detects
the sweet mellowness of cellos,
the roundness of a clarinet...
yes, even the iridescence of clashing cymbals.
And, as the symphony swells to crescendo,
its dynamic energy adds a flood of color
to your musical canvas.

For those who can hear the difference,
these are the elusive pleasures
that often remain hidden
in the grooves of fine recordings.
These are the thrilling
new listening experiences that
are released for your enjoyment when
you use quality components by Pickering.

PICKERING and company, incorporated

Pickering High Fidelity Components are available through leading Radio Parts distributors everywhere; detailed literature sent upon request. Address Department C-7

Oceanside, L. I., New York



**WORLD'S FASTEST SELLING
VOLT-OHM MILLIAMMETER**

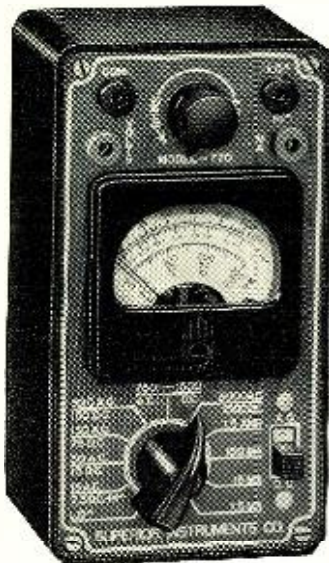

Model 770
is an accurate pocket-size V.O.M.
Measures only 3 1/8" x 5 7/8" x 2 1/4".

**Sensitivity
1000 ohms per volt**

- ★ Uses latest design 2% accurate 1 Mil. D'Arsonval type meter.
- ★ Same zero adjustment holds for both resistance ranges. It is not necessary to readjust when switching from one resistance range to another. This is an important time-saving feature never before included in a V.O.M. in this price range.
- ★ Housed in round-cornered, molded case.
- ★ Beautiful black etched panel. Depressed letters filled with permanent white, insures long-life even with constant use.

The Model 770 comes complete with self-contained batteries, test leads and all operating instructions.

- Specifications:**
- 6 A.C. VOLTAGE RANGES:
0-15/30/150/300/1500/3000 Volts.
 - 6 D.C. VOLTAGE RANGES:
0-7.5/15/75/150/750/1500 Volts.
 - 4 D.C. CURRENT RANGES:
0-1.5/15/150 MA. 0-1.5 Amps.
 - 2 RESISTANCE RANGES:
0-500 Ohms 0-1 Megohm.

**\$14⁹⁰
NET**

**AT
YOUR
RADIO
PARTS
JOBBER**

Write Dept. RN-12 for catalog of complete line.



Manufactured and Guaranteed by
SUPERIOR INSTRUMENTS CO.
227 Fulton Street • New York 7, N. Y.

New Zealand—Revised schedules for Radio New Zealand are to Australia 1300-1515, ZL2, 9.540, 1530-0145, ZL10, 15.220, 0200-closedown, ZL2, 9.540; to Pacific Islands, 1300-1515, ZL18, 9.520, 1530-2345, ZL4, 15.280, 0000-closedown, ZL18, 9.520; at present, closedown is 0545 weekdays, 0620 Sat., 0500 Sun.

Nicaragua—YSUA, 6.102, noted recently to after 2330. (Stark, Texas)

Norway—LLK, 11.852, Oslo, noted 1140 with music; closed down 1200 with English and Norwegian announcements; strong signal in England.

The Oslo University's experimental transmitter, 7.240, was heard this fall around 1700-1735 when closed with singing by a choir; could not be found parallel on listed 11.850; QSL card and letter were received, said "next year at Festival Time will use 7.210 as there has been much Russian QRM" on 7.240 in Norway.

Pakistan—Radio Pakistan, Karachi, noted near 17.715 with news 0330-0340, then news in Urdu, followed by native music; closes 0430. Still tests to Turkey, United Kingdom 1430-1600 on 9.484, 11.914; heard to Indonesia at 0630-0715 on 17.835 in parallel with 15.270 in all-native session; heard with news on 11.845 at 1015-1030. (Pearce, England) Is heard on 11.885 with oriental music 2015-2100; identified in English 2045. (West, Va.) The 15.335 channel is parallel in this transmission.

Panama—HO50, Panama City, Radio Programas, sent QSL card; listed HO50, 5.995, Panama City; HP5A, 11.700, Panama City; HP5K, 6.005, Colon, and HOJA, 9.650, Chitre. (Patterson, Ga.) HOLA, 9.505, heard 2230-2300. (Pelegri, N. Y.)

Peru — OAX1A, 6.157, Chiclayo, Radio Delcar, noted again to 2330 sign-off. (Stark, Texas)

Philippines—The Radio Free Asia relay is scheduled over 6.110 and 11.940 daily except Mondays 0700-0920 (English 0845-0910). (WRH)

Poland—Warsaw, 7.175, begins Italian broadcast 0100. (Pearce, England) Winter schedules for English broadcasts to Europe include 0130-0200, 6.140, 7.155, 5.995; 1200-1230, 7.175, 9.555; 1230-1300, 6.115, 9.555, 7.145; 1400-1430, 6.115, 9.555, 7.145; 1430-1455, 6.140, 7.155, 5.975; 1730-1800, 6.140, 7.155, 5.975; on Wednesday, Saturday at 0930-1030 on 9.527 and 7.155 has a special musical session for English-speaking listeners called "Music, the Common Language of All People." (Catch, England) Noted closing down 1345 on 11.80 with slogan "This is Warsaw For Peace and Understanding Among All People." (Boice, Conn.) Heard on 5.995 at 0013 tune-in with French. (Bellington, N. Y.)

Portugal—Lisbon, 6.372, noted 1925 with CWQRM and QRN; noted on 9.740A at 2000-2100 sign-off in Portuguese news, music, poems. (Pelegri, N. Y.) Lisbon is heard often on 11.963A around 0700, usually at good level. (Niblack, Ind.) Is heard on 15.125 to 0800. (Leary, Ind.)

Reunion—Radio Reunion now uses

RADIO & TELEVISION NEWS

FREE OFFER
LIMITED TIME ONLY

TUBES

3 lbs. of good usable radio service parts with every 100 tubes ordered; a kit of assorted radio repair hardware free with every 50 tubes ordered!

TV SET SPECIALS!

"Famous Name Television Sets!"



• Automatic Gain Control

• Saw Tooth A F C
• Standard Coil Tuner—adaptable to U H F

• Transformer-operated throughout—no selenium Rectifiers.

• ALL THE EXCLUSIVE FEATURES OF MOST EXPENSIVE SETS
• Meet all Standard RTMA requirements
• Finished in luxurious mahogany

Chassis only . . . complete with all tubes including 17" Rectangular picture tube and speaker **\$12950**

Chassis only . . . complete with all tubes including 20" Rectangular picture tube and speaker **\$14950**

17" Table Model complete with cabinet \$149.00
20" Table Model complete with cabinet. 169.00
21" Table Model complete with cabinet. 179.00
Console Sets \$20.00 additional.
Lined Oak Finish. \$12.50 extra

17" TV CONVERSION KIT
Consisting of rectangular tube, 70 Degree Yoke, Beautiful Mask and Flyback Transformer. comp. **\$2995**

20" TV CONVERSION KIT, as above . . . complete **\$3395**

TV ANTENNAS

8 Element Conical ("it works") only **\$2.95**

10 Element conical . . . rugged throughout only **\$3.95**

Double bay array, with stacking bars . . . 6.95
4 Bay array, with harness and stacking bars . . . 13.85

NEW DAVIS SUPER-VISION TV ANTENNA

Unbeatable for fringe area and DX—The only television antenna with a money-back guarantee. With the new Electronic Dipole Separators, **\$1995** less mast.

5" aluminum mast heavy gauge 1 1/2" diam. with interlocking end. Slip two sections together for a ten footer . . . each **90c**

OUTDOOR TV ANTENNA SPECIAL!
Famous Make Folded Dipole Inline Antenna—no assembly necessary—elements snap in place with guaranteed positive lock. At this low price, we cannot mention manufacturer's name. **ONLY \$495**

Fringe Area DOUBLE "V" TV ANTENNA KIT

High Gain, Best Pictures Possible . . . complete with 300 ohm line, Insulators, guy wire, hardware, full size antenna with double length 9 ft. mast **\$695** Complete

300 OHM TWIN LEAD

55 Mil. 1,000 ft. Only **\$10.95**
20 Gauge, 80 mil web 1000 ft. \$16.95
100 ft. 1.89

I. F. TRANSFORMER 456 Kc 19c
PILOT LIGHTS Type No. 47
10 for **39c** 100 for **\$2.95**

VOLUME CONTROLS with switch, 2" shaft 1 meg, 1/2 meg, 1/4 meg **34c ea.**
SINGLE ION TRAPS ea. **15c**
OUTPUT TRANSFORMER for 50L6 **29c**
for 6V6 **39c**

UNIVERSAL OUTPUT TRANSFORMER, 12 watt **79c**
CHIMNEY MOUNT for TV antenna **98c**
WELLER SOLDER GUN **\$8.95**
3 SPEED G. I. CHANGER **24.95**
6 foot **LINE CORD UL** 10 for **1.95**
TV INTERLOCK CORDS ea. **49c**

ALL TUBES are guaranteed for one year . . . individually boxed

Very BEST BRANDS available for immediate delivery!

TUBE SPECIALS!

1B3GT ea. 95c	6B17 ea. 79c	6B27 ea. \$1.29	7N7 ea. 69c
1X2A ea. 89c	6BK7 ea. 89c	6CD6G ea. 1.49	12A77 ea. 89c
6AU6 ea. 59c	6BQ6GT ea. 85c	6U8 ea. 89c	12AU7 ea. 65c
6BG6G ea. \$1.49	6BQ7 ea. \$1.19	6V3 ea. 1.29	807 ea. \$1.55

0Z4 59c	6AL5 69c	6Q7GT \$.59	7R7 \$.89	25AC5GT . \$1.04
0Z4G 65	6AQ5 74	6R7GT69	7S7 1.07	25BQ6GT . 1.15
1A5GT 69	6AQ681	6S459	7V769	25L6GT . . . 59
1A7 69	6AR574	6S7GT 1.15	7W7 1.07	25W4GT . . . 69
1B3GT 95	6AT659	6S8GT69	7X689	25Z5 1.04
1B5 29c	6A5590	6SA7GT69	7X769	25Z6GT . . . 69
1C7G 29c	6AU5GT 69	6SC769	7Y4 73c	32L7GT . . . 1.15
1E7 59	6AU6 59c	6SD7GT99	7Z4 73c	35A599
1H5GT 59	6AV6 59c	6SF559	12A7 1.15	35B5 69c
1J6GT 69	6B4G 1.44	6SF5GT59	12A869	35C569
1L4 69	6B5 79	6SH759	12AH7 1.45	35L669
1LA4 1.19	6B6G79	6SH7GT69	12AL554	35W445
1LA6 1.19	6B8GT 1.15	6SJT 59c	12AT659	35Y4 99c
1LC5 69	6BA659	6SJ7GT 59c	12AT789	35Z359
1LC6 1.19	6BA769	6SK7GT 59c	12AU669	35Z459
1LD5 95	6BC569	6SL7GT69	12AU765	35Z555
1LE5 1.19	6BC779	6SN7GT69	12AV659	35Z6G 95
1LH4 1.19	6BD5GT 89	6SQ7 59c	12AV789	35/5179
1LN5 1.19	6BE659	6SQ7GT 59c	12AW695	36 1.06
1N5GT 69	6BF569	6SR7GT59	12AX769	3772
1P5GT 69c	6BF669	6SS772	12AX759	38 88c
1Q5GT 69c	6BG6G 1.49	6T7G 1.15	12BA659	39/4472
1R5 69c	6BH6 69c	6T889	12BA769	4169
1S5 69c	6BJ6 69c	6U569	12BE6 59c	4269
1T4 69c	6BK798	6U6GT 69c	12BF6 59c	43 72c
1U4 69c	6BL779	6U7G 69c	12BH769	45 72c
1U5 59	6BN689	6V3 1.29	12C8 1.15	45Z569
1V 88	6BQ6GT 85	6V889	12C8 1.15	46 89c
1X2A 89	6BQ7 1.19	6V6GT69	12F5GT 65c	47 89c
2A3 1.15	6BZ7 1.29	6W4GT 59c	12G6 65c	50A589
2A5 79	6C459	6X4 59c	12J5GT54	50B569
3LF4 1.19	6C5GT 69c	6X5GT 59c	12K7GT69	50C5 69c
3Q4 69	6C6 69c	6Y6G69	12Q7GT69	50C6G 1.04
3Q5GT 1.08	6C8G 1.15	6Z4/84 72	12SA7GT 69	50L669
3S4 69c	6CB669	7A469	12SC769	50X679
3V4 69c	6CD6G 1.49	7A589	12SF5GT 69c	50Y669
5T4 1.40	6D6/78 1.10	7A673	12SH7GT 69	70L789
5U4G 59	6D8G 1.15	7A773	16S17GT 59	71A87
5V4G 87	6E569	7A873	12SK7GT 69	75 69c
5W4 59c	6F5GT 59c	7B473	12SL7GT 69	77 69c
5W4GT 59c	6F6GT 59c	7B573	12SN7GT 99	78/6D6 1.10
5Y3GT 45	6F8G 1.15	7B673	12SQ769	8069
5Y4G 54	6G6G95	7B773	12SQ7GT 69	83 1.45
5X4G 81c	6H6GT 59	7B873	12SR7GT 69	84/6Z4 72
5Z3 81c	6J5GT 59	7C4 1.30	122395	8579
6A3 1.15	6J6 1.04	7C573	14A789	117L7 1.40
6A7 1.21	6J7G69	7C6 73c	14AF793	117N789
6A8GT 69	6J8G 1.15	7C769	14B698	117P7 1.40
6AB7 1.15	6K5GT69	7E669	14B8 89c	117Z659
6AC5GT 89c	6K6GT59	7E769	14C5 1.07	807 1.55
6AC7 89c	6K7GT69	7F789	14C798	813 10.95
6AG5 69	6K8GT69	7F8 1.47	14F789	1294 29c
6AG7 89	6L5G95	7G769	14F889	161945
6AH6 1.40	6L6G 95c	7H769	19B6G 1.49	162929
6AK5 89	6L6GA 95c	7J769	19T889	2050 2.00
6AK6 1.08	6L769	7K7 1.07	20 1.40	2051 1.15
	6N6G 1.40	7L769	24A69	719387
	6N7GT 69c	7N7 69c		VT51 29c
	6P5GT 69c	7Q7 69c		VT52 29c

TUBE KITS—BEST BRANDS AT BEST PRICES

3Q4, 1T4, 1R5, 1S5. List Value \$8.00. Tube Kit only	\$1.98
3S4, 1T4, 1S5, 1R5. List Value \$7.80. 4 Tube Kit	\$1.98
1U4, 3S4, 1S5, 1R5. List Value \$7.80. All Four Tubes for	\$1.98
3V4, 1R5, 1S5, 1T4. List Value \$7.30. All for	\$1.98
117Z3, 1U5, 1V5, 1R5, 1T4. AC-DC Portable Kit. All for	\$2.49
12AT6, 12BA6, 12BE6, 35W4, 50B5. 5 Tubes for	\$2.59
50L6GT, 35Z5GT, 12SQ7GT, 12SK7G, 12SA7G. 5 Tubes for	\$3.22

P. M. SPEAKERS
12" Coaxial PM Speakers **\$12.95** ea.
High fidelity with high pass filter attached. 20 watt; 40-17500 cps response; 8 ohm VC.
SPECIAL PRICE
6" P. M. Speakers **\$1.39**
Standard Replacement



TV PICTURE TUBES

ONE FULL YEAR GUARANTEE—All Types

SIZE	PRICE	SIZE	PRICE
10-Inch	\$1095	16-Inch	\$1795
12-Inch	\$1295	17-Inch	\$1995
14-Inch	\$1595	19-Inch	\$2295
7-Inch	\$1595	20-Inch	\$2395
15-Inch	\$1695	21-Inch	\$2595

RESISTOR KITS—Insulated 1/2, 1 and 2 watt assortment of most used values, I.R.C. Ohmite, Stackpole, Speer, etc. **\$2.95**

TERMS, 20% DEPOSIT with order, balance C.O.D. All shipments F.O.B. Chicago
Orders Less Than \$5.00—\$1.00 Service Charge

PREMIER Radio Tube Division 551 W. Randolph St. Chicago 6, Illinois ANdover 3-1590
CONTINENTAL CORPORATION

Service men — BOOST YOUR INCOME — SAVE HUNDREDS of DOLLARS

—these TRANSVISION Instruments are *real necessities*—a "must" for your shop if you are not to throw good money away.

Here's why: —

1. **TESTING**—you can accurately test Cathode Ray Tubes.
2. **REACTIVATING**—you can save many dim or worn out tubes by reactivation.
3. **SPARKING OUT ELECTRICAL LEAKAGE** — many Cathode Ray Tubes develop electrical leakage. This can now be repaired.

CRT TESTER-REACTIVATOR-SPARKER

3 Instruments in 1, making a complete CRT testing and repair unit. Compact, dependable, profitable.

It's a combination of the Transvision **TESTER-REACTIVATOR** plus A **SPARKER** in one handy instrument. It **TESTS PICTURE TUBES**—measures Cathode emission, locates shorts between elements, locates high resistance shorts or leakage as high as 3 megohms. **REACTIVATES DIM TUBES. SPARKS OUT ELECTRICAL LEAKAGE** in picture tubes. Fully Guaranteed

\$34⁹⁵
net

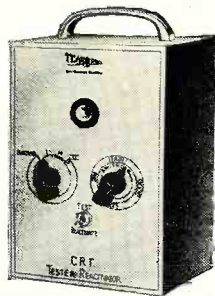

CRT TESTER-REACTIVATOR

2 Instruments in 1. As a **REACTIVATOR** it renews brightness, sharpness, and detail of old dim CR Tubes, without removal of tube. It's also an accurate **TESTER**: *Measures Cathode emission, locates shorts between elements, locates high resistance shorts or leakage as high as 3 megohms.* 110V-60 cycles; wt. 3 lbs. Fully Guaranteed.

\$19⁹⁵
net

CRT TESTER-SPARKER

2 Instruments in 1. As a **PICTURE TUBE SPARKER**, it sparks out electrical leakage between elements. *Saves many picture tubes and small tubes which would usually be discarded.* Cathode-grid leakage is an especially common occurrence. The *Sparker* also gives a rapid check of gas condition of the tube.

As a **TESTER** it provides a variable 8,000-14,000 D.C. supply—useful for analyzing hard-to-solve deflection problems. Fully Guaranteed.

\$25⁹⁵
net



FIELD STRENGTH METER

for better TV installations. Make more efficient, more profitable TV installations, and save half the work, with the Transvision Field Strength Meter. *Especially good for fringe areas*—measures field strength as low as 10 microvolts. A great buy at this low price.

Model FSM-1, complete with tubes

\$59
net

Order direct from **TRANSVISION, INC.**, New Rochelle, N. Y.

RUSH THIS COUPON

TRANSVISION, INC., Dept. RN-125

NEW ROCHELLE, N. Y.

Please send

\$..... deposit enclosed; send C.O.D. in full enclosed; send prepaid.

Name

Address

4.820 at 2145-2245, 0315-0415, 0900-1200 (or 1215); on Mon., Wed. runs to 1300. (WRH)

Roumania — *Radio Bucharest* is noted with news 1600 on 6.215, 9.250. (Hawthorne, Australia, via Radio Australia) Is heard on the 9.250 channel in Eastern USA at that time.

Saudi-Arabia — Djeddah is operating on two new channels—6.175 and 7.245—heard in Sweden by Engberg at 1110-1145; noted by Bellington, N. Y., around 2230-2302 (sign-on and sign-off varies somewhat).

Somalia — *Radio Mogadishu*, 7.385, noted with news in Italian around 1225-1235, and closing down 1301 with light music after identification. (Pearce, England)

South Africa—SABC, 11.937, Johannesburg, noted with *English* for Africa from 1200. (Pearce, England)

Southern Rhodesia—ZCAF, 3.320, Salisbury, noted 1240 with popular records, followed at 1250 by stock market quotations; 1257 musical interlude, followed at 1300 by BBC news relay; fair level but with bad CWQRM at times. (Catch, England)

Spain—FED, Valladolid, noted on measured 7.002 at strong level 0900; closed 0930 with "Arriba Espana! Viva Franco!" "La Voz de Falanage," 7.380, Madrid, noted signing on with Falangist March 1630. (Pearce, England) Malaga has returned to the air on 7.022, sign-on is believed to be 1600 when relays news in Spanish from Madrid to 1615; signs off 1833 following Spanish National Anthem; fair level but often has amateur CWQRM. *Radio Mediterraneo*, Valencia, has moved to about 6.994 where is heard around 1600-1830 sign-off. (Kary, Pa.)

Madrid, 9.363, is good level in Wisconsin at 2210 in *English* for North America. (Lund)

Surinam—PZH5, 5.752A, noted signing off 2058 with Dutch National Anthem. (Levy, N. Y.)

Sweden—*Radio Sweden* noted on 6.065 with Home Service relay at 1350, excellent signal in Britain. (Catch) Noted on 15.155 with *English* to South America 0600-0615, then with Swedish. (Walem, Belgium) Heard with *English* to North America around 1900-1915, then Swedish, on 9.535. (Pivnik, N. Y.) And at 1200 on 15.155 with news. (Leary, Ind.)

Switzerland — HER2, 6.055, Berne, noted 1415 with *English* session for the United Kingdom and Ireland; excellent level. (Catch, England) Berne noted ending *English* 2215 on 7.21, 9.535, 11.865; reopens 2320 announcing 6.165, 7.21, 9.535, 9.665, 11.865. (Bishop, Ohio)

Syria—*Radio Damascus*, 11.913A, still has French 1530-1630, and *English* 1630-1730 closedown, with news 1715. Heard on 11.74 at 1635 in Arabic, signing off 1700. (Pearce, England)

Tahiti—*Radio Tahiti*, 6.135, Papeete, sometimes is readable in French around 0030-0130 sign-off. (Kary, Pa.)

Taiwan (Formosa)—BED4, 11.920, Taipei, noted 1305 with Chinese music; *English* 1324-1350. (Pearce, Eng-

land) "The Voice of Righteousness Broadcasting Station," Taipei, Taiwan, Free China, is QRA of BEC36, 7.400. (Radio Sweden) BEC32, 9.775, Taipei, is audible some days 0615. (Kary, Pa.)

Tanganyika—Radio Dar-es-Salaam has changed schedule to 1130-1230 Mon.-Sat. with programs in Swahili, 1230-1330 Mon. only program in English, on 1250 kc., 3.251, and 5.505; power for each transmitter is 0.25 kw. (WRH)

Tangier—Radio Africa, 7.126, noted 0840 at good level with music, announcements in Spanish. The DUX Radio session in Swedish from this station is Tuesdays 1500-1530 and Thursdays 1530-1600. (Pearce, England) Despite reports to the contrary, Radio International, Tangier, is still using 6.110, noted around 1800. (Catch, England)

Thailand—According to Hutchins, Australia, Bangkok has been heard 0630 ending English session (which begins 0500) and saying that frequencies are now 15.630, 11.904, 7.140, 6.240, and 825 kc. Hutchins found 11.910 at good level; 6.240, fair; 15.630, very weak, while 7.140 could not be located.

Turkey—Istanbul University will shortly operate a 1 kw. transmitter in addition to its present 500-watt one. (Cushen, N. Z.) Plans have been made for a more powerful transmitter at Izmir and for a new transmitter at Malatya; Izmir now operates on 6.383. (Patrick, England, via ISWC, London)

Radio Ankara was noted recently on (announced) 9.53 with English session for North America 1815-1900, evidently moved from (former) 9.515. (Sutton, Ohio) Heard on 15.160 with native music 1540, news in French 1530; English for Europe-Britain 1600.

Uruguay—CXA10, Radio Electrica, noted recently around 11.90 at 1820 with symphonic music, Spanish identification; at times is as low as 11.895A. (Bellington, N. Y.)

USA—AAH, 11.996A, Seattle, Washington, of the Alaskan Communications System, was noted testing 1105 tune-in. (Niblack, Ind.)

USSR—A Soviet outlet was noted recently on 6.055 in parallel with 6.11 with English at 0130-0200; best on 6.055, weak on 6.11. (Balbi, Calif.) Moscow, 7.165, has German session 1515-1530. (Kary, Pa.)

Radio Moscow is noted around 15.100A at 2030-2200 with English for North America. (Brown, Texas) Lists English news for 1830, 2000, 2100, 2200, 2300, 2400, and 0030 over 15.33, 15.25, 15.23, 15.11, 11.91, 11.83, 11.81, 11.71, 9.67, 9.65, 9.55, 7.24. (Parrish, Ga.) (Actually, some of these outlets are from satellite countries.—K.R.B.)

Acknowledgement

Thanks for the splendid cooperation. Keep your reports coming to Kenneth R. Boord, 948 Stewartstown Road, Morgantown, West Virginia, USA. Good listening! . . . K.R.B.

December, 1952

TV DIRECT FROM THIS GREAT FACTORY TO YOU

BRINGS YOU

Finest Quality at Lowest Prices



TRANSVISION

TV KITS, WIRED CHASSIS, and SETS
CABINETS, COMPONENTS, INSTRUMENTS, and ACCESSORIES

MAKE MONEY

on Top Quality TV Picture Tubes:

- **TRADE-IN ALLOWANCE**

Make from \$2.00 to \$5.00 glass allowance on each "dud."

- **FULL 2 YR. GUARANTEE:**

Only Transvision gives you a Guarantee for 24 months.

FREE BOOKLET: "INSIDE CRT, or What You Should Know About Picture Tubes." Written by CRT experts, illustrated. It will MAKE MONEY FOR YOU. WRITE FOR IT NOW.

FREE CHART: Write for Picture Tube Interchangeability Chart.

COMPARE: Get the full details on the Transvision tube deal today.



New . . . TRANSVISION Picture Tube PRICES

Tube Type	Cost, WITH GLASS allowance	Cost, WITHOUT GLASS allowance
10BP4	\$11.80	\$13.80
12 1/2" Glass (any type)	13.45	15.75
12 1/2" Metal (any type)	13.95	16.25
14RP4	16.50	18.25
16" Metal (any type)	19.90	23.20
16" Round or Rect. (any type)	18.90	22.25
17BP4	18.90	22.25
19" Metal or Glass (any type)	23.95	28.95
20CP4	26.95	31.95

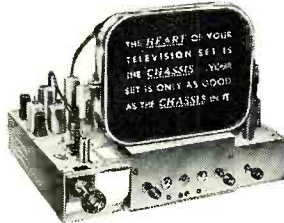

Sensational Offer:

TV \$39

KITS DOWN*

Build World's Finest Chassis—the A4

***BUILD THE FINEST CHASSIS MONEY CAN BUY** with the famous A4 Kit by Transvision. **PAY AS YOU WIRE—only \$39 for the starting package.** Easy to assemble, enjoyable, educational—gets you the most superb TV set imaginable. Easiest to service, too. Don't put it off. With these easy terms you can get started now.

Also **WIRED CHASSIS at LOW COST.** The A4 in completely wired chassis form gives you the world's finest TV set, with latest circuits and extra sensitivity for fringe areas. Gives clearer, brighter picture. Easy to service and keep up to date; built to last for years. Write for amazing low prices.

SIZES: The A4 Kit and Wired Chassis are available in 17" and 20" sizes. Also with **REMOTE CONTROL.**

BEAUTIFUL TV CONSOLES

Ideal for Custom-Building or Conversion. Factory prices start from \$49. Send for Cabinet Catalog now.



MULTI-SET CONNECTORS

feed up to 5 TV Sets from 1 Antenna
Prices: Multi-Set Conn. for 2 sets. . . . \$4.95 list*
For 3 or 4 sets. 7.95 list*
*Dealers, write for discounts

U. H. F. ADAPTERS

will be available for all Transvision Sets and Kits.

Write for Transvision's Factory Agent Plan and complete literature

FREE: EXTRA INCOME EVERY MONTH from hints in "TV and Electronics Notes." Request or send 5¢ to cover cost of sample copy, plate and mailing for FREE Subscription. Monthly issues are gold mines of info on New Products, Sales Service, Conversion, etc. **WRITE DEPT. RN-12 TODAY!**

TRANSVISION, INC. NEW ROCHELLE, N. Y.

RIGHT!

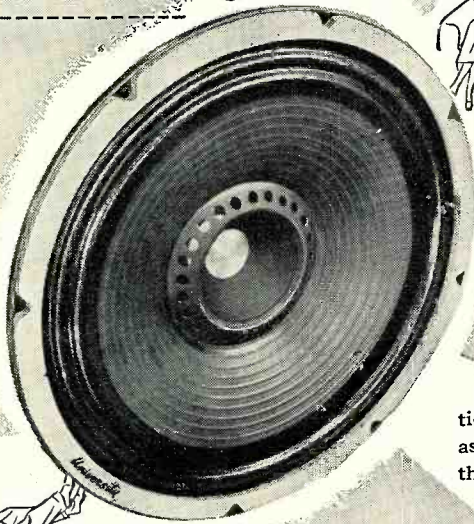

— from
any
angle

A challenging answer to low cost, wide-angle high fidelity reproduction. Diffusicone-12 is a newly engineered speaker with exclusive dual concentric cone design, which diffuses the normally beam-like high frequencies. Results in exceptionally uniform response . . . assures full range reception over the entire listening area.

Write today for Bulletin N12
— address inquiries to Desk 62.

THE NEW

University DIFFUSICONE-12

An Engineering Achievement of UNIVERSITY LOUDSPEAKERS INC.
80 So. Kensico Ave., White Plains, New York

Magnetic Pickup Preamp

(Continued from page 35)

tographs was built on a standard 4" by 4" by 1½" open-end chassis. For lowest hum, it was found necessary to position the parts with some care, to keep low-level high-impedance circuit components away from 60-cycle electric fields. Note that in the under-chassis view, the amplifier parts are all physically small and tend to be tucked away in corners and up against the chassis.

If care is taken, a highly satisfactory unit can be built in this small size. However, if space is available, it will save a lot of fussing if a larger chassis, say 4" by 6" is employed, and if the shielding is more complete. The open chassis job is sensitive to its environment—"hummy" in some, quiet in others. A closed chassis with a bottom plate and a tube shield is recommended.

REFERENCES

1. Goodell, John D.: "Problems in Phonograph Record Reproduction," *Radio & Television News*, November, 1950
2. Ellis, J.: "Bass Compensation," *Wireless World*, September, 1947
3. Williamson, D. T. N.: "High-Quality Amplifier Modifications," *Wireless World*, May, 1952
4. Fleming, L.: "Equalized Pre-Amplifier Using Single-Stage Feedback," *Audio Engineering*, March, 1950
5. Fleming, L.: "Controlling Hum in Audio Amplifiers," *Radio & Television News*, November, 1950

—30—

CURING DRIFT

By SOL DAVIS

FOUND that my National HRO 5TAI receiver worked extremely well in dry weather but drifted as much as 200 dial divisions during the humid summer months or in damp weather.

Upon removing the coils I found that they were literally dripping with condensation. After considering how I could handle this problem, I purchased a small bottle of General Cement's polystyrene "Q" coil dope and began the rather tedious task of applying the dope to the coil forms.

The treatment should be given not only to the oscillator coil but to the r.f. and converter coils. Each application of the dope reduced the amount of drift due to humidity. A total of 15 coats was applied over a period of about three months. There are four sets of coils and four coil forms in each set. Each coil should be permitted to dry from two to three hours in order to insure that the polystyrene "jacket" is tough enough to keep the water from between the turns as well as off the coil wires.

Drift has been reduced to less than ten dial divisions (about .7 kc.) and undoubtedly this could be reduced by applying still more layers of the dope.

Needless to say, the receiver has to be re-aligned after this treatment as the inductance of the coils is affected somewhat, as is the "Q". The "Q" change was negligible as far as signal strength was concerned.

This procedure would probably help all of the HRO-5, 5T, M, MX, M-RR, M-TM, SR, and JR series receivers as they are all similarly constructed.

—30—

EQUIPTO STEEL DRAWERS

12-inch

Will Not Damage Costly Parts!

Ignitions • Voltage Regulators • Lead-in Cables • Anchors • Pipe Hangers • Any-thing with loose wire ends kept completely safe from accidental damage • Small Transformers • MC Pickup Cartridges • Small "Mikes" • Small brackets • Phonograph Needles • Bolts & Nuts • Drive Rings • Bridle Rings

One piece construction -front, back, bottom, with all-welded sides— NO HOLES

Embossed grooves along the sides for cross dividers — NO HOLES

Instantly visible, extra large label holders on all cross dividers and on front of drawer—NO HOLES

STOCK SAVING • MONEY SAVING WASTE PREVENTION

What good are parts that have been mangled? None! And they cost the repair man money. Too much money to overlook the fact that Equipto drawers and cabinets are designed to prevent waste and damage to valuable parts. When stopping to realize that every time you pull an ordinary drawer out, one with open slots along the sides, small parts can not help protruding and very easily catch on the frame and either break or damage beyond repair; and every time this happens it costs you from a few cents to many dollars. Multiply this by a very few times and you are really losing money. After all, you are in business to make money. Stop wasting your parts and money!

NO. 8 8 DRAWERS 12" DEEP
NO. 11 18 DRAWERS 12" DEEP
NO. 22 18 DRAWERS 18" DEEP

◀The handiest unit you ever had for taking care of your small parts. Stack, use individually or as insert in shelving or under counters. A wonderful item for sales in stores or for keeping small parts handy in Electrical, Radio and TV repair shops. Equipto's most popular item.

Stack them high for the convenience of lots of drawer space. ▶



EQUIPTO Division of Aurora Equipment Co.
800 Prairie • Aurora, Illinois
Phone: Aurora 9231

Write for FREE Catalog

40 YEAR

Television DX
(Continued from page 53)

—and in a matter of minutes a lot of TV sets would be perking.

Getting the XYL—or “wife” to the uninitiated—into the act is pretty important, unless you are working on a job in which you can monitor signals during the day. For a lot of the best “openings” occur during the daytime, when the OM is off earning a living.

What is a typical “opening” like? Let’s take a look at the log for June 18th.

At 9:00 a.m. Houston began to make an appearance—with diagonal bars appearing on the screen, which occasionally would break into a picture. After an hour or so the picture would stay in sync most of the time, and the sound came up to the understandable level.

At 12:45, Houston dropped out completely. But at 3:30 p.m., WSB in Atlanta appeared, with an excellent picture, which lasted for a couple of hours and got better and better. So it was expected that more signals would develop, and sure enough, at 5:30 KOTV on Channel 6 in Tulsa came in, followed by KEYL, San Antonio, and WAGA, Atlanta, fighting it out on Channel 5.

At 8:30 p.m. Atlanta was back on Channel 2, but there was some inter-

ference in the background. The interference finally grabbed the ball, and it was KTSL in Los Angeles. KTSL dropped down into the snow after a few minutes—but was still making diagonal bars on the screen at 10 p.m.

The next morning a new one, WDTV Pittsburgh, pounded in bright and early at 7:10 a.m. on Channel 3. An unidentified station was on Channel 4, and another on Channel 2. At 9:00 a.m. WJBK was identified on Channel 2, and at 10:00 a.m. WKZO Kalamazoo came in. During the next couple of hours several more stations were picked up but not identified—and not until KPRC reappeared on Channel 2 at 7:30 p.m. was it possible to get call letters. KPRC stayed on for a few minutes—then faded out—and the “opening” was over. Two days elapsed before another signal was picked up, when KNXT in Hollywood appeared at 11:35 a.m. with a good picture, but not one shred of sound, to be followed a couple of hours later by KRON on Channel 4 in San Francisco—and another “opening” was on.

The “openings” mostly follow a similar pattern—with the more distant stations being heard first and last—and closer stations in between. Likewise, most of the time signals appear first on Channel 2, then on the higher frequencies up to Channel 6 if conditions are ideal, then gradually work back to Channel 2. There are excep-

tions—but Channel 2 is the channel to watch the most.

But what if you have a local station on Channel 2? Then Channel 4 is probably your other best bet—because there is pretty apt to be interference on Channel 3 from the local. If both Channel 2 and 4 are occupied, better find some other indoor sport except when the locals are off the air.

If there are no interfering signals—or if you are one of the many people in areas with one or no stations—then TV DX-ing is a lot of fun. And it is about to open up again—for the records show that December is the next best month to June for TV DX-ing. After mid-December you should receive it quite frequently. It will drop out in January—but you will have had a crack at it.

Actually, long distance TV reception has a lot of practical angles. It provides a way for the technician to get a crack at actual reception before a station opens up nearby. It will provide local publicity.

But most important, in the writer’s opinion, is that it gives the old hand at radio an intriguing new experience. The writer—who was winding coils at 14 years, and trying to coax in the London BBC station on a one tube UX-199 short-wave set—has worked the world with a 10 meter phone rig. But no thrill in radio ever quite came up to that of seeing the snow fall away and the first long distance TV sta-

**SATISFACTION
Guaranteed
OR MONEY REFUNDED!**

**Budget-minded radio men like
to do business with STEVE-EL**

Manufactured under license by RCA. RMA Guarantee on all parts and ONE FULL YEAR guarantee on picture tube.

STEVE-EL TELEVISION SETS

STEVE-EL Television sets work where others fail because they are built of the finest materials and designed by top electronic engineers. Standard COIL CAS-CODE TUNER makes them perfect for fringe area reception.

Features:

- Standard coil Cascode tuner.
- Large HI-FI speaker.
- Hand rubbed, stain finished genuine mahogany cabinet.
- AGC.
- Moulded condensers.
- Picture tube.
- Adaptable for UHF and color.
- Synchronized FM audio system.
- Factory wired, aligned and tested.
- Mounted in cabinet.

Send for LATEST
"BARGAIN BOOK"

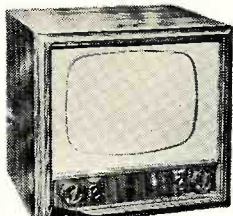

**17" TABLE MODEL
\$153
COMPLETE**

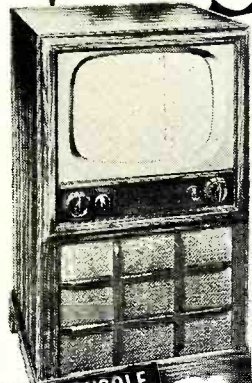

**17" CONSOLE
\$171
COMPLETE**

20" Console.....\$191.00
21" Console..... 214.00

20" Table Model...\$179.00
21" Table Model... 189.00

**STANDARD BRAND
Guaranteed TUBES**

Each Individually Boxed
(Manuf. of tubes refuses permission to mention name because tubes are FAR BELOW FAIR TRADE.)

1A7	\$.89	6BG6	\$.91	12AT6	
1B3	\$.97	6BK6	\$.86	12AT7	\$.99
1H5	\$.76	6BK7	\$.86	12AV7	\$.89
1R5	\$.79	6BQ6	1.23	12AX7	1.09
1S5	\$.79	6BQ7	1.31	12AX7	\$.99
1T4	\$.79	6C4	1.29	12BA6	\$.69
1U5	\$.79	6CB6	\$.54	12BA6	\$.69
1X2A	\$.78	6CD6	\$.79	12BE6	\$.69
3Q4	\$.94	6J5	2.39	12BH7	\$.99
3Q5	\$.89	6J6	\$.59	12SA7	\$.79
3V4	\$.91	6K6	\$.94	12SK7	\$.79
5U4	\$.73	6K7	\$.64	12SN7	\$.84
5V4	\$.69	6SA7	\$.74	12SQ7	\$.68
5Y3	\$.97	6SH7	\$.76	14A7	\$.84
6AC7	1.08	6SJ7	\$.79	14B6	\$.94
6AG5	1.08	6SK7	\$.78	25B06	1.49
6AH6	1.29	6SL7	\$.76	25L6	\$.69
6AK5	1.29	6SN7	\$.91	25W4	\$.78
6AL5	1.39	6SQ7	\$.86	25Z6	\$.67
6AQ5	\$.68	6T8	\$.69	35L6	\$.86
6AT6	\$.69	6V6GT	\$.99	35W4	\$.52
6AV6	\$.68	6W4	\$.72	35Z5	\$.51
6AU6	\$.61	6X5	\$.69	50A5	\$.96
6BA6	\$.69	7C5	\$.59	50B5	\$.66
6BC5	\$.69	7F7	\$.74	50C6	\$.69
6BE6	\$.89	7K7	\$.74	50L6	\$.69
	\$.79	7N7	1.09	11Z3	\$.64
			\$.84	11Z7	\$.93
				11Z7	1.69

Above Only Partial List of Tubes—
Send for complete list.

STEVE-EL ELECTRONICS CORP.

VISIT OUR
NEW STORE

Dept. N-12 61 Reade St., New York 7, N. Y. COrtlandt 7-0086

tion come threading in. There is something a bit magic about TV—which is above and beyond ordinary radio.

And—there is something else.

Ten years of salesmanship hadn't convinced the YF that ham radio had much to offer. But something about scooping the neighbors with TV seems to the intrigue the lady of the house—or at any rate, intrigued *one* lady—who actually logged most of the reception at the Johnsons.

In fact, she was a little sad, as was the writer, the night recently when KFEL-TV Channel 2 broke the silence in Denver and came on the air—in the process killing off the best TV DX band.

But the other night a husky signal began interfering with KFEL's signal—not too strong, because of a temporary set-up.

The best guess was that it was Los Angeles. And a quick trip to Channel 4 revealed San Francisco coming through—the picture weak, full of snow, dropping in and out of vertical sync. But DX!

Everything seemed right again. December, here we come!

-30-

Sell Portables

(Continued from page 44)

they are displaying portables every month of the year.

A "Follow the Sun" promotion initiated by *Westinghouse Electric Corp.* in 1950 attempted to stimulate portable sales in southern states during the winter months. The successful result of this program has led the company to recognize the importance of merchandising portables year-round. This year the company has prepared a diversified Christmas promotion designed primarily to boost the sale of portable radios.

The radio dealer who begins his portable radio promotion campaign on Memorial Day and winds it up after Labor Day is only scratching the surface of potential portable radio sales, according to H. G. Baker, vice-president in charge of *RCA Victor's* Home Instrument Department.

"The portable radio is 'seasonal' 365 days out of the year," he said. "Each and every week in the year, hot or cold, snow or sun, millions of potential portable radio customers take to the out-of-doors—traveling, vacationing, hiking, week-ending, hayriding, weenie roasting, and sleighing. Aggressive advertising and well-directed promotions are the primary tools required by the dealers to convince the outdoor set that the portable is as much fun on these fall, winter, and springtime outings as it is on summer jaunts.

"Because the portable radio has year-round use, it has year-round gift appeal for all members of the family," Mr. Baker said. "With advertising, sales promotion, and in-store displays keyed to the gift theme, the dealer should have little difficulty in establishing the portable

to the

ELECTRICAL ENGINEER

or

PHYSICIST

with experience in

RADAR

or

ELECTRONICS

Hughes Research and Development Laboratories, one of the nation's leading electronics organizations, are now creating a number of new openings in an important phase of their operations.

Here is what one of these positions offers you:

THE COMPANY

Hughes Research and Development Laboratories, located in Southern California, are presently engaged in the development and production of advanced radar systems, electronic computers and guided missiles.

THE NEW OPENINGS

The positions are for men who will serve as technical advisors to government agencies and companies purchasing Hughes equipment—also as technical consultants with engineers of other companies working on associated equipment. Your specific job would be essentially to help insure successful operation of Hughes equipment in the field.

THE TRAINING

On joining our organization, you will work in the Laboratories for several months to become thoroughly familiar with the equipment which you will later help users to understand and properly employ. If you have already had radar or electronics experience, you will find this knowledge helpful in your new work.

WHERE YOU WORK

After your period of training—at full pay—you may (1) remain with the Laboratories in Southern California in an instructive or administrative capacity, (2) become the Hughes representative at a company where our equipment is being installed, or (3) be the

Hughes representative at a military base in this country or overseas (single men only). Compensation is made for traveling and moving household effects, and married men keep their families with them at all times.

YOUR FUTURE

In one of these positions you will gain all-around experience that will increase your value to our organization as it further expands in the field of electronics. The next few years are certain to see large-scale commercial employment of electronic systems. Your training in and familiarity with the most advanced electronic techniques now will qualify you for even more important future positions.

How to apply:

HUGHES

RESEARCH AND
DEVELOPMENT LABORATORIES

Engineering Personnel Department
Culver City,
Los Angeles County, California

If you are under thirty-five years of age, and if you have an E.E. or Physics degree, write to the Laboratories, giving resumé of your experience.

Assurance is required that relocation of the applicant will not cause disruption of an urgent military project.

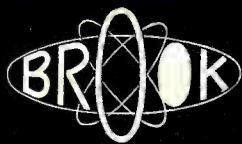

introduces with great pleasure

a new series of High-Quality Audio Amplifiers featuring the COMPLETELY NEW Model 4A Pre-amplifier.

The new pre-amplifier, combined with BROOK world-famous power amplifiers, Model 10C or 12A, offers the music lover sound reproduction so lifelike and natural, it cannot be described. YOU MUST HEAR IT.



Model 10C4 30 watt

New Features:

- Record Playback Characteristic Control offers 9 positions to match all types of records.
- Complete automatic compensation for bass-loudness characteristics of the human ear.
- Greater range of bass boost and attenuation. Bass characteristics at 50 cycles adjustable from minus 18 db to plus 24 db, in addition to automatic bass boost. Slope continues down to below 20 cycles.
- Low Frequency Range extended down another octave.
- Lower Hum Level.
- Tubes: 1-6J7 (or 1620), 2-6SJ7's, 2-6C4's (all triode-connected).
- 10-position bass and treble controls employ stepped two-stage R-C networks.
- 5 input channels:
 - 4 inputs (two of which are 1 meg) for FM, AM, TV, Recorders, Crystal Pickups.
 - 1 hi-gain input for magnetic, variable reluctance capacitance pickups, or microphone.

luctance capacitance pickups, or microphone.

- Higher gain for low-output pickups.
- Convenient connections on rear panel.
- Low impedance output of pre-amplifier, due to feedback circuit, permits use of line to basic amplifier up to 100 ft.
- Dimensions: 14 1/2" x 7 3/4" x 3 1/2" high.
- Output jack on rear panel for use with recorders, or "de-commercializer" furnished with amplifier.
- Luxurious gold-finished consolle, with highly polished solid walnut end blocks, has removable lucite escutcheon to facilitate cabinet or panel-mounting.
- ALL THE FINE PERFORMANCE AND WORKMANSHIP CHARACTERISTIC OF THE BROOK.

Model 12A4 10 watt



WRITE FOR COMPLETE TECHNICAL DATA, INCLUDING NAME OF YOUR LOCAL DEALER. DEPT. RL-2

BROOK ELECTRONICS, INC.
34 DeHART PLACE, ELIZABETH 2, N.J.



EVERY RADIOMAN

Can Use These **SERVICE HINTS!**

Valuable Manual Yours—**FREE!**

Every page of "How to Simplify Radio Repairs" is packed with on-the-bench, practical ideas. Contains photos, charts, diagrams—no fluff—no vague theory. In plain every-day language it gives you priceless suggestions—new servicing ideas. You'll use and benefit from the experience of experts. Partial list of contents: How to Localize Trouble; How to Service Amplifiers; How to Test for Distortion; How to Test Audio Circuits; How to Test Speakers; How to Find Faults in Oscillators; How to Test Radio Parts—and it's all yours—**FREE!** No obligation.

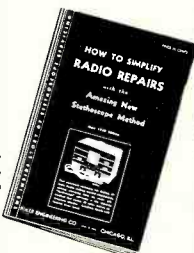

SEND COUPON OR GOVERNMENT POSTCARD FOR YOUR FREE COPY TODAY!

FEILER ENGINEERING CO., Dept. 12H-2
5026 N. Monticello Ave., Skokie, Ill.
(Suburb of Chicago)

Please RUSH my FREE copy of "How to Simplify Radio Repairs."

Name

Address

City Zone State

STAR SPECIALS

NEWEST ITEMS! LOWEST PRICES!

BARGAIN LOW PRICE FLYBACK TRANSFORMER
(Similar to GE 77J 1)

Regular \$11.00 list price high voltage transformer similar to General Electric 77J1. Used for general replacement in many sets up to 14KV and with up to 10" tubes. Not available elsewhere at our low price!

A-1827 Flyback Transformer **\$2.49**

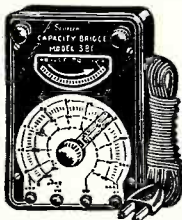

Simpson Model 381 CAPACITY BRIDGE

Direct-reading in micro-microfarads and microfarads; no multiplying factors or intricate switching. Three ranges to read 20-5000 mmf, 0.005-2.0 mfd, and 1.0-500 mfd. Compact bakelite case measures only 3 3/8 x 5 1/2 x 2 3/8"; etched aluminum panel. For 115-volt 50-60 cycles.

\$27.93



Price Slashed! 65 MA SELENIUM RECTIFIERS

Brand new, famous make 65 ma. selenium rectifiers used by servicemen and builders. Standard replacement for many AC-DC sets and other transformerless power supplies. Stock up now at our low price! **65c** ea. A-1598 65 ma. Selenium Rectifier **65c** ea. 10 for only \$5.90! 100 for only \$54.00!

COMPLETE STOCKS All Standard Brands Just off the press... **BIG BARGAIN BULLETIN**

STAR ELECTRONIC DISTRIBUTORS, INC.
Dept. RN 11—7736 S. Halsted, Chicago 20, Ill.

as a gift that is useful and practical, yet appealingly 'different.' The portable is a welcome sight under the Christmas tree, a desirable gift for graduations, birthdays, anniversaries and Mother's and Father's Days, and can be a year-round profit-maker for dealers who promote it on an around-the-calendar basis."

Another company that has long understood the need for year-round selling of portables is the *Zenith Radio Corporation*. Mr. D. H. Grigsby, the company's advertising manager, puts it this way:

"We have always considered portables as a year-round item. True, we do more advertising and promotion of them during the Summertime but, at the same time, we do not entirely halt our promotional efforts after Labor Day.

"The Christmas Season is one of the big selling seasons for portable radios and they will be given an important part in our Christmas promotion and advertising plans. We will maintain mention of portables in our regular national magazine advertising, and up-to-date advertisements for dealer use in local newspapers will be supplied throughout the Winter Season."

To further indicate the trend of year-round portable promotion, one has only to view the number of new models that are being introduced other than during the spring season. Most recently *The Hallicrafters Company* announced the introduction of what they feel is their top quality portable, the TW1000. Years ago it was considered sales heresy to even mention a new portable radio during what was then termed the "off-season."

The emergence of a year-round portable market has naturally affected the growth of battery sales.

L. S. Thees, general sales manager of the Tube Department of *RCA Victor*, evaluates the battery potential as follows:

"Sales of replacement radio batteries and component parts as well, are keyed to the number of portable radios in use and to the frequency of use. Today, more portables are being used more often than ever before.

"To capitalize on this expanding market, the radio service dealer must educate set owners in his market area to the fact that maximum portable radio performance the year round depends on periodic service check-ups and maintenance the year round," he said.

"In his efforts to promote the importance of round-the-calendar maintenance, the radio service dealer should be alert to the possibility of coordinating promotions with neighboring radio dealers, travel agencies, sporting goods stores, and other retailers who cater to the out-door set," Mr. Thees declared. "From such associations can come mutually beneficial exchanges of mailing lists, joint window displays, and cooperative advertising and sales promotion efforts."

PLATT WISHES ALL HIS FRIENDS A MERRY CHRISTMAS!

NOW YOU CAN SHOP AT EITHER OF
PLATT'S TWO GREAT STORES!
NEW BRANCH STORE: 159 Greenwich St., N.Y.C.
MAIN STORE: 489 Broome St., N.Y.C. (Send
all Mail Orders here.)



RECEIVERS		USED	NEW
BC-453—190 to 550 KC.		\$29.95	\$49.95
BC-454—3 to 6 MC.		\$12.95	19.95
BC-455—6 to 9 MC.	9.95	11.95	16.95

TRANSMITTERS		USED	NEW
A-958—2.1 to 3 MC.		7.95	29.95
BC-458—5.3 to 7 MC.		9.95	17.95
ARCS-T-19—3 to 4 MC.		24.95	34.95
BC-459—7 to 9.1 MC.			24.95
T-15 ARC 5—500 to 800 KC.			29.95

ADDITIONAL EQUIPMENT		USED	NEW
BC-456 Modulator.	2.49	2.95	5.95
BC-450 Control Box (3 Receiver)	1.49	1.95	2.75
BC-451 Control Box (Transmitter)	1.29	1.79	2.39
BC-442 Relay Unit (ANT)	2.39	2.89	3.69
Plugs: PL-147, 148, 151, 152, 153, 154, 155—EACH		1.25	
Flexible Shafting with gear to fit receiver.			2.69
3 Receiver Rack	1.79	2.29	2.98
2 Transmitter Rack	1.69	2.39	3.97
Single Transmitter Rack			3.97
DM-32 Dynamotor for Command Set.	3.95	5.95	
DM-33 Dynamotor for Command Set.	2.95	3.95	
Mounts for 2 Trans. Rack, 3 Rec. Rack, Modulator, & Antenna Relay Unit.		1.95	

LIMITED QUANTITY

COMMAND SET BC-455—6 to 9.1 MC. Excellent, 95% completely wired—a few minor parts included require assembling. Instructions included. **ONLY \$6.95**

COMMAND TRANSMITTER—Navy and Army Type—3 to 4 MC. 75% complete spare parts—LIMITED QUANTITY. **\$8.95**

HEADSETS

HS-33 low impedance with cord and plug, used, fine condition	\$2.79
HS-23 high impedance, BRAND NEW with ear pads	4.95
HS-32 low impedance, BRAND NEW with ear pads, cord and PL-54 plug	\$5.39
HS-35—BRAND NEW—Western Electric	5.95
CD-307A Cords, 6 ft. NEW	.89
H-16/U high impedance. Includes two receiving units	3.95
HS-16 high impedance—used	2.49

ARMY TEST UNIT I-236

Meter is contained in a metal box 5 1/2" long x 3 3/4" wide x 3 1/4" deep. Comes complete with test leads and instruction book. Can be used for testing between AC and DC measuring resistances of circuits, checking fuses and testing capacitors. **SPECIAL \$4.19**

Multifester Foundation BIAS METER 1-97A

Contains a zero center 3 1/2" round Marion voltmeter calibrated 0-100 volts each side. Movement is one mill each side of center. The unit is mounted in a steel box 7" x 5" x 4 1/2" and contains 8 contact push button, line cord dual 100 MFD at 200 V DC condenser, a potentiometer 6 1/2 RC 1% wire wound non-inductive resistors: one 400 ohm, two 2500 ohm, one 5000 ohm, one 10,000 ohm, one 15,000 ohm. Excellent for building a zero center multimeter with ranges of 1, 10, 100, 1000 volt. **COMPLETE BRAND NEW \$5.95**

VHF Excellently Reconditioned Guaranteed

SCR-522 AIRBORNE COMMAND EQUIPMENT
Frequency Range 100 to 156 mcs. in 4 channels receiver and transmitter. Crystal controlled. Complete equipment. Consists of trans/rec, control box BC-602, dynamotor PE-94, AN104A antenna, plugs, etc. Power input with PE-94 is 28 v. Electrically Tested—Complete as Shown. **Only \$129.50**
BRAND NEW—PRICES ON REQUEST

20 POUNDS OF ASSORTED RADIO PARTS
A TERRIFIC BUY AT **ONLY \$2.79**

ELECTRIC MEGAPHONE SYSTEM



For Rural Areas, Hotels, Commercial Steamers, Ball Parks, Etc.

U. S. NAVY Type PAE-1 Electric Megaphone equipment is designed for voice reinforcement in much the same manner as, but to a greater degree than, the familiar acoustic megaphone. Consists of Megaphone Unit (which combines a microphone and reproducer in a single assembly), Portable Amplifier which electrically amplifies the output signal of the microphone section of the megaphone and feeds this amplified signal to the reproducer section, Charging Rack for recharging the self-contained storage battery of the portable amplifier. **BRAND NEW—A TREMENDOUS VALUE! DEMONSTRATION GIVEN AT EITHER OF \$149.50**
PLATT'S STORES

NEW SUPPLY ARRIVED! LIMITED QUANTITY TRANSMITTER-RECEIVER Navy Model ABA-1 (CG-43AAG)

Army Model SCR-515A, known as the BC-645 450 MC — 15 Tubes

BRAND NEW—ORIGINAL CARTON
Can be easily converted for phone or CW 2-way communication. Covering for the following bands: 420-450 MC ham band, 450-460 MC for fixed or mobile, 460-470 MC for citizens, 470-500 MC television experimental. Size 10 1/2 x 13 1/2 x 4 3/4. Contains 15 tubes: 4—7F7, 4—7H7, 2—7E6, 2—6P6, 2—955, 1—WE-316A door knob. Price includes Dynamotor, Control Box, Mount, Tubes. **\$34.95**

NOW! Fill Your Battery Only Twice a Year
with Automatic Battery Filler
Made by leading Detroit Auto. Mfr. Doubles battery life over ordinary type. Prevents battery breakdowns, fits all cars, instantly installed. **ONLY 89c COMPLETE**

CD 307A CORDS
with PL 55 Plug and JK 26 Jack, long cord. **SPECIAL! 79c**

TURBO AMPLIFIER
4 tube Amplifier used by U. S. Air Force. 115 V. Input at 400 cycles. Without tubes—**BRAND NEW \$119**
SPECIAL

Field Telephones
Army surplus, completely reconditioned and electrically tested, using 2 flash light cells and a pair of interconnecting wires. **GUARANTEED—like new. \$20.95**

PE 98 12 VOLT DYNAMOTOR
Excellent Condition. **SPECIAL! \$39.95**

NEW! COMMERCIAL MOBILE EQUIPMENT

NOW BEING MANUFACTURED BY
Platt Manufacturing Corp.

Has many new features. Latest design, compact, easy to handle. Excellent Price. Write for data and price.

MINIMUM ORDER \$2.00

Immediate Delivery—Send 25% deposit on C.O.D. orders. All shipments F.O.B., N.Y.C. (N.Y.C. residents add sales tax to your remittance.)

PLATT BREAKS ALL PRICES! TEST EQUIPMENT SALE AT NEW BRANCH STORE

Here's your chance to pick up excellent buys in Test Equipment—but they must hurry! Quantity is limited—so first come, first serve. All equipment is on display at Platt's New Branch Store, 159 Greenwich St., N.Y.C. (off Cortlandt St.) Mail Orders go to Main Store.

Eico 221 or Merit M-345 VTVM

4 1/2" meter with adjustable pointer to zero center for AC & FM discriminator alignment. AC-DC Ranges: 0-3/10/100/500/1000 V. 5 Resistance Ranges: 2 ohms—1000 megs. DB scale for audio and gain measurements. Completely wired & tested—ready for use—**SPECIAL! WHILE THEY LAST! \$34.95**

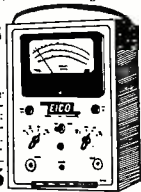

EICO MODEL 320 SIGNAL GENERATOR

Freq. Coverage on fundamentals: 150 KC to 1200 KC. 1-3 to 102 megs on 7 calibrated harmonics. Completely wired & tested—ready for operation. **SPECIAL! \$24.95**

RADIO CITY PRODUCTS Model 449 VOLTOHMETER

AC-DC output: 1000 V. ohmage up to 2 megs. In metal case with zero adjusting knob on front panel. Ready for use. **ONLY A LIMITED NUMBER LEFT—SO \$14.95**
RUSH! SPECIAL!

APPROVED Model A-200 SIGNAL GENERATOR

Freq. Range: 100 KC to 75 megs in 8 signal harmonics. AC operated. Excellent for CW & FM alignment. This special buy cannot last long—so please hurry so that you aren't disappointed. **\$21.95**

BRAND NEW SPEAKER SALE!

3" P.M. .79c 5" P.M. \$1.49
4" P.M. \$1.39 8" P.M. \$2.95
12" P.M. \$4.95

A full line of Recording Tape, Crystals, Pickups, Phono Motors, and the New G.E. Reluctance Cartridge are available at Platt's Branch Store. It will pay you to come in and browse around a bit!

BC-221 Frequency Meter

Real Value! QUANTITY IS LIMITED—so first come, first served. They are just like new, with original calibration charts (range 125-20,000 KC with crystal check points in all ranges. Complete with crystal and tubes. **\$129.50**
MODULATED TYPE \$159.50
AC POWER SUPPLY 179.50
These Frequency Meters are factory tested, checked for frequency alignment and GUARANTEED.

MN-26 INSTALLATION

MN-26C RECEIVER—Remote control commercial type navigational. Indicates direction of any desired transmitting station. 3 bands—frequency range: 150 KC to 1500 KC; has 12 6V type tubes. Brand New—**\$39.95**
Original Cost \$600.00

TUBES	BRAND NEW! JANI BOXED!	TUBES
1B22 69c	100R 49c	864 19c
1B23 \$3.75	114B 29c	954 13c
2C22 14c	21A 9c	1616 45c
2C26 9c	304TH 29c	1619 15c
2C26A 9c	304TH \$5.95	1625 22c
3B22 \$1.19	316A 29c	1626 13c
3C24 98c	371B 29c	1629 22c
3D5 39c	388A 59c	7193 19c
3DP1 \$1.79	471A \$1.19	9002 69c
7C4 39c	482A \$1.19	9006 18c
10Y 49c	722A 99c	E1148 49c
12RSY 39c	801A 49c	RK34 99c
15R 39c	824 29c	VR92 14c
39/44 29c	843 17c	VT127 15c

PLATT ELECTRONICS CORP.
DEPT. A, 489 BROOME ST., NEW YORK 13, N. Y.
PHONES: WO 4-0827 and WO 4-0828



3-SPEED PORTABLE ELECTRIC PLAYER



New 1953 model! Has crystal pick-up with all-purpose 3-speed needle! MODEL JP-25 housed in sturdy wood case covered with durable two-tone leatherette material.

EA. \$19.95 In lots of 3—Ea. \$18.95

JACKSON HI-FI AM-FM CHASSIS

Advanced design—Superior Components—Unexcelled performance! Chrome-plated chassis!

With separate RF amplifier, covers 87.5-108.5 MC on FM band; and 540-1620 Kc. on AM band. 3.2 ohm output transformer. Chassis comes complete with 6 tubes plus rectifier, mounting parts and complete instructions. For 105-125 V, 60 cycles AC. 7" high, 12" wide, 6 1/2" deep. MODEL FABA. \$54.95



10 W. HI-FI PUSH-PULL AMPLIFIER

• Bass & Treble Boost! Sensational Buy!

A full 10 watt Hi-Fi Amplifier, completely assembled. Has built-in PRE-AMP. 4 Inputs: 1 crystal phono, 1 magnetic phono, 1 radio, 1 mike. 4 Controls: 1 Bass, 1 Treble, 1 Volume, 1 Phono-radio Switch. Output Impedances: 4, 8, 16 ohms. Frequency response 20 to 20,000 cps at less than 1/2 of 1% distortion. With tubes. \$32.95

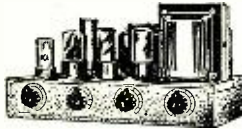

UTAH 15" PM SPEAKER

21.5 oz. Alnico V Magnet. Will respond up to 17,500 cps and down to 20 cps. HOT SPECIAL! Only \$14.95



12" PM SPEAKER

• Top Quality—Special This Month!

A full size 12" PM speaker worth much more. Cone is designed to bring out full rounded tones. Voice coil impedance 8ohms. Shpg. wt. 6 lbs. \$3.95 Each Lots of 3 Single, Each \$4.95

IRISH PLASTIC RECORDING TAPE



BRAND NEW! NOT SURPLUS. This First Grade recording tape is 1/4 in. wide. Frequency response: 50 to 8,000 cy. Plastic reel included with each.

600 FT. \$1.35 1,200 FT. \$2.10

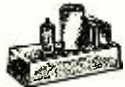

PHONO PRE-AMPLIFIER

For use with G.E. and other low level magnetic pickups. Ample bass boost provided. Operates on 115 volt AC. Sizes 4 1/2" x 2 1/4" x 3 1/2". Complete with 12AX7 tube.

\$8.95

SPEAKER VALUES!

4"	\$1.39	4x6"	\$1.99
5"	1.49	6x9"	3.49
6"	1.69	8"	3.45
6" Sq.	2.25	10"	3.95

300 OHM TWIN LEAD-IN LINE

• Low-Loss Genuine Polyethylene

1,000 FT. SPOOL \$12.95
In Lots of 3 EACH SPOOL 12.50

All orders F.O.B. Los Angeles. Minimum order \$2.00. All goods subject to prior sale. 25% deposit required with order.

Olympic Electronics Supply

Distributors

1440 W. Olympic Blvd., Los Angeles 15, Calif.

U.H.F. Antennas

(Continued from page 38)

useful in places where a broader characteristic might lead to ghost images or other interferences.

In the u.h.f. band, making each leg length equal to two or more wavelengths would not result in an unwieldy array. Thus, at a frequency of 470 mc., one wavelength is equal to approximately 24 inches and two wavelengths would be 48 inches. Suitable mechanical support can be furnished by a cross-arm mast which is mounted at the top end of a pipe. The array would then be oriented with the resistor end pointing in the direction of the station.

Stacking of rhombic antennas can be employed for increased gain just as it can with any other type of array. Separation of one-half wavelength is recommended and under these conditions a gain increase of 2 db occurs over the entire band. Stacking will also increase the vertical directivity and this may reduce the number of undesired signals which the array picks up. It will be found that reflections of waves upward from the earth tend to be more numerous at ultra-high frequencies. Hence increased

vertical directivity will often prove to be highly beneficial at the higher frequencies. This is a good point to keep in mind.

Stacked "V"

A broadband u.h.f. array which has received a considerable amount of attention is the stacked "V" antenna shown in Fig. 13. Stacked "V"s and rhombics belong to that class of antennas known as long-wire antennas. If we take a wire which is more than one wavelength long and use this for reception, the response pattern will be as shown in Fig. 14A. If two such wires are arranged to form a "V," the over-all pattern assumes the shape shown in Fig. 14B. The response is now essentially bi-directional although a number of minor lobes do exist.

The gain of a "V" antenna is dependent on the leg length and on the value of the angle which the two wires make with each other. Gain increases more or less directly with leg length and so it would appear advisable to make each wire as long as possible. The only difficulty encountered in this respect is antenna support because if the unit is to be supported entirely at one end, the wire length cannot be too great or the array will swing back and forth in the wind leading to eventual breakage.

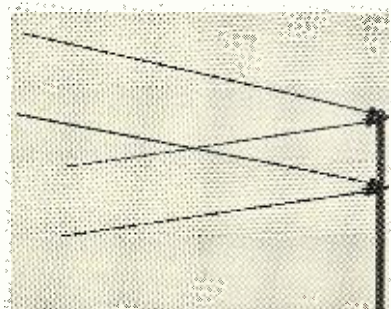

Fig. 13. (A) A stacked "V" antenna. This type has proved popular in early tests.

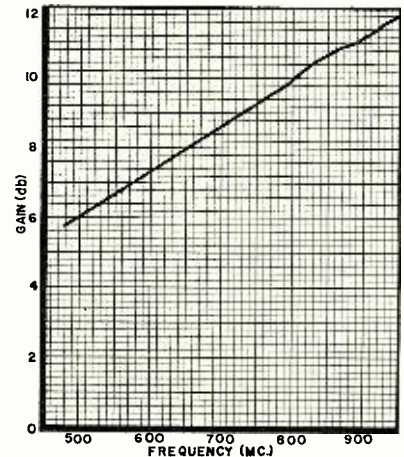

Fig. 13. (B) Gain characteristics of the stacked "V" antenna shown in photo (A).

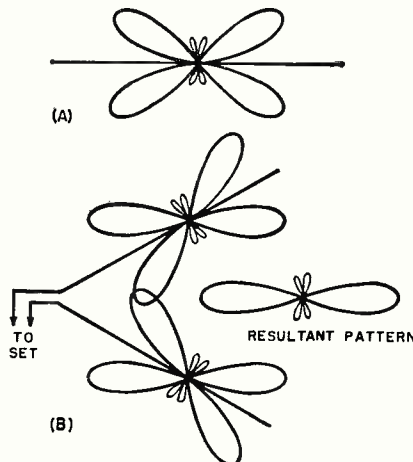

Fig. 14. Formation of "V" antenna response. The curves indicated are ideal; actual curves are modified. (A) Curves for wire longer than 1λ. (B) Individual response patterns and resultant pattern.

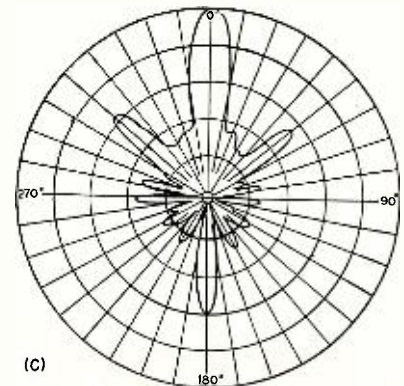

Fig. 14. (C) The directional response pattern of an actual stacked "V" antenna.

Also, too much structural vibration frequently results in signal variation. A good compromise in physical length is between 50 and 55 inches. This is still several wavelengths long at the lowest u.h.f. operating frequency and provides good gain.

The best suitable "V" angle lies between 40° and 60° and the compromise figure of 50° is frequently chosen.

Stacking of two "V" antennas one-half wavelength apart (at the lowest operating frequency) provides an increase in gain while at the same time making the vertical response narrower. The two "V" sections are connected by a short length of 300-ohm line. Connection of the lead-in line is then made to the mid-point of this section. 300-ohm transmission line is used for this, too.

The simple construction of this antenna, its extremely wide-band coverage, plus the fact that its gain rises with frequency make it appealing for installations. A rising gain characteristic is desirable to offset the increased attenuation which occurs at the higher frequencies.

The directivity pattern of a stacked "V" antenna (Fig. 14C) shows that minor lobes can cause interference in areas where secondary signals are present. However, in reasonably clear areas, the high gain afforded by this array makes it attractive.

It may be mentioned in passing that a leg length of 55 inches is close to being a quarter wavelength at lower v.h.f. channels. Thus, the stacked "V" will, in many instances, operate satisfactorily on both v.h.f. bands as well as on the u.h.f. band.

Other Antennas

While we have more or less ignored present v.h.f. antennas as far as their application to the u.h.f. band is concerned, there is no reason why they could not be employed for u.h.f. reception. If anything, their smaller size at u.h.f. frequencies makes them more suitable for stacking and consequently can provide greater gain.

As an illustration, consider the 4-bay folded dipole array shown in Fig. 15. Each folded dipole is one-half wavelength long from end to end or one full wavelength all the way around. Separation between bays is one-half wavelength while all reflectors are made 5 per-cent longer than a folded dipole. The gain of this array is approximately 12 db and the directivity is such that the beam angle is only 25°. See Fig. 16. There are several secondary lobes, but they are small and can ordinarily be disregarded.

Connection between the several bays is made with commercially available 450-ohm open wire transmission line. Also, the 450-ohm line is employed to bring the signal to the receiver. The attenuation of open wire lines is considerably lower than either the familiar 300-ohm twin-lead or any of the coaxial cables and, in this respect, is desirable for u.h.f. application.

PHOTOFACT USERS TELL THE EXPERT WAY TO TACKLE ANY TV-RADIO SERVICE JOB

here's what you do:

1

Determine the make and model number of the set on your bench. Use your PF INDEX to find the applicable PHOTOFACT Folder—takes just 60 seconds.

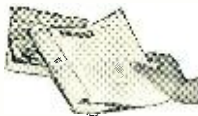

2

Reach into your PHOTOFACT library for the proper Folder. You're ready for time-saving, work-saving, expert service action.



3

YOU HAVE YOUR HANDS ON THE ONE TOOL YOU'LL USE ON EVERY JOB

Here's what you find in PHOTOFACT Folders: A uniform, consistent presentation of *complete* service data, *accurate* because it's based on actual analysis of the production receiver. And here are the exclusive features—Standard Notation Schematics with voltages and wave forms right on the diagrams; chassis view photos, top and bottom, with all parts and relationships shown, all alignment points given, all parts identified; tube placement diagrams, top and bottom, all tubes and functions indicated, even socket pin locations shown, including fuse location guide and rating; tube check chart showing common troubles and tubes responsible; complete alignment instructions, including oscilloscope patterns; resistance measurements taken at every tube socket; separate photos of TV tuner, showing all parts locations and alignment points; photos of cabinet showing service controls; complete disassembly instructions; complete parts lists, each part identified by circuit symbol and keyed to schematics and photos—showing ratings, manufacturer's original part number and proper replacements available from 29 leading components manufacturers—plus—dial cord stringing instructions; special service instructions (such as horizontal sweep circuit adjustments, etc.)—everything you have a right to expect in the world's finest TV-Radio service data . . .

4

NOW HERE'S HOW YOU SAVE TIME AND EARN MORE

You're ready to tackle the job—any job—because you have *all* the answers *instantly* at your finger tips in PHOTOFACT. Here are the *practical* ways it works for you: Suspect a tube? Diagnose and replace the defective tube in seconds

—the tube location chart shows you which one and where. Operating voltages correct? The exact answers are right on the schematic—available at a glance. Need fuse replacement? The answer's right on the tube location guide. Defective component? There's the *right* replacement in the parts list. For these and a hundred other problems, PHOTOFACT provides the *instant, correct* solution. That's why the experts use PHOTOFACT—the practical way to *save time and earn more.*

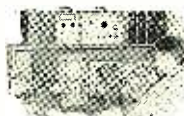

Yes, your PHOTOFACT Service Data is the ONE TOOL YOU'LL USE ON EVERY SERVICE JOB

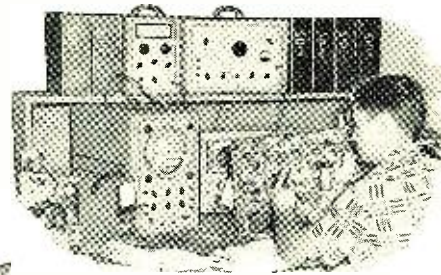

if you're not using the Expert Way—we'll prove you'll save time and earn more with PHOTOFACT service data

FREE SERVICE TECHNICIANS HERE'S OUR OFFER:

We'll send you any Photofact Folder listed in the "PF INDEX and Technical Digest." If you haven't an Index, get a Free copy from your local Photofact distributor or write us for it today. To obtain Free Folder, be sure to state Photofact Set and Folder Number exactly as shown in the Index.

NOW—learn for yourself how PHOTOFACT makes your TV and Radio repair work *quicker, easier, more profitable.* We want you to get and use an actual PHOTOFACT Folder. We want you to know why over 35,000 expert service technicians count on this invaluable data daily—count on it for *successful, profitable* business. Get your FREE Folder now. Examine, compare. Then try the Expert Way on your very next job. You'll discover why you can't afford to be without PHOTOFACT!

NOTE: Our FREE Folder offer is limited to Service Technicians only. Attach coupon to your letterhead or business card, and mention your jobber's name. Experimenters and others may obtain the Photofact Folder by remitting amount shown below.

HOWARD W. SAMS & CO., INC.

HOWARD W. SAMS & CO., INC.
2203 E. 46th St., Indianapolis 5, Ind.

I am a Service Technician. Send me Free Folder No. which appears in Photofact Set No. (as listed in the PF Index).

I am an Experimenter. Enclosed \$ Send Folder No. which appears in Photofact Set No. (TV—\$1.00. AM/FM—50c. Record Changer or Communications Receiver—75c).

Name

Address

City Zone State

EASY PAY PLAN!

PAY AS YOU EARN! Ask your distributor about this desirable plan. Only \$18.39 puts the entire profit-boosting Photofact library in your shop now!

Complete control of materials and manufacturing procedures

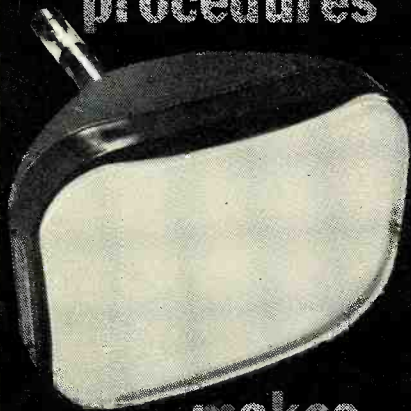

makes Tung-Sol Tubes dependable!

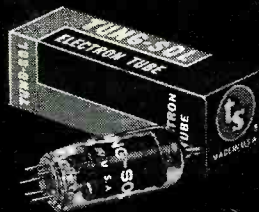

You can build a reputation on Tung-Sol Quality

TUNG-SOL
RADIO, TV TUBES, DIAL LAMPS

TUNG-SOL ELECTRIC INC., Newark 4, N. J.
Sales Offices: Atlanta • Chicago • Culver City
Dallas • Denver • Detroit • Newark

Tung-Sol makes All-Glass Sealed Beam Lamps, Miniature Lamps, Signal Flashers, Picture Tubes, Radio, TV and Special Purpose Electron Tubes.

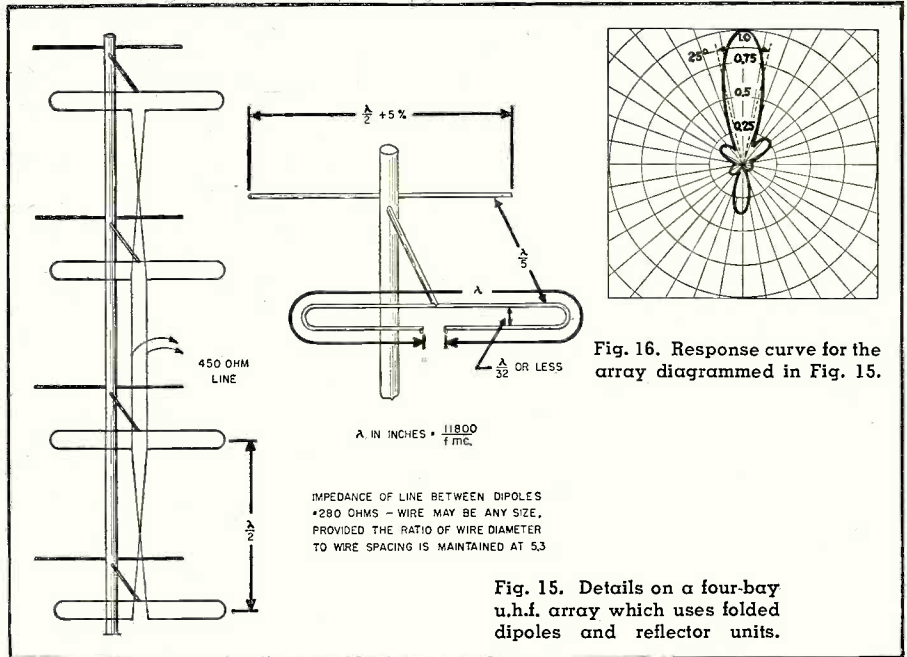

However, when connection is to be made at the receiver, a mismatch occurs because receiver input impedances are either 300 ohms balanced or 75 ohms, unbalanced. To effect a match between the 450-ohm open wire line and 300 ohms input impedance, we can either use a quarter-wave line having a characteristic impedance of

368 ohms or we can taper the two wires on the 450-ohm line inward until the impedance they present is 300 ohms. The taper should be very gradual, extending over a distance of two wavelengths. See Fig. 20. This serves to gradually step down the 450-ohm open line impedance to 300 ohms, at which point direct connection can be

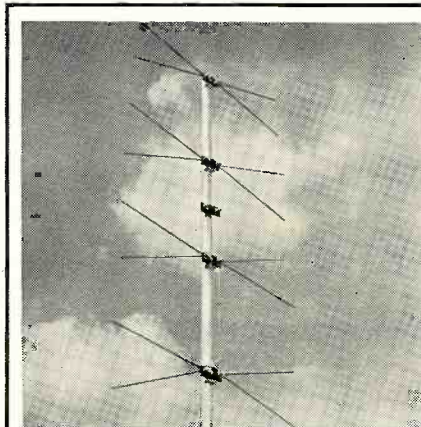

Fig. 17. A four-bay conical array which is suitable for u.h.f. television work.

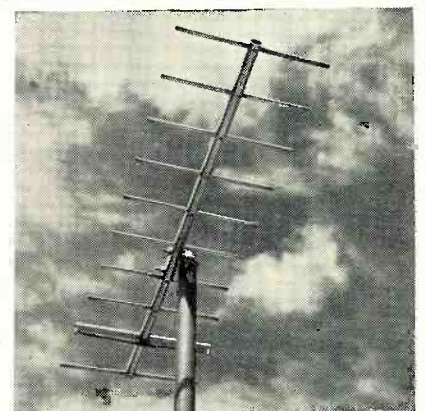

Fig. 18. A u.h.f. yagi. A large number of directors can be used, increasing the gain.

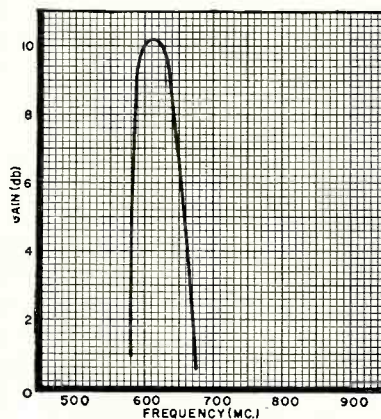

Fig. 19. (A) The gain characteristic of a yagi antenna for u.h.f. reception.

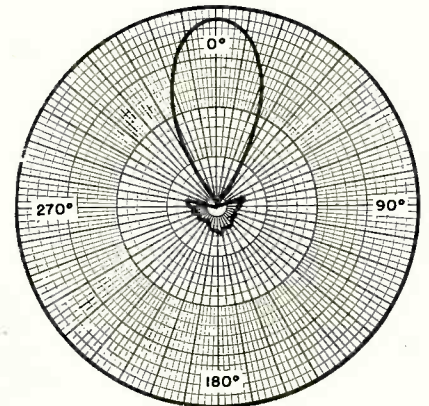

Fig. 19. (B) Directional response of a yagi. The minor lobes are very small.



Fig. 20. How to connect a 450-ohm line to a 300-ohm line without having a mismatch.

made to the receiver. (It may be possible to connect the open-wire line directly to the balanced receiver input without noticeable loss of signal or the formation of ghosts. Receiver input impedances, although stated to be 300 ohms, often vary considerably above and below this value.)

When the receiver input impedance is 75 ohms, unbalanced, then a matching device (known as a balun) must be inserted between the transmission line and the receiver. A balun would be required, too, between an incoming 75-ohm coaxial cable and a balanced 300-ohm receiver input. In the final article of this series, the construction of baluns will be covered.

A 4-bay stacked conical is shown in Fig. 17. This is another adaptation of a very popular v.h.f. array. Spacing between bays is one-half wavelength and connections between the four units is similar to that shown in Fig. 15.

A favorite fringe area antenna on the low bands is the yagi. Properly dimensioned, the same array can be gainfully employed for the reception of ultra-high frequency signals. The unit shown in Fig. 18 will have a gain of almost 10 db at its resonant frequency and a fairly sharp directional pattern. See Fig. 19. Of course, whether the yagi is employed at u.h.f. or v.h.f. frequencies, its gain falls off rapidly on either side of resonance. In areas of interference this property can be of great value; at other times the narrow bandpass can be more of a disadvantage than an advantage.

(Because of the lower relative "Q" of tuning systems at u.h.f., of which the antenna is one, the yagi can still be employed to receive something like 5 or 6 adjacent channels at frequencies near 500 mc. At 900 mc., this number increases to nine or ten. However, by comparison with other u.h.f. arrays, the frequency response of a yagi must still be considered as being very narrow.)

The more elements that are added to a yagi (in this case, directors), the greater the gain and the narrower the beam angle. Also, with more elements, the input impedance presented by the dipole decreases. To present an impedance of 300 ohms, the diameter of one rod of the dipole is greater than the diameter of the other rod. Actually, the impedance of this particular dipole, by itself, is in the vicinity of 600 ohms. However, when the reflector and directors are added, the impedance value decreases to 300 ohms. By altering the spacing and the diameter of the rods in the folded dipole, various impedances can be obtained.

(To be continued)



HERE ARE JUST A FEW OF THE
BIG VALUES
IN THE LATEST 148 PAGE
B-A CATALOG
WRITE US IF YOU HAVE NOT RECEIVED IT

BURSTEIN-APPLEBEE CO.

1012-14 McGee St., Kansas City 6, Mo.

- Send Free B-A Catalog No. 531.
 My order is attached for items from below.

\$..... enclosed.

Name.....

Address.....

City..... State.....

ELECTRIC PHONOGRAPHS



Portable type—plays 78, 45 or 33½ RPM, 7, 10 or 12" records from 110 volt AC outlet.

Top quality 3 speed motor, Crystal Pick-up with long life replaceable needle, Alnico V PM Speaker matched to a high gain 2 watt amplifier for outstanding tone quality.

Cabinet is luggage type of sturdy wood, covered with attractive leatherette, size 10½ x 12½ x 5½". Simple—easy to select the speed desired—any child can operate it.

No. 36A109. Shpg. wt. 9½ lbs.

NET EACH..... **\$18.88**

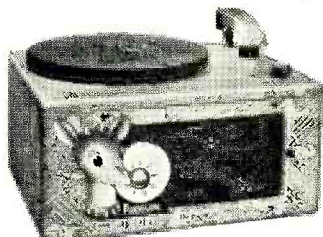

Kiddie Model. Cleverly designed to thrill any child. Large colorful decals light up while phono is turned on.

Plays standard 7, 10 or 12" 78 RPM records from 110 volt AC outlet. Simple-to-operate. Features include a 2-tube (including rectifier) Amplifier; 4" Alnico V PM Speaker; lightweight crystal pickup. Has good tone quality and excellent performance.

Smart simulated leather covered cabinet sturdily built, takes abuse. Size 12 x 10 x 5½". Wt. 10 lbs.

RUDOLPH THE RED-NOSED REINDEER
Rudolph's red nose lights up when record is playing.

No. 32A71. NET EACH..... **\$17.33**

THE LONE RANGER
Horse's head lights up when record is playing.

No. 32A72 NET EACH..... **\$17.33**

ORDER DIRECT FROM THIS AD—BUT ORDER EARLY FOR ITEMS WANTED FOR CHRISTMAS TRADE!
INCLUDE ALLOWANCE FOR POSTAGE
ALL OVERPAYMENTS WILL BE REFUNDED

RADIO-PHONO COMB.

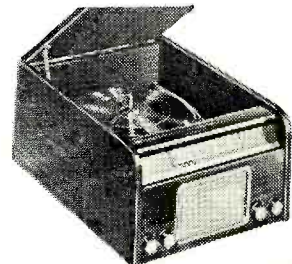

Sleekly styled, compactly designed. Blends perfectly into any room setting. Mahogany furniture wood cabinet produces the rich full tone that is only possible in wood cabinet models.

Radio is latest design super-het circuit with two dual purpose tubes provides 6 tube performance. Tubes: 12SA7GT, 12SK7GT, 12SQ7GT, 50L6GT and 35Z5GT. . . . Extra large illuminated slide rule dial is easy to read—easy to tune. . . . 4 x 6" Alnico 5 PM speaker plus wood cabinet baffling produces finest tone.

Variable tone control selects desired pitch. . . . Complete with built-in loop antenna.

Changer is the very popular VM tri-o-matic that automatically plays 7", 10" and 12" records at 33½, 45 or 78 RPM. Intermixes 10" and 12" records of the same speed. Features turnover crystal cartridge with long life needles, for improved tone and longer record life.

Size 15" W., 19½" L. and 9½" H. Wt. 35 lbs. Operates on 110-125 volts, 60 cycles AC.

No. 32A59.

NET EACH..... **\$54.95**

POWERFUL 6-TUBE (INCLUDING RECTIFIER) AC-DC RADIO

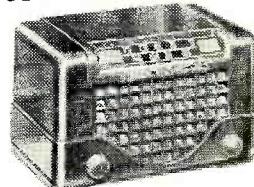

Highly sensitive Super-Het with six tubes (including rectifier), of which two are Dual Purpose and Beam Power Output making possible 7 tube performance and power to provide GOOD RECEPTION IN AREAS AND DISTANCES FROM STATIONS BEYOND THE CAPABILITIES OF THE USUAL SMALL SET. Large 5" PM Speaker assures Outstanding Tone Quality. Has Full Vision Slide Rule Dial. . . . illuminated and with calibrated wave band easy to tune, easy to read. Tuning Range—Standard Broadcast band from 540 KC to 1630 KC. Has built-in high efficiency loop antenna and AVC. Tubes: 12SA7GT, 12SK7GT, 12SQ7GT, 35L6GT and 35Z5. Modern design plastic cabinet, 10 x 6½ x 6¼". Supplied complete. . . . ready to play from any 105-125 volt 50-60 cycle AC or DC power line. wt. 8 lbs.

No. 30C66. Walnut. Special, Each..... **\$16.88**

No. 30D14. Ivory Special, Each..... **\$17.88**



BURSTEIN-APPLEBEE CO.

1012-14 MCGEE ST. KANSAS CITY, MO.

SAVE WITH NATIONAL ELECTRONICS!

SPECIALISTS in TV ANTENNAS
ACCESSORIES AND EQUIPMENT FOR ALL LOCATIONS

Rocket DIRECTRONIC MOTORLESS TV ANTENNA

- 360° Electronically Switched Beam
- No Motors
- No Roof Orientation
- No Electric Power
- No Ghosts



AX-599 Direc-
tronic, As
Shown **\$16.95**

Flick of Switch Clears Picture Instantly. Provides same clear pictures as rotating aerials costing 4 times as much. Electronically beams in all directions with full 360° rotation. You select direction with Directronic Beam Selector located at set. Model AX-599 stacked array includes 18 hi-tensile aluminum elements, 1 set connecting studs, Universal U-Clamps for mast, Directronic Beam Switch, and 75-feet of TRI-X lead-in. Model AX-59 Directronic 9-element Single... **\$10.35**

Rocket SUPER GAIN 10 ELEMENT YAGI
Designed for finest pictures in ultra-fringe weak signal areas. **TWIN-DRIVEN** for Channels 2-6—Uni-driven for Channels 7-13. Single array—11 db gain. Stacked array 14 db gain. Less mast. Channels 2, 3 or 4... **\$21.00** Channels 5 or 6... **\$18.60** Channels 7-13... **\$8.50**

LOWEST PRICES ON ANTENNA ACCESSORIES

Mast Steel (Dualcoated 5' crimped) 1 1/4" O.D.	\$ 1.05
Mast Steel (Dualcoated 10') 1 1/4" O.D.	1.95
Mast Connectors for 1 1/4" O.D. mast	.59
Chimney Mount Complete with Straps	1.19
Peak Roof Saddle (will take up to 1 1/2" O.D.)	1.59
Lightning Arrestor-TV	.69
Galvanized Steel Guy Wire—6/20	3/4c ft.
Galvanized Steel Guy Wire—11/20	1 1/2c ft.
Rocket Twin-lead—7/32 strand—4 ft.	4c ft.
#100 Mil Lo Loss 10 strand Twin Lead	20.95
Rocket Open Line Twin-Lead (500' reel)	1.0c
Stand-off Screw Insulators—3"	.03
Wall Bracket—6" clearance	1.49
Wall Bracket—12" clearance	2.49

ALL PRICES F.O.B., CLEVELAND, OHIO
Do not remit more than complete purchase price. Pay shipping charges on receipt of goods. 25% deposit on C.O.D. orders, please. Money-back guarantee.

ROCKET 5 ELEMENT YAGI
EXCELLENT PICTURES IN FRINGE AREAS

Designed for high gain with minimum interference from ghosts and noise due to directivity pattern. Produces clear sharp pictures. 5 heavy aluminum elements include one folded dipole, one reflector, three directors. Strong molded insulator. Non-slip mast clamp. Completely pre-assembled, less mast. Channels 2, 3, or 4... **\$7.95** Channels 5 or 6... **\$6.95** Channels 7 through 13... **\$3.95**
When ordering specify exact channel number desired.



Perfect Pictures In Fringe Areas

Rocket Super-Fringe Antenna FOR ALL CHANNELS

This truly sensational TV antenna is THE ANSWER to super-fringe area reception. Twenty-four driven elements provide a balanced all-channel db gain that produces astounding results at 125 or more miles from transmitter. For the ultra-fringe location, we strongly recommend this powerful antenna as the "Finest All-Channel TV Antenna On The Market Today." **Model 400-E, \$27.95**

- ±3 Anodized Aluminum Elements (guaranteed against staining or tarnishing)
- Solid Cast-Aluminum Back-up Blocks
- Plexi-glass Hi-dielectric Insulators
- Aluminum Washers and Stand-offs
- Cadmium-plated Nuts & Bolts
- 3 1/2" Dowel Pins
- Light Weight—no thrust bearing required on Rotor for average installation
- Size: 92" wide—80" high

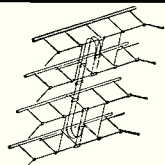

LOOK AT THESE AMAZING FEATURES

- Clears pictures up to 125 miles and more from station!
- 12 driven elements on high band!
- 12 driven elements on low band!
- High gain-low noise ratio!
- One transmission line!
- Total weight only 8 lbs.!

Conicals—5 element array... **\$3.95**
Stacked 2 Bay array with tie rods... **8.65**
Prices Subject to Change Without Notice

National Electronics OF CLEVELAND
THE HOUSE OF TV VALUES
112 Delco Building, Cleveland 3, Ohio

Loudspeaker Design
(Continued from page 58)

impelled forward under a powerful driving force. In this case a large amount of acoustic work will be performed. The power wasted as heat will thus be greatly reduced, and the conversion efficiency will be correspondingly increased.

Voice-Coil Cooling

The loudspeaker is an electromechanical device which absorbs electrical power to produce acoustical power. It is a device in which the acoustic output is produced by the vibratory motion of the diaphragm. These vibratory motions may be put to work to cool the voice coil just as in an electric motor the armature may often turn a built-in air turbine to cool the heated elements within the motor.

Cooling effects may be realized from these diaphragm vibrations only when a path for the circulation of air currents around the elements to be cooled exists. The design shown in Fig. 7A provides a natural path for such circulating currents.

The apex area of the diaphragm is sealed off by the duralumin dome. When the diaphragm moves outward, this apex area sucks in filtered air through the felt and cambric dust shields at the rear opening to the central hole in the magnet. The cool air thus drawn in by suction is forced past the heated voice coil and removes the heat which is generated in this area. On the backward motion of the diaphragm, the sealed off apex area pumps the air back out through the same openings. Forced cooling of the voice coil is thus provided, a feature which provides a more efficient power handling capacity of the electrical system of the speaker.

Voice Coil Stability

To ensure high power rating, which is essential in a speaker designed to adequately handle high peaks of program power, it is necessary that the voice coil into which all the electrical power will be fed shall be as stable as possible—both mechanically and thermally. Stability of a mechanical structure may be obtained by sheer weight or, more judiciously, by proper mechanical design. The latter method is naturally the more efficient course where conservation of weight is essential. The voice coil must, of course, be wound on a cylindrical form. Ordinary cylindrical forms are not stable circumferentially. They may be stabilized by the addition of ribbed structures running circularly around their walls. The application of such a strengthening device may be seen in Fig. 5 where the arrow (C) points to the ribbed area of the die-formed duralumin voice coil winding form. In contrast to ordinary paper voice coil forms, this one-piece duralumin braced structure affords an accurate and

TV Receiver Sensitivity Measurements made Simple with

The New "SensiMeter"*
Portable

...a "must" in fringe areas



Net **\$129.50**
*Est. Applied for

- * Takes the guesswork out of TV service
- * Checks receiver from antenna terminals to picture tube
- * Microvolt scale is divided into 3 sections as a guide for the servicemen
- * Sensitivity testing is accepted by servicemen as the best method of determining the cause of bad pictures

Approved by leading television manufacturers!

Carried by leading jobbers!

SI SERVICE INSTRUMENTS COMPANY
422 South Dearborn Street, Chicago 3, Illinois

BIG VALUE at a Low Price



Model M-G 18

You'll look long and hard before you'll find an 18-watt amplifier with mike and phono inputs, bass and treble controls, output impedances from 4 to 500 ohms, and two speaker outlet sockets, that will outperform this M-G unit. You'll pay much more for one of equal performance.

Compare its value . . . or that of any of the six other M-G models . . . with amplifiers of other makes. You'll say it's the biggest value on the market for the money.

FREE Catalog

Catalog 200 shows the entire line of M-G Sound Equipment. Get your copy today!



M-G DON McGOHAN, INC.
3700 W. ROOSEVELT RD., CHICAGO 24, ILL.

DON'T MISS THIS 110V AC UNIT FULL OF VALUABLE

BURIED TREASURE



for only

\$249

Postpaid

REMEMBER! IT'S DELIVERED TO YOUR DOOR FREE

10 UNITS ONLY 22.39

ORDER TODAY

Here's a buy that comes once in a lifetime. Imagine an electronic unit* that can be modified to serve many purposes . . . for the Serviceman, Ham, Engineer, Tinkerer or Hobbyist. Now! You should even buy it for the component parts alone (listed below) and be ahead of the game at least 5 times. The man who knows value will send in his order today to make sure that he won't miss out on this opportunity.

WHERE CAN YOU GET A DEAL LIKE THIS?

- 1—115V-6.3V Filament Transformer
- 1—S.P.S.T. Sensitive Plate Relay
- 1—S.P.S.T. Switch
- 4—Paper Tubular Condensers
- 1—Electrolytic Condenser
- 1—Potentiometer

Fits Into Many Uses

*This set is completely wired . . . schematic diagrams are furnished for possible changeovers

ORDER YOURS TODAY!

- 6—Carbon Resistors
- 7—Wire Wound Resistors
- Pilot Lamp, Dial Assembly
- 3—Tube Sockets
- Plastic Cabinet—5¼ x 5 x 3¼
- Knobs, Feet and assorted Hardware

DON'T PASS UP THIS OPPORTUNITY

MANUEL KLEIN CO.

94 Chamber St., New York 7, N.Y.
REctor 2-6460

A HOT Little BOOSTER for HOT Front Ends

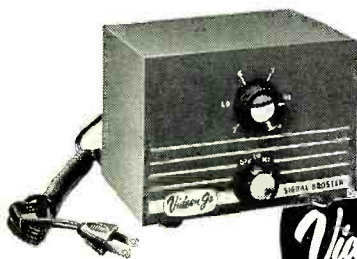

\$24.95

LIST

Videon Jr.

VIDEON JR. won't oscillate with the hot front ends of new sets!

PERFORMANCEWISE—It's tops

PRICEWISE—It's right . . . and as for customer satisfaction, you cut costly call backs when you install a VIDEON JR.

Write For Descriptive Folder And Name Of Your Distributor

Watch for it . . . The NEW Videon UHF Converter

ELECTRONIC CORPORATION

222 East Ohio Street · Indianapolis, Indiana



December, 1952

From miniature to giant . . . insuline METAL GOODS for every requirement!



INSULINE manufactures one of the most diversified lines of metal goods . . . built-up in the past 32 years by supplying every type needed by manufacturers, servicemen, engineers and hams. Huge stocks are maintained from the smallest cabinet to massive transmitter racks . . . for immediate shipment.

If your requirements are special, INSULINE can produce anything in metal . . . steel, aluminum, brass, copper, etc. . . to your specifications. Our facilities are adequate to manufacture your complete job from beginning to end . . . in fast time. Send prints and specifications for estimate.

Guide to Illustrations

1. Slip Cover Aluminum Box.
2. Utility Cabinet with built-in chassis.
3. Sloping Panel Cabinet.
4. Multi-Use Cabinet.
5. "Watchmaster" Precision Timer (American Time).
6. Chassis Base.
7. Portable Transmitter Cabinet.
8. Portable Amplifier Case.
9. Transmitter Rack.

Write Dept. RN-12 for latest catalog. Over 2000 items, including metal goods, tools, hardware, components, television and accessories.

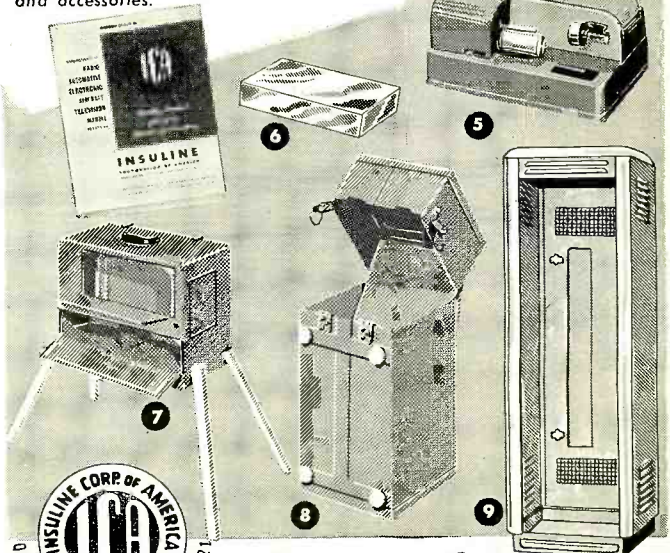

insuline
CORPORATION OF AMERICA

INSULINE BUILDING • 36-02 35th AVENUE • LONG ISLAND CITY, N. Y.
West Coast Branch & Warehouse: 1335 S. Flower St., Los Angeles, Calif.
Exclusive Canadian Sales Agents: Canadian Marconi Company, Toronto



Special Offer On This Complete RADIO ENGINEERING LIBRARY

New, Up-To-Date Edition of Famous Library Covers! Whole Field of Radio Engineering. Places Latest Facts, Standards, Data, Practice, and Theory At Your Fingertips.

The five big volumes of the new edition of the Radio Engineering Library now include the very latest facts, standards, data, and practice. This Library will help solve hundreds of problems for designers, researchers, engineers, and students in any field based on radio.

Written by leading radio engineers, these books cover circuit phenomena, networks, tube theory, vacuum tubes, amplification, measurements, etc.—give specialized treatment of all fields of practical design and application. They provide you with a complete and dependable encyclopedia of facts.

- 5 Volumes, 3872 Pages, 2770 Illustrations.
- Eastman's FUNDAMENTALS OF VACUUM TUBES, 3rd Edition.
- Terman's RADIO ENGINEERING, 3rd Edition.
- Everitt's COMMUNICATION ENGINEERING, 2nd Edition.
- Hund's HIGH FREQUENCY MEASUREMENTS, 2nd Edition.
- Henney's RADIO ENGINEERING HANDBOOK, 4th Edition.

SEND NO MONEY

Special Low Price—Easy Terms

On this special offer you get this Library for \$37.50, instead of \$43.50. You save \$6.00 and may pay on easy terms. Mail coupon below to examine the Library FREE for 10 days. No obligation. These books are recognized as standard works; you are bound to need them. So take advantage of this special money-saving offer. Mail coupon at once!

McGraw-Hill Book Co., Dept. RTN-12-52
327 West 41st St., New York 18, N. Y.

Send for 10 days' FREE trial, the RADIO ENGINEERING LIBRARY. If not satisfied I will return books. Otherwise I will send \$7.50, plus delivery charges, then, and \$6 a month for 5 months. (Reg. price \$43.50; you save \$6).

Name.....

Home Address..... RTN-12-52

City & State.....

We'll Pay Delivery Charges if you enclose \$7.50 first payment WITH coupon. Same return privilege for full refund.

sturdy support for the voice coil winding.

In addition to mechanical stability, the duralumin voice coil support offers the advantage of thermal stability with respect to the voice coil. Whenever heat is generated there will be thermal expansion. Materials of a like nature expand to the same degree. Unlike materials will expand unequally. In the case of a copper voice coil on a paper form, the copper (upon being heated) will expand more than the paper and tends to pull away from its paper support, or will deform it. Such action is, of course, disastrous to long life expectancy for the voice coil structure. In the case of the duralumin suspension, the thermal expansion is close to that of the copper of the voice coil, thus the full strength of the bond between the voice coil and its support is maintained.

Metal is a better heat radiator than paper, therefore the generated heat will be more quickly radiated from the duralumin voice coil support than would be the case for a paper support. Thus through its mechanical rigidity, its thermal radiating characteristics, and its advantageous thermal expansion such a rigid die-formed support for the voice coil assembly enables the voice coil structure to be fabricated to very close concentric tolerances. Because of this invariant concentricity of the voice coil, the magnetic gap width in which the voice coil vibrates may be reduced in width. This will yield greater flux density in the gap which will, in turn, result in higher conversion efficiency.

Transient Response

Not only does conversion efficiency improve with increased gap flux, but transient response is likewise improved. The transient response of a loudspeaker is an index of its ability to follow faithfully sudden input signal changes. If the speaker mechanism is sluggish, it will not respond to sharp incoming pulses and the reproduction will lose the brilliance of the sharp attack of the note. If, on the other hand, the speaker continues to vibrate after the electrical counterpart of a note has stopped, then there will be "hangover" of the note as produced by the loudspeaker. This will cause the music to sound muddy and indistinct and there will be a lack of definition in the reproduction. Attack and lag time characteristics of the loudspeaker may be controlled by the electrical damping which results from high magnetic gap energy.

In the last analysis a loudspeaker is a true electrical motor. Electrical power is fed into it, and mechanical power is produced by it. All the electrical laws governing simple electric motors apply equally to the loudspeaker. As the voice coil of a loudspeaker vibrates in the magnetic gap, there is induced in it a counter electromotive force. This counter e.m.f. limits the current through the voice coil and is reflected in the electrical

Every Ham His Own Santa Claus!

Our best wishes to all—with a sled-full of new, different Holiday values. At these sensational low prices, you can afford to give yourself a gift!

BC-683 FM RECEIVER
10 meter, 35 W. Freq.: 27-38.5 MC. 8 tubes, 10-channel, push-button control. 12 V. input. With tubes, less dyn. & crystals. Good cond. **\$47.50**
SPECIAL

BC-684 TRANSMITTER for above. **\$24.50**
BOTH UNITS: **\$69.95**

BC-923-A FM RECEIVER
10 meter, with tubes, less dyn. (Tuning dials missing on some.) Fair cond. **\$34.50**
BC-924 TRANSMITTER for above. **\$24.50**
BOTH UNITS: **\$56.95**

WALKIE TALKIE
Long range, 10 lbs. portable transmitter. Crystal control. Freq. 3,000-6,500 Kc. Metal carrying case. Complete, ready to operate with collapsible antenna, 5" PMT mike-speaker, all tubes and batteries. New. **\$125.00**
PER PAIR

TD-1 CHEST SET: With F-1 carbon button. F.B. for hand or Marine use. New. **\$2.95**
BC-1072 VHF TRANSMITTER: 150-200 MC. 60 cycles input. Complete with 3-amp. Vario and all tubes. Excel. cond. **\$24.50**
END-OF-EAR SPECIAL

BC-1068 VHF TUNABLE RECEIVER: 150-200 MC. 110 VAC. 60 cycle input. Easily converted to 2 meters. With all tubes, excel. cond. **\$39.95**

DYNAMOTORS 6 & 12 V.

PE-101: 12 or 24 V. in. 400 V. @ 130 ma output. See Aug./52 CC for conv. to 6 VOLTS. New, boxed.	\$ 4.95
PE-103: 6 or 12 V. in 500 V. @ 160 ma. With filter base & New.	34.95
BD-77: 12 V. in.: 1,000 V. output @ 350 mls	14.95
DM-35: 12 V. in.: 624 V. output @ 225 mls	22.50
COMMAND RECEIVER DYNAMOTOR: 12 V., used	7.95

WET CELL BATTERIES

24 V. EXIDE AIRCRAFT. New, orig. box. **\$15.95**
12 V. 37 amp @ 5-hr. rate. New. **12.95**
4 V. For TBY Transceiver. New. HOT! **4.95**

APN-1 TRANSCEIVER
For 420 MC. A-1 deal for ham or citizens' band. With tubes & schematic. **\$17.95**
Excel. cond.

FM WOBULATOR: From APN-1. With schematic. **\$5.50**

BC-375 TUNING UNITS: don't specify frequencies. Used, good cond. **1.95**
SPECIAL THIS MONTH

TRANSFORMERS

KEYNOR: Swinging choke. 5-25 H. @ 300 ma. New. **\$ 5.95**
AMITRON: 5 V. @ 194 amp. In.: 105-125 VAC. 60 cyc. Excel. cond. & an excel. WPT. **34.50**

HALLICRAFTERS: Part of SX-28 110/220 VAC. 60 cyc. 580 V.C.T. @ 275 ma. 6.3. **4.95**
amp. NEW @ 3.5 amp.; 5 V. @ 3 amp. **4.95**

BC-375 MODULATION XFMR: New. **4.95**
SPECIAL

8" PM SPEAKER: 6 ohm VC. New. **\$3.95**
4" PM SPEAKER: 6 ohm VC. New. **2.95**
CS-78 CASE: for BC-375 Tuning Unit. 5 cases. **3.95**

MIKES & HEADSETS

T-24: New. \$4.95	T-17: Used. guar. \$4.95
T-25: D. N.P., not surplus. 9.95	HS-23: Hi Imp. New. 4.95
HS-33: Lo Imp. 3.95	HS-30: Lo Imp. New. 2.50

CD-HEADSET EXTENSION CORD: With order only **.79**

BEAT COMMAND EQUIPMENT: Sold as is. **.79**

MD-7 PLATE MODULATOR: **\$6.50**
5.3-7 MC. **\$2.95** 7-9.1 MC. **5.50**

Make extra gift dough NOW by rushing in your new and used radio gear. We buy it fast at peak-high prices. WRITE TODAY!

VHF ARC-5 TRANSMITTER AND RECEIVER: T-23 and VHF ARC-5 Receiver R-28. Freq.: 100-156 MC. With all tubes. Excel. cond. **\$69.95**
BOTH FOR

TRANSMITTER: BC-375. 100 W. Phone or CW Complete with 24 V. dynamotor, tuning unit, all tubes & plugs. Excel. cond. **\$47.50**
RADIO RANGE RECEIVER: BC-1206-CM. New. **9.95**

ARC-5 OR 274-N TRANSMITTERS

2-1.3 mcs. Used, good cond.	\$19.95
1.5-3 mcs. Brand new.	24.50
3-6 mcs. Less tubes.	6.95
3-6 mcs. With tubes.	9.95
6-9.1 mcs. Brand new.	14.95
6-9.1 mcs. Used. Less tubes.	8.95

ARC-5 OR 274-N RECEIVERS

19-55 kc. Excel. cond.	\$14.95
1.5-3 mcs. Brand new.	24.50
3-6 mcs. Less tubes.	6.95
3-6 mcs. With tubes.	9.95
6-9.1 mcs. Brand new.	14.95
6-9.1 mcs. Used. Less tubes.	8.95

MD-7 ARC-5 PLATE MODULATOR: Excel. cond. **14.95**

RACK FOR DUAL TRANSMITTER (274-N) **3.95**
RACK FOR DUAL TRANSMITTER ARC-5. **3.95**
TRIPLE RECEIVER RACK. **5.00**
DUAL RECEIVER CONTROL BOX: BC-496, New. **2.95**

BC-442-A ANTENNA RELAY with 50 cond. condenser. Excel. cond. **3.95**
COMMAND RECEIVER FLEX CABLE. **2.95**
9-12 Ft. long

12 V. COMMAND RECEIVER DYNAMOTOR: New. **12.95**

BC-625 TRANSMITTER: Part of SCR-522. Freq. range: 100-156 MC. Less tubes. A **\$13.95**
HOT BUY!
BC-624 RECEIVER: Part of SCR-522. Freq. range 100-156 MC. Less tubes. **\$19.75**
TERRIFIC THE PAIR **\$29.95**

ARC-4 VHF TRANSCEIVER: For novice, 2-meter, CD or CAP. All tubes. Excellent cond. SPECIAL. **\$32.50**
NOTE: With any purchase of \$5.00 or more you can order our Xmas Special Surprise Package. 20 lbs. **\$2.95**
All orders F.O.B. Los Angeles. 25% deposit required. All items subject to prior sale.

COLUMBIA ELECTRONIC SALES
522 South San Pedro St. Los Angeles 13, Calif.

change because of its functional flexibility. Should it dry up, harden, and become brittle, or in other ways alter its original built-in compliance characteristics, the resonance of the speaker may be altered with subsequent loss of its acoustic match to the enclosure in which it is installed. To this end, the loudspeaker rim compliance should be capable of maintaining its mechanical compliance characteristic.

To prevent such a change in the mechanical flexibility of the rim of the cone, this important area is treated with a specially formulated plastic impregnation. This plastic rim treatment provides a thin but tenacious bond to the areas of the cone where maximum bending of the fibers of the cone occur, thus protecting this flexible area against rupture and weathering, as well as safeguarding its built-in resilience.

Vibrational Stability

In treating the problems of improved speaker design, this discussion started with an explanation of the wide angle dispersion through the use of the "Diffusicone" system; it then progressed to a study of the importance of magnet size upon acoustic performance, and then, in turn, revealed how the diaphragm mechanical characteristic affects acoustic performance. Having thus returned to the diaphragm, we will close the circle by referring again to the "Diffusicone" system, but this time not in an acoustical sense. We shall examine it mechanically. From the photographs and the sketches, it will be noted that this element provides a mechanical bridge between the apex dome at the voice coil area and a section of the diaphragm proper considerably removed from the apex area. This mechanical bridge in conjunction with the diaphragm wall itself, which also terminates at the voice coil area, serves to provide double reinforcement of the voice coil against mechanical shift away from its carefully aligned position in the magnetic gap, and also serves to maintain the voice coil concentricity.

Improved speaker design may be obtained by increasing the angular dispersion of the high frequencies by means of an apex area diffusion system comprised of two concentric horns, the outer horn being terminated in an additional dispersion ring; the magnetic efficiency may be improved by the use of a "W" shaped magnet which reduces magnetic circuit losses; voice coil protection may be obtained by structurally stabilizing the voice coil form by means of a dural ribbed winding form and through the mechanical bridge of the diffusion system; forced cooling of the voice coil may be realized by the judicious "W" design of the magnet; high conversion efficiency may be realized by heavy-duty magnet of Alnico V; an investment protection may be afforded through certified, acoustically-correct diaphragm-basket assembly replacement.

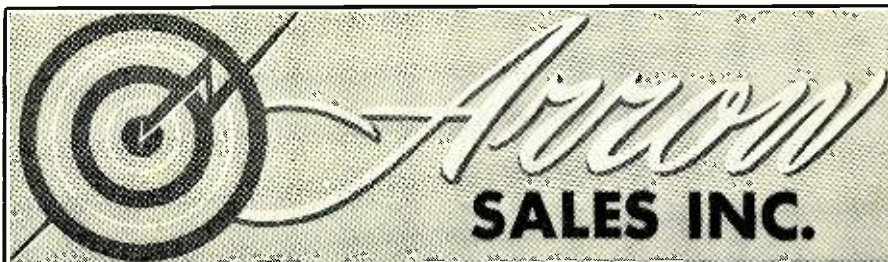

AN/APS-4
Airborne radar. New.
Complete P.U.R.

AN/APS-6
Airborne radar set. New.
Complete P.U.R.

AN/APR-4
RECEIVER & TUNING UNIT..... P.U.R.

RADAR TEST EQUIPMENT
Complete line. What are your needs?

Check these Items - Write for Prices!

BC-733-D LOCALIZED RECEIVER. Complete with tubes and crystals.
DM-53-A DYNAMOTOR for above.
FT-293 MOUNT for 733
BC-732 CONTROL BOX for 733.
ARN-7 Complete installation.
SCR-269-G Complete installation.
BC-639 VHF TUNABLE RECEIVER 100-156 MC.
SCR-522 VHF Complete installation.
DY-112 V. DYNAMOTOR—For converting Command Receivers to 12 V. operation.

MT-68 MOUNTING RACK for RTA-11B, R89/ARN-5 GLIDE PATH RECEIVER.
R57 GLIDE PATH RECEIVER.
BC-638-A FREQUENCY METER.
BC-376-A TEST OSCILLATOR.
ID6/APN-4 LORAN INDICATOR.
R9/APN-4 LORAN RECEIVER POWER SUPPLY.
RT34/APS-13 TAIL-WARNING TRANSCIEVER 420 MC.
BC-640 50 W. VHF XMT Crystal control 100-156 MC.
AN/APS-6 AIRBORNE RADAR SET

Monthly Specials!
RT-34/APS-13 420 MC. TRANSCIEVER with 5 stages of 30 MC. IP amplifier strip. Less tubes & R.F. section. With dynamotor. **\$9.95**
2 TRANSMITTERS
BC-457 (4-5.3 MC) and **BC-458** (5-3.7 MC). Command transmitters. Shipment just in. Limited Quantity. Less tubes and xtals. Good cond. EACH \$4.95 PER SET..... \$9.50

AN/ARC-5
R-28/ARC-5 RECEIVER 100-156 MC. **\$49.50**
With tubes. Like New.....
T-23/ARC-5 TRANSMITTER 100-156 MC. With tubes. Like New..... \$47.50
BOTH UNITS FOR ONLY \$92.50

SCR-625 FAMOUS MINE DETECTOR
For prospectors, miners, oil companies, plumbers, etc. New.
WHILE THEY LAST! \$59.50

COMMAND EQUIPMENT (SCR-274N)

	Used	New
BC-442 ANTENNA RELAY. Less cond. with cond.	\$3.95	\$ 1.95
BC-451 TRANSMITTER CONTROL BOX	2.95	2.95
BC-450 3-RECEIVER REMOTE CONTROL BOX	2.95	2.95
MC-215 MECHANICAL DRIVE SHAFT. For Iserb.	2.95	2.95
BC-496 2-POSITION RECEIVER CONTROL BOX	12.95	2.95
BC-459 Less tubes	9.95	14.95
BC-455 6-9 MC RECEIVER. With tubes	7.95	9.95
Less tubes	7.95	9.95
BC-454 (4-6 MC) With tubes	9.95	6.95
Less tubes	6.95	6.95

	Used	New
BC-453 With tubes	\$19.95	
Less tubes	14.95	
MC-211 90° ANGLE COUPLING UNIT		\$0.95
FT-234 MOUNTING RACK for single transmitter	2.95	3.50
FT-226 MOUNTING RACK for 2 Command Xmt's		3.95
FT-221 MOUNTING PLATE for FT-220		1.50
FT-220 MOUNTING RACK for 3 receivers		2.25
FT-225 MOUNTING PLATE for BC-456		2.25
BC-456 MODULATOR. For SCR-274.		4.50
Complete set of 4 tubes for transmitter		1.95

TCS
12 V. operation. Transmitter-Receiver Antenna Loading Coil. 1 1/2-10 MCS. 45 W. P.U.R.

LEAR ACTUATOR
24 VDC. Turns 11,000 r.p.m. Geared to 1,100 r.p.m. Excellent condition.
SPECIAL \$9.95

ARC-4 TRANSCIEVER
140-144 MC. Complete with control box, tubes. 12/24 VDC dynamotor with schematic. This is a special reduction for this month only. **\$32.50**
Like new
MT-101 ARC-4 New \$4.50

REVERSIBLE MOTOR
RL-42 24 VDC. With antenna reel and clutch.
USED \$4.50
NEW 6.75

Miscellaneous Specials!

HS-18 HEADSET. 8,000 ohms. New \$2.45
HS-23 HEADSET. High imp. New 4.95
HS-30 HEADSET. Featherweight type. Low imp. New. \$2.49 USED 1.49
HS-33 HEADSET. Low imp. New. 9.95
HS-38 HEADSET. USED, excel. cond. 1.49
NEW 3.50
T-26 CHEST TYPE MIKE. With cord and plug. 2.75
T-32 DESK STAND MIKE. Good, used cond. 2.75
LIP MIKE. Navy type. New.98

BC-709 INTERPHONE AMPLIFIER. With tubes, less batt. With manual. NEW. 3.95
PE-101 DYNAMOTOR. Used. ONLY FEW LEFT. 1.95
CD-307 EXTENSION CORD. For HS-23-33. NEW.95
RS-38 MIKE. NEW. 4.95
NEW. 1.75
BC-605 INTERPHONE AMPLIFIER. With dual mike input circuit. NEW 5.95
RM-13 COMPLETE REMOTE CONTROL BOX. For 3 separate transceivers. With TS-13 handset, decibel output meter and BE-8 ringer unit. 110 V. AC operated. Excel. cond. 29.50
FL-8 RANGE FILTER. 1.95

TUBES!	TUBES!	TUBES!	TUBES!	TUBES!
16JP4 \$19.95	304TH \$6.95	5CP1 \$4.95	3FP7 \$2.25	5BP7 \$2.25
16AP4 24.95	304TL 8.95	5BP4 4.95	4AP10 1.49	900289
16PD4 19.95	830-B 2.75	5FP7 2.25	211D69	900199

MP-22 MOBILE ANTENNA. MOUNTING RACK. Complete with hardware. New. \$ 3.95
TU-17 TUNING UNIT. (2-3 MC.) For BC-223 Xmt. Used 2.95
I-70 "S" TUNING METER. NEW. 2.50
WOBLATOR. See p. 43 Dec. '51 RADIO NEWS
BC-1023 75 MC. MARKER BEACON RECEIVER. Complete with tubes, mtg. rack. NEW 10.95
TU-25 TUNING UNIT. (3-5.5 MC.) For BC-223 Xmt. Used 2.95

IN-4A L/R TUNING METER. Used. \$ 3.95
FL-5 RANGE FILTER. 1.95
TS-13 HAND SET TELEPHONE. NEW 7.75
BC-1033 75 MC MARKER BEACON RECEIVER. Complete with tubes. P.U.R.
FIELD TELEPHONE. BE-8. Complete BRAND NEW. SPECIAL. ONLY 27.50

INDUSTRIAL CORPORATIONS
We carry one of the most complete stocks in U. S. of Military Electronic Equipment, Test Equipment, and Aircraft Electronics. Call or write for free catalogue.

COMBO
BC-624 VHF RECEIVER. Freq. range 100-156 MC. Less tubes & crystals, with conversion dope. Used, good cond. **\$19.95**
BC-625 VHF TRANSMITTER. Freq. range 100-156 MC. Less tubes & crystals, with conversion dope. Used, good condition. **\$12.95**
BOTH TRANSMITTER & RECEIVER. Per Set **\$29.95**

\$5.00 MINIMUM ORDER ACCEPTED. All items subject to prior sale. All shipments F.O.B. warehouse. Calif. residents add tax with remittance. 20% deposit required. Please specify shipping instructions with order. **EQUIPMENT WANTED!** Highest prices paid for all types of Electronic Gear!

ARROW SALES, INC. 7460 Varna Ave., Dept R
North Hollywood, California
POplar 5-1810
Cable Address: ARROWSALES



FOR ELECTRONIC COMPONENTS

We offer immediate delivery from our vast stock of more than 25,000 items—all standard make, carefully inspected and fully guaranteed. Our prices are below market.

Always Check Wells' Stock First!

ADEL CLAMPS
ANTENNAS
Insulators, Mast Sections
BINDING POSTS
BLOWERS
CABLE ASSEMBLIES
CHOKES
COILS
CONDENSERS



Oil Filled, Bathtub, Hearing Aid, Transmitting
Micas, Silver Micas, Ceramic, Variable, Trimmer

CRYSTALS
DYNAMOTORS & BRUSHES
FILTERS

FUSES & MOUNTINGS
GENERATORS
GROUND RODS
HEADSETS



JACKS
JACK BOXES
KEYS, Telegraph
KNOBS
LAMPS
LORD MOUNTS
LUGS

MOTORS & BRUSHES
PLUGS
RECTIFIERS

Selenium, Copper Oxide, Meter, Diode
RESISTORS—All Types

SELSYNS
SOCKETS
SWITCHES
Aircraft, Micro, Switchettes, Toggle



TIMERS
TUBING—Flexible
TUNING SHAFTS
TRANSFORMERS—All Types
VIBRATORS
WALKIE TALKIES



Available Now!

A complete signal corps stock number listing of items in our stock. Write for listing No. SG-200. (For government agencies and contractors only.)

Manufacturers and distributors—write for Radio-Electronics Catalog No. H 501.

Write, Wire, Phone Your Requirements

all phones: **SEeley 8-4143**



833 W. Chicago Ave. Dept. R. Chicago 22, Ill.

International TV (Continued from page 33)

miles away, on a high-quality *Desmet* TV receiver, and was used as a stand-by by the *R.T.F.*

The 9000 mc. signal received at Cassel and handed on to the *B.B.C.* was then fed to the British 819-405 line converter, also of the 819-CRT-405 camera type.

The transformed 405-line British standard signal was used to modulate the microwave link going from Cassel to London in four "hops," with intermediate stations at Alembon (near the French coast), Swingate (near Dover), and Wrotham. From Cassel to Alembon, a distance of 18 miles, a *Marconi* radio link was used, operating on a frequency of approximately 7000 mc.

From Alembon to Swingate, 40 miles, the signal crossed the Channel on a carrier frequency of approximately 4500 mc. From Swingate to Wrotham, 49 miles, a similar link was used, working on the same band. Equipment for both of these "hops" was made by *E.M.I.*

From Wrotham to London, 23 miles, a radio link made by *S.T.C.* was used. This operated on approximately 4500 mc.

At London, the demodulated signal (after a nearly 300-mile voyage on radio links) was amplified and controlled and fed to the Alexandra Palace television transmitter working on 41.5 mc. sound and 45 mc. vision. This transmitter covers the southern part of Great Britain.

Simultaneously this signal was sent over the coaxial cable that links London to Birmingham and Manchester. The use of the coaxial link was possible because of the relatively narrow bandwidth of the British standards (video frequencies being limited to 2.8 mc.).

Coaxial Link

From London to Birmingham, the cable extends over 120 miles, with eleven repeater stations in actual use out of the 43 provided in case the British adopt a greater bandwidth in the future.

From Birmingham to Manchester the coaxial cable covers a distance of over 90 miles, with repeater stations spaced at about six-mile intervals.

At Birmingham the coaxial route branches off to the nearby Sutton Coldfield television transmitter which covers the central portion of the country with a power of 30 kw. for video on a 61.75 mc. carrier and 12 kw. for the sound on a 58.25 mc. carrier.

From Manchester a short coaxial cable goes to the Holme Moss television transmitter, similar to the Sutton Coldfield outlet, with a video power of 45 kw.

The coaxial route ends at Manchester. To link the Scottish transmitter of Kirk O'Shotts to Manchester,

RADIO Surplus Buys

CRYSTALS

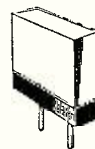

... in FT 241-A Holders— $\frac{1}{2}$ " Pin SPC. Marked in 54th OR 72nd Harmonic MC Freq. Listed below by fundamental frequency with fractions omitted.

500 KC Crystals. **\$1.95**
.....ea.
1000 KC Crystals **\$3.95**
.....ea.

370	407	444	476	509
372	408	445	477	511
374	409	446	479	512
375	411	447	480	513
376	412	448	481	514
377	413	450	483	515
379	414	451	484	516
380	415	452	485	518
381	416	453	486	519
383	418	454	487	520
384	419	455	488	522
385	420	456	490	523
386	422	457	491	525
387	423	458	492	526
388	424	459	493	527
390	426	461	494	529
391	428	462	495	530
392	427	463	496	531
393	429	464	497	533
394	430	465	498	534
395	431	466	501	536
396	433	468	502	537
397	434	469	503	538
398	435	470	504	540
400	436	472	505	
401	437	473	506	
402	438	474	507	
403	440	475	508	
404	441			
405	442			
406	443			

\$1.00
Each

10 for \$8.00, Postpaid

FOLLOWING CRYSTALS AVAILABLE IN FT 243 HOLDERS $\frac{1}{2}$ " PIN SPACING

3500	7150	8075
3590	7350	8200
6075	8006.7	
6140	8025	
6150		
7075		

\$1.00
EACH

11 for \$10.00 Postpaid

PLEASE ENCLOSE FULL AMOUNT WITH ORDER
QUANTITIES AVAILABLE
WRITE FOR YOUR REQUIREMENTS

C & H SALES CO.

Box 356-DT, E. Pasadena Sta. Pasadena 8, Cal.

HI-GAIN TUNER-BOOSTER

LESS TUBES WITH DIAL

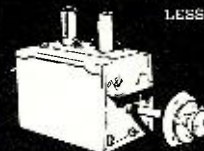

\$4.75

COMPLETE WITH TUBES

\$6.00

SOLVE POOR T. V. RECEPTION WITH A HI-GAIN BOOSTER. BANISH WEAK FRINGE AREAS. REDUCE SNOW. THIS UNIT COMES TO YOU AS A HIGHLY SERVICEABLE HIGH-GAIN TUNER. USES 6J6 TUBES IN VERY EFFICIENT HI-Q CIRCUIT. HAS 8 TUNED CIRCUITS USING PURE SILVER INDUCTANCES AND INDIVIDUAL COMPENSATION PROVIDING HIGH GAIN ON CHANNELS 7 TO 13. BUILT IN 5:1 VERNIER DRIVE. THIS IS A COMPLETE DEPARTURE FROM ORDINARY TUNERS.

ALL NECESSARY PARTS AND INSTRUCTIONS ARE INCLUDED TO CONVERT THIS UNIT IN A FEW MINUTES TO ONE OF THE HIGHEST GAIN BOOSTERS ON THE MARKET.

SEND FOR OUR NEW BULLETIN LISTING PICTURE AND RECEIVING TUBES, SPEAKERS AND MANY OTHER T. V. COMPONENTS AT TERRIFIC PRICE REDUCTIONS.

SHIPMENTS SENT POSTPAID WHEN FULL PAYMENT IS ENCLOSED WITH ORDER. 25% DEPOSIT ON C.O.D. SHIPMENTS OPEN ACCOUNT PRIVILEGES TO RATED FIRMS.

DE CRAY AND ASSOCIATES

11842 W. Jefferson Boulevard
Culver City, California

circuit as an increase in impedance. The extent of this back e.m.f. depends in part upon the strength of the gap flux. In a weak field, it is low; in a strong field it is high.

Now consider the effect of this back e.m.f. on the loudspeaker when it suddenly stops acting as a motor and instantaneously turns into a generator, as would be the case at the sudden cessation of the voice coil signal current. The momentum of the moving diaphragm would normally keep the voice coil vibrating through the field of flux for a period of time which depends upon how soon the kinetic energy of the moving diaphragm can be dissipated. Since, however, the moving voice coil cuts lines of flux in the gap as it swings in and out of the gap, the generated electromotive force induced in the coil (not the back e.m.f. in this case) will set up a current through the coil which will, in turn, give rise to a magnetic field of its own around the coil.

According to the immutable laws of action and reaction, this induced field will be built up in such a direction as to oppose the field which originally was the cause of its existence, which latter field is, of course, the gap flux. This opposition or bucking action of the driving field and the induced field will tend to grind the system to a halt. The higher the gap flux, the greater the bucking field, the faster the stop. The end effect is that when the driving signal stops, the diaphragm is damped to a standstill when enough gap flux is available to critically damp the system. This method of electrical damping by means of powerful magnetic flux is one which represents high efficiency in contrast to damping by mechanically viscous means. In the latter method electrical input power is dissipated in the form of heat instead of being converted into radiated power.

Diaphragm Distortion

There are cases of loudspeaker design where it is necessary to resort to a lightweight diaphragm in order to obtain any appreciable output. With such light and often mechanically unstable diaphragms, it is usually difficult to maintain tone without harmonic frequency generation. As a result we hear not only the original tone, but overtones as well. This sort of harmonic distortion may not be particularly unpleasant, but it does give rise to new frequencies and beats between frequencies which were not part and parcel of the original music. The addition of all these generated frequencies certainly removes the speaker from the high-fidelity, or faithful-reproducer, class.

Just as disturbing to clean reproduction is "cone cry" which is the tendency of the diaphragm to physically break up into geometric areas which vibrate independently, and at frequencies which are not harmonically related. These chains of spurious frequencies are mathematically known as the Bessel series, in contrast to the

THE Unbeatable Combination

VHF + UHF + Matchless Fringe Area Reception

with **One**

Fretaray

Antenna Installation

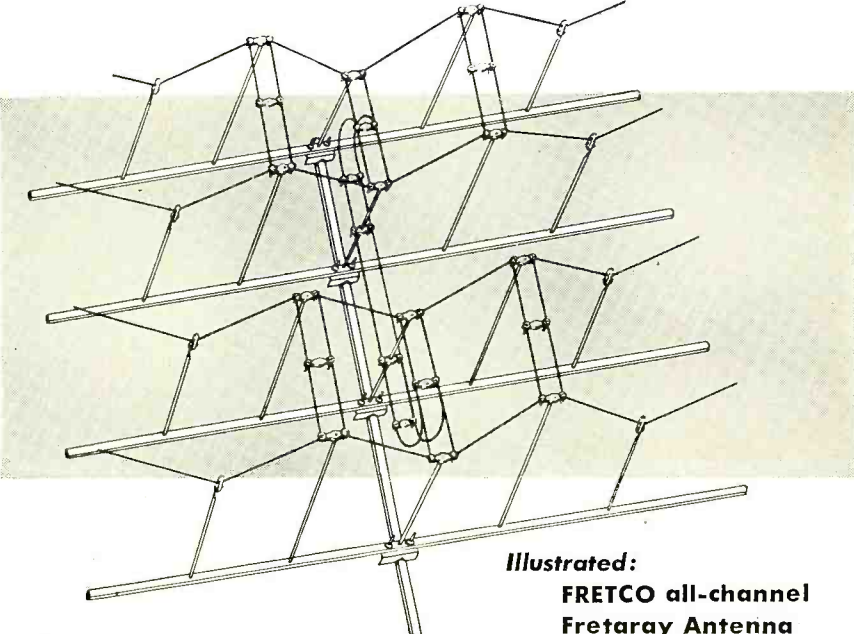

Illustrated:
FRETCO all-channel Fretaray Antenna

The FRETARAY all-channel antenna delivers the Unbeatable Combination in the TV antenna field. A VHF . . . UHF . . . and brilliantly performing FRINGE AREA antenna.

ONE installation and your ready for everything. Sturdy all aluminum construction . . . completely assembled . . . needs only one transmission line . . . bargain priced.

See your dealer or write for complete FRETARAY literature.

Fretco Incorporated—
Pittsburgh 19, Penna.

COMPLETE TRAINING

FOR BETTER RADIO-TV SERVICE JOBS



ONLY \$12
for the complete 2-volume course

3 MONTHS TO PAY

Let these two great new Ghirardi training books teach you to handle all types of AM, FM, and TV service jobs by approved professional methods—and watch your efficiency and earnings soar!

Completely modern, profusely illustrated and written so you can easily understand every word, these books pave the way to fast, accurate service on any type of home radio-TV-electronic equipment ever made. Each book is brand new. Each contains the latest data on the latest methods and equipment—NOT a re-hash of old, out-of-date material. Each is co-authored by A. Ghirardi whose famous RADIO PHYSICS COURSE and MODERN RADIO SERVICE were, for 20 years, more widely used for military, school and home study training than any other books of their type!

THE NEW Ghirardi RADIO-TV SERVICE LIBRARY

Almost 1500 pages and over 800 clear illustrations show step-by-step how to handle every phase of modern troubleshooting and servicing.

1—Radio and Television Receiver TROUBLESHOOTING AND REPAIR

A complete guide to profitable professional methods. For the novice it is a comprehensive training course. For the experienced serviceman, it is a quick way to "brush up" on specific jobs, to develop improved techniques or to find fast answers to puzzling service problems. Includes invaluable "step-by-step" service charts. 320 pages, 417 illus., price \$6.75 separately.

2—Radio and Television Receiver CIRCUITRY AND OPERATION

This 669-page volume is the ideal guide for servicemen who realize it pays to know what really makes modern radio-TV receivers "tick" and why. Gives a complete understanding of basic circuits and circuit variations; how to recognize them at a glance; how to eliminate guesswork and useless testing in servicing them. 417 illus. Price separately \$6.

New low price easy terms

If broken into lesson form and sent to you as a "course," you'd regard these two great books as a bargain at \$50 or more! Together, they form a complete modern servicing library to help you work faster, more efficiently and more profitably. Completely indexed so you can look up needed facts in a jiffy.

Under this new offer, you save 75c on the price of the two books—and have the privilege of paying in easy installments while you use them! No lessons to wait for. You learn fast—and you learn right!

10-DAY EXAMINATION PRIVILEGE

Dept. RN-122, Rinehart Books, Inc.,
Technical Division,
232 Madison Ave., New York 16, N. Y.

Send me GHIRARDI'S NEW 2-VOL. SERVICE LIBRARY. I enclose \$3 as my first installment and will send you \$3 a month for three months until the total price of only \$12.00, plus a few cents postage, is paid. It is understood I may read the books for 10 days. Then, if not satisfactory, I will return them postage paid and you agree to refund my \$3 and cancel the remaining installments. (Books shipped postpaid for full remittance with order—same return privilege.)

Name

Address

City, Zone, State

Employer's Name & Address

OUTSIDE U.S.A.—\$13.00 cash only. Same 10-day return privilege with money refunded.

harmonically related frequencies of the Fourier series. The fact that these frequencies of the Bessel series are not harmonically related tends to produce an odd and harsh "cry" of the cone when energized by prolonged notes which may occur in the middle of the audible spectrum and to which the light diaphragm may be particularly sensitive.

To overcome the mechanical instability of light, cones which produce both harmonic and nonharmonic distortion one expedient is to employ a heavy diaphragm which will reduce the cone deformations while vibrating. This is, however, merely a short-sighted solution since there will be a corresponding loss in high-frequency efficiency as well. Such a dilemma may be circumvented by an integrated balance between diaphragm weight, pulp formulation, and diaphragm geometrical contour, as in the diaphragm engineered for this application. The diaphragm pulp formulation is a special long fiber stock which provides a high degree of internal stability. These long pulp fibers are thoroughly mixed and blended and then molded into a one-piece homogeneous member by means of a carefully-controlled process. A water resistant resin is included when the pulp is mixed. The homogeneous nature of the diaphragm so formed out of these long intermixed pulp elements, along with the added resins, enables the diaphragm to vibrate as one member with minimum cone break-up effects.

The choice of such a material for the diaphragm permits the design of a shallower-than-usual cone. There are several advantages to a shallow cone, provided, of course, that it is a stable one. First, if we look upon the cone as a form of horn energized at its apex (which it actually is for the high frequencies in which we are interested), the fast flare of such a shallow horn will produce wider angular dispersion of the high frequencies than will the slow flare of a deep cone. Second, if we examine the geometrics of a shallow cone and a deep one of the same paper density and rim size, it will be evident that there is less mass to the shallow cone. This results in greater conversion efficiency. Third, there is a saving in space afforded by the shallow diaphragm type of assembly which permits more effective utilization of the back volume of the acoustic enclosure with which the speaker is to be used.

Rim Compliance Stability

In one common type of enclosure, the bass reflex cabinet, it is the usual practice to tune the cabinet by adjusting its port (or vent) size so that it tunes with the physical dimensions of the enclosure to resonate at the resonant frequency of the speaker. Once tuned, one should expect the system to remain fairly well fixed. The compliant rim of the speaker is the only mechanical element of a frequency-determining nature which may suffer



END-OF-YEAR CLEARANCE

POWER TRANSFORMERS

WESTINGHOUSE Pri. 115v 50-60 cy. Sec. 650v c.t. @ 250 mils; 12.6v c.t. @ 5 amps; (6.3v @ 5 amps; 6.3v @ 5 amps) 5v @ 3 amps. Electrostatically shielded. Brand new. Ship. wt. 13 lbs. **\$4.49**

STANGOR Pri. 110 v., 125v. 50-60 cy. Sec. 900v c.t. @ 325 mils; 6.3v @ 5.5 amps; 6.3v @ 4.5 amps; 5v @ 6 amps, upright mt. Ship. Wt. 21 lbs. Reduced to **\$8.95**

PHILCO Pri. 115v. 50-60 cy. Sec. 650v c.t. @ 150 mils, 6.5v @ 4.5 amps; 6.3v @ .3 amps; 5v @ 3 amps, Half-shell mtg. Ship. Wt. 9 lbs. Reduced to **\$3.69**

THE FAMOUS WILLIAMSON AMPLIFIER FOUNDATION KIT

1 Power trans. 810 volts CT @ 225 mils. 6.3v @ 8 amps. 5.0v @ 3 amps. \$ 6.95
2—10 Mfd 600 volt oil cond. with brackets 2.28
1—12 Hy 250 mil choke 70 ohms. 2.95
*1 Hi fidelity Chicago output trans.

Schematic included—Total value \$35.00.
*Available only in Kit
OUR very low price. **\$15.99**

10 MFD-600V OIL CONDENSERS

Sprague and C.D. Diam: 2 3/8" Height: 3 3/8" 99c ea. Brackets 15c ea.)
Complete with brackets. **\$2.75**
3 for

METERS

SIMPSON Model 125, 3 1/2" round. **\$2.99**
0-1.4 ma. basic. Tube check scale
WESTON Model 731 3" sq. 0-1 amps d.c.; 0-5 amps d.c. Each. **\$4.95**
4 1/2" Famous Make 0-200 microamp meter with multitester scale. **\$9.95**
Brand new

RCA 15" DUO-CONE SPEAKER

Model 515-S1, 25 watts, hi-fidelity extended range. 16 ohms impedance. List \$60.49.
Very Special **\$28.95**

RCA 12" SPEAKER

3.2 ohms voice coil, each \$ 3.85
3 for **11.00**

JENSEN 12" EXTENDED RANGE

PM-12 RX, 12 watts, 8 ohm voice coil. \$23.80 list. **\$9.95**

PHOTO FLASH CONDENSERS

Low voltage. Sprague latest type. 525 mfd @ 450v. One condenser equivalent to 35 watt second strobe unit. Brand new. Special. \$11.95
Sprague Electronic Flash Handbook. How to build 4 popular flash units using above condensers 35c ea. FREE with condensers.

BATTERY CHARGER

115v 50-60 cy. 6 amp. Charges at 6 amp rate; tapers to 3 amp. Complete with 2" meter. 7" high, 4 1/2" long, 4" wide. **\$8.95**

TERMS: 20% cash with order, balance C.O.D. unless rated. Prices F.O.B. our warehouse in N. Y. C. Minimum order \$3. NOTE: Due to conditions beyond our control, prices are subject to change.

Phone WOrth 4-3270

ACORN ELECTRONICS CORP.
76 Vesey St., Dept. N-12, New York 7, N. Y.

OPEN WIRE LINE

\$3.95 POSTPAID in U.S.A.
Per 100 Feet

100, 150, 200, 250 FT. REELS

- Extremely Low Loss
- Polystyrene Spacers 6" Apart
- No. 18 Copperweld Wire
- Ideal for Fringe Areas
- Very Finest Quality
- Immediate Delivery Via P.P.

R. J. BUCHAN CO.

Box 9 BRICELYN, MINN.

a microwave link, was installed with seven intermediate stations. The link works both ways, on frequencies on the order of 4000 mc. with an average distance of 30 miles between repeater stations. The total length of the link is 250 miles and it carries a 3 mc. channel in both directions.

All of the intermediate stations are remotely controlled and the main equipment is duplicated. In case of failure, the changeover to the standby duplicate is automatic.

The antennas consist of wave guide horns feeding parabolic dish reflectors 10 feet in diameter. These are mounted on steel towers whose height varies from 20 to 200 feet, depending on the local altitude. The half-power point beamwidth is 1.5 degrees and the power fed to the antenna is 1 watt.

The Kirk O'Shotts transmitter is similar to the other regional transmitters.

All of the programs for this first French-British television week were produced in Paris by directors of both nationalities. The programs were principally designed to show viewers a cross-section of Paris life, not only under its best-known "tourist" aspect, such as night clubs, cabarets, museums, etc., but also in its everyday life.

During seven days, 13½ hours of common programs were telecast, mostly of the outside pickup type. Seventeen full programs were produced in sixteen different locations in or near Paris—which is believed to be some sort of record for a seven-day period. One program was produced in the French studios.

Speakers of both nationalities were employed, either simultaneously or on two different lines, according to the type of program being transmitted. When the common programs were not being transmitted, B.B.C. and R.T.F. broadcast their separate features according to their usual schedules.

Some of the highlights in the week-long program included an "introduction" to Paris from the second floor of the Eiffel Tower and, in the evening, "Stars in the Sky," a cabaret show from the Eiffel Tower; "Paris Artists," the cellars of Saint-Germain des Pres and a visit to the sculptures of the Louvre; a fashion show aboard a Seine tourist ship; a nightclub show at "La Nouvelle Eve"; high mass in the king's cathedral at Saint Denis; French national day with military parades in the morning and the customary street dancing in the evening.

All who were concerned with this record-breaking event wonder if the Scotsman, somewhere in Edinburgh, who watched the parade in Paris gave any but a casual thought to the fact that the picture he was seeing had traveled such a long way and undergone so many transformations during its 750 mile voyage from Paris. The operation took but 4 milliseconds to complete—but many manhours were represented by this, the first, international TV!

-30-

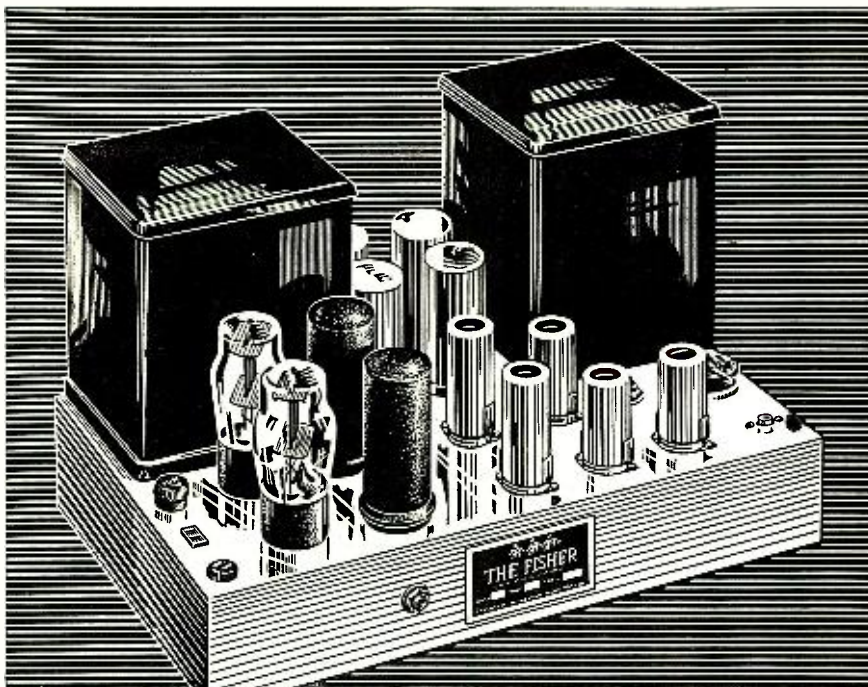

TOMORROW'S AUDIO TODAY!

FISHER

All-Triode Amplifier AND Master Audio Control

■ THE FISHER Laboratory Standard Amplifier is, beyond a shadow of a doubt, *the world's finest all-triode amplifier*—and yet moderately priced. FEATURES: High output—less than .3% harmonic distortion at 40 watts (.08% at 10 watts.) Intermodulation distortion below .8% at 40 watts. Uniform response within .1 db, 20-20,000 cycles; 1 db, 5 to 100,000 cycles. Hum and noise better than 92 db below full output. Quality components, beautiful workmanship. **\$159.50**

■ THE FISHER Master Audio Control can be used with *any* amplifier. Intermodulation distortion is virtually unmeasurable; complete, professional phonograph equalization settings and tone controls; genuine F-M loudness control; 5 inputs and 5 independent input level controls; cathode follower outputs. Finest preamplifier. Self-powered. **\$94.50**

Write for illustrated brochure and full specifications.

FISHER RADIO CORPORATION • 39 E. 47th ST., N. Y.



HARVEY

For the Finest in Audio

THE ORIGINAL WILLIAMSON HR-15 AMPLIFIER KIT

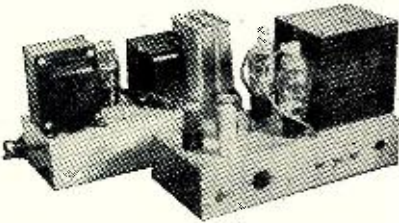

The famous, original Williamson HR-15... still acclaimed the leader... In kit form, with the original Partridge output Transformer. Assemble this kit, and in 3 hours or less, enjoy the finest sound you ever heard. Operates from a tuner, phono-preamp, crystal pick-up, or other signal source. Absolute gain is 70.8 db with 20 db of feedback. Frequency response: $\pm .5$ db, from 10 to 100,000 cps. Output impedances to match all speakers from 1.7 to 109 ohms. Kit is complete with 5 tubes (1-5V4, 2-6SN7, and 2-5881 (or 807 if requested), 2-Punched Chassis, 2-Resistor Mounting Strips, Sockets, Partridge WWFB Output Transformer, Assembly Instructions, and All Other Necessary Parts for Amplifier and Power Supply.\$76.50

PARTRIDGE OUTPUT TRANSFORMERS — Available Separately. WWFB.....\$26.00

HR-15T WILLIAMSON Kit—Furnished as above, with TRIAD Transformers and Chokes\$69.50

NOTE: HR-15 and HR-15T Kits may be had with British KT-66 Output tubes for \$3.00 additional.

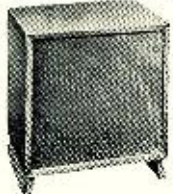

R-J SPEAKER ENCLOSURES FLOOR MODELS

Designed for use with ANY 12 or 15 inch speaker, this new sensation in high fidelity has no counterpart in anything available today. The R-J is a new concept. Large enough only to accommodate the speaker, it reproduces tones to the lowest limits of audibility, cleanly and without hangover. The R-J is the amazing solution to the problem of space versus quality. Model FM (Mahogany)\$49.95
Model FB (Blonde)..... 54.50
Model F15UM (Unfinished Mahogany) 15" only 43.35

Specify for 12 or 15 inch speaker.

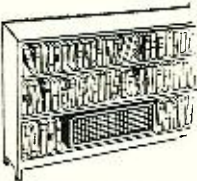

BOOKSHELF MODELS

The new famous R-J cabinet developed to new dimensions. Small enough to permit it to be inconspicuously mounted on a bookcase shelf. Reproduces amazingly clean, smooth, bass fundamentals while permitting direct radiation of high frequencies. An ideal system where space is at a premium or as an extension reproducer in an extra room. May be finished to match the decor.

Model S-8-U for 8 inch speakers (11" high x 10" deep x 23½" long).....\$24.50
Model S-12-U for 12 inch speakers (24" high x 10" deep x 21" long)..... 29.50

Write Dept. RN 12 for the new Harvey
HIGH FIDELITY AUDIO CATALOG

NOTE: Price Net, F.O.B., N.Y.C. and subject to change without notice.



Harvey

RADIO COMPANY, INC.

103 W. 43rd St., N.Y. 36, N.Y. • LU 2-1500

Within the Industry

(Continued from page 26)

section houses commercial sound equipment, another is devoted to recorders, while the third has been set aside for high-fidelity equipment. In the latter section, special acoustic treatment simulates home conditions as far as possible and enables the customer to get a true picture of how the equipment will sound in his home.

A custom-built switching console permits instant demonstration of a wide combination of pickups, tuners, preamps, basic amplifiers, packaged amplifiers, speakers, and baffles. Banks of identical baffles permit speaker comparisons under equal conditions.

* * *

STANDARD COIL PRODUCTS CO. INC. has purchased four acres of plant development ground in the Melrose Park district of Chicago. The additional acreage adjoins the company's present plant facilities which now represent over 350,000 square feet... **LITTELFUSE, INC.** is now occupying its new plant at 1865 Miner Street in Des Plaines, Illinois. A new one-story brick building houses all production facilities under a single roof... **ELECTRONIC REGULATOR CORPORATION** has completed construction of its new 15,600 square foot plant and administrative building at Norwalk, Conn. . . . Completion of its multi-million dollar plant at Metuchen, New Jersey, has been announced by **WESTINGHOUSE ELECTRIC CORPORATION**. The new facility was designed for the mass production of television and radio receivers. Enclosed railroad spurs and truck docks at both ends of the building facilitate receiving and shipping... **MEASUREMENTS CORPORATION** of Boonton, New Jersey, has acquired a new plant in Randolph Township, New Jersey. Twelve miles from the main plant, the new facility consists of a modern building with 15,000 square feet of manufacturing space... **UNITED RADIO & ELECTRONICS CO.** is now occupying a new building at 1924 South Grand Avenue in Los Angeles... **DORMEYER INDUSTRIES**, Chicago manufacturer of transformers, solenoids, and coils, has announced that its new plant at 3416-36 Milwaukee Avenue in Chicago is now operating full scale. The two-story modern brick building provides 44,000 square feet of manufacturing space... **MAJOR APPLIANCES, INC.**, Miami distributors, has moved into its new, modern building at 2201 N.W. 17th Avenue in Miami. The new structure houses the company's general headquarters, offices, and warehouse facilities... **INTEX COMPANY, INC.**, exporters of radio, television, and electrical products, has moved its offices to new and larger quarters at 136 Liberty Street in New York City... **HARRY A. LASURE COMPANY**, electronic manufacturers' representatives, has purchased a new building at 9041 West Pico Blvd. in Los Angeles to provide

office and warehousing space adequate to handle the large increase in sales volume... **KASSLER & COMPANY, INC.** recently held an "open house" to celebrate its move to new and larger quarters at 7636 Santa Monica Boulevard in Los Angeles. The new headquarters provide display, office, service, and warehouse facilities under a single roof.

-50-

Spot Radio News

(Continued from page 18)

a turmoil. Noting that the fate of 31 licensees (in cities where channel changes have been authorized) are involved in this decision, the Commissioner said: "I am convinced that had... these... licensees... been advised by the Commission that they might be subjected to hearings on competing applications when the *show-cause* orders were issued requiring a move to a different channel from the one occupied, the Commission would still have been in the *ice age*, because these licensees, for their own protection, would have objected to the *show-cause* orders in order to avoid competitive hearings with new applicants for the new assignments in their respective communities."

Reviewing the consideration of mileage separation in these instances, Sterling noted that... "It is well known that because of the mileage separation required between cities in order to provide an engineeringly sound, nationwide assignment plan, there is a chain reaction which affects co-channel assignments hundreds of miles from a particular city. It is obvious from the above that the assignment proceedings and the *show-cause* proceedings were interdependent and constituted a single plan of action on the part of the Commission."

THE WASHINGTON COMMUNICATIONS circle received a thumping bit of news a few days before Fall set in when the White House released an announcement disclosing that the Commission's warring dissenter, Robert F. Jones, had decided to return to law practice and join a battery of counsellors in Washington.

During a hush visit to the President's quarters, Jones presented his letter of resignation, which said in part: "I want to thank you again for the opportunity which you gave me to serve on this important commission of the federal government. I have found a great deal of pleasure in adding this experience to my years of public service. I am grateful to have participated as a Commissioner in the development of administrative law which is playing so important a part in the everyday life of the American people."

The first Commissioner to resign since the passage of the McFarland Act amendments, Jones will not be obligated to comply with the Act's

requirement barring members of the Commission from practicing for a year before the agency, since his resignation, entered within a year of enactment, meets the Act's proviso that such persons would be exempted.

Jones took office in '47 following the withdrawal of the nomination of Ray C. Wakefield. Before coming to Washington, the former Commissioner had been a part owner of the *Northwestern Ohio Broadcasting Corp.*, which now operates WIMA in Lima.

Several persons had been suggested for the vacated Commission post: William P. Massing, assistant secretary of the Commission and a staff executive for over twenty years; Benedict P. Cottone, FCC's general counsel; Edward P. Morgan, formerly a Justice Department attorney; and Dr. Franklin Dunham, chief of radio and television in the U. S. Department of Education.

The President announced a recess appointment, Eugene H. Merrill, mining engineer formerly with the National Production Authority and Defense Production Administration. Prior to this experience he was chief of communications of the U. S. Military Government in Germany. In January, when Congress reconvenes, he may be nominated for the balance of Jones' year and a half term.

FREQUENCY PROBLEMS which now prevail in the police and fire services, received an extremely comprehensive analysis during the annual meeting of the International Municipal Association in Boston, by the Commission's chief of safety and special radio services, Edwin L. White.

Boldly declaring that our ability to use the spectrum has not kept pace with the growth of the use of radio, the government specialist said that we know . . . "how to make improved use of the spectrum, but are saddled with a great deal of equipment which might be considered obsolete in the light of present-day techniques."

In view of this condition, it was noted, the services are beginning to find themselves cramped in their ability to meet all of the demands made on the communications system.

Pointing out that everyone admits that the best method that can be used by every licensee revolves about the use of his own frequency, so that it is possible to operate in the manner and with the equipment best suited to the pocketbook, requirements, and pet ideas, White declared that such an ideal cannot be attained since . . . "the physical limitations of the frequency spectrum make this impossible." Thus, he added, we must explore and find the means that must be adopted to meet the communication needs of all.

In a review of frequency-selection possibilities open in solving the problem, the old low band assignments were probed. It was revealed that many of the first police radio systems are still operating in the 2-megacycle

No "CANNED" Effect.

WEATHERS

FREQUENCY MODULATION PHONOGRAPH PICKUP SYSTEM

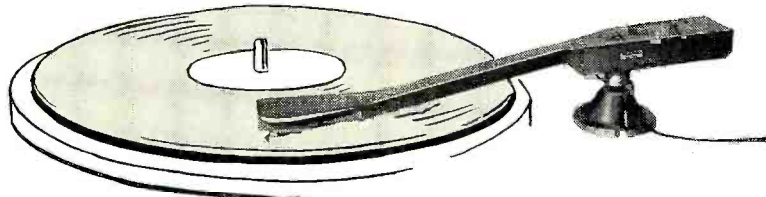

REALISM without "NOISE"



W-2 FM Capacitance Pickup Cartridge

- Greatly Reduced Stylus Pressure
- Extended Record and Stylus Life
- Negligible Distortion
- Negligible Needle Talk
- No Undamped Resonances
- No Hum From Motor Field
- Triple Play Single Stylus Model Plays ALL Records

NEW! Weathers Reproducer Arm for the W-2 FM Capacitance Pickup



W-212 Arm and W-202 Cartridge Set for any 16" transcription turntable

(For Standard W-2 Cartridge Only)

Protect your investment in new records with the one gram stylus pressure of the Weathers cartridge and arm. You will be amazed at the reduction in stylus wear. A new standard in record reproduction which must be heard to be fully appreciated. The low mass of the Weathers stylus follows every groove undulation perfectly without distorting the groove wall.

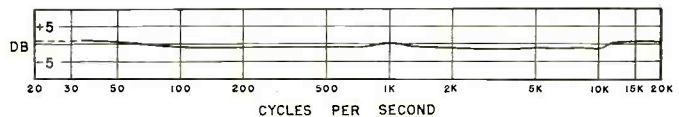

Typical frequency response curve produced with Cook Series 10 Test Record. (Response over 500 cycles compensated to obtain constant velocity characteristic.) Terminals provide compensation based on AES Standard Playback Curve or constant-amplitude response, as preferred.

SIMPLE INSTALLATION COMPONENTS

Each cartridge, or cartridge and arm set, includes a Weathers oscillator with pickup cable receptacle and power cable for one 6AT6 tube. Power cable may be connected to user's amplifier (receptacle supplied) or to Weathers W-22 Power Supply, sold separately. The new W-21A oscillator is factory-adjusted with the cartridge and pickup cable in each set and does not ordinarily require further adjustment, even after tube replacement.



Oscillator

Power Supply

CARTRIDGE FOR STANDARD RECORD PLAYERS

The W-202-C Universal Cartridge Set is available for installation in modern record players, manual and automatic, and in standard makes of transcription arms. Stylus pressure may be adjusted to 3 grams or less when installed in a Webster automatic changer or RCA-45 record player. W-202-C Universal Cartridge Set is electrically identical with the W-202 and W-212 Standard Set (used only with the Weathers arm), but the stylus compliance is slightly reduced.

WEATHERS INDUSTRIES

BOX 531

66 E. GLOUCESTER PIKE, BARRINGTON, NEW JERSEY

See your distributor or write for literature

IT'S NEWARK

For the Best Buys in Audio

NEWARK'S FM-AM RECEIVER

Hi-fi FM-AM chassis featuring push-pull audio output. FM circuit is drift-compensated. Has full range bass-treble tone control and phono jack with built-in preamp for magnetic pickups. Chassis is complete with 12" PM speaker, built-in AM and FM antennas, 12 tubes (including rectifier), all hardware, and escutcheon. Size, 13½x9x9". Wt., 20 lbs.

96G034. SPECIAL PRICE..... 69.50

SAVE ON THE FAMOUS BRUSH MICROPHONE

It's another sensational Newark value—the famous Brush BA-116 microphone which originally sold for \$8.61—now selling, while quantities last, at the very low price of \$5.95! This rugged microphone is ideal for tape recording, PA, or Amateur use. Response, 50 to 6,000 cycles. Output level, -53 db. High impedance. Shock-mounted crystal cartridge. Has ⅜"-27 thread. Brown finish. Wt., 1½ lbs.

54F350. SPECIAL PRICE..... 5.95

SAVE ON THE FAMOUS REGENCY BOOSTER

The popular model DB-410 booster which originally sold for \$19.11—now only \$14.11. Mahogany plastic case. With 6J6 tube. Wt., 6 lbs.

90F150 SPECIAL PRICE..... 14.11

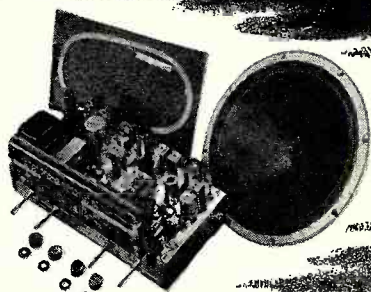

Tops for Tape Recording



Top Value in a TV Booster

Order from Department R-12

Send for FREE Catalog

223 W. MADISON ST.



CHICAGO 6, ILLINOIS

ELECTRIC COMPANY

Examine FREE

PULSE TECHNIQUES

by S. Moskowitz and J. Racker

Get this new self-training book for 10 days' free examination

Here is everything you need to know about pulse techniques—a subject of increasing importance in television, communications, and all electronic equipment. This book covers transient response of linear networks, design of pulse networks, pulse shaping and clamp circuits, pulse generation, measurement, and instruments, pulse communication systems, and aerial navigations aids.

PARTIAL CONTENTS: Fourier-transform method. Response of an ideal low-pass filter to a step voltage. Physical significance of response curves. Response to a pulse series. Determination of network response by Fourier transforms. Use of partial fractions in the solution of transform problems. Laplacian transform and inverse Laplacian of a step voltage. Typical network problems using L transforms. High-pass RC filter. Pulse transformers. Step-voltage build-up time response of a step-down transformer. Delay-time response. Special coaxial delay lines. Design of lumped lines. Supersonic delay lines. Shunt-peaking amplifier. Four-terminal coupling networks. Transmission-line amplifiers. Cathode follower. Limited circuits. Clipping circuits. Peak-riding clipper. Integrating circuits. Positive-bias restorer. Electron-coupled pulse oscillators. Relaxation oscillators. Multi-vibrators. Sweep circuits. Time calibration. Pulse-counting systems. Commutation. Modulation. Synchronization. Commercial pulse communication system. Introduction to radar systems. Timing unit. Radar receiver. Naval system. Loran system. Get this authoritative handbook today! Coupon below brings you "Pulse Techniques" on FREE trial for 10 days. Mail it NOW!

—MAIL COUPON TODAY.

Prentice-Hall, Inc., Dept. M-RTN-1252
70 Fifth Avenue, New York 11, N. Y.

Please send me a copy of PULSE TECHNIQUES for FREE examination. Within 10 days I will either return the book and owe nothing, or keep it and remit \$2.65 down (plus postage) and \$2 monthly for 2 months.

Name

Address

City..... Zone..... State.....

NOW... quickly, easily
cut SQUARE and
OBLONG openings
in radio chassis



WITH THE GREENLEE No. 731 SQUARE RADIO CHASSIS PUNCH

Now, in 1½ minutes or less you can do hole-cutting jobs that might take an hour with old "drilling and filing" methods. Simply insert GREENLEE Punch and turn with an ordinary wrench... a square or oblong opening is cut immediately. An indispensable, timesaving tool that pays for itself in a hurry.



In sizes ⅜", ¼" and 1"

GREENLEE



Write today for facts and prices on this handy Punch. Greenlee Tool Co., 1892 Columbia Ave., Rockford, Ill.

band; some of these operators would like to shift to higher bands but are stymied by budget restrictions. In some instances these frequencies are useful since they permit longer distance coverage. However, the frequencies are also perfect for direction finding and can be used as a means of navigation by either standard aircraft or even guided missiles, and thus constitute a defense communications problem. Noting that the use of AM and narrow bands in these lower frequencies requires the use of expensive higher power equipment to overcome noise and static, the government's agent declared that... "in the long run, supplementary base stations in the v.h.f. band with low power requirements might well prove cheaper than a lesser amount of high-power low-frequency stations."

Describing the 35- to 50-megacycle band as quite attractive to the police, White noted that this band is subject to long-range interference, and thus it becomes necessary to balance this fact against the extra antenna heights and other means that may... "be necessary to obtain service equivalent to that obtainable from frequency bands which are less subject to long-range interference."

Two bands were described as the best for current demands: 150 and 450 megacycles. The former has been found so effective that authorizations have poured into the offices of the Commission, causing acute congestion. A partial solution, it was noted, lies in the 450-megacycle band, particularly in urban locations.

Surveying the virtues of channel splitting as a means of adding frequencies, White said: "We have had some objection from existing licensees to channel splitting on the ground that because of insufficient receiving selectivity, the man on the adjacent channel will cause interference."

Continuing his frequency-application dissertation, the special-services chief said that frequency sharing has received careful study by industry and with productive results. In his opinion, it would be impossible to... "make the limited frequencies work without industry cooperation."

Outlining the progress achieved in public safety radio services, White said that at the end of the year there were some 212,000 outstanding licenses. Over 11,000 of these were in the public safety services; over 7000 in police and almost 800 in fire operations. Currently there is a backlog of over 11,000 applications for various types of public services, which it is hoped will be cleaned up before the year is over.

THE HEAVY COSTS OF THEATER TV have been revealed in a special report prepared by the Long Lines Department of the telephone company for motion picture producers and exhibitors, and filed as an exhibit for hearings in Washington.

The brief disclosed that a south-

bound channel and one northbound channel serving New York, Trenton, Philadelphia, Atlantic City, Wilmington, Washington, and Baltimore, covering seven transmitting and thirteen receiving stations, would cost over \$40,000 for sight and nearly \$8000 for audio lines, when billed on a monthly basis for eight consecutive hours daily, and for links from Philadelphia to Reading and Allentown, Pa.

For the same areas, three southbound channels and one northbound channel, serving thirteen transmitting and some 29 receiving stations would cost over \$85,000 for video and over \$16,000 for audio. And for six southbound channels and two northbound channels, involving service to 27 transmitters and 58 receiving stations, the charges jump to over \$170,000 for visual and over \$34,000 for sound.

The report also contained estimated charges for service to 15 to 20 theaters in Washington. For the simplest arrangement, the costs would be around \$8300 for video and about \$550 for audio. The most complex setup would cost over \$9000 for video and around \$650 for audio. The theater owners were also told that installation and equalization charges would also appear on the bill, and these might run from over \$350 to around \$1500 plus.

EDUCATIONAL TV, the gospel of the Commission's headman and Madame Commissioner Henneck, once more has been described as a revolutionary medium that every educator should cheer by Chairman Walker, this time at a meeting in Harrisburg. Addressing a session of the Joint Committee on Educational Television for Pennsylvania at the Annual Education Congress, he declared that instruction by television can help the more than 10,000,000 illiterates now living here, making them more able citizens, more valuable to industry, more valuable to the Armed Forces, and better consumers.

Walker viewed a television channel as a turnpike through the ether . . . "a turnpike which scorns time and distance and over which . . . it is possible to send unending cargoes of educational programs."

THE VITAL COMMUNICATION links required during the frightening disasters that may follow atomic blasts, or floods, fires and tornadoes, underwent a thrilling ham test a short while ago, as the American National Red Cross coast-to-coast teletype network operating from Washington relayed messages received by radio to amateur coordinators in Washington, Chicago, and San Francisco. Fixed, portable, and mobile stations went into action as the coordinators flashed word of duties to be performed. Here was a brilliant display of moving cooperation, illustrative of the rousing brotherhood spirit of the hams of the nation. . . . L.W.

December, 1952



Sensational TUBE SAVINGS

70% to 90% Off List!

Thousands of tube buyers have recognized the tried and true performance, plus economical service of Rad-Tel fully guaranteed tubes. Each tube is rigidly tested, each tube is a standout value—sufficient reason why Rad-Tel tubes are the sensation of the nation.

All Tubes Individually Boxed! Same Day Service!

✓ **Check this list for Fully 90-Day Guaranteed Tubes**

Type	Price	Type	Price	Type	Price	Type	Price	Type	Price
0B3/VR90	.75	5U4G	.45	6BF5	.41	6557	.42	125N7GT	.52
1A5GT	.46	5V4	.73	6BF6	.37	6T8	.56	125Q7GT	.44
1A6G	.59	5W4	.50	6BG6G	1.25	6U4	.60	125R7	.49
1A7GT	.47	5X4	.40	6BH6	.46	6U5	.44	14A7	.50
1A85	.59	5Y3	.32	6BJ6	.39	6U6	.63	14I7	.60
1B3	.65	5Y4G	.35	6BK7	.59	6U8	.61	14W7	.60
1B5	.59	5Z3	.46	6BL7	.59	6V3	.93	19BG6G	.95
1B7GT	.59	6A3	.59	6BQ6GT	.59	6V6GT	.39	19C8	.70
1CSGT	.43	6A7	.59	6BQ7GT	.72	6W4GT	.44	19T8	.79
1E7	.29	6A8	.62	6BY5	.65	6W6GT	.44	19V8	.89
1H4G	.48	6AB4	.44	6BZ7	.90	6X4	.37	25AV5	.63
1H5GT	.40	6AG5	.43	6C4	.37	6X5GT	.42	25BQ6GT	.42
1G6	.60	6AJ5	.90	6C5GT	.39	6Y6G	.48	25L6GT	.39
1L4	.46	6AK5	.75	6C6	.44	7A4	.47	25Z5	.40
1LC5	.51	6AL5	.38	6CD6G	1.11	7AF7	.53	25Z6GT	.37
1N5	.46	6AQ5	.39	6D6	.45	7B4	.44	25W4	.56
1P5	.57	6AQ6	.37	6E5	.48	7C6	.40	26	.45
1Q5	.58	6AR5	.37	6F5GT	.39	7E6	.49	27	.39
1R5	.45	6AS5	.50	6F7	.37	7F7	.59	35B5	.40
155	.39	6AT6	.37	6G6G	.52	7X7	.70	35C5	.39
1T4	.45	6AV5	.83	6GGT	.41	12AL5	.37	35L6GT	.41
1T5	.53	6AU6	.38	6J5GT	.37	12AT6	.37	35W4	.37
1U4	.45	6AV6	.37	6J6	.52	12AT7	.56	35Z4	.39
1U5	.39	6AX4	.53	6J7G	.43	12AU6	.38	35Z5GT	.37
1X2	.63	6B4G	.64	6J8	.69	12AU7	.43	36	.60
2A3	.70	6B5	.64	6K5	.47	12AV6	.39	41	.42
2X2	1.50	6BA6	.39	6K6GT	.37	12AV7	.59	42	.42
3A4	.45	6BA7	.57	6K7	.44	12AX4	.48	43	.55
3E5	.46	6BC5	.44	6L6	.64	12AX7	.48	45	.55
3Q4	.46	6BC7	.71	6Q7	.45	12AZ7	.69	50R5	.39
3Q5GT	.49	6BD5GT	.59	6S4	.38	12BA6	.38	50C5	.39
354	.46	6BD6	.45	658	.53	12BD6	.45	50C6	.59
3V4	.47	6BE6	.39	65A7GT	.43	12BE6	.39	50L6GT	.41
				65B7GT	.41	12BF6	.39	50V6	.46
				65F5GT	.46	12BH7	.63	50Y7	.50
				65G7GT	.41	12J5GT	.42	70L7GT	1.09
				65H7	.73	12Q7G	.39	75	.41
				65J7GT	.41	12S8	.70	76	.44
				65K7GT	.41	12SA7GT	.44	78	.47
				65L7GT	.48	12SG7GT	.52	80	.35
				65M7GT	.52	12S7	.44	80V6	.46
				65O7GT	.37	12SK7GT	.48	117L7	.99
				65R7GT	.45	12SL7GT	.47	117Z3	.37
								807	.99

Rad-Tel TUBE CO.

"Integrity Is Our Chief Asset"

Phone: Essex 5-2947

Unlimited Opportunities in RADIO ENGINEERING

DEGREE IN 27 MONTHS

Complete Radio Engineering course, including Telev., U.H.F. and F.M. Bachelor of Science Degree also in Mech., Civil, Elect., Chem., and Aero. Eng.; Bus. Adm., Acct. Extensive campus, modern buildings, well equipped labs. Low cost. Prep courses. Personalized, practical instruction. Founded 1884. Placement service. Growing shortage of engineers. Prepare now for unlimited opportunities ahead. Enter January, March, June, September. Write for catalog.

TRI-STATE COLLEGE

16122 College Ave. ANGOLA, INDIANA

TERMS: A 25% deposit must accompany all orders—balance C.O.D. All shipments F.O.B. Irvington warehouse. Orders under \$10—\$1.00 Handling Charge. Subject to prior sale.

Enlarged Quarters to Serve You Better!

**115 COIT STREET
IRVINGTON 11, N. J.**

GARRARD

WORLD'S FINEST
AUTOMATIC RECORD
CHANGER

MODEL RC 80
\$4230 net
less cartridges

3 Speeds . . . fully automatic with automatic stop

Garrard Sales Corp., Dept. R-12
164 Duane St., N. Y. 13, N. Y.

Send GARRARD Fact Sheet.

Name.....
Address.....
City.....Zone.....State.....

Can be used with your present set.

How to use

KRYLON[®]

to cut down contract service calls

Krylon is a tough, quick-drying Acrylic coating with many important TV applications. To apply, just push the button on the aerosol can and spray—that's all you do!



Because of its high dielectric strength, Krylon helps prevent corona. Here technician Bernard Vanella—on the staff of dealer Mort Farr, Philadelphia—"Krylon-izes" high voltage coil and insulation, the socket of the high voltage rectifier, component parts of the rectifier circuit.



Edward Weigand, Farr service man, sprays Krylon on entire antenna. Krylon shuts out moisture, rain, salt spray—prevents corrosion and pitting—keeps picture quality at peak.

"Krylon-izing" increases your customer's satisfaction and jumps your own profits! Nationally advertised to your customers!

TECHNICAL CHARACTERISTICS

Dielectric constant—2.8 to 2.4
(1,000 cycles)

Dielectric strength—400 to 800 (number of volts necessary to cause electric arc through Krylon coat one mil thick)

Electrical resistance — 10^{10} ohms/om³

See your jobber, or write direct.

**KRYLON, Inc., Dept. 2712
2601 N. Broad St., Phila. 32, Pa.**

Cascade-Cascade (Continued from page 49)

d.c. isolation for the moment and considering only the i.f. or r.f. equivalent. Fig. 4C shows the same circuit redrawn to show the two coils wound on the same form and merely tapped at the center. Figs. 4A, B, and C are all exactly the same circuit from the standpoint of r.f. If we go one step further and eliminate the condensers used to tune each half of the coil and substitute the input and output capacities of the tubes, we have the circuit of the transformers used in the cascade-cascade. See Fig. 3. This particular arrangement has several advantages in v.h.f. amplifier design. First among these is the reduction in shunt capacity which permits higher values of inductance to be built into the tuned circuits. When the input capacity of one tube is paralleled across the output capacity of another tube as in single coil amplifier designs, the resulting reduction in inductance causes a very low effective value of Z_p for the tube load. Under such conditions, the gain possibilities of the tube are largely wasted. High losses also result from the parallel loading of the two tubes across a common inductance. This leads to broad response and poor noise figures. The physical design of these double-tuned transformers is extremely simple. They are all wound close spaced, tapped at one point and slug tuned. The coils tune with the slug just starting to enter the end which has the smallest tube capacity across it. For this reason, the slug acts partially as a small trimmer capacity and because of the tight coupling between the two windings, tuning one end also tunes the other. Or, in other words, the whole coil tunes as if there were two condensers in series across the whole winding and one were fixed and the other variable. There is some effect from the iron also, and both of these effects are complementary.

The mixer stage is quite conventional and uses a pentode-triode for economy of space and high gain. The use of a pentode at this point is justified because the gain of the r.f. amplifier is so great that the mixer stage is operated at a sensitivity level far below the point at which it can contribute any significant noise to the system. The i.f. band, which is 4 mc. wide, with a center frequency of 10 mc., is fed out of the 6X8 mixer, across a choke in the plate circuit, to the grid of one triode section of a 12AT7. This section, in conjunction with the choke-coupled plate of the mixer, acts as a simple, broadband impedance-matching transformer to match the high impedance plate to the low impedance input of the receiver. The output impedance of the cathode follower is designed to be 300 ohms which is a good match for most communications receivers.

Injection voltage is obtained from a harmonic crystal oscillator, operating on its 5th overtone in a typical regenerative oscillator circuit which has been described many times before by others. The output of the oscillator feeds a second triode section, which is one-half of the 6X8, where it is multiplied by 4.

Starting with a fundamental crystal frequency of 6800 kc., this is multiplied 20 times in the manner just described so that the injection frequency is 136 mc. As mentioned before, this produces an i.f. band ranging from 8 to 12 mc. which must be tuned by the communications receiver. By electing to use an injection frequency which is lower than the incoming signal frequency, one very useful purpose is served. An i.f. passband results which is numerically related to the incoming signal frequency in a convenient manner. The band will be four megacycles wide. The low end of the 2-meter band will correspond with 8 mc. on the receiver dial. The high end will correspond to 12 mc. on the receiver dial. Any frequency between 144 mc. and 148 mc. can be easily interpolated. For instance, 145.2 mc. will be found at 9.2 mc. on the receiver dial, etc. The calibration of the converter becomes as good as that of the communications receiver with which it is used.

In aligning or adjusting the finished converter, a vacuum tube voltmeter and a grid dip meter are almost essential. The grid dip meter should be used to set the r.f. coils to the center of the band. Next, the vacuum tube voltmeter is used to tune the oscillator coil until the crystal oscillates. Reading voltage across the oscillator grid resistor will determine when the crystal breaks into oscillation. This is marked by a sudden change in grid current. The slug should be adjusted until the point is found where the oscillator will restart each time the "B+" is switched on and off. The quadrupler is adjusted by tuning this for maximum developed bias on the grid of the 6X8. This voltage should be around -3 volts for good mixer efficiency. Using the grid dip meter to check the frequency of this coil is wise since the coil can be tuned to the third harmonic, or 102 mc. as well as the fourth, or 136 mc.

After preliminary alignment, the unit should be put on an antenna and the r.f. stages staggered by listening to stations or ignition noise and peaking the input and mixer stages on the high end of the band while adjusting the interstage coil to the low end. This will result in a reasonably flat gain curve throughout the band with sharp attenuation starting around 143 mc.

The results obtainable from this converter have been enthusiastically reported from many sections of New England where large numbers of hams have seen and heard it at their local amateur clubs. Those who have built it report superior performance to any-

thing used to date. The measured gain from antenna input to cathode follower output is 225. This is accomplished with very little noise. In typical locations, the noise at the output terminals of the receiver is 80% antenna and environmental noise, such as ignition noise, man-made interference and other unidentifiable noises. Removal of the antenna results in a noiseless receiver. Construction is simple and straightforward. Physical layout, Fig. 5, should be closely adhered to and the components copied exactly or oscillation and instability may result. The knob shown in the photograph, Fig. 1, is attached to a variable cathode resistor in the first triode. This is used as an r.f. gain control to decrease gain when working high-powered local signals which otherwise tend to overload the converter and receiver. It will not be required in most locations unless there are other 2-meter stations operating within a few blocks.

-30-

Mac's Service Shop
(Continued from page 54)

a mechanical labor charge for removing and replacing the set based on an hourly rate that will adequately cover such items as the mechanic's salary—which will equal what he could get in a garage—the overhead of the department, and a reasonable profit on the mechanical operation. In addition there will be a labor and parts charge to cover the actual repairing of the set on the bench. Here again the labor charge will take into consideration auto radio department overhead, technician's salary, and profit. The customer looking at this bill will be made to realize why the installation of an item that is inexpensive in itself can still result in a bill of several dollars.

"What makes you think they will pay it?"

"Several things: for one, anyone who has any auto work done these days is pretty well accustomed to paying well for it. A fifty-dollar charge for putting a five dollar part into an automatic transmission is not at all unusual with some cars. Secondly, the higher charges of TV service have helped to accustom people to paying for electronic service. Thirdly, when an auto radio goes bad the customer cannot rob the kitchen or the bedroom of a set and keep on listening as is the case when the living room receiver goes out. Either he has the car set fixed or he rides in silence—a most revolting development for many moderns. There that dead set sits and constantly reminds him that his 'Whooper-Dooper Eight' has an imperfection, a gadget that will not work. You'd be surprised how something like this can prey on the mind of a car-lover."

"If I know you, you've probably dreamed up some new ideas for equipping that department, too."

ORDER BY MAIL FROM WHOLESALE RADIO

Low Prices • Complete Stocks • Fast Shipments

All Directional TV AERIAL

Same Clear Pix As Expensive Motor Rotating Aerial Systems!

FOR FRINGE AREA **\$18.95**

COMPLETE with three 3/32 ft. masts, 75 ft. 3 conductor cable. Beam selector sw., guy rings and mounting base. Electronically beams complete 360° rotation to give clear pic on all channels. You choose direction with directronic selector sw. mounted on or near TV set. Complete double stacked array with 18 hi-stensil double alloy aluminum elements. Extra 3 cond. lead-in—4c per ft. if required. AX 599 same as TX 599 less masts, guy ring and mounting base...\$16.95

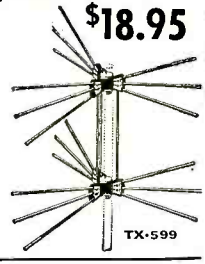

Hot As A Pistol! Dealers Selling 'Em By Dozens New! Sensational, Sound AMPLIFIER

COMPLETE WITH TUBES **\$1075** & SPEAKER..

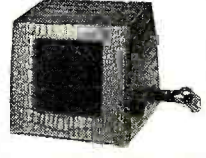

Nearly everybody has a use for this sensational new amplifier. Use with all speed record players and eliminate special wiring and hookups to radio or TV. Use with FM tuner. Use a pair with microphones as intercom. Use for parties, meetings, baby minder, etc. Full range volume control with on-off switch. 5" Alnico 5 PM speaker. Input jack for phono or mike. Attractive cabinet covered in simulated alligator leather. 7 3/4" w—8 1/2" h—6" d. Complete with tubes: 35Z5GT, 50L6GT, 12SQ7. AC or DC 105-120 V. 25-60 cycles. Wt. 2 1/2 lbs. Order Model S-311.

End-of-Year CLOSEOUT! Masco Sky Chief TV Booster

Made by one of America's most famous electronic houses. Takes 300 ohm twin lead or 75 ohm coaxial. Two 6J6's and selenium rect. One tuning control. UL app. Reg. \$40 List **\$16.95**



More Big Booster Bargains! While They Last!
\$45.33 Masco Super Sky Chief.....\$33.24
20.97 Standard B-51..... 15.37
19.50 Astatic BT-1..... 14.30
20.97 Astatic BT-2..... 15.37
26.97 Automatic Booster 1T75A. Fully automatic for all channels. Requires No Tuning..... 19.77

The Perfect Christmas Gift! CUSTOM MADE AUTO RADIOS

All with 6 tubes, 3-gang cond. Automatic volume control. Permanent magnet dynamic speaker with powerful Alnico 5 magnet. Easy vision slide rule dial. No holes to drill. Installs in 3 to 4 min. Especially designed for the individual car.

Ford '49, '50.....	WF-100	
Dodge, Plymouth '49, '50.....	WD-200	
Ford '51.....	WF-151	
Ford '52.....	WF-152	
Dodge, '51, '52.....	WD-251	
Chevrolet, '51, '52.....	WC-351	
Hudson, '48, '49, '50, '51, '52.....	WH-451	
Studebaker, '50, '51, '52.....	WS-551	
Henry J, '51.....	WK-751	
Chevrolet, '49, '50.....	WC-300	
Chevrolet, '49, '50.....	WC-300	\$41.97
Plymouth, '51, '52.....	WP-651	41.97

Only **\$3997**

HI-FI CARTRIDGES

GE RPX-050 with dual reversible sapphire stylus.....\$ 8.37
GE RPX-051 same as RPX-050 less stylus... 5.26
GE RPX-052 with combination .001 diamond and .003 sapphire stylus..... 23.37
GE RPX-040 with .003 sapphire..... 5.97
GE RPX-041 with .001 sapphire..... 5.97
GE RPX-042 less stylus..... 4.35
GE RPX-046 Professional type (less stylus) 6.87
GE RPX-047 Broadcast type (less stylus)... 9.27
PICKERING S1405 Sapphire LP Stylus... 15.00
PICKERING D1405 Diamond LP Stylus... 36.00

Pilot HI-FI AM-FM TUNER

All New Advanced Design
Model AF 821
Self contained power supply. With tone controls in flat position audio frequency response is within plus or minus 2 db. Maximum undistorted audio output is 7 volts **\$99.95**



DELUXE CLOCK RADIO

Beautiful Wood Cabinet!
Telechron Clock with Sleep Switch
Top quality 5-tube AC-DC superhet Chassis
CL-152-B Blonde
CL-152-M Mahogany
\$2497

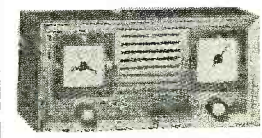

Address Orders to Dept. RN-12 Write for Free FYI Bulletin

WHOLESALE RADIO PARTS CO., Inc.

311 W. BALTIMORE ST., BALTIMORE 1, MD.

NEW! MOSLEY WALL-THRU

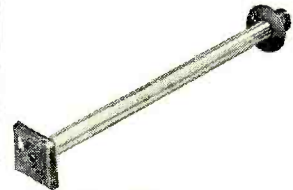

For TV, FM and Amateur Transmission Line
• Fits Any Wall Up to 13" Thick!
• Completely Weather-Proof!
• For Standard Flat 300 Ohm Line or RG-59/U Co-ax Cable!
• MOSLEY Lead-In Socket Can Be Mounted Direct to Inside Plate!
• Precision Molded Polystyrene End Plates!
• Easily, Quickly Installed!

Cat. No. 625 List Price \$1.95
Cat. No. 625-PK Wall Thru, complete with MOSLEY Universal TV Lead-In Socket and Plug. List Price \$3.00

MOSLEY ELECTRONICS
2125 Lackland Road Overland, Missouri

... to servicemen
who really want to
learn to use the
OSCILLOSCOPE
fully and accurately!

A complete
guide to using
the handiest
service instru-
ment of all...
... On all kinds
of jobs!...
Written so you
can really
understand it

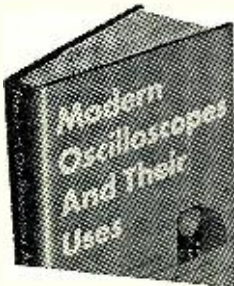

**MODERN OSCILLOSCOPES
AND THEIR USES**

By JACOB H. RUITER, Jr.
of Allen B. DuMont Laboratories, Inc.
326 pages, 370 illustrations, \$6.00



Like most servicemen, you've probably read a lot about oscilloscopes—but still don't know how to use them as well as you'd like to.

If so, here's the book you've been looking for!

In MODERN OSCILLOSCOPES AND THEIR USES, Mr. Ruiter starts right at the beginning. He shows how oscilloscopes are designed and how they work. Then he explains exactly how, why and where to use them.

No involved mathematics. No puzzling theoretical discussions. Instead, this world famous authority gets right down to earth in answering the questions that have probably kept you from taking full advantage of the money-making service possibilities in oscilloscopes.

**HOW TO HANDLE TOUGH JOBS
EASIER AND FASTER**



From routine troubleshooting to handling the toughest realigning and adjusting jobs, each operation is carefully explained. These include determining where and how to use the oscilloscope; how to make connections; how to adjust circuit components; how to set the controls—AND, ABOVE ALL, HOW TO ANALYZE PATTERNS.

From dozens of pattern photos you see and learn to recognize patterns that are wrong, nearly right and exactly right!

**SAVE HUNDREDS OF DOLLARS
IN AM-FM-TV SERVICE TIME!**



Busy servicemen have told us that the television service section of MODERN OSCILLOSCOPES alone is worth the entire price of the book. Here you get exact procedures for aligning the I-F stages; aligning V-F tuned circuits in the mixer stage; checking gain of the picture I-F stage by stage; troubleshooting the sweep circuits . . . and dozens of other jobs. Similar big sections cover use of the oscilloscope in AM and FM radio servicing and other electronic uses.

No other type of specific service training can mean so much to you in terms of increasing your efficiency and earning power. Use coupon today!

READ IT 10 DAYS at our risk!

Dept. RN-122, RINEHART BOOKS, Inc.
Technical Division
232 Madison Avenue, New York 16, New York

Send MODERN OSCILLOSCOPES AND THEIR USES for 10-DAY FREE EXAMINATION. If book is satisfactory, I will then send you \$6.00 promptly in full payment. If not, I will return book postpaid in good condition and owe you nothing.

Name.....
Address.....
City, Zone, State.....
Employers' Name and Address.....
Price outside U.S.A.: \$6.50, cash only. Money back if you return book within 10 days.

"Well, it's going to be well equipped. The work on auto sets will be done at a special bench right there in the room. In addition to a full complement of hand tools, this bench will have its own signal generator, tube tester, v.t.v.m., scope for checking vibrators, and variable-voltage power supply. Then there will be the bench-on-wheels I spoke of before that can be rolled right up alongside the car. This will carry every kind of end wrench, socket wrench, screwdriver, chisel, punch, hammer, and hole saw that the mechanic can use. There will also be quarter-inch and half-inch electric drills. Three separate extension cords going out from the bench will allow the mechanic to have light where he needs it without the necessity for untangling and changing a single cord every time he moves from one side of the dash to the other.

"The top of this portable bench will carry a volt-ohmmeter with special long test leads for reaching inside the car. There will be another variable voltage supply that can be used on the set in the car in place of the car battery and so simulate conditions of high and low battery voltage without using the battery at all. A really accurate d.c. ammeter will be on the portable bench for determining the true current drawn by the set—a pretty significant bit of information in many cases. Still another item on the top of the bench will be a really sensitive signal tracer with a carefully shielded probe for tracking noise down to its source."

"How about parts? Are you going to stock them heavily?"

"I intend to carry a good stock of vibrators, auto radio tubes, noise suppression items, car antennas, buffer condensers, and other parts of the 'universal' type; but no great amount of money is going to be tied up in special tuning mechanisms, custom kits, trick i.f. transformers, etc. Rather than have several hundred dollars worth of these slow-moving items lying around on the shelf, it is better to use telegrams and the telephone to get them from the jobber or manufacturer when needed.

"I've already written letters to all the well-known auto set manufacturers asking them for the name and address of their nearest jobbers who carry really complete stocks of replacement parts. On top of that I've explained that I'm going to try and give really fast service on their sets and have asked permission to wire for badly-needed parts the jobber does not have on hand and have these shipped directly to me with the billing being done through the jobber. While I don't always get this permission, I do get the name of a man at the factory whom I can call in an emergency. Finally, I asked to be put on the mailing list to receive all factory bulletins on the auto sets."

"I suppose you're going to be as fussy about turning out perfect auto radio service work as you already are

**STAN-BURN
E-P-A-R-K-E**

ANTENNAE SPECIALS

DOUBLE V 3/8"	1.11	12 or more
DOUBLE V 3/8" Dowel	\$2.98	\$2.20
DOUBLE V 1/2" Dowel	3.45	2.45
10 Element Conical 3/8"	4.85	2.55
10 Element Conical 1/2"	3.55	2.55
Folded HI Straight Low Quick Rig		
1/2" elements	4.25	3.25
WINDOW CONICALS	4.95	3.75
5 FOOT SWEDGED	.79	.69
10 FOOT PLAIN	1.39	1.29
TV WIRE		
55 Mil. 300 OHM	\$14.95	M Ft.
72 OHM COAXIAL	45.00	M Ft.

CATHODE RAY TUBE SPECIALS

Standard Brands—Unconditionally Guaranteed

GENERAL ELECTRIC	21EP4A	33.98
STP4	24AP4	66.55
7JP4		
10BP4A	10BP4A	13.00
10LPA	12LPA	16.20
12KP4A	14BP1	18.50
12LPA	15DP4	20.50
12LPA	16EP4A	22.60
14CP4	16EP4A	22.60
14EP4	16DP/HP4A	22.60
16AP4A	16JPA	22.60
16DP4A	16LPA	22.60
16GP4	16KP4A	22.60
16KP4	17BP4	23.70
16KP4	19PA	25.90
17CP4	19AP4	25.90
19AP4A	20CP4	28.00
20CP4	21EP4	29.50
20LPA	16EP4A Rauland	38.20

CHASSIS 630 REGAL with Cascade Tuner. \$139.50
211 T3 FLY BACK (Similar to RCA) 2.98
OPEN FACE CABINET 39.00

TRANSFORMERS

RCA type for 16" to 24" X032 \$3.85
G.E. type for 16" to 24" X045 \$3.85
These are very special prices while they last!

DEFLECTION YOKES

COSINE FERRITE TODD YOKE 70" \$4.20

SPECIALS

4 Prong Vibrators, each. \$ 1.29
Lots of 12 or more. 1.19
Standard TV Tuners, 18.95
12" Heavy Slug Speaker. Special 4.98

Audio Devices, Discs and Scotch Tape in Stock

Audio Plastic Red Oxide Plastic tape—
Half-hour spool. \$2.30 One-hour spool. \$3.30

WIRE RECORDERS IN STOCK

WILCOX GAY Model 2A10 \$ 89.97
PENTRON Model 9T3C—24 Hour Tape Recorder Net 134.50

RADIO CRAFTSMAN

Model RC2—Hi-F Amplifier Net 42.89
Model RC10—AM-FM Tuner Net 130.84
Model CS—Williamson Amplifier Net 99.45

Cascade Guaranteed Tuners (with tubes)
SPECIAL! While they last. \$21.95

AUTHORIZED DISTRIBUTORS for General Electric, Kenrad, Tung-Sol, National Union, Jewel, De Wald, Regal, Automatic and Setchel Carlson.

We carry a complete line of popular makes of Radio and TV tubes, at 50% discount. Also many other special purpose and transmitting types, and all electronic parts and equipment at lowest prices. Send us a list of your requirements for prompt quotations.
Terms: 20% with order. Balance COD. All prices FOB, NEW YORK Warehouse. Minimum order \$5.00.
Write for our latest price list to Dept. RN-122

STAN-BURN RADIO and ELECTRONICS CO.
(C.B.S. THEATRE BLDG.)
1697 BROADWAY • NEW YORK 19, N.Y.

EQUIPMENT NEEDED!
BC-348, BC-342, ART-13
I-152, BC-788, BC-611

Also interested in other airborne electronics.
Top dollar paid. Inquiries answered promptly.
V & H Radio & Electronic Supply Co.
2033 W. Venice Blvd. Los Angeles 6, Calif.
Phone: REpublic 3-1127

COLOR TELEVISION

Color TV is just one of 30 modern subjects included in new I. C. S. course in *FM and Television Servicing*. Other up-to-date, low-cost courses—391 in all. Engineering. Business. Special technical training. Study in your spare time. Set your own pace. Individual instruction from experts. Diploma awarded. I. C. S. is oldest and largest. Known and respected the world over.

FREE "SUCCESS" BOOK! 36 pages packed with worth-while tips on "How to Succeed." Gives you step-by-step plan of action. Pocket-size edition. Man or woman—young or old—if you make \$2000 or \$20,000 a year, this book can help you. Send for it plus free catalogs on career that interests you.

International Correspondence Schools
Scranton, Pa.

Please send "How to Succeed" book and catalog on course in.....
Name..... Age.....
Address.....

about house radio and TV sets," Barney said resignedly.

"Worse," Mac retorted, "because we'll have more to lose. This new department can either help or hurt the business we already have. If we turn out a sloppy auto radio job, we'll not only lose that customer's future auto work, but in all likelihood we'll also lose his house radio and television service.

"Still," Mac continued, as much to himself as to Barney, "I think it is a good gamble. The whole thing, as I see it, rests on several good solid facts: first, there is the fact that the demand for auto radio service is a large and rapidly-growing thing. Secondly, this field is notoriously neglected by most technicians; consequently the competition is at a minimum. Thirdly, one of the technician's main objections to auto radio service—that it requires him to perform mechanical work that he does not like and does not do efficiently—can be overcome by having a trained mechanic do this part of the job. Fourthly, by keeping charges tied to actual costs and by doing the billing in such a manner that the customer can readily understand what he is paying for, there is no reason why this branch of service work cannot be made to pay just as well as any other."

"And maybe when the customers get hep to the fact that the way their sets are mounted in the automobiles can make five or ten dollars difference in every service charge, they will demand that the car makers put them where we can get them in and out easier," Barney suggested.

-50-

ARMY MARS APPOINTS

THE Army has announced the appointment of Major James A. Long, Signal Corps, to be Army Chief of the Military Affiliate Radio System (MARS) replacing Capt. Lester A. Peterson who has received a new assignment with Headquarters, U.S. Army, Alaska.

Major Long will direct the operation of Army MARS and coordinate policy with the Air Force MARS Chief, Major Charles C. Mack. By joint agreement he will also serve as secretary of the MARS Advisory Committee which is made up of representatives of the Armed Forces, Red Cross, Federal Civil Defense Administration, FCC, and ARRL. This committee meets quarterly to advise the Chief Signal Officer, USA, and the Director of Communications, USAF.

-50-

DINNER MEETING

THE Quarter Century Wireless Association will hold its Fifth Anniversary dinner meeting on Friday, December 5th at Fraunces Tavern, Pearl and Broad Streets in New York.

Members and their guests are invited to this event which promises to be one of the club's outstanding meetings. An excellent program has been prepared by the committee.

For information on tickets, contact John DiBlasi, W2FX, 259 W. 14th Street, New York, New York.

-50-

December, 1952



FOR FINEST TV RECEPTION

FOR USE WHEREVER TOUGH WEATHER CONDITIONS PREVAIL
TESTED AND RECOMMENDED FOR FINEST UHF - VHF RECEPTION

GOODLINE SHEATH-LEED—a NEW DON GOOD PRODUCT—is our fine Standard *GOODLINE AIRLEAD encased in a tubing of pure polyethylene of finest quality to protect it under all-weather and all-climatic conditions. It is especially recommended for use in coastal areas where salt spray encrusts the regular leadline, in hot humid areas, where much alternate rainfall and strong sunlight prevails and where leadlines are subjected to frost, snow and icy conditions.



Exhaustive tests made after two years have shown that the average flat or round 300 ohm leadline installed within two blocks from the ocean will give but 2 to 4 weeks of satisfactory operation due to salt spray deposits encrusting the leadline. With GOODLINE SHEATH-LEED protection, the product gives highly satisfactory service for a year and more.

For finest trouble-free reception—even in areas where more favorable weather Prevails—INSIST UPON HAVING GOODLINE SHEATH-LEED INSTALLED FOR YOUR LEADLINE.

NO. 803-GS SHEATH-LEED: STANDARD BROWN GOODLINE AIRLEAD. Sheathed in pure Polyethylene Standard Brown LEED-SHEATH (another new Don Good product). For 300 ohm use. 1,000 foot reels—standard length... Shorter lengths available.

NO. 823-GS SHEATH-LEED: Color—Golden-Clear Goodline Air Lead. Sheathed in Silver-Gray Pure Polyethylene LEED-SHEATH (another new Don Good Product). GOLDEN-CLEAR GOODLINE AIRLEAD is electronic polyethylene in its purest form, and when shielded from ultra-violet light with Silver-Gray LEED-SHEATH, the installation will give years of trouble-free service. For 300 ohm use. 1,000 foot reels—standard length... Shorter lengths available.

NO. 733-GA: *GOODLINE AIRLEAD. THE BASIS OF FINEST TV RECEPTION.

FEATURES: 1—Sharp, clean, "snow-free" pictures—with 80% of loss producing dielectric web removed. 2—Correct impedance for "ghost-free" reception. Nominal 300 ohms. 3—Lower in cost than other leadlines purported to accomplish same results. 4—Correct spacing for minimum radiation loss. Less than 1% of operating wave length. 5—Fully insulated—approved by safety experts. 6—Pure, electronic polyethylene insulation—specially treated by our chemists for extreme weather. 7—Highly efficient conductors: Flexible, stranded—to insure long life. 8—Easily installed with standard insulators. 9—Packaged: 100'—250'—500'—1,000'—2,500'. Colors: Standard Brown, Golden-Clear and Silver-Gray.

IF YOUR JOBBER or TV DEALER CANNOT SUPPLY, WRITE FOR SAMPLES AND NEW LITERATURE

*Patent Pending. *Trade Mark. U.S. and Foreign Patents Pending

EXCLUSIVE LICENSEE AND SOLE MANUFACTURER

Don Good, INC.

1014 FAIR OAKS AVENUE

SOUTH PASADENA, CALIFORNIA

OUTSTANDING GOODLINE PRODUCTS:

DON GOOD, INC. Manufacturers: Sheath-Leed & Leed-Sheath Protection. Goodline Airlead.

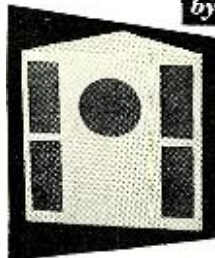

For
Corner
Folded
Horn
Enclosures

Assemble your own folded horn from a Cabinart Kit. Gain a full octave of clean bass that is never reproduced by ordinary cabinets.

#61 (12" speaker).....19.95*
#63 (15" speaker).....23.95*

*Net prices, slightly higher West and South. Sold only through radio parts distributors.

KITS
by Cabinart

... now available in select white gum wood
will take a beautiful blond or mahogany finish

For Bass Reflex & Equipment Cabinets

Will accommodate any combination of high fidelity components. Removable panels for future equipment changes. Loud speaker cabinet is acoustically correct, tuned for the average 12" or 15" speaker. Overall Dimensions: 33 1/2" high, 23" wide, 16" deep. Tuner compartment inside dimensions: 20" high, 21 3/4" wide, 15 1/4" deep. Baffle Volume: 6 cubic feet. Also available assembled—write for additional information.

#80 (Equipment kit) 27.00*
#8112 (12" speaker) 18.00*
#8115 (15" speaker) 18.00*



All Kits include:

- 5/8" white gum plywood cut to size
- Baffle pre-cut for 12" or 15" speaker
- Saran Plastic Acousti cloth
- Hardware • Plastic Wood
- Sandpaper • Glue
- Kimsul Acoustic Insulation
- Assembly Instructions
- Finishing Instructions

G & H WOOD PRODUCTS COMPANY
75 NORTH 11th ST. BKLYN. 11, N. Y.
Pioneers in radio furniture
for high fidelity equipment.

WINCHARGER

NEW LOW COST TELESCOPING TV ANTENNA SUPPORT

Pat. Applied For
Wincharger, pioneer in guyed tower, presents a new design in HIGH QUALITY, RUGGED, DURABLE TV Antenna Support Masts at a budget price. Properly guyed, these masts will support large antenna arrays against high winds and heavy ice loads.

**SAFER
EASIER
FASTER**

Exclusive 3-Point SAFETY CLAMPING RING

with a smoother curving surface, provide maximum rigidity against tube twisting and loosening inside each other due to high winds. Also, allowing a straighter mast.



AUTOMATIC SAFETY CLIP

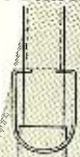

Assembly Tool. Snaps in place with a "click", warning that tube has been pulled out as far as it can safely go. Made of heavy-gauge spring steel wire. This is an exclusive Wincharger safety feature.

A WINCHARGER BASE FOR EVERY TYPE ROOF

Hinged Foot for flat and sloping roofs.



Ridge Straddler... for use on broad or ridged roofs, such as tile, etc.

Ridge Straps... A simple mounting where there is no ridge roll to bridge.



Sell **WINCHARGER**

**SAFETY and FASTER,
EASIER INSTALLATION.**

Sell **WINCHARGER**

**TELESCOPING TV
ANTENNA SUPPORT
MASTS**

Order now from your jobber—
or write for complete details

**WINCHARGER
CORPORATION
SIOUX CITY 2, IOWA**

RADIO-TV Service Industry News

AS REPORTED BY THE
TELEVISION TECHNICIANS LECTURE BUREAU

H. F. BERSHE, manager of renewal sales activities for the RCA Tube Department, is noted for his intensely interesting and graphic presentations of what the industry is doing, where it is going, and about when it will get there.

Mr. Bershe did not disappoint the parts distributors, manufacturers, and representatives who sat in on his talk at the NEDA annual convention in Atlantic City in September. He took the cover off his crystal ball and revealed a glowing picture of the future size of and opportunities in "this fastest growing business on earth."

Since his talk was directed to parts distributors, Mr. Bershe directed their attention to the responsibilities they must assume if they hope to share in the greater opportunities the industry will provide in the months and years ahead. Since distributor growth will be closely paralleled by an expanding service industry, service businessmen will be interested in this forecast of future distributor requirements:

"You know from the facts presented here that, *in general*, the electronics distributing industry—*must*—*in the next eight years—grow three and a half times* its present size to keep up with industry growth. And a careful analysis of your 1960 operating statement will tell you—in specific terms—what your requirements will be for store and warehouse space. The analysis may reveal a need for three or four times the number of *people* you now employ. It is *likely* to reveal that you should start today to streamline and modernize *procedures* that were obsolete a long time ago and that will surely break down under the terrific weight of the renewal electronics volume of tomorrow.

"These 1955 and 1960 operating statements, drawn in the year 1952, will tell you the shocking truth relative to the *capital* you will need to keep up with the fastest growing business on earth."

His forecast for the future included a discussion of the potentials of u.h.f. television, microwave systems, transistors (with an estimate that 42,000,000 of these little devices will be built into equipment in the year 1956!), color television, and industrial television.

His estimate of electronics equipment that will be in use on December 31, 1952, included: Radios (home, auto, portable sets)—110,000,000; television sets—20,250,000; broadcast AM-FM stations—2940; television stations—125; non-broadcast commercial stations—500,000; amateur stations—110,000; and industrial electronics—accounting for 13% of the national electronics renewal volume.

What About Service?

With this glowing picture of the industry's future fresh in their minds NEDA members and their guests stepped into a panel session that took the lid off the parts distributor's individual and collective responsibility in solving the problems that beset the servicing industry.

Mort Farr, president of NARDA, Al Haas, president of the TCA of Philadelphia, and John T. Thompson, manager of *G-E* replacement tube sales, completed a panel session that was slated to cover "How Distributors Can Do a Better Selling Job," with a series of talks that provided the most remarkable triple coincidence your editors have ever heard. These three speakers, each an outstanding representative of a different segment of the industry, delivering talks that were prepared independently of each other, made almost identical recommendations to the parts distributors about what they *must* do to help relieve the pressure of bad public opinion of service.

Mort Farr, reflecting the opinions of radio and appliance dealers who operate their own servicing departments, first focused attention on the need for whole-hearted parts distributor cooperation in helping dealers and service operators to do a better public relations job, to develop practical, dynamic promotions for the sale of the products of the industry and to help dealers and technicians develop better forms and to interchange good business-operating ideas.

Al Haas, whose interpretation of current trends in the industry is that of the independent service businessmen, pointedly took distributors to task for permitting the sources of their bread and butter income to drift into their

present predicament. With respect to distributor cooperation he said:

"In this connection I believe you should consider, and reconsider, in the light of today's problems, your relation to the independent service industry. If your association and its every chapter is not doing its very best to raise the level, the standards and the strength of the independent service industry, *your customers*, I think you are rendering a disservice to yourself and delivering a body blow to your position in the electronics industry.

"You can do a better selling job by making us better customers. Some of you, particularly those from your Keystone chapter, have shown the foresight and leadership—I repeat, *the foresight and leadership!*—to do the necessary and obvious job which will, I hope, ultimately effect the kind of program that is so desperately needed by the independent segments of our industry.

"This program, sponsored by our Joint Electronics and Radio Committee on Service in Philadelphia, and originated by independent parts distributor and service elements in that city, has done a magnificent job in Philadelphia to date. It has been sorely hampered by lack of funds, lack of cooperation, and lack of understanding among its industry contemporaries, but it has not suffered from lack of imagination, ideas, energy, and sound resourceful efforts to stabilize our industry.

"The Joint Committee has done much pioneering during the year or so of its life. Because of its enlightened leadership it could do so much more—for you, for me, and for our industry. It could help to lead the way out of our chaos if only all of us would take the time and make the effort to understand it and then, get behind it with all the resources at our command."

John T. Thompson said that the industry is faced "with a public relations *repair* job, to relieve the highly-trained, completely-honest, thoroughly-conscientious average service dealer of the burden of a soiled reputation."

He said that the program must be headed by electronic components manufacturers and actively endorsed and supported by distributors and dealers. He claimed that unorganized dealers cannot, by themselves, change the tide of public opinion and pointed out that suspicion of the technician has become a threat to the entire industry.

He said that close relationships between various segments of the industry are vital as a base from which to work to provide proof that the service dealer is an honest, conscientious businessman.

Third, he said, distributors and manufacturers must help the technician to improve his operations. He said that dealers should be trained in efficient business practices, effective promotion of their businesses, and advertising their policies of honest billing and good work.

SEE LEO FIRST FOR . . .

hallicrafters

I can SAVE you money . . . Liberal Trade-ins



Leo I. Meyerson
WØGFO

SPECIAL NOTICE—NEW SX-73 NOW AVAILABLE AND IN STOCK — \$975.00



\$169.50

S-76 RECEIVER

Extra selectivity with double superhetrodyne circuit. One RF, two conversion and 3 IF stages. Range 550-1550 Kc, 1.7-34 Mc in four bands. 8 tubes plus voltage regulator and rectifier. Complete with tubes, less speaker.



\$199.50

SX-71 RECEIVER

Double Conversion sharp selectivity, plus built-in NBFM at moderate cost. 11 tubes plus voltage regulator and rectifier. Low down payment.

NAME YOUR TERMS • LOW DOWN PAYMENTS • PERSONALIZED SERVICE

HALLICRAFTERS RECEIVERS AVAILABLE FOR IMMEDIATE SHIPMENT

S-38C	\$49.50	S-72 Portable	\$109.95
S-40B	\$99.95	SX-62	\$289.50
S-81	\$49.50	S-78A	\$89.50
S-82	\$49.50	R-46 Speaker	\$19.95

Famous WRL RADIO REFERENCE MAP 25c



CU on 10-20 & 75 Meters

NEW LOG BOOK 25c

For mobile or fixed station. Spiral binding. Full column log listing all FCC required info. Will accommodate 1,925 stations. "Q" signals, phonetic alphabet, amateur international prefixes.

PHONE 7795

WRITE—WIRE



JUST OFF THE PRESS!

WRL 1953 CATALOG

Send for your copy today. Contains everything new in radio and television. Jam-packed with bargains. Leo I. Meyerson, WØGFO



Send For FREE Copy

WORLD RADIO LABORATORIES

744 West Broadway
Council Bluffs, Iowa

R-12

Please send me:

- | | |
|--|---------------------------------------|
| <input type="checkbox"/> Radio Map | <input type="checkbox"/> SX-71 Info |
| <input type="checkbox"/> New Catalog | <input type="checkbox"/> S-76 Info |
| <input type="checkbox"/> Used Equipment List | <input type="checkbox"/> New Log Book |

Name

Address

City

State

MAKE THIS YOUR HOME FOR IMPORTANT WORK UNDER IDEAL CONDITIONS!

- TEST & INSPECTION ENGINEERS
- ELECTRONIC ENGINEERS
- FIELD ENGINEERS
- LAB. TECHNICIANS
- TV RECEIVER DESIGN ENGINEERS

NEEDED TO WORK ON: YOU BENEFIT FROM high wages, a modern, air-conditioned plant, paid vacations and holidays, group insurance and a good chance for advancement. Housing immediately available in the beautiful suburban and country areas that surround the Bendix Radio plant.

Write, Phone or Wire Mr. E. O. COLE, Dept. O

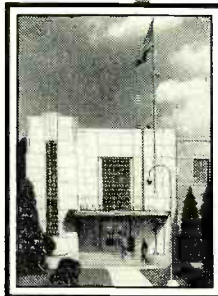

Bendix Radio

DIVISION OF BENDIX AVIATION CORPORATION
BALTIMORE 4, MARYLAND

IN STOCK at HUDSON The NEW **STANCOR CR TUBE BOOSTER**

The ONLY Booster in its Price Range With 2 degrees of Tube Brilliance

SAVE THAT PICTURE TUBE! Add months to its useful life with the new, handy Stancor Tube Booster, P-8192. Easy to install... saves valuable time... meets the needs of every TV serviceman. It is compact, self-contained and can be used with any size CR Tube where dimming is due to low cathode emission. By far the most convenient CR tube booster ever built! Has 18" leads between the booster and the connector plug, allowing booster to be placed anywhere in set... no connections to solder. Only **\$2.89**



NEW 1953 HUDSON CATALOG FREE!

Keep up-to-date with the latest in Radio, TV and Industrial Electronics. Save time and money with this complete, new buying guide! Over 196 pages of Radio, TV, Tubes, Test Instruments... for Industry, Amateur, Service Technicians. World's finest High Fidelity and Audio Equipment, plus the latest JAN Cross-Reference GUIDE and all types of fully approved JAN components.

ALL Standard Makes in Stock for Prompt Delivery — AT LOWEST POSSIBLE PRICES.

HUDSON
RADIO & TELEVISION CORP.

48 WEST 48th ST. • 212 FULTON ST.
New York 36, N. Y. • Circle 6-4060 • New York 7, N. Y.

Send for your FREE Copy Today

One Call for All!

Hudson Radio & TV Corp.

48 West 48th St., New York 36, N. Y. (Dept. A-12)

Please send FREE copy of 1953 Hudson Catalog.

I enclose \$..... Please ship

..... Stancor CR Tube Boosters #P-8192

@ \$2.89 ea. \$.....

Name

Address

City..... Zone..... State.....



New—Standard Brands—Guaranteed TUBES

OA2	\$1.00	6G6G	\$1.10	812	\$2.75
OA3/VR75	1.10	6AC7W	2.75	813	11.95
OB2	1.40	6AJ5	1.95	814	2.95
OB3/VR90	.95	6AK5WE	1.50	815	2.90
OC3/VR105	1.00	6AL5W	2.00	828	9.95
OD3/VR150	1.90	6AN5	3.65	829	9.95
IA3	1.00	6AN6	2.75	829B	11.95
IB22	2.25	6AR6	2.25	830B	2.75
IB23	8.95			833A	34.95
IB24 West	9.50			836	3.45
IB27	14.50			837	1.45
IB32	3.10			845	8.50
IN21B	2.75			852	19.95
IN22	1.25			860	3.75
IN23	4.25			861	19.95
IN23A	2.25			869B	53.00
IN23B	3.50			872A	2.75
IN38	1.50			874	1.10
IN40	8.50	6A56	2.30	884	1.60
IN55	2.75	6F4	4.50	931A	6.50
IN58A	1.25	6H4	6.95	944	3.3
IN63	2.39	6SN7WGT	2.00	955	.49
1T5GT	.95	12AY7	4.50	957	.49
2A1F	8.95	12X7	1.25	959	1.10
2C39	25.00	15R	.69	959	2.95
2C40	9.95	100TH	8.50	977CX	Write
2C43	19.95	250R	8.95	974	2.00
2C44	1.19	200TH	20.00	1005	.69
2C51	5.95	304TH	8.95	1006	2.75
2D22	4.95	304TL	8.95	1012	.90
2D24 W	2.49	307A/RK75	4.25	1624	1.45
2E26	2.95	350A	5.95	1625	.39
2K22	49.50	350B	3.49	1626	1.39
2K23	49.50	350C	1.49	1627	1.39
2K25	29.50	393A	8.95	1632	1.69
2K26	32.00	394A	8.95	2051	1.40
2K29	23.95	417A	8.50	2051	1.40
2K41	110.00	434A	19.95	5611	115.00
2K42	110.00	456B	3.50	5635	8.95
2K48	110.00	456C	3.50	5639	8.95
2X2	.59	464A	10.95	5645	8.95
3A4	.85	605CX	2.75	5646	8.95
3A5	.85	702A	2.75	5651	3.95
3AP1	8.95	703A	4.95	5654	4.30
3B23	4.95	705A	1.50	5672	2.00
3B24	4.95	705B	17.50	5676	3.35
3B24W	7.50	715B	8.95	5678	2.25
3B26	3.50	717A	1.50	5678	4.25
3B27	3.50	721A	2.95	5687	4.25
3C22	80.00	722A	1.95	5687	4.25
3C24/24G	1.50	724B	2.95	5694	2.60
3C33	1.50	724B	2.95	5694	2.60
3C45	16.95	730A	25.00	5704	4.50
3D19	4.95	12-32	39.50	5728	2.95
3E29	13.95	802	3.25	5744	2.95
3F17	1.95	805	3.25	5744	2.95
3G17	3.95	807W	9.95	619CX	5.95
3H7	3.95	807W	9.95	619CX	5.95
4B24	6.95	809	2.95	5814	3.25
4-65A	47.99	810	10.95	5823	2.95
4-125A	25.00	811	3.50	5825	2.95
4X150A	32.50			5815	1.00
4X500A	100.00			6026	Write
5B1	4.95			8015	1.95
5B4	4.50			8012	1.95
5C1	4.50	50-15	\$5.95	9001	1.25
5C22	35.00	50-20	10.00	9002	1.25
5D21	19.95	50-32	12.50	9003	1.50
5F47	4.95	12-20	7.50	9004	.69
5R19	4.50	12-32	10.00	9005	1.50
5R46Y	1.50	100-20	14.50	9006	.69
6G1	12.50			1T5GT	.95

YOUR SURPLUS WANTED
We pay Highest Prices!

Vacuum Capacitors
50-15 \$5.95
50-20 10.00
50-32 12.50
12-20 7.50
12-32 10.00
100-20 14.50

J. S. H. SALES CO.
Dept. R-16, 7552 Melrose Ave., Los Angeles 46, Calif.

!!TUBE CLEARANCE SALE!! 90-DAY GUARANTEE!
Standard brands; unsealed cartons.
#24, 26, 27, 34, 39, 41, 42, 55, 56, 85.
#39 or 9K729c ea.
#14L, 1H6, 1J6, 6B7, 6F5, 6G5, 6SD7, 6SH739c ea.
#35, 45, 71, 77, 1L4, 5Y3, 5Y4, 5U4, 6F6, 6F7, 6G7, 6SA7, 6SK7, 6G3, 6U759c ea.
#147, 11C6, 2A5, 2A6, 6A3, 6A6, 6B8, 6C7, 6S7, 7A7, 7AG7, 7C7, 7Y4, 12SN769c ea.
#47, 50 or 57, 7A7, 7AG7, 7C7, 7Y4, 12SN769c ea.
CK303AX SUB-MINIATURE PENTODE\$1.89

HS-33 HEADSET . . . 10-impd. 13" cord, PL-54. 2.69
SPONGE RUBBER PHONE CUSHIONS . . . per pair39
DYNAMIC HEADSET & HAND MIKE (MK11)3.49
SHIELDED PHONO WIRE . . . coils 20-75 ft.03
RADIO HARDWARE TIREASURE . . . FULL LB.89
CAN OF NUTS, Screws, Washers, Lugs, etc.49
"ALNICO MAGNETS", "H" SHOE, 1" x 3/8" x 3/4"49
ROUND BAR . . . 2" x 3/8" O.D. . . . ea. 59c; 10/5.50
BLACK MOUNTAIN . . . 1/2" x 1 1/2" x 3/8" . . . ea. 25c; 12/2.50
FLAT BAR . . . 1 1/2" x 1" x 5/16"ea. 79c; 6/3.95
ALNICO "CHIP" MAGNETS . . . small irreg.1.50
BLOCK MAGNET KIT . . . Powerful Bar, Block, "U" Rod, etc. Kit of 10 ass'd.1.98
(WRITE FOR LATEST "ALNICO" SUPPLEMENT)



"Jumbo Radio Parts Kit"
17 Full Lbs. of Coils, Condensers, Switches, Controls, Wire, Hardware, Resistors, Sockets, Plus Much, Much More!! (Shpg. wt. 20 lbs.) **\$3.95**

DE-MAGNETIZER . . . 115V. AC. Highly efficient. \$1.29
TU-17 TUNING UNITS (BC223) . . . 2.3Mc. 2.49
BC-606B INTERPHONE CONTROL BOX 4.50
4 GANG VARIABLE . . . 230 mmfd. per sect. 1.29
2 GANG VARIABLE . . . 115 V. 60 cy. 1650 RPM. 5/16" O.D. shaft. Superhet or TRP. Either69
IN21 CRYSTAL DIODES . . . ea. 69c; 10/6.50
CABINET STAY HINGE . . . Powerful spring type49
SUPPORTS cabinet or trunk lid to 70" angle49
CABINET DRAW SLIDES . . . silent, ball-bearing49
13" (9" ext.) \$2.10 pr.; 15" (11" ext.) \$2.25 pr.; 16 1/2" (12 1/2" ext.) \$2.39 pr.; Hvy. Duty 16 1/2" x 12 1/2" all-steel3.25
MOTOR SPECIALS! . . . 1/40 H.P. AC MOTOR (Robbins & Myers) . . . 115 V. 60 cy. 1650 RPM. 5/16" O.D. shaft. Complete with starting condenser & SPDT switch4.95
1/17 H.P. MOTOR (G.E.) . . . 1720 RPM. 7 amp. Shunt wound. 3/8" shaft. 110 V. DC. 4 3/4" x 5 1/2" . . . Shpg. wt. 13 lbs.2.95

"DIRECT FACTORY SPEAKER REPAIRS SINCE 1927"
Min. order \$3.00. 20% deposit req. on all C.O.D.'s.
Full remittance with foreign orders. Please add sufficient postage—excess refunded.

EOTONE RADIO CORP.
67 Day Street
New York 7, N. Y.

Fourth, he said that manufacturers and distributors must tell the public directly of the merits of the technician.

"Denying the statements made about the TV serviceman isn't going to correct the situation. What is needed is a positive attack on the problem," Mr. Thompson said.

He cited the full-page advertisements in support of television technicians which the G-E Tube Department ran in *Life* and *Collier's*.

"Here is an attempt to give prestige to the serviceman. Here is the serviceman in his true light—a businessman who has invested better than \$3000 in test equipment, trucks, and other facilities, a skilled technician who has taken intensive training to get his unique ability, an honest, conscientious 'professional' who is a necessary part of television enjoyment."

With all of this attention focused on the problems of the service industry it is the individual service businessman's responsibility to try to "do for himself." A great many very good folders and flyers are being made available to carry the story of service to the set owning public. But they won't do any good unless set owners read them. It is the responsibility of the service industry to help put this material in the hands of the people whose opinions of the service industry need to be changed.

Normally, we voice opinions about prices only when we need something and have to pay for it. This is especially true of service. A user is seldom riled up about service or service charges when his set is working all right. It's when the set needs repairs or adjustments that a consciousness of cost descends on him—and dissatisfaction develops if the charges are misunderstood. That is the best time to give the set owner literature about the intricacies of TV and the problems involved in servicing.

G-E's Billboards

The *General Electric Company* has backed up its recommendations for industry help in solving service problems with a well-rounded public relations campaign in the interests of the independent service industry.

Distributors who attended the NEDA convention came face to face with another phase of the G-E program—billboard advertising.

The television billboards were spotted on all incoming highways, near railroad tracks, on the main road from the nearest airport, near main business intersections and eating places, as well as the famed Atlantic City boardwalk.

Industrial TV

In discussing the potentials of industrial TV, Hal Bershe said this: "Now listen carefully. Industrial television, a new and fabulous electronics frontier, is probably the *greatest forward step ever taken in increasing man's capabilities.*"

Citing the myriad of applications for industrial TV in industry, business, science, education, religion, and politics, Mr. Bershe said: "Today, now, industrial TV is practical for millions of applications. Do you realize that in this statement we are suggesting that millions of television cameras may someday be placed in service? Have you considered the possibility of stocking Vidicon camera tubes, as you now do with 6L6's? And do you realize that today's price of the Vidicon is around \$400.00 each?"

He was speaking of the commercial version of the Vidicon camera tube for industrial TV applications recently announced by RCA. This new Vidicon camera tube is small enough to fit into a television camera about the size of a 16 mm. home movie camera.

It utilizes a photoconductive layer that has sufficient sensitivity for televising scenes with 100 to 200 foot-candle illumination and with a spectral response approaching that of the human eye.

Dage Industrial TV Camera

About a week after Mr. Bershe's talk, the Dage Electronics Corporation of Indianapolis took the wraps off its sensationally new TV camera. This camera, which measures just 14" long by 9 3/8" high by 4 3/8" wide, operates with any standard 16 mm. lens and is fitted for mounting to a standard camera tripod.

The unit is completely self-contained. It can be wired into one or more standard television receivers which can be used without alterations.

The Dage camera, priced at \$2850, may well usher in that fabulous new era of industrial TV. Its price is about half that of the industrial TV units that have been on the market and its small size and versatility make it adaptable to a host of applications.

Industrial TV Course

Staff members of the Television Technicians Lecture Bureau have long contended that with the advent of industrial television on a broad scale a whole new vista of opportunities would open up for independent service businessmen. Wired TV will be "tailored" in its installations to serve each application most efficiently. This will open a new field of opportunity for competent local and sectional organizations to handle installation and maintenance requirements.

As part of its program of furnishing the service industry with important technical information just as soon as it is needed, the Bureau staff has prepared a ten-lesson course in industrial television for TV service operators and experienced TV technicians. Complete instructions for building an inexpensive television camera are included as a part of the course.

Planning is now under way to present a lecture and demonstration of industrial TV in all major centers of the country during 1953 under the

December, 1952

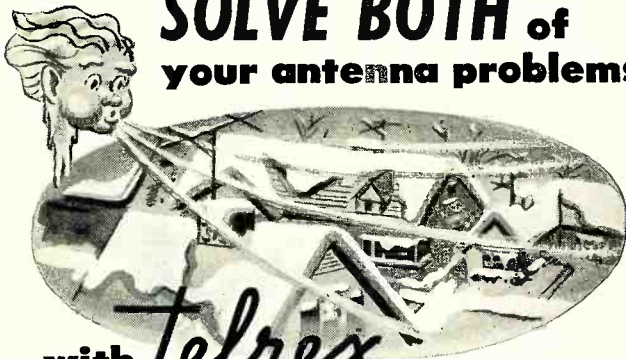

"CONICAL-V-BEAMS"

REGISTERED TRADE MARK

SOLVE BOTH of your antenna problems

with *telrex* -FOR TV, FM AND UHF!

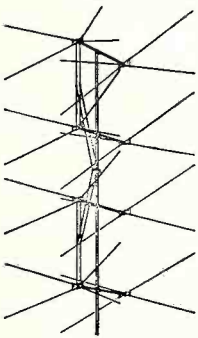

THERE'S A **TELREX** FOR EVERY PURPOSE AND EVERY TYPE RECEPTION AREA - WRITE TODAY FOR NEW LITERATURE

1. PERFORMANCE AT EXTREME RANGE

Only Telrex offers the long distance, all-station champion. The Telrex 8X-TV, illustrated, will outperform any antenna or combination of cut-to-frequency antennas. It is unequalled for long distance reception up to 200 miles. If the 8X-TV does not provide a useable signal, TV reception is impossible or impractical.

2. WEATHER-DURABLE CONSTRUCTION

Install the all-weather, ruggedized antennas that withstand extremes of climate. Telrex production engineers have combined sterling-quality lightweight materials, superb engineering and metal working craftsmanship to produce antennas that you can install and forget! Factory ratings on all models are conservative.

ALSO! EXCLUSIVE MANUFACTURERS OF THE "FISHBONE" SERIES SINGLE CHANNEL TO ELEMENT ARRAYS



AMERICA'S OUTSTANDING TELEVISION BEAM

Be sure it's a "CONICAL-V-BEAM" look for the *telrex* TRADEMARK

ASBURY PARK 7, N. J.

Just Out!

bigger better

17TH edition

Radio's MASTER

- 1220 pages
- 80,000 items
- 8,000 illustrations
- 8" x 11" - 5 lbs.

Publisher's price \$6.50 - your price through your regular parts distributor \$1.95.

The right part when you need it for service

This permanent, hard cover Official Buying Guide of the electronic-TV parts and equipment industry with its comprehensive detailed index, eliminates the need for maintaining files of small catalogs and manufacturers' literature. Radio's Master catalogs 90% of TV and electronic equipment. Not merely part number listings - complete descriptions, specifications and illustrations written and compiled by each manufacturer. Enables you to make comparisons or substitutions right now!



UNITED CATALOG PUBLISHERS, INC.
110 Lafayette St., New York 13

co-sponsorship of RADIO & TELEVISION NEWS magazine.

New Association

According to Mr. Bershe's estimate of sales, industrial electronics equipment is now absorbing more than one-eighth of the renewal tube sales volume. Although most parts distributors have observed the steady increase in the field of industrial electronics applications this development has escaped the attention of most service operators. However, the growth of this phase of the electronics industry is supposed to accelerate rapidly after the defense program reaches its peak and material becomes available for wide exploitation of the immeasurably large field of industrial electronics applications.

However, a number of major service operators have kept informed on the progress of industrial electronics developments and have discussed the problems of installation and maintenance of this type of equipment on a national scale with a number of manufacturers. Many of these manufacturers feel that the only alternative to their setting up and operating their own national servicing departments would be a national organization of competently managed, adequately financed, and technically-manned independent service companies who could handle maintenance assignments on a local or sectional basis.

These manufacturers feel that a national organization of independent servicing companies with contact offices in New York and Chicago, could render a real service in the orderly development of the industrial electronics field—and also that of industrial television. They point out, however, that all equipment of this type is designed and built for specific applications and the national servicing organization must be prepared to furnish its affiliated companies with adequate training aids and maintenance information on every type of equipment sold by cooperating manufacturers.

Plans are now under way for the formation of a national organization which will be known as the National Industrial Electronics Service Associates. Even as the plans were being discussed by the service principals in this move they were approached by manufacturers of equipment designed for industrial applications who are vitally interested in working with such a group on a national basis.

Details of this national independent servicing organization will be carried in this department in the very near future.

New Service Business Formula?

Can you—profitably—make TV service calls at \$1.95 for labor for each call? Or handle in-shop service, including pick-up and delivery of the set, for \$4.95 per set for labor?

In Chicago, the Authorized TV Service Club, Inc., has built a fabu-

ATR

For
AC CURRENT ANYWHERE



STANDARD AND HEAVY DUTY INVERTERS

For Inverting D. C. to A. C. . . .
Specially Designed for operating A. C. Radios, Television Sets, Amplifiers, Address Systems, and Radio Test Equipment from D. C. Voltages in Vehicles. Ships, Trains, Planes and in D.C. Districts.

ATR ✓ NEW MODELS ✓ NEW DESIGNS ✓ NEW LITERATURE

A Battery, Eliminator, DC-AC Inverters, Auto Radio Vibrators

See your jobber or write factory

AMERICAN TELEVISION & RADIO CO.
Quality Products Since 1931
SAINT PAUL 1, MINNESOTA-U. S. A.

MERIT PLATE TRANSFORMERS

1100 VCT/150MA	\$ 6.47
1320/1100VCT/250MA, 40V Bias Tap	8.08
2160VCT/125MA; 1000VCT/150MA	9.99
1800, 1600VCT/225MA	9.70
2900, 2350VCT/300MA	24.11
4200, 3600 VCT/300MA	30.58
5800, 4770VCT/300MA (Sq. Csa)	47.04

MERIT FILAMENT TRANSFORMERS

2.5VCT/10AMP/10KV INS	\$ 3.67
5VCT/3AMP/2500V INS	2.50
5VCT/30AMP/2500V INS	6.47
6.3VCT/1AMP/2500V INS	1.65
6.3V/1.2AMP/5KV INS (TV REPL)	2.12
6.3VCT/3AMP; 6.3VCT/3AMP/2500V INS	4.06
5VCT/3AMP; 6.3VCT/3AMP/2500V INS	4.06
10VCT/10AMP/3KV INS	5.88
12.6VCT/2AMP/2500V INS	2.64
25.2VCT/1AMP/2500V INS	2.64
12.6V/7AMP or 25.2V/3.5AMP/2500V INS	5.88

MERIT FILTER CHOKES

15HY/85MA/1500V INS	\$ 2.94
10HY/110MA/1500V INS	2.94
12HY/150MA/1500V INS	3.53
15HY/150MA/2KV INS	5.14
5HY/200MA/1500V INS	4.11
10HY/150MA	3.82
10HY/200MA } 3KV INS	4.70
10HY/250MA	6.47
8HY/300MA	6.76

MERIT UNIVERSAL MODULATION

PRI-2000-2000/50MA Per Side; SEC-2000-2000/50/100MA* 15 WATTS	\$ 6.32
PRI-2000-2000/150MA Per Side; SEC-2000-2000/150-300MA* 60 WATTS	9.41
PRI-2000-2000/220-440* 125 WATTS	13.23

*SERIES—PARALLEL

TUBE SPECIALS

NEW—STANDARD BRAND—GUARANTEED!			
7JP4	\$18.50	807	\$2.25
10BP4A	19.50	816	1.17
12LP4A	21.90	866A	1.75
17BP4A	22.90	HY75A	4.23
19AP4A	37.50	3A5	1.75
20CP4A	36.75	5R4GY	1.65
21EP4A	38.50	6AS7G	4.25

All prices F.O.B. our warehouse New York

LEEDS RADIO CO.

75 Vesey St. Dept. A New York City 7

South River
★ ★ NEWS ★ ★

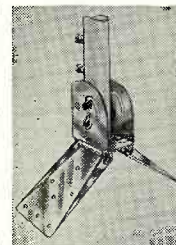

PEAK & FLAT ROOF MOUNT Model PFM-1

(New improved model with drop lock feature)

Heavy gauge steel, embossed for extra strength, hot dip galvanized. Adjustable flaps permit mounting on any peak, flat or pitched roof. Mast socket, mounted on swivel, drops and locks securely. It accommodates masts to 1 5/8" O. D. With hardware.

South River Antenna Mounting Accessories are carried by every leading TV Parts Jobber from coast to coast.

Write for your copy of our new 1953 catalog.

SOUTH RIVER METAL PRODUCTS CO., INC.
SOUTH RIVER, N. J.

PIONEER AND OUTSTANDING PRODUCER OF FINEST LINE OF ANTENNA MOUNTS

lous business under its plan of a \$10.00 annual club membership fee and \$1.95 for each home service call. When told of this plan the average service operator says, "Oh sure, they just pad the list of parts used and make up the difference in the labor charges." But the records of the club indicate that this is not true; they insist that their service technicians do not replace one tube or one part other than those absolutely necessary to get the set working properly.

What's the secret? Arthur G. Shiffman, founder and president of Authorized TV Service Clubs, says that the success of the "service club plan" is determined by several factors, chiefly:

1. It can succeed only as a volume operation.
2. Service to club members must be given promptly and efficiently.
3. Sales of replacement parts and tubes must be held strictly to those required to put the set in good operating condition. Padded parts and tube sales would kill the plan.
4. Service technicians must be carefully and painstakingly coached in the basics for maintaining good customer relations.
5. Service technicians must be top caliber men. Remuneration must be above average to attract and keep such men. Incentive plans must be based upon work completed and not on parts and tube sales.

Paul Gibson, the well-known and popular WBBM commentator, accepted the account on his program only after a very critical personal check-up of its reputation with club members. In accepting the account he wrote:

"The majority of them expressed complete satisfaction with the club and the service they have received as members . . . Everything indicates you people really desire to render worthwhile service . . ."

Now it is not uncommon for one Gibson broadcast—he handles a daily program—to bring in more than one hundred new members in a day. —30—

HAM AWARD

THE Tube Department of General Electric Company has established an award in recognition of "outstanding public service" by amateur radio operators during 1952.

Known as the "Edison Radio Amateur Award", the following rules of eligibility have been set up: Nominations may be made by any ham, club, association, or individual; Service must have been performed during 1952 while candidate was operating in U. S.; The candidate must hold an FCC-issued ham license; Nominations must be post-marked by Dec. 31, 1952 and should include name of candidate, his address, call letters, and description of service.

In addition to receiving national recognition for his achievement, the award winner will be presented with the Edison Radio Amateur Trophy and a 24-hour wristwatch.

Nominations should be sent to the Edison Award Committee, Tube Dept., General Electric Co., Schenectady, N. Y.

—30—

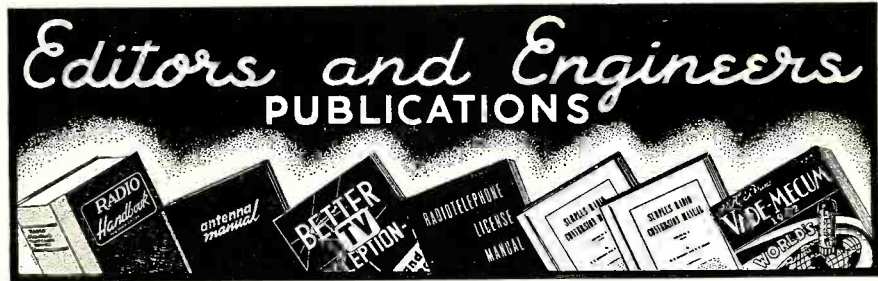

GET THE MOST FOR YOUR MONEY!

THIRTEENTH EDITION RADIO HANDBOOK

A ONE-VOLUME LIBRARY. Practical, how-to-build and how-to-do-it. Extensive simplified theory. Reference data. Profusely illustrated and fully indexed. 734 pages at less than a cent a page.

TWENTY-EIGHT BIG CHAPTERS include: Introduction, D.C. Circuits, Vacuum Tube Principles, V. T. Amplifiers, Radio Receiver Fundamentals, Generation of Radio-Frequency Energy, Amplitude Modulation, FM and Single-Sideband Transmission, Transmitter Design, Keying and Control, Transmitter Adjustment and Loading, Radiation, Propagation and Transmission Lines, Antennas and Antenna Matching, High-Frequency Directive Antenna Arrays, V-H-F and U-H-F Antennas, Rotatable Antenna Arrays, TV and Broadcast Interference, Workshop Practice, Mobile Equipment and Installation.

HOW-TO-BUILD-IT CHAPTERS on: Receiving Equipment (8 items), Exciters and Low-Power Transmitters (7 items), High-Frequency Power Amplifiers (5 items), Speech and Amplitude Modulation Equipment (11 items), Transmitter Construction (4 items), Power Supplies (14 items), Test and Measurement Equipment (16 items), Radio Mathematics and Calculations, and Reference Data. **\$6.00** per copy

RADIOTELEPHONE LICENSE MANUAL

Now, in one convenient volume, complete study-guide questions with clear, concise answers for preparation for all U.S.A. commercial radiotelephone operator's license examinations. Contains four elements: I. QUESTIONS ON BASIC LAW; II. BASIC OPERATING PRACTICE; III. BASIC RADIOTELEPHONE; IV. ADVANCED RADIOTELEPHONE. **\$3.75** per copy

BETTER TV RECEPTION in Fringe and Low-Signal Areas NEW SECOND EDITION

The book which has taken the failure out of many unsuccessful fringe area installations, and has improved the picture for many discouraged TV owners. Practical, easy to understand. How to reduce interference, minimize fading, eliminate ghosts. How to choose the best boosters and receivers, transmission lines and antennas. **\$2.50** per copy

12TH EDITION RADIO HANDBOOK (All-constructional)

Detailed constructional information on a wealth of radio communication equipment. Simple, easy-to-understand text and clear, detailed photographs. **\$3.00** per copy
12th edition **RADIO HANDBOOK** in Spanish, **\$4.50** postpaid

9TH EDITION WORLD'S RADIO TUBES (Brans' Vade Mecum)

THE ONLY BOOK which includes ALL MAKES OF U.S. TUBES and all foreign. More than 15,000 receiving and transmitting tubes from 253 manufacturers. **\$5.00** per copy

ANTENNA MANUAL, a Necessity for Every Radio Man

300 pages of help on antenna, feed line, radiation, and propagation for all frequencies up to 1000 Mc. including FM and TV. **\$3.50** per copy

SURPLUS RADIO CONVERSION MANUAL (in Two Volumes)

Conversion data for most common items of surplus electronic equipment. All conversions shown yield a useful item of equipment; send for list. **\$2.50** for either volume

BUY FROM YOUR DISTRIBUTOR

AT PRICES SHOWN, OR ADD 10% ON DIRECT MAIL ORDERS TO EDITORS and ENGINEERS, Ltd., 1302 KENWOOD ROAD, SANTA BARBARA, CALIF. Bookstores order from BAKER AND TAYLOR CO., Hillside, New Jersey

PEN-OSCIL-LITE

Extremely convenient test oscillator for all radio servicing; alignment • Small as a pen • Self powered • Range from 700 cycles audio to over 600 megacycles u.h.f. • Output from zero to 125 v. • Low in cost • Used by Signal Corps • Write for information.

GENERAL TEST EQUIPMENT
38 Argyle Buffalo 22, N. Y.

TURN YOUR EXCESS GEAR INTO READY CASH!

Especially Need BC-348, BC-342, ART-13, I-152, BC-788, BC-611, and any other surplus equipment.
For Top Prices, Write
BOB SANETT
5404 1/2 Packard St. Los Angeles, Calif.
Phone: WEbster 1-7414

GET INTO ELECTRONICS



You can enter this uncrowded, interesting field. Defense expansion, new developments demand trained specialists. Study all phases radio & electronics theory and practice: TV; FM; broadcasting; servicing; aviation, marine, police radio. 18-month course. Graduates in demand by major companies. U.S. or equivalent required. Begin Jan. March, June, Sept. Campus life. Write for catalog.

VALPARAISO TECHNICAL INSTITUTE
Dept. RD Valparaiso, Indiana

VITAL BOOKS FOR THE TV Service Technician

"Servicing TV in the Customer's Home"

Saves you time, work and chassis-hauling on outside TV service calls. Shows you how to make successful repairs on the spot using these methods: employing VTVM and capacitor probe to trace down trouble; "tube-pulling" to diagnose trouble by observing audio and picture effects; performance tests through analysis of test pattern; adjustment techniques developed for field servicing. Saves time, avoids chassis removal. 96 pages, 5½ x 8½".
ORDER TC-1. Only.....\$1.50



"Making Money in TV Servicing"

Tells how to start and operate a profitable TV service shop. Covers: overall planning, initial investment, selecting location, finances, budget control, work control, overhead, service charges, purchasing, operating and personnel problems, service contracts, customer relations, collections, advertising, etc. Written by a successful authority in the TV service field—sound, practical advice. 136 pages, 5½ x 8½".
ORDER MM-1. Only.....\$1.25

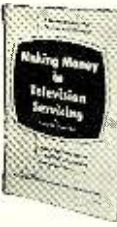

"Television Antennas" New 2nd Edition

A complete treatment of TV receiving antennas, based on actual field experience. Shows how to select proper antennas for given locations; explains how to install and solve troubles. Chapters on: antenna principles; construction; analysis of all commercial types; full installation data and short-cut hints; TV antenna problems and trouble-shooting. Fully illustrated. 224 pages, 5½ x 8½".
ORDER TAG-1. Only.....\$2.00



"Television Tube Location Guides"

VOL. 3. Shows tube positions and functions in hundreds of important TV sets. Helps save servicing time. Often, looking at the picture or listening to the sound, provides the clue to the trouble. Frequently, a tube failure is the cause. This guide, with its clear, accurate tube placement and function diagrams, makes trouble diagnosis and tube replacement quick and easy, without removing chassis. 192 pages. All new diagrams continuing coverage from Vol. 2.



ORDER TGL-3. Only.....\$2.00
VOL. 2. Over 200 pages of tube placement diagrams not included in Vols. 1 and 3.
ORDER TGL-2. Only.....\$2.00
VOL. 1. Over 200 pages of diagrams not in Vols. 2 and 3. ORDER TGL-1. Only.....\$1.50

"Photofact Television Course"

A full, easy-to-understand explanation of TV principles, operation and practice. Covers Cathode Beam Formations and Control, Beam Deflection Systems, Beam Mod. and Synchron.; analyzes CR tubes, camera tubes, voltage supplies, saw-tooth generators, sync. circuits, control functions, antenna circuits, RF input tuning, IF systems, AGC, DC restoration, etc.; with full bibliography and glossary. 208 pages, 8½ x 11".
ORDER TV-1. Only.....\$3.00



HOWARD W. SAMS & CO., INC.

Order from your Parts Jobber today, or write direct to Howard W. Sams & Co., Inc. 2203 East 46th Street, Indianapolis 5, Ind.

My (check) (money order) for \$..... enclosed. Send the following books:

- TC-1 MM-1 TAG-1
 TGL-3 TGL-2 TGL-1 TV-1

Name.....

Address.....

City.....Zone.....State.....

Mobile Transmitter

(Continued from page 43)

By this method, the coast-down voltage output from the dynamotor is not applied to the transmitter after it is desired to cease transmitting.

The dynamotor low voltage input circuit should be wired with no smaller than No. 8 wire in the most direct manner possible, and the chassis of the auto should not be depended upon for the ground connection. This is shown by the heavy lines of Fig. 7.

The Chevrolet automobile has ample space under the hood, directly opposite the original equipment battery, to install a duplicate battery and holder. The auxiliary cutout relay, RL₁, allows the auxiliary battery to be charged in parallel with the regular battery. When the generator is not charging, only the auxiliary battery furnishes power to the transmitter.

Fig. 8 is a diagram of an a.c. power supply capable of operating the entire mobile installation for bench testing, emergency exercises, etc. If the receiver "B-plus" drain is more than 135 volts at 40 ma., V₂ and R₁ may be eliminated and R₃ connected directly to pin 6 of SO₆. Adjust R₃ to a resistance value that will drop the 500 volts to the value required for the particular receiver in use. The push-to-talk feature is not available when the a.c. supply is in use. The "send-receive" switch, S₃, provides all the necessary functions of turning the transmitter and receiver on and off, and the "receiver on" switch, S₂, allows the receiver to be turned on for zero beating or monitoring while the transmitter is on.

The interconnecting cables are made up according to Fig. 13. Cable "A" is used from SO₁ in the transmitter to SO₃ in the control system, or to SO₇ in the a.c. power supply. An identical cable is used from SO₄ in the receiver to SO₆ in the a.c. supply. For normal battery operation of the receiver, cable "B" is used from SO₄ in the receiver to J₁ in the control system. The 6.3 volt heater supply leads in cable "A"

Fig. 13. Wiring diagram of the interconnecting cables for battery or a.c. operation of the mobile radio installation described.

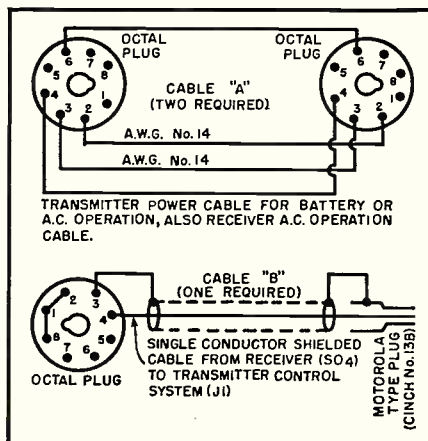

should be of No. 14 or No. 12 wire, unless the cable length is very short. Normally, the a.c. power supply is placed on the floor immediately underneath the auto receiver. The entire installation can be converted from battery to full a.c. operation, or vice versa, in less than thirty seconds time.

-30-

TV Intermittents

(Continued from page 47)

mon of these defects involves a shrinking or darkened picture whenever the line voltage drops. The fact that this is due to line voltage variations can only be ascertained by connecting the set to a low a.c. line and since this is not always available a simple service aid can be constructed. Fig. 1 shows this unit which consists of a double-pole, single-throw switch, a fuse and fuse holder, a male and female a.c. plug and any old power transformer. The transformer used here had a 12.6 volt winding which was connected either aiding or bucking to obtain 12.6 volts more or less than the line voltage. If a 12.6 volt winding is not available, two 6.3 volt sections can be used in series, or a 6.3 and a 5 volt winding will also do. The power rating of the transformer is not important since only the 12.6 volt winding carries substantial currents and these windings are usually designed to handle several amperes. The male plug is connected to the line and the receiver under test is plugged into the female outlet. Throwing the switch from high to low voltage will naturally produce some change in picture size and brightness, but if the picture becomes much smaller than the screen mask under low line voltage, a defect exists. Most often a new horizontal, vertical, or rectifier tube cures this type of defect, but sometimes other parts have aged or become defective. In addition to the picture size it is also possible that other circuits suffer from low line voltage. Low "B plus" on the i.f. section reduces the gain of these stages and can give a weaker picture. In some receivers a voltage divider provides negative bias to certain tubes and when this bias goes below a critical value, incorrect tube operation occurs and this can cause a variety of defects.

All cases of intermittents due to low line voltage can be diagnosed by connecting a voltmeter to different "B plus" and "B minus" points and checking voltages while low line voltage is provided. A 10% d.c. voltage variation can usually be tolerated in all but the flyback section which is often more critical. When the flyback section is affected and the line voltage in the customer's home tends to run low, the best remedy is to install a step-up transformer as shown in Fig. 1, with switching provisions to cut out the 12.6 volt winding whenever the line voltage appears normal.

The second type of voltage intermittent is due to high line voltage and invariably consists of breakdown of a condenser or HV trouble. The scheme described for obtaining voltages higher and lower than the a.c. line is very helpful in such cases. Operating a set with higher voltage often brings out the intermittent condenser at once. HV trouble can also be cleared up this way since a 10% increase in "B plus" voltage results in a proportional increase in HV and the additional 1000 volts or so will bring on arcing and corona whenever the tendency exists. Cleaning HV wiring, keeping solder joints smooth and rounded all help reduce these troubles. Applying anti-corona dope at critical points is the final step in repairing such defects.

Humidity Intermittents

This type of defect is often attributed to other causes such as high line voltage or heat, but actually the majority of HV intermittents during the hot months are due to excess humidity. When the air contains a greater proportion of moisture it becomes less of an insulator and HV trouble appears. In addition to HV trouble there are some types of paper condensers where the wax seal has melted or was too thin to begin with so that moisture can get into the foil. Usually these condensers show some leakage even in dry weather, but under humid conditions the leakage becomes excessive and shows up as a defect. Especially critical are coupling condensers in the video, audio, sync, and sweep sections.

In some instances intermittent HV troubles occur which cannot be located except by the high line voltage method described before, but the humidity condition must also be reproduced. A simple and inexpensive way to obtain the desired humidity right at the service bench involves placing a plastic cloth, cellophane sheet, or tarpaulin over the entire TV chassis. With the set turned on, a small vaporizer is located inside the "oven." Any commercial vaporizer as sold in drug-stores for the relief of colds, or else a hotplate with a pot of boiling water will do. Within a few minutes after steam develops, the moisture under the cover will be high enough to cause condensation to form on the inside. Any tendency to HV trouble will appear quickly under these conditions and the exact trouble spot will be visible due to arcing or the bluish glow of corona. This simple, home-made "air chamber" can save hours of checking, repairing, and re-repairing.

Whenever insulating boards break down in high humidity this is a sign that moisture has seeped in underneath the wax or lacquer coating. Before re-waxing or lacquering the piece it is necessary to remove the moisture. This can be done by baking the insulation board for at least 15 minutes under a heat lamp before

YEP, THERE'S STILL A SANTA CLAUS!

12 CHANNEL T-V TUNER

Complete front end, famous make "Silver Circle." Furnished with original factory instructions, less tubes. Dozens of uses: receivers, converters, etc. The TV bargain of the year for builders, amateurs, students. These are factory rejected for minor damage, but all easily repaired. ONLY \$1.95 each, 3 for \$5.00

RF AMMETER, 0-4 amps, 27 round, thermocouple type. Has 1" scale-spread between 1 and 3 amps. NEW \$3.95

NOVICE 80 METER CW XMTR

Here's a neat and compact surplus item which converts very simply to 3700-3750 KC crystal controlled. Condition? Guaranteed suitable instructions? Yes, we furnish them! Complete, comprehensive, step-by-step; nothing left to guesswork. This is 5-3-7, the command transmitter which has been such a favorite with old-timers. ONLY \$7.95

80 METER RECEIVER

3-6 MC Command, with schematic, excellent electrically, but shop work. Satisfaction guaranteed. \$14.95

NOVICE 2-METER VOICE XMTR-RECVR ARC-4. A standard for two meter conversion. Excellent used, all tubes, conversion converters, etc. (The tubes alone are worth more than \$30.00 at surplus prices) Less dynamotor \$37.50

12 or 1 volt ARC-4 dynamotor \$30.50
TUBE GRAB BAG. At least 10 tubes of special interest; new types, old types, big ones, little ones; some new, some used but good. A big value at \$1.39

4 USES—4 DOLLARS

The most versatile dynamotor in surplus! The best dynamotor for conversion to 6 V. Multiple windings! After conversion you get choice of 130 or 350 v at 20 MA or 250 v at 100 MA. No brushes to shift around, no mechanical work. Or use it as a 2:1 or 1:2 step-up or step-down transformer for DC voltage! Changes 6 to 12, or 12 to 24, or vice versa, up to 3 A. Or use it as a GENERATOR. Turn with motor, get 12 v DC at 12.0 A or 24 v DC at 6.3 A, plus high voltage. Includes easily removable self-contained 800:1 sealed-in gear reduction unit. Complete dope sheet \$4.00

PE-103 SPECIAL. A standard mobile dynamotor power supply. Delivers 500 vdc, 0.16 amps, with choice of two inputs, 6 V at 21 amps or 12 V at 11 amps. Complete with filter base, relays, input cables. Excellent tech. sheet. LIKE NEW \$24.50

CD-501, output cable for PE-103, 8', w/plugs \$3.50

COMMAND EQUIPMENT

With free dope sheets and schematics

BC-455, 6-9 mc. NEW \$12.95. GOOD USED. \$7.95

T-19/ARC-5, 3-4 mc. Excellent. \$14.50

BC-457 or T-20/ARC-5, 4-5.3 mc. Like new \$8.95

MOD BC-456, Brand new \$5.95. Excellent used \$2.49

As is, for parts \$1.19

274N PLUG, 7-pin male plug to fit back of command

rcvrs. and xmtrs. This is the same plug as used in the racks. NEW, each \$1.00

Local Control Adapter Parts for 274N or ARC-5 rcvr. Exact pot, switch, knobs, etched plate, and instruction data. Ready to mount. \$1.29

SPLINE TUNING KNOB \$1.29

12 VOLT COMMAND DYNAMOTOR For receivers SCR-274N, ARA, ARC-5. Plugs onto rear end, 250 V, 60 ma., DY-1/ARC-2X. Guaranteed good condition \$7.95

Less plug-in base \$5.95

A VIBRATOR BUY. 6 or 12 volts, self-rectifying, hermetically sealed. Can take high overloads. With socket and schematic. Specify volts. ONLY 89c

ANTENNA MAINT SECTIONS, MS-49, 50, 51, 52, 55. New, original packing. \$1.29 Each

AUDIO SUPER-SPECIALS

SUPER HI-Q high cut choke, 0.65 H. 55 ohms DC. Tune with 001-0004 MF. ONLY .98c

LOW CUT, 5 H. 284 ohms. Tune with 1 MF. Or use as 50 ma filter choke. ONLY .98c

QUINCY Transformer for mike to push-pull grids, flat 30 to 15,000 CPS; other for push-pull output, tapped sec., turns 14:1, in unit with resistors, condensers, etc. BOTH FOR ONLY \$1.29

PHASE SPLITTER, or low-level mixer, or hybrid, or push-pull unit. Has 3 windings, each exactly 1:1 to any other; essentially flat 100-15,000 CPS. BRAND NEW, ONLY .69c

VINYLYTE SPAGHETTI, clear, 0.166 ID. three 25' lengths for only .96c

EASY MONEY! We're still buying surplus. Tell us what you've got, its condition, and your price. If we like it you'll get our check quick.

G. L. ELECTRONICS 905 S. VERMONT AVE. LOS ANGELES 6, CALIF. ALL PRICES F. O. B. LOS ANGELES. CALIF. BUYERS ADD SALES TAX

THERMADOR

POWER TRANSFORMERS & CHOKES

New Manufacture! Guaranteed One Year!

Type "A", Fully Enclosed POWER TRANSFORMER

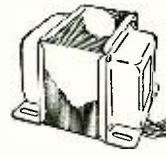

PRI: 115 v 50/60 cycles
SEC: 750 v 250 ma CT

6.3 v, 3 a
5.0 v, 3 a

Shipping Wt. 13 lbs. \$7.95

POWER TRANSFORMER 5A-1225

PRI: 115 v 50/60 cycles
SEC: 600-400-0-400-600 v,
250 ma

6.3 v, 3 a
5.0 v, 3 a

Shipping Wt. 17 lbs. \$10.80

SMOOTHING CHOKE 7A-1225

12 H, 250 ma. \$6.90
Shipping Wt. 11 lbs.

SWINGING CHOKE 7A-5250

5 to 30 Hz \$6.90
250 to 25 ma. Shipping Wt. 11 lbs.

OUTPUT TRANSFORMER BARGAIN

5000 ohms input to TWO outputs, 300 ohms or 3.5 ohms. Use as output for 12A6, 6V6, etc., or as matching transformer to speaker or headset. Potted, shielded, BRAND NEW, only \$7.9c

12 VOLT FIL. XFORMER or line voltage booster. Inpt 110 v, 60 cy; output 9 to 13 volts in 1 volt steps at 3 amps. Free schematic shows many uses. NEW \$1.89

PRECISION CALIBRATED TUNER

Build a Q-meter or an audio oscillator, a signal generator, a VFO, an ultra-stable receiver, or your name it! Lab-standard accuracy and resetability. 3 gang condenser assembly with 4" precision dial etched 1.5-12 mc in 3 bands plus a reference scale. Triangular plastic hairline indicator; 50:1 ratio drive assembly, all gears spring-loaded double-section. Has tuning lock. Plates are two single spaced 250 uuf, and one double-spaced 260 uuf section. Use standard spaced section to eliminate drift. ONLY \$4.95

BROADCAST BAND & AERO

MN-26-C Remote Controlled navigational direction finder and communications receiver. Manual DF in any one of three freq. bands, 150 to 1500 KC. 24 V. Self-contained dynamotor supply. Complete installation, including receiver, control box, loop, azimuth control, Left-Right Indicator, plugs, loop transmission line, and flex. shafts. BRAND NEW, ORIG. PACK \$69.50

MN-26-C alone, New \$39.50

MN-20-E Loop, Brand new \$6.95

MN-52 Crank drive, New \$2.50

BUILD TV-FM-AM SWEEP GENERATOR

(See Dec. Radio & TV News) Now you can build that "VERSATILE SWEEP FREQUENCY GENERATOR"! We've got a few more of those vital APN-1 magnetic units. With reprint of the article \$6.95

SUPER HI-FI HEADSET BUY!

Uses annular-grooved plastic fibre cones with voice coils in speakers, and padded chamois ear muffs to obtain capacity for correct, accurate sound. Gives finest music reproduction, flat far beyond upper and lower limits of auditory perception. Pair in series has measured impedance of 600 ohms at 1000 cycles, obtained with built-in high quality transformers. However, severe mismatching makes no apparent difference. Far superior to crystal phones. Manufacturer's net price is \$45.00 per pair! (Each unit can also be used as high quality dynamic mike with 300 ohm output impedance.) They come to you checked out with freshly laundered chamois pads in cellophane bag. ONLY \$7.95

PORTABLE POWER KITS

1. Includes 2 volt, 20 AH wet cell, lightweight transport plastic, fibrite separators, 3 ball hydrometer, 4" x 3" x 5 1/2" high, shipped dry; also 2 volt synchronous vibrator, no tube needed; also 2 volt charger, 115 50/60 cy in. This high quality unit uses step-down transformer and dry disc rectifier, with pilot lamp in output to indicate and regulate charging rate. With eyepiece type battery filter and instructions. ALL 4 ITEMS, BRAND NEW \$4.95

2. Six volt Vibrapak kit. Vibrator plus non-sync transformer with two outputs: 345 v, 145 ma for plates, 15 v for bias. With schematic. BRAND NEW \$2.95

LEARN TELEVISION
ELECTRONICS and RADIO
Engineering Laboratory and Classroom
Training. Day and Evening Classes.
for illustrated Catalog
ELECTRONICS INSTITUTE, Inc.
21 HENRY, DETROIT 1, MICH.

SEND FOR OUR
BIG BULLETIN
DOW RADIO, INC.
1759 E. Colorado St. Pasadena 4, Calif.
PHONE: SYcamore 3-1196

Moody Kit TOOLS ARE A MUST
IN RADIO, T.V. AND
ELECTRONICS
Your tool box is incomplete if it lacks Moody Kit precision small tool sets. The PA-5 Kit shown contains five interchangeable Allen type and Phillips head screw drivers. Ask to see the complete Moody line at your local stores.
SEND FOR FREE DESCRIPTIVE BOOKLET
Moody MACHINE PRODUCTS CO. INC.
4 Culver Street, Providence 5, Rhode Island

L. A. HAM SHACK SELLS FOR LESS

METERS



WESTON • SANGAMO
ALL NEW • ALL D. C. • 2" SQUARE

0-5 Ma } \$3.29
0-15 Ma } EACH
0-50 Ma } or
0-100 Ma } 3 for
0-200 Ma } \$9.00
0-300 Ma }
0-500 Ma }

Mfg's inquiries: lots over 100



"5" METER

Illuminated face. Full scale reading of 5 ma. A standard value for most "S" Meter Circuits. 2 3/8" Black face.

New \$2.49
Amp Meter, No. 60-0-60.
New \$1.29

COMMAND AND/OR ARC5 TRANSMITTERS and RECEIVERS

3-6 MC Receiver Used \$8.95—New \$17.95
6-9.1 Receiver Used 8.95—New 12.95
Triple Receiver Rack 1.95
V.H.F. ARC5 Transmitter or Receiver,
Complete w/tubes Used 24.95

	Used	New
4-5.3 MC Transmitter with tubes	\$ 8.95	
5.3-7 MC Transmitter with tubes	8.95	
7-9.1 MC Transmitter with tubes	9.95	\$19.95
3-4 MC Transmitter with tubes	18.95	
28V Receiver Command		
Dynamotors	0.97	

MODULATORS

	Used	New
BC-456 with Tubes, less dyn...	2.95	
MD-7 Modulator Dynamotor, 28V	2.95	
BC-433 Receiver—with tubes...	24.95	
MN-26C Compass Receiver...	24.95	\$39.50
MN-26Y Compass Receiver...	24.95	39.50
BC-357 Marker Beacon Rec. W.O. Tube	5.95	

Cash with order. Prices subject to change without notice. California orders please include 3 1/2% Sales Tax. Please include approximate postage—Excess will be refunded. What Have You in Surplus? Submit

L. A. HAM SHACK

1306 BOND STREET, at PICO
LOS ANGELES 15, CALIFORNIA

CIVIL AIR DEFENSE or 2 METERS

ARC-4, W/tubes. Good, used.....\$29.95
522 Trans.-Receiver. W/tubes. Good, used \$9.50
Modulation Transformer. BC-375. New 2.49
BC-306 Antenna Loading 1.95
GP-7 Navy Transmitter: 100 watt master os.
Can use on any freq. from 350-9050 kc. by using
proper plug-in. With 1 tuning unit.....\$17.95
FL8 Filters—A's, B's, C's New 1.95
FL5 Filters New .95
Hand Keys—J-38 New 1.19
Heineman Circuit 115 V., 20 amp. 1.39
Breakers 115 V., 5 amp. .97

TRANSFORMERS

12V 24V 2am 110V primary.....\$2.95
BC-434 Control.....Used—\$1.95 New—\$2.95
Code Tapes for TG-10 15 rolls. New.....7.95
BC-906 Absorption Type Freq. Meter Range
150-225 mc. 0.500 DC Microm. Used \$11.50
Field Phones E-E 8's.....Used \$29.50 pr.

DYNAMOTORS

PE103 New Case.....\$29.95
PE-73 29V. @ 20 amps. output 1000V @
.350 amps New 9.95
PE-77 14V @ 40 amps output 1000V @
.350 amps New 24.95
RL-42B Antenna Reel Ass. Less wire. New 9.95

OIL CONDENSERS

Standard Makes—New

2 mfd 600V	\$0.49
4 mfd 600V	1.39
1 mfd 1000V	.69
3 mfd 4000V	7.95
.5 mfd 2500V	1.49
10 mfd 600V	2.95
2 mfd 2500V	3.95
2 mfd 5000V	\$8.95
2 mfd 7500V	29.59



HEAD SETS

HS-30 New \$1.95
HS-23 Used \$2.95
Matching Transformer for HS-30 .69
RG-7U Coax Cable, 97.5 ohms..... foot .08
MIKE CHEST SET "F-1" button..... New 2.95

applying the external insulation again.

Summary

Intermittent defects are always more annoying than permanent troubles, but if a clear method of approach is used they can be handled efficiently and profitably by any technician. By observing the condition under which the intermittent occurs it can be classified into one of four basic types: mechanical, heat, voltage, or humidity. The next step leads to localizing the intermittent to one particular section of the receiver and this is done by observing which portions are affected and which receiver sections appear to function continuously. Once the defect has been classified, the condition under which it occurs is simulated on the test bench, and after that the troubleshooting and repairing are no more difficult than if a permanent defect were involved.

FCC ACTION

THE Federal Communications Commission has recently ruled that until further order of the Commission, the showing that the applicant actually operated an amateur radio station or stations for the periods of time specified in Section 12.27 will not be required in cases where it is shown that the applicant was unable to conduct such operation because he was on active duty in the Armed Forces of the United States or was duly enrolled as an employee of an agency of the Federal Government and in the course of such employment was on duty in a foreign country continuously during the last year of the license term; provided that any such employee of the Federal Government shall submit with his application for renewal of license a statement signed by his agency head, or the chief of the bureau or division in which he is employed, attesting to such appointment.

ON-THE-SPOT BATTERY RECORDER

WALKIE-RECORDALL 8 lb. miniature BATTERY RECORDER-PLAYBACK
Continuous, permanent, accurate, indexed recording at only 5c per hr. Instantaneous, permanent playback. Picks up sound up to 80 ft. Records conferences, lectures, dictation, 2-way phone & sales talks; while walking, riding or flying. Records in closed briefcase with "hidden mike"! Write for Detailed Literature.

MILES REPRODUCER CO., INC.
812 BROADWAY Dep't RN-12 NEW YORK 3, N. Y.

ATTENTION

Distributors in Chan. #12 Territory

We are in Production on 5, 10 & 12-Element—most efficient YAGI ever designed. MANY TERRITORIES STILL OPEN. We Welcome your Inquiries.

FRENCHY RADIO MFG. CO.

164 W. Parker St. Scranton 8, Pa.

STANDARD BRANDS TUBES INDIVIDUALLY BOXED
STANDARD WARRANTY New Low Prices BRAND NEW!!

OZ4 \$.49	5V4G ... \$.89	6B4G ... \$.89	6E5 \$.69	6V6GT .. \$.51	198G6G \$1.59
1B3GT .. .79	5Y3G35	6BA649	6F6GT49	6W4GT .. .49	19T879
1L459	6AB455	6BA769	6H651	6W6GT .. .59	25AV5GT .95
1R559	6AC789	6BC559	6J5GT49	6X444	25BQ6GT .98
1S469	6AG559	6BE652	6J669	6X5GT39	25L6GT .. .49
1S559	6AG795	6BF563	6K6GT49	12A7E .. .42	25Z6GT .. .45
1T459	6AH695	6BG6G .. 1.69	6L6GA .. .95	12A77 .. .69	35B555
1U463	6AK585	6BH665	6SA7GT .. .55	12A7U .. .49	35C555
1U555	6AL549	6BJ655	6SC769	12A7V .. .59	35L6GT .. .55
1X2A72	6AQ549	6BL789	6SF552	12BA6 .. .49	35W437
30468	6AQ645	6BN685	6SH759	12BE6 .. .52	35Z5GT .. .35
305GT .. .65	6AR549	6BQ698	6SJ749	12BH7 .. .74	50B555
35459	6AS556	6BQ798	6SL7GT .. .59	12SA7GT .56	50C555
3V459	6AT641	6C444	6SN7GT .. .55	12SG7 .. .55	50L6GT .. .54
5T4 1.19	6AU649	6C541	6SQ7GT .. .45	12SK7GT .57	117N7GT 1.35
5U4G49	6AV5GT .. .99	6CB659	6SR745	12SN7GT .66	117P7GT 1.35
	6AV641	6CD6G .. 1.65	6T879	12SQ7GT .57	117Z3 .. .49

Many other types equally low priced—include all your tube needs with your order.

One of the largest stocks in the country!

Min. Order \$25.00. Terms: 25% with order, balance C.O.D.

All prices subject to change without notice, F.O.B. New York City. Mail order division.

Television Materials Corp.

125 Cedar St., New York 6, N. Y. • COlrandt 7-4307

U.H.F. LEAD-IN

A TELEVISION transmission line that meets the special requirements of u.h.f. reception has been developed by RCA engineers and is being manufactured by Anaconda Wire and Cable Company.

Announced at a press conference held recently in New York City, the new lead-in line comprises a balanced line with approximately 270 ohm impedance and optimum dielectric dimensions. It is designed to provide excellent reception despite adverse effects of rain, salt water, dirt, and electrical interference.

Attenuation at 500 mc. is 3.6 db per 100 feet and 5.1 db per 100 feet at 900 mc. Dimensions are approximately 1/2" x 3/8".

Known as the Anaconda u.h.f. line (ATV-270), the new lead-in will be made available to the entire television industry.

Close-up of the RCA-Anaconda u.h.f. lead-in.

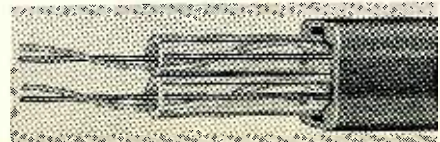

A Meterless V.T.V.M.
(Continued from page 61)

with each applied voltage on the paper scale. Use as many calibration points as are desired.

The author found that ordinary dry batteries, in good condition, provide an excellent source of calibration voltage.

Once the scale is prepared in this manner, it may be removed and carefully redrawn in ink. Before permanently affixing the final scale to the front of the instrument, give it two or three coats of clear plastic or lacquer.

If, for any reason, the direction of deflection obtained for a given applied voltage polarity is not the desired one, simply reverse the connection leads to the plates used for horizontal deflection.

Operation and Application

The exact technique for using the instrument to measure voltages depends on whether the instrument has been calibrated for "zero-center" "left-zero" or "right-zero." If calibrated for "zero-center" no special technique is required.

To measure a d.c. voltage, connect the instrument to the voltage to be measured and read the indicated voltage directly on the scale. If more than full-scale deflection is obtained, turn the "Range Selector" switch to a higher range, and again read the voltage directly, using an appropriate multiplying factor (depending on the range selected).

To measure peak-to-peak a.c. voltages, use the instrument in exactly the same fashion. However, in this case, a voltage indication will be obtained on both sides of "zero," with the peak-to-peak voltage indicated by the difference between the extreme limits of deflection. If a high frequency voltage is being measured, the indication will appear as a "band" of light across the screen.

One particularly good feature of this instrument becomes apparent when it is used to measure a.c. voltages. An indication of both the negative and the positive peaks of the applied signal is obtained at the same time. Thus, if the positive (or negative) peak is greater (as will often happen in the case of pulsed or complex signals), the peak amplitude of each may be read immediately and directly.

If the builder has used a "left-zero" or "right-zero" scale, it will be necessary to center the indicator, using the "Zero Adjustment" control, in order to use this technique for measuring a.c. voltages. For d.c. measurements, to reverse polarity, the "Zero Adjustment" is used to move the indicator line to the opposite end of the scale (full scale) and the calibrated scale "read backwards."

Where d.c. and a.c. are present together and it is desired to read only the a.c. component, a blocking condenser may be used in the input circuit. —50—

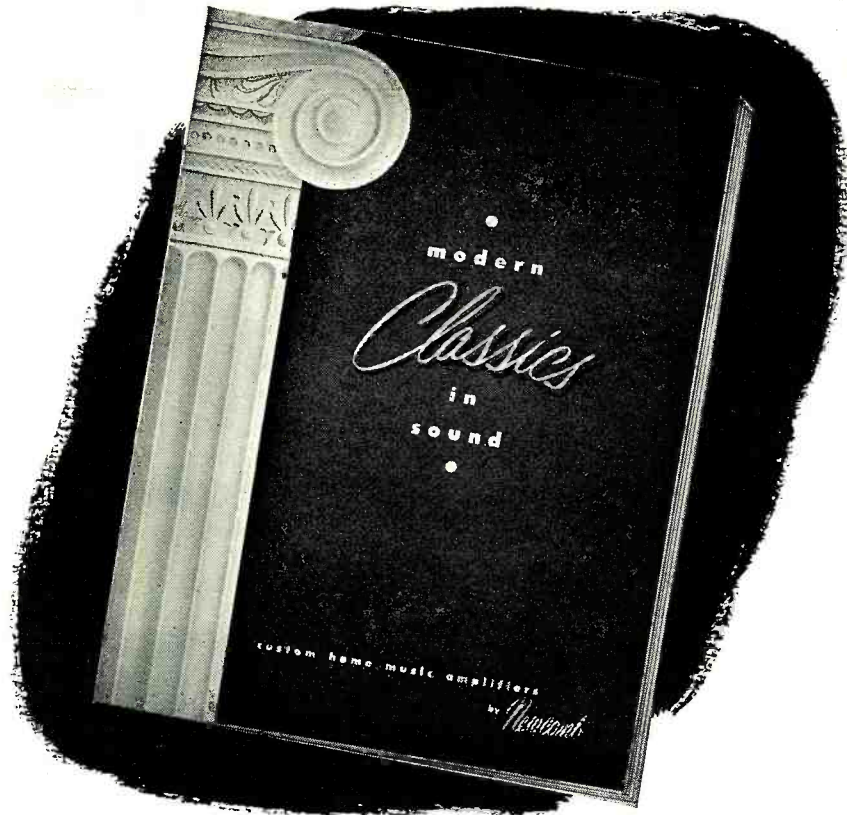

The crowning achievement of 15 years quality leadership.

Music lovers are discovering a brilliant new world of musical enjoyment. They are actually hearing whole octaves more music from their own favorite recordings with custom home music systems built around the remarkable new amplifiers by Newcomb. Revolutionary new, exclusive features make them sound better, simpler to operate and much easier to install. If you love good recorded music and want to hear all of it... better than you have ever heard it before... write for this Newcomb catalog of 8 matchless amplifiers for all types of home installations. Installation diagrams are included.

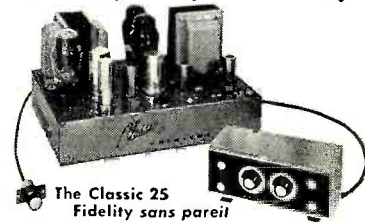

The Classic 25
Fidelity sans pareil
There is nothing comparable to this 25 watt ultra fidelity amplifier with exclusive "Audi-balance" and "Adjusta-panel."

Write Dept. 7 for Catalog



Classic 15 A-15 A-104R A-104 AM-10R AM-10 A-10

NEWCOMB

6824 LEXINGTON AVENUE, HOLLYWOOD 38, CALIFORNIA



Print Your Own

Cards, Stationery, Advertising, labels, circulars, photo and movie titles, church work, tags, etc. Save money. Sold direct from factory only. Raised printing like engraving, too. **Print for Others, Good Profit.** Have a home print shop. Easy rules supplied. Pays for itself in a short time. Write for free catalog of outfits and all details. Write: **KELSEY PRESSES, B-72, Meriden, Conn.**

We Pay Highest Cash \$\$\$\$ Prices for RADIO & AIRCRAFT ELECTRONICS EQUIPMENT

You'll be pleasantly and profitably surprised at the prices we pay for needed parts and equipment. Simply send us a description of what you have—tell us your top dollar asking price—and we'll shoot back a prompt reply! Convert that equipment to ready cash now! Write: **ALVARADIO SUPPLY CO., Division R-4** 4665 Melrose Ave. Los Angeles 29, Calif. OLYMPIA 2155

RADIO ENGINEERING DEGREE IN 27 MONTHS

Radio engineering is a big field. There's room for you in it—if you're good. Get first-class training at Indiana Tech. Intensive specialized course, including strong basis in mathematics and electrical engineering, advanced radio theory and design, television, electronics. Modern laboratories. Low rate. Also B.S. DEGREE IN 27 MONTHS in Aeronautical, Chemical, Civil, Electrical and Mechanical Engineering. G.I. Government approved. Enter December, March, June, September. You can earn part of your expenses right here in Fort Wayne while you are studying.

INDIANA TECHNICAL COLLEGE

9122 E. Washington Blvd., Fort Wayne 2, Indiana
Please send me free information on B.S. Engineering Degree in 27 months as checked.

- Radio-Television Mechanical Aeronautical Electrical

Name
Address

20-20 PLUS!

S-268-Q Output Transformer

±1 db 8—80,000 cycles
80 watts 30—40,000 cycles

20 watts at 10 cycles
40 watts at 15 cycles

Insertion loss
0.3 db

Primary impedances
8,000CT & 2,000CT

Connected between halved impedances, frequency response is extended at each end; between doubled impedances, ±1 db 15—45,000 cycles.



Write today for the new 1953 Peerless Catalog

Perfect with KT-66 and 6146 tubes

PEERLESS
Electrical Products

A DIVISION OF

ALTEC
LANSING CORPORATION

9356 Santa Monica Blvd., Beverly Hills, Calif.
161 Sixth Avenue, New York 13, New York

Carrier-Current Intercom

(Continued from page 45)

6SJ7 audio amplifier and a 6AK6 audio power amplifier. The suppressor grid of the 6AK6 is connected to the output of the 6SJ7 through condenser C_s . However, there are no adverse effects with this arrangement. The 6AK6 operates in every respect as a normal class "A" audio power amplifier. The grounding of the suppressor grid through R_s results in the same performance as with a direct ground. The reason for this unconventional arrangement will become evident when the transmitting circuit is studied. The fact that operation during "receive" does not require grounding of the suppressor grid is fortunate, inasmuch as additional switching connections are not needed.

When the "transmit-receive" switch, S_1 , is actuated, the circuit is converted from a receiver to a transmitter. During "transmit," the 6AK6 becomes a suppressor-grid-modulated Hartley oscillator. The 6SJ7 is used as a speech amplifier-modulator, and the PM speaker becomes the microphone. The 1N34 diode is not used. The fact that the cathode bias resistor, R_c , is allowed to remain in the 6AK6 cathode circuit during "transmit" is of no consequence, since most of the grid bias is obtained from the grid-leak, R_g . This, again, is fortunate in the interest of switching simplicity. Although the suppressor grid is "dead" when the 6AK6 is functioning as a class "A" audio amplifier during "receive," this electrode now permits 80% modulation of the 6AK6 class "C" oscillator. Resistor R_s limits plate voltage during "transmit"; without this resistance, the suppressor grid becomes inert, as is the case during "receive" when high voltage is impressed on the plate through the output transformer.



Front view of the home-built intercom. The entire unit is housed in a compact and inconspicuous cabinet. A spring-loaded switch is actuated when unit is used to transmit and released during reception.

It should be appreciated that the oscillator circuit uses the screen grid in the same manner as the plate of a grounded-plate-triode Hartley oscillator. Therefore, this method of modulation is not quite the same as conventional suppressor-grid modulation in which the radio frequency output is extracted from the plate. No negative bias is required for the suppressor, but a small r.f. bypass condenser may be required if the leads in this circuit pick up r.f. A 250 μ fd. condenser connected directly from terminal 2 of the 6AK6 to ground will remedy this trouble. The effect of r.f. on the suppressor grid is to lower the modulation capability of the tube. This trouble will not arise unless long leads result from an improper layout of the components. The screen-dropping resistance, R_s , remains in the circuit during both "transmit" and "receive." For the latter function, it has negligible effect. During "transmit," it is necessary to permit the suppressor

Under chassis view of one of the two intercom units required for the "system."

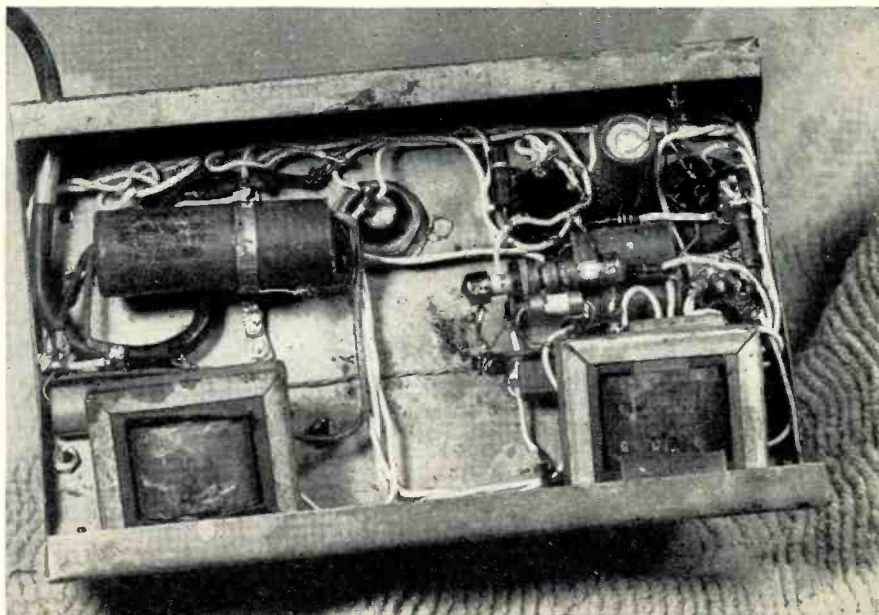

grid to have the required control of the electron stream.

The power supply is a conventional full-wave rectifier with a pi filter. The role of R_{11} is two-fold. First, best results will be obtained when the power supply output voltage under load during "transmit" is between 180 and 220 volts. Second, this resistor increases the r.f. loading impedance of the power supply. A transformer and full-wave rectification arrangement is greatly superior for this purpose to the "a.c.-d.c." type of power supply used in small broadcast receivers, notwithstanding the simplicity of the latter circuit.

The prospect of radiation field strength exceeding FCC limits is negligible due to the low power, low frequency, and the adverse conditions for the power lines to act as an antenna. In some cases, radio or television interference can result when the set is plugged in close to one of the units. The entrance of such interference is more likely to be through radiation rather than through the line itself. Enclosing the units in metallic cabinets and shielding the line cord will eliminate, or greatly reduce, such interference. -30-

Capacitance Relay
(Continued from page 51)

across R_2 . C_2 is then adjusted until the indicated voltage is about half of the maximum. This indicates that the oscillations are weak. The potentiometer R_2 is adjusted so that the relay just opens from the closed position. If no v.t.v.m. is available, the setting of R_2 and C_2 can be found by experiment since the two controls do interact. As a start set potentiometer R_2 so that the grid receives the full detector output voltage, then adjust C_2 so that the relay just opens from the closed position. If this position cannot be found, set the R_2 arm down a little lower and repeat the adjustment of C_2 . After a little practice, the device can be set up rapidly to any desired sensitivity. Well, there you have it—an economical device, easily built, for which the parts values are non-critical, and for which there can be found an almost infinite variety of uses in the home or place of business. -30-

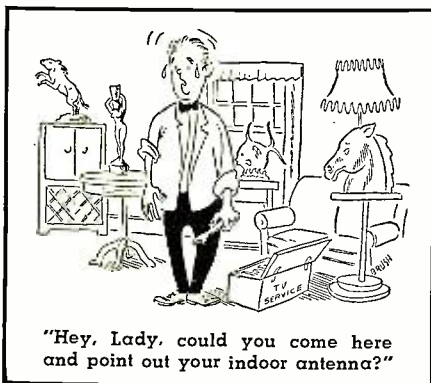

Brighter, Sharper, TV Reception

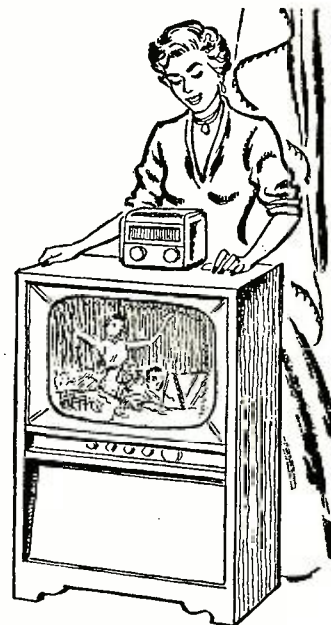
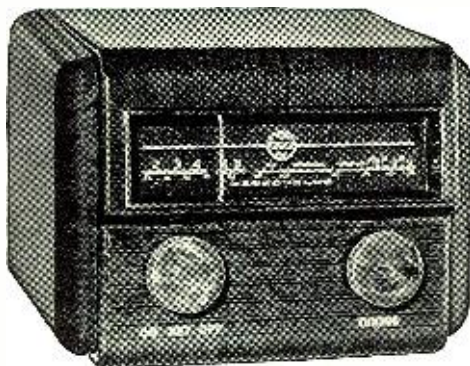

with the **TURNER** Model TV-2 Booster

You get clearer, sharper pictures with a minimum of annoying interference and snow even in weak signal areas with the TURNER TV-2 Booster. It's designed with an eye to beauty as well as outstanding performance. The rich, mahogany plastic cabinet is a handsome addition to any room . . . the high quality cascode circuit reduces noise and snow, producing an excellent picture even in extreme fringe areas.

The TURNER Booster is simple in operation. A single tuning knob permits fine adjustment for best reception of picture and audio over all 12 TV channels. The unit is quickly and easily installed on any television set. Get the best possible TV reception . . . get the TURNER Model TV-2 Booster!

The **TURNER** Company 900 17th St. N.E. Cedar Rapids, Iowa
IN CANADA:

Canadian Marconi Company, Toronto, Ont., and Branches.



EXPORT:

Ad. Auriema, Inc., 89 Broad Street, New York 4, N. Y.

New Electronic Headquarters—
VAN SICKLE RADIO SUPPLY CO.
1320 So. Calhoun St. Phone E-4136
FORT WAYNE 2, IND.

Please note new address. Eugene Van Sickle, Owner

RADIO and TELEVISION ELECTRONICS



in all Technical Phases
New Classes (Day and Evening) Start 1st of Dec., Mar., June, Sept.

Free Placement Service for Graduates
For Free Catalog write Dept. RN-52

RCA INSTITUTES, INC.

A Service of Radio Corporation of America
350 WEST 4th ST. NEW YORK 14, N. Y.

WATCH FOR THE NEW
ZIFF-DAVIS
PUBLICATION

SEA STORIES

Thrilling Tales of the Deep!

On sale at your favorite newsstand
January 20, 1953

RIDER TEK- FILE*

easy-to-use
packaged
tv
service
information—
it's
complete...
accurate...
factory-
authorized—
at
your
jobbers
now...
only
\$2 per pack

*dependable replacement parts listing beginning with Pack 57

JOHN F. RIDER
PUBLISHER, INC.

480 Canal Street,
New York 13, N. Y.

NEW TV PRODUCTS on the Market

FIELD STRENGTH METER

Of interest to television technicians, engineers, and manufacturers, is the new u.h.f.-v.h.f. field strength meter recently introduced to the trade by *Erwood, Inc.*, 1770 Berneau Street, Chicago 13, Illinois.

The new meter is designed to determine the strength of signals avail-



able at any given location and covers all the frequencies used today in television and FM broadcasting. It may also be used to determine the relative efficiency of different types of antennas as well as the optimum height.

The v.h.f. range is continuous from 52 to 218 mc., with 60 per-cent of full-scale deflection being provided by a 100 mv. input. The u.h.f. range is continuous from 470 to 890 mc., with 50 per-cent of full-scale meter deflection for 100 mv. input. The meter uses 11 tubes, has a power consumption of 70 watts, and is housed in a compact carrying case which measures 10 $\frac{3}{4}$ " x 11 $\frac{1}{4}$ " x 14 $\frac{1}{4}$ ".

REMOTE CONTROLS

Teleflex Incorporated, P. O. Box 69, North Wales, Pa., is currently offering a line of remote controls that has been designed expressly for television applications.

Motion is transmitted linearly by "Teleflex" cable operating in either tension or compression. Unlimited rotary motion is obtained by meshing

the helix of the cable with a specially hobbled wheel in a control box.

Available in three sizes, the new controls can be incorporated so as to permit tuning controls in the television set to be located at the rear of the chassis for easy servicing.

A brochure on these remote controls is available without charge.

REPLACEMENT PARTS

Todd-Tran Corp. of Mount Vernon, New York, has developed a new line of cosine deflection yokes and flybacks which is now available for distribution.

Tradenamed "Green Band," the new yokes employ rigid nylon segments for inter-coil insulation. The resulting greater dielectric strength of this material, at operating temperatures, reduces the danger of breakdown to a minimum. Among the special properties claimed for these yokes are high deflection sensitivity, good line and corner focus, high "Q" geometry, coil balance to within one turn, minimum leakage flux, etc.

The "Green Band" flyback transformers have the coil windings and connecting terminals completely encapsulated-vacuum-encased in a cast plastic dielectric. They are particularly desirable in large picture tube, wide-sweep, high-voltage applications.

A deflection yoke replacement guide is now available from local distributors or from the company direct.

CROSSBAR GENERATOR

A crossbar generator which has been designed especially for television receivers and picture tubes is now being marketed by *United Technical Laboratories*, Morristown, New Jersey.

The new instrument, the Model CB-101, may be connected to several television chassis points for adjustment data or used as a test pattern source to modulate TV signal generators.

When Answering Advertisements

Please Mention

**RADIO & TELEVISION
NEWS**



2-YEAR WARRANTY

Smith-Baldwin

SPEAKERS and TRANSFORMERS

Write for Catalog

CONSOLIDATED RADIO PRODUCTS COMPANY
350 WEST ERIE STREET CHICAGO 10, ILLINOIS

WANTED

Navy Selsyns—types IF, IG, ICT, 5F, 5G, 6G, 7G, etc. Autosyns: AY1, AY5, AY10ID, AY20I, etc. Tubes, Test Equipment, Signal Corps Equipment; Send Lists. Top Prices.

ELECTRO-110 Pearl Street•Boston

SCHEMATICS—CONVERSIONS FOR SURPLUS GEAR

NEW LIST! MANY ADDITIONS!

Send stamped, self addressed envelope for List B. Add 25c for chart explaining AN nomenclature.

R. E. BOX 1220

GOODHEART BEVERLY HILLS, CAL.

RADIO & TELEVISION NEWS

The unit may also be connected directly to the picture tube pins so that tube operation may be checked without removing the receiver chassis from the cabinet. Special leads and connectors are supplied for connecting the instrument to the video amplifier or picture tube pins.

TV TUBE TESTER

Anko Manufacturing Company, Inc., 7311 West Burleigh Street, Milwaukee 10, Wisconsin, has developed a new, dynamic performance TV tube tester which is said to reduce tube testing time on most receivers to ten minutes.

Tradenamed the "Teletest," the new unit has been designed for the service shop, service dealer, jobber or department store TV department. The unit is so designed that the time consuming switching and selecting operations together with the usual tube selector charts have been eliminated. Only one meter, with a single scale, positively indicates "good" or "bad" tube condition. Picture tubes can be tested by means of a single adapter cord and plug without removing them from the sets.

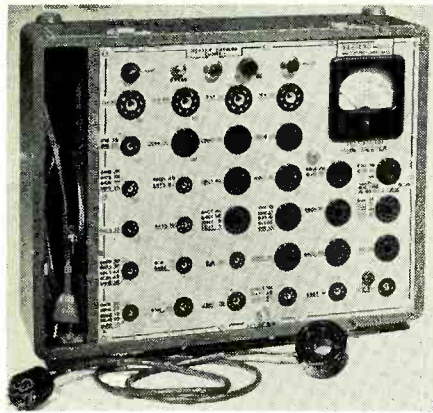

TV SCREWDRIVER

The Insuline Corporation of America, 36-02 35th Avenue, Long Island City 1, New York, has brought out a long alignment screwdriver, measuring 12 inches, which has been especially designed for service work on deep and complicated television chassis.

Made of flexible bone fiber, with screwdriver blades at both ends, the non-metal screwdriver protects the technician against possible shock and prevents short-circuits.

LOW-COST BOOSTER

To meet the demand for a compact, low-cost television booster, Blonder-Tongue Laboratories, Inc. of 526-536 North Avenue, Westfield, New Jersey, has introduced its Model HA-3 three-stage unit.

Featuring a new low-noise circuit, the unit includes automatic "on-off" operation, a switch for attenuating strong signals, u.h.f. adaptability, and a metal cabinet. The booster can be used with indoor antennas as well as in fringe and weak signal areas. It can be installed in less than a minute, according to the company.



REPLACEMENT TRANSFORMER

Thordarson-Meissner, Mt. Carmel, Illinois, has developed a universal replacement power transformer which has been designated as the Model T26R00.

Although designed especially for the TV replacement field, the new transformer is applicable in other circuits as well. Through use of tapped secondary windings, two secondary windings, two rectifier and four heater windings, the T26R00 will replace power transformer in over 1200 ex-

Federated

FEATURES

TELE MATIC

New Telematic
WAVE TRAP for the
new Amateur Band (21 Mc)



Designed to peak sharply from 13.5 to 31 M.C. with maximum attenuation and minimum TV signal loss.
MODEL WT-14E \$3.50 list

New Telematic
Automatic LINE SWITCH

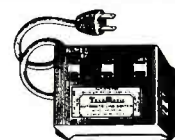

Automatic on and off switch for booster, rotor, lamp or other equipment used with TV set. Eliminates unsightly tangle of wires. Housed in sturdy compact metal case.
MODEL SW-58 \$5.95 list

New Dual Stage
CRT BOOSTER
by Telematic



Stepping switch adds extra life to cathode ray tube by giving TWO-STAGE INTENSIFICATION.
MODEL CR-54 \$5.95 list
Also available: Single Stage
MODEL CR-64 \$3.50 list

TELEMATIC
ANTENNAS!

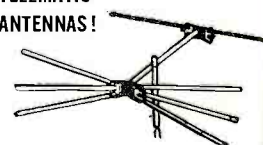

See the complete line of Telematic antenna "buys" at FEDERATED! featuring

- Highest Gain!
- Easy Assembly!
- Sturdy Construction
- Longer Life!

Stop TV INTERFERENCE

caused by AUTO & TRUCK



IGNITION
with the
TELEMATIC
IGNITION
FILTER

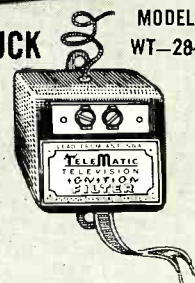

Eliminates picture tear, streaking and flutter caused by passing traffic. Easily installed — No special tools needed. Now available at your nearest FEDERATED Supply Center — or order by mail. \$2.00 PREPAID.

FREE!

Write for valuable T.V.I. Booklet & Catalog. Jampacked with latest information on Television and newest ways to eliminate interference.

Federated Purchaser

THE ONLY COAST TO COAST ELECTRONICS DISTRIBUTOR

New York City 66 Day St. Olgyb-9-9050	Los Angeles 911 S. Grand Ave. TRinity 1761	Newark, N. J. 114 Hudson St. Market 3-9035	Allentown, Pa. 1115 Hamilton St. Phone 3-7441	Easton, Pa. 925 Northampton St. EASTON 4259
---	--	--	---	---

THE NEW

Regency

VB-1 Voltage Booster*

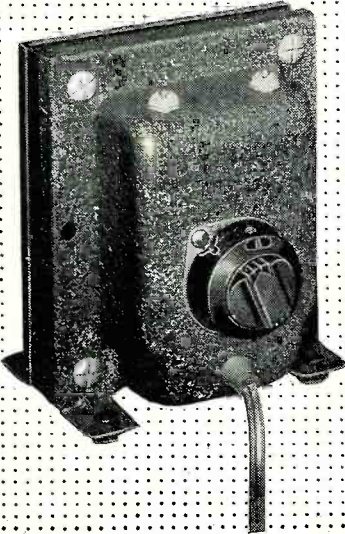

Get peak performance from your TV set or any electrical device drawing 350 watts or less. Maintains full 117 volt power supply. Insures full size TV picture when low line voltage shrinks picture size.

THE VB-1, \$19.95 LIST

*by the makers of the Regency VHF TV booster and UHF TV converter

Ask any radio parts jobber for further information or write:
I.D.E.A., INC., REGENCY DIVISION
7900 Pendleton Pike, Indianapolis 26
Cherry 2466

EASY TO LEARN CODE

It is easy to learn or increase speed with an Instructograph Code Teacher. Affords the quickest and most practical method yet developed. For beginners or advanced students. Available tapes from beginner's alphabet to typical messages on all subjects. Speed range 5 to 40 WPM. Always ready—no QRM.



ENDORSED BY THOUSANDS!

The Instructograph Code Teacher literally takes the place of an operator-instructor and enables anyone to learn and master code without further assistance. Thousands of successful operators have "acquired the code" with the Instructograph System. Write today for convenient rental and purchase plans.

INSTRUCTOGRAPH COMPANY

4711 SHERIDAN ROAD, CHICAGO 40, ILLINOIS

MORE CASH

For Your Radio Equipment

We've moved—and need Radio & Aircraft parts and equipment to fill our new warehouse. Write:

CANDEE-ARCO
Dept. T-8, P. O. Box 1187
Magnolia Park Station
Burbank, Calif.

FREE

Write today for "How to Service T. V. Receivers" with the HICKOK VIDEO GENERATOR.

The Hickok Electrical Instrument Co.
10824 Dupont Ave., Cleveland, Ohio

PAY LESS FOR TUBES

INDIVIDUALLY BOXED • FULLY TESTED • EACH TUBE GUARANTEED FOR SIX MONTHS

Type	Price	Type	Price	Type	Price	Type	Price
1B3GT	\$.63	6A55	\$.50	6J6	\$.62	12AX7	\$.61
1H5GT	.46	6AT6	.38	6K6GT	.41	12BA6	.45
1L4	.57	6AU6	.43	6L6G	.80	12BE6	.47
1L6	.58	6AV6	.38	6L6CA	.80	12BH7	.63
1N5GT	.57	6B4G	.96	6S4	.46	12SA7GT	.52
1R5	.56	6BA6	.45	6SA7GT	.52	12SK7GT	.50
1S5	.47	6BA7	.60	6S17GT	.47	12SL7GT	.61
1T4	.56	6BC5	.53	6SK7GT	.50	12SN7GT	.54
1T5GT	.71	6BD5GT	.89	6SL7GT	.62	12SQ7GT	.42
1X2	.67	6BE6	.47	6SN7GT	.54	19B6G	1.39
3Q5GT	.65	6BF5	.60	6SQ7GT	.42	19C8	.94
354	.55	6BG6	1.34	6T8	.78	19T8	.79
3V4	.56	6BH6	.57	6V6GT	.46	25B06	.89
5U4G	.41	6BJ6	.48	6W4GT	.45	25L6GT	.48
5V4G	.73	6BK7	.85	6W6GT	.57	25Z6GT	.42
5Y3E	.34	6BL7	.83	6X4	.34	35A5	.48
5Y3GT	.30	6BQ6	.89	6X5GT	.33	35B5	.47
6AB4	.46	6BQ7	.85	6Y6G	.59	35C5	.47
6AG5	.54	6C4	.34	7N7	.52	35L6GT	.47
6AK5	.95	6CB6	.53	12AT6	.38	35W4	.31
6AK6	.63	6CD6	1.85	12AT7	.68	35Z6GT	.30
6AL5	.40	6F6GT	.45	12AU6	.43	50C5	.47
6AQ5	.46	6F8G	.93	12AU7	.53	50L6	.47
6AQ6	.42	6H6GT	.49	12AV6	.38	117Z3	.39
6ARS	.38	6J5GT	.40	12AV7	.80	117Z6	.68

Each tube is performance-proven. 25% deposit must accompany all orders. Balance C.O.D. All prices F.O.B., N.Y.C. If remittance is made with order, you can deduct 2%. \$1.00 handling charge for orders under \$10.00. Subject to Prior Sale.

PHILLIPS TUBE COMPANY 2610 E. 16th Street
Brooklyn 35, N. Y.

isting TV models. This feature eliminates the necessity for the service dealer to stock 25 or 30 different transformers to cover the replacement field.

Four universal brackets are furnished, enabling easy mounting either vertically, horizontally, above, or below the chassis. Long color-coded leads and a color-coded diagram printed on the transformer, speed up the replacement job.

Complete details are available from the company on request.

TOWER AMPLIFIER SYSTEM

The Engineering Products Department of Radio Corporation of America's RCA Victor Division has announced the development of new tower amplifier equipment for use in the company's community TV "Antenaplex" systems to provide high-gain TV signal amplification in areas where signal strength is low.

The Type SX-8CT tower amplifier system is designed for use in "Antenaplex" systems for one-, two-, or three-channel service. The equipment boosts the incoming signal to a level sufficient to carry it to the next amplifying station. Associated converter equipment is used with the tower amplifier system for converting the incoming frequencies to those used in the outgoing channels of the tower amplifier.

Technical details on the new system are available from the Engineering Products Department of the company, Camden, New Jersey.

MATTISON RECEIVER

Mattison Television and Radio Corporation, 893 Broadway, New York 3, New York, has announced the addition of "The Heritage" to its line of home receivers.

The set is housed in a genuine mahogany cabinet with crotch mahogany panelled doors. The illuminated channel selector light is incorporated in the cabinet and turns on when the channel is being tuned and off when the program is on the screen. The



cabinet also has a built-in insulated compartment to prevent cabinet damage from chassis heat. The cabinet measures 40" high, 32½" wide, and 23½" deep.

"The Heritage" houses the company's 630 chassis with a tunable built-in booster for DX reception. The model is also obtainable without this feature if desired.

NEW TEST EQUIPMENT

Industrial Television, Inc., 369 Lexington Avenue, Clifton, New Jersey, has added a field strength meter to its line of fringe-area television equipment.

Known as the IT-105R field-strength meter, the new unit is designed to



meet the need for such measurements for both u.h.f. and v.h.f. signals. A speaker is included in this model to provide audible indication and to eliminate the need for earphones. Supplemental equipment in the form of a battery pack permits its use in locations where power is not available.

Channels 2 through 82 are covered, 72 or 300 ohm input, while the signal strength from 0 to 50,000 microvolts is read on a 4 1/2" rectangular meter.

For convenience, the IT-105R is equipped with a leather handle and sling strap.

ANTENNA GUY WIRE

Samson Cordage Works, 89 Broad Street, Boston, Massachusetts, has recently introduced a plastic coated antenna guy wire which has been designed to be used in place of galvanized wire in TV antenna installations.

The wire has a tensile strength of over 425 pounds and its plastic cover will withstand abnormally low or high temperatures, according to the company. The plastic cover is not affected by acids in industrial smokes, nor by the moisture in the air to the same extent as galvanized wire, hence it is claimed to last twice as long as galvanized wire under comparable installation conditions.

Further information on this new antenna guy wire is available from the company on request.

LOW-COST YAGIS

The LaPointe-Plascomold Corporation of Rockville, Connecticut, has announced the availability of a new line of low-cost yagis which has been trademarked the "Delta" line.

Included are five-, eight-, and twelve-element yagis which incorporate a delta matching system. This delta

ANTENNA EQUIPMENT



MAST BASES—INSULATED:

MP-132 BASE—Illustrated at left—1" heavy coil spring, 2" insulator. Overall length: 1 1/2". Weight: 2 1/2 lbs. Price \$3.95

MAST BASE—Insulated type with heavy coil spring and 3" dia. insulator. Requires 1" hole for mounting. Weight: 4 lbs. \$5.95

MAST SECTIONS FOR ABOVE BASES

Tubular steel, copper coated, painted, in 3 ft. sections, screw-in type. MS-53 can be used to make any length with MS-52-51-50-49 for taper. Any section..... 50c Each
Larger Diameter Sections: MS-55-54.... \$1.25 Each

CORDS—CABLES

CD-501 Cord f/GN-45 Generator \$2.50
CD-318 Cord w/PL-68 & SW-141 & JK-48F... .89
CD-307 Cord—6.5 Ft. w/PL-55 & JK-26..... .89
CD-604 Cord w/C-110 Trans. & 1L-54 Plug... .89
CD-365 Cord for LI-21 Loop..... 1.50
MC-215 Tuning Shaft for 274N..... 2.00

AIRCRAFT CONTROL CABLE

3/32"—7x14 Strand, Weatherproofed, Galvanized, 220 lb. Test. Ideal for Television Guying and many other uses. Prices: 3/2c per Ft.—1000 Ft. or more @ 3c per Ft.

TRANSFORMERS AND CHOKES

TRANSFORMERS—110 V. 60 CYCLE PRIMARIES:
6.3 V. 1 Amp... 1.25 24 V. 1 Amp... 1.95
24 V. 1/2 Amp... 1.50 24 V. 6.5 Amp... 5.95
G—24—or 30 Volt 8 Amp..... 5.95
Two 12 V. 4 A. windings, gives 12 V. 8 A. or 24 V. 4 A. 5.95
325-0-325 V. 50 MA.—6.3 V. 2.5 A.; 6.3 V. .6 A. (Rect. 6x5) Half Shell—2 7/8"x3 3/8"x3"—No. T-23-28..... 2.75
440 VCT/70 MA.—5 V. 2 A.—6.3 V. 4 A..... 3.35
700 VCT/200 MA.—6.3 V. 4 A.—6.3 V. 4 A.—5 V. 3 A. 4.95
490 VCT/60 MA.—5 V. 2 A.; 6.3 V. 4 A.; 6.3 V. 2 A. 3.25
460 VCT/90 MA.—5 V. 3 A.; 6.3 V. 4 A. 3.75
175-0-175 V. 40 MA.—6.3 V. @ 2.4 A.; 6.3 V. @ .6 A.; Halfshell 2 3/4"x2 3/8"x2 3/8"—No. T-23-40..... 1.75
350-0-350 V. 90 MA.—6.3 V. @ 3 A.; 5 V. @ 3 A.; Upright—3 1/4"x3 1/4"x3 1/4"..... 3.25

CHOKES

5 Henries—150 MA. 85 ohms DC—Res. Cased. \$1.95
8 Henries—150 MA. 200 ohms..... 1.95
5-20 Henries—300 MA. 110 ohms, 1000 V. Ins. 3.95

MISCELLANEOUS

TA-12B TRANSMITTER with Tubes—Used... \$39.95
R1/ARR-1 Receiver—easily converted to 220 MC. (See R.N. Jan. '49) Complete w/Tubes. NEW... \$4.95
RA-10 DB Receiver—24 Volt with Tubes and Dynamotor—Used \$29.95

AMPLIFIERS

BC-367 Amplifier—w/Tubes, less Dyn..... \$4.95
BC-605—With Tubes, Used..... 3.95
BC-709—W/Tubes—New: \$4.95 Used: 3.95
BC-347—Less Tubes—New: \$2.95 Used: 1.95

POWER SUPPLIES

PE-157 POWER SUPPLY—2 Volt Vibrator Supply, operates from BB-54 2 Volt Battery mounted in Case. Output voltage 1.4 V. 1/4 Amp 125 V. 50 MA. Less Brator \$4.95
BB-54 2 Volt Dry Battery 2.95
MP-25 BA Power Supply & Modulator 1/TA-12—New: \$29.95
Power Supply No. 3 f/Mark II No. 19 Radio Set, 12 or 24 V. Two 1M Dynamotors: 500 V. 50 MA.; 275 V. 110 MA.—New: \$12.95
PE-104 Vibrator Unit f/BC-654..... 10.95
550C Vibrator f/PE-104—New..... 1.95
VB-16 Vibrator f/PE-237—SCR-694—New... 4.95
VB-9 Vibrator—6 Volt 4 Prong—New..... 1.00
VB-8 Vibrator—2 Volt—New..... 1.00

COMMAND TRANSMITTERS

Complete with Tubes & Crystals

BC-457 Transmitter—4 to 5.3 MC.—Used... \$ 8.95
BC-458 Transmitter—5.3 to 7 MC.—Used.... 7.95
BC-459 Transmitter—7 to 9 MC.—NEW.... 22.95
T-20/ARC-5 Transmitter—4 to 5.3 MC. NEW 12.95
BC-456 Modulator, NEW: \$5.95—Used... 2.95
Transmitter Rack—Single: \$1.50—Dual... 2.00
Rec. Back—Dual: \$1.50 Modulator—Mtg. 1.50
Rec. Dyn.—Used: \$2.95 Trans. Dyn. Used: 2.95

BLOWERS—115 VAC 60 CYCLE



SINGLE TYPE: (Illustrated at left) 100 CFM. 2 1/2" intake; 2" outlet. Complete size: 5" x 6". Order No. RN-520... \$7.99
DUAL TYPE: 100 CFM. 4" intake; 2" Dis. Each Side. Complete Size: 8" x 6". Order No. RN-800 \$12.95
COMPACT TYPE: 108 CFM. Motor built inside squirrel cage. 4 1/2" intake; 3 3/4" x 3" Dis. Complete size: 4 1/2" W x 8 3/8" H x 8 3/8" D. Order No. RN-860 \$13.50
FLANGE TYPE: 140 CFM. 3 1/2" intake; 2 1/2" Dis. Complete size: 7 1/2" W x 7 1/4" H x 6 3/4" D. Order No. RN-865 \$12.95
FLANGE TWIN: 275 CFM. 4 1/2" intake; 3 1/4" x 3" Dis. Complete size: 11 1/2" W x 8 3/8" H x 8 1/16" D. Order No. RN-134..... \$20.95

DYNAMOTORS

DYNAMOTOR and BLOWER: 9 Volts DC input; output 450 Volts 60 MA. 4500 RPM. At 6 Volts DC input: output 260 Volts 65 MA. 3000 RPM. \$4.95

PE-101C DYNAMOTOR... NEW \$3.95

INPUT:	OUTPUT:	STOCK No.:	PRICE:
14 V. DC	600 V. 300 MA.	BD-86	\$9.95
12 V. DC	220 V. 70 MA.	DM-24	6.95
12 V. DC	220 V. 100 MA.	DM-18	4.95
14 V. DC	375 V. 150 MA.	DM-375	8.95
14 V. DC	330 V. 135 MA.	DM-330	7.95
14 V. DC	500 V. 500 MA.	FB-50	14.95
12 or 24 V. DC	275 V. 110 MA.	USA/0516	3.95
12 V. DC	250 V. 50 MA.	DM-25	8.95
12 or 24 V. DC	500 V. 50 MA.	USA/0515	3.95
12 or 24 V. DC	440 V. 200 MA.		
	225 V. 100 MA.	D-104	14.95
28 V. DC	250 V. 60 MA.	PE-86	5.95

AERIAL WIRE—Phosphorus Bronze #16 Stranded, 200 lb. test. Weatherproof. 150 Ft. on Reel. RL-3 w/Clips \$1.50
Telephone Wire—3 Cond. copper & steel. 525 Ft. 4.75

Address Dept. RN • Minimum Order \$5.00 • Prices F.O.B., Lima, O. • 25% Deposit on C.O.D. Orders

FAIR RADIO SALES

132 SOUTH MAIN ST. LIMA, OHIO

Now JSC Announces Expanded 300 Ohm TV Lead In Wire Line!



JSC proudly announces a complete range for:

22-gauge copper	20-gauge copper
40 mil	40 mil
55 mil	55 mil
70 mil	70 mil
80 mil	80 mil
100 mil	100 mil

4-Conductor Rotor Wire

Perforated 300 Ohm Open Wire

JSC has highest quality wire at lowest possible prices. Lithographic spools of orange and blue individually packed 1000 feet to the metal spool.

See your nearest JSC distributor who proudly displays the blue and orange disc of quality.

Depend on... CONCORD

SENSATIONAL BUY!

3 SPEED AUTOMATIC PORTABLE RECORD PLAYER With AMPLIFIER



Our Low Price **\$49.50**

Plays all 3 speed records with lid closed. Volume and Tone controls on outside. Powerful 3-tube amplifier, 5" Alnico 5 PM Speaker. Plays 12-10" or 10-12" and 12-7" all 3 speeds. Deluxe wood case covered in striking washable cloth. 17 3/4" x 15" x 8 5/8". Wt. 2 1/2 lbs. 110 V. A.C.



RED HOT BUY! Famous Make CLOCK RADIO

Superhet. Self-starting clock-sweep-second movement. Molded plastic cabinet. Ebony

Walnut, lots of 3,
Each \$16.95
Single, Each..... \$17.95

Lots of 3, Each... **\$15.95**
Single, Each..... \$16.95

Lowest Price Ever! SINGLE SPEED PORTABLE RECORD PLAYER With AMPLIFIER



Our Low Price **\$14.95**

Constant single speed motor, 2-tube amplifier, volume control and switch. 4 1/2" Alnico 5 PM Speaker. Luggage wood case 12 5/8" x 10 1/2" x 5 1/2". Wt. 9 lbs. 110 V A.C. 3-SPEED PORTABLE PLAYER **\$17.95** similar to above



TOP XMAS VALUE! KIDDIE PHONOGRAPH

Our Low Price **\$10.95**

A world of fun for the kiddies. All year 'round! Electric phonograph with acoustic tone arm. Colorfully decorated, sturdy, "open-face" wooden case. Designed for full quality reproduction.

Send TODAY for your copy of our latest Buyer's Guide!

CONCORD RADIO

53-L Vesey Street, New York 7, N. Y.
Phone: Dlgby 9-1132

OPEN THURSDAYS UNTIL 9 O'CLOCK

VALUES GALORE!

- RADIO
- TELEVISION
- ELECTRONIC BUYER'S GUIDE

CONCORD

RADIO

53 Vesey St. N. Y.

CONCORD RADIO, 53-L Vesey St., N. Y. 7
Dept. N-12
Send me at once your latest Buyer's Guide,
Free of Charge.

Name

Address

City State

match will replace the standard driven element of the company's "Vee-D-X" JC yagi and will provide exact 300-ohm termination. Except for the new matching method, the five-element antenna, Model DC, is exactly the same as the company's five-element JC model, both in performance and in construction.

The "Delta" line features all aluminum, lightweight, preassembled construction; high-gain five-element performance; and 6 mc. bandwidth.

CONTACT CLEANER

Fischer Distributing Co., 118 Duane Street, New York, N. Y. is now merchandising "Quietone," a new contact cleaner and lubricant manufactured by the Quietone Division of R. & L. Radio-Television.

The new product is said to be a highly effective cleaner, is non-inflammable, non-corrosive or solvent to metals or plastics, does not affect in any way oscillator frequency characteristics, yet provides non-greasy lubrication action.

"Quietone" may be used on television or radio equipment, electronic gear, on test equipment, etc. It may be used on any and all electrical contacts either for maintenance or as a protection for new equipment.

It is being marketed in a 2 ounce dropper bottle, a 2 ounce plastic spray squeeze bottle, 8 ounce bottle, or in quart sizes.

Full details are available from the distributor on request.

ANTENNA SELECTOR

A low-loss, triple-circuit antenna selector is now being marketed by Technical Appliance Corporation of Sherburne, New York.

The new unit, Catalogue No. 873, has been designed primarily for the selection at the receiver of signals from any one of three antennas. Maximum transfer of energy with minimum loss is attained through positive contact points and an impedance closely matching the transmission line.

In addition to its primary use, the manufacturer suggests that the unit may be used as a selector in a television showroom by switching the signals from the antenna to any of three receivers or in audio systems where the signals from the amplifier are to be switched from one speaker to another.

SELF-COUPLING MASTS

Snyder Manufacturing Company, Philadelphia 40, Pa., has recently introduced a new television antenna mast section, the MIO-X.

Precision built and self-coupling, the new units have a heavy-duty "3-Cote" finish inside and outside, being rust-proof "Bonderized" with a coat of primer paint and a coat of baked heavy plastic enamel.

Each mast section is 10 feet long and sections come packed 10 to a carton.

Modulation Monitor

(Continued from page 55)

end of the plate tank decreases, this voltage becomes less positive than the cathode of the diode, the diode ceases to conduct, and any further decrease in voltage appears across the neon lamp. It can now be seen that if the plate voltage is removed from the final and the potentiometer R_3 is adjusted so that the voltage across the lamp is exactly equal to its ionizing potential, the unit will be adjusted for indication of 100% negative peak modulation. This is true because the lamp will flash each time the voltage on the plate tank drops to zero, which is 100% negative peak modulation.

If the voltage at the cathode of the diode is made more positive than the ionizing potential of the lamp, it will flash at some value less than 100%. The percentage modulation for a given value of cathode voltage can be calculated from one of the following formulas:

$$\% \text{ Modulation} = \frac{E_p + (E_s - E_k)}{E_p} \times 100$$

or:

$$E_k = E_p + E_s - E_p \frac{(\% \text{ Mod.})}{100}$$

where:

E_p = Final plate voltage.

E_s = Striking potential of neon lamp.

E_k = Positive voltage on the cathode of the diode.

The value of plate voltage will affect the percentage for any value less than 100%. However, when unit is set to flash at 100%, the expression $(E_s - E_k)$ in the formula reduces to zero and any changes in plate voltage will have no effect upon the accuracy of the indication.

While there are no special precautions necessary in the construction of this unit, R_1 and R_2 should be constructed of several resistors in series, particularly in transmitters using very high plate voltages. This is to preclude the possibility of arcing across the resistors. NE-2 lamps are used in the unit shown, however, any small neon lamps will serve. The voltage applied to R_3 and E_k is not critical, the only requirement is that it be greater than E_k in the formula for the value of modulation desired.

Due to the small size of this unit and its freedom from mechanical difficulties, it may easily be built into mobile or portable rigs, affording a low cost and almost foolproof means of maintaining the desired high level of modulation.

The authors believe that such a unit as this should be standard equipment for all plate modulated amateur transmitters. If it were, we believe that many of the amateurs who are unwittingly over-modulating and spluttering over a wide band would apply a counter-clockwise motion to their mike gain controls.

952 INDEX

VOLUMES 47-48

As a service to our readers we are again presenting a complete listing of all feature articles which appeared in RADIO & TELEVISION NEWS during 1952. We suggest you keep this for reference.

AMATEUR

ANTENNAS

- An Antenna Tuning Unit (Bumbaugh, W6HI) 63 Sept.
- Folded Long Wires (Perthel, W9MWD) 125 Mar.
- Slide Tuning the 75-Meter Loading Coil (Najork, W2HNH) 52 Jan.
- The Aluminum Foil Beam (Ulyat, W3PTW) 55 Feb.

CONVERTERS

- Converter Receives Both Phone and C.W. (Johnson, WØLBV) 60 Sept.
- Improved Broadband Converters (Kaufman, W6YOV) 39 July
- Subminiature 75-Meter Mobile Converter (Lanzalotti, W2DVX & French, W2KQJ) 39 Oct.

MISCELLANEOUS

- A Duo-Diode Modulation Monitor (Lucas, DL4ZV & Peters, DL4VJ) .. 55 Dec.
- An Adapter for NBFM Reception (De Castro) 58 Apr.
- An Improved Speech Clipper (Watkins, W5JXO) 55 Aug.
- A Sharply Tuned A.F. Amplifier (Turner, K6AI) 65 Feb.
- Hams Again at Disaster Scene (Sagert, W9BEF) 34 July
- Microwaves for the "Ham" (Freedman, W6YUQ) 31 Aug.
- The Cascade-Cascade on 2 Meters (Tomer, W1PIM) 48 Dec.
- The Electronic Brain "Codytper" (Dorfman) 46 Mar.
- TVI Trouble Ahead 78 June

TRANSMITTERS

- A Beat-Frequency V.F.O. (Kline, W2DKE) 48 Jan.
- A Low Cost Exciter Unit (Clemens, W9ERN) 40 Feb.
- A Midget V.F.O. (Purvis, W3QQA) .. 43 Mar.
- A Mobile 75-Meter V.F.O. (Crusiberry, W9DVV) 52 Apr.
- A Multi-Band V.F.O. Mobile Transmitter (Watkins, W5JXO) 39 Dec.
- A Novel Multi-Band Tuning Circuit (Zaayer, PAØUN) 42 July
- A Novice Transmitter Kit (Lagenour, W9LEI) 45 Nov.
- A Single-Sideband Transmitter Adapter (Clemens, W9ERN) 43 Apr.
- A 35-Watt Novice Transmitter (Taylor, W8NAF) 55 Oct.
- A 250-Watt TVI-Proof Transmitter (Lewis, W8MQU) 35 June
- A Two-Meter Miniature Disaster Transmitter (Kirchhoff, W2FAR & Bulkeley, W2QUJ) 61 May
- A Vacuum Tube Keyed Transmitter (Gallagher, W5HZB) 39 Jan.
- 150-Watt Universal R.F. Amplifier (Clemens, W9ERN) 53 Mar.
- Stability Plus with the Franklin Oscillator (Kirchhoff, W2FAR & Bulkeley, W2QUJ) 56 Feb.



RADCOM IS YOUR GUIDE FOR Quality...

RADIO and ELECTRONICS NEEDS

TUBES for every purpose . . . Available NOW

CK 1005 \$ 0.85	2J26 \$24.50	IN-27 \$ 1.59
CWL 803 3.90	2J27 24.50	IN-47 8.50
EF-5069	2J31 29.75	559 1.35
GL 623 10.35	2J32 59.95	6AK589
GL 8020 1.50	2J33 39.39	6AL549
HY 61525	2J34 38.50	6BH689
VR-105-30 1.35	2J36 120.00	6CB679
VR-75-OA3 1.35	2J37 12.70	700A 17.50
1B29 2.45	2J39 49.50	700B 18.50
1B35 10.98	2J48 28.50	700C 27.00
161674	2J50 27.50	700D 18.50
161945	2J62 49.45	703A 5.98
162939	OZ4A-CK100369	706EY 39.50
163373	CD3-VR/15098	724B 3.45
1P22 13.00	2J889R-A 250.00	725A 8.90
2050 1.47	3B25 4.50	866-A 1.50
2X2A 1.89	3C24G 1.75	874 1.39
2J21 10.69	3E29 14.95	95539
2J21A 9.25	450TH 44.00	95745
2J22 7.90	IN-23 1.35	900280

THOUSANDS IN STOCK

TEST INSTRUMENTS

Model 300A Wave Analyzer (Hewlett-Packard) • EE-65-F Test Set • E-400 Sweep Signal Generator • I-98-A Signal Generator • I-222A Signal Generator • 19X Hickok Microvolt Generator • 155 RCA Scopes 715 RCA Scope Console • 546B G.R. Microvoltage • 720A G.R. Het. Freq. Meter • 726A G.R. Vac. Tube Voltmeter.

MANY OTHER TYPES IN STOCK: YOUR REQUIREMENTS WILL RECEIVE PROMPT ATTENTION.

RADCOM also specializes in reconstructing Radio & Communication equipment. All types SCR Test and Navy-type Radio equipment always in stock.

WE NEED: Top prices for TCS-7 and up. SCR-274N, SCR-399 Equipment JB-70, JB-60, BC-939A, BC-610-E, RA-63 EE8, BC-614-E, PE-95, PE-197, Trailer K-52, Cords, LS-3 Speakers, SCR-508, BC-604, BC-603, FT-237 Transmitters, Crystal Sets. SCR-506, BC-653-A, DM-40-A, FT-253-A, BC-658-A, BC-312, BC-342, BC-652-A, SCR-300, BC-1000. Tel. BiGelow 2-6666 ALL PRICES SUBJECT TO CHANGE WITHOUT NOTICE Telegraph WUX, Newark, N. J.

SPECIAL ARC-4 VHF TRANSCEIVER

Sensational all-purpose unit. 2 meter or civilian defense. Frequency range 140-144 MC/S. Less tubes and dynamotor. ONLY

\$19.95

CRV-46151 AIRCRAFT RADIO RECEIVERS

105 to 9050 Kc. 4 bands including L.F. Ship, B.C. and amateur 80 and 40 meter. Easily converted to AC operation. 8 1/2 x 7 1/2 x 1 1/4, less tubes & dynamotor. ONLY

\$22.75

Prices F.O.B. Newark, N. J.

Always Right With Earl White

RADCOM Engineering Co. 8 Livingston St. Newark 3, N. J.

TELEPHONE EQUIPMENT & PARTS

- New TS9 handsets with butterfly flip switch in handle Each 56.50
- Reconditioned TS9 handsets with new shell. Each 5.50
- New W.E. P1W handsets with rubber cord and a PL47 plug. Each 6.50
- New 4 1/2 foot rubber cords with PL47 plug. Each .75
- Reconditioned operators' head and chests sets HS19—Single receiver Each 5.50
- Double receiver Each 6.50
- Wall telephones with dial. Each 8.50
- Reconditioned upright desk telephones (for intercoms—extensions, etc.) Each 2.95
- Rebuilt like new Solid type handsets W/3 cond. cord Each 4.95
- New W.E. UA 38 and B-365 relays. Each 1.95
- Reconditioned and tested EES telephones in stained leather bags. Each 18.50
- Sound power field telephones like new. Each 25.00
- New receiver and transmitter elements (like and interchangeable with W.E. AFI and F1). Each 1.00
- Upright desk telephones with dial and ringer box, excellent condition. Each 11.00
- Reconditioned RD 71 switchboards magnet 6 line Each 45.00
- TS13 handsets with P.L. 68 & 35 plugs. Each 8.50
- TS13 handsets with P.L. 68 & 35 plugs. Each 8.50

Terms: Check with order.—F.O.B. Brooklyn, New York

EASTERN TELEPHONE CO.

323 Vanderbilt Avenue Brooklyn 5, N. Y.

GOING FAST DON'T MISS THESE BUYS

LINK & BOSCH MOBILE POLICE RADIO, 5 TUBES, FIXED TUNED 2-3mc, ADJUSTABLE SQUELCH CONTROL, W/6V input mtr. gen. supply (250V/55ma out). INSTALLATION OF SIMPLE SWITCHING ALLOWS USE/boat; ship to ship, ship to shore, Coast Guard service, used clean cond. \$ 8.95 UNITS USING VIBRATOR POWER SUPPLY 9.95 SAME UNITS AS ABOVE, XTAL CONTROL OSCILLATOR 10.95

- Western Electric #18B MOBILE 32-40mc RECEIVER. 7 TUBES W/BUILT IN SPEAKER, MTR. GEN. SUPPLY W/NOISE FILTER. IDEAL FOR TRUCK OR CAR SERVICE. USED CLEAN CONDITION. BARGAIN @ \$24.95, less tubes. \$21.95
- VIBRATOR PACK, 6V in. 250V/55ma. used CARTER GENERATOR, same specs as above. 4.95
- BATTERY CHARGER, 6 volt, 2-5 amp, taper COMPACT 27MC XMITTER ASSY. complete w/ 3A5 dual triode, easily reworked/cit. band. \$2.95
- PRECISION CRYSTAL, 27.253mc/.04 tol. newly mid. band mode oscillator, complete w/holder. 4.25
- WHIP ANTENNA SECTIONS, MS-49 to MS-56. 45
- 12 1/2 ft. S1.60; 16 1/2 ft. S1.95; 24 1/2 ft. 2.95
- IDEAL/20 motor vert. beam elements. 30 1/2 ft. 4.25
- HAYDON SYNCHRONOUS MOTOR, 24 volts 60cy. will operate on 115V line with series capacitor. high torque geared shaft output. 5 RPHR. w/cmp. 1.25
- 600 VOLT D.C. OIL CAPACITORS
- 3 MF RECT. \$0.59
- 10 MF RECT. \$2.45
- 3 MF RECT. 1.45
- 10 MF RECT. 1.45
- 4 MF TLAD TYPE 75
- 20 MF RECT. 2.95
- 8 MF RECT. 1.45
- 60 MF RECT. 6.95
- 8x2 MFD (6 term) suitable networks, special. 4.95
- BATTERY CHARGER, 6 volt, 2-5 amp taper. 7.95
- ROSIN CORE SOLDER, 40-60, .062 dia. 5 lbs. 3.65
- AFSCO ELECTRIC AMPLIFR. input 2V/600Z output 5V/600Z, tot. distortion 0.9%/1000 Cy. high & low freq. switch varies from minus 15dB to plus 15dB suitable for high quality audio systems. 29.95
- AUTOMATIC ELECTRIC type 13 SWITCH SWITC. 8-12 VDC coil, 3 pole 25 position, 360 degree 8.95
- Save C.O.D. Fees, Incl. Postage, Express Refunded

ELECTRONIC SPECIALTY SUPPLY CO. 58 WALKER ST. NYC 13, N.Y. WALKER 5-8187

COMPARE!

AND SEE FOR YOURSELF
The Famous RAY-SCOPE

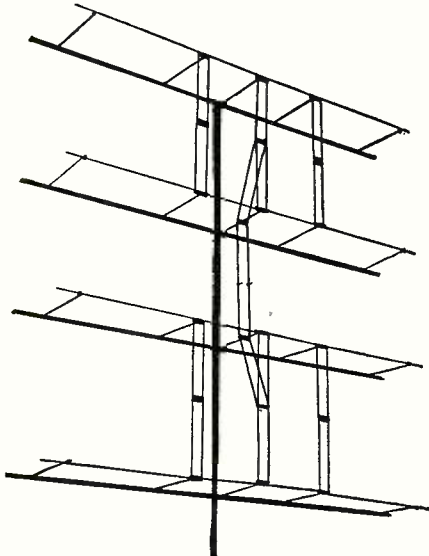

The most talked about TV antenna designed for extreme fringe areas with exceptionally high gain on all channels.

Completely pre-assembled, light in weight, life-long construction. For power plus, it's the RAY-SCOPE.

The Famous RAY-SCOPE "400"

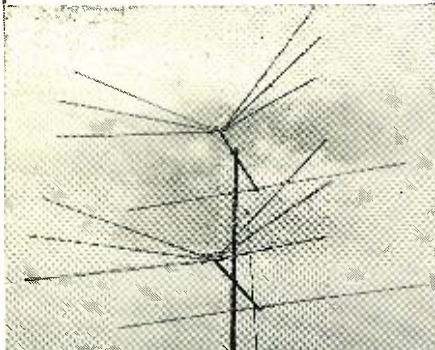

IT'S HERE! Just flip out elements and tighten wingnuts. The ultimate in pre-assembled conicals. Acclaimed to be the supreme leader in its field. Highest gain in fringe areas, solid aluminum casting front and rear element brackets, seamless tubing thruout with all-weather inserts, solid aluminum stacking bars, parts easily replaced and absolutely no loose hardware.

DON'T DELAY—SEE ONE TODAY

WRITE TODAY FOR CATALOGUE AND PRICES

Manufactured only by
The DI-CO TV & Plastic Co., Inc.
Milford, Conn.

Territories Available for Reps. & Jobbers

Look For This Trademark



The R.C.O.—A Remote Control Oscillator (Clemens, W9ERN)..... 40 Aug.
Three Tubes on 2 Meters (Kirchhoff, W2FAR & Bulkley, W2QUJ)..... 40 Sept.

AM-FM

MISCELLANEOUS

A Dual-Channel AM Receiver (Southworth) 66 Mar.
A Low-Cost 152-162 mc. Converter (Smith, W8VVD) 54 May
An "Extra" Superhet (Wickfield)... 43 Feb.
A Remote-Control Tuner (Southworth) 56 Oct.
A Remotely-Controlled AM Tuner (Ellis) 72 Sept.
A Shirt Pocket Radio (Johnson, Jr., W9LQX) 42 Jan.
FM Booster Improvement (Cohn)... 108 Nov.
Improved FM Sensitivity (Mitchell)... 148 Apr.
"Pre-Fab" Tuners (Collins)..... 52 Mar.
The Versatile 6BN6 (Strother)..... 42 May

SERVICING

Adapters to Speed Up Your Service (Darr) 50 Apr.
Mac's Radio Service Shop (Frye)... 62 Jan.
Mac's Radio Service Shop (Frye)... 68 Feb.
Mac's Radio Service Shop (Frye)... 70 Mar.
Mac's Radio Service Shop (Frye)... 64 Apr.
Mac's Radio Service Shop (Frye)... 60 May
Mac's Radio Service Shop (Frye)... 62 June
Mac's Radio Service Shop (Frye)... 61 July
Mac's Radio Service Shop (Frye)... 60 Aug.
Mac's Radio Service Shop (Frye)... 70 Sept.
Mac's Radio Service Shop (Frye)... 68 Oct.
Mac's Radio Service Shop (Frye)... 72 Nov.
Mac's Radio Service Shop (Frye)... 54 Dec.
Successful Servicing of Automobile Receivers (Saltzman) 34 Jan.

AUDIO

AMPLIFIERS

A Compact High-Gain Amplifier (Hust) 58 Jan.
A High-Quality Audio Amplifier (Miller) 38 Feb.
A High-Quality Auditorium Amplifier (Hust) 65 Apr.
A Low-Cost Audio Amplifier (Brewer) 50 Mar.
An Economy Audio Amplifier (Philactos) 56 Nov.
A Portable P.A. System (Garner, Jr.) 42 Nov.
A Preamp for Magnetic Pickups (Creviston) 34 Dec.
4 Problem Preamps (Augsburger)... 60 Nov.
High Quality 50-Watt Amplifier (Baumgardner) 58 Mar.
The Radio & Television News Preamp 50 Nov.
Unique Sound Alarm for Deaf Persons (Davis, Jr., M.D.)..... 48 Aug.

MISCELLANEOUS

A Carrier-Current Intercom (Gottlieb) 45 Dec.
A High-Quality Speaker System (Ballew) 69 Oct.
A Multi-Station Intercom (Sandretto) 66 Nov.
A Two-Station Intercom (Wentworth) 68 Sept.
Artificial Hangover in Audio Circuits (Southworth) 60 Jan.
Audio Goes Mobile..... 35 Aug.
Audio Simplified (Part 5) (Fidelman) 54 Jan.
Audio Simplified (Part 6) (Fidelman) 70 Feb.
Audio Simplified (Part 7) (Fidelman) 72 Mar.
Audio Simplified (Part 8) (Fidelman) 74 Apr.
Audio Simplified (Part 9) (Fidelman) 68 May
Binaural Compensation in Single-Channel Reproduction (Southworth) 56 May
Build This Mixer-Equalizer (Hust)... 66 Feb.
Cabinetry (Markell) 35 Nov.
Corner Loudspeaker Enclosure (Dorf) 48 Mar.
Custom Audio (Becker)..... 46 Nov.
Factors Influencing High Fidelity (Parker) 64 June
Fourth Annual A.E.S. Convention.. 94 Nov.
Front End Control Unit for William-

WALDOM SUPERIOR COMPONENTS

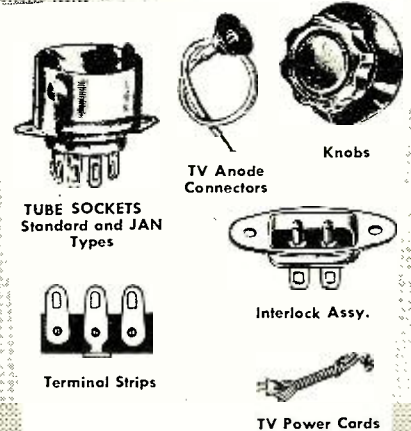

WALDOM also supplies quality CRO-NAME parts

- TV Mask, Glass and Enamel-on-Kits
- Cro-Rex Tuners
- Escutcheons
- Title Plates
- Dial Plates
- Switch Plates
- Radio Knobs
- Instrument Drives
- Instrument Dials

FREE SEND FOR 1952 WALDOM CATALOGS

- SC2—WALDOM Superior Electronic Components and CRO-NAME Products.
- 52—WALDOM Replacement Speaker Cone Manual.

WALDOM ELECTRONICS, INC.
911 N. Larrabee St., Chicago 10, Ill.

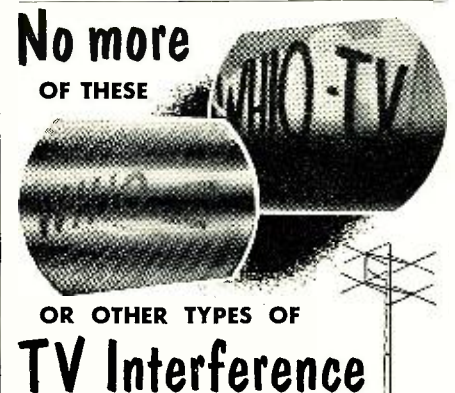

which enter television receiver thru antenna system and power line.

BLOCK BOTH paths of entry with a Drake High Pass Filter installed in antenna lead-in and a Drake LN-5 Power Line Filter plugged into 110 AC outlet at set.

High Pass Antenna Filters

TV-300-50HP 20 Mc IF—300 ohm \$5.95 list
TV-300-54HP 44 Mc IF—300 ohm \$6.95 list

Power Line Filter

LN-5 "Inductube"..... \$9.70 list

Available from dealers and distributors everywhere,
or write to **R. L. Drake Co.**
Dept. R of: 11 Langworth St., Dayton 2, Ohio

DRAKE FILTERS ARE USED OR RECOMMENDED BY MOST TV RECEIVER MANUFACTURERS

RADIO & TELEVISION NEWS

son Amplifier (Rose).....	39	June
Hi-Fi Loudspeaker Design (Cohen).....	56	Dec.
Horn-Loading Loudspeaker Enclosure (Plach & Williams).....	38	May
Loudspeaker Enclosure Design Data (Data-Print No. 2).....	51	June
Loudspeaker Enclosures (Fidelman).....	49	June
Magnetic Tape Duplication (Wortman).....	40	Apr.
Practical Sound Engineering (Conclusion) (Tremaine).....	66	Jan.
Public Address Systems Aid Barkers (Kauke).....	35	July
Pulses in Sound Reproduction (Southworth).....	59	July
Remote Volume Control (Ellis).....	64	Nov.
The "Dialaudio" System (Meyer).....	61	Aug.
Using the 6U8 in a High-Quality Audio System (Jones, Jr.).....	46	Sept.
Which Tube for Audio? (Houle).....	46	July

PHONO

Low-Pass Phonograph Filter Design (Sinker).....	38	Jan.
---	----	------

RECORDING

Cinematic Recording (Blaney).....	46	Aug.
Magnetic Tape and the CBC (Wortman).....	38	June
New Tape Recorder Has Many Features (Berlant).....	48	Nov.
Quality Disc Recording With Home Equipment (Moore).....	38	Nov.
Unique Magnetic-Tape Applications (Wortman).....	38	July

TONE CONTROLS

Phono-Equalizer Chart (Boegli).....	94	Apr.
The Loudness Control—An Aid to Higher Fidelity (Pickett).....	38	Mar.
Universal Design Curves for Tone-Control Circuits (Part 1) (Knight).....	32	July
Universal Design Curves for Tone-Control Circuits (Part 2) (Knight).....	42	Aug.
Universal Design Curves for Tone-Control Circuits (Part 3) (Knight).....	48	Sept.
Universal Design Curves for Tone-Control Circuits (Part 4) (Knight).....	46	Oct.

BOOK REVIEWS

An Introduction To Acoustics (Randall).....	138	Sept.
Antennas: Theory and Practice (Schelkunoff & Friis).....	138	Sept.
Application Of The Electronic Valve In Radio Receivers And Amplifiers (Dammers, et al.).....	138	Sept.
Audels Television Service Manual (Anderson).....	124	Aug.
Design And Construction Of A Wheatstone Bridge (Technological Developments).....	124	Aug.
Direct Current Machinery (Siskind).....	66	Dec.
Foundations of Wireless (Scroggie).....	92	Feb.
Fundamentals of Electronics (Mitchell).....	178	Nov.
High Frequency Transmission Lines (Jackson).....	153	Jan.
How To Pass Radio License Examinations (Drew).....	160	Apr.
Low-Cost Radio Reception (Mercier).....	120	May
Make Music Live (Greene, Radcliffe, & Scharff).....	119	May
Mandl's Television Servicing (Mandl).....	135	June
Microphones (BBC, Engineering Training Dept. Staff).....	120	May
Most-Often-Needed 1952 Radio Diagrams and Servicing Information (Beitman, ed.).....	66	Dec.
Most-Often-Needed 1952 Television Servicing Information (Beitman).....	159	Apr.
Musical Engineering (Olson).....	134	June
Primer Of Electronics And Radiant Energy (Caverly).....	124	Aug.
Principles of Radio (Henny & Richardson).....	161	Apr.
Radar and Electronic Navigation		

Spot TV trouble symptoms at a glance

... fix them twice as fast!

NOW! SAVE HUNDREDS OF DOLLARS IN TV SERVICING TIME!

The short cut way of handling up to 90% of your television troubleshooting by the easy PICTURE ANALYSIS METHOD!



Ghirardi's PIX-O-FIX TV TROUBLE FINDING GUIDE Vol. 1

Covers
24 common television troubles identified by actual TV screen photos.

190 possible causes of these troubles identified and localized to the particular stage of the receiver where they are most likely to occur.

253 definite, easily understood remedies for these troubles.

4,500 words in CAUSE and REMEDY section to explain step by step what to do.

Just Out!

Hours of tedious, time-consuming troubleshooting can be cut to minutes. Repairs can be made twice as fast!

Just "dial" the new Ghirardi PIX-O-FIX TV TROUBLEFINDER GUIDE until the actual TV screen photo appearing in its "window" matches the screen picture on the defective set you are repairing. The proper Trouble Key Number also appears on the guide. This directs you to the tabulation giving all possible causes of this particular trouble and the stage or section of the receiver

in which it is most likely to occur. But this is only the beginning!

The Pix-O-Fix Guide not only helps you locate the trouble quickly but then shows you exactly how to fix it. Step-by-step repair instructions follow. In most cases, the particular component most likely to be faulty is specified. Quick tests to apply to it are explained. If part substitution is likely to be more effective than an instrument test, this is recommended.

PIX-O-FIX is applicable to all television receivers. Operation is clear and simple. Money-back guarantee if you're not more than satisfied!

Note:

Ghirardi's PIX-O-FIX is designed and sold as a professional TV service device for servicemen—NOT as a "fix-it-yourself" gadget for use by consumers.

Only \$1.

10 DAY Money back Guarantee

Dept. RN-122, Rinehart Books, Inc., Technical Div., 232 Madison Ave., New York 16, N. Y.

Enclosed is \$1 for which please rush a PIX-O-FIX TROUBLE FINDER GUIDE. If not satisfactory, I will return it postpaid within 10 days and you guarantee to refund my \$1.

Name _____
Street _____
City, Zone, State _____

PRICE OUTSIDE U. S. A. \$1.25 cash—same return privilege.

TRAIN At Home FOR OPPORTUNITIES IN UHF-TV SERVICING

Set Your Own Pace with This Practical Program!

Get in on the ground floor of this fast-growing field. Train now to cash in on the opportunities that are yours in UHF-TV SERVICING with proven, practical T.C.I. training. Here is non-mathematical training that's complete down-to-cases . . . up-to-the-minute. Here is training you take in your spare time, without leaving your present job! Think of it—in your own home you learn TV set conversion, master antenna installation, the latest in UHF-TV, money-making short cuts and much more. You learn to trouble-shoot, test and repair TV sets the only practical way—by actually doing this work yourself!

HERE'S HOW YOU LEARN BY DOING!

You get the experience you need by working on a large screen, modern TV receiver that's given to you with the course and is yours to keep. As an optional feature you get two weeks of field experience on service calls and on the repair bench with one of Chicago's largest independent TV servicing organizations. You profit from the experience and know-how of men in the field. Not through books alone but by actually doing the work yourself, you get the knowledge you need to qualify for opportunities in UHF-TV SERVICING! Age is no barrier. Many T.C.I. students are over 40! Mail Coupon for full facts, FREE Catalog and SAMPLE LESSON. Act NOW!

VETERANS discharged since June 27, 1950 are eligible for G.I. benefits. Check coupon.

TELEVISION Communications Institute
205 W. Wacker Dr.,
Dept. 1-AD, Chicago 6, Ill.

MAIL NOW FOR FREE BOOKLET

THESE MEN LIKE YOURSELF SAY T. C. I. TRAINS YOU BEST!

"I've almost completed your course now, but I have been servicing TV sets since almost the beginning of the course." E.R.M., Rhode Island.

"Thanks to your course, jobs that used to take me several hours now take but a few minutes to complete." W.L.K., Wash.

"I like the easy way your lessons are presented. I'm very pleased with your course and have recommended it to a friend." L.R.S., Texas.

TELEVISION COMMUNICATIONS INST.
205 W. Wacker Dr., Dept. 1-AD, Chicago 6, Ill.
YES! Rush full facts on UHF-TV training. Include FREE Catalog and Sample Lesson. I am not obligated. Salesman will not call.

Name _____ Veterans Check here
Address _____
City _____ Zone _____ State _____
 BEGINNERS: Check here for information on Pre-TV Radio Course.

one model for all tv sets

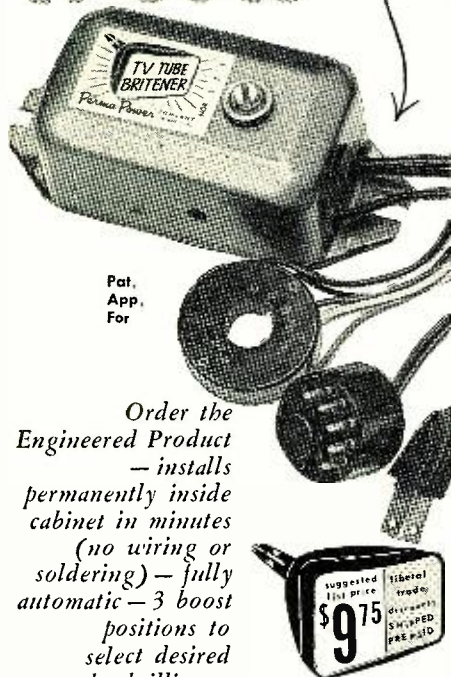

Pat.
App.
For

Order the
Engineered Product
— installs
permanently inside
cabinet in minutes
(no wiring or
soldering) — fully
automatic — 3 boost
positions to
select desired
tube brilliance.



- ★ For either Series — or Parallel-wired filaments.
- ★ Increases electron emission, makes dim tubes BRITE
- ★ Isolates filament, relieves cathode-filament shorts.
- ★ Line power supply, does not disturb any TV Set circuits.
- ★ Made to sell, packaged to sell.

Write for complete, illustrated literature. ORDER TODAY!
SOLD through recognized wholesalers ONLY.



(Sonnenberg)	119	May
Radio And Television TV Receiver Troubleshooting And Repair (Ghirardi & Johnson)	159	Apr.
Radio Spectrum Conservation (RTMA & IRE)	66	Dec.
Radiotelephone License Manual (Smith)	138	Sept.
Receiving Tube Substitution Guide Book (Middleton)	92	Feb.
Reference Data For Radio Engineers (Federal Telephone and Radio Corp. Staff)	131	Mar.
Simplified Radio Servicing By Com- parison Method (Beitman)	134	June
Sound Recording And Reproduction (Godfrey & Amos)	132	Oct.
Survey Of Radio-Frequency Trans- mission Lines and Wave Guides (Winlund)	104	July
Television (Kerkhof & Werner)	66	Dec.
Television Engineering (Fink)	131	Mar.
Television Factbook No. 14 (Tele- vision Digest Staff)	160	Apr.
Television Interference (Rand, et al.)	153	Jan.
Test Instrument Applications Manual (Noll)	124	Aug.
The Radio Amateur's Handbook (ARRL Staff)	134	June
The Recording And Reproduction of Sound (Read)	159	Apr.
The Saturday Review Home Book Of Recorded Music And Sound Reproduction (Canby, Burke, & Kolodin)	140	Sept.
Transmitting Valves (Heyboer & Zijlstra)	104	July
TV and Electronics as a Career (Kamen & Dorf)	92	Feb.
TV Consultant (Cisin)	66	Dec.
TV Troubleshooting and Repair Guide Book (Middleton)	178	Nov.
20 Basic Points For TV Receiver Service (Saunders)	124	Aug.
Vade-Mecum 1952 (P.H.Brans Staff)	132	Oct.
Why You Should Not Try to Fix Your Own TV (Burke)	179	Nov.

BUSINESS MANAGEMENT

A Look at the Parts Distributor (Becker)	51	May
Can You Pay Yourself a Salary? (Ashe)	116	June
Radio-TV Service Industry News...	142	Jan.
Radio-TV Service Industry News...	106	Feb.
Radio-TV Service Industry News...	100	Mar.
Radio-TV Service Industry News...	126	Apr.
Radio-TV Service Industry News...	146	May
Radio-TV Service Industry News...	100	June
Radio-TV Service Industry News...	86	July
Radio-TV Service Industry News...	134	Aug.
Radio-TV Service Industry News...	124	Sept.
Radio-TV Service Industry News...	146	Oct.
Radio-TV Service Industry News...	172	Nov.
Radio-TV Service Industry News...	128	Dec.
Sell Portables Year-Round	44	Dec.
Selling Maintenance—And Yourself (Johnson, Y. O.)	40	Mar.

GENERAL

CIRCUITS (THEORY)		
Crystal Diodes in Modern Electronics (Part 4) (Armstrong)	63	Jan.
Crystal Diodes in Modern Electronics (Part 5) (Armstrong)	62	Feb.
Crystal Diodes in Modern Electronics (Part 6) (Armstrong)	56	Mar.
Crystal Diodes in Modern Electronics (Part 7) (Armstrong)	70	Apr.
Crystal Diodes in Modern Electronics (Part 8) (Armstrong)	46	June
Industrial Electronics (Bukstein)	64	Aug.
Microwave Klystron Oscillators (Part 1) (Racker & Perenic)	54	Apr.
Microwave Klystron Oscillators (Part 2) (Racker & Perenic)	64	May
Saturable Reactors (Levey)	68	Mar.
Selenium Rectifiers (Niciejewski)	66	Oct.
Survey of Transistor Development		

QUIET...

USE
'Q-'

**FOR
QUIET CONTROLS
and CONTACTS**

ONE DROP

- Cleans and preserves all controls and contacts
- Eliminates noise
- Retards corrosion
- Harmless to insulation and soldered joints
- Sediment-free
- No sediment on contacts

Full 3-ounce bottle **69¢** Buy a bottle today at your Grayburne parts-distributor

ONE DROP KEEPS IT ON THE "Q-T"

GRAYBURNE

103 Lafayette Street, New York 13, N.Y.

GREYLOCK 1953 CATALOG

AN ESSENTIAL BUYING GUIDE for every RADIO & TV SERVICEMAN!

featuring:

- GREYLOCK TUBES, at new low prices!
- STANDARD BRAND TUBES, tremendous values!
- COMPLETE STOCKS OF STANDARD BRAND LINES

Including:

INSTRUMENTS EICO Jackson EMC Oak Ridge	HARDWARE, TOOLS ICA Walco Jackson Irons Phillips Guns X-celite Eby Mueller	BOOKS Howard Sams Rider Coyne Editors & Engineers	RADIOS, SOUND EQUIPMENT Penron Bogen Challenger Atlas Sound Steelman Phones Gen'l Industries Esquire Clock Radios	OTHER TOP BRANDS C-D Vibrators, Converters, Antenna Rotators Merit Transformers RMS Antennas, Accessories Sprague Condensers Stanwyck Coils GE Lamps Acetone Needles Shure Microphones RMS Antennas, Accessories Electrovoice Burgess Batteries Quam-Nichols Speakers Regency Boosters
---	--	--	--	---

GREYLOCK ELECTRONICS SUPPLY CO.
115 Liberty St., N. Y. 6
Phone BE. 3-0224

GREYLOCK ELECTRONICS, Dept. N-12
115 Liberty St., N. Y. 6

Send FREE Catalog #200 at once to

Name

Address

City..... State.....

(Part 1) (Slade).....	43	Sept.
Survey of Transistor Development (Part 2) (Slade).....	64	Oct.
Survey of Transistor Development (Slade) (Part 3).....	68	Nov.
The Junction Transistor (Renne)....	38	Apr.
The New G-10 Germanium Dot Rectifier (Ferguson)	42	June
Vacuum Tubes as Variable Resistance Circuit Elements (Denny)....	72	Apr.

MISCELLANEOUS

A Novel Capacitance Relay (Graham, W2PDI/1)	50	Dec.
An Unusual High-Voltage Generator (Kaufman)	59	Sept.
A Simple Improvement for Regenerative Receivers (Cohn).....	78	May
Blinking Lights (Sienkiewicz).....	102	Feb.
Calibrating Plain Dials (Houle)....	105	Sept.
Constant K Type High-Pass Filter Design (Yamasita)	54	Aug.
Constant K Type Low-Pass Filter Design (Yamasita)	54	Sept.
Midget Radio-Controlled Auto (Minor)	35	Oct.
Mobility of Communications (Wilson)	35	May
Multi-Layer Coil Calculator Nomograph (Yamasita)	54	July
Packaged Radar (Wagner).....	42	Oct.
Radio & Television News Test Bench (Data-Print No. 6).....	51	Oct.
Radio Control on the Citizens Band (MacNabb)	35	Mar.
Reactance Chart	54	Oct.

POWER SUPPLIES

A Variable-Voltage Power Supply (Graham)	66	Sept.
---	----	-------

SHORT-WAVE

International Short-Wave (Boord)...	57	Jan.
International Short-Wave (Boord)...	69	Feb.
International Short-Wave (Boord)...	71	Mar.
International Short-Wave (Boord)...	69	Apr.
International Short-Wave (Boord)...	67	May
International Short-Wave (Boord)...	48	June
International Short-Wave (Boord)...	58	July
International Short-Wave (Boord)...	65	Aug.
International Short-Wave (Boord)...	71	Sept.
International Short-Wave (Boord)...	72	Oct.
International Short-Wave (Boord)...	63	Nov.
International Short-Wave (Boord)...	59	Dec.

INDUSTRY

Electronic Equipment Industry Advisory Subcommittees	126	May
Electronic Growth in the Pacific Southwest (Painter)	38	Aug.
High-Speed Tandem Winding Machines (Wolin)	45	Jan.
Mobile Radio (Part 1) (Sands).....	35	Sept.
Mobile Radio (Part 2) (Sands).....	43	Oct.
Mobile Radio (Part 3) (Sands).....	53	Nov.
Mobile Radio (Part 4) (Sands).....	62	Dec.
1952 Electronic Parts Show Program	174	May
Radio on the Main Line (Sands)....	31	Jan.
Ranch Radio (Johnson, WØLBV)....	27	July
Two-Way Radio for Industry (Franke)	63	June
WCEMA-IRE West Coast Meet (Power)	80	Aug.

TELEVISION

ANTENNAS		
A Phased TV Beam Antenna (Prewitt)	36	Jan.
Problems of Indoor Antenna Reception (Noll & Mandl).....	42	Mar.
Stacking Four Z-Matched Yagis (Greenberg & Harris).....	57	Apr.
Television Transmission Lines (Buchsbaum)	46	May
The "Q-Tee" (Carpenter).....	56	July
The Yagi (O'Leary).....	59	Oct.
TV Receiving Antenna Testing Techniques (Pollack)	58	Sept.

Merit's TV full-line offers the most complete line possible for universal replacement plus exact replacements where required. A new Merit TV Replacement Guide No. 405— including universal components and exact replacements for over 6000 models and chassis—can be obtained from your Jobber or by writing: MERIT COIL AND TRANSFORMER CORP., 4425 N. Clark Street, Chicago 40.



Merit IF-RF Coils include a complete line of TV replacements.

MERIT FOR MAXIMUM COVERAGE WITH MINIMUM STOCK

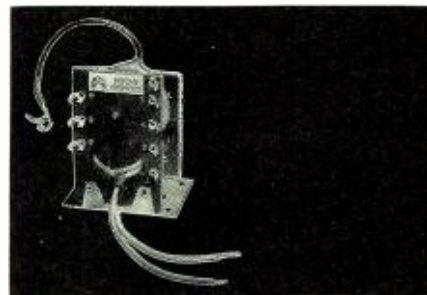

New in the Merit line of practical recommendations is the Model HVO-9 AUTOFORMER for exact replacement in RCA Hoffman and Hallicrafters. Designed for picture tubes 21" and up.

BURTON BROWN ADVERTISING

PHOTOCON SALES

417 N. Foothill Blvd. SY camore 2-4131
Pasadena 8, Calif. RY an 1-6751

FREE 24 PAGE SURPLUS SALES CATALOG

WANTED new or clean used electronic surplus. Please state exact description of the condition and details of modification. Include lowest price in first letter.

Audio Oscillator Hewlett-Packard 200 top		
LM & BC-221 Frequency Meter with cal. book, crystal, and tubes.....	Exc.	\$110.00
TS-352/U Weston Test Set.....	Exc.	99.50
TS-173/UR Frequency Meter 90-450 mc. complete with crystal, cal. book, & 115 VAC. Power Supply... Like new		600.00
TS-148/UP.....	New Mfg.	PUR*
Signal Generator 196A.....	Like new	PUR*
Million Signalizer Radio & TV. Like new		PUR*
Impedance Bridge G50A General Radio. Like New		PUR*
Dumont 208 Scope.....	Exc.	PUR*
TS-146/UP X-Band Signal Genera- tor.....	Exc.	PUR*
TS-12/AP X-Band Signal Generator.....	Exc.	PUR*
TS-34/AP Portable Oscilloscope.....	Exc.	350.00
TS-12 Test Set for X-Band Box 1 & 2 complete	Exc.	PUR*
Measurements Corp. Model 82 Stand- ard Signal Generator 20cy.-50mc. Exec.		PUR*
305B Floor model Oscilloscope 7" tube RCA	Exc.	PUR*
Kay Electronic Mega-Sweep 100kc. to 1000 mc.	Exc.	PUR*
APR-4 Search Receiver.....	PUR*	
Tuning Units for APR-4 Receiver....	PUR*	
BC-348, BC-312, BC-342 Receivers....	PUR*	
APS-3	Exc.	PUR*
SCR-284 Fields Sets.....	Exc.	PUR*
APN4A or B.....	Exc.	PUR*
APR-5A	Exc.	PUR*
SCR-545 Radar Trailer.....	PUR*	
Type 120A Test Set 130-210 mc. Bonton Radio Corp.	PUR*	
Antenna AT 104/APN9.....	New	20.00
Automatic Pilot Inverter Type DA Input 28VDC. @ 12 amps. Output 115V., 3 phase, 400 cps. 115VA	Exc.	80.00
RG-8/U Coaxial Cable.....	15/ft.	
RG-58/U Coaxial Cable.....	.06/ft.	
T-17 Ifand Microphone with cord and PL-68	Exc.	4.50
IS-23 8000 ohm. Used \$2.95	New	5.95
IS-18 8000 ohm. Used 1.75	New	2.25
IS-33 600 ohm. Used 3.50	New	6.95
IS-38 600 ohm. Used 1.75	New	2.25

NOTE: One of the largest and most complete electronic surplus stocks in the country. We have thousands of tubes, capacitors, plugs, accessories, transmitters, receivers, test equipment, etc. Send us your requirements.

TERMS: Prices F.O.B. Pasadena, California, 25% on all C.O.D. orders. Californians add 3% Sales Tax. Prices subject to change without notice.

QUIET...

USE 'Q-T'

Quiets and Preserves

Radio and Television Controls and Contacts

ONE DROP

- Cleans and preserves all controls and contacts
- Eliminates noise
- Retards corrosion
- Harmless to insulation and soldered joints
- Sediment-free—No sediment on contacts
- Does not contain any artificial coloring

69¢ Full 3-ounce bottle

Buy a bottle today at your Grayburne distributor

ONE DROP KEEPS IT ON THE "Q-T"

GRAYBURNE

103 Lafayette Street, New York 13, N.Y.

The C-800 is here
to bring you new
record performance!

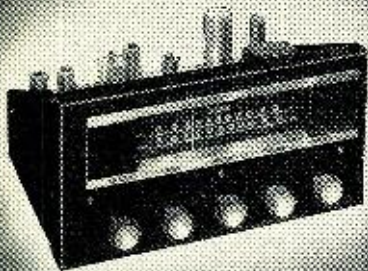

the new
craftsmen 800
FM-AM TUNER
with built-in phono
preamplifier and
record equalizer

Now—Craftsmen brings you a tuner that matches all your finest records... is setting new records for versatility, too. The C-800 is further evidence that Craftsman leadership in high fidelity is something you can put your finger on, something you can hear.

- Front-panel-selected equalization for AES, LP or EUROpean recording characteristics. Inverse feedback compensated dual-triode phono preamp for correct turnover and roll-off characteristics.
- Improved AM reception. Wider bandwidth for better fidelity, and sharper IF bandpass "skirts" for greater selectivity.
- Double-shadow tuning eye and AFC (no drift) on FM simplifies tuning. Front-panel AFC cut-out for tuning weak stations.
- Efficient new layout. Bottom plate, completely shielded chassis minimize oscillator radiation, assure tuner isolation.
- Cathode follower audio output for remote installations; 2 volts at less than 1/2% dist. Detector output also has cathode follower for recording applications.
- Bass and treble controls continuously variable from attenuation to boost—flat position clearly marked. Selector positions: FM, FM with AFC, AM, TV, LP, AES, EUR, and SPare.
- Mahogany-finish wood cabinet available.

HIGH FIDELITY—LOW COST! C-400 audio amplifier offers 10 watts ± 1 db., 15—20,000 cps., less than 1% distortion. New streamlined chassis design.

Write today for information

THE RADIO
craftsmen INC.
Dept. R-12, 4401 N. Ravenswood Ave.
Chicago 40, Ill.

U.H.F. Antennas (Kiver)..... 36 Dec.

CONVERSIONS

TV Conversions for Large Tubes (Buchsbbaum) 50 Sept.
Television Conversion Guide (Data-Print No. 5)..... 51 Sept.
Television Picture Tube Replacement Guide (Data-Print No. 4).... 51 Aug.

MISCELLANEOUS

A Continuous U.H.F. Tuner (Kleidon) 38 Sept.
A Remote-Control for Your TV Set (Gottlieb, W6HDM)100 Apr.
Built-in Home TV Systems (Kamen) 78 Jan.
Cathode-Ray Tube Rejuvenators (Eisenberg) 62 Oct.
Evolution of the 630TS (Buchsbbaum) 52 Feb.
Improved Intercarrier Sound System (Buchsbbaum) 36 July
International TV is Here (Martin)... 31 Dec.
U. S. Television Stations and Network Links (Data-Print No. 1).... 83 May
WABD's TV Transmitter (Helt).... 47 Apr.
What is Eidophor?..... 94 Aug.
What's Ahead for Small-Town Television? (Sklarewitz) 31 June

SERVICE NOTES

Check That Picture Tube (Kroeger). 84 Mar.
Crispening and Resolution Improvement in TV Receivers (Noll)....106 Apr.
D. C. Voltages in Television Receivers (Frieborn) 59 Feb.
Electrostatic Focus for Picture Tubes (Buchsbbaum) 62 Mar.
Eliminating Outside TVI (Ledbetter). 30 July
Eliminating 21 mc. Interference (Buchsbbaum) 48 Oct.
Horizontal and Vertical Suppression Circuits and Their Use (Lerner)... 82 Feb.
Interlacing Troubles and Vertical Sync Circuits (Frieborn)..... 64 Mar.
Interpreting that TV Pattern (Part 1) (Kleidon) 35 Apr.
Interpreting that TV Pattern (Part 2) (Kleidon) 43 May
Interpreting that TV Pattern (Part 3) (Kleidon) 59 June
Locating TV Intermittents (Buchsbbaum) 46 Dec.
Map Your Fringe Area Signal (Noll & Mandl) 50 July
Miniature TVI Wavetraps (Turner, K6AI) 41 Nov.
Quality Control of TV Tubes (Squier, Jr.) 49 Feb.
Self-Focus Picture Tubes (Noll)....122 Nov.
Servicing Noise-Rejection Circuits (Rhodes) 60 Apr.
Servicing Picture Tubes (Ledbetter). 36 Aug.
Simple Service Aids (Buchsbbaum).. 50 Jan.
Television Signal Strength Calculation Charts for Proper Antenna Selection (Data-Print No. 3)..... 51 July
Television "Snow" (Buchsbbaum)... 58 Nov.
The New Philco 40 mc. I.F. Tuner (Lerner) 50 May
The TV Picture Tube (Buchsbbaum).. 50 Aug.
Trends in Large Screen TV Circuits (Mueller) 42 Sept.
Tube Substitutions for TV Receivers (Chertock) 98 Feb.
TV Antenna Couplers for Multi-Set Operation (Buchsbbaum) 48 Apr.
U.H.F. Conversion Methods (Part 1) (Edwards) 56 June
U.H.F. Conversion Methods (Part 2) (Edwards) 47 July

TEST EQUIPMENT

AMATEUR

A Superregenerative TVI Checker (Smith, W8VVD) 70 Oct.

AM-FM

A High Gain Signal Tracer-Amplifier (Deller, W8ALV)..... 50 Feb.

FALL SALE PRICES SLASHED

T.V. TUBES—ROCK BOTTOM PRICES
In lots of 6 each No. only

6BG6 99c 6BQ6 74c
19R66 99c 6AG3 49c
12AX7 59c 6CD6 \$1.29
6CB6 59c 6S4 49c
6AK5 79c

Westinghouse Kuprox Rectifier 0.64 Amp. 28 Volts. Reg. \$11.00 ea. Special. \$1.95

12 BRAND NEW 10" PHONO RECORDS—Ass't Jazz—Popular, Rhythm—Blues. Please specify. \$1.79

Single Pole—10 Pos. 2 Gang Switch..... 29c

2 piece, 5 pole Male and Female separable Amphenol plugs. Both with Flex. shielded cables. Approx. 5 ft. long. 85c pair..... 3 pr. for \$1.00

Grind your own Crystals. Pure Brazilian Quartz. Various sizes and thicknesses. 1/4 lb. pkg. \$1.00

4 Tube Drilled Chassis. 4 1/2"x6 1/2"x1 1/2". 29c each

4 inch P.M. SPEAKER..... \$1.50

5 in. 450 ohm Dynamic Speaker..... \$1.35

Signal Corps Phones—2 M. Ohms (8 M. Ohms Imp.) \$1.25

2 Ft. Ext. Cord (and Plug)..... 40c

TOBE TUBULAR ELECTROLYTICS

20-20 MFD. 150 V. 49c 30-30 MFD. 150 V. 57c

40-40 MFD. 150 V. 59c

Low-Loss Short Wave Lock Type Air Trimmer Variable Condensers

3 Pl.—20Mmfd. 14c

7 Pl.—25-30 Mmfd. 15c

8 Pl.—30-35 Mmfd. 16c

14 Pl.—56 Mmfd. 24c

3 GANG T.R.F. VARIABLE CONDENSERS .000365 Con. 65c

D.P.D.T. SLIDE TOGGLE SWITCH 15c

1,000 OHM WIRE WOUND POTENTIOMETER..... 15c

30 WATT FILER CHOKE SHIELDED..... 3 for \$1.25

PIEZO CRYSTAL HOLDERS. 12 for \$1.00—\$6.00 per C

RCA Band Switches: 3 band. 30c 6 gang. 4 pos. 4-5 band. 40c

3 gang. 3 pos. 3 band. 30c 6 gang. 4 pos. 4-5 band. 40c

Trimmer-Padder Ass't.—all isolantite—singles, dual; triples—100 asst. \$2.25

Philco push button Rotary Switch Double Pole..... 35c

ATTENTION: Prospectors, Explorers for Hidden Treasures! Construct a U.S. Army Type of Metallic Mine Detector Amplifier. Amplifier unit (des. tubes and batteries) with cables, headphone cord, and jack. Army wiring diagram. Type AN/PRS-1..... \$1.95

8 or 9 Gang Push Button Switch..... 49c

DRILLED CHASSIS FOR 5-6 tubes 5"x10"x1 1/2". 25c

PHONE JACKS—OPEN & CLOSED AUTO..... 18c

5AL5 PHONO RECORD ALBUMS—1" comp. 15c; 1 1/2" comp. 15c; 2" comp. 15c; 3" comp. 15c; 4" comp. 15c; 5" comp. 15c; 6" comp. 15c; 7" comp. 15c; 8" comp. 15c; 9" comp. 15c; 10" comp. 15c; 11" comp. 15c; 12" comp. 15c

VULCAN HEAVY DUTY 100 WATT SOLDERING IRON. Built for U.S.N.—Brand New—Equip. sells for \$8.50. OUR PRICE \$2.95

12SK7 TUBES—Bayonet missing. Perfect condition. 8 for \$2.00

MINIMUM ORDER \$3.00—NO C.O.D. SHIPMENTS—PLEASE INCLUDE POSTAGE

NEWARK SURPLUS MATERIALS CO.
324 Plane Street Dept. DE NEWARK 1, N. J.

SHOCKED?

by a "hot" ac-dc chassis? Not if you use our #55 Isolation Xformer! Prim 117v sec 117v or 135v & 6.3 tap. 2 1/4"x2 1/2"x3. 35 wats. With plug & outlet. Shpg. wt. 3 lbs. \$ 2.45
TIME delay relay 110v 6 to 120 secs. \$12.95
RELAY, small 4PDT 12vdc 70 ohms. \$ 1.95
FILAMENT xfmr 6.3-1.3a, 14 oz. 89c
VARIABLE 3-15 mmf #HF 1 1/2" shft. 49c
Please include postage. Write for catalogue.

EMPIRE ELECTRONICS CO.

409 Ave. L, Brooklyn 30, N. Y. Cloverdale 2-2411

STATEMENT REQUIRED BY THE ACT OF AUGUST 23, 1912, AS AMENDED BY THE ACTS OF MARCH 3, 1933, AND JULY 1, 1947, AND THE DISTRICT STATES CODE, SECTION 233: SHOWING THE OWNERSHIP, MANAGEMENT, AND CIRCULATION OF Radio & Television News, published monthly at Chicago, Illinois, for October 1, 1952.

1. The names and addresses of the publisher, editor, managing editor, and business managers are: Publisher, Ziff-Davis Publishing Company, 185 North Wabash Avenue, Chicago 1, Ill.; Editor, Oliver Reed, 366 Madison Avenue, New York 17, New York; Managing editor, Wm. A. Stocklin, 366 Madison Avenue, New York 17, New York; Business manager, G. E. Carney, 366 Madison Avenue, New York 17, New York.

2. The owner is: Ziff-Davis Publishing Company, 185 North Wabash Avenue, Chicago 1, Ill.; William B. Ziff, 185 North Wabash Avenue, Chicago 1, Ill.; E. G. Davis, 185 North Wabash Avenue, Chicago 1, Ill.; A. Ziff, 185 North Wabash Avenue, Chicago 1, Ill.; S. Davis, 185 North Wabash Avenue, Chicago 1, Ill.

3. The known bondholders, mortgagees, and other security holders owning or holding 1 percent or more of total amount of bonds, mortgages, or other securities are: Modern Woodmen of America, Rock Island, Illinois.

4. Paragraphs 2 and 3 include, in cases where the stockholder or security holder appears upon the books of the company as trustee or in any other fiduciary relation, the name of the person or corporation for whom such trustee is acting; also the statements in the two paragraphs show the affiant's full knowledge and belief as to the circumstances and conditions under which stockholders and security holders who do not appear upon the books of the company as trustees, hold stock and securities in a capacity other than that of a bona fide owner.

5. The average number of copies of each issue of this publication sold or distributed, through the mails or otherwise, to paid subscribers during the 12 months preceding the date shown above was: (This information is required from daily, weekly, semi-weekly, and triweekly newspapers only.)

G. E. CARNEY, Business Manager.
Sworn to and subscribed before me this 22nd day of September, 1952.

Irving L. Jacobson, Notary Public.
[SEAL] (My commission expires March 30, 1953.)

AMERICA'S FASTEST GROWING TV ANTENNA MANUFACTURER DAVIS ELECTRONICS

THERE MUST BE A REASON

THE REASON IS: The DAVIS SUPER-VISION is the finest antenna built for V.H.F. ALL CHANNEL and for FRINGE AREA and DX RECEPTION...With ELECTRONIC DIPOLE SEPARATORS. A steady flow of enthusiastic letters from users all over the U. S. attests to this fact—and is outstanding proof of its UNIVERSAL ACCEPTABILITY.

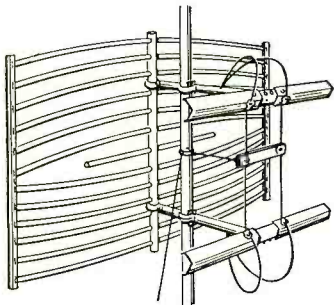

"THE ORIGINAL ANTENNA SOLD WITH A MONEY-BACK GUARANTEE"

1. EXCELLENT FOR FRINGE AREA and DX RECEIVING—and broad band receiving with high gain on all channels—2 through 13.
2. CLEARER PICTURES UP TO 125 MILES OR MORE—from the station.
3. GHOST PROBLEMS REDUCED or eliminated due to excellent pattern.
4. PROVIDES 10 DB OR MORE GAIN ON HIGH CHANNELS where gain is needed most.
5. EXCELLENT FRONT TO BACK RATIO on all channels. No co-channel interference.
6. MINIMIZES INTERFERENCE: Airplane Flutter—Diathermy and Ignition—F.M.—Neon Signs—X-Ray—Industrial—Etc.
7. ELIMINATES DOUBLE STACKED ARRAYS, and out-performs 2 bay yagis on low band and 4 bay yagis on high channels.
8. ONLY ONE TRANSMISSION LINE NECESSARY.
9. NO WORRY OVER POSSIBLE CHANNEL CHANGES on either high or low channels.

AT YOUR JOBBERS, OR WRITE TO:

DAVIS ELECTRONICS 1-21
4313 West Magnolia Blvd., Burbank, California
SIRS: RUSH INFORMATION TO ME AS CHECKED BELOW:
 Send Free Technical Data on new SUPER-VISION ANTENNA.
 Send Name and Address of NEAREST JOBBER.
Name _____
Street _____
City _____ State _____

Advance with ELECTRONIC CITY

You need firm grasp of fundamentals to keep pace with these complex, fast-growing fields. In thorough 2-year course learn electricity, electronics, physics, mathematics, drafting, etc. Other engineering and technical courses. Coed. Day, evening. 44th year. Write for Catalog.

FRANKLIN TECHNICAL INSTITUTE
46 Berkeley Street Boston 16, Mass.

SPEAKER RECONING

Complete line Cones, Spiders, Rings and Voice Coils. Custom Built Voice Coils. Low prices. Write for Parts List and Reconing information.

WESTERN ELECTRONICS CO.
3164 West Colfax Denver 4, Colo.

A No-Cost Signal Generator (Schlossberg & Berkowitz).....	62 July
An Improved Resonance Indicator (Gottlieb)	44 June
A Versatile Wavemeter (Roberson).....	70 Nov.
A V.T.V.M. Adapter (Joy, WØKKR).....	46 Jan.
Convert Your Signal Generator into a Grid-dip Oscillator (Smith, W8VVD)	66 Aug.
Novel Test Meter (Weiss & Clark).....	42 Apr.

AUDIO

A Beat-Frequency Audio Oscillator (Shields)	48 May
A Laboratory Quality Square-Wave Generator (Berkoff)	46 Feb.
Audio-Frequency Ammeter (Crevis-ton)	59 May

MISCELLANEOUS

Add an Astigmatism Control to Your CRO (Garner, Jr.).....	58 Oct.
A Deflection Amplifier Covering Range up to 100 kc. (Vaughn, Jr.).....	112 Nov.
A Frequency-Compensated Attenuator (Garner, Jr.).....	56 Sept.
A Low-Capacity Instrument Probe (Louis)	64 Sept.
A Meterless V.T.V.M. (Garner, Jr.).....	60 Dec.
An Inexpensive TV Cross-Bar Generator (Garner, Jr.).....	40 May
A Professional Type Geiger Counter (Watkins, W5JXO)	35 Feb.
A Tubeless Saw-Tooth Oscillator (Louis)	52 May
A Unique TV Signal Tracing Probe (Louis)	58 Aug.
Bias Box for TV Alignment (Barlett).....	94 Sept.
DX Television (Johnson, WØLBV).....	52 Dec.
Picture Tube Emission Tester and Rejuvenator (Goldberg)	39 Sept.
Sinusoidal Sweep Expansion (Lehnert, W9NDK)	74 Nov.
Test Instrument for Checking Fly-back Transformers (Weiss).....	90 Oct.
The Multi-Signal Generator (Garner, Jr.)	44 Aug.

-50-

PHOTO CREDITS

Page	Credit
31, 32	Radiodiffusion et Television Francaise
33 (top)	British Broadcasting Corporation
33 (bottom)	"Radio 51"
36, 38 (Fig. 7A), 44 (bottom right)	Radio Corporation of America
38 (Fig. 10)	J.F.D. Manufacturing Co.
44 (top)	Zenith Radio Corporation
44 (top left)	Westinghouse Electric Corporation
44 (center left)	Hallicrafters Company
44 (bottom left)	Emerson Radio & Phonograph Corp.
56, 57	University Loudspeakers, Inc.
59, 94	Nordwestdeutscher Rundfunk
62	Bendix Radio
63	Motorola Inc.
64 (bottom)	Lampkin Laboratories
108	La Pointe-Plascomold Corp.
110	Technical Appliance Corporation
136	Anaconda Wire & Cable Company

ERRATA

C₁₈ in the circuit diagram of Fig. 3 ("The RADIO & TELEVISION NEWS PRE-AMP," page 51, November 1952 issue) should be a 250 μ fd. mica condenser and not a 250 μ d. unit as specified in the "Equalizer" parts list.

* * *

In the same article, R₇, the "Volume Control," is in conjunction with S₃ and not S₁, as stated in Fig. 3.

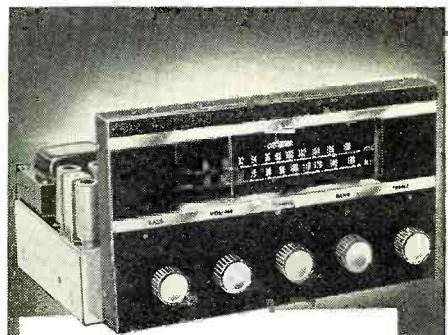

We rest our case on evidence you can hear



Words can't prove the performance of this superb High Fidelity Tuner. Neither can witness-

es. When it's time for a decision, your judgement of the CRAFTSMEN 10 is based on one thing: evidence you hear with your own ears. Listen—and the conclusive evidence of incomparable sensitivity and flexibility will turn your trial into a lifetime of distinctly better listening.

the
craftsmen 10
high fidelity
FM-AM tuner

- Two cathode followers furnish both audio output and detector output for remote installations.
- Built-in pre-amplifier, compensated for variable reluctance pick-ups.
- Automatic Frequency Control entirely eliminates drift, simplifies tuning.
- 5 microvolts sensitivity on both FM and AM.
- 10 kc filter on AM eliminates inter-station squeal.
- Bass and treble tone controls for boost, cut, or 20-20,000 cycle flat response.

JUDGE THE C-500 TOO!

Williamson all-triode circuit—99.99% distortion-free!



high fidelity by craftsmen
means distinctly better listening

For information, write to:
The radio CRAFTSMEN, Inc.
Dept. R-12, 4401 N. Ravenswood Ave.,
Chicago 40, Ill.

MOR · THAN
90,000
RCP
MULTITESTERS
Model 447B
 and their prototypes
IN USE ALL OVER
THE WORLD!

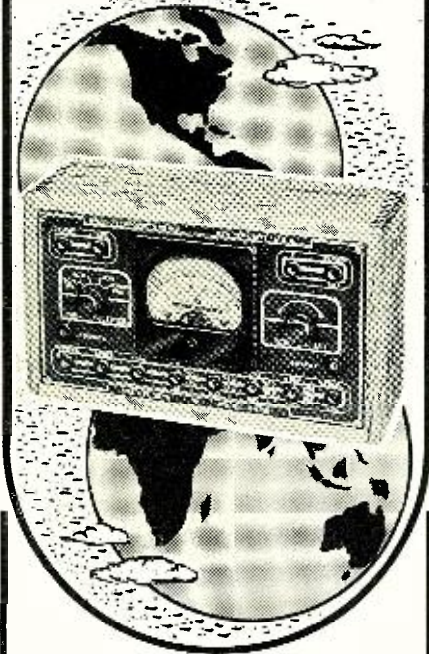

\$17.95

SUCH POPULARITY
MUST BE DESERVED!

The exceptional value of the 447B Model is made possible by the tremendous quantities produced. The resulting very low price is responsible for its great popularity. These units are in a class with other makes of testers that sell for considerably more. A 3" square D'Arsonval meter is used, having an accuracy of 2%. Accuracy of AC voltage measurements is improved by use of a new gold plated copper oxide rectifier.

RANGES

DC Voltmeter: 0-5-50-250-500-2500 Volts.
 AC Voltmeter: 0-10-100-500-1000 Volts.
 Output Voltmeter: 0-10-100-500-1000 Volts.
 DC Milliammeter: 0-1-10-100-1000 M.A.
 DC Ammeter: 0-1-10 Amperes.
 Ohmmeter: 0-10,000 Ohms—1 Megohm—10 Megohms Ext.
 Decibel Meter: -8 to +55 decibels.

MODEL 447B—Open face, oak case. Size 5" x 8 1/2" x 3". Weight 21 oz. Complete with batteries. Price **\$17.95**

MODEL 447BP—Portable, oak case with carrying handle, cover and test leads. Size 6 1/2" x 8 1/2" x 4 1/2". Weight 24 oz. Complete with batteries. Price **\$21.95**

Buy from your jobber. Insist on R.C.P. instruments. Write for Latest Catalog to Dept. RN-12

RADIO CITY PRODUCTS CO., INC.



152 West 25th Street New York 1, N. Y.



GET in on the fun of operating your own licensed transmitter. I guarantee you will memorize the International Morse Code alphabet within two hours by my simple picture method, or return method within five days and I will refund your money.

COMPLETE COURSE ONLY \$1
 NOTHING ELSE TO BUY!
 OTTO LUTHER, NEW PRESTON, CONN.

INDEX
OF *Advertisers*

DEC.
 1952

While every precaution is taken to insure accuracy, we cannot guarantee against the possibility of an occasional change or omission in the preparation of this index.

ADVERTISER	PAGE	ADVERTISER	PAGE
Acorn Electronics Corporation	116	McGee Radio Company	82, 83, 84
Airex Radio Corporation	85	McGowan, Inc., Don	112
Alliance Mfg. Company	91	McGraw-Hill Book Company	114
Allied Radio Corporation	9	Master Mobile Mounts	92
Altec Lansing Corporation	138	Merit Coil & Transformer Corporation	149
Alvaradio Supply Company	137	Michel Manufacturing Company	152
American Television & Radio Company	132	Miles Reproducer Company	136
Argos Products Company, Inc.	66	Milwaukee School of Engineering	92
Arkay-Radio Kits, Inc.	96	Moody Machine Products Company, Inc.	135
Arrow Sales, Inc.	117	Mosley Electronics	125
Ashe Radio Company, Walter	95	Moss Electronic Distr. Company	81
Audel & Company, Theo	96	National Electronics of Cleveland	112
Barry Electronics Corporation	153	National Radio Institute	3
Belden Manufacturing Company	6	National Schools	19
Bell Telephone Laboratories, Inc.	12	Nation Wide Radio	90
Bendix Radio	129	Newark Electric Company, Inc.	122
Brook Electronics, Inc.	106	Newark Surplus Materials	150
Brush Development Company	26	Newcomb Audio Products Company	137
Buchan WOTJF, Richard J.	116	Nostrand, D. Van	84
Burstein-Applebee Company	111	Offenbach & Reimus Company	94
C & H Sales Company	118	Ohmite Manufacturing Company	28
Candee-Airco	142	Olson Radio Warehouse	88, 89
Candler System Company	90	Olympic Electronics Supply	108
Capitol Radio Engineering Institute	87	Peak Electronics	90
Centralab, Inc.	10, 11	Perma Power	148
Channel Master Corporation	29	Phillips Tube Company	142
Cleveland Institute of Radio Electronics	79	Photocon Sales	149
Collins Audio Products	22, 23	Pickering & Company, Inc.	98
Columbia Electronic Sales	114	Platt Electronics	107
Communication Equipment Company	80	Poly-Tech Company	86
Concord Radio Corporation	144	Premier Radio Tube Company	99
Consolidated Radio	140	Prentice Hall, Inc.	86 & 122
Coyne Electrical School	153	Progressive Electronics Company	93
Davis Electronics	151	Pyramid Electric Company	30
DeForest's Training, Inc.	5	Quietrole Company	92
DeCray & Assoc., Frank W.	118	RCA Institutes	27
Di-Co. TV & Plastic Company, Inc.	146	RCA Institutes, Inc.	139
Dow Radio, Inc.	135	R.W. Electronics	97
Drake Company, R. L.	146	Radcom Engineering Company	145
Eastern Telephone Company	145	Radio City Products, Inc.	152
Editors & Engineers, Ltd.	133	Radio Craftsmen, Inc.	150, 151
Electro Sales Company	140	Radio Ham Shack, Inc.	103
Electronic Specialty Supply Company	145	Rad-Tel Tube Company	123
Electronics Institute, Inc.	135	Rauland Corporation	65
Empire Electronics	150	Raytheon Manufacturing Company	21
Equipto	102	Regency	96, 142
Esege Sales	136	Rider Publishers, Inc., John F.	140
Fair Radio Sales	143	Rinehart Books	116, 126, 147
Federated Purchaser, Inc.	141	Sams & Company, Inc., Howard W.	109, 133
Feiler Engineering Company	106	Sanett, Bob	134
Fisher Radio	119	Service Instruments Company	112
Franklin Technical Institute	151	Service Products	152
Frenchy Manufacturing Company	136	South River Metal Products Company, Inc.	132
Fretec Television Company	115	Sprayberry Academy of Radio	13
G & H Wood	127	Stan Burn Radio & Electronics	126
G L Electronics	135	Star Electronics Distributor, Inc.	106
Garrard Sales Corporation	123	Steve-El Electronics Corporation	104
General Electric Company	15	Stevens-Walden, Inc.	16
General Test Equipment	33	Superior Instrument	98
Good, Inc., Don	127	Supreme, Inc.	90
Goodheart, R. E.	140	TAB	154
Grayburne Corporation	148, 149	Television Communications Institute	147
Greenlee Tool Company	122	Television Materials Corporation	136
Greylock Electronics Supply Company	148	Telrex, Incorporated	131
Halldorson Company	86	Terado Company, The	24
Hallcrafters Company, The	7	Transvision, Inc.	100, 101
Harvey Radio Company	120	Triad Transformer Manufacturing Company	14
Heath Company	67, 77	Trijo Manufacturing Company	123
Henry Radio Stores	153	Tri-State College	123
Hickok Electrical Instrument Company	142	Tung-Sol Electric, Inc.	110
Hudson Radio & TV	130	Turner Company	139
Hughes Aircraft	105	United Catalogue Publishers, Inc.	131
Hytron Radio & Electronics Company	25	University Loudspeakers, Inc.	102
Indiana Technical College	137	V & H Radio & Electronics	126
Instructograph Company	142	Valparaiso Technical Institute	133
Insuline Corporation of America	113	Van Sickle Radio Supply Company	139
International Correspondence Schools	126	Videon Electronic Corporation	113
J. F. D. Manufacturing Company	17	Waldon Electronics, Inc.	146
J. S. H. Sales Company	143	Walters Industries	121
Jersey Specialty Company	143	Weller Electric Corporation	18
Kelsey Company, The	137	Wells Sales, Inc.	118
Klein Company, Manuel	113	Western Electronics Company	151
Krylon, Inc.	124	Wholesale Radio Parts Company	125
LaPointe Plascamold Corporation	20	Wincharger Corporation	128
Leeds Radio Company	132	World Radio Laboratories, Inc.	129
Leotone Radio Company	130		
Luther, Otto	152		

AC-DC Music Amplifier

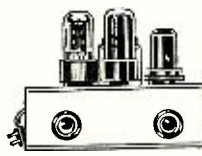

Volume and tone control.

1.5 w. output.

See your jobber.

MICHEL MFG. CO.

227 N. Water St.
 Milwaukee 2, Wis.

New Proximity Probe

Tests All TV Hi Voltage Supply Systems

INSTANTLY checks hi-voltage transformer action-horizontal oscillator-sweep output-damper-hi-voltage rectifier, etc. Used under actual operating conditions. Determines exact procedure to trouble shoot no raster problems and interlocks. No connections—no shocks—saves time—clips in pocket. Used by professional TV servicemen for home calls and bench work. Complete instructions enclosed.

Send check or M.O. **\$3.95** Fully Guaranteed Postpaid U.S.A. Net

SERVICE PRODUCTS CO.

Box 215 Lawrence, Mass.

RADIO & TELEVISION NEWS

Classified

Rate 50c per word. Minimum 10 words

RADIO ENGINEERING

COMPLETE radio, electronics theory & practice: television; broadcasting; servicing; aviation, marine, police radio. 12 or 18 months. Catalog. Valparaiso Technical Institute, Dept. N, Valparaiso, Ind.

SALE

ALL types of Antennas for Amateur and TV Aluminum Tubing. Willard Radcliff, Fostoria, Ohio.

FOR SALE: brand new guaranteed quality tested tubes at 70% off list. Many other items. Write for circular. Williams Electronics Co., 168 Washington St., New York 7, N. Y.

TV and FM Antennas. Yagi, Conical, Bow-Tie. Mounts, accessories. Lowest prices. Wholesale Supply Co., Dept. H, Lunenburg, Mass.

RADIO and television tubes, parts, less than wholesale. Send for list. Box 921, Boise, Idaho.

DIAGRAMS Radio, Record Changers, Recorders, 75c; Television with Service Data, \$1.25 up. State manufacturer and model number. Assorted diagrams five prewar, or three postwar, \$1.10. Kramer's Radio Service, Dept. M7, 36 Columbus Ave., New York 23, N. Y.

TUBES and equipment bought, sold, and exchanged. For action and a fair deal, write B. N. Gensler, W2LNI, 136 Liberty, N. Y. 6, N. Y.

RECORD Changer parts for leading makes. We ship everywhere. Friend's Wholesale Distr., 106 N. 6th St., Philadelphia 6, Pa.

ULTRA-Fidelity Stephens P-63-HF reproducer. Consider trade Hammond Organ Speaker. R. S. Bond, 6255 Desco, Dallas 5, Tex.

WANTED

WANTED: Radiosonde #AMQ-1C or 1D. Must be in original sealed overseas export pack. Any quantity accepted. Write now to K & L Radio Parts Co., 1406 Venice Blvd., Los Angeles 6, Calif.

ALL types of receiving and transmitting tubes. Surplus receivers and transmitters. Electro Mart, 168 Washington St., New York, N. Y.

AN/APR-4, other "APR-" "ARR-" "TS-" "IE-" ARC-1, ARC-3, ART-13, everything surplus; Tubes, Manuals, Laboratory equipment. Describe, price in first letter. Engineering Associates, 434 Patterson Rd., Dayton 9, Ohio.

WANTED: Federal type 101B voice-frequency fingers Signal Corps type TA-3/FT. Box 529, % Radio & Television News, 185 N. Wabash Ave., Chicago 1, Ill.

WANTED: Western Electric gray-finished equipment cabinets for 19" panels. Heights of 2'6", 3'6", 7'0" and 7'6". Box 530, % Radio & Television News, 185 N. Wabash Ave., Chicago 1, Ill.

WANTED. Top prices paid. Navy Selsyns IDG, 1F, 1CF, 5CT, 5D, 5DG, 5G, 6G, 7G, etc. and BC-348, BC-221, AN/ART-13, AN/ARC-1, AN/ARC-3, RTA-1B, AN/APR-4. Lectronic Research, 719 Arch St., Philadelphia.

CORRESPONDENCE COURSE

USED Correspondence Courses and Books sold and rented. Money back guarantee. Catalog free. (Courses bought.) Lee Mountain, Pisgah, Ala.

COMPLETE instructions, how to check and repair radios. Only \$1.00. Slates Radio Service, Corsicana, Texas.

MISCELLANEOUS

SPEAKERS repaired, wholesale prices, guaranteed workmanship. Amprite Speaker Service, 70 Vesey St., New York City 7.

BUILD inexpensive electronic multimeter, instructions \$1.00, component tester, instructions \$1.00, particulars free. Technological Developments, 475-M Fifth Avenue, New York 17, N. Y.



What Do You Want to Trade In on a New Hallicrafters?

I have a complete stock of Hallicrafters receivers and transmitters. We will give you the best doggone trade-in in the world because we need used receivers badly for our trade. What do you have? Write me about it. I give you prompt delivery, 90-day FREE service and the world's lowest credit terms. Write, wire, phone, or visit either store today for the best deal. Export orders solicited.

Bob Henry
W4ARA

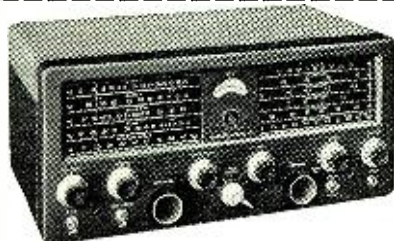

Popular Double-IF Model SX-71

A double superheterodyne circuit receiver at modest cost. Built-in narrow band FM reception. Temperature compensated, voltage regulated. 5 position band selector for 538-1650 kc, 1600-4800 kc, 4.6-13.5 mc, 12.5-35 mc, 46-56 mc. 11 tubes plus voltage regulator and rectifier. Only \$199.50



All-Wave Receiver Model SX-62

Covers 540 kc to 109 mc—including AM, FM, and SW broadcasts. Six bands: 540-1620 kc, 1620 kc-4.9mc, 4.9 mc-15 mc, 15-32 mc, 27-56 mc (AM-FM), 54-109 mc (AM-FM). Only \$289.50. Other popular Hallicrafters models: S-76, \$169.50; S-40B, \$99.95; S-72, \$109.95; S-72L, \$119.95; S-81, \$49.50; S-82, \$49.50.

Henry Radio Stores
11240 Olympic Blvd. LOS ANGELES 25 CALIF.
"WORLD'S LARGEST DISTRIBUTORS OF SHORT WAVE RECEIVERS"

Standard R.M.A. Warranty	TUBES	Tube Orders over \$8 with Full Remittance - Postpaid U.S.A.
QAZ	\$.95 4X150-A	\$35.00 408-A (WE)
QW2	1.10 5P7	1.95 450-TH
1A7-GT	.80 5U4-G	.55 717-A
1B5-GT	.80 5V4-G	.98 803
1B27	14.95 5X4-G	1.25 805
1L4	.69 6A5	.60 H11
1N21-B	2.75 6AK5	.74 H11-A
1N23-A	2.00 6AN5	1.25 H12
1N23-B	3.49 6C4	.43 H15
1N34	.62 6J6	.93 832-A
1N34-A	.73 6J7	.70 866-A
1N48 (GE)	.55 6L7	.85 872-A (GE)
1N54	.89 6N7-W	.95 874
1X2-A	.95 7030	.85 900
2AF1	8.50 12A6	.65 1822
2C43 (GE)	15.95 FG-105	18.50 1825
2E24	2.85 250-TH	18.75 1831
2E30	2.15 304-TH	7.00 2050
3RP1	5.75 304-TL	8.00 5515
3R11	9.50 310-A (WE)	5.95 5554
3C23	10.50 311-A (WE)	6.50 8020
3S4	.85 373-A (WE)	4.00 9001 (RCA)
4E27	12.95 374-A (WE)	3.50 9004 (RCA)

Current (Continuous)	18/14 Volts	36/28 Volts	54/42 Volts	130/100 Volts
1 Amp.	\$ 1.25	\$ 2.10	\$ 3.60	\$ 7.50
2 Amps.	2.20	3.60	6.50	10.50
2 1/2 Amps.				13.00
4 Amps.	3.75		8.75	
5 Amps.	4.95	7.95	12.95	27.00
6 Amps.	5.90	9.00	14.00	33.00
10 Amps.	8.75	12.00	20.00	40.00
12 Amps.	11.00	16.00	25.50	50.00
20 Amps.	13.25	24.00	36.00	90.00
24 Amps.	16.00	31.00	39.50	98.00
30 Amps.	18.50	36.00		
36 Amps.	25.50	45.00		

SELENIUM RECTIFIERS—FULL-WAVE BRIDGE TYPES

• New, Selenium Rectifier Transformers
PRI: 115 V., 60 cycles in. 4 Amps. \$ 8.75
SEC: 9, 12, 18, 24, and 36 12 Amps. 15.75
unit 2 Amps. 3.75

• 115V. PRI.—36V. 50 amp second XFM'R. \$57.50
• 115V. PRI.—5V @ 190 Amp. SEC. \$59.50
• 115/220V. 60 cy. PRI. SEC.: 1.5, 30.5, 33.5 and 36.5V @ 4 AMPS. Herm. sealed. \$62.50

• New Selenium Rectifier Chokes
4 Amps.—.07 hy.—6 ohm \$7.95
12 Amps.—.01 hy.—1 ohm \$14.95
24 Amps.—.004 hy.—.025 ohm \$29.95

We can manufacture other Selenium Rectifier, Selenium Rectifier Supplies, XFMRs, & Chokes. Call or write for fast delivery.

• AR-11—SUPERHET RCVR & 50 WATT XMTR w/built in 110 vac pwr. supply. Unit 12"x8"x3" for 20, 40, & 80 meters. Brand New. A complete station for only \$99.50

BARRY ELECTRONICS CORP.
136 Liberty Street, N. Y. 6, N. Y. REctor 2-2562
Terms: 25% with order, balance C.O.D.—Send a few cents for postage—All merchandise guaranteed, F.O.B. N.Y.C. Remember, you may order tubes not listed!

GET INTO ONE OF THESE GREATER OPPORTUNITY FIELDS

Electricity or Radio-Television

TRAIN IN THE GREAT SHOPS OF COYNE

OLDEST, BEST EQUIPPED SCHOOL OF ITS KIND IN U. S.

Come to the Great shops of Coyne in Chicago. Get practical training in TELEVISION—RADIO—ELECTRICITY—ELECTRONICS—vital in Defense Program. Prepare now for a better job in industry or higher rating in Armed Forces.

Approved for Veterans—finance plan—enroll now, pay most of tuition later. Part time employment service while training if needed. Special tuition plan for men of Draft Age.

FREE BOOK Clip coupon for Big Free Illustrated Book. No obligation. No salesman will call. Act NOW.

B. W. Cooke, President
A TECHNICAL TRADE INSTITUTE CHARTERED NOT FOR PROFIT Established 1899 500 S. Paulina, Chicago

COYNE SCHOOL
ELECTRICITY ★ TELEVISION
RADIO ★ REFRIGERATION ★ ELECTRONICS

B. W. COOKE, Pres.
COYNE School
500 S. Paulina St., Chicago 12, Ill. Dept. 85-H
Send FREE BOOK and details on:
 RADIO-TELEVISION ELECTRICITY

NAME.....
ADDRESS.....
CITY.....STATE.....



POWER TRANSFORMERS

2500V for Crt 6.3V/6A, 2.5
w/1.75" csd Hvins \$7.98
1320V & 375VCT/110ma, 5.3
V/3A, 2.5V/3.25A, 5.3
V/2.5A, 6.3V/3A Hvins \$6.98
1000VCT/200MA, 18V/3.5A,
6.3V/5A, 5V/6A, \$6.98; 2 For \$12.98
1000VCT/45MA, 7.5V/80ma, 2.5V/3A,
3Vc/3A, 3Vc/3A, 3Vc/3A, 3Vc/3A,
6.3Vct, 3A csd Hvins can be used
23 rating Raytheon Hypersil Core. 4.98
950VCT/100MA, 5V/3A, 6.3V/3A, 3.49
45V/1A, 10V/1.5A, 5.49
900V/35MA, 2x2.5V/2A, 3.49
1.5 pair two 2.5V/2A, 2.5V/2A, 4.98
840VCT/110MA, 530Vct/21ma, 2x5V/
3A, 6.3Vct 1A, 6.3Vct/3A, 4.98
770VCT/85MA, 6.3V/3A, 6.3V/3A, 4.98
750VCT/200MA, 6.3V/5A, 5V/4amp, 6.49
700VCT/85MA, 6.3V/3A, 6.3V/7.5A, 3.25
650VCT/150MA, 5V/3A, 6.3V/2.1A, 2.98
700VCT/120MA, 2x6.3V/3A, 6.3V/1A
550VCT/150MA, 5V/3A, 6.3V/3A, 3.49
500VCT/60MA, 6.3V/4A Hsld, 2.98
420VCT/90MA, 6.3V/1.9A w/Inpt 6,
12, 24, 1.5V/1.5A, 1.5V/1.5A, 1.5V/1.5A,
Vibrator xfmr 1.98

FILAMENT TRANSFORMERS

6.3Vct/4A (rud 6.3V) H'sld Hvins, \$2.69
3V/1.5A, 30.95; 6.3Vct/6A, 1.98
2.5V/2A, 2/1.49; 7.5Vct/12A
24.6A csd, 4.98; 10.98
2.5 vct/10 amp, 24V/1.25 csd, 1.98
5Kvins, 3.59; 2x12V/2A, 3.89
5V/2A, 5V/3A, 2.5V/3A, 2.98
5V/60A, 13.98; 5V/115A, 16.95

FILTER CHOKES

Dual 30Hy/60ma Csd, \$.98
18Hy/40ma AC/DC H'sld, 3 for \$2.25
12Hy/80ma/Csd/H'sld/3Kvins USN, 2.25
Dual 10Hy/85MA, HMSLD, 1.98
10Hy/125ma/10V/3Kvins/1Kvins, 3.79
50Hy/125ma/Csd/H'sld, 2.89
12Hy/300ma/Csd/3Kvins/H'sld, 4.95
20Hy/300ma or 15V/400ma, 12Kvins, 3.95
13.5Hy 1A/17Kvins/Raytheon, 39.95
10Hy 200ma Hmsld Jefferson, 2.95
8Hy 225ma Thordarson, 3.50

RELAY SPECIALS

SPST Min size, 115VAC
3DA CTS 98c; 3 for \$2.75
SPDT Min size, 115V AC
3DA CTS \$1.39; 3 for \$3.75
SPDT 24VDC/5A CTS All
Fsd 98c; 6 For \$5
SPNO 115VAC/15A CTS \$Dunn, \$2.98
PDT&SPNO 12VDC/10A CTS, 2.98

PLATE TRANSFORMERS

1100vct/212MA, Pri 115 Cased, \$ 6.50
3000V/10MA Cased HVins, 8.95
5500V/650MA USN WSTGHS, 69.95
15000V as VPBLR W.E. Sig3H5629
7500V/35MA, 19.95

SELENIUM RECTIFIERS

We specialize in Rectifiers and Power supplies to your specifications. Immediate delivery.
Current 18/14 26/18 36/28 54/40 130/100
1AMP 1.25 2.00 3.00 6.00 10.50
2AMP 2.20 3.60 6.50 10.50
3AMP 3.75 6.75 8.75 27.00
4AMP 4.95 8.95 12.00 27.00
10AMP 6.75 9.98 12.00 20.00 40.00
12AMP 8.50 16.20 20.00 25.00 50.00
14AMP 13.20 24.00 30.00 35.00 70.00
24AMP 16.00 31.00 39.50 98.00
30AMP 18.50 24.30 36.00
36AMP 25.50 36.00
Full Wave Selen Rect & Trans. in Kit form.
All 115V/60cy inputs.
up to 14VDC at 25 amps, \$ 23.98
up to 28VDC at 12 amps, 31.98
up to 28VDC at 48 amps, 149.50
up to 20VDC at 25 amps, 12.98
*This 6 amp supply has no ageing taps.

RECTIFIER XFORMERS

18-19-20-24-21-4Vols/12amp \$14.98
31-32-34-36-38-40-42-44-46-48-50-52-54-56-58-60-62-64-66-68-70-72-74-76-78-80-82-84-86-88-90-92-94-96-98-100-102-104-106-108-110-112-114-116-118-120-122-124-126-128-130-132-134-136-138-140-142-144-146-148-150-152-154-156-158-160-162-164-166-168-170-172-174-176-178-180-182-184-186-188-190-192-194-196-198-200-202-204-206-208-210-212-214-216-218-220-222-224-226-228-230-232-234-236-238-240-242-244-246-248-250-252-254-256-258-260-262-264-266-268-270-272-274-276-278-280-282-284-286-288-290-292-294-296-298-300-302-304-306-308-310-312-314-316-318-320-322-324-326-328-330-332-334-336-338-340-342-344-346-348-350-352-354-356-358-360-362-364-366-368-370-372-374-376-378-380-382-384-386-388-390-392-394-396-398-400-402-404-406-408-410-412-414-416-418-420-422-424-426-428-430-432-434-436-438-440-442-444-446-448-450-452-454-456-458-460-462-464-466-468-470-472-474-476-478-480-482-484-486-488-490-492-494-496-498-500-502-504-506-508-510-512-514-516-518-520-522-524-526-528-530-532-534-536-538-540-542-544-546-548-550-552-554-556-558-560-562-564-566-568-570-572-574-576-578-580-582-584-586-588-590-592-594-596-598-600-602-604-606-608-610-612-614-616-618-620-622-624-626-628-630-632-634-636-638-640-642-644-646-648-650-652-654-656-658-660-662-664-666-668-670-672-674-676-678-680-682-684-686-688-690-692-694-696-698-700-702-704-706-708-710-712-714-716-718-720-722-724-726-728-730-732-734-736-738-740-742-744-746-748-750-752-754-756-758-760-762-764-766-768-770-772-774-776-778-780-782-784-786-788-790-792-794-796-798-800-802-804-806-808-810-812-814-816-818-820-822-824-826-828-830-832-834-836-838-840-842-844-846-848-850-852-854-856-858-860-862-864-866-868-870-872-874-876-878-880-882-884-886-888-890-892-894-896-898-900-902-904-906-908-910-912-914-916-918-920-922-924-926-928-930-932-934-936-938-940-942-944-946-948-950-952-954-956-958-960-962-964-966-968-970-972-974-976-978-980-982-984-986-988-990-992-994-996-998-1000-1002-1004-1006-1008-1010-1012-1014-1016-1018-1020-1022-1024-1026-1028-1030-1032-1034-1036-1038-1040-1042-1044-1046-1048-1050-1052-1054-1056-1058-1060-1062-1064-1066-1068-1070-1072-1074-1076-1078-1080-1082-1084-1086-1088-1090-1092-1094-1096-1098-1100-1102-1104-1106-1108-1110-1112-1114-1116-1118-1120-1122-1124-1126-1128-1130-1132-1134-1136-1138-1140-1142-1144-1146-1148-1150-1152-1154-1156-1158-1160-1162-1164-1166-1168-1170-1172-1174-1176-1178-1180-1182-1184-1186-1188-1190-1192-1194-1196-1198-1200-1202-1204-1206-1208-1210-1212-1214-1216-1218-1220-1222-1224-1226-1228-1230-1232-1234-1236-1238-1240-1242-1244-1246-1248-1250-1252-1254-1256-1258-1260-1262-1264-1266-1268-1270-1272-1274-1276-1278-1280-1282-1284-1286-1288-1290-1292-1294-1296-1298-1300-1302-1304-1306-1308-1310-1312-1314-1316-1318-1320-1322-1324-1326-1328-1330-1332-1334-1336-1338-1340-1342-1344-1346-1348-1350-1352-1354-1356-1358-1360-1362-1364-1366-1368-1370-1372-1374-1376-1378-1380-1382-1384-1386-1388-1390-1392-1394-1396-1398-1400-1402-1404-1406-1408-1410-1412-1414-1416-1418-1420-1422-1424-1426-1428-1430-1432-1434-1436-1438-1440-1442-1444-1446-1448-1450-1452-1454-1456-1458-1460-1462-1464-1466-1468-1470-1472-1474-1476-1478-1480-1482-1484-1486-1488-1490-1492-1494-1496-1498-1500-1502-1504-1506-1508-1510-1512-1514-1516-1518-1520-1522-1524-1526-1528-1530-1532-1534-1536-1538-1540-1542-1544-1546-1548-1550-1552-1554-1556-1558-1560-1562-1564-1566-1568-1570-1572-1574-1576-1578-1580-1582-1584-1586-1588-1590-1592-1594-1596-1598-1600-1602-1604-1606-1608-1610-1612-1614-1616-1618-1620-1622-1624-1626-1628-1630-1632-1634-1636-1638-1640-1642-1644-1646-1648-1650-1652-1654-1656-1658-1660-1662-1664-1666-1668-1670-1672-1674-1676-1678-1680-1682-1684-1686-1688-1690-1692-1694-1696-1698-1700-1702-1704-1706-1708-1710-1712-1714-1716-1718-1720-1722-1724-1726-1728-1730-1732-1734-1736-1738-1740-1742-1744-1746-1748-1750-1752-1754-1756-1758-1760-1762-1764-1766-1768-1770-1772-1774-1776-1778-1780-1782-1784-1786-1788-1790-1792-1794-1796-1798-1800-1802-1804-1806-1808-1810-1812-1814-1816-1818-1820-1822-1824-1826-1828-1830-1832-1834-1836-1838-1840-1842-1844-1846-1848-1850-1852-1854-1856-1858-1860-1862-1864-1866-1868-1870-1872-1874-1876-1878-1880-1882-1884-1886-1888-1890-1892-1894-1896-1898-1900-1902-1904-1906-1908-1910-1912-1914-1916-1918-1920-1922-1924-1926-1928-1930-1932-1934-1936-1938-1940-1942-1944-1946-1948-1950-1952-1954-1956-1958-1960-1962-1964-1966-1968-1970-1972-1974-1976-1978-1980-1982-1984-1986-1988-1990-1992-1994-1996-1998-2000-2002-2004-2006-2008-2010-2012-2014-2016-2018-2020-2022-2024-2026-2028-2030-2032-2034-2036-2038-2040-2042-2044-2046-2048-2050-2052-2054-2056-2058-2060-2062-2064-2066-2068-2070-2072-2074-2076-2078-2080-2082-2084-2086-2088-2090-2092-2094-2096-2098-2100-2102-2104-2106-2108-2110-2112-2114-2116-2118-2120-2122-2124-2126-2128-2130-2132-2134-2136-2138-2140-2142-2144-2146-2148-2150-2152-2154-2156-2158-2160-2162-2164-2166-2168-2170-2172-2174-2176-2178-2180-2182-2184-2186-2188-2190-2192-2194-2196-2198-2200-2202-2204-2206-2208-2210-2212-2214-2216-2218-2220-2222-2224-2226-2228-2230-2232-2234-2236-2238-2240-2242-2244-2246-2248-2250-2252-2254-2256-2258-2260-2262-2264-2266-2268-2270-2272-2274-2276-2278-2280-2282-2284-2286-2288-2290-2292-2294-2296-2298-2300-2302-2304-2306-2308-2310-2312-2314-2316-2318-2320-2322-2324-2326-2328-2330-2332-2334-2336-2338-2340-2342-2344-2346-2348-2350-2352-2354-2356-2358-2360-2362-2364-2366-2368-2370-2372-2374-2376-2378-2380-2382-2384-2386-2388-2390-2392-2394-2396-2398-2400-2402-2404-2406-2408-2410-2412-2414-2416-2418-2420-2422-2424-2426-2428-2430-2432-2434-2436-2438-2440-2442-2444-2446-2448-2450-2452-2454-2456-2458-2460-2462-2464-2466-2468-2470-2472-2474-2476-2478-2480-2482-2484-2486-2488-2490-2492-2494-2496-2498-2500-2502-2504-2506-2508-2510-2512-2514-2516-2518-2520-2522-2524-2526-2528-2530-2532-2534-2536-2538-2540-2542-2544-2546-2548-2550-2552-2554-2556-2558-2560-2562-2564-2566-2568-2570-2572-2574-2576-2578-2580-2582-2584-2586-2588-2590-2592-2594-2596-2598-2600-2602-2604-2606-2608-2610-2612-2614-2616-2618-2620-2622-2624-2626-2628-2630-2632-2634-2636-2638-2640-2642-2644-2646-2648-2650-2652-2654-2656-2658-2660-2662-2664-2666-2668-2670-2672-2674-2676-2678-2680-2682-2684-2686-2688-2690-2692-2694-2696-2698-2700-2702-2704-2706-2708-2710-2712-2714-2716-2718-2720-2722-2724-2726-2728-2730-2732-2734-2736-2738-2740-2742-2744-2746-2748-2750-2752-2754-2756-2758-2760-2762-2764-2766-2768-2770-2772-2774-2776-2778-2780-2782-2784-2786-2788-2790-2792-2794-2796-2798-2800-2802-2804-2806-2808-2810-2812-2814-2816-2818-2820-2822-2824-2826-2828-2830-2832-2834-2836-2838-2840-2842-2844-2846-2848-2850-2852-2854-2856-2858-2860-2862-2864-2866-2868-2870-2872-2874-2876-2878-2880-2882-2884-2886-2888-2890-2892-2894-2896-2898-2900-2902-2904-2906-2908-2910-2912-2914-2916-2918-2920-2922-2924-2926-2928-2930-2932-2934-2936-2938-2940-2942-2944-2946-2948-2950-2952-2954-2956-2958-2960-2962-2964-2966-2968-2970-2972-2974-2976-2978-2980-2982-2984-2986-2988-2990-2992-2994-2996-2998-3000-3002-3004-3006-3008-3010-3012-3014-3016-3018-3020-3022-3024-3026-3028-3030-3032-3034-3036-3038-3040-3042-3044-3046-3048-3050-3052-3054-3056-3058-3060-3062-3064-3066-3068-3070-3072-3074-3076-3078-3080-3082-3084-3086-3088-3090-3092-3094-3096-3098-3100-3102-3104-3106-3108-3110-3112-3114-3116-3118-3120-3122-3124-3126-3128-3130-3132-3134-3136-3138-3140-3142-3144-3146-3148-3150-3152-3154-3156-3158-3160-3162-3164-3166-3168-3170-3172-3174-3176-3178-3180-3182-3184-3186-3188-3190-3192-3194-3196-3198-3200-3202-3204-3206-3208-3210-3212-3214-3216-3218-3220-3222-3224-3226-3228-3230-3232-3234-3236-3238-3240-3242-3244-3246-3248-3250-3252-3254-3256-3258-3260-3262-3264-3266-3268-3270-3272-3274-3276-3278-3280-3282-3284-3286-3288-3290-3292-3294-3296-3298-3300-3302-3304-3306-3308-3310-3312-3314-3316-3318-3320-3322-3324-3326-3328-3330-3332-3334-3336-3338-3340-3342-3344-3346-3348-3350-3352-3354-3356-3358-3360-3362-3364-3366-3368-3370-3372-3374-3376-3378-3380-3382-3384-3386-3388-3390-3392-3394-3396-3398-3400-3402-3404-3406-3408-3410-3412-3414-3416-3418-3420-3422-3424-3426-3428-3430-3432-3434-3436-3438-3440-3442-3444-3446-3448-3450-3452-3454-3456-3458-3460-3462-3464-3466-3468-3470-3472-3474-3476-3478-3480-3482-3484-3486-3488-3490-3492-3494-3496-3498-3500-3502-3504-3506-3508-3510-3512-3514-3516-3518-3520-3522-3524-3526-3528-3530-3532-3534-3536-3538-3540-3542-3544-3546-3548-3550-3552-3554-3556-3558-3560-3562-3564-3566-3568-3570-3572-3574-3576-3578-3580-3582-3584-3586-3588-3590-3592-3594-3596-3598-3600-3602-3604-3606-3608-3610-3612-3614-3616-3618-3620-3622-3624-3626-3628-3630-3632-3634-3636-3638-3640-3642-3644-3646-3648-3650-3652-3654-3656-3658-3660-3662-3664-3666-3668-3670-3672-3674-3676-3678-3680-3682-3684-3686-3688-3690-3692-3694-3696-3698-3700-3702-3704-3706-3708-3710-3712-3714-3716-3718-3720-3722-3724-3726-3728-3730-3732-3734-3736-3738-3740-3742-3744-3746-3748-3750-3752-3754-3756-3758-3760-3762-3764-3766-3768-3770-3772-3774-3776-3778-3780-3782-3784-3786-3788-3790-3792-3794-3796-3798-3800-3802-3804-3806-3808-3810-3812-3814-3816-3818-3820-3822-3824-3826-3828-3830-3832-3834-3836-3838-3840-3842-3844-3846-3848-3850-3852-3854-3856-3858-3860-3862-3864-3866-3868-3870-3872-3874-3876-3878-3880-3882-3884-3886-3888-3890-3892-3894-3896-3898-3900-3902-3904-3906-3908-3910-3912-3914-3916-3918-3920-3922-3924-3926-3928-3930-3932-3934-3936-3938-3940-3942-3944-3946-3948-3950-3952-3954-3956-3958-3960-3962-3964-3966-3968-3970-3972-3974-3976-3978-3980-3982-3984-3986-3988-3990-3992-3994-3996-3998-4000-4002-4004-4006-4008-4010-4012-4014-4016-4018-4020-4022-4024-4026-4028-4030-4032-4034-4036-4038-4040-4042-4044-4046-4048-4050-4052-4054-4056-4058-4060-4062-4064-4066-4068-4070-4072-4074-4076-4078-4080-4082-4084-408

EICO
TEST INSTRUMENTS

GUARDS CBS *Columbia*
HIGH STANDARDS OF
TELEVISION PRODUCTION QUALITY

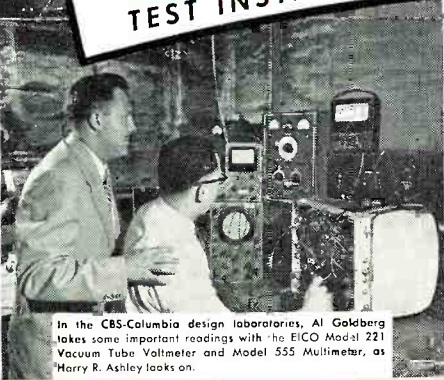

In the CBS-Columbia design laboratories, Al Goldberg takes some important readings with the EICO Model 221 Vacuum Tube Voltmeter and Model 555 Multimeter, as Harry R. Ashley looks on.

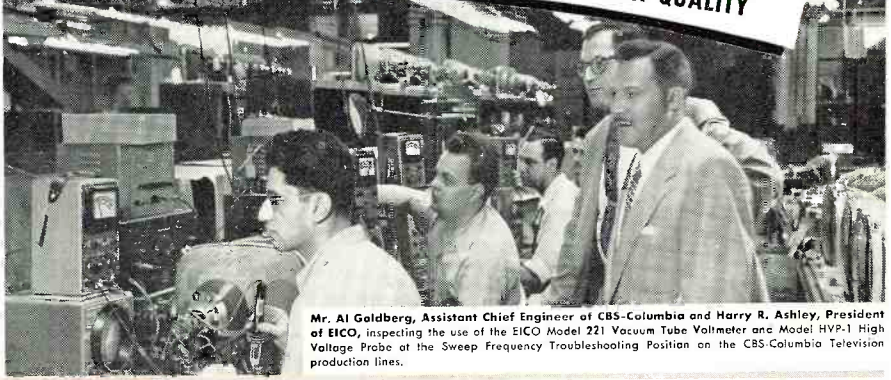

Mr. Al Goldberg, Assistant Chief Engineer of CBS-Columbia and Harry R. Ashley, President of EICO, inspecting the use of the EICO Model 221 Vacuum Tube Voltmeter and Model HYP-1 High Voltage Probe at the Sweep Frequency Troubleshooting Position on the CBS-Columbia Television production lines.

KITS-Wired Instruments
For Laboratory Precision at Lowest Cost—
the Leaders Look to **EICO!**

WHY does CBS-Columbia, Inc., one of America's great headline-makers in Television set production, use EICO Test Instruments on both its new Television production lines and in its design laboratories?

BECAUSE like Emerson, Tele-King, Teletone, Majestic, and many another famous TV manufacturer coast to coast, CBS-Columbia knows that

- ONLY **EICO** TEST EQUIPMENT DELIVERS ALL 10 **EICONOMICAL** FEATURES
1. Laboratory Precision
 2. Lowest Cost
 3. Lifetime Dependability
 4. Speedy Operation
 5. Rugged Construction
 6. Quality Components
 7. Latest Engineering
 8. Super-Simplified Assembly and Use Instructions
 9. Laboratory-Styled Appearance
 10. Exclusive EICO Make-Good Guarantee

Before You buy any higher-priced equipment, be sure You look at the **EICO** line—in *Wired* as well as *Kit form!* Each **EICO** product is jam-packed with unbelievable value. **YOU** be the judge—compare, see **EICO** instruments today—in stock at your local jobber—and **SAVE 50%! Write NOW for FREE newest Catalog 12-R.**

FOLLOW THE LEADERS... INSIST ON EICO!

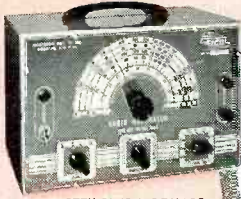

NEW 377K SINE & SQUARE WAVE AUDIO GEN. KIT \$31.95. WIRED \$49.95

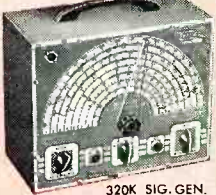

320K SIG. GEN. KIT \$19.95. WIRED \$29.95
322K SIG. GEN. KIT \$23.95. WIRED \$34.95

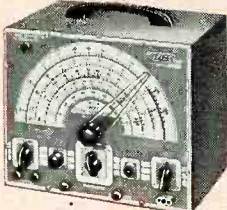

360K SWEEP GEN. KIT \$34.95
WIRED \$49.95

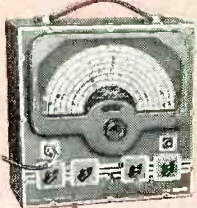

315K DELUXE SIG. GEN. KIT \$39.95
WIRED \$59.95



1040K BATTERY ELIM. KIT \$25.95 WIRED \$34.95



1171K RES. DECADE BOX KIT \$19.95
WIRED \$24.95



NEW 536K MULTIMETER KIT \$12.90.
WIRED \$14.90.
1000 OHMS/VOLT

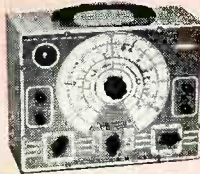

950K R-C BRIDGE & R-C-L COMP. KIT \$19.95
WIRED \$29.95

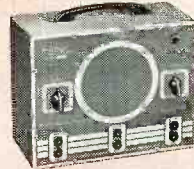

145K SIG. TRACER KIT \$19.95
WIRED \$28.95

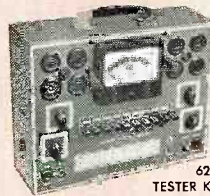

625K TUBE TESTER KIT \$34.95
WIRED \$49.95



221K VTVM KIT \$25.95 WIRED \$49.95



CRA PIX TUBE ADAPTOR for Tube Tester \$4.50



NEW 565K MULTIMETER KIT \$24.95.
WIRED \$29.95.
20,000 OHMS/VOLT

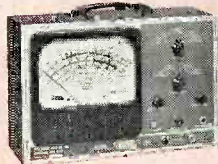

NEW 214K VTVM KIT \$34.95.
WIRED \$54.95. 7 1/2" METER

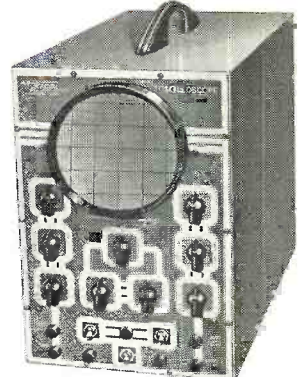

425K 5" PUSH-PULL SCOPE KIT \$44.95. WIRED \$79.95



HIGH VOLTAGE PROBE \$6.95

AMERICA'S GREATEST INSTRUMENT VALUES BEAR THE NAME —

EICO Reg. U.S. Pat. Off.

ELECTRONIC INSTRUMENT CO., INC.
84 Withers Street, Brooklyn 11, N. Y.

Easy to sell...



Easy to install...

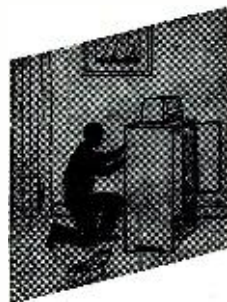

Easy to use...



Made to order for you and your customers

Any way you look at it, the precision-built Mallory UHF Converter is just what you'll need to cash in on the extra profits available when UHF comes to town.

EASY TO SELL because it gives reception of *all* UHF channels to *all* TV sets without sacrifice of *any* VHF channels. And the buyer gets high quality picture definition.

EASY TO INSTALL because the job can be done right in the customer's home without special tools . . . no soldering . . . no aligning. It takes just a few minutes to connect antenna leads and power lines from converter to set.

EASY TO USE because of simple band switching—familiar type tuning control for channel selection.

FIELD TESTED AND PROVED, the Mallory UHF Converter is about the size of a small table radio, attractively styled, mahogany color plastic cabinet.

ASK YOUR MALLORY DISTRIBUTOR TODAY to show you the Mallory UHF Converter. See for yourself what a real sales opportunity it offers. And ask about the sales-building advertising and sales promotion program Mallory has worked out to help boost sales.

Mallory UHF Converter

*Make Sure ...
Make it Mallory*

P. R. MALLORY & CO. INC.
MALLORY
 CAPACITORS . . . CONTROLS . . . VIBRATORS
 SWITCHES . . . RESISTORS . . . RECTIFIERS
 VIBRABACKS . . . POWER SUPPLIES . . . FILTERS
*Reg. U.S. Pat. Off.
APPROVED PRECISION PRODUCTS

P. R. MALLORY & CO., Inc., INDIANAPOLIS 6, INDIANA